



HAL
open science

The Representation and Selection of Prepositions

Jesse Tseng

► **To cite this version:**

Jesse Tseng. The Representation and Selection of Prepositions. Linguistics. Edinburgh University, 2000. English. NNT: . halshs-00004845

HAL Id: halshs-00004845

<https://theses.hal.science/halshs-00004845>

Submitted on 5 Oct 2005

HAL is a multi-disciplinary open access archive for the deposit and dissemination of scientific research documents, whether they are published or not. The documents may come from teaching and research institutions in France or abroad, or from public or private research centers.

L'archive ouverte pluridisciplinaire **HAL**, est destinée au dépôt et à la diffusion de documents scientifiques de niveau recherche, publiés ou non, émanant des établissements d'enseignement et de recherche français ou étrangers, des laboratoires publics ou privés.

The Representation and Selection of Prepositions

Jesse L. Tseng



Doctor of Philosophy
Institute for Communicating and Collaborative Systems
Division of Informatics
University of Edinburgh
2000

Abstract

In the literature on prepositions, a distinction between “lexical” and “functional” uses is commonly assumed. In most theoretical accounts, this contrast is treated as a binary classification, and every preposition is assigned one of two distinct representations, depending on its lexical or functional status.

In this thesis I investigate the nature of the lexical vs. functional distinction for prepositions, and I argue that these two uses correspond to cardinal points of a spectrum of prepositional uses. This spectrum can be modelled descriptively as the interaction of two properties: form-fixedness and perceived meaningfulness. At the functional corner of the spectrum, prepositions are characterized by low meaningfulness and high fixedness, while at the lexical corner, prepositions have high meaningfulness and low fixedness. There are also, however, prepositions that are perceived to be both meaningful and fixed, and these present a problem for the notion of a simple binary lexical vs. functional dichotomy.

A number of empirical tests have been proposed for inducing a binary classification of prepositional uses—for example, formation of the pseudopassive and *wh*-questions, and specifier attachment. While these are all interesting phenomena individually, they do not converge on a single classification collectively, and I conclude that there are no broad generalizations to be captured by postulating a primitive lexical vs. functional distinction theoretically.

My own analysis, formalized in the framework of Head-Driven Phrase Structure Grammar, includes two binary distinctions between contentful vs. empty prepositions, and between prepositions with syntactically selected form vs. those without. The interaction of these distinctions results in an idealized representation of the three-cornered descriptive spectrum of meaningfulness and fixedness. I discuss various ways in which my more or less discrete formal representations can give rise to gradient behavior on a descriptive level.

In my account, depending on the context, prepositions can be selected based on form, content, or both at the same time. There is a trend in the literature towards analyzing prepositional selection as a phenomenon governed primarily by semantic considerations. Many of the insights of these approaches can also be accommodated in my analysis. In general, however, I argue that the empirical facts are more straightforwardly explained if both syntactic and semantic selection mechanisms are allowed.

This thesis also includes a proposal for extending the HPSG MARKING Theory to allow a unified treatment of four types of grammatical marking: prepositions and case in nominal contexts, and complementizers and verb form in verbal contexts.

Acknowledgments

At the University of Edinburgh, I would like to thank above all my advisers, Claire Grover and Marc Moens, for their unfailing support and encouragement. Their guiding influence is evident throughout this dissertation. At times, the only thing keeping this project afloat was their belief in it, which was far more constant than my own. The greater part of the credit for this completed work therefore goes to them.

Thanks also to Ewan Klein, who taught my first course in HPSG (and later gave me the chance to teach it myself), and to Janet Hitzeman and Sheila Glasbey, who supervised preliminary work for this thesis. I am indebted to Betty Hughes for all manner of administrative and practical assistance.

Some of the ideas in this thesis were developed during a visit to CSLI in autumn 1998. I am grateful to Ivan Sag, Dan Flickinger, and Ann Copestake for a warm welcome and challenging discussions. The text of the dissertation was finally put together at the University of Tübingen, and my thanks go to Erhard Hinrichs and to everyone in the Tübingen HPSG community, who turned the place into a real thesis factory during the year 2000.

My studies at the University of Edinburgh were arranged and in large part funded by the Marshall Aid Commemoration Commission. I would like to thank the members of the Commission and my fellow Marshall scholars for this unforgettable experience. I am particularly grateful to Catherine Reive for her support and assistance during my time in the UK.

Finally, I thank all of my friends—officemates, classmates, flatmates, pub-mates, travel-mates, e-mail mates. Thanks for keeping me from turning into an empty preposition.

Declaration

I declare that this thesis was composed by myself and that the work contained therein is my own except where explicitly stated otherwise in the text. This work has not been submitted for any other degree or professional qualification except as specified.

Jesse L. Tseng

Table of Contents

1 A Spectrum of Prepositional Uses	15
1.1 Dimensions of Variation	15
1.1.1 Lexical vs. functional	15
1.1.2 Type A and Type B	16
1.1.3 Type AB prepositions	18
1.2 Meaningfulness	20
1.2.1 Degrees of meaningfulness	20
1.2.2 Prepositional meanings	21
1.2.3 Paraphrase	24
1.2.4 Independent contexts	25
1.2.5 Meaning vs. content	27
1.3 Form-Fixedness	28
1.3.1 External trigger	28
1.3.2 Internal trigger	31
1.3.3 Other triggers	32
1.4 Interaction	33
2 Discrete Classification of Prepositional Uses	37
2.1 Constructing Classifications	37
2.2 Lexical Form	39
2.2.1 Primary prepositions	40
2.2.2 Fixable forms	41
2.3 Cohesiveness	43
2.3.1 Single-word synonyms	44
2.3.2 Coordination	46
2.3.3 Intervening adjuncts	47
2.4 PP Movement	50

2.4.1 Topicalization	50
2.4.2 Pied-piping	51
2.5 Preposition Stranding	52
2.5.1 <i>Wh</i> -movement	52
2.5.2 Pseudopassivization	53
2.6 Question Forms	54
2.6.1 Examples	55
2.6.2 Classification	56
2.6.3 Remaining problems	58
2.6.4 Non- <i>wh</i> proforms	59
2.7 Projection Properties	60
2.7.1 Complementation	60
2.7.2 Modification	63
2.7.3 Specifiers	64
2.8 Interaction of Criteria	66
2.8.1 Classification by multiple criteria	67
2.8.2 Binary classification	69
2.9 Summary	70
3 Approaches to Prepositional Analysis	71
3.1 Extended projection	71
3.1.1 Semantic transparency	72
3.1.2 Categorical features	73
3.1.3 Semi-lexical heads	74
3.2 Headedness of PPs	75
3.2.1 Head properties	75
3.2.2 Base properties	76
3.2.3 Case prepositions	78
3.3 PP Attachment	80
3.4 HPSG Analyses	82
3.4.1 Transparent prepositions	82
3.4.2 Prepositions as markers	84
3.4.3 Meaningful prepositions	87
3.5 Summary	89

4	Prepositions in HPSG	91
4.1	Minimal Recursion Semantics	91
4.1.1	Semantic percolation in MRS	91
4.1.2	Modifications and additions	93
4.2	Prepositional Content	96
4.2.1	Content prepositions	96
4.2.2	Empty prepositions	99
4.2.3	ARG-ST and MOD	104
4.2.4	Predicativity	107
4.3	Prepositional Form	109
4.3.1	Syntactic identity	109
4.3.2	Marker Ps and free Ps	112
4.4	Selection	114
4.4.1	Type B vs. Type A selection	114
4.4.2	Double selection	117
4.4.3	Non-selection	120
4.5	Prepositions in the Lexicon	121
4.5.1	Hierarchy	121
4.5.2	Lexemes	121
4.5.3	Expansion	122
4.6	Summary: Overlapping Analyses	124
5	Mechanisms of Preposition Selection	127
5.1	Semantic Patterns	127
5.1.1	Argument Principle	128
5.1.2	Type A uses	130
5.2	Limits of Semantic Selection	132
5.2.1	Distinct lexical relations	133
5.2.2	Vague semantics	136
5.3	HPSG Approaches	138
5.3.1	Restricted Linking	138
5.3.2	Reformulation	140
5.3.3	Virtual content	140
5.4	Summary	142

6	Prepositions, Case, and HPSG Marking Theory	143
6.1	Functional Similarity	143
6.1.1	Case Grammar	143
6.1.2	Alternations	144
6.1.3	NP markers	145
6.2	HPSG Marking Theory	146
6.2.1	Standard Marking Theory	146
6.2.2	Application to NP marking	147
6.2.3	Dative alternation	148
6.2.4	MARKING lists	150
6.3	Extension to VP Marking	151
6.3.1	Complementizers	152
6.3.2	Case and verb form	153
6.3.3	Complementizers and verb form	153
6.3.4	Visibility	154
6.4	Summary	155
7	Conclusions	157
7.1	Summary of Results	157
7.2	Further Questions	158
	References	161

Chapter 1

A Spectrum of Prepositional Uses

The class of prepositions contains relatively few elements, compared to the “major” syntactic categories N, V, and A. Nevertheless, this small set of elements has a wide variety of uses, with different uses exhibiting strikingly divergent grammatical properties. The goal of this thesis is to provide an account of the observed range of prepositional behavior.

In the descriptive and theoretical literature, a distinction is often made between lexical and functional prepositions. These two subclasses of prepositions are best considered as the poles of a spectrum of prepositional uses. In this chapter I suggest a way of modelling this spectrum by means of two dimensions of gradient variation: meaningfulness and form-fixedness.

1.1 Dimensions of Variation

1.1.1 Lexical vs. functional

Linguistic elements are commonly classified as lexical/contentive on the one hand, as opposed to functional/grammatical on the other hand. Broadly speaking, lexical elements are used primarily to contribute meaning, while functional elements appear in a construction primarily to satisfy grammatical constraints. For example, ordinary nouns, verbs, and adjectives—the bulk of the vocabulary of a language—are substantive elements, while auxiliary verbs, determiners, and complementizers are examples of functional elements.

The intuitive appeal of the lexical vs. functional distinction is very strong, but its theoretical status is a matter of considerable debate. There are a number of grammatical properties that can be used as indicators of lexical or functional status, from phonology and morphology, to distribution and closed vs. open class membership, to syntactic and semantic properties. Taken individually, however, most of these criteria are incomplete, or they give unclear (and occasionally incorrect) results, and taken collectively, they do not converge on a single classi-

fication (Cann, 2000).

If we consider the major categories N, V, and A, it is clear that the majority of their members are lexical elements. It is possible to identify small subcategories of functional elements; we could consider pronouns, auxiliary verbs, and determiners to be functional subsets of N, V, and A. This brings up several interesting issues of categorization and representation, because exactly which elements go into these subsets is not always clear. For example, consider the noun/pronoun *one*, the verb/auxiliary *dare*, and the adjective/determiner *such*. On the other hand, these problematic cases are highly exceptional, and for the vast majority of cases, functional or lexical status is clear.¹

The situation is not as straightforward in the case of prepositions. It is commonly recognized that there are functional prepositions, sometimes referred to as “case-marking” and “non-predicative” prepositions, and the typical example is:

- (1) John gave a book to Mary.

It is immediately clear that we will not be able to identify an exclusively functional subset of P, because *to* can also be a lexical preposition:

- (2) Mary went to the racetrack.

One could argue that similar situations arise with N, V, and A above. For instance, the verbs *do* and *have* can be used both as auxiliaries and as regular verbs. But such cases are very rare: the great majority of pronominal, auxiliary, and determiner forms are exclusively functional. The opposite is true of prepositions: as we will see, all prepositional forms with functional uses also have lexical uses. Furthermore, they also have uses that are neither clearly functional nor clearly lexical, presenting a challenge for the notion of a simple functional vs. lexical dichotomy. And we are not dealing with a small number of highly exceptional cases; a significant proportion of all forms in the category P can be shown to exhibit this behavior.

1.1.2 Type A and Type B

The following two sets of examples illustrate the distinction between lexical and functional prepositional uses. In the following discussion, however, it will be useful to use the more neutral labels “Type A” and “Type B” corresponding to “lexical” and “functional,” respectively:

- (3) Type A:
a. The first guests should start arriving just after 8 o'clock.

¹The question remains whether the “functionality” of pronouns, auxiliaries, and determiners is a unified phenomenon that should be analyzed as such theoretically.

- b. Mary's office is at the other end of the hall.
 - c. The museum runs special tours for young children.
 - d. Our visitors brought us maple syrup from Vermont.
 - e. The magician stuffed the rabbit in his top hat.
 - f. An error message appeared on the screen.
 - g. Jack drank two cups of coffee with his dessert.
- (4) Type B:
- a. Your dog takes after its owner: irritable and smelly.
 - b. Jennifer is good at predicting the lottery results.
 - c. The guards won't fall for the same trick twice.
 - d. He tried desperately to prevent the film from being released.
 - e. Delicate negotiations resulted in a satisfactory compromise.
 - f. Everyone picked on the new student.
 - g. I suggest that we dispense with lengthy introductions.

These examples provide an intuitive basis for the distinction between Type A and B prepositions², which I will try to characterize more concretely in descriptive terms.

A good starting point is simply to look at the large amount of terminology that already exists in the literature for referring to this distinction, in addition to the labels “functional” and “lexical.” There is a particularly rich variety of terms for Type B prepositions, many of which highlight a particular descriptive property felt to be associated with them. For example, a Type B preposition can be called “governed” (Fillmore, 1968) or “determined” (Bennett, 1975), because it is dependent on another word in the construction, and this word determines its lexical form. This governor is usually a verb, but it can sometimes be an adjective as in (4b), or more rarely a noun (*an attempt at the world record*) or another preposition (*everyone except for James*).³

²More precisely, we should refer to Type A and Type B *uses* (tokens) of a particular prepositional *form* (type) in a particular context, but in practice, I will often use the shorter formulation. Also, a “Type A (B) PP” is a prepositional phrase headed by a Type A (B) preposition, and a “Type A (B) construction” is a grammatical construction containing a Type A (B) prepositional use. I will sometimes use “Type A” and “Type B” alone to refer collectively to the sets of Type A and Type B constructions.

³A further note on terminology: Verbs that combine with Type B prepositions are known as “prepositional verbs” (Quirk, Greenbaum, Leech, & Svartik, 1985), and the NP complement of the preposition is called the “prepositional object” of the verb (by analogy with the direct and indirect object). For example, in sentence (4f), the prepositional verb *pick* governs the preposition *on* and *the new student* is the prepositional object.

A number of labels refer to the fact that Type B prepositions seem to have indistinct or non-autonomous meaning: “synsemantic” (Fries, 1991), “colorless” (Zribi-Hertz, 1984; Spang-Hanssen, 1963). I have already mentioned the term “non-predicative” (Pollard & Sag, 1994), which suggests both semantic and syntactic deficiency. It is easy to check that these two properties—being fixed by another word and having indistinct meaning—hold for all of the Type B examples in (4). In fact, I take these to be the defining properties of Type B prepositional uses, although they first have to be explained in more detail. Finally, we have also seen the label “case-marking” (Gazdar, Klein, Pullum, & Sag, 1985) associated with Type B uses, which suggests that they have something in common with the grammatical notion of case. For example, the preposition *to* in (1) in the previous section has the same function as the dative case in some other languages.⁴ This is an interesting idea, but not one that translates readily into a descriptive property like the ones above, so I will leave it to the side for now.

Type A prepositions, on the other hand, exhibit the “opposite” properties from Type B prepositions: they have clearly discernible meaning, and they are not governed by another word that fixes their form. Again, these criteria need to be properly defined, but on an intuitive level, they do appear to be valid for the examples above in (3). To a lesser extent, these observations are reflected in the terminology used in previous accounts to refer to Type A uses: “non-determined,” “autosemantic,” “predicative.” The set of dedicated terms is smaller here, because in some sense, Type A prepositions are simply “ordinary” prepositions, while Type B uses are in some way exceptional.

One thing to notice about the existing terminology is that many authors use pairs of opposing terms for Type A and Type B: lexical vs. non-lexical, predicative vs. non-predicative. I have avoided this practice, because it makes premature assumptions about the nature of the data and how it should be analyzed. In particular, the use of such terms implicitly implies that every prepositional use can be classified as either Type A or Type B. As we will see, however, it is not at all straightforward to partition prepositional uses in this way.

1.1.3 Type AB prepositions

While many more examples can be found that have more or less the same properties as the Type A and Type B examples above, there is also a large class of constructions that do not fit convincingly into either category. According to my intuitions, the following examples all have intermediate status between Type A and Type B, and therefore I refer to them as Type AB constructions:

⁴In fact, I consider this use of *to* to be a Type AB use (see the next section).

- (5) Type AB:
- a. The new building was named after a generous benefactor.
 - b. There was a knock at the door, but I ignored it.
 - c. We should never have invested in a start-up called “Doofus.”
 - d. The train for Moscow has already left.
 - e. The entire shipment suffered from improper handling.
 - f. For this topic, researchers rely on secondary sources.
 - g. The veteran actor was awarded with a golden statuette.

There seems to be considerable diversity within this group of examples; some tend more towards the Type A examples in (3), some more towards the Type B examples in (4). But none of them fits squarely into either group. Like Type A cases, Type AB prepositions seem to make a semantic contribution, although it might be of a very abstract, metaphorical, or otherwise less immediately identifiable nature. At the same time, however, the lexical form of a Type AB preposition is governed by another word in its context, and in this sense, Type AB uses pattern with Type B uses. The form-government in the Type AB case may seem “weaker” than in the Type B case, but it is definitely stronger than in Type A constructions.

In other words, a Type AB preposition shares certain properties with both Type A and Type B prepositions. This also means, however, that it fails to display all of the properties of either a Type A or a Type B preposition, and this makes the classification of the examples in (5) uncertain.

I use the label “Type AB” as opposed to (for example) “Type C” because I do not want to suggest necessarily that we now have a third subset of prepositional uses to account for, in addition to Type A and Type B. It is clear that there is no distinct boundary between Type A and Type AB, or between Type B and Type AB; in fact, there is no doubt that some speakers would disagree with my classification of the specific examples above. On the other hand, every speaker could construct similar sets of examples, according to his or her own intuitions, illustrating the same point—that there is a gradient of prepositional uses between Type A and Type B.

The existence of this gradient is occasionally acknowledged in the descriptive literature (e.g., Quirk et al., 1985) but the issue is mostly ignored in theoretical work. This is unsurprising, since linguists generally have to work with discrete representations and true gradience (i.e., variation along a continuum) cannot be represented in such formalisms. On the other hand, continuous variation with respect to descriptive properties does not necessarily imply that true gradience must also be present in the grammar. As a simple example, we can think of

grammatical theories that identify a small set of thematic roles such as Agent, Patient, Experiencer, and so on (e.g., Case Grammar (Fillmore, 1968) and its descendants). These theories recognize the fact that we can discern arbitrarily fine distinctions between the semantic roles assigned by different predicates, but not all of these distinctions have grammatical significance.

Similarly, we might be able to reduce the prepositional gradient to a series of more or less discrete classes, each of which are accounted for with a separate analysis. Perhaps the entire gradient can even be reduced somehow to a simple binary classification, corresponding to the lexical vs. functional distinction that we started with. From what we have seen so far, no discrete classification, much less a binary one, can be taken for granted from the outset. It is clear that the issue of gradience should be addressed as part of any analysis of prepositions. As we have seen, however, classificatory labels like “functional” vs. “non-functional” and “predicative” and “non-predicative” leave little room for such considerations.

In the rest of this chapter I consider the nature of the prepositional gradient in more detail. First, I take a closer look at the two descriptive properties of meaningfulness and fixedness that I used above to characterize the distinction between Type A and Type B uses. Then I discuss the interaction of these properties and show that the one-dimensional gradient of prepositional uses suggested here is more accurately modelled by a two-dimensional spectrum.

1.2 Meaningfulness

As discussed above in §1.1.2, one of the ways in which Type A and Type B prepositional uses differ is with respect to meaning. Type A prepositions appear to have clear, identifiable meanings, while Type B prepositions have indistinct meanings that are highly dependent on the context. As a preliminary definition, “meaningfulness” measures the strength or identifiability of a preposition’s meaning; Type A and B prepositions therefore lie at the high and low ends of the scale of meaningfulness, respectively.

1.2.1 Degrees of meaningfulness

The meaningfulness of a preposition is a perceptual property, and as such, it shows variation along a continuous scale. To demonstrate this, I repeat the Type B and AB examples from (4)–(5) here, but rearranged very roughly in order of increasing meaningfulness, according to my intuitions:

- (6) Type B:
- a. I suggest that we dispense with lengthy introductions.
 - b. The guards won’t fall for the same trick twice.

- c. Everyone picked on the new student.
 - d. Jennifer is good at predicting the lottery results.
 - e. Your dog takes after its owner: irritable and smelly.
 - f. Delicate negotiations resulted in a satisfactory compromise.
 - g. He tried desperately to prevent the film from being released.
- (7) Type AB:
- a. The new building was named after a generous benefactor.
 - b. We should never have invested in a start-up called “Doofus.”
 - c. For this topic, researchers rely on secondary sources.
 - d. The entire shipment suffered from improper handling.
 - e. There was a knock at the door, but I ignored it.
 - f. The train for Moscow has already left.
 - g. The veteran actor was awarded with a golden statuette.

These examples show a broad trend from minimal to maximal meaningfulness. The two sets overlap; the examples at the end of set (6) are more meaningful than those at the beginning of set (7). This is an indication of the arbitrariness of the division between Type B and Type AB. The last few examples in (7), in turn, are fully meaningful and merge into Type A. Incidentally, the Type A examples in (3) cannot be ranked; all of the prepositions there are maximally meaningful.

The precise ranking of the examples in (6)–(7) is not very stable; almost any two adjacent examples could be switched around without noticeably disrupting the overall effect. Apparently speakers can only discern coarse distinctions in meaningfulness. It seems that meaningfulness is not a single property, but instead it reflects the influence of a number of sometimes conflicting factors.

1.2.2 Prepositional meanings

All of the more frequent prepositions are very versatile, and a lot of research has gone into ways of identifying and organizing the many polysemous meanings that a preposition can have. For the most part, however, studies have focused on the meanings of spatial and temporal prepositions (e.g., Bennett, 1975; Hawkins, 1985; Brugman, 1988). They deal with issues like locative vs. directional meaning, or the spatial configurations where one uses *over* vs. *above*, and so on. It is apparent that these questions are relevant within the class of Type A constructions, but shed little light on Type B uses of prepositions, or how the spectrum from Type A to Type B should be characterized.

Transferred spatial meanings

Nevertheless, authors who investigate spatial prepositional meanings often make the point that an understanding of spatial uses goes a long way towards explaining the use of prepositions in non-spatial situations. In many cases, components of the spatial meaning are more or less transparently discernible:

- (8) a. They have already spoken with each other over the phone.
- b. We must be over the worst of it by now.
- c. The rebels have control over the northwestern provinces.

On the other hand, the claim is easily overstated. For example, consider the following:

- (9) Stop fussing over the details.

It may be tempting to see some elements of the spatial meaning of *over* in this example. Very figuratively speaking, someone’s attention is “covering” the details; the details are “under” scrutiny. But this cannot really explain why *over* is used here instead of any other preposition, or why it is not used in the following contexts:

- (10) a. dwelling on the details
- b. caring about the details
- c. seeing to the details
- d. dealing with the details

At some point, then, *over* loses so much of its spatial meaning that we have to turn to other explanations for its occurrence.

The tendency for spatial meanings to be transferred to non-spatial domains therefore suggests one way of accounting for the scale from highly meaningful to less strongly meaningful uses. As an example, consider the definitions for the preposition *from*, adapted from its OED entry:

- (11) a. point of departure for spatial movement: *the voyage from Delos*
- b. removal or separation: *extracted from coconuts*
- c. starting point for spatial measurement: *extends from 59th to 110th Street*
- d. absence or remoteness: *a great distance from the ocean*
- e. abandonment of an abstract state: *freed from enslavement*
- f. starting point in time: *from now until Easter*
- g. starting point for non-motion actions: *seen from his perspective*

- h. set of choices: *four bulls from the herd*
- i. derivation or source: *made from walnut shells*
- j. reason or cause: *tired from the long journey*
- k. agent: *boos and hisses from the audience*
- l. unlikeness: *different from the other candidates*
- m. rule or standard: *a dress made from a pattern*

I have roughly arranged the spatial meanings first, followed by “increasingly non-spatial” meanings. It is apparent that meaningfulness decreases for the uses further down the list, although not drastically.

Core senses vs. prototypes

In the literature on prepositional polysemy, two general techniques are used for modelling ranges of meaning as in (11). First, the “core sense” or Gesamtbedeutung approach identifies a particular component that is common to all of the meanings in (11). The obvious choice for the core sense of *from* is the notion of SOURCE, although it is evident that this notion must be very abstractly understood to cover all of the meanings observed. There are a number of ways to account for the other components of meaning that are present with particular uses of *from* (e.g., motion, temporality, causation, comparison). The simplest approach is just to assume several lexical entries for *from*, all of which include SOURCE but perhaps additional content as well. Some authors, like Bennett (1975), prefer to avoid enlarging the lexicon and attribute non-core meaning to context (although it is unclear how this proposal can be formalized satisfactorily).

The second general approach to polysemy is based on prototypes (Rosch, 1978), an idea developed in more linguistic terms in the form of Jackendoff’s (1983) preference rule systems. In such a model, a category can be characterized by a number of prototypical features, none of which is absolutely required for category membership. In other words, the members of the category share a “family resemblance” without necessarily sharing any particular core features. Strictly speaking, then, the added complexity of a prototype model is not necessary for *from*, because a core sense is identifiable. This is actually unusual, however, for such a frequently occurring preposition. Typically, prepositions have meanings that are less straightforwardly related, and prototypes have proven very useful for categorizing these meanings (Hawkins, 1985; Brugman, 1988).

Both of these models can be used to account for degrees of meaningfulness, although this has not been a goal of existing studies as far as I know. In a core sense approach, prepositional uses that only express the core meaning will be less meaningful than those where additional

components of meaning are present. In a prototype model, we might expect meanings that are closer to the prototypical spatial sense to be perceived as more meaningful than less prototypical uses.

Non-spatial meanings

On the other hand, the meaningfulness of a preposition is not just a function of “how spatial” it is. Although spatial relations have privileged status, and all of the most frequent prepositions have spatial origins diachronically, non-spatial uses of prepositions can still be strongly meaningful. A particularly clear example is the preposition *for*, which expresses a wide range of non-spatial relations:

- (12) a. The emperor lived for another thirty years.
- b. It turned out that he paid someone to take the exam for him.
- c. The museum runs special tours for young children.
- d. We paid \$100 for the sculpture.
- e. That is an argument for tighter security.

In fact, the original spatial meaning of *for* (‘before,’ ‘in front of’) has been lost completely.

1.2.3 Paraphrase

Meaningfulness is a fundamentally intuitive notion, and I cannot offer any methods for measuring it explicitly, but there are some “tests” that get at the meaning of a preposition. For instance, if the meaning of a preposition is very strong and identifiable, it is usually possible to replace it with another phrase with similar meaning:

- (13) a. The train for Moscow has already left.
- b. The train headed towards/going to/with destination Moscow has already left.

On the other hand, it is hard to say what an appropriate paraphrase of the following use of *for* would be:

- (14) a. The guards won’t fall for the same trick twice.

With some imagination, this could be a remnant of the obsolete spatial meaning of *for* mentioned above:

- (14) b. ? The guards won’t fall before/in the face of the same trick twice.

The modified version draws attention to the metaphorical extension of *fall*, whereas (according to my intuitions) in the original sentence, *fall* does not feel linked to its literal use in this way.

Sometimes prepositions with intuitively low meaningfulness can be paraphrased:

- (15) a. The plants were unable to adapt to the new climate.
 b. The plants were unable to adapt in the face of the new climate.

This results in part from the fact that *adapt* can be used intransitively, and so the syntactic structures of the two examples are not the same. Although (15b) means something very similar to (15a), it cannot be said that *to* means ‘in the face of’ (at least not very strongly).

1.2.4 Independent contexts

With some effort, it is usually possible to think of a meaning for every prepositional use. A characteristic of weak meanings, however, seems to be that they do not travel well; in other contexts, the same meaning is unavailable. In particular, we are interested in how the meaning of the preposition holds up when it is in a syntactically independent position. In such cases, we get the clearest perception of the preposition’s meaning with minimal interference from the context.

Predication

For example, a preposition must be strongly meaningful to appear in a predicative context. I will consider the canonical case—after the copula *be*. In order to apply this test, we usually have to change the structure of the test item completely, and there is a danger of introducing confounding factors. The idea is to keep the “semantic context” as constant as possible:

- (16) An error message appeared on the screen.
 a. An error message was on the screen.
 b. * The appearance of the error message was on the screen.
- (17) She was born in September.
 a. * She was in September.
 b. Her birth was in September.

Here I have put the PP in a predicative context where the predication subject is one of the NPs from the original sentence, or an NP referring to the entire event in the original sentence. The results in these two cases are positive: a predication structure can be constructed where the preposition has the same perceived meaning as in the original example.

Now consider the following:

- (18) The plan smacks of big brotherism.
 a. * The plan is of big brotherism.
 b. * The smacking of the plan is of big brotherism.
- (19) The dog takes after its owner.
 a. * The dog is after its owner.
 b. * The dog’s taking is after its owner.

The results here reflect the low meaningfulness of these prepositions. We can also consider other predicative environments—e.g., after raising verbs like *seem*, after *consider*-type verbs and verbs of perception, or in absolutive phrases. The results show consistently that *of big brotherism* and *after its owner* cannot serve as predicates while retaining the (very weak to nonexistent) meanings they have in the original sentences.

The predication test can give the wrong results with some strongly meaningful prepositions because for some reason they simply cannot appear in predicative environments:

- (20) Jennifer met the man with no eyebrows.
 a. * The man/Jennifer was with no eyebrows.
 b. * Jennifer’s encounter was with no eyebrows.

Another pitfall of the test is that PP complements are sometimes allowed to appear across the copula:

- (21) a. I handed the message to Jack.
 b. The message was to Jack.

The grammaticality of (21b) seems to indicate a positive result, but note the following:

- (22) a. I handed the watermelon to Jack.
 b. * The watermelon was to Jack.

The *to*-PP in (21b) seems to be licensed by *message*. The predication test is therefore sensitive to other factors besides the meaningfulness of the preposition.

Modification

The ability to appear in modifier position is also a sign of meaningfulness:

- (23) The man travelled from Vienna.
 a. the man from Vienna
 b. * the travel from Vienna

- (24) The city is counting on new investments.
- a. * the city on new investments
 - b. * the counting on new investments

This test is more difficult to apply because in general PP modifiers occur in the same positions as PP complements.

The predication and modification tests are not meant as real criteria for meaningfulness; we have seen that they are not totally reliable, and they are not sensitive to degrees of meaningfulness. They do illustrate the point that meaningfulness results from a combination of factors. If a preposition retains its meaning in different contexts, we have a good indication that the meaning is actually associated with the preposition itself. On the other hand, if a preposition loses its meaning when it is put into another construction, then it seems plausible to attribute the meaning to the original context, and not necessarily to the preposition.

1.2.5 Meaning vs. content

In discussing meaningfulness as a descriptive property, it is important to draw a distinction between meaning and semantic content. Semantic content is a theoretical notion, part of the formal representation of a linguistic element. The natural approach is to represent a preposition's content in such a way that it accounts for its perceived meaning. In principle, however, there does not have to be an exact correlation between meaning and content. There may be reasons for representing a meaningless preposition as semantically contentful, or a meaningful one as semantically empty. In both of these situations, however, the theoretical analysis is suspicious, unless it also offers a convincing explanation for how the extreme mismatch between the perceived and the actual semantics comes about.

More typically, we should aim for a broad correlation between a preposition's semantic content and its meaningfulness. As mentioned above, though, it is useful to distinguish inherent vs. contextual meaning. The lexical content of a preposition gives rise to its inherent meaning, but its interaction with other elements gives rise to additional contextual meaning. It is not always obvious, of course, what the inherent meaning of an element is, and what should be attributed to context.

I assume that context effects are always additive. In other words, an element can pick up additional meaning by virtue of appearing in a particular context, but its inherent meaning cannot be suppressed. Methodologically, this means that prepositions that have low meaningfulness can be represented as having no semantic content.

1.3 Form-Fixedness

The second descriptive property that distinguishes Type A and Type B prepositional uses is form-fixedness (henceforth simply "fixedness"). Type B prepositions characteristically show high fixedness while Type A prepositions show low fixedness. In general, however, prepositions can also exhibit intermediate degrees of fixedness. As a simple definition, if a preposition in a given context shows high fixedness, this means that replacing it with another prepositional form results in ungrammaticality:

- (25) a. Delicate negotiations resulted in an acceptable compromise.
 b. * Delicate negotiations resulted at/for/on/to/with/by an acceptable compromise.

A clearer way of demonstrating the effect of fixedness is to leave the preposition unspecified and consider how many forms can "fill in the blank." The lower the number, the higher the degree of fixedness.

- (25) c. Delicate negotiations resulted [_P _____] an acceptable compromise.

The only preposition that can appear here is *in*.

On the other hand, a preposition with low fixedness can be replaced by other forms to produce new, grammatical structures:

- (26) a. The magician put the rabbit in his top hat.
 b. The magician put the rabbit on/behind/under/beside his top hat.
 c. The magician put the rabbit [_P _____] his top hat.

In (26c) there are many ways to fill in the blank grammatically.

This is not to suggest, however, that fixedness can be measured numerically by applying the insertion test in (1.3) and (26c) and simply counting the allowable forms. In fact there are different ways for a preposition to be fixed, but only one of them is relevant to the Type A vs. Type B distinction.

1.3.1 External trigger

All of the Type B examples we have seen so far are cases where the preposition is fixed by a word external to the PP. In example (25a), the verb *resulted* is responsible for the high fixedness of the preposition *in*. We can easily confirm this by leaving the subject and prepositional object NPs unspecified:

- (27) a. [_{NP} _____] resulted in [_{NP} _____].
 b. * [_{NP} _____] resulted at/for/on/to/with/by [_{NP} _____].

We can fill in the blanks in (27a) in any number of ways to produce a grammatical string, but there is no way to do this in (27b), where the preposition no longer has the form required by the verb.

Multiple frames

We only considered six different forms in (27b); we should ask whether any other prepositions besides *in* can appear with *resulted*:

(28) [NP _____] resulted [p _____] [NP _____].

One preposition that comes to mind is *from*, but it cannot appear in place of *in* in the original sentence (25a). Instead, we have to switch the subject and object:

- (29) a. ? Delicate negotiations resulted from an acceptable compromise.
 b. An acceptable compromise resulted from delicate negotiations.

We are evidently dealing with two different versions of the verb *resulted* with opposite linking patterns. The first version means ‘produced a result’ and selects the preposition *in*, while the second means ‘came about as a result’ and selects *from*. The insertion test in (28) therefore has to be applied cautiously.

The second version of *resulted* also illustrates another possible pitfall of the test. Unlike in (25a), in sentence (29b) we can omit the PP:

- (30) a. * Delicate negotiations resulted. (produced a result)
 b. An acceptable compromise resulted. (was the result)

We can then add various PP adjuncts to sentence (30b):

- (31) An acceptable compromise resulted {
 at three o'clock AM.
 on Sunday.
 with much hoopla.

Strictly speaking, then, *at*, *on*, *with*, and other prepositions actually can appear in the P slot in (28). So the insertion test has to be applied in a more sophisticated way, with semantic labels attached to the ‘blanks’:

- (32) a. [NP < cause >] resulted [p _____] [NP < effect >].
 b. [NP < effect >] resulted [p _____] [NP < cause >].

We can now be sure that we are testing the right verb, with the correct subcategorization and argument linking frames. In (32a), the only choice for P is *in*, and in (32b) the only choice is *with*. Both contexts therefore show high fixedness, with the external fixing trigger *resulted*.

Unique trigger

We can apply the insertion test to (25) in a different way to confirm that the verb *resulted* is the only fixing trigger in this construction:

- (33) a. Delicate negotiations [v _____] in an acceptable compromise.
 b. Delicate negotiations [v _____] [p _____] an acceptable compromise.

Example (33a) tests whether the entire construction somehow fixes the verb (or vice versa). And the results are negative, since other verbs can appear in place of *resulted*:

- (34) Delicate negotiations ended/culminated/bore fruit/concluded in an acceptable compromise.

The context does restrict us semantically to a particular set of predicates, all of which serve as fixing triggers for *in*. The connection between the semantics of a verb and the preposition it governs is an important topic, which I devote more attention to in Chapter 5.

The results of test (33a) tell us nothing in particular about the preposition. The relevant test is really (33b), and it turns out that we can find pairs of verbs and prepositions to fill in the blanks:

- (35) Delicate negotiations {
 arrived at
 allowed for
 converged on
 led to
 } an acceptable compromise.

In other words, the NPs in (33b) are not responsible for fixing the preposition. In combination with the test in (32a), we can conclude that the verb *resulted* is the only fixing trigger in example (25a).

A particular structural relationship must exist between an external fixing trigger and the preposition it fixes. In particular, the PP headed by the fixed preposition P must be a complement of the trigger X:

- (36)
$$\begin{array}{c} X' \\ \diagdown \quad \diagup \\ X \quad PP \\ \quad \quad \quad \diagdown \quad \diagup \\ \quad \quad \quad P \quad (NP) \end{array}$$

One or more other constituents can intervene between X and PP.

There are various degrees of fixedness by an external trigger. As we have seen, the verb *result* fixes two prepositions, *in* and *from*, but here the prepositions mark different arguments of the verb. Similarly, the verbs *look* and *agree* both govern a number of prepositions, but always with different meaning:

- (37) a. look at/for/into/upon/to
b. agree with/to/on

On the other hand, there are situations where different prepositions are possible, without necessarily leading to a difference in meaning:

- (38) a. talk of/about Jack
b. ask too much from/of Jack
c. fight with/against Jack
d. turn to/into stone

1.3.2 Internal trigger

Prepositions can also be form-fixed by their complements:

- (39) a. Those people are in the know.
b. Those people are [p _____] the know.

In (39b), the only preposition that can go in the blank is *in*. Clearly the NP *these people* and the verb *are* have nothing to do with fixing the preposition:

- (40) [_{NP} _____] [_V _____] [p _____] the know.

However we fill in the NP and V blanks, the only preposition that can precede *the know* is *in*.

If we take the complement *the know* away, the preposition is no longer fixed:

- (41) a. Those people are [p _____] [_{NP} _____].
b. Those people are on the third floor/into modern dance/out of peanut butter/...

The complement of *in* in (39a) is therefore the unique fixing trigger.

Other examples of PPs containing internal fixing triggers are given below:

- (42) a. in a bind, out of sorts, on a roll
b. at least, by far, in general, for good
c. on sale, at home, with child
d. by myself, beside herself

Evidently, these phrases have exceptional properties. The NP complements in (42a) do not occur anywhere else with the same meaning (insofar as they have meaning). In (42b) the trigger is an adjective, which cannot normally occur as a prepositional complement. The prepositions in (42c) combine with bare non-referential nouns, also a non-canonical complementation pattern. And finally, the triggers in (42d) must be reflexive.

It is tempting to dismiss combinations like these as idioms, and simply list them in the lexicon. On the other hand, there are a large number of them, and there are general patterns to be accounted for, like the complementation properties just mentioned. I will not consider these fixed PPs in this thesis; it is clear that they will require a different analysis from the external trigger cases in the previous section.

It is easy to distinguish prepositions fixed by internal vs. external triggers, by applying the insertion test. We should ask whether it is possible for a preposition to be form-fixed by two triggers at once.

- (43) a. * Jack relies on sale.
b. * Jennifer stared at least.
c. * We believe in a bind.
d. * He swears by himself.

Internal and external triggers appear to be incompatible. Internally fixed PPs always appear in modifier or predicative positions, so they are blocked in these examples. Externally fixed PPs only appear in complement positions, as in (36). In principle, then predicative complement PPs might allow two triggers, but I have found no convincing examples of this configuration.

1.3.3 Other triggers

A few prepositions have unique subcategorization properties that ensure that they appear in high fixedness contexts where few if any other prepositions can replace them:

- (44) a. Those were the actions of Tony Blair qua politician, not Blair the family man.
b. I had to pay a fine of \$5 per book.
c. They went ahead with the experiment, our objections notwithstanding.

Qua and *per* both take N' complements, and *notwithstanding* can appear postpositionally. They are also completely meaningful, however, so there is no question that they should be considered Type A prepositions.

The entire context serves as a fixing trigger in idiomatic expressions:

- (45) a. fit to a tee
b. by and large, by and by
c. head over heels

I will not consider the analysis of idioms at all. The Type A vs. Type B distinction is hardly relevant in these cases. It should be said, however, that the distinction between idiomatic

constructions and Type B PP constructions is apparently gradient. For example, we could analyze example (46a) by assuming that the noun *glutton* is a fixing trigger for the preposition *for*:

- (46) a. a glutton for punishment
 b. ? a glutton for perversely creative punishment
 c. ? a glutton for porridge

On the other hand, the other examples show that the entire NP in (46a) has more or less become a fixed expression.

1.4 Interaction

So far I have discussed the properties of meaningfulness and fixedness independently, but we have already seen indications of their interaction. Prepositions that are strongly meaningful tend to be weakly fixed. In fact, modifying prepositions, which are always strongly meaningful, cannot be (externally) fixed. In other words, adjunct PPs (with the exception of excluded cases as in (42)) are always Type A PPs. On the other hand, prepositions that are highly fixed tend to have low meaningfulness.

This pattern of interaction can be understood in terms of preposition selection, or licensing. Every linguistic context has constraints attached to it that must be satisfied by any element that fills that context. These constraints typically refer to either form or meaning. If there are no constraints on the form of the element that fills the context, then there must be constraints on its meaning, and the other way around. No (communicative) contexts are completely unconstrained.

In a context where several prepositions can alternate with one another, there are evidently no strong constraints on form, so a particular preposition will be chosen for its meaning. There are other contexts where a preposition is not expected or allowed to contribute any meaning, and here selection by form is the only possibility, and the preposition will show a high degree of fixedness.⁵ These are the ideal cases, corresponding to Type A and Type B contexts, respectively.

⁵I am excluding metalinguistic examples such as the following:

- a. “_____” is an English preposition.
 b. And then she said “_____.”

Contexts like these call for more than just form and meaning constraints; they require a mechanism whereby entire linguistic signs can be selected.

As we have seen, there are intermediate Type AB cases where it seems that both form and meaning are selected to some extent. In a sense, there is a division of labor between these two kinds of selection. One possible model of this state of affairs is shown here:

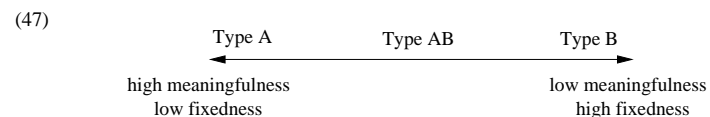

This model assumes that meaningfulness and fixedness are complementary properties—i.e., they vary inversely. Under this model, Type AB prepositions might be called “half” meaningful and “half” form-fixed. Both form and meaning constraints are therefore necessary to ensure a “complete” selection of the appropriate preposition.

In principle, however, the division of labor between fixedness and meaningfulness may not be as efficient as the one-dimensional model in (47) suggests. The following model assumes a weaker link between the two properties:

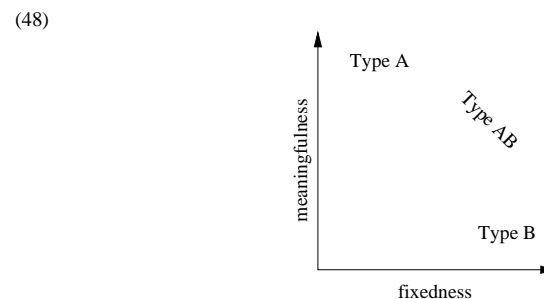

As already mentioned, we do not expect to find any prepositions with both low meaningfulness and low fixedness. Otherwise, meaningfulness and fixedness can vary independently. The Type A and Type B endpoints of the linear model in (47) correspond to two corners of the two-dimensional spectrum in (48). Unlike (47), however, the model in (48) does not specify a particular path (e.g., the diagonal) between the Type A and Type B corners along which intermediate Type AB prepositions must fall. Instead, Type AB prepositions can fall anywhere in the upper-right portion of the spectrum.

One way of thinking about the interaction of the properties of meaningfulness and fixedness is through the notion of grammaticalization. Many fixed, semantically non-decomposable Type B constructions have their origins in free, compositional Type A constructions in some earlier stage of the language. Through time, the preposition in question moves from the Type A corner in (48) to the Type B corner—i.e., it becomes more syntactically fixed and less semantically transparent. These two processes do not necessarily progress at the same rate, though. In other

words, there is no predictable path of grammaticalization from one corner to the other. We can only say that the preposition somehow crosses through the Type AB part of the spectrum in the course of its historical development. In the current stage of the language, we see a snapshot of these ongoing grammaticalization processes, and so we find prepositional uses spread throughout the three-cornered spectrum.

Chapter 2

Discrete Classification of Prepositional Uses

As we saw in the previous chapter, in descriptive terms, prepositional uses form a spectrum rather than a collection of distinct types. Nevertheless, with the goal of a formal analysis in mind, it is worthwhile to consider various methods of inducing a discrete classification. Most theoretical accounts incorporate the lexical vs. functional distinction in some form, but given only the gradient properties of meaningfulness and fixedness, there are no salient divisions where we can draw the boundaries for any discrete subclasses. It is therefore crucial to ask whether any other methods are available for distinguishing lexical and functional prepositions in a principled way.

In this chapter I focus on empirical criteria that have been proposed in the literature for inducing a partition of prepositional uses into lexical and functional subsets. I examine how accurately they reflect our intuitive and descriptive understanding of the distinction, and whether they allow us to construct a reliable discrete classification of prepositional constructions.

2.1 Constructing Classifications

In this section I explain the procedure used for constructing and evaluating a binary classification based on an empirical criterion. Generally, an author makes a claim of the following form:

- (1) All Type A constructions have property X.
All Type B constructions have property Y.

This is the ideal case. It can also be that the claim only mentions Type A or Type B uses, and prepositions of the other type may or may not have the property in question. More generally,

it is usually the case that the scope of a claim is limited to a specific subset of prepositional constructions. For example, many of the claims I examine in the following sections (e.g., pseudopassivization, *wh*-question formation) apply only to verbal constructions containing a PP. Partial claims like these can still be useful, but they can only induce a partial classification.

Assuming that the claim in (1) is valid—and as we will see, several claims in the literature fall at this first hurdle—we can turn it into a classificatory test for prepositional constructions. To do this, we use the properties X and Y as criteria for membership in two classes A^+ and B^+ as follows:

- (2) A^+ = all constructions having property X
 B^+ = all constructions having property Y

We already know that Type A constructions will end up in A^+ , and all Type B constructions in B^+ . Our hope is that property X also picks out some Type AB constructions and groups them with Type A in A^+ , and similarly for property Y and B^+ . The resulting sets A^+ and B^+ might then be the lexical and functional classes we are looking for.

A number of conditions must be met, however, before we can accept the classification in (2):

- (3) a. No prepositional construction can have both property X and property Y.
b. All constructions should have either property X or property Y.
c. For every construction, it should be very clear if it has or does not have properties X and Y.

The first condition ensures that A^+ and B^+ are disjoint, and the second ensures that all constructions will fall into either A^+ or B^+ .¹ In many cases, X and Y are complementary properties, so condition (3a) is automatically satisfied. Condition (3b) is more difficult; as mentioned above, many of the tests I will look at systematically exclude large classes of constructions.

The third condition in (3) is really the most important, because our main reason for turning to empirical criteria is to find a clear and reliable method for dividing prepositional uses into two classes. If the test in question gives vague or unstable results, then the classification it induces will be no better than one based on intuition alone.

If we have gotten this far successfully, then the classification in (2) is a binary partition of the kind we are after. The sets A^+ and B^+ are supersets of Type A and Type B, respectively, and they divide up the class of Type AB examples between them. The properties X and Y

¹Strictly speaking, we should also be interested in classifications that fail to meet one or both of these conditions, because in principle it could be useful to allow some prepositions to be both lexical and functional, or neither functional nor lexical. Since existing analyses that depend on the lexical vs. functional distinction do not accommodate these possibilities, however, I will focus on proper binary partitions.

reduce the gradient spectrum of prepositional uses into a discrete binary classification. This is not the end of the story, however, because in principle, every valid criterion that we find using this procedure induces a different A^+/B^+ partition. We only have evidence of a true lexical vs. functional classification if a number of independent empirical criteria can all be shown to draw the line between A^+ and B^+ in the same place. Only then can we justify the incorporation of a $[\pm\text{FUNCTIONAL}]$ feature (for example) in a formal account of prepositions. Otherwise, we have to analyze the results of each test as a separate phenomenon.

2.2 Lexical Form

The classificatory criteria I will consider are of two main types: “constituent” criteria and “transformational” criteria.² Constituent criteria refer to properties already present in the test item—e.g., is the preposition transitive or intransitive? Transformational criteria usually require some change to be made to the test item (e.g., insert, move, or delete material) and the (non-)grammaticality of the resulting string determines the result of the test. The advantage of constituent criteria is that they generally give unambiguous results, but they often apply meaningfully to only a subset of all cases, and therefore only induce partial classifications. Transformational criteria are more widely applicable, but they rely on grammaticality judgments, which can be very unstable.

The criterion I examine in this section is the simplest possible constituent criterion, involving only the lexical form of the preposition. It is clear from the data we have already seen that a single preposition can have both Type A and Type B uses (as well as Type AB uses); in general we cannot classify a preposition without considering its context. It is apparent, however, that not all prepositional forms have Type B uses. Forms like *alongside*, *despite*, *circa*, and *vis-à-vis*, never occur in Type B contexts. There must be some subset (call it \mathcal{F}) of syntactically fixable forms from which all Type B prepositions are chosen. Put in a slightly different way, we can identify \mathcal{F} such that the following claim is true:

- (4) Prepositional forms outside of \mathcal{F} have only Type A uses.

This claim is not of the form in (1), so we cannot use it to make a classification of the form in (2). We know, however, that all Type A constructions are supposed to end up in the “lexical” subset A^+ . The statement in (4) therefore gives us a sufficient condition for A^+ membership:

- (5) $A^+ \supset$ uses of prepositional forms not in \mathcal{F}

Prepositional forms in \mathcal{F} will in principle have both Type A and Type B uses, so we have to find other methods of classifying constructions that contain them. The partial classification in (5) is

²These terms are taken from Carvell and Svartvik (1969).

still useful, however. And to maximize its usefulness, our goal is to define \mathcal{F} as restrictively as possible, while preserving the validity of the claim in (4).

2.2.1 Primary prepositions

Lehmann (1986) divides the set of prepositional forms into two classes as follows (p. 4):

- (6) a. A primary adposition is one which expresses an elementary objective or a grammatical meaning and is morphologically simple, such as *of*, *in*.
 b. A secondary adposition is one which expresses not a grammatical, but an objective meaning and which may be morphologically complex and/or transparent, such as *below*, *during*.

Lehmann also discusses constructions involving relational nouns, such as *on top of* and *at the back of*, which are referred to elsewhere as “complex prepositions” (Quirk & Mulholland, 1964). These three divisions are focal positions on a continuous scale of grammaticalization, so there is no distinct boundary between primary and secondary forms, or between secondary and complex forms. For Lehmann, this means that these particular subdivisions have “no special theoretical status,” but it is still helpful to consider the definitions in (6) in more detail.

The notions of “objective” vs. “grammatical” meaning are inexplicit but we can at least assume that a preposition with low meaningfulness (e.g., Type B uses) cannot be considered “objectively” meaningful, but must instead be “grammatically” meaningful. According to (6), then, Type B prepositions must be chosen from the set of primary adpositions, which therefore must be a superset of the set \mathcal{F} we are looking for. The question now is whether we can reliably identify this set of primary prepositions based on other criteria.

Lehmann mentions a morphological criterion: primary adpositions are morphologically simple. This implies that forms with identifiable morphological structure cannot be used in Type B constructions. This seems to hold for clearly complex forms like *inside* and *notwithstanding*; I can think of no Type B uses for these prepositions. A few morphologically complex forms, however, cannot be dismissed so easily:

- (7) a. The DA was strangely reluctant to look into the bribery allegations.
 b. Someone bumped into me and I dropped the dessert.
 c. He came into his fortune selling canned mashed potatoes in the '50s.
 (8) a. The customer insisted upon a full refund.
 b. One day you may be called upon to do me a small service in return.
 (9) a. The staff will have to do without their Christmas bonus this year.

- b. The lost backpackers went without food for a week.

The examples in (9) contain clear cases of Type AB uses of *without*: the preposition is both highly fixed and highly meaningful. Some of the other examples, however, particularly *bump into* in (7b) and *call upon* in (8b), are arguably Type B uses. In other words, these are morphologically complex forms with “grammatical meaning,” showing that Lehmann’s semantic and morphological criteria are not always consistent.

Lehmann also mentions *below* as an example of a secondary preposition in (6b), but given his definition, it is unclear whether he considers it to be morphologically transparent or not. If *below* counts as transparent, then there are several other equally transparent forms that have Type B uses:

- (10) a. She asked after my pet guinea pig, as if she cared.
 b. Jack is constantly fussing over the shape of his gigantic moustache.
 c. We’ll see about the chances of your application now, after that caper.
 d. I came across your name in the membership list.

These are potential counterexamples, like *into* and *upon* above, but one could also argue that *after*, *about*, and *across* are actually morphologically simple, primary prepositions. Morphology alone is not sufficient to define the set of primary forms.

König and Kortmann (1991) adopt Lehmann’s categories and offer more complete characterizations. They distinguish the following “layers of prepositions” (p. 112):

- (11) a. a group of very frequent, typically monosyllabic prepositions, with a broad range of meanings that includes very abstract, ‘grammatical’ meanings and uses
 b. a group of less frequent, typically disyllabic and morphologically complex prepositions with a narrow range of more specific meanings and uses
 c. a group of phrasal or complex prepositions, which tend to be very rare and are composed of relational nouns and prepositions of the first group

Unfortunately, even as they add more identifying criteria, König and Kortmann admit that they “coincide only very roughly.” Furthermore, they mention that the prepositions that can appear with prepositional verbs (i.e., as Type B prepositions) belong to “a very restricted set,” but they back away from identifying this set (which is our target set \mathcal{F}) with the set of forms in (11a).

2.2.2 Fixable forms

The notion of primary preposition does not correspond to a distinct set of forms, so it does not provide a basis for identifying the set \mathcal{F} . We can still use the descriptive characterizations above, however, to get a rough idea of the set of forms we need to keep in mind.

We want \mathcal{F} to include all prepositional forms that can be syntactically fixed by an external trigger, as discussed in §1.3.1. As we have seen, there seems to be no way to deduce the membership of this set based on criteria like morphology or frequency, so here I proceed by brute force. Mindt and Weber (1989) give lists of all one-word prepositional forms found in the BROWN and LOB corpora. From this set, I have picked out the following forms as an approximation of \mathcal{F} :

- (12) a. of, in, to, for, with, on/upon, at, by, from, into, after, than, out, across, down, up, off, as
 b. about, through, over, between, under, against, without, toward (towards), around (round), along, like

The forms in the first group have more or less indisputable Type B uses. The ones in the second group can be fixed, but they always seem to have a significant degree of meaningfulness—i.e., they have Type AB uses. I attach no particular importance to this division, which is as unclear as the division between Type B and Type AB itself. Group (12b) includes one or two forms that some might argue do not belong in \mathcal{F} at all. This uncertainty corresponds to the fuzzy boundary between Type A and Type AB. It is not possible to establish the exact membership of \mathcal{F} beyond all doubt; here I have chosen to err on the side of over-inclusiveness.

According to (5) above, we can classify all instances of forms not listed as members of \mathcal{F} in (12) as members of the “lexical” set A^+ . Mindt and Weber give about 100 prepositional forms in all, and there are about 30 forms in \mathcal{F} , so this is a significant result. On the other hand, \mathcal{F} includes all of the most frequently occurring forms. In fact, according to Mindt and Weber’s counts, the forms in (12) make up over 95% of all (single-word) prepositions in BROWN and LOB. We therefore still have no classification for the vast majority of prepositional uses.

As for complex (multi-word) prepositions, as in (13), none of these belong in the fixable subset \mathcal{F} :

- (13) in spite of, with respect to, on top of, in return for, in common with, by dint of

Complex prepositions are interesting because they show varying degrees of internal fixedness, and at some point it becomes unclear whether we have a complex preposition or a free syntactic combination (Quirk & Mulholland, 1964). I will leave complex forms out of consideration in the rest of this study, since they contribute little to the lexical vs. functional question. A fuller investigation of the internal morphosyntax of complex prepositions, however, is a highly relevant topic for further research.

Before leaving the issue of prepositional form, we should consider the possibility of formulating a claim like (4) for Type B prepositions. In other words, are there any prepositional

forms that can only appear in Type B contexts? The answer to this question seems to be no. The only imaginable candidate is the form *of*, which is sometimes said to be semantically vacuous. The following examples, however, contain meaningful uses of *of*:

- (14) a. Is this antique toaster really of any value?
 b. At the center of the scandal are Bob Williamson and Bill Robertson, both of Boston, MA.

This means that we cannot formulate a sufficient condition for B⁺ membership based on lexical form alone (cf. (5)).

In the remaining sections of this chapter, I turn to empirical criteria that take context into account in order to classify prepositional uses.

2.3 Cohesiveness

The spectrum of prepositional uses from Type A to Type B is commonly characterized in terms of “cohesiveness” or “cohesion” (Jespersen, 1927; Chomsky, 1965; Carvell & Svartvik, 1969; DeArmond, 1977). The notion of cohesiveness can be roughly characterized in both semantic and syntactic terms. Semantically, a cohesive combination is likely to have non-compositional or non-literal meaning. Syntactically, the components of a cohesive combination are closely linked, and are likely to resist being split up (e.g., as the result of extraction).

With respect to prepositional uses, the claim is that Type B constructions are cohesive (i.e., the selecting head and the Type B preposition form a cohesive combination) while Type A constructions are incohesive. The rough characterizations offered above leave room for several degrees of cohesiveness, so on an intuitive level, the notion of cohesiveness is not very useful for inducing a strict partition of prepositional constructions. In this section, however, I examine a number of tests that are meant to reduce the gradient scale of cohesiveness to a discrete binary division between cohesive and incohesive constructions.

Before turning to particular tests, however, let us consider the validity of the claim in general:

- (15) All Type A constructions are incohesive.
 All Type B constructions are cohesive.

Given a naive understanding of cohesiveness, the Type B part of the claim seems reasonable; the head and the preposition in a Type B combination are strongly linked syntactically (the head form-governs the preposition) and generally the meaning of the combination cannot be derived compositionally from its parts. On the other hand, it is not as clear that the Type A half of the

claim in (15) is true. Type A PPs can be either complements or adjuncts, and the combination of a head and a complement PP will be syntactically more cohesive than the combination of a head and an adjunct PP:

- (16) a. How can you stay [in this dusty apartment]?
 b. I can't stop sneezing [in this apartment].
 (17) a. The chicken walked [across the road].
 b. They're renovating [across the road].

The PPs in the (a) examples are typically analyzed as complements, while the same PPs are used as adjuncts in the (b) examples. The combinations *stay in* and *walked across* give the impression of being more cohesive than *sneezing in* and *renovating across*, although all four involve Type A prepositional uses. Depending on where we draw the line between cohesive and incohesive, the (a) examples here may end up being cohesive, thereby falsifying the claim in (15).

In the end, however, this is a moot point, because in fact none of the tests discussed in this section turns out to be an indicator of cohesiveness. Without an empirical basis for the cohesive vs. incohesive distinction, we cannot evaluate the validity of the claim in (15), and we cannot use it to generate a partition of prepositional uses.

2.3.1 Single-word synonyms

According to many authors, one indication of semantic cohesiveness between a verb and a preposition is the existence of a single-word synonym for the combination. A cohesive combination of a verb and a preposition is “logically equivalent” to a transitive verb (Sweet, 1891). Poutsma (1904) explains (§3.36):

- (18) The verb is so closely connected with the P as to express with it a sense-unit, which in many cases, either in the same language or in any of the kindred languages, may approximately be expressed by a transitive verb.

He gives the example *speaking about*, which is more or less equivalent to *discuss*, while the combination *listen to* has the transitive counterparts *écouter* in French and *aanhoren* in Dutch. The proposed test for cohesiveness is therefore as follows:

- (19) cohesive = single-word synonym available
 incohesive = no single-word synonym available

Combined with (15) above, we arrive at the following claim:

(20) Type A constructions: no synonym available

Type B constructions: synonym available

This claim immediately goes wrong with Type A complements. For example, *stay in* in (16a) and *walked across* in (17a) above can be replaced by the transitive verbs *inhabit/occupy* and *cross/traverse*, respectively. Verbs of motion are a particularly rich source for Type A combinations with single-word transitive synonyms: *go in = enter*, *sneak into = infiltrate*, *sail around = circumnavigate* (Quirk et al., 1985, §16.12). As in the last two examples, the single-word synonyms are often Latinate forms where the preposition is more or less transparently incorporated into the verb. There is also a smaller class of cases where the incorporation of the preposition is even more obvious: *step over = overstep*, *lie under = underlie*, *pass by = bypass*.

Constructions with complement PPs therefore systematically contradict the Type A part of the claim in (20). With adjunct constructions, however, it is mostly true that single-word synonyms are unavailable: *cough behind*, *vanish despite*. Still, a number of counterexamples can be found: *predate = exist before*, *permeate = spread throughout*, *browse = look through*.

(21) a. Wait for the signal; don't {act before} it.

b. Wait for the signal; don't {anticipate} it.

(22) a. Some weirdo {disrobed in front of} us in the supermarket.

b. Some weirdo {flashed} us in the supermarket.

Evidently, the proposed definition in (19) is wrong. There is no grammatical restriction that prevents incohesive combinations from having single-word synonyms. The lexicon is not subject to this type of constraint.

Similarly, there cannot be a principle requiring the lexicon to contain a single-word synonym for every Type B combination. Dixon (1982) gives the following counterexamples (p. 4):

(23) a. He {held against} me the fact that I voted for the other candidate.

b. Music tends to {grow on} one.

Other examples are *fall for*, *belong to*, and *ask after*. There is no synonym available in these cases. It may be true in some intuitive sense that a cohesive combination expresses a "possible word" (Hornstein & Weinberg, 1981) but not every possible word has to be realized as an actual word.

The claim in (20) is unusable. The lexicon (or the lexicon of a "kindred language") cannot distinguish Type A and Type B combinations for us.

2.3.2 Coordination

Another supposed indicator of cohesiveness is the possibility of coordination with a transitive verb. It is claimed in several descriptive grammars, including Poutsma (1904, §3.45), Kruisinga (1925, §1871), and Jespersen (1927, §13.8), that a cohesive verb-prepositional combination can be coordinated either before or after a transitive verb, with both verbs sharing a single object.

(24) cohesive = coordination with transitive verb possible

incohesive = coordination with transitive verb impossible

The following examples are Kruisinga's:

(25) a. He refused to accept, or listen to, or even to consider, the opinions of those who differed from him.

b. It caught hold of and satisfied the higher imagination of contemporaries more than any other political movement.

It is typically the case that the conjuncts in a coordination structure have to be constituents, and they have to be of the same type (in some relevant sense). At first sight, the examples in (25) contain non-constituent coordination structures, but they are nevertheless grammatical. A common explanation is that cohesive verb-preposition sequences (and some more complicated sequences like *caught hold of*) can be (re-)analyzed as complex verbs (van Riemsdijk, 1978; Hornstein & Weinberg, 1981; Rauh, 1991b). This reduces the structures in (25) to straightforward instances of V coordination. Under such an analysis, a cohesive combination is not only "logically equivalent" to a transitive verb, but it is also syntactically equivalent to one in certain environments. On the other hand, incohesive combinations are assumed not to admit a complex verb analysis, so coordination with a transitive verb should be disallowed.

The claim to be evaluated is the following:

(26) Type A constructions: coordination impossible

Type B constructions: coordination possible

Carvell and Svartvik (1969) give the following contrasting examples (p. 43):

(27) a. * He sprang backwards with and emitted a yelp. (Type A)

b. He looked at and admired the effigy. (Type B)

In fact, I disagree with the judgment in (27a); for me, this sentence is not wholly ungrammatical, although it is not as natural as (27b). The two examples cannot be fairly compared, because *sprang* takes an additional intervening complement in (27a). Note the awkwardness of the following Type B examples:

- (28) a. ? We attributed the poor results to and terminated Jack's involvement.
 b. ? Everyone preferred the new yoga instructor to and abandoned Jennifer.

The degraded acceptability of (28) is comparable to that of (27a), in my judgment.

If we consider Type A constructions involving intransitive verbs, it turns out that coordination is possible after all:

- (29) a. Jennifer ignored and worked straight through her lunch hour.
 b. Jack once went fishing near and adored the Rocky Mountains.

Here we have instances of non-constituent coordination that cannot be explained by complex verb formation, since *worked straight through* and *fishing near* are not cohesive sequences. Nevertheless, the constructions are grammatical.

All of these examples, both cohesive and incohesive, can be treated as cases of Right-Node Raising, which operates quite freely whenever two or more conjuncts share the same string on the right periphery. RNR can give rise to quite dramatic non-constituent coordination structures:

- (30) a. We still adhere to, but they have long since dispensed with the principle of "no shoes, no shirt, no service."
 b. The critic slept during, but later claimed to have greatly enjoyed the third act.
 c. The guests drank cocktails before, wine during, and whisky after the meal.

I will not say anything more specific about the analysis of RNR.³ I simply note that the availability of RNR severely handicaps the coordination-based definition of cohesiveness in (24) and the claim in (26). Also, given an RNR analysis, it is no longer necessary to appeal to a complex verb analysis to explain the non-constituent coordination in the cohesive case.⁴

2.3.3 Intervening adjuncts

Cohesive and incohesive constructions are supposed to show differences with respect to the possibility of inserting intervening material between the verb and preposition (Mitchell, 1958) and between the preposition and its complement (Jespersen, 1927). Here is the relevant claim:

- (31) Type A: insertion (i) possible between V and P,
 (ii) impossible after P
 Type B: insertion (i) impossible between V and P,
 (ii) possible after P

³See for example Ross (1967) and McCawley (1982).

⁴Complex verb formation is still useful in the analysis of other phenomena like pseudopassivization (see §2.5.2).

Let us consider both insertion points in turn.

It is natural to expect that a cohesive Type B verb-preposition combination should resist being split apart by inserted material, while an incohesive Type A combination should allow it. In fact, insertion is possible in both cases:

- (32) Type B:
 a. They belong allegedly to an underground criminal organization.
 b. Everyone picked constantly on the new student.
 c. This hair-loss remedy consists entirely of common household ingredients.
- (33) Type A:
 a. The puddle evaporated quickly in the afternoon sun.
 b. The signal stopped unexpectedly after three hours.
 c. She giggled uncontrollably during her interview.

Adverb insertion in Type B constructions can be slightly awkward, as in (32a), but on the other hand it can be perfectly natural, as in (32c). The insertion test does not appear to work as claimed.

It is also possible to insert PP adjuncts between V and P instead of single adverbs:

- (34) Type B:
 a. They belong in their spare time to an underground criminal organization.
 b. Everyone picked without mercy on the new student.
 c. This hair-loss remedy consists for the most part of common household ingredients.
- (35) Type A:
 a. The puddle evaporated within minutes in the afternoon sun.
 b. The signal stopped without warning after three hours.
 c. She giggled like a crazy woman during her interview.

Again, the Type B examples resist insertion slightly, in contrast to the Type A cases, but the difference is not clear enough to produce a distinct classification. I conclude that the test of inserting material between the verb and preposition is not useful for classification.

Turning now to the position between the preposition and its complement, it seems at first sight that insertion should be impossible in general, for both Type A and Type B PPs:

- (36) a. * The signal stopped after unexpectedly three hours. (Type A)
 b. * Everyone picked on constantly the new student. (Type B)

Even if cohesive Type B verb-preposition combinations are similar to transitive verbs in some sense, we still expect insertion to be blocked, because in general transitive verbs resist being split from their direct objects:

- (37) * Everyone teased constantly the new student.

Jespersen (1927), however, provides some examples in which adjuncts appear directly after the preposition in a Type B construction (§13.9.4):

- (38) a. She went through, in that brief interval, emotions such as some never feel.
 b. Mr. Reeves having sent for from his study Bishop Burnet's History.
 c. I will dispose of at Piedimulera all the things with which...
 d. I came across, at the very bottom, the manuscript of the preceding narrative.

These examples are definitely marked stylistically. There are at least two ways to account for them. First of all, the inserted material could be of a parenthetical nature. I offer no real explanation for parenthetical insertion, but it seems that parenthetical elements, whatever they are, can appear in practically any syntactic position. In particular, we can construct similar examples with Type A constructions:

- (39) a. The accident happened during—in all honesty—an unauthorized tea break.
 b. The butter-churning competition is at, if I remember correctly, three o'clock.

The second possibility is that the prepositions in (38) are separated from their complements by Heavy NP Shift. Consider the following examples where the prepositional objects have been modified:

- (40) a. She went through, in that brief interval, strong emotions.
 b. * Mr. Reeves having sent for from his study a book.
 c. * I will dispose of at Piedimulera everything.
 d. I came across, at the very bottom, that manuscript.

The middle two examples are considerably worse here, with "lighter" NPs. Sentences (40a) and (40d) are still grammatical; perhaps the parenthetical analysis is still available in these cases. Heavy NP shift of the prepositional complement is not limited to Type B constructions:

- (41) a. The missing files were discovered under, after hours of searching, a huge pile of poker chips that no one had noticed before.
 b. * The missing files were discovered under, after hours of searching, my sandwich.
 (42) a. Jennifer disappeared with, early this morning, six jars of my prize-winning applesauce.

- b. * Jennifer disappeared with, early this morning, the money.

I will not go into detail about the analysis of these examples. It is sufficient to note that, contrary to the claim in (31), the insertion of intervening material between the preposition and its complement is possible in both Type A and Type B constructions.

In conclusion, none of the criteria discussed in this section reliably distinguish Type A and Type B examples, and so there is no point in considering how they handle intermediate Type AB constructions. The intuition remains that Type B constructions are more cohesive than Type A constructions, but in the absence of an empirical test, the notion of cohesiveness is no more helpful than meaningfulness and fixedness in establishing a discrete classification of prepositional uses.

2.4 PP Movement

The test I consider in this section is the transformational criterion of moving the PP out of the VP. There are two versions of this kind of movement: PP fronting (topicalization) and pied-piping of PP in *wh*-questions and relative clauses. Technically, both of these are instances of *wh*-movement, which is assumed to operate quite freely, although subject to the familiar island and crossover constraints. We might expect the cohesiveness of Type B constructions, however, to impose further restrictions on PP movement, because such transformations split up the verb and preposition:

- (43) Type A PPs undergo *wh*-movement.
 Type B PPs disallow *wh*-movement.

2.4.1 Topicalization

To evaluate this claim, first consider the case of topicalization:

- (44) Type A
 a. On the screen an error message appeared.
 b. ? In his pyjamas Jack ate dinner.
 c. * By public transportation commuters like to travel.
 (45) Type B
 a. * With lengthy introductions we dispensed.
 b. * To an underground organization they belong.
 c. * Of the gross error everyone accused Jack.

Type B PPs generally do not topicalize, as predicted by (43), but apparently most Type A PPs also resist this transformation. On the other hand, topicalization is not a purely syntactic process; it is also affected by semantic, pragmatic, and prosodic factors. With the appropriate manipulation of these factors, some Type B PPs can be topicalized:

(46) To *such* a disreputable organization I would never belong!

Carvell and Svartvik (1969) use PP fronting as a classifying test, and specifically discard cases like (46) where emphatic intonation is required. With this restriction, they note that the test very rarely applies positively. With respect to topicalization, then, only the second part of the claim in (43) is valid.

2.4.2 Pied-piping

According to claim (43), Type A PPs should allow pied-piping, and Type B PPs should not. The first statement seems to hold, but things are more uncertain for Type B constructions:

(47) Type A

- a. On which screen did the error message appear?
- b. In which outfit did Jack eat dinner?
- c. By what means of transport do commuters like to travel?

(48) Type B

- a. ? With which introductions should we dispense?
- b. To which organization do they belong?
- c. ? Of which error did they accuse Jack?

The following Type B examples (and judgments) are taken from the literature:

- (49) a. ?* After whom did she look? (Quirk et al., 1985, §16.15)
 b. After whom does John take? (Dixon, 1982, p. 6)

Judgments in this area seem to be confused by register effects and prescriptive pressures. A peculiarity of English is that preposition stranding is generally preferred to pied-piping of PP. (Note that all of the examples above, both Type A and Type B, sound more natural with the preposition stranded.) Pied-piping is used more or less exclusively in formal registers, where knowledge of prescriptive rules tends to have strong influence. The examples above suggest that there is a difference in behavior between Type A and Type B constructions, but not a very robust one.

The corresponding relative clause constructions give similar results:

(50) Type A

- a. the screen on which the error message appeared
- b. the outfit in which Jack ate dinner
- c. the means of transport by which commuters like to travel

(51) Type B

- a. ? the introductions with which we dispensed
- b. the organization to which they belong
- c. the error of which they accused Jack
- d. ? the grandparent after whom John takes (most)

Again, judgments for the Type B examples are unstable. Overall, the Type B examples here are slightly more acceptable than the *wh*-question examples above, but the effect cannot be confirmed based on so little evidence.

In summary, the following revised claim seems to be valid:

(52) Type A PPs undergo pied-piping.

Type B PPs disallow (non-emphatic) topicalization.

Here we have a claim of the form (1), but note that it violates some of the conditions in (3). First, the properties in (52) overlap; for example, the Type A *by*-PP in (47c) and (50c) undergoes pied-piping, but it also disallows topicalization in (44c). The claim in (52) therefore does not give rise to a disjoint classification. Furthermore, as we saw, judgments of the pied-piping data can be very unclear, so this property fails to satisfy condition (3c). The criterion of PP movement cannot give us the A^+/B^+ partition we want.

2.5 Preposition Stranding

Next I consider the possibility of moving just the prepositional complement out of the PP. This can happen as the result of either *wh*-movement or NP-movement (pseudopassivization).

2.5.1 *Wh*-movement

Preposition stranding through *wh*-movement is quite unrestricted. Both Type A and Type B prepositions can be stranded, and so we cannot use this as a test to distinguish them. There are cases, however, where stranding is disallowed. These examples are from Hornstein and Weinberg (1981, p. 56):

- (53) a. * What time did John arrive at?

- b. * What inning did the Yankees lose the ball game in?

Hornstein and Weinberg claim that VP-internal PPs allow stranding, but VP-external PPs (e.g., sentence modifiers) do not. This does not add anything useful in terms of classification, however. We already know that all adjuncts are Type A PPs, and so they have to end up in A⁺ no matter what the stranding facts are.

And as a matter of fact, I disagree that the sentences in (53) are ungrammatical; for me, their status is at worst somewhat awkward (and certainly no worse than their pied-piped counterparts). I assume that preposition stranding by *wh*-movement is generally available for all PPs (modulo the usual bounding constraints on movement), but influenced by various non-syntactic factors. See, for example, the functional account of Takami (1992).

2.5.2 Pseudopassivization

Pseudopassivization (or the prepositional passive) is one of the most often mentioned tests for classifying prepositional uses. It is found in both descriptive and theoretical work, including Kruisinga (1925, §1871), Jespersen (1927, §13.9, §15.6.4), and Chomsky (1965). The possibility of promoting the prepositional object to passive subject position is seen as a characteristic of prepositional verb constructions.

- (54) Type A constructions disallow pseudopassivization
Type B constructions allow pseudopassivization

The following sets of examples illustrate this claim:

- (55) Type B
- Lengthy introductions will be dispensed with, so we can finish before midnight.
 - Jennifer's real motives were only hinted at by her guarded comments.
- (56) Type A
- * 8 o'clock should be arrived after by most of the guests. (cf. Most of the guests should arrive after 8 o'clock.)
 - * Buses and trains are travelled by every day by hundred of thousands of commuters. (cf. Thousands of commuters travel by buses and trains every day.)

On the other hand, it is easy to find examples that falsify the claim:

- (57) Type B
- * The underground organization was belonged to by all of our neighbors.
 - * Several parts are consisted of by their plan.

- (58) Type A
- This table is so low, it can't be sat at comfortably.
 - I had the feeling I was being walked behind.

Pseudopassivization therefore turns out to be another fallible criterion. The extensive literature on this topic makes it clear that notions like the Type A vs. Type B distinction or "cohesiveness" cannot be used to predict when the pseudopassivization is possible. Extensive data and discussion can be found in Couper-Kuhlen (1979). For functional and pragmatic accounts of pseudopassivization, see Takami (1992), Davison (1980) and Riddle and Sheintuch (1983).

An additional weakness of the pseudopassive test is that it only applies to intransitive constructions. Typically, the object of a preposition cannot passivize if a direct object is also present:

- (59) Type A
- * The three-hour long movie was eaten two hot dogs and a large popcorn during. (cf. I ate two hot dogs and a large popcorn during the three-hour long movie.)
 - * A terrible state was left the kitchen in. (cf. They left the kitchen in a terrible state.)
- (60) Type B
- * The theft can hardly be accused Jenny of. (cf. We can hardly accuse Jenny of the theft.)
 - * In the summertime, hot chocolate is definitely preferred ice cream to. (cf. In the summertime, people prefer ice cream to hot chocolate.)

With some fixed phrases, however, where the verb and direct object NP form a highly cohesive combination, the prepositional passive is available:

- (61) a. Inevitably, some of our agents were simply lost track of.
b. Jack felt that he was made a fool of by the interviewer.

For further discussion of such constructions, see Ziv and Sheintuch (1981).

2.6 Question Forms

Quirk et al. (1985, §16.15) and Carvell and Svartvik (1969) suggest another criterion involving *wh*-transformation. In this case the issue is not the movement itself, but the *wh*-word used in question formation. The claim is that in a Type B construction, the prepositional object can be replaced by the *wh*-words *who* or *what*, but the entire Type B PP cannot be replaced by any

wh-word. With Type A constructions, on the other hand, questions are formed using one of the adverbial *wh*-words *where*, *when*, *how*, etc., either in place of the entire Type A PP or just the complement of the preposition.

(62) Type A constructions form questions with *where*, *when*, *how*, *why*

Type B constructions form questions with *who*, *what*

Essentially the same criterion can be constructed for relative clause formation; as far as I see, the results are the same, so I will focus on *wh*-question formation, which is somewhat easier to apply.

2.6.1 Examples

The following example illustrates the behavior of Type B constructions, which give relatively straightforward results with this test:

(63) The exam consists of two essays.

a. What does the exam consist *(of)?

b. * How/Where does the exam consist?

As discussed in §2.4, pied-piping is strongly dispreferred for most Type B PPs, so sentence (63a) is the only natural question form for this construction. Also note that the preposition cannot be omitted in the question form. In other words, *what* cannot be a PP-proform; it can only replace the complement of the preposition. The same holds for *who*.

A few Type A examples are given here:

(64) The conference begins on Tuesday.

a. When does the conference begin?

b. * When does the conference begin on?

c. * What does the conference begin (on)?

(65) They drove to Johannesburg.

a. Where did they drive?

b. Where did they drive to?

c. * What did they drive (to)?

(66) This clock comes from the Black Forest.

a. Where does this clock come from?

b. * Where does this clock come?

c. * What does this clock come (from)?

The (a) and (b) examples here show that the presence of the preposition in the question construction can be either prohibited, optional, or obligatory. A number of semantic factors are involved here. In the case of PPs expressing temporal or spatial location, the proforms *when* and *where* generally replace the entire PP, and the preposition can only be retained in rare cases. *Where* can also replace directional PPs indicating destination or motion towards (cf. the obsolete form *whither*), or it can replace just the prepositional complement in these cases, so that the preposition appears in the question form, as in (65b). *Where* cannot express the meaning of motion from (cf. *whence*), and in these constructions the preposition (usually *from*, as in (66)) must be retained. In the case of temporal “directional” PPs, the preposition also appears in the question:

(67) a. Until when is this license valid?

b. Since when have you been so popular?

Note that the choice between stranding and pied-piping is a separate issue here. Finally, the *wh*-adverbs *how* and *why* do not co-occur with prepositions.

2.6.2 Classification

Consider the classification induced by the claim in (62):

(68) Classification by question forms:

A⁺: questions with *where*, *when*, *how*, *why*

B⁺: questions with *who*, *what*

For this to be a proper classification, no constructions should satisfy the criteria for membership in both A⁺ and B⁺. So far, the examples we have seen are uniquely classified into either A⁺ or B⁺, as shown by the ungrammaticality of the example in (63b) and of the (c) examples in (66). This is not the case for all constructions, however.

The following, for example, should go into B⁺, according to the (a) questions, but they also (marginally) allow questions with *where* or *when*:

(69) They settled on Tuesday (for the spy exchange).

a. What did they settle on?

b. ? When did they settle on?

c. * When did they settle?

(70) Jack was looking forward to Australia the most.

a. What was Jack looking forward to the most?

b. ? Where was Jack looking forward to the most?

- c. * Where was Jack looking forward the most?

The adverbial (b) versions are definitely dispreferred. The crucial observation about these examples, however, is that the preposition is always obligatory, even with *wh*-adverbs, in contrast to examples (64)–(65) above.

With a second group of exceptional cases, *who* or *what* can be used for constructions that ought to be classified as members of A^+ :

- (71) We will sit on the ground if there are no benches.
 a. What will we sit on if there are no benches?
 b. ? Where will we sit on if there are no benches?
 c. Where will we sit if there are no benches?
- (72) You are speaking after the President.
 a. Who are you speaking after?
 b. ? When are you speaking after?
 c. When are you speaking?

In these cases, both question forms in (a) and (c) are totally natural. The distinction between this set of exceptions and the previous one lies in the *wh*-adverb versions. The (b) examples are again marginal; as explained above, locative *when* and *where* generally replace entire PPs. The (c) examples here, however, are grammatical, whereas omitting the preposition in (69c) and (70c) is impossible.

These observations allow us to formulate the following improved classification:

- (73) Classification by question forms (revised):
- B^+ : (i) questions with *who*, *what* possible, and
 (ii) all question forms must retain preposition
- A^+ : all other constructions

Now it is clear that A^+ and B^+ do not overlap, since the conditions for A^+ membership are the opposite of those for B^+ . Explicitly, a construction goes in A^+ either if no *wh*-question with *who* or *what* can be formed (e.g., (65), (67)) or if any question form is available where the *wh*-word replaces the entire PP. With this classification, the constructions in (69)–(70) go correctly into B^+ , and the ones in (71)–(72) go correctly into A^+ .

A further advantage of this formulation is that no particular set of *wh*-adverbs needs to be specified. Therefore constructions that require more complex forms like *how long* and *how quickly* are correctly grouped with A^+ :

- (74) They finished the assignment in three hours.
 a. * What did they finish the assignment in?
 b. * When did they finish the assignment (in)?
 c. How quickly did they finish the assignment?

2.6.3 Remaining problems

Recall that with some directional PPs, as in (66) and (67), the preposition is required to co-occur with the *wh*-adverb. In order to prevent these from being wrongly classified as members of B^+ , we have to ensure that *who* and *what* questions are always impossible. For example, see (66c) above, and the following variants of (67):

- (75) a. * Until what is this license valid?
 b. * Since what have you been so popular?

Unfortunately, however, this correlation of properties does not always hold:

- (76) These horses were stolen from the King.
 a. Who were these horses stolen *(from)?
 b. Where were these horses stolen *(from)?
- (77) This secret decoder came out of a cereal box.
 a. What did this secret decoder come *(out of)?
 b. Where did this secret decoder come *(out of)?

These two (Type A) examples are incorrectly classified as members of B^+ according to (73).

Another large class of Type A constructions end up in B^+ because *who* and *what* are the only *wh*-words available for question forms. Note that the set of *wh*-adverbs *where*, *when*, *how*, and *why* are only appropriate proforms for PPs (and sometimes NPs) with particular semantics. There are simply no suitable proforms for some Type A examples, even if we allow complex forms like *how quickly*. The following is adapted from Quirk et al. (1985, §16.15):

- (78) Peter went fishing with his brother.
 a. Who did Peter go fishing with?
 b. * How/Where did Peter go fishing?

Here, *who* is the only possible *wh*-form to choose from, and it must always co-occur with the preposition, so this Type A example is a member of B^+ .

Finally, there are cases where Type B constructions are wrongly classified as A^+ members. The following is also from Quirk, et al.:

- (79) She died of pneumonia.
- a. What did she die of?
 - b. How did she die?

This example satisfies the first B⁺ criterion in (73), but it fails the second, so it must go into A⁺.

Note that all of the counterexamples for the revised classification in (73) presented in this section are also problematic for the original, simpler classification in (68).

2.6.4 Non-*wh* proforms

The question formation test is related to a test proposed by Rauh (1993) involving proform substitution. She makes the following claim:

- (80) A Type A PP can be replaced by a syntactic proform *there*, *then*, or *therefore*.
A Type B PP cannot be replaced by a proform.

Rauh notes that this criterion runs into trouble for the reasons already discussed above: “the set of possible, semantically marked prepositional proforms is relatively small and is by far exceeded by the set of meanings which are attributed to prepositions” (p. 113). Also, for unconvincing reasons, Rauh accepts *therefore* as a proform for PPs expressing cause, but rejects *thus* and *how* as proforms for manner PPs.

Nevertheless, she uses the proform test criterion as evidence for non-lexical (i.e., Type B) status (p. 134):

- (81) a. Bill is good at tennis.
b. * Bill is good there/then/therefore/thus.

We have already seen that this test is not foolproof. The Type A PP in (78b) has no appropriate proform, while the Type B example in (79) does:

- (82) a. Peter went fishing with his brother.
b. * Peter went fishing there/then/therefore/thus.
- (83) a. She died of pneumonia.
b. ? She died therefore.
c. She died thereof.

The example in (83) is especially interesting because it brings up a kind of proform that Rauh overlooks. Combinations of *here/there/where*+P are stylistically marked as high register, but with this in mind, such proforms are possible with a number of Type B constructions:

- (84) a. the harvest, whereupon all our lives depend
b. the final report and any questions pertaining thereto

In conclusion, PP proforms appear to show the same range of behavior as full PPs, including both Type A and Type B uses, and so proform substitution does not provide a method for classifying prepositions uses.

2.7 Projection Properties

The next set of properties I consider has to do with syntactic structure within the PP. Prepositions are typically considered to be X-bar heads (Jackendoff, 1973, 1977). This means roughly that they combine with zero or more complements to the right (in English) to form a P' projection. This intermediate P' projection can be modified by adjuncts, and finally it combines optionally with a specifier to the left to form a maximal P'' or PP projection.

It has been suggested that prepositions at the Type B end of the spectrum project simpler phrasal structures than those at the Type A end (Rauh, 1991b, 1993):

- (85) Type A prepositions have full projection properties
Type B prepositions have restricted projection properties

This claim must be evaluated at each level of projection.

2.7.1 Complementation

I start with the question of whether prepositional uses can be classified according to their complementation patterns. We can apply a constituent (i.e., non-transformational) test and see if any complementation patterns are associated only with the Type A end of the prepositional spectrum. We have already seen many examples of the most typical pattern: a preposition taking a single NP complement: *to John*, *at the market*, *with the fishes*. We know that this pattern is found with all types of prepositions from Type A to Type B, so it gives us no basis for classification.

Rauh (1993) claims that Type B (“non-lexical”) prepositions only exhibit the [____ NP] complementation pattern, and so they are not strictly subcategorized like Type A prepositions, which show a wider range of complementation possibilities. As we will see shortly, this is not true, but we can formulate a weaker claim:

- (86) Type A prepositions show the full range of complementation patterns.
Type B prepositions only allow a subset *S* of complementation patterns.

To evaluate this claim, we first need a list of all possible complementation patterns for prepositions. Here is the P' expansion rule given in Jackendoff (1977):

$$(87) \quad P' \rightarrow P - \left\{ \begin{array}{l} (\text{NP}) - (\text{PP}) \\ (\bar{S}) \end{array} \right\}$$

This suggests that every preposition must have one of the following subcategorization frames:

- (88) a. [____]
 b. [____ NP]
 c. [____ PP]
 d. [____ \bar{S}]
 e. [____ NP PP]

We already know that the “canonical” frame in (88b) must be in \mathcal{S} , which means that it is not useful for classificatory purposes. Let us consider the other four cases in turn.

The following lists give examples of forms that can appear as intransitive prepositions:

- (89) a. in, on, through, around, over
 b. up, down, out, off
 c. home, upstairs, afterwards

The forms in lists (89a)–(89b) have both transitive and intransitive uses; those in (89b) occur more frequently intransitively. The “adverbs” in list (89c) are sometimes analyzed as obligatorily intransitive prepositions (Klima, 1965).

We are interested in whether Type B prepositions can be intransitive. The answer is yes:

- (90) a. The quarreling neighbors finally made up after 15 years.
 b. In the last lap, my legs suddenly gave out.
 c. When he came to, he found himself chained to Nelson’s Column.
 d. It was unwise to turn that offer down.

These are examples of phrasal verb constructions, and the underlined words are referred to as “verbal particles,” and they are sometimes thought of as adverbs, or assigned to their own specialized category. Neither of these options is very illuminating, however, and I follow Emonds (1972) and Jackendoff (1973) in analyzing verbal particles as intransitive prepositions. The subcategorization frame [____] is therefore also in \mathcal{S} , and has no classificatory value.

Next there are a number of prepositions that take PP complements. It is interesting to note that these constructions also illustrate the Type A to Type B spectrum. The PP complements in

the following three sets of examples are headed by Type A, Type AB, and Type B prepositions, respectively:

- (91) a. from under the ground, for after dinner
 b. from out of the box, along with his sister, away from the city
 c. instead of Mary, because of the weather

We are more interested, however, in the main prepositions in (91). And we find that prepositions taking PP complements can be of Type B (or perhaps Type AB in the first two examples below):

- (92) a. I bought this radio off of a shady-looking character downtown.
 b. These clothes are made out of paper.
 c. The bored children are waiting for after dinner.
 d. He’ll definitely agree to above \$80,000.

What these have in common with “ordinary” [P + NP] Type B constructions is that the complement of the preposition has a nominal interpretation. For example, the PP in (92c) can be paraphrased as *for the time/event after dinner* and the one in (92d) as *to an offer/amount above \$80,000*. The existence of cases like (92) means that the subcategorization frame [____ PP] is also in \mathcal{S} , and therefore cannot be used to identify Type A prepositions.

Subordinating conjunctions like *while*, *because*, *since*, and *before* can be analyzed as prepositions taking sentential complements. These examples have only Type A uses. However, complementizers like *that*, *whether*, and *if* can also be treated as prepositions, following Emonds (1985). And the “preposition” *that* certainly has Type B uses:

- (93) I see that you’ve been to the tanning studio again.

There is evidence, then, that the [____ \bar{S}] frame should go into \mathcal{S} . Keep in mind, however, that we already know that most prepositions that have this complementation pattern, like *while* and *before*, have only Type A uses, because they are not in the subset of “fixable” forms (see §2.2).⁵

Finally, we have the rather “exotic” possibility in (88e). The following examples are from Jackendoff (1973):

- (94) a. A Martian gzrch lumbered [down the street toward the frightened garbage collector].
 b. A drunken bassoonist staggered [into the smoky room from out of the cold].

⁵If we adopt Emonds’s proposal to treat complementizers as prepositions, then we must add *that*, *whether*, and *if* to the set of fixable forms in (§2.2).

- c. The mice raced [from one end of the park to the other].
- d. Max sent the trilogy [to Bill in New York].

I do not agree with Jackendoff's structural analysis in these cases. The first three examples are better treated as sequences of two PPs, while example (94d) seems to involve PP-internal modification. I will return to the issue of modification in the next section.

Jackendoff (1977) does give one example, however, that I consider a genuine instance of the [P + NP + PP] complementation pattern:

- (95) across the street from Bill's house

A small number of locative prepositions like *across*, *down*, and *through* do subcategorize for an NP and a PP headed by *from*. The *from*-PP has the syntactic properties of a complement (e.g., it is non-iterable, and its position within the whole PP is fixed) and it also expresses a semantically obligatory argument in the locative relation.

Another good candidate for a ditransitive treatment is the preposition *from* itself in temporal *from... to...* constructions:⁶

- (96) The meeting lasted [from 5 to 10 o'clock].

We cannot, therefore, discount ditransitive prepositions altogether, although they are much rarer than Jackendoff suggests. As far as the Type A vs. Type B distinction goes, however, all of the prepositions exhibiting this complementation pattern have clear spatial or temporal meanings, and so they cannot be Type B prepositions. The subcategorization frame [____ NP PP] therefore is *not* an element of *S*.

In summary, of the five subcategorization frames listed in (88), only [____ NP PP] is outside of *S*. In other words, a preposition exhibiting this complementation pattern cannot be of Type B. This criterion is not at all useful, however, since it classifies only a tiny minority of all prepositional constructions.

2.7.2 Modification

The topic of PP-internal modification is hardly ever mentioned in the literature, but by analogy with nouns, verbs, and adjectives, it is reasonable to assume that adjuncts can attach to P' (and possibly PP) projections:

- (97)
- $$P' \rightarrow P' - \left\{ \begin{array}{l} PP \\ AdvP \end{array} \right\}$$

⁶I thank Dan Flickinger for bringing this example to my attention.

Such a rule offers a promising analysis for Jackendoff's example (94d). The possibility of iteration, for example, motivates a modifier treatment:

- (98) Max sent the trilogy [to Bill in New York at our main branch in his top floor office].

In contrast, under Jackendoff's analysis, the preposition *to* in this example would have to have the subcategorization frame [____ NP PP PP PP].

Rauh (1993) also assumes that prepositions allow post-modifying elements, along the lines of (97), and she makes the further claim that only prepositions on the Type A end of the spectrum (her "lexical prepositions") allow post-modification. Prepositions on the Type B end ("case prepositions"), on the other hand, do not allow P' modification.

In its weakest form, Rauh's claim appears to be true: a P' headed by a Type B preposition cannot be modified. After all, Type B prepositions are meaningless by definition, so there is no semantic relation available for an adjunct to modify. This result is not particularly helpful, though, because the fact is that PP-internal modification is highly restricted in general, for all types of prepositions. The *Bill in New York* example (94d) discussed earlier is a convincing example, in my opinion, but consider Rauh's examples (p. 106, 110):

- (99) a. Bill went past the house along the river.
 b. Bill stood behind the door near the wall.
 c. He stayed at his sister's near Brighton
 d. Bill arrived at five o'clock sharp.
 e. Bill arrived at five o'clock in the morning.
 f. Bill arrived at the station near London.

All of these constructions admit more plausible analyses that do not involve P' modification. The verb *went* in example (99a) selects two PP complements (cf. examples (94a)–(94c) above). In (99b), *near the wall* could just as well modify the verbal projection. This is also true for *near Brighton* in (99c); alternatively, *near Brighton* could be analyzed as an NP-internal adjunct. Finally, in the three *arrived* sentences, the modifiers are almost certainly NP-internal.

I conclude that while adjunction to P' is possible, it is not at all widespread. It is true that Type B prepositions do not allow it, but then neither do the vast majority of Type A prepositions. A classificatory criterion based on modification is therefore of very limited use.

2.7.3 Specifiers

The commonly recognized PP specifiers are words like *right*, *clear*, and *straight*, and degree phrases like *six miles*, *halfway*, *two hours*, and *entirely* (Jackendoff, 1973; Emonds, 1985).

Rauh (1991,1993) claims that only Type A prepositions allow specifiers, which suggests a simple transformational criterion:

- (100) Type A prepositions allow specifiers.
Type B prepositions take no specifiers.

Some of Rauh's examples are given here (1993, p. 106, 133):

- (101) a. The store is right across the street.
b. Bill arrived two hours before Mary.
- (102) a. * Bill believes right in science.
b. * Bill is good right at tennis.

There are, unfortunately, exceptions to Rauh's claim, in both directions. Some Type B prepositions can combine with specifiers. Zwicky (1992) offers the following example (p. 375):

- (103) I gave the box right to Kim.

In fact, this example is probably better classified as a Type AB case, but the following contain clearer instances of Type B uses:

- (104) a. The company belongs partly to the government.
b. This cereal consists entirely of sugar and fat.
c. Her comments hinted right at what we all feared most.
d. Jack sneaked out of the supply closet and bumped right into his boss.

With adverbial forms like *entirely* and *partly*, there is some uncertainty about the analysis because they could also be modifiers of the verb. The specifier analysis seems secure in (104b), however, since the position of *entirely* is quite fixed:

- (105) ? (Entirely) this cereal (entirely) consists of (entirely) sugar and fat (entirely).

And finally, the treatment of *right* in (104c)–(104d) as a PP specifier is fully uncontroversial.

Verbal particles also provide many counterexamples to the claim that Type B prepositions take no specifiers. Recall from the discussion of (90) above that phrasal verb particles can be analyzed as intransitive prepositions. Many of these are Type B prepositions, but nevertheless allow specifiers:

- (106) a. John turned the job right down.
b. Bill folded the map right up.
c. Mike figured you right out, didn't he?

Rauh's account of the specifier criterion is purely syntactic: she suggests that while Type A PPs contain a specifier position, Type B PPs do not. There is also a semantic component to specifier attachment, however. I suggest that all prepositions can potentially combine with a specifier syntactically, but at the same time, a specifier can only appear if it makes an appropriate semantic contribution. The fact that specifiers occur less frequently with Type B prepositions follows from the fact that Type B prepositions have no semantic content. Under certain conditions, specifier attachment is still possible, however; I will return to this issue in the next chapter.

We can also expect to find Type A prepositions that are semantically incompatible with degree phrases and other specifiers:

- (107) a. * It is cheaper to travel right/straight/halfway/completely by public transportation.
b. * Jack fortified the punch right/straight/halfway/completely with cheap vodka.

We might propose an ad hoc syntactic mechanism like deleting the specifier position in these cases, or stipulating that *by* and *with* only project to P' , not to P'' . These proposals are unmotivated, however, and unnecessary. Specifier attachment is blocked here because this use of *by* and this use of *with* are semantically incompatible with all possible specifiers. The existence of data like this, and like the Type B examples above, demonstrates the unreliability of the proposed claim in (100).

2.8 Interaction of Criteria

The results of our survey of potential tests for classifying prepositions have been somewhat disappointing. Some of the proposed criteria (e.g., synonym substitution, pseudopassivization) are inadequate because they give results inconsistent with our original Type A vs. Type B distinction. Other criteria are inadequate because they only induce a partial classification, either because they only apply to a subset of all prepositions (e.g., complementation) or because they give unclear results, resulting in a fuzzy boundary between A^+ and B^+ (e.g., pied-piping).

Ideally, if we had found a number of adequate, clear-cut criteria, the next step would be to check if they all converged on the same A^+/B^+ partition. A positive result would have been overwhelming evidence that the spectrum of prepositional uses could actually be reduced to a discrete binary classification at some level of grammatical representation.

We have not found such straightforward evidence, but it may be that we can still induce a discrete classification based on more complex interactions among the criteria we have assembled. For example, the pseudopassivization test and the specifier test give more or less clear results, which very roughly reflect the Type A vs. Type B distinction. Constructions on the

Type A end of the scale generally do not allow pseudopassivization (with many exceptions) and those on the Type B end do (with many exceptions). Type A-end prepositions take specifiers and Type B-end prepositions do not (again, with exceptions). By combining these two tests, we can come up with a more reliable classification:

- (108) a. $A^+ = Spec, \neg Pass$
 b. $B^+ = \neg Spec, Pass$

This is not really a partition, because it leaves out cases where both tests apply positively or both negatively. Some of these are cases where one of the tests gives the “wrong” result. We will also find double positive or double negative results if the two criteria divide up Type AB uses in different ways (which is more than likely). The classification in (108) is inconclusive for all of these cases.

Also, note that if both tests happen to give the “wrong” result on the same item, then this item will still be incorrectly classified. We can minimize this problem by adding more tests to the classificatory criteria in (108). As the number of tests increases, the chances that all of them give the wrong result on any one item decreases. But on the other hand, for a given test item, the chances that at least one test gives the wrong result increases, and this item will be left out of the classification. Simply combining different tests conjunctively therefore leads to a more accurate, but less inclusive classification.

One possible improvement to this approach is to allow more complicated combinations of tests, including implication and disjunction. We could then formulate conditions like “three out of four of the following criteria must hold.” We could also assign different weights to the tests and somehow calculate a score for every prepositional use, and then determine the membership of A^+ and B^+ based on these scores.

2.8.1 Classification by multiple criteria

The idea of combining tests opens up an enormous range of possibilities, and the challenge is deciding how to proceed in a principled manner and end up with something of linguistic value. I have not looked further into this line of research myself, but there is an existing study which happens to be exactly relevant. Carvell and Svartvik (1969) discuss statistical techniques for inducing a linguistic classification based on the results of applying a large number of tests to a set of examples. The data they use consists of sentences matching the pattern $N_1 V p N_2$, and their starting point is the Type A vs. Type B distinction, which they illustrate with the following examples:

- (109) a. She sent for his coat.
 b. She came with his coat.

They apply the following tests to a set of 146 sentences taken from novels. They use most of the well-known criteria that I discussed in the previous sections, plus a few that they consider to have “reasonably conceivable relevance” to the classification task at hand:

- (110) a. Pseudopassivization (P)
 b. Coordination with transitive verb (C)
 c. Question formation with *who/what* (Q)
 d. Question formation with *wh*-adverb (A)
 e. Deletion of PP
 f. PP fronting without subject-auxiliary inversion (M)
 g. Actual and potential animacy of N_1, N_2
 h. Noun class of N_1, N_2
 i. Modification of N_1, N_2
 j. Definiteness of N_1, N_2
 k. Abstractness of N_1, N_2
 l. Presence of adjuncts
 m. Prepositional form

Carvell and Svartvik collect data from two informants. This seems insufficient for an empirical study, but the authors’ aim in this study is only to illustrate a general methodology, and not to find a serious classification for the particular domain of prepositional constructions. Keeping this in mind, we can still have a look at their results in broad terms.

The most powerful criteria for classificatory purposes turn out to be P, C, A, Q , and M , all of which we have already come across in the preceding discussion. Interestingly, Carvell and Svartvik find that criteria P and C are nearly exactly correlated (see (111a) below), although they do mention that C is “less reliable.” Q is judged to be a useful criterion overall, even though the two informants gave conflicting responses for many test items. Criterion M turns out to be powerful, but it applies positively to only 19 out of 146 test items. Criteria P is by far the most important. In addition to the correlation with C , Carvell and Svartvik claim that the property $+P$ “predicts $-A$ and $-M$ and, almost always, $+Q$ ”:

- (111) a. $+P \Leftrightarrow +C$
 b. $+P \Rightarrow -A, -M, +Q$

In light of what we know about coordination and pseudopassivization from the discussion in previous sections, these statements can only be considered rough generalizations at best. First, the property $+C$ is much more widespread than $+P$. Consider the following, for instance:

- (112) a. Jack chuckled throughout the ceremony.
 b. Jack chuckled throughout and disrupted the ceremony. ($+C$)
 c. * The ceremony was chuckled throughout by Jack. ($-P$)

Example (112a) is a counterexample to (111a). Similarly, there are plenty of counterexamples to the implication $+P \Rightarrow -A$ in (111b):

- (113) a. The Dalai Lama sat on this cushion.
 b. This cushion was sat on by the Dalai Lama. ($+P$)
 c. Where did the Dalai Lama sit? ($+A$)

Carvell and Svartvik use various techniques to produce several different classifications, but their most linguistically oriented one divides the data into five classes based on P , A , and Q :

- (114) Class 1: $+P (= -A, +Q)$
 Class 2: $-P, -A, +Q$
 Class 3: $-P, +A, +Q$
 Class 4: $-P, +A, -Q$
 Class 5: $-P, -A, -Q$

Class 5 is really a residual group whose members show more diversity than similarity; by considering more features this class could be redistributed among the other four. Classes 1–4 can be roughly characterized by cohesiveness, with Class 1 containing the most closely cohesive constructions and Class 4 containing the least cohesive ones.

2.8.2 Binary classification

The classification in (114) has many interesting features, but remember that we are looking for a binary partition of prepositional uses. As one suggestion, we could merge the more cohesive Classes 1 and 2 and the less cohesive Classes 3 and 4 to produce the following partition:

- (115) $A^+ = -P, +A$
 $B^+ = +P$ or $(-P, -A, +Q)$

This is definitely an improvement on classification based on pseudopassivization alone. The combination $-P, +A$ is a good condition for A^+ ; I can think of no Type B examples that end up in A^+ by mistake. Also, the disjunctive condition for B^+ allows most non-passivizable

Type B examples, as in (57) above (repeated here) still to end up correctly in B^+ because they have the properties $-A, +Q$:

- (116) a. * The underground organization was belonged to by all of our neighbors. ($-P$)
 b. * Where did all of our neighbors belong (to)? ($-A$)
 c. What did all of our neighbors belong to? ($+Q$)
 (117) a. * Several parts are consisted of by their plan. ($-P$)
 b. * How does their plan consist? ($-A$)
 c. What does their plan consist of? ($+Q$)

On the other hand, we already know that many Type A constructions, like (58) and (113b) above, allow pseudopassivization, and these are then incorrectly included in B^+ according to (115). Finally, the residual Class 5 from (114) is completely neglected; these cases, with the properties $-P, -A, -Q$, are left unclassified by (115).

2.9 Summary

There are any number of ways to combine the tests listed in (110) and the many other criteria discussed in this chapter in order to induce a binary classification of prepositional constructions. With increasingly elaborate modifications, we could improve the accuracy and coverage of the classification in (115) to make it come closer and closer to our intuitive idea of the lexical vs. functional distinction.

The result of all this, however, would not be an independent empirical test for lexical vs. functional status, because it would have been constructed explicitly to match our intuitions. In other words, the intuitive distinction remains primary. But this is exactly what we hoped to avoid by turning to empirical criteria, because our intuitions about the lexical vs. functional divide are too fuzzy to serve as a basis for classification.

What we have seen in this chapter is that there is no single empirical test that we can depend on, much less a battery of converging tests, as often promised in the literature. In conclusion, then, we have neither a sound intuitive basis, nor solid empirical motivation for introducing a discrete lexical vs. functional division in the grammatical representation of prepositions.

Chapter 3

Approaches to Prepositional Analysis

I turn now to a more detailed discussion of theoretical proposals for representing the distinction between Type A and Type B uses of prepositions. Although many authors recognize this distinction, there are not many concrete proposals in the literature for representing it. As we will see, none of the existing analyses are able to handle the entire range of prepositional behavior, but most of them do capture some aspects of the Type A vs. Type B distinction successfully, and therefore give us an idea of what the ingredients of a full account might be.

3.1 Extended projection

Grimshaw's (1991) extended projection proposal relies heavily on the functional vs. lexical distinction. She introduces a binary feature *F* to encode functional ([+F]) vs. lexical ([-F]) status. The feature [$\pm F$] behaves somewhat like an additional categorial feature, in addition to *N* and *V*. Nouns and determiners are both represented categorially as [+N, -V], for example, but they have distinct *F* values: nouns are lexical [-F] while determiners are functional [+F].

The lexical vs. functional distinction also applies within the category of prepositions, and corresponds to our Type A vs. Type B distinction. A Type A construction has the following structure:

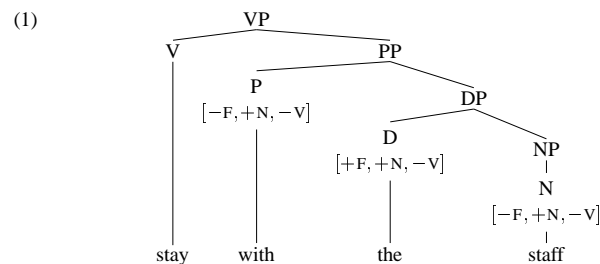

In contrast, a Type B construction is represented as follows:

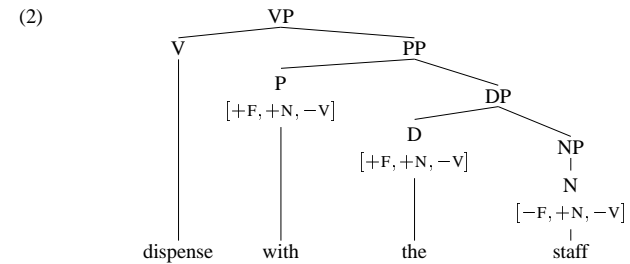

The feature specifications in the two examples are significant for Grimshaw's notion of extended projection. The DP in both examples above is an extended projection of NP because *D* is (i) functional and (ii) categorially indistinct from *N*. In the Type B example in (2), these two conditions are also satisfied by the PP, which is therefore also an extended projection of NP. This is not the case in (1), because the *P* is lexical, not functional. Therefore, the extended projection of NP in (1) stops at DP and does not extend to the PP "shell."

3.1.1 Semantic transparency

The notion of extended projection in (1–2) is relevant for, among other things, semantic role assignment. According to Grimshaw, semantic roles can be assigned via extended projections. For example, a transitive verb selects a DP complement, but it can assign a semantic role to the NP inside the DP, because the DP is an extended projection of the NP. Similarly, the prepositional verb in (2) can assign a role to the NP because its functional PP complement is an extended projection of the NP. This kind of non-local semantic role assignment is blocked in (1), however; the verb *stay* can only assign an argument role to the PP.

There is indeed a difference in argument structures of *stay* and *dispense*. In (1), *stay* expresses a two place relation between an external theme argument and an internal argument denoting a location, or a state; we are mostly interested in the internal argument. Very broadly speaking, there is a "staying event," and this event involves the state of something or someone being with the staff. The staff itself is not directly involved in the staying event conceptually, so semantically the argument expressed by the NP does not receive a semantic role from the verb.

Now consider example (2). The verb *dispense* also expresses a two place relation, between an external agent argument and an internal theme, which is the entity that "gets dispensed with". It seems incorrect to say that there is "dispensing event" which takes place with the staff, or somehow involves someone or something being with the staff. Instead, there is a "dispensing-

with event” that involves the staff directly. This conceptual frame suggests a semantic argument structure where the verb assigns a semantic role directly to the NP, in much the same way as the transitive verb *eliminate* assigns a role to its direct object in *eliminate the staff*.

Grimshaw’s analysis accounts for this difference in quite an interesting way, but on the other hand, it is apparent that she needs a large amount of syntactic apparatus (the feature F, the definition of extended projection, and the stipulation that extended projections license non-local role assignment) in order to explain a fundamentally semantic distinction. The fact that *with* in (1) blocks role assignment to its NP complement is without a doubt tied to the fact that *with* has its own semantics, and its own argument structure in this construction. And analogously, the fact that the verb *disperse* can “see through” the PP and assign a role to the NP in (2) is tied to the fact that *with* is semantically empty in this case. In other words, I suggest that semantic behavior should be accounted for via semantic representation. In Grimshaw’s analysis, semantic behavior is accounted for via syntactic features.

A syntactic approach using the feature $[\pm F]$ might be the right approach, if functional and lexical prepositions exhibit differences in syntactic behavior, in addition to their transparency vs. opacity with respect to argument role assignment. As shown in the last chapter, however, there are no syntactic criterion that reliably distinguish between a set A^+ of $[-F]$ prepositions and a set B^+ of $[+F]$ prepositions. Instead, for a given prepositional use, Grimshaw can only decide the value of F based on the semantic role assignment facts: if the preposition blocks non-local assignment, then it is $[+F]$, and if it allows non-local assignment, then it is $[-F]$. In other words, the specification $[-F]$ really means $[+MEANINGFUL]$ and $[+F]$ means $[-MEANINGFUL]$. An analysis that contained $[\pm MEANINGFUL]$ as a syntactic feature would certainly be suspicious; for the same reasons, Grimshaw’s use of $[\pm F]$ for prepositions is inappropriate.

3.1.2 Categorial features

In Grimshaw’s analysis, prepositions have the categorial features $[+N, -V]$, just like nouns and determiners. In most accounts, however, prepositions are argued to be categorially distinct from nouns, generally carrying the features $[-N, -V]$ (Chomsky, 1970; Stowell, 1981). Grimshaw’s departure from this standardly accepted representation seems to be motivated only by theory-specific considerations. In the case of functional prepositions, this categorial identity between P and N is necessary in order for the PP to be an extended projection of the NP. In the lexical case, the PP is not an extended projection of the NP, so it would be possible to assign the features $[-N, -V]$ to $[-F]$ prepositions.

Van Riemsdijk (1998) argues against Grimshaw’s treatment of prepositions for the same

reason. He offers several arguments to show that functional and lexical prepositions are not distinct from each other categorially, but both are categorially distinct from nouns. For example, both functional and lexical PPs in Dutch (and to a lesser extent in German) can be extraposed, but NPs cannot (p. 28):

- (3) a. Hij gaat [op zondagochtend] altijd golfen
he goes on Sunday morning always golfing
b. Hij gaat altijd golfen [op zondagochtend].
- (4) a. Ik had niet [op zoveel mensen] gerekend.
I had not on so many people reckoned
'I hadn't counted on so many people.'
b. Ik had niet gerekend [op zoveel mensen].
- (5) a. Ik had niet zoveel mensen verwacht.
I had not so many people expected
b. *Ik had niet verwacht zoveel mensen.

The standard assumption that P and N are decomposed into $[-N, -V]$ and $[+N, -V]$, respectively, accounts for these observations straightforwardly. Grimshaw’s representations in (1)–(2) do not.

3.1.3 Semi-lexical heads

Van Riemsdijk (1998) offers an alternative to Grimshaw’s theory of extended projection, also depending on notions of functionality. His main innovation is the use of two binary features F and G to encode functional vs. lexical status. This leaves room for two intermediate categories, which he refers to as “semi-lexical.”

With regard to prepositional uses, it is tempting to apply the notion of semi-lexical head to the analysis of Type AB uses. In fact, however, van Riemsdijk goes in a different direction, and ends up with an analysis where the lexical prepositions in other accounts (e.g., Grimshaw’s) are instead semi-lexical. Type B prepositions are presumably still treated as functional. The existence of fully lexical prepositions is left in doubt; van Riemsdijk suggests that perhaps intransitive prepositions are lexical. I will not go into any more details about this account; aside from the issue of categorial representation discussed above, van Riemsdijk offers no improvement over Grimshaw’s analysis of the Type A vs. Type B distinction. In particular, he gives no further insight into the representation of Type AB prepositional uses.

3.2 Headedness of PPs

Throughout this thesis it has been assumed that all prepositions are syntactic heads, but in fact it has been suggested that the differences between Type A and Type B prepositions point to a difference in syntactic head status.

3.2.1 Head properties

The notion of syntactic head is well-established, but it turns out to be difficult to pin down with explicit definitions. There are a number of grammatical properties that can be considered to be indicators of head status. For example, the head in a given syntactic combination is normally the semantic functor, the morphosyntactic locus, the subcategorizand, the government trigger, the agreement target, the distributional equivalent, and the obligatory element. For a discussion of these terms, see Zwicky (1985) and Hudson (1987), who come to opposite conclusions about whether all of these indicators give consistent results. (See also Cann (1993) for a discussion of both analyses.)

Zwicky and Hudson are in agreement with regard to PPs: both conclude that P is the syntactic head in [P + NP] (e.g., *towards those penguins*). Zwicky notes that P governs accusative case on NP, and if we adopt Emonds's (1972) proposals about intransitive prepositions, then P is also the subcategorizand, the distributional equivalent, and the obligatory element in [P + NP]. There is also limited evidence (e.g., from Welsh) that P can show agreement with NP. These arguments are valid for both Type A and Type B PPs; in other words, there is evidence that prepositions are always heads.

On the other hand, the identification of the morphosyntactic locus, which Zwicky considers to be the only reliable indicator of head status, is only possible in Type B PPs. He gives the examples *inform Sandy of the news* and *tell the news to Sandy*, where the prepositions *of* and *to* bear morphosyntactic features that indicate the relation between the PPs and the verbs. Type A PPs are not involved in such external syntactic relations, so there is no evidence that [P + NP] has a morphosyntactic locus in the Type A case. In Zwicky's (1985) account, then, Type A prepositions are less securely identified as syntactic heads than Type B prepositions.

This is a rather counterintuitive result, and in fact, in Zwicky's (1993) discussion of head properties, he takes the opposite view. "Ordinary [i.e., Type A] Adpositions, as in *send books to China* or *eating sushi with your friends* are unproblematically Heads" (p. 306). On the other hand, PPs headed by "grammatically used" adpositions¹ are problematic because the preposition is the category determinant and the morphosyntactic locus, but the NP is the "external

¹Zwicky's examples are the three prepositions in *give money to Pat* and *the discovery of flying pigs by Chris* (p. 306).

representative." Zwicky's evidence for this is that adpositionally marked dependents in some languages (e.g., Niuean, Tigre, Acehnese) trigger agreement morphology on the verb.

3.2.2 Base properties

It is worthwhile to take a closer look at Zwicky's (1993) proposals. In this analysis, Zwicky takes an intermediate position between Zwicky (1985) and Hudson (1987). He divides the head-like notions identified in earlier studies into three groups; within these groups, the properties are claimed to coincide:

- (6) a. F: semantic functor, agreement target, government trigger, lexically subcategorized
- b. H: morphosyntactic locus, lexical (as opposed to phrasal), category determinant
- c. B: external representative, required element, classifying semantics

Instead of a single notion of syntactic head, then, we have three functions that can be independently assigned in every combination. In the prototypical case, the same element is identified as F, H, and B (the labels stand for "functor," "head," and "base"). In "ordinary" (Type A) prepositional constructions, for example, the preposition exhibits all three sets of properties in (6). Zwicky suggests that in Type B PPs, the preposition is F and H, but the NP complement is B, for the reasons mentioned above.

In fact, the identification of B in a Type B PP is not altogether clear. The external representative (REP) of a combination is the element that triggers agreement on an external head, lexically subcategorizes the external head, and serves as the distributional equivalent of the entire combination. The oblique agreement data that Zwicky presents (mentioned in the previous section) therefore point to the NP as REP, although this phenomenon is evidently very rare. Subcategorization is determined by maximal projections, so neither P nor NP can be said to subcategorize the set of verbs. On the other hand, it is definitely P that contributes the features that are eventually relevant for subcategorization, which means that P also has REP-like properties.

The identification of REP as the distributional equivalent also leads to indeterminate results. Zwicky gives no formal definition of distributional equivalence, although it is open to many different interpretations. With a very restrictive definition, neither P nor NP counts as the distributional equivalent in [P + NP]. For example, no NP or P has the same distribution as the Type B PP in (7a):

- (7) a. The island relies on tourism
- b. * The island relies tourism.
- c. * The island relies on.

Cann (1993) gives a more inclusive definition that allows the context to be chosen freely. If P (or NP) is the distributional equivalent, then for every Type B PP, there must be some context where the PP can be replaced by just the P (or NP) alone. For example, there are a number of verbs that select either a Type B PP or just an NP:

- (8) a. Jack believed (in) his sister.
 b. The committee approved (of) the plan.
 c. The athlete had once battled (with) cancer.

There is usually a noticeable shift in meaning between the two variants, so technically the context is not the same. Moreover, this alternation is not common, and it does not occur with all potentially Type B prepositions, so in general we cannot say that NP is distributionally equivalent to PP.

There are even fewer cases where a Type B preposition can appear in place of a full Type B PP. Normally, the NP complement of a Type B preposition cannot be omitted:

- (9) a. * Jack believed in.
 b. * The committee approved of.

And Type B verbal particles cannot be made transitive:

- (10) a. Jennifer looked the number up (*the list/...).
 b. By midnight, half of the guests were passed out (*of consciousness/...).

A few examples can be found that go against this generalization:

- (11) a. Everyone knocked off (work) at lunchtime.
 b. The patient slowly came to (consciousness/her senses).

It is clear, however, that these are conventionalized constructions where the NP is also strongly constrained. They certainly do not provide evidence that P is distributionally equivalent to PP.

According to (6c), the element identified as B should also be the required element. Like distributional equivalence, this notion can be defined more or less restrictively, and the two notions are closely related. If one element in a combination is the distributional equivalent, then the other element cannot be obligatory. The converse is not true however; otherwise the result above (that neither P nor NP is the distributional equivalent) would imply that both P and NP are required elements. In fact, (8) and (11) give examples of contexts where P and NP can be deleted. As mentioned already, however, these cases are exceptional and in the vast majority of contexts, P and NP are in fact both obligatory, which suggests that both are B elements. This poses a problem for Zwicky's account because the functions F, H, and B should only be associated with one element in a combination.

B elements are also supposed to have "classifying" as opposed to "contributory" semantics. Zwicky gives the example *red apple*, which refers to a kind of apple, not to a kind of red. The noun *apple* therefore has classifying semantics, and is B in this combination. Outside of the nominal domain, this distinction is less relevant, but we can still say for example that *eat apples* refers to an instance of eating, and not to apples. Similar considerations apply to Type A PPs; in *toward those penguins*, *behind the table*, and *because of the penguins*, it is the preposition that provides classifying semantics (Hudson, 1987, p. 114). With Type B PPs, judgments are much weaker. For example, in sentence (7a), the PP *on tourism* does not obviously refer to an instance of 'on' or to a kind of tourism. Neither element in the combination can be said convincingly to have classifying semantics.

In summary, it is not clear that the properties in (6c) coincide, and at least in the case of Type B PPs, it is impossible to assign the labels B and non-B with any degree of certainty. This leaves Zwicky's proposal to distinguish Type A and Type B prepositions B vs. non-B elements on shaky ground. It is equally plausible to argue that all prepositions, both Type A and Type B, are prototypical syntactic heads, combining all three functions F, H, and B.

3.2.3 Case prepositions

Rauh (1993, 1991) assumes a more traditional binary distinction between heads and non-heads, and argues for a non-head analysis of Type B prepositions. The PP *on approval* in her example (12) has the structure in (13):

(12) Bill depends on approval. (1991, p. 208)



Rauh provides a wide range of arguments for the NP analysis in (13); nearly all of her observations, however, are incorrect, or they provide no direct motivation for treating Type B prepositions as syntactic non-heads.

First, she claims that Type B prepositions have severely limited projection properties, allowing no specifiers or modifiers and only exhibiting one complementation pattern [____ NP]. But as discussed in §2.7, Type B prepositions actually have much the same projection properties as Type A prepositions. Rauh also notes that Type B PPs cannot be replaced by proforms (e.g., *there*, *then*), but in §2.6.4 we saw that this claim is also wrong.

Rauh offers coordination data to further motivate the structure in (13):

- (14) a. * Bill believes in science and during his life.
 b. * Bill is good at tennis and in London.
 c. * Bill is an expert on instruments and in London.

It is unclear how these examples support any claim about the headedness of the PPs.

On top of this, Rauh notes that Type B prepositions assign case, and she assumes that they express relational content. But these are both characteristics of syntactic heads, not non-heads. In short, the arguments that Rauh presents for her analysis are unconvincing. She also mentions observations by O'Grady (1985), who notes that the NP complements of Type B prepositions participate in external (i.e., clause-level) phenomena like control of PRO and floated quantifier interpretation, whereas NPs in Type A PPs do not (p. 160, 162):²

- (15) Bare NPs
 a. Harry gave John_i a book PRO_i to read.
 b. I visited the men_i several times each_i.
- (16) Type B PPs
 a. He pleaded [with the boys_i] PRO_i to leave.
 b. He talked [to the girls_i] several times each_i.
- (17) Type A PPs
 a. * Harry put a book [near John_i] PRO_i to read later.
 b. * She hit the nail [with hammers_i] several times each_i.

Rauh takes this to be evidence that Type B PPs are really NPs syntactically. O'Grady himself argues, however, that a syntactic account is untenable, and the real explanation lies in the semantic differences between Type A and Type B prepositions. Specifically, he attributes the difference in behavior to the fact that the NP complement in a Type A PP receives a thematic role from the preposition, but in a Type B PP the role is assigned by the external verb. This is the same distinction underlying the extended projection accounts discussed in §3.1; there, too, a syntactic analysis was found to be inappropriate. The phenomena in (15)–(17) are fundamentally semantic, and they do not provide relevant evidence for any particular syntactic analysis of PPs. As we have seen throughout the previous chapter and in this chapter, as far as purely syntactic properties are concerned, Type A and Type B PPs are not distinguishable.

Rauh herself admits a syntactic problem with the structure in (13): the lower NP should not be able to move out of the higher NP, because of the A-over-A condition (Chomsky, 1964). In

²It should be noted that these, like most of the other tests discussed in the previous chapter, are not completely clear-cut criteria.

order to allow preposition stranding, Rauh claims that both structures below are available for the V' in (12):

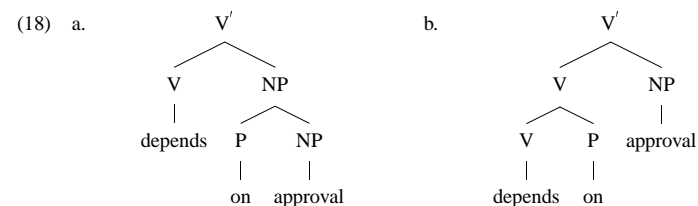

Some kind of restructuring as in (18b) is probably necessary for analyzing pseudopassives, but it should not be required for stranding by *wh*-movement. Consider the following:

- (19) Jennifer stole a coconut from Jack.
 a. * Jack was stolen a coconut from.
 b. Who did Jennifer steal a coconut from?

The intervening NP *a coconut* blocks restructuring in (19a), while the grammaticality of (19b) indicates that restructuring is unnecessary. Rauh's analysis cannot accommodate example (19b). On the other hand, a more standard analysis where Type B PPs are actually headed by P allows an explanation of the contrast in (19), because *wh*-movement incurs no A-over-A violation in (19b), even without restructuring.

A final argument against Rauh's proposal is that it disallows a unified treatment of transitive and intransitive Type B prepositions. By analyzing verbal particles (or at least a subset of them) as intransitive prepositions, we can explain why they exhibit the same properties and show the same range of Type A and Type B uses as transitive prepositions. There is no plausible way, however, to relate a structure like (13) with a structure containing only a preposition and no NP.

One valuable insight that Rauh's analysis incorporates is the idea that Type B prepositions are functionally similar to case affixes. Just as some verbs subcategorize for direct objects marked with accusative case, the verb *depends* selects an object marked by *on*. It is possible, however, to account for the case-like properties of Type B prepositions without going to the extremes of Rauh's analysis. All indications point to P as the syntactic head in Type B (and all other) PPs.

3.3 PP Attachment

Chomsky (1965) is sometimes mentioned as an early account of the Type A vs. Type B distinction in structural terms. He gives the following example, which has both a Type A and a Type

B reading (p. 101):

(20) He decided on the boat.

In the Type A case, the PP is interpreted as a place adverbial ('He made his decision while on the boat') while in the Type B case, the sentence means 'He chose the boat.' For Chomsky, the difference between the two readings reflect the degree of "cohesion" between the verb *decided* and the preposition *on*, and the two possibilities correspond to two different attachment points for the PP. The following structures illustrate the difference (although they are not Chomsky's exact representations):

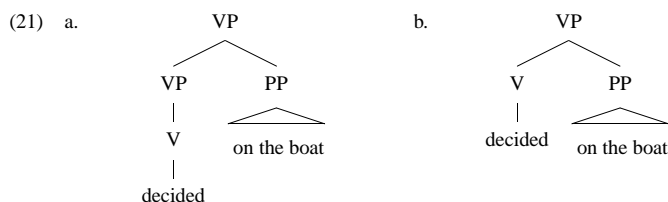

Place and time adverbials are analyzed as "Verb Phrase Complements" (i.e., VP sisters), as in (21a), while PPs that play a role in the subcategorization of verbs are "Verbal Complements" (i.e., sisters of V), as in (21b). Chomsky gives a few further examples of subcategorizing complements: *dash into the room*, *last for three hours*, *remain in England*.³

It is clear, then, that Chomsky's analysis is not an account of the Type A vs. Type B distinction at all, but an account of the complement vs. adjunct distinction. As we know, all Type B PPs are complements, but the converse is not true. The two distinctions are therefore linked, but not equivalent.

Despite occasional citations by other authors (e.g., Jolly, 1987; DeArmond, 1977; Bennett, 1975), Chomsky (1965) provides no account of the Type A vs. Type B distinction. Consider the following example:

(22) He remained on the boat.

Here the Type A PP *on the boat* is a complement of the verb *remained*, so the VP will have the same structure as the Type B version of (20) in (21b). This analysis offers no explanation for the different properties of the constructions in (21b) and (22).

³According to van Riemsdijk (1978), Chomsky provides these examples to illustrate a third degree of cohesion, in between the two represented in (21). It is possible to interpret Chomsky's analysis in this way, but then it is unclear how to translate his slightly divergent treatment of the two kinds of subcategorizing PPs into current syntactic notation.

3.4 HPSG Analyses

In this rest of this chapter I give an overview of existing proposals for handling prepositions in the framework of Head-Driven Phrase Structure Grammar (Pollard & Sag, 1987, 1994). For the most part, these run into the same difficulties as the analyses discussed already: they assume a discrete binary division of prepositional uses and offer no satisfying account of the existence of intermediate (Type AB) cases.

The most complete statement of the HPSG formalism and various grammatical analyses in HPSG can be found in Pollard and Sag (1994). The discussion of prepositions there is very limited, but it does include an explicit proposal for treating Type B prepositions as semantically empty heads. I discuss this analysis in §3.4.1. In §3.4.2 I examine an alternative approach that treats Type B prepositions as syntactic non-heads. Finally, in §3.4.3 I review proposals for handling Type A prepositions in HPSG.

3.4.1 Transparent prepositions

Pollard and Sag (1994) use the labels "predicative" and "non-predicative" (or "case-marking"), roughly corresponding to what I call "Type A" and "Type B" prepositions, respectively. In the following discussion I avoid the authors' terminology in favor of my own, in part because of the general arguments against using directly opposing labels (see the end of §1.1.3). In this case, "predicative" and "non-predicative" are particularly misleading because in addition to their necessarily inexplicit, intuitive function as labels for prepositions, they are also used formally within HPSG to refer to a particular feature [\pm PRD] carried by all substantive categories. This feature in turn is correlated with a number of syntactic and semantic properties.

Without a doubt, the distinction between Type A vs. Type B prepositions and that between [$+$ PRD] vs. [$-$ PRD] prepositions are closely related. The use of a single set of terminology suggests that they are equivalent, and this is an oversimplification. After all, one distinction is gradient and the other is strictly binary. In the following text, I use the terms "predicative" and "non-predicative" exclusively to refer to the syntactic features [$+$ PRD] and [$-$ PRD]. A detailed discussion of these features and their role in the analysis of prepositions appears in §4.2.4.

The discussion of prepositions in Pollard and Sag (1994) focuses almost entirely on Type B uses, and the analysis is mainly driven by binding theory observations. The following sentence is given as an example of a Type B prepositional use:

(23) Kim depends on Sandy.

The binding possibilities for the prepositional object position in this construction are exactly parallel to the those in the case of a "bare" NP object with no preposition:

- (24) a. John_i depends [on himself_i].
- b. * John_i depends [on him_i].
- (25) John_i trusts himself_i/*him_i.

In HPSG, binding constraints are formulated as constraints on the cooccurrence of nominal elements on the ARG-ST list of selecting heads—the verbs in these examples. The judgments in (25) are easy to explain because both the antecedent and the pronoun are direct syntactic dependents of the verb, and so they appear automatically on the ARG-ST list of *trusts*. In the other construction in (24), however, the the pronoun is only obliquely linked to the verb, and it is the PP that appears on the ARG-ST of *depends*, and its internal structure is inaccessible. Therefore, the same binding constraint cannot be used to explain both (24) and (25). This is undesirable, in light of the exactly parallel behavior of the two examples.

Instead, these data motivate an analysis where the PP in the *depend on* construction “looks like” its own NP object for binding purposes. In other words, given a semantically based binding theory as in HPSG, the PP in (24a) has its categorial identity and other syntactic properties determined by the preposition *on*, but all of its semantic information copied from the NP *himself*. With such an approach, the ARG-ST lists of *depends* and *trusts* in the above examples are identical as far as binding constraints are concerned, and we have a single analysis for both sets of judgments.

Pollard and Sag propose the following lexical entry for Type B *on* in order to achieve this result:

$$(26) \left[\begin{array}{l} \text{CAT} \\ \text{HEAD} \left[\begin{array}{l} \text{prep} \\ \text{PFORM } on \\ \text{PRD } - \\ \text{MOD } none \end{array} \right] \\ \text{SUBJ } \langle \rangle \\ \text{COMPS } \langle \text{NP}[\text{acc}] : \boxed{1} \rangle \\ \text{CONT } \boxed{1} \text{ } nom\text{-obj} \end{array} \right]$$

This preposition projects the following PP in (24a):

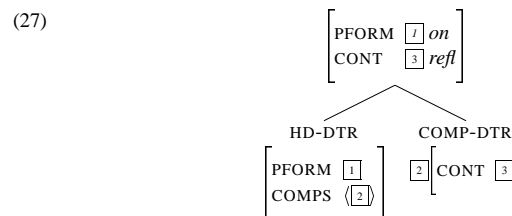

The top node of this tree has the desired form: for all syntactic purposes (e.g., selection by the verb *depends*), the phrase looks like an *on*-PP, and for all semantic purposes (e.g., binding) it looks like a reflexive pronoun.

In this example, Pollard and Sag explain that “the head preposition makes no contribution to the CONTENT of the PP.” In one sense, this is true, because all of the semantics comes originally from the NP object. In another sense, though, the preposition actually contributes *all* of the CONTENT of the PP. The end result in (27) is that the content $\boxed{3}$ is structure shared between the pronoun and the PP, but the percolation of this information is in fact strictly head-driven. This is purely a theory-internal requirement, a consequence of the HPSG Semantics Principle:⁴

- (28) In a headed phrase, the CONTENT value is token-identical to that of the adjunct daughter if the DTRS value is of sort *head-adj-struct*, and with that of the head daughter otherwise.

This is the sole motivation for the CONT representation in the lexical entry of *on* in (26), which is otherwise completely at odds with the intuition that this use of *on* is semantically empty. I doubt that anyone has the intuition that the word *on* in sentence (24a) actually means ‘himself.’

It would be preferable to represent Type B *on* as having null content in its lexical entry. Given the Semantics Principle as stated in (28), however, this would lead to the entire PP also having null content. A quick solution to this problem would be to specify in the principle that in these particular PPs, the NP is to be identified as the semantic head. This would be nothing but a stipulation, however. In my own analysis, presented later in this chapter, Type B prepositions are explicitly represented as semantically empty lexical items, and the fact that the complement NP is then the semantic head is made to follow as a direct consequence of this.

3.4.2 Prepositions as markers

An alternative analysis of Type B prepositions is to treat them as elements of the functional syntactic category *marker* (Heinz & Matiasek, 1994; Badia, 1996). The following German

⁴This is a simplified formulation of the Semantics Principle, ignoring quantification.

example, taken from Heinz and Matiassek, contains an instance of Type B *auf*:

- (29) Der Mann wartet auf den Installateur.
 the man waits on the plumber-acc
 ‘The man is waiting for the plumber.’

The verb *wartet* is a prepositional verb, just like its English counterpart *wait*. In the marker analysis, the PP in (29) has the following structure:

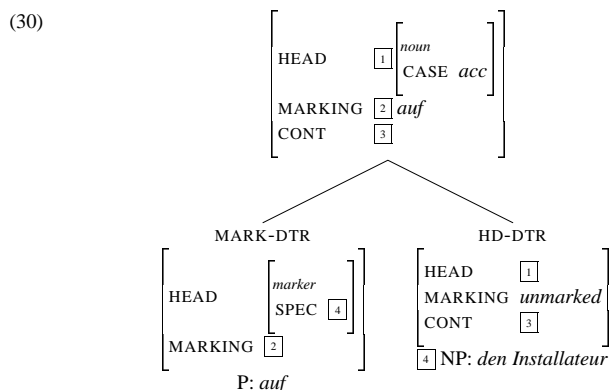

As a marker, *auf* is assumed to have no semantics (although it is unclear how this is supposed to be represented), and in this construction, the NP is the semantic and syntactic head, so it structure shares its semantics directly with the phrase. This account therefore sidesteps the difficulties faced by the Pollard and Sag (1994) analysis discussed in the previous section.

Badia (1996) gives more detailed arguments in favor of a marker analysis of Type B prepositions in HPSG. First he mentions the fact that Type B PPs in Catalan participate in argument control; we have already seen similar data for English in (16) above, and there I argued that a semantic explanation is more appropriate than a syntactic one. Badia also shows that the NP complement of a Type B preposition can trigger agreement on an element outside the PP (p. 127):

- (31) Joan va aconsellar [a les noies_i] mostrar-se
 Joan AUX advise [to the girls_i] show-REFL
 contentes_i/*content/*contenta/*contents.
 happy_i-fem.pl/*masc.sg/*fem.sg/*masc.pl
 ‘Joan advised the girls to show themselves (to be) happy.’

This particular example, however, is an instance of the previous phenomenon (oblique control) combined with ordinary agreement. As mentioned at the end of §3.2.1, there are languages

that provide examples of “real” oblique agreement. Again, however, this phenomenon is open to semantic explanation; I return to this topic in the next chapter (see §4.2.2).

Badia also offers a syntactic argument based on coordination: a verb plus its Type B preposition can be coordinated with a transitive verb, with both sharing a single NP object. This claim was discussed in §2.3.2 and dismissed as a reliable criterion for distinguishing Type A and Type B constructions. Badia himself admits that the evidence is “a bit tentative.”

Next, he offers some arguments that are more specific to HPSG. First, analyzing Type B prepositions as markers brings together the notions of semantic and syntactic head. But this distinction is needed in analyzing other constructions—for example, head-adjunct structures, and possibly determiner-noun and auxiliary-verb combinations. Unless one makes a serious proposal to eliminate the semantic vs. syntactic head distinction altogether, Badia’s argument does not hold. Second, he suggests that a marker analysis explains why a Type B preposition only governs the case of its complement and imposes no semantic restrictions. In principle, though, a marker can specify whatever constraints in its SPEC value that a head can specify via COMPS. Although the two types of selection are handled by different principles (the SPEC Principle and the Valence Principle, respectively), the formal mechanism—unification of two SYNSEM objects—is identical in both cases. Nothing about subcategorization properties (or the apparent lack thereof) follows simply by virtue of adopting a marker analysis.

Finally, Badia makes the point that treating Type B prepositions as markers eliminates the need to stipulate that they structure-share their CONTENT values with their complements’ CONTENT values (see the lexical entry in (26), for example). As mentioned above, I agree that this is a weakness of the standard account, and it is an advantage of the marker analysis that Type B prepositions/markers can be represented “faithfully” as semantically empty. As an ad hoc proposal, we could introduce a *content* subtype called *null-cont* to serve as the CONTENT value of semantically empty markers.

Note, however, that Badia’s argument only shows that a more sophisticated approach to semantically empty heads is needed in HPSG; it does not provide direct motivation for a marker analysis in particular. And in fact, as we have seen, there are many problems with analyses that treat Type B PPs to be NPs categorially. The marker analysis has the additional drawback that it no longer treats the preposition itself as a member of P. The many lexical similarities between the Type A and Type B versions of a preposition (e.g., phonological form, case assigning properties, morphosyntactic behavior⁵) no longer come for free, but must be dealt with

⁵English prepositions do not exhibit many morphosyntactic alternations; one possible example is the correspondence between complex transitive forms (*out of paper*, *off of the shelf*) and simple intransitives (*out*, *off*) (Quirk et al., 1985, §9.13). As for cross-linguistic evidence, here I have in mind P+Det contractions in Romance and German, inflection of P in Welsh, and alternating forms for stranded vs. non-stranded prepositions in Dutch.

explicitly (an issue that is left unaddressed by the authors mentioned here).

The treatment of Type B prepositions as markers in HPSG is therefore unattractive. It is preferable to treat all prepositions as syntactic heads, as done in standard HPSG. However, the use of MARKING Theory is an interesting feature of the analysis considered here. MARKING Theory is an underdeveloped component of HPSG that is highly relevant for the issue of prepositional selection. I will return to this topic in Chapter 6.

3.4.3 Meaningful prepositions

As mentioned already, the discussion of prepositions in Pollard and Sag (1994) mainly addresses the issue of Type B prepositions. It is possible nevertheless to piece together a likely standard analysis for meaningful Type A prepositions. First of all, as mentioned above in §3.4.1, Type A prepositions are called “predicative” and this label also implies the presence of the feature [+PRD]. Lexical heads specified as [+PRD] are SUBJ-unsaturated:

$$(32) \quad \left[\begin{array}{l} \textit{word} \\ \text{HEAD} \mid \text{PRD} \mid + \end{array} \right] \Rightarrow \left[\text{SUBJ} \langle \{ \} \rangle \right]$$

For non-verbal categories, there is a further requirement that the subject must be assigned a semantic role; in other words, the subject expresses the external argument of the head’s semantic relation. For predicative nouns, the subject is assigned the referential argument role (cf. Higginbotham, 1985). For predicative adjectives, the external argument is the same as the modified argument. For (spatial) prepositions, the external argument is the theme or “trajector” in Space Grammar (Hawkins, 1985). The subject of a predicative verb does not have to be associated with a semantic role: *I can hear it raining*.

Consider the following example:

(33) There was too much sauce on the pizza.

Here we have a predicative Type A PP as the complement of a copular verb. Putting together the facts above, we end up with the following lexical entry for Type A *on* in (33):

$$(34) \quad \left[\begin{array}{l} \text{CAT} \\ \\ \text{CONT} \mid \text{NUCL} \end{array} \left[\begin{array}{l} \text{HEAD} \left[\begin{array}{l} \textit{prep} \\ \text{PRD} \mid + \end{array} \right] \\ \text{SUBJ} \langle \text{NP}_{[1]} \rangle \\ \text{COMPS} \langle \text{NP}_{[2]} \langle \textit{acc} \rangle \rangle \\ \\ \text{FIGURE} \left[\begin{array}{l} \textit{locative-on} \\ \text{FIGURE} \mid [1] \\ \text{GROUND} \mid [2] \end{array} \right] \end{array} \right] \right]$$

Note that several issues are left undecided. First, consider the HEAD features PFORM and MOD, which do not appear in (34). According to the type hierarchy, these attributes are appropriate for all prepositions, but in this example, it does not matter whether or how their values are instantiated. PFORM is only required when a selecting head constrains the lexical form of the preposition; this is not the case with *is* in sentence (33). MOD is only useful in head-adjunct structures. In (33) the PP is a complement, not an adjunct, and so it makes no difference if the preposition has [MOD: *none*] or [MOD: *synsem*].

Similar issues of indeterminacy arise when we consider adjunct constructions:

(35) The sauce on the pizza was too garlicky.

Here again, the PFORM value of *on* is unimportant. And while MOD plays a crucial role in the analysis of this example, it is not clear whether or how SUBJ valency is involved. If we assume that *on* is “predicative” in the sloppy sense, and that this implies [+PRD] in the formal sense, and this in turn implies the presence of a SUBJ element, then we have another piece of excess formalism.

It could be argued that underspecification is an inherent and often desirable characteristic of HPSG. Moreover, it is natural for a feature to be crucial in some analyses, and play no role at all in others. On the other hand, systematic patterns of feature use and disuse like those demonstrated above should be recognized and accounted for. Another problem is that some pairs or groups of features carry redundant information. PFORM and PHONOLOGY are perhaps suspicious in this regard. The features SUBJ and MOD are also redundant: semantically, the functions of SUBJ selection in the analysis of sentence (33) and MOD selection in (35) are identical, in that they both link an external argument to the FIGURE role. A complete account of prepositions should capture such generalizations.

Finally, the most serious problem facing the HPSG analyses presented here is that none of them address Type A and Type B prepositions at the same time. They all implicitly assume a clean division between the two and then concentrate on just one or the other. We have

seen, however, that this clear-cut division does not exist. The challenge is to move from the Type B analyses in §3.4.1 and §3.4.2 to the Type A analyses in this section, accommodating intermediate cases along the way.

3.5 Summary

None of the existing proposals discussed in this chapter provides a satisfactory account of the spectrum of prepositional uses from Type A through Type AB to Type B. At most, the authors offer distinct treatments for lexical (predicative) prepositions on the one hand, and functional (non-predicative) prepositions on the other. They neglect Type AB cases where lexical and functional analyses must in some sense overlap.

The proposals mentioned here do highlight some differences in behavior among prepositions that must be accounted for in an adequate analysis. Most important among these is the observation that some prepositions are transparent with respect to various primarily semantic phenomena, while others are not. In other words, grammatical processes like semantic role assignment, agreement, and binding sometimes have access to the features of the PP-internal NP, whereas in other cases, the PP forms an opaque “shell” around the NP. These observations do not, however, motivate the introduction of binary features like $[\pm F]$ (Grimshaw, 1991) or $[\pm PRD]$ (Pollard & Sag, 1994).

The identification of the syntactic head in prepositional constructions has been another matter of controversy in previous accounts. Some authors have suggested that differences in behavior among PPs should be attributed to differences in syntactic headedness. We have seen in this chapter, however, that the evidence points to a uniform treatment of all prepositions as syntactic heads.

In regard to HPSG specifically, I conclude that the standard analysis of Pollard and Sag (1994) is still to be preferred over more recent proposals. In my own analysis, presented in the following chapter, I will follow the spirit of the standard approach, while taking fuller advantage of the formal framework of HPSG to provide a more explanatory account of prepositional behavior.

Chapter 4

Prepositions in HPSG

In the last chapter I argued against theoretical accounts of prepositional selection and behavior that assume a discrete binary classification of prepositions. Instead, the observed range of prepositional uses from Type A through Type AB to Type B calls for a more sophisticated analysis that incorporates different degrees of meaningfulness and variability.

In this chapter I present an account of prepositional representation in HPSG. First, in section §4.1 I discuss the modified version of Minimal Recursion Semantics (MRS) that I use for my semantic representations. Then in the remainder of the chapter I propose constraints on the lexical entries of prepositions that determine their interaction with other elements in a construction.

4.1 Minimal Recursion Semantics

I adopt Minimal Recursion Semantics for representing HPSG CONTENT values (Copestake, Flickinger, & Sag, 1997). MRS is more fully elaborated than the CONTENT theory in standard HPSG, and it has a number of features that make it preferable for handling prepositions. In this section I go over the relevant features of MRS and I suggest various modifications that are appropriate for the framework in general, and useful for my prepositional analysis in particular.

4.1.1 Semantic percolation in MRS

My main motivation for the move to MRS is the flexibility offered by list-valued representation of semantic content via the LISZT attribute. One consequence of this is that the semantics of phrases is built up more compositionally than in standard HPSG. In Pollard and Sag (1994), semantics is fully head-driven (although it is driven by the semantic head, not the syntactic head). An informal statement of the HPSG Semantics Principle was given in (28) in §3.4.1.

In contrast, phrases in MRS inherit semantic content from all daughters directly. The MRS Semantics Principle is formalized as the following constraint on the type *phrase*:¹

(1) MRS Semantics Principle (standard)

$$hd\text{-}phrase \Rightarrow \left[\begin{array}{l} \text{CONT} \left[\begin{array}{l} \text{INDEX} \boxed{1} \\ \text{KEY} \boxed{2} \\ \text{LISZT} \boxed{3} \oplus \boxed{4} \oplus \boxed{5} \end{array} \right] \\ \text{HEAD-DTR} \mid \text{CONT} \left[\begin{array}{l} \text{KEY} \boxed{2} \\ \text{LISZT} \boxed{3} \end{array} \right] \\ \text{NON-HEAD-DTR} \mid \text{CONT} \mid \text{LISZT} \boxed{4} \\ \text{C-CONT} \left[\begin{array}{l} \text{INDEX} \boxed{1} \\ \text{LISZT} \boxed{5} \end{array} \right] \end{array} \right]$$

MRS allows the possibility of non-compositional semantics introduced by the construction itself; this is encoded in C-CONT | LISZT. The semantics of the phrase (i.e., its LISZT value) is simply the concatenation of the semantics of both daughters and that of the construction.

Like standard HPSG, MRS uses the notion of a semantic head, possibly distinct from the syntactic head. NP determiners and all modifiers are syntactic non-heads, but they are treated as semantic heads in that they supply the values of C-CONT | INDEX, which according to (1) is structure-shared with the INDEX of the phrase. Formally, specifier-head phrases and head-adjunct phrases are non-head compositional phrases, subject to the following constraint:²

$$(2) \quad nonhead\text{-}compositional\text{-}phrase \Rightarrow \left[\begin{array}{l} \text{NON-HEAD-DTR} \mid \text{CONT} \mid \text{INDEX} \boxed{1} \\ \text{C-CONT} \mid \text{INDEX} \boxed{1} \end{array} \right]$$

In all other headed phrases, the semantic head daughter is identified with the syntactic head:

$$(3) \quad head\text{-}compositional\text{-}phrase \Rightarrow \left[\begin{array}{l} \text{HEAD-DTR} \mid \text{CONT} \mid \text{INDEX} \boxed{1} \\ \text{C-CONT} \mid \text{INDEX} \boxed{1} \end{array} \right]$$

Two aspects of the MRS account of semantic percolation presented here are worth noting. First, although the syntactic head is not always the semantic head, it always provides the phrasal KEY value, according to (1). The KEY attribute encodes selectable semantic content, in contrast to the “total” semantic content given by the LISZT list, which is assumed to be inaccessible for

¹Note that this constraint only covers the case of headed phrases. Furthermore, I have omitted the attributes HANDEL, H-STORE and H-CONS, which are used to handle scope interaction.

²Again, in (2) and (3) I simplify by ignoring quantification.

purposes of external selection. This formulation excludes cases where the KEY relation might be idiosyncratically specified by the construction—for example, in idiomatic constructions like *kick the bucket*. It is also unclear what happens if the syntactic head is semantically empty—for example, in Type B prepositional constructions and possibly also in auxiliary verb constructions. In these cases, it should be the non-head daughter whose KEY relation is passed to the phrase.

Second, the attribute C-CONT | INDEX is actually unnecessary, because the constraints on *nonhead-compos-ph* and *head-compos-ph* in (2)–(3) could refer directly to CONT | INDEX instead. But for purposes of quantification (details of which I have omitted) it is convenient for C-CONT to mediate the sharing of information between the daughters and the mother. In my analysis which follows, I take further advantage of this intermediary function of C-CONT in the percolation of semantic information.

4.1.2 Modifications and additions

In the rest of this section I present a modified version of MRS that preserves existing analyses (of quantification and adjunction, and so on) while accommodating the analysis of semantically empty heads. I also formalize some of the ideas from Copestake et al. (1997) that will be useful for my account of prepositions in the remaining sections of this chapter.

Revised Semantics Principle

I propose that the attributes KEY and INDEX should be list-valued; this not only admits the possibility of representing empty semantic content, but it also allows easy combination and manipulation of semantic information from different sources. Moreover, in contrast to (1), where the phrasal KEY value is always taken from the head daughter, I assume instead that C-CONT provides the KEY value. My revised Semantics Principle (for headed phrases) is given below:

(4) MRS Semantics Principle (revised)

$$hd\text{-phrase} \Rightarrow \left[\begin{array}{l} \text{CONT} \left[\begin{array}{l} \text{KEY} \langle \boxed{1} \textit{rel} \rangle \\ \text{INDEX} \langle \boxed{2} \textit{index} \rangle \\ \text{LISZT} \langle \boxed{3} \oplus \boxed{4} \oplus \boxed{5} \rangle \end{array} \right] \\ \text{HEAD-DTR} \mid \text{CONT} \mid \text{LISZT} \boxed{3} \\ \text{NONHEAD-DTR} \mid \text{CONT} \mid \text{LISZT} \boxed{4} \\ \text{C-CONT} \left[\begin{array}{l} \text{KEY} \langle \boxed{1}, \dots \rangle \\ \text{INDEX} \langle \boxed{2}, \dots \rangle \\ \text{LISZT} \boxed{5} \end{array} \right] \end{array} \right]$$

According to this constraint, the phrase shares the single element of its KEY list with the first element of its C-CONT | KEY list, and similarly for INDEX.

I assume that in both head compositional and non-head compositional phrases the C-CONT | KEY value is determined by combining the KEY values of the daughters according to the following constraint:

$$(5) \quad \textit{compositional-phrase} \Rightarrow \left[\begin{array}{l} \text{HEAD-DTR} \mid \text{CONT} \mid \text{KEY} \boxed{1} \\ \text{NONHEAD-DTR} \mid \text{CONT} \mid \text{KEY} \boxed{2} \\ \text{C-CONT} \mid \text{KEY} \boxed{1} \oplus \boxed{2} \end{array} \right]$$

The KEY value of the head daughter takes precedence over that of the non-head. In combination with (4), this means that in most cases the head daughter's KEY relation will percolate to the mother. This is also what the original MRS Semantics Principle in (1) specifies, but my formulation leaves open the possibility of non-compositional headed phrases that are subject to (4) but not to (5). The crucial difference between my revised version and the original is in the analysis of semantically empty head daughters. In such cases, the KEY list of the head daughter must be empty, so the contribution from the non-head daughter will be first element of the C-CONT | KEY list in (5). According to (4), then, the non-head's content will percolate to the whole phrase. This analysis will be discussed in more detail with respect to empty prepositions in §4.2.2.

We still need constraints on the two subtypes of *compositional-phrase* in order to account for INDEX percolation:

$$(6) \quad \textit{head-compos-phrase} \Rightarrow \left[\begin{array}{l} \text{HEAD-DTR} \mid \text{CONT} \mid \text{INDEX} \boxed{1} \\ \text{NON-HEAD-DTR} \mid \text{CONT} \mid \text{INDEX} \boxed{2} \\ \text{C-CONT} \mid \text{INDEX} \boxed{1} \oplus \boxed{2} \end{array} \right]$$

$$(7) \quad \textit{nonhead-compos-phrase} \Rightarrow \left[\begin{array}{l} \text{HEAD-DTR} \mid \text{CONT} \mid \text{INDEX} \boxed{1} \\ \text{NON-HEAD-DTR} \mid \text{CONT} \mid \text{INDEX} \boxed{2} \\ \text{C-CONT} \mid \text{INDEX} \boxed{2} \oplus \boxed{1} \end{array} \right]$$

In a head-compositional phrase, the head daughter's INDEX takes precedence and will appear first in the phrasal C-CONT | INDEX list. Again, the effect of this constraint diverges from that of the standard MRS formulation in (3) when the head daughter is semantically empty (and therefore has an empty INDEX list). In this case the non-head daughter's INDEX will be first in C-CONT | INDEX, and it will become the phrasal INDEX, according to (4).

In a non-head compositional phrase (i.e., specifier-head or head-adjunct structure), the daughters' INDEX lists are concatenated in the opposite order. In fact, since specifiers and

adjuncts always have non-empty INDEX lists (they are never semantically empty), we could simply keep the original constraint in (2) above.

As in (2)–(3) above, I have said nothing about the the percolation of *HANDEL*, *H-STORE*, and *H-CONS* values in (6) and (7). The constraints proposed in Copestake et al. (1997) can be adopted without modifications, leaving the original MRS account of quantification intact.

Additional constraints

In the rest of this section I present a few additional principles for MRS. These are quite straightforward assumptions that are left unformalized in Copestake et al. (1997). For example, there is a link between *KEY* and *INDEX* features in lexical entries: the *INDEX* value “is unified either with the event variable for verbal semantic structures, or with the instance variable for nominal structures” (p. 5). The following constraint on *word* formalizes this statement:

$$(8) \quad \left[\begin{array}{c} \text{word} \\ \text{CONT} \mid \text{KEY} \left\langle \left[\begin{array}{c} \text{event-rel} \\ \text{EVENT} \quad \boxed{1} \end{array} \right] \vee \left[\begin{array}{c} \text{nom-rel} \\ \text{INST} \quad \boxed{1} \end{array} \right] \right\rangle \end{array} \right] \Rightarrow \left[\text{CONT} \mid \text{INDEX} \langle \boxed{1} \rangle \right]$$

In phrases, on the other hand, the *INDEX* cannot always be determined from the *KEY* value in this way. In particular, in constructions involving intensional modifiers like *former* and *alleged*, the phrasal *INDEX* is crucially distinct from the value of *INST* in the *KEY* relation.

The converse of constraint (8) as it stands does not hold, because *event-rel* and *nom-rel* in the left hand side do not cover all possible types of *KEY* relations. We also have *quant-rel*, for example, and modifiers may also require a different type of *KEY* relation. For my purposes, the following constraint is sufficient:

$$(9) \quad \left[\begin{array}{c} \text{word} \\ \text{CONT} \mid \text{INDEX} \langle \text{index} \rangle \end{array} \right] \Rightarrow \left[\begin{array}{c} \text{word} \\ \text{CONT} \mid \text{KEY} \langle \text{relation} \rangle \end{array} \right]$$

A non-empty *INDEX* list implies a non-empty *KEY* list. This also means that any word with no *KEY* relation cannot have an index.³

Next, the relationship between *KEY* and *LISZT* should be explicitly formalized. The *LISZT* value encodes all of the semantic content of a *sign*, while *KEY* singles out the component of the *sign*’s content that is visible for semantic selection. It makes sense, therefore, to ensure that the *KEY* relation (if any) is chosen from the collection of relations in *LISZT*. Formally:

³I assume here that the *CONT* | *KEY* list is maximally singleton.

$$(10) \quad \left[\begin{array}{c} \text{sign} \\ \text{CONT} \mid \text{KEY} \langle \boxed{1} \rangle \end{array} \right] \Rightarrow \left[\text{CONT} \left[\begin{array}{c} \text{KEY} \langle \boxed{1} \rangle \\ \text{LISZT} \langle \dots, \boxed{1}, \dots \rangle \end{array} \right] \right]$$

The converse of this principle is also reasonable: Any *sign* with a non-empty *LISZT* must choose a *KEY* relation from among its *LISZT* relations. In other words, any contentful *sign* must be open to semantic selection. Nothing in my analysis depends on this further assumption, but the two implications can be combined in the following constraint:

$$(11) \quad \left[\begin{array}{c} \text{word} \\ \text{CONT} \mid \text{KEY} \langle \boxed{1} \rangle \end{array} \right] \Leftrightarrow \left[\begin{array}{c} \text{word} \\ \text{CONT} \mid \text{LISZT} \langle \dots, \boxed{1}, \dots \rangle \end{array} \right]$$

4.2 Prepositional Content

Now that the general theoretical foundations are in place, I turn to the main topic of this chapter, the analysis of prepositions in HPSG. I begin with the issue of semantic representation. As discussed in §1.2, fine distinctions in meaningfulness can be observed among prepositional uses, but these are not necessarily the result of fine distinctions at the level of semantic representation. In my analysis I make only a broad distinction between prepositions that have content and prepositions with empty content.

Content and empty prepositions are represented as subtypes of *prep-lex*:

$$(12) \quad \begin{array}{c} \text{prep-lex} \\ \swarrow \quad \searrow \\ \text{content-prep-lex} \quad \text{empty-prep-lex} \end{array}$$

The lexical type *prep-lex* is defined as follows:

$$(13) \quad \text{prep-lex} \Leftrightarrow \left[\begin{array}{c} \text{word} \\ \text{HEAD} \quad \text{prep} \end{array} \right]$$

4.2.1 Content prepositions

Prepositions that are clearly meaningful, including all Type A uses, have semantic content. Such prepositions have lexical entries of the type *content-prep-lex*:

$$(14) \quad \text{cont-prep-lex} \Rightarrow \left[\text{CONT} \mid \text{KEY} \langle \text{prep-rel} \rangle \right]$$

The information contained in this constraint is minimal; it only says that content prepositions have a *KEY* relation of type *prep-rel*. For an element to be semantically contentful in MRS, it

must have a non-empty LISZT list. According to the constraint given above in (10), we know that the KEY relation in (14) must also appear in the preposition's LISZT list.

Further consequences of the feature specification in (14) are discussed below.

Prepositional relations

I assume that all prepositional relations include at least an external argument role. In spatial and temporal relations, this role is variously referred to as the theme, trajector, figure, or locatum. There is normally also an internal argument, corresponding to the landmark or the ground. In my representations I use the generic role names EXT-ARG and INT-ARG for all prepositional relations. This is a departure from standard HPSG, where maximally specific role names (e.g., GIVER, SINGER, POSSESSED) are preferred. Because attributes are not hierarchically organized, this practice makes it difficult to state generalizations across relations. See Davis (1996) for discussion of this point; he relies on more general role attribute names like ACTOR and UNDERGOER in order to state argument linking constraints.

In the canonical case, a preposition has both an internal and an external argument, and both are expressed syntactically:

- (15) a. at 7 o'clock

$$\left[\begin{array}{l} \textit{temp-at-rel} \\ \text{EXT-ARG } \textit{index} \\ \text{INT-ARG } \textit{"7 o'clock"} \end{array} \right]$$

- b. in London

$$\left[\begin{array}{l} \textit{dir-in-rel} \\ \text{EXT-ARG } \textit{index} \\ \text{INT-ARG } \textit{"London"} \end{array} \right]$$

Many transitive prepositions can optionally occur intransitively, with the internal argument understood anaphorically or by convention:

- (16) a. I've never seen this man before. (i.e., before now)
 b. The doctor is in/out. (i.e., in/out of the office)
 c. Put some clothes on! (i.e., on your body)

Some prepositions are obligatorily intransitive, but an underlying two-place relation is still identifiable:

- (17) a. beforehand

$$\left[\begin{array}{l} \textit{temp-before-rel} \\ \text{EXT-ARG } \textit{index} \\ \text{INT-ARG } \textit{index} \end{array} \right]$$

- b. upstairs

$$\left[\begin{array}{l} \textit{loc-at-rel} \\ \text{EXT-ARG } \textit{index} \\ \text{INT-ARG } \textit{"upstairs"} \end{array} \right]$$

In other cases, there really is no internal argument role:

- (18) a. turn the volume down

$$\left[\begin{array}{l} \textit{down-rel} \\ \text{EXT-ARG } \textit{"volume"} \end{array} \right]$$

- b. switch the light on

$$\left[\begin{array}{l} \textit{on-rel} \\ \text{EXT-ARG } \textit{"light"} \end{array} \right]$$

Here, *down* and *on* express one-place predicates. The volume does not go down anything (cf. *walking down the street*)—it just goes down. The light does not end up on anything (cf. *landing on the roof*)—it is simply on. One might be tempted to treat these as members of another category—adjectives, for example—but they exhibit more preposition-like properties (e.g., the possibility of *right* as a specifier).

Finally, there are a number of locative prepositions that I assume assign two internal argument roles (recall example (95) in Chapter 2, repeated here):

- (19) across the street from Bill's house

$$\left[\begin{array}{l} \textit{loc-across-rel} \\ \text{EXT-ARG } \textit{index} \\ \text{INT-ARG } \textit{"street"} \\ \text{INT-ARG2 } \textit{"B's house"} \end{array} \right]$$

In order to specify a location using a predicate like *across*, two landmarks are necessary.

Since prepositions show diversity with regard to internal argument role assignment, I propose just the following constraint on prepositional relations:⁴

$$(20) \quad \textit{prep-rel} \Rightarrow \textit{event-rel} \ \& \ \left[\text{EXT-ARG } \textit{index} \right]$$

As we will see shortly, assigning an external argument role has significant consequences for the semantic and syntactic combinatory potential of PPs headed by content prepositions.

I assume that *prep-rel* is a subtype of *event-rel*, which is also used for verbal semantic relations. *Event-rel* basically corresponds to *qppsoa* in standard HPSG semantics—i.e., it encodes

⁴The value of EXT-ARG here should actually be *index* \vee *handle* in order to accommodate modifier scope interaction.

a relation name and a collection of argument roles. In MRS, however, events are also assumed to introduce an event variable:

$$(21) \quad \text{event-rel} \Rightarrow \left[\text{EVENT } \textit{index} \right]$$

MOD values

I propose the following constraint linking the KEY and MOD values of prepositions:

$$(22) \quad \left[\begin{array}{l} \textit{word} \\ \text{HEAD} \\ \text{CONT} \mid \text{KEY} \left\langle \begin{array}{l} \textit{prep-rel} \\ \text{EXT-ARG} \left[\boxed{1} \right] \end{array} \right\rangle \end{array} \right] \Leftrightarrow \left[\begin{array}{l} \textit{word} \\ \text{HEAD} \\ \text{MOD} \left[\begin{array}{l} \textit{synsem} \\ \text{CONT} \mid \text{INDEX} \left[\boxed{1} \right] \end{array} \right] \end{array} \right]$$

Any preposition that assigns an external argument role is a potential modifier; more precisely, modification is one mechanism by which the external argument role can be assigned. Conversely, if a preposition has a MOD value, it must be associated with the preposition's external argument role.⁵

Putting together all the information added by various constraints so far, we have the following expanded version of the type definition in (14):

$$(23) \quad \text{cont-prep-lex} \Rightarrow \left[\begin{array}{l} \text{HEAD} \mid \text{MOD} \left[\text{CONT} \mid \text{INDEX} \left[\boxed{1} \right] \right] \\ \text{CONT} \left[\begin{array}{l} \text{KEY} \left\langle \begin{array}{l} \textit{prep-rel} \\ \text{EVENT} \left[\boxed{2} \right] \\ \text{EXT-ARG} \left[\boxed{1} \right] \end{array} \right\rangle \\ \text{INDEX} \left[\boxed{3} \right] \\ \text{LISZT} \langle \dots, \boxed{2}, \dots \rangle \end{array} \right] \end{array} \right]$$

4.2.2 Empty prepositions

Prepositions with no lexical content, or “empty prepositions,” have much simpler structure. These include all Type B prepositions, and they are subject to the following constraint:

$$(24) \quad \text{empty-prep-lex} \Rightarrow \left[\text{CONT} \mid \text{LISZT} \langle \rangle \right]$$

⁵Again, there is a simplification here, because the external argument role can be linked to the *HANDEL* of the modified element, not its *INDEX*.

Again, the right hand side of this constraint specifies very little information, only that an empty preposition has an empty *LISZT* list. This is exactly what empty content means in MRS. As a consequence of the other constraints we have in place already, we know that the *KEY* and *INDEX* lists in (24) must also be empty (by constraints (10) and (9), respectively).

Because empty prepositions must have empty *KEY* lists, constraint (22) above implies that they must also have the feature *[MOD: none]*. In other words, a PP headed by an empty preposition can never appear as an adjunct. We therefore arrive at the following expanded definition for empty prepositions:

$$(25) \quad \text{empty-prep-lex} \Rightarrow \left[\begin{array}{l} \text{HEAD} \mid \text{MOD } \textit{none} \\ \text{CONT} \left[\begin{array}{l} \text{KEY} \langle \rangle \\ \text{INDEX} \langle \rangle \\ \text{LISZT} \langle \rangle \end{array} \right] \end{array} \right]$$

Semantic transparency

One of the properties of semantically empty prepositions is that they license non-local instances of phenomena that are otherwise strictly local. We have seen, for example, that empty prepositions are transparent with respect to semantic role assignment by an external head (§3.1), and with respect to binding theory (§3.4.1). Consider the PP in the following sentence (already discussed as example (23) in the previous chapter):

$$(26) \quad \text{Kim depends on Sandy.}$$

As in standard HPSG, I consider *on* to have no semantic content here. Recall that in the standard analysis, the preposition is actually represented as having the semantic content of its complement. Under my account, this is unnecessary, and the lexical entry for non-contentful *on* really encodes no content.

The structure of the PP in (26) is given below, with particular attention paid to the percolation of semantic information:

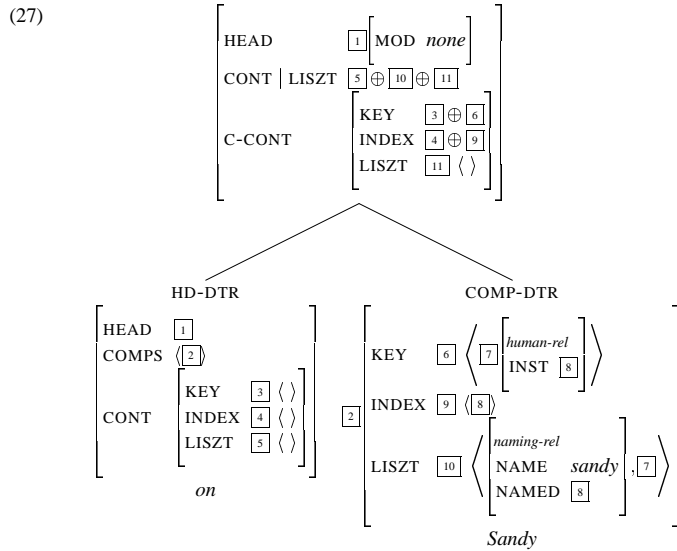

The two daughters are both words, so they obey the constraint in (9) linking their KEY and INDEX values. Since PPs are compositional phrases, they must conform to constraint (5): the C-CONT | KEY value of the mother is the concatenation of the KEY list of the head daughter followed by that of the non-head daughter. PPs are furthermore head-compositional phrases, so according to constraint (6), the value of C-CONT | INDEX is the concatenation of the preposition's INDEX list followed by its complement's INDEX list.

No construction specific content is specified in C-CONT | LISZT. The LISZT value of the phrase is the concatenation of the LISZT lists of both daughters and of the construction. Given that many of the lists mentioned here are in fact empty, the top node in (27) can be more simply expressed as:

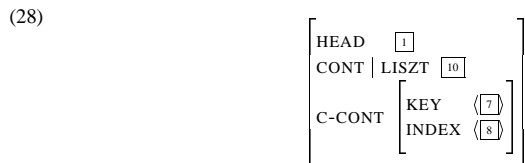

The Semantics Principle in (4) requires the PP to take as its KEY relation the first element of its C-CONT | KEY list—i.e., the *human-rel* [7]. The INDEX value of the PP is the first (and only) element [8] in its C-CONT | INDEX list. In other words, the PP *on Sandy* headed by empty *on* has the following CONTENT:

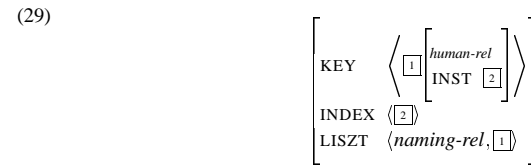

The fact that the referential index of the NP complement is also the index of the PP allows us to account for the binding observations below (repeated from example (24) in §3.4.1):

- (30) a. John_i depends [on himself_i].
 b. * John_i depends [on him_i].

The standard HPSG analysis works here. The NP *John* locally o-commands the PP on the ARG-ST list of *depends*. If the PP is co-indexed with *John*, as in (30), then a reflexive pronoun is allowed (because these must be locally o-bound) while a non-reflexive pronoun is blocked (because these cannot be locally o-bound). For binding purposes, a PP headed by an empty preposition looks exactly like its NP complement.

The same is true for semantic role assignment, because this is also accomplished by means of referential indices in HPSG. More generally, however, semantic selection (i.e., selectional restriction) involves the KEY relation, but again in this case the PP has the same KEY value as its NP complement. We can therefore explain why the following examples are odd (out of context):

- (31) a. ? Kim depends on Wednesday.
 b. ? Kim depends on the rooftops.
 c. ? Kim depends on the way to the post office.

Broadly speaking, the NPs here do not refer to entities that can normally be depended on. The verb is able to enforce semantic constraints directly on the NP in spite of the intervening preposition.

Syntactic transparency?

It is important to note that empty prepositions are only semantically transparent. I have said very little about the syntactic features in (27), but according to standard HPSG assumptions, the percolation of HEAD and VALENCE information is strictly driven by the syntactic head. This holds for PPs, whether they are headed by contentful or empty prepositions. Syntactic processes that involve a PP are only allowed to refer to information that is visible in the SYNSEM value of the PP level. Crucially, the internal structure of the PP, encoded in the DAUGHTERS value, is inaccessible.

In a PP headed by an empty preposition, the complement's CONTENT features are passed up to the PP level, but none of its syntactic features like case and valency are, so this kind of information should not play any role in grammatical phenomena outside of the PP. As discussed in the last chapter, however, Type B prepositions are transparent with respect to some phenomena that are sometimes considered to be syntactic. For example, O'Grady (1985) notes that NPs inside Type B PPs can serve as antecedents for floated quantifiers and as argument controllers. Napoli (1989) notes the same effect in secondary predication constructions. In HPSG, all of these are treated as semantic phenomena, and so the behavior of Type B PPs is a result of the fact that they are semantically empty.

As mentioned briefly in §3.2, in a few languages verbs show agreement with adpositionally marked dependents (Zwicky, 1992, 1993). For example, verbs in Niuean sometimes agree in number with their subjects and direct objects, but these are marked by prepositions indicating ergative or absolutive case (Seiter, 1983). In Tigre, indirect objects (marked with a preposition corresponding to English *to*) can trigger agreement on the verb (Davies, 1986). And finally, in Acehnese (and in other Indonesian languages), passive verbs agree with their logical subjects, which are expressed with PPs like English *by*-phrases (Lawler, 1977).

All of these examples involve PPs that are arguably headed by empty prepositions. I do not know if this is true for all cases of oblique agreement, but the data at hand pose no problem for the analysis proposed here (or for the standard HPSG treatment discussed in §3.4.1). In HPSG agreement features are encoded in the INDEX value, which is part of CONTENT. The INDEX of the NP complement of an empty preposition is therefore visible at the PP level, and allowed to trigger agreement outside the PP.

Finally, in languages with richer case systems than English, we can find examples where non-local case government seems to be involved. In Russian, for example, the preposition *za* 'behind' governs either the accusative or the instrumental case. Sometimes the two patterns show a difference in semantics (e.g., directional vs. locative), but when *za* is used as an empty preposition, this becomes a purely syntactic distinction. The choice is not arbitrary, however:

- (32) a. My bojimsja za det'i/*det'mi
 we fear behind children-acc/*instr
 'We fear for the children.'
- b. My prismatrivajim za det'mi/*det'i.
 we look behind children-instr/*acc
 'We look after the children.'

In these examples it must be the verb that ultimately determines the case of the prepositional object. This does not mean, however, that we have to allow the verb to have direct access to the syntactic features of the NP (e.g., by somehow passing them up to the PP). Instead, the

preposition *za* governs the case of its complement as usual, and in accordance with locality principles. The verb in each example then has to select the correct variant of *za*; in §4.3 I discuss how this selection is accomplished, again locally.

4.2.3 ARG-ST and MOD

So far, the definitions of *cont-prep-lex* and *empty-prep-lex* say nothing about the value of ARG-ST, which is a crucial part of lexical representations in HPSG. Recent work has focused on the relationship between ARG-ST and the valence lists (Sag, 1997; Bouma, Malouf, & Sag, 1998). In those analyses, ARG-ST contains all potential SUBJ and COMPS elements, although the exact mappings between the various lists can be disrupted by processes like extraction, passivization, and complement inheritance.

MOD elements as binders

The following principles are adapted from Bouma et al.:

- (33) a. Argument Realization

$$verb \vee prep \Rightarrow \left[\begin{array}{l} \text{ARG-ST} \quad \boxed{1} \\ \text{DEPS} \quad \boxed{1} \oplus list \end{array} \right]$$

- b. Dependent Realization

$$word \Rightarrow \left[\begin{array}{l} \text{SUBJ} \quad \boxed{1} \\ \text{COMPS} \quad \boxed{2} \ominus list(gap-synsem) \\ \text{DEPS} \quad \boxed{1} \oplus \boxed{2} \end{array} \right]$$

The DEPENDENTS list is introduced to license adjuncts and to allow adjunct extraction; it is identical with the ARG-ST list with zero or more adverbials appended to the end. Broadly speaking, the elements on the DEPS list are distributed between SUBJ and COMPS. The SUBJ list is usually assumed to be maximally singleton; it can also be empty. COMPS contains all the other DEPS elements, as long as they are not of type *gap-synsem*, corresponding to extracted elements. Note that Bouma et al. adopt an analysis where adjuncts are selected by the heads they modify as optionally instantiated complements.

As we saw above in §4.2.2, ARG-ST is also where binding constraints operate. Consider the following contrasts:

- (34) a. a sentence_i about itself_i/*it_i
 b. a player_i against himself_i/*him_i

The pattern in (34a) suggests that (a SYNSEM object corresponding to) *itself* must be locally o-commanded by (a SYNSEM object corresponding to) *sentence* on some ARG-ST list. The ARG-ST list of *sentence* is not an option, because under standard assumptions, *sentence* does not appear on its own ARG-ST list. If we consider the preposition *about*, we know by Dependent Realization (33b) that the complement *itself* appears on ARG-ST. We could ensure that *itself* is locally o-commanded on this list by assuming that *about* has a non-empty SUBJ list.

A SUBJ element is standardly assumed for [+PRD] elements (see the next section), but the PPs in (34) are modifiers, not predicative complements. What we need is a constraint like the following:

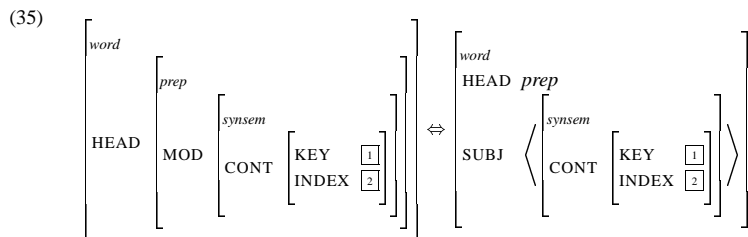

If a preposition has a MOD element, then it must also have a SUBJ element with the same KEY and INDEX values. For instance, since *about* in (34a) modifies the noun *sentence* via MOD, then (35) requires an element with the same KEY value to appear on its SUBJ list. This means, in turn, that a *synsem* object with the index of *sentence* must appear at the head of the ARG-ST list of *about*, locally o-commanding the pronoun. Binding constraints then require the reflexive *itself* rather than the non-reflexive *it*.

Alternative analysis

It is possible to analyze the PPs in (34) as reduced relative clauses, in which case they are [+PRD], and they have non-empty SUBJ lists anyway, independently of the constraint in (35). Any post-nominal PP modifier can be expanded to a full relative clause.⁶

(36) a. a sentence_i that is about itself_i/*it_i

⁶The converse is not true:

- (1) a. A president who is out of shape is disgraceful.
 b. * A president out of shape is disgraceful.
 c. An out of shape president is disgraceful.

Such examples only seem to be found with “metaphorical PPs” like *out of shape*, *over the hill*, *under the weather* (Maling, 1983). They show “adjectival” behavior in that they can often occur pre-nominally, but not post-nominally.

b. a player_i who is against himself_i/*him_i

According to Sag’s (1997) analysis, if the PPs in (34) above are reduced relatives, they are subject to the following constraint:

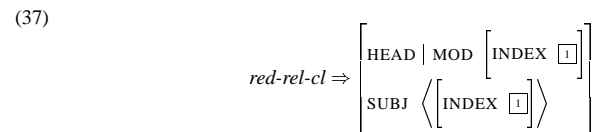

Note the similarity between this and the constraint in (35). In other words, if we discard (35), the link between SUBJ and MOD still has to be stated somewhere.

I argue that this link is properly stated as a constraint on lexical entries, not encoded as a property of reduced relative constructions. The following German examples involve pre-nominal adjectival modifiers:

- (38) a. der auf sich_i (selbst) stolze Mann_i
 the on REFL (self) proud man
 ‘the man proud of himself’
 b. * der auf ihn_i (selbst) stolze Mann_i
 the on him (self) proud man

The adjective *stolze* selects a Type B PP complement, and modifies the noun *Mann*. The binding patterns are the same as in the English examples above. This means that the modified element *Mann* must appear on the ARG-ST list of *stolze* along with the PP (which has nominal content, because *auf* is an empty preposition). A reduced relative analysis is not plausible here, because full relative clauses are not allowed in pre-nominal position:

- (39) a. * der der auf sich selbst stolz ist Mann
 the who on REFL self proud is man
 ‘the man who is proud of himself’
 b. der Mann, der auf sich selbst stolz ist

In other words, we need a constraint on adjectives similar to the one for prepositions in (35), giving adjectives non-empty SUBJ specifications even when they are not in predicative contexts. Unfortunately, similar evidence is not available for prepositions, because pre-nominal PPs are generally blocked in German (van Riemsdijk, 1990):

- (40) a. ein Spieler gegen sich
 a player against REFL
 ‘a player against himself’
 b. * ein gegen sich Spieler

On the other hand, it is not clear that post-nominal reduced relatives are actually allowed in German, so it is preferable to treat the PP in (40a) as a non-predicative modifier. In this case, constraint (35) is necessary to account for the binding facts (which are the same as in English).

4.2.4 Predicativity

Like other substantive categories (nouns, verbs, adjectives), prepositions are further partitioned with respect to predicativity. As discussed in §3.4.3, predicative lexical heads are SUBJ-unsaturated. The relevant constraint is repeated here:

$$(41) \quad \left[\begin{array}{l} \text{word} \\ \text{HEAD} \mid \text{PRD} \mid + \end{array} \right] \Rightarrow \left[\text{SUBJ} \langle \{ \} \rangle \right]$$

Because of the constraint in (35), the implication is false in the other direction. Every preposition with a MOD element (i.e., every content preposition) has a non-empty SUBJ list. This could be argued to be an undesirable result, because if (41) were a biconditional, we might be able to eliminate the attribute PRD altogether, and rely on SUBJ alone. But in fact, both attributes are needed, because their values percolate differently within the PP. The value of the HEAD feature PRD remains unchanged throughout the PP, but the SUBJ list changes in accordance with the Valence Principle.

PRD and SUBJ

On the other hand, it has been suggested that predicative prepositions never actually combine with a subject syntactically, in a head-subject phrase (Davis, 1996). Instead, the unexpressed SUBJ element is always controlled by something outside of the PP. If this is true, then the values of PRD and SUBJ both remain constant throughout the PP. We could then eliminate the feature [+PRD] and refer to [SUBJ: ⟨{ }⟩] instead (and [SUBJ: ⟨ ⟩] instead of [-PRD]).⁷

In fact, however, there are cases where PPs do contain syntactically realized subjects. The following examples are from Pollard and Sag (1994, p. 110–111):

- (42) a. With [Noriega in power], we'll have to cancel our vacation.
 b. We feared [Noriega in power].
 c. We didn't like [the party on a Tuesday].
 d. They wanted [the party on a Tuesday].

⁷Note that we would also have to discard the \Rightarrow implication in constraint (35).

In these examples, the maximal PP projection will be SUBJ-saturated but still [+PRD]. The selecting heads must refer to both of these features in their COMPS specifications to block examples like the following:

- (43) a. * They wanted [on a Tuesday]. ([+PRD] only)
 b. * They wanted [the party was on a Tuesday]. ([SUBJ: ⟨ ⟩] only)

We can conclude that PRD is needed as an independent feature alongside SUBJ.

SUBJ and MOD

Here is the final version of the type definition for content prepositions, adding in the effect of the constraint in (35):

$$(44) \quad \text{cont-prep-lex} \Rightarrow \left[\begin{array}{l} \text{HEAD} \mid \text{MOD} \left[\text{CONT} \left[\begin{array}{l} \text{KEY} \langle \boxed{1} \rangle \\ \text{INDEX} \langle \boxed{2} \rangle \end{array} \right] \right] \\ \text{SUBJ} \left\langle \left[\text{CONT} \left[\begin{array}{l} \text{KEY} \langle \boxed{1} \rangle \\ \text{INDEX} \langle \boxed{2} \rangle \end{array} \right] \right] \right\rangle \\ \text{CONT} \left[\begin{array}{l} \text{KEY} \left\langle \begin{array}{l} \text{prep-rel} \\ \boxed{3} \end{array} \right\rangle \left[\begin{array}{l} \text{EV-ARG} \langle \boxed{4} \rangle \\ \text{EXT-ARG} \langle \boxed{2} \rangle \end{array} \right] \\ \text{INDEX} \langle \boxed{4} \rangle \\ \text{LISZT} \langle \dots, \boxed{3}, \dots \rangle \end{array} \right] \end{array} \right]$$

The fact that the MOD and SUBJ elements share KEY (and therefore INDEX) values not only accounts for the binding data discussed earlier, but it also ensures that from a semantic viewpoint, the combinatory potential of a PP is the same whether it is involved in modification or predication. In particular, the semantic effect of both operations is the assignment of the preposition's EXT-ARG role. Moreover, a preposition cannot enforce one set of semantic constraints on its subject's KEY relation and another set of constraints on its MOD element's KEY. The syntactic requirements on SUBJ and MOD may be different, however; for example, a PP can modify an N' (i.e., SPR-unsaturated) but it should take a saturated NP as a subject.

Semantically empty prepositions carry the feature [MOD: none] (see (25)), so constraint (35) requires them to have empty SUBJ lists (assuming that the SUBJ list is maximally single-ton). An empty SUBJ list in turn implies [-PRD], by (41):

(45)

$$empty\text{-}prep\text{-}lex \Rightarrow \left[\begin{array}{l} HEAD \left[\begin{array}{l} MOD \textit{ none} \\ PRD \textit{ -} \end{array} \right] \\ SUBJ \langle \rangle \\ CONT \left[\begin{array}{l} KEY \langle \rangle \\ INDEX \langle \rangle \\ LISZT \langle \rangle \end{array} \right] \end{array} \right]$$

It is clear from this definition that empty PPs must have extremely restricted distribution. They can never appear in predicative contexts, or as adjuncts. Empty PPs can only be selected as non-predicative complements.

4.3 Prepositional Form

In standard HPSG, following GPSG (Gazdar et al., 1985), every preposition carries the HEAD feature PFORM, which encodes the lexical form of the preposition. PPs headed by *to*, for example, have the feature [PFORM: *to*], and are therefore syntactically distinct from PPs headed by other prepositions. Words like *listen* and *belong* refer to this feature in their COMPS specifications in order to select a *to*-PP.

The idea behind this analysis is quite straightforward, and I will adopt it in my own analysis. There are a number of issues, however, that are left unaddressed in the standard account. This section focuses on the representation of prepositional form and the formalization of selection mechanisms based on prepositional form.

4.3.1 Syntactic identity

The attribute PFORM takes values of type *pform*, and the subtypes of *pform* include *to*, *of*, *by*, and so on. These subtypes are the “names” of the prepositions “to,” “of,” “by,” and so on, and external fixing triggers use them to pick out the particular preposition they want. It has never been explicitly explained, however, what these names really are. In particular, how do we know if two prepositions have the same name or different names?

Lexical and phonological selection

As a first approximation, perhaps every prepositional lexical entry needs a unique name. In this case, the set of *pform* subtypes is isomorphic to the set of prepositions in the lexicon. This approach is far too extreme, however. For one thing, the PFORM value would redundantly encode information that is already visible elsewhere in the sign. For example, the information

in the HEAD value remains constant at every level of projection, by the Head Feature Principle. If some external head wants to select a PP headed by a [+PRD] preposition, for example, then it can refer to this feature directly in the PP’s representation. It is not necessary, and not desirable to have distinct *pform* subtypes for the predicative and non-predicative versions of the same preposition. Similarly, no distinctions in CONTENT should be encoded in the inventory of PFORM subtypes. If a head needs to constrain something in the CONTENT of a contentful preposition, all of these features are visible on the PP, in accordance with the Semantics Principle in (4). On the other hand, if an empty PP is required, the selecting head can refer to the feature [MOD: *none*] at the PP level.

Now I turn to distinctions that should be encoded in the PFORM value. Most obviously, prepositions with distinct PHONOLOGY usually have distinct names. For example, semantically empty *with* and semantically empty *to* have identical representations, apart from PHON, and this single difference matters very much to a selecting head. This head has access, however, to its PP complement’s SYNSEM value, not to its PHON value. We could work around this with the following constraint:

(46)

$$prep\text{-}lex \Rightarrow \left[\begin{array}{l} PHON \langle \boxed{\textit{phoneme-string}} \rangle \\ HEAD | PFORM \boxed{\textit{ }} \end{array} \right]$$

Under this analysis, every P projection would carry a copy of its head’s phonology as its PFORM value. This approach allows us to get rid of some formal machinery by eliminating the type *pform* from the signature; in principle, this is attractive. But the constraint suggested in (46), while technically unproblematic, is suspicious for various reasons. For instance, there are no heads that govern any preposition starting with a particular phoneme, or having a certain number of syllables. This kind of information is never relevant in syntactic selection, and HPSG captures this fact by allowing only *synsem* selection. The structure in (46) violates this general principle and predicts the possibility of phonological selection phenomena that are never attested.

Moreover, constraint (46) means that phonological distinctness implies PFORM distinctness. There are two classes of counterexamples to this. First, forms like *toward/towards*, *round/around*, and *on/upon* can be interchangeable with regard to syntactic selection, although they still require separate lexical entries (e.g., to account for register effects). This can be easily handled by assigning them non-distinct PFORM values.⁸ Second, as discussed in §2.2.2, most

⁸In the case of *on* and *upon*, we actually need distinct *pform* subtypes that are subsumed by a common supertype, because Type B *on* and *upon* do not have exactly the same distribution: *drone onⁿ upon*, *put uponⁿ on*. On the other hand, *toward/towards* and *round/around* are more or less interchangeable, or perhaps reflect regional differences (so some speakers may only accept one of the two variants).

prepositional forms (i.e. those outside of the “fixable set” \mathcal{F}) are never involved in syntactic selection; these forms do not need distinct PFORM values. These prepositions should not be subject to the constraint in (46). Instead, they should all carry a special PFORM value that encodes the fact that they cannot be targeted by external form-governing heads.

Non-phonological distinctions

I conclude that (46) should be rejected. In the end, we do need a dedicated type *pform*, whose subtypes partially mirror the set of prepositional PHON values, without actually encoding any real phonological information. I have already discussed cases where distinct phonology does not imply distinct PFORM. In the other direction, there are situations where prepositions with non-distinct phonological forms nevertheless must have distinct PFORM values.

Recall the Russian example (32), which was presented as an apparent instance of non-local case government from a verb into its Type B PP complement. Similar examples can be found in German, where spatial prepositions like *an* can govern either accusative or dative case, depending on the semantics. Type B uses of *an* retain specific case government properties:

- (47) a. Ich denke oft an meine/*meiner Kindheit zurück
 I think often at my childhood-acc/*dat back
 ‘I often think back on my childhood.’
 b. Ich sterbe an deinem/*deinen Instant-Kaffee.
 I die at your instant coffee-dat/*acc
 ‘I am dying from your instant coffee.’

At the PP level, there is no indication of the case of the NP, because the PPs are COMPS-saturated, and the CASE value of the NP is not passed up to the PP in any other way. Examples like these can be analyzed without resorting to non-local mechanisms if we assume that the two prepositions *an* here and the two versions of *za* in (32) have distinct PFORM values, despite being homophonous. In particular, the *pform* hierarchy for German includes subtypes *an_{acc}* and *an_{dat}*, and Russian has the *pform* subtypes *za_{acc}* and *za_{instr}*.

It should be mentioned that by adopting a marker analysis for Type B prepositions, as in §3.4.2, we could avoid this duplication of *pform* subtypes. For each pair of examples in (32) and (47), a single *pform* subtype is sufficient, because the case of the NP is still visible at the PP/marked NP level. This is one argument in favor of the marker approach, but as discussed earlier, it is a problematic analysis in other ways. Also, a number of (non-HPSG) analyses, such as Rauh (1991b), assume that Type B prepositions are chosen purely phonologically. Such an approach cannot handle these Russian and German examples.

Valence properties are also relevant for syntactic selection. Specifically, some verbal particles are to be analyzed as intransitive prepositions. For example, the combination *heave to*

involves only the word *to* and not an entire PP headed by *to*, as in the case of *listen* or *belong*. Now the question is, do transitive and intransitive *to* need to have distinct PFORM values or can they share a single *pform* subtype? On the one hand, the selecting head could refer to syntactic properties that are already encoded elsewhere in its PP complement. For example, *heave* and *listen* might refer to the same PFORM value *to*, but then *heave* further specifies that its PP complement is [+LEX], while *listen* combines with a [-LEX] PP complement.

It seems inappropriate to rely on independent constraints on PFORM and LEX, however, because there are no heads that specify a PFORM value but allow either value of LEX. In §3.2.2 I mentioned a couple of possible counterexamples: *come to (consciousness)* and *knock off (work)*. These examples are clearly of an exceptional nature, however, and they do not illustrate a productive pattern that needs to be accommodated. I would simply assume distinct lexical entries for *come* combining with *to consciousness* and *come* combining with *to* alone. *Knock off work*, on the other hand, is completely idiomatic (e.g., *work* cannot be extracted or pronominalized) and must be analyzed exceptionally anyway.

Furthermore, the set of forms that occur as transitive Type B prepositions is not the same as the set of possible Type B particles. For example, *up*, *down*, and *off* are common as particles, but never head phrasal Type B PPs. In the other direction, *with*, *at*, and *for* are among the forms that only occur transitively, and never as Type B particles. This suggests, then, that selecting a particular PFORM value should also imply the selection of the complementation properties of the governed preposition. In other words, we need two distinct *pform* subtypes corresponding to particle vs. prepositional *to*. The same applies to forms like *in*, *on*, and *over*.

In conclusion, in addition to phonological distinctions, differences in case government properties and valence features should also lead to distinct *pform* subtypes. For English, we can ignore the issue of case, because examples like (47) never come up.

4.3.2 Marker Ps and free Ps

We need a *pform* subtype corresponding to each prepositional form in the set \mathcal{F} of fixable forms. Below I split the forms up into three groups:

- (48) a. of, for, with, at, from, into, after, than, as, between, under, against, without, toward/towards, like
 b. out, down, up, off, along
 c. in, to, on, upon, by, across, through, over, about, around/round

The forms in the first group are exclusively prepositional, while those in the second occur only as particles in Type B contexts. For the forms in the third group, we need distinct *pform* sub-

types for prepositional and particle variants. I will represent these as in_{prep} and in_{prt} whenever the distinction is crucial.

As discussed in §2.2.2, some of the forms I include in (48) are open to debate. On the other hand, this is not an unreasonably large set, and it is better to include one or two superfluous forms than to leave any necessary ones out. Similarly, the subgroup (48c) may be too inclusive; I leave further refinement of (48) aside now in order to focus on the overall analysis.

For prepositional forms outside of \mathcal{F} , we need a “dead” type to serve as a non-selectable PFORM value. I will call this subtype *free*. I assume the simplest possible hierarchy under *pform*:

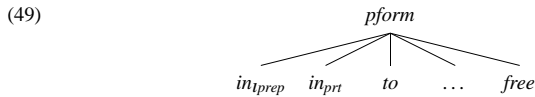

There is no real hierarchical organization of the subtypes. There is no evidence, for example, that the two forms of *in* form a natural class, or that all of the non-free forms should be grouped together. There are no heads that syntactically select a preposition, but then allow it to have any of the forms in (48). On the other hand, as mentioned in footnote 8, it may be useful to assume a common supertype for on_{prep} and $upon_{prep}$ for cases like *agree on/upon sth*. Similarly, we have alternations like *complain of/about sth* and *require sth from/of sb* which suggest some minor hierarchical structure under *pform*. In my opinion, these alternations are not so widespread and systematic that we are forced to build them into the hierarchy (as opposed to relying on explicit disjunction in the lexical entries of the selecting heads). I will not try to resolve this issue here; I leave the precise hierarchy under *pform* as a matter for future research.

I make a distinction between “marker” uses of prepositions which are syntactically selected via PFORM, and “free” uses which are not.⁹ All Type A prepositions are therefore free, and all Type B prepositions are marker Ps. I define *free-prep-lex* and *mark-prep-lex* as exhaustive subtypes of *prep-lex*:

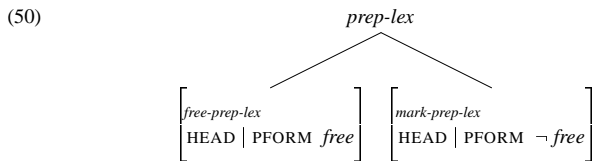

Note that, like *prep-lex* itself, *free-prep-lex* and *mark-prep-lex* are not very well motivated types, but they are useful as a notational convenience.

⁹The motivation for the label “marker” will become clear in Chapter 6.

In general, all prepositions in \mathcal{F} exist in both free and marker variants. The choice depends on the context of the preposition. This will be demonstrated in the next section, where I discuss different kinds of preposition selection.

4.4 Selection

At this point, we have two formal distinctions between marker and free prepositions, and between content and empty prepositions. These correspond roughly to the descriptive distinctions of fixedness and meaningfulness introduced in Chapter 1. The interaction of these two distinctions should therefore give rise to formal representations of the cardinal points of the spectrum of prepositional uses. Prepositions in the Type A corner are to be analyzed as “free content” prepositions, while those in the Type B corner are “empty marker” prepositions.

In this section, I start with examples of these more familiar cases, before moving on to a discussion of instances of less “canonical” selection.

4.4.1 Type B vs. Type A selection

Empty marker Ps

The following lexical entry for *dispense* illustrates the selection of a Type B preposition (*with*):

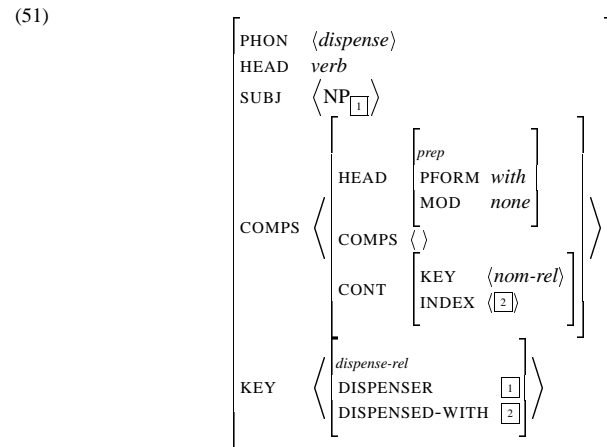

The fact that *with* must be an empty preposition is a consequence of the [MOD: none] requirement. The preposition does not contribute its own semantics, so this means that the nominal CONTENT of the prepositional object appears at the PP level. As we have already seen, this

means that *dispense* has access to the NP for purposes of semantic role assignment, and the NP can participate in binding, control, secondary predication, and so on.

The COMPS list in (51) also specifies [PFORM: *with*], which ensures that the PP will be headed by a marker preposition with the right form.

Free content Ps

Type A prepositions are syntactically free and semantically contentful. Type A PPs can be either complements or adjuncts. Here I give an example of the selection of a Type A complement, in order to show the contrast with the Type B example above. See the next section for a discussion of adjunct PPs.

Consider the following sentence:

- (52) Jennifer stayed with the group.

Here the PP *with the group* is a complement of *stayed*, but there is no selection of syntactic form:

- (53) Jennifer stayed in/behind/outside the group.

I assume the following entry for the verb in these examples:

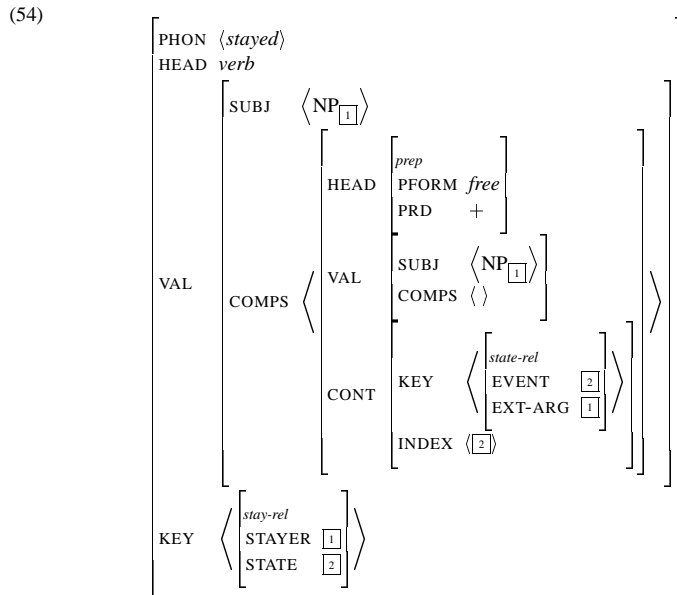

The verb *stayed* selects a predicative PP complement, with *free* form. The subject of *stayed* controls the unexpressed SUBJ element of the PP, and this ensures that it is assigned the EXT-ARG role of the preposition.¹⁰ The prepositions in the *stayed* examples above are therefore chosen only for their semantics; they have to express some kind of state. The verb enforces semantic requirements via the KEY value of its PP complement.

Purely semantic selection

Another approach to Type B prepositions is possible. Given that heads can enforce arbitrarily specific semantic constraints on their complements, perhaps Type B prepositions are fixed via KEY, not via PFORM. In other words, the verb *dispense* in (51) above could require a PP complement with the KEY relation *with-rel*.

This analysis represents a complete departure from what I have presented so far in this chapter. Type B prepositions can no longer be semantically empty. This causes problems for the analysis of phenomena that require Type B prepositions to be semantically transparent: binding, semantic role assignment, control, oblique agreement. On the other hand, we could introduce a feature called P-OBJ in the CONTENT of prepositions that encodes the CONTENT of the prepositional object. Alternatively, Davis (1996) proposes a HEAD feature AGR, which in the case of PPs encodes the agreement properties of the preposition's NP object.

There is evidence that something like P-OBJ or AGR is needed, because even Type A prepositions are sometimes transparent for binding and other phenomena:

- (55) a. The Republicans_i packed the legislature [with [?]themselves_i/*them_i]. (Wechsler, 1997, p. 151)
- b. Jack sat [next to the girls_i] several times each_i.

Therefore the claim that the NP inside a Type A PP is always inaccessible to external processes is too strong.

On the other hand, it seems wrong to replace PFORM selection with KEY selection. It is suspicious, first of all, that Type B prepositions, which have the weakest perceived meanings, are actually subject to the most stringent semantic constraints. For example, consider the following:

- (56) a. We dispensed with needless formalities.
- b. * We dispensed using/regarding/by means of/accompanied by/involving/with respect to needless formalities.

¹⁰There is probably also a raising version of *stay* that assigns no STAYER role and copies the SUBJ element of its predicative complement into its own SUBJ list.

If *with* in (56a) is semantically selected, then we might expect that it could be replaced by semantically similar words or phrases. In fact, this is impossible, and under a purely semantic account, we would have to claim that none of the synonyms in (56b) means exactly what *with* means, and *dispense* is very particular about the semantics of its PP complement. This is a counter-intuitive result.

Furthermore, all of the distinctions argued above to be reflected in the *pform* hierarchy now have to be encoded in the hierarchy of *prep-rel*. None of those distinctions were of a semantic nature; instead they involved phonological form, case government properties, and valence. This is not necessarily problematic. For example, in languages where a preposition can govern different cases, this corresponds to semantic differences in Type A contexts, so it might be plausible to refer to different semantic relations for Type B preposition selection also.

On the other hand, the distinction between Type B prepositions and particles is more troublesome. The form *up*, for example, is only used as a particle (*give up*). Semantically, this means that heads like *give* cannot select the same *up-rel* found associated with transitive *up* constructions like

- (57) a. Jennifer walked [up the stairs].
b. * The enemy gave [up the stairs].

What KEY relation should *give* require instead? In this case we seem to need an *intrans-up-rel* that has no obvious argument structure, or any semantics at all.

It is clear, then, that KEY selection is not the appropriate mechanism for fixing prepositional forms, at least not in all cases. We do need a separate mechanism for selecting prepositions syntactically via PFORM.

4.4.2 Double selection

It is natural to treat some Type AB prepositions as cases where syntactic and semantic selection are both at work. In other words, they can be analyzed as “content-marker” prepositions. As an example, consider the following:

- (58) They presented Jack with a check for \$2 million.

The *with*-PP complement has the same instrumental meaning here as it does in adjunctive contexts:

- (59) a. They appeased Jack with a check for \$2 million.
b. Jack paid for the villa with a check for \$2 million.

In other words, *presented* selects a PP complement to express the means by which the presenting is carried out. Usually, there are a number of ways to express means, but *presented* only allows one:

- (60) a. * They presented Jack using/by means of a check.
b. They appeased Jack using/by means of a check.
c. Jack paid for the villa using/by means of a check.

In addition to specifying the semantics of its PP complement, then, *presented* also constrains its PFORM value.

Adjuncts

Before looking at the analysis of (58), let us first consider the representation of the Type A adjunct PPs in (59):

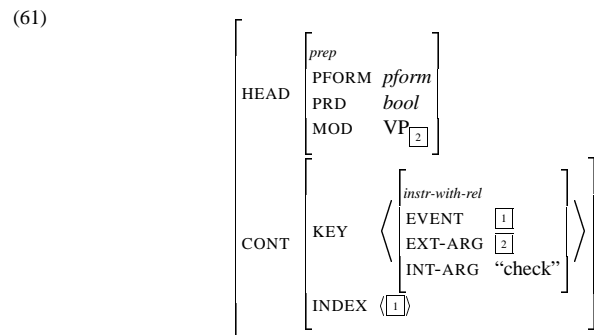

Note that there is nothing to require any particular instantiation of the PFORM value. Obviously it cannot be *to* or *at*, for instance, because there is no version of *with* in the lexicon with these PFORM values. The choice is between [PFORM: *with*] and [PFORM: *free*]. It would be desirable to have [PFORM: *free*] here. Similarly, [-PRD] would be appropriate, but so far nothing requires it.

Under the standard HPSG analysis, where there is an extra ID schema for combining heads with adjuncts, the features PFORM and PRD can be instantiated by the construction:

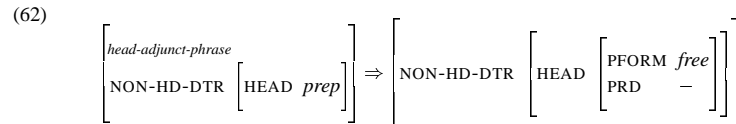

In other words, if the adjunct in a head-adjunct phrase is a preposition, then it must have *free* form, and it must be non-predicative.

Recall, however, the alternative proposal in Bouma et al. (1998) (which points back at the earlier HPSG account in Pollard and Sag (1987)) where adjuncts are selected by the heads they modify. The idea is that adjuncts can be freely instantiated at the end of the DEPENDENTS list, and then end up on the COMPS list via Dependent Realization (33b) (assuming that they are to be canonically realized). In this case, we can require that any PP adjuncts on DEPS must have the specifications [-PRD] and [PFORM: *free*]. In fact, this approach accommodates a wider range of adjuncts; in particular, secondary predications might be analyzed as [PFORM: *free*], but [+PRD], with an unexpressed subject controlled by another ARG-ST element.

Content marker Ps

Now I turn to the complement PP example in (58), which is headed by the following verb:

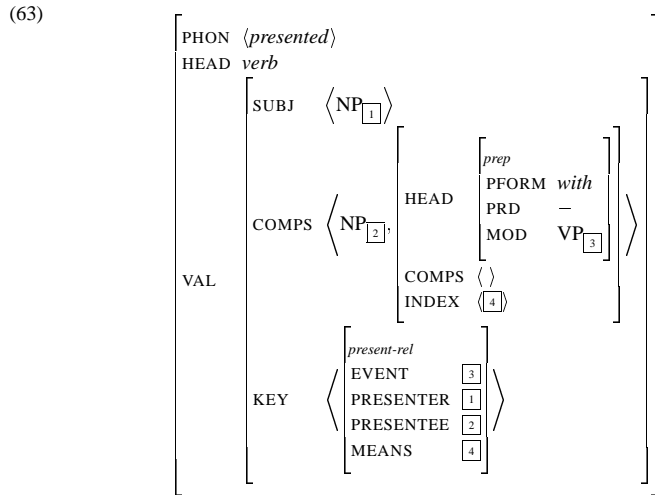

In (58), the *with*-PP is selected as a complement, but semantically, it behaves like the adjuncts in (59). The verb *presented* fills in the MOD value of the PP, thereby linking itself to the external argument of the PP. The crucial difference is that, as a complement, the PP is subject to PFORM selection as well.

I assume that the PP complement in (63) is non-predicative; there is no direct motivation for this, since PRD and SUBJ play no crucial role in the analysis. The primary characteristic of a predicative context is that it licenses elements of different syntactic categories. This is

not the case with the complement of *presented*, but we could also attribute this to the PFORM constraint.

Wechsler (1997) claims that instrumental *with* is never predicative, but this seems to be too strong:

- (64) a. His new production is with a cast of unknowns.
- b. The next attack will be with a banana cream pie.

What we can say is that predicative *with* never takes a verbal subject:

- (65) a. *To produce a play is with a cast of unknowns.
- b. *That he attacked me was with a banana cream pie.

I conclude that the PP complement in (63) should be [-PRD] (although note that it does still have a SUBJ element, because all content prepositions have subjects).

4.4.3 Non-selection

We can also ask if there are any empty free prepositions. In principle, they can exist:

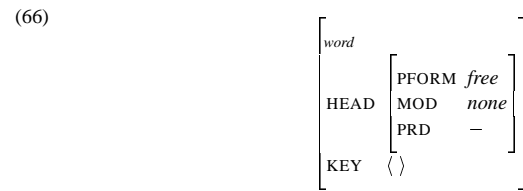

This lexical item has neither a selectable PFORM value nor a KEY relation. In other words, there is no way for an external head to get hold of a preposition with such a lexical entry.

There may be contexts where such lexical entries are called for:

- (67) “___” is an English preposition.

This example is clearly of an exceptional, metalinguistic nature, however. I exclude such cases from consideration: every preposition must be licensed by virtue of its syntactic form, or its semantic content, or both. This requirement is enforced by the following constraint:

(68)

$$\left[\begin{array}{l} \text{synsem} \\ \text{HEAD } \textit{prep} \end{array} \right] \Rightarrow \left[\text{HEAD } \left[\text{PFORM } \neg \textit{free} \right] \vee \left[\text{MOD } \textit{synsem} \right] \right]$$

Every prepositional category must either have a fixed PFORM value or it must have (potentially) modifying semantics.¹¹ This applies not only to prepositions in the lexicon, but to all prepositional *synsem* objects that appear in the valence lists or in the SPEC or MOD values of other heads. With this constraint in place, we exclude prepositions like (66) and all their projections, and we prevent heads, specifiers, and modifiers from selecting empty free PPs.

4.5 Prepositions in the Lexicon

4.5.1 Hierarchy

The content vs. empty and free vs. marker distinctions give rise to three subtypes of *prep-lex*:

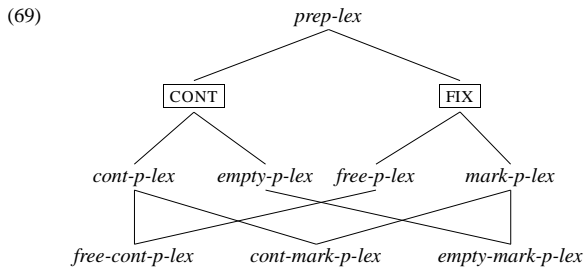

The constraint just given in (68) blocks the existence of a fourth subtype inheriting from *empty-p-lex* and *free-p-lex*.

4.5.2 Lexemes

The other ingredient we need to construct the lexicon of prepositions is a set of prepositional lexemes. For example, the lexeme of *with* can be represented as follows:

(70)

$$\text{WITH-lex} \Rightarrow \text{trans-prep-lex} \& \left[\begin{array}{l} \text{HEAD} \mid \text{PFORM } \textit{with} \vee \textit{free} \\ \text{KEY} \langle \rangle \vee \langle \textit{acc-with-rel} \vee \textit{instr-with-rel} \vee \dots \rangle \end{array} \right]$$

With is in \mathcal{F} , the set of fixable forms, so it must have a unique PFORM value; on the other hand, it can also be a free preposition. The lexeme also includes the different KEY relations that *with*

¹¹Note that I rely on [MOD: *synsem*] here rather than [KEY: *prep-rel*], which might seem like a more appropriate choice. But [KEY: *prep-rel*] is only sufficient to identify a contentful preposition at the *word* level. In a PP, the KEY value is not necessarily the same as the head preposition's KEY value (which may be empty). In order to state (68) as a constraint on *synsem*, we have to refer to the attribute MOD, whose value is guaranteed to match the head preposition.

can have; the KEY list can also be empty. The types *trans-prep-lex* and *intrans-prep-lex* are defined as follows:

(71) a.

$$\text{trans-prep-lex} \Rightarrow \left[\begin{array}{l} \text{ARG-ST} \left[\begin{array}{l} \boxed{1} \oplus \langle \text{NP}_{\boxed{2}} \rangle \\ \text{SUBJ} \left[\boxed{1} \right] \\ \text{KEY} \langle \rangle \vee \langle \left[\text{INT-ARG} \left[\boxed{2} \right] \right] \rangle \end{array} \right] \end{array} \right]$$

b.

$$\text{intrans-prep-lex} \Rightarrow \left[\begin{array}{l} \text{ARG-ST} \left[\boxed{1} \right] \\ \text{SUBJ} \left[\boxed{1} \right] \end{array} \right]$$

A transitive preposition has an NP on its ARG-ST list, in addition to its subject (if any). This NP is linked to the internal argument role in the preposition's KEY relation (if any). Argument Realization and Dependent Realization in (33) ensure that the complement NP ends up on the COMPS list if it is to be canonically realized. In the intransitive case, the ARG-ST list contains at most a subject.

4.5.3 Expansion

The combination of the three-way partition in (69) and the additional dimension of transitivity means that a given prepositional form can be associated with up to six lexical entries (modulo distinctions among word senses). Specifications in the lexeme definition determine which entries can actually be generated. For example, the *WITH-lex* in (70) licenses the following three lexical entries for *with*:

(72) *WITH-lex* & *free-cont-p-lex* =

$$\left[\begin{array}{l} \text{HEAD} \left[\begin{array}{l} \text{MOD} \left[\begin{array}{l} \text{CONT} \left[\begin{array}{l} \text{KEY} \left[\boxed{1} \right] \\ \text{INDEX} \left[\boxed{2} \right] \end{array} \right] \end{array} \right] \\ \text{PFORM } \textit{free} \end{array} \right] \\ \text{ARG-ST} \left[\boxed{3}, \boxed{4} \right] \\ \text{SUBJ} \left\langle \boxed{3} \left[\begin{array}{l} \text{CONT} \left[\begin{array}{l} \text{KEY} \left[\boxed{1} \right] \\ \text{INDEX} \left[\boxed{2} \right] \end{array} \right] \end{array} \right] \right\rangle \\ \text{COMPS} \left\langle \boxed{4} \text{NP}_{\boxed{5}} \right\rangle \\ \text{CONT} \left[\begin{array}{l} \text{KEY} \left\langle \boxed{6} \left[\begin{array}{l} \textit{with-rel} \\ \text{EXT-ARG} \left[\boxed{2} \right] \\ \text{INT-ARG} \left[\boxed{5} \right] \end{array} \right] \right\rangle \right\rangle \\ \text{LISZT} \left[\boxed{6} \right] \end{array} \right] \end{array} \right]$$

(73) WITH-lex & cont-mark-p-lex =

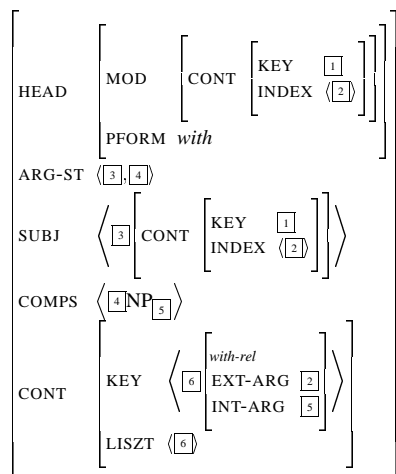

(74) WITH-lex & empty-mark-p-lex =

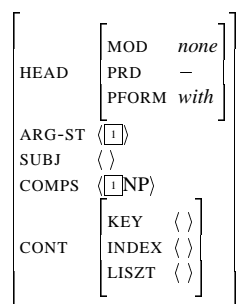

The only difference between the free content P in (72) and the content marker P in (73) is the PFORM value. At first glance, the content marker P in (73) and the empty marker P in (74) look dramatically different, but the basic difference between them is that the content marker P has a KEY relation, while the empty marker P does not.

The empty marker P in (74) projects a Type B PP that can be selected as the complement of a verb like *disperse* in (51). By virtue of the empty lists in the CONTENT value in (74), the semantics of the nominal complement of *with* will appear as the selectable semantic content of

the PP. The free content P in (72) projects a Type A PP that can appear as a complement, as in sentence (52), or an adjunct, as in the examples in (59). And finally, the lexical entry in (73) heads the Type AB PP complement selected by verbs like *presented* in (63).

4.6 Summary: Overlapping Analyses

The account I have presented here allows three kinds of PP selection, which correspond to three lexical subtypes for prepositions, as shown in the hierarchy in (69). This three-way distinction is broadly related to the descriptive spectrum of prepositional uses presented in Chapter 1 in the following way: clearly Type A prepositions are analyzed as free content Ps like (72), and clearly Type B prepositions are analyzed as empty marker Ps like (74). This means that content marker Ps as in (73) must give rise to Type AB uses.

These implications do not hold in the other direction, however. In other words, some prepositions that are formally represented as free content or empty marker Ps might be characterized descriptively as Type AB cases. The choice of analysis depends on two judgments: whether the preposition is meaningful enough to be represented as a content P, and whether the preposition is syntactically fixed enough to be represented as a marker P. In making these decisions, we are guided by the tests discussed in Chapter 1. For example, PPs headed by meaningful prepositions should be able to appear in other (predicative or modifying) contexts with the same meaning (see §1.2.4), while fixedness can be judged by using the substitution test to identify an external fixing trigger (see §1.3.1).

As we know, however, these tests are only indicative, and at best only a fuzzy boundary can be drawn between meaningful vs. meaningless and between fixed vs. non-fixed. Some uncertainty will therefore remain in matching the empirical data to the formal representations. This was already seen to be a problem for the standard HPSG account, and for all of the other proposals described in the previous chapter.

My analysis fits the data more closely than these existing accounts do because it does not assume that all prepositions are either lexical (i.e., free content Ps) or functional (i.e., empty marker Ps). Semantic contentfulness and syntactic form-fixedness are not required to co-vary; instead, the possibility is left open for the set of content Ps and the set of marker Ps to overlap, allowing certain prepositions to be syntactically and semantically selected at the same time. The existence of this overlap also allows a more plausible model for Type A to Type B grammaticalization, since the change from non-fixed to fixed and from meaningful to meaningless can take place in two gradual steps, rather than in one dramatic leap.

In summary, in order to avoid making a discrete binary distinction among prepositions, I have (somewhat counter-intuitively) introduced the three-way division in (69). The boundaries

between free content and content marker Ps on the one hand, and between content marker and empty marker Ps on the other, are not assumed to be clear-cut, however. The same argument could be made in a binary lexical vs. functional account (e.g., in the standard HPSG analysis), but then we predict that the only uncertain cases are those where both meaningfulness and fixedness are difficult to decide. But in fact it is much more common to find prepositions that are clearly fixed, but whose meaningfulness is debatable, and vice versa. These intermediate cases are exactly the ones predicted by and accommodated in my account.

Chapter 5

Mechanisms of Preposition Selection

The analysis I presented in the previous chapter allows syntactic selection of prepositions via the PFORM attribute as well as semantic selection via KEY (sometimes simultaneously). It is indisputable that we need some way of choosing prepositions based on their content; this type of selection applies, for example, for all Type A prepositions in adjunct and predicative contexts. On the other hand, it also seems clear that there are cases of truly idiosyncratic Type B selection as in *ask after sb* and *accuse sb of sth*, and here a purely syntactic mechanism is appropriate.

Within the set of Type AB constructions, however, it is not clear where semantic selection stops and syntactic selection takes over. Broadly speaking, this amounts to deciding which prepositions are contentful and which are semantically empty, because empty prepositions can only be syntactically selected. In a lot of the literature, it is taken for granted that examples like *rely on* and *give to* involve semantically empty, syntactically selected prepositions. On the other hand, the prepositions in such examples often show a degree of meaningfulness, so it is perhaps tempting to explain their occurrence semantically.

In this chapter I discuss proposals beginning with Gawron (1986) that take the strong position that all (or nearly all) prepositions are semantically contentful. This makes it possible to reduce the importance of purely syntactic selection of prepositions significantly.

5.1 Semantic Patterns

The following examples contain Type B prepositional uses:

- (1) a. We can only hope for a miracle.
- b. Ernie is good at tennis.
- c. Someone should talk to the Pope, he looks bored.

At issue here is what needs to be specified as idiosyncratic information in the lexical entries of the heads *hope*, *good*, and *talk*. It is uncontroversial, for example, that the entry for *hope* must indicate its subcategorization frame [____ PP], and its semantic content—a two-place relation, with associated restrictions (i.e., what kinds of entities can hope and what kinds can be hoped for). In addition to this, it is typically assumed that *hope* specifies explicitly in its lexical entry that its PP complement must be headed by *for*.

But the identity of the governed preposition is not completely idiosyncratic. The examples in (1) are instances of more general patterns:

- (2) a. wish, pray, ask, long, try, hunger, yearn; desire, aspiration, search, quest, thirst; hungry, lonely, dying
- b. great, awful, OK, lousy, bad; expert, master, failure; excel, fail, succeed
- c. speak, whisper, whistle, sing, murmur, shout, explain, complain, signal

Like *hope*, the verbs, nouns, and adjectives in (2a) combine with *for*. These words clearly form a semantic group; they all express the notion of desire, and the complement of *for* identifies the object of desire. Similarly, the words in (2b) govern *at*, just like *good* in (1b). Semantically, they all involve an appraisal of skill or success, and the *at*-PP identifies the activity. And finally, the verbs in (2c) and *talk* in (1c) are verbs of communication that select the preposition *to* to mark the recipient of the communicated signal.

An analysis of preposition selection should account for the semantic patterns in (1)–(2); surely it cannot be that the words in each group all pick out the same preposition by chance. In this section I look at proposals that deal with examples like these by assuming that the prepositions are semantically contentful.

5.1.1 Argument Principle

In Gawron's (1986) account, PPs can have a variety of functions, which combine with verbs or VPs according to different syntactic and semantic combination rules. The main point of his proposal is that a preposition has the same lexical content no matter what kind of PP it heads. This means, among other things, that Type B prepositions can be (and in fact must be) selected for the same semantic reasons as their Type A counterparts.

Gawron assumes that all prepositions (with the exception of passive *by* and *of* in nominalizations) express two place relations. For example, the content of *for* is as follows:¹

¹In this discussion I use highly simplified representations that do not reflect all of the details of Gawron's analysis, which is formalized using Situation Semantics. Also, what I present here is a Gawron-style analysis; Gawron himself does not discuss verbs of desire in detail.

- (3)
- $\text{desire}(x,y)$

In this relation, the external argument x , which in principle can be either an individual or an event, desires the internal argument y . The verb *hope* expresses the following relation:

- (4)
- $\text{hope}(x,y)$

Syntactically, *hope* subcategorizes for a PP complement linked to its internal argument y . By stipulation, complement PPs must identify their external arguments with one of the verb's arguments. Some complement PPs also share their internal arguments with the verb; these are called argument PPs. In the case of *hope*, the PP complement must be an argument PP.

The fact that *hope* combines with *for* is not the result of any explicit specification in the lexical entry of *hope*. Instead, Gawron proposes the following Argument Principle:

- (5) A complement PP is an argument PP if and only if the lexical relation of its head preposition is a component of the verb's lexical relation.

We know that the complement of *hope* is an argument PP, because it shares both its arguments with *hope*. In order to satisfy (5), the preposition that heads the argument PP must express a relation that is a component of the hope relation. The following entailment is true:

- (6)
- $\text{hope}(x,y) \Rightarrow \text{desire}(x,y)$

In other words, *desire* is a component of *hope*, and since *for* expresses the relation *desire*, it is licensed to head the PP complement of *hope*.

In this analysis, although *for* is semantically contentful, it does not contribute anything new to the semantics of the sentence. For example, consider sentence (1a) again:

- (1) a. We can only hope for a miracle.

The two arguments of *for* are "we" and the miracle, but these are already the arguments of *hope* and they would be participants in the event even without the preposition:

- (7) We can only hope that they take mercy on us.

Also, *for* expresses *desire*, but this is a more general relation than hoping, so in combination with *hope*, *for* is completely redundant.

The same analysis applies to the other verbs in (2a), and it can presumably be extended to accommodate the nouns and adjectives also. These words all express relations that have *desire* as a component (and they all select PP complements), so they combine with argument PPs headed by the semantically contentful, but redundant preposition *for*.

5.1.2 Type A uses

Gawron's main claim is that the Type A and Type B uses of a preposition have the same lexical content. If *for* expresses the relation *desire* with verbs of desire, then we should also expect to see Type A uses of *for* with this content. Gawron discusses the analysis of benefactive *for* as in

- (8) Bob made a sweater for Sue (for Mary).

But here he is mostly interested in the possibility of iteration, and he pays no attention to the relational content of *for*, giving it simply as $\text{for}(x,y)$. It is not clear that *desire* is involved here, but this could be a homophonous version of *for*, and we have to look elsewhere for Type A uses of the version of *for* in (1a).

Lexical decomposition

Jolly (1993, 1987) suggests that the uses of *for* in (1a) and (8) are in fact related. Her analysis is formulated in the framework of Role and Reference Grammar, where semantic representation is based on lexical decomposition, along the lines of Dowty (1979) and Jackendoff (1983, 1990). Below are the sentences that Jolly gives to illustrate what she calls "purposive" *for*:²

- (9) a. Rita sings for fun.
-
- b.
- $\text{want}(r, \text{have-fun}(r)) \ \& \ [\text{sing}(r) \ \text{CAUSE} \ \text{have-fun}(r)]$

- (10) a. John left for Miami.
-
- b.
- $\text{want}(j, \text{be-at}(j, m)) \ \& \ [\text{leave}(j, \text{---}) \ \text{CAUSE} \ \text{be-at}(j, m)]$

- (11) a. John baked a cake for Rita.
-
- b.
- $\text{want}(j, \text{have}(r, c)) \ \& \ [\text{bake}(j, c) \ \text{CAUSE} \ \text{have}(r, c)]$
-
- c.
- $\text{want}(j, [\text{NOT} \ \text{bake}(r, c)]) \ \& \ [\text{bake}(j, c) \ \text{CAUSE} \ [\text{NOT} \ \text{bake}(r, c)]]$

- (12) a. John hopes for a Mercedes.
-
- b.
- $\text{hope}(j, \text{have}(j, m))$

Jolly's proposal is that all of these uses of *for*, including the Type B use in (12) have the same lexical content.

According to Jolly, the logical structure (LS) of purposive *for* has two components:

- (13) a.
- $\text{want}(x, LS_2)$
-
- b.
- $[\text{LS}_1 \ \text{CAUSE} \ \text{LS}_2]$

²I have simplified Jolly's semantic representations somewhat.

In addition to the idea of desire or wanting, *for* includes the idea that some event (which is identified by the verb that *for* combines with) causes the desired event to come about. This causal component is missing in Type B uses, as in (12), so the core meaning of *for* is simply want.³ Note that this already falsifies the claim that *for* expresses the same lexical content in all of the contexts above.

Underdetermined semantics

On the other hand, we could ask if the causal component in (13b) is really necessary. For example, if we take away the CAUSE part of the semantic representations in (9)–(11) and leave just the VP’s semantics behind, we still end up with more or less reasonable analyses:

- (9) b'. $\text{sing}(r) \ \& \ \text{want}(r, \text{have-fun}(r))$
 (10) b'. $\text{leave}(j, _) \ \& \ \text{want}(j, \text{be-at}(j, m))$
 (11) b'. $\text{bake}(j, c) \ \& \ \text{want}(j, \text{have}(r, c))$
 c'. $\text{bake}(j, c) \ \& \ \text{want}(j, [\text{NOT bake}(r, c)])$

But now consider the semantic contribution of *for*, the want relation. Unlike the desire relation we considered above in (3), want takes an entire event, not just an individual, as the “wanted” argument. But syntactically, *for* only takes an NP complement, usually identifying an individual, like Miami. In principle, there are any number of desirable events involving Miami in some way—e.g., being in Miami, not being in Miami, thinking about Miami, Miami hosting the Olympics—so why is only one specific event—being in Miami—allowed in (10)?

The CAUSE component of *for* in (13b) can help explain this. Not only does *for* introduce a desirable event (somehow involving the referent of its NP object), but this event must also be one that can be caused by the event corresponding to the modified VP. For example, the event of John leaving from somewhere can cause him to be in Miami, but it cannot cause Miami to host the Olympics (cf. *John voted for Miami*). The identity of the desired event is therefore left up to world knowledge and context effects. But consider the following:

- (14) a. Rita sings for Miami.
 b. $\text{want}(r, \text{be-at}(r, m)) \ \& \ [\text{sing}(r) \ \text{CAUSE be-at}(r, m)]$
 (15) a. Rita sings for hoarseness.
 b. $\text{want}(r, \text{be-hoarse}(r)) \ \& \ [\text{sing}(r) \ \text{CAUSE be-hoarse}(r)]$

³Jolly implicitly assumes that hope implies want.

Even if we somehow know that by singing, Rita can cause herself to end up in Miami, we cannot say (14a). Similarly, sentence (15a) should be able to express the idea that Rita wants to make herself hoarse by singing.

It may be possible to come up with a theory of causation and a theory of “desirability” that can fill in LS₂ in (13). On the other hand, another approach would be to assume different versions of *for* (e.g., destination *for*, benefactive *for*, deputative *for*, etc.) that include more specific constraints on the desired event. Jolly herself mentions, for example, that in the deputative reading of *for*, as in (11c), LS₂ = [NOT LS₁]. This is not quite right (the agentive participants are distinct in LS₁ and LS₂) but it acknowledges the idea that (13a) is just the core sense of *for*, and we need more specific lexical entries to account for the actual uses of the preposition.

Explanatory power

Jolly’s analysis also demonstrates the major drawback of the core sense approach: in order to accommodate all of the uses of *for* in (9)–(12), the core sense must be very general. There is then the danger that it no longer identifies one particular preposition uniquely. For example, the same semantic components proposed for *for* in (13) are also found in the following examples:

- (16) a. Jennifer walked to the shop.
 b. $\text{want}(j, \text{be-at}(j, s)) \ \& \ [\text{walk}(j) \ \text{CAUSE be-at}(j, s)]$
 (17) a. Jack hacked away at the sculpture.
 b. $\text{want}(j, \text{destroy}(j, s)) \ \& \ [\text{hack}(j) \ \text{CAUSE destroy}(j, s)]$

In fact, just about any event involving a volitional agent can be assigned a logical structure of this form. This weakens Jolly’s claim that the uses of *for* above are intimately related.

Like many analyses of prepositional polysemy, then, Jolly’s account is interesting from the viewpoint of description and categorization. It is less useful, however, as a predictive account. I will discuss the implications of this with respect to Type B preposition selection in the next section.

5.2 Limits of Semantic Selection

From what we have seen so far of Gawron and Jolly’s analyses, it seems plausible to assume that Type B prepositions are semantically contentful, at least in some cases. In this section, I discuss whether there is any real advantage to be gained from this assumption. In fact, the motivation for contentful Type B prepositions turns out to be questionable. Moreover, even if we adopt this proposal, it is still not enough to eliminate the need for an additional mechanism for syntactic selection of Type B prepositions.

5.2.1 Distinct lexical relations

Gawron makes the strong claim that the same lexical content can be assumed for both Type A and Type B prepositions. This allows a tremendous simplification of the lexicon, and it means that we should be able to explain the semantic behavior of Type B prepositions just by looking at the properties of their Type A counterparts.

Impingement verbs

Unfortunately, Gawron gives no convincing examples to motivate his claim. The one case he discusses involves verbs of “impingement”:

- (18) a. Jack hit the fence with the stick.
 b. Jack hit the stick against the fence.
- (19) a. John broke the vase with the hammer.
 b. John broke the hammer against the vase.

These two verbs *hit* and *break* are meant to illustrate the difference between argument PPs as in (18) and “co-predicating” PPs as in (19). This is not a very clear distinction. It depends on the assumption, for example, that the stick is an argument of *hit* in (18a) but the hammer is not an argument of *break* in (19a). Gawron’s argument is that all hitting events involve an instrument, but not all breaking events do. Jolly’s approach to *break* is more satisfactory: breaking events always include a cause, and this cause might involve an instrument like the hammer in (19a). Under this analysis, both *with*-PPs above are argument PPs.

The distinction between the two *against*-PPs is also unclear. Gawron calls *against the fence* an argument PP in (18b), but in fact it must be a controlled PP complement in his analysis, because it expresses a semantically obligatory argument (like an argument PP) but the preposition is variable, and it makes a non-redundant semantic contribution:

- (20) a. Jack hit the stick on/under/beside/around the fence.

The classification of *against the vase* in (19b) is also uncertain. Gawron denies that it expresses an argument of *break*, but again, this is a questionable assumption, and otherwise this PP would also have to be a controlled PP, not a co-predicating PP. In short, it is not at all obvious that we are dealing with Type A and Type B uses of *with* and *against* in (18)–(19), so these examples do not provide very strong support for Gawron’s claim.

Desire

We looked in detail at Gawron’s treatment of Type B *for* with verbs of desire above. Jolly’s analysis of *for* suggested that Type A and Type B uses involved related, but distinct lexical content. In particular, Type A uses of *for* include a causal component that is not associated with Type B *for*. It is crucial for Gawron’s account, however, that if *for* means desire in Type B argument PPs, then we should also find Type A uses of *for* with precisely the same content.

Wechsler (1995), in discussing Gawron’s analysis, offers the following examples to show that “*for*-PPs occur as adjuncts with this same desiderative sense” (p. 66):

- (21) a. Students for a Democratic Society.
 b. John worked for peace.
 c. John ran for cover when it started to rain.

The idea of desire is somehow involved in all of these cases, but in my opinion they do not confirm the claim that Type A and Type B uses are semantically equivalent.

First of all, the analysis of *for cover* in (21c) as an adjunct is disputable. According to Gawron’s definition, the external argument of *for* would have to be a situation and not just the individual John. In this case *for* cannot introduce the relation *desire*; the situation of John running does not desire cover. The following suggests that the PP is a complement of *ran*:

- (22) John ran when it started to rain. *He did it for cover.

In fact, I think an argument PP analysis is plausible in this case. In other words, *run* expresses a two-place relation $run(x,y)$, holding between the runner and the intended goal. This relation implies *desire*(x,y), so the Argument Principle allows *for* to appear.

Gawron would most likely disagree with this analysis; it is possible to run without having an intended goal, so *run* must be just a one-place relation. Then the preposition *for* introduces the idea of desire, and then it is up to “bondedness relations” to determine the causal connection between the two facts $run(j)$ and $desire(j,cover)$. On the other hand, there is evidence that *run* puts rather subtle restrictions on the complement of *for*:

- (23) a. John ran for the doctor.
 b. * John ran for the thief.

Suppose that in (23a), the verb tells us that John ran, and the *for*-PP tells us that John desired the doctor. We can bond these facts together naturally by guessing that there was some kind of emergency, and John’s desire to get the doctor as soon as possible caused him to run. Similar considerations apply in (23b): John desired the thief, and we can guess that the thief was trying to get away, so John had to run. But sentence (23b) is ungrammatical. In other words, the

complement of *for* is constrained in ways that cannot be explained by the semantic relation *desire*, or by general interpretative mechanisms. The only remaining option is to conclude that *cover* in (21c) and the *doctor* in (23a) are arguments of *ran*. Wechsler's sentence (21c) is therefore not a valid example.

Example (21b) is a more likely candidate for an adjunct PP construction. Note the following:

(24) John worked (hard). He did it for peace.

But now *for* cannot have the content *desire*; it must be something like *support* or *promote*, because events cannot *desire*. So this example provides no support for Gawron and Wechsler's claim. Alternatively, we could treat *for peace* as a controlled adjunct (basically a secondary predication). After all, it is reasonable to assume that *desire(j,peace)* is part of the semantics of (21b). In this case, however, I argue that *for* introduces a different relation that could be called *favor*. The same sense is involved in example (21a).

Consider the following contrasts:

- (25) a. John hopes for a miracle/too much/a democratic society/peace/*himself.
 b. John works for *a miracle/*too much/a democratic society/peace/himself.
 c. Students for *a Miracle/*Too Much/a Democratic Society/Peace/?Themselves.

Type B *for* in (25a) accepts a different range of internal arguments than *for* in the other two contexts. This is unexpected according to Gawron's account, which predicts that more or less any "desirable" argument is allowed in *for*-adjunct, but a narrower range of arguments should be possible with *hope for*, because *hope* is a more specific relation than *desire*. In fact, however, the patterns in (25) show that two different relations are involved. If anything, a wider range of arguments is allowed in the Type B case.

Another piece of evidence for the distinction is the following:

- (26) a. Students against a Democratic Society
 b. John worked against peace.
 c. * We hope against a miracle.

The Type A version of *for* in (21a)–(21b) can be replaced by *against* to express the opposite semantic relation. This is not possible in with *hope* (26c). On the other hand, the ungrammaticality of this example can be explained on combinatorial grounds: the internal argument of *against* (the miracle) is not an argument of the verb, so the PP is not an argument PP, and the subcategorization properties of *hope* are not satisfied. But the contrast can also be shown with synonyms:

- (27) a. Students in favor of a Democratic Society
 b. John worked in favor of peace.
 c. * We hope in favor of a miracle.

This confirms that different relations are involved in the Type A and Type B cases.

Motivation

I have only discussed a few examples, and Gawron's approach could in principle be motivated by a single instance of Type A *for* expressing *desire*. As far as I can tell, however, there are no convincing cases; *for* always introduces either a more specific relation, or perhaps a completely unrelated one.

Consider the implications for Gawron's account. Given any Type B preposition, it is a simple matter to invent a semantic relation for it that makes the Argument Principle account work out. If it turns out that we can also use this semantic relation to account for Type A uses of the preposition, then we can simplify the lexicon and we have a well-motivated, economical analysis. On the other hand, as we have seen with verbs of *desire*, it sometimes turns out that we need to assume a separate lexical entry that for some reason can only be used in Type B contexts. And suspiciously, in exactly those contexts, the content of the preposition is completely redundant.

5.2.2 Vague semantics

Although there is no strong motivation for the *desire* version of *for*, intuitively it seems plausible, and there is no indisputable evidence against assuming that Type B prepositions are contentful. It is true that Type A and Type B prepositions have distinct semantic properties, as I have discussed in earlier chapters. Although these can be conveniently explained by assuming that Type B prepositions are semantically empty, this is not the only conceivable approach. But would we actually gain anything by assigning semantic content to Type B prepositions? In particular, would it eliminate the need for purely syntactic selection via PFORM?

We have already seen indications that verbs like *hope* are fixing triggers:

- (28) We hope for/*in desire of/*wanting/*with a view to a miracle.

It could be that *hope* requires its complement to have a *desire-rel* in its KEY value, but in addition to that, it is very particular about how this relation is expressed syntactically. The most straightforward explanation is that *for* is a marker preposition with [PFORM: *for*].

Underdetermined selection

The existence of semantic patterns of Type B preposition selection as in (2) is taken as an indication that Type B prepositions are contentful. Under a semantic approach, the procedure for dealing with these examples is as follows. We consider all of the words in the group, and find some semantic component that they all have in common, and call this the content of the preposition that they all combine with.

As a quick example, consider the words in (2b), all of which select *at*. Semantically, they all involve an agent engaged in some activity, so we can simply assign the content $\text{engage}(x,y)$ to *at*. The Argument Principle then licenses the occurrence of *at*, “explaining” this widespread pattern of selection.

As in the case of *for*, there are no Type A uses of *at* that express engage . The OED offers a supposedly current meaning for *at*: “With actions in or with which one is engaged.” The most recent examples given, however, are from the 19th century and are no longer possible in current (American) English:

- (29) a. † And idled away the mornings at billiards.
 b. † I trace the matron at her loved employ.
 c. † The case... is still at hearing.

Nowadays this usage is only preserved in a few fixed phrases:

- (30) a. at work, at play, at war, hard at it
 b. * at hard work, at Monopoly, at civil war, at absolutely nothing

Synchronically, then, if we assume that there is still a lexical item *at* expressing $\text{engage}(x,y)$, then we have to explain somehow why it only occurs with the words in (2b) and in the handful of conventionalized phrases in (30a) exist.

The other problem is that engage is a very broad notion, and we therefore expect *at* to occur in a wider range of contexts:

- (31) a. We are dealing with the repairs now.
 b. Jack participated in the game.
 c. Jennifer benefits from stealing her friends’ jewellery.
 d. I resorted to blackmail.

All of these examples include the idea of an agent engaged in an activity, and the activity corresponds to the internal argument of the preposition, so according to the Argument Principle, there is no reason why *at* should not appear here. But it cannot:

- (32) a. * We are dealing at the repairs now.
 b. * Jack participated at the game.
 c. * Jennifer benefits at stealing her friends’ jewellery.
 d. * I resorted at blackmail.

One of Gawron’s own examples is *with* in (18a) and (19a) above, which he assumes to express $\text{incidence}(x,y)$ —i.e., argument *y* “acts directly upon” *x*. Obviously, such a general relation is going to lead to overgeneration:

- (33) a. The king died from/*with the poison.
 b. The mouse reacted to/*with the stimulus.
 c. The patient complained about/*with back pains.

To maintain a semantic analysis, we have to refine the content of Type B prepositions to make very subtle distinctions, so that they will combine with exactly the right group of words, and no others. In my opinion, this is a hopeless task, and until it is demonstrated that semantic distinctions are sufficient for determining Type B selection, a syntactic mechanism based on PFORM must be assumed, and heavily relied upon.

5.3 HPSG Approaches

Wechsler (1995) discusses semantically-motivated preposition selection in HPSG. To some extent he adopts Gawron’s proposals, although he acknowledges that some Type B prepositions must be accounted for by syntactic selection.

5.3.1 Restricted Linking

Wechsler’s Restricted Linking Principle is more or less a direct translation of Gawron’s Argument Principle into HPSG (p. 72):

- (34) Restricted Linking Principle

$$\left[\begin{array}{l} \text{CAT} \mid \text{HEAD } \textit{verb} \\ \text{CONT} \left[\begin{array}{l} \text{REL } \textit{v-rel} \\ \text{ROLES } \langle \dots \text{V-ROLE}^{[+r]} \dots \rangle \end{array} \right] \end{array} \right] \Rightarrow \left[\begin{array}{l} \text{CAT} \mid \text{SUBCAT } \langle \dots \text{XP}[\textit{p-rel} \langle \dots [\text{P-ROLE}: \square] \dots \rangle] \rangle \\ \text{CONT} \mid \text{ROLES } \langle \dots [\text{V-ROLE}: \square]^{[+r]} \dots \rangle \end{array} \right]$$

where this entailment holds:

$$\forall x \square [\textit{v-rel}(\dots \text{V-ROLE} : x \dots) \rightarrow \textit{p-rel}(\dots \text{P-ROLE} : x \dots)]$$

This constraint introduces some non-standard HPSG notation that I will not explain in detail. In words, it says that a verb whose content includes a semantically restricted argument role must link this argument to a PP complement. Moreover, the verbal relation must entail the prepositional relation.

The parallel with Gawron’s analysis is quite obvious. The account of verbs of desire is exactly the same as the one above in §5.1.1, assigning the preposition *for* the following lexical entry:

$$(35) \quad \left[\begin{array}{l} \text{CAT} \\ \text{CONT} \end{array} \left[\begin{array}{l} \text{HEAD } \textit{prep} \\ \text{SUBCAT } \langle \text{NP}_{[1]} \rangle \\ \text{REL } \textit{desire} \\ \text{ROLES } \langle [\text{DESIRER}], [\text{DESIRED}: [1]] \rangle \end{array} \right] \right]$$

I argued above that this lexical entry has to be restricted somehow to occur exclusively in Type B contexts, because this semantic relation is not generally available for Type A uses of *for*:

- (36) a. I desire an audience with the Pope.
b. * I am for an audience with the Pope.

Wechsler also discusses PPs headed by “recipient” *to* and *for* as instances of restricted linking:

- (37) a. John baked a cake for/*to Mary.
b. John mailed a cake to/*for Mary.

The preposition *for* expresses the relation $\textit{int-rec}(x, y, z)$ where “ x performs an action on z with the intention that y receive z .” *To* expresses a more specific relation $\textit{int-cause-rec}(x, y, z)$ where “ x performs an action with the intention that an action cause y to receive z .” In (37b), the verbal relation certainly entails $\textit{int-cause-rec}$, so the RRL allows *to* here. Given that $\textit{int-cause-rec}$ entails $\textit{int-rec}$, anywhere recipient *to* is allowed, recipient *for* should also be possible. This is not true, however, as (37b) shows. Wechsler acknowledges this problem but offers no solution.

Wechsler’s RLP evidently has a broader scope than Gawron’s Argument Principle if it also covers the benefactive adjunct in (37a). Clearly the two-place *bake* relation cannot entail the three-place $\textit{int-rec}$, so the interpretation of entailment in (34) needs to be clarified. Wechsler assumes that all verbal relations can be extended by the addition of one or more adjunct roles, so if we add a RECIPIENT role to *bake*, then it entails $\textit{int-rec}$, and then the RLP licenses the preposition *for*.

5.3.2 Reformulation

Wechsler later presents a reworking of his analysis that takes better advantage of the formal machinery of HPSG. This follows up on suggestions by Pollard and Sag (1994) that non-predicative (i.e., Type B) PPs might be analyzed as having relational or situational content that is structure-shared with the $\text{CONT} \mid \text{NUCL}$ of the selecting verb. Wechsler allows all verbs to subcategorize for any number of PP complements, all of which share their CONTENT with the verb:

$$(38) \quad \textit{verb} \Rightarrow \left[\begin{array}{l} \text{SUBCAT } \langle \dots, \text{PP}: [1]^* \rangle \\ \text{CONTENT } [1] \end{array} \right]$$

The idea is that any PP whose semantics unifies with the semantics of the verb should be able to appear as an optional complement. This approach therefore includes Gawron’s semantically redundant argument PPs, but also applies to a wide range of semantically compatible co-predicating PPs and adjuncts. The idea is developed further in Wechsler (1997).

With respect to Type B preposition selection, this reformulation still runs into the same problems as the Gawron-style approach. In particular, it is still necessary to assume distinct lexical entries for Type A and Type B uses, on semantic grounds, and there is no way to prevent the Type B entry from appearing in inappropriate contexts.

In general, another drawback of Wechsler’s account is that nothing stops iteration of the optional PPs. If one PP’s CONTENT unifies with the verb’s CONTENT, then in principle the same PP can occur an arbitrary number of times. Wechsler’s motivation is to simplify the representation of verbal subcategorization, but the statement in (38) is perhaps too simple, and too unconstrained.

The CONTENT sharing in (38) is also problematic. If all of the prepositions and the verb end up having the same CONTENT, it is impossible to account for scope effects.

5.3.3 Virtual content

Consider again the discussion of the “engagement” words in (2b). A semantic account of *at* selection would involve assuming the following lexical entry:

$$(39) \quad \left[\begin{array}{l} \text{PHON} \quad \langle at \rangle \\ \text{ARG-ST} \quad \langle \text{NP}_1, \text{NP}_2 \rangle \\ \text{KEY} \quad \left\langle \begin{array}{l} \text{engage-rel} \\ \text{ACTOR} \quad [1] \\ \text{ACTIVITY} \quad [2] \end{array} \right\rangle \end{array} \right]$$

One shortcoming of this analysis is that it overgenerates. This lexical item cannot be used in all syntactic environments, but exclusively as a Type B preposition in combination with an engagement word:

- (40) a. I am engaged in/*at fishing.
 b. * I am at fishing.

Also, as shown in (31)–(32), *at* cannot be used in place of other Type B prepositions, even where the semantic relation in (39) is appropriate. I conclude that this lexical entry does not exist (anymore). This leaves us no explanation for the semantic pattern in (2b), however. On the one hand, some semantic patterns should be considered to be frozen remnants of a prepositional meaning that is no longer current. But on the other hand, some patterns still seem to be productive.

One possible approach to these cases is to introduce a semantic constraint like this one:

$$(41) \quad \left[\begin{array}{l} \text{word} \\ \text{ARG-ST} \quad [1] \oplus \langle \text{PP}_2 \rangle \oplus [3] \\ \text{KEY} \quad \left\langle \begin{array}{l} \text{engage-rel} \\ \text{ACTIVITY} \quad [2] \end{array} \right\rangle \end{array} \right] \Rightarrow \left[\text{ARG-ST} \quad [1] \oplus \langle \text{PP}[at] \rangle \oplus [3] \right]$$

In other words, a word that expresses engagement and subcategorizes for a PP complement to mark the engaged-in activity must choose the marker preposition *at*. This treatment accounts for the same data and makes the same predictions as a Wechsler-style approach. The crucial difference is that the lexical entry in (39) is not assumed to exist.

The constraint in (41) runs into the same problems with respect to the data in (31)–(32). This seems to suggest that a default constraint is necessary; *at* is selected unless the lexical entry already specifies a different PFORM value. I will not pursue the technical details of a default formulation here, but in recent literature there has been a growing trend in favor of enriching the HPSG formalism to take advantage of defaults (Sag, 1997; Ginzburg & Sag, ms).

5.4 Summary

In this chapter I have presented arguments against treating preposition selection as a primarily semantically motivated phenomenon. Cases toward the Type B corner of the spectrum of prepositional uses are more satisfactorily accounted for as instances of syntactic selection of prepositional form.

At first glance, the existence of semantic patterns in Type B prepositional selection as in (1)–(2) is compelling motivation for assigning semantic content to the prepositions in those constructions. This argument is significantly weakened, however, by two observations. First, Type B prepositions typically cannot be shown to express their supposed semantic content in any contexts other than the Type B constructions in question. This means that we still need separate lexical entries for the Type A and Type B versions of all prepositions, and furthermore, we have to prevent Type B prepositions from showing up in Type A contexts, and vice versa. It is not clear how this can be done by referring to the semantics of the prepositions alone.

Second, the meanings that are assigned to Type B prepositions to account for semantic patterns of selection are generally so abstract and broad that they overlap. We should therefore expect that Type B prepositions should be interchangeable in many constructions, but we know that this is not the case. Type B prepositions are characterized by a high degree of form-fixedness.

In contrast, the distribution of Type B prepositions is straightforwardly accounted for by treating Type B selection as a purely syntactic phenomenon. The price to pay is accepting that the lexicon contains a set of prepositions which are all semantically empty, but which are nevertheless carefully distinguished in the language.

This state of affairs can be understood from a historical perspective. Type B constructions show remnants of once productive prepositional meanings that have disappeared from the language in the meantime. The prepositions are retained in these constructions because they are now syntactically fixed, and not because they still express any particular semantic content. Many cases, where isolated combinations like *fall for* and *belong to* have been grammaticalized, can be readily dismissed as “accidents” of historical development. But when a significant number of semantically related constructions have been preserved, it is tempting to treat the prepositions as more than historical remnants. In both situations, however, the mechanism of selection is fundamentally the same—syntactic, not semantic.

Chapter 6

Prepositions, Case, and HPSG

Marking Theory

In this chapter I extend my treatment of prepositional representation selection to a number of other closely related parts of the grammar. First I consider nominal case marking. It is often recognized that prepositions and case markers have a lot in common. Since Fillmore (1968) there have been various attempts to formalize this idea, but the nature of the link between case and prepositions has not been properly captured in theoretical accounts. In this chapter I discuss the idea that grammatical case and prepositions are two kinds of NP marking, and I propose a unified analysis of grammatical marking within HPSG Marking Theory.

At the end of the chapter I briefly discuss the idea of using the same formal apparatus to handle two kinds of VP marking—verb form and complementizers—whose behavior mirrors that of case markers and prepositions.

6.1 Functional Similarity

6.1.1 Case Grammar

In Fillmore's (1968) Case Grammar, prepositions (as well as morphological case affixes) are analyzed as realizations of an underlying *Kasus* category. The various *Kasus* elements (such as Agentive, Dative, and Instrumental) are semantic notions, corresponding to thematic roles in more recent frameworks.

The lexical entry of a verb includes a case frame that specifies the *Kasus* categories it combines with—i.e., the semantic roles it assigns to its arguments. Each *Kasus* element is associated with a particular preposition or case inflection. In English, for example, Agentive case is associated with a null case ending or with the preposition *by*:

- (1) a. [Jack] kissed Jenny.

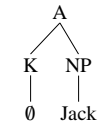

- b. Jenny was kissed [by Jack].

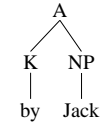

It is apparent from the examples that Fillmore gives that the correspondence between *Kasus* elements and their surface realizations is many to many. For example, Objective case is marked variously by morphological accusative case and by the prepositions *for* and *at*. In other situations, *for* can realize Dative case, and *at* can realize *Locative* case. Fillmore's proposals as they stand are not explicit enough to account for this in a principled way.

6.1.2 Alternations

The evidence linking prepositions and case comes primarily from cross-linguistic considerations. Where one language uses an NP marked with a particular morphological case, another language uses an NP in combination with a particular preposition. Cross-linguistically, the uses of PPs and case marked NPs overlap significantly. As a simple example, NPs marked with the instrumental case in Russian correspond to instrumental *with*-phrases and agentive *by*-phrases in English:

- (2) Russian vs. English

- a. Ivan pisał karandashom.
Ivan wrote pencil-INSTR
Ivan was writing with a pencil.
- b. Rabota byla sdelana kosmonavtom.
work was done astronaut-INSTR
The work was done by an astronaut.

Note that the English examples include a Type A preposition and a Type B one. Similarly, the instrumental case in Russian can be considered to have Type A and Type B uses. In fact, the same spectrum of meaningfulness and fixedness established for prepositions in Chapter 1 can also be applied to case marking (Zwicky, 1992; Kilby, 1981).

Historical evidence shows that case affixes are often derived from prepositions (or postpositions). It is also possible to find synchronic evidence within a single language. For example,

English has the dative and benefactive alternations, where *to-* and *for-* phrases correspond to case-marked NPs. Also, nominative subjects alternate with *by-* phrases in the passive, and pronominal genitives alternate with postnominal *of-* phrases. In Finnish, which has a much richer case system, many semantic relations can be expressed with either case marking or adpositions (Sulkala & Karjalainen, 1992):

- (3) a. laukutta / ilman laukua
 bag-*abessive* without bag-*partitive*
 ‘without a bag’
- b. koirineen / koiran kanssa
 dogs-*comitative* dog-*genitive* with
 ‘with his/her dog’

All of the alternations mentioned above are either lexically or semantically conditioned. For instance, not all verbs that subcategorize for a dative *to-* phrase participate in the dative alternation. Ideally, we might hope to find a language where a particular morphological case and a particular preposition are always in free variation, in all contexts. This would be the most compelling evidence for a single underlying feature with two syntactic realizations. From a functional point of view, however, totally free variation is rare, and I have not come across any such examples.

6.1.3 NP markers

Broadly speaking, there is a (universal) hierarchy of grammatical relations, ranging from the “core” structural relations (e.g., subject, direct object, oblique object) to the “peripheral” relations (e.g., location, manner, cause) (Blake, 1994). These represent the various ways in which the semantic content of an NP can be incorporated into the semantic structure of a larger construction. A core NP is assigned a semantic role by the governing verb (or other head)—i.e., it expresses an argument of the verbal predicate. Peripheral relations have more independent semantics, and they assign semantic roles to their NPs directly.

Cross-linguistically, prepositions and case markings are the morphosyntactic signals used to identify these abstract NP functions. The two notions are therefore fundamentally related, but at the same time they must remain distinct. As mentioned above, within a single language, the two strategies are not normally interchangeable. English clauses, for example, have case-marked subjects and objects, while other NPs are marked prepositionally:

- (4) We-*nom* delivered them-*acc* to a client in Chicago on Thursday.

A proper treatment of prepositions and case must balance the similarities and differences between them; previous analyses have failed to achieve this balance. On the one hand, some

linguists account for the similarities by merging the categories NP and PP. Recall, for example, the discussion of Grimshaw’s and Rauh’s proposals in §3.1 and §3.2.3. Under this assumption, NPs and PPs are predicted to have the same syntactic properties, but in fact this is not the case. We have seen plenty of evidence for this. NPs and PPs have different distributions, and they are targeted by different syntactic processes.

On the other hand, the alternative analysis is to maintain the categorial distinction between NP and PP (Jackendoff, 1977; Emonds, 1985). Here, the differing syntactic behavior of NPs and PPs is easily explained, but any formal link between prepositions and case is lost.

These two approaches represent opposite extremes. Prepositions and case should share some syntactic features, but the syntactic distinction between them cannot be completely neutralized. In traditional phrase structure analyses, using only simple syntactic categories like N and P, this kind of partial overlapping of grammatical features is impossible to represent. A more expressive formalism like HPSG allows us to strike the right balance between the two kinds of analyses discussed above.

6.2 HPSG Marking Theory

6.2.1 Standard Marking Theory

The structure in (5) below shows an example of the use of MARKING in standard HPSG:

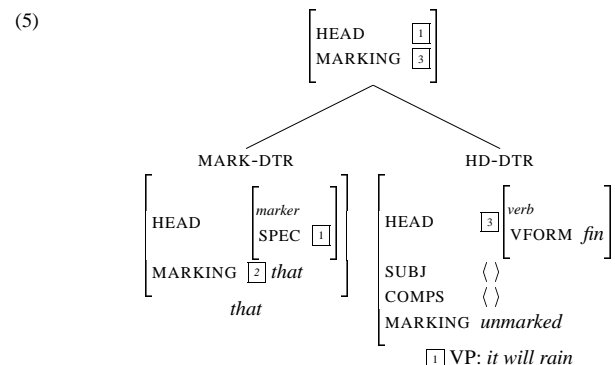

A sentence (i.e., a saturated VP) combines with the complementizer *that* (which is of category *marker*) via the Head-Marker Schema. *That* can combine with finite clauses or base form (subjunctive) clauses, but not with infinitive clauses. This selection is encoded in its SPEC value, and the SPEC Principle ensures that the SPEC value of the marker daughter unifies with the SYNSEM of the head daughter (the VP). Finally, the MARKING Principle ensures that

the MARKING value of *that* is passed up to the mother phrase, overriding the head daughter's original *unmarked* specification.

It is evident from this example that quite a lot of formal machinery is in place for dealing with MARKING in HPSG. It is surprising, therefore, how infrequently this machinery is used. In fact, in Pollard and Sag (1994), MARKING is only ever used in the analysis of Comp+S constructions as in (5). And yet every sign in the grammar is assumed to carry a MARKING value as part of its CATEGORY specification. All NPs, for example, are implicitly assumed to be *unmarked*, but this feature plays no part in any NP analyses. This is clearly an undesirable state of affairs.

An obvious solution, favored in some recent work (Van Eynde, 1998; Sag, 1997), is to do away with MARKING altogether and find an alternative analysis for complementizers. I argue for the opposite approach: keep the MARKING apparatus and develop it further, making it a more strongly motivated part of HPSG. The analysis of Comp+S constructions should involve some notion of syntactic marking. I argue that a number of other grammatical phenomena, including prepositional phenomena, also call for a similar approach.

6.2.2 Application to NP marking

Standard HPSG makes no attempt to capture the relationship between prepositions and case. There is nothing in the signs for PPs and case-marked NPs to indicate that prepositions and case-marking share a common function as NP markers.

A transitive verb, for example, subcategorizes for an accusative NP complement; the NP's case is governed via its CASE attribute. On the other hand, a prepositional verb subcategorizes for a PP complement headed by a particular preposition (*approve of*, *listen to*, *dispense with*) by referring to the PP's PFORM value. The similarity between these two instances of selection is clear: in both cases the verb combines with an NP, but it requires the NP to be marked in a particular way so that it can serve a particular grammatical function. The fact that two unrelated features PFORM and CASE are involved obscures the underlying parallelism between the two processes.

I propose that CASE and PFORM should be merged into a single HEAD feature called MARKING, taking values of type *marking*.¹ The subtypes of *marking* correspond to (a subset of) the universal inventory of grammatical relations discussed above. For a given language, only the syntactically relevant relations are encoded. English, for example, has the following *marking* hierarchy:

¹The connection between this attribute and the existing MARKING attribute is discussed below in §6.3.

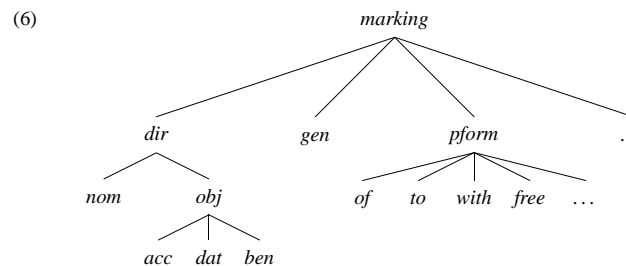

The subtypes *nominative*, *genitive*, and *objective* correspond to the morphological cases; *nominative* and *objective* are grouped under *direct* because non-pronominal nouns have only a single direct case form. The hierarchy under *pform* is the same as the one discussed in §4.3.2.

A number of recent studies have focused on case assignment in HPSG (Heinz & Matiasek, 1994; Przepiórkowski, 1996; Müller, 1998). My proposed modification is consistent with all of their results. By merging PFORM and CASE, we do not lose any distinctions, but we are able to express generalizations that could not be captured economically before.

6.2.3 Dative alternation

The subtypes *dative* and *benefactive* in (6) are needed in the analysis of the dative and benefactive alternations. The verb *give*, for example, which participates in the dative alternation, has the following lexical entry:

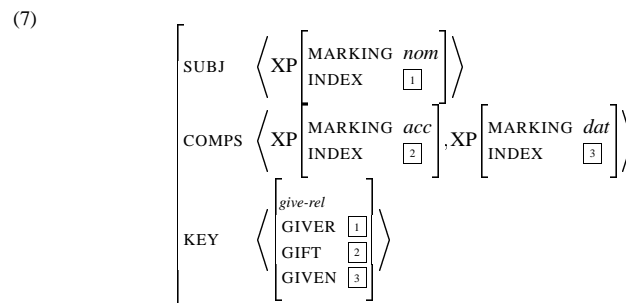

The dependents of the verb are only selected via MARKING and not by syntactic category. Potentially, they can be realized as any kind of (saturated) phrase. However, there is no English preposition with the feature [MARKING: *nom*]; only nouns can carry this feature, so the subject must be realized as an NP. The same is true for the accusative object; there is no accusative preposition in English.

The dative complement, on the other hand, can be realized either as an NP inflected for objective case (since *obj* subsumes *dat*), or as a PP headed by *to*, which has the following lexical entry:

$$(8) \quad \left[\begin{array}{l} \text{MARKING } \textit{dat} \vee \textit{to} \\ \text{SUBJ } \langle \rangle \\ \text{COMPS } \langle \text{XP}[\text{MARKING } \textit{acc}] \rangle \end{array} \right]$$

The disjunctive MARKING value reflects the fact that *to* also has non-dative uses that never alternate with case marking (e.g., *listen to*). Note that there is another lexical entry for the directional preposition *to*, which is semantically contentful.

The relative surface ordering of the complements of *give* depends on whether the dative complement is expressed as an NP or a PP. I assume that this is due to general constraints determining the order of complements in English. For example, NP complements come before PP and S complements.² If we also assume that dative NPs precede accusative NPs, then the two grammatical orderings are licensed and the two ungrammatical ones are blocked:

- (9) a. Jack gave flowers [to Jenny]. *Jack gave [to Jenny] flowers.
 b. Jack gave Jenny flowers. *Jack gave flowers Jenny.

I leave the exact formulation aside here; in particular, the interaction of this analysis with binding theory should be examined.

Verbs that take a dative complement, but do not participate in the dative alternation simply have a more fully specified COMPS list. For example, the verb *donate* selects a non-alternating PP[*dat*] complement, while the verb *cost* selects a non-alternating NP[*dat*]:

- (10) a. George donated his books to the library.
 b. *George donated the library his books.
 c.

$$\left[\begin{array}{l} \textit{donate} \\ \text{COMPS } \langle \text{XP}[\text{MARKING } \textit{acc}], \text{PP}[\text{MARKING } \textit{dat}] \rangle \end{array} \right]$$

- (11) a. The pizza cost Tony ten dollars.
 b. *The pizza cost ten dollars to Tony.
 c.

$$\left[\begin{array}{l} \textit{cost} \\ \text{COMPS } \langle \text{NP}[\text{MARKING } \textit{dat}], \text{XP}[\text{MARKING } \textit{acc}] \rangle \end{array} \right]$$

²I am considering unmarked word order here, ignoring heavy NP shift and stylistic effects.

The benefactive alternation between *for*-PPs and objective case NPs can be analyzed in a very similar way, with the assumption that the benefactive adjunct appears on the COMPS list. This contradicts the standard HPSG treatment of modifiers, but it has been proposed in recent work (Bouma et al., 1998).

6.2.4 MARKING lists

The phenomenon of multiple case marking (Blake, 1994; Dench & Evans, 1988), or case stacking, seems to require the MARKING attribute to take a list as its value. The following example is from the Australian language Martuthunira (Dench, 1995):

- (12) a. Ngayu nhawu-lha tharnta-a mirtily-marta-a thara-ngka-marta-a.
Isg.nom see-past euro-acc joey-prop-acc pouch-loc-prop-acc
 ‘I saw that euro with a joey in its pouch.’

Here the noun ‘euro’ bears accusative case as the object of the verb ‘see,’ the noun ‘joey’ bears proprietive case (‘with a joey’), and the noun ‘pouch’ bears locative case (‘in the pouch’). In addition to these “inherent” case specifications, however, the last two nouns also carry case suffixes as a result of NP-internal case concord. We can account for this by assuming that an adjunct NP appends a copy of the MARKING list of the NP it modifies to the end of its own MARKING list:

$$(13) \quad \left[\begin{array}{l} \text{MOD } \left[\begin{array}{l} \textit{synsem} \\ \text{MARKING } \boxed{1} \textit{list}(\textit{marking}) \end{array} \right] \\ \text{MARKING } \langle \textit{marking} \oplus \boxed{1} \rangle \end{array} \right]$$

The structure of the accusative NP ‘the euro with a joey in its pouch’ in (12a) is shown below:

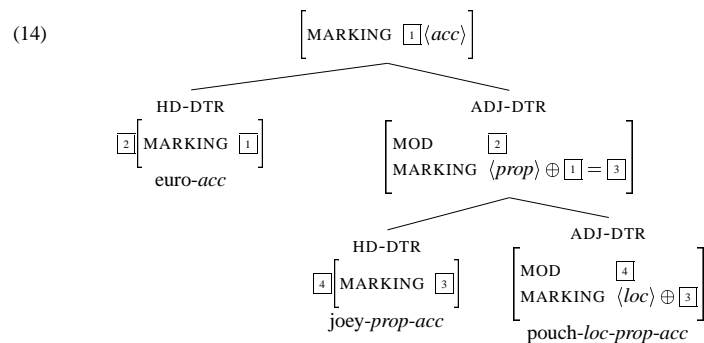

The suffixation requirements are “passed down” the tree, so each noun has a list of MARKING specifications that determines its morphological form.

Case inflection can be represented by lexical rules that add phonological information and MARKING specifications. Two examples are given below:

- (15) a. Proprietary Case Lexical Rule

$$\begin{bmatrix} \text{PHON} & \boxed{1} \\ \text{MARKING} & \boxed{2} \end{bmatrix} \mapsto \begin{bmatrix} \text{PHON} & \boxed{1} \oplus \langle \text{marta} \rangle \\ \text{MARKING} & \boxed{2} \oplus \langle \text{prop} \rangle \end{bmatrix}$$

- b. Accusative Case Lexical Rule

$$\begin{bmatrix} \text{PHON} & \boxed{1} \\ \text{MARKING} & \boxed{2} \end{bmatrix} \mapsto \begin{bmatrix} \text{PHON} & \boxed{1} \oplus \langle a \rangle \\ \text{MARKING} & \boxed{2} \oplus \langle \text{acc} \rangle \end{bmatrix}$$

Successive application of these two lexical rules to the basic (i.e., unmarked) lexical entry for ‘joey’ will give us the doubly-marked form ‘joey-prop-acc’ as it appears in sentence (12a):

(16)

$$\begin{array}{c} \begin{bmatrix} \text{PHON} & \langle \text{mirtily} \rangle \\ \text{MARKING} & \langle \rangle \end{bmatrix} \xrightarrow{\text{PropLR}} \begin{bmatrix} \text{PHON} & \langle \text{mirtily}, \text{marta} \rangle \\ \text{MARKING} & \langle \text{prop} \rangle \end{bmatrix} \\ \xrightarrow{\text{AccLR}} \begin{bmatrix} \text{PHON} & \langle \text{mirtily}, \text{marta}, a \rangle \\ \text{MARKING} & \langle \text{prop}, \text{acc} \rangle \end{bmatrix} \end{array}$$

I have only dealt with the morphological form here; details of semantic analysis have been left out.

There are no prepositions involved in this Martuthunira example. Case stacking in Japanese and Korean, however, has been analyzed as involving sequences of postpositions and case markers (Urushibara, 1991).³ This gives further evidence for the merging of CASE and PFORM into a single attribute.

6.3 Extension to VP Marking

I have proposed handling NP marking using the HEAD feature MARKING feature, but as discussed in §6.2.1, MARKING already exists as a CATEGORY-level feature, and it is used primarily for complementizer constructions. In the remainder of this chapter I argue that complementizer and verb form marking should also involve the HEAD | MARKING attribute.

³It must be said that not all authors recognize a distinction between postpositions and case particles in Japanese and Korean (Sells, 1995; Gerds & Youn, 1988).

6.3.1 Complementizers

In contrast to the standard analysis illustrated in (5), I treat complementizers as heads. This analysis is found in many syntactic theories, and the same has been proposed recently for HPSG by (Sag, 1997). This allows us to treat MARKING as a HEAD feature, and to eliminate the MARKING Principle. Furthermore, complementizers no longer need to carry a SPEC specification; they select a complement via COMPS like other heads. The original CAT | MARKING attribute is also unnecessary.

Now we have two types of grammatical phenomena handled by the HEAD | MARKING feature: complementizer marking and NP marking. Since the former only involves verbal structures and the latter only involves prepositions and NPs the two analyses do not interfere with one another. So there is no technical problem with encoding both types of information in the value of the same feature. On the other hand, it is methodologically suspicious to use a single feature if the two phenomena are completely unrelated.

In fact, complementizers turn out to be analogous to prepositions in several ways; and so the use of the feature MARKING to analyze both of them is justified. First, consider some descriptive arguments. As the category label suggests, complementizers turn clauses into complements. Finite clauses typically cannot appear in complement (or subject) position without a complementizer:

- (17) a. the suggestion *(that) aliens have visited Earth
 b. *(That) aliens have visited Earth is regrettable.
 c. conditions *(for) sanctions to be lifted

The function of the complementizers in these examples is similar to that of the prepositions in Type B constructions:

- (18) a. the parting *(of) the Red Sea
 b. Living bodies consist *(of) vital humors and essences.
 c. Jack dotes *(on) Jenny.

In these cases the prepositions allow the NPs to appear as complements where plain NPs are disallowed. Type B *of* and *for* act as “NP complementizers” here.

The distinction between Type A and Type B uses of prepositions is arguably also found in the case of complementizers. The semantic contribution of *that* and *for* in (17) above seems negligible, but in other cases, complementizers are chosen for semantic reasons. The interrogative complementizers *if* and *whether* are required by predicates expressing uncertainty or choice:

- (19) a. Jack couldn't decide whether/*for to run or hide.
 b. Jenny wondered if/*that she would arrive on time.

If subordinating conjunctions like *because*, *when*, *although* are also complementizers, as often assumed, then they are clear examples of Type A complementizers.

6.3.2 Case and verb form

Another similarity between prepositions and complementizers is that they both govern another kind of marking that is expressed morphologically on their complements. Prepositions govern case, and complementizers govern verb form. For example, the complementizer *that* requires a finite clause as its complement, while *for* subcategorizes for an infinitive clause. Verb form is therefore the counterpart of case in verbal domains.

Verb form is only marked on the verb in English, but in other languages it triggers agreement morphology throughout the clause. I illustrate with an Australian example, this time from Ngarluma (Dench & Evans, 1988):

- (20) Ngayi nyurnti-ka-rna mangjuru-ku, palu-la mirta-ngka-lyi milpa-nguru-la.
Isg.nom dead-cause-past kangaroo-acc that-loc not-loc-time come-act-loc
 'I killed a kangaroo before he came up.'

Here, the temporal function of the subordinate clause is marked by locative case on the verb 'come,' and this case marking spreads to the subject and negative modifier of the verb. The parallel with case marking in the NP is unmistakable.

6.3.3 Complementizers and verb form

Above we saw examples where the two kinds of NP marking were in alternation. The same phenomenon is observed with the two kinds of VP marking.

The following examples show that VP or clausal functions that are expressed by morphology and word order in English can be signalled syntactically by complementizers in other languages:

- (21) a. Que Juan venga ahora. (Spanish)
 that Juan come now
 'Let/May Juan come now.'
 b. Czy jest jeszcze bigos? (Polish)
 if is still bigos
 'Is there any bigos left?'

Within English, inverted word order (which can be triggered by a verb form) alternates with the complementizer *if* in conditional constructions:

- (22) a. Had he not gone, we would have won.
 b. If he hadn't gone, we would have won.

To summarize, we have the following analogy:

- (23) prepositions : case :: complementizers : verb form

On the strength of the suggestive parallels between these four kinds of grammatical marking, I propose that they should all be encoded in the HEAD | MARKING value.

6.3.4 Visibility

The proposed structures for PP and CP are shown below:

- (24) a.
-
- b.
-

One prediction made by this analysis is that only the highest MARKING value (i.e., the one contributed by P or C) should be relevant for syntactic phenomena that refer to PP or CP. The case and verb form marking values should be inaccessible outside the phrase.

As we saw in Chapter 4 (examples (32) and (47)), an external head that selects PP can appear to determine the case of the preposition's complement. Similar examples can be found with VP marking. In the following constructions, the VFORM value inside a *that*-CP continues to be relevant to the external syntax:

- (25) a. I demand that he leave/*leaves immediately. (Pollard & Sag, 1994, p. 44)
 b. I will see that he *leave/leaves immediately.

There are two ways to deal with these cases. First, as in the nominal examples, we can assume that there are distinct *cform* subtypes for *that* selecting a *base* form VP vs. a *finite* form VP. The other possibility would be to explain the choice semantically, although it would be a challenge to capture the difference in meaning between the two CPs in (25).

6.4 Summary

In this chapter I have proposed an extension of my treatment of prepositions to the analysis of case marking in order to capture the close functional similarity between these two kinds of NP marking. I have also suggested a further extension into the VP domain, to cover the analogous phenomena of complementizer and verb-form marking. All four of these grammatical categories or features can be described in terms of meaningfulness and fixedness, and they exhibit the full spectrum of uses from Type A through Type AB to Type B. Furthermore, the overlapping of forms and functions among these four kinds of grammatical marking motivates a unified analysis.

I have presented a modified version of the MARKING apparatus in HPSG to account for the representation and interaction of marking in nominal and verbal structures. This proposal gives increased prominence to the notion of marking, which is an underdeveloped part of standard HPSG.

The main point of divergence from the standard theory argued for here is the treatment of complementizers as syntactic heads, which is in line with existing analyses of marker prepositions and subordinating conjunctions. This move allows us to streamline the formal apparatus for handling MARKING significantly. For example, we can now propagate MARKING information as a HEAD feature, eliminating the need for a special MARKING Principle. Furthermore, the MARKING attribute combines the functions of the PFORM, CASE, and VFORM attributes of standard HPSG, so that these closely interrelated pieces of information have a uniform representation, and interactions among them can be encoded simply in the type hierarchy under *marking*.

Chapter 7

Conclusions

7.1 Summary of Results

This thesis challenges a number of assumptions about the behavior of prepositions and their formal analysis. To begin with, I called into question the long-standing distinction between lexical and functional uses of prepositions, which has found its way into most current theoretical accounts. Prepositions in fact exhibit a wider range of uses, and the lexical vs. distinction in its simplest form is inadequate both for descriptive and for theoretical purposes.

Instead, I suggested that prepositional uses can be more accurately described using the following two-dimensional spectrum:

(1)

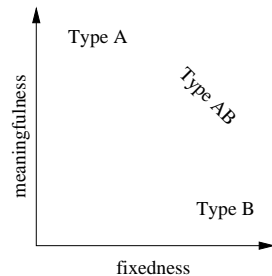

It is evident from this model that a satisfactory account of prepositional behavior cannot focus only on the ideal Type A and Type B cases, but it must also deal appropriately with the many cases that fall in between these two corners of the spectrum.

In my analysis, the descriptive property of meaningfulness was formalized as a distinction between content vs. empty prepositions, while the property of fixedness was formalized by the marker vs. free preposition distinction. These two distinctions interact in the following way to

yield three kinds of prepositional lexical entries:

(2)

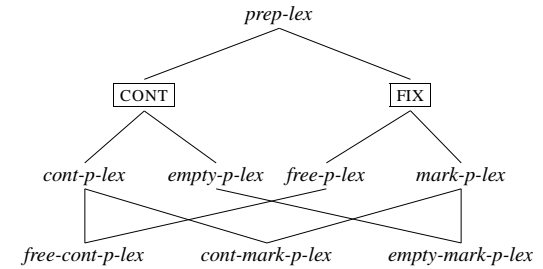

Free content Ps are selected semantically via their KEY relations, while empty marker Ps are selected syntactically via PFORM. These two subtypes correspond broadly to the lexical and functional prepositions found in many earlier theoretical proposals, including standard HPSG. In addition, however, my account allows content marker Ps, which are open to both syntactic and semantic selection. Content marker Ps provide the necessary bridge between the lexical and functional analyses, which would otherwise be divided by an impossibly abrupt transition.

The choice between a content vs. an empty P analysis can be especially difficult, since meaningfulness is a highly intuitive notion that is not readily accessible to empirical evaluation. In much recent work on prepositions, the trend has been to assign semantic content even to prepositions with only weakly perceived meaningfulness, in order to treat preposition selection as a primarily semantic phenomenon. I argued, however, that this over-emphasis on semantic selection forces the adoption of unmotivated and unexplanatory semantic representations, and even then, a syntactic selection mechanism is still needed to prevent overgeneration. The importance of syntactic selection via PFORM should not be underestimated.

Finally, I made some connections between the analysis of prepositions and the analysis of other kinds of grammatical marking: case marking in NPs and complementizer and verb form marking in VPs. The spectrum of uses in (1) is applicable to all four of these phenomena. Moreover, the interactions among these kinds of marking suggest strongly that they should all be handled in a similar way. I adapted the MARKING Theory of HPSG in order to allow a unified analysis.

7.2 Further Questions

The proposals in this thesis were motivated mostly by considering the behavior of English prepositions, with occasional cross-linguistic data. The analysis would certainly benefit from a broader comparative perspective, in particular with respect to the claims about case marking

and VP marking in Chapter 6.

Another useful approach would be to study earlier stages of English (and other languages) since the distribution of prepositions in the spectrum in (1) is primarily the result of past and ongoing grammaticalization processes. A careful examination of the historical development of Type B constructions from earlier Type A constructions would shed light on the proper treatment of intermediate Type AB cases in the current stage of the language.

The proposed analysis depends on two binary distinctions (content vs. empty and marker vs. free) to represent two gradient perceptual properties (meaningfulness and fixedness). The fuzziness of the distinctions is in a sense accommodated by the fact that the boundaries between the free content and the content marker analyses and between the content marker and the empty marker analyses are less abrupt than in the lexical vs. functional case. But true gradience is not built into the representations. Further investigation (e.g., psycholinguistic studies) should be undertaken to determine if we need to find a way to enrich the expressive power of our formal apparatus in this way.

References

- Badia, T. (1996). Prepositions in Catalan. In S. Balari & L. Dini (Eds.), *HPSG in Romance* (pp. 111–150). Stanford, CA: CSLI Publications.
- Bennett, D. C. (1975). *Spatial and temporal uses of English prepositions: An essay in Stratificational Semantics*. London: Longman.
- Blake, B. J. (1994). *Case*. Cambridge: Cambridge University Press.
- Bouma, G., Malouf, R., & Sag, I. (1998). A unified theory of complement, adjunct, and subject extraction. In G. Bouma, G.-J. M. Kruijff, & R. T. Oehrle (Eds.), *Proceedings of the joint conference on Formal Grammar, Head-Driven Phrase Structure Grammar, and Categorical Grammar* (pp. 83–97). Saarbrücken.
- Brugman, C. M. (1988). *The story of over: Polysemy, semantics, and the structure of the lexicon*. New York: Garland.
- Cann, R. (1993). Patterns of headedness. In G. G. Corbett, N. M. Fraser, & S. McGlashan (Eds.), *Heads in grammatical theory* (pp. 44–72). Cambridge: Cambridge University Press.
- Cann, R. (2000). Functional vs. lexical: a cognitive dichotomy. In R. D. Borsley (Ed.), *The nature and function of syntactic categories*. San Diego: Academic Press. (Syntax and Semantics Vol. 32)
- Carvell, H. T., & Svartvik, J. (1969). *Computational experiments in grammatical classification*. The Hague: Mouton.
- Chomsky, N. (1964). *Current issues in linguistic theory*. The Hague: Mouton.
- Chomsky, N. (1965). *Aspects of the theory of syntax*. Cambridge, MA: MIT Press.
- Chomsky, N. (1970). Remarks on nominalization. In R. A. Jacobs & P. S. Rosenbaum (Eds.), *Readings in English Transformational Grammar* (pp. 184–221). Waltham, MA: Ginn.
- Copestake, A., Flickinger, D., & Sag, I. A. (1997). *Minimal Recursion Semantics: An introduction*.
- Corbett, G. G., Fraser, N. M., & McGlashan, S. (Eds.). (1993). *Heads in grammatical theory*. Cambridge: Cambridge University Press.
- Couper-Kuhlen, E. (1979). *The prepositional passive in English: A semantic-syntactic analysis, with a lexicon of prepositional verbs*. Tübingen: Max Niemeyer Verlag.

- Davies, W. D. (1986). *Choctaw verb agreement and Universal Grammar*. Dordrecht: Reidel.
- Davis, A. (1996). *Lexical semantics and linking in the hierarchical lexicon*. Unpublished doctoral dissertation, Stanford University.
- Davison, A. (1980). Peculiar passives. *Language*, 56, 42–66.
- DeArmond, R. C. (1977). On *decide on* and similar constructions in English. *Glossa*, 11(1), 20–47.
- Dench, A. C. (1995). *Martuthunira: A language of the Pilbara region of Western Australia*. Canberra: Pacific Linguistics.
- Dench, A. C., & Evans, N. (1988). Multiple case-marking in Australian languages. *Australian Journal of Linguistics*, 8, 1–47.
- Dixon, R. M. W. (1982). The grammar of English phrasal verbs. *Australian Journal of Linguistics*, 2(1), 1–42.
- Dowty, D. (1979). *Word meaning and Montague Grammar*. Dordrecht: Reidel.
- Emonds, J. E. (1972). Evidence that indirect object movement is a structure-preserving rule. *Foundations of Language*, 8, 546–561.
- Emonds, J. E. (1985). *A unified theory of syntactic categories*. Dordrecht: Foris.
- Fillmore, C. J. (1968). The case for case. In E. Bach & R. T. Harms (Eds.), *Universals in linguistic theory* (pp. 1–88). London: Holt, Rinehart and Company.
- Fries, N. (1991). Prepositions and prepositional phrases: A contrastive analysis. In G. Rauh (Ed.), *Approaches to prepositions* (pp. 53–75). Tübingen: Gunter Narr.
- Gawron, J. M. (1986). Situations and prepositions. *Linguistics and Philosophy*, 9, 327–382.
- Gazdar, G., Klein, E., Pullum, G. K., & Sag, I. A. (1985). *Generalized Phrase Structure Grammar*. Cambridge, MA: Harvard University Press.
- Gerdts, D. B., & Youn, C. (1988). Korean psych constructions: Advancement or retreat? In L. MacLeod, G. Larson, & D. Brentari (Eds.), *CLS 24: Papers from the 24th annual regional meeting of the Chicago Linguistic Society* (pp. 155–175).
- Ginzburg, J., & Sag, I. A. (ms). *English interrogative constructions*. Stanford, CA: CSLI Publications.
- Grimshaw, J. (1991). *Extended projection*.
- Hawkins, B. W. (1985). *The semantics of English spatial prepositions*. Unpublished doctoral dissertation, UCSD. (Distributed by L.A.U.T., Trier.)
- Heinz, W., & Matiasek, J. (1994). Argument structure and case assignment in German. In J. Nerbonne, K. Netter, & C. Pollard (Eds.), *German in Head-Driven Phrase Structure Grammar* (pp. 199–236). Stanford, CA: CSLI Publications.
- Higginbotham, J. (1985). On semantics. *Linguistic Inquiry*, 16, 547–593.

- Hornstein, N., & Weinberg, A. (1981). Case theory and preposition stranding. *Linguistic Inquiry*, 12, 55–91.
- Hudson, R. A. (1987). Zwicky on heads. *Journal of Linguistics*, 23, 109–132.
- Jackendoff, R. (1990). *Semantic structures*. Cambridge, MA: MIT Press.
- Jackendoff, R. S. (1973). Base rules for PPs. In S. R. Anderson & P. Kiparsky (Eds.), *A Festschrift for Morris Halle* (pp. 345–356). New York: Holt, Rinehart, and Winston.
- Jackendoff, R. S. (1977). *X-bar syntax: A study of phrase structure*. Cambridge, MA: MIT Press.
- Jackendoff, R. S. (1983). *Semantics and cognition*. Cambridge, MA: MIT Press.
- Jespersen, O. (1927). *A modern English grammar on historical principles. Part III: Syntax (second volume)*. London: Allen & Unwin.
- Jolly, J. A. (1987). An analysis of selected English prepositions within the framework of Role and Reference Grammar. *Davis Working Papers in Linguistics*(2), 60–114.
- Jolly, J. A. (1993). Preposition assignment in English. In R. D. Van Valin (Ed.), *Advances in Role and Reference Grammar* (pp. 275–310). Amsterdam: John Benjamins.
- Kilby, D. (1981). On case marking. *Lingua*, 54, 101–133.
- Kiss, T., & Meurers, D. (Eds.). (1998). *Current topics in constraint-based theories of Germanic syntax*. Saarbrücken.
- Klima, E. S. (1965). *Studies in diachronic syntax*. Unpublished doctoral dissertation, Harvard University, Cambridge, MA.
- König, E., & Kortmann, B. (1991). On the reanalysis of verbs as prepositions. In G. Rauh (Ed.), *Approaches to prepositions* (pp. 109–125). Tübingen: Gunter Narr.
- Kruisinga, E. (1925). *A handbook of present-day English. Part II: English accident and syntax*, 3 (4th ed.). Utrecht: Kemink en Zoon.
- Lawler, J. M. (1977). A agrees with B in Achenese: A problem for Relational Grammar. In P. Cole & J. M. Sadock (Eds.), *Grammatical relations* (pp. 219–248). New York: Academic Press. (Syntax and Semantics Vol. 8)
- Lehmann, C. (1986). Grammaticalization and linguistic typology. *General Linguistics*, 26, 3–22.
- Maling, J. (1983). Transitive adjectives: A case of categorial reanalysis. In F. Heny & B. Richards (Eds.), *Linguistic categories: Auxiliaries and related puzzles* (Vol. 1, pp. 253–289). Dordrecht: Reidel.
- McCawley, J. D. (1982). Parentheticals and discontinuous constituent structure. *Linguistic Inquiry*, 13, 91–106.
- Mindt, D., & Weber, C. (1989). Prepositions in American and British English. *World Englishes*, 8, 229–238.

- Mitchell, T. F. (1958). Syntagmatic relations in linguistic analysis. *Transactions of the Philological Society*, 101–118.
- Müller, S. (1998). Case in German: an HPSG analysis. In T. Kiss & D. Meurers (Eds.), *Current topics in constraint-based theories of Germanic syntax* (pp. 113–132). Saarbrücken.
- Napoli, D. J. (1989). *Predication theory: A case study for indexing theory*. Cambridge: Cambridge University Press.
- O’Grady, W. (1985). Thematic dependency and semantic interpretation. *Canadian Journal of Linguistics*, 30, 159–177.
- Pollard, C., & Sag, I. A. (1987). *Information-based syntax and semantics, Volume 1: Fundamentals*. Stanford, CA: CSLI Publications.
- Pollard, C., & Sag, I. A. (1994). *Head-Driven Phrase Structure Grammar*. Stanford, CA: CSLI Publications. (Distributed by University of Chicago Press.)
- Poutsma, H. (1904). *A grammar of late modern English. Part I: The Sentence*. Groningen: P. Noordhoff.
- Przepiórkowski, A. (1996). Case assignment in Polish: Towards an HPSG analysis. In C. Grover & E. Vallduví (Eds.), *Edinburgh Working Papers in Cognitive Science, volume 12: Studies in HPSG* (pp. 191–228). Edinburgh: Centre for Cognitive Science.
- Quirk, R., Greenbaum, S., Leech, G., & Svartik, J. (1985). *A comprehensive grammar of the English language*. London: Longman.
- Quirk, R., & Mulholland, J. (1964). Complex prepositions and related sequences. *English Studies, Supplement to Vol. 45*, 64–73.
- Rauh, G. (Ed.). (1991a). *Approaches to prepositions*. Tübingen: Gunter Narr.
- Rauh, G. (1991b). Prepositional forms in the lexicon: problems and suggestions. In G. Rauh (Ed.), *Approaches to prepositions* (pp. 169–223). Tübingen: Gunter Narr.
- Rauh, G. (1993). On the grammar of lexical and non-lexical prepositions in English. In C. Zelinsky-Wibbelt (Ed.), *The semantics of prepositions: From mental processing to natural language processing* (pp. 99–150). Berlin: Mouton de Gruyter.
- Riddle, E., & Sheintuch, G. (1983). A functional analysis of pseudo-passives. *Linguistics and Philosophy*, 6, 527–563.
- Rosch, E. (1978). Principles of categorization. In E. Rosch & B. Lloyd (Eds.), *Cognition and categorization* (pp. 27–46). Hillsdale, NJ: Erlbaum.
- Ross, J. R. (1967). *Constraints on variables in syntax*. Unpublished doctoral dissertation, MIT. (Published as *Infinite Syntax!* Norwood, NJ: ALEX, 1986.)
- Sag, I. A. (1997). English relative clause constructions. *Journal of Linguistics*, 33, 431–484.
- Seiter, W. J. (1983). Subject–Direct Object raising in Niuean. In D. M. Perlmutter (Ed.), *Studies in Relational Grammar 1* (pp. 317–359). Chicago: University of Chicago Press.

- Sells, P. (1995). Korean and Japanese morphology from a lexical perspective. *Linguistic Inquiry*, 26, 277–325.
- Spang-Hanssen, E. (1963). *Les prépositions incolores du français moderne*. Copenhagen: G. E. C. Gads Forlag.
- Stowell, T. (1981). *Origins of phrase structure*. Unpublished doctoral dissertation, MIT.
- Sulkala, H., & Karjalainen, M. (1992). *Finnish*. London: Routledge.
- Sweet, H. (1891). *A new English grammar: Logical and historical. part I*. Oxford: Clarendon.
- Takami, K. ichi. (1992). *Preposition stranding: From syntactic to functional analyses*. Berlin: Mouton de Gruyter.
- Urushibara, S. (1991). *Ey/Eykey*: A postposition or a case marker? In S. Kuno, J. Whitman, Y.-S. Kang, I.-H. Lee, J. Maling, & Y.-J. Kim (Eds.), *Harvard studies in Korean linguistics IV* (pp. 421–432). Cambridge, MA: Department of Linguistics, Harvard University.
- Van Eynde, F. (1998). Functional projections and Dutch complementizers. In T. Kiss & D. Meurers (Eds.), *Current topics in constraint-based theories of Germanic syntax* (pp. 149–164). Saarbrücken.
- van Riemsdijk, H. (1978). *A case study in syntactic markedness: The binding nature of prepositional phrases*. Dordrecht: Foris. (2nd edition of 1982.)
- van Riemsdijk, H. (1990). Functional prepositions. In H. Pinkster & I. Genée (Eds.), *Unity in diversity: Papers presented to Simon C. Dik on his 50th birthday* (pp. 228–241). Dordrecht: Foris.
- van Riemsdijk, H. (1998). Categorical feature magnetism: The endocentricity and distribution of projections. *Journal of Comparative Germanic Linguistics*, 2, 1–48.
- Wechsler, S. (1995). *The semantic basis of argument structure*. Stanford, CA: CSLI Publications.
- Wechsler, S. (1997). Prepositional phrases from the twilight zone. *Nordic Journal of Linguistics*, 20, 127–154.
- Ziv, Y., & Sheintuch, G. (1981). Passives of obliques over direct objects. *Lingua*, 54, 1–17.
- Zribi-Hertz, A. (1984). *Orphan prepositions in French and the concept of 'null pronoun'*. Bloomington: Indiana University Linguistics Club.
- Zwicky, A. M. (1985). Heads. *Journal of Linguistics*, 21, 1–29.
- Zwicky, A. M. (1992). Jottings on adpositions, case inflections, government, and agreement. In D. Brentari, G. N. Larson, & L. A. Macleod (Eds.), *The joy of grammar: A Festschrift in honor of James D. McCawley* (pp. 369–383). Amsterdam: John Benjamins.
- Zwicky, A. M. (1993). Heads, bases and functors. In G. G. Corbett, N. M. Fraser, & S. McGlashan (Eds.), *Heads in grammatical theory* (pp. 292–315). Cambridge: Cambridge University Press.