



**HAL**  
open science

# Tangential families and minimax solutions of Hamilton-Jacobi equations

Gianmarco Capitanio

► **To cite this version:**

Gianmarco Capitanio. Tangential families and minimax solutions of Hamilton-Jacobi equations. Mathematics [math]. Université Paris-Diderot - Paris VII, 2004. English. NNT: . tel-00008669

**HAL Id: tel-00008669**

**<https://theses.hal.science/tel-00008669v1>**

Submitted on 3 Mar 2005

**HAL** is a multi-disciplinary open access archive for the deposit and dissemination of scientific research documents, whether they are published or not. The documents may come from teaching and research institutions in France or abroad, or from public or private research centers.

L'archive ouverte pluridisciplinaire **HAL**, est destinée au dépôt et à la diffusion de documents scientifiques de niveau recherche, publiés ou non, émanant des établissements d'enseignement et de recherche français ou étrangers, des laboratoires publics ou privés.

**UNIVERSITÉ PARIS VII – DENIS DIDEROT**

**UFR de Mathématiques**

**THÈSE DE DOCTORAT**

pour l'obtention du Diplôme de  
**DOCTEUR DE L'UNIVERSITÉ PARIS VII**  
Spécialité : Mathématiques

Présentée et soutenue publiquement par :

**GIANMARCO CAPITANIO**

---

**Familles tangentielles et solutions de minimax  
pour l'équation de Hamilton–Jacobi**

---

soutenue le 25 Juin 2004 devant le jury composé de

Vladimir ARNOLD	Directeur
Marc CHAPERON	
Victor GORYUNOV	Rapporteur
Harold ROSENBERG	
Jean-Claude SIKORAV	Rapporteur
Claude VITERBO	



# Remerciements

Je voudrais tout d'abord exprimer ma profonde gratitude à mon maître Vladimir Arnold, pour m'avoir transmis son amour pour la Mathématique et pour m'avoir appris la Mathématique que j'aime.

Je remercie Marc Chaperon pour avoir été mon directeur pendant une année, pour m'avoir posé le problème dont la réponse est (je l'espère) le Chapitre 4 de la Thèse. C'est pour moi un grand plaisir qu'il soit membre du jury.

Je suis reconnaissant à Victor Goryunov et Jean-Claude Sikorav pour avoir accepté de rapporter ma Thèse et d'être membres du jury. Je remercie également Harold Rosenberg et Claude Viterbo pour avoir accepté d'être membres du jury.

Je remercie très chaleureusement Franco Cardin, qui a été mon Professeur à Padoue, pour m'avoir introduit à la Géométrie avec son cours de Topologie, pour m'avoir conseillé un certain livre de Mécanique, et pour m'avoir toujours encouragé.

Je remercie tous ceux qui m'ont aidé pendant la préparation de cette Thèse: F. Aicardi, Yu. Chekanov, E. Ferrand, M. Garay, R. Uribe et les autres membres de notre séminaire.

Je voudrais remercier le personnel de l'Université Paris VII, notamment Michèle Wasse et Claudine Roussel pour leur aide et leur patience.

Je remercie tous mes amis qui m'ont soutenu et supporté pendant ces années, en particulier Ana, Gianmarco, Hyacinth, Emanuela, Malek, Miriam, Ronald et Zoé. Grazie, gracias, choukran et merci!

Ringrazio di tutto cuore la mia famiglia, mamma, papà e Gabriele, per la fiducia che hanno sempre avuto in me, per essermi sempre stati vicini per incoraggiarmi e sostenermi, e per avermi dato i mezzi per realizzare le mie scelte.

Et naturellement je remercie ma Mannou pour... tout!



# Résumé

Cette Thèse porte sur les familles tangentielles et les équations de Hamilton–Jacobi. Ces deux sujets sont reliés à des thèmes classiques en théorie des singularités, comme la théorie des enveloppes, les singularités des fronts d’onde et des caustiques, la géométrie symplectique et de contact. Les premiers trois chapitres de la Thèse sont consacrés à l’étude des familles tangentielles, à la classification de leurs singularités stables et simples, et à leur interprétation dans le cadre de la Géométrie de Contact. Le dernier chapitre est dédié à l’étude des solutions de minimax pour l’équation de Hamilton–Jacobi, notamment à la classification de leurs singularités génériques de petite codimension.

PREMIER CHAPITRE. Dans ce chapitre on introduit la définition de famille tangentielle: il s’agit d’un système de rayons émanés tangentiellement par une source curviligne (appelée support). Cette classe de familles de courbes planes apparaît dans plusieurs domaines des mathématiques, comme par exemple la géométrie différentielle, la théorie des singularités des caustiques et des fronts d’onde, et l’optique géométrique. Par exemple, les géodésiques tangentes à une courbe dans une surface riemannienne forment une famille tangentielle (géodésique). Toutefois, la définition de famille tangentielle a été donnée explicitement pour la première fois dans cette Thèse.

Dans l’esprit du modèle physique qui a inspiré la définition de famille tangentielle, il est naturel de déformer les familles tangentielles parmi les familles tangentielles: ces déformations sont appelées *tangentielles*. Une telle déformation survient, par exemple, lorsqu’on considère les familles des géodésiques tangentes à une courbe et on perturbe la métrique. Dans ce chapitre on étudie les singularités stables de germes de familles tangentielles (par rapport à la L–R équivalence). Le résultat principal est le suivant.

THÉORÈME. *Il existe exactement deux singularités de germes de familles tangentielles, stables par petites déformations tangentielles, notée I, II et représentées par les germes  $(\xi + t, t^2)$  et  $(\xi + t, \xi t^2)$ , la courbe support étant  $y = 0$ ; les enveloppes correspondantes sont lisses ou bien ont une auto-tangence d’ordre 2.*

Ce résultat a des applications en géométrie riemannienne. Par exemple, on en déduit que les auto-tangences d’ordre 2 des enveloppes des (germes de) familles tangentielles géodésiques sont génériquement stables par petites déformation de la métrique. Ce résultat élémentaire est, à ma connaissance, nouveau.

On étudie aussi des exemples de familles tangentielles globales, les familles des grands cercles sur la sphère, tangents à un méridien générique. Cet exemple porte à généraliser aux enveloppes les énoncés et les conjectures du “dernier Théorème géométrique de Jacobi”,

concernant le nombre de cusps dans les caustiques associées à un point donné sur une surface riemannienne. Notamment, lorsque l'on remplace un point de la surface par une petite courbe fermée, la notion de caustique (d'ordre  $n$ ) de ce point est remplacée par celle d'enveloppe (d'ordre  $n$ ) des géodésiques tangentes à la courbe. Les énoncés et les conjectures sur le nombre de cusps des caustiques sont remplacés par des énoncés et des conjectures sur le nombre de cusps des enveloppes. Cet exemple montre les liens entre les familles tangentielles, le “dernier énoncé géométrique de Jacobi”, les singularités des caustiques et des fronts d'onde, le collapse lagrangien et la généralisation de Tabachnikov de la théorie de Sturm classique.

DEUXIÈME CHAPITRE. Le deuxième chapitre de la Thèse est dédié à la classification des singularités simples des familles tangentielles (i.e., dont la modalité est zéro). Nous démontrons que les singularités simples (non stables) de germes de familles tangentielles forment deux séries infinies et quatre singularités sporadiques, dont nous donnons les formes normales et les enveloppes correspondantes. En suite, on étudie les déformations tangentielles miniverselles des ces germes, ce qui conduit à étudier les diagrammes de bifurcation et les perestroikas de petite codimension des enveloppes correspondantes. Parmi les perestroikas décrites ici, certaines n'avaient jamais été étudiées avant ce travail.

Les résultats de ce chapitre sont reliés et parfois généralisent des théories très remarquables, comme par exemple la théorie des projections des surfaces de l'espace dans le plan, la théorie des fonctions sur une variété ayant un bord, la théorie des applications du plan dans le plan.

TROISIÈME CHAPITRE. Dans le troisième chapitre nous construisons la version de contact de la théorie des enveloppes. A toute famille tangentielle on peut associer une surface dans le fibré cotangent projectivisé, appelée le *graphe Legendrien* de la famille tangentielle.

THÉORÈME. *Les graphes Legendriens des germes de familles tangentielles ayant une singularité I ou II sont respectivement lisses ou ont génériquement une singularité de type “double parapluie de Whitney” (c'est-à-dire  $A_1^\pm$ ).*

Les autres singularités des graphes legendriens des germes de familles tangentielles ayant une singularité II sont aussi étudiées: on retrouve ici deux séries de singularités,  $A_n^\pm$  and  $H_n$ , qui apparaissent déjà dans la Théorie de Mond des applications du plan dans l'espace.

Ensuite, nous étudions la stabilité des graphes legendriens sous déformations induites par déformations tangentielles des familles correspondantes.

THÉORÈME. *Les doubles parapluies de Whitney sont des singularités des graphes Legendriens stables par petites déformations tangentielles des familles qui les engendrent.*

Dans la théorie de Mond déjà citée, les doubles parapluies de Whitney ne sont pas stables. Ces résultats sont aussi reliés à la théorie des fonctions sur les variétés avec un bord.

On étudie aussi les projections des graphes Legendriens dans le plan. Pour cette étude, on considère une relation d'équivalence sur l'ensemble des graphes Legendriens, préservant la structure fibrée de leur espace ambiant. Les formes normales des projections des graphes legendriens avec un “double parapluie de Whitney” sont données. Ce résultat généralise certains théorèmes de la théorie des projections de surfaces de O. A. Platonova, O. P. Shcherbak

et V. V. Goryunov. De plus, les perestroikas des graphes Legendriens sous déformations *non* tangentielles, appelées *bec à bec legendrien*, sont nouvelles.

Les résultats de ce chapitre ouvrent la voie à plusieurs généralisations, qui pourront conduire à des applications de la théorie développée à l'étude des équations aux dérivées partielles.

QUATRIÈME CHAPITRE. Le dernier chapitre porte sur l'étude des solutions de minimax des équations de Hamilton–Jacobi. Ces équations aux dérivées partielles apparaissent en plusieurs domaines des mathématiques et de la physique, notamment les Systèmes Dynamiques, le Calcul des Variations, la Théorie du Contrôle, les Jeux Différentiels, la Mécanique du Continu, l'Economie Mathématique et l'Optique.

Les solutions de minimax sont des solutions faibles de problèmes de Cauchy pour les équations de Hamilton–Jacobi, construites à partir des familles génératrices (quadratiques à l'infini) des solutions géométriques de ces problèmes. Le cadre ici est la Géométrie Symplectique. Ces solutions ont été introduites par Marc Chaperon (suivant une idée de J.C. Sikorav), et ont été étudiées, parmi d'autres auteurs, par Claude Viterbo.

On donne une nouvelle construction de la solution de minimax en termes de la Théorie de Morse, ce qui en permet une meilleure compréhension. Avec ce point de départ, on démontre la stabilité du minimax d'une fonction par petites déformation. Ce résultat (nouveau) fournit une démonstration géométrique très simple de la continuité du minimax.

En suite, nous présentons une caractérisation géométrique de la solution de minimax, qui permet de la déterminer aisément à partir de la solution multivoque du problème de Cauchy. Ce résultat est basé sur un Théorème très profond de Chekanov and Pushkar sur les décompositions admissibles des fronts d'onde et sur les invariants des nœuds legendriens.

Comme application de ces résultats, on classifie les singularités génériques de la solution de minimax.

THÉORÈME. *Les singularités de codimension au plus 2 de la solution de minimax sont les mêmes que celles de la solution de viscosité.*

Ce résultat, bien connu dans le cas de Hamiltoniens convexes ou concaves, reste vrai même dans le cas générale, lorsque les solutions de minimax et celles de viscosité sont différentes. Ce résultat peut conduire à des exemples dans lesquels la solution de minimax a une signification physique.

Les résultats de ce chapitre ont été publiés dans les articles suivants: *Generic singularities of minimax solutions to Hamilton–Jacobi equations*, à paraître dans *Journal of Geometry and Physics*, et *Caractérisation géométrique des solutions de minimax pour l'équation de Hamilton–Jacobi*, *Enseignement Mathématique* (2), 49 (2003), no 1–2, 3–34.





# Abstract

This Thesis is based on two different subjects, tangential families and minimax solutions to Hamilton–Jacobi equations, which are related to several classical themes in Singularity Theory, as for instance Envelope Theory, Singularities of Caustics and Wave Fronts, Symplectic and Contact Geometry. The first three chapters are devoted to the study of tangential families and to the classification of their stable and simple singularities, and to their interpretation in the frame of Contact Geometry. The last chapter is devoted to the study of minimax solutions to Hamilton–Jacobi equations and the classification of their generic singularities of small codimension.

CHAPTER 1. In this chapter we introduce the definition of tangential family: it is a system of rays emanating tangentially from a curve (called support). This class of families of plane curves arises in many mathematical branches, as for instance Differential Geometry, Singularity Theory of Caustics and Wave Fronts and Geometric Optics. For example, the tangent geodesics of a curve in a Riemannian surface form a (geodesic) tangential family. However, the definition of tangential family is explicitly given for the first time in this Thesis.

Following the physical model inspiring the theory, it is natural to deform a tangential family within the set of tangential families: such a deformation is called tangential. Tangential deformations arise for instance when one consider a geodesic tangential family in a Riemannian surface and one perturb the metric.

In this chapter we classify, up to L-R equivalence, the stable tangential family singularities (under small tangential deformations). Our main result is the following.

*THEOREM. There exists exactly two stable tangential family singularities (under small tangential deformations), denoted by I, II and represented by the map germs  $(\xi + t, t^2)$  and  $(\xi + t, \xi t^2)$ , the support being  $y = 0$ ; the corresponding envelopes are smooth and have an order 2 self-tangency.*

This result has several applications in Differential Geometry. For example, we deduce that order 2 self-tangencies of envelopes of geodesic tangential families are generically stable under small deformations of the metric. This elementary result is, to my knowledge, new.

We also study an example of global geodesic tangential family, namely the family of great circles tangent to a generic meridian. This example allows to generalize to envelopes the statements and conjectures of the “Last Geometrical Theorem of Jacobi”, concerning the number of cusps in the caustics associated to a given point in a Riemannian surface. The statements and conjectures describing the caustics are replaced by similar statements concerning the envelopes of the geodesics tangent to the curve. This example shows the link

between tangential families, the Last Geometrical Theorem of Jacobi, the Singularities of Caustics and Wave Fronts, the Legendrian collapse and the Tabachnikov's generalization of Sturm Theory.

CHAPTER 2. Chapter 2 is devoted to the classification of simple singularities of tangential family germs (i.e., singularities with no moduli). We prove that the simple singularities form two infinite series and four sporadic singularities. We give their normal forms and their corresponding envelopes.

Next, we give miniversal tangential deformations of these normal forms; this allows us to describe the bifurcation diagrams of small codimension envelope perestroikas. Among the resulting bifurcation diagram, some do not appear earlier in Projection Theory. The results of this chapter are related to many remarkable theories, as the Theory of Projections of Surfaces in the Plane, the Theory of Projection of Complete Intersections, the Theory of Functions on Manifold with Boundary and Theory of Mappings from  $\mathbb{R}^3$  to  $\mathbb{R}^2$ .

CHAPTER 3. In this Chapter we construct the Legendrian version of Envelope Theory. To any tangential family one can associate a surface in the projectivized cotangent bundle, called the *Legendrian graph* of the family.

THEOREM. *The singularities of Legendrian graphs of tangential family germs, having a singularity I or II, are smooth or have a "Double Whitney Umbrella" (i.e. a singularity  $A_1^\pm$ ).*

We also study non typical singularities of legendrian graphs generated by tangential family germs having a singularity II: we find two infinite series of singularities, namely  $A_n^\pm$  and  $H_n$ , arising in the general Mond's Theory of mapping from  $\mathbb{R}^2$  to  $\mathbb{R}^3$ . Tangential deformations of tangential families induce deformations on their Legendrian graphs.

THEOREM. *The Double Whitney Umbrellas are stable singularities of Legendrian graphs under small tangential deformations of the generating tangential families.*

In Mond's Theory, the Double Whitney Umbrellas are not stable. These results are related with the Theory of Functions on a manifold with boundary.

Next, we study how Legendrian graphs project into their apparent contour. For this, we consider an equivalence relation preserving the fibered structure of the projectivized cotangent bundle. We give normal forms of typical Legendrian graph projection up to this equivalence relation. Our result generalize some theorems in the Theories of Projections of O. A. Platonova, O. P. Shcherbak and V. V. Goryunov. Furthermore, the Legendrian graph perestroika under non tangential deformations of the generating family, called *Legendrian bec à bec*, is new. Some results of this Chapter may lead to several generalizations and applications in the study of PDE.

CHAPTER 4. The last Chapter deals with minimax solutions to Hamilton–Jacobi equations. These PDE's appear in many branches of Mathematics and Physics, as for instance Dynamical System, Variational Calculus, Control Theory, Differential Games, Continuum Mechanics, Geometric Optics and Economy. Minimax solutions are weak solutions of Cauchy problems for Hamilton–Jacobi equations, constructed from generating families (quadratic at infinity)

of geometric solutions of these problems. The setting here is Symplectic Geometry. Minimax solutions have been introduced by Marc Chaperon (following an idea of Jean-Claude Sikorav), and they have been studied by Claude Viterbo, among other authors.

We give a new construction of the minimax solution in terms of Morse Theory, leading to a good understanding of these solutions. With such a starting point, we prove the stability of the minimax of a function under small deformation of the function. This (new) result leads to a geometric natural proof of the continuity of minimax solutions.

Next, we present a geometric characterization of minimax solutions, which allow to find easily the minimax solution from the graph of the multivalued solution to the Cauchy Problem. This result is based on a deep theorem of Chekanov and Pushkar about wave fronts admissible decompositions and invariants of Legendrian knots.

As an application of our results, we classify small codimension generic singularities of minimax solutions.

**THEOREM.** *The singularities of minimax and viscosity solutions of codimension  $t$  most 2 coincide.*

This result, well known in the case of convex or concave Hamiltonians, holds also in the general case, as for instance when minimax and viscosity solutions are different. This result may lead to examples in which minimax solution has physical meaning.

The results of this Chapter has been published in the following papers: *Generic singularities of minimax solutions to Hamilton–Jacobi equations*, to appear in Journal of Geometry and Physics and *Caractérisation géométrique des solutions de minimax pour l'équation de Hamilton–Jacobi*, Enseignement Mathématique (2), 49 (2003), no 1–2, 3–34.



# Contents

<b>1</b>	<b>Stable tangential families and their envelopes</b>	<b>1</b>
1.1	Introduction . . . . .	1
1.2	Presentation of the results . . . . .	3
1.2.1	Tangential families and their envelopes . . . . .	3
1.2.2	Equivalences of tangential families . . . . .	4
1.2.3	Tangential family germs of small codimension . . . . .	7
1.2.4	Tangential deformations and envelope stability . . . . .	9
1.3	Examples and applications . . . . .	11
1.3.1	Projective tangential families . . . . .	11
1.3.2	Geodesic tangential families . . . . .	12
1.3.3	A global geodesic tangential family on the sphere . . . . .	13
1.4	Proof of Theorems 1.2.1, 1.2.2 and 1.2.3 . . . . .	15
1.4.1	Prenormal forms of tangential families . . . . .	15
1.4.2	Preliminary results of Singularity Theory . . . . .	17
1.4.3	Proof of Theorem 1.2.1, 1.2.1 and 1.2.3 . . . . .	18
<b>2</b>	<b>Simple tangential families and perestroikas of their envelopes</b>	<b>23</b>
2.1	Introduction . . . . .	23
2.2	Simple singularities of tangential families . . . . .	24
2.2.1	Preliminary results on tangential families . . . . .	24
2.2.2	Classification of tangential families . . . . .	26
2.2.3	Simple tangential families . . . . .	27
2.2.4	Miniversal tangential deformations . . . . .	29
2.2.5	Adjacencies of tangential family singularities . . . . .	30
2.3	Bifurcation diagrams of simple singularities . . . . .	31
2.3.1	Bifurcation diagrams of singularities $S_{1,n}$ . . . . .	31
2.3.2	Bifurcation diagram of the singularity $S_{2,2}$ . . . . .	33
2.3.3	Bifurcations diagrams of the singularities $T_n$ . . . . .	34
2.4	Proofs . . . . .	36
2.4.1	Prenormal forms of tangential families . . . . .	36
2.4.2	Preliminary background of Singularity Theory . . . . .	38
2.4.3	$S_1$ -type tangential families . . . . .	40
2.4.4	$S_2$ -type tangential families . . . . .	49
2.4.5	$T$ -type tangential families . . . . .	55
2.4.6	Proof of Theorem 2.2.3 . . . . .	58

<b>3</b>	<b>Singularities of Legendrian graphs and singular tangential families</b>	<b>63</b>
3.1	Introduction . . . . .	63
3.2	Presentation of the results . . . . .	64
3.2.1	Envelopes of tangential families . . . . .	64
3.2.2	Legendrian graphs and their singularities . . . . .	66
3.2.3	Stability of singularities of Legendrian graphs . . . . .	68
3.2.4	Normal forms of Legendrian graph projections . . . . .	69
3.2.5	Singular tangential families and their envelopes . . . . .	71
3.3	Proofs . . . . .	74
3.3.1	Parameterizations of Legendrian graphs . . . . .	74
3.3.2	Proof of Theorem 3.2.2 . . . . .	76
3.3.3	Preliminary background of Singularity Theory . . . . .	78
3.3.4	Proof of Theorem 3.2.4 . . . . .	79
3.3.5	Proof of Proposition 3.3.8 . . . . .	81
3.3.6	Proof of Theorems 3.2.5, 3.2.6 and 3.2.7 . . . . .	85
	<b>References</b>	<b>86</b>
<b>4</b>	<b>Minimax solutions to Hamilton-Jacobi equations</b>	<b>91</b>
4.1	Introduction . . . . .	91
4.2	Minimax values of functions . . . . .	93
4.2.1	Preliminary results . . . . .	93
4.2.2	Morse complex of generic functions . . . . .	95
4.2.3	Incident, coupled and free critical points . . . . .	97
4.2.4	Minimax critical values . . . . .	99
4.3	Minimax solutions to Hamilton–Jacobi equations . . . . .	102
4.3.1	Generating families of Lagrangian submanifolds . . . . .	102
4.3.2	Geometric solutions . . . . .	104
4.3.3	Minimax solutions . . . . .	107
4.4	Characterization of minimax solutions . . . . .	109
4.4.1	Preliminary notations . . . . .	109
4.4.2	Admissible decompositions of wave fronts . . . . .	110
4.4.3	Characterization of the minimax solution . . . . .	112
4.4.4	Vanishing triangles . . . . .	115
4.5	Generic singularities of minimax solutions . . . . .	118
	<b>References</b>	<b>121</b>

# Chapter 1

## Stable tangential families and their envelopes

ABSTRACT. We study tangential families, i.e. 1-parameter families of rays emanating tangentially from given curves. We classify, up to the Left-Right equivalence, the stable singularities of tangential family germs under tangential deformations, i.e., deformations of the germs among tangential family germs. We prove that there are exactly two stable singularities of tangential family germs and we prove that the corresponding envelopes are smooth or have a second order self-tangency. We give examples where these families and deformations naturally arise, proving for instance that the second order self-tangency of the envelope of any geodesic tangential family germ defined by a curve in a Riemannian surface is stable under small deformations of the metric.

### 1.1 Introduction

Envelope Theory is a classical subject in Geometry, deeply related to the Theories of Caustics and Wave Fronts, that naturally arises in Geometric Optics and Singularity Theory.

The (geometric) envelope of a family of plane curves is a new curve, tangent at each point to a curve of the family. For example, the envelope of all the normal lines to a non-circular ellipse is a closed curve, affine equivalent to the astroid. This curve is the locus determined by the semicubic cusps of the ellipse equidistant fronts (see figure 1.1).

Envelope Theory has a long history, which beginning may be considered Huygens' investigation of caustics of rays of light, in the second half of the XVII Century. However, it is only with René Thom's paper [28], published in 1963, that Envelope Theory has been cleared up by Singularity Theory. Thom showed, in particular, that the only generic singularities of envelopes of 1-parameter families of plane curves are semicubic cusps and transversal self-intersections. The normal forms of generic families of plane curves have been found by V.I. Arnold. He proved that a generic family can be reduced, near a regular point of its envelope, to one of three normal forms (listed in section 1.2.2 below). These normal forms are discussed in [4], Ch. I, §3. Some of them first appeared in [2]; see also [3].

In this chapter we study a special class of families of curves, that we call tangential families. This case is not covered by Thom's nor Arnold's theories. A family of tangent curves to a given curve (the support of the family) is a tangential family if it can be parametrized by



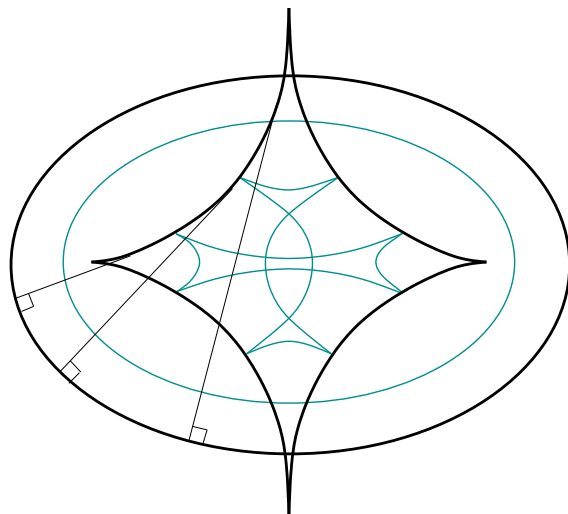

Figure 1.1: Envelope of the normal lines to an ellipse.

the tangency point of its curves with the support, as for instance a system of rays emanating tangentially from a support curve. For a first investigation of envelopes of tangential families (in the case of singular support) see [15] and [16].

Tangential families naturally arise in Geometry of Caustics (see [10]) and in Differential Geometry. For example, any curve in the Euclidean plane or in a Riemannian surface defines the tangential family of its tangent lines or tangent geodesics. In these two examples a perturbation of the Euclidean or Riemannian structure induces a deformation of the family such that the deformed families are tangential. More generally, we call tangential deformation of a tangential family every deformation of it among tangential families.

The aim of this chapter is to classify the tangential family germs which are stable under small tangential deformations.

This chapter is divided into three parts. In the first part we present our results. Namely, we prove that there are exactly two stable singularities of tangential family germs; the equivalence relation we consider here is the usual Left–Right equivalence. The envelopes of stable tangential family germs are smooth or have a second order self-tangency (see figure 1.2).

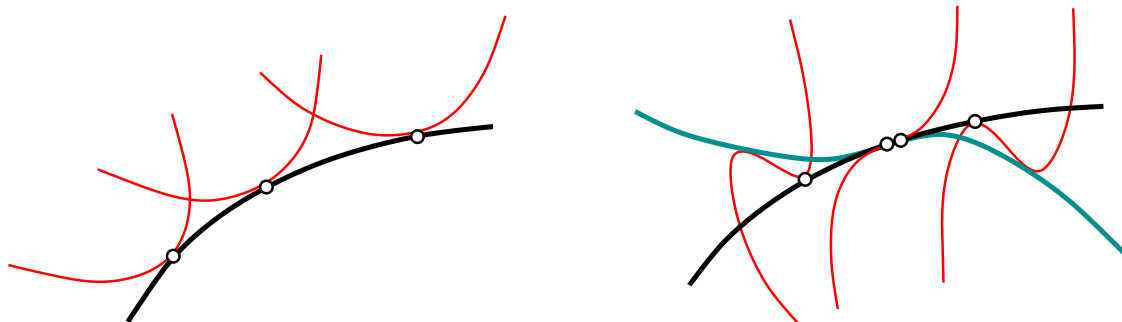

Figure 1.2: Two non equivalent tangential family germs.

The second part is devoted to some applications of this theory. We generalize the basic example of the lines tangent to a curve replacing the usual lines with the “straight” lines defined by a local projective or Riemannian structure. As a consequence of our classification, we prove that the second order self-tangencies of envelopes of projective or geodesic tangential family germs are stable under small perturbations of the structure. Moreover, we discuss an example of a global geodesic tangential family on the two-sphere, namely the family of the great circles tangent to a generic sphere parallel. This example shows that the theory of tangential families is related to the Last Geometrical Theorem of Jacobi and its generalizations, including singularities of caustics, Lagrange collapses and Tabachnikov’s generalizations of the classical Sturm Theory (cf. [7], [9]).

In the last part we prove the results announced in the first part, using standard techniques of Singularity Theory of smooth maps, as for instance the Preparation Theorem of Mather, Malgrange, Weierstrass and the Finite Determinacy Theorem.

## 1.2 Presentation of the results

Unless otherwise specified, all the objects considered below are supposed smooth, that is of class  $\mathcal{C}^\infty$ ; by curve we mean a dimension 1 embedded submanifold of  $\mathbb{R}^2$ .

### 1.2.1 Tangential families and their envelopes

Let us consider a mapping  $f : \mathbb{R}^2 \rightarrow \mathbb{R}^2$  of the plane  $\mathbb{R}^2$ , whose coordinates are denoted by  $\xi$  and  $t$ . If  $\partial_t f$  vanishes nowhere, then  $f$  defines the 1-parameter family of the plane curves parameterized by  $f_\xi := f(\xi, \cdot)$  and indexed by  $\xi$  (indicating the curve in the family). The curves in the family may have double points. The mapping  $f$  is called a *parameterization* of the family.

DEFINITION. The 1-parameter family parameterized by  $f$  is a *tangential family* if the partial derivatives  $\partial_\xi f$  and  $\partial_t f$  are parallel non zero vectors at every point  $(\xi, t = 0)$ , and the image of the mapping  $\xi \mapsto f(\xi, 0)$  is a curve, called the *support* of the family.

In other terms, a family of plane curves, tangent to  $\gamma$ , is a tangential family whenever it can be parameterized by the tangency points of the family curves with the family support.

DEFINITION. The *graph* of the tangential family parameterized by  $f$  is the surface

$$\Phi := \{(q, p) : q = f(\xi, 0), p = f(\xi, t), \xi, t \in \mathbb{R}\} \subset \gamma \times \mathbb{R}^2 .$$

Let us consider the two natural projections of the family graph on the support and on the plane, respectively  $\pi_1 : (q, p) \mapsto q$  and  $\pi_2 : (q, p) \mapsto p$ .

REMARK. The first projection  $\pi_1$  is a fibration; the images by  $\pi_2$  of its fibers are the curves of the family.

DEFINITION. The *criminant set* (or *envelope in the source* in Thom’s notations) of a tangential family is the critical set of the projection  $\pi_2$  of its graph to the plane. The *envelope* of the family is the apparent contour of its graph in the plane (i.e., the critical value set of  $\pi_2$ ).

REMARK. The envelope of a tangential family is the critical value set of any of its parameterizations. In particular, the support of a tangential family belongs to its envelope.

Let us end this section with some examples.

EXAMPLE 1.2.1. The family of the tangent lines to the parabola  $y = x^2$  is parameterized by

$$f(\xi, t) := (\xi + t, \xi^2 + 2\xi t) .$$

The discriminant set is  $\{t = 0\}$ , so the envelope of the tangent lines coincides with the support parabola.

EXAMPLE 1.2.2. Let us consider in the plane  $\{x, y\}$  the tangential family of support  $y = 0$ , defined by the graphs  $y = P_\xi(x)$  of the polynomials

$$P_\xi(x) := (x - \xi)^2(x - 2\xi) ,$$

shown in figure 1.3. Its envelope is the union of the  $x$ -axis and the curve  $x^3 + 27y = 0$ .

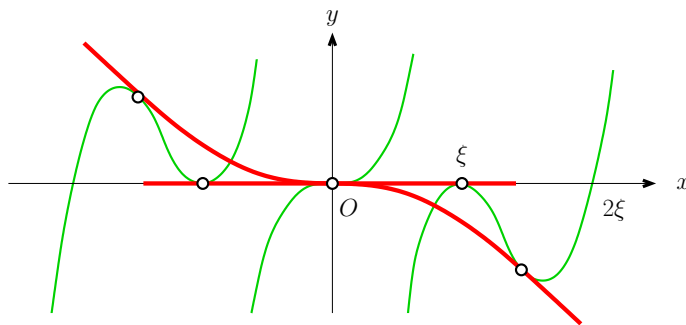

Figure 1.3: The tangential family of Example 1.2.2.

Given a family of plane curves, a branch of its envelope is said to be *geometric* near a fixed point if the family is tangential at this point, taking this branch as support. The envelopes of the tangential families considered in the preceding examples are all geometric.

EXAMPLE 1.2.3. The envelope of the tangent lines of the cubic parabola  $y = x^3$  is

$$\{y = x^3\} \cup \{y = 0\} .$$

The line  $\{y = 0\}$  belongs to the family and no other line in the family is tangent to it. Hence, this branch of the envelope is not geometric.

## 1.2.2 Equivalences of tangential families

Our study of tangential families being local, without loss of generality, we can consider their parameterizations as map germs  $(\mathbb{R}^2, 0) \rightarrow (\mathbb{R}^2, 0)$ , that is, as elements of  $(\mathfrak{m}_2)^2$ , where  $\mathfrak{m}_2$  is the space of function germs in two variables vanishing at the origin.

REMARK. The graph of any tangential family germ is smooth.

DEFINITION. We will denote by  $X_0$  the subset of  $(\mathfrak{m}_2)^2$  formed by all the map germs parameterizing locally a tangential family:  $f \in (\mathfrak{m}_2)^2$  belongs to  $X_0$  if and only if  $\partial_\xi \bar{f}(\xi, 0)$  and  $\partial_t \bar{f}(\xi, 0)$  are parallel non zero vectors for every map  $\bar{f} : \mathbb{R}^2 \rightarrow \mathbb{R}^2$  which germ at  $(0, 0)$  is  $f$ , provided that  $\xi$  is small enough.

In this definition, the two parameters  $\xi$  and  $t$  play different roles:  $\xi$  is the parameter on the base of the family and  $t$  is the parameter on each fiber of the family. However, to study envelopes of tangential families we do not need to distinguish the parameters. In this case we will use the notation  $(s, t)$  instead of  $(\xi, t)$  for the parameters, keeping the letter  $\xi$  for the variable on the support.

Let us denote by  $\text{Diff}(\mathbb{R}^2, 0)$  the group of the diffeomorphism germs of the plane keeping fixed the origin, and by  $\mathcal{A}$  the direct product  $\text{Diff}(\mathbb{R}^2, 0) \times \text{Diff}(\mathbb{R}^2, 0)$ . Consider the subgroup  $\mathcal{A}_\xi$  of  $\mathcal{A}$ , formed by the diffeomorphism germs  $(\varphi, \psi) \in \mathcal{A}$  such that  $\varphi$  is fibered with respect to the first variable, that is of the form

$$(\xi, t) \mapsto (\Xi(\xi), T(\xi, t)) .$$

Then the groups  $\mathcal{A}_\xi$  and  $\mathcal{A}$  act on  $(\mathfrak{m}_2)^2$  by the rule

$$(\varphi, \psi) \cdot f := \psi \circ f \circ \varphi^{-1}$$

(this means changing the coordinate systems in the source and in the target of the map germ).

DEFINITION. Two map germs  $f, g \in (\mathfrak{m}_2)^2$  are *Left-Right equivalent*, or  *$\mathcal{A}$ -equivalent*, if they belong to the same  $\mathcal{A}$ -orbit, that is, if there exists a commutative diagram

$$\begin{array}{ccc} (\mathbb{R}^2, 0) & \xrightarrow{f} & (\mathbb{R}^2, 0) \\ \downarrow & & \downarrow \\ (\mathbb{R}^2, 0) & \xrightarrow{g} & (\mathbb{R}^2, 0) \end{array}$$

in which the vertical arrows are diffeomorphism germs. Similarly,  $f$  and  $g$  are *fibered Left-Right equivalent*, or  *$\mathcal{A}_\xi$ -equivalent*, if they belong to the same  $\mathcal{A}_\xi$ -orbit.

DEFINITION. The *singularity* of a tangential family  $f \in X_0$  is its  $\mathcal{A}$ -equivalence class.

REMARK. The set  $X_0$  is  $\mathcal{A}_\xi$ -invariant being not  $\mathcal{A}$ -invariant:

$$\mathcal{A}_\xi \cdot X_0 = X_0 , \quad \mathcal{A} \cdot X_0 \neq X_0 .$$

Indeed, for every  $f \in X_0$ , the orbit  $\mathcal{A} \cdot f$  contains map germs not defining tangential families:  $\mathcal{A} \cdot f \not\subset X_0$ .

EXAMPLE 1.2.4. The map germ parameterizing the family of the tangent lines of a parabola, considered in Example 1.2.1, is  $\mathcal{A}$ -equivalent to the map germ  $(\xi, t) \mapsto (\xi, t^2)$ . This germ is not a parameterization of a tangential family.

If two tangential family germs are  $\mathcal{A}_\xi$ -equivalent, then there exists a diffeomorphism of the plane sending the curves of the first family into those of the second family. This does not hold in general if the two families are  $\mathcal{A}$ -equivalent, being not  $\mathcal{A}_\xi$ -equivalent. This is the reason why in order to classify tangential family germs it is natural to consider the  $\mathcal{A}_\xi$ -equivalence instead of  $\mathcal{A}$ -equivalence.

REMARK. V.I. Arnold showed (see [2], [3] and [4]) that every generic 1-parameter family of (possibly singular) plane curves, near a regular point of its envelope, is  $\mathcal{A}_\xi$ -equivalent to one of the following three normal forms:

(a)  $(\xi, t) \mapsto (\xi + t, t^2),$

(b)  $(\xi, t) \mapsto (\xi + \xi t + t^3, t^2),$

(c)  $(\xi, t) \mapsto (t, (\xi + t^2)^2).$

The family germs parameterized by these normal forms in the plane  $\{x, y\}$  are depicted in figure 1.4. The envelopes of these families are the lines  $y = 0$ . Note that only the families

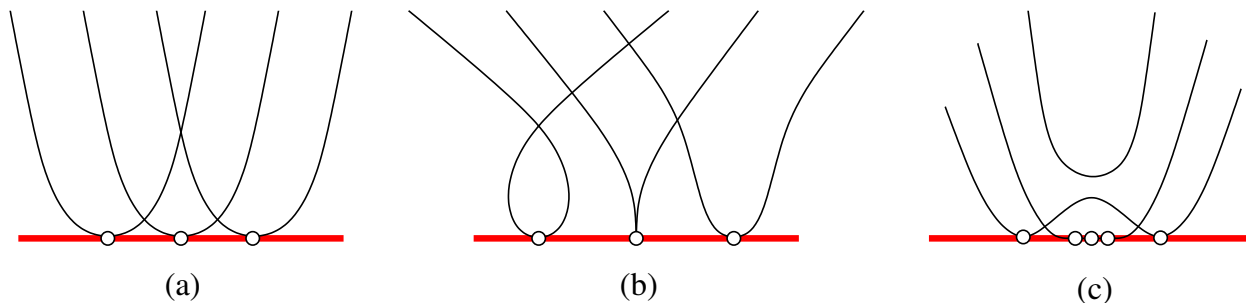

Figure 1.4: Generic families of curves near a regular point of the envelope.

which are  $\mathcal{A}_\xi$ -equivalent to the normal form (a) are tangential families. The converse is discussed at the end of the next section.

In order to classify tangential family germs with respect to their envelopes, we can consider  $\mathcal{A}$ -equivalence instead of  $\mathcal{A}_\xi$ -equivalence, since the envelope of a tangential family is diffeomorphic to the critical value set of every map germ  $\mathcal{A}$ -equivalent to any of its parameterizations. In particular, envelopes of  $\mathcal{A}$ -equivalent tangential families are diffeomorphic.

DEFINITION. We denote by  $X \subset (\mathfrak{m}_2)^2$  the set of all the map germs which are  $\mathcal{A}$ -equivalent to tangential family germs:

$$X := \bigcup_{f \in X_0} (\mathcal{A} \cdot f).$$

Note that  $X$  is invariant under the action of the Left–Right equivalence:  $\mathcal{A} \cdot X = X$ . The set  $X$  is the union of  $\mathcal{A}$ -orbits, which are immersed submanifolds. Their smoothness has to be understood as the smoothness of their restrictions to every jet space  $J^N(\mathbb{R}^2, \mathbb{R}^2)$ , endowed with the standard  $\mathcal{C}^N$  topology. Indeed, the action of  $\mathcal{A}$  on  $(\mathfrak{m}_2)^2$  gives rise to the quotient action of  $\mathcal{A}^N$  on  $J^N(\mathbb{R}^2, \mathbb{R}^2)$ , where  $\mathcal{A}^N$  is the group of  $N$ -jets at  $(0, 0)$  of pairs of local diffeomorphisms. Since  $\mathcal{A}^N$  is a Lie group acting algebraically on the finite dimensional space  $J^N(\mathbb{R}^2, \mathbb{R}^2)$ , its orbits are immersed submanifolds (see [26]).

### 1.2.3 Tangential family germs of small codimension

In this section we study the  $\mathcal{A}$ -orbits in the set  $X$  of small codimension. In order to do this, we introduce first some definitions.

DEFINITION. Given a tangential family germ, the fiber  $\pi_2^{-1}(0,0)$  defines a unique characteristic direction in the tangent plane to the family graph at the origin, that we call the *vertical direction*.

Let  $\hat{f}$  be a mapping from the plane to the plane, which germ at the origin  $f$  belongs to  $X_0$ . A *branch* passing through the origin of the criminant set of the tangential family germ  $f$  is any irreducible component of the restriction of the  $\hat{f}$ -critical set to an arbitrary small neighborhood of the origin.

LEMMA 1.2.1. *Given any tangential family, the branch of its criminant set, whose projection in the plane is the support of the family, is non vertical.*

An example of the statement of Lemma 1.2.1 is shown in figure 1.5. The proof is given in section 1.4.1.

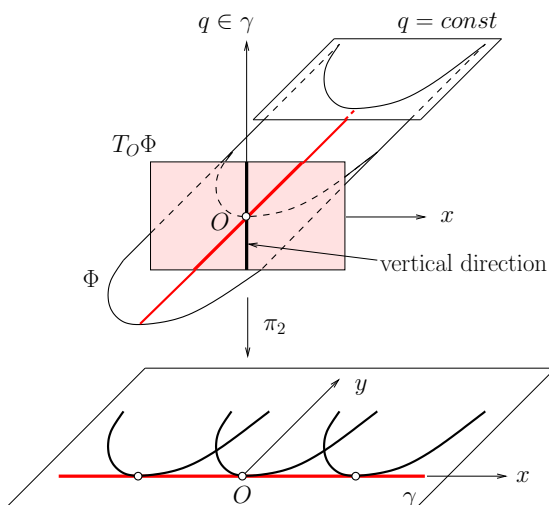

Figure 1.5: The vertical direction.

DEFINITION. A tangential family germ is said to be of *first type* if its criminant set has only one branch at the origin; the germ is said to be of *second type* if its criminant set has exactly two branches passing through the origin and these branches are smooth, non vertical and transversal one to the other.

We point out that in the preceding definition one has to count the envelope branches with their multiplicity.

EXAMPLE 1.2.5. The family of the tangent lines of  $y = x^2$  is of first type at every point of the parabola. The family of tangent lines of  $y = x^3$  and the tangential family of Example

1.2.2 are of second type at the origin. The tangential family germ parameterized near the origin by the map germ

$$(\xi, t) \mapsto (\xi + t, t^4 + 4t^2\xi^2)$$

is not of first neither of second type. Indeed, its discriminant set has three branches meeting the origin, namely, the support  $y = 0$  and the origin  $(0, 0)$  counted twice, corresponding to the two complex branches of equations  $t = (1 \pm i)\xi$ .

The type of a tangential family germ does not depend on the choice of its parameterization but only on its  $\mathcal{A}$ -orbit: if  $f \in X_0$  is of first or second type, then every element in  $(\mathcal{A} \cdot f) \cap X_0$  is of the same type.

The next statement is a geometric characterization of the first and second type tangential families. The proof is given in section 1.4.1.

**PROPOSITION 1.2.1.** *A tangential family germ at  $O$  is of first type if and only if all the family curves tangent to the support near  $O$  have tangency order 1. If a tangential family germ is of second type at  $O$ , then the family curve, tangent to the support at  $O$ , has tangency order greater than 1 (the tangency order of the other family curves close to this one being 1).*

Let us denote respectively by I and II the subsets of  $X$  formed by the map germs which are  $\mathcal{A}$ -equivalent to first and second type tangential family germs respectively.

**THEOREM 1.2.1.** *The sets I and II define two singularities of tangential family germs, whose representatives are listed in the table below, together with their extended codimensions and the codimensions of the corresponding  $\mathcal{A}$ -orbits in  $(\mathfrak{m}_2)^2$  (cf. section 1.4.2):*

Singularity	Representative	Codim <sub>e</sub>	Codim
I	$f_{\text{I}}(s, t) := (s + t, t^2)$	0	1
II	$f_{\text{II}}(s, t) := (s + t, st^2)$	1	3

Moreover, all the other  $\mathcal{A}$ -orbits in  $X$  have codimension at least 4 in  $(\mathfrak{m}_2)^2$ .

The proof is in section 1.4.2. Theorem 1.2.1 has the following consequences.

**COROLLARY 1.2.1.** *The tangential family germs of fixed type are  $\mathcal{A}$ -equivalent.*

**COROLLARY 1.2.2.** *The envelope of any tangential family germ of first type is smooth, while that of any tangential family germ of second type has a second order self-tangency.*

Let us end this section discussing the action of  $\mathcal{A}_\xi$  on  $X_0 \subset X$ . Theorem 1.2.1 does not hold if we consider the  $\mathcal{A}_\xi$ -equivalence instead of the  $\mathcal{A}$ -equivalence; indeed, the tangential family germs of second type do not define an  $\mathcal{A}_\xi$ -singularity.

**EXAMPLE 1.2.6.** The tangential families considered in Examples 1.2.2 and 1.2.3 are  $\mathcal{A}$ -equivalent but not  $\mathcal{A}_\xi$ -equivalent.

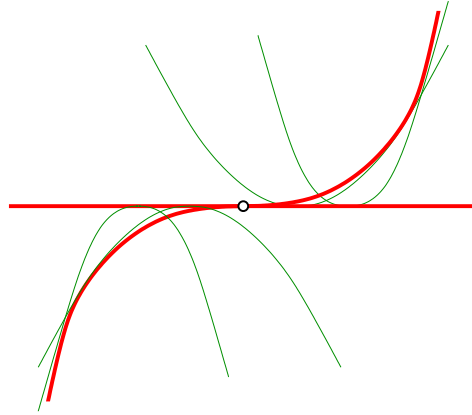

Figure 1.6: The tangential family germ representing the singularity II.

However, the two map germs in Theorem 1.2.1 are tangential family germs, taking  $s = \xi$  as distinguished parameter. In particular, the representative of the singularity I is one of Arnold's normal forms discussed in section 1.2.2 (the family (a) in figure 1.4). The tangential family germ representing the singularity II is shown in figure 1.6.

Therefore, a 1-parameter family of plane curves is  $\mathcal{A}_\xi$ -equivalent to the map germ representing the orbit I if and only if it is a tangential family germ of first type, that is, if it belongs to the  $\mathcal{A}$ -orbit I. In other words, the set  $I \cap X_0$  is the intersection of an  $\mathcal{A}_\xi$ -orbit with  $X_0$ .

On the other hand, it turns out that the set  $II \cap X_0$  contains infinitely many  $\mathcal{A}_\xi$ -orbits, each one being of infinite codimension.

### 1.2.4 Tangential deformations and envelope stability

In this section we introduce the definition of tangential deformation and we state our main result.

In some situations, as for instance in the study of geodesic tangential family evolution under small perturbations of the metric, it would be natural to perturb a tangential family only among tangential families.

**DEFINITION.** A  $p$ -parameter *tangential deformation* of a tangential family germ  $f \in X_0$  is a  $p$ -parameter family of mappings

$$\{F_\lambda : \mathbb{R}^2 \rightarrow \mathbb{R}^2, \lambda \in \mathbb{R}^p\},$$

such that the germ at the origin of  $F_0$  is  $f$  and  $F_\lambda$  parameterizes a tangential family whenever  $|\lambda|$  is small enough.

For example, the translation of the origin is a 2-parameter tangential deformation. Note that the support of a tangential family does not change, up to diffeomorphisms, under tangential deformations of the family.



DEFINITION. A tangential family singularity is said to be *stable* if for every representative  $f$  of it, and for every tangential deformation  $\{F_\lambda : \lambda \in \mathbb{R}^p\}$  of  $f$ , the tangential family parameterized by  $F_\lambda$  has a singularity  $\mathcal{A}$ -equivalent to that of  $f$  at some  $\lambda$ -depending point arbitrary close to the origin for  $\lambda$  small enough.

We may state now our main result.

THEOREM 1.2.2. *The singularities I and II are the only stable singularities of tangential family germs under small tangential deformations.*

We have the following consequence of Theorem 1.2.2.

COROLLARY. *The envelopes of the tangential family germs of first and second type are stable under small tangential deformations.*

The stability of the envelope second order self-tangency singularity is understood here as follows. Let  $\{F_\lambda : \lambda \in \mathbb{R}^p\}$  be a tangential deformation of  $f \in \Pi \cap X_0$  and let  $\mathcal{U}$  be an arbitrary small neighborhood of  $(0, 0)$  in  $\mathbb{R}^2$ . Then the envelope of the tangential family parameterized by  $F_\lambda$  has a second order self-tangency at some  $\lambda$ -depending and family-dependent point of  $\mathcal{U}$ , provided that  $\lambda$  is small enough.

According to Thom, the second order self-tangency is not a stable envelope singularity under general deformations. This means that there exists deformations of singularity II, which are not of tangential type, destroying the envelope second order self-tangency.

In section 1.4.2 we will prove the next result.

THEOREM 1.2.3. *The mapping  $F : \mathbb{R}^2 \times \mathbb{R} \rightarrow \mathbb{R}^2$ , defined by*

$$F(s, t; \lambda) := (s + t, \lambda s + st^2),$$

*is an  $\mathcal{A}$ -miniversal deformation of the mapping  $F_0$ , whose germ at the origin is  $f_{\text{II}}(s, t)$ .*

The definition of  $\mathcal{A}$ -miniversal deformation is recalled in section 1.4.2.

Theorem 1.2.3 allows us to prove the stability of the singularity II (the stability of the map germ  $f_{\text{I}}$ , which singularity is a fold, being well known). The direction  $(0, s)$  is transversal to the  $\mathcal{A}$ -orbit II at the point  $f_{\text{II}}$ . To see this, denote by  $F_\lambda$  the map obtained from  $F$  fixing the parameter value  $\lambda$ . For  $\lambda < 0$  the critical value set of  $F_\lambda$  has two smooth branches, while for  $\lambda > 0$  it has two branches, having each one a semicubic cusp (see figure 1.7).

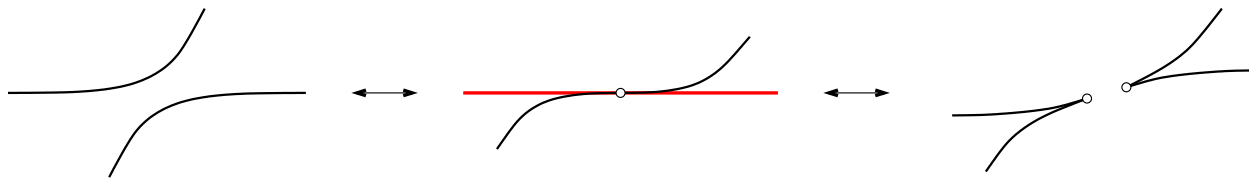

Figure 1.7: The “bec à bec” perestroika.

Such a perestroika is called “bec à bec” in Thom’s notation. In particular,  $F$  is not a tangential deformation. This proves the announced transversality and that the singularity II is stable under small tangential deformations.

The fact that the only stable singularities are I and II will be proven in section 1.4.3.

REMARK. The critical value sets of  $F_\lambda$  form a surface in the three-dimensional space  $\{x, y, \lambda\}$ , diffeomorphic to a semicubical edge –this holds for any  $\mathcal{A}$ -miniversal deformation of any element of II. In suitable coordinates  $\{u, v, w\}$ , the bec à bec perestroika can be described as the metamorphose of the level sets of the function  $w^2 - u$  on the cuspidal edge  $u^3 = v^2$  near the critical value 0, as shown in figure 1.8 (see [3], example 4.6).

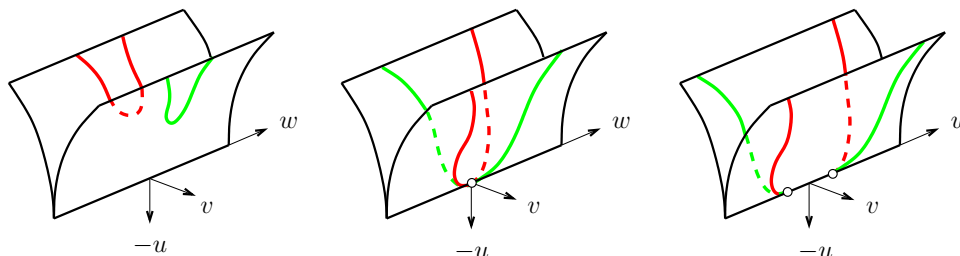

Figure 1.8: Level sets  $w^2 - u = c$  on the cuspidal edge  $u^3 = v^2$  ( $c < 0$  on the left,  $c = 0$  in the center and  $c > 0$  on the right).

## 1.3 Examples and applications

The simplest example of a tangential family is given by the tangent lines of a curve. We generalize it by replacing the Euclidean structure (defining usual lines) by a local projective structure or a Riemannian structure. In this way we may associate to each curve a tangential family, formed by the straight tangent lines or the tangent geodesic of the curve for the given structure.

The general results concerning envelopes of tangential family germs and their stability stated above provide some new results the applications discussed in this section. In particular, we obtain in section 1.3.3 a generalization to the envelopes of the Last Geometric Theorem of Jacobi and of the conjectures related to it.

To apply the results of section 1.2, we use the fact that the families defined as explained below and their deformations admit a smooth parameterization. This is a consequence of the Regularity Theorem for the solutions of second order differential equations with respect to the initial conditions, and its variants involving parameters and systems of equations.

### 1.3.1 Projective tangential families

A (*local*) *projective structure* is the structure given, at any point of the plane near the origin, by a second order differential equation (see [4]). The graphs of its solutions are, by definition, the *straight lines* for this structure. For instance, the standard projective structure in the Euclidean plane is defined by the equation  $y'' = 0$ . A projective structure is said to be *flat* if there exists a change of local coordinates bringing it to the standard projective structure.

REMARK. Let us fix a flat projective structure. The envelope of the straight lines tangent to a curve, having an inflection point, contains the support curve and the straight line, tangent to it at the inflection point. In particular, the envelope is not geometric.

Let us consider a curve  $\gamma$  in the plane  $\mathbb{R}^2$ , endowed with a projective structure. The straight lines tangent to  $\gamma$  define a tangential family, that we call the *projective tangential family of support*  $\gamma$ .

**COROLLARY.** *Let us consider the germ of the projective tangential family of support  $\gamma$  at a point  $P \in \gamma$ . If  $P$  is an ordinary point of  $\gamma$ , the family envelope is the germ of  $\gamma$  at  $P$ . If  $P$  is a simple inflection point of  $\gamma$ , then the family envelope has two branches passing through  $P$  (one of which is the support); these two branches have generically a second order self-tangency at  $P$ : the curve germs for which the claim does not hold are contained in the union of two codimension 1 submanifolds in the space of the curve germs having an inflection point at  $P$ .*

**REMARK.** This Corollary provides a criterion distinguishing non flat projective structures. Indeed, suppose that there exists a curve, having a simple inflection point, such that the envelope of its tangent straight lines is geometric. Then the projective structure is not flat.

Consider a projective tangential family of support  $\gamma$ . A deformation of the projective structure induces a tangential deformation of the projective family. In this setting, Theorem 1.2.2 reads as follows.

**COROLLARY.** *The second order self-tangency of the envelope of any projective tangential family germ is stable under small perturbations of the projective structure.*

### 1.3.2 Geodesic tangential families

Let  $\gamma$  be a curve in a Riemannian surface. The geodesics tangent to  $\gamma$  form a tangential family, that we call the *geodesic tangential family of support*  $\gamma$ .

**COROLLARY.** *Let us consider the geodesic tangential family germ at a point  $P$  of its support  $\gamma$ . If  $P$  is an ordinary point of  $\gamma$ , then the envelope of the family germ is the germ of  $\gamma$  at  $P$ . If  $P$  is a simple inflection point of  $\gamma$ , then the envelope of the family germ has two branches passing through the point  $P$  (one of which is the family support). Generically, these two branches have a second order self-tangency at  $P$ : the curve germs  $\gamma$  for which the claim does not hold are contained in the union of two codimension 1 submanifolds in the space of all the curve germs having an inflection point at  $P$ .*

Perturbations of the metric of the Riemannian surface induce tangential deformations on geodesic tangential families.

**COROLLARY.** *The second order self-tangencies of envelopes of geodesic tangential family germs in a Riemannian surface are stable under small deformations of the metric.*

**COROLLARY.** *The second order self-tangencies of envelopes of geodesic tangential family germs in a surface in the Euclidean three-space are stable under small deformations of the surface (equipped with the induced metric).*

We point out that the preceding Corollaries of Theorems 1.2.1 and 1.2.2 hold only in the local setting.

### 1.3.3 A global geodesic tangential family on the sphere

In this section we discuss an example of a global geodesic tangential family whose envelope has infinitely many branches.

Let  $S^2$  be the radius 1 two-sphere in the Euclidean three-space, centered at the origin. We consider  $S^2$  equipped with the induced metric. Let  $\gamma_r \subset S^2$  be a circle of radius  $r < 1$  in  $\mathbb{R}^3$ . Then consider the geodesic tangential family of support  $\gamma_r$ , depicted in figure 1.9.

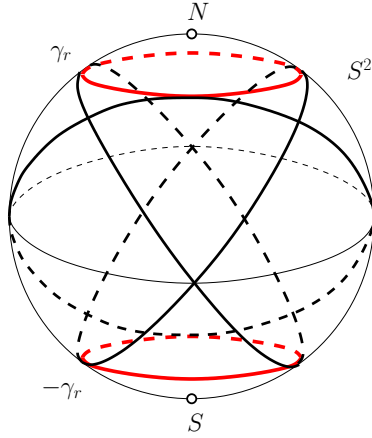

Figure 1.9: The geodesic tangential family of a spherical circle.

Let us denote by

$$f : S^1 \times \mathbb{R} \rightarrow S^2$$

a global parameterization of this family, where for every  $\xi \in S^1 \simeq \gamma_r \subset S^2$ , the map  $f(\xi, \cdot) : \mathbb{R} \rightarrow S^2$  is a  $2\pi$ -periodical parameterization of the  $S^2$  great circle passing through the point  $\xi$ . Therefore, the solutions of the equation  $\det Df(\xi, t) = 0$  are the curves  $C_n := (\xi \in S^1, t = n\pi)$ ,  $n \in \mathbb{Z}$ , in the space  $S^1 \times \mathbb{R}$ . Hence, the envelope of the family  $f$  has two branches, namely  $\gamma_r$  and its opposite circle  $-\gamma_r$ , each one having infinite multiplicity. Let us denote by  $E_n := f(C_n)$  the images of the branches  $C_n$  of the discriminant set of the family. Note that  $E_n = (-1)^n \gamma_r$ .

Let  $\tilde{S}^2$  be a small perturbation of the sphere, for instance an ellipsoid. Such a deformation induces a tangential deformation on the geodesic tangential family. Let us denote by  $\tilde{\gamma}_r$  the support of the perturbed family, which is a small perturbation of the circle  $\gamma_r$ , and by

$$\tilde{f} : S^1 \times \mathbb{R} \rightarrow \tilde{S}^2$$

a global parameterization of the perturbed geodesic tangential family.

Let us fix  $N, M \in \mathbb{N}$  arbitrary large,  $N < M$ . If the perturbation of the sphere is small enough (the required smallness depending on  $M$ ), the solutions  $\tilde{C}_n$  of  $\det D\tilde{f} = 0$  are pairwise disjoint small perturbations of the solutions  $C_n$  of  $\det Df = 0$ , for every  $n < M$ .

**DEFINITION.** The envelope branch  $\tilde{E}_n = \tilde{f}(\tilde{C}_n)$  will be called the *order  $n$  envelope of  $\tilde{\gamma}_r$* .

Each one of these envelopes is a small perturbation of the corresponding branch  $E_n$  of the  $f$ -envelope. Since the unperturbed geodesic tangential family is of first type at every point

of its envelope, by Theorem 1.2.2 the perturbed family is of first type at any point of the envelope branches  $\tilde{E}_n$  for every  $|n| < N$ , provided that the perturbation is small enough. In such a global setting, self-intersection singularities between different branches may arise.

The envelopes  $\tilde{E}_n$  of  $\tilde{\gamma}_r$  can be viewed as caustics, which are the images under a geodesic flow of the preceding envelopes  $\tilde{E}_{n-1}$ . Therefore generic singularities of spherical caustics, such as semicubic cusps and transversal self-intersection, may arise in the envelopes  $\tilde{E}_n$ , when  $N < n < M$ .

**THEOREM 1.3.1.** *For every fixed  $r > 0$  and  $N, M \in \mathbb{N}$ , the envelopes  $E_n$  of order  $|n| < N$ , are smooth closed spherical curves, and the envelopes  $E_n$  of order  $|n| < M$ , are spherical caustics, whose Maslov number is equal to zero, provided that  $\tilde{S}^2$  is close enough to  $S^2$ .*

We consider now a fixed arbitrary small perturbation  $\tilde{S}^2$  of the sphere, and we shrink the initial support curve  $\gamma_r$  toward the north pole; in other words, we consider the limit situation as  $r \rightarrow 0$ .

We shall discuss first the unperturbed family. When  $\gamma_r$  reduces to the north pole, the geodesic tangential family becomes the sphere meridian family. All the envelope branches shrink to a point, namely the even order branches to the north pole, the odd order branches to the south pole.

On the deformed sphere, when  $r$  becomes arbitrary small, the support  $\tilde{\gamma}_r$  shrinks to a point  $P$  and the envelope branches  $\tilde{E}_n$ , defined for  $n < M$ , approach the caustics of order  $n$  associated to this point. Let us recall that the caustic of a point on a Riemannian surface is the set of the intersection points of infinitesimally close geodesics starting at this point, see [7], i.e. the set of conjugated points of the initial point.

If the perturbed sphere  $\tilde{S}^2$  is a generic convex surface close enough to  $S^2$ , then the Last Geometrical Theorem of Jacobi states that the first caustic of any generic point has at least 4 cusps (see [9]). Thus, we have the following.

**THEOREM 1.3.2.** *If  $r$  is small enough, then the first order envelope of  $\tilde{\gamma}_r$  has at least four cusps, provided that  $\tilde{S}$  is a generic convex surface close to the sphere.*

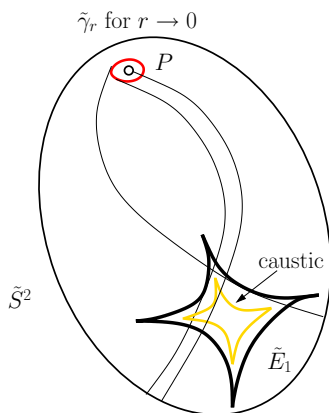

Figure 1.10: The Last Geometrical Theorem of Jacobi for envelopes.

The situation of Theorem 1.3.2 is illustrated in figure 1.10. Conjecturally, every caustic of a generic point on a generic convex surface has at least four cusps, but it is unproved (to my knowledge) even for the surfaces close to a sphere. More precisely, for a fixed  $n$ , the caustic of order  $n$  of a point has at least four cusps, provided that the perturbation is small enough. But whether it holds simultaneously for all the values  $n$  provided that the perturbation is small enough is still a conjecture (see [9]). This conjecture can be generalized to the envelopes of closed convex smooth curves of small length on convex surfaces.

## 1.4 Proof of Theorems 1.2.1, 1.2.2 and 1.2.3

### 1.4.1 Prenormal forms of tangential families

Let us start reducing every tangential family germ to a map germ, depending on some parameters. In order to do this, let us define as follows three real coefficients  $k_0$ ,  $k_1$  and  $\alpha$ , depending on the family. Let us consider a tangential family in the plane  $\mathbb{R}^2$ . Let  $P$  be the point of the family support we want to study. Let us fix a new coordinate system  $\{x, y\}$  in the plane, centered at  $P$ , in which the equation of the support is  $y = 0$  near the origin.

Consider the family curve which is tangent to the support at  $(\xi, 0)$ . Then define  $k_0$  and  $k_1$  by the expansion  $k_0 + k_1\xi + o(\xi)$  of half of its curvature at this point (for  $\xi \rightarrow 0$ ). The coefficient  $\alpha$  is similarly defined by the expansion  $k_0t^2 + \alpha t^3 + o(t^3)$  for  $t \rightarrow 0$  of the function whose graph is the family curve which is tangent to the support at the origin. We will denote by  $\delta(n)$  any function in two variables with vanishing  $n$ -jet at the origin.

**THEOREM 1.4.1.** *Every tangential family germ is  $\mathcal{A}$ -equivalent to a map germ of the form*

$$(s, t) \mapsto (s, k_0t^2 + (\alpha - k_1)t^3 + k_1t^2s + t^2 \cdot \delta(1)) ,$$

where  $k_0$ ,  $k_1$  and  $\alpha$  are the coefficients, depending on the family, defined above.

The map germ in Theorem 1.4.1 will be called a *prenormal form* of the family. Note that the prenormal form does not belong to the set  $X_0$ .

*Proof.* For any given tangential family, let us choose an orthogonal coordinate system as in the above definition of the coefficients  $k_0$ ,  $k_1$  and  $\alpha$ . The map  $\xi \mapsto (\xi, 0)$  parameterizes the support. For any small enough value of  $\xi$ , consider the family curve corresponding to the support point  $(\xi, 0)$ . Near this point, the curve can be parameterized by its projection  $\xi + t$  on the  $x$ -axis. In this manner we get a parameterization of the family, that can be written as

$$(\xi, t) \mapsto (t + \xi, k_0t^2 + k_1t^2\xi + \alpha t^3 + t^2 \cdot \delta(1)) . \quad (1.1)$$

Taking in this map  $s := t + \xi$  and  $t$  as new parameters, we obtain the map germ in the statement.  $\square$

We prove now Lemma 1.2.1 (announced in section 1.2.3), stating that for every tangential family germ, the branch of its discriminant set, whose projection in the plane is the family support, is non vertical (i.e. it is transversal to the vertical direction defined in section 1.2.3).

*Proof of Lemma 1.2.1.* Let us consider a tangential family germ of support  $\gamma$ , parameterized by a map germ  $f$  of the form (1.1). Consider in the three-space  $\gamma \times \mathbb{R}^2$  the local coordinates  $\{\xi, x, y\}$ , where  $\{x, y\}$  is the coordinate system fixed on the plane. Then the family graph  $\Phi$  is parameterized near the origin  $O = (0, 0, 0)$  by the map germ  $(\xi, t) \mapsto (\xi, f(\xi, t))$ , and its tangent space  $T_O\Phi$  at the origin has equation  $y = 0$ . In the local coordinates, the projection  $\pi_2 : \Phi \rightarrow \mathbb{R}^2$  writes as  $\pi_2(\xi, f(\xi, t)) = f(\xi, t)$ . Therefore, the vertical direction in  $T_O\Phi$  is  $(1, 0, 0)$ . On the other hand,  $\gamma$  is parameterized by  $\xi \mapsto f(\xi, 0)$ , so the velocity at the origin of the corresponding criminant branch is  $(1, 1, 0)$ . This proves that this branch is non vertical at  $O$ .  $\square$

The type of a tangential family germ is completely determined by the coefficients  $k_0$ ,  $k_1$  and  $\alpha$  of its prenormal form.

**PROPOSITION 1.4.1.** *A tangential family germ is of first type if and only if  $k_0 \neq 0$ ; it is of second type if and only if  $k_0 = 0$  and  $k_1 \neq 0, \alpha$ .*

*Proof.* Let us consider a tangential family of support  $\gamma$  and graph  $\Phi$ . Let  $f$  be the prenormal form of the family. Then  $\Phi$  is parameterized by

$$(s, t) \mapsto (s - t, s, f(s, t)) ,$$

and the vertical direction in  $T_O\Phi$  is  $(1, 0, 0)$ . The equation  $\det Df(s, t) = 0$  can be written as

$$2k_0t + 2k_1st + 3(\alpha - k_1)t^2 + t \cdot \delta(1) = 0 .$$

The solution  $t = 0$  defines the criminant set branch, whose projection is the family support. Dividing the equation by  $t$  we get

$$2k_0 + 2k_1s + 3(\alpha - k_1)t + \delta(1) = 0 . \tag{1.2}$$

This equation has at least a solution passing through the origin if and only if  $k_0 = 0$ . Hence, the tangential family is of first type if and only if  $k_0 \neq 0$ .

Assume from now on  $k_0 = 0$ . In this case equation (1.2) has exactly one smooth solution passing through  $(0, 0)$  if and only if at least one of the coefficients  $k_1$  and  $(\alpha - k_1)$  is non zero. If  $k_1 \neq 0$ , the solution is the graph of a function

$$S(t) = -\frac{3(\alpha - k_1)}{2k_1} t + o(t) , \quad \text{for } t \rightarrow 0 .$$

The velocity in  $T_O\Phi$  of the corresponding branch is  $(S'(0) - 1, S'(0), 0)$ , which is non vertical if and only if  $S'(0) \neq 0$ , that is,  $\alpha \neq k_1$  and it is transversal to the the first criminant branch velocity  $(1, 1, 0)$ . On the other hand, assume  $\alpha \neq k_1$ . In this case the solution of equation (1.2) is the graph of a function

$$T(s) = -\frac{2k_1}{3(\alpha - k_1)} s + o(s) , \quad \text{for } s \rightarrow 0 .$$

The velocity of the corresponding branch in  $T_O\Phi$  is  $(1 - T'(0), 1, 0)$ , which is non vertical. This branch is tangent to the first criminant branch if and only if  $k_1 = 0$ . Therefore, the tangential family parameterized by  $f$  (in the case  $k_0 = 0$ ) is of second type if and only if  $k_1 \neq 0, \alpha$ . The Proposition is now proven.  $\square$

Taking into account the geometrical meaning of the coefficients, Proposition 1.2.1 follows from Proposition 1.4.1.

## 1.4.2 Preliminary results of Singularity Theory

The proof of Theorems 1.2.1 and 1.2.3 is based on the reduction of the prenormal form to a polynomial map germ and the computation of the corresponding  $\mathcal{A}$ -miniversal deformation. In order to do this, first we recall some facts on Singularity Theory of smooth maps. For a complete presentation of this theory, we refer the reader to [11], [13] or [26].

As before, let us denote respectively by  $s, t$  and  $x, y$  the coordinates in the source and in the target space of a map germ  $f : (\mathbb{R}^2, 0) \rightarrow (\mathbb{R}^2, 0)$ . Such a germ defines, by the formula  $f^*g := g \circ f$ , a homomorphism from the ring  $\mathcal{E}_{x,y}$  of the function germs on the target to the ring  $\mathcal{E}_{s,t}$  of the function germs on the source. Hence we can consider every  $\mathcal{E}_{s,t}$ -module as an  $\mathcal{E}_{x,y}$ -module via this homomorphism.

Let  $\langle f \rangle \subset \mathcal{E}_{s,t}$  be the ideal generated by the components of  $f$  (for the structure of  $\mathcal{E}_{s,t}$ -module). Let us recall the well known Preparation Theorem of Mather-Malgrange-Weierstrass, in the case we deal with: *the module  $\mathcal{E}_{s,t}$  is finitely generated as  $\mathcal{E}_{x,y}$ -module if and only if the quotient space  $\mathcal{E}_{s,t}/\langle f \rangle$  is a real vector space of finite dimension; moreover, a basis of the vector space provides a generator system of the module.* From now on, we shall use the notation  $\mathfrak{m}_{s,t}$  instead of  $\mathfrak{m}_2$  to point out that the variables of the considered germs are  $s$  and  $t$ .

The *extended tangent space* at  $f$  to its orbit  $\mathcal{A} \cdot f$  is the subspace of  $\mathcal{E}_{s,t}^2$  defined by

$$T_e \mathcal{A}(f) := \mathcal{E}_{s,t} \cdot J(f) + f^*(\mathcal{E}_{x,y}) \cdot \mathbb{R}^2 ,$$

where  $J(f)$  is the real vector space spanned by the first order partial derivatives of  $f$ . In a similar way we define the *tangent space* at  $f$  to its orbit  $\mathcal{A} \cdot f$  by

$$T \mathcal{A}(f) := \mathfrak{m}_{s,t} \cdot J(f) + f^*(\mathfrak{m}_{x,y}) \cdot \mathbb{R}^2 .$$

The *extended codimension* (resp., the *codimension*) of a map germ  $f$  is the dimension of the quotient space  $\mathcal{E}_{s,t}^2/T_e \mathcal{A}(f)$  (resp.,  $(\mathfrak{m}_{s,t})^2/T \mathcal{A}(f)$ ) as a real vector space.

It is well known that the *map germs of finite (extended) codimension are finitely determined, i.e.  $\mathcal{A}$ -equivalent to their Taylor's polynomial of some finite order* (Finite Determinacy Theorem). In [26] is proven that *the restriction of the tangent space  $T \mathcal{A}(f)$  to every  $N$ -jet space  $J^N(\mathbb{R}^2, \mathbb{R}^2)$  is equal to the usual tangent space in this space of the restriction of the orbit  $\mathcal{A} \cdot f$  at the point  $j^N f$ .* Thus, the codimension in  $(\mathfrak{m}_{s,t})^2$  of the orbit  $\mathcal{A} \cdot f$  is equal to the codimension of the map germ  $f$ .

Consider an  $\ell$ -parameter *deformation*  $F$  of a mapping germ  $f \in (\mathfrak{m}_{s,t})^2$ , i.e., a family of maps

$$\{F_\lambda : \mathbb{R}^2 \rightarrow \mathbb{R}^2, \lambda \in \mathbb{R}^\ell\} ,$$

where  $F_\lambda := F(\cdot; \lambda)$ . A *deformation  $\mathcal{A}$ -equivalent to  $F$*  is, by definition, a family  $\{g_\lambda F_\lambda\}$ , where  $\{g_\lambda\}$  is some deformation of the identity element of the group  $\mathcal{A}$ .

Let  $h : (\mathbb{R}^m, 0) \rightarrow (\mathbb{R}^\ell, 0)$  be a smooth map germ. By definition, the *deformation induced from  $F$  by the map  $h$*  is the  $m$ -parameter deformation  $\{F_{h(\lambda)}\}$ . A deformation  $F$  of the germ  $f$  is said to be  *$\mathcal{A}$ -versal* if any deformation of  $f$  is  $\mathcal{A}$ -equivalent to a deformation induced from  $F$ . This means that every deformation  $F'$  of  $f$  can be represented as

$$F'(s, t; \mu) \equiv \psi(F(\varphi(s, t; \mu), h(\mu)), \mu) ,$$



where  $\varphi(s, t; \mu)$  and  $\psi(x, y; \mu)$  are deformations of the identity diffeomorphisms of the source  $\mathbb{R}^2$  and target  $\mathbb{R}^2$ , respectively (it is not required that  $\varphi(0; \mu) = 0$  and  $\psi(0; \mu) = 0$  for  $\mu \neq 0$ ). An  $\mathcal{A}$ -versal deformation for which the base has the smallest possible dimension is called *miniversal*.

Let  $F$  be a deformation of  $f$  and let  $\lambda_1, \dots, \lambda_\ell$  be coordinates in its base,  $\lambda(0) = 0$ . Consider the initial velocities of  $F$ :

$$\dot{F}_i = \partial_{\lambda_i} F(s, t; 0), \quad i = 1, \dots, \ell.$$

The deformation  $F$  is said to be *infinitesimally  $\mathcal{A}$ -versal* if its initial velocity vectors together with the extended tangent space  $T_e \mathcal{A}(f)$  to  $f$  span the full extended space  $\mathcal{E}_{s,t}^2$  of variations of  $f$ . In other words, the map  $\lambda \mapsto F_\lambda$  of the base  $(\mathbb{R}^\ell, 0)$  of the deformation into  $(\mathcal{E}_{s,t}^2, f)$  is required to be transverse to the  $\mathcal{A}_e$ -orbit of  $f$ ;  $\mathcal{A}_e$  is the pseudogroup  $\mathcal{R}_e \times \mathcal{L}_e$ , which is the product of the pseudogroups  $\mathcal{R}_e$  and  $\mathcal{L}_e$  of local diffeomorphisms of the source space and the target space. The condition of infinitesimal  $\mathcal{A}$ -versality amount to the following relation being fulfilled:

$$\mathcal{E}_{s,t}^2 = T_e \mathcal{A}(f) + \mathbb{R} \cdot \left\{ \dot{F}_1, \dots, \dot{F}_\ell \right\}$$

The Versality Theorem states that *a deformation is  $\mathcal{A}$ -versal if and only if it is infinitesimally  $\mathcal{A}$ -versal*. Moreover a uniqueness theorem also holds: *any  $\ell$ -parameter  $\mathcal{A}$ -versal deformation of  $f$  is  $\mathcal{A}$ -equivalent to the deformation induced from any other  $\ell$ -parameter  $\mathcal{A}$ -versal deformation of  $f$  by a diffeomorphic mapping of the bases*.

### 1.4.3 Proof of Theorem 1.2.1, 1.2.1 and 1.2.3

We can now start the proof of Theorem 1.2.1. We have to show that any map germ belonging to I or II is  $\mathcal{A}$ -equivalent to the map germs  $f_I$  or  $f_{II}$  respectively. The proof is, in both cases, divided into two steps. The first one is the formal  $\mathcal{A}$ -equivalence between  $f_I$  (resp.,  $f_{II}$ ) and any germ in I (resp., II); let us recall that two map germs are formally  $\mathcal{A}$ -equivalent if they are  $\mathcal{A}$ -equivalent modulo arbitrary large order terms. The second step is to verify that the map germ has finite codimension. In this case the formal  $\mathcal{A}$ -equivalence implies the  $\mathcal{A}$ -equivalence.

Let us begin bringing the map germs of the set I to the map germ  $h_1(s, t) := (s, t^2)$ , which is  $\mathcal{A}$ -equivalent to

$$f_I(s, t) = (s + t, t^2).$$

**PROPOSITION 1.4.2.** *Every element of the set I is  $\mathcal{A}$ -equivalent to  $h_1$ .*

*Proof.* All the prenormal forms of first type tangential family germs are  $\mathcal{A}$ -equivalent to map germs of the form  $(s, t^2 + \delta(2))$ . Consider now such a germ  $\tilde{h}_1$ , that can be written as

$$(s, t) \mapsto (s, t^2 + P_r(s, t) + \delta(r)),$$

where  $P_r$  is a homogeneous polynomial  $\sum_{j=0}^r b_j s^j t^{r-j}$  of order  $r > 2$ , and define

$$\varphi(s, t) := \left( s, t - \frac{1}{2} \sum_{j=0}^{r-1} b_j s^j t^{r-j-1} \right), \quad \psi(x, y) := (x, y - b_r x^r).$$

Then  $(\psi \circ \tilde{h}_1 \circ \varphi)(s, t) = (s, t^2 + \delta(r))$ . Iterating this argument, we obtain that the initial prenormal form is formally  $\mathcal{A}$ -equivalent to  $(s, t) \mapsto (s, t^2)$ . Finally, the formal  $\mathcal{A}$ -equivalence implies the  $\mathcal{A}$ -equivalence, due to the stability of the fold  $h_1$ , meaning that the extended codimension of  $h_1$  is zero.  $\square$

We end the study of the orbit I by the computation of its codimension, its extended codimension being zero, due to the fold stability.

**PROPOSITION 1.4.3.** *The codimension of the map germ  $h_1$  is equal to 1.*

*Proof.* By the Preparation Theorem,  $\mathfrak{m}_{s,t}$  is generated, as  $\mathcal{O}_{x,y}$ -module, by the map germs  $s, t, t^2$ . Since  $\partial_s h_1 = (1, 0)$  and  $\partial_t h_1 = (0, 2t)$ , the tangent space  $T\mathcal{A}(h_1)$  contains all the vector monomials  $(s^p t^q, 0)$  and  $(0, s^p t^q)$  for  $p + q \geq 1$  except  $(0, t)$ . Therefore we have:

$$(\mathfrak{m}_{s,t})^2 = T\mathcal{A}(h_1) \oplus \mathbb{R} \cdot \begin{pmatrix} 0 \\ t \end{pmatrix},$$

so the codimension of  $h_1$  is equal to 1.  $\square$

Let us now prove that all the map germs in the set II are  $\mathcal{A}$ -equivalent to the map germ  $h_2(s, t) := (s, t^2(s + t))$ , and then to the map germ

$$f_{\text{II}}(s, t) = (s + t, st^2).$$

**PROPOSITION 1.4.4.** *Every map germ in II is formally  $\mathcal{A}$ -equivalent to  $h_2$ .*

*Proof.* By Theorem 1.4.1 and Proposition 1.4.1, every element of II is  $\mathcal{A}$ -equivalent to a map germ

$$(s, t) \mapsto (s, (\alpha - k_1)t^3 + k_1 st^2 + t^2 \cdot \delta(1)), \quad k_1 \neq 0, \alpha.$$

which is  $\mathcal{A}$ -equivalent, by rescaling, to a map germ  $\tilde{h}_2$  of the form

$$(s, t) \mapsto (s, t^2(s + t) + P_r(s, t) + \delta(r)),$$

where  $P_r$  is a homogeneous polynomial of order  $r > 3$ . We shall now prove that every map germ of this form is  $\mathcal{A}$ -equivalent to a map germ of the form  $(s, t) \mapsto (s, t^2(s + t) + \delta(r))$ . This equivalence provides by induction the formal  $\mathcal{A}$ -equivalence between the initial prenormal form and  $h_2$ , proving the Proposition.

We can kill the coefficient of the monomial  $s^{r-j}t^j$  in  $P_r$  for any fixed  $j \in \{2, \dots, r\}$ , changing only the coefficient of  $s^{r-j+1}t^{j-1}$  and coefficients of some higher order terms in the second component of  $\tilde{h}_2$ . This is made by the coordinate change

$$(s, t) \mapsto (s, t + cs^{r-j}s^{j-2}),$$

for a suitable  $c \in \mathbb{R}$ . Up to such coordinate changes, we may assume

$$P_r(s, t) = As^{r-1}t + Bs^r.$$

Moreover, we can also suppose  $B = 0$ , up to the coordinate change

$$(x, y) \mapsto (x, y - Bx^r).$$

Now set

$$\varphi(s, t) := (s + 3As^{r-2}/2, t - As^{r-2}/2) ;$$

then we have

$$\left(\hat{h}_2 \circ \varphi\right)(s, t) = \left(s + As^{r-2}, t^2(s + t) + \delta(r)\right) .$$

Such a germ is formally  $\mathcal{A}$ -equivalent to a germ of the same form with  $A = 0$ .  $\square$

**PROPOSITION 1.4.5.** *The extended codimension and the codimension of the map germ  $h_2$  are equal to 1 and 3.*

To prove this Proposition we need the following Lemma.

**LEMMA 1.4.1.** *All the vector monomials  $(s^p t^q, 0)$  for  $p + q \geq 1$  and  $(0, s^i t^j)$  for  $p + q \geq 3$  belong to the tangent space  $T\mathcal{A}(h_2)$ .*

*Proof.* The tangent space  $T\mathcal{A}(h_2)$  contains the following vectors:

$$\begin{aligned} & \begin{pmatrix} s \\ st^2 \end{pmatrix}, \begin{pmatrix} t \\ t^3 \end{pmatrix}, \begin{pmatrix} 0 \\ 3t^3 + 2st^2 \end{pmatrix}, \begin{pmatrix} 0 \\ 3st^2 + 2ts^2 \end{pmatrix}, \\ & \begin{pmatrix} s \\ 0 \end{pmatrix}, \begin{pmatrix} 0 \\ s \end{pmatrix}, \begin{pmatrix} t^3 + st^2 \\ 0 \end{pmatrix}, \begin{pmatrix} 0 \\ t^3 + st^2 \end{pmatrix}. \end{aligned}$$

Hence, the vector monomials  $\{(s^p t^q, 0) : p + q = 1\}$  and  $\{(0, s^i t^j) : i + j = 3\}$  belong to the tangent space. Now assume that

$$\{(s^p t^q, 0) : p + q = n\} \cup \{(0, s^i t^j) : i + j = n + 2\} \subset T\mathcal{A}(h_2) \quad (1.3)$$

for some fixed  $n \geq 1$ . Since the tangent space is an  $\mathcal{E}_{x,y}$ -module, this implies that  $(s^{p+1} t^q, 0)$  for  $p + q = n$  and  $(0, s^{i+1} t^j)$  for  $i + j = n + 2$  belong to the tangent space. Moreover we have

$$s^p t^q \partial_s h_2 = \begin{pmatrix} t^{n+1} \\ t^{n+3} \end{pmatrix}, \quad s^p t^q \partial_t h_2 = \begin{pmatrix} 0 \\ 3t^{n+3} + 2st^{n+2} \end{pmatrix} .$$

This proves that also  $(t^{n+1}, 0)$  and  $(0, t^{n+3})$  lie in the tangent space, so inclusion (1.3) holds for  $n + 1$ .  $\square$

*Proof of Proposition 1.4.5.* We have

$$\langle f \rangle_{\mathcal{E}_{s,t}} = \langle s, t^3 + st^2 \rangle_{\mathcal{E}_{s,t}} = \langle s, t^3 \rangle_{\mathcal{E}_{s,t}},$$

so the real vector space  $\mathfrak{m}_{s,t}/(\langle f \rangle \cdot \mathfrak{m}_{s,t})$  is generated by  $s, t, t^2, t^3$ . By the Preparation Theorem, we have

$$(\mathfrak{m}_{s,t})^2 = T\mathcal{A}(h_2) \oplus \mathcal{E}_{s,t} \cdot \left\{ \begin{pmatrix} 0 \\ t \end{pmatrix}, \begin{pmatrix} 0 \\ t^2 \end{pmatrix} \right\}, \quad (1.4)$$

since  $(s, 0), (t, 0), (t^2, 0), (t^3, 0)$  and  $(0, t^3)$  belong to the tangent space due to Lemma 1.4.1, together with  $(0, s)$ . This Lemma implies also

$$h_2^*(\mathfrak{m}_{x,y}) \cdot \left\{ \begin{pmatrix} 0 \\ t \end{pmatrix}, \begin{pmatrix} 0 \\ t^2 \end{pmatrix} \right\} = T\mathcal{A}(h_2) \oplus \mathbb{R} \cdot \begin{pmatrix} 0 \\ st \end{pmatrix} .$$

Thus, equation (1.4) can be written as follows

$$(\mathfrak{m}_{s,t})^2 = T\mathcal{A}(h_2) \oplus \mathbb{R} \cdot \left\{ \begin{pmatrix} 0 \\ t \end{pmatrix}, \begin{pmatrix} 0 \\ st \end{pmatrix}, \begin{pmatrix} 0 \\ t^2 \end{pmatrix} \right\}. \quad (1.5)$$

So the codimension of  $h_2$  is equal to 3.

We obtain from equality (1.5) and Lemma 1.4.1 that

$$\mathcal{E}_{s,t}^2 = T_e\mathcal{A}(h_2) \oplus \mathbb{R} \cdot \begin{pmatrix} 0 \\ t \end{pmatrix}. \quad (1.6)$$

Indeed  $(1, 0)$ ,  $(0, 1)$ ,  $(0, t^2) = \partial_s h_2 - (1, 0)$  and  $(0, 2st) = \partial_t h_2 - (0, t^2)$  belong to the extended tangent space. Hence the extended codimension of  $h_2$  is 1.  $\square$

By Proposition 1.4.1, the other  $\mathcal{A}$ -orbits in  $X$  (except I) are contained in the closure of the orbit II, so their codimension is at least 4. This completes the proof of Theorem 1.2.1.

Equality (1.6) implies that the mapping  $\mathbb{R}^2 \times \mathbb{R} \rightarrow \mathbb{R}^2$ , defined by

$$(s, t; \mu) \mapsto (s, \mu t + t^3 + st^2),$$

is an  $\mathcal{A}$ -miniversal deformation of the map germ  $h_2$ . Thus, the mapping

$$(s, t; \lambda) \mapsto (s + t, \lambda s + st^2)$$

is an  $\mathcal{A}$ -miniversal deformation of the map germ  $f_{\text{II}}$ . Theorem 1.2.3 is proven.

Finally, it remains to complete the proof of Theorem 1.2.2: for this, we have to show that the singularities I and II are the only stable singularities of tangential family germs. Let us consider a tangential family germ  $f$  on prenormal form. Then the deformation  $f + \lambda(0, t^3 + t^2s)$  is tangential, and it is not trivial whenever  $f$  is not of first nor second type. Indeed, for every small enough  $\lambda$ , the deformed family has a singularity of type II (Proposition 1.4.1). This proves that every tangential family germ, stable under small tangential deformations, has a singularity I or II. The proof of Theorem 1.2.2 is now completed.



# Chapter 2

## Simple tangential families and perestroikas of their envelopes

ABSTRACT. Tangential families are 1-parameter families of rays emanating tangentially from given curves. We classify tangential family germs according to their envelope degeneracies: we prove that there are two infinite series and four sporadic simple tangential families (together with the two stable singularities studied in [17]). We give their normal forms and miniversal tangential deformations, and we describe the corresponding envelope perestroikas of small codimension. We also discuss envelope singularities of some non simple tangential families.

### 2.1 Introduction

In [17] we introduced a special class of 1-parameter families of smooth plane curves, called *tangential families*. A tangential family is a 1-parameter family of rays emanating tangentially from a curve. In [15] and [16] we have considered also tangential families with singular support (the singularity being a semicubic cusp).

Tangential families naturally arise in the Geometry of Caustics (see for example [10]) and in Differential Geometry. For instance, every smooth curve in a Riemannian surface defines the tangential family of its tangent geodesics.

The theory of tangential families is related to Singularity Theory, namely to the classical theories of Thom and Arnold on envelopes of 1-parameter families of curves. Actually, Thom proved that the only generic singularities of such envelopes are semicubic cusps and transversal self-intersections (see [28]). Arnold gave the three normal forms to which is possible to bring a generic family near a regular point of its envelope by a coordinate change (see [2], [3]). Tangential family theory is a generalization of envelope theory. Indeed, every 1-parameter family of plane curves is tangential, with respect to every generic point of any geometric branch of its envelope.

We have shown in [17] that there are exactly two singularities of tangential family germs which are stable under small tangential deformations (i.e., deformations among tangential families). We have also proved that the corresponding envelopes are smooth or have a second order self-tangency.

In this chapter we study the simple singularities of tangential family germs, their miniver-

sal tangential deformations and the corresponding perestroikas occurring to the family envelopes.

The chapter is divided into three parts. In the first part we present our results. We prove that there are two infinite series and four sporadic simple tangential family germs which are unstable. Our classification is a particular case of the more general classification of simple projections of surfaces from the space to the plane, due to V. V. Goryunov (see [24], see also [12]). We give the normal forms and miniversal tangential deformations of simple singularities of tangential family germs. Moreover we study envelopes of non simple tangential families in some particular case. In the second part we describe the small codimension perestroikas occurring to envelopes of simple tangential families under small tangential deformations. In the last part of the chapter we prove our results.

## 2.2 Simple singularities of tangential families

Unless otherwise specified, all the objects considered below are supposed real and of class  $\mathcal{C}^\infty$ ; by plane curve we mean an embedded dimension 1 submanifold of  $\mathbb{R}^2$ .

### 2.2.1 Preliminary results on tangential families

Let us consider a map  $f : \mathbb{R}^2 \rightarrow \mathbb{R}^2$  of the plane  $\mathbb{R}^2$ , whose coordinates are denoted by  $\xi$  and  $t$ . Whenever the partial derivative  $\partial_t f$  vanishes nowhere, such a mapping defines the 1-parameter family of plane curves parameterized by  $t$ , indicating the point on the curve, and indexed by  $\xi$ , indicating the curve in the family. The map  $f$  is called a *parameterization* of the family. We set  $f_\xi(t) := f(\xi, t)$ .

DEFINITION. The 1-parameter family parameterized by  $f$  is called a *tangential family* if its partial derivatives  $\partial_\xi f$  and  $\partial_t f$  are parallel non zero vectors at every point  $(\xi, 0)$ , and the image of the mapping  $\xi \mapsto f(\xi, 0)$  is a curve, called the *support* of the family.

In other terms, a family of plane curves, tangent to  $\gamma$ , is a tangential family whenever it can be parameterized by the tangency points of the family curves with the support.

The *graph* of such a family is by definition the smooth surface

$$\Phi := \{(q, p) : q = f(\xi, 0), p = f(\xi, t), \xi, t \in \mathbb{R}\} \subset \gamma \times \mathbb{R}^2.$$

Let us denote by  $\pi$  the projection  $(q, p) \mapsto p$  of the graph on  $\mathbb{R}^2$ . The *criminant set* (or *envelope in the source* in Thom's notations) of the tangential family is the critical set of  $\pi$ . The *envelope* is the apparent contour of the graph in the plane (i.e. the critical value set of  $\pi$ ). It turns out that the support of the family belong to the family envelope.

Below we will study tangential families near a fixed point of their supports, settled at the origin. Without loss of generality, we may consider their parameterizations as map germs  $(\mathbb{R}^2, 0) \rightarrow (\mathbb{R}^2, 0)$ . Note that graphs of tangential family germs are smooth.

Let  $\mathcal{A}$  be the direct product  $\text{Diff}(\mathbb{R}^2, 0) \times \text{Diff}(\mathbb{R}^2, 0)$ , where  $\text{Diff}(\mathbb{R}^2, 0)$  is the group of the diffeomorphism germs of the plane keeping fixed the origin. Denote by  $\mathfrak{m}_{\xi, t}$  the space of

function germs  $(\mathbb{R}^2, 0) \rightarrow (\mathbb{R}, 0)$  in the variables  $\xi$  and  $t$ . Then  $\mathcal{A}$  acts on the space  $(\mathfrak{m}_{\xi,t})^2$  by

$$(\varphi, \psi) \cdot f := \psi \circ f \circ \varphi^{-1}, \quad (\varphi, \psi) \in \mathcal{A}, \quad f \in (\mathfrak{m}_{\xi,t})^2.$$

Two elements of  $(\mathfrak{m}_{\xi,t})^2$  are *Left-Right equivalent*, or  $\mathcal{A}$ -*equivalent*, if they belong to the same orbit under the action of the group  $\mathcal{A}$ . Thus, the envelopes of  $\mathcal{A}$ -equivalent tangential family germs are diffeomorphic.

Let us denote by  $X_0$  the subset of  $(\mathfrak{m}_{\xi,t})^2$  formed by the tangential family germs. The *tangential family singularity* of a tangential family  $f \in X_0$  is by definition its  $\mathcal{A}$ -equivalence class.

Given a tangential family, the fiber  $\pi^{-1}(0, 0)$  defines a *vertical direction* in the tangent plane of the family graph at the origin of  $\gamma \times \mathbb{R}^2$ .

A *branch* passing through the origin of the discriminant set of a tangential family  $f$  is any irreducible component of the restriction of the critical set of  $f$  to an arbitrary small neighborhood of the origin.

DEFINITION. A tangential family is said to be of *first type* if its discriminant set has only one branch passing through the origin, of *second type* if it has exactly two branches passing through the origin and these branches are smooth, non vertical and transversal one to the other.

We will denote by  $X$  (resp. I, II) the set of all the map germs in  $(\mathfrak{m}_{\xi,t})^2$  which are  $\mathcal{A}$ -equivalent to tangential family germs (resp. tangential family germs of first type, of second type). By construction, these sets are union of  $\mathcal{A}$ -orbits, so they are invariant under the  $\mathcal{A}$ -action. Note that  $X$  is the smallest  $\mathcal{A}$ -invariant set in  $(\mathfrak{m}_{\xi,t})^2$  containing the set  $X_0$  of the tangential family germs.

Let us recall that a *p-parameter tangential deformation* of a tangential family germ  $f \in X_0$  is a *p-parameter family* of tangential families, parameterized by a *p-parameter family* of maps

$$\{F_\lambda : \mathbb{R}^2 \rightarrow \mathbb{R}^2, \lambda \in \mathbb{R}^p\},$$

such that the germ of  $F_0$  at the origin is  $f$ . For instance, the translation of the origin is a tangential deformation with two parameters.

The singularity of a tangential family germ is said to be *stable* if for every representative  $f$  of it and for every tangential deformation  $\{F_\lambda : \lambda \in \mathbb{R}^p\}$  of  $f$ , the tangential family parameterized by  $F_\lambda$  has a singularity  $\mathcal{A}$ -equivalent to that of  $f$  at some point arbitrary close to the origin, for every  $\lambda$  small enough.

We quote now from [17] the main result about stable tangential family germs.

THEOREM 2.2.1. *The sets I and II defines two singularities, which are all the stable singularities of the tangential families. The table below lists the representatives of these singularities, their extended codimensions and the codimensions of their orbits in  $(\mathfrak{m}_{\xi,t})^2$ .*

Singularity	Representative	Codim <sub>e</sub>	Codim
I	$(\xi, t^2)$	0	1
II	$(\xi, t^3 + t^2\xi)$	1	3



It follows from the Theorem that the envelope of every first type tangential family germ is smooth, while that of every second type tangential family germ has a second order self-tangency (see figure 2.1), and that these envelope singularities are stable under small tangential deformations.

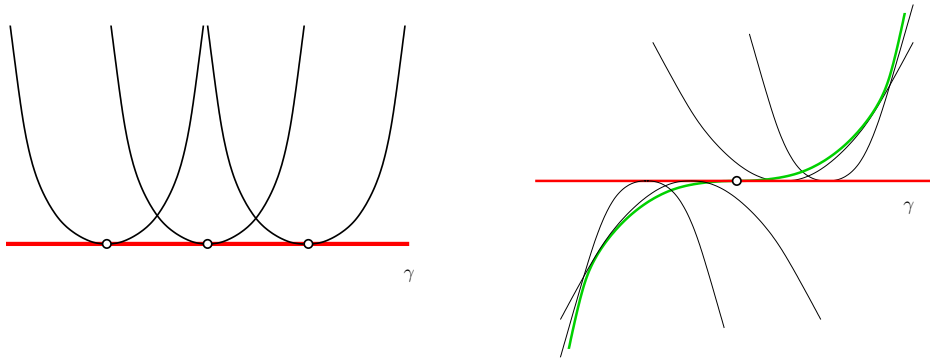

Figure 2.1: Stable tangential family germs of first and second type.

The stability of the envelope second order self-tangency is understood here as follows. Let  $\{F_\lambda : \lambda \in \mathbb{R}^p\}$  be a tangential deformation of a second type tangential family and let  $\mathcal{U}$  be an arbitrary small neighborhood of  $(0, 0)$  in  $\mathbb{R}^2$ . Then the envelope of the tangential family parameterized by  $F_\lambda$  has a second order self-tangency at some  $\lambda$ -dependent and family-dependent point of  $\mathcal{U}$ , provided that  $\lambda$  is small enough.

### 2.2.2 Classification of tangential families

The set  $X$  of the map germs  $\mathcal{A}$ -equivalent to tangential family germs is naturally decomposed into classes of tangential family singularities, that is, into  $\mathcal{A}$ -invariant sets, according to the degeneracies of the corresponding envelopes. We will now define such a decomposition.

Let us recall that for any tangential family  $f \in X$ , the branch of its discriminant set, which projects into the family support, is never vertical (Lemma 1.2.1 in [17]). Therefore, the discriminant set of any tangential family germ  $f \in X_0$ , which is not of first nor of second type, realizes one among the following configurations:

- (S) the discriminant set of  $f$  has two (smooth) branches crossing at the origin, one of which is vertical;
- (T) the discriminant set of  $f$  has two (smooth) branches crossing at the origin, which are tangent;
- (U) the discriminant set of  $f$  has more than two branches crossing at the origin or at least a singular branch passing through the origin.

In the preceding classification, one has to count every branch with its multiplicity and also branches reduced to a point. Note that the properties  $S$ ,  $T$  and  $U$  do not depend on the choice of the parameterization of the family, but only on its  $\mathcal{A}$ -orbit.

DEFINITION. A tangential family is said to be *of type*  $S$ ,  $T$  or  $U$  if it satisfies the condition (S), (T) or (U) respectively.

We denote by  $S$ ,  $T$  and  $U$  the subsets of  $X$  formed by the map germs  $\mathcal{A}$ -equivalent to parameterizations of tangential family germs of type  $S$ ,  $T$  and  $U$  respectively. These sets are disjoint and  $\mathcal{A}$ -invariant; in particular, they define three classes of tangential family singularities. These classes, together with the stable singularities I and II, cover all the tangential family singularities; indeed,

$$S \cup T \cup U = X \setminus (\text{I} \cup \text{II}) .$$

Let us refine the preceding classification.

DEFINITION. Let us fix  $n \in \mathbb{N} \cup \{\infty\}$ . A tangential family of type  $S$  is *of type*  $S_n$  whenever the tangency order between its criminant set and the vertical direction is equal to  $n$ . A tangential family of type  $T$  is *of type*  $T_n$  whenever its criminant set has a self-tangency of order  $n$ .

To complete our classification we need some notations. We say that a curve has a singularity of order  $b/a$  at a fixed point if in a suitable coordinate system  $\{x, y\}$ , centered at this point, the curve is parameterized by  $t \mapsto (t^a, t^b + o(t^b))$ , where  $a, b \in \mathbb{N}$ ,  $a < b$  and  $a$  does not divide  $b$ . For example, a semicubic cusp has a singularity of order  $3/2$ . We will say that the singular curve is tangent to the smooth curve, whose equation in the suitable coordinate system is  $y = 0$ .

By the very definition, the envelopes of the  $S_1$ -type tangential families have cusps of order  $(2n + 3)/2$  at the origin (for some  $n \in \mathbb{N} \cup \{\infty\}$ ).

DEFINITION. A tangential family of type  $S_1$  is said to be *of type*  $S_{1,n}$  if its envelope has a cusp of order  $(2n + 3)/2$  at the origin.

We will denote by  $S_n$ ,  $T_n$  and  $S_{1,n}$  the subsets of  $X$  composed by the map germs  $\mathcal{A}$ -equivalent to tangential family germs of the corresponding type.

### 2.2.3 Simple tangential families

We may state now our main results concerning the classification of tangential family singularities, which are proven in sections 2.4.3, 2.4.4 and 2.4.5.

THEOREM 2.2.2. *For every  $n \in \mathbb{N}$ , the sets  $S_{1,n}$  and  $T_n$  are orbits for the action of  $\mathcal{A}$  on  $X$ . The set  $S_2$  split off into the four  $\mathcal{A}$ -orbits of the map germs  $(\xi, t^5 + t^2\xi + t^6)$ ,  $(\xi, t^5 + t^2\xi \pm t^9)$  and  $(\xi, t^5 + t^2\xi)$ .*

Therefore, these orbits define some singularities, denoted by  $S_{1,n}$ ,  $T_n$ ,  $S_{2,2}$ ,  $S_{2,3}^\pm$  and  $S_{2,4}$ .

DEFINITION. A map germ  $f \in X$  is said to be *simple* if, by an arbitrary sufficiently small perturbation of it, we can obtain representatives of only a finite number of tangential family singularities. A tangential family singularity is *simple* whenever its representatives are simple.

Note that a map germ  $f \in X$  is simple if and only all the points of the orbit  $\mathcal{A} \cdot f$  are simple.

**THEOREM 2.2.3.** *The simple tangential family singularities are exactly those listed in the table below, together with their normal forms, extended codimensions and codimensions of the corresponding orbits in  $(\mathbf{m}_{\xi,t})^2$ .*

Singularity	Normal form	$\text{codim}_e$	$\text{codim in } (\mathbf{m}_{\xi,t})^2$
I	$(\xi, t^2)$	0	1
II	$(\xi, t^3 + t^2\xi)$	1	3
$S_{1,n}$	$(\xi, t^4 + t^2\xi + t^{2n+3})$	$n + 1$	$n + 3$
$T_n$	$(\xi, t^3 + t^2\xi^{n+1})$	$2n + 1$	$2n + 3$
$S_{2,2}$	$(\xi, t^5 + t^2\xi + t^6)$	3	5
$S_{2,3}^\pm$	$(\xi, t^5 + t^2\xi \pm t^9)$	4	6
$S_{2,4}$	$(\xi, t^5 + t^2\xi)$	5	7

This table is part of Goryunov's classification of simple projections of surfaces from  $\mathbb{R}^3$  into  $\mathbb{R}^2$  ([24]).

The proof of the Theorem is given in section 2.4.6.

We shall now describe the envelopes of simple tangential families. First, we introduce a definition. A parameterized curve with a singularity  $b/a$  is *asymmetric* to a smooth curve tangent to it at the singular point if it is contained into one of the two domains cut off near the singular point by the smooth curve. For example, a cusp of order  $5/2$  parameterized by  $t \mapsto (t^2, t^4 + t^5)$  is asymmetric to  $y = 0$ , while a cusp of order  $5/2$  parameterized by  $t \mapsto (t^2, t^5)$  is symmetric to  $y = 0$ .

**COROLLARY.** *The envelope of every simple tangential family germ has two tangent branches, one of which is the support of the family, provided that the family is not of first type. Moreover:*

- (i) *for every  $S_{1,n}$ -type family, the second branch of the envelope has a cusp of order  $(2n + 3)/2$  at the tangency point, the cusp being asymmetric to the support;*
- (ii) *for every  $S_2$ -type tangential family, the second branch of the envelope has a singularity of order  $5/3$  at the tangency point;*
- (iii) *for every  $T_n$ -type family, the second branch of the envelope is smooth, and it has a tangency of order  $3n + 2$  with the support.*

The envelope singularities of the simple tangential families are shown in figure 2.2. In this figure, as in those below, the natural number over a tangency point between two smooth branches denotes their tangency order; the rational number over a singular point denotes the order of the singularity.

We end this section describing the envelopes of non simple tangential families in the cases of  $S_n$ -type families, for  $n \geq 3$ . The envelopes of such families have two branches, one of them being the family support.

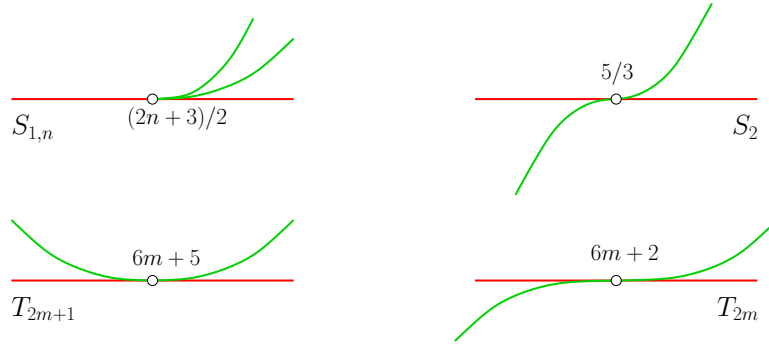

Figure 2.2: The envelopes of the simple tangential families.

**THEOREM 2.2.4.** *For  $n \geq 3$ , the envelope second branch of every  $S_n$ -type tangential family germ has a singularity of order  $(n + 3)/(n + 1)$  at the tangency point with the support. If  $n$  is even, this singularity is a cusp, which is asymmetric to the support.*



Figure 2.3: Envelopes of  $S_n$ -type tangential families for  $n \geq 3$ .

The Theorem will be proven in section 2.4.3.

### 2.2.4 Miniversal tangential deformations

The standard definition of versality of map germ deformations can be applied in a natural way to the tangential deformations.

**DEFINITION.** A  $p$ -parameter tangential deformation  $F : \mathbb{R}^2 \times \mathbb{R}^p \rightarrow \mathbb{R}^2$  of a tangential family germ  $f \in X_0$  is said to be an  $\mathcal{A}$ -versal tangential deformation if any tangential deformation of  $f$  is  $\mathcal{A}$ -equivalent to a tangential deformation induced from it.

This means that every tangential deformation  $G : \mathbb{R}^2 \times \mathbb{R}^q \rightarrow \mathbb{R}^2$  of  $f$  can be represented as  $G(\xi, t; \mu) \equiv \Psi(F(\Phi(\xi, t; \mu), \Lambda(\mu)); \mu)$ , where  $\Phi(\xi, t; \mu)$  and  $\Psi(\xi, t; \mu)$  are deformations of the identity diffeomorphisms of the source  $\mathbb{R}^2$  and the target  $\mathbb{R}^2$  and  $\Lambda$  is a map germ  $(\mathbb{R}^q, 0) \rightarrow (\mathbb{R}^p, 0)$ . It is not required that  $\Phi(0, 0; \mu) = 0$  and  $\Psi(0, 0; \mu) = 0$  for  $\mu \neq 0$ .

A *miniversal* tangential deformation is a versal deformation for which the base dimension  $p$  is minimal. The number  $p$  is the same for all the  $\mathcal{A}$ -equivalent map germs; it is by definition the *tangential codimension* of the unperturbed tangential family.

**THEOREM 2.2.5.** *The  $\mathcal{A}$ -miniversal tangential deformations of the map germs representing the tangential family simple singularities (except  $T_n$  for  $n > 1$ ) are listed in the table below, together with their tangential codimensions  $\tau$ .*



We denote by  $(L)$  some class of non simple singularities. For instance,  $(S_n)_{n \geq 3}$  denotes the union of all the singularities of type  $S_n$ , for  $n \geq 3$ . In the case of non simple singularities, the arrow  $(L) \rightarrow K$  means that there exists some singularity  $L' \subset (L)$  adjacent to  $K$ ; similarly,  $(L) \rightarrow (K)$  means that there exists two singularities  $L' \subset (L)$  and  $K' \subset (K)$  such that  $L' \rightarrow K'$ . The main adjacencies of non simple singularities are as follows:

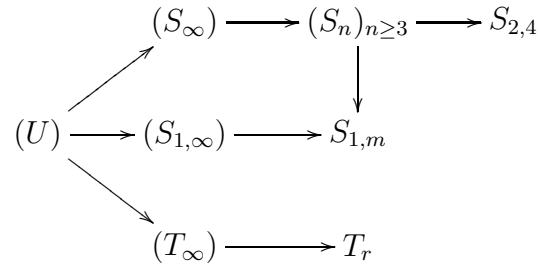

## 2.3 Bifurcation diagrams of simple singularities

We shall discuss here the bifurcation diagrams of small codimension simple singularities of tangential family germ, and the perestroikas occurring to the envelopes of these families under small  $\mathcal{A}$ -miniversal tangential deformations.

For this, let us recall some definitions. Let  $L$  be a tangential family singularity of tangential codimension  $n$ . Denote by  $F : \mathbb{R}^2 \times \mathbb{R}^n \rightarrow \mathbb{R}^2$  a miniversal tangential deformation of a representative  $f$  of the singularity  $L$ .

The *discriminant of  $f$*  is the submanifold of  $\mathbb{R}^n$  formed by the parameter values  $\lambda$  for which the critical value set of  $F_\lambda$  has more complicated singularities than for some arbitrary close value of  $\lambda$ .

The germ at the origin of the discriminant does not depend (up to diffeomorphisms) on the choice of the miniversal deformation of  $f$  neither on the choice of  $f$  in  $L$ . We call this hypersurface germ the *discriminant* of the tangential family singularity. The *bifurcation diagram* of a singularity is its discriminant, together with the corresponding envelopes perestroikas.

### 2.3.1 Bifurcation diagrams of singularities $S_{1,n}$

Let  $F$  be the  $\mathcal{A}$ -miniversal tangential deformation of the singularity  $S_{1,1}$  given in Theorem 2.2.2:

$$F(\xi, t; \lambda) = (\xi, t^4 + t^2\xi + t^5 + \lambda t^3) .$$

For any  $\lambda$ , the support of the family has equation  $y = 0$ . The critical value set of  $F_\lambda$  has a second branch  $\delta_\lambda$ . If  $\lambda \neq 0$ , the germ at the origin of  $F_\lambda$  belongs to the  $\mathcal{A}$ -orbit II; hence,  $\delta_\lambda$  has a tangency of order 2 with the support.

For  $\lambda < 0$ ,  $\delta_\lambda$  has a semicubic cusp and a transversal self-intersection. When  $\lambda$  goes to zero, these two singular points collide, and a cusp of order  $5/2$ , asymmetric to the support, arises. For  $\lambda > 0$ , the self-intersection point becomes complex, and the only singularity of  $\delta_\lambda$  is the semicubic cusp.

The perestroika of the envelope singularity  $S_{1,1}$ , resulting by the above discussion, is depicted in figure 2.4 (in which  $\gamma$  denotes the family support).

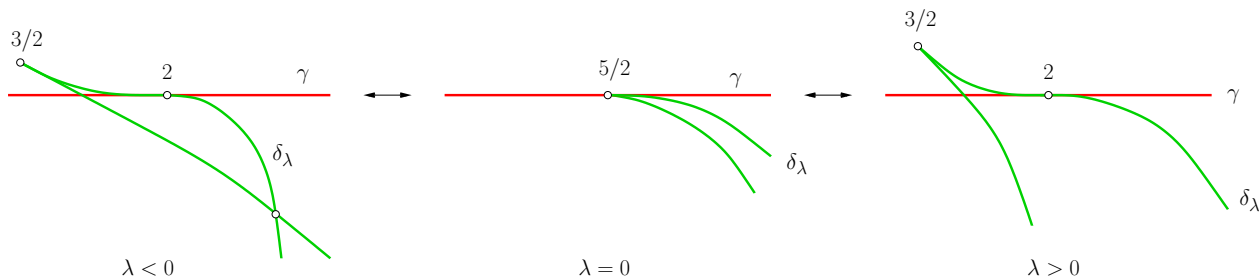

Figure 2.4: Envelope perestroika of the singularity  $S_{1,1}$ .

Let us consider in the 3-space  $\{x, y, \lambda\}$  the singular surface

$$M := \{(F_\lambda(\xi, t), \lambda) : \det DF_\lambda(\xi, t) = 0\} ,$$

formed by the critical value sets of  $F_\lambda$ . This surface, shown in figure 2.5, is the union of the plane  $\{y = 0\}$ , formed by the support curves, and the singular surface, formed by the branches  $\delta_\lambda$ .

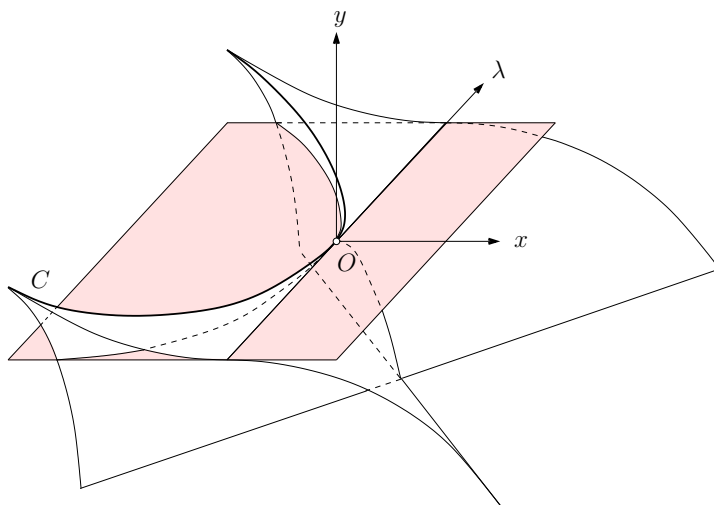

Figure 2.5: The singular surface  $M$ .

**REMARK.** The surface  $M$  is diffeomorphic to a folded umbrella with a cubically tangent smooth surface; the half-line of the umbrella self-intersection points is tangent to the smooth surface. The surface  $M$  is also diffeomorphic to the surface formed by the tangent lines of the curve  $t \mapsto (t, t^2, t^4)$ , corresponding to the curve  $C$  in figure 2.5, with the osculating plane at its flattening point  $O$ .

The singular surface  $M$  appears in many problems in Singularity Theory. For instance,  $M$  can be described as the set in the space  $\{a, b, c\}$  consisting of the polynomials  $X^4 + aX^3 + bX^2 + c$  with multiple roots. This surface arises also in Kazaryan's theory about set of fundamental systems of solutions of a linear differential equation and in Shcherbak's theory of tangential singularities of projective curves (see [12], §4).

REMARK. The discriminant of  $S_{1,n}$  contains the flag  $V_{n-1} \supset V_{n-2} \supset \dots \supset V_0$ , where

$$V_i := \{\lambda_j = 0 : j = 1, \dots, n - i\} .$$

To each stratum  $V_i \setminus V_{i-1}$  corresponds tangential families of type  $S_{1,i}$ , according to adjacency  $S_{1,n} \rightarrow S_{1,n-1}$  (where, by convention,  $S_{1,0} = \text{II}$ ).

The discriminant of the singularity  $S_{1,2}$  is represented in figure 2.6. It has been found for me experimentally by Francesca Aicardi. Notice that it contains the flag  $V_1 \supset V_0$  and a curve, corresponding to a self-tangency of the envelope second branch.

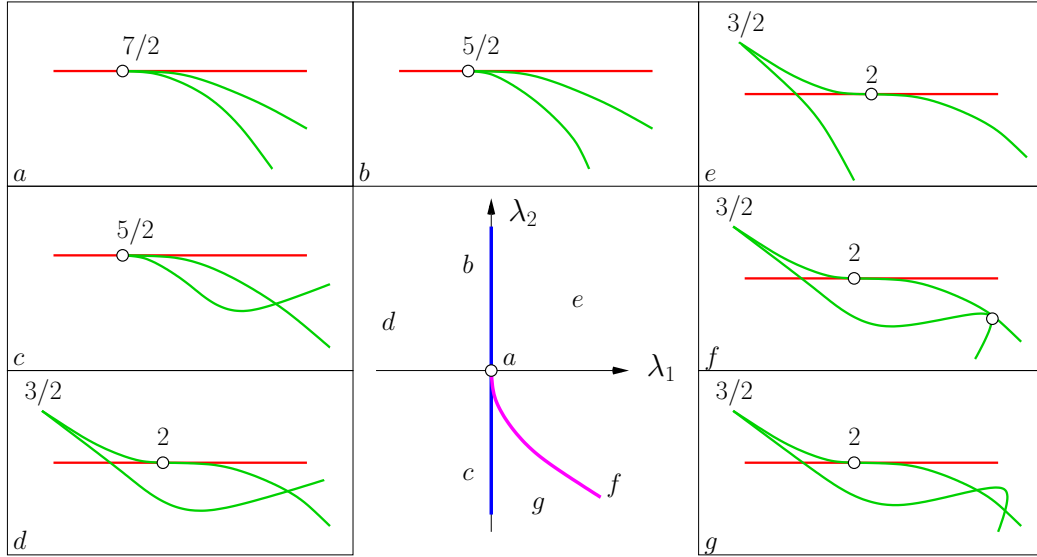

Figure 2.6: Bifurcation diagram of the singularity  $S_{1,2}$ .

### 2.3.2 Bifurcation diagram of the singularity $S_{2,2}$

Let  $G$  be the  $\mathcal{A}$ -miniversal tangential deformation of the singularity  $S_{2,2}$ :

$$G(\xi, t; \lambda_1, \lambda_2) = (\xi, t^5 + t^2\xi + t^6 + \lambda_1 t^3 + \lambda_2 t^4) .$$

The equation  $\det DG_\lambda = 0$  has two solutions,  $t = 0$  and  $\xi = \Xi(t)$ . The branch of the critical value set corresponding to the first solution is the  $x$ -axis (the support  $\gamma$  of the family); the second branch  $\delta_\lambda$  is parameterized by  $t \mapsto G_\lambda(t, \Xi(t))$ . It turns out that the latter branch has singular points at the solutions of the equation

$$24t^3 + 15t^2 + 8\lambda_2 + 3\lambda_1 = 0 .$$

One of these solutions does not vanish when  $\lambda_1$  and  $\lambda_2$  go to zero. The corresponding singular point of  $\delta_\lambda$  is a semicubic cusp, which is far from the support (even for  $\lambda \rightarrow 0$ ). The preceding equation has two other solutions, which becomes zero at  $\lambda_1 = \lambda_2 = 0$ , provided that  $\lambda_1 \leq \varphi_1(\lambda_2)$ , where

$$\varphi_1(\lambda_2) = \frac{16}{45}\lambda_2^2 + o(\lambda_2^2) , \quad \text{for } \lambda_2 \rightarrow 0 .$$



Thus, the discriminant of  $S_{2,2}$  contains the curve  $\lambda_1 = \varphi_1(\lambda_2)$ , which is close to a parabola near the origin. When  $\lambda$  belongs to this curve,  $\delta_\lambda$  has a singularity  $4/3$ .

Similarly, there are three other branches  $\lambda_1 = \varphi_i(\lambda_2)$ ,  $i = 2, 3, 4$ , corresponding to the following degeneracies of the critical value set of  $G_\lambda$ : a cusp of  $\delta_\lambda$  belongs to  $\gamma$ ;  $\delta_\lambda$  has a self-intersection at a point of  $\gamma$ ;  $\delta_\lambda$  has a self-intersection at a cusp point. The curves  $\lambda_1 = \varphi_i(\lambda_2)$  are close to some parabolæ near the origin, i.e.  $\varphi_i(\lambda_2) = c_i\lambda_2^2 + o(\lambda_2^2)$  for  $\lambda_2 \rightarrow 0$ , with  $c_2 > c_3 > 0 > c_4$ .

The discriminant of the singularity is completed by the  $\lambda_2$  axis: when  $\lambda_1 = 0$ ,  $\delta_\lambda$  has a cusp of order  $5/2$  at its tangency point with the support, according to the adjacency  $S_{2,2} \rightarrow S_{1,1}$ . The discriminant of the singularity  $S_{2,2}$  and the corresponding envelope perestroikas are illustrated in figure 2.7. To my knowledge, this perestroika did not appear earlier.

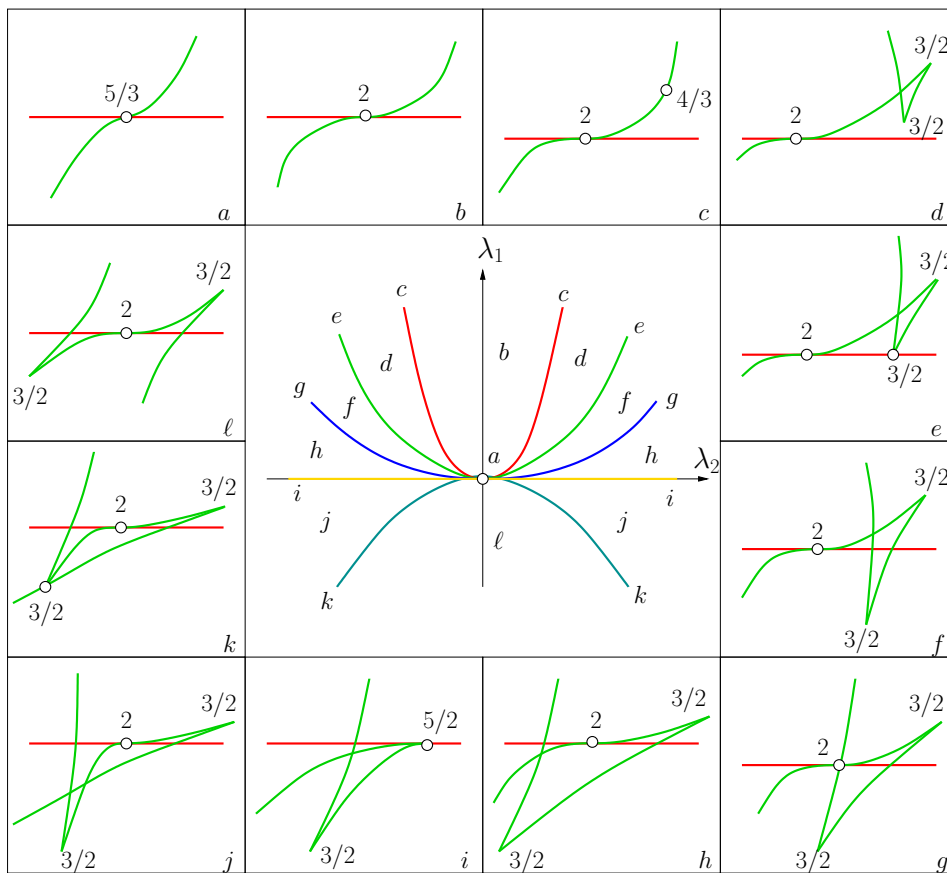

Figure 2.7: Bifurcation diagram of the singularity  $S_{2,2}$ .

### 2.3.3 Bifurcations diagrams of the singularities $T_n$ .

Let  $H$  be the tangential deformation of the singularity  $T_n$ :

$$H(\xi, t; \lambda_1, \dots, \lambda_n) = \left( \xi, t^3 + t^2\xi^{n+1} + t^2 \sum_{i=1}^n \lambda_i \xi^{i-1} \right).$$

The envelope of  $H_\lambda$  has two branches; one of them is the support of the family  $y = 0$ , which is kept fixed by the deformation. Denote again by  $\delta_\lambda$  the envelope second branch of  $H_\lambda$ . This branch is the graph  $y = P_\lambda(x)$  of the polynomial  $P_\lambda := \frac{4}{27}Q_\lambda^3$ , where

$$Q_\lambda(x) := x^{n+1} + \lambda_n x^{n-1} + \dots + \lambda_1 ,$$

which is the miniversal deformation of  $x^{n+1}$  for the Right equivalence on the space of function germs  $(\mathbb{R}, 0) \rightarrow \mathbb{R}$ .

The discriminant of the deformation  $H_n$  of the singularity  $T_n$  is the set formed by the values  $\lambda$  for which  $P_\lambda$  has roots of multiplicity greater than 3. If  $Q_\lambda$  has a root of multiplicity  $m$ , then  $P_\lambda$  has a root of multiplicity  $3m$ . Thus, we have the following.

**THEOREM 2.3.1.** *The discriminant of the deformation  $H_n$  of the singularity  $T_n$  is diffeomorphic to a dimension  $n$  swallowtail.*

The bifurcation diagrams of the deformations  $H_n$  of the singularities  $T_n$  are depicted in figures 2.8, 2.9 and 2.10 for  $n = 1, 2$  and 3 respectively. Let us recall that for  $n = 1$  the deformation  $H$  is a miniversal tangential deformation.

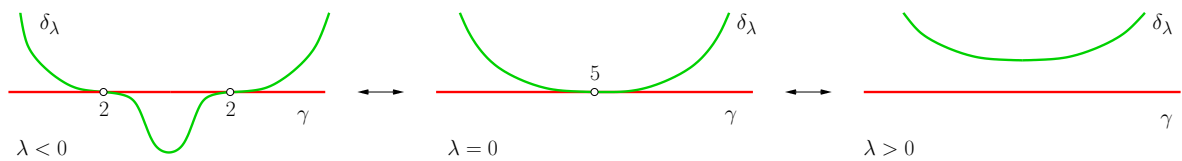

Figure 2.8: Bifurcation diagram of the singularity  $T_1$ .

In the case of the singularity  $T_2$ , the parameter plane is divided into 4 orbits. In the orbit  $d$  a singularity  $T_1$  arises, according to the adjacency  $T_2 \rightarrow T_1$ .

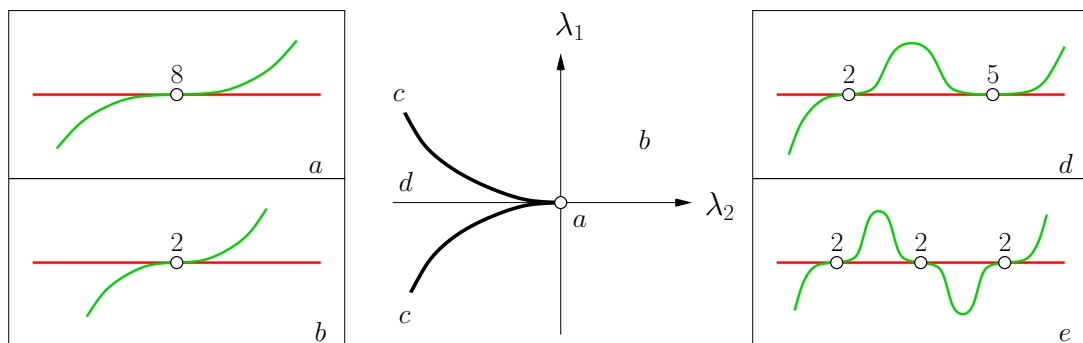
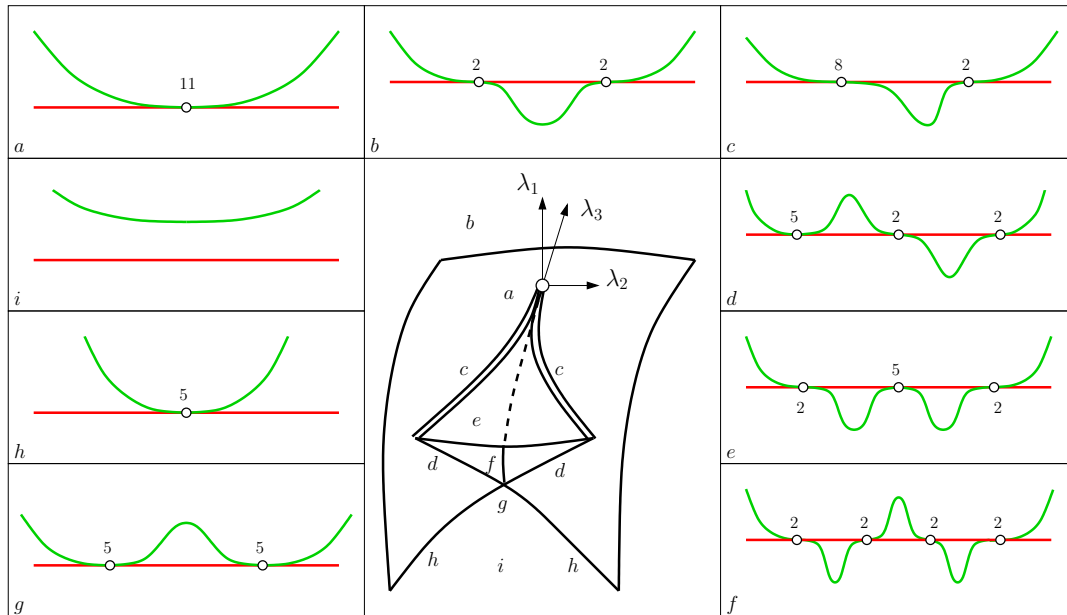

Figure 2.9: Bifurcation diagram of the deformation  $H_2$ .

Similarly, in the case of the singularity  $T_3$  the parameter space split off into 9 orbits. In the orbit  $c$  a singularity  $T_2$  arises, and in the orbits  $d, e, g$  and  $h$  some singularities  $T_1$  appear, according to the adjacencies  $T_3 \rightarrow T_2 \rightarrow T_1$ .

Figure 2.10: Bifurcation diagram of the deformations  $H_3$ .

## 2.4 Proofs

### 2.4.1 Prenormal forms of tangential families

Let us quote from [17] a standard prenormal form (for the  $\mathcal{A}$ -equivalence) of map germs parameterizing tangential families.

Let us fix a tangential family, defined near the origin and a coordinate system, centered at this point, in which the family support is defined locally by the equation  $y = 0$ . Consider the curve of the family, which is tangent to the support at  $(\xi, 0)$ . Let  $2 \sum_{i=0}^{\infty} k_i \xi^i$  be the expansion for  $\xi \rightarrow 0$  of its curvature at the tangency point, so its curvature at the origin is equal to  $2k_0$ . Let also  $k_0 t^2 + \alpha t^3 + o(t^3)$  be the expansion for  $t \rightarrow 0$  of the function whose graph is the tangent curve to the support at the origin. We will denote by  $\delta(n)$  any function of two variables with vanishing  $n$ -jet at the origin.

The following statement is a slight refinement of those in [17]; the proof is the same.

**THEOREM 2.4.1.** *Every tangential family germ is  $\mathcal{A}$ -equivalent to a map germ of the form*

$$(\xi, t) \mapsto \left( \xi, (\alpha - k_1)t^3 + t^2 \sum_{i=0}^{\infty} k_i \xi^i + t^3 \cdot \delta(0) \right),$$

where the coefficients  $k_i$  and  $\alpha$ , depending on the family, are defined as above.

The germ in the above statement is called *prenormal form*. Note that the prenormal form of a tangential family germ is not unique, namely, the coefficients  $\alpha$  and  $k_i$  depend on the coordinate system used to define them. However, the following characterizations of tangential family types in terms of these coefficients do not depend on the choices made for

their definition. In [17] we proved that a tangential family germ is of first type if and only if  $k_0 \neq 0$ ; it is of second type if and only if  $k_0 = 0$  and  $k_1 \neq 0, \alpha$ . Therefore, for any tangential family germ which is not of first nor of second type we have  $k_0 = 0$  and  $k_1(k_1 - \alpha) = 0$ .

Let us characterize the tangential families of type  $S$ ,  $T$  and  $U$  by their prenormal form.

**PROPOSITION 2.4.1.** *A tangential family germ is of type  $S$ ,  $T$  or  $U$  if and only if the parameters of its prenormal form verify  $\alpha = k_1 \neq 0$ ,  $\alpha \neq k_1 = 0$  or  $\alpha = k_1 = 0$  respectively. More precisely,*

- (i) *a tangential family is of type  $S_n$  if and only if its prenormal form, evaluated at  $\xi = 0$ , can be written, for  $t \rightarrow 0$ , as  $t \mapsto (0, at^{n+3} + o(t^{n+3}))$ , for some  $a \neq 0$ ;*
- (ii) *a tangential family is of type  $T_n$  if and only if  $k_i = 0$  for every  $i = 0, \dots, n$  and  $\alpha, k_{n+1} \neq 0$ .*
- (iii) *a tangential family is of type  $U$  if and only if its prenormal form can be written as  $(\xi, t) \mapsto (\xi, t^2 \cdot \delta(1))$ .*

*Proof.* Let us consider the prenormal form  $f$  of a tangential family germ (we assume that the family is not of first type, i.e.,  $k_0 = 0$ ). The discriminant set equation associated to  $f$  can be written as:

$$3(\alpha - k_1)t^2 + 2k_1t\xi + 2t \cdot \delta(1) = 0. \quad (2.1)$$

The first branch of the discriminant set, corresponding to the solution  $t = 0$ , projects into the family support. The family is of type  $S$  if and only if the second branch is transversal to the first one, i.e., if and only if the corresponding solution of (2.1) is the graph of a function  $t \mapsto \Xi(t)$ . In particular,  $\Xi'(0) = -3(\alpha - k_1)/(2k_1)$  and  $k_1 \neq 0$ . The family graph  $\Phi$  is parameterized by  $(\xi, t) \mapsto (t - \xi, f(\xi, t))$ , and the vertical direction at the origin in  $T_0\Phi$  is  $(1, 0, 0)$ . The velocity at the origin of the second discriminant branch is  $(\Xi'(0) - 1, -\Xi'(0), 0)$ , so the branch is vertical if and only if  $\Xi'(0) = 0$ , that is, if  $\alpha = k_1$ . Assume now  $\alpha = k_1$ . Suppose also that there exists  $a \neq 0$  and  $n \in \mathbb{N}$  such that

$$f(0, t) = (0, at^{n+3} + o(t^{n+3})) \quad \text{for } t \rightarrow 0.$$

We shall prove that this assumption is equivalent to the belonging of  $f$  to  $S_n$ . Indeed, we have

$$\Xi(t) = -\frac{a(n+3)}{2k_1} t^{n+1} + o(t^{n+1}), \quad \text{for } t \rightarrow 0.$$

Therefore, the second discriminant branch is parameterized near the origin by

$$t \mapsto \left( t + o(t), -\frac{a(n+3)}{2k_1} t^{n+1} + o(t^{n+1}), \frac{(n+1)a}{2} t^{n+3} + o(t^{n+3}) \right), \quad (2.2)$$

so it is tangent to the vertical direction at the origin, with tangency order equal to  $n$ . This means that the family is of type  $S_n$ . Conversely, if the family is of type  $S_n$ , then the second solution of the discriminant set equation (2.1) is tangent to the  $t$ -axis, the tangency order being equal to  $n$ . This implies that the function  $\Xi$  can be written as  $\Xi(t) = O(t^n)$ . This is the case if and only if  $f(0, t) = (0, at^{n+3} + o(t^{n+3}))$  with  $a \neq 0$ . The first assertion is proven.

Suppose now that the tangential family  $f$  is of type  $T$ . Then the second solution of (2.1) is the graph of a function  $\xi \mapsto \tau(\xi)$ , such that  $\tau'(0) = -(2k_1)/(3(\alpha - k_1))$ . In particular,  $\alpha \neq k_1$ . The velocity at the origin of the corresponding criminant branch is  $(\tau'(0) - 1, 1, 0)$ , which is parallel to the velocity  $(-1, 1, 0)$  of the first branch if and only if  $k_1 = 0$ . Assume now  $k_1 = \dots = k_n = 0$  and  $k_{n+1} \neq 0$ . In this case

$$\tau(\xi) = -\frac{2k_{n+1}}{3\alpha}\xi^{n+1} + o(\xi^{n+1}), \quad \text{for } \xi \rightarrow 0.$$

The corresponding criminant branch is parameterized near the origin by

$$\xi \mapsto \left( -\xi - \frac{2k_{n+1}}{3\alpha}\xi^{n+1} + o(\xi^{n+1}), \xi, \frac{4k_{n+1}^3}{27\alpha^2}\xi^{3(n+1)} + o(\xi^{3(n+1)}) \right).$$

Therefore, the criminant set has a self-tangency of order  $n$  at the origin, i.e., the family is of type  $T_n$ . Conversely, if the family is of type  $T_n$ , then the two solutions of the criminant set equation (2.1) have a self-tangency of order  $n$  at the origin. This implies that the function  $\tau$  can be written as  $\tau(\xi) = O(\xi^n)$ , so  $k_1 = \dots = k_n = 0$  and  $k_{n+1} = 0$ .

Finally, let us consider a tangential family whose prenormal form is  $(\xi, t) \mapsto (\xi, t^2 \cdot \delta(1))$ . Then the criminant set equation is of the form  $t\varphi(\xi, t) = 0$ , where  $\varphi$  is a function with vanishing 1-jet. The Newton diagram of this equation shows that the equation  $\varphi^{\mathbb{C}} = 0$ , where  $\varphi^{\mathbb{C}}$  is the complexification of  $\varphi$ , has more than three branches or it has at least one singular branch passing through the origin. On the other hand, if the 1-jet of  $\varphi$  is not vanishing, then  $f$  has a singularity I, II,  $S$  or  $T$ .  $\square$

Note that the above characterization of the  $U$ -type tangential families provides the adjacencies  $(U) \rightarrow S_n$  and  $(U) \rightarrow T_n$ .

Theorem 2.2.4 follows from the parameterization (2.2).

## 2.4.2 Preliminary background of Singularity Theory

In this section we recall some standard notations we will use in the proofs of Theorems 2.2.2 and 2.2.5; here we follow [11], [13], [26]. A map germ

$$f : (\mathbb{R}^2, 0) \rightarrow (\mathbb{R}^2, 0)$$

defines, by the formula  $f^*g := g \circ f$ , a homomorphism from the ring  $\mathcal{E}_{x,y}$  of the function germs in the target to the ring  $\mathcal{E}_{\xi,t}$  of the function germs in the source. Hence we can consider every  $\mathcal{E}_{\xi,t}$ -module as an  $\mathcal{E}_{x,y}$ -module via this homomorphism.

The *extended tangent space* to the  $\mathcal{A}$ -orbit  $\mathcal{A} \cdot f$  at  $f$  is the subspace of  $\mathcal{E}_{\xi,t}^2$  defined by

$$T_e\mathcal{A}(f) := \mathcal{E}_{\xi,t} \cdot J(f) + f^*(\mathcal{E}_{x,y}) \cdot \mathbb{R}^2,$$

where  $J(f)$  is the real vector space spanned by the first order partial derivatives of  $f$ . In a similar way, we define the *tangent space* at  $f$  as

$$T\mathcal{A}(f) := \mathfrak{m}_{\xi,t} \cdot J(f) + f^*(\mathfrak{m}_{x,y}) \cdot \mathbb{R}^2.$$

Note that  $T_e\mathcal{A}(f)$  and  $T\mathcal{A}(f)$  are  $\mathcal{E}_{x,y}$ -modules, being in general not  $\mathcal{E}_{\xi,t}$ -modules. The codimension in  $(\mathfrak{m}_{\xi,t})^2$  of an  $\mathcal{A}$ -orbit  $\mathcal{A} \cdot f$  is the dimension of the quotient space  $(\mathfrak{m}_{\xi,t})^2/T\mathcal{A}(f)$  as real vector space.

Let  $\langle f \rangle$  be the  $\mathcal{E}_{\xi,t}$ -ideal generated by the components of  $f$ . Let us recall that the Preparation Theorem of Weierstrass-Malgrange-Mather (see [26]) states that the  $\mathcal{E}_{x,y}$ -module  $\mathcal{E}_{\xi,t}$  is finitely generated if and only if the quotient space  $\mathfrak{m}_{\xi,t}/\langle f \rangle$  is a real vector space of finite dimension; moreover a basis of the latter space provides a generator system of the module.

Let us consider now the space  $\mathbb{R}[[\xi, t]]$  endowed with a quasihomogeneous filtration defined by the weights  $\deg(\xi) = a$  and  $\deg(t) = b$ . We assume that  $a$  and  $b$  are coprime natural numbers. A function germ  $f \in \mathfrak{m}_{\xi,t}$  is said to be *quasihomogeneous* of degree  $d$  if for any  $\lambda > 0$  we have  $f(\lambda^a \xi, \lambda^b t) = \lambda^d f(\xi, t)$ . In particular, a monomial  $\xi^p t^q$  has weighted degree equal to  $ap + bq$ . A polynomial (function germ, power series) has *order*  $d$  if all its monomials have degree  $d$  or higher. If all the monomials of the polynomial have degree  $d$ , we shall say that the polynomial is quasihomogeneous of weighted degree  $d$ . A polynomial  $P$  (function germ, power series) is said to be *semiquasihomogeneous* of degree  $d$  if it is of the form  $P' + R$ , where  $P'$  is a quasihomogeneous polynomial of degree  $d$  and  $R$  is of order greater than  $d$ . Note that we do not assume any nondegeneracy condition on  $P'$ . A (formal) vector field  $V$  has order  $d$  if differentiation in the direction of the field  $V$  raises the order of any function by not less than  $d$ .

In [13] the following estimate is proven.

LEMMA 2.4.1. *Let  $f$  be a power series of order  $d$  and  $V = u \partial_\xi + v \partial_t$  a formal vector field of order  $d' > 0$ . Then the Taylor series*

$$\varphi(\xi + u(\xi, t), t + v(\xi, t)) = \varphi(\xi, t) + (u \partial_\xi \varphi + v \partial_t \varphi)(\xi, t) + R(\xi, t)$$

*has remainder term  $R$  of order greater than  $d + d'$ .*

Let  $f = (f_1, f_2)$  be an element of  $(\mathfrak{m}_{\xi,t})^2$ , whose components  $f_1$  and  $f_2$  are semiquasihomogeneous function germs (of different degree) for the fixed quasihomogeneous filtration. In order to simplify some forthcoming computations, we introduce the *reduced tangent space* to the  $\mathcal{A}$ -orbit at the point  $f$ , defined by

$$T_r\mathcal{A}(f) := \mathfrak{g}_+(f) + f^*(\mathcal{M}) ,$$

where  $\mathfrak{g}_+(f)$  is the space of the vector field germs having positive order, and  $\mathcal{M}$  is the  $\mathcal{E}_{x,y}$ -module defined by

$$\mathcal{M} := (\mathfrak{m}_{x,y}^2 \oplus \mathbb{R} \cdot y) \times (\mathfrak{m}_{x,y}^2 \oplus \mathbb{R} \cdot x) ,$$

and  $\mathfrak{m}_{x,y}^2$  is the second power of the maximal ideal  $\mathfrak{m}_{x,y}$ . Note that the reduced tangent space is an  $\mathcal{E}_{x,y}$ -module, being in general not an  $\mathcal{E}_{\xi,t}$ -module; furthermore,  $T_r\mathcal{A}(f) \subset T\mathcal{A}(f)$ .

PROPOSITION 2.4.2. *Let  $P$  and  $Q$  be two quasihomogeneous polynomials of weighted degree  $p$  and  $q$  respectively. Then the map germ  $f = (f_1, f_2)$  is  $\mathcal{A}$ -equivalent to a map germ of the form*

$$(f_1 + P + \delta(p), f_2 + Q + \delta(q)) ,$$

*provided that the reduced tangent space  $T_r\mathcal{A}(f)$  contains a map germ of the form*

$$(P + \delta(p), Q + \delta(q)) .$$

*Proof.* By the hypothesis, there exists a vector field  $V = v_1 \partial_\xi + v_2 \partial_t$  of positive order and a map germ  $W = (w_1, w_2)$  in  $\mathcal{M}$ , such that

$$V \cdot f + W \circ f^* = (f_1 + P + \delta(p), f_2 + Q + \delta(q)) .$$

Moreover, by the very definition of the reduced tangent space, the map germs

$$\varphi : (\xi, t) \mapsto (\xi + v_1(\xi, t), t + v_2(\xi, t)) ,$$

$$\psi : (x, y) \mapsto (x + w_1(x, y), y + w_2(x, y)) ,$$

are diffeomorphism germs. Let  $P = P^s + P^t$  and  $Q = Q^s + Q^t$  the decompositions of the polynomials  $P$  and  $Q$  such that

$$V \cdot f = (P^s + \delta(p), Q^s + \delta(q)) , \quad W \circ f^* = (P^t + \delta(p), Q^t + \delta(q)) .$$

Since  $V$  is a vector field of positive order, by the estimate in Lemma 2.4.1 we have

$$f(\xi + v_1(\xi, t), t + v_2(\xi, t)) = (f_1(\xi, t) + P^s(\xi, t) + \delta(p), f_2(\xi, t) + Q^s(\xi, t) + \delta(q)) ,$$

so we have

$$(\psi \circ f \circ \varphi) = (f_1 + P + \delta(p), f_2 + Q + \delta(q)) .$$

which is what we had to show. □

### 2.4.3 $S_1$ -type tangential families

In this section we will prove the statements in Theorems 2.2.2 and 2.2.5 concerning the  $S_1$ -type tangential families.

Let us set

$$f_n(\xi, t) := (\xi, t^4 + t^2\xi + t^{2n+3}) .$$

**THEOREM 2.4.2.** *Every set  $S_{1,n}$  is an  $\mathcal{A}$ -orbit in  $(\mathfrak{m}_{\xi,t})^2$ . In particular, every tangential family of type  $S_{1,n}$  is  $\mathcal{A}$ -equivalent to the map germ  $f_n$ .*

Next, we compute the codimensions of these orbits.

**THEOREM 2.4.3.** *The codimension of the orbit  $S_{1,n}$  in  $(\mathfrak{m}_{\xi,t})^2$  is equal to  $n + 3$ .*

Finally, we determine the  $\mathcal{A}$ -miniversal tangential deformations of the map germs  $f_n$ .

**THEOREM 2.4.4.** *The extended codimension of  $f_n$  is  $n + 1$ . The mapping  $\mathbb{R}^2 \times \mathbb{R}^n \rightarrow \mathbb{R}^2$ , defined by*

$$(\xi, t; \lambda_1, \dots, \lambda_n) \mapsto \left( \xi, t^4 + t^2\xi + t^{2n+3} + \sum_{i=1}^n \lambda_i t^{2i+1} \right) ,$$

*is an  $\mathcal{A}$ -miniversal tangential deformation of the normal form  $f_n$ . In particular, the tangential codimension of  $f_n$  is  $n$ .*

To prove the preceding statements, we need to describe the tangent space to the orbits  $S_{1,n}$  at  $f_n$ . Let us denote by  $\tilde{\mathfrak{m}}_{\xi,t}^p$  the  $\mathcal{E}_{\xi,t}$ -ideal generated by the monomials of degree  $p$  in the quasihomogeneous filtration of  $\mathbb{R}[[\xi, t]]$  defined by  $\deg(t) = 1$  and  $\deg(\xi) = 2$ , and by  $\tilde{\delta}(p)$  any function whose Taylor series has order equal to  $p$  in this filtration.

A *vector monomial* of degree  $p$  is by definition an element of  $(\mathfrak{m}_{\xi,t})^2$  having a component which is a monomial, the other component being zero.

LEMMA 2.4.2. *The tangent space  $T\mathcal{A}(f_n)$  contains the space*

$$\tilde{\mathfrak{m}}_{\xi,t}^{2n+1} \times \tilde{\mathfrak{m}}_{\xi,t}^{2n+3} .$$

Moreover, also the vector monomials  $(0, t^{2\ell+2})$  belong to  $T\mathcal{A}(f_n)$  for every natural number  $\ell$ .

### Proof of Theorem 2.4.2

By Lemma 2.4.2 and the Finite Determinacy Theorem, the representative  $f_n$  is  $\mathcal{A}$ -finitely determined. Thus, to prove Theorem 2.4.2 we have only to show that every map germ belonging to the set  $S_{1,n}$  is formally  $\mathcal{A}$ -equivalent to  $f_n$ .

By Proposition 2.4.1, the prenormal form of any  $S_{1,n}$ -type tangential family may be written as

$$(\xi, t) \mapsto \left( \xi, bt^4 + \alpha t^2 \xi + t^2 \cdot \tilde{\delta}(2) \right) .$$

Since  $\alpha$  and  $b$  are non zero, we may assume  $\alpha = b = 1$  by rescaling.

LEMMA 2.4.3. *Every tangential family of type  $S_1$  is formally  $\mathcal{A}$ -equivalent to a map germ of the form*

$$(\xi, t) \mapsto \left( \xi, t^4 + t^2 \xi + \sum_{i=1}^{\infty} b_i t^{2i+3} \right) , \quad (2.3)$$

for some real coefficients  $b_i$ .

*Proof.* This follows from the geometry of the admissible chains in the Newton Diagram of the second component of the germs of the form

$$(\xi, t) \mapsto \left( \xi, t^4 + t^2 \xi + t^2 \cdot \tilde{\delta}(2) \right) ,$$

see figure 2.11 (this terminology is explained in [13]).

Namely, suppose our prenormal form  $\mathcal{A}$ -equivalent to a map germ

$$(\xi, t) \mapsto \left( \xi, t^4 + t^2 \xi + \sum_{i=1}^m b_i t^{2i+3} + P(\xi, t) + Q(\xi, t) + \tilde{\delta}(2m+5) \right) ,$$

where  $P$  and  $Q$  are quasihomogeneous polynomial of weighted degree  $2m+4$  and  $2m+5$  respectively, without terms  $\xi^{m+2}$  nor  $t\xi^{m+2}$ . By a coordinate change  $(\xi, t) \mapsto (\xi, t + p(\xi, t))$  for a suitable quasihomogeneous polynomial  $p$  of weighted degree  $2m+2$ , we can bring  $P$  to



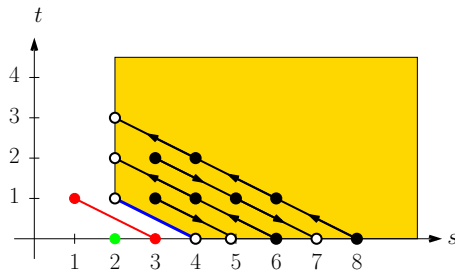

Figure 2.11: Admissible chains in the Newton Diagram of the prenormal form.

$ct^2\xi^{m+1}$  (changing possibly the coefficients of  $Q$ ). Now it is easy to check that such a germ is formally  $\mathcal{A}$ -equivalent to

$$(\xi, t) \mapsto \left( \xi, t^4 + t^2\xi + \sum_{i=1}^m b_i t^{2i+3} + Q(\xi, t) + \tilde{\delta}(2m+5) \right).$$

By a coordinate change  $(\xi, t) \mapsto (\xi, t + q(\xi, t))$ , where  $q$  is a quasihomogeneous polynomial of degree  $2m+3$ , we can reduce  $Q$  to  $b_{2m+5}t^{2m+5}$ . The Lemma is now proven by induction.  $\square$

REMARK. A tangential family is of type  $S_{1,n}$  if and only if it is formally  $\mathcal{A}$ -equivalent to a map germ of the form (2.3) such that  $b_i = 0$  for  $i < n$  and  $b_n \neq 0$ . In this case we may assume  $b_n = 1$  after rescaling.

We achieve the proof of Theorem 2.4.2 by induction. Assume that the map germ (2.3), with  $b_i = 0$  for  $i < n$  and  $b_n = 1$ , is formally  $\mathcal{A}$ -equivalent to

$$(\xi, t) \mapsto \left( \xi, t^4 + t^2\xi + t^{2n+3} + \sum_{i \geq m} b_i t^{2i+3} \right)$$

for some  $m > n$ . By a polynomial coordinate change we can take this germ to the form

$$(\xi, t) \mapsto \left( \xi, t^4 + t^2\xi + t^{2n+3} + ct^{2n+3}\xi^{m-n} + \tilde{\delta}(2m+3) \right).$$

Then there exists two constant  $A$  and  $B$  such that the preceding germ is transformed into

$$(\xi, t) \mapsto \left( \xi, t^4 + t^2\xi + t^{2n+3} + c't^2\xi^2 + \tilde{\delta}(2m+3) \right)$$

under  $(\xi, t) \mapsto (\xi, t + t\xi^{m-n}, t)$  and  $(x, y) \mapsto (x, y + Bx^{m-n}y)$ . Such a germ is  $\mathcal{A}$ -equivalent to

$$(\xi, t) \mapsto (\xi - c'\xi^2, t^4 + t^2\xi + t^{2n+3} + \tilde{\delta}(2m+3))$$

by  $(\xi, t) \mapsto (\xi - c'\xi^2, t)$ , and then it is formally  $\mathcal{A}$ -equivalent to

$$(\xi, t) \mapsto (\xi, t^4 + t^2\xi + t^{2n+3} + \tilde{\delta}(2m+3)).$$

Now the argument of Lemma 2.4.3 provides the formal  $\mathcal{A}$ -equivalence with a germ of the type

$$(\xi, t) \mapsto \left( \xi, t^4 + t^2\xi + t^{2n+3} + \sum_{i \geq m+1} b'_i t^{2i+3} \right).$$

Theorem 2.4.2 is therefore proven.

**Proof of Theorem 2.4.3**

The  $\mathcal{E}_{\xi,t}$ -ideal  $\langle f_n \rangle$  is generated by  $\xi$  and  $t^4$ ; indeed,

$$\langle \xi, t^4 + t^2\xi + t^{2n+3} \rangle_{\mathcal{E}_{\xi,t}} = \langle \xi, t^4 + t^{2n+3} \rangle_{\mathcal{E}_{\xi,t}} = \langle \xi, t^4 \rangle_{\mathcal{E}_{\xi,t}},$$

since  $1 + t^{2n-1}$  is invertible in  $\mathcal{E}_{\xi,t}$ . Therefore, the  $\mathbb{R}$ -space  $\mathfrak{m}_{\xi,t}/(\langle f_n \rangle \cdot \mathfrak{m}_{\xi,t})$  is generated by  $\{\xi, \xi t, t^4\xi, t^5\}$ , so, by the Preparation Theorem,  $\mathfrak{m}_{\xi,t}$  is generated, as  $\mathcal{E}_{x,y}$ -module, by  $\{\xi, t, t^2, t^3, t^4\}$ . Now, for  $i \in \mathbb{N}$ ,  $t^i \partial_{\xi} f_n = (t^i, t^{i+2})$ , and  $(0, t^4), (0, t^6)$  belong to the tangent space (Lemma 2.4.2). Hence, we have

$$(\mathfrak{m}_{\xi,t})^2 = T\mathcal{A}(f_n) + f_n^*(\mathcal{E}_{x,y}) \cdot \left\{ \begin{pmatrix} 0 \\ t \end{pmatrix}, \begin{pmatrix} 0 \\ t^2 \end{pmatrix}, \begin{pmatrix} 0 \\ t^3 \end{pmatrix}, \begin{pmatrix} 0 \\ t^5 \end{pmatrix} \right\}. \quad (2.4)$$

LEMMA 2.4.4. *The following inclusion holds:*

$$\begin{aligned} f_n^*(\mathcal{E}_{x,y}) \cdot \left\{ \begin{pmatrix} 0 \\ t \end{pmatrix}, \begin{pmatrix} 0 \\ t^2 \end{pmatrix} \right\} &\subset T\mathcal{A}(f_n) + \mathbb{R} \cdot \left\{ \begin{pmatrix} 0 \\ t \end{pmatrix}, \begin{pmatrix} 0 \\ t^2 \end{pmatrix}, \begin{pmatrix} 0 \\ t\xi \end{pmatrix} \right\} + \\ &+ f_n^*(\mathcal{E}_{x,y}) \cdot \left\{ \begin{pmatrix} 0 \\ t^3 \end{pmatrix}, \begin{pmatrix} 0 \\ t^5 \end{pmatrix} \right\}. \end{aligned}$$

LEMMA 2.4.5. *For  $\ell \in \mathbb{N}$ , the following inclusion holds:*

$$\begin{aligned} f_n^*(\mathcal{E}_{x,y}) \cdot \left\{ \begin{pmatrix} 0 \\ t^{2\ell+1} \end{pmatrix} \right\} &\subset T\mathcal{A}(f_n) + \mathbb{R} \cdot \begin{pmatrix} 0 \\ t^{2\ell+1} \end{pmatrix} + \\ &+ f_n^*(\mathcal{E}_{x,y}) \cdot \left\{ \begin{pmatrix} 0 \\ t^{2\ell+3} \end{pmatrix}, \begin{pmatrix} 0 \\ t^{2\ell+5} \end{pmatrix} \right\}. \end{aligned}$$

By these two Lemmas and Lemma 2.4.2, we may rewrite (2.4) as

$$\mathfrak{m}_{\xi,t}^2 = T\mathcal{A}(f_n) \oplus \mathbb{R} \cdot \left\{ \begin{pmatrix} 0 \\ t^2 \end{pmatrix}, \begin{pmatrix} 0 \\ t\xi \end{pmatrix} \right\} \oplus \bigoplus_{i=0}^n \mathbb{R} \cdot \begin{pmatrix} 0 \\ t^{2i+1} \end{pmatrix}, \quad (2.5)$$

implying that the codimension of the map germ in  $(\mathfrak{m}_{\xi,t})^2$  is equal to  $n + 3$  and proving Theorem 2.4.3.

We end this section with the proofs of Lemmas 2.4.4 and 2.4.5.

*Proof of Lemma 2.4.4.* We have

$$\begin{aligned} f_n^*(\mathcal{E}_{x,y}) \cdot \begin{pmatrix} 0 \\ t \end{pmatrix} &= \mathbb{R} \cdot \begin{pmatrix} 0 \\ t \end{pmatrix} + f_n^*(\mathfrak{m}_{x,y}) \cdot \begin{pmatrix} 0 \\ t \end{pmatrix} = \\ &= \mathbb{R} \cdot \begin{pmatrix} 0 \\ t \end{pmatrix} + f_n^*(\mathcal{E}_{x,y}) \cdot \left\{ \begin{pmatrix} 0 \\ t\xi \end{pmatrix}, \begin{pmatrix} 0 \\ t^5 + t^3\xi + t^{2n+4} \end{pmatrix} \right\}. \end{aligned} \quad (2.6)$$

By Lemma 2.4.2, the vector monomial  $(0, t^{2n+4})$  belongs to the tangent space  $T\mathcal{A}(f_n)$ , so we have

$$f_n^*(\mathcal{E}_{x,y}) \cdot \begin{pmatrix} 0 \\ t^5 + t^3\xi + t^{2n+4} \end{pmatrix} \subset T\mathcal{A}(f_n) + f_n^*(\mathcal{E}_{x,y}) \cdot \left\{ \begin{pmatrix} 0 \\ t^3 \end{pmatrix}, \begin{pmatrix} 0 \\ t^5 \end{pmatrix} \right\}. \quad (2.7)$$

On the other hand we have

$$f_n^*(\mathcal{E}_{x,y}) \cdot \begin{pmatrix} 0 \\ t\xi \end{pmatrix} = \mathbb{R} \cdot \begin{pmatrix} 0 \\ t\xi \end{pmatrix} + f_n^*(\mathcal{E}_{x,y}) \cdot \left\{ \begin{pmatrix} 0 \\ t\xi x \end{pmatrix}, \begin{pmatrix} 0 \\ t\xi y \end{pmatrix} \right\}. \quad (2.8)$$

Since

$$t\xi y = t^5\xi + t^2\xi^2 + t^{2n+3}\xi$$

and  $(0, t^{2n+3}\xi)$  belongs to  $T\mathcal{A}(f_n)$  we obtain:

$$f_n^*(\mathcal{E}_{x,y}) \cdot \begin{pmatrix} 0 \\ t\xi \end{pmatrix} \subset T\mathcal{A}(f_n) + \mathbb{R} \cdot \begin{pmatrix} 0 \\ t\xi \end{pmatrix} + f_n^*(\mathcal{E}_{x,y}) \cdot \left\{ \begin{pmatrix} 0 \\ t\xi^2 \end{pmatrix}, \begin{pmatrix} 0 \\ t^2 \end{pmatrix}, \begin{pmatrix} 0 \\ t^5 \end{pmatrix} \right\}.$$

Now,

$$\xi \partial_t f_n - (0, (2n+3)t^{2n+2}\xi) = (0, 4t^3\xi + 2t\xi^2) \in T\mathcal{A}(f_n),$$

so we have that

$$f_n^*(\mathcal{E}_{x,y}) \cdot \begin{pmatrix} 0 \\ t\xi^2 \end{pmatrix} \subset T\mathcal{A}(f_n) + f_n^*(\mathcal{E}_{x,y}) \cdot \begin{pmatrix} 0 \\ t^3 \end{pmatrix} \quad (2.9)$$

As a consequence of (2.6), (2.7), (2.8) and (2.9) we obtain:

$$f_n^*(\mathcal{E}_{x,y}) \cdot \begin{pmatrix} 0 \\ t \end{pmatrix} \subset T\mathcal{A}(f_n) + f_n^*(\mathcal{E}_{x,y}) \cdot \left\{ \begin{pmatrix} 0 \\ t^2 \end{pmatrix}, \begin{pmatrix} 0 \\ t^3 \end{pmatrix}, \begin{pmatrix} 0 \\ t^5 \end{pmatrix} \right\}. \quad (2.10)$$

We consider now the  $\mathcal{E}_{x,y}$ -ideal generated by  $(0, t^2)$ . Due to Lemma 2.4.2, the vector monomials  $(0, t^6)$ ,  $(0, t^4\xi)$ ,  $(0, t^{2n+5})$  and

$$(0, t^2\xi) = (0, y) - (0, t^4) - (0, t^{2n+3})$$

belong to  $T\mathcal{A}(f_n)$ , so  $(0, t^2x)$ ,  $(0, t^2y) \in T\mathcal{A}(f_n)$ , and then

$$f_n^*(\mathbf{m}_{x,y}) \cdot \begin{pmatrix} 0 \\ t^2 \end{pmatrix} = f_n^*(\mathcal{E}_{x,y}) \cdot \left\{ \begin{pmatrix} 0 \\ t^2x \end{pmatrix}, \begin{pmatrix} 0 \\ t^2y \end{pmatrix} \right\} \subset T\mathcal{A}(f_n),$$

which implies that

$$f_n^*(\mathcal{E}_{x,y}) \cdot \begin{pmatrix} 0 \\ t^2 \end{pmatrix} \subset T\mathcal{A}(f_n) + \mathbb{R} \cdot \begin{pmatrix} 0 \\ t^2 \end{pmatrix}. \quad (2.11)$$

The Lemma follows from inclusions (2.10) and (2.11).  $\square$

*Proof of Lemma 2.4.5.* Let us consider the  $\mathcal{E}_{x,y}$ -submodule  $f_n^*(\mathbf{m}_{x,y}) \cdot (0, t^{2\ell+1})$  of  $\mathcal{E}_{\xi,t}^2$ , generated by  $(0, t^{2\ell+1}x) = (0, t^{2\ell+1}\xi)$  and

$$(0, t^{2\ell+1}y) = (0, t^{2\ell+5} + t^{2\ell+3}\xi + t^{2(\ell+n+1)}).$$

The vector  $(0, 2t^{2\ell+3} + t^{2\ell+1}\xi)$  belongs to the tangent space, indeed it is a real linear combination of  $t^{2\ell}\partial_t f_n$  and  $(0, t^{2(\ell+n+1)})$ . Therefore,

$$f_n^*(\mathcal{E}_{x,y}) \cdot \begin{pmatrix} 0 \\ t^{2\ell+1}\xi \end{pmatrix} \subset T\mathcal{A}(f_n) + f_n^*(\mathcal{E}_{x,y}) \cdot \begin{pmatrix} 0 \\ t^{2\ell+3}\xi \end{pmatrix}. \quad (2.12)$$

In a similar way, it is easily checked that  $(0, 2t^{2\ell+5} + t^{2\ell+3}\xi) \in T\mathcal{A}(f_n)$ . Hence,

$$f_n^*(\mathcal{E}_{x,y}) \cdot \begin{pmatrix} 0 \\ t^{2\ell+1}y \end{pmatrix} \subset T\mathcal{A}(f_n) + f_n^*(\mathcal{E}_{x,y}) \cdot \begin{pmatrix} 0 \\ t^{2\ell+5} \end{pmatrix}. \quad (2.13)$$

Inclusions (2.12) and (2.13) prove Lemma 2.4.5.  $\square$

**Proof of Theorem 2.4.4**

As we have seen, the  $\mathcal{E}_{\xi,t}$ -ideal  $\langle f_n \rangle$  is generated by  $\xi$  and  $t^4$ , so  $\{1, t, t^2, t^3\}$  is a generator system of the  $\mathcal{E}_{x,y}$ -module  $\mathcal{E}_{\xi,t}$ . The vector monomials  $(1, 0)$ ,  $(0, 1)$ ,  $(t^2, 0) = t^2 \partial_\xi f_n - (0, t^4)$  and  $(0, t^2) = \partial_\xi f_n - (1, 0)$  belong to the extended tangent space  $T_e \mathcal{A}(f_n)$ . Hence, we have

$$\mathcal{E}_{\xi,t}^2 = T_e \mathcal{A}(f_n) + f_n^*(\mathcal{E}_{x,y}) \cdot \left\{ \begin{pmatrix} t \\ 0 \end{pmatrix}, \begin{pmatrix} 0 \\ t \end{pmatrix}, \begin{pmatrix} t^3 \\ 0 \end{pmatrix}, \begin{pmatrix} 0 \\ t^3 \end{pmatrix} \right\} \quad (2.14)$$

We deduce from  $t \partial_\xi f_n = (t, t^3)$  and  $t^3 \partial_\xi f_n = (t^3, t^5)$  that

$$T_e \mathcal{A}(f_n) + f_n^*(\mathcal{E}_{x,y}) \cdot \left\{ \begin{pmatrix} t \\ 0 \end{pmatrix}, \begin{pmatrix} t^3 \\ 0 \end{pmatrix} \right\} \subset T_e \mathcal{A}(f_n) + f_n^*(\mathcal{E}_{x,y}) \cdot \left\{ \begin{pmatrix} 0 \\ t^3 \end{pmatrix}, \begin{pmatrix} 0 \\ t^5 \end{pmatrix} \right\} .$$

This inclusion and identity (2.14) imply

$$\mathcal{E}_{\xi,t}^2 = T_e \mathcal{A}(f_n) + f_n^*(\mathcal{E}_{x,y}) \cdot \left\{ \begin{pmatrix} 0 \\ t \end{pmatrix}, \begin{pmatrix} 0 \\ t^3 \end{pmatrix}, \begin{pmatrix} 0 \\ t^5 \end{pmatrix} \right\} .$$

and therefore, by Lemma 2.4.2, Lemma 2.4.4 and Lemma 2.4.5, that

$$\mathcal{E}_{\xi,t}^2 = T_e \mathcal{A}(f_n) \oplus \bigoplus_{i=0}^n \mathbb{R} \cdot \begin{pmatrix} 0 \\ t^{2i+1} \end{pmatrix} .$$

Thus, the extended codimension of  $f_n$  is  $n + 1$  and the mapping  $F : \mathbb{R}^2 \times \mathbb{R}^{n+1} \rightarrow \mathbb{R}^2$  defined by

$$F(\xi, t; \mu, \lambda_1, \dots, \lambda_n) := \left( \xi, t^4 + t^2 \xi + t^{2n+3} + \mu t + \sum_{i=1}^n \lambda_i t^{2i+1} \right) ,$$

is an  $\mathcal{A}$ -miniversal deformation of the map germ  $f_n$ .

Let us consider a miniversal tangential deformation

$$G : \mathbb{R}^2 \times \mathbb{R}^p \rightarrow \mathbb{R}^2 , \quad (t, \xi; \alpha) \mapsto G(\xi, t; \alpha)$$

of the tangential family  $f_n$ . Due to the versality of  $F$ , there exists a map germ

$$\Lambda : (\mathbb{R}^p, 0) \rightarrow (\mathbb{R}^{n+1}, 0) , \quad \alpha \mapsto (\mu(\alpha), \lambda_1(\alpha), \dots, \lambda_n(\alpha)) ,$$

such that  $G_\alpha$  is equivalent to  $F_{\Lambda(\alpha)}$  whenever  $|\alpha|$  is small enough. Since  $G$  is a tangential deformation of the tangential family  $f_n$ , the support of  $G_\alpha$  is a smooth deformation of the support of  $f_n$ , whose equation is  $y = 0$  and which is the projection of the discriminant set branch defined by  $t = 0$ .

We claim that  $\mu \equiv 0$  on a small enough neighborhood of the origin in  $\mathbb{R}^p$ . Indeed, let  $\bar{\alpha}$  be an arbitrary small parameter value, such that  $\mu(\bar{\alpha})$  is not vanishing. The discriminant set of  $F_{\Lambda(\bar{\alpha})}$  is defined by the equation

$$4t^3 + 2t\xi + (2n+3)t^{2n+2} + \mu(\bar{\alpha}) + \sum_{i=1}^n (2i+1)\lambda_i(\bar{\alpha})t^{2i} = 0 .$$

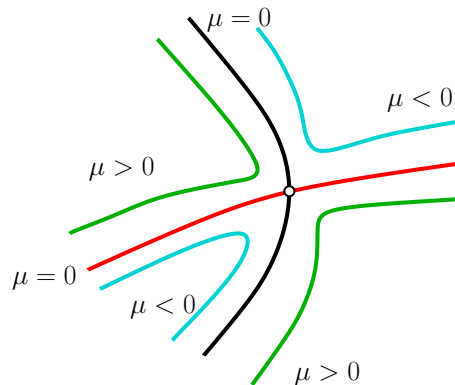

Figure 2.12: Morse perestroika of the discriminant set.

Then the discriminant set experiences a Morse perestroika, as illustrated in figure 2.12, whenever the parameter values pass from 0 to  $\bar{\alpha}$ . Indeed the  $(\xi, t)$ -function on the left-hand side of the equation has an index 1 critical point at  $(0, 0)$ , whose corresponding critical value is  $\mu(\alpha)$ .

As a consequence, the envelope of  $F_{\Lambda(\alpha)}$  experiences a bec à bec perestroika. This is impossible, since  $G$  is a tangential deformation of  $f_n$ . On the other hand, by Theorem 2.4.1 we have that  $F_{\Lambda(\alpha)}|_{\mu=0}$  is  $\mathcal{A}$ -equivalent to a tangential families for every choice of the smooth map germ

$$\alpha \mapsto (\lambda_1(\alpha), \dots, \lambda_n(\alpha)) ,$$

provided that  $\alpha$  is small enough. We have therefore proven that  $F|_{\mu=0}$  is an  $\mathcal{A}$ -miniversal tangential deformation of the tangential family  $f_n$ . Theorem 2.4.4 is proven.

### Proof of Lemma 2.4.2

Let us consider the following two families of claims, depending on a natural parameter  $\ell \in \mathbb{N}$ :

- $\mathcal{P}(\ell)$ : the vectors  $(0, t^{(2n-1)\alpha+4\ell})$  belong to  $T\mathcal{A}(f_n)$  for  $\alpha \in \{0, \dots, \ell\}$ ;
- $\mathcal{Q}(\ell)$ : the vectors  $(0, t^{(2n-1)\alpha+4\ell+2})$  belong to  $T\mathcal{A}(f_n)$  for  $\alpha \in \{0, \dots, \ell\}$ .

LEMMA 2.4.6. *The claims  $\mathcal{P}(\ell)$  and  $\mathcal{Q}(\ell)$  hold for all  $\ell \in \mathbb{N}$ .*

It follows immediately from this Lemma that all the vector monomials  $(0, t^{2i+2})$ ,  $i \in \mathbb{N}$ , belong to  $T\mathcal{A}(f_n)$ . Furthermore, every vector monomial  $(0, \xi^p t^{2(i-p)+3})$  of weighted degree  $2i + 3$  belongs to the tangent space, whenever  $i \geq n$ . Indeed,

$$t^{2(i-p-n)+1} \xi^p \partial_t f_n = (0, 4t^{2(i-p-n+2)} \xi^p + 2t^{2(i-p-n+1)} \xi^{p+1} + (n+3)t^{2(i-p)+3} \xi^p) ,$$

and the vector monomials  $(0, t^{2(i-p-n+2)})$ ,  $(0, t^{2(i-p-n+1)})$  belong to the tangent space due to the preceding remark. Therefore, we have:

$$\{0\} \times \tilde{\mathfrak{m}}_{\xi, t}^{2n+3} \subset T\mathcal{A}(f_n) .$$

Now, this inclusion and the equality

$$\xi^p t^q \partial_\xi f_n = (\xi^p t^q, \xi^p t^{q+2})$$

imply

$$\tilde{\mathbf{m}}_{\xi,t}^{2n+1} \times \tilde{\mathbf{m}}_{\xi,t}^{2n+3} \subset T\mathcal{A}(f_n) .$$

Lemma 2.4.2 is therefore proven modulo Lemma 2.4.6.

We prove now Lemma 2.4.6. The proof is carried out by induction, and it is divided into three steps.

FIRST STEP. *The claims  $\mathcal{P}(1)$  and  $\mathcal{Q}(1)$  hold.*

First note that  $(0, t^2\xi) = \xi\partial_\xi f_n - (x, 0)$  belongs to the tangent space  $T\mathcal{A}(f_n)$ . Since

$$(0, y) = (0, t^4 + t^2\xi + t^{2n+3}) , \quad t\partial_t f_n = (0, 4t^4 + 2t^2\xi + (2n+3)t^{2n+3}) ,$$

the vector monomials  $(0, t^4)$  and  $(0, t^{2n+3})$  lie in  $T\mathcal{A}(f_n)$ , i.e.,  $\mathcal{P}(1)$  holds. Now, the claim  $\mathcal{P}(1)$  implies that the following vectors belong to the tangent space:

$$\begin{aligned} & - t^3 \partial_t f_n - (0, 2t^4\xi) = (0, 4t^6 + (2n+3)t^{2n+5}) , \\ & - t^4 \partial_\xi f_n = (t^4, t^6) , \\ & - (y, 0) = (t^4 + t^2\xi + t^{2n+3}, 0) , \\ & - t^{2n+3} \partial_\xi f_n = (t^{2n+3}, t^{2n+5}) , \\ & - t^2\xi \partial_\xi f_n - (0, t^4\xi) = (t^2\xi, 0) . \end{aligned}$$

Since these vectors are linearly independent, we have that  $(0, t^6)$  and  $(0, t^{2n+5})$  are in the tangent space, that is,  $\mathcal{Q}(1)$  holds.

SECOND STEP. *Assume that the claims  $\mathcal{P}(i)$  and  $\mathcal{Q}(i)$  hold for every  $i = 1, \dots, \ell - 1$ . Then  $\mathcal{P}(\ell)$  holds.*

By the binomial formula, we have

$$y^\ell = \sum_{i=0}^{\ell} \sum_{j=0}^{\ell-i} \frac{\ell!}{(\ell-i-j)! i! j!} t^{(2n-1)i+4\ell-2j} \xi^j .$$

All the vector monomials in the expansion, provided by the preceding formula for the vector  $(0, y^\ell)$ , belong to the tangent space  $T\mathcal{A}(f_n)$ , whenever they are divisible by a non zero power of  $\xi$ . Indeed, fix  $J \in \{1, \dots, \ell\}$ . Up to a constant multiplicative factor, the vector monomials divisible by  $\xi^J$  are  $(0, t^{(2n-1)i+4\ell-2J}\xi^J)$  for  $i \in \{1, \dots, \ell - J\}$ . Such a germ lies in  $T\mathcal{A}(f_n)$ , due to the claim  $\mathcal{Q}(\ell - m)$  with  $\alpha = i$  if  $J = 2m + 1$  is odd, due to the claim  $\mathcal{P}(\ell - m)$  with  $\alpha = i$  if  $J = 2m$  is even. Therefore,

$$v_0 := \left( 0, \sum_{j=0}^{\ell} \binom{\ell}{j} t^{(2n-1)j+4\ell} \right) \in T\mathcal{A}(f_n) .$$

By assertion  $\mathcal{Q}(\ell - 1)$ , the vectors  $(0, t^{(2n-1)i+4\ell-2})$  are in  $T\mathcal{A}(f_n)$  for  $i = 0, \dots, \ell - 1$ . Hence, we set

$$\begin{aligned} v_i & := t^{(2n-1)i+4\ell-3} \partial_t f_n - (0, 2t^{(2n-1)i+4\ell-2}\xi) = \\ & = (0, 4t^{(2n-1)i+4\ell} + (2n+3)t^{(2n-1)(i+1)+4\ell}) \in T\mathcal{A}(f_n) . \end{aligned}$$

We have defined  $\ell + 1$  vectors  $v_0, \dots, v_\ell$ , involving only the  $\ell + 1$  vector monomials  $e_j := (0, t^{(2n-1)j+4\ell})$  for  $j = 0, \dots, \ell$ . Let us consider the vector space  $\mathbb{R}^{\ell+1}$ , formally generated by the vectors  $e_j$ . Let  $A$  be the square matrix of order  $\ell + 1$ , which columns are the components of  $v_j$  in this basis:

$$A := \left( \begin{array}{c|cccc} \binom{\ell}{0} & 4 & 0 & \cdots & 0 \\ \binom{\ell}{1} & 2n+3 & 4 & \ddots & \vdots \\ \vdots & 0 & 2n+3 & \ddots & 0 \\ \vdots & \vdots & \ddots & \ddots & 4 \\ \binom{\ell}{\ell} & 0 & \cdots & 0 & 2n+3 \end{array} \right) .$$

Expanding the determinant by the first column and using the binomial formula, we find  $\det A = (2n+7)^\ell \neq 0$ , thus  $A$  is invertible. This implies that the vector monomials  $e_i$  belong to the tangent space  $T\mathcal{A}(f_n)$ , i.e. the claim  $\mathcal{P}(\ell)$  holds.

**THIRD STEP.** *Assume that the claims  $\mathcal{P}(i)$  and  $\mathcal{Q}(i)$  hold for  $i = 1, \dots, \ell - 1$ . Then  $\mathcal{Q}(\ell)$  holds.*

It is easily verified that the germs

$$\begin{aligned} & - (t^{(2n-1)\alpha+4j-2}, 0) , \quad j = 0, \dots, \ell, \quad \alpha = 0, \dots, j, \\ & - (t^{(2n-1)\alpha+4i}, 0) , \quad i = 0, \dots, \ell - 1, \quad \alpha = 0, \dots, i, \end{aligned}$$

belong to the tangent space (here we have used that  $\mathcal{P}(\ell)$  holds). As in the preceding step, this allow us to prove that all the vector monomials in the expansion, provided by the binomial formula for the vector  $(y^\ell, 0)$ , are in  $T\mathcal{A}(f_n)$  whenever they are divisible by  $\xi$ . Thus we set

$$w_0 := \left( \sum_{j=0}^{\ell} \binom{\ell}{j} t^{(2n-1)j+4\ell}, 0 \right) \in T\mathcal{A}(f_n) .$$

By the claim  $\mathcal{P}(\ell)$ , we have  $(0, t^{(2n-1)i+4\ell}) \in T\mathcal{A}(f_n)$  for all  $i = 0, \dots, \ell - 1$ , so we may define:

$$\begin{aligned} w_{i+1} & := t^{(2n-1)i+4\ell-1} \partial_t f_n - 2 (0, t^{(2n-1)i+4\ell} \xi) \\ & = (0, 4t^{(2n-1)i+4\ell+2} + (2n+3)t^{(2n-1)(i+1)+4\ell+2}) \in T\mathcal{A}(f_n) . \end{aligned}$$

Furthermore, set  $w_{\ell+1+j} := t^{(2n-1)j+4\ell} \partial_t f_n$  for  $j = 0, \dots, \ell$ .

We have defined  $2(\ell + 1)$  vectors  $w_k$ , involving only the  $2(\ell + 1)$  vector monomials

$$\varepsilon_j := (t^{(2n-1)j+4\ell}, 0) , \quad \varepsilon_{\ell+1+j} := (0, t^{(2n-1)j+4\ell+2}) ,$$

for  $j = 0, \dots, \ell$ . Consider the space  $\mathbb{R}^{2(\ell+1)}$  formally generated by the basis

$$\{\varepsilon_k : k = 0, \dots, 2\ell + 1\} .$$

Denote by  $B$  the square matrix of order  $2\ell + 2$ , formed by the coordinates of the vectors  $w_k$  in this basis:

$$B := \left( \begin{array}{c|cc|c} \binom{\ell}{0} & & & \mathbb{I}_{\ell+1} \\ \vdots & & \mathbb{O} & \\ \binom{\ell}{\ell} & & & \\ \hline 0 & 4 & & \mathbb{O} \\ \vdots & 2n+3 & \ddots & \\ \vdots & & \ddots & 4 \\ 0 & \mathbb{O} & & 2n+3 \\ \hline & & & \mathbb{I}_{\ell+1} \end{array} \right),$$

where  $\mathbb{I}_{\ell+1}$  is the identity matrix of order  $\ell + 1$ . This matrix is equivalent to

$$\tilde{B} = \left( \begin{array}{c|c} \tilde{A} & \mathbb{O}_{\ell+1} \\ \hline * & \mathbb{I}_{\ell+1} \end{array} \right),$$

where  $\tilde{A}$  is the matrix obtained from the matrix  $A$  in the second step of the proof, replacing 4 and  $2n + 3$  by  $-4$  and  $-(2n + 3)$ . Therefore  $\det \tilde{B} = (-2n - 7)^\ell \neq 0$ . Hence  $B$  is invertible, and the map germs  $\{\varepsilon_k : k = 0, \dots, 2\ell + 1\}$  belong to  $T\mathcal{A}(f_n)$ . In particular, the claim  $\mathcal{Q}(\ell)$  holds. This ends the proof.

#### 2.4.4 $S_2$ -type tangential families

By Proposition 2.4.1, every tangential family of type  $S_2$  can be parameterized by a map germ of the form

$$(\xi, t) \mapsto (\xi, t^5 + t^2\xi + \tilde{\delta}(5)), \quad (2.15)$$

where  $\tilde{\delta}(n)$  denotes any function whose Taylor series has order  $n$  in the space  $\mathbb{R}[[\xi, t]]$ , equipped with the quasi homogeneous filtration defined by the weights  $\deg(\xi) = 3$  and  $\deg(t) = 1$ .

Let us denote by  $\tilde{\mathfrak{m}}_{\xi,t}^n$  and  $\tilde{J}(n)$  respectively the ideal and the real vector space of  $\mathcal{E}_{\xi,t}$  generated by the monomials  $\xi^p t^q$  of degree  $3p + q = n$ . We set also  $\tilde{J}(p, q) := \tilde{J}(p) \times \tilde{J}(q)$ . Let

$$g(\xi, t) := (\xi, t^5 + t^2\xi)$$

be the quasihomogeneous part of the germs (2.15).

The statements in Theorems 2.2.2 and 2.2.5 about the  $\mathcal{A}$ -orbits of the  $S_2$ -type tangential families are proven by the following three theorems.

**THEOREM 2.4.5.** *The map germ  $g$  is 9- $\mathcal{A}$ -determined, and there are exactly four  $\mathcal{A}$ -orbits in  $X$  over  $g$ , represented by the map germs*

- $g_2(\xi, t) := (\xi, t^5 + t^2\xi + t^6)$ ,
- $g_3^\pm(\xi, t) := (\xi, t^5 + t^2\xi \pm t^9)$ ,
- $g_4(\xi, t) := g(\xi, t) = (\xi, t^5 + t^2\xi)$ .

We denote by  $S_{2,2}$ ,  $S_{2,3}^\pm$  and  $S_{2,4}$  respectively the  $\mathcal{A}$ -orbits  $\mathcal{A} \cdot g_2$ ,  $\mathcal{A} \cdot g_3^\pm$  and  $\mathcal{A} \cdot g_4$ .



**THEOREM 2.4.6.** *The codimensions of the orbits  $S_{2,2}$ ,  $S_{2,3}^\pm$  and  $S_{2,4}$  in  $(\mathfrak{m}_{\xi,t})^2$  are respectively 5, 6 and 7.*

**THEOREM 2.4.7.** *The extended codimensions of  $g_2$ ,  $g_3^\pm$  and  $g_4$  are 3, 4 and 5. The map germs*

$$\begin{aligned} (\xi, t; \lambda_1, \lambda_2) &\mapsto (\xi, t^5 + t^2\xi + t^6 + \lambda_1 t^3 + \lambda_2 t^4) , \\ (\xi, t; \lambda_1, \lambda_2, \lambda_3) &\mapsto (\xi, t^5 + t^2\xi \pm t^9 + \lambda_1 t^3 + \lambda_2 t^4 + \lambda_3 t^6) , \\ (\xi, t; \lambda_1, \lambda_2, \lambda_3, \lambda_4) &\mapsto (\xi, t^5 + t^2\xi + \lambda_1 t^3 + \lambda_2 t^4 + \lambda_3 t^6 + \lambda_4 t^9) . \end{aligned}$$

*are  $\mathcal{A}$ -miniversal tangential deformations of the map germs  $g_2$ ,  $g_3^\pm$  and  $g_4$  respectively. In particular, the tangential codimensions of these germs are 2, 3 and 4.*

### Proof of Theorem 2.4.5.

We start the proof of Theorem 2.4.5 by the computation of the reduced tangent space  $T_r\mathcal{A}(g)$  of the map germ  $g$ .

**LEMMA 2.4.7.** *The space  $\tilde{\mathfrak{m}}_{\xi,t}^8 \times \tilde{\mathfrak{m}}_{\xi,t}^{10}$  is contained in  $T_r\mathcal{A}(g)$ .*

It follows from the Lemma that  $(\mathfrak{m}_{\xi,t}^{10})^2$  is contained in the extended tangent space  $T_e\mathcal{A}(g)$ ; in particular, the map germ  $g$  is finitely determined.

*Proof.* The proof is by induction. By a direct computation one shows that

$$\tilde{J}(8, 10) \cup \tilde{J}(9, 11) \cup \tilde{J}(10, 12) \subset T_r\mathcal{A}(g).$$

Now, assume that  $T_r\mathcal{A}(g)$  contains the vector space

$$\tilde{J}(n, n+2) \cup \tilde{J}(n+1, n+3) \cup \tilde{J}(n+2, n+4) ;$$

then it contains also  $\tilde{J}(n+3, n+5)$ . Indeed, since the reduced tangent space is an  $\mathcal{E}_{x,y}$ -module, it contains  $\xi \cdot \tilde{J}(n, n+2)$ ; moreover

$$\begin{aligned} t^{n+1}\partial_t g &= (0, 5t^{n+5}) \pmod{\xi \cdot \tilde{J}(n, n+2)} , \\ t^{n+3}\partial_\xi g &= (t^{n+3}, t^{n+5}) , \end{aligned}$$

therefore also  $(t^{n+3}, 0)$  and  $(0, t^{n+5})$  belong to the reduced tangent space.  $\square$

Let us recall now a well known general theorem on  $\mathcal{A}$ -finite determinacy, due to Gaffney ([23], see also [11] and [29]): *the map germ  $g$  is  $r$ - $\mathcal{A}$ -determined if and only if*

$$(\mathfrak{m}_{\xi,t}^{r+1})^2 \subset T_e\mathcal{A}(\hat{g}) + (\mathfrak{m}_{\xi,t}^{2r+2})^2$$

*for every germ  $\hat{g}$  with the same  $r$ -jet as  $g$ .* By Lemma 2.4.7, the preceding inclusion holds with  $r = 9$ , so the map germ  $g$  is 9- $\mathcal{A}$ -determined.

We shall now complete the proof of Theorem 2.4.5. To bring any map germ, whose quasihomogeneous part is  $g$ , to one among the map germs  $g_i$ , we will use Proposition 2.4.2 at each step of the reduction. Let  $\hat{g}$  be a map germ of the form (2.15), namely

$$(\xi, t) \mapsto \left( \xi, t^5 + t^2\xi + P_6(\xi, t) + \tilde{\delta}(6) \right) ,$$

where  $P_6(\xi, t) = a_1 t^6 + a_2 t^3 + a_3 \xi^2$  is a quasihomogeneous polynomial of weighted degree equal to 6. Let us consider the quasihomogeneous vector field of degree 1,  $V_1 := (a_2/2)t^2 \partial_t$ . Since  $V_1 \cdot g = (0, 5a_2 t^6/2 + a_2 t^3 \xi)$ , the coordinate changes

$$(\xi, t) \mapsto (\xi, t - a_2 t^2/2), \quad (x, y) \mapsto (x, y - a_3 x^3),$$

take our germ to the form

$$(\xi, t) \mapsto \left( \xi, t^5 + t^2 \xi + (a_1 - 5a_2/2)t^6 + \tilde{\delta}(6) \right). \quad (2.16)$$

Let us set  $a := (a_1 - 5a_2/2)$ . Then the initial germ is  $\mathcal{A}$ -equivalent to a map germ of the form

$$(\xi, t) \mapsto \left( \xi, t^5 + t^2 \xi + a t^6 + \tilde{\delta}(6) \right).$$

Since all the vector monomials  $(0, \xi^p t^q)$  of weighted degree 7 and 8 belong to  $T_r \mathcal{A}(g)$ , such a germ is  $\mathcal{A}$ -equivalent to a germ on the form:

$$(\xi, t) \mapsto \left( \xi, t^5 + t^2 \xi + a t^6 + \tilde{\delta}(8) \right).$$

which may be rewritten as

$$(\xi, t) \mapsto \left( \xi, t^5 + t^2 \xi + a t^6 + P_9(\xi, t) + \tilde{\delta}(9) \right),$$

where  $P_9(\xi, t) := b_1 t^9 + b_2 t^6 \xi + b_3 t^3 \xi^2$  is a quasihomogeneous polynomial of weighted degree equal to 9. Indeed, we may assume –up to a coordinate change in the target space– that the coefficient of  $(0, \xi^3)$  is vanishing. Consider the order 4 homogeneous vector field  $V_4 := v_4(\xi, t) \partial_t$ , where

$$v_4(\xi, t) = \frac{2b_2 - 5b_3}{4} t^5 + \frac{b_3}{2} t^2 \xi.$$

Then the coordinate change  $(\xi, t) \mapsto (\xi, t - v_4(\xi, t))$  reduces the preceding germ to the case  $P_9(\xi, t) = c t^9$ , where  $c = b_1 - 5b_2/2 + 25b_3/4$ .

If the coefficient  $a$  of  $(0, t^6)$  is not vanishing, we may normalize it to 1 (changing the value of  $c$ ). In this case, we can kill the last term in  $P_9$ . In order to do this, we consider the following vector field germ:

$$W := \frac{6c}{5} \xi^2 \partial_\xi + c \left( \frac{2}{5} t \xi - \frac{1}{5} t^5 \right) \partial_t.$$

We have:

$$W \cdot \hat{g} = \left( \frac{6c}{5} \xi^2, -\frac{6c}{5} (t^5 \xi + t^2 \xi^2 + t^6 \xi) - c t^9 \right).$$

Hence, the coordinate changes

$$(\xi, t) \mapsto \left( \xi + \frac{6c}{5} \xi^2, t + \frac{2c}{5} t \xi - \frac{c}{5} t^5 \right), \quad (x, y) \mapsto \left( x - \frac{6c}{5} x^2, y + \frac{6c}{5} xy \right),$$

bring  $\hat{g}$  to the following form

$$(\xi, t) \mapsto \left( \xi, t^5 + t^2\xi + t^6 + \tilde{\delta}(9) \right)$$

(here we use the estimate of Lemma 2.4.1). If the coefficient  $a$  of  $(0, t^6)$  is zero, we can not kill the term  $(0, t^9)$ . By a coordinate change, we can transform the map germ into

$$(\xi, t) \mapsto \left( \xi, t^5 + t^2\xi + b t^9 + \tilde{\delta}(9) \right) .$$

If  $b$  is not vanishing, we may normalize it to  $\pm 1$ . Since  $g$  is 9- $\mathcal{A}$ -determined, this implies that the initial germ is  $\mathcal{A}$ -equivalent to one among the four map germs  $g_2, g_3^\pm$  and  $g_4$ . Theorem 2.4.5 is proven.

### Proof of Theorem 2.4.6.

In order to compute the codimensions of the orbits  $S_{2,2}, S_{2,3}^\pm$  and  $S_{2,4}$  in  $(\mathfrak{m}_{\xi,t})^2$ , first we describe the tangent spaces to the orbits at the germs  $g_2, g_3^\pm$  and  $g_4$ .

LEMMA 2.4.8. *The following inclusions hold:*

- $\tilde{\mathfrak{m}}_{\xi,t}^3 \times \mathfrak{m}_{\xi,t}^5 \subset T\mathcal{A}(g_2)$ ,
- $\tilde{J}(3, 5) \cup (\tilde{\mathfrak{m}}_{\xi,t}^5 \times \mathfrak{m}_{\xi,t}^7) \subset T\mathcal{A}(g_3)$ ,
- $\tilde{J}(3, 5) \cup \tilde{J}(5, 7) \cup \tilde{J}(6, 8) \cup (\tilde{\mathfrak{m}}_{\xi,t}^8 \times \mathfrak{m}_{\xi,t}^{10}) \subset T\mathcal{A}(g_4)$ .

The proof of this Lemma is provided by some easy computations completing Lemma 2.4.7.

We may compute now the  $S_2$ -orbit codimensions. In all the four cases we deal with, the ideal  $\mathfrak{m}_{\xi,t}/(\langle g_i \rangle \cdot \mathfrak{m}_{\xi,t})$ , where  $i = 2, 3, 4$ , is generated by

$$\{\xi, t, t^2, t^3, t^4, t^5\}$$

(the forthcoming computations being identical for  $g_3^+$  and for  $g_3^-$ , we omit from now on the sign  $\pm$ ). Since  $t^j \partial_{\xi} g_i = (t^j, t^{j+2}) \in T\mathcal{A}(g_i)$ , we obtain from the Preparation Theorem and Lemma 2.4.8 that

$$(\mathfrak{m}_{\xi,t})^2 = T\mathcal{A}(g_i) + g_i^*(\mathcal{E}_{x,y}) \cdot \left\{ \begin{pmatrix} 0 \\ t \end{pmatrix}, \begin{pmatrix} 0 \\ t^2 \end{pmatrix}, \begin{pmatrix} 0 \\ t^3 \end{pmatrix}, \begin{pmatrix} 0 \\ t^4 \end{pmatrix}, \begin{pmatrix} 0 \\ t^6 \end{pmatrix} \right\} . \quad (2.17)$$

Consider first the case  $i = 2$ , concerning the orbit  $S_{2,2}$ . Then  $(0, t^6)$  belong to the tangent space; moreover, by Lemma 2.4.8, we have

$$g_2^*(\mathcal{E}_{x,y}) \cdot \begin{pmatrix} 0 \\ t \end{pmatrix} \subset T\mathcal{A}(g_2) \oplus \mathbb{R} \cdot \left\{ \begin{pmatrix} 0 \\ t \end{pmatrix}, \begin{pmatrix} 0 \\ \xi t \end{pmatrix} \right\} . \quad (2.18)$$

Indeed,  $(0, ty)$ ,  $(0, tx^2)$  and  $(0, txy)$  have weighted degrees at least 5. Similarly, the monomials  $xt^\alpha$  and  $yt^\alpha$  have weighted degrees at least 5 whenever  $\alpha \geq 2$ , so

$$g_2^*(\mathcal{E}_{x,y}) \cdot \begin{pmatrix} 0 \\ t^\alpha \end{pmatrix} = T\mathcal{A}(g_2) \oplus \mathbb{R} \cdot \begin{pmatrix} 0 \\ t^\alpha \end{pmatrix} . \quad (2.19)$$

Therefore, we obtain, from equality (2.17) by inclusions (2.18) and (2.19), the equality

$$(\mathbf{m}_{\xi,t})^2 = T\mathcal{A}(g_2) \oplus \mathbb{R} \cdot \left\{ \begin{pmatrix} 0 \\ t \end{pmatrix}, \begin{pmatrix} 0 \\ t\xi \end{pmatrix}, \begin{pmatrix} 0 \\ t^2 \end{pmatrix}, \begin{pmatrix} 0 \\ t^3 \end{pmatrix}, \begin{pmatrix} 0 \\ t^4 \end{pmatrix} \right\}, \quad (2.20)$$

proving that the codimension of the map germ  $g_2$  is equal to 5.

REMARK. The preceding equality provides the adjacency  $S_{2,2} \rightarrow S_{1,1}$ .

We consider now the orbits  $S_{2,2}^\pm$ . In both cases, we have:

$$\begin{aligned} g_3^*(\mathcal{E}_{x,y}) \cdot \begin{pmatrix} 0 \\ t \end{pmatrix} &\subset T\mathcal{A}(g_3) \oplus \mathbb{R} \cdot \begin{pmatrix} 0 \\ t \end{pmatrix} + g_3^*(\mathcal{E}_{x,y}) \cdot \left\{ \begin{pmatrix} 0 \\ tx \end{pmatrix}, \begin{pmatrix} 0 \\ ty \end{pmatrix} \right\} \subset \\ &\subset T\mathcal{A}(g_3) \oplus \mathbb{R} \cdot \left\{ \begin{pmatrix} 0 \\ t \end{pmatrix}, \begin{pmatrix} 0 \\ t\xi \end{pmatrix} \right\} + g_3^*(\mathcal{E}_{x,y}) \cdot \left\{ \begin{pmatrix} 0 \\ tx^2 \end{pmatrix}, \begin{pmatrix} 0 \\ txy \end{pmatrix}, \begin{pmatrix} 0 \\ t^6 \end{pmatrix} \right\} \subset \\ &\subset T\mathcal{A}(g_3) \oplus \mathbb{R} \cdot \left\{ \begin{pmatrix} 0 \\ t \end{pmatrix}, \begin{pmatrix} 0 \\ t\xi \end{pmatrix} \right\} + g_3^*(\mathcal{E}_{x,y}) \cdot \begin{pmatrix} 0 \\ t^6 \end{pmatrix}. \end{aligned}$$

For this computation, we have used the fact that  $t^2 \partial_t g_3 = (0, 5t^6 + 2t^3\xi + 6t^7)$ , implying that

$$g_3^*(\mathcal{E}_{x,y}) \cdot \begin{pmatrix} 0 \\ t^3\xi \end{pmatrix} \subset T\mathcal{A}(g_3) + \mathbb{R} \cdot \begin{pmatrix} 0 \\ t^6 \end{pmatrix},$$

and the fact that  $t\xi x^2$ ,  $t\xi y$  have weighted degree greater than 6, so the corresponding vector monomials  $(0, t\xi x)$  and  $(0, t\xi y)$  belong to the tangent space. Similarly, we have:

$$\begin{aligned} g_3^*(\mathcal{E}_{x,y}) \cdot \begin{pmatrix} 0 \\ t^2 \end{pmatrix} &\subset T\mathcal{A}(g_3) + \mathbb{R} \cdot \begin{pmatrix} 0 \\ t^2 \end{pmatrix}, \\ g_3^*(\mathcal{E}_{x,y}) \cdot \begin{pmatrix} 0 \\ t^3 \end{pmatrix} &\subset T\mathcal{A}(g_3) + \mathbb{R} \cdot \left\{ \begin{pmatrix} 0 \\ t^3 \end{pmatrix}, \begin{pmatrix} 0 \\ t^6 \end{pmatrix} \right\}, \\ g_3^*(\mathcal{E}_{x,y}) \cdot \begin{pmatrix} 0 \\ t^4 \end{pmatrix} &\subset T\mathcal{A}(g_3) + \mathbb{R} \cdot \begin{pmatrix} 0 \\ t^4 \end{pmatrix}, \\ g_3^*(\mathcal{E}_{x,u}) \cdot \begin{pmatrix} 0 \\ t^6 \end{pmatrix} &\subset T\mathcal{A}(g_3) + \mathbb{R} \cdot \begin{pmatrix} 0 \\ t^6 \end{pmatrix}. \end{aligned}$$

By these inclusions, we get from (2.18) the equality

$$(\mathbf{m}_{\xi,t})^2 = T\mathcal{A}(g_3) \oplus \mathbb{R} \cdot \left\{ \begin{pmatrix} 0 \\ t \end{pmatrix}, \begin{pmatrix} 0 \\ t\xi \end{pmatrix}, \begin{pmatrix} 0 \\ t^2 \end{pmatrix}, \begin{pmatrix} 0 \\ t^3 \end{pmatrix}, \begin{pmatrix} 0 \\ t^4 \end{pmatrix}, \begin{pmatrix} 0 \\ t^6 \end{pmatrix} \right\}, \quad (2.21)$$

proving that the codimension of the map germs  $g_3^\pm$  in  $(\mathbf{m}_{\xi,t})^2$  are equal to 6.

REMARK. The preceding equality provides the adjacency  $S_{2,3}^\pm \rightarrow S_{2,2}$ .

Finally we consider the orbit  $S_{2,3}$ . We have:

$$\begin{aligned}
g_4^*(\mathcal{E}_{x,y}) \cdot \begin{pmatrix} 0 \\ t \end{pmatrix} &\subset T\mathcal{A}(g_4) \oplus \mathbb{R} \cdot \left\{ \begin{pmatrix} 0 \\ t \end{pmatrix}, \begin{pmatrix} 0 \\ t\xi \end{pmatrix}, \begin{pmatrix} 0 \\ t^6 \end{pmatrix}, \begin{pmatrix} 0 \\ t^9 \end{pmatrix} \right\}, \\
g_4^*(\mathcal{E}_{x,y}) \cdot \begin{pmatrix} 0 \\ t^2 \end{pmatrix} &\subset T\mathcal{A}(g_4) + \mathbb{R} \cdot \begin{pmatrix} 0 \\ t^2 \end{pmatrix}, \\
g_4^*(\mathcal{E}_{x,y}) \cdot \begin{pmatrix} 0 \\ t^3 \end{pmatrix} &\subset T\mathcal{A}(g_4) + \mathbb{R} \cdot \left\{ \begin{pmatrix} 0 \\ t^3 \end{pmatrix}, \begin{pmatrix} 0 \\ t^6 \end{pmatrix}, \begin{pmatrix} 0 \\ t^9 \end{pmatrix} \right\}, \\
g_4^*(\mathcal{E}_{x,y}) \cdot \begin{pmatrix} 0 \\ t^4 \end{pmatrix} &\subset T\mathcal{A}(g_4) + \mathbb{R} \cdot \left\{ \begin{pmatrix} 0 \\ t^4 \end{pmatrix}, \begin{pmatrix} 0 \\ t^9 \end{pmatrix} \right\}, \\
g_4^*(\mathcal{E}_{x,y}) \cdot \begin{pmatrix} 0 \\ t^6 \end{pmatrix} &\subset T\mathcal{A}(g_4) + \mathbb{R} \cdot \left\{ \begin{pmatrix} 0 \\ t^6 \end{pmatrix}, \begin{pmatrix} 0 \\ t^9 \end{pmatrix} \right\}, \\
g_4^*(\mathcal{E}_{x,y}) \cdot \begin{pmatrix} 0 \\ t^9 \end{pmatrix} &\subset T\mathcal{A}(g_4) + \mathbb{R} \cdot \begin{pmatrix} 0 \\ t^9 \end{pmatrix}.
\end{aligned}$$

By these inclusions, we get from (2.18) the equality

$$\begin{aligned}
(\mathbf{m}_{\xi,t})^2 &= T\mathcal{A}(g_4) \oplus \mathbb{R} \cdot \left\{ \begin{pmatrix} 0 \\ t \end{pmatrix}, \begin{pmatrix} 0 \\ t\xi \end{pmatrix}, \begin{pmatrix} 0 \\ t^2 \end{pmatrix}, \begin{pmatrix} 0 \\ t^3 \end{pmatrix} \right\} \oplus \\
&\oplus \mathbb{R} \cdot \left\{ \begin{pmatrix} 0 \\ t^4 \end{pmatrix}, \begin{pmatrix} 0 \\ t^6 \end{pmatrix}, \begin{pmatrix} 0 \\ t^9 \end{pmatrix} \right\}
\end{aligned} \tag{2.22}$$

proving that the codimension of the map germ  $g_4$  in  $(\mathbf{m}_{\xi,t})^2$  is equal to 7.

REMARK. The preceding equality provides the adjacency  $S_{2,4} \rightarrow S_{2,3}$ .

The proof of Theorem 2.4.6 is completed.

### Proof of Theorem 2.4.7.

We complete the study of  $S_2$ -type tangential families computing their  $\mathcal{A}$ -miniversal tangential deformations.

Since the vectors  $(0, t^2)$  and  $(0, t\xi)$  belong to the extended tangent space  $T_e\mathcal{A}(g_2)$ , from equality (2.20) we get:

$$(\mathcal{E}_{\xi,t})^2 = T_e\mathcal{A}(g_2) \oplus \mathbb{R} \cdot \left\{ \begin{pmatrix} 0 \\ t \end{pmatrix}, \begin{pmatrix} 0 \\ t^3 \end{pmatrix}, \begin{pmatrix} 0 \\ t^4 \end{pmatrix} \right\},$$

Similarly we have:

$$\begin{aligned}
(\mathcal{E}_{\xi,t})^2 &= T_e\mathcal{A}(g_3^\pm) \oplus \mathbb{R} \cdot \left\{ \begin{pmatrix} 0 \\ t \end{pmatrix}, \begin{pmatrix} 0 \\ t^3 \end{pmatrix}, \begin{pmatrix} 0 \\ t^4 \end{pmatrix}, \begin{pmatrix} 0 \\ t^6 \end{pmatrix} \right\}, \\
(\mathcal{E}_{\xi,t})^2 &= T_e\mathcal{A}(g_4) \oplus \mathbb{R} \cdot \left\{ \begin{pmatrix} 0 \\ t \end{pmatrix}, \begin{pmatrix} 0 \\ t^3 \end{pmatrix}, \begin{pmatrix} 0 \\ t^4 \end{pmatrix}, \begin{pmatrix} 0 \\ t^6 \end{pmatrix}, \begin{pmatrix} 0 \\ t^9 \end{pmatrix} \right\}.
\end{aligned}$$

These formulæ prove that the mappings

$$\begin{aligned} G_2 &: \mathbb{R}^2 \times \mathbb{R}^3 \rightarrow \mathbb{R}^2, \\ G_3^\pm &: \mathbb{R}^2 \times \mathbb{R}^4 \rightarrow \mathbb{R}^2, \\ G_4 &: \mathbb{R}^2 \times \mathbb{R}^5 \rightarrow \mathbb{R}^2, \end{aligned}$$

defined by

$$\begin{aligned} G_2 &: (\xi, t; \mu, \lambda_1, \lambda_2) \mapsto (\xi, t^5 + t^2\xi + t^6 + \mu t + \lambda_1 t^3 + \lambda_2 t^4), \\ G_3^\pm &: (\xi, t; \mu, \lambda_1, \lambda_2, \lambda_3) \mapsto (\xi, t^5 + t^2\xi \pm t^9 + \mu t + \lambda_1 t^3 + \lambda_2 t^4 + \lambda_3 t^6), \\ G_4 &: (\xi, t; \mu, \lambda_1, \lambda_2, \lambda_3, \lambda_4) \mapsto (\xi, t^5 + t^2\xi + \mu t + \lambda_1 t^3 + \lambda_2 t^4 + \lambda_3 t^6 + \lambda_4 t^9), \end{aligned}$$

are  $\mathcal{A}$ -miniversal deformations of the map germs  $g_2$ ,  $g_3^\pm$  and  $g_4$  respectively. In particular, the extended codimensions of the latter germs are 3, 4 and 5. As in the proof of Theorem 2.4.5, we see that these deformations are tangential if and only if  $\mu \equiv 0$ , and that in this case we get a miniversal tangential deformation.

## 2.4.5 $T$ -type tangential families

In this section we will complete the proof of Theorem 2.2.2, proving the statements concerning the  $T$ -type tangential families.

Let us consider the space  $\mathbb{R}[[\xi, t]]$  endowed with the quasihomogeneous filtration defined by the weights  $\deg(t) = n + 1$  and  $\deg(\xi) = 1$ . As usual, we denote by  $\tilde{\delta}(m)$  any function whose Taylor series has order  $m$  in this filtration, and by  $\tilde{\mathfrak{m}}_{\xi, t}^m$  the  $\mathfrak{m}_{\xi, t}$ -ideal generated by the monomials  $\xi^p t^q$  of weighted degree  $p + (n + 1)q = m$ .

By Proposition 2.4.1, the prenormal form of any  $T_n$ -type tangential family can be written as

$$(\xi, t) \mapsto (\xi, \alpha t^3 + k_{n+1} t^2 \xi^{n+1} + \tilde{\delta}(3n + 3)) , \quad (2.23)$$

Since  $\alpha$  and  $k_{n+1}$  are non zero, we may assume by rescaling  $\alpha = k_{n+1} = 1$ .

**THEOREM 2.4.8.** *Every set  $T_n$  is an  $\mathcal{A}$ -orbit; in particular, every map germ belonging to  $T_n$  is  $\mathcal{A}$ -equivalent to the map germ*

$$h_n(\xi, t) := (\xi, t^3 + t^2 \xi^{n+1}) .$$

**THEOREM 2.4.9.** *For every  $n \in \mathbb{N}$ , the codimension in  $(\mathfrak{m}_{\xi, t})^2$  of the  $\mathcal{A}$ -orbit  $T_n$  is equal to  $2n + 3$ .*

**THEOREM 2.4.10.** *The extended codimension of  $h_n$  is  $2n + 1$ . The mapping  $H_n : \mathbb{R}^2 \times \mathbb{R}^n \rightarrow \mathbb{R}^2$ , defined by*

$$H_n(\xi, t; \lambda_1, \dots, \lambda_n) := \left( \xi, t^3 + t^2 \xi^{n+1} + \sum_{i=1}^n \lambda_i t^2 \xi^{i-1} \right) ,$$

*is a tangential deformation of the map germ  $h_n$ . Moreover, for  $n = 1$  the deformation is a miniversal tangential deformation.*

### Proof of Theorem 2.4.8

We start the proof of Theorem 2.4.8 by a Lemma, concerning the tangent space and the reduced tangent space of the  $\mathcal{A}$ -orbit at  $h_n$ .

LEMMA 2.4.9. *The following inclusions hold for every  $n \in \mathbb{N}$ :*

$$\tilde{\mathbf{m}}_{\xi,t} \times \tilde{\mathbf{m}}_{\xi,t}^{3n+3} \subset T\mathcal{A}(h_n) , \quad \tilde{\mathbf{m}}_{\xi,t}^2 \times \tilde{\mathbf{m}}_{\xi,t}^{3n+4} \subset T_r\mathcal{A}(h_n) .$$

*Proof.* Let us consider the monomials of (weighted) degree  $M := (n+1)m + p$ , where  $m \in \mathbb{N} \setminus \{1, 2\}$  and  $p \in \{0, \dots, n\}$ , that is,

$$\{\xi^{(n+1)i+p} t^{m-1} : i = 0, \dots, m\} .$$

Now, for  $i = 0, \dots, m-2$ , consider the following vectors:

$$\begin{aligned} - \xi^{M-3n-2} \partial_\xi h_n - (x^{M-3n-2}, 0) &= (0, (n+1)\xi^{M-2(n+1)} t^2), \\ - t^{m-2-i} \xi^{i(n+1)+p} \partial_t h_n &= (0, 2t^{m-i-1} \xi^{(i+1)(n+1)+p}), \\ - (x^{(m-3)(n+1)+p} y) &= (0, t^3 \xi^{(m-3)(n+1)+p} + t^2 \xi^{(m-2)(n+1)+p}). \end{aligned}$$

These vectors belong to  $T\mathcal{A}(h_n)$  whenever  $M \geq 3n+3$  and to  $T_r\mathcal{A}(h_n)$  whenever  $M \geq 3n+4$ .

We have defined  $m+1$  linearly independent vectors, involving only the  $m+1$  degree  $M$  monomials in the second component. Therefore we have

$$\{0\} \times \tilde{\mathbf{m}}_{\xi,t}^{3n+3} \subset T\mathcal{A}(h_n) , \quad \{0\} \times \tilde{\mathbf{m}}_{\xi,t}^{3n+4} \subset T_r\mathcal{A}(h_n) .$$

Since  $\partial_\xi h_n = (1, (n+1)t^2 \xi^n)$ , every vector monomial  $(\xi^a t^b, 0)$  of degree 1 (resp., of degree 2) belongs to the tangent space to  $h_n$  (resp., to the reduced tangent space).  $\square$

This Lemma implies in particular that the map germ  $h_n$  is finitely  $\mathcal{A}$ -determined. Hence, to prove Theorem 2.4.8, we have to show that every map germ in  $T_n$  is formally  $\mathcal{A}$ -equivalent to  $h_n$ .

This follows from the fact that  $h_n$  is a quasihomogeneous map germ and that every map germ of the form

$$(\xi, t) \mapsto (0, \tilde{\delta}(3n+3))$$

belongs to  $T_r\mathcal{A}(h_n)$ . So, due to Proposition 2.4.2, every map germ of the form (2.23) is formally  $\mathcal{A}$ -equivalent to  $h_n$ . This ends the proof.

### Proof of Theorem 2.4.9

By the Preparation Theorem, the  $\mathcal{E}_{x,y}$ -module  $\mathbf{m}_{\xi,t}$  is generated by  $\xi, t, t^2, t^3$ , indeed

$$\langle h_n \rangle_{\mathcal{E}_{\xi,t}} = \langle \xi, t^3 + t^2 \xi^{n+1} \rangle_{\mathcal{E}_{\xi,t}} = \langle \xi, t^3 \rangle_{\mathcal{E}_{\xi,t}} .$$

Therefore, by Lemma 2.4.9, we have:

$$(\mathbf{m}_{\xi,t})^2 = T\mathcal{A}(h_n) + h_n^*(\mathcal{E}_{x,y}) \cdot \left\{ \begin{pmatrix} 0 \\ t \end{pmatrix}, \begin{pmatrix} 0 \\ t^2 \end{pmatrix} \right\} . \quad (2.24)$$

Using again Lemma 2.4.9, we obtain:

$$\begin{aligned} h_n^*(\mathcal{E}_{x,y}) \cdot \begin{pmatrix} 0 \\ t \end{pmatrix} &\subset T\mathcal{A}(h_n) \oplus \bigoplus_{i=0}^{2n+1} \mathbb{R} \cdot \begin{pmatrix} 0 \\ t\xi^i \end{pmatrix}, \\ h_n^*(\mathcal{E}_{x,y}) \cdot \begin{pmatrix} 0 \\ t^2 \end{pmatrix} &\subset T\mathcal{A}(h_n) \oplus \bigoplus_{i=0}^n \mathbb{R} \cdot \begin{pmatrix} 0 \\ t^2\xi^i \end{pmatrix}. \end{aligned}$$

Since  $\partial_t h_n = (0, 3t^2 + 2t\xi^{n+1})$ , these inclusions and identity (2.24) lead to:

$$(\mathbf{m}_{\xi,t})^2 = T\mathcal{A}(h_n) \oplus \bigoplus_{i=0}^{n+1} \mathbb{R} \cdot \begin{pmatrix} 0 \\ t\xi^i \end{pmatrix} \oplus \bigoplus_{i=0}^n \mathbb{R} \cdot \begin{pmatrix} 0 \\ t^2\xi^i \end{pmatrix} \quad (2.25)$$

This formula shows that the codimension in  $(\mathbf{m}_{\xi,t})^2$  of the  $\mathcal{A}$ -orbit  $T_n$  is equal to  $2n + 3$ .

### Proof of Theorem 2.4.10

Since the vector monomials  $(1, 0)$ ,  $(0, 1)$  and  $(0, t^2\xi^n)$  belong to the extended tangent space to the orbit  $T_n$  at  $h_n$ , we deduce from (2.25) the following equality:

$$\mathcal{E}_{\xi,t}^2 = T_e\mathcal{A}(h_n) \oplus \bigoplus_{i=0}^n \mathbb{R} \cdot \begin{pmatrix} 0 \\ t\xi^i \end{pmatrix} \oplus \bigoplus_{i=0}^{n-1} \mathbb{R} \cdot \begin{pmatrix} 0 \\ t^2\xi^i \end{pmatrix}, \quad (2.26)$$

which implies that the mapping  $\mathcal{H}_n : \mathbb{R}^2 \times \mathbb{R}^{2n+1} \rightarrow \mathbb{R}^2$ , defined by

$$\mathcal{H}_n(\xi, t; \lambda, \mu) := \left( \xi, t^3 + t^2\xi^{n+1} + \sum_{i=0}^n \mu_i t\xi^i + \sum_{i=0}^{n-1} \lambda_i t^2\xi^i \right),$$

is an  $\mathcal{A}$ -miniversal deformation of the map germ  $h_n$ . In particular, the extended codimension of  $h_n$  is  $2n + 1$ .

The deformation  $\mathcal{H}_n$  is tangential if and only if all the  $\mu_i$ 's are vanishing. Indeed, assume  $\lambda_0 = \dots = \lambda_{n-1} = 0$ . Then the equation of the critical set of the perturbed germ is

$$3t^2 + 2t\xi^{n+1} + \sum_{i=0}^n \mu_i \xi^i = 0.$$

If the deformation is tangential, this equation has two solutions, which are the graphs of two functions of  $\xi$  (for  $\mu_i$ 's small enough). Now, the discriminant of the equation is:

$$4\xi^{2n+2} - 12 \sum_{i=0}^n \mu_i \xi^i,$$

which is non negative in a whole neighborhood of  $\xi = 0$  if and only if all the  $\mu_i$ 's are vanishing. On the other hand, it follows from Theorem 2.2.1, Proposition 2.4.1 and Theorem 2.4.8 that  $\mathcal{H}_n|_{\mu=0}$  is a tangential deformation.



However, this not implies that the deformation is miniversal, that is, that every tangential deformation of the map germ  $h_n$  is induced from  $\mathcal{H}_n|_{\mu=0}$ . We shall prove now that this is the case when  $n = 1$ .

Let  $H' : \mathbb{R}^2 \times \mathbb{R}^p \rightarrow \mathbb{R}^2$ ,  $(t, \xi; \alpha) \mapsto H'(\xi, t; \alpha)$ , a tangential deformation of  $h_1$ . Then, due to the  $\mathcal{A}$ -versality of  $\mathcal{H}_1$ ,  $H'$  is  $\mathcal{A}$ -equivalent to

$$(t, \xi; \alpha) \mapsto \mathcal{H}_1(t, \xi; \lambda(\alpha), \mu(\alpha)) ,$$

for some mapping  $\alpha \mapsto (\lambda(\alpha), \mu(\alpha))$  vanishing at  $\alpha = 0$ . The critical set equation of the mapping  $\mathcal{H}_1(\cdot; \lambda(\alpha), \mu(\alpha))$  is

$$3t^2 + 2t(\lambda_0(\alpha) + \xi^2) + (\mu_0(\alpha) + \mu_1(\alpha)\xi) = 0 .$$

The deformation is tangential, so the equation discriminant is non negative, at least in the vicinity of  $(\xi = 0, \alpha = 0)$ . Since the expansion of the discriminant can be written for  $\xi \rightarrow 0$  as

$$4(\lambda_0(\alpha) - 3\mu_0(\alpha)) - 12\mu_1(\alpha)\xi + o(\xi) ,$$

so  $\mu_0(\alpha)$  is vanishing at every  $\alpha$  such that  $\lambda_0(\alpha) = 0$ . On the other hand, the deformed family is a first type tangential family whenever  $\lambda_0(\alpha) \neq 0$ , so it is  $\mathcal{A}$ -equivalent to  $(\xi, t) \mapsto (\xi, t^2)$ . Therefore, there exists a coordinate change of the space  $\mathbb{R}^2$ , depending on  $\alpha$ , taking  $\mathcal{H}_1(\xi, t; \lambda_0(\alpha); \mu_0(\alpha), \mu_1(\alpha))$  to  $\mathcal{H}_1(\xi, t; \lambda_0(\alpha); 0, \mu_1(\alpha))$ . In this case, the discriminant of the critical set equation can be rewritten for  $\xi \rightarrow 0$  as  $4\lambda_0(\alpha) - 12\mu_1(\alpha)\xi + o(\xi)$ . As before, the tangentiality condition implies that  $\mu_1$  is vanishing over  $\lambda_0^{-1}(0)$ , and then we can assume, up to a coordinate change, that  $\mu_1$  is vanishing everywhere. Hence, we have shown that the initial tangential deformation  $H'$  is induced by  $\mathcal{H}_1|_{\mu=0}$ ; that is,  $\mathcal{H}_1|_{\mu=0}$  is an  $\mathcal{A}$ -miniversal tangential deformation of the map germ  $h_1$ .

### 2.4.6 Proof of Theorem 2.2.3

Let us recall the statement of Theorem 2.2.3: *the tangential family simple singularities are exactly I, II,  $S_{1,n}$ ,  $T_n$ ,  $S_{2,2}$ ,  $S_{2,3}$ ,  $S_{2,4}$ , where  $n$  is any natural number.*

To prove this Theorem we have to show that all the tangential family singularities belonging to the classes  $S_{1,\infty}$ ,  $T_\infty$ ,  $S_n$  for  $n > 2$  and  $U$  are not simple. We shall prove now these assertions.

**FIRST CLAIM:** *The tangential family singularities of type  $S_{1,\infty}$  and  $T_\infty$  are not simple.*

Indeed, the orbits  $S_{1,\infty}$  (resp.,  $T_\infty$ ) are contained in the closure of the orbits  $S_{1,n}$  (resp.,  $T_n$ ) for every  $n \in \mathbb{N}$ .

**SECOND CLAIM:** *The tangential family singularities of type  $S_n$  are not simple, whenever  $n \geq 3$ .*

We start proving the non simplicity of a special family of germs. Let us consider  $\mathbb{R}[[\xi, t]]$  endowed with the quasihomogeneous filtration defined by  $\deg(\xi) = 4$  and  $\deg(t) = 1$ . We denote by  $\tilde{J}(m, n)$  the space of the vector polynomials of weighted degree smaller or equal to  $m$  in the first coordinate and to  $n$  in the second;  $\tilde{\delta}(m)$  is any function having order  $m$  Taylor series.

Let us denote by  $f_a$  a 1-parameter family of germs of the form

$$(\xi, t) \mapsto (\xi, t^6 + t^2\xi + t^7 + at^9 + \tilde{\delta}(9)) ,$$

where  $a \in \mathbb{R}$ . Note that  $f_a$  belongs to  $S_3$  for every  $a$ . We shall prove now that we can not kill the terms  $(0, at^9)$ ; by this, we mean that two map germs  $f_a$  and  $f_b$  are not  $\mathcal{A}$ -equivalent, provided that  $a \neq b$ . We do this by an explicit computation. Obviously, if two map germs  $f_a$  and  $f_b$  are not  $\mathcal{A}$ -equivalent in  $\tilde{J}(7, 9)$  for the induced action of the group  $\mathcal{A}$ , they can not be  $\mathcal{A}$ -equivalent in the whole space  $(\mathfrak{m}_{\xi, t})^2$ .

Every coordinate change  $(\varphi, \psi)$  acting on the (weighted) jet  $j^{7,9}f_a$  is as follows:

$$\varphi(\xi, t) = (\xi + P(\xi, t), t + Q(\xi, t))$$

$$\psi(x, y) = (x + cy, y + dx^2) ,$$

where  $c, d \in \mathbb{R}$  and  $P$  and  $Q$  are polynomials of order 5 and 2 respectively:

$$P(\xi, t) = a_1t^5 + a_2t\xi + a_3t^6 + a_4t^2\xi + a_5t^7 + a_6t^3\xi ,$$

$$Q(\xi, t) = b_1t^2 + b_2t^3 + b_3t^4 + b_4\xi ,$$

where  $a_i, b_i \in \mathbb{R}$ . Consider the polynomial  $g$  obtained from  $f_a$  under the conjugacy by  $(\varphi, \psi)$ . We impose to the resulting germ  $g$  to belong to the family  $\{f_a : a \in \mathbb{R}\}$ , that is  $g = f_b$  for some  $b$  depending on  $a, a_i, b_i, c, d$ .

Let us first compute the action of  $(\varphi, \psi)$  on the jet of order  $(5, 7)$  of  $f_a$ :

$$j^{5,7}g = (\xi + a_1t^5 + a_2t\xi, t^6 + t^2\xi + (1 + a_1 + 6b_1)t^7 + (a_2 + 2b_1)t^3\xi) .$$

The condition  $j^{5,7}g = j^{5,7}f_b$  implies that  $a_1 = a_2 = b_1 = 0$ . We consider next the jet of order  $(6, 8)$ :

$$j^{6,8}g = (\xi + (a_3 + c)t^6 + (a_4 + c)t^2\xi, t^6 + t^2\xi + t^7 + (a_3 + 6b_2)t^8 + (a_4 + 2b_2)t^4\xi + d\xi^2) .$$

The condition on  $g$  is equivalent to the following conditions on the coordinate changes:

$$\begin{cases} a_3 + c = 0 \\ a_4 + c = 0 \\ a_3 + 6b_2 = 0 \\ a_4 + 2b_2 = 0 \\ d = 0 \end{cases} .$$

Since these equations are linearly independent, we get  $a_3 = a_4 = b_2 = c = d = 0$ . We have now the next jet

$$j^{7,9}g = (\xi + a_5t^7 + a_6t^3\xi, t^6 + t^2\xi + t^7 + (a + a_5 + 6b_3)t^9 + (a_6 + 2b_3 + 6b_4)t^4\xi + 2b_4t\xi^2) .$$

The condition  $j^{7,9}g = j^{7,9}f_b$  is equivalent to the following equation system

$$\begin{cases} a_5 = 0 \\ a_6 = 0 \\ a + a_5 + 6b_3 = b \\ a_6 + 2b_3 + 6b_4 = 0 \\ 2b_4 = 0 \end{cases}$$

providing the solutions  $a_5 = a_6 = b_3 = b_4 = 0$  and  $a = b$ .

Therefore, two map germs  $f_a$  and  $f_b$  can not be  $\mathcal{A}$ -equivalent whenever  $a \neq b$ . This means that in the neighboring of each map  $f_a$  there are infinitely many  $\mathcal{A}$ -orbits; that is,  $f_a$  is non simple.

Let us consider now a map germ  $f$  lying in  $S_3$ . Assume  $f$  on the prenormal form:

$$f(\xi, t) = (\xi, t^6 + t^2\xi + \tilde{\delta}(6))$$

(here we use Proposition 2.4.1). Due to the geometry of the Newton Diagram of the second component of this germ, it is easy to see that  $f$  is  $\mathcal{A}$ -equivalent to a map germ whose Taylor expansion is of the form

$$(\xi, t) \mapsto (\xi, t^6 + t^2\xi + At^7 + Bt^9 + \tilde{\delta}(9)) ;$$

the formal argument to prove this is the same used in the proof of Lemma 2.4.3 in section 2.4.3. If  $A \neq 0$ , we may normalize it to 1. Now  $f$  is of the form  $f_a(\xi, t) + (0, \tilde{\delta}(9))$ , so in the neighborhood of  $f$  there are infinitely many  $\mathcal{A}$ -orbits. On the other hand, if  $A$  is vanishing, we consider the following deformation:  $F_\varepsilon(\xi, t) := f(\xi, t) + (0, \varepsilon t^7)$ . For every  $\varepsilon \neq 0$ ,  $F_\varepsilon$  is  $\mathcal{A}$ -equivalent to a non simple germ, so  $f$  is also non simple.

We have proven that there are no  $S_3$  singularities which are simple. Finally, the sets  $S_n$  for  $n > 3$  are in the closure of  $S_3$ , so there are no  $S_{n>4}$  and  $S_\infty$  singularities which are simple. This concludes the proof of the second claim.

We remark that one can prove the non simplicity of the singularities  $S_{n \geq 4}$  by the following argument. Consider a tangential family of type  $S_4$ . Its critical value set has, up to a coordinate change, a branch of the form  $t \mapsto (t^5, t^7 + o(t^7))$ . These curves are non simple, as proven by Bruce and Gaffney in [14] (see also [8]). This implies that also the corresponding tangential families are non simple.

**THIRD CLAIM:** *The tangential family singularities of type  $U$  are non simple.*

We start the proof of the last claim with a particular case. Let us consider a 1-parameter family of map germs  $\{f_a : a \in \mathbb{R}\}$  of the form

$$f_a : (\xi, t) \mapsto \left( \xi, \frac{1}{4}t^4 + \frac{2}{3}at^3\xi + \frac{1}{2}t^2\xi^2 + t^2 \cdot \delta(2) \right) .$$

For every  $a$ ,  $f_a$  is of type  $U$ , due to Proposition 2.4.1. Let us consider the complexification  $f_a^{\mathbb{C}} : \mathbb{C}^2 \rightarrow \mathbb{C}^2$  of  $f_a$ . The critical set equation of  $f_a^{\mathbb{C}}$  is

$$t(t^2 + 2at\xi + \xi^2 + \delta(2)) = 0 , \tag{2.27}$$

having as solutions  $t = 0$  and the graphs of two functions that can be written as  $t_{1,2}(\xi) = \xi(a \pm \sqrt{a^2 - 1})$ . Let us consider the complex tangent space  $T_0^{\mathbb{C}}\Phi_a$  to the graph  $\Phi_a$  of the family  $f_a$ . Note that the equation of  $T_0^{\mathbb{C}}\Phi_a$  in the three-space  $\{\xi, x, y\}$  is  $y = 0$ . The vertical direction at the origin and the three solutions of the equation (2.27) define the following four complex directions in  $T_0^{\mathbb{C}}\Phi_a$ :

$$(-1, 1, 0), (1, 0, 0), (a - 1 + \sqrt{a^2 - 1}, 1, 0), (a - 1 - \sqrt{a^2 - 1}, 1, 0).$$

These four directions define four points on the projective complex line, namely  $-1, \infty, P := a - 1 + \sqrt{a^2 - 1}$  and  $Q := a - 1 - \sqrt{a^2 - 1}$ . The complex Cross Ratio of these points is a function of the parameter  $a$ :

$$\text{CR}_{\mathbb{C}}(-1, \infty; P, Q) = 2a^2 - 1 + 2\sqrt{a^2 - 1}.$$

The Cross Ratio associated to a tangential family is invariant under coordinate changes, that is,  $\mathcal{A}$ -equivalent tangential families have the same Cross Ratio. Therefore, two germs  $f_a$  and  $f_b$  are non  $\mathcal{A}$ -equivalent if their Cross Ratios are different, that is, if  $|a| \neq |b|$ . This proves that the singularity containing a map germ  $f_a$  for some  $a$  is not simple.

Consider now the prenormal form  $f$  of any  $U$ -type tangential family:  $f(\xi, t) = (\xi, t^3 \cdot \delta(1))$ . Consider the 1-parameter deformation of  $f$ , defined by:

$$F_{\varepsilon}(\xi, t) := f(\xi, t) + (0, \varepsilon(t^4 + t^2\xi^2)).$$

For every  $\varepsilon$  small enough, such a germ is  $\mathcal{A}$ -equivalent to some map germ in the family  $\{f_a : a \in \mathbb{R}\}$ . Hence, in the vicinity of  $f$  there are infinitely many  $\mathcal{A}$ -orbits, so the singularity  $\mathcal{A} \cdot f$  is non simple.

This ends the proof of the last claim and of Theorem 2.2.3.



# Chapter 3

## Singularities of Legendrian graphs and singular tangential families

ABSTRACT. We construct the Legendrian version of envelope theory. The Legendrian graph of a tangential family is the union of the Legendrian lifts of the family curves in the projectivized cotangent bundle. We investigate singularities of Legendrian graphs of first and second type tangential family germs and we study their stability under small tangential deformations of the families generating them. We also find the normal forms of the projections of these Legendrian graphs into the plane. This Legendrian construction allows us to consider singular tangential families, i.e. 1-parameter families of rays emanating tangentially from a given curve with a semicubic cusp.

### 3.1 Introduction

Tangential families are 1-parameter families of rays emanating tangentially from a given smooth curve. Tangential families and their envelopes (or caustics) are natural objects in Differential Geometry: for instance, every curve in a Riemannian surface defines the tangential family of its tangent geodesics.

The theory of tangential families is a generalization of the study developed by Thom (see [28]) and Arnold for plane envelopes (see [2] and [3]). Indeed, every 1-parameter family of plane curves is tangential, with respect to generic points of its geometric envelope branches.

In [17] we studied the stability of singularities of tangential family germs and their envelopes under small tangential deformations, i.e. deformations of the family among tangential families. In [18] we classified the simple singularities of tangential family germs and we described the corresponding envelope perestroikas.

In this chapter we construct the Legendrian version of the envelope theory. In particular, we interpret the envelope of a tangential family as the apparent contour of a certain surface in the projectivized cotangent bundle of the plane. This surface, that we call the Legendrian graph of the family, is the union of the Legendrian lifts of the family curves in the projectivized cotangent bundle.

Our first result concerns singularities of Legendrian graphs and their stability under small tangential deformations. We prove that in this setting the double Whitney umbrella is stable. In the theory of singularities of mappings from the plane to the three space, constructed by

Mond in [27], this singularity of the image surface is not stable.

Our result is related to the theory of functions on manifolds with boundary, constructed by Arnold and Lyashko (see [12]). More precisely, it is an example of a mapping from a surface with boundary to the plane, the boundary being the lifting in the Legendrian graph of the support of the family.

Furthermore, we find normal forms of projections of Legendrian graphs into the plane (in the case of tangential families of first and second type). This result is related to the theory of projections of surfaces into the plane, constructed by O. A. Platonova and O.P. Shcherbak (see [12]) and to the theory of projections of complete intersections, due to V. V. Goryunov ([24]). Our result is new when the projected surface is singular (actually the double Whitney umbrella). Our study is also related to the theory of singular Lagrangian varieties and their Lagrangian mappings, constructed by A. B. Givental in [25].

The Legendrian construction allows us to consider singular tangential families, i.e. 1-parameter families of rays emanating tangentially from given curves with semicubic cusps. These families are defined from tangential families via the projective duality. We discuss envelopes of singular families. Our results generalize the study of envelopes of 1-parameter families of curves tangent to a curve having a semicubic cusp, carried out in [15] and [16].

This chapter is divided into two parts. In the first part we state our results. The second part is devoted to the proofs.

## 3.2 Presentation of the results

Unless otherwise specified, all the objects considered below are supposed real and of class  $\mathcal{C}^\infty$ ; a plane curve is a dimension 1 embedded submanifold of the plane.

### 3.2.1 Envelopes of tangential families

Let  $f : \mathbb{R}^2 \rightarrow \mathbb{R}^2$  be a mapping of the source plane, equipped with the coordinates  $\xi$  and  $t$ , to another plane. If  $\partial_t f$  vanishes nowhere, then the mapping defines the 1-parameter family of plane curves parameterized by  $t$ , indicating the point on the curve, and indexed by  $\xi$ , indicating the curve in the family. The family curves may have self-intersections. The mapping  $f$  is called a *parameterization* of the family. We set  $f_\xi(t) := f(\xi, t)$ .

DEFINITION. The 1-parameter family parameterized by  $f$  is a *tangential family* if the partial derivatives  $\partial_\xi f$  and  $\partial_t f$  are parallel non zero vectors at every point  $(\xi, t = 0)$ , and the image of the mapping  $\xi \mapsto f(\xi, 0)$  is a curve, called the *support* of the family.

In other terms, a family of plane curves tangent to  $\gamma$  is a tangential family whenever it can be parameterized by the tangency points of the family curves with the support. We will denote such a family by  $\{\Gamma_\xi : \xi \in \mathbb{R}\}$ , where  $\Gamma_\xi$  is the curve, tangent to the support at  $f(\xi, 0)$ , corresponding to the parameter value  $\xi$ .

Below we will consider tangential families near a fixed point of the support, settled at the origin. Thus, without loss of generality, we can consider the parameterizations of tangential families as elements of  $(\mathfrak{m}_{\xi,t})^2$ , i.e. map germs  $(\mathbb{R}^2, 0) \rightarrow (\mathbb{R}^2, 0)$  in the variables  $\xi, t$ .

The *graph* of a tangential family  $f$  is the surface

$$\Phi := \{(q, p) \in \gamma \times \mathbb{R}^2 : q = f(\xi, 0), p = f(\xi, t), \xi, t \in \mathbb{R}\}.$$

Graphs of tangential family germs are smooth. The *envelope* of the family is the apparent contour of its graph under the projection  $\pi : \Phi \rightarrow \mathbb{R}^2$ ,  $\pi(q, p) := p$ . The *criminant set* (or the *envelope in the source*) is the critical set of  $\pi$ .

The fiber  $\pi^{-1}(0, 0)$  defines a *vertical direction* in the tangent space of the graph at the origin. A tangential family germ is said to be of *first type* if its criminant set has only one branch at the origin, of *second type* if it has exactly two branches passing through the origin and these branches are smooth, non vertical and transversal each other.

Let  $\text{Diff}(\mathbb{R}^n, 0)$  be the group of the diffeomorphism germs  $(\mathbb{R}^n, 0) \rightarrow (\mathbb{R}^n, 0)$ . The group  $\mathcal{A}_n := \text{Diff}(\mathbb{R}^2, 0) \times \text{Diff}(\mathbb{R}^n, 0)$  acts on the space  $(\mathfrak{m}_{\xi, t})^n$  of the map germs  $(\mathbb{R}^2, 0) \rightarrow (\mathbb{R}^n, 0)$  by

$$(\varphi, \psi) \cdot f := \psi \circ f \circ \varphi^{-1}.$$

Two map germs in  $(\mathfrak{m}_{\xi, t})^n$  are said to be *Left-Right equivalent*, or  $\mathcal{A}_n$ -equivalent, if they belong to the same  $\mathcal{A}_n$ -orbit. In this section we consider the case  $n = 2$ , below, we will deal with the case  $n = 3$ .

We will denote by  $X$  (resp. I, II) the set of all map germs in  $(\mathfrak{m}_{\xi, t})^2$  which are  $\mathcal{A}_2$ -equivalent to tangential family germs (resp. tangential family germs of first type, of second type). By construction, these sets are union of  $\mathcal{A}_2$ -orbits, so they are invariant under the  $\mathcal{A}_2$ -action.

**DEFINITION.** A *p-parameter tangential deformation* of a tangential family germ  $f$  is a  $p$ -parameter family of tangential families, parameterized by a  $p$ -parameter family of maps  $\{F_\lambda : \mathbb{R}^2 \rightarrow \mathbb{R}^2, \lambda \in \mathbb{R}^p\}$ , such that the germ of  $F_0$  at the origin is  $f$ .

By a geometrical point of view, tangential deformations are deformations inducing smooth deformations on the family support, the latter being a branch of the envelope.

We quote now from [17] the main result about stable tangential family germs.

**THEOREM 3.2.1.** *The sets I and II defines two singularities, which are all the stable singularities of tangential family germs. The table below lists the normal forms of these singularities, their extended codimensions and the codimensions of their orbits in the space  $(\mathfrak{m}_{\xi, t})^2$ .*

Singularity	Representative	$\text{codim}_e$	$\text{codim}$
I	$(\xi, t^2)$	0	1
II	$(\xi, t^3 + t^2\xi)$	1	3

It follows from the Theorem that the envelope of every first type tangential family germ is smooth, while that of every second type tangential family germ has a second order self-tangency, and that these envelope singularities are stable under small tangential deformations.



### 3.2.2 Legendrian graphs and their singularities

In this section we define Legendrian graphs generated by tangential family germs and we study their singularities up to the Left-Right equivalence in the case of tangential family germs of first and second type.

Let us recall some standard constructions in contact geometry; for details, we refer the reader to [5].

A *contact element* on a given manifold is a hyperplane in a tangent space. The set of all contact elements on a given manifold  $B$  of dimension  $m$  is fibered over  $B$ , and the fiber over a point of  $B$  is the projectivized cotangent space of  $B$  at this point (called the point of contact). This set of all contact elements of  $B$  is called the space of the *projectivized cotangent bundle*  $PT^*B$ . Its dimension  $2m - 1$  is odd and it carries a natural contact structure.

This structure is defined by the following construction. A velocity of motion of a contact element is called *admissible* if the velocity of the point of contact belongs to the contact element. It is easy to see that the admissible velocities form a hyperplane at any given point of  $PT^*B$ , and that these hyperplanes define a contact structure.

The set of all the contact elements, tangent to any particular submanifold of  $B$ , is an integral manifold of their contact structure of  $PT^*B$ . The dimension of such an integral manifold is always  $m - 1$ . The integral submanifolds of this maximal dimension of a contact structure are called *Legendrian submanifolds*. Thus, to every submanifold of the base manifold  $B$  there corresponds a Legendrian submanifold of the projectivized cotangent bundle. The Legendrian manifold will be called the *Legendrian lift* of the initial submanifold in the base. For instance, the Legendrian submanifold corresponding to a hypersurface of  $B$  is the set of the tangent spaces of the hypersurface. It is naturally diffeomorphic to the hypersurface.

We shall apply this construction to the plane curves forming a tangential family. Let  $\{\Gamma_\xi : \xi \in \mathbb{R}\}$  be a tangential family and  $PT^*\mathbb{R}^2$  the projectivized cotangent bundle to the plane  $\mathbb{R}^2$ , endowed with the standard contact structure and with the Legendrian fibration  $\pi : PT^*\mathbb{R}^2 \rightarrow \mathbb{R}^2$ . To any curve  $\Gamma_\xi$  of the family we may associate its Legendrian lift  $\hat{\Gamma}_\xi$  defined by

$$\hat{\Gamma}_\xi := \{(p, L) : L \text{ is the tangent line to } \Gamma_\xi \text{ at } p \in \Gamma_\xi\} \subset PT^*\mathbb{R}^2 .$$

Each curve  $\Gamma_\xi$  is parameterized by a smooth map, and the only admitted singularities for the curve are self-intersections. Thus, the Legendrian lift of  $\Gamma_\xi$  is well defined.

**DEFINITION.** The *Legendrian graph* of a tangential family is the surface  $\Lambda$  of  $PT^*\mathbb{R}^2$  formed by the Legendrian lifts of the family curves:

$$\Lambda := \bigcup_{\xi \in \mathbb{R}} \hat{\Gamma}_\xi .$$

Note that the envelopes of tangential families are  $\pi$ -apparent contours of their Legendrian graphs.

As done for tangential families, we will consider local parameterizations of Legendrian graphs: we will identify any Legendrian graph to any map germ parameterizing the graph at the point, whose projection in the plane is the point near which is defined the tangential family generating the graph.

Without loss of generality, we can assume that these local parameterizations are map germs  $(\mathbb{R}^2, 0) \rightarrow (\mathbb{R}^3, 0)$ , that is, elements of the space  $(\mathfrak{m}_{\xi,t})^3$ . On this space acts the group  $\mathcal{A}_3$ , as we explained in section 3.2.1.

DEFINITION. The  $\mathcal{A}_3$ -equivalence class of a map germ parameterizing a Legendrian graph is called a *Legendrian graph singularity*.

The meaning of the classification of Legendrian graph singularities up to the Left-Right equivalence is that we are looking at Legendrian graphs as surfaces in the 3-space: this classification does not consider the fibration neither the contact structure in the projectivized cotangent bundle. The classification of Legendrian graphs up to an equivalence relation preserving the fiber structure of the cotangent bundle is the object of section 3.2.4.

We will say that a Legendrian graph is of *first type* (resp., *second type*) if it is generated by a tangential family germ of first type (resp., second type). Let us denote by  $\hat{X} \subset (\mathfrak{m}_{\xi,t})^3$  the set of the local parameterizations of the Legendrian graph, and by  $\hat{\Pi}$  the smaller  $\mathcal{A}_3$ -invariant set containing the map germs in  $(\mathfrak{m}_{\xi,t})^3$  parameterizing Legendrian graph germs of second type. These two sets define two classes of singularities of Legendrian graphs. It turns out that  $\hat{X}$  and  $\hat{\Pi}$  are submanifolds of  $(\mathfrak{m}_{\xi,t})^3$ .

THEOREM 3.2.2. *The Legendrian graph germs of first type are smooth, while those of second type have generically a singularity  $A_1^\pm$ . The Legendrian graph germs of second type which do not have a singularity  $A_1^\pm$  form a codimension 1 (non connected) submanifold of  $\hat{\Pi}$ . These Legendrian graph germs have a singularity belonging to the series  $A_n^\pm$  or  $H_n$  for  $n \geq 2$  or  $n = \infty$ .*

Let us recall that, by definition, a mapping from the plane to the three space has a singularity  $A_n^\pm$  if it is  $\mathcal{A}_3$ -equivalent to the map germ

$$(\xi, t) \mapsto (\xi, t^2, t^3 \pm t\xi^{n+1}).$$

The singularities  $A_n^+$  and  $A_n^-$  are  $\mathcal{A}_3$ -equivalent if and only if  $n$  is even. A mapping has a singularity  $H_n$  if it is  $\mathcal{A}_3$ -equivalent to the map germ

$$(\xi, t) \mapsto (\xi, \xi t + t^{3n-1}, t^3).$$

All these singularities  $A_n^\pm$  and  $H_n$  are simple, that is, by an arbitrary sufficiently small perturbation of each one of them, we can obtain representatives of only a finite number of singularities. The singularities  $A_1^-$  and  $A_1^+$  are shown in figure 3.1. They are also called *double Whitney umbrella*, with real handles in the case  $A_1^-$  and complex handles in the case  $A_1^+$ .

REMARK. Singularities  $B_n^\pm$ ,  $C_n^\pm$ ,  $F_4$  of map germs from  $\mathbb{R}^2$  to  $\mathbb{R}^3$  appear as singularities of Legendrian graph germs which are not of first nor second type. In particular, it turns out that the Legendrian graph of a  $S$ -type tangential family germ has a singularity  $B_n^\pm$ . For the classification of simple tangential family germs we refer the reader to [18].

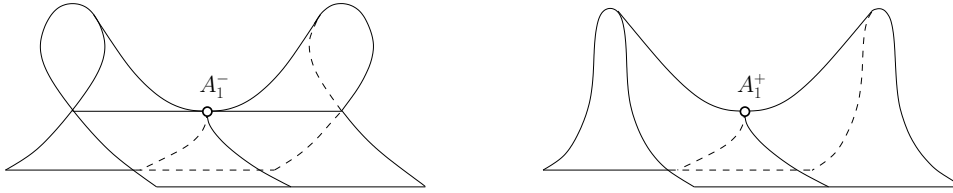

Figure 3.1: Double Whitney umbrella.

### 3.2.3 Stability of singularities of Legendrian graphs

In this section we investigate the stability of Legendrian graph singularities under deformations induced by tangential deformations of the families generating the graphs.

DEFINITION. A  $p$ -parameter family of surfaces  $\{\Lambda_\lambda : \lambda \in \mathbb{R}^p\} \subset PT^*\mathbb{R}^2$  is said to be a  $p$ -parameter tangential deformation of the Legendrian graph germ  $\Lambda$  whenever there exists a tangential deformation  $\{\Gamma^\lambda : \lambda \in \mathbb{R}^p\}$  of the tangential family  $\Gamma^0$  generating  $\Lambda$ , such that every  $\Lambda_\lambda$  is the Legendrian graph generated by  $\Gamma^\lambda$ .

Let  $\Lambda$  be the germ of a Legendrian graph at a point  $P$ .

DEFINITION. The singularity of  $\Lambda$  at  $P$  is said to be *stable under small tangential deformations* if for every tangential deformation  $\{\Lambda_\lambda : \lambda \in \mathbb{R}^p\}$  of  $\Lambda$  and for every small enough  $\lambda$ , the surface  $\Lambda_\lambda$  has an  $\mathcal{A}_3$ -equivalent singularity at some  $\lambda$ -depending point arbitrary close to  $P$ .

THEOREM 3.2.3. *The double Whitney umbrella  $A_1^\pm$  (together with the embedding singularity) is the only singularity of Legendrian graph germs which is stable under small tangential deformations.*

The perestroika occurring to Legendrian graphs having a singularity  $A_1^\pm$  and to their apparent contours under non tangential deformations of the subjacent families are discussed in section 3.2.4.

We end the study of the singularities of Legendrian graph germs describing their adjacencies. A Legendrian graph singularity  $L$  is said to be *adjacent* to a Legendrian graph singularity  $K$ , and we write  $L \rightarrow K$ , if every Legendrian graph in the  $\mathcal{A}_3$ -orbit  $L$  can be deformed into a Legendrian graph in  $K$  by an arbitrary small tangential deformation. If  $L \rightarrow K \rightarrow K'$ , the class  $L$  is also adjacent to  $K'$ . In this case we omit the arrow  $L \rightarrow K'$ . The hierarchy of the Legendrian graph singularities (under small tangential deformations) is as follows (where  $E$  stay for embedding).

$$\begin{array}{ccccccc}
 E & \longleftarrow & A_1^\pm & \longleftarrow & A_2 & \longleftarrow & A_3^\pm & \longleftarrow & \cdots \\
 & & & \swarrow & & & & & \\
 & & & & H_2 & \longleftarrow & H_3 & \longleftarrow & \cdots
 \end{array}$$

We point out that there are no adjacencies between singularities of the classes  $A_n^\pm$  and  $H_m$ , except  $H_2 \rightarrow A_1^\pm$ .

### 3.2.4 Normal forms of Legendrian graph projections

In this section we study how Legendrian graphs project into the envelopes of their generating tangential families. In other terms, we find normal forms of Legendrian graphs of first and second type under an equivalence relation preserving the fiber structure of the projectivized cotangent bundle  $PT^*\mathbb{R}^2$ .

We start defining the equivalence relation for global Legendrian graphs.

DEFINITION. The projections of two Legendrian graphs  $\Lambda_1$  and  $\Lambda_2$  by the Legendrian fibration  $\pi : PT^*\mathbb{R}^2 \rightarrow \mathbb{R}^2$  into the plane are said to be *equivalent* if there exists a commutative diagram

$$\begin{array}{ccccc} \Lambda_1 & \xrightarrow{i_1} & PT^*\mathbb{R}^2 & \xrightarrow{\pi} & \mathbb{R}^2 \\ \downarrow & & \downarrow & & \downarrow \\ \Lambda_2 & \xrightarrow{i_2} & PT^*\mathbb{R}^2 & \xrightarrow{\pi} & \mathbb{R}^2 \end{array}$$

in which the vertical arrows are diffeomorphisms and  $i_1, i_2$  are inclusions of the Legendrian graphs into the projectivized cotangent bundle.

Such an equivalence is a pair, formed by a diffeomorphism between the two Legendrian graphs and a diffeomorphism of the projectivized cotangent bundle fibered over its base (which is not presumed to be a contactomorphism).

REMARK. Apparent contours of Legendrian graphs under equivalent projections are diffeomorphic.

In terms of map germs, this equivalence relation reads as follows. Consider two local parameterizations  $F, G : (\mathbb{R}^2, 0) \rightarrow (\mathbb{R}^3, 0)$  of two Legendrian graphs. In the local context, we may assume that the projection  $\pi$  is the germ at the origin of the mapping  $(x, y, z) \mapsto (x, y)$ . The projections of the Legendrian graphs parameterized by  $F$  and  $G$  are equivalent if and only if there exists a commutative diagram

$$\begin{array}{ccccc} (\mathbb{R}^2, 0) & \xrightarrow{F} & (\mathbb{R}^3, 0) & \xrightarrow{\pi} & (\mathbb{R}^2, 0) \\ \downarrow & & \downarrow & & \downarrow \\ (\mathbb{R}^2, 0) & \xrightarrow{G} & (\mathbb{R}^3, 0) & \xrightarrow{\pi} & (\mathbb{R}^2, 0) \end{array}$$

in which the vertical arrows are germs of diffeomorphisms fixing the origin. This equivalence is provided by a pair  $(\varphi, \psi) \in \mathcal{A}_3$ , in which  $\psi$  is fibered over the plane with respect to  $\pi$ ; i.e.  $\psi$  is of the form

$$\psi(x, y, z) = (X(x, y), Y(x, y), Z(x, y, z)) .$$

Let us denote by  $\mathcal{A}_3^*$  the subgroup of  $\mathcal{A}_3$  formed by all the above pairs  $(\varphi, \psi)$ . This subgroup inherits the action of  $\mathcal{A}_3$  on the space  $(\mathfrak{m}_{\xi, t})^3$ . Two projections of Legendrian graphs are locally equivalent if and only if the local parameterizations of the two Legendrian graphs are  $\mathcal{A}_3^*$ -equivalent.

DEFINITION. The *singularity* of the germ of a projection of a Legendrian graph (or the  $\mathcal{A}_3^*$ -singularity of a Legendrian graph) is the  $\mathcal{A}_3^*$ -equivalence class of this germ.

A class of Legendrian graph  $\mathcal{A}_3^*$ -singularities is by definition any subset of  $\hat{X}$  which is invariant under the action of the group  $\mathcal{A}_3^*$ . Any  $\mathcal{A}_3$ -singularity of Legendrian graph defines a class of  $\mathcal{A}_3^*$ -singularities. So, the set of the Legendrian graph germs having an  $\mathcal{A}_3$ -singularity  $A_1^\pm$  is a class of  $\mathcal{A}_3^*$ -singularities.

DEFINITION. A (polynomial) *normal form* for a singularity class  $L$  (for any equivalence relation) is a smooth map  $\Phi : B \rightarrow (\mathbb{R}[\xi, t])^3$  of a finite dimensional smooth manifold (diffeomorphic to a vector space) into the space of triples of polynomials that satisfies the following conditions:

- 1) the image  $\Phi(B)$  intersects all the orbits in  $L$ ;
- 2) the preimage of any orbit in  $L$  under  $\Phi$  is a finite subset of  $B$ ;
- 3) the preimage of the complement of  $L$  is contained in some proper hypersurface of  $B$ .

The dimension of  $B$  is called the *modality* of the singularity class.

We can state now our main result on the projections of Legendrian graphs.

THEOREM 3.2.4. *The germs of projections of Legendrian graphs of first and second type (except the union of two codimension 1 submanifolds in  $\hat{\Pi}$ ) are  $\mathcal{A}_3^*$ -equivalent to the projection germs of the surfaces parameterized by the map germs  $f$  in the 3-space  $\{x, y, z\}$  by a pencil of lines parallel to the  $z$ -axis, where  $f$  is the normal form in the following table, according to the type of the Legendrian graph.*

Type	Singularity	Normal form	Restrictions
I	fold	$(\xi, t^2, t)$	$\emptyset$
II	$A_1^\pm$	$(\xi, t^3 + t^2\xi + at\xi^2, t^2 + bt^3)$	$a \neq -1, 0$ $a < 1/3$

The real numbers  $a$  and  $b$  in the table are moduli. Moreover, a Legendrian graph germ of second type, parameterized by the above normal form, has an  $\mathcal{A}_3$ -singularity  $A_1^+$  if and only if  $0 < a < 1/3$ , it has an  $\mathcal{A}_3^*$ -singularity  $A_1^-$  if and only if  $-1 \neq a < 0$ .

The typical singularities of Legendrian graph projections, listed in the table above, are depicted in figure 3.2.

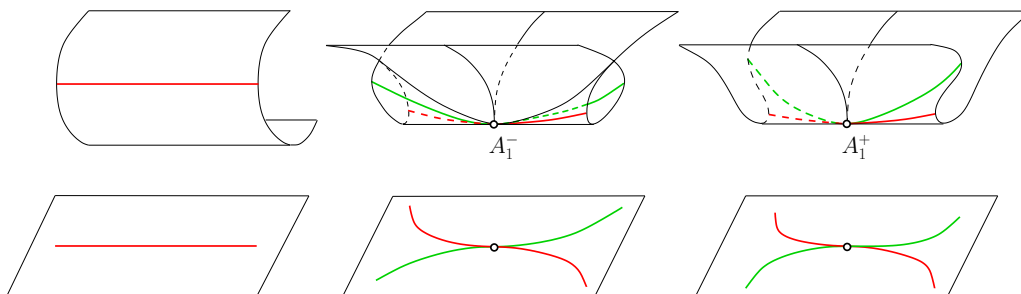

Figure 3.2: Typical Legendrian graph projections.

The second order self-tangency singularity of envelopes of second type tangential family germs is not stable under deformations of the family which are not of tangential type (see [17]). Under such a deformation, the envelope experiences a bec à bec perestroika, that may be interpreted as the apparent contour on the plane of the perestroika occurring to the corresponding Legendrian graph, shown in figure 3.3.

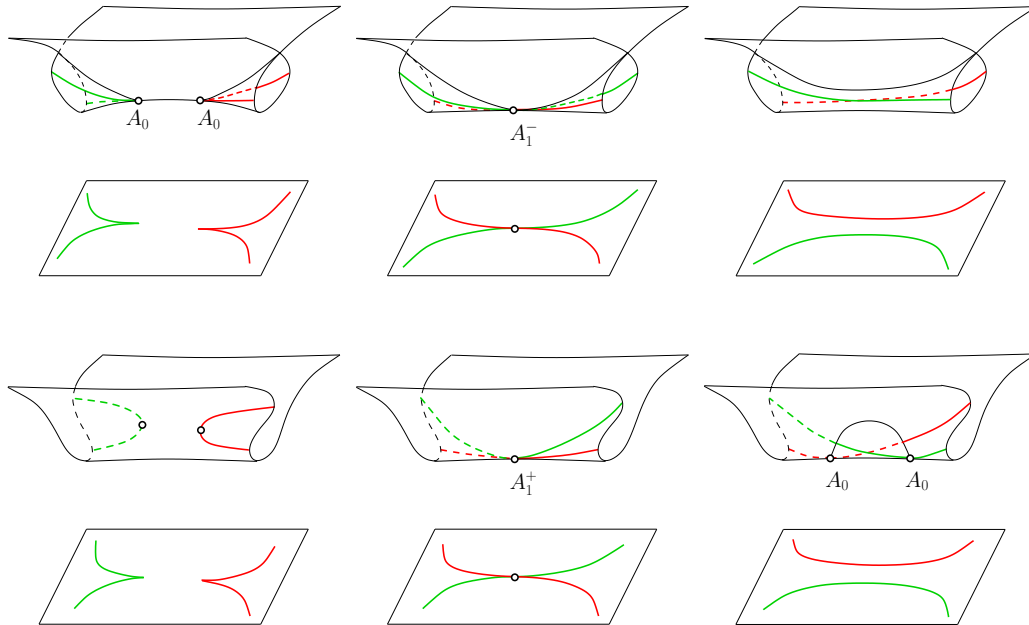

Figure 3.3: Legendrian bec à bec perestroika.

We call it the *Legendrian bec à bec perestroika*. Actually, there are two Legendrian bec à bec perestroika, according to the sign of the Legendrian graph singularity  $A_1^\pm$ . Figure 3.3 has been obtained investigating the critical sets of the  $\mathcal{A}_3$ -miniversal deformation of the normal form in Theorem 3.2.4, defined by

$$G : (\lambda; \xi, t) \mapsto (\xi, \lambda t + t^3 + t^2\xi + at\xi^2, t^2 + bt^3) .$$

This deformation is non trivial, because the critical value sets of  $G_\lambda$  are not diffeomorphic each other when  $\lambda$  crosses 0. On the other hand, it is well known that the extended codimension of the map germs belonging to  $A_1^\pm$  is 1, so  $G$  is an  $\mathcal{A}_3$ -miniversal deformation.

### 3.2.5 Singular tangential families and their envelopes

As an application of the preceding results, in this section we study tangential families whose supports have semicubic cusps.

First we recall a further construction in contact geometry (see again [5]). Denote by  $\mathbb{P}^n$  the real projective  $n$ -space. In this case, there exists a natural isomorphism

$$PT^*\mathbb{P}^n \simeq PT^*(\mathbb{P}^{n*}) ,$$

where  $\mathbb{P}^{n*}$  is the dual projective space of  $\mathbb{P}^n$ . This isomorphism associates to a contact element of  $\mathbb{P}^n$  (that is, to a projective hyperplane and to one of its points) the dual contact

element of  $\mathbb{P}^n$  (consisting of the projective hyperplane considered as a point of  $\mathbb{P}^{n*}$ , and of the point of  $\mathbb{P}^n$ , considered as a hyperplane in  $\mathbb{P}^{n*}$ ).

Thus, the manifold of the contact elements of the projective space is equipped with two contact structures: the first is that of  $PT^*\mathbb{P}^n$ , the other comes from  $PT^*\mathbb{P}^{n*}$ . These two contact structure coincide.

Now let us consider a smooth hypersurface in  $\mathbb{P}^n$ . Its tangent contact elements form a Legendrian submanifold  $L$  in  $PT^*\mathbb{P}^n$ . The fibration  $\pi : PT^*\mathbb{P}^n \rightarrow \mathbb{P}^n$  is a Legendrian fibration. The image of the Legendrian submanifold  $L$  in  $\mathbb{P}^{n*}$  is called the *dual hypersurface* to the initial one.

The dual hypersurface of a smooth hypersurface is the image of the corresponding Legendrian submanifold of  $PT^*\mathbb{P}^n$  under the Legendrian projection  $\pi^* : PT^*\mathbb{P}^n \rightarrow \mathbb{P}^{n*}$ .

EXAMPLE. Let us consider the case  $n = 2$ . Let  $\gamma$  be any smooth curve in the projective plane  $\mathbb{P}^2$  and let  $\gamma^*$  be its dual curve in  $\mathbb{P}^{2*}$ . If  $\gamma$  is convex, then  $\gamma^*$  is also smooth and convex; if  $\gamma$  has a simple inflection point,  $\gamma^*$  has a semicubic cusp at the corresponding point. Moreover,  $(\gamma^*)^* = \gamma$ .

REMARK. The affine version of this projective construction is called the *Legendre transformation*. More precisely, if the initial hypersurface is given by the equation  $w = f(q)$ , and the dual one by  $v = g(p)$ , then the function  $g$  is called the Legendre transformation of  $f$ .

Thus, every tangential family in  $\mathbb{P}^2$  defines, via the projective duality, a new 1-parameter family of (maybe singular) planes curves in the dual plane  $\mathbb{P}^{2*} \simeq \mathbb{P}^2$ . If the support of the tangential family is convex near a fixed point, the dual family is also tangential near the corresponding point.

DEFINITION. A *singular tangential family* is the dual family of a tangential family in  $\mathbb{P}^2$ , whose support has an inflection point at the origin (that is, the tangency order between  $\gamma$  and its tangent line at the origin is at least 2).

Supports of singular tangential families have cusp points. The *envelope* of a singular tangential family is by definition the  $\pi^*$ -apparent contour of the Legendrian graph of the corresponding smooth family.

As done for tangential family germs in [17], we can identify the germ of any singular tangential family at the support cusp point to a family local parameterization, considered as a map germ in  $(\mathfrak{m}_{\xi,t})^2$ . The group  $\mathcal{A}_2$  acts on this space, as explained in section 3.2.1. Two singular tangential family germs are by definition  $\mathcal{A}_2$ -equivalent if their local parameterization are  $\mathcal{A}_2$ -equivalent.

We denote by  $Y \subset (\mathfrak{m}_{\xi,t})^2$  the set formed by the map germs  $\mathcal{A}_2$ -equivalent to some singular tangential family. A singular tangential family is said to be of first or second type if it is dual to a family of first or second type respectively.

The next theorems, which proofs are given in section 3.3.6, describe the envelopes of typical first and second type singular tangential family germs. These results generalize the theorems concerning the envelopes of 1-parameter families of smooth curves, tangent to a support curve having a semicubic cusps, presented in [15] and [16].

THEOREM 3.2.5. *The envelope of any singular tangential family germ of first type coincides with its support and it is stable under small deformations of the family.*

REMARK. The stability of the cusp points as envelope singularities has been proven by Thom in [28]. However, the envelope stability does not imply the stability of the singular tangential family germs. Actually, the singular tangential families, whose envelopes have cusp points, have singularities which are not simple, as Dufour proved in [22]. In this paper, the study of the envelope of a 1-parameter family of smooth hypersurfaces in  $\mathbb{R}^n$  is reduced to the study of a diagram

$$\mathbb{R} \xleftarrow{f} \mathbb{R}^n \xrightarrow{h} \mathbb{R}^n,$$

in which  $f$  is a fibration and  $h$  is the inclusion mapping of the fibers of  $f$  in the ambient space  $\mathbb{R}^n$ . The envelope is the set of the critical values of  $h$ . For these map diagrams, a natural equivalence relation is defined.

Figure 3.4 shows a singular tangential family of first type and its dual family.

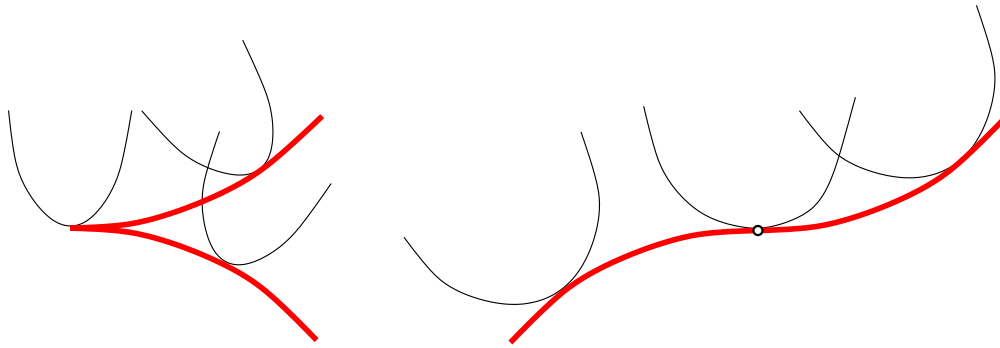

Figure 3.4: A first type singular tangential family and its dual family.

Let us denote by  $\text{II}^*$  the subset of  $(\mathfrak{m}_{\xi,t})^2$  formed by the map germs which are  $\mathcal{A}_2$ -equivalent to local parameterizations of singular tangential families of second type. Note that  $\text{II}^*$  is invariant under the action of  $\mathcal{A}_2$ , so it defines a singularity class.

**THEOREM 3.2.6.** *The set  $\text{II}^*$  is a smooth submanifold of  $(\mathfrak{m}_{\xi,t})^2$ . The envelopes of typical second type singular tangential family germs have three tangent branches at the origin, each one having a semicubic cusp at this point. The family germs for which this claim does not hold form a subset which is the union of a finite number of codimension 1 submanifolds of  $\text{II}^*$ .*

Figure 3.5 shows a typical singular tangential family of second type and its dual family. A branch in the singular family envelope, indicated in the figure by a dotted line, corresponds to the curve traced by the inflection points of the curves of the dual family. Note that the curves forming a typical second type singular tangential family have cusps.

In the class of the non typical singular tangential families of second type there is the class formed by the families whose curves are smooth, except the family curve tangent to the support at the origin, which may have a cusp. We denote by  $Z$  the subset of  $(\mathfrak{m}_{\xi,t})$  formed by the map germs which are  $\mathcal{A}_2$ -equivalent to parameterizations of singular tangential families of this class. It turns out that  $Z$  is a smooth codimension 1 submanifold of  $\hat{\text{II}}$ .



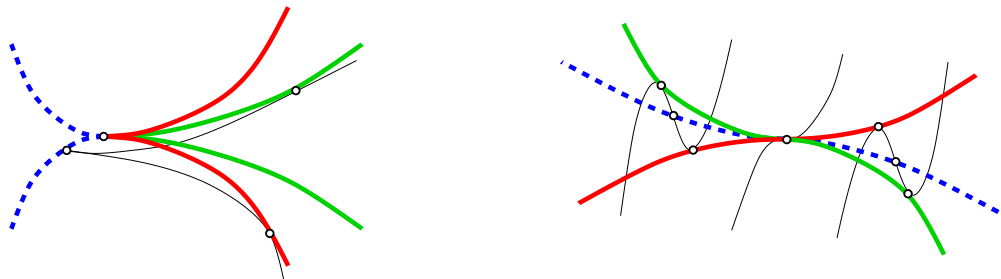

Figure 3.5: A typical singular tangential family of second type and its dual family.

**THEOREM 3.2.7.** *The envelope of any singular tangential family germ in  $Z$  (except the union of a finite number of codimension 1 submanifolds) has two tangent branches at the origin, having both a semicubic cusp at this point.*

A typical second type singular tangential family belonging to  $Z$  and its dual family are represented in figure 3.6.

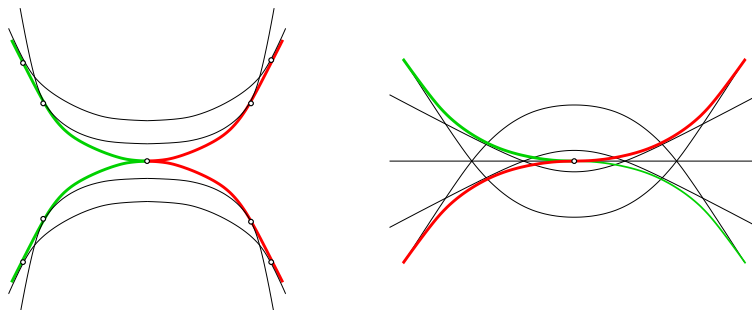

Figure 3.6: A typical singular tangential family in  $Z$  and its dual family.

It turns out that for these families, the curvature radius of the family curve at the tangency point goes to infinity as the point approaches the cusp point. Under this hypothesis, Theorem 3.2.7 has been proven directly in [15] and [16]. In these papers we also study the stratification of the submanifold formed by such families, according to the envelopes degeneracies.

## 3.3 Proofs

### 3.3.1 Parameterizations of Legendrian graphs

In this section we construct explicit parameterizations of Legendrian graphs.

Let us consider a tangential family. Without loss of generality, we may assume that the point we want to study is the origin and that the support of the family is tangent at this point to the  $x$ -axis. Indeed, a rigid motion of the plane obviously induces a transformation in the projectivized cotangent bundle which does not change the  $\mathcal{A}_3$ -singularity neither the  $\mathcal{A}_3^*$ -singularity of the Legendrian graph generated by the family.

Under these hypothesis, the support  $\gamma$  of the family is the graph of a function  $g$  near the origin. Let  $K(x)$  be the curvature at  $(x, g(x))$  of the family curve corresponding to this point, and  $K_\gamma(x)$  the curvature of the family support at the same point. Then define the coefficients  $k_0$  and  $k_1$  by the expansion  $k_0 + k_1x + o(x)$  for  $x \rightarrow 0$  of the function  $(K(x) - K_\gamma(x))/2$ . Moreover, define the coefficients  $\beta_0$  and  $\beta_1$  by the expansion for  $x \rightarrow 0$ ,  $\beta_0x^2 + \beta_1x^3 + o(x^3)$ , of the function  $g$ . Similarly, let us define  $\alpha \in \mathbb{R}$  by the expansion for  $x \rightarrow 0$ ,  $(k_0 + \beta_0)x^2 + (\alpha + \beta_1)x^3 + o(x^3)$ , of the function, whose graph (near the origin) is the family curve tangent to the support at  $(0, 0)$ .

We denote by  $\delta(n)$  any function of the two variables  $\xi, t$  whose  $n$ -jet at the origin vanishes.

**PROPOSITION 3.3.1.** *Every tangential family, whose support is tangent to the  $x$ -axis at the origin, admits a local parameterization at  $(0, 0)$  of the form*

$$(\xi, t) \mapsto (\xi + t, u_2(\xi, t) + u_3(\xi, t) + t^2 \cdot \delta(1)) , \quad (3.1)$$

where  $u_2$  and  $u_3$  are the following homogeneous polynomial:

$$\begin{aligned} u_2(\xi, t) &:= k_0t^2 + \beta_0(t + \xi)^2 , \\ u_3(\xi, t) &:= \alpha t^3 + k_1t^2\xi + \beta_1(t + \xi)^3 , \end{aligned}$$

and the coefficients  $\alpha, k_0, k_1, \beta_0$  and  $\beta_1$  are defined as above.

*Proof.* For any given tangential family, let us choose a new orthogonal coordinate system as in the above definition of the coefficients  $k_i, \beta_i$  and  $\alpha$ . The map  $\xi \mapsto (\xi, g(\xi))$  parameterizes the support near  $(0, 0)$ . For any small enough value of  $\xi$ , consider the family curve corresponding to the support point  $(\xi, g(\xi))$ . Near this point, the tangent curve can be parameterized by its projection  $\xi + t$  on the  $x$ -axis. In this manner we get the required parameterization of the tangential family.  $\square$

**REMARK.** The coordinate change  $(x, y) \mapsto (x, y - g(x))$  takes the parameterization (3.1) to the form

$$(\xi, t) \mapsto (\xi + t, k_0t^2 + \alpha t^3 + k_1t^2\xi + \delta(3)) ,$$

which is called the *prenormal form* of the family in [17] and [18]. As we proved in these papers, the tangential family parameterized by (3.1) is of first type if and only if  $k_0 \neq 0$  and it is of second type if and only if  $k_0 = 0$  and  $k_1 \neq 0, \alpha$ .

Given a tangential family, parameterized by a map germ of the form (3.1), we can identify (locally at the origin) the space of the projectivized cotangent bundle  $PT^*\mathbb{R}^2$  of the plane  $\mathbb{R}^2 = \{x, y\}$  with the space  $J^1(\mathbb{R}, \mathbb{R}) \simeq \mathbb{R}^3 = \{x, y, z\}$  of the 1-jets of functions in the variable  $t$  ( $\xi$  is viewed as a parameter).

In this space, the Legendrian graph generated by the family admits the following local parameterization:

$$(\xi, t) \mapsto (\xi + t, u_2(\xi, t) + u_3(\xi, t) + t^2 \cdot \delta(1), \partial_t u_2(\xi, t) + \partial_t u_3(\xi, t) + t \cdot \delta(1)) .$$

The coordinate change  $(\xi, t) \mapsto (\xi - t, t)$  takes this germ to the form

$$\begin{aligned} (\xi, t) \mapsto & \left( \xi, (k_0t^2 + \beta_0\xi^2) + ((\alpha - k_1)t^3 + k_1t^2\xi + \beta_1\xi^3) + \delta(3), \right. \\ & \left. (2k_0t + 2\beta_0\xi) + ((3\alpha - 2k_1)t^2 + 2k_1t\xi + 3\beta_1\xi^2) + \delta(2) \right) . \end{aligned} \quad (3.2)$$

We call such a germ the *standard parameterization* of the Legendrian graph associated to the tangential family parameterized by (3.1).

### 3.3.2 Proof of Theorem 3.2.2

The proof of Theorem 3.2.2 consists in the reduction of standard parameterizations of Legendrian graphs to their  $\mathcal{A}_3$ -normal forms.

Let us begin with the case of first type tangential families.

**PROPOSITION 3.3.2.** *Every map germ of the form (3.2) is  $\mathcal{A}_3$ -equivalent to  $(\xi, t) \mapsto (\xi, 0, t)$ , provided that  $k_0 \neq 0$ .*

*Proof.* If  $k_0 \neq 0$ , the map germs of the form (3.2), that is

$$(\xi, t) \mapsto (\xi, k_0 t^2 + \beta_0 \xi^2 + \delta(2), 2k_0 t + 2\beta_0 \xi + \delta(1)) ,$$

are  $\mathcal{A}_3$ -equivalent to

$$(\xi, t) \mapsto (\xi, t^2 + \delta(2), 2t + \delta(1)) ,$$

and then to the 1-jet  $(\xi, 0, t)$ , which is  $\mathcal{A}_3$ -sufficient (that is, every map germ having the same jet is  $\mathcal{A}_3$ -equivalent to it).  $\square$

We consider now the Legendrian graphs generated by the tangential families of second type.

**PROPOSITION 3.3.3.** *Every map germ of the form (3.2), with  $k_0 = 0$  and  $k_1$  being different from the four values  $0, \alpha, 3\alpha/2$  and  $3\alpha$ , is  $\mathcal{A}_3$ -equivalent to a map germ of the form*

$$(\xi, t) \mapsto (\xi, t^3 \pm t\xi^2, t^2) ,$$

where  $\pm$  is the sign of  $(k_1 - 3\alpha)(\alpha - k_1)/k_1^2$ .

*Proof.* If  $k_0 = 0$ , all the map germs (3.2) are  $\mathcal{A}_3$ -equivalent to

$$(\xi, t) \mapsto (\xi, (\alpha - k_1)t^3 + k_1 t^2 \xi + \delta(3), (3\alpha - 2k_1)t^2 + 2k_1 t \xi + \delta(2)) \quad (3.3)$$

by  $(x, y, z) \mapsto (x, y - \beta_0 x^2 - \beta_1 x^3, z - 2\beta_0 x - 3\beta_1 x^2)$ . Now, the coordinate changing

$$(\xi, t) \mapsto \left( \xi, t + \frac{k_1}{3\alpha - 2k_1} \xi \right)$$

brings this germs to the form:

$$\left( \xi, (\alpha - k_1)t^3 + \frac{k_1^2}{3\alpha - 2k_1} t^2 \xi + \frac{k_1^2(k_1 - 3\alpha)}{(3\alpha - 2k_1)^2} t \xi^2 + \frac{k_1^3(2\alpha - k_1)}{(3\alpha - 2k_1)^3} \xi^3 + \delta(3), \right. \\ \left. (3\alpha - 2k_1)t^2 - \frac{k_1^2}{3\alpha - 2k_1} \xi^2 + \delta(2) \right) . \quad (3.4)$$

Now, making

$$(x, y, z) \mapsto \left( x, y - \frac{k_1^2}{3\alpha - 2k_1}xz - \frac{k_1^3(2\alpha - k_1)}{(3\alpha - 2k_1)^3}x^3, z + \frac{k_1^2}{3\alpha - 2k_1}x^2 \right)$$

and by rescaling we obtain

$$(\xi, t) \mapsto (\xi, t^3 \pm t\xi^2 + \delta(3), t^2 + \delta(2)) \quad , \quad (3.5)$$

where  $\pm$  is the sign of  $(k_1 - 3\alpha)(\alpha - k_1)$ . These germs are  $\mathcal{A}_3$ -equivalent to

$$(\xi, t) \mapsto (\xi, t^3 \pm t\xi^2 + \delta(3), t^2 + \delta(3)) \quad .$$

In [27], Theorem 1:2, it is proven that the 3-jet  $(\xi, t^3 \pm t\xi^2, t^2)$  is  $\mathcal{A}_3$ -sufficient. Thus, every standard parameterization of a Legendrian graph, satisfying the hypothesis of the Proposition, is  $\mathcal{A}_3$ -equivalent to this 3-jet.  $\square$

Therefore, the Legendrian graph germs of first type are smooth and the Legendrian graph germs of second type have generically an  $A_1^\pm$  singularity. The second type Legendrian graph germs, having not this singularity, belong to the set formed by all the map germs in  $\hat{\Pi}$  which are  $\mathcal{A}_3$ -equivalent to standard parameterizations whose coefficients satisfy  $2k_1 = 3\alpha$  or  $3\alpha = k_1$ . Let us recall that for second type tangential family germs we have  $k_1 \neq 0, \alpha$ . Hence, the image of the set of non typical Legendrian graphs in the parameter plane  $\{\alpha, k_1\}$  is the union of the lines  $2k_1 = 3\alpha$  or  $3\alpha = k_1$  without the origin, so it is a submanifold in the manifold of second type Legendrian graph germs (which is the complement of the lines  $k_1 = 0$  and  $k_1 = \alpha$  in the plane). Therefore, the non typical second type Legendrian graphs form a submanifold in  $\hat{\Pi}$  of codimension 1. This submanifold is not connected.

It remains to consider the case of a second type tangential family germ, whose Legendrian graph is parameterized by a map germ belonging to these two submanifolds.

**PROPOSITION 3.3.4.** *Assume  $k_0 = 0$  and  $3\alpha = 2k_1 \neq 0$ . Then, every map germ of the form (3.2), except those belonging to an infinite codimension submanifold of  $\hat{\Pi}$ , is  $\mathcal{A}_3$ -equivalent to*

$$(\xi, t) \mapsto (\xi, t^3, t\xi + t^{3n-1})$$

for some  $n \geq 2$ ,

*Proof.* We obtain from (3.3) by the coordinate change  $(\xi, t) \mapsto (\xi, t - \xi)$  the map germs

$$(\xi, t) \mapsto \left( \xi, -\frac{k_1}{3}t^3 - 3k_1t\xi^2 + \frac{4k_1}{3}\xi^3 + \delta(3), 2k_1t\xi - 2k_1\xi^2 + \delta(2) \right) \quad ,$$

which are  $\mathcal{A}_3$ -equivalent to

$$(\xi, t) \mapsto (\xi, t^3 + t\xi^2 + \delta(3), t\xi + \delta(2))$$

and then to

$$(\xi, t) \mapsto (\xi, t^3 + \delta(3), t\xi + \delta(3)) \quad .$$

The proposition is now a consequence of Mond's classification of germs whose 3-jet is  $\mathcal{A}_3$ -equivalent to  $(\xi, t) \mapsto (\xi, t^3, t\xi)$  (see [27], section 4.2.1): every map germ, satisfying the hypothesis of the Proposition, is  $\mathcal{A}_3$ -equivalent to a map germ  $(\xi, t^3, t\xi + t^{3n-1})$  or belongs to a submanifold of  $\hat{\Pi}$ , contained in the closure of all the orbits of these germs. Since the codimensions in  $(\mathfrak{m}_{\xi,t})^2$  of these orbits grow with  $n$ , the codimension of the submanifold of the remaining germs is infinite.  $\square$

**PROPOSITION 3.3.5.** *Assume  $k_0 = 0$  and  $k_1 = 3\alpha \neq 0$ . Then, every map germ of the form (3.2), except those belonging to an infinite codimension submanifold of  $\hat{\Pi}$ , is  $\mathcal{A}_3$ -equivalent to*

$$(\xi, t) \mapsto (\xi, t^3 \pm t\xi^{n+1}, t^2)$$

for some  $n \geq 2$ .

*Proof.* As in the proof of Proposition 3.3.3, we find that the map germs (3.2), with  $k_0 = 0$  and  $k_1 = 3\alpha$ , are  $\mathcal{A}_3$ -equivalent to a map germ of the form

$$(\xi, t) \mapsto (\xi, t^3 + \delta(3), t^2 + \delta(2)) .$$

As above, the proposition is now a consequence of Mond's classification of germs whose 2-jet is  $\mathcal{A}_3$ -equivalent to  $(\xi, t) \mapsto (\xi, 0, t^2)$  (see [27], §4.1).  $\square$

Propositions 3.3.2, 3.3.3, 3.3.4 and 3.3.5 imply Theorem 3.2.2.

### 3.3.3 Preliminary background of Singularity Theory

In this section we recall some notations and results of Singularity Theory we will use in next sections. For details, we refer the reader to [11], [13] or [26].

A map germ  $f \in (\mathfrak{m}_{\xi,t})^3$  defines, by  $f^*g := f \circ g$ , a homomorphism from the ring  $\mathcal{E}_{x,y,z}$  of the function germs in the target to the ring  $\mathcal{E}_{\xi,t}$  of the function germs in the source. Hence, every  $\mathcal{E}_{\xi,t}$ -module has a structure of  $\mathcal{E}_{x,y,z}$ -module via this homomorphism.

To prove Theorem 3.2.4, we have to find normal forms of map germs (3.3) for the  $\mathcal{A}_3^*$ -equivalence. In order to follow the usual scheme for this reduction, the main remark is the following.

**REMARK.** The Finite Determinacy Theorem for the equivalence relation we consider has been proven by V. V. Goryunov in [24]. On the other hand, the subgroup  $\mathcal{A}_3^*$  is a *nice geometric subgroup* of  $\mathcal{A}_3$ . Thus, by Damon's general theory ([20], [21]), the Finite Determinacy Theorem holds for its action on  $(\mathfrak{m}_{\xi,t})^3$ .

As usual, we define the *extended tangent space* to the orbit  $\mathcal{A}_3^* \cdot f$  at a map germ  $f$  for the action of  $\mathcal{A}_3^*$  as follows:

$$T_e\mathcal{A}_3^*(f) := \mathcal{E}_{\xi,t} \cdot J(f) + f^*(\mathcal{E}_{x,y}) \cdot \left\{ \begin{pmatrix} 1 \\ 0 \\ 0 \end{pmatrix}, \begin{pmatrix} 0 \\ 1 \\ 0 \end{pmatrix} \right\} + f^*(\mathcal{E}_{x,y,z}) \cdot \begin{pmatrix} 0 \\ 0 \\ 1 \end{pmatrix} ,$$

where  $J(f)$  is the real vector space spanned by the first order partial derivatives of  $f$ . Note that  $T_e\mathcal{A}_3^*(f)$  is an  $\mathcal{E}_{x,y}$ -module, being not in general an  $\mathcal{E}_{\xi,t}$ -module nor an  $\mathcal{E}_{x,y,z}$ -module.

The *reduced tangent space* to the  $\mathcal{A}_3$ -orbit  $\mathcal{A}_3 \cdot f$  at  $f$  is by definition the following subspace of  $\mathcal{E}_{\xi,t}^3$ :

$$T_r \mathcal{A}_3^*(f) := \mathfrak{g}_+(f) + f^*(\mathcal{M}^*) \cdot \mathbb{R}^2 ,$$

where  $\mathfrak{g}_+(f)$  is the space of all the vector field germs having positive order<sup>1</sup> and  $\mathcal{M}^*$  is the  $\mathcal{E}_{x,y}$ -module defined by

$$\mathcal{M}^* := (\mathfrak{m}_{x,y}^2 \oplus \mathbb{R} \cdot y) \times (\mathfrak{m}_{x,y}^2 \oplus \mathbb{R} \cdot x) \times (\mathfrak{m}_{x,y,z}^2 \oplus \mathbb{R} \cdot \{x, y\})$$

Note that the reduced tangent space is an  $\mathcal{E}_{x,y}$ -module and

$$T_r \mathcal{A}_3^*(f) \subset T_e \mathcal{A}_3^*(f) .$$

**PROPOSITION 3.3.6.** *Let  $P, Q$  and  $R$  be three homogeneous polynomials of degree  $p, q$  and  $r$  respectively. Then the map germ  $f = (f_1, f_2, f_3)$  is  $\mathcal{A}_3^*$ -equivalent to a map germ*

$$(f_1 + P + \delta(p), f_2 + Q + \delta(q), f_3 + R + \delta(r)) ,$$

*provided that the reduced tangent space at  $f$  contains a map germ*

$$(P + \delta(p), Q + \delta(q), R + \delta(r)) .$$

The proof of this Proposition is identical to the proof given in [18] for the similar Proposition involving map germs of  $(\mathfrak{m}_{\xi,t})^2$ .

For  $p, q, r \in \mathbb{N}$ , we denote by  $J(p)$  the real vector space of dimension  $p + 1$  formed by the homogeneous polynomials of degree  $p$  in the variables  $\xi$  and  $t$ , and by  $J(p, q, r)$  the real vector subspace  $J(p) \times J(q) \times J(r)$  of  $(\mathfrak{m}_{\xi,t})^3$ .

### 3.3.4 Proof of Theorem 3.2.4

In this section we prove Theorem 3.2.4. Recall that standard parameterizations of Legendrian graphs are  $\mathcal{A}_3^*$ -equivalent to map germs of the form (3.2):

$$(\xi, t) \mapsto \left( \xi, (k_0 t^2 + \beta_0 \xi^2) + ((\alpha - k_1) t^3 + k_1 t^2 \xi + \beta_1 \xi^3) + \delta(3), \right. \\ \left. (2k_0 t + 2\beta_0 \xi) + ((3\alpha - 2k_1) t^2 + 2k_1 t \xi + 3\beta_1 \xi^2) + \delta(2) \right) .$$

**PROPOSITION 3.3.7.** *Every map germ (3.2) is  $\mathcal{A}_3^*$ -equivalent to the map germ  $(\xi, t) \mapsto (\xi, t^2, t)$ , provided that  $k_0 \neq 0$ .*

*Proof.* The initial germ is  $\mathcal{A}_3^*$ -equivalent to a map germ

$$(\xi, t) \mapsto (\xi, t^2 + \delta(2), t + \delta(1)) .$$

It is easily checked that the reduced tangent space at  $(\xi, t^2, t)$  contains the space  $\mathfrak{m}_{\xi,t}^2 \times \mathfrak{m}_{\xi,t}^3 \times \mathfrak{m}_{\xi,t}^2$ . Due to the quasi homogeneity of this germ, this implies the formal  $\mathcal{A}_3^*$ -equivalence to the initial germ and their  $\mathcal{A}_3^*$ -finite determinacy. The Proposition is therefore proven.  $\square$

---

<sup>1</sup>A vector field has order  $d$  if differentiation in the direction of the field raises the order of any function by not less than  $d$ .

We consider now Legendrian graphs of second type tangential families. So, we assume from now on  $k_0 = 0$ . By the coordinate changes considered at the beginning of the proof of Proposition 3.3.3, we transform (3.2) into (3.4). After killing the terms on  $(0, \xi^3, 0)$ ,  $(0, 0, \xi^2)$  and rescaling, we get

$$(\xi, t) \mapsto (\xi, t^3 + t^2\xi + at\xi^2 + \delta(3), t^2 + \delta(2)) , \quad (3.6)$$

where  $a := (\alpha - k_1)(k_1 - 3\alpha)/k_1^2$ .

REMARK. For any tangential family germ of second type, whose Legendrian graph has a singularity of type  $A_1^\pm$ , we have  $a < 1/3$ . Indeed,

$$a - \frac{1}{3} = -\frac{(3\alpha - 2k_1)^2}{3k_1^2} < 0 ,$$

since  $3\alpha \neq 2k_1$ . The sign of  $a$  is the same sign  $\pm$  in the  $\mathcal{A}_3$ -normal form in Proposition 3.3.3.

LEMMA 3.3.1. *Every map germ (3.6), such that  $a \neq 0, 1/3$ , is  $\mathcal{A}_3^*$ -equivalent to a map germ*

$$(\xi, t) \mapsto (\xi, t^3 + t^2\xi + at\xi^2 + \delta(3), t^2 + bt^3 + \delta(3)) , \quad (3.7)$$

for some  $b \in \mathbb{R}$ .

*Proof.* To prove the Lemma it is enough to show that the quotient space

$$J(2, 4, 3)/\langle(0, 0, t^3)\rangle_{\mathbb{R}}$$

is contained in the reduced tangent space at the quasi homogeneous part of (3.7),

$$F_0(\xi, t) := (\xi, t^3 + t^2\xi + at\xi^2, t^2) .$$

For this, let us consider the following vectors, lying in  $T_r\mathcal{A}_3^*(F_0)$ :

$$\begin{aligned} v_{1+i} &:= t^{2-i}\xi^i \partial_t F_0 , \\ v_{4+i} &:= t^{2-i}\xi^i \partial_\xi F_0 , \quad \text{for } i = 0, 1, 2 , \\ v_7 &:= (x^2, 0, 0) , \\ v_8 &:= (0, x^4, 0) , \\ v_9 &:= (0, 0, x^3) , \\ v_{10} &:= (0, 0, y) , \\ v_{11} &:= (0, 0, xz) . \end{aligned}$$

Consider the square matrix, whose columns are the projections of these vectors on the space  $\mathbb{R}^{11}$ , spanned by the vector monomials

$$(t^2, 0, 0), \dots, (\xi^2, 0, 0) , (0, t^4, 0), \dots, (0, \xi^4, 0) , (0, 0, t^2\xi), \dots, (0, 0, \xi^3) .$$

This matrix is invertible, indeed its determinant  $18a(1 - 3a)$  does not vanish under our hypothesis, so all the preceding monomials belong to the reduced tangent space. The Proposition is proven.  $\square$

The next Proposition completes the proof of Theorem 3.2.4.

**PROPOSITION 3.3.8.** *Every map germ (3.7), such that  $a \neq -1, 0, 1/3$ , is  $\mathcal{A}_3^*$ -equivalent to a map germ of the form*

$$F(\xi, t) := (\xi, t^3 + t^2\xi + at\xi^2, t^2 + bt^3) .$$

*for some constant  $b$ .*

Notice that the conditions  $a \neq 0, 1/3$  are always satisfied by any standard parameterization of generic tangential family germ, provided that its Legendrian graph has an  $A_1^\pm$  singularity. On the other hand,  $a \neq -1$  is a new condition, giving rise to the codimension 1 submanifold for which Theorem 3.2.4 does not hold. This submanifold is formed by typical second type tangential family germs (i.e. their Legendrian graphs have singularities  $A_1^\pm$ ).

The proof of the Proposition is carried out by long computations, and it is left to the next section.

### 3.3.5 Proof of Proposition 3.3.8

The proof of Proposition 3.3.8 is subdivided into two Lemmas.

**LEMMA 3.3.2.** *Every map germ (3.7), with  $a \neq -1, 0$  and  $1/3$ , is formally  $\mathcal{A}_3^*$ -equivalent to the above normal form  $F$  of Proposition 3.3.8.*

**LEMMA 3.3.3.** *For  $a \neq -1, 0, 1/3$ , the map germ  $F$  is  $\mathcal{A}_3^*$ -finitely determined.*

To prove Lemma 3.3.2 we compute the reduced tangent space at the quasi homogeneous part

$$F_0(\xi, t) = (\xi, t^3 + t^2\xi + at\xi^2, t^2)$$

of the normal form  $F$ .

**LEMMA 3.3.4.** *The reduced tangent space  $T_{r, \mathcal{A}_3^*}(F_0)$  contains the space*

$$\mathfrak{m}_{\xi, t}^3 \times \mathfrak{m}_{\xi, t}^5 \times \mathfrak{m}_{\xi, t}^4 ,$$

*provided that  $a \neq -1, 0, 1/3$ .*

Lemma 3.3.2 follows from this Lemma and Proposition 3.3.6.

*Proof.* The proof is by induction.

**STARTING STEP.** *We have  $J(3, 5, 4) \subset T_{r, \mathcal{A}_3^*}(F_0)$ .*



We prove this claim by a direct computation. Let us set

$$\begin{aligned}
w_{1+i} &:= t^{3-i}\xi^i\partial_t F_0, \text{ for } i = 0, 1, 2, 3, \\
w_{5+i} &:= t^{3-i}\xi^i\partial_\xi F_0, \text{ for } i = 0, 1, 2, 3, \\
w_9 &:= (x^3, 0, 0), \\
w_{10} &:= (y, 0, 0), \\
w_{11} &:= (0, x^5, 0), \\
w_{12} &:= (0, x^2y, 0), \\
w_{13} &:= (0, 0, x^4), \\
w_{14} &:= (0, 0, z^2), \\
w_{15} &:= (0, 0, xy).
\end{aligned}$$

All these vectors belong to  $T_r\mathcal{A}_3^*(F_0)$ . Let us consider the square matrix formed by the coordinates of the vectors  $w_j$  in the space  $J(3, 5, 4)$ , identified to the space  $\mathbb{R}^{15}$  fixing the basis of vector monomials

$$(t^3, 0, 0), \dots, (0, 0, \xi^4).$$

It turns out that its determinant is

$$-16a(a+1)(3a-1).$$

Therefore, under the hypothesis of Proposition 3.3.8, the matrix is invertible, so all the vector monomials forming the basis of  $J(3, 5, 4)$  belong to the reduced tangent space. The claim of the starting step is proven.

**INDUCTION STEP.** *If  $J(n-1, n+1, n)$  is contained in  $T_r\mathcal{A}_3^*(F_0)$ , then the same holds for  $J(n, n+2, n+1)$ .*

Since  $T_r\mathcal{A}_3^*(F_0)$  is an  $\mathcal{E}_{x,y}$ -module via  $F_0$ , the induction hypothesis implies that all the vector monomials of  $J(n, n+2, n+1)$ , which are divisible by  $\xi$ , belong to the reduced tangent space. Then let us define

$$\begin{aligned}
u_1 &:= t^n\partial_\xi F_0 = (t^n, t^{n+2}, 0) && \text{mod } (\xi \cdot \mathcal{E}_{\xi,t})^3, \\
u_2 &:= t^n\partial_t F_0 = (0, 3t^{n+2}, 2t^{n+1}) && \text{mod } (\xi \cdot \mathcal{E}_{\xi,t})^3, \\
u_3 &:= \begin{cases} (y^m, 0, 0) = (t^n, 0, 0) & \text{mod } (\xi \cdot \mathcal{E}_{\xi,t})^3, \text{ if } n = 3m, \\ (0, y^m, 0) = (0, t^{n+2}, 0) & \text{mod } (\xi \cdot \mathcal{E}_{\xi,t})^3, \text{ if } n+2 = 3m, \\ (0, 0, y^m) = (0, 0, t^{n+1}) & \text{mod } (\xi \cdot \mathcal{E}_{\xi,t})^3, \text{ if } n+1 = 3m. \end{cases}
\end{aligned}$$

Therefore, we can write each vector monomial

$$(t^n, 0, 0), (0, t^{n+2}, 0), (0, 0, t^{n+1})$$

as a linear combination of the vectors  $u_1, u_2, u_3$  and of some element of  $T_r\mathcal{A}_3^*(F_0)$ . Thus, these vector monomials belong to the reduced tangent space. This proves the induction inclusion

$$J(n, n+2, n+1) \subset T_r\mathcal{A}_3^*(F_0)$$

and achieves the proof of the Lemma.  $\square$

Notice that Lemma 3.3.4 provides also the  $\mathcal{A}_3^*$ -finite determinacy of  $F_0$ . Hence, Proposition 3.3.8 is now proven in the case  $b = 0$ . We assume from now on  $b \neq 0$ .

The proof of Lemma 3.3.3 is carried out again by induction.

STARTING STEP. *The following inclusion holds:*

$$J(3, 5, 4) \cup J(4, 6, 5) \cup \left( \{0\} \times \{0\} \times J(6) \right) \subset T_e \mathcal{A}_3^*(F) .$$

Let us start with a preliminary remark. Consider the following elements of  $T_e \mathcal{A}_3^*(F)$ :

$$\begin{aligned} u_1 &:= \xi \partial_\xi F - (x, 0, 0) , \\ u_2 &:= t \partial_t F , \\ u_3 &:= (0, y, 0) , \\ u_4 &:= (0, 0, z) . \end{aligned}$$

Since  $u_1 + u_2 - 3u_3 - 3u_4 = (0, 0, -t^2)$  and  $u_1 + u_2 - 3u_3 - 2u_4 = (0, 0, bt^3)$ , we have that  $(0, 0, t^2)$  and  $(0, 0, t^3)$  are in the extended tangent space. Moreover,  $(0, 0, y) - (0, 0, t^3 + t^2\xi) = (0, 0, at\xi^2)$ . Since  $a \neq 0$ , the vector monomial  $(0, 0, t\xi^2)$  belongs to the extended tangent space.

Now let us set:

$$\begin{aligned} w_{1+i} &:= t^{3-i}\xi^i \partial_t F , \text{ for } i = 0, \dots, 3 , \\ w_{5+i} &:= t^{4-i}\xi^i \partial_t F , \text{ for } i = 0, \dots, 4 , \\ w_{10} &:= (0, x^2y, 0) , \\ w_{11} &:= (0, x^3y, 0) , \\ w_{12} &:= (0, y^2, 0) , \\ w_{13} &:= (0, 0, y^2) , \\ w_{14} &:= (0, 0, z^2) , \\ w_{15} &:= (0, 0, yz) , \\ w_{16} &:= y \partial_\xi F - (y, 0, 0) , \\ w_{17} &:= xy \partial_\xi F - (xy, 0, 0) . \end{aligned}$$

These 17 vectors of the extended tangent space involve only the vector monomials  $(0, \xi^p t^q, 0)$  for  $p + q = 5, 6$  and  $(0, 0, \xi^p t^q)$  for  $p + q = 4, 5, 6$ . Due to the preliminary remark, we know that

$$(0, 0, t^3 \xi^i) , (0, 0, t^2 \xi^{i+1}) , (0, 0, t \xi^{i+2}) , (0, 0, \xi^{i+3})$$

lie in the extended tangent space for  $i = 1, 2, 3$ . Then, let us consider the real subspace of dimension 17 of the vector space

$$J(3, 5, 4) \cup J(4, 6, 5) \cup \left( \{0\} \times \{0\} \times J(6) \right) ,$$

spanned by the vector monomials

$$(0, t^5, 0), \dots, (0, t\xi^4, 0), (0, t^6, 0), \dots, (0, t^5\xi, 0), \\ (0, 0, t^4), (0, 0, t^5), (0, 0, t^4\xi), (0, 0, t^6), (0, 0, t^5\xi), (0, 0, t^4\xi^2) .$$

Let us consider the square matrix, whose columns are the coordinates of the projections of the vectors  $w_i$  over the above space  $\mathbb{R}^{17}$ . Its determinant is

$$216ab^3(3a - 1) ,$$

then the matrix is invertible under the hypothesis of Proposition 3.3.8. This implies that

$$\{0\} \times \left( J(5) \cup J(6) \right) \times \left( J(4) \cup J(5) \cup J(6) \right) \subset T_e \mathcal{A}^*(F) .$$

It is now easy to check that also  $(J(3) \cup J(4)) \times \{0\} \times \{0\}$  is contained in extended the tangent space. Indeed, for  $p + q = 3, 4$ , we have

$$\xi^p t^q \partial_\xi F = (\xi^p t^q, 0, 0) \quad \text{mod} \left( \{0\} \times \left( J(5) \cup J(6) \right) \times \left( J(4) \cup J(5) \cup J(6) \right) \right) .$$

The starting step is proven.

**INDUCTION STEP.** *If  $J(n - 2, n, n - 1) \cup J(n - 1, n + 1, n)$  is contained in  $T_e \mathcal{A}_2^*(F)$ , then the same holds for  $J(n, n + 2, n + 1)$ .*

We have to prove only that  $(t^n, 0, 0)$ ,  $(0, t^{n+2}, 0)$  and  $(0, 0, t^{n+1})$  belong to the extended tangent space. Since  $b \neq 0$  and

$$t^{n-1} \partial_t F = (0, 0, 3bt^{n+1}) \quad \text{mod} \ J(n - 1, n + 1, n) ,$$

we have  $(0, 0, t^{n+1}) \in T_e \mathcal{A}_3^*(F)$ . In the case  $n = 3m + 2$ , the monomial  $(0, 0, t^{3m+4})$  lies to the tangent space, indeed, by the induction hypothesis,  $(0, 0, t^{3m+1})$  is in the tangent space and its product by  $z$  gives  $(0, 0, t^{3m+3} + bt^{3m+4})$ .

Define:

$$u_1 := t^n \partial_\xi F = (t^n, t^{n+2}, 0) \quad \text{mod} \ (\xi \cdot \mathcal{E}_{\xi, t})^3 , \\ u_2 := \begin{cases} (y^m, 0, 0) = (t^n, 0, 0) \quad \text{mod} \ (\xi \cdot \mathcal{E}_{\xi, t})^3 , & \text{if } n = 3m , \\ (0, y^{m+1}, 0) = (0, t^{n+2}, 0) \quad \text{mod} \ (\xi \cdot \mathcal{E}_{\xi, t})^3 , & \text{if } n = 3m + 1 . \\ (0, 3t^{n+2}, 0) \quad \text{mod} \ (\xi \cdot \mathcal{E}_{\xi, t})^3 , & \text{if } n = 3m + 2 , \end{cases}$$

where we have used the equality

$$t^n \partial_t F - (0, 0, 2t^{n+1} + 3bt^{n+2}) = (0, 3t^{n+2}, 0)$$

and the preceding remark. The vector monomials  $(t^n, 0, 0)$   $(0, t^{n+2}, 0)$  can be expressed as linear combinations of these vectors and of some vector monomials of the extended tangent space, so they belong to  $T_e \mathcal{A}_3^*(f)$ . This proves that  $J(n, n + 2, n)$  is contained in the tangent space. Lemma 3.3.3 is now proven.

### 3.3.6 Proof of Theorems 3.2.5, 3.2.6 and 3.2.7

In this section we prove the results of section 3.2.5, concerning singular tangential families.

Let us consider a tangential family, parameterized by a map germ  $f$  whose Taylor expansion is (3.1), that is:

$$(\xi, t) \mapsto (\xi + t, (k_0 + \beta_0) t^2 + \beta_0 t\xi + \beta_0 \xi^2 + (\alpha + \beta_1) t^3 + (k_1 + 3\beta_1) t^2\xi + 3\beta_1 t\xi^2 + \beta_1 \xi^3 + \delta(3)) .$$

The family support is then parameterized by

$$\xi \mapsto (\xi, \beta_0 \xi^2 + \beta_1 \xi^3 + o(\xi^3)) ,$$

for  $\xi \rightarrow 0$ . So, the dual curve to the support has a semicubic cusp if and only if  $\beta_0 = 0$  and  $\beta_1 \neq 0$ . It follows that any singular tangential family has a local parameterization  $g$  (which is the Legendre transformation of  $f$ ), whose expansion at the origin is

$$(2k_0 t + \delta(1), k_0 t^2 + 2k_0 \xi t + \delta(2)) .$$

If  $k_0 \neq 0$ , then  $t = 0$  is the only branch of the curve  $\det Dg = 0$  passing through the origin. Therefore the envelope of a singular tangential family of first type reduces to its support. Theorem 3.2.5 is proven.

Let us consider now a parameterization  $f$  of a second type tangential families. The set  $\text{II}^*$  of the second type singular tangential family germs is the smallest  $\mathcal{A}_2$ -invariant subset in  $(\mathfrak{m}_{\xi,t})^2$  containing the Legendre transformations of the prenormal parameterizations (3.1) of the dual family germs verifying  $k_0 = \beta_0 = 0$ . Hence  $\text{II}^*$  is smooth (in the sense that its restrictions to every jet space  $J^N(\mathbb{R}^2, \mathbb{R}^2)$  are smooth).

In this case the expansion of the local parameterization  $g$  of a second type singular tangential family germ writes as follows:

$$\begin{aligned} (\xi, t) \mapsto & (3(\alpha + \beta_1) t^2 + 2(k_1 + 3\beta_1) t\xi + 3\beta_1 \xi^2 + \delta(2), \\ & (2\alpha + 2\beta_1) t^3 + (6\beta_1 + 3\alpha + k_1) t^2\xi + (2k_1 + 6\beta_1) t\xi^2 + 2\beta_1 \xi^3 + \delta(3)) . \end{aligned}$$

The equation  $\det Dg = 0$  has three solutions  $(\xi, t = t_i(\xi))$  vanishing at the origin:

$$t_0(\xi) = 0 , \quad t_1(\xi) = \frac{2k_1}{k_1 - 3\alpha} \xi + o(\xi) , \quad t_2(\xi) = \frac{k_1 + 3\beta_1}{3(\alpha + \beta_1)} \xi + o(\xi) .$$

Notice that these three solutions are well defined whenever  $k_1 \neq 3\alpha$ . By replacing these expressions in the expansion of  $g$ , we obtain the local parameterizations

$$\xi \mapsto (A_i \xi^2 + o(\xi^2), B_i \xi^3 + o(\xi^3))$$

of the three branches of the singular tangential family, where

$$\begin{aligned}
A_0 &= 3\beta_1 , \\
B_0 &= 2\beta_1 , \\
A_1 &= \frac{4k_1^3 + 27k_1^2\beta_1 - 54\alpha\beta_1k_1 + 27\alpha^2\beta_1}{(3\alpha - \beta_1)^2} , \\
B_1 &= \frac{2(k_1 - \alpha)(4k_1^3 + 27k_1^2\beta_1 - 54\alpha\beta_1k_1 + 27\alpha^2\beta_1)}{(k_1 - 3\alpha)^3} , \\
A_2 &= -\frac{k_1^2 + 6k_1\beta_1 - 9\alpha\beta_1}{3(\alpha + \beta_1)} , \\
B_2 &= \frac{k_1^3 - 9k_1^2\alpha - 27k_1\beta_1^2 - 54k_1\alpha\beta_1 + 27\alpha\beta_1^2 + 54\alpha^2\beta_1}{27(\alpha + \beta_1)^2} .
\end{aligned}$$

Therefore, these branches have three semicubic cusps whenever

$$(k_1 - 3\alpha) \prod A_i B_i \neq 0 .$$

This means that the set in  $\Pi^*$  for which the three envelope cusps are not all semicubic may be described as the smallest  $\mathcal{A}_2$ -invariant set containing the prenormal forms such that

$$(k_1 - 3\alpha) \prod A_i B_i = 0 .$$

Indeed, this equation defines a finite union of submanifolds of  $J^N(\mathbb{R}^2, \mathbb{R}^2)$  of codimension at worst 1 for every  $N \in \mathbb{N}$ . This ends the proof of Theorem 3.2.6.

The curves forming a singular tangential family are smooth if and only if the dual family curves have not inflection points, that is, if and only if  $\alpha + \beta_1 = 0$ ; so, the set  $Z$  of such singular families is smooth. In this case the last solution  $t_2$  computed above is not defined and the envelope has only two branches, parameterized by map germs whose expansions are

$$\xi \mapsto \left( \tilde{A}_i \xi^2 + o(\xi^2), \tilde{B}_i \xi^3 + o(\xi^3) \right) ,$$

where  $A_0 = -3\alpha$ ,  $B_0 = -2\alpha$  and

$$A_1 = 4k_1 - 3\alpha , \quad B_1 = \frac{8(k_1 - \alpha)(4k_1 - 3\alpha)}{k_1 - 3\alpha} .$$

Theorem 3.2.7 is proven.

# Bibliography

- [1] ARNOLD, V. I.: *Mathematical methods of classical mechanics*. Graduate Texts in Mathematics, 60. Springer-Verlag, New York, 1989. xvi+508 pp.
- [2] ARNOLD, V. I.: “On the envelope theory”. *Uspekhi Math. Nauk.* 3, **31** (1976), 248–249 (in Russian).
- [3] ARNOLD, V. I.: “Wave front evolution and equivariant Morse lemma”. *Comm. Pure Appl. Math.* 6, **29** (1976), 557–582.
- [4] ARNOLD, V. I.: *Geometrical methods in the theory of ordinary differential equations*. Second edition. Fundamental Principles of Mathematical Sciences, 250. Springer-Verlag, New York, 1988. xiv+351 pp.
- [5] ARNOLD, V. I.: *Contact geometry and wave propagation*. Monographie N° 34 de l’Enseignement Mathématique 1989, 56 pp.
- [6] ARNOLD, V. I.: *Singularities of caustics and wave fronts*. Dordrecht, Kluwer Academic Publ. 1990.
- [7] ARNOLD, V. I.: *Topological invariants of plane curves and caustics*. University Lecture Series, 5. A. M. S., Providence, RI, 1994.
- [8] ARNOLD, V. I.: “Simple singularities of curves”. *Tr. Mat. Inst. Steklova* **226** (1999), *Mat. Fiz. Probl. Kvantovoi Teor. Polya*, 27–35; translation in *Proc. Steklov Inst. Math.* 3, **226** (1999) 20–28.
- [9] ARNOLD, V. I.: “Topological problems in wave propagation theory and topological economy principle in algebraic geometry”. The Arnoldfest (Toronto, ON, 1997), 39–54, Fields Inst. Commun., 24, Amer. Math. Soc., Providence, RI, 1999.
- [10] ARNOLD, V. I.: “Astroidal geometry of hypocycloids and the Hessian topology of hyperbolic polynomials”. *Uspekhi Mat. Nauk.* 6, **56** (2001), 3–66; english translation in *Russian Math. Surveys* 6, **56** (2001) 1019–1083.
- [11] ARNOLD, V. I., GORYUNOV, V. V., LYASHKO, O. V., VASILIEV, V. A.: *Singularity theory. I*. [Reprint of Dynamical systems. VI, Encyclopædia Math. Sci., 6, Springer, Berlin, 1993]. Springer-Verlag, Berlin, 1998. iv+245 pp.

- [12] ARNOLD, V. I., GORYUNOV, V. V., LYASHKO, O. V., VASILIEV, V. A.: *Singularity Theory II. Applications*. Dynamical systems VIII, Encyclopædia Math. Sci., 39, Springer, Berlin, 1993.
- [13] ARNOLD, V. I., GUSEĬN-ZADE, S. M., VARCHENKO, A. N.: *Singularities of differentiable maps. Vol. I. The classification of critical points, caustics and wave fronts*. Monographs in Mathematics, 82. Birkhäuser Boston, Inc., Boston, MA, 1985. xi+382 pp.
- [14] BRUCE, J. W., GAFFNEY, T. J.: “Simple singularities of mappings  $\mathbb{C}, 0 \rightarrow C^2, 0$ ”. *J. London Math. Soc. (2)* **26** (1982), no. 3, 465–474.
- [15] CAPITANIO, G.: “On the envelope of 1-parameter families of curves tangent to a semicubic cusp”. *C. R. Math. Acad. Sci. Paris* **3**, **335** (2002), 249–254.
- [16] CAPITANIO, G.: “Singularities of envelopes of curves tangent to a semicubic cusp”. To appear in Proc. of Suzdal International Conf. 2002 on Differential Equations and Dynamical Systems.
- [17] CAPITANIO, G.: “Stable tangential families and their envelopes”. Preprint of the Institut de Mathématiques de Jussieu. Chapter 1 of the Thesis.
- [18] CAPITANIO, G.: “Simple tangential families and perestroikas of their envelopes”. In preparation. Chapter 2 of the Thesis.
- [19] CAPITANIO, G.: “Legendrian graphs and singular tangential families”. In preparation. Chapter 3 of the Thesis.
- [20] DAMON, J.: “The unfolding and determinacy theorems for subgroups of  $\mathcal{A}$  and  $\mathcal{H}$ ”. Singularities, Part 1 (Arcata, Calif., 1981), 233–254, *Proc. Sympos. Pure Math.*, **40**, Amer. Math. Soc., Providence, RI, 1983.
- [21] DAMON, J.: *The unfolding and determinacy theorems for subgroups of  $\mathcal{A}$  and  $\mathcal{H}$* . Mem. Amer. Math. Soc. 50 (1984), no. 306, x+88 pp.
- [22] DUFOUR, J.-P.: “Triplets de fonctions et stabilité des enveloppes”. *C. R. Acad. Sci. Paris Sér. I Math.* **10**, **293** (1981), 509–512.
- [23] GAFFNEY, T.: “A note on the order of determination of a finitely determined germ”, *Invent. Math.*, **52** (1979), 127–130.
- [24] GORYUNOV, V. V.: “Singularities of projections of complete intersections”, *J. Soviet. Math.*, **27** (1984), 2785–2811.
- [25] GIVENTAL, A. B.: “Singular Lagrangian varieties and their Lagrangian mappings”, *Sovrem. Probl. Matematiki. Noveishie Dostizheniya*, **33** (VINITI AN SSSR, Moscow, 1988); english transl. in *J. Soviet. Math.*, (1990), 3246–3278.

- [26] MARTINET, J.: *Singularities of smooth functions and maps*, London Mathematical Society Lecture Note Series, 58. Cambridge University Press, Cambridge-New York, 1982. xiv+256 pp.
- [27] MOND, D.: “On the classification of germs of maps from  $\mathbb{R}^2$  to  $\mathbb{R}^3$ ”. *Proc. London Math. Soc.* (3), **50** (1985), 333–369.
- [28] THOM, R.: “Sur la théorie des enveloppes”. *J. Math. Pures Appl.* 9, **41** (1962), 177–192.
- [29] WALL, C. T. C.: “Finite determinacy of smooth map-germs”. *Bull. Lond. Math. Soc.*, **13** (1981), 481–539.





# Chapter 4

## Minimax solutions to Hamilton-Jacobi equations

ABSTRACT. Minimax solutions are weak solutions to Cauchy problems involving Hamilton–Jacobi equations, constructed from generating families (quadratic at infinity) of their geometric solutions. We give a new construction of the minimax in terms of Morse theory, and we show its stability under small perturbations of the generating family. We show that max–min solutions are equal to minimax solutions. We consider wave fronts corresponding to geometric solutions as graphs of multivalued solutions of Cauchy problems, and we give a geometric criterion to find their minimax. Furthermore, we classify the small codimension generic singularities of minimax solutions.

### 4.1 Introduction

Hamilton–Jacobi equations play an important role in many fields of mathematics and physics, as for instance calculus of variations, optimal control theory, differential games, continuum mechanics and optics.

Let us consider a Cauchy Problem involving a Hamilton–Jacobi equation. For small enough time  $t$  the solution  $u$  is classically determined using the characteristic method. Although  $u$  is initially smooth, there exists in general a critical time beyond which characteristics cross. After this time, the solution  $u$  is multivalued and singularities appear.

Therefore, the problem how to extract “true solutions” from geometric solutions and multivalued solutions naturally arises. In this context, the construction of the viscosity solution is the most known approach, due to its existence and uniqueness properties.

Following Maslov, the classical characteristic method leads to considering a Lagrangian submanifold in the space-time cotangent bundle, called the geometric solution, as generalized solution of  $(CP)$ . Its “projection” in the space of 0-jets over  $Q$  is, in general, the graph of a multivalued function.

The study of singularities of solutions of Hamilton–Jacobi equations was begun by V. I. Arnold in 1972 and led him to the theory of the singularities of wave fronts and caustic and to the discovery of their relation with the discriminants of reflection groups (see [2]). This approach can be generalized to the study of singularities of solutions of general PDE equations, see [19].

In 1991 Marc Chaperon proposed in [12] a geometric method to construct weak solutions to Cauchy Problems for Hamilton–Jacobi equations:

$$(CP) \begin{cases} \partial_t u(t, q) + H(t, q, \partial_q u(t, q)) = 0, & \text{for all } t > 0, q \in Q, \\ u(0, q) = u_0(q), & \text{for all } q \in Q, \end{cases}$$

of Hamiltonian  $H$  and initial condition  $u_0$  on a manifold  $Q$ . The minimax method provides a criterion to extract a true function from it.

This construction is based on generating families quadratic at infinity of Lagrangian submanifolds. Existence and uniqueness Theorem for these families allows to associate to each point of the space-time a function, which is quadratic at infinity in the parameters (the generating family evaluated at this point). The function defined by its minimax critical value is a Lipschitz weak solution of  $(CP)$ , called minimax solution.

The minimax solution has the same analytic properties of the viscosity solution, namely existence and uniqueness theorems hold. However, the minimax solution is in general different from the viscosity solution (they coincide in the case of convex or concave Hamiltonians).

This chapter is divided into four parts.

In the first part we describe a new construction of the minimax critical value of a function quadratic at infinity, based on Morse Theory. This construction provides a simple characterization of minimax values of generic functions quadratic at infinity in terms of their Morse complex. The main result of this part is the stability of the minimax critical value under small deformations of the function.

In the second part we recall the definition of the geometric solution to  $(CP)$  and we prove that it is isotopy equivalent to the zero section of the space-time cotangent bundle. Hence, it admits a unique generating family quadratic at infinity  $S(t, q; \xi)$ . The minimax solution at the point  $(t_0 > 0, q_0)$  is then the minimax critical value of the generating family evaluated at this point:

$$\min \max \{ \xi \mapsto S(t_0, q_0; \xi) \} .$$

The minimax stability leads to a new, geometric, proof of the minimax solution continuity. Moreover, we show that the other solution proposed by Chaperon in [12], called maxmin solution, and constructed in an analogous way, actually is equal to the minimax solution.

In the third part we explain how reduce the problem of finding the minimax solution associated to a given wave front (graph of a multivalued function) in any dimension to the case of such a front in dimension 1. Then a recent Theorem by Chekanov and Pushkar ([15], [14] and [20]) leads to a purely combinatoric geometric criterion providing the graph of the minimax solution on the wave front.

In the last part of the chapter we study generic minimax singularities of codimension at most 2. Our investigation is based on the classification of generic singularities of minimax functions, given by Joukovskaia in [22]. It turns out that not all these generic singularities may arise in minimax solutions to Hamilton–Jacobi equations. This is due to global topological properties of multivalued solutions (Chekanov’s invariants of wave fronts).

Namely, we prove that the generic singularities of codimension at most 2 of the minimax solution and of the viscosity solution are the same. This result may be useful to find examples in which the minimax solution has a physical meaning.

The results presented in this chapter has been published in [8] and [9].

## 4.2 Minimax values of functions

### 4.2.1 Preliminary results

Let  $X$  be a topological space,  $D^n$  an oriented disc of dimension  $n$  and  $\psi : \mathbb{S}^{n-1} \rightarrow X$  a smooth map. We endow the disc boundary  $\mathbb{S}^{n-1} = \partial D^n$  with the induced orientation. The pair  $\sigma^n := (D^n, \psi)$  is called a *dimension  $n$  cell*. The result of attaching the cell  $\sigma^n$  to  $X$  is the space  $X \cup D^n$  modulo the identification of any point  $x \in \mathbb{S}^{n-1}$  with its image  $\psi(x)$ . The resulting space is denoted by  $X \cup \sigma^n$  as well as  $X \cup_\psi D^n$ .

A *cell space* is a space obtained attaching cells (a finite number for each dimension) to a finite collection of points (0-cells). A cell space is called *cell complex* if any cell is attached to a cell of smaller dimension.

It is well known that every cell space is homotopy equivalent to a cell complex, see for instance [17], §4.

Let  $X$  be a cell complex. The union of all its cells of dimension not greater than  $n$  is called the  *$n$ -skeleton* of  $X$ , denoted by  $X^n$ . Thus we have the sequence of skeletons

$$X^0 \subset \cdots \subset X^k \subset \cdots \subset X.$$

The quotient space  $X^{k-1}/X^{k-2}$ , where  $X^{k-2}$  is identified to a point, is a bouquet of dimension  $k-1$  spheres. Let us consider a cell  $\sigma^k = (D^k, \psi)$  and the map:

$$\psi_i : \partial D^k = \mathbb{S}^{k-1} \xrightarrow{\psi} X^{k-1} \xrightarrow{Id} X^{k-1}/X^{k-2} \xrightarrow{\pi_i} \mathbb{S}_i^{k-1},$$

where  $\pi_i$  is the projection on the  $i$ -th sphere in the bouquet. Let  $\sigma_i^{k-1}$  be the cell of  $X$  corresponding to the sphere  $\mathbb{S}_i^{k-1}$ .

DEFINITION. The *incidence coefficient* of two cells  $\sigma^k$  and  $\sigma_i^{k-1}$  is the integer

$$[\sigma^k : \sigma_i^{k-1}] := \deg(\psi_i) \in \mathbb{Z}.$$

Let us set  $E := \mathbb{R}^K$ . Let  $f : E \rightarrow \mathbb{R}$  be a generic function, i. e., a good Morse function (a function is of Morse type if all its critical points are non degenerate and it is a good function if all its critical values are different). We assume that  $f$  is of class  $\mathcal{C}^2$  and that the set of its critical points is finite. By the Morse Lemma, near a critical point  $\bar{\xi}$  of  $f$  there exists a coordinate system  $\{\xi_1, \dots, \xi_K\}$  in which the function writes as:

$$f(\xi_1, \dots, \xi_K) = f(\bar{\xi}) - \xi_1^2 - \cdots - \xi_k^2 + \xi_{k+1}^2 + \cdots + \xi_K^2.$$

The integer  $k$ , denoted by  $\text{ind}(\bar{\xi})$ , is the *index* of the critical point  $\bar{\xi}$ .

For every  $\lambda \in \mathbb{R}$ , set

$$E_f^\lambda = E^\lambda := \{\xi \in E : f(\xi) \leq \lambda\}.$$

Let us recall now two basic theorems in Morse theory. We refer to [23] for the proofs.

THEOREM 4.2.1. *If  $f$  has no critical values in  $[a, b]$ , then  $E^a$  and  $E^b$  are diffeomorphic.*

THEOREM 4.2.2. *Let  $c$  be the only critical value of  $f$  in  $[c - \varepsilon, c + \varepsilon]$  and let  $k$  be the index of the corresponding critical point. Then  $E^{c+\varepsilon}$  and  $E^c$  retract to the space obtained by attaching a dimension  $k$  cell to  $E^{c-\varepsilon}$ .*

Therefore, every generic function on  $E$  defines a cell decomposition of the space and there is a 1 : 1 correspondence between its cells and the critical points of the function (see [26]).

EXAMPLE 4.2.1. The function  $f(x, y) := x^2 - y^2$  has only one critical point, the origin, of index 1. The sets  $E^\lambda$  are depicted in figure 4.1. For  $\lambda > 0$ ,  $X^\lambda$  retracts over the space obtained from  $X^{-\lambda}$  attaching a segment (1-cell) to its boundary.

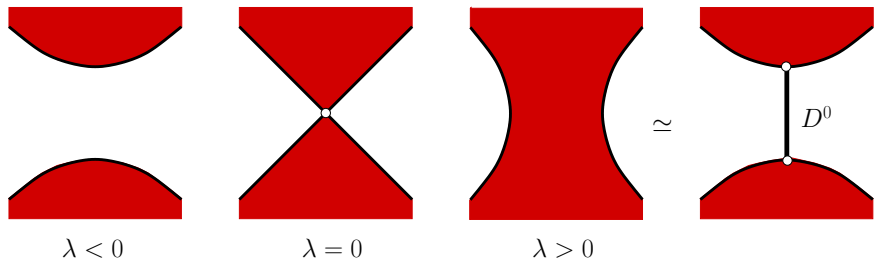

Figure 4.1: Perestroika of the sublevel sets of  $x^2 - y^2$ .

REMARK. Theorems 4.2.1 and 4.2.2 hold for every good Morse function (even with an infinite number of critical points) whenever the gradient field is well defined and integrable; for example whenever the function satisfies the Palais–Smale condition: every sequence  $\{\xi_n\}_{n \in \mathbb{N}}$ , such that  $\nabla f(\xi_n) \rightarrow 0$  for  $n \rightarrow \infty$ , admits a convergent subsequence, provided that  $\{f(\xi_n)\}_{n \in \mathbb{N}}$  is bounded.

Let  $\xi, \eta$  be two critical points of  $f$ . We will denote by  $[\xi : \eta]$  the incidence coefficient of their corresponding cells. Note that  $[\xi : \eta] \neq 0$  implies that  $\text{ind}(\xi) = \text{ind}(\eta) + 1$  and  $f(\xi) > f(\eta)$ .

The geometrical meaning of the incidence number is the following: two critical points have non zero incidence number if and only if there exists a generic smooth deformation of the function along which they collapse and then disappear.

EXAMPLE 4.2.2. Let  $f : \mathbb{R} \rightarrow \mathbb{R}$  be the function  $f(x) = x^3 - \varepsilon x$ , represented in figure 4.2. For negative  $\varepsilon$  it has two critical points,  $\xi = -\sqrt{\varepsilon/3}$  and  $\eta = \sqrt{\varepsilon/3}$ , of index 1 and 0 respectively. When  $\varepsilon$  goes to zero, the two points collapse at the origin, and for  $\varepsilon > 0$  the function has no critical points. Thus,  $[\xi : \eta] \neq 0$ .

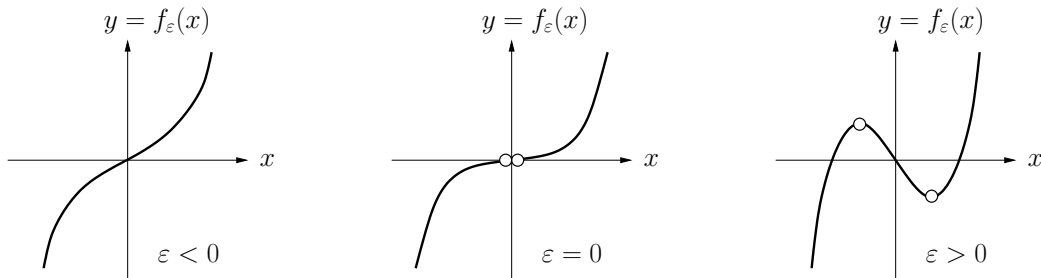

Figure 4.2: Birth/death of critical points.

### 4.2.2 Morse complex of generic functions

Denote by  $\{\xi_1^k, \dots, \xi_{\#(k)}^k\}$  the set of the index  $k$  critical points of  $f$ , ordered according to their values:  $f(\xi_\ell^k) < f(\xi_{\ell+1}^k)$ .

DEFINITION. The *Morse complex* associated to  $f$  is the cell complex  $(M_*^f, \partial_*)$ , defined as follows:

- the dimension  $k$  chain space  $M_k^f$  is the set of the formal linear combinations over  $\mathbb{Q}$  of index  $k$  critical points:

$$M_k^f := \left\{ \sum_{\ell=1}^{\#(k)} \alpha_\ell \xi_\ell^k : \alpha_\ell \in \mathbb{Q} \right\} \simeq \mathbb{Q}^{\#(k)} ;$$

- the boundary operator is the linear map  $\partial_k : M_k^f \rightarrow M_{k-1}^f$  defined by:

$$\partial \xi_\ell^k := \sum_{m=1}^{\#(k-1)} [\xi_\ell^k : \xi_m^{k-1}] \xi_m^{k-1}.$$

For the proof of the equality  $\partial^2 = 0$  we refer to [17], §4.

Let  $b > 0$  be a real number big enough for that the interval  $(-b, b)$  contains the critical value set of  $f$ . Theorem 4.2.1 implies that  $E^\lambda \simeq E^{-b}$  for  $\lambda \leq -b$  and  $E^\lambda \simeq E^b$  for  $\lambda \geq b$ . We define  $E^{\pm\infty} := E^{\pm b}$ .

REMARK. By Theorems 4.2.1 and 4.2.2, we have that  $E/E^{-\infty}$  is a cell space, homotopy equivalent to the Morse complex  $(M_*^f, \partial_*)$ . This implies that

$$\tilde{H}_*(M_*^f, \partial_*) \simeq \tilde{H}_*(E/E^{-\infty}) \simeq \tilde{H}_*(E, E^{-\infty}) ,$$

where  $\tilde{H}_*$  denotes the reduced  $\mathbb{Q}$ -homology complex.

Following Cerf ([11]), S.A. Barannikov proved that it is possible to “diagonalize” the Morse complex. Actually, we consider homology groups over  $\mathbb{Q}$  (instead of  $\mathbb{Z}$ ) in order to make possible the diagonalization.

ALGEBRAIC LEMMA ([5]). *For each chain space  $M_k^f$  there exists a generator system, represented by an invertible upper triangular matrix of dimension  $\#(k)$ , taking the Morse complex to canonical form, i.e., the new ordered generators*

$$\{\Xi_\ell^k : \ell = 1, \dots, \#(k), k = 1, \dots, K\}$$

verify one among the following conditions:

$$\partial \Xi_\ell^k = 0 \quad \text{or} \quad \partial \Xi_\ell^k = \Xi_m^{k-1}. \tag{4.1}$$

Moreover, every complex with ordered generator system admits a unique canonical form.

REMARK. It is possible to define the boundary operator in another way:

$$\delta : M_k^f \rightarrow M_{k-1}^f, \quad \delta \xi_\ell^k := \sum_m \beta(\xi_\ell^k, \xi_m^{k-1}) \xi_m^{k-1},$$

where  $\beta(\xi_\ell^k, \xi_m^{k-1})$  is the algebraic number of integral curves of the vector field  $-\nabla f/|\nabla f|^2$  joining  $\xi_\ell^k$  to  $\xi_m^{k-1}$ . Since the process of attaching cells is induced by retraction of the spaces  $E^\lambda$  along the integral curves of this vector field, we have that  $[\xi_\ell^k : \xi_m^{k-1}] \neq 0$  if and only if there exists at least one integral curve joining the two corresponding critical points. Actually,  $\beta(\xi_\ell^k, \xi_m^{k-1}) = [\xi_\ell^k : \xi_m^{k-1}]$ .

*Proof of the Algebraic Lemma.* The proof is by induction. Assume that the generators  $\Xi_j^h$  satisfy (4.1) for  $h = k$ ,  $j \leq \ell$  and for  $h < k$ ,

$$j \in \{1, \dots, \#(h-1)\}.$$

Let  $Q$  be the set of indices  $q$  such that  $\Xi_q^{k-1} = \partial \Xi_{q^*}^k$  for some  $q^* \leq \ell$ , and

$$P := \{1, \dots, \#(k-1)\} \setminus Q.$$

Then the equality

$$\partial \xi_{\ell+1}^k = \sum_{m=1}^{\#(k-1)} \alpha_m \Xi_m^{k-1}$$

may be written as

$$\partial \left( \xi_{\ell+1}^k - \sum_{q \in Q} \alpha_{q^*} \Xi_{q^*}^k \right) = \sum_{p \in P} \alpha_p \Xi_p^{k-1}.$$

If  $\alpha_p = 0$  for all  $p$  in  $P$ , then the new generator

$$\Xi_{\ell+1}^k := \xi_{\ell+1}^k - \sum_{q \in Q} \alpha_{q^*} \xi_{q^*}^k$$

is in canonical form, indeed  $\partial \Xi_{\ell+1}^k = 0$ . Otherwise, let  $p_0$  be the greatest index in  $P$  for which  $\alpha_{p_0} \neq 0$ :

$$\partial \left( \xi_{\ell+1}^k - \sum_{q \in Q} \alpha_{q^*} \Xi_{q^*}^k \right) = \alpha_{p_0} \Xi_{p_0}^{k-1} + \sum_{p_0 > p \in P} \alpha_p \Xi_p^{k-1}. \quad (4.2)$$

Now replace  $\Xi_{p_0}^{k-1}$  by

$$\tilde{\Xi}_{p_0}^{k-1} := \Xi_{p_0}^{k-1} + \frac{1}{\alpha_{p_0}} \sum_{p_0 > p \in P} \alpha_p \Xi_p^{k-1},$$

which is still of the form (4.1):  $\partial \tilde{\Xi}_{p_0}^{k-1} = \partial \Xi_{p_0}^{k-1} = 0$ . Then equality (4.2) becomes

$$\frac{1}{\alpha_{p_0}} \partial \left( \xi_{\ell+1}^k - \sum_{q \in Q} \alpha_{q^*} \Xi_{q^*}^k \right) = \tilde{\Xi}_{p_0}^{k-1};$$

so the generator

$$\Xi_{\ell+1}^k := \frac{1}{\alpha_{p_0}} \left( \xi_{\ell+1}^k - \sum_{q \in Q} \alpha_{q^*} \Xi_{q^*}^k \right)$$

satisfies  $\partial \Xi_{\ell+1}^k = \tilde{\Xi}_{p_0}^{k-1}$ . This proves the Lemma.  $\square$

### 4.2.3 Incident, coupled and free critical points

The incidence number of critical point pairs leads to a natural partition of the critical set of  $f$  in the following way.

Let  $(M_*^f, \partial_*)$  be the Morse complex in canonical form of a generic function  $f : E \rightarrow \mathbb{R}$ . To every critical point  $\xi_\ell^k$  of  $f$  we may associate the canonic generator  $\Xi_\ell^k$  by the relation

$$\Xi_\ell^k = \sum_{j \leq \ell} \alpha_j \xi_j^k, \quad \text{where } \alpha_\ell \neq 0.$$

DEFINITION. Two critical points  $\xi_\ell^k$  and  $\xi_m^{k-1}$  are *incident* if  $[\xi_\ell^k : \xi_m^{k-1}] \neq 0$ , *coupled* if  $\partial \Xi_\ell^k = \Xi_m^{k-1}$ . A critical point is *free* if it is not coupled to any critical point.

DEFINITION. We call *Morse diagram* of  $f$  the following representation of its Morse complex. Consider  $K + 1$  vertical axes, with the same scale and the origins at the same level, and indexed from the right on the left from 0 to  $K$ . On the  $k$ -th axis we consider the critical points of index  $k$ , according to their values. We join incident points by a dotted line and coupled points by a continuous line (see figure 4.3).

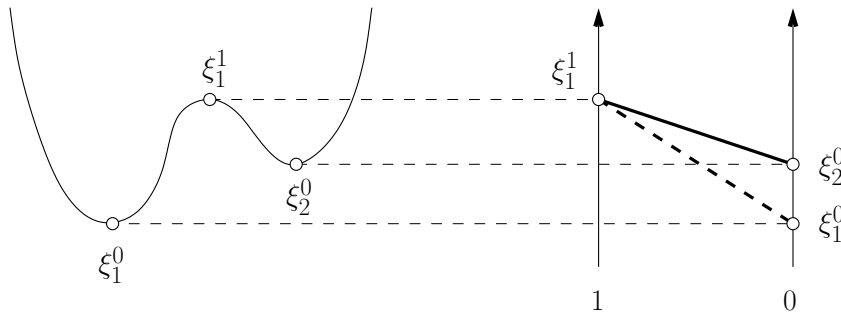

Figure 4.3: The Morse diagram of  $\xi \mapsto \xi^4 - \xi^2 + \xi$ .

REMARK. From each critical point many dotted lines may come out but no more than two continuous line (in this case, the two lines are separated by the axis containing the critical point). All these lines, oriented from critical points of greater index to critical points of smaller index, have negative slope.

PROPOSITION 4.2.1. Let  $\xi_\ell^k, \xi_m^{k-1}$  be two coupled critical points. Then  $f(\xi_m^{k-1})$  is the maximal value among those realized by the critical points, incident to  $\xi_\ell^k$ , verifying

$$[\xi_j^k : \xi_m^{k-1}] = 0 \quad \text{for all } j < \ell;$$

$f(\xi_\ell^k)$  is the minimal value among those realized by the critical points, incident to  $\xi_m^{k-1}$ , verifying

$$[\xi_\ell^k : \xi_j^{k-1}] = 0 \quad \text{for all } j > m.$$

PROPOSITION 4.2.2. A critical point  $\xi$  is free if and only if for every incident critical point  $\eta$  to  $\xi$  there exists an incident critical point  $\xi'$  to  $\eta$  such that

$$|f(\xi') - f(\eta)| < |f(\xi) - f(\eta)|.$$



Both Propositions are a consequence of the definition of the index  $p_0$  in the proof of the Algebraic Lemma.

Propositions 4.2.1 and 4.2.2 allow us to characterize the coupled and the free critical points of  $f$  as follows. Let  $\Sigma$  be the critical set of  $f$ . Denote by  $C_1$  a pair of critical points realizing the minimum of the set

$$\{f(\xi) - f(\eta) : \xi, \eta \in \Sigma, [\xi : \eta] \neq 0\} .$$

Then define by induction  $C_{i+1}$  from  $C_1, \dots, C_i$  as a pair of critical points realizing the minimum of the set

$$\{f(\xi) - f(\eta) : \xi, \eta \in \Sigma \setminus (C_1 \cup \dots \cup C_i), [\xi : \eta] \neq 0\} .$$

After a finite number of steps, we decompose the critical set into the disjoint union of pairs  $C_i$  and a set  $F$  which does not contains incident critical points, i. e.  $[\xi : \eta] = 0$  for every  $\xi, \eta \in F$ .

REMARK. Two critical points of  $f$  are coupled if and only if they belong to the same pair  $C_i$  in the preceding critical set decomposition; a critical point is free if and only if it belongs to  $F$ .

PROPOSITION 4.2.3. *The pairs of coupled critical points of  $f$  and  $-f$  are the same.*

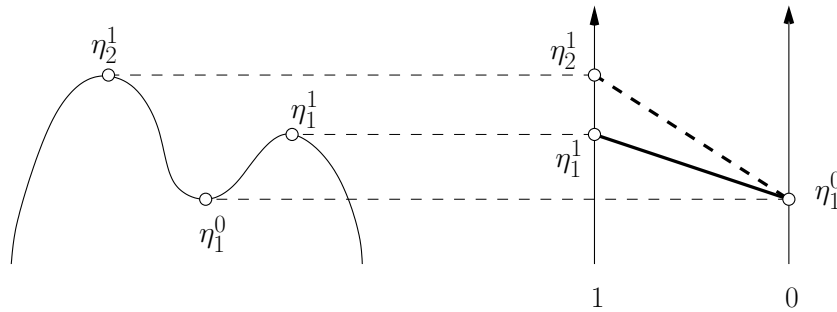

Figure 4.4: Morse diagram of  $\xi \mapsto -(\xi^4 - \xi^2 + \xi)$ .

*Proof.* An index  $k$  critical point  $\xi_\ell^k$  of  $f$  is an index  $K - k$  critical point  $\eta_m^{K-k}$  of  $-f$ . Set  $c := f(\xi_\ell^k)$ . By Theorem 4.2.2 we have:

$$E_f^{c+\varepsilon} \simeq E_f^{c-\varepsilon} \cup \sigma_\ell^k, \quad E_{-f}^{-c+\varepsilon} \simeq E_{-f}^{-c-\varepsilon} \cup \eta_m^{K-k} .$$

Now,  $\partial\sigma_\ell^k$  and  $\partial\eta_m^{K-k+1}$  are incident, so we have

$$[\sigma_j^i, \sigma_h^{i-1}] = \pm[\eta_h^{K-i+1}, \eta_j^{K-i}]$$

(see [17], vol. III, §18). Therefore, the Morse complex of  $f$  and  $-f$  have the same incident critical points. Since we obtain the Morse diagram of  $-f$  from the diagram of  $f$  with a symmetry preserving line slopes (cf. figure 4.4), Proposition 4.2.2 implies that the pairs of coupled critical points of  $f$  and  $-f$  are the same.  $\square$

### 4.2.4 Minimax critical values

In this section we define the minimax critical value of a function and we state its main properties.

Let now  $f : E \rightarrow \mathbb{R}$  be a function of class  $\mathcal{C}^2$ , quadratic at infinity, that is  $f$  is a non degenerate quadratic form outside a compact set. We do not assume here that  $f$  is a good Morse function.

For  $\lambda \in \mathbb{R}$ , consider the natural restriction mappings  $\varrho_\lambda : E \rightarrow E^\lambda$ , inducing the natural homomorphisms between the relative reduced  $\mathbb{Q}$ -homology groups:

$$\varrho_\lambda^* : \tilde{H}_*(E, E^{-\infty}) \rightarrow \tilde{H}_*(E^\lambda, E^{-\infty}) .$$

Since  $f$  is quadratic at infinity, we have:

$$\tilde{H}_*(E, E^{-\infty}) \simeq \tilde{H}_*(E/E^{-\infty}) \simeq \tilde{H}_*(\mathbb{S}^{k_\infty}) ,$$

where  $k_\infty$  is the index of the quadratic part of  $f$ . Let  $\Gamma$  be a generator of the only non trivial homology group  $\tilde{H}_{k_\infty}(E, E^{-\infty}) \simeq \mathbb{Q}$ .

DEFINITION. The *minimax* of  $f$  is the real number

$$\min \max(f) := \inf \{ \lambda \in \mathbb{R} : \varrho_\lambda^* \Gamma \neq 0 \} .$$

REMARK. The infimum defining the minimax exists and it is finite, indeed  $\varrho_\lambda^* \gamma = \gamma \neq 0$  and  $\varrho_{-\lambda}^* \gamma = 0$  whenever  $\lambda > a$ ; it does not depend on the choice of the generator  $\gamma$ . Moreover, the minimax of a function is a critical value, since by definition the topology of the sublevel sets  $X^\lambda$  changes when  $\lambda$  crosses the minimax value.

In the case of generic functions, we can characterize the minimax value using the classification of its critical points given in section 4.2.3.

THEOREM 4.2.3. *Let  $f$  be a generic function quadratic at infinity. Then  $f$  has exactly one free critical point, of index  $k_\infty$ , and the minimax of  $f$  is its value.*

*Proof.* Let  $\xi$  be a critical point of  $f$ ,  $\Xi$  the corresponding canonic generator of its Morse complex. Then  $\xi$  is free if and only if

$$\partial \Xi = 0 \quad \text{and} \quad \Xi \notin \partial M^f ,$$

that is, if and only if the class  $[\Xi]$  is non zero in  $H_*(M^f, \partial)$ . We deduce from the isomorphism  $\tilde{H}_*(E, E^{-\infty}) \simeq \tilde{H}_*(M_*^f, \partial_*)$  that there exists one and only one generator  $\Xi_\ell^{k_\infty}$  whose homology class is well defined and non trivial. Hence,  $\Xi_\ell^{k_\infty}$  is a multiple of  $\Gamma$ . So  $f$  has exactly one free critical point, which index is  $k_\infty$ , and the minimax is realized by this point.  $\square$

In order to make effective this characterization also in the general case we have to perturb non generic functions.

DEFINITION. A *p-parameter deformation* of  $f$  is a smooth  $p$ -parameter family

$$\{ f_\lambda : E \rightarrow \mathbb{R}, \lambda \in \mathbb{R}^p \}$$

of  $\mathcal{C}^2$ -functions having the same quadratic part at infinity that  $f = f_0$ , that is, there exists a compact set  $K \subset E$  such that  $f_\lambda = Q_\infty$  outside  $K$  for every small enough  $\lambda$ , where  $Q_\infty$  is the quadratic part of  $f$ .

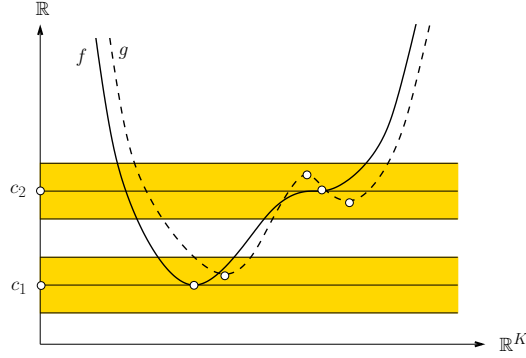

Figure 4.5: Small deformation of a non generic function.

**THEOREM 4.2.4.** *The minimax value of a function is stable under small deformations of it.*

*Proof.* Let  $c_1 < \dots < c_r$  be the critical values of  $f$ . Fix  $\varepsilon > 0$  small enough for that  $c_i + \varepsilon < c_{i+1} - \varepsilon$  for every  $i = 1, \dots, r-1$ . If  $g$  is a small enough perturbation of  $f$ , its critical values belong to

$$\bigcup_{i=1, \dots, r-1} (c_i - \varepsilon, c_i + \varepsilon)$$

(see figure 4.5). Therefore,  $E^{c_i + \varepsilon}$  and  $E_g^{c_i + \varepsilon}$  are diffeomorphic, as well as  $E^{c_i - \varepsilon}$  and  $E_g^{c_i - \varepsilon}$ . This implies that

$$\tilde{H}_*(E^{c_i + \varepsilon}) \simeq \tilde{H}_*(E_g^{c_i + \varepsilon}) \quad \text{and} \quad \tilde{H}_*(E^{-\infty}) \simeq \tilde{H}_*(E_g^{-\infty}).$$

Now set

$$\begin{aligned} A_k &:= H_k(E^{-\infty}), & B_k &:= \tilde{H}_k(E^{c_i + \varepsilon}), & C_k &:= \tilde{H}_k(E^{c_i + \varepsilon}, E^{-\infty}), \\ A'_k &:= H_k(E_g^{-\infty}), & B'_k &:= \tilde{H}_k(E_g^{c_i + \varepsilon}), & C'_k &:= \tilde{H}_k(E_g^{c_i + \varepsilon}, E_g^{-\infty}). \end{aligned}$$

Then we have the following long exact sequences in relative homology:

$$\begin{array}{ccccccccc} \dots & \longrightarrow & A_k & \longrightarrow & B_k & \longrightarrow & C_k & \longrightarrow & A_{k-1} & \longrightarrow & B_{k-1} & \longrightarrow & \dots \\ & & \simeq \downarrow & & \simeq \downarrow & & \downarrow & & \downarrow \simeq & & \downarrow \simeq & & \\ \dots & \longrightarrow & A'_k & \longrightarrow & B'_k & \longrightarrow & C'_k & \longrightarrow & A'_{k-1} & \longrightarrow & B'_{k-1} & \longrightarrow & \dots \end{array}$$

The well known Five Lemma proves the isomorphism:

$$\tilde{H}_k(E^{c_i + \varepsilon}, E^{-\infty}) \simeq \tilde{H}_k(E_g^{c_i + \varepsilon}, E_g^{-\infty}).$$

Now denote by  $u = c_\ell$  the minimax of  $f$ . Then for every  $i$  from 1 to  $\ell - 1$  we have

$$\tilde{H}_{k_\infty}(E_g^{u + \varepsilon}, E_g^{-\infty}) \neq 0 \quad \text{and} \quad \tilde{H}_{k_\infty}(E_g^{c_i + \varepsilon}, E_g^{-\infty}) = 0,$$

showing that the minimax of  $g$  belongs to  $(u - \varepsilon, u + \varepsilon)$ . The Theorem is proven.  $\square$

The minimax of  $f$  admits the following “dual” construction. Consider

$$\check{E}^\lambda := \{\xi \in E : f(\xi) \geq \lambda\} ,$$

and the natural restriction mappings  $\check{\rho}_\lambda : \check{E} \rightarrow E^\lambda$ . Fix a generator  $\Delta$  of the only non trivial relative homology group  $\tilde{H}_{K-k_\infty}(E, \check{E}^{+\infty}) \simeq \mathbb{Q}$ .

DEFINITION. The *max-min* of  $f$  is the real number

$$\max \min(f) := \sup\{\lambda \in \mathbb{R} : \check{\rho}_\lambda^* \Delta \neq 0\} .$$

THEOREM 4.2.5. *The minimax of a function is equal to its max-min.*

*Proof.* By Theorem 4.2.4 we may assume  $f$  generic. Then it follows from Proposition 4.2.3 and Theorem 4.2.3 that

$$\min \max(f) = - \min \max(-f) .$$

On the other hand, we have

$$\max \min(f) = - \min \max(-f) .$$

This ends the proof. □

The next result will be useful in section 4.4.

PROPOSITION 4.2.4. *Let  $f$  be a good function,  $c$  the value of a degenerate critical point and  $\varepsilon > 0$  arbitrary small. Let us suppose that there exists a 1-parameter deformation  $f_\lambda$  such that:*

- for  $\lambda < 0$  small enough,  $f_\lambda$  has no critical values in  $(c - \varepsilon, c + \varepsilon)$ ;
- for  $\lambda > 0$  small enough,  $f_\lambda$  has exactly two critical values in  $(c - \varepsilon, c + \varepsilon)$ , realized by two non degenerate critical points  $\xi_1$  and  $\xi_2$ .

*Then  $\xi_1$  and  $\xi_2$  are coupled.*

*Proof.* Let us set  $g := f_\lambda$  for a positive arbitrary small value of  $\lambda$ , and  $h := f_\lambda$  for a negative arbitrary small value of  $\lambda$ . The same argument used in the proof of Theorem 4.2.4, up to consider  $E^{c-\varepsilon}$  instead of  $E^{-\infty}$ , shows that:

$$\tilde{H}_*(E_g^{c+\varepsilon}, E_g^{c-\varepsilon}) \simeq \tilde{H}_*(E_h^{c+\varepsilon}, E_h^{c-\varepsilon}) .$$

By Theorem 4.2.2, we have  $\tilde{H}_*(E_h^{c+\varepsilon}, E_h^{c-\varepsilon}) = 0$ . Therefore we obtain

$$\tilde{H}_*(E_g^{c+\varepsilon}, E_g^{c-\varepsilon}) = 0 ,$$

so  $\xi_1$  and  $\xi_2$  are incident. Then they are coupled by Proposition 4.2.1. □

## 4.3 Minimax solutions to Hamilton–Jacobi equations

### 4.3.1 Generating families of Lagrangian submanifolds

Let  $X$  be a smooth manifold of dimension  $n$ ,  $T^*X$  its cotangent bundle. Denote by  $\pi : T^*X \rightarrow X$  the natural fibration  $(x, y) \mapsto x$ . The bundle  $T^*X$ , endowed with the canonical symplectic form  $dy \wedge dx$ , is a symplectic manifold of dimension  $2n$ .

A *Hamiltonian isotopy* is the time  $T$  flow of a Hamiltonian

$$h : [0, T] \times T^*X \rightarrow T^*X .$$

All the isotopies considered below are Hamiltonian. Two submanifolds of the cotangent bundle are *isotopy equivalent* if there exists an isotopy transforming one into the other.

A submanifold of  $T^*X$  is called *Lagrangian* if the symplectic form vanishes on it and its dimension is equal to  $n$ . Hamiltonian isotopies transform Lagrangian submanifolds into Lagrangian submanifolds.

DEFINITION. A *generating family* of a Lagrangian submanifold  $L \subset T^*X$  is a  $\mathcal{C}^2$ -function  $S : X \times \mathbb{R}^K \rightarrow \mathbb{R}$  such that

$$L = \{ (x, \partial_x S(x; \xi)) : \partial_\xi S(x; \xi) = 0 \} ,$$

where  $S$  verifies also the rank condition

$$\text{rk} \left( \partial_{\xi\xi}^2 S, \partial_{\xi x}^2 S \right) |_{\partial_\xi S=0} = \max = K .$$

Given a generating family  $S$ , the following operations give rise to new generating families  $T$  of the same Lagrangian submanifold:

- (o) *Addition of a constant:*  $T(x; \xi) = S(x; \xi) + C$  for  $C \in \mathbb{R}$ ;
- (i) *Stabilization:*  $T(x; \xi, \eta) = S(x; \xi) + Q(\eta)$ , where  $Q$  is a non degenerate quadratic form;
- (ii) *Diffeomorphism:*  $T(x; \eta) = S(x; \xi(x, \eta))$ , where  $(x; \eta) \mapsto (x, \xi(x, \eta))$  is a fibered diffeomorphism with respect to the coordinate  $x$ .

The stabilization is the only operation changing the number of parameters in the generating family.

DEFINITION. Two generating families are *equivalent* if it is possible to obtain one from the other by a finite sequence of the preceding operations.

Actually, it turns out that if two generating families are equivalent, then one can obtain one from the other by a stabilization (to make equal the number of parameters), followed by a fibered diffeomorphism and adding a constant (see [25]).

DEFINITION. A generating family is *quadratic at infinity* (GFQI) if there exists a non degenerate quadratic form  $Q_\infty$  such that  $S(x; \xi) = Q_\infty(\xi)$ , whenever  $|\xi|$  is large enough (the required largeness of  $\xi$  being independent from  $x$ ).

The GFQI are an important class of generating families, due to the following existence and uniqueness result. The existence statement has been proven by Sikorav in [24], the uniqueness statement by Viterbo in [27], see also [25].

**THEOREM (SIKORAV–VITERBO).** *Let  $X$  be a closed manifold (i.e. a boundaryless compact manifold). Every Lagrangian submanifold of  $T^*X$ , isotopy equivalent to the zero section*

$$\{(x; 0) : x \in X\} \subset T^*X$$

*admits a unique GFQI modulo the preceding equivalence relation.*

**REMARKS.** (1) The Theorem still holds in the case of non compact manifold, provided that the projection of the Lagrangian submanifold into the base is 1 : 1 outside a compact set.

(2) There exists a contact version of the existence statement concerning Legendrian submanifolds of the jet space  $J^1X$ , due to Yu. Chekanov (see [13]). However in this context there is not, to my knowledge, an analogous of the uniqueness statement.

Let us denote by

$$\Sigma_L := \{(x, y) \in L : \text{rk } D\pi|_L(x, y) < n\}$$

the set of singular points of the projection from  $L$  to  $X$ .

**DEFINITION.** The apparent contour  $\pi(\Sigma_L)$  of  $L$  in  $X$  by the projection  $\pi$  is called the *caustic* of  $L$ .

Generically, the set of the singular points of a Lagrangian submanifold is the union of the codimension 1 submanifold formed by the simple singular points (for which the rank of  $D\pi|_L$  is  $n - 1$ ) and a finite collection of submanifolds which codimension is at least 3 (see [1]).

A Lagrangian submanifold  $L$  is *exact* if the Liouville's 1-form  $y dx$  is exact over it, that is, if there exists a function  $\zeta : L \rightarrow \mathbb{R}$  such that  $y dx|_L = d\zeta$ . In this case, we can associate to  $L$  a Legendrian submanifold

$$\{(x, \zeta(x, y), y) : (x, y) \in L\}$$

in the contact space  $J^1X = \{(x, z, y)\}$  of 1-jets over  $X$ , equipped with the standard contact form  $dz - y dx$ . This Legendrian submanifold is defined up to an additive constant in  $z$ .

**DEFINITION.** The *wave front associated to  $L$*  is the image in the space  $J^0X = \{(x, z)\}$  of 0-jets over  $X$  of its Legendrian lift under the natural projection  $J^1X \mapsto J^0X$ ,  $(x, z, y) \mapsto (x, z)$ .

If  $S$  is a GFQI of  $L$ , then its Legendrian lift is

$$\{(x, S(x; \xi), \partial_x S(x; \xi)) : \partial_\xi S(x; \xi) = 0\} ,$$

so the corresponding wave front is

$$\{(x, S(x; \xi)) : \partial_\xi S(x; \xi) = 0\} .$$

**DEFINITION.** The *Maxwell set* of  $L$  is the set formed by all the points  $x \in X$  for which the function  $\xi \mapsto S(x; \xi)$  is not good.

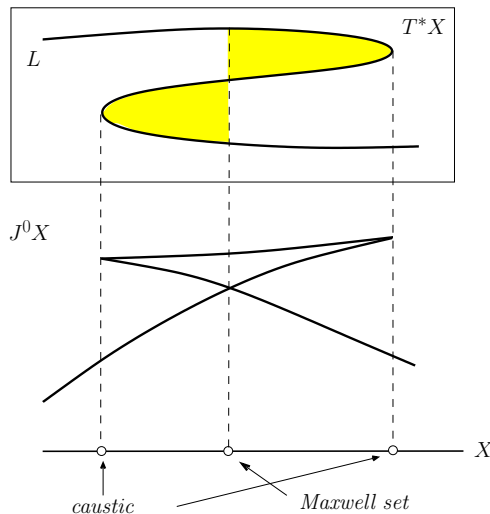

Figure 4.6: The wave front associated to a Lagrangian curve.

REMARKS. (1) By the Viterbo’s Uniqueness Theorem, the Maxwell sets of Lagrangian submanifolds do not depend on the choice of their GFQI.

(2) The natural projection of the wave front generated by  $S$  to the base  $X$  is a fibration outside its caustic and Maxwell set (see figure 4.6).

(3) The Maxwell set of a generic Lagrangian submanifold is a stratified hypersurface (i.e., it is a finite union of smooth, pairwise disjoint arc connected manifolds, called strata, such that the closure of each stratum is the stratum itself and a finite collection of smaller dimension strata), see [2].

### 4.3.2 Geometric solutions

Let us consider the Cauchy Problem for a Hamilton–Jacobi equation on a manifold  $Q$  (boundaryless but not necessary compact), defined by a Hamiltonian  $H : [0, +\infty[ \times T^*Q \rightarrow \mathbb{R}$  of class  $\mathcal{C}^2$  on  $]0, +\infty[ \times T^*Q$  and continuous at the boundary, and by the  $\mathcal{C}^1$ -initial condition  $u_0 : Q \rightarrow \mathbb{R}$ :

$$(CP) \begin{cases} \partial_t u(t, q) + H(t, q, \partial_q u(t, q)) = 0, & \forall t > 0, q \in Q \\ u(0, q) = u_0(q), & \forall q \in Q . \end{cases}$$

In this section we define the geometric solution of  $(CP)$ , which is a Lagrangian submanifold in the cotangent bundle of the space-time. By the Theorem of Sikorav–Viterbo it has a “unique” FGQI, denoted by  $S$  and defined up to an additive constant. Fixing this constant in an suitable way,  $S$  is a (maybe multivalued) solution of our Cauchy problem. In the next section we will use the minimax method to select a unique critical point of  $\xi \mapsto S(t, q; \xi)$  over every  $(t, q)$ . In this way we will obtain a well defined section of the wave front, providing a weak solution of the Cauchy Problem.

Let us consider on the cotangent bundle  $T^*Q = \{(q, p)\}$ , endowed with the standard

symplectic form  $dp \wedge dq$ , the Hamiltonian field  $X_H = (\partial_p H, -\partial_q H)$  and its flow

$$\varphi : [0, +\infty[ \times T^*Q \rightarrow T^*Q .$$

Its components  $\varphi^t(q, p) = (\tilde{q}(t), \tilde{p}(t))$ , called the *characteristics* of  $X_H$ , are the solutions of the Hamilton equations

$$\begin{cases} \frac{d}{dt}\tilde{q}(t) = \partial_p H(t, \tilde{q}(t), \tilde{p}(t)), \\ \frac{d}{dt}\tilde{p}(t) = -\partial_q H(t, \tilde{q}(t), \tilde{p}(t)), \end{cases}$$

verifying the initial conditions  $\tilde{q}(0) = q$  and  $\tilde{p}(0) = p$ .

Let  $L_0 := \{(q, du_0(q)) : q \in Q\}$  be the Lagrangian submanifold of  $T^*Q$  generated by the initial condition  $u_0$  and let  $L_t := \varphi^t(L_0)$  be its time  $t$  evolution.

REMARKS. (1) The submanifold  $L_0$  is isotopic to the zero section. The isotopy is generated by the Hamiltonian  $-u_0$ .

(2) Every  $L_t$  is a Lagrangian submanifold, isotopy equivalent to the zero section of  $T^*Q$ . Indeed,  $L_t$  is isotopic to  $L_0$  by  $\varphi^{-t}$  and the isotopies form a group.

(3) It follows that  $L_t$  is exact and, by the Sikorav–Viterbo Theorem, it admits a unique GFQI, that we will denote by  $S_t(q; \xi)$ .

Let us consider now the space-time  $\mathcal{Q} := \mathbb{R} \times Q$ , and its cotangent bundle  $T^*\mathcal{Q} = \{(t, q; \tau, p)\}$ , equipped with the standard symplectic form  $dp \wedge dq + d\tau \wedge dt$ . The components of the flow  $\Phi : [0, +\infty[ \times T^*\mathcal{Q} \rightarrow T^*\mathcal{Q}$ , generated by the autonomous Hamiltonian  $\tau + H$ , are

$$\Phi^s(t, q; \tau, p) = (t + s, \tilde{q}(t + s); \tilde{\tau}(t + s), \tilde{p}(t + s)),$$

where  $\tilde{q}, \tilde{p}$  are the characteristics of  $X_H$  such that  $\tilde{q}(t) = q, \tilde{p}(t) = p$ , and  $\tilde{\tau}(t) = -H(t, \tilde{q}(t), \tilde{p}(t))$ .

For  $t \geq 0$ , let us consider the inclusion mappings

$$i_t : T^*Q \hookrightarrow T^*\mathcal{Q}, \quad (q, p) \mapsto (t, q; -H(t, q, p), p) .$$

A direct computation shows that the submanifold formed by the union of the characteristic curves of  $\Phi$  issuing from  $i_0(L_0)$ ,

$$L := \bigcup_{s>0} \Phi^s(i_0(L_0)) \subset T^*\mathcal{Q},$$

is Lagrangian. Furthermore, for any fixed time  $T > 0$ , the submanifold

$$L^T := \bigcup_{0 < s < T} \Phi^s(i_0(L_0))$$

is also Lagrangian.

DEFINITION. The Lagrangian submanifold  $L$  is called the *geometric solution* to  $(CP)$ , and  $L^T$  is called the *truncated geometric solution* at time  $T$ .

REMARK. The flow  $\Phi^s$  translates  $L$  by a time  $s$  along the characteristics:

$$\Phi^s(i_t(L_t)) = \Phi^s \circ \Phi^t(i_0(L_0)) = \Phi^{s+t}(i_0(L_0)) = i_{s+t}(L_{s+t})$$

(flow semigroup property).



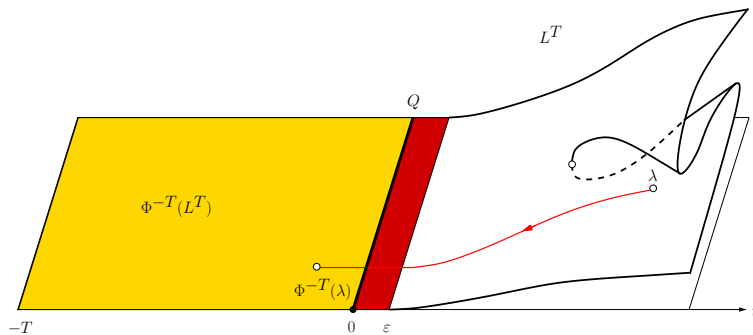

Figure 4.7: The isotopy transforming the geometric solution into the zero section.

**THEOREM 4.3.1.** *For every  $T$ , the truncated geometric solution  $\Lambda^T$  is isotopy equivalent to the zero section in  $T^*\mathcal{Q}$ .*

*Proof.* For small enough time there exists a classical solution to (CP). Hence we may assume without loss of generality that there exists  $\varepsilon > 0$  such that  $L$  is equal to the zero section over  $(0, \varepsilon) \times Q$ . Therefore  $H = 0$  in a neighborhood of  $t = 0$  and we can define a  $\mathcal{C}^2$ -function  $\tilde{H}$  extending  $H$  by 0 to negative times. Hence, the flow  $\tilde{\Phi}$  generated by  $\tau + \tilde{H}$  extends the initial flow  $\Phi$  to the whole time axis. The Lagrangian submanifold

$$\tilde{L} := \bigcup_{s \in \mathbb{R}} \tilde{\Phi}^s(i_0(L_0)) \subset T^*\mathcal{Q}$$

is equal to  $L$  in the half space  $\{t > 0\}$  and to the zero section in the half space  $\{t < 0\}$ . As a consequence,  $\tilde{\Phi}^{-T}$  is an isotopy between  $L^T$  and the zero section (see figure 4.7).  $\square$

Theorem 4.3.1 allows us to apply the Sikorav–Viterbo Theorem to the truncated geometric solution to (PC).

**COROLLARY.** *The truncated geometric solution  $L^T$  admits a unique GFQI (modulo the equivalence relations (i) and (ii) defined above) whose graph at  $t = 0$  is equal to that of the initial condition  $u_0$ .*

From now on,  $S$  will be such a GFQI.

*Proof.* Let  $\tilde{S}(t, q; \xi)$  be a GFQI of  $L^T$ . Since it is a primitive of the Liouville's 1-form  $p dq$  on  $L_0$ , we have:

$$d\tilde{S}(0, q; \bar{\xi}_0(q)) = du_0(q) dq ,$$

where  $\bar{\xi}_0(q)$  is the only critical point of  $\xi \mapsto S_0(q; \xi)$ . Therefore, there exists  $C \in \mathbb{R}$  for which  $S := \tilde{S} + C$  verifies  $S(0, q; \bar{\xi}_0(q)) = u_0(q)$  for all  $q \in Q$ .  $\square$

**REMARK.** It is possible to construct global generating families of geometric solutions as follows. The *action functional*

$$\int pdq - H dt$$

is a global generating family of  $L$ , whose parameters belong to an infinite dimension space. By a fixed point method, proposed by Amann, Conley and Zehnder, one can obtain a true generating family (whose parameters belong to a finite dimension space), see [10].

The exact Lagrangian submanifold

$$L_t := pr \circ \Phi^t(\sigma) \subset T^*Q ,$$

is by definition the *geometric solution at time  $t$*  of  $(CP)$ . These submanifolds are the isochrone sections of the global geometric solution. It is easy to check that  $L_t$  is isotopic to the zero section. By the Uniqueness Theorem, its GFQI is  $S_t(q; \xi) := S(t, q; \xi)$ .

DEFINITION. We call *multivalued solution* (resp., *multivalued solution at time  $t$* ) to  $(CP)$  the graph of  $S$  (resp.,  $S_t$ ).

Examples of geometric and multivalued solutions are shown in figure 4.8.

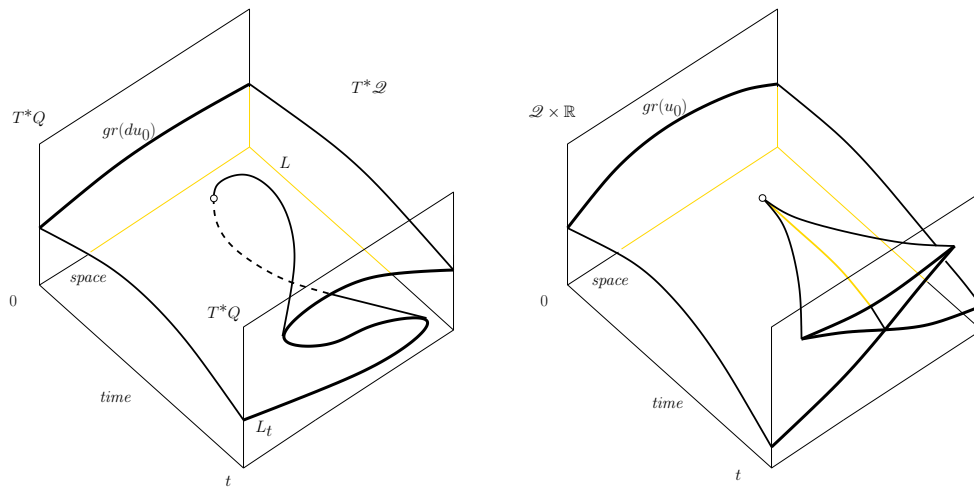

Figure 4.8: Geometric and multivalued solutions.

### 4.3.3 Minimax solutions

Let  $S$  be the GFQI of the geometric solution to  $(CP)$ . The function  $\xi \mapsto S(t, q; \xi)$  is quadratic at infinity, so we may consider its minimax critical value, introduced in section 4.2.4.

DEFINITION (CHAPERON). The *minimax solution* to  $(CP)$  is the function

$$u(t, q) := \min \max \{ \xi \mapsto S(t, q; \xi) \} .$$

REMARK. For a Cauchy Problem on a non compact manifold, as for instance in the case  $Q = \mathbb{R}^n$ , we define the minimax solution as follows. Let  $(H_n)_n$  be a sequence of smooth Hamiltonians with compact support in the space variables (at least for finite times). Then, at any Cauchy Problem defined by  $H_n$  and the given initial condition, we associate its minimax solution  $u_n$ , defined as above. By definition, the minimax solution of the initial Cauchy Problem is the limit of the solutions  $u_n$  for  $n \rightarrow \infty$ .

REMARK. In [12], Marc Chaperon introduced also the *max-min solution*, defined similarly by

$$(t, q) \mapsto \max \min \{ \xi \mapsto S(t, q; \xi) \} .$$

Actually, by Theorem 4.2.5, it coincides with the minimax solution.

Among other authors, minimax solutions has been studied by M. Chaperon ([12]), T. Joukovskaïa ([22]), and C. Viterbo ([28]).

THEOREM 4.3.2 (CHAPERON). *The minimax solution is a weak solution to (CP), Lipschitz on finite times, which not depends on the choice of the GFQI.*

Recall that a weak solution to (CP) is a continuous and almost everywhere differentiable function, solving in these points the Hamilton–Jacobi equation; moreover, its restriction at  $t = 0$  is equal to the initial condition.

*Proof.* By Theorem 4.2.4, we may assume without loss of generality that the geometric solution to (CP) is generic. In this case its caustic and Maxwell set have zero measure.

The continuity of the minimax solution is a consequence of the minimax stability stated in Theorem 4.2.4. Indeed, fix a point  $(t_0, q_0)$  in the space time. For all  $(t, q)$  arbitrary close to  $(t_0, q_0)$ , the function  $\xi \mapsto S(t, q; \xi)$  is an arbitrary small deformation of  $\xi \mapsto S(t_0, q_0; \xi)$  and  $u(t, q)$  is arbitrary close to  $u(t_0, q_0)$ .

If  $(t_0, q_0)$  is not in the Maxwell set, the Implicit Function Theorem guarantees that there exists a neighborhood  $\mathcal{U}$  of  $(t_0, q_0)$  in  $]0, +\infty[ \times Q$ , in which the free critical point of  $\xi \mapsto S(t, q; \xi)$  is a  $\mathcal{C}^1$ -function  $\bar{\xi}(t, q)$ , solving  $\partial_\xi S(t, q; \xi) = 0$ . Hence, for all  $(t, q) \in \mathcal{U}$ , we have  $u(t, q) = S(t, q; \bar{\xi}(t, q))$ , so  $u$  is of class  $\mathcal{C}^1$ .

This formula implies also that the minimax is a solution of the Hamilton–Jacobi equation on  $\mathcal{U}$ . Indeed, we have:

$$\partial_t u(t, q) = \partial_t S(t, q; \bar{\xi}(t, q)), \quad \partial_q u(t, q) = \partial_q S(t, q; \bar{\xi}(t, q)) ;$$

on the other hand, we have:

$$\partial_t S(t, q; \bar{\xi}(t, q)) + H(t, q, \partial_q S(t, q; \bar{\xi}(t, q))) = 0 ,$$

since  $S$  generates the geometric solution. We have therefore proven that outside a zero measure set the minimax is differentiable and it solves the equation. Moreover by construction it satisfies the initial condition.

Since  $H$  and  $u_0$  are Lipschitz, in a finite time the tangent spaces to the isochrone wave fronts associated to the geometric solution can not be vertical. So the minimax solution is Lipschitz on  $[0, T]$  for every fixed  $T$ .

Finally it follows from the Viterbo’s Uniqueness Theorem that the minimax solution does not depend on the choice of the GFQI of the geometric solution.  $\square$

REMARK. Claude Viterbo showed that an analogous statement holds assuming Hamiltonian functions and initial conditions only Lipschitz, see [28]. This is done approaching  $H$  and  $u_0$  by sequences  $\{H_n\}_{n \in \mathbb{N}}$  and  $\{\sigma_n\}_{n \in \mathbb{N}}$  of smooth Hamiltonians and initial conditions. For all

$n \in \mathbb{N}$  we consider the minimax solution  $U[H_n, \sigma_n]$  of the Cauchy Problem defined by the Hamiltonian  $H_n$  and the initial condition  $\sigma_n$ . It turns out that the function defined by

$$\lim_{n \rightarrow +\infty} U[H_n, \sigma_n]$$

is a weak solution to the Cauchy Problem of Hamiltonian  $H$  and initial condition  $u_0$ .

We end this section discussing the relations between minimax and viscosity solutions. Viscosity solutions to Hamilton–Jacobi equations have been introduced by Crandall and Lions in [16], following the generalizations proposed by Kruzhkov for the Hopf’s formulæ.

DEFINITION. A continuous function  $v : \bar{\mathbb{R}}^+ \times Q \rightarrow \mathbb{R}$  is a *viscosity solution* of (CP) if

$$\partial_t \psi(t, q) + H(t, q, \partial_q \psi(t, q)) \leq 0 \quad (\text{resp.}, \geq 0)$$

for any test function  $\psi \in \mathcal{C}^1(\mathbb{R}^+ \times Q)$  for which  $v - \psi$  attains a local maximum (resp., local minimum) at  $(t, q)$ .

Existence and Uniqueness Theorems for the viscosity solution are proven in [16]. When the Hamiltonian defining our Hamilton–Jacobi equation is convex or concave in the momenta, the viscosity solution is explicitly given by the Lax–Hopf formula (Theorem of Bardi and Evans, [6]). In this case, the relation between minimax and viscosity solutions is well known.

THEOREM 4.3.3 (JOUKOVSKAIA, [22]). *The minimax solution and the viscosity solution of (CP) are equal, provided that the Hamiltonian defining the equation is convex or concave in the variables  $p$ .*

In general, there are no exact formulæ of Lax–Hopf type providing the viscosity solution for nonconvex nor concave Hamiltonians. Izumiya and Kossioris constructed in [21] the viscosity solution beyond its first critical time. Actually, they proved that in the general case the Lagrangian graph of the viscosity solution is not necessarily contained in the geometric solution of the Hamilton–Jacobi equation. Hence, the minimax solution and the viscosity solution are in general different.

## 4.4 Characterization of minimax solutions

### 4.4.1 Preliminary notations

Let  $J^0\mathbb{R} \simeq \mathbb{R}^2 = \{(q, z)\}$  be the space of 0-jets over  $\mathbb{R}$  and  $\pi_0 : J^0\mathbb{R} \rightarrow \mathbb{R}$  the natural fibration  $(q, z) \mapsto q$ . A *wave front* in  $J^0\mathbb{R}$  is the image of a Legendrian curve in the contact space  $J^1\mathbb{R} \simeq \mathbb{R}^3 = \{(q, z, p)\}$  under the projection

$$\pi_1 : (q, z, p) \mapsto (q, z) .$$

The only singularities of generic wave fronts are semicubic cusps and transversal self-intersections.

Let  $\Sigma$  be a wave front in  $J^0\mathbb{R}$ . A *section* of  $\Sigma$  is every connected maximal subset  $\sigma$  of  $\Sigma$  which is the graph of a piecewise smooth function

$$\chi_\sigma : \pi_0(\sigma) \rightarrow \mathbb{R} .$$

A *branch* of  $\Sigma$  is a smooth section. A front is *long* if, outside a compact set of  $\mathbb{R}$ , it is the graph of a smooth function. Note that in the 1-jet set up we are considering, all the fronts are *flat*, that is, their tangent lines are nowhere vertical.

A flat front may be cooriented fixing at any point the normal vector with positive  $z$  component. If the front is also oriented, we may distinguish two type of cusps: *positive*, if we pass from a branch to the other according to the coorientation, *negative* otherwise.

Two Legendrian curves in  $J^1\mathbb{R}$  are (*Legendrian*) *isotopy equivalent* if there exists a smooth path joining them in the space of the embedded Legendrian curves. A self-tangency is by definition *safe* if the coorientations of the tangent branches are opposite, *dangerous* otherwise. The generic perestroikas occurring to wave fronts under Legendrian isotopies are the following, illustrated in figure 4.9: *cuspidal birth/death*, *triple intersection*, *cuspidal crossing* and *safe self-tangency*. These perestroikas are the projections of the Reidemeister moves for Legendrian knots (see e.g. [3]).

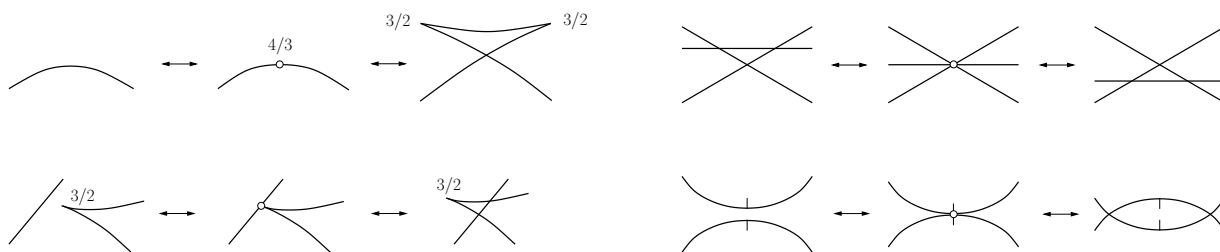

Figure 4.9: Generic singularities along isotopies of wave fronts.

Note that the dangerous self-tangencies are not permitted because they correspond to self-intersections of the Legendrian curve projecting into the front. Flat fronts can have only dangerous self-tangencies.

The number of cusps in a front, counted with their signs, is invariant under Legendrian isotopies, and it is called *Maslov number*.

#### 4.4.2 Admissible decompositions of wave fronts

In this section we recall the construction of a new invariant of Legendrian knots, due to Yu. Chekanov and P. Pushkar, that will lead to our geometric characterization of minimax solutions.

The projection of a Legendrian knot from  $J^1\mathbb{R}$  to  $J^0\mathbb{R}$  by  $\pi_1$  is a closed wave front. Let  $\Sigma$  be a generic front of this type.

A *decomposition* of  $\Sigma$  is a collection of closed curves  $X_1, \dots, X_n \subset \Sigma$ , having a finite number of self intersections, such that

$$X_1 \cup \dots \cup X_n = \Sigma$$

and  $X_i \cap X_j$  is a finite number of points whenever  $i \neq j$ .

A double point  $x \in X_i \cap X_j$  of  $\Sigma$  is a *jump* (or a *switch*) if  $X_i$  and  $X_j$  are not smooth at  $x$ ; it is of *Maslov type* if the number of cusps (counted with their signs) along the front between two intersecting branches at  $x$  is 0.

DEFINITION. A decomposition  $(X_1, \dots, X_n)$  of  $\Sigma$  is said to be *admissible* if:

- (1) Every curve  $X_i$  is homeomorphic to a disc boundary:  $\partial X_i = B_i$ ;
- (2) for  $i \in \{1, \dots, n\}$  and  $q \in \mathbb{R}$ , the set  $B_i(q) := \{z \in \mathbb{R} : (q, z) \in B_i\}$  is connected; in particular, it is a cusp of the front whenever it is a point;
- (3) if  $(q_0, z) \in X_i \cap X_j$  ( $i \neq j$ ) is a jump, then for  $q \neq q_0$  close enough to  $q_0$ , the set  $B_i(q) \cap B_j(q)$  is  $B_i(q)$ , or  $B_j(q)$ , or is empty;
- (4) all the jumps of the front are of Maslov type.

REMARK. Conditions (1) and (2) imply that every curve  $X_i$  has exactly two cusps, dividing it into two components  $\sigma_i^+$  et  $\sigma_i^-$ , where for all  $(q, z_i^\pm) \in \sigma_i^\pm$  we have  $z_i^- \leq z_i^+$ . Condition (3) is equivalent to ask that there are no jump points realizing the *forbidden configurations*, shown in figure 4.10.

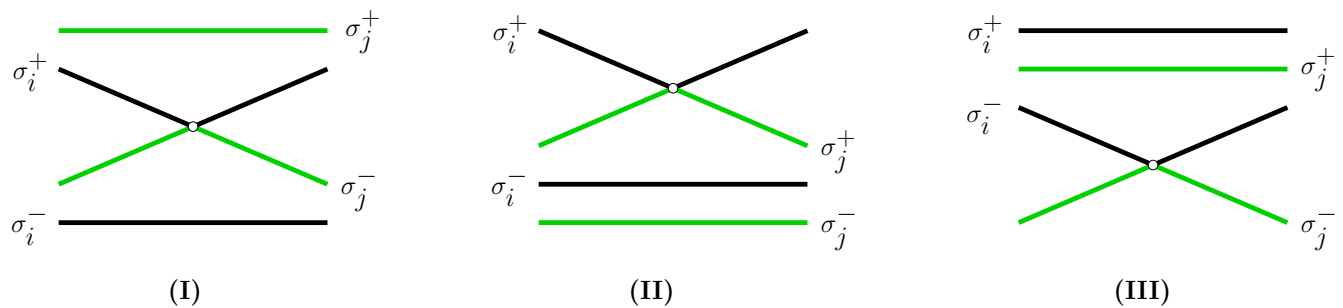

Figure 4.10: Forbidden configurations near a jump point.

THEOREM (CHEKANOV–PUSHKAR, [14], [15], [20]). *The number of admissible decompositions of a wave front, projection of a Legendrian knot, is invariant under Legendrian isotopies of the knot; moreover, the number of curves in the decomposition minus the number of jumps is constant along the isotopy.*

REMARK. Eliashberg has given in [18] a prefiguration (without proof) of Chekanov–Pushkar Theorem. This paper of Eliashberg suggested to J.C. Sikorav the initial idea of minimax solution, next developed by Chaperon.

Chekanov–Pushkar Theorem allow to distinguish non Legendrian isotopic wave fronts having the same Bennequin-number (that is, the self-linking number of a framed oriented legendrian knot) and the same Maslov number (see [20]).

EXAMPLE 4.4.1. Figure 4.11 shows two decompositions of a generic front, projection of a Legendrian knot. The front is isotopy equivalent to the *lips front* (having two cusps and no jumps). By the Chakanov–Pushkar Theorem it admits only one admissible decomposition (on the left).

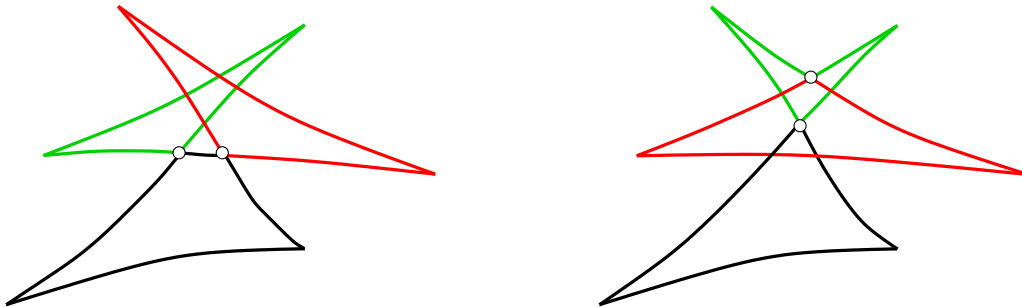

Figure 4.11: Decompositions of a wave front isotopic to the lips front.

### 4.4.3 Characterization of the minimax solution

Let us come back to the Cauchy Problem ( $CP$ ), namely in the case  $Q = \mathbb{R}$ . Fix  $t_0 > 0$ . Let  $S$  be a GFQI of the geometric solution  $L$  (truncated at  $T > t_0$ ). The Uniqueness Theorem implies that  $S_{t_0}(q; \xi) := S(t_0, q; \xi)$  is the GFQI of the geometric solution at time  $t_0$ ,  $L_{t_0} = L \cap T^*(\{t_0\} \times \mathbb{R})$ . Therefore minimax solutions associated to  $L$  and  $L_{t_0}$  have the same value at  $(t_0, q_0)$  and  $q_0$  respectively, namely

$$\min \max \{ \xi \mapsto S(t_0, q_0; \xi) \} .$$

DEFINITION. A long flat wave front in  $J^0\mathbb{R}$  is a *multivalued solution* if it is isotopy equivalent to the zero section and it is projection of an embedded Legendrian curve.

It follows from sections 4.3.2 and 4.3.3 that the wave fronts associated to the geometric solutions  $L_t$  are multivalued solutions (up to replace the Cauchy Problem by a sequence of approximating problems).

REMARK. The Uniqueness Theorem gives a method to reduce the problem to finding the minimax solution to ( $CP$ ) to the case  $Q = \mathbb{R}$ . Indeed, let us consider the solution  $L$  of the more general problem. Let  $S$  be its GFQI,  $\Sigma$  the corresponding wave front and

$$\{ \gamma_\lambda : \lambda \in [0, 1] \} \subset T^*\mathcal{Q}$$

a smooth 1-parameter family of curves (in the space-time) parameterized by  $s \mapsto \gamma_\lambda(s)$ . We assume that the family fullfills the following conditions:

- (A) the first curve  $\gamma_0$  is contained in the boundary  $t = 0$ ;
- (B) the limits  $\gamma_\lambda(\pm\infty)$  are two points of the space-time boundary  $\{0\} \times Q$ , which are independent of the parameter value  $\lambda$ ;
- (C) for every  $\lambda \in [0, 1]$ , the curve  $\gamma_\lambda$  is transversal to the caustic and the Maxwell set of the geometric solution.

The restriction  $L_\lambda$  of the geometric solution to the cotangent bundle to  $\gamma_\lambda$  is a connected Lagrangian curve, whose GFQI is  $S(\gamma_\lambda(s); \xi)$ . The minimax of its graph  $\Sigma_\lambda$  over a point  $s$  is equal to the minimax of  $\Sigma$  over  $\gamma_\lambda(s)$ . Moreover, by construction  $\Sigma_\gamma$  is a multivalued solution. Indeed,  $\Sigma_\gamma$  is flat and long; the mapping  $\lambda \mapsto \Sigma_\lambda$  is a Legendrian isotopy transforming the front  $\Sigma_1$  into the zero section of  $T^*Q$ , see figure 4.12.

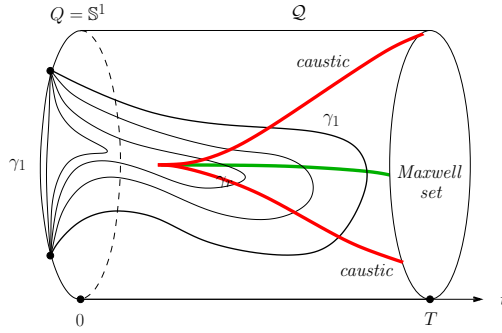

Figure 4.12: Reduction to the unidimensional case ( $Q = \mathbb{S}^1$ ).

We are going to study minimax sections of multivalued solutions in  $J^0\mathbb{R}$ , using the classification of critical points given in section 4.3. Let us consider a multivalued solution  $\Sigma$  at time  $t$  and its GFQI, denoted by  $S$ . Every branch of the front corresponds to a critical value of  $\xi \mapsto S_t(q; \xi)$ .

**DEFINITION.** The *index* of a branch is the index of its corresponding critical point minus the index of the quadratic part of  $S$ .

The index of a branch does not depend on the choice of the GFQI. Note that the unbounded branch of the front has index 0, as well as the minimax section. Moreover, the index changes by +1 (resp., -1) passing through a positive cusp (resp., negative cusp).

In order to use the Chekanov—Pushkar Theorem, we need to close our wave front adding a “section at infinity”. To do this, we cut off the front outside a compact set  $K$  containing all the compact branches of the front and then we close it adding two cusps and a (flat) section at infinity  $\sigma_\infty$ , disjoint to the other sections of the front, as illustrated in figure 4.13.

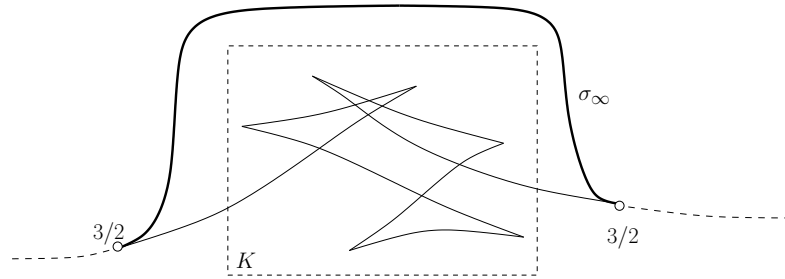

Figure 4.13: Closing multivalued solutions.

We denote by  $\tilde{\Sigma}$  such a front, which is equal to  $\Sigma$  inside  $K$ . Since the minimax section is equal to the maxmin section, nothing changes if the section at infinity overpasses or downpasses  $K$ . The new front  $\tilde{\Sigma}$  is the projection of a Legendrian knot.

When  $q$  run on  $\mathbb{R}$ , every pair of coupled critical points of  $S$  moves on the front along two sections, forming a closed curve. We denote by  $X_i$  these curves and by  $X_0$  the remaining curve in  $\tilde{\Sigma}$ . This curve is the union of the section at infinity  $\sigma_\infty$  and a section  $\mu$ , which is equal to the minimax of the non compact front inside  $K$ .



**THEOREM 4.4.1.**  $(X_0, X_1, \dots, X_n)$  is the only admissible decomposition of  $\tilde{\Sigma}$ .

*Proof.* By section 4.2.3, the curves  $X_0, X_1, \dots, X_n$  satisfy admissible decomposition axioms (1) and (2). Axiom (4) is also satisfied. Indeed, the difference between the indices of two branches is the number of cusps between them along the front (Proposition 4.2.4).

It remains to check that axiom (3) is verified, i.e. forbidden configurations never arises. For each curve  $X_i = \sigma_i^+ \cup \sigma_i^-$ , and  $q$  inside  $\pi_0(X_i)$ , we denote  $(q, \xi_i^+) \in \sigma_i^+$  and  $(q, \xi_i^-) \in \sigma_i^-$ , with  $\xi_i^+ > \xi_i^-$ , the two points of the curve over  $q$ . For  $X_0 = \sigma_\infty \cup \mu$ , we denote the two points over  $q$  by  $(q, \xi_\infty) \in \sigma_\infty$  and  $(q, \xi_\mu) \in \mu$ , where  $\xi_\infty > \xi_\mu$ . Let  $J$  be a jump point,  $q_J := \pi_0(J)$ ,  $q \neq q_J$  arbitrary close to  $q_J$ .

Assume first  $J \in X_i \cap X_j$ , with  $i \neq j$  non zero. The Morse diagrams of  $\xi \mapsto S(q; \xi)$  corresponding to forbidden configurations (I), (II) and (III) are in contradiction with Proposition 4.2.1, as proven by figure 4.14 for configuration (I) and by figure 4.15 for configurations (II) and (III).

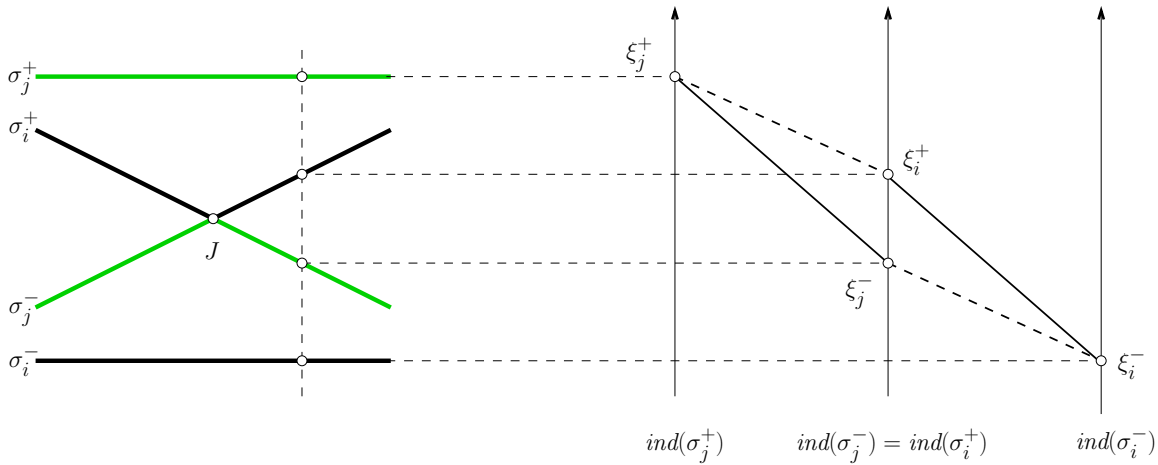

Figure 4.14: Morse diagram of forbidden configuration (I).

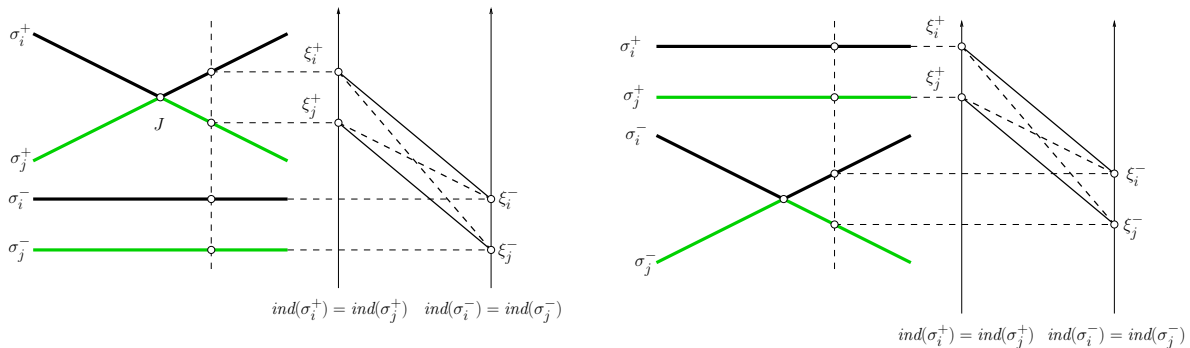

Figure 4.15: Morse diagram of forbidden configurations (II) and (III).

Since  $\sigma_\infty$  has no jumps, it remains to consider a jump point  $J \in \mu \cap X_i$ ,  $i > 0$ . We assume that the section at infinity overpasses all the bounded sections of the front. Therefore, for

these jumps the forbidden configuration (III) is not possible. Configurations (I) and (II) lead to Morse diagrams in contradiction with Proposition 4.2.2, see figure 4.16.

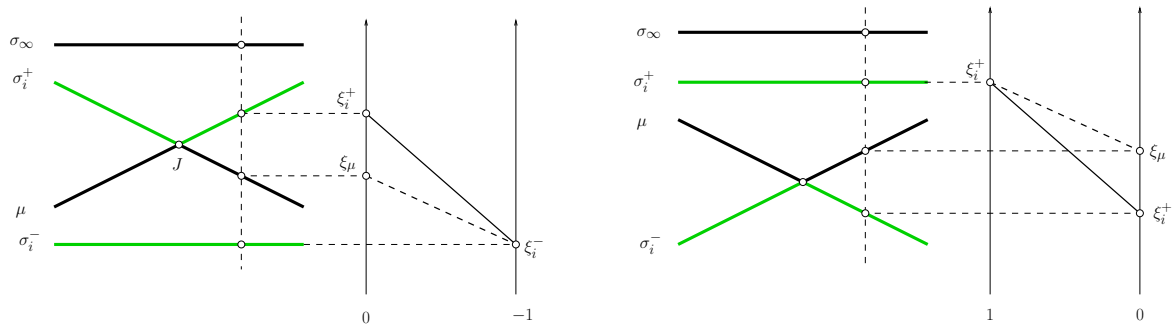

Figure 4.16: Morse diagram of forbidden configurations (I) and (II).

We have proven that our decomposition is admissible.

Since the Legendrian curve projecting into the front  $\Sigma$  is isotopy equivalent to the zero section,  $\tilde{\Sigma}$  is isotopy equivalent to the lips front. Hence, by the Chekanov–Pushkar Theorem,  $\tilde{\Sigma}$  has exactly one admissible decomposition. This completes the proof.  $\square$

REMARKS. (1) Theorem 4.4.1 provides a combinatoric criterion to finding the minimax section of a given dimension 1 wave front (of multivalued solution type). Actually, it is enough to find the only admissible decomposition of the closed front associated to the multivalued solution. The section coupled to the section at infinity is the minimax section.

(2) The axioms characterizing the admissible decompositions of wave fronts have been defined by Chekanov and Pushkar as a generalization of the classification of the critical points of a function. In this sense, Theorem 4.4.1 is the simple case whose generalization is the Chekanov–Pushkar Theorem.

EXAMPLE 4.4.2. We deduce from Theorem 4.4.1 and Example 4.4.1 that the minimax section of the front in figure 4.17 is the bold line.

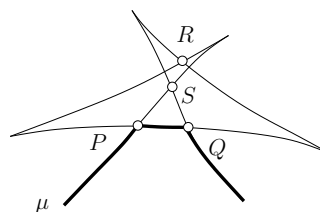

Figure 4.17: The minimax section of the front in Example 4.4.1

### 4.4.4 Vanishing triangles

In this section we describe an effective method to replace a multivalued solution by a simpler one, having the same minimax section. This leads to finding the minimax section of the initial wave front iterating this method.

DEFINITION. A triple intersection is said to be *homogeneous* if the branches intersecting at the triple point have the same index (cf. §4.4.3).

Homogeneous triple intersections are the only perestroikas changing in a catastrophic way (i.e. non continuous way) admissible decompositions of multivalued solutions (see figure 4.18).

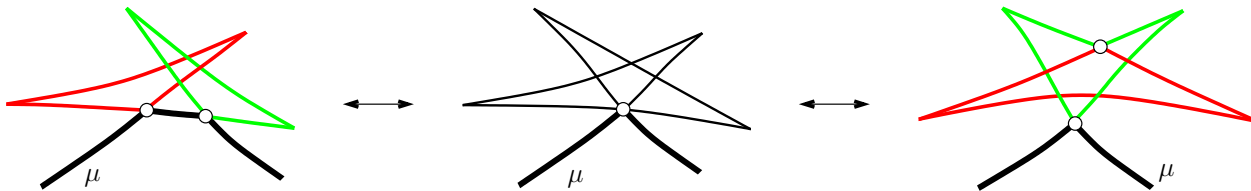

Figure 4.18: Catastrophic change of the admissible decomposition.

Every homogeneous double point (i.e. intersection of two branches having the same index) of an oriented multivalued solution defines in the front a closed connected curve according to the front orientation. Such a curve is called a *triangle* whenever it has exactly two cusps. The double point is the *vertex* of the triangle.

Let  $\Sigma$  be a multivalued solution and  $T$  a triangle on it. Fix an arbitrary small ball centered at the vertex of  $T$ , intersecting only the two branches of the front meeting at the double point. We denote by  $\Sigma - T$  a multivalued solution equal to  $\Sigma \setminus T$  outside the ball and smooth inside it (see figure 4.19).

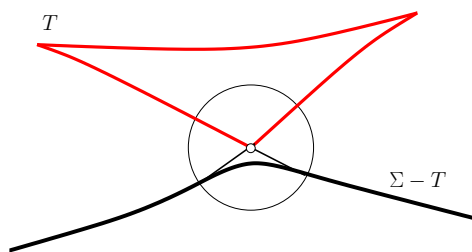

Figure 4.19: The front  $\Sigma - T$ .

DEFINITION. A triangle  $T$  of  $\Sigma$  is *vanishing* if there exists a Legendrian isotopy joining  $\Sigma$  and  $\Sigma - T$  among multivalued solutions without homogeneous triple intersections.

The following Theorem provides an effective method to simplify recursively a given multivalued solution. After a finite number of steps, we get a smooth multivalued solution, which is actually the graph of the minimax solution to the initial problem.

THEOREM 4.4.2. *Let  $\Sigma$  be a multivalued solution and  $\Sigma = \mu \cup X_1 \cup \dots \cup X_N$  its admissible decomposition, induced from that of the closed front  $\tilde{\Sigma}$  ( $\mu$  being the minimax section). Then  $\Sigma$  is smooth or has a vanishing triangle  $T$  among the decomposition curves  $X_i$ . In this case, the admissible decomposition of  $\Sigma - T$  is induced by that of  $\Sigma$ . In particular, the minimax of  $\Sigma$  and  $\Sigma - T$  are equal outside the ball centered at the vertex of the vanishing triangle  $T$ .*

*Proof.* Consider the connected graph associated to the admissible decomposition of  $\tilde{\Sigma} = \pi_1(\tilde{L})$ , i.e., the graph having a vertex for every curve in the decomposition and an edge connecting two vertices for each jump between the corresponding curves. The Chekanov–Pushkar Theorem implies that the number of curves forming the decomposition minus the number of jumps is invariant under Legendrian isotopies.

Since  $\tilde{L}$  is isotopy equivalent to a circle, projecting into the lips front, this number is 1 for every front obtained closing multivalued solutions. Hence the graph is actually a tree, which leaves (i.e. vertex from which only one edge goes out) are triangles. Finally, it is easy to check that the triangles, which are curves in the decomposition, are vanishing.  $\square$

EXAMPLE 4.4.3. Consider the front  $\Sigma$  depicted in figure 4.20, together with the tree associated to the admissible decomposition of the front.

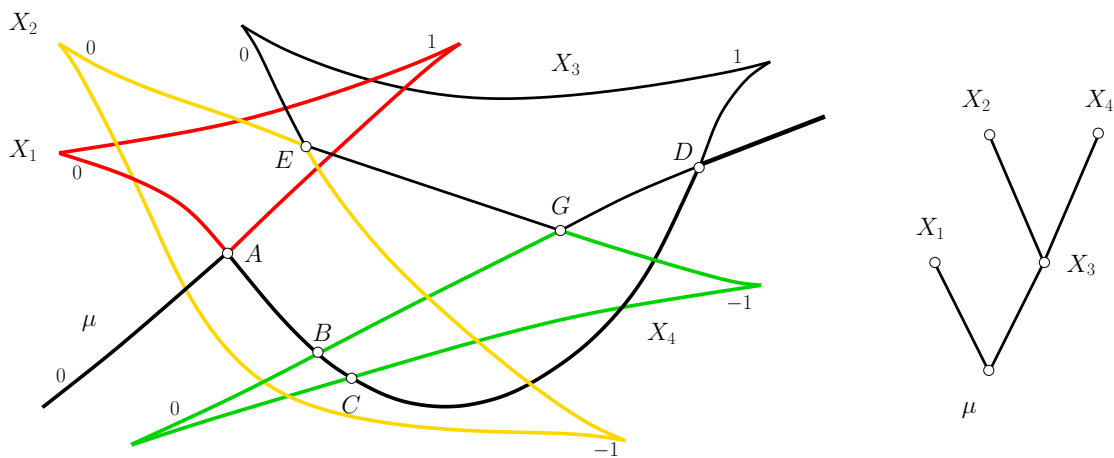

Figure 4.20: The wave front  $\Sigma$  in Example 4.4.3 and its tree.

We claim that the minimax section  $\mu$  is the section designed by a bold line. We apply Theorem 4.4.2. The triangles  $T_A, T_E$  and  $T_G$ , whose vertices are  $A, E$  and  $G$ , are vanishing. Thus, outside three arbitrary small balls, centered at  $A, E$  and  $G$ , the minimax of the front coincides to the minimax of the front  $\Sigma' := ((\Sigma - T_A) - T_E) - T_G$ , depicted in figure 4.21. Now  $T_D$  is vanishing, so the minimax is the announced section of the initial front.

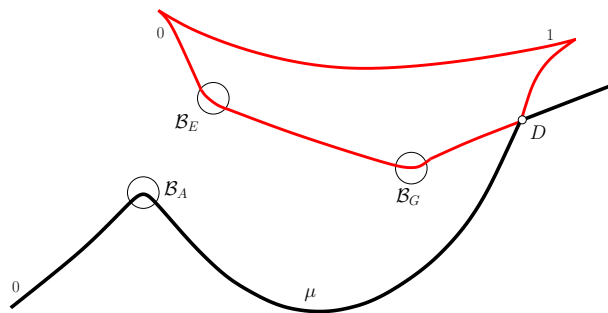

Figure 4.21: The wave front  $\Sigma'$  in Example 4.4.3.

## 4.5 Generic singularities of minimax solutions

In this section we will classify generic singularities of minimax solutions to Hamilton–Jacobi equations, whose codimension is at most 2, up to the Left–Right equivalence fibered on the time direction. Namely, let us consider the Cauchy Problem

$$(CP) \begin{cases} \partial_t u(t, q) + H(t, q, \partial_q u(t, q)) = 0, & \text{for all } t > 0, q \in \mathbb{R}^n, \\ u(0, q) = u_0(q), & \text{for all } q \in \mathbb{R}^n, \end{cases}$$

defined by a Hamiltonian  $H : \mathbb{R}^+ \times T^*\mathbb{R}^n \rightarrow \mathbb{R}$  of class  $\mathcal{C}^2$  on  $]0, +\infty[ \times T^*\mathbb{R}^n$  and continuous at the boundary, and by the  $\mathcal{C}^1$ -initial condition  $u_0 : \mathbb{R}^n \rightarrow \mathbb{R}$ . We denote by  $q = (q_1, \dots, q_n)$  the space coordinate.

DEFINITION. A Cauchy Problem (CP) is said to be *generic* whenever its geometric solution  $\Lambda$  is generic as Lagrangian submanifold of the cotangent bundle  $T^*\mathbb{R}^n$ .

We define now the equivalence relation we will use to classify the singularities of the minimax solutions of these problems.

Let us consider two functions

$$f, g : \mathbb{R} \times \mathbb{R}^n \rightarrow \mathbb{R}$$

and let  $a, b$  be two points of the space-time  $\mathbb{R} \times \mathbb{R}^n$ .

DEFINITION. The germ of  $f$  at  $a$  and the germ of  $g$  at  $b$  are said to be *fibered L–R equivalent on the time* (or *equivalent*) if there exists two diffeomorphism germs  $\varphi, \psi$  such that

$$\begin{array}{ccc} (\mathbb{R} \times \mathbb{R}^n, a) & \xrightarrow{u} & (\mathbb{R}, u(a)) \\ \varphi \downarrow & & \psi \downarrow \\ (\mathbb{R} \times \mathbb{R}^n, b) & \xrightarrow{v} & (\mathbb{R}, v(b)) \end{array}$$

and  $\varphi$  is fibered with respect to the time axis:

$$\varphi(t, x) = (T(t), X(t, x)) .$$

A *singularity* of a function germ for this equivalence relation is its equivalence class. A Cauchy Problem (CP) is said to be *generic* if its geometric solution is a generic lagrangian submanifold. As before, we will assume that the restriction of the geometric solution over  $[0, T] \times \mathbb{R}^n$  is 1 : 1 with the base. A minimax solution of a generic Cauchy Problem is also called *generic*.

REMARK. In [22], Joukovskaia proved that the singular set of every generic minimax solution (i.e., the set formed by the points where the solution is not differentiable) is a closed stratified hypersurface, diffeomorphic at any point to a semi-algebraic hypersurface.

THEOREM 4.5.1. *Let  $u$  be a generic minimax solution and let  $(t, q)$  be a point belonging to a codimension  $c = 1, 2$  stratum of its singular set. Then the germ of  $u$  at this point is equivalent to one of the map germs at  $(0, 0)$  in the table below.*

$c$	<i>Normal form</i>
1	$ q_1 $
2	$\min\{ q_1 , t\}$
2	$\min\{Y^4 - tY + qY : Y \in \mathbb{R}\}$

The images of these normal forms (for  $n = 1$ ) are depicted in figure 4.22. These map germs are also the normal forms of the generic singularities (of codimension at most 2) of the viscosity solution, whose classification has been done by Bogaevski in [7] via Lax-Hopf type formulæ.

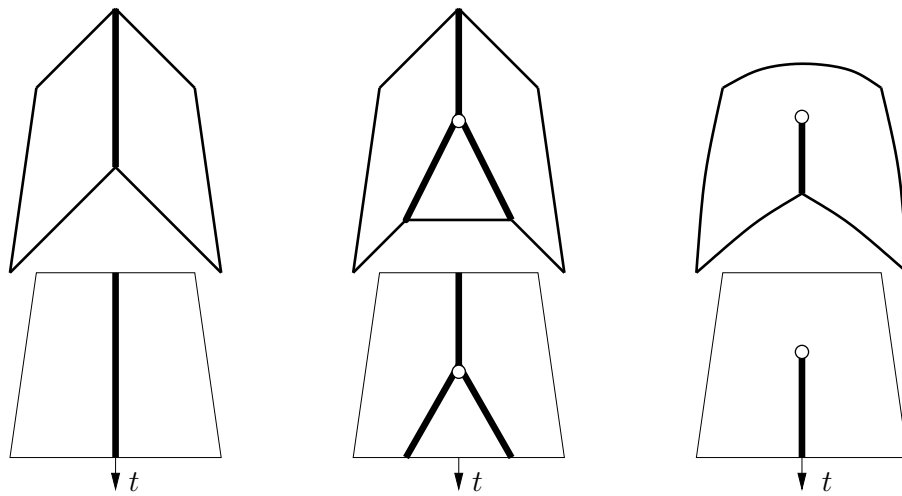

Figure 4.22: Generic singularities of minimax solutions.

REMARK. These singularities are stable. By this, we mean the following. Let  $u$  be the minimax solution of a Cauchy Problem ( $CP$ ). Consider a smooth deformation ( $CP_\lambda$ ),  $\lambda \in \mathbb{R}^\ell$ , of it (including a deformation of the Hamilton–Jacobi equation and of the initial condition). Denote by  $u_\lambda$  the minimax solution of the deformed problem ( $CP_\lambda$ ). The stability of the singularity of  $u$  at the point  $a$  means that every minimax solution  $u_\lambda$  of the perturbed problem ( $CP_\lambda$ ) has an equivalent singularity at a point  $a_\lambda$  arbitrary close to  $a$ , provided that  $\lambda$  is small enough.

Joukovskaia studied, in her PhD thesis [22], the generic singularities of minimax functions, i.e., functions defined as minimax levels of GFQI of Lagrangian submanifolds (which are not necessarily geometric solutions of Hamilton–Jacobi equations).

Our Theorem states that not all the singularities of minimax functions may be realized as singularities of minimax solutions. This is a consequence of global topological obstructions, essentially due to the existence of the wave front invariants discovered by Chekanov and Puskar. Here the situation is similar to that of viscosity solutions, in which not all the metamorphosis of Maxwell sets of minimum functions may be realized by shock waves (see [4]).

To prove Theorem 4.5.1 we will show that some singularities in the general list, given by Joukovskaia, do not arise as singularities of minimax solutions. In order to do this, let us recall her Theorem.

**THEOREM (JOUKOVSKAIA, [22]).** *Every generic minimax function on  $\mathbb{R} \times \mathbb{R}^n$  is equivalent, at any point in a codimension 2 stratum of its singular set, to one of the map germs listed in Theorem 4.5.1 (for  $c = 2$ ) or to one of the following map germs:*

- (a)  $(t; q_1, \dots, q_n) \mapsto \max\{t, -|q_1|\}$ ;
- (b)  $(t; q_1, \dots, q_n) \mapsto \max\{|q_1|, \max\{-|q_1|, t\}\}$ .

The images of the normal forms (a) and (b) are shown in figure 4.23.

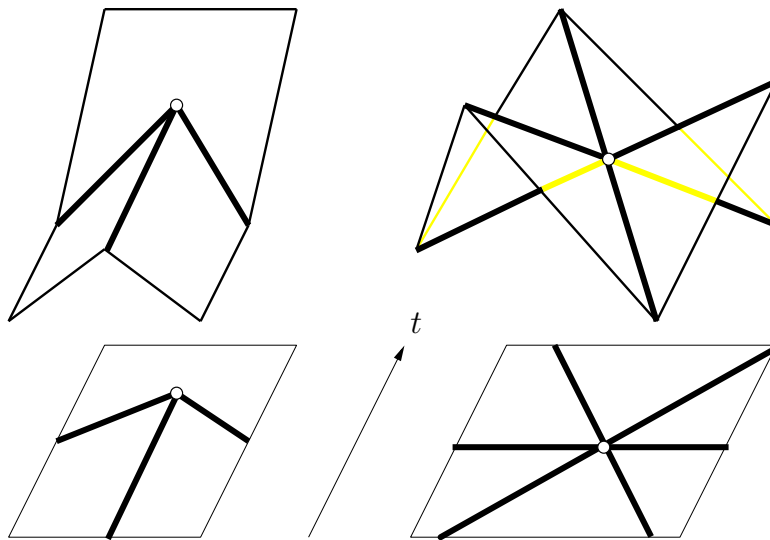

Figure 4.23: Singularities (a) and (b) of minimax functions.

**REMARK.** The problem of the classification of singularities of minimax solutions of higher codimensions is open and, in my opinion, it is interesting (namely, the generic singularities arising in the physically interesting space dimensions 2 and 3).

*Proof of Theorem 4.5.1.* Without loss of generality, we may assume  $n = 1$ . Let us consider a multivalued solution having a singularity (a) or (b). In both cases, we may suppose, by a coordinate change fibered in the time direction, that the singular point is the origin. For both singularities, there are three 0-index branches crossing at this point. Now fix an arbitrary small neighborhood  $U$  of the origin in  $\mathbb{R}^2$ ; then there exists an arbitrary small time  $t$  such that the isochrone multivalued solution at this time takes over the isochrone section of  $U$  the configuration shown in the left part of figure 4.24; moreover, all the other front branches are smooth over  $U$ . Let us denote by  $\alpha$ ,  $\mu$  and  $\beta$  the three branches intersecting at the singular point, as shown in the figure:  $\alpha \leq \mu \leq \beta$ . The minimax section  $\mu$  has three jumps in  $A$ ,  $B$  and  $C$ , shrinking to the homogeneous triple point at the origin as  $t$  goes to 0. We point out that this configuration arises for the singularity (a) as well as for the singularity (b).

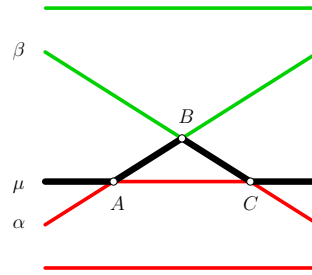

Figure 4.24: Configuration of the multivalued solution near a singularity (a) or (b) of the minimax solution.

By Theorem 4.4.2 we may recursively eliminate the vanishing triangles in the multivalued solution without changing the minimax section neither the other pairs of coupled sections. Hence, after a finite number of such operations, the front is composed by the (graph of the) minimax solution, the (global) section  $\alpha$  and its coupled section  $\alpha^*$ , see the right part of figure 4.25. Indeed, the section  $\alpha$  does not belong to a vanishing triangle, since it has two

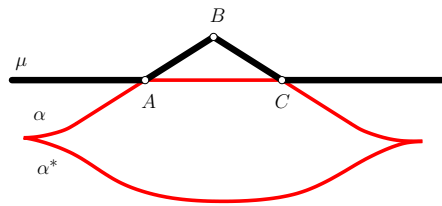

Figure 4.25: Multivalued solution configurations near the singular point.

jumps. This front is not a multivalued solution. Hence, multivalued solutions can not have singularities (a) nor (b). □

In other words, both singularities (a) and (b) imply the existence of a cycle in the graph associated to a decomposition of an isochrone multivalued solution of the Cauchy Problem. This is impossible, since all the graphs associated to admissible decompositions of isochrone multivalued solutions are trees, due to Theorem 4.4.2.





# Bibliography

- [1] ARNOLD, V. I.; *Mathematical methods of classical mechanics*. Graduate Texts in Mathematics, 60. Springer-Verlag, New York, 1989. xvi+508 pp.
- [2] ARNOLD, V. I.; *Singularities of caustics and wave fronts*. Dordrecht, Kluwer Academic Publ. 1990.
- [3] ARNOLD, V. I.; “Invariants and perestroikas of wave fronts on the plane”. *Proc. V.A. Steklov Inst. Math.*, **209** (1995), 11–64.
- [4] ARNOLD, V. I.; GORYUNOV, V. V.; LYASHKO, O. V.; VASIL’EV, V. A.: *Singularity Theory II. Applications*. Dynamical systems VIII, Encyclopædia Math. Sci., 39, Springer, Berlin, 1993.
- [5] BARANNIKOV, S. A.; “The framed Morse complex and its invariants”, Singularities and bifurcations. *Adv. Soviet Math. 21 Amer. Math. Soc., Providence, RI* (1994), 93–115.
- [6] BARDI, M., EVANS, L. C.; “On Hopf’s formulas for solutions of Hamilton-Jacobi equations”. *Nonlinear Anal.* **8** (1984), no. 11, 1373–1381.
- [7] BOGAEVSKI, I. A.; “Singularities of viscosity solutions of Hamilton-Jacobi equations”. *Singularity theory and differential equations* (Kyoto, 1999). Sūrikaiseikikenkyūsho Kōkyūroku No. 1111 (1999), 138–143.
- [8] CAPITANIO, G.; “Caractérisation géométrique des solutions de minimax pour l’équation de Hamilton-Jacobi”. *Enseign. Math. (2)* **49** (2003) 3–34.
- [9] CAPITANIO, G.; “Generic singularities of minimax solutions to Hamilton–Jacobi equations”. To appear in *Journal of Geometry and Physics*.
- [10] CARDIN, F.; “The global finite structure of generic envelope loci for Hamilton–Jacobi equations”. *Journal of Math. Physics* (2) **43** (2002), 417–430.
- [11] CERF, J.; “La stratification naturelle des espaces de fonctions différentiables réelles et le Théorème de la pseudo-isotopie”. *Inst. Hautes Etudes Sci. Publ. Math.* **39** (1970), 5–173.
- [12] CHAPERON, M.; “Lois de conservation et géométrie symplectique”. *C. R. Acad. Sci. Paris 312 série I* (1991), 345–348.

- [13] CHEKANOV, YU.; “Critical points of quasi-functions and generating families of legendrian manifolds”. *Funktsional. Anal. i Prilozhen.* (2) **30** (1996), 56–69 ; traduction en anglais in *Funct. Anal. Appl.* (2) **30** (1996), 118–128.
- [14] CHEKANOV, YU.; “New invariants of legendrian knots”. *European Congress of Mathematics, Barcelona , Volume II, Progress in Mathematics 202*, Birkhauser 2000 .
- [15] CHEKANOV, YU., PUSHKAR, P.; “Arnold’s four cusps conjecture and invariants of legendrian knots”. *in preparation*.
- [16] CRANDALL, M. G., LIONS, P.-L.; “Viscosity solutions of Hamilton-Jacobi equations”. *Trans. Amer. Math. Soc.* **277** (1983), no. 1, 1–42.
- [17] DUBROVIN, B.A., FOMENKO, A.T., NOVIKOV, S.P.; *Modern geometry—methods and applications. Part III. Introduction to homology theory*. Graduate Texts in Mathematics, 124. Springer-Verlag, New York, 1990. x+416 pp.
- [18] ELIASHBERG, YA. M. “A theorem on the structure of wave fronts and its application in symplectic topology”. *Functional Anal. Appl.* **21** (1987), no. 3, 227–232.
- [19] GIVENTAL, A. B.; “Whitney singularities of solutions of partial differential equations”. *J. of Geom. and Ph.* **15** (1995) 353–368.
- [20] GORYUNOV, V. V.; “Plane curves, wavefronts and Legendrian knots”. *Phil. Trans. R. Soc. Lond. A* (2001), **359**, 1497–1510.
- [21] IZUMIYA, S., KOSSIORIS, G. T.; “Bifurcations of shock waves for viscosity solutions of Hamilton-Jacobi equations of one space variable”. *Bull. Sci. Math.* **121** (1997), no. 8, 619–667.
- [22] JOUKOVSKAÏA, T.; “Singularités de minimax et solutions faibles d’équations aux dérivées partielles”. *PhD Thesis at Paris VII University* 1993.
- [23] MILNOR, J.; *Morse theory*. Princeton University Press 1963.
- [24] SIKORAV, J.-C.; “Problèmes d’intersection et de points fixes en géométrie hamiltonienne”. *Comment. Math. Helvetici* **62** (1987), 62–73.
- [25] THÉRET, D.; “A complete proof of Viterbo’s uniqueness Theorem on generating functions”. *Topology and its appl.* **96** (1999) 249–266.
- [26] VASSILIEV, V. A.; *Introduction to topology*. AMS STML 14, 2001.
- [27] VITERBO, C.; “Symplectic topology as the geometry of generating functions”. *Math. Annalen* **292** (1992) 685–710.
- [28] VITERBO, C.; “Solutions d’équations d’Hamilton-Jacobi et géométrie symplectique”. *Séminaire sur les équations aux dérivées partielles*, Palaiseau, 1996.