



**HAL**  
open science

# Improvement of the engineering efficiency in a systems engineering context, case of automotive products and related manufacturing systems engineering

Etienne Lardeur

► **To cite this version:**

Etienne Lardeur. Improvement of the engineering efficiency in a systems engineering context, case of automotive products and related manufacturing systems engineering. Engineering Sciences [physics]. Ecole Centrale Paris, 2003. English. NNT : . tel-00011608

**HAL Id: tel-00011608**

**<https://theses.hal.science/tel-00011608>**

Submitted on 14 Feb 2006

**HAL** is a multi-disciplinary open access archive for the deposit and dissemination of scientific research documents, whether they are published or not. The documents may come from teaching and research institutions in France or abroad, or from public or private research centers.

L'archive ouverte pluridisciplinaire **HAL**, est destinée au dépôt et à la diffusion de documents scientifiques de niveau recherche, publiés ou non, émanant des établissements d'enseignement et de recherche français ou étrangers, des laboratoires publics ou privés.

ECOLE CENTRALE PARIS

N° attribué par la bibliothèque

|\_|\_|\_|\_|\_|\_|\_|\_|\_|\_|\_|\_|\_|\_|\_|

---

THESE DE DOCTORAT

DISCIPLINE: GENIE INDUSTRIEL

---

**Amélioration de la performance de l'ingénierie dans un  
contexte d'Ingénierie Système :**  
*Cas du développement conjoint des produits automobiles et  
de leurs systèmes de fabrication*

---

*Rédigée en Anglais*

Présentée par

**Etienne Lardeur**

Pour l'obtention du GRADE DE DOCTEUR  
de L'ECOLE CENTRALE PARIS

Sous la direction de Jean-Claude Bocquet

**Soutenue le 03 décembre 2003**

*Devant le jury composé de:*

Chris McMahon	University of Bristol	Président
Alain Bernard	IRRCYN	Rapporteur
Serge Tichkiewitch	INPG / L3S	Rapporteur
Christian Auzet	PSA Peugeot Citroën	Examineur
Alain Maurice	PSA Peugeot Citroën	Examineur
Jean-Claude Bocquet	EC Paris / LGI	Examineur



ECOLE CENTRALE PARIS

Affiliated Library number

|\_|\_|\_|\_|\_|\_|\_|\_|\_|\_|\_|\_|\_|\_|\_|

---

PH. D. THESIS

DISCIPLINE: INDUSTRIAL ENGINEERING

---

---

**Improvement of the engineering efficiency in a systems  
engineering context, case of automotive products and  
related manufacturing systems engineering**

---

Prepared and defended at the  
Industrial Engineering Laboratory of Ecole Centrale Paris

By

**Etienne Lardeur**

**Defended: December 3<sup>rd</sup>, 2003**

*Jury:*

Chris McMahon	University of Bristol	Presidency
Alain Bernard	IRRCYN	Report
Serge Tichkiewitch	INPG / L3S	Report
Christian Auzet	PSA Peugeot Citroën	Examination
Alain Maurice	PSA Peugeot Citroën	Examination
Jean-Claude Bocquet	EC Paris / LGI	Direction







*« Mais j'étais un fils.  
Les fils ne savent pas que leurs mères sont mortelles ».*  
*Albert Cohen, Le livre de ma mère.*

*A la mémoire de Maman,*





## Contents

<i>Introduction</i> .....	13
<i>Chapter 1. Industrial challenges and research issues</i> .....	19
<i>Chapter 2. State of the art</i> .....	35
<i>Chapter 3. Automotive SE extension: eASE</i> .....	63
<i>Chapter 4. eASE Evaluation and Control</i> .....	77
<i>Chapter 5. eASE Deployment and Application</i> .....	89
<i>Chapter 6. eASE Instrumentation</i> .....	97
<i>Conclusions and Perspectives</i> .....	109
<i>References</i> .....	115
<i>Résumé détaillé en français</i> .....	125
<i>Table of contents, Lists of Figures and Tables</i> .....	143
<i>Appendix: Questionnaire</i> .....	149



## Remerciements (acknowledgements)

Pour les raisons professionnelles liées au contexte international de mes recherches, j'ai tenu à rédiger ce mémoire en langue anglaise. Aussi je conseille vivement aux lecteurs francophones de se rendre en page 115 pour y trouver un résumé détaillé en français, qui fait office de guide de lecture.

Je salue donc en premier lieu la gentillesse dont mes rapporteurs, mon président de jury et mes correcteurs (*-trices !*) ont fait preuve en acceptant cet exercice linguistique.

Je remercie Jean-Claude Bocquet pour m'avoir accueilli dans son laboratoire en acceptant d'assumer la direction de ma thèse. Merci beaucoup pour l'autonomie ainsi que la confiance que tu m'as accordées et qui ont fait de cette thèse une très chouette aventure.

Je remercie également Christian Auzet. En tant qu'encadrant au sein de PSA Peugeot Citroën, tu n'as tout simplement jamais failli dans ta fonction de père spirituel.

Je remercie Chris McMahon pour me faire l'honneur de présider mon jury.

Messieurs Alain Bernard et Serge Tichkiewitch, soyez assurés de ma gratitude pour accepter d'étudier et de porter votre jugement sur mon travail.

Je remercie chaleureusement Anne et Sylvie, ainsi que mes collègues et amis du laboratoire Génie Industriel de l'ECP, et en particulier mon « jumeau de thèse » Barthélemy. Votre hospitalité et votre bonne humeur constante ont contribué à faire de ces trois années de thèse un pur moment de bonheur.

Qu'Alain Maurice soit ici vivement remercié pour la détermination exemplaire dont il fait preuve dans le déploiement de l'Ingénierie Système Automobile. J'adresse d'ailleurs mon entière gratitude à tous les collègues, passés et présents, de l'équipe ISA (et assimilés), et particulièrement François Croc, pour m'avoir fait partager sa conception aiguë de l'honnêteté intellectuelle.

Enfin, à ceux qui auront été surpris par la citation choisie en début de thèse, je leur confie qu'aucun mot de ce mémoire n'a été écrit sans que j'éprouve pour ma mère disparue une émotion profonde. Ma thèse lui est complètement dédiée. Je remercie avec d'autant plus de chaleur Anne, toute ma famille ainsi que tous mes amis, qui m'ont permis de tenir dans ces moments douloureux. Ils sont mes plus fervents supporters et sans eux l'écriture de ce manuscrit n'aurait probablement pas abouti.



# **Introduction**

---

## Challenges and lacks in the engineering field

The ability of the manufacturing firms to identify the needs of customers, translate them into requirements and quickly engineer the systems<sup>1</sup> that satisfy these requirements and that can be produced at low cost, is the key for any economic success (see [Ulrich K.T. and Eppinger S.D., 1995]). To achieve these goals, the firms have to consider, in addition to the customer needs, those of the whole stakeholders, i.e. any enterprise, organization, or individual having an interest or a stake in the outcome of the engineering of a system through its life-cycle (see [EIA632, 1998]): users, manufacturers, installers, testers, maintainers, project managers, shareholders...

Thus, the achievement of such challenges requires the involvement of all the functions guided by these stakeholders, in cross-functional and interdisciplinary organizations involving many areas of expertise<sup>2</sup> that play a role in the engineering of the system. It is generally argued that the better the work of these people is coordinated, the better the performance of the overall project will be (see [Oosterman B., 2001] and [Eppinger Steven D., Whitney Daniel E. *et al.*, 1994]). Considering the fact that “engineering” appears as the most important life-cycle stage determining project performance (see [Standish Group, 1994] and [Bellut S., 1990]), the interdependencies of the areas of expertise have to be managed, as well as their own engineering performance.

This Thesis will show that such management is practically hard to achieve, not only because of the difficulty of designing an engineering approach supporting it, but also because of the process that will deploy the defined approach and its related cultural challenges. Furthermore, the profusion of engineering methods and tools really contrasts with the relative lack of structured approaches that practically set them up.

---

<sup>1</sup> According to standard [ISO9000, 2000], a system is a combination of interactive elements organized to achieve one or more stated purpose. According to standard [EIA632, 1998], a system is one or more end products (for car manufacturers: the vehicle) and sets of related enabling products (such as the manufacturing systems) that allow end products, over their life cycle of use, to meet stakeholder needs and expectations.

<sup>2</sup> The term “area of expertise” refers to any engineering team acting in the systems engineering with its own technical focus.

## Research question and objectives

This Thesis has been realized in the department in charge of the definition, the communication and the adjustment of the development master plans, and especially in the team in charge of Systems Engineering deployment, which has been affiliated to this department in year 2000, as soon as top managers have decided to deploy SE. The role of the SE team is to define, train and provide help for the application of the *Automotive Systems Engineering* (ASE) methodology.

The objective of PSA Peugeot Citroën is to achieve its developments within 2 years. A development planning supports it, which can be considered as the link between the top managers strategic point of view and the operational realization. It must ensure the coherence between the objectives and available resources, and be in line with real practices of the engineering teams.

To ensure the expected relevance, PSA Peugeot Citroën has progressively decided to deploy:

- Automotive Systems Engineering in order to structure the engineering design process,
- Information systems implementation, in order to support the data flow during the development process.

This Thesis focuses on Automotive Systems Engineering deployment and also address the instrumentation issue of the theoretical results.

Thus, a related issue is: **to prepare instrumentation aspects [I1].**

A conceptualization of the stated lacks and challenges for industrial performance improvement leads us to the following research question:

*How to shift areas of expertise from their actual practices locally optimized to a structured methodological target, globally optimized?*

Chapter 1 will deeply detail the issues induced by this research question in: the purpose is therefore to provide a methodological framework, i.e. the Automotive Systems Engineering (ASE) processes, and also the deployment processes of these processes.



Such assertion could lead the reader naturally to the following “reading question”:

*Why Systems Engineering?*

Automotive Systems Engineering (ASE) aims to provide for PSA Peugeot Citroën an adequate and structured “theoretical” approach for the development of the new vehicles, which deployment is increasingly effective.

This leads to the subject of the Thesis, of which global objective is to build and deploy a common framework for engineering of automotive products and related manufacturing systems. The general industrial problematic is to provide the most efficient development system design for PSA Peugeot Citroën, in order to reach the time-to-market objectives. ASE is the selected approach to do it. Thus, the global objective is to enable the maximization of ASE deployment profit.

Because of its industrial background, the ASE Framework of an automotive company must take into account the development of the vehicles and the related manufacturing systems. In 2000, the current ASE approach was not sufficient and ASE utilization had to be extended to and promoted in the engineering of manufacturing systems.

My related objectives were:

- **[O1] To develop an extended framework, that fully details the application of ASE to the production domain [O1a], and describes the engineering coordination of automotive products and related manufacturing systems [O1b],**
- **[O2] To provide an engineering design process (and associated methods, tools and constant references and updates) in order to enhance the improvement of the current engineering practices<sup>3</sup>[O2a], whatever their initial level of performance could be [O2b].**

The research issue related to [O2] is therefore: **to know how to realize performance measurement in the engineering field [I2].**

---

<sup>3</sup> a “practice” refers to the activity and the way this activity is performed.

## Outline of the Thesis

Figure 1 depicts the contents of the Thesis. **Chapter 1** details the industrial background of this study and my research area and scope. It formulates the proceeding of the successive research questions and presents the action plan. **Chapter 2** represents the materials used to support the research orientation, through review and analyze of the current literature. Engineering design approaches are studied. Systems Engineering (SE) is detailed in relation with these design methods, and the engineering performance measurement field is developed. **Chapter 3** describes the ASE extension (extended Automotive SE: *eASE*), presented as the theoretical advances. Regarding manufacturing systems engineering, **Chapter 4** and **Chapter 5** present as practical results the *eASE* Evaluation and Control (Chapter 4), providing global evaluation, for the local improvements of the *eASE* Deployment and Application (Chapter 5). **Chapter 6** introduces the *eASE* instrumentation. The integrated methods and tools approach is presented as the work process. The first steps of this process are detailed and illustrated. Conclusions and directions for further research suggestions complete this dissertation.

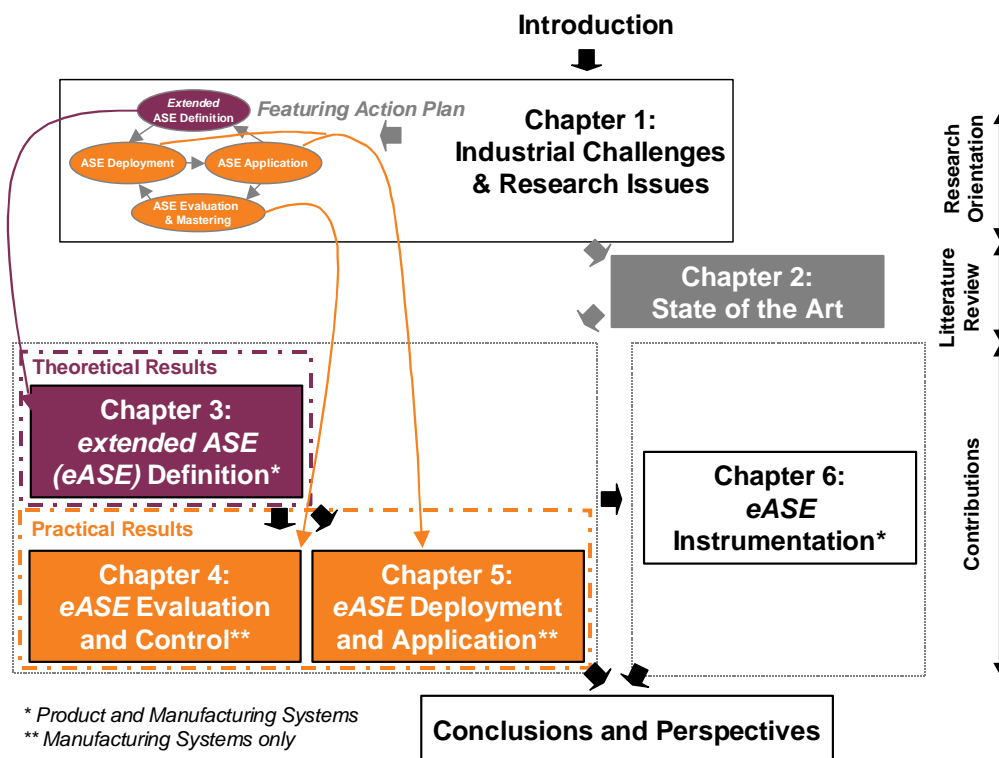

Figure 1. Outline of this Thesis



# **Chapter 1. Industrial challenges and research issues**

---

The purpose of this chapter is to build and justify my research orientation.

This chapter starts with three statements about engineering approaches in the field of industrial performance. Then the industrial background of the study is detailed: the industrial needs and challenges, which open to the objectives and issues. Next, the research area and scope is presented.

A presentation and a justification of the contents of the Thesis is build by giving the research orientation in line with the previously identified objectives and issues (see Table 3. Mapping between {Objectives, Issues} and the items of the Thesis).

The presentation of the action plan detailing the research orientation concludes this chapter.

## 1.1 Three statements

Three studies bring statements that show the importance of the role played by engineering approaches for industrial performance, notably in automotive industry.

- First, the Chaos Report [Standish Group, 1994] demonstrates that engineering approaches effectiveness highly impacts projects success,
- Second, the analysis performed by [Bellut S., 1990] confirms the engineering approaches importance through a relative comparisons of engineering and manufacturing life-cycle stages,
- Third, an internal statement [PSA, 1998] shows the role of engineering approaches in the worldwide car manufacturer competition.

These three studies are the basis of the research orientation.

### 1.1.1 *Engineering approaches and project failure*

*How engineering approaches are involved in project failure?*

The Chaos Report brings an empirical justification, notably with four case studies, of how an engineering approach could contribute to project success.

The Standish Group has led an investigation on project failure in the United States. Despite the fact that projects were mainly software development, this survey was wide and representative, with 365 respondents and 8 380 applications made in large, medium or small enterprises of various industry segments, e.g., banking, securities, manufacturing, retail, health care, insurance, services, ...

Results are described by the rates depicted in Figure 2. Overall, the success rate was only 16%, while challenged projects accounted for 53% and impaired for 31%.

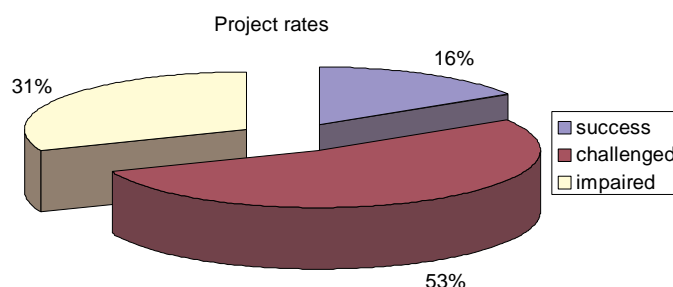

Figure 2. Project success and failure [Standish Group, 1994]

Successful projects are those completed on time and on budget, with all features as initially expected. Challenged projects were completed but over-budget, over-time and fewer features than originally expected. Impaired projects were cancelled during the development cycle.

Regarding particularly the large companies, only 9% of projects were successful, 61,5% were challenged and 29,5% were cancelled.

Cost overruns of combined challenged and impaired projects amount to 189% in average (178% for large companies), while average time overrun amounts to 222% (230% for large companies). In average, 61% of originally specified features were available (42% only for large companies).

The Standish Group has asked project managers about the reason why projects succeed or fail. Project success factors are detailed and ordered in Table 1, while Table 2 details the factors for challenged or canceled projects.

The three major reasons of success are *user involvement*, *executive management support*, and *clear statement of requirements*. Without them, chance of success decreases dramatically. These reasons highly depend on engineering aspects. The major failure reasons are related to inputs (needs, requirements, involvement) and also mainly depend on engineering aspects.

Thus, engineering approaches effectiveness highly impacts projects success. Furthermore, such approaches have to be extremely robust in terms of requirements engineering.

The Chaos report also states that managers believe that there are more project failures now than five years ago and ten years ago.

Project Success Factors	% of Responses
1. User Involvement	15.9%
2. Executive Management Support	13.9%
3. Clear Statement of Requirements	13.0%
4. Proper Planning	9.6%
5. Realistic Expectations	8.2%
6. Smaller Project Milestones	7.7%
7. Competent Staff	7.2%
8. Ownership	5.3%
9. Clear Vision & Objectives	2.9%
10. Hard-Working, Focused Staff	2.4%
Other	13.9%

Table 1. Project success factors [Standish Group, 1994]

Combined Factors (challenged – cancelled)	% of Responses (balanced average)
1. Incomplete Requirements & Specifications	12.9%
2. Lack of User Input or Involvement	12.5%
3. Changing Requirements & Specifications	10.8%
4. Lack of Executive Support	8%
5. Lack of Resources	7.8%
6. Unrealistic Expectations	7.2%
7. Technology Incompetence	6.1%
8. Unclear Objectives	3.6%
9. Unrealistic Time Frames	2.9%
10. Lack of Planning	2.6%
11. New Technology	2.5%
12. Didn't Need It Any Longer	2.4%
Other	20.7%

Table 2. Project failure factors, from [Standish Group, 1994]

**1.1.2 Engineering versus manufacturing stage optimization**

*If engineering and manufacturing play a role in industrial performance improvement, which of these two life-cycle stages do we have to optimize in order of priority?*

Considering the evolution of the economical aspects during a project in the manufacturing firms, the engineering stage is related to the manufacturing stage with a factor nine [Bellut S., 1990]: this means that any decision taken during the engineering stage (including industrialization stage) will have a financial consequence nine times deeper than a choice made in the manufacturing stage, as described in Figure 3.

The optimization of engineering (of which improvement issue is no older than half a century) could be nine times more relevant than the optimization of manufacturing (of which limits seem to be reached). Furthermore, the engineering stage in automotive industry has to survive what has been called by Lerat [Lerat J.-P., 2003]: “the second death of Henry Ford”. It means that instead of being ruled by the manufacturing rationalization, the development of new vehicle has to consider new approaches, more adapted to complex products engineering, in order to find new architectures.

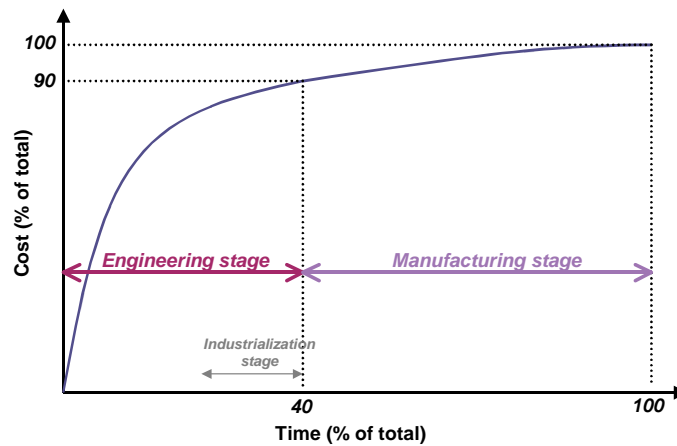

Figure 3. Costs involved by decisions taken during a development project

While hard sciences (as quantitative mathematic approaches) are frequently requested for manufacturing systems or product design and optimization, the development system design and optimization have to be supported by soft and qualitative approaches combining technical, managerial, economical, sociological and organizational skills, grouped under the term industrial engineering.

This confirms the importance of structured engineering approaches and confers an enthusiastic interest in deeply studying the development system that performs the engineering stage.

### ***1.1.3 Engineering approaches in the worldwide competition***

*Does engineering approaches could assist worldwide competition?*

The basic needs for a successful end product development (a new vehicle) concern its quality, cost, time to market and time to deliver, maintainability, security, retirement, ... It also has to be innovative and provide comfort functions. Nowadays, the vehicles are more and more compared to those of the concurrent firms, based on these characteristics. The increasing place of Japanese vehicle in the European market implies to search worldwide solutions to this worldwide issue.

One of the most relevant characteristic used in order to compare the car manufacturers performance is the development times. It measures the ability of a firm to quickly engineer new vehicles, providing the most attractive product for the customers.

According to a statement made at PSA Peugeot Citroën in Sept. 1998 [PSA,



1998], Figure 4 presents the classification of nine world car manufacturers, regarding the development times measured between the definitive choice of a shape (style) for the new vehicle and the start of its marketing.

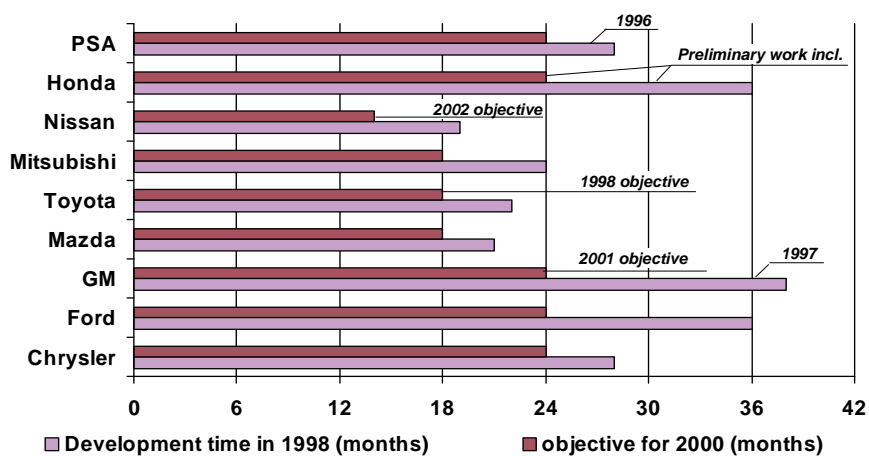

Figure 4. Development time's objectives

The superiority of the Japanese car manufacturers is crushing. The Toyota Production System must be here cited. The main idea is that the Japanese car manufacturers give first more interest to manufacturing systems constraints than market tendencies, in comparison with other car manufacturers.

Regarding PSA Peugeot Citroën, the objective for 2000 amounted to 2 years, *versus* 28 months in 1996 and 36 months in 1990. But these objectives were not sufficiently supported by rigorous approaches, and were very hard to reach, leading to frequent schedule overrun.

Every automotive companies are trying to reduce their development times to stay competitive, and they must design the best engineering approaches in order to structure their development planning and support their engineering performance improvement.

## **1.2 Industrial background: related objectives and issues**

PSA Peugeot Citroën is the 6<sup>th</sup> ranking global automotive group, characterized by one technical, industrial and financial potential serving the two marques Peugeot and Citroën.

### **1.2.1 Industrial needs**

The objective of PSA Peugeot Citroën is to achieve its “standard”<sup>4</sup> developments within 2 years only (as seen in Figure 3), in order to allow its ambitious commercial expectations. In 2000, the firm PSA planned 25 new models commercially launched between 2001 and 2004).

The 2 years objective is supported by a development planning (see Figure 5).

Approximately 4 000 PSA collaborators contribute by their activities directly (1 000) or indirectly to the design, development and industrialization of a new vehicle: a limited project team plans, evaluates and controls the technical processes (performed by the areas of expertise involved in automotive products and manufacturing systems engineering) and the contractual processes (performed by the acquisition department and supported by the areas of expertise).

Thus, the engineering master plan can be considered as the link between the strategic point of view of top managers and the operational point of view. It must ensure the coherence between the objectives and the available resources, and be in line with real practices of the engineering teams.

---

<sup>4</sup> the development is considered as a « standard » development when the new vehicle is expected to be developed on the basis of an existing engine and rolling structure.

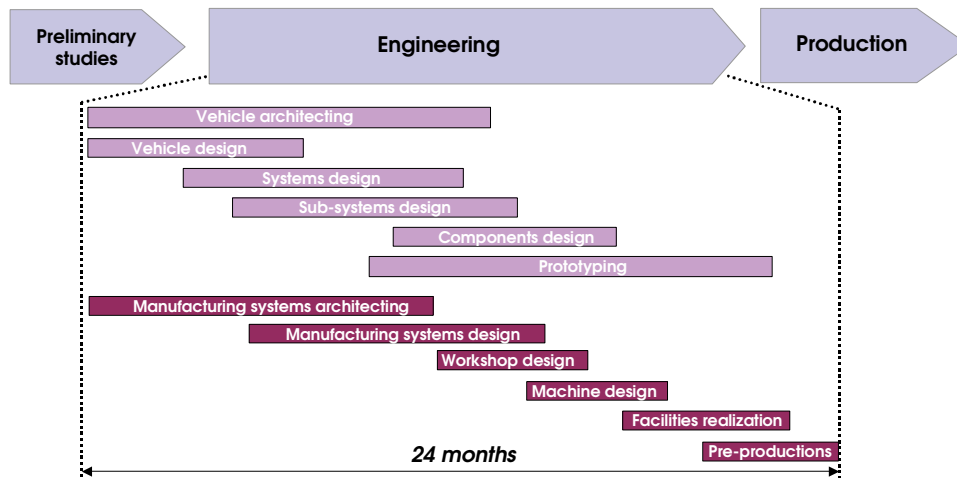

Figure 5. PSA Peugeot Citroën “standard” development planning

The planning depicted in Figure 5 would not be relevant without being structured and supported by well adjusted engineering design approaches, providing an efficient coordination of engineering through information control.

To ensure the awaited relevance, PSA Peugeot Citroën has progressively decided to deploy Systems Engineering in order to structure the engineering design process.

The industrial needs described in this section implies an objective for this Thesis, as well as any action of the team in charge of Automotive SE deployment.

The related objective is:

**- [O3] To get short term practical results while keeping a 10-15 years prospective vision.**

### **1.2.2 Detailing the industrial challenges**

The competition between car manufacturers induces a lot of challenges. The numerous concurrency and also benchmarks studies brought a line to follow in order to win the competition. Benchmarking usually concerns military, aeronautic and aerospace industries, because of the complexity of the products they have to develop.

#### **Vehicle complexity**

Nowadays, vehicles are increasingly complex notably due to the increasing number of electronic functions, for comfort and safety reasons. This

can also be measured studying the product architecture and the different ways to split it into sub-systems (according to the systemic, the modular or the integrated approaches). A resulting product complexity, due to the interaction between the parts of the product architecture, has also to be managed. This leads to the need of structured engineering approaches to manage these statements of complexity of organizations and products.

Furthermore, the market target of the car manufacturers cannot be compared to that one of the cited fields of industry. Customers are different and rules or standards do not have the same basis. The most noteworthy difference concerns the manufacturing domain.

As soon as a complex product is also characterized by a high diversity and high production volumes, with 3,5 million units worldwide expected in 2004, related manufacturing engineering becomes crucial and has to be successful. It is the case in the automotive industry.

### ***Manufacturing systems complexity***

Manufacturing systems are concerned by the increasing complexity of their control, the integration of innovative technologies, the integration of human factors, it also implies a complex mission due to the diversity of the products and the multiplicity of the projects. Manufacturing Systems contents are, for instance, production plans and schedules, manufacturing policies and procedures, manufacturing facilities, jigs, special tools and equipment, production processes and materials, production and assembly manuals, measuring devices, and manufacturing and procurement personnel, as enumerated in [EIA632, 1998]. A systemic definition of the manufacturing system could be the aggregation of all these contents, with dynamic interactions.

### ***Engineering complexity***

SE standard [EIA632, 1998] describes the relationship between a system and the related systems implied in each stage of the life-cycle. Those systems are called *enabling products* and their engineering may play a significant role in the engineering of the *end product*. Manufacturing systems engineering is one of the most important *enabling products* that constraint the engineering of a vehicle. The *production stage* plays a crucial role for the final cost and quality of the product. This leads to a kind of duality between product and manufacturing systems. In the *engineering stage*, the characteristics of the manufacturing systems engineering also bring many justifications: almost half of all the engineers of a company are concerned, it represents the major part of the

investments, it induces the main timing constraints, notably because of the manufacturing of the machine tools.

In this context, a global program has to combine the designs of product and the related manufacturing systems through considering manufacturing systems as systems to engineer, and rebalancing engineering coordination between automotive products and associated manufacturing systems.

The issue related to these three sections about complexity is: **to manage vehicle and manufacturing systems engineering complexity [I3].**

### ***Profusion of engineering approaches***

The automotive companies are trying to reduce their development times to stay competitive, finding relevant approaches to structure their development planning and improve their engineering performance.

The bibliographical research made for this Thesis has revealed the existence of an impressive number of available and upcoming approaches and related methods and tools supporting engineering design. But could this profusion be considered as a feather in one's cap?

To reduce time-to-market and usually to improve the engineering performance, academic and industry fields have developed numerous approaches in engineering design. A given company has for first challenge to create and define or select and adapt, and then implement the most relevant approaches and associated methods and tools.

The Systems Engineering approach, coming from aerospace and military industry and selected by PSA Peugeot Citroën, and the Concurrent Engineering approach, grouping numerous interesting researches and applications, should be cited (these approaches will be naturally detailed in this Thesis in Chap. 2: State of the art). This increasing "methodological interest" has led to what could be called an "engineering approaches" complexity, which can be considered as extra issue for the firms.

The related issue is: **to define the most efficient engineering approach, notably among the numerous existing methods and approaches [I4].**

### ***Deployment of engineering approaches: the change cultural challenge***

Even if the companies solve their "engineering approaches" complexity, notably through the definition of the theoretical interfaces between a given set of approaches, how the development system could concretely perform its work according to the methodological target?

The deployment of engineering approaches addresses a cultural challenge. Automotive industry is indeed a very recent field considering SE deployment. The actual way of thinking is really different than SE methodology, and the engineering teams succeed in developing new vehicles with the traditional engineering design methods. Despite the frequent project development schedule overruns, the economical success of the PSA Peugeot Citroën vehicles covers up the fact that the limits in term of complexity management are reached, needing new methods to work with.

Moreover, it is generally argued that the manufacturing cultures do not share the same objectives as in other SE cultures, as described in [Iliff R. C., 2002]. The areas of expertise in the product engineering domain are rather close to those of aerospace and electronic industry. They do not represent a crucial source of specificities. Conversely, the manufacturing engineering domain brings the most specific aspects, because of its areas of expertise, as those in charge of the engineering of the smelting processes, the painting processes, the body processes, the assembly processes, etc.

<p>The related issue is: <b>to take into account the heterogeneity and the specificities of the areas of expertise [15].</b></p>
--

## 1.3 Research area and scope

### 1.3.1 Designing a development system

#### Engineering approach in the development system

From the Systems Engineering point of view, the development system of a company can be seen like any other complex systems, as a kind of enabling system<sup>5</sup> that have to be designed in order to support the development stage of the end product. The development system is here also activated for the engineering of the manufacturing system.

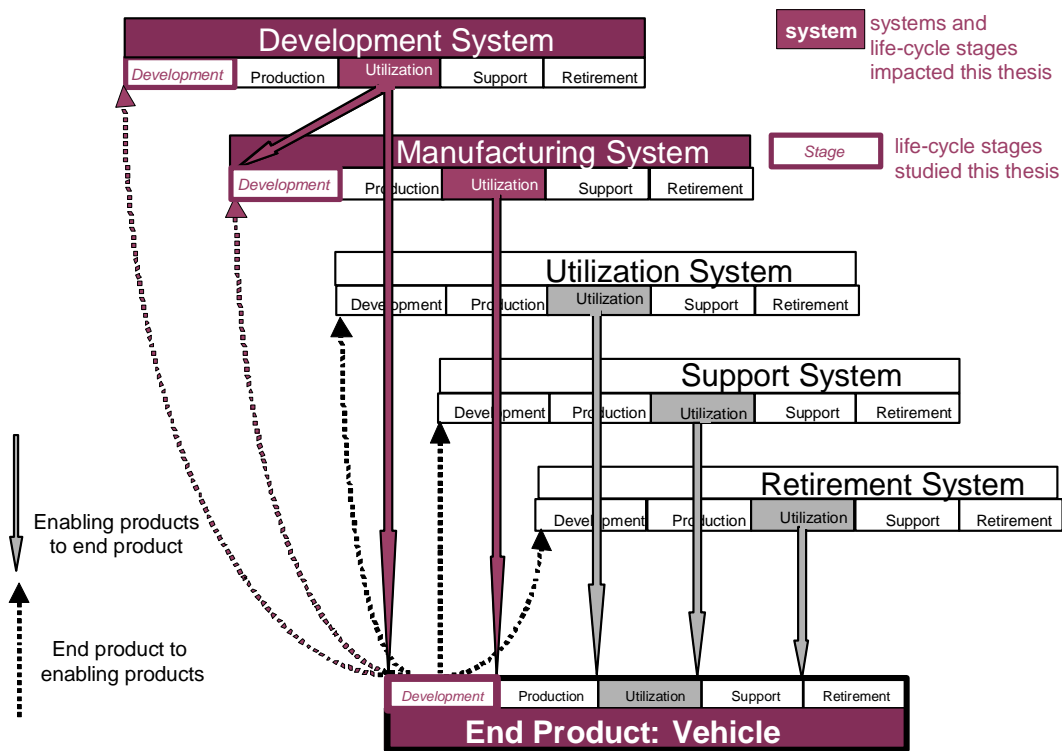

Figure 6. System interaction with typical enabling systems

The scope is represented by the purple area of the Figure 6 (adapted from [ISO15288, 2001]), presents. An engineering approach will have direct impacts

<sup>5</sup> An enabling system (ISO15288:2001) is a system that complements the system of interest (or end product, which is for us the vehicle) during its life-cycle stages but does not contribute directly to its functionality (e.g., when the system enters its production stage, an (enabling) production system is required).

on development and production of the end product, but also indirect impacts on the development of the development system.

### ***Transform the development system***

An illustration of a Systems Engineering (SE) transformation project in aircraft industry, regarding supporting tools for requirement engineering, has been reported by [Choveau E. and de Chazelles P., 2001], and confirmed by [Thomas J., 2002]. It considers the development system as an *enabling system* to assist, providing methods and tools to reach the methodological target described in the SE framework of the company. It is now argued by these Airbus SE teams that the appropriation<sup>6</sup> by operational is a key factor of success. They had to emphasize on the direct benefits for practical tasks of the proposed new way of doing. This confirms the importance of deployment actions supporting the cultural change challenge.

### ***Organizational and technical components***

Deployment of an engineering approach also addresses the issue of the gap between strategic and operational levels, providing intermediate views or models of the project and technical artifacts, as work breakdown structures, responsibility assignment matrix, product architectures, functional models, ... Thus, deployment of an engineering approach must ensure the link between organizational and technical approaches, for instance throughout projects organization and product architectures (e.g., [Oosterman B., 2001]).

## ***1.3.2 A generic approach considering life-cycle stages***

Considering the typical stages of a product life-cycle [ISO15288, 2001] (concept stage, development stage, production stage, utilization stage, support stage, retirement stage), the research is focused on the development stage, according to the statement made in section 1.1.2 entitled "Engineering versus manufacturing stage optimization". The technical processes performed during this stage are: engineering, implementation, integration, verification, transition, and validation. The Thesis focuses on engineering activities and necessary relationships between engineering and other technical processes, like integration, as explained in Figure 6.

The scope of "engineering" is vast and multidisciplinary. It regroups different expertise domains. Engineering of a system could imply a variety of

---

<sup>6</sup> Appropriation of a given approach means that the way the operational teams do their activities changes from target to usual.



mechanical, electronic, software, organizational and even sociological skills. Despite this variety of sub-fields, the aim is to keep a generic approach.

Each engineering design approach aims to improve the performance of the developments. But, only a limited part of research work is dedicated to generic approaches of engineering, as done by [Chen D. and Doumeingts G., 1998] and [Harani Y., 1997]. The lack of generic approaches in terms of engineering of products and related manufacturing systems is deeper. Numerous research works have led to optimal integrated design, but focusing only on a restricted number of areas of expertise in terms of manufacturing systems. This observation is confirmed by the implementations of these approaches (i.e. supported by tools), as seen in the field of Design For X (as Design for Manufacturing or Design for Assembly), with a lot of contributions specific to few areas of expertise, as for instance [Lee Rong-Schean, Chen Yuh-Min *et al.*, 1997] for molding systems, [Maropoulos P.G., Yao Z. *et al.*, 2000] for welding systems or [Zha X.F. and Dhu H., 2002] for assembly systems.

### **1.3.3      *A specific approach regarding systems***

The complete life-cycle of a system is increasingly taken into account during the engineering of the system (Cf. the title of SE Standard ISO 15 288, "System engineering - System life-cycle processes" [ISO15288, 2001]). Thus, the manufacturing systems are only one kind of the numerous types of systems that have to be engineered during a vehicle program.

Furthermore, PSA Peugeot Citroën engineering teams do not represent the whole engineering resources and forces acting in the development of new vehicles. The suppliers are increasingly involved for their engineering experiences and skills. PSA Peugeot Citroën is not only the designer of new products, but also the designer and the user of the related industrial systems, which will manufacture the vehicles. Therefore, the most relevant optimum PSA has to reach is the optimal coordination of products and related manufacturing systems engineering. Thus, this Thesis have studied in order of priority, a local optimum that may neither include the suppliers' work in terms of engineering nor the other systems to design. However, generic materials were found and developed in order to treat each system associated throughout the whole life-cycle stages. These advances are also valid regarding the relationship between PSA and its suppliers.

## 1.4 Research orientation

The research orientation is described and justified by the following Table, see the *Introduction* and previous section of *Chapter 1* to find detail about Issues and Objectives.

<i>Issues and Objectives</i>		<i>Items of the Thesis</i>		
I4	To define the most efficient engineering approach, notably among the numerous existing methods and approaches.	The selection and the description of a set of methods for their contribution to my goals.	§2.1, page 36	Literature review <i>State of the Art (S2)</i>
I3	To manage vehicle and manufacturing systems engineering complexity.	The description of SE and the justification of its benefits.	§2.2, page 47	
I2	To know how to realize performance measurement in the engineering field.	The selection and description of measurement approaches.	§2.3, page 54	
O1a	To develop an extended framework, that fully details the application of ASE to the production domain.	The construction of the first part of the extended ASE framework ( <i>eASE</i> ).	Chapter 3, page 63	Theoretical and practical contributions: <i>Action plan (S3,4,5 and 6)</i>
O1b	To develop an extended framework, that describes the engineering coordination of automotive products and related manufacturing systems.	The construction of the second part of the extended ASE framework ( <i>eASE</i> ).	Chapter 3, page 63	
O2a	To provide an engineering design process in order to enhance the improvement of the current engineering practices...	The extended ASE framework ( <i>eASE</i> ) Evaluation and Control process.	Chapter 4, page 77	
O2b	... whatever their initial level of performance could be.	The global <i>eASE</i> assessment process and a progressive local improvement, featuring notably roadmaps.	Chapter 4, page 77	
I5	To take into account the heterogeneity and the specificities of the areas of expertise.	The surveys made for: the ASE extension, the <i>eASE</i> Evaluation and Control and the <i>eASE</i> Deployment and Application.	Chapter 3, page 63 Chapter 4, page 77 Chapter 5, page 89	
O3	To get short term practical results while keeping a 10-15 years prospective vision.	The concrete <i>eASE</i> Deployment and Application process	Chapter 5, page 89	
I1	To prepare instrumentation aspects.	The integrated methods and tools approach for the <i>eASE</i> Instrumentation	Chapter 6, page 97	

Table 3. Mapping between {Objectives, Issues} and the items of the Thesis

## 1.5 Action plan

The action plan addresses the deployment process aiming to improve engineering performance. This process is build from an industrial and an academic point of views.

From an industrial point of view, the approach is analog to the implementation of CE described by [Singh K. J. and Lewis J. W., 1997]: the key to success lies in “managing for performance” through top-down institutional changes, standardized infrastructure and bottom-up implementations. The top-down changes are driven by the Automotive SE (ASE) framework, as a process model to follow. Standardization is realized through best practices and objectives in terms of product, process and organization models to achieve, in order to reach the ASE target. Each implementation is a part of an iterative process, starting from the identification of a potential bottom-up operational improvement.

From a more academic point of view, all these materials will be justified through the State of the Art, and the justifications added to the other chapters. The contributions to the existing Automotive Systems Engineering deployment have been introduced in [Lardeur E., Bocquet J.-C. *et al.*, 2001], and are described in Figure 7.

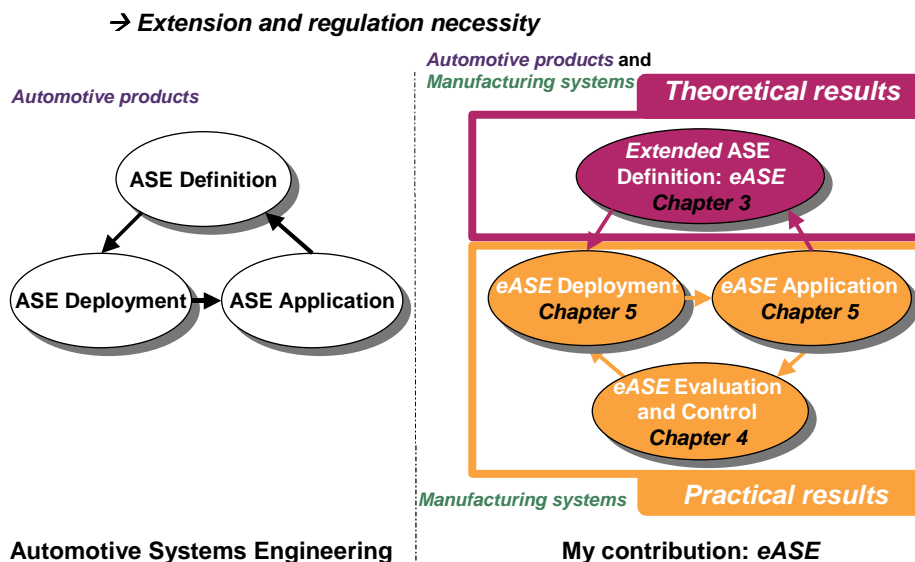

Figure 7. My contributions

Figure 7 shows how the extension necessity issue has led to an *extended Definition of Automotive SE*, and the regulation necessity issue to a *eASE Evaluation and Control* activity.

## Chapter 2. State of the art

---

The purpose of this state of the art is to introduce the standards and references available in the scientific literature for field of the research scope, emphasizing the key concepts supplying the research orientation.

First, the exploration of engineering design methods is presented, because of their filiations with Systems Engineering (SE). Then, the contents of the SE methodology are deeply explained. Next, the engineering performance measurement methods and tools are developed, notably with the introduction of the capability and maturity models, in line with the selection of SE and also the initial objectives in terms of performance measurement.

Figure 1 shows the relations between the items of this State of the art the activities of the action plan.

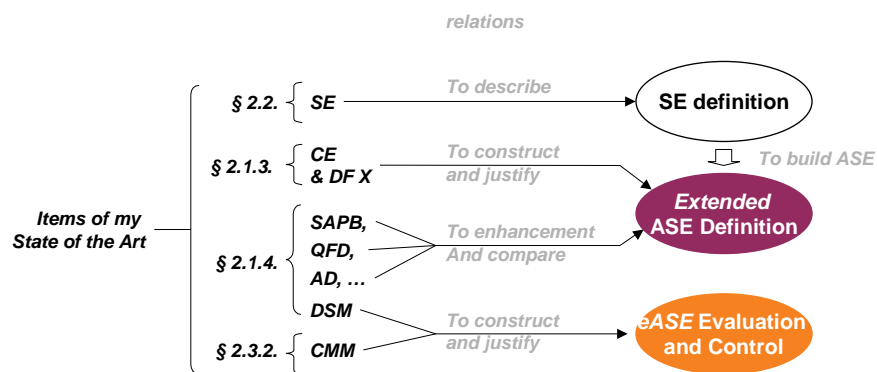

Figure 8. Items of the State of the Art

To conclude, this state of the art details the academic positioning.

## 2.1 Engineering methods and approaches

As seen in chapter 1, the industry faces several issues regarding engineering design, such as increasing complexity of products, world-wide competition, shorter time-to-market, etc... These issues address the need of improvement in terms of effectiveness and efficiency of existing engineering design processes, as it would be detailed in this chapter. Engineering design research aims at helping industry by developing approaches and methods in order to improve the interplay between design processes and their results, the design artifacts.

Engineering design concerns technical, managerial, organizational, economical and methodological points of view of the design and development of a system.

This section could have been entitled “process models for improving engineering design processes”, because any engineering design approach is related to a given process model<sup>7</sup>, which aims to improve the engineering design performance, using a set of methods that bring a value-added in terms of engineering or engineering deployment.

First, the theoretic relation between approaches and methods is described. Then, the large field of engineering design methods and approaches is explored, providing an overview of the variety of process models. Concurrent Engineering (CE) and Design for Manufacturing (DFM) are developed as the closest approaches for the **construction** and the **justification** of the theoretical results, notably identifying their contributions and their limits for the *eASE* framework (*extended Automotive Systems Engineering*). Next, a few other relevant models are presented, because of their potential contribution to eASE processes Definition or eASE Deployment and Application, by **enhancement** and **comparison**.

---

<sup>7</sup> A process models is an organized group of related activities that work together to create a result value [Hammer M. and Champy D., 1993]. Practices are effectively interrelated, and process modeling aims to a better understanding of what is and has to be done.

### **2.1.1 Approach and methods: head and muscles**

An “approach” is the way the process is built and the underlying objectives it is looking for. This concerns a strategic level. The covering of an “approach” is wide and concerns the global engineering design.

A “method” is a value-added item used during the engineering design, which transforms a defined set of inputs to a defined set of outputs. This concerns an operational level.

The covering of a “method” is restricted and concerns a local and focused design issue. The best definition of both terms could be inspired by the relationship they have each other. Considering a biological analogy, the “approach” would be the skeleton and the “methods” would be the muscles. The “approach” is characterized by a given cinematic behavior but muscles are necessary for the body to move.

This relationship would be used and detailed in the sub-section on methodological integration (see §2.2.2, page 51).

### **2.1.2 Different models for engineering design**

The engineering design has several different interpretations. The main differences between these interpretations will be detailed in this sub-section.

The literature provides several models that can be divided into many kind of models: descriptive and prescriptive models, phase-based or activity-based models, product-oriented or problem-oriented models, systematic or concurrent models, mono or multidisciplinary models, ...

#### ***Prescriptive – Descriptive classification***

Figure 9 introduces a set of models on the basis of the descriptive / prescriptive classification made from [Blessing L.T.M., 1996].

be. Another possible division of engineering design approaches could be the contrast between systematic models and concurrent models.

The choice of this classification among the others is restrictive, arbitrary and mainly justified by its contribution to the definition of Systems Engineering. The purpose is here to show the notions of which SE is made, because it is argue that SE is often limited to the “V cycle” presentation, despite the fact that SE process model covers a wider perimeter.

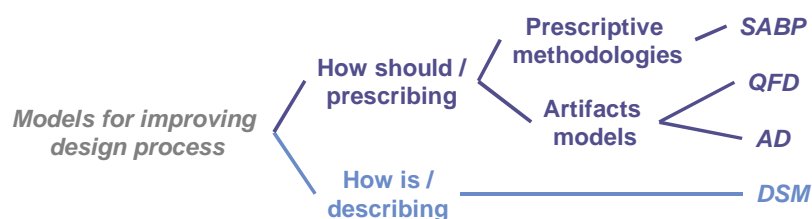

Figure 9. Relevant models through a descriptive / prescriptive classification

Descriptive models represent how design actually takes place. Prescriptive models represent effective and efficient design processes of how design should

Moreover, the relationship between a prescriptive model and a descriptive model will be deeply detailed, while studying the software instrumentation of the methodological principles, in chapter 6.

### ***Other interesting classifications and research contributions***

Regarding other types of classification, or contribution to a given approach, see the synthesis provided by [Tate D. and Nordlund M., 1996], dealing with the activity-based approach and the phase-based approach, and by [Tichkiewitch S. and Brissaud D., 2000], dealing with the professional-based approach. The work of [Tate D. and Nordlund M., 1996] must also be cited for their contribution on design approaches understanding, and the interesting synthesis in this field, made by [Oosterman B., 2001] or [Eynard B., Girard P. *et al.*, 1997] (*in French*).

Another complete side of research in the field of engineering design is the "Data-centered" approaches and other trends, i.e. the new technologies, the collaborative, the cooperative, the innovative and the knowledge based approaches. The collaborative and the cooperative views are increasingly taken into account to remedy the lack of CE approaches, based on the emergent communication technologies and the increasing problematic of knowledge sharing and capitalization. These trends lead to a new set of approaches, which are the combination of many existing models.

Existing work deals with coordination systems including product models and process models (and sometimes Manufacturing Systems models), supporting integrated design. The case studied by [Whitfield R. I., 2001] is an example, around the design coordination problematic of Alex Duffy, where manufacturing is still neglected. CIRP community produces several studies of integrated design focused on technical point of view of restricted area of expertise, as for instance assembly or molding. It contributes to solve the issue of design for manufacturing or design for assembly, ... . Gathering technical point of view and design coordination, the study made by [Tichkiewitch S. and

Brissaud D., 2000] describes the necessity of *coordination methods* in a concurrent engineering environment: an *activity-based* approach – provided for in this Thesis by SE – must be coupled with a *professionally-based* approach to build a coordination system. The study discusses an interesting typology of coordination systems base on different principles of coordination (for instance: *an optimum exists, an agreement can be reached, complexity must be managed globally, constraints can be expressed, ...*). Considering the fact that SE methodology has been constructed to follow many of these principles, SE could provide a well structured approach to coordinate engineering. This coordination problematic can be normalized through process models approaches. Several recent standards are based on a *process modeling* structure, in order to organize all the development tasks that have to be performed by a given enterprise.

French Ph.D. Thesis dealt about information systems supporting many kind of design processes: [Menand S., 2002] for knowledge based systems, [Bacha R., 2002] for engineering of production stage support and [Eynard B., 1999], for engineering pf product support These studies emphasize the importance of object oriented approach structuring information systems (see e.g., [Eynard B., Girard P. *et al.*, 1997]).

Cooperation and coordination of the Prosper CNRS program is mainly based on empirical studies (e.g., [Legardeur J., Merlo C. *et al.*, 2003]). Cooperation versus coordination is deepened by [Boujut J.-F. and Laureillard P., 2002], and the paper of [Boujut J.-F. and Blanco E., 2003] opens to the computer support approach in this field. A special focus on information systems notions is presented according to the systemic approaches by [Bernard J., 1992].



### **2.1.3 Relevant models to build the eASE Framework**

“Although the term *concurrent engineering* conveys different ideas to different people it generally signifies a more systematic and comprehensive way of planning and executing work so that all the needed input is collected and brought to bear on the task. Yesterday’s word for the same thing might have been *systems engineering*”.

K. J. Cleetus (see [Cleetus K.J., 1992])

This introductive quotation is extracted from the Concurrent Engineering Research Center technical report entitled “Definition of Concurrent Engineering”, written by Cleetus in 1992 (see [Cleetus K.J., 1992]).

The first sentence shows that *concurrent engineering* allows now a large number of different meanings. CE seems indeed to provide the automatic answer to any engineering design issue, according to its systematic usage as keyword in the scientific research literature. However, CE is not supported by any unique and shared standardization, and does not to provide a coherent way of thinking. These statements have lead to the paradox revealed by [Huang G. Q. and Sheldon D. F., 1993]: “If concurrent engineering is the answer, [we have unfortunately lost the notion of] what [was] the question?”

The second sentence introduces the term *systems engineering*. Cleetus probably ignore at this juncture what SE is expected to become for the industry. SE is effectively recent, according to its rise in the scientific research literature since the beginning of the 1990’s. SE could be viewed as a structured and standardized way to assure the fully integrated development and realization of products which meet stakeholders’ expectations (see [INCOSE and AIAA]). The SE standardization has been realized and promoted by many organizations acting in complex systems development. Some research works resort to SE definition and utilization to remedy the lack of CE or other existing engineering design approaches, notably the industrial study of [Loureiro G., Leaney P. G. *et al.*, 1999] in Ford company.

Any engineering design approach induces the use of a given set of selected design methods. The systemic approach underlined in SE enables this selection in an enterprise-wide point of view. This is one of the reason why the notion of *methodological integration* will be developed in order to illustrate SE.

## ***Concurrent Engineering***

### **Description of Concurrent Engineering:**

The CE description represents a large part of this state of the art. Actually, the theoretical principles have really been inspired by CE deployment experiences, notably because of the same “enterprise-wide” issues than those revealed by the emergence of CE.

CE environment allows multiple interpretations, which could blur any CE state of the art (see for instance the prolific work of [Banares-Alcantara R., 2000] or [Wunram M., 1999]).

For instance, the French language has multiple translations for “Concurrent Engineering”, emphasizing the fact that CE has numerous dimensions:

- “Concurrent”, mainly in order to show that activities are interrelated, because the results of these activities evolve jointly during the development process,
- “Simultaneous”, mainly in order to show that activities are performed in a parallel and iterative fashion,
- “Integrated”, mainly in order to show that activities lead to global optimization in terms of development solution.

Kusiak and Salomone use both terms concurrent and simultaneous (see [Kusiak A. and Park K., 1990], [Gu P. and Kusiak A., 1993] and [Salomone T.A., 1995]), while Preston White appends the term integrated (see [Preston White K. Jr., 1999]).

Definitions for concurrent engineering are also various. The two following definitions are selected because they providing together the most complete view of the different dimensions contained in CE.

According to Sohlenius (see [Sohlenius G., 1992]): « *Concurrent engineering is an expression for the ambition to increase the competitiveness by decreasing the lead time and still improving quality and cost. The main methodology is to integrate the product development and the development of the design and production process.* »

According to Cleetus (see [Cleetus K.J., 1992]): « *Concurrent Engineering is a systematic approach to integrated development of a product and its related processes that emphasizes response to customer expectations and embodies team values of cooperation, trust, and sharing in such a manner that decision making proceeds with large intervals of parallel working by all life-cycle perspectives, synchronized by comparatively brief exchanges to produce consensus.* »

Concurrent Engineering can be consequently viewed as a global approach regarding product, processes and organization.

**Contribution and limits of CE:**

According to Singh (see [Singh K. J. and Lewis J. W., 1997]), the key to success lies in “managing for performance”, through top-down *institutional* changes, standardized *infrastructure* and bottom-up incremental *implementation* of the new concepts.

The CE experiences provide numerous examples of deployment issues, combining implementation of design methods and design tools, and including organizational actions.

As said by Cleetus (see [Cleetus K.J., 1992]), “yesterday’s word for [concurrent engineering] might have been systems engineering”. Thus CE can be viewed as one of the essential basis for SE definition. This assumption is confirmed by the benefits of the Systems Engineering process in Concurrent Engineering, underlined by Matty (see [Matty G.E. Jr., 1995]). For instance, the role of the system engineer has been pointed out through the CE studies, and notably by Harding (see [Harding J.A. and Popplewell K., 1996]). CE studies refers now to a SE perspective as a way to implement CE environment (see e.g., [Kusiak A. and Larson N., 1999]).

The first limit is that CE does not provide indeed a complete process model as unique reference, as SE. It is a collection of interesting objectives and global improvement approaches, but too many works may refer to CE without being coherent together.

Furthermore, a complete part of CE studies seems to focus first on product engineering, including product life-cycle processes, but often neglecting the own engineering of the related systems, such as manufacturing system.

Nevertheless, the other part of CE studies deal with Design for Manufacturing approach, in line with CE approaches.

Now DFM has to be explored, in order to complete the positioning of SE regarding the treatment of manufacturing design issues.

## ***Design For X***

### **Description of Design for X:**

Product specification focuses first in customers needs. However, these needs are not sufficient to solve all the specific design issues of a given system. Design for X is a concept that has emerged, where the letter "X" represents the other characteristics or design objectives needed to engineer a product, such as reliability, robustness, serviceability, environmental impact, manufacturability, changeover or even disassembly. Design for manufacturing (DFM) is the most common of DFX methodologies, which directly address the manufacturing cost to the product design. As an extension, design for assembly (DFA) emphasized on assembly process.

As seen for other specific approaches, DF X requires cross-functional teams, gathering multidisciplinary competencies.

Based on the fact the DFM can be viewed as an illustration of DF X, DFM will only be detailed in order to treat the different cases of DF X approaches.

The DFM methodology is performed throughout the development process, and aims to estimate and then reduce manufacturing costs (of components, of assembly and of supporting production. The typical process of DFM methods includes also impact studies, in order to control engineering changes it induces on the product (see [Ulrich K.T. and Eppinger S.D., 1995]).

Reducing manufacturing costs implies to understand the process design. Key techniques are for instance: standardization of components, redesigning product to reduce the number of manufacturing operations, minimizing complexity.

### **Using DF X for Concurrent Engineering:**

Despite the fact that Ulrich and Eppinger (see [Ulrich K.T. and Eppinger S.D., 1995]) present the DFM as an autonomous approach to improve product design and development, number of others publications present the DFM as the natural continuity of CE (see e.g., [Salomone T.A., 1995] and [Preston White K. Jr., 1999]). This statement contributes to blur CE aims and scope.

The following view of the relationship between DF X and CE could be here suggested, which aims to be more neutral: *"From DF X to "DF •(Xi)" where Xi could represent all the different DF Xs initiatives"*.

As seen with the design for manufacture and assembly (DFMA) (see [Edwards K.L., 2002]), extensions of DF X to "DF •(Xi)", the more integrated the Xi design objective is, the more concurrent are the engineering processes.

From restricted and dedicated project phases to an integrated process model that earliest take any Xi objectives into account (i.e. using DF X to enhance CE environment)

A SE point of view of DFM contribution (see [Preston White K. Jr., 1999]), may show that DF X approaches could lead to several activities and rules, disseminated through the engineering processes from the beginning to the end of product design activities.

Thus, a wider technical scope and a wider temporal integration of DF X approaches would lead to a more efficient contribution to Concurrent Engineering environment.

**Contributions and limits of DF X:**

A DF X approach could promote the technical and economical importance of what implies the "X" for the product development. The SE requirement analysis approaches are trying to involve the whole systems solicited during the product life-cycle, distinguishing product and process requirements (see [Abadi C. D. and Bahil T., 2002]), and relevant with the DF X approaches.

Thus DFM have to be promoted in order to introduce the manufacturing point of view in the product design teams.

The first limit is that teams would be composed of at least 30 members (the 16 areas of expertise and also the experts each technology or synthesis domain of the product design). It will lead to organizational issues.

Furthermore, the DF X addresses too specific constraints, and does not allow to consider the developments of manufacturing systems as themselves.

A generic process model including several areas of expertise in the manufacturing domain has to be defined, in order to reach a more dynamic interaction between product engineering and manufacturing systems engineering.

Concurrent Engineering and DFM provide key basis for the SE explanation and extension. These approaches deals with implementation issues and associated collaborative, virtual, information technology issue and invite us explore these aspects more deeply.

### **2.1.4 Models potentially contributing to SE**

A tools taxonomy, as a set of methods supporting the Systems Engineering process, is proposed by Oliver (see [Oliver D. W., 1995]). This study confirms the role played by a selection of models in the SE definition, deployment and application.

Systematic Approach of Pahl and Beitz, Quality Function Deployment and Axiomatic Design are here introduced, as methods or approaches providing relevant notions and potential contributions according to the research orientations. Others methods could also have been more precisely introduced, but their interest in terms of contribution and explanation of SE were more limited than those chosen.

To conclude, the Design Structure Matrix technique is presented, because of its potential role for further research work.

#### ***Interest of the Systematic Approach of Pahl & Beitz***

According to [Blessing L.T.M., 1996], the prescriptive methodologies have common features, as the division into three major stages: problem definition, conceptual design and detail design. A logical sequence of tasks enable to drive the design process, in the systematic approach designed by [Pahl G. and Beitz W., 1996] that mainly concerns the field of mechanical engineering.

#### ***Quality Function Deployment method (QFD)***

Numerous papers are dealing with the use of QFD in a Systems Engineering context. For instance, the link between SE and QFD is deeply studied in the paper of [Clausing D. and Cohen L., 1999], and QFD has been practically used in Ford Company, as seen in the paper of [Loureiro G., Leaney P. G. *et al.*, 1999].

#### ***Axiomatic Design***

Axiomatic Design has been derived production systems design. The application to the manufacturing engineering domain has been developed by [Reynal V. A., 1998]. It is more briefly presented by [Cochran D. S. and Reynal V. A., 1997], focusing on design and evaluation of manufacturing system design. Many research have been produced at MIT (Massachusetts Institute of Technology) in this field, gathered by the notion of *Production System Design* framework, detailed by [Kuest K. M., 1999], [Kim Y.-S., 1999] and [Ali M., 1997]. This framework enables to connect manufacturing design objectives to

operation design parameters, focusing on design of operations, i.e. the architectural design of the manufacturing systems.

Axiomatic Design could also focus other fields in engineering design, like reliability, as studied by [Arcidiacono G., 2000].

The interest of Axiomatic Design to enhance a Systems Engineering environment will be detailed in section 2.2.2, page 51.

### ***Other methods***

The potential contributions of design methods to SE processes will be detailed (see Table 5, page 52), based on various surveys and references about Value Analysis, Functional Analysis (FAST), TRIZ (ARIZ), Robust Design, FMECA Analysis and Preliminary Risk Analysis & Fault and Event Trees.

### ***Use of Design Structure Matrix***

The fundamental notions of DSM have been established by [Whitney Daniel E., 1990]. DSM has been practically used in Ford Motor Company, as seen in the paper of [Qi D. and Berry P.W., 2003]. The work of [Browning T. R., 1998] about the link between DSM and Concurrent Engineering must be here cited. DSM technique could also deal with engineering processes, as taught by [Browning T. R., Fricke E. *et al.*, 2003], in their tutorial during INCOSE symposiums.

Even though this technique has not been applied, it appears as a good answer for the two aspects it deal with: technique improvement, and process improvement. The conclusion about DSM is that such technique could be applied, according to the work of the DSM organization, increasingly developed in SE community and especially in the automotive industry.

DSM limits according to the objective are the following (shared by [Oosterman B., 2001]): it seems difficult to enact the validity of the interactions, which support and configure further improvements. The exchange of information seems not enough accurate to enable the improvement of practical situations.

## 2.2 Systems Engineering

The bibliographical investigation leads to the conclusion that *Systems Engineering* does practically not appear in the references that are not openly dedicated to SE community. Inversely, the more academic papers from SE community deal with existing engineering design theories. However, SE is historically based on these theories. This is the reason why the large field of engineering design approaches has been previously explored. Moreover, the SE implementation in a company can - partially or entirely - feed of their contents. This explain why the methodological integration point of view will be used in order to describe SE.

### 2.2.1 *SE description*

Regarding the SE presentation, the theoretical advances are starting from existing considerable theoretical results: the company had already began the definition and deployment of SE to the vehicle engineering. A framework already exists, and the theoretical contributions will be presented according to this precious basis.

SE is deployed as an entire design methodology, used to engineer, realize and integrate the products and the related manufacturing systems.

SE describes a maximalist<sup>8</sup> view of all the processes performed to develop a complex system, considering his entire life-cycle and systems consequently implied<sup>9</sup>, based on a structural decomposition of the system into sub-systems and including the project management.

The whole description should include enterprise processes, project processes and technical processes performed by a given organization, and agreement processes between two organizations.

---

<sup>8</sup> all the tasks required to develop a system are described in the processes, with a sufficient level of abstraction to be as well understood by all of the engineers, from any dept. they come.

<sup>9</sup> the *enabling systems* are any system that provides the means for any stages of the *system of interest's* life-cycle (development, production, test, deployment, training, support and disposal). SE can also be applied to the *enabling systems*, therefore treated as a new *system of interest* - depending on their complexity.



Here, priority has been given to the technical processes, more related with concrete work of engineers. But the chosen way to describe a generic and complete framework of the design process can be considered as a mix of:

- activity-based and phase-based models<sup>10</sup> (details can be read in [Tate D., 1999]), which prompts us to describe related processes,
- prescriptive and descriptive models, which allow a professional-based approach.

Focusing on system design, four technical processes of SE are *directly* concerned: Stakeholders Needs Definition Process, Requirement Analysis Process and Architectural Design Process composed of Logical Design Process and Physical Design Process. These four processes divide design in 4 domains (Needs, Requirements, Functions, Components).

*Mapping* and *zigzagging* can be done between all these domains. About *mapping*, the implementation of SE currently advocates the use of matrix to ensure traceability of engineering's data and have a visual control of the coupling between them. About *zigzagging*, the approach concerns first the functional and the physical decomposition, where sub-systems are defined, to which the processes are applied with recursiveness.

This didactical introduction of SE technical processes is inspired by the notion of *mapping* and *zigzagging* in Axiomatic Design (see next section).

SE describes a view of all the processes that have to be performed in order to engineer and develop a complex system, considering its complete life cycle.

In Figure 10, the whole description of SE build from the [ISO15288, 2000] description includes four types of processes: enterprise processes, project processes and technical processes performed by a given organization, and agreement processes between two organizations. All the tasks required to develop a system are entirely described in these processes, as shown in [EIA632, 1998] or [IEEE1220, 1995]. Engineers from any area of expertise can adapt it. It allows to combine an activity-based approach and a professional-based approach, according to [Tichkiewitch S. and Brissaud D., 2000].

---

<sup>10</sup> So SE is able to help us providing to the organization the (emerging) new model of the design process needed - as written by Derrick Tate - to "*accurately [describe] the sequence of activities performed and [...] to guide designers more effectively*".

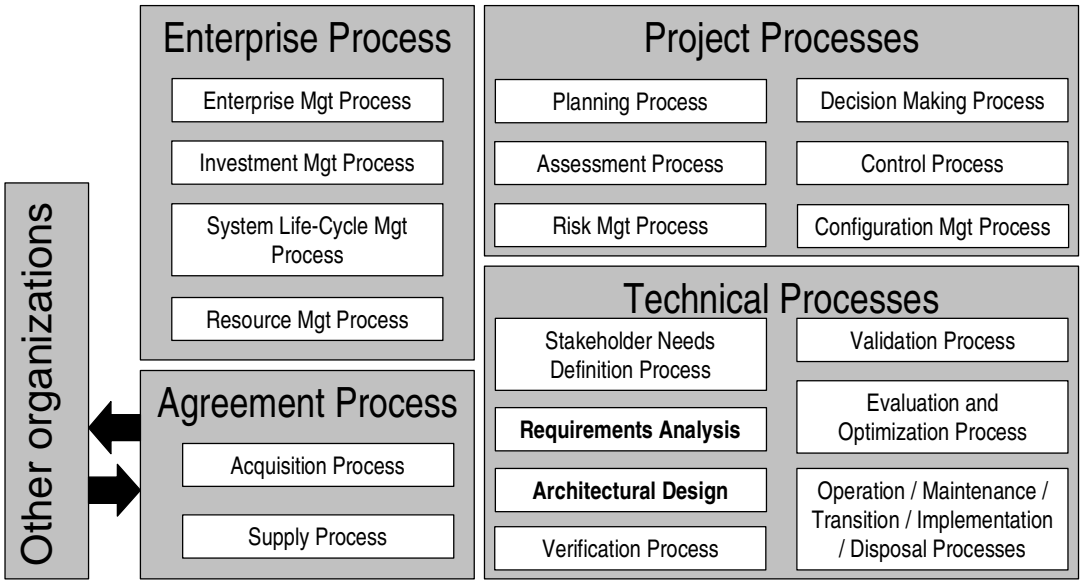

Figure 10. Processes for Engineering a System

The development programs are detailed on the basis of the *Hierarchical System Structure (HSS)* of the system, resulting from the Simon’s hierarchical concept in [Simon H.A., 1981]. The *HSS* represents an architectural design result: for each level, systems are split into sub-systems as new design boundaries. It induces the organization of the project management, through building blocks, matching the product architecture and the organization, as developed in [Oosterman B., 2001] and also described in [EIA632, 1998], and as shown in Figure 11.

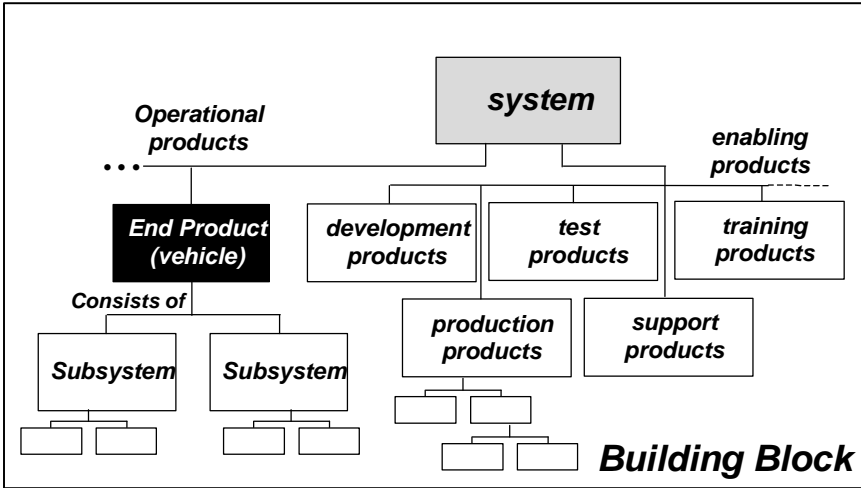

Figure 11. Building Block in EIA 632

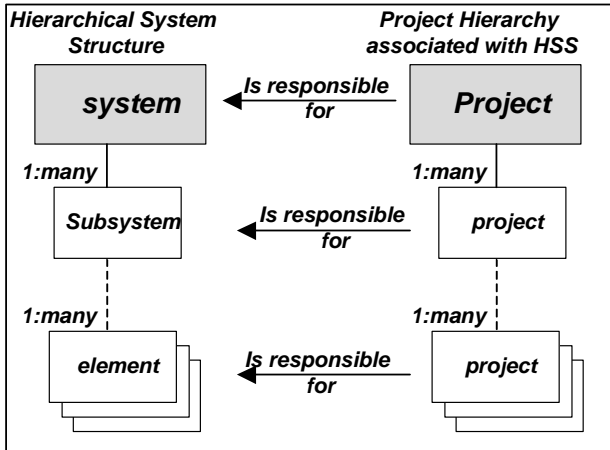

Figure 12. Mapping between Project hierarchy and Hierarchical System Structure

The item (systems) of a *HSS* consists in design boundaries that lead to the creation or the adaptation of the systems. The engineering of each system of both *HSSs* are described with iteration of the two major technical activities of SE – Requirements Analysis and Architectural Design.

This presentation is expressly succinct: to learn more practically the contents of SE, see the illustration of the extended Automotive SE application given in Chapter 3.1.

To complete SE contents description, many descriptions on differences and mutual enhancement between SE methodology and existing design methods are available in [Preston White K. Jr., 1998], and through the methodological integration point of view in [Lardeur E., Bocquet J.-C. *et al.*, 2002], which provides a mapping between SE processes and existing design methods. This explains why the methodological integration notion is here detailed.

## 2.2.2 *The Methodological Integration*

SE cannot be considered as others design methods, but rather a way to deploy best practices around the entire description of the engineering processes. Considering only 4 essential phases, also called *four C* (collect, create, construct and product), [Cavallucci D. and Lutz P., 2000] replaces 8 design methods (through the contents of each methods described by phases too). The designer should be able to increase the relevance of his project with a minimum number of changes to his design habits.

### ***Feeding SE's Processes with existing theories and methods***

The methodological integration point of view has been explored, where design processes are restricted to a few essential phase. Considering now that the company framework already provides a detailed description of the logical order of design tasks, the early hypotheses of methodological integration must be revised.

This study is based on the survey of existing methods of the chapter 2 state of the art of Cavallucci (see [Cavallucci D., 1999]), on a selection of papers from SE community is listed in Table 4, and on the detailed description of the processes. Table 5 gives an idea of potential contributions of design methods to SE processes.

<i>Design Methods</i>	<i>References from INCOSE Symposia for further details</i>
Value Analysis & Functional Analysis (FAST)	SE as model making [Tronstad Y. D., 1995] & function analysis and decomposition using Function Analysis Systems Technique [Wixson J. R., 1999]
TRIZ (ARIZ)	The Systematic Methodology of Inventive Problem Solving - TRIZ: a review [Savransky S. D., 1999]
QFD	A SE approach to optimize customer satisfaction on complex systems [Lakey P. B., 1995]
Axiomatic Design & Robust Design	Lessons Learned Teaching Systems Engineering to Practicing Engineers with Mixed Backgrounds [Boppe C. W., 1999]
FMECA Analysis	Failure management and the design of complex systems [Fisher J., 1995]
Prel. Risk Analysis & Fault and Event Trees	Life-cycle risk management [Brekka L. T., 1995]
Design Structure Matrix	Enabling changes in systems throughout the entire life-cycle – key to success? [Schulz A. P., Clausing D. <i>et al.</i> , 1999]

Table 4. Reference for examples of concrete contributions (applications)

<i>Design Methods</i>	Needs Definition	Requirements Analysis	Functional Design	Physical Design	Verif. & Valid.	Eval. & Opt.
Functional Analysis		✓✓	✓✓			
Value Analysis	✓	✓	✓✓	✓		✓✓
TRIZ (ARIZ)		✓	✓✓	✓		✓
QFD	✓✓	✓✓		✓		✓
Axiomatic Design		✓✓	✓✓	✓✓		✓
Robust Design	✓	✓		✓	✓✓	✓✓
FMEC Analysis				✓✓		
Prel. Risk Analysis		✓	✓			
Fault and Event Trees			✓	✓		
Design Structure Matrix			✓✓			✓✓
...						

Table 5. Potential Contributions of Design Methods to Technical Processes in SE

Three types of marks identify where a design method, as described in Table 6:

<i>Contribution of the method</i>	imperative	desirable	no contribution
Marks	✓✓	✓	<i>empty boxes</i>

Table 6. Type of marks for methods contribution

*Automotive products, Manufacturing systems or both?*

The interest of this approach is not restricted to the production of an *intelligent* toolbox of design methods. As described in quoted references, direct benefits can be extracted considering focal points and coverage of methods.

Identifying exactly which tasks call a method, how, why, etc. also gives their consistency to SE Design Processes and is a way to increase performance of development.

“Feeding” SE with existing design methods is not a one-way view, both will enhance mutually.

### ***Mutual enhancement SE – Design Methods***

The three design processes of SE give birth to four domains: Needs, Requirements, Functional domain and Physical domain.

As done in Axiomatic Design (AD), *mapping* and *zigzagging* can be done among all these domains.

Too much specificities and disparities of knowledge and practices are faced here to be able to describe exactly how to do the decompositions. Furthermore, Needs and Requirements aren't yet treated with explicit decomposition.

A very schematic simultaneous description of each method brings a good idea of the similarities, as shown in Figure 13.

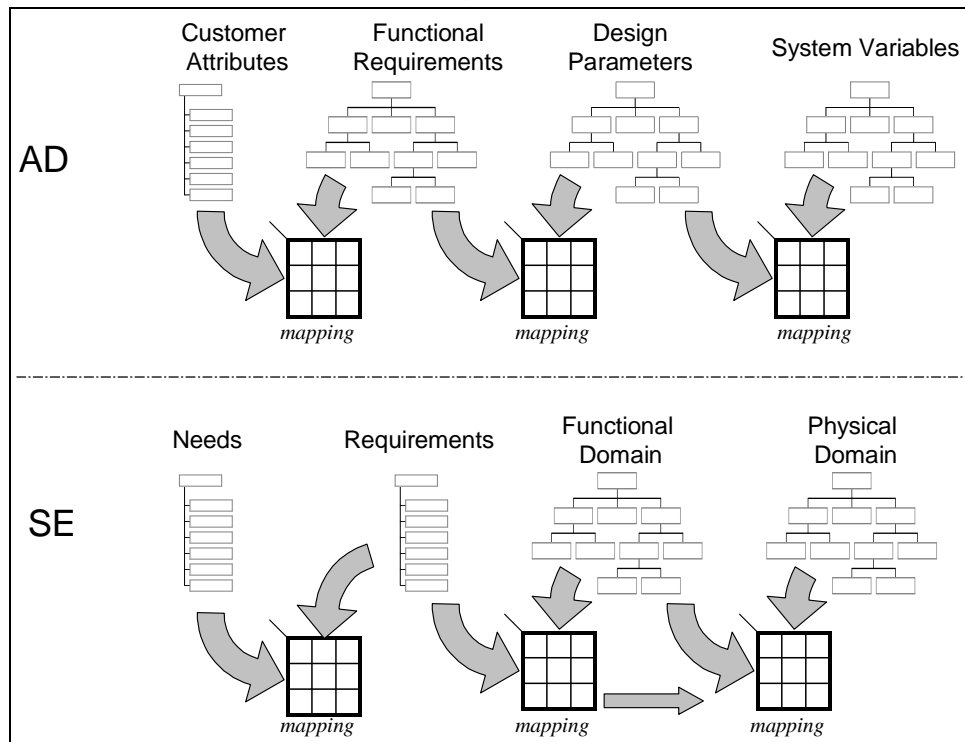

Figure 13. Very schematic comparison of AD and SE

SE can therefore partially take advantage of AD: Two major benefits can be respectively found exploring the introduction in SE of AD uses of *mapping* and *zigzagging*. The first benefit comes from the greater use of AD's *design matrix* analysis and the second by formalizing and improving *zigzagging* in each discipline.

On the other hand, AD's actual efforts in hierarchical decomposition [Cochran D. S., Eversheim W. *et al.*, 2000] can be supported by SE concepts, including Technical Processes, as for instance the Implementation Process.

## 2.3 Engineering performance measurement

There are many approaches regarding assessment techniques. The differences come from the various problematic of decision-making, supported by several approaches, such as rational, probabilistic and psychological approaches, leading to different techniques. Thus, the most powerful performance measurement approach seems to be a controlled combination of various techniques (see [AFIS, 1999]).

The issue is here to design the best assessment process: the engineering performance amelioration consists in improving the engineering practices, done more efficiently with: optimized resources use, reduced development times, controlled costs and defined quality level. Such improvement is crucial for any firm to remain competitive.

The elaboration of performance metrics and the coercion of operational teams into working in line with the Thesis results and systems engineering methods could have been the research process. A research performed tight with operational issues have been rather done, in order to build more relevant metrics, but above all in order to give for these operational teams instantaneous benefits from the research work.

Furthermore, engineering performance improvement is not a part of the quality insurance process. This explain why this research is not restricted to the definition and application of engineering indicators, but also address the transformation of the real engineering practices, provided through self-designed specific processes, as deployment of SE for methods aspects or integrated approach for tools aspects.

Moreover, because of the variety of products or manufacturing systems, the product performance is not directly treated, as studied very deeply by [Yannou B., 2001] but also process performance, because of the methodological target to reach.

To conclude this introduction, design process models are linked to engineering approaches, as underlined by [Eynard B., Girard P. *et al.*, 1997], emphasizing on the importance of process models to improve engineering. The approaches of [Lorino P., 1995], have here to be cited in the field of Process Models guidance. An engineering approach can always be associated with a related process model.

### **2.3.1 Performance assessment approaches**

Proceed as done at the firm Looked Martin<sup>11</sup> in order to assess SE benefits was here simply not possible: starting simultaneously two “blind projects”, with the same resources and the same objectives, but using SE or other methods. SE project has revealed deeply more efficient.

#### **Absolute measure versus relative comparison approaches.**

Two different approaches are available for performance assessment: based on “*absolute*” measures of the **characteristics of the practices**, or based on “*relative*” comparison of the practices themselves to **standardized practices**.

Regarding **characteristics of a practice**, dashboards are the most usual tool to support any measurement approach, especially as soon as the aim of the assessment is to enable control of considered practices [Fernandez A., 1999]. The items concerned by any assessment can be taken from the components of a cross view combining the three decomposition levels of a system: strategic, informational or operational, and regarding the products, the processes or the organizations.

Regarding **standardized practices**, models have emerged that are dedicated to the assessment of capability and maturity of a given set of practices. The improvement can be achieved through the definition and the application of the development process models, pursuant to the capability and maturity models.

Because of SE context, the *relative* comparison approach has been chosen and will be deeply detailed.

#### **Efficiency versus effectiveness assessment.**

Differences between efficiency and effectiveness have been studied in [Perrin J., 1999], and J.M. Hazebroucq, author of a Ph.D. Thesis dealing with performance in project management (see [Hazebroucq J.M., 1992]), has underlined the notion of efficiency to complete the notion of effectiveness (see also [Hazebroucq J.M., 1999]).

In the field of engineering design, the *effectiveness* is related to the performance of the design result, and the *efficiency* is related to the performance of the design process. For the successive reasons explained in the introduction of this section, the Thesis will focus only on engineering *efficiency*, notably because my work deals with Process Models.

---

<sup>11</sup> Looked Martin is known as the first firm that reached the CMM level 5.



### **2.3.2 Capability and Maturity Model (CMM)**

According to the literature available in the SE network, CMM seems to provide the most efficient models for performance assessment and consequently for performance improvement. The *integrated* CMM is born thanks to one of the first INCOSE initiative [INCOSE, 1996].

Capability Maturity Model™ Integration (CMMI<sup>12</sup>) aims to pursue enterprise-wide process improvement.

The CMMI project comes from the Systems Engineering context. It has been sponsored by U.S. Department of Defense (DoD), involving a large number of organizations throughout the world. This project consisted in the gathering of the previous CMMs sources into a CMMI framework and a CMMI model [CMMI, 2000] to support performance improvement and integration activities in companies.

The three sources models are: (1) Capability Maturity Model for Software (SW-CMM), (2) Electronic Industries Alliance/Interim Standard (EIA/IS) 731, and (3) Integrated Product Development Capability Maturity Model (IPD-CMM). Although the previous discipline-specific models have proven useful to many organizations, the use of multiple models was problematic. Thus, a model that successfully integrates disciplines and has integrated assessment support would solve this problem.

CMMI is also consistent and compatible with International Organization for Standardization/International Electro-technical Commission (ISO/IEC) 15504 (see [CMM, 1998] for details). The need of a global consistence and coherence of models has been confirmed and discussed in [Pollak B., 1998].

CMMI projects evolve, toward an increasingly integrated model. The research work is based on the most recent reference available in 2002, i.e. version 1.0., which is the version that founded the selected Micro Assessment Guide of SECATT. The research work has not been up-dated in conformance with the evolution from version 1.0. to 1.1.. Despite this lack of “configuration management” conscientiousness, it is decided to detail the contents of the CMMI model according to the latest version (i.e. version 1.1. [CMMI, 2003]) and especially from its poster version that could provide an efficient CMM tool.

#### **Contents of CMMI**

CMMI supports two different representations: staged and continuous. The components of both representations are Process Areas (listed and numbered for

---

<sup>12</sup> CMMI is a service mark of Carnegie Mellon University

instance in Table 9), specific goals, specific practices, generic goals, generic practices, sub-practices, typical work products, discipline amplifications, generic practices elaborations, and references.

CMMI may focus on four discipline-specific models: SE (Systems Engineering), SW (Software Engineering), IPPD (Integrated Product and Process Development) or SS (Supplier Sourcing).

A Maturity Level is a combination of  $n$  listed PAs (from process management, project management, engineering or support domains).

	Maturity Level 2	ML 3	ML 4	ML 5
Process Areas	$n_2$ * PAs <sup>13</sup>	$n_3$ * PAs	$n_4$ * PAs	$n_5$ * PAs
CL 5	Generic Goals and associated Generic Practices for CL 5			
CL 4	GGs – GPs (CL4)			
CL 3	GGs – GPs (CL3)			
CL 2	GGs – GPs (CL2)			
Capability Level 1	GGs – GPs (CL1)			
	List of Specific Goals related to each Process Area			
	(Sub-)List of Specific Practices associated to the Specific Goal			

Table 7. Articulation of CMMI model components

The specific goals organize specific practices and the generic goals organize generic practices. Each specific and generic practice corresponds to a capability level. Specific goals and specific practices apply to individual process areas. Generic goals and generic practices apply to multiple process areas. The generic goals and generic practices define a sequence of capability levels that represent improvements in the implementation and effectiveness of all the processes to improve.

CMMI models are designed to describe discrete levels of process improvement, throughout two kind of representation: staged and continuous. These two points of view come from the way different sources were previously build [Cusick K., 1996].

The staged representation [CMMI, 2002a] provides a sequence of improvements, beginning with basic management practices and progressing through a predefined path of successive levels. Each level serves as a base for the next one. This representation enables organizations comparison based on maturity levels taken as scale and providing single ratings between sub-parts of the organization, such as project teams or areas of expertise.

---

<sup>13</sup>  $n_i$  represents the number of PAs related to a the maturity level number “i”

The continuous representation [CMMI, 2002b] allows to select an order of improvement that best meets a given set of business objectives. It enables organizations comparisons, process area by process area, based on results through the use of equivalent staging.

A synthesis is depicted in Table 8 that shows the difference between both representations in terms of performance improvement point of view: what items are the inputs according to the assessment objectives, and what items are improved as outputs.

Representation	Staged	Continuous
Inputs (objectives)	Through targeted Maturity Level in given <b>Process Areas</b>	All <b>Process Areas</b>
Outputs	<b>Generic Practices</b> improvements via standardized improvements processes, related to Generic Goals	Specific practices and <b>Generic Practices</b> improvements via Capability Level improvement

Table 8. Comparison between Staged and Continuous CMM representations

The importance of the role played, in both representations, by the linkage between **Process Areas** and **Generic Practices**, must be emphasized.

Choice between staged and continuous representations and choice of a discipline-specific model induce the cultural issues faced for any technology transition.

Actually, neither the choice between staged and continuous representations, because of these “cultural reasons”, nor the differences between discipline-specific models will not be faced and considered. Systems Engineering is quite unfamiliar at PSA Peugeot Citroën, and especially in the manufacturing systems domain.

Moreover, because previous CMM references are not yet implemented in automotive industry, the research work is not concerned by the existing relationship between sources of CMMI and its result, as staged or continuous representations, which provide respectively a easier transition from SW-CMM for staged representation, and EIA/IS 731 or ISO/IEC 15504 for continuous representation.

Thus, cultural and scope reasons lead to the use of lighter references, supporting CMMI® concepts.

**Micro Assessment Kit of SECAT LCC®**

The Micro Assessment Kit of SECAT LCC is divided into three pocket guides, dedicated to three roles contributing to the Systems Engineering success of the company: the Program Manager, the Systems Engineer and the

Organizational Leader. An information guide details the objectives of the pocket guides, presentation and instructions.

The Micro Assessment Kit has its own traceability to the Systems Engineering CMM. It only emphasizes the lower improvement levels (see , in , where stages 4 and 5 are almost not concerned).

PA#14. Improve Org. Std SE Process	.	.				<i>Stage</i>
PA#08. Ensure Quality	.	.			<i>Stage</i>	5
PA#17. Provide Skills & Knowledge	.	.	.	.	4	
PA#16. Manage SE Support Environment	.	.	<i>Stage</i>	.		
PA#15. Manage Product Line Evolution	.	.	3	.		
PA#13. Define Org. Std. SE Process		.				
PA#12. Plan Technical Effort	.	.	.	.		
PA#11. Monitor and Control Tech. Effort	.	<i>Stage</i>	.	.		
PA#10. Manage Risk	.	2	.	.		
PA#09. Manage Configuration	.	.	.	.		
PA#04. Integrate Disciplines	.	.	.	.		
PA#18. Coordinate work / suppliers	.	.	.	.		
PA#07. Verify and Validate System	.	.	.	.		
PA#06. Understand customer needs...	<i>Stage</i>	.	.	.		
PA#05. Integrate System	1	.	.	.		
PA#03. Evolve System Architecture	.	.	.	.		
PA#02. Derive & Allocate Requirements	.	.	.	.		
PA#01. Analyze Candidate Solutions	.	.	.	.		
<i>CMM Level</i>	1	2	3		4	5

Table 9. Top level traceability between CMM and SECAT LCC  
Pocket Guides

Each pocket guide is composed of about forty questions. Answers are recorded in a “progress scorecard”, with the following scoring method:

- 0, when the task does not happen or does not generate useful result,
- 1, when the task is occasionally performed or generates useful results,
- 2, when the task is performed and consistently produces useful results,
- n/a, when the task is not applicable now.

Based on the results for each pocket guide, worksheets are provided in the information guide, in order to calculate a single number “improvement stage” score. Answers are reported for each Stage, from the three pocket guide to a recapitulating table, with the restrictive scoring methods “yes” or “no”. The “improvement stage” score is the ratio between the sum of “yes” and the sum of “yes” plus the sum of “no”.

### ***Systems Engineering discipline misunderstanding***

A major benefit of Pocket Guides is that no SE experience or even specific knowledge is required. Systems Engineering is an often misunderstood discipline, notably because its own glossary, very far from usual ones, especially in mechanical engineering field. This series of Pocket Guides clearly defines what must be done for effective systems engineering to be practiced within an organization.

Individuals can evaluate themselves against the CMM® Pocket Guides, tracking their own performance using the progress score sheets in the back of every Pocket Guide. They can periodically, possibly once per month or once per quarter, ask themselves the questions in their Pocket Guide and see if they are performing the practices on their program or across programs as appropriate. They can track how their answers change, and use it to identify where they are weak and have an opportunity for improvement.

### ***Contributions and limits of CMM and Pocket Guides***

CMM and Pocket Guides are here chosen to support only “one quarter” of the total engineering performance assessment field, as described in Table 10:

	<i>Absolute measure</i>	<i>Relative comparison</i>
Effectiveness		
Efficiency		X

Table 10. Selected assessment approach

The specific choice of focusing on engineering *efficiency* measured by *relative* comparison to standardized practices leads to following drawbacks. First, Process Areas (PA) definitions may vary through the different sources models. The major drawback is that neither the listed sources models nor CMMI does provide a simple framework, and it is globally excluded to work for operational teams with such references (representing every time more than 600 pages). The aim is not to train designers to apply so complex and numerous criteria to their work.

CMM and Pocket Guides seems to provide a practical results, but still not pertinent for an engineering domain where Systems Engineering is unfamiliar or even unknown.

Thus, an adaptation will be necessary to lead any assessment.

## 2.4 Academic positioning

A benchmark extended to academic research and to traditional engineering fields has been provided. A state of the art of engineering design methods has been notably built, which provide an essential and almost first bridge between SE community and others industrial and academic communities.

The research scope is here shared by many industrial and research community, such as International Council on Systems Engineering and its annual symposium, Design Society and the International Conference on Engineering Design), CIRP and its Design Seminar, American Society of Mechanical Engineers and the Design Engineering Technical conferences), or PRIMECA (the French software resources for mechanical engineering pole) and its International Conference on Integrated Design and Manufacturing in Mechanical Engineering. These institutions belong to different networks.

This Ph.D. study proposes a first bridge between SE and other design methods, and related communities. Despite the fact that SE is based on existing theories. SE is not usually mentioned in other references. They are not openly dedicated to the SE community. Few articles from the SE community deal explicitly with existing design theories, as seen with the Systems Engineering interpretation of the DFM methodology [Preston White K. Jr., 1999].

The area of interest of the Annual Symposiums of the International Council on Systems Engineering (INCOSE): "SE Application, Modeling & Simulation, SE Management, System Analysis/Process, Measurement and Education/Standards" shows similarities with "Design Research, Design Management, Design Methods and Design Application (Industry & Education)" which are the areas of interest of the International Conference on Engineering Design (ICED). The main difference seems to be that SE focuses more on Industry than on Research.

The positioning of my research work is depicted in Table 11, page 62 which introduces some of the most interesting conferences of the research domain, and lists our contributions.

To conclude, a set of publication have been selected, detailing an approach based on the SE process model as a optimal balance between descriptive / prescriptive approaches, systematic / concurrent approaches, (re)building a bridge between different academic and industrial research networks. The methodological integration point of view is used mainly because of the nature of the SE process model, open to specific methods.

Existing methods and approaches will not be directly enhanced by such research work, because it focuses only on SE improvement. But such work could provide a indirect mutual enhancement.

Considering indeed common standpoints of design processes, studies on methodological integration only deal with essential phases of design: the “four C”: collect, create, construct and product, for Cavallucci [Cavallucci D. and Lutz P., 2000]; and a *minimalist* design process for Martin [Martin C., 2001].

SE provides a wider description of engineering processes, improving the interest of such a methodological integration.

<i>Scope</i>	<i>Conference</i>	<i>Publication</i>
<b>Systems Engineering</b>	International Council On SE (INCOSE) Symposium and the Systems Engineering Journal	[Lardeur E. and Auzet C., 2003] [Lardeur E., Auzet C. <i>et al.</i> , 2003a] [Lardeur E., Auzet C. <i>et al.</i> , 2003b]
	European SE Conference (EUSEC) and “Conférence de l’Association Française d’IS” (AFIS)	[Lardeur E., Bocquet J.-C. <i>et al.</i> , 2001]
<b>Industrial Engineering</b>	International CIRP Design Seminar of the International Institution for Production Research	[Lardeur E., Auzet C. <i>et al.</i> , 2003c]
	Integrated Design and Manufacturing in Mechanical Engineering (IDMME) conference and the book Recent advances in IDMME	[Lardeur E., Bocquet J.-C. <i>et al.</i> , 2002] [Lardeur E., Bocquet J.-C. <i>et al.</i> , 2003a]
	International Conference on Concurrent Enterprising (ICE)	[Lardeur E., Bocquet J.-C. <i>et al.</i> , 2003b]
	International Conference on Concurrent Engineering (CE)	- <i>a publication could be planned</i>
	“Colloque national du Pôle de Ressources Informatiques pour la Mécanique” (PRIMECA)	[Lardeur E., Bocquet J.-C. <i>et al.</i> , 2003c]
<b>Design</b>	Design Engineering Technical Conference and Design Theory and Methodology Conference of the American Society of Mechanical Engineers (ASME / DETC & DTM)	- <i>a publication could be planned</i>
	The Transaction on Systems, Man and Cybernetics, Computing Engineering in Systems Application of the Institute of Electrical and Electronics Engineers (IEEE / CESA)	[Lardeur E. and Longueville B., 2003] <i>(Invited Session)</i>
	International Conference on Engineering Design (ICED) of the Design Society	- <i>a publication could be planned, but maybe too focused on product design only</i>

Table 11. Contributions synthesis, illustration of my positioning

## **Chapter 3. Automotive SE extension: *eASE***

---

The purpose of this chapter is to present the extension of the existing Automotive Systems Engineering framework of PSA Peugeot Citroën. The theoretical advances have led to what is called the *eASE* framework, for *extended Automotive Systems Engineering* framework.

First, the extension of the application of the ASE framework to the manufacturing systems development is described. It takes the specific aspects of the production domain into account. This extension is illustrated by a didactic example of a staple-remover manufacturing systems engineering. This first theoretical contribution enables to build an integrated framework for the coordination of automotive products and related manufacturing systems. This coordination framework is detailed and then illustrated by the same didactic example. Some details about the perspectives opened by the chapter concludes it.



## **3.1 Applicability to Manufacturing Systems**

### ***Actual PSA Peugeot Citroen SE Framework***

Actual Automotive SE Framework is described notably from SE standards [ISO15288, 2000] and [EIA632, 1998], in a set of internal and confidential documents, and still evolve to be increasingly exhaustive.

[Auzet C., 1999], represents the master “ASE Document” that ensure the technical coherence of the complete PSA Peugeot Citroën ASE Framework. Many documents have been written after this one, emphasizing on the various ASE Processes (see Figure 10. Processes for Engineering a System, page 49).

These documents are parts of a collection called “Guide for Automotive Systems Engineering”. The aim of this set of guides is to describe the methodological target. Each document contains the purpose, the concepts, the description of the process and associated helpful methods, and is completed by a template when it is required. Each document is written by a different member of the ASE deployment team, according to the required expertise. This documentation is the reference for ASE deployment, it represents the ASE definition activity. Any document has been verified, enhanced and validated by a working group of experts of the company. I was always involved in the review process of the documents, as the other ASE deployment team members.

The fact that the coherence has been preserved despite the widening of the ASE framework and the increasing number of successful application of ASE brings another proof of the ASE efficiency and consistency.

This documentation is also supported by a training program, through different focus and level of complexity, depending on the role of the participants in the company: technicians, engineers of a given domain (e.g., product or manufacturing systems) a given area of expertise, or managers.

### ***Getting specific aspects from manufacturing systems domain***

The specific information can be typically provided by reading the repositories of a given area of expertise or interrogating its experts. This implies the use of a questionnaire, which also pertains to the current engineering practices. Such questionnaire aims to identify the specific aspects of generic activities. After collecting all the specific aspects, a better understanding of the heterogeneity allows to define a generic engineering design approach, compatible with the specific engineering practices.

This explains the evaluation questionnaire (see Chapter 4) has been used in order to collect additional information. This elaboration process ensures the relevance of the theoretical advances according to the real engineering practices of the engineering teams.

### ***Theoretical aspects of eASE for manufacturing systems***

The following text is not company specific. It has been written before the document [Auzet C. and Lardeur E., 2003], which is now the reference document for any application in the company.

A common framework, provided by SE, where processes regarding Manufacturing Systems Development as well as Product Development are described, gives a new approach to describe data exchange between engineering tasks.

This example shows eASE principles and only concerns the first level of decomposition, in spite of SE's interest to drive design of all levels.

The *staple remover* design gave the followings results and choices :

- product physical decomposition (See Figure 14),
- choices of followings materials and processes (based on feasibility and cost analysis studies, called by E & O (Evaluation and Optimization) and V & V (Verification and Validation) technical support processes of the product design): (*make*) cutting and stamping stainless steel, extruding plastic, riveting plastic grip and metallic tooth, riveting parts into final product; (*buy*) springs, rivets (two sizes), plastic bars, steel rolls,
- choices of followings principles : same plastic grips for each L and U-parts and same riveting.

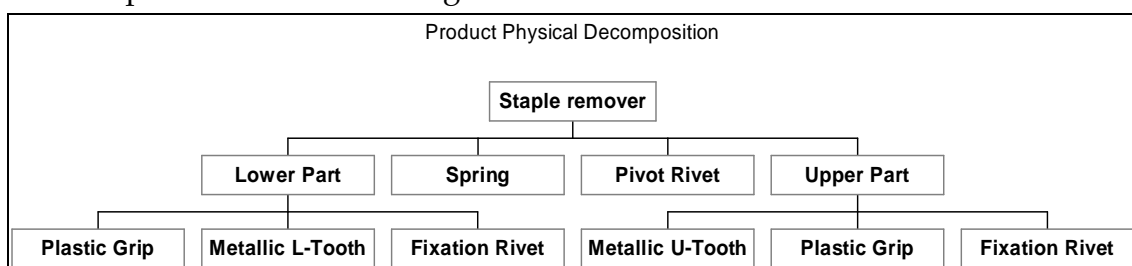

Figure 14. Staple remover physical decomposition

This decomposition can be transformed as shown in Figure 15, and constitutes a source of requirements, complemented by others stakeholders needs and including product design choices. Allocations of requirements to functions can consequently be done, and some constraints can directly affect components (See Figure 15).

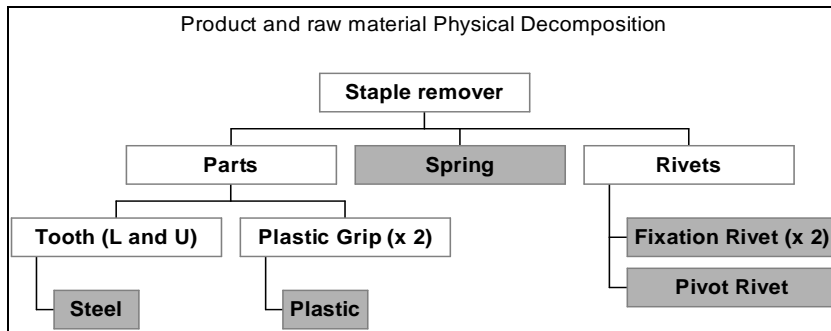

Figure 15. Up-upgraded staple remover physical decomposition

Products that are physically present in the manufacturing system are taken with requirements and results of functional analysis to construct the logical architecture of the production system, introduced in Figure 16.

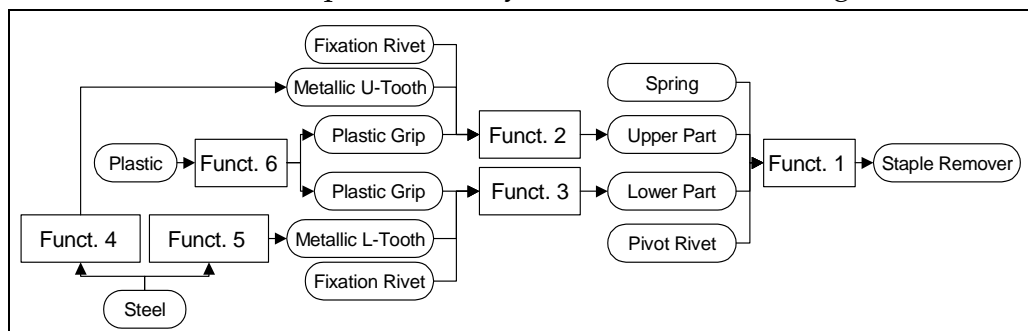

Figure 16. Logical Architecture, with macro-functions

Functions are initially determined by requirements, and logical decomposition is driven with possibility of allocation of a function to a feasible organic solution. The matrix of Functions and components of the manufacturing system is given in Figure 17 .

	Components Conveyors	Positioning Machine	Pivot Riveting Machine	Rivet Conveyors	Flexible Fixation Machine	Metal Conveyors	Flexible Riveting Machine	Plastic Stamp Cell	Extrusion Machine	Functions	Sectors
Rivet Teeth			x							Funct. 1	Assembly
Supply Pivot Rivets	x										
Place Teeth and Spring		x									
Supply U-Teeth	x										
Supply L-Teeth	x										
Supply Springs	x								Funct. 2 & 3	Sub-Assembly	
Fix Grip to Metal Part				x							
Supply Fixation Rivets			x						Funct. 4 & 5	Metal	
Stamp Steel (2 types)						x					
Cut Steel						x					
Unroll Steel						x					
Supply Steel Rolls					x						
Extrude Plastic								x	Funct. 6	Plastic	
Supply Plastic							x				

Figure 17. Allocation Matrix of Functions and Components

Considering the first level of decomposition will lead us to the flow chart of Figure 18.

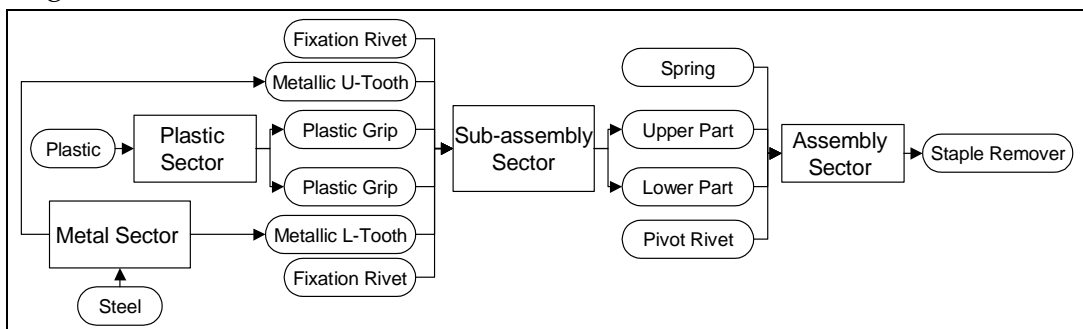

Figure 18. Physical Architecture, with sub-systems (sectors)

Evaluation & Optimization and Verification & Validation processes can be performed at each level of design to ensure efficiency. Technical processes of SE can also be done (they have started with all valid information of upper level) to sub-systems, including emergent properties of design and maintaining the traceability of engineering data.

In this field, as a specific document, the Technical Specification template for manufacturing systems requirement engineering has been built, made with support of a working group members.

### 3.2 eASE for coordination of engineering

The following concepts are not company specific (Illustrations regarding PSA Peugeot Citroën are presented in the next section). It has been written before the document [Auzet C. and Lardeur E., 2003], which is now the reference document for any application in the company.

For confidential reasons, the theoretical contributions presentation is here restricted, notably the whole advances held in the company are not presented, regarding a more accurate description of systems into two types of artifacts.

#### 3.2.1 Methodological concepts

As shown in Figure 10. Processes for Engineering a System, page 49, processes for engineering a system are divided into four types. Table 12 identifies these four types by their ability to be applied distinctly or commonly to the Products and/or the Production Systems.

Type of Processes	distinctly	commonly	common or distinct "objects"
Enterprise Processes		✓	resources and investments.
Agreement Processes	✓		contracts.
Project Processes		✓	teams, delays, risks, decisions and information.
Technical Processes	✓		technical documents, models and artifacts.

Table 12. Distinction or community principles for the processes

Technical and Agreement processes provide a generic description and can be distinctly applied to Product and Production Systems. The role of Enterprise and Project processes is to bring coordination in the development of Products and Production Systems needed to produce them.

It also seems necessary to characterize in the whole technical tasks realized by a development team those that belong or contribute to Products, Productions Systems or both. The four *Knowledge Areas* of the PMBOK Guide [PMBOK, 1996] and the description of the *Project Management Context* are directly concerned with establishing a link between Product Systems and Production Systems, as shown in Table 13.

Of course, links are more complicated than described in Table 13: for instance Risk Quantification, where risks concern simultaneously Products and Production Systems, cannot be restricted to an additive or multiplicative link.

Items of PMBoK	Link between Products and Production Systems
<i>Project Coordination (in Project Management Context)</i>	Multi-projects and Development Team Coordination through Enterprise Organization
<i>Project Integration Management</i>	Project Plan Development
<i>Project Time Management</i>	Activity Sequencing, Schedule Development and Control
<i>Project Communication Management</i>	Information Distribution
<i>Project Risk Management</i>	Risk Identification and Risk Quantification

Table 13. Management Links between Products and Production Systems development

The coordination engineering data between developers is also technically very complex and must be described in SE with the best practices known in Concurrent Engineering, to ensure wide information distribution, especially in terms of coordination.

The research work of [Marle F., 2002a] provides good reference to concludes this justification. Among the whole links existing in the project management field, he has identified seven kind of links: hierarchy, resources, sequence, contribution, influence, similitude and exchange (see also the publication of [Marle F., 2002b] in English). The basic SE methodology leans on these links, such as *hierarchy* in Hierarchical Systems Structure. The need of coordination could be supported by *exchange* and *influence* links

### **3.2.2 *eASE* coordination framework**

#### ***Coordination framework construction: artifacts, natures of processes, links***

First, the analysis of Table 12 shows two kind of artifacts to handle with, regarding an end product and related enabling systems (for instance automotive product and manufacturing systems):

- Processes applied commonly to systems require a previously identification of these systems, because they are indeed the artifacts to handle with,
- Processes applied distinctly to different systems imply to create links between applications of these processes to the system, an activity performed for a given system is indeed the artifact to handle with.

Second, because of the nature of the SE processes, and referring to Figure 10, which presents the adaptation of the [ISO15288, 2001] cartography, the coordination, in the field of engineering, is only effective when performing the

project processes. Therefore a coordination can be materialized for project processes, and enterprise processes or agreement processes do not contain any coordination ability. A more detailed coordination link concerns activities: technical processes contain the activities performed for the systems (the application of a given systems engineering process), and are managed by the project processes. This lead to two type of links: between **systems** and **activities**.

Third, engineering data also deal with the results of the application of the processes. This justifies a third type of link, supporting these results. Among the different results created through the application of SE processes, only one kind of activity lead to representations combining end product **and** related enabling products: the technical activities of the enabling product (e.g. the manufacturing systems engineering design, where products to forge, to paint, to assemble, etc. must be represented or modeled). Thus, a third type of link is modeled between automotive product and manufacturing systems, regarding manufacturing systems engineering only.

This topology of links is therefore justified by taxonomical aspects, by construction. The utilization of the links (what does any link enable for engineering coordination) also justifies this topology.

**The first level of link**

The description and the management of the first level of link enable to **plan and control the engineering**. The connections between systems of each HSS can be planed *a priori* in order to plan and control an entire program. Project managers can refer to the frame shown in Figure 19, where arrows represent the links: the exchange of a type of information (the value of which is as yet unknown) between two levels of the broken down systems form each *hierarchical system structure*.

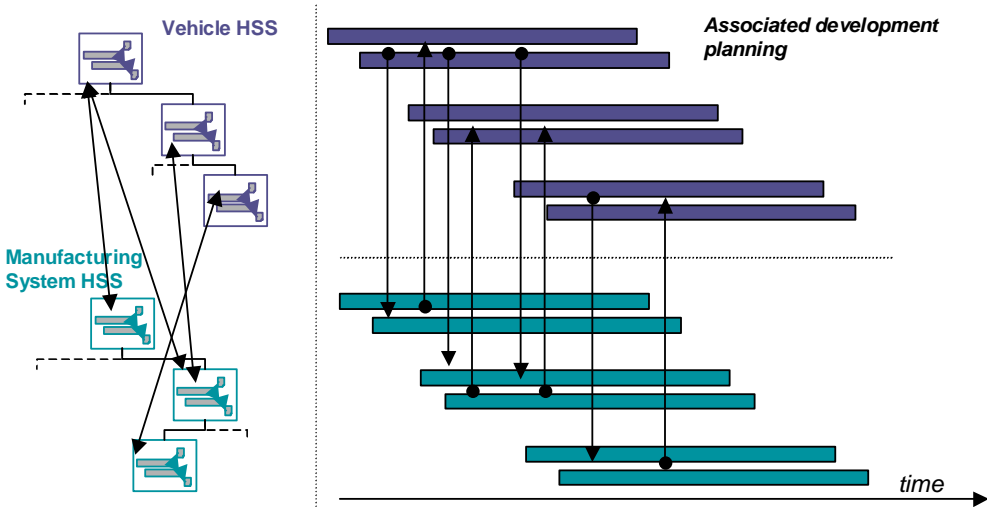

Figure 19. The first level of link

This first link is refined when the engineering of the product or the manufacturing system is performed. As soon as the architectures are found, this link becomes a relation between defined systems of each *hierarchical system structure* and targeted information exchange (still not assigned a value) could be planned.

### **The second level of link**

The second level of link is induced by the relations described with the first level of link. The description and the management of these links enable us to optimize concretely the simultaneous engineering of product and related manufacturing systems in real terms. Exchange of information must occur between the distinct technical tasks of each system. Information flow will function as a trigger or a simple entry of the activities or as a result to be transmitted to other activities. The bold arrows in Figure 20 describe a kind of link, between requirements analysis and architectural design tasks of a product and a related production system.

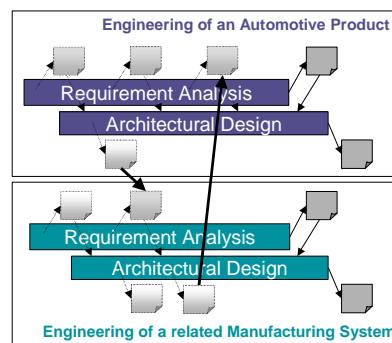

Figure 20. The second level of link (excerpt between technical tasks)

As described in [EIA632, 1998], an essential contribution of *enabling product* design for *end product* design is located in requirements engineering. This point of view can be confirmed: requirement analysis of the *end product* provides the source of information acquired from each *enabling products*. However, a description of engineering, as architectural design of the *enabling products* was neglected in this standard. A model of coordination can now be suggested.

Real values must be considered, because they introduce feasibility and timing constraints.

### **The third level of link**

The third level of link is asymmetric. It is the area where manufacturing system engineering results are optimized. This link enables us to **optimize the**



**manufacturing system.** The engineering of the product is not directly concerned. This third type of link is described in the result of the architectural design process with logical or physical representation of the manufacturing system.

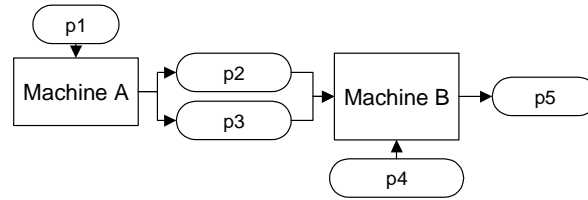

Figure 21. the third level of link

Figure 21 shows a physical architecture of a manufacturing system, where p1, p2, p3, p4 , p5 are the products, Machine A and B are the components of the manufacturing system, and the arrows between machines and products are the third type of link.

To give an illustration of the Thesis approach, the elementary example of the engineering of a staple remover and its associated manufacturing system is presented in the next section.

### 3.3 Illustration of *eASE* for engineering coordination

This partial example shows *eASE* principles applied to the engineering of a staple remover. The engineering of the manufacturing system of the staple remover has already been presented in previous sections.

As a second part of application, the implementation of the new coordination framework is here described in the same example

In this example, the following *HSSs*, are shown in Figure 22:

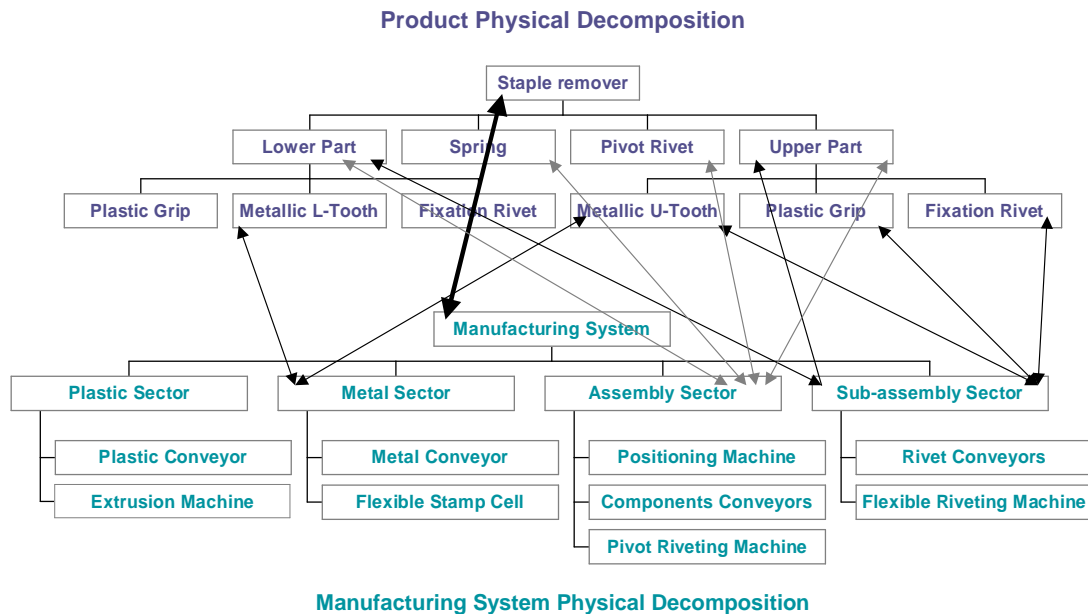

Figure 22. Illustration of the first level of link

Each association between product and production systems can be managed as a connection between systems of each *hierarchical system structure*. This is the first type of link. Each link can be planned as an information to obtain at one date in order to drive the program. Figure 7 is a partial representation where the bold arrow shows the initial link between the staple remover and its manufacturing system, the gray arrows show the links for the assembly sectors and the others arrows are used for some other illustrations.

This information is assigned values in the second type of link. As done in Figure 23, a planning of this program could be built, technically based on SE (i.e. considering Requirements Analysis and Architectural Design and the iterative progression of the engineering through *hierarchical system structures*). Expressed by level of systems, a schedule could be drawn that conduces to the well known “V” representation (“descendant” engineering branch only, integration activities must be represented in order to draw the climbing branch of the “V”).

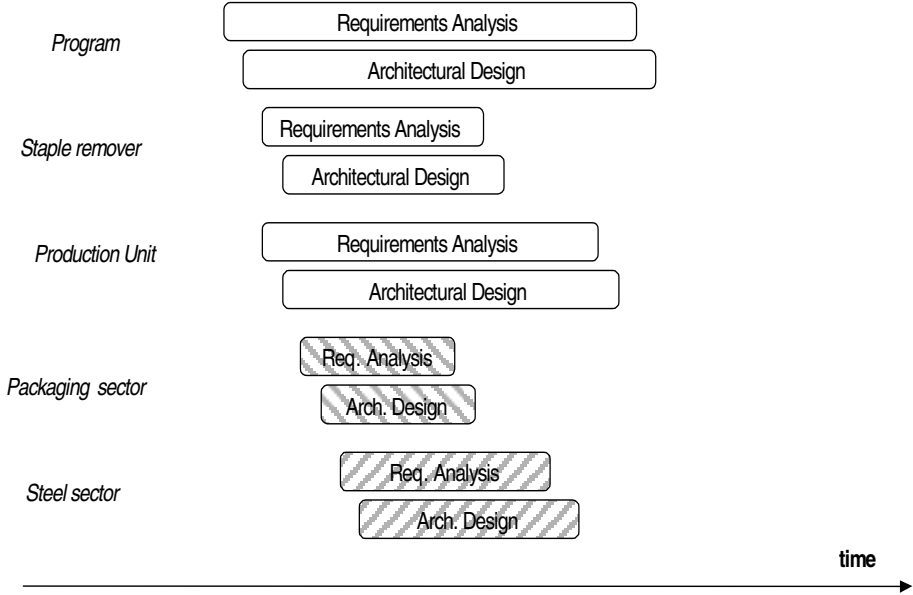

Figure 23. Temporal planning of the program

This temporal planning shows the high concurrency of engineering activities.

The following examples of information with real values concern the optimization of the profile of the packaging.

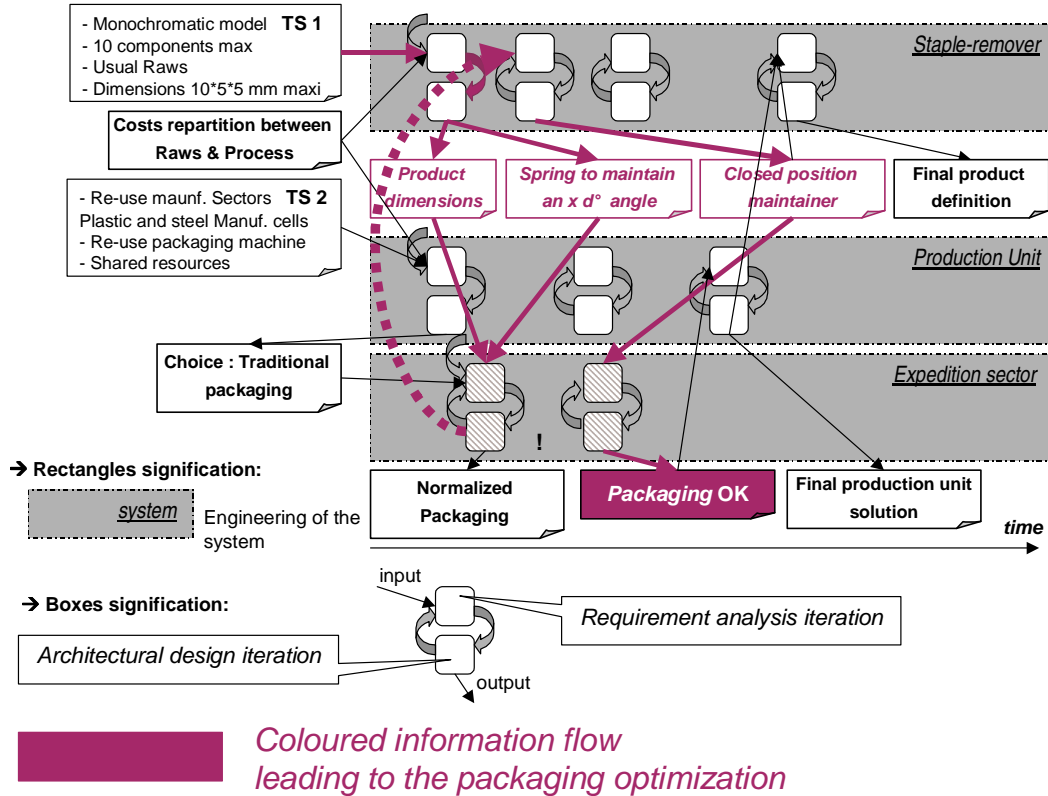

Figure 24. Illustration of the second level of link (Optimization of the packaging)

To enhance the legibility of this diagram, see only the colored information flow, which represents the propagations of constraints leading to the packaging optimization. This illustration shows how small a piece of steel has been defined in order to maintain the staple remover in a closed position. It allows the use of a standardized packaging. The iterative process can be observed. It is also approximately temporally described, through boxes iterations.

To complete theses illustrations, Figure 25 represents an example of the manufacturing system design result, as an illustration of the third level of link.

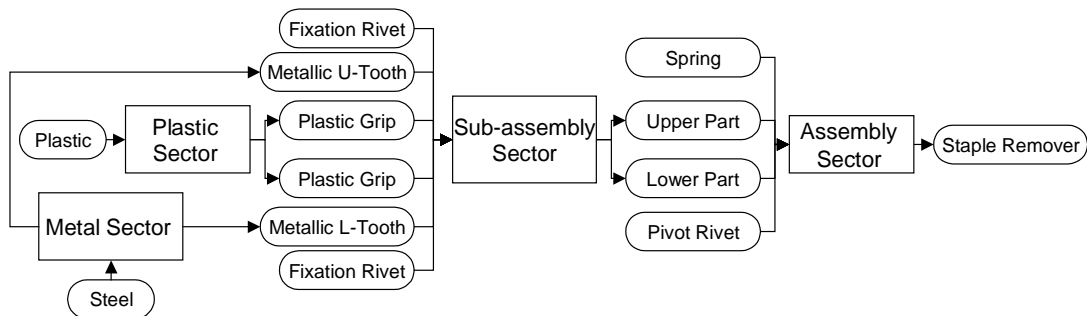

Figure 25. Illustration of the third level of link

### **3.4 Discussion and perspectives**

This theoretical contribution leads to the definition of the *eASE* framework, used in the next chapters for evaluation, control, deployment and application activities. The *eASE* theory implies to describe and manage numerous links, through many point of view. The illustrations provided in this chapter are not enough representative, because reality is much more complex. Despite this simplification, pictures are still difficult to clear up. This explain the importance of the instrumentation problematic, detailed in chapter 6.

The necessity of information systems to support these engineering coordination principles is therefore obvious. Furthermore, the theoretical principles could be refined through formalization constraints.

Thus, while chapter 4 and chapter 5 deal with practical contribution, chapter 6 deals with a prolongation of the theoretical contributions toward their software instrumentation.

## **Chapter 4. *eASE* Evaluation and Control**

---

The purpose of this chapter is to provide methods and tools to assess and then determine where the actual development practices have to be improved.

This chapter presents two kinds of evaluation and control. It begins with a maturity assessment carried out in a working group that has enabled an important information acquisition regarding real practices and the relevant configuration of further local practices improvements. Then, the improvement made on process models is explained. The scope is the area of expertise contributing to the manufacturing systems engineering.

### **Two kinds of evaluation were done:**

- Based on interviews, combined to information acquisition (also when there is no relevant process model to assess). This will allow the improvement of local practices, resulting from concrete enhancements of the identified weaknesses.
- Based on process models, as soon as they are described. This will allow the improvement of local practices, resulting from structured enhancements of the related process models.

## 4.1 Interview-based assessment approach

### 4.1.1 *Objective and scope*

*Reminder:* Senior managers in the manufacturing systems domain have judged in 2001 that the existing ASE framework was insufficient to enable manufacturing systems engineering. An action was decided, regarding the improvement of the ASE framework of the company, in order to take into account the specific aspects of the manufacturing systems in the 16 areas of expertise listed in Table 14.

List of interviewed areas in the manufacturing domain (alphabetical order)
Assembly process engineering
Automation engineering
Vehicle axle manufacturing systems engineering
Body process engineering
Engine and gearbox manufacturing systems engineering
Industrial strategy for assembly process
Industrial strategy for manufacturing systems engineering
Metal assembly and soldering engineering
Painting process engineering
Production software architecting and implementation
Production systems acquisition
Prototype building
Resource (compressed air and power) supplying engineering
Supply acquisition
Supplying flows engineering
Vehicle geometric conformation process

Table 14. Interviewed areas of expertise

The area “Industrial strategy for manufacturing systems engineering” can be considered as a sub-area of “Industrial strategy”, and only one area of expertise was missing (“Forge and foundry systems”). This implies a study about 93% *theoretically* representative (incomplete information about practices of the areas were acquired).

That was the best possible opportunity to also assess the areas of expertise, in order to explain *eASE* to manufacturing systems engineering experts and configure further *eASE* deployment.

### 4.1.2 **Process**

A working group has been assembled under my chairmanship and control. This was a 9 months study that required one coordinator to manage the 10 members of the working group and implying 25 experts. The first orientation of the working group was to increase the cover of our investigation, in order to get a company-wide agreement. It was decided to implicate specialists from each area of expertise in the manufacturing systems engineering. We decided to carry out interviews, where:

- the first objective was to get the complete map of existing deliverables and activities for each area, in order to add a generalization of quoted practices to our *eASE* framework,
- the second objective was to assess each area.

Our scope concerned here only the areas of expertise belonging to the manufacturing systems domain, but we had also to be able to perform SE improvement in automotive product domain. A third objective was therefore to test our process for further deployments in automotive product domain, considering the fact that we will focus only on the second objective (the assessment) because we would not expect to achieve the first objective (the complete map of deliverables and activities is already done for vehicle engineering domain).

Thus, our objective was to determine and then reduce the gap between existing practices and an *eASE* target, as soon as this improvement could solve a concrete issue faced by the area. Our assessment process follows the 6 phases proposed by [Sheard S.A., Lykins H. *et al.*, 2000], and we have introduced a phase 1bis, to adapt the selected reference to our field of investigation, see Table 15:

<b>Phase 1:</b>	Select Model.
<b>Phase 1bis:</b>	Tailoring, adaptation to the manufacturing system domain.
<b>Phase 2:</b>	Evaluation.
<b>Phase 3:</b>	Determine where to improve.
<b>Phase 4 and 5:</b>	Obtain funding and make improvements (see next section for details).
<b>Phase 6:</b>	Repeat.

Table 15. Interview-based assessment process



### **4.1.3 Model Selection**

In *Phase 1* we have selected the staged reference of Systems Engineering Capability and Maturity Models™ [CMMI, 2000] that provided the most relevant model of assessment. Based on the Capability and Maturity Models, and precisely the Micro Assessment Kit of SECAT LCC© [SECAT LLC, 1998], we have created and submitted a template of questionnaire to the working group. We took the Kit [SECAT LLC, 1998] as the operational result that covers the *Process Areas* of the CMM (the Systems Engineering practices), as described in [Cusick K. and Bruce J., 1999], which provides a mapping between the three parts of the Kit [SECAT LLC, 1998], the *Process Areas* and the CMM's maturity levels (see for more details Table 9. Top level traceability between CMM and SECAT LCC Pocket Guides, page 59).

### **4.1.4 Tailoring: our questionnaire**

In *Phase 1bis*, we also had to adapt initial questions to the specific aspects of the manufacturing culture. The activities are provided by SE standards as [EIA632, 1998] or [ISO15288, 2000].

Our questionnaire is divided into two parts. Each part aims to get specific information of how the area of expertise works. For a better understanding of the various descriptions about the questionnaire, please see the version enclosed in the Appendix (in French).

Part one is composed of four open questions, which purpose is to define the objective, the interlocutors, the scope of the area of expertise and its actual description of the links between automotive products and manufacturing systems engineering. Part one does not directly contribute to the assessment of the area and provides only a basic information in order to identify its hierarchical systems structures and the links between systems and between activities performed for these systems.

Part two is composed of eight domains that cover the three parts of the Kit [SECAT LLC, 1998]. These domains also cover the four types of SE processes (as seen in Figure 10. Processes for Engineering a System, page 49). Grouping of questions by domain was done in order to decrease the number of questions and simplify the interview. At the beginning of each domain, we ask for the specific scope of and the references used by the area of expertise. Table 16 shows the relationship between the eight domains of our questionnaire and the SE processes. For a better understanding of the French Appendix, this table also describes some examples of questions subjects.

<b>Domain</b>	<b>Related eASE processes</b>	<b>Subjects of questions (examples)</b>
<b>Project Management</b>	Planning Process Control Process Risk Management Process	<i>Quality, Cost and Time, Human resource, Activity integration, Responsibilities, Risks, Management</i>
<b>Relation with suppliers</b>	Acquisition Process Supply Process	<i>Suppliers selection, Make or buy tasks, Problem solving process</i>
<b>Needs definition</b>	Stakeholder Needs Definition Process Verification and Validation Process	<i>Capture, exhaustiveness, synthesis, verification, documentation and evolution of needs</i>
<b>Requirement Analysis</b>	Requirement Analysis Process Verification and Validation Process	<i>Coherence, feasibility, traceability, tools support, documentation and technical reviews regarding requirement</i>
<b>Design</b>	Architectural Design Process Evaluation Process Optimization Process Verification and Validation Process	<i>Requirement satisfaction, selection criteria modeling and simulation, documentation and technical reviews regarding solutions</i>
<b>Integration and validation</b>	Integration Process Transition Process Implementation Process Verification and Validation Process	<i>Planning, methods support, tools support, documentation, evolutions regarding verifications</i>
<b>Technical management</b>	Configuration Management Process Risk Management Process	<i>Documentation, up-dates, risks, problems, quality objectives and tools support</i>
<b>Area management</b>	Enterprise Processes Decision Making Process	<i>Knowledge sharing and capitalization, decisions, benchmarking and technological survey</i>

Table 16. Survey of the domains of the questionnaire

Thus, each domain of our questionnaire consists of five or six questions, which are focused on the activity to be explored. Two questions on maturity and success conclude the questions of each domain. Considering the fact that we interviewed experts of areas, 18 % of the questions in the Guides of [SECAT LLC, 1998] were not used in our questionnaire, which is mainly the part regarding the third level of maturity (or over) that concerns the role of the organizational leader.

Figure 26 presents the mapping between the Guides [SECAT LLC, 1998] and our questionnaire.

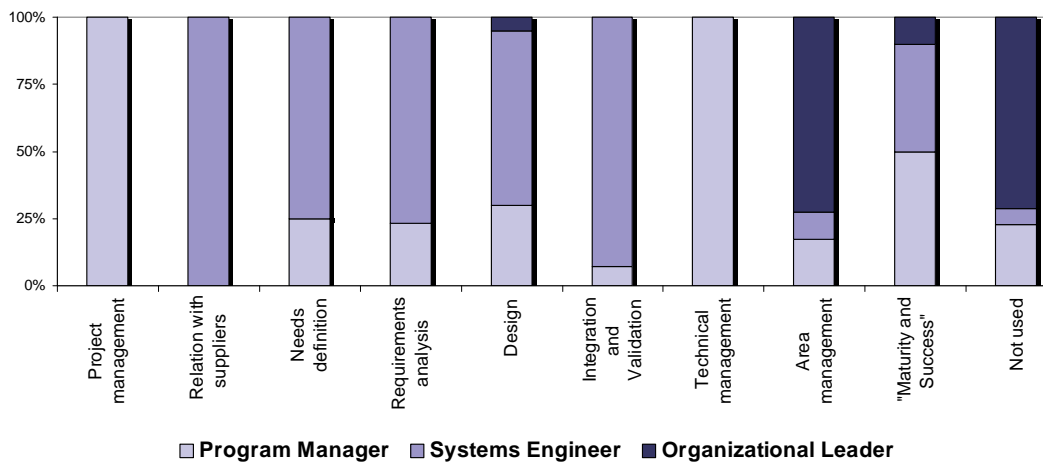

Figure 26. Utilization of the three parts of the SECAT© Kit

As seen in the State of the Art, items of the three Guides are related to CMM maturity levels through Table 9. This explains why we are able to justify the traceability between our own questions and the maturity levels.

Figure 27 describes the distribution of maturity levels for each domain of our questionnaire.

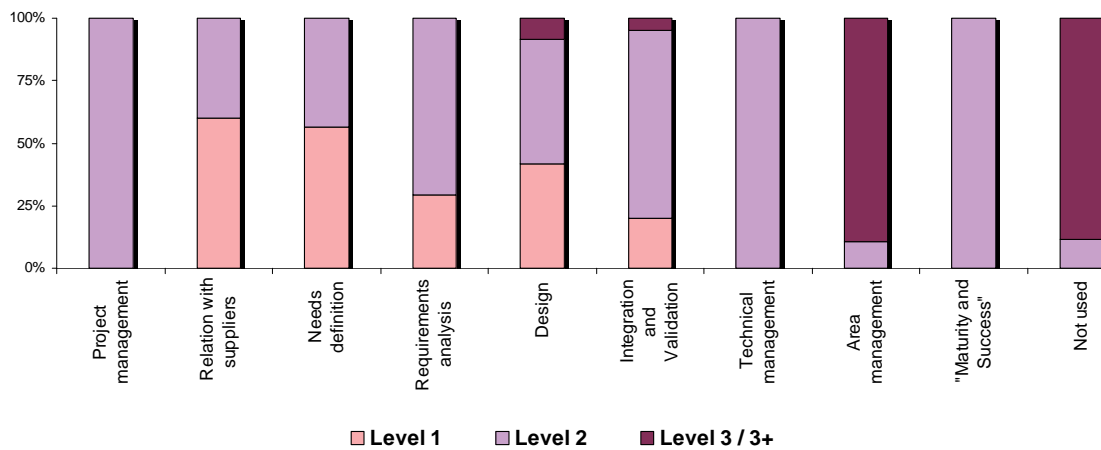

Figure 27. Link with CMM's maturity level

**The questions:**

For each activity, we asked how it was performed. We noted a formalization level for each activity, as described in Table 17:

Points	When...
0	the activity is not performed.
1	the activity is done informally.
2	the activity is done or informally (usually) or formally (occasionally).
3	the activity is done formally (usually).
4	the activity is completely integrated in the repository of the area.
-	the activity is excluded from the boundary of the area (not taken into account).

Table 17. Formalization level

The more the activity is formalized, the more we have to identify the associated deliverable, or template, or tool.

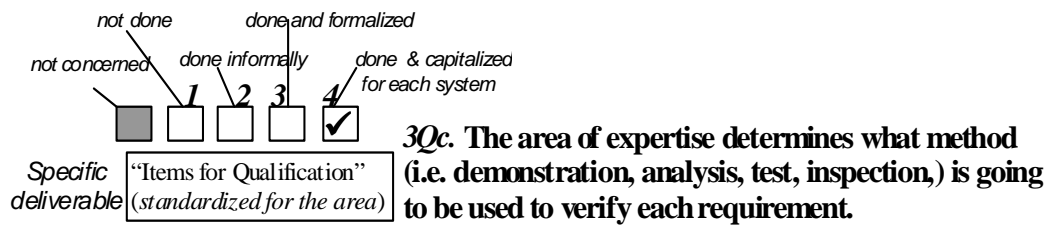

Figure 28. Example of question

Figure 28 shows an example of question, see Appendix for more details.

### 4.1.5 Results

**Determine which area could improve: global assessment results.**

Figure 8 presents the average of our results for the sixteen areas interviewed.

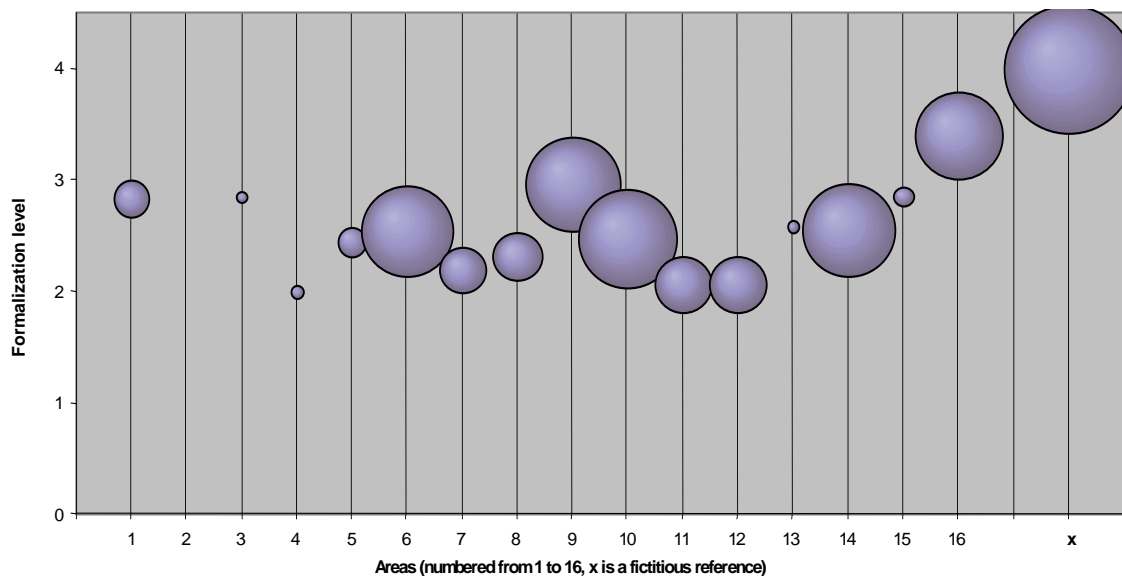

Figure 29. Global assessment results

The size of the spheres shows the relevance of the evaluation. This size is related to the effective number of answers we get through the interview. A fictitious area *x* is shown as reference: the best result and the more relevant evaluation. We can conclude that the interviewed area has already a good formalization level. It shows that the local engineering improvement actions could often concern deliverables, because many of them already exist.

These global results allow us to identify the weaknesses in terms of engineering practices. We are now able to determine priorities for engineering improvement considering the 16 areas of expertise. These priorities would be determined considering concrete issues faced by a given area.

**Determine where the area has to improve: methodological roadmaps.**

Questionnaires are now used to build methodological roadmaps for each area of expertise, as shown in figure 9, for an anonymous area.

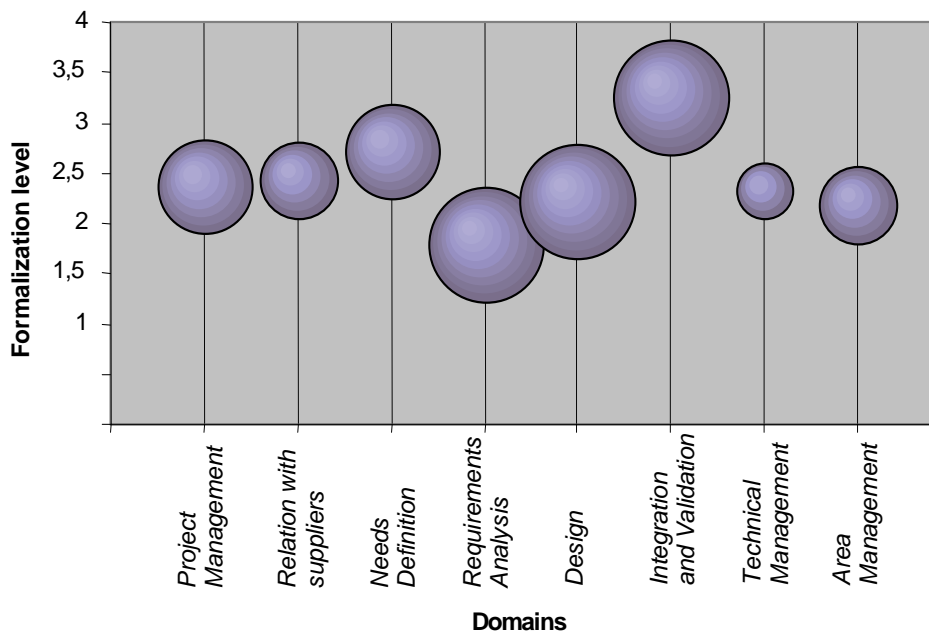

Figure 30. Example of more accurate results for one area

These local results allow us to identify the activities that could be improved. The ultimate *eASE* targets would be the fourth level of formalization, reached for all the *eASE* activities of an area in each domain. This very long time objective can be reached defining several intermediate steps, thanks to the building and the interpretation of the theoretical roadmaps.

In this example, the area of expertise could have chosen to improve the efficiency of its requirement analysis practices. It is precisely the case of study that will be detailed in the next Chapter.

#### **4.1.6 Discussion on assessment**

PSA Peugeot Citroën is now able to count upon our questionnaire and the CMM™ levels. These actions on *eASE* evaluation and control have to be generalized to any field concerned by practices improvement, as soon as the evaluation is made in relation with an external reference.

The relevance of the choices (e.g., of [CMMI, 2000]) was confirmed by the parallel progress in terms of SE deployment in automotive product domain: a translation of [SECAT LLC, 1998] has been ordered and is now available in order to perform the assessment approach in the entire research and development branch, not started yet. Therefore, the interview based approach can be considered as a first validation of the relevance of practices improvement through Systems Engineering CMM™ for the entire company. This work also ensures that manufacturing systems domain specificities can be taken into account. Basic information is now available to justify that the interviewed areas of expertise are able to prepare efficiency improvements in the field of engineering.

## **4.2 Process Model-based approach**

### **4.2.1 *Process modeling and process improvement***

Beside the question of process modeling, treated earlier, process models allow another type of evaluation. Only few of the 16 areas have already described the sequence of their own engineering tasks according explicitly to SE standards. As soon as this work has been performed, a more accurate assessment could be provided, including for instance temporal views and resources views. Logical sequences of technical tasks are described and then checked according to *eASE* (see for instance Figure 20, which describes a fictitious SE technical process) A process improvement can be reached, increasing the accordance of these descriptions to the *eASE* methodology. This work has been done for three areas of expertise of the manufacturing domain, regarding the industrialization tasks of twelve different systems (automotive products): vehicle axle, engine and gearbox manufacturing engineering areas and the area working on forge and foundry systems engineering (which was not interviewed).

These descriptions include and dissociate the tasks regarding the study and development of related manufacturing systems. I have taken part in the reviews of these process models, as ASE experts. It represents a 10 months study and approximately 10% of my time spent. I have made remarks leading to an increasing accordance of the descriptions to the *eASE* methodology. The improvement of engineering efficiency was not observed, because the profits for the area of expertise were measured in terms of engineering management.

### **4.2.2      *Discussion on process modeling***

These descriptions can only be considered as targets to reach. It is a prescriptive modeling rather than a descriptive modeling. That means that a given process improvement on prescriptive descriptions will not be directly effective in real practices. Despite this drawback, such models can be improved with structured methods, as done by T. R. Browning with the application of the Design Structured Matrix applied to Process Modeling [Browning T. R., 2002]. Furthermore, such structured methods allow integration [Browning T. R., 2002]. Models of logical sequence of SE tasks regarding the engineering of given systems in a hierarchical system structure can be integrated, leading to complete models regarding the engineering of the complete system. Regarding my theoretical advances, integration between product views and manufacturing system views would be helpful.





## **Chapter 5. *eASE* Deployment and Application**

---

The purpose of this chapter is to provide methods and tools to support improvement of development practices.

First, the scope of the improvement actions is detailed. Then, the generic improvement process is presented. It is next applied to a representative case of study in the field of requirement analysis. This case allows to conclude empirically on the potential profits made with SE application in terms of engineering efficiency improvement.

## 5.1 Scope

The *eASE* Deployment and Application mainly concern (for the moment) just a part of the methods: *eASE* applied to manufacturing systems engineering. Further work will be more focused on the engineering coordination with *eASE*. Furthermore, the *eASE* Deployment and Application cases do not concern all of the 16 areas. Many cases of study were done with many areas, and it's not possible to detail here all these work, which are actually various in terms of scope and action.

My quotidian activity was to advice engineers and technicians of the manufacturing engineering domain, asking to me for methodological support. Sometimes my answers are limited, as for instance SE presentation or training, SE handbook promotion, restricted meetings, ... and sometimes the issue identified by the area requires a bigger attention, leading to an improvement project to realize.

The birth of a complete improvement project using *eASE* is also a question of maturity level of the areas, and their own ability to admit the potential profit of using *eASE* to solve a given issue.

## 5.2 Generic process for local practices improvement

In case of real project to set up in order to provide a methodological improvement, the process is the following:

The *eASE* deployment and application process is always dedicated to the specific practices of a given area. It's a "operational-centered" process, which means that *eASE* is not imposed, but brings solution to existing issue. The sequence of tasks detailed in Table 18 is performed:

<b>Task 1:</b>	Case analysis, that consists in a stakeholder's needs analysis.
<b>Task 2:</b>	First action proposal, in terms of methodological materials and processes.
<b>Task 3:</b>	Working group consultations and reviews, to define the most profitable action.
<b>Task 4:</b>	Deployment's preparative work, to adapt methodological materials and processes.
<b>Task 5:</b>	Assistance for first application, help given to specialists.
<b>Task 6:</b>	Evolutions by feedbacks from application.
<b>Task 7:</b>	Repeat.

Table 18. Practices improvement process

This generic process is then adapted for each local improvement's project, regarding objectives, scope, resources, time, costs, ...

The aim is to render operational teams as autonomous as possible, through appropriation of systems engineering practices.

## 5.3 A representative case of study

One of the most representative case of study has been selected here among the practical contributions.

### ***Task 1: Case analysis***

The considered area is in charge of the engineering of manufacturing workshop for the engine and the gearboxes. The objective is to improve the requirements analysis tasks of the complete workshop.

### ***Task 2: First action proposal***

As a first action proposal, a new generic template and guidelines for the requirements document is provided, also called the Technical Specification (TS) of a system. This generic material was build during a previous project regarding the improvement of the *eASE* handbook. This work was done through the adaptation of the template already available for the products, soliciting a validation working group to review and improve my first draft up to an operational result, based on the experience of its members. The validation process was a first opportunity to explain *eASE* applied to manufacturing systems, and acquire valuable information about the specific aspects of the manufacturing systems in each area of expertise.

### ***Task 3: Action decided***

This first TS template was of course insufficient, and it has to be closer to the specific practices of the considered area.

After meetings, we decided with experts of the area to provide a new intermediate specific template. Thus, the deployment's preparative work was to build a specific TS template and guidelines, as describes in Figure 31:

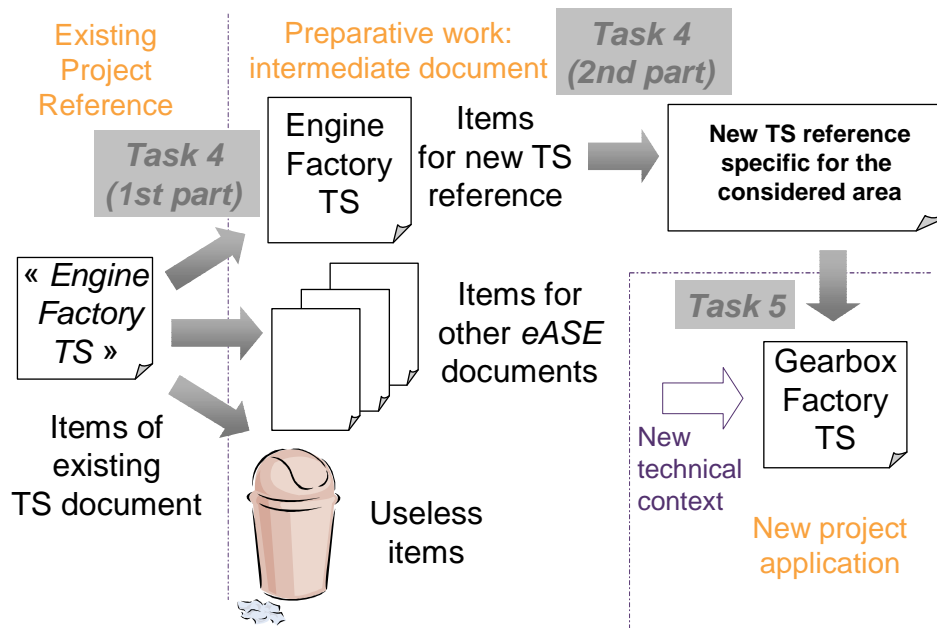

Figure 31. Action performed

This illustration introduces:

- the two part of *Task 4*: a sort of the items of a TS reference and the building of a new specific TS reference;
- the Task 5, which consists in the first application of the new reference.

#### **Task 4: Preparative work**

We took as reference the “TS” of an existing project regarding the engineering of a new factory for a new type of engine. This document was one of the best existing document, nearest to a *eASE* TS, and was selected because of its similarities with the factory to be designed. After treatment, this “TS” was not in conformity with the *eASE* methodology. The main characteristics of the existing technical documentation are that requirements and design architectures are not explicitly separated (it was done but not formally), and that a partial hierarchical system structures of the manufacturing system exists.

Figure 32 presents the distribution of the 251 items of the existing document in the *eASE* documents. 63 % of the items were valid, following *eASE* principles. 12 % of the items were useless. The other items concerned other documents.

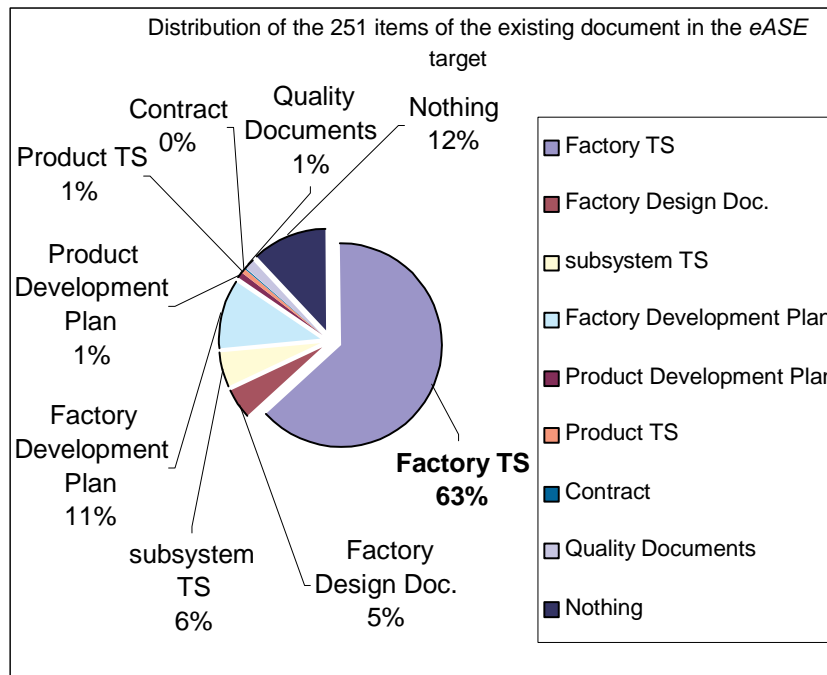

Figure 32. Mapping between existing document and eASE target

Considering that the engineering efforts made in a development team are dependent on the number of items on which they have worked (the basic hypothesis could be “1 item to write = 1 unit of resource consumption”), we can assume the analysis presented in Figure 33. The items are here divided into other kind of types: those to be reworked / or not, those regarding other teams (product or contract), and those representing anticipated efforts or wasted efforts.

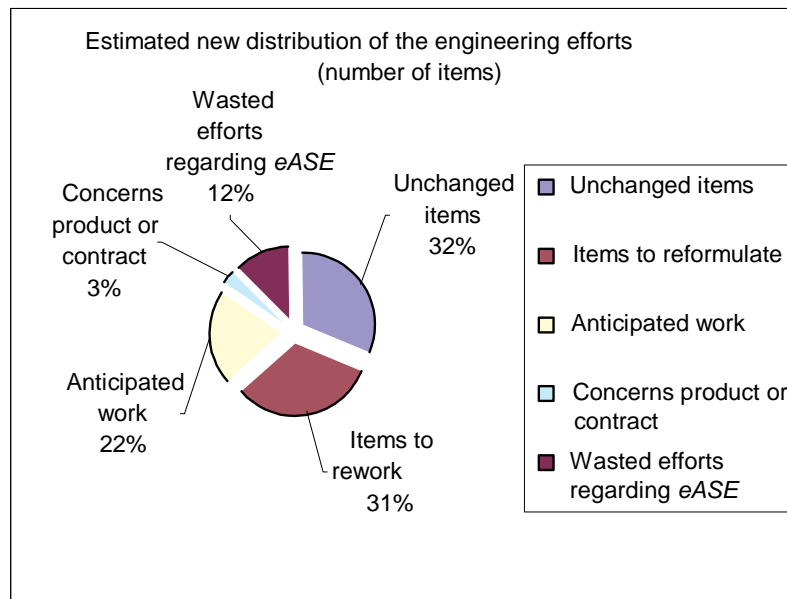

Figure 33. New distribution of the efforts

One of the most significant result is that *eASE* application enables to achieve an overall reduction of the engineering efforts. Figure 34 presents the outcome, where extra efforts are represented by the items to be reformulated, and minus efforts are represented by the other categories of items (anticipated work, products or contracts, and wasted efforts), considering that the excepted unmodified items will need a same effort.

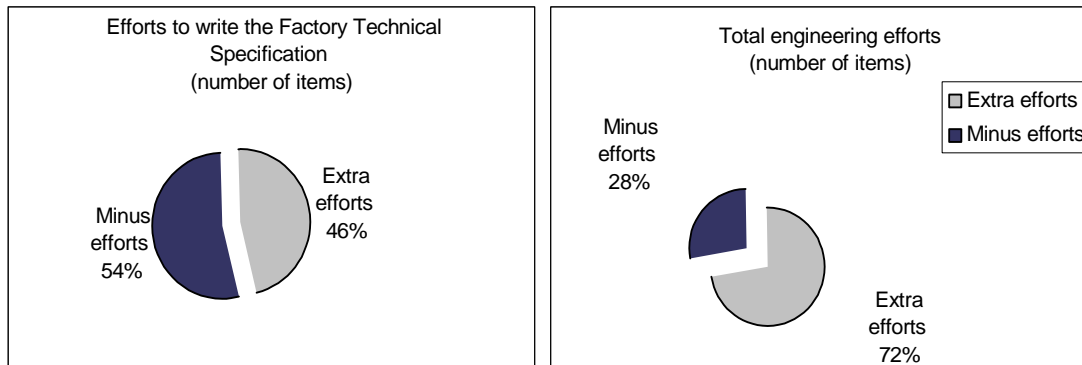

Figure 34. Resulting efforts

On the left, the “non evolution” of engineering effort required to write the Technical Specification is depicted. On the right, the evolution of engineering effort is depicted: the now 28 % of minus effort are the 12 % “wasted efforts regarding SE” (direct profits), the now 72 % of extra efforts are the 22 % of “anticipated work”. This leads to much engineering efforts but anticipated, which is approximately the same as that without *eASE*. This result represents a real improvement in terms of timing: TS validation might have occurred sooner, with a higher TS quality.

### **Tasks 5, 6 and 7: Application**

Based on this preparative deployment materials, and considering of course the new technical context, I have assisted the concrete work of the specialists of the area during the requirement engineering of the new gearboxes factory.

A second review of the generic template has attempted to be closer to real-world practices, through this application

Considering the concrete benefits obtained from this first application, they have decided to continue the *eASE* deployment, and a similar assistance was given in order to write the design document and the justifications documents of the factory, following *eASE* methodology.



## **5.4 Discussion**

Benefits of such project are always acknowledged by operational teams. It provides a more complete and a more targeted work, it increases the confidence in terms of verification and validation processes and ensures the robustness of the design processes. The risk of project failure has been concretely decreased.

Such initiatives are generalized to other domains and areas, as soon as an improvement is needed. Furthermore, one of the major feedback is that the teams are progressively autonomous on such subjects, thanks to the “operational-centered” process defined here. Another relevant feedback is the noticed improvement in terms of communication during the project, thanks to the *eASE* application.

## **Chapter 6. *eASE* Instrumentation**

---

The purpose of this chapter is to detail the issue of the theoretical advances instrumentation. The related issue is to prepare the instrumentation of eASE principles.

First, the modeling problematic is presented, as a first step of the integrated method and tool approach. This approach has been designed during a study made at the laboratory with Longueville B. (see [Lardeur E. and Longueville B., 2003]). The purpose of this approach was to enable the construction of an integrated framework combining recent advances in the Systems Engineering domain and in the Knowledge Management domain.

Perspectives are introduced, opened by the realization of the first step of this approach. Then, the actions in terms of need expression are detailed. To conclude, an overview of the potential contribution of the existing tools available at PSA Peugeot Citroën is given.

## 6.1 An integrated methods and tools approach

Nowadays, the technological evolutions in the field of information systems supporting engineering approaches induce an “integrated methods and tools” approach, in order to take advantages from software solutions.

Engineering information has now to be considered as data to manage electronically: analyzed, treated, shared, accessed, archived, updated, deleted... Data are not restricted to results of engineering tasks (as parts lists, mechanic outlines, ...) but also concern new types of system descriptions (as requirements, functional models, physical architectures, design justifications, decisions, ...). Actual tools do not support any overall engineering approach. Furthermore, the information is not only considered as critical results to perform the engineering but also studied as knowledge to deal with. This leads to numerous programs, and a resulting software complexity to handle.

This lead to the issue of relevance between theory and its software instrumentation, solved through the integrated methods and tools approach described Figure 35.

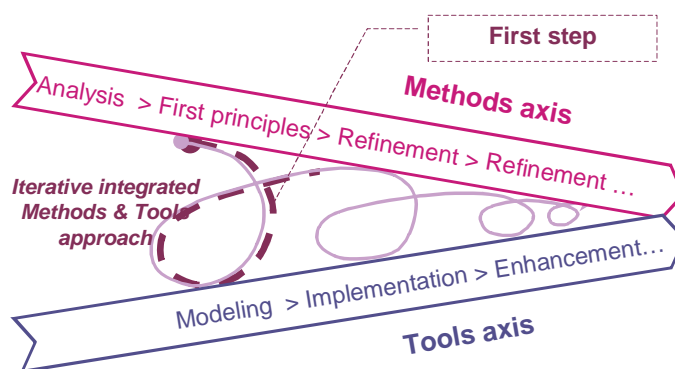

Figure 35. Integrated methods and tools approach

This iterative integrated approach can be viewed as the progressive gathering of methods and tools aspects.

To prepare eASE instrumentation, the first iteration of the approach has been experienced. This step will be described in the following sections.

## 6.2 Modeling problematic

The results (i.e. the *eASE* framework) are composed of many theoretical principles. On methods aspects, these notions are only described through figures, without any formalization constraints. This section tries to operate the modeling problematic. It first focuses on the choice made of a modeling approach that increases the relevance of the expression of my theoretical principles and prepare the implementation. Then, the modeling of the engineering items is detailed, such as *systems, hierarchical structures, information flows, links,...*

### 6.2.1 *Choice of the modeling approach*

The theoretical approach concerns complex items, and requires functionally very precise descriptions. Thus, the choice of a modeling approach supporting the Object Oriented Approach was natural. The differences between STEP EXPRESS and UML (notably based on [Arnold F. and Podehl G., 1998]) have been studied, pointing out the following characteristics: easy to use, legible, supporting dynamic aspects, including constraints expression possibility. These points lead to choose the UML approach. Next, the selection of a certain level of detail has been decided.

Thus, UML Class Diagrams are here only presented; They could describe any type of system or relationship or professional specific aspect, in order to emphasize the different choices made regarding the possible implementation of the theoretical approach. *Cardinalities* and *methods* are rarely described, and only the more relevant *attributes* are shown.

The first objective of UML modeling is to provide coherent and structured models subject to unique interpretation. The second objective is to come up, for any approach, with a specific and independent model that could be easily interfaced with others.

Object Constraint Language™ (OCL) and tools for model verification were used in order to reach such objectives. OCL is used to construct each model and ensure the coherence of the different models. This language enables to integrate in the models the constraints that cannot be explicitly represented by UML Class Diagrams. The models are also tested with examples, e.g. generated objects diagrams, using USE.2.0.1™ software (Bremen University) to design and check the OCL constraints.

## 6.2.2 Items to model

### Models for systems

The *system* is the first item to model. Following the principles, *systems* are described through tree views, called *Hierarchical System Structures (HSSs)*. The decomposition principle could lead me to choose the composite pattern of [Gamma E., Helm R. *et al.*, 1995], described in Figure 36. Association type must be *composition*, in order to enable the construction of a tree structure. The composite pattern only supports a fixed decomposition, because it leads to the impossibility to decompose a given *SystemLeaf*. Thus, the model described in the right part of Figure 36 has been built. It now enables a real elaboration (dynamic extension) of the decomposition.

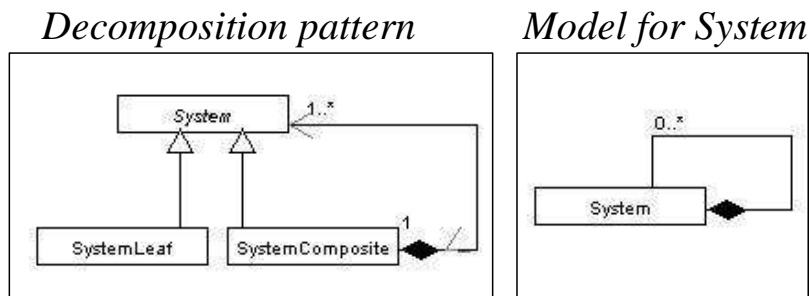

Figure 36. System decomposition modeling

Based on this choice, the types of the systems must be modeled. The modeling of this characteristic could lead me to the three following alternatives, described in Figure 37.

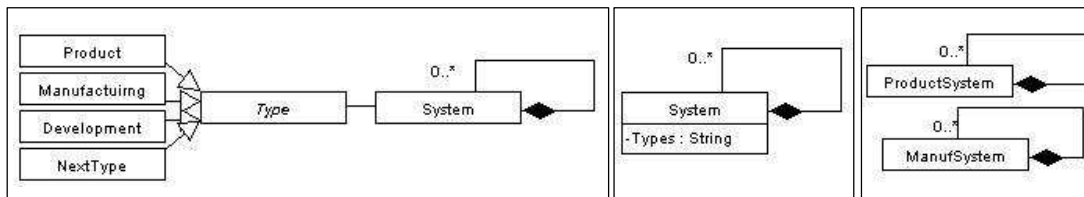

Figure 37. Three alternatives for types of systems modeling

The *type* characteristic may be supported by a UML class, an attribute of the class, or each type of system could be modeled separately. The two first alternatives may require an OCL (Object Constraint Language) constraint, which would be in this case: *“context System inv : self.system->notEmpty implies self.type=self.system.type”*.

The first alternative seems to be the more interesting choice, because the relationship between each *type* of *system* depends on the relationship between their *types*, which could be described in a unique parameter, and constrain the creation of the links. This point could also be expressed with the OCL (Object

Constraint Language), regarding the *type* class. It can also be expressed through the attribute *type* in a generic *system* class, represented in the second alternative. The last alternative is selected, mainly in order to improve the clarity of next descriptions, because they are based on the unique relationship between a product and its associated manufacturing system.

### **Model for SystemLink**

In the modeling context described above (i.e. the choice of the third alternative), the *SystemLink* would be described as described in Figure 38.

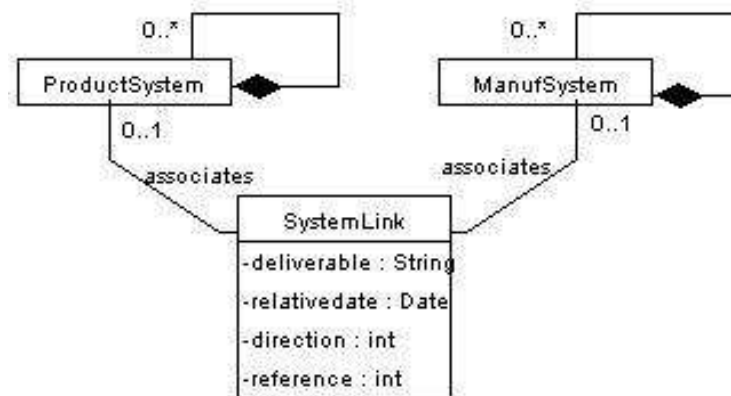

Figure 38. The *SystemLink* modeling

For this link, the theory has shown that four attributes were at least required to support the principles: the *deliverable* is the awaited information or product exchanged between the related systems, the *relativedate* would concern a stake defined a priori, the *direction* has to be checked and the *reference* would support status of the link and versions management. Other attributes may appear from the implementation problematic, supporting software features, which were not been considered here.

### **Models for ActivityLink**

The modeling of *ActivityLink* could be done with a generic model of the technical activities or considering each activity independently.

Generic alternative leads to the same models than constructed for *SystemLink*. An *activity* class is introduced, which is described by the attributes *name*, *input* and *output*. The basic theoretical principle is to join the activities with the system they are performed for, as shown in Figure 39.

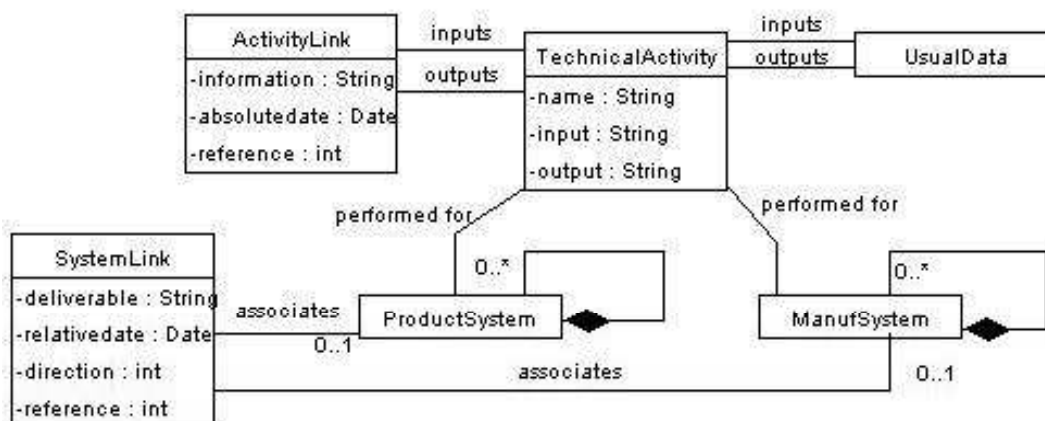
Figure 39. The *ActivityLink* modeling

This model is not sufficient because the usual data exchanged between the technical activities cannot be neglected: a *UsualData* class could be drawn as done for *ActivityLink*. The primary difference between these two classes is the relevance of contained date for the coordination problematic. During a project, common data can be considered either as a *ActivityLink*, or as a *Usualdata*, depending on what it describes.

There is no *direction* attribute for the *ActivityLink* class, because it is described by attributes *input* and *output*. Contrary to what has been done for *SystemLink*, the date is now described by the attribute *asbolutedate*: an *ActivityLink* has to be defined with a concrete value. This aspect of the relation between the two links will be detailed hereafter.

This model does not include the technical coordination tasks that control the engineering, because of presentation choice about the activities for one given system, and not those *between* systems.

This statement could leads to make a compromise between a generic view, where all technical activities performed for a system are adapted from an unique SE framework, and a specific view, which more easily takes into account the specific aspects of each area of work.

### **Relationship between SystemLink and ActivityLink**

The questions asked through the modeling problematic points out the complexity of the relationship between *SystemLink* and *ActivityLink*.

At first sight, the nature of *SystemLink* and *ActivityLink* is very different. This difference is justified in a static point of view, because they connect different items: systems for *SystemLink*, and activity for *ActivityLink*. Considering a dynamic (or even temporal) point of view, *SystemLink* may be considered as the origin of *ActivityLink*, and conversely, a *ActivityLink* may be identified between two technical tasks because of its relevance, and implicate

the creation of a *SystemLink* between the two induced systems. Figure 40 describes two modeling alternatives:

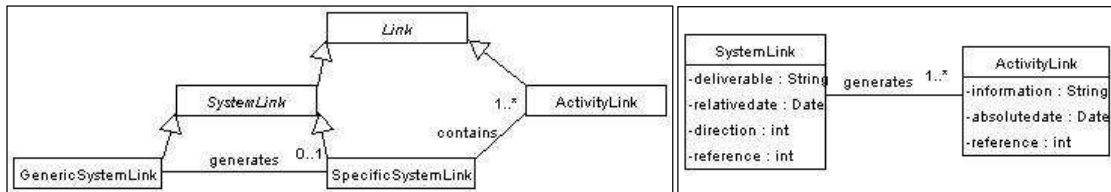

Figure 40. Models for links relationship

On the left, the model is based on the distinction of two “sub-types” of *SystemLink*: a *GenericSystemLink* and a *SpecificSystemLink* is made. The specific *SystemLink* would be generated by a generic *SystemLink*, and would be the unique source of *ActivityLink*.

On the right, the model is based on the creation of *ActivityLink* from *SystemLink*, or inversely to consolidate *ActivityLink* in *SystemLink*.

This alternative is illustrated by a short example in the object diagram depicted in Figure 41:

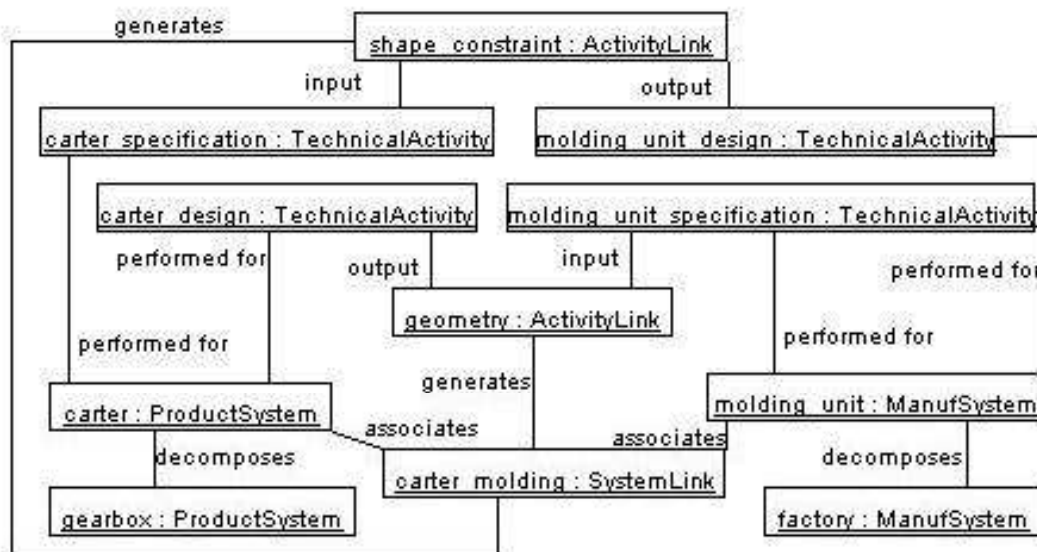

Figure 41. Object diagram for *SystemLink* and *ActivityLink*

The link between the carter of the gearbox and the molding unit of the factory generates the exchange of the geometry of the carter and the shape constraints due to the molding technology, as activity links.

The choice between the two alternatives introduced above depends on tools aspects, and may only be done in further work.



### **6.2.3      *Discussing the modeling problematic***

This first study brings real added value to the knowledge of the methodological aspects. Issues are rising regarding information the have to be carried out by the models. For instance, what kind of information should be included to represent activities? Or how could be managed new systems types?

A decision and coordination models interfacing (see, [Lardeur E. and Longueville B., 2003]) has been realized through the modeling approach.

The integrated methods and tools approach allow to gather my prescriptive models and the descriptive models of [Longueville B., Stal Le Cardinal J. *et al.*, 2003] regarding knowledge-based models with decision making process modeling.

Lessons learned from this study are the following: the modeling activities can be realized separately, if based on the same modeling protocol. Modularity and communication ability is improved thanks to UML use. Class diagrams allow to understand in detail and without misinterpretation the theoretical principles and their relations. Using the same language is the preliminary step to better understand various professional specific aspects. Based on coherent analysis, level of details and approaches in process modeling, UML appears as a generic modeling language that support communication and model interfacing.

The research work identifies the need of generic modeling patterns in the context of engineering. The purpose of such patterns is to support and homogenize the modeling of engineering problem: dynamic decomposition into hierarchical systems structures, process and information flows representation, ... In addition, the research work underlines the relevance of the OCL language and its validation with appropriate tools to check constraints in object diagrams. The model verification is an entire part of the modeling protocol. Most of the modeling choices and the associated OCL constraints are justified by verifications of the models alternative with object diagrams. Hence model verification is confirmed as a fundamental step for model validation.

To conclude, the modeling problematic is restrictive and does not give all the required answers to an implementation problematic. The industrial needs are here restricted to a methodological need. Moreover, information levels of detail have to be defined. These models were theoretically checked, but the lack of real value must be solved.

Studying software aspects would help to refine the theory more deeply. This theory is confronted with the concrete application of the new principles, taken as constraints and rules to follow, through UML modeling.

## 6.3 Supporting tools

### 6.3.1 *Features required: toward a Technical Specification*

The basic needs for a "system for coordinating engineering" are here emphasized with the following list of expected features:

1	Global data entry easiness
2	Organization by project and systems
3	Modeling of hierarchical system structure (HSS) for the product and the manufacturing system
4	Modeling of the links between systems of both HSSs
5	Modeling of SE processes
6	Simulation of SE processes
7	Modeling of technical information exchanged during concurrent engineering
8	Information flow management (e.g., triggered activity, ...)
9	Evolution management and configuration management
10	Legibility of displayed views
11	Information accessibility and sharing facility, including security aspects
12	Interfaces with other tools

Table 19. List of expected features

### 6.3.2 *Analysis of existing software tools*

Among the various SE software, some of them are available at PSA Peugeot Citroën: Statemate™ from I-Logix, DOORS™, from Telelogic and CORE™, from Vitech Corporation. They are omnipresent in the SE industrial networks, as exhibitors during conferences, providing demonstrations and courses. There is also the unmarketable Telemac©, developed in PSA initially to support the requirement engineering of telematic systems, notably to manage the technical information exchange with the suppliers.

The scope of Statemate™ in PSA Peugeot Citroën is dedicated to requirement analysis and design of electronic systems, it was not relevant to manage the links defined between automotive product and related manufacturing systems engineering. The fact that Telemac has been designed to satisfy specific needs for requirement analysis, further developments would have been required in order to make its analysis relevant for my study.

These tools were already chosen to support part of Automotive Systems Engineering activities in the company. It was consequently an obvious choice to focus primarily my tests on those software.

Furthermore, the selection process leading to the validation of a new tool to be implemented in the company takes at least one year and implies the information system branch of the society and financial resources that had to be planned earlier. Thus, in software domain, the research rather focus on use improvement of the two existing software rather than studying others.

Benchmark on other tools was consequently limited to gather unverified information available from other tool suppliers during Systems Engineering events, which will not be reported in this Thesis.

Finally, creating and developing new tools is not part of the company policy. In terms of perspectives, the results on the modeling of the theoretical principles would be restricted to be used for the elaboration of a prototype only.

### **List of DOORS™ characteristics**

<i>First use</i>	Used to support requirement analysis.
<i>Deployment method</i>	Deployed <i>via</i> a top-down approach. Training internship available. Specific implementation for each project.
<i>Utilization</i>	From x in 1998 to y licenses today. Chosen by z projects.
<i>Scope</i>	Applied for requirement engineering at the vehicle level only, especially in order to synthesize information for project technical management.
<i>Link</i>	Linked with MS Word™ documents.

Table 20. List of DOORS™ characteristics

### **List of CORE™ characteristics**

First use	Used mainly to support process descriptions (support of product engineering rarely and locally) in area of expertise.
Deployment method	Deployed via a top-down approach. Deployed experimentally. Training internship available.
Utilization	An average of n licenses from 1998 to 2003. Chosen by n area of expertise.
Scope	Applied for process modeling at the engine and gearbox business unit, automotive product development teams and manufacturing systems development teams.
Link	Linked with MS Project™.

Table 21. List of CORE™ characteristics

**Test procedure and results**

The software were tested with the so-called “staple-remover” illustration (cf. 3.3), according to the function they had to support (Cf. 6.3). Five types of mark identify the relevance of the tool to perform a given function, as described in Table 22. The results are described in Table 23.

Function...	Not applicable	Inefficient	Low efficient	Efficient	Optimal
Symbol	N/A	--	-	+	++
Comments	<i>The function is out of the scope of this tool</i>	<i>Adaptation is required but impossible</i>	<i>Adaptation is required ad possible</i>	<i>Tool is adapted to this function</i>	<i>Tool is primarily dedicated to this function</i>

Table 22. Notations for the tool analysis

	<i>Functions / Tool</i>	CORE™	DOORS™
1	Data entry	-	+
2	Organization	-	+
3	HSS <sup>14</sup> modeling	+	-
4	System Link modeling	++	--
5	Process modeling	++	N/A
6	Process simulation	++	N/A
7	Activity Link modeling	++	--
8	Data management	+	-
9	Configuration management	-	-
10	Legibility	-	+
11	Accessibility	-	-
12	Interfacing	+	-

Table 23. Analysis of CORE™ and DOORS™

These results confirm the interest of CORE™ *versus* DOORS™ for those kind of use. Neither CORE™ nor DOORS™ are appropriate to support the theoretical principles.

---

<sup>14</sup> Hierarchical Systems Structure



## **Conclusions and Perspectives**

---

The purpose of this chapter is to recapitulate the various contributions of this Thesis.

It describes the answers brought to the research issues and the objectives of the Thesis, opening to its perspectives.

The conclusions and perspectives of this Thesis are justified, notably because the traceability between {items of the conclusions and the perspectives} and {issues and objectives} has been done. Regarding the research orientation (see Table 3, page 33), the final accomplishments are presented as described in Table 24, page 113, in line with the issues and the objectives previously identified (ordered here differently). The same presentation is done for the perspectives of the Thesis, as described in Table 25, page 114.

The main accomplishments and perspectives of this Thesis can be expressed according to five axis: Repository enrichment, instrumentation, academic contribution, performance assessment and performance improvement.

### ***Repository enrichment axis***

The objective of extended Automotive Systems Engineering framework definition has been fully achieved.

PSA Peugeot Citroën Automotive Systems Engineering framework has been enriched. The scope of the Systems Engineering application has been widened to manufacturing systems engineering, and consequently to coordination of automotive products and related manufacturing systems engineering. Furthermore, this extension has been checked with concrete operational practices in the production domain, thanks to the surveys made with the questionnaire.

The perspective is to get concrete values, i.e. the hierarchical system structures of the manufacturing systems, the identification and the management of the links between automotive product and related manufacturing systems engineering, in order to improve the potential outcomes of the Thesis.

These theoretical results have also been refined thanks to the realization of the first step of the iterative integrated methods and tools approach developed to solve the instrumentation problematic. This leads to the instrumentation axis.

### ***Instrumentation axis***

Regarding instrumentation aspects, the first step of a designed integrated methods and tools approach has been done.

The term “preparation” has been defined. This allows to conclude that the instrumentation preparation issue has been fully solved. The modeling activities now ensure the robustness of the theoretical principles, leading to their refinement and the expression of requirements to an information system. The first step of the integrated methods and tools approach has been validated through model verifications. While the objective was *to prepare instrumentation*, the perspective could be *to realize software implementation*.

Thus the perspective in terms of instrumentation is mainly to be considered at PSA Peugeot Citroën as an acknowledge stakeholder for needs and constraints expression and then validation of future software tools in the field of engineering data support.

### ***Academic contribution axis***

Theoretical principles have been defined and experienced in order to manage the engineering of automotive products and related manufacturing systems. This leads to the justification of Systems Engineering (SE) profits for vehicle and manufacturing systems engineering. The related issue is fully solved, at least theoretically.

Moreover a positioning among the existing engineering approaches and methods has been realized and the notion of methodological integration has been improved according to SE. Because of the impossibility to cover 100% of the existing theories in the field of engineering, the estimated rate of accomplishment amounts only to 50 % (see Table 24).

The theoretical principles are not company specific, thus the main perspective is that the results could be enlarged to other industry fields or widen to a entire product life-cycle development.

As soon as the systems are developed by the company, the principles defined in this Thesis allow the coordination of any concurrent engineering of a given system and the systems in relation through any stage of its life-cycle. For

instance, the principles may be applied to the concurrent development of manufacturing systems and their maintenance systems. The theory may also be applied in other field of industry, as soon as the systems to develop are complex enough.

Another example may be the integration of any suppliers' development process in the master engineering process of the company, and their coordination.

Because of the justification made on the potential benefits of Systems Engineering, the academic contribution of this Thesis could be promoted in other engineering research communities. For instance, such results could be submitted as paper to the American Society of Mechanical Engineers conferences, because this research branch has not been covered yet.

### ***Performance assessment axis***

The selected approach deals with engineering *efficiency* assessment, according to *relative comparisons* of engineering practices to standardized practices. Because the assessment process is only based on "one quarter" of the complete field of investigation that could have been covered, performance assessment issue accomplishment rate amounts to 25%. This rate could have been twice times less, but thanks to the generic principles provided here, the process applied to manufacturing systems engineering could be transposed to the engineering of any systems or engineering coordination.

Furthermore, the eASE Evaluation and Control process, i.e. the interview-based approach and the process model-based approach, has been experienced and validated in the field of manufacturing systems engineering, with practical results.

The first perspective could be to investigate the other engineering assessment fields, i.e. evaluation based on *effectiveness* or *absolute measures*. For instance, this could lead to build dashboards about Systems Engineering deliverables quality. Then, the eASE Evaluation and Control process could be consequently improved.

Another interesting perspective could be the application of the eASE Evaluation and Control process in the vehicle engineering field, in line with the global objective of Systems Engineering profit maximization.

Regarding the process model-based improvement approach, a crucial perspective is to support them with appropriate techniques, such as Design Structure Matrix method for process modeling. This could be concretely done through a research collaboration with Tyson Browning, because of his noteworthy work in the domain and his INCOSE membership, simplifying the professional exchanges.



### ***Performance improvement axis***

The eASE local and progressive improvement process has been developed and experienced on concrete cases of study. The objective is theoretically fully achieved, but practically, improvements actions have to be generalized in every areas of expertise, and not only those of the production domain. This represents the main perspective in terms of performance improvement.

Methodological targets could now be identified, and progressive stages of improvement have been detailed. This process ensures to keep a prospective vision while acting for short terms practical results.

The main perspective, in line with Systems Engineering profit maximization, could be to apply the eASE Deployment and Application process in the vehicle engineering field, in order to generalize concrete improvement actions, notably regarding vehicle engineering and engineering coordination.

Another perspective could be to determine frequently an adequate methodological target, mainly because the industrial background could evolve.

PSA Peugeot Citroën development system perimeter could stretch out or shrink, depending on economical trends, and the target in terms of engineering activities will have to follow this evolution.

This consideration leads to a global perspective formulation.

*The Systems Engineering application is required to ensure the relevance between marketing objectives and the operational engineering tasks.*

*This is a long-term objective that implies a progressive transformation of PSA Peugeot Citroën development system. Regarding the whole processes and approaches defined here, one of the most important perspectives of this Thesis is the prolongation of the eASE deployment for the entire research and development branch of PSA Peugeot Citroën.*

*The theoretical principles defined in this Thesis are not company specific, thus the results could be enlarged to other industry fields or widen to the entire product life-cycle development.*

*Thus, other companies or research laboratory may be inspired by this work.  
Who knows? Maybe yours...*

<i>Issues and Objectives (reminder)</i>		<i>Accomplishments (and estimated rates)</i>	
I1	To prepare instrumentation aspects.	The first step of a designed integrated methods and tools approach has been done.	100%
I2	To know how to realize performance measurement in the engineering field.	“One quarter” of the complete field of investigation has been covered: assessment of engineering efficiency according to relative comparisons of engineering practices to standardized practices.	25%
I3	To manage vehicle and manufacturing systems engineering complexity.	Theoretical principles have been defined and experienced, leading to the justification of Systems Engineering (SE) profits for vehicle and manufacturing systems engineering.	100%
I4	To define the most efficient engineering approach, notably among the numerous existing methods and approaches.	A positioning has been realized and the notion of methodological integration has been improved according to SE.	50%
I5	To take into account the heterogeneity and the specificities of the areas of expertise.	Surveys have been realized, based on integrated models (software, systems, products), in line Systems Engineering, and experienced for 16 areas of expertise.	100%
O1a	To develop an extended framework, that fully details the application of ASE to the production domain.	The extended ASE framework ( <i>eASE</i> ) has been developed and theoretically checked.	100%
O1b	To develop an extended framework, that describes the engineering coordination of automotive products and related manufacturing systems.		
O2a	To provide an engineering design process in order to enhance the improvement of the current engineering practices...	Regarding Manufacturing Systems engineering: the <i>eASE</i> Evaluation and Control process has been developed and validated.	25%
O2b	... whatever their initial level of performance could be.	Regarding Manufacturing Systems engineering: the <i>eASE</i> local and progressive improvement process has been developed.	100%
O3	To get short term practical results while keeping a 10-15 years prospective vision.	Regarding Manufacturing Systems engineering: the methodological target has been identified. The definition of progressive stages of improvement has been detailed.	100%

Table 24. Accomplishments

## 114 - Conclusions and Perspectives

<i>Issues and Objectives (reminder)</i>		<i>Perspectives</i>
I1	To prepare instrumentation aspects	To be acknowledged as a real stakeholder contributing to software implementation.
I2	To know how to realize performance measurement in the engineering field.	To investigate the other engineering assessment fields, i.e. evaluation based on <i>effectiveness</i> or <i>absolute measures</i> . For instance, building of dashboards about Systems Engineering deliverables quality.
I3	To manage vehicle and manufacturing systems engineering complexity.	The theoretical principles are not company specific, thus the results could be enlarged to other industry fields or widen to a entire product life-cycle development. For instance: - coordination of any end product related to any enabling product engineering, as soon as the enabling product is developed by the company, - integration and coordination of any suppliers' development process.
I4	To define the most efficient engineering approach, notably among the numerous existing methods and approaches.	To promote the description of SE and the justification of its benefits in other engineering research communities. For instance, submit an academic paper to the American Society of Mechanical Engineers conferences.
I5	To take into account the heterogeneity and the specificities of the areas of expertise.	To confirm the transposition ability to other industry fields, in line with the extra extension suggested for the engineering complexity management issue (I3).
O1a	To develop an extended framework, that fully details the application of ASE to the production domain.	To perform eASE instrumentation, as suggested for the instrumentation preparation issue (I4). To get concrete values, i.e. the identification and the management of the links between automotive product and related manufacturing systems engineering.
O1b	To develop an extended framework, that describes the engineering coordination of automotive products and related manufacturing systems.	
O2a	To provide an engineering design process in order to enhance the improvement of the current engineering practices...	To improve the eASE Evaluation and Control process with an investigation in the other engineering assessment fields suggested for the performance measurement issue (I2). To apply the eASE Evaluation and Control process in the vehicle engineering field. To support with appropriate techniques the process model-based improvement approach.
O2b	... whatever their initial level of performance could be.	
O3	To get short term practical results while keeping a 10-15 years prospective vision.	To generalize concrete improvement actions, notably regarding vehicle engineering and engineering coordination. To determine frequently how could evolve the methodological target.

Table 25. Perspectives

## References

---

*From Abadi to Banares-Alcantara*

- [1] **Abadi C. D. and Bahil T.** *"Separating Product and Process Requirements"*, in *International Council On Systems Engineering*, 2002, Los Angeles.
- [2] **AFIS**, *"Indicators"*, 1999, Working group for Maturity Models & Indicators - French SE Association "AFIS".
- [3] **Ali M.**, *"Production System Design Methodology with Emphasis on Sub-system and Equipment Design"*, M.Sc. Thesis of the *Department of Mechanical Engineering*, 1997, Massachusetts Institute of Technology, Cambridge, MA (USA).
- [4] **Arcidiacono G.**, *"Axiomatic Design for Reliability"* in *ATA*, 2000, Vol. 53-7/8, p. 309-315.
- [5] **Arnold F. and Podehl G.**, *"Best of Both Worlds - A mapping from EXPRESS-G to UML"*, 1998, University of Kaiserslautern, Germany, Kaiserslautern.
- [6] **Auzet C.**, *"Guide Démarche d'Ingénierie Système Automobile (Automotive Systems Engineering Guide)"*, 1999, PSA Peugeot Citroën, confidential documentation.
- [7] **Auzet C. and Lardeur E.**, *"Guide complémentaire à la démarche d'Ingénierie Système Automobile - Développement des systèmes de production associés aux systèmes produits (manufacturing systems engineering with Systems Engineering guide)"*, 2003, PSA Peugeot Citroën, confidential documentation.
- [8] **Bacha R.**, *"De la gestion des données techniques pur l'ingénierie de production"*, Ph.D. Thesis of the *Laboratoire Productique-Logistique*, 2002, Ecole Centrale Paris, Chatenay-Malabry.
- [9] **Banares-Alcantara R.**, *"Concurrent Process Engineering: State of the Art and Outstanding Research Issues"* in Working paper for TWG4, 2000, p. 18.

## 116 - References

### From Bellut to Cavallucci

- [10] **Bellut S.**, *"La compétitivité par la maîtrise des coûts CCO et analyse de la valeur"*, ed. AFNOR/GESTION, 1990.
- [11] **Bernard J.**, *"Approche systémique de l'entreprise et de son informatisation"*. Organisation Industrielle, 1992, Paris, MASSON.
- [12] **Blessing L.T.M.** *"Comparison of Design Models Proposed in Prescriptive Literature"*, in COST A3 /COST A4 International Research Workshop on *"The role of design in the shaping of technology"*, 1996, Lyon.
- [13] **Boppe C. W.** *"Lessons Learned Teaching Systems Engineering to Practicing Engineers with Mixed Backgrounds"*, in *Ninth Annual International Symposium of the International Council on Systems Engineering*, 1999, Brighton, England.
- [14] **Boujut J.-F. and Blanco E.**, *"Intermediary Objects as a Means to Foster Co-operation in Engineering Design"* in *Computer Supported Cooperative Work*, 2003, Vol. 12(2), p. 205-219.
- [15] **Boujut J.-F. and Laureillard P.**, *"A co-operation framework for product-process integration in engineering design"* in *Design Studies*, 2002, Vol. 23, p. 497-513.
- [16] **Brekka L. T.** *"Life Cycle Risk Management"*, in *The Fifth Annual International Symposium of the National Council on Systems Engineering*, 1995, St. Louis, Missouri.
- [17] **Browning T. R.**, *"Process Integration Using the Design Structure Matrix"* in *The Journal of The International Council on Systems Engineering*, 2002, Vol. 5(3), p. 180-193.
- [18] **Browning T. R.** *"Use of dependency structure matrices for product development cycle time reduction"*, in *the Fifth ISPE International Conference on Concurrent Engineering: Research and Application*, 1998, Tokyo, Japan.
- [19] **Browning T. R., Fricke E., and Negele H.** *"Tutorial: Process Modeling in a Systems Engineering Context"*, in *The 13th Annual International Symposium INCOSE 2003*, 2003, Washington, DC.
- [20] **Cavallucci D.**, *"Contribution à la conception de nouveaux systèmes mécaniques par intégration méthodologique, Chapitre 2 : Etat de l'art des méthodes de conception de nouveaux produits"*, Ph.D. Thesis of the *Laboratoire de Recherche en Productique de Strasbourg*, 1999, Ecole Nationale Supérieure des Arts et Industries de Strasbourg, Strasbourg.
- [21] **Cavallucci D. and Lutz P.** *"Intuitive Design Method (IDM), a new approach on design methods integration"*, in *First International Conference on Axiomatic Design*, 2000, Cambridge, MA USA, ICAD2000.

- [22] **Chen D. and Doumeingts G.** "Basic concepts of the general theory of design : a state-of-the-art", in *9th Symposium INFORMATION CONTROL in Manufacturing*, 1998, Nancy - Metz, France.
- [23] **Choveau E. and de Chazelles P.** "Application de l'Ingénierie Système pour la définition d'une démarche d'Ingénierie des Exigences pour l'Airbus A380", in *Deuxième Conférence Annuelle de l'Association Française d'Ingénierie Système*, 2001, Toulouse, FR, AFIS.
- [24] **Clausing D. and Cohen L.** "System Flowdown Using Enhanced QFD", in *Ninth Annual International Symposium of the International Council on Systems Engineering*, 1999, Brighton, England.
- [25] **Cleetus K.J.**, "Definition of Concurrent Engineering", 1992, Concurrent Engineering Research Center, Morgantown, WV.
- [26] **CMM**, "Top-Level Standards Map, relations between ISO 12207, ISO 15504 (Jan 1998 TR), Software CMM v1.1 and v2, Draft C", 1998, Tantara Inc. ([www.tantara.ab.ca](http://www.tantara.ab.ca)), Calgary, CA.
- [27] **CMMI**, "Capability Maturity Model Integrated (poster)", in *CMMI-SE/SW/IPPD/SS*, 2003, Carnegie Mellon - Software Engineering Institute, Pittsburgh.
- [28] **CMMI**, "Capability Maturity Model Integrated CMMI-SE/SW", 2000, Carnegie Mellon - Software Engineering Institute, Pittsburgh.
- [29] **CMMI**, "CMMI-SE/SW/IPPD/SS - Continuous Representation", 2002 (b), Carnegie Mellon - Software Engineering Institute, Pittsburgh.
- [30] **CMMI**, "CMMI-SE/SW/IPPD/SS - Staged Representation", 2002 (a), Carnegie Mellon - Software Engineering Institute, Pittsburgh.
- [31] **Cochran D. S., et al.**, "The Application of Axiomatic Design and Lean Management Principles in the Scope of Production System Segmentation" in *The International Journal of Production Research*, 2000, Vol. 38(6), p. 1377-1396.
- [32] **Cochran D. S. and Reynal V. A.** "Axiomatic Design of Manufacturing Systems - Creating a Methodology for Process Improvement", in *Second World Congress on Intelligent Manufacturing Processes and Systems*, 1997, Budapest, Hungary.
- [33] **Cusick K.**, "Improvement Stages (cross talk)" in *The Journal of Defense Software Engineering*, 1996, Vol. October 1996, p. 22-24.
- [34] **Cusick K. and Bruce J.** "A CMM For All Disciplines", in *Ninth Annual International Symposium of the INCOSE*, 1999, Brighton, UK.

## 118 - References

### *From Edwards to Hazebroucq*

- [35] **Edwards K.L.**, *"Towards more strategic product design for manufacture and assembly : priorities for concurrent engineering"*, 2002, School of computing and technology, University of Derby, Derby, UK.
- [36] **EIA632**, *"Processes for Engineering a System"*, in *ANSI/EIA-632-1998*, 1998, EIA.
- [37] **Eppinger Steven D., et al.**, *"A model-based method for organizing tasks in product development"* in *Research in Engineering Design*, 1994, Vol. 6(1), p. 1-13.
- [38] **Eynard B.**, *"Modélisation du produit et des activités de conception, contribution a la conduite et a la traçabilité du processus d'ingénierie"*, Ph.D. Thesis of the *Ecole doctorale des sciences physiques et de l'ingénieur*, 1999, Université Bordeaux 1, Bordeaux.
- [39] **Eynard B., Girard P., and Chen D.** *"Un modèle produit support à la conduite de processus de conception"*, in *Deuxième Congrès International Franco-Québécois de Génie Industriel*, 1997, Albi, France.
- [40] **Fernandez A.**, *"Les nouveaux tableaux de bord pour piloter l'entreprise"*, 1999, Paris, Editions d'Organisation.
- [41] **Fisher J.** *"Failure Management and the Design of Complex Systems"*, in *The Fifth Annual International Symposium of the National Council on Systems Engineering*, 1995, St. Louis, Missouri.
- [42] **Gamma E., et al.**, *"Design Patterns, Elements of reusable Object-Oriented software"*, 1995, Addison-Wesley Publishing Company.
- [43] **Gu P. and Kusiak A.**, *"Concurrent Engineering, Methodology and Applications"*. *Advances in Industrial Engineering*, Vol. 19, 1993, Elsevier Science Publishers, 330.
- [44] **Hammer M. and Champy D.**, *"Le Reengineering"*, 1993, Paris, DUNOD.
- [45] **Harani Y.**, *"Une approche multi-modèles pour la capitalisation des connaissances dans le domaine de la conception"*, Ph.D. Thesis of the *Institut National Polytechnique de Grenoble*, 1997.
- [46] **Harding J.A. and Popplewell K.**, *"Driving concurrency in a distributed concurrent engineering project team: a specification for an Engineering Moderator"* in *International Journal of Production Research*, 1996, Vol. 34(3), p. 841-861.
- [47] **Hazebroucq J.M.**, *"La nouvelle conception de la performance : être efficace, oui, mais aussi efficient."* in *Revue Gestion 2000*, 1999.
- [48] **Hazebroucq J.M.**, *"La performance dans le management des projets"*, Ph.D. Thesis of the *Institut d'Administration des Entreprises*, 1992, Lille.

- [49] **Huang G. Q. and Sheldon D. F.**, *"If Concurrent Engineering is the Answer, What is the Question?"* in IMECHE AUTOTECH, 1993, Vol. C462/46/108.
- [50] **IEEE1220**, *"IEEE Trial-Use Standard for Application and Management of the System Engineering Process"*, in IEEE Std 1220-1994, 1995, IEEE, New-York.
- [51] **Iilff R. C.** *"A Question of Context - Why Manufacturing Cultures Don't Understand Systems Engineering"*, in International Council On Systems Engineering, 2002, Los Angeles.
- [52] **INCOSE**, *"Systems Engineering Capability Assessment Model"*, 1996, International Council on Systems Engineering.
- [53] **INCOSE and AIAA**, *"Systems Engineering, a way of thinking, a way of doing business, enabling organized transition from need to market"*, 1997, Jointly written by the American Institute of Aeronautics and Astronautics, and the International Council on Systems Engineering.
- [54] **ISO15288**, *"Life Cycle Management & System Life Cycle Processes"*, in ISO 15288 CD2, Canada, Editor, 2000, ISO/IEC.
- [55] **ISO15288**, *"System Engineering - System Life Cycle"*, in ISO 15288 CD3 Processes, Canada, Editor, 2001, ISO/IEC.
- [56] **Kim Y.-S.**, *"A system complexity approach for the integration of product development and production system design"*, in Department of Mechanical Engineering, 1999, Massachusetts Institute of Technology, Cambridge, MA (USA).
- [57] **Kuest K. M.**, *"The Development of the Production System Design Decomposition Framework"*, M.Sc. Thesis Department of Mechanical Engineering, 1999, Massachusetts Institute of Technology, Cambridge, MA (USA).
- [58] **Kusiak A. and Larson N.**, *"Concurrent Engineering"*, in Handbook for systems engineering and management, Andrew P. Sage and William B. Rouse, Editor, 1999, John Wiley and Sons, Inc., New York, p. 327-370.
- [59] **Kusiak A. and Park K.**, *"Concurrent engineering: decomposition and scheduling of design activities"* in International Journal of Production Research, 1990, Vol. 28(10), p. 1883-1900.
- [60] **Lakey P. B.** *"A Systems Engineering Approach to Optimize Customer Satisfaction on Complex Systems"*, in The Fifth Annual International Symposium of the National Council on Systems Engineering, 1995, St. Louis, Missouri.



## 120 - References

### *From Lardeur to Lardeur*

- [61] **Lardeur E. and Auzet C.** "Deployment of SE including Manufacturing Systems development: Practical Aspects", in *The 13th Annual International Symposium INCOSE 2003*, 2003, Washington, DC.
- [62] **Lardeur E., Auzet C., and Bocquet J.-C.** "Co-ordination of product and related manufacturing systems design with systems engineering", in *2003 International CIRP Design Seminar*, 2003 (c), Grenoble, France.
- [63] **Lardeur E., Auzet C., and Bocquet J.-C.** "Deployment of SE including Manufacturing Systems development: Theoretical Aspects", in *The 13th Annual International Symposium INCOSE 2003*, 2003 (a), Washington, DC.
- [64] **Lardeur E., Auzet C., and Bocquet J.-C.**, "Deployment of the Systems Engineering methodology in automotive industry, including Manufacturing Systems engineering" submitted to *The Journal of The International Council on Systems Engineering*, 2003 (b).
- [65] **Lardeur E., Bocquet J.-C., and Auzet C.** "Coordination des ingénieries des produits et des systèmes de production associés par l'Ingénierie Système", in *8ème Colloque national sur la conception mécanique intégrée et la productique*, 2003 (c), La Plagne, FR.
- [66] **Lardeur E., Bocquet J.-C., and Auzet C.** "Etude sur l'évaluation de la performance globale des activités de conception des systèmes complexes et de leurs systèmes de production", in *Deuxième Conférence Annuelle de l'Association Française d'Ingénierie Système*, 2001, Toulouse, FR, AFIS.
- [67] **Lardeur E., Bocquet J.-C., and Auzet C.** "Systems Engineering used in Products and Manufacturing Systems development : case of Automotive Industry", in *The Forth International Conference on Integrated Design and Manufacturing in Mechanical Engineering - Selected for Kluwer Publishing*, 2002, Clermont-Ferrand, FR.
- [68] **Lardeur E., Bocquet J.-C., and Auzet C.**, "Systems Engineering used in Products and Manufacturing Systems development : case of Automotive Industry", in *Recent Advances in Integrated Design and Manufacturing in Mechanical Engineering*, D.C. G. GOGU, P. CHEDMAIL and P. RAY, Editor, 2003 (a), KLUWER Academic Publishers.
- [69] **Lardeur E., Bocquet J.-C., and Auzet C.** "Using Systems Engineering to enhance Concurrent Engineering environment through Modeling Problems", in *9th International Conference of Concurrent Enterprising*, 2003 (b), Espoo, Finland.
- [70] **Lardeur E. and Longueville B.** "Mutual enhancement of Concurrent Engineering and Knowledge Management through process modeling: toward an integrated framework", in *CESA, Invited Session on "Object Oriented Approaches for Production Systems Modeling"*, 2003, Lille, France.

- [71] **Lee Rong-Schean, Chen Yuh-Min, and Lee Chang-Zou**, "Development of a concurrent mold design system: A knowledge-based approach" in *Computer Integrated Manufacturing Systems*, 1997, Vol. 10(4), p. 287-307.
- [72] **Legardeur J., et al.** "Coopération et coordination dans les processus de conception", in *8ème Colloque national sur la conception mécanique intégrée et la productivité*, 2003, La Plagne, FR.
- [73] **Lerat J.-P.** "Will car manufacturers survive the second death of Henry Ford?" in *The 13th Annual International Symposium INCOSE 2003*, 2003, Washington, DC.
- [74] **Longueville B., Stal Le Cardinal J. and Bocquet J.-C.** "Toward a Project Memory for Innovative Production Design, a Decision-making Process Model", in *The 14th International Conference on Engineering Design*, 2003, Stockholm, Sweden.
- [75] **Lorino P.**, "Le déploiement de la valeur par les processus" in *Revue française de gestion*, 1995.
- [76] **Loureiro G., Leaney P. G., and Hodgson M.** "A Systems Engineering Framework for Integrated Automotive Development", in *Ninth Annual International Symposium of the International Council on Systems Engineering*, 1999, Brighton, England.
- [77] **Marle F.**, "Modèles d'informations et méthodes pour aider à la prise de décision en management de projet", Ph.D. Thesis of the *Laboratoire Génie Industriel*, 2002 (a), Ecole Centrale Paris, Paris.
- [78] **Marle F. bis** "Plan more by planning less: contributions to a fractal planning process", in *PMI Research Conference 2002*, 2002 (b), Seattle.
- [79] **Maropoulos P.G., et al.**, "An integrated design and planning environment for welding: Part 1: Product modeling and Part 2: Process Planning" in *Journal of Materials Processing Technology*, 2000, Vol. 107(1-3), p. 3-14.
- [80] **Martin C.**, "Process design modeling through methodological integration", Ph.D. Thesis of the *Laboratoire Productique - Logistique*, 2001, Ecole Centrale PARIS, PARIS.
- [81] **Matty G.E. Jr.** "The Benefits of the Systems Engineering Process in Concurrent Engineering", in *The Fifth Annual International Symposium of the National Council on Systems Engineering*, 1995, St. Louis, Missouri.
- [82] **Menand S.**, "Modélisation pour la réutilisation des processus de conception multiacteurs", Ph.D. Thesis of the *GILCO Gestion Industrielle, Logistique et Conception*, 2002, Institut National Polytechnique de Grenoble, Grenoble.
- [83] **Oliver D. W.** "A Systems Engineering Tools Taxonomy", in *The Fifth Annual International Symposium of the National Council on Systems Engineering*, 1995, St. Louis, Missouri.

## 122 - References

### *From Oosterman to Secat LCC*

- [84] **Oosterman B.**, *"Improving Product Development Projects by Matching Product Architecture and Organization"*, 2001, Ph.D. Thesis of the Rijksuniversiteit Groningen, Groningen.
- [85] **Pahl G. and Beitz W.**, *"Engineering Design: A Systematic Approach"*, 1996, London, Springer Verlag.
- [86] **Perrin J.**, *"Pilotage et évaluation des processus de conception"*, 1999, Paris, Ouvrage collectif du groupe ECOSIP, Collection Economiques, Ed. l'Harmattan.
- [87] **PMBOK**, *"A Guide to the Project Management Body of Knowledge"*, in *PMBOK Guide*, 1996, Project Management Institute, Newtown Square, Pennsylvania USA.
- [88] **Pollak B.**, *"Discussion with Members of the CMMI Steering Group, moderated by Bill Pollak"*, in *INCOSE Website*, 1998, SEI Interactive.
- [89] **Preston White K. Jr.**, *"Systems Design"*, in *Handbook for systems engineering and management*, Andrew P. Sage and William B. Rouse, Editor, 1999, John Wiley and Sons, Inc., New York, p. 455-481.
- [90] **Preston White K. Jr.**, *"Systems Design Engineering"* in *The Journal of The International Council on Systems Engineering*, 1998, Vol. 1(4), p. 285-302.
- [91] **PSA**, *"Presentation to the executive board"*, 1998, Personal report, PSA Peugeot Citroën.
- [92] **Qi D. and Berry P.W.** *"Managing System Interface Requirements Reconciliation using Design Structure Matrix Method"*, in *The 13th Annual International Symposium INCOSE 2003*, 2003, Washington, DC.
- [93] **Reynal V. A.**, *"Production System Design and Its Implementation in the Automotive and Aircraft Industry"*, Ph.D. Thesis of the Department of Mechanical Engineering, 1998, Massachusetts Institute of Technology, Cambridge, MA (USA).
- [94] **Salomone T.A.**, *"What every engineer should know about concurrent engineering"*, 1995, New York, Dekker.
- [95] **Savransky S. D.** *"The Systematic Methodology of Inventive Problem Solving - TRIZ: a review"*, in *Ninth Annual International Symposium of the International Council on Systems Engineering*, 1999, Brighton, England.
- [96] **Schulz A. P., et al.** *"Total Technology Development - Shifting the View in Systems Development"*, in *Ninth Annual International Symposium of the International Council on Systems Engineering*, 1999, Brighton, England.
- [97] **SECAT LLC**, *"Micro Assessment Guide & Pocket Guide Information"*, in *CMMs-To-Go*, 1998.

- [98] **Sheard S.A., Lykins H., and Armstrong J.R.**, "Overcoming Barriers to Systems Engineering Process Improvement" in *The Journal of The International Council on Systems Engineering*, 2000, Vol. 3(2), p. 59-67.
- [99] **Simon H.A.**, "*The Science of the Artificial*", ed. M. Press, 1981, Cambridge, USA, MA.
- [100] **Singh K. J. and Lewis J. W.**, "Concurrent Engineering: institution, infrastructure and implementation" in *International Journal of Technology Management*, 1997, Vol. 14(6-8), p. 727-738.
- [101] **Sohlenius G.**, "Concurrent Engineering" in *Annals of the CIRP*, 1992, Vol. 41(2).
- [102] **Standish Group**, "*The Chaos Report ([www.standishgroup.com](http://www.standishgroup.com))*", 1994.
- [103] **Tate D.**, "*A Roadmap for Decomposition: Activities, Theories, and Tools for System Design*", Ph.D. Thesis of the *Department of Mechanical Engineering*, 1999, Massachusetts Institute of Technology, Cambridge, MA (USA).
- [104] **Tate D. and Nordlund M.** "A Design Process Roadmap as a General Tool for Structuring and Supporting Design Activities", in *Second World Conference on Integrated Design and Process Technology*, 1996, Austin, TX.
- [105] **Thomas J.** "Airbus: the way from a unique Experiment to an acknowledged Global Player, as invited speaker", in *The Third European Systems Engineering Conference*, 2002, Toulouse, France, EuSEC2002.
- [106] **Tichkiewitch S. and Brissaud D.** "Co-Ordination Between Product and Process Definitions in a Concurrent Engineering Environment", in *The 50th General Assembly of CIRP*, 2000, Sydney, Australia.
- [107] **Tronstad Y. D.** "Systems Engineering as Model Making", in *The Fifth Annual International Symposium of the National Council on Systems Engineering*, 1995, St. Louis, Missouri.
- [108] **Ulrich K.T. and Eppinger S.D.**, "*Product Design and Development (1st edition)*", 1995, New York, McGraw-Hill.
- [109] **Whitfield R. I., C.G., Duffy A. H. B., Hills B.**, "A System for Co-ordinating Concurrent Engineering", in *International Conference on Engineering Design*, 2001, Glasgow.
- [110] **Whitney Daniel E.**, "Designing the design process" in *Research in Engineering Design*, 1990, Vol. 2, p. 3-13.
- [111] **Wixson J. R.** "Function Analysis and Decomposition using Function Analysis Systems Technique", in *Ninth Annual International Symposium of the International Council on Systems Engineering*, 1999, Brighton, England.

## 124 - References

*From Wunram to Zha*

- [112] **Wunram M.**, *"Development of a methodology and mapping mechanism for assessing and improving the product development practice toward Concurrent Engineering"*, 1999, Research Report of the University of Bremen, Bremen.
  
- [113] **Yannou B.**, *"Préconception de Produits"*, 2001, Research Direction Capacitation Dissertation of the Institut National Polytechnique de Grenoble - Laboratoire Productique-Logistique de l'Ecole Centrale de Paris, Paris.
  
- [114] **Zha X.F. and Dhu H.**, *"A PDES/STEP based model and system for concurrent integrated design and assembly planning"* in *Computer-Aided Design*, 2002, Vol. 34(14), p. 1087-1110.

## **Résumé détaillé en français**

---

### **Amélioration de la performance de l'ingénierie dans un contexte d'Ingénierie Système**

#### ***Cas du développement conjoint des produits automobiles et de leurs systèmes de fabrication***

Le premier objectif de ce résumé détaillé en français est de fournir au lecteur non anglophone une description complète du contenu du mémoire. Un objectif secondaire est de proposer un guide de lecture grâce à l'indexation de son contenu (les pages sont indiquées, et accessibles par l'intermédiaire de liens hypertextes sur la version informatique).

Cette thèse a été réalisée de novembre 2000 à octobre 2003 au sein du groupe PSA Peugeot Citroën, dans le service responsable de la définition, de la communication et de l'ajustement des plannings de développement des nouveaux véhicules, et plus particulièrement dans l'entité chargée de définir et de déployer la démarche d'Ingénierie Système Automobile.

#### ***Plan***

Ce mémoire de thèse est organisé de la manière suivante : l'introduction présente succinctement le contexte (*Challenges and lacks in the engineering field, page 14*), la problématique et les principaux objectifs de l'étude (*Research question and objectives, page 15*) ainsi que la structuration du mémoire (*Outline of the Thesis, page 17*) ; le chapitre 1 (*Industrial challenges and research issues, page 19*) détaille les différents enjeux industriels, le périmètre concerné par la thèse et les questions de recherche déduites. Les contributions sont précisées par le plan d'action ; le chapitre 2 (*State of the art, page 35*) présente l'état de l'art, en réponse

- 126 - [1] **Abadi C. D. and Bahil T.** "Separating Product and Process Requirements", in *International Council On Systems Engineering*, 2002, Los Angeles.
- [2] **AFIS**, "Indicators", 1999, Working group for Maturity Models & Indicators - French SE Association "AFIS".
- [3] **Ali M.**, "Production System Design Methodology with Emphasis on Sub-system and Equipment Design", M.Sc. Thesis of the Department of Mechanical Engineering, 1997, Massachusetts Institute of Technology, Cambridge, MA (USA).
- [4] **Arcidiacono G.**, "Axiomatic Design for Reliability" in *ATA*, 2000, Vol. 53-7/8, p. 309-315.
- [5] **Arnold F. and Podehl G.**, "Best of Both Worlds - A mapping from EXPRESS-G to UML", 1998, University of Kaiserslautern, Germany, Kaiserslautern.
- [6] **Auzet C.**, "Guide Démarche d'Ingénierie Système Automobile (Automotive Systems Engineering Guide)", 1999, PSA Peugeot Citroën, confidential documentation.
- [7] **Auzet C. and Lardeur E.**, "Guide complémentaire à la démarche d'Ingénierie Système Automobile - Développement des systèmes de production associés aux systèmes produits (manufacturing systems engineering with Systems Engineering guide)", 2003, PSA Peugeot Citroën, confidential documentation.
- [8] **Bacha R.**, "De la gestion des données techniques par l'ingénierie de production", Ph.D. Thesis of the *Laboratoire Productique-Logistique*, 2002, Ecole Centrale Paris, Chatenay-Malabry.
- [9] **Banares-Alcantara R.**, "Concurrent Process Engineering: State of the Art and Outstanding Research Issues" in Working paper for TWG4, 2000, p. 18.

aux questions de recherche : les modèles et approches d'ingénierie sont présentés pour leur contribution à la méthodologie d'Ingénierie Système, qui est ensuite explicitée, enfin la thématique d'évaluation de performance des activités de développement est traitée ; le chapitre 3 (*Automotive SE extension: eASE, page 63*) montre l'extension apportée à l'Ingénierie Système Automobile et notamment la construction du cadre de conception conjointe des produits et des systèmes de production, ce sont les résultats théoriques regroupés et désignés par l'acronyme *eASE* pour *extended Automotive Systems Engineering*; le chapitre 4 (*eASE Evaluation and Control, page 77*) présente la méthode outillée d'évaluation mise à disposition des équipes de développement de systèmes de fabrication de PSA Peugeot Citroën pour identifier leurs marges de progrès. La méthode outillée permet d'appliquer de manière adaptée l'Ingénierie Système afin d'améliorer la performance des activités de développement ; le chapitre 5 (*eASE Deployment and Application, page 89*) montre le cas d'application pratique le plus significatif réalisé afin d'améliorer concrètement l'efficacité d'un processus d'ingénierie ; pour finir, le chapitre 6 (*eASE Instrumentation, page 97*) introduit la perspective d'instrumentation des résultats théoriques. En

- [1] **Abadi C. D. and Bahil T.** "Separating Product and Process Requirements", in *International Council On Systems Engineering*, 2002, Los Angeles.
- [2] **AFIS**, "Indicators", 1999, Working group for Maturity Models & Indicators - French SE Association "AFIS".
- [3] **Ali M.**, "Production System Design Methodology with Emphasis on Sub-system and Equipment Design", M.Sc. Thesis of the Department of Mechanical Engineering, 1997, Massachusetts Institute of Technology, Cambridge, MA (USA).
- [4] **Arcidiacono G.**, "Axiomatic Design for Reliability" in *ATA*, 2000, Vol. 53-7/8, p. 309-315.
- [5] **Arnold F. and Podehl G.**, "Best of Both Worlds - A mapping from EXPRESS-G to UML", 1998, University of Kaiserslautern, Germany, Kaiserslautern.
- [6] **Auzet C.**, "Guide Démarche d'Ingénierie Système Automobile (Automotive Systems Engineering Guide)", 1999, PSA Peugeot Citroën, confidential documentation.
- [7] **Auzet C. and Lardeur E.**, "Guide complémentaire à la démarche d'Ingénierie Système Automobile - Développement des systèmes de production associés aux systèmes produits (manufacturing systems engineering with Systems Engineering guide)", 2003, PSA Peugeot Citroën, confidential documentation.
- [8] **Bacha R.**, "De la gestion des données techniques par l'ingénierie de production", Ph.D. Thesis of the Laboratoire Productique-Logistique, 2002, Ecole Centrale Paris, Chatenay-Malabry.
- [9] **Banares-Alcantara R.**, "Concurrent Process Engineering: State of the Art and Outstanding Research Issues" in Working paper for TWG4, 2000, p. 18.

conclusion, un bilan des travaux est dressé et les perspectives de recherche sont introduites.

## *Introduction*

Le contexte de cette étude est marqué par la nécessité pour les entreprises d'améliorer la performance de leurs processus de développement, qui correspond à l'intégration de différents métiers<sup>15</sup> représentant des disciplines distinctes contribuant à un objectif d'entreprise. Dans ce contexte, la problématique générale à laquelle la thèse répond est la suivante :

*Comment faire évoluer les métiers, à partir de leurs pratiques actuelles optimisées localement, vers une cible méthodologique répondant à un optimum global ?*

Pour répondre à cette problématique, la cible méthodologique développée par PSA Peugeot Citroën est l'Ingénierie Système Automobile.

---

<sup>15</sup> un "métier" correspond à une composante de l'organisation en recherche et développement, qui contribue par son expertise à l'ingénierie d'un système technique (produit automobile comme système manufacturier).



- 128 - [1] **Abadi C. D. and Bahil T.** "Separating Product and Process Requirements", in *International Council On Systems Engineering*, 2002, Los Angeles.
- [2] **AFIS**, "Indicators", 1999, Working group for Maturity Models & Indicators - French SE Association "AFIS".
- [3] **Ali M.**, "Production System Design Methodology with Emphasis on Sub-system and Equipment Design", M.Sc. Thesis of the Department of Mechanical Engineering, 1997, Massachusetts Institute of Technology, Cambridge, MA (USA).
- [4] **Arcidiacono G.**, "Axiomatic Design for Reliability" in *ATA*, 2000, Vol. 53-7/8, p. 309-315.
- [5] **Arnold F. and Podehl G.**, "Best of Both Worlds - A mapping from EXPRESS-G to UML", 1998, University of Kaiserslautern, Germany, Kaiserslautern.
- [6] **Auzet C.**, "Guide Démarche d'Ingénierie Système Automobile (Automotive Systems Engineering Guide)", 1999, PSA Peugeot Citroën, confidential documentation.
- [7] **Auzet C. and Lardeur E.**, "Guide complémentaire à la démarche d'Ingénierie Système Automobile - Développement des systèmes de production associés aux systèmes produits (manufacturing systems engineering with Systems Engineering guide)", 2003, PSA Peugeot Citroën, confidential documentation.
- [8] **Bacha R.**, "De la gestion des données techniques par l'ingénierie de production", Ph.D. Thesis of the *Laboratoire Productique-Logistique*, 2002, Ecole Centrale Paris, Chatenay-Malabry.
- [9] **Banares-Alcantara R.**, "Concurrent Process Engineering: State of the Art and Outstanding Research Issues" in Working paper for TWG4, 2000, p. 18.

Les objectifs ont été d'étendre la méthodologie d'Ingénierie Système Automobile au domaine des systèmes de production et d'étudier son utilisation pour l'amélioration de l'efficacité des processus d'ingénierie. La contribution ne se restreint donc pas à l'ingénierie des systèmes de production, et porte en quelque sorte sur la maximisation du profit lié à l'utilisation de l'Ingénierie Système pour le développement de produits automobiles et des systèmes de fabrication associés.

### ***Enjeux industriels et questions de recherche***

Trois constats corroborent l'intérêt de la thèse : l'étude du rapport Chaos [Standish Group, 1994] montre de manière empirique l'importance des approches d'ingénierie dans la réussite des projets de développement (*page 20*) ; l'analyse proposée par [Bellut S., 1990] confirme l'intérêt d'optimiser prioritairement l'ingénierie en comparant l'impact économique des décisions prises en phase d'ingénierie et en phase de production (*page 22*) ; le constat réalisé par PSA Peugeot Citroën à propos des délais de développement des véhicules des différents constructeurs mondiaux [PSA, 1998] permet de

- [1] **Abadi C. D. and Bahil T.** "Separating Product and Process Requirements", in *International Council On Systems Engineering*, 2002, Los Angeles.
- [2] **AFIS**, "Indicators", 1999, Working group for Maturity Models & Indicators - French SE Association "AFIS".
- [3] **Ali M.**, "Production System Design Methodology with Emphasis on Sub-system and Equipment Design", M.Sc. Thesis of the Department of Mechanical Engineering, 1997, Massachusetts Institute of Technology, Cambridge, MA (USA).
- [4] **Arcidiacono G.**, "Axiomatic Design for Reliability" in *ATA*, 2000, Vol. 53-7/8, p. 309-315.
- [5] **Arnold F. and Podehl G.**, "Best of Both Worlds - A mapping from EXPRESS-G to UML", 1998, University of Kaiserslautern, Germany, Kaiserslautern.
- [6] **Auzet C.**, "Guide Démarche d'Ingénierie Système Automobile (Automotive Systems Engineering Guide)", 1999, PSA Peugeot Citroën, confidential documentation.
- [7] **Auzet C. and Lardeur E.**, "Guide complémentaire à la démarche d'Ingénierie Système Automobile - Développement des systèmes de production associés aux systèmes produits (manufacturing systems engineering with Systems Engineering guide)", 2003, PSA Peugeot Citroën, confidential documentation.
- [8] **Bacha R.**, "De la gestion des données techniques pur l'ingénierie de production", Ph.D. Thesis of the Laboratoire Productique-Logistique, 2002, Ecole Centrale Paris, Chatenay-Malabry.
- [9] **Banares-Alcantara R.**, "Concurrent Process Engineering: State of the Art and Outstanding Research Issues" in Working paper for TWG4, 2000, p. 18.

conclure sur la prévalence des approches d'ingénierie pour garantir la réussite des projets, car elles relient les objectifs stratégiques aux pratiques réelles des équipes de développement (*page 23*).

PSA Peugeot Citroën a pour objectif de réaliser l'ingénierie d'un nouveau véhicule (dans des conditions spécifiques) en deux ans. La démarche d'Ingénierie Système Automobile a donc été définie pour assurer la cohérence entre les pratiques d'ingénierie contribuant à cet objectif.

Les enjeux industriels sont triples: sur le plan technique, la complexité croissante des véhicules (notamment dans le domaine électronique) mais aussi des systèmes industriels qui les produisent et la complexité résultante de leur ingénierie ; sur le plan méthodologique, la profusion des méthodes censées supporter une approche d'ingénierie optimale ; sur un plan plus humain, l'évolution des pratiques traditionnelles vers l'Ingénierie Système qui représente une nouvelle manière d'agir (*page 25*) .

La thèse correspond donc à l'étude d'une transformation des pratiques de développement. Le périmètre couvre l'ingénierie des systèmes automobiles et celle des systèmes qui les fabriquent. Il s'agit de concevoir et mettre en œuvre

- 130 - [1] **Abadi C. D. and Bahil T.** "Separating Product and Process Requirements", in *International Council On Systems Engineering*, 2002, Los Angeles.
- [2] **AFIS**, "Indicators", 1999, Working group for Maturity Models & Indicators - French SE Association "AFIS".
- [3] **Ali M.**, "Production System Design Methodology with Emphasis on Sub-system and Equipment Design", M.Sc. Thesis of the Department of Mechanical Engineering, 1997, Massachusetts Institute of Technology, Cambridge, MA (USA).
- [4] **Arcidiacono G.**, "Axiomatic Design for Reliability" in *ATA*, 2000, Vol. 53-7/8, p. 309-315.
- [5] **Arnold F. and Podehl G.**, "Best of Both Worlds - A mapping from EXPRESS-G to UML", 1998, University of Kaiserslautern, Germany, Kaiserslautern.
- [6] **Auzet C.**, "Guide Démarche d'Ingénierie Système Automobile (Automotive Systems Engineering Guide)", 1999, PSA Peugeot Citroën, confidential documentation.
- [7] **Auzet C. and Lardeur E.**, "Guide complémentaire à la démarche d'Ingénierie Système Automobile - Développement des systèmes de production associés aux systèmes produits (manufacturing systems engineering with Systems Engineering guide)", 2003, PSA Peugeot Citroën, confidential documentation.
- [8] **Bacha R.**, "De la gestion des données techniques par l'ingénierie de production", Ph.D. Thesis of the *Laboratoire Productique-Logistique*, 2002, Ecole Centrale Paris, Chatenay-Malabry.
- [9] **Banares-Alcantara R.**, "Concurrent Process Engineering: State of the Art and Outstanding Research Issues" in Working paper for TWG4, 2000, p. 18.

une approche d'ingénierie *générique* car elle couvre l'ensemble du cycle de vie du produit, et *spécifique* car elle concerne l'optimum précis de l'ingénierie conjointe du *produit* et ses *process*, interne au groupe PSA Peugeot Citroën.

L'orientation de recherche est détaillée dans le tableau page suivante. Il traduit celui de la page 33, qui met en correspondance les objectifs et les questions de recherche (*codés O et I*) avec les éléments de l'état de l'art et les différentes contributions apportées à travers le plan d'action.

- [1] **Abadi C. D. and Bahil T.** "Separating Product and Process Requirements", in *International Council On Systems Engineering*, 2002, Los Angeles.
- [2] **AFIS**, "Indicators", 1999, Working group for Maturity Models & Indicators - French SE Association "AFIS".
- [3] **Ali M.**, "Production System Design Methodology with Emphasis on Sub-system and Equipment Design", M.Sc. Thesis of the Department of Mechanical Engineering, 1997, Massachusetts Institute of Technology, Cambridge, MA (USA).
- [4] **Arcidiacono G.**, "Axiomatic Design for Reliability" in *ATA*, 2000, Vol. 53-7/8, p. 309-315.
- [5] **Arnold F. and Podehl G.**, "Best of Both Worlds - A mapping from EXPRESS-G to UML", 1998, University of Kaiserslautern, Germany, Kaiserslautern.
- [6] **Auzet C.**, "Guide Démarche d'Ingénierie Système Automobile (Automotive Systems Engineering Guide)", 1999, PSA Peugeot Citroën, confidential documentation.
- [7] **Auzet C. and Lardeur E.**, "Guide complémentaire à la démarche d'Ingénierie Système Automobile - Développement des systèmes de production associés aux systèmes produits (manufacturing systems engineering with Systems Engineering guide)", 2003, PSA Peugeot Citroën, confidential documentation.
- [8] **Bacha R.**, "De la gestion des données techniques pur l'ingénierie de production", Ph.D. Thesis of the Laboratoire Productique-Logistique, 2002, Ecole Centrale Paris, Chatenay-Malabry.
- [9] **Banares-Alcantara R.**, "Concurrent Process Engineering: State of the Art and Outstanding Research Issues" in Working paper for TWG4, 2000, p. 18.

Tableau 1: Un plan de lecture pour le mémoire

Objectifs et questions de recherche		Éléments de la Thèse		
I4	Définir l'approche d'ingénierie la plus efficace, notamment parmi les nombreux modèles existants.	La sélection et la description d'un jeu de modèles, pour leur contribution à mon objectif.	§2.1, page 36	Analyse bibliographique : État de l'art (S2)
I3	Gérer la complexité de l'ingénierie du véhicule et ses systèmes de fabrication.	La description de l'Ingénierie Système et la justification des ses avantages.	§2.2, page 47	
I2	Savoir comment réaliser l'évaluation de la performance dans le domaine de l'ingénierie.	La sélection et la description d'approche d'évaluation.	§2.3, page 54	
O1a	Étendre l'application de l'Ingénierie Système Automobile au domaine des systèmes de production.	La construction de la première partie de la démarche étendue d'Ingénierie Système Automobile (eASE).	Chapter 3, page 63	Contributions Thésaurisation

- 132 - [1] **Abadi C. D. and Bahil T.** "Separating Product and Process Requirements", in *International Council On Systems Engineering*, 2002, Los Angeles.
- [2] **AFIS**, "Indicators", 1999, Working group for Maturity Models & Indicators - French SE Association "AFIS".
- [3] **Ali M.**, "Production System Design Methodology with Emphasis on Sub-system and Equipment Design", M.Sc. Thesis of the Department of Mechanical Engineering, 1997, Massachusetts Institute of Technology, Cambridge, MA (USA).
- [4] **Arcidiacono G.**, "Axiomatic Design for Reliability" in *ATA*, 2000, Vol. 53-7/8, p. 309-315.
- [5] **Arnold F. and Podehl G.**, "Best of Both Worlds - A mapping from EXPRESS-G to UML", 1998, University of Kaiserslautern, Germany, Kaiserslautern.
- [6] **Auzet C.**, "Guide Démarche d'Ingénierie Système Automobile (Automotive Systems Engineering Guide)", 1999, PSA Peugeot Citroën, confidential documentation.
- [7] **Auzet C. and Lardeur E.**, "Guide complémentaire à la démarche d'Ingénierie Système Automobile - Développement des systèmes de production associés aux systèmes produits (manufacturing systems engineering with Systems Engineering guide)", 2003, PSA Peugeot Citroën, confidential documentation.
- [8] **Bacha R.**, "De la gestion des données techniques par l'ingénierie de production", Ph.D. Thesis of the *Laboratoire Productique-Logistique*, 2002, Ecole Centrale Paris, Chatenay-Malabry.
- [9] **Banares-Alcantara R.**, "Concurrent Process Engineering: State of the Art and Outstanding Research Issues" in Working paper for TWG4, 2000, p. 18.

O1b	Etendre l'application de l'Ingénierie Système Automobile à la coordination de la conception conjointe des produits et des systèmes de production.	La construction de la deuxième partie de la démarche étendue d'Ingénierie Système Automobile (eASE).	Chapter 3, page 63
O2a	Fournir une méthode outillée pour améliorer les pratiques d'ingénierie actuelles...	Le processus d'évaluation et de contrôle de la démarche étendue d'Ingénierie Système Automobile.	Chapter 4, page 77
O2b	... quel que soit leur niveau de performance initial.	Le processus d'évaluation globale d'eASE et d'identification des améliorations locales à réaliser par la construction de feuilles de routes.	Chapter 4, page 77
I5	Prendre en compte l'hétérogénéité et les spécificités des métiers.	Le questionnaire réalisé pour l'extension, puis l'évaluation, le contrôle, le déploiement et l'application de la démarche étendue d'Ingénierie Système Automobile.	Chapter 3, page 63 Chapter 4, page 77 Chapter 5, page 89

- [1] **Abadi C. D. and Bahil T.** "Separating Product and Process Requirements", in *International Council On Systems Engineering*, 2002, Los Angeles.
- [2] **AFIS**, "Indicators", 1999, Working group for Maturity Models & Indicators - French SE Association "AFIS".
- [3] **Ali M.**, "Production System Design Methodology with Emphasis on Sub-system and Equipment Design", M.Sc. Thesis of the Department of Mechanical Engineering, 1997, Massachusetts Institute of Technology, Cambridge, MA (USA).
- [4] **Arcidiacono G.**, "Axiomatic Design for Reliability" in *ATA*, 2000, Vol. 53-7/8, p. 309-315.
- [5] **Arnold F. and Podehl G.**, "Best of Both Worlds - A mapping from EXPRESS-G to UML", 1998, University of Kaiserslautern, Germany, Kaiserslautern.
- [6] **Auzet C.**, "Guide Démarche d'Ingénierie Système Automobile (Automotive Systems Engineering Guide)", 1999, PSA Peugeot Citroën, confidential documentation.
- [7] **Auzet C. and Lardeur E.**, "Guide complémentaire à la démarche d'Ingénierie Système Automobile - Développement des systèmes de production associés aux systèmes produits (manufacturing systems engineering with Systems Engineering guide)", 2003, PSA Peugeot Citroën, confidential documentation.
- [8] **Bacha R.**, "De la gestion des données techniques pur l'ingénierie de production", Ph.D. Thesis of the Laboratoire Productique-Logistique, 2002, Ecole Centrale Paris, Chatenay-Malabry.
- [9] **Banares-Alcantara R.**, "Concurrent Process Engineering: State of the Art and Outstanding Research Issues" in Working paper for TWG4, 2000, p. 18.

O3	Agir pratiquement avec des équipes opérationnelles tout en gardant une vision prospective 10-15 ans.	L'application concrète de la démarche étendue d'Ingénierie Système Automobile.	<i>Chapter 5, page 89</i>	
I1	Traiter la thématique d'instrumentation des méthodes.	L'approche intégrée des méthodes et des outils.	<i>Chapter 6, page 97</i>	

- 134 - [1] **Abadi C. D. and Bahil T.** "Separating Product and Process Requirements", in *International Council On Systems Engineering*, 2002, Los Angeles.
- [2] **AFIS**, "Indicators", 1999, Working group for Maturity Models & Indicators - French SE Association "AFIS".
- [3] **Ali M.**, "Production System Design Methodology with Emphasis on Sub-system and Equipment Design", M.Sc. Thesis of the Department of Mechanical Engineering, 1997, Massachusetts Institute of Technology, Cambridge, MA (USA).
- [4] **Arcidiacono G.**, "Axiomatic Design for Reliability" in *ATA*, 2000, Vol. 53-7/8, p. 309-315.
- [5] **Arnold F. and Podehl G.**, "Best of Both Worlds - A mapping from EXPRESS-G to UML", 1998, University of Kaiserslautern, Germany, Kaiserslautern.
- [6] **Auzet C.**, "Guide Démarche d'Ingénierie Système Automobile (Automotive Systems Engineering Guide)", 1999, PSA Peugeot Citroën, confidential documentation.
- [7] **Auzet C. and Lardeur E.**, "Guide complémentaire à la démarche d'Ingénierie Système Automobile - Développement des systèmes de production associés aux systèmes produits (manufacturing systems engineering with Systems Engineering guide)", 2003, PSA Peugeot Citroën, confidential documentation.
- [8] **Bacha R.**, "De la gestion des données techniques par l'ingénierie de production", Ph.D. Thesis of the *Laboratoire Productique-Logistique*, 2002, Ecole Centrale Paris, Chatenay-Malabry.
- [9] **Banares-Alcantara R.**, "Concurrent Process Engineering: State of the Art and Outstanding Research Issues" in Working paper for TWG4, 2000, p. 18.

Le plan d'action (voir la Figure 7, page 34) consiste à mettre en évidence les problématiques d'extension et de régulation sur la situation initiale, décrite par une boucle fermée non asservie, comportant les trois étapes clés qui sont la *Définition*, le *Déploiement*, et l'*Application* de l'Ingénierie Système Automobile. Il s'agit d'étendre la démarche existante pour son application aux systèmes de production, et de réguler son déploiement pour optimiser la boucle citée, impliquant une nouvelle étape clé d'évaluation et de contrôle.

## *Etat de l'art*

L'état de l'art (page 35) présente les différentes approches et méthodes d'ingénierie, notamment celles que l'on qualifie de *prescriptives*. Le *Concurrent Engineering* (page 41) et le *Design for X* (page 43) sont détaillés, en raison du rôle qu'ils ont joué dans la construction du cadre de conception conjointe des produits et des systèmes de production en Ingénierie Système. D'autres approches et méthodes sont introduites (page 45), à titre d'exemples de modèles potentiellement contributeurs pour la mise en œuvre de l'Ingénierie Système, permettant de construire mon positionnement méthodologique (page 61, et voir

- [1] **Abadi C. D. and Bahil T.** "Separating Product and Process Requirements", in *International Council On Systems Engineering*, 2002, Los Angeles.
- [2] **AFIS**, "Indicators", 1999, Working group for Maturity Models & Indicators - French SE Association "AFIS".
- [3] **Ali M.**, "Production System Design Methodology with Emphasis on Sub-system and Equipment Design", M.Sc. Thesis of the Department of Mechanical Engineering, 1997, Massachusetts Institute of Technology, Cambridge, MA (USA).
- [4] **Arcidiacono G.**, "Axiomatic Design for Reliability" in *ATA*, 2000, Vol. 53-7/8, p. 309-315.
- [5] **Arnold F. and Podehl G.**, "Best of Both Worlds - A mapping from EXPRESS-G to UML", 1998, University of Kaiserslautern, Germany, Kaiserslautern.
- [6] **Auzet C.**, "Guide Démarche d'Ingénierie Système Automobile (Automotive Systems Engineering Guide)", 1999, PSA Peugeot Citroën, confidential documentation.
- [7] **Auzet C. and Lardeur E.**, "Guide complémentaire à la démarche d'Ingénierie Système Automobile - Développement des systèmes de production associés aux systèmes produits (manufacturing systems engineering with Systems Engineering guide)", 2003, PSA Peugeot Citroën, confidential documentation.
- [8] **Bacha R.**, "De la gestion des données techniques pur l'ingénierie de production", Ph.D. Thesis of the Laboratoire Productique-Logistique, 2002, Ecole Centrale Paris, Chatenay-Malabry.
- [9] **Banares-Alcantara R.**, "Concurrent Process Engineering: State of the Art and Outstanding Research Issues" in Working paper for TWG4, 2000, p. 18.

la Table 4, page 51). L'Ingénierie Système (page 47) est ensuite décrite. Enfin, les méthodes d'évaluation des pratiques de développement sont introduites (page 54), et notamment les modèles de maturités (page 56) et leur utilisation pour construire la démarche outillée. Le cadre choisi est l'évaluation de l'efficacité des processus de développement mesurée par comparaison avec des pratiques de développement standardisées.

### ***eASE : Extension de l'ISA***

L'extension de l'Ingénierie Système Automobile (page 63) consiste à définir la méthodologie appliquée au développement des systèmes de production. Cette application est illustrée par l'exemple didactique de l'ingénierie d'un ôte-agrafe et son système de fabrication. Cette contribution théorique a permis de construire une approche intégrée pour concevoir les produits automobiles et les systèmes de production associés (page 68), notamment axée sur l'identification et la gestion de trois types de liens :

- entre les systèmes produit et les systèmes de production modélisés dans les arborescences de développement,



- 136 - [1] **Abadi C. D. and Bahil T.** "Separating Product and Process Requirements", in *International Council On Systems Engineering*, 2002, Los Angeles.
- [2] **AFIS**, "Indicators", 1999, Working group for Maturity Models & Indicators - French SE Association "AFIS".
- [3] **Ali M.**, "Production System Design Methodology with Emphasis on Sub-system and Equipment Design", M.Sc. Thesis of the Department of Mechanical Engineering, 1997, Massachusetts Institute of Technology, Cambridge, MA (USA).
- [4] **Arcidiacono G.**, "Axiomatic Design for Reliability" in *ATA*, 2000, Vol. 53-7/8, p. 309-315.
- [5] **Arnold F. and Podehl G.**, "Best of Both Worlds - A mapping from EXPRESS-G to UML", 1998, University of Kaiserslautern, Germany, Kaiserslautern.
- [6] **Auzet C.**, "Guide Démarche d'Ingénierie Système Automobile (Automotive Systems Engineering Guide)", 1999, PSA Peugeot Citroën, confidential documentation.
- [7] **Auzet C. and Lardeur E.**, "Guide complémentaire à la démarche d'Ingénierie Système Automobile - Développement des systèmes de production associés aux systèmes produits (manufacturing systems engineering with Systems Engineering guide)", 2003, PSA Peugeot Citroën, confidential documentation.
- [8] **Bacha R.**, "De la gestion des données techniques par l'ingénierie de production", Ph.D. Thesis of the *Laboratoire Productique-Logistique*, 2002, Ecole Centrale Paris, Chatenay-Malabry.
- [9] **Banares-Alcantara R.**, "Concurrent Process Engineering: State of the Art and Outstanding Research Issues" in Working paper for TWG4, 2000, p. 18.

- entre les activités de développement qui sont réalisées pour ces systèmes,
- entre les systèmes produits et les systèmes de productions dans la phase de production, lorsque les produits font partie du flux de production.

La démarche étendue porte le nom anglais *eASE* pour : *extended Automotive Systems Engineering*.

### ***eASE : Evaluation et Contrôle***

L'évaluation et le contrôle de l'Ingénierie Système Automobile étendue (page 77) consistent à fournir aux métiers de développement du domaine des systèmes de fabrication un outil pour évaluer globalement leurs pratiques actuelles d'ingénierie, sur la base de questionnaire (page 78) ou en mettant en conformité par rapport à l'Ingénierie Système Automobile les descriptions de leurs processus d'ingénierie (page 86), lorsqu'elles existent. Sur ce thème d'efficacité des processus, une perspective se dégage, qui porte sur le besoin de se doter de méthodes dédiées comme la méthode « *Design Structure Matrix* » (page 87). La démarche d'interview permet l'évaluation relative de niveaux de

- [1] **Abadi C. D. and Bahil T.** "Separating Product and Process Requirements", in *International Council On Systems Engineering*, 2002, Los Angeles.
- [2] **AFIS**, "Indicators", 1999, Working group for Maturity Models & Indicators - French SE Association "AFIS".
- [3] **Ali M.**, "Production System Design Methodology with Emphasis on Sub-system and Equipment Design", M.Sc. Thesis of the Department of Mechanical Engineering, 1997, Massachusetts Institute of Technology, Cambridge, MA (USA).
- [4] **Arcidiacono G.**, "Axiomatic Design for Reliability" in *ATA*, 2000, Vol. 53-7/8, p. 309-315.
- [5] **Arnold F. and Podehl G.**, "Best of Both Worlds - A mapping from EXPRESS-G to UML", 1998, University of Kaiserslautern, Germany, Kaiserslautern.
- [6] **Auzet C.**, "Guide Démarche d'Ingénierie Système Automobile (Automotive Systems Engineering Guide)", 1999, PSA Peugeot Citroën, confidential documentation.
- [7] **Auzet C. and Lardeur E.**, "Guide complémentaire à la démarche d'Ingénierie Système Automobile - Développement des systèmes de production associés aux systèmes produits (manufacturing systems engineering with Systems Engineering guide)", 2003, PSA Peugeot Citroën, confidential documentation.
- [8] **Bacha R.**, "De la gestion des données techniques pur l'ingénierie de production", Ph.D. Thesis of the Laboratoire Productique-Logistique, 2002, Ecole Centrale Paris, Chatenay-Malabry.
- [9] **Banares-Alcantara R.**, "Concurrent Process Engineering: State of the Art and Outstanding Research Issues" in Working paper for TWG4, 2000, p. 18.

maîtrise des domaines d'expertise et l'évaluation des pratiques de chaque métier pour chaque domaine de l'ingénierie : management, besoin, exigence, conception, intégration, ... L'objectif est de déterminer où mener des actions d'améliorations locales dans les métiers, notamment à l'aide de feuilles de routes méthodologiques (*page 84*).

### ***eASE : Déploiement et Application***

Le déploiement et l'application de l'Ingénierie Système (*page 89*) consistent à mettre en œuvre des actions selon un processus centré sur les activités des opérationnels et leurs besoins en terme d'amélioration. Il s'agit d'analyser une situation problématique et d'y remédier, en collaboration avec le métier afin d'améliorer ses pratiques et en proposant une application adaptée des principes d'Ingénierie Système. L'objectif étant de rendre le métier aussi autonome que possible par l'appropriation des pratiques d'IS. Cette contribution est illustrée par un exemple concret d'amélioration effectuée dans le domaine de la spécification d'une nouvelle usine de fabrication de boîtes de vitesses. Cela

- 138 - [1] **Abadi C. D. and Bahil T.** "Separating Product and Process Requirements", in *International Council On Systems Engineering*, 2002, Los Angeles.
- [2] **AFIS**, "Indicators", 1999, Working group for Maturity Models & Indicators - French SE Association "AFIS".
- [3] **Ali M.**, "Production System Design Methodology with Emphasis on Sub-system and Equipment Design", M.Sc. Thesis of the Department of Mechanical Engineering, 1997, Massachusetts Institute of Technology, Cambridge, MA (USA).
- [4] **Arcidiacono G.**, "Axiomatic Design for Reliability" in *ATA*, 2000, Vol. 53-7/8, p. 309-315.
- [5] **Arnold F. and Podehl G.**, "Best of Both Worlds - A mapping from EXPRESS-G to UML", 1998, University of Kaiserslautern, Germany, Kaiserslautern.
- [6] **Auzet C.**, "Guide Démarche d'Ingénierie Système Automobile (Automotive Systems Engineering Guide)", 1999, PSA Peugeot Citroën, confidential documentation.
- [7] **Auzet C. and Lardeur E.**, "Guide complémentaire à la démarche d'Ingénierie Système Automobile - Développement des systèmes de production associés aux systèmes produits (manufacturing systems engineering with Systems Engineering guide)", 2003, PSA Peugeot Citroën, confidential documentation.
- [8] **Bacha R.**, "De la gestion des données techniques par l'ingénierie de production", Ph.D. Thesis of the *Laboratoire Productique-Logistique*, 2002, Ecole Centrale Paris, Chatenay-Malabry.
- [9] **Banares-Alcantara R.**, "Concurrent Process Engineering: State of the Art and Outstanding Research Issues" in Working paper for TWG4, 2000, p. 18.

traduit l'activité que j'ai menée en tant que collaborateur du groupe PSA Peugeot Citroën pour de nombreuses autres initiatives du même ordre.

Le cas proposé permet de conclure empiriquement (*page 96*) sur les apports de l'Ingénierie Système pour l'amélioration de l'efficacité du processus d'ingénierie considéré, car globalement l'effort à fournir pour la phase de spécification est conservé tandis qu'on constate une amélioration de l'exploitabilité des documents ainsi élaborés.

- [1] **Abadi C. D. and Bahil T.** "Separating Product and Process Requirements", in *International Council On Systems Engineering*, 2002, Los Angeles.
- [2] **AFIS**, "Indicators", 1999, Working group for Maturity Models & Indicators - French SE Association "AFIS".
- [3] **Ali M.**, "Production System Design Methodology with Emphasis on Sub-system and Equipment Design", M.Sc. Thesis of the Department of Mechanical Engineering, 1997, Massachusetts Institute of Technology, Cambridge, MA (USA).
- [4] **Arcidiacono G.**, "Axiomatic Design for Reliability" in *ATA*, 2000, Vol. 53-7/8, p. 309-315.
- [5] **Arnold F. and Podehl G.**, "Best of Both Worlds - A mapping from EXPRESS-G to UML", 1998, University of Kaiserslautern, Germany, Kaiserslautern.
- [6] **Auzet C.**, "Guide Démarche d'Ingénierie Système Automobile (Automotive Systems Engineering Guide)", 1999, PSA Peugeot Citroën, confidential documentation.
- [7] **Auzet C. and Lardeur E.**, "Guide complémentaire à la démarche d'Ingénierie Système Automobile - Développement des systèmes de production associés aux systèmes produits (manufacturing systems engineering with Systems Engineering guide)", 2003, PSA Peugeot Citroën, confidential documentation.
- [8] **Bacha R.**, "De la gestion des données techniques pur l'ingénierie de production", Ph.D. Thesis of the Laboratoire Productique-Logistique, 2002, Ecole Centrale Paris, Chatenay-Malabry.
- [9] **Banares-Alcantara R.**, "Concurrent Process Engineering: State of the Art and Outstanding Research Issues" in Working paper for TWG4, 2000, p. 18.

### ***eASE : Instrumentation***

En guise de prolongement de ces contributions et dans le cadre de la conception conjointe des produits automobiles et de leurs systèmes de production en Ingénierie Système, la problématique d'instrumentation des méthodes est abordée (*page 97*), en détaillant l'approche intégrée des méthodes et des outils logiciels conçue (*page 98*). La première étape de cette approche a été réalisée et consiste à modéliser les principes théoriques en vue de leur implémentation (*page 99*). Cette action permet notamment de rendre plus concrets ces principes par raffinement. Cette modélisation permet aussi d'interfacier<sup>16</sup> l'approche *eASE*, plutôt *prescriptive*, avec d'autres points de vues, plutôt *descriptifs*. Elle abouti à la formulation d'exigences pour les systèmes d'information supportant l'ingénierie, c'est à dire un ensemble de fonctionnalités requises (*page 105*). Ces exigences ont permis d'évaluer les outils disponibles dans le groupe PSA Peugeot Citroën qui étaient potentiellement

---

<sup>16</sup> Comprendre le sens informatique.

- 140 - [1] **Abadi C. D. and Bahil T.** "Separating Product and Process Requirements", in *International Council On Systems Engineering*, 2002, Los Angeles.
- [2] **AFIS**, "Indicators", 1999, Working group for Maturity Models & Indicators - French SE Association "AFIS".
- [3] **Ali M.**, "Production System Design Methodology with Emphasis on Sub-system and Equipment Design", M.Sc. Thesis of the Department of Mechanical Engineering, 1997, Massachusetts Institute of Technology, Cambridge, MA (USA).
- [4] **Arcidiacono G.**, "Axiomatic Design for Reliability" in *ATA*, 2000, Vol. 53-7/8, p. 309-315.
- [5] **Arnold F. and Podehl G.**, "Best of Both Worlds - A mapping from EXPRESS-G to UML", 1998, University of Kaiserslautern, Germany, Kaiserslautern.
- [6] **Auzet C.**, "Guide Démarche d'Ingénierie Système Automobile (Automotive Systems Engineering Guide)", 1999, PSA Peugeot Citroën, confidential documentation.
- [7] **Auzet C. and Lardeur E.**, "Guide complémentaire à la démarche d'Ingénierie Système Automobile - Développement des systèmes de production associés aux systèmes produits (manufacturing systems engineering with Systems Engineering guide)", 2003, PSA Peugeot Citroën, confidential documentation.
- [8] **Bacha R.**, "De la gestion des données techniques par l'ingénierie de production", Ph.D. Thesis of the *Laboratoire Productique-Logistique*, 2002, Ecole Centrale Paris, Chatenay-Malabry.
- [9] **Banares-Alcantara R.**, "Concurrent Process Engineering: State of the Art and Outstanding Research Issues" in Working paper for TWG4, 2000, p. 18.

appropriés à la mise en œuvre de la conception conjointe selon les principes sus-citée (page 105).

## **Conclusion**

En conclusion (page 109), les principales contributions de ce travail de recherche sont de deux ordres : théoriques et pratiques.

Les résultats théoriques comprennent l'enrichissement du référentiel PSA Peugeot Citroën et étendent le périmètre d'application de l'Ingénierie Système Automobile à la conception conjointe des produits automobiles et leurs systèmes de fabrication. Cette extension est validée par les pratiques du terrain, grâce à l'investigation menée à l'aide du questionnaire présenté dans le Chapitre 4. La portée des résultats théoriques débouche sur la problématique de l'instrumentation logicielle de ces concepts. Qui donne donc lieu à une autre contribution des travaux de recherche, centrée sur la modélisation des principes théorique en vue de leur raffinement et d'une implémentation logicielle.

Les résultats pratiques portent sur l'ingénierie des systèmes de fabrication et comprennent la mise à disposition d'une méthode outillée d'évaluation

- [1] **Abadi C. D. and Bahil T.** "Separating Product and Process Requirements", in *International Council On Systems Engineering*, 2002, Los Angeles.
- [2] **AFIS**, "Indicators", 1999, Working group for Maturity Models & Indicators - French SE Association "AFIS".
- [3] **Ali M.**, "Production System Design Methodology with Emphasis on Sub-system and Equipment Design", M.Sc. Thesis of the Department of Mechanical Engineering, 1997, Massachusetts Institute of Technology, Cambridge, MA (USA).
- [4] **Arcidiacono G.**, "Axiomatic Design for Reliability" in *ATA*, 2000, Vol. 53-7/8, p. 309-315.
- [5] **Arnold F. and Podehl G.**, "Best of Both Worlds - A mapping from EXPRESS-G to UML", 1998, University of Kaiserslautern, Germany, Kaiserslautern.
- [6] **Auzet C.**, "Guide Démarche d'Ingénierie Système Automobile (Automotive Systems Engineering Guide)", 1999, PSA Peugeot Citroën, confidential documentation.
- [7] **Auzet C. and Lardeur E.**, "Guide complémentaire à la démarche d'Ingénierie Système Automobile - Développement des systèmes de production associés aux systèmes produits (manufacturing systems engineering with Systems Engineering guide)", 2003, PSA Peugeot Citroën, confidential documentation.
- [8] **Bacha R.**, "De la gestion des données techniques par l'ingénierie de production", Ph.D. Thesis of the Laboratoire Productique-Logistique, 2002, Ecole Centrale Paris, Chatenay-Malabry.
- [9] **Banares-Alcantara R.**, "Concurrent Process Engineering: State of the Art and Outstanding Research Issues" in Working paper for TWG4, 2000, p. 18.

globale de l'efficacité des processus de développement et de mise en œuvre d'actions d'amélioration locale. La méthode outillée permet d'évaluer les pratiques actuelles et de bâtir, en fonction des besoins et de la volonté des métiers, des plans d'action d'amélioration ciblée des pratiques.

La représentativité des études réalisées justifie la valeur ajoutée de l'Ingénierie Système.

### *Perspectives*

Les avancées théoriques nécessitent d'être alimentées par les données concrètes du terrain. Il s'agit par exemple de consolider des arborescences de développement des systèmes de production, ainsi qu'identifier et gérer les liens ou échanges d'information entre les ingénieries des produits automobiles et leurs systèmes manufacturiers. Ces données étendent notamment les perspectives des travaux à l'instrumentation logicielle des principes de conception conjointe des produits et des systèmes de fabrication dans les systèmes d'information, comme détaillé au chapitre 6.

Sur le champ des méthodes, la perspective vise la cible Ingénierie Système Automobile étendue, c'est à dire développer les véhicules et leurs systèmes de

- 142 - [1] **Abadi C. D. and Bahil T.** "Separating Product and Process Requirements", in *International Council On Systems Engineering*, 2002, Los Angeles.
- [2] **AFIS**, "Indicators", 1999, Working group for Maturity Models & Indicators - French SE Association "AFIS".
- [3] **Ali M.**, "Production System Design Methodology with Emphasis on Sub-system and Equipment Design", M.Sc. Thesis of the Department of Mechanical Engineering, 1997, Massachusetts Institute of Technology, Cambridge, MA (USA).
- [4] **Arcidiacono G.**, "Axiomatic Design for Reliability" in *ATA*, 2000, Vol. 53-7/8, p. 309-315.
- [5] **Arnold F. and Podehl G.**, "Best of Both Worlds - A mapping from EXPRESS-G to UML", 1998, University of Kaiserslautern, Germany, Kaiserslautern.
- [6] **Auzet C.**, "Guide Démarche d'Ingénierie Système Automobile (Automotive Systems Engineering Guide)", 1999, PSA Peugeot Citroën, confidential documentation.
- [7] **Auzet C. and Lardeur E.**, "Guide complémentaire à la démarche d'Ingénierie Système Automobile - Développement des systèmes de production associés aux systèmes produits (manufacturing systems engineering with Systems Engineering guide)", 2003, PSA Peugeot Citroën, confidential documentation.
- [8] **Bacha R.**, "De la gestion des données techniques par l'ingénierie de production", Ph.D. Thesis of the *Laboratoire Productique-Logistique*, 2002, Ecole Centrale Paris, Chatenay-Malabry.
- [9] **Banares-Alcantara R.**, "Concurrent Process Engineering: State of the Art and Outstanding Research Issues" in Working paper for TWG4, 2000, p. 18.

production selon les principes d'IS. Ce pré-requis pour assurer la cohérence entre les objectifs commerciaux du groupe et les développements, représente un objectif à long terme qui sous-tend une transformation progressive du système de développement de PSA Peugeot Citroën. L'efficacité de la méthode outillée d'évaluation globale et de mise en œuvre d'améliorations locales a été montrée dans le domaine de l'ingénierie des systèmes de fabrication. Cet outil peut à l'avenir permettre de définir des étapes successives de progrès en terme de pratiques de développement, selon les besoins d'amélioration et les ressources propres à chacune des équipes d'ingénierie du groupe PSA Peugeot Citroën. Lorsqu'elles existent, les descriptions des processus peuvent être directement évaluées et améliorées en regard de l'Ingénierie Système. Une perspective de cet axe d'amélioration est de s'appuyer sur des méthodes appropriées, afin d'agir sur l'efficacité des processus de développement.

La principale perspective de ces travaux confirme l'intérêt, par tous les moyens sus-cités, de la poursuite du déploiement de l'Ingénierie Système pour la branche recherche et développement du groupe PSA Peugeot Citroën.

# **Table of contents, Lists of Figures and Tables**



## Table of contents

<b><i>Introduction</i></b> .....	<b>13</b>
<b>Challenges and lacks in the engineering field</b> .....	<b>14</b>
<b>Research question and objectives</b> .....	<b>15</b>
<b>Outline of the Thesis</b> .....	<b>17</b>
<b><i>Chapter 1. Industrial challenges and research issues</i></b> .....	<b>19</b>
<b>1.1 Three statements</b> .....	<b>20</b>
1.1.1 Engineering approaches and project failure .....	20
1.1.2 Engineering versus manufacturing stage optimization .....	22
1.1.3 Engineering approaches in the worldwide competition .....	23
<b>1.2 Industrial background: related objectives and issues</b> .....	<b>25</b>
1.2.1 Industrial needs .....	25
1.2.2 Detailing the industrial challenges.....	26
Vehicle complexity.....	26
Manufacturing systems complexity .....	27
Engineering complexity .....	27
Profusion of engineering approaches.....	28
Deployment of engineering approaches: the change cultural challenge.....	28
<b>1.3 Research area and scope</b> .....	<b>30</b>
1.3.1 Designing a development system .....	30
Engineering approach in the development system .....	30
Transform the development system.....	31
Organizational and technical components .....	31
1.3.2 A generic approach considering life-cycle stages .....	31
1.3.3 A specific approach regarding systems.....	32
<b>1.4 Research orientation</b> .....	<b>33</b>
<b>1.5 Action plan</b> .....	<b>34</b>
<b><i>Chapter 2. State of the art</i></b> .....	<b>35</b>
<b>2.1 Engineering methods and approaches</b> .....	<b>36</b>
2.1.1 Approach and methods: head and muscles.....	37
2.1.2 Different models for engineering design .....	37
Prescriptive – Descriptive classification.....	37
Other interesting classifications and research contributions.....	38
2.1.3 Relevant models to build the eASE Framework .....	40
Concurrent Engineering.....	41
Design For X .....	43
2.1.4 Models potentially contributing to SE.....	45
Interest of the Systematic Approach of Pahl & Beitz .....	45
Quality Function Deployment method (QFD) .....	45

Axiomatic Design .....	45
Other methods .....	46
Use of Design Structure Matrix .....	46
<b>2.2 Systems Engineering.....</b>	<b>47</b>
2.2.1 SE description.....	47
2.2.2 The Methodological Integration.....	51
Feeding SE's Processes with existing theories and methods .....	51
Mutual enhancement SE – Design Methods .....	52
<b>2.3 Engineering performance measurement.....</b>	<b>54</b>
2.3.1 Performance assessment approaches .....	55
2.3.2 Capability and Maturity Model (CMM) .....	56
Contents of CMMI.....	56
Micro Assessment Kit of SECAT LCC© .....	58
Systems Engineering discipline misunderstanding .....	60
Contributions and limits of CMM and Pocket Guides .....	60
<b>2.4 Academic positioning.....</b>	<b>61</b>
<b>Chapter 3. Automotive SE extension: eASE.....</b>	<b>63</b>
<b>3.1 Applicability to Manufacturing Systems .....</b>	<b>64</b>
Actual PSA Peugeot Citroen SE Framework .....	64
Getting specific aspects from manufacturing systems domain .....	64
Theoretical aspects of eASE for manufacturing systems.....	65
<b>3.2 eASE for coordination of engineering .....</b>	<b>68</b>
3.2.1 Methodological concepts.....	68
3.2.2 eASE coordination framework.....	69
Coordination framework construction: artifacts, natures of processes, links.....	69
The first level of link.....	70
The second level of link .....	71
The third level of link.....	71
<b>3.3 Illustration of eASE for engineering coordination.....</b>	<b>73</b>
<b>3.4 Discussion and perspectives .....</b>	<b>76</b>
<b>Chapter 4. eASE Evaluation and Control.....</b>	<b>77</b>
<b>4.1 Interview-based assessment approach.....</b>	<b>78</b>
4.1.1 Objective and scope .....	78
4.1.2 Process .....	79
4.1.3 Model Selection .....	80
4.1.4 Tailoring: our questionnaire .....	80
4.1.5 Results.....	83
4.1.6 Discussion on assessment .....	85
<b>4.2 Process Model-based approach.....</b>	<b>86</b>
4.2.1 Process modeling and process improvement.....	86
4.2.2 Discussion on process modeling .....	87

<b>Chapter 5. eASE Deployment and Application .....</b>	<b>89</b>
<b>5.1 Scope.....</b>	<b>90</b>
<b>5.2 Generic process for local practices improvement.....</b>	<b>91</b>
<b>5.3 A representative case of study.....</b>	<b>92</b>
Task 1: Case analysis .....	92
Task 2: First action proposal.....	92
Task 3: Action decided .....	92
Task 4: Preparative work .....	93
Tasks 5, 6 and 7: Application.....	95
<b>5.4 Discussion .....</b>	<b>96</b>
<b>Chapter 6. eASE Instrumentation.....</b>	<b>97</b>
<b>6.1 An integrated methods and tools approach.....</b>	<b>98</b>
<b>6.2 Modeling problematic .....</b>	<b>99</b>
6.2.1 Choice of the modeling approach .....	99
6.2.2 Items to model .....	100
Models for systems .....	100
Model for SystemLink.....	101
Models for ActivityLink.....	101
Relationship between SystemLink and ActivityLink.....	102
6.2.3 Discussing the modeling problematic .....	104
<b>6.3 Supporting tools.....</b>	<b>105</b>
6.3.1 Features required: toward a Technical Specification.....	105
6.3.2 Analysis of existing software tools.....	105
List of DOORS™ characteristics .....	106
List of CORE™ characteristics .....	106
Test procedure and results .....	107
<b>Conclusions and Perspectives .....</b>	<b>109</b>
Repository enrichment axis .....	109
Instrumentation axis.....	110
Academic contribution axis .....	110
Performance assessment axis .....	111
Performance improvement axis .....	112
<b>References .....</b>	<b>115</b>
<b>Résumé détaillé en français .....</b>	<b>115</b>
<b>Table of contents, Lists of Figures and Tables .....</b>	<b>143</b>
<b>Appendix: Questionnaire .....</b>	<b>149</b>

## List of Figures

Figure 1. Outline of this Thesis .....	17
Figure 2. Project success and failure [Standish Group, 1994].....	20
Figure 3. Costs involved by decisions taken during a development project.....	23
Figure 4. Development time' s objectives.....	24
Figure 5. PSA Peugeot Citroën “standard” development planning .....	26
Figure 6. System interaction with typical enabling systems .....	30
Figure 7. My contributions.....	34
Figure 8. Items of the State of the Art.....	35
Figure 9. Relevant models through a descriptive / prescriptive classification.....	38
Figure 10. Processes for Engineering a System.....	49
Figure 11. Building Block in EIA 632.....	49
Figure 12. Mapping between Project hierarchy and Hierarchical System Structure .....	50
Figure 13. Very schematic comparison of AD and SE .....	53
Figure 14. Staple remover physical decomposition .....	65
Figure 15. Up-graded staple remover physical decomposition .....	66
Figure 16. Logical Architecture, with macro-functions .....	66
Figure 17. Allocation Matrix of Functions and Components.....	67
Figure 18. Physical Architecture, with sub-systems (sectors).....	67
Figure 19. The first level of link .....	70
Figure 20. The second level of link (excerpt between technical tasks).....	71
Figure 21. the third level of link.....	72
Figure 22. Illustration of the first level of link .....	73
Figure 23. Temporal planning of the program.....	74
Figure 24. Illustration of the second level of link (Optimization of the packaging).....	75
Figure 25. Illustration of the third level of link.....	75
Figure 26. Utilization of the three parts of the SECAT© Kit.....	82
Figure 27. Link with CMM's maturity level.....	82
Figure 28. Example of question.....	83
Figure 29. Global assessment results.....	83
Figure 30. Example of more accurate results for one area.....	84
Figure 31. Action performed .....	93
Figure 32. Mapping between existing document and eASE target.....	94
Figure 33. New distribution of the efforts .....	94
Figure 34. Resulting efforts.....	95
Figure 35. Integrated methods and tools approach .....	98
Figure 36. System decomposition modeling .....	100
Figure 37. Three alternatives for types of systems modeling .....	100
Figure 38. The SystemLink modeling .....	101
Figure 39. The ActivityLink modeling .....	102
Figure 40. Models for links relationship .....	103
Figure 41. Object diagram for SystemLink and ActivityLink .....	103

## List of Tables

<i>Table 1. Project success factors [Standish Group, 1994]</i> .....	21
<i>Table 2. Project failure factors, from [Standish Group, 1994]</i> .....	22
<i>Table 3. Mapping between {Objectives, Issues} and the items of the Thesis</i> .....	33
<i>Table 4. Reference for examples of concrete contributions (applications)</i> .....	51
<i>Table 5. Potential Contributions of Design Methods to Technical Processes in SE</i> .....	52
<i>Table 6. Type of marks for methods contribution</i> .....	52
<i>Table 7. Articulation of CMMI model components</i> .....	57
<i>Table 8. Comparison between Staged and Continuous CMM representations</i> .....	58
<i>Table 9. Top level traceability between CMM and SECAT LCC Pocket Guides</i> .....	59
<i>Table 10. Selected assessment approach</i> .....	60
<i>Table 11. Contributions synthesis, illustration of my positioning</i> .....	62
<i>Table 12. Distinction or community principles for the processes</i> .....	68
<i>Table 13. Management Links between Products and Production Systems development</i> .....	69
<i>Table 14. Interviewed areas of expertise</i> .....	78
<i>Table 15. Interview-based assessment process</i> .....	79
<i>Table 16. Survey of the domains of the questionnaire</i> .....	82
<i>Table 17. Formalization level</i> .....	83
<i>Table 18. Practices improvement process</i> .....	91
<i>Table 19. List of expected features</i> .....	105
<i>Table 20. List of DOORS™ characteristics</i> .....	106
<i>Table 21. List of CORE™ characteristics</i> .....	106
<i>Table 22. Notations for the tool analysis</i> .....	107
<i>Table 23. Analysis of CORE™ and DOORS™</i> .....	107
<i>Table 24. Accomplishments</i> .....	113
<i>Table 25. Perspectives</i> .....	114

## **Appendix: Questionnaire**

---

### **Questionnaire of the interview-based assessment approach.**

This questionnaire is an Adobe™ “portable document format” file (\*.pdf), generated from a Microsoft Word™ file (\*.doc). This template makes easier the guidance of the interviews. Answers are directly reported in the file by the lead-interviewer, by box-checking and text entering. At the beginning, the opened file can be initialized and at the end of the session, the lead-interviewer can click on the “archive” button and the results of the interview are automatically exported in an Adobe™ “form data” file (\*.fdf). Microsoft Visual Studio™ was used to program the file converter, from \*.fdf files to \*.txt pre-formatted files. Then, results were automatically calculated and fed from data manually imported to a new sheet of a Microsoft Excel™ file (\*.xls). These results are those displayed in Figure 29. Global assessment results, page 83 and Figure 30. Example of more accurate results for one area, page 84.

Visual Studio™, Adobe Acrobat Writer™ and Microsoft Excel™ were chosen because they provided the needed features and were available.



