



HAL
open science

Development of a new reinforced titanium alloy: Basic research and technological transfer for the Ti-6Al-4V/TiB material

Maidier García de Cortázar

► To cite this version:

Maidier García de Cortázar. Development of a new reinforced titanium alloy: Basic research and technological transfer for the Ti-6Al-4V/TiB material. Material chemistry. Université Sciences et Technologies - Bordeaux I, 2006. English. NNT: . tel-00129356

HAL Id: tel-00129356

<https://theses.hal.science/tel-00129356>

Submitted on 6 Feb 2007

HAL is a multi-disciplinary open access archive for the deposit and dissemination of scientific research documents, whether they are published or not. The documents may come from teaching and research institutions in France or abroad, or from public or private research centers.

L'archive ouverte pluridisciplinaire **HAL**, est destinée au dépôt et à la diffusion de documents scientifiques de niveau recherche, publiés ou non, émanant des établissements d'enseignement et de recherche français ou étrangers, des laboratoires publics ou privés.

N° d'ordre : 3195

THÈSE

PRESENTEE A

L'UNIVERSITÉ BORDEAUX 1

ÉCOLE DOCTORALE DES SCIENCES CHIMIQUES

Par **Maidier García de Cortázar**

Ingénieur ETSII

POUR OBTENIR LE GRADE DE

DOCTEUR

SPÉCIALITÉ : PHYSICO-CHIMIE DE LA MATIÈRE CONDENSÉE

*Etude de la faisabilité et du transfert de technologie pour
l'alliage Ti-6Al-4V renforcé par du monoborure de titane*

*Development of a new reinforced titanium alloy:
Basic research and technological transfer for the Ti-6Al-4V/TiB material*

Thèse soutenue le 18 juillet 2006

Après avis de MM:

J.TARTERA BARRABEIG

Professeur, UPC Barcelone

Rapporteur

C.ESTOURNES

Chargé de Recherche

Rapporteur

Devant la commission d'examen formée de :

MM C.DELMAS

Directeur de recherche

ICMCB

Président

Y.LE PETITCORPS

Professeur

ICMCB

Examineur

J.GOÑI

Docteur Ingénieur

INASMET

Examineur

S.GOURDET

Docteur Ingénieur

EADS

Examineur

Iñigo, Uxue eta Marinari
Familiari

ACKNOWLEDGEMENTS

I would like to extend my deepest thank to those who have encouraged, motivated and guided me. Professeur Yann Le Petitcorps and Dr. Javier Goñi for your direction and support, your helpful guidance and suggestions have greatly improved the quality of this work. I also thank you for your generosity, modesty and friendship.

In addition I would like to thank INASMET-Tecnalia and the ICMCB-CNRS for the opportunity to do this thesis. Special thanks are due to INASMET-Tecnalia's employees; Israel, Sonia, Chris, Pedro, Marina, Xabi, Iñigo, Javi,...their experience, knowledge and support have been very helpful.

Finally, the work performed herein would not have happened without the encouragement and confidence provided by my *friends* at INASMET-Tecnalia and my family, thank you very much!

ACRONYM LIST

| | |
|---------|---|
| BE | Blended Elemental |
| CHIP | Cold plus Hot Isostatic Pressing |
| CVD | Chemical Vapour Deposition |
| EBM | Electron Beam Melting |
| EBPVD | Electron Beam Physical Vapour Deposition |
| FFF | Foil Fibre Foil |
| HIP | Hot Isostatic Pressing |
| IHPTET | Integrated High Performance Turbine Engine Technology |
| IM | Induction Melting |
| IMC | Intermetallic Matrix Composites |
| MA | Mechanical Alloying |
| MCF | Metal Coated Fibre |
| MIG | Metal Inert Gas |
| MMC | Metal Matrix Composites |
| NASP | National Aero-Space Plane |
| PM | Powder Metallurgy |
| PVD | Physical Vapour Deposition |
| RSP | Rapid Solidified Powders |
| SHS | Self-propagating High-temperature Synthesis |
| SPS | Spark Plasma Sintering |
| TIG | Tungsten Inert Gas |
| TMC | Titanium Matrix Composites |
| TMCTECC | Titanium Matrix Composite Turbine Engine Component Consortium |
| VAR | Vacuum Arc Remelting Process |

TABLE OF CONTENTS

| | |
|--|-----------|
| Acknowledgements | i |
| Acronym List | ii |
| Introduction | 1 |
| 1 Introduction aux matériaux composites à matrice de titane | 2 |
| 2 Contexte de la recherche | 3 |
| 3 Organisation du document de thèse | 4 |
| 1 An Introduction to Titanium Matrix Composites | 6 |
| 2 Motivation for the investigation | 7 |
| 3 Thesis format | 8 |
| Chapter 1: Background and literature review | 10 |
| 1 Introduction | 11 |
| 2 Titanium Matrix Composites TMCs | 11 |
| 2.1 Continuously reinforced TMCs..... | 12 |
| 2.1.1 Tow based TMCs..... | 14 |
| 2.1.2 Monofilament reinforced TMCs..... | 16 |
| 2.2 Discontinuously reinforced TMCs..... | 34 |
| 2.2.1 Particulate reinforced TMCs..... | 34 |
| 2.2.2 In-situ composites..... | 35 |
| 2.2.3 Economical aspects..... | 44 |
| 3 Previous studies of the TMC system assessment | 47 |
| 4 Conclusions | 51 |
| Chapter 2: Production of TiB by SHS | 54 |
| 1 Introduction | 55 |
| 2 Self-propagating High-temperature Synthesis (SHS) | 57 |
| 2.1 Thermodynamical considerations..... | 57 |
| 2.1.1 The Boron Titanium system..... | 58 |
| 2.2 Variable effects..... | 61 |
| 3 Experimental procedure | 66 |
| 3.1 SHS reactions: the synthesis of materials on the Ti-B system..... | 66 |

| | |
|--|------------|
| 3.1.2 Phase identification | 74 |
| 3.1.3 Microstructure | 76 |
| 3.1.4 Selection criteria | 80 |
| 3.2 Simultaneous synthesis and compaction: How to remove the porosity..... | 82 |
| 3.2.1 Description of the material obtained | 87 |
| 4 Conclusions | 92 |
| | |
| Chapter 3: In-situ reinforced TMCs produced by investment casting | 94 |
| | |
| 1 Introduction..... | 95 |
| 2 Titanium Investment Casting..... | 96 |
| 3 Experimental procedure | 100 |
| 3.1 Equipment and Process | 100 |
| 3.1.1 Induction melting..... | 103 |
| 3.1.2 Centrifugal casting | 104 |
| 3.1.3 Mould preparation | 108 |
| 3.2 Casting experiments | 110 |
| 3.2.1 Master compound addition..... | 110 |
| 4 Conclusions | 121 |
| | |
| Chapter 4: Technology transfer..... | 122 |
| | |
| 1 Technology transfer..... | 123 |
| 1.1 Requirements..... | 123 |
| 1.2 Industrial process | 124 |
| 1.3 Selection of representative components..... | 125 |
| 1.4 Castings | 127 |
| 1.4.1 Definition of the castings..... | 127 |
| 1.4.2 Results and discussion..... | 128 |
| 2 Cost analysis..... | 134 |
| 2.1 Manufacturing processes | 134 |
| 2.2 Cost estimate-assumptions | 137 |
| 2.2.1 Mass breakdown..... | 138 |
| 2.2.2 Master compound production..... | 139 |
| 2.2.3 Moulding and Casting..... | 140 |
| 2.2.4 Finishing operations | 141 |
| 3 Conclusions | 142 |

| | |
|--|------------|
| Conclusions and future directions | 143 |
| 1 Conclusions et perspectives..... | 144 |
| 1.1 Conclusions | 144 |
| 1.2 Perspectives | 145 |
| 1 Conclusion and future directions..... | 146 |
| 1.1 Conclusions | 146 |
| 1.2 Future directions | 148 |
| References..... | 150 |
| ANNEX I: Metallurgical characterization procedure | 158 |
| ANNEX II: Tensile test results..... | 159 |

INTRODUCTION

1 Introduction aux matériaux composites à matrice de titane

Le titane et plus particulièrement les différents alliages de titane sont des matériaux attractifs pour des applications de haute technologie. Cependant, dans le domaine de l'aéronautique, des améliorations doivent encore être apportées pour les rendre compétitifs avec les aciers à hautes résistances ou les super alliages à base de nickel. C'est dans ce contexte, que depuis plus de 30 ans, un effort continu a été effectué pour augmenter les performances mécaniques de ces alliages en les renforçant par des filaments, fibres ou particules de céramiques.

Les gains apportés par les composites à matrice de titane (CMT) concernent leurs propriétés physiques et mécaniques telles que la résistance à la rupture, la rigidité, la dureté. Comme dans tout matériau composite, l'orientation du renfort dans la matrice impose les propriétés au matériau composite. En fonction des sollicitations du matériau, on peut alors concevoir des pièces de CMT avec des renforts continus, des renforts discontinus, les renforts peuvent être orientés ou disposés de façon aléatoire de manière à contrôler l'isotropie ou l'anisotropie des propriétés du matériau.

Depuis plus de 30 ans, des recherches importantes ont été effectuées sur les CMT renforcés par des filaments continus de carbure de silicium (SiC_{CVD}), on peut dire aujourd'hui que c'est avec ce type de renforcement que les recherches sont le plus abouties. Ces matériaux possèdent des propriétés mécaniques proches de celles des aciers avec une densité environ deux fois moindre, c'est dans ce contexte que les avionneurs ou les motoristes se sont intéressés à ces matériaux pour des applications bien spécifiques. Les efforts de recherche ont porté sur (1) des aspects scientifiques tels que la minimisation de la réaction chimique entre le renfort de carbure de silicium et la matrice de titane, (2) des aspects techniques, sur les différents procédés d'élaboration, (3) des aspects économiques sur la réduction des coûts sur le renfort lui-même et sur le procédé d'élaboration.

Le coût prohibitif de ces matériaux composites pour des applications de grande diffusion ont motivé les chercheurs à proposer de nouveaux renforts pour le titane. Pour cela, il fallait maintenir les performances mécaniques proches de celles données par le carbure de silicium (rigidité, dureté), tout en améliorant les points identifiés avec le carbure de silicium (réactivité thermochimique, contraintes résiduelles) et coût du renfort. La diminution de coût a conduit à imposer la morphologie du renfort, celle-ci doit être particulière ou tout au mieux filiforme mais discontinue, les contraintes thermochimiques et mécaniques ont quant à elles conduit au choix du

monoborure de titane (TiB) comme renfort «idéal» pour le titane. Le TiB n'étant pas disponible à l'état particulaire ou fibreux, il peut être obtenu par précipitation *in-situ* dans la matrice de titane. En phase solide ou en phase liquide, le monoborure de titane précipite sous une forme aciculaire au sein de la matrice de titane, ce qui garantit la stabilité thermodynamique du couple renfort/matrice et permet un transfert de charge renfort/matrice.

2 Contexte de la recherche

Ce travail de thèse a été effectué dans le cadre d'un programme européen «GROWTH» intitulé High performance and competitive new titanium reinforced alloy for aeronautical applications (NEWTIRAL), (GRD2-2000-30405,2004). L'objectif principal est d'évaluer les performances, les procédés d'élaboration (phase solide (métallurgie des poudres) ou liquide (fonderie de précision)) et les potentialités d'applications d'alliages de titane renforcés par du monoborure de titane. Parmi les deux voies d'élaboration, nous avons en charge avec l'ICMCB-CNRS le développement de la voie liquide à l'échelle du laboratoire puis ensuite nous devons effectuer un transfert de technologie vers le partenaire industriel (SETTAS-DONCASTER) pour la réalisation de prototypes conçus par EADS-CCR.

Une des difficultés dans l'élaboration par fonderie des composites Ti/TiB est l'incorporation du bore dans le métal liquide. Ce point a été traité Frédéric Dartigues (2004) qui a également effectué sa thèse dans le cadre de ce programme. Dans son cas, le TiB était introduit dans l'alliage à partir d'un composite Ti-6Al-4V/ (20% Vol.)TiB préparé par métallurgie des poudres à partir de poudre de titane alliée (Ti-6Al-4V) et de poudres de TiB₂, ce composite étant ensuite dilué puis totalement dissous au sein du titane liquide, à la solidification le TiB re-précipite dans la matrice d'alliage de titane. La phase de préparation du composite Ti-6Al-4V/20%TiB par métallurgie des poudres, impliquant une phase de densification et de transformation du TiB₂ en TiB, pouvait amener un coût supplémentaire au matériau.

Dans le cadre de cette thèse, nous avons évalué un procédé différent d'obtention du TiB, susceptible d'abaisser le coût du matériau final. Ce procédé appelé SHS (Self-propagating High-temperature Synthesis) et qui conduit à l'obtention de TiB utilise également des poudres pour fabriquer le matériau qui sera ensuite dilué dans l'alliage de titane liquide. Il diffère cependant pour les raisons suivantes : il est nécessaire que la source de bore soit du bore et non un composé à base de bore, le métal est quant à lui du titane et non son alliage. Pour que la réaction d'auto-

combustion ait lieu, il est nécessaire d'apporter du bore en quantité suffisante, de ce fait, la quantité de borure de titane ainsi formée est également importante (supérieure à 60% en volume). Contrairement au procédé développé par F. Dartigues dans sa thèse, la transformation du bore en TiB par réaction avec le titane se fait en phase liquide. Par contre, et comme cela a été fait par F. Dartigues, le composite final est obtenu par un procédé de fonderie au cours duquel, le composite ainsi préparé par l'un ou l'autre de ces procédés est dilué dans l'alliage de titane (Ti-6Al-4V) en fusion. Nous avons également étudié le transfert de technologie des travaux faits au laboratoire vers un site industriel et nous avons complété ceci par une approche économique de la fabrication d'un prototype par les différentes voies d'élaboration du matériau composite.

3 Organisation du document de thèse

La thèse est organisée en quatre chapitres contenant les points suivants :

Un chapitre bibliographique faisant l'état des recherches et des applications réalisées ces 20 dernières années sur les matériaux composites à matrice de titane à renforcement continu et à renforcement discontinu. Ce chapitre fait ressortir les efforts faits ces dernières années sur le système Ti/TiB.

Le chapitre 2 est consacré au procédé d'auto-combustion (SHS). Dans ce chapitre, nous avons dans un premier temps travaillé sur les aspects fondamentaux du procédé et notamment sur les conditions thermodynamiques qui favorisaient la réaction, puis nous avons construit et instrumenté un équipement et préparé des échantillons Ti/TiB à différentes fractions volumiques de TiB (comprises entre 50 et 80%). A l'issue de cette première étude, nous avons élaboré des matériaux dont la composition en TiB a été optimisée, ces matériaux étant destinés à être ensuite fondu et dilué dans un alliage de titane lors de la réalisation de pièces par le procédé de fonderie en cire perdue.

Le chapitre 3 est consacré au procédé de fusion. Les charges en quantités définies de composite Ti/T60%TiB, élaborées par SHS sont fondues avec du Ti-6Al-4V de façon à ajuster la composition du composite final entre 0 et 10%, c'est-à-dire proche de la composition de l'eutectique (9% TiB). La fusion est effectuée par induction et la coulée par centrifugation se fait dans un moule en céramique. Des éprouvettes de caractérisations microstructurales et mécaniques ont ainsi été réalisées.

Afin de répondre à la demande des partenaires industrielles impliqués dans ce programme, nous avons réalisé une étude technique sur le transfert de technologie et une étude économique comparative des différents procédés évalués dans le programme européen. Cette partie est détaillée dans le chapitre 4.

En conclusion, nous ferons un bilan de cette étude et nous donnerons nos perspectives sur ce sujet.

1 An Introduction to Titanium Matrix Composites

Titanium and titanium alloys are very attractive materials for advanced applications due to their intrinsic properties. Further improvements are needed to make them competitive with high strength steels or Ni-based alloys in specialized applications that demand properties beyond the levels provided by the conventional titanium alloys. This demand for increased performances continues to drive material development efforts to explore new concepts such as Titanium Matrix Composites (TMC), which involve the reinforcement of the titanium or titanium alloys.

The main advantages of TMCs are the increased mechanical and physical properties, i.e. strength, stiffness, hardness etc. The direction of the reinforcements dictates the properties, providing the option to tailor specific properties in specific directions. It is important to distinguish between continuously reinforced and discontinuously reinforced TMCs. Although they share some common features they also display different ones, for example the isotropy or anisotropy of properties.

For over 30 years, TMCs continuously reinforced with silicon carbide (SiC) monofilaments have been highly regarded and reached maturity through huge development efforts. The benefits of this kind of TMCs, that can match the strength and stiffness of steel at roughly half the weight, have been recognized mainly by airframe and turbine engine manufacturers. Nevertheless, some drawbacks, such as the prohibitive cost of SiC monofilaments, the manufacturing cost and complexity, the chemical instability between the fibre and the matrix and their coefficient of thermal expansion mismatch together with highly anisotropic properties of these composites, have restricted their use to the mentioned highly specialized applications.

The need to develop new high-performance and low-cost TMCs arose due to these limitations. Their research and development will lead to gain not only for the aerospace industry, but other weight-sensitive and mass-production industries such as automotive, medical, sport, etc.

From the technical point of view, the ideal reinforcement for titanium alloys should meet the following criteria: superiority in physical and mechanical properties (stiffness, strength, hardness, etc.), thermodynamical stability and minimum difference in thermal expansion between the two constituents. Another interesting feature is the possibility to reinforce the material in the required direction, or in all directions, to obtain isotropic properties.

Previous studies have proved that the titanium monoboride (TiB) meets all the above mentioned requirements. The TiB can be obtained by means of *in-situ* techniques. These techniques involve a chemical reaction resulting in the formation of a thermodynamically stable reinforcing phase within the metal matrix. Unlike reinforcements added from external sources, *in-situ* formed ones consist of contaminant-free interfaces and the composites obtained present isotropic properties.

2 Motivation for the investigation

The present thesis has been developed under the frame of an European GROWTH Project entitled: "High performance and competitive new titanium-reinforced alloys for aeronautical applications" ("NEWTIRAL") (GRD2-2000-30405, 2004), which was focused on the development of *in-situ* TiB reinforced TMCs. The main objective of this European project was to produce low cost TMCs with future industrial viability. In this project our work, in cooperation with the ICMCB-CNRS, was to investigate the liquid route, in particular the investment casting route, as potential production process. The production of discontinuously (TiB) reinforced TMCs via investment casting has been sought as a means of reducing cost. This could be competitive, reliable and the way to introduce TMCs into a number of industrial applications. The technology transfer of the developments achieved at lab scale to the industrial partner (SETTAS-DONCASTER) for the production of the demonstrators provided by the end user (EADS-CCR) was also our task within the project.

One of the major limitations of the investment casting process is the boron source addition into the melt to obtain *in-situ* formed TiB reinforcements. This topic has been part of the investigation performed by F. Dartigues in his thesis (F. Dartigues, 2004), which has been carried out in the frame of the same European project. In his work, where different boron sources have been assessed, TiB has been presented as the most suitable one to be used in an investment casting process. However, despite the direct addition of TiB being an interesting choice, TiB can not be obtained in powder form and it is not easy to get.

This introduces the motivation for the research and development presented in this thesis. Taking into account the impediments mentioned above, the objective is to study the production of TiB by a novel and cost-effective process called Self-propagating High-temperature Synthesis (SHS). The resulting TiB could be used later in an investment casting process to finally obtain *in-situ* reinforced net-shape TMCs.

In order to meet the broad objectives outlined, specific goals such as the production of TiB by SHS, the addition of this TiB to an investment casting process and the production of sound net-shape TMCs, have been researched and developed during the course of this work.

3 Thesis format

While the main part of the work has been devoted to investigate, from a scientific/technical point of view, a process to obtain new high-performance and low-cost TMCs, the work also has an industrial profile and thus has been completed with a technology transfer from the lab scale to the industrial scale.

The work is presented in five chapters. These chapters, and a brief description of each one, are given below:

- Background and literature review: the scientific literature available and its influence on the current study will be assessed. This will include a survey of the literature on TMCs for the last 20 years.
- Production of TiB by Self-propagating High-temperature Synthesis (SHS): In this chapter, where the objective is to obtain the TiB by SHS for its subsequent use as boron source in the investment casting process, the SHS technique and its features will be investigated in depth. A general description of the SHS technique, specifically for the Ti-B system, sample preparation, property measurements and the equipment used in these experiments are discussed.
- *In-situ* reinforced TMCs produced by investment casting: The investment casting process and its peculiarities for titanium alloys will be analyzed in order to describe the effect of the boron source in this process. This effect will be evaluated by the study of the dissolution of the boron source in the titanium melt and the precipitation of the TiB. The composites produced will be characterized.
- Technology transfer: Several castings will be done at industrial facilities to assess the industrial viability of the process developed in the thesis. This part will be completed with an evaluation

of the cost of the TMCs components produced by this process and a comparison to the unreinforced titanium components produced presently in industry.

- Conclusions: this final chapter will provide a summary of the research and the conclusions achieved. It will also point out some recommendations and future work.

CHAPTER 1

BACKGROUND AND LITERATURE REVIEW

1 Introduction

In addition to the two main methods for improving the properties of materials (alloying and processing), during the last decades a third option has gained importance; the combination of two materials to create a composite.

Alloying has led to controlled structures, increased strength, improved physical properties and chemical resistance control of the materials against effects such as corrosion and oxidation. New processing techniques have led to altered microstructures depending on the specific property required.

The third option is the composite fabrication. Here different materials are combined to create a composite with superior properties. In this sense, metal matrix composites seek to combine the high strength and stiffness of a ceramic with the damage tolerance and toughness provided by the metal.

Titanium alloys stand out mainly due to their high specific strength and excellent corrosion resistance. However other properties (stiffness, hardness, friction, properties at high temperature, etc.) are required to be improved up as they are limiting their use to some specific applications. Therefore over the last years titanium matrix composites (TMCs) have been developed as an alternative.

The objective of the present chapter is to review the last 20 years of developments in an international context with relation to TMCs, in order to provide a basis for the present thesis.

2 Titanium Matrix Composites TMCs.

Titanium Matrix Composites (TMCs) are advanced materials made of titanium or titanium alloy matrices mixed either with continuous or discontinuous reinforcements.

Regarding continuous reinforcements, those in the form of tows from individual monofilaments have been distinguished. The first ones are several hundreds or thousands of fibres with

diameters in the order of 10-20 μm while individual monofilaments have a considerable larger diameter in the order of 100-150 μm .

Discontinuous reinforcements, which contribute to lower improvements in terms of mechanical properties when compared to those properties achieved with continuous reinforcements, show other advantages such as lower cost, simple production process as well as isotropy. These discontinuous reinforcements are either chopped fibres (1-3mm) or particles (1-10 μm).

2.1 Continuously reinforced TMCs

Continuous reinforcements exist as tows or as monofilaments. The former are less expensive and easier to handle during processing, but shows lower strength than the more expensive and large diameter monofilaments. These reinforcements are very sensitive to chemical attack by the matrix since even a small amount of interaction can significantly decrease the composite mechanical properties.

Thus, care must be taken to select a matrix reinforcement system that is chemically compatible otherwise a protective fibre coating must be used. A wide range of coatings and depositions methods have been proposed in the literature in order to protect fibres from chemical attack (*R.R. Kieschke et al., 1991, C.M. Warwick et al., 1991, S. Ochiai et al., 1998, J.F. Frometin et al., 1995*).

Due to the high melting point of titanium and its high reactivity in the liquid state, solid state consolidation, such as Hot Isostatic Pressing (HIP) or uniaxial Vacuum Hot Pressing (VHP), is currently the most used manufacturing technique used. Processing alternatives and cost reductions are thus limited to the raw material and to the pre-processing phase. Foil Fibre Foil (FFF), Vacuum Plasma Spraying (VPS), Physical Vapour Deposition (PVD) and liquid coating are some of these pre-processing techniques (*H.P. Degisher, 2001*).

Secondary processing techniques are problematic, since damage to the reinforcement is difficult to avoid, and so a near-net-shape approach is always advisable, similar to the methodology used for fibre reinforced organic matrix composites.

The mechanical properties of continuously reinforced TMCs depend highly on the reinforcements used (*Table 1*) and are of anisotropic nature. That is: they offer the highest value of strength and

stiffness along the axis of the reinforcements, though the transverse properties may be even lower than those of unreinforced titanium alloys. Thus, potential applications are limited to components that are subjected to largely uniaxial stress.

| Fibre | Modulus GPa | Strength GPa | Density (g/cm ³) | CTE 10 ⁻⁶ /°C | Ref./Supplier |
|--|----------------|-----------------|---------------------------------|-----------------------------|----------------|
| PAN Carbon fibre | 230 | 3.53 | 1.76 | -0.41 | Toray T300 |
| Pitch Carbon fibre | 517 | 2.07 | 2.05 | -1.46 | BP-Amoco P-75S |
| 99% Al ₂ O ₃ fibre | 373 | 3.2 | 3.8 | 8 | 3M Nextel 610 |
| Boron monofilament | 400 | 3.6 | 2.57 | 4.5 | Specialty Mat. |
| 100% Al ₂ O ₃ single cristal | 470 | 3.5 | 3.96 | 9 | Saphikon |
| Sigma 1140 ⁺ SiC monofilament | 400 | 3.2 | 3.4 | 4.5 | QinetiQ |
| Sigma 2156 SiC monofilament | 410 | 3.4 | 3.4 | 4.5 | QinetiQ |
| SCS-6 TM monofilament | 380 | 3.45 | 3 | 4.1 | Specialty Mat. |
| Ultra SCS TM monofilament | 415 | 5.86 | 3 | 4.1 | Specialty Mat. |

Table 1: Properties of continuous reinforcements.

2.1.1 Tow based TMCs.

To avoid the high cost of monofilament-reinforced TMCs, research efforts have been made to produce titanium composite reinforced with lower cost tow-based fibres available in the market, such as carbon fibres or alumina fibre tows (*Table 1*). First ones were quickly given up to reinforce titanium alloys due to the severe chemical reaction problems. In addition any type of coating attempt became very difficult and expensive due to the disposition of fibres in the form of tows.

Alternatively, alumina fibres were investigated in a research program performed at 3M Company as potential cost-effective reinforcements for titanium alloys (*R.R.Kieschke et. al, 1995*). The reinforcements used in this investigation were alumina fibres (NextelTM 610) of 12µm average diameter in the form of tows to provide strength and stiffness to the titanium matrices, while offering a close thermal expansion match.

The Coefficient of Thermal Expansion (CTE) is a very important parameter when selecting reinforcement for any composite material. Changes in temperature can cause internal stresses to be set up as a result of differential thermal contractions between the different constituents.

In this investigation, the titanium matrix was applied to the alumina tow by PVD technique and then these coated fibres were consolidated to form the final composite material. The Ti/Al₂O₃ system is thermochemically unstable so the fibres are progressively dissolved in the matrix. The use of sacrificial fibre coatings investigated previously (C.G.Rhodes *et. al*, 1985), such as carbon-based or carbon/TiB₂ chemical vapour deposition (CVD) films were not suitable to overcome this problem. A coating of around 4µm thickness in a system where the fibre diameter is ~12µm and the fibre-to-fibre spacing is ~5 µm is not suitable. Therefore, thin (~500nm) fibre coatings of Nb/Y₂O₃ were developed to protect Al₂O₃ fibres in order to avoid these chemical interactions with the matrix. Results obtained showed no reaction between the Y₂O₃ and the titanium matrix (R.R. Kieschke *et al.*, 1991).

Besides the problems coming from fibre-matrix chemical reactivity, other problems derived from the nature of the Al₂O₃ fibres within the tow need to be overcome. On the one hand, those related with coating inhomogeneities due to the technical difficulties during the own fibre coating process and, on the other hand, those coming from final fibre's distribution (*Figure 1*). The damage induced in a composite due to coating inhomogeneities or badly oriented fibres have a large influence on the final composite properties.



*Figure 1: Misaligned fibres in a Ti/Al₂O₃ system (R.R.Kieschke *et. al*, 1995).*

Even though the fibre-matrix reactivity problem could be overcome or at least significantly reduced by means of thin non-reactive interface coatings applied to the tow reinforcement, the main technical problems shown by these TMCs are related to the fibre size and/or tow-based fibre format. These problems could be significantly reduced using continuous monofilaments instead of tow-based fibres. This has been the main reason to give up this intensive three-year research program and approach the use of monofilament reinforcements.

2.1.2 Monofilament reinforced TMCs

Boron and carbon monofilaments developed in the 1960's were the first high-strength and high-modulus fibres with potential benefits to reinforce light alloys. Moreover, they proved to be incompatible with titanium matrices because of the high reactivity which resulted in a subsequent strength reduction. To overcome this problem, a thin coating was developed to be used as a diffusion barrier. This thin coating designed for preventing any chemical interaction was added by vapour deposition. From those coatings investigated, SiC turned out to be the most suitable one although it did not completely protect carbon and boron fibres from reactivity with titanium matrices.

These experiences led to the development of single-crystal sapphire (Al_2O_3) and continuous silicon carbide (SiC) monofilaments in the 1970's. Some years later, single crystal sapphire filaments with a diameter in the order of 150 μm were available at a commercial scale under the trade name of Saphikon®. Although they presented attractive mechanical properties (*Table 1*) and a very interesting thermal expansion coefficient matching that of titanium, they showed some disadvantages compared with SiC monofilaments: they were both chemically incompatible with titanium alloys and expensive.

Hence, after 40 years of developments, SiC monofilaments seem to be the most interesting continuous reinforcements for titanium alloys even though the SiC/Ti system is not in thermodynamic equilibrium, and consequently some compounds precipitate and grow at the matrix-reinforcement interface.

SiC fibres have been adapted to reinforce titanium alloys by the incorporation of a pyrocarbon coating to reduce the reaction zone between the silicon carbide monofilament and the titanium

matrix. However, a real diffusion barrier to avoid this chemical reaction has not been found yet and a brittle interface results during processing or subsequent elevated temperature exposure.

During elevated-temperature exposure, the fibre coating is consumed while the reaction layer increases. The growth rate obeys Arrhenius' law and it is believed to be a diffusion-limit process (Figure 2).

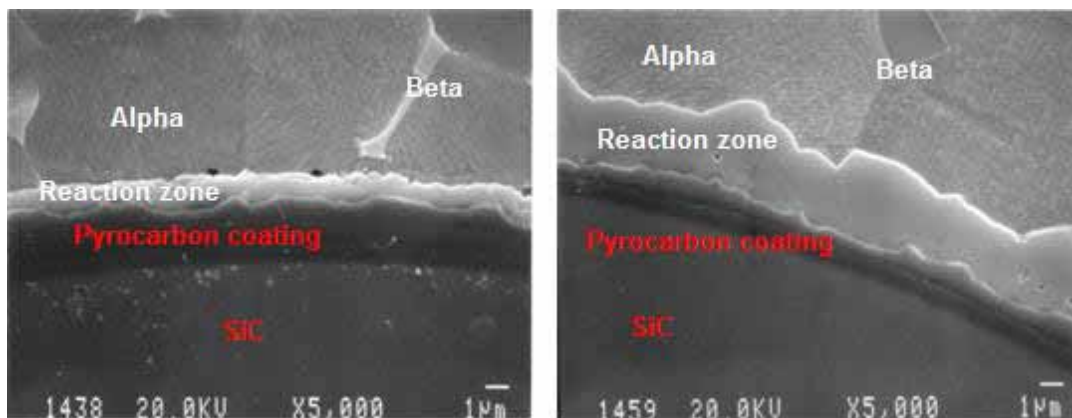

Figure 2: SEM images of Ti6Al4V/SCS-6TM composite interface: a) as processed at 950°C, 1h b) heat treated condition at 800°C for 500h. Reaction constant and activation energy were estimated as $0.0048\text{m/s}^{1/2}$ and 255KJ/mol respectively (M.García de Cortázar et al., 2001).

Once this brittle interface or reaction layer has grown to a thickness beyond a critical value, the strength drops rapidly (Figure 3).

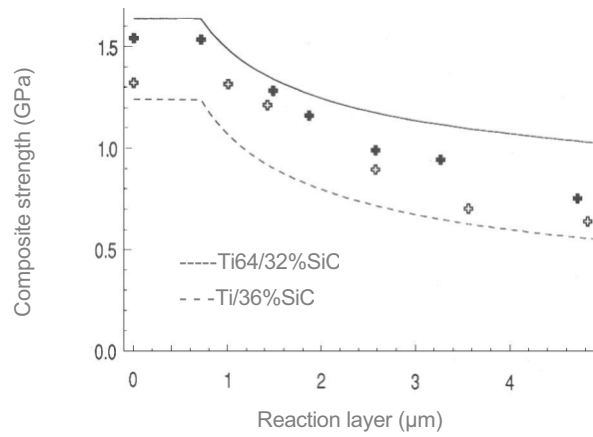

Figure 3: Variation of composite strength vs. interfacial reaction layer thickness for axial tensile loading of two long fibre reinforced composites: CP Ti and Ti-6Al4V matrixes reinforced with SCS-6 monofilament (T.Onzawa et al., 1991).

The fibre-matrix interface is a critical constituent of composites since load transfer from the matrix to the high-modulus fibre and vice-versa occurs through the interface. It is this load transfer behaviour that distinguishes composites from monolithic materials.

In addition, as the CTE of titanium is nearly twice that of the fibre (9 vs. $4 \times 10^{-6}/\text{K}$), residual stresses are originated during cooling down from the processing temperature ($\sim 950^\circ\text{C}$) and consequently micro cracks initiated at the reaction interface (*Figure 4*).

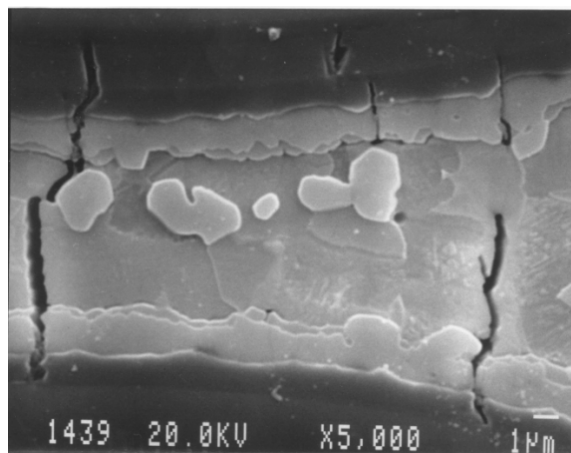

Figure 4: Cracks generated between SiC fibres located too close to each other within the titanium matrix during cooling down from the processing temperature (J.Coletto et al. 2002).

However, these monofilaments are the most popular ones for continuous reinforcement of titanium alloys. They are produced by chemical vapour deposition (CVD) on an electrically heated core substrate. Two companies share the SiC fibre market nowadays: Specialty Materials Inc. (formerly Textron) in the USA with the SCS fibre series and QinetiQ (formerly DERA) in the UK with the Sigma series.

Among the SCS fibres, the SCS-6TM has essentially been established as the industry standard, in particular for titanium alloys, while the Ultra SCSTM has been developed as an alternative for those applications that require much higher strengths. Both have a diameter of $\sim 140 \mu\text{m}$ and are deposited on a $33 \mu\text{m}$ carbon core which is overcoated with a $1.5 \mu\text{m}$ thick pyrolytic carbon layer. Although their architectures are quite similar, they differ mainly in their composition as well as in their microstructure. The microstructure in the Ultra SCSTM is much finer and the chemical

composition is different, as it can be observed in the electron probe microanalysis (EPMA) showed in Figure 5.

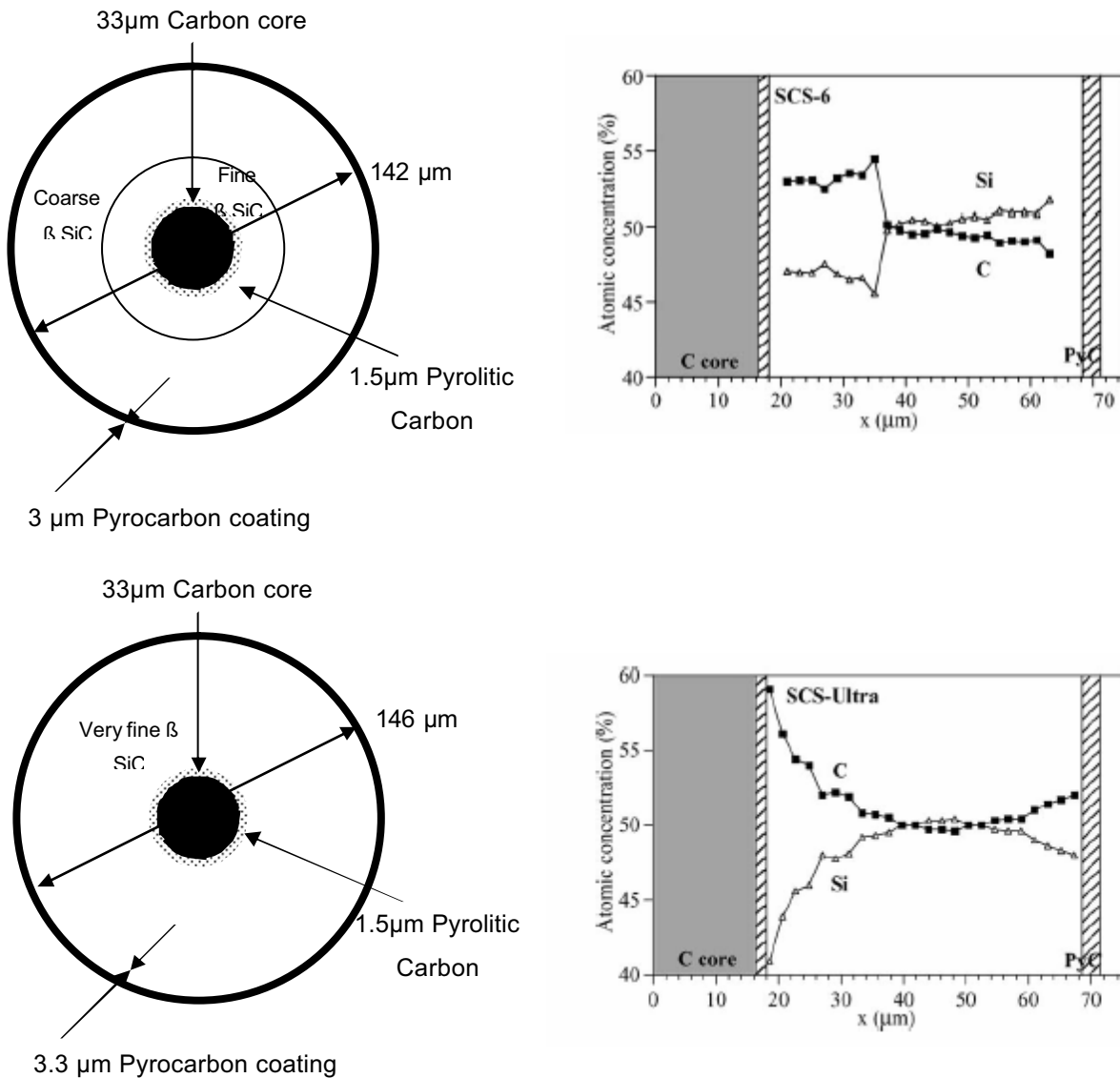

Figure 5: Schematic cross-section and EPMA radial profile of the SCS-6TM and Ultra SCSTM SiC fibres (G.Chollon et. al, 2004).

Alternatively, in the Sigma series a smaller-diameter (15 µm) tungsten wire is used as the substrate. The SM2156 is a developed version similar to the commercial SM1140+, but with an

outer diameter of 141 μm instead of 105 μm . In this new version, the amount of free silicon codeposited with SiC has been reduced to improve the stiffness and thermal stability of the filament (Figure 6).

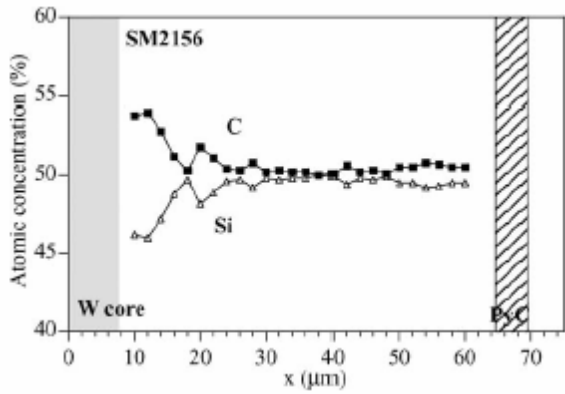
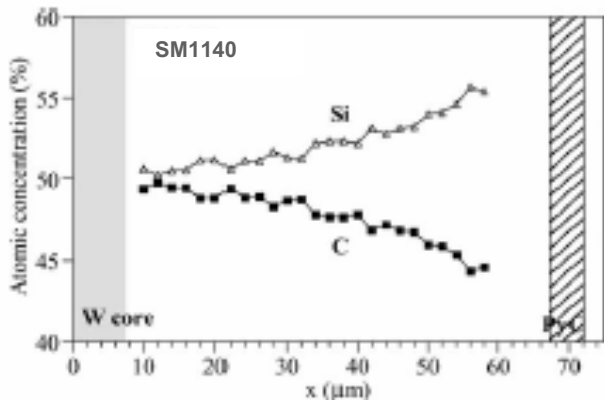
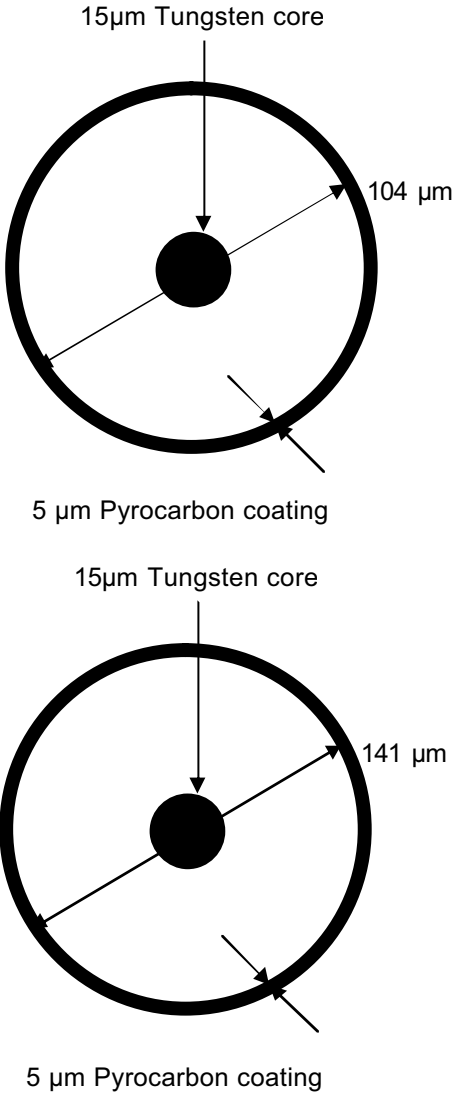

Figure 6: Schematic and EPMA radial profile of the SM1140+ and SM2156 (G.Chollon et. al, 2004).

In the SCS fibre series, a thick pyrolytic carbon layer decouples the C-core to the SiC, which is in a chemical equilibrium so that there is no observable reaction between the core and the SiC in a consolidated TMC (*Figure 7*).

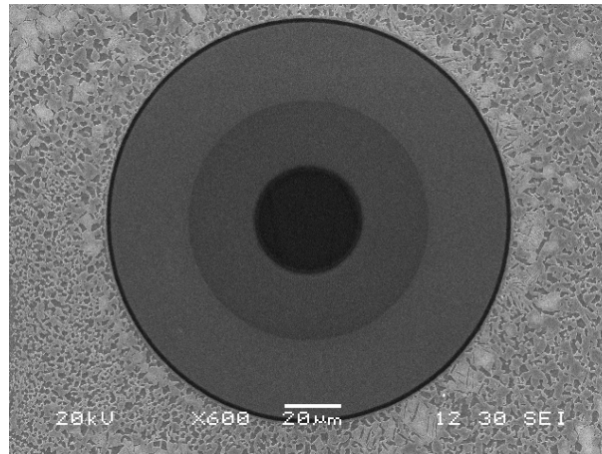

Figure 7: SEM micrograph of the SCS-6TM/Ti₂AlNb composite (M.García de Cortázar et. al, 2005).

Alternatively, in the Sigma series a tungsten core is used. Tungsten is available in relatively defect-free, large spools, unlike carbon monofilaments. Therefore, the cost of producing W/SiC fibre is lower than that of producing C/SiC. Also, the modulus of the first one is higher and this is desirable. However, the W/SiC reaction at the core of these fibres occurs during TMC fabrication or subsequent use at elevated temperature leading to a reduction of its properties (*M.L. Gambone and D.B. Gundel, 1997*).

It deserves to be mentioned that a new process to grow diamond monofilament is under development at the University of Bristol. The investigation began in 1991 and it is based on the chemical vapour deposition (CVD) process. Although much work remains to be done, in particular to improve the actual growth rate (~0.5µm/h), the monofilaments display outstanding properties (*Table 2*) and maintain their properties up to high temperatures.

| | SCS-6 | SM2156 | CVD-diamond |
|---|---------|--------|-------------|
| \varnothing (μm) | 144 | 141 | 120-150 |
| $\varnothing_{\text{core}}$ (μm) | C(33+3) | W(15) | W(50) |
| E (GPa) | 356 | 385 | 930 |

Table 2: Elastic modulus at room temperature (G.Chollon, Prentice, May et. al, 2004).

In this process, the diamond coating is deposited onto a tungsten core of 50 μm diameter and the resulting W/diamond monofilaments are in the range of 120 to 150 μm in diameter. As mentioned, if growth rates could be increased to economically viable levels ($\sim 10\text{m/min}$ for CVD-SiC), such diamond fibres may prove to be useful for reinforcing titanium alloys. However this fibre alternative is not currently feasible.

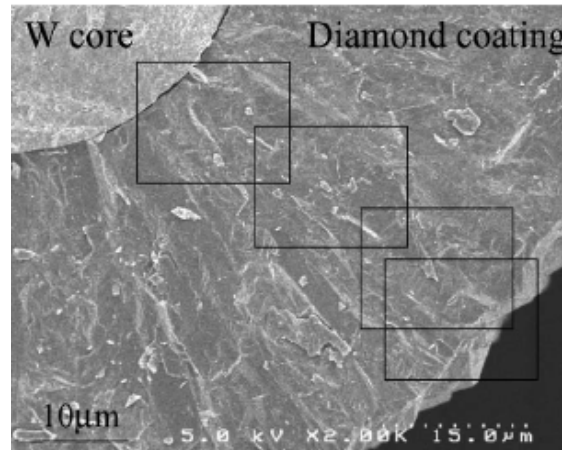

Figure 8: Diamond coating deposited onto a tungsten core (G.Chollon, Prentice, May et. al, 2004).

To summarize: the composite system made up of titanium alloy as matrix material and silicon carbide monofilaments as reinforcements has been by far the most studied system for continuously reinforced titanium-matrix composites and at present it is the only one commercially available.

2.1.2.1 Ti/SiC system

Programs and applications

The development of this composite system has been maturing for over 30 years and many investigations have been performed to improve the processing and to understand the behaviour of this composite material. An intense effort has been directed towards the understanding, characterisation and life prediction of these composites, to reduce cost and to improve production routes.

In the US, through a combination of corporate funding and a variety of US government sponsored development efforts, the three most significant programs supporting these investigations have been the following:

- National Aero-Space Plane (NASP) program (1988-1992).
- Integrated High Performance Turbine Engine Technology (IHPTET) program (1988-2005).
- Titanium Matrix Composite Turbine Engine Component Consortium (TMCTECC) program (1994-2000).

The first program was conducted to evaluate advanced materials in support of the NASP airframe design. TMC evaluation was a significant part of the program and was a combined effort by the five NASP prime contractors to develop high temperature SiC reinforced TMC for use as primary structure on the NASP airframe. The NASP airframe design was based on the assumption of a metallic outer skin and substructure for most surfaces with the TMC acting as the thermal protection system (TPS).

The IHPTET program, a three phase program, started in 1988 with the objective of doubling the gas turbine propulsion capability by the end of 2005. The program has been successful in achieving the stated goals, and technology developed and demonstrated has been transferred to production engine programs.

The third program (TMCTECC), with a budget of 26 million US\$, was built on the lessons learned in the previous two. It started in 1994 and scheduled to finish in the 2000. The programme was

focused on reasonable TMC components for gas turbine engine applications through the development of improved processing methods. Through a combination of Lean Manufacturing principles and Six-Sigma improvement methods, processes were developed that reduced cost and improved reliability.

The result of the improvements enabled the transition of the technology from development to production status:

- Ti6242/SiC Nozzle Actuator Piston Rod

Nozzle Actuator Piston Rod of the two Pratt & Whitney F119 engines used on the F-22 aircraft. The material used in this application was a solid rod of 13-8Cr-Ni precipitation hardened stainless steel. Now it has been replaced by a Ti6Al-2Sn-4Zr-2Mo alloy reinforced with SiC fibre manufactured by the metal wire process.

This Ti/SiC piston represents the first aeronautic application of this composite system (*Figure 9*).

- Ti6242/SiC Nozzle Actuator Links

Based on the experience gained from the actuator piston rod, the Ti/SiC was certified for nozzle links on the General Electric F110 engine, used in the F-16 aircraft.

The material used in this application was a square tube of Inconel 718. Now it has been replaced by a Ti6Al-2Sn-4Zr-2Mo alloy reinforced with SiC fibre manufactured by the metal powder process.

This new link has been certified for F110 engine in the F-16 aircraft (*Figure 9*).

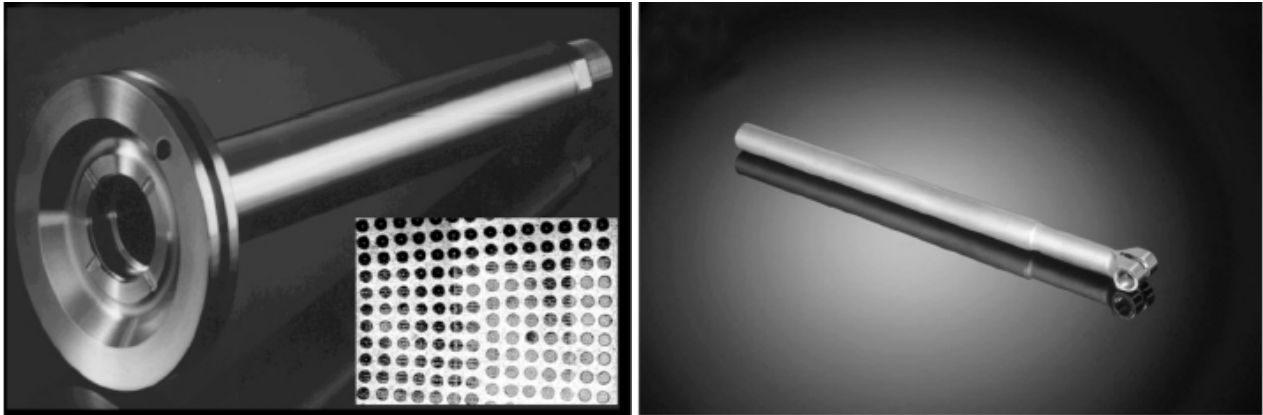

Figure 9: Jet engine applications of titanium-matrix composites. Left, a nozzle actuator piston rod used on the Pratt & Whitney F119 engine for F-22 aircraft. Right, a nozzle actuator link from the General Electric F110 engine, used in the F-16 aircraft (D.B.Miracle, 2001).

Outside of the US, in Europe, TMCs also became the subject of significant research efforts, both in private projects, renowned R&D centres and universities working together, and within the framework of large European projects financially supported by the European Commission. Worth mentioning are the activities started in the 1980's at DLR in Germany in collaboration with MTU (Daimler Chrysler) and those initiated in UK at the Defence Evaluation and Research Agency (DERA) who designed, developed and engineered this outstanding material for construction of bladed rings (BLING) in the low-pressure compressor of the turbine. Other applications such as landing gear components have also been investigated and tested. On June 2003, SP aerospace and the Dutch government performed the world's first test flight of a primary structural landing gear component in TMC (*Figure 10*).



Figure 10: a) Installation of the TMC Lower Drag Brace in the F16 Main Landing Gear, b) Touchdown (SP Aerospace, 2003).

A Lower Drag Brace for the F16 main landing gear was developed by SP aerospace (*Figure 11*). The TMC based material was supplied by FMW Composite Systems (USA) and the Royal Netherlands Air Force (RNLAF) provided full support and flight clearance for the test flight on their F16 “Orange Jumper” test aircraft.

The flight demonstrated that the use of TMC material is feasible for primary structural landing gear applications. The TMC technology is expensive however, costing about three times with respect to the reference component.

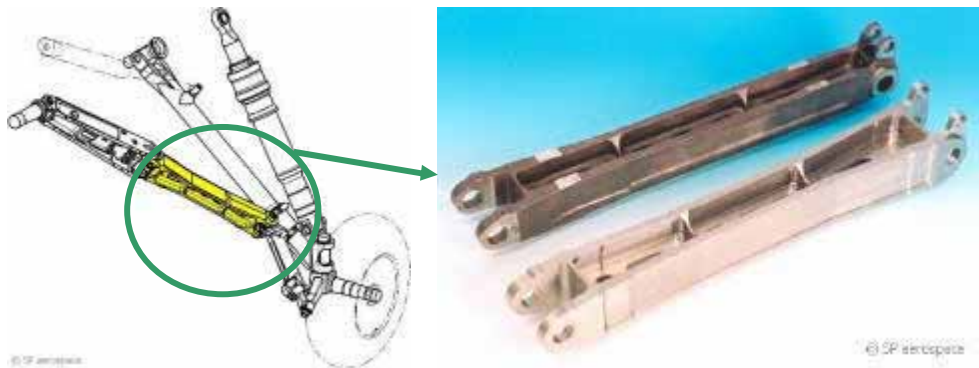

Figure 11: a) Original main landing gear with the Lower Drag Brace, b) TMC Lower Drag Brace in front of the reference part, the high strength steel part. The achieved weight reduction is approximately 40%, from 7.7kg to 4.5kg. (SP Aerospace, 2003).

For space applications, programs financially supported by the European Space Agency (ESA) through Technology Research Programs (TRP) started in 1998. During these investigations, titanium Intermetallic Matrix Composites IMCs have been recognised as promising materials for future “metallic” Thermal Protection System (TPS) applications in Reusable Launch Vehicles (RLVs), representing a good alternative instead of the dense nickel-based alloys. These successful programs will be continued with the validation of this material in a real space-flight experiment, called EXPERT, scheduled for the beginning of the 2007. Thus, the Expert project, where an IMC panel will be introduced for flight testing (Figure 12) will be a great opportunity to demonstrate the capabilities of TMCs for space applications.

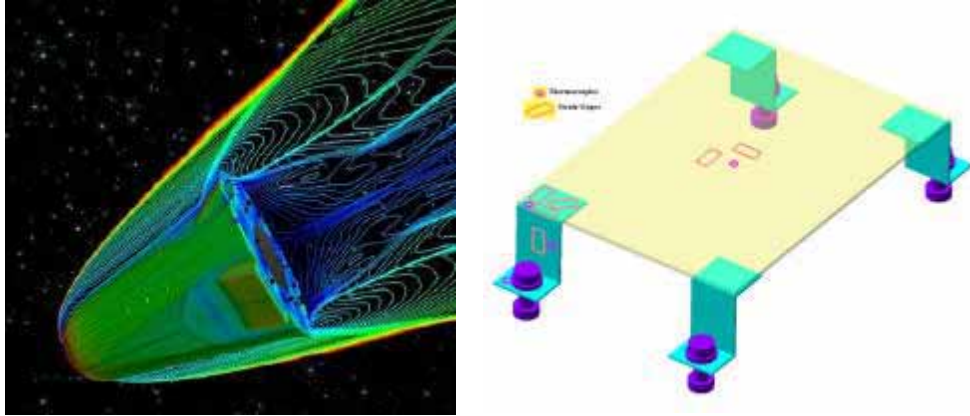

Figure 12: a) EXPERT capsule (ESA), b) Metallic TPS design made of an IMC for the EXPERT experiment (Inasmet, 2004).

Processes and costs

The major drawback of this material has been its high cost. This problem has been approached mainly by American companies, in particular within the TMCTECC program.

The three primary areas of development were:

1. SiC fibre cost reduction.
2. Development of pre-processing concepts.
3. Simplified manufacturing methods.

SiC fibre reduction cost. The cost of the SCS fibres has been notably reduced, mainly due to processing and manufacturing improvements. In a time frame of 10 years, it has been reduced for a factor of 4 (Figure 13):

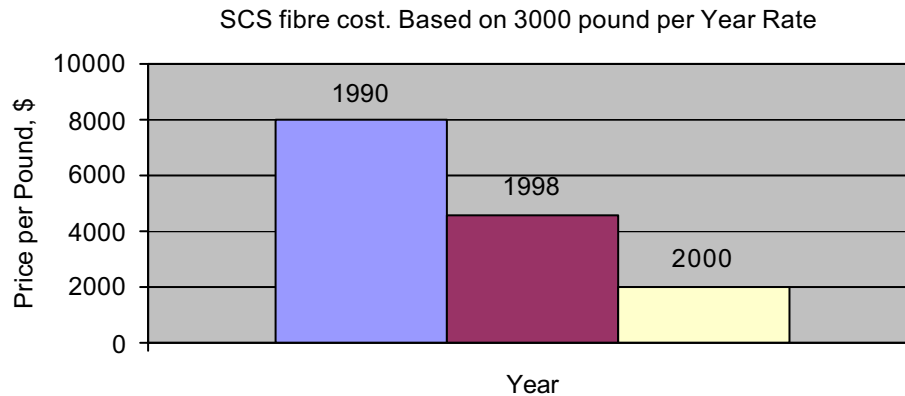

Figure 13: SiC fibre cost evolution (FMW Composite Systems, 2003).

Development of pre-processing concepts. The second improvement area has been the preparation or manipulation of the Ti/SiC before being consolidated by HIPing or by hot pressing. The improvements have been achieved by the development of pre-processing concepts that eliminate the cost inherent to the primary method for producing this type of composites: the foil fibre foil (FFF) method.

As the name suggests, in the FFF method (S.C.Jah, *et al.*, 1991) thin titanium foils and fibre mats weaved by metallic ribbons are sequentially stacked, before being consolidated. In addition to the fibre cost, the production of foil, metal ribbon and the weaving process are very expensive. Particularly the foil production is a tedious and costly process, thus the initiative has been to use titanium metal sources that are affordable and readily available in the existing industrial base, such as powder, wire and bar forms.

The titanium powder-based pre-processing approaches developed previously were the tape casting process (W.H. Hanusiak, 1997) and the plasma spraying process (Y.Y. Zhao, 1993). In the former, unidirectional fibre tape is combined with titanium powder to form a bi-layer preform sheet with fibres on one side and metal powder on the other, it is held together by an adhesive binder. In the plasma spraying process, the matrix material in the form of powder, is injected into a high temperature plasma flame where it is melted to form a spray of liquid droplets. The droplets are accelerated towards a rotating cylinder on which a continuous fibre or monofilament is wound with

a precise spacing between consecutive fibres. The sprayed matrix infiltrates the interfibre region, solidifies, and binds the fibres into a single layer composite or monotape. In both cases the resulting monotapes are then stacked together and consolidated by hot isostatic or unidirectional pressing.

The benefits are the elimination of the foil production process, the weaving process, the metal ribbon for waving as well as the associated cost and quality issues. In fact, one of the two existing industrial applications, the Nozzle Actuator Piston Rod (*Figure 9a*), is manufactured using the tape casting process based on titanium powder.

The pre-processing based on titanium wire was developed (*W.H. Hanusiak, 1998*) using unidirectional fibre tape combined with titanium wire to form a bi-layer preform with fibres on one side and titanium wire on the other. They are held together by an adhesive binder. The fibre tape is arranged by winding a continuous filament onto a drum. A wire layer is wound over the fibre layer and adhesively bonded together to form a bi-layer preform. This process is in many ways analogous to the previously described tape casting process. The benefits are particularly clear in rotating component designs, due to the geometrical constraints of foil or powder-based preforms. The other industrial application, the Nozzle Actuator Link (*Figure 9b*), is manufactured by this process.

Finally, the pre-processing based on titanium bar was developed by deposition conversion of the bar directly into a titanium alloy coating on the SiC fibre by physical vapour deposition (PVD). This metal-coated fibre (MCF) preform can be woven into a mat or wrapped to form rings. This is the most suitable method to obtain high precision or locally reinforced components.

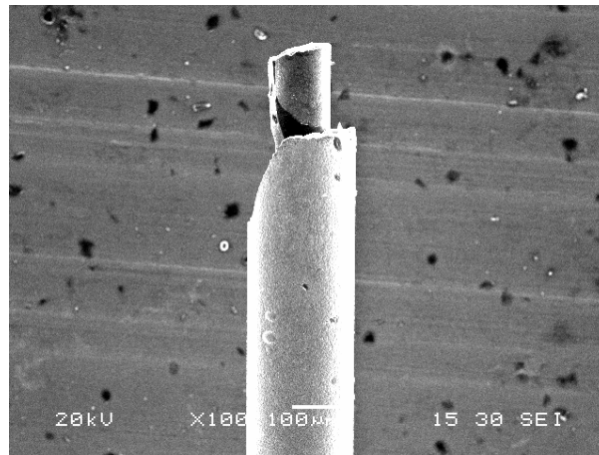

Figure 14: SM2156 fibre coated by titanium matrix (M.García de Cortázar et. al, 2005).

An alternative pre-processing route recently developed and patented (B.Drambrine, et al., 2001) is the liquid state coating of the fibre with Ti alloy. The process consists in running the SiC fibre at very high speed through liquid titanium alloy. During this process, although the fibre is in contact with the titanium only for a few tenths of a second, a part of the pyrolytic protective carbon coating of the SiC monofilament is consumed due to its reactivity with the liquid titanium. The process requires particularly high strength and thermally stable monofilament reinforcements. This has motivated the development of the monofilaments at the European firm QinetiQ, the SM2156.

Simplified manufacturing methods. The third improvement area has been the complete manufacturing cycle. The application of lean manufacturing methods, that is, combined operations or tooling to decrease manufacturing complexity, to reduce defects and to increase quality has led to a general reduction of the cost (Figure 15).

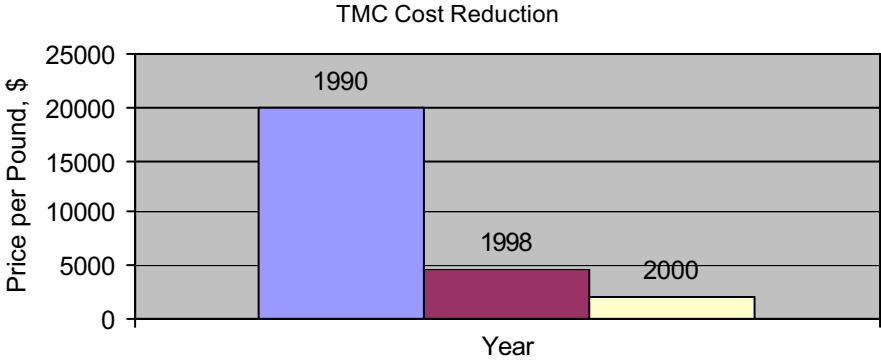

Figure 15: TMC cost improvements achieved since the NASP program (FMW Composite Systems, 2003).

2.2 Discontinuously reinforced TMCs

Discontinuously reinforced TMCs are made of a titanium or titanium alloy matrix with a discontinuous reinforcing phase. Their main advantages include their isotropic properties and that they are easier to produce compared to continuously reinforced ones using secondary conventional processes. However, the mechanical properties reached are lower than those presented by continuously reinforced TMCs loaded parallel to the reinforcement direction.

The isotropic nature opens a far wider range of potential applications than those that exist for continuously reinforced TMCs. Moreover, the properties are tailorable as a result of the flexibility in terms of the size, final volume fraction, composition and morphology of the reinforcements.

2.2.1 Particulate reinforced TMCs

The first discontinuously reinforced TMCs were produced by traditional processing routes, where ceramic reinforcements were prepared separately prior to the composite fabrication and subsequently added to the titanium matrix in a molten or powdered form. However, most of these reinforcements were developed to reinforce metal matrix composites, e.g. chopped carbon or graphite fibres, Al_2O_3 short fibres, SiC and TiC particles. These are chemically unstable in titanium alloy during the usual high-temperature-processes, resulting in damage of the reinforcements and degraded properties. The coating approach used with continuous monofilaments to decrease the reactivity between the reinforcement and the titanium matrix has also been considered, but it is not cost-effective and it is difficult to achieve for the development of these particulate reinforced TMCs. Therefore, during the last 15 years efforts have been made to overcome these drawbacks and the investigations have led to the development of novel discontinuously reinforced composites, called *in-situ* reinforcements, which are synthesized in a titanium matrix by chemical reactions between selected elements during the composite fabrication step itself. The main advantage of this new type of composites is the chemical stability between the reinforcing phases produced and the titanium matrix.

2.2.2 *In-situ* composites

A number of different alternative processing techniques has evolved most recently in an effort to optimize the structure and properties of *in-situ* ceramic phase reinforced MMCs and particularly for aluminium and copper-based composites (S.C. Tjong, 2000). However, only some of them have been evaluated to produce titanium-based composites.

A brief review of the status of these processes is given below.

2.2.2.1 Production processes

2.2.2.1.1 Casting

Elements or compounds react *in-situ* to form reinforcing phases in the presence of a liquid metallic phase, titanium or titanium alloys in this case. They are directly added into the molten metal and consequently the ceramic reinforcements grow *in-situ* through the reaction between reactant and the components of the melt.

This process has been extensively investigated and it is already used to manufacture aluminium matrix composites, because of its simplicity, flexibility and cheapness (X. Wang, et al., 1999). However, there is very little discussion in the literature about attempts to produce TMCs through this casting process. This could be because of the high melting point of titanium and its high reactivity with the reinforcements in the liquid state and the problems involved in melting and casting titanium and its corresponding composites.

Elemental additions of boron, carbon and silicon result in TiB, TiC and TiSi₂ reinforcements formation based on the following reactions (Soboyejo et al., 1994, 1995, 1997, Lederich et al., 1994):

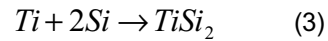

Zhang *et al.* and Lu *et al.* (Xiaonong Zhang, 1999 and Weijie Lu, 2001) have also investigated the production of TiC and TiB reinforcements simultaneously based on the reaction between Ti and B₄C. In these investigations, Ti and B₄C powders were blended and compacted into pellets to be subsequently melted.



The composite presents an inhomogeneous distribution and large variations of the reinforcements morphologies (*Figure 16*). The temperature reached during the reaction of these compounds with titanium alloys is so high that not only the crystal structure but also the solidification path plays an important role in determining the final reinforcement morphology and microstructure. The TiB has a needle-shaped morphology, shorter or larger size depending on the solidification paths followed. The TiC, with NaCl-type structure, grows into dendritic shaped morphology and equiaxed shaped morphology particles depending also on the solidification path followed (*Figure 16*).

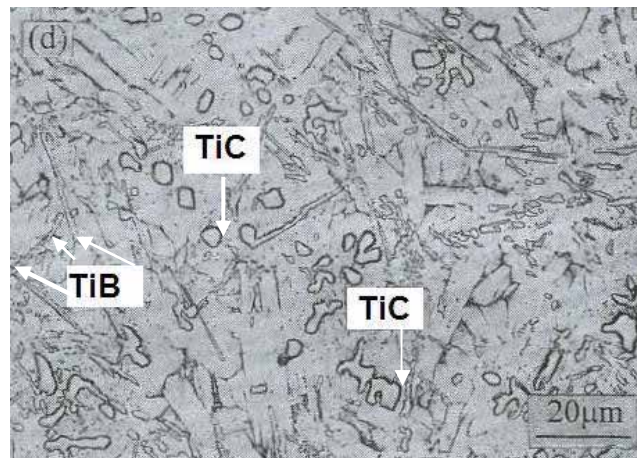

Figure 16: TiC and TiB distributed in titanium alloys (Xiaonong Zhang, 1999).

The particular case of TiB, its precipitation and morphology obtained, has been investigated by F. Dartigues in his thesis (Dartigues F., 2004). In this investigation, elemental boron addition and other boron-containing compounds have been evaluated as boron source to the titanium melt.

Direct addition of boron or VB_2 to liquid titanium presents drawbacks, not only problems derived from the handling but also those derived from the transformation. These kind of boron sources, before being dissolved in the molten titanium, are first transformed into TiB_2 and then into TiB. By using TiB_2 as boron source, besides the high temperature required, TiB_2 is also transformed to TiB before it is dissolved. If TiB is used as boron source, as soon as the temperature reaches the liquidus temperature the material is melted and dissolution of TiB takes place.

2.2.2.1.2 Rapid solidification

To overcome some of the difficulties identified in the casting route previously detailed such as the low solid solubility of dispersoids forming the reinforcements, their inhomogeneous distribution and variation on reinforcement morphology, rapid solidification techniques have also been investigated. At a high enough solidification rate the solid solubility of forming elements can be extended to a much higher level to produce a supersaturated solid solution. Afterwards an annealing treatment at suitable temperatures is needed to decompose the supersaturated solid solution and produce finer stable particles with a uniform distribution. In an investigation performed by Z. Fan (Fan, Z., 1996), titanium alloy reinforced with TiB and yttrium oxide has been obtained with a refined particle size

and an uniform distribution compared with the microstructure of the same alloy obtained by conventional casting.

2.2.2.1.3 Powder metallurgy

So far, this is the most investigated process and there are several works reported in the literature that differ basically in the initial state or condition of the powders:

- *Commercial powders.*
- *Pre-alloyed gas atomised powders.*
- *Rapidly solidified powders.*
- *Mechanically mixed or mechanical alloyed powders.*

Powder metallurgy routes start with the alloying and/or cold pressing step of the powders followed by a sintering or hot isostatically pressing step to form the final composite materials.

Commercial powders

Dynamet Technology Inc. (S.Abkowitz, 1998) has developed a proprietary process to manufacture titanium matrix composites discontinuously reinforced with titanium carbides or titanium borides, CermeTi[®] materials.

The process, called Cold plus Hot Isostatic Pressing (CHIP) process, involves blending of powders and cold isostatic pressing in a reusable elastomeric tooling to produce a compact (*Figure 17*). This green compact is sintered in vacuum and hot isostatically pressed. TiC and TiB₂ are used as additives, the former is stable during sintering or HIPing and the TiB₂ particles react with the titanium *in-situ* transforming them into TiB.

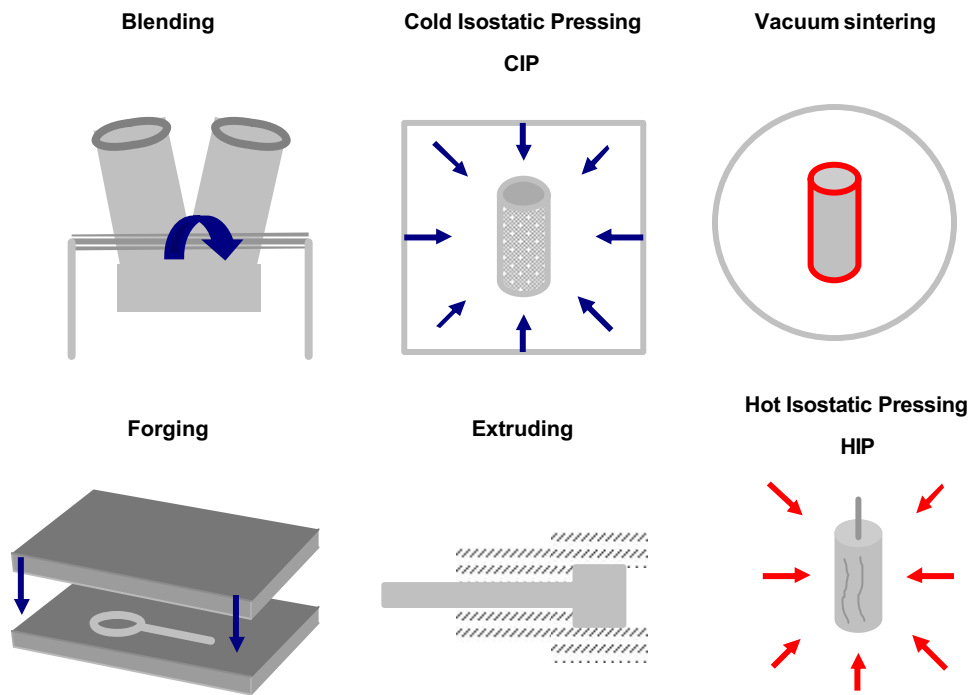

Figure 17: A scheme of the CHIP process.

A similar process is the one developed in the Toyota Central Research and Development Laboratory (*T.Saito et al., 1995*). This pioneering work has led to the introduction, for the first time, of TMCs in the automotive market. In 1998, Toyota Corporation adopted intake and exhaust valves made of discontinuously reinforced TMCs for the engine of its *Altezza* car (*O. Chauerte, 2003*).

In this process, called blended elemental (BE), the powders are blended, die compacted and vacuum sintered. Afterwards, induction heating is conducted to extrude the valve stem, followed by forging for the valve face. After correcting the bending of the stem part, an annealing treatment to control the microstructure is performed.

The reinforcement used to reinforce the titanium matrix in this application is the TiB. Titanium alloy powders and TiB₂ powders react during sintering to form the TiB.

Pre-alloyed gas atomised powders

Another process to produce discontinuously reinforced titanium matrix composites is based on the use of pre-alloyed *in-situ* reinforced titanium alloy powders and the subsequent consolidation by standard titanium consolidation methods such as hot isostatic pressing (HIP) or direct extrusion.

Yolton *et al.* (C.F. Yolton, 1995, 2004) have investigated this pre-alloyed approach to produce discontinuously reinforced titanium composites. Pre-alloy powders reinforced with TiB and/or TiC are produced in a gas atomizer unit which consists of a melting chamber, an atomization tower and a cyclone collector. The starting charge material is melted in an induction melting crucible within the melt chamber. The boron is added as titanium diboride powder and carbon as graphite powder. After the charge is fully melted and homogenized it is bottom poured and atomized with high-pressure argon gas.

The pre-alloyed powder approach offers a means of producing alloys with uniform and fine dispersions of TiB and TiC.

Rapidly solidified powders

Discontinuously reinforced titanium matrix composites have also been manufactured using rapid solidified powders (W.O. Soboyejo, 1994), followed by consolidation by standard hot isostatic pressing (HIP) and/or direct extrusion.

Rapid solidified powders (RSP) produced using a plasma arc melting centrifugal atomization facility have been used to obtain *in-situ* titanium matrix composites reinforced with TiB and TiSi₂.

The result is a titanium composite material with homogeneously distributed fine precipitates, needle-shaped TiB and spherical TiSi₂.

Mechanical alloying (MA)

Mechanical alloying is another solid-state powder process in which an initial blend of powders is repeatedly kneaded together and re-fractured until a powder is produced in which each particle has the composition of the initial powder blend. The process involves the deformation, welding and fracture of powder particles (*Figure 18*).

When this route is used for titanium and its alloys, the control of the atmosphere is critical, thus a good control over the milling environments is essential.

This process has been used for the production of Ti/TiB composites by Goodwing *et al.* (*T.M.T. Godfrey, 2000*). The TiB₂ is incorporated into either titanium or titanium alloy powders, blended and milled. Then mixture of powders is hot isostatic pressed and the TiB₂ reacts with the titanium or titanium alloy powder to form TiB reinforcements. Subsequent heat treatment is also applied to ensure the complete conversion into TiB.

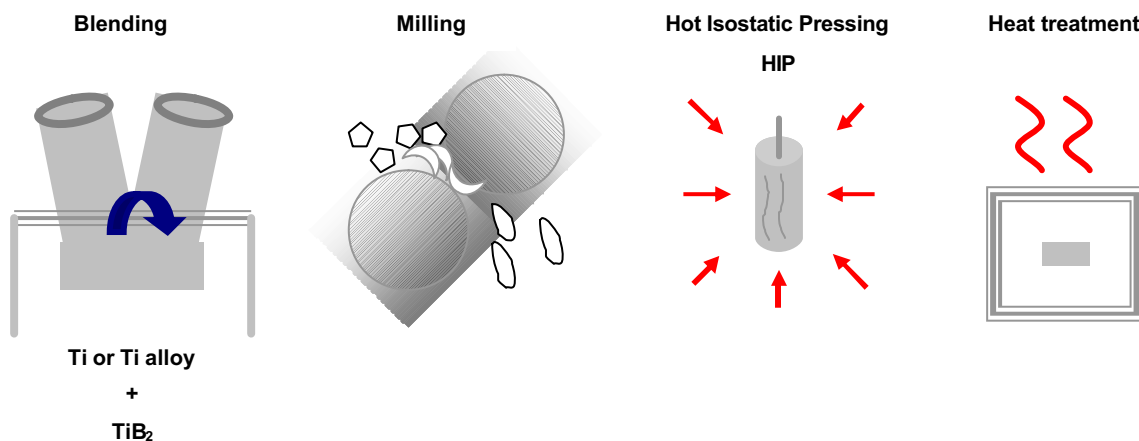

Figure 18: A scheme of the mechanical alloying process used to produce Ti/TiB composites.

Although the TiB reinforcements can be produced by additions of either B or TiB₂, the later is considered to be more appropriate for the MA process due mainly to its lower oxygen content. In

addition, a matrix such as the Ti6Al4V was considered to be too hard, and therefore did not mix well with either the boron or with TiB₂. The use of lower strength matrices, such as commercial pure titanium is highly recommended. However, comparing the mechanical properties of both matrix materials, Ti6Al4V alloy without any kind of reinforcements shows higher properties (70% higher) than those shown by pure titanium alloys. Properties hardly achievable by reinforcing pure titanium alloy.

2.2.2.1.4 Self-propagating High-temperature Synthesis (SHS)

Self-propagating High-temperature Synthesis process, developed by Merzhanov *et al.* in the late 1960s, is a combustion process that results in the formation of valuable products starting from commercial powders. The process involves an exothermic, self-sustaining reaction which propagates through a mixture of compressed powders. The powders of the constituent elements are mixed and compacted before being ignited from the sample surface with a heat flux (heated wire, electric spark, laser beam, etc.) (Figure 19).

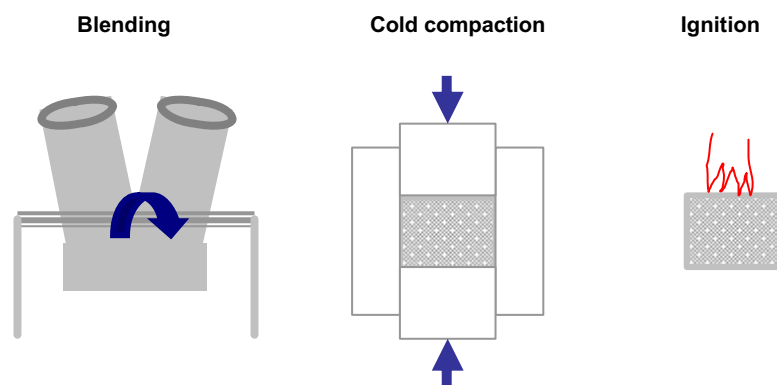

Figure 19: A scheme of the SHS process.

Once ignited, due to the high enthalpy of reaction, there is sufficient heat release to render the reaction self-propagating and a combustion wave travels along the reactants converting them into the required product. The duration of the heating is markedly shorter than the time of reaction, which lasts some seconds.

Products of combustion synthesis are generally porous and require further processing to obtain dense bodies.

The first SHS production was for refractory metal compounds and ceramics but now other materials can be synthesized by this technology, such as cermets of metals or intermetallics. However, literature on SHS processing of cermets is few and limited to Al-based materials. Theoretically, SHS processing appears to be much more problematic for metallic than it is for intermetallics. For intermetallics, the reactions for the reinforcement formation and matrix formation are exothermic, whereas for metallic cermets, the matrix acts as a diluent, which may cause damping of the combustion wave. Therefore, only ceramic reinforcements with a high heat of formation are suitable for SHS processing of TMCs. Another basic requirement is that the high fraction of ceramic reinforcement should be maintained to ensure that the reaction does not cease owing to an excessive dilution of the matrix material. Therefore, the process is especially suitable for producing titanium matrix composites with a high volume fraction of ceramic phases, i.e. cermet composites.

The next table (*Table 3*) summarizes the differences in terms of reinforcement morphologies produced by the different processes. The morphology depends not only on the process but also on the reinforcement content and even on the post treatment.

| Process | Morphology | Ref. | |
|-----------------------------|--|---|-----------------------------------|
| Ingot metallurgy | Coarse TiB needles l/d~10-20 | Soboyejo <i>et al.</i> , 1994,1995,1997 | |
| | TiSi ₂ Small spherical 1µm | Soboyejo <i>et al.</i> , 1997 | |
| | TiB needles dendritic or equiaxed shaped TiC | Xiaonong Zhang, 1999 Weijie Lu, 2001 | |
| | Proeutectic and primary TiB needles | Dartigues F., 2004 | |
| | Dendritic shape TiC | Myonung-Gyun Kim, 2005 | |
| | Coarse TiB needle l~20µm Coarse Y ₂ O ₃ cubic l~2µm | Fan, Z., 1996 | |
| Rapid Solidification | TiB needle l<1 µm | Fan, Z., 1996 | |
| | Y ₂ O ₃ cuboidal l< 50nm | | |
| PM | Commercial powders | TiB needles l~10-20 d~2-5 µm TiC particles d~2-15 µm | T.Saito, 1995 S.Abkowitz, 2004 |
| | Gas atomised powders | TiB needles l~5-10 µm d~1-2 µm TiC particles d~1-2 µm | C.F.Yolton, 1995, 2004 |
| | Rapidly solidified powders | TiSi ₂ particles d~1µm TiB needles l~5-10 µm d~1-4 µm | W.O.Soboyeto, 1994 |
| | Mechanical alloying | TiB needles l~10-50 d~1-5 µm | T.M.T. Godfrey, 2000 |
| | SHS | Carbide and borides cermets | Z. A. Munir, 1989 |

Table 3: Review of the morphology of reinforcements obtained from different production processes.

2.2.3 Economical aspects

Nowadays, discontinuously reinforced TMCs commercially available are the ones produced by Dynamet Company through the CHIP process based on PM techniques. And the one and only industrial application is the Ti/TiB valve introduced by Toyota for the engine of its *Altezza* car, where the material is produced by a similar process (called Blended Elemental process) also based on PM techniques.

These composites require specific and costly sintering or HIPing steps and in addition they have to be forged and/or machined to achieve the right shape of the final component (*Figure 20*).

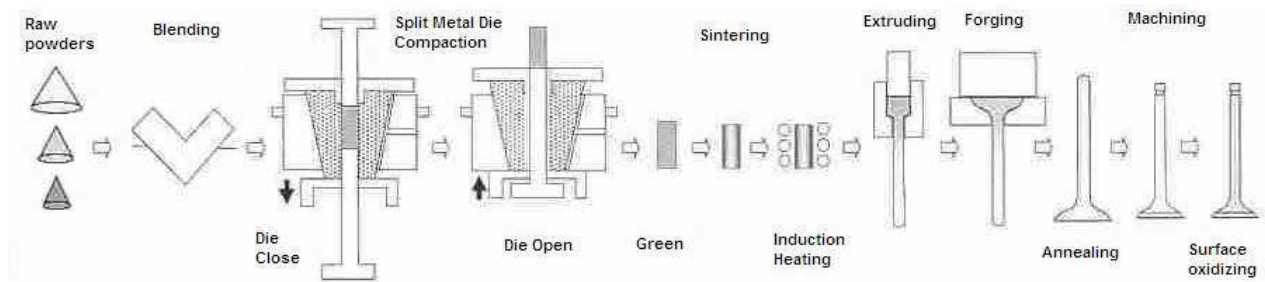

Figure 20: Production steps followed for the Toyota engine valves production by the so called BE process (T. Saito, 1995).

The results obtained from an assessment of production cost already performed (*GRD2-2000-30405, D6.1*) reveal that sintering/HIPing itself and extrusion if used are the dominant factors within the cost breakdown (*Table 4*). Moreover, HIPing used in conjunction with techniques such as extrusion or forging seems to be unavoidable necessary to ensure good mechanical properties besides producing near net-shape components.

| Manufacturing steps | Titanium bar + full machining | PM + HIP + Extrusion |
|--|--------------------------------------|-----------------------------|
| Raw material | | 5.3% |
| Blending + compacting | | 6.8% |
| HIP | 14.7% | 26% |
| Extrusion | | 27% |
| Machining, finish operations, stress relieving, quality, etc | 85.3% | 35.2% |
| Overall cost | 659 € | 1276 € |

Table 4: Cost Breakdown for the production of a piston rod of an aeronautic hydraulic actuator. Comparison between conventional fabrication process (Ti bar fully machined) and composite production process based on PM techniques (PM + HIP + Extrusion) (GRD2-2000-30405, D6.1).

3 Previous studies of the TMC system assessment

Lately, in this continuous search of high performance and low cost TMCs, some relevant studies have been carried out to select the most suitable matrix-reinforcement systems and the corresponding production route that makes them attractive in these terms.

From the different investigations performed, it is worth mentioning the studies carried out by T.Saito *et al.* (T. Saito, 1995) in the Toyota Central Research & Development Centre, by S.Gorsse (S.Gorsse, 1999), in particular in his thesis, where more than 40 compounds to reinforce titanium alloys were evaluated, and finally, the research done in the University of Utah by R. Chandran *et al.* (K.S. Ravi Chandran, 2004). In this case, the direction for future development in terms of choice of titanium matrix compositions as well as the realistic possibilities of near term commercial applications at industrial scale have been largely discussed.

To select the most suitable matrix-reinforcement system, these investigations have considered different aspects, besides the composition. These aspects or these selection criteria used are described below:

Mechanical criteria

The main role of the reinforcement in a composite material is to increase the final matrix properties and in particular to withstand the applied load. The weight is also important when it comes to substituting a conventional material by a composite one, therefore the specific properties (properties/density) have been considered as one requirement. Among the reinforcements evaluated there are, stiff, hard and high melting point carbides, silicides, borides, nitrides (despite their poor oxidation resistance) and even some oxides (Table 5).

| Reinforcement | Density g/cm ³ | Modulus GPa | Specific Modulus GPa cm ³ /g |
|---------------------------------|------------------------------|----------------|--|
| TiC | 4.91 | 450-460 | ~92 |
| B ₄ C | 2.51 | 445-449 | ~177 |
| SiC | 3.22 | 420-430 | ~134 |
| TiSi ₂ | 4.39 | 256 | 58 |
| Ti ₅ Si ₃ | 4.31 | 235 | 55 |
| TiB | 4.5 | 550 | 122 |
| TiB ₂ | 4.52 | 529-560 | ~124 |
| AlN | 3.26 | 345 | 106 |
| TiN | 5.21 | 250 | 48 |
| Al ₂ O ₃ | 4 | 350-490 | ~100 |
| MgO | 3.6 | 350 | 97 |

Table 5: Mechanical properties of the reinforcements evaluated in these different studies (T. Saito, 1995, S. Gorsse, 1999 and K.S. Ravi Chandran, 2004).

Thermo-mechanical criteria

Residual stresses generated due to the difference in thermo mechanical behaviour between the reinforcements and the titanium alloys have also being a selection criteria. For this purpose, in general, the methodology used has been to compare the Coefficient of Thermal Expansion (CTE) of the reinforcements to that of the titanium alloy. However S. Gorsse applied also a simplified mathematical model to make a first estimation of the possible axial stresses generated in the matrix material due to the temperature change during a simulated manufacturing process (Table 6). The values obtained are:

| Reinforcement | CTE 10^{-6} K^{-1} | s_z (MPa) |
|--------------------------------|------------------------------|-------------|
| TiC | 7.4-8.8 | 400 |
| B ₄ C | 5.2-5.5 | 960-900 |
| SiC | 4-5 | 1170-980 |
| TiB | 8.6 | 310 |
| TiB ₂ | 6.4-8 | 490-440 |
| AlN | 5.6 | 770 |
| TiN | 9.3 | - |
| Al ₂ O ₃ | 8.1-9 | 310-210 |

Table 6: CTE and calculated axial stresses of the reinforcements evaluated in different studies (T. Saito, 1995, S.Gorsse, 1999 and K.S. Ravi Chandran, 2004).

Chemical criteria

The thermodynamic stability of the compounds with titanium alloy has been evaluated. Among those stable, the insolubility of the elements comprising the reinforcing compound in the titanium matrix and the titanium atoms in the reinforcing compound, minimum mutual solubility has also been checked (Table 7).

| Reinforcement | Maximum Solubility (at.%) (Matrix) (Reinforcement) |
|--------------------------------|---|
| TiC | 1.2 at.%-15 at.% (C) |
| B ₄ C | unstable in Ti alloy (carbide and boride compounds) |
| SiC | unstable in Ti alloy (carbide and silicide compounds) |
| TiB | <0.001 at.%-1.0 at.% (B) |
| TiB ₂ | unstable in Ti alloy (TiB) |
| TiN | 22 at.%-26at.% (N) |
| Al ₂ O ₃ | unstable in Ti alloy (oxygen dissolution in titanium) |

Table 7: Solubility of different atoms from the reinforcements within Ti and titanium atoms in the reinforcement (T. Saito, 1995, and S.Gorsse, 1999).

Morphology

On the basis of the stiffening and strengthening theories, to have a composite effect, the reinforcement has to be stiff enough, and must have fibre shape to present a sufficient aspect ratio (Length/Diameter) to allow an efficient load transfer between the two constituents.

The following criteria (S.Gorsse, 1999) have been defined with respect to the reinforcement morphology:

- Sufficient aspect ratio (Length/diameter), higher than the critical value of 10.
- Small diameter $d < 5\mu\text{m}$

All these investigations agree that among the potential reinforcements considered the **TiB is the most promising** since it is the only one that meets mechanical, thermo mechanical, chemical and morphological requirements.

- High specific modulus ($\sim 122 \text{ GPa cm}^3/\text{g}$).
- Almost the same CTE as titanium alloys ($8.6 \times 10^{-6} \text{ K}^{-1}$ to $9 \times 10^{-6} \text{ K}^{-1}$) consequently low residual stresses.
- Thermodynamic stability of TiB in titanium and minimum solubility of boron in titanium.
- Needle-shaped morphology.

4 Conclusions

As far as continuously reinforced TMCs are concerned, the industrial application is limited to the Ti/SiC system for some engine applications in the military. This system has been highly regarded and matured through huge development efforts, however some important limitations have not been solved yet.

Technical limitations:

- Properties of anisotropic nature.
- Chemical instability between the SiC fibres and titanium alloys.
- Thermally induced residual stresses due to CTE mismatch of the constituents.
- The production route is limited to solid state consolidation processes and the existing different pre-processing concepts do not ensure a perfect fibre distribution of the SiC fibres in the composites.
- Low formability.

Economical limitations:

There has been more than an order of magnitude cost reduction of this composite system over the past 10 years however it is still excessive expensive (*Figure 15*).

Discontinuously reinforced TMCs, particularly those reinforced with *in-situ* formed reinforcements, are currently the main subject of interest. They have a clean interface and present other interesting features as well:

- Isotropic properties.
- The possibility to use different processing routes to obtain them. In fact several solid state and even some liquid state processes can be used.
- *In-situ* reinforced composites avoid complex handling or pre-processing lay-ups of reinforcements.
- These composites could be recyclable which has never been the case in the field of TMCs.

- These composites could be shaped and finished by the secondary processes that may include forging, extrusion, heat treating, machining, joining, etc., if necessary.

Among the possible *in-situ* formed reinforcements already assessed, TiB is the most suitable one. It is the only one that meets mechanical, thermo-mechanical, chemical and morphological requirements.

The preliminary features of the *in-situ* TiB reinforced TMCs compiled in this literature review demonstrate the potential shown by these composites. However, nowadays the industrial applications are very few and limited to components produced by solid state, specifically, powder metallurgy processes. This could be explained considering the early stage of development of these materials.

The production of these composites via investment casting is very attractive from the cost point of view. Nevertheless, there are some avenues for improvement in the composites produced by investment casting. For example the boron source and the production of this boron source can have a great impact in this respect. From different boron source alternatives already assessed, TiB is the most suitable as the others present some drawbacks. On the one hand, the high temperature they need for dissolving and on the other hand, the transformation they suffer before they get dissolved.

The idea is to produce the TiB in a first stage and then to be introduced it in the investment casting process. However, despite the direct addition of TiB being an interesting choice, TiB can not be treated in powder form and is not easily obtained. One option is to produce TiB by the Vapour-Liquid-Solid (VLS) process, but it presents toxicity and handling difficulties. Another option is conventional powder metallurgy, but this is costly as different alloying, compacting and sintering steps are needed to obtain it.

The present investigation is motivated by these reasons. Taking into account the difficulties mentioned above, the initial objective is to study the possibility to produce TiB by the cost-effective process called Self-propagating High-temperature Synthesis (SHS). Next, is to study the dissolution of this TiB to finally obtain *in-situ* TiB reinforced TMCs via investment casting.

The alternative process proposed in this research is a combination of the SHS and the investment casting to obtain *in-situ* reinforced net-shape TMCs. The process has the potential to overturn the concept of cost/performance of conventional MMCs and in particular TMCs.

CHAPTER 2

PRODUCTION OF TiB BY SHS

1 Introduction

Self-propagating High-temperature Synthesis (SHS) is a process that takes advantage of the extreme heat generated by the exothermic reaction during the formation of some compounds. When a compact of constituent powders is ignited, the exothermic reaction propagates in a self-sustaining mode converting the initial reactants into final products in a one-step process.

The process of SHS is shown schematically in *Figure 21*. This figure shows a combustion (front) wave which has progressed partially down the sample at a velocity v , leaving behind, the product of combustion. Although the reaction is highly exothermic and consequently self-sustaining, it does not self-initiate without the addition of any external energy. So, external heat addition is required to start the reaction.

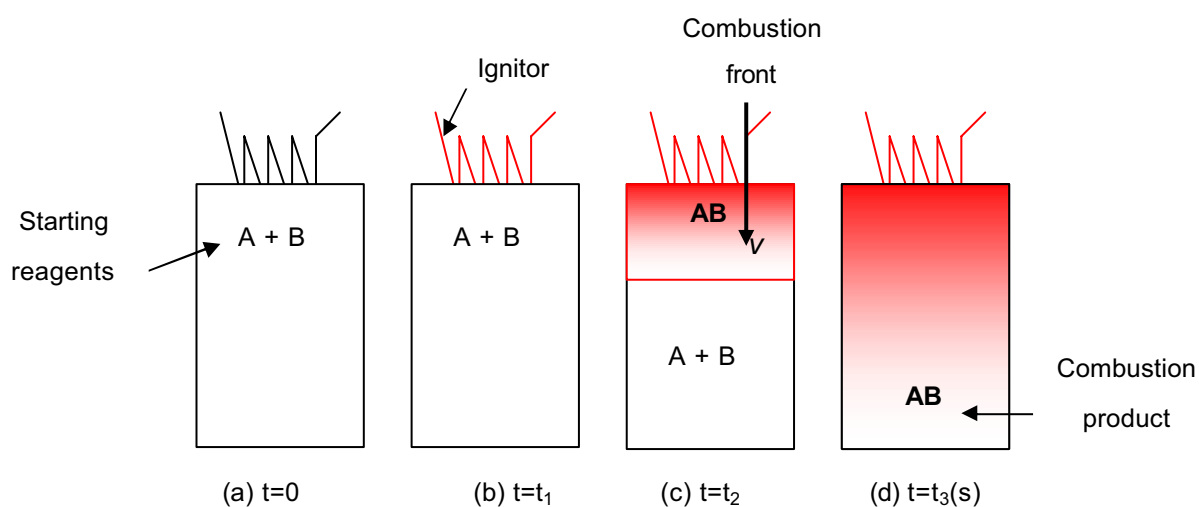

Figure 21: Principle of the SHS: propagation of the combustion wave through a cylindrical sample: (a) reactant powder mixture with the ignitor, (b) ignition, (c) propagation and (d) end of the reaction.

Some of the potential advantages of the SHS process are:

- The simplicity of the process; simple equipment and fast process (reduced to seconds).
- The low energy requirement; local heating of the powder is necessary to ignite the reaction and the process itself does not need any external energy.
- The high purity of the products; impurities are evaporated during the process due to the high temperature of the combustion wave.

Some of the potential drawbacks of the SHS process are:

- A possible incomplete reaction.
- The presence of porosity if a pressure is not applied.
- The risk of explosion of the reactants is not well controlled.

Different types of SHS systems can be classified depending on the nature of the reactants, the most popular are as follows:

- Reduction combustion synthesis.
- Gasless combustion based on powder mixture reaction with little or no gas evolution.
- Gas-solid combustion, with a reactive gas infiltration.

In the present study, where the objective is to obtain the TiB by SHS for its subsequent use in the investment casting process, a gasless combustion based on titanium and boron powder mixture reaction will be investigated.

2 Self-propagating High-temperature Synthesis (SHS)

2.1 Thermodynamical considerations

In the SHS process where high temperature reaction takes place, the maximum temperature possible during the exothermic reaction is that attained under the adiabatic condition.

Considering for example:

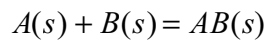

where A and B react to form a solid product AB; the theoretical maximum temperature, designated as the adiabatic temperature T_{ad} , can be calculated from the heat capacities and enthalpies of formation and transformation.

$$\Delta H^0_{T_0} = \int_{T_0}^{T_{ad}} C_p(AB)dT \quad (5)$$

where $\Delta H^0_{T_0}$ is the enthalpy of formation of AB at T_0 and C_p is the molar heat capacity of the product. *Equation 5* is based on the assumption that the product of combustion is solid at the adiabatic temperature. However, the high values of calculated T_{ad} clearly indicate that in a large number of cases the product is partially or wholly melted. In such cases, when the product constituents undergo any phase transformation below the T_{ad} thus calculated, the corresponding changes in the enthalpy and heat capacities have to be taken into account and T_{ad} recalculated. If one of the products is in the molten condition, then its melting point itself is the T_{ad} and the fraction in molten condition f .

$$\Delta H^r_{T_0} = \int_{T_0}^{T_{ad}} C_p dT + f \Delta H_m \quad (6)$$

where ΔH_m is the latent heat of fusion.

In SHS reaction investigations, T_{ad} has been considered a very important thermodynamic data. In fact, based on an empirical criterion suggested by Novikov *et al.* (N.P. Novikov *et al.*, 1975) the knowledge of this T_{ad} , can make it possible to estimate whether a combustion reaction will become self-sustaining or not. According to this investigation, for the particular case of the synthesis of some titanium carbides and titanium borides, the adiabatic temperature must be equal or higher than 1800 K (1527°C) for a reaction to be self-sustaining.

2.1.1 The Boron Titanium system

The assessed Ti-B system contains the following equilibrium phases, as shown in the phase diagram presented in *Figure 22*:

- Solid solutions; high temperature bcc (β Ti), low temperature hcp (α Ti) and rhombohedral (β B).
- TiB and TiB₂ compounds.
- And Ti₃B₄ which is formed from the melt only in a narrow temperature range.

Boron is only slightly soluble, being the solubility less than 1 at.% in (β Ti) and (α Ti).

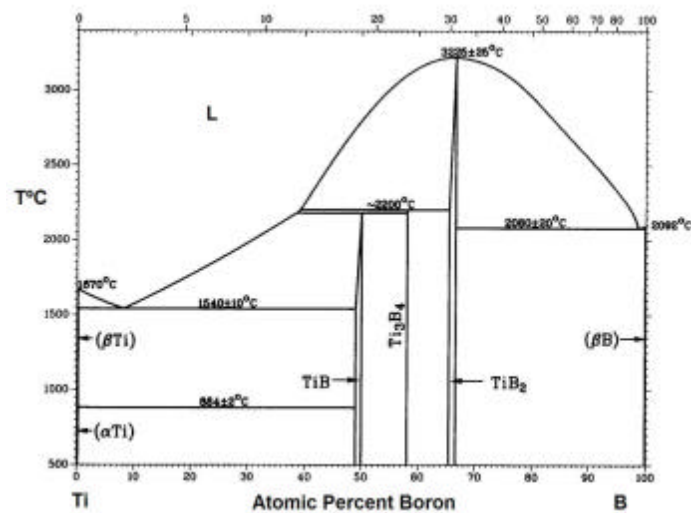

Figure 22: Ti-B phase diagram (J.L. Murray et al., 1987).

From this phase diagram and from thermodynamic data of pure elements and compounds (J.L. Murray *et al.*, 1987), the Gibbs energy of the following chemical reactions is calculated:

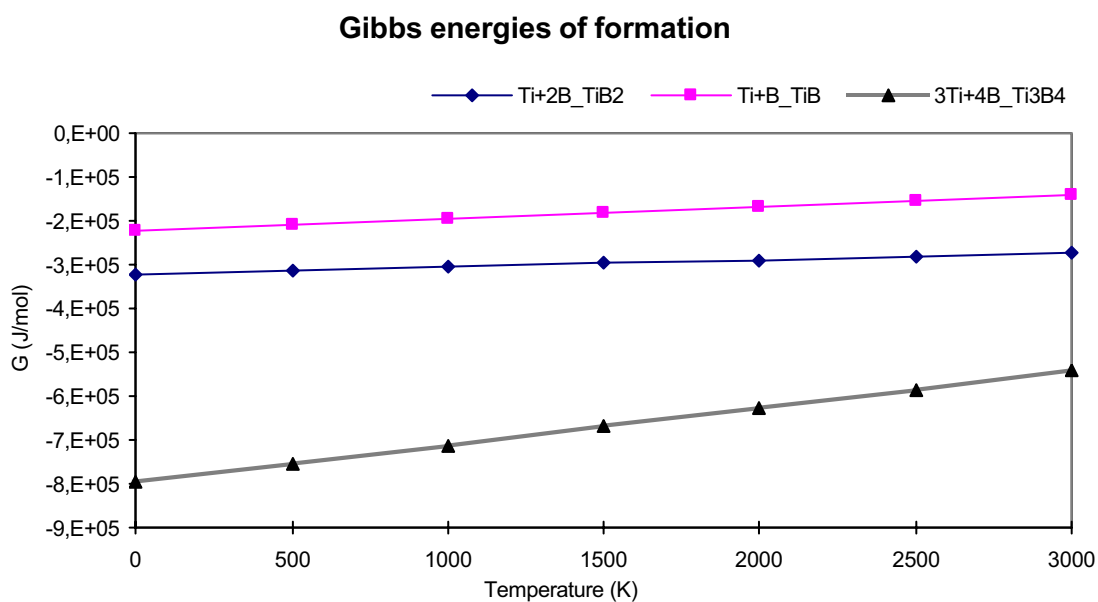
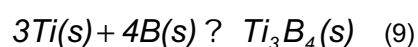
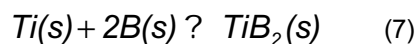
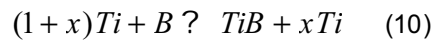

Figure 23: Free energy of formation (G) of Titanium compounds calculated.

The Gibbs energies of these three reactions are all negative (Figure 23), indicating that the reactions can take place. However, the TiB is the selected compound in our study, thus the objective is to obtain it and to avoid the formation of any other compound existing in this system

such as the TiB_2 or Ti_3B_4 . Therefore, the basis of the study is the following reaction starting from Ti and B elemental powders, a reaction synthesis in which TiB is chemically synthesized *in-situ* within a titanium matrix:



2.1.1.1 Theoretical adiabatic temperature calculation

For the Ti-B system, the theoretical values of T_{ad} calculated for different compositions are shown in *Figure 24*. They have been obtained using the *Equation 5*, when the products are solid at the adiabatic temperature. However, as the adiabatic temperature increases (as high as the titanium melting point, 1933 K), the products are partially melted, so the values have been calculated from the *Equation 6*. The latter equation takes into account the phase change.

From these calculated theoretical values, it can be concluded that the Ti content has an influence on the T_{ad} , the higher the Ti content, the lower the T_{ad} .

These values can also be used to estimate whether a combustion reaction will become self-sustaining or not, if it is higher than 1800 K it could be assumed that it will become self-sustaining. Therefore, in line with this empirical criterion, and according to the values showed in *Figure 24*, it can be concluded that TiB content higher than 50wt.% is necessary if it is wanted to carry out the reaction in a self-sustaining mode. For this composition, the theoretical temperature reached in the reaction is 1943 K.

2.1.1.2 Liquid phase

During the reaction, the temperature reached could be higher than the melting point of the product obtained. The product in this case, is composed by Ti and TiB. When the temperature reached is over 1933 K (the melting point of Titanium), part of the product, titanium in this case, is melted. In fact, it is important to take into account this liquid-state phase in order to get advantage of the viscosity of the system. This way by load application, in case it is interesting, it should be possible to obtain a dense product (*Figure 24*).

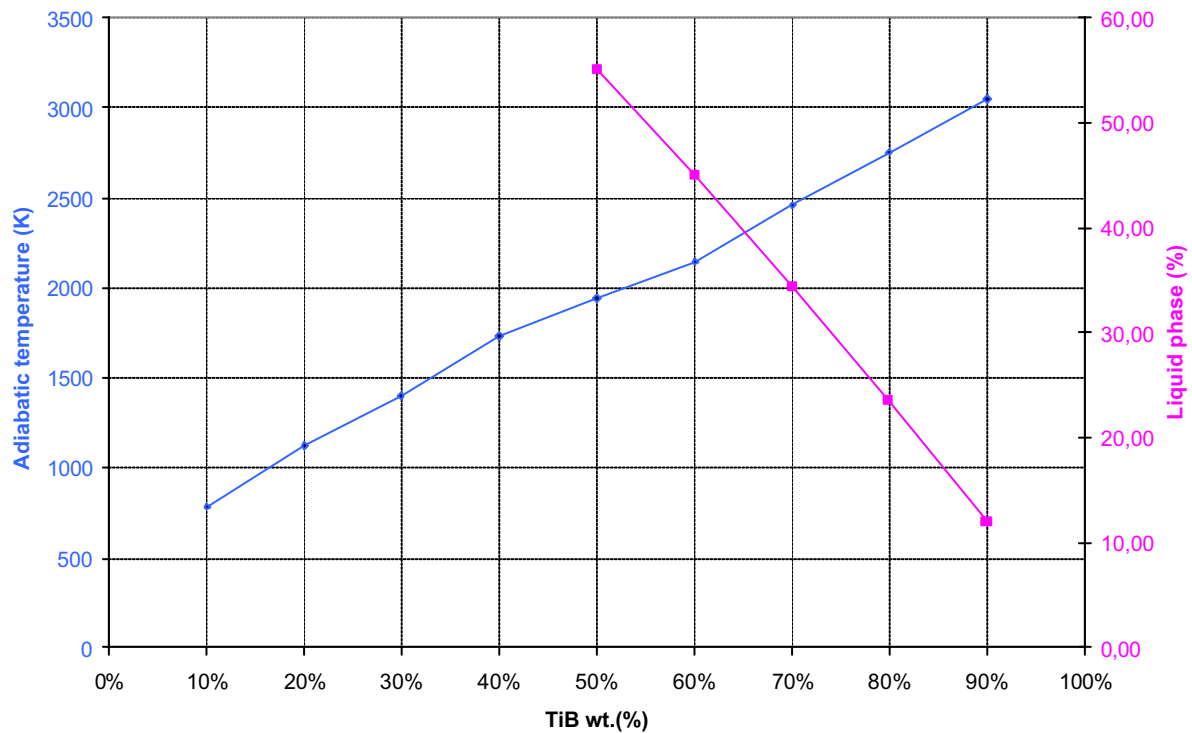

Figure 24: T_{ad} and liquid phase (%) evolution with TiB wt. %.

Based on these preliminary theoretical values, the composition with TiB content higher than 50wt. % presents the most promising characteristics for a reaction to be both self-sustaining and easy to compact by load application.

2.2 Variable effects

Even though the combustion process can be theoretically characterized by an adiabatic temperature, as described in the previous section, heat losses are significant and adiabatic conditions are seldom achieved in actual lab conditions.

An important consideration concerning the adiabatic deviation has to do with the geometry of the sample, specifically the surface area-to-volume ratio. An indication of the influence of this

parameter on the degree of heat loss and the effect of the diameter of the cylindrical sample on the combustion temperature has been investigated by Maslov *et al.* (V.M. Maslov *et al.*, 1978) (Figure 25). The temperature increases with increasing diameter up to a saturation value, then becomes relatively constant with a further increase in sample size.

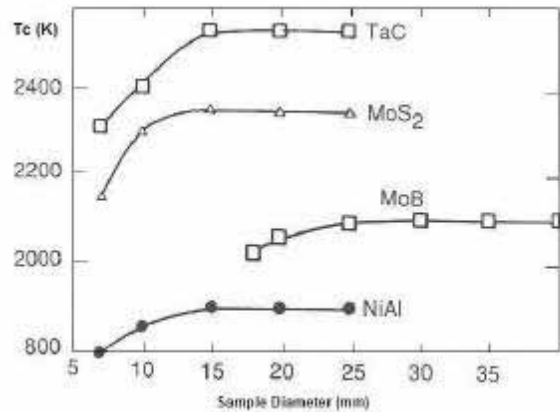

Figure 25: Combustion temperature as a function of pellet diameter for various mixtures (V.M. Maslov *et al.*, 1978).

This factor should be taken into account in the design of the study of any SHS reaction. During the sample preparation, the powder mixture should be previously cold compacted to obtain a green pellet of a minimum diameter in order to assure a constant combustion temperature achievable by the system.

In this sense, a diameter of 15 mm for the compacted pellet has been considered a prerequisite in the experimental procedure followed.

Azatyán *et al.* (T.S. Azatyán, 1977) have also investigated the influence of the particle size on the combustion temperature (T_c) and combustion velocity for Ti+C mixtures (*Table 8*).

| Particle size of titanium (μm) | T_c ($^{\circ}\text{C}$) experimental | Combustion rate (cm s^{-1}) |
|--|--|---|
| <45 | 2797 | 3.6 |
| 125-160 | 2527 | 2.2 |
| 250-280 | 2387 | 1.3 |

Table 8: Dependence of the particle size on the temperature and combustion velocity for the Ti-C system (T.S. Azatyán *et al.*, 1977).

According to this investigation, both the combustion temperature and the velocity decrease as the Ti particle size increases. A more interesting evidence of changes in the combustion process resulting from an increase in particle size is demonstrated by the results depicted in *Figure 26*.

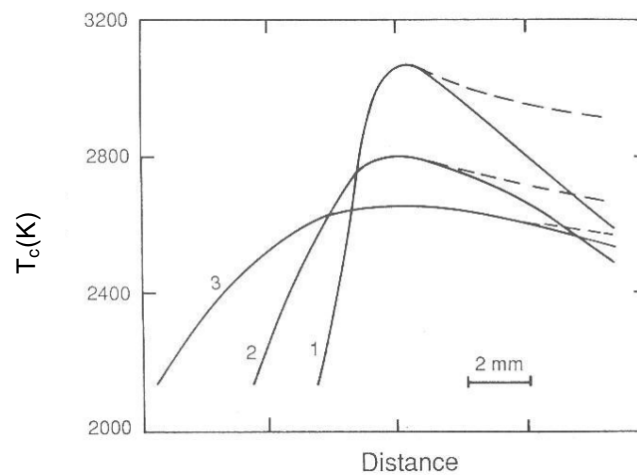

Figure 26: Temperature profiles along the sample during combustion of Ti+C mixtures with different Ti particles sizes. Curve 1: $r_0 < 45 \mu\text{m}$; Curve 2: $r_0 = 120\text{-}160 \mu\text{m}$; Curve 3: $r_0 = 250\text{-}280 \mu\text{m}$ (T.S. Azatyan et al, 1977).

The temperature profile of the combustion front becomes wider as the particle size increases, indicating that the reaction is taking place over a wider region of the sample. This broadening of the combustion front is not a consequence of the lowering of the combustion temperature. Although the combustion temperature changes with volume fraction, the general temperature profile remains basically unchanged (T.S. Azatyan et al, 1977). Thus, the broadening of the reaction front is a consequence of a decrease in the degree of completeness of the reaction as a result of an increase in Ti particle size. This lack of completeness of the reaction is shown in *Figure 27* in which the percentage of free carbon in the product resulting from the combustion and the velocity of combustion are plotted as a function of the particle size. For a Ti particle size of $< 50 \mu\text{m}$, a relatively small ($< 0.5\%$) amount for unreacted (free) carbon is detected in the final product.

As the particle size increases to about 300 μm the percent of unreacted carbon exceeds 9% in the final product.

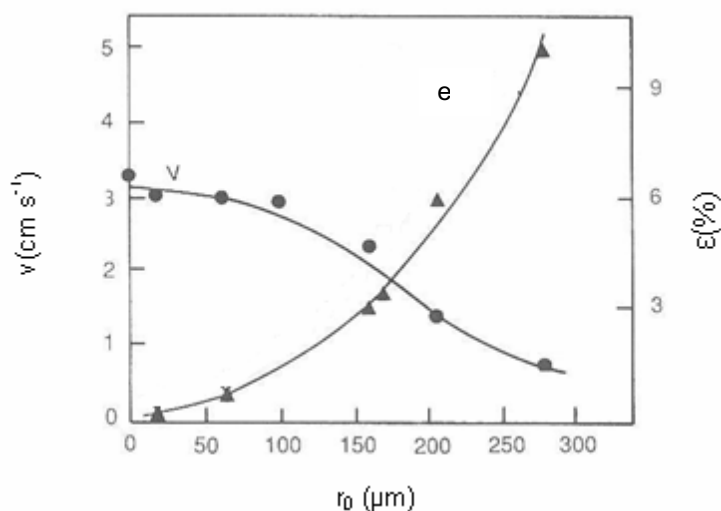

Figure 27: Dependence of velocity and percentage of free carbon (e) on the particle size of titanium in Ti+C mixture (V. M. Shkiro, et al., 1975).

Taking into account these studies and the conclusions obtained, the commercial powders that are going to be used in this study are amorphous boron powders and granular morphology with average particle size of $\sim 3\mu\text{m}$ as well as angular or porous titanium powders with average particle size always below $150\mu\text{m}$.

The effect of the overall sample porosity has been also investigated (A.I. Kirdyashkin et al., 1982). The heat transfer in the combustion zone is different depending on the density. At low densities, the heat in the combustion zone is not effectively transferred and can lead to oscillatory combustion or even extinction of the reaction. Similar results are obtained for high densities due to the fast heat transfer from the combustion zone. Thus an optimum green density of compact is required to obtain steady state combustion. From previous experimental data available an apparent density in the range of 50% to 60% of the theoretical value is considered to be a suitable range.

3 Experimental procedure

Two main parts are distinguished in the experimental part. The first one devoted to the analysis and understanding of the SHS process particularly applied to the Titanium-Boron system. This first part allows to get familiar with this processing technique as it deals with the investigation of the synthesis mechanisms and analysis of the obtained material.

In the second part, the “real” production of TiB for its subsequent use in titanium investment casting is treated. Some requirements imposed by the conventional investment casting process itself, such as the prerequisite to start from a dense and weldable material, and others concluded from the study of the Ti-B system have been the base for the design of a suitable process to produce the required TiB.

3.1 SHS reactions: the synthesis of materials for the Ti-B system

The product will be synthesized by the direct reaction of elements in the form of powders, amorphous boron and Commercially Pure ASTM Titanium Grade 3 powders (*Table 9*). However, and additionally, the possibility to use the novel Sponge Titanium fines with less oxygen content instead of the Commercially Pure ASTM Titanium Grade 3 powders has also been assessed.

| Powder | Morphology structure | Average particle size | Chemical composition (wppm) | |
|---------------|--------------------------|-----------------------|-----------------------------|------|
| | | | O | C |
| CP Ti Grade 3 | Angular and crystallized | ~ 130 μm | 3300 | 1200 |
| Boron | Granular and amorphous | ~ 2.3 μm | 80 | - |
| Ti sponge | Porous and crystallized | < 150 μm | 1200 | 130 |

Table 9: Raw materials used in the SHS process; powder characteristics.

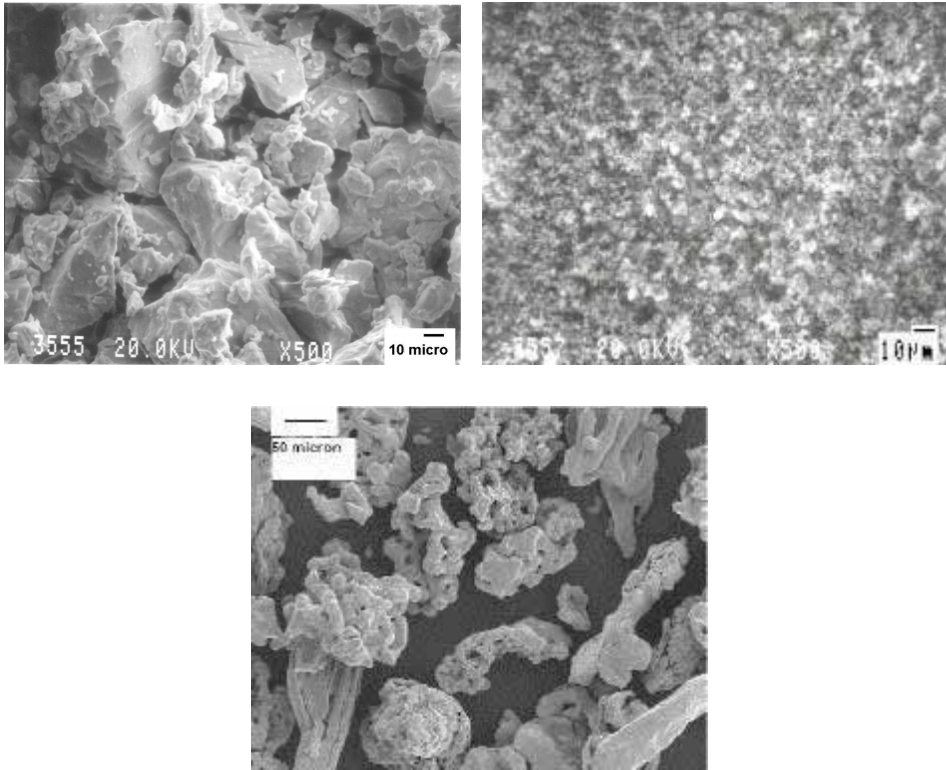

Figure 28: a) Cp Ti Grade 3 powders, b) Amorphous boron powders and c) Ti sponge powders morphology.

The raw material's selection was done taking into account the influence of the particle size in combustion parameters (Figure 27). It is desired to avoid unreacted boron as much as possible in the final product. Particles above 150µm have been rejected to finally select powders with lower size and homogeneous distributions.

The synthesis of powders by SHS is a process carried out through two main stages. In the first step, all the reagents are prepared. This preparation involves the mixing and the cold compaction of the reagents to obtain a green pellet. This preparation is performed using standard mixer and presses. On the other hand the synthesis is carried out inside a reactor. This reactor is a simple stainless steel container designed with special systems to control the parameters involved in the SHS process. These systems are: an ignition system to start the reaction, thermocouples to

control the temperature and a vacuum pump together with an argon flow to control the atmosphere inside the reactor.

3.1.1.1 Reagents preparation

Titanium (CP Ti Grade3) and amorphous boron powders (*Table 10*) are homogeneously dry mixed (6 hours) in turbula-type mixer with alumina balls and subsequently cold compacted into cylindrical pellets (d~15mm, h~25mm) by a uniaxial single-acting press up to the apparent density of 60% of the theoretical value.

3.1.1.2 Synthesis

The compact pellet, containing a tungsten coil to ignite the reaction and two thermocouples to measure the temperature of the combustion, are introduced in the reactor. The figure below shows the preparation of the green pellet out of the reactor. On the left side (*Figure 29a*) a detail of the preparation of the tungsten coil in the upper part of the green pellet and the system to ignite it can be observed. The photo on the right side (*Figure 29b*) is a detail of the back side of the pellet where two thermocouples have been located to measure the temperature.

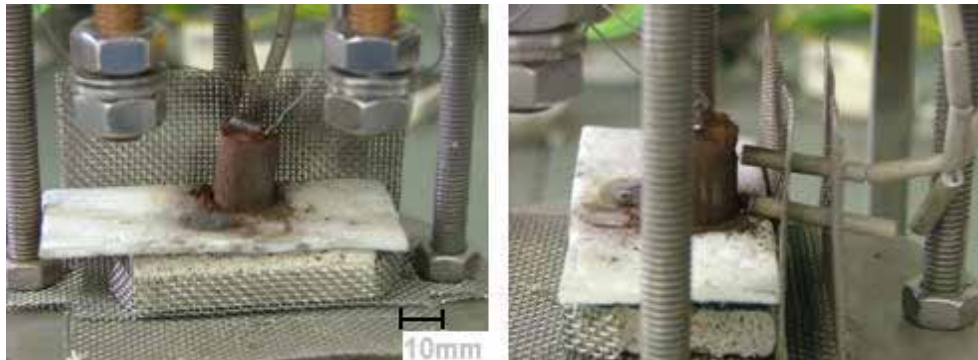

Figure 29: a) Green pellet of titanium and boron powder mixture with the ignition tungsten coil in the upper part, b) Detail of the thermocouples placed in the sample.

The reactor has been designed not only to control the reaction parameters but also to make it possible to observe the reaction. *Figure 30a* is a detail of the introduction of the pellet inside the reactor, before it is closed. Once the reactor is closed and after vacuum and two argon purges, the reaction is initiated by heating the tungsten coil at the upper part of the pellet. *Figure 30b* shows a special peephole designed to locate the video camera and obtain images of the reaction. In this figure, the systems for the vacuum, argon, heat, and thermocouples can also be observed. The images obtained by the camera will be used as well to measure the combustion velocity of the reaction.

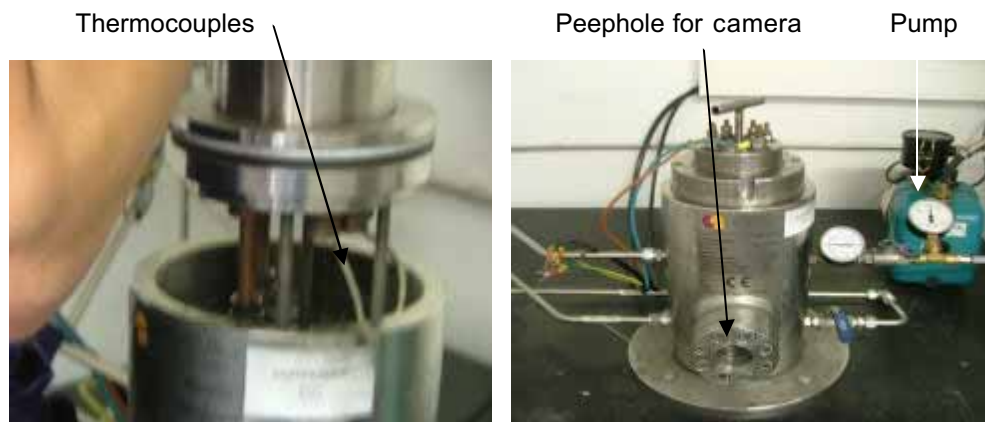

Figure 30: a) Introduction of the sample in the reactor, b) Detail of the reactor with its mechanisms for the vacuum, thermocouples and heat flux.

3.1.1.3 Combustion temperature and combustion wave velocity, stability and mode

The composition selection has been done according to the conclusions obtained from the thermodynamic theoretical calculations. Based on theoretical adiabatic temperature calculations (*Figure 24*) it has been concluded that compositions with TiB contents higher than 50 wt.% are needed for the reaction to be propagated in a self-sustaining mode.

Consequently, samples with five different compositions, those corresponding to TiB contents between 50 to 90 wt.% have been prepared (see *Table 10*).

| TiB wt.% + Ti wt.% | T _c (K) | V (cm s ⁻¹) |
|--------------------|------------------------------|-------------------------|
| TiB 90% + Ti 10% | 2348 | 4 |
| TiB 80% + Ti 20% | 2056 | 2.36 |
| TiB 70% + Ti 30% | 1949 | 1.71 |
| TiB 60% + Ti 40% | 1945 | 0.73 |
| TiB 50% + Ti 50% | <u>Does not react</u> | |

Table 10: Combustion temperature and combustion wave velocity of the different reactions.

For the described sample dimensions ($d \sim 15\text{mm}$, $h \sim 25\text{mm}$) and under the mentioned conditions, the sample composition at which the wave has not been self-propagated and the combustion extinguished has been 50wt.%TiB. Conversely, for the samples with compositions ratios higher than 50 wt.% of TiB the reactions have become self-propagated.

Although the combustion temperature measured is several hundreds Kelvin lower than the theoretically calculated T_{ad} (*Table 10*), it is above the melting point of titanium, confirming that the titanium is melted by the reaction heat. Titanium acts not only as a reactant, but also as a diluent, the higher the titanium content is, the more the heat needed to melt titanium, that is, the lower the combustion temperature. The trend of the combustion temperature variation however, is consistent with that of the theoretical adiabatic temperature calculated. In connection with the influence of the sample diameter on the combustion temperature (*Figure 25*), it has been observed that the increase of the sample diameter is a potential alternative to increase the combustion temperature and consequently, to increase the composition range at which the reaction is self-propagating.

The velocity and the combustion wave stability and mode have been studied using a high speed digital imaging camera which captures up to 50 frames per second (*Figure 31*).

The combustion wave velocity decreases with titanium content, indicating that the change in the velocity of the wave is affected through changes in the combustion temperature.

During the first experiments it was not possible to record any picture due to the intense combustion light. The image was completely overexposed. However, it was feasible to capture the pictures of the combustion using a special dark filter, similar to those used in welding processes.

As the light intensity depends on the temperature and consequently on the TiB content, different types or grades of dark filters have been tried to get images of the different reactions. Finally, the most suitable lens has been selected to see all the reactions. Nevertheless, the difference in light intensity from the sample with 90 wt.%TiB to the one with 60 wt.% is evident.

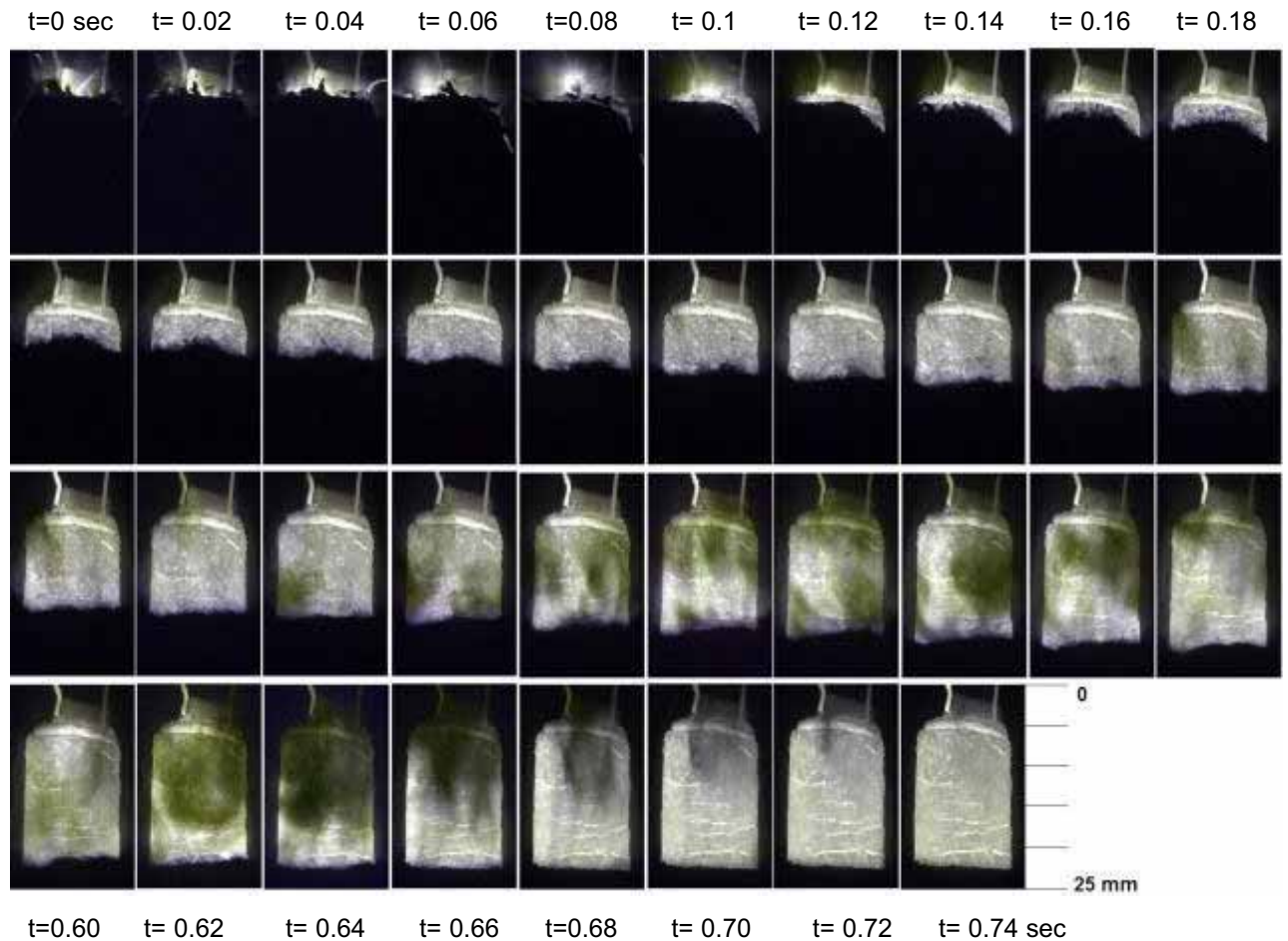

Figure 31: Photographic sequence of Ti/80wt.% TiB, with 50 frames per second.

The possibility to obtain 50 frames per second allows not only to measure the velocity but also to have full information on the combustion front propagation. Once initiated, the combustion wave propagates in a steady state mode, leading to a layered structure visible on the exterior surface of the pellet. It was observed that growth occurred only in the axial direction. In the sequence of pictures (*Figure 31*), light layers can be observed which correspond to the trace of the combustion front. Evidence of the front resulting in a rough surface and the internal porosity is shown in the following *Figure 32*.



Figure 32: a) Surface of the reacted sample, Ti/80wt.% TiB, in the form of a layered pattern, b) Section of the sample, evidence of the internal porosity.

3.1.2 Phase identification

The phase constituency of the final composites has been verified using X-Ray diffraction patterns, on samples sectioned as previously shown in *Figure 32b*. For those with TiB contents higher than 80wt.%, because of the high porosity, to obtain diffraction patterns the samples needed to be reduced to powder. The existence of titanium and TiB is confirmed in every case or composition, as well as the absence of unreacted boron.

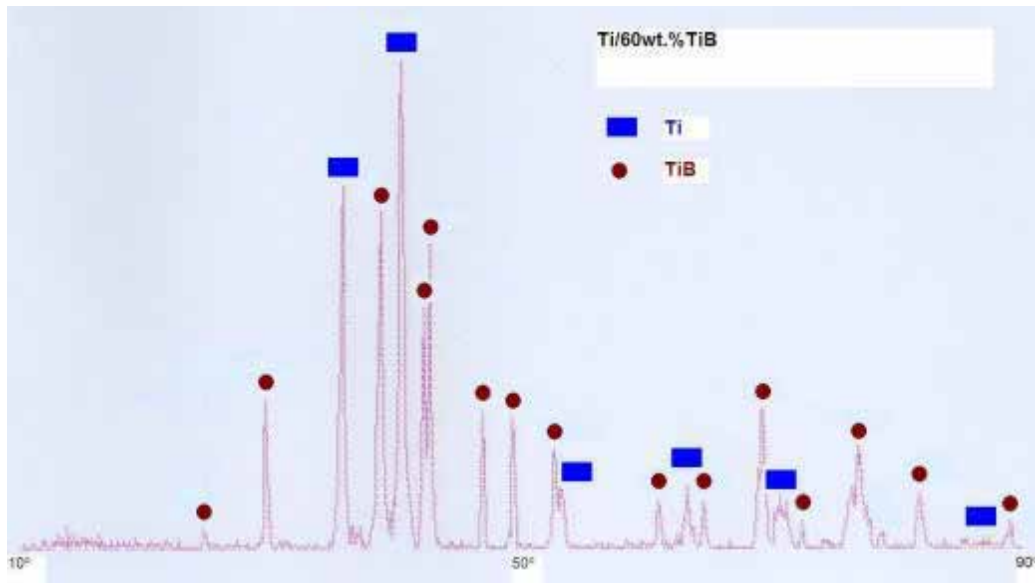

Figure 33: X-ray diffraction pattern for a Ti/60wt.% TiB composition.

However, as the amount of B increases, when the composition is above 80wt.% TiB, the X-ray diffraction patterns show both TiB_2 and Ti_3B_4 peaks in addition to the titanium and TiB ones. Representative X-ray diffraction pattern and the peak designation for the Ti/90wt.% TiB is shown in the Figure 34.

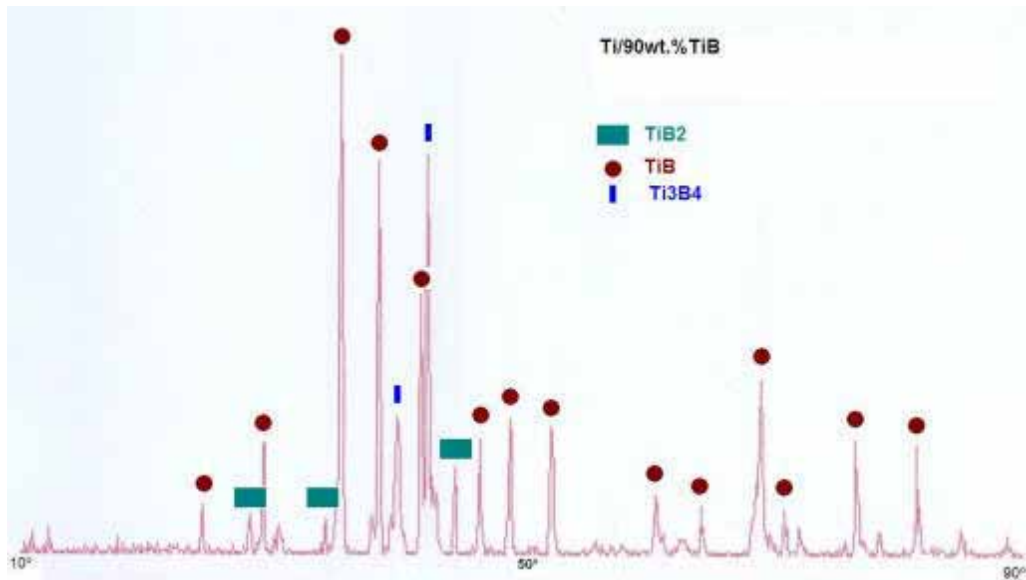

Figure 34: X-ray diffraction pattern for a Ti/90wt.% TiB composition.

3.1.3 Microstructure

The material obtained through the SHS process is a porous material. *Figure 35* is a compilation of SEM micrographs obtained from polished cross sections of the samples with different TiB contents. Differences on microstructure and mainly on the tendency of the porosity, reinforcement distribution and reinforcement morphology according to the different compositions are detectable.

Figure 35 shows the material with the higher TiB (right side) content which has been compared with the one with the lower (left side), as representatives of the maximum and minimum concentrations of TiB obtainable by the mixture of Ti and B in the SHS process.

Evidence of the porosity can be seen from the SEM micrographs. Although there is no clear trend of porosity increase, the material with highest boron content presents the higher porosity and it can be assumed that the material containing TiB_2 and Ti_3B_4 is more porous than that containing only titanium and TiB.

Regarding the microstructure, as the TiB volume fraction increases the distribution of the reinforcements is less homogeneous and clusters of reinforcements can be observed. In addition to the inhomogeneous distribution of the reinforcements, colonies of TiB_2 and Ti_3B_4 are visible for compositions above the 80 wt.%TiB.

The first two micrographs show the difference in porosity, in fact not only difference in pore quantity but also in the pore size. The pore size increases from $\sim 100\mu\text{m}$ (*Figure 35a*) to 200-300 μm for the highly reinforced material (*Figure 35b*). Looking into one of these big pores (*Figure 35f*), colonies containing TiB_2 and Ti_3B_4 compounds mentioned before are distinguished.

In the second line of these micrographs, difference on the reinforcement distribution is distinguished. The material with 60wt.%TiB the reinforcement distribution is relatively homogeneous while *Figure 35d* is a clear example of non homogeneous distribution. At higher magnifications (*Figure 35f*) clusters of reinforcements are clear even inside the pore.

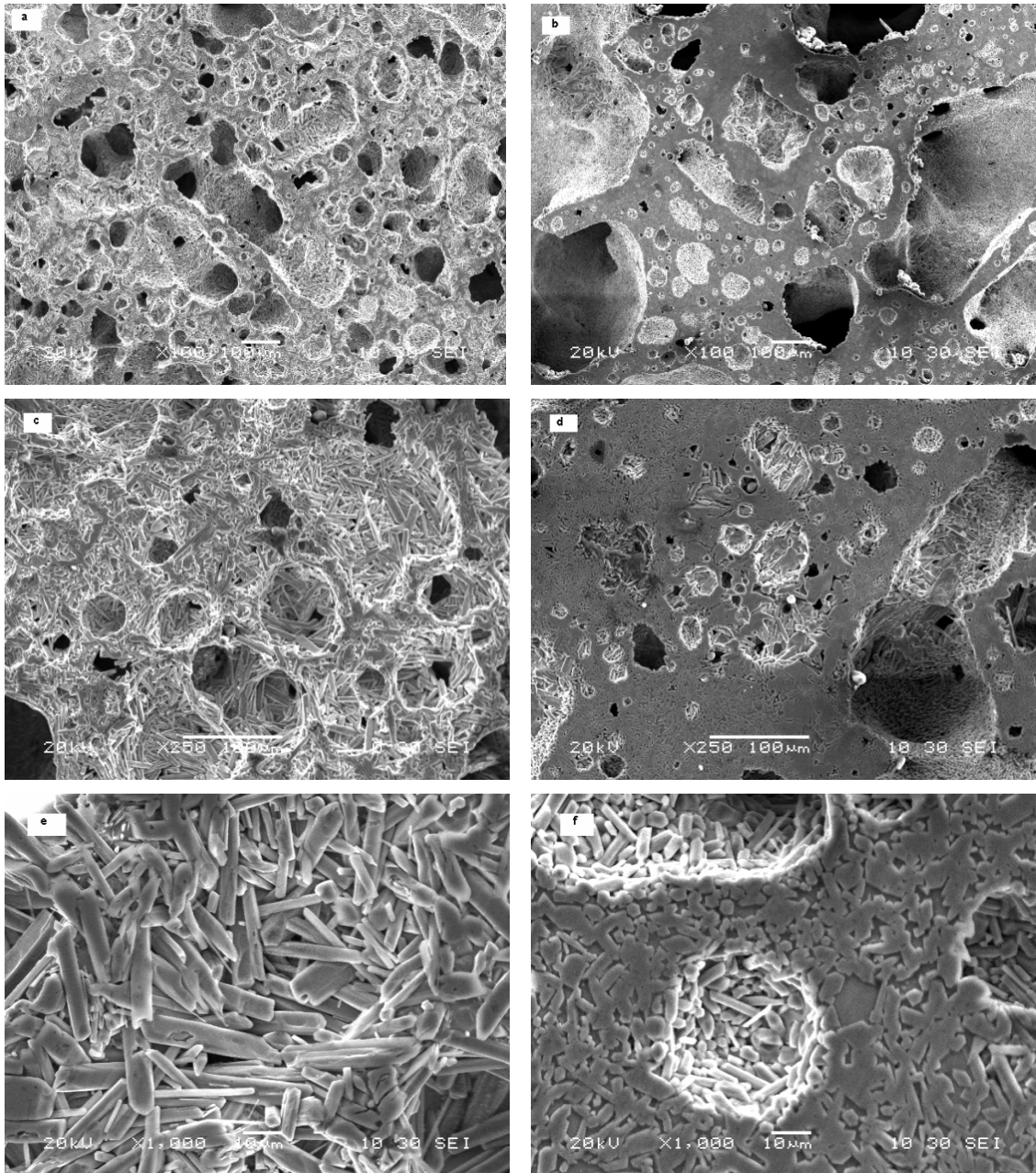

Figure 35: SEM micrographs of polished products: a) Ti/60wt.%TiB (x100), b) Ti/90wt.%TiB (x100), c) Ti/60wt.%TiB(x250), d) Ti/90wt.%TiB (x250), e) Ti/60wt.%TiB (x1000), f) Ti/90wt.%TiB (x1000).

The morphology of TiB is needle like morphology, with diameters around 2-5 μm and lengths around 5-20 μm (Figure 36).

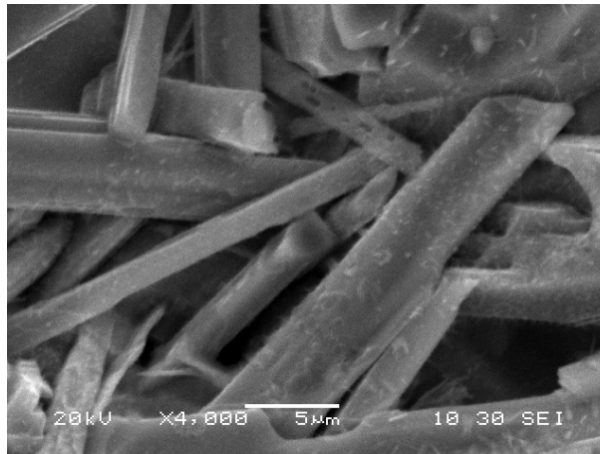

Figure 36: SEM image of the morphology of TiB in the Ti/60wt.%TiB material.

Figure 37 shows clusters of these TiB crystals. Some of them are interconnected but others are individually distributed and they present a hexagonal cross section. According to different studies (X. Zhang *et al.*, 1999 and W. Lu *et al.*, 2001) regarding the crystallographic relationships between TiB and titanium, it can be assumed that the formation of more than one (relatively short) TiB is the result of the spatial diffusion limitations of boron atoms and interceptions with other TiB. The crystal structure of TiB is B27 class orthorhombic structure (Figure 38), characterized by zig-zag chains of boron atoms parallel to the axial [010] direction with each B atom lying at the centre of a trigonal prism of six Ti atoms. Therefore, TiB exhibits a much faster growth along [010] direction than along [001] and [100] directions and the surface is bound by planes of the (100) family, the final result being a more or less hexagonally shaped cross section.

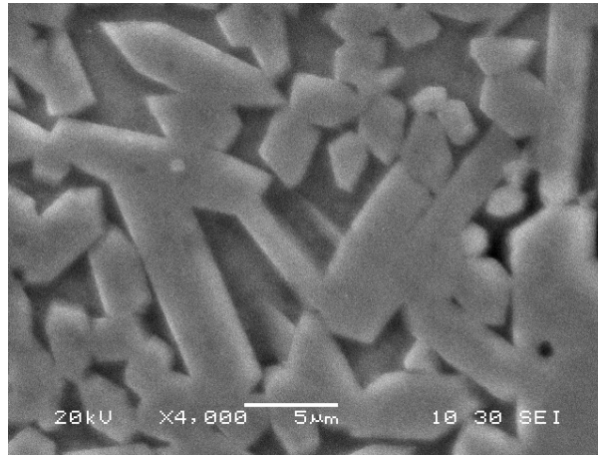

Figure 37: SEM image of the of TiB clusters in the Ti/90wt.%TiB material.

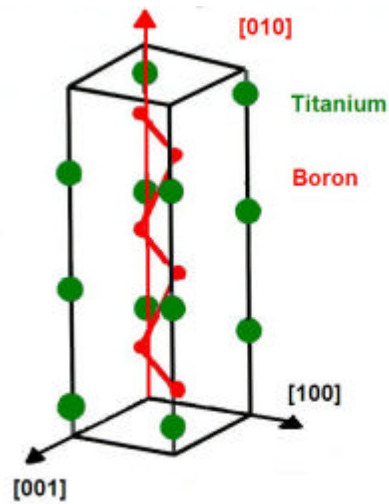

Figure 38: TiB crystal structure (B.F. Decker et al., 1954).

3.1.4 Selection criteria

The following aspects have been considered for the selection of the most suitable composition as well as procedure:

- TiB compounds and the absence of unreacted boron are confirmed in all the samples with different compositions. However, as the boron amount increases in the mixture, the reinforcement distribution is less homogenous and TiB appears in the form of clusters. Besides, in these highly concentrated samples, TiB_2 and Ti_3B_4 compounds are also present.
- The material obtained via the SHS process is intended to be used as a boron source in the casting process to precipitate *in-situ* TiB reinforcements during the solidification step. Related to this TiB precipitation, some general aspects should be considered:
 - TiB is recommended as a boron source for the casting process versus other compounds such as TiB_2 due to its direct dissolution in the titanium melt.
 - Homogeneous distribution with individual or single TiB compounds is more favourable than for TiB clusters. Otherwise the dissolution is more difficult and longer to reach.
- Melting and casting of titanium alloys require special and very high vacuum conditions. The melting process can be done by induction or arc. In the process based on vacuum arc remelting (VAR), a consumable electrode billet is progressively melted by an electric current.

In this case, the material with the boron source must be welded to the consumable electrode to make it possible to pre-introduce it in the vacuum process. Therefore:

- The material is recommended to be a dense material able to withstand a welding process without being damaged.
- Due to difficulties associated to the welding of dissimilar materials, a boron source containing high concentration of titanium is recommended.

The process and the composition of the material to be produced in the second part of this experimental work has been defined in accordance with all these aspects.

The process

The investigation will be devoted to the study of the densification of the material obtained by the SHS process. Pores should be closed by the application of pressure during the propagation, taking advantage of the liquid state of the titanium during the passing of the propagation wave.

The composition

From the results and conclusions obtained from this first part, the composition of 60wt.% of TiB has been selected. The selection has been done based on the following criteria:

- Presence of titanium and TiB as well as absence of any other compound such as boron, TiB_2 or Ti_3B_4 .
- Homogenous distribution of individual or single TiB compounds.
- High % of liquid phase (titanium), favourable aspect during the pressure application step.
- Less % of TiB, favourable during the adding (welding) step needed in the casting process.

Therefore, the second part of this experimental work will be focused on the study of simultaneous synthesis and densification of titanium with around 60wt. %TiB to be used later as a boron source in the casting process.

3.2 Simultaneous synthesis and compaction: How to remove the porosity

The possibility of simultaneous synthesis and densification of the products manufactured by the SHS process could present practical advantages. However, it could be even a requirement in some cases, such as the one investigated in this work, where the boron source should be welded to the consumable electrode and so, a dense material is required.

As it was confirmed before, the combustion temperature for the selected composition (~60wt.% of TiB) is over the melting point of titanium. The titanium is melted and therefore the viscosity of the system allow it to apply pressure and so to obtain a dense product as required.

Raw material and equipment description

When it comes to defining the raw material and dimension of the “real” samples to be used in the casting process, some adaptations have been done with respect to the previous experiments in order to obtain the maximum efficiency.

In this sense and related to the sample dimension, bigger samples were tried. The diameter of the sample was increased (~75mm) while the height was maintained (~25mm). This modification is in line with the study of the influence of the former parameter on the degree of heat loss (*Figure 25*).

On the other hand, as regards the raw material selection, CP Ti Grade 3 was used at the beginning but later, owing to its lower oxygen content, Ti sponge was also tried (*Table 9*). The only difference in the process parameters derived from this change was related to the pressure needed in the preliminary cold compaction step. Difference in the powder morphology has implied an increase in the applied pressure from 10 to 30MPa to reach the required apparent density of 60% of the theoretical value.

Apart from this tuning of parameters, no modifications related to the mixing and cold compaction were done, and the samples were prepared with the same conventional equipment used before; the turbula mixer and the die.

A special setup was designed to perform the simultaneous synthesis and the densification of the material, which is done in air as it is necessary to use a press. The following figure (*Figure 39*) shows the equipments used:

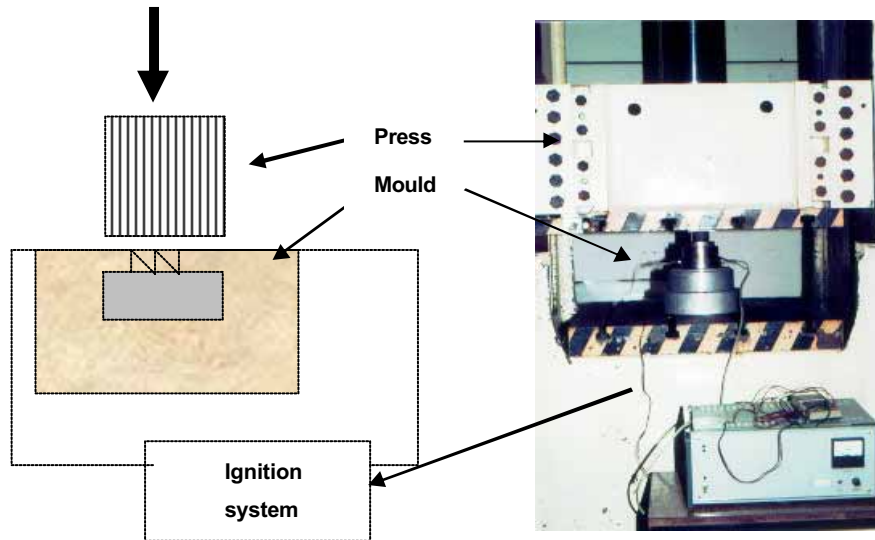

Figure 39: A layout of the equipment used to produce the dense material.

The sample, a mixture of titanium and boron powders, is introduced in a mould. This mould is designed (*Figure 40*) in such a way that it can confine the compact sample during the reaction and densification and allows the expulsion of volatile impurity gases evolved during the reaction. During the densification step, the compact behaves as a porous viscous body so containment is solved using different types of sand (*Figure 41*). These sands also act as a pressure transmitting medium, creating a quasi isostatic stage of stress on the compact. The base of the mould is filled with fine sand which is covered with a thin layer of diatomite to act as thermal insulator. The sample and the tungsten coil are placed and further covered with diatomite. The remaining part is filled with coarse sand up to the ventilation holes. Afterwards, fine sand is used to cover all the mould before it is closed.

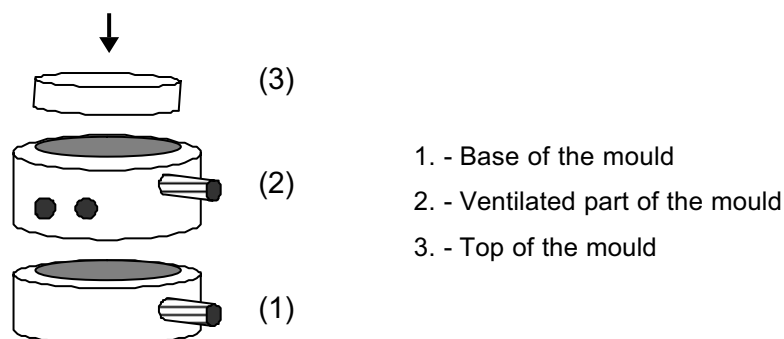

Figure 40: A layout of the mould.

The reaction is ignited by an electrically heated tungsten coil, which is situated at the sample surface and the combustion wave propagates in a self-sustaining mode from this heated part to the full sample. The compact is immediately pressed just after the combustion wave passes and while it is still in the hot and plastic condition. The pressure is kept for seconds.

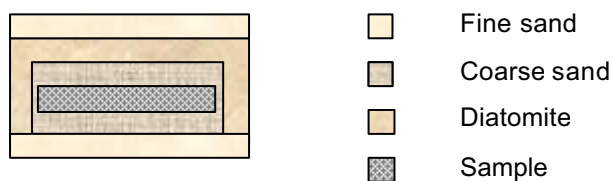

Figure 41: Different types of sand used inside the mould.

The timing of this simultaneous synthesis and densification process is very important (*Figure 42*):

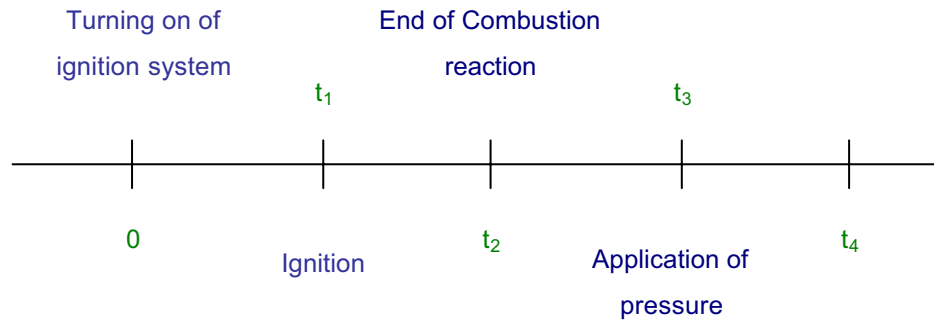

Figure 42: Synthesis + densification reaction process timing.

The pressure application moment (t_3), which corresponds to the delay between tuning on the system and pressure application is of great importance. It is essential to identify and optimise this parameter since it could determine the quality of the sample and it could avoid problems of porosity, cracks, oxygen entrapment, etc.

In addition to this parameter there are others, such as the applied pressure and the period of time for its application that could also be optimized. Non-optimun values for these parameters could cause residual streses or even not fully densified samples.

The information obtained from the reaction thermograms previously obtained in the Ti-B system study has been used to define these process parameters. For example, in the following thermogram (*Figure 43*), which corresponds to the reaction described in the *Figure 31*, the pressure should be applied after 3 seconds into the process and not before, as this would lead to the front quenching. On the other hand, the pressure should be applied during at least 4 seconds (while the product is in a viscous state and pressure application is more efficient).

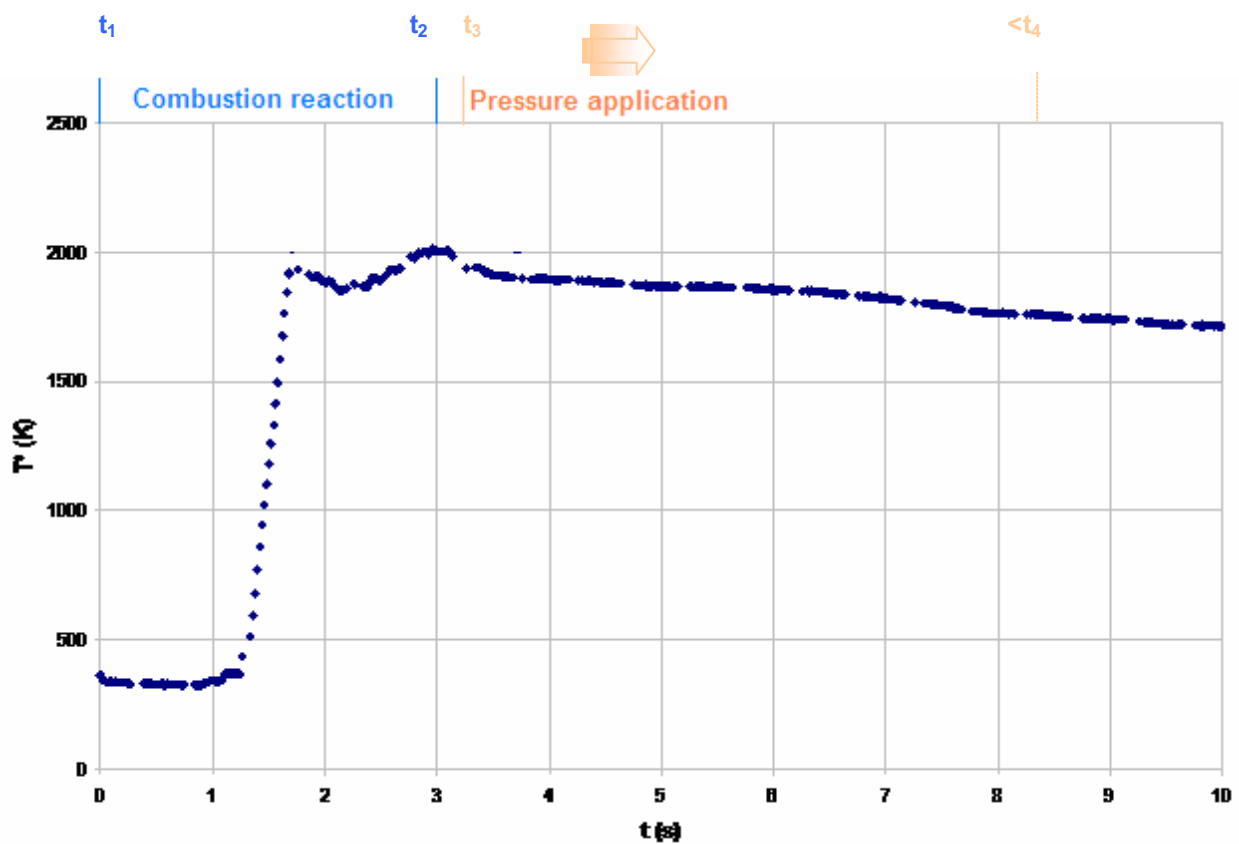

Figure 43: Definition of the synthesis + densification process parameters according to the thermogram.

For the selected composition (Ti with 60%wt.TiB) a pressure of 70MPa has been applied after 3 seconds and kept for 15 seconds.

3.2.1 Description of the material obtained

Figure 44 is a direct comparison of the material obtained with pressure and without pressure application for the same TiB composition.

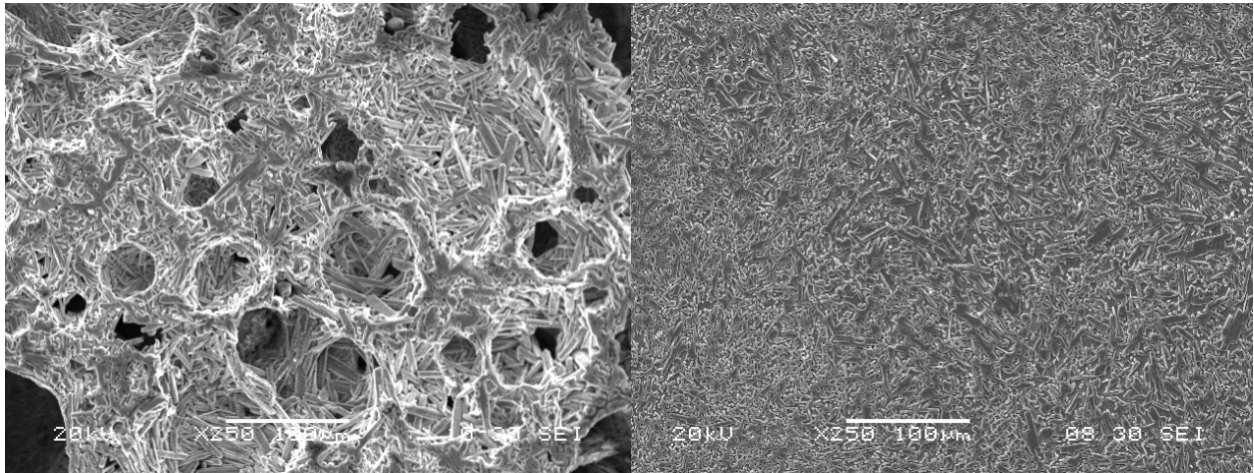

Figure 44: SEM micrographs of the Ti with 60wt.%TiB: a) Ti with 60wt.%TiB x250 without pressure application, b) Ti with 60wt.%TiB x250 with pressure application.

The micrographs demonstrate that through the simultaneous synthesis and densification process a fully dense material has been obtained. Microstructural analysis also reveals that there is no difference between the material obtained by pressure or without pressure application concerning TiB distribution, size and morphology. The distribution of TiB in the titanium matrix is homogeneous. Table 11 summarizes the main features of the dense material obtained. The morphology of TiB compounds and the influence of using low oxygen content raw material is quantified:

| Raw material | Composition | Reinforcement | | | Chemical comp. |
|-----------------------|--------------|-----------------|--------------|------------|----------------|
| | | Morphology | TiB diameter | TiB length | O (wppm) |
| CP Ti Grade3 Boron | Ti/60wt.%TiB | Needle shape | 2-5µm | 5-20µm | 13100 |
| Ti sponge Boron | | | | | 7000 |

Table 11: Characteristics of the material produced by simultaneous synthesis and densification.

The phase constituency has been checked using X-Ray diffraction pattern. The peaks confirm that the only phases present correspond to titanium and TiB.

Properties

The material obtained is called a “cermet” material. This is a class of highly reinforced composite material consisting of two components, ceramic and metallic, where the ceramic content is higher than the metallic one.

Due to by the high ceramic content, these materials are suitable for applications such as cutting or polishing tools. Their features are different from those required for TMCs where the idea is to improve some titanium alloy properties (rigidity, strength, hardness and wear), but maintaining a minimum of ductility. Technically the properties of this cermet material do not achieve these minimum ductility levels required.

However, the features of this cermet material are of particular interest. This information could be used to estimate the improvement that could be obtained by the addition of this kind of reinforcement to a titanium matrix.

Rigidity

The morphology of the TiB, with its continuous boron chain along the length, suggests that it may have significant elastic anisotropy. *Table 12* compiles different elastic modulus values available for TiB: estimated, indirectly measured from different composites or assumed, as reported in different studies.

| Reinforcement | Young's Modulus (GPa) | Reference |
|---------------|-----------------------|-------------------------------|
| TiB | 550 | Z. Fan, <i>et al.</i> 1995 |
| TiB | 371 | R. Atri, <i>et al.</i> , 1999 |
| TiB | 482 | S.Gorsse <i>et al.</i> , 2003 |

Table 12: Compilation of Young's Modulus of TiB.

The values do not only differ owing to the measurement method but also because of the composite production and therefore, distribution and morphology of the TiB. For example, Z.Fan *et al.*, obtained the modulus of a composite (Ti/TiB 10%) produced by rapid solidification. Atri *et al.*, calculated the elastic modulus of TiB from elastic modulus data of Ti-TiB composites with TiB contents of 30-83vol.% on the basis of the Tsai-Halping theory. Later, following the same Halpin-Tsai method the modulus of TiB was estimated to be 482 GPa (S.Gorsse *et al.*, 2003). This estimation was based on an extruded Ti-TiB composite having a high degree of TiB reinforcement alignment.

In the present study the modulus of Ti/60wt.% TiB has been estimated by the sonic method, which is based on determining the velocity at which sound waves propagate in the material:

$$E = \frac{V_L^2 \rho (1 + \gamma)(1 - 2\gamma)}{1 - \gamma} \quad (11)$$

where:

V_L = Propagation speed

ρ = Density

γ = Poisson's ratio

The propagation speed measured is introduced in the equation (11) and considering the Poisson's ratio and density of the composite, the Young's modulus of the Ti/TiB material is estimated.

The modulus for this highly concentrated cermet is 276GPa. Applying the rule of mixtures the estimated rigidity of TiB is ~400GPa that is approximately that obtained in the studies mentioned previously (*Table 12*).

Hardness and wear

The TiB presence influences the stiffness, the hardness and the wear properties of the material as well. The Vickers hardness increases with TiB addition: values up to 1251 HV1 (1Kg) have been measured in the Ti/60wt.%TiB material.

To conclude it is also interesting to mention the effect of the TiB on the wear loss of the material. This cermet material presents a wear loss of less than 3% of that suffered by the unreinforced titanium alloy.

As expected, the effect of the high concentration of TiB in the titanium matrix is important on those physical and mechanical properties mentioned (see *Figure 45*).

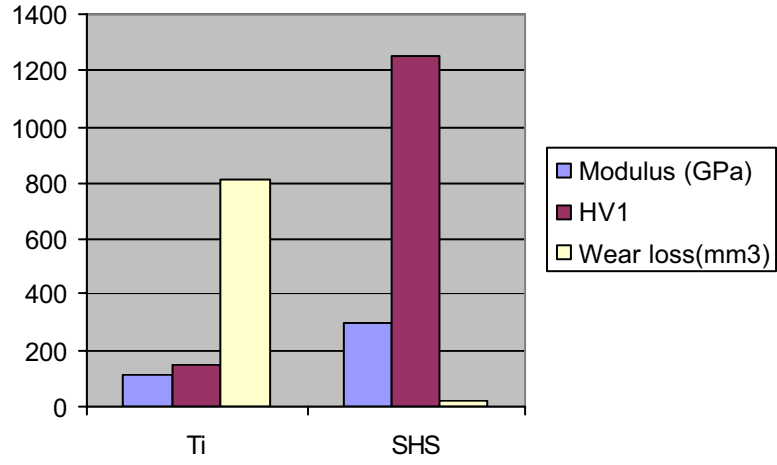

Figure 45: Properties of Pure Titanium vs. Ti/60wt.%TiB produced by SHS.

4 Conclusions

This chapter began with the following question:

Is the SHS technique a feasible way to produce TiB?

To try to answer this question, the SHS process and the material obtained via this process have been studied and assessed. Firstly the SHS process has been described, its principle, its limitations concerning the Ti-B system, its advantages, and also its drawbacks. Afterwards, the production of TiB and its characterization has been introduced.

Next, the main conclusions obtained in this chapter are pointed out:

- It has been proven that the SHS technology is a very useful process to obtain Ti/TiB cermets of different compositions. It is important to note that these materials can easily be tailored and synthesised. They can be obtained in a fully dense state or in a porous state.
- It is of prime importance to do a thermodynamic analysis in order to select the most suitable synthesis conditions as a function of the reaction temperature and the amount of liquid phase present in the process.
- To get the material in a dense state, special attention should be paid to the reaction velocity as well as to the time at which the product remains in viscous state. These factors have a strong influence in the compaction parameters (load to be applied and load application time).
- Samples of around 350gr with planar surface, suitable to be welded, have been obtained.
- The mechanical properties obtained for the Ti/TiB cermet material give an indication of the improvements (rigidity, hardness and wear) that could be achieved by TiB addition in titanium alloys.
- The advantages of the technology in terms of processing and cost are remarkable:
 - Very simple equipment is required and it can be done in air even with titanium and boron powders.
 - Low energy is required, only a local heating is necessary in order to ignite the reaction and the process itself needs no more additional external energy.

- The process lasts a few seconds.
- However, the process presents some drawbacks. The high volume fraction of boron which is necessary to propagate the reaction makes the obtained cermet material very difficult to machine or to cut.

Thus, the question about feasibility is affirmatively answered, however, this is only an intermediate step to obtain the final goal. Therefore, the question now is the following;

Is it possible to use this material in a conventional titanium investment casting to obtain TMCs with *in-situ* formed TiB reinforcements?

CHAPTER 3:

IN-SITU REINFORCED TMCs PRODUCED BY INVESTMENT CASTING

1 Introduction

The investment casting process and its peculiarities for titanium alloys will be analyzed first, and then we will discuss the effect of the boron source in this process. The equipment, the mould, the process of melting, of casting and of finishing of conventional titanium investment casting will be used as reference to evaluate the effect of the boron source. This effect will be assessed by the study of the dissolution of the boron source (TiB) in the titanium melt and the re-precipitation of the TiB. Afterwards, the composite will be characterized.

2 Titanium Investment Casting

Casting can be considered as the classical near net-to-shape manufacturing process. Complex components can often be produced for which conventional production methods would be too complex or expensive. Due to very extensive metal removal by machining from the ingot to the final component, and the relative expense of titanium material, casting offers a high cost saving potential. Moreover, titanium and titanium alloy machining present some particular features due to the unique physical and chemical properties of titanium:

- The low thermal conductivity of titanium hinders quick dissipation of the heat caused by machining. This leads to increased the wear of the cutting tools.
- The low modulus of elasticity of titanium leads to significant spring back after deformation under load. This causes titanium parts to move away from the cutting tool during machining.
- The high chemical reactivity leads to a tendency for galling of titanium with the cutting tool.

The two casting methods used for titanium alloys are rammed graphite mould casting and investment casting.

The rammed graphite mould casting uses powdered graphite mixed with organic binders. Patterns typically are made of wood. The mould material is pneumatically rammed around the pattern and cured at high temperature in a reducing atmosphere to convert the organic binders to pure carbon. The moulding process and the tooling are essentially the same as for sand moulding in ferrous and nonferrous foundries. It is considered an economical process and particularly suitable for large castings.

On the other hand, investment casting is used in preference to graphite mould casting when close tolerances, thinner sections, smaller draft angles, and better quality surfaces are required. The lost wax investment casting process is preferred since it yields a high surface quality and precise dimensional components. In this process, which is schematically described in *Figure 46*, firstly a wax model is manufactured. These wax models are then assembled in a cluster, coated with ceramic slurries, and dried. In the next production stage, the ceramic green bodies are dewaxed in a furnace. Burning provides the required stability to the ceramic form for the actual casting process

and simultaneously removes wax residues left. Finally, the ceramic cavity is used as a mould where the melt is poured to obtain the final component.

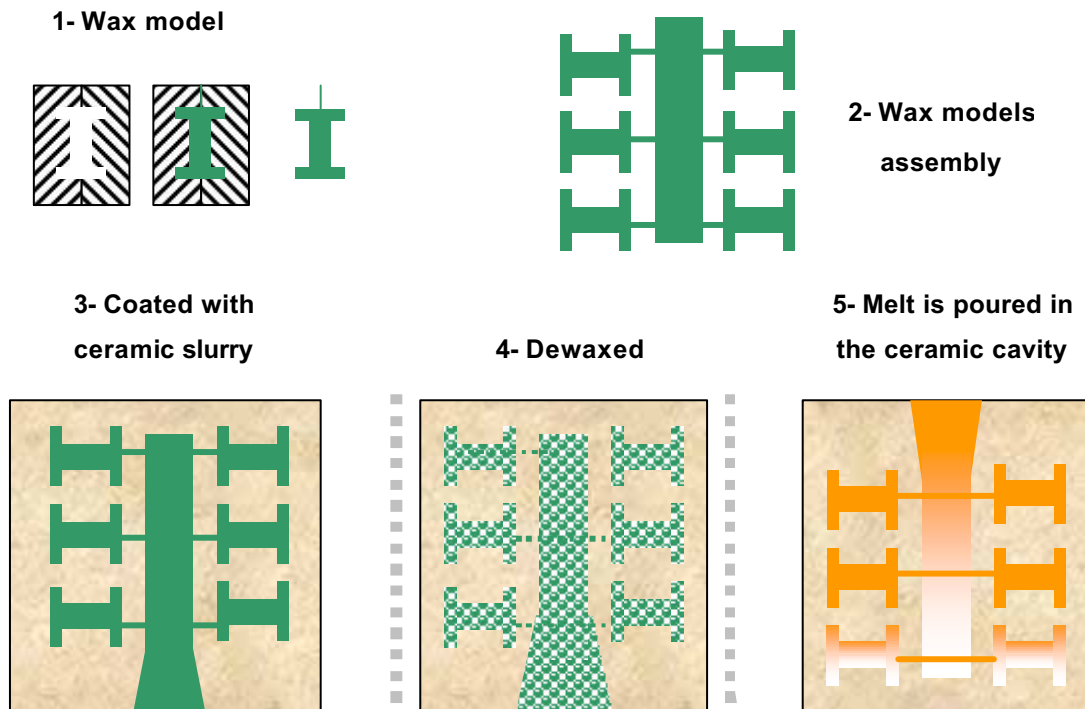

Figure 46: Production sequence in the investment casting process.

Melting

Titanium in the liquid state has a very high chemical activity. It reacts strongly with oxygen, nitrogen, hydrogen, and water and also reacts with almost all the refractory crucible materials at high temperatures. Therefore, melting must be carried out in special crucibles under inert atmosphere.

Although different melting processes are available for titanium alloys (*Table 13*), all of them have in common vacuum or/and inert atmosphere melting.

| Type | Use |
|---|---|
| Electron Beam Melting (EBM) | Rare. Evaporation of alloying elements. |
| Vacuum Arc Remelting Process (VAR/VAM) (consumable titanium electrode) | Typical melting equipment |
| Induction Melting (IM) | Small mass product parts |
| Plasma | Remelting. Refining |

Table 13: Melting processes for titanium.

Among them, the dominant method of melting titanium in the industry is the VAR/VAM method with a consumable titanium electrode. The molten metal is contained in a water cooled copper crucible while confined in a vacuum chamber. This technique called “skull melting” prevents the highly reactive liquid titanium from dissolving the crucible because it is contained in a solid skull frozen against the water cooled crucible wall. When an adequate melt quantity has been obtained, the residual electrode is quickly retracted, and the crucible is tilted for pouring into the moulds. A skull of solid titanium remains in the crucible for reuse in a subsequent pour or for later removal.

Consumable titanium electrodes are either ingot metallurgy forged billet, consolidated revert wrought material, selected foundry returns or combination of all of these. They are produced by welding process and the casting specification or user requirements dictate the composition of revert materials used in these electrodes construction.

Moulding material

The material of investment moulds used for titanium casting is different from that used for other alloys. Due to the titanium’s strong affinity for oxygen, conventional refractory based on silica and alumina/silica can not be used to produce moulds for titanium investment casting. Moulds made of such refractories result in castings having low quality and porosity defects. To avoid these problems titanium investment moulds must be made of high stability refractories. Regardless of these high stability refractory materials, some metal-mould reaction inevitably occurs due to

titanium reduction of the ceramic oxides. Thus the oxygen rich surface of the casting stabilizes the α phase, usually forming a metallographically distinct layer so called “ α -case” on the casting surface.

Casting

Another factor to take into account is the fluidity of the molten material. In the case of titanium this is poor and could lead to shrinkage and gas defects, as well as filling defects. Besides, in solid state, titanium reactivity increases dramatically upon 880°C, thus limiting the maximum preheating temperature of the moulds to be filled in, which in turn leads to higher mould filling difficulties. To overcome this problem systems are usually equipped with centrifugal casting units in order to aid in the mould filling and casting solidification.

Finishing

In spite of the special refractory material used in the moulding, titanium picks up some constituents from the moulding material or from the residual gases in the furnace atmosphere during the manufacturing process. These constituents diffuse into the surface and form the mentioned α -case (thickness of a few tenths of a millimetre), which is usually removed by chemical milling.

Finally Hot Isostatic Pressing (HIP) is used to close any porosity of microshrinkage evidence due to the poor feeding during solidification.

Titanium alloys

Titanium alloys have not been evolved enough to fit them into the corresponding routes as it was done for other materials such as iron, bronze or aluminium. To date all produced titanium castings are based on traditional wrought product compositions. Foundrymen have learned how to deal with these wrought alloys and to adapt the casting processes in order to improve their castability and mould filling limitations. It can be stated that all commercial alloys can be practically used for casting parts.

The well known Ti6Al4V (Ti64) dominates the industry because it has dominated wrought industry production since its introduction in the early 1950's.

| Alloy | Property | Application | Relative usage of casting |
|------------------------------|----------------------------|----------------------------|---------------------------|
| Ti6Al4V(a+β) | Strength, weight | General purpose | 88% |
| CP Ti (a) | Corrosion resistance | Chemical industry | 7% |
| Ti6Al2Sn4Zr2Mo0.1Si (a+β) | Elevated temperature creep | Moderated/high temperature | 2% |
| Ti5Al3.5Sn3Zr1Nb0.3Si (a) | Elevated temperature creep | High temperatures | <1% |

Table 14: Estimated relative usage of Ti alloys (Source: Handbook Titanium Alloys ISBN 0-87170-481-1).

3 Experimental procedure

3.1 Equipment and Process

Only two types of lab scale equipments are nowadays available in the European market to cast small quantities of titanium (<50gr) (Table 15). Both are mainly used in dental laboratories.

| Description | Type I | Type II |
|----------------|---|---|
| Crucible | Ceramic crucible (SiO ₂ and ZrO ₂) | Copper crucible |
| | In both cases the crucible is in contact with molten titanium | |
| Heating system | High frequency induction melting | Arc melting |
| Casting | Centrifugal casting | Differential pressure casting |
| Supplier | Linn (Germany), Manfredi (Italy). | J. Morita (Japan), Schutz or Dentaureum (Germany), Orotig (Italy) |

Table 15: Main characteristics of the titanium lab scale equipments.

The titanium investment casting foundry involved in the NEWTIRAL program, as industrial partner to study the pre-industrialization of the process developed at lab scale, is the Belgian foundry SETTAS-DONCASTER. In this company, the system employed to obtain titanium components is, the one most often industrially employed: vacuum arc melting with a consumable electrode, equipped with a centrifugal casting unit.

This system is practically a combination of the two lab scale equipments mentioned. On the one hand, the melting is based on arc melting which corresponds to the second type of machines and on the other hand, the casting is based on a centrifugal force which matches with the first type.

In the case of metal matrix composites, the solidification step followed is very important in the final reinforcement distribution and the application of centrifugal forces could have an effect on this aspect. This is why the lab scale equipment selected to investigate the production of TMCs has been the one equipped with the centrifugal casting device. Furthermore, the centrifugal casting is also used at the industrial foundry involved in the program which has been another reason when selecting the equipment to be used at lab scale.

Summarizing, the equipment selected to make the lab scale experiments has been the Neutrodyn EasyTi supplied by Manfredi. It is based on lost wax moulding, high frequency induction melting and centrifugal force assisted casting. In this equipment, the casting is carried out under controlled atmosphere achieved by purges of vacuum and injection of argon. The chamber of the centrifugal casting device used is shown (see *Figure 47*):

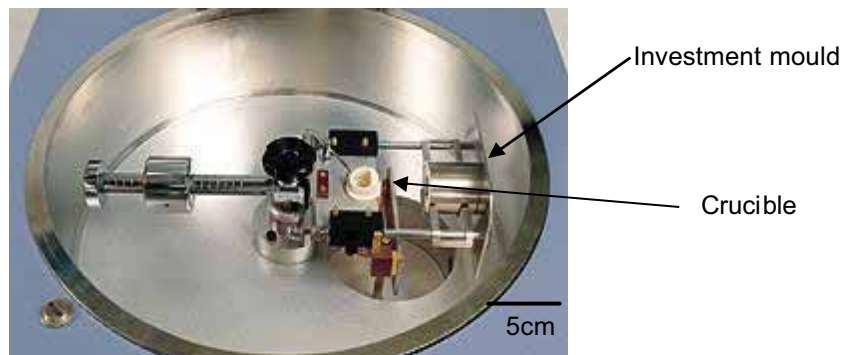

Figure 47: Lab scale centrifugal casting device.

It consists of a horizontal arm on which the mould, produced by a conventional lost wax process, is secured at one end in front of the crucible with a pouring spout butted up to the open end of the mould. The weight of this assembly and the metal charge is counterbalanced by adjustable weights at the other end of the bar. At its centre, the bar is mounted on a vertical spindle that rotates. The chamber is closed with a cover where a peephole with an optical pyrometer is located. The principle is illustrated in *Figure 48*.

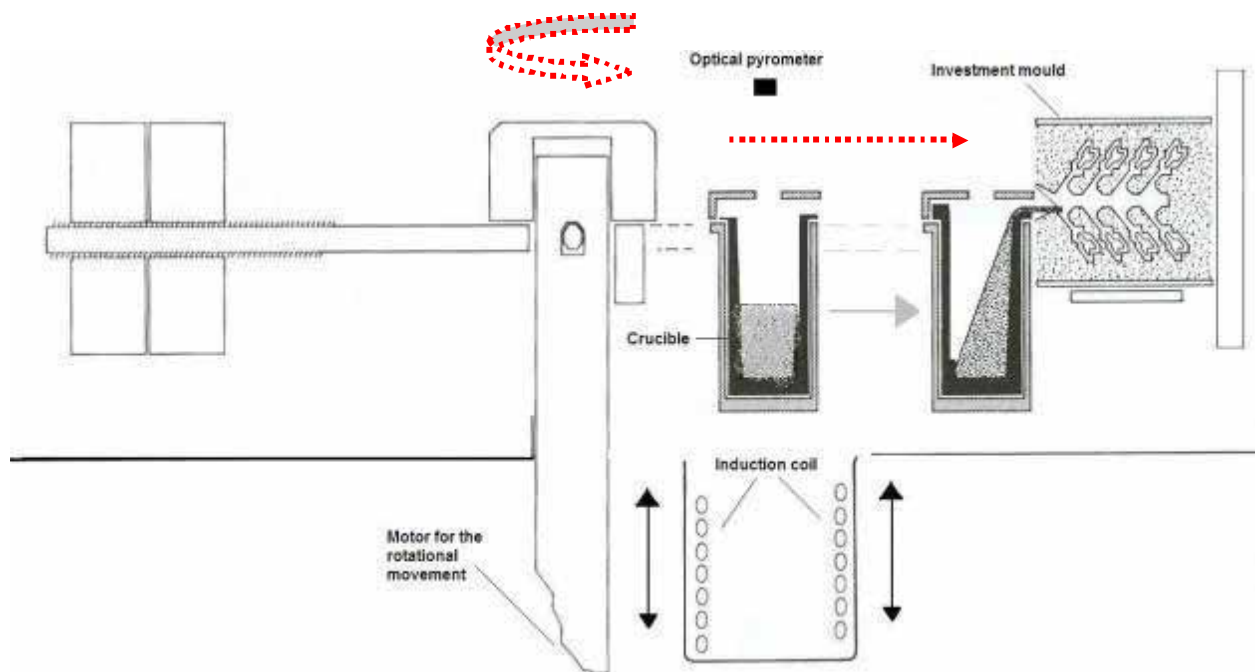

Figure 48: Sectional illustration of the principle of the centrifugal casting device with induction melting.

The material to be melted is introduced in the crucible and once it is melted the induction coil moves down, the crucible approaches the mould assisted by a spring and the arm starts spinning. The material fills the mould due to the forces acting on it.

3.1.1 Induction melting

Induction heating is used to melt the load of metal within the crucible. In the induction heating system, an alternating current in the coil sets up an electromagnetic field that creates a spinning current within the material (*Figure 49*). This spinning current generates heat due to the resistivity of the material.

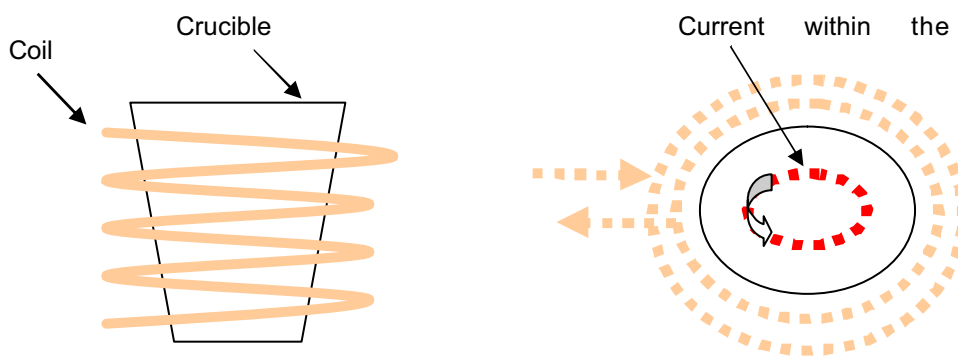

Figure 49: Principle of the induction heating.

A non-conductive ceramic crucible is used that does not interfere with the action of induction coils. The crucible is coated with a refractory painting (yttrium-ceria layer) in order to avoid as much as possible the reaction of the titanium melt with the crucible.

3.1.2 Centrifugal casting

The way in which metal flows into the mould and the complete filling of the mould are critical to the success of a cast part. Moreover, in the case of metal matrix composites, the segregation of reinforcements or any effect on the microstructure and distribution of them is also significant.

Centrifugal casting or the centrifugal forces acting in this type of process could have an effect on this aspect. Therefore, the forces acting in the system and the centrifugal effect on the microstructure and reinforcement distribution will be discussed.

In the coordinate system that is rotating around the axis with a constant angular velocity ω , two forces emerge as follows:

$$\begin{array}{ccc}
 \text{Centrifugal} & & \text{Coriolis} \\
 \leftarrow \text{—————} \rightarrow & & \leftarrow \text{—————} \rightarrow \\
 \vec{F} = -m \vec{\omega} \times (\vec{\omega} \times \vec{r}) - 2m (\vec{\omega} \times \vec{v}) & &
 \end{array}$$

where “ F ” is the resulting force, “ m ” is the mass of the material, “ v ” is the velocity of the material in the rotating system, and “ w ” indicates the rotation. The first term in the equation indicates the centrifugal force that acts from the rotating centre to the outer direction. The second term is known as the Coriolis force that depends on the velocity of the material, angular velocity and the angle of these vectors. The higher the velocity of the melt, the larger the Coriolis force is.

In the centrifugal casting machine used, the rotation is anti-clockwise and the material moves outward, thus the sum of the Coriolis force and the centrifugal force creates a preferential zone to fill the mould cavity with the melt (*Figure 50*). This preferential zone should be considered when designing the cavity of the mould.

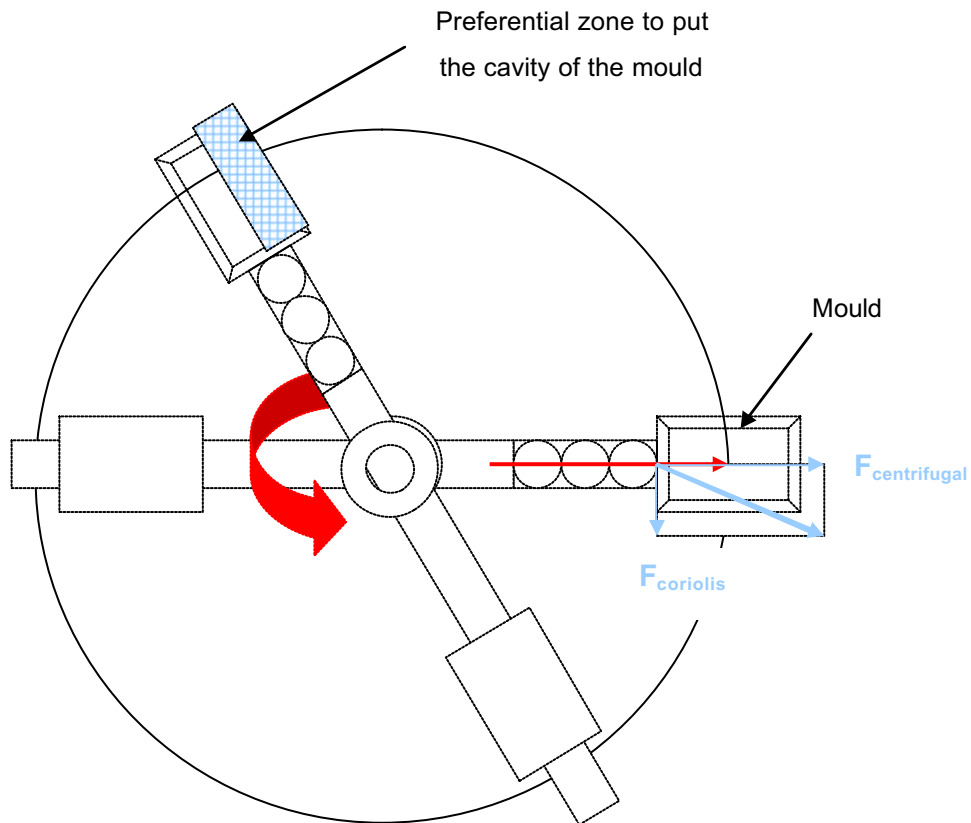

Figure 50: Preferential zone to fill the mould cavity due to the forces acting in the system.

Reinforcement segregation could occur during centrifugal casting owing to difference in density between molten metal of base alloy and particles (C.G.Kang, 1994). A particle which is suspended in molten metal is submitted to a vertical acceleration due to gravity and to a centrifugal acceleration. The vertical movement of the particles can be ignored because the centrifugal acceleration is much higher than gravity one which allows the vertical displacement of the particles.

An aluminium alloy reinforced with silicon carbide particles has been selected to analyse any possible segregation effect as a preliminary study to the titanium reinforced with titanium boride system mainly for two reasons. The first one is that the aluminium silicon carbide system ensures the melting of the matrix while the particles are suspended. And the second reason is the difference in relative density between molten matrix and particle (Table 16). Therefore, this system is more likely to suffer segregation than the titanium reinforced with titanium boride system.

| | Density (g cm ⁻³) | Melting T ^a |
|---------|-------------------------------|------------------------|
| Al9SiMg | 2.67 | ~600°C |
| SiC | 3.22 | ~2700°C |
| CPTi | 4.51 | ~1668°C |
| Ti6Al4V | 4.4 | ~1650°C |
| TiB | 4.51 | ~2200°C |

Table 16: Density and melting temperatures of the different materials analysed.

The mould used to evaluate this possible segregation has been specially designed to analyse this effect. It consists of a flat surface that covers the entire horizontal surface available in the mould, the preferential and the standard zone of the mould (*Figure 51*). This way, it will be possible to observe any difference along the horizontal surface if it exists.

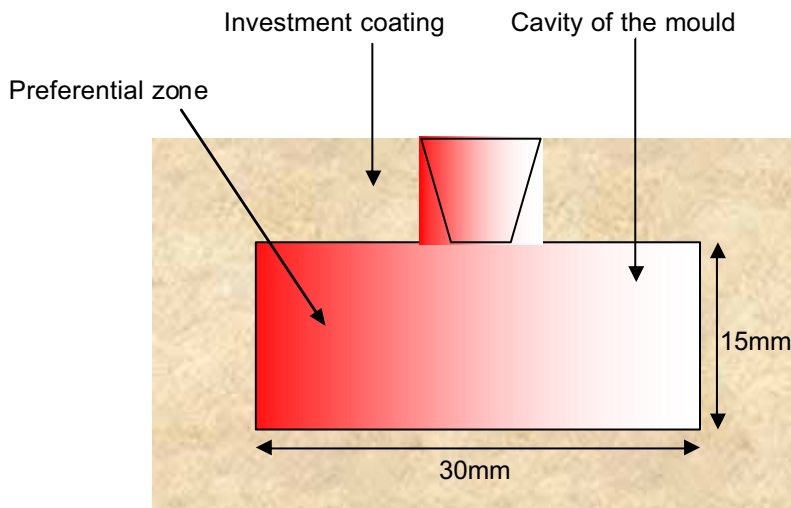

Figure 51: Geometry of the mould used to study the centrifugal effect on the reinforcement distribution.

The material used for this assessment has been the commercial Duralcan F3S.10S type metal matrix composite material produced by stir casting. It consists of an aluminium alloy (Al9SiMg) reinforced with 10vol.% of SiC particulates (10 μ m). The Duralcan material has been cast using a velocity of 600 r.p.m which is the maximum for this lab equipment.

The microstructure of the material centrifugally cast has been compared to that of the material as received from the supplier.

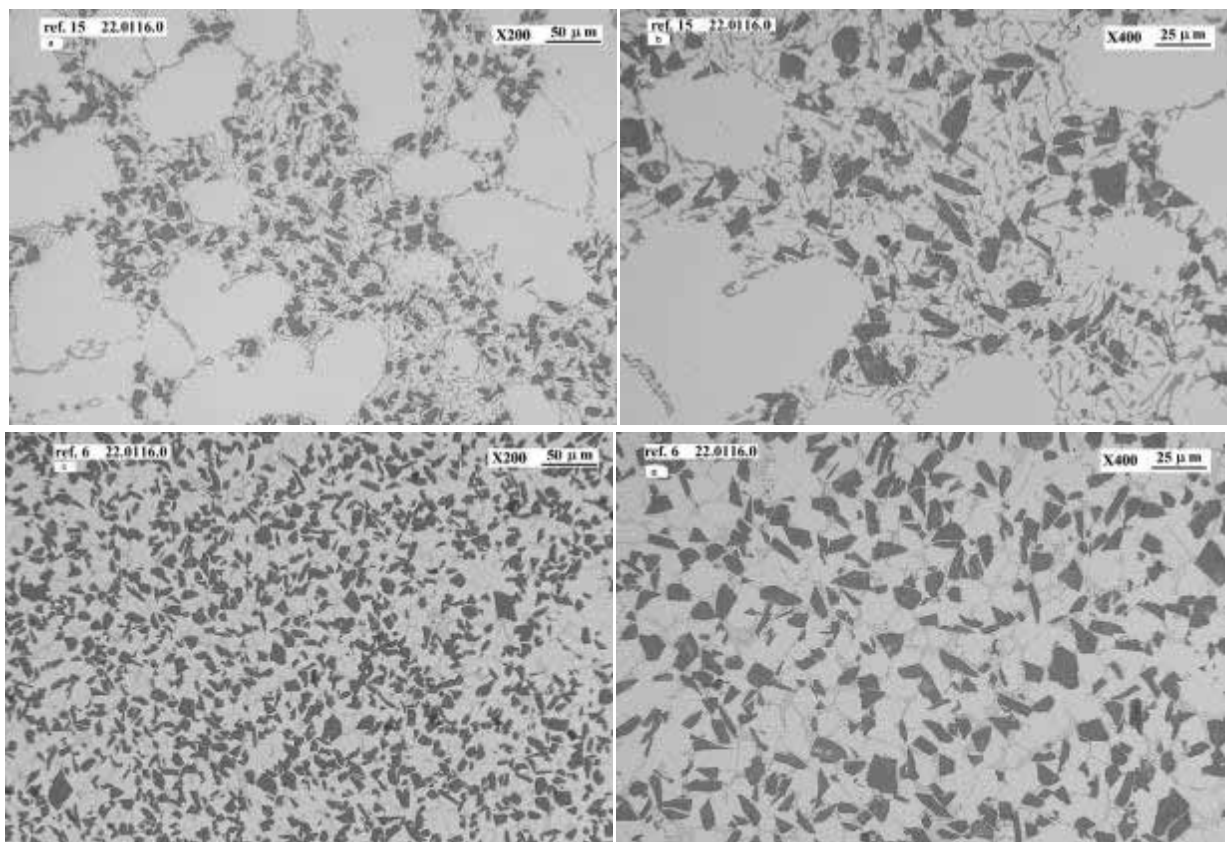

Figure 52: Optical micrographs showing the microstructure of aluminium matrix reinforced with silicon carbide particles: a) A359/10%SiC as supplied(x200), b) A359/10%SiC as supplied (x400), c) A359/10%SiC centrifugal casting (x200), d) A359/10%SiC centrifugal casting (x400).

The results show a microstructural refinement and essentially a much better microstructural homogeneity of the centrifugally cast material in comparison to that of the stir cast one. The microstructure obtained after the centrifugal casting is more homogeneous and with a smaller

grain size. Both the alpha aluminium phase and the eutectic one have decreased in size. In the samples received from the supplier, the SiC particles have been pushed into the interdendritic regions by the growing dendrites, causing severe clustering. For the centrifugally cast material, it seems likely that the SiC particles have avoided the growing dendrites acting as a cutting tool during the rotating movement, so that less pushing has occurred and so no clustering.

Throughout the sample the distribution of the SiC particulates is homogeneous and there is no evidence of segregation or difference in the particles distribution. This has been confirmed by micro-hardness measurements performed and shown in *Figure 53*.

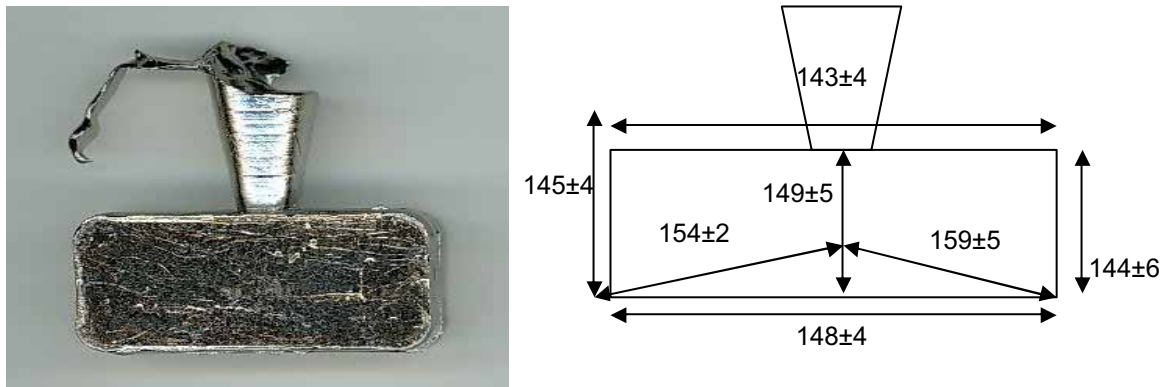

Figure 53: Micro-hardness (Hv200) measurements mean values of the A359/10%SiC centrifugally cast sample.

From this preliminary analysis any possible centrifugal force effect on the reinforcement segregation when this reinforcement is in solid state can be ruled out.

3.1.3 Mould preparation

The main steps followed for the mould production have been those used in the lost wax process:

- Pattern and feeder system formed in wax.

- Assembly coating by investment material: refractory ceramic ($\text{MgO-Al}_2\text{O}_3$) and binder (ethyl silicate).
- Baking of the mould: ceramic sintering and dewaxing.

The form and dimensions of the wax pattern have been defined taking as reference a tensile test specimen dimension. The objective has been to obtain directly by investment casting a TMC sample to be tested afterwards. The small capacity of the equipment and consequently the small space to locate the mould inside the chamber limited the possibility to obtain only one sample per mould. The location of the cavity inside the mould has been designed according to the previously described theoretical centrifugal forces analysis. The existence of this preferential zone has been confirmed through some casting experiments that have shown the influence of these forces in the mould filling during the centrifugal casting. *Figure 54* shows the dimensions of the wax pattern and the two samples cast using the same rotating velocity (the maximum; 600r.p.m.) that differ in the location of the mould cavity. The one on the left corresponds to the location of the cavity theoretically less favourable where an incomplete filling is evident. The one on the right corresponds to the cavity located in the preferential zone and consequently the one selected for the present study.



Figure 54: The centrifugal forces influence in the mould filling.

3.2 Casting experiments

The two industrially most used titanium materials (*Table 14*) have been selected as matrix materials in the present investigation: Commercially Pure titanium (ASTM Grade 2) and Ti6Al4V (ASTM Grade 5). They will hereafter be referred to as CPTi and Ti64.

From the preliminary trials carried out to melt and cast these materials (CPTi and Ti64), the following aspects can be pointed out:

- Due to the lack of automation of the equipment, melting has to be visually controlled. Titanium reacts vigorously with the crucible; one second too long after melting has detrimental consequences for the casting.
- In the crucible, the first material which starts to melt is the one located in the outer part or surface of the ingot. This first melted material initially fills the base of the crucible and forms a local thin metal “skull”.
- 30 gr. of titanium (which is the maximum for this equipment) take around 45 seconds to be melted. A similar amount of time is needed for both type of materials (CPTi and Ti64).

Both, CPTi and Ti64, with different amounts of master compound have been cast in order to obtain *in-situ* reinforced TMCs. Hot Isostatic Process (HIP) is used to eliminate any porosity from the cast samples before being mechanically tested. The parameters used in the HIP process have been those used for conventional unreinforced castings, 920°C/100MPa/120minutes.

In addition to these composites, samples of the corresponding base titanium materials (CPTi and Ti64) have also been cast in an identical manner for a comparison of the microstructure and properties.

3.2.1 Master compound addition

During the induction heating the material in the crucible (titanium ingot with the master compound inside) is heated. The dissolution of the master compound (Ti/60wt%TiB) requires high temperature and time. This is a problem when using a ceramic crucible as the time inside the crucible must be limited to avoid the reaction of the melt with the crucible material. For low

amounts of master compound, as soon as the temperature reaches the liquidus the material melts and the dissolution of the TiB occurs. However for higher amounts, this is much longer and problematic as the material inside the crucible can react. During the experiments carried out in this study, samples with final volume fraction above 12vol.% have presented reactivity problems. For lower concentrations, the master compound has been completely dissolved and the TiB precipitated within the matrix during the solidification of the mixture.

3.2.1.1 Microstructure

The addition of the master compound has had a big influence on the final microstructure of the cast samples. It is interesting to note that in both alloys its addition has significantly refined the microstructure.

The microstructure of the CPTi cast without any addition of master compound consists of colonies of serrated alpha plates (*Figure 55a*). On the other hand, when master compound has been added to the CPTi, these alpha plates have been reduced with the TiB precipitation. The same effect has been observed for the Ti64 alloy. The microstructure of the unreinforced Ti64 cast alloy consists of individual long alpha grains having common orientation with them within the prior beta grains. This structure is similar in appearance to the woven pattern of a basket and therefore usually referred to as basket weave structure. The TiB precipitation has had a refining effect, it has decreased the beta and alpha grain sizes. The alpha grains in this case appear to be shorter and thicker (*Figure 55d*).

The following figures show the microstructures of the CPTi and Ti6Al4V materials with or without reinforcements. The grain size reduction can be clearly seen comparing these micrographs as they have been obtained at the same (x200) magnification.

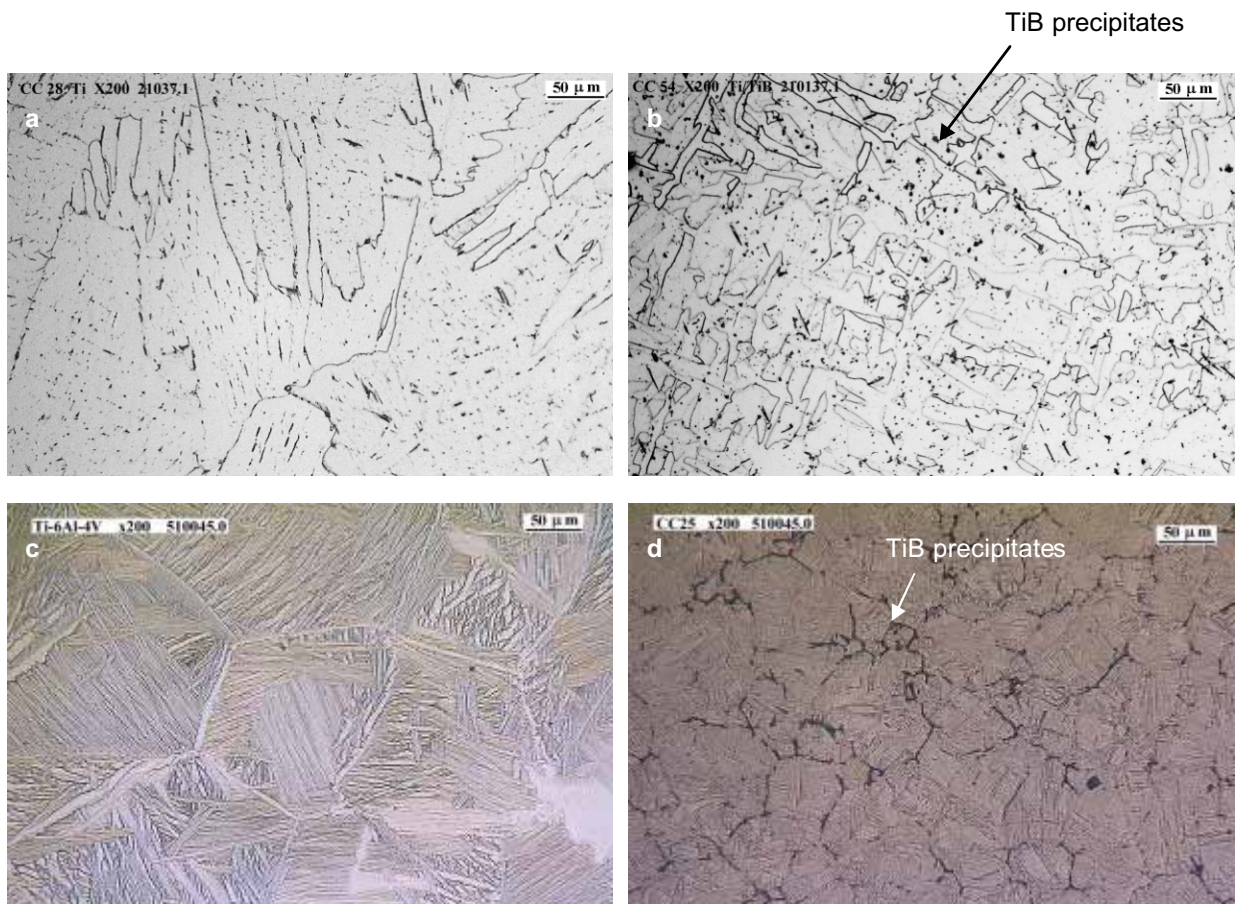

Figure 55: Effect of the boron source into the CPTi and Ti6Al4V microstructure: a) CPTi, b) CPTi/TiB, c) Ti6Al4V, d) Ti6Al4V/TiB.

3.2.1.2 TiB precipitation and morphology

The eutectic composition in the Ti-B phase diagram and also in the case of Ti6Al4V alloy is around 9%vol. TiB (*T.Saito, 2005*). Three different zones have been distinguished in relation to the TiB precipitation and morphology (*Figure 56*). The one corresponding to the eutectic composition (TiB %vol.~9), the area which corresponds to the hypoeutectic composition (TiB % vol.<9) and finally the area which corresponds to the hypereutectic one (TiB %vol. >9). In all cases the morphology of the TiB is needle shaped, shorter or larger depending on the solidification paths.

For the hypoeutectic composition the solidification path is as follows: at liquidus temperature grains of β -Ti precipitate first. Between liquidus and solidus temperature these β grains grow. At the eutectic temperature, there exist β grains and a liquid solution with eutectic composition. Below this temperature, the liquid solution precipitates in very fine TiB needles. Finally at the transformation allotropic temperature ($\beta \rightarrow \alpha$), the α phase precipitates from the β grains.

In this region, the TiB needles are distributed at the boundary of the prior β grain (*Figure 56a*).

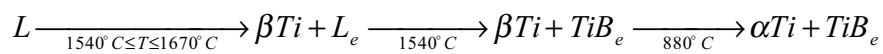

At eutectic composition, fine and long needles precipitate (*Figure 56b*).

For the hypereutectic composition: at liquidus temperature large primary TiB needles precipitate and grow in the liquidus and solidus temperature interval. At eutectic temperature, large primary TiB needles and liquid solution with eutectic composition exist. Eutectic needles precipitate between the primary needles.

In this region, the TiB needles are distributed in the matrix (*Figure 56c*).

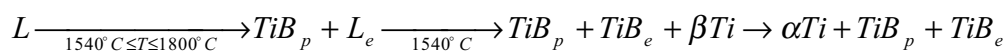

Due to its crystal structure the TiB grows faster along [010] direction than along others (*Figure 57*).

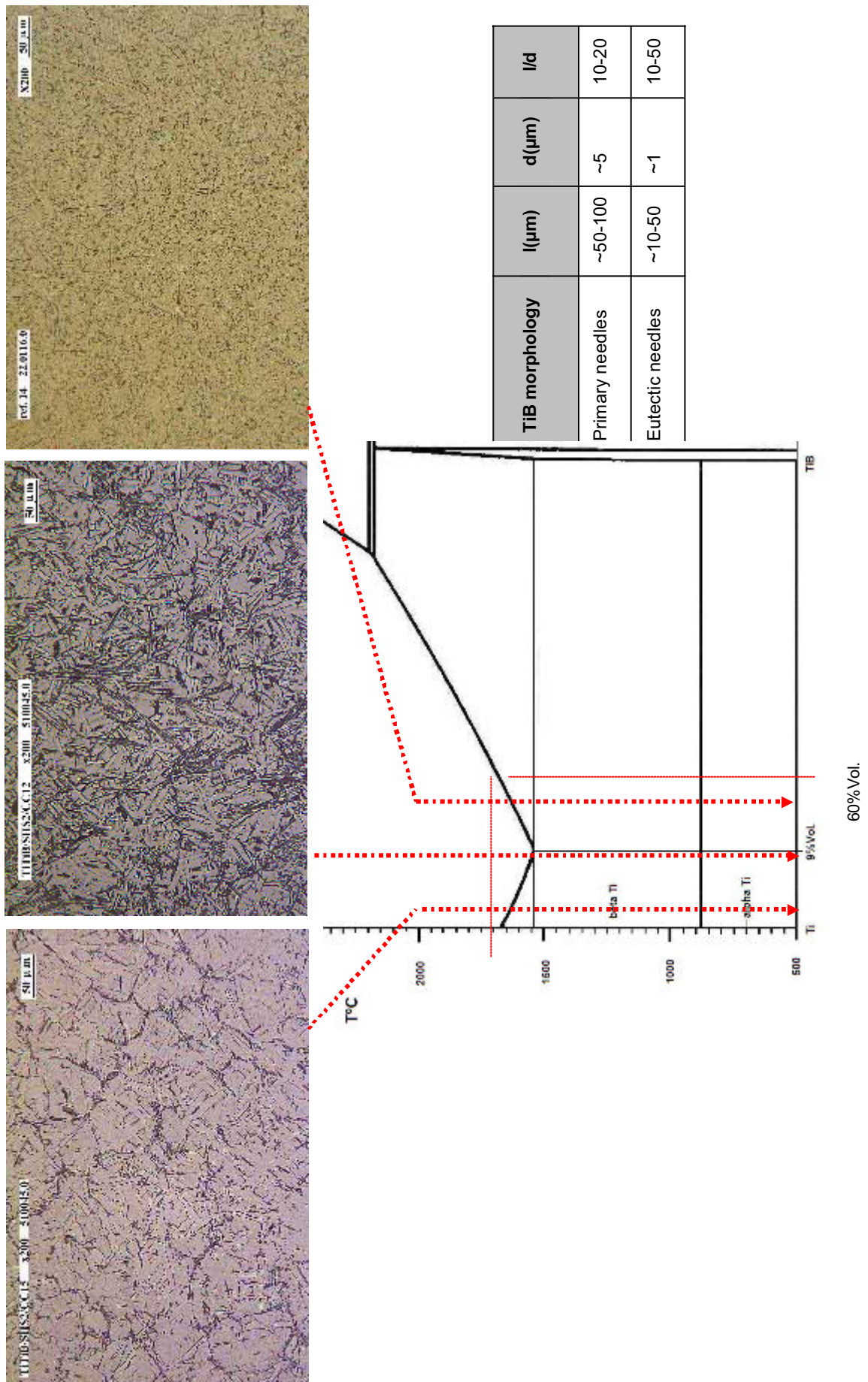

Figure 56: Morphology and precipitation of TiB depending on the TiB volume fraction.

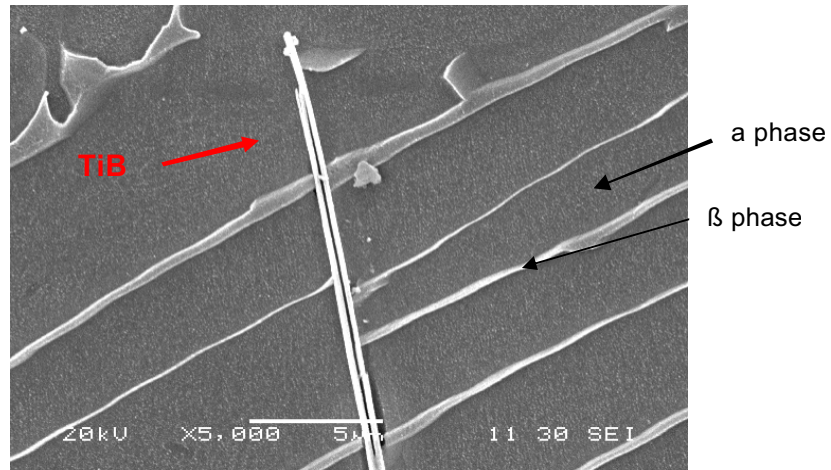

Figure 57: Needle shaped TiB crystal in a Ti6Al4V/TiB composite.

3.2.1.3 Mechanical properties

The microstructure confirms that the reinforcements are short whiskers in the titanium matrix, forming a discontinuously reinforced composite material. Mechanical properties of this kind of composites are in between the dispersion strengthened and fibre strengthened extremes, because both matrix and reinforcements bear substantial proportions of the load. This means that composite modulus and strength are expected to be increased, coupled with reduction in ductility. In fact, this has been confirmed in different studies where the mechanical properties of these discontinuously reinforced TMCs have been measured. In the following table (*Table 17*) some of these results are summarized.

In the present investigation it has been considered interesting to analyse thoroughly the volume fraction where the material presents some ductility. For this purpose, the tensile test properties of the composites with low volume fraction of reinforcement where the ductility is expected to be retained have been tested. Tensile tests at room temperature have been carried out following the standard EN 10002-1:2001. The results obtained as well as the results found in the literature are shown in the *Table 17*.

| Matrix | Vol.% | E(GPa) | YS(MPa) | UTS(MPa) | % elongation | Process | Ref |
|---------|-------|--------|---------|----------|--------------|----------------------|--|
| Ti | 0 | 100 | 448 | 550 | 15 | Casting | Handbook Ti Alloys ISBN 0-87170-481-1 |
| Ti6Al4V | 0 | 108 | 758 | 930 | 12 | Casting | Handbook Ti Alloys ISBN 0-87170-481-1 |
| Ti | 15 | 139 | 842 | 903 | 0.4 | VAR + hot swaging | K.B Panda et al., 2003 |
| Ti6Al4V | 10 | 136 | 540 | 1000 | 0.25 | MA + HIPing | T.M.T. Godfrey et al., 2000 |
| Ti6Al4V | 20 | 170 | 1181 | 1251 | 0.5 | PM + HIPing | S. Gorsse et al., 2003 |
| Ti6Al4V | 40 | 210 | - | 864 | 0 | PM + HIPing | S. Gorsse et al., 2003 |
| Ti | 0 | - | 416 | 492 | 25 | Casting + HIPing | Present study |
| Ti | 0.25 | - | 463 | 572 | 23.1 | Casting + HIPing | Present study |
| Ti | 0.5 | - | 638 | 761 | 19.1 | Casting + HIPing | Present study |
| Ti | 1 | - | 701 | 801 | 20 | Casting + HIPing | Present study |
| Ti | 3 | - | 811 | 898 | 10.9 | Casting + HIPing | Present study |
| Ti | 5 | - | 925 | 950 | 2 | Casting + HIPing | Present study |
| Ti | 7 | - | - | 810 | - | Casting + HIPing | Present study |
| Ti6Al4V | 0 | - | 900 | 1061 | 8.7 | Casting + HIPing | Present study |
| Ti6Al4V | 0.25 | - | 926 | 1014 | 7.75 | Casting + HIPing | Present study |
| Ti6Al4V | 0.5 | - | 1035 | 1115 | 3.4 | Casting + HIPing | Present study |
| Ti6Al4V | 0.5 | - | 1013 | 1178 | 3.4 | Casting + HIPing | Present study |
| Ti6Al4V | 1 | - | - | 1084 | 2 | Casting + HIPing | Present study |
| Ti6Al4V | 1 | - | - | 1133 | - | Casting + HIPing | Present study |

Table 17: Room temperature tensile properties of discontinuously reinforced Ti alloys with different vol.% of TiB reinforcements.

The results obtained from the mechanical tests confirm that for both matrices there is a volume fraction range where the material increases the strength while maintaining some ductility. However the transformation between the ductile behaviour to the fragile one is different depending on the matrix alloy. Composites with final volume fractions below 5% for CPTi present elastic behaviour while this value is down to 1vol.% in the case of the Ti64 matrix.

In these low volume fraction ranges the amount of TiB is not enough to promote a composite effect (load transfer). Besides the microstructures show that the TiB needles precipitate at the prior beta grain boundary (*Figure 58*) which means that reinforcements are not homogeneously distributed in the matrix and therefore they do not contribute to the Orowan strengthening mechanism either. Therefore it could be concluded that, another mechanism such as the strengthening due to grain size refinement could be the only responsible of the strength of the resulting composite.

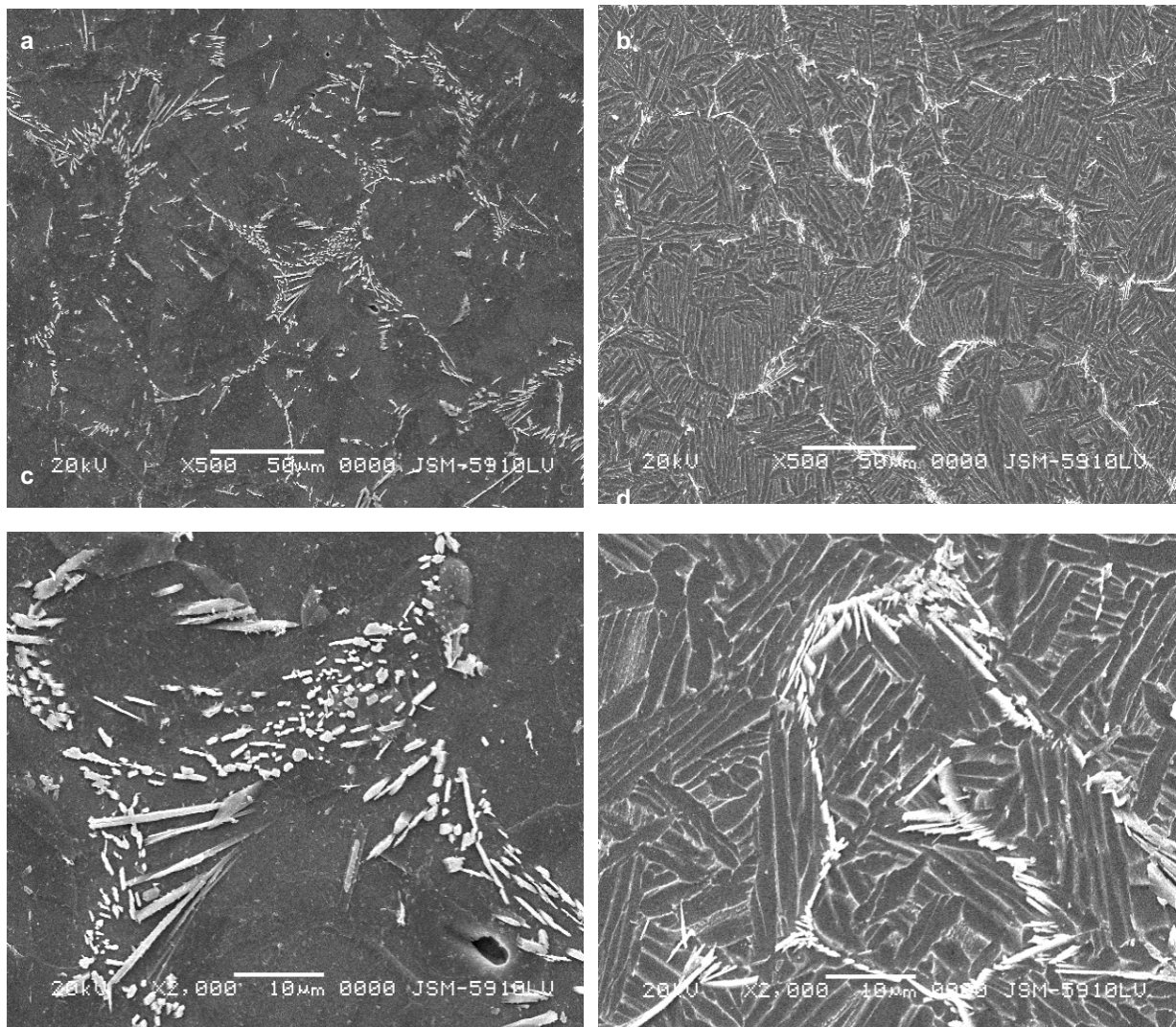

Figure 58: Detail of the TiB distribution in the grain boundary regions: a) and c) for Ti/3%vol.

TiB, b) and d) Ti6Al4V/1% vol. TiB

3.2.1.4 Fracture

Fracture surfaces of the mechanically tested samples have been observed as well as analysed just in the vicinity of these fracture surfaces. The objective has been to examine not only the fracture mode but also the influence of the reinforcement on the crack initiation and propagation.

As expected from the tensile test results, the preliminary observation by SEM of the fracture surface of these tested samples with low reinforcement volume fractions reveals a ductile fracture mode. The rupture is transgranular for Ti64 and intergranular for Ti64/TiB (due to the presence of TiB) at the grain boundary for the composite. However as the TiB content increases a certain tendency of fragility is detected. This tendency is shown in the following fracture surface SEM images, where the transition from the ductile dimples that were present in the unreinforced material to brittle cleavage morphology originated for the TiB reinforcements is clear (*Figure 59*).

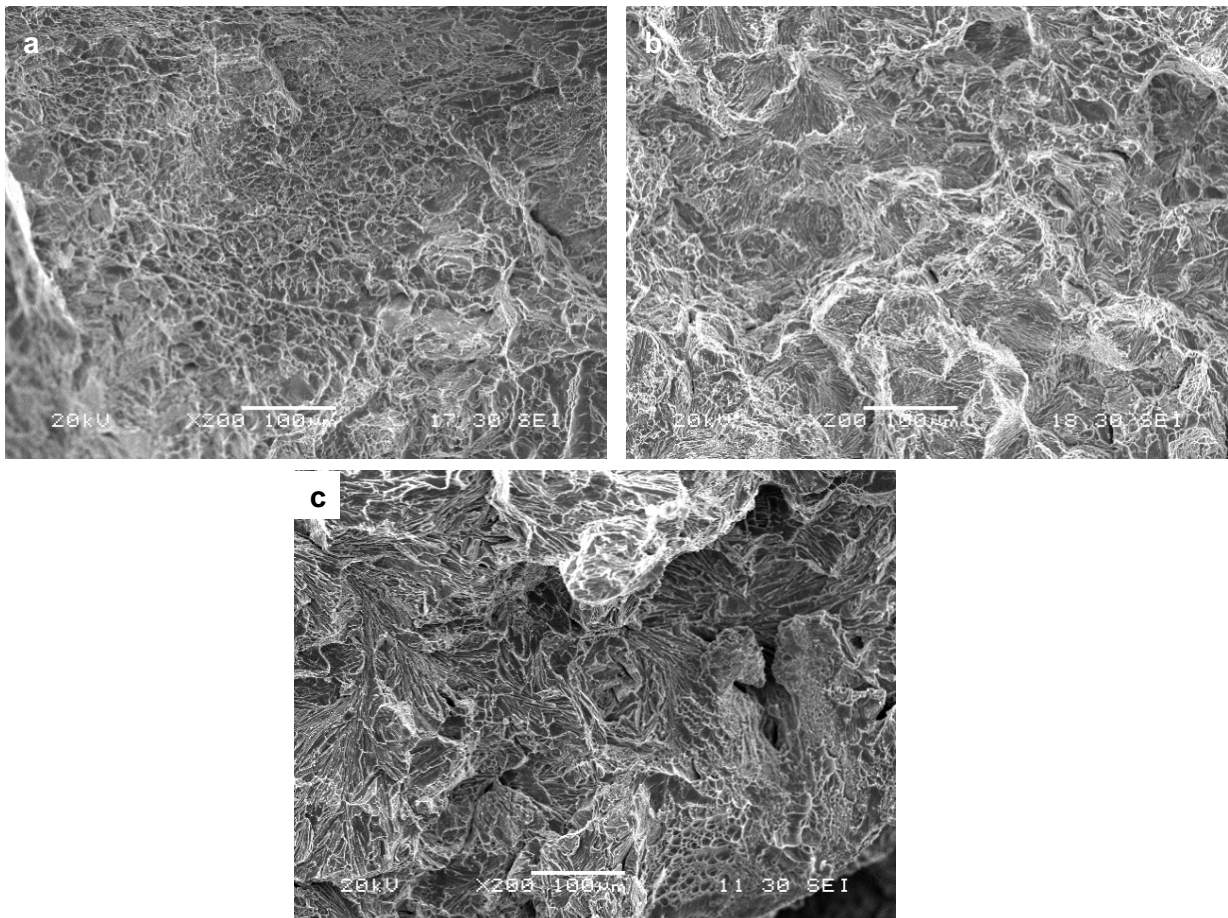

Figure 59: Fracture surfaces of tensile tested samples: a) Ti64, b) Ti64/0.5%vol.TiB, c) Ti64/1%vol.TiB.

Micro cracks tend to be initiated within the reinforcements themselves and these micro cracks propagate easily at the interface and continue the propagation fitting the direction along the TiB/matrix interfaces. In *Figure 60* the remaining TiB reinforcements in the fracture surface can be seen, and how, the crack has propagated along the interface to finish in a complex or zigzag crack path. In *Figure 61* debonding at and along the TiB/matrix interface due to the tension load applied is observed.

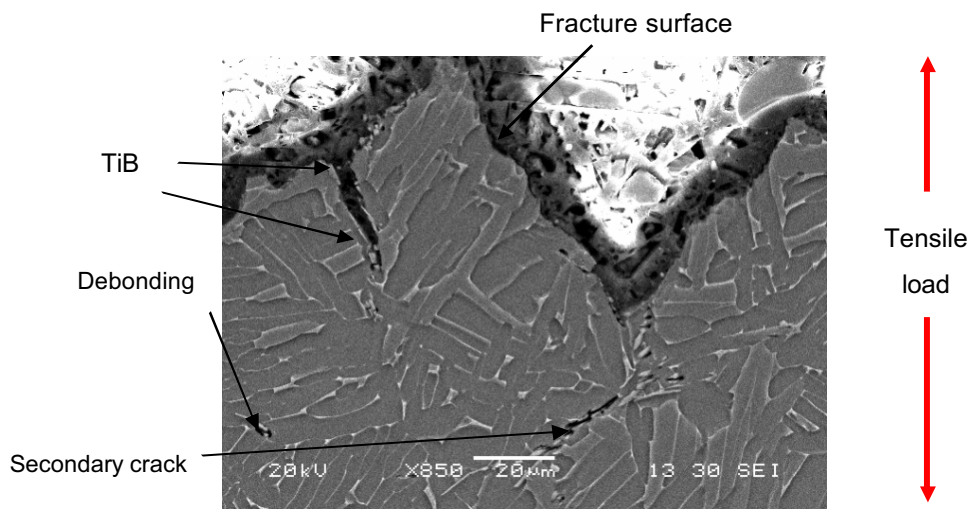

Figure 60: Fracture surface of Ti6Al4V/0.5%vol.TiB.

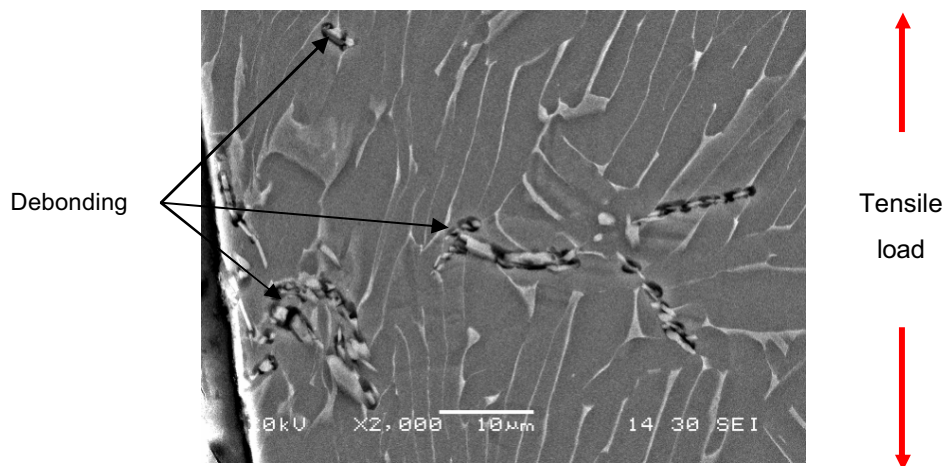

Figure 61: Detail of matrix interface debonding just below the fracture surface in Ti6Al4V/0.5%vol TiB composite.

As soon as the volume fraction of TiB in the material is increased, the distance between two TiB crystals is decreased and the cracks can easily propagate from one TiB crystal to the other (*Figure 62*).

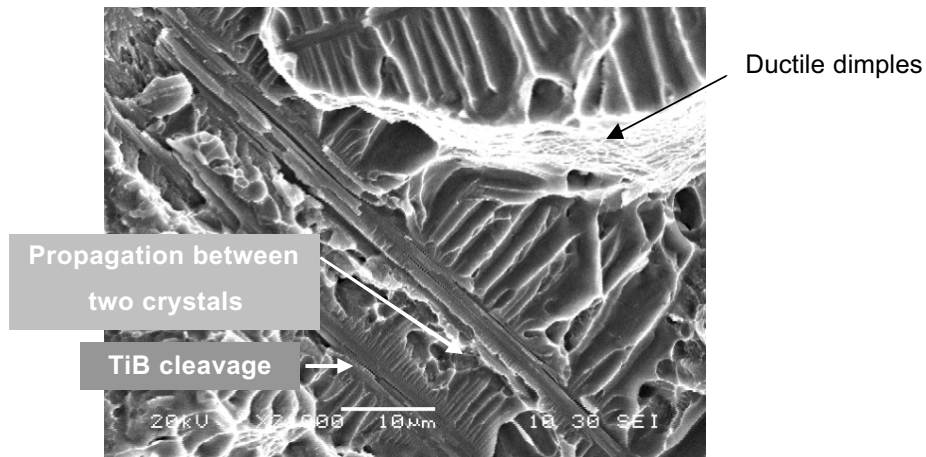
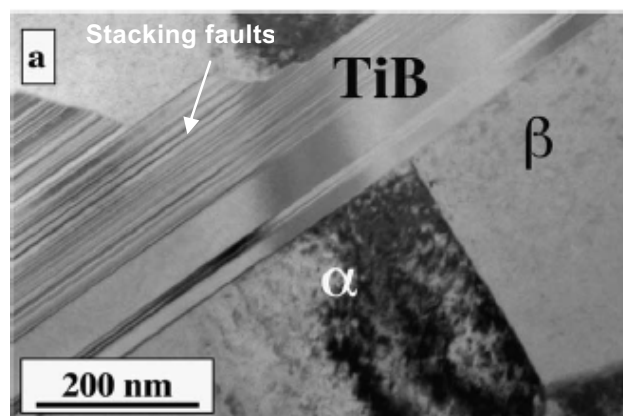

Figure 62: Fracture surface of a Ti6Al4V/1%vol. TiB composite after a tensile test.

This feature has been described in F.Dartigues thesis (*F.Dartigues, 2004*). Due to the presence of stacking faults inside the TiB crystal (*Figure 63*) the rupture starts in the crystal and the TiB cleaves according to specific crystallographic planes towards the titanium matrix crystals. The poor bonding between the atoms in the TiB crystal is probably the main cause of the crack initiation.



*Figure 63: Bright-field TEM image showing a TiB crystal, with a high density of faults, in a Ti64 matrix (*D.Hill, et al., 2005*).*

4 Conclusions

This chapter began with the following question;

Is it possible to use the master compound produced by SHS in a titanium investment casting to obtain TMCs with *in-situ* formed TiB reinforcements?

From the analysis performed in the present chapter it can be concluded that it is possible. In this analysis *in-situ* formed TiB reinforced TMCs have been obtained as well as characterized and the following conclusions can be pointed out:

- Final volume fraction of TiB in the composite is limited to ~12%Vol. due to reactivity problems between the melt and the ceramic crucible. The dissolution of the master compound produced by SHS (Ti/60wt%TiB) requires high temperatures and times, and this is a problem when using a ceramic crucible since the time inside the crucible must be limited to avoid any reaction of the melt with the crucible material.
- The distribution and morphology of TiB reinforcement depend on the final volume fraction of TiB in the composite. It is a needle-shaped morphology, with larger or shorter needles depending on the solidification path. In the hypoeutectic region the reinforcements are distributed in the prior beta grain boundary, while the distribution is along the matrix when the composition is hypereutectic.
- The addition of the master compound refines significantly the cast microstructure.
- Increasing the volume fraction of the reinforcement improves both the strength and modulus. By contrast, the higher the TiB content, the lower the ductility. A compromise has to be determined (with optimum volume fraction) in order to get both strength and ductility.
- The TiB plays an important role in the crack initiation and also in the crack propagation, which advances along the TiB/matrix interface and it is the responsible of the complex nature of the crack path.

CHAPTER 4:

TECHNOLOGY TRANSFER

1 Technology transfer

The present thesis has been developed under the frame of an European project, called NEWTIRAL (GRD2-2000-30405), whose main goal was to produce low cost TMCs with future industrial viability. To assess the industrial viability a technology transfer of the developments achieved at lab scale has been done to cast demonstrators at industrial facilities.

This last chapter has been completed with an evaluation of the cost of the TMCs components produced by the process developed along the thesis and a comparison to that of the titanium unreinforced components presently produced.

1.1 Requirements

The industrialization of Ti cast parts has been a main concern for the aeronautical industry as they may offer simultaneously a weight reduction and an improvement of properties with potential significant cost reduction. For AIRBUS Commercial Aircrafts the main target for the use of titanium alloys remains the engine pylon (*K.-H Rendigs, 2003*). The engine pylon is an important structural element connecting the aircraft engine to the wing. One of the main substructures of the pylon is the primary structure which has to direct the engine thrust to the wing and it is the vector of transmission of aerodynamic, inertial and propulsive loads. Furthermore, a variety of aspects have to be considered when looking for a new material for the pylon primary structure. These can be summarized into mechanical properties, stability in the presence of severe environments as well as ease of processing and reasonable cost.

Up to now, the basic material of Airbus aircraft pylons primary structure has been steel. To be able to deal with the A380 weight objectives, Airbus decided to replace as much steel as possible with titanium alloy parts in the A380 pylon structure.

The aeronautical company involved in the NEWTIRAL program as end user (EADS-CCR) has been in charge of defining the requirements to fulfil the above detailed specific potential application needs. They are an exceptional combination of high strength, ductility and fracture toughness. Particularly, an improvement of the Ti64 stiffness, strength and fracture toughness while maintaining the ductility above the 5%.

1.2 Industrial process

There is a huge difference between the quantities cast at lab scale (~35gr) and at industrial scale (~350 kg). In addition to this, there is another difference which is the melting system. The casting in both cases is assisted by centrifugal movement and the moulding based on lost wax moulding.

Regarding the melting system, at lab scale the induction melting has been used while the industrial process is based on vacuum skull melting using a consumable electrode. In this system, as shown in *Figure 64*, the molten metal is contained in a water-cooled copper crucible. This technique prevents the highly reactive liquid titanium from dissolving the crucible because it is contained in a solid skull frozen against the water cooled crucible wall. Therefore some of the limitations present at lab scale, associated to the use of ceramic crucibles, will disappear when using this melting system.

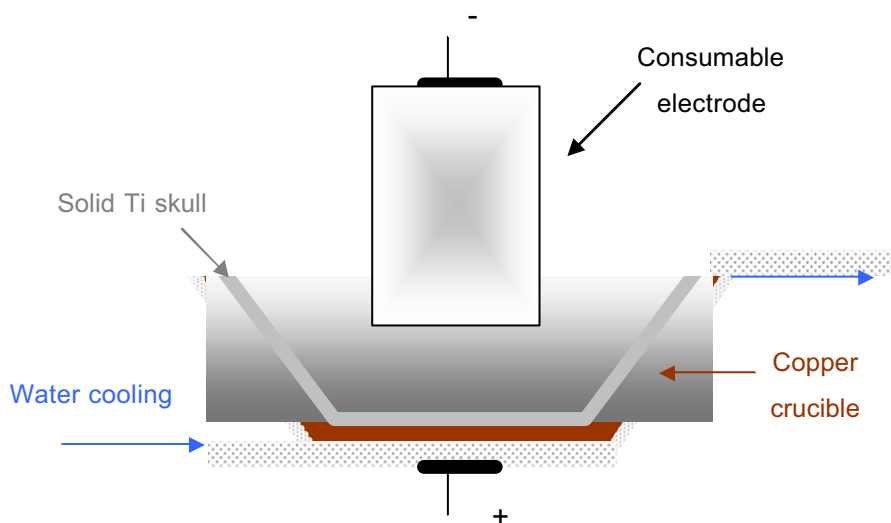

Figure 64: Melting system used at industrial scale.

The consumable titanium electrode is produced by welding, through MIG process, either ingot metallurgy forged billet, consolidated revert wrought material, selected foundry returns or combination of all of these. Thus, the SHS master compound will be also welded to the electrode using a similar process.

1.3 Selection of representative components

Mechanical properties of cast parts strongly depend on both the casting process and the geometry and dimensions of the model. Thus, it was decided to cast samples with different thicknesses and complex shape details in order to evaluate the properties of the composite. Moreover, the cast samples have to permit the machining of test specimens. This is why it was defined to cast two different types of demonstrators and several plates with different thicknesses (*Figure 66*).

First demonstrator: The design is based on an existing structural rib that is part of the engine pylon in the Airbus A320 which is currently made of Ti64 casting (*Figure 65a*), but simplified and tailored for development purposes. Although simplified, it has enough complexity to assess not only mechanical properties of the composite but also ability to pour complex shapes as well as identifying new processing needs. In the following the original rib and the demonstrator with the dimensions and the weight are shown (*Figure 65*).



Figure 65: a) Rib of the engine pylon (A320), dimensions 600x400x80mm 4Kg, b) "first demonstrator" (simplified rib), dimensions 300x200x40mm, 12Kg.

Second demonstrator: This demonstrator is a basic “eye-fitting” in two different sizes. It is a representative sample with simple geometry and a large thickness, allows to evaluate thick products and to machine specific test samples (fracture toughness, Impact test, etc.,) which require high thicknesses. Two different sizes have been defined for this demonstrator: 0.7 Kg and 7.3 Kg.

Plates with different thickness: Plates of 170mmx3500mm with thicknesses of 7mm, 17mm and 50mm to obtain samples for characterisation.

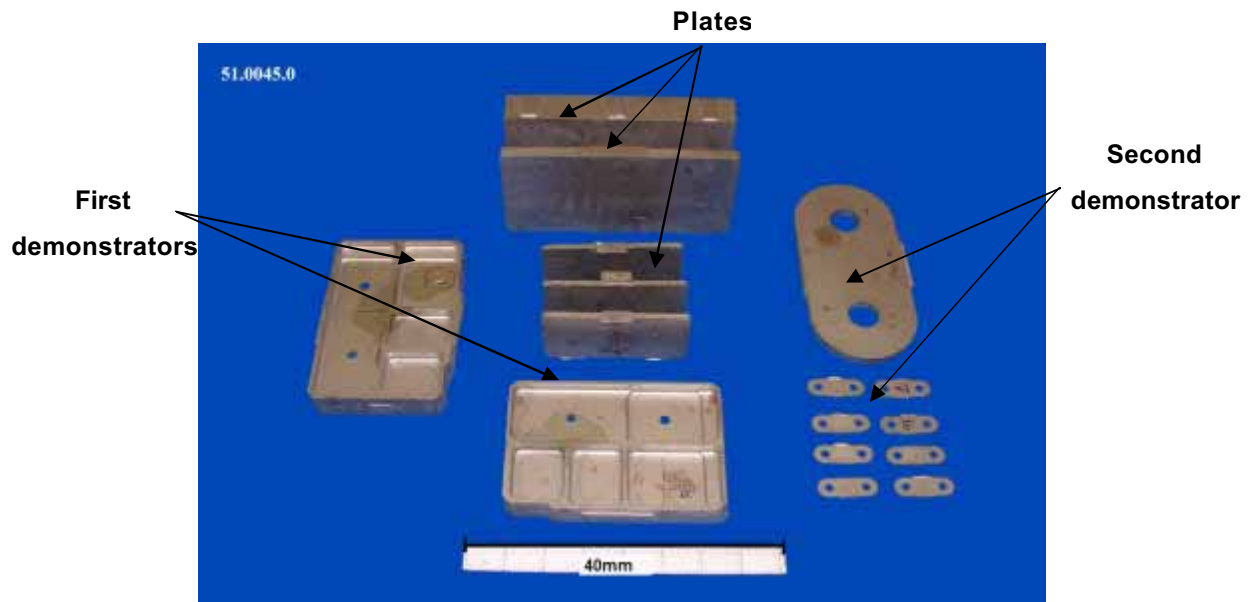

Figure 66: Photographs of the cast demonstrators at industrial scale.

1.4 Castings

1.4.1 Definition of the castings

Matrix alloy: Between the two titanium alloys investigated at lab scale to be used as matrix materials, the Ti64 has been selected to be used at industrial scale mainly because it is the most widely used titanium alloy for cast components in aeronautic¹.

TiB volume fraction: Four different castings have been defined. The first one, an unreinforced Ti64 casting (as reference) and the others *in-situ* reinforced Ti6Al4V/TiB castings. The TiB volume fraction has been defined based on the preliminary results obtained at lab scale as well as to achieve the technical requirements defined by the end-user. A volume fraction of around 0.5%vol. TiB has been selected for the first casting.

Production of master compound: On the one hand, the process based on the SHS technique was used and on the other hand, a process based on the conventional PM technique (the process used by F.Dartigues in his thesis (*F.Dartigues, 2004*)). This way any possible effect of the boron source production in the final TMC product could be also evaluated.

1. First casting: Ti6Al4V cast reference.

To perform rigorous scientific work, it is crucial to get real references without boron addition. It allows to understand the influence of the material and process on the results.

2. Second casting: Ti6Al4V/0.5TiB (SHS).

Highly concentrated master compound (Ti/60%TiB) produced by SHS process and welded to the electrode. The quantity selected was that to obtain 0.5%vol of TiB in the final casting.

3. Third casting: Ti6Al4V/0.5TiB (PM).

Master compound (Ti6Al4V/20%TiB) produced by PM and welded to the electrode. The quantity selected was that to obtain 0.5%vol. of TiB in the final casting.

4. Fourth casting: Ti6Al4V/1TiB (PM).

Master compound (Ti6Al4V/20%TiB) produced by PM process and welded to the electrode. The quantity selected was that to obtain 1%vol. of TiB in the final casting.

¹ Ti64 represents more than 90% titanium alloys and 100% of the titanium cast parts used by EADS on its AIRBUS aircrafts.

The fourth casting was decided and defined subsequently to the first three ones. The main reason was the interest to increase the volume fraction of TiB due to the promising results obtained in the previous castings. The master compound used in this last casting was produced by PM. The reason was that at that moment the material available to carry out the casting was the one produced by PM.

1.4.2 Results and discussion

The characterization carried out consisted of microstructure analysis and tensile tests at room and high temperatures (300°C and 400°C).

1.4.2.1 Microstructure

The influence of the TiB in the microstructure, its grain refinement effect, has been confirmed in the material obtained at industrial scale. The addition of TiB from a highly concentrated (60%TiB) master compound produced by SHS or from a lower concentrated (20%TiB) master compound produced by conventional PM, results in similar microstructures. It consists of transformed beta containing alpha laths with TiB precipitation in the prior beta boundary (*Figure 67*).

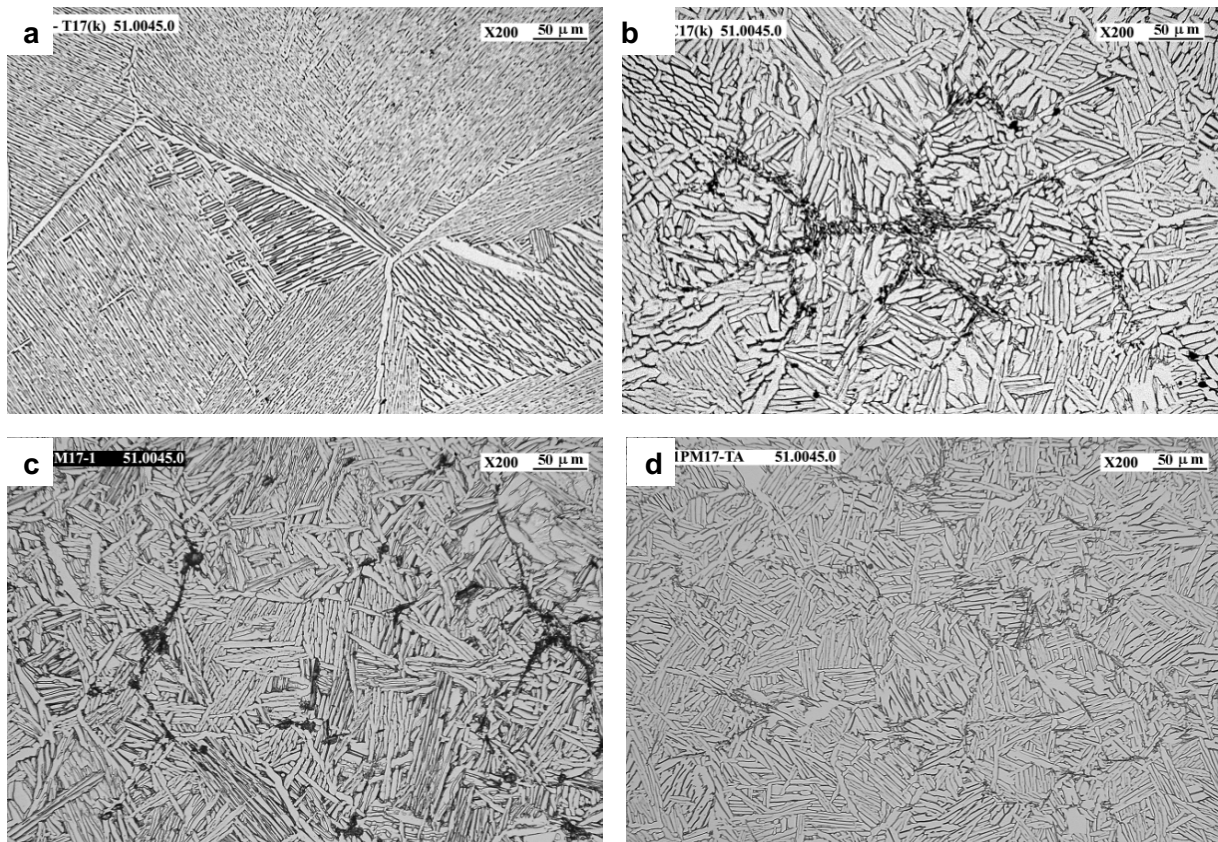

Figure 67: Optical micrographs obtained from the 17mm cast plate with different vol.%TiB: a) Ti64, b) Ti64/0.5vol.%TiB (SHS), c) Ti64/0.5vol.%TiB (PM) and d) Ti64/1vol.%TiB (PM).

The grain size measurement performed under ASTM E-112 standard demonstrates this TiB grain refinement effect (Table 18). As expected, the cast plate thickness also has an influence on the grain size due to the cooling rate: the thinner the cast plate the smaller the grain size. This can be concluded from Table 18: for the same volume fraction of TiB, the cast plate thickness is responsible for a reduction in grain size. Besides, it can be observed that the composite produced using the PM (20%TiB) master alloy and those produced using SHS (60%TiB) master alloy have similar grain sizes. There is a small difference between them but this is deemed insignificant.

| Ref. | Thickness | N° | Grain size (μm) |
|---------------------|-----------|---------|------------------------------|
| Ti6Al4V | 7 | 00 | 508 |
| Ti6Al4V/0.5TiB(SHS) | 7 | 5 | 63 |
| Ti6Al4V/0.5TiB(PM) | 7 | (4)-5 | (90)-63 |
| Ti6Al4V | 17 | 00 | 508 |
| Ti6Al4V/0.5TiB(SHS) | 17 | 4-5 | 90-63 |
| Ti6Al4V/0.5TiB(PM) | 17 | (3)-4-5 | (127)-90-63 |
| Ti6Al4V/1TiB(PM) | 17 | 5-6 | 63-45 |
| Ti6Al4V | 50 | 00 | 508 |
| Ti6Al4V/0.5TiB(SHS) | 50 | 2-3 | 180-127 |
| Ti6Al4V/0.5TiB(PM) | 50 | 2-3-4 | 180-127-90 |

Table 18: Grain size measurements under ASTM E-112 standard.

The SEM observations with higher magnification of the microstructure reveals the distribution and morphology of the TiB in the matrix, confirming those results previously obtained at lab scale. The TiB precipitates are short, needle-shaped, with a diameter of the order of a micron and with a length range of 10-50 μm . They are distributed in the form of colonies in the prior beta grain boundaries (*Figure 68*).

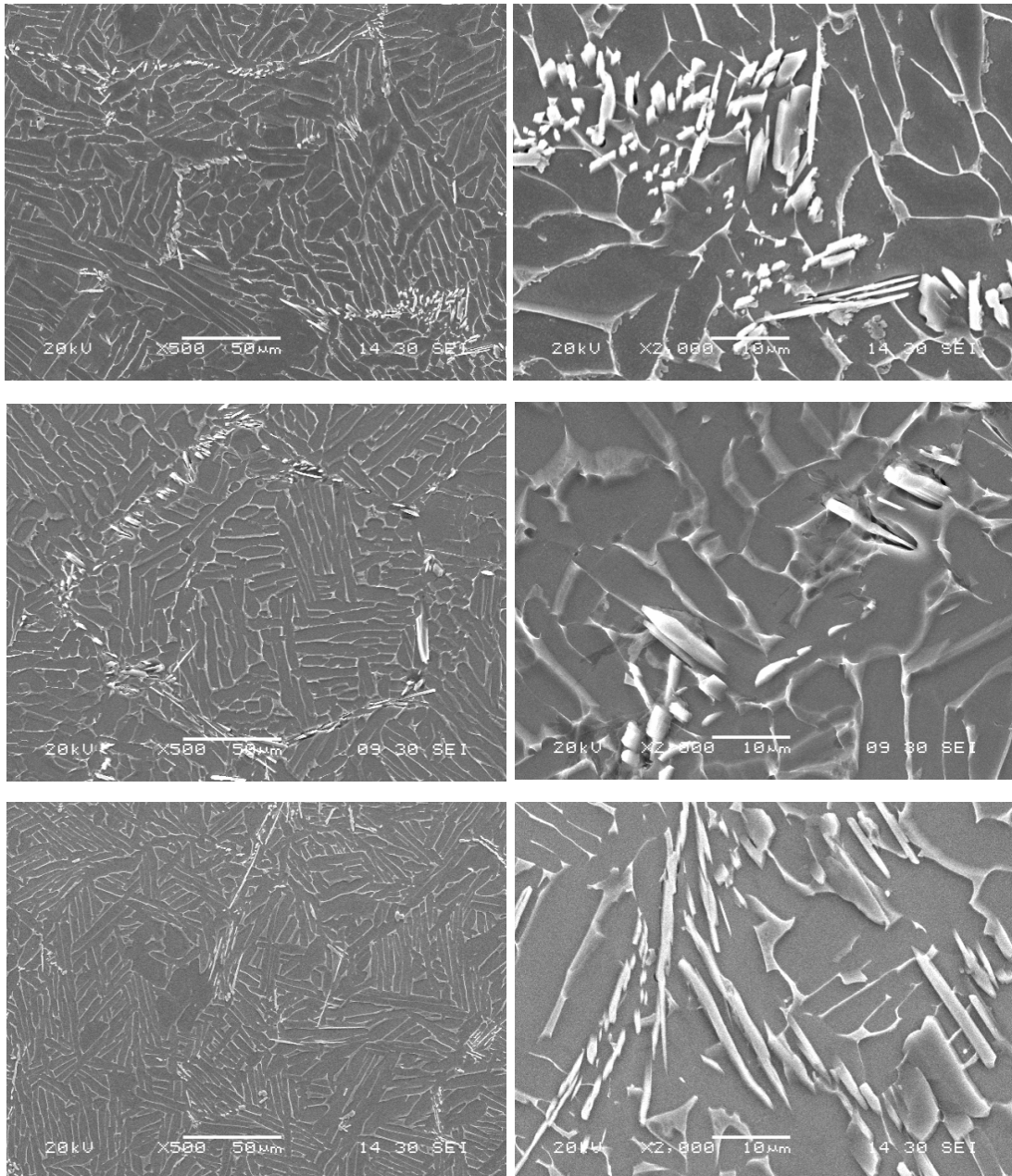

Figure 68: SEM images of industrially cast $Ti6Al4V/TiB$ composites: a) $Ti6Al4V/0.5\%vol. TiB (SHS)x500$, b) $Ti6Al4V/0.5\%vol. TiB (SHS)x2000$, c) $Ti6Al4V/0.5\%vol. TiB (PM)x500$, d) $Ti6Al4V/0.5\%vol. TiB (PM)x2000$, e) $Ti6Al4V/1\%vol. TiB (PM)x500$, f) $Ti6Al4V/1\%vol. TiB (PM)x2000$.

1.4.2.2 Tensile tests

Tensile tests were carried out following the standard EN 10002-1:2001 at different temperature conditions: room, 300°C and 400°C. The table, showing the results of the tests performed at each temperature, is annexed (Annex II).

The thickness of the cast component influences the properties of the material. From the tensile test results (*Figure 69*), it can be concluded that strength values are almost the same for the samples obtained from the plates of the three different thicknesses (50mm, 17mm and 7mm). However, elongation values differ as a function of the thickness of the cast material.

The following graph represents the results corresponding to the tests samples obtained from the plates of 50mm, 17mm and 7mm of Ti64 material.

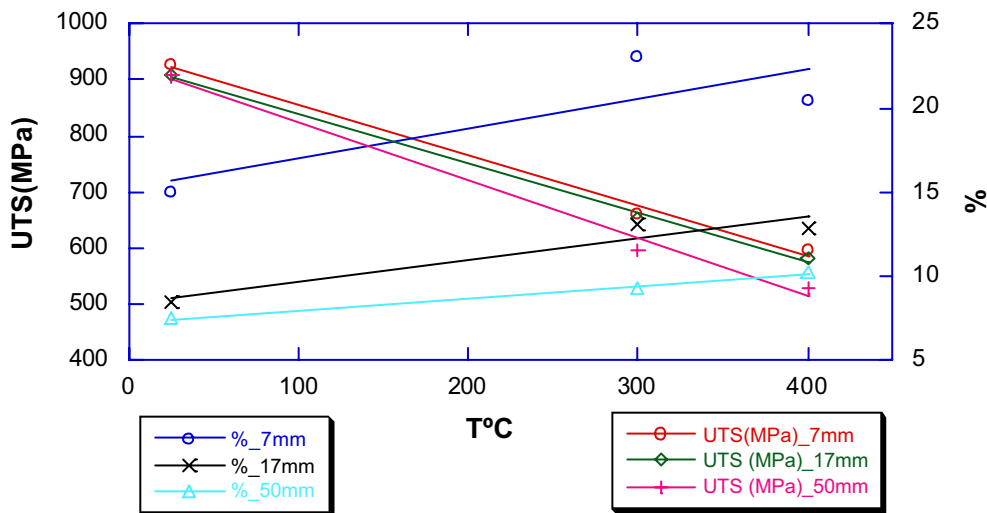

Figure 69: Influence of the cast part thickness on the strength and elongation for Ti64 cast material.

In view of the influence of the thickness of the cast part, to study only the influence of the TiB on the final material properties, samples obtained from cast parts of the same thickness have been compared. In particular, samples obtained from cast parts of 17 mm thickness.

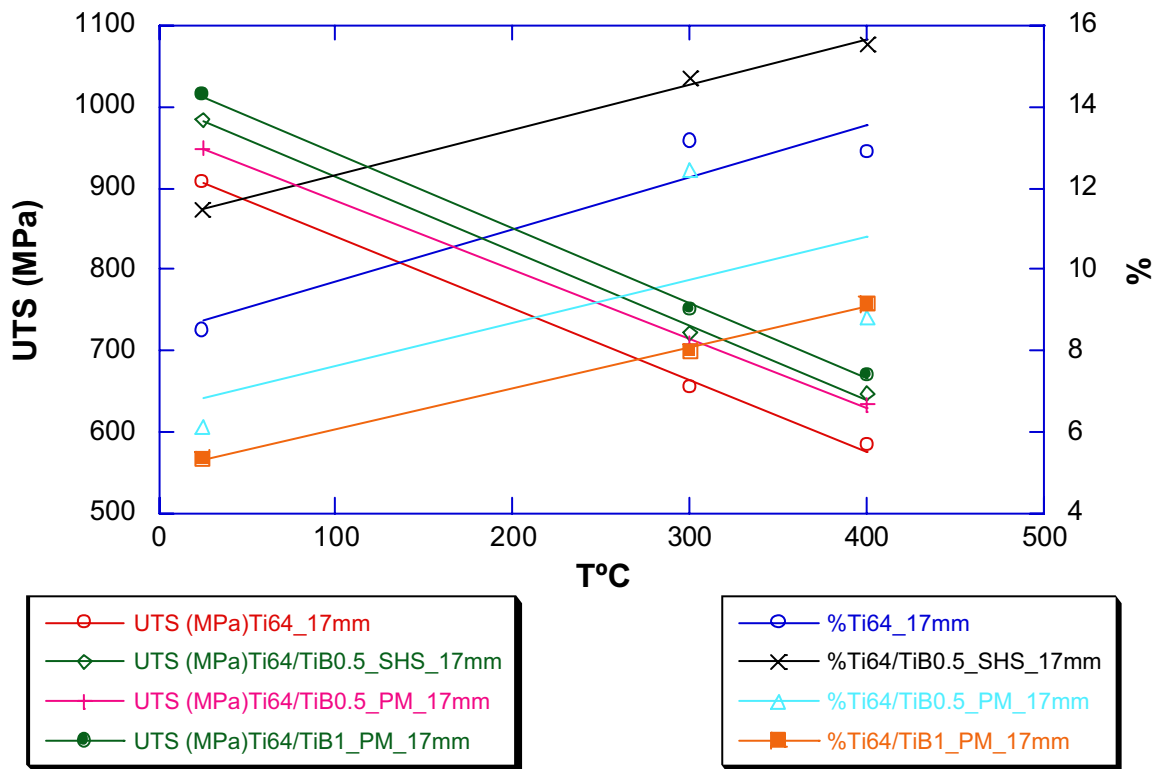

Figure 70: Influence of the TiB content and the production route in the strength and elongation of Ti64 matrix.

The results represented in *Figure 70* show an improvement in tensile strength as the TiB content increases even at 300°C and 400°C. In general, this increase in strength is associated to a decrease in the elongation of the test sample. However, composite material coming from the reinforcement produce by SHS process presents higher strength and elongation values than the one produced by PM for the same boron content. It is also interesting to notice that the elongation of the Ti64/0.5%vol.TiB_SHS is even higher than the one corresponding to the unreinforced Ti64 material.

2 Cost analysis

The cost analysis has been focused on the “first demonstrator” component (*Figure 65b*).

In this cost analysis, three different manufacturing alternatives have been assessed:

- Conventional Ti64 investment casting.
- Ti64/TiB investment casting, with the master compound produced by PM.
- Ti64/TiB investment casting, with the master compound produced by SHS.

2.1 Manufacturing processes

In the first manufacturing process assessed, conventional investment casting process, no master compound is added to the electrode. In the other two processes analyzed, a master compound is added. The difference lies in the production of this master compound which is obtained through two different and alternative production techniques: the powder metallurgy (PM) or the Self-propagating High-temperature synthesis technique (SHS).

- Master compound produced by PM: Ti/20%TiB produced by mechanical blending (TiB₂ and titanium powder), encapsulation, hot degassing and HIPing.
- Master compound produced by SHS: Ti/60%TiB produced by powder mixing (amorphous boron and titanium powder), cold compaction and ignition (SHS).

This master compound is added to the electrode and its complete dilution occurs during the electrode melting step. After casting some additional steps are needed. These steps are similar to those used when casting conventional Ti64 alloys:

- Chemical milling to eliminate outer brittle “a case” on cast surfaces.
- HIPing process to close any internal porosity.
- Post heat treatment under vacuum, so that thermal stresses out of casting are released.

- A final chemical etching step to remove possible casting surface contamination (although stress relieved is done in vacuum but a little contamination can occur) and for surface finished accuracy.

The complete sequence used to produce titanium composite with controlled volume fraction of TiB reinforcement is shown in *Figure 71*. In this flow diagram the different steps involved in each of the manufacturing processes and the main features are pointed out.

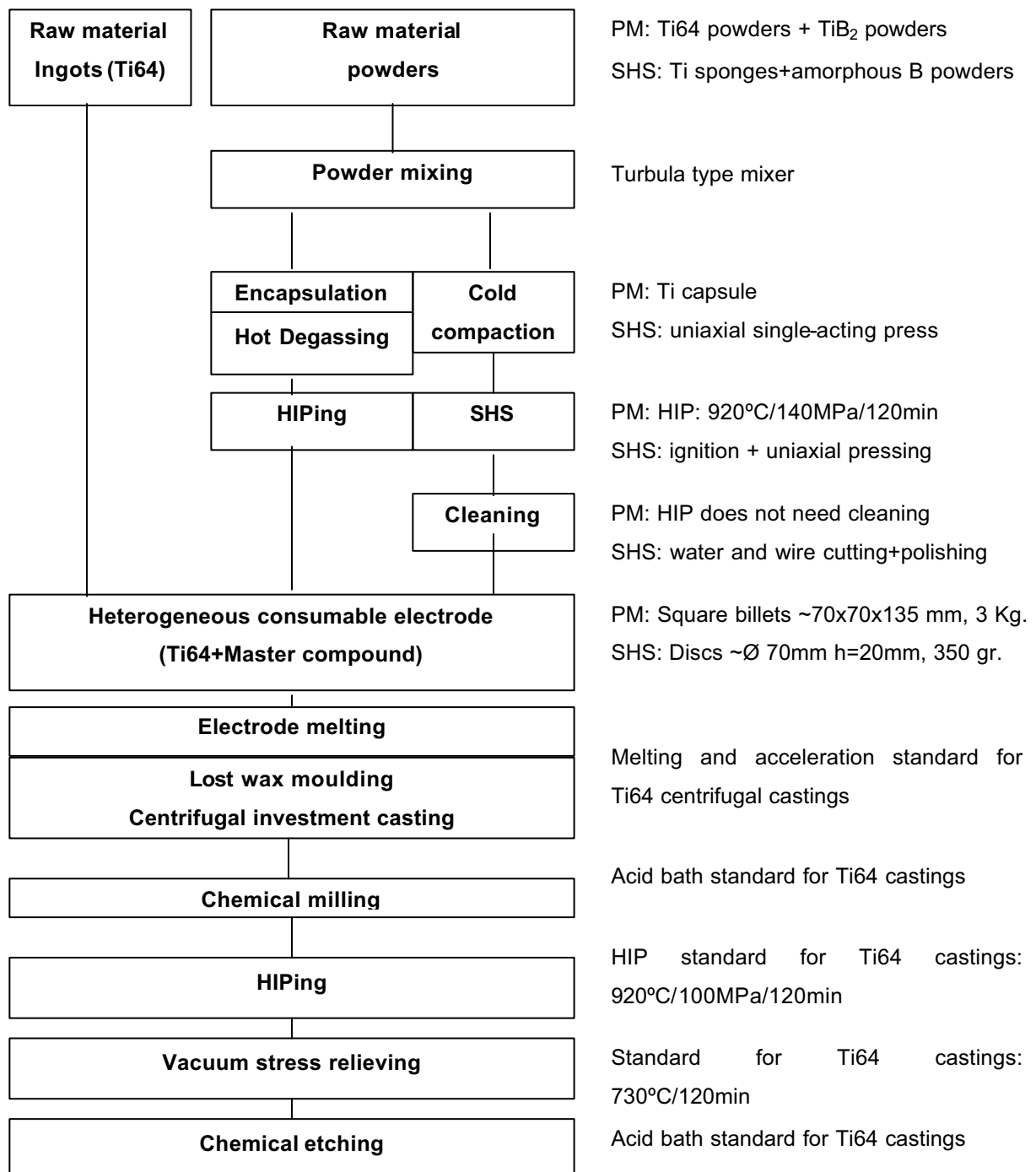

Figure 71: Manufacturing flow diagram.

2.2 Cost estimate-assumptions

Each step of the sequence used to produce the material has been evaluated separately to compare the cost of producing one demonstrator of Ti64 using conventional investment casting and the cost of the same demonstrator of Ti64/TiB produced with two different master alloy sources (PM and SHS).

According to the end user's experience producing this type of Ti64 components for aircrafts as well as its experience casting titanium alloys, the following scenario has been considered:

- Demonstrator: 12Kg.
- 6 demonstrators per pouring: $6 \times 12\text{kg}$ per demonstrator: 72kg cast mass.
- Casting ratio 5:1. Means that 5Kg electrode mass must be used to obtain a net cast mass of 1Kg. The difference is to fill dead volumes tundish, piping and so on. Then the total mass of the consumable electrode is $5 \times 72\text{kg} = 360\text{ kg}$.
- After pouring, the useless solidified mass is partly recovered and recycled (~60%) to produce a new electrode core. This recovered mass is not considered for cost evaluation, whereas remainder 40% is wasted and therefore must be accounted as an implicit cost.
- Efficiency = 0.95. That is, 95% of master compound is fully melted and mixed with the electrode core.

2.2.1 Mass breakdown

According to the master compound nature, the raw material needed to produce the electrode of 360Kg to finally obtain a concentration of Ti64/1wt.%TiB has been calculated:

| | Master compound (PM) + investment casting (20wt%) | | Master compound (SHS) + investment casting (60wt%) | |
|--------------------------|---|-----------------|--|-----------------|
| | Total per pour | Wasted per pour | Total per pour | Wasted per pour |
| TiB ₂ powders | 2.69Kg | 1.076 Kg | | |
| Ti64 powers | 20.04Kg | 8.016 Kg | | |
| Ti64 ingots | 337.27kg | 134.908 Kg | 353.70 Kg | 141.48 Kg |
| B powders | | | 0.70 Kg | 0.28 Kg |
| Ti powders | | | 5.6 Kg | 2.24 Kg |

Table 19: Mass breakdown to obtain an electrode of 360Kg calculated according to the master compound source.

In the next *Table 20* the cost of the raw materials used is presented:

| | Powders | | | | Ingot |
|-------|---------|------------------|------------|-------------|---------|
| | Ti6Al4V | TiB ₂ | Ti(sponge) | B amorphous | Ti6Al4V |
| Price | 100€/Kg | 75€/Kg | 25€/Kg | 360€/Kg | 30€/Kg |

Table 20: Price of the raw materials used to produce the consumable electrode.

2.2.2 Master compound production

Master compound produced by PM:

- Cost of the capsule made of titanium encapsulation and HIPing: 136.25€ per billet (billet of 3Kg).

Master compound produced by SHS:

- Personal and facility cost is shared along full production resulting in 15€ per disc unit. This cost is calculated considering that 18 discs manufactured in one batch.
- Cleaning of the discs: 40€ per disc unit.

In the case of the SHS master compound, the cost is mainly that corresponding to the cleaning process. Once the SHS reaction is completed and the master compound material produced, it is necessary to clean the disc to eliminate the sand and other impurities of the disc surface (*Figure 72*).

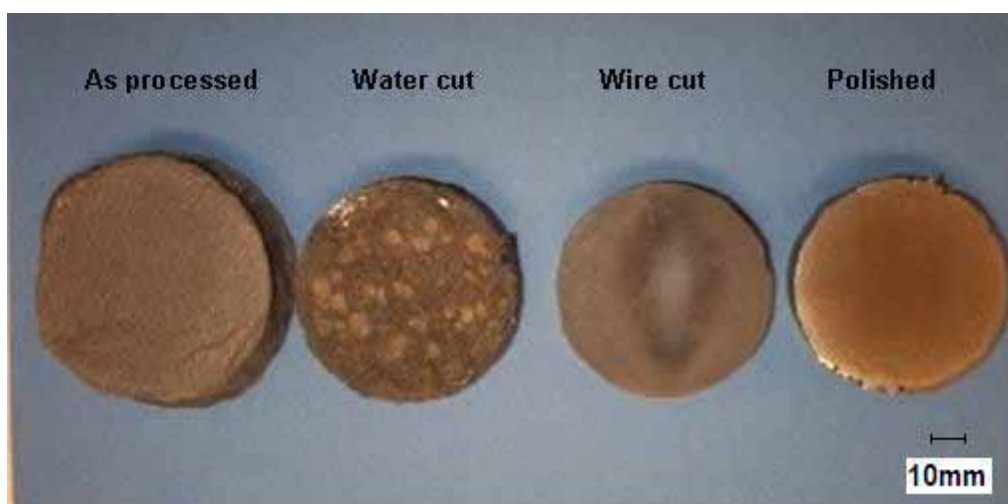

Figure 72: Sequence followed to clean the master compound produced by SHS.

2.2.3 Moulding and Casting

The moulding and casting costs at a rough estimate are the following:

- Wax investment moulding: wax injection into the die, wax assembly and final shell making. These shells are not reusable. An important part of the shell work is done by a robot being the consumed manpower 21% of the total.
- The investment casting itself, which includes the entire manufacturing until the demonstrator is produced. Many operations can be include here: table assembly, melt, casting, disassembly, shock blasting, cutting, fettling, welding repair if necessary, machining of residual feeders, sand blasting. All of them consume 65% of the total manpower.
- Quality control that according to applicable standards on casting consists on: X-Ray, dimensional and visual inspections. The residual manpower is consumed at the quality inspection (14% of the total manpower).

Through all these stages, it is assumed that costs of needed tools, facilities and infrastructures are included, as well as their estimated depreciation.

2.2.4 Finishing operations

Finally, the cost of the finishing operations should be considered. These are, chemical milling, HIPing (including stainless steel foils to wrap in cast parts) and stress releasing (under vacuum).

Table 21 summarizes different costs described above which have been estimated on the basis of quotations/estimations for the steps involved in each production route.

| Cost per demonstrator | Ti64 investment casting | Master compound (PM) + investment casting | Master compound (SHS) + investment casting |
|---|-------------------------|---|--|
| Raw powders | | 147€ | 26€ |
| Ti64 ingots electrode material | 720€ | 675€ | 707€ |
| SHS process | | | 45€ |
| Cleaning | | | 120€ |
| Capsule | | 37€ | |
| Encapsulation + HIPing | | 187€ | |
| Master compound addition | | 6€ | |
| Consumable electrode cost | 720€ | 1052€ | 904€ |
| Lost wax moulding | | 736€ | |
| Investment casting | | 2348€ | |
| Quality control | | 640€ | |
| Chemical milling + HIP + stress relieve | | 1260€ | |
| TOTAL COST | 5702€ | 6034€ | 5886€ |

Table 21: Cost breakdown for the production of a 12 Kg weight demonstrator.

3 Conclusions

- The process developed is suitable to obtain *in-situ* TiB reinforced TMCs at industrial scale. This could lead to a quick industrialisation of the developed process.
- The microstructure, the distribution, and morphology of the presented reinforcements in the material obtained at industrial scale hardly differ from the samples obtained at lab scale.
- The cost increment (*Table 22*) to produce Ti64/TiB composites by casting with respect to the conventional Ti64 is less than 6%, whatever the master compound production process might be. The dominant cost factor is the casting itself (which comprises lost wax moulding and investment casting), whereas cost impact of additional matters like master compound production and powders are in practice negligible. Moreover, the cost of the electrode is well below the cost of the casting.

| Cost per cast unit | Ti64 investment casting | Master compound (PM) + investment casting | Master compound (SHS) + investment casting |
|----------------------|-------------------------|---|--|
| Electrode | 12.6% | 13.62% | 12.6% |
| Master compound | - | 3.83% | 2.91% |
| Moulding + casting | 56.14% | 53.04% | 54.38% |
| Quality control | 9.14% | 8.63% | 8.85% |
| Finishing operations | 22.1% | 20.88% | 21.41% |
| TOTAL COST | 5702 (100%) | 6034 (100%) | 5886 (100%) |
| Increment | | 5.8% | 3.2% |

Table 22: Cost summary for the proposed demonstrator of 12Kg.

CONCLUSION AND FUTURE DIRECTIONS

1 Conclusions et perspectives

1.1 Conclusions

L'étude bibliographique a montré que depuis plus de 20 ans des recherches importantes ont été réalisées sur les matériaux composites à matrice de titane (Ti) renforcée par des filaments continus de carbure de silicium (SiC_{CVD}). L'élaboration de ces matériaux nécessite des prouesses techniques dues aux constituants eux-mêmes (grande réactivité chimique entre le carbure de silicium et le titane, aspect filiforme du renfort qui complique la mise en forme, coût important du renfort) ce qui restreint fortement le domaine d'application des composites à matrice de titane. D'un autre côté et bien que ce soit récent les travaux sur les matériaux composites à matrice de titane renforcée par des cristaux de TiB ont trouvé rapidement un domaine d'application. C'est par le procédé de métallurgie des poudres que les premières pièces ont été réalisées, alors que la voie liquide n'a pas été pratiquement étudiée. Nous avons donc souhaité dans le cadre de cette thèse et pour répondre aux exigences technico-économiques, évaluer la faisabilité de ces composites par un procédé mettant en jeu la fonderie de précision. Nous avons d'abord eu à trouver le moyen d'incorporer le bore dans le titane liquide. Pour cela, il a été nécessaire d'élaborer un pré-composite très chargé en TiB et ensuite ce pré-composite a été dissous dans l'alliage de titane liquide, lors de la solidification de nouveaux cristaux de TiB précipitent « in-situ » en quantité définie par le taux de dilution choisi. La préparation du pré-composite a nécessité la mise au point d'un nouveau procédé d'élaboration (SHS) basé sur l'exothermicité de la réaction $\text{Ti} + \text{B} \rightarrow \text{TiB}$. Par ce procédé, nous avons obtenu des composites Ti/TiB à 60%massique de TiB. Les aiguilles de TiB formées ont un diamètre variant de 2 à 5 microns et une longueur comprise entre 5 et 20 microns.

Les avantages du procédé SHS peuvent être résumés ainsi :

- (1) en partant de poudres de titane et de bore, la réaction conduit uniquement à la formation du monoborure de titane, les autres borures ne sont pas formés,
- (2) Ce procédé génère des porosités dans le matériau, pour éliminer ces porosités, il est possible d'appliquer une pression,
- (3) La technologie et les équipements sont simples, l'énergie nécessaire pour amorcer la réaction est très faible et la réaction s'auto alimente par la suite à condition qu'il y ait suffisamment de bore dans le mélange ce qui impose que la fraction de TiB doit être supérieure à 60% ,
- (4) La réaction a lieu en quelques secondes.

Une fois dilué dans l'alliage de titane liquide, il y a une précipitation «in-situ» du TiB à la solidification. La dissolution de la charge de composite est d'autant plus longue que la teneur en TiB dans le composite final est importante. Nous avons été limités à une teneur en TiB de 12%volumique. Au-delà de cette fraction volumique, les temps de réaction sont longs et entraînent une réaction chimique entre l'alliage de titane liquide et le creuset en céramique.

La précipitation du TiB entraîne un affinement de la microstructure du titane quand celui-ci est pur ou des grains de phase alpha et bêta dans le cas de l'alliage de titane Ti-6Al-4V. La morphologie borure de titane est aciculaire et dépend de la teneur en bore de part et d'autre de l'eutectique dans le binaire Ti-TiB. Pour la composition hypo-eutectique en bore, les aiguilles précipitent aux anciens joints de grain bêta, leur diamètre est de l'ordre de 1micron et leur longueur variant de 10 à 50 microns. Dans le cas de la composition eutectique, les aiguilles sont réparties de façon homogène et pour la composition hyper-eutectique, on trouve un mélange d'aiguilles de morphologie grossière dites aiguilles primaires de TiB et des aiguilles beaucoup plus fines et régulières issues de la transformation eutectique. Compte tenu du cahier des charges qui avait été fixé sur les performances mécaniques, nous nous sommes intéressés uniquement aux compositions hypo-eutectique à faible fraction de TiB. Un compromis dans la teneur en TiB a du être trouvé afin de maintenir une ductilité suffisamment importante tout en augmentant la limite d'élasticité et la résistance à la rupture du matériau. Dans ce cas, la fraction volumique de TiB est trop faible pour espérer un effet de renforcement par transfert de charge et donc le module de Young du composite ne peut pas être amélioré, l'amélioration de la résistance à la rupture et de la limite d'élasticité en traction a alors été imputée à l'affinement de la microstructure.

La viabilité industrielle du procédé a également été démontrée sur le plan technologique mais aussi sur le plan économique. Le surcoût de fabrication d'un tel composite a été estimé à seulement 6% par rapport au coût de la coulée d'une pièce en alliage de titane Ti-6Al-4V.

1.2 Perspectives

Le choix du TiB comme renfort s'est fait sur ses performances mécaniques (rigidité), sa stabilité thermochimique avec le titane et sa morphologie filiforme. Le renforcement du titane par un mécanisme de transfert de charge F/M impose alors une fraction volumique élevée, au moins proche de celle de la composition eutectique, dans ce cas la ductilité du matériau chute de façon importante. Si l'on souhaite maintenir une déformation plastique conséquente, il est alors nécessaire de diminuer la quantité de phase fragile, c'est-à-dire le borure de titane. Nous avons supposé par l'analyse des fractographies que le TiB avait tendance à se cliver et que la rupture du TiB se propageait dans la matrice de titane. L'origine de ce clivage a été associé à des macles

dans le cristal de TiB. Nous proposons alors dans le cas où il n'est pas nécessaire d'assurer un transfert de charge entre fibre matrice, d'utiliser un autre type de renfort ne présentant pas ce genre de défauts cristallins. Au démarrage de l'étude, nous avons hésité entre le TiB et le TiC comme renfort et nous avons éliminé le TiC uniquement parce que sa morphologie n'était pas aciculaire. Compte tenu de ces résultats et dans le cas où la ductilité du composite est privilégiée, nous proposons d'étudier l'effet du TiC sur la microstructure du composite. Le TiC ne se clive pas comme le TiB et précipite sous une morphologie plus ou moins sphériques ce qui n'est pas un inconvénient compte tenu de la faible fraction volumique. Nous recommandons cependant de bien contrôler la taille des particules de TiC et de maintenir si possible une taille sub-micronique. Le TiC présente également l'avantage d'être obtenu par le procédé SHS comme cela est le cas pour le TiB.

1 Conclusion and future directions

1.1 Conclusions

The survey of the literature on Titanium Matrix Composites (TMC) of the past 20 years shows that the main development efforts have been done for the continuously reinforced Ti/SiC system. However, due to some important technical limitations that have not been solved yet and the high cost of this kind of composites, their use is limited to a few commercial applications. The preliminary features of discontinuously TiB reinforced TMCs demonstrate the potential shown by this new family of composites, even though it is in its early development stages.

The most-investigated production process is solid state powder metallurgy one, but the production via investment casting is considered very attractive from the cost point of view. There is some room for improvement in the composites produced by investment casting, for example boron source and its production.

Therefore, the proposed process has been a combination of the Self-propagating High-temperature Synthesis (SHS) and the investment casting to produce discontinuously TiB reinforced net-shape TMCs.

The SHS technology is a very useful process to obtain a suitable boron source to be added in the investment casting process and thus, to produce discontinuously TiB-reinforced titanium matrix composites via casting. By means of the SHS technology, highly reinforced Ti/TiB (TiB>60wt.%)

master compounds can be obtained in a fully dense state or in a porous state. The master compound presents a homogeneous distribution of TiB. Needle-shaped TiB reinforcements with diameters of around 2-5 μm and lengths of around 5-20 μm are obtained.

The advantages of the SHS technology are remarkable:

- Feasibility to obtain a master compound with titanium and TiB, and absence of any other compound such as boron, TiB_2 or Ti_3B_4 . The TiB is preferable to other boron sources to be added to the titanium melt due to its direct and complete dissolution.
- Possibility to obtain this master compound in a dense or porous state, making its use easier in an industrial casting process.
- Simple technological equipment is required. Its high productive capacity and ecological parameters decrease the number of technological stages in comparison with conventional technologies.
- Low energy is required, only a local heating source is necessary in order to ignite the reaction, and the process itself needs no more additional external energy.
- The process lasts a few seconds.

The SHS technique also presents some limitations such as the high volume fraction of boron which is required to propagate the reaction. Only highly reinforced (>60wt.%TiB) master compounds or cermets can be obtained by this process which are very difficult to machine or cut.

By the addition of the master compound, produced by SHS, *in-situ* TiB reinforced titanium matrix composites can be obtained by investment casting. During melting this master compound is directly and completely dissolved. Throughout the solidification, boron reacts with titanium and thus *in-situ* TiB reinforcements are again formed. The dissolution of the highly reinforced master compound in the titanium melt requires high temperature and time. This has not been a problem for obtaining castings with TiB final volume fractions up to 12%vol. However, for higher volume fractions, this could be a problem when using a ceramic crucible, since the time inside the crucible must be limited to avoid any reaction of the melt with the crucible material. In the industry, the dominant method of melting titanium is the vacuum arc melting process where copper crucibles are used to reduce the melt-crucible reactivity problem.

The discontinuously TiB reinforced cast samples obtained from the addition of the master compound produced by SHS present a significantly refined microstructure. The TiB precipitation

has a refining effect decreasing the alpha plates in the CPTi, but in the Ti6Al4V alloy it decreases both the alpha and beta grain sizes. The morphology of the TiB is needle-shaped, shorter or larger depending on the solidification path. Three different zones can be distinguished with respect to the TiB precipitation and morphology. The one corresponding to the hypoeutectic composition, the area which corresponds to the eutectic composition, and finally the area which corresponds to the hypereutectic one. In the hypoeutectic composition, eutectic needles with diameters of around 1µm and lengths of around 10-50µm are distributed at the boundary of the prior beta grains. While for the eutectic and hypereutectic compositions, eutectic and primary needles (with diameters around 5µm and lengths around 50-100µm) are distributed in the matrix.

Increasing the volume fraction of reinforcements in the cast composites improves the strength. In contrast, the higher the TiB content the lower the ductility. Therefore, a compromise has to be reached about the TiB content in order to get the desired strength and ductility values. The requirements for the specific application considered in the present investigation, have been stiffness and strength, maintaining ductility values above 5% at both room and high temperatures. For composites with low volume fractions in the hypoeutectic region, improvements in tensile strength of around 10% compared to the Ti6Al4V have been achieved while maintaining similar ductility values to that of the unreinforced alloy.

The industrial viability of the process has been confirmed. The cost increment to produce discontinuously TiB reinforced titanium matrix composites via investment casting with respect to conventional titanium alloys at industrial scale is less than 6% whatever the master compound production process might be (PM or SHS). The dominant cost factor is the casting itself (which comprises lost wax moulding and investment casting) whereas the cost impact of additional matters like master compound production and powders are in practice negligible.

1.2 Future directions

The present thesis has been developed based on the assumption that the TiB is the most suitable reinforcement for titanium alloys because it meets the most important mechanical, thermo-mechanical, chemical, and morphological criteria. The reinforcement is desired to be fibre-shaped to present a sufficient aspect ratio to allow an efficient load transfer between the two constituents. However, the strengthening mechanisms could be different depending on the TiB volume fraction in the final composite.

For low volume fractions (hypoeutectic) the strengthening effect, that is the improvement in properties obtained, is a result of the refinement of matrix microstructure. On the other hand, for higher volume fractions (hypereutectic) the reinforcements could have additional effects apart from the microstructural refinement, such as the classical composite strengthening (load transfer). In this last case the morphology or aspect ratio of the reinforcement is important.

In the shorter-term mechanical testing of the high volume fraction composites (hypereutectic) should be undertaken.

It has been demonstrated that with low TiB volume fractions very attractive properties are achieved, and that the improvements are mainly derived from the microstructure refinement. Therefore *in-situ* formed reinforcements, not necessarily with needle-shaped morphology, could be considered in the future as candidates to improve titanium and titanium alloys.

One of these potential alternative reinforcements could be the TiC which has been ruled out in the preliminary reinforcement selection, because its morphology is not needle shape but yields particles with equiaxial shapes. The TiC presents very attractive features, and the reaction to obtain it is highly exothermic, therefore suitable to be produced by SHS. There is a clear improvement of titanium alloy properties that could be achieved mainly by microstructure refinement and thus, some other reinforcements might also be investigated.

REFERENCES

REFERENCES

- ABKOWITZ S., ABKOWITZ S., FISHER H., SCHWARTZ, P.J. (2004). "CermeTi® discontinuously Reinforced Ti-Matrix Composites: Manufacturing, Properties, and Applications". *JOM*, May, 2004, pp.37-41.
- ABKOWITZ S., ABKOWITZ S., WEIHRAUCH P. F.; HEUSSI H. L; ZIMMER W. (1998) "P/M Titanium composite". US Patent N°: WO9824575.
- ATRI, R., RAVICHANDRAN, K. S., JHA S. K, (1999). "Elastic Properties of In-situ Processed Ti-TiB Composites Measured by Impulse Excitation of Vibration," *Materials Science and Engineering*, Vol. A271, 1999, pp. 150-159
- AZATYAN, T.S., MAL'TSEV, V.M., MERZHANOV, A.G., SELEZNEV, V.A., (1977). "Combust. Explos. Shock Wave USsR 13, pp.156.
- CHANDRAN, K.S.R., PANDA K.B., SAHAY S.S., (2004). "TiB_w-reinforced Ti Composites: Processing, Properties, Application, Prospects and Research Needs". *JOM*, May 2004, pp.42-48.
- CHOLLON, G., NASLAIN, R., PRENTICE, C., SHATWELL, R., MAY, P., (2004). "High temperature properties of SiC and diamond CVD-monofilaments". *Journal of the European Ceramic Society*.
- COLETO J., GARCIA DE CORTAZAR M., MAUDES J., MITXELENA I.,SAINZ X., GOÑI J., (2002). "Utilización de técnicas metalográficas para control microestructural de composites de matriz metálica aplicados en componentes aeronáuticos y electrónicos". 2º Jornada de Metalografía y Caracterización microestructural. San Sebastián, Spain.
- DAMBRINE, B., MARCEL, G., (2001). "Method for metal coating of fibres by liquid process". US Patent N°: US6174570.
- DARTIGUES, F., (2004). "La precipitation à la solidification du monoborure de titane dans l'alliage de titane (Ti-6Al-4V) peut-elle modifier sa microstructure et son comportement mécanique?" THESE PRESENTEE A L'UNIVERSITE BORDEAUX I N° d'ordre: 2868.
- DEGISHER, H.P., (2001). "Assessment of metal matrix composites for innovations". Thematic network within Brite Euram. Contact n° BRRT-CT98-5061.
- DURET, N., (2003). "Titanium for Damage Tolerance Applications on A380". *Ti-2003 Science and Technology*. Proceedings of the 10th World Conference on Titanium. Volume IV, pp.2667-2671.

-
- FAN, Z., MIODOWNK A.P., CHANDRASEKARAN, L., WARD-CLOSE, C.M., (1995). "Microstructural investigation of a rapidly solidified Ti-6Al-4V-1B-0.5Y alloy". *Journal of Materials Science* 30 (1995) pp.1653-1660.
 - FMW Composite System, Inc. (2003). "Titanium Matrix Composite (TMC) Status". *Ti-2003 Science and Technology*. Proceedings of the 10th World Conference on Titanium. Volume IV, pp.2463-2469.
 - FROMETING, J.F., DEBRAY, K., LE PETITCORPS, Y., MARTIN, E., QUENISSET, J.M., 1995 "Interfacial zone design in titanium-matrix composites reinforced by SiC filaments". *Composite Science and Technology* 56 (1996) pp.767-775.
 - GAMBONE, M.L., GUNDEL, D.B. (1997). "The Effect of W-Core/SiC Reaction on the Strength of SiC Fibres in SiC/Ti Alloys Composites". *Key Engineering Materials Vols. 127-131* pp.1251-1258.
 - GARCIA DE CORTAZAR, M. (2005). Private project ESTEC/Contract N° 15509/01/NL/CK.
 - GARCIA DE CORTAZAR, M., TORREGARAI A., GOÑI J., MITXELENA I., COLETO J., (2001). "Microstructural characterization and a reaction kinetics study of SCC6/Ti6Al4V composite interface". *Interfacial Phenomena in Composite Materials 2001*. Extended Abstracts of the 7th International Conference 11-14 September 2001, Arcachon France, pp.64-65.
 - GODFREY, T.M.T., WISBEY, A., GOODWING, P.S., BAGNALL, K., WARD-CLOSE, C.M., (2000). "Microstructure and tensile properties of mechanically alloyed Ti-6Al-4V with boron additions". *Materials Science and Engineering A282* (2000) pp.240-250.
 - GORSSE S., (1999). "De nouvelles approches sur les matériaux composites à matrice de titane" "THESE PRESENTÉE A L'UNIVERSITÉ BORDEAUX I" N° d'ordre: 2080.
 - GORSSE S., MIRACLE D.B., (2003) "Mechanical properties of Ti-6Al-4V/TiB composites with randomly oriented and aligned TiB reinforcements. *Acta Mater.* 51(9), pp.2427-2442. (2003)
 - GRD2-2000-30405 (2001-2004). "High Performance and Competitive new Titanium Reinforced Alloys for Aeronautic applications". Growth project "NEWTIRAL".
 - HANUSIAK, W.H., HANUSIAK, L.B., PARNELL, SPEAR, S.R., ROWE, C.R (1997) "Methods of Making Preforms for Composite Material Manufacture". US Patent N°US5624516.
 - HANUSIAK, W.H., HANUSIAK, L.B., PARNELL, SPEAR, S.R., ROWE, C.R (1998) "Wire Preforms for Composite Material Manufacturing and Methods of Making". US Patent N°US5763079.

-
- HILL, D., BARNERJEE, R., HUBER, D., TILEY, J., FRASER H.L., (2005) "Formation of equiaxed alpha in TiB reinforced Ti alloy composites". *Scripta Materialia* 52, pp. 357-392.
 - INASMET, 2004. Document Code: IMC-PP-1875-01-INAS. Funding Organization: ESA.
 - JHA, S.C., FOSTER, J.A., PANDEY, A.K., DELAGI, R.G. (1991) "MMC's Via Titanium Aluminide Foils". *Adv. Mater. & Proc.*, April, 1991, pp.87-90.
 - KANG C.G., ROHATGI P.K., NARENDRANATH C.S., COLE G. S., (1994). "A solidification analysis on Centrifugal Casting of Metal Matrix Composites Containing Graphite Particles" *ISIJ International*, Vol.34, No.3, pp247-254.
 - KIESCHKE R.R., SOMEHK R. E., CLYME T.W., (1991) "Sputter Deposited Barried Coatings of SiC Monofilaments for Use in Reactive Metallic Matrices" *Acta Met. et Mat.*, 39, pp.427-36 and pp.445-52.
 - KIESCHKE, R.R., DEBE, H.E., McCULLOUGH, C., and GRIFFIN, C.J., (1995). "Processing of tow-based titanium composites". *Recent advances in Titanium Metal Matrix Composites*. Edited by F.H.Froes and J.Storer, pp. 3-17.
 - KIRDYASHKIN, A.I., MAKSIMIV, Y.M., MERZHANOV, A.G., (1982). "Combust. Explos. Shock Waves USSR 17 pp.591.
 - LEDERICH, R.J., SOBOYEJO, W.O., and SRIVATSAN T.S., (1994). "Preparing Damage-Tolerant Titanium-Matrix Composites". *JOM*, November 1994. pp 68-71.
 - LU WEIJIE, ZHANG DI, ZHANG XIAONONG, WU RENJIE, (2001). "Creep rupture life of *in-situ* synthesized (TiB+TiC)/Ti matrix composites". *Scripta Materialia*, Vol.44, No.10, pp.2449-2455.
 - MAJUMDAR B.S., (1998)."Fibre-Matrix Interface". *Titanium Matrix Composites Mechanical Behaviour*, ISBN No. 1-56676-567-6,pp113-167.
 - MASLOV, V.M., BOROVINSKAYA I.P., MERZHANOV, A.G., (1978) "Combustion Explosion Shock Waves" USSR 14 pp.618.
 - *Materials properties Handbook, Titanium Alloys*. ISBN 0-87170-481-1.
 - MAY, P.W., "Diamond Thin Films: A 21st Century Material" *Phil. Trans. R. Soc. Lond. A*, 358 (2000) 473-495.
 - MIRACLE, D.B., (2001). "Aeronautical Applications of Metal Matrix Composites" *ASM Handbook: Volume 21, Composites*, (eds. D.B. Miracle and S. Donaldson), *ASM International, Material Park, OH*, pp 1043-1049.
 - MUNIR, Z.A., ANSELMI-TAMBURINI, U. (1989). "Self-Propagating exothermic reactions: Synthesis of High Temperature Materials by Combustion". *Materials Science Reports* 3 (1989), pp.277-365.

-
- MURRAY, J.L., LIAO, P.K., SPEAR, K.E., (1987). "The B-Ti (Boron Titanium) System" *Phase diagrams of Binary Titanium Alloys*, pp 33-38.
 - MYOUNG-GYUN KIM, SYOUNG SUNG, YOUNG JIG KIM, (2005). "Synthesis of in-situ Titanium Carbide Particle Reinforced Titanium composites" *Materials Science Forum* Vols. 475-479 pp 963-966.
 - NOVIKOV, N.P., BOROVINSKAYA I.P., MERZHANOV A. G., (1975). "Combustion Processes in Chemical Technology and Metallurgy". Ed. A.G. Merzhanov, Chernogolovka (1975), pp.175.
 - OCHIAI S., HOJO M., (1998). "Effects of pre-existent crack in double and gradient coatings on the crack extension into fibre and interfacial debonding" *Journal of Materials Science*. Volume 33, Number 2, pp347-355.
 - ONZAWA T., SUZUMURA A., KIM J.H., (1991). "Influence of Reaction zone Thickness on Tensile Strength for Titanium Matrix Composites Reinforced with SiC Fibre". *Composite: Design, Manufacture and Applications*, Hawaii, USA, S.W.Tsai and G.S.Springer (eds.) SAMPE, pp.19J/1-19J/10.
 - PANDA, K.B., RAVI CHANDRAN K.S., (2003) *Metall. And Mater. Trans A*, 34A (9), pp.1993-2003.
 - RANGANATH, S., (1997). "A review on particulate-reinforced titanium matrix composites". *Journal of Materials Science* Volume 32: Number1: January 1997.
 - RENDINGS, K.- H., (2003). "Titanium Products Used at AIRBUS". *Ti-2003 Science and Technology*. Proceedings of the 10th World Conference on Titanium. Volume IV, pp.2659-2666.
 - RHODES, C.G., SPURLING, R.A., (1985). "Fibre-matrix reaction zone growth kinetics in SiC reinforced Ti-6Al-4V as studied by TEM". *Special Technical Testing Publication* 864.
 - SAITO, T., (2004). "The Automotive Application of Discontinuously Reinforced TiB-Ti Composites". *JOM*, May, 2004, pp.33-36.
 - SAITO, T., FURUTA, T., TAKAMIYA,H. (1995). "Sintering behaviour and thermal stability of a TiB particle reinforced PM Beta Titanium matrix composite". *Titanium '95 Birmingham* UK, pp. 2763-2770.
 - SAITO, T., FURUTA, T., YAMAGUCHI,T. (1995). "Development of low cost titanium matrix composite". *Recent advances in Titanium Metal Matrix Composites*. Edited by F.H.Froes and J.Storer, pp. 33-45.
 - SAITO, T., (2005). "Ti-B Alloy for Automobile Use". *Workshop on Titanium Alloys Modified with Boron*. October 11-13, 2005 at Dayton, Ohio, USA.

- SCHAUERTE, O., (2003). "Titanium in Automotive Production". Edited by Cristoph Leyens and Manfred Peters *Titanium and titanium Alloys*, pp.467-481.
- SHKIRO, V.M., BOROVINSKAYA, I.P., (1975). "Combustion Processes in Chemical Technology and Metallurgy", pp.253.
- SOBOYEJO, W.O., LEDERICH, R.J., SASTRY, S.M.L. SASTRY (1994). "Mechanical behaviour of damage tolerant TiB whisker-reinforced *in-situ* titanium matrix composites". *Acta Metall.mater.* Vol, 42, N°8, pp.2579-2591.
- SOBOYEJO, W.O., LEDERICH, R.J., SRIVATSAN T.S., and REEDE K., (1995). "Mechanical Properties of damage tolerant TiB whisker-reinforced *in-situ* titanium matrix composites". *Intrinsic and extrinsic Fracture Mechanisms in Inorganic Composite Systems*. Edited B J.L. Lewandowski and W.H .Hunt Jr. The Minerals Metals & Materials Society, 1995, pp. 167-182.
- SP AEROSPACE, 2003. <http://www.sp-aerospce.com>
- TJONG S.C., MA Z.Y., (2000). "Microstructural and mechanical characteristics of in-situ metal matrix composites". *Materials Science and Engineering*, R29, Nos. 3-4, 15 August 2000.
- UPADHYAYA, D., BRYDSON, R., TSAKIROPOULOS, P., AR-CLOSE C.M., FROES, F.H., (1995). "A comparison of SCS6/Ti6Al4V and sigma SM1240/Ti-6Al4V composite Systems: A Microstructural characterization". *Recent advances in Titanium Metal Matrix Composites*. Edited by F.H.Froes and J.Storer, pp. 139-166.
- WANG, X., BRYDSON, R., JHA, A., ELLIS, J., (1999). "Microstructural analysis of Al alloys dispersed with TiB₂ particulate for MMC applications". *J*
- WARWICK C.M., SMITH J.E. (1991). "Interfacial Reactions in Ti Alloys Reinforced with C/TiB₂ – Coated SiC Monofilament, in Metal Matrix Composites – processing Microstructure and Properties, 12th RisØ Int. Symp., Denmark pp.735-40.
- WEIJIE LU, DI ZHANG, XIAONONG ZHANG AND RENJIE WU (2001). "Creep rupture life of in-situ synthesized (TiB+TiC)/Ti matrix composite". *Scripta Materialia*. 44 (2001) pp.2449-2455.
- XIAONONG ZHANG, WEIJIE LÜ, DI ZHANG AND RENJIE WU (1999). " *In-situ* technique for synthesis (TiB + TiC)/Ti composites". *Scripta Materialia*, Vol. 41, N°1, pp.39-46.
- XINGHONG ZHANG, QIANG XU, JIECAI HAN, KVANIN, V. L., (2003), "Self-propagating High-temperature combustion synthesis of TiB/Ti composites" *Materials Science and Engineering A348* (2003) pp.41-46.
- YOLTON, C. F., (2004). "The Pre-Alloyed Powder Metallurgy of Titanium with Boron and Carbon additions". *JOM*, May, 2004, pp.56-59.

- YOLTON, C.F., (1995). "Evaluation of a Discontinuously Reinforced Ti-6Al-4V composite". Titanium '95: Science and Technology. pp. 2755-2762
- ZHANG XIAONONG, LÜ WEIJIE, WU RENJIE, (1999). "In-situ technique for synthesizing (TiB + TiC) /TiC composites". *Scripta Materialia*, Vol. 41, No.1, pp.39-46.
- ZHAO Y.Y, GRANT P.S., (1993) "The microstructure of spray formed Ti-6Al-4V/SiC metal matrix composites" *J. Microscopy*, 169 (1993), pp. 263.

ANNEXES

ANNEX I

METALLURGICAL CHARACTERIZATION PROCEDURE

Ray diffraction analysis

X-Ray diffraction (XRD) phase analysis was performed using a Siemens D500 equipment, working with copper at a wavelength of 1.54 Å (monochromatic radiation), and the identification of the crystalline phases using a data base of JCPDS (Joint Committee of Powder Diffraction Standards).

Running from a 2 θ angle of 10 through to 90 degrees, at 40kV and 30mA. Steps were in increments of 0.1 degrees, and counts were collected for 4 seconds at each step.

Optical microscopy and SEM

Sample preparation:

- Cutting of the sample under wet environment using abrasive SiC cutting tools. Deformation and overheating must be avoided as they can both cause changes in microstructure.
- Samples embedded in epoxy resin under pressure and temperature conditions.
- Polishing using polishing machines which allow working at different sample rotation speed; changeable load applied on the sample and polishing time. In the first stage of the polishing, sandpaper (made of SiC) with different roughness to polish gradually the sample and eliminate the defects introduced by the most rough sandpapers. Finally the samples were polished using cloths with different size of diamond particles.

Etching:

Two different etching reactants have been used.

- Kroll's reagent (1-3ml HF, 2-6 ml HNO₃, H₂O to 1000ml) to reveal the TiB reinforcements.
- Ammonium bifluoride (NH₄HF₂) in H₂O (2%) to reveal matrix general microstructure, α , and α - β contrast.

A REICHERT- JUNG optical microscope with different magnifications and with associated photo camera has been used. The equipment is provided with polarized light, light and dark field, Normasky (interdifferential contrast), fluorescence module, magnifying from 12 to 1000.

Electron scanning microscope (SEM + EDS)

Jeol JSM 5910 LV Scanning Electron Microscope (SEM) with associated Oxford Inca 300 energy dispersive spectroscopy probe (EDS) was used.

ANNEX II

TENSILE TEST RESULTS

Tensile tests of the material cast at industrial scale were carried out using INSTRON 5500R equipment, following the standard EN 10002-1:2001, at 2 mm/minute, and at different temperature conditions: room, 300°C and 400°C. At least two tests were carried out at each of these conditions in order to acquire reliable data. In some cases, when there was enough material, up to 4 tests at each temperature were carried out.

The samples required for these tests were also designed under standard: EN 10002-1:2001.

Two different types of specimen have been manufactured. Cylindrical specimen were machined from the thicker ingots (17mm and 50mm) and flat specimen from the thinner ones (7 mm in thickness). To adapt the flat specimen to the tooling for the high temperature tests, it was necessary to drill a hole in them.

Below, mean values of the tests and the geometry of the samples used are shown.

Tensile test results:

| Ref. | Description | Temp. (°C) | YS 0,2% (MPa) | UTS (MPa) | (%) |
|---------------------|-------------|------------|---------------|-----------|--------|
| Ti64_50 | 50mm plate | RT | 869,25 | 907,00 | 7,506 |
| Ti64/0.5TiB(SHS)_50 | 50mm plate | RT | 879,75 | 982,75 | 8,480 |
| Ti64/0.5TiB(PM)_50 | 50mm plate | RT | 861,00 | 923,50 | 5,75 |
| Ti64_50 | 50mm plate | 300 | 531,00 | 597,33 | 9,324 |
| Ti64/0.5TiB(SHS)_50 | 50mm plate | 300 | 569,75 | 727,75 | 13,865 |
| Ti64/0.5TiB(PM)_50 | 50mm plate | 300 | 570,50 | 686,50 | 7,35 |
| Ti64_50 | 50mm plate | 400 | 455,50 | 531,00 | 10,219 |
| Ti64/0.5TiB(SHS)_50 | 50mm plate | 400 | 482,50 | 654,50 | 13,346 |
| Ti64/0.5TiB(PM)_50 | 50mm plate | 400 | 502,50 | 625,00 | 13,75 |
| Ti64_17 | 17mm plate | RT | 852,33 | 908,33 | 8,498 |
| Ti64/0.5TiB(SHS)_17 | 17mm plate | RT | 899,67 | 984,33 | 11,466 |
| Ti64/0.5TiB(PM)_17 | 17mm plate | RT | 878,50 | 949,00 | 6,10 |
| Ti64/1TiB(PM)_17 | 17mm plate | RT | 948,50 | 1014,50 | 5,35 |
| Ti64_17 | 17mm plate | 300 | 552,00 | 654,25 | 13,160 |
| Ti64/0.5TiB(SHS)_17 | 17mm plate | 300 | 586,50 | 721,50 | 14,707 |
| Ti64/0.5TiB(PM)_17 | 17mm plate | 300 | 583,50 | 708,50 | 12,45 |
| Ti64/1TiB(PM)_17 | 17mm plate | 300 | 622,50 | 751,00 | 8,00 |
| Ti64_17 | 17mm plate | 400 | 471,00 | 583,25 | 12,906 |
| Ti64/0.5TiB(SHS)_17 | 17mm plate | 400 | 493,75 | 646,75 | 15,513 |
| Ti64/0.5TiB(PM)_17 | 17mm plate | 400 | 511,50 | 633,50 | 8,8 |
| Ti64/1TiB(PM)_17 | 17mm plate | 400 | 545,00 | 671,00 | 9,15 |
| Ti64_7 | 7mm plate | RT | 840,50 | 927,00 | 15,014 |
| Ti64/0.5TiB(SHS)_7 | 7mm plate | RT | 887,50 | 989,50 | 18,267 |
| Ti64/0.5TiB(PM)_7 | 7mm plate | RT | 852,00 | 961 | 12,10 |
| Ti64_7 | 7mm plate | 300 | 525,50 | 660,00 | 23,027 |
| Ti64/0.5TiB(SHS)_7 | 7mm plate | 300 | 566,50 | 729,50 | 18,615 |
| Ti64/0.5TiB(PM)_7 | 7mm plate | 300 | 562,5 | 707,5 | 14,25 |
| Ti64_7 | 7mm plate | 400 | 461,50 | 598,50 | 20,493 |
| Ti64/0.5TiB(SHS)_7 | 7mm plate | 400 | 496,50 | 673,00 | 19,159 |
| Ti64/0.5TiB(PM)_7 | 7mm plate | 400 | 504,00 | 659,00 | 11.65 |

Dimensions of the samples used in the tensile tests:

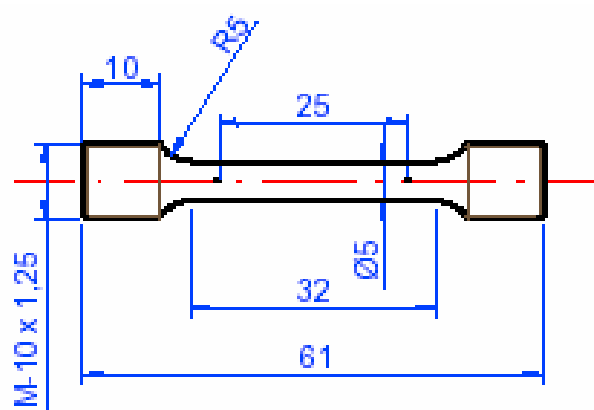
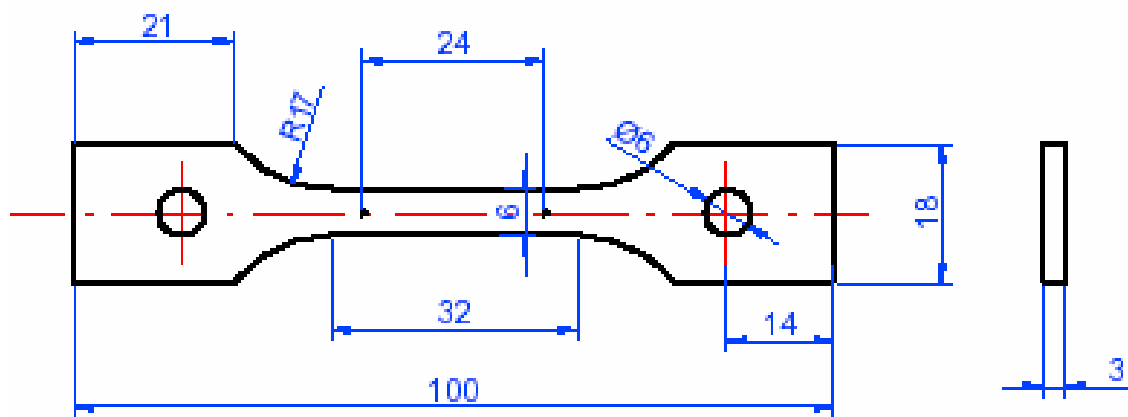
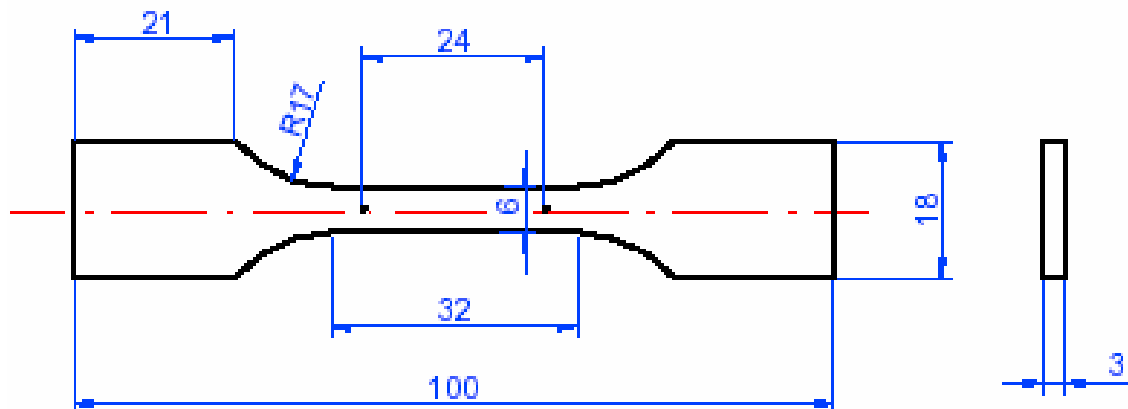

RESUME

Le matériau composite à matrice de titane renforcée par des cristaux discontinus de monoborure de titane (TiB) constitue une classe nouvelle de matériaux destinés à des applications de haute technologie. Ces composites présentent des avantages car le procédé d'élaboration permet l'obtention de pièces de formes complexes à moindre coût par rapport aux composites à matrice titane renforcée par des filaments continus. Le procédé d'obtention de composites Ti/TiB nécessite deux étapes de fabrication: (1) au cours de la première étape un pré-composite de fraction volumique élevée en TiB est obtenu par un procédé d'autocombustion (SHS), (2) lors d'une seconde étape, ce composite est dilué dans l'alliage de titane liquide pour obtenir la fraction volumique désirée. Des composites de fraction volumique en TiB comprise entre 0 et 10% ont été élaborés puis caractérisés. La microstructure de la matrice est affinée et les performances mécaniques sont améliorées par la présence du TiB. Finalement, une étude technico-économique de ce procédé a été réalisée pour évaluer la viabilité industrielle du matériau et du procédé.

Mots Clefs

Matrice de titane, renfort discontinu, précipitation «*in-situ*», autocombustion, SHS, fonderie de précision du titane, TiB, monoborure de titane.

ABSTRACT

Discontinuously reinforced titanium alloys containing *in-situ* formed TiB needles are emerging as candidate materials for advance applications. This new family of titanium composites presents technical advantages, and it can be less expensive and easily amenable for net-shape manufacturing relative to titanium metal matrix composites developed to date. The production of a master compound by a novel and cost-effective process called Self-propagating High-temperature Synthesis (SHS) has been approached. This master compound could be subsequently used in an investment casting process to obtain TiB reinforced net-shape titanium matrix composites. The SHS technique and its features have been investigated in depth before defining and producing a suitable master compound. Cast samples obtained from the addition of the master compound have been produced and the most important issues concerning the processing, microstructure and mechanical properties highlighted. Finally the industrial viability of the process has been assessed and an estimation of the cost increment compared to the unreinforced titanium castings performed.

Key Words

Discontinuously reinforced titanium, *In-situ* TiB, Self-propagating High-temperature Synthesis (SHS), Investment casting, microstructure, mechanical properties.