



HAL
open science

Multi-modal Interaction in Collaborative Virtual Environments: Study and analysis of performance in collaborative work

Sehat Ullah

► **To cite this version:**

Sehat Ullah. Multi-modal Interaction in Collaborative Virtual Environments: Study and analysis of performance in collaborative work. Human-Computer Interaction [cs.HC]. Université d'Evry-Val d'Essonne, 2011. English. NNT: . tel-00562081

HAL Id: tel-00562081

<https://theses.hal.science/tel-00562081>

Submitted on 2 Feb 2011

HAL is a multi-disciplinary open access archive for the deposit and dissemination of scientific research documents, whether they are published or not. The documents may come from teaching and research institutions in France or abroad, or from public or private research centers.

L'archive ouverte pluridisciplinaire **HAL**, est destinée au dépôt et à la diffusion de documents scientifiques de niveau recherche, publiés ou non, émanant des établissements d'enseignement et de recherche français ou étrangers, des laboratoires publics ou privés.

N° d'identification : 2011EVRY0003

UNIVERSITE D'EVRY-VAL D'ESSONNE
Laboratoire d'Informatique, Biologie Intégrative
et Systèmes Complexes



Thesis Submitted for the degree of Doctor of Philosophy (PhD)
Université d'Evry-Val d'Essonne
Speciality : Robotics

**Multi-modal Assistance for Collaborative
3D Interaction: Study and analysis of
performance in collaborative work**

Sehat ULLAH

Defended on : 26/01/2011

JURY

S. Coquillart	: Director of research, INRIA Rhône-Alpes, Examiner
G. Moreau	: Associate Professor, Ecole Centrale de Nantes, Reviewer
A. Lécuyer	: Research Scientist, INRIA Rennes, Reviewer
P. Richard	: Assistant Professor, Université d'Angers, Co-supervisor
S. Otmane	: Associate Professor, Université d'Evry, Co-supervisor
M. Mallem	: Professor, Université d'Evry, Supervisor

Acknowledgments

I would like to offer my cordial acknowledgements to all those individuals and organizations who provided me support during the course of this research work.

In this regard, I am thankful to my supervisory committee that includes Dr.Malik Mallem (Professor, University of Evry), Dr.Pual Richard (Assistant Professor, University of Angers) and Dr.Samir Otmane (Associate Professor, University of Evry) who conferred great confidence on me and offered me a place in their team. I acknowledge all their valuable suggestions, guidance, support and encouragement.

I am thankful to Sabine Coquillart (Director of research at INRIA Rhône-Alpes) for presiding the jury. I am also thankful to Dr.Guillaume Moreau (Associate Professor, Ecole Centrale de Nantes) and Dr.Anatole Lécuyer (Research scientist at INRIA Rennes) for accepting the heavy responsibility of reviewing this thesis.

Similarly, I would like to offer thanks to Etienne Colle and Said Mammar, former and current directors respectively of the IBISC (Informatique, Biologie Intégrative et Systèmes Complexes) Lab, University of Evry.

I am also thankful to the HEC (Higher Education Commission) of Pakistan, on awarding me scholarship for this thesis.

As part of collaboration between IBISC and LISA Labs, in VarSCW (Virtual and Augmented reality Supported Collaborative Work) project, I spent about one year in LISA (Laboratoire d'Ingénierie et Systèmes Automatisés) University of Angers, where I carried out most of my experiments. In this regard, I am thankful to the Director of LISA, Prof.Jean-Louis Boimond, and the administration who gave me a warm welcome in their lab. I am thankful to Emmanuelle Richard (Assistant professor, University of Angers) for her constant encouragement. I am also thankful to my colleagues of LISA, including Damien Chamaret, Mickael Naud and Ludovic Hamon with whom I had a very nice time.

I am also thankful to all members of the RATC (Réalité Augmenté et Travail Collaboratif) research team at IBISC. Similarly special thanks goes to the technical staff of IBISC including Dr.Frédéric Davesne (Research engineer) and Florant Percoit (Network and system administrator).

I should also not forget my family members who always remembered me in their prayers. In this regard I am thankful to my wife for her encouragement and prayers. Similarly, I

ACKNOWLEDGMENTS

am thankful to my sons Muhammad Salman and Muhammad Hasnain for their patience while I was far away from them for four years.

Abstract

The recent advancement in the field of high quality computer graphics and the capability of inexpensive computers to render realistic 3D scenes have made it possible to develop virtual environments where two or more users can co-exist and work collaboratively to achieve a common goal. Such environments are called Collaborative Virtual Environments (CVEs). The potential application domains of CVEs are many, such as military, medical, assembling, computer aided designing, teleoperation, education, games and social networks etc..

One of the problems related to CVEs is the user's low level of awareness about the status, actions and intentions of his/her collaborator, which not only reduces users' performance but also leads to non satisfactory results. In addition, collaborative tasks without using any proper computer generated assistance are very difficult to perform and are more prone to errors.

The basic theme of this thesis is to provide assistance in collaborative 3D interaction in CVEs. In this context, we study and develop the concept of multimodal (audio, visual and haptic) assistance of a user or group of users. Our study focuses on how we can assist users to collaboratively interact with the entities of CVEs. We propose here to study and analyze the contribution of multimodal assistance in collaborative (synchronous and asynchronous) interaction with objects in the virtual environment. Indeed, we propose and implement various multimodal virtual guides. These guides are evaluated through a series of experiments where selection/manipulation task is carried out by users both in synchronous and asynchronous mode.

The experiments were carried out in LISA (Laboratoire d'Ing erie et Syst emes Automatis es) lab at University of Angers and IBISC (Informatique, Biologie Int egrative et Syst emes Complexes) lab at University of Evry. In these experiments users were asked to perform a task under various conditions (with and without guides). Analysis was done on the basis of task completion time, errors and users' learning. For subjective evaluations questionnaires were used.

The findings of this research work can contribute to the development of collaborative systems for teleoperation, assembly tasks, e-learning, rehabilitation, computer aided design and entertainment.

Résumé

Les progrès récents dans le domaine de l'infographie et la capacité des ordinateurs personnels de rendre les scènes 3D réalistes ont permis de développer des environnements virtuels dans lesquels plusieurs utilisateurs peuvent co-exister et travailler ensemble pour atteindre un objectif commun. Ces environnements sont appelés Environnements Virtuels Collaboratifs (EVCs). Les applications potentielles des EVCs sont dans les domaines militaire, médical, l'assemblage, la conception assistée par ordinateur, la téléopération, l'éducation, les jeux et les réseaux sociaux.

Un des problèmes liés aux EVCs est la faible connaissance des utilisateurs concernant l'état, les actions et les intentions de leur(s) collaborateur(s). Ceci réduit non seulement la performance collective, mais conduit également à des résultats non satisfaisants. En outre, les tâches collaboratives ou coopératives réalisées sans aide ou assistance, sont plus difficiles et plus sujettes aux erreurs.

Dans ce travail de thèse, nous étudions l'influence de guides multi-modaux sur la performance des utilisateurs lors de tâches collaboratives en environnement virtuel (EV). Nous proposons un certain nombre de guides basés sur les modalités visuelle, auditive et haptique. Dans ce contexte, nous étudions leur qualité de guidage et examinons leur influence sur l'awareness, la co-présence et la coordination des utilisateurs pendant la réalisation des tâches. À cette fin, nous avons développé une architecture logicielle qui permet la collaboration de deux (peut être étendue à plusieurs utilisateurs) utilisateurs (distribués ou co-localisés). En utilisant cette architecture, nous avons développé des applications qui non seulement permettent un travail collaboratif, mais fournissent aussi des assistances multi-modales aux utilisateurs. Le travail de collaboration soutenus par ces applications comprend des tâches de type "Peg-in-hole", de télé-manipulation coopérative via deux robots, de télé-guidage pour l'écriture ou le dessin.

Afin d'évaluer la pertinence et l'influence des guides proposés, une série d'expériences a été effectuée au LISA (Laboratoire d'Ingénierie et Systèmes Automatisés) à l'Université d'Angers et au Laboratoire IBISC (Informatique, Biologie Intégrative et Systèmes Complexes) à l'Université d'Evry. Dans ces expériences, les utilisateurs ont été invités à effectuer des tâches variées, dans des conditions différentes (avec et sans guides). L'analyse a été effectuée sur la base du temps de réalisation des tâches, des erreurs et de l'apprentissage des utilisateurs. Pour les évaluations subjectives des questionnaires ont été utilisés.

Ce travail contribue de manière significative au développement de systèmes collaboratifs pour la téléopération, la simulation d'assemblage, l'apprentissage de gestes techniques, la rééducation, la conception assistée par ordinateur et le divertissement.

Contents

Acknowledgments

Abstract

Résumé

Contents

Table of Figures	10
List of Tables	14

INTRODUCTION 1

I STATE OF THE ART 5

1 Virtual Reality Interfaces and 3D Interaction 6

1.1 Introduction	6
1.2 3D interfaces for interaction with VEs	8
1.2.1 Motion Tracking Systems	8
1.2.1.1 Optical tracking systems	8
1.2.1.2 Magnetic tracking systems	8
1.2.1.3 Acoustic tracking systems	9
1.2.1.4 Hybrid systems	10
1.2.2 Haptic Interfaces	10
1.2.2.1 Tactile feedback interfaces	10
1.2.2.2 Force feedback interfaces	11
1.3 3D Interaction	22
1.3.1 Interaction techniques	22
1.3.2 Interaction paradigm	22
1.3.3 Interaction metaphor	22

1.3.4	The fundamental tasks of 3D interaction	22
1.3.4.1	Navigation	22
1.3.4.2	Selection	23
1.3.4.3	Manipulation	23
1.3.4.4	Application control	24
1.3.5	Classification of 3D interaction	24
1.3.5.1	Exocentric interaction techniques	25
1.3.5.2	Egocentric interaction techniques	25
1.3.5.3	Hybrid interaction techniques	25
1.3.6	Haptic interaction	26
1.3.7	Assistance in 3D interaction	27
1.3.7.1	Visual assistance	28
1.3.7.2	Haptic assistance	30
1.3.7.3	Auditory assistance	30
1.3.7.4	Properties of virtual guides	31
1.4	Conclusion	32
2	Architecture and requirements of Collaborative Virtual Environments	33
2.1	Introduction	33
2.1.1	Applications of collaborative work	33
2.1.2	Types of collaborative work	34
2.1.3	Some definitions	34
2.1.3.1	Presence	34
2.1.3.2	Awareness	35
2.2	Existing work related to collaborative virtual environments	35
2.2.1	Systems for teleconferencing	35
2.2.2	Collaborative teleoperation of robot via internet	38
2.2.3	Collaborative interaction with molecules and other objects	39
2.2.4	Collaborative work with haptic feedback	44
2.3	Requirements of Distributed CVEs	46
2.3.1	Avatars	47
2.3.2	Audio/video Support	47
2.3.3	Flexible Support of Various Data Characteristics	48
2.3.3.1	Quality of service	48
2.3.3.2	Size of data	48
2.3.3.3	Queued/Unqueued Data	48
2.3.3.4	Persistent/Transient Data	49
2.3.4	Data model for collaborative virtual environments	49
2.3.4.1	Shared centralized model	49
2.3.4.2	Replicated homogeneous model	49
2.3.4.3	Shared distributed with peer-to-peer update	50

2.3.4.4	Shared distributed with client–server database	50
2.3.5	Characteristics of network for distributed VEs	51
2.3.5.1	Bandwidth	51
2.3.5.2	Distribution	51
2.3.5.3	Latency	51
2.3.5.4	Reliability	51
2.4	Conclusion	51
II	CONTRIBUTION	54
3	Modeling virtual guides for Collaborative Environments	55
3.1	Introduction	55
3.2	Problem definition	56
3.3	Cooperative manipulation of virtual objects	57
3.3.1	Software architecture	58
3.3.1.1	Device registration	58
3.3.1.2	User data management and network	58
3.3.1.3	Events management	58
3.3.1.4	Awareness and coordination model	60
3.3.1.5	Models for virtual guides	64
3.3.2	Task and Description of the VE	64
3.3.3	Multimodal collaborative virtual guides	67
3.3.3.1	Visual guides	67
3.3.3.2	Audio guides	69
3.3.3.3	Haptic guides	70
3.4	Conclusion	75
4	Experiments and evaluations: study of collaborative performance	76
4.1	Introduction	76
4.2	Study of the collaborative/cooperative performance	76
4.2.1	Experiment I : Contact coloring and audio guides	76
4.2.1.1	Experimental protocol	77
4.2.1.2	Analysis of the results	78
4.2.2	Experiment II : Force substitution, shadows and communication	80
4.2.2.1	Experimental protocol	80
4.2.2.2	Analysis of the results	81
4.2.3	Experiment III : Force substitution and shadows in single user VE	83
4.2.3.1	Experimental protocol	83
4.2.3.2	Analysis of results	84
4.2.4	Comparison of the experiment II & III	86
4.2.5	Experiment IV : Force feedback and haptic guides	87

4.2.5.1	Experimental protocol	88
4.2.5.2	Analysis of the Results	89
4.2.6	Experiment V : Cooperative teleoperation with robots	91
4.2.6.1	Description of the virtual environment	91
4.2.6.2	Experimental protocol	91
4.2.6.3	Task description	92
4.2.6.4	Analysis of the results	92
4.2.7	Experiment VI : Influence of viewpoint and tactile feedback on cooperative work	94
4.2.7.1	Modeling of the robot	94
4.2.7.2	Cooperative operation of the robot	95
4.2.7.3	Experiment and analysis of the results	98
4.3	The Concept of What You Feel Is What I Do	103
4.3.1	Architecture of the system	104
4.3.2	Model of the haptic guide	104
4.3.3	Experiment and evaluation	107
4.3.3.1	Experimental protocol	107
4.3.3.2	Analysis of the results	107
4.3.3.3	Discussion	108
4.4	Conclusion	108
5	Experiments and evaluations: multimodal guidance in single-user VEs	110
5.1	Introduction	110
5.2	The role of assistance in teleoperation and 3D interaction	110
5.3	Modeling and description of the multi-modal guides	112
5.3.1	Conical multi-modal guide	112
5.3.1.1	Visual cone	113
5.3.1.2	Haptic cone	113
5.3.2	Spherical multi-modal guide	116
5.3.2.1	Visual sphere	117
5.3.2.2	Haptic sphere	117
5.4	Experiments and evaluations	118
5.4.1	VR platform	118
5.4.2	Software architecture	119
5.4.3	Experimental Protocol	121
5.4.4	Analysis of the results of the experiment I	123
5.4.4.1	Task completion time	123
5.4.4.2	Subjective analysis	124
5.4.5	Analysis of results of the experiment II	124
5.4.5.1	Task completion time	124
5.4.5.2	Subjective analysis	124

5.5	Conclusion	126
Conclusion and perspectives		127
5.6	Conclusion	127
5.7	Perspectives and future work	128
		129
Bibliography		129
Appendix		141
5.8	Appendix A :	141
5.9	Appendix B :	141
5.10	Appendix C :	142
5.11	Appendix D:	143
5.12	Appendix E:	144
5.13	Appendix F:	145
5.14	Appendix G : EVRA Platformed of the IBISC Lab	146
5.14.1	Large scale semi-immersive environment of evr@	146
5.14.1.1	System of visualization	146
5.14.1.2	Optical tracking	147
5.14.1.3	Data gloves	148
5.14.1.4	Force feedback system (SPIDAR)	148
5.14.2	Mobile environment of evr@	148
5.14.3	Software platform	149
5.14.4	Slave site of the evr@ platform	149

List of Figures

1.1	Illustration of the three I (adopted from (Burdea and Coiffet, 1993)).	7
1.2	(a) Flystic TM , and (b) dataglove equipped with spherical infrared reflectors.	9
1.3	The Polhemus patriot TM (adopted from (Polhemus, 2010))	9
1.4	The Nintendo Wiimote TM	10
1.5	(a) CyberGlove TM , and (b) CyberTouch TM (adopted form (Immersion, 2010))	12
1.6	(a) Phantom desktop TM , (b) Phantom Premium TM 1.5/6 DOF, (c) Phantom Premium TM 3.0/6 DOF (d), and Phantom Premium TM 1.5/3 DOF (adopted from (SensAble, 2010))	14
1.7	Some models of the omega x, of force dimension (a) Omega3 (b)omega6 (c) Omega7 (adopted from (Forcedimension, 2010))	14
1.8	(a) The CyberGlove TM , (b) the CyberGrasp TM , and the (c) CyberForce TM (adopted from (Immersion, 2010))	16
1.9	(a) The haptic wand, (b) the MagLev wrist TM , and (c) the Haptic master TM (Images (a), (b) & (c) adopted from (Quanser, 2010; Micro_systems_labs, 2010; Moog_Systems, 2010) respectively)	17
1.10	(a) 5-DOF Haptic Interface, and (b) a user operating the device (adopted from (Lee et al., 2000))	17
1.11	Different versions of the SPIDAR (a) SPIDAR I (b) SPIDAR II (c) SPIDAR for two hands (d) SPIDAR 8 (e) SPIDAR-G and (f) SPIDAR-H (adopted from (Makoto, 2002; Kohno et al., 2001; Luo et al., 2003)	19
1.12	SPIDAR frame : positions and coordinates of the actuators.	20
1.13	Illustration of navigation techniques (adopted from (Bowman et al., 1997))	23
1.14	Illustration of selection techniques (adopted from (Bowman, 1999))	24
1.15	The system of Sayers and Paul : the master robot (left), and the slave robot (right)(adopted from (Sayers and Paul, 1994)).	28
1.16	Illustration of visual guides in the teleoperation of a FANUC LR-MATE 200i robot (Images taken from (Otmame and Davesne, 2009)) : (a) a user controlling the robot, and (b) side viewpoint of the virtual robot and workspace.	29

1.17	Screenshot of mine planning stage, showing geological layers of rocks and road tunnel(adopted from (Gunn, 2005))	30
2.1	Illustration of the (a) virtual room for teleconference (adopted from (Frécon and Nöu, 1998)) and (b) table for meeting and learning (adopted from (Dumas et al., 1999))	36
2.2	Illustration of the (a) NPSNET virtual environments for military training and (b) exercises (Capps et al., 2000; Macedonia et al., 1995)	37
2.3	User interface of the Group-slicer project (extracted from (Simmross-Wattenberg et al., 2005)).	38
2.4	Telepresence environments for tele-collaboration and tele-work: (a) Portal to a distant office, (b) France Telecom R&D Telepresence Wall, (c) Telepresence session in the TELEPORT room, (d) VIRTUE setup : Virtual Team User Environment (image extracted from (Otmane et al., 2008)).	39
2.5	Illustration of collaborative teleoperation between IBSIC and LISA (adopted from (Otmane et al., 2008)).	40
2.6	The virtual environment for collaborative use of resources in telemining (adopted from (Nicholas, 2004))	40
2.7	Molecular interaction ((a) behavior of protein molecule to the drug molecule(adopted from (Steed et al., 2003)) (b) collaborative manipulation of molecules (adopted from (Chastine et al., 2005)))	41
2.8	Collaborative manipulation of an objet in VE ; (a) building, (b) object to move, and (c) avatars (adopted from (Mortensen et al., 2002))	42
2.9	(a) Collaborative VE, and (b) construction of a cube from the smaller cubes (adopted from (Heldal et al., 2006))	42
2.10	Collaborative VE (a) collaboration in the presence of human social interaction, (b) cooperative manipulation (adopted from (Roberts et al., 2004))	43
2.11	NICE system : (a) avatar giving a flower to another, and (b) a child interacting with an avatar in a CAVE systems (adopted form (Roussos et al., 1997))	43
2.12	The virtual environment for tele-rehabilitation (adopted from (Popescu et al., 2002)).	44
2.13	Illustration collaborative work using bent ray technique, Here both rays are bent because they attempt to modify car position at the same time in opposite directions (adopted from (Aguerrece et al., 2009a)).	44
2.14	Tele handshake system : (a) virtual environment, and (b) a user during experiment (adopted from (Alhalabi and Horiguchi, 2001))	45
2.15	Illustration of the CVE with haptic haptic feedback : (a) collaborative sculpting, and (b) collaborative sculpting and coloring (adopted from (Gunn, 2006))	46
2.16	The interface of the DIVIPRO ³ project	47
2.17	Illustration of the shared centralized model.	50
2.18	Illustration of the different types of distribution.	52

3.1	Illustration of some trajectories in a cooperative Peg-in-hole task. . . .	57
3.2	The proposed software architecture for cooperative/collaborative manipulation : (a) Scenario of collaboration between two remote users using replicated approach, (b) Modules of the CVE on a single station.	59
3.3	Illustration of objects, auras and possibility of communication between pairs.	60
3.4	Illustration of the spatial model for awareness.	61
3.5	Illustration of collaborative assembly chain	63
3.6	Illustration of Peg-in-hole VE : (a) top view of the task, (b) snapshot of the user viewpoint during the task.	65
3.7	Illustration of the grasping conditions for object manipulation.	66
3.8	Illustration of the cooperative Peg-in-hole task.	66
3.9	Illustration of the visual representation of the forces applied by the operators during cooperative manipulation.	69
3.10	Illustration of the use of shadows in CVE.	71
3.11	Illustration of the attractive haptic guide (top view).	71
3.12	Illustration of speed control haptic guide (top view), users are moving in (-Z) direction	73
3.13	Illustration of the mutual force (top view)	73
4.1	Presentation of the users' responses to the questionnaire.	79
4.2	User learning of various conditions.	79
4.3	Mean and standard deviation of task completion for various conditions	81
4.4	Errors during task execution	82
4.5	Single-user configuration for the Peg-in-hole task.	83
4.6	Average task completion for various conditions.	85
4.7	Average errors with standard deviation for various conditions of the experiment III	85
4.8	Illustration of VE (top view).	87
4.9	Two users performing the cooperative Peg-in-hole task using the VR platform of LISA.	88
4.10	Average task completion time with std for various conditions.	89
4.11	Average number of errors with std for various conditions.	90
4.12	User learning during task repetition.	91
4.13	Illustration of the virtual environment with robots (Fanuc)	92
4.14	Illustration of the cooperative manipulation via the FANUC robots. . .	93
4.15	Average task completion time with std for various conditions.	94
4.16	Errors during task execution with robots.	95
4.17	Top view of the robot and its various parts.	96
4.18	Right (shifted) view of the workcell.	96
4.19	Front view of the workcell.	97
4.20	Perpendicular view of the workcell.	97

4.21	Rotation of Wiimote TM about x-axis	98
4.22	Rotation of Wiimote TM about z-axis	99
4.23	The expert during task execution in the immersive configuration	100
4.24	A subject during experiment on the desktop configuration	100
4.25	Illustration of the task completion time in different conditions	101
4.26	Illustration of robot's movement in condition C1 (along various axis)	102
4.27	Illustration of robot's movement in condition C2	102
4.28	Illustration of robot's movement in condition C3	103
4.29	Illustration of the model of haptic guide.	104
4.30	Illustration of the writing through haptic guide.	105
4.31	Illustration of the dynamic haptic interaction in distributed CVE (a) User 1 with SPIDAR-GH of the semi-immersive platform (b) user 2 with SPIDAR-GM of the mobile platform.	106
4.32	Illustration of the alphabets and geometric forms written with the help of haptic guide.	107
5.1	The use of visual guide in augmented reality systems (EVR@ Platform of IBISC Laboratory).	111
5.2	Illustration of the 3D interaction technique called "FOLLOW-ME".	112
5.3	Illustration of the conic type multimodal guide.	113
5.4	Illustration of the steps for object selection	114
5.5	Illustration of the multimodal guide of spherical shape.	116
5.6	State transition diagram between the zones of the spherical multimodal guide	117
5.7	VR platform of IBISC Lab : (a) SPIDAR with large screen, and (b) system architecture.	120
5.8	Illustration of the software architecture	121
5.9	The VE used for the experiment	122
5.10	Task completion time with std for various conditions.	123
5.11	Response to the questionnaire : (a) spherical guides, and (b) conical guides.	125
5.12	Task completion time for various conditions	126
5.13	Different components of the semi-immersive platform of Evr@.	146
5.14	The DLP Mirage 4000 projector of the evr@ platform.	147
5.15	Tracking system of the semi-immersive platform (a) Infrared camera (b) Flystick with shining balls	147
5.16	Data Gloves of Fifth dimension	148
5.17	Illustration of the structure of SPIDAR-G	148
5.18	The mobile platform of Evr@ (a) external view (b) internal view	149
5.19	Robot Fanuc LR MATE 200i.	150

List of Tables

1.1	Different models of Phantom and their specifications.	13
1.2	Characteristics of different versions of Omega devices.	15
1.3	Specifications of the Haptic wand.	16
1.4	Specifications of the Haptic Master TM	18
3.1	The properties of the visual guide base on change in color.	67
3.2	The properties of arrow based visual guide.	68
3.3	Properties of shadow based visual guide.	70
3.4	Properties of the audio guide.	72
3.5	Properties of the attractive haptic guide	74
3.6	Properties of the speed control guide	75
4.1	Mean and standard deviation of task completion time (sec.) for various conditions.	78
4.2	Mean and standard deviation of task completion for various conditions	81
4.3	The percentage of responses for the options (condition) of each question	82
4.4	Average task completion time and standard deviation for various conditions.	84
4.5	Average errors with standard deviation for various conditions of the experiment III	84
4.6	Average task completion time with std for various conditions of the experiment II & III.	86
4.7	Average errors with std for various conditions of the experiment II & III.	86
4.8	Average task completion time with std for various conditions.	89
4.9	Average task completion time with std for various conditions.	93
4.10	User perception of the alphabets through the haptic Guide.	108
4.11	User perception of forms through the haptic Guide.	108
5.1	The properties of the visual guide (cone).	114
5.2	The properties of the haptic guide (cone).	115
5.3	The properties of the visual guide of spherical shape	118
5.4	The properties of haptic guide of spherical shape.	119
5.5	Scale for the response of the questions.	123

INTRODUCTION

Context and problem definition

Virtual reality (VR) is a research area that lies at the crossroads of several fields such as computer graphics, computer aided design, simulation, teleoperation, audiovisual, collaboration, etc.. VR empowers man to change the course of events in a synthetic environment and thus to interact with virtual entities. It uses many hardware devices and software techniques for each application domain. The 3D interaction is considered as the driving component of virtual reality. It allows the user to interact (navigate, select, manipulate and control the application) in a virtual environment (VE). These latter have received much attention from the research community because of their many advantages. They not only provide flexible and less expensive solutions but also enable us to record data and analyze it more precisely.

Stereoscopic vision and sound are successfully being used and have become integral parts of the VEs. Similarly, to enable realistic haptic interaction, research is underway in many dimensions such as the development of haptic devices, cognitive and perception related studies. In this context, users should be given assistance to increase their performance during task execution in VEs. The assistance (virtual guides) may be visual, auditive, haptic or a combination of these.

The recent advancement in the field of high quality computer graphics, networks and the capability of inexpensive personal computers to render realistic 3D scenes have made it possible to develop VEs where two or more users can co-exist and work collaboratively to achieve a common goal. Such environments are called Collaborative Virtual Environments (CVEs). There are many potential application domains of CVEs such as military, medical, assembling, computer aided designing, teleoperation, education, games, social networks etc.. However, the effectiveness of CVEs depends on the effective interactions of a group of users with shared entities. Indeed, when multiple users operate in the same world, there are several constraints to be respected in particular those related to coordination of actions of different users and awareness of other users' interactions with each other and the objects of the CVE.

In single user VEs, virtual guides are normally used to achieve better user performance and enhance task's precision. The performance is usually measured in terms of time, precision/error and security during task accomplishment. On the other hand, in CVEs, performance and precision depends on all users involved in the task. The task becomes more challenging as it requires tight coupling among the users and specially if they are not co-located. In this case, users should not only perceive the presence of each other but

should also be aware of each other's status and actions.

The basic theme of our research is to render assistance in collaborative 3D interaction in CVEs. In this context, we study and develop the concept of multimodal (audio, visual and haptic) assistance of a user or group of users. Our study focuses on how we can assist users to collaboratively interact with the entities of CVEs. We propose here to study and analyze the contribution of multimodal assistance in collaborative (synchronous and asynchronous) interaction with objects in VEs. Indeed, we propose and implement various multimodal virtual guides. These guides are evaluated through a series of experiments where selection/manipulation task is carried out by users both in synchronous and asynchronous mode.

Thesis organization

This thesis is divided into two parts. The first part is composed of two chapters that review the state of the art. The second part, which consists of three chapters, presents our contribution. In the following, we briefly summarize the contents of chapters.

Chapter 1

In the first chapter, we present the state of the art related to VR interfaces and 3D interaction techniques. Then, we will present an analysis of assistance provided to users in order to ameliorate their performance.

Chapter 2

The second chapter starts with the introduction of the mode of interaction in CVEs followed by some definitions (presence, awareness etc.). Then we present a brief state of the art related to CVEs, followed by its requirements (user identity, communication support, quality of service etc.). We conclude this chapter with a review and analysis of different modes of collaborative interactions (synchronous and asynchronous).

Chapter 3

In the third chapter, we present the models and formalism of the proposed virtual guides designed for collaborative 3D interaction. These guides make use of visual, audio and haptic modalities on the basis of our *awareness and coordination* model. This model is based on the concept of *aura set* and *task set*. In addition, we present a software architecture that we used for the development of applications that allow collaboration between two remote as well as co-located users. Similarly, we present the description of the CVE and task used for experiments and evaluations.

Chapter 4

In the fourth chapter, we present the experiments and evaluations carried out in different CVEs. The objective of these experiments is to study, that how our proposed virtual guides (visual, audio and haptic) influence coordination and awareness between users. In

addition, their effect on users' performance in the execution of a cooperative/collaborative task is investigated. A "Peg-in-hole" task was selected as experimental task for the first four studies. In the fifth study, the experimental task is to cooperatively inverse a stack of two cylinders via two robots. In these studies, assistance is provided through sound, visual and haptic guides (human-scale SPIDAR is used for haptic rendering).

In the sixth experiment, we present a study on the influence of viewpoints and tactile feedback on users' performance during the execution of cooperative task. Here the cooperative task is carried out via a virtual robot (3DoF) where each user controls separate degrees of freedom of the robot. In the last experiment of this chapter, we present the concept of "What You Feel Is What I DO (WYFIWID)" between two distant users. This concept allows a user to feel (via haptics) the actions carried out by another user.

Chapter 5

In the fifth chapter, we study other types of multimodal guides. In this context, we propose two types of multimodal guides (combines visual and haptic modalities), the first one is omni directional and help users to select an object in the VE. The second guide lets users select an object from a specific direction. The purpose of this guide is not only to provide assistance in VE, but also for VR assisted teleoperation.

A conclusion that summarizes the results of this research work is presented in the last part. Some perspectives and future works are also given.

Main contributions

We summarize below the main contributions of this thesis.

- Proposition of the *coordination and awareness* model for users assistance in CVEs.
- Design, implementation and evaluation of the visual, auditive and haptic guides for CVEs.
- Study and evaluation of the haptic guides in a (simulated) telemanipulation task via two robots.
- Study and analysis of the viewpoint and tactile feedback on a cooperative manipulation task.
- Proposition of the concept WYFIWID, its implementation and evaluation.

PUBLICATIONS

1. Sehat Ullah, Paul Richard, Samir Otmane, Mickael Naud, Malik Malle, "Haptic guides in cooperative virtual environments: Design and human performance evaluation", in proceedings of 8th IEEE Haptic Symposium, pages 457-462, 2010, March 25- 26, Boston, USA.
2. Sehat Ullah, Nassima Ouramdane, Samir Otmane, Paul Richard, Frédéric Davesne, Malik Malle, "Augmenting 3D Interactions with haptic guides in a Large-Scale Virtual Environment", International Journal of Virtual Reality, pages 25-31, Vol. 8, N° 2. 2009.
3. Sehat Ullah, Paul Richard, Samir Otmane, Malik Malle, "Human Performance in Cooperative Virtual Environments: the Effect of Visual Aids and Oral Communication" International Journal of Virtual Reality, pages 37-44, Vol. 8, N° 4. 2009.
4. Sehat Ullah, Paul Richard, Samir Otmane, Malik Malle, "Cooperative Teleoperation Task in Virtual Environment: the Influence of Visual Aids and Oral Communication". International Conference on Informatics Control, Automation and Robotics (ICINCO 09), pages 374-377, July 2-5, 2009, Milan, Italy.
5. Michael Naud, Sehat Ullah, Paul Richard, Samir Otmane, Malik Malle, "Effect of tactile feedback and viewpoint on task performance in a collaborative virtual environment" In proceedings of Joint Virtual Reality Conference, EGVE-ICAT-EURO VR (JVRC 09), December 7-9, 2009, pages 19-20, Lyon, France.
6. Sehat Ullah, Paul Richard, Samir Otmane, Malik Malle, "The Effect of Audio and Visual Aids on Task Performance in Distributed Collaborative Virtual Environments" 2nd Mediterranean Conference on Intelligence Systems and Automation (CISA 09), pages 196-201, March 23-25, 2009, Zarsis, Tunisia.
7. Sehat Ullah, Samir Otmane, Paul Richard, Malik Malle, "The Effect of Haptic Guides on Human Performance in Virtual Environments", International Conference on Computer Graphics Theory and Applications (GRAPP 09), pages 322-327, February 5-8, 2009, Lisbon, Portugal.
8. Damien Chamaret, Mickael. Naud, Ludovic Hamon, Sehat Ullah, E. Richard, P. Richard, "Human-Scale Haptic Interaction Using the SPIDAR", In proceedings of VRC09 - Joint Virtual Reality Conference of EGVE - ICAT - EuroVR, pages 123-128, December 7- 9, 2009, Spidar Anniversary Symposium, Lyon, France.
9. Sehat Ullah, Samir Otmane, Paul Richard, "Haptic Feedback in Large-Scale VEs: Evaluation of SPIDAR-G", Proceedings of 4th International Conference on Enactive Interfaces (ENACTIVE07), pages 189-192, November 19-22, 2007, Grenoble, France.
10. Sehat Ullah, Xianging Liu, Samir Otmane, Paul Richard and Malik Malle " What You Feel Is What I DO: A study of dynamic haptic interaction in distributed collaborative virtual environment" In 14th International Conference on Human-Computer Interaction (HCI 2011) (Accepted)

Part I

STATE OF THE ART

Chapter 1

Virtual Reality Interfaces and 3D Interaction

1.1 Introduction

Virtual Reality (VR) combines the technologies and techniques to allow human users to interact with Virtual Environment (VE) in a manner where he/she can have the feelings like that of the real world or close to it. The term "Virtual Reality" was first introduced by Jaron Lanier in 1986.

"We are speaking about a technology that uses computerised clothing to synthesise shared reality. It recreates our relationship with the physical world in a new plane, no more, no less. It doesn't affect the subjective world ; it doesn't have anything to do directly with what's going on inside your brain. It only has to do with what your sense organs perceive (Lanier, 1988)."

After the emergence of the concept it was defined by many researchers. For example, Aukstakalnis et Blatner gave a very general definition, they consider it as a means by which human visualize, manipulate and interact with computers and extremely complex data (Aukstakalnis and Blatner, 1992). Ellis described it as "an advanced human-computer interface that simulates a realistic environment and allows participants to interact with it" (Ellis, 1994).

The techniques of virtual reality are based on the real time interaction with an artificial world, with the help of behavioral interfaces that allow the immersion "pseudo-natural" of the user(s) in this environment. This world may be imaginary or artificial simulation of some aspects of the real world (Fuchs et al., 2003). The objective of VR is to allow a person (or many) to perform a sensorimotor and cognitive activity in the artificial world (Fuchs et al., 2003).

Burdea and Coiffet have identified three basic components for VR (see Figure 1.1), that are Immersion, Interaction and Imagination (Burdea and Coiffet, 1993). The user

interacts in a virtual environment that must be represented in a realistic way to give a feeling of immersion for the user. This environment must respond in real time to user actions.

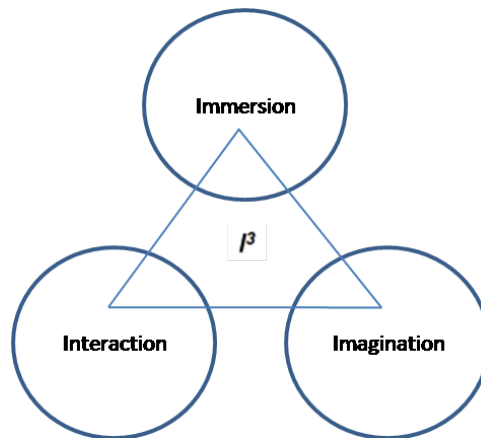

Figure 1.1: Illustration of the three I (adopted from (Burdea and Coiffet, 1993)).

Virtual Environment (VE) is the 3D representation of the real or imaginary data with which we can interact in real time (Hachet, 2003). According to the degree of immersion, VEs can be divided into the following categories (Kalawsky, 1996).

- Non-Immersive Virtual Environment "NIVE"
- Semi-Immersive Virtual Environment "SIVE"
- Fully-Immersive Virtual Environment "FIVE"

Bowman (Bowman, 1999) defines immersion as the feeling of being present, which is provided by some virtual environments. According to him, a user is "immersed" when he feels that the virtual world that surrounds him has replaced the physical world with some degree (Bowman, 1999). Presence is actually the sensation given to the user of being part of the virtual world and the objects that surround him are really present or exist (Burkhardt et al., 2003; Mestre and Fuchs, 2006; Stoffregen et al., 2003).

The interaction plays an important role in the realism of VEs and the immersion of user within it. To enable the user to interact with the virtual world more naturally, we must have interfaces and 3D interaction techniques that are simple, natural and effective. In addition, to enhance users' performance in VEs, they should be given some kind of guidance or assistance.

In this chapter, we will present the state of the art of VR interfaces and 3D interaction techniques. Then, we will present an analysis of user assistance for increasing performance in virtual and remote environments.

1.2 3D interfaces for interaction with VEs

1.2.1 Motion Tracking Systems

Motion trackers are generally used to locate the user in the virtual environment. They are used to measure in real-time the positions and orientations of a user in 3D space. Motion trackers use one of the following physics domains.

- Optics;
- Electromagnetism;
- Acoustics;
- Hybrid systems.

1.2.1.1 Optical tracking systems

The basic concept of these systems is the use of camera. The camera can be a video camera that uses visible light or infrared type.

2D tracking of an object is possible with a single video camera. To have 3D tracking and get the six degrees of freedom (3 translations and 3 rotations) we must have a minimum of two cameras. Each camera sees the target object from a different angle, the position and orientation are calculated using the epipolar geometry between two planes of the images.

This system uses the size, color, or shape of the moving object to follow. The advantages are that the system is cheaper and in a controlled environment, tracking may be robust and accurate.

The disadvantages are that the system is very sensitive to lighting conditions and the hiding of the camera or the target object. Similarly, tracking is difficult when there are similar objects in the scene.

On the other hand the infrared system uses small reflectors (shining balls) that are detected by the infrared cameras. These balls can be placed on the head, hand or other body parts of users and thus their position and orientation can be calculated. FlystickTM is one of the well known VR interfaces that uses infrared reflectors (see Figure 1.2-a). Similarly, these reflectors can also be mounted on other devices, such as data gloves (see Figure 1.2-b). One main drawback of these systems is the problem of occultation.

1.2.1.2 Magnetic tracking systems

Magnetic tracking systems are based on variations of magnetic fields. The most well known device that uses magnetic fields is the Polhemus PatriotTM (Polhemus, 2010). This

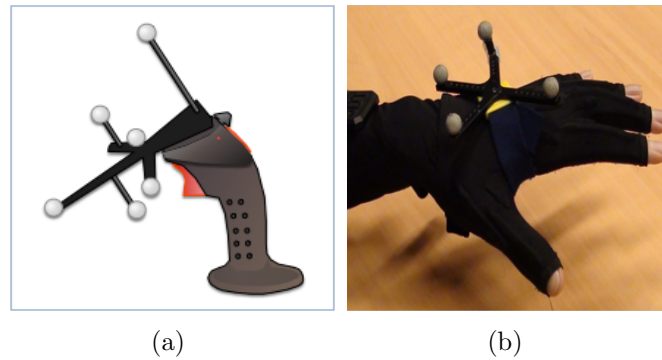

Figure 1.2: (a) FlysticTM, and (b) dataglove equipped with spherical infrared reflectors.

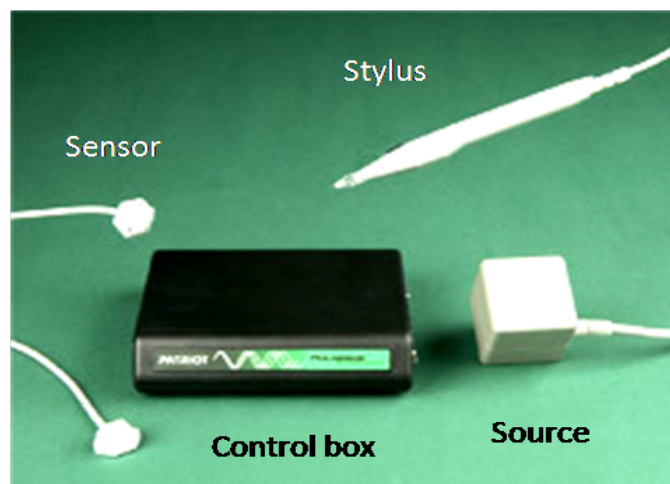

Figure 1.3: The Polhemus patriotTM (adopted from (Polhemus, 2010))

system is composed of three main elements which are the control box, the source and receivers (sensor) and a power supply (see Figure 1.3).

The source contains several magnetic coils that create a magnetic field when an electric current passes through them. The source is used as the reference of the system.

Receivers are also composed of magnetic coils, but they are used to detect the magnetic field emitted by the source. The position and orientation of receivers are then measured relative to the source.

These systems are cheaper but they are less accurate compared to optical systems (infrared). The magnetic field is also disturbed in the presence of electronic devices.

1.2.1.3 Acoustic tracking systems

These tracking systems consist of acoustic sensors and ultrasound transmitters. Usually, the sensors are fixed in the environment and the user wears the ultrasound emitters. The system calculates the position and orientation of the user based on time it takes for

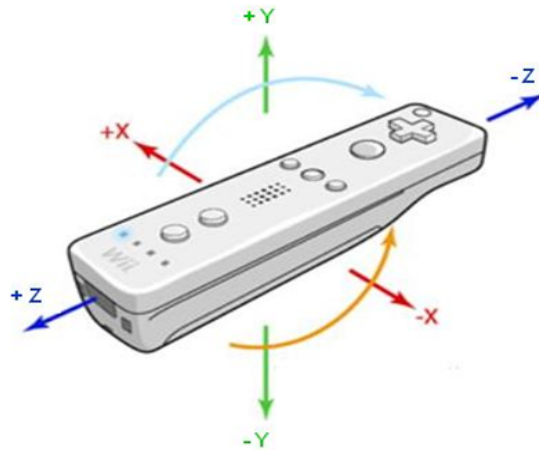

Figure 1.4: The Nintendo WiimoteTM.

the sound to reach the sensors.

The acoustic tracking systems have many disadvantages. The sound travels relatively slowly, therefore the rate of updates on the position of a target is also slow. The environment can also affect the efficiency of the system because the speed of sound in air can change due to change in temperature, humidity or barometric pressure of the environment.

1.2.1.4 Hybrid systems

In category, we can include the Nintendo WiimoteTM (see Figure 1.4) which is a new video game controller (Nintendo[®], 2010). It consists of two accelerometers, multiple buttons, a small speaker and a vibrator. It is also equipped with infrared sensors. To connect to the computer, it makes use of the bluetooth technology. Bluewand is an other device which is very similar to the WiimoteTM and was designed by Fuhrmann et al. (Fuhrmann et al., 2003)

1.2.2 Haptic Interfaces

Since the advent of VR technology, the researchers are trying to integrate several human senses for better immersion of users in Virtual/Augmented Reality (AR) Environments. It is obvious that the more human senses are integrated in the VE the better will be the immersion. The haptic sense is very important in the real world to perform a task. It is composed of tactile and force feedback. The integration of this sense in the virtual world enhances user's performance in tasks accomplishment.

1.2.2.1 Tactile feedback interfaces

The tactile interfaces are used to simulate the shape, size, surface conditions and temperature of virtual objects. These interfaces can be classified into four categories based on their technology.

- **Pneumatic:** These interfaces use air or gas to inflate or deflate their small constituent balloons. A compressor is used to control pressure in the balloons. The well known interfaces of this type are the “teletact” and “dataglove” of Zimmerman (Zimmerman et al., 1987; Stone, 1992).
- **Vibro–tactile:** These interfaces are based on vibro-motors or electromagnetic coils that are placed at different locations on the user’s hand. The most famous interfaces of this type are CyberTouchTM and TouchMasterTM developed by the “Immersion” and “EXOS” respectively (Immersion, 2010; Marcus and Churchill, 1989).

The CyberTouchTM (see Figure 1.5-b), is a tactile feedback device based on CyberGloveTM (see Figure 1.5-a). The CyberTouchTM consists of small vibro-tactile stimulators mounted on each finger of the CyberGloveTM. Each stimulator can be individually programmed to vary the intensity of sensation of touch. The stimulators can generate simple sensations such as pulses or sustained vibrations, but they can also produce complex combinations of tactile feedback. The use of CyberTouchTM in virtual world allows the user to feel the presence of an object in his/her hand or under his/her fingers.

- **Electro–tactile:** These interfaces simulate the sensation of pressure or vibration using electrodes that are placed in contact with the human skin. The sensory receptors of human skin are excited by the current transmitted to the electrodes (Iwata et al., 2001; Johnson, 1992; James F., 1993; Cutt, 1993).
- **Thermique:** These interfaces are used to simulate the temperature of a virtual object. Several approaches are possible for thermal stimulation of the skin, for example microwaves or infrared radiation and the use of air or liquid (Caldwell et al., 1995).

1.2.2.2 Force feedback interfaces

1.2.2.2.a Performance criteria: Many force feedback devices have been developed and used in teleoperation and virtual reality, but there is no universal interface that can be used in all types of applications. However, to assess the performance of force feedback devices, some criteria have been proposed (Fuchs et al., 2003).

Transparency: For a device to be transparent it is necessary that it allows a more natural interaction with the environment. In the ideal case, the operator should feel that he/she is directly manipulating the virtual or remote objects without feeling the presence of the device. Defining transparency, we talk about the transparency of free–space and contact. Transparency in free-space is that, the device should allow the user to move as freely as possible. For this, the device must provide an adequate workspace where the user can move freely. In addition the device should be light weight so that to avoid the fight against inertia during the fast movements of the user.

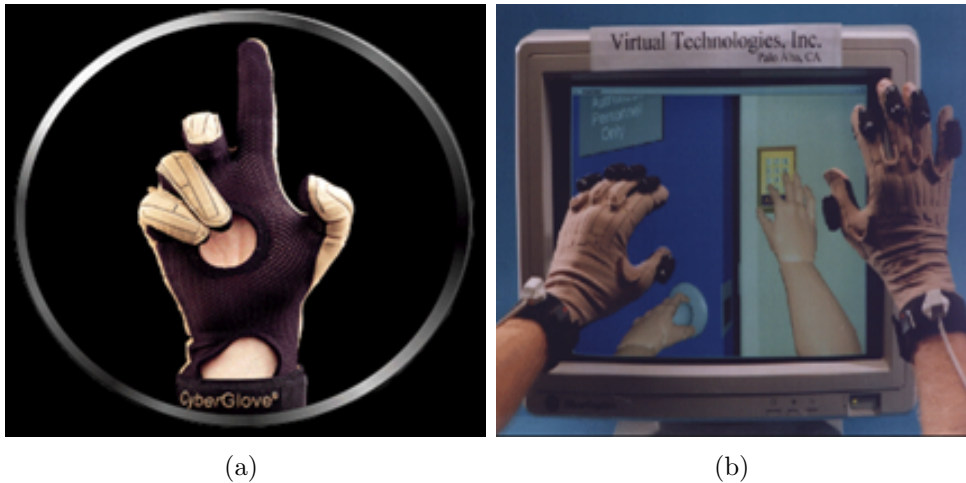

Figure 1.5: (a) CyberGloveTM, and (b) CyberTouchTM (adopted form (Immersion, 2010))

Workspace: Ideally, the haptic interface should not hinder the users movements and should allow them to work comfortably without straining their joints. In addition, the device should not allow users to perform occasional movements having larger amplitudes.

Posture and Grasping with hand: In order to perform a task in a virtual or remote environment, it is necessary for the user to adopt a posture as comfortable as possible depending on the task to achieve. For example to move objects over long distances, the user needs to be standing and moving.

Similarly he/she will adopt another posture, while manipulating objects in a smaller space. So the task has a great influence on movements and posture of the user. Therefore, these parameters play a significant role in the specification of the workspace of a force feedback interface.

Human hands are very complex and allow human beings to have different types of grasping while manipulating objects. For example, the object may be grasped between the palm and fingers of the hand to have more security and stability. In this case the contact surface between the hand and the object is important but the fingers' movement is limited. On the other hand, for accurate and dexterous manipulation, the object is usually grasped with fingers.

Static capacity and force resolution: It is difficult for a given user to receive a high level force for a long time because it causes him/her to tire quickly. This tiredness may effect the accuracy and user performance during task accomplishment. Therefore, it is desirable to have a limited range of force feedback.

The force feedback may be applied for a short duration, and that, a strong force may not be required during the entire application. For example, when exploring the environment, it is not necessary to have force feedback but it is required while touching an object.

Specification	Phantom omni	Phantom premium 3.0	Phantom premium 1.5	Phantom premium desktop
DoF	6	6	6	6
Work space (mm)	160x120x70	838x584x406	381x267x191	160x120x120
Maximum Force(N)	3.3	22	8.5	7.9
Minimum Force(N)	0.88	3	1.5	1.75
Inertia (apparent masse)	45g	<220g	<136g	45g

Table 1.1: Different models of Phantom and their specifications.

Similarly, while lifting an object the users must have realistic feelings of its weight, but it is not necessary nor desirable to exert force with scale 1 : 1. For security reasons, force feedback is generally controlled.

The force resolution can be defined as the minimum force perceptible that a device can render.

Dynamic stiffness, inertia and bandwidth: The mass of force feedback interfaces must be minimized because a greater mass may create problems while moving or stop the device quickly. The sensation of stiffness is also very important while using a force feedback device. Experience shows that stiffness of about 1500 to 3000 N/m is sufficient to give a good impression of a virtual surface stiffness. This value is 20,000 N/m to perceive a surface completely rigid.

The motor bandwidth is the frequency in which the operator can generate force or positions signals, and sensory bandwidth is the frequency band in which he/she can feel displacements or forces. If the signal frequency is constant, a person can follow a frequency of 2Hz to 5Hz.

In the following, we present some force feedback devices and their characteristics.

1.2.2.2.b PHANTOM: The PHANTOM Desktop 1.5/6 DOF, (see Figure 1.6-a) provides precise input and good haptic rendering. It has from 3 to 6DOF, it is portable and easy to install. However, it suffers from a relatively small workspace (160 x 120 x 120 mm). Another problem with this kind of device is that they provide force feedback for one hand only (Burdea, 2000). Figure 1.6 and Table 1.1 present some models of PHANTOM and their characteristics given in (SensAble, 2010).

1.2.2.2.c The Omega devices: These devices are based on a parallel mechanical structure. With their interchangeable effectors, they can provide rotation and active grasping (see Figure 1.7). These devices combine the force, stiffness and performance (Forcedimension, 2010). There are several models such as the omega 3, omega 6, omega 7, whose characteristics are given in the Table 1.2.

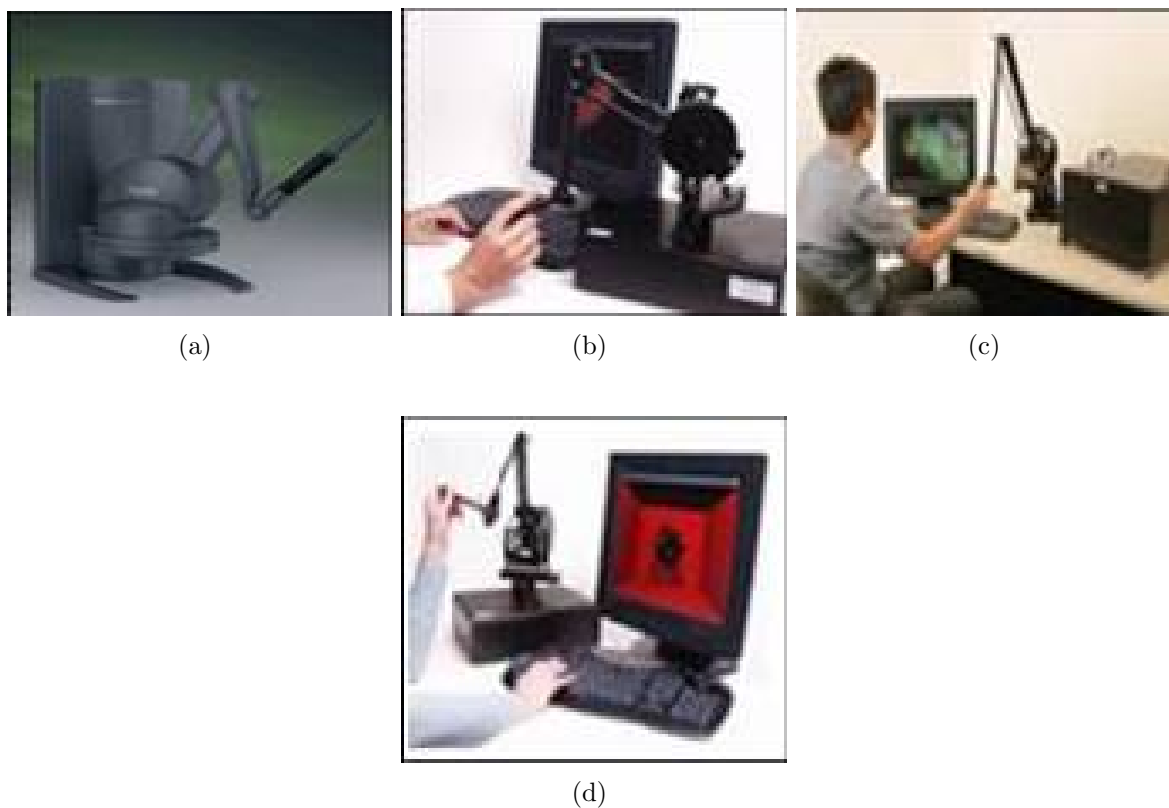

Figure 1.6: (a) Phantom desktopTM, (b) Phantom PremiumTM 1.5/6 DOF, (c) Phantom PremiumTM 3.0/6 DOF (d), and Phantom PremiumTM 1.5/3 DOF (adopted from (SensAble, 2010))



Figure 1.7: Some models of the omega x, of force dimension (a) Omega3 (b)omega6 (c) Omega7 (adopted from (Forcedimension, 2010))

Specification	Omega 3	Omega 6	Omega 7
Work space (mm)	160x110	160x110	160x110
Force (N)	12	12	8
Resolution	<0.01mm	<0.01mm	0.06mm

Table 1.2: Characteristics of different versions of Omega devices.

1.2.2.2.d Exoskeletons: These devices provide higher degrees of freedom (DOF) to the user. They are suitable for dexterous manipulation and immersive environments. However, users have to bear their weight. Similarly, they are usually not able to resist and/or prevent the movement of the user. We present two exoskeletons type devices (CyberGraspTM and CyberForceTM) in the following.

CyberGraspTM: The CyberGraspTM is the only haptic glove commercially available. The exoskeleton structure of CyberGraspTM is based on cables. The interface is powered by electric actuators that can apply a force up to 12 N on each finger. The exoskeleton structure is placed on the back of the user’s hand, and requires the placement of actuators in a remote control box. The weight of the system remains approximately 450g, even if the actuators are positioned remotely. This remains a cause of fatigue for the user while performing a task in VE.

CyberForceTM: The CyberForceTM is an exoskeleton device with fixed base, developed by immersion (Immersion, 2010). It can constrain both the position of the user’s hand and the movements of his/her fingers. The device has six degrees of freedom (6DoF) and can precisely measure the translation and rotation of the user’s hand. The workspace of the CyberForceTM is 12 x 12 inch.

The use of CyberForceTM with CyberGraspTM can allow to simulate the control of a virtual steering while feeling its weight and inertia. In addition, it allows the user to feel resistance during penetration in a simulated wall. The problems of this device are again its weight on the user and limited workspace.

1.2.2.2.e The 5-DOF Haptic Wand: Designed and constructed by Prof. Tim Salcudean, at the University of British Columbia. This haptic interface has five Degrees of Freedom (DOF, three in translation and two in rotation) (Quanser, 2010). This is achieved using an arrangement of a double pantograph. Each pantograph is directly controlled by two DC motors attached to its shoulders and another more powerful DC Motor, at its back. The effector is connected to the terminal points of the pantograph using universal joints (see Figure 1.8 (a)). Its main characteristics are given in the Table 1.3.

1.2.2.2.f The MagLev wrist: The device is based on magnetic levitation (Berkelman and Hollis, 1997). The power supply, amplifiers and control processors of the device are contained in a small box. A handle protrudes from the top of the box that is used by the user. The device is capable of a movement of 25mm in translation and 15 – 20 degrees in rotation (Micro_systems_labs, 2010). The maximum force and torque are 55N and 6Nm respectively. The stiffness is 25N/mm and its sensitivity in position ranges from

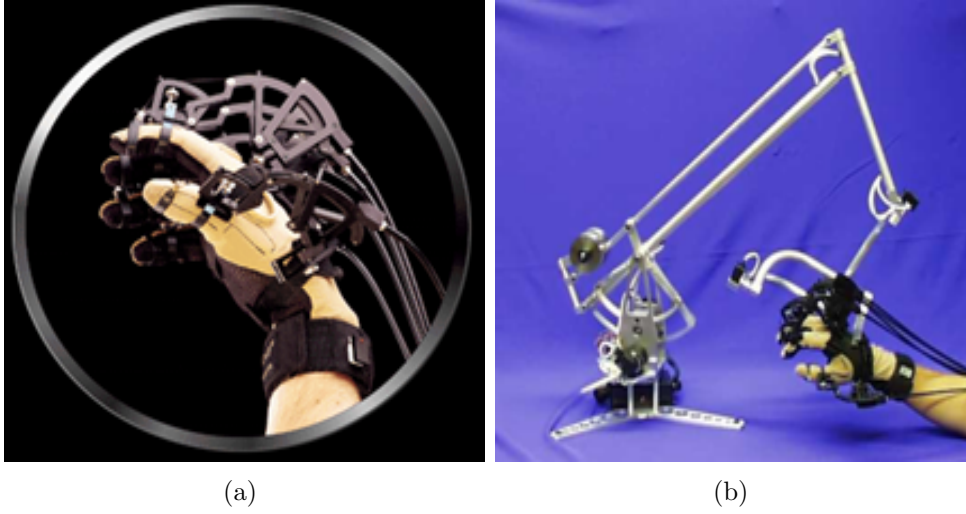

Figure 1.8: (a) The CyberGloveTM, (b) the CyberGraspTM, and the (c) CyberForceTM (adopted from (Immersion, 2010))

Workspace				
X(mm)	Y(mm)	Z(mm)	Roll(o)	Pitch(o)
± 240	85 – 335	215 – 235	± 85	± 65
Maximum force				
F _x (N)	F _y (N)	F _z (N)	T _x (N.mm)	T _y (N.mm)
2.3	2.1	3.0	230	250

Table 1.3: Specifications of the Haptic wand.

5 to 10 μ m. The MagLev wrist is shown in the Figure 1.9-b.

1.2.2.2.g The Haptic MASTERTM: It is a force feedback device (Figure 1.9-c) with 3 degrees of freedom (3DOF) (Moog_Systems, 2010). It has the ability to simulate the weight and force that human beings are encountered in variety of tasks. Variant characteristics or specifications are given in Table 1.4.

1.2.2.2.h Haptic interface 5-DOF: This is a haptic device having 5DoF (three in translation and two in rotation) and use Stylus as an effector (Orbit_system_Lab, 2010). Stylus is connected to three actuator rods in left while two from the right. The buttons on the stylus are used to control the application. The interface is able to provide a workspace of 40cm in translation and approximately ± 60 degrees in rotation (Lee et al., 2000). The resolution in position is 0.007mm and the maximum force that it can provide is 8N (Orbit_system_Lab, 2010). The device is shown in the Figure 1.10.

1.2.2.2.i The SPIDAR: The SPIDAR (SPace Interface Device for Artificial Reality) is a string-based force feedback device that was invented by Makoto Sato, in 1989 (Hirata and Sato, 1992; Makoto, 2002). It has successfully been used in many studies and applications (Tarrin et al., 2003; Luo et al., 2003; Richard et al., 2006; Ullah et al., 2007; Chamaret et al., 2009; Coquillart, 2009). A wire is attached to a motor through a pulley

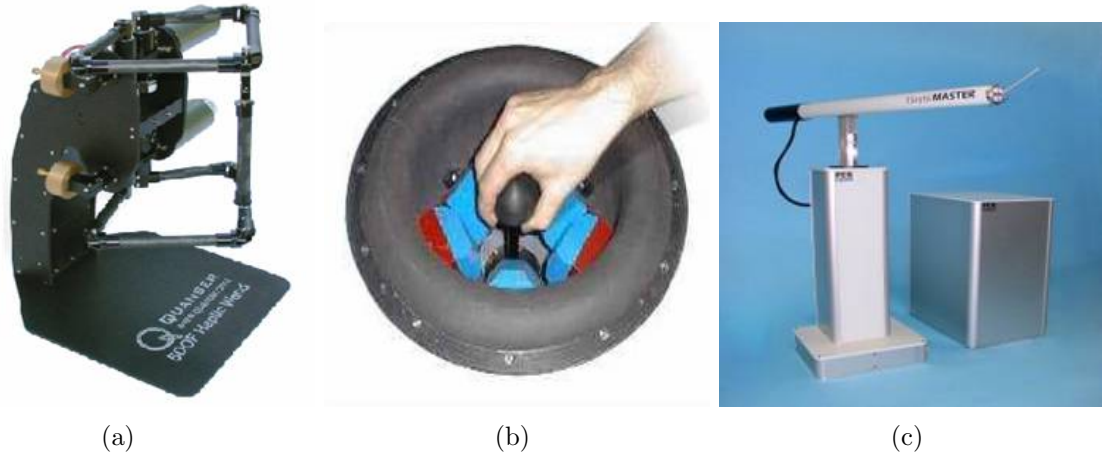

Figure 1.9: (a) The haptic wand, (b) the MagLev wristTM, and (c) the Haptic masterTM (Images (a), (b) & (c) adopted from (Quanser, 2010; Micro_systems_labs, 2010; Moog_Systems, 2010) respectively)

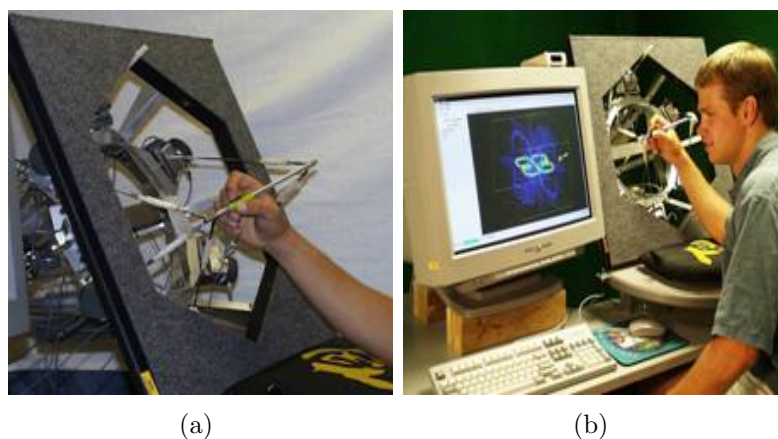

Figure 1.10: (a) 5-DOF Haptic Interface, and (b) a user operating the device (adopted from (Lee et al., 2000))

Resolution in position	Sensitivity in force	Maximum Force in output	Inertia simulated	Velocity maximum	Maximum simulated stiffness
0.000004m	<0.01N	250N	2kg	1m/s	5x10000N/m

Table 1.4: Specifications of the Haptic MasterTM.

on one side and to an end effector on the other side. Motors are responsible for folding/unfolding the wire around the pulley. Each motor is equipped with an encoder that takes into account the length of a string. The position and orientation of the end effector is calculated from wires' length. There are several versions of SPIDAR:

SPIDAR I: The device uses four motors, which are mounted on the frame in the manner illustrated in Figure 1.11-a. The force is exerted on a single finger of the user, using the four strings.

SPIDAR II: The SPIDAR II uses 8 motors and exerts forces on two fingers of the user's hand. This version of SPIDAR allows the user to grasp and manipulate virtual objects more naturally. The user can also feel the weight and size of virtual objects using two fingers. The SPIDAR II is illustrated in Figure 1.11-b.

SPIDAR for two Hands: In general, human beings use their two hands while performing real world tasks. To have this capability in the virtual environment, the SPIDAR for two hands has been designed. In fact, this device includes two SPIDAR II in a single frame as given in the Figure 1.11-c.

SPIDAR 8: The SPIDAR 8 is not very different from SPIDAR II, but it uses both hands of the user and exerts forces on the four fingers of each hand. The Figure 1.11-d illustrates SPIDAR 8.

SPIDAR-G: This is another version of SPIDAR with 6 DoF (3DOF for translation and rotation). It uses eight motors that are attached to a single effector. The Figure 1.11-e shows a SPIDAR-G.

SPIDAR-H (Human scale SPIDAR): This version of SPIDAR was developed to be used in large scale immersive and/or semi immersive environments. Using this SPIDAR user can manipulate virtual objects with both hands, and can also navigate independently in the environment. The structure of SPIDAR-H is shown in the Figure 1.11-f.

Measurement of position of the SPIDAR: We know that wires are attached to their respective pulleys on one side and to an end effector on the other side. The position of the effector in space is determined from the length of these strings using the calibration information. As shown in (Bouguila et al., 2000) consider the actuators (motor, pulley, encoder) are mounted on the corners (vertices) of the structure whose coordinates are represented by the points A0, A1, A2 and A3, respectively, in the Figure 1.12.

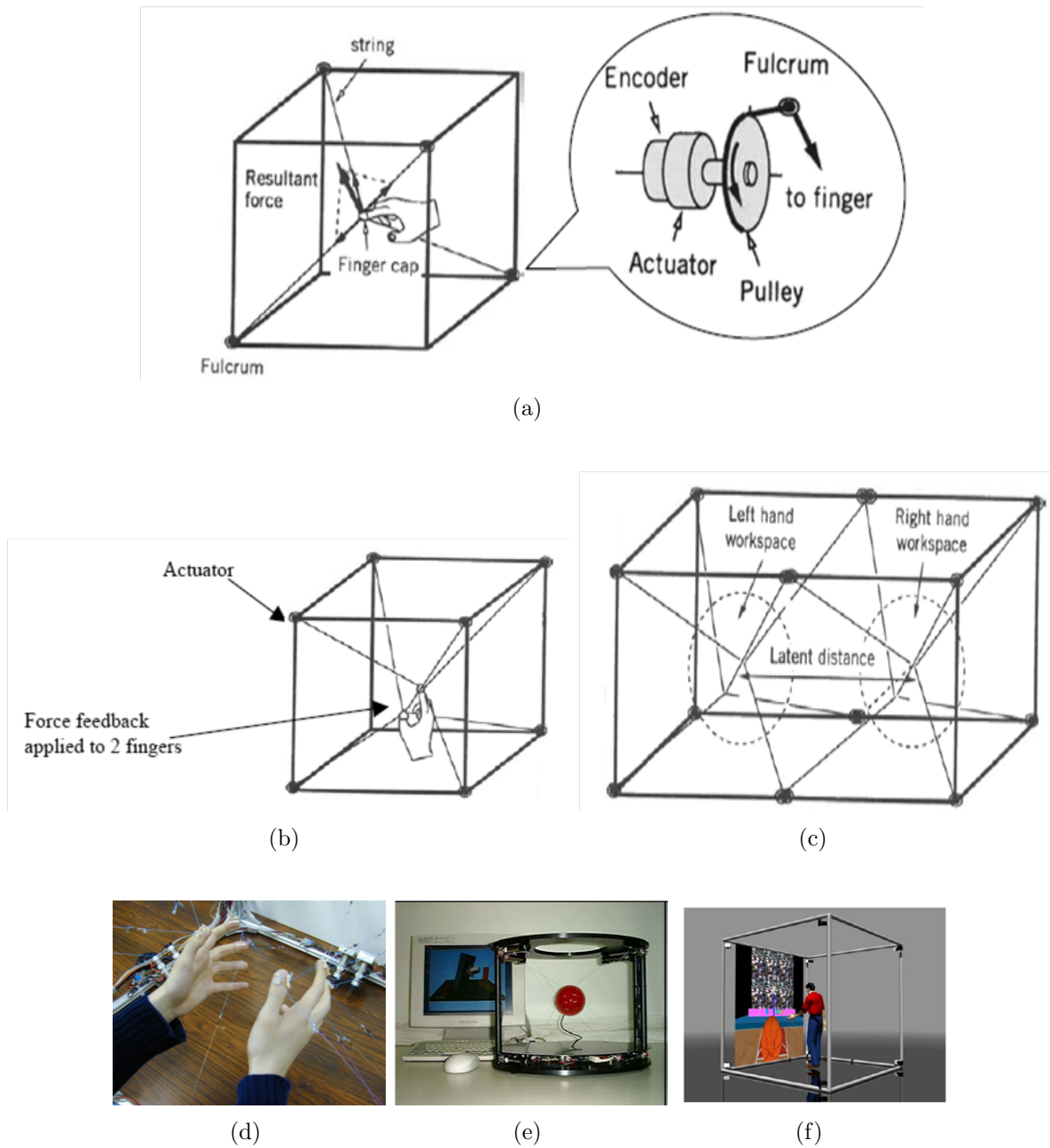

Figure 1.11: Different versions of the SPIDAR (a) SPIDAR I (b) SPIDAR II (c) SPIDAR for two hands (d) SPIDAR 8 (e) SPIDAR-G and (f) SPIDAR-H (adopted from (Makoto, 2002; Kohno et al., 2001; Luo et al., 2003)

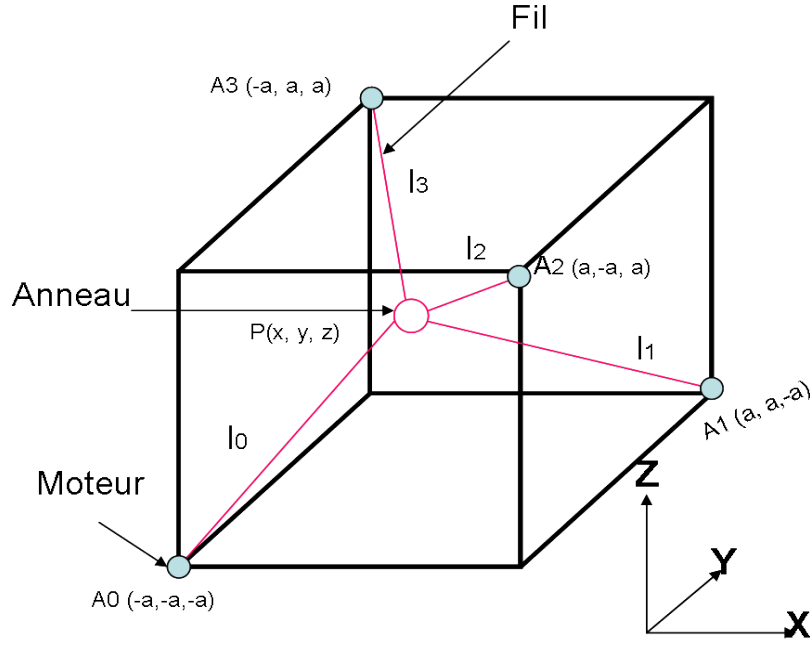

Figure 1.12: SPIDAR frame : positions and coordinates of the actuators.

If we consider the center of the structure as origin $(0, 0, 0)$, then the coordinates of points where the strings are attached to the pulleys can be given (as shown in the Figure 1.12). If we consider $P(x, y, z)$, the point that represents the position of the effector at any given time and space, then we can calculate the position of the effector as follows :

$$l_0^2 = (x + a)^2 + (y + a)^2 + (z + a)^2 \quad (1.1)$$

$$l_1^2 = (x - a)^2 + (y - a)^2 + (z + a)^2 \quad (1.2)$$

$$l_2^2 = (x - a)^2 + (y + a)^2 + (z - a)^2 \quad (1.3)$$

$$l_3^2 = (x + a)^2 + (y - a)^2 + (z - a)^2 \quad (1.4)$$

Where l_i ($i = 0, 1, 2, 3$) represents the length of the strings. To find the coordinates x, y, z of point P , the equations (1.1, 1.2, 1.3, 1.4) are used and we obtain:

$$x = \frac{(l_0^2 - l_1^2 - l_2^2 + l_3^2)}{8a} \quad (1.5)$$

$$y = \frac{(l_0^2 - l_1^2 + l_2^2 - l_3^2)}{8a} \quad (1.6)$$

$$z = \frac{(l_0^2 + l_1^2 - l_2^2 - l_3^2)}{8a} \quad (1.7)$$

Measurement of Forces: The SPIDAR effector is connected to the motors (four in the case of the human-scale SPIDAR and height for the SPIDAR G) through strings and each string can get some tension via its corresponding motor. The SPIDAR uses the resulting tension of the strings as force. The resultant force at effector's level acts

on the user's hand. The mathematical representation of the resultant force is given in equation 1.8.

$$\vec{F}_t = \sum_{i=0}^n a_i \vec{u}_i, (a_i > 0) \quad (1.8)$$

In the case of the SPIDAR G, there is rotational force is well, which is taken into account and calculated as given in (Luo et al., 2003) and is shown in equation 1.9.

$$\vec{F}_r = \sum_{i=0}^n a_i \vec{u}_i * d_i, (a_i > 0) \quad (1.9)$$

Where a_i represents the value of the string's (i) tension , and \vec{u}_i is the unit vector of tension (for $i = 0 \dots n$, where $n = 3$), d_i is the distance covered by the string.

Characteristics of the SPIDAR: The SPIDAR has many advantages:

- The workspace is generally larger and re-configurable.
- User is generally free in his/her movements.
- It does not disturb the visualization of the virtual environment.
- The device is almost weightless.
- Its integration in 3D interaction techniques is easy.
- It allows manipulation with one and/or both hands.

On the other hand it also has some drawbacks :

- The SPIDARs are usually in the form of prototype systems and their hardware and software installation is not obvious.
- Another problem of the SPIDAR is that, its accuracy decreases as the distance between the effector and the center of the workspace increases. In addition, the maximum force that could be display in any direction decreases as well.

1.3 3D Interaction

The interaction plays a very important role in the effective use of a computer and its different applications. The interaction can be defined as a language of communication between man and machine. This language is the set of actions/reactions loop between human and computer through sensory and motor interfaces and interaction techniques (Sternberger and Bechmann, 2005). In case of two dimensional (2D) environments, the paradigm of Windows, Icons, Menu and Pointing (WIMP) is well developed and known, that allows us to use our computers and their applications with efficiency and comfort.

The 3D interaction is like a system that uses a software as input to connect the various hardware devices and software technologies to run an application in output. These different softwares allow the user to use the devices that are on his/her disposal, via drivers that provide access to low-level devices, and high level application software. The various interaction techniques lies between the material layer (low-level) and the application layer (high level) (Ouramdane, 2008).

1.3.1 Interaction techniques

In VR, users need to interact with the objects of the virtual world. An interaction technique is the method that allows to perform an interaction task in a VE (Bowman, 1999; Hachet, 2003). Foley et al. consider it as how to use a device to accomplish a task on a computer (Foley et al., 1996).

1.3.2 Interaction paradigm

In VR, the interaction paradigm can be defined as a set of rules and techniques to enable the user to perform tasks of interaction within a virtual environment (Bowman, 1999; Poupyrev et al., 1998; Mine, 1995). According to Ouramdane, interaction paradigm is a method that allows a user to interact with its virtual environment (Ouramdane, 2008).

1.3.3 Interaction metaphor

The metaphor of interaction means that a real object or concept is used as a virtual tool to interact with the virtual environment (Sternberger, 2006). An interaction metaphor combines all interaction techniques that use the same virtual tool or the same concept to interact with entities in the virtual world.

1.3.4 The fundamental tasks of 3D interaction

1.3.4.1 Navigation

The navigation includes all viewpoint movements of the users in virtual environments. The objective of navigation is to reach a predefined or a searching location. Navigation in virtual environments may or may not takes its inspiration from the movements or navigation of the human beings in the real world.

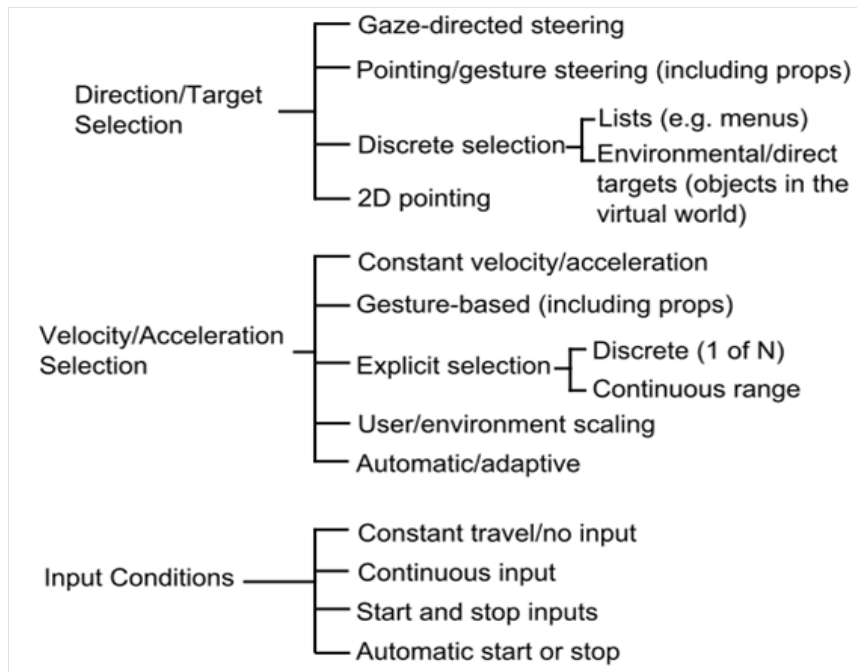

Figure 1.13: Illustration of navigation techniques (adopted from (Bowman et al., 1997))

Mackinlay et al. have divided the navigation in two types: the first is the general movement of the user, where he/she is free and can go to any point in the virtual environment (Mackinlay et al., 1990). In the second case the movement is controlled and the user follows a defined path to reach a target.

Similarly Bowman et al. have defined two major components of navigation: the displacement (travel) and the search of a route (way finding) (Bowman et al., 1997). Similarly they presented a taxonomy of navigation techniques in the VE (Bowman et al., 1997) (see Figure 1.13). The displacement is the motor component of navigation and means the physical movement of the user from one place to another. The route search is the cognitive component of navigation that allows users to locate/identify himself in the environment and then choose a path to move (Fuchs et al., 2006).

1.3.4.2 Selection

To manipulate an object in the real world, at first step, human beings always grasp it in hand(s). In Human-Computer Interaction (HCI), selection is the task of acquisition or designation of a target. For example, in Graphical User Interface (GUI) system, an icon is selected through a mouse click. Bowman et al. define the selection as the designation of an object or a set of objects in order to achieve a goal in the virtual environment (Bowman et al., 2005). Bowman et al. have also presented a taxonomy of object selection in VEs (Bowman, 1999) (see Figure 1.14)

1.3.4.3 Manipulation

Manipulation is usually the main goal of a 3D interaction system. Usually, the manipulation task is performed after selecting an object or set of objects. Manipulation can

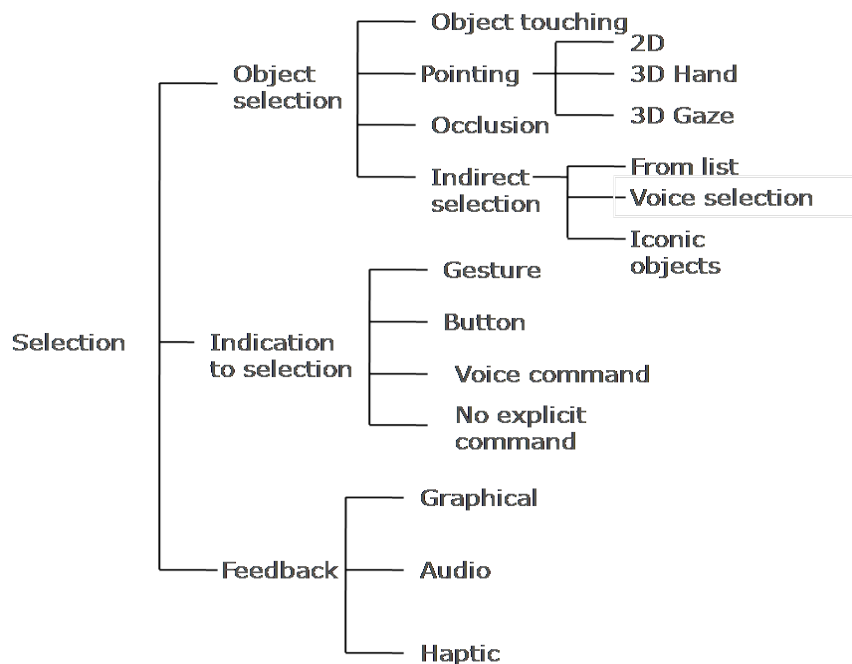

Figure 1.14: Illustration of selection techniques (adopted from (Bowman, 1999))

be defined as a process that allows to change the properties of an object or set of objects of the virtual world. For example, to change the position, orientation, color and texture, etc..

1.3.4.4 Application control

Application control can be defined as a task that combines all the techniques that allow users to communicate with the system or application using an interface. The control of application allows users to run a command to achieve a specific goal or objective.

According to Bowman et al. (Bowman et al., 2005) application/system control is a task that allows the user to:

- Run a particular application of the system ;
- Change the mode of interaction ;
- Change state of the system.

1.3.5 Classification of 3D interaction

The existing 3D interaction techniques related to virtual environments can be grouped into two types (Poupyrev et al., 1998; Poupyrev and Ichikawa, 1999) : i.e exocentric and egocentric techniques.

1.3.5.1 Exocentric interaction techniques

In the exocentric type of interaction user itself is not within the virtual environment but he/she has the power to act on objects of the virtual world. This interaction is also known as “God’s eye viewpoint”.

One of the first metaphors for selection and manipulation that is based on exocentric interaction has been proposed by Stoackley et al. (Stoackley et al., 1995). They use a miniature representation of the virtual scene that allows the user to act indirectly on the virtual objects in the scene. The user holds a model of the virtual world in his non-dominant hand and manipulates objects with his dominant hand. This approach is also called “world-in-miniature”. The major drawback of using the “world-in-miniature” is the description and manipulation of objects that are small at the origin.

To overcome this problem, Pierce et al. have proposed the technique of Voodoo Dolls (Pierce et al., 1999). This gives the user the ability to create his/her own virtual world of miniature objects that are called “dolls”. The manipulation of the selected object is done through the technique called “head crusher” (Pierce et al., 1997). Here, a miniature model of the object and its immediate environment is created in the non dominant hand. The dominant hand is used to move and rotate the small created object. This technique allows the manipulation of objects of various sizes near the user.

1.3.5.2 Egocentric interaction techniques

In the egocentric type interaction the user is considered within the virtual environment. Egocentric techniques are further divided into two types: virtual pointer and virtual hand. In case of the virtual pointer, object is selected and/or manipulated when the vector emanating from the pointer intersects the object (Pierce et al., 1997). Ray casting technique uses the same principle (Mine et al., 1997). Similarly the “flash light” technique uses an infinite cone for selection, but is based on the same principle (Liang and Green, 1994).

The virtual hand metaphor is inspired by man’s real hand that he/she uses to select and/or manipulate objects. A virtual representation of the real hand is used and the selection is made when it touches an object in the virtual world (Sturman et al., 1989). The technique “Go-Go” (Poupyrev et al., 1996) also called “arm-extension” is based on the same principle of virtual hand but uses a nonlinear function between the real hand and his virtual representative. Chen and Bowman have introduced a concept called *domain-specific design* (DSD) that uses domain knowledge for designing 3D interaction techniques (Chen and Bowman, 2009).

1.3.5.3 Hybrid interaction techniques

This Technique combines the characteristics of egocentric and exocentric techniques. For example, the technique HOMER (Hand-centered Object Manipulation Extending Ray-casting) which uses the fastness of the Ray-Casting technique for the selection and the precision of Simple Virtual Hand for manipulation (Bowman et al., 1997). The “scaling”

(Mine et al., 1997) technique is another example of hybrid interaction techniques that uses gaze direction for selection. When a virtual object is selected in the image plane, the system enlarges the user or reduces the object so that the virtual hand can really touch the object.

1.3.6 Haptic interaction

The origin of haptic is the Greek word “haphe” or “haptesthai”, which is related to the sense of touch or contact. Haptic technology refers to the interfaces that use the sense of touch by applying forces and/or vibrations in order to transfer haptic informations to the user. This stimulation is used to create virtual objects with mechanical or physical properties. As presented by Burdea, in (Burdea, 2000) haptic includes force feedback (simulating object’s hardness, weight and inertia) and tactile feedback (simulating object’s size, surface conditions, temperature etc.).

As given in (Fuchs et al., 2003), the telepresence with force feedback was the first work that was done in the nuclear industry in the mid 50s. This was a “master slave”, configuration allowing user to manipulate nuclear materials with the remote slave robot device while controlling it via a mechanical master arm.

In 80s, a significant progress in computer and robotic control systems has been made. At that time, it was possible to develop master arm and slave with a different structure. It means that, the master arms were more adopted to user’s abilities, while the slave arms were more task oriented. These advances have enabled the teleoperation techniques to be used wherever man can not intervene directly, either because the environment is hostile, or inaccessible.

The enormous progress of information technology also allowed the researcher to use such devices not only in teleoperation tasks but also in virtual environments. VR applications started using haptic devices from early 90s (Adachi et al., 1995; Mark et al., 1996). At start, the robotic arms (master) of the first generation were used in virtual reality, but later on, more specific force feedback devices were developed for virtual reality applications. Haptic rendering can be defined as the process of calculating and generating forces in response to user interactions with virtual objects (Salisbury and Srinivasan, 1997).

Akamatsu et MacKenzie studied the influence of haptic feedback on object selection, using a 2D haptic mouse (Akamatsu and Mackenzie, 1996). They showed that different haptic feedback improved the task completion time and the time taken to stop the cursor once the target is hit. In contrast, the tactile feedback tended to degrade the accuracy of the experimental subjects. Hasser et al. proposed to generate forces, attracting users towards a target (Hasser et al., 1998). They reported that haptic feedback resulted in a slight improvement of task completion time for selection tasks. In order to enable the disable persons to make the efficient use of computer, an artificial damping has been proposed for the reduction of the sudden and high frequency movements (Hwang et al., 2001).

One popular and simple interface that provides the impression of real-world force is “props” (Hinckley, 1996). The “props” is a small physical object that is similar to the one

to be manipulated in the virtual world. This interface allows the user to manipulate virtual objects in a natural way and provides a tactile and kinesthetic feedback. Ortega and Coquillart have investigated the integration of active force feedback and props in immersive visual display with co-location. In this study a prop is attached to a haptic device, to provide realistic grasp information as well as force feedback (Ortega and Coquillart, 2005).

Several studies have been carried out to investigate the influence of haptic feedback on navigation in VEs. For example, Van Veen and Van Erp, used tactile vibrators to provide information about direction during navigation (Veen and van Erp, 2003). In a simulated helicopter flight, they showed that the pilot was able to compensate for helicopter's drift caused by reduced visibility by using the vibrators. Lécuyer et al. have proved that force feedback can improve the perception of motion of a user moving passively in a virtual environment (Lécuyer et al., 2004). In their experiment the wrist of the user was forced to turn the same angle as the turns of the desired path in the virtual world via a force feedback device.

Miller and Zeleznik, have studied the influence of haptic interfaces with WIMP paradigm. For this, they have developed haptic assistance for icons, menu and alignment guides while moving windows. In their experiments they concluded that these guides could greatly improve the drag and drop operations of icons. On the other hand, they degraded the performance of the user while navigating through menus (Miller, 1998).

Similarly Komerska and Ware have also made a study to use the haptic feedback with plans and options of menus (Komerska and Ware, 2004). They observed that haptic limitation of pointer within the menu options and magnetism slightly increased execution time, but added considerably to the accuracy of selection.

Dominjon, in his PhD thesis, also carried out a study of object manipulation with force feedback in human scale virtual environments (Dominjon, 2006).

1.3.7 Assistance in 3D interaction

Human beings, uses many tools for their assistance in their daily lives, in order to improve their performance and acquire more precision in task. For example, the use of a ruler allows us to draw a line faster and straight (Rosenberg, 1992). In other words, we can say that these tools not only increase the success of work but also reduce the risk of failure and damage to the workspace. Taking inspiration from the tools of assistance of the real world, researcher conceptualized and designed various tools (virtual fixtures) to provide assistance in the tasks of teleoperation and virtual reality.

Virtual fixtures (guides) can be defined as computer generated aids that gives sensation of physical structures (Rosenberg, 1992). In the context of teleoperation, Rosenberg reported that the virtual guides superimposed on sensory feedback of the remote environment, could act to reduce brain processing required to perform the task, reducing the burden of certain sensory modalities, and especially can provide precision and performance that exceeds the natural capacity of man. The visual, auditory and haptic modalities may

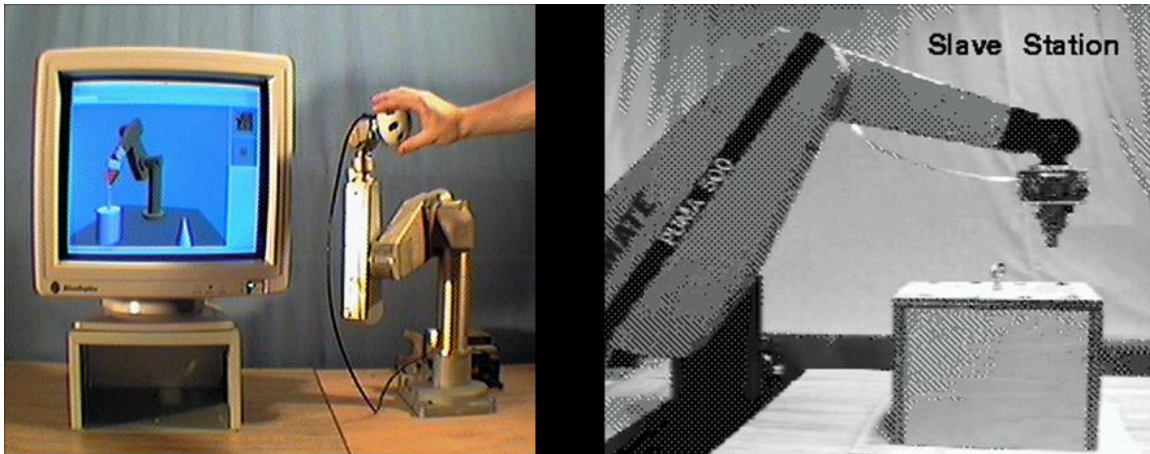

Figure 1.15: The system of Sayers and Paul : the master robot (left), and the slave robot (right)(adopted from (Sayers and Paul, 1994)).

be used alone or in various combinations to form virtual guides.

Similarly haptic guides are defined as signals of position and force generated by the software and applied to the human operators via the robotic system. The haptic guides are used to help men perform robot-assisted manipulation, by limiting operator's movement in specific regions and/or influence the movement along a desired path (Abbott et al., 2005). In the following subsections, we present various guides (assistance) used in VEs and teleoperations.

1.3.7.1 Visual assistance

Rosenberg, introduced for the first time the concept of virtual guides (Virtual Fixtures) in a system of telepresence (Rosenberg, 1992; Rosenberg, 1993). In this context, the operator controls a real robot via an exoskeleton to perform insertion tasks. During task accomplishment the operator can feel the presence of virtual guides using haptic and/or auditory cues. User studies revealed that virtual guides improve users performance up to 70 percent.

Other important works that use virtual guides were carried out by Sayers and Paul, where the operator works with a virtual representation of the remote real robot. The actions undertaken in the virtual world are observed then sent as a sequence of instructions to the real robot (Sayers and Paul, 1994) (see Figure 1.15).

Another important study on virtual guides was done by Samir Otmane under ARITI (Augmented Reality Interfaces for Teleoperation via the Internet) project. In this work, several guides have been formalized and used to provide assistance to the user for the teleoperation of a robot (Otmane, 2000) (see Figure 1.16).

Bergamasco et al. have also proposed the use of visual indicators (arrows) allowing the user to estimate the forces exerted on him/her while manipulating virtual objects (Bergamasco, 1992).

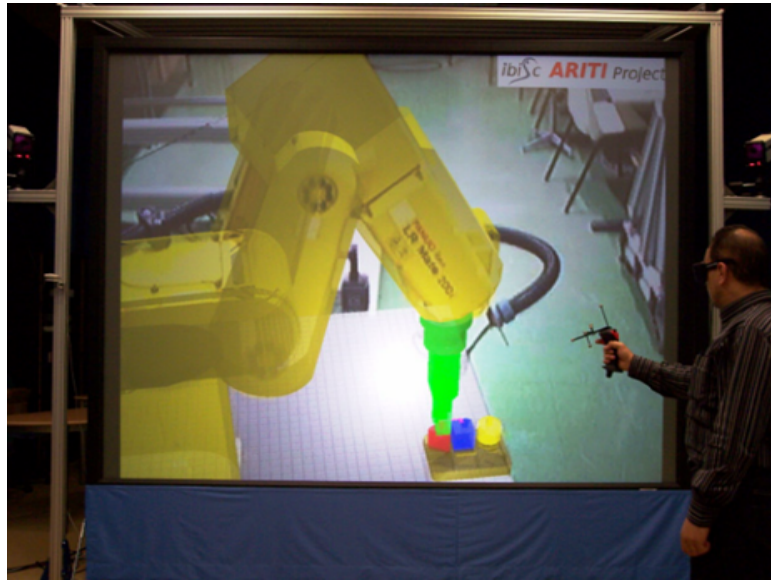

(a)

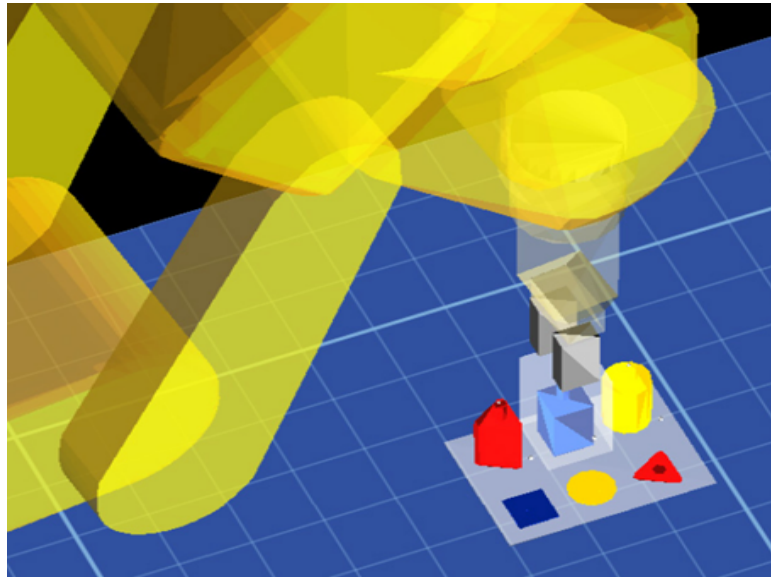

(b)

Figure 1.16: Illustration of visual guides in the teleoperation of a FANUC LR-MATE 200i robot (Images taken from (Otmane and Davesne, 2009)) : (a) a user controlling the robot, and (b) side viewpoint of the virtual robot and workspace.

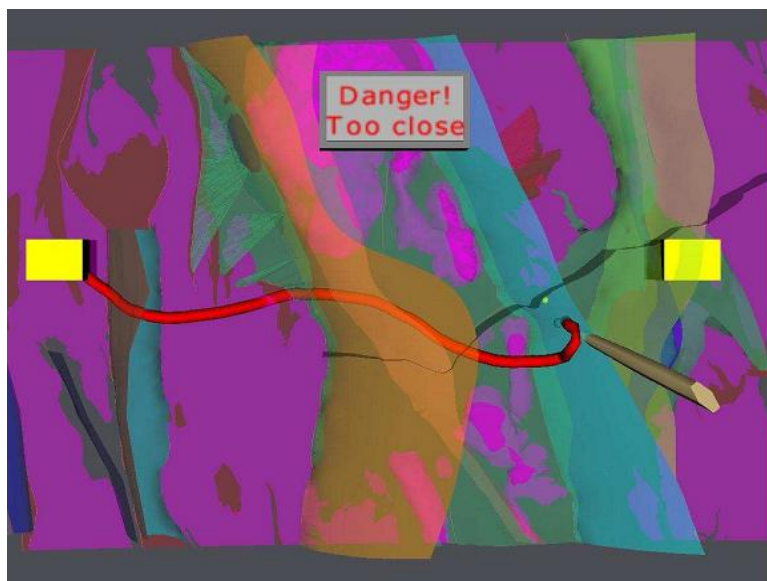

Figure 1.17: Screenshot of mine planning stage, showing geological layers of rocks and road tunnel(adopted from (Gunn, 2005))

1.3.7.2 Haptic assistance

Chris Gunn has reported the development of a 3D immersive environment that contains geological information (Gunn, 2005). The environment allows the user to design road that has been planned from the surface to the underground mine. To design an optimal route while respecting various constraints, such as avoiding dangerous areas, slopes and sharp curves, they use three types of haptic guides. The first guide is a repulsive force from hazardous areas within geology. When the user's tool approaches these areas, they feel a force pushing them apart.

The second force prevents them from designing a road with a higher slope that is too difficult for trucks to climb. The third force was designed to avoid a curve that is too narrow for trucks while turning.

Lécuyer et al. studied the influence of haptic feedback on the performance of human operators, in an insertion task. The results showed that, in the presence of the force feedback, the operators were more focused on the accuracy of the task rather than the speed of task execution (Lécuyer et al., 2002).

Chamaret et al. have also observed that haptic assistance (guide) increases users' performance in accessibility tasks (Chamaret et al., 2010).

1.3.7.3 Auditory assistance

The auditory feedback can be used in the VEs to help users to perform a task. Diaz et al. studied the improvement made by an auditory feedback on user performance in tasks of accessibility. The results showed that the auditory feedback enabled the operator to

anticipate and correct his/her trajectory (Diaz et al., 2006).

Similarly, Richard et al. have studied the performance of human operators in the context of multisensory interaction (visual, audio, haptic) in VE. The results indicated that the force feedback not only increased performance but also reduced the error rate. It was also shown that the replacement of force feedback by auditory feedback has led to similar results (Richard et al., 1996; Richard et al., 1994).

1.3.7.4 Properties of virtual guides

In his research, Otmane et al. found that virtual guides must have the following properties according to the nature and context of their use (Kheddar, 1997).

- **Attachment:** Each virtual guide can be attached to a virtual object or a location of the virtual environment. It can be attached in a static way (it is fixed in one location or a virtual object attached to individual) or dynamic (it appears after an event, for example, on collision detection). Thus, we define for each guide a position and orientation in space defined by the virtual environment.
- **Zone of influence:** A virtual guide may be associated with a zone (as volume, surface or otherwise) that will act as a basin of attraction or simply a zone of action. In general, a zone of influence is defined by an analytical equation (static or parameterized) which defines (totally or partially) the shape of the guide.
- **Condition of activation:** Each guide is associated with a condition of activation.
- **Function:** The function of the guide defines its *raison d'être*. It may be expressed through actions to establish within the virtual guide.
- **Condition of deactivation:** The condition of deactivation stops the virtual guide of functioning. It can be defined as a negation of the condition of activation or achieving a desired end state.

Prada and Payandeh also suggested that some aspects must be defined and used in the most basic abstraction of Virtual Fixture/guides (VF) (Prada and Payandeh, 2009). These properties are:

- **Geometric Properties:** This set of properties defines the type and size of primitive representing the VF in the scene. The primitive determines if VF is represented by a sphere, cone, cylinder or rectangular prism in space. Size may be the radius, height, width and length of the primitive.

- **Graphic and spatial properties:** These define the visual information and the positioning of VF and provide support for the display in graphics applications. Visual information can be the color, transparency or mesh primitive. The spatial properties are primarily the position and orientation of the primitive.
- **Properties related to the environment:** These properties represent the details of the environment to have the VF aware of different objects in the scene.
- **Properties of force:** These properties represent some of the data and methods needed to calculate and provide force feedback. The data includes the performance, direction and magnitude of force, and information about the force feedback device.

1.4 Conclusion

We started this chapter with the definition of virtual reality (VR) and virtual environments (VEs). We also described the three basic components of VR proposed by Burdea and Coiffet : Immersion, Interaction and Imagination.

Then, we presented a state of the art on existing VR interfaces. The methodology we adopted for this is presenting these interfaces on the bases of their technologies. For example interfaces based on motion sensors, magnetic and acoustic tracking etc. We also described the benefits and disadvantages of these interfaces. A large part of this section has been devoted to haptic interfaces. This part was further divided into two, i.e interfaces that provide tactile feedback and interfaces that provide force feedback. We described some existing haptic interfaces, based of their technology and other characteristics such as degree of freedom (DOF), workspace, resolution, bandwidth, etc.

In the last part of this chapter, we discussed the role of assistance for task accomplishment in virtual or remote environments. In this context, we have described some existing work on visual, haptic and auditory assistance. We noted that all these aids have been provided in the single-user environments.

In the next chapter we will present a state of the art related to collaborative work in VEs.

Chapter 2

Architecture and requirements of Collaborative Virtual Environments

2.1 Introduction

There are many situations where the nature of task is very complex and it is very difficult or impossible to be performed by a single person, so the task is accomplished by two or more people in collaboration. For example, the design of a complex machine (aircraft, engine etc) or a large building requires collaboration. Similarly the surgical tasks and multi-player games require collaboration among several people. Due to the importance of collaboration in the accomplishment of tasks in real world, researchers have already begun to address the development of collaborative virtual environments (CVEs).

In the next section, we present the application areas for collaborative virtual environments followed by some definitions (presence, awareness etc.). Then we present the existing work in the domain. The last part of the chapter presents models and requirements of CVEs.

2.1.1 Applications of collaborative work

VR systems have emerged as powerful tools to train people in tasks that are either costly or dangerous to replicate in the real world (Richard J. Adams, 2001). The flight simulation is the well known area where civil and military pilots are trained using virtual environments. Similarly, training for assembly tasks (Richard J. Adams, 2001) and repair have already got the attention of researchers, but most of these tasks may be better achieved in collaboration.

The collaborative work can also be applied in the field of teletherapy for the rehabilitation of stroke patients (Popescu et al., 2002). In recent years telesurgery has gained the attention of researchers because experts surgeons in certain domains are very rare and

it is not always possible for them to go to geographically remote hospitals. So we hope that the telesurgery system will help solve this problem. It is also evident that surgery is a collaborative task and it is usually done by more than one experts or the expert is at least given the assistance. It means that telesurgery is an other candidate area for collaborative work. Teleming is another area of great interest where the mechanism of collaboration can be applied to optimize resource utilization and increase productivity. Other areas where CVEs may be applied are military, education, CAD and scientific data exploration.

2.1.2 Types of collaborative work

The collaborative interaction is one of the major challenges of research in the field of Collaborative Virtual Environments (CVEs). The objective of this research is to allow multiple users (co-located or distant) to share a virtual space and interact with objects in it. Collaboration in VEs can be classified as follows (Margery et al., 1999; Otto et al., 2006; Aguerreche et al., 2009b).

- The environments in which users perceive the co-presence through their avatars, but each user can independently interact with objects. Any change to the attribute of an object or scene by a user is visible to all his/her collaborators.
- The environments which allow multiple users to co-exist, but only one user is active at any given time and is able to interact and/or manipulate objects. The others remain passive and wait their turn.
- The environments in which two or more users can manipulate the same object. This type of manipulation can be asynchronous, for example if a user moves an object from one place to another, then a second user moves it farther away, or when multiple users synchronously move an object. Synchronous/simultaneous manipulation is also known as cooperative manipulation (Pinho et al., 2008).

2.1.3 Some definitions

2.1.3.1 Presence

We know that CVEs enable multiple users to co-exist and work together. With the aim that the common task is done in a natural way and have better performance, it is required that users must see each other and be aware of the status and actions of other users in the virtual world. Here presence is related to collaborative VEs and is used in a social context, referring to the sensation of being together with other persons.

It is also clear that human body plays an important role in communication (Goebbels et al., 2003). For this purpose, each user must have a representation in the environment, which not only signifies his own presence but also allows others (users) to detect and/or

identify him/her in the virtual world. In addition, this representation gives us information such as position and orientation of a user relative to other users and objects in the environment.

The representation of users in the environment is used for their identity, to make distinction among multiple users and identify their activities and status in the environment (Goebbels et al., 2003).

2.1.3.2 Awareness

The awareness is defined as feelings of a user about the presence of other users in the shared space. We can say that it is the knowledge of a user about the actions, intentions and status of other users in collaborative virtual environment. The Awareness measures the extent, nature or quality of interaction between two objects or users (Greenhalgh, 1997). Greenberg et al. have categorized awareness into three types (Greenberg et al., 1996).

- Informal awareness is the general sense of a person about people in his work community. Informal awareness facilitates limited and casual interaction.
- Social awareness is the information that a person maintains about others in a social or conversational context: for example, knowing about a person's attention and level of interest. It is normally achieved through non-verbal channels such as gaze and facial expressions.
- Group structural awareness is the knowledge about people's roles and responsibilities and their status.
- Workspace awareness is the knowledge about the people's identity, location and activities.

2.2 Existing work related to collaborative virtual environments

In this section we present some existing work related to CVEs.

2.2.1 Systems for teleconferencing

MASSIVE (Model, Architecture, and System for Spatial Interaction in Virtual Environments) is a prototype collaborative virtual environment designed for teleconferencing (Greenhalgh and Benford, 1995). The system enables multiple participants at different sites to have real-time communication using different media. In particular, the system is able to use auditory, visual and textual channels as means of communication.

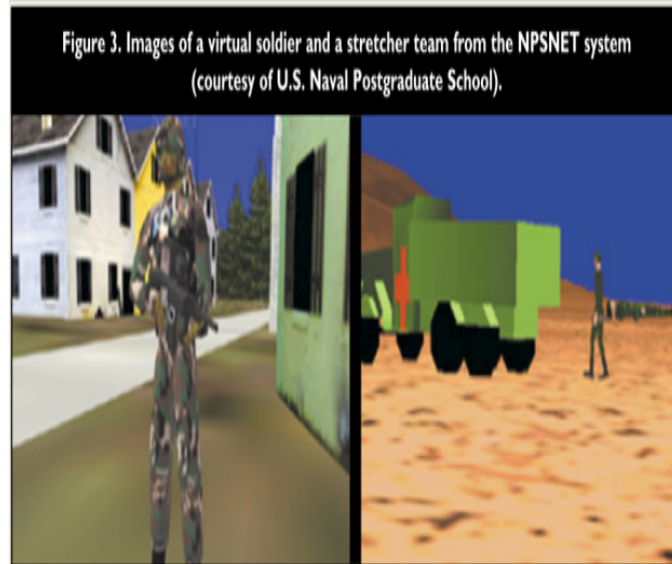

Figure 2.1: Illustration of the (a) virtual room for teleconference (adopted from (Frécon and Nöu, 1998)) and (b) table for meeting and learning (adopted from (Dumas et al., 1999))

Frécon and Nou have developed the “Virtual room” (Frécon and Nöu, 1998). It is a collaborative virtual environment that supports geographically remote users, the environment is based on the fundamentals of the DIVE system and a set of virtual tools designed to facilitate and organize individual and group work. The DIVE system initially supported text and audio communication, and was able to represent the users in the form of avatars in the VE. The motivation for the choice of the room is due to the fact that it provides social collaboration (i.e physical proximity and ease of access) among team members. The standard rooms generally offer tools for collaboration such as white boards, flip charts or overhead projectors. In addition they contain ordinary furniture such as chairs, tables and shelves. The virtual room also provides facilities such as given in Figure 2.1-a. Another work that uses the metaphor of meeting around a table for collaborative task has been reported by Dumas et al. in (Dumas et al., 1999). This environment can be used for meeting as well as learning purposes (see Figure 2.1-b).

NPSNET is a 3D networked virtual environment system developed at the Computer Science Department of the U.S. Naval Postgraduate School. It is designed to support large-scale military training and simulation exercises (Capps et al., 2000; Macedonia et al., 1995) (see Figure 2.2).

Mer et al. have carried out an important project “**Argonaute 3D**” in the medical field (Le Mer et al., 2004). The project uses the system **SPIN-3D** as a base, and allows doctors to access medical records of individual patients, and 3D reconstructed data of MRI or other scanners. A virtual room is available and that allows physicians, represented by avatars to communicate. The communication can be vocal or through gestures using their avatars. Similarly, the Group-Slicer (Simmross-Wattenberg et al., 2005) project allows physicians to share data to analyze clinical cases (see Figure 2.3). Interaction with data is done asynchronously, but the communication is synchronous.



(a)

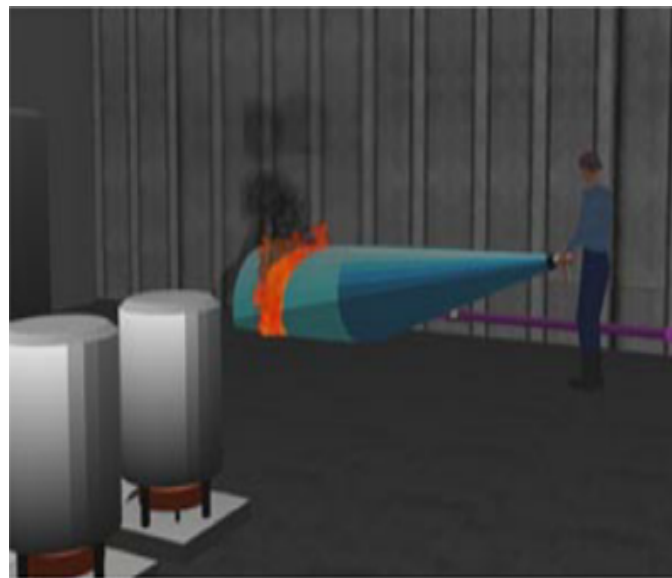

(b)

Figure 2.2: Illustration of the (a) NPSNET virtual environments for military training and (b) exercises (Capps et al., 2000; Macedonia et al., 1995)

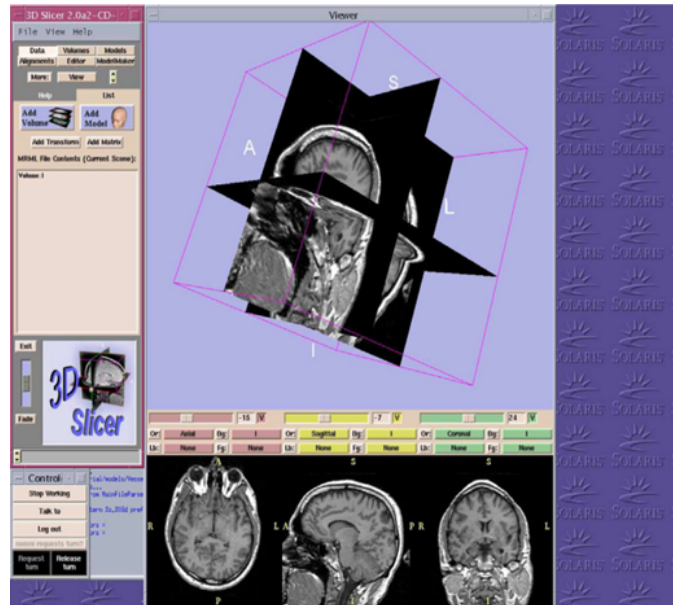

Figure 2.3: User interface of the Group-slicer project (extracted from (Simmross-Wattenberg et al., 2005)).

The **Part@ge**¹ project was funded by the French National Research Agency (ANR) (2006-2009). Its basic themes of research include collaborative work and co-operative interaction in CVEs. This project is a continuation of activities of the **PERF-RV**² project. Among the results obtained under **Part@ge**, we can refer the work of Bouguet et al., that is related to the telepresence in CVEs (Bouguet et al., 2007). This concept exploits the advantages of synchronous tools for sharing documents and video conferencing systems of high quality.

Otmane et al. have used the term CWEs (Collaborative Working Environments) for the systems of telepresence (see Figure 2.4). A common characteristic of the CWEs systems is that they all extend the real space by a virtual space providing a common world coordinate system, where the local and the remote participants are part of (Otmane et al., 2008).

2.2.2 Collaborative teleoperation of robot via internet

Collaborative teleoperation of robot was carried out from two distant sites as part of the ARITI project (Otmane et al., 2008). The work is illustrated in the Figure 2.5. An important feature of this application is the use of heterogeneous platforms to control the robot using TCP/IP. The two sites involved in this operation are IBISC (Informatique, Biologie Intégrative et Systèmes Complexes) and LISA (Laboratoire d'Ingénierie des Systèmes Automatisés). The IBISC platform uses an Augmented Reality (AR) video feedback while the interaction is done using a Fly StickTM (an optical tracking system). The LISA platform uses a video feedback and a SPIDAR system for robot's control and interaction.

¹<http://partage.ingenierium.com/>

²<http://www.perfrv.org/vitrine/resultats/commun/ColloqueFinal/rapports/SyntheseFinale.fr.pdf>

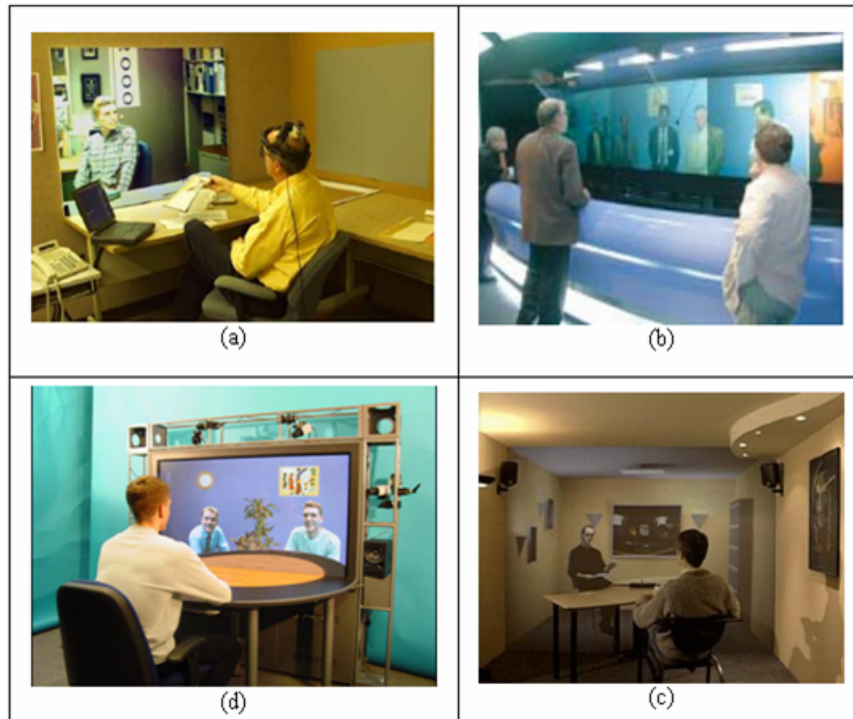

Figure 2.4: Telepresence environments for tele-collaboration and tele-work: (a) Portal to a distant office, (b) France Telecom R&D Telepresence Wall, (c) Telepresence session in the TELEPORT room, (d) VIRTUE setup : Virtual Team User Environment (image extracted from (Otmane et al., 2008)).

The platforms are linked to each others via Internet and a website provides a triple video feedback including the two platforms and the robot. Voice communication is achieved through the GSM network to save bandwidth and increase the safeness by using two different communication channels between the platforms.

The work presented in (Nicholas, 2004) suggests a collaborative approach to tele-operation in mining environments and reports significant benefits that can be obtained if the operators are allowed to share the tele-operated equipment as common resources. The evaluation of the proposed system was carried out using a virtual environment (see Figure 2.6).

2.2.3 Collaborative interaction with molecules and other objects

Virtual reality has long been used in various branches of medical science, for example (Hiroshi et al., 2000) have presented a prototype system in which the behavior of protein molecules in relation to a drug molecule is studied in a virtual environment while using a force feedback device (Phantom). This prototype aims to help design new drugs against diseases. The ability to visualize the results of 3D volumes of medical images of human brain enhances the understanding of anatomy and can be decisive for the diagnosis of disease and pre-surgical planning.

2.2. EXISTING WORK RELATED TO COLLABORATIVE VIRTUAL ENVIRONMENTS

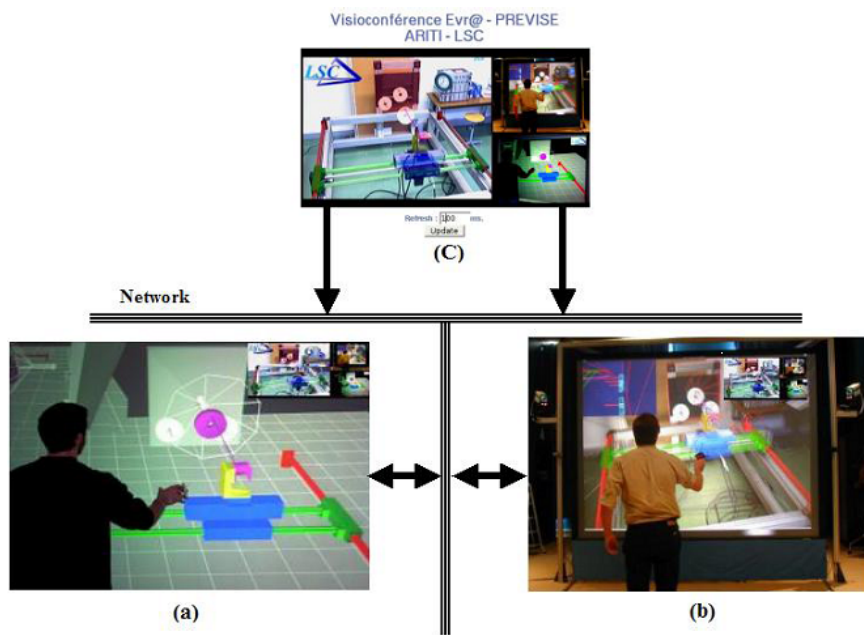

Figure 2.5: Illustration of collaborative teleoperation between IBSIC and LISA (adopted from (Otmame et al., 2008)).

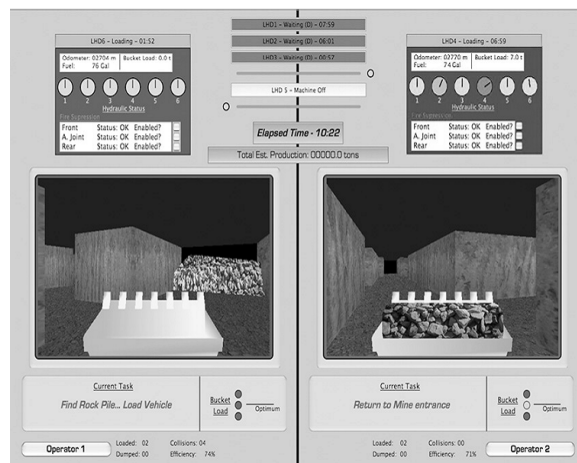

Figure 2.6: The virtual environment for collaborative use of resources in telemining (adopted from (Nicholas, 2004))

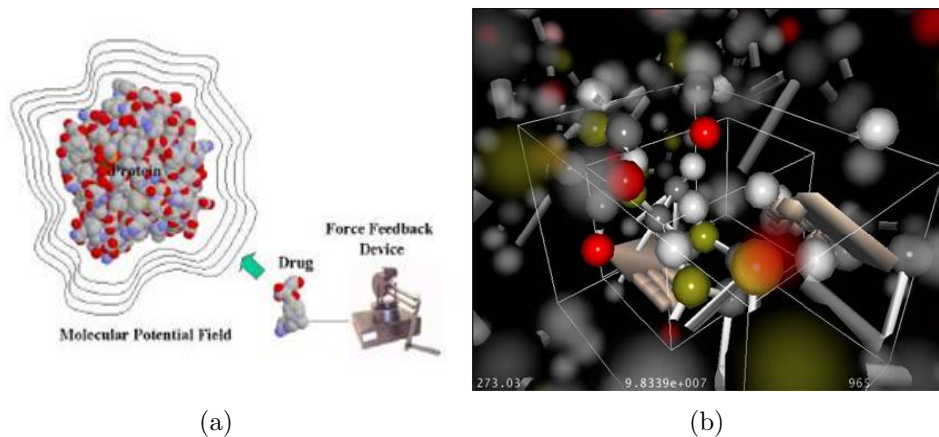

Figure 2.7: Molecular interaction ((a) behavior of protein molecule to the drug molecule(adopted from (Steed et al., 2003)) (b) collaborative manipulation of molecules (adopted from (Chastine et al., 2005)))

Steed et al. (see Figure 2.7-a) describes the visualization of complex data from brain images (MR) using 2D and 3D representations on an immersive display system (Steed et al., 2003).

Similarly (Chastine et al., 2005) presented a system of molecular modeling and visualization. The main contribution of this work is to design and implement a flexible, collaborative system that integrates seamlessly with a molecular dynamics simulator. The system enables biologists and chemists to build, manipulate and test their hypothesis while using a collaborative virtual environment (see Figure 2.7-b).

“Collaboration in Tele-Immersive Environments” (Mortensen et al., 2002) is an important work that allows the collaborative manipulation of objects in a distributed virtual environment. The system was developed on the basis of the DIVE (Hagsand, 1996) platform. Simple avatars have been used to represent the users in the virtual environment (see Figure 2.8-c). The task was to cooperatively move a block through a predefined path in a building. The system was evaluated on the basis of task completion time, co-presence and realism. Average results were reported for the first two variables, but the results for the third showed a low degree of similarity with the real world.

The question whether a task that requires active interaction, can be better performed by a single user or multiple users in collaboration, has been studied in (Heldal et al., 2006). The VE contained eight small cubes and each face of all cubes has a distinct color. The experiment for users, was to build a big cube from the small ones such that the big cube gets a separate colors for all faces. The experiment was performed by one user as well as by two remote users connected through network. Results revealed that users performed better in collaboration as compared to single user setup (see Figure 2.9). A similar experiment was also carried out by HRIMECH in order to study different interaction metaphors in CVE (Hrimech, 2009).

The work described in (Roberts et al., 2004) is very interesting and has studied both the collaborative and cooperative manipulation (Buttolo et al., 1997) of objects in the

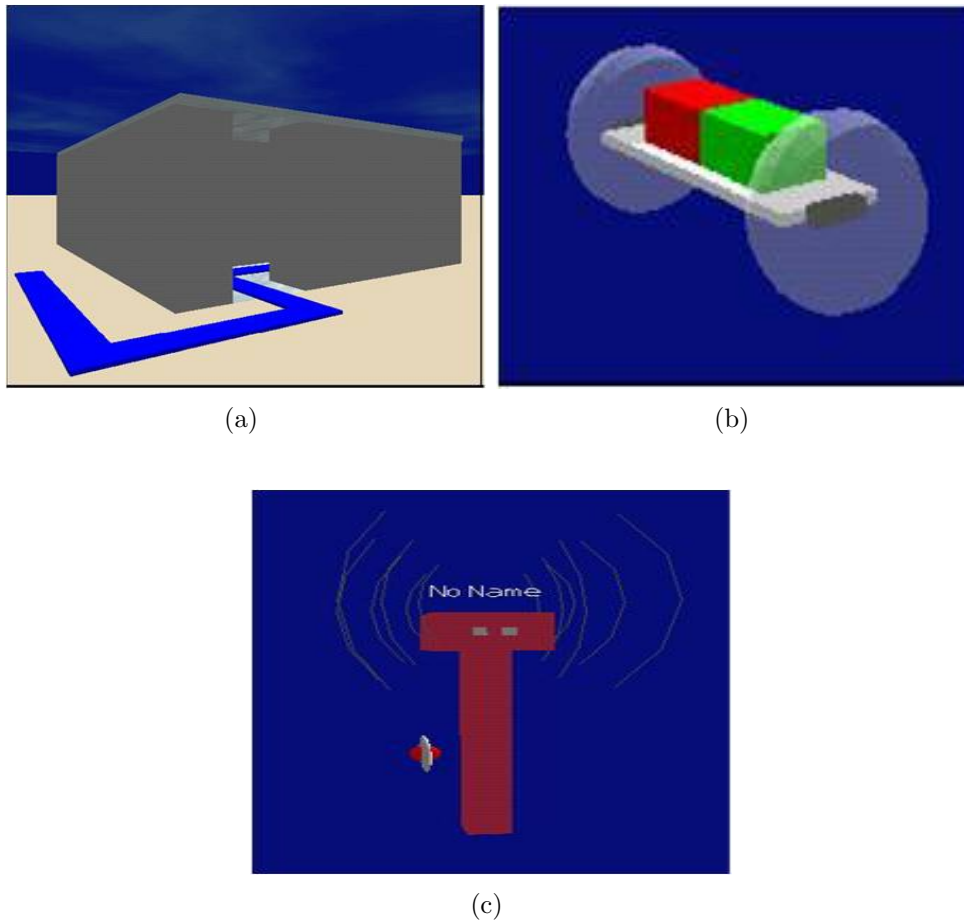

Figure 2.8: Collaborative manipulation of an object in VE ; (a) building, (b) object to move, and (c) avatars (adopted from (Mortensen et al., 2002))

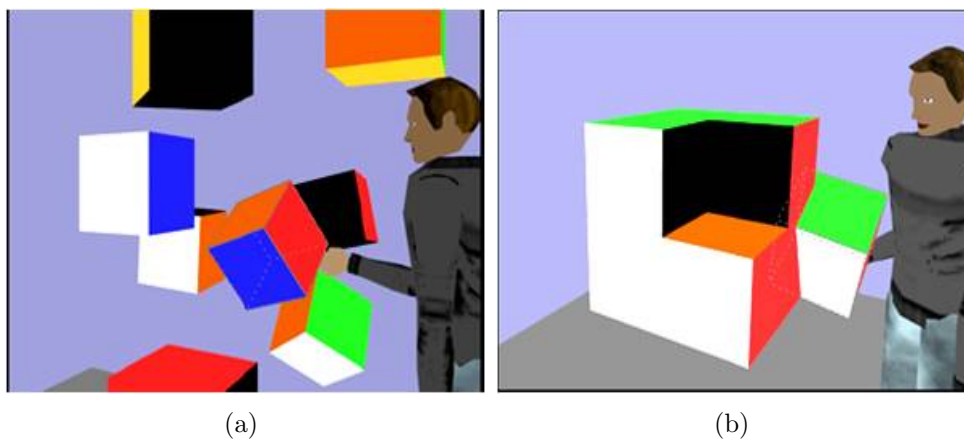

Figure 2.9: (a) Collaborative VE, and (b) construction of a cube from the smaller cubes (adopted from (Heldal et al., 2006))

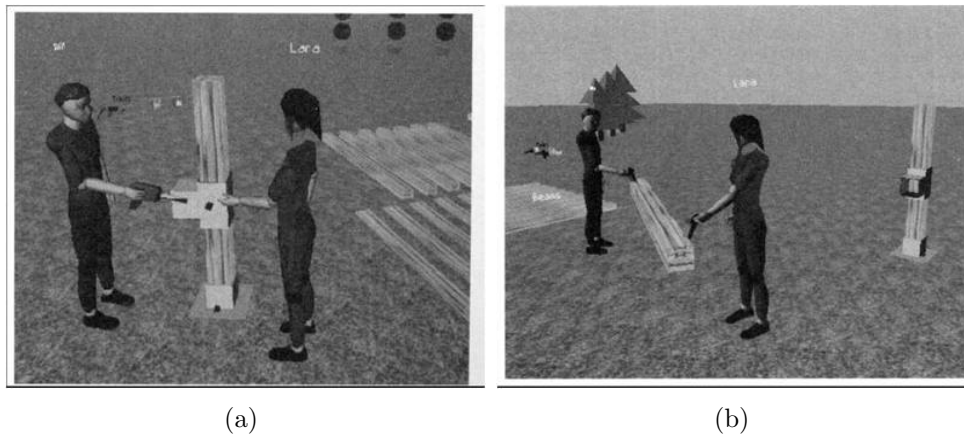

Figure 2.10: Collaborative VE (a) collaboration in the presence of human social interaction, (b) cooperative manipulation (adopted from (Roberts et al., 2004))

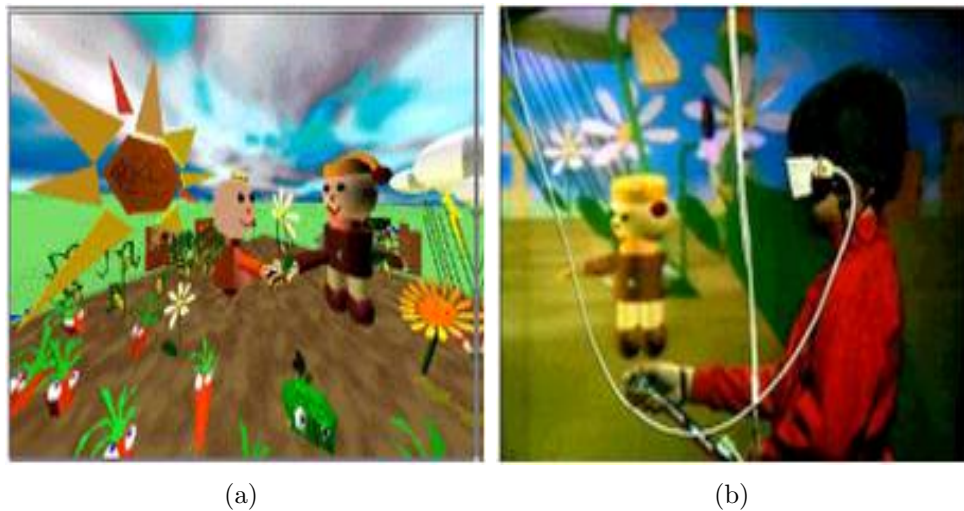

Figure 2.11: NICE system : (a) avatar giving a flower to another, and (b) a child interacting with an avatar in a CAVE systems (adopted from (Roussos et al., 1997))

presence of human's social collaboration in a virtual environment. The experiments were conducted between the two remotely situated immersive environments (CAVE). The environments were developed using DIVE (Hagsand, 1996) platform. Humanoid avatars have been used to represent users in the environment.

“Narrative Immersive constructionniste/Collaborative Environments”(NICE) (Roussos et al., 1997) is a virtual island for young children where they can do collaborative work such as planting, and can grow vegetables and flowers (see Figure 2.11). Children are represented by avatars, and can speak to other children at a distance or other characters in the scene. A child can reduce his/her avatar to the size of a mouse and can crawl under the garden to see the roots' system.

A shared VE for tele-rehabilitation was designed to support real-time communication and remote interaction between patient and therapist. Each site has a tele-rehabilitation workstation with a video camera and an RMII force feedback glove. Both users can control

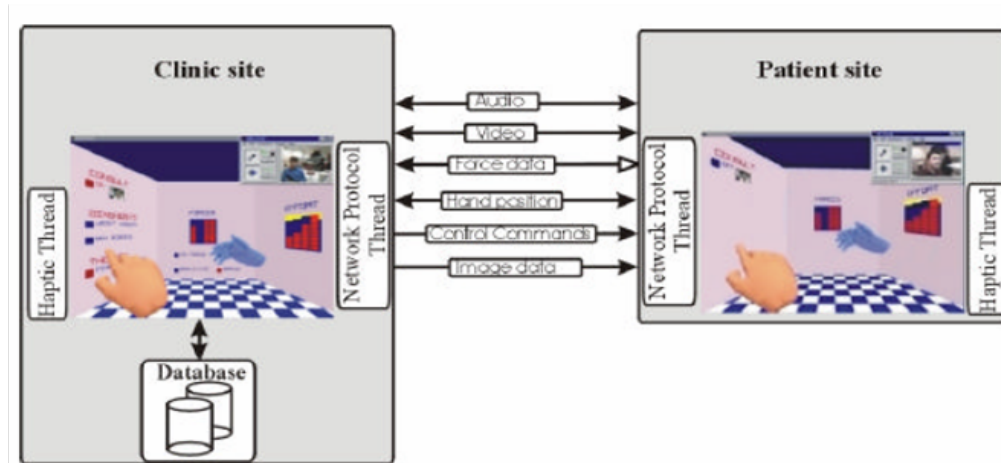

Figure 2.12: The virtual environment for tele-rehabilitation (adopted from (Popescu et al., 2002)).

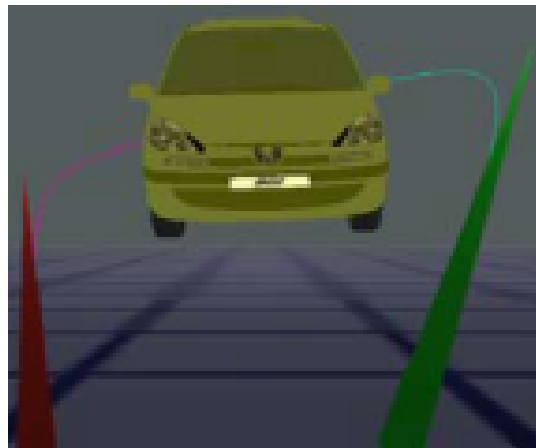

Figure 2.13: Illustration collaborative work using bent ray technique, Here both rays are bent because they attempt to modify car position at the same time in opposite directions (adopted from (Aguerreche et al., 2009a)).

a virtual hand and interact haptically with virtual objects. The shared sense of space and presence allow patient-therapist interactions mediated by haptic devices. The system allows the therapist to apply remote physical therapy and collect patient data (Popescu et al., 2002) (see Figure 2.12).

Laurent et al. have proposed a new formalism for 3D interaction in virtual environments in which they define interactive objects and interaction tools and the communication mechanism between them (Aguerreche et al., 2009a). They use bent ray metaphor (Riege et al., 2006) during collaborative interaction (see Figure 2.13).

2.2.4 Collaborative work with haptic feedback

In this section, we present the collaborative work with force feedback. The lack of force feedback in simulations using only the visual sense may seriously hamper user proprioception, effectiveness and sense of immersion while manipulating objects in virtual environments (Buttolo et al., 1997).

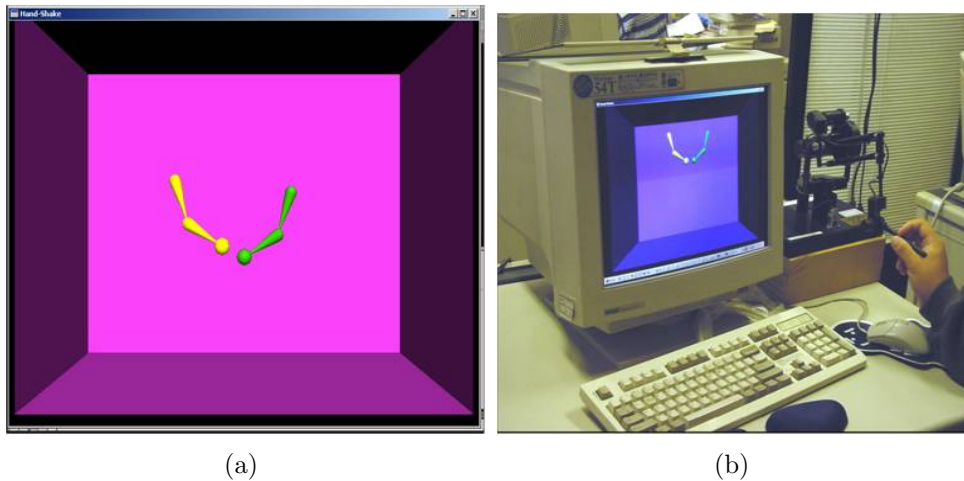

Figure 2.14: Tele handshake system : (a) virtual environment, and (b) a user during experiment (adopted from (Alhalabi and Horiguchi, 2001))

To assess the presence of haptic feedback in shared virtual environments, a system was presented in (Alhalabi and Horiguchi, 2001), which allows two remote users to meet and have tele handshaking experience using force feedback (see Figure 2.14).

Similarly (Jordan et al., 2002; Sallnäs et al., 2000) have designed a system in which two users can interact directly via a haptic interface on the network. The task of the experimental subjects was to make cooperatively lift a box in a virtual environment. Questionnaire was used for the evaluation of the system. Analysis of the questionnaire revealed that realism of the task and users' co-presence increased with the introduction of force feedback.

Another detailed study was carried out in (Basdogan et al., 2000). The proposed system presents a configuration that allows two users to share and work together in a single virtual environment from two different places. A single computer is used to run the software (virtual environment), and allows two users to connect. The first user uses a display and haptic device (phantom) locally connected to the computer, while the second user, who sets in another room, connects his/her devices (display and phantom) with the system via extension cables.

A heterogeneous scalable architecture that supports haptic interaction in collaborative tasks was proposed in (Shen et al., 2003). But all these systems use the force feedback for realism and not for the guidance in the collaborative environment. McSig is a multimodal learning environment for partially sighted students to learn character shapes and signatures collaboratively with their teachers. Here, the teacher and student are connected to the same machine (Plimmer et al., 2008).

CHASE (Collaborative haptic and structured editing) is a synchronous design tool that provides tele-pointers and allows users to work simultaneously on a large worksheet where each user keeps his separate view. CHASE allows users to locate their collaborator

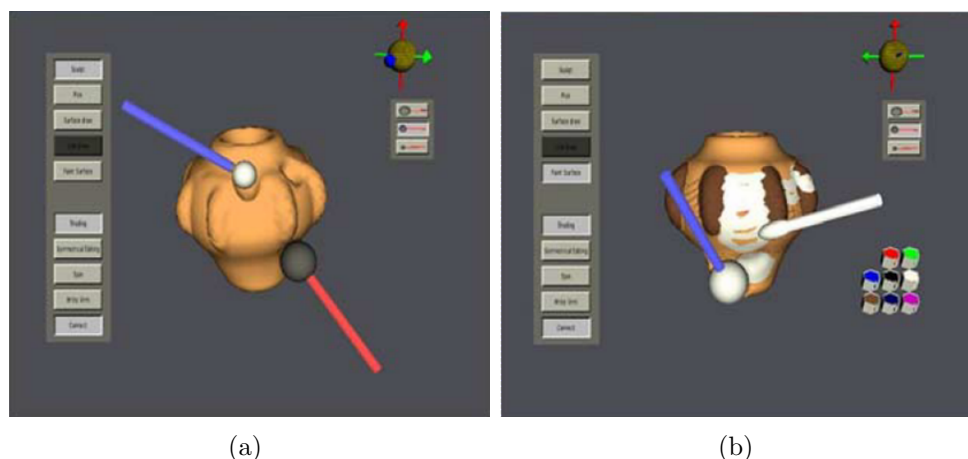

Figure 2.15: Illustration of the CVE with haptic feedback : (a) collaborative sculpting, and (b) collaborative sculpting and coloring (adopted from (Gunn, 2006))

using haptic (Oakley et al., 2001).

A virtual environment, that allows two remote users to sculpt in collaboration, was presented in (Gunn, 2006). Here, haptic feedback is used to sense the tool's pressure on the clay and prevent simultaneous editing of a vertex (see Figure 2.15). Similarly, Chan et al. have reported the use of vibro-tactile feedback to facilitate the turn taking in collaborative environment, but only one user remains in control and has the right to manipulate objects at a given time, the remaining users are passive and wait their turn (Chan et al., 2008).

The DIVIPRO³ project is an application of CAD prototyping that allows multiple users to manipulate and interact together with virtual models. The goal is to make assembly operations to verify the maintenance process. DIVIPRO can use the PHANTOM haptic device.

The collaborative work that requires a strong coupling between the user has not been studied in the context of haptic guides.

2.3 Requirements of Distributed CVES

Based on the final objectives, each project has some requirements that play an important role in its design, development, implementation, and performance. Leight et al. and shirmohammadi et al. describe some general requirements of collaborative virtual environments which we will present and discuss in the next section (Leigh et al., 1997; Shirmohammadi and Georganas, 2001).

³<http://aig.cs.man.ac.uk/divipro/index.php>

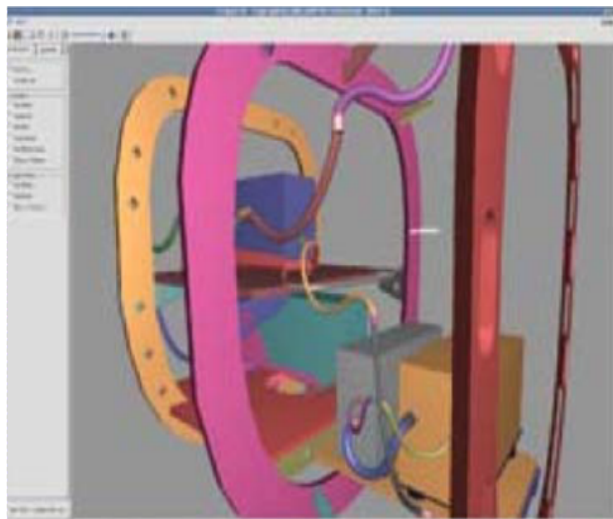

Figure 2.16: The interface of the DIVIPRO³ project

2.3.1 Avatars

Each collaborative virtual environment use some graphical representation for its users. For example Frécon and Nou have presented a virtual environment for teleconferencing where humanoid avatars have been used for users' representation (Frécon and Nöu, 1998). These avatars use name tags for identification purposes. Similarly (Roberts et al., 2004) uses humanoid avatars to perform synchronous and asynchronous tasks in a collaborative virtual environment.

On the other hand, there are systems which allow collaboration between two users where each user is represented by a ball having distinct color (Basdogan et al., 2000; Sallnäs et al., 2000).

Therefore, the elaborateness of the avatar varies according to the task and objectives of the environment. The humanoid avatars allow communication through non-verbal channels, like gestures, eye gaze, body movement and orientation etc., enhance the sense of co-presences (Roberts et al., 2004). This may also increase the user performance, but consequently increases network traffic and complexity of the system. On the other hand, with simple avatars there will be less traffic on the network and low complexity, but low level of social interactions in the case of complex tasks/applications.

2.3.2 Audio/video Support

Audio (voice telephony) is one of the most important channels added to the CVEs, especially those designed for teleconferencing applications (Greenhalgh and Benford, 1995; Frécon and Nöu, 1998). It has been demonstrated that latencies above 200ms will lead to deterioration in the conversation. When the latency increases the amount of time spent in post-conversion also increases, and consequently the amount of useful information to be conveyed in conversation decreases (Leigh et al., 1997).

Videoconferencing is useful in cases where it is important for participants to see each other face to face for negotiating tasks. In the traditional conference room videoconferencing, the video provides a way to express a sense of co-presence. In VR however this sense is created through the use of avatars (Greenhalgh and Benford, 1995), (Frécon and Nöu, 1998) and hence we believe video will play a less significant role in collaboration.

2.3.3 Flexible Support of Various Data Characteristics

The transmission, storage and data management in CVEs is very important and is affected by four attributes including quality of service, size of data, persistence and queues (Leigh et al., 1997).

2.3.3.1 Quality of service

For closely coordinated work in CVEs, minimum levels of network latency and jitter are desirable. In addition, both reliable and unreliable protocols of uni-cast, broadcast and multi-cast transmission are needed to optimally transport different classes of CVE data (3D tracker data, state information, streamed audio/video feeds, geometric models, large scientific data sets.)

2.3.3.2 Size of data

It can be classified into the following three categories (Leigh et al., 1997).

- Small–Event data: These can be unreliable tracker data, and reliable state and event data. These typically require priority transmission with low latency.
- Medium–Atomic data: These are data that are small enough to fit in the physical memory of the client because it must be processed as one atomic “chunk.” Examples of these are 3D geometries representing individual objects in the VR scene.
- Large–Segmented data: these are data that are too large to fit in the physical memory of the client and hence can only be accessed in smaller segments. Large scientific data sets and long pre-digitized video streams fit this category.

2.3.3.3 Queued/Unqueued Data

Data that are sent to clients or servers, regardless of whether they are stored in a database or not, need to be either queued or non-queue. For example, world state information may be non-queued since only the latest information is necessary. Queued data are data which must all arrive at a client or server in order.

2.3.3.4 Persistent/Transient Data

Persistent data characterize data which need to be stored in a database for later use. These data remain in the database after all the clients leave the CVE. All state data that is crucial to the resumption of a client in a CVE session must be persistent. Models and scientific data sets that will be loaded into CVE are also prime candidates for database storage.

Transient data are data that are not stored in a database. An example of this kind of data are command messages that might be sent between clients to effect events or audio/video data streams. An exception to this definition is when transient data is stored in a database to allow replay of events at a later time. In this case the data are more accurately characterized as persistent rather than transient.

2.3.4 Data model for collaborative virtual environments

Perhaps the most difficult decision to build a collaborative virtual environment is to determine where to place the data related to objects and state of the virtual world. This decision affect the scale, the requirements of communication, and data reliability of CVEs (Macedonia and Zyda, 1997). The most popular models that have also been given in (Leigh et al., 1997; Macedonia and Zyda, 1997) are discussed in the following.

2.3.4.1 Shared centralized model

In this model, all shared data are stored on a central server and simultaneously accessible to all client computers via a network connection. The main advantage of this system is that it simplifies management of multiple clients, particularly in situations where strict concurrency control is required. However, its intermediary role for the delivery of data can impose an additional delay in the system. Another disadvantage is that if the central server fails, none of the clients can connect and interact with each other. Despite these drawbacks, this architecture is always useful for collaboration among small groups (Leigh et al., 1997; Macedonia and Zyda, 1997).

2.3.4.2 Replicated homogeneous model

Here, each client contains a fully replicated copy of the environment, including information on terrain, model's geometry, textures, and the behavior of all that is represented in the virtual environment (Leigh et al., 1997; Macedonia and Zyda, 1997). Any change to the state of an object at one client (such as change in position of an object or collision between two objects) is communicated to all other clients. The advantage of this approach is that messages are relatively small. The disadvantages are that it is relatively inflexible and that as virtual environment content increases so must everyone's database. Moreover, over time, the world becomes inconsistent among the participants through the loss of state and event messages (Macedonia and Zyda, 1997). For example the system presented in (Jordan et al., 2002), has implemented this mechanism. Similarly (Popescu et al., 2002) present a virtual environment designed for remote therapy also use the same method.

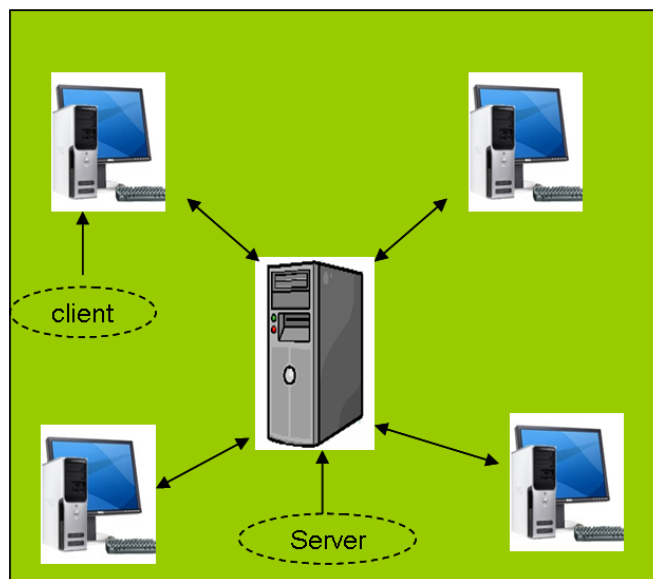

Figure 2.17: Illustration of the shared centralized model.

2.3.4.3 Shared distributed with peer-to-peer update

This approach simulates a wide-area shared memory structure in which objects that are instantiated at one site are automatically replicated at all the remote sites. With this method the application development is simple but don't promise a high performance. Each newly connected client must form point-to-point connections with all the participating clients (Leigh et al., 1997).

A disadvantage of this approach is that it is difficult to scale up because of the communications costs associated with maintaining reliability and consistent data across wide area networks (Macedonia and Zyda, 1997). Modeling complex or dense objects, such as constructing a large CAD model or changing a terrain database, is very expensive (though highly desirable) in terms of the number of polygons that might be created, changed, and communicated over a network (Macedonia and Zyda, 1997). DIVE (Hagsand, 1996) is a very good example of a platform that supports this method.

2.3.4.4 Shared distributed with client-server database

This model can be seen as an extension of the traditional client-server model, here the virtual world is divided between several clients and the communication is mediated by a central server. The server is responsible to keep record of which part of the virtual world has been stored at which client. However, in a dynamic large scale world, the servers can quickly become I/O bottlenecks, increasing the inherent latency of the virtual environment (Macedonia and Zyda, 1997).

2.3.5 Characteristics of network for distributed VEs

2.3.5.1 Bandwidth

Bandwidth is very important and determines the size and richness of a distributed virtual environment. Distributed VR can require enormous bandwidth to support multiple users, video, audio and the exchange of 3D graphic primitives and models in real-time. In addition, the combination of data requires new protocols and techniques to properly handle data on a network link (Macedonia and Zyda, 1997).

2.3.5.2 Distribution

Three distribution schemes have been described in (Macedonia and Zyda, 1997) (see Figure 2.18). Multi-cast services allow arbitrarily sized groups to communicate over a network via a single transmission by the source. Multi-cast provides one-to-many and many-to-many communication services for applications such as teleconferencing and distributed simulation in which there is a need to communicate with several machines simultaneously. For example, a teleconference multi-cast allows a host to simultaneously send voice and video to a set of (but not necessarily all) places. With emission (broadcast), the data is sent to all machines but in uni-cast or point-to-point communication is established between two hosts.

2.3.5.3 Latency

Another dimension of communication is latency which effect the interactive and dynamic nature of the virtual environment. If a distributed environment is to emulate the real world, it must operate in real-time in terms of human perception (Macedonia and Zyda, 1997). A system that involves human operators must deliver data (packets) with minimal latency and generate textured 3D graphics at 30-60 Hz to guarantee the illusion of reality (Wloka, 1995).

2.3.5.4 Reliability

Reliability means that systems can logically assume that data sent is always received correctly. To guarantee the delivery of data, the underlying network architecture must use acknowledgment and error recovery schemes but as result that can introduce large amounts of delay (Macedonia and Zyda, 1997). It means that there is a trade-off between reliable delivery and latency.

2.4 Conclusion

After the introduction of collaborative virtual environments (CVEs), we presented the potential domains where CVEs may be implemented and consequently their potential benefits.

Then, we presented the three types of interaction that can be carried out in CVEs. In the first category, we have CVEs that involve multiple users, but only one is active and able to interact with the virtual objects. The others remain passive and wait their turn.

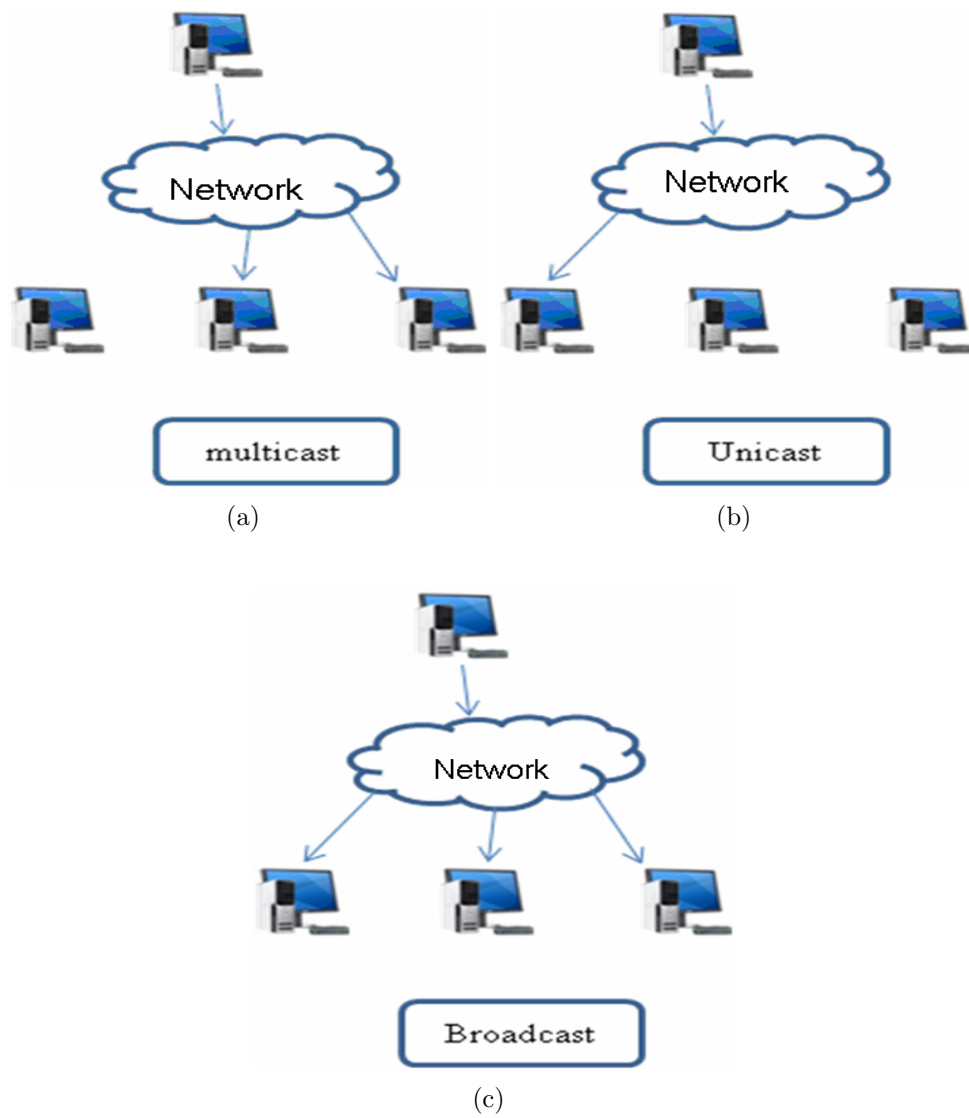

Figure 2.18: Illustration of the different types of distribution.

In such CVEs, there are two important issues to be considered, (1) we need to have a user management mechanism for trun changing, (2) a mechanism to ensure consistency of the environment so that all passive users can see the changes and/or operations made by the active user.

In the second category, we have CVEs that involve multiple users, all of them being active. However, each user interacts independently with objects. Then we have another type of CVEs in which two or more users can interact with the same object. This type of interaction can be asynchronous or synchronous. In asynchronous interaction, one or more operations (selection, manipulation etc.) are carried out by multiple users in a sequence on the same object. For example, if one user changes the position of an object then another user rotates it. In synchronous interaction, multiple users simultaneously interact with the same object. Furthermore, different user may interact/change the same or different attributes of the common object. For example, if a user is changing the place of an object while another is painting it and similarly, if two or more users are changing the place of an object.

The synchronous manipulation is also called cooperative manipulation which is considered as one of the difficult tasks. Cooperative manipulation requires tight coupling and coordination among users involved in the task. Similarly, the interaction techniques developed for single user VEs can not be applied directly to the CVEs. Therefore, it necessary to investigate the development of interaction techniques and assistance mechanism that are specific to CVEs.

In the second section of this chapter, we presented a brief review of collaborative work related to various fields such as teleconferencing, teleoperation of the robot, study and design of molecules and objects manipulation. Some of these works have also used force feedback but only for realism of the environment and not for guidance or assistance.

In addition we have described the general needs of collaborative virtual environments. Although all CVEs can not have the same needs because of their final goals or objectives. We have also presented various data models and network features of CVEs.

Part II
CONTRIBUTION

Chapter 3

Modeling virtual guides for Collaborative Environments

3.1 Introduction

There are many potential application areas for VR. This gave a strong motivation to the scientific community to study and develop 3D interaction techniques (*selection, manipulation, navigation* and *application control*), integrate multi sensory feedbacks and develop dedicated technology solutions to have more realistic VEs. These interaction techniques have mostly been developed in a single-user context. Keeping in mind the real world, where many tasks are performed in collaboration/cooperation, researchers have begun to develop collaborative virtual environments (CVEs) (Benford and Fahlén, 1993; Benford et al., 1994; Greenhalgh and Benford, 1995; Hagsand, 1996; Margery et al., 1999; Sallnäs et al., 2000; Goldberg et al., 2002; Alhalabi and Horiguchi, 2001; Mortensen et al., 2002; Steed et al., 2003; Chastine et al., 2005) that allow two or more users to coexist and achieve tasks in collaboration and/or cooperation.

Here it is important to note that collaborative work in VE can be based (i) on a distributed software architecture, involving the use of multiple remote machines and / or (ii) on the use of a local machine and VE shared by several users. Both approaches have been investigated in our study.

In this chapter, we present the software architecture that we used for the development of the application that allows collaboration between two users (remote and co-localize). In addition, we will study the importance of coordination and awareness between users during the execution of collaborative and/or cooperative tasks. In this context, we propose various sensory guides such as visual, audio and haptic.

3.2 Problem definition

Collaborative tasks are often complex and must meet a number of constraints, which include precise and stable selection/manipulation with minimum cognitive load on the user. In general, the classical techniques of selection and manipulation can not be utilized directly in collaborative tasks involving the selection and manipulation by multi-users.

The 3D interaction techniques (selection, manipulation and navigation) have mostly been proposed and developed for single-user VEs. However, a number of researchers have shown interest in collaborative work in VEs and in particular, developed and discussed the interaction paradigms and metaphors to facilitate coordination and collaborative performance of operators in CVEs (Benford and Fahlén, 1993; Benford et al., 1994; Hagsand, 1996; Margery et al., 1999; Alhalabi and Horiguchi, 2001; Mortensen et al., 2002; Steed et al., 2003; Chastine et al., 2005; Hrimech, 2009; Chellali, 2009).

Developing and implementing realistic CVEs is really challenging because it needs to consider and solve a number of issues. For this purpose, a software architecture must be developed that allows multiple users to exchange information in order to accomplish a collaborative and/or cooperative task in a shared virtual environment. It is particularly important that the architecture and communication protocol must lead to a CVE that promises consistency for all users, and reduces the latency of data or information exchange. It is also necessary to develop paradigms and interaction metaphors to facilitate coordination and collaborative performance of operators in CVEs. It should also provide them with necessary information that allow them to strengthen their sense of co-presence and situational awareness (awareness).

In this context, it seemed appropriate to study the multimodal aspects and the capacity of human beings to process sensory information of various kinds (i.e visual, auditory, tactile and kinesthetic). The use of various sensory channels (visual, auditory and haptic) for information feedback in single-user EVs has led to numerous studies (Massimino and Sheridan, 1989; Salisbury and Srinivasan, 1997; Richard, 1996; Diaz et al., 2006; Lécuyer, 2002; Richard et al., 1996; Prada and Payandeh, 2009).

One of our hypotheses is that among the sensory data, haptic feedback (tactile and kinesthetic) is essential to perform certain cooperatives tasks, and contribute greatly to enhance users' performance and the sense of presence in CVEs.

The work related to CVEs has already presented in chapter 2 in which some authors have studied the integration and use of force feedback (Basdogan et al., 2000; Sallnäs et al., 2000; Jordan et al., 2002; Mortensen et al., 2002; Plimmer et al., 2008; Oakley et al., 2001; Gunn, 2006; Chan et al., 2008). We observed that these studies used force feedback to enhance the realism of the tasks in CVEs. The assistance in collaborative work, through haptic or multimodal guides has rarely been studied.

An equally important issue is related to the placement and management of dynamic point of view (virtual camera) of each user in the CVE.

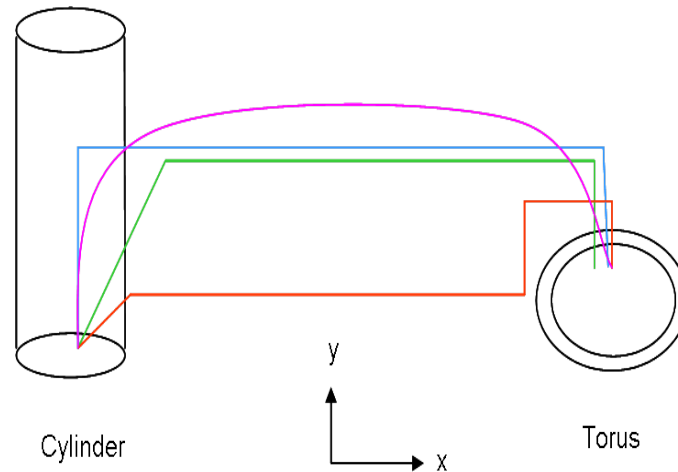

Figure 3.1: Illustration of some trajectories in a cooperative Peg-in-hole task.

3.3 Cooperative manipulation of virtual objects

As given in the Chapter 2 (section 2.1.2), cooperative work means the simultaneous manipulation of an object by two or more users. Here, we take the example of the famous “Peg-in-Hole” task. We consider a scenario where two remote users share the same VE. The task is to cooperatively select (pick-up) the object (a cylinder in our case), manipulate (transport) it and then put it in the specified place (torus) (see Figure 3.1). In this type of manipulation, both collaborators will have the following problems:

- Which path is to follow for the manipulation of the object. The Figure 3.1 illustrates some paths from the set of all possible trajectories;
- How a user may know the intentions of his collaborator;
- How a user may know the current status of his/her collaborator. For example, to know that, whether the collaborator is in contact with the object or not;

Therefore, we can say that in this CVE, this type of manipulation is the most difficult because it requires very close coordination between the collaborators. In addition, the actions of both users have a strong influence on the other one.

In order to achieve better performance in the execution of a cooperative task, it is required that users must have a good knowledge (awareness) about their collaborators.

In order to achieve coordination and enhance awareness in cooperative manipulation, we proposed multimodal guides. For evaluation of these guides, we proposed to perform various experiments. For this purpose, we have developed a CVE (based on the software architecture presented in section 3.3.1) that allows two distant users to cooperatively perform a task. The task consists of selection, manipulation and insertion of cylinders in

torus.

3.3.1 Software architecture

Software architecture plays an important role in the success and effectiveness of collaborative or cooperative VEs. It is related to, how different users will share the same virtual world and data (centralized, distributed or replicated), what type of protocol (UDP, TCP, etc.) must be used and what type of data must flow through the network to maintain consistency. In literature there are very few important works on frameworks for cooperative systems (Margery et al., 1999).

The architecture depicted in the Figure 3.2 has been designed to allow two co-localized or remote users to undertake a cooperative work that requires close coupling between two users. Similarly, it can be used for collaborative work as well. The architecture contains various modules which are described below.

3.3.1.1 Device registration

The device registration module initializes the devices. The architecture is very flexible and supports many devices such as the *Polhemus patriotTM*, any *Phantom*, the *SPIDAR* and the Nintendo *Wii moteTM*. The user is provided a particular type of assistance through virtual guides depending on the registration status of devices in the registration module. For example, if the current device is *Polhemus patriotTM* for a user then he/she can only be given visual or auditory assistance. Similarly, haptic guides can be used in presence of *Phantom* and/or *SPIDAR*.

3.3.1.2 User data management and network

In case of remote users, we use the replicated approach and install the same application on two machines connected through network. The data received by the *User data management* module is not only applied to the local environment but is also sent to the remote one via the network module. Similarly, the data from the remote machine is received by the network module.

The most frequently exchanged data between the two machines in our case are the position and orientation of the input devices controlled by the users. It means that one user simultaneously controls the movement of two (3D pointer) avatars on two different stations. Therefore, if a pointer triggers an event on a station, then it is also triggered on the second station at the same time. In order to have reliable and continuous streaming between the two nodes, we use a peer-to-peer connection via TCP. In case of two co-localized users, we do not need the network module and therefore it is deactivated.

3.3.1.3 Events management

Events are very important in distributed collaborative virtual environments implemented using replicated approach. They are used to evoke an action simultaneously in the two remote environments and thus help in maintaining consistency. We divided the

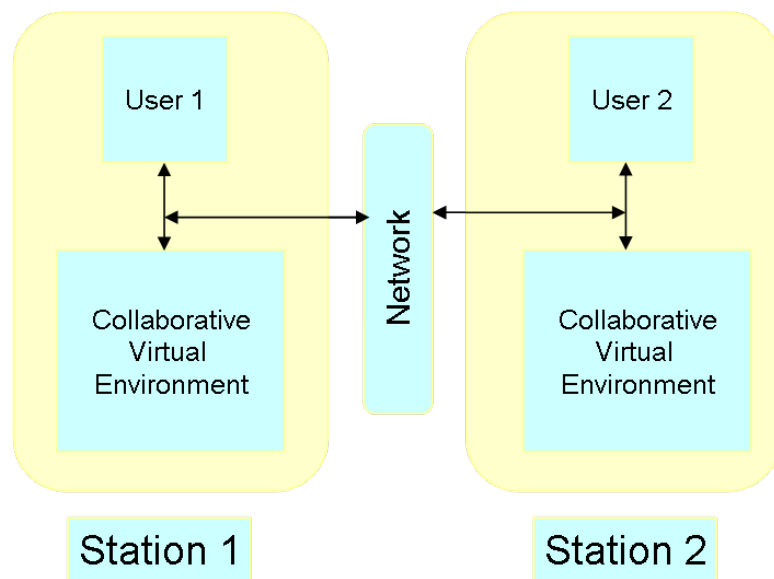

(a)

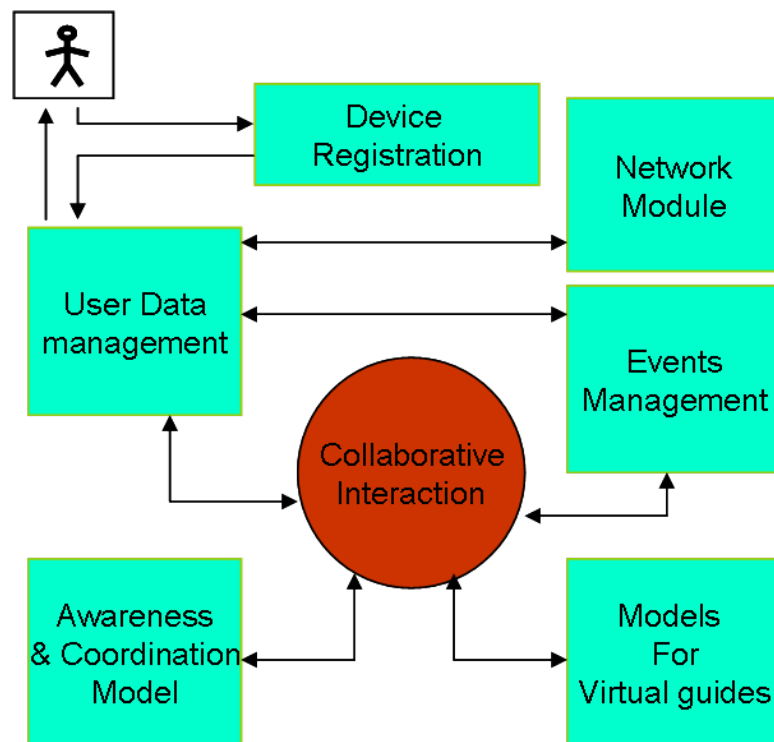

(b)

Figure 3.2: The proposed software architecture for cooperative/collaborative manipulation : (a) Scenario of collaboration between two remote users using replicated approach, (b) Modules of the CVE on a single station.

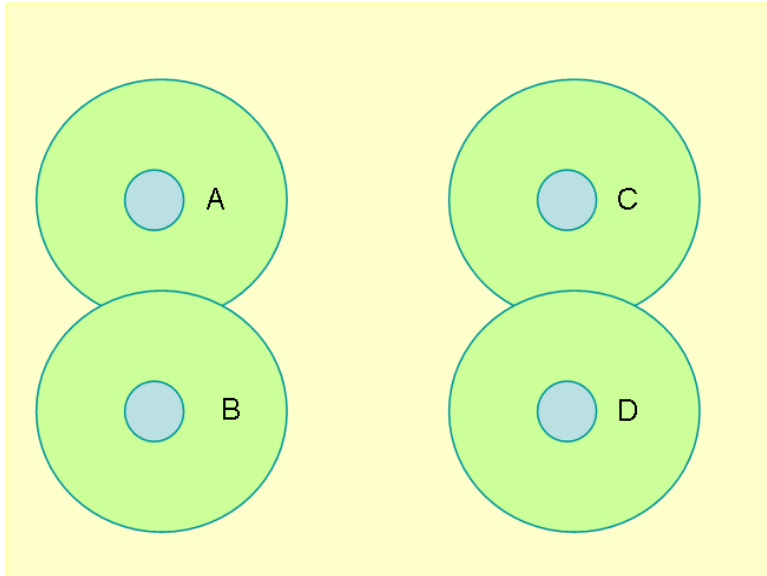

Figure 3.3: Illustration of objects, auras and possibility of communication between pairs.

events in two types: (1) external events that are sent by the users via their input devices such as pressing a key to activate a guide, and (2) internal events are dynamically produced by the application during interaction, for example event of collision detection. The events management module take care of all events and their consequent actions.

3.3.1.4 Awareness and coordination model

According to our hypothesis, coordination between users is a very influential factor for undertaking a collaborative and/or cooperative task in VEs. However, a better coordination is achieved through awareness. Therefore, it is necessary to have a model that not only allows interaction (between user/object, user/user) but also enhance mutual awareness of users. The model that we propose, is based on the spatial model of interaction of Benford (Benford and Fahlén, 1993) and is presented below.

3.3.1.4.a Aura set The fundamental concept of this model is the use of some properties of space to enable interaction between objects. The basic of these is aura, which is defined as a bounding region surrounding an object that limits its presence in the virtual world (Benford and Fahlén, 1993). The auras move along the objects as they move in the virtual space. Interaction between two objects becomes possible whenever their auras collide or overlap.

According to Benford's basic model of spatial interaction, if we consider the four objects (A, B, C, D) of Figure 3.3, there are only two pairs that allow communication and should be aware of each other, but there are six combinations possible.

CVEs can be thought of as a combination of objects and users' avatars sets.

$$CVE = \{O, U\}$$

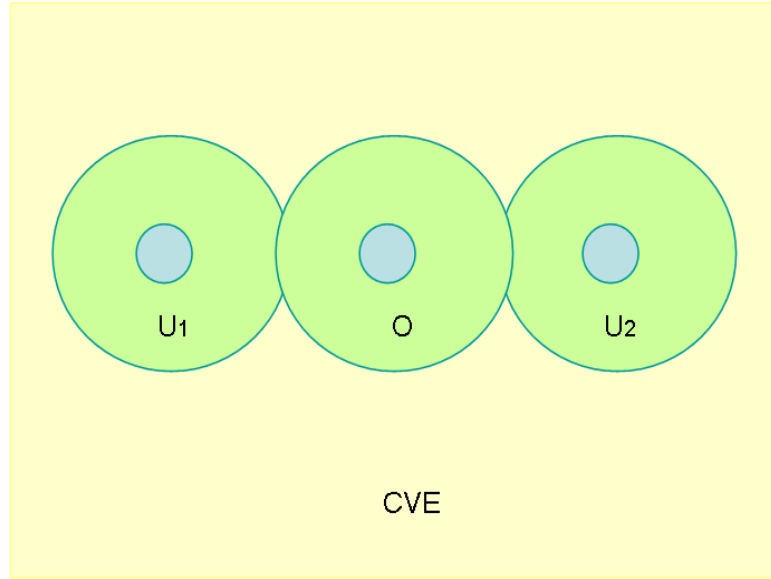

Figure 3.4: Illustration of the spatial model for awareness.

$$U = \{u_1, u_2, u_3, \dots, u_n\}$$

$$O = \{o_1, o_2, o_3, \dots, o_j\}$$

Where 'U' and 'O' represent the set of users and objects respectively. In Cooperative virtual environments, more than one user can interact with the same object. In this context the auras of all users are not necessary to collide with each other. For example in the Figure 3.4, the aura of the object 'A' is in collision with both users 'U1' and 'U2'. But on the other hand the auras of U1 and U2 do not collide directly with each other. According to the basic spatial model of benford they do not qualify for communication and hence will have zero awareness between them.

In order to effectively accomplish a cooperative task the awareness among the collaborators is required, for which communication is essential. For this purpose we introduce a new concept of aura set. Each object in the VE will have an aura set consisting of all those users whose aura collide with it. Now all the users of the aura set of an object will be able to communicate with each other and therefore will have mutual awareness. Formally we can represent this as:

If the auras of the users $u_1 \dots u_m$ are in collision with the aura of the object o_k

Then:

$$\text{Aura set } o_k = \{ u_1, u_2, u_3, \dots, u_m \}$$

Now,

if $u_i \in \text{Aura set } (o_k)$ and $u_j \in \text{Aura set } (o_k)$, then:

Awareness: $u_i \leftrightarrow u_j$ is 1 (It means that u_i and u_j should have mutual awareness)

Otherwise it is 0.

The aura set is dynamic and grows as new users enter into the object's aura and shrink as they leave. The awareness matrix can be written as:

$$\mathbf{A} = \begin{matrix} & \begin{matrix} o_1 & o_2 & o_3 & \dots & o_m \end{matrix} \\ \begin{matrix} u_1 \\ u_2 \\ u_3 \\ \vdots \\ u_n \end{matrix} & \begin{pmatrix} a_{11} & a_{12} & a_{13} & \dots & a_{1m} \\ a_{21} & a_{22} & a_{23} & \dots & a_{2m} \\ a_{31} & a_{32} & a_{33} & \dots & a_{3m} \\ \vdots & \vdots & \vdots & & \vdots \\ a_{n1} & a_{n2} & a_{n3} & \dots & a_{nm} \end{pmatrix} \end{matrix}$$

If the aura of user (u_i) and that of the object (o_j) are in collision, then $a_{ij} = 1$, otherwise it is zero.

Further more if, $a_{ij} = 1$ and $a_{(i+p)j} = 1$

Then the awareness $u_i \leftrightarrow u_{j+p}$ is 1, where $p \geq 1$.

3.3.1.4.b Task set There are many situations where a task accomplishment requires tight coupling among multiple users. For example, if two or more persons lift a heavy object and change its place in the virtual environment. In this case the collaborators must be aware of each other's status and actions. They should also be able to negotiate on how to lift and manipulate the object. In addition if any user detaches during task execution then the rest should know that who has lost control. Similarly if he joins back then the remaining users should be notified. In this case the awareness can be formalized in the following way.

Set of users (U) subscribed to perform one or more operations (T) on object (O).

$$T = U \rightarrow O,$$

$$\text{If } T(t) = u_j \rightarrow o_k \text{ and } T(t) = u_m \rightarrow o_k$$

It means that user u_j and u_m will cooperatively perform an operation on object o_k , then they should have mutual awareness :

$$u_m \leftrightarrow u_j \text{ is } 1$$

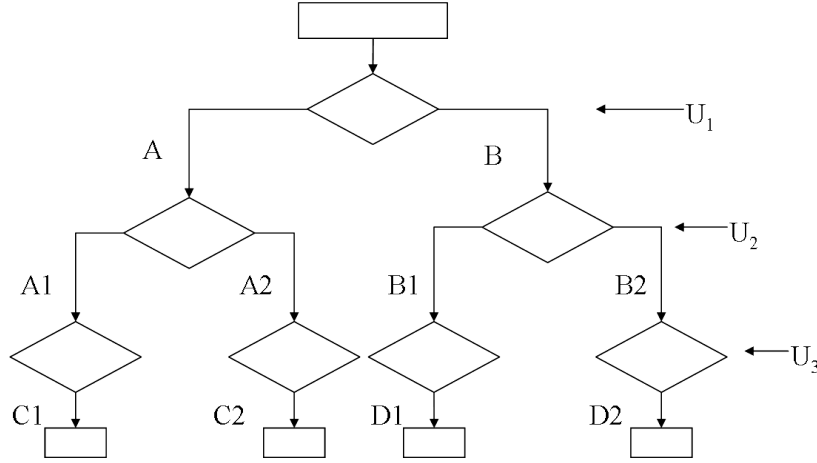

Figure 3.5: Illustration of collaborative assembly chain

Similarly if the same object has to be manipulated by many users in a sequence. In this context the awareness may be formalized in the following way.

If $T_i(t) = u_j \rightarrow o_k$

and $T_l(t + 1) = u_m \rightarrow o_k$

Then the awareness: $u_m \rightarrow u_j$ is 1 (user u_m should be aware of user u_j)

There may be other situations where a task consists of multiple subtasks. In order to complete the main task, one or two users are in charge of a subtask. Consider a virtual environment for assembly task (see Figure 3.5). Three users are involved to assemble three constituent parts into a single product. Four different version of the same product can be produced depending on the part selection of the users. User (U_1), who is on the starting point, can select either part 'A' or 'B'. He puts the selected part on a conveyer belt that arrives at U_2 's station after some time. For user U_2 group selection totally depends on the part sent by (U_1). In a given group User U_2 then selects a part, assembles it with the former one and sends it to the U_3 . The part selection of U_3 depends on the selection of the U_2 . In this context the task may be effectively performed if a user is aware of his/her predecessors' actions or tasks.

For this purpose we propose the concept of task set. A task set consists of more than one subtasks need to be carried out to achieve a common goal or task. The subtasks are carried in sequence. In addition the number of subtasks and their executers are also known in advance.

Task set $S = \{ T_1, T_2, T_3, \dots, T_n \}$, $n > 1$

Now,

if $T_i \in S$ and $T_j \in S$

Where T_j depends on T_i

In addition if, $u_k \rightarrow T_i$ and $u_l \rightarrow T_j$ (Tasks T_j and T_i are performed by the user u_l and u_k respectively.)

Then, the awareness should be 1 for : $u_l \rightarrow u_k$. (u_l should be aware of u_k)

3.3.1.5 Models for virtual guides

We designed virtual guides to provide assistance, awareness and allow coordination to users in collaborative work. These guides make use of visual, audio and haptic modalities. Their design is mainly based on the concept of aura set and task set (depending on the task's nature) presented in the section 3.3.1.4. The models and description of these guides are presented in the section 3.3.3.

3.3.2 Task and Description of the VE

The virtual environment for cooperative manipulation has a simple cubic structure (36cm each side), consisting of three walls, floor and ceiling (see Figure 3.6-a, 3.6-b). In addition, the EV has four cylinders, each having a distinct color and positioned lengthwise in a row. In front of each cylinder at a distance of 30cm, there is a torus of the same color. All cylinders have the same size of 1.5cm. The red, green, blue and yellow toruses have the internal radii of 1.6, 1.8, 2.0 and 2.20cm, respectively. Cylinders and toruses are 4cm apart. Each user is represented by a sphere of distinct color in the VE.

The task in this study is the accomplishment of “Peg-in-Hole” task by two users. Here both users will cooperatively pick up a cylinder and put it in the torus whose color corresponds to that of the former. The first condition that should become true for manipulation of the cylinder is that, the two spheres (representing users) must be in contact with it. When the first condition is satisfied, we must also verify the following two conditions.

$$D_h \geq 2 * R_c - K$$

$$D_v \leq T$$

Where D_h et D_v represent the horizontal and vertical distance between the centers of the two spheres respectively. Similarly R_c is the radius of the cylinder and K is a positive constant (see Figure 3.7). It should be noted here that the auras of the spheres and cylinders are equal to their respective volumes.

These conditions are used to have a stable and realistic transportation of the cylinder. Once these conditions are satisfied, the cylinder can be moved (see Figure 3.8) and place in its corresponding torus.

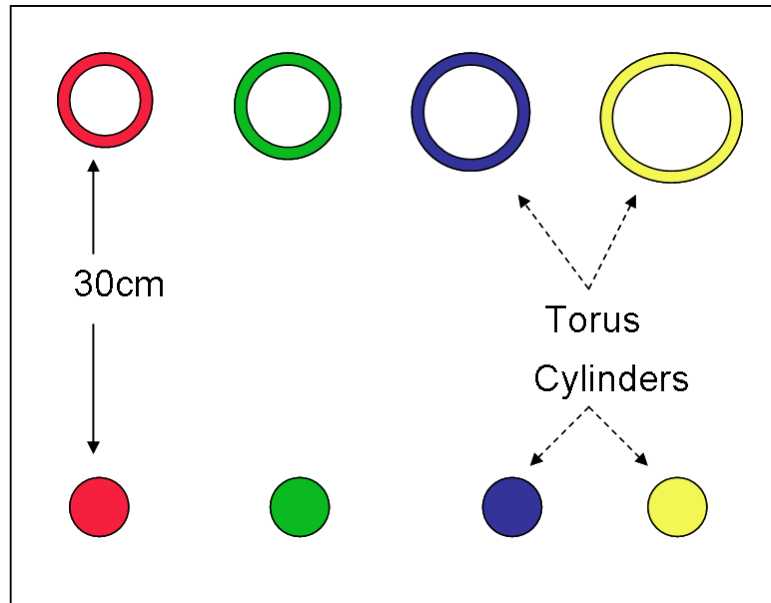

(a)

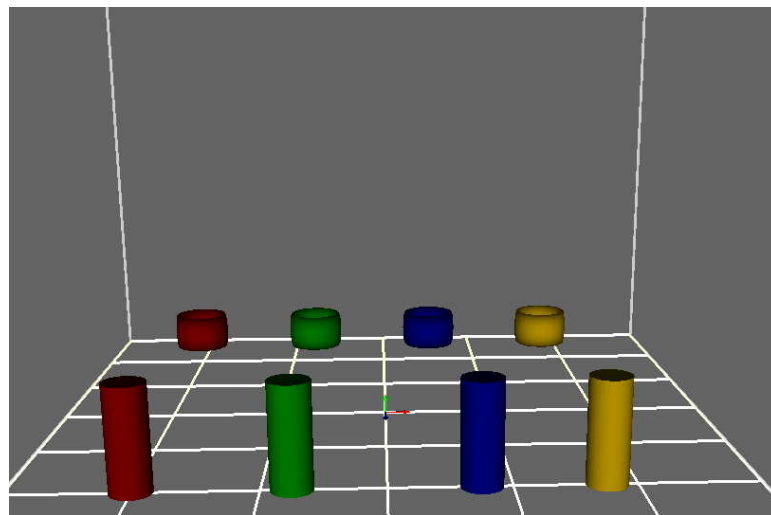

(b)

Figure 3.6: Illustration of Peg-in-hole VE : (a) top view of the task, (b) snapshot of the user viewpoint during the task.

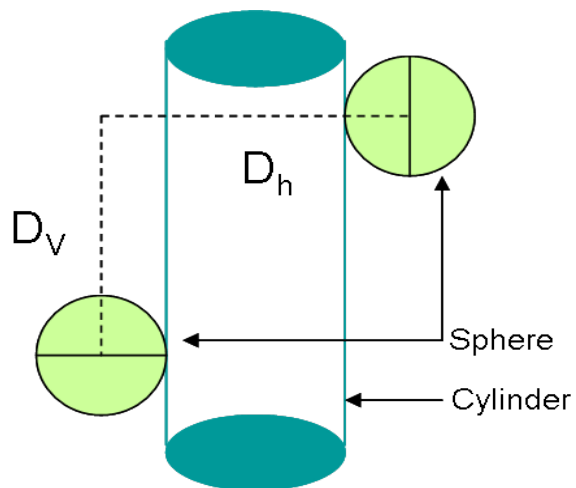

Figure 3.7: Illustration of the grasping conditions for object manipulation.

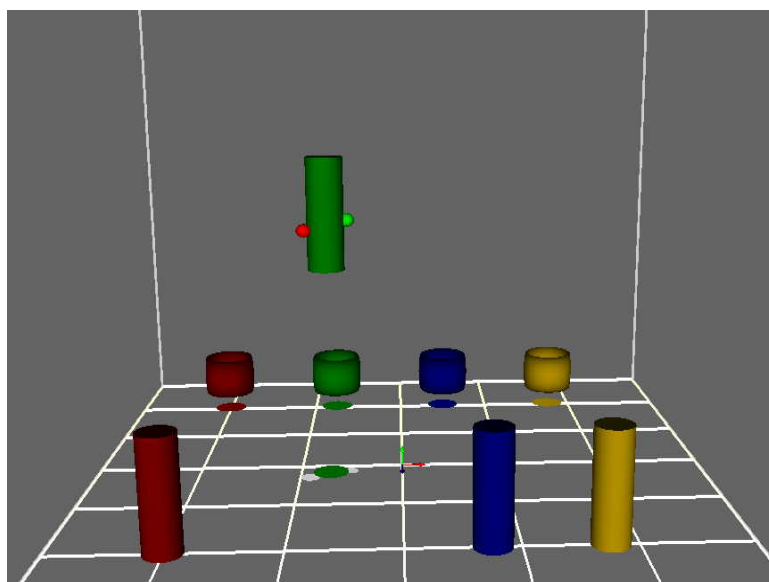

Figure 3.8: Illustration of the cooperative Peg-in-hole task.

Properties	Description
Name	<i>Change_color</i>
Goal	<i>The objective of this guide is to enhance coordination, awareness and performance during a cooperative task</i>
Type	<i>Visual</i>
Status	<i>Dynamic</i>
Function	<i>the object (cylinder) takes the color of the sphere to which it is in contact/collision</i>
Pre-condition	<i>when a single user is in contact with the object (cylinder)</i>
Post-condition	<i>when both users are in contact with the object (cylinder)</i>

Table 3.1: The properties of the visual guide base on change in color.

3.3.3 Multimodal collaborative virtual guides

Assuming improvement in coordination, awareness and performance of the users in the cooperative task (as described above), we integrated different virtual guides into the simulation. Each guide has been implemented according to the formalism proposed by Otman (Otmane, 2000).

3.3.3.1 Visual guides

3.3.3.1.a Change of color When the application is launched and the network connection is successfully established between the two machines, each user will see his/her sphere (3D cursor) in the virtual world. He/she also sees the cursor of his/her collaborator. If a user touches one of the cylinders, it takes the color of the corresponding sphere. This color will be transparent, indicating that the second user is not in collision with the cylinder. When the second user will come in contact with the same cylinder, so the later will take the color (not transparent) of the second sphere. Consequently the users will be able to cooperatively move the cylinder in EV (Ullah et al., 2009c).

If one of the spheres detaches from the cylinder during the execution of the task, the cylinder stops moving and takes the color (with transparency) of the sphere still attached. The second user will simply wait until the first come back in contact with the cylinder. It means that a user will have the awareness about the status and actions of his/her partner through change in color during task execution. When users successfully put a cylinder in its corresponding torus, it will change color indicating the completion of the task. The properties of this guide are represented the Table 3.1.

Properties	Description
Name	<i>Guide_force_substitution</i>
Goal	<i>The objective of this guide is to enhance coordination, awareness and performance during a cooperative task</i>
Type	<i>Visual</i>
Status	<i>Dynamic</i>
Function	<i>The arrow appears, pointing in opposite direction to the force applied by the user on the object (cylinder).</i>
Pre-condition	<i>When collision take place between the sphere of a user and object (cylinder)</i>
Post-condition	<i>When there is not collision between sphere and the object (cylinder)</i>

Table 3.2: The properties of arrow based visual guide.

3.3.3.1.b Visual representation of forces We also implemented a visual guide which is the graphical representation of forces applied by users on the cylinders (see Figure 3.9). This representation of forces not only informs the operators about the magnitude of force they apply on the cylinder but also helps them to better comply with the conditions of stability. If a user touches a cylinder, an arrow will appear pointing in the direction opposite to the force applied by the user on the cylinder. The arrow has many advantages, first it indicates the collision between the cylinder and the sphere of a user, on the other hand, if any user loses control of the cylinder during manipulation, his/her arrow disappears and the cylinder stops moving (see Figure 3.9). The second user just waits for the first, to come back in contact with the cylinder. In this way, both users will be aware of the status and actions of each other through arrows (appearing/disappearing) during task execution. The length of the arrow increases or decreases depending on the penetration of the sphere in the cylinder (see Eq 3.1) (Ullah et al., 2009b).

$$F = l_0 + kx \quad (3.1)$$

Where l_0 represents the initial length of the arrow, x is the penetration of the sphere in cylinder and k is a positive constant.

For each user the color of the arrow corresponds to the color of his/her sphere. The Table 3.2 represents the properties of this guide.

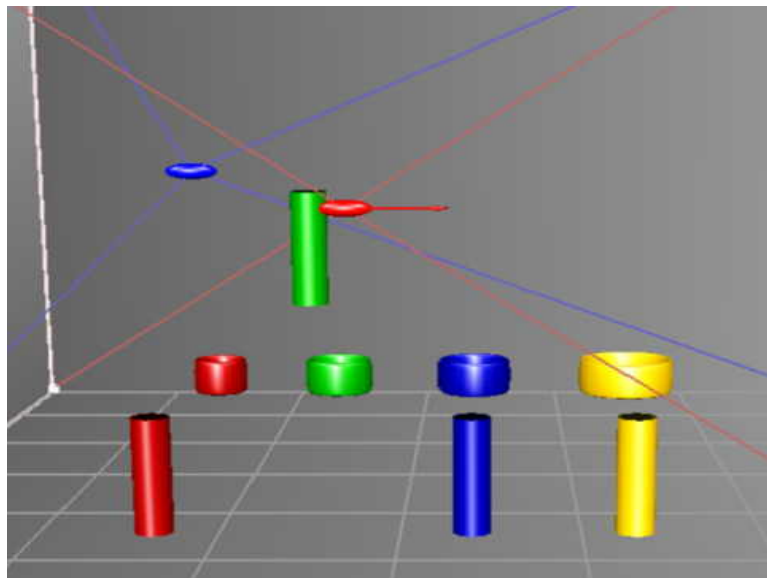

Figure 3.9: Illustration of the visual representation of the forces applied by the operators during cooperative manipulation.

3.3.3.1.c Shadows To have knowledge of the relative positions of different objects in the virtual environment, we use shadows for all objects in the environment. The shadow not only gives information about the contact of the user’s sphere with the cylinder, but also providing feedback on the position of the cylinder relative to its corresponding torus during manipulation (Ullah et al., 2009b). The properties are given in the Table 3.3.

3.3.3.2 Audio guides

As we described earlier, we selected to study two types of sound feedback: a sound guide associated with an event and vocal communication between the two operators during the planning and execution of the cooperative task.

3.3.3.2.a Audio guide In the case of the audio guide, we have assigned two different sounds to each sphere (Ullah et al., 2009c). The first sound occurs whenever the collision of the sphere and a cylinder takes place and the second sound occurs at their separation. It means that both the spheres have two unique sounds one each for collision and separation. Therefore, during task execution one can easily recognize that who is in contact or lost control of the cylinder. Consequently the auditory guide may play a role not only in performance but in the awareness as well. The properties of this guide can be seen in the Table 3.4.

3.3.3.2.b Vocal communication Humans often make use of oral communication while performing collaborative tasks in the real world. To accomplish cooperative work in the virtual environments in more realistic manner, to achieve high performance and increase co-presence of users, we use oral communication. For this purpose we utilize teamspeak software (Team_speak_software, 2010) that allows two or more users to com-

Properties	Description
Name	<i>Guide_shadows</i>
Goal	<i>The objective of this guide is to enhance coordination, awareness and performance during a cooperative task</i>
Type	<i>Visual</i>
Status	<i>static</i>
Pre-condition	<i>When the shadow activation button is pressed</i>
Post-condition	<i>When the shadow deactivation button is pressed</i>

Table 3.3: Properties of shadow based visual guide.

municate on the network using a headset and microphone.

Oral communication allows users to negotiate and exchange information on various events, such as increasing or decreasing speed, losing control of the cylinder and reaching over the torus (Ullah et al., 2009b).

3.3.3.3 Haptic guides

We found in the state of the art that haptic feedback had been mainly used to increase the realism of CVEs and less to increase the collaborative performance of operators. To assist operators in the cooperative “Peg-in-Hole” task, we designed and implemented various types of haptic guides: An *attractive haptic guide*, a *speed control haptic guide* and *mutual force* (Ullah et al., 2010). As we mentioned earlier in this chapter, our hypothesis is that the haptic feedback is indispensable in cooperatives manipulation tasks. However, it is necessary to identify the required information related to each type of task and then propose the relevant haptic feedbacks or guides.

3.3.3.3.a Attractive haptic guide If one of the user touches the cylinder, and if the position of the effector of the second user corresponds to a point on the cylinder, then the second user will feel an attractive force towards the cylinder (see Figure 3.11). The attractive guide serves two purposes, firstly it allows a user to know about the status and actions of his/her collaborator. Secondly, if a user loses control of the cylinder during manipulation, then he/she is immediately brought back towards the cylinder by the attractive force. The properties of this guide are given in the Table 3.5.

Here the positions of the cylinders, user1 and user2 are represented by the equations 3.2, 3.3 and 3.4 respectively.

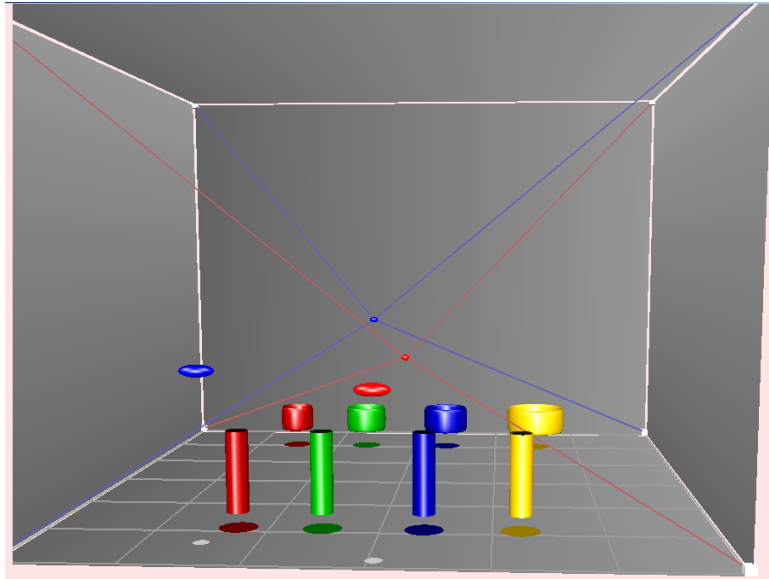

Figure 3.10: Illustration of the use of shadows in CVE.

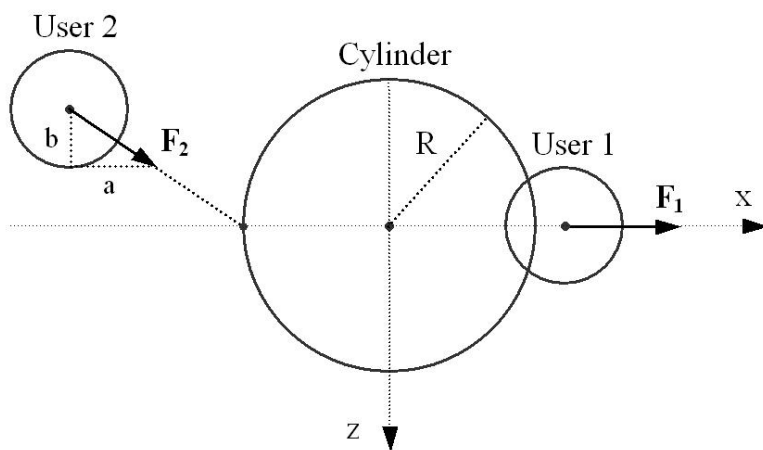

Figure 3.11: Illustration of the attractive haptic guide (top view).

Properties	Description
Name	<i>Guide_audio</i>
Goal	<i>The objective is to enhance coordination, awareness and performance of the users in cooperative task</i>
Type	<i>audio</i>
Status	<i>Dynamic</i>
Function	<i>When a sphere comes in contact or separates from the cylinder, a sounds is produced for each case</i>
Pre-condition	<i>Collision (a) Separation (b) with object (cylinder)</i>
Post-condition	<i>When the particular sound file finishes execution</i>

Table 3.4: Properties of the audio guide.

$$POS_{cyl} = (X_{cyl}, Y_{cyl}, Z_{cyl}) \quad (3.2)$$

$$POS_{u1} = (X_{u1}, Y_{u1}, Z_{u1}) \quad (3.3)$$

$$POS_{u2} = (X_{u2}, Y_{u2}, Z_{u2}) \quad (3.4)$$

Similarly “R” and “r” represents the radius of cylinders and spheres (3D cursor) respectively. K is a positive constant. The attractive force is calculated as:

$$\vec{F}_1 = K[(X_{u1} - r) - (X_{cyl} + R)]\vec{u}_x \quad (3.5)$$

$$|\vec{F}_2| = |\vec{F}_1| \quad (3.6)$$

$$\vec{F}_2 = a\vec{u}_x + b\vec{u}_z \quad (3.7)$$

where,

$$a = \frac{|\vec{F}_2| \cdot [X_{u2} - (X_{cyl} - R)]}{\sqrt{(Z_{cyl} - Z_{u2})^2 + [(X_{cyl} - R) - X_{u2}]^2}} \quad (3.8)$$

and

$$b = \frac{|\vec{F}_2| \cdot (Z_{cyl} - Z_{u2})}{\sqrt{(Z_{cyl} - Z_{u2})^2 + [(X_{cyl} - R) - X_{u2}]^2}} \quad (3.9)$$

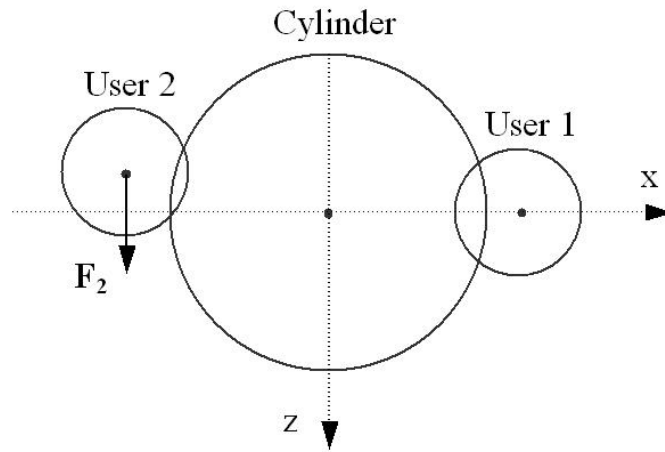

Figure 3.12: Illustration of speed control haptic guide (top view), users are moving in (-Z) direction

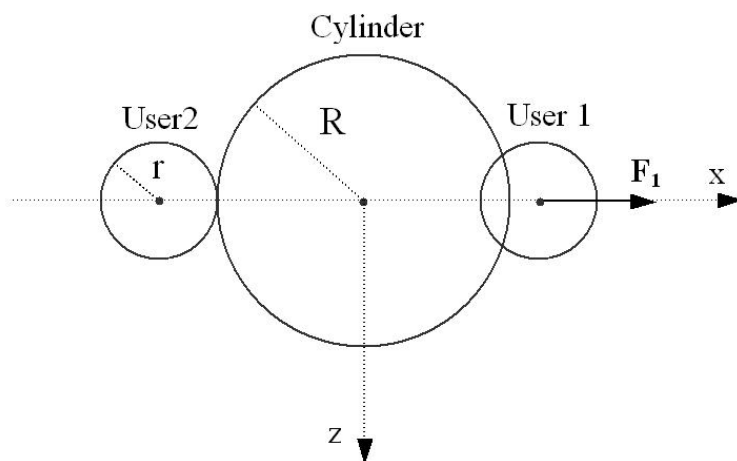

Figure 3.13: Illustration of the mutual force (top view)

Properties	Description
Name	<i>attractive_haptic_Guide</i>
Goal	<i>The objective of this guide is to ameliorate the coordination, awareness and performance of the users during a cooperative task's execution</i>
Type	<i>Haptic</i>
Status	<i>Dynamic</i>
Function	<i>The user who is not in contact with the object (cylinder) is attracted towards the object.</i>
Pre-condition	<i>When a single user is in contact with the object (cylinder) and the position of the second corresponds to a point on the object</i>
Post-condition	<i>When both users are in contact with the object (cylinder)</i>

Table 3.5: Properties of the attractive haptic guide

3.3.3.3.b Speed control haptic guide In order to have a smooth manipulation (transportation) of the object with minimum errors, we propose another guide called “Speed control haptic guide” that provides a small resistance to the user whose speed is faster as compared to his/her collaborator and the distance between the two exceeds a certain threshold (see Figure 3.12). The name “speed control haptic guide” is given because the difference in speed causes the difference in position beyond the threshold. The magnitude of the force for this guide is calculated by the equation 3.10.

$$\vec{F}_2 = K(Z_{u1} - Z_{u2})\vec{u}_z \quad (3.10)$$

Here \vec{F}_2 is the resistive force felt by the user2 because he/she moves too fast as compared to his/her collaborator (user1) (see Figure 3.12).

3.3.3.3.c Mutual force feedback This feedback, allows the user to feel a force as a function of the penetration of their spheres in the cylinder. This force not only increases the realism of the task but also enables users to easily manipulate the object. The magnitude of the force is calculated according to the equation 3.11. \vec{F}_2 is calculated in the same way (see Figure 3.13).

$$\vec{F}_1 = K[(X_{u1} - r) - (X_{cyl} + R)]\vec{u}_x \quad (3.11)$$

Properties	Description
Name	<i>Speed_control_haptic_guide</i>
Goal	<i>The objective of this guide is to ameliorate the coordination, awareness and performance of the users during a cooperative task's execution</i>
Type	<i>Haptic</i>
Status	<i>Dynamic</i>
Function	<i>The user who is faster than his/her collaborator is slightly blocked by the resistive force.</i>
Pre-condition	<i>When the distance between the two users exceeds the predefined threshold.</i>
Post-condition	<i>When the distance between the two collaborators is less than the specified threshold</i>

Table 3.6: Properties of the speed control guide

3.4 Conclusion

After the introduction of the problems related to cooperative manipulation/work, we proposed several virtual guides to assist users to perform the task more effectively and to enhance their perception of co-presence, mutual awareness and coordination. The virtual guides that we have proposed in this chapter, include visual guides (such as contact base color changing, force visualization and shadows) and audio guides. We have also studied the influence of oral communication between the remote collaborators during task execution.

In this chapter, we have also proposed haptic guides. In this context, we presented models of the two haptic guides (attractive and speed control) and normal force feedback (based on contact with the object). The objective of these guides was to provide assistance to users in a cooperative task that requires close coordination. In addition, in such tasks one user's actions have a strong influence on the other user.

In order to evaluate our proposed virtual guides, some of them we presented in this chapter and some will be presented in this next chapter, we will carry out experiments to study their influence on users' performance. For this purpose we developed an application that allows two remote users to achieve a collaborative/cooperative manipulation task. The application was developed on the basis of our "software architecture" presented in Section 3.3.1. Here we also proposed the concept of aura sets and task sets as models for coordination and awareness in CVEs.

Chapter 4

Experiments and evaluations: study of collaborative performance

4.1 Introduction

This chapter is dedicated to **multi-user experiments**. These experiments are carried out in the environments developed on the basis of the software architecture presented in chapter 3 (section 3.3.1). The purpose of these experiments is to study the effect of multi-sensory guides on users' coordination, awareness and performance during collaborative/cooperative task execution. The Peg-in-hole task was selected as experimental task for the first four studies. In the fifth study, the experimental task is to cooperatively inverse a stack of two cylinders via two robots. In these studies, assistance is provided through sound, visual and haptic guides. In the sixth experiment, we present a study on the influence of viewpoints and tactile feedback on the performance of two users during the execution of a cooperative task. Here the cooperative task is carried out via a virtual robot where each user controls separate degrees of freedom of the virtual robot. In the last experiment of this chapter, dynamic haptic interaction between two remote users, based on the concept of "What You Feel Is What I DO (WYFIWID)" is presented.

4.2 Study of the collaborative/cooperative performance

4.2.1 Experiment I : Contact coloring and audio guides

The objective of this experiment is to study the influence of *sound* and *contact coloring* guides on users' coordination, awareness and performance in cooperative manipulation of the virtual objects (Ullah et al., 2009c). These guides were presented in chapter 3 (section 3.3.3.1). The task to be performed in this experiment is a cooperative Peg-in-hole task.

We installed our application on two computers (Pentium 4) connected via LAN (Local Area Network). Each machine has 2GHZ processor and 1GB of memory. Each computer has an Nvidia graphics card and a standard sound card. The first computer used a CRT monitor (17 inch) to display the virtual world, while a 24 inches plate display screen was attached to the second. Similarly, each VR system was equipped with a Polhemus PatriotTM as an input device.

4.2.1.1 Experimental protocol

To assess the effects of visual and audio guides on user performance in cooperative manipulation of objects, we conducted a user evaluation. For this purpose, six subjects participated in the form of three groups (G1, G2, G3). All participants were men, right handed and had ages of 22-45 years. To familiarize them with the system, each group was given a short briefing and a pre-trial in which they experienced all feedbacks with the instructor as collaborator.

After the successful start of the application, each user could see two spheres on their screens. To start the task at the same time, users were required to place their spheres in the center (predefined) of the virtual world. After five seconds, they saw a message on their screen to begin the task. The experiment was conducted using the following three conditions.

- C1: No guide
- C2: Visual guide (contact coloring)
- C3: Audio guide

In order to avoid any training transfer between condition, the order of the conditions for the groups was counterbalanced in the following manner:

- G1: C1, C2, C3
- G2: C2, C1, C3
- G3: C3, C2, C1

The subjects were asked to put all cylinders in their corresponding torus in a single trial. Each group had exactly four trials in each condition. The selection order of the cylinders was also the same for all groups (start from the red, go in a sequence and finish

Conditions	Mean	Standard deviation
C1	218.33	25.65
C2	140.5	43.13
C3	109.33	14.63

Table 4.1: Mean and standard deviation of task completion time (sec.) for various conditions.

at yellow).

We recorded the task completion time of each trial. After the task, we gave a questionnaire to each user to collect subjective responses.

4.2.1.2 Analysis of the results

In this section we present and analyze the results of the experiment presented above. We focus initially on the analysis of *task completion time* (objective data). Then, we discuss the results obtained via the *questionnaire* (subjective data). Finally we analyze the *learning process* during task repetition.

4.2.1.2.a Task completion time The ANOVA for task completion time ($F(2, 2) = 35.34, P < 0.05$) is significant. The mean and standard deviation of task completion time under each condition is given in the Table 4.1. Comparing the task completion time of C1 with that of C2 and C3, we obtained statistically significant results. It means that visual and audio guides have improved the performance of users. However comparing the task completion time of condition C2 with C3 is not significant. It means that the two guides (visual and audio) provided almost the same level of guidance.

4.2.1.2.b Subjective evaluation In this section, we analyze the response collected through questionnaire (see appendix A). It is clear from the Figure 4.1 that option A has zero percent response for all the questions. Taking the responses for question 1, we observed that 83.33 percent users have preference for condition C2 and only 16.66 percent liked condition C3. Similarly, the second question which is related to the two feedbacks, 66.66 and 33.33 percent of the users responded for C2 and C3 respectively. The third question which is about the difficulty of different parts of the cooperative work, half of the users reported the cooperative manipulation of the object more difficult while for the rest half the placement was more difficult. For the fourth question all the users reported that they could better perceive the actions of their partner under condition C2 (visual).

4.2.1.2.c User learning Learning is defined as the performance improvement of users/groups during task repetition. The results show that the subjects completed the task under condition C1, in 240 sec (std: 22.91) in the first trial and in 195 sec (std: 27.83) in the last trial. For condition C2, the task was performed in 155 sec (std: 42.64) in the first trial, whereas it took 125 sec (Std: 33.08) in the last trial test. Similarly, using condition C3, the task was completed in 123 sec (std: 18.02) in the first trial and in 100 sec (std: 21.63) in the last trial (see Figure 4.2).

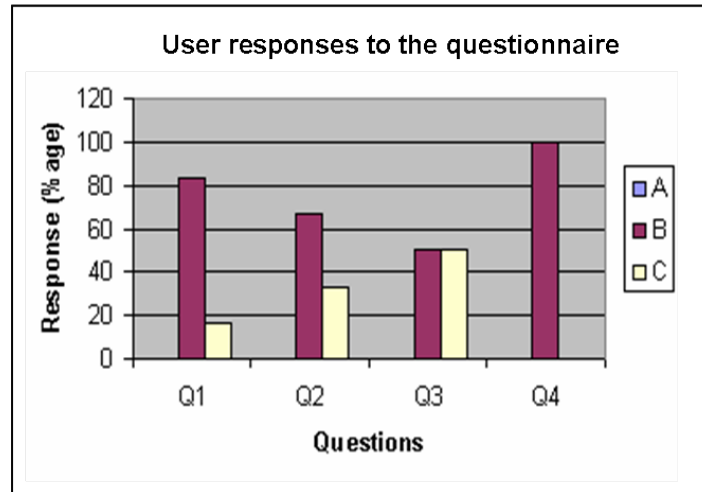

Figure 4.1: Presentation of the users' responses to the questionnaire.

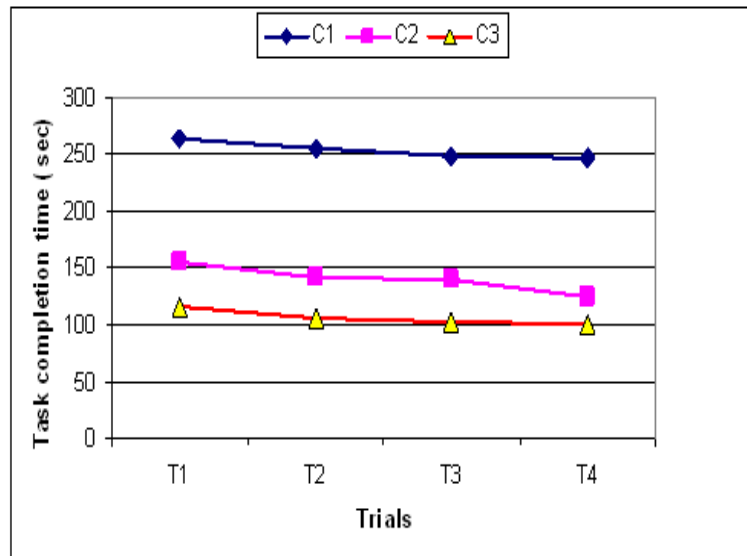

Figure 4.2: User learning of various conditions.

As a result we got the performance improvement of 18.75%, 19.35% and 18.69% for conditions C1, C2 and C3 respectively. We observe that there is a considerable learning process in the sequence of trials under each condition, but on the other hand, there was no significant difference between the learning processes of various conditions.

4.2.1.2.d Discussion Analysis of the task completion time, subjects' responses to the questionnaire and their comments revealed that our proposed guides (visual and audio) have been very helpful to users for manipulating objects in CVE. Moreover, these guides not only improved user performance, but also enabled them to perceive the actions of their partners. Although the task completion time of C3 is less than C2, but statistically, there is no significant difference between the two. The users reacted more quickly to audio guide as compared to visual guide. On the other hand, the majority of users preferred the visual assistance, and they all reported a better perception of the actions of their partners

in this condition.

4.2.2 Experiment II : Force substitution, shadows and communication

In this experiment we study the effect of visual guides (visual representation of force, shadows) and oral communication on collaborative performance (Ullah et al., 2009b). The description and working mechanism of these guides have been presented in the chapter 3 (section 3.3.3.1)

4.2.2.1 Experimental protocol

In this experiment ten volunteers (five male and five female) participated. They were Master and PhD students. All participants performed the experiment with the same person who was expert of the field and also of the proposed system. To adapt the subjects with the system, they were given a short briefing and a pre-trial in which they experienced all feedbacks. Users were required to start the application on their respective machines. After the successful start of the application, each user could see two spheres on their screens. To pick up and manipulate a cylinder the expert and the subject must touch (through their spheres) it from right and left sides respectively. The experiment was performed under the following conditions.

- C1: Shadow;
- C2: shadow+ force substitution;
- C3: shadow + force substitution + oral communication;
- C4: No guidance;

All ten subjects performed the experiment using random combinations of the four conditions. We recorded the manipulation time for each cylinder. The timer starts when both users' sphere initially come in contact with a cylinder and stops when it is put in its corresponding torus. Similarly, we recorded the number of times the cylinder was dropped as errors in manipulation. Once the task was completed, all subjects were given a questionnaire, to collect their subjective responses and comments.

Subjects must put all cylinders in their corresponding toruses in a single trial. There were exactly four trials under each condition. Thus, each subject had 64 manipulation in all conditions. The selection order is the same as described in the previous experiment.

Conditions	Mean (sec)	standard deviation
C1	30.7	6.17
C2	22.39	3.10
C3	24.48	3.93
C4	38.31	7.94

Table 4.2: Mean and standard deviation of task completion for various conditions

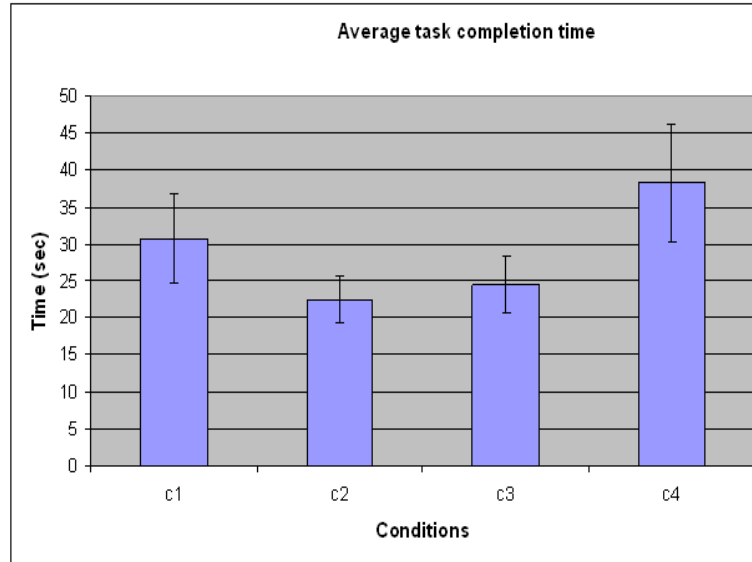

Figure 4.3: Mean and standard deviation of task completion for various conditions

4.2.2.2 Analysis of the results

In this section we present and analyze the results, including task completion time and errors. Similarly user responses collected by the questionnaire are also examined and discussed.

4.2.2.2.a Task completion time The ANOVA for the task completion time is ($F(3, 9) = 16.02, P < 0.05$) significant. The mean and standard deviation of task completion time for each condition is given in the Table 4.2. Comparing the task completion time of condition C1, C2 and C3 with that of C4, we obtained statistically significant results. It means that visual guides (shadow and arrow) and oral communications have improved the performance of users. Comparing the task completion time of condition C2 with C1 gives significant ANOVA. It means that the arrow has a strong influence on the users' performance as compared to shadow. However the comparison of task completion time of condition C2 with C3 does not give significant ANOVA. In other words we can say that oral communication don't have much influence on users' performance in terms of task execution time.

4.2.2.2.b Errors during task execution When the sphere of a user moves away and does not remain in contact with the cylinder during task execution then the cylinder stops moving and it is considered as an error. Here we present a comprehensive analysis

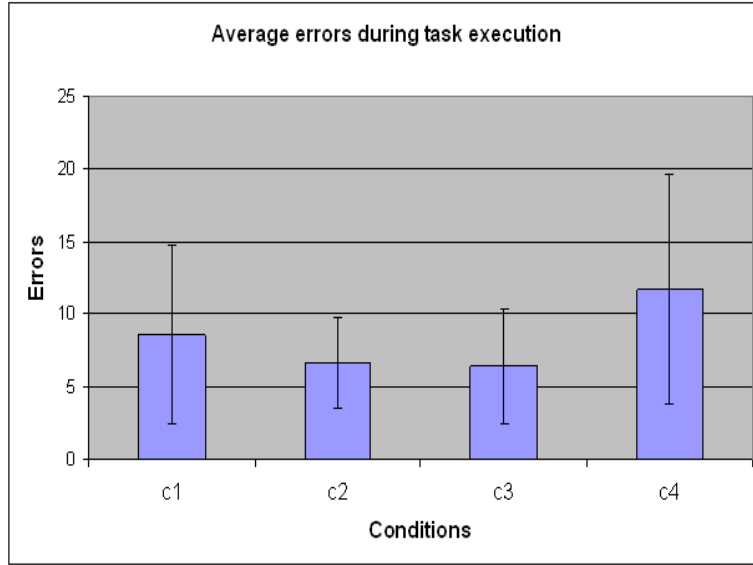

Figure 4.4: Errors during task execution

Questions	C1				C2				C3				C4			
1	0	30	70	0	10	70	20	0	90	10	0	0	0	0	0	100
2	0	30	70	0	10	70	20	0	90	0	10	0	0	0	0	100
3	0	20	80	0	10	70	20	0	90	10	0	0	0	0	0	100
4	0	20	80	0	10	70	20	0	90	10	0	0	0	0	0	100

Table 4.3: The percentage of responses for the options (condition) of each question

of the errors made during task accomplishment. The conditions C1, C2, C3 and C4 have average errors of 8.6 (std 4.6), 6.6 (std: 3.5), 6.4 (std 3.2) and 11.7 (std: 5.7) respectively. Like task completion time, errors are less in conditions C2 and C3 as compared to conditions C1 and C4 (see Figure 4.4).

4.2.2.2.c Subjective analysis Here we present analysis of the users' responses and comments collected through questionnaire (see appendix B). For each question there were four options and subjects had to rate each of them according to their preference. Therefore, each option of a question (condition) had to get a vote for 1st, 2nd, 3rd and 4th position in response to a question. The percentage of users' preferences are given the Table 4.3. The columns (C1, C2, C3, C4) are further divided into four sub-columns. The first sub-column represents the vote for the first preference (position) and the second sub-column for the second preference (position) and so on. Here, C3, C2 and C1 are the first, second and third preference of the users, respectively.

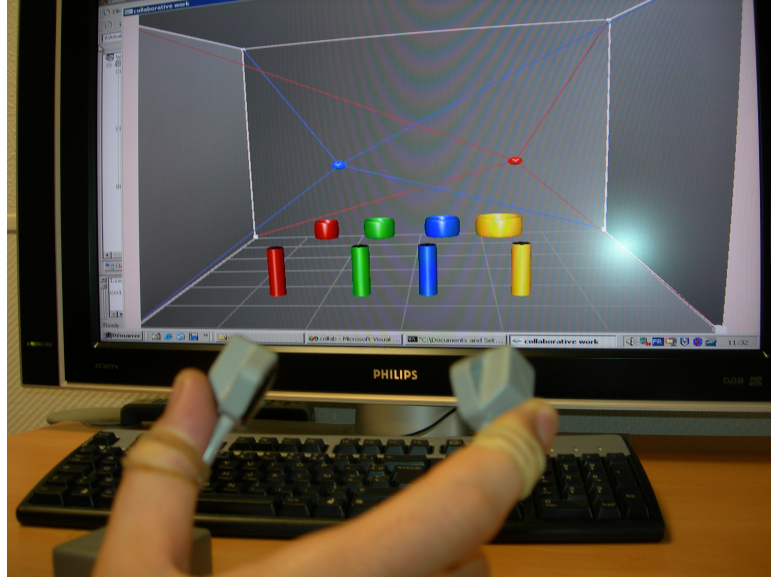

Figure 4.5: Single-user configuration for the Peg-in-hole task.

4.2.2.2.d Discussion Analysis of objective and subjective data showed that the visual guides (force substitution and shadow) and oral communication have greatly helped users in cooperative manipulation of objects in the VE. In addition, these guides not only improved the performance of users, but also enabled them to perceive the actions of their partners. Comparison of task completion time of the condition C1 with C2 gives significant ANOVA. It means that the force substitution (arrow) has a strong influence on the users' performance as compared to shadow.

However, the comparison of the task completion time of C2 with C3 does not give significant ANOVA. It means that the conditions provided almost the same level of guidance but majority of the users preferred the assistance provided by C3 (force substitution + shadow + oral communication), because "oral communication" enabled them to have close coordination during task execution.

4.2.3 Experiment III : Force substitution and shadows in single user VE

In this experiment we study the effect of visual guides (visual representation of force and shadow) on user performance in a single-user configuration while performing the same Peg-in-hole task (Ullah et al., 2009e). In addition the results of this experiment are compared to those of the experiment II presented in section 4.2.2.

4.2.3.1 Experimental protocol

To perform the experiment (Peg-in-hole) in the mono-user configuration, two Polhemus sensors were used on the same machine. Both sensors were attached to the right hand of the user in a way that the sensor corresponding to red and blue spheres were on the index finger and thumb, respectively (see Figure 4.5).

This experiment was performed by ten volunteers including five males and five females. They were master students and all of them were right handed. Each subject got a short

Conditions	Mean	standard deviation
C1	6.34	1.51
C2	6.27	0.82
C4	8.09	1.14

Table 4.4: Average task completion time and standard deviation for various conditions.

Conditions	Mean	standard deviation
C1	1.16	0.72
C2	1.17	0.48
C4	1.47	1.02

Table 4.5: Average errors with standard deviation for various conditions of the experiment III

briefing and a pre-trial. The task was to pick-up the cylinder and put it in its specified torus. The experiment was conducted using the following conditions:

- C1: Shadow;
- C2: Shadow + force substitution;
- C4: No assistance.

There were four trials under each condition and the order of selection was the same as described in the previous experiments. For evaluation, we recorded the task completion time and errors during task accomplishment. User responses were also collected through a questionnaire.

4.2.3.2 Analysis of results

4.2.3.2.a Task completion time The ANOVA for task completion time is ($F(2, 9) = 7.52, P < 0.05$) significant. Comparing the task completion time of condition C1 with that of C4, we obtain significant ANOVA. Similarly, the comparison of C2 with C4 also gives significant ANOVA. On the other hand the comparison of C1 and C2 gives us non significant ANOVA.

These results show that the shadow has an influence, but force substitution has no influence on the user performance in the single-user configuration (see Table 4.4 and 4.6)

4.2.3.2.b Errors during task execution The ANOVA ($F(2, 9) = 0.49, P > 0.05$) result for error analysis is not significant. In single-user configuration, users have more control over the position of their fingers and therefore led to very few errors in all conditions (see Table 4.5 and Figure 4.7).

4.2.3.2.c Subjective analysis For subjective assessment we use, responses and comments of the users that we collected through the questionnaire (see appendix C). Here

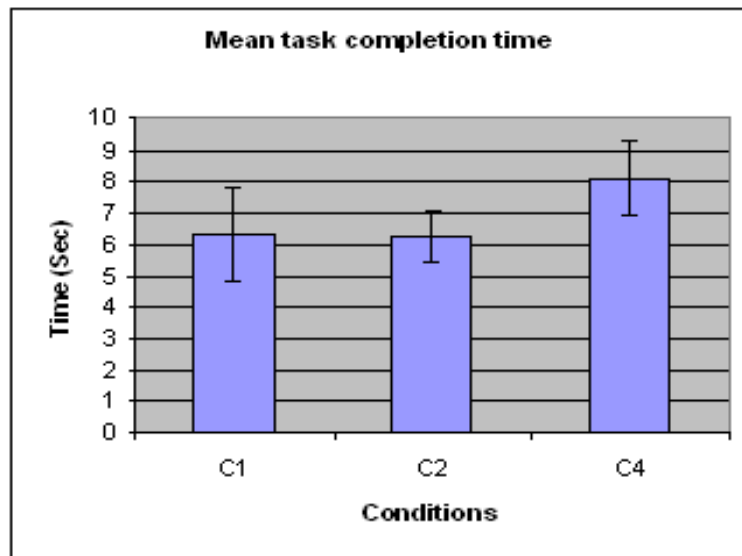

Figure 4.6: Average task completion for various conditions.

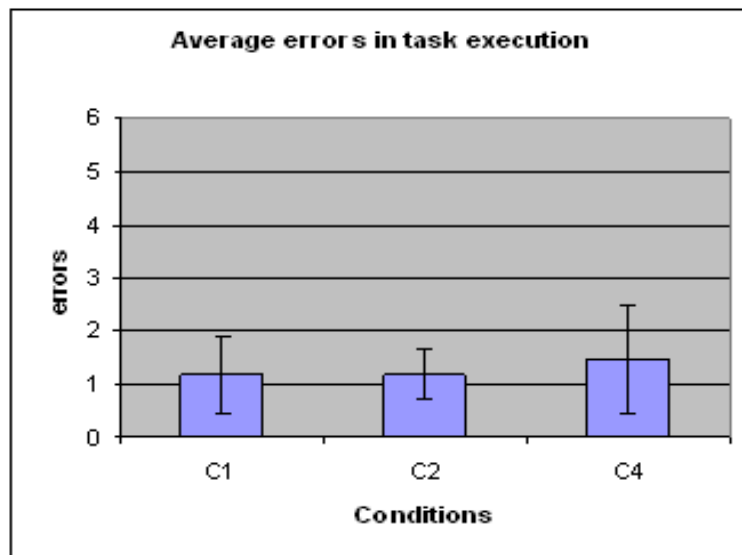

Figure 4.7: Average errors with standard deviation for various conditions of the experiment III

Experiment/conditions	C1		C2		C4	
	time	std	time	std	time	std
II multi-user	30.07	6.17	28	3.11	38.31	7.94
III mono-user	6.34	1.5	6.26	0.82	8.09	1.13

Table 4.6: Average task completion time with std for various conditions of the experiment II & III.

Experiment/condition	C1		C2		C4	
	errors	std	errors	std	errors	std
II multi-user	8.6	4.6	6.6	3.5	11.7	5.7
III mono-user	1.16	0.72	1.17	0.48	1.47	1.02

Table 4.7: Average errors with std for various conditions of the experiment II & III.

90 % of the users preferred the condition C1, and the majority of users were of the view that C1 has greatly helped them during task accomplishment as compared to the other conditions. Similarly, the selection, manipulation and placement was difficult for 20 % 70 % and 10 % of the users respectively.

4.2.4 Comparison of the experiment II & III

The purpose of this section is to compare the influence of guides on users performance in single-user and two-user configurations (Ullah et al., 2009e). The Table 4.6 presents the task completion time of the experiment I and II. There are two sub-columns under each condition in which the first contains the average task completion time and second contains its standard deviation.

We observe that task completion time is very less in single user configuration as compared to the two user set-up.

Similarly, Table 4.7 presents the average errors with standard deviation for various conditions of the experiment II and III.

These results indicate that the task is more complex to perform in cooperative configuration as compared to the single-user configuration. The shadow has provided significant assistance to users in both configurations. On the other hand the visual guide (force substitution in the current experiment) is more effective in cooperative work, because it not only gives the information to users on their own status, but also about that of their collaborators.

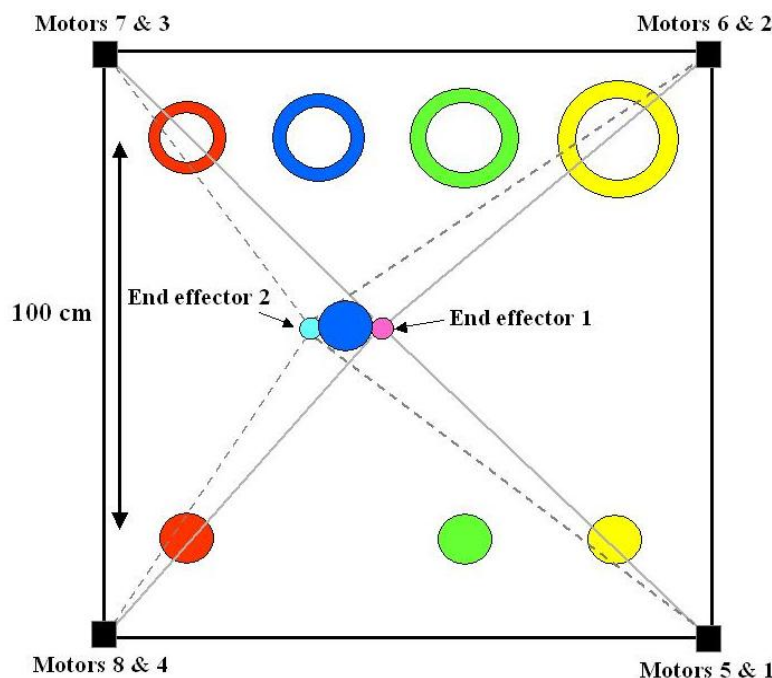

Figure 4.8: Illustration of VE (top view).

4.2.5 Experiment IV : Force feedback and haptic guides

The experiment presented in this section aims to assess and compare the influence of haptic guides described in chapter 3 (section 3.3.3.3), in a cooperative manipulation task (Ullah et al., 2010). The task is the same as discussed before (Peg-in-Hole). It is run on the platform of virtual reality called VIREPSE (Virtual Reality Platform for Simulation and Experimentation) (Richard et al., 2006). The two operators are next to each other and visualize the CVE in stereoscopic mode on the same screen. Oral communication between the two operators is direct. In addition, it is enriched by non-verbal information (movements, gestures and facial expression).

The environment used for this experiment has the same structure as the previous environment. The difference lies in the difference of size, the current one use a large screen of the VIREPSE platform. In front of each cylinder at a distance of 100cm is a torus of the same color. All cylinders have the same size of 4.5cm. The red, green, blue and yellow toruses have the internal radii of 4.6, 4.8, 5.0 and 5.20cm, respectively. Cylinders and toruses are 12cm apart. Similarly each user is represented by a sphere of distinct color in the VE.

We modeled two virtual SPIDARs (3DOF) and used them as robots (see Figure 4.8). At each corner of the cube, a motor for one of SPIDAR has been mounted. The end effector of SPIDARs were represented by two spheres of different colors. The movements of these spheres are controlled by real SPIDARs. Each effector uses 4 strings (represented by dotted and smooth lines) for connection to its corresponding motors. Users' movements are constrained by the strings of the two SPIDARs. In order to select and manipulate a cylinder, one of the end effectors (3D spheres) will remain in contact with its right side and other to its left.

We installed the software on a Pentium 4 type PC. The machine has 2Ghz Processor (5130 Dual Xeon) and 4GB of memory. The system is equipped with a powerful graphics

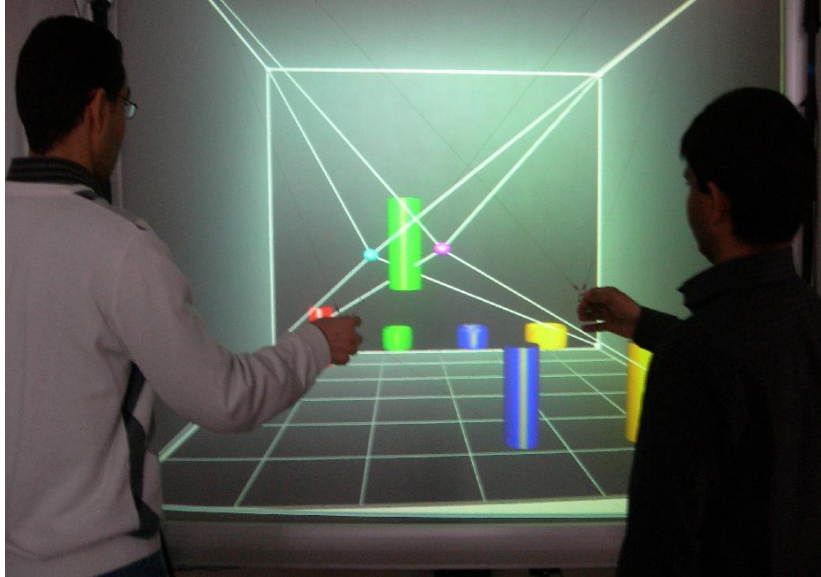

Figure 4.9: Two users performing the cooperative Peg-in-hole task using the VR platform of LISA.

card (NVIDIA). We use a large (2m x 2.5m) rear-projected screen for display and polarized glasses for stereoscopic viewing.

4.2.5.1 Experimental protocol

To evaluate the haptic guides and study their effect on user performance while cooperatively manipulating objects in VE, we conducted users experiments. For this purpose, a group of ten male volunteers participated. They were Master and PhD students. All participants performed the experiment with the same person who was expert in the field and also of the proposed system.

All subjects did a pre-trial of the experiment in which they experienced all conditions provided for evaluation. Once the application is launched, users could see two effectors (purple and blue sphere connected to the wires) of the virtual SPIDARs on the screen. The purple and blue spheres represent the effector of the expert and subject respectively. The experiment was conducted under the following four conditions.

- C1= No force feedback
- C2= Force feedback (mutual force)
- C3= Attractive haptic guide
- C4= Speed control haptic guide

Conditions	Average(sec)	standard deviation
C1	17.24	2.09
C2	11.61	2.35
C3	14.43	2.31
C4	14.27	2.41

Table 4.8: Average task completion time with std for various conditions.

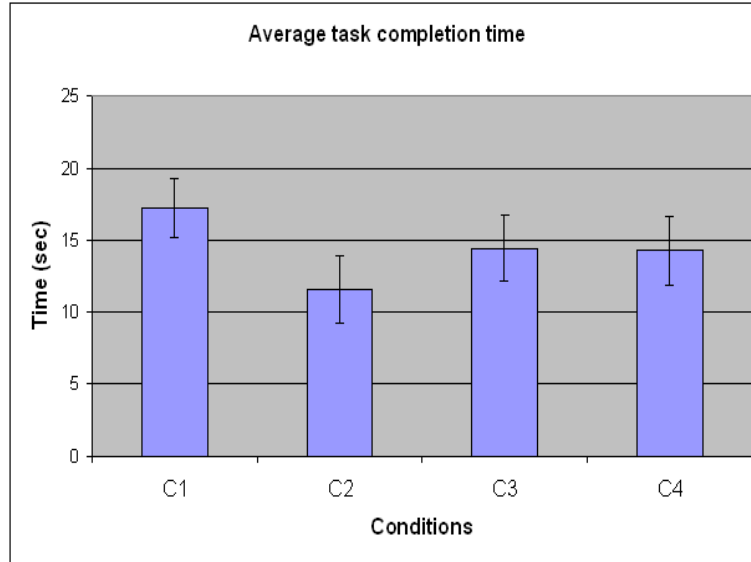

Figure 4.10: Average task completion time with std for various conditions.

All ten subjects performed the experiment using counter-balanced combinations of the four conditions. We recorded the manipulation time of each cylinder. Similarly the errors were also recorded. Users have to put all cylinders in their corresponding toruses cores in a single trial. Each group had exactly five trials for each condition. So each user performed 80 manipulations. The selection order of the cylinders was also the same for all groups (starting from the red, and finish at yellow). After the completion of the experiment, we gave a questionnaire to each user to collect responses for subjective evaluation.

4.2.5.2 Analysis of the Results

The collaborative performance is evaluated on the bases of *task completion* time and *errors* done during task execution. Similarly, *user learning* and *subjective data* of the questionnaire are also used for evaluation.

4.2.5.2.a Task completion time For task completion time the ANOVA ($F(3, 9) = 10.01, P < 0.05$) is significant. The average task completion time with standard deviation of each condition is given in the Table 4.8. Comparing the task completion time of condition C1 with that of C2, C3 and C4 give us significant ANOVA. These results showed that haptic guides have an influence on users performance in cooperative manipulation of objects in the VE.

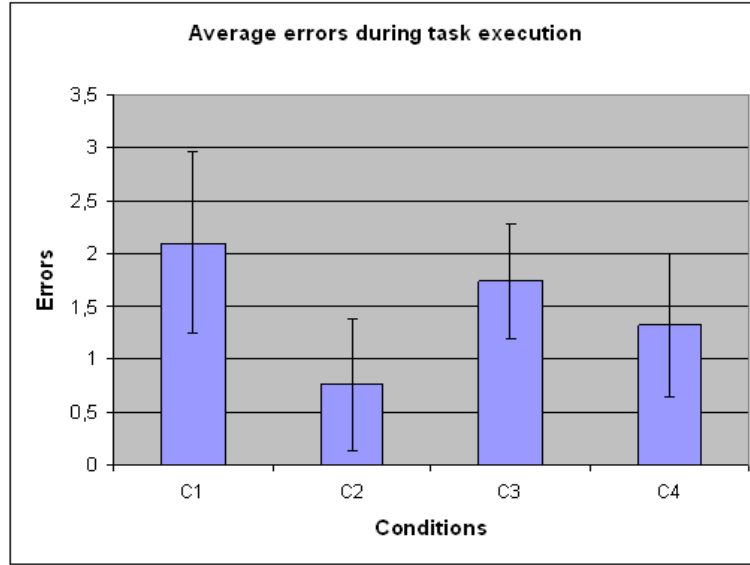

Figure 4.11: Average number of errors with std for various conditions.

4.2.5.2.b Errors during task execution We present a comprehensive analysis of errors made during task execution (see Figure 4.11). Here C1 has an average of 2.1 errors with std 0.86. Similarly C2, C3 and C4 have errors of 0.76 (std: 0.62), 1.74 (std 0.55) and 1.32 (std: 0.68) respectively. We see that C2, C3 and C4 have considerably low errors as compared to C1.

4.2.5.2.c Subjective evaluation In this section, we analyze the responses collected through the questionnaire (see appendix D). The questionnaire had four questions, each with three to four possible answers.

For the first question 40 % of the subjects preferred C2 while 30 % each opted for C3 and C4. For the second question the conditions C1, C2, C3 and C4 obtained the preference of 0%, 30%, 30% and 40% subjects respectively. According to 70% of the subjects, manipulation (transport) was the most difficult part of the task. The 30 % have marked the placement of objects as the most difficult part of the task. To the last question, 40% of the subjects had better perception of co-presence in condition C4. The opinion of 60% of subjects was divided equally between the conditions C2 and C3.

4.2.5.2.d User learning In this section, we analyze the performance improvement of users as a result of task repetition. The results show that subjects performed the task in 19.4 sec in the first trial and in 15.3 sec in the fifth trial using condition C1. In condition C2 they performed the task in 13.62 sec and 10 sec in the first and fifth trials respectively. In condition C3, they performed the task in 16 sec and in 13.04 sec in the first and fifth trials, respectively. Similarly, we have the average time of 17.05 sec for the first trial and 12 sec for the fifth trial, using the condition C4.

As a result we got the performance improvement of 21.13%, 26.80%, 18.5% and 29.62% for the conditions C1, C2 and C3 and C4, respectively (see Figure 4.12).

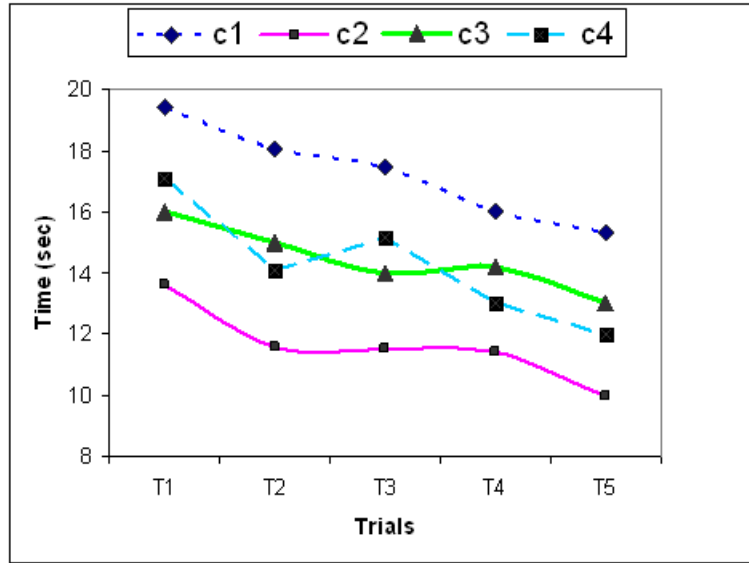

Figure 4.12: User learning during task repetition.

4.2.6 Experiment V : Cooperative teleoperation with robots

The experiment presented in this section is based on a cooperative tele-manipulation task involving the *selection*, *manipulation* and *placement* of objects, using two robot manipulators. The objective is to study and compare the influence of the proposed haptic guides. This task is certainly less standard than the previous task, but simulates a relatively generic teleoperation. The two operators are next to each other and visualize the CVE in stereoscopic mode on the same screen, using the VIREPSE platform.

4.2.6.1 Description of the virtual environment

The VE for this experiment is a room where two FANUC robots have been placed in front of each other (see Figure 4.13). The central part of both tables is within the common workspace of the robots. Two cylinder have been placed in stack form on the front table. The second table contains a blue circular disc that will serve as final position for the two cylinders. The purple and blue sphere will be used by their corresponding users to control the movements of right (orange) robot and left (yellow) robot respectively. Once the sphere touches the end effector of the corresponding robot, then it will follow the movements of the former, and the sphere will be no more visible.

4.2.6.2 Experimental protocol

To assess the proposed haptic guides in the robotic environment, we conducted user experiments. For this purpose, a group of ten male volunteers participated. They were all master students. All participant performed the task with the same person who was the expert in the field and also of the proposed system.

All participant were given a pre-trial, in order to get them familiar with the system. During the experiment, the expert was operating the right robot while the subjects were operating the left one. The experiment was done using the following conditions.

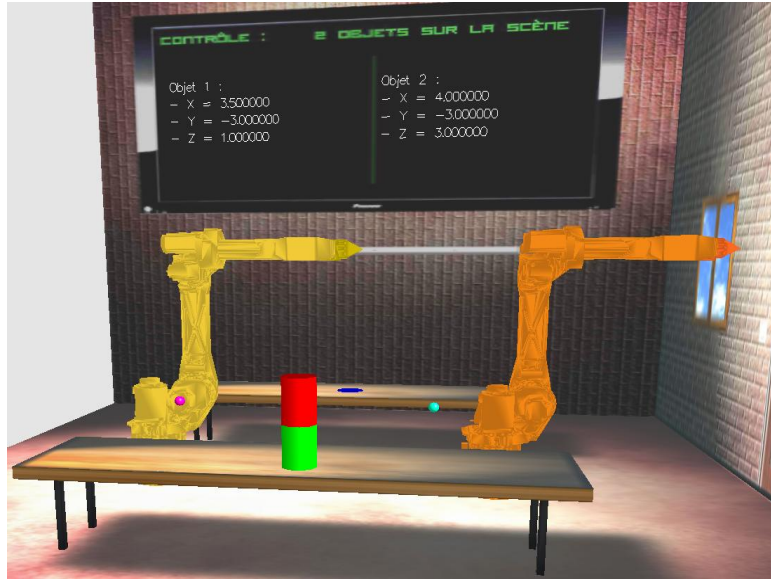

Figure 4.13: Illustration of the virtual environment with robots (Fanuc)

- C1= No force feedback;
- C2= force feedback normal;
- C3= Attractive haptic guide;
- C4= Speed control haptic guide.

All subjects performed the experiment using different counter balanced combinations of the four conditions. The manipulation time and errors were recorded. For subjective evaluation, we used a questionnaire.

4.2.6.3 Task description

The experimental task was to cooperatively select (pick-up), the red cylinder and place it on the blue disc on the second table. The green cylinder is then put on the red (see Figure 4.14). There were four trials under each condition, so each user had exactly 40 manipulation of the objects.

4.2.6.4 Analysis of the results

4.2.6.4.a Task completion time For task completion time the ANOVA ($F(3, 9) = 22.89, P < 0.05$) is significant. The average and standard deviations of task completion time for various conditions are given in the Table 4.9.

Comparing the task completion time of condition C1 with that of C2, C3 and C4 gives us significant ANOVA. Similarly, the comparison of C2 with C3 and C4 also give

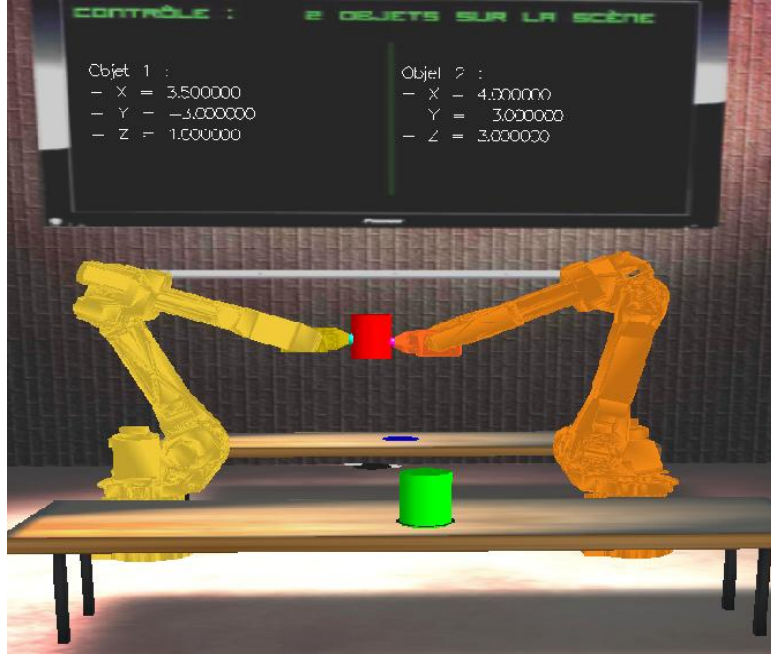

Figure 4.14: Illustration of the cooperative manipulation via the FANUC robots.

Conditions	Average (sec)	standard deviation
C1	28.8	4.01
C2	23.76	1.58
C3	21.12	2.30
C4	20.41	1.14

Table 4.9: Average task completion time with std for various conditions.

us significant ANOVA. On the other hand the comparison of C3 with C4 does not give significant result.

These results show that haptic guides have an influence on users and increase their performance in cooperative manipulation of objects via robots.

4.2.6.4.b Errors during task execution We present the errors that were made during task execution (see Figure 4.16). Here C1 has an average of 11.4 errors with std 3.76. Similarly, C2, C3 and C4 have 5.14 (std: 1.97), 4.28 (std: 2.60) and 4.04 (std: 1.53) errors respectively. In addition, C2, C3 and C4 have errors considerably low as compared to C1. On the other hand, there is no significant difference among the errors of C2, C3 and C4.

4.2.6.4.c Subjective evaluation In this section, we analyze the responses collected through the questionnaire (see appendix E). The questionnaire had three questions, each with three to four options.

For the first question 50 % of subjects preferred C4 while 33.33 % and 16.66 % opted for C2 and C3 respectively. For the second question the conditions C2, C3 and C4 ob-

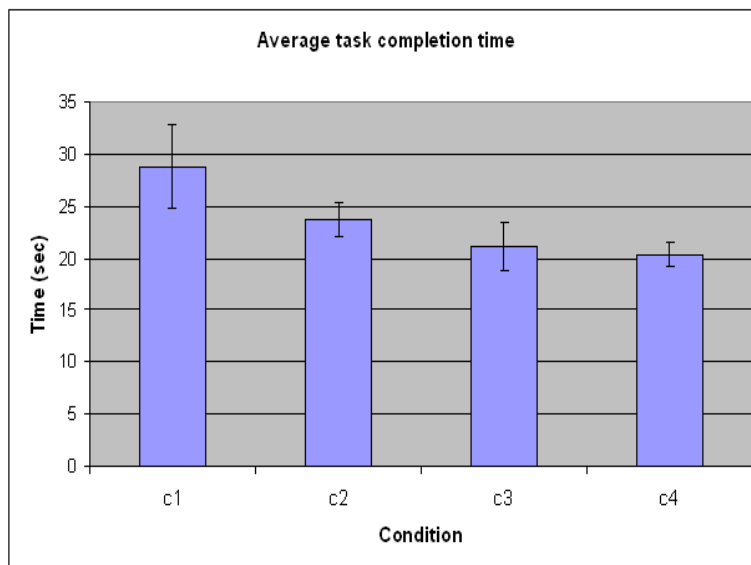

Figure 4.15: Average task completion time with std for various conditions.

tained the preference of 0 %, 33.33 % and 66.66 % subjects respectively. Similarly, for the third question, the conditions C1, C2, C3 and C4 got the preference of 0%, 16.66 %, 50 % and 33.33 % subjects respectively.

Based on users' comments and responses collected through the questionnaire, we concluded that haptic guides increased coordination and awareness between users during the execution of the task, and thus resulted in better performance.

4.2.7 Experiment VI : Influence of viewpoint and tactile feedback on cooperative work

In the real world, it is not possible for two people to have the same view of an object, but it can be achieved through virtual reality, when two or more users share the same virtual environment through different computers. To study the effect of different viewpoints of the virtual world while performing a cooperative task, we have modeled a virtual robot (3DOF) that can be cooperatively operated by two users to manipulate objects in a room (robotic workcell) (Naud et al., 2009). On the other hand we also present the effect of tactile feedback on the cooperative work.

4.2.7.1 Modeling of the robot

We will call the room where the robot is fixed as “workcell”. It has a cubic structure that contains two tables placed at different depths. Three cylinders of different sizes and colors are placed on the left table.

The virtual robot consists of four parts (see Figure 4.17). The first part consists of two supporting rods (S1 and S2), they are fixed on the left and right sides of the workcell. The second part also consists of two rods (R1 and R2) which are placed perpendicular to

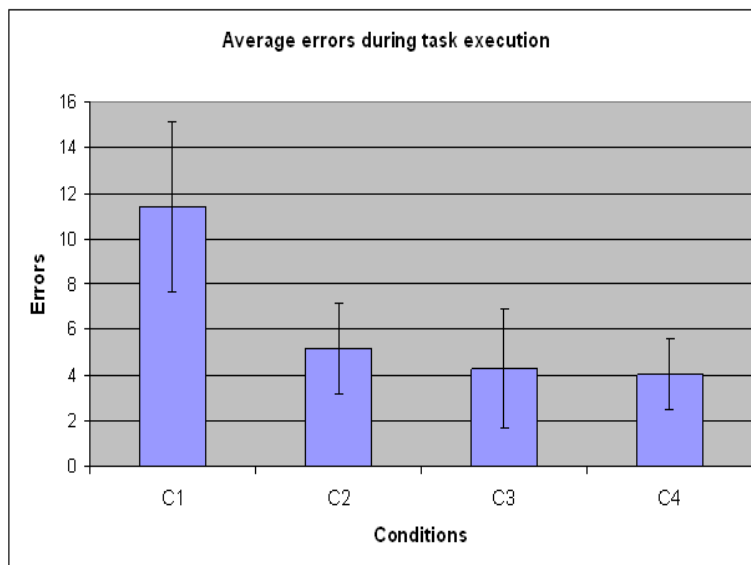

Figure 4.16: Errors during task execution with robots.

the first part. The second part is movable on the first part. The third part is a square block (C) which is movable on the second part. The fourth and last part of the robot is a magnetic grip (M) which is attached to the center of block C through four strings. Each string is attached to a corner of the block. The robot has three degrees of freedom (3DOF) and capable to access almost any part of the workcell for the selection/manipulation of an object. The position “P” of “M” at a given time is described by equation 4.1:

$$P = (X, Y, Z) \quad (4.1)$$

$$X = (x_0 - L/2) \quad (4.2)$$

$$Y = \sqrt{(l^2 - (L/2)^2)} + h \quad (4.3)$$

$$Z = (Z_{R2} - Z_{R1})/2 \quad (4.4)$$

Here x_0 represents the position of the left-front of the block “C” and L is its length. Similarly l represents the length of wire connecting “M” to the block “C”, and for all four wires must be of equal length. The “h” represents the height of the grip M. In addition Z_{R1} and Z_{R2} represent the position of R1 and R2 on the fixed rods.

4.2.7.2 Cooperative operation of the robot

The robot presented in the previous section has three degrees of freedom (3DOF) and can be operated on by one or two users. In this study, two users will cooperatively operate the robot. For this purpose, we use two computers (remotely located and connected through LAN) to share the same virtual environment between two users, while having

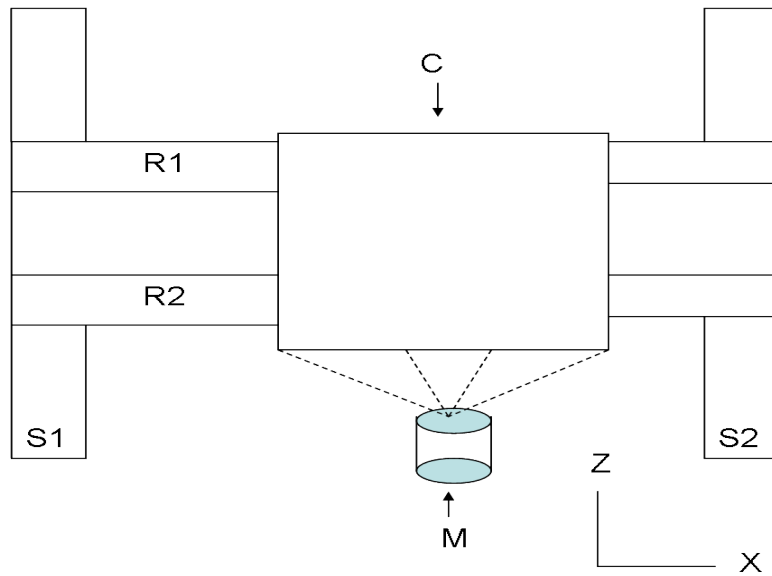

Figure 4.17: Top view of the robot and its various parts.

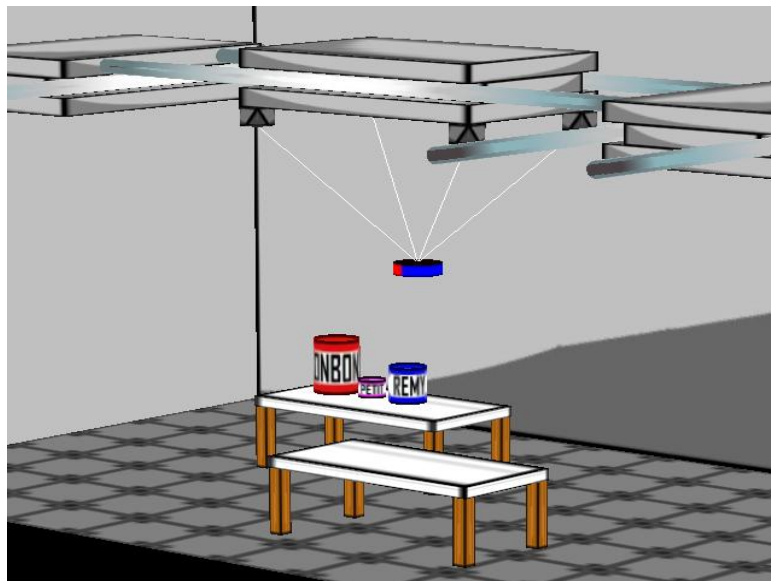

Figure 4.18: Right (shifted) view of the workcell.

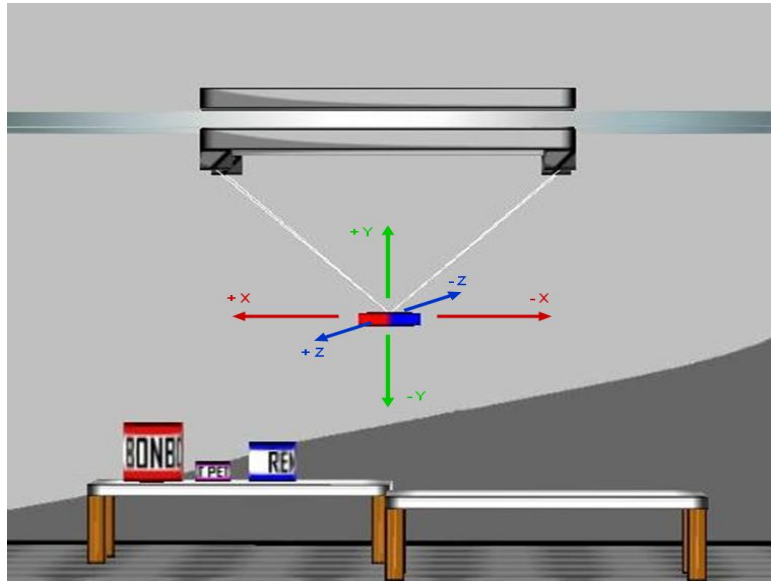

Figure 4.19: Front view of the workcell.

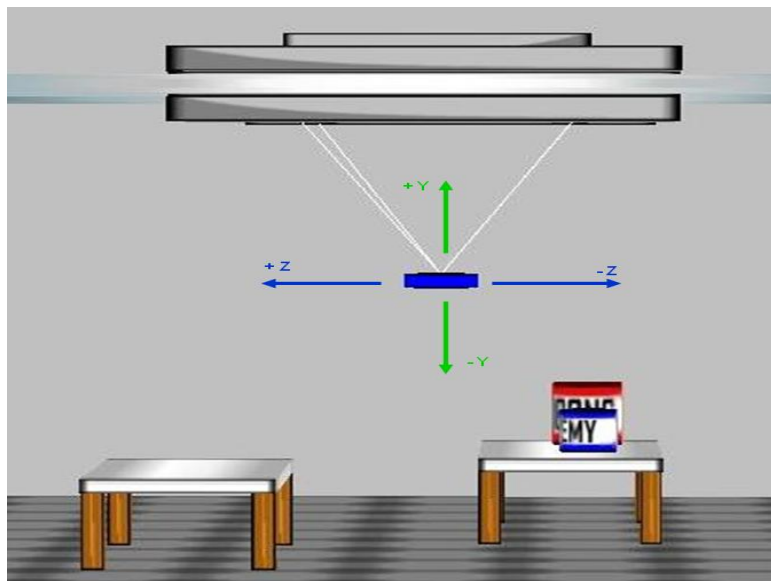
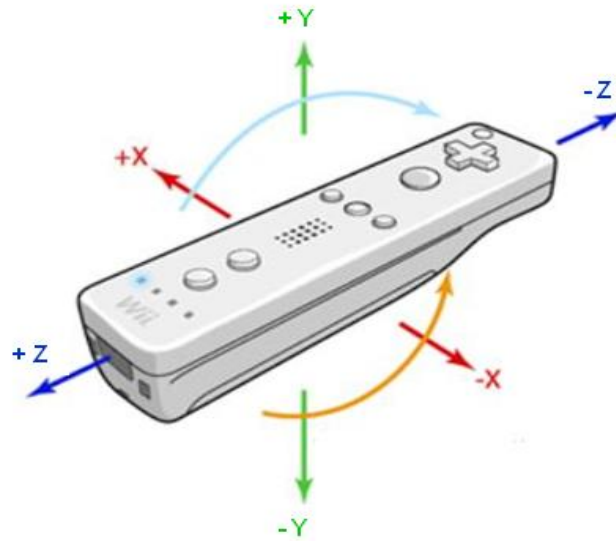

Figure 4.20: Perpendicular view of the workcell.

Figure 4.21: Rotation of WiimoteTM about x-axis

either the same viewpoint or different. The WiimoteTM is used as input device for the robot's operation.

The first operator controls the z-axis (forth/backward) movements of the robot. This movement is done by rotating the WiimoteTM around its x-axis (see Figure 4.21). In addition, this operator is also responsible for moving the magnetic grip (M) of the robot along y-axis. This is achieved using two buttons (+, -) of the WiimoteTM. The second user controls the lateral (x-axis) movements of the robot. This movement is done by rotating the WiimoteTM around its z-axis (see Figure 4.22). In addition, the second user is responsible for picking and releasing the objects. This is achieved by using button (A) of the WiimoteTM.

4.2.7.3 Experiment and analysis of the results

In order to evaluate the above system, we perform user experiments and analyze the results.

4.2.7.3.a Experimental protocol Twelve subjects (male) participated in the experiment. They had normal or corrected to normal sight and had ages from 22-30 years. All participants did the experiment with the same person who was the expert of the task. To perform the experiment, the expert and subjects used "human scale" (see Figure 4.23) and "desktop" (see Figure 4.24) VR configurations respectively. Each subject was given a short briefing about the working of the system. Similarly they had also a pre-trial, in which they experienced all conditions. The following conditions were used for the experiment.

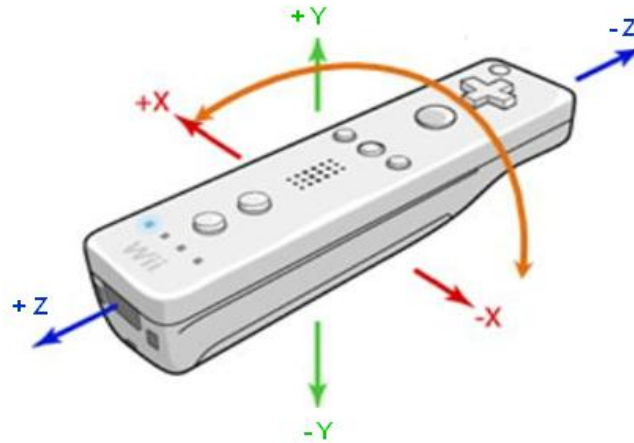

Figure 4.22: Rotation of WiimoteTM about z-axis

- C1: The same viewpoint (for the expert and subject)
- C2: Perpendicular viewpoint
- C4: Perpendicular viewpoint + tactile feedback

In conditions C2 and C3, the subjects have the Perpendicular view of the workcell. In addition, the cylinder's selection by the expert in condition C3, triggers vibration on his/her own WiimoteTM and that of the subject as well. In all conditions the viewpoint of the expert was the same as illustrated in the Figures 4.19. The subjects had to control the robot's movements along y-axis and z-axis. Similarly, expert was in charge of the lateral (x-axis) movements and object selection/deselection as well.

4.2.7.3.b Task completion time The ANOVA ($F(2,11)=111.38$) of task completion time is significant, indicating the influence of perpendicular viewpoint on users' performance. The task completion time of condition C1, C2 and C3 is 164.9 sec (std: 19.7), 93.7 sec (std: 5.8) and 93.6 sec (std: 8.9) respectively (see Figure 4.25). In contrast, we did not observe a significant influence of the tactile feedback on task execution time in this case. However, it surely played a role in user awareness.

4.2.7.3.c Task synchronization As described above, the objective of this work is to allow two users to control different degrees of freedom of the robot for the object manipulation. The control of the different degrees of freedom of the robot can be termed as subtasks. For example, the Figure 4.26 shows the movement of the expert and the novice as a function of time. The red line represents the movement of the expert on x-axis while the black and blue lines represent the movement of non-experts on the z-axis

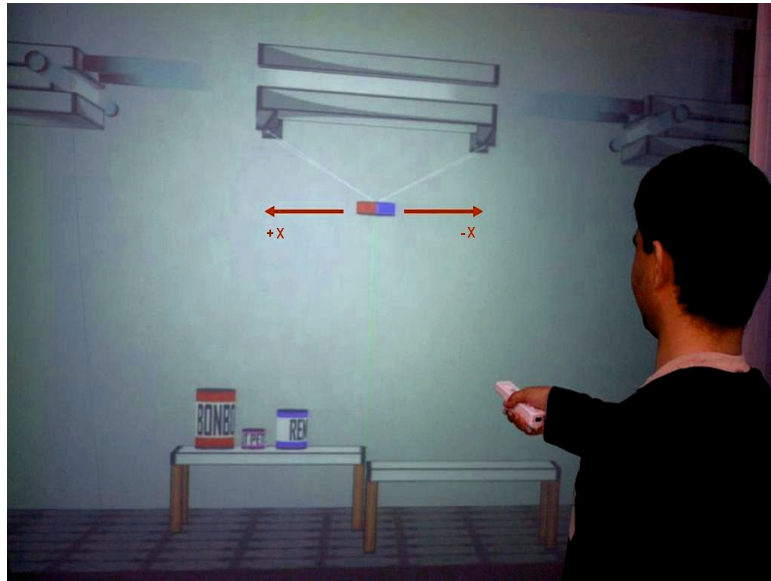

Figure 4.23: The expert during task execution in the immersive configuration

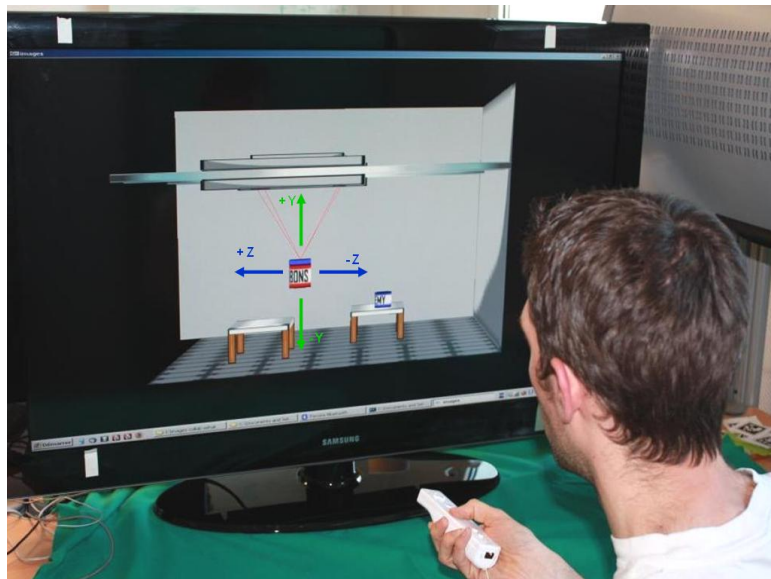

Figure 4.24: A subject during experiment on the desktop configuration

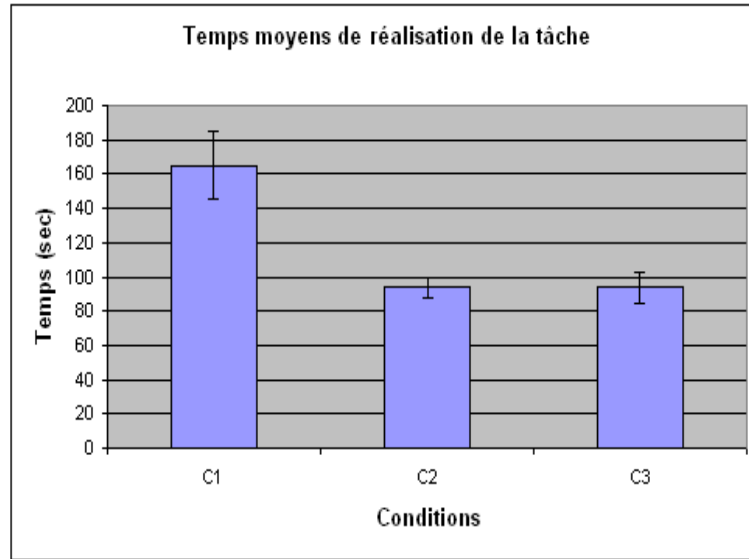

Figure 4.25: Illustration of the task completion time in different conditions

and y-axis respectively. These movements are shown in Figure 4.27, and 4.28 in the same way for various conditions (C1, C2). Figure 4.26 shows that once the object has been selected by the expert, the non-expert has done a slight up-wards (Y-axis) movement. The expert has continued to move horizontally, but non-expert has not changed its depth until the former completed his subtask. In contrast, if we look at the Figure 4.27, and 4.28, we see that the expert and non-expert are executing their subtasks synchronously. The synchronization has been achieved by using different viewpoints (perpendicular).

4.2.7.3.d Subjective evaluation In this section, we analyze the responses gathered through the questionnaire (see appendix F). The questionnaire had four questions.

In response to the first question, 100% users preferred the condition C3 (view perpendicular + tactile feedback). In response to the second question 60% and 40% of the users opted for C2 and C3 respectively. As response to the third question, 91% and 9% subjects preferred C3 and C2, respectively, for the better perception of the actions of their collaborators.

To summarize, we can say that perpendicular view helped subjects to perform the task more efficiently. On the other hand, the tactile feedback increased the awareness of subjects during task execution.

4.2.7.3.e Discussion We have presented a collaborative virtual environment that allows two users to operate a virtual robot from two remote machines connected by LAN. In this context, we studied the effect of viewpoint and tactile feedback on task execution, awareness and coordination of the users. Twelve subjects participated in experiments to evaluate the system.

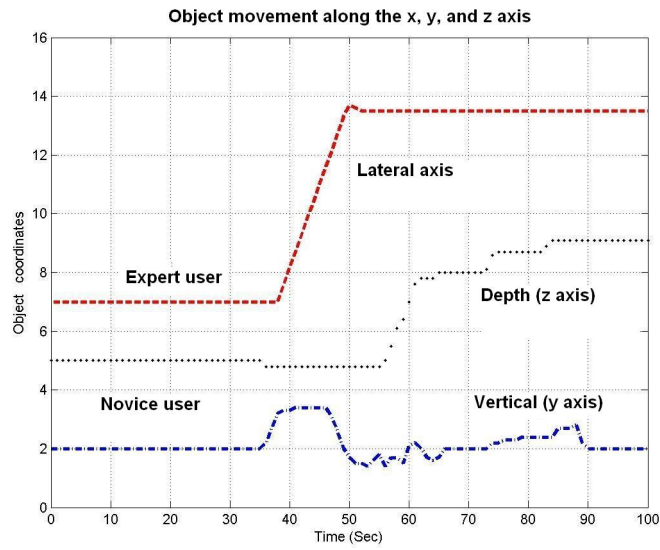

Figure 4.26: Illustration of robot's movement in condition C1 (along various axis)

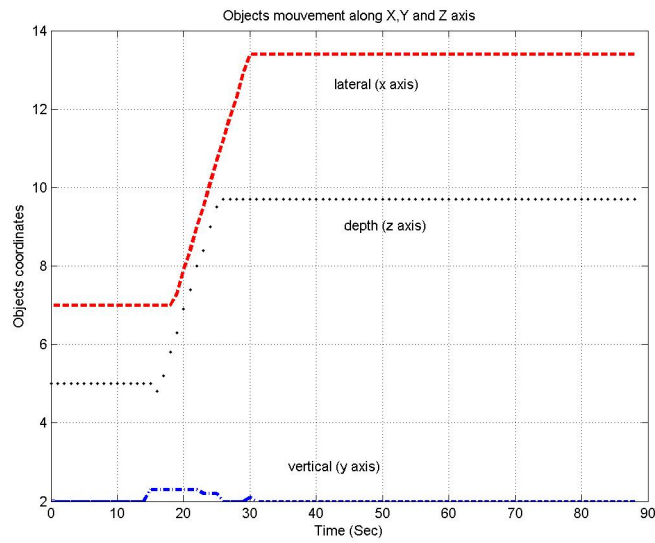

Figure 4.27: Illustration of robot's movement in condition C2

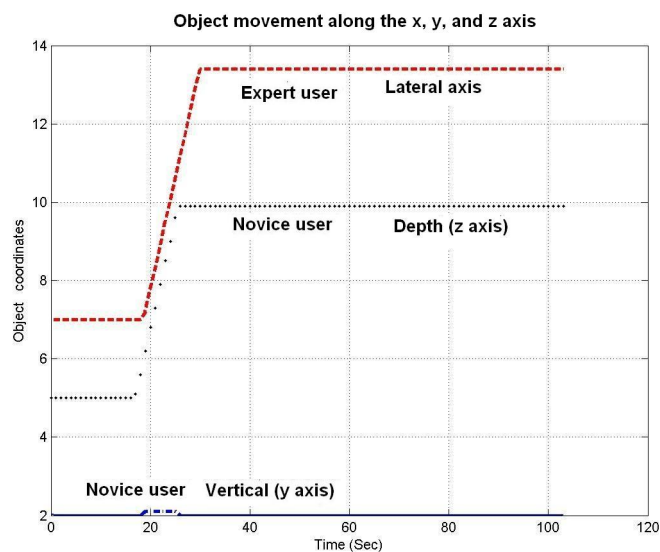

Figure 4.28: Illustration of robot's movement in condition C3

The results revealed a significant effect of viewpoint on task execution and coordination between users. The tactile feedback had no effect on task completion time. However, subjective data collected via questionnaire revealed that tactile feedback increase awareness of the users.

4.3 The Concept of What You Feel Is What I Do

Haptic feedback plays a vital role in learning or transferring motor skills (Bluteau et al., 2008; Morris et al., 2007; Feygin et al., 2002; Tsuneo and Kazuyuki, 2000). Most of these systems are single user and use the mechanism of record and play of force and position values. Similarly, Chellali et al. have also investigated the learning of an insertion task through haptic feedback (Chellali et al., 2010). In this study, they allowed two users to see the virtual world using two desktop displays with the same computer while sending the position values of the master Virtuoso to the slave through network.

In this section we introduce the concept of “What You Feel Is What I Do” (WYFI-WID) (Ullah et al., 2011). The concept is fundamentally based on a haptic guide that allows an expert to control the hand of a distant partner. When the haptic attractive guide is active, then all movements of the expert's hand (via the input device) in 3D space are reproduced by the hand of his/her remote partner through a force feedback device.

This guide can be used to train children to learn the alphabets of different languages as well as geometric shapes and drawings. In addition, it can also be used for the rehabilitation of stroke patients or teaching complexes procedures.

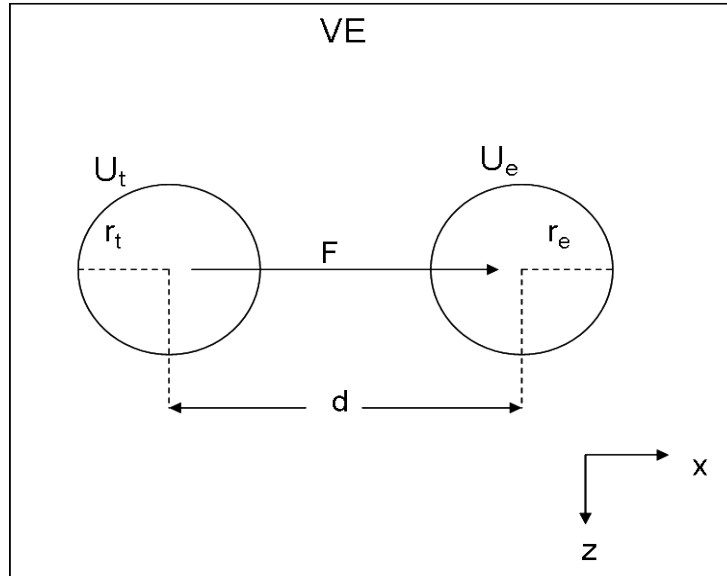

Figure 4.29: Illustration of the model of haptic guide.

4.3.1 Architecture of the system

We use the same architecture as presented in the chapter 3, that enables two remote users to work collaboratively in a VE. Here we implement this architecture in its simplest form, and acquire collaboration between two remote users (expert and non-expert). This architecture can be easily extended to its “one-to-many” form. It means that a single user will be able to guide the hand’s movement of many users (trainees).

4.3.2 Model of the haptic guide

The name “What You Feel Is What I Do” is given to the concept because of the force that acts on the hand of the trainee. When all conditions for the activation of the haptic guide are true, then all the movements of the expert’s hand in 3D space (via 3D input device) are reproduced by non-expert’s hand using a force feedback device (Phantom and SPIDAR in our case).

The spatial information (position) of the two input devices are mutually exchanged and viewed on both machines, but the force is locally calculated on the trainee’s machine.

Referring to the Figure 4.29, U_e and U_t represent the sphere of the expert and trainee respectively. Similarly, r_e et r_t are the radii of the spheres representing the expert and non-expert (trainee), respectively. The distance between the two is represented by “d”.

$$P_{ue} = (X_{ue}, Y_{ue}, Z_{ue}) \quad (4.5)$$

$$P_{ut} = (X_{ut}, Y_{ut}, Z_{ut}) \quad (4.6)$$

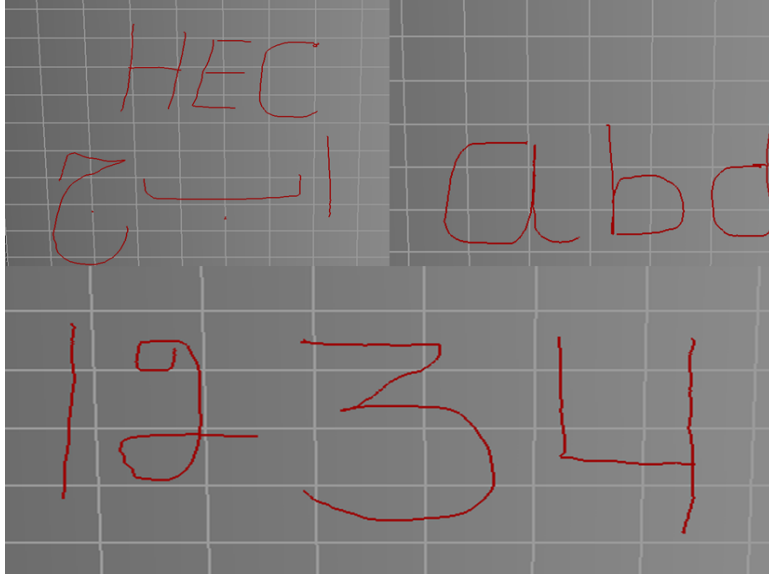

Figure 4.30: Illustration of the writing through haptic guide.

Here, P_{ue} and P_{ut} represent the position of the spheres of the expert and trainee, respectively. To activate the guide, the expert invokes an event, such as pressing a button of the Phantom omni. This event will change the color of the sphere of the expert on both machines. The second condition that must also be true for guide's activation is:

$$d \leq (r_e * r_t) * k \quad (4.7)$$

Where k is constant. The guiding force that attracts the sphere of non-expert to the center of the expert's sphere is calculated according to equation 4.8.

$$F = K * ((X_{ue} - X_{ut})_x + (Y_{ue} - Y_{ut})_y + (Z_{ue} - Z_{ut})_z) \quad (4.8)$$

Where K is a constant and can be determined experimentally to have a smooth force, but not very rigid. This guide can be used to teach children the alphabets and numbers of various languages (such as English, Arabic, etc.), geometric shapes and drawings (see Figure 4.30) in the supervision of an expert (teacher). The guide does not need to record characters, numbers or geometric shapes in advance.

The concept was implemented using two different configurations. The first implementation was carried out at LISA lab, University of Angers France. Here we used two desktop computers connected through LAN. Each computer was equipped with a Phantom omni. The second implementation was carried out in IBISC lab, University of Evry, using the Evr@ platform (see Figure 4.31). Here, SPIDAR-GH and SPIDAR-GM of evr@ platform were used for 3D tracking as well as for force rendering. Where SPIDAR-GH and SPIDAR-GM means that both of them are SPIDAR-Gs (6DoF) but one is Human scale (H) and the other is Medium scale (M).

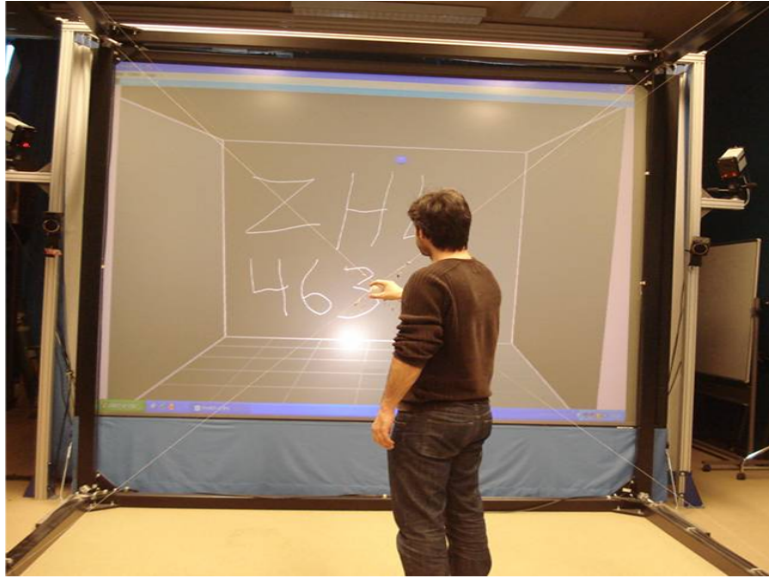

(a)

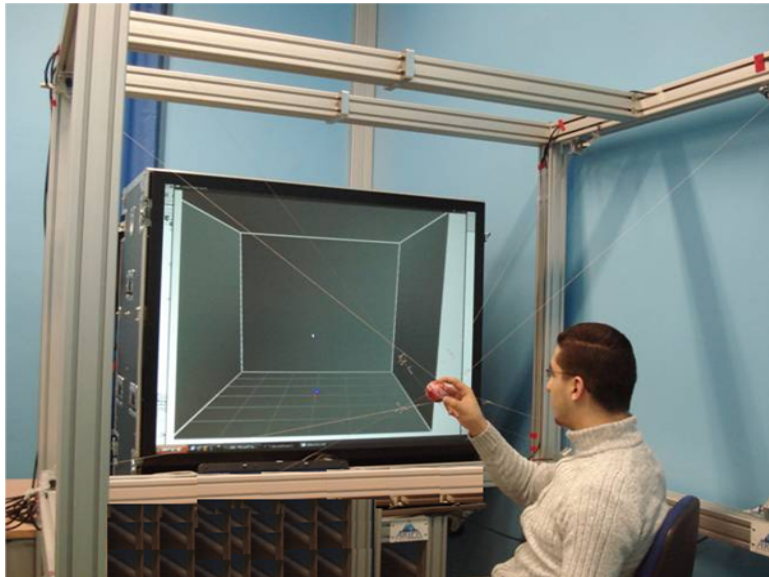

(b)

Figure 4.31: Illustration of the dynamic haptic interaction in distributed CVE (a) User 1 with SPIDAR-GH of the semi-immersive platform (b) user 2 with SPIDAR-GM of the mobile platform.

L G M R S P Z W B N

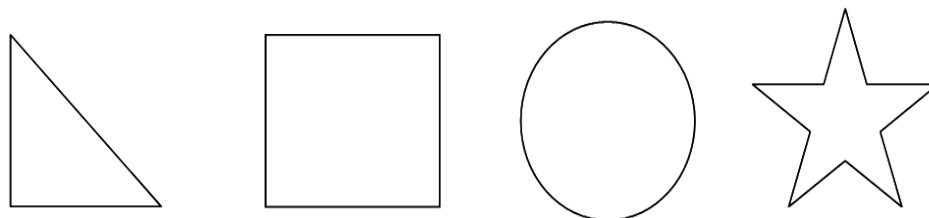

Figure 4.32: Illustration of the alphabets and geometric forms written with the help of haptic guide.

4.3.3 Experiment and evaluation

In this section, we present the experiment performed for the evaluation of our proposed guide and concept “WYFIWID”.

4.3.3.1 Experimental protocol

To evaluate the system, twenty volunteers participated in the experiment. They were Master and PhD students. The majority of them had no prior experience of using a haptic device. They all made the experiment with the same expert. We installed our application on two machines (one for experts and others for subjects) connected via a LAN. Both machines were equipped with an Phantom omni. Once the application is started and the network connection is successfully established between the two machines, two spheres (red and blue) could be seen on both screens. The red and blue sphere were assigned to the expert and subjects respectively.

The subjects were asked to bring their spheres close to that of the expert when the later changes its color (for example, becomes green). In addition, each subject was asked when the force begins to guide his hand, then he/she must not look at the screen to avoid learning through visual movements of the cursor (sphere).

Whenever the guiding force terminates, he/she must write the alphabet or geometric shape on a paper to which he/she thinks his/her hand movement corresponds to.

There were two sessions of guidance. The subjects were guided to write ten alphabets and four geometric forms in the first and second session respectively (sees Figure 4.32). At the end, they also responded to a questionnaire.

4.3.3.2 Analysis of the results

Table 4.10 represents the percentage of correct answers using haptic guidance for alphabets writing. Here, we see that the overall percentage of correct answers is high, but

Alphabets	L	G	M	R	S	P	Z	W	B	N
% of correct responses	100	90	100	85	95	90	85	80	100	100

Table 4.10: User perception of the alphabets through the haptic Guide.

Forms	Triangle	Square	Circle	Star
% of correct responses	100	100	100	90

Table 4.11: User perception of forms through the haptic Guide.

there are some subjects, who did not correctly perceive some alphabets. This misconception was mainly due to the difference between the method of writing a character by the expert and the subject.

Similarly, the Table 4.11 shows that the first three geometric forms have been correctly recognized by all subjects, only 10 % of the subjects perceived the star incorrectly.

In response to the questionnaire, majority of the users were enthusiastic and reported that they found the experience very interesting. Similarly, we asked them to rate the level of guidance that they were provided. For this purpose we used a scale (1-2-3-4-5). Where, 1 = low level of guidance and 5 = high level of guidance. The average response was 3.84 (std: 0.68).

4.3.3.3 Discussion

The concept of “WYFIWID” is fundamentally based on a haptic guide that allows an expert to control the hand of a remote person. By using this guide, every movement of the hand of the expert (via the input device) in 3D space is reproduced by the hand of the second person (trainee/non-expert for example) using a haptic device.

We implemented this guide in a manner, where an expert can guide the hand of a naive to write letters and geometric shapes. Analyzing the results of subjective evaluation, we observed that users found the haptic guidance very interesting and effective. This guide can be used to teach children the writing of alphabet and numbers of various languages and drawings. It may also be used for the rehabilitation of stroke patients.

4.4 Conclusion

In this chapter we presented a number of experimental studies both in collaborative and mono-user VEs. The CVEs were developed on the basis of the software architecture presented in chapter 3 (section 3.3.1). The purpose of these experiments was to study the effect of multi-sensory guides on users’ coordination, awareness and performance during collaborative/cooperative task execution. The “Peg-in-Hole” was selected as experimental task for the first three studies where visual and sound guides were evaluated.

Two experiments (fourth and fifth) were dedicated for the assessment of haptic guides. In the 4th experiment, two users cooperatively performed the “Peg-in-Hole” task in a large scale virtual environment. In the 5th experiment, two virtual robots (FANUC) were used for cooperative object manipulation. The experimental task was to cooperatively inverse a stack of two cylinders via two robots. Here the objective was to simulate the telemanipulation task in presence of haptic guides. In both cases, the human scale SPIDAR (2 X 3DoF) was used in a semi-immersive configuration for haptic rendering.

In the sixth experiment, we presented a study on the influence of view points and tactile feedback on the performance of two users during the execution of a cooperative task. Here the cooperative task was carried out via a virtual robot where each user was controlling separate degrees of freedom of the virtual robot. Results revealed that different viewpoints had a significant effect on task execution and coordination between users. The tactile feedback had no effect on the execution time of the task. However, subjective data collected through questionnaire proved that the tactile feedback was more useful for users’ awareness.

In the last part of the collaborative section, the concept “WYFIWID” was presented. This concept is also based on the haptic guide that allows a novice to follow the movements of the hand of an expert while using a force feedback device. This guide can be used for children to learn the writing of alphabets and numbers of various languages and geometric shapes. In addition, it can also be used for rehabilitation of stroke patients.

Results revealed that our proposed guides have had a significant influence not only on users performance but also on their co-presence, coordination and awareness during task accomplishment. In addition, users also appreciated the oral communication.

Chapter 5

Experiments and evaluations: multimodal guidance in single-user VEs

5.1 Introduction

In this chapter we introduce the concept, models and evaluation of multimodal guides designed to provide assistance to single-users virtual and remote environments. In this context, we propose two types of multimodal guides, the first is omni directional and help users to select an object in the virtual environment. The second guide lets users to select an object from a specific direction (Ullah et al., 2009a; Ullah et al., 2009d).

5.2 The role of assistance in teleoperation and 3D interaction

Teleoperation is the area where human operators control and/or operate (from their master site) robots located in remote environments (slave site), which are either inaccessible or hostile. In order to effectively perform a teleoperation task, human operators are often provided with some aid/assistance at their local stations (where master device is located).

These aids include virtual guides, which have proved to be valuable tools (Rosenberg, 1993). Otmane et al. introduced an augmented reality system for tele-operation using virtual guides for precise selection and manipulation of objects (Otmane et al., 2000) (see Figure 5.1). Here, the human operator controls the movements of the virtual robot and the real robot (slave) at remote location follows these movements. In this task if the user positions the virtual robot's grip over the object (target), the visual guide appears, helping the user to correctly move the arm down wards to reach the target.

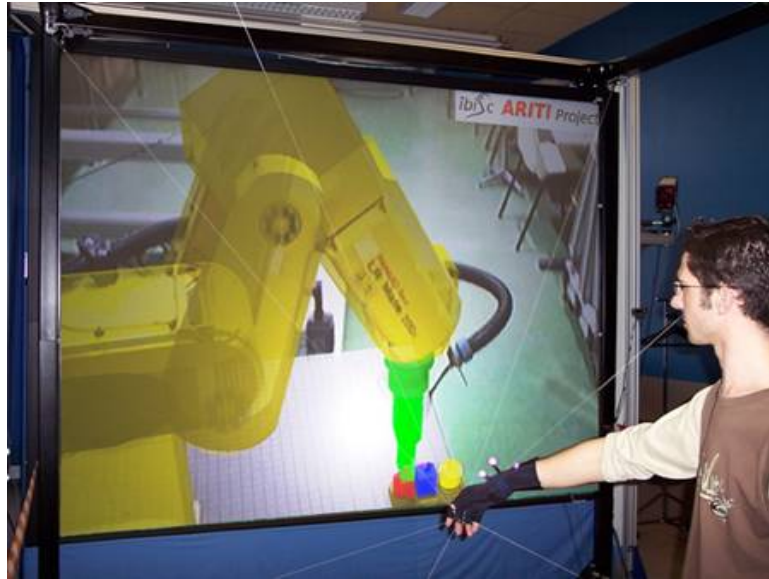

Figure 5.1: The use of visual guide in augmented reality systems (EVR@ Platform of IBISC Laboratory).

On the other hand, this guide is only visual and puts no constraints on the movements of the user once it is activated. In this context, the user may lose precision while moving towards the target.

Ouramdane et al. have also proposed a 3D interaction technique called "follow-me" (Ouramdane et al., 2006). This technique has been developed to provide assistance for objects selection and manipulation in VEs. In this technique the VE is divided into three zones in which the interaction has its own granularity (see Figure 5.2).

- Free manipulation zone: in this zone the user can freely interact with the environment with 6DOF.
- Intermediate manipulation zone: In the second zone, the movement of the user becomes more accurate and stable, but without the loss of any degrees of freedom.
- Precise manipulation zone: In the third zone, the user is very close to its target and his/her movements are guided. In fact, user's movements become more accurate but lose some degrees of freedom.

In the precise manipulation zone, the "follow-me" technique reduces the degree of freedom of the virtual pointer (user avatar), but physically, the user is free and can move his hand in any direction. This may confuse the user and create problems at cognitive level. In order to resolve these problems, we propose multimodal guides which are presented in the following section.

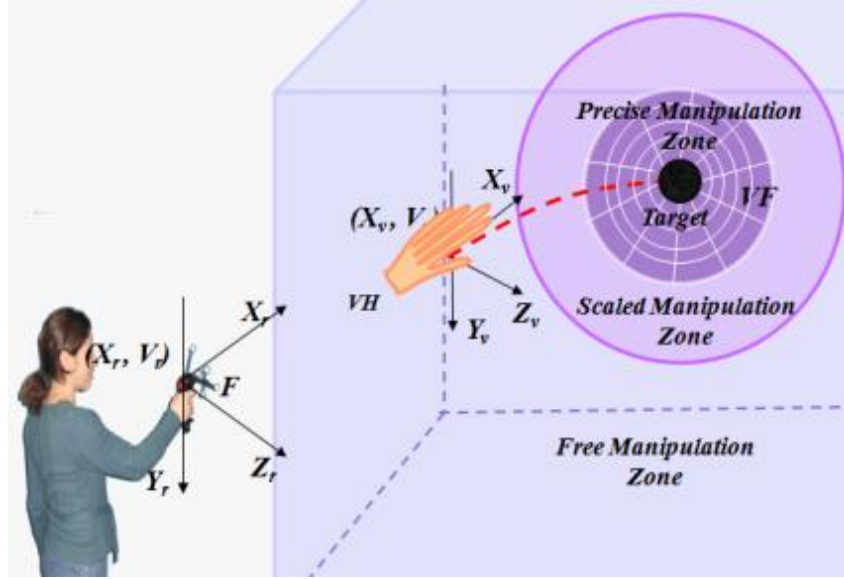

Figure 5.2: Illustration of the 3D interaction technique called "FOLLOW-ME".

5.3 Modeling and description of the multi-modal guides

In this section, we present two multimodal guides. The name multimodal is given because they combine visual and haptic modalities. The first of these is the conical while the second is spherical multimodal guide.

5.3.1 Conical multi-modal guide

The basic concept of this guide is to divide the virtual environment into three zones. According to Figure 5.3 the green cone and red cone represent the second and third zone respectively. The rest of the environment constitutes the first zone (the free zone).

- The free zone: In this zone, the user freely interacts and no assistance is provided to him/her;
- The zone of visual guidance: In the second zone, the user is assisted by a visual guide (cone is this case);
- The zone of haptic guidance: In the third zone, the user is given haptic guidance.

In case of conical guide, objects are selected from a specific direction. In this context, the virtual pointer always throw a laser beam in the direction of selection. In addition, a set called "candidate set" is calculated that contains all the objects through which the laser beam passes. The candidate set is dynamic and its contents vary depending on the position of the pointer in the virtual environment. The guides will be activated on the nearest object in the candidate set once the rest of the conditions for guide's activation

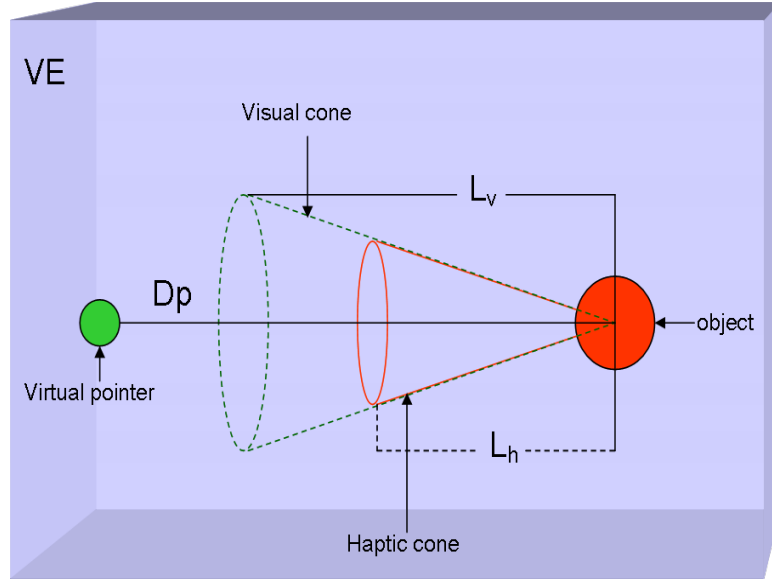

Figure 5.3: Illustration of the conic type multimodal guide.

are also satisfied (see Figure 5.4). In the following two subsections, we are going to present the visual and haptic guides that comprise the conical multimodal guide.

5.3.1.1 Visual cone

This guide defines the second zone of the VE (see Figure 5.3), it appears dynamically on an object of the candidate set for which the condition (see Eq 5.1) becomes true. This guide indicates the user that his/her position is optimal relative to the object, and if he/she continues to advance inside the cone, the object can be precisely selected.

$$D_p \leq L_v \quad (5.1)$$

Where D_p is the distance between the object and the virtual pointer, L_v is the length of visual cone. The properties of this guide are given in the Table 5.1.

5.3.1.2 Haptic cone

Referring to the Figure 5.3, the red cone inside the green represents the haptic zone. This cone is not shown visually but when the user enters this area, he/she is haptically guided towards the object. We don't need to have a visual representation for haptic cone because visual assistance is already provided by the first cone (see the Figure 5.3). Here the most important point is that, we augment visual assistance by haptic. The haptic guide is activated once the condition 5.2 is satisfied.

$$D_p \leq L_h \quad (5.2)$$

Where D_p is the distance between the object and the virtual pointer, L_h is the length of the haptic cone. The force of attraction is calculated either by equation 5.3 or equation 5.4.

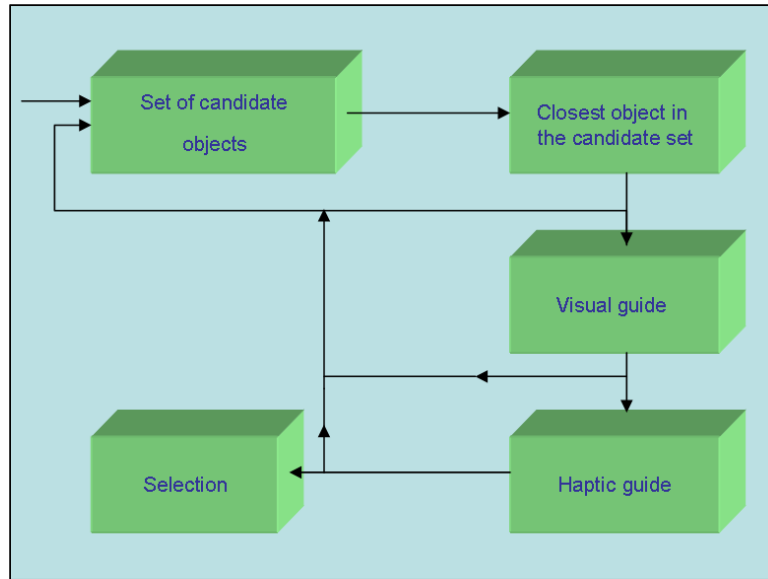

Figure 5.4: Illustration of the steps for object selection

Properties	Description
Name	<i>Visual_cone</i>
Objective	<i>The objective of this guide is to assist users for object selection in VEs or virtual reality based teleoperation</i>
Type	<i>Visual</i>
Status	<i>Dynamic</i>
Function	<i>A visual cone appears on the closest object of the candidate set</i>
Pre-condition	<i>When the condition $D_p \leq L_v$ becomes true</i>
Post-condition	<i>The object is selected or the user goes out of the visual cone</i>

Table 5.1: The properties of the visual guide (cone).

Properties	Description
Name	<i>Haptic_cone</i>
Goal	<i>The objective of this guide is to haptically assist users for object selection in VEs or virtual reality based teleoperation</i>
Type	<i>Haptic</i>
Status	<i>Dynamic</i>
Function	<i>The user is provided haptic guidance towards the object to be selected</i>
Pre-condition	<i>When the condition $D_p \leq L_h$ becomes true</i>
Post-condition	<i>The object is selected or user goes out of the haptic cone</i>

Table 5.2: The properties of the haptic guide (cone).

$$F = \frac{(K * L_h)}{D_p}, D_p \neq 0 \quad (5.3)$$

$$F = \frac{K}{1 + D_c} + \frac{(V_{t+1} - V_t)}{\Delta t} \quad (5.4)$$

Here, $K > 0$ is constant and represents the minimum force. According to equation 5.3, the force of attraction increases when the distance D_p decreases and vice versa.

According to the equation 5.4, D_c represents the distance between the pointer and the axis passing through the center of the cone. In this case, the magnitude of guiding force also depends on user's velocity towards the object. If the velocity V_{t+1} increases compared to the previous V_t , then force will also increase and otherwise.

In addition, if collision between the virtual pointer and the mesh of the cone is detected then the user is haptically prevented to go outside of the cone through its walls. The properties of this guide are given in the Table 5.2.

5.3.1.2.a Guidance vs prevention by haptics Haptics can generally be classified into guiding and forbidden-regions type forces. The guiding force (Guidance virtual fixtures) helps users to follow a desired path or surface. This can be either of admittance or impedance type (Richard J. and Blake, 1999). The impedance type guides act as magnetic fields, actively influence the movement of the user. On the other hand, admittance type guides are more influenced by the user movements (Abbott et al., 2005).

The forbidden-region type haptic guides limit the user's motion to a particular region of the workspace. These can also be as impedance or admittance type forces. Here the

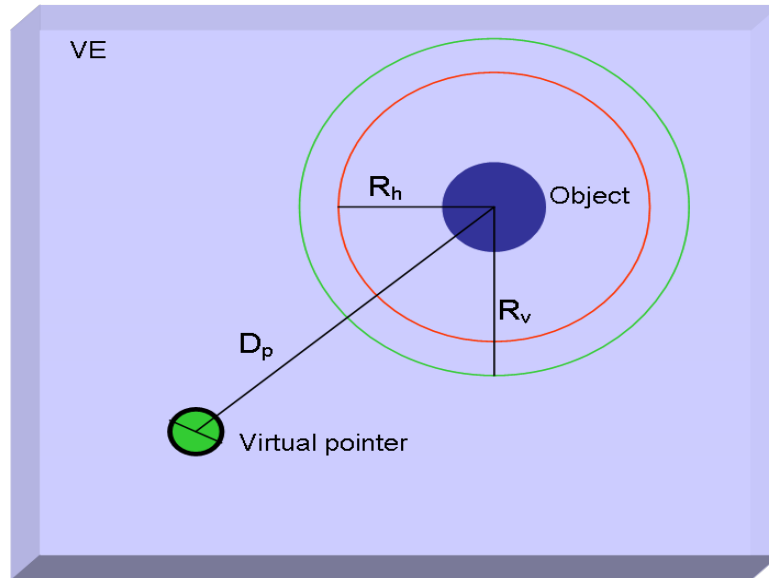

Figure 5.5: Illustration of the multimodal guide of spherical shape.

impedance-type forces act simply as virtual walls, while the admittance-type forces are implemented by having no motion in the forbidden region (Abbott et al., 2005).

The haptic guide that we propose is hybrid in nature because it provides (1) a guiding force for the user to reach the target (object). (2) Similarly, the guide prevents the user, to go out of the haptic cone through its walls. Inside the haptic cone the user always receives the attractive force, in addition its magnitude changes as a function of the pointer's position.

5.3.2 Spherical multi-modal guide

Here the concept of the virtual environment's division is again applied. According to the Figure 5.5 the green and red spheres represent the second and third zone respectively. The rest of the environment constitutes the first zone (free zone).

- The free zone: In this zone, the user interacts freely but without assistance.
- The zone of visual guidance: In the second zone, the user is assisted by a visual guide of spherical shape.
- The zone of haptic guidance: In this zone, a haptic sphere (invisible) helps the user to reach the target (object).

Figure 5.6 shows the transition of users between different zones of the VE.

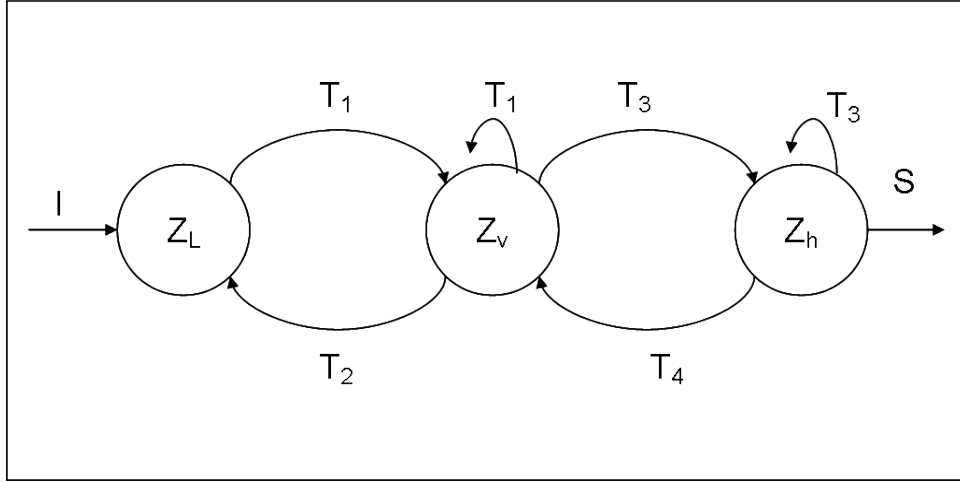

Figure 5.6: State transition diagram between the zones of the spherical multimodal guide

- I: initialization
- Z_L : Free Zone, Z_v : Zone of spherical visual guide , Z_h : Zone of spherical haptic guide
- T_1 : $D_p \leq R_v$, T_2 : $D_p > R_v$, T_3 : $D_p \leq R_h$, T_4 : $D_p > R_h$
- S: object selection

Where R_v and R_h are the radii of visual and haptic sphere respectively. Similarly, D_p represents the distance between the object and the virtual pointer (see Figure 5.5).

5.3.2.1 Visual sphere

This guide defines the second zone of the VE (see Figure 5.5), it appears dynamically on the object nearest to the virtual pointer in the virtual world. Its properties are given in the Table 5.3

5.3.2.2 Haptic sphere

Referring to the Figure 5.5, the red sphere inside the green represents the haptic zone. This sphere is not shown visually but when the user enters this zone, he/she is haptically guided towards the object. We don't need to display the haptic sphere because visual assistance is already provided by the first sphere (see Figure 5.5). Here the most important point is that, we augment visual assistance by haptic. The attractive force is calculated either by equation 5.5 or equation 5.6.

Properties	Description
Name	<i>Visual_sphere</i>
Goal	<i>The objective of this guide is to provide visual assistance to the user in 3D interaction</i>
Type	<i>Visual</i>
Status	<i>Dynamic</i>
Function	<i>visual sphere appears on the object to be selected</i>
Pre-condition	<i>When the condition $D_p \leq R_v$ is satisfied</i>
Post-condition	<i>The object is selected or the user exits from the visual zone</i>

Table 5.3: The properties of the visual guide of spherical shape

$$F = \frac{(K * R_h)}{D_p}, D_p \neq 0 \quad (5.5)$$

$$F = K + \frac{(V_{t+1} - V_t)}{\Delta t} \quad (5.6)$$

Here, $K > 0$ is a constant and defines the minimum attractive force. According to equation 5.5, the force of attraction increases when the distance D_p decreases and vice versa.

According to the equation 5.6, the magnitude of guiding force depends on user's velocity towards the object. If the velocity V_{t+1} is greater than the previous V_t , the force will also increase and otherwise. The properties of this guide are given in Table 5.4.

5.4 Experiments and evaluations

In this section we present the experiments that we conducted for the evaluation of our proposed guides.

5.4.1 VR platform

For the experiments, we use a semi-immersive platform equipped with a rear-projected large screen (3m x 2.5m) where polarized glasses are used for stereoscopic viewing. In addition to stereo sound and optical tracking system, a force feedback device (SPIDAR) is used for haptic rendering. We use human scale (3m x 3m x3m) SPIDAR (6DoF) that

Properties	Description
Name	<i>Haptic_shpere</i>
Goal	<i>The objective of this guide is to provide haptic assistance to the user in 3D interaction</i>
Type	<i>Haptic</i>
Status	<i>Dynamic</i>
Function	<i>The user is haptically guided towards the object to be selected</i>
Pre-condition	<i>When the condition $D_p \leq R_h$ is satisfied</i>
Post-condition	<i>The object is selected or user exits from the haptic sphere</i>

Table 5.4: The properties of haptic guide of spherical shape.

has placed in front of the large screen (see Figure 5.7-a).

Here, the motors have been mounted on the frame as shown in Figure 5.7-b. The HDHC (High Definition Haptic Controller) takes the encoders' counts to calculate the position and orientation of the grip/effector. Communication between the HDHC and PC is made via USB 2.0.

The strings of SPIDAR don't hide any part of the screen and makes it a transparent device. Similarly, the strings put no danger for the user.

5.4.2 Software architecture

In order to implement the models of the proposed guides, we developed a software that has a client-server architecture (see Figure 5.8). The software has two main parts, i.e server and client, that are installed on two separate machines connected through network. The server was developed in C++, and it performs the following tasks.

- Establish connection between PC and HDHC;
- Calibrate the SPIDAR;
- Take the position and orientation of SPIDAR;
- Apply the force vectors.



(a)

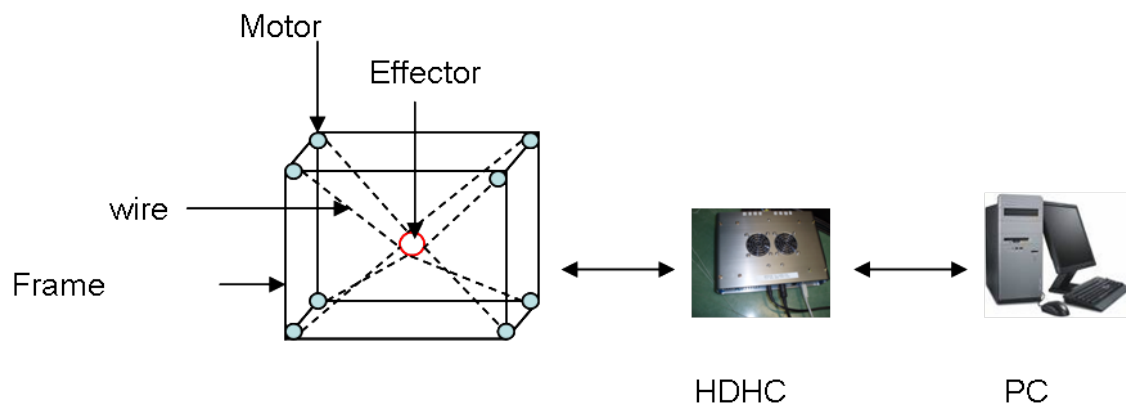

(b)

Figure 5.7: VR platform of IBSIC Lab : (a) SPIDAR with large screen, and (b) system architecture.

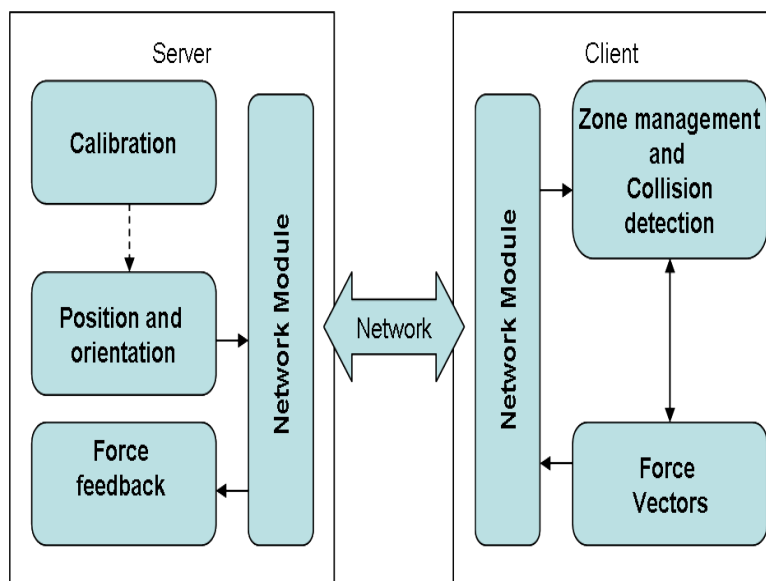

Figure 5.8: Illustration of the software architecture

The client part has been developed in Virtools dev4.0. This part is responsible for the presentation of the VE and supports the user interaction with virtual objects. The position and orientation of SPIDAR, sent by the server are applied to the virtual pointer. On the other hand, the server receives force vectors.

5.4.3 Experimental Protocol

To study the effect of the proposed haptic guides on human performance, twenty subjects including 16 males and four females participated in the experiments. They were either master or phd students having age from 23-35 years. All were right handed and had prior knowledge of the interactions in VEs. We divided the participants into two groups of ten people. Each group was composed of eight males and two females. The first group performed the experiment to evaluate the spherical guides while the second group did the same for conical guides.

Once the application is launched, the spidar is calibrated and the network connection is successfully established between the two machines (SPIDAR server and Virtools client), then the user will see the VE on the screen. The VE contains four small spheres in the same vertical plane and a baton used as pointer (manipulator) whose movements are controlled directly by the user via SPIDAR (see Figure 5.9).

The task is to select an object and place it on the red zone (left in the environment), from where it returns to its original position and the user selects it again. In this way, each object is selected and moved five times during a single trial. All users have exactly two trails of their corresponding experience. The experiments were performed using the following conditions.

- C1: Visual sphere;

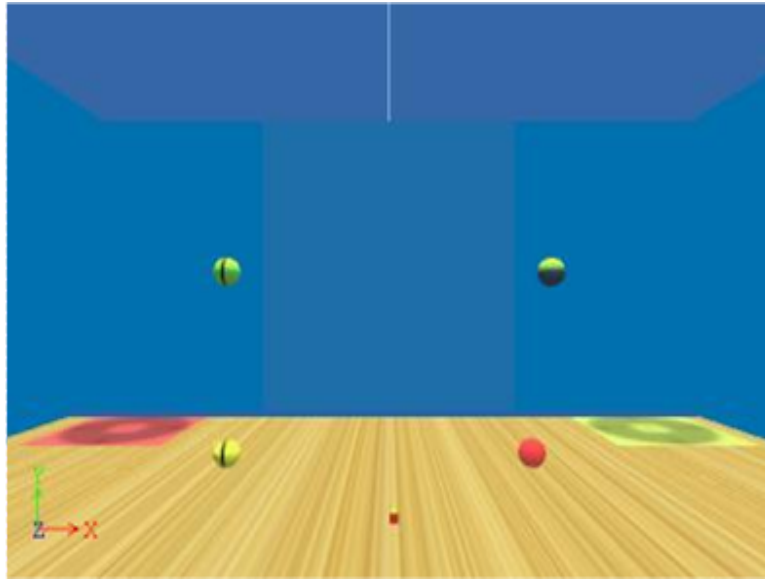

Figure 5.9: The VE used for the experiment

- C2: Haptic sphere + Visual sphere;
- C3: Visual cone;
- C4: Haptic cone + Visual cone.

The first group used the conditions C1 and C2. Half subjects of this group used C1 in their first trial and rest half used C2 in the first trial. The second group used the conditions C3 and C4. Half subjects of this group used C3 in their first trial while the rest half started with C4.

The task completion time was recorded for all subjects. For subjective evaluation, we collected user's responses through a questionnaire. The questionnaire had the following three questions. In all conditions (C1, C2, C3, C4), the display was stereoscopic.

- Q1: To what extent, the selection was easy without force feedback?
- Q2: To what extent, do you think that force feedback provided you guidance in object selection?
- Q3: Do you think, the interaction becomes more realistic with force feedback?

Users were asked to answer each question according to the scale given in the Table 5.5.

Q1	Not-easy	1-2-3-4-5-6-7	Very easy
Q2	No guidance	1-2-3-4-5-6-7	high level guidance
Q3	Not realistic	1-2-3-4-5-6-7	very realistic

Table 5.5: Scale for the response of the questions.

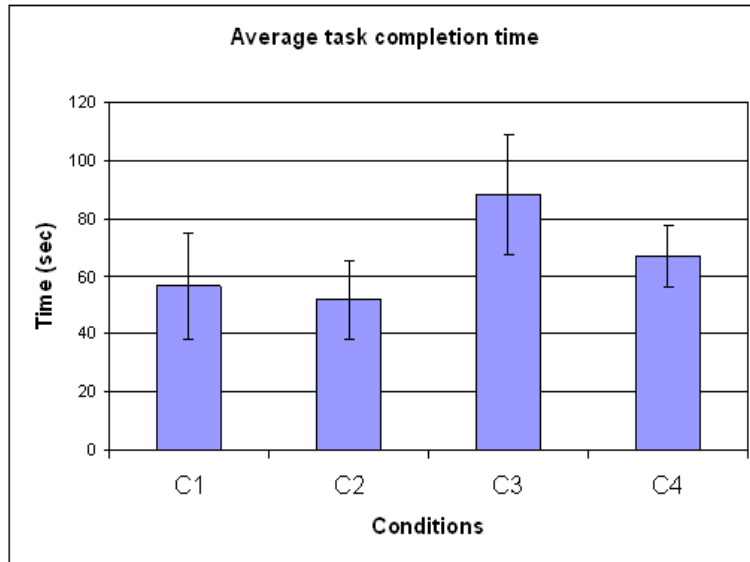

Figure 5.10: Task completion time with std for various conditions.

5.4.4 Analysis of the results of the experiment I

In this section, we present the analysis of results such as task completion time and responses collected through questionnaire. These results corresponds the experiments, where we used the models 5.3 and 5.5 to calculate forces for conical and spherical haptic guides respectively.

5.4.4.1 Task completion time

Referring to the Figure 5.10, the task completion time of conditions C1, C2, C3 and C4 is 56.7 sec (std: 18.5), 51.9 sec (std: 13.6), 88.3 sec (std: 20.8) and 67.0 sec (std: 10.9) respectively. The comparison of time C1 (visual sphere) with C2 (haptic sphere) gives non significant ANOVA ($F(1,9) = 1.59, P > 0.05$). Although the result is not statistically significant, but still there is considerable difference in task completion time that demonstrates the effectiveness of haptic sphere. Similarly, if we compare C3 (visual cone) with C4 (haptic cone) we obtain ($F(1,9) = 25.78, P < 0.05$) significant ANOVA. It means that the conical haptic guide has a strong influence on user performance.

5.4.4.2 Subjective analysis

Figure 5.11-a represents the average of the user responses to the questionnaire for spherical guide. Here the average of response to the first question is 5 (std: 1). Similarly, question 2 has an average value of 5.6 (std 1.1). Question 3 has also the average value of 5.6 but the std is 1.2. It proves that visual guide (spherical) provides assistance for object selection, but the subjects are more satisfied when the former is augmented with haptic guide.

Figure 5.11-b represents the average of the user responses to the questionnaire for spherical guide. Here the average of response to the first question is 5.1 (std: 1.36). Similarly, question 2 has an average value of 5.5 (std: 0.79). Question 3 has the average value of 5 but the std is 1.5. It proves that visual guide (conical) provides assistance for object selection, but the subjects are more satisfied when the former is augmented with haptic guide.

5.4.5 Analysis of results of the experiment II

In this section, we present the analysis of results such as task completion time and responses collected through questionnaire. These results corresponds to the experiments, where we used the models (equation 5.4 and 5.6) to calculate forces for conical and spherical haptic guides respectively.

5.4.5.1 Task completion time

Referring to the Figure 5.12, the task completion time for conditions C1, C2, C3 and C4 is 55.7 sec (std: 18.83), 46.77 sec (std: 14.8), 84.88 sec (std: 20.93) and 69.0 sec (std: 12.74) respectively. The comparison of C1 (visual sphere) with C2 (haptic sphere) gives non significant ANOVA. Although the result is not statistically significant, but still there is considerable difference in task completion time that demonstrates the effectiveness of haptic sphere. Similarly, if we compare C3 (visual cone) with C4 (haptic cone) we obtain non significant ANOVA.

Comparing the results of experiment I with that of experiment II, we observed quite resemblance.

5.4.5.2 Subjective analysis

To summarize the responses and comments of users, we concluded that both visual and haptic guides have provided assistance to them in selecting objects, but they preferred haptic guides. The spherical haptic guide allowed them to complete the task faster as compared to the conic, because the latter has restricted users to select object from a specific direction.

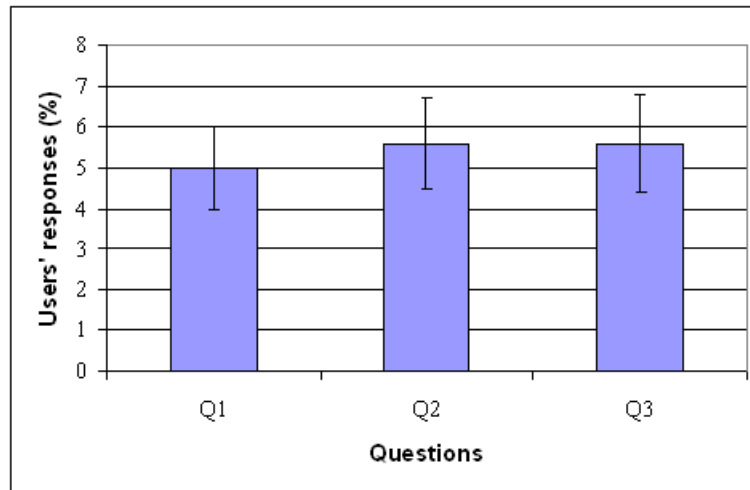

(a)

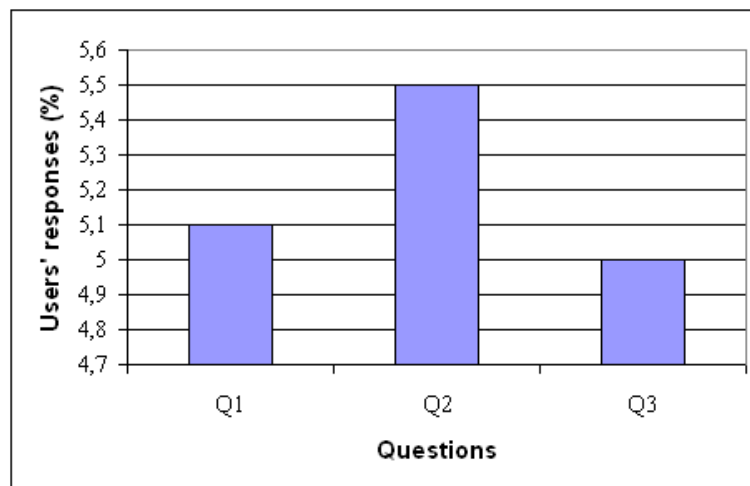

(b)

Figure 5.11: Response to the questionnaire : (a) spherical guides, and (b) conical guides.

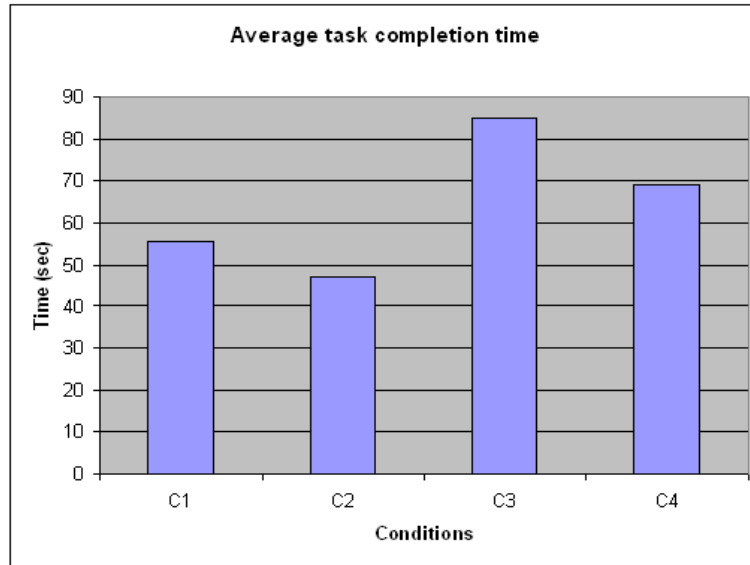

Figure 5.12: Task completion time for various conditions

5.5 Conclusion

We have proposed new haptic guides to assist users in the selection of objects in virtual or remote environments. Spherical guide is omni-directional and provides visual aid in the second zone and haptic aid in the third zone, centered on the object of interest. The second guide is conical type that gives the guidance when the selection is desired from a specific direction. This guide not only gives the attractive force towards the object but also prevents the virtual pointer to leave the cone through its walls.

To evaluate the proposed guides, two groups, each consisting of ten subjects performed the experiments in a VE. The task was to select four targets using visual and haptic guides. Both haptic guide (spherical and conical) resulted in less task completion time as compared to their corresponding visual guides (visual sphere and cone). It was also noted that task completion time increased for conical guides as compared to the spherical because users were more cautious in approaching to the object in the first case. All participants reported that visual guides provided assistance, but they were more satisfied with haptic guides. On the other hand we did not observe a significant difference between the results of the experiment I and II.

Although, we evaluated the guides presented in this chapter in mono-user VEs, but they can be easily used in CVEs that allow asynchronous manipulation.

Conclusion and perspectives

5.6 Conclusion

The recent advancement in the field of high quality computer graphics and the capability of inexpensive personal computers to render realistic 3D scenes have made it possible to develop virtual environments where two or more users can co-exist and work collaboratively to achieve a common goal. Such environments are called Collaborative Virtual Environments (CVEs). The potential applications of CVEs are in military, medical, assembling, computer aided designing, teleoperation, education, games and social networks.

Although, CVEs promise more benefits but they are more challenging as compared to the single user VEs. For example, to efficiently carry out a collaborative task, the participants need to feel the presence of their collaborator(s) and have means of communication with each other. The communication may be verbal or non verbal such as pointing to, looking at or through facial expressions. The design and implementation of these systems specially for distant users has really been a challenging job for the researchers. For example the architecture of the virtual world may be client server or a replicated one. In case of client server architecture the known problems of network load and latency arise. Similarly in replicated solution the consistency of two or more sites need to be addressed.

Regardless of any architecture, the most important problem related to CVEs is the user's low level of awareness about the status, actions and intentions of his/her collaborator(s), which not only reduces users' performance but also leads to non satisfactory results. In addition, collaborative tasks without using any proper computer generated assistance are very difficult to perform and are more prone to errors.

To investigate the importance of awareness and coordination in CVEs, we proposed various virtual guides (visual, audio and haptic). In order to evaluate these guides, we carried out a number of experimental studies. These experiments were carried out in the environments developed on the basis of the software architecture presented in chapter 3 (section 3.3.1). The purpose of these experiments was to study the effect of the proposed guides on users' coordination, awareness and performance during collaborative/cooperative task execution.

The "Peg-in-Hole" was selected as experimental task for the first four studies. In the fifth study, the experimental task was to cooperatively inverse a stack of two cylinders via two robots. In these studies, assistance was provided through sound, visual and haptic

guides. In the sixth experiment, we presented a study on the influence of view points and tactile feedback on the performance of two users during the execution of cooperative task. Here the cooperative task was carried out via a virtual robot where each user controlled separate degrees of freedom of the virtual robot. In the last experiment of this part, dynamic haptic interaction between two remote users, based on the concept of "What You Feel Is What I DO (WYFIWID)" was presented.

In the last chapter, we introduced the concept, models and evaluation of multimodal guides designed for teleoperation and single-user VEs. In this context, we proposed two types of multimodal guides, the first is omni directional and help users to select an object in the virtual environment. The second guide lets users select an object from a specific direction. The purpose of this guide was not only to provide assistance in virtual environment, but also in teleoperation assisted by virtual reality.

In summary, we can say that our multi-modal collaborative system was very successful because it not only allowed the collaboration of distant but also that of co-localized users (two for the moment) to undertake a cooperative task. In addition it was flexible enough that various devices such as Polhemus patriot, Phantom omni, SPIDAR and Wiimote were integrated and used during experiments. Experimental results revealed that all our proposed guides (Visual, Audio and Haptic) significantly contributed to increase users' performance, awareness and coordination during the execution of the cooperative/collaborative task. Similarly, the haptic guides that were evaluated in single user setup also proved to be valuable.

5.7 Perspectives and future work

There are many perspectives of our work both from application and research point of view. The findings of this research work can significantly contribute to the development of collaborative systems for teleoperation, assembly tasks, e-learning, rehabilitation, CAD and entertainment. Similarly, research can be carried out in many directions, for example, to study the concurrent manipulation problem in presence of more than two users. It is also possible to use the two users scenario but select a more complex task as case study. Further work can be carried on the study of cooperative manipulation with two robots in presence of haptic guides to extend it to the Augmented Reality (AR) application. In addition, the influence of network delay on cooperative manipulation tasks also remains an important topic of research.

We evaluated the guides presented in the fifth chapter in mono-user VEs, but they can be easily used in CVEs that allow asynchronous manipulation. Furthermore the conic multimodal guide can be integrated into ARITI project to haptically guide user in object's selection via robot manipulator.

Bibliography

- Abbott, J. J., Panadda, M., and Okamura, A. M. (2005). Haptic virtual fixtures for robot-assisted manipulation. In *Proceedings of the 12th International Symposium of Robotics Research*, pages 49–64.
- Adachi, Y., Kumano, T., and Ogino, K. (1995). Intermediate representation for stiff virtual objects. In *Virtual Reality Annual International Symposium, 1995. Proceedings.*, pages 203–210.
- Aguerreche, L., Duval, T., and Arnaldi, B. (2009a). A description of a dialog to enable interaction between interaction tools and 3d objects in collaborative virtual environments. In *Proceedings of VRIC 2009*, pages 63–73.
- Aguerreche, L., Duval, T., and Lécuyer, A. (2009b). 3-hand manipulation of virtual objects. In *Joint Virtual Reality Conference of EGVE - ICAT - EuroVR*, pages 153–156.
- Akamatsu, M. and Mackenzie, S. I. (1996). Movement characteristics using a mouse with tactile and force feedback. *Int. J. Hum.-Comput. Stud.*, 45(4):483–493.
- Alhalabi, M. O. and Horiguchi, S. (2001). Tele-handshake: Cooperative shared haptic virtual environment. *EuroHaptics*, pages 1–12.
- Aukstakalnis, S. and Blatner, D. (1992). *Silicon Mirage : The Art and Science of Virtual Reality*. Peach Pit Press.
- Basdogan, C., Ho, C.-H., Srinivasan, M. A., and Slater, M. (2000). An experimental study on the role of touch in shared virtual environments. *ACM Trans. Comput.-Hum. Interact.*, 7(4):443–460.
- Benford, S., Bowers, J., Fahlén, L. E., and Greenhalgh, C. (1994). Managing mutual awareness in collaborative virtual environments. In *VRST '94: Proceedings of the conference on Virtual reality software and technology*, pages 223–236, River Edge, NJ, USA. World Scientific Publishing Co., Inc.
- Benford, S. and Fahlén, L. (1993). A spatial model of interaction in large virtual environments. In *ECSCW'93: Proceedings of the third conference on European Conference on Computer-Supported Cooperative Work*, pages 109–124, Norwell, MA, USA. Kluwer Academic Publishers.
- Bergamasco, M. (1992). The glad-in-art project. In *Proceedings of Imagina'92 Conference*.

- Berkelman, P. and Hollis, R. L. (1997). Dynamic performance of a magnetic levitation haptic device.
- Bluteau, J., Gentaz, E., Coquillart, S., and Payan, Y. (2008). Haptic guidances increase the visuo-manual tracking of japanese and arabic letters. In *International Multisensory Research Forum*, Hamburg, Germany.
- Bouguet, A., Coldefy, F., Guérin, J., Louis-dit Picard, S., and Pavy, D. (2007). Environnement virtuel pour téléprésence collaborative 3d. In *Actes des 2èmes journées AFRV*, pages 33–37.
- Bouguila, L., Ishii, M., and Sato, M. (2000). Multi-modal haptic device for large-scale virtual environments. In *Multimedia '00: Proceedings of the eighth ACM international conference on Multimedia*, pages 277–283, New York, NY, USA. ACM.
- Bowman, A., Kruijff, E., and Laviola, J. Poupyrev, I. (2005). *3D User Interfaces : Theory and Practice*. Addison-Wesley.
- Bowman, D. A. (1999). *Interaction Techniques for Common Tasks in Immersive Virtual Environments : Design, Evaluation, and Application*. PhD thesis, Georgia Institute of Technology.
- Bowman, D. A., Koller, D., and Hodges, L. F. (1997). Travel in immersive virtual environments: An evaluation of viewpoint motion control techniques. In *Proceedings of the Virtual Reality Annual International Symposium*, pages 45–52.
- Burdea, G. C. (2000). Haptic feedback for virtual reality. In *special issue on Virtual Prototyping, International Journal of Design and Innovation Research*, volume 2, pages 17–29.
- Burdea, G. C. and Coiffet, P. (1993). *La réalité virtuelle*, chapter 2, pages 243–251. Hermès Paris.
- Burkhardt, J.-M., Bardy, B., and Lourdeaux, D. (2003). Immersion, réalisme et présence dans la conception et l'évaluation des environnements virtuels. In *Psychologie Française*, pages 35–42.
- Buttolo, P., Oboe, R., and Hannaford, B. (1997). Architectures for shared haptic virtual environments. *Computer Graphics*, 21(4):421–429.
- Caldwell, D., Kocak, O., and Andersen, U. (1995). Multi-armed dexterous manipulator operation using glove/exoskeleton control and sensory feedback. In *IROS '95: Proceedings of the International Conference on Intelligent Robots and Systems-Volume 2*, page 2567, Washington, DC, USA. IEEE Computer Society.
- Capps, M., Mcgregor, D., Brutzman, D., and Zyda, M. (2000). Npsnet-v: A new beginning for dynamically extensible virtual environments. In *IEEE Computer Graphics and Applications*, pages 12–15.
- Chamaret, D., Naud, M., Hamon, L., Ullah, S., Richard, E., and Richard, P. (2009). Human-scale haptic interaction using the spidar. In *proceedings of JVRC09 - Joint Virtual Reality Conference of EGVE - ICAT - EuroVR, Spidar Anniversary Symposium*, pages 123–128.

- Chamaret, D., Ullah, S., Richard, P., and Naud, M. (2010). Integration and evaluation of haptic feedbacks: from cad models to virtual prototyping. In *International Journal on Interactive Design and Manufacturing*, volume 4, pages 87–94.
- Chan, A., Maclean, K., and Mcgreneere, J. (2008). Designing haptic icons to support collaborative turn-taking. In *International Journal of Human-Computer Studies*, volume 66, pages 333–355.
- Chastine, J. W., Brooks, J. C., Zhu, Y., Owen, G. S., Harrison, R. W., and Weber, I. T. (2005). Ammp-vis: a collaborative virtual environment for molecular modeling. In *VRST '05: Proceedings of the ACM symposium on Virtual reality software and technology*, pages 8–15, New York, NY, USA. ACM.
- Chellali, A., Dumas, C., and Milleville, I. (2010). Wyfiwif: A haptic communication paradigm for collaborative motor skills learning. In *Proceedings of the Web Virtual Reality and Three-Dimensional Worlds*, Freiburg, Germany.
- Chellali, M.-E.-A. (2009). *Étude des interactions homme-machine pour l'élaboration du référentiel commun dans les environnements virtuels collaboratifs*. PhD thesis, Université de Nantes.
- Chen, J. and Bowman, D. A. (2009). Domain-specific design of 3d interaction techniques: An approach for designing useful virtual environment applications. In *Presence*, volume 18, pages 370–386.
- Coquillart, S. (2009). The string haptic workbench from research to applications. In *proceedings of JVRC09 - Joint Virtual Reality Conference of EGVE - ICAT - EuroVR, Spidar Anniversary Symposium*, pages 109–111.
- Cutt, P. (1993). Tactile displays : Adding the sense of touch to virtual environments. In *Proceedings of Virtual Reality Systems'93 Conference*.
- Diaz, I., Hernantes, J., Mansa, I., Lozano, A., Borro, D., Juan Gil, J., and Sanchez, E. (2006). Influence of multisensory feedback on haptic accessibility tasks. In *Virtual Reality*, volume 10, pages 31–40.
- Dominjon, L. (2006). *Contribution à l'étude des techniques d'interaction 3D pour la manipulation d'objets avec retour haptique en environnement virtuel à échelle humaine*. PhD thesis, Université d'Angers.
- Dumas, C., Saugis, G., Chaillou, C., Degrande, S., and Viaud, M.-L. (1999). A 3-d interface for cooperative work. In *Virtual Reality Journal*, pages 15–25.
- Ellis, S. R. (1994). What are virtual environments? In *Proceedings of IEEE Computer Graphics and Applications*, pages 17–22. IEEE.
- Feygin, D., Keehner, M., and Tendick, R. (2002). Haptic guidance: experimental evaluation of a haptic training method for a perceptual motor skill. In *Proceedings of the 10th Symposium on Haptic Interfaces for Virtual Environment and Teleoperator Systems*, pages 40–47.
- Foley, J., Van Dam, A., Feiner, S., and Hugues, J. (1996). *Computer graphics Principles and Practice*. Addison-Wesley, 2e edition.

- Forcedimension (2010). <http://www.forcedimension.com>.
- Frécon, E. and Nöu, A. A. (1998). Building distributed virtual environments to support collaborative work. In *VRST '98: Proceedings of the ACM symposium on Virtual reality software and technology*, pages 105–113, New York, NY, USA. ACM.
- Fuchs, P., Arnaldi, B., and Tisseau, J. (2003). *La réalité virtuelle et ses applications*, chapter 1, pages 3–52. Les Presses de l'Ecole des Mines de Paris.
- Fuchs, P., Moreau, G., Burkhardt, G.-M., and Coquillart, S. (2006). *le traité de la réalité virtuelle, volume 2: L'interfaçage, l'immersion et l'interaction en environnement virtuel*. Edition Les Presses de l'Ecole des Mines de Paris.
- Fuhrmann, T., Klein, M., and Odendahl, M. (2003). Bluewand-a versatile remote control and pointing device. In *KiVS Kurzbeiträge*, pages 81–88.
- Goebbels, G., Lalioti, V., and Göbel, M. (2003). Design and evaluation of team work in distributed collaborative virtual environments. In *VRST '03: Proceedings of the ACM symposium on Virtual reality software and technology*, pages 231–238, New York, NY, USA. ACM.
- Goldberg, K., Chen, B., Solomon, R., Bui, S., Farzin, B., Heitler, J., Poon, D., and Smith, G. (2002). Collaborative teleoperation via the internet. *Proceedings of IEEE International Conference on Robotics and Automatio*, pages 2019–2024.
- Greenberg, S., Gutwin, C., and Cockburn, A. (1996). Awareness through fisheye views in relaxed-wysiwis groupware. In *Proceedings of Graphics Interface*, pages 28–38. Morgan-Kaufmann.
- Greenhalgh, C. (1997). Large scale collaborative virtual environments. In *PhD thesis, University of Nottingham*.
- Greenhalgh, C. and Benford, S. (1995). Massive: a collaborative virtual environment for teleconferencing. *ACM Trans. Comput.-Hum. Interact.*, 2(3):239–261.
- Gunn, C. (2005). Using force fields as a user interface device. In *proceedings of Virtual Reality Conference, VR2005*.
- Gunn, C. (2006). Collaborative virtual sculpting with haptic feedback. In *Virtual Reality*, volume 10, pages 73–83. Springer London.
- Hachet, M. (2003). *Interaction avec des environnements virtuels affichés au moyen d'interfaces de visualisation collective*. PhD thesis, Université Bordeaux I.
- Hagsand, O. (1996). Interactive multiuser ves in the dive system. *IEEE MultiMedia*, 3(1):30–39.
- Hasser, C., Goldenberg, A., Martin, K., and Rosenberg, L. (1998). User performance in a gui pointing task with a low-cost force-feedback computer mouse. In *Proceedings of the ASME Dynamic Systems and Control Division, American Society of Mechanical Engineers*, pages 151–156.

- Heldal, I., Spante, M., and Connell, M. (2006). Are two heads better than one?: object-focused work in physical and in virtual environments. In *VRST '06: Proceedings of the ACM symposium on Virtual reality software and technology*, pages 287–296, New York, NY, USA. ACM.
- Hinckley, K. (1996). *Haptic Issues for Virtual Manipulation*. PhD thesis, School of Engineering and Applied Science University of Virginia.
- Hirata, Y. and Sato, M. (1992). 3-dimensional interface device for virtual work space. In *Proceedings of the 1992 IEEE/RSJ International Conference on IROS*, volume 2, pages 889–896.
- Hiroshi, N., Eriko, T., Masaaki, H., Hiroshi, M., and Hiroshi, T. (2000). Molecular virtual reality system with force feedback device. *Int Conf Artif Real Telexistence*, pages 161–166.
- Hrimech, H. (2009). *Evaluation de métaphores d'interaction pour le travail collaboratif entre sites distants d'immersion virtuelle*. PhD thesis, Ecole Nationale Supérieure d'Arts et Métiers, ParisTech.
- Hwang, F., Langdon, P., Keates, S., and Clarkson, J. (2001). Haptic assistance to improve computer access for motion-impaired users. In *eurohaptics Birmingham*.
- Immersion (2010). <http://www.immersion.com>.
- Iwata, H., Yano, H., Nakaizumi, F., and Kawamura, R. (2001). Project feelex: adding haptic surface to graphics. In *SIGGRAPH '01: Proceedings of the 28th annual conference on Computer graphics and interactive techniques*, pages 469–476, New York, NY, USA. ACM.
- James F., K. (1993). Force feedback and textures simulating interface device. In *United States Patent*, number 7390157.
- Johnson, A. D. (1992). Programmable tactile stimulator array system and method of operation. In *United States Patent*, number 5165897.
- Jordan, J., Mortensen, J., Oliveira, M., Slater, M., Tay, B. K., Kim, J., and Srinivasan, M. A. (2002). Collaboration in a mediated haptic environment. *The 5th Annual International Workshop on Presence*.
- Kalawsky, R. (1996). Exploiting virtual reality techniques in education and training: Technological issues. In *SIMA Report*.
- Kheddar, A. (1997). *Téléopération basée sur le concept du robot caché*. PhD thesis, Université Pierre et Marie Curie, France.
- Kohno, Yoshio and Walairact, S., Hawegawa, S., Koike, Y., and Sato, M. (2001). Evaluation of two-handed multi-finger haptic device spidar-8. In *Proceedings of ICAT*.
- Komerska, R. and Ware, C. (2004). A study of haptic linear and pie menus in a 3d fish tank vr environment. *Haptic Interfaces for Virtual Environment and Teleoperator Systems, International Symposium on*, pages 224–231.

- Lanier, J. (1988). A vintage virtual reality interview. <http://www.jaronlanier.com/vrint.html>.
- Lécuyer, A. (2002). *Contribution to the study of haptic and pseudo-haptic feed-backs and their impact on simulations of assembly/maintenance operations in aeronautics*. PhD thesis, Université Paris XI Orsay, France.
- Lécuyer, A., Mégard, C., Burkhardt, J.-M., Ccr, E., Lim, T., Coiffet, P., Graux, L., and Coquillart, S. (2002). The effect of haptic, visual and auditory feedback on an insertion task on a 2-screen workbench. In *Proceedings of the Immersive Projection Technology Symposium*.
- Lécuyer, A., Vidal, M., Joly, O., Mégard, C., and Berthoz, A. (2004). Can haptic feedback improve the perception of self-motion in virtual reality? *Haptic Interfaces for Virtual Environment and Teleoperator Systems, International Symposium on*, 0:208–215.
- Le Mer, P., Soler, L., Pavy, D., and Bernard, A. (2004). Argonaute 3d : a real-time cooperative medical planning software on dsl network. In *Studies in health technology and informatics*, volume 98.
- Lee, C. D., Lawrence, D. A., and Pao, L. Y. (2000). A high-bandwidth force-controlled haptic interface. In *symposium on haptic interfaces for teleoperation and virtual reality, international congress and exposition*.
- Leigh, J., Johnson, A. E., and DeFanti, T. A. (1997). Issues in the design of a flexible distributed architecture for supporting persistence and interoperability in collaborative virtual environments. In *Supercomputing '97: Proceedings of the 1997 ACM/IEEE conference on Supercomputing (CDROM)*, pages 1–14, New York, NY, USA. ACM.
- Liang, J. and Green, M. (1994). Jdcad : a highly interactive 3d modeling system. In *Computer Graphics (SIGGRAPH'93 Proceedings)*, pages 499–506.
- Luo, Y., Jun, M., Katsuhito, A., Shoichi, H., and Makoto, S. (2003). Development of new force feedback interface for two-handed 6dof manipulation spidar-g &g system. In *ICAT*.
- Macedonia, M. R. and Zyda, M. J. (1997). A taxonomy for networked virtual environments. *IEEE MultiMedia*, 4(1):48–56.
- Macedonia, R. M., David, R. P., and Michael, J. Z. (1995). A network architecture for large scale virtual environments. In *Proceedings IEEE Virtual Reality Annual International Symposium (VRAIS95)*.
- Mackinlay, J. D., Card, S. K., and Robertson, G. G. (1990). Rapid controlled movement through a virtual 3d workspace. In *Proceedings of the 17th annual conference on Computer graphics and interactive techniques*, pages 171–176.
- Makoto, S. (2002). Development of string-based force display: Spidar. In *IEEE VR Conference*.
- Marcus, B. and Churchill, P. (1989). Human hand sensing for robotics and teleoperations.

- Margery, D., Arnaldi, B., and Plouzeau, N. (1999). A general framework for cooperative manipulation in virtual environments. *Virtual Environments'99 Proceedings of the Eurographics Workshop*, pages 169–178.
- Mark, W. R., Randolph, S. C., Finch, M., Van Verth, J. M., and Taylor, II, R. M. (1996). Adding force feedback to graphics systems: issues and solutions. In *SIGGRAPH '96: Proceedings of the 23rd annual conference on Computer graphics and interactive techniques*, pages 447–452, New York, NY, USA. ACM.
- Massimino, M. and Sheridan, T. (1989). Variable force and visual feedback effects on teleoperator man/machine performance. In *Proceedings of the NASA Conference on Space Telerobotic*, pages 1751–1756.
- Mestre, D. and Fuchs, P. (2006). *Immersion et Présence*. Le traité de la Réalité Virtuelle, 3eme Edition, Ecole des Mines de Paris.
- Micro_systems_labs (2010). <http://www.msl.ri.cmu.edu>.
- Miller, T. (1998). Implementation issues in adding force feedback to the x desktop. In *Phantom Users Group Workshop*.
- Mine, M. R. (1995). Virtual environment interaction techniques. Chapel Hill, NC 27599-3175 TR95-018, Departement of Computer Science, University of North California.
- Mine, M. R., Brooks, J. F. P., and Sequin, C. H. (1997). Moving objects in space : Exploiting proprioception in virtual-environment interaction. *Computer Graphics*, 31:19–26.
- Moog_Systems (2010). <http://www.fcs-cs.com>.
- Morris, D., Tan, H., Barbagli, F., Chang, T., and Salisbury, K. (2007). Haptic feedback enhances force skill learning. In *Proceedings of the Second Joint EuroHaptics Conference and Symposium on Haptic Interfaces for Virtual Environment and Teleoperator Systems*, pages 21–26, Washington, DC, USA. IEEE Computer Society.
- Mortensen, J., Vinayagamoorthy, V., Slater, M., Steed, A., Lok, B., and Whitton, M. C. (2002). Collaboration in tele-immersive environments. In *EGVE '02: Proceedings of the workshop on Virtual environments 2002*, pages 93–101, Aire-la-Ville, Switzerland, Switzerland. Eurographics Association.
- Naud, M., Ullah, S., Richard, P., Otmane, S., and Mallem, M. (2009). Effect of tactile feedback and viewpoint on task performance in a collaborative virtual environment. In *proceedings of Joint Virtual Reality Conference(JVRC)*, pages 19–20.
- Nicholas, W. (2004). Cooperative control in tele-operated mining environments. In *courses.ece.ubc.ca/518/previous/hit2004/papers/Wilkinson.pdf*.
- Nintendo[®] (2010). <http://www.nintendo.com/wii/console/controllersremote>.
- Oakley, I., Brewster, S., and Gray, P. (2001). Can you feel the force? an investigation of haptic collaboration in shared editors. In *Proceedings of Eurohaptics*, pages 54–59.
- Orbit_system_Lab (2010). <http://osl-www.colorado.edu>.

- Ortega, M. and Coquillart, S. (2005). Prop-based haptic interaction with co-location and immersion: an automotive application. In *Have 2005, Canada*.
- Otmane, S. (2000). *Télétravail Robotisé et Réalité Augmentée :Application à la Téléopération via Internet*. PhD thesis, Université d'Evry Val d'Essonne France.
- Otmane, S. and Davesne, F. (2009). Utilization of human scale spider-g in the framework of assistance to 3d interaction in a semi-immersive ar/vr platform. In *Joint Virtual Reality Conference EGVE-ICAT-EURO VR (JCVR 2009)*, pages 129–134.
- Otmane, S., Mallem, M., Kheddar, A., and Chavand, F. (2000). Active virtual guide as an apparatus for augmented reality based telemanipulation system on the internet. *IEEE Computer Society*, pages 185–191.
- Otmane, S., Ouramdane, N., and Mallem, M. (2008). *End-to-End QoS Engineering in Next Generation Heterogenous Networks*, chapter Towards collaborative teleoperation based on human-scale networked mixed reality environments, pages 377–406. jointly by Wiley & sons and ISTE.
- Otto, O., Dave, R., and Robin, W. (2006). A review on effective closely-coupled collaboration using immersive cve's. In *VRCIA '06: Proceedings of the 2006 ACM international conference on Virtual reality continuum and its applications*, pages 145–154. ACM.
- Ouramdane, N. (2008). *Vers un système d'assistance à l'interaction 3D pour le travail et le télétravail collaboratif dans les environnements de réalité virtuelle et augmentée*. PhD thesis, Université d'Evry, France.
- Ouramdane, N., Otmane, S., Davesne, F., and Mallem, M. (2006). Follow-me: a new 3d interaction technique based on virtual guides and granularity of interaction. In *VRCIA '06: Proceedings of the 2006 ACM international conference on Virtual reality continuum and its applications*, pages 137–144, New York, NY, USA. ACM.
- Pierce, J. S., Forsberg, A., Conway, M. J., Hong, S., Zeleznik, R., and Mine, M. R. (1997). Image plane interaction techniques in 3d immersive environments. In *Proceedings of 1997 Symposium on Interactive 3D Graphics*, pages 39–43.
- Pierce, J. S., Stearns, B. C., and Pausch, R. (1999). Voodoo dolls: seamless interaction at multiple scales in virtual environments. In *I3D '99: Proceedings of the 1999 symposium on Interactive 3D graphics*, pages 141–145, New York, NY, USA. ACM.
- Pinho, M. S., Bowman, D. A., and Freitas, C. M. D. S. (2008). Cooperative object manipulation in collaborative virtual environments. *Journal of the Brazilian Computer Society*, 14:54 – 67.
- Plimmer, B., Crossan, A., Brewster, S. A., and Blagojevic, R. (2008). Multimodal collaborative handwriting training for visually-impaired people. In *CHI '08: Proceeding of the twenty-sixth annual SIGCHI conference on Human factors in computing systems*, pages 393–402, New York, NY, USA. ACM.
- Polhemus (2010). http://www.polhemus.com?page=motion_patriot.
- Popescu, G. V., Burdea, G., and Rares, B. (2002). Shared virtual environments for telerehabilitation. In *Proceedings of Medicine Meets Virtual Reality*, pages 362–368.

- Poupyrev, I. and Ichikawa, T. (1999). Manipulation object in virtual worlds: Categorization and empirical evaluation of interaction techniques. *Visual languages and Computing*, 10(1):19–35.
- Poupyrev, I., Weghorst, S., Billinghamurst, M., and Ichikawa, T. (1996). The go-go interaction technique non-linear mapping for direct manipulation in vr. In *Proceedings of the ACM Symposium on User Interface Software and Technology (UIST '96)* Press, pages 79–80.
- Poupyrev, I., Weghorst, S., Billinghamurst, M., and Ichikawa, T. (1998). Egocentric object manipulation in virtual environment: Empirical evaluation of interaction techniques. In *Computer Graphics Forum, EUROGRAPHICS'98 Issue*, pages 41–52.
- Prada, R. and Payandeh, S. (2009). On study of design and implementation of virtual fixtures. In *Virtual Reality*, volume 13, pages 117–129.
- Quanser (2010). <http://www.quanser.com>.
- Richard, P. (1996). *Analyse de l'interaction homme-monde virtuel lors de tâches de manipulation d'objets déformables*. PhD thesis, Université Pierre et Marie Curie, France.
- Richard, P., Birebent, G., Coiffet, P., Burdea, G. C., Gomez, D., and Langrana, N. A. (1996). Effect of frame rate and force feedback on virtual object manipulation. *Presence*, 5(1):95–108.
- Richard, P., Chamaret, D., Inglese, F.-x., and Ferrier, J.-l. (2006). Human-scale virtual environment for product design: Effect of sensory substitution. In *The International Journal of Virtual Reality*, volume 5, pages 37–44.
- Richard, P., Coiffet, P., Kheddar, A., and England, R. (1994). A comparison of haptic, visual and auditive force feedback for deformable virtual objects. pages 49–62.
- Richard J., A. and Blake, H. (1999). Stable haptic interaction with virtual environments. *IEEE Transactions on Robotics and Automation*, 15:465–474.
- Richard J. Adams, Daniel Klowden, B. H. (2001). Virtual training for a manual assembly task. In *Haptics-e*, volume 2.
- Riege, K., Holtkamper, T., Wesche, G., and Frohlich, B. (2006). The bent pick ray: An extended pointing technique for multi-user interaction. In *3DUI '06: Proceedings of the 3D User Interfaces*, pages 62–65, Washington, DC, USA. IEEE Computer Society.
- Roberts, D., Wolff, R., Otto, O., Kranzlmüller, D., Anthes, C., and Steed, A. (2004). Supporting social human communication between distributed walk-in displays. In *VRST '04: Proceedings of the ACM symposium on Virtual reality software and technology*, pages 81–88, New York, NY, USA. ACM.
- Rosenberg, L. (1992). The use of virtual fixtures as perceptual overlays to enhance operator performance in remote environments. In *AL/CF-TR-1994-0089*.
- Rosenberg, L. (1993). The use of virtual fixtures to enhance telemanipulation with time delay. In *Proceedings, ASME Winter Annual Meeting on Haptic Interfaces for Virtual environment and Teleoperator Systems*.

- Roussos, M., Johnson, A. E., Leigh, J., Vasilakis, C. A., Barnes, C. R., and Moher, T. G. (1997). (nice): Combining constructionism, narrative and collaboration in a virtual learning environment. *Computer Graphics*, 31(3):62–63.
- Salisbury, J. and Srinivasan, M. (1997). Phantom-based haptic interaction with virtual objects. *Computer Graphics and Applications, IEEE*, 17(5):6–10.
- Sallnäs, E.-L., Rasmus-Gröhn, K., and Sjöström, C. (2000). Supporting presence in collaborative environments by haptic force feedback. *ACM Trans. Comput.-Hum. Interact.*, 7(4):461–476.
- Sayers, C. P. and Paul, R. P. (1994). An operator interface for teleprogramming employing synthetic fixtures. *Presence*, 3(4):309–320.
- SensAble (2010). <http://www.sensable.com>.
- Shen, X., Bogsanyi, F., Ni, L., and Georganas, N. (2003). A heterogeneous scalable architecture for collaborative haptics environments. *Proceedings of the 2nd IEEE International Workshop on Haptic, Audio and Visual Environments and Their Applications*, pages 113 – 1187.
- Shirmohammadi, S. and Georganas, N. D. (2001). An end-to-end communication architecture for collaborative virtual environments. *Comput. Netw.*, 35(2-3):351–367.
- Simmross-Wattenberg, F., Carranza-Herrezuelo, N., Palacios-Camarero, C., Pablo Casaseca, J., Angel Martin-Fernandez, M., Aja-Fernandez, S., Juan, R.-A., Carl-Fredrik, W., and Carlos, A.-L. (2005). Group-slicer: a collaborative extension of the 3d-slicer. *Journal of Biomedical Informatics*, 38(6):431–442.
- Steed, A., Alexander, D., Cook, P., and Parker, C. (2003). Visualizing diffusion-weighted mri data using collaborative virtual environment and grid technologies. In *TPCG '03: Proceedings of the Theory and Practice of Computer Graphics 2003*, page 156, Washington, DC, USA. IEEE Computer Society.
- Sternberger, L. (2006). *Interaction en réalité virtuelle*. PhD thesis, Université Louis Pasteur de Strasbourg 1.
- Sternberger, L. and Bechmann, D., editors (2005). *Deformable ray-casting interaction technique*, IEEE Young Virtual Reality Conference.
- Stoackley, R., Conway, M. J., and Pausch, R. (1995). Virtual reality on a wim : Interactive worlds in miniature. In *Proceedings of CHI: Human Factors in Computing Systems*, pages 265–272.
- Stoffregen, T., Badry, B.G. Smart, L., and Pagulayan, R. (2003). On the nature and evaluation of fidelity in virtual environments. In *L.J. Hettinger and M.W. Haas (Eds), Psychological issues in the design and use of virtual and adaptative environments*, pages 111–128.
- Stone, R. (1992). Virtual reality and telepresence. In *Robotica*, volume 10, pages 461–467.
- Sturman, D. J., Zeltzer, D., and Pieper, S. (1989). Hands-on interaction with virtual environments. In *ACM Symposium on User Interface Software and Technology*, pages 19–24.

- Tarrin, N., Coquillart, S., Bouguila, L., and Makoto, S. (2003). The string haptic workbench: a new haptic workbench solution. In *Computer Graphics Forum*, volume 3, pages 583–589.
- Team_speak_software (2010). <http://www.teamspeak.com>.
- Tsuneo, Y. and Kazuyuki, H. (2000). Human skill transfer using haptic virtual reality technology. In *the 6th international symposium on experimental robotics*, volume 250, pages 351–360.
- Ullah, S., Liu, X., Otmane, S., Richard, P., and Mallem, M. (2011). What you feel is what i do (wyfiwid): A study of dynamic haptic interaction in distributed collaborative virtual environment. In *14th International Conference on Human-Computer Interaction (HCI2011)*.
- Ullah, S., Otmane, S., and Richard, P. (2007). Haptic feedback in large-scale ves: Evaluation of spidar-g. In *proceedings of 4th International Conference on Enactive Interfaces*, pages 189–192.
- Ullah, S., Ouramdane, N., Otmane, S., Richard, P., Davesne, F., and Mallem, M. (2009a). Augmenting 3d interactions with haptic guides in a large-scale virtual environment. In *The International Journal of Virtual Reality*, volume 8, pages 25–31.
- Ullah, S., Richard, P., Otmane, S., and Mallem, M. (2009b). Cooperative teleoperation task in virtual environment: the influence of visual aids and oral communication. In *International Conference on Informatics Control, Automation and Robotics (ICINCO 09)*, pages 374–377.
- Ullah, S., Richard, P., Otmane, S., and Mallem, M. (2009c). The effect of audio and visual aids on task performance in distributed collaborative virtual environments. In *proceedings of 2nd Mediterranean Conference on Intelligence Systems and Automation (CISA 09)*, pages 196–201. American Society of Physics (AIP).
- Ullah, S., Richard, P., Otmane, S., and Mallem, M. (2009d). The effect of hatpic guides on humane performance in virtual environments. In *proceedings of International Conference on Computer Graphics Theory and Applications (GRAPP 09)*, pages 322–327.
- Ullah, S., Richard, P., Otmane, S., Naud, M., and Mallem, M. (2009e). Human performance in cooperative virtual environments: the effect of visual aids and oral communication. In *The International Journal of Virtual Reality*, volume 8, pages 79–86.
- Ullah, S., Richard, P., Otmane, S., Naud, M., and Mallem, M. (2010). Haptic guides in cooperative virtual environments: Design and human performance evaluation. In *proceedings of IEEE Symposium on haptics*, pages 457–462.
- Veen, H. V. and van Erp, J. (2003). Providing directional information with tactile torso displays. In *EuroHaptics*.
- Wloka, M. (1995). Lag in multiprocessor virtual reality. In *Presence:Teleoperators and Virtual Environments*, volume 4, pages 50–63.

Zimmerman, T. G., Lanier, J., Blanchard, C., Bryson, S., and Harvill, Y. (1987). A hand gesture interface device. In *CHI '87: Proceedings of the SIGCHI/GI conference on Human factors in computing systems and graphics interface*, pages 189–192, New York, NY, USA. ACM.

Appendix

5.8 Appendix A :

- Q1: What condition did you prefer? (a) C1 (b) C2 (c) C3
- Q2: Which feedback did you find most suitable? (a) C1 (b) C2 (c) C3
- Q3: Which part of the task was most difficult? (a) selection (b) manipulation (c) placement
- Q4: What condition allowed the better perception of the actions of your partner? (a) C1 (b) C2 (c) C3

5.9 Appendix B :

This questionnaire is composed of two parts, the first contains general information about subjects and the second includes questions to respond.

Last Name :

First Name :

Sex :

Age :

Dominant Hand:

Experience in VR : 1/2/3/4/5

- Q1: What condition did you prefer? Classify by the order of your preference.

C1 : Shadow, C2: Force substitution + Shadow, C3 : Force substitution + Shadow + Oral Communication C4 : No guidance,

- Q2: Which feedback did you find most suitable?

C1 : Shadow, C2: Force substitution + Shadow, C3 : Force substitution + Shadow + Oral Communication C4 : No guidance,

- Q3: In what condition did you feel better the presence of your collaborator? Classify by the order of your preference. (a) C1 (b) C2 (c) C3 (d) C4

C1 : Shadow, C2: Force substitution + Shadow, C3 : Force substitution + Shadow + Oral Communication C4 : No guidance,

- Q4: In what condition did you achieve a close coordination with your collaborator? Classify by the order of your preference.

C1 : Shadow, C2: Force substitution + Shadow, C3 : Force substitution + Shadow + Oral Communication C4 : No guidance,

5.10 Appendix C :

This questionnaire is composed of two parts, the first contains general information about subjects and the second includes the questions to respond.

Last Name :

First Name :

Sex :

Age :

Dominant Hand:

Experience in VR : 1/2/3/4/5

- Q1: What condition did you prefer? Classify by the order of your preference.

C1: Shadow, C2: Force substitution + Shadow, C4 : No guidance

-
- Q2: What feedback helped you more during task execution? Classify by the order of your preference.

C1: Shadow, C2: Force substitution + Shadow, C4 : No guidance

- Q3: Which part of the task did you find most difficult ?

A : Selection, B : Manipulation (transportation), C : Placement

5.11 Appendix D:

This questionnaire is composed of two parts, the first contains general information about subjects and the second includes the questions to respond.

Last Name :

First Name :

Sex :

Age :

Dominant Hand:

Experience in VR : 1/2/3/4/5

- Q1: What is your preferred condition? why

((a) C1 (b) C2 (c) C3 (d) C4

- Q2: What feedback helped you more for object's selection and placement?

(a) C1 (b) C2 (c) C3 (d) C4

- Q3: In which condition (feedback) you perceived better the actions of your collaborator?

(a) C1 (b) C2 (c) C3 (d) C4

The conditions C1, C2, C3 and C4 are defined as follows:

C1=: No guidance

C2= : Normal force feedback

C3= attractive haptic guide

C4= Speed control haptic guide.

5.12 Appendix E:

This questionnaire is composed of two parts, the first contains general information about subjects and the second includes the questions to respond.

Last Name :

First Name :

Sex :

Age :

Dominant Hand:

Experience in VR : 1/2/3/4/5

- Q1: What is your preferred condition? why

(a) C1 (b) C2 (c) C3 (d) C4

- Q2: Which condition did you find most useful?

(a) C1(b) C2(c) C3 (d) C4

- Q3: Which part of the task was most difficult.

(a) Selection (b) Manipulation (c) Placement

- Q4: In which condition (feedback) you perceived better the actions of your collaborator?

(a) C1 (b) C2 (c) C3 (d) C4

For the questions 1, 2 and 4 the conditions are defined as:

C1=: No guidance , C2= : Normal force feedback, C3= Attractive guide, C4= speed control guide.

5.13 Appendix F:

This questionnaire contains some general information about users and three questions

Last Name :

First Name :

Sex :

Age :

Dominant Hand:

Experience in VR : 1/2/3/4/5

- Q1: What condition gives more the feeling of co-presence?

(a) C1 (b) C2 (c) C3 (d) C4

- Q2: In what conditions did you work better with your collaborator?

(a) C1 (b) C2 (c) C3 (d) C4

- Q3: In what condition did you perceive better the actions/intentions of your collaborator?

(a) C1 (b) C2 (c) C3 (d) C4

For all questions the conditions are defined as:

C1= The same viewpoint

C2= Perpendicular viewpoint

C3= Perpendicular viewpoint with tactile feedback

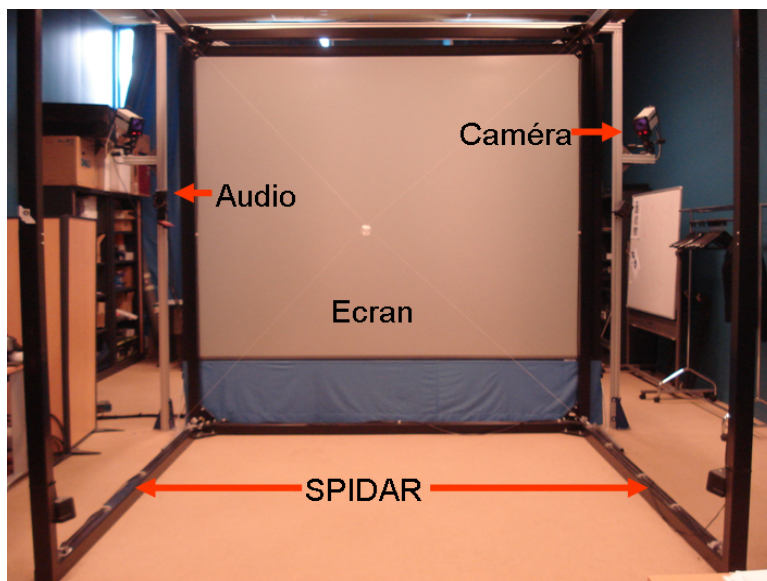

Figure 5.13: Different components of the semi-immersive platform of Evr@.

5.14 Appendix G : EVRA Platformed of the IBISC Lab

The EVR@ (Environnements Virtuels et de Réalité Augmentée) platform is the technological platform of IBISC Laboratory. Funding for this has been provided in part by the CNRS and the General Council of Essonne. It is composed of two sub-platforms installed in two different rooms.

- In the first room, A large scale semi-immersive platform of MR (Mixed Reality) has been installed (see Figure 5.13) ;
- In the second room, we have the second MR platform that has mobile structure (see Figure 5.18-a and 5.18-b).

These two platforms of EVR@ provide the technological base for collaborative work. The objective is to study mono-user and multi-user (collaborative) interaction in the environments of Virtual and Augmented Reality.

In the following, we present different devices and material of the EVR@ platform.

5.14.1 Large scale semi-immersive environment of evr@

5.14.1.1 System of visualization

This system consists of large (3.2m X 2.4m) rear-projected screen (see Figure 5.14 (a)). For projection, a DLP MIRAGE 4000 projector is used. The projector's frequency



Figure 5.14: The DLP Mirage 4000 projector of the evr@ platform.



Figure 5.15: Tracking system of the semi-immersive platform (a) Infrared camera (b) Flystick with shining balls

is 120Hz and has been placed behind the screen. The projector supports active stereoscopy for which Crystal Eyes 3 glasses are used. In addition, the graphic server is equipped with Quadro FX3000 graphics card.

5.14.1.2 Optical tracking

In order to trace the movements of the user or some parts of his/her body (arm, head etc.) and allow human machine interaction, the optical tracking system has been installed. This consists of two infrared cameras (ARTTrack) and some shining plastic balls. These balls can be mounted on different devices such as *Flystick* (see Figure 5.15-b) and data gloves.



Figure 5.16: Data Gloves of Fifth dimension

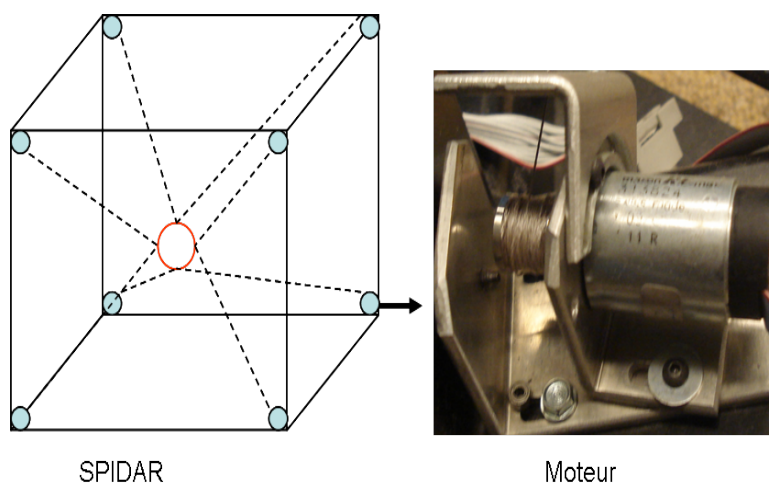

Figure 5.17: Illustration of the structure of SPIDAR-G

5.14.1.3 Data gloves

The EVR@ platform is also equipped with two pairs of Data gloves of Fifth Dimension (see Figure 5.16).

5.14.1.4 Force feedback system (SPIDAR)

The semi-immersive platform of evr@ is also equipped with a SPIDAR (Space Interface Device for Artificial Reality). This is a human scale SPIDAR-G and has 6DOF both in position and in force. The 8 motors have been mounted on the corner of the cubic frame (see Figure 5.17).

5.14.2 Mobile environment of evr@

The second part of EVR@ platform is a mobile platform and relatively small. This platform is also equipped with a rear-projected screen. Here the projector output is

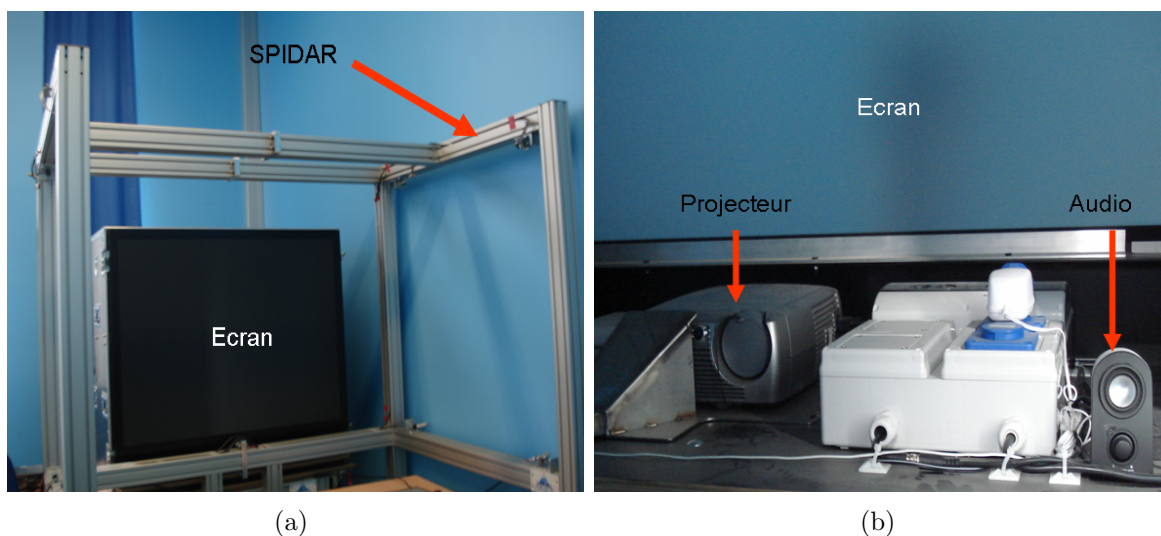

Figure 5.18: The mobile platform of Evr@ (a) external view (b) internal view

thrown on the screen through a mirror. In addition, we have stereoscopic sound system and medium size SPIDAR-G (see Figure 5.18).

5.14.3 Software platform

For software installation, the EVR@ platform is composed of three servers. Each sever is assigned a dedicated function. For example, one server responsible for haptic rendering while the other two control the optical tracking and graphic rendering respectively. Communication between them is achieved through LAN.

5.14.4 Slave site of the evr@ platform

At the client/slave site of the evr@ platform there is a robot of type FANUC LR MATE 200i. It has six degree of freedom and consists of an end effector with articulated mechanical structure(see Figure 5.19).



Figure 5.19: Robot Fanuc LR MATE 200i.

