



**HAL**  
open science

# Prototypage Rapide et Génération de Code pour DSP Multi-Coeurs Appliqués à la Couche Physique des Stations de Base 3GPP LTE

Maxime Pelcat

► **To cite this version:**

Maxime Pelcat. Prototypage Rapide et Génération de Code pour DSP Multi-Coeurs Appliqués à la Couche Physique des Stations de Base 3GPP LTE. Réseaux et télécommunications [cs.NI]. INSA de Rennes, 2010. Français. NNT : 2010ISAR0011 . tel-00578043

**HAL Id: tel-00578043**

**<https://theses.hal.science/tel-00578043v1>**

Submitted on 18 Mar 2011

**HAL** is a multi-disciplinary open access archive for the deposit and dissemination of scientific research documents, whether they are published or not. The documents may come from teaching and research institutions in France or abroad, or from public or private research centers.

L'archive ouverte pluridisciplinaire **HAL**, est destinée au dépôt et à la diffusion de documents scientifiques de niveau recherche, publiés ou non, émanant des établissements d'enseignement et de recherche français ou étrangers, des laboratoires publics ou privés.

# Thèse



**THESE INSA Rennes**  
sous le sceau de l'Université européenne de Bretagne  
pour obtenir le titre de  
**DOCTEUR DE L'INSA DE RENNES**  
Spécialité : Traitement du Signal et des Images

présentée par

**Maxime Pelcat**

**ECOLE DOCTORALE : MATISSE**

**LABORATOIRE : IETR**

## Rapid Prototyping and Dataflow-Based Code Generation for the 3GPP LTE eNodeB Physical Layer Mapped onto Multi-Core DSPs

**Thèse soutenue le 17.09.2010**  
devant le jury composé de :

**Shuvra BHATTACHARYYA**

Professeur à l'Université du Maryland (USA) / Président

**Guy GOGNIAT**

Professeur des Universités à l'Université de Bretagne Sud / Rapporteur

**Christophe JEGO**

Professeur des Universités à l'Institut Polytechnique de Bordeaux / Rapporteur

**Sébastien LE NOURS**

Maître de conférences à Polytech' Nantes / Examinateur

**Slaheddine ARIDHI**

Docteur / Encadrant

**Jean-François NEZAN**

Professeur des universités à l'INSA de Rennes / Directeur de thèse

<b>Acknowledgements</b>	<b>1</b>
<b>1 Introduction</b>	<b>3</b>
1.1 Overview	3
1.2 Contributions of this Thesis	7
1.3 Outline of this Thesis	7
<b>I Background</b>	<b>9</b>
<b>2 3GPP Long Term Evolution</b>	<b>11</b>
2.1 Introduction	11
2.1.1 Evolution and Environment of 3GPP Telecommunication Systems	11
2.1.2 Terminology and Requirements of LTE	12
2.1.3 Scope and Organization of the LTE Study	14
2.2 From IP Packets to Air Transmission	15
2.2.1 Network Architecture	15
2.2.2 LTE Radio Link Protocol Layers	16
2.2.3 Data Blocks Segmentation and Concatenation	17
2.2.4 MAC Layer Scheduler	18
2.3 Overview of LTE Physical Layer Technologies	18
2.3.1 Signal Air transmission and LTE	18
2.3.2 Selective Channel Equalization	20
2.3.3 eNodeB Physical Layer Data Processing	21
2.3.4 Multicarrier Broadband Technologies and Resources	22
2.3.5 LTE Modulation and Coding Scheme	26
2.3.6 Multiple Antennas	29
2.4 LTE Uplink Features	30
2.4.1 Single Carrier-Frequency Division Multiplexing	30
2.4.2 Uplink Physical Channels	31
2.4.3 Uplink Reference Signals	33
2.4.4 Uplink Multiple Antenna Techniques	34
2.4.5 Random Access Procedure	35
2.5 LTE Downlink Features	37

2.5.1	Orthogonal Frequency Division Multiplexing Access	37
2.5.2	Downlink Physical Channels	38
2.5.3	Downlink Reference Signals	40
2.5.4	Downlink Multiple Antenna Techniques	40
2.5.5	UE Synchronization	42
<b>3</b>	<b>Dataflow Model of Computation</b>	<b>45</b>
3.1	Introduction	45
3.1.1	Model of Computation Overview	45
3.1.2	Dataflow Model of Computation Overview	47
3.2	Synchronous Data Flow	50
3.2.1	SDF Schedulability	50
3.2.2	Single Rate SDF	52
3.2.3	Conversion to a Directed Acyclic Graph	53
3.3	Cyclo Static Data Flow	53
3.3.1	CSDF Schedulability	54
3.4	Dataflow Hierarchical Extensions	54
3.4.1	Parameterized Dataflow Modeling	55
3.4.2	Interface-Based Hierarchical Dataflow	57
<b>4</b>	<b>Rapid Prototyping and Programming Multi-core Architectures</b>	<b>61</b>
4.1	Introduction	61
4.1.1	The Middle-Grain Parallelism Level	61
4.2	Modeling Multi-Core Heterogeneous Architectures	63
4.2.1	Understanding Multi-Core Heterogeneous Real-Time Embedded DSP MPSoC	63
4.2.2	Literature on Architecture Modeling	64
4.3	Multi-core Programming	65
4.3.1	Middle-Grain Parallelization Techniques	65
4.3.2	PREESM Among Multi-core Programming Tools	67
4.4	Multi-core Scheduling	68
4.4.1	Multi-core Scheduling Strategies	68
4.4.2	Scheduling an Application under Constraints	69
4.4.3	Existing Work on Scheduling Heuristics	70
4.5	Generating Multi-core Executable Code	73
4.5.1	Static Multi-core Code Execution	73
4.5.2	Managing Application Variations	74
4.6	Conclusion of the Background Part	74
<b>II</b>	<b>Contributions</b>	<b>77</b>
<b>5</b>	<b>A System-Level Architecture Model</b>	<b>79</b>
5.1	Introduction	79
5.1.1	Target Architectures	79
5.1.2	Building a New Architecture Model	82
5.2	The System-Level Architecture Model	83
5.2.1	The S-LAM operators	83
5.2.2	Connecting operators in S-LAM	83
5.2.3	Examples of S-LAM Descriptions	84

5.2.4	The route model . . . . .	86
5.3	Transforming the S-LAM model into the route model . . . . .	88
5.3.1	Overview of the transformation . . . . .	88
5.3.2	Generating a route step . . . . .	88
5.3.3	Generating direct routes from the graph model . . . . .	88
5.3.4	Generating the complete routing table . . . . .	89
5.4	Simulating a deployment using the route model . . . . .	90
5.4.1	The message passing route step simulation with contention nodes . . . . .	90
5.4.2	The message passing route step simulation without contention nodes . . . . .	91
5.4.3	The DMA route step simulation . . . . .	91
5.4.4	The shared memory route step simulation . . . . .	91
5.5	Role of S-LAM in the Rapid Prototyping Process . . . . .	92
5.5.1	Storing an S-LAM Graph . . . . .	92
5.5.2	Hierarchical S-LAM Descriptions . . . . .	92
<b>6</b>	<b>Enhanced Rapid Prototyping</b> . . . . .	<b>95</b>
6.1	Introduction . . . . .	95
6.1.1	The Multi-Core DSP Programming Constraints . . . . .	95
6.1.2	Objectives of a Multi-Core Scheduler . . . . .	96
6.2	A Flexible Rapid Prototyping Process . . . . .	97
6.2.1	Algorithm Transformations while Rapid Prototyping . . . . .	97
6.2.2	Scenarios: Separating Algorithm and Architecture . . . . .	99
6.2.3	Workflows: Flows of Model Transformations . . . . .	101
6.3	The Structure of the Scalable Multi-Core Scheduler . . . . .	103
6.3.1	The Problem of Scheduling a DAG on an S-LAM Architecture . . . . .	104
6.3.2	Separating Heuristics from Benchmarks . . . . .	104
6.3.3	Proposed ABC Sub-Modules . . . . .	106
6.3.4	Proposed Actor Assignment Heuristics . . . . .	107
6.4	Advanced Features in Architecture Benchmark Computers . . . . .	108
6.4.1	The route model in the AAM process . . . . .	108
6.4.2	The Infinite Homogeneous ABC . . . . .	108
6.4.3	Minimizing Latency and Balancing Loads . . . . .	109
6.5	Scheduling Heuristics in the Framework . . . . .	111
6.5.1	Assignment Heuristics . . . . .	112
6.5.2	Ordering Heuristics . . . . .	113
6.6	Quality Assessment of a Multi-Core Schedule . . . . .	114
6.6.1	Limits in Algorithm Middle-Grain Parallelism . . . . .	114
6.6.2	Upper Bound of the Algorithm Speedup . . . . .	116
6.6.3	Lowest Acceptable Speedup Evaluation . . . . .	116
6.6.4	Applying Scheduling Quality Assessment to Heterogeneous Target Architectures . . . . .	117
<b>7</b>	<b>Dataflow LTE Models</b> . . . . .	<b>119</b>
7.1	Introduction . . . . .	119
7.1.1	Elements of the Rapid Prototyping Framework . . . . .	119
7.1.2	SDF4J : A Java Library for Algorithm Graph Transformations . . . . .	119
7.1.3	Graphiti : A Generic Graph Editor for Editing Architectures, Algorithms and Workflows . . . . .	120

7.1.4	PREESM : A Complete Framework for Hardware and Software Code-sign	121
7.2	Proposed LTE Models	121
7.2.1	Fixed and Variable eNodeB Parameters	121
7.2.2	A LTE eNodeB Use Case	122
7.2.3	The Different Parts of the LTE Physical Layer Model	124
7.3	Prototyping RACH Preamble Detection	124
7.4	Downlink Prototyping Model	128
7.5	Uplink Prototyping Model	129
7.5.1	PUCCH Decoding	130
7.5.2	PUSCH Decoding	131
<b>8</b>	<b>Generating Code from LTE Models</b>	<b>135</b>
8.1	Introduction	135
8.1.1	Execution Schemes	135
8.1.2	Managing LTE Specificities	137
8.2	Static Code Generation for the RACH-PD algorithm	137
8.2.1	Static Code Generation in the PREESM tool	137
8.2.2	Method employed for the RACH-PD implementation	140
8.3	Adaptive Scheduling of the PUSCH	142
8.3.1	Static and Dynamic Parts of LTE PUSCH Decoding	143
8.3.2	Parameterized Descriptions of the PUSCH	143
8.3.3	A Simplified Model of Target Architectures	145
8.3.4	Adaptive Multi-core Scheduling of the LTE PUSCH	146
8.3.5	Implementation and Experimental Results	149
8.4	PDSCH Model for Adaptive Scheduling	153
8.5	Combination of Three Actor-Level LTE Dataflow Graphs	153
<b>9</b>	<b>Conclusion, Current Status and Future Work</b>	<b>155</b>
9.1	Conclusion	155
9.2	Current Status	156
9.3	Future Work	156
<b>A</b>	<b>Available Workflow Nodes in PREESM</b>	<b>159</b>
<b>B</b>	<b>French Summary</b>	<b>163</b>
B.1	Introduction	163
B.2	Etat de l'Art	164
B.2.1	Le Standard 3GPP LTE	164
B.2.2	Les Modèles Flot de Données	166
B.2.3	Le Prototypage Rapide et la Programmation des Architectures Multicoeurs	167
B.3	Contributions	169
B.3.1	Un Modèle d'Architecture pour le Prototypage Rapide	169
B.3.2	Amélioration du Prototypage Rapide	171
B.3.3	Modèles Flot de Données du LTE	173
B.3.4	Implémentation du LTE à Partir de Modèles Flot de Données	173
B.4	Conclusion	176

*CONTENTS*

v

<b>Glossary</b>	<b>189</b>
<b>Personal Publications</b>	<b>191</b>
<b>Bibliography</b>	<b>201</b>





---

## Acknowledgements

---

I would like to thank my advisors Dr Slaheddine Aridhi and Pr Jean-Francois Nezan for their help and support during these three years. Slah, thank you for welcoming me at Texas Instruments in Villeneuve Loubet and for spending so many hours on technical discussions, advice and corrections. Jeff, thank you for being so open-minded, for your support and for always seeing the big picture behind the technical details.

I want to thank Pr Guy Gogniat and Pr Christophe Jego for reviewing this thesis. Thanks also to Pr Shuvra S. Bhattacharyya for presiding the jury and to Dr Sébastien Le Nours for being member of the jury.

It has been a pleasure to work with Matthieu Wipliez and Jonathan Piat. Thank you for your friendship, your constant motivation and for sharing valuable technical insights in computing and electronics. Thanks also to the IETR image and rapid prototyping team for being great co-workers. Thanks to Pr Christophe Moy for his LTE explanations and to Dr Mickaël Raulet for his help on dataflow. Thanks to Pierrick Menuet for his excellent internship and thanks to Jocelyne Tremier for her administrative support.

This thesis also benefited from many discussions with TIers: special thanks to Eric Biscondi, Sébastien Tomas, Renaud Keller, Alexandre Romana and Filip Moerman for these. Thanks to the High Performance and Multi-core Processing team for the way you welcomed me to your group.

This thesis benefited from many free or open source tools including Java, Eclipse, JFreeChart, JGraph, SDF4J, LaTeX... Thanks to the open source programmers that participate to the general progress of knowledge.

I am also grateful to Pr Markus Rupp and his team for welcoming me at the Technical University of Vienna and to Pr Olivier Déforges for supporting this stay. This summer 2009 was both instructive and fun and I thank you for that.

I am thankful to the many chocolate cheesecakes of the Nero café in Truro, Cornwall that were eaten while writing this document: you were delicious.

Many thanks to Dr Cédric Herzet for his help on mathematics and his Belgian fries. Thanks to Karina for reading and correcting this entire document.

Finally, Thanks to my friends, my parents and sister and to Stéphanie for their love and support during these three years.



### 1.1 Overview

The recent evolution of digital communication systems (voice, data and video) has been dramatic. Over the last two decades, low data-rate systems (such as dial-up modems, first and second generation cellular systems, 802.11 Wireless local area networks) have been replaced or augmented by systems capable of data rates of several Mbps, supporting multimedia applications (such as DSL, cable modems, 802.11b/a/g/n wireless local area networks, 3G, WiMax and ultra-wideband personal area networks). One of the latest developments in wireless telecommunications is the **3GPP Long Term Evolution (LTE)** standard. LTE enables data rates beyond hundreds of Mbit/s.

As communication systems have evolved, the resulting increase in data rates has necessitated higher system algorithmic complexity. A more complex system requires greater flexibility in order to function with different protocols in diverse environments. In 1965, Moore observed that the density of transistors (number of transistors per square inch) on an integrated circuit doubled every two years. This trend has remained unmodified since then. Until 2003, the processor clock rates followed approximately the same rule. Since 2003, manufacturers have stopped increasing the chip clock rates to limit the chip power dissipation. Increasing clock speed combined with additional on-chip cache memory and more complex instruction sets only provided increasingly faster single-core processors when both clock rate and power dissipation increases were acceptable. The only solution to continue increasing chip performance without increasing power consumption is now to use **multi-core chips**.

A **base station** is a terrestrial signal processing center that interfaces a radio access network with the cabled backbone. It is a computing system dedicated to the task of managing user communication. It constitutes a communication entity integrating power supply, interfaces, and so on. A base station is a real-time system because it treats continuous streams of data, the computation of which has hard time constraints. An LTE network uses advanced signal processing features including Orthogonal Frequency Division Multiplexing Access (OFDMA), Single Carrier Frequency Division Multiplexing Access (SC-FDMA), Multiple Input Multiple Output (MIMO). These features greatly increase the available data rates, cell sizes and reliability at a cost of an unprecedented level of processing power. An LTE base station must use powerful embedded hardware platforms.

Multi-core Digital Signal Processors (DSP) are suitable hardware architectures to execute the complex operations in real-time. They combine cores with processing flexibility and hardware coprocessors that accelerate repetitive processes.

The consequence of evolution of the standards and parallel architectures is an increased need for the system to support multiple standards and multicomponent devices. These two requirements complicate much of the development of telecommunication systems, imposing the optimization of device parameters over varying constraints, such as performance, area and power. Achieving this device optimization requires a good understanding of the application complexity and the choice of an appropriate architecture to support this application. **Rapid prototyping** consists of studying the design tradeoffs at several stages of the development, including the early stages, when the majority of the hardware and software are not available. The inputs to a rapid prototyping process must then be models of system parts, and are much simpler than in the final implementation. In a perfect design process, programmers would refine the models progressively, heading towards the final implementation.

Imperative languages, and C in particular, are presently the preferred languages to program DSPs. Decades of compilation optimizations have made them a good tradeoff between readability, optimality and modularity. However, imperative languages have been developed to address sequential hardware architectures inspired on the Turing machine and their ability to express algorithm parallelism is limited. Over the years, **dataflow languages** and models have proven to be efficient representations of parallel algorithms, allowing the simplification of their analysis. In 1978, Ackerman explains the effectiveness of dataflow languages in parallel algorithm descriptions [Ack82]. He emphasizes two important properties of dataflow languages:

- **data locality**: data buffering is kept as local and as reduced as possible,
- **scheduling constraints reduced to data dependencies**: the scheduler that organizes execution has minimal constraints.

The absence of remote data dependency simplifies algorithm analysis and helps to create a dataflow code that is correct-by-construction. The minimal scheduling constraints express the algorithm parallelism maximally. However, good practises in the manipulation of imperative languages to avoid recalculations often go against these two principles. For example, iterations in dataflow redefine the iterated data constantly to avoid sharing a state where imperative languages promote the shared use of registers. But these iterations conceal most of the parallelism in the algorithms that must now be exploited in multi-core DSPs. Parallelism is obtained when functions are clearly separated and Ackerman gives a solution to that: “to manipulate data structures in the same way scalars are manipulated”. Instead of manipulating buffers and pointers, dataflow models manipulate **tokens**, abstract representations of a data quantum, regardless of its size.

It may be noted that digital signal processing consists of processing streams (or flows) of data. The most natural way to describe a signal processing algorithm is a graph with nodes representing data transformations and edges representing data flowing between the nodes. The extensive use of Matlab Simulink is evidence that a graphically editable plot is suitable input for a rapid prototyping tool.

The 3GPP LTE is the first application prototyped using the Parallel and Real-time Embedded Executives Scheduling Method (**PREESM**). PREESM is a rapid prototyping tool with code generation capabilities initiated in 2007 and developed during this thesis with the first main objective of studying LTE physical layer. For the development of this

tool, an extensive literature survey yielded much useful research: the work on dataflow process networks from University of California, Berkeley, University of Maryland and Leuven Catholic University, the Algorithm-Architecture Matching (AAM) methodology and SynDEX tool from INRIA Rocquencourt, the multi-core scheduling studies at Hong Kong University of Science and Technology, the dynamic multithreaded algorithms from Massachusetts Institute of Technology among others.

PREESM is a framework of plug-ins rather than a monolithic tool. PREESM is intended to prototype an efficient multi-core DSP development chain. One goal of this study is to use LTE as a complex and real use case for PREESM. In 2008, 68% of DSPs shipped worldwide were intended for the wireless sector [KAG<sup>+</sup>09]. Thus, a multi-core development chain must efficiently address new wireless application types such as LTE. The term multi-core is used in the broad sense: a base station multi-core system can embed several interconnected processors of different types, themselves multi-core and heterogeneous. These multi-core systems are becoming more common: even mobile phones are now such distributed systems.

While targeting a classic single-core Von Neumann hardware architecture, it must be noted that all DSP development chains have similar features, as displayed in Figure 1.1(a). These features systematically include:

- A textual language (C, C++) compiler that generates a sequential assembly code for functions/methods at compile-time. In the DSP world, the generated assembly code is native, i.e. it is specific and optimized for the Instruction Set Architecture (ISA) of the target core.
- A linker that gathers assembly code at compile-time in an executable code.
- A simulator/debugger enabling code inspection.
- An Operating System (OS) that launches the processes, each of which comprise several threads. The OS handles the resource shared by the concurrent threads.

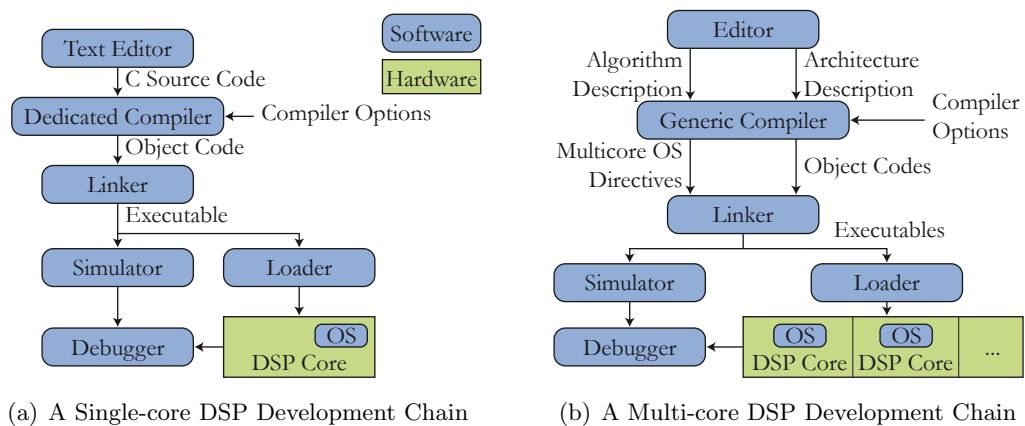

**Figure 1.1:** Comparing a Present Single-core Development Chain to a Possible Development Chain for Multi-core DSPs

In contrast with the DSP world, the generic computing world is currently experiencing an increasing use of bytecode. A bytecode is more generic than native code and is Just-In-Time (JIT) compiled or interpreted at run-time. It enables portability over several ISA

and OS at the cost of lower execution speed. Examples of JIT compilers are the Java Virtual Machine (JVM) and the Low Level Virtual Machine (LLVM). Embedded systems are dedicated to a single functionality and in such systems, compiled code portability is not advantageous enough to justify performance loss. It is thus unlikely that JIT compilers will appear in DSP systems soon. However, as embedded system designers often have the choice between many hardware configurations, a multi-core development chain must have the capacity to target these hardware configurations at compile-time. As a consequence, a multi-core development chain needs a complete input architecture model instead of a few textual compiler options, such as used in single-core development chains. Extending the structure of Figure 1.1(a), a development chain for multicore DSPs may be imagined with an additional input architecture model (Figure 1.1(b)). This multi-core development chain generates an executable for each core in addition to directives for a multi-core OS managing the different cores at run-time according to the algorithm behavior.

The present multi-core programming methods generally use test-and-refine methodologies. When processed by hand, parallelism extraction is hard and error-prone, but potentially extremely optimal (depending on the programmer). Programmers of Embedded multi-core software will only use a **multi-core development chain** if:

- the development chain is configurable and is compatible with the previous programming habits of the individual programmer,
- the new skills required to use the development chain are limited and compensated by a proportionate productivity increase,
- the development chain eases both design space exploration and parallel software/hardware development. Design space exploration is an early stage of system development consisting of testing algorithms on several architectures and making appropriate choices compromising between hardware and software optimisations, based on evaluated performances.
- the exploitation of the automatic parallelism of the development chain produces a nearly optimal result. For example, despite the impressive capabilities of the Texas Instruments TMS320C64x+ compiler, compute-hungry functions are still optimized by writing intrinsics or assembly code. Embedded multi-core development chains will only be adopted when programmers are no longer able to cope with efficient hand-parallelization.

There will always be a tradeoff between system **performance and programmability**; between system genericity and optimality. To be used, a development chain must connect with legacy code as well as easing design process. These principles were considered during the development of PREESM. PREESM plug-in functionalities are numerous and combined in graphical **workflows** that adapt the process to designer goals. PREESM clearly separates algorithm and architecture models to enable design space exploration, introducing an additional input entity named **scenario** that ensures this separation. The deployment of an algorithm on an architecture is automatic, as is the static code generation and the quality of a deployment is illustrated in a graphical **“schedule quality assessment chart”**. An important feature of PREESM is that a programmer can debug code on a single-core and then deploy it automatically over several cores with an assured absence of deadlocks.

However, there is a limitation to the compile-time deployment technique. If an algorithm is highly variable during its execution, choosing its execution configuration at

compile-time is likely to bring excessive suboptimality. For the highly variable parts of an algorithm, the equivalent of an OS scheduler for multi-core architectures is thus needed. The resulting **adaptive scheduler** must be of very low complexity, manage architecture heterogeneity and substantially improve the resulting system quality.

Throughout this thesis, the idea of rapid prototyping and executable code generation is applied to the LTE physical layer algorithms.

## 1.2 Contributions of this Thesis

The aim of this thesis is to find efficient solutions for LTE deployment over heterogeneous multi-core architectures. For this goal, a **fully tested method for rapid prototyping and automatic code generation** was developed from dataflow graphs. During the development, it became clear that there was a need for a new input entity or scenario to the rapid prototyping process. The scenario breaks the “Y” shape of the previous rapid prototyping methods and totally separates algorithm from architecture.

Existing architecture models appeared to be unable to describe the target architectures, so a novel architecture model is presented, the **System-Level Architecture Model** or S-LAM. This architecture model is intended to simplify the high-level view of an architecture as well as to accelerate the deployment.

Mimicing the ability of the SystemC Transaction Level Modeling (TLM) to offer scalability in the precision of target architecture simulations, a **scalable scheduler** was created, enabling tradeoffs between scheduling time and precision. A developer needs to evaluate the quality of a generated schedule and, more precisely, needs to know if the schedule parallelism is limited by the algorithm, by the architecture or by none of them. For this purpose, a literature-based, graphical **schedule quality assessment chart** is presented.

During the deployment of LTE algorithms, it became clear that, for these algorithms, using execution latency as the minimized criterion for scheduling did not produce good load balancing over the cores for the architectures studied. A new **scheduling criterion embedding latency and load balancing** was developed. This criterion leads to very balanced loads and, in the majority of cases, to an equivalent latency than simply using the latency criterion.

Finally, a **study of the LTE physical layer** in terms of rapid prototyping and code generation is presented. Some algorithms are too variable for simple compile-time scheduling, so an **adaptive scheduler** with the capacity to schedule the most dynamic algorithms of LTE at run-time was developed.

## 1.3 Outline of this Thesis

The outline of this thesis is depicted in Figure 1.2. It is organized around the rapid prototyping and code generation process. After an introduction in Chapter 1, Part I presents elements from the literature used in Part II to create a rapid prototyping method which allows the study of LTE signal processing algorithms. In Chapter 2, the 3GPP LTE telecommunication standard is introduced. This chapter focuses on the signal processing features of LTE. In Chapter 3, the dataflow models of computation are explained; these are the models that are used to describe the algorithms in this study. Chapter 4 explains the existing techniques for system programming and rapid prototyping.

The S-LAM architecture model developed to feed the rapid prototyping method is presented in Chapter 5. In Chapter 6, a scheduler structure is detailed that separates the

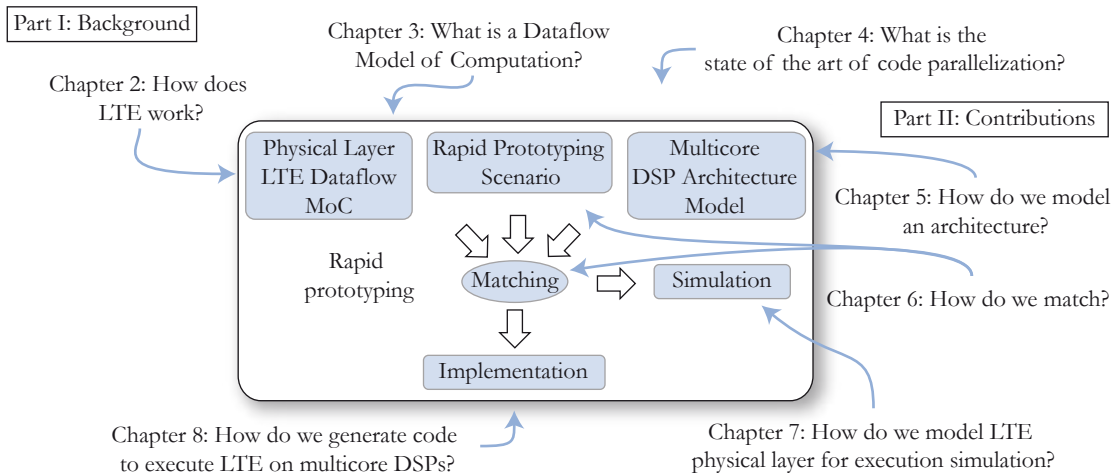

**Figure 1.2:** *Rapid Prototyping and Thesis Outline*

different problems of multi-core scheduling as well as some improvements to the state-of-the-art methods. The two last chapters are dedicated to the study of LTE and the application of all of the previously introduced techniques. Chapter 7 focuses on LTE rapid prototyping and simulation and Chapter 8 on the code generation. Chapter 8 is divided into two parts; the first dealing with static code generation, and the second with the heart of a multi-core operating system which enables dynamic code behavior: an adaptive scheduler. Chapter 9 concludes this study.



**Part I**

**Background**



## 2.1 Introduction

### 2.1.1 Evolution and Environment of 3GPP Telecommunication Systems

Terrestrial mobile telecommunications started in the early 1980s using various analog systems developed in Japan and Europe. The Global System for Mobile communications (GSM) digital standard was subsequently developed by the European Telecommunications Standards Institute (ETSI) in the early 1990s. Available in 219 countries, GSM belongs to the second generation mobile phone system. It can provide an international mobility to its users by using inter-operator roaming. The success of GSM promoted the creation of the Third Generation Partnership Project (3GPP), a standard-developing organization dedicated to supporting GSM evolution and creating new telecommunication standards, in particular a Third Generation Telecommunication System (3G). The current members of 3GPP are ETSI (Europe), ATIS(USA), ARIB (Japan), TTC (Japan), CCSA (China) and TTA (Korea). In 2010, there are 1.3 million 2G and 3G base stations around the world [gsm10] and the number of GSM users surpasses 3.5 billion [Nor09].

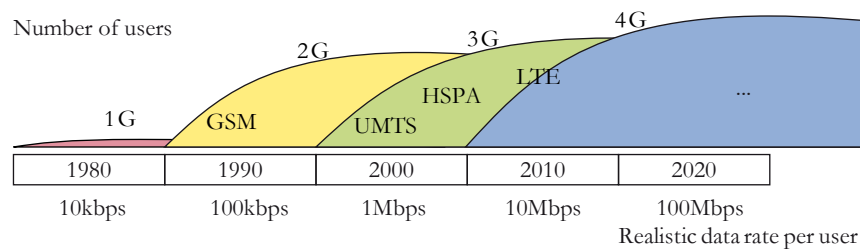

**Figure 2.1:** 3GPP Standard Generations

The existence of multiple vendors and operators, the necessity interoperability when roaming and limited frequency resources justify the use of unified telecommunication standards such as GSM and 3G. Each decade, a new generation of standards multiplies the data rate available to its user by ten (Figure 2.1). The driving force behind the creation of new standards is the radio spectrum which is an expensive resource shared by many interfering technologies. Spectrum use is coordinated by ITU-R (International Telecommunication

Union, Radio Communication Sector), an international organization which defines technology families and assigns their spectral bands to frequencies that fit the International Mobile Telecommunications (IMT) requirements. 3G systems including LTE are referred to as ITU-R IMT-2000.

Radio access networks must constantly improve to accommodate the tremendous evolution of mobile electronic devices and internet services. Thus, 3GPP unceasingly updates its technologies and adds new standards. The goal of new standards is the improvement of key parameters, such as complexity, implementation cost and compatibility, with respect to earlier standards. Universal Mobile Telecommunications System (UMTS) is the first release of the 3G standard. Evolutions of UMTS such as High Speed Packet Access (HSPA), High Speed Packet Access Plus (HSPA+) or 3.5G have been released as standards due to providing increased data rates which enable new mobility internet services like television or high speed web browsing. The 3GPP Long Term Evolution (LTE) is the 3GPP standard released subsequent to HSPA+. It is designed to support the forecasted ten-fold growth of traffic per mobile between 2008 and 2015 [Nor09] and the new dominance of internet data over voice in mobile systems. The LTE standardization process started in 2004 and a new enhancement of LTE named LTE-Advanced is currently being standardized.

### 2.1.2 Terminology and Requirements of LTE

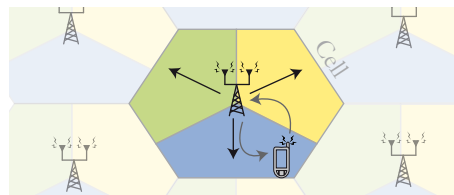

**Figure 2.2:** *A three-sectored cell*

A LTE terrestrial base station computational center is known as an evolved NodeB or **eNodeB**, where a NodeB is the name of a UMTS base station. An eNodeB can handle the communication of a few base stations, with each base station covering a geographic zone called a cell. A cell is usually three-sectored with three antennas (or antenna sets) each covering  $120^\circ$  (Figure 2.2). The user mobile terminals (commonly mobile phones) are called User Equipment (**UE**). At any given time, a UE is located in one or more overlapping cells and communicates with a preferred cell; the one with the best air transmission properties. LTE is a duplex system, as communication flows in both directions between UEs and eNodeBs. The radio link between the eNodeB and the UE is called the downlink and the opposite link between UE and its eNodeB is called uplink. These links are asymmetric in data rates because most internet services necessitate a higher data rate for the downlink than for the uplink. Fortunately, it is easier to generate a higher data rate signal in an eNodeB powered by mains than in UE powered by batteries.

In GSM, UMTS and its evolutions, two different technologies are used for voice and data. Voice uses a circuit-switched technology, i.e. a resource is reserved for an active user throughout the entire communication, while data is packet-switched, i.e. data is encapsulated in packets allocated independently. Contrary to these predecessors, LTE is a totally packet-switched network using Internet Protocol (IP) and has no special physical features for voice communication. LTE is required to coexist with existing systems such as UMTS or HSPA in numerous frequency configurations and must be implemented without perturbing the existing networks.

LTE Radio Access Network advantages compared with previous standards (GSM, UMTS, HSPA...) are [STB09]:

- **Improved data rates.** Downlink peak rate are over 100 Mbit/s assuming 2 UE receive antennas and uplink peak rate over 50Mbit/s. Raw data rates are determined by  $Bandwidth * Spectral\ Efficiency$  where the bandwidth (in Hz) is limited by the expensive frequency resource and ITU-R regulation and the spectral efficiency (in bit/s/Hz) is limited by emission power and channel capacity (Section 2.3.1). Within this raw data rate, a certain amount is used for control, and so is hidden from the user. In addition to peak data rates, LTE is designed to ensure a high system-level performance, delivering high data rates in real situations with average or poor radio conditions.
- **A reduced data transmission latency.** The two-way delay is under 10 millisecond.
- **A seamless mobility** with handover latency below 100 millisecond; handover is the transition when a given UE leaves one LTE cell to enter another one. 100 millisecond has been shown to be the maximal acceptable round trip delay for voice telephony of acceptable quality [STB09].
- **Reduced cost per bit.** This reduction occurs due to an improved spectral efficiency; spectrum is an expensive resource. Peak and average spectral efficiencies are defined to be greater than 5 bit/s/Hz and 1.6 bit/s/Hz respectively for the downlink and over 2.5 bit/s/Hz and 0.66 bit/s/Hz respectively for the uplink.
- **A high spectrum flexibility** to allow adaptation to particular constraints of different countries and also progressive system evolutions. LTE operating bandwidths range from 1.4 to 20 MHz and operating carrier bands range from 698 MHz to 2.7GHz.
- **A tolerable mobile terminal power consumption** and a very low power idle mode.
- **A simplified network architecture.** LTE comes with the System Architecture Evolution (SAE), an evolution of the complete system, including core network.
- **A good performance for both Voice over IP (VoIP)** with small but constant data rates **and packet-based traffic** with high but variable data rates.
- **A spatial flexibility** enabling small cells to cover densely populated areas and cells with radii of up to 115 km to cover unpopulated areas.
- The support of **high velocity UEs** with good performance up to 120 km/h and connectivity up to 350 km/h.
- The management of up to **200 active-state users per cell** of 5 MHz or less and 400 per cell of 10 MHz or more.

Depending on the type of UE (laptop, phone...), a tradeoff is found between data rate and UE memory and power consumption. LTE defines 5 UE categories supporting different LTE features and different data rates.

LTE also supports data broadcast (television for example) with a spectral efficiency over 1 bit/s/Hz. The broadcasted data cannot be handled like the user data because it is sent in real-time and must work in worst channel conditions without packet retransmission.

Both eNodeBs and UEs have emission power limitations in order to limit power consumption and protect public health. An outdoor eNodeB has a typical emission power of 40 to 46 dBm (10 to 40 W) depending on the configuration of the cell. An UE with power class 3 is limited to a peak transmission power of 23 dBm (200 mW). The standard allows for path-loss of roughly between 65 and 150 dB. This means that For 5 MHz bandwidth, a UE is able to receive data of power from -100 dBm to -25 dBm (0.1 pW to 3.2  $\mu$ W).

### 2.1.3 Scope and Organization of the LTE Study

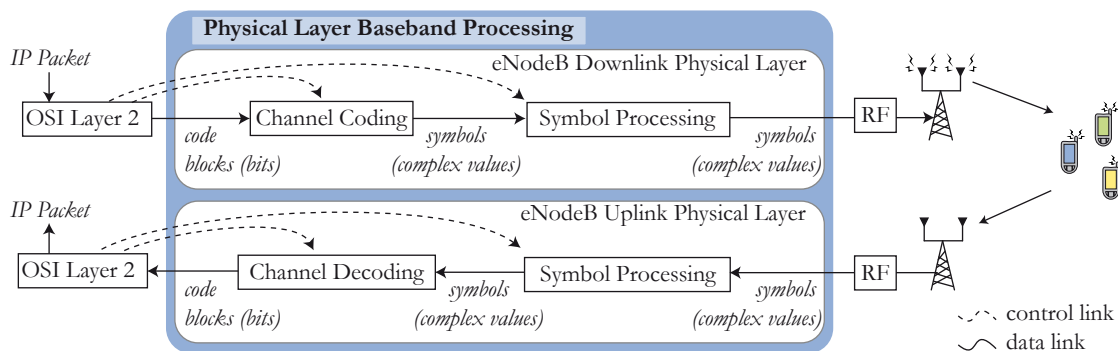

**Figure 2.3:** Scope of the LTE Study

The scope of this study is illustrated in Figure 2.3. It concentrates on the Release 9 LTE physical layer in the eNodeB, i.e. the signal processing part of the LTE standard. 3GPP finalized the LTE Release 9 in December 2009. The physical layer (Open Systems Interconnection (OSI) layer 1) uplink and downlink baseband processing must share the eNodeB digital signal processing resources. The downlink baseband process is itself divided into channel coding that prepares the bit stream for transmission and symbol processing that adapts the signal to the transmission technology. The uplink baseband process performs the corresponding decoding. To explain the interaction with the physical layer, a short description of LTE network and higher layers will be given (in Section 2.2). The OSI layer 2 controls the physical layer parameters.

The goal of this study is to address the most computationally demanding use cases of LTE. Consequently, there is a particular focus on the highest bandwidth of 20 MHz for both the downlink and the uplink. An eNodeB can have up to 4 transmit and 4 receive antenna ports while a UE has 1 transmit and up to 2 receive antenna ports. An understanding of the basic physical layer functions assembled and prototyped in the rapid prototyping section is important. For this end, this study considers only the baseband signal processing of the physical layer. For transmission, this means a sequence of complex values  $z(t) = x(t) + jy(t)$  used to modulate a carrier in phase and amplitude are generated from binary data and for each antenna port. A single antenna port carries a single complex value  $s(t)$  at a one instant in time and can be connected to several antennas.

$$s(t) = x(t)\cos(2\pi ft) + y(t)\sin(2\pi ft) \quad (2.1)$$

where  $f$  is the carrier frequency which ranges from 698 MHz to 2.7GHz. The receiver gets an impaired version of the transmitted signal. The baseband receiver acquires complex values after lowpass filtering and sampling and reconstructing the transmitted data.

An overview of LTE OSI layers 1 and 2 with further details on physical layer technologies and their environment is presented in the following sections. A complete description

of LTE can be found in [DPSB07], [HT09] and [STB09]. Standard documents describing LTE are available on the web. The UE radio requirements in [36.09a], eNodeBs radio requirements in [36.09b], rules for uplink and downlink physical layer in [36.09c] and channel coding in [36.09d] with rules for defining the LTE physical layer.

## 2.2 From IP Packets to Air Transmission

### 2.2.1 Network Architecture

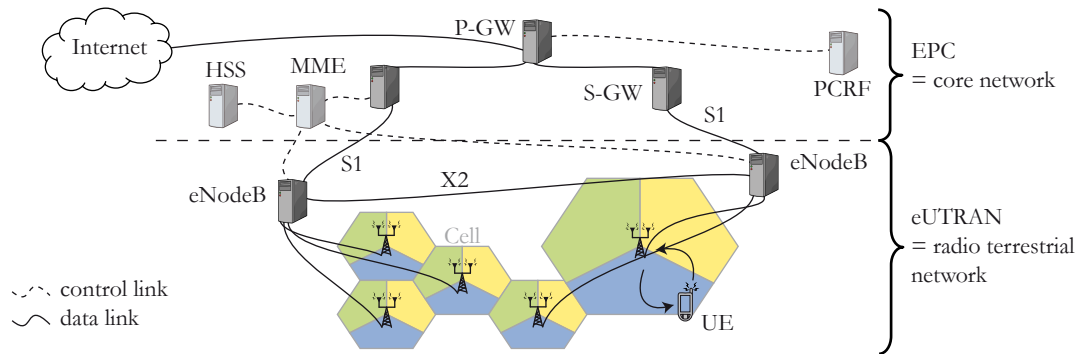

Figure 2.4: LTE System Architecture Evolution

LTE introduces a new network architecture named System Architecture Evolution (SAE) and is displayed in Figure 2.4 where control nodes are grayed compared with data nodes. SAE is divided into two parts:

- The Evolved Universal Terrestrial Radio Access Network (**E-UTRAN**) manages the radio resources and ensures the security of the transmitted data. It is composed entirely of eNodeBs. One eNodeB can manage several cells. Multiple eNodeBs are connected by cabled links called X2 allowing handover management between two close LTE cells. For the case where a handover occurs between two eNodeBs not connected by a X2 link, the procedure uses S1 links and is more complex.
- The Evolved Packet Core (**EPC**) also known as core network, enables packet communication with internet. The Serving Gateways (**S-GW**) and Packet Data Network Gateways (**P-GW**) ensure data transfers and Quality of Service (QoS) to the mobile UE. The Mobility Management Entities (**MME**) are scarce in the network. They handle the signaling between UE and EPC, including paging information, UE identity and location, communication security, load balancing. The radio-specific control information is called Access Stratum (**AS**). The radio-independent link between core network and UE is called Non-Access Stratum (**NAS**). MMEs delegate the verification of UE identities and operator subscriptions to Home Subscriber Servers (**HSS**). Policy Control and charging Rules Function (**PCRF**) servers check that the QoS delivered to a UE is compatible with its subscription profile. For example, it can request limitations of the UE data rates because of specific subscription options.

The details of eNodeBs and their protocol stack are now described.

## 2.2.2 LTE Radio Link Protocol Layers

The information sent over a LTE radio link is divided in two categories: the **user-plane** which provides data and control information irrespective of LTE technology and the **control-plane** which gives control and signaling information for the LTE radio link. The protocol layers of LTE are displayed in Figure 2.5 differ between user plane and control plane but the low layers are common to both planes. Figure 2.5 associates a unique OSI Reference Model number to each layer. layers 1 and 2 have identical functions in control-plane and user-plane even if parameters differ (for instance, the modulation constellation). Layers 1 and 2 are subdivided in:

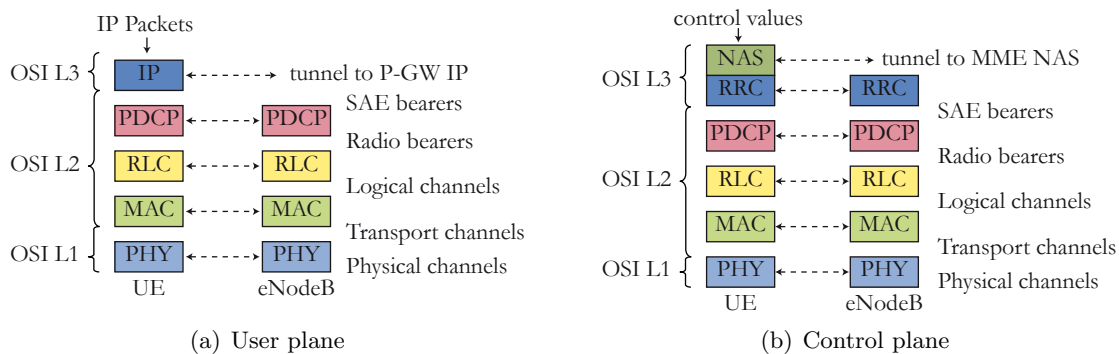

**Figure 2.5:** *Protocol Layers of LTE Radio Link*

- **PDCP layer** [36.09h] or layer 2 Packet Data Convergence Protocol is responsible for data ciphering and IP header compression to reduce the IP header overhead. The service provided by PDCP to transfer IP packets is called a radio bearer. A radio bearer is defined as an IP stream corresponding to one service for one UE.
- **RLC layer** [36.09g] or layer 2 Radio Link Control performs the data concatenation and then generates the segmentation of packets from IP-Packets of random sizes which comprise a Transport Block (TB) of size adapted to the radio transfer. The RLC layer also ensures ordered delivery of IP-Packets; Transport Block order can be modified by the radio link. Finally, the RLC layer handles a retransmission scheme of lost data through a first level of Automatic Repeat reQuests (ARQ). RLC manipulates logical channels that provide transfer abstraction services to the upper layer radio bearers. A radio bearer has a priority number and can have Guaranteed Bit Rate (GBR).
- **MAC layer** [36.09f] or layer 2 Medium Access Control commands a low level retransmission scheme of lost data named Hybrid Automatic Repeat reQuest (HARQ). The MAC layer also multiplexes the RLC logical channels into HARQ protected transport channels for transmission to lower layers. Finally, the MAC layer contains the scheduler (Section 2.2.4), which is the primary decision maker for both downlink and uplink radio parameters.
- **Physical layer** [36.09c] or layer 1 comprises all the radio technology required to transmit bits over the LTE radio link. This layer creates physical channels to carry information between eNodeBs and UEs and maps the MAC transport channels to these physical channels. The following sections focus on the physical layer with no distinction drawn between user and control planes.



**Layer 3** differs in control and user planes. Its Control plane handles all information specific to the radio technology, with the MME making the upper layer decisions. The User plane carries IP data from system end to system end (i.e. from UE to P-GW). No further detail will be given on LTE non-physical layers. More information can be found in [DPSB07] p.300 and [STB09] p.51 and 79.

Using both HARQ, employed for frequent and localized transmission errors, and ARQ, which is used for rare but lengthy transmission errors, results in high system reliability while limiting the error correction overhead. The retransmission in LTE is determined by the target service: LTE ensures different Qualities of Service (QoS) depending on the target service. For instance, the maximal LTE-allowed packet error loss rate is  $10^{-2}$  for conversational voice and  $10^{-6}$  for transfers based on TCP (Transmission Control Protocol) OSI layer 4. The various QoS imply different service priorities. For the example of a TCP/IP data transfer, the TCP packet retransmission system adds a third error correction system to the two LTE ARQs.

### 2.2.3 Data Blocks Segmentation and Concatenation

The physical layer manipulates bit sequences called Transport Blocks. In the user plane, many block segmentations and concatenations are processed layer after layer between the original data in IP packets and the data sent over air transmission. Figure 2.6 summarizes these block operations. Evidently, these operations do not reflect the entire bit transformation process including ciphering, retransmitting, ordering, and so on.

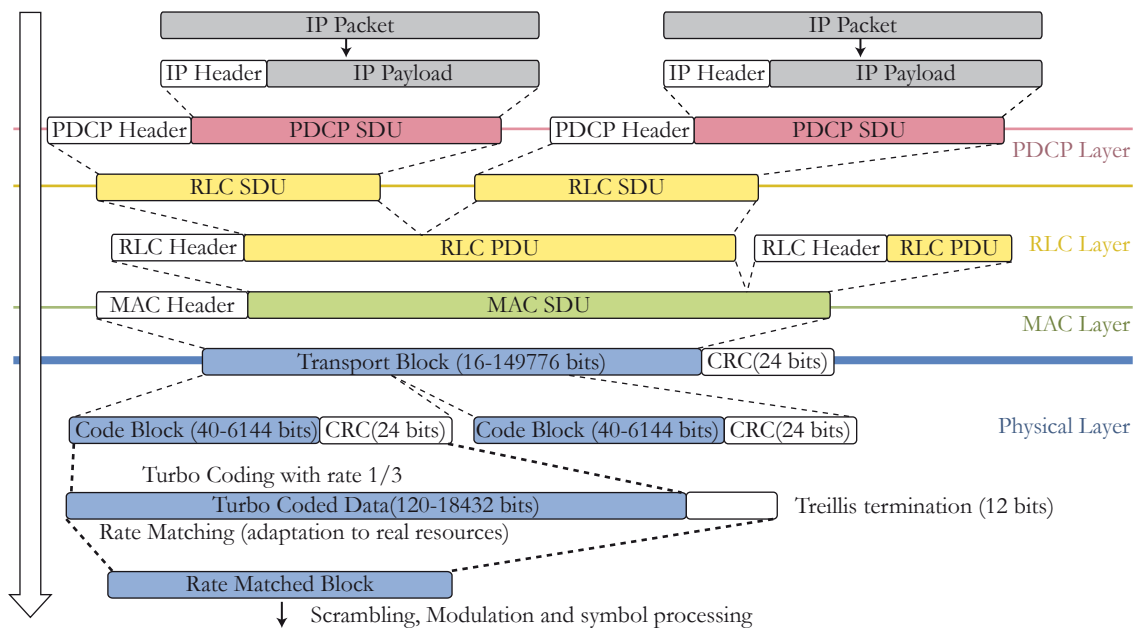

**Figure 2.6:** Data Blocks Segmentation and Concatenation

In the PDCP layer, the IP header is compressed and a new PDCP header is added to the ciphered Protocol Data Unit (PDU). In the RLC layer, RLC Service Data Units (SDU) are concatenated or segmented into RLC PDUs and a RLC header is added. The MAC layer concatenates RLC PDUs into MAC SDUs and adds a MAC header, forming a Transport Block, the data entity sent by the physical layer. For more details on layer 2 concatenation and segmentation, see [STB09] p.79. The physical layer can carry downlink a Transport Blocks of size up to 149776 bits in one millisecond. This corresponds to a data rate of

149.776Mbit/s. The overhead required by layer 2 and upper layers reduces this data rate. Moreover, such a Transport Block is only possible in very favorable transmission conditions with a UE capable of supporting the data rate. Transport Block sizes are determined from radio link adaptation parameters shown in the tables of [36.09e] p.26. An example of link capacity computing is given in Section 7.2.2. In the physical layer, Transport Blocks are segmented into Code Blocks (CB) of size up to 6144 bits. A Code Block is the data unit for a part of the physical layer processing, as will be seen in Chapter 7.

## 2.2.4 MAC Layer Scheduler

The LTE MAC layer adaptive scheduler is a complex and important part of the eNodeB. It controls the majority of the physical layer parameters; this is the layer that the study will concentrate on in later sections. Control information plays a much greater role in LTE than in the previous 3GPP standards because many allocation choices are concentrated in the eNodeB MAC layer to help the eNodeB make global intelligent tradeoffs in radio access management. The MAC scheduler manages:

- the **radio resource allocation** to each UE and to each radio bearer in the UEs for both downlink and uplink. The downlink allocations are directly sent to the eNodeB physical layer and those of the uplink are sent via downlink control channels to the UE in uplink grant messages. The scheduling can be dynamic (every millisecond) or persistent, for the case of long and predictable services as VoIP.
- the **link adaptation** parameters (Section 2.3.5) for both downlink and uplink.
- the **HARQ** (Section 2.3.5) commands where lost Transport Blocks are retransmitted with new link adaptation parameters.
- the **Random Access Procedure** (Section 2.4.5) to connect UEs to a eNodeB.
- the **uplink timing alignment** (Section 2.3.4) to ensure UE messages do not overlap.

The MAC scheduler must take data priorities and properties into account before allocating resources. Scheduling also depends on the data buffering at both eNodeB and UE and on the transmission conditions for the given UE. The scheduling optimizes link performance depending on several metrics, including throughput, delay, spectral efficiency, and fairness between UEs.

## 2.3 Overview of LTE Physical Layer Technologies

### 2.3.1 Signal Air transmission and LTE

In [Sha01], C. E. Shannon defines the capacity  $C$  of a communication channel impaired by an Additive White Gaussian Noise (AWGN) of power  $N$  as:

$$C = B \cdot \log_2\left(1 + \frac{S}{N}\right) \quad (2.2)$$

where  $C$  is in bit/s and  $S$  is the signal received power. The **channel capacity** is thus linearly dependent on bandwidth. For the largest possible LTE bandwidth, 20MHz, this corresponds to 133 Mbit/s or 6.65 bit/s/Hz for a  $S/N = 20dB$  Signal-to-Noise Ratio or SNR (100 times more signal power than noise) and 8 Mbit/s or 0.4 bit/s/Hz for a -5dB SNR (3 times more noise than signal). Augmenting the transmission power will result in

an increased capacity, but this parameter is limited for security and energy consumption reasons. In LTE, the capacity can be doubled by creating two different channels via several antennas at transmitter and receiver sides. This technique is commonly called Multiple Input Multiple Output (**MIMO**) or spatial multiplexing and is limited by control signaling cost and non-null correlation between channels. It may be noted that the LTE target peak rate of 100Mbit/s or 5 bit/s/Hz is close to the capacity of a single channel. Moreover, the real air transmission channel is far more complex than its AWGN model. Managing this complexity while maintaining data rates close to the channel capacity is one of the great challenges of LTE deployment.

LTE signals are transmitted from terrestrial base stations using electromagnetic waves propagating at light speed. LTE cells can have a radii of up to 115km, leading to a transmission latency of about 380  $\mu$ s in both downlink and uplink directions. The actual value of this latency depends on the cell radius and environment. Compensation of this propagation time is performed by UEs and called **timing advance** ([STB09] p.459).

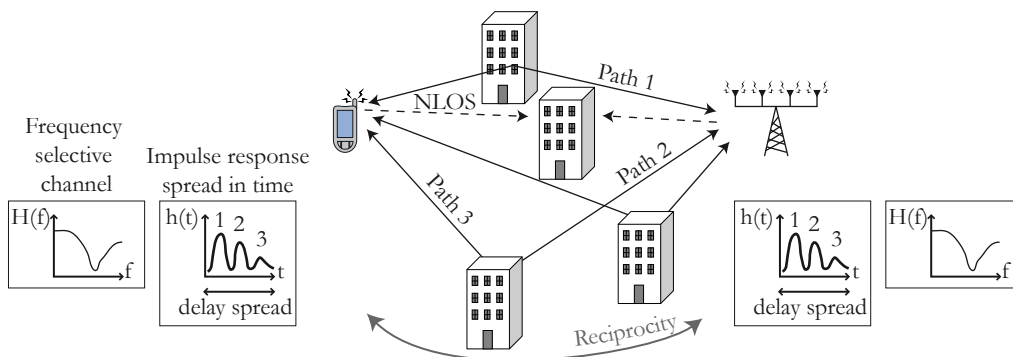

**Figure 2.7:** Radio Propagation, Channel Response and Reciprocity Property

Moreover, the signal can undergo several reflections before reaching its target. This effect is known as **multiple path propagation** and is displayed in Figure 2.7. In the time domain, multiple reflections create a Channel Impulse Response (CIR)  $h(t)$  with several peaks, each corresponding to a reflection. This effect elongates a received symbol in time and can cause Inter Symbol Interference (ISI) between two successive symbols. The ISI introduces a variable attenuation over the frequency band generating a frequency selective channel. For a given time and a given cell, there are frequency bands highly favorable to data transmission between the eNodeB and a given UE due to its position in space whereas these frequency bands may not be favorable to another UE.

Additional to channel selectivity, the environment parameters that compromise air transmission are fading, noise and interference. In LTE, the **frequency reuse factor** is 1, i.e. adjacent base stations of a single operator employ the same frequency carrier band. This choice complicates interference handling at cell edges. Ignoring interference, a single air transmission channel is usually modeled with channel convolution and additive noise, which gives in the discrete time domain:

$$y(n) = h(n) * x(n) + w(n), \quad (2.3)$$

where  $n$  is the discrete time and  $T_s$  is the sampling period,  $x(n)$  and  $y(n)$  are respectively the transmitted and received signals in discrete time,  $h(n)$  is the channel impulse response (Figure 2.7) and  $w(n)$  is the noise. The equivalent in Fourier discrete domain gives:

$$Y(k) = H(k)X(k) + W(k), \quad (2.4)$$

where  $k$  is the discrete frequency. In order to estimate  $H(k)$ , known reference signals (also called pilot signals) are transmitted. A reference signal cannot be received at the same time as the data it is aiding. Certain channel assumptions must be made, including slow modification over time. The time over which a Channel Impulse Response  $h(t)$  remains almost constant is called **channel coherence time**. For a flat Rayleigh fading channel model at 2 GHz, modeling coherence time is about 5 millisecond for a UE speed of 20 km/h ([STB09] p. 576). The faster the UE moves, the faster the channel changes and the smaller the coherence time becomes.

The UE velocity also has an effect on radio propagation, due to the **Doppler effect**. For a carrier frequency of 2.5 GHz and a UE velocity of 130 km/h, the Doppler effect frequency shifts the signal up to 300 Hz ([STB09] p.478). This frequency shift must be evaluated and compensated for each UE. Moreover, guard frequency bands between UEs are necessary to avoid frequency overlapping and Inter Carrier Interference (ICI).

Figure 2.7 shows a Non-line-of-sight (NLOS) channel, which occurs when the direct path is shadowed. Figure 2.7 also displays the property of **channel reciprocity**; the channels in downlink and in uplink can be considered to be equal in terms of frequency selectivity within the same frequency band. When downlink and uplink share the same band, channel reciprocity occurs, and so the uplink channel quality can be evaluated from downlink reception study and vice-versa. LTE technologies use channel property estimations  $H(k)$  for two purposes:

- **Channel estimation** is used to reconstruct the transmitted signal from the received signal.
- **Channel sounding** is used by the eNodeBs to decide which resource to allocate to each UE. Special resources must be assigned to uplink channel soundings because a large frequency band exceeding UE resources must be sounded initially by each UE to make efficient allocation decisions. The downlink channel sounding is quite straightforward, as the eNodeB sends reference signals over the entire downlink bandwidth.

Radio models describing several possible LTE environments have been developed by 3GPP (SCM and SCME models), ITU-R (IMT models) and a project named IST-WINNER. They offer tradeoffs between complexity and accuracy. Their targeted usage is hardware conformance tests. The models are of two kinds: matrix-based models simulate the propagation channel as a linear correlation (equation 2.3) while geometry-based models simulate the addition of several propagation paths (Figure 2.7) and interferences between users and cells.

LTE is designed to address a variety of environments from mountainous to flat, including both rural and urban with Macro/Micro and Pico cells. On the other hand, Femtocells with very small radii are planned for deployment in indoor environments such as homes and small businesses. They are linked to the network via a Digital Subscriber Line (DSL) or cable.

### 2.3.2 Selective Channel Equalization

The air transmission channel attenuates each frequency differently, as seen in Figure 2.7. Equalization at the decoder site consists of compensating for this effect and reconstructing

the original signal as much as possible. For this purpose, the decoder must precisely evaluate the channel impulse response. The resulting coherent detection consists of 4 steps:

1. Each transmitting antenna sends a known **Reference Signal** (RS) using predefined time/frequency/space resources. Additional to their use for channel estimation, RS carry some control signal information. Reference signals are sometimes called pilot signals.
2. The RS is decoded and the  $H(f)$  (Equation 2.4) is computed for the RS time/frequency/space resources.
3.  $H(f)$  is interpolated over time and frequency on the entire useful bandwidth.
4. Data is decoded exploiting  $H(f)$ .

The LTE uplink and downlink both exploit coherent detection but employ different reference signals. These signals are selected for their capacity to be orthogonal with each other and to be detectable when impaired by Doppler or multipath effect. Orthogonality implies that several different reference signals can be sent by the same resource and still be detectable. This effect is called Code Division Multiplexing (CDM). Reference signals are chosen to have constant amplitude, reducing the transmitted Peak to Average Power Ratio (PAPR [RL06]) and augmenting the transmission power efficiency. Uplink reference signals will be explained in 2.4.3 and downlink reference signals in 2.5.3.

As the transmitted reference signal  $X_p(k)$  is known at transmitter and receiver, it can be localized and detected. The simplest least square estimation defines:

$$H(k) = (Y(k) - W(k))/X_p(k) \approx Y(k)/X_p(k). \quad (2.5)$$

$H(k)$  can be interpolated for non-RS resources, by considering that channel coherence is high between RS locations. The transmitted data is then reconstructed in the Fourier domain with  $X(k) = Y(k)/H(k)$ .

### 2.3.3 eNodeB Physical Layer Data Processing

Figure 2.8 provides more details of the eNodeB physical layer that was roughly described in Figure 2.3. It is still a simplified view of the physical layer that will be explained in the next sections and modeled in Chapter 7.

In the **downlink data encoding, channel coding** (also named link adaptation) prepares the binary information for transmission. It consists in a Cyclic Redundancy Check (CRC) /turbo coding phase that processes Forward Error Correction (FEC), a rate matching phase to introduce the necessary amount of redundancy, a scrambling phase to increase the signal robustness, and a modulation phase that transforms the bits into symbols. The parameters of channel coding are named Modulation and Coding Scheme (MCS). They are detailed in Section 2.3.5. After channel coding, **symbol processing** prepares the data for transmission over several antennas and subcarriers. The downlink transmission schemes with multiple antennas are explained in Sections 2.3.6 and 2.5.4 and the Orthogonal Frequency Division Multiplexing Access (OFDMA), that allocates data to subcarriers, in Section 2.3.4.

In the **uplink data decoding**, the **symbol processing** consists in decoding Single Carrier-Frequency Division Multiplexing Access (SC-FDMA) and equalizing signals from the different antennas using channel estimates. SC-FDMA is the uplink broadband

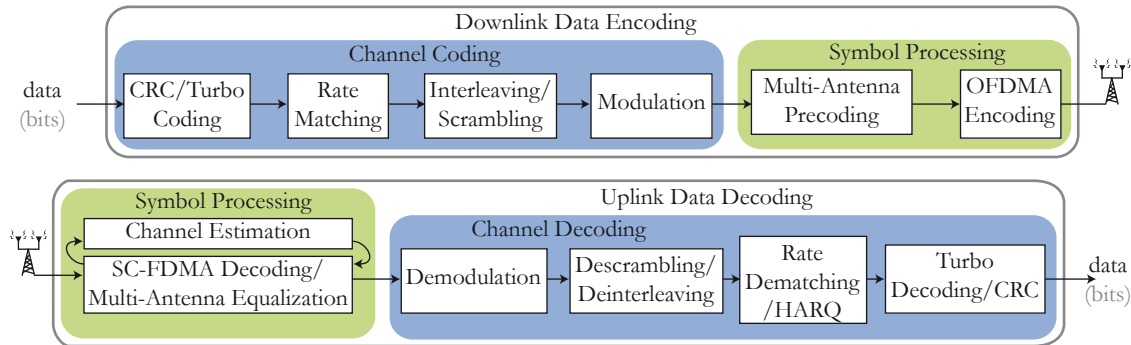

**Figure 2.8:** Uplink and Downlink Data Processing in the LTE eNodeB

transmission technology and is presented in Section 2.3.4. Uplink multiple antenna transmission schemes are explained in Section 2.4.4. After symbol processing, uplink **channel decoding** consists of the inverse phases of downlink channel coding because the chosen techniques are equivalent to the ones of downlink. HARQ combining associates the repeated receptions of a single block to increase robustness in case of transmission errors.

Next sections explain in details these features of the eNodeB physical layer, starting with the broadband technologies.

### 2.3.4 Multicarrier Broadband Technologies and Resources

LTE uplink and downlink data streams are illustrated in Figure 2.9. The LTE uplink and downlink both employ technologies that enable a two-dimension allocation of resources to UEs in time and frequency. A third dimension in space is added by Multiple Input Multiple Output (MIMO) spatial multiplexing (Section 2.3.6). The eNodeB decides the allocation for both downlink and uplink. The uplink allocation decisions must be sent via the downlink control channels. Both downlink and uplink bands have six possible bandwidths: 1.4, 3, 5, 10, 15, or 20 MHz.

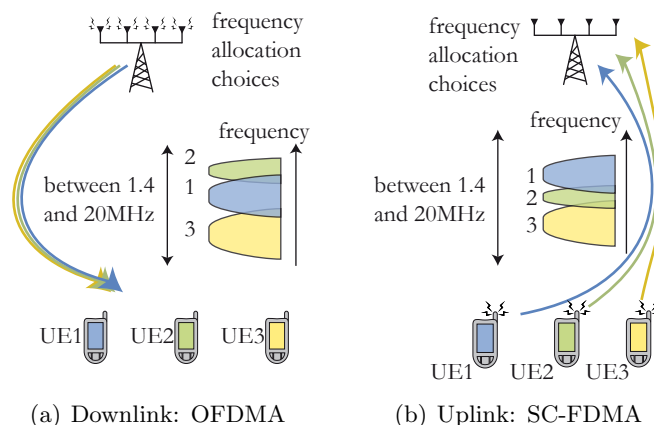
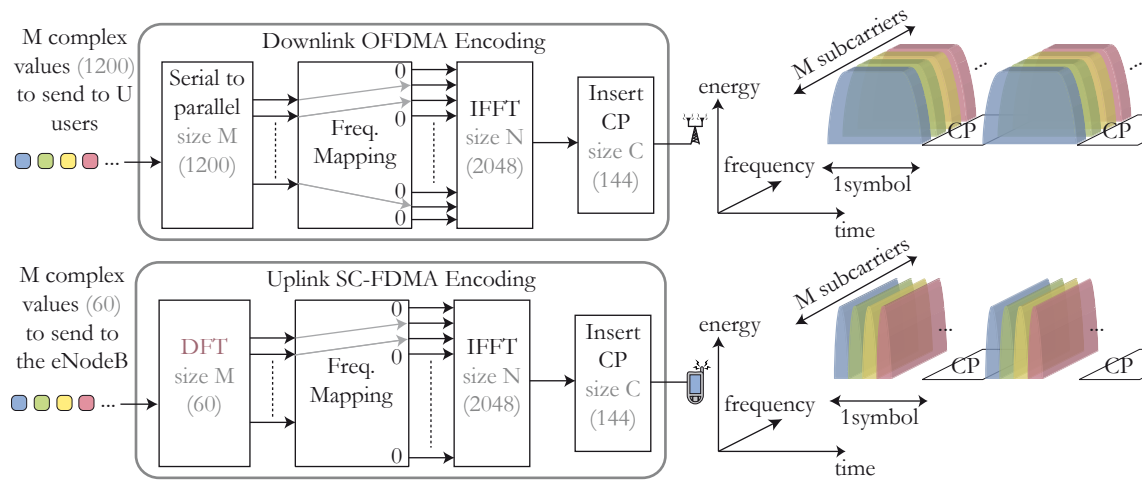

**Figure 2.9:** LTE downlink and uplink multiplexing technologies

**Broadband Technologies**

The multiple subcarrier broadband technologies used in LTE are illustrated in Figure 2.10. Orthogonal Frequency Division Multiplexing Access (**OFDMA**) employed for the downlink and Single Carrier-Frequency Division Multiplexing (**SC-FDMA**) is used for the uplink. Both technologies divide the frequency band into subcarriers separated by 15 kHz (except in the special broadcast case). The subcarriers are orthogonal and data allocation of each of these bands can be controlled separately. The separation of 15 kHz was chosen as a tradeoff between data rate (which increases with the decreasing separation) and protection against subcarrier orthogonality imperfection [R1-05]. This imperfection occurs from the Doppler effect produced by moving UEs and because of non-linearities and frequency drift in power amplifiers and oscillators.

Both technologies are effective in limiting the impact of multi-path propagation on data rate. Moreover, the dividing the spectrum into subcarriers enables simultaneous access to UEs in different frequency bands. However, SC-FDMA is more efficient than OFDMA in terms of Peak to Average Power Ratio (PAPR [RL06]). The lower PAPR lowers the cost of the UE RF transmitter but SC-FDMA cannot support data rates as high as OFDMA in frequency-selective environments.



**Figure 2.10:** Comparison of OFDMA and SC-FDMA

Figure 2.10 shows typical transmitter implementations of OFDMA and SC-FDMA using Fourier transforms. SC-FDMA can be interpreted as a linearly precoded OFDMA scheme, in the sense that it has an additional DFT processing preceding the conventional OFDMA processing. The frequency mapping of Figure 2.10 defines the subcarrier accessed by a given UE.

Downlink symbol processing consists of mapping input values to subcarriers by performing an Inverse Fast Fourier Transform (IFFT). Each complex value is then transmitted on a single subcarrier but spread over an entire symbol in time. This transmission scheme protects the signal from Inter Symbol Interference (ISI) due to multipath transmission. It is important to note that without channel coding (i.e. data redundancy and data spreading over several subcarriers), the signal would be vulnerable to frequency selective channels and Inter Carrier Interference (ICI). The numbers in gray (in Figure 2.10) reflect typical parameter values for a signal of bandwidth of 20 MHz. The OFDMA encoding is processed in the eNodeB and the 1200 input values of the case of 20MHz bandwidth carry the data of all the addressed UEs. SC-FDMA consists of a small size Discrete Fourier Transform

(DFT) followed by OFDMA processing. The small size of the DFT is required as this processing is performed within a UE and only uses the data of this UE. For an example of 60 complex values the UE will use 60 subcarriers of the spectrum (subcarriers are shown later to be grouped by 12). As noted before, without channel coding, data would be prone to errors introduced by the wireless channel conditions, especially because of ISI in the SC-FDMA case.

### Cyclic Prefix

The Cyclic Prefix (CP) displayed in Figures 2.10 and 2.11 is used to separate two successive symbols and thus reduces ISI. The CP is copied from the end of the symbol data to an empty time slot reserved before the symbol and protects the received data from timing advance errors; the linear convolution of the data with the channel impulse response is converted into a circular convolution, making it equivalent to a Fourier domain multiplication that can be equalized after a channel estimation (Section 2.3.2). CP length in LTE is 144 *samples* = 4.8 $\mu$ s (normal CP) or 512 *samples* = 16.7 $\mu$ s in large cells (extended CP). A longer CP can be used for broadcast when all eNodeBs transfer the same data on the same resources, so introducing a potentially rich multi-path channel. Generally, multipath propagation can be seen to induce channel impulse responses longer than CP. The CP length is a tradeoff between the CP overhead and sufficient ISI cancellation [R1-05].

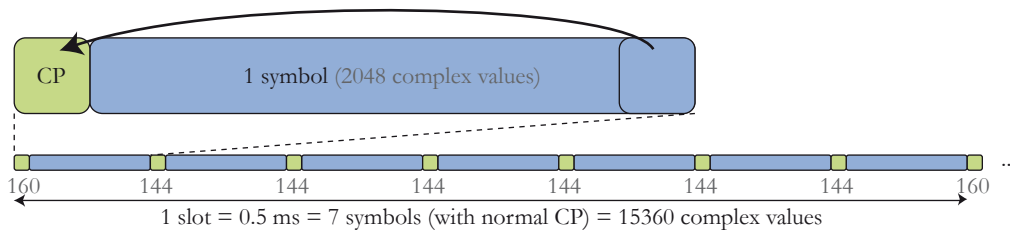

Figure 2.11: Cyclic Prefix Insertion

### Time Units

Frequency and timing of data and control transmission is not decided by the UE. The eNodeB controls both uplink and downlink time and frequency allocations. The allocation base unit is a block of 1 millisecond per 180kHz (12 subcarriers). Figure 2.12 shows 2 PRBs. A PRB carries a variable amount of data depending on channel coding, reference signals, resources reserved for control...

Certain time and frequency base values are defined in the LTE standard, which allows devices from different companies to interconnect flawlessly. The LTE time units are displayed in Figure 2.12:

- A **basic time unit** lasts  $T_s = 1/30720000s \approx 33ns$ . This is the duration of 1 complex sample in the case of 20 MHz bandwidth. The sampling frequency is thus  $30.72MHz = 8 \times 3.84MHz$ , eight times the sampling frequency of UMTS. The choice was made to simplify the RF chain used commonly for UMTS and LTE. Moreover, as classic OFDMA and SC-FDMA processing uses Fourier transforms, symbols of size power of two enable the use of FFTs and  $30.72MHz = 2048 \times 15kHz = 2^{11} \times 15kHz$ , with 15kHz the size of a subcarrier and 2048 a power of two. Time duration for all other time parameters in LTE is a multiple of  $T_s$ .



- A **slot** is of length  $0.5\text{millisecond} = 15360T_s$ . This is also the time length of a PRB. A slot contains 7 symbols in normal cyclic prefix case and 6 symbols in extended CP case. A Resource Element (RE) is a little element of 1 subcarrier per one symbol.
- A **subframe** lasts  $1\text{millisecond} = 30720T_s = 2\text{slots}$ . This is the minimum duration that can be allocated to a user in downlink or uplink. A subframe is also called Transmission Time Interval (TTI) as it is the minimum duration of an independently decodable transmission. A subframe contains 14 symbols with normal cyclic prefix that are indexed from 0 to 13 and are described in the following sections.
- A **frame** lasts  $10\text{millisecond} = 307200T_s$ . This corresponds to the time required to repeat a resource allocation pattern separating uplink and downlink in time in case of Time Division Duplex (TDD) mode. TDD is defined below.

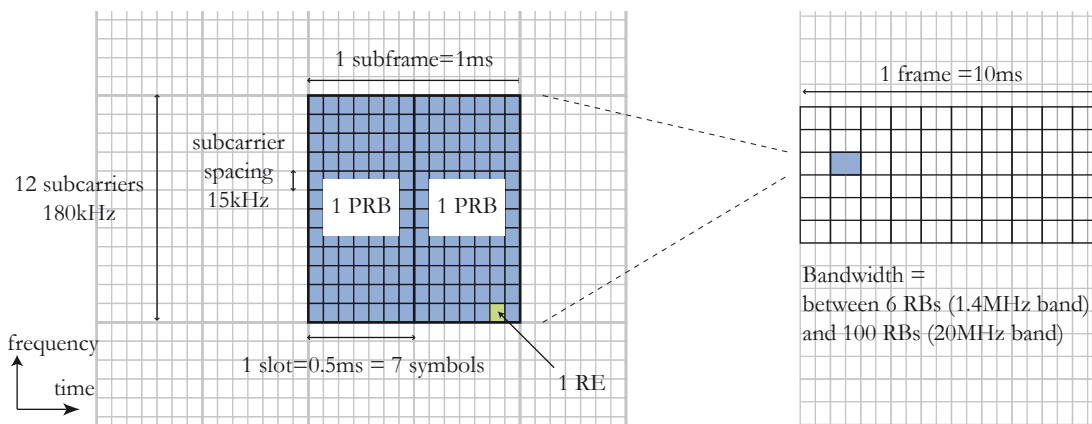

**Figure 2.12:** LTE Time Units

In the LTE standard, the subframe size of 1 millisecond was chosen as a tradeoff between a short subframe which introduces high control overhead and a long subframe which significantly increases the retransmission latency when packets are lost [R1-06b]. Depending on the assigned bandwidth, an LTE cell can have between 6 and 100 resource blocks per slot. In TDD, special subframes protect uplink and downlink signals from ISI by introducing a guard period ([36.09c] p. 9).

## Duplex Modes

Figure 2.13 shows the duplex modes available for LTE. Duplex modes define how the downlink and uplink bands are allocated relative to each other. In Frequency Division Duplex (**FDD**) mode, the uplink and downlink bands are disjoint. The connection is then full duplex and the UE needs to have two distinct Radio Frequency (RF) processing chains for transmission and reception. In Time Division Duplex (TDD) mode, the downlink and the uplink alternatively occupy the same frequency band. The same RF chain can then be used for transmitting and receiving but available resources are halved. In Half-Duplex FDD (**HD-FDD**) mode, the eNodeB is full duplex but the UE is half-duplex (so can have a single RF chain). In this mode, separate bands are used for the uplink and the downlink but are never simultaneous for a given UE. HD-FDD is already present in GSM.

ITU-R defined 17 FDD and 8 TDD frequency bands shared by LTE and UMTS standards. These bands are located between 698 and 2690 MHz and lead to very different channel behavior depending on carrier frequency. These differences must be accounted for

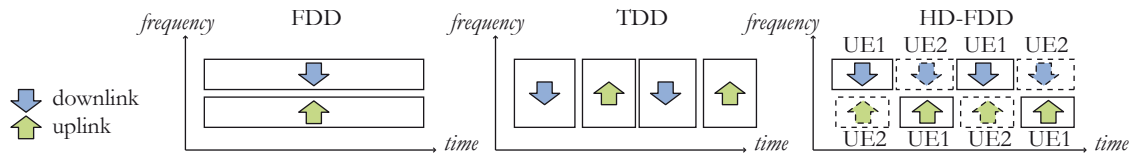

**Figure 2.13:** Different types of LTE duplex modes

during the calibration of base stations and UEs. The following Sections will focus on FDD mode.

### 2.3.5 LTE Modulation and Coding Scheme

Within a single LTE cell, a given UE can experience different Signal-to-Interference plus Noise Ratio (SINR) depending on the radio properties of its environment: the distance of the base station antenna, the base station emission power, the interference of other users, the number of diversity antennas, and so on. Several LTE channel coding features are created in order to obtain data rates near channel capacity in every situation. Channel coding operations are usually very computationally complex operations, and parameters for optimization must be chosen with care. For the case of one antenna port, two LTE physical layer parameters can be modified to maximize the throughput. These parameters are called **Modulation and Coding Scheme (MCS)**:

- The **channel coding rate** is a parameter which determines the amount of redundancy to add in the input signal to allow Forward Error Correction (FEC) processing. A higher redundancy leads to more robust signal at the cost of throughput.
- The **modulation scheme** refers to the way data symbols are associated to a set of transmit bits. A symbol is a complex value that is used to modulate a carrier for air transmission. Three schemes are available in LTE: QPSK, 16-QAM and 64-QAM. They associate 2, 4 and 6 bits respectively to a single symbol and this number of bits is the modulation level. Of the three modulation schemes, QPSK is the most robust for transmission errors but 64-QAM allows the highest throughput ([36.09c] p.79).

The downlink channel quality estimation required for downlink MCS scheme choice is more complex than for its uplink equivalent. However, the report of downlink channel quality is vital for the eNodeB when making downlink scheduling decisions. In FDD mode, no reciprocity of frequency selective fading between uplink and downlink channels can be used (Section 2.3.1). The UE measures downlink channel quality from downlink reference signals and then reports this information to its eNodeB. The UE report consists of a number between 0 and 15, generated by the UE, representing the channel capacity for a given bandwidth. This number is called CQI for **Channel Quality Indicator** and is sent to the eNodeB in the uplink control channel. The CQI influences the choice of resource allocation and MCS scheme. In Figure 2.14(a), the channel coding rate and modulation rate are plotted against CQI, and the global resulting coding efficiency. It may be seen that the coding efficiency can be gradually adapted from a transmission rate of 0.15 bits/resource element to 5.55 bits/resource element.

CQI reports are periodic, unless the eNodeB explicitly requests aperiodic reports. Periodic reports pass through the main uplink control channel known as the Physical Uplink Control Channel (PUCCH, Section 2.4.2). When PUCCH resources are unavailable, the

reports are multiplexed in the uplink data channel known as the Physical Uplink Shared Channel (PUSCH, Section 2.4.2). Aperiodic reports are sent in the PUSCH when explicitly requested by the eNodeB. Periodic CQI reports have a period between 2 and 160 millisecond. Periodic CQI reports contain one CQI if no spatial multiplexing is used or two CQI (one per rank) in the case of rank 2 downlink spatial multiplexing (Section 2.3.6). Aperiodic CQI modes exist including one CQI for the whole band and possibly an additional CQI for a set of preferred subbands ([36.09e] p.37). The choice of following the UE recommendation is given to the eNodeB. After receiving the UE report, the eNodeB sends data using the downlink data channel known as the Physical Downlink Shared Channel (PDSCH, Section 2.5.2). Control values are simultaneously transmitting in the main downlink control channel known as the Physical Downlink Control Channel (PDCCH, Section 2.5.2). These PDCCH control values carry Downlink Control Information (DCI) which include the chosen MCS scheme, HARQ parameters.

Figure 2.14(b) shows the effect of MCS on the throughput of a LTE transmission using a single antenna, a bandwidth of 1.4MHz, no HARQ and one UE. With only one UE in the cell, there can be no interference, so SINR is equal to SNR (Signal-to-Noise Ratio). The results were generated by the LTE simulator of Vienna University of Technology with a Additive White Gaussian Noise (AWGN) channel model and published in [MWI<sup>+</sup>09]. It may be seen that, for the studied channel model, a throughput close to the channel capacity can be achieved if the link adaptation is well chosen. It may also be noted that this choice is very sensitive to the SNR.

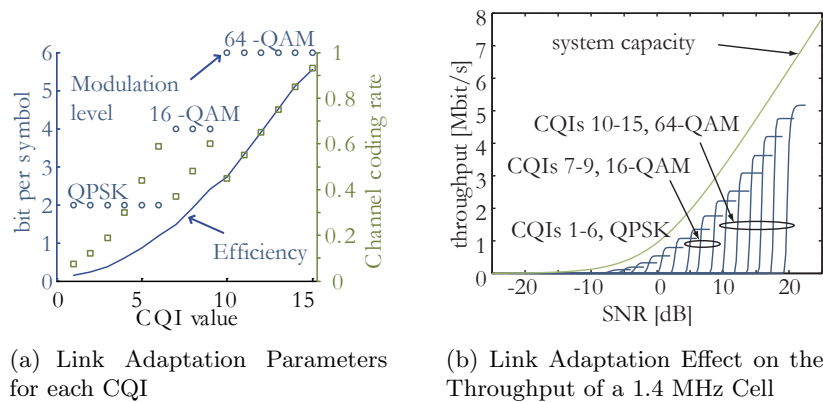
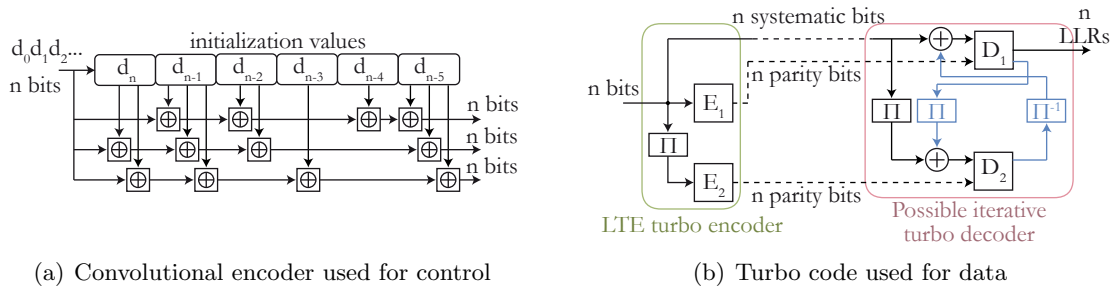

**Figure 2.14:** LTE Link Adaptation

The techniques used to add redundancy and process Forward Error Correction (FEC) are different for control and data channels. The majority of control information in the PDCCH and the PUCCH use tail biting convolutional coding, sequence repetition and pruning while data channels (PDSCH, PUSCH) use turbo coding, sequence repetition and pruning ([Rum09] p.76).

The **convolutional code** used for control in LTE (Figure 2.15(a)) has a 1/3 rate i.e. the code adds 2 redundant bits for each information bit. The encoder was chosen for its simplicity to allow to easier PDCCH decoding by UEs. Indeed, a UE needs to permanently decode many PDCCH PRBs, including many that are not intended for decoding and so this permanent computation must be limited. Convolutional coding is well suited for a FEC system with small blocks because it is not necessary to start in a predefined state. Moreover, convolutional codes can be efficiently decoded using a Viterbi decoder [CS94]. The absence of predefined state is important because a predefined starting state has a cost

in the encoded stream. Instead, the 6 last bits of the encoded sequence serve as starting state of the encoder, transforming a linear convolution into a circular convolution, in the same way as the Cyclic Prefix with the channel impulse response. This technique is named tail biting.



**Figure 2.15:** LTE Forward Error Correction methods

A **turbo code** [BG07] in LTE (Figure 2.15(b)) introduces redundancy in all LTE transmitted data. It has a rate of  $1/3$  and consists of an interleaver and two identical rate-1 convolutional encoders  $E_1$  and  $E_2$ . One convolutional encoder ( $E_1$ ) processes the input data while the other convolutional encoder ( $E_2$ ) processes a pseudo-randomly interleaved version of the same data. The turbo coder outputs a concatenation of its unmodified input (systematic bits) and the two convoluted signals (parity bits). The resulting output facilitates FEC because there is little probability of having a low Hamming weight (number of 1s in the bit stream), thus improving detection. Each Code Block is independently turbo coded. A Code Block size ranges from 40 to 6144 bits (Section 2.2.3). Turbo coding is very efficient for long Code Blocks but it necessitates 12 tail bits containing no information that reduce its efficiency for small blocks.

Turbo coding and decoding are two of the most demanding functions of the LTE physical layer. Special coprocessors for turbo coding and decoding are included in multi-core architectures intended to handle eNodeB physical layer computation. Turbo iterative decoders ([Pyn97] and Figure 2.15(b)) contain two convolution decoders that calculate the A Posteriori Probability (APP) of their input. At each iteration of the decoder, the detection belief of the decoded bit increases. APPs are stored in Log Likelihood Ratio (LLR) integer values where the sign indicates the detected binary value (0 or 1) and the amplitude indicates the reliability of the detection. For each bit, the turbo decoder outputs an LLR. Such a decoder, manipulating not only raw bits but also detection belief, is called soft decision decoder. For the possibility of HARQ retransmissions, LLR values of preceding receptions are stored to allow the combination of the preceding with the new reception. This combining operation can increase the signal to noise ratio in a code block and hence increase the odds for a successful decoding by the Turbo decoder.

After convolutional or turbo coding, the bits enter a circular Rate Matching (RM) process where they are interlaced, repeated and pruned to obtain the desired coding rate (Figure 2.14(a)) with an optimal amount of spread redundancy.

### Hybrid Automatic Repeat reQuest

HARQ retransmission of lost blocks is a part of link adaptation. HARQ introduces redundancy in the signal to counteract the channel impairments. Moreover, HARQ is **hybrid** in the sense that each retransmission can be made more robust by a stronger modulation and by stronger channel coding.

An eNodeB has 3 milliseconds after the end of a PUSCH subframe reception to process the frame, detect a possible reception error via Cyclic Redundancy Check (CRC) decoding and send back a NACK bit in the PDCCH. The uplink HARQ is synchronous in that a retransmission, if any, always appears 8 millisecond after the end of the first transmission. This fixed retransmission scheme reduces signaling in PUCCH. The repetitions can be adaptive (each one with a different MCS scheme), or not.

Downlink HARQ is consistently asynchronous and adaptive. There is at least 8 millisecond between two retransmissions of a Transport Block. It introduces more flexibility than the uplink scheme at the cost of signaling.

When a Transport Block is not correctly received, 8 different stop-and-wait processes are enabled, for both downlink and uplink receivers. This number of processes reduces the risk of the communication being blocked while waiting for HARQ acknowledgement, with the cost of memory to store the LLRs for each process (Section 2.3.5). Data from several repetitions are stored as LLRs and recombined, making HARQ hybrid.

### 2.3.6 Multiple Antennas

In LTE, eNodeBs and UEs can use several antennas to improve the quality of wireless links:

- eNodeB baseband processing can generate up to 4 separate downlink signals. Each signal is allocated to an antenna port. The eNodeB can also receive up to 4 different uplink signals. Two antennas sending the same signal are processed at the baseband processing as a single antenna port.
- A UE can have 2 receive antennas and receive 2 different signals simultaneously. It can have 2 transmit antennas but the UE will switch between these antennas as it has only one RF amplifier,.

Multiple transmit antennas ( $N_T > 1$ ), receive antennas ( $N_R > 1$ ) or both can improve link quality and lead to higher data rates with higher spectral efficiency. For a precise introduction to MIMO channel capacity, see [Hol01]. Different multiple antenna effects can be combined:

- **Spatial diversity** (Figure 2.16(a)) consists of using different paths between antenna sets to compensate for the selective frequency fading of channels due to multipath transmission. There are two modes of spatial diversity: transmission or reception. Transmission spatial diversity necessitates several transmit antennas. Combining several transmit antennas consists in choosing the right way to distribute data over several antennas. A common technique is named Space-Time Block Coding (STBC) where successive data streams are multiplexed in the channels and made as orthogonal as possible to enhance the reception diversity. The most common of these codes is Alamouti; it offers optimal orthogonality for 2 transmit antennas [Ala07]. No such optimal code exists for more than 2 antennas. Reception spatial diversity (Figure 2.16(a)) uses several receive antennas exploiting the diverse channels, by combining their signal with Maximal-Ratio Combining (MRC).
- **Spatial multiplexing gain**, sometimes called MIMO effect is displayed in Figure 2.16(b) for the case  $N_T = N_R = 2$ . It consists of creating several independent channels in space, exploiting a good knowledge of the channels and reconstructing the original data of each channel. MIMO can increase the throughput by a factor

of  $\min(N_T, N_R)$  but this factor is never obtained in real life because multiple paths are never totally uncorrelated and channel estimation requires additional reference signals. MIMO actually takes advantage of the multipath scattering that spatial diversity tries to counteract.

- **Beamforming**, also called array gain, consists of creating constructive and destructive interference of the wavefront to concentrate the signal in a given spatial direction. This is displayed in Figure 2.16(c). These interferences are generated by several transmitting antennas precoded by factors named beam patterns.

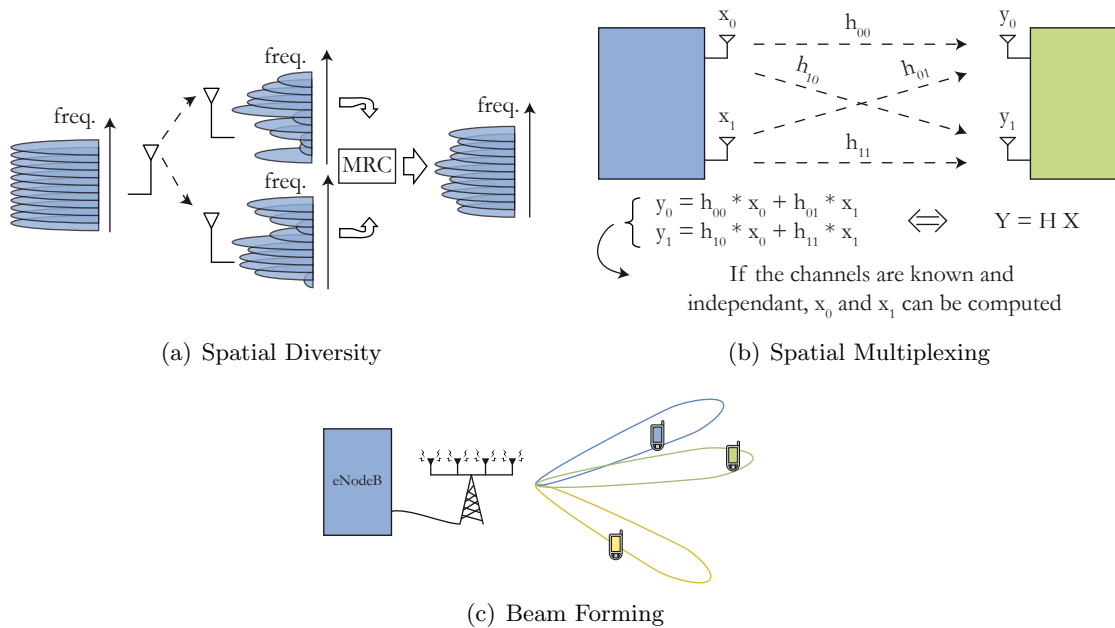

Figure 2.16: LTE link adaptation

Without spatial multiplexing, every PRB corresponding to a single UE has the same MCS. In downlink spatial multiplexing mode, two separate MCS can be used for two different Transport Blocks sent simultaneously to a UE. A more complex scheme was shown to greatly increase the control with only slightly higher data rates [R1-06a].

## 2.4 LTE Uplink Features

### 2.4.1 Single Carrier-Frequency Division Multiplexing

#### Uplink Pilot Signals

The SC-FDMA presented earlier is also known as DFTS-OFDM (DFT-Spread Orthogonal Frequency Division Multiplexing). A discussion on uplink technology choices can be found in [CMS06]. A SC-FDMA decoder in the eNodeB necessitates a channel estimation to equalize the received signal. This channel estimation is performed sending Zadoff-Chu (ZC) sequences known to both the UE and the eNodeB. ZC sequences will be explained in Section 2.4.3. These sequences are called Demodulation Reference Signals (DM RS) and are transmitted on the center symbol of each slot (Figure 2.17). The eNodeB also needs to allocate uplink resources to each UE based on channel frequency selectivity, choosing

frequency bands that are most favorable to the UE. DM RS are only sent by a UE in its own frequency band; they do not predict if it is necessary to allocate new frequencies in the next subframe. This is the role of Sounding Reference Signal (SRS). The positions of DM RS and SRS in the uplink resource blocks is illustrated in Figure 2.17.

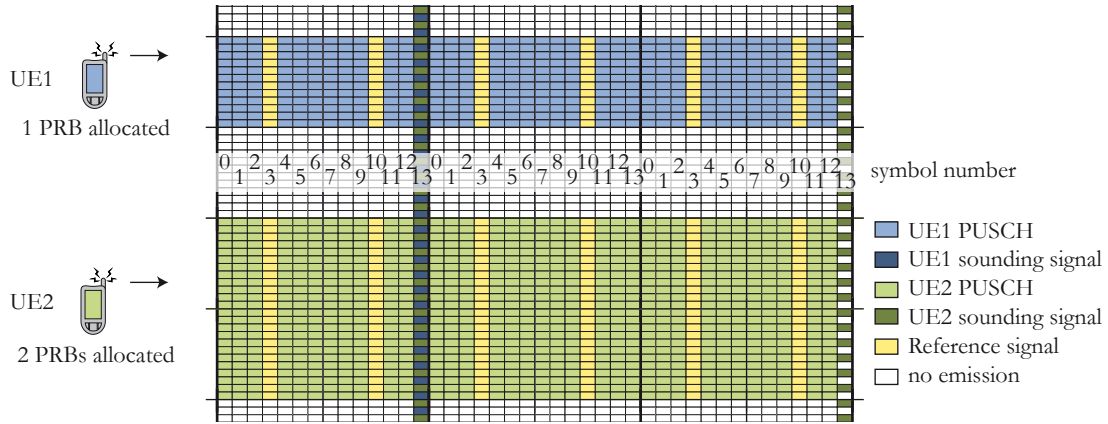

Figure 2.17: Reference Signals location in the uplink resources

DM RS are located in symbols 3 and 10 of each subframe. When explicitly requested by the eNodeB, SRS signals of ZC sequences are sent in the in symbol 13 location. The SRS for a given UE is located every 2 subcarriers using the Interleaved FDMA (IFDMA) method. A 10-bit PDCCH message describes the time, period (between 2 and 320 millisecond) and bandwidth for the UE to send the SRS message. For more details on SRS, see [STB09] p.370. As both DM RS and SRS are Constant Amplitude Zero AutoCorrelation (CAZAC) sequences, two UEs can send each their SRS using the same resources provided they use different cyclic shifts, making sequences orthogonal (Section 2.4.3). The eNodeB is then able to separate the two different pilot signals. Figure 2.17 displays an example of three subframes with UE 1 transmitting data on one fixed PRB with a SRS cycle of more than 2 millisecond and UE 2 sending data on two fixed PRBs with a SRS cycle of 2 millisecond.

### 2.4.2 Uplink Physical Channels

Uplink data and control streams are sent using three physical channels allocated on the system bandwidth:

- The **Physical Uplink Shared Channel (PUSCH)** carries all the data sent between a eNodeB and its UEs. It can also carry some control. LTE PUSCH only supports localized UE allocations, i.e. all PRBs allocated to a given UE are consecutive in frequency.
- The **Physical Uplink Control Channel (PUCCH)** carries the major part of the transmitted control values via uplink.
- **Physical Random Access Channel (PRACH)** carries the connection requests from unconnected UEs.

Figure 2.18 illustrates the localization of the physical channels for the example of a 5 MHz cell. The PUCCH is localized on the edges of the bandwidth while PUSCH occupies most of the remaining PRBs. PUCCH information with redundancy is sent on pairs of PRBs called regions (indexed in Figure 2.18), where the two PRBs of a region are located

on opposite edges. This technique is called frequency hopping and protects the PUCCH against localized frequency selectivity. There are typically 4 PUCCH regions per 5 MHz band. However, the eNodeB can allocate the PUSCH PRBs in PUCCH regions if they are not needed for control. Multiple UE control values can be multiplexed in PUCCH regions via Code Division Multiplexing (CDM).

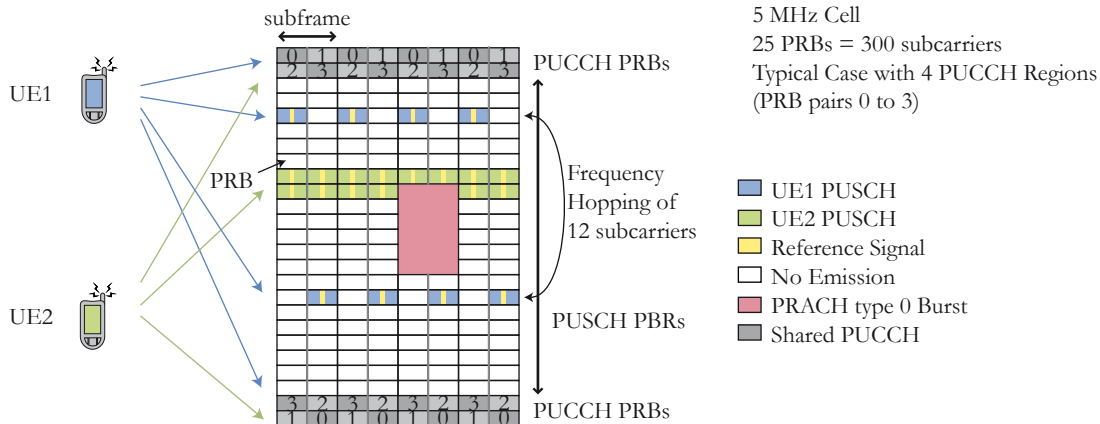

**Figure 2.18:** *Uplink Channels*

Uplink decisions are generally taken by the eNodeB MAC scheduler and transmitted via downlink control channels. Consequently, the UEs are not required to send back these eNodeB decisions to the eNodeB, thus reducing the overhead of the PUCCH. 7 PUCCH region formats are defined according to the kind of information carried. The PUCCH contains the requests for more uplink data resources via an uplink Scheduling Request bit (SR), and the Buffer Status Reports (BSR) signals the amount of pending data from the UE PUSCH to the eNodeB. The PUCCH also signals the UE preferences for downlink Modulation and Coding Scheme (MCS, Section 2.3.5) including:

- **Hybrid Automatic Repeat reQuest (HARQ)**, Acknowledgement (ACK), or Non Acknowledgement (NACK) are stored in 1 or 2 bits and require HARQ retransmissions if data was lost and the Cyclic Redundancy Check (CRC) was falsely decoded.
- A **Channel Quality Indicator (CQI, Section 2.3.5)** consists of 20 bits transporting indicators of redundancy 1 or 2 which recommend a MCS to the eNodeB for each transmitted Transport Block.
- **MIMO Rank Indicator (RI)** and **Precoding Matrix Indicator (PMI)** bits which recommend a multiple antenna scheme to the eNodeB (Section 2.3.6).

The PUCCH carries this control information periodically. If PRB is unavailable in the PUCCH, the PUSCH can carry some control information. Additionally, the eNodeB can request additional aperiodic CQI and link adaptation reports. These reports are sent in PUSCH and can be much more complete than periodic reports (up to 64 bits).

The PRACH is allocated periodically over 72 subcarriers (6 PRBs, Figure 2.18). Employing 72 subcarriers is favorable because it has the widest bandwidth available for all LTE configurations between 1.4 MHz and 20 MHz. The PRACH burst can last between 1 and 3 subframes depending on the chosen mode; long modes are necessary for large cells. The PRACH period depends on the adjacent cell configurations and is typically several subframes. See Section 2.4.5 and [STB09] p.421 for more details on the PRACH.



The uplink is shared between several transmitting UEs with different velocities and distances to the eNodeB. Certain precautions must be taken when multiple UEs are transmitting simultaneously, one of which is the **timing advance**. Timing advance consists of sending data with the corrected timing, so compensating for the propagation time and allowing the synchronization of all data received at the eNodeB. The correct timing advance is evaluated using the timing received from the PRACH bursts.

### 2.4.3 Uplink Reference Signals

In uplink communication, a Demodulation Reference Signal (DM RS) is constructed from a set of complex-valued Constant Amplitude Zero AutoCorrelation (CAZAC) codes known as Zadoff-Chu (ZC) sequences [Chu72] [Pop92]. ZC sequences are computed with the formula:

$$z_q(n) = \exp\left(\frac{-j\pi qn(n+1)}{N_{ZC}}\right) \quad (2.6)$$

where  $n$  is the sample number,  $q$  is the sequence index ranging from 1 to  $N_{ZC} - 1$ , and  $N_{ZC}$  is the sequence size. Three ZC sequences of length 63 with indexes 25, 29 and 34 are illustrated in Figure 2.19. Their amplitude and the amplitude of their Fourier transform are constant, keeping low the PAPR of their transmission (Figure 2.19(a)). All three sequences have an autocorrelation close to the Dirac function, enabling the creation of several orthogonal sequences from a single sequence using cyclic shifts. It may also be noted that the cross correlation between two ZC sequences with different indices is small compared to the autocorrelation peak (Figure 2.19(b)). Consequently, two sequences can be decoded independently when sent simultaneously as long as their indices or cyclic shifts are different.

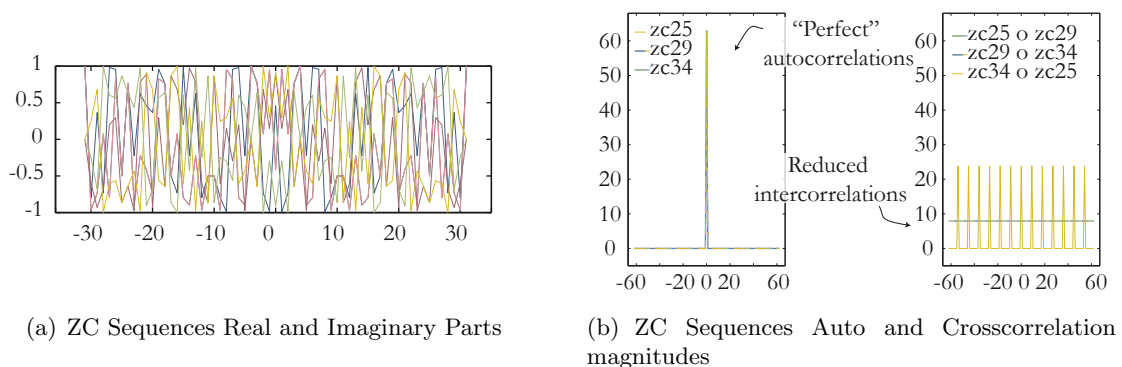

**Figure 2.19:** Length-63 Zadoff-Chu Sequences with index 25, 29 and 34

Each uplink DM RS of length  $N_P$  consists of a ZC sequence with the highest prime size smaller than  $N_P$ . The ZC sequence is cyclically extended to  $N_P$  elements and then cyclically shifted by  $\alpha$  elements. For the smallest DM RS sizes of 12 and 24 elements, special codes replace ZC sequences because they outperform the ZC sequences in these cases ([STB09] p.361). DM RS primarily serve to estimate the channel. They also carry information in their sequence index  $q$  and cyclic shift  $\alpha$ , namely an ID to determine which destination eNodeB of the DM RS and to identify the transmitting UE for the case of Multi-User MIMO (MU-MIMO, Section 2.4.4). Indices and shifts are vital in preventing UEs and cells from interfering with each other.

ZC sequences are used elsewhere in LTE systems, in particular as Sounding Reference Signal (SRS, 2.5.5) and in random access procedure (Section 2.4.5).

#### 2.4.4 Uplink Multiple Antenna Techniques

In the first release of LTE, UEs were limited to one transmission amplifier. Uplink single-user spatial multiplexing is thus not possible but multiple UE antennas can still be exploited for better system throughput. Firstly, UEs can optionally have two transmit antennas and switch between them depending on the channel quality. This method known as **antenna selection** necessitates one SRS signal per antenna to report on channel quality. This increase in diversity must be weighed against the cost of this additional SRS signal in overhead

Secondly, **reception spatial diversity** (Section 2.3.6) is often exploitable because the majority of eNodeBs have several receive antennas, each of which have known channel responses  $h_i$ . Naming the received values:

$$y = hx, \quad (2.7)$$

where each antenna stream has already been equalized (Section 2.3.2) and thus  $h = [h_1 h_2 \dots h_N]^T$  is the vector of channel responses, each being a scalar and  $x = [x_1 x_2 \dots x_N]^T$  and  $y = [y_1 y_2 \dots y_N]^T$  are the transmitted and received signal vectors across N antennas. The MRC detected signal is given by:

$$\hat{x} = \frac{h^H y}{h^H h} \quad (2.8)$$

where  $\hat{x}$  is the complex detected symbol. MRC favors antennas which can receive high power signals. .

Thirdly, **Multi-User MIMO** (MU-MIMO) also called Spatial Division Multiple Access (SDMA) consists of allocating the same resources to 2 UEs in the eNodeB and using the channel differences in frequency selectivity between UEs to separate the signals while decoding. Using MIMO can greatly increase the data rate and only requires special processing in the eNodeB. It necessitates orthogonal uplink DM RS reference sequences with different cyclic shift to independently evaluate the channel of each UE. Eight different DM RS cyclic shifts are defined in LTE for this purpose. This scheme is often called Virtual MU-MIMO because no added complexity is required at the UE: it is not necessary for the UE to know it shares the same resources with another UE. The complexity increases only at eNodeB side.

A 2x2 MU-MIMO scheme is equivalent to that shown in Figure 2.16(b) but with the transmit antennas connected to separate UEs. Spatial multiplexing decoding, also known as MIMO detection, consists of reconstructing an estimate vector  $\hat{x}$  of the sent signal vector  $x$  from  $y$  and  $H$  (Figure 2.16(b)) in the eNodeB. The four channels in  $H$  can be considered to be flat fading (not frequency selective) because they have been individually equalized upon reception (Section 2.3.2); the channel is thus constant over all SC-FDMA subcarriers. The two most common low complexity linear MIMO detectors are that of **Zero Forcing** (ZF) and of **Minimum Mean-Square Error** (MMSE). In the ZF method, where  $\hat{x} = Gy$  is the vector of detected symbols and  $y$  is the vector of received symbols,  $G$  is computed as the pseudo inverse of  $H$ :

$$G = (H^H H)^{-1} H^H. \quad (2.9)$$

The ZF method tends to amplify the transmission noise. The MMSE method is a solution to this problem, with:

$$G = (H^H H + \sigma^2 I)^{-1} H^H. \quad (2.10)$$

where  $\sigma^2$  is the estimated noise power and  $I$  the identity matrix. Many advanced MIMO decoding techniques [Lar09] [Tre04] exist, notably including Maximum Likelihood Receiver (MLD) and Sphere Decoder (SD).

### 2.4.5 Random Access Procedure

The random access procedure is another feature of the uplink. While preceding features enabled high performance data transfers from connected UEs to eNodeBs, the random access procedure connects a UE to a eNodeB. It consists of message exchanges initiated by an uplink message in the **PRACH** channel (Section 2.4.2). It has two main purposes: synchronizing the UE to the base station and scheduling the UE for uplink transmission. The random access procedure enables a UE in idle mode to synchronize to a eNodeB and become connected. It also happens when a UE in connected mode needs to resynchronize or to perform a handover to a new eNodeB. The scheduling procedure uses the MME (Section 2.2.1) which is the network entity managing paging for phone calls. When a phone call to a given UE is required, the MME asks the eNodeBs to send paging messages with the UE identity in the PDCCH. The UE monitors the PDCCH regularly even in idle mode. When paging is detected, it starts a random access procedure. The random access procedure starts when the UE sends a PRACH signal.

Special time and frequency resources are reserved for the PRACH. Depending on the cell configuration, a PRACH can have a period from 1 to 20 milliseconds. The signal has several requirements. One is that an eNodeB must be able to separate signals from several UEs transmitted in the same allocated time and frequency window. Another constraint is that the eNodeB must decode the signal rapidly enough to send back a Random Access Response (RAR) in PDSCH. A typical time between the end of PRACH reception and RAR is 4 milliseconds ([STB09] p.424). The PRACH message must also be well protected against noise, multipath fading and other interference in order to be detectable at cell edges. Finally, the resources dedicated to PRACH must induce a low overhead.

The chosen PRACH signals are ZC sequences of length 839, except in the special TDD format 4, which is not treated here. Good properties for ZC sequences are explained in Section 2.4.3 where their use in reference signals is described. A set of 64 sequences (called signatures) is attributed to each cell (out of 838 sequences in total). A signature is a couple  $(n_S, n_{CS})$  where  $n_S \leq N_S \leq 64$  is the root index and  $n_{CS} \leq N_{CS} \leq 64$  is the cyclic shift so that  $N_{CS} = \lceil 64/n_S \rceil$ . A combination of a root and a cyclic shift gives a unique signature out of 64. A tradeoff between a high number of roots and a high number of cyclic shifts must be made. It will be seen that for more cyclic shifts, the easier the decoding becomes (Section 7.3). Each eNodeB broadcasts the first of its signatures and the other signatures are deduced by the UE from a static table in memory ([36.09c] p.39). A UE sends a PRACH message, by sending one of the 64 signatures included in the eNodeB signature set.

A PRACH message occupies 6 consecutive PRBs, regardless of the cell bandwidth, during 1 to 3 subframes. This allocation is shown in Figure 2.18. A UE sends PRACH messages without knowing the timing advance. A Cyclic Prefix (CP) large enough to cover the whole round trip must be used to protect the message from ISI with previous symbol. A slightly bigger Guard Time (GT) with no transmission must also be inserted after sending

the PRACH message to avoid ISI with next symbol. GT must be greater than the sum of round trip and maximum delay spread to avoid overlap between a PRACH message and the subsequent signal. Depending on the cell size, the constraints on CP and GT sizes are different. Five modes of PRACH messages exist allowing adaption to the cell configuration ([36.09e] p.31). The smallest message consists of the 839 samples of one signature sent in one subframe over  $800\mu\text{s} = 30720 * 0.8T_S = 24576T_S$  with CP and GP of about  $100\mu\text{s}$ . This configuration works for cells with a radius under 14 km and thus a round trip time under  $14 * 2/300000 = 93\mu\text{s}$ . The longest message consists of 1697 samples (twice the 839 samples of one signature) sent in 3 subframes over  $1600\mu\text{s} = 30720 * 1.6T_S = 49152T_S$  with CP and GP of about  $700\mu\text{s}$ . This configuration is adapted to cells with a radius up to 100 km and thus a round trip time up to  $100 * 2/300000 = 667\mu\text{s}$ .

In 100 km cells, the round trip time can be almost as long as the transmitted signature. Thus no cyclic shift can be applied due to the ambiguity when receiving the same root with different cyclic shifts: the signal could result from separate signatures or from UEs with different round trips. The smaller the cell is, the more cyclic shifts can be used for one root resulting in a less complex decoding process and greater orthogonality between signatures (see auto and intercorrelations in Figure 2.19(b)).

In the frequency domain, the six consecutive PRBs used for PRACH occupy  $6 * 0.180 = 1.08\text{MHz}$ . The center band of this resource is used to send the 839 signature samples separated by 1.25kHz. When the guard band is removed from the signal, it may be seen that the actual usable band is  $839 * 1.25 = 1048.75\text{MHz}$ .

Two modes of random access procedure exist: the most common is the contention-based mode in which multiple UEs are permitted to send a PRACH signal in the same allocated time and frequency window. Contention-free mode is the other possibility and for this case, the eNodeB ensures that only a single UE can send a given ZC sequence for a given time and frequency window. The contention-free mode will not be presented here; see [STB09] for more details.

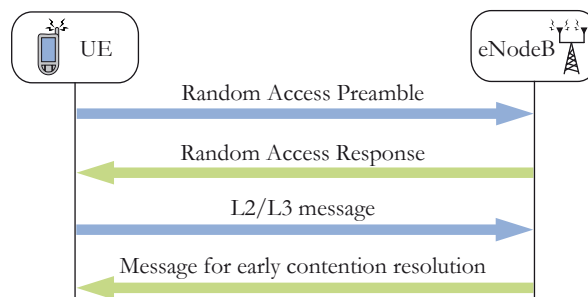

**Figure 2.20:** *Contention-Based Random Access Procedure.*

Figure 2.20 illustrates the contention-based random access procedure. Within the UE, the physical layer first receives a PRACH message request from upper layers with a PRACH starting frequency and mode, message power and parameters (root sequences, cyclic shifts...). A temporary unique identity called Random Access Radio Network Temporary Identifier (RA-RNTI) identifies the PRACH time and frequency window. Then, then UE sends a PRACH message using the given parameters. The UE monitors the PDCCH messages in subframes subsequent to the PRACH burst and if the RA-RNTI corresponding to that UE is detected, the corresponding PDSCH PRBs are decoded and RAR information is extracted. If no PDCCH message with the RA-RNTI of the UE is detected, the random access procedure has failed, and so a new PRACH message will be scheduled. More details on PRACH can be found in [36.09e] p.16.

An 11-bit timing advance is sent by the eNodeB to the UE within the RAR message ([36.09e] p.8). This timing advance is derived from the downlink reception of the previous downlink message, and ranges from 0 millisecond to 0.67 millisecond (the round trip in a 100 km cell) with a unit of  $16 T_s = 0.52 \mu\text{s}$ . When the position of the UE is changed, its timing advance alters. Timing advance updates can be requested by the eNodeB in MAC messages if a modification of the reference signal reception timing is measurable by the eNodeB. These update messages are embedded in PDSCH data.

In the RAR, the eNodeB allocates uplink resources and a Cell Radio Network Temporary Identifier (C-RNTI) to the UE. The first PUSCH resource granted to the UE is used to send L2/L3 messages carrying the random access data: these include connection and/or scheduling requests, and the UE identifier.

The final step in the contention-based random access procedure is the downlink contention resolution message in which the eNodeB sends the UE identifier corresponding to the successful PRACH connection. A UE which does not receive a message which includes its own identifier will conclude that the random access procedure has failed, and will restart the procedure.

## 2.5 LTE Downlink Features

### 2.5.1 Orthogonal Frequency Division Multiplexing Access

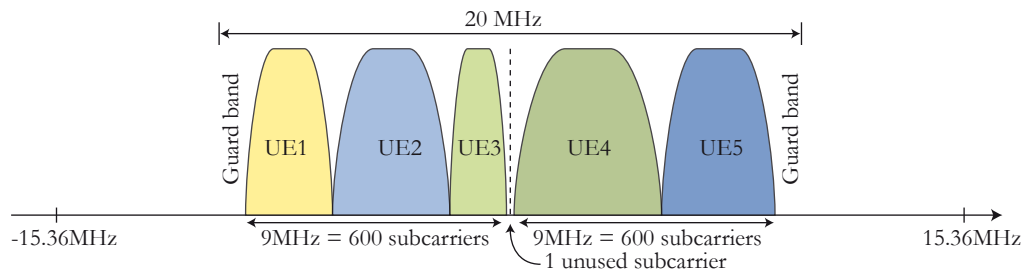

**Figure 2.21:** Baseband Spectrum of a Fully-Loaded 20 MHz LTE Downlink

In contrast to uplink communications, a single entity, the eNodeB, handles the transmission over the whole bandwidth for the downlink. Transmission over a wide frequency band (up to 20 MHz) and use of several antennas (4 or more) is possible because eNodeBs are powered by mains electricity and so the RF constraints are reduced compared to a UE. Consequently, a higher PAPR is allowed in the downlink than in the uplink ([STB09] p.122).

Figure 2.21 displays the frequency use of a fully-loaded 20 MHz LTE downlink with localized UE allocation. A total bandwidth of 18 MHz is effectively used by the 1200 subcarriers, with the central subcarrier left unused because it may be “polluted” by RF oscillator leakage. The transmitted signal must fit within the transmission mask defined in [36.09c]. Depending on bandwidth, the number of subcarriers varies according to Table 2.1. The number of PRBs per slot ranges from 6 in a 1.4 MHz cell to 100 in a 20 MHz cell. A configuration of 110 PRBs per slot in a 20 MHz cell with guard band reduction is also possible to increase data rates at the cost of a more complex radio frequency management. The number of subcarriers in the sampling band is a function of power of 2 (except for the 15 MHz case). A consequence of a subcarrier number power of two is that OFDMA and SC-FDMA baseband processing (Section 2.3.4) can be executed faster by employing the Fast Fourier Transform (FFT) algorithm to convert data into the Fourier domain.

**Table 2.1:** LTE downlink Bandwidth Configurations

Bandwidth(MHz)	1.4	3	5	10	15	20
Resource Blocks per Slot	6	15	25	50	75	100
Number of Data Subcarriers	72	180	300	600	900	1200
Used Bandwidth (MHz)	1.08	2.25	4.5	9	13.5	18
Minimal Sampling Rate (MHz)	1.92	3.84	7.68	15.36	23.04	30.72
Number of Subcarriers in Sampling Band	128	256	512	1024	1536	2048

Figure 2.22 shows that non-contiguous PRBs can be allocated to a UE using the downlink communication stream, enhancing protection against frequency selectivity at the cost of increasing control information. Frequency hopping between two PRBs in a single frame (for the case where two UEs exchange their PRBs) can also reinforce this protection [R1-07]. Note that all PRBs associated with a single UE have identical modulation and coding schemes because little gain increase is seen if PRBs of one UE have different modulation and coding schemes [R1-06a]. Figure 2.22 also shows the downlink cell specific reference signals that are inserted in symbols 0, 1 and 4 of each slot. Antenna ports 1 and 2 insert 4 reference values each per slot. Antenna ports 3 and 4 insert only 2 reference values each per slot. For each additional antenna, a reference signal overhead is added but multiple antennas can bring significant gain compensating for this throughput reduction(Section 2.3.6). The maximum possible reference signal overhead is:  $(2 * 4 + 2 * 2) / (7 * 12) = 14.3\%$ . Reference signals must be interpolated to be used in coherent decoding; they must consequently reflect most of the channel properties by covering the entire time/frequency resources. Using the channel coherence bandwidth and channel coherence time worst case estimation, the diamond shape localization of reference signals was chosen as a tradeoff between overhead and channel estimation accuracy. Downlink RS are length-31 Gold sequences (Section 2.5.3) initialized with the transmitting cell identifier. An eNodeB can send additional UE-specific RS (for beam forming) or broadcast RS (for broadcasted data) ([STB09] p.163).

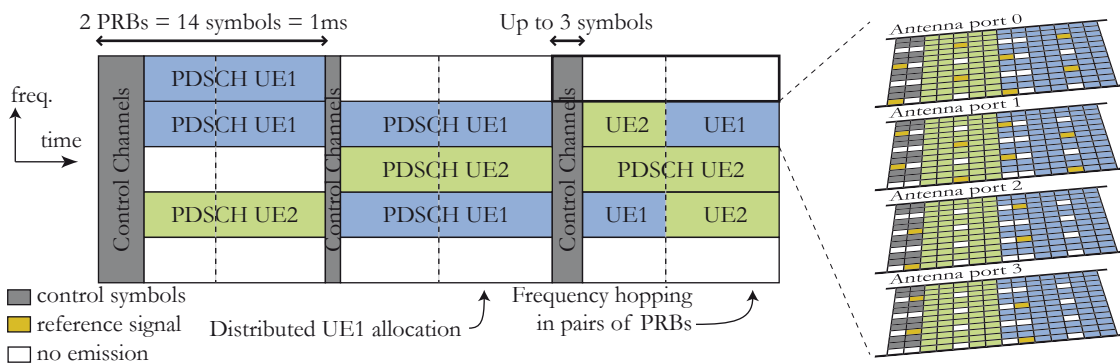
**Figure 2.22:** Downlink multiple user scheduling and reference signals

## 2.5.2 Downlink Physical Channels

Like in uplink communications, the downlink bits are transmitted through several physical channels allocated to specific physical resources:

- The **Physical Broadcast Channel** (PBCH) broadcasts basic information about the cell. It is a low data rate channel containing the Master Information Block (MIB), which includes cell bandwidth, system frame number. It is sent every 10 milliseconds and has significant redundancy on the 72 central subcarriers of the bandwidth (Section 2.5.5).
- The **Physical Downlink Control Channel** (PDCCH) is the main control channel, carrying Downlink Control Information (DCI [STB09] p.195). There are ten formats of DCI each requiring 42 to 62 bits. Each format signals PRB allocations for uplink and downlink, as well as UE power control information, the Modulation and Coding Scheme (MCS, Section 2.3.5) and request for CQI (Section 2.3.5). Every downlink control channel is located at the beginning of the subframe, in symbol 1, 2 or 3. Downlink MCS is chosen using UE reports in PUCCH (Section 2.4.1) but the eNodeB has the liberty to choose a MCS independent of the UE recommendation.
- The **Physical Control Format Indicator Channel** (PCFICH) is a physical channel protected with a high level of redundancy, indicating how many PDCCH symbols (1, 2 or 3) are sent for each subframe. Certain exceptions in the number of control symbols exist for broadcast and small band modes. This channel is transmitted in symbol 0, “stealing” resources from PDCCH.
- The **Physical Downlink Shared Channel** (PDSCH) is the only data channel, which carries all user data. There are seven PDSCH transmission modes, which are used depending multiple antenna usage, as decided by the eNodeB (Section 2.5.4). The transmission mode is part of the DCI sent in PDCCH. PDSCH also infrequently carries System Information Blocks (SIB) to complete the MIB information of the cell in PBCH channel.
- The **Physical Hybrid ARQ Indicator Channel** (PHICH) carries uplink HARQ ACK/NACK information, which request retransmission of uplink data when the Cyclic Redundancy Check (CRC) was incorrectly decoded (Section 2.3.5). CRC is added to an information block to detect infrequent errors, producing a small amount of redundancy. This process is called Forward Error Correction (FEC, Section 2.3.5). PHICH is sent using the same symbols as PDCCH.
- The **Physical Multicast Channel** (PMCH) is used to broadcast data to all UEs via Multimedia Broadcast and Multicast Services (MBMS). This special mode was especially created to broadcast television, and is not considered in this document.

A UE must constantly monitor the control channels (PDCCH, PCFICH, PHICH). Due to the compact localization of control channels in the first few symbols of each subframe, a UE can execute some “micro sleeps” between two control zones, and thus save power when no PRB with the identifier of the UE was detected in the subframe. Special modulation and coding schemes are used for control channels. PDCCH is scrambled, and adds bitwise length-31 Gold sequences, equivalent to those used in downlink reference signals, initialized with UE identifier. Gold sequences are specific bit sequences that are explained in the next section. Several MU-MIMO UEs can receive PDCCH on the same PRBs using Code Division Multiplexing (CDM). PBCH and PDCCH are coded with convolutional code instead of turbo code because convolutional codes are better suited for small blocks (Section 2.3.5 and [STB09] p.237).

### 2.5.3 Downlink Reference Signals

In downlink communication, three types of reference signals are sent: cell specific, UE specific and broadcast specific RS (2.5.1). Only the cell specific RS, which are the most common are considered in this study. Downlink RS are constructed from length-31 Gold sequences. **Gold sequences** are generated using 31-bit shift registers and exclusive ORs (Figure 2.23).  $x_1$  and  $x_2$  are called maximum length sequences or M-sequences, and are spectrally flat pseudo-random codes but can carry up to 31 bits of data. While  $x_1$  initial value is a constant,  $x_2$  initial value carries the data. In order for two Gold codes with close initialization to be orthogonal, the 1600 first outputs are ignored. The resulting signal shift improves the code PAPR and the two Gold codes from different eNodeBs are orthogonal, enabling a UE to decode the signal reliably [R1-08]. The PAPR of reference signals is very important because the reference signals are often power boosted compared to data.

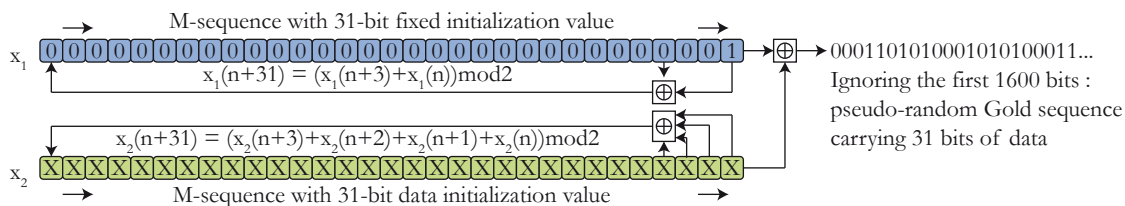

**Figure 2.23:** Gold Pseudo Random Sequence Generation

The initialization value of a Gold sequence is generated from the physical layer cell identity number, the slot number within the radio frame, the symbol number within the slot, and an indicator of normal or extended CP. The Gold sequence bits are QPSK modulated and transmitted on RS allocated resources. The same length-31 Gold bit sequences are used for scrambling data over the frequency band in Section 2.5.1.

### 2.5.4 Downlink Multiple Antenna Techniques

LTE PDSCH can combine spatial diversity, MIMO and beam forming (Section 2.3.6). Two successive processes map the data to the eNodeB multiple antenna ports:

1. The **code block to layer mapping** associates each code block with one or two layers ([36.09c] p.47). A layer is a set of bits that is multiplexed in frequency or in space with other layers. In LTE Release 9, two code blocks can be multiplexed simultaneously and the number of layers used is called Rank Indicator (RI) and is between 1 and 4. If two code blocks are sent simultaneously in the same resource, spatial multiplexing is exploited (Section 2.3.6).
2. The **precoding** jointly processes each element of the layers to generate the  $n_T$  antenna port signals. It consists of multiplying the vector containing one element from each of the RI layers with a complex precoding matrix  $W$ . An antenna port can be connected to several antennas but these antennas will send an identical signal and so be equivalent to a single antenna with improved frequency selectivity due to diversity. The number of antenna ports  $n_T$  is 1, 2 or 4. In LTE, precoding matrices are chosen in a set of predefined matrices called a “codebook” ([36.09c] p.48). Each matrix has an index call Precoding Matrix Indicator (PMI) in the current codebook.



Figure 2.24 illustrates the layer mapping and precoding for **spatial diversity** for different numbers of RI and  $n_T$ . **Space-Frequency Block Coding (SFBC)** is used to introduce redundancy between several subcarriers. SFBC is simply introduced by temporally separating the values such as Space-Time Block Coding (STBC, Section 2.3.6) prior to the IFFT which is executed during OFDMA encoding. In Figure 2.24(a), one Code Block is sent to two antennas via two layers. The precoding matrix used to introduce SFBC follows the Alamouti scheme [Ala07]. In Figure 2.24(b), a derived version of the Alamouti scheme is adapted for transmission diversity with SFBC over four antenna ports. Of every four values, two are transmitted using a pair of antenna ports with certain subcarriers and the two remaining values are transmitted on the other pair of antennas over different subcarriers. Antenna ports are not treated identically: antenna ports 3 and 4 transmit less reference signal so due to the resulting poorer channel estimation, these ports must not be paired together.

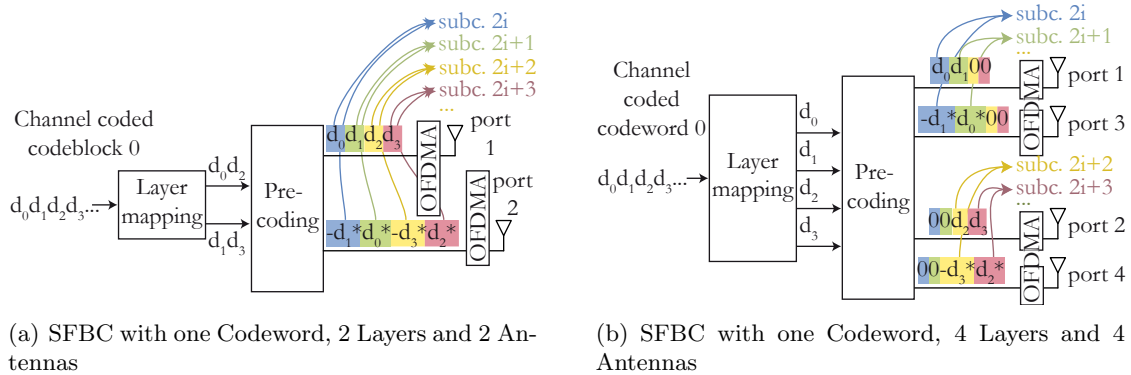

**Figure 2.24:** Layer Mapping and Precoding for Spatial Diversity with Different Multi-antenna Parameters

There are 7 PDSCH modes defining how the eNodeB exploits multiple antennas in its communication with a UE:

1. In **transmission mode 1**, no multiple antenna technique is used.
2. In **transmission mode 2**, there are several antennas but no spatial multiplexing. One Transport Block is sent per TTI with antenna diversity (Figures 2.24(a) and 2.24(b)).
3. In **transmission mode 3**, open loop spatial multiplexing (MIMO) is used, i.e. the UE does not feed back information that would enable UE-specific precoding (i.e. beam forming). This precoding scheme is known as Cyclic Delay Diversity (CDD). It is equivalent to sending each subcarrier in a different direction, increasing frequency diversity of each transmitted Code Block.
4. In transmission mode 4, closed loop spatial multiplexing (MIMO) is used. The UE feeds back a RI and a PMI to advise the eNodeB to form a beam in its direction, i.e. by using the appropriate transmit antennas configuration. It also reports one Channel Quality Indicator (CQI) per rank, allowing the eNodeB to choose the MCS for each Transport Block.
5. In transmission mode 5, MU-MIMO is used (Section 2.4.4). Each of two UEs receives one of two transmitted Transport Blocks in a given resource with different precoding matrixes.

6. In transmission mode 6, there is no spatial multiplexing (rank 1) but UE precoding feedback is used for beamforming.
7. Transmission mode 7 corresponds to a more accurate beam forming using UE-specific downlink reference signals.

Examples of closed loop and open loop **spatial multiplexing** encoding are illustrated in Figure 2.25. In Figure 2.25(a), the closed loop is used: the UE reports a PMI to assist in the eNodeB choice of a good precoding matrix  $W$ . In Figure 2.25(b), there is no UE feedback, so the two multiplexed code blocks are transmitted with a maximum transmission diversity configuration with CDD. While matrix  $U$  mixes the layers, matrix  $D$  creates different spatial beams for each subcarrier which is equivalent to sending each subcarrier in a different directions. Finally,  $W$  is the identity matrix for two antenna ports and a table of predefined matrices used successively for four antenna ports. The objective of  $W$  is to decorrelate more the spatial layers.

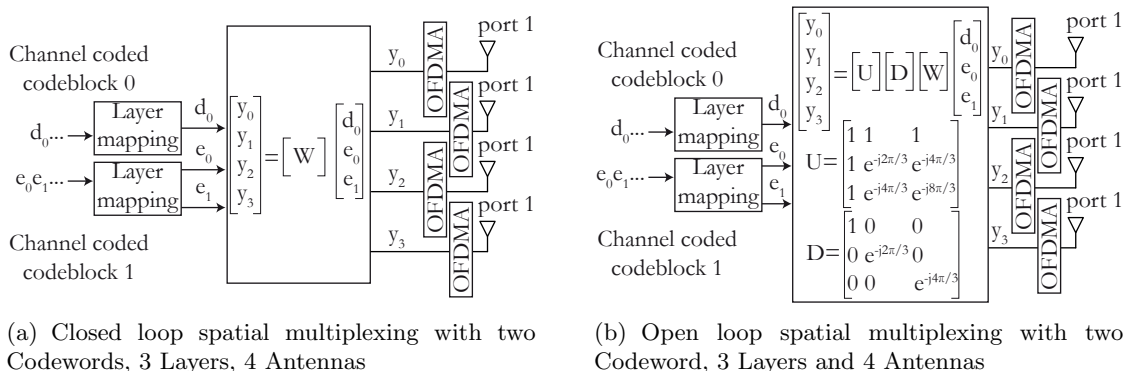

**Figure 2.25:** Layer Mapping and Precoding for Spatial Multiplexing with different multi-antenna parameters

A UE knows the current transmission mode from the associated PDCCH format. MIMO detectors for the LTE downlink are located in the UEs; the ZF or MMSE techniques presented in Section 2.4.4 are used for the decoding. This topic is not within the scope of this study. More information on LTE downlink MIMO detectors can be found in [WEL09].

## 2.5.5 UE Synchronization

Synchronizing the UE with the eNodeB is a prerequisite to data exchanges. A UE will monitor the eNodeB downlink synchronization signals when it requires a new connection (initial synchronization) or during a handover (new cell identification). The synchronization signals communicate the time basis as well as the cell identifier, bandwidth, cyclic prefix length and cell duplex mode. Four types of downlink signals must be decoded by the UE for synchronization: the Primary Synchronization Signal (PSS), the Secondary Synchronization Signal (SSS), the Physical Broadcast Channel (PBCH) and the downlink Reference Signal (RS). These signals give a UE information about the cell identity and parameters, as well as the quality of the channel.

1. The **Primary Synchronization Signal** (PSS) consists of a Zadoff-Chu (ZC) sequence with length  $N_{ZC}$  63 and index  $q$  25, 29 or 34. These sequences are illustrated

in Figure 2.19. The middle value is “punctured” to avoid using the DC subcarrier and so is sent twice in each frame using the 62 central subcarriers (Figure 2.26). A ZC length of 63 enables fast detection using a 64 point FFT and using 62 subcarriers  $\leq 6$  PRBs makes the PSS identical for all bandwidth configurations between 6 and 110 PRBs.  $q$  gives the cell identity group (0 to 2) which is usually used to distinguish between the three sectors of a three-sectored cell (Section 2.1.2).

2. The **Secondary Synchronization Signal** (SSS) consists of a length-31 M-sequence, equivalent to the one used to generate Gold sequences (Section 2.5.3), duplicated and interleaved after different cyclic shifts. The 62 values obtained are used for Binary Phase Shift Keying (BPSK, 1 bit per symbol) coded and sent like PSS. The signal is initialized with a single cell identifier of a possible 168 which is used by a given UE to distinguish between adjacent cells. The cyclic shift gives the exact start time of the frames. The channel response knowledge contained in the PSS enables the UE to evaluate the channel for coherent detection of SSS.
3. The **Physical Broadcast Channel** (PBCH) (Section 2.5.1) is read only during initial synchronization to retrieve basic cell information.
4. **Downlink RS** (Section 2.5.3) is decoded to evaluate the current channel impulse response and the potential of a handover with a new cell identification and better channel properties.

The localization of PSS, SSS and PBCH in FDD mode with normal cyclic prefix is shown in Figure 2.26. In this cell configuration, the 62 values of PSS and SSS are sent in the center of subframe symbols 6 and 5 respectively and repeated twice in a radio frame, i.e. every 5 millisecond. The PBCH is sent over 72 subcarriers and 4 symbols once in each radio frame. The relative positions of PSS and SSS communicate to UEs the type of duplex mode (TDD, FDD or HD-FDD) and CP length of the cell.

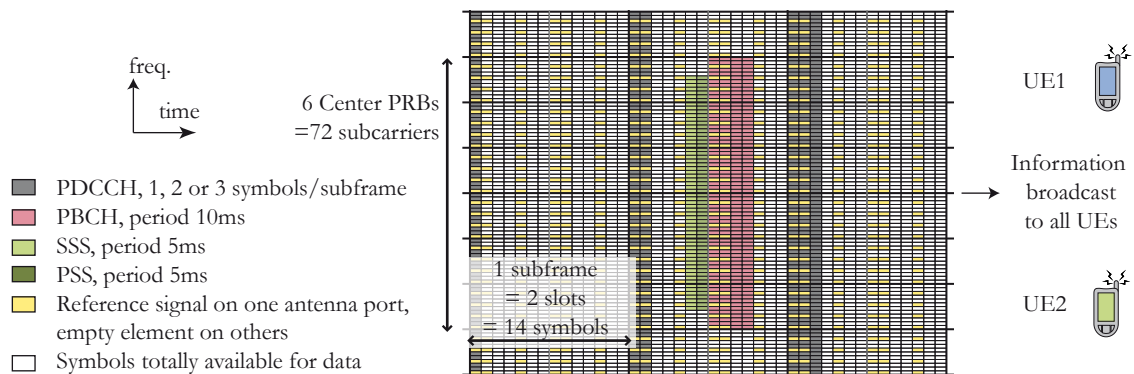

**Figure 2.26:** Downlink PSS, SSS, RS and PBCH localization in subframes.

This section detailed the features of the LTE physical layer. Next section introduces the concept of dataflow Model of Computation and details the models that are used in this study to represent the LTE eNodeB physical layer processing.



## 3.1 Introduction

To study the LTE physical layer on multi-core architectures, a Model of Computation (MoC) is needed to specify the LTE algorithms. This MoC must have the necessary expressivity, must show the algorithm parallelism and must be capable of locating system bottlenecks. Additionally, it must be simple to use and sufficiently intuitive for designers to manage rapid prototyping. In the following sections, the concept of Model of Computation is introduced and the models which will be used to describe LTE are detailed. After an overview, Section 3.2 focuses on the Synchronous Dataflow model (SDF), which forms the foundation of numerous MoCs as it can be precisely analyzed. Section 3.3 explains an extension of SDF which compactly expresses the behavior of an algorithm. Finally, Section 3.4 describes hierarchical dataflow models which enable compositions of sub-parts.

### 3.1.1 Model of Computation Overview

A Model of Computation (MoC) defines the semantics of a computational system model, i.e. which components the model can contain, how they can be interconnected, and how they interact. Every programming language has at least one (often several) underlying MoCs. A MoC describes a method to specify, simulate and/or execute algorithms. MoCs were much promoted by the Ptolemy and Ptolemy II projects from the University of California Berkeley. In [CHL97], Chang, et al. explain how several MoCs can be combined in the Ptolemy tool. MoCs can serve three different purposes:

1. **Specification:** A specification model focuses on clearly expressing the functionalities of a system. It is especially useful in standards documents.
2. **Simulation:** A simulation model is used to extract knowledge of a system when the current implementation is not available. It may be much simpler than the final code and is focused precisely on the features of interest.
3. **Execution:** An execution model must contain all the information for the final code execution.

These objectives are not mutually exclusive but it is sufficiently complex to obtain all three simultaneously. The International Technology Roadmap for Semiconductors (ITRS) predicts that unified models covering the three problems will be available around 2020 [fS09]. The unified model is called “executable specification”.

The definition of MoCs is broad and covers many models that have emerged in the last few decades. The notion of a Model of Computation is close to the notion of a programming paradigm in the computer programming and compilation world. Arguably, the most successful MoC families, in terms of adoption in academic and industry worlds are:

- **Finite State Machine MoCs (FSM)** in which states are defined in addition to rules for transitioning between two states. FSMs can be synchronous or asynchronous [SLS00]. The rules depend on control events and a FSM MoC is often used to model control processes. The actual computation modeled by a FSM is performed at transitions. The FSM MoC is often preferred for control-oriented applications. The imperative programming paradigm is equivalent to a FSM in which a program has a global state which is modified sequentially by modules. The imperative programming paradigm is the basis of the most popular programming languages including C. Its semantics are directly related to the Turing machine / Von Neumann hardware it targets. It is often combined with a higher-level Object-Oriented Programming (OOP) MoC, in particular in C++, Java and Fortran programming languages.
- **Process Network MoCs (PN)** in which concurrent and independent modules known as processes communicate ordered tokens (data quanta) through First-In First-Out (FIFO) channels. Process Network MoCs are often preferred to model signal processing algorithms. The notion of time is usually not taken into account in Process Network MoCs where only the notion of causality (who precedes whom) is important. The **dataflow Process Networks** that will be used in the rest of the thesis are a subset of Process Networks.
- **Discrete Event MoCs (DE)** in which modules react to events by producing events. Modules themselves are usually specified with an imperative MoC. These events are all tagged in time, i.e. the time at which events are consumed and produced is essential and is used to model system behavior. Discrete Event MoCs are usually preferred to model clocked hardware systems and simulate the behavior of VHDL and Verilog coded FPGA or ASIC implementations.
- **Functional MoCs** in which a program does not have a preset initial state but uses the evaluation result of composed mathematical functions. Examples of programming languages using Functional MoCs include Haskell, Caml and XSLT. The origin of functional MoCs lies in the lambda calculus introduced by Church in the 1930s. This theory reduces every computation to a composition of functions with only one input.
- **Petri Nets** which contain unordered channels named transitions, with multiple writers and readers and local states called places, storing data tokens. Transitions and states are linked by directed edges. A transition of a Petri Net fires, executing computation and producing tokens on its output arcs, when a token is available at the end of all its input arcs [SLS00] [SLWS99]. Comparing with a FSM MoC, the advantage of Petri Nets is their ability to express parallelism in the system while a FSM is sequential.

- **Synchronous MoCs** in which, like in Discrete Events, modules react to events by producing new events but contrary to Discrete Events, time is not explicit and only the simultaneity of events and causality are important. Programming languages based on Synchronous MoCs include Signal, Lustre and Esterel.

The MoCs that are considered in this thesis are all within the above **Process Network MoCs**. The previous list is not exhaustive. A more complete description of most of these MoCs can be found in [SLS00].

### 3.1.2 Dataflow Model of Computation Overview

In this thesis, the physical layer of LTE, which is a signal processing application, is modeled. The targeted processing hardware is composed of Digital Signal Processors (DSP) and the signal arrives at this hardware after a conversion into complex numbers (Section 2.1.3). The obvious choice of MoC to model the processing of such a flow of complex numbered data is **Dataflow Process Network**. In [LP95], Lee and Parks define Dataflow Process Networks and locate them precisely in the broader set of Process Network MoCs. The MoCs discussed in following Sections are illustrated in Figure 3.1. Each MoC is a tradeoff between expressivity and predictability. MoCs are divided into main branch models and branched off models:

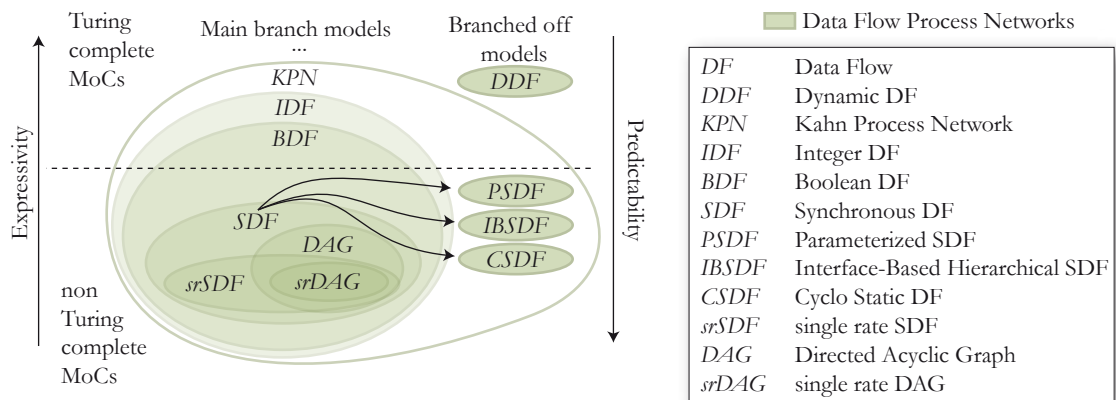

Figure 3.1: Main Types of Process Network Model of Computation

- **Main branch models** as shown in Figure 3.1 are all subsets of the Kahn Process Network (KPN) MoC [Kah74], which adds constraints to the models that contain them. KPN consists of continuous processes that communicate through infinite lossless FIFO channels. The continuity property is explained in [LP95]. The outputs of a network of continuous processes can be computed iteratively, i.e. it can be factorized to one minimum “fixed point” [LP95], where the computation is repeated. An important property of KPN is that FIFO channel writes are non-blocking and FIFO channel reads are blocking. KPN is the only non-dataflow MoC in Figure 3.1. Dataflow Process Networks additionally specify the behavior of their processes when they receive and send data. These processes are then called actors and fire when they receive data tokens, themselves producing data tokens. A set of firing rules defines when an actor fires. Firing and actor consists in starting its preemption-free execution. Other main branch models are restrictions of the KPN model with different firing rule definitions.

- **Branched off models** are derived from main branch models with added features adapting their targeted usage to a particular problem, meaning that these models are no longer subsets of higher-level main branch MoCs.

When a given MoC is Turing complete, this MoC expresses all possible algorithms. Figure 3.1 distinguishes Turing complete MoCs from those that are non-Turing complete. The non-Turing complete MoCs have limited expressiveness but they enable more accurate compile-time studies. Many Dataflow Process Network MoCs have been introduced in the literature, each offering a tradeoff between compile-time predictability and capacity to model dynamic run-time variability. They differ mostly by their firing rules:

- **Dynamic Data Flow MoC (DDF)** is a MoC with special firing rules and is thus a dataflow process network MoC; but a DDF actor can “peek” at a token without consuming it, thus defining non blocking reads not allowed in KPN. This property can make DDF non deterministic and complicate its study [LP95]. Compared with KPN, DDF has advantages as a dataflow model. Contrary to the KPN processes, DDF actors do not necessitate a multi-tasking OS to be executed in parallel. A simple scheduler that decides which actor to execute depending on the available tokens is sufficient. The CAL language software execution method is based on this property [JMRW10].
- **The Synchronous Dataflow MoC (SDF)** has been the most widely used dataflow MoC because of its simplicity and predictability. Each SDF actor consumes and produces a fixed number of tokens at each firing. However, it is not Turing complete and cannot express conditions in an algorithm. Figure 3.2(a) shows a SDF algorithm. The small dots represent tokens already present on the edges when the computation starts.
- **The single rate SDF MoC** is a subset of SDF. A single rate SDF graph is a SDF graph where the production and consumption of tokens on an edge are always equal (Figure 3.2(b)).
- **The Directed Acyclic Graph MoC (DAG)** is also a subset of SDF. A DAG is a SDF graph where no path can contain an actor more than once, i.e. a graph that contains no cycle (Figure 3.2(c)).
- **The single rate Directed Acyclic Graph MoC** is a DAG where productions and consumptions are equal.
- **The Boolean Dataflow MoC (BDF)** is a SDF with additional special actors called **switch** and **select** (Figure 3.2(d)). The **switch** actor is equivalent to a demultiplexer and the **select** actor to a multiplexer. The data tokens on the unique input of a switch are produced on its true (respectively false) output if a control token evaluated to true (respectively false) is sent to its control input. The BDF model adds control flow to the SDF dataflow and it is this control that makes the model Turing complete.
- **The Integer Data Flow MoC (IDF)** is the equivalent of BDF but where the control tokens are integer tokens rather than Boolean tokens.
- **The Cyclo Static Dataflow MoC (CSDF)** extends SDF by defining fixed patterns of production and consumption (Figure 3.2(e)). For instance, a production pattern of (1,2) means that the actor produces alternatively one and two tokens when it fires.



- **The Parameterized SDF MoC (PSDF)** is a hierarchical extension of SDF that defines production and consumption relative to parameters that are reevaluated at reconfiguration points. Parameterized dataflow is a meta-modeling technique adding reconfigurability to a static model.
- **The Interface-Based Hierarchical SDF MoC (IBSDF)** is also a hierarchical extension of SDF that insulates the behavior of its constituent graphs, making them easy to combine and study. Interface-Based hierarchical dataflow is a meta-modeling technique which adds a hierarchy to a static model.

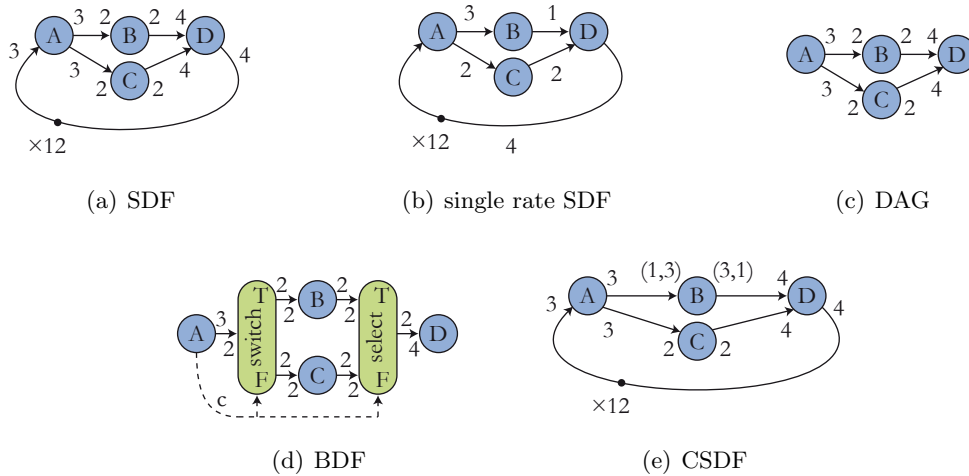

**Figure 3.2:** A Few Dataflow MoC Graph Examples

The above list is not complete. Many more dataflow MoCs have been defined and new models are studied in this thesis in the context of the PREESM tool development. Dataflow process networks only specify how actors communicate but cannot give the complete execution semantics (for example, an actor performing an addition still needs a description of this behavior to execute). If a Dataflow MoC is used for execution, it appears as a **coordination language** and must be combined with a **host language** defining actor behavior [LP95]. C code can be used as a software host language or Hardware Description Language (HDL) code as a hardware host language. CAL is a host language that can target both software and hardware implementation generation. In this study of LTE, C code is used as the host language but the code generation is flexible and may be adapted to other programming languages.

Process networks are usually employed to model one execution of a repetitive process. For a single application, descriptions with different **scales** are often possible. When modeling an H.264 60 Hz full-HD video decoder for instance, a graph describing the decoding of one 16x16 pixels macro-block can be created and executed 486000 times per second. It is also possible to create a graph describing the decoding of one picture and repeat this description 60 times/s; or a graph describing the decoding of one group of pictures and which is then repeated several times per second. The right scale must be chosen, a scale which is too large produces graphs that are too large in terms of number of actors and complicates the study, whereas a scale that is too small will usually lead to sub-optimal implementations [Nez02].

Aside from the scale, the **granularity** is another important parameter in describing an application. In [Sin07], Sinnen defines the granularity  $G$  of a system as the minimum

execution time of an actor divided by the maximum transfer time of an edge. Using this definition which depends on both algorithm and architecture, in a coarse grain system where  $G \gg 1$ , actors are seen to be “costly” compared to the data flowing between them. High granularity is a desirable property for system descriptions because transfer time between operators does not add to the time efficiency of the system.

Because of different granularities and scales, there are several ways to describe a single application. Choosing the correct MoC and using this model correctly is vital to obtain efficient prototyping results. In following sections, SDF, CSDF, and hierarchical extensions of SDF are presented in more detail. The general theory of dataflow process networks can be found in [LP95]. This thesis concentrates on the models used in the study of LTE physical layer algorithms: SDF and its extensions.

## 3.2 Synchronous Data Flow

The Synchronous Dataflow (SDF) [LM87] is used to represent the behavior of an application at a coarse grain. An example of SDF graph is shown in Figure 3.2(a). SDF can model loops but not code behavioral modifications due to the nature of its input data. For example, an “if” statement cannot be represented in SDF.

The SDF model can be represented as a finite directed, weighted graph characterized by the graph  $G = \langle V, E, d, p, c \rangle$  where :

- $V$  is the **set of nodes**; each node represents an actor that performs computation on one or more input data streams and produces one or more output data streams.
- $E \subseteq V \times V$  is the **edge set**, representing channels which carry data streams.
- $d : E \rightarrow \mathbb{N}$  is the **delay** function with  $d(e)$  the number of initial tokens on an edge  $e$  (represented by black dots on the graph).
- $p : E \rightarrow \mathbb{N}^*$  is the **production** function with  $p(e)$  representing the number of data tokens produced by the  $e$  source actor at each firing and carried by  $e$ .
- $c : E \rightarrow \mathbb{N}^*$  is the **consumption** function with  $c(e)$  representing the number of data tokens consumed from  $e$  by the  $e$  sink actor at each firing.

This graph is a **coordination language**, and so only specifies the topology of the network but does not give any information about the internal behavior of actors. The only behavioral information in the model is the amount of produced and consumed tokens. If only a simulation of the graph execution is needed, the actor behavior can usually be ignored and a few parameters like Deterministic Actor Execution Time (DAET) are necessary. However, if the model will be used to generate executable code, a host code must be associated with each actor.

### 3.2.1 SDF Schedulability

From a connected SDF representation, it should be possible to extract a valid single-core schedule as a finite sequence of actor firings. The schedulability property of the SDF is vital; this enables the creation of a valid multi-core schedule. A valid schedule can fire with no deadlock and its initial state is equal to its final state.

A SDF graph can be characterized by a matrix close to the incidence matrix in graph theory and called **topology matrix**. The topology matrix  $\mathbf{\Gamma}$  is a matrix of size  $|E| \times |V|$ ,

in which each row corresponds to an edge  $e$  and each column corresponds to a node  $v$ . The coefficient  $\Gamma(i, j)$  is positive and equal to  $N$  if  $N$  tokens are produced by the  $j^{\text{th}}$  node on the  $i^{\text{th}}$  edge. Conversely, the coefficient  $\Gamma(i, j)$  is negative and equal to  $-N$  if  $N$  tokens are consumed by the  $j^{\text{th}}$  node on the  $i^{\text{th}}$  edge.

**Theorem 3.2.1.** *A SDF graph is consistent if and only if  $\text{rank}(\mathbf{\Gamma}) = |V| - 1$*

Theorem 3.2.1 implies that there is an integer Basis Repetition Vector (BRV)  $q$  of size  $|V|$  in which each coefficient is the repetition factor for the  $j^{\text{th}}$  vertex of the graph in a schedule returning graph tokens in their original state. This basic repetition vector is the positive vector  $q$  with the minimal modulus in the kernel of the topology matrix such as  $\mathbf{\Gamma} \cdot q = \{0\}$ . Its computation is illustrated in Figure 3.3. The BRV gives the repetition factor of each actor for a complete cycle of the network. Figure 3.3 shows an example of an SDF graph, its topology matrix and a possible schedule:

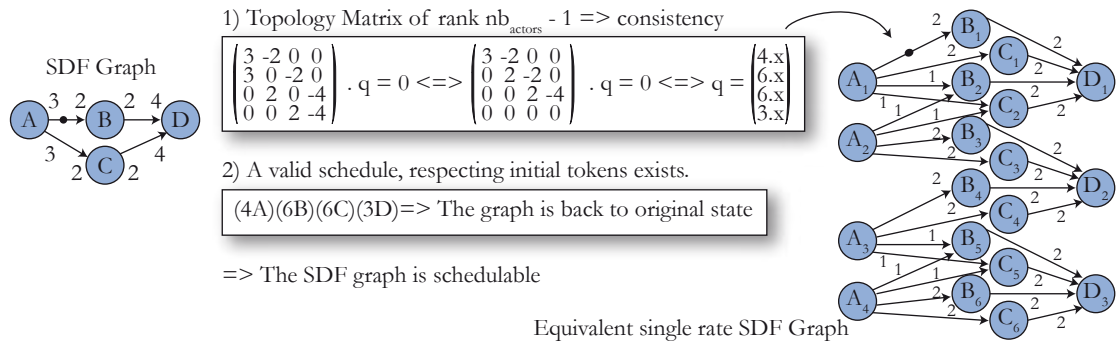

**Figure 3.3:** *The Topology Matrix and Repetition Vector of an SDF Graph*

**Consistency** means that tokens cannot accumulate indefinitely in part of the graph [BL93] [LM87]. Consistency is a necessary (but not sufficient) condition for a SDF graph to be schedulable.

**Theorem 3.2.2.** *A SDF graph is schedulable if and only if it matches two conditions:*

1. *it is consistent,*
2. *a sequence of actor firing can be constructed, containing the numbers of firings from the basic repetition vector and respecting the actor firing rules (an actor can fire only if it has the necessary input tokens).*

The second condition can be called **deadlock freeness**. This condition is not respected when there are insufficient initial tokens and if an actor stays blocked (or deadlocked) indefinitely. The procedure to construct a single-core schedule to demonstrate schedulability is detailed in [BELP95]. In Figure 3.3, the chosen single-core scheduler respects Single Appearance Scheduling (SAS); a schedule where all instances of a given actor are grouped together. The single-core SAS schedule is optimal for code size. Other single-core schedules exist, where other parameters are optimized.

The ability to check graph schedulability before commencing algorithm and architecture matching is enormously advantageous. It means the algorithm graph is valid, regardless of the architecture on which it is mapped. The checking graph schedulability is one part of the total hardware and algorithm separation needed for a multi-core software development chain.

It may be noted that the above method is valid only for connected graphs. It cannot model several unconnected algorithms mapped on the same multi-core architecture. The case of a graph without enough edges to connect all vertices ( $|E| < |V| - 1$ ) implies  $\text{rank}(\mathbf{\Gamma}) < |V| - 1$  and the graph is then considered non-schedulable. The “normal” case of a connected graph study implies  $|E| \geq |V| - 1$ . To obtain the Basis Repetition Vector and check schedulability, the equation  $\mathbf{\Gamma} \cdot q = \{0\}$  needs to be solved with  $q$  integer and  $q \neq \vec{0}$ . This equation can be solved using the Gauss algorithm as displayed in Algorithm 3.1. Using the Bachman-Landau asymptotic upper bound notation [CLRS01], the algorithm has a complexity of  $O(|V|^2|E|)$  in non-trivial cases. It results in  $O(|V|^2)$  divisions and  $O(|V|^2|E|)$  matrix loads and store accesses.

---

**Algorithm 3.1: Basis Repetition Vector Computation of  $\mathbf{\Gamma}$** 

---

**Input:** A topology matrix  $\mathbf{\Gamma}$  of size  $|E| \times |V|$   
**Output:** A Basis Repetition Vector of size  $|V|$  if  $\text{rank}(\mathbf{\Gamma}) = |V| - 1$ , false otherwise

```

1 i = j = 1;
2 while i ≤ |E| and j ≤ |V| do
3   Find pivot (greatest absolute value)  $\mathbf{\Gamma}_{kj}$  with  $k \geq i$ ;
4   if  $\mathbf{\Gamma}_{kj} \neq 0$  then
5     Swap rows i and k;
6     Divide each entry in row i by  $\mathbf{\Gamma}_{ij}$ ;
7     for l = i + 1 to |E| do
8       Subtract  $\mathbf{\Gamma}_{lj}$ *row i from row l;
9     end
10    i=i+1;
11  end
12  j=j+1;
13 end
14 if  $\mathbf{\Gamma}$  has exactly  $|V| - 1$  non null rows then
15   Create VRB  $v = (1, 1, 1, \dots)$ ;
16   for l = |V| - 1 to 1 do
17     Solve equation of row l where only the rational  $v_l$  is unknown;
18   end
19   Multiply v by the least common multiple of  $v_i, 1 \leq i \leq |V|$ ;
20   return v;
21 else
22   return false;
23 end

```

---

### 3.2.2 Single Rate SDF

The single rate Synchronous Dataflow model is a subset of the SDF where the productions and consumptions on each edge are equal. An example of single rate SDF graph is shown in Figure 3.2(b). It can thus be represented by the graph  $G = \langle V, E, d, t \rangle$  where  $V$ ,  $E$  and  $d$  are previously defined and  $t : E \rightarrow \mathbb{N}$  is a function with  $t(e)$  representing the number of data tokens produced by the  $e$  source actor and consumed by the  $e$  sink actor at each firing. A SDF graph can be converted in its equivalent single rate SDF graph by duplicating each actor (Figure 3.3). The number of instances is given by the BRV; the edges must be duplicated properly to connect all the single rate SDF actors.

An algorithm to convert a SDF graph to a single rate SDF graph is given in [SB09] p. 45. It consists of successively adding actors and edges in the single rate SDF graph and has a complexity  $O(|V| + |E|)$  where  $V$  and  $E$  are the vertex set and the edge set respectively of the single rate SDF graph.

### 3.2.3 Conversion to a Directed Acyclic Graph

One common way to schedule SDF graphs onto multiple processors is to first convert the SDF graph into a precedence graph so that each vertex in the precedence graph corresponds to a single actor firing from the SDF graph. Thus each SDF graph actor  $A$  is “expanded into”  $q_A$  separate precedence graph vertices, where  $q_A$  is the component of the BRV that corresponds to  $A$ . In general, the precedence graph reveals more functional parallelism as well as data parallelism. A valid precedence graph contains no cycle and is called DAG (Directed Acyclic Graph) or Acyclic Precedence Expansion Graph (APEG). In a DAG, an actor without input edge is called **entry actor** and an actor without output edge is called **exit actor**. Unfortunately, the graph expansion due to the repeatedly counting each SDF node can lead to an exponential growth of nodes in the DAG. Thus, precedence-graph-based multi-core scheduling techniques, such as the ones developed in [Kwo97], generally have a complexity that is not bounded polynomially in the input SDF graph size, and can result in prohibitively long scheduling times for certain kinds of graphs [PBL95].

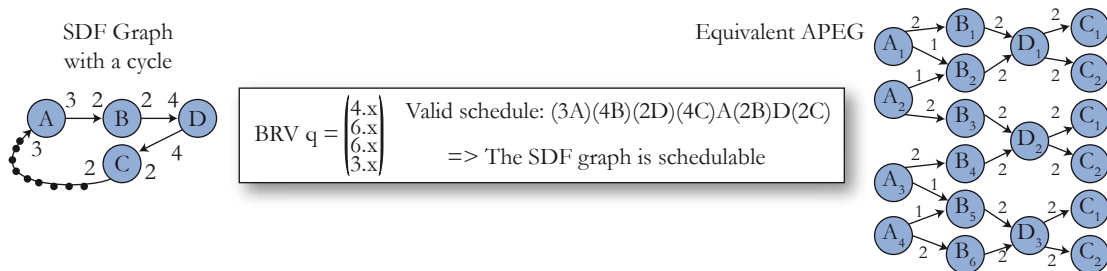

**Figure 3.4:** SDF Graph and its Acyclic Precedence Expansion Graph

Converting a single rate SDF graph into its corresponding DAG simply consists of ignoring edges with initial tokens. If the graph is schedulable, each of its cyclic paths will contain at least one initial token. Removing edges with initial tokens naturally breaks these cycles and creates a DAG. Using this precedence graph as the algorithmic input for scheduling results in inter-iteration dependencies not being taken into account. Converting a non-single rate SDF graph into its corresponding DAG is also possible but is a more complex operation as cycles must be unrolled before ignoring edges with initial tokens [Pia10].

## 3.3 Cyclo Static Data Flow

The Cyclo Static Dataflow (CSDF) model is introduced in [BELP95] and an example graph is shown in Figure 3.2(e). The CSDF model cannot express more algorithms than SDF but it can express certain algorithms in a reduced way. CSDF can also enhance parallelism and reduce memory necessary for execution. CSDF is used in the study of LTE uplink and downlink streams. The token production and consumption of each actor can vary over time, following a periodic form statically chosen. For example, an actor can consume one token, then two tokens, then one token again, and so on. In this example,

the actor has two phases. In CSDF, token productions and consumptions are patterns instead of scalars. A SDF model can be represented as a finite directed, weighted graph characterized by the graph  $G = \langle V, E, d, \phi, p, c \rangle$  where :

- $V$  is the **set of nodes**; each node representing an actor.
- $E \subseteq V \times V$  is the **edge set**, representing data channels.
- $d : E \rightarrow \mathbb{N}$  is the **delay** function with  $d(e)$  the number of initial tokens on an edge  $e$ .
- $\phi : V \rightarrow \mathbb{N}$  is the **phase** function with  $\phi(v)$  the number of phases in the pattern execution of  $v$ .
- $p : E \times \mathbb{N} \rightarrow \mathbb{N}^*$  is the **production** function with  $p(e, i)$  representing the number of data tokens produced by the  $e$  source actor at each firing of phase  $i$  and carried by  $e$ .
- $c : E \times \mathbb{N} \rightarrow \mathbb{N}^*$  is the **consumption** function with  $c(e, i)$  representing the number of data tokens consumed from  $e$  by the  $e$  sink actor at each firing of phase  $i$ .

The CSDF model introduces the notion of actor state; an actor does not behave the same at each firing. However, the fixed pattern of execution permits to check the graph schedulability at compile-time.

### 3.3.1 CSDF Schedulability

Like a SDF graph, a CSDF graph can be characterized by its topology matrix. The topology matrix  $\mathbf{\Gamma}$  is the matrix of size  $|E| \times |V|$ , where each row corresponds to an edge  $e$  and each column corresponds to a node  $v$ . The coefficient  $\mathbf{\Gamma}(i, j)$  is positive and equal to  $\sum_{k=1}^{\phi(j)} p(i, k)$  if a pattern  $p(i, k)$  is produced by the  $j^{th}$  node on the  $i^{th}$  edge. Conversely, the coefficient  $\mathbf{\Gamma}(i, j)$  is negative and equal to  $-\sum_{k=1}^{\phi(j)} c(i, k)$  if a pattern  $c(i, k)$  is consumed by the  $j^{th}$  node on the  $i^{th}$  edge.

The topology matrix gathers the cumulative productions and consumptions of each actor during its complete period of execution. A CSDF graph  $G$  is consistent if and only if the rank of its topology matrix  $\mathbf{\Gamma}$  is one less than the number of nodes in  $G$  (Theorem 3.2.1). However, the smallest vector  $q'$  in  $\mathbf{\Gamma}$  null space is not the BRV.  $q'$  only reflects the number of repetitions of each complete actor cycle and must be multiplied for each actor  $v$  by its number of phases  $\phi(v)$  to obtain the BRV  $q$ :

$$q = \mathbf{\Phi} \times \mathbf{q}', \quad \text{with} \quad \mathbf{\Phi} = \text{diag}(\phi(v_1), \phi(v_2), \dots, \phi(v_m)) \quad (3.1)$$

A valid sequence of firings with repetitions given by the BRV is still needed to conclude the schedulability of the graph. The process is illustrated in Figure 3.5. It can be concluded on CSDF schedulability as in the SDF case. Figure 3.6 illustrates a compact representation of a CSDF graph and its SDF equivalent. In this simple example, the number of vertices has been reduced by a factor 2.3 by using CSDF instead of SDF.

## 3.4 Dataflow Hierarchical Extensions

A hierarchical dataflow model contains hierarchical actors. Each hierarchical actor contains a net of actors. There are several ways to define SDF actor hierarchy. The first SDF

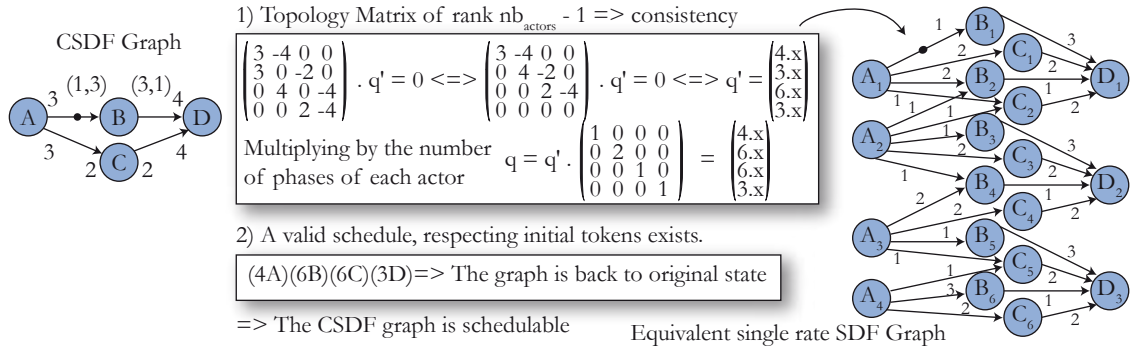

**Figure 3.5:** The Topology Matrix and Repetition Vector of a CSDF Graph

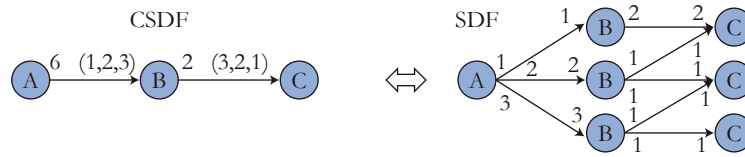

**Figure 3.6:** Illustrating Compactness of CSDF Model Compared to SDF

hierarchy was that of clustering described in [PBL95] by Pino, et al. The study takes a bottom-up approach and defines rules that extract the actors from a complex graph which can be clustered within a coarser-grain actor. The primary advantage of this technique is that clustered actors are then easier than the individual actors in scheduling process manipulations.

However, the type of hierarchy that is of interest in this thesis is a top-down one: a SDF hierarchy that allows a designer to compose sub-graphs within an upper-level graph. Two such hierarchy models have been defined and both will be studied in this thesis: the Parameterized SDF (PSDF [BB01]) and the Interface-Based Hierarchical SDF (IBSDF [PBPR09]).

### 3.4.1 Parameterized Dataflow Modeling

Parameterized dataflow modeling is a technique that can be applied to all dataflow models with deterministic token rates, in particular to SDF and CSDF [BB02]. It consists of creating a hierarchical view of the algorithm whose subsystems are then composed of 3 graphs:

- the body graph  $\phi_b$ : this is the effective dataflow sub-graph. Its productions and consumptions depend on certain parameters. These parameters are called topology parameters because they affect the topology of the body graph. The behavior of the actors (not expressed in the coordination language) depends on parameters that will be called actor parameters.
- the init graph  $\phi_i$ : this graph is launched one time only when a subsystem interface is reached, i.e. once per **invocation** of the subsystem. It performs a reconfiguration of the subsystem, setting parameters that will be common to all  $\phi_b$  firings during the invocation.  $\phi_i$  does not consume any data token.
- the subInit graph  $\phi_s$ : it is launched one time before each body graph firing and also sets parameters.  $\phi_s$  can consume data tokens.

Parameterized dataflow modeling is generally applied to SDF graphs. In this case, it is called PSDF for Parameterized Synchronous Dataflow. A complete description of PSDF can be found in [BB01]; only the properties of interest to LTE are studied here. Figure 3.7 shows a small PSDF top graph  $G$  with three actors  $A$ ,  $B$ , and  $C$ .  $A$  and  $B$  are atomic SDF actors, i.e. they contain no hierarchical subsystem.  $C$  contains a PSDF sub-graph with one topology parameter  $r$  and two actor parameters  $p$  and  $q$ . A compressed view of a single-core schedule for  $G$  is also displayed in the Figure. The internal schedule of  $\phi_b$  is not shown because this schedule depends on the topology parameter  $r$  alone.

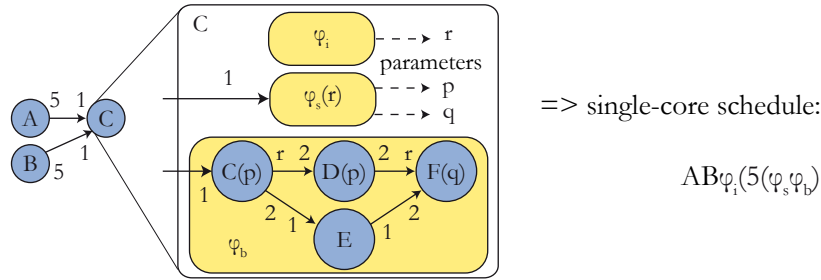

**Figure 3.7:** *PSDF Example*

PSDF can also be seen as a dynamic extension of SDF because token productions and consumptions depend on topology parameters that can vary at run-time. The PSDF parameter values must be restricted to a domain (a set of possible values) to ensure that the graph can be executed with a bounded memory. The set of the graph  $G$  parameter domains is written  $DOMAIN(G)$ . Similarly, the token rate at each actor port is limited to a maximum token transfer function and the delays on each edge are limited to a maximum delay value.

The most interesting property of PSDF is that its hierarchical form enables the compile-time study of local synchrony in the subsystem [BB01]. Local synchrony ensures that each local synchronous subsystem of a PSDF graph can be scheduled in SDF fashion: either switching between pre-computed SDF schedules or scheduling at run-time. For a given set of parameters values  $C$ , the graph  $instance_G(C)$  is locally synchronous if:

1.  $instance_G(C)$  is consistent (consistency is defined in Section 3.2) and deadlock-free,
2. the maximum token transfer function and maximum delay value are respected,
3. each subsystem in  $instance_G(C)$  is locally synchronous.

$G$  is locally synchronous (independent of its parameter values) if:

1.  $\phi_b$ ,  $\phi_i$  and  $\phi_s$  are locally synchronous for a given parameter value set  $C \subset DOMAIN(G)$ ,
2.  $\phi_i$  and  $\phi_s$  produce one parameter token per firing,
3. the number of dataflow input tokens of  $\phi_s$  is independent of the general dataflow input of the subsystem,
4. the productions and consumptions at interfaces of  $\phi_b$  do not depend on parameters configured in  $\phi_s$ .



If  $G$  is locally synchronous, a local SDF schedule can be computed at run-time to execute the graph. Though  $\phi_i$  and  $\phi_s$  can set both topology and actor parameters, general practice is for  $\phi_s$  to only change actor parameters so identical firings of  $\phi_b$  occur for each subsystem invocation. When this condition is satisfied, a local SDF schedule only needs to be computed once after  $\phi_i$  is executed. Otherwise, the local SDF schedule needs to be computed after each  $\phi_s$  firing.

In this LTE study, Parameterized CSDF is also of interest; this is equivalent to PSDF except the parameters are not only scalars but can be patterns of scalars similar to the CSDF model. For this thesis, the PDSF init and the PSDF sub-init graphs employed are degenerated graphs containing only a single actor and do not consume or produce any data tokens. They are thus represented by a simple rectangle illustrating the actor execution (Chapter 8).

### 3.4.2 Interface-Based Hierarchical Dataflow

Interface-Based Hierarchical Dataflow Modeling is introduced by Piat, et al. in [PBR09] and [PBPR09]. Like Parameterized Dataflow Modeling, it may be seen as a meta-model that can be applied to several deterministic models. The objective of Interface-Based Hierarchical Dataflow Modeling is to allow a high-level dataflow graph description of an application, composed of sub-graphs. If an interface is not created to insulate the upper graph from its sub-graphs, the actor repetitions of sub-graphs can result in the actor repetitions of the upper graph appearing illogical to the programmer. The Interface-Based Hierarchical Dataflow Modeling has been described in combination with SDF in the so-called Interface-Based Hierarchical SDF or IBSDF. The model obtained encapsulates sub-graphs and protects upper graphs. Encapsulation is a very important model property; it enables the combination of semiconductor intellectual property cores (commonly called IPs) in electronic design and is the foundation of object oriented software programming.

The operation of hierarchy flattening consists of including a sub-graph within its parent graph while maintaining the general system behavior. Figure 3.8(a) shows an example of a SDF graph with a hierarchical actor of which the programmer will probably want the sub-graph to be repeated three times. Yet, the sub-graph behavior results in a very different flattened graph, repeating the actor  $A$  from the upper graph. Figure 3.8(b) illustrates the same example described in as a IBSDF graph. Source and sink interfaces have been introduced. The resulting flattened graph shape is more intuitive. The additional broadcast actors have a circular buffering behavior: as each input is smaller in size than the sum of their outputs, they duplicate each input token in their output edges.

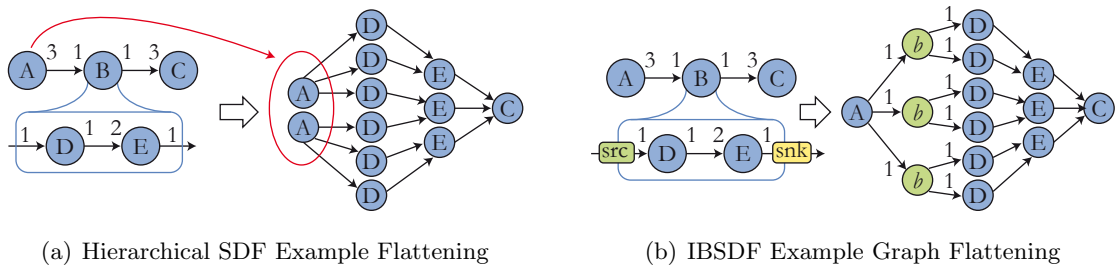

**Figure 3.8:** Comparing Direct Hierarchical SDF with IBSDF

Compared with other SDF actors, the IBSDF interfaces have specific behavior. They are designed to constitute code closures (i.e. semantic boundaries). The IBSDF type of

hierarchy is closer to host language semantics such as C, Java and Verilog. The additional features have been shown to introduce no deadlock [PBPR09].

A Source node is a bounded source of tokens which represents the tokens available for a sub-graph iteration. This node acts as an interface to the outside world. A source port is defined by the four following rules:

1. **Source production homogeneity:** A source node *Source* produces the same amount of tokens on all its outgoing connections  $p(e) = n \quad \forall e \in \{Source(e) = Source\}$ .
2. **Interface Scope:** The source node remains write-locked during an iteration of the sub-graph. This means that the interface cannot be externally filled during the sub-graph execution.
3. **Interface boundedness:** A source node cannot be repeated, thus any node consuming more tokens than available from the node will consume the same tokens multiple times (i.e. circular buffer).  $c(e) \% p(e) = 0 \quad \forall e \in \{source(e) = source\}$ .
4. **SDF consistency:** All the tokens available from a source node must be consumed during an iteration of the sub-graph.

A sink node is a bounded sink of tokens that represent the tokens to be produced by one iteration of the sub-graph. This node behaves as an external interface. A sink node is defined by the four following rules:

1. **Sink producer uniqueness:** A sink node *Sink* only has one incoming connection.
2. **Interface Scope:** The sink node remains read-locked during an iteration of the sub-graph. This means that the interface cannot be externally read during the sub-graph execution.
3. **Interface boundedness:** A sink node cannot be repeated, thus any node producing more tokens than needed will write the same tokens multiple times (i.e. ring buffer).  $p(e) \% c(e) = 0 \quad \forall e \in \{target(e) = Sink\}$ .
4. **SDF consistency:** All tokens consumed by a sink node must be produced during an iteration of the sub-graph.



**Figure 3.9:** IBSDF Sub-Graph Example and Its Single Rate Equivalent

Source and sink nodes cannot be repeated, providing a fixed reference interface to combine these nodes in an upper level graph. A source node, behaving as a circular buffer, sends the same tokens to its graph possibly several times. A sink node, behaving as a circular buffer, stores the last tokens received from its graph. Figure 3.9 shows an example of an IBSDF graph and its single rate equivalent. IBSDF has an extremely important property: an IBSDF graph is schedulable if and only if its constituent SDF

sub-graphs are schedulable [PBR09]. Moreover, the interfaces do not influence SDF sub-graph schedulability. Independently applying the SDF BRV calculation to each algorithm part with complexity  $O(|V|^2|E|)$  presented in Section 3.2 makes the overall calculation much faster.

In this thesis, IBSDF is the model chosen to describe LTE algorithms for rapid prototyping. Several features have been added for the use of IBSDF in PREESM to enhance expressivity and ease code generation. The final model is presented in section 6.2.1.

While chapters 2 and 3 introduced the target application of this study and the MoCs available to model it, chapter 4 will detail the process of rapid prototyping, which will be applied to LTE in the following chapters.



---

## Rapid Prototyping and Programming Multi-core Architectures

---

### 4.1 Introduction

This chapter gives an over view of the existing work on rapid prototyping and multi-core deployment in the signal processing world. The concept of rapid prototyping was introduced in Figure 1.2 when outlining the structure of this thesis. It consists of automatically generating a system simulation or a system prototype from quickly constructed models. Rapid prototyping may be used for several purposes; this study uses it to manage the parallelism of DSP architectures. Parallelism must be handled differently for the macroscopic or microscopic views of a system. The notions that are developed in this section will be used to study LTE in Part II. Section 4.2 gives an insight into embedded heterogeneous architectures. Section 4.3 is an overview of the multi-core programming techniques and Section 4.4 focuses on the internal mechanism of multi-core scheduling. Finally, Section 4.5 presents some results from the literature on automatic code generation.

#### 4.1.1 The Middle-Grain Parallelism Level

The rapid prototyping and programming method focuses on particular classes of algorithms and architecture, and a certain degree of parallelism. This study targets signal processing applications running on multi-core heterogeneous systems and the objective is to exploit their middle-grain parallelism. These terms are defined in next sections.

The problem of parallel execution is complex and analysis is aided if it is broken down into sub-problems. An application does not behave similarly at system-level or low-level. Three levels of granularity are usually evoked in literature and concurrency can be exploited at each of these three levels: Instruction-Level Parallelism (ILP), Thread-Level Parallelism (ThLP) and Task-Level Parallelism (TLP). An **instruction** is a single operation of a processor defined by its Instruction Set Architecture (ISA). The term **task** is used here in the general sense of program parts that share no or little information with each other. Tasks can contain several **threads** that can run concurrently but have data or control dependencies. The three levels of granularity are used to specify parallelism in a hierarchical way. Table 4.1 illustrates the current practices in parallelism extraction of applications.

The **Task Level Parallelism** concerns loosely coupled processes with few depen-

**Table 4.1:** *The Levels of Parallelism and their Present Use*

Parallelism Level	Target Architectures	Source Code	Parallelism Extraction
Instruction-Level	SIMD or VLIW Architectures	Imperative or functional programming languages (C, C++, Java...)	Parallel optimizations of a sequential code by the language compiler
Thread Level	Multi-core architecture with multi-core RTOS	Multi-threaded programs, parallel language extensions...	Compile-time or run-time partitioning and scheduling under data and control dependency constraints
Task Level	Multi-core architecture with or without multi-core RTOS	Loosely-coupled processes from any language	Compile-time or Run-time partitioning and scheduling

dependencies. Processes are usually fairly easy to execute in parallel. Processes can either be assigned to a core manually or by a Real-Time Operating System (RTOS). The few shared resources can usually be efficiently protected manually.

The **Instruction-Level Parallelism** has been subject of many studies in the 1990s and 2000s and effective results have been obtained, either executing the same operation simultaneously (Single Instruction Multiple Data or SIMD) or even different independent operations simultaneously (Very Long Instruction Word or VLIW [DSTW96]) on several data sets. Instruction-Level Parallelism can now be extracted automatically by compilers from sequential code, for instance written in C, C++ or Java. The most famous SIMD instruction set extensions are certainly the MMX and Streaming SIMD Extensions (SSE) x86. The Texas Instruments c64x and c64x+ Digital Signal Processor (DSP) cores have VLIW capabilities with 8 parallel execution units (Section 5.1.1). There is a natural limit to such parallelism due to dependencies between successive instructions. Core instruction pipelines complete the SIMD and VLIW parallelism, executing simultaneously different steps of several instructions. Instruction-level parallelizing and pipelining are now at this limit and it is now the middle-grain parallel parallelism functions with some data dependency that need further study: the Thread-Level Parallelism (ThLP).

**Thread Level Parallelism** is still imperfectly performed and multi-threading programming may not be a sustainable solution, due to its non-predictability in many cases, its limited scalability and its difficult debugging [Lee06]. Yet, ThLP is the most important level for parallelizing dataflow applications on the current multi-core architectures including a small number of operators because ThLP usually contains much parallelism with reduced control, i.e. “stable” parallelism. The term operator will be used to designate both software cores and hardware Intellectual Properties (IP), the latter being dedicated to one type of processing (image processing, Fourier transforms, channel coding...). In past decades, the studies on operating systems have focused on the opposite of thread parallelization: the execution of concurrent threads on sequential machines, respecting certain time constraints. The concept of thread was invented for such studies and may not be suited for parallel machines. The solution to the parallel thread execution problem possibly lies in code generation from dataflow models. Using dataflow models, threads

are replaced by actors that have no side effects, are purely functional and communicate through well defined data channels [LP95]. A side effect is a modification of a thread state by another thread due to shared memory modifications. Using actors, thread-Level parallelism then becomes **Actor Level Parallelism** (ALP); the general problem of managing parallelism at ThLP and ALP will be called **middle-grain parallelism**.

While task and instruction parallelism levels are already managed efficiently in products, middle-grain parallelism level is still mostly at a research phase. The PREESM framework aims to provide a method for an efficient and automatic middle-grain parallelization.

## 4.2 Modeling Multi-Core Heterogeneous Architectures

### 4.2.1 Understanding Multi-Core Heterogeneous Real-Time Embedded DSP MPSoC

The target hardware architectures of this thesis are associated with a great number of names and adjectives. These terms need definitions:

- **DSP** can refer to both Digital Signal Processing and Digital Signal Processor. In this thesis, DSP is used to refer to Digital Signal Processors, i.e. processors optimized to efficiently compute digital signal processing tasks.
- An **embedded system** is a calculator contained in a larger system embedded into the environment it controls. Real-time embedded systems include mobile phones, multimedia set-top boxes, skyrocket and, of interest in this thesis, wireless communication base stations. Only systems with very strict constraints on power consumption will be considered; this does not include hardware architectures consuming tens or hundreds of Watts such as Graphical Processing Units (GPU) or general purpose processors. The study concentrates on Digital Signal Processors (DSP), which are well suited for real-time embedded signal processing systems.
- A **real-time system** must respect the time constraints defined by the running application and produce output data at the exact time the environment requires it. Real-time systems include video or audio decoding for display, machine-tool control, and so on.
- **Multi-Core** is a generic term for any system with several processor cores able to concurrently execute programs with Middle-grain or Task-Level Parallelism.
- **Heterogeneous** refers to the existence of different types of operators within the system. It can also refer to the non-symmetrical access to resources, media with differing performances or cores with different clock speeds.
- A **Multi-Processor System-on-Chip** or MPSoC is a term widely used to designate a multi-core system embedded in a single chip.

In general, modern multi-core embedded applications are manually programmed, using C or C++ sequential code, and optimized using assembly code. Manual multi-core programming is a complex, error-prone and slow activity. The International Technology Roadmap for Semiconductors (ITRS) evaluates that embedded software productivity doubles every five years; this is a much slower growth than that of processor capabilities. ITRS predicts the cost of embedded software will increase until 2012 where it will reach

three times the total cost of embedded hardware development. At that time, parallel development tools are predicted to reduce software development costs drastically [fS09]. The goal of this study is to contribute to this evolution.

Today, Multi-core digital signal operators, including up to several DSPs, face a choice. They may choose to use a small number of complex cores or to use many simple ones. The more cores are involved, the more complex the problem of exploiting them correctly becomes. With a few exceptions, the present trend in powerful digital signal processing architectures is to embed a small number of complex processor cores on one die [KAG<sup>+</sup>09]. Software-defined radio, where signal processing algorithms are expressed in software rather than in hardware, is now widely used for embedded systems including base stations. However, certain repetitive compute-hungry functionalities can make a totally software-defined system suboptimal. Hardware accelerators, also known as coprocessors, can process compute-hungry functionalities in a power-efficient way. They cost programming flexibility but increase the system power efficiency. The current work studies heterogeneous multi-core and multi-processor architectures with a few (or a few tens) complex DSP cores associated with a small number of hardware coprocessors. Architectures with more than a few tens of operators are (currently) called “many-core”.

In following sections, the term multi-core system is used for the very general case of either one processor with several cores or several interconnected processors. The next section explores architecture modeling for such systems.

#### 4.2.2 Literature on Architecture Modeling

Today, processor cores are still based on the **Von Neumann model** created in 1946, as illustrated in Figure 4.1. It consists of a memory containing data and programs, an Arithmetic and Logic Unit (ALU) that processes data, input and output units that communicate externally, and a control unit that drives the ALU and manages the program. Externally, this micro-architecture can be seen as a black box implementing an **Instruction Set Architecture** (ISA), writing/reading external memory and sending/receiving messages. Such an entity is called an operator. An operator can have an ISA so restricted that it is no longer considered to a processor core but a coprocessor dedicated to one or a few tasks.

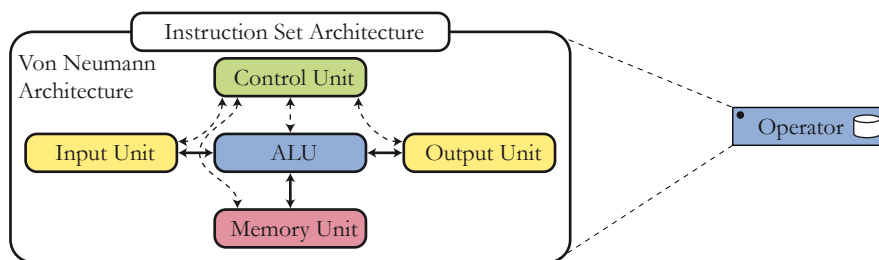

**Figure 4.1:** *The Von Neumann Architecture of an Operator*

The literature on architecture models is less extensive than that of algorithm models. The majority of the literature focuses on classifying architectures, and associating specific architectures to categories. Processors have been split between Complex Instruction Set Computer (CISC) and Reduced Instruction Set Computer (RISC) depending on their instruction set complexity [Hea95]. The limit between CISC and RISC machines is generally unclear. Many instruction sets exist, each with its own tradeoff between core clock speed and advanced instruction capabilities. Tensilica [Ten] is a company known for tools capa-



ble of generating DSP cores with customizable ISA. Thus, CISC or RISC may no longer be a valid criterion to define a processor.

The Flynn taxonomy [Fly72] has introduced four categories of machines classified depending on their instruction and/or data parallelism at a given time: Single Instruction Single Data (SISD), Single Instruction Multiple Data (SIMD), Multiple Instruction Single Data (MISD) and Multiple Instruction Multiple Data (MIMD). MIMD machines, requiring many control information at each clock cycle, have been implemented using Very Long Instruction Words (VLIW). MIMD systems have a sub-classification [BEPT00] based on their memory architecture types, splitting MIMD machines into 3 categories:

- A **Uniform Memory Access** (UMA) machine has a memory common to all its operators which is accessed at the same speed with the same reliability. This shared memory is likely to become the bottleneck of the architecture; two solutions can increase the access speed: it may be divided into banks attributed to a specific operator in a given time slot or it may be accessed via a hierarchical cache.
- A **Non Uniform Memory Access** (NUMA) machine has a memory common to all its operators but access speed to this memory is heterogeneous. Some operators have slower access speeds than others.
- A **NO Remote Memory Access** (NORMA) machine does not have a shared memory. Operators must communicate via messages. NORMA architecture is usually called **distributed architecture** because no centralized memory entity exists.

In Chapter 5, a new system-level architecture model is introduced. Architecture models exist in the literature but they were not suited to model target architectures for rapid prototyping. The SystemC language [sys] and its Transaction Level Modeling (TLM) is a set of C++ templates that offers an efficient standardized way to model hardware behavior. Its focus is primarily the study and debugging of the hardware and software functionalities before the hardware is available. It defines abstract modules that a programmer can customize to its needs. For this rapid prototyping study, more precise semantics of architecture element behaviors are needed than those defined in SystemC TLM. Another example of language targeting hardware simulation is a language created by the Society of Automotive Engineers (SAE) and named Architecture Analysis and Design Language (AADL [FGHI06]). The architecture part of this language is limited to the three nodes: processor, memory and bus. Processes and threads can be mapped onto the processors. This model is not adaptable to the study presented here because it focuses on imperative software containing preemptive threads and the architecture nodes are insufficient to model the target architectures with Direct Memory Accesses (DMA) and switches (Section 5.1.1).

In next section, existing work on multi-core programming is presented.

## 4.3 Multi-core Programming

### 4.3.1 Middle-Grain Parallelization Techniques

Middle-grain parallelization consists of four phases: **extraction**, **assignment**, **ordering** and **timing**. Parallel actors must be extracted from the source code or model and all their dependencies must be known. Parallel actors are then assigned (or mapped) to operators available in the target architecture. Their execution on operators must also be

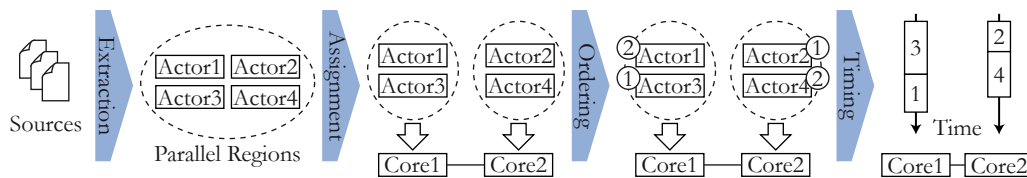

**Figure 4.2:** *The Four Phases of Middle-Grain Parallelization: Extraction, Assignment, Ordering and Timing*

ordered (or scheduled) because usually, there are fewer operators than actors. Finally, a start time for the execution of each actor must be chosen. The four tasks of extraction, assignment, ordering and timing, are illustrated in Figure 4.2. Graham showed in the 1960s that relaxing certain constraints in a parallel system with dependencies can lead to worsened performance when using a local mapping and scheduling approach [Gra66], making middle-grain parallelism extraction a particularly complex task.

In [POH09], Park, et al. divide the current embedded system design methods into 4 categories based on their input algorithm description. All four methods focus on the middle-grain parallelism level:

- **Compiler-based** design methods extract middle-grain parallel actors from sequential code such as C-code, and map actors on different operators to enable their parallel execution. The method is analogous to that broadly adopted for the Instruction-Level. The obvious advantage of this method is the automatic parallelization of legacy code and, for an efficient compiler, no further effort is required from software engineers to translate their code. The key issue in the complex operation of parallelism extraction is to find middle-grain actors, coarse-grained enough to group data transfers efficiently and fine-grained enough to enable high parallelism. Using imperative and sequential code as an input, these methods are very unlikely to exploit all the algorithm potential parallelism. An example of a compiler implementing compiler-based method is the MPSoC Application Programming Studio (MAPS) from Aachen RWTH University [CCS<sup>+</sup>08] which generates multi-threaded C code from sequential C code and parallelizes these threads.
- **Language-extension** design methods consist of adding information to a sequential language that eases parallel actors' extraction. With Open Multiprocessing (OpenMP [opeb]) for instance, a programmer can annotate C, C++ or Fortran code and indicate where he wants parallelism to be extracted. The CILK language [BJK<sup>+</sup>95] from the Massachusetts Institute of Technology is another example of such a technology adapted to C++. The compiler automates the mapping and transfers of parallel actors. OpenMP is already supported by the majority of the C, C++ and Fortran compilers. It was developed for Symmetric Multi-Processor (SMP) architectures and is likely to offer sub-optimal solutions for heterogeneous architectures. Other language extensions for parallelism that exist are less automated: Message Passing Interface (MPI), OpenCL [opea] or the Multicore Association API [mca] which offers APIs for manual multi-core message passing or buffer sharing.
- **Platform-based** methods actually refers to a single solution based on a Common Intermediate Code (CIC) [KKJ<sup>+</sup>08], equivalent to a compiler Intermediate Representation (IR) with parallelism expressivity. It is intended to create an abstraction of the platform architecture to the compiler front-end that extracts parallelism.

- **Model of Computation (MoC)-based** design methods describe high-level application behavior with simple models. While compilation-based parallelization appeals to programmers because they can almost seamlessly reuse their huge amount of existing sequential code (generally in C or C++), MoC-based design methods bring several advantages compared with previous methods. They are aimed at expressing high-level algorithm descriptions into simple textual files or graph-based Graphical User Interfaces. MoC-based methods have three great advantages. Firstly, parallelism is naturally expressed by a graph. An extraction with a compilation algorithm will always under-performing on certain cases. The first step of Figure 4.2 becomes straightforward. Secondly, certain rules of a model-based design (such as schedulability) can be verified at compile-time and correct-by-construction high-level code may be generated. Thirdly, the transaction-level form of dataflow graphs can enable co-simulation of entities of different forms. This is why the Transaction-Level Modeling (TLM [Ghe06]) of SystemC is based on a dataflow MoC. Hardware-defined modules can be interconnected with software-defined modules.

As explained in Chapter 3, dataflow MoCs have been chosen to represent algorithms in the development of the rapid prototyping method and the prototyping framework PREESM.

### 4.3.2 PREESM Among Multi-core Programming Tools

There exist numerous solutions to partition algorithms onto multi-core architectures. If the target architecture is homogeneous, several solutions will generate multi-core code from C with additional information (OpenMP [opeb], CILK [BJK<sup>+</sup>95]). In the case of heterogeneous architectures, languages such as OpenCL [opea] and the Multicore Association Application Programming Interface (MCAPI [mca]) define ways to express parallel properties of a code. However, they are not currently linked to efficient compilers and run-time environments. Moreover, compilers for such languages would have difficulty in extracting and solving the bottlenecks inherent to graph descriptions of the architecture and the algorithm. A bottleneck is a feature limiting the system performance.

The Poly-Mapper tool from PolyCore Software [pol] offers functionalities similar to PREESM but, in contrast to PREESM, has manual mapping/scheduling. Ptolemy II [Lee01] is a simulation tool that supports many computational models. However, it has no automatic mapping and its current code generation for embedded systems is focused on single-core targets. Another family of frameworks existing for dataflow based programming is based on CAL [EJ03] language and it includes OpenDF [BBE<sup>+</sup>08]. OpenDF employs a more dynamic model than PREESM but its related code generation does not currently support multi-core embedded systems.

Closer in principle to PREESM are the Model Integrated Computing (MIC [KSLB03]), the Open Tool Integration Environment (OTIE [Bel06]), the Synchronous Distributed Executives (SynDEx [GLS99]), the Dataflow Interchange Format (DIF [HKK<sup>+</sup>04]), and SDF for Free (SDF3 [Stu07]). Both MIC and OTIE cannot be found on internet. According to the literature, MIC focuses on the transformation between algorithm domain-specific models and meta-models while OTIE defines a single system description that can be used during the whole signal processing design cycle.

DIF is designed as an extensible repository of representation, analysis, transformation and scheduling of dataflow language. DIF is a Java library which allows the user to go from graph specification using the DIF language to C code generation. However, the IBSDF model (Section 3.4.2) as used in PREESM is not available in DIF.

**Table 4.2:** *Scheduling strategies*

	assignment	ordering	timing
fully dynamic	run	run	run
static-assignment	compile	run	run
self-timed	compile	compile	run
fully static	compile	compile	compile

SDF3 is an open source tool implementing certain dataflow models and providing analysis, transformation, visualization, and manual scheduling as a C++ library. SDF3 implements the Scenario Aware Dataflow (SADF [The07]), and provides a Multi-Processor System-on-Chip (MP-SoC) binding/scheduling algorithm to output as MP-SoC configuration files.

SynDEx and PREESM are both based on the AAM methodology [GS03] but these tools do not possess the same features. SynDEx is not open source, has a unique Model of Computation that does not support schedulability analysis and the function of code generation is possible but not provided with the tool. Moreover, the architecture model of SynDEx is at too high a level to account for bus contentions and DMA used in modern chips (multi-core processors of MP-SoC) in mapping/scheduling.

The features that differentiate PREESM from the related works and similar tools are :

- The tool is open source and accessible online,
- The algorithm description is based on a single well-known and predictable model of computation,
- The scheduling is totally automatic,
- The functional code for heterogeneous multi-core embedded systems can be generated automatically,
- The IBSDf algorithm model provides a helpful hierarchical encapsulation thus simplifying the scheduling [PBPR09].

The rapid prototyping method used in this study and the PREESM tool have a multi-core scheduler as the central feature. The multi-core scheduling techniques proposed in this study are based on well-known algorithms from the literature presented in next section.

## 4.4 Multi-core Scheduling

### 4.4.1 Multi-core Scheduling Strategies

In [Lee89], Lee develops a taxonomy of scheduling algorithms that distinguishes run-time and compile-time scheduling steps. The choice of the scheduling steps executed at compile-time and the ones executed at run-time is called a scheduling strategy. The taxonomy of scheduling strategies is summarized in Table 4.2. These strategies are displayed on the left-hand side column and are ordered from the most dynamic to the most static.

The principle in [Lee89] is that a maximal number of operation should be executed at compile time because it reduces the execution overhead due to run-time scheduling. For a given algorithm, the lowest possible scheduling strategy in the table that enables suited schedules should thus be used.

The fully static strategy is based on the idea that the exact actor relations and execution times are known at compile-time. When this is the case, the operators do not need to be synchronized at run-time, they only need to produce and consume their data at the right moment in the cycle. However, the modern DSP architectures with caches and RTOS that manipulate threads do not qualify for this type of strategy. The self-timed strategy which still assigns and orders at compile-time but synchronizes the operators is well suited to execute a SDF graph on DSP architecture. This strategy has been the subject of much study in [SB09] and will be used in Chapter 8. The static assignment strategy consists of only selecting the assignment at compile time and delegating the task to order and fire actors to a RTOS on each core. This method is quite natural to understand because the RTOS on each core can exploit decades of research on efficient run-time single-core thread scheduling. Finally, the fully dynamic strategy makes all choices at run-time. Being very costly, fully dynamic schedulers usually employ very simple and sub-optimal heuristics. In Section 8.3, a technique implementing a fully dynamic strategy and named adaptive scheduling is introduced. Adaptive scheduling schedules efficiently the highly variable algorithms of LTE.

The scheduling techniques for multi-core code generation most applicable for LTE physical layer algorithms are the self-timed and adaptive scheduling ones. [Lee89] claims that self-timed techniques are the most attractive software scheduling techniques in terms of tradeoff between scheduling overhead and run-time performance but the highly variable behavior of the LTE uplink and downlink algorithms compels the system designer to develop adaptive technique(Chapter 8).

#### 4.4.2 Scheduling an Application under Constraints

Using directed acyclic dataflow graphs as inputs, many studies have focused on the optimization of an application behavior on multi-core architectures. The main asset of these studies is the focus they can give on the middle-grain behavior of an algorithm. They naturally ignore the details of the instructions execution and deal with the correct partitioning of data-driven applications. Concurrent system scheduling is a very old problem. It has been extensively used, for example, to organize team projects or distributing tasks in factories.

A model of the execution must be defined to simulate it while making assignment and ordering choices. In this study, an actor or a transfer fires as soon as its input data is available. This execution scheme corresponds to a self-timed schedule (Section 4.4.1) [SB09]. Other execution schemes can be defined, for instance triggering actors only at periodic clock ticks. A self-timed multi-core schedule execution can be represented by a Gantt chart such as the one in Figure 4.3. This schedule results from the scheduling of the given algorithm, architecture and scenario.

The scenario will be detailed in Chapter 6 and the architecture model in Chapter 5. The next section explains scheduling techniques.

Multi-core scheduling under constraints is a complex operation. This problem has been proven to be in the NP-complete (Non-deterministic Polynomial-time-complete) complexity class [Bru07]. Many “useful” problems are NP-complete and [GJ90] references many of them. The properties of NP-complete problems are that:

1. the verification that a possible solution of the problem is valid can be computed in polynomial time. In the scheduling case, verifying that a schedule is valid can be done in polynomial time [CLRS01].

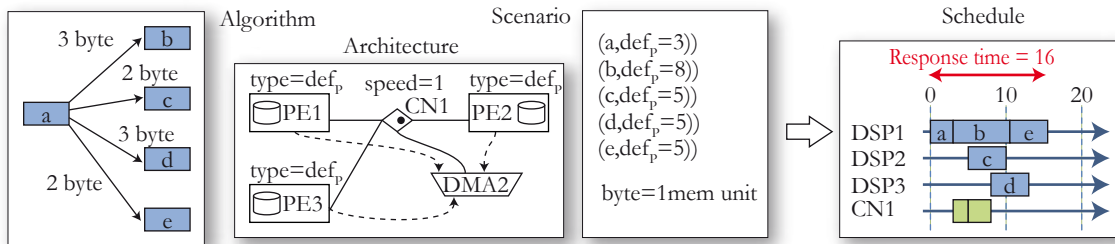

Figure 4.3: Example of a schedule Gantt chart

2. an NP-complete problem can be “converted” into any other NP-complete problem in polynomial time. This means that solving one NP-complete problem in polynomial time would result in solving them all in polynomial time,
3. unfortunately, no polynomial time algorithm for NP-complete problems is known and it is likely that none exists.

Proving that a problem is NP-complete consists in finding a polynomial transformation from the considered problem to a known NP-complete problem. An example of such a polynomial transformation is given in [SB09] p.49. The multi-core scheduling problem is NP-complete, so heuristics must be found that offer a tradeoff between computational time and optimality of results.

#### 4.4.3 Existing Work on Scheduling Heuristics

The literature on multi-core scheduling is extensive. In [Bru07], Brucker gives a large overview of scheduling algorithms in many domains.

Assignment, ordering and timing can be executed either at compile-time or at run-time, defining a scheduling strategy. In his PhD thesis [Kwo97], Kwok gives an overview of the existing work on multi-core compile-time scheduling and puts forward three low complexity algorithms that he tested over random graphs with high complexity (in the order of 1000 to 10000 actors). In this PhD, the objective function is always the latency of one graph iteration.

Multi-core scheduling heuristics can be divided into three categories depending on their target architecture:

1. **Unbounded Number Of Clusters** (UNC) heuristics consider architectures with infinite parallelism, totally connected and without transfer contention.
2. **Bounded Number of Processors** (BNP) heuristics consider architectures with a limited number of operators, totally connected and without transfer contention.
3. **Arbitrary Processor Network** (APN) heuristics consider architectures with a limited number of operators, not totally connected and with transfer contention.

From the first UNC heuristic by Hu in 1961 [Hu61], many heuristics have been designed to solve the BNP and then the APN generic problems. The architecture model of the APN is the most precise one. This category needs to be addressed because modeled heterogeneous architectures are not totally connected.

Most of the heuristics enter in the BNP **static list scheduling** category. A static list scheduling takes as inputs:

- A DAG  $G = (V, E)$ ,
- an execution time for each vertex  $v$  in  $V$  which is the same on every operator because each is homogeneous,
- a transfer time for each edge  $e$  in  $E$  which is the same between any two operators because they are totally connected with perfectly parallel media,
- a number of operators  $P$ .

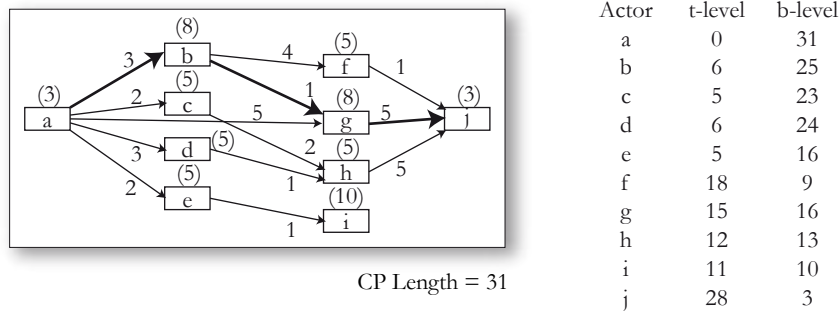

**Figure 4.4:** *T-Level and B-Level of a Timed Directed Acyclic Graph*

For each actor in the DAG (Section 3.2), timings can be computed that feed the scheduling process. DAG timings are displayed in Figure 4.4; they include:

1. The **t-level** or **ASAP** (As Soon As Possible) starting time of an actor  $v$  is the time of the longest path from an entry actor to  $v$ . It represents the earliest execution time of  $v$  if no assignment and ordering constraint delays  $v$ .
2. The **b-level** of  $v$  is the time of the longest path from  $v$  to an exit actor (including the duration of  $v$ ).

The **Critical Path** (CP) is the longest path between an entry actor and an exit actor in the DAG (Section 3.2.3) considering actor and edge durations. In Figure 4.4, the critical path is shown with larger lines. Timing a whole graph has a complexity  $O(|E| + |V|)$  because each actor and edge must be scanned once (forward for t-level and backward for b-level).

A static list scheduling heuristic consists of three steps:

1. **Find a DAG topological order.** A topological order is a linear ordering of the vertices of the DAG  $G = (V, E)$  such that if there is a directed edge between two actors  $u$  and  $v$ ,  $u$  appears before  $v$  [Sin07]. In [Mu09], Mu gives an algorithm to find an arbitrary topological order with a complexity  $O(|V| + |E|)$ , which is the minimal possible complexity [RvG99]. A directed graph is acyclic if and only if a topological order of its actors exists.
2. **Construct an actor list** from the topological order. This step is straightforward but necessitates a list ordering of complexity at least  $O(|V|.log(|V|))$  [RvG99].
3. **Assign and order actors** in order of the actor list without questioning the previous choices. The usual method to assign actors is to choose the operator that offers the earliest start time and add the actor at the end of its schedule. Kwok gives such an algorithm in [Kwo97] with a complexity  $O(P.(|E| + |V|))$ .

Static list scheduling heuristics are “greedy” algorithms because they make locally optimal choice but never consider these choices within the context of the whole system. Kwok gives an algorithm in  $O(|E| + |V|)$  to find an optimized actor list named **CPN-dominant list** based on the DAG critical path. Actors are divided into three sets:

1. **Critical Path Nodes (CPN)** are actors that belong to the critical path. To ensure a small latency, they must be allocated as soon as possible.
2. **In-Branch Nodes (IBN)** are actors that are not CPN. For each IBN  $v$ , a path exists between  $v$  and a CPN node or between a CPN node and  $v$ . This property means that scheduling choices of IBN nodes are likely to affect the CPN choices. They have a medium priority while mapping.
3. **Out-Branch Nodes (OBN)** are the actors that are neither CPN nor IBN. Their ordered execution on operators can also affect the execution latency but with lower probability than CPN and IBN. They have a low priority while mapping.

In the CPN-Dominant list, CPN nodes are inserted as soon as possible and OBN as late as possible while respecting the topological order. Figure 4.5 shows a CPN-Dominant list and the types (CPN, IBN or OBN) of the actors. The global complexity of the static list scheduling using a CPN-dominant list is  $O(|V|.log(|V|) + P.(|E| + |V|))$ .

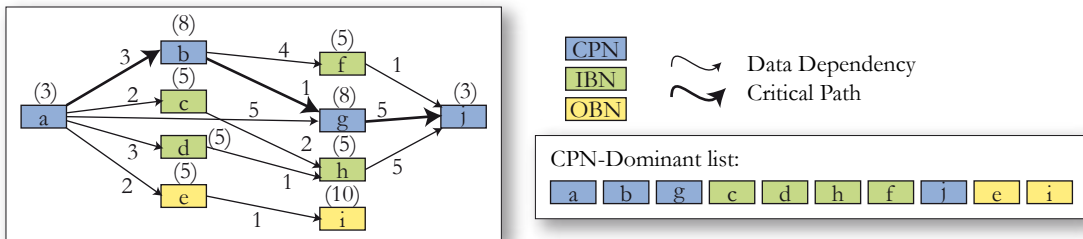

**Figure 4.5:** Construction of an Actor List in Topological Order

Dynamic list scheduling is another family of scheduling heuristics in which the order of the actors in the priority list is recomputed during the ordering process. [Jan03] advises against dynamic list scheduling heuristics because their slightly improved results compared to static list scheduling do not justify their higher complexity.

The FAST (Fast Assignment and Scheduling of Tasks) algorithm enters in the **neighborhood search** category. This algorithm starts from an initial solution, which it then refines, while testing local modifications. The FAST algorithm is presented in [Kwo97] and [KA99]. The FAST algorithm can run for an arbitrary length of time defined by user to refine the original solution. It consists of macro-steps in which CPN nodes are randomly selected and moved to another operator. One macro-step contains many micro-steps in which IBN and OBN nodes are randomly picked and moved to another operator. At each micro-step, the schedule length is evaluated and the best schedule is kept as a reference for the next macro-step. There is hidden complexity in the micro-step because the t-level of all the actors affected by the new assignment of an actor  $v$  must be recomputed to evaluate the schedule length. The affected actors include all the successors of  $v$  as well as all its followers in the schedules of its origin and target operators and their successors. Generally, these vertices represent a substantial part of the DAG graph. One micro step is thus always at least  $O(|E| + |V|)$ .



A Parallel FAST algorithm (or PFAST) is described in [Kwo97] and is an algorithm which can multi-thread the FAST execution. The CPN-dominant list is divided into sub-lists in topological order. Each thread processes the FAST on one sub-list, the results are grouped periodically and the best scheduling is kept as a starting point for the next FAST iteration. The PFAST heuristic is implemented in PREESM.

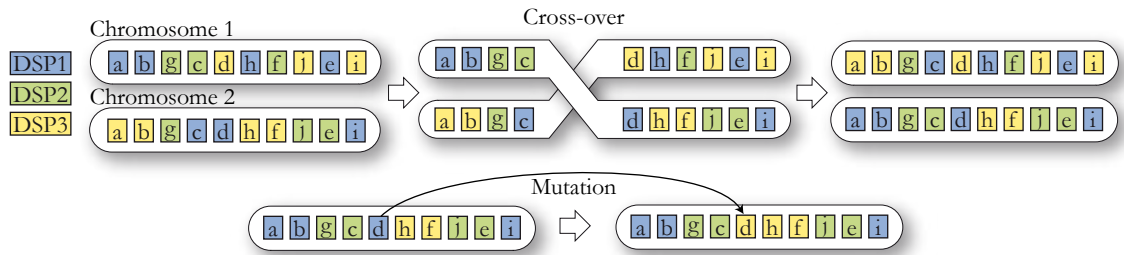

Figure 4.6: Genetic Algorithm Atomic Operations: Mutation and Cross-Over

A great advantage of the FAST algorithm is that it generates many schedules over time. A “population” of schedules can be generated by storing the  $N$  found schedules that had the lowest latency. In the population, each schedule ordered following the CPN-Dominant list is called a chromosome and each actor assignment is called a gene. For this initial population, a genetic algorithm can be launched on assignments and recursively the two operations displayed in Figure 4.6:

- A **mutation** randomly changes the assignment of one randomly selected actor (gene) in the schedule (chromosome).
- A one-point **cross-over** mixes two chromosomes, exchanging their assignments from the beginning to the crossover point.

After each step, which includes one mutation and one cross-over, the schedule latency is evaluated and the best schedule is kept.

All the above techniques are BNP scheduling heuristics and do not take into account inter-processor transfer ordering or contention between transfers sharing the same resource. [Sin07] and [Mu09] address this problem known as **edge scheduling**. The edge scheduling problem under constraints is NP complete [MKB06]. In Chapter 6, heuristics for edge scheduling are developed within a scheduling framework. PREESM uses modified versions of the list, FAST and genetic algorithms described above. These modified algorithms are discussed in Chapter 6.

## 4.5 Generating Multi-core Executable Code

The scheduling strategy (Section 4.4.1) greatly influences how code is generated from a scheduled graph. Two main choices exist: generating a static execution when no OS is necessary or to rely on an OS capable of adaptive scheduling. The term “adaptive” is used instead of “dynamic” to avoid confusion with dynamic list scheduling (Section 4.4.3).

### 4.5.1 Static Multi-core Code Execution

For applications that do not vary greatly from computed behavior, i.e. close estimates of its actor timings are computable, the code may be generated following the self-timed

scheduling strategy (Section 4.4.1). The Algorithm Architecture Matching method (AAM, previously AAA [GLS99]) is a method which generates self-timed coordination code from a quasi-static schedule of a dataflow graph. The MoC used is specific to the method and can contain conditions. Linear executions on each operator are interconnected with data transfers and synchronized with semaphores.

In [BSL97], Bhattacharyya, et al., present a self-timed code execution technique with reduced synchronization costs for the SDF MoC. The optimization removes the synchronization point and still protects data coherency when successive iterations of the graph overlap. Synchronizations are the overhead of a self-timed execution compared to a fully-static one. Synchronizations between the linear executions on each operator must be minimized for the code execution performances to match the simulation Gantt chart. Additionally, the buffer sizes are bounded to enable execution with limited FIFO sizes. Ideas in [BSL97] are extended in [SB09].

In [BKKB02] and [MKB06], the authors add to the minimization of the inter-core synchronization the idea of communication ordering. This idea, equivalent to edge scheduling (Section 4.4.3), can greatly reduce the latency of the graph execution.

In Section 8.2, a code generation technique is developed and applied to the Random Access Procedure part of the LTE physical layer processing.

#### 4.5.2 Managing Application Variations

The study of LTE will show that some algorithms are highly variable over time. In [BLMSv98], Balarin, et al. present an overview of the scheduling data problem and control-dominated signal processing algorithms. The lack of good models for scheduling adaptively algorithms when their properties vary over time is noted. [HL97] develops quasi-static scheduling techniques which schedule dynamic graphs at compile time. Quasi-static scheduling seeks an algorithm that enables good system parallelism in all cases of algorithm execution.

Studies exist that schedule variable algorithms at run-time. The Canals language [DEY<sup>+</sup>09] constitutes an interesting hierarchical dataflow approach to such run-time scheduling that appears similar to the hierarchical models in the Ptolemy II rapid prototyping tool, with each block having a scheduler [BHLM94] and a high-level scheduler invoking the schedulers of its constituent blocks. The Canals language focuses on image processing algorithms that can be modeled by a flow-shop problem [Bru07], i.e. several independent jobs each composed of sequential actors. Another dataflow run-time scheduling method that focuses on flow-shop problems is developed in [BBS09].

Section 8.3 presents an adaptive scheduler that uses a simplified version of the list scheduling algorithm in Section 4.4.3 and solves the LTE uplink scheduling problem in real-time on embedded platforms. In this scheduler, dataflow graphs are used as an Intermediate Representation for a Just-In-Time multi-core scheduling process.

## 4.6 Conclusion of the Background Part

In the Introduction Chapter, Figure 1.2 illustrated how the three background chapters are coordinated with the four contribution chapters.

The background chapters introduced three different domains necessary to understand multi-core and dataflow-based LTE rapid prototyping. The features of the LTE standard were detailed in Chapter 2. Chapter 3 explained the concept of dataflow Model of Computation that will be used to model LTE. Finally, existing work on rapid prototyping and

multi-core programming were developed in Chapter 4.

In the next chapters, contributions are explained that enhance the process of rapid prototyping: a new architecture model in Chapter 5, advanced rapid prototyping techniques in Chapter 6, LTE dataflow models in Chapter 7 and LTE multi-core code generation in Chapter 8.



**Part II**

**Contributions**



## 5.1 Introduction

For the LTE physical layer to be properly prototyped, the target hardware architectures need to be specified at system-level, using a simple model focusing on architectural limitations. The System-Level Architecture Model (S-LAM), which enables such specifications, is presented in Section 5.2. Sections 5.2.4 and 5.3 explain how to compute routes between operators from an S-LAM specification and Section 5.4 shows how transfers on these routes are simulated. Finally, the role of the S-LAM model in the rapid prototyping process is discussed in Section 5.5.

### 5.1.1 Target Architectures

It is Multi-Processor System-on-Chip (MPSoC) and boards of interconnected MPSoCs which are the architectures of interest and will be modeled. Modeling the system-level behavior is intended to be highly efficient, and employs a careful tradeoff between simulation accuracy and result precision. As the desired functionalities are generally software generation and hardware system-level simulation, the majority of the architecture details (local caches, core micro-architectures...) are hidden from system-level study by the compiler and libraries.

The hardware boards available for this LTE study are:

- One board containing two Texas Instruments TMS320TCI6488 processors (Figure 5.1).
- One board containing one Texas Instruments TMS320TCI6486 processor (Figure 5.3).

Both boards are based on DSP cores of type c64x+ [ins05]. A c64x+ core is a VLIW core that can execute up to 8 instructions per clock cycle. Instructions are 32-bit or 16-bit, implying an instruction word of up to 256 bits. The instructions themselves are SIMD: one c64x+ core embeds two multiply units, each one with the capacity of processing four 16-bit x 16-bit Multiply-Accumulates (MAC) per clock cycle. Each core can thus execute eight MAC per cycle.

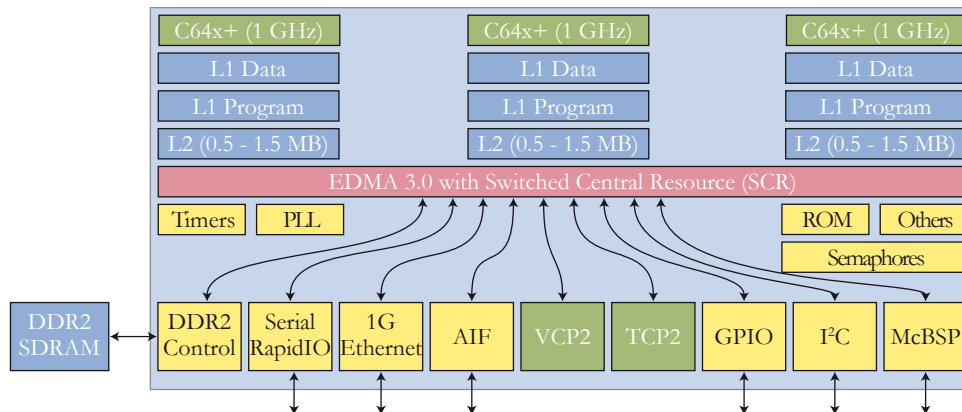

**Figure 5.1:** *TMS320TCI6488 Functional Block Diagram*

Figure 5.1 shows a block diagram of the Texas Instruments TMS320TCI6488 processor [tms07]. For simplicity, this processor will be called tci6488. Each of the three cores of a tci6488 is a c64x+ core clocked at 1 GHz. The cores of a tci6488 can thus execute up to 24 GMAC per second (Giga Multiply-Accumulates per second) for a power consumption of several Watts.

No internal memory is shared by the cores. Each core has a 32 kBytes Level 1 program memory and a 32 kBytes Level 1 data memory. A pool of 3 MBytes of Level 2 memory can be distributed among the three cores in one of two configurations: 1 MB/1 MB/1 MB or 0.5 MB/1 MB/1.5 MB. The cores communicate with each other and with coprocessors and peripherals using an Enhanced Direct Memory Access named EDMA3. The EDMA3 is the only entity in the chip with access to the entire memory map. The processor uses a DDR2 interface to connect to a Double Data Rate external RAM.

The tci6488 has many embedded peripherals and coprocessors. The Ethernet Media Access Controller (EMAC) offers a Gigabit Ethernet access while the Antenna Interface (AIF) provides six serial links for retrieving digital data from the antenna ports. Each link has a data rate of up to 3.072 Gbps and is compliant with OBSAI and CPRI standards. A standardized serial RapidIO interface can be used to connect other devices with data rates up to 3.125 Gbps. The tci6488 has two coprocessors: the TCP2 and the VCP2 accelerate the turbo decoding and Viterbi decoding of a bit stream respectively (Chapter 2). Cores and peripherals are interconnected by the Switched Central Resource (SCR), which is an implementation of a switch. A switch is a hardware component that connects several components with ideally no contention. Sinnen gives three examples of switch implementations: the crossbar, the multistage network and the tree network ([Sin07] p.18). Each offers a different tradeoff between hardware cost and contention management.

Figure 5.2 displays a photograph of a tci6488 die. It is fabricated using a 65-nm process technology. The internal memory, the three DSP cores, the Switched Central Resource, the coprocessors and peripherals are all clearly marked on the figure. It may also be seen that each c64x+ core represents only 8.5% of the chip surface area despite the fact that it is a state-of-the-art high performance DSP core. Meanwhile, the 3 MBytes of internal memory represent one third of the chip surface area. It may be concluded that embedding several cores in a single DSP has significantly less impact on the chip size than providing extended on-chip memory. However, interconnecting cores and coprocessors is not a negligible operation: 11.5% of the surface area is dedicated to the switch fabric



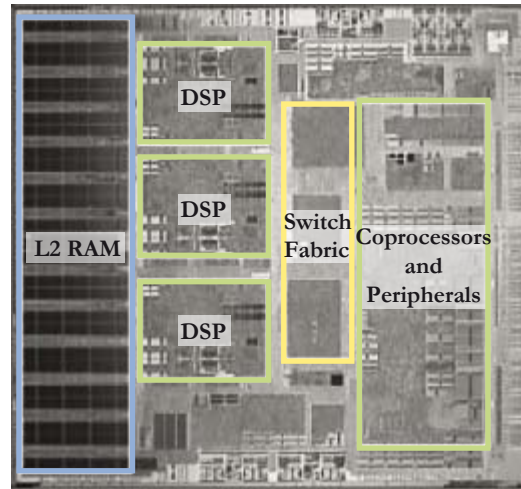

**Figure 5.2:** *Picture of a TMS320TCI6488 Die*

interconnecting the elements.

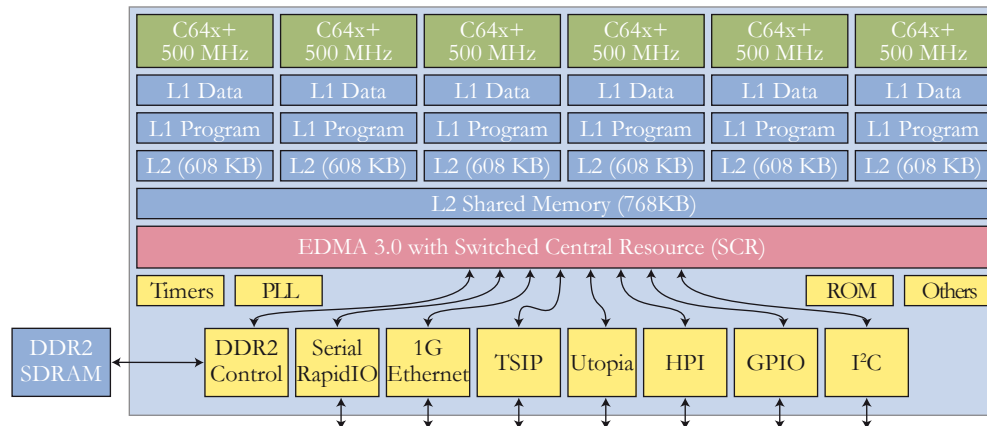

**Figure 5.3:** *TMS320TCI6486 Functional Block Diagram*

Figure 5.3 is a block diagram of the internal structure of a TMS320TCI6486 processor. For simplicity, this processor will be referred to as tci6486. This processor has six embedded c64x+ cores clocked at 500 MHz. Like the tci6488, it can execute up to 24 GMAC per second. The six cores share a Level 2 Memory of 768 kBytes, with each locally containing 608 kBytes of Level 2 memory. Like the tci6488 cores, each core has a 32 kBytes Level 1 program memory and a 32 kBytes Level 1 data memory. The tci6486 has, among other peripherals, a serial RapidIO link, Gigabit Ethernet port and a controller of external DDR2 memory.

Previous paragraphs have focused on recent high performance DSP architectures targeted for base station applications. However, a recent LTE study details a new multi-core DSP architecture, which is not yet commercially named, and was introduced in [Fri10]. This architecture is specifically optimized for the LTE application. It has a clock speed of up to 1.2 GHz and a total capability of up to 256 GMAC per second. The new DSP cores of this chip are backward compatible with C64x+ cores and offer additional floating-point capabilities for easier high-range computation. There is a “multi-core navigator” which is an evolved DMA system that does not necessitate any intervention from the DSP cores

to queue, route and transfer data. This navigator simplifies inter-core communication in addition to communication with coprocessors and external interfaces. A FFT coprocessor accelerates the FFT computations which are numerous in the LTE physical layer computation. The new architecture has an on-chip hierarchical network-on-chip named TeraNet 2, offering a data rate of more than 2 Terabits per second between cores, coprocessors, peripherals and memory. This network supports several configurations of the operators (cores or coprocessors). The new device contains a shared memory associated with an optimized multi-core memory controller, which is also shared.

The tci6488 and tci6486 can be analyzed using the categories defined in Section 4.2. The tci6488 has no internal shared memory; at coarse grain, it can be considered as an MIMD architecture of type NORMA. However, when connected to an external DDR2 memory, it becomes an UMA architecture for this memory because all cores have equal access rights. The tci6486 with its internal shared memory is an MIMD UMA architecture. However, only a small portion of its internal memory is shared; data locality is thus important, even in this UMA architecture. At fine grain, the c64x+ micro-architecture of the cores in both processors is also an MIMD architecture of type UMA. The categories of MIMD and UMA are not sufficient to describe the system-level behavior of a processor for a rapid prototyping tool. They can only focus on some specificities of the architecture without including its global system-level behavior. A model based on operators and their interconnections is necessary to study the possible parallelism of the architecture.

These parallel architectures necessitate rapid prototyping to simulate their behavior and may benefit from automatic multi-core code generation.

### 5.1.2 Building a New Architecture Model

Among the objectives of this thesis is to create a graph model for hardware architectures that represent the hardware behavior at a system-level, ignoring the details of implementation while specifying the primary properties. Such a model must be sufficiently abstract to model new architectures including additional features without the need for specific nodes. As the target process is rapid prototyping, the model must be simple to use and understand and must also facilitate multi-core scheduling. Grandpierre and Sorel define in [GS03] an architecture model for rapid system prototyping using the AAM methodology. Their model specifies four types of vertices: operator, communicator, memory and bus. An operator represents a processing element that can be either an IP or a processor core. A communicator represents a Direct Memory Access (DMA) unit that can drive data transfers without blocking an operator. The model is comprehensively defined in Grandpierre's PhD thesis ([Gra00]). A bus is a communication node for which data transfers compete. As the original model is unable to model switches, Mu extends it in [Mu09], adding IPs and communication nodes that model switches. Switches are bus interconnections that (theoretically) offer perfect contention-free connections between the busses they connect. This is a necessary addition to the model for this study, as the SCR of target processors is a switch. In Section 5.2.3, the architecture model of [Mu09] is shown not to be sufficiently expressive to represent the targeted architectures. It also leads to an inefficient scheduling process.

The following sections define a new architecture model named System-Level Architecture Model or S-LAM. This model is an extension of the original architecture model of Grandpierre [GS03].

## 5.2 The System-Level Architecture Model

The simplification of the architecture description is a key argument to justify the use of a system-level exploration tool like PREESM over the manual approach. Maintaining high expressiveness is also important because the majority of embedded architectures are now heterogeneous. These observations led to the System-Level Architecture Model described in the following sections.

### 5.2.1 The S-LAM operators

An S-LAM description is a topology graph which defines data exchanges between the cores of a heterogeneous architecture. Instead of “core”, the term “operator”, defined by Grandpierre in his PhD thesis [Gra00], is used. This is due to the fact there is no difference between a core and a coprocessor or an Intellectual Property block (IP) at system-level. They all take input data, process it and return output data after a given time. In S-LAM, all the processing elements are named operators and only their name and type are provided.

Even with several clock domains, execution times must be expressed using one time unit for the entire system. Due to the high complexity of modern cores, it is no longer possible for the clock rate to express the time needed to execute a given actor. Consequently, times in S-LAM are defined for each pair (*actor, operatortype*) in the scenario instead of using the clock rate of each core. IPs, coprocessors and dedicated cores all have the ability to execute a given set of actors specified in the scenario as constraints. An operator comprises a local memory to store its processed data. Transferring data from one operator to another operator via an interconnection effectively means transferring the data from local memory of one operator to the other. The following sections explain how operators may be interconnected in S-LAM.

### 5.2.2 Connecting operators in S-LAM

Two operators may not be connected by merely using an edge. Nodes must be also inserted in order to provide a data rate to the interconnections. The goal of system simulation is to identify and locate bottlenecks, i.e. the particular features that limit the system speed, significantly increase the power consumption, augment the financial costs, and so on. S-LAM was developed to study the particular constraint of speed; reducing this constraint is essential for the study of LTE. Additional features may be needed to explore power or memory consumption. The vertex and edge types in the System-Level Architecture Model, shown in Figure 5.4, are thus:

- the **parallel node** models a switch with a finite data rate but a perfect capacity to transfer data in parallel. It can be employed to model a switch. As long as a bus does not seem to be a potential bottleneck, it may also be modeled with a parallel node. Parallel nodes reduce simulation complexity as it eliminates the costly transfer ordering step on this communication node,
- the **contention node** models a bus with finite data rate and contention awareness. This node should be used to test architecture bottlenecks,
- the **RAM** models a Random Access Memory, and must be connected to a communication node. Operators read and write data through this connection. An operator has access to a RAM if a set-up link exists between them.

- the **DMA** models a Direct Memory Access. A core can delegate the control of communications to a DMA via a set-up link. DMA must also be connected to a communication node. Delegating a transfer to a DMA will allow the core to process in parallel with the transfer, after a set-up time,
- the **directed (resp. undirected) link** shows data to be transferred between two components in one (respectively both) direction(s),
- the **set-up link** only exists between an operator and a DMA or a RAM. It allows an operator to access a DMA or RAM resource. The set-up link to a DMA provides the time needed for setting-up a DMA transfer.

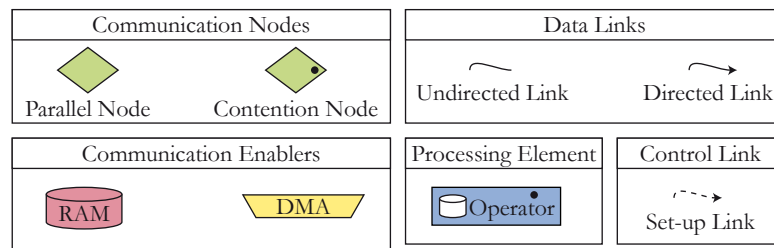

**Figure 5.4:** *The elements of S-LAM*

Both parallel and contention nodes are called Communication Nodes (CN). Directed and undirected links are both called data links. A black dot in a component in Figure 5.4 shows where contention is taken into account. Contention is expressed as sequential behavior. An operator has contention; it cannot execute more than one actor at a time. A contention node has contention; it cannot transfer more than one data packet at a time. Simulating elements with contention during deployment phase is significantly time-consuming because an ordering of their actors or transfers must be computed. A Gantt chart of the deployment simulation of elements with contention will contain one line per operator and one line per contention node. Connecting an operator to a given DMA via a set-up link requires that this operator allows the DMA the control of its transfers through communication nodes connected to the same DMA via a data link.

### 5.2.3 Examples of S-LAM Descriptions

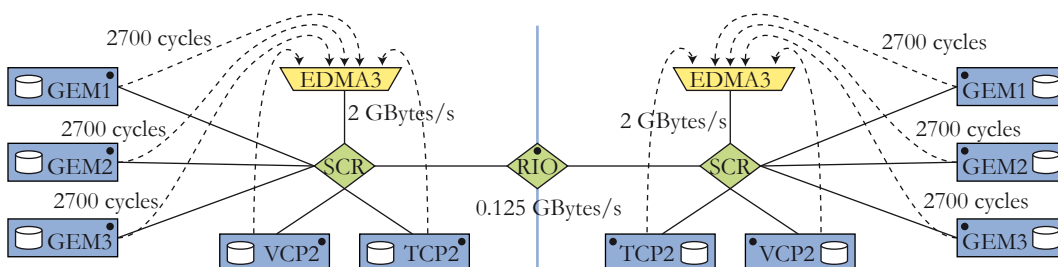

**Figure 5.5:** *S-LAM description of a board with two tc16488 using EDMA3 for communications local to a processor*

An S-LAM description models an architecture behavior rather than a structure. The most logical way to model a tci6488 is to use the EDMA3 to copy data from local memory of one core to the local memory of another. Figure 5.5 shows the S-LAM of two tci6488 with clock rate of 1GHz connected via their RapidIO links. Since the SCR is a switch element, contention may be ignored on this component because a switch limits much contention. The RapidIO link at  $1\text{Gbit/s} = 0.125\text{GByte/s} = 0.125\text{ Byte/cycle}$  is likely to be the bottleneck of the architecture. It is represented by a single contention node. Each core operator contains both a C64x+ core and a local L2 memory. These operators delegate both their intra-processor and inter-processor transfers to the EDMA3. The local transfers were benchmarked in [PAN08]. The results were a data rate of  $2\text{GByte/s}$  and a set-up time of 2700 cycles; these are the values used in S-LAM for this study. The Turbo and Viterbi coprocessors, TCP2 and VCP2, each have one local memory for their input and output data.

The simulation of an application on this architecture can be represented by a Gantt chart with 11 lines if all the operators and communication nodes are used. The actors and transfers on the 11 nodes with contention must be ordered while mapping the algorithm on the architecture. This may be contrasted with the architecture model developed by Mu in [Mu09] which computes the contention on each bus and produces a Gantt chart with 24 lines for the same example. The fundamental difference is the ordering process, which is a complex operation and is reserved in the current study for the architecture bottlenecks only. Moreover, the absence of set-up link in Mu's model would make the description of Figure 5.5 ambiguous where the model identifies the core that delegates its transfers to a given DMA.

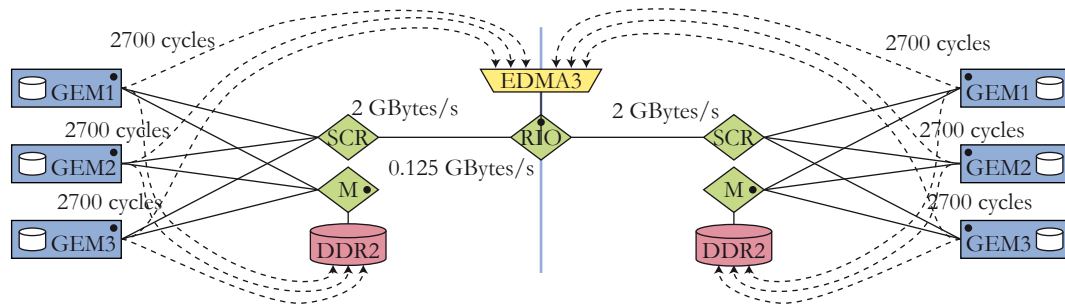

**Figure 5.6:** S-LAM description of a board with 2 tci6488 using DDR2 shared memory for communications local to a processor

The previous model is not the only possibility for a board with two tci6488. The shared DDR2 external memory may also be used when exchanging data between c64x+ cores in a single tci6488 processor. For this case, the S-LAM description can be that of Figure 5.6. VCP2 and TCP2 have been removed from the block diagram for clarity. The local transfers are much slower when the external memory is used and these transfer easily become an architecture bottleneck. Thus, accesses to the local memory are linked to a specific contention node. Only one EDMA3 node is used to model the two DMAs of the two processors. The following example illustrates the abstraction of the S-LAM architecture.

Figure 5.7 shows the two possible models described above for a tci6486 processor. The first uses EDMA3 to copy data from the local memory of one core to the local memory of another. The second uses the shared L2 memory to transfer data. Note that the two media: shared memory and local memory to local memory copy, could be combined; in this case, the SCR node would need to be duplicated to distinguish between the two different

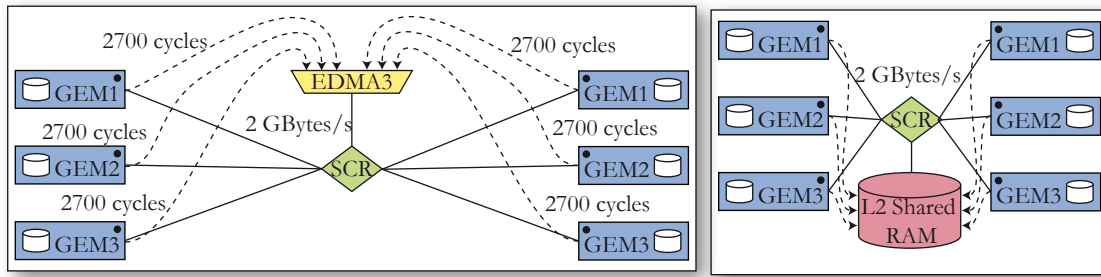

Figure 5.7: S-LAM description of a tci6486 processor

route steps, as will be explained in following sections.

As an example of S-LAM expressiveness, Figure 5.8(a) shows a unidirectional ring architecture where each operator communicates through a ring of connections. Figure 5.8(b) shows a daisy chain architecture where each operator can only communicate with its two adjacent neighbors. Figure 5.8(c) shows an architecture with three operators where each pair of operators share a memory. It may be noted that the S-LAM description is unambiguous and simple for all three architectures. These examples show that S-LAM is an expressive, yet simple model.

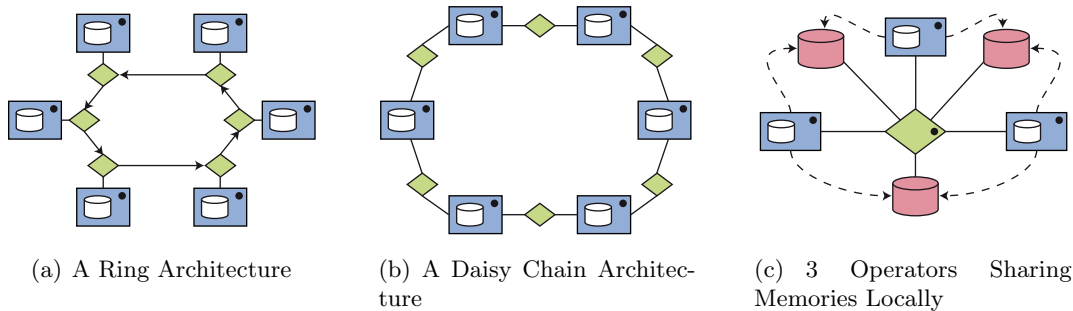
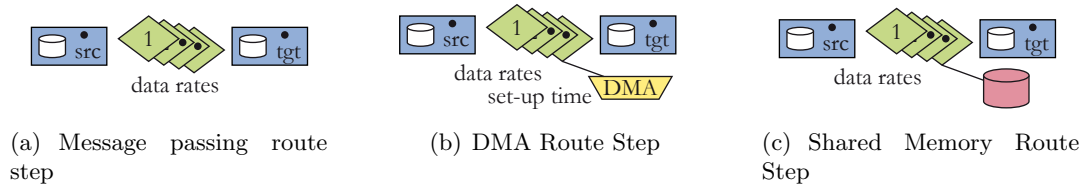

Figure 5.8: S-LAM Descriptions of Architecture Examples

The S-LAM gives a simplified description of an architecture focusing on the real bottlenecks of the design. In order to accelerate the rapid prototyping process, the S-LAM model does not directly feed the scheduler. The S-LAM model is first transformed into a so-called “route” model that computes the routes available for carrying information between two operators. The transformation of S-LAM model into a route model is analogous to transforming a SDF graph into a DAG graph; the original model is more natural, expressive and flexible while the second one is better adapted to scheduling.

#### 5.2.4 The route model

A route step represents an interconnection between two operators. A route is a list of route steps and represents a way to transfer data between two operators, whether or not they are directly connected. A direct route between two operators is a route containing only a single route step, and allows the data to be transferred directly from one operator to another without passing through an intermediate operator. In a fully connected architecture, a direct route between two given operators will always exist. In a more general case, it is necessary to construct routes to handle chained transfers of the a data stream along a given route in the generated simulation and code.



**Figure 5.9:** *The Types of Route Steps*

There are three types of route steps interconnecting operators in the S-LAM model of Section 5.2. Each of the three is associated with a specific type of transfer. The choice of code behavior model is linked to the generated code. The behavior of the modeled code is the result of a self-timed static execution of the code [SB09] [Lee89]. This static execution occurs when each operator runs an infinite static loop of execution at maximal speed, executing code when input data is available, and otherwise waiting for data availability. RTOS scheduling is not modeled and neither are thread preemptions, nor external event waits. The statically generated code is self-timed and uses data transfer libraries that fit the route step behaviors in Figure 5.9. Additional modifications may be introduced in the LTE models that make the simulation of external events possible.

The types of route step, as shown in Figure 5.9 are:

1. The **message passing** route step: the source operator sends data to the target operator via message passing. The data flows serially through one or several route steps before reaching the target. The source and target operators are involved in the process by defining path and controlling the transfer.
2. The **DMA** route step: the source operator delegates the transfer to a DMA that sends data to the target operator via message passing. After a set-up time, the source operator is free to execute another actor during this transfer.
3. The **shared memory** route step: the source operator writes data into a shared memory and the target operator then reads the data. The position of the RAM element (the communication node to which one of the route step communication nodes is connected) is important because it selects the communication nodes used for writing and for reading.

This list of route steps is not exhaustive: there are other data exchange possibilities. For instance, transitioned memory buffers [BW09] is currently not modeled in this study. In this route step, it is not the data in transitioned memory buffers which is transferred but the “ownership” of this data which is transferred from one operator to another. Thus, it is vital to protect the data against concurrent accesses. Studying such route step would be of interest, as they increase synchronization but can reduce memory needs. Routes can be created from routes steps to interconnect operators. The route model contains two parts: an operator set containing all the operators in the architecture and a routing table, which is a map assigning the best route to each pair of operators (*source, target*). The route model accelerates the deployment simulations because it immediately provides the best route between two operators without referring to the S-LAM graph. The transformation of S-LAM into route model is explained in next section.

### 5.3 Transforming the S-LAM model into the route model

S-LAM was developed in order to simplify the multi-core scheduling problem of the PREESM tool. The route pre-calculation that launches this complexity reduction will now be studied.

#### 5.3.1 Overview of the transformation

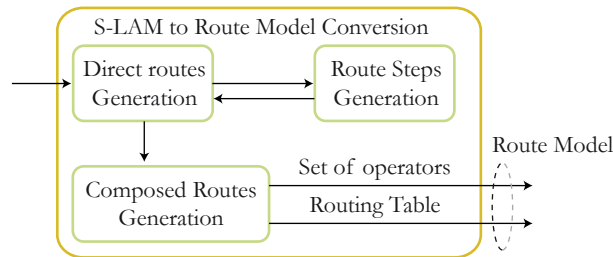

**Figure 5.10:** *The route model generation*

The generation of the route model is detailed in figure 5.10. Transforming an S-LAM graph into routes is performed in three steps: route steps are generated first, followed by the generation of direct routes and finally by the composed routes. Each step is detailed below.

#### 5.3.2 Generating a route step

From a source operator, a target operator and a list of communication nodes connecting these two operators, a route step with one of the types defined in Section 5.2.4 can be generated. While creating the route step, the communication nodes are scanned and connections to DMA or RAM vertices are searched to determine the current route step type. If a DMA or RAM is found, its incoming set-up links are searched and if these links do not have same source as the current route step, the DMA or RAM is ignored. The advantage of using set-up links is that transfers that are independent of a DMA or a RAM can share a communication node with other DMA-driven and RAM transfers. Contentions between all transfers on a given communication node can be simulated.

#### 5.3.3 Generating direct routes from the graph model

Using the route step generation function, the direct route generation code parses the graph starting with the source operators *src*. The algorithm displayed in Algorithms 5.1 and 5.2 scans the communication nodes and maintains lists of previously visited nodes. When a target operator *tgt* is met, the exploreRoute function in Algorithm 5.2 generates a route step using the method in Section 5.3.2. If the new route step has a lower cost than the one (if any) in the table, a new route only containing the new step is stored in a table named routing table. The cost of a route is defined as the sum of the costs of its route steps. The cost of a route step depends on the route step type and is calculated using a typical data size, set in the scenario.

The complexity of the algorithm is  $O(PC^2)$  where  $P$  is the number of operators in the graph and  $C$  the number of communication nodes. This high complexity is not a problem provided architectures remain relatively small. After direct route generation, the routing table contains all the direct routes between interconnected operators. In S-LAM,



---

**Algorithm 5.1:** Direct routes generation

---

**Input:** An S-LAM model  
**Output:** The Corresponding Route Model

```

1 foreach operator src in operators do
2   foreach interconnection i in outgoing or undirected edges of src do
3     if the edge other end is a communication node n then
4       Add the node n to a list l of already visited nodes;
5       Call exploreRoute(src,n,l);
6     end
7   end
8 end

```

---



---

**Algorithm 5.2:** exploreRoute

---

**Input:** An operator *src*, a communication node *n*, a list of nodes *l*  
**Output:** The best routes from *src* to its direct neighbors  
*/\* This recursive function scans the communication nodes and adds a route when reaching a target operator \*/*

```

1 foreach interconnection i in outgoing and undirected edges of n do
2   if the other end of the edge is a communication node n2 then
3     Create a new list l2 containing all the elements of l;
4     Add n2 to l2;
5     Call exploreRoute(src,n2,l2);
6   else
7     if the other end of the edge is an operator tgt then
8       Generate a route step from src, tgt and the list of nodes l;
9       Get the routing table current best route between src and tgt;
10      if the new route step has a lower cost than the table route then
11        Set it as the table best route from src to tgt;
12      end
13    end
14  end
15 end

```

---

non totally-connected architectures are authorized. The routes between non-connected operators are still missing at the end of the direct routes generation; they are added during the composed routes generation.

### 5.3.4 Generating the complete routing table

The routes between non-connected operators are made of multiple route steps. Routes with multiple route steps are built using a Floyd-Warshall algorithm [CLRS01] provided in Algorithm 5.3. The route between a source *src* and a target *tgt* is computed by composing previously existing routes in the routing table and retaining those with the lowest cost.

The Floyd-Warshall algorithm results in the best route between two given operators with a complexity of  $O(P^3)$  and is proven to be optimal for such a routing table construction. The complexity of the routing table computation is not problematic for this study because the architectures are always a small number of cores; the routing table con-

---

**Algorithm 5.3:** Floyd-Warshall algorithm: computing the routing table
 

---

**Input:** An S-LAM model  
**Output:** The Corresponding Route Model

```

1 foreach operator k in operators do
2   foreach operator src in operators do
3     foreach operator tgt in operators do
4       Get the table best route from src to k;
5       Get the table best route from k to tgt;
6       Compose the 2 routes in a new route from src to tgt;
7       Evaluate the composition;
8       Compare the table best route from src to tgt with the composition;
9       if the composition has a lower cost then
10        | Set it as the table best route from src to tgt in the table;
11        end
12     end
13   end
14 end

```

---

struction of a reasonably interconnected architecture with 20 cores was benchmarked at less than 1 second. This may be compared to mapping/scheduling activities for the same architecture which require several minutes. The route model simply consists of this table and the set of operators for the S-LAM model input. If the table is incomplete, i.e. if, in the routing table, a best route does not exist for a pair of operators (*src*, *tgt*), then the architecture is considered to be not totally connected via routes. The PREESM scheduler does not handle such non-connected architectures. In this case, PREESM will stop and return an error before starting the mapping and scheduling process. The overall complexity of S-LAM routing is  $O(P.(P^2 + C^2))$ . In the next section, transfers are simulated in PREESM using routes.

## 5.4 Simulating a deployment using the route model

Depending on the route step type, certain transfer simulations are inserted into the execution Gantt chart in addition to actor simulations. The simulation of a data transfer is now described for each type of route step.

### 5.4.1 The message passing route step simulation with contention nodes

Part 1 of Figure 5.11 shows the simulation of a single message passing transfer between actor1 mapped on *src* and actor2 mapped on *tgt*. The transfer blocks the two contention nodes in the route step during the transfer time. The data rate of the transfer (in Bytes per cycle) is the lowest data rate of the communication nodes (which is the bottleneck of this particular communication). Source and target operators are actively transferring the data and are thus unavailable until its completion.

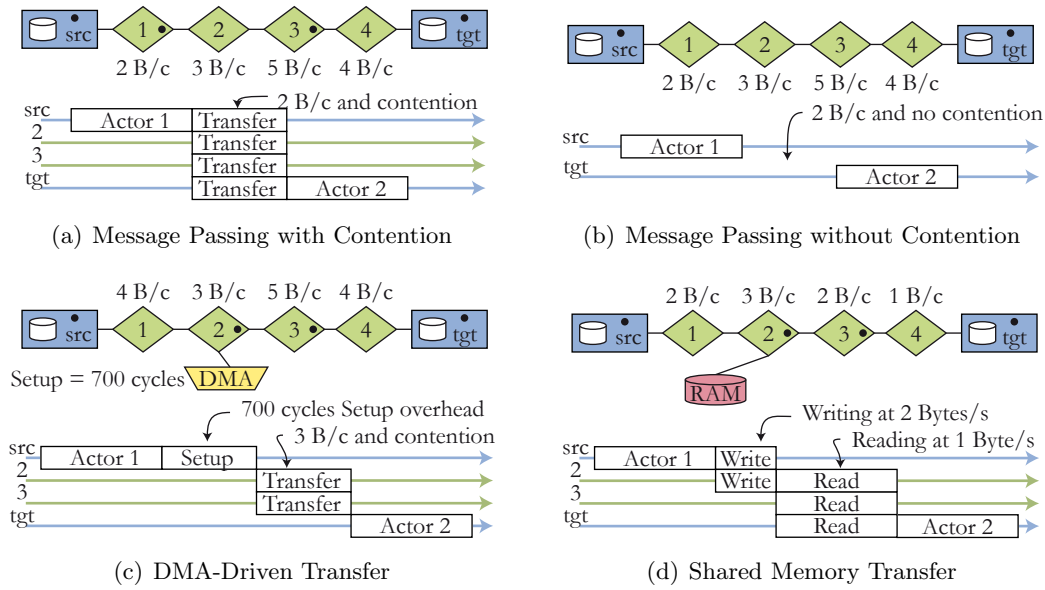

Figure 5.11: Impact of route types on the simulation of a transfer

### 5.4.2 The message passing route step simulation without contention nodes

If there is no contention node present, such as in Part 2 of Figure 5.11, there will not be a line in the Gantt chart for the transfer but the actor2 will be delayed until the transfer is complete. This transfer model is equivalent to those used by Kwok in his mapping and scheduling algorithms [Kwo97], where parallel nodes take into account the transfer delays but ignore contentions.

### 5.4.3 The DMA route step simulation

The simulation of a DMA transfer is shown in Part 3 of Figure 5.11. The set-up overhead for the transfer is mapped onto the source operator; this transfer is then equivalent to that of single message passing except that the operators are not involved in the transfer. In practice, the overhead corresponds to the set-up time of the DMA, i.e. the time to write the transfer description into the DMA registers.

### 5.4.4 The shared memory route step simulation

The simulation of a shared memory transfer is shown in Part 4 of Figure 5.11. First, the source operator writes the data to the shared memory and then the target operator reads it. The left-hand side communication nodes are occupied during writing and the right-hand side nodes during reading. The writing and reading data rates can be different. They are both limited by the maximum data rates of the memory and of the communication nodes. This transfer model means that shared data buffers are not used “in place” by the actors. Instead, they manipulate local copies of the data. This choice costs memory for the local copies but can reduce the algorithm latency in certain cases.

## 5.5 Role of S-LAM in the Rapid Prototyping Process

The S-LAM model was developed to be the input of the rapid prototyping process. It is the S-LAM that is represented by the architecture model block in the diagram shown Figure 1.2. The typical size of architecture in a S-LAM graph in PREESM is between a few cores and a few dozens of cores.

### 5.5.1 Storing an S-LAM Graph

S-LAM consists of components and interconnections, each with a type and specific properties. This model is naturally compatible with the IP-XACT model [SPI08], an IEEE standard from the SPIRIT consortium [SPI08] intended to store XML descriptions for any type of architecture. The IP-XACT language is a coordination language: it specifies components and their interconnection but not their internal behavior. In the IP-XACT organization, a top-level design will contain component instances. These instances reference component files that can contain several views, some referencing sub-designs. Figure 5.12 displays a simple S-LAM description and part of its corresponding IP-XACT design file.

A very simplified subset of IP-XACT is used where a component can have either one view referencing a single sub-design or no view at all; in that case they are atomic components. It is the existence of sub-designs that makes hierarchical descriptions possible.

### 5.5.2 Hierarchical S-LAM Descriptions

In PREESM, each design and component is stored in a separate IP-XACT file with two specific extensions: “\*.design” and “\*.component”. Hierarchical representations use a special vertex called “hierConnection” that links several levels of hierarchy. The structure of a hierarchical S-LAM description matches how an IP-XACT model is stored: a hierConnection component in a sub-design corresponds to the component port that references it. The architecture in Figure 5.12 contains a hierConnection enabling the connection of one tci6488 to another component via RapidIO. It is possible to flatten an S-LAM description, generating a single complete design.

Figure 5.13 shows a hierarchical description which, once flattened, gives the architecture equivalent seen in Figure 5.5. It may be noted that the VCP2 and TCP2 coprocessors have been ignored for simplicity. The intermediate component file is necessary because it is the structure chosen for IP-XACT storage. It contains component parameters such as the memory address and memory range of its internal addressing system.

S-LAM provides the architectural input for the rapid prototyping process. The next section details the compile-time scheduling enhancements created during this thesis.

```

<?xml version="1.0" encoding="UTF-8"?>
<spirit:design xmlns:spirit="http://www.spiritconsortium.org/XMLSchema/SPIRIT/1.4">
  <spirit:name>tc16488_inside</spirit:name>
  <spirit:componentInstances>
    <spirit:componentInstance>
      <spirit:instanceName>GEM1</spirit:instanceName>
      <spirit:componentRef spirit:library="ti" spirit:name="C64x+"
        spirit:vendor="ti" spirit:version="1"/>
      <spirit:configurableElementValues>
        <spirit:configurableElementValue spirit:referenceId=
          "componentType">operator</spirit:configurableElementValue>
      </spirit:configurableElementValues>
    </spirit:componentInstance>
    <spirit:componentInstance>
      <spirit:instanceName>SCR</spirit:instanceName>
      ...
    </spirit:componentInstance>
    <spirit:componentInstance>
      <spirit:instanceName>EDMA3</spirit:instanceName>
      ...
    </spirit:componentInstance>
    ...
  </spirit:componentInstances>
  <spirit:interconnections>
    <spirit:interconnection>
      <spirit:name/>
      <spirit:activeInterface spirit:busRef="bus" spirit:componentRef="GEM1"/>
      <spirit:activeInterface spirit:busRef="bus" spirit:componentRef="SCR"/>
    </spirit:interconnection>
    ...
  </spirit:interconnections>
  <spirit:hierConnections>
    <spirit:hierConnection spirit:interfaceRef="rio_port">
      <spirit:activeInterface spirit:busRef="bus" spirit:componentRef="SCR"/>
    </spirit:hierConnection>
  </spirit:hierConnections>
</spirit:design>
  
```

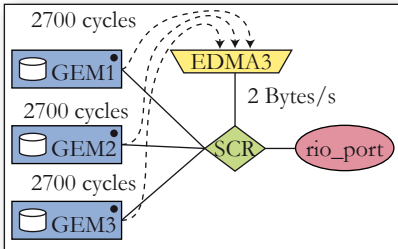

Figure 5.12: Storing an S-LAM Description in an IP-XACT Design File

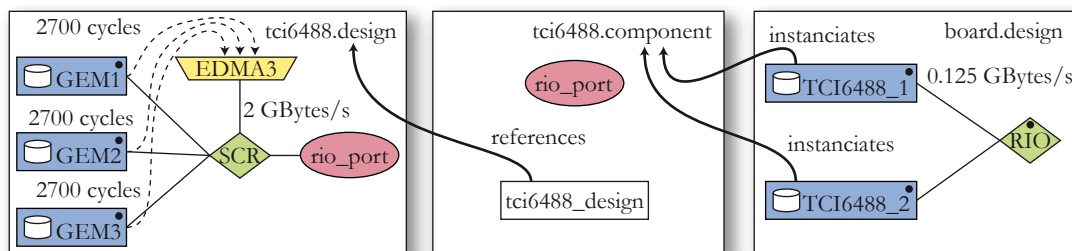

Figure 5.13: A tci6488 Hierarchical S-LAM and its Flattened S-LAM Equivalent



## 6.1 Introduction

In Chapter 4, an overview of the multi-core scheduling problem and solutions presented in the literature were summarized. A flexible rapid prototyping process has an important role to play in all the design steps of a multi-core DSP system. This chapter details several methods developed during this thesis for enhancing, in speed, accuracy and flexibility the rapid prototyping of distributed systems. These methods are used for different phases of the rapid prototyping process, and include a complete separation between algorithm and architecture in description phase (Section 6.2), a scheduler structure separating the different necessary heuristics (Sections 6.3, 6.4 and 6.5) and a clear display of the resulting schedule performances (Section 6.6).

### 6.1.1 The Multi-Core DSP Programming Constraints

Gatherer and Biscondi [GB09] state that the most important metrics for a high-performance embedded multi-core DSP are, in order of importance, **power, real-time performance, and financial cost**. From a hardware point of view, optimizing a system consists of providing more MIPS (Million Instructions per Second) or MMACs (Million Multiply Accumulates per Second) per Watt to the programmer while maintaining the device cost. From a software point of view, it consists of providing the highest number of possible functionalities for a given hardware while maintaining or reducing software programming costs. Hardware and software codesign consists of jointly optimizing the hardware and the software. The rapid prototyping of an application, such as base station baseband processing, on several architectures performs the important task of optimizing the system parameters. This is sometimes called design space exploration, and is most effective when approached as a codesign, as the optimization of the above three metrics is simultaneous.

The first constraint, **power consumption**, is highly dependent on the architecture and frequency of the target processor. Estimating the limits and advantages of target architectures in early stages of implementation is vital in making the most power efficient choices. Another parameter that influences the power consumption of a multi-DSP system is the locality of data and computation. A globally shared memory is a solution that can not scale to more than a few cores and a distributed memory necessitates an

early study of data and code location. Finally, load balancing the DSP cores assists in reducing the chip “hot spots”, easing power dissipation and increasing processor reliability. For battery-powered handheld devices, a limit of 1 Watt for the entire system is usual. [KAG<sup>+</sup>09] gives an idea of power dissipation constraints in highly reliable (or carrier-grade) communication systems such as LTE base stations: in an Advanced Telecommunications Computing Architecture (ATCA) rack of carrier cards, each carrier card can dissipate up to 200 Watts and, to obtain a long-term reliable system, each chip on the rack should maintain power consumption under approximately 10 Watts. This constraint immediately disqualifies general purpose processors which consume tens of Watts.

The second constraint, **real-time performance**, can be defined by two metrics:

- The **execution time**  $T_e$  is the minimum period that must separate two consecutive inputs for the system to correctly process all input data. The execution time is the inverse of the **throughput**, which is the maximal input data frequency a system can process.
- The **latency**  $T_r$ , also called response time, is the time separating the end of input arrival and the end of its processing. On a multi-core architecture, we have  $T_e \leq T_r$ .

The reason that the latency is greater than the execution time is that several processed input streams are pipelined, reducing  $T_e$  but often increasing  $T_r$ . The parallelism exploited by pipelining is called **functional parallelism** [HHBT09]. The parameter of execution time is used to evaluate whether an architecture can support the data throughput needed, and the latency must be minimized to ensure the system reacts “soon enough” to a command. For instance, the two-way global delay of LTE is required to stay under 10 milliseconds for a user to have a feeling of good system reactivity. This requirement limits the system latency and parallelism must be exploited to reduce  $T_r$ . The portion of algorithm parallelism that can be used to reduce latency is called **data parallelism** [HHBT09]. Data and functional parallelism are often combined and intricated in real applications. In general, both data and functional parallelisms must be exploited to obtain an efficient system.

The system **financial cost** depends on many parameters but one important factor in cost reduction is the ability to detect a wrong choice in the development process as rapidly as possible. This detection can be achieved by a high level of programmability and early system simulations. These are both available in the Rapid prototyping process, meaning that this process may have a significant role in reducing the financial cost of a design.

### 6.1.2 Objectives of a Multi-Core Scheduler

The scheduler is the most important part of a multi-core rapid prototyping framework: it is here that the algorithm and architecture are combined. The role of a scheduler is to return an “efficient” multi-core schedule in an “acceptable” time. Schedule efficiency is usually expressed as a **speedup** which is the factor of acceleration from using a multi-core instead of a single core. This notion is introduced for homogeneous architectures and can extend to heterogeneous ones if a main type of core, corresponding to a standard behavior, is chosen. The speedup is then computed only for the cores in the architecture that are of main type. An efficient schedule offers a high acceleration reflected by a high speedup given for the algorithm and architecture constraints. Section 6.6 provides a visual method of assessing a schedule quality in terms of speedup.

In a practical situation of multi-core scheduling, heuristic complexity expressed in asymptotic notation (Section 4.4.3) is not sufficient to evaluate the real cost of a scheduling



heuristic and so scheduling times which are considered as “acceptable” must be additionally defined. For run-time scheduling, the scheduling deadline is usually less than one second and depends on the real-time constraints of the application. Run-time scheduling for LTE will be discussed in Section 8.3. For compile-time rapid prototyping, a scheduling time of a few minutes is acceptable to obtain a rough idea of the system behavior. This means that a programmer can run a schedule and vary its parameters several times in an hour. However, a scheduling time of a few days is acceptable for a schedule of advanced quality compared to the rapid prototyping schedule.

A high flexibility is essential for the rapid prototyping process. The following sections define features developed during this thesis which serve to enhance this process.

## 6.2 A Flexible Rapid Prototyping Process

Each implementation has specific constraints and objectives. A rapid prototyping method must adapt to these needs; this is the goal of the flexible rapid prototyping process presented in this thesis. In Figure 1.2 of the introduction, a single matching node was seen to be the convergence point of the algorithm and the architecture. The internal functionalities of this matching node in the presented framework are displayed in Figure 6.1. Prior to multi-core scheduling, the algorithm and the architecture are transformed to extract their parallelism adequately for the scheduling. The input algorithm is described in an IBSDF graph and the architecture in an S-LAM graph. An additional input named scenario is generated, and controls the prototyping parameters. Additional to simulation and code generation, internal data, including algorithm, architecture or schedules, can be exported in files that feed other tools. All the functionalities in the process are optional and may be combined in graphical workflows to provide advanced flexibility to the programmer. These elements are explained in the following sections.

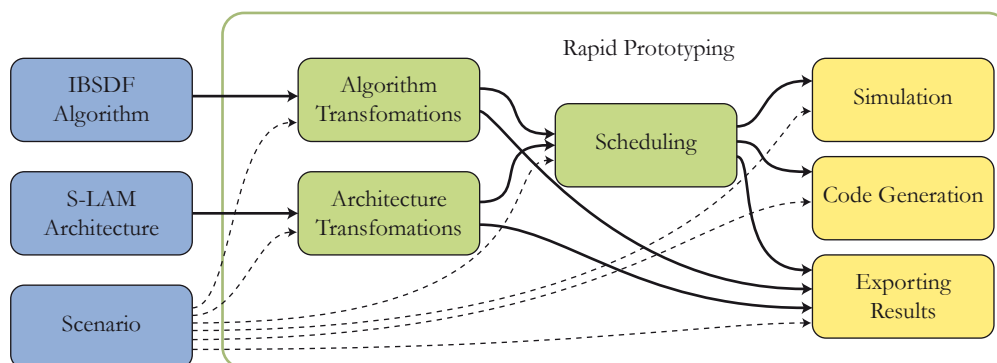
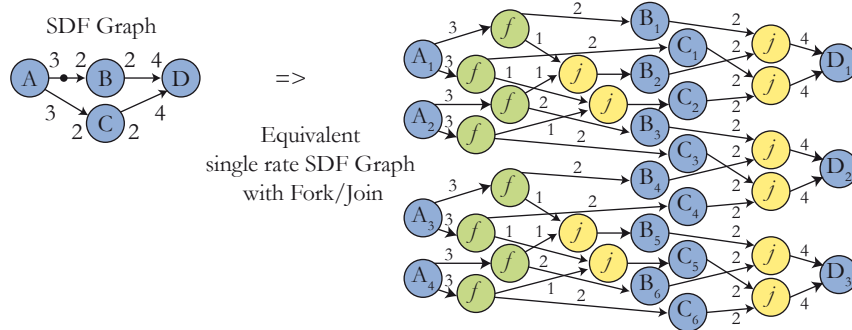

Figure 6.1: Overview of the Rapid Prototyping Process

### 6.2.1 Algorithm Transformations while Rapid Prototyping

Due to its advantages of hierarchy, predictability and parallelism expressiveness, IBSDF is the chosen algorithm input of the rapid prototyping process and was proposed by Piat in [PBPR09]. The top level of its hierarchy contains the actors to schedule. The top level is converted into a DAG before scheduling (Section 3.2.3). The degree of graph flattening influences the resulting schedules as does the time necessary to obtain them. Some special vertices which are introduced in the model are now described.

The typical number of actors for scheduling in PREESM is between one hundred and several thousand. The IBSDF model was developed to describe an application consistent with this size for the rapid prototyping process. With IBSDF, sub-graphs can be combined to build a hierarchical application. The strength of this system is that the behavior of a sub-graph can not make the top graph behave unexpectedly, and the schedulability can be checked at compile-time, independently for each hierarchy level. The model is constructed so that the **interface** of an actor, i.e. the number of its input and output edges and their sizes, remains unmodified when the graph is transformed. For instance, converting the SDF graph of Figure 6.2 to a single rate SDF graph (Section 3.2.2) adds fork and join vertices that are only used to split or gather data between edges. The edges going from and to  $A$ ,  $B$ ,  $C$  and  $D$  actors are unchanged between the SDF and single rate SDF graphs. Protecting the interface of an actor is important because it is necessary to link this interface to a host code and this host code needs to know where to retrieve or send the data tokens and whether the data is being sent or received.



**Figure 6.2:** *Creating a Single Rate SDF with Fork and Join Actors*

PREESM is the rapid prototyping tool that serves as a laboratory for the methods presented in this thesis. The actor interfaces are specified in PREESM using the generic CORBA Interface Description Language (IDL). Each actor is associated with a loop function prototype defined in an IDL file that specifies the right parameters in the right order. Ports are added to the IBSDF graph to identify the edges and port names are referenced in the IDL files. In Figure 6.3, the prototype of a filter function is displayed. The data productions and consumptions (in tokens) are specified in the graph and not in the IDL file. The input “size” here is a constant value set in graph parameters; IDL can reference constant values additionally to edges. As IDL is language-independent, the coordination code as well as its stored parameters and actor interfaces are then independent of the host code.

Additionally to the loop function prototype, the IDL file provides the generic prototype of the initialization function call associated with an actor. Initialization functions are used to create initial tokens in the graph whereas loop functions are called at each iteration of the actor.

Sometimes it is necessary to broadcast the same data to several receiving actors in a configurable way. The broadcast actor was introduced in Section 3.4.2 to solve hierarchical flattening problems. When generating imperative code from dataflow models, broadcasts can be implemented by memory copies or pointer references depending on data locality. The problem of static code generation will be discussed in Section 8.2.

If the IBSDF graph is only partially flattened, it is possible for the graph transformation module to generate clusters of actors [PL95]. The use of clusters aims to reduce the number of actors to schedule in the mapping process and to provide a loop-compressed

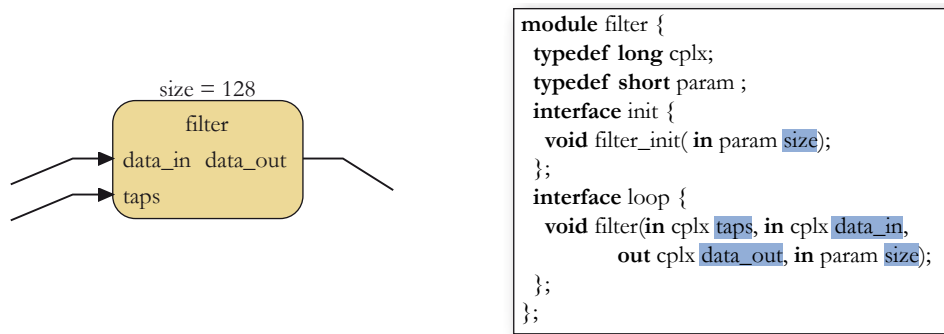

**Figure 6.3:** Example of an IBSDF Actor with Ports and its IDL Prototype

representation in the generated code of each operator. The advanced code generation from clustered IBSDF descriptions is developed in [Pia10].

## 6.2.2 Scenarios: Separating Algorithm and Architecture

The role of a scenario is to separate the algorithm and architecture models, making them independent of one another. It constitutes the third input of the rapid prototyping process (Figure 6.1). This separation of the algorithm and architecture models is also used in the AAM methodology and is programmed in the SynDEx tool [GS03].

### Content of a Scenario

A scenario gathers several types of information. The scenario:

- references an algorithm and an architecture. Several scenarios can combine the same algorithm and architecture.
- defines the constraints of the scheduling assignment process. It allows the programmer to fix the assignment of certain actors to given operators. This way, a hardware coprocessor may be defined as dedicated to certain actors and can not execute other actors. As IBSDF algorithms are hierarchical, these assignments are hierarchical, and apply to all actors including those that contain a graph with other actors.
- associates reference times with each couple (*actor, operatortype*).
- parameterizes the implementation simulation.
- assigns values to algorithmic graph parameters. The programmer can thus switch between several configurations and prototype several test cases simultaneously.

The advantage of switching scenarios is that a programmer can easily test one algorithm on several architectures, several algorithms on one architecture or explore several sets of parameters.

### Application Timing on a Target Architectures

In Dataflow MoCs, the actors are not timed. The only relation considered between actors is causality, i.e. who precedes whom. However, the primary constraint of the LTE application is latency. Each couple (*actor, operatortype*) must be associated with a time representing its behavior. This time is saved in the scenario to protect the algorithm abstraction.

The execution time of a software actor is usually complex and variable. The targeted algorithm granularity describes an entire application with approximately one thousand actors. This implies that the actors usually contain conditioning (i.e. there are “if” or “branch” constructs in the host code). As there are several execution possibilities, an actor with conditioning can not be deterministically timed at compile-time. Moreover, dataflow descriptions do not include the environment in the model of data or control exchanges. Actors are usually included in dataflow descriptions that wait for an external event before executing code or sending token. These actors naturally have unpredictable execution times. However, some execution test cases can be timed using a profiler or instrumenting the software to collect timestamps.

More unpredictability is generated from the hardware. Most general purpose processor cores can execute Out-of-Order (OoO) instructions, changing the instruction execution order at run-time depending on input data availability. A DSP core like the c64x+ (Section 5.1.1) has no such capacity, making it more predictable than general purpose processors. However, it has features that complicate predictions:

- The 11-stage pipeline of the c64x+ core greatly complicates the cycle-accurate time prediction of the different cases of a code with conditioning.
- The L1 cache with automatic coherence management is another source of prediction complexity. Certain actor execution orders can cache the data at more appropriate times than other actor execution orders. The actor time can be evaluated under favorable cache conditions (warm cache) and unfavorable cache conditions (cold cache).
- When using external DDR2 memory, a part of the internal L2 memory can serve as a cache for external accesses, again adding unpredictability.

Despite these variations, a programmer can evaluate system-level behavior of an implementation from a typical execution time, known as Deterministic Actor Execution Time (DAET). DAET can either be Worst-Case Execution Times (WCET) for testing fixed deadlines or warm and cold cache average times to test the typical system behavior in favorable and unfavorable conditions. The type of DAET is influenced by the real-time category of the system. The result of a hard real-time computation is considered useless if it is returned too late while the result of a soft real-time system provides decreasing service quality when its lateness increases. LTE is a hard real-time system. Its final implementation must be tested under WCET conditions. However, average times are used in this study which focuses on the early design process and where it is the system-level behavior which is of interest.

The time unit is not specified in the scenario. Time is a natural integer and it is the role of the programmer to choose a time quantum. Evidently, an easily manipulatable time quantum is desirable; 1 nanosecond is usually employed as it has a relationship with the clock period. For example, this quantum is natural for the tci6488 at 1 GHz because it corresponds to the CPU clock period. To prototype the tci6486 at 500 MHz, a time quantum of 2 nanoseconds, the CPU clock period or 1 nanosecond, which is half the clock period, are obvious choices.

### The Scenario Simulation Parameters

Several simulation parameters are set in the scenario. They include:

- **Token types:** in the application graph, edges carry tokens, which are an abstract data quantum. Each edge has a token type, for example, “cplx” for complex value.

This token type must remain abstract for the application to be combined with an architecture. Thus, the scenario protects the algorithm MoC abstraction, defining a token type size for each data token. Like the time quantum, the token size unit is abstract. For example, the programmer can choose a unit size of 1 Byte or 1 kBytes. The usual unit for the target architectures of this study is one Byte. The complex symbol values in LTE are usually stored as one 16-bit real part and one 16-bit imaginary part. In this case, the size of *cplx* is then 4.

- **Main operator and Communication Node (CN).** The scenario associates a main operator and a main CN (Section 5.2) to the architecture. These are the elements that are primarily studied during scheduling. The schedule quality assessment chart, as explained in Section 6.6, evaluates the execution speedup of operators in the S-LAM architecture of the same type as the main operator. It may be noted that the main operator and communication node are the components which are subject to the greatest number of optimizations by the scheduling algorithms.

In PREESM, time and constraint information can be imported in a scenario from Excel sheets. A programmer can generate these times from formulas or benchmarks and import them automatically. It is the existence of such implementation details that increases the ease and rapidity of use of a development chain .

### 6.2.3 Workflows: Flows of Model Transformations

Workflows are graphically edited graphs which represent the successive transformations necessary for the input models to simulate or generate executable code. Workflows are used in the PREESM tool to tune the rapid prototyping process. The three kinds of graphs, algorithm, architecture and workflow, are edited through use of the same generic graph editor named Graphiti [Grab]. Appendix A references all nodes presently existing in PREESM. Unlike when working with scenarios a programmer can use the same workflow to prototype several applications and architectures. Two common workflows will be presented below.

#### A Workflow to Prototype an Application

Rapid prototyping consists of simulating an implementation and then extracting information from this simulation. The workflow in Figure 6.4 prototypes the three elements (*scenario*, *algorithm*, *architecture*).

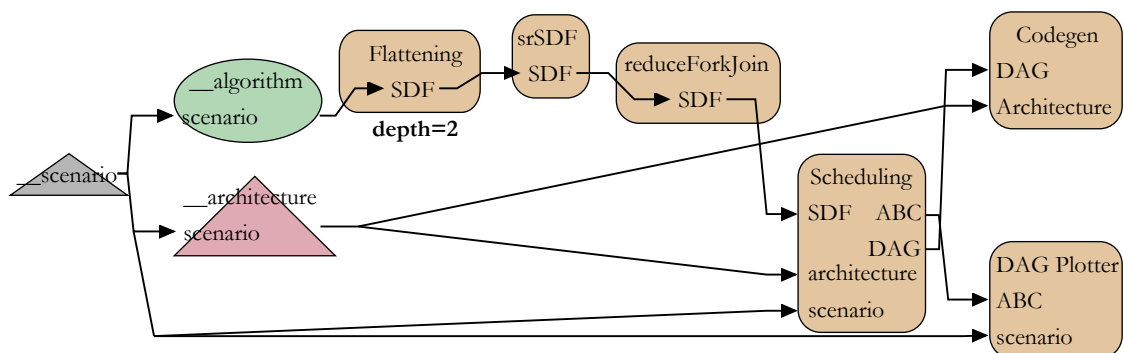

Figure 6.4: A Workflow for Prototyping an Application

A scenario outputs the algorithm and the architecture, and is the only node without an input edge. The shape of the workflow graph is intuitive, as a scenario always references one specific algorithm and one specific architecture. A workflow is applied to a scenario as this scenario initially contains or references all information necessary for the rapid prototyping process. The output of the algorithm node is an IBSDf graph and the architecture node outputs an S-LAM graph.

In the Figure 6.4, three transformations are applied to the IBSDf graph. The two highest levels of hierarchy are first flattened by the “Flattening” node with parameter  $depth = 2$ . Its top level is then converted into a single rate SDF graph (Section 3.2.2) by the single rate SDF transformation node. The single rate SDF transformation provides the scheduler with a graph of high potential parallelism as all vertices of the SDF graph are repeated according to the SDF graph’s Basic Repetition Vector. Consequently, the number of vertices to schedule is greater than in the original graph. Additionally, the single rate SDF conversion is likely to introduce multiple Fork and Join actors (Section 6.2.1). The third transformation is applied by node “reduceForkJoin” and minimizes the number of these spurious actors.

The purpose of these transformations is to reveal the potential parallelism of the algorithm and to simplify the work of the actor scheduler. The programmer can tune the depth parameter of the hierarchy flattening node, choosing between a highly parallel implementation and a fast scheduling process. The most complex phase of the rapid prototyping process is the multi-core scheduling step. The efficiency of this step may be increased by reducing the complexity of its input algorithm top level.

The Scheduling workflow node converts the SDF graph into a Directed Acyclic Graph (DAG), which has a lower expressivity than SDF graph but is a more suitable input for the mapping/scheduling (Section 3.2.3). The PREESM mapping/scheduling process [PMAN09] generates a deployment by statically choosing an operator to execute each actor (mapping or assignment) and producing an overall order to the actors (scheduling or ordering) (Section 4.4.3). The structure of the PREESM scheduler is detailed in Section 6.3.

As a result of the deployment, a Gantt chart of the execution is displayed by the “DAG Plotter” and certain information on the resulting implementation is displayed (percentage of load and memory necessary for each operator). The quality of the schedule determined is displayed graphically in the **schedule quality assessment chart** (Section 6.6).

The code generated by the “Codegen” workflow node is known as the coordination code, and consists of one block of local code per actor in the DAG (including one function call for an actor with no hierarchy), a static schedule of the actors for each processor, and data transfers and synchronizations between the processors. The coordination code is first generated in a generic imperative XML format and then converted into a host code (C code for this study) by an Extensible Stylesheet Language Transformation (XSLT [w3c]). The host code is hand-written. Static code generation will be further explained in Section 8.2 when it is applied to the LTE random access algorithm.

## A Workflow Combining Rapid Prototyping with SystemC Simulations

Accurate deployment simulations can be generated from the deployment through the use of SystemC-based [sys] simulator. This simulator, developed by Texas Instruments, is not publicly available. The workflow, shown in Figure 6.5, exports the DAG of its execution, produced by the scheduling node, in a graphml format. From this DAG, a XSL transformation can generate a XML or a text file. The SystemC simulation process requires two inputs and both are generated from the DAG using two different XSL files. In Figure 6.5,

it may be seen that two specific files are generated that feed the SystemC rapid prototyping process: one LUA file and one GraphML file. Graph transformations, identical to those shown in Figure 6.4 could be used to prepare the algorithm graph before scheduling (hierarchy flattening...) in this workflow.

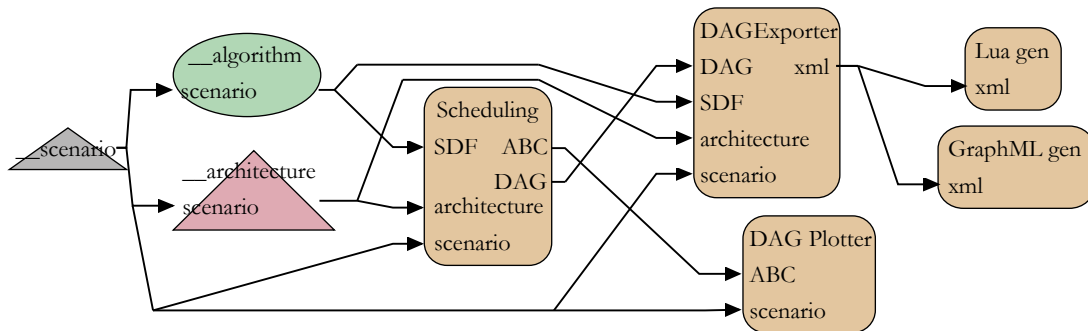

**Figure 6.5:** A workflow Combining Rapid Prototyping with SystemC Simulations

The rapid prototyping process and the SystemC simulator are highly complementary. The rapid prototyping process necessitates a simplified model of the architecture behavior. The S-LAM model contains a suitably simplified view to allow the acceleration of the rapid prototyping process. The SystemC simulator has a complete model of the architecture but has no automatic assignment heuristic and, without a rapid prototyping tool, actor assignments must be processed manually. Consequently, it can compute a cycle-accurate simulation of the implementation and check the accuracy of the rough simulation performed during rapid prototyping.

For example, the EDMA3 module in the tci6488 processor (Section 5.1.1) has six Transfer Controllers (TC), and each TC is able to packetize and transfer data in parallel. The EDMA3 is a master of the Switched Central Resource (SCR) which has specific bus configurations for each connected element. The resulting system behavior is highly complex. In Figure 5.5, the SCR is represented by a parallel node driven by the EDMA3. In LTE applications, the rapid prototyping S-LAM model generates latency estimates with an error of less than 10% compared to the calculations of the more complete EDMA3 model of the SystemC simulator. The pairing of a fast simulation for prototyping and a precise simulation to evaluate the resulting system favors efficient design choices at reduced costs. The SystemC accurate simulation can be used to evaluate the scheduler performance.

Moreover, only connected IBSDF graphs may be checked for schedulability with the method described in Section 3.2. Consequently, several unconnected applications that share a multi-core architecture are not within the scope of current work. However, several unconnected applications can be checked for schedulability and scheduled separately and then combined to be concurrently simulated in a SystemC simulator.

### 6.3 The Structure of the Scalable Multi-Core Scheduler

As explained in Chapter 4, scheduling is a complex process for which heuristics must be finely tuned to provide good schedules at reduced cost.

### 6.3.1 The Problem of Scheduling a DAG on an S-LAM Architecture

Formalizing the scheduling problem for PREESM rapid prototyping, the inputs are represented as:

- a set of operators  $O = o_i (i = 1, \dots, |O|)$  and a set of Contention Nodes  $CN = CN_i (i = 1, \dots, |CN|)$  contained in a S-LAM architecture description,
- a set of actors  $V = V_i (i = 1, \dots, |V|)$  and a set of data edges  $E = E_i (i = 1, \dots, |E|)$  contained in an algorithm DAG  $G$ .
- A scheduling scenario  $S$  adding behavior to the abstract models.

The input to the algorithm is a graph where concurrency between actors is expressed. Consequently, the parallelism extraction phase, illustrated in Figure 4.2, is omitted from the multi-core scheduling process. Moreover, as the assignment is static, the generated code may be self-timed, avoiding unnecessary scheduling costs; the timing phase is thus transparent because it only depends on actor availability. Two operations remain in the scheduling process:

- **assignment:** each actor is assigned an operator and each edge is assigned a set of CN.
- **ordering:** The actors are processed by one operator and the edges processed by each CN are ordered.

If no CN is defined or if transfer competitions are ignored, the scheduling problem is reduced to actor scheduling. Otherwise, transfers must also be scheduled on routes retrieved from the S-LAM route model (Section 5.2.4). In next section, the structure of a scalable scheduler is described. This scheduler separates the different problems of scheduling.

### 6.3.2 Separating Heuristics from Benchmarks

The scheduler architecture presented in this section is implemented in the PREESM tool; thus it is called the PREESM scheduler. However, underlying method can be applied generally:

- a scheduler intended for rapid prototyping should offer scalable schedule accuracy and scalable scheduling time,
- such scalable behavior may be extended if the assignment heuristic is separated from the architecture benchmark computer.

All scheduling heuristics are based on the same principle: the heuristic takes certain assignment and ordering decisions, the resulting implementation cost is computed, and then this cost is used to determine subsequent assignments. In the literature, all algorithms embed both assignment decisions and implementation cost evaluation. Moreover, if the minimized cost is the total execution latency (which is the most common case), a cost evaluation requires both the actors on operators and the edges on the CNs to be ordered. The PREESM scheduler splits these functionalities into two sub-modules which share minimal interfaces: the **task assignment** sub-module and the **Architecture Benchmark**



**Computer** (ABC) sub-module. The task assignment sub-module assigns actors to operators and then queries the ABC sub-module, which then evaluates the cost of the proposed solution.

At heuristic initialization, the ABC sub-module transmits the number of operators available to the actor assignment sub-module. Next, the actor assignment sub-module assigns actors to operators, and communicates these actor assignments to the ABC sub-module, which then returns the associated cost (infinite if the deployment is impossible). This process is illustrated in Figure 6.6. One advantage of this approach is that any task assignment heuristic may be combined with any ABC sub-module, leading to many different scheduling possibilities. For instance, an ABC sub-module minimizing deployment memory or energy consumption can be used without modifying the task assignment heuristics. The new sub-module will only return a cost of a different type. The S-LAM architecture is an input of the ABC sub-module (Figure 6.6). Another advantage is that the assignment heuristic can be architecture-independent. Indeed, it bases its assignment choices only on abstract costs and the number of operators available.

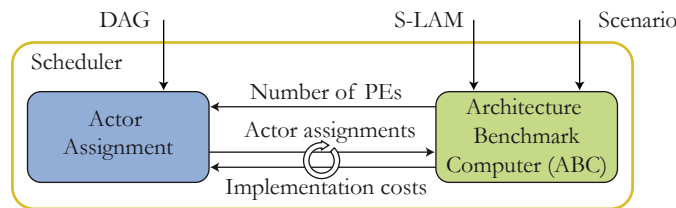

**Figure 6.6:** The Scheduler Sub-modules: Actor Assignment and ABC

The interface between the ABC sub-module and the actor assignment sub-module consists of:

- $assign : V, O \rightarrow \emptyset$  where  $assign(v, o)$  assigns the actor  $v$  to the operator  $o$ ,
- $free : V \rightarrow \emptyset$  where  $free(v)$  breaks the assignment of the actor  $v$ ,
- $getLocalCost : V \rightarrow \mathbb{N}$  where  $getCost(v)$  returns the cost of the actor  $v$  assignment alone (in an ABC returning latency cost, it returns the execution time of  $v$  given its assignment),
- $getLocalCost : E \rightarrow \mathbb{N}$  where  $getCost(e)$  returns the cost of the edge  $e$  assignment alone (in an ABC returning latency cost, it returns the transfer time of  $e$  given its assignment),
- $getCost : I \rightarrow \mathbb{N}$  where  $getCost(i)$  returns the cost of the implementation  $i$  (in an ABC returning latency cost, it returns the global latency of the implementation). If certain assignments are not chosen, the implementation is incomplete and the ABC will return  $\infty$  if it can not evaluate the cost of a partially assigned implementation.
- $getFinalCost : V \rightarrow \mathbb{N}$  where  $getFinalCost(v)$  returns the cost of the actor  $v$  assignments in the implementation (in a ABC returning latency cost, it returns the finishing time of  $v$  given its assignment),
- $getFinalCost : O \rightarrow \mathbb{N}$  where  $getFinalCost(o)$  returns the cost of the operator  $o$  assignments in the implementation (in a ABC returning latency cost, it returns the finishing time of the last actor which is assigned on  $o$ ),

The ABC is free to return abstract costs of any type, including memory costs, energy costs, execution time. The ABC interface with the assignment heuristic provides the information necessary for both partial implementation and total implementation evaluations. The next section details the actor assignment heuristics and ABC sub-modules that have been of interest to this study.

### 6.3.3 Proposed ABC Sub-Modules

During a scheduling process, an ABC sub-modules initially receives the S-LAM architecture description and the scenario. It is then responsible for assigning a cost to the schedules it receives. The primary constraint of LTE algorithms is latency. Several ABCs have thus been developed to minimize this parameter, evaluating the implementation latency in different cases of execution and with scalable precision, reusing the concept of time scalability introduced in SystemC Transaction Level Modeling (TLM) [Ghe06]. These sub-modules are called latency ABCs. SystemC TLM defines several levels of temporal system simulations, from untimed to cycle-accurate precision. This concept been extended to the development of several ABC latency models with different time precisions. Currently, the types of coded latency ABCs are:

- The **loosely-timed ABC** that accounts for task times of operators and transfer costs on PN and CN. However, it does not consider transfer contention (ignoring the difference between Parallel and Contention Nodes in the S-LAM architecture).
- The **approximately-timed ABC** that associates each inter-core contention node with a constant rate and simulates contentions on CNs.
- The **accurately-timed ABC** that includes the set-up time necessary to initialize a parallel transfer controller such as Texas Instruments Enhanced Direct Memory Access (EDMA [tms07]). This set-up time is scheduled in the core which triggers the transfer. Accurately-timed latency ABC executes the S-LAM simulation presented in Section 5.4.
- The **infinite homogeneous ABC** which is a special ABC that performs an algorithm execution simulation on a homogeneous architecture containing an infinite number of cores with main type. It may be noted that for this study, the main core type of an S-LAM architecture is defined in the input scenario. This ABC enables the extraction of the critical path of the graph (Section 4.4.3). The use of infinite homogeneous ABCs is detailed in Section 6.4.2.

All these latency ABCs have the capability to **balance the loads** of the system. Joint latency minimization and load balancing is explained in Section 6.4.3.

One role of latency ABCs is to order actors on operators and (possibly) edges on CNs. Ordering elements while minimizing constraints is equivalent to single-core scheduling, which is a NP-complete problem. Latency ABCs delegate actor and edge ordering to ordering heuristics that can be chosen independently. Up to three separate heuristics may used simultaneously : assignment, actor ordering and transfer ordering. Latency ABCs involve complex mechanisms to insert and remove actors corresponding to transfers. When needed, a time keeper calculates t-level and b-level of each actor. T-level and b-level are needed for list scheduling (4.4.3) and for schedule latency evaluation. The structure of latency ABCs is displayed in Figure 6.7.

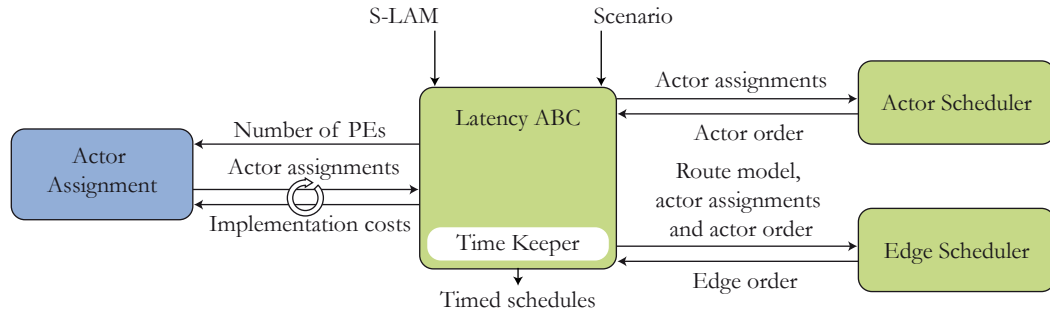

Figure 6.7: Structure of a Latency ABC

When a data token is transferred from one operator to another, transfer actors are created and then mapped to the CNs of the chosen route. A route may pass through several other operators (Section 5.2). If invoked, the edge scheduling sub-module orders the route steps on CNs. Edge scheduling can be executed with algorithms of varying complexity, which results in another level of scalability. The primary advantage of the scheduler structure is the independence of scheduling algorithms from cost type and benchmark complexity. Section 6.4 demonstrates how latency ABCs conform to the scheduler architecture and provide advanced benchmarking.

### 6.3.4 Proposed Actor Assignment Heuristics

The behavioral commonality of the majority of scheduling algorithms resulted in the choice of the scheduler module structure. Currently, three algorithms are coded in PREESM and are modified versions of the algorithms introduced by Kwok and described in Section 4.4.3: a list scheduling algorithm, the FAST algorithm with its parallel version PFAST and a genetic algorithm. Figure 6.8 shows several different assignment heuristics and latency ABCs. It may be noted that having a choice between three of each sub-module category, the result is nine possible tradeoffs between precision and time.

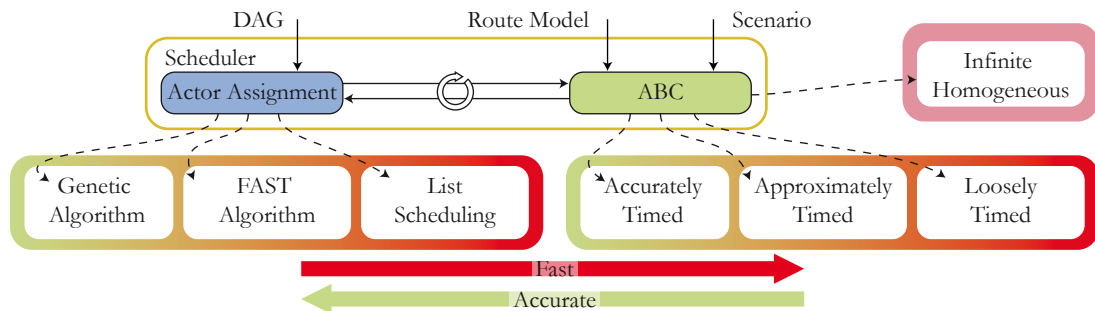

Figure 6.8: Assignment and Existing Versions of ABCs

Combining heuristics and ABCs, experiments may be performed on the transformed versions of the list, and the FAST and genetic algorithms from Section 4.4.3. The original heuristics in the literature were algorithms limited to the Bounded Number of Processors (BNP) while the extended models are used for the architecture heterogeneity of Arbitrary Processor Networks (APN) described in S-LAM. The next section explains how ABCs and heuristics are integrated into the global schedule process.

## 6.4 Advanced Features in Architecture Benchmark Computers

ABCs link the S-LAM model and the actor assignment process. The next section demonstrates how S-LAM and route models connect to the ABC and then details certain advanced features of latency ABCs.

### 6.4.1 The route model in the AAM process

Simulating data transfers during mapping and scheduling makes the deployment simulations more complex because vertices representing transfers are dynamically added to and removed from the graph. The addition of new cores to the architecture should not increase the mapping and scheduling complexity exponentially. To achieve this goal, the S-LAM is transformed into the route model before the mapping and scheduling procedures. The resulting scheduling time-complexity on a ring architecture was shown to be linear in [PNP<sup>+</sup>09]. The process of transforming the S-LAM model into a route model was presented in Section 5.3.

### 6.4.2 The Infinite Homogeneous ABC

The infinite homogeneous ABC is unique because its intended use is to extract general information from the algorithm rather than assisting assignment heuristics, which is the general purpose of latency ABCs. This ABC enables Unbounded Number of Clusters (UNC) studies of an implementation; these studies are useful in computing the span and the work of the algorithm under certain constraints, in addition to the critical path, where:

- The **critical path** is the longest path in the whole acyclic graph. To calculate, a typical Communication Node needs to be defined with a given data rate and a typical operator type with DAET for each actor. The main CN and main operator are chosen in the scenario. The critical path can then be computed as presented in Section 4.4.3.
- The **span** is the critical path when communication cost is ignored, i.e. in the UNC case. Its length corresponds to an ideal minimal latency on an infinite homogeneous architecture with infinitely fast media.
- The **work** is the execution time of the entire graph on one operator with typical operator type. It is the sum of actor DAETs.

To study these properties, only data dependencies between actors need to be considered and actors need not be ordered on their operators. The infinite homogeneous ABC enables the creation of the CPN dominant list necessary for the list scheduling described in Section 4.4.3. The name of this ABC can be misleading :It does not require an infinite architecture, but an architecture with sufficient operators in  $O$  to execute as many actors in parallel as possible. There exists  $O_{min}$  so that if  $|O| \geq O_{min}$ , the latency of the schedule is equal to the critical path length and  $O_{min} \leq |V|$  because with more than  $|V|$  operators, each actor can be assigned to a different operator and adding operators can not reduce the critical path.

### 6.4.3 Minimizing Latency and Balancing Loads

Load balancing is an important property for a schedule. This feature spreads the processing load and the power dissipation over all operators and reduces the temperature of the system. All preceding techniques have focussed on minimizing the latency. This section presents a method that jointly optimizes latency and load balancing. Both parameters, latency and load balancing, will be shown to be equivalent in the Unbounded Number of Clusters (UNC) case and non-equivalent in Bounded Number of Processors (BNP) and Arbitrary Processor Network (APN) cases (Section 4.4.3). A method is then proposed to allow joint optimization in BNP and APN cases. This method maybe activated for any latency ABC, transforming the returned cost.

#### Equivalence of Problems in UNC Case

Minimizing latency and balancing loads are quite ‘similar’ problems. Indeed, in the little constrained UNC scheduling case (Section 4.4.3), the following theorem states:

**Theorem 6.4.1.** *When scheduling a DAG on an Unbounded Number of Clusters (UNC), the problem of balancing the loads is equivalent to the problem of minimizing latency.*

**Proof:** We have:

- $\vec{V}$  a vector containing all the actors  $v_i \in V$ , with  $V$  the actor set of the DAG,
- $\vec{O}$  a vector containing all the operators executing at least one actor in the operator set  $O$ ,
- $P = |\vec{O}| \leq |\vec{V}|$  the number of operators executing at least one actor,
- $f_i \geq 0, i \in 1, \dots, |\vec{V}|$  the DAET of each actor  $v_i$  on any operator in  $\vec{O}$  (Section 3.2),
- $l_j \geq 0, j \in 1, \dots, P$  the load of each operator  $o_j$ , i.e. the DAET sum of the actors it executes,
- $m_l$  the average of the operator loads.

$\vec{l} = [l_1, \dots, l_P]$  is called the vector of loads and  $\mathcal{L}$  the space of load repartitions with  $\forall \vec{l}, \vec{l} \in \mathcal{L}$ . The homogeneity of the architecture ensures the conservation of the work  $W$ :

$$W = \sum_{i=1}^{|\vec{V}|} f_i = \sum_{j=1}^P l_j. \quad (6.1)$$

**Problem 1: Latency Minimization.** Under the UNC conditions and with the constraint of minimizing latency, all actors in the critical path, and only these actors, should be assigned to a single operator that becomes the most loaded operator and contains no ‘hole’ in its schedule. Otherwise, the number of operators increases without reducing the latency. The latency is then equal to the critical path and is thus minimal. In this case, the latency  $L$  is also equal to the highest load:  $L = \max_{j \leq P}(l_j)$ . The procedure of minimizing the latency consists of searching for a load configuration  $\vec{l}_{latency}^*$  so that:

$$\vec{l}_{latency}^* = \arg \min_{\vec{l} \in \mathcal{L}} (\max_{j \leq P}(l_j)). \quad (6.2)$$

$\max_{j \leq P}(l_j) \geq 1/P \sum_{i=1}^{|V|} f_i$  with equality if and only if a schedule exists with  $l_j = W/P, \forall j$ .

**Problem 2: Load Balancing.** To balance the loads, it is necessary to minimize the variance between the loads. If  $m_l = W/P$  is the average of the loads and  $\sigma^2 = 1/P \sum_{j=1}^P (l_j - m_l)^2$ , minimizing the variance of the loads will balance the loads, and consists of searching for a load configuration  $\vec{l}_{loads}^*$  such that:

$$\vec{l}_{loads}^* = \arg \min_{\vec{l} \in \mathcal{L}} \frac{1}{P} \sum_{j=1}^P (l_j - m_l)^2 = \arg \min_{\vec{l} \in \mathcal{L}} \frac{1}{P} \sum_{j=1}^P l_j^2. \quad (6.3)$$

Note that  $\sigma^2 \geq 0$  and  $\sigma^2 = 0$  if and only if the loads are perfectly balanced with  $l_j = W/P, \forall j$ . It may be hypothesized that any distribution of loads is possible:

**Hypothesis 6.4.1.**  $\mathcal{L} = (\mathbf{R}^+)^P$ .

The solutions for problems 1 and 2 are then identical and given by  $l_j = W/P, \forall j$ . In reality, the above hypothesis 6.4.1 is not true because loads are partial sums of arbitrary DAETs  $f_i$ . The question then becomes: is the result still valid if  $\mathcal{L} \neq (\mathbf{R}^+)^P$ ? The positive proof with  $P = 2$  can be performed graphically.

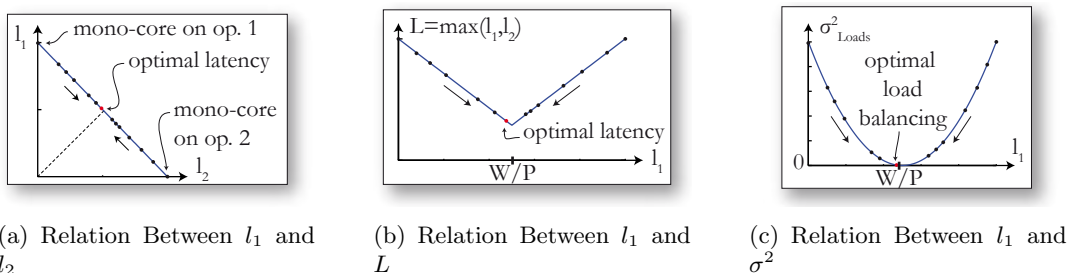

**Figure 6.9:** Study Of the Latency And Variance Behavior in the Case of 2 Operators

In Figure 6.9(a), it may be noted that the discrete values of the loads of operators 1 and 2 fall on a line of best fit between the states which represent either  $o_1$  or  $o_2$  processing the whole work. The conservation of the work in Equation 6.1 implies that  $l_2$  depends on  $l_1$  with  $l_2 = W - l_1$ . In Figure 6.9(b), the values of the latency  $L = \max_{j \leq P}(l_j)$  are displayed relative to  $l_1$ .

In Figure 6.9(c), the variance between the loads  $\sigma^2$  is shown to alter when  $l_1$  changes. The two cost functions in Figures 6.9(b) and 6.9(c) are convex with the same unique minimum point at  $l_j = \frac{W}{P}, \forall j$ . If  $l_1^*$  is the optimal load configuration for problem 1, it is also the optimal load configuration for problem 2. In the more general case of  $P \geq 2$ , the two functions are still convex functions due to the conservation of work. These two functions have the same unique minimum point corresponding to a latency  $L = W/P$ .

Therefore, it may be seen that the two problems are also equivalent in the case of discrete loads.

### Non-Equivalence of Problems in BNP and APN Cases

Figure 6.10 illustrates a very simple example where minimizing the latency in a Bounded Number of Processor (BNP) scheduling (Section 4.4.3) makes the load balancing worse.

The example of Figure 6.10(a), demonstrates that balanced loads result in a different assignment from that of Figure 6.10(b) where latency is minimized. The success of load balancing is evaluated by the eventual variance of the loads  $\sigma_{Loads}^2$  that must be minimized. This evaluation procedure is explained below.

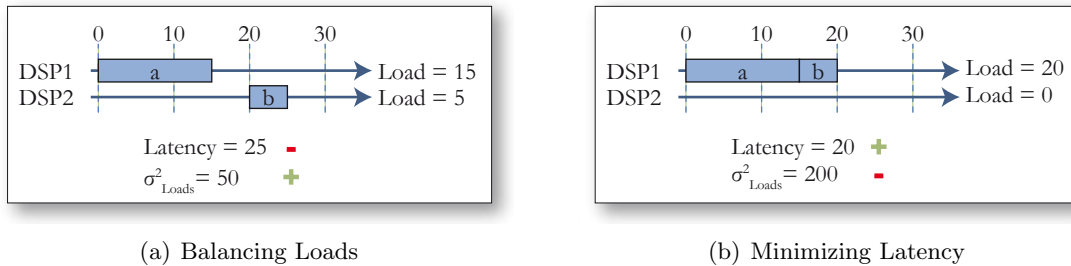

**Figure 6.10:** Example showing that Minimizing Latency is not Equivalent to Balancing Loads in the BNP Scheduling Problem

The two problems of latency minimization and load balancing are not equivalent in BNP conditions and even less so in APN conditions because transfer ordering is present which often penalizes distributed systems when minimizing latency.

### Minimizing the latency under a load balancing constraint

As the two problems of latency minimization and load balancing are not equivalent in the BNP case and even more divergent in the Arbitrary Processor Network (APN) case, the two constraints need to be considered separately during scheduling process and a good compromise between the two must be established. A basis for this tradeoff may be to employ a latency ABC that returns a composite cost which includes latency minimization and load balancing:

$$C = L + \lambda \cdot \sigma, \text{ with } \sigma = \sqrt{\frac{1}{N} \sum_{j=1}^P (l_j - m_l)^2}. \quad (6.4)$$

where  $L$  is the latency,  $\lambda$  a Lagrange multiplier and  $\sigma$  is the standard deviation of the loads. Experiments show that efficient results are obtained for a simple  $\lambda = 1$ . Figure 6.11 shows results of the rapid prototyping of a complete LTE description on the unnamed architecture presented in Section 5.1.1 and in [Fri10]. The algorithm IBSDF after flattening has 464 vertices and 572 edges. The FAST algorithm is run 30 times, each time during 60 seconds with 5 second macrosteps. The loosely timed latency ABC is used. Points represent 15 solutions found with a composite cost and a Lagrange multiplier of 1, while diamonds represent solutions found minimizing only latency. It can be observed that the load balancing is significantly improved using the composite cost when, except for one abnormal solution, the latency is not significantly worsen.

## 6.5 Scheduling Heuristics in the Framework

There are two types of scheduling heuristics: assignment heuristics that assign actors to operators, and ordering heuristics that order actors on each operator and also order transfers on each Communication Node. Heuristics of both types are presented below As

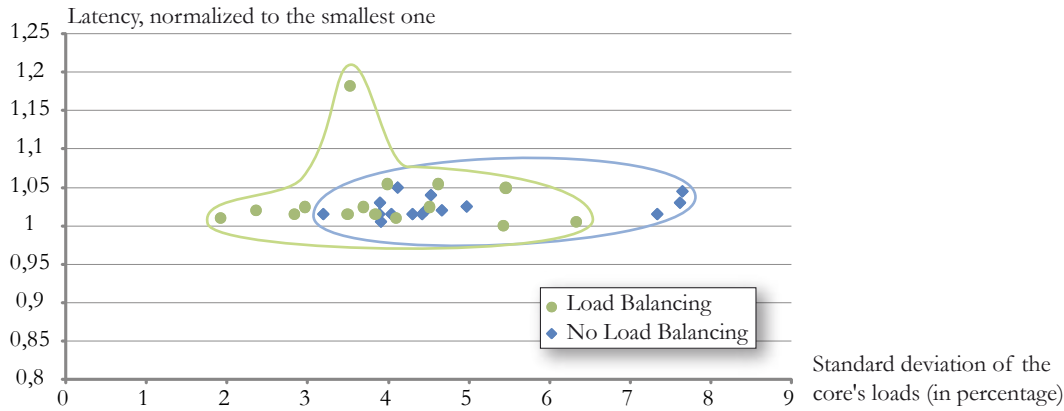

**Figure 6.11:** Comparing Schedules with and without load balancing criterium.

both these complementary types of scheduling heuristics are necessary for the solution, they are then combined in the scheduler structure as shown in Figures 6.7 and 6.6.

### 6.5.1 Assignment Heuristics

From the scheduling inputs defined in Section 6.3.1, APN versions of the list, and FAST and genetic scheduling algorithms from Section 4.4.3 are developed using ABCs. Scheduling the actors for self-timed execution on multi-core architecture consists of associating  $v$  a core number  $c(v) \in \mathbb{N}$  and a local scheduling order  $o(v) \in \mathbb{N}$  with each task. The pair  $S(v) = (c(v), o(v))$  is called the schedule of  $v$ . A schedule is valid if  $\forall v \in V, S(v)$  respects four conditions:

1. Each actor schedule is unique:

$$\forall (v_1, v_2) \in V^2, v_1 \neq v_2 \Rightarrow S(v_1) \neq S(v_2). \quad (6.5)$$

2. The selected cores respect the total number of available operators:  $c(v) < C, \forall v \in V$ .
3. The local schedules respect the topological order of the graph:  $\forall (v_1, v_2) \in V^2$  if there is a path from  $v_1$  to  $v_2$  and  $c(v_1) = c(v_2)$ , then  $o(v_1) \leq o(v_2)$ .
4. The implementation cost returned by the ABC respects:  $cost(S(V)) < \infty$

#### Static List Scheduling

Static list scheduling using ABCs is described in Algorithm 6.1. An overview of this procedure was presented in Section 4.4.3. After the list ordering step, which is closely linked to infinite homogeneous simulation, the assignment heuristic can be used with any latency ABC. It is not straightforward to combine static list scheduling with the minimization of parameters other than latency because of the list ordering part and the necessity to evaluate partial schedules. However, it is possible to combine static list scheduling with the load balancing method presented in Section 6.4.3.

#### FAST and Genetic Heuristics

The underlying principles of the FAST algorithm from Kwok are discussed in Section 4.4.3. This algorithm uses an ABC and is described in Algorithm 6.2. The macro step and the



**Algorithm 6.1: Static\_List\_Scheduling**( $G, M$ )

---

**Input:** A DAG  $G = (V, E, w, c)$  and a route model  $M$   
**Output:** A schedule  $S$  of  $G$  on the route model  $M$

- 1 Create an Infinite Homogeneous ABC:  $IH - ABC(G, M)$  and a latency ABC:  $L - ABC(G, M)$ ;
- 2 Retrieve the number of operators  $|O|$  from  $L - ABC(G, M)$ ;
- 3  $NodeList \leftarrow$  Sort the actors in  $V$  in CPN-Dominant order using costs from  $IH - ABC(G, M)$ ;
- 4 **for** each  $v \in NodeList$  **do**
- 5      $i \leftarrow$  Select an operator index  $o < |O|$  to execute  $v$  using costs from  $L - ABC(G, M)$ ;
- 6     If no operator exists that can execute  $v$  with a finite cost, return an error;
- 7     Assign the actor  $v$  to  $o_i$ ;
- 8 **end**

---

FAST algorithm are halted when after a given amount of time. In PREESM, these times are specified in seconds and must be tuned to obtain good results. The programmer can stop the FAST process at any time, and the best schedule found is then returned. The time complexity is thus hard to evaluate and the randomness of the neighborhood search makes the FAST algorithm non-deterministic.

The fact that the FAST algorithm only assesses the cost of completely scheduled applications makes it compatible with any type of ABC. It could thus be used to minimize memory, power consumption or a joint cost function. Keeping the best outputs of the macro steps, a population of schedules can be generated and mutations and cross-overs can be applied recursively (Section 4.4.3) in a genetic algorithm. A genetic heuristic is a means of improving schedules without being blocked in a locally optimal point. It can also be combined with any type of ABC.

### 6.5.2 Ordering Heuristics

In the scheduling algorithms presented above, the ABC recalculates the order of an actor when the heuristic assigns an actor to a new operator. Moreover, when transfer competition is taken into account on a Contention Node (CN), the order of the transfer is also computed. The algorithm used to recalculate this order can be changed to obtain a better compromise between scheduling time and schedule quality.

Currently, two algorithms are implemented in PREESM:

- The **simple ordering heuristic** follows the CPN-Dominant scheduling order given by the task list resulting from the list scheduling algorithm. Transfers are assigned an order related to their sender or receiver. This order is likely to be quite sub-optimal but there is a fixed complexity  $O(1)$ .
- The **switching ordering heuristic** is more accurate. When a new actor or transfer needs to be scheduled, the algorithm looks for the earliest **hole** in the operator or CN schedule of sufficient size to contain the candidate. This hole must be after the candidate's predecessors in the schedule so as not to introduce new costly synchronizations. It then inserts the actor or transfer in this hole. This algorithm is in  $O(|V|(|E| + |V|))$ , which can greatly increase the general complexity because it is applied each time an actor is assigned or a transfer is scheduled. However, the

---

**Algorithm 6.2: FAST\_Scheduling**( $G, S_0, M, \text{maxFastTime}, \text{maxMacrostepTime}$ )

---

**Input:** A DAG  $G = (V, E, w, c)$ , an initial schedule  $S_0$ , a route model  $M$  and two parameters  $\text{maxFastTime}$  and  $\text{maxMacrostepTime}$

**Output:** A schedule  $S$  of  $G$  on the route model  $M$

```

1 Set  $S = S_0$ ;
2 Create an ABC of desired type  $ABC(G, M)$ ;
3 reset fastTime;
4 while  $\text{fastTime} < \text{maxFastTime}$  and the programmer did not stop the process do
5   reset macrostepTime;
6   Change the assignment of a randomly chosen Critical Path Node (CPN)  $v_{CPN}$ ;
7    $S_{store} = S$ ;
8   while  $\text{macrostepTime} < \text{maxMacrostepTime}$  do
9     Change the assignment of a randomly chosen non-CPN node  $v_{non-CPN}$ ;
10    if  $ABC$  returns a higher cost than before then
11      Change back the assignment;
12    end
13  end
14  if  $ABC$  returns a higher cost than before then
15     $S = S_{store}$ ;
16  end
17 end
18 return  $S$ ;

```

---

algorithm execution time is still realistic in practice and is counterbalanced by good performance.

The scheduler framework enables the comparison of different edge scheduling algorithms using the same task scheduling sub-module and architecture model description. The switching ordering heuristic has good performance when combined with FAST on a system with transfer contention because it adaptively reschedules actors and transfers during the macro and micro steps (Algorithm 6.2).

The previous section discussed methods for obtaining good schedules. Next, the method of assessing the quality of a schedule will be explained.

## 6.6 Quality Assessment of a Multi-Core Schedule

Quality assessment of an automatically generated schedule is an important feature of a multi-core development chain because it identifies the weaknesses of the system. This section details a graphical quality assessment chart which pinpoints a lack of algorithm or architecture parallelism, in addition to diagnosing underperforming schedules.

### 6.6.1 Limits in Algorithm Middle-Grain Parallelism

The obvious metric for algorithm parallelism in terms of latency is the speedup  $S(n) = T(1)/T(n)$  where  $T(1)$  is the latency on one core, also called the **work** (Section 6.4.2) and  $T(n)$  the latency on  $n$  cores. Other metrics of parallelism based on execution time (Section 6.1.1) could be developed but in the case of LTE, latency is the primary time constraint.

Maximal algorithm speedups started to be discussed in 1967, when Amdahl describes an evaluation method of an intrinsic algorithm parallelism. His theorem simply states that if a portion  $r_s$  of a program is sequential, the execution speedup that may be attained using multiple homogeneous cores compared to one core is limited to  $1/r_s$ , independent of the number of cores [Amd67]. For example, a program with 20% of sequential code has a speedup limit of 5. This formula, known as the Amdahl's law, subsequently led to pessimism about the future of multi-core programming. Indeed, if as low as 20% of sequential code limits the speedup to five, creating architectures with more than a few cores may be useless. Figure 6.12(a) illustrates this limit for several cases of sequential program portions. The maximal speedup according to Amdahl's law on  $n$  homogeneous cores is given by:

$$S \leq S_{maxAmdahl}(n) = \frac{1}{r_s + \frac{1 - r_s}{n}}. \quad (6.6)$$

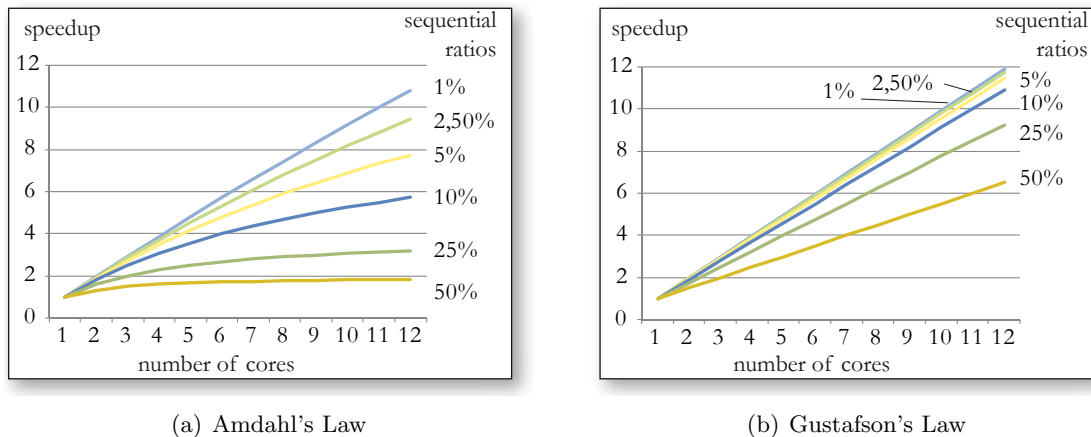

Figure 6.12: Theoretical Speedup Limits

Thankfully, this formula is an over-simplified view of reality, as it defines a perfectly parallel fixed program portion that can be distributed over any number of cores and a fixed sequential program portion, where execution time does not depend on the number of executing cores. These assumptions are based on the idea that a main execution thread spawns parallel threads when data-parallel operations need to be executed and retrieves the data after the end of the parallel program portion. Such model is far from exploiting all the parallelism from an application (data parallelism as well as pipelining). In [Gus88], Gustafson proposes a new model where the serial section of the code represents the same portion of the execution, regardless of the number of cores. The inherent idea is that more cores enable the execution of new portions of the code in parallel. For example, the execution on a given number of cores will spend 20% of the time on sequential code. The execution time on one core is then  $T(1) = r_s(n) + n(1 - r_s(n))$  for any  $n$  when the execution time on  $n$  cores is  $T(n) = r_s(n) + (1 - r_s(n)) = 1$ . The resulting maximal speedup on  $n$  homogeneous cores is shown in Figure 6.12(b) for several sequential part ratios. It is called Gustafson-Barsis law and given by:

$$S \leq S_{maxGustafson}(n) = n - r_s \cdot (n - 1). \quad (6.7)$$

While Amdahl's law is pessimistic for the parallel calculation possibilities of an al-

gorithm, the Gustafson-Barsis law is optimistic and shows that Amdahl's law was not a strict limit, as previously believed. With a sequential section of 20%, the Amdahl maximal speedup on 10 cores is 3.6 while the Gustafson maximal speedup is 8.2. Amdahl and Gustafson laws, as well as Karp-Flatt metric [KF90], are based on the very unrealistic idea that the middle-grain parallelism of algorithm is concentrated in perfectly parallel zones. With graphs of program execution, more realistic parallelism metrics can be used as advised by Leiserson in [Lei05]. Contrary to the previous laws, Leiserson's intent is only to evaluate the available parallelism present in the high-level model of the code; however, the figures are more reliable because they are based on algorithm properties that are more precise than parallel and sequential program sections.

### 6.6.2 Upper Bound of the Algorithm Speedup

It is important to evaluate the quality of the computed schedule. For that purpose, the speedup increase that occurs as the number of cores is augmented is of interest. For this study, communication times are not considered because they greatly depend on the architecture. The only input for the evaluation of the possible speedup included in this study is the algorithm. It is assumed that the architecture is homogeneous and has an infinite speed media. The first limit that must be considered is the work length. The work is the sum of all actor execution times and corresponds to the algorithm latency on one core  $T(1)$  (Section 6.4.2). Except in the exotic case of superlinear speedups which appear when the work decreases with the increasing number of cores, the work will be distributed on all  $n$  cores and so:

$$T(n) \leq T(1)/n \Rightarrow S \leq S_{sup_{work}} = n. \quad (6.8)$$

This speedup limit is a function of the number of available cores. Another general limitation can be found in the length of the **span**, i.e. the critical path when communications are ignored. Both work and span were shown to be calculable by the infinite homogeneous ABC in Section 6.4.2. No matter how well the algorithm is parallelized, the latency can not be reduced to less than the critical path. The critical path length  $T_\infty$  adds a new constraint on the speedup:

$$T(n) \geq T_\infty \Rightarrow S \leq S_{sup_{span}} = T(1)/T_\infty. \quad (6.9)$$

As these upper bounds have been defined, a minimum acceptable performance may be researched.

### 6.6.3 Lowest Acceptable Speedup Evaluation

As compile-time scheduling computation is used with list scheduling and probabilistic refinements, its performance should always be equal to or better than the basic "greedy" scheduler. The "greedy" scheduler executes actors as soon as they become available. At each time step, there are either more than  $n$  available actors, where  $n$  of them are dispatched on the cores and the step is called **complete** or there are less than  $n$  available actors, and they are all dispatched on the cores and the step is called **incomplete**. Graham [Gra69] and Brent [Bre74] give an limit inferior to the latency that such a "greedy" scheduler can obtain using the Greedy Scheduling Theorem (GST):

$$T(n) \leq \frac{T(1)}{n} + T_\infty \Rightarrow S \geq S_{inf_{GST}} = \frac{T(1)}{\frac{T(1)}{n} + T_\infty}. \quad (6.10)$$

The proof of GST can be found in [Lei05]. If a result worse than GST is obtained, the compile-time scheduling process can not be considered successful. Again, this theorem does not take into account the communication times due to hardware constraints that can make real schedules sub-optimal. From the previously defined upper and lower bounds on speedup, a chart can be derived, displaying the optimality of an algorithm schedule latency.

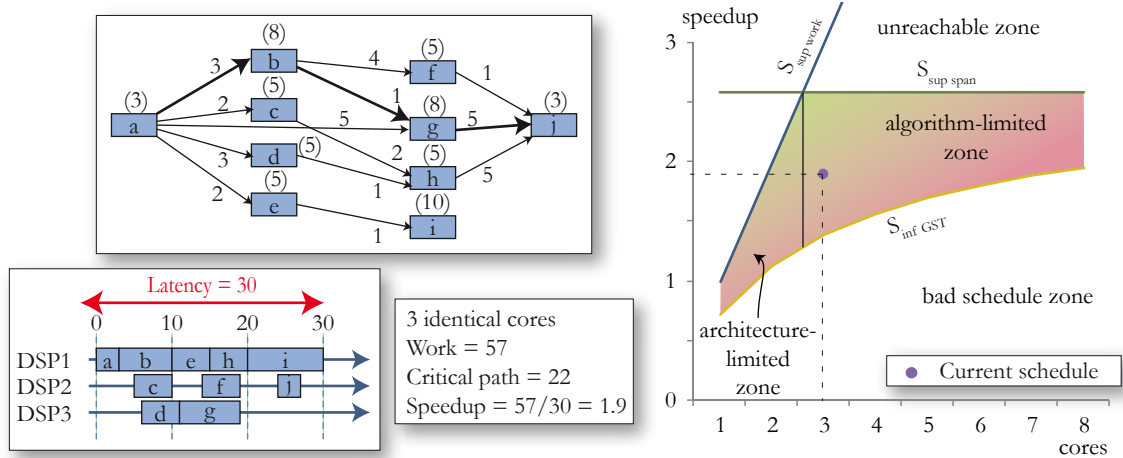

Figure 6.13: Speedup Chart of an Example DAG Scheduling

Figure 6.13 displays the speedup optimality assessment of a small DAG scheduling procedure. The DAG is annotated with its Deterministic Actors Execution Times (in brackets) and the time cost of its transfers. To be efficient, the scheduling must be inside the space delimited by the three curves. The best results are obtained when it is closest to the upper left corner. Moreover, depending on the number of cores, its parallelism is either limited by the number of cores in the architecture (architecture-limited zone) or by the degree of parallelism in the graph (algorithm-limited zone). In [Sin07], Sinnen defines the Communication to Computation Ratio (CCR) as the sum of communication time costs divided by the sum of computation time costs in a scheduled graph. Figure 6.13 makes sense as long as  $CCR \ll 1$  is in the tested schedule. This constraint is not a real problem because  $CCR \ll 1$  is also a condition for the implementation to be efficient.

#### 6.6.4 Applying Scheduling Quality Assessment to Heterogeneous Target Architectures

The previous calculations were all based on homogeneous architectures but their use can be extended to heterogeneous target architectures if certain precautions are taken. The target architectures of this study (Section 5.1.1) have cores of homogeneous type c64x+ that perform the majority of the operations in the application. The c64x+ core type must be set in the scenario as the main operator type. The parallelism of the cores with main type can thus be studied in the quality assessment chart. The results are complicated by the fact that coprocessors improve the speedup and increased communications degrade the speedup. The number of cores in the speedup chart refer only to cores with main operator type. The second precaution is that any actor executed by coprocessors must be forced on that coprocessor to allow the specific study of the behavior of c64x+ cores.

In order to compute work and span, the infinite homogeneous ABC is run to simulate a UNC execution of the code (Section 6.4.2). It calculates the algorithm work using

DAETs with software actors on maintype cores and hardware actors on their respective coprocessors. The span is different than the critical path length computed for the list scheduling because it does not take into account the transfers in the infinite homogeneous architecture. The span is computed by scheduling the graph on a UNC architecture with an infinite number of main .type cores and coprocessors with non-null loads.

Under these conditions, the speedup chart provides a quick evaluation of the optimality of the main system cores under the constraint of fixed mappings. It can be used to evaluate whether a lower granularity in the algorithm is necessary to extract more parallelism or, conversely, if certain actors should be clustered.

After this introduction of enhanced rapid prototyping features, the following chapters will discuss the modeling of LTE for rapid prototyping and code generation.

## 7.1 Introduction

The objectives of rapid prototyping are introduced in Chapter 1. Figure 6.1 illustrates the process of rapid prototyping. Technical background on the subject is explored in Chapter 4. In this chapter, models for the LTE rapid prototyping process are explained. From these models, execution can be simulated and optimized using multi-core scheduling heuristics and code can also be generated. The LTE models are novel and can complement the standard documents for a better understanding of the LTE eNodeB physical layer. After a general view of the LTE model is given in Section 7.2, the three parts of the LTE eNodeB physical layer are detailed in sections 7.3, 7.4 and 7.5. LTE rapid prototyping is processed by a Java-base framework which includes PREESM. The elements of this framework are introduced in following sections.

### 7.1.1 Elements of the Rapid Prototyping Framework

The framework for rapid prototyping that was constructed during this thesis contains three main elements: PREESM, Graphiti and SDF4J. The framework is illustrated in Figure 7.1 and detailed in [PPW<sup>+</sup>09]. All the blocks in Figure 7.1 except SDF4J are open-source plug-ins for the Eclipse environment [ecl]. They can use and extend the advanced functionalities of Eclipse in terms of graphical user interface and framework organization. In the PREESM project, special attention is given to program tools that will be maintained in the long term, using encapsulation and design patterns [GHJV95] (visitor, abstract factory, singleton, command...). Execution time of the different workflow elements is optimized to offer prototyping solutions as expeditiously as possible.

### 7.1.2 SDF4J : A Java Library for Algorithm Graph Transformations

The java library named SDF4J (Synchronous Dataflow for Java) manipulates dataflow graphs and is available in Sourceforge [sdf]. This library can process SDF graphs (Section 3.2) and its subsets (DAG...) as well as IBSDf (Section 3.4.2). It performs the algorithm graph transformations called in the workflows, as explained in Section 6.2.3, including hierarchy flattening, schedulability verification (Section 3.2), transformation into a DAG

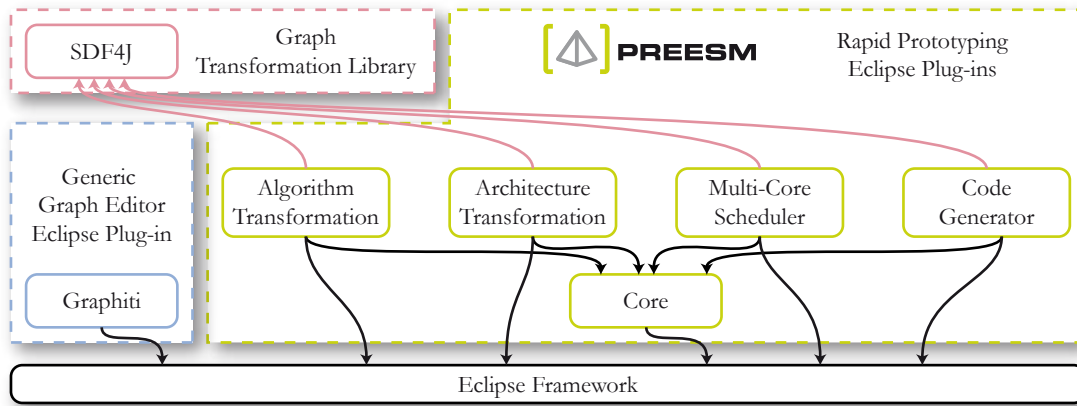

**Figure 7.1:** An Eclipse-based Rapid Prototyping Framework

(Section 3.2.3), and clustering methods based on [Sar87]. SDF4J also contains a parser and a writer of GraphML files [BEH<sup>+</sup>01] to load and store its graphs.

### 7.1.3 Graphiti : A Generic Graph Editor for Editing Architectures, Algorithms and Workflows

Graphiti provides a generic graph editor and is completely independent from PREESM. It is written using the Graphical Editor Framework (GEF). The editor is generic in the sense that any type of graph may be represented and edited. Graphiti is routinely used with the following graph types and associated file formats : CAL networks [EJ03] [Jan07], S-LAM architectural representations stored in IP-XACT format (Section 5.2), SDF and IBSDf graphs stored in GraphML format and PREESM workflows (Section 6.2.3), stored in specific XML files.

The type of graph is registered within the editor by a **configuration**. A configuration is a structure that describes :

1. The **abstract syntax** of the graph (types of vertices and edges, and attributes allowed for objects of each type),
2. The **visual syntax** of the graph (colors, shapes, and so on),
3. Transformations from the file format in which the graph is defined to Graphiti's XML file format  $\mathcal{G}$ , and vice-versa (Figure 7.2).

Two kinds of input transformations are supported: from custom XML to Graphiti XML format and from text to Graphiti XML format (Figure 7.2). XML is transformed to XML using Extensible Stylesheet Language Transformation (XSLT [w3c]). The second input transformation parses the input text to its Concrete Syntax Tree (CST) represented in XML according to a LL(k) grammar by the Grammatica [graa] parser. Similarly, two kinds of output transformations are supported, from XML to XML and from XML to text.

Graphiti handles **attributed graphs** [JE01]. An attributed graph is defined as a directed multigraph  $G = (V, E, \mu)$  where  $V$  the set of vertices, and  $E$  the multiset of edges (there can be more than one edge between any two vertices).  $\mu$  is a function  $\mu : (\{G\} \cup V \cup E) \times A \mapsto U$  that associates instances with attributes from the attribute name set  $A$  and values from  $U$ , the set of possible attribute values. A built-in **type** attribute is defined so that each instance  $i \in \{G\} \cup V \cup E$  has a type  $t = \mu(i, \mathbf{type})$ , and only admits



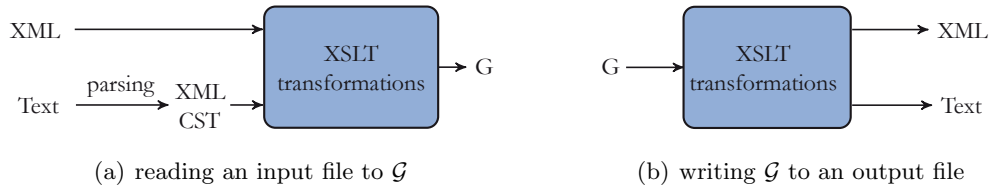

**Figure 7.2:** *Input/output with Graphiti's XML format  $\mathcal{G}$*

attributes from a set  $A_t \subset A$  given by  $A_t = \tau(t)$ . Additionally, a type  $t$  has a visual syntax  $\sigma(t)$  that defines its color, shape and size.

To edit a graph, the user selects a file and the matching configuration based on the file extension is computed. The transformations defined in the configuration file are then applied to the input file and result in a graph defined in Graphiti's XML format  $\mathcal{G}$  as shown in Figure 7.2. The editor uses the visual syntax defined by  $\sigma$  in the configuration to draw the graph, vertices and edges. For each instance of type  $t$  the user can edit the relevant attributes allowed by  $\tau(t)$  as defined in the configuration. Saving a graph consists of writing the graph in  $\mathcal{G}$ , and transforming it back to the input file's native format.

Graphiti generates workflow graphs, IP-XACT and GraphML files that are the primary inputs of PREESM rapid prototyping. The GraphML files containing the algorithm model are loaded and stored in PREESM by the SDF4J library.

#### 7.1.4 PREESM : A Complete Framework for Hardware and Software Codesign

PREESM itself is composed of several Eclipse plug-ins (Figure 7.1). The core parses and executes workflows, calling methods from the other plug-ins of PREESM. It includes the SDF4J library and contains the classes of all objects exchanged in workflows (Section 6.2.3). The core is the only compulsory element for PREESM. Other plug-ins can be added to extend PREESM functionalities. The algorithm and architecture transformation plug-ins provide graph transformations to the workflow. The algorithm transformation plug-in generally calls SDF4J functionalities. The multi-core scheduler contains all the features discussed in Chapter 6. The code generation plug-in generates self-timed executable code (Section 4.4.1) from schedules provided by the multi-core scheduler. Code generation will be extended in Chapter 8.

## 7.2 Proposed LTE Models

### 7.2.1 Fixed and Variable eNodeB Parameters

Certain parameters of an eNodeB do not change during its whole life span and other parameters change every millisecond. For the rapid prototyping process, simulation use cases must be chosen that represent real-life execution cases. The compile-time and run-time actor scheduling must take into account the life spans of parameters and to manage static parameters, no scheduling overhead should be introduced at run-time.

The **duplex mode** (Section 2.3.4) is a fixed parameter determined during the network construction. The **bandwidth** of an eNodeB and the cyclic prefix mode (normal or extended) are also fixed network parameters. Once a frequency band has been bought by an operator, the eNodeB is configured to exploit fully this bandwidth. The number

of available **subcarriers** is consequently also a fixed parameter, as are the **size of the Fourier transforms** in SC-FDMA and OFDMA encoding and decoding (Section 2.3.4).

The format and localization of the RACH preamble, as well as the number of roots and cyclic shifts (Section 2.4.5) are stable. These parameters depend only on the environment of the eNodeB and are not permitted to vary over time because they must provide a stable access point for UEs. Thus, the RACH decoding has no variable parameters.

The **number of antennas** for uplink, downlink and PRACH is stable. The **multiple antenna schemes** for uplink and downlink are determined in the eNodeB (Sections 2.3.6, 2.4.4 and 2.5.4). Each eNodeB may have a preferred multiple antenna scheme corresponding to its environment (rural and flat, mountainous, urban...) but a number of different modes are likely to be used depending on the channel quality of each user.

It is the highly variable parameters of an eNodeB that depend on the UE connections. In PUSCH, the **number of UEs** sending data changes every TTI of one millisecond (Section 2.3.4). The **number of Code Blocks** sent (Section 2.3.5) and the **sizes of these Code Blocks** also changes every TTI depending on the services accessed by each UE (telephony, web...). The repartition of this data in the frequency band can differ for each slot of 0.5 millisecond because of frequency hopping (Section 2.4.2). In PDSCH, the number of variables is approximately the same as in PUSCH but with an additional degree of freedom in the **number of transport blocks sent to a UE** during a TTI. In PUSCH, with the exception of MU-MIMO, there is no spatial multiplexing so only one transport block per TTI is transmitted (Section 2.4.4). In PDSCH, 2x2 spatial multiplexing can be employed (Section 2.5.4) and a single UE can receive two transport blocks in one TTI.

The **modulation and coding scheme** (Section 2.3.5) is specific to each UE so will also varies in every TTI. The transport block size and number of transport blocks for a UE determines for each TTI the quantity of data exchanged with the core network (Figure 2.4).

As a consequence of these parameter variations, RACH preamble decoding is a static operation that can be studied entirely at compile-time while uplink decoding and downlink encoding are highly variable over time. Despite these variations, case studies may be chosen so behavioral information can be extracted from the corresponding dataflow graphs at compile-time. A typical use case is presented in next section.

## 7.2.2 A LTE eNodeB Use Case

In order to study LTE multi-core execution, typical use cases must be defined. We present here a typical eNodeB and its performance. The objective of this section is to explain the important features that must be taken into account when evaluating LTE physical layer performance. Considering a FDD eNodeB with 20MHz downlink and uplink and 100 PRBs per slot, the system behavior can be evaluated using information given in Chapter 2. A configuration of four transmission and four reception antenna ports (Section 2.3.6) is chosen for this eNodeB.

### Uplink Performances

Firstly, considering the PUSCH with standard cyclic prefix, each PUSCH resource block contains  $6 \text{ symbols} * 12 \text{ subcarriers} = 72 \text{ resourceelements}$ ; one additional symbol is used as a reference symbol (Figure 2.17). Table 7.1 gives the capacity of Resource Elements (RE) and resource blocks in bits and deduces the raw bit rates for the current case. This total data rate must be shared between all UEs. The base time unit for data allocation to

**Table 7.1:** *Maximal Raw Bit Rates of Uplink Resources*

Modulation Scheme	bits/RE	bits/PRB	bits/pair of PRBs	max raw bit-rate
QPSK	2	144	288	28.8 Mbit/s
16-QAM	4	288	576	57.6 Mbit/s
64-QAM	6	432	864	86.4 Mbit/s

a UE is a single TTI of one millisecond; thus it can be seen that a pair of PRBs contain the minimum amount of bits that can be allocated to a UE.

From these raw data rates, the multiple control overheads must be subtracted:

- The outer PRBs are reserved for PUCCH. This exact number is typically up to 16 PUCCH regions, i.e. 16 PRBs per slot are kept for PUCCH ([STB09]). It may be noted that the modulation and coding scheme is different between PUSCH and PUCCH; thus the PUCCH raw bit rate cannot be directly deduced from this calculation.
- The rate matching process (Section 2.3.5) has a rate of “useful data” between 7.6% and 93%. The channel coding rate is linked to the chosen modulation scheme (Figure 2.14(a)).
- The transmission of the PRACH channel requires part of the uplink bandwidth. In a typical case of a cell with radius smaller than 14 km, a preamble of format 0 can be allocated every 2 milliseconds. It results in 6 PRBs every 2 milliseconds, so uses approximately 3% of the resources.

Thus, the maximal PUSCH data rate may be evaluated, including these overheads. Under ideal conditions where 64-QAM can be employed over the entire bandwidth with 93% channel coding rate, a PUSCH data rate of  $86.4 * 0.93 * 0.81 = 65 \text{ Mbit/s}$  can be attained. The CRCs and the overhead of the upper layers are not taken into account; these parameter also reduce the final bit rate available to the UEs IP layer. The uplink transmission process is constructed to allow the LTE uplink data rate requirement of 50 Mbit/s to be attained.

### Downlink Performances

The downlink performance evaluation uses the table of transport block sizes in [36.09e] p.26. The transport block size (in bits) depends on the number of allocated PRBs, and on an index named  $I_{TBS}$  (Index of Transport Block Size). Downlink Control Information (DCI, Sections 2.3.5 and 2.5.2) sent in PDCCH to a UE details the link adaptation parameters and determines the  $I_{TBS}$ . From the  $I_{TBS}$ , the maximal downlink data rates for a given modulation scheme, with 2x2 spatial multiplexing (2 transport blocks) can be evaluated. The results are shown in Table 7.2.

The displayed data rates target only PDSCH and include the control channel costs. As above, these maximal data rates are those of the physical layer. Upper layers will further reduce the effective data rate available to the IP layer of the UEs.

The following sections focus on models of multi-core execution for the physical layer of LTE eNodeBs. To study the system-level and the link-level data behavior of the LTE

**Table 7.2:** *Maximal Raw Bit Rates of PDSCH*

Modulation Scheme	$I_{TBS}$	bits/2TBs	max raw bitrate
QPSK	9	31704	31.7 Mbit/s
16-QAM	15	61664	61.7 Mbit/s
64-QAM	26	149776	149.8 Mbit/s

downlink, an open source simulator under Matlab is provided by the Technical University of Vienna [MWI<sup>+</sup>09].

### 7.2.3 The Different Parts of the LTE Physical Layer Model

LTE physical layer decoding can be divided into three major actors: **random access decoding**, **uplink decoding** and **downlink encoding**. Uplink decoding and random access decoding are frequency multiplexed in the same symbols but they are separated in this study for two reasons: firstly, both actors are very costly, and are potentially parallel and secondly, while PRACH decoding is a completely static operation, uplink decoding execution varies every millisecond. Thus studying each actor separately allows better and fast optimization.

The scale and granularity of the three actor descriptions must be defined (Section 3.1.2). The scale is determined by the application. For PRACH decoding, the obvious scale results from a graph decoding a complete preamble sent over 1, 2 or 3 milliseconds. This preamble transmission time depends on preamble type. The latency of one RACH preamble detection then is minimized. For uplink and downlink actors, graphs could be constructed where each processes one symbol (decoding a 71.4  $\mu$ s period) but this would introduce too much low-level conditioning, including parameters with static patterns.

Another possibility would be to design uplink and downlink graphs representing one entire frame (decoding 10 milliseconds) but this solution leads to very large graphs and HARQ puts latency constraint on subframe processing, not frame processing. Thus, the correct scale for uplink and downlink graphs is the time to process one subframe (1 millisecond). The granularity is chosen so that atomic actors (with no hierarchy) have relatively close execution times. A typical actor execution time is a few thousand of cycles. In the following sections, models of random access decoding, uplink decoding and downlink encoding with user- selected scale will be presented.

## 7.3 Prototyping RACH Preamble Detection

Random Access Channel Preamble Detection (RACH-PD) consists of decoding the multiplexed and non-synchronized messages from the UEs attempting to connect to the eNodeB (Section 2.4.5). The preamble is transmitted on the Physical RACH (PRACH) channel over a specified time-frequency resource, denoted as a **slot**, available with a certain cycle period and a fixed bandwidth of six PRBs. Within each slot, a guard period is reserved at each end to maintain time orthogonality between adjacent slots.

The method used to execute RACH-PD is the hybrid time-frequency domain approach described in [STB09] p.449 and [JMB]. With this method, the PRACH message decoder can start before the whole message has been received. It uses small FFTs and is based on downsampling and anti-aliasing. The Power Delay Profile (PDP) is then computed. It

consists of the norm of the periodic correlation of each Zadoff-Chu sequence (Section 2.4.3) with the received sequence. A peak in the Power Delay Profile indicates the detection of a signature and the location of the peak provides the timing advance of the transmitting UE, i.e. the propagation time between UE and eNodeB. Peak detection must take into account the noise in received samples; thus, the noise is estimated and the threshold for peak detection depends on this estimation. To compute the correlation between received signal and signatures, the convolution with complex conjugate is used.

The case studied in this section assumes a RACH-PD for a cell size of 115 km. This is the largest cell size supported by LTE and is also the case requiring the most processing power. According to [36.09c], preamble format#3 is used with 21,012 complex samples as a cyclic prefix, followed by a preamble of 24,576 samples followed by the same 24,576 samples repeated. In this case, the slot duration is 3 milliseconds which gives a guard period of 21,996 samples.

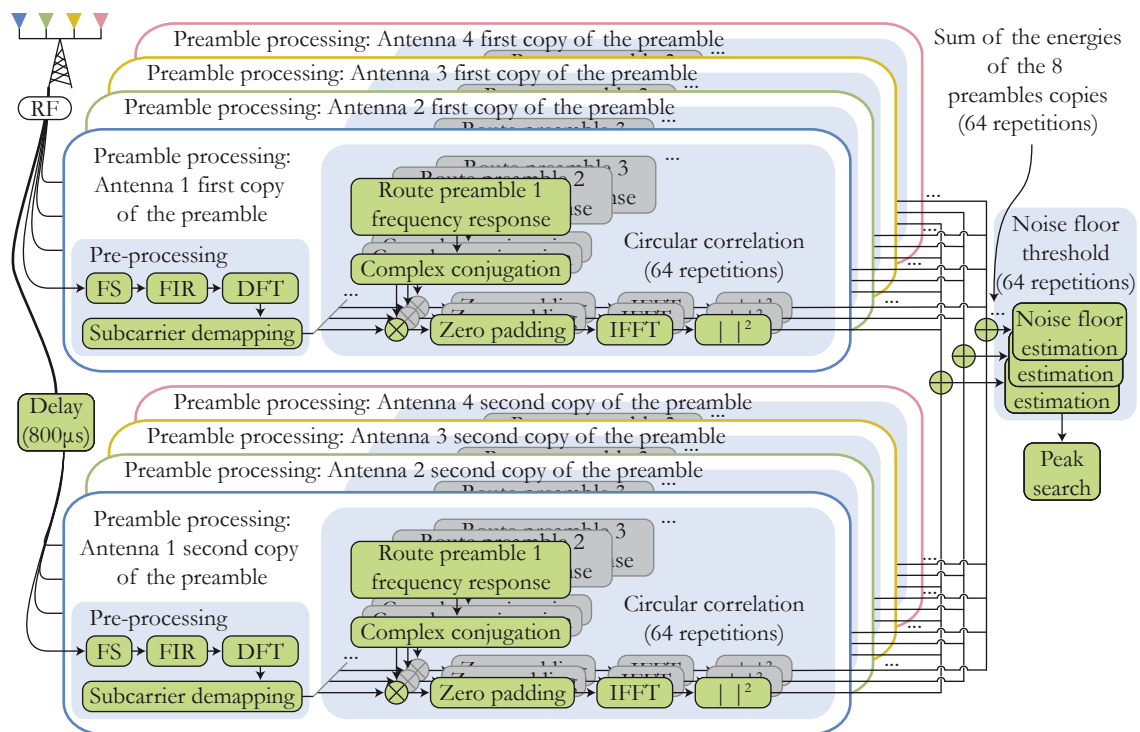

Figure 7.3: RACH-PD Algorithm Model

As per Figure 7.3, the algorithm for the RACH preamble detection can be summarized in the following steps [JMB]. The dataflow graph in Figure 7.3 illustrates the actors contained by the IBSDf description.

1. After cyclic prefix removal, the **pre-processing actor** isolates the RACH bandwidth by shifting the data in frequency (Frequency Shifting, FS) and band-pass filtering it with downsampling (Finite Impulse Response, FIR). The data is then transformed into the frequency domain (DFT) and the subcarriers of interest are selected (subcarrier demapping).
2. Next, the **circular correlation actor** correlates data with pre-stored preamble root sequences in order to discriminate between simultaneous messages from several users. The complex conjugates of the root sequences are directly retrieved from

memory; consequently, the correlation step only costs a complex multiplication. The circular correlation actor also applies an IFFT to return to the temporal domain and calculates the energy of each root sequence correlation. The more roots there are, the more circular correlations are processed. This is why cyclic shifts are used when possible to reduce the number of root (Section 2.4.5).

3. Then, the **noisefloor threshold actor** collects these energies and estimates the noise level for each root sequence.
4. Finally, the **peak search actor** detects all signatures sent by the users in the current time window. It additionally evaluates the transmission timing advances, correlated with the distance of the transmitting UEs. The timing advances are sent to the MAC layer which then transmits each value to the appropriate UE to command a compensation.

In general, there are three parameters of RACH which are highly dependent on the cell size, and may be varied: the number of receive antennas, the number of root sequences and the number of repetitions of the same preamble. The case with 115 km cell size implies 4 antennas, 64 root sequences, and 2 repetitions, as shown in Figure 7.3.

The goal of rapid prototyping of a RACH-PD can be to determine, through simulation, the number of c64x+ cores needed by the architecture to manage the 115km cell RACH-PD algorithm. The RACH-PD algorithm behavior is described as a IBSDf graph in PREESM. The algorithm can be easily adapted to different eNodeB use cases by tuning the graph parameters. The IBSDf description is derived from the representation in Figure 7.3. After a total flattening (Section 3.4.2), the graph contains 2209 vertices. This high number may be reduced by merging actors and/or reducing the flattening degree. Placing these actors onto the different cores by hand would be greatly time-consuming. As seen in Section 7.1.4 the rapid prototyping PREESM tool provides automatic scheduling, avoiding the problem of manual placement.

A significant point to note is that RACH decoding has an absence of feedback edge and a total independence of preceding preamble detection iterations. In the IBSDf graph description of RACH-PD, the graph is actually acyclic and the SDF to DAG transformation has no effect on its topology. The graph also displays a high parallelism that can be extracted at compile-time. Indeed, its topology depends only on parameters that are fixed for the lifespan of an eNodeB. Thus, no assignment step is needed at run-time to optimally execute RACH-PD on a distributed architecture. The parallelism can be evaluated in terms of span, length and potential speedup using the quality assessment chart from Section 6.6, computed in PREESM. However, this chart does not take communication costs or heterogeneity into account. An architecture exploration is needed to perform a precise and complete hardware and software codesign.

### Architecture Exploration

The four architectures explored are shown in Figure 7.4. The cores are all homogeneous Texas Instrument c64x+ DSP running at 1 GHz [TMS08]. The connections are made via DMA-driven routes. The first architecture is a single-core DSP such as the TMS320TCI6482. The second architecture is dual-core, with each core similar to that of the TMS320TCI6482. The third is a tri-core and is equivalent to the tci6488 (Section 5.1.1). Finally, the fourth architecture is a theoretical architecture for exploration only, as it is a quad-core. The exploration goal is to determine the number of cores required

to run the random RACH-PD algorithm in a 115 km cell and how to best distribute the operations on the given cores.

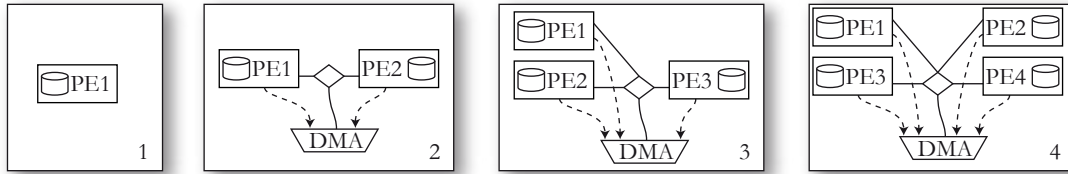

**Figure 7.4:** *Four architectures explored*

To solve the deployment problem, each operation is assigned an experimental timing (in terms of CPU cycles) in the scenario. These timings are measured with deployments of the actors on a single C64x+. Since the C64x+ is a 32-bit fixed-point DSP core, the algorithms must be converted from floating-point to fixed-point prior to these deployments. The EDMA is modeled as a parallel node controlled by a DMA (Chapter 5) transferring data at a constant rate and with a given set-up time.

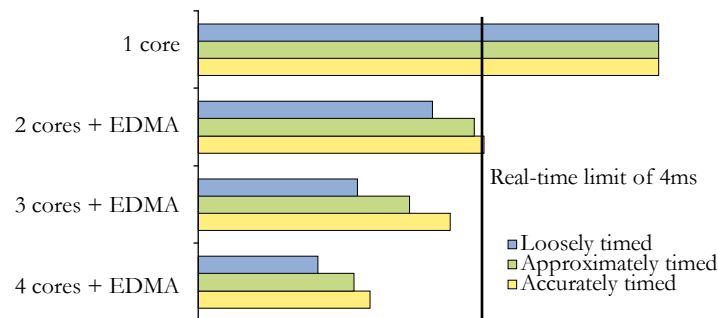

**Figure 7.5:** *Timings of the RACH-PD algorithm schedule on target architectures*

The PREESM automatic scheduling process is applied for each architecture. The workflow used is close to that of Figure 6.4. The simulation results obtained are shown in Figure 7.5. The list scheduling heuristic is used with loosely-timed, approximately-timed and accurately-timed ABCs. Due to the 115 km cell constraints, preamble detection must be processed in less than 4 milliseconds (Section 2.4.5).

The experimental timings were measured on code executions using a tci6488. The timings feeding the simulation are measured in loops, each calling a single function with L1 cache activated. For more details about C64x+ cache, see [TMS08]. This warm cache case represents the application behavior when local data access is ideal and so will lead to an optimistic simulation. The RACH application is well suited for a parallel architecture, as the addition of one core reduces the latency dramatically. Two cores can process the algorithm within a time frame close to the real-time deadline with loosely and approximately timed models but high data transfer contention and high number of transfers make the dual-core architecture not sufficient when accurately timed model is used.

The 3-core solution is best: its CPU loads (less than 86% with accurately-timed ABC) are satisfactory and do not justify the use of a fourth core, as can be seen in Figure 7.5. The high data contention in this case study justifies the use of several ABC models; simple models are used for fast results and more complex models are then employed to correctly dimension the system.

## 7.4 Downlink Prototyping Model

Encoding the LTE downlink consists of preparing the different data and control channels and multiplexing them in the radio resources. Depending on the amount of control necessary in a subframe, the 1, 2 or 3 first symbols carry the control channels (Section 2.5.2). The remaining resources are shared between data channel (PDSCH), broadcast channels and reference signals. To encode the LTE downlink, the baseband processing retrieves the data Transport Blocks (TB) from the MAC layer (Figure 2.6) and applies channel coding to them. Control channels and reference signals are then generated and multiplexed with the data channel prior to MIMO encoding.

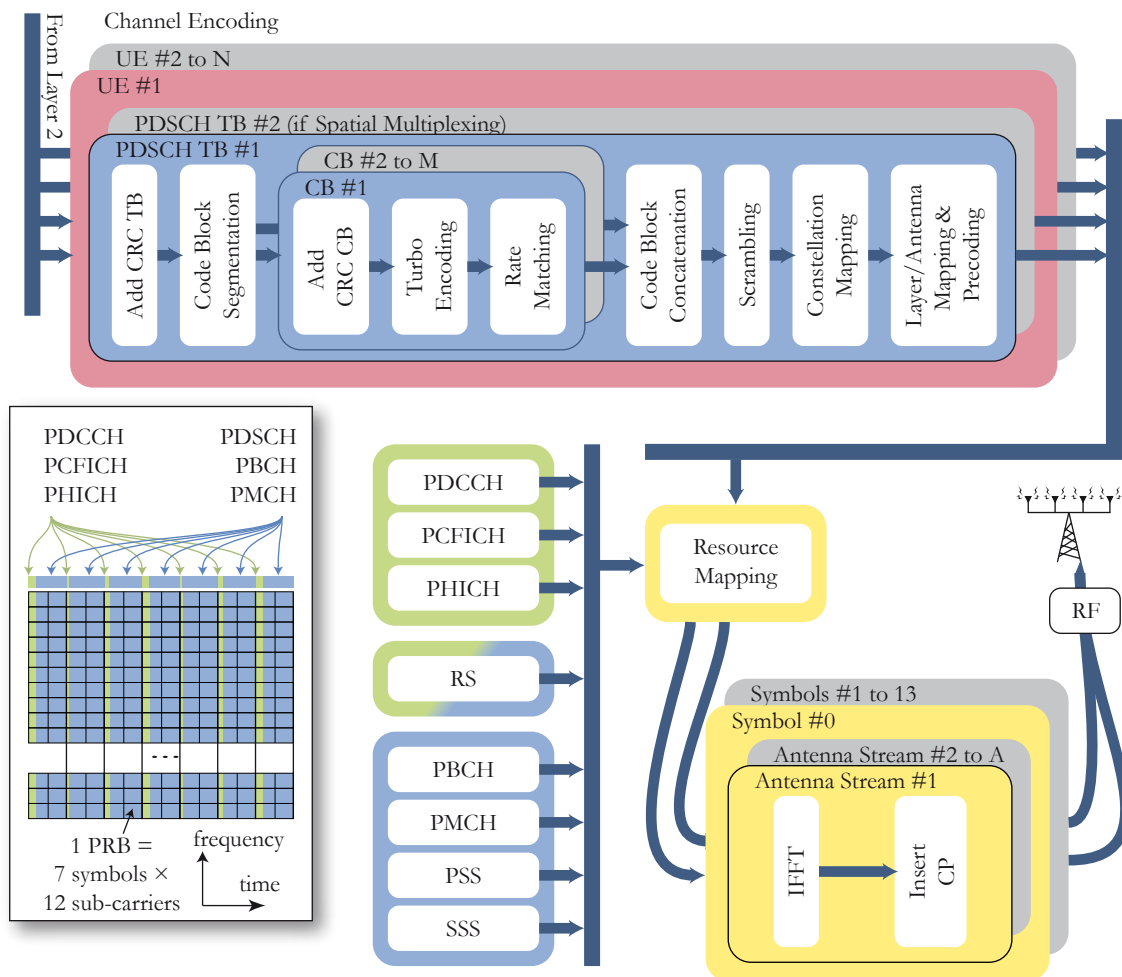

Figure 7.6: Downlink Decoding

A dataflow graph for encoding rapid prototyping is shown in Figure 7.6. It is composed of three parts:

- during **channel encoding** the PDSCH data bits are transformed into symbols (Section 2.5.2). First, a Cyclic Redundancy Check (CRC) is added to each TB. The TB is then segmented into Code Blocks (CB) and each CB also receives a CRC. These CRCs enable the detection of errors when a UE decodes PDSCH. The resulting code block with CRC is Turbo-Encoded and rate-matched (Section 2.3.5) to introduce



the exact amount of desired redundancy in the binary information for Forward Error Correction (FEC). Then, the encoded code-blocks are concatenated before being scrambled and constellation mapped. Scrambling spreads the redundant data evenly to protect it against the frequency-selective air channel and a constellation mapping is chosen among QPSK, 16-QAM and 64-QAM. The data is now composed of symbols. The decisions are not shown in Figure 7.6 but all decisions (Hybrid ARQ parameters for retransmission, Modulation scheme, Antenna mapping mode, and so on) are sent by the MAC layer. Finally, the symbols are mapped to layers and the layers are precoded and mapped to antenna ports (Section 2.5.4). Layer mapping and precoding depend on the multiple antenna PDSCH mode (spatial multiplexing or not, open or closed loop) chosen by the MAC layer.

- during the **control and broadcast channels generation**, channel symbols are generated to be multiplexed with PDSCH. The primary control channel, PDCCH, as well as PCFICH and PHICH channels are mapped to the first 1, 2 or 3 symbols of the encoded subframe (Section 2.5.2). Certain Reference Symbols (RS) also appear in these first symbols. PBCH broadcast channel values are generated only if the current subframe contains cell information broadcast, which is the case once every frame of 10 milliseconds. PBCH values are multiplexed with PDSCH, multicast channel PMCH, RS and Synchronization Symbols (PSS and SSS, Section 2.5.5) in the remaining 13, 12 or 11 symbols of the subframe.
- in the **front-end**, each complex value of the previously mentioned physical channels is associated with a Resource Element (RE) in the Resource Mapping procedure. Resource mapping is a bottleneck in the application because all symbols from all UEs must be collected prior to forwarding them to the rest of the front-end. An IFFT is then applied to convert each symbol of each antenna port into the time domain for transmission and a cyclic prefix is inserted between each symbol to reduce inter-symbol interferences (Section 2.3.2).

The PDSCH processing dominates the computation cost of other downlink physical channels. It is for this reason that it is divided into actors while PHICH generation is seen as a single “black box”. When described in an IBSDF, the number of repetitions of each actor (per TB, per CB, per UE, per antenna port...) is determined by the number of data tokens flowing between the different actors in the graph. Like the RACH-PD IBSDF description, the downlink encoding graph is fairly parallel and is already an acyclic graph. Unlike the RACH-PD IBSDF description, its topology depends on certain parameters (number of receiving UEs, number of TBs, size of these TBs and number of CBs) that vary each subframe because the subframe is the basic time unit for UE allocation (Section 2.3.2). It must be noted that only typical or worst-case downlink test cases can be studied in PREESM.

## 7.5 Uplink Prototyping Model

The uplink model is divided into PUCCH and PUSCH models. Decoding the PUCCH uplink control channel is a complex and potentially parallel operation. Contrary to the PDCCH encoding that may be represented as a single actor, as in Figure 7.6, the PUCCH model is presented as a complex graph. It may be noted that the PUCCH and PUSCH graphs process the same raw symbols received by the antennas.

### 7.5.1 PUCCH Decoding

Decoding PUCCH consists of extracting resource blocks at the edge of the bandwidth from the raw data received by the antenna and then processing them to retrieve the uplink control bits. The localization of PUCCH in the bandwidth was explained in Section 2.4.2.

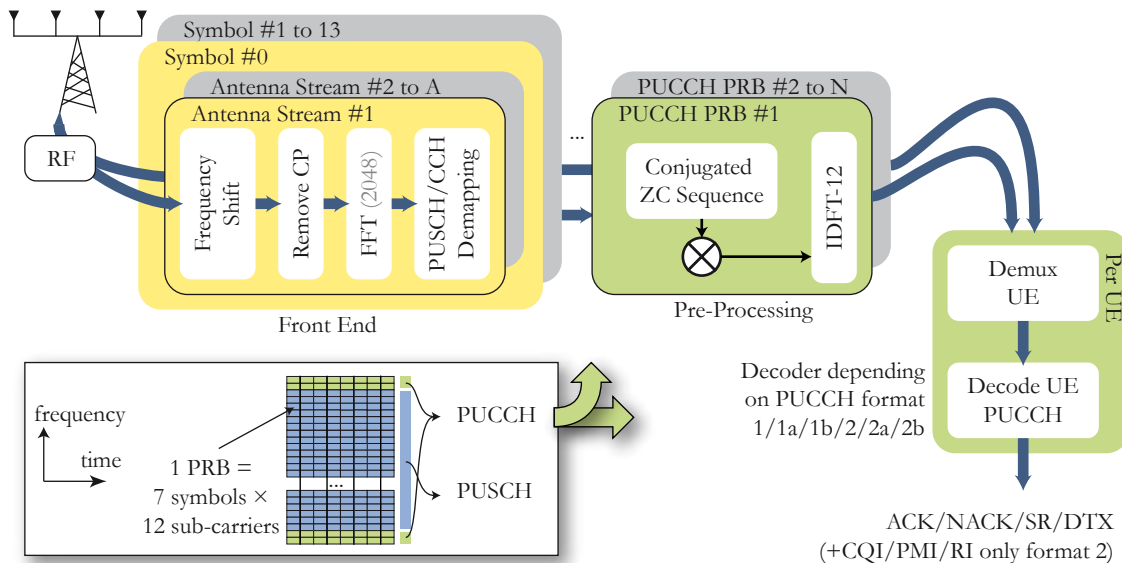

**Figure 7.7:** *PUCCH Decoding*

A dataflow graph for decoding PUCCH is displayed in Figure 7.7. The PUCCH decoding consists in three distinct steps:

- The **front end** is common to PUCCH and PUSCH. The uplink subcarriers are frequency shifted by half the width of a subcarrier, i.e. by 7.5 kHz, to reduce distortions on the central resource blocks from the local oscillator. A frequency shift of 7.5 kHz is thus first applied to the received signal to compensate for this shift. The problem does not appear in downlink because one subcarrier (named d.c. subcarrier) is punctured (Figure 2.21). In uplink, the same solution would worsen the PAPR and thus increase UE power consumption ([STB09] p.353). The CP is then removed and the symbols are transformed to the frequency domain by a FFT. The FFT size depends on the bandwidth (Table 2.1) with a maximum of 2048 points in the 20 MHz bandwidth case with 1200 subcarriers. Finally, resource elements from the band edges are used in the PUCCH decoding procedure while the center elements are used in the PUSCH decoding.
- The **pre-processing** step demultiplexes the PUCCH information from multiple UEs which was transmitted over the same resources using CDM (Section 2.4.1). For the UE, CDM encoding consists of multiplying, in the frequency domain, the data with a Zadoff-Chu Sequence of length 12 and with a given cyclic shift. Thus, it is possible for two UEs using the same ZC sequence with different cyclic shift to use the same PBR. For each PRB, there are twelve possible cyclic shifts. To decode the CDM, a multiplication with the Zadoff-Chu sequence is applied followed by a DFT of the size of a PRB.
- In the **decoder** step, the UE data is then demultiplexed and, depending on the PUCCH block format, certain information is extracted, using Reed-Muller decoding

to decode CQI (Section 2.3.5). ACK is reported by the UE in the case of a correct downlink reception; NACK for a failed downlink reception (when the CRC indicated errors in transmission) and DTX means that the UE did not even detect in PDCCH that it had data to receive in PDSCH.

The information extracted from PDCCH is reported to the MAC layer, which controls the downlink communication. The PDCCH can also contain an uplink Scheduling Request (SR) when a UE requires more PUSCH resources.

### 7.5.2 PUSCH Decoding

PUSCH decoding is the most complex graph in the LTE eNodeB physical layer model. It contains seven parts and is illustrated in Figure 7.8:

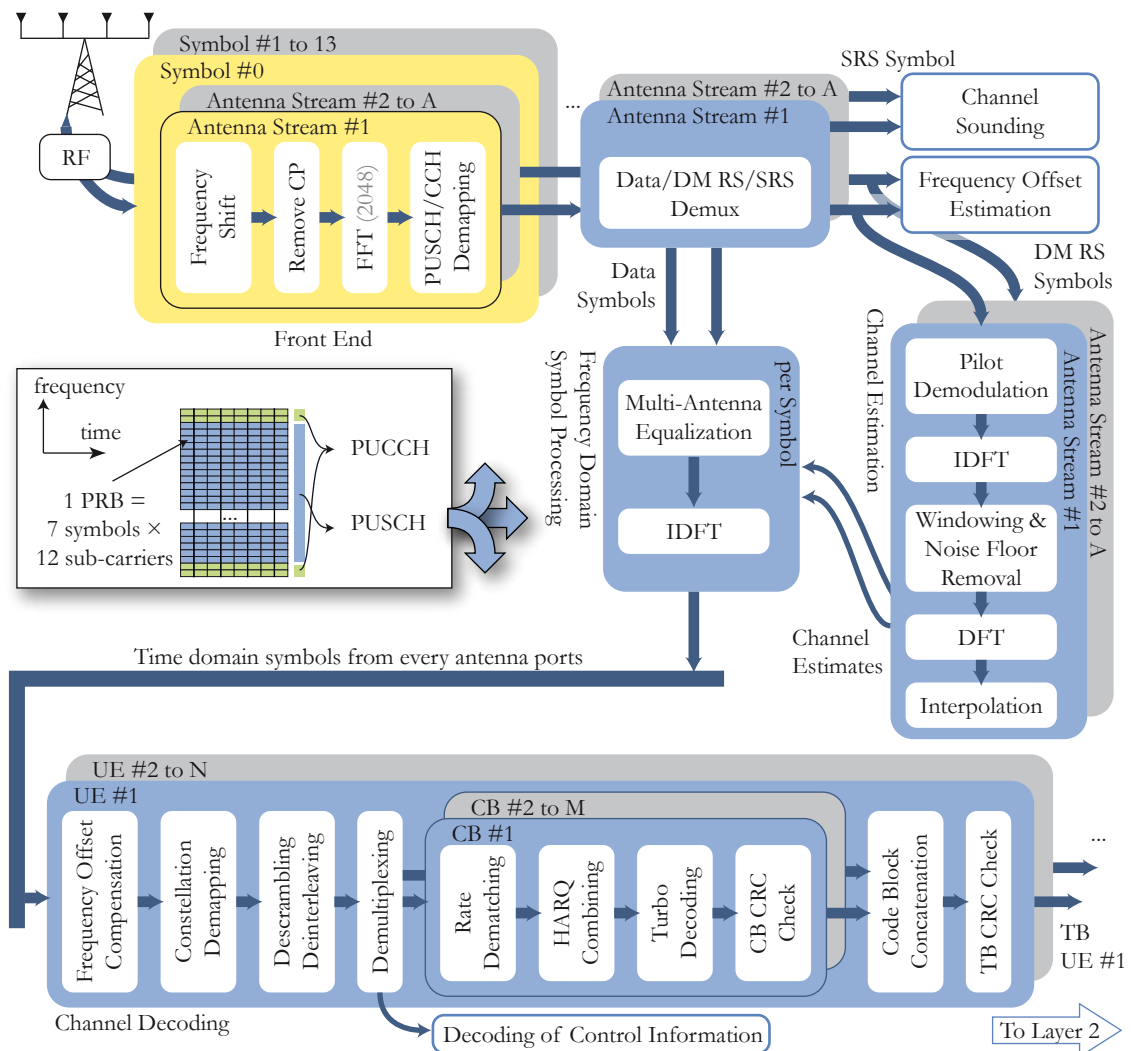

Figure 7.8: PUSCH Decoding

- The **front end** is common to PUCCH and PUSCH and was explained in Section 7.5.1. It outputs the physical resource blocks dedicated to PUSCH in frequency domain.

- The **data/DM RS/SRS demultiplexer** separates the reference signals from the data resource elements.
- The **channel sounding** processes the SRS symbol 13 and sends sounding information to the MAC layer (Section 2.4.1). This information is used to schedule UEs in the subsequent subframe.
- the **frequency offset estimation** evaluates the Doppler effect experienced by each UE data TB due to UE velocity. The estimation uses the two reference DM RS symbols 3 and 10 (Section 2.3.1). The frequency offset is then transmitted to the MAC layer and influences the channel decoding.
- the **channel estimation** processes the ZC sequences from the two DM RS symbols to compute the Channel Impulse Response (CIR). The pilot subcarriers from different UEs are first separated. They are then transformed into time domain by an IDFT. The DM RS signal is synchronized and noise removed. Finally, the signal is transformed back into frequency domain, the CIR is evaluated and is linearly interpolated to find the CIR of each of the eleven data symbols.
- The **frequency domain symbol processing** first combines the data from different antenna ports, equalizing them (Section 2.3.2) and using either MRC or MIMO decoding, depending on the UE multiple antenna scheme employed (Section 2.3.6). As with channel estimation, the data from each UE is processed independently because it may have different MCS than other UEs. The data is then transformed into time domain by an IDFT. It may be noted that the equalizer processes the data from all antenna ports together. Moreover, after Frequency Domain Symbol Processing, the data from all the symbols must be gathered for joint processing. These two bottlenecks limit functional parallelism, introducing additional causality in the system but they cannot be avoided.
- The **channel decoding** step is approximately the inverse operation of the downlink channel encoding explained in Section 7.4. The transport block values of each UE are processed, extracting bits from the time-domain symbols. The frequency offset due to the Doppler effect is compensated and data is demapped, descrambled and deinterleaved. A second demultiplexing of data and control is necessary at this point because certain control values can be multiplexed with data if PDCCH capacity is insufficient ([STB09] p.398). Each CB is then dematched and combined with any previous HARQ repetition. A hidden feedback edge exists because code blocks from previous iterations of the graph are maintained in the MAC layer for future combination with the subsequent repetition. After Turbo decoding, the CRC is checked to verify whether data was lost and a new HARQ repetition is necessary. CBs are finally gathered and the TB CRC is checked.

Contrary to the downlink part, only one TB per UE can be received in a subframe because no spatial multiplexing other than MU-MIMO is allowed. In order to obtain a correct simulated decoding latency, the IBSDF graph must account for the fact that each symbol is received with a delay of 1/14 millisecond more than the preceding one. As there is no notion of time in IBSDF and it is the scenario alone that introduces timings for actors, a “trick” must be used to include these delays. This “trick” consists of introducing a fake processing element in the architecture, which this study will call Antenna Interface (AIF). A “dummy” delay actor is added to the algorithms, assigned to AIF, associated

with a 1/14 millisecond timing on AIF in the scenario. This actor is preceded by another “dummy” actor whose use is to repeat the delay. A feedback edge on the delay actor ensures the order of execution of its instances. The original graph and its form after transformation to a single rate graph are shown in Figure 7.9. The delay from the first “dummy” actor must be subtracted from the latency. The same technique can be used in the downlink model to receive transport blocks at disparate times.

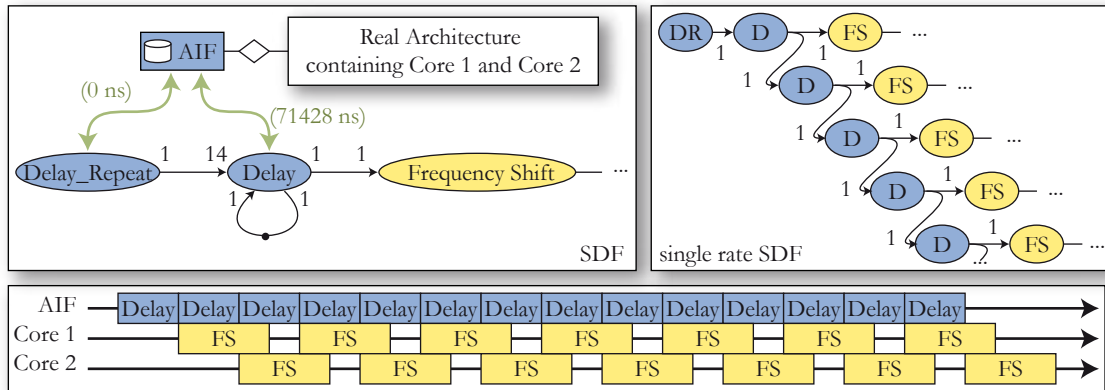

**Figure 7.9:** *Introducing Delays in a IBSDF Description to Simulate Events*

It may be noted that the data rate of both uplink and downlink communications between baseband processing and antenna ports can be a challenge. For a 20MHz cell with 30.72 MHz sampling rate and 4 antenna ports and with complex data of 16-bit real and imaginary parts, the antenna data rate is almost 4Gbit/s in both directions. Consequently, the hardware antenna interface needs to support very high data rates. The complex AIF data exchanges can be studied at system-level using PREESM and S-LAM Contention Nodes, without considering all the details of implementation.

Of course, when the RACH-PD, downlink and uplink graphs are all prototyped together, the result is an extensive graph. Synchronization can then be specified for the reception time of the downlink transport blocks and also the reception time of the uplink symbols, using the “trick” presented above. This chapter presented LTE modelization for rapid prototyping. The next chapter explains code generation from LTE dataflow graph descriptions.



## 8.1 Introduction

Literature on automatic multi-core code generation was reviewed in Section 4.5 and scheduling strategies in Section 4.4.1. In this section, generated code execution schemes are defined, detailing how code is generated from a given scheduling strategy. Code generation for RACH-PD (Section 8.2), PUSCH (Section 8.3) and PDSCH (Section 8.4) is then explained. Combining the three dataflow paths is discussed finally in Section 8.5.

### 8.1.1 Execution Schemes

In [BW09], Bell and Wood advise programmers on multi-core programming. The architectures they study are the same DSPs targeted by this study. Their recommended method for parallelizing applications is based on a test-and-refine approach and is manual with steps that are different from those of Figure 4.2. The report then presents the two execution schemes which form the basis of distributed code generation: the master/slave scheme and the dataflow scheme. Instead of “dataflow” scheme, the terminology “decentralized scheme” will be used to avoid confusion with dataflow MoC. An execution scheme differs from a MoC in that it defines the architecture of a running code, with run-time system considerations that MoCs do not model.

- The **master/slave scheme**, illustrated in figure 8.1(a), consists of a centralized execution control code in a master task that posts actors to slaves tasks. In this model, actors are often called jobs but this term is usually used for actors which are loosely coupled with respect to each other. A master or a slave task can be entirely software-defined or have certain parts that have been hardware accelerated. Each task can be locally contained in threads controlled by an OS or be the only computation of an operator. The centralized control code simplifies the efficient distributed execution of the various applications, i.e applications are dominated by the control code rather than data because these applications require a centralized knowledge of the control values to efficiently reconfigure the parallel execution. [BW09] advises use of the master/slave scheme for RLC and MAC Layers of telecommunication systems (Section 2.2.2), as these layers are always dominated by the control code. For

instance, in LTE, the eNodeB MAC scheduler is a complex control-dominated operation which varies greatly depending on the state of the communication (number and distance of the connected users, quality of the channels, MIMO schemes, and so on). A master can either be an “intelligent” unit, posting actors where they will be most efficiently executed or a simple pool of actors that the slaves monitor for actor availability.

- The **decentralized scheme**, illustrated in figure 8.1(b), consists of independent tasks which wait for input data, process it and send it without use of a global execution arbitrator. This scheme corresponds to a “real” dataflow implementation where computation is triggered solely by data arrival. Naturally, this scheme is well suited to dataflow application implementation and [BW09] advises the use of the decentralized scheme when implementing the physical layer of telecommunication systems. However, as the uplink and downlink streams of the LTE eNodeB physical layer are quite balanced between data and control, the most appropriate execution scheme for these algorithms is clearly a mix of the master/slave and decentralized schemes.

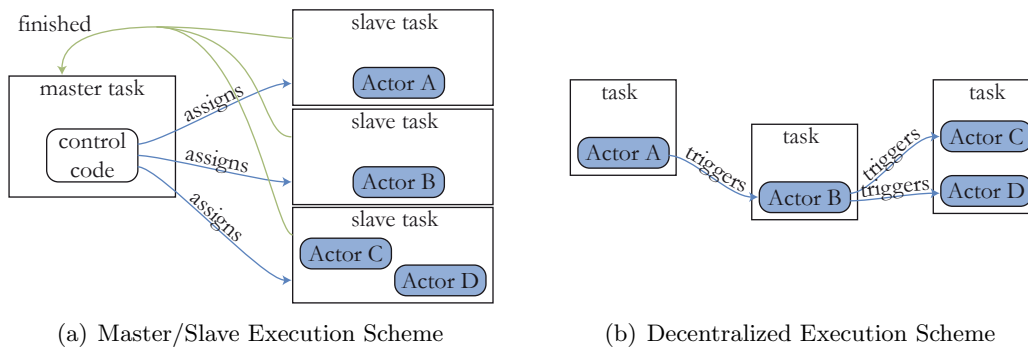

**Figure 8.1:** *Execution Schemes*

As centralized resources in distributed architectures usually form system bottlenecks, the centralization of the master in the master/slave scheme is a real issue. **Hierarchical approaches** can reduce the problem. In a hierarchical multi-core scheduler, a top-level scheduler assigns a pool of operators to a part of the application. The assignment and scheduling of that subsystem is then managed by a lower-level scheduler which is located elsewhere. Pools of operators can overlap; in this case, a time-sharing scheme is necessary for each shared operator. This is usually performed by the top-level scheduler reconsidering its choices periodically. System introspection (monitoring operator activity) can also be used to choose when to reconsider top-level assignment. [HjHL06] is an example of such a hierarchical scheduler with two levels.

Both master/slave and decentralized schemes can be used to generate code from dataflow MoCs. However, the most appropriate execution scheme depends on the chosen scheduling strategy (Section 4.4.1). Static-assignment, self-timed and fully static scheduling strategies can be implemented using both master/slave and decentralized schemes. However, all three strategies execute the assignment step at compile time to simplify runtime and avoid the need for a centralized control code. Consequently, the most efficient execution scheme for static-assignment, self-timed and fully static scheduling strategies is the decentralized scheme. Conversely, the fully dynamic scheduling strategy necessitates



a run-time actor assignment. This strategy demands the centralization of either the execution control code or the pool of actors. Therefore, the master/slave scheme is the only possible execution scheme for this scheduling strategy. The relation between scheduling strategies and execution schemes is illustrated in Figure 8.2 and the two pairs of strategy/scheme that this study uses for LTE are highlighted.

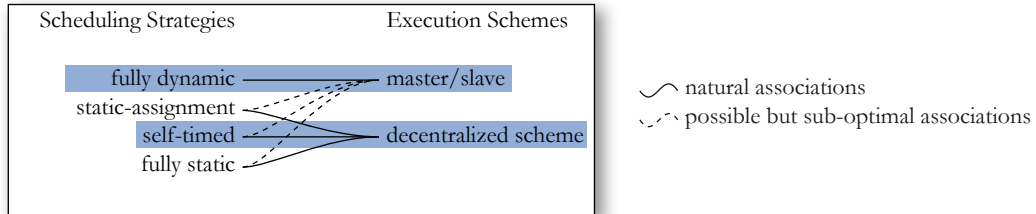

**Figure 8.2:** Possible Associations of Scheduling Strategies to Execution Schemes

A master element containing a multi-core scheduler is the central piece of a multi-core RTOS. Such a system, if highly optimized, could improve embedded multi-core programming by offering an abstraction of heterogeneous computing not available today.

### 8.1.2 Managing LTE Specificities

For each dataflow graph, the right scheduling strategy needs to be selected depending on the variable behavior of target application and architecture. Once the scheduling strategy is chosen, the execution scheme is chosen, as seen in Figure 8.2. For the RACH-PD algorithm, the couple self-time scheduling/decentralized scheme is the most suitable solution due to static system behavior (Section 7.2) as well as the fact that the execution time of the target operators cannot be precisely known. For the processing of control channels (PUCCH, PDCCH...), the limited costs of the actors mean that a static self-time scheduling/decentralized scheme is a good solution because adaptive scheduling would incur an unacceptably high overhead.

Conversely, the very high variability of the PUSCH and PDSCH algorithms in addition to their high computing cost make a more complex strategy, such as master/slave execution scheme, desirable.

Using quasi-static multi-mode schedule selection [HL97], all possible combinations of parameters must be scheduled and a tradeoff found at compile-time, which would be impossible with the PUSCH and PDSCH because of the high number of cases (Section 8.3.4). PUSCH and PDSCH necessitate the use of run-time adaptive scheduling instead of multi-mode compile-time scheduling. These two code generation ideas are developed in the following sections.

## 8.2 Static Code Generation for the RACH-PD algorithm

The RACH-PD is a static algorithm, so it can be efficiently parallelized using the PREESM framework code generation.

### 8.2.1 Static Code Generation in the PREESM tool

The PREESM tool code generation uses the **self-timed scheduling strategy** (Section 4.4.1) and the **decentralized execution scheme**. Many principles are adapted from the AAM methodology and incorporated into the tool [GS03]. The code generated by

the PREESM tool is analogous to a coordination code (Section 3.2). The host code and communication libraries (Section 3.2) must be manually coded.

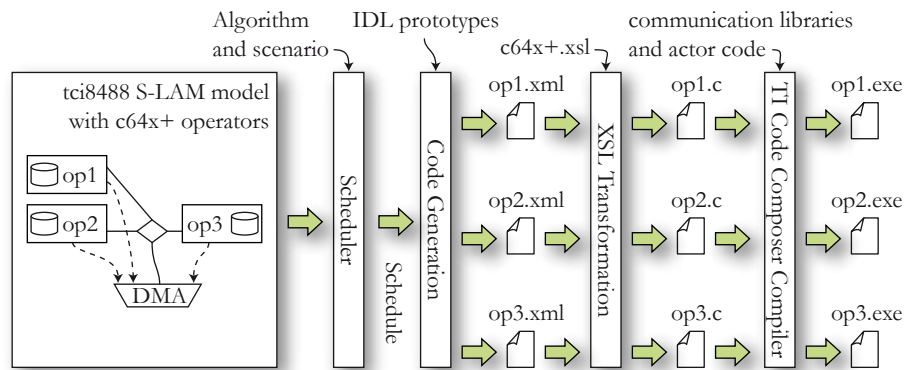

**Figure 8.3:** Code generation Procedure on a tci6488

To generate code statically, the static scheduling of the input algorithm on the input architecture must have been defined. A typical PREESM workflow performing code generation is displayed in Figure 6.4. For each operator, the generated code consists of an initialization phase and a loop endlessly repeating the part of the algorithm graph assigned to this operator. Special code loops are generated from IBSDF descriptions for the non-flattened and repeated hierarchical actors in order to obtain a compact code [PBPR09]. Each atomic actor generates a function call on its assigned core as explained in Section 6.2.1. The function call prototype is defined in an IDL file. The path of the IDL files is a parameter of the code generation workflow node. From the deployment information provided by the scheduler, the code generation module creates a generic representation of the code in XML. This code is then XSLT-transformed to produce the specific code for the target. The code generation flow for a tri-core tci6488 target processor (Section 5.1.1) is illustrated in Figure 8.3.

The XML generic code representation is illustrated by an example in Figure 8.4, which shows the XML code file generated for the operator op1 of Figure 8.3. The file contains a static buffer allocator, a computation thread and a communication thread. It also contains an operator type which indicates which XSLT transformation file to use when generating the coordination code, in this case “c64x+.xsl”. The two threads communicate via statically allocated shared buffers and semaphores. The communication thread controls the DMA and waits for completion of transfers, while the computation thread executes code in parallel, calling functions with parameters of type constant or buffer.

PREESM currently supports the C64x and C64x+ based processors from Texas Instruments with a DSP-BIOS Operating System [dsp] and the x86 processors with a Windows Operating System. Device-specific code libraries have been developed to manage the communications and synchronizations between the target cores [PAN08]. The XSLT transformation generates calls to the appropriate predefined communication library, which are dependent on the route type and on the names of the communication nodes between operators in the S-LAM architecture model (Chapter 5). The inter-core communication schemes supported include TCP/IP with sockets, Texas Instruments EDMA3 [PAN08] and RapidIO link [rap].



Figure 8.4: XML Generic Code Representation

Figures 8.5 and 8.6 show the behavior of a very simple application with three actors  $A$ ,  $B$  and  $C$  when mapped on two cores of a tci6488. In Figure 8.5(a), the actors are assigned to operators. In Figure 8.5(b), a graph of the code execution is shown where the data and the semaphores are displayed. The data is sent via a shared buffer that, combined with semaphores, implements a FIFO queue of size 1. Semaphores need to synchronize the transfer, successively informing the receive operator that the buffer is full and the sender that the buffer is empty and ready for the next iteration. The initial token on the feedback semaphore edge in Figure 8.5(b) shows that the semaphore signaling an empty buffer targets the next iteration of the graph. Also in Figure 8.5(b), the send and receive operations are gathered in one actor because they are synchronized by the communication library. The general problem of bounding FIFOs for executing SDF graphs is discussed in Chapter 10 of [SB09]. The solution employed is to add feedback edges with tokens to limit the number of firings of the actors that are otherwise always free to fire. For example, an actor with no input edge could fire many times before any other actor fires, piling many tokens in its output FIFO queues.

Figure 8.5(c) shows a Gantt chart of the graph execution where  $C$  can be executed in parallel with a transfer from operator 1 to operator 2 because of the synchronization between the DMA and the communication thread. The semaphores synchronizing communication and computation threads need to be initialized during code initialization phase. Figure 8.6 shows, as a Petri net (Section 3.1.1), the executions of the two threads running on each core of the architecture. The petri net details clearly the accesses to semaphores; this representation is often used to represent code generation synchronization in the Algorithm Architecture Matching (AAM) method [MARN07]. Figures 8.6 and 8.5(b) show equivalent representations, one typical from the AAM method and the other using dataflow graph graphic conventions.

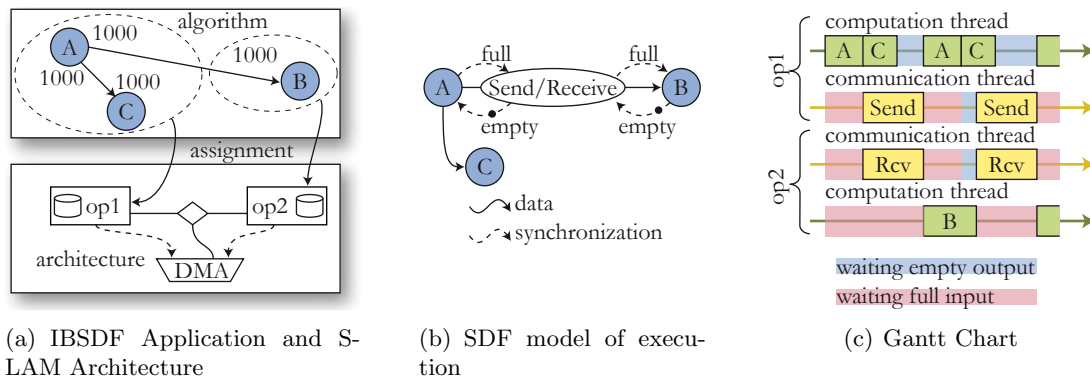

**Figure 8.5:** Code Behavior of a an Example of Message Passing with DMA

## 8.2.2 Method employed for the RACH-PD implementation

The development of the communication library to transfer data using EDMA3 (Section 5.1.1) on a tci6488 is explained in [PAN08]. The complete code generation of RACH-PD is also detailed. From a Matlab model of the RACH encoding and decoding, a C host code of the RACH-PD and the generated coordination code, a highly efficient multi-core development and debugging method can be constructed. The debugging phase can be fully executed on a single-core PC, using Matlab to generate test vectors and display the results, and using PREESM to generate coordination code. The efficient implementation of the

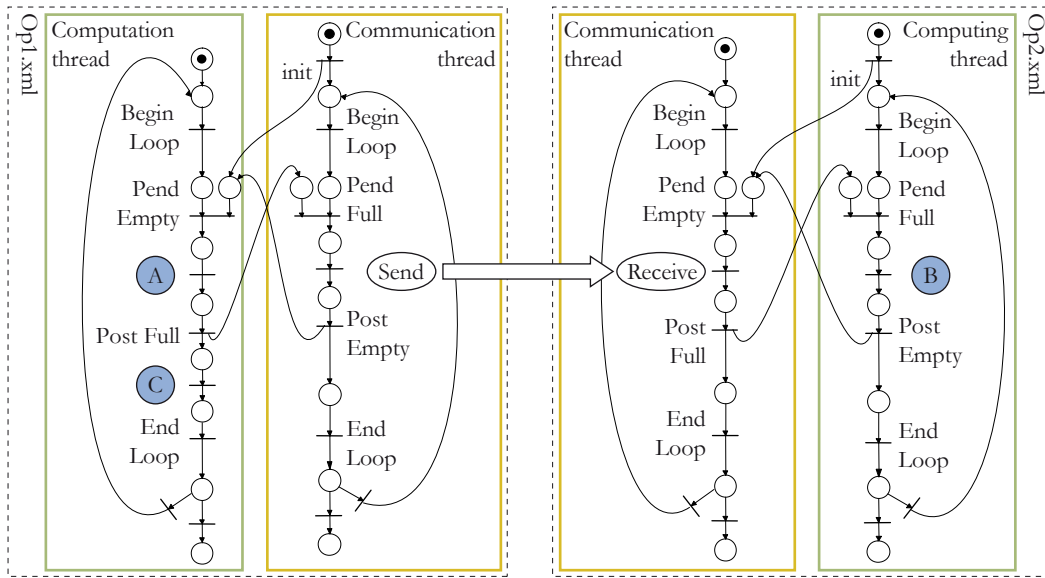

Figure 8.6: Petri Net of Execution of the Application in Figure 8.5(a)

embedded multi-core deployment is then generated seamlessly. This method, illustrated in Figure 8.7, was successfully applied to RACH-PD during this thesis. It can be divided into six steps:

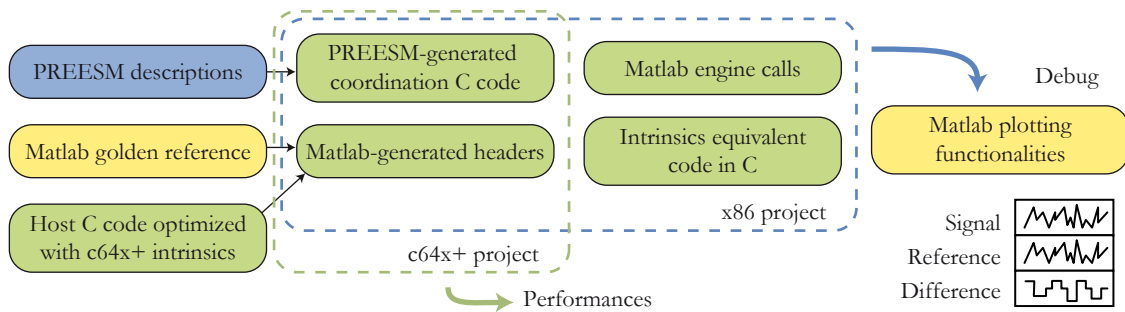

Figure 8.7: Method for the RACH-PD Algorithm Implementation.

1. RACH-PD functions are written in C, inspired by a Matlab “golden” code which encodes and decodes the PRACH channel. Each C function of the RACH-PD embedded code is hand-written, adding c64x+ intrinsics to optimize for speed. Intrinsics specify assembly calls in a C code. Each function is then instrumented and run independent of target to collect execution timestamps and allow evaluation of their cost.
2. PREESM generates two coordination codes from the IBSDF description of RACH-PD illustrated in Figure 7.3 and two S-LAM architecture models: a single-core x86 and the targeted multi-core embedded platform. The x86 architecture will serve for debugging phase and the target for the implementation. The actor timings previously measured are used to simulate the execution while scheduling the graph.
3. Matlab encodes an input signal containing RACH preambles and then decodes it. It generates large header files in C code containing buffers with the data at several

steps in the decoding process, which are displayed in Figure 7.3, such as before and after FIR, before and after correlation, before and after IFFT, and so on.

4. The code is run on a x86, adding C reference code for each c64x+ intrinsic and linking to the Matlab engine for displaying the results in Matlab. The decoded signal is contained in a Matlab-generated header. At each decoding step, a separate header is generated by Matlab, and then the golden reference and the embedded solution are plotted using Matlab engine. Code errors and insufficient data accuracy are clearly visible in the plots, which can thus be used to debug the code.
5. communication libraries are hand-written and then debugged for the target (alternatively, appropriate communication libraries may be retrieved if a previous project has used the same architecture).
6. Maintaining the identical host code but switching the coordination code, the RACH-PD is run on the target architecture to test its speed and accuracy of its results. Both the intrinsic equivalent C code and the Matlab engine calls are then removed from the embedded project. No deadlock will appear at this point, as data dependencies are handled during only automatic scheduling.

The above method has several benefits. Firstly, the code can be debugged without consideration of parallel programming problems. Secondly, the debugging phase is faster than debugging with the target board because it involves no cross-compilation. Lastly, the parallelism has been entered into the PREESM framework which facilitates the re-deployment of the algorithm on new architectures. These advantages make static code generation a powerful tool for creating embedded multi-core code.

Code has been generated and tested for the RACH-PD algorithm. The resulting implementation is deadlock-free but needs many manual tweaks to reduce its synchronization and memory consumption and the final result is compatible with the simulated results from Figure 7.5 in terms of cadence (a cadence under 4 millisecond is obtained) but not in terms of latency. Some memory and synchronization optimizations are still needed in PREESM to obtain automatically an optimized code.

The static code generation process is efficient only if the actor times are relatively stable and the coordination topology is absolutely stable. This is the case for RACH-PD but not for PUSCH decoding and PDSCH encoding. In the next section, a technique to automatically schedule PUSCH on multi-core embedded systems is developed.

### 8.3 Adaptive Scheduling of the PUSCH

The underlying goal of adaptive scheduling is to create the central part of an efficient multi-core RTOS for signal processing applications on heterogeneous architectures. An adaptive scheduler needs to schedule its application efficiently with very little overhead. The implemented system is dedicated to a specific task. Consequently, the scheduler can adapt at compile time or during system launch to the system specificities and run efficiently afterwards. The adaptive scheduler implements a **fully dynamic scheduling method** and is an element of the master entity in a **master/slave execution scheme**. A difference of the adaptive scheduler when compared to usual operating systems is that the adaptive scheduler manipulates actors instead of threads and should not need preemption, if actors are small enough, to respect application real-time constraints. Context switching is thus useless for adaptive scheduling and deadlocks or race conditions do not exist.

In Section 4.4, adaptive scheduling approach was introduced. Adaptive scheduling is a fully dynamic scheduling method which assigns actors to operators at run-time and orders them using simple heuristics. Processing the LTE PUSCH in the eNodeB consists of receiving the multiplexed data from connected UEs, decoding it and transmitting it to the upper layers of the standard stack (Section 7.5). Depending on the number of active UEs and on their instantaneous data rates, the decoding load may vary dramatically. A multi-core adaptive scheduler has capacity to recompute a schedule for the algorithm every millisecond. One important function of adaptive scheduler is to maintain low uplink latency. The LTE standard has strict constraints in terms of latency, limiting the available time for both uplink and downlink processing. The scheduler uses a graph modeling technique, as during the rapid prototyping phase, to determine the execution timing from the DAET of each actor on each operator. The schedule is determined after an “on-the-fly” simulation of the application execution. The next section introduces the PUSCH model for run-time scheduling.

### 8.3.1 Static and Dynamic Parts of LTE PUSCH Decoding

The PUSCH decoding operation (Figure 7.8) can be divided in two parts :

1. The static part: **FFT front end processing and multiple antenna Minimum Mean Square Error (MMSE) equalization**. The parameters of these two operations (number of receive antennas, Frequency Division Duplex (FDD) or Time Division Duplex (TDD), bandwidth, and so on) are fixed during run-time. The Cyclic Prefix (CP) is removed, the frequency is shifted by 7.5 kHz as stipulated by the 3GPP LTE standard, the symbols are converted into frequency domain by a Fast Fourier Transform (FFT) and equalized using received reference signals. The data from up to four antennas is then combined and the subcarriers are reordered. Finally, an Inverse Discrete Fourier Transform (IDFT) reconverts the data back into the time domain per user basis.
2. The dynamic part: **channel decoding**. For this operation, the parameters (number of connected UEs, number of allocated Resource Blocks, modulation order, and so on) are highly variable during run-time. The multi-core scheduling of this dynamic part must be adaptive.

The first and static part of processing can be represented as an IBSDf graph and demonstrates a high level of parallelism. Consequently, the corresponding self-timed parallel schedule can be processed at compile time using PREESM [PPW<sup>+</sup>09], which will also generate a self-timed code similar to that generated for RACH-PD (Section 8.2). The multi-core scheduling of the second and dynamic part needs to be adapted at run-time to the varying parameters. A discussion of the constraints on these varying parameters follows in the next Section.

### 8.3.2 Parameterized Descriptions of the PUSCH

The parameters of PUSCH decoding are specified in the eNodeB MAC layer. They are available at least 1 millisecond before the start of the decoding. This property makes parameterized dataflow (Section 3.4.1) particularly suitable for describing PUSCH decoding because this millisecond allows the construction of an execution graph and the subsequent search for an efficient multi-core schedule using this graph.

The most common use of parameterized dataflow is to describe an algorithm in a hierarchical PSDF graph where init and sub-init phases  $\phi_i$  and  $\phi_s$  modify topology and actor parameters at different levels. Such a PSDF description of the PUSCH decoding is displayed in Figure 8.8. In this usage, the static part is not developed because it is parallelized at compile-time (Section 8.3.1). The dynamic part is simplified compared with the graph displayed in Figure 7.8: actors have been merged to reduce the final size of the graph. Figure 8.8 is divided into two actors at top level: the **convergence** actor that gathers data from all subframe symbols and the **ChannelDecoding** actor. The top-level initialization phase  $\phi_i$ , is executed once per graph invocation (i.e. once per millisecond), and initializes parameters carrying the maximum number of Code Blocks (CB) per UE, and the maximum size of the CBs. In the sub-init phase  $\phi_s$ , the number of UEs is retrieved from the MAC layer before each graph execution. The channel decoding actor is repeated nb\_UE times, as many times as there are UEs sending data in the subframe, as a consequence of token productions and consumptions. The channel decoding actor contains a hierarchy with five actors. The **keepCurrentTones** actor filters the subcarriers used for data transmission and transmits the resultant subcarriers to the **perUEProcessing** which processes the frequency offset compensation, channel decoding, constellation demapping, descrambling, deinterleaving and demultiplexing. The **BitProcessing** actor gathers rate dematching and HARQ combining information while the **Turbo Decoding** actor associates turbo decoding with CB CRC checking. Finally, the **CRCCheck** actor checks the CRC of the TB. At each invocation of ChannelDecoding, which occurs for each UE, the number of CBs is modified as well as the size of these CBs. For a topology parameter to be modified before each iteration of the graph, it must be modified in the sub-init graph  $\phi_s$  of ChannelDecoding to be executed before each execution of the body  $\phi_b$ . Some actors parameters are also modified in  $\phi_s$ , such as code rate, modulation, MU-MIMO mode.

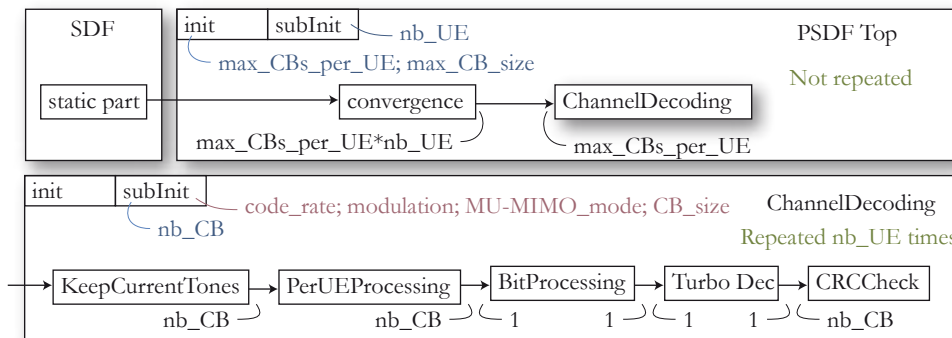

**Figure 8.8:** PSDF Description of the Uplink.

In all the LTE graphs of the current study, there is no feedback path in the physical layer. The SDF graph in Figure 8.8 is a Directed Acyclic Graph (DAG, Section 3.2.3). Knowing all UE and CB parameters in advance of a subframe allows the global reconfiguration of the PUSCH graph instead of reacting locally to the variations of parameters in sub-init graphs such as in Figure 8.8. The benefit of such a global reconfiguration is to provide a system view of subframe decoding and to enable a simulation of the code execution on a heterogeneous multi-core architecture using the compile-time methods presented in Section 4.4. To achieve a global graph, patterns of token production and consumption are used as in Parameterized Cyclo Static Dataflow Graphs (PCSDF) 3.3. A run-time system cannot handle the Basis Repetition Vector (BRV) computation of a PCSDF graph to instantiate the actors. The input model of the adaptive scheduler is thus reduced to



acyclic graphs and called Parameterized Cyclo Static Directed Acyclic Graph (PCSDAG). This is not a new model; it is a subset of the Parameterized CSDF model. Compared with the Parameterized CSDF, the PCSDAG has been simplified and has no cycle. It contains only a single vertex without input edge and the number of firings of this vertex is fixed to 1.

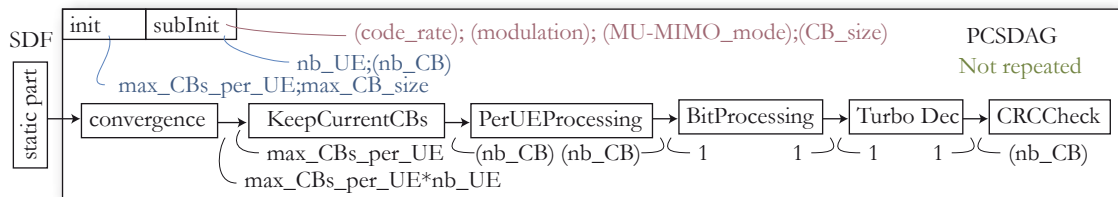

Figure 8.9: PCSDAG Description of the Uplink.

A PCSDAG description of the LTE PUSCH decoding is shown in Figure 8.9. Both data token production and consumption of each PCSDAG edge is set by the MAC scheduler. The token production and consumption can either be a single integer value or a pattern of integer values. The PCSDAG has no hierarchy but the parameter  $(nb\_CB)$  is a template which provides the number of CB for each UE, and all actor parameters are now templates which assign its own parameters:  $nb\_CB = \{nb\_CB(UE1), nb\_CB(UE2), nb\_CB(UE3)\dots\}$  to each CB. For example, a consumption of the number of CBs per UE can contain the pattern  $\{10, 5, 3, 1, 1\}$ , meaning that the actor will consume 10 data tokens on the first firing, 5 on the second and so on. 1 millisecond before each subframe, all production and consumption patterns are set by the MAC scheduler. The PCSDAG can then be extended into a single rate DAG (Section 3.2.3) and the resulting single rate DAG is scheduled. The DAETs of the LTE PUSCH graph actors also depend on pattern parameters set by the MAC scheduler. The domain of  $nb\_UE$  is between 0 and 100 UEs (ignoring PUCCH) because each pair of PRBs can be associated with a different UE and the domain of each pattern element in  $nb\_CB$  is between 1 and 13 CBs. PCSDAG can model LTE PUSCH decoding in a very compact way.

In the next section, the architecture model of the adaptive scheduler is explained.

### 8.3.3 A Simplified Model of Target Architectures

The processors targeted by this study are the heterogeneous multi-core DSPs introduced in Section 5.1.1 and boards interconnecting several of them. They include the 6-core tci6486 and the 3-core tci6488. Combinations of these DSPs (interconnected between test boards with RapidIO serial links for instance) are also targeted architectures. The dataflow graph scheduling techniques naturally handle heterogeneity in data links and operators, treating targets with coprocessors, different DSP frequencies and different communication media. For example, the tci6488 includes a turbo decoding coprocessor that can perform the Forward Error Correction (FEC) [STB09] decoding part of the PUSCH processing.

Using S-LAM (Chapter 5) in the adaptive scheduler would not be realistic in terms of memory and computing cost. Therefore, a very simple architecture model is used. In this model, the DAET of actors in the single rate DAG are linked to operator types, enabling operator heterogeneity. A matrix is created where each oriented pair of source and sink operators is associated with a transfer speed in Gbytes/s. This matrix is displayed in Figure 8.10 and its results are compared to that of S-LAM for an example consisting of one tci6486 and one tci6488.

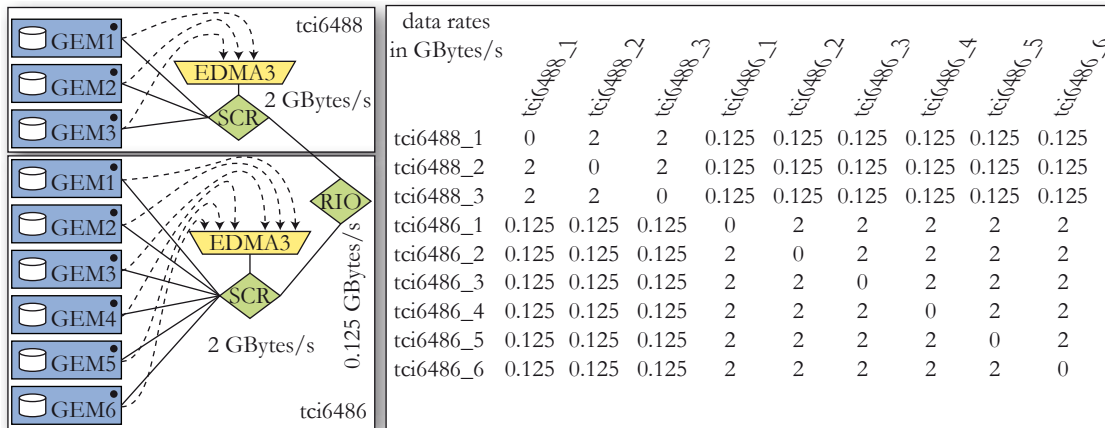

**Figure 8.10:** Target Architecture Example in S-LAM and Adaptive Scheduler Matrix Model: a tci6488 and a tci6486 Connected with a RapidIO Serial Link.

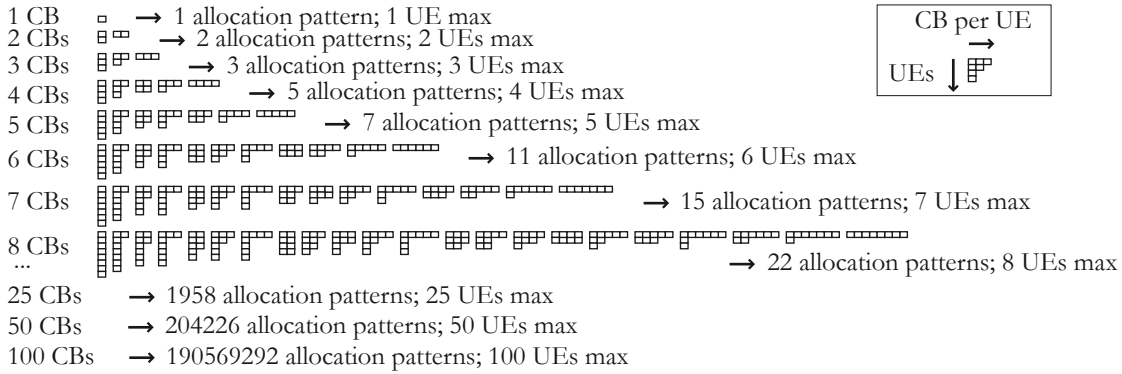

**Figure 8.11:** The problem of allocating CBs to UEs is equivalent to integer partitions represented here in Ferrer diagrams.

### 8.3.4 Adaptive Multi-core Scheduling of the LTE PUSCH

An obvious solution to efficiently schedule a dynamic algorithm onto a heterogeneous architecture is to schedule all possible configurations at compile-time and then switch between the pre-computed schedules at run-time. The limits of such an approach are now analyzed.

#### The Limits of Pre-computed Scheduling

Assigning a given number of CBs to UEs is a similar problem to partitioning the number of CBs into a sum of integers. The problem of integer partitioning is illustrated by Ferrer diagrams in Figure 8.11. Given a number  $N_{CB}$  of CBs to assign, a Ferrer diagram gives the possible number of different allocation configurations  $p(N_{CB})$ , i.e. the possible number of different graphs to schedule and map for a given quantity of CBs. The number of CBs  $N_{CB}$  allocated every millisecond also varies between 0 and  $N_{CB_{MAX}}$ . In Section 2.3.4, the maximum number of pairs of PRBs per subframe was shown to be a constant for each eNodeB and is fixed between 6 and 100 depending on the LTE system bandwidth.  $N_{CB_{MAX}}$  is equal to the maximum number of pairs of PRBs per subframe because PRB pair is the minimum resource released to a code block. The total number of different

possible graphs for a given eNodeB PUSCH is:

$$P(N_{CB_{MAX}}) = \sum_{i=1}^{N_{CB_{MAX}}} p(i). \quad (8.1)$$

For the simplest case of a 1.4MHz LTE system bandwidth with only a maximum of 6 CBs to allocate, the number of possible graphs is 29. It is feasible to pre-compute and store the scheduling of these 29 graphs. However, the number of graphs increases exponentially with  $N_{CB}$ ; the still relatively simple case of 3MHz with a maximum of 12 CBs generates 271 graphs. Considering that for  $P(50) = 1295970$ , it can be concluded that the scheduling of all LTE PUSCH cases with bandwidth higher than 3MHz cannot realistically be statically scheduled.

It must be noted that the above calculation of cases for each bandwidth only takes into account topology modifications and not execution time modifications due to the variable size of the CBs. The next section explains an adaptive scheduler that can efficiently schedule PUSCH despite topology and CB size variations.

### Structure of the Adaptive Multi-core Scheduler

The adaptive multi-core scheduler algorithm is illustrated in Figure 8.12. There is an initialization phase that generates the PCS DAG object from a manual description and pre-computes the graph parameter expressions. The following processing steps are called each millisecond when the MAC scheduler changes the CB allocation. These scheduler steps consist of 2 operations:

- The **graph expansion** which transforms the PCS DAG into a single rate DAG with shape dependent on the PCS DAG parameters.
- The **list scheduling algorithm** which maps each actor in the single rate DAG to an operator (core or coprocessor) in the architecture.

The goal of the initialization step of the adaptive scheduler is to maximally reduce the loop step complexity. The expressions of the PCS DAG edge productions and consumptions are then parsed and converted into a Reverse Polish Notation (RPN) stack using the Shunting-yard algorithm [Dij60]. RPN specifies the order of expression evaluation in an efficient bracket-less expression. This technique allows the adaptive scheduler to manipulate efficiently the PCS DAG patterns, which is essential in a run-time scheduler.

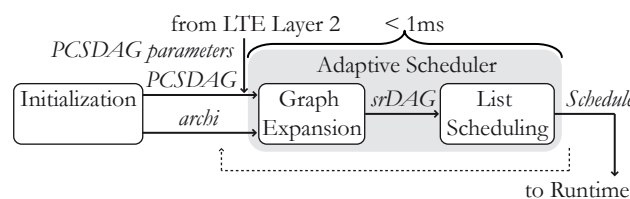

**Figure 8.12:** Adaptive multi-core scheduling steps: graph expansion and list scheduling steps are called in a loop every millisecond.

The output of the adaptive scheduler feeds a run-time procedure. This procedure may implement a multi-core API (OpenCL [opea], Multi-core Association [mca]). The sum of graph expansion and list scheduling execution times must stay under 1 millisecond for the scheduler to be an approach of interest in LTE PUSCH processing. These two operations are detailed in the following Sections.

### Adaptive Expansion of PCSDAG into Single Rate DAG

A single rate DAG (Section 3.1.2) is a graph with no cycle, in which each edge has equal data production and consumption. All single rate DAG actors are instances of PCSDAG actors. Each single rate DAG actor is fired only once.

Figure 8.13 gives four examples of single rate DAG graphs generated from the expansion of the PCSDAG in Figure 8.9 with different allocation schemes. The number of (possible) vertices in a single rate DAG may be calculated by:

$$V = 2 + 3 * nb\_UE + 2 * N_{CB}. \quad (8.2)$$

Thus, for the PUSCH example, the maximal size of the corresponding single rate DAG is 502 vertices with 100 UEs and 100 CBs allocated in the subframe. To generate the second case shown in the figure (2 UEs - 5 CBs), we have  $nb\_UE = 2$ ,  $CBs\_UE = \{2, 3\}$ , and  $max\_CBs\_UE = 3$  from the PCSDAG graph (of Figure 8.9).

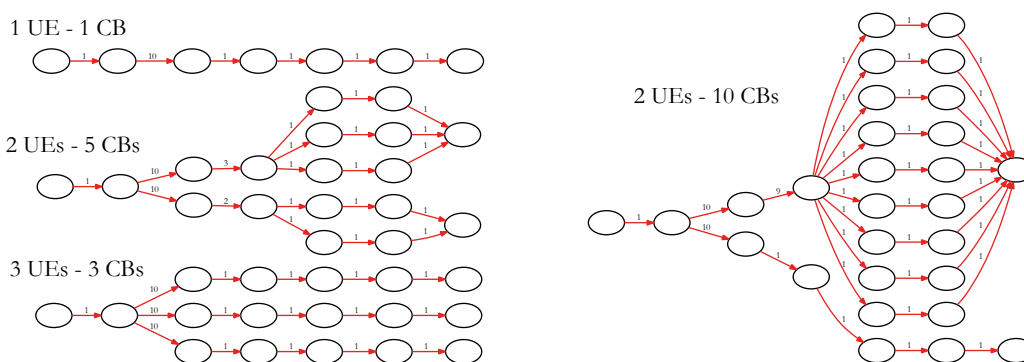

**Figure 8.13:** Examples of single rate DAG graphs generated from the PCSDAG description in Figure 8.9.

The adaptive scheduler algorithm calculates the number of firings of each actor, using the productions and consumptions of the incoming edges (as computed from RPN expression stacks) and the firings of the preceding actors only. This calculation is then stored in the Basis Repetition Vector (BRV) presented in Section 3.2. The absence of a loop in the graph and the existence of only one source vector with a single firing enables this “time-greedy” method in  $O(|E| + |V|)$ , where  $|E|$  and  $|V|$  are the number of edges and the number of vertices in the single rate DAG respectively. There is no schedulability checking in the expansion step. Once the BRV has been calculated and the single rate DAG vertices have been created, the appropriate edges are added to interconnect them.

This technique may be contrasted with SDF. SDF schedulability checking and expansion into single rate SDF requires a study of the null space of the topology matrix presented in Section 3.2. The method, described in Algorithm 3.1, has a time complexity of  $O(|V|^2|E|)$ . Although yielding good results, the time cost of this operation excludes its execution in a realistic run-time scheduler.

After the expansion of the PCSDAG graph, the resulting single rate DAG is then ready for the list scheduling step. This operation is explained in the next Section.

### List Scheduling of the Single Rate Directed Acyclic Graph

The static list scheduling operation used is a simplified version of the “time-greedy” algorithm described in Section 4.4.3. The list scheduling process is illustrated in Figure 8.14

and an example of a Gantt chart generated by the adaptive scheduler (Figure 8.15) gives an idea of the resulting scheduling complexity.

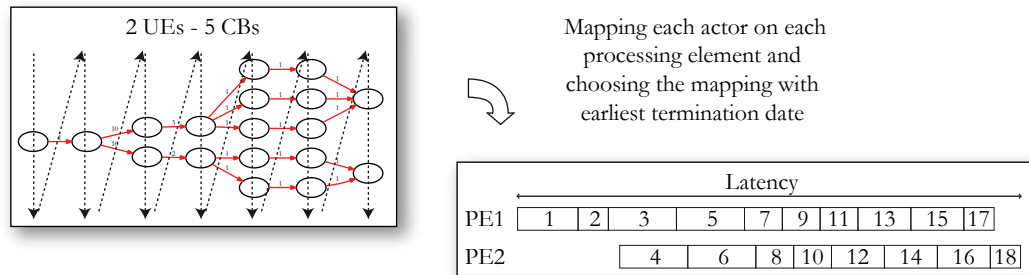

**Figure 8.14:** Example of list scheduling of Single Rate DAG actors.

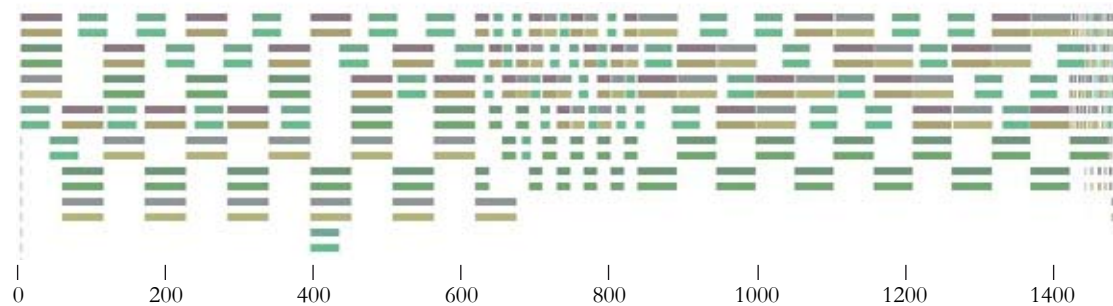

**Figure 8.15:** Example of a schedule Gantt chart: case with 100 CBs and 100 UEs on the architecture from Figure 8.10 with one core reserved for the scheduling.

As may be seen in Figure 8.14, there is no actor reordering process before the list scheduling algorithm is executed. In the LTE PUSCH case, the consequences for the scheduling quality are limited because all the paths from the first actor to actors without successors are equivalent, except for the DAETs of the actors. A suboptimal input list results in a multiplication of the latency by a factor  $\lambda \leq 2 - 1/n$  where  $n$  is the number of target cores [Gra66]. This result is an approximation as the calculation ignores the data transmission latencies. The single rate DAG is not reordered in the adaptive scheduler is because the topological order of the single rate DAG with its absence of cycle, is naturally deduced from the PCS DAG. Searching for another topological order for the single rate DAG would require the prohibitively time consuming actor list construction with  $O(|V|.log(|V|))$  time complexity presented in Section 4.4.3. Without this reordering operation, the adaptive scheduler cost is perfectly linear with the input graph size and architecture size. The next Section illustrates this behavior for an implementation of the adaptive scheduler.

### 8.3.5 Implementation and Experimental Results

The adaptive scheduler implementation genericity, compactness and speed were developed with special care, due to their vital role. The entire code, including private members and inlined accessors, is written in C++.

### Memory Footprint of the Adaptive Scheduler

In order to reduce execution time, the adaptive scheduler contains no dynamic allocation. Its memory footprint (Figure 8.16) is only 126 kBytes. Each c64x+ core of the tci6486 and the tci6488 processors of Section 5.1.1 has an internal local L2 memory of 608 kBytes and 500 to 1500 kBytes respectively. Thus, the memory footprint is sufficiently small to fit within the internal local L2 memory of a single core of either processor.

Half of the memory footprint is used by the graphs. The relatively large size of the PCSDAG in memory is due to the patterns stored in RPN. The single rate DAG graph has a size sufficient to contain any possible LTE PUSCH configuration. One third of the footprint is used by the code.

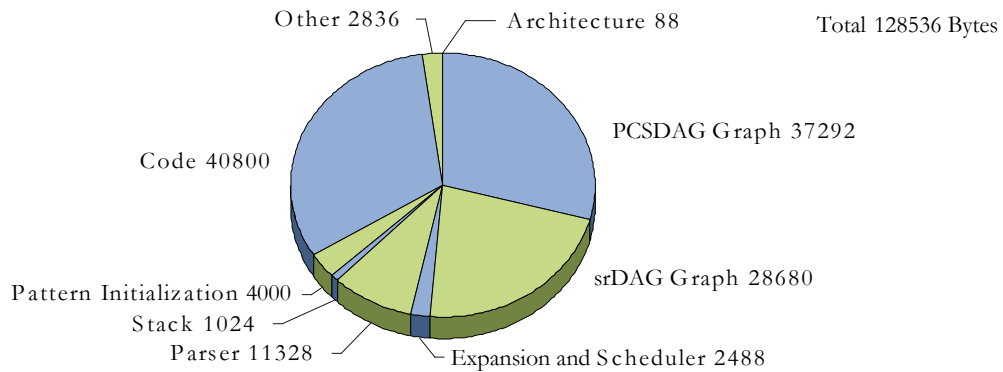

**Figure 8.16:** Memory Footprint, in Bytes, of the Statically Allocated Adaptive Scheduler.

### Impact of Graph and Architecture Sizes on the Adaptive Scheduler Speed

Figure 8.17 shows that the execution time of the Adaptive Scheduler increases linearly with the graph size. The graph expansion time for very small single rate DAGs is due to the constant RPN parameter evaluation. The worst case execution time is less than 950,000 cycles, enabling real-time execution on a c64x+ at 1GHz. However, a load of 95% for the scheduling core is unwise for a real application. For this case, further optimizations would be necessary to lower the load.

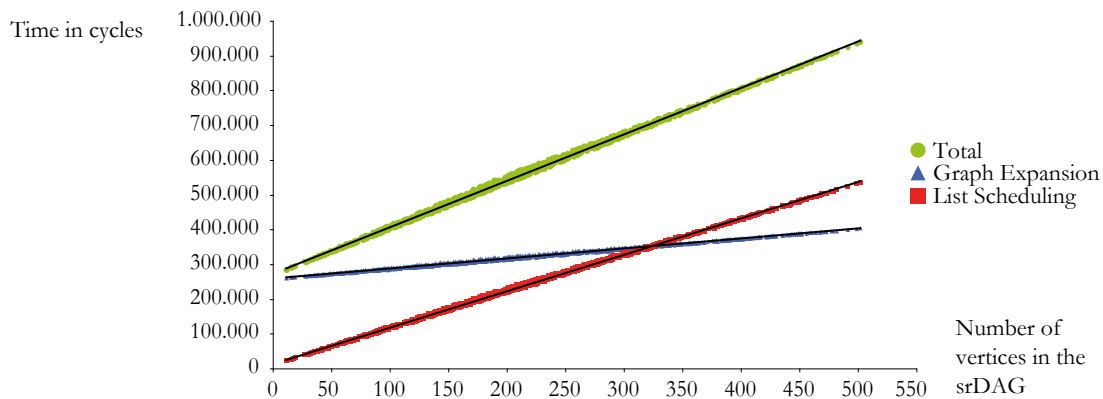

**Figure 8.17:** Impact of single rate DAG graph size on the LTE PUSCH scheduling execution time on the architecture of Figure 8.10 with one core reserved for the scheduling.

In Figure 8.18, adaptive scheduler execution time is shown to increase linearly with

the number of cores in the architecture. The graph shows the case where the single rate DAG size is fixed to 502 and the number of cores varies. Moreover, it may be seen from this figure that the graph expansion time only varies with PCS DAG parameters, and does not depend on architecture size. The maximum number of cores targeted by the present implementation with a DSP at 1GHz is 9 (this includes a dedicated core for scheduling). Specific optimizations for Texas Instruments chips with intrinsic and pragma can improve this result.

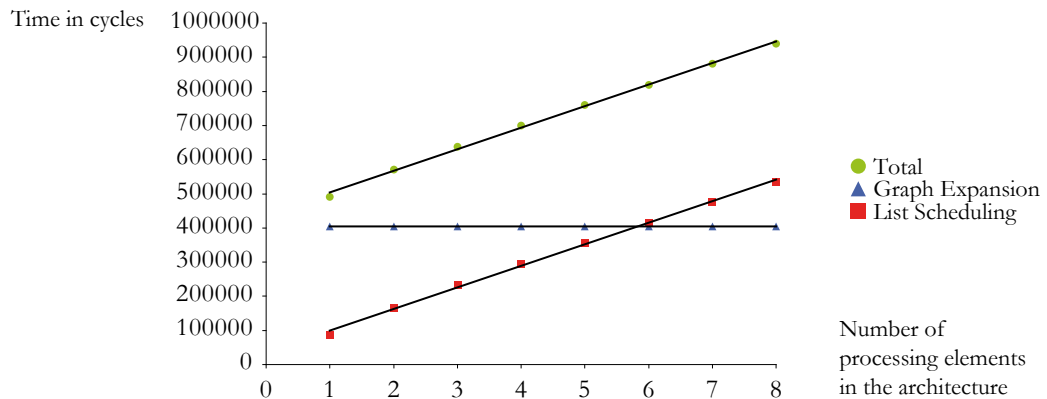

**Figure 8.18:** Impact of the number of operators on the LTE uplink scheduling execution time in an LTE PUSCH worst case.

### Evaluating the Limits of the Target Architecture

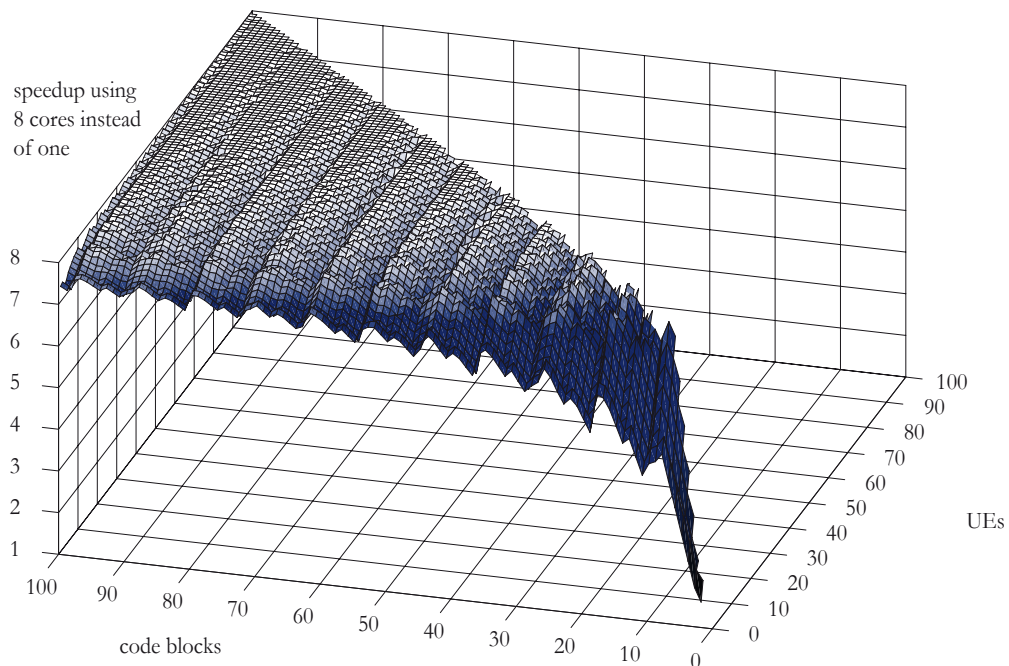

**Figure 8.19:** Schedule speedup vs. number of CBs and UEs using the architecture from Figure 8.10.

The latency of the dynamic part of LTE PUSCH depends greatly on the instantaneous

number of decoded CBs, the size of those CBs that influences their decoding time, and the instantaneous number of communicating UEs. Figure 8.19 shows the increase in speed obtained with the use of multiple cores, instead of a single 700MHz c64x+. For this test, each CB has a size of one pair of PRBs and can transport 760 bits. The speed increase approaches the theoretical maximum of  $(6*0.7+2*1)/0.7 = 8.8$  times when the single rate DAG becomes larger and exercises more data parallelism. The architecture of Figure 8.10 has one core of the tci6488 dedicated to scheduling and no coprocessor, and is likely to be sufficient to decode the LTE PUSCH dynamic part in 1 millisecond for 50 CBs and 50 UEs, i.e. for the 10MHz bandwidth case. The execution time of the static part of the algorithm is not taken into account in this simulation. The problem of the multi-core partitioning of the static part then becomes easier as it can be solved at compile-time. However, this operation will need to be pipelined with the dynamic part in order to respect the 1 millisecond execution time limit. The load of the core executing the scheduler will need to be limited as discussed above and the dynamic part combined with the static part.

### Comparing the Run-Time Simplified Scheduling Results with the Compile-Time FAST Scheduling Results

In order to be able to schedule efficiently at run-time, simplifications have been made in the scheduling heuristic: no initial list ordering and no neighborhood search are used. A scheduler workflow node named “dynamic queuing” is available in PREESM to evaluate the efficiency of the simplified adaptive scheduler (Appendix A). Figure 8.20 shows the difference in latency and load balancing of schedules obtained with the FAST heuristic and with the simplified adaptive scheduler heuristic. The application and architecture are the same as for Figure 6.11. The FAST is executed during 60 seconds without balancing the loads (Section 6.4.3). It may be seen in Figure 8.20 that using simplified adaptive scheduler heuristic instead of FAST, the latency is increased by about 15% while the load balancing remains approximately stable (it is even improved in some cases). Given the large difference in processing time, the simplified adaptive scheduler heuristic is thus performing well.

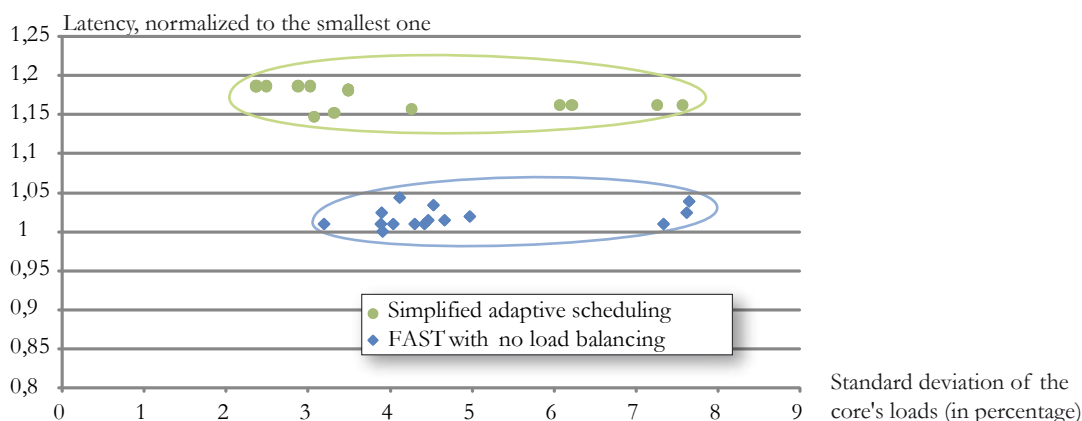

**Figure 8.20:** Comparing Run-Time Heuristic Schedules with FAST Schedules

In the next section, the PDSCH model is studied and shown to be close to the PUSCH model.



## 8.4 PDSCH Model for Adaptive Scheduling

In the rapid prototyping model of downlink decoding displayed in Figure 7.6, the channel encoding shows many similarities with the uplink channel decoding shown in Figure 7.8. However, the significant difference is that the number of TBs per UE varies between one and two and must be chosen, and this parameter must be resolved adaptively for each UE.

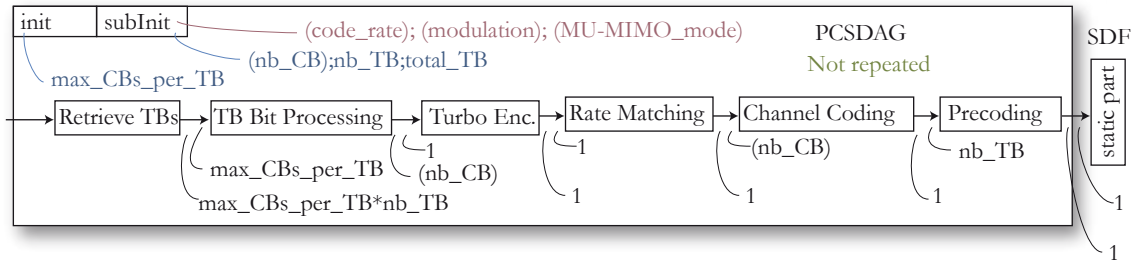

**Figure 8.21:** PCSDAG Model of the PDSCH LTE Channel.

PDSCH decoding dominates the LTE downlink decoding. A PDSCH PCSDAG model for adaptive scheduling is proposed in Figure 8.21. This model is topologically close to that of PUSCH, shown in Figure 8.9. Actors from Figure 7.6 have been clustered to reduce their number. TB bit processing gathers CRC additions and code block segmentations; turbo encoding embeds CB CRC additions; and channel coding contains concatenation, scrambling and constellation mapping.  $nb\_TB$  gives the total number of TBs to encode in the subframe and  $(nb\_CB)$  the pattern of the number of CBs in each TB.

The maximum graph size is 803 actors. Scheduling this graph adaptively is thus more costly than scheduling PUSCH and further optimizations of the scheduler will be necessary to minimize this cost. The next section briefly addresses the combination of uplink decoding, downlink encoding and RACH-PD for entire LTE physical layer execution of an eNodeB.

## 8.5 Combination of Three Actor-Level LTE Dataflow Graphs

Currently, the majority of signal processing applications have similar structures with three distinct levels of behavior. Reusing the terminology from Section 4.1.1, these levels are:

- Instruction-level with both control and data streams, efficiently described by imperative MoCs and efficiently executed on Von Neumann machines from these descriptions.
- Data-dominated actor-level, which is well suited for distributed architectures, provided sufficient data rate is available between operators. Models at this level are called concurrency models in the literature.
- Loosely-coupled task-level which is dominated by control streams and is well suited for modeling with state machines.

The LTE eNodeB physical layer follows this model structure with three actor-level tasks: RACH-PD, uplink and downlink which are connected by the control-dominated

MAC layer, and contain actors which locally mix control and data dependencies. The appropriate global execution scheme for the LTE physical layer is certainly a two-level hierarchical scheduler (Section 8.1.1) with a master/slave task-level scheduler and three actor-level adaptive schedulers. The technique for task-level scheduling could be based on [HjHL06] where a given task is associated with a particular operator pool depending on its “desire” (the number of operators it reclaims) and the number of available operators. The job scheduling algorithm utilized is named Dynamic Equipartitioning (DEQ), and assigns the same number of operators to each job unless these jobs desire less (the metric is called desire). The three actor-level adaptive schedulers then have the goal to use the pool they control for maximum benefit. The next chapter develops the conclusion of the thesis and introduces possible future work.

---

## Conclusion, Current Status and Future Work

---

### 9.1 Conclusion

The most recent algorithms and architectures for embedded systems have become so complex that a **system-level** view of projects from the early design stages to the implementation is now necessary in order to avoid bad design choices and to meet deadlines. A multi-core DSP implementation of a 3GPP LTE base station is representative of these new complex systems which require high optimization. The software of such a heterogeneous embedded distributed system cannot be efficiently developed without a special development chain based on rapid prototyping and system-level simulation. In this thesis, **software rapid prototyping** methods were developed to replace certain tedious and sub-optimal steps of the present test-and-refine methodologies for embedded software development. These techniques were applied to the study of a 3GPP LTE base station physical layer.

Building a high-level view of a distributed and heterogeneous embedded system brings **new challenges** compared with sequential software development chains. An intimidating number of complex problems arise when algorithm actors are assigned to architecture operators and algorithm data transfers are assigned to architecture communication nodes. A compromise must be made between model expressivity and power of analysis. Thankfully, a large amount of relevant literature exists, due to the search for heuristics to solve similar parallelization problems such as organizing factories, and projects. In this thesis, heuristics from the literature are presented and enhanced for integration in automatical prototyping processes for heterogeneous embedded systems.

A system-level view requires **new algorithm and architecture models**. When extracting algorithm parallelism from sequential imperative code, it is tempting to make the transition between sequential and distributed machines seamless. However, imperative code introduces useless dependencies to an algorithm and adds a new and unnecessary parallelism extraction problem to the existing challenges. In this thesis, several dataflow algorithm models are presented and their use to model LTE is justified and explained. They naturally express algorithm parallelism and have already been intensely studied. A new simple and expressive System-Level Architecture Model is also introduced, enabling high speed simulations.

Programming a distributed embedded system at high-level, designers have several **con-**

**straints to respects** and **costs to optimize**. Moreover, these costs are highly dependent on the system. An embedded software development chain must adapt to these different costs and assess the quality of the resulting solutions: it must consist of a framework embedding functionalities rather than a monolithic tool. In this thesis, the PREESM rapid prototyping framework was presented. It embeds many functionalities, each with multiple parameters. Importantly, a graphical schedule quality assessment chart was also introduced. It displays the parallelism available in an algorithm in terms of latency and shows the present use of this parallelism in the system.

Finally, code generation from model-based descriptions was explained. LTE physical layer algorithms were detailed and previously evoked methods were applied to the implementation of LTE on multi-core DSPs. These approaches revealed limitations in the compile-time methods for multi-core scheduling. Depending on the particular algorithm used, **the compile-time or the run-time multicore scheduling method** should be chosen. The resulting run-time system can be based on different multi-core scheduling strategies and different execution schemes and must balance the correct use of the parallel architecture with the scheduling overhead.

## 9.2 Current Status

As part of developing new techniques for rapid prototyping and code generation, their behavior is tested in the PREESM scheduling framework or the multi-core adaptive scheduler. Rapid prototyping with PREESM already offers a user-friendly interface under Eclipse and has many features explained in this thesis, including control of actor granularity, an optimization of system latency and load balancing, the support of multiple algorithms and architecture topologies, interoperator transfer ordering, static code generation, and so on. The PREESM framework can be found on the Web under Sourceforge. Many configurations of LTE have been tested with PREESM and code was implemented and tested for the RACH-PD with communication libraries developed for TCP on a PC and for the tci6488 processor.

## 9.3 Future Work

The PREESM scalable scheduler has been designed to enable the comparison and optimization of assignment and ordering heuristics separately. Combining existing heuristics detailed in the literature and newly developed heuristics, and improving PREESM scheduling will allow increasingly complex graphs to be efficiently scheduled.

New applications are currently tested under PREESM including a MPEG4 part 2 intra encoder and decoder. They show limits in the optimality of generated code that already appeared in RACH-PD code generation. These limits will be solved by reducing the inter-core synchronization. Extensions of the algorithm IBSDF model are also tested. They enable the modeling of conditions in PREESM and could bring to a coupling of PREESM and the adaptive scheduler.

Certainly the most important future work will be to manage memory during rapid prototyping. Memory management should appear in several places in the process. Memory-conscious scheduling can avoid scheduling choices that are impossible to execute because of memory size limitations. Memory minimization heuristics have been developed in the literature to use the same buffers for the storage of several non-overlapping data tokens; these heuristics will be incorporated in the PREESM buffer allocation to reduce the memory needs of the generated code. Memories that are local to operators are often complex

and cached; the S-LAM model will be extended to include a simple description of these internal memories including the cached data accesses.

For adaptive scheduling, scheduler latency and memory footprint can be further reduced by optimizing the intermediate graph storage, to increase competitiveness for LTE and other applications. Such a scheduler could be adapted to several other problems, including audio and video processing applications with high variability.



## APPENDIX A

---

### Available Workflow Nodes in PREESM

---

The following workflow nodes are shown as they appear in their Graphiti edition. A node class ID identifies its behavior. Each node is provided by the Preesm plug-in precised here. New plug-ins defining new nodes can be programmed. Some port types are known (SDF, architecture, DAG, scenario...) and transfer specific data structures. The port name “xml” is used when xml data files are loaded or stored. This edge does not carry data but only states a precedence. Any other type of port can be used for precedence edges.

Inputs

Graphic Elements	Params	Remarks
	None	<p>These three nodes must appear exactly once in the workflow. The scenario is the only node without an input edge. The names are specific and must have the double underscore. The scenario references its relative IBSDF algorithm and S-LAM architecture: that is why there are edges between them.</p>

Transformations

Graphic Elements	Plug-in - Class ID	Parameters	Parameters
	GraphTransfo org.ietr.preesm .plugin.transforms .flathierarchy	Flattens levels of hierarchy from an algorithm	<b>depth</b> (2): number of hierarchy levels to flatten
	GraphTransfo org.ietr.preesm .plugin.transforms .sdf2hsdf	Transforms a SDF graph into a single rate SDF one	None
	GraphTransfo org.ietr.preesm .plugin.transforms .ReduceExplode Implode	Reduces as much as possible the number of fork/join vertices in the graph	None
	GraphTransfo org.ietr.preesm .plugin.exportXml .sdf4jgml	Saves a graph in a graphml file	<b>path</b> (/MyProject/MyFile.graphml): Eclipse path of the written file <b>openFile</b> (true/false): opens automatically the exported file
	Mapper org.ietr.preesm .plugin.mapper.plot	Plots the Gantt of a schedule and shows the quality assessment plan of the schedule	None
	Mapper org.ietr.preesm .plugin.mapper .listscheduling	Schedules the algorithm on the architecture using the Kwok static list scheduling heuristic	<b>simulatorType</b> (LooselyTimed; approximatelyTimed;AccuratelyTimed): ABC <b>edgeSchedType</b> (Simple;Switcher): Chosen edge scheduling heuristic <b>balanceLoads</b> (true/false): Additional load minimization constraint for the schedulings
	Mapper org.ietr.preesm .plugin.mapper.fast	Schedules the algorithm on the architecture using the Kwok FAST scheduling heuristic	<b>simulatorType</b> : see above <b>edgeSchedType</b> : see above <b>balanceLoads</b> : see above <b>fastTime</b> (1000): Timeout in seconds of the whole FAST mapping if uninterrupted <b>fastLocalSearchTime</b> (20): Local search time <b>displaySolutions</b> (true/false): plots intermediate Gantts

Figure A.1: Workflow Nodes







Transfo Graphic Elements	Plug-in - Class ID	Parameters	Parameters
	<p>Mapper</p> <p>org.ietr.preesm .plugin.mapper.pfast</p>	Schedules the algorithm on the architecture using the Kwok parallel FAST scheduling heuristic	<p><b>simulatorType</b>: see above</p> <p><b>edgeSchedType</b>: see above</p> <p><b>balanceLoads</b>: see above</p> <p><b>fastTime</b>: timeout (in s) of one FAST process</p> <p><b>fastLocalSearchTime</b>: see above</p> <p>displaySolutions: see above</p> <p><b>nodesMin</b> (10): Minimum number of actors associated to one scheduling core</p> <p><b>procNumber</b> (2): Number of scheduling cores</p> <p><b>fastNumber</b> (100): Max number of FAST iterations before stopping PFASST</p>
	<p>Mapper</p> <p>org.ietr.preesm .plugin.mapper .standardgenetic</p>	Schedules the algorithm on the architecture using a genetic scheduling heuristic	<p><b>simulatorType</b>: see above</p> <p><b>edgeSchedType</b>: see above</p> <p><b>balanceLoads</b>: see above</p> <p><b>fastTime</b>: see above</p> <p><b>fastLocalSearchTime</b>: see above</p> <p><b>fastNumber</b>: see above</p> <p><b>generationNumber</b> (100): number of generations before timeout</p> <p><b>populationSize</b> (100): actors in a population</p>
	<p>Mapper</p> <p>org.ietr.preesm .plugin.mapper .pgenetic</p>	Schedules the algorithm on the architecture using a parallel genetic scheduling heuristic	<p><b>simulatorType</b>: see above</p> <p><b>edgeSchedType</b>: see above</p> <p><b>balanceLoads</b>: see above</p> <p><b>fastTime</b>: see above</p> <p><b>fastLocalSearchTime</b>: see above</p> <p><b>fastNumber</b>: see above</p> <p><b>generationNumber</b>: see above</p> <p><b>populationSize</b>: see above</p> <p><b>procNumber</b>: see above</p>
	<p>Mapper</p> <p>org.ietr.preesm .plugin.mapper .DynamicQueuing Transformation</p>	Schedules the algorithm on the architecture using an oblivious list scheduling heuristic	<p><b>simulatorType</b>: see above</p> <p><b>listType</b> (topological;optimised): Type of list used for scheduling. It can be any topological list or one optimized by studying the graph critical path</p>
	<p>Mapper</p> <p>org.ietr.preesm. plugin.mapper. exporter.impl ExportTransform</p>	Exports a graph with schedule information into a graphml file	<p><b>path</b> (/MyProject/MyFile.graphml): Eclipse path of the written file</p> <p><b>openFile</b> (true;false): opens automatically the exported file</p>
	<p>Mapper</p> <p>org.ietr.preesm .XsltTransform</p>	Transforms a xml file into a xml or text file using a xslt sheet.	<p><b>inputFile</b> (/MyProject/MyFile.xml): Eclipse path of the xml input file</p> <p><b>outputFile</b> (/MyProject/MyFile.lua): Eclipse path of the output text file</p> <p><b>xsltFile</b> (/MyProject/MyFile.xslt): Eclipse path of the xslt sheet</p>
	<p>Mapper</p> <p>org.ietr.preesm .plugin.mapper .scenariogen .ScenarioGenerator</p>	Generates a new scenario from an input scenario and the constraints of an exported DAG	<p><b>dagFile</b> (/MyProject/outDAG.xml): DAG which constraints are imported</p> <p><b>scenarioFile</b> (/MyProject/in.scenario): scenario initializing all the other parameters</p>

Figure A.2: Workflow Nodes

Transfo Graphic Elements	Plug-in - Class ID	Parameters	Parameters
	Codegen org.ietr.preesm .plugin.codegen	Generates code from the output DAG of a scheduling	<b>sourcePath</b> (/MyProject/MySources): output path to store the sources <b>xslLibraryPath</b> (/MyProject/MyArchiXSL): path where all the xslt sheets corresponding to the cores are stored
	ArchiTransfo org.ietr.preesm .plugin.architransfo .transforms .ArchiStructure Exporter	Exports an S-LAM architecture into an IP-XACT file	<b>path</b> (/MyProject/MyFile.design): Eclipse path of the written file <b>openFile</b> (true;false): opens automatically the exported file
	ArchiTransfo org.ietr.preesm .plugin.architransfo .transforms .HierarchyFlattening	Flattens degrees of hierarchy in an S-LAM architecture	<b>depth</b> (2): number of hierarchy levels to flatten

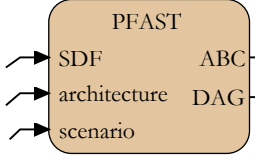
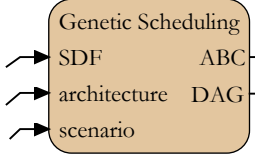
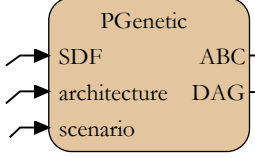
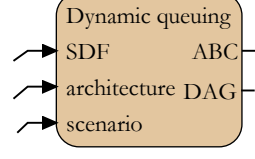
**Figure A.3:** *Workflow Nodes*

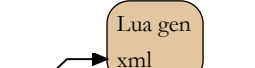
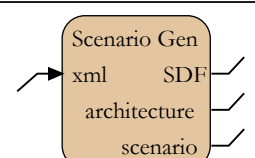
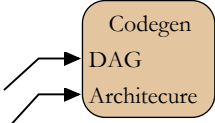
## B.1 Introduction

Le standard 3GPP Long Term Evolution (**LTE**) constitue l'un des derniers développements dans le domaine des télécommunications sans fil terrestres. Il permet des taux de données de plusieurs centaines de Mbit/s. Une station de base LTE, généralement appelée **eNodeB**, est un ordinateur qui traite et retransmet les données transmises entre tous les utilisateurs présents dans la zone de couverture d'une antenne terrestre (cellule) et le coeur du réseau. Ce ordinateur est un système temps-réel dont la consommation doit être limitée alors même que les calculs qu'il effectue sont complexes. La couche physique est la couche basse du modèle OSI (Open System Interconnection) qui désigne les calculs de traitement du signal spécifiques aux technologies de transmission des signaux. La couche physique du LTE est particulièrement complexe et coûteuse en terme de puissance de calcul.

Les processeurs de traitement du signal (**DSP**) modernes ont des architectures matérielles adaptées aux contraintes de consommation et de performance des stations de base LTE. Cependant, pour limiter leur consommation et leur échauffement, les DSPs sont maintenant multi-coeurs, ce qui complique le développement de leurs programmes. De plus, ils contiennent des optimisations matérielles (co-processeurs spécialisés, Direct Memory Accesses, plusieurs niveaux de cache...) qui les rendent hétérogènes et compliquent encore leur programmation et l'évaluation de leurs performances.

Cette thèse a pour objectif d'automatiser le partitionnement des différentes parties de la couche physique du LTE sur les coeurs d'architectures hétérogènes constituées de un ou plusieurs DSPs. Pour cela, un outil appelé **PREESM** (Parallel and Real-time Embedded Executives Scheduling Method) est développé avec le premier objectif d'automatiser des déploiements du LTE. PREESM réalise deux opérations : le **prototypage rapide** consistant à évaluer rapidement par simulation l'efficacité du déploiement et la **génération de code** consistant à produire automatiquement le code parallèle du déploiement. PREESM préfigure ce que pourrait être une chaîne de développement multi-coeurs.

La Figure [B.1](#) illustre le processus de prototypage rapide avec simulation et

génération de code. Les entrées du processus sont une description des algorithmes du LTE, une description de l'architecture matérielle des DSPs et un scénario fournissant des informations et des contraintes au prototypage rapide. Les algorithmes sont décrits en utilisant des **graphes flot de données** qui permettent une extraction efficace du parallélisme qu'ils contiennent. Les éléments d'un graphe flot de données sont appelés acteurs. Les architectures sont décrites en utilisant un nouveau modèle graphique nommé S-LAM pour System-Level Architecture Model. Le coeur du travail de parallélisation consiste à faire des choix de placement et d'ordonnancement des acteurs de l'algorithme sur les coeurs de l'architecture.

Ce résumé est organisé à l'image du corps de la thèse pour pouvoir aisément se référer au texte intégral. La structure de la thèse est résumée dans la Figure B.1. Une première partie (B.2) traite de l'état de l'art. Elle se décompose en une explication du standard 3GPP LTE, une section traitant des modèles de calculs et en particulier des modèles flot de données et une section détaillant les techniques existantes de parallélisation de code. La seconde partie (B.3) présente les contributions de cette thèse. La Section B.3.1 introduit un modèle d'architecture pour le prototypage rapide. La Section B.3.2 détaille des méthodes permettant d'améliorer le prototypage rapide et d'évaluer la qualité d'un déploiement. La Section B.3.3 décrit les modèles du LTE développés durant cette thèse ainsi que leur simulation. Enfin, la Section B.3.4 explique comment générer du code pour exécuter les différents algorithmes du LTE et la Section B.4 conclut l'étude.

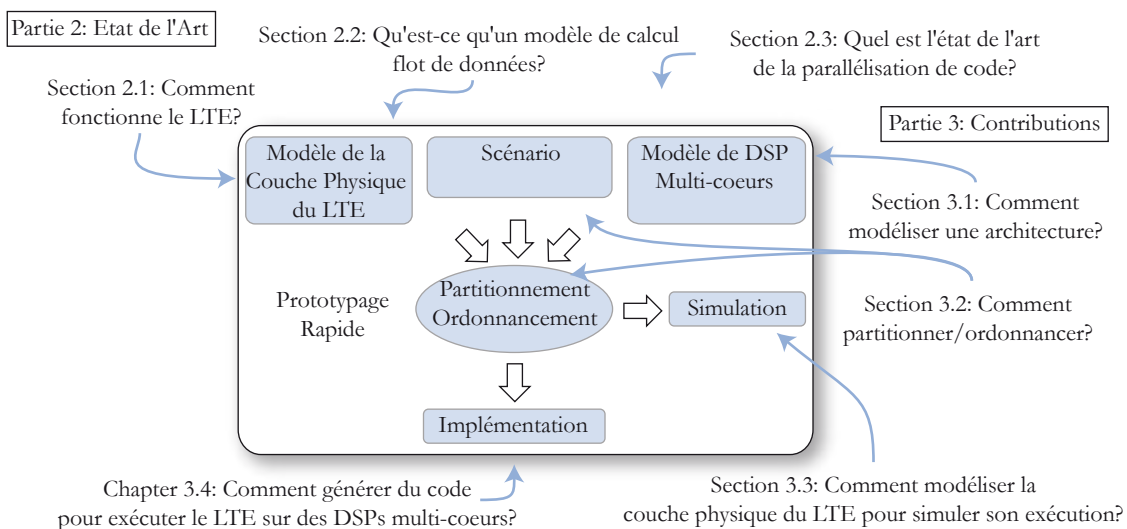

Figure B.1 – Prototypage Rapide et Plan de la Thèse

## B.2 Etat de l'Art

### B.2.1 Le Standard 3GPP LTE

#### Contexte de l'Etude

Le 3GPP est l'organisation développant les standards de télécommunication les plus répandus sur la planète. La troisième génération de standards (3G) désigne un en-

semble de standards successifs apportant chacun une amélioration des performances du système. L'UMTS (Universal Mobile Telecommunication System) fut le premier standard de troisième génération. Deux évolutions de l'UMTS, HSPA (High Speed Packet Access) et HSPA+, ont augmenté la vitesse de transfert de données. Le standard LTE est le successeur du HSPA+ et représente une modification profonde du réseau comparé à ses prédécesseurs. De plus, contrairement à ses prédécesseurs, le standard LTE manipule la voix comme les données sous forme de paquets IP (Internet Protocol).

Les spécifications du système LTE étant en pleine évolution, nous considérons le standard dans sa version 9 finalisée en décembre 2009. Tel qu'illustré par la Figure B.2, cette étude se concentre sur l'implémentation de la couche physique du LTE dans les stations de base. La couche physique se compose d'un lien descendant encodant le signal à envoyer aux utilisateurs et d'un lien montant décodant le signal reçu des utilisateurs. Chaque lien contient une étape de codage canal adaptant le signal binaire à transmettre aux conditions de transmissions et d'une étape de traitement des symboles complexes générés par la modulation du signal. Nous ne considérons pas dans cette étude les parties modulation de porteuse et amplification (bloc RF de la figure).

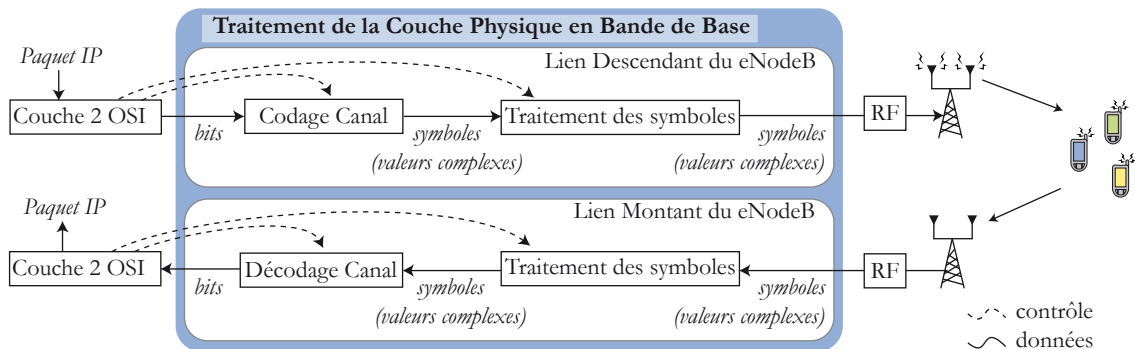

Figure B.2 – Objets de l'Etude du LTE

### Objectifs du LTE

Comparé aux précédents standards, le LTE a de très fortes contraintes de performance :

- **Des taux de transfert sans précédent.** Le lien descendant supporte 100 Mbit/s en supposant des récepteurs à deux antennes et le lien montant 50 Mbit/s.
- **Une latence réduite** à 10 millisecondes pour la réponse à un message.
- **Un coût par bit réduit** par une meilleure utilisation de la bande de fréquence allouée.
- **Une flexibilité du spectre** avec la possibilité de déployer un lien montant et un lien descendant chacun sur des bandes de fréquences de largeurs paramétrables entre 1.4 MHz et 20 MHz.

- **Une consommation réduite des terminaux** en déportant autant que possible la complexité des calculs dans la station de base.
- **Une architecture du réseau simplifiée.** Cette architecture, nommée System Architecture Evolution (SAE) redéfinit à la fois la partie accès radio et la partie coeur du réseau.
- **Le transport efficace à la fois de la voix et des données,** le tout en utilisant la technologie IP (Internet Protocol).
- **Des cellules de taille très variables,** couvrant de quelques mètres (femto-cells) à 115 km (macrocells) pour s'adapter aux densités de population locales.
- **La connectivité d'utilisateurs à grande vitesse.** Un utilisateur devant pouvoir rester connecté même s'il voyage à 350 km/h.
- **La gestion de communications simultanées avec de nombreux utilisateurs** (200 à 400 selon la largeur de bande).

Ces contraintes ont nécessité l'utilisation de techniques complexes à la fois pour les deux liens montant et descendant. Ces techniques rendent la couche physique du LTE complexe et coûteuse.

### Technologies de la Couche Physique du LTE

Les liens montant et descendant sont tous deux à large bande. Le spectre de chaque lien est divisé en sous-porteuses transportant des composantes différentes du flux de données. Le lien descendant utilise une technologie nommée OFDMA (Orthogonal Frequency Division Multiplexing Access) qui optimise les débits de données alors que le lien montant utilise la technologie SC-FDMA (Single Carrier-Frequency Division Multiplexing Access) qui offre un bon compromis entre débit et consommation électrique de l'amplificateur de puissance de l'utilisateur. La réduction de cette consommation est primordiale car les utilisateurs ont le plus souvent un terminal alimenté par batterie. Les techniques OFDMA et SC-FDMA utilisent une estimation précise de la qualité instantanée du canal de transmission. Elles sont combinées avec de multiples antennes d'émission et de réception permettant des débits plus élevés grâce au multiplexage spatial, souvent appelé effet MIMO (Multiple Input Multiple Output).

Une procédure nommée "Random Access Procedure" permet à de nouveaux utilisateurs de se connecter à une station de base. Ils envoient pour cela une signature dans une zone temps/fréquence préallouée. Le processus de détection des signatures envoyées s'appelle la détection de préambules. Cette détection est coûteuse en terme de calculs et son comportement est différent de ceux des liens montant et descendant. La détection de préambules sera modélisée à part dans la Section [B.3.3](#).

### B.2.2 Les Modèles Flot de Données

Les modèles flot de données ont prouvé leur efficacité pour la modélisation d'applications parallèles avec dépendances de données. Ils représentent les applications par des graphes dont les noeuds (ou acteurs) sont des entités de code séquentiel et

les arcs représentent des données circulant entre les acteurs. La Figure B.3 illustre quelques modèles flot de données. Chaque modèle est un compromis entre expressivité et analysabilité. L'expressivité détermine quels algorithmes seront modélisables alors que l'analysabilité détermine quelles informations sur le comportement du code pourront être extraites durant la phase de compilation. Une grande analysabilité est nécessaire pour pouvoir partitionner au moment de la compilation les différentes parties de l'algorithme. Un modèle Turing complet permet de représenter un algorithme quelconque. La compacité du modèle varie également, i.e. sa capacité à représenter un algorithme avec peu d'éléments.

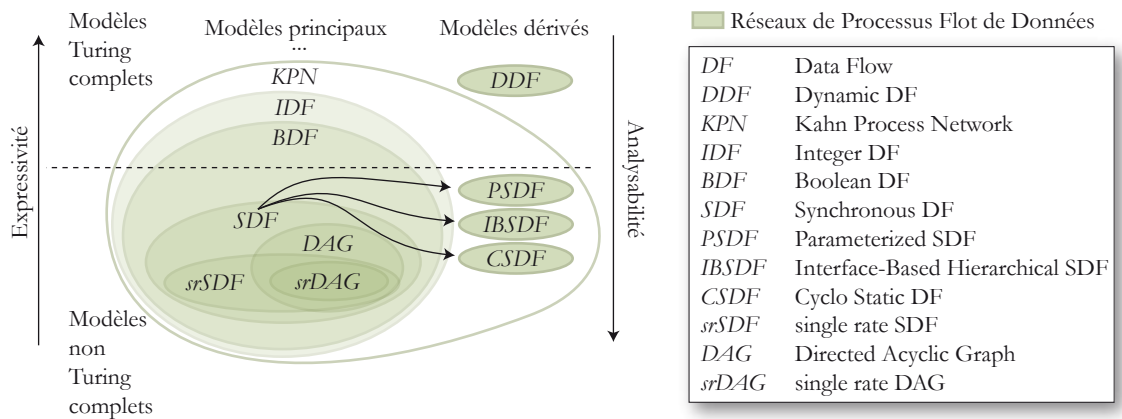

Figure B.3 – Modèles de Calcul Flot de Données

Les modèles que nous utilisons pour représenter le LTE sont une version modifiée du SDF (Synchronous Dataflow) nommée IBSDf (Interface-Based Hierarchical Synchronous Dataflow) et une version modifiée du PSDF (Parameterized Synchronous Dataflow) nommée PCSDAG (Parameterized Cyclo Static Directed Acyclic). Le SDF et le PSDF sont des modèles de la littérature fréquemment utilisés. Le IBSDf est un modèle ajoutant au SDF une hiérarchie contrôlée par l'utilisateur pour simplifier la description des algorithmes. Le PCSDAG est un modèle à la fois rapide à analyser et suffisamment expressif pour modéliser les algorithmes très variables du LTE.

### B.2.3 Le Prototypage Rapide et la Programmation des Architectures Multicoeurs

La programmation d'architectures multi-coeurs a donné lieu à de nombreux travaux de recherche conduisant à des résultats très différents dépendant des objectifs et contraintes de l'étude (programmation générique à tous type d'applications ou spécifique au traitement du signal, architectures homogènes ou hétérogènes, mémoire partagée ou distribuée, minimisation de la latence ou du débit de données traitées...). Nous nous intéressons particulièrement ici aux applications de traitement du signal dont la couche physique du LTE fait partie. Les architectures cible sont hétérogènes à mémoire distribuée ou partagée et nous minimisons principalement la latence d'exécution car elle est la principale contrainte de la couche physique du standard LTE.

Nous pouvons distinguer trois niveaux de parallélisme : le niveau instruction, le niveau thread et le niveau tâche. Le parallélisme de grain moyen (niveau thread ou acteur dans le cadre du flot de données) est le parallélisme le moins traité dans la

littérature et le plus utile pour minimiser la latence de la couche physique du LTE sur architecture distribuée. Cette thèse a donc pour objectif le parallélisme à grain moyen.

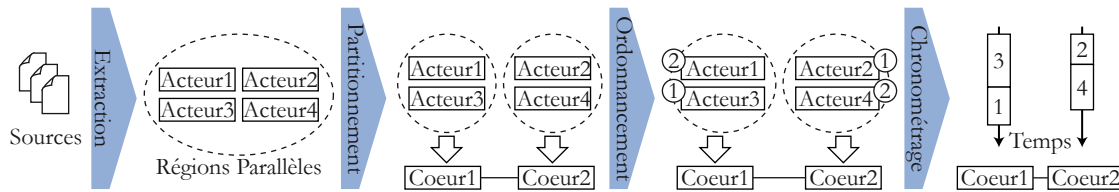

**Figure B.4** – Les quatre phases de la parallélisation à grain moyen : extraction, partitionnement, ordonnancement et chronométrage

La parallélisation d’un code à grain moyen consiste en quatre étapes (Figure B.4) :

- L’ **extraction** consiste à extraire les zones potentiellement parallèles (acteur dans le cadre du flot de données) du code source.
- Le **partitionnement** consiste à choisir un coeur/coprocesseur pour exécuter chaque acteur.
- L’ **ordonnancement** consiste à ordonner l’exécution des acteurs assignés à un même coeur/coprocesseur.
- Le **chronométrage** consiste à choisir le moment où chaque acteur est exécuté.

Dans le domaine que nous étudions ici, les systèmes embarqués, [POH09] distingue quatre classes de méthodes pour effectuer une parallélisation à grain moyen :

- Les **méthodes basées sur la compilation** consistent à extraire les zones parallèles d’un code séquentiel par des méthodes de compilation.
- Les **extensions de langage** consistent à laisser le développeur ajouter des instructions spécifiques à un code séquentiel pour préciser comment le paralléliser.
- La **méthode basée sur la plateforme** se réfère à une technique particulière de l’auteur.
- Les **méthodes basées sur les modèles flot de données** consistent à décrire le comportement général des algorithmes avec un modèle simple à étudier pour la parallélisation.

Les méthodes flot de données ont l’avantage de supprimer l’étape d’extraction puisque les modèles sont conçus pour exprimer naturellement le parallélisme. Nous choisissons de résoudre le problème de l’exécution parallèle du LTE en développant l’outil PREEISM basé sur les modèles flot de données. Cet outil est développé dans le cadre de la thèse en collaboration avec Texas Instruments. Le développement de l’outil est partagé avec deux autres doctorants : Jonathan Piat et Matthieu Wipliez. L’outil est open source et disponible sur internet. Il automatise la phase de partitionnement et génère un code dit “self-timed”, c’est à dire partitionné et ordonné.



à la compilation (partitionnement statique) tout en laissant le système d'exécution faire la phase de chronométrage.

Le partitionnement statique est illustré par la Figure B.5. Le graphe d'algorithme contient cinq acteurs  $a, b, c, d$  et  $e$  et des arcs symbolisant le transfert de données entre acteurs. Le graphe d'architecture contient trois coeurs et un DMA (Direct Memory Access) qui se charge de piloter leurs transferts. Le scénario contient des temps typiques d'exécution pour chaque acteur sur chaque type de coeur. A partir de ces informations, le partitionneur choisit le partitionnement, l'ordonnancement et le chronométrage et simule l'exécution en l'affichant dans un graphique de Gantt. L'étape de chronométrage n'est pas transmise à la phase d'exécution. Les problèmes de partitionnement et d'ordonnancement pour minimiser la latence sont NP-complets : il est donc nécessaire de trouver des heuristiques pour les résoudre.

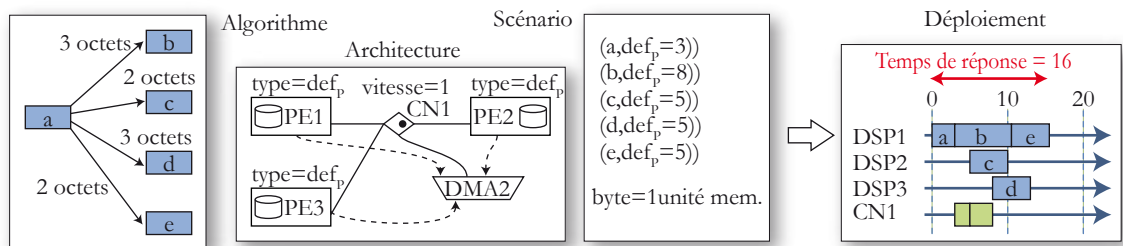

**Figure B.5** – Partitionnement multi-coeurs à partir d'un modèle flot de données de l'algorithme et d'un graphe d'architecture

De très nombreuses heuristiques ont été inventées pour résoudre le problème de partitionnement et d'ordonnancement. [Kwo97] référence et évalue de nombreuses méthodes avant d'en proposer trois nouvelles : une méthode gloutonne, une méthode nommée FAST utilisant des sauts probabilistes et un algorithme génétique. Ces trois algorithmes ont été implémentés dans l'outil PREESM et la méthode gloutonne est utilisée dans un partitionneur adaptatif présenté Section B.3.4.

Les quatre prochaines sections détaillent les contributions de cette thèse.

## B.3 Contributions

### B.3.1 Un Modèle d'Architecture pour le Prototypage Rapide

Le **modèle d'architecture S-LAM** (System-Level Architecture Model) est un nouveau modèle permettant de décrire simplement des comportements complexes. La Figure B.6 montre les différents éléments constituant le modèle. L'élément principal est l'opérateur qui représente un calculateur séquentiel capable d'exécuter des acteurs. Les liens de données, orientés ou non, relient les opérateurs à des noeuds de communication. Les noeuds de communication permettent des interconnexions multi-points de liens de données. Il en existe deux types :

- Les **noeuds de compétition** prennent en compte la compétition des différents transferts qui transitent par eux.
- Les **noeuds parallèles**, à l'inverse, peuvent faire transiter simultanément plusieurs transferts entre plusieurs paires d'opérateurs.

Utiliser un lien de compétition ajoute un coût à la simulation d'un déploiement sur cette architecture car il faut ordonnancer les transferts sur ce noeud. Le développeur peut donc régler la complexité de simulation de son modèle en plaçant des noeuds de compétition sur les liens susceptibles de limiter la performance du système.

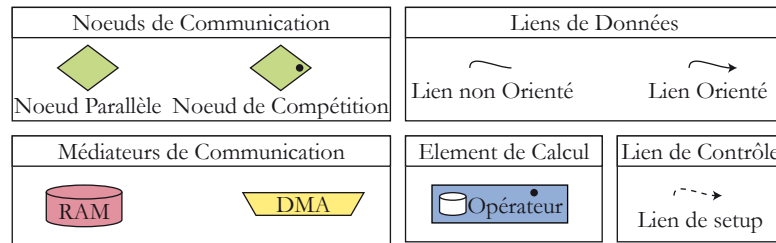

**Figure B.6** – Elements du modèle d'architecture S-LAM

La RAM (Random Access Memory) est une mémoire que peuvent se partager plusieurs opérateurs. Si le chemin entre deux opérateurs contient une RAM, ils communiquent en se partageant une mémoire ; sinon, il s'envoient des messages. Le DMA (Direct Memory Access) est un gestionnaire de transferts qui permet à un opérateur d'effectuer des calculs en parallèle avec ses propres transferts. Le lien de "setup" permet de préciser quel opérateur peut programmer quel DMA et combien de temps est nécessaire pour cette programmation.

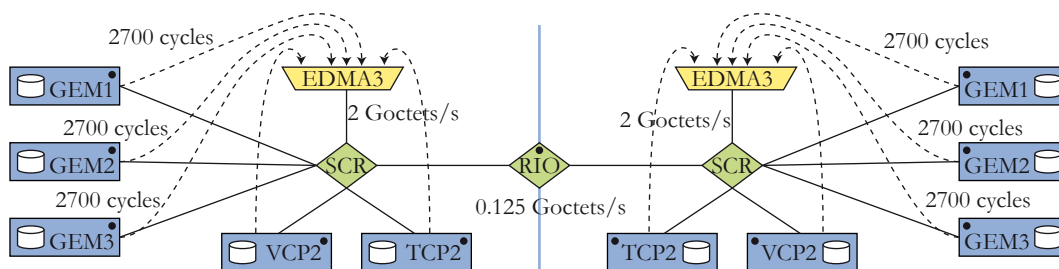

**Figure B.7** – Exemple d'un modèle S-LAM : deux DSPs TMS320TCI6488

La Figure B.7 montre un exemple de description S-LAM. Deux processeurs de type TMS320TCI6488 sont connectés par un lien de type RapidIO de vitesse 1 G bits/s. Chaque processeur contient trois coeurs (GEM) de type c64x+. Les communications locales des processeurs se font via un lien parallèle nommé SCR (Switched Central Resource) de vitesse 2 G octets/s. Des coprocesseurs permettent d'accélérer les encodage/décodage Viterbi (VCP2) et turbo (TCP2). Tous les transferts, y compris entre processeurs, sont pilotés par les DMAs dont le démarrage nécessite 2700 cycles. Ce modèle simple décrit précisément le comportement réel de l'architecture.

A partir du modèle S-LAM, un routage est calculé et permet d'accélérer la simulation de l'architecture. Chaque paire d'opérateurs est alors associée au meilleur lien qui les relie et ce lien est utilisé pour le prototypage rapide. Le résultat est un modèle expressif, simple et rapide à simuler.

### B.3.2 Amélioration du Prototypage Rapide

De nouvelles méthodes de prototypage rapide sont introduites dans l’outil PREESM. Elles améliorent la flexibilité, les performances et l’ergonomie de l’outil de partitionnement automatique. Une première méthode est l’utilisation du **scénario** et du **“workflow”**. Le scénario contient les informations liées à la fois à l’algorithme et à l’architecture. Il est stocké au format XML dans PREESM et permet de réutiliser tout algorithme avec toute architecture. Un “workflow” est un graphe décrivant l’enchaînement des transformations appliquées aux entrées du prototypage rapide. Le workflow de la Figure B.8 applique trois transformations à l’algorithme d’entrée (flattening, srSDF et reduceForkJoin), puis partitionne l’algorithme pour l’architecture (scheduling), génère un code “self-timed” et affiche le diagramme de Gantt du déploiement. Ce workflow peut être exécuté dans l’outil PREESM, qui applique alors les transformations spécifiées sur les modèles d’entrée.

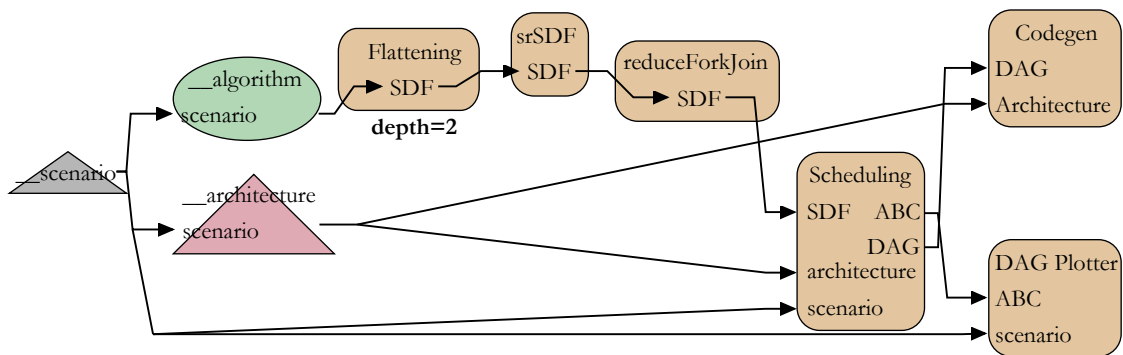

Figure B.8 – Exemple d’un “workflow” rendant flexible le prototypage rapide

Le partitionnement est calculé par un **partitionneur composite** dont la structure est illustrée Figure B.9. Une partie calcule les choix de partitionnement pendant que l’autre, nommée ABC (Architecture Benchmark Computer), calcule le coût des déploiements obtenus. Plusieurs implémentations sont disponibles pour les deux parties, permettant un choix dans la complexité et la précision du partitionneur. De plus, le coût retourné par l’ABC étant abstrait, il peut représenter indifféremment une latence, un coût mémoire, une consommation d’énergie ou un coût composite. Cette structure permet de minimiser simplement différents critères.

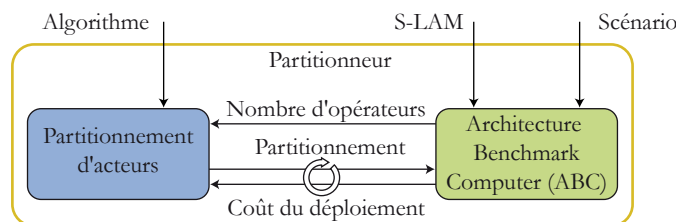
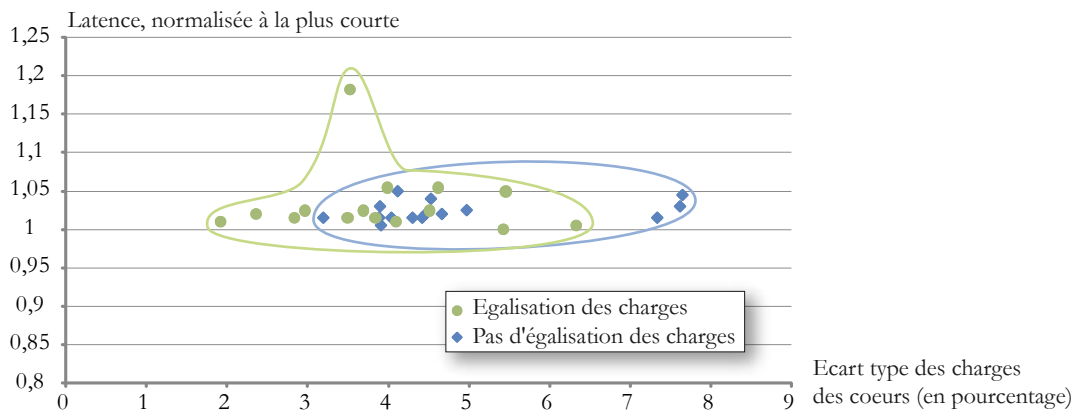

Figure B.9 – Structure interne d’un partitionneur flexible

Un exemple de coût composite est l’équilibrage des charges de calcul entre les opérateurs. Cet équilibrage est positif pour la consommation électrique du circuit. Il est naturel lorsque l’on minimise la latence, dans l’hypothèse (imaginaire) d’une architecture à une infinité d’opérateurs avec des liens infiniment rapides. Le

nombre limité d'opérateurs, leur caractère hétérogène, ainsi que les liens de données limités rendent différents les deux critères latence et équilibrage des charges. Une solution efficace est d'utiliser un ABC retournant un coût composite : la somme de la latence et de l'écart type des charges. La Figure B.10 montre le résultat de cette modification de coût sur un exemple d'application du LTE. Les charges sont sensiblement équilibrées et la latence n'est pas sensiblement détériorée.



**Figure B.10** – *Équilibrage des charges de calculs entre les différents opérateurs*

Dans le cas le plus courant où la minimisation de la latence d'exécution est l'objectif principal du partitionnement, la qualité d'un déploiement peut être évaluée par le "speedup". Le speedup correspond à l'accélération du calcul due à l'utilisation d'une architecture distribuée. Il est égal au temps d'exécution sur un opérateur divisé par le temps d'exécution sur l'architecture distribuée. Ce speedup peut être affiché, pour une architecture homogène, sur un graphique illustré Figure B.11. Le graphique de la partie droite permet d'évaluer le déploiement situé en bas à gauche de la figure. L'algorithme étudié est placé en haut à gauche de la figure. Le travail correspond à la somme des temps d'exécution des acteurs et le chemin critique est le plus long chemin entre un acteur entrant et un acteur sortant. Sur ce graphique, généré à partir du modèle d'algorithme, le point correspond au déploiement que l'on veut évaluer. Le speedup est donné en ordonnée et le nombre d'opérateurs homogènes en abscisse. Trois courbes circonscrivent une zone correspondant aux déploiements de bonne qualité :

- La courbe  $S_{sup_{work}}$  signifie que le speedup ne peut pas être supérieur au nombre d'opérateurs
- La courbe  $S_{sup_{span}}$  signifie que l'algorithme a une limite en terme de parallélisme
- La courbe  $S_{inf_{GST}}$  est donnée par le "Greedy Scheduling Theorem" (GST). Ce théorème fixe un minimum de parallélisme que tout algorithme glouton peut atteindre à partir d'un algorithme donné. Un déploiement sous cette limite signifie que les efforts de partitionnement intelligent à la compilation n'ont pas conduit à un résultat satisfaisant. Plusieurs raisons peuvent expliquer des performances inférieures à la limite GST : un lien de données trop lent entre les opérateurs ou de mauvais choix de partitionnement/ordonnancement.

Moyennant quelques précautions, l'affichage du speedup peut également être utilisé pour des architectures hétérogènes. Cet affichage permet d'évaluer rapidement

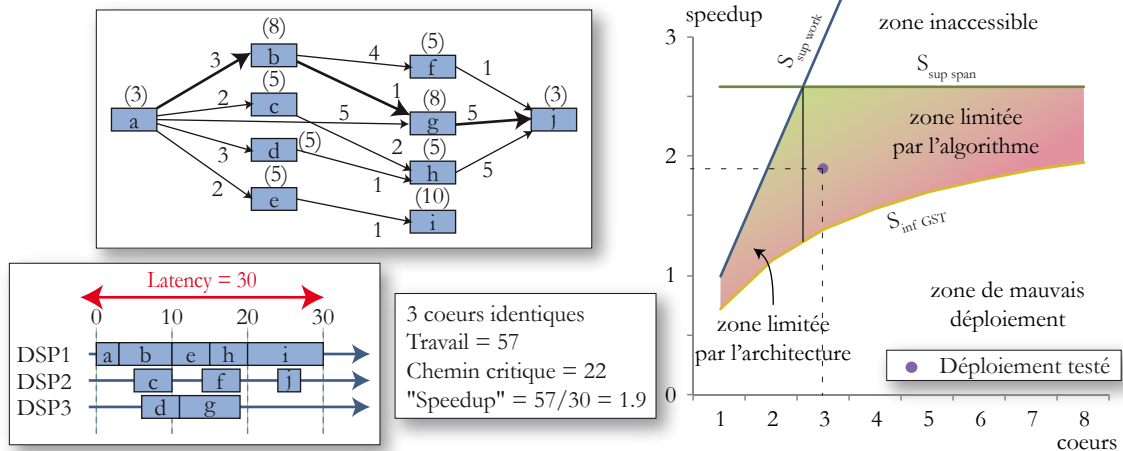

Figure B.11 – Affichage graphique de la qualité d'un déploiement

le déploiement obtenu lors d'un partitionnement automatique. Il améliore donc la phase de prototypage rapide.

### B.3.3 Modèles Flot de Données du LTE

Les méthodes de prototypage rapide précédemment expliquées sont appliquées aux algorithmes du LTE. Trois graphes flot de données hiérarchiques sont décrits en utilisant le modèle IBSDF :

- **La détection de préambule** correspondant à l'écoute permanente d'une ressource temps/fréquence dans laquelle les utilisateur non connectés peuvent envoyer un message pour se connecter à la station de base.
- **Le décodage du lien montant** correspondant à la récupération des données envoyées par chaque utilisateur dans la cellule
- **L'encodage du lien descendant** correspondant à la préparation des données descendantes avant l'envoi aux utilisateurs.

Ces trois graphes d'algorithme décrivent chacun le calcul d'une milliseconde de données. Ce choix vient du fait que l'allocation d'utilisateurs à des ressources fréquentielles est effectuée chaque milliseconde. A partir de ces graphes, nous pouvons effectuer des prototypages rapides pour évaluer par exemple quelle architecture est la plus à même d'exécuter efficacement un algorithme. L'outil PREESM est régulièrement utilisé par des ingénieurs de Texas Instruments pour prototyper leurs déploiements. PREESM peut en outre générer les entrées d'un simulateur SystemC développé par Texas Instruments, simulant précisément le comportement de l'architecture pour un déploiement donné.

### B.3.4 Implémentation du LTE à Partir de Modèles Flot de Données

Un **code statique** sous forme de fichiers C est généré à partir du déploiement. Il appelle les fonctions C correspondant aux acteurs. Le partitionneur fixe le partitionnement et l'ordonnement au moment de la compilation. Ce code n'est donc

adapté qu'à des algorithmes dont le comportement est relativement stable dans le temps. C'est le cas de la détection de préambule qui correspond à une écoute permanente et stable d'éventuels messages. La procédure de génération de code dans PREESM est illustrée dans la Figure B.12. Le partitionneur calcule le déploiement en utilisant le graphe S-LAM de l'architecture, le graphe IBSDF de l'algorithme et un scénario. Un code générique au format XML est ensuite généré. Des fichiers IDL (Interface Description Language) donnent le prototype de chaque fonction appelée par la génération de code. Une transformation XSL transforme le code générique XML en un code C ayant la bonne syntaxe pour l'opérateur cible. Finalement, le compilateur génère un exécutable par opérateur en utilisant des bibliothèques de transfert ainsi que le code des acteurs. Cette méthode de génération de code est appliquée à la détection de préambule. Le décodage du lien montant et l'encodage du lien descendant nécessitent de prendre en compte leur grande variabilité.

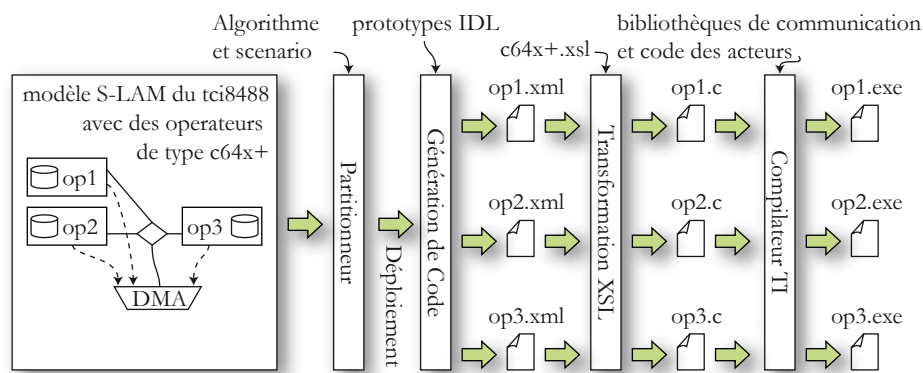
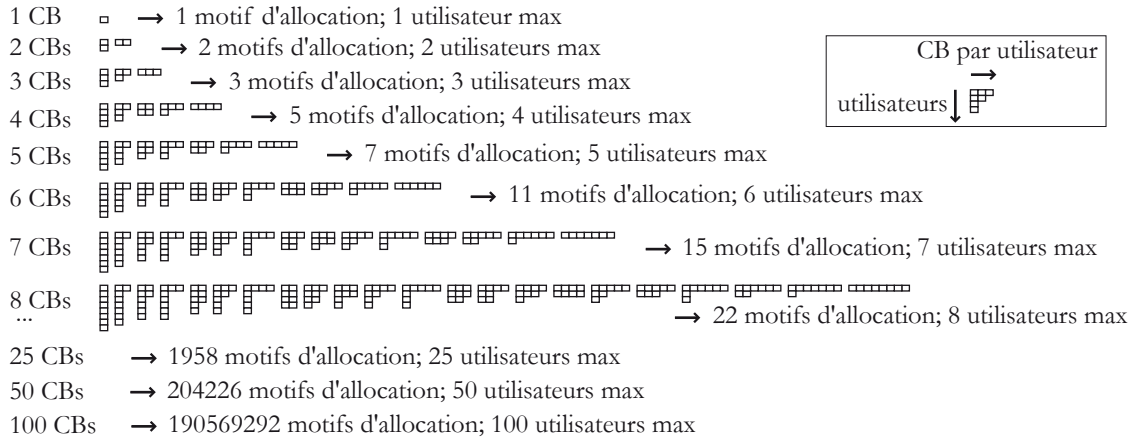

Figure B.12 – Génération de code “self-timed” à partir du déploiement statique

Chaque milliseconde, la station de base échange des données avec ses utilisateurs connectés. Les données sont rassemblées en “Code Blocks” (CB) de taille variable. Le type de cellule le plus évolué peut allouer simultanément 100 CBs à jusqu'à une centaine d'utilisateurs. La Figure B.13 illustre le nombre d'allocations possibles lorsque l'on alloue  $N$  CBs à des utilisateurs. Le nombre d'allocations possibles augmente exponentiellement avec le nombre de CBs alloués : il atteint presque 200 millions pour 100 CBs. La taille variable des CBs ainsi que leur nombre également variable augmente encore considérablement le nombre de possibilités de configurations. La configuration des graphes du décodage du lien montant et de l'encodage du lien descendant dépend de ces allocations et ces algorithmes extrêmement variables se prêtent mal au partitionnement statique.

Une solution au partitionnement du décodage du lien montant et de l'encodage du lien descendant est de partitionner durant l'exécution, alors que tous les paramètres instantanés du graphe sont connus. Il faut alors quitter le schéma d'exécution décentralisé utilisé dans la génération de code statique et utiliser à la place un schéma d'exécution maître/esclave (Figure B.14). Dans le schéma d'exécution décentralisé, tous les opérateurs sont équivalents et exécutent les acteurs qui leur sont assignés statiquement. Les acteurs s'exécutent dès que leurs données d'entrée sont disponibles. Dans le schéma d'exécution maître/esclave, un opérateur maître dirige les opérations et assigne dynamiquement les acteurs à des opérateurs esclaves. Pour ce nouveau schéma d'exécution, il faut concevoir le code de contrôle dont l'élément principal est un **partitionneur adaptatif**.



**Figure B.13** – Diagrammes de Ferrer : les différentes allocations possible de  $N$  CBs à des utilisateurs

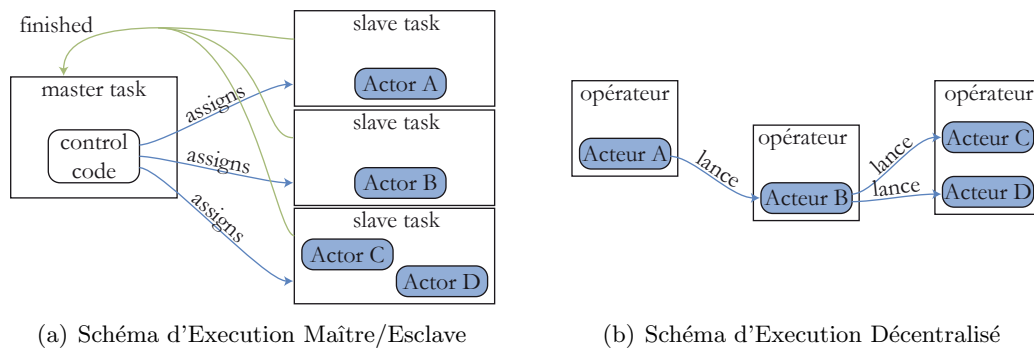

**Figure B.14** – Schémas d'Execution

La Figure B.15 illustre la structure d'un partitionneur adaptatif basé sur un modèle flot de données. Une phase d'initialisation exécutée au démarrage génère un graphe paramétré de type PCSDAG qui représente le comportement global de l'algorithme. A partir de ce graphe de référence et des paramètres instantanés, un graphe de type single rate DAG est généré chaque milliseconde durant une phase d'expansion du graphe. Ce graphe généré représente l'exécution d'une instance du graphe incluant les instances des acteurs et les transferts de données. Une phase de partitionnement choisit ensuite le partitionnement de chaque acteur. Les deux opérations expansion et partitionnement doivent être extrêmement efficace pour être exécutées dans tous les cas en moins d'une milliseconde, c'est à dire le temps séparant deux choix d'allocation différents.

Les performances du partitionneur adaptatif développé durant cette thèse sont illustrées Figure B.16. Ce partitionneur permet de déployer en temps réel le décodage des données du lien montant à condition que le nombre d'opérateurs esclaves soit inférieur à 8. Un tel partitionneur ouvre de nouvelles perspectives pour la parallélisation d'algorithmes extrêmement variables tels que le décodage du lien montant et l'encodage du lien descendant dans les stations de base LTE.

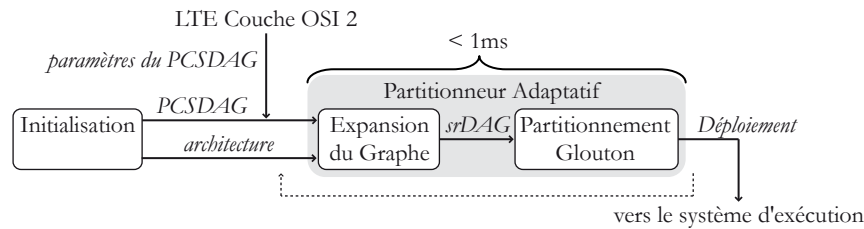

**Figure B.15** – Structure interne du partitionneur adaptatif

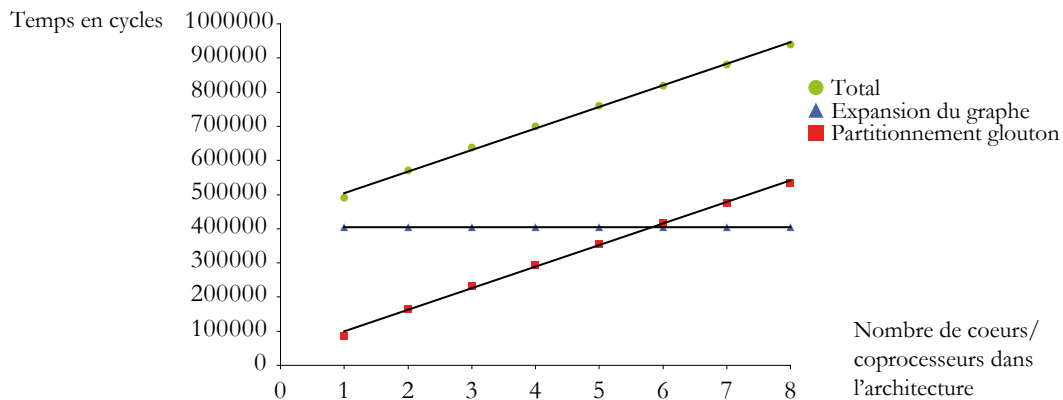

**Figure B.16** – Temps d'exécution pire cas du partitionneur adaptatif appliqué au décodage des données du lien montant en fonction du nombre d'opérateurs esclaves

## B.4 Conclusion

Les solutions logicielles et matérielles des systèmes embarqués modernes sont devenues tellement complexes qu'une étude au niveau système est maintenant nécessaire pour éviter les mauvais choix de conception et respecter les contraintes. L'implémentation sur DSP multi-cœurs du traitement du signal des stations de base 3GPP LTE est un exemple de ces systèmes complexes. Durant cette thèse, des méthodes de prototypage rapide utilisant les modèles flot de données ont été mises en place. Elles permettent de simuler le déploiement d'un algorithme sur une architecture distribuée et de générer un code efficace.

Les contributions de cette thèse sont de plusieurs types. Un nouveau modèle d'architecture est introduit. Il est simple, expressif, et permet une simulation rapide de l'architecture décrite. Un nouvel outil nommé PREESM pour le prototypage rapide est présenté. Une nouvelle structure interne pour le partitionneur, c'est à dire le coeur du prototypage rapide sur architecture distribuée, est introduite et expliquée. Elle rend le processus adaptable et permet de minimiser plusieurs types de fonction de coût pendant le partitionnement. Un exemple de fonction de coût est donné ; il permet d'égaliser efficacement les charges de calcul sur les différents opérateurs, ce qui a généralement un effet positif sur la consommation électrique du système. De nombreux modèles de calcul sont expliqués et le choix de modèles pour décrire la couche physique du 3GPP LTE est justifié. Le fonctionnement et l'agencement des algorithmes du LTE sont détaillés ainsi que des méthodes pour simuler l'exécution et générer le code. Lorsque cela est possible, par exemple pour



---

la détection de préambule, le partitionnement statique conduit à une génération de code qui ne remet pas en cause le partitionnement des acteurs. Dans les cas plus complexes, par exemple les liens montant et descendant, un partitionnement en-ligne est calculé. Le partitionneur adaptatif en-ligne est temps réel sur les liens montant et descendant et constitue donc une solution possible à leur implémentation parallèle.



---

## List of Figures

---

1.1	Comparing a Present Single-core Development Chain to a Possible Development Chain for Multi-core DSPs . . . . .	5
1.2	Rapid Prototyping and Thesis Outline . . . . .	8
2.1	3GPP Standard Generations . . . . .	11
2.2	A three-sectored cell . . . . .	12
2.3	Scope of the LTE Study . . . . .	14
2.4	LTE System Architecture Evolution . . . . .	15
2.5	Protocol Layers of LTE Radio Link . . . . .	16
2.6	Data Blocks Segmentation and Concatenation . . . . .	17
2.7	Radio Propagation, Channel Response and Reciprocity Property . . . . .	19
2.8	Uplink and Downlink Data Processing in the LTE eNodeB . . . . .	22
2.9	LTE downlink and uplink multiplexing technologies . . . . .	22
2.10	Comparison of OFDMA and SC-FDMA . . . . .	23
2.11	Cyclic Prefix Insertion . . . . .	24
2.12	LTE Time Units . . . . .	25
2.13	Different types of LTE duplex modes . . . . .	26
2.14	LTE Link Adaptation . . . . .	27
2.15	LTE Forward Error Correction methods . . . . .	28
2.16	LTE link adaptation . . . . .	30
2.17	Reference Signals location in the uplink resources . . . . .	31
2.18	Uplink Channels . . . . .	32
2.19	Length-63 Zadoff-Chu Sequences with index 25, 29 and 34 . . . . .	33
2.20	Contention-Based Random Access Procedure. . . . .	36
2.21	Baseband Spectrum of a Fully-Loaded 20 MHz LTE Downlink . . . . .	37
2.22	Downlink multiple user scheduling and reference signals . . . . .	38
2.23	Gold Pseudo Random Sequence Generation . . . . .	40
2.24	Layer Mapping and Precoding for Spatial Diversity with Different Multi-antenna Parameters . . . . .	41
2.25	Layer Mapping and Precoding for Spatial Multiplexing with different multi-antenna parameters . . . . .	42
2.26	Downlink PSS, SSS, RS and PBCH localization in subframes. . . . .	43
3.1	Main Types of Process Network Model of Computation . . . . .	47

3.2	A Few Dataflow MoC Graph Examples . . . . .	49
3.3	The Topology Matrix and Repetition Vector of an SDF Graph . . . . .	51
3.4	SDF Graph and its Acyclic Precedence Expansion Graph . . . . .	53
3.5	The Topology Matrix and Repetition Vector of a CSDF Graph . . . . .	55
3.6	Illustrating Compactness of CSDF Model Compared to SDF . . . . .	55
3.7	PSDF Example . . . . .	56
3.8	Comparing Direct Hierarchical SDF with IBSDF . . . . .	57
3.9	IBSDF Sub-Graph Example and Its Single Rate Equivalent . . . . .	58
4.1	The Von Neumann Architecture of an Operator . . . . .	64
4.2	The Four Phases of Middle-Grain Parallelization: Extraction, Assignment, Ordering and Timing . . . . .	66
4.3	Example of a schedule Gantt chart . . . . .	70
4.4	T-Level and B-Level of a Timed Directed Acyclic Graph . . . . .	71
4.5	Construction of an Actor List in Topological Order . . . . .	72
4.6	Genetic Algorithm Atomic Operations: Mutation and Cross-Over . . . . .	73
5.1	TMS320TCI6488 Functional Block Diagram . . . . .	80
5.2	Picture of a TMS320TCI6488 Die . . . . .	81
5.3	TMS320TCI6486 Functional Block Diagram . . . . .	81
5.4	The elements of S-LAM . . . . .	84
5.5	S-LAM description of a board with two tci6488 using EDMA3 for commu- nications local to a processor . . . . .	84
5.6	S-LAM description of a board with 2 tci6488 using DDR2 shared memory for communications local to a processor . . . . .	85
5.7	S-LAM description of a tci6486 processor . . . . .	86
5.8	S-LAM Descriptions of Architecture Examples . . . . .	86
5.9	The Types of Route Steps . . . . .	87
5.10	The route model generation . . . . .	88
5.11	Impact of route types on the simulation of a transfer . . . . .	91
5.12	Storing an S-LAM Description in an IP-XACT Design File . . . . .	93
5.13	A tci6488 Hierarchical S-LAM and its Flattened S-LAM Equivalent . . . . .	93
6.1	Overview of the Rapid Prototyping Process . . . . .	97
6.2	Creating a Single Rate SDF with Fork and Join Actors . . . . .	98
6.3	Example of an IBSDF Actor with Ports and its IDL Prototype . . . . .	99
6.4	A Workflow for Prototyping an Application . . . . .	101
6.5	A workflow Combining Rapid Prototyping with SystemC Simulations . . . . .	103
6.6	The Scheduler Sub-modules: Actor Assignment and ABC . . . . .	105
6.7	Structure of a Latency ABC . . . . .	107
6.8	Assignment and Existing Versions of ABC s . . . . .	107
6.9	Study Of the Latency And Variance Behavior in the Case of 2 Operators . . . . .	110
6.10	Example showing that Minimizing Latency is not Equivalent to Balancing Loads in the BNP Scheduling Problem . . . . .	111
6.11	Comparing Schedules with and without load balancing criterium. . . . .	112
6.12	Theoretical Speedup Limits . . . . .	115
6.13	Speedup Chart of an Example DAG Scheduling . . . . .	117
7.1	An Eclipse-based Rapid Prototyping Framework . . . . .	120
7.2	Input/output with Graphiti's XML format $\mathcal{G}$ . . . . .	121

7.3	RACH-PD Algorithm Model . . . . .	125
7.4	Four architectures explored . . . . .	127
7.5	Timings of the RACH-PD algorithm schedule on target architectures . . . . .	127
7.6	Downlink Decoding . . . . .	128
7.7	PUCCH Decoding . . . . .	130
7.8	PUSCH Decoding . . . . .	131
7.9	Introducing Delays in a IBSDF Description to Simulate Events . . . . .	133
8.1	Execution Schemes . . . . .	136
8.2	Possible Associations of Scheduling Strategies to Execution Schemes . . . . .	137
8.3	Code generation Procedure on a tci6488 . . . . .	138
8.4	XML Generic Code Representation . . . . .	139
8.5	Code Behavior of a an Example of Message Passing with DMA . . . . .	140
8.6	Petri Net of Execution of the Application in Figure 8.5(a) . . . . .	141
8.7	Method for the RACH-PD Algorithm Implementation. . . . .	141
8.8	PSDF Description of the Uplink. . . . .	144
8.9	PCSDAG Description of the Uplink. . . . .	145
8.10	Target Architecture Example in S-LAM and Adaptive Scheduler Matrix Model: a tci6488 and a tci6486 Connected with a RapidIO Serial Link. . . . .	146
8.11	The problem of allocating CBs to UEs is equivalent to integer partitions represented here in Ferrer diagrams. . . . .	146
8.12	Adaptive multi-core scheduling steps: graph expansion and list scheduling steps are called in a loop every millisecond. . . . .	147
8.13	Examples of single rate DAG graphs generated from the PCSDAG description in Figure 8.9. . . . .	148
8.14	Example of list scheduling of Single Rate DAG actors. . . . .	149
8.15	Example of a schedule Gantt chart: case with 100 CBs and 100 UEs on the architecture from Figure 8.10 with one core reserved for the scheduling. . . . .	149
8.16	Memory Footprint, in Bytes, of the Statically Allocated Adaptive Scheduler. . . . .	150
8.17	Impact of single rate DAG graph size on the LTE PUSCH scheduling execution time on the architecture of Figure 8.10 with one core reserved for the scheduling. . . . .	150
8.18	Impact of the number of operators on the LTE uplink scheduling execution time in an LTE PUSCH worst case. . . . .	151
8.19	Schedule speedup vs. number of CBs and UEs using the architecture from Figure 8.10. . . . .	151
8.20	Comparing Run-Time Heuristic Schedules with FAST Schedules . . . . .	152
8.21	PCSDAG Model of the PDSCH LTE Channel. . . . .	153
A.1	Workflow Nodes . . . . .	160
A.2	Workflow Nodes . . . . .	161
A.3	Workflow Nodes . . . . .	162
B.1	Prototypage Rapide et Plan de la Thèse . . . . .	164
B.2	Objets de l'Etude du LTE . . . . .	165
B.3	Modèles de Calcul Flot de Données . . . . .	167
B.4	Les quatre phases de la parallélisation à grain moyen : extraction, partitionnement, ordonnancement et chronométrage . . . . .	168
B.5	Partitionnement multi-coeurs à partir d'un modèle flot de données de l'algorithme et d'un graphe d'architecture . . . . .	169

---

B.6	Elements du modèle d'architecture S-LAM . . . . .	170
B.7	Exemple d'un modèle S-LAM : deux DSPs TMS320TCI6488 . . . . .	170
B.8	Exemple d'un "workflow" rendant flexible le prototypage rapide . . . . .	171
B.9	Structure interne d'un partitionneur flexible . . . . .	171
B.10	Equilibrage des charges de calculs entre les différents opérateurs . . . . .	172
B.11	Affichage graphique de la qualité d'un déploiement . . . . .	173
B.12	Génération de code "self-timed" à partir du déploiement statique . . . . .	174
B.13	Diagrammes de Ferrer : les différentes allocations possible de N CBs à des utilisateurs . . . . .	175
B.14	Schémas d'Execution . . . . .	175
B.15	Structure interne du partitionneur adaptatif . . . . .	176
B.16	Temps d'exécution pire cas du partitionneur adaptatif appliqué au décodage des données du lien montant en fonction du nombre d'opérateurs esclaves . . . . .	176

---

## List of Tables

---

2.1	LTE downlink Bandwidth Configurations . . . . .	38
4.1	The Levels of Parallelism and their Present Use . . . . .	62
4.2	Scheduling strategies . . . . .	68
7.1	Maximal Raw Bit Rates of Uplink Resources . . . . .	123
7.2	Maximal Raw Bit Rates of PDSCH . . . . .	124





3G	Third Generation Telecommunication System, <a href="#">11</a>
3GPP	Third Generation Partnership Project, <a href="#">11</a> , <a href="#">20</a>
AADL	Architecture Analysis and Design Language, <a href="#">65</a>
AAM	Algorithm Architecture Matching, <a href="#">73</a> , <a href="#">137</a>
ACK	HARQ Acknowledgement, <a href="#">32</a>
AIF	Antenna Interface, <a href="#">80</a> , <a href="#">132</a>
ALP	Actor Level Parallelism, <a href="#">62</a>
ALU	Arithmetic and Logic Unit, <a href="#">64</a>
APEG	Acyclic Precedence Expansion Graph, <a href="#">53</a>
APN	Arbitrary Processor Network, <a href="#">70</a> , <a href="#">107</a> , <a href="#">108</a>
ARQ	Automatic Repeat reQuest, <a href="#">16</a>
ASAP	As Soon As Possible, <a href="#">71</a>
AWGN	Additive White Gaussian Noise, <a href="#">18</a> , <a href="#">26</a>
BDF	Boolean Dataflow Graph, <a href="#">48</a>
BNP	Bounded Number of Processors, <a href="#">70</a> , <a href="#">107</a> , <a href="#">108</a>
BPSK	Binary Phase Shift Keying, <a href="#">42</a>
BRV	Basis Repetition Vector, <a href="#">51</a> , <a href="#">144</a>
BSR	Buffer Status Report, <a href="#">18</a> , <a href="#">32</a>
C-RNTI	Random Access Radio Network Temporary Identifier, <a href="#">37</a>
CAZAC	Constant Amplitude Zero AutoCorrelation, <a href="#">33</a>
CB	Code Block, <a href="#">128</a>
CDD	Cyclic Delay Diversity, <a href="#">41</a>
CDM	Code Division Multiplexing, <a href="#">21</a> , <a href="#">31</a> , <a href="#">39</a>
CIR	Channel Impulse Response, <a href="#">19</a> , <a href="#">131</a>
CISC	Complex Instruction Set Computer, <a href="#">64</a>
CN	Communication Node, <a href="#">84</a> , <a href="#">100</a>
CP	Critical Path, <a href="#">71</a>

---

CP	Cyclic Prefix, <a href="#">24</a> , <a href="#">35</a>
CPN	Critical Path Node, <a href="#">72</a>
CQI	Channel Quality Indicator, <a href="#">26</a> , <a href="#">32</a> , <a href="#">38</a> , <a href="#">41</a>
CRC	Cyclic Redundancy Check, <a href="#">21</a> , <a href="#">28</a> , <a href="#">32</a> , <a href="#">38</a> , <a href="#">128</a>
CSDF	Cyclo Static Dataflow Graph, <a href="#">48</a> , <a href="#">53</a>
DAET	Deterministic Actor Execution Time, <a href="#">50</a> , <a href="#">100</a> , <a href="#">109</a>
DAG	Directed Acyclic Graph, <a href="#">48</a> , <a href="#">103</a> , <a href="#">147</a>
DCI	Downlink Control Information, <a href="#">38</a>
DDF	Dynamic Dataflow Graph, <a href="#">48</a>
DDR	Double Data Rate, <a href="#">80</a>
DE	Discrete Event, <a href="#">46</a>
DFT	Discrete Fourier Transform, <a href="#">23</a>
DM RS	Demodulation Reference Signal, <a href="#">30</a> , <a href="#">33</a>
DMA	Direct Memory Access, <a href="#">65</a> , <a href="#">82</a> , <a href="#">83</a>
DSL	Digital Subscriber Line, <a href="#">20</a>
DSP	Digital Signal Processor, <a href="#">47</a> , <a href="#">63</a>
E-UTRAN	Evolved Universal Terrestrial Radio Access Network, <a href="#">15</a>
EMAC	Ethernet Media Access Controller, <a href="#">80</a>
eNodeB	evolved NodeB, <a href="#">12</a> , <a href="#">15</a>
EPC	Evolved Packet Core, <a href="#">15</a>
ETSI	European Telecommunications Standards Institute, <a href="#">11</a>
FAST	Fast Assignment and Scheduling of Tasks, <a href="#">72</a> , <a href="#">107</a>
FDD	Frequency Division Duplex, <a href="#">25</a>
FEC	Forward Error Correction, <a href="#">21</a> , <a href="#">26</a> , <a href="#">27</a> , <a href="#">38</a> , <a href="#">128</a>
FFT	Fast Fourier Transform, <a href="#">37</a>
FIFO	First-In First-Out, <a href="#">46</a>
FSM	Finite State Machine, <a href="#">46</a>
GPU	Graphical Processing Unit, <a href="#">63</a>
GSM	Global System for Mobile Communications, <a href="#">11</a>
GT	Guard Time, <a href="#">35</a>
HARQ	Hybrid Automatic Repeat reQuest, <a href="#">16</a> , <a href="#">18</a> , <a href="#">32</a>
HD-FDD	Half-Duplex FDD, <a href="#">25</a>
HDL	Hardware Description Language, <a href="#">49</a>
HSPA	High Speed Packet Access, <a href="#">12</a>
HSS	Home Subscriber Server, <a href="#">15</a>
IBN	In-Branch Node, <a href="#">72</a>

---

IBSDF	Interface-Based Hierarchical Synchronous Dataflow Graph, <a href="#">48</a> , <a href="#">57</a> , <a href="#">167</a>
ICI	Inter Carrier Interference, <a href="#">19</a>
IDF	Integer Dataflow Graph, <a href="#">48</a>
IDL	Interface Description Languages, <a href="#">138</a>
IFFT	Inverse Fast Fourier Transform, <a href="#">23</a>
ILP	Instruction-Level Parallelism, <a href="#">61</a>
IMT	International Mobile Telecommunications, <a href="#">11</a>
IP	Intellectual Property, <a href="#">62</a> , <a href="#">83</a>
IP	Internet Protocol, <a href="#">12</a> , <a href="#">16</a>
ISA	Instruction Set Architecture, <a href="#">61</a> , <a href="#">64</a>
ISI	Inter Symbol Interference, <a href="#">19</a> , <a href="#">23</a>
ITRS	International Technology Roadmap for Semiconductors, <a href="#">45</a>
ITU-R	International Telecommunication Union, Radio Communication Sector, <a href="#">11</a> , <a href="#">20</a>
KPN	Kahn Process Network, <a href="#">47</a>
LTE	Long Term Evolution, <a href="#">12</a>
M-sequence	Maximum length sequence, <a href="#">39</a>
MAC	Medium Access Control, <a href="#">16</a>
MCS	Modulation and Coding Scheme, <a href="#">21</a> , <a href="#">26</a> , <a href="#">38</a> , <a href="#">131</a>
MIB	Master Information Block, <a href="#">38</a>
MIMD	Multiple Instruction Multiple Data, <a href="#">64</a>
MIMO	Multiple Input Multiple Output, <a href="#">22</a> , <a href="#">29</a> , <a href="#">41</a>
MISD	Multiple Instruction Single Data, <a href="#">64</a>
MLD	Maximum Likelihood, <a href="#">35</a>
MME	Mobility Management Entity, <a href="#">15</a> , <a href="#">35</a>
MMSE	Minimum Mean-Square Error, <a href="#">34</a>
MoC	Model of Computation, <a href="#">45</a>
MPSoC	Multi-Processor System-on-Chip, <a href="#">63</a> , <a href="#">79</a>
MRC	Maximal-Ratio Combining, <a href="#">29</a>
MU-MIMO	Multi-User MIMO, <a href="#">33</a> , <a href="#">34</a> , <a href="#">41</a>
NACK	HARQ Non Acknowledgement, <a href="#">32</a>
NAS	Non Access Stratum, <a href="#">15</a>
NLOS	Non-line-of-sight, <a href="#">19</a>
NORMA	NO Remote Memory Access, <a href="#">65</a>
NUMA	Non Uniform Memory Access, <a href="#">65</a>
OBN	Out-Branch Node, <a href="#">72</a>
OFDMA	Orthogonal Frequency Division Multiplexing Access, <a href="#">21</a> , <a href="#">22</a> , <a href="#">37</a> , <a href="#">166</a>
OOP	Object-Oriented Programming, <a href="#">46</a>
OSI	Open Systems Interconnection, <a href="#">14</a>

---

P-GW	Packet Data Network Gateway, 15
PAPR	Peak to Average Power Ratio, 21, 23, 37
PBCH	Physical Broadcast Channel, 38, 42
PCFICH	Physical Control Format Indicator Channel, 38
PCRF	Policy Control and charging Rules Function, 15
PCSDAG	Parameterized Cyclo Static Directed Acyclic Graph, 144, 167, 174
PDCCH	Physical Downlink Control Channel, 26, 38
PDCP	Packet Data Convergence Protocol, 16
PDSCH	Physical Downlink Shared Channel, 26, 38, 41, 135
PDU	Protocol Data Unit, 17
PFASST	Parallel Fast Assignment and Scheduling of Tasks, 72, 107
PHICH	Physical Hybrid ARQ Indicator Channel, 38
PMCH	Physical Multicast Channel, 38
PMI	Precoding Matrix Indicator, 32, 40, 41
PN	Process Network, 46
PRACH	Physical Random Access Channel, 31, 35, 124
PRB	Physical Resource Block, 24
PREESM	Parallel and Real-time Embedded Executives Scheduling Method, 137
PSDF	Parameterized Synchronous Dataflow Graph, 48, 55, 167
PSS	Primary Synchronization Signal, 42
PUCCH	Physical Uplink Control Channel, 26, 31
PUSCH	Physical Uplink Shared Channel, 26, 31, 135
QoS	Quality of Service, 15
RA-RNTI	Random Access Radio Network Temporary Identifier, 36
RACH-PD	Random Access Channel Preamble Detection, 124, 135
RAM	Random Access Memory, 83
RAR	Random Access Response, 35, 36
RE	Resource Element, 24, 122
RF	Radio Frequency, 22, 25, 37
RI	Rank Indicator, 32, 40, 41
RISC	Reduced Instruction Set Computer, 64
RLC	Radio Link Control, 16
RS	Reference Signal, 21, 39, 42
RTOS	Real-Time Operating System, 61
S-GW	Serving Gateway, 15

S-LAM	System-Level Architecture Model, <a href="#">82</a> , <a href="#">103</a>
SAE	Society of Automotive Engineers, <a href="#">65</a>
SAE	System Architecture Evolution, <a href="#">13</a> , <a href="#">15</a> , <a href="#">18</a>
SC-FDMA	Single Carrier-Frequency Division Multiplexing Access, <a href="#">21</a> , <a href="#">22</a> , <a href="#">37</a> , <a href="#">166</a>
SCR	Switched Central Resource, <a href="#">80</a> , <a href="#">82</a>
SD	Sphere Decoder, <a href="#">35</a>
SDF	Synchronous Dataflow Graph, <a href="#">48</a> , <a href="#">50</a>
SDF4J	Synchronous Dataflow for Java, <a href="#">119</a>
SDMA	Spatial Division Multiple Access, <a href="#">34</a>
SDU	Service Data Unit, <a href="#">17</a>
SFBC	Space-Frequency Block Coding, <a href="#">40</a>
SIB	System Information Block, <a href="#">38</a>
SIMD	Single Instruction Multiple Data, <a href="#">62</a> , <a href="#">64</a>
SINR	Signal-to-Interference plus Noise Ratio, <a href="#">26</a>
SISD	Single Instruction Single Data, <a href="#">64</a>
SNR	Signal-to-Noise Ratio, <a href="#">18</a> , <a href="#">26</a>
SR	Scheduling Request, <a href="#">131</a>
SRS	Sounding Reference Signal, <a href="#">30</a> , <a href="#">33</a>
SRs	Scheduling Request, <a href="#">32</a>
SSE	Streaming SIMD Extensions, <a href="#">62</a>
SSS	Secondary Synchronization Signal, <a href="#">42</a>
STBC	Space-Time Block Coding, <a href="#">29</a> , <a href="#">40</a>
TB	Transport Block, <a href="#">128</a>
TDD	Time Division Duplex, <a href="#">25</a>
ThLP	Thread-Level Parallelism, <a href="#">61</a>
TLM	Transaction Level Modeling, <a href="#">65</a>
TLP	Task-Level Parallelism, <a href="#">61</a>
TTI	Transmission Time Interval, <a href="#">24</a>
UE	User Equipment, <a href="#">12</a> , <a href="#">15</a>
UMA	Uniform Memory Access, <a href="#">65</a>
UMTS	Universal Mobile Telecommunications System, <a href="#">12</a>
UNC	Unbounded Number Of Clusters, <a href="#">70</a> , <a href="#">108</a>
VLIW	Very Long Instruction Word, <a href="#">62</a> , <a href="#">64</a>
VoIP	Voice over IP, <a href="#">13</a> , <a href="#">18</a>
WCET	Worst-Case Execution Time, <a href="#">100</a>
XSLT	Extensible Stylesheet Language Transformation, <a href="#">138</a>
ZC	Zadoff-Chu Sequence, <a href="#">30</a> , <a href="#">33</a> , <a href="#">42</a>
ZF	Zero Forcing, <a href="#">34</a>



- [1] M. Pelcat, J.-F. Nezan, and S. Aridhi, *Adaptive multicore scheduling for the LTE uplink*, NASA/ESA AHS 2010, Anaheim.
- [2] M. Pelcat, J. Piat, M. Wipliez, J.-F. Nezan, and S. Aridhi. *An open framework for rapid prototyping of signal processing applications*, EURASIP Journal on Embedded Systems, 2009.
- [3] M. Pelcat, J.-F. Nezan, J. Piat, J. Croizer, and S. Aridhi, *A System-Level architecture model for rapid prototyping of heterogeneous multicore embedded systems*, DASIP 2009, Sophia Antipolis.
- [4] J. Piat, S. S. Bhattacharyya, M. Pelcat, and M. Raulet, *Multi-core code generation from interface based hierarchy*, DASIP 2009, Sophia Antipolis.
- [5] M. Pelcat, P. Menuet, S. Aridhi and J-F. Nezan, *Scalable compile-time scheduler for multi-core architectures*, DATE 2009, Nice.
- [6] M. Pelcat, P. Menuet, S. Aridhi and J-F. Nezan, *A Static Scheduling Framework for Deploying Applications on Multicore Architectures*, PDCN 2009, Innsbruck.
- [7] M. Pelcat, S. Aridhi and J-F. Nezan, *Optimization of automatically generated multi-core code for the LTE RACH-PD algorithm*, DASIP 2008, Brussels.
- [8] J. Piat, M. Raulet, M. Pelcat, P. Mu and O. Déforges, *An extensible framework for fast prototyping of multiprocessor dataflow applications*, IDT 2008, Monastir.
- [9] F. Décologne, M. Blestel, M. Raulet and M. Pelcat, *Specific Functional Units for SVC: Textual description and CAL implementation*, M15432, 84th MPEG Meeting Document Register, Archamps, France, 2008.
- [10] M. Pelcat, M. Blestel and M. Raulet, *From AVC Decoder to SVC: Minor Impact on a Dataflow Graph Description*, 26th Picture Coding Symposium. PCS 2007, Lisbon.
- [11] M. Pelcat, M. Raulet, O. Déforges, M. Blestel and J-F. Nezan, *Implementing SVC from RVC AVC: description of the specific SVC FUs*, M14965, 82th MPEG Meeting Document Register, Shenzhen, 2007.

- [12] M. Raulet, M. Pelcat and M. Blestel, *From AVC to SVC: minor and major modifications in a RVC decoder implementation*, M14655, 81st MPEG Meeting Document Register, Lausanne, Switzerland, 2007.
- [13] M. Pelcat, M. Blestel, M. Raulet and J-F. Nezan, *Evolutions of RVC so as to handle SVC decoding*, M14463, 80th MPEG Meeting Document Register, San José, 2007.
- [14] G. Roquier, M. Pelcat, M. Raulet, M. Wipliez, J-F. Nezan and O. Déforges, *A scheme for implementing MPEG-4 SP codec in the RVC framework*, M14457, 80th MPEG Meeting Document Register, San José, 2007.



---

## Bibliography

---

- [36.09a] 3GPP: TS 36.101. Evolved Universal Terrestrial Radio Access (E-UTRA); user equipment (ue) radio transmission and reception (Release 9), December 2009. [15](#)
- [36.09b] 3GPP: TS 36.104. Evolved Universal Terrestrial Radio Access (E-UTRA); base station (bs) radio transmission and reception (Release 9), December 2009. [15](#)
- [36.09c] 3GPP: TS 36.211. Evolved Universal Terrestrial Radio Access (E-UTRA); physical channels and modulation (Release 9), December 2009. [15](#), [16](#), [25](#), [26](#), [35](#), [37](#), [40](#), [125](#)
- [36.09d] 3GPP: TS 36.212. Evolved Universal Terrestrial Radio Access (E-UTRA); multiplexing and channel coding (Release 9), December 2009. [15](#)
- [36.09e] 3GPP: TS 36.213. Evolved Universal Terrestrial Radio Access (E-UTRA); physical layer procedures (Release 9), December 2009. [18](#), [27](#), [36](#), [37](#), [123](#)
- [36.09f] 3GPP: TS 36.321. Evolved Universal Terrestrial Radio Access (E-UTRA); medium access control (mac) protocol specification (Release 9), December 2009. [16](#)
- [36.09g] 3GPP: TS 36.322. Evolved Universal Terrestrial Radio Access (E-UTRA); radio link control (rlc) protocol specification (Release 9), December 2009. [16](#)
- [36.09h] 3GPP: TS 36.323. Evolved Universal Terrestrial Radio Access (E-UTRA); packet data convergence protocol (pdcp) specification (Release 9), December 2009. [16](#)
- [Ack82] W. B. Ackerman. Data flow languages. *Computer*, 15(2):15–25, 1982. [4](#)
- [Ala07] S. M Alamouti. A simple transmit diversity technique for wireless communications. *The best of the best: fifty years of communications and networking research*, page 17, 2007. [29](#), [41](#)
- [Amd67] G. M Amdahl. Validity of the single processor approach to achieving large scale computing capabilities. In *Proceedings of the April 18-20, 1967, spring joint computer conference*, pages 483–485, 1967. [115](#)

- [BB01] B. Bhattacharya and S.S. Bhattacharyya. Parameterized dataflow modeling for DSP systems. *Signal Processing, IEEE Transactions on*, 49(10):2408–2421, 2001. 55, 56
- [BB02] B. Bhattacharya and S. Bhattacharyya. Consistency analysis of reconfigurable dataflow specifications. In *Lecture notes in computer science*, pages 308–311, 2002. 55
- [BBE<sup>+</sup>08] S. Bhattacharyya, G. Brebner, J. Eker, J. Janneck, M. Mattavelli, C. von Platen, and M. Raulet. OpenDF - a dataflow toolset for reconfigurable hardware and multicore systems. SIGARCH Comput. Archit. News, 2008. 67
- [BBS09] J. Boutellier, S. S Bhattacharyya, and O. Silven. A low-overhead scheduling methodology for fine-grained acceleration of signal processing systems. *Journal of Signal Processing Systems*, 2009. 74
- [BEH<sup>+</sup>01] U. Brandes, M. Eiglsperger, I. Herman, M. Himsolt, and M. S. Marshall. Graphml progress report, structural layer proposal. In P Mutzel, M Junger, and S Leipert, editors, *Graph Drawing - 9th International Symposium, GD 2001 Vienna Austria,*, pages 501–512, Heidelberg, 2001. Springer Verlag. 120
- [Bel06] P. Belanovic. *An Open Tool Integration Environment for Efficient Design of Embedded Systems in Wireless Communications*. PhD thesis, Technischen Universitat Wien, 2006. 67
- [BELP95] G. Bilsen, M. Engels, R. Lauwereins, and J. A. Peperstraete. Cyclo-static data flow. In *Acoustics, Speech, and Signal Processing, 1995. ICASSP-95., 1995 International Conference on*, volume 5, 1995. 51, 53
- [BEPT00] J. Blazewicz, K. Ecker, B. Plateau, and D. Trystram. *Handbook on parallel and distributed processing*. Springer, 2000. 65
- [BG07] C. Berrou and A. Glavieux. Near optimum error correcting coding and decoding: Turbo-codes. *The best of the best: fifty years of communications and networking research*, page 45, 2007. 28
- [BHLM94] J. Buck, S. Ha, E. A Lee, and D. G Messerschmitt. Ptolemy: A framework for simulating and prototyping heterogeneous systems. *International Journal of Computer Simulation*, 4(2):155–182, 1994. 74
- [BJK<sup>+</sup>95] R. D Blumofe, C. F Joerg, B. C Kuszmaul, C. E Leiserson, K. H Randall, and Y. Zhou. Cilk: An efficient multithreaded runtime system. In *Proceedings of the fifth ACM SIGPLAN symposium on Principles and practice of parallel programming*, 1995. 66, 67
- [BKKB02] N. Bambha, V. Kianzad, M. Khandelia, and S. S Bhattacharyya. Intermediate representations for design automation of multiprocessor DSP systems. *Design Automation for Embedded Systems*, 7(4), 2002. 74
- [BL93] J. T. Buck and E. A. Lee. Scheduling dynamic dataflow graphs with bounded memory using the token flow model. In *1993 IEEE International Conference on Acoustics, Speech, and Signal Processing, 1993. ICASSP-93.*, volume 1, 1993. 51

- [BLMSv98] F. Balarin, L. Lavagno, P. Murthy, and A. Sangiovanni-vincentelli. Scheduling for embedded Real-Time systems. *IEEE DESIGN and TEST OF COMPUTERS*, pages 71–82, 1998. [74](#)
- [Bre74] R. P Brent. The parallel evaluation of general arithmetic expressions. *Journal of the ACM (JACM)*, 21(2):201–206, 1974. [116](#)
- [Bru07] P. Brucker. *Scheduling Algorithms*. Springer Verlag, 2007. [69](#), [70](#), [74](#)
- [BSL97] S. S Bhattacharyya, S. Sriram, and E. A Lee. Optimizing synchronization in multiprocessor DSP systems. *IEEE Transactions on Signal Processing*, 45(6), 1997. [74](#)
- [BW09] David Bell and Greg Wood. Multicore programming guide. Technical report, Texas Instruments, August 2009. [87](#), [135](#), [136](#)
- [CCS<sup>+</sup>08] J. Ceng, J. Castrillon, W. Sheng, H. Scharwachter, R. Leupers, G. Ascheid, H. Meyr, T. Isshiki, and H. Kunieda. MAPS: an integrated framework for MP-SoC application parallelization. In *Proceedings of the 45th annual conference on Design automation*, pages 754–759, 2008. [66](#)
- [CHL97] W. T Chang, S. Ha, and E. A Lee. Heterogeneous simulation - mixing discrete-event models with dataflow. *The Journal of VLSI Signal Processing*, 15(1):127–144, 1997. [45](#)
- [Chu72] D. Chu. Polyphase codes with good periodic correlation properties. *IEEE Transactions on Information Theory*, 18(4):531 to 532, 1972. [33](#)
- [CLRS01] Thomas H. Cormen, Charles E. Leiserson, Ronald L. Rivest, and Clifford Stein. *Introduction to Algorithms*. The MIT Press, 2nd edition, September 2001. [52](#), [69](#), [89](#)
- [CMS06] C. Ciochina, D. Mottier, and H. Sari. Multiple access techniques for the uplink in future wireless communications systems. *Third COST 289 Workshop*, July 2006. [30](#)
- [CS94] R.V. Cox and C.E.W. Sundberg. An efficient adaptive circular viterbi algorithm for decoding generalized tailbiting convolutional codes. *IEEE Transactions on Vehicular Technology*, 43(1):57–68, feb 1994. [27](#)
- [DEY<sup>+</sup>09] A. Dahlin, J. Ersfolk, G. Yang, H. Habli, and J. Lilius. The canals language and its compiler. In *Proceedings of th 12th International Workshop on Software and Compilers for Embedded Systems*, pages 43–52, 2009. [74](#)
- [Dij60] EW Dijkstra. Algol 60 translation. *Supplement, Algol 60 Bulletin*, 10, 1960. [147](#)
- [DPSB07] Erik Dahlman, Stefan Parkvall, Johan Skold, and Per Beming. *3G Evolution: HSPA and LTE for Mobile Broadband*. Academic Press Inc, June 2007. [15](#), [17](#)
- [dsp] TMS320 DSP/BIOS Users Guide (SPRU423F). [138](#)

- [DSTW96] A. L Davis, E. J Stotzer, R. E Tatge, and A. S Ward. Approaching peak performance with compiled code on a VLIW DSP. *Proceedings of ICSPAT Fall*, 1996. 62
- [ecl] Eclipse Open Source IDE : Available Online. <http://www.eclipse.org/downloads/>. 119
- [EJ03] J. Eker and J. W. Janneck. CAL Language Report. Technical report, ERL Technical Memo UCB/ERL M03/48, University of California at Berkeley, December 2003. 67, 120
- [FGHI06] P. H Feiler, D. P Gluch, J. J Hudak, and CARNEGIE-MELLON UNIV PITTSBURGH PA SOFTWARE ENGINEERING INST. The architecture analysis & design language (AADL): an introduction. Technical report, 2006. 65
- [Fly72] M. J Flynn. Some computer organizations and their effectiveness. *IEEE Transactions on Computers*, 100:21, 1972. 65
- [Fri10] Arnon Friedmann. Enabling LTE development with TI new multicore SoC architecture SPRY134. Technical report, Texas Instruments, 2010. 81, 111
- [fS09] International Technology Roadmap for Semiconductors. Design. [www.itrs.net](http://www.itrs.net), 2009. 46, 64
- [GB09] Alan Gatherer and Eric Biscondi. Multicore DSP programming models [In the spotlight]. *IEEE Signal Processing Magazine*, 26(6):224, 220–222, 2009. 95
- [Ghe06] Frank Ghenassia. *Transaction-Level Modeling with SystemC: TLM Concepts and Applications for Embedded Systems*. Springer-Verlag New York, Inc., 2006. 67, 106
- [GHJV95] E. Gamma, R. Helm, R. Johnson, and J. Vlissides. *Design patterns: elements of reusable object-oriented software*. Addison-wesley Reading, MA, 1995. 119
- [GJ90] Michael R. Garey and David S. Johnson. *Computers and Intractability; A Guide to the Theory of NP-Completeness*. W. H. Freeman & Co., 1990. 69
- [GLS99] T. Grandpierre, C. Lavarenne, and Y. Sorel. Optimized rapid prototyping for real-time embedded heterogeneous multiprocessors. In *Hardware/Software Codesign, 1999. (CODES '99) Proceedings of the Seventh International Workshop on*, pages 74–78, 1999. 67, 74
- [graa] Grammatica parser generator : Available Online. <http://grammatica.percederberg.net/>. 120
- [Grab] Graphiti Editor : Available Online. <http://sourceforge.net/projects/graphiti-editor/>. 101
- [Gra66] R. L Graham. Bounds for certain multiprocessing anomalies. *Bell System Technical Journal*, 45(9), 1966. 66, 149
- [Gra69] R. L Graham. Bounds on multiprocessing timing anomalies. *SIAM JOURNAL ON APPLIED MATHEMATICS*, 17:416—429, 1969. 116

- [Gra00] Thierry Grandpierre. Modélisation d'architectures parallèles hétérogènes pour la génération automatique d'exécutifs distribués temps réel optimisés. <http://www.inria.fr/rrrt/tu-0666.html>, November 2000. Grandpierre, Thierry. 82, 83
- [GS03] T. Grandpierre and Y. Sorel. From algorithm and architecture specifications to automatic generation of distributed real-time executives: a seamless flow of graphs transformations. In *MEMOCODE '03*, pages 123–132, 2003. 68, 82, 99, 137
- [gsm10] GSM-UMTS network migration to LTE. Technical report, 3G Americas, February 2010. 11
- [Gus88] J. L Gustafson. Reevaluating amdahl's law. *Communications of the ACM*, 31(5):532–533, 1988. 115
- [Hea95] S. Heath. *Microprocessor architectures RISC, CISC and DSP*. Butterworth-Heinemann Ltd. Oxford, UK, UK, 1995. 64
- [HHBT09] Wolfgang Haid, Kai Huang, Iuliana Bacivarov, and Lothar Thiele. Multiprocessor SoC software design flows. *IEEE Signal Processing Magazine*, 26(6):64–71, 2009. 96
- [HjHL06] Yuxiong He, Wen jing Hsu, and Charles E. Leiserson. Provably efficient two-level adaptive scheduling, 2006. 136, 154
- [HKK<sup>+</sup>04] C.-J. Hsu, F. Keceli, M.-Y. Ko, S. Shahparnia, and S. S. Bhattacharyya. Dif: An interchange format for dataflow-based design tools. 2004. 67
- [HL97] S. Ha and E. A Lee. Compile-time scheduling of dynamic constructs in dataflow program graphs. *IEEE Transactions on Computers*, 46, 1997. 74, 137
- [Hol01] Bengt Holter. On the capacity of the mimo channel—a tutorial introduction. In *IEEE Norwegian Symposium on Signal Processing*, pages 167–172, 2001. 29
- [HT09] Harri Holma and Antti Toskala. *LTE for UMTS - OFDMA and SC-FDMA Based Radio Access*. John Wiley and Sons, may 2009. 15
- [Hu61] T. C. Hu. Parallel sequencing and assembly line problems. *Operations Research*, 9(6):841–848, 1961. 70
- [ins05] TMS320C64x/C64x+ DSP CPU and instruction set reference guide. *Texas Instruments, User manual SPRU732C*, 2005. 79
- [Jan03] T. H.J Janecek. Static vs. dynamic List-Scheduling performance comparison. *Acta Polytechnica*, 43(6), 2003. 72
- [Jan07] J. W. Janneck. NL - a Network Language. Technical report, ASTG Technical Memo, Programmable Solutions Group, Xilinx Inc., July 2007. 120
- [JE01] J. W. Janneck and R. Esser. A predicate-based approach to defining visual language syntax. In *In Symposium on Visual Languages and Formal Methods, HCC01, Stresa*, pages 40–47, 2001. 120

- [JMB] J. Jiang, T. Muharemovic, and P. Bertrand. Random access preamble detection for long term evolution wireless networks. Patent Nr 20090040918. [124](#), [125](#)
- [JMRW10] J. W Janneck, M. Mattavelli, M. Raulet, and M. Wipliez. Reconfigurable video coding: a stream programming approach to the specification of new video coding standards. In *Proceedings of the first annual ACM SIGMM conference on Multimedia systems*, pages 223–234, 2010. [48](#)
- [KA99] Y. K Kwok and I. Ahmad. FASTEST: a practical low-complexity algorithm for compile-time assignment of parallel programs to multiprocessors. *IEEE Transactions on Parallel and Distributed Systems*, 10(2):147–159, 1999. [72](#)
- [KAG<sup>+</sup>09] L. J Karam, I. AlKamal, A. Gatherer, G. A Frantz, D. V Anderson, and B. L Evans. Trends in multicore DSP platforms. *IEEE Signal Process. Mag.*, 26(6):38–49, 2009. [5](#), [64](#), [96](#)
- [Kah74] G. Kahn. The semantics of a simple language for parallel programming. *Information processing*, 74:471–475, 1974. [47](#)
- [KF90] A. H Karp and H. P Flatt. Measuring parallel processor performance. *Communications of the ACM*, 33(5):539–543, 1990. [116](#)
- [KKJ<sup>+</sup>08] S. Kwon, Y. Kim, W. C Jeun, S. Ha, and Y. Paek. A retargetable parallel-programming framework for MPSoC. *ACM Transactions on Design Automation of Electronic Systems (TODAES)*, 13(3):39, 2008. [66](#)
- [KSLB03] G. Karsai, J. Sztipanovits, A. Ledeczki, and T. Bapty. Model-integrated development of embedded software. *Proceedings of the IEEE*, 91(1):145–164, 2003. [67](#)
- [Kwo97] Yu-Kwong Kwok. *High-performance algorithms of compile-time scheduling of parallel processors*. PhD thesis, Hong Kong University of Science and Technology, 1997. [53](#), [70](#), [71](#), [72](#), [73](#), [91](#), [169](#)
- [Lar09] E. G Larsson. MIMO detection methods: How they work. *IEEE Signal Processing Magazine*, 26(3):91–95, 2009. [35](#)
- [Lee89] E. A Lee. Scheduling strategies for multiprocessor real-time DSP. In *IEEE Global Telecommunications Conference and Exhibition. Communications Technology for the 1990s and Beyond*, 1989. [68](#), [69](#), [87](#)
- [Lee01] E.A. Lee. Overview of the ptolemy project. *Technical memorandum UCB/ERL M01/11, University of California at Berkeley*, 2001. [67](#)
- [Lee06] E.A. Lee. The problem with threads. *Computer*, 39(5):33–42, 2006. [62](#)
- [Lei05] C. E Leiserson. A minicourse on dynamic multithreaded algorithms. 2005. [116](#), [117](#)
- [LM87] E.A. Lee and D.G. Messerschmitt. Synchronous data flow. *Proceedings of the IEEE*, 75(9):1235–1245, 1987. [50](#), [51](#)
- [LP95] E. A. Lee and T. M. Parks. Dataflow process networks. *Proceedings of the IEEE*, 83(5):773–801, 1995. [47](#), [48](#), [49](#), [50](#), [63](#)

- [MARN07] S. Moreau, S. Aridhi, M. Raullet, and J.-F. Nezan. On modeling the RapidIO communication link using the AAA methodology. In *DASIP*, 2007. 140
- [mca] The Multicore Association. <http://www.multicore-association.org/home.php>. 66, 67, 147
- [MKB06] N. K. Bambha M. Khandelia and S. S Bhattacharyya. Contention-conscious transaction ordering in multiprocessors DSP systems. In *IEEE Transactions on Signal Processing*, 2006. 73, 74
- [Mu09] Pengcheng Mu. *Rapid Prototyping Methodology for Parallel Embedded Systems*. PhD thesis, INSA Rennes, 2009. 71, 73, 82, 85
- [MWI<sup>+</sup>09] Christian Mehlführer, Martin Wrulich, Josep Colom Ikuno, Dagmar Bosanska, and Markus Rupp. Simulating the long term evolution physical layer. In *Proc. of the 17th European Signal Processing Conference (EUSIPCO 2009)*, Glasgow, Scotland, August 2009. 27, 124
- [Nez02] J F Nezan. *Integration de services video Mpeg sur architectures paralleles*. PhD thesis, IETR INSA Rennes, 2002. 49
- [Nor09] Terry Norman. The road to LTE for GSM and UMTS operators. Technical report, Analysys Mason, 2009. 11, 12
- [opea] OpenCL. <http://www.khronos.org/opencl/>. 66, 67, 147
- [opeb] OpenMP. <http://openmp.org/wp/>. 66, 67
- [PAN08] Maxime Pelcat, Slaheddine Aridhi, and Jean Francois Nezan. Optimization of automatically generated multi-core code for the LTE RACH-PD algorithm. 0811.0582, November 2008. *DASIP 2008*, Bruxelles : Belgique (2008). 85, 138, 140
- [PBL95] Jos Luis Pino, Shuvra S Bhattacharyya, and Edward A Lee. A hierarchical multiprocessor scheduling framework for synchronous dataflow graphs. *Laboratory, University of California at Berkeley*, pages 95–36, 1995. 53, 55
- [PBPR09] J. Piat, S. S Bhattacharyya, M. Pelcat, and M. Raullet. Multi-core code generation from interface based hierarchy. *DASIP 2009*, 2009. 55, 57, 58, 68, 97, 138
- [PBR09] J. Piat, S. S. Bhattacharyya, and M. Raullet. Interface-based hierarchy for synchronous data-flow graphs. submitted SAMOS conference IX, july 2009. 57, 59
- [Pia10] Jonathan Piat. *Data Flow modeling and multi-core optimization of loop patterns*. PhD thesis, INSA Rennes, 2010. 53, 99
- [PL95] Jose Luis Pino and Edward A Lee. Hierarchical static scheduling of dataflow graphs onto multiple processors. *IEEE International Conference on Acoustics, Speech, and Signal Processing*, pages 2643–2646, 1995. 98
- [PMAN09] Maxime Pelcat, Pierrick Menuet, Slaheddine Aridhi, and Jean-Francois Nezan. Scalable Compile-Time scheduler for multi-core architectures. In *DATE*, 2009. 102

- [PNP<sup>+</sup>09] Maxime Pelcat, Jean Francois Nezan, Jonathan Piat, Jerome Croizer, and Slaheddine Aridhi. A System-Level architecture model for rapid prototyping of heterogeneous multicore embedded systems. *DASIP*, 2009. 108
- [POH09] Hae-Woo Park, Hyunok Oh, and Soonhoi Ha. Multiprocessor SoC design methods and tools. *IEEE Signal Processing Magazine*, 26(6):72–79, 2009. 66, 168
- [pol] PolyCore Software Poly-Mapper tool. <http://www.polycoresoftware.com/products3.php>. 67
- [Pop92] B.M. Popovic. Generalized chirp-like polyphase sequences with optimum correlation properties. *IEEE Transactions on Information Theory*, 38(4):1406–1409, 1992. 33
- [PPW<sup>+</sup>09] Maxime Pelcat, Jonathan Piat, Matthieu Wipliez, Jean Francois Nezan, and Slaheddine Aridhi. An open framework for rapid prototyping of signal processing applications. *EURASIP Journal on Embedded Systems*, 2009. 119, 143
- [Pyn97] R. Pyndiah. Iterative decoding of product codes: block turbo codes. In *Proceedings of the 1st International Symposium on Turbo Codes and Related Topics*, pages 71–79, 1997. 28
- [R1-05] R1-050587 - OFDM radio parameter set in Evolved UTRA downlink, June 2005. 23, 24
- [R1-06a] R1-060039 - adaptive modulation and channel coding rate control for single-antenna transmission in frequency domain scheduling, January 2006. 30, 38
- [R1-06b] R1-062058 - E-UTRA TTI size and number of TTIs, September 2006. 25
- [R1-07] R1-073687 - RB-level distributed transmission method for shared data channel in E-UTRA downlink, August 2007. 38
- [R1-08] R1-081248 - PRS sequence generation for downlink reference signal, April 2008. 40
- [rap] RapidIO. <http://www.rapidio.org/home/>. 138
- [RL06] B. Rihawi and Y. Louet. Peak-to-Average power ratio analysis in MIMO systems. *Information and Communication Technologies, 2006. ICTTA'06. 2nd*, 2, 2006. 21, 23
- [Rum09] M. Rumney. *LTE and the evolution to 4G wireless: design and measurement challenges*. Wiley, 2009. 27
- [RvG99] A. Radulescu and A. J.C van Gemund. On the complexity of list scheduling algorithms for distributed-memory systems. In *Proceedings of the 13th international conference on Supercomputing*, pages 68–75, 1999. 71
- [Sar87] V. Sarkar. *Partitioning and scheduling parallel programs for execution on multiprocessors*. PhD thesis, Stanford, CA, USA, 1987. 120



- [SB09] Sundararajan Sriram and Shuvra S. Bhattacharyya. *Embedded Multiprocessors: Scheduling and Synchronization, Second Edition*. CRC press edition, 2009. 53, 69, 70, 74, 87, 140
- [sdf] SDF4J : Available Online. <http://sourceforge.net/projects/sdf4j/>. 119
- [Sha01] C. E. Shannon. A mathematical theory of communication. *ACM SIGMOBILE Mobile Computing and Communications Review*, 5(1):55, 2001. 18
- [Sin07] Oliver Sinnen. *Task Scheduling for Parallel Systems (Wiley Series on Parallel and Distributed Computing)*. Wiley-Interscience, 2007. 49, 71, 73, 80, 117
- [SLS00] M. Sgroi, L. Lavagno, and A. Sangiovanni-Vincentelli. Formal models for embedded system design. *IEEE Design & Test of Computers*, 17(2):14–27, 2000. 46, 47
- [SLWS99] M. Sgroi, L. Lavagno, Y. Watanabe, and A. Sangiovanni-Vincentelli. Synthesis of embedded software using free-choice petri nets. In *Proceedings of the 36th annual ACM/IEEE Design Automation Conference*, pages 805–810, 1999. 46
- [SPI08] SPIRIT Schema Working Group. IP-XACT v1.4: A specification for XML meta-data and tool interfaces. Technical report, The SPIRIT Consortium, March 2008. 92
- [STB09] Stefania Sesia, Issam Toufik, and Matthew Baker. *LTE, The UMTS Long Term Evolution: From Theory to Practice*. Wiley, 2009. 13, 15, 17, 19, 20, 31, 32, 33, 35, 36, 37, 38, 39, 123, 124, 130, 132, 145
- [Stu07] S. Stuijk. *Predictable Mapping of Streaming Applications on Multiprocessors*. PhD thesis, Technische Universiteit Eindhoven, 2007. 67
- [sys] Open SystemC initiative web site. <http://www.systemc.org/home/>. 65, 102
- [Ten] Tensilica. <http://www.tensilica.com/>. 64
- [The07] B.D. Theelen. A performance analysis tool for Scenario-Aware streaming applications. In *Quantitative Evaluation of Systems, 2007. QEST 2007. Fourth International Conference on the*, pages 269–270, 2007. 68
- [tms07] TMS320TCI6488 DSP platform, texas instrument product bulletin (sprt415), 2007. 80, 106
- [TMS08] TMS320C64x/C64x+ DSP CPU and instruction set reference guide, texas instrument technical document (SPRU732G), February 2008. 126, 127
- [Tre04] R. Trepkowski. *Channel Estimation Strategies for Coded MIMO Systems, MS Thesis*. PhD thesis, Virginia Polytechnic University, Blacksburg, Va., June 2004, 2004. 35
- [w3c] w3c XSLT standard. <http://www.w3.org/Style/XSL/>. 102, 120
- [WEL09] Di Wu, Johan Eilert, and Dake Liu. Evaluation of MIMO symbol detectors for 3GPP LTE terminals. In *Proc. 17th European Signal Processing Conference (EUSIPCO)*, Glasgow, Scotland, 2009. 42



## Résumé

Le standard 3GPP LTE (Long Term Evolution) est un nouveau standard de télécommunication terrestre fournissant des débits sans précédent à des utilisateurs en mobilité. LTE permet des débits de plusieurs centaines de Mbit/s grâce à l'utilisation de technologies avancées. Ces technologies rendent la couche physique du LTE complexe et particulièrement coûteuse en termes de puissance de calcul. Les données émises et reçues par les antennes terrestres de type LTE sont traitées dans des stations de base appelées eNodeB.

Les processeurs de traitement du signal (DSP) sont largement employés dans les stations de base pour calculer les algorithmes de la couche physique. Les DSPs de dernière génération sont des systèmes complexes et hétérogènes incluant plusieurs cœurs et coprocesseurs pour trouver le meilleur compromis entre énergie consommée, souplesse de programmation et puissance de calcul. Il n'existe pas actuellement de solution idéale pour distribuer les parties d'une application comme le LTE sur les différents cœurs contenus dans un eNodeB. La programmation multi-cœurs est encore principalement une tâche manuelle et coûteuse basée sur des méthodes itératives de test et d'optimisation.

Dans cette thèse, nous présentons une méthode de travail pour le prototypage rapide et la génération de code automatique. Cette méthode aide les programmeurs de DSP multi-cœurs en automatisant les phases de conception les plus complexes. Nous utilisons des méthodes basées sur les descriptions d'algorithmes par graphes flux de données et nous proposons un nouveau modèle d'architecture. Nous combinons ensuite des méthodes de la littérature dans un distributeur/ordonnanceur multi-cœurs hors-ligne flexible et évolutif. Certains algorithmes de la couche physique du LTE étant trop variables pour une distribution hors-ligne, nous présentons un distributeur adaptatif capable de faire des choix en temps réel sur la base de temps d'exécution prédits. Enfin, nous appliquons les méthodes précédentes pour étudier le comportement des algorithmes de la couche physique du LTE sur des DSPs multi-cœurs.

## Abstract

The 3GPP Long Term Evolution (LTE) is a new terrestrial telecommunication standard providing unprecedented data rates to mobile users. LTE enables data rates beyond hundreds of Mbit/s by using advanced technologies. The use of these technologies requires highly complex LTE physical layer at the two communication nodes (mobile and base station). An LTE base station, known as an eNodeB, necessitates much power to process the data transmitted and received by the LTE terrestrial antennas.

Digital Signal Processors (DSP) are commonly employed to compute physical layer algorithms in base stations. Modern DSPs are highly complex and heterogeneous systems with several embedded cores and co-processors allowing the best trade-off between power consumption, programmability and computational performance. No ideal solution has been found to automatically assign application parts over the multiple cores contained in an eNodeB. For the majority of cases, multi-core programming is still a manual and time-expensive task based on test-and-refine methods.

In this thesis, we design a rapid prototyping and code generation framework that assists programmers of multi-core DSPs by automating the most complex design phases. We employ methods based on dataflow graph descriptions of algorithms and we develop a new architecture model. We then combine techniques from the literature in a flexible and scalable compile-time multi-core scheduler. As some algorithms of the LTE physical layer are too variable for static assignment, we present a simple adaptive scheduler that computes real-time assignment choices based on predicted execution times. Finally, we employ the resulting framework and adaptive scheduler to study the deployment of LTE algorithms on multi-core DSPs.