



HAL
open science

Development of an ultra-fast X-ray camera using hybrid pixel detectors.

Arkadiusz Dawiec

► **To cite this version:**

Arkadiusz Dawiec. Development of an ultra-fast X-ray camera using hybrid pixel detectors.. Human-Computer Interaction [cs.HC]. Université de la Méditerranée - Aix-Marseille II, 2011. English. NNT : . tel-00631274

HAL Id: tel-00631274

<https://theses.hal.science/tel-00631274v1>

Submitted on 12 Oct 2011

HAL is a multi-disciplinary open access archive for the deposit and dissemination of scientific research documents, whether they are published or not. The documents may come from teaching and research institutions in France or abroad, or from public or private research centers.

L'archive ouverte pluridisciplinaire **HAL**, est destinée au dépôt et à la diffusion de documents scientifiques de niveau recherche, publiés ou non, émanant des établissements d'enseignement et de recherche français ou étrangers, des laboratoires publics ou privés.



CPPM-T-2011-01

UNIVERSITÉ DE LA MÉDITERRANÉE AIX-MARSEILLE II
FACULTÉ DES SCIENCES DE LUMINY

163, avenue de Luminy
13288 Marseille Cedex 09

THÈSE DE DOCTORAT

Spécialité : Instrumentation

présentée par

Arkadiusz DAWIEC

en vue de obtenir le grade de docteur de l'Université de la Méditerranée

Développement d'une caméra X couleur ultra-rapide
à pixels hybrides

Development of an ultra-fast X-ray camera
using hybrid pixel detectors

Soutenue le 4 mai 2011, devant le jury composé de :

Mr Jean-François BERAR	Rapporteur
Mr Jean-Claude CLEMENS	Examineur
Mr Bernard DINKESPILER	Co-encadrant
Mr Wojciech DULINSKI	Examineur
Mr Richard JACOBSSON	Rapporteur
Mr Eric KAJFASZ	Examineur
Mr Christian MOREL	Directeur de thèse

Acknowledgements

I would like to express my gratitude to many people who have helped me and made this thesis possible.

First and foremost I want to thank my thesis supervisor, Professor Christian Morel, leader of the imXgam group, for his motivation, patience and support during my research and thesis-writing times.

I would like to thank my thesis committee: Jean-François Bélar, Jean-Claude Clémens, Bernard Dinkespiler, Wojciech Dulinski, Richard Jacobsson and Eric Kajfasz, for their insightful comments and questions.

My endless gratitude goes to my co-supervisor Bernard Dinkespiler, who was a great mentor, source of knowledge and new ideas. My sincere thanks also goes to Jean-Claude Clémens, who was always open for a fruitful discussion and willing to share his knowledge. It was a real privilege to work with them.

Special thanks goes to Pierre-Yves Duval, for his work on software development, his advices and comments that helped me to finish this project.

I am grateful to Franck Debarbieux who helped me to prepare and conduct a final test of the camera with a mouse. In this place I also wish to express my warm thanks to the members of the imXpad group, for their friendliness and all of the invaluable support that I have received from them during my work.

I would like to thank our synchrotron partners: Stéphanie Hustache, Kadda Medjoubi (SOLEIL), Jean-François Bélar, Nathalie Boudet (ESRF), for their kind support that have been of great value during my studies.

I am indebted to our secretary ladies, Fanny, H el ene and Esthere, for helping me to find my way through all the bureaucratic and administration issues and thus helped me to concentrate on my research.

Last but not least, I wish to thank my family for their support. Especially, I owe my loving thanks to my wife Edyta, without her encouragement and understanding it would not have been impossible for me to finish this work.

Abstract

Title :

Development of an ultra-fast X-ray camera using hybrid pixel detectors.

Abstract :

The aim of the project, of which the work described in this thesis is part, was to design a high-speed X-ray camera using hybrid pixels applied to biomedical imaging and for material science. As a matter of fact the hybrid pixel technology meets the requirements of these two research fields, particularly by providing energy selection and low dose imaging capabilities. In this thesis, high frame rate X-ray imaging based on the XPAD3-S photons counting chip is presented. Within a collaboration between CPPM, ESRF and SOLEIL, three XPAD3 cameras were built. Two of them are being operated at the beamline of the ESRF and SOLEIL synchrotron facilities and the third one is embedded in the PIXSCAN II irradiation setup of CPPM. The XPAD3 camera is a large surface X-ray detector composed of eight detection modules of seven XPAD3-S chips each with a high-speed data acquisition system. The readout architecture of the camera is based on the PCI Express interface and on programmable FPGA chips. The camera achieves a readout speed of 240 images/s, with maximum number of images limited by the RAM memory of the acquisition PC. The performance of the device was characterized by carrying out several high speed imaging experiments using the PIXSCAN II irradiation setup described in the last chapter of this thesis.

Keywords :

Hybrid pixels, XPAD3, photon counting, PCI Express, X-ray imaging, X-ray camera, FPGA

Résumé

Titre :

Développement d'une caméra à rayons X ultra-rapide utilisant des détecteurs à pixels hybrides.

Résumé :

L'objectif du projet, dont le travail présenté dans cette thèse est une partie, était de développer une caméra à rayons X ultra-rapide utilisant des pixels hybrides pour l'imagerie biomédicale et la science des matériaux. La technologie à pixels hybrides permet de répondre aux besoins de ces deux champs de recherche, en particulier en apportant la possibilité de sélectionner l'énergie des rayons X détectés et de les imager à faible dose. Dans cette thèse, nous présentons une caméra ultra-rapide basée sur l'utilisation de circuits intégrés XPAD3-S développés pour le comptage de rayons X. En collaboration avec l'ESRF et SOLEIL, le CPPM a construit trois caméras XPAD3. Deux d'entre elles sont utilisées sur les lignes de faisceau des synchrotrons SOLEIL et ESRF, et le troisième est installé dans le dispositif d'irradiation PIXSCAN II du CPPM. La caméra XPAD3 est un détecteur de rayons X de grande surface composé de huit modules de détection comprenant chacun sept circuits XPAD3-S équipés d'un système d'acquisition de données ultra-rapide. Le système de lecture de la caméra est basé sur l'interface PCI Express et sur l'utilisation de circuits programmables FPGA. La caméra permet d'obtenir jusqu'à 240 images/s, le nombre maximum d'images étant limité par la taille de la mémoire RAM du PC d'acquisition. Les performances de ce dispositif ont été caractérisées grâce à plusieurs expériences à haut débit de lecture réalisées dans le système d'irradiation PIXSCAN II. Celles-ci sont décrites dans le dernier chapitre de cette thèse.

Mots-clés :

Pixels hybrides, XPAD3, comptage de photons, PCI Express, imagerie à rayons X, caméra à rayons X, FPGA

Contents

Introduction	1
1 Physics of X-ray imaging	3
1.1 X-ray interaction with matter	5
1.1.1 Photoelectric effect	5
1.1.2 Scattering	6
1.1.3 X-ray attenuation and filtration	10
1.1.4 Radiation damage	12
1.2 Imaging techniques with X-rays	13
1.2.1 Radiography	14
1.2.2 Crystallography	16
2 Semiconductor pixel detectors	19
2.1 Principle of operation	19
2.1.1 Semiconductors physics	19
2.1.2 Charge collection	27
2.1.3 Signal formation	32
2.1.4 Noise in semiconductor detectors	33
2.2 Semiconductor pixel detectors	34
2.2.1 Charge Coupled Devices (CCD)	34
2.2.2 Monolithic pixel sensor	35
2.2.3 Hybrid pixel detector	38
3 XPAD3 X-ray camera	51
3.1 Introduction	51
3.2 XPAD3 photon counting chip	52
3.2.1 Global architecture	52
3.2.2 Pixel details	53
3.2.3 Modes of operation	55
3.2.4 Global configuration registers	58
3.2.5 Calibration	59
3.2.6 Data transfer	62
3.3 Architecture of the XPAD3 camera	63
3.3.1 Overview	63
3.3.2 Detection modules	65
3.3.3 The HUB board	77
3.3.4 The PCI Express [®] board	85

3.3.5	Software library	97
4	Experimental results	105
4.1	Example of synchrotron source experiments	105
4.1.1	Powder diffraction of a BaTiO ₃ polycrystalline sample	106
4.1.2	Diffraction on an epitaxial GaInAs film grown on GaAs substrate	108
4.2	Fast readout results	109
4.2.1	The PIXSCAN II demonstrator	109
4.2.2	Study of a free falling steel ball	112
4.2.3	Mechanical Swiss watch	119
4.2.4	Mouse angiography	124
	Conclusions and prospects	131
A	PCI Express Configuration Space	135
B	Example of a data acquisition program	137
C	Influence of the Stokes force on a free falling ball	141
D	Relation between the diameter of a circle and its RMS	145
E	Software design tools	147
E.1	Software tools	147
E.2	Programming guidelines	148
	List of Figures	150
	List of Tables	159

Introduction

The progress in X-ray imaging techniques has continued since the time of their discovery by Wilhelm Röntgen at the end of XIXth century. The first application of X-rays was radiography and was initiated with the first public presentation of an X-ray image of the hand of the famous Swiss anatomist Albert von Kölliker, two months after Röntgen's discovery. Shortly after, their use in determining the atomic structure of crystals were discovered, thus initiating a new field of science called X-ray crystallography. Since then, advance in both the fields of X-ray medical imaging and X-ray crystallography depends on the improvement of X-ray sources and X-ray detectors. Currently, CCD detectors that were state-of-the-art at the end of the XXth century cannot fully benefit from new high intense X-ray synchrotron beams. Similarly, detectors that are currently used medical imaging have reached their limits in terms of minimum radiation dose to the patients in order to get images with sufficient contrast and quality. The hybrid pixel technology applied to photon counting is an example of a recent advance applied to X-ray detection. These type of devices offer a quite high signal-to-noise ratio (SNR) at a low radiation dose. Additionally, the possibility to count single photons and to select energies independently in every pixel opens the possibility to perform experiments that were hardly feasible most recently. Moreover, hybrid pixels can be read out much faster than CCDs, and potentially without dead time.

The work presented in this thesis is based on the development of hybrid pixels detectors for X-ray photon counting, which is carried out within the imXgam group at CPPM. The goal of this thesis was to design and develop a high frame rate data acquisition system for the XPAD3 hybrid pixel camera.

The structure of the thesis reads as follows.

Chapter 1 contains a theoretical introduction to the physics of the X-ray radiation. The interactions of X-ray photons with matter are described, as well as the main techniques used in X-ray imaging for biomedical and crystallography applications.

In chapter 2, different designs of semiconductor pixel detectors are discussed. The first part of this chapter includes the physics of the semiconductors that is required to comprehend the concept of semiconductor detectors, whereas in the second part, different architectures of the semiconductor pixel detectors are described.

A detailed description of the architecture of the XPAD3 detector is given in chapter 3. This chapter starts with the description of the XPAD3 photon counting chip, followed by a detailed description of the readout system developed within this work.

Three experiments were carried out to demonstrate and characterize the performance of the the XPAD3 camera. A short data analysis of each of these experiments is given in chapter 4. Moreover, results of two experiments that were carried out at the SOLEIL synchrotron facility are also presented.

Finally, the presentation of this thesis ends with some conclusions and prospects.

Chapter 1

Physics of X-ray imaging

Radiation can be described as emission and propagation of energy through matter. Depending on the level of energy per quanta, and thus on its ability to ionize matter, radiation can be classified either as *non-ionizing* or *ionizing* (see figure 1.1) [74]. Non-ionizing radiation covers all the spectrum of electromagnetic radiation with the frequency below $\sim 10^{15}$ MHz (i.e. near ultraviolet, visible light and radio waves). Ionizing radiation has an energy exceeding the ionization potential of atoms. There are two different types of ionizing radiation, *indirect* and *direct*. Indirect ionization is done in a two-step process: i) release of charged particles by a photon (i.e. an electron or an electron/positron pair) and ii) energy deposition in the atom. Indirectly ionizing radiation covers the electromagnetic spectrum with frequencies above near-ultraviolet ($\sim 10^{15}$ MHz) and neutrons. Directly ionizing

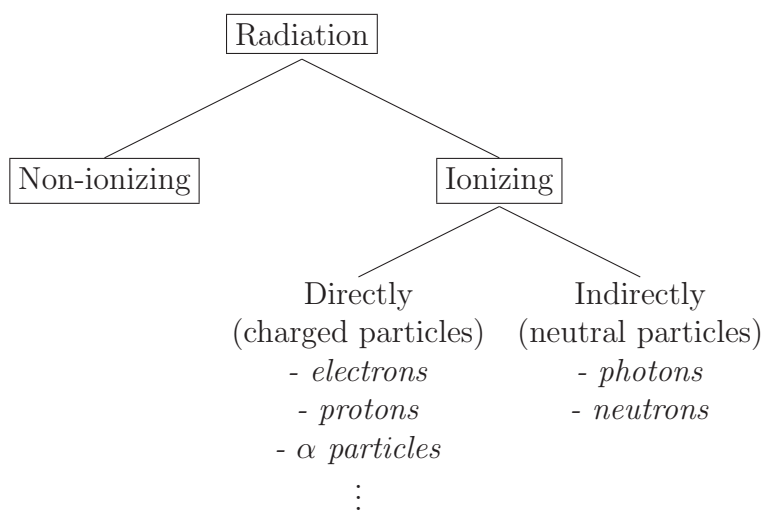

FIGURE 1.1: Classification of radiation [74].

radiation comprises charge particles like electrons, protons, alpha-particles and heavy ions. Charge particles deposit their energy in the absorber through direct Coulomb interaction with orbital electrons of an atom.

X-ray radiation is a form of electromagnetic radiation discovered in 1895 by Wilhelm C. Röntgen. X-rays have a frequency between $3 \times 10^{16} \text{ Hz}$ and $3 \times 10^{19} \text{ Hz}$ (figure 1.2). Thus, according to the formula

$$E = \frac{hc}{\lambda} \quad (1.1)$$

where h is the Planck's constant ($6.626 \times 10^{-34} \text{ J} \cdot \text{s}$), c is the speed of light ($\approx 3 \times 10^8 \text{ m/s}$) and λ is the wavelength, the energy E of X-ray photons varies from 120 eV to 120 keV , which is enough to ionize atoms and molecules [62]. X-rays with a wavelength longer than 1 nm are called *soft* X-rays and those with shorter wavelengths are called *hard* X-rays. The wavelength of hard X-rays is of the order of 1 \AA ($1 \text{ Angstrom} = 10^{-10} \text{ m}$). This length is comparable to atomic sizes, which makes them very useful for diffraction experiments. The most usual sources of X-rays are X-ray tubes, where radiation is produced as a result of deceleration of very fast electrons hitting a solid object (target). The resulting spectrum is composed of two components, a continuous spectrum of X-rays coming from *bremsstrahlung* (braking radiation) and *characteristic X-ray peaks* resulting from direct ionization of shell electrons of the target atoms [50]. Vacancies created in the K-shell of the atom are filled by electrons dropping from the upper shells while emitting X-rays with energies corresponding to the energy difference between

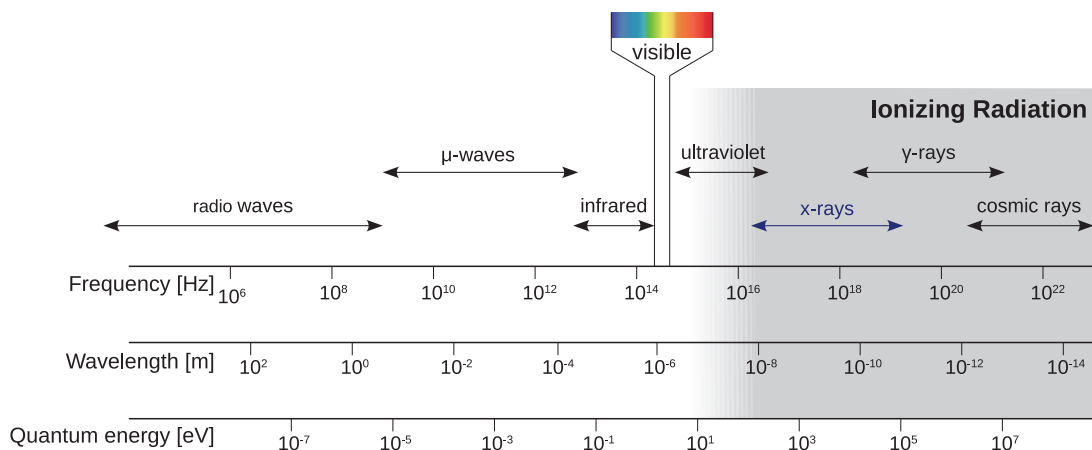

FIGURE 1.2: Spectrum of electromagnetic radiation.

the atomic levels. X-rays produced by transitions from the L-shells are called K_α and those from the M-shells are K_β . The second source of X-rays are synchrotron radiation facilities where accelerated electrons move within circular trajectories. Some electromagnetic devices such as wigglers are also radiating energy in the X-ray domain.

1.1 X-ray interaction with matter

When an X-ray photon is traversing through matter, there are three possible outcomes: i) it can transfer its energy to atoms of the material, ii) it can be scattered, or iii) it can pass through it without interacting. The probability that an interaction occurs is expressed in terms of a *cross section* (σ). The bigger the cross section, the higher the probability of interaction will be. A cross section is expressed in units of *barns*, where 1 *barn* = 10^{-24} cm^2 . The total cross section is the sum of the cross sections of the different possible interactions between the photons and the absorber.

1.1.1 Photoelectric effect

The photoelectric effect results from a collision between the incident photon and an inner-shell electron of an atom (see figure 1.3). During this interaction, the total energy of the photon is transferred to the electron. If the energy of the photon (E_{ph}) is higher than the binding energy of the electron, this electron can be ejected and become a free photoelectron. The kinetic energy of the photoelectron (T_e) is the difference between the photon energy and the electron binding energy ($E_{binding}$).

$$T_e = E_{ph} - E_{binding} \quad (1.2)$$

The photoelectric effect is responsible for the ionization of the atom by creating a vacancy in one of the electron shells. This vacancy is filled by a cascade of electron transitions and emission of characteristic X-rays or Auger electrons with energies corresponding to the difference between the binding energies of the shells. The photoelectric cross section depends on the energy of the X-ray photon. The photoelectric effect is most probable when $E_{ph} \cong E_{binding}$ and decreases with increasing E_{ph} . When the process becomes energetically possible, the probability of interaction suddenly increases and appears as an edge in the cross section curve

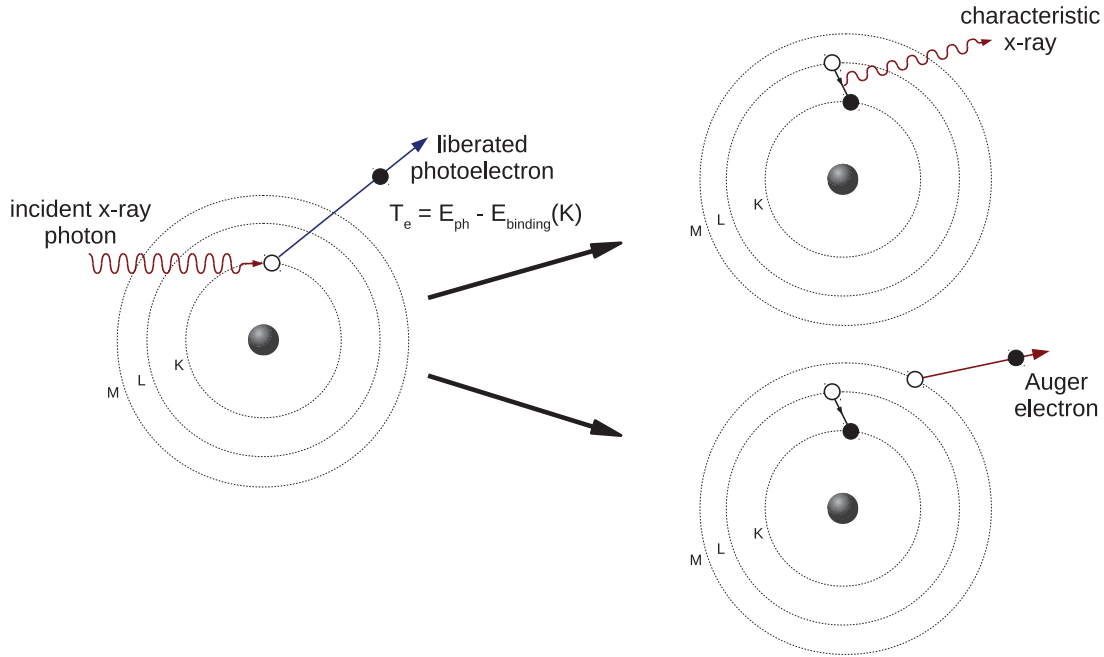

FIGURE 1.3: Photoelectric effect. An X-ray photon with energy E_{ph} interacts with a K shell electron that becomes a free photoelectron with a kinetic energy equals to the difference between E_{ph} and the binding energy of the K -shell electron $E_{binding}(K)$.

(figure 1.4). The edge related to the K -shell at $E_{binding}(K)$ is called K -edge and the ones to the L -shell at $E_{binding}(L)$ L -edges, and so forth.

A good approximation of the photoelectric cross section is given by the equation

$$\sigma \approx \frac{Z^5}{(E_{ph})^{7/2}}, \text{ for } E_{ph} < m_e c^2; \quad (1.3)$$

where Z represents atomic number of the absorber. It can be seen that the photoelectric effect becomes important for high Z atoms and for photons with an energy below 1 MeV , hence it has a large cross section in the range of X-ray energies.

1.1.2 Scattering

A scattering interaction occurs when the direction of an incident photon is altered from its original trajectory. The scattering process may cause energy loss to the photon. In this case, it is called *inelastic scattering*, otherwise it is called *elastic scattering*.

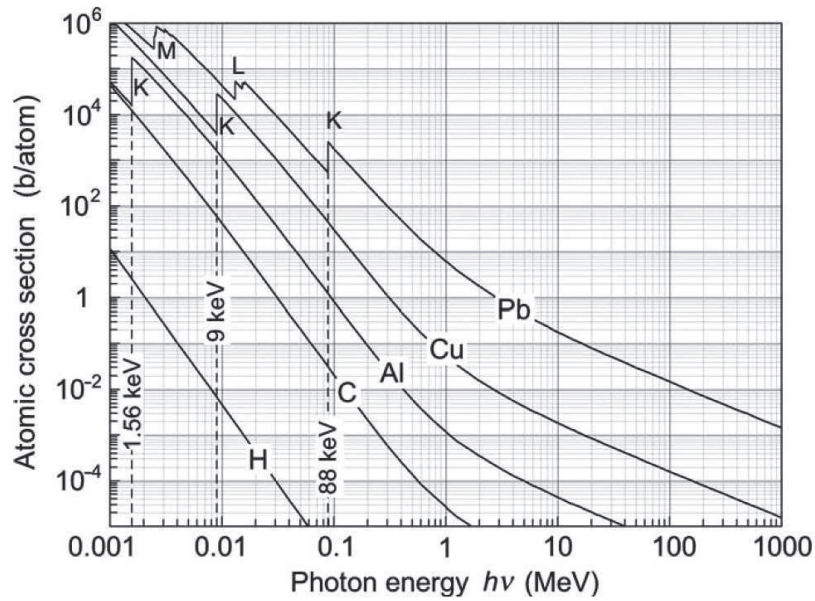

FIGURE 1.4: Cross section of the photoelectric effect for various materials (from [74]).

1.1.2.1 Elastic scattering

Elastic scattering, also called coherent or Rayleigh scattering, is a collision between an X-ray photon and an electron of the target atom. During the interaction, the atom absorbs the change of the momentum and the photon is being scattered with an angle θ (figure 1.5). There are no energy transfers from the incident photon to the absorber: the energies of the scattered and incident photons are the same ($E_{ph} = E'_{ph}$). The scattering angle depends on the energy of the incident

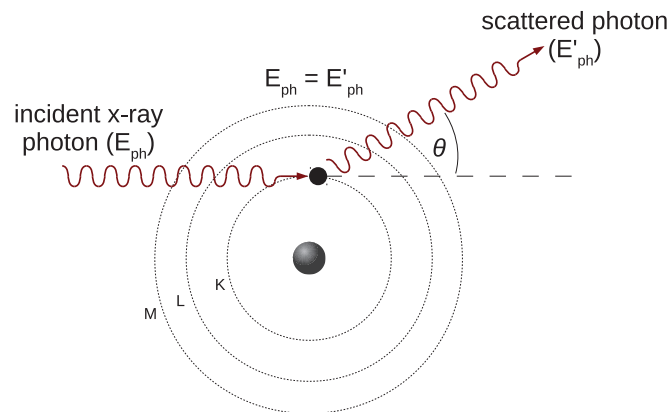

FIGURE 1.5: Elastic scattering.

photon and probability of interaction increases at low scattering angles. Elastic scattering is important for X-rays with low energies and for nucleus with high atomic numbers.

The differential cross section of Rayleigh scattering can be described by the formula

$$\frac{d\sigma_R}{d\Omega} = \frac{r_e^2}{2}(1 + \cos^2\theta)\{F(x, Z)\}^2 \quad (1.4)$$

where $d\Omega = 2\pi \sin\theta d\theta$, which is equivalent to

$$\frac{d\sigma_R}{d\theta} = \pi r_e^2 \sin\theta (1 + \cos^2\theta)\{F(x, Z)\}^2 \quad (1.5)$$

where $F(x, Z)$ is an *atomic form factor* that depends on the momentum transfer $x = \sin(\theta/2)/\lambda$. The square of this component represents the probability that the Z electrons of the absorber atom acquire the photon momentum without absorbing its energy. The atomic form factor decreases from Z towards zero when the scattering angle θ increases.

1.1.2.2 Inelastic scattering

Inelastic scattering takes place when a change of direction is accompanied with a loss of energy by the incident photon. This process is also known as the incoherent or Compton scattering. When an X-ray photon collides with a weakly-bound electron of an atom, it loses part of its energy, which is absorbed by the electron being removed from its shell and becomes a free electron. The mechanism of the interaction is shown in figure 1.6. After scattering, the incident photon with an

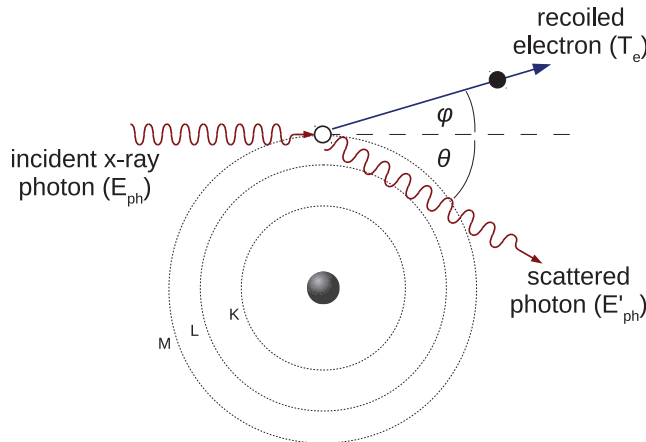

FIGURE 1.6: Compton scattering.

initial energy E_{ph} has become a new photon with a lower energy E'_{ph} and with a direction altered by an angle θ . The photon scattering angle can take values from 0° (forward scattering) to 180° (back scattering). The electron (recoiled or Compton electron) is ejected from its outer shell with a kinetic energy T_e at an angle ϕ from the direction of the initial photon. Both, the scattered photon and the recoiled electron may have enough energy to cause further ionization in the target material.

From the relativistic relationships of the energy and momentum conservation, the energy of the scattered photon (E'_{ph}) as a function of the photon scattering angle θ is expressed by the following formula

$$E'_{ph} = E_{ph} \frac{1}{1 + \alpha(1 - \cos\theta)} \quad (1.6)$$

where

$$\alpha = \frac{E_{ph}}{m_e c^2} = \frac{E_{ph}}{511 \text{ keV}} \quad (1.7)$$

represents the incident photon energy normalized to the rest mass energy of the electron $m_e c^2$. In case of forward scattering, the energy of the photon remains the same ($E_{ph} = E'_{ph}$).

The kinetic energy of the recoil electron is given by the difference between the energies of the incident and scattered photons

$$T_e = E_{ph} - E'_{ph} = E_{ph} \frac{\alpha(1 - \cos\theta)}{1 + \alpha(1 - \cos\theta)} \quad (1.8)$$

For a given incident photon energy, the maximum energy transferred to the Compton electron is when the photon is backscattered ($\theta = 180^\circ$ and $\phi = 0^\circ$).

The electronic cross section of Compton Scattering (${}_e\sigma_C$) on a quasi-free electron was first derived in 1929 by Oscar Klein and Yoshio Nishina [61] and is expressed by the following formula [74]

$${}_e\sigma_C = 2\pi r_e^2 \left\{ \frac{1 + \alpha}{\alpha^2} \left[\frac{2(1 + \alpha)}{1 + 2\alpha} - \frac{\ln(1 + 2\alpha)}{\alpha} \right] + \frac{\ln(1 + 2\alpha)}{2\alpha} - \frac{1 + 3\alpha}{(1 + 2\alpha)^2} \right\} \quad (1.9)$$

where r_e is the classical electron radius ($2.82 \times 10^{-15} m$) and α is the normalized photon energy as in equation 1.7. The ${}_e\sigma_C$ is independent of the atomic number Z of the absorber, since it is a reaction with a quasi-free electron. Therefore, its binding energy can be neglected. The atomic cross section of Compton scattering

$({}_a\sigma_C)$ is proportional to the atomic number of the absorber Z

$${}_a\sigma_C = Z_e\sigma_C \quad (1.10)$$

1.1.3 X-ray attenuation and filtration

Attenuation is the reduction in the intensity of an X-ray beam resulting from the absorption or the scattering of the X-ray photons after travelling through matter. The intensity of an attenuated monochromatic beam of energy E is given by the equation

$$N = N_0 e^{-\mu(\delta, E, Z)x} \quad (1.11)$$

where N_0 is the intensity of the incident beam, μ is the linear attenuation coefficient for a material with an atomic number Z and x is the thickness of the material. N represents the number of photons that have passed through the material without interacting. With high energy X-rays and thin, low Z absorbers, no interactions are often the most probable case. The linear attenuation coefficient is expressed in inverse length units (cm^{-1}) and is dependent on the density of the absorber δ . Therefore, more often a mass attenuation coefficient $\mu_m = \mu/\delta$ is used, since it is independent from the density. It is expressed in units of cm^2/g . The mass attenuation coefficient is related to the probability of the interaction per mass unit. Therefore it can be expressed as a cross section using following relationship

$$\mu_m = \sigma \frac{N_A}{A} \quad (1.12)$$

where N_A is Avogadro's number ($6.022 \times 10^{23} atom/mol$) and A is atomic mass. The total mass attenuation coefficient $\mu_{m, total}$ is the sum of the attenuation coefficients for all the different types of photon interactions:

$$\begin{aligned} \mu_{m, total} &= \mu_{m, ph} + \mu_{m, C} + \mu_{m, R} \\ &= (\sigma_{ph} + \sigma_C + \sigma_R) \frac{N_A}{A} \end{aligned} \quad (1.13)$$

where $\mu_{m, ph}$, $\mu_{m, C}$, $\mu_{m, R}$ are the mass attenuation coefficients for the photoelectric effect, the Compton and the Rayleigh scatterings, and σ_{ph} , σ_C and σ_R are the corresponding cross sections. In figure 1.7, the relative percentages of photon interactions with water are shown as a function of the photon energy. It can be seen that in the lower energy range, the photoelectric effect is dominant, whereas

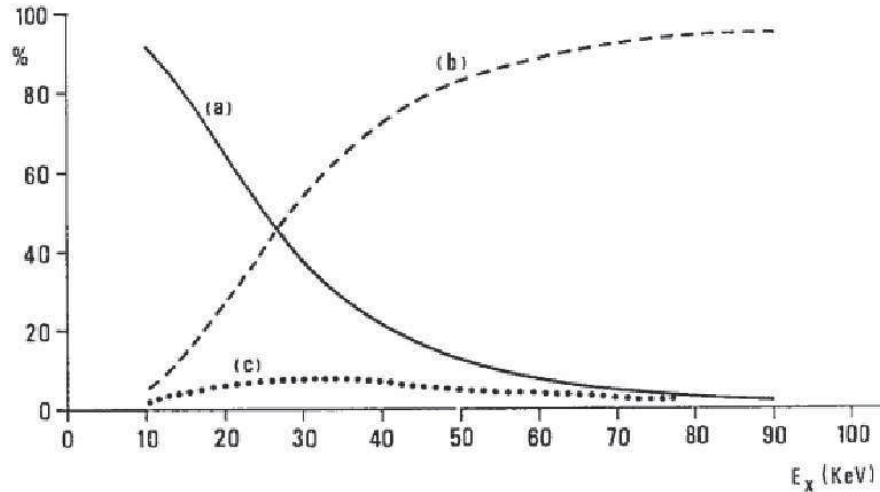

FIGURE 1.7: Relative percentages of photon interactions with water as a function of energy for three different processes: a) photoelectric effect, b) Compton scattering and c) Rayleigh scattering (from [15]).

in the higher energy range, Compton scattering contributes to most of the attenuation. The Rayleigh scattering is an elastic interaction and does not contribute significantly to the total attenuation whatever the energy of the photon.

The spectrum of X-rays generated from an X-ray tube comprises soft X-rays that are ineffective in terms of imaging for the purpose of medical radiography, but are nonetheless absorbed by the imaged object and thus contribute to the total radiation dose absorbed by the patient. Therefore soft X-rays are selectively removed from the spectrum by using a sheet of metal placed between the X-ray source and

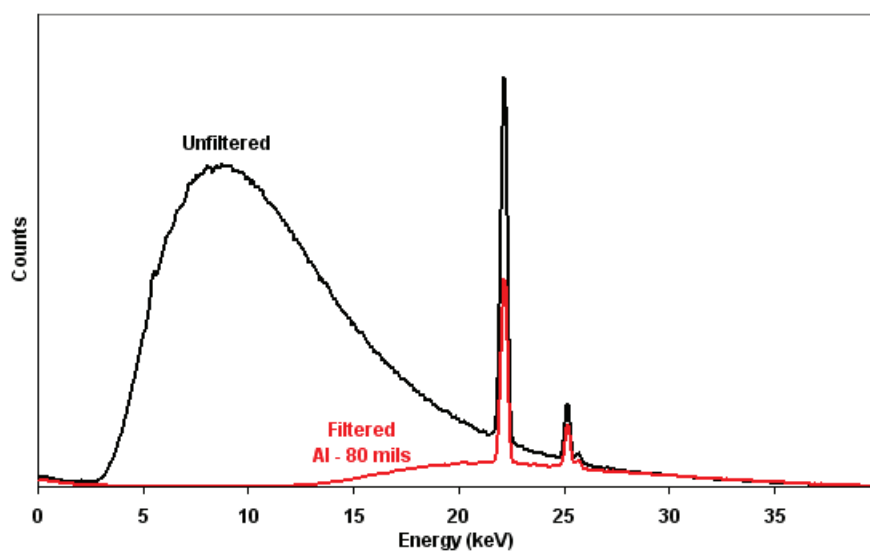

FIGURE 1.8: X-ray spectra with (red) and without (black) 2 mm aluminium filtering.

the object. This piece of additional material attenuates the X-ray beam predominantly within this useless part of the spectrum. Most often, aluminium (Al with $Z = 13$) or glass (SiO_2 with $Z = 14$) filters are used, which attenuate almost all X-rays with energies below 15 keV . In figure 1.8, spectra of the beam are shown before and after filtration with 2 mm of aluminium. It can be seen that most of the low energetic photons have been cut off from the original spectrum.

1.1.4 Radiation damage

Effects caused by the X-ray radiation have a cumulative nature and are related to the energy deposited in the absorber during irradiation, which may lead to malfunctioning of electronics devices or damages in biological tissues. Two radiation dose figures are used to measure the magnitude of radiation exposure, *equivalent dose* for biological tissues and *absorbed dose* for other media. The absorbed dose is defined by the amount of the energy deposited in the media per absorber unit mass and is expressed in SI units in *Gray* (Gy)

$$1\text{ Gy} = \frac{1\text{ J}}{1\text{ kg}} \quad (1.14)$$

The equivalent dose depends on the deposited energy, but also on the nature of the particle that loses its energy in the traversed distance. It is defined by a quality factor Q . Hence, equivalent dose is the product of absorbed dose multiplied by the factor Q , and is expressed in SI unit in *Sievert* (Sv). In case of X-rays the quality factor Q is equal to 1.

The main effects caused by X-rays in electronics devices are due to energy deposition in the insulator region (silicon dioxide, SiO_2) of the transistors, which leads to a degradation of the performance or damages of the device. As a result of the ionization caused by an incident particle, e-h pairs are created in the SiO_2 region. Parts of the pairs do not recombine after interaction and start to drift under the presence of an electric field, as shown in figure 1.9. This leads to two parasitic effects: i) hole trapping in the insulator causing charge buildup in the region and ii) rise of the defects in the interface region between silicon and silicon dioxide, $Si - SiO_2$. The defects in the interface regions are traps in the boundary region between different materials where charge may get blocked, thus changing the energy distribution in the region, i.e. introduces new energy levels in the band gap in the $Si - SiO_2$ region. Numerous traps are created during the fabrication process and ionization activates them or induces new ones. These two effects,

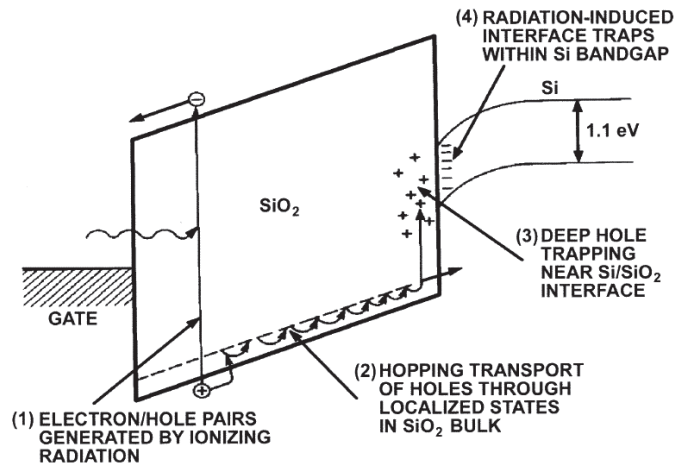

FIGURE 1.9: Schematic drawing of the effects caused by ionizing radiation in MOS devices (from [65]).

charge buildup in the silicon dioxide and interface defects, modify the threshold voltage of the transistor that causes failures or at least malfunction of the device. In addition to this, the first effect (holes trapping in the insulator) may lead to the creation of parasitic channels in NMOS transistors, thus resulting in a rise of the leakage current in the device. Holes trapped in the dioxide region can be released by increasing the temperature, which increases its mobility (this process is called *annealing*).

1.2 Imaging techniques with X-rays

Almost since they were discovered, X-rays were found to be useful as a messenger reporting on the internal structure of solid object. The two main applications of X-ray imaging are radiography, spectroscopy and crystallography.

Radiography is a transmission based technique with which X-ray photons pass through the investigated object and are detected by the detector. The resulting image reflects the intensity of the beam after passing through the studied object. This projection carries information on the total mass attenuation of the object along the direction of the rays. This technique is nowadays a primary method used in medical imaging diagnostic as well as in industrial applications (e.g. homeland security, product inspection).

X-ray spectroscopy is based on the measurement of the absorption cross-section in the region of absorption edges. This technique allows to study structures and

properties of various materials (e.g. liquids, crystals, doped materials for electronics). Crystallography is a technique that allows to reconstruct the arrangement of the atoms in a crystal by striking it with an X-ray beam and analysing the pattern created by the scattered photons.

In this chapter, selected techniques that are interesting from the perspective of the use of the XPAD3 X-ray camera will be presented in more details.

1.2.1 Radiography

The two principal techniques of X-ray radiological imaging are radiography and computed tomography. The images produced by conventional radiography result from a 2D conical projection of a 3D object, as depicted in figure 1.10. This projection image is sometimes difficult to interpret. Computed tomography (CT) is using many of the projections regularly sampled all around the object to reconstruct slices through the object.

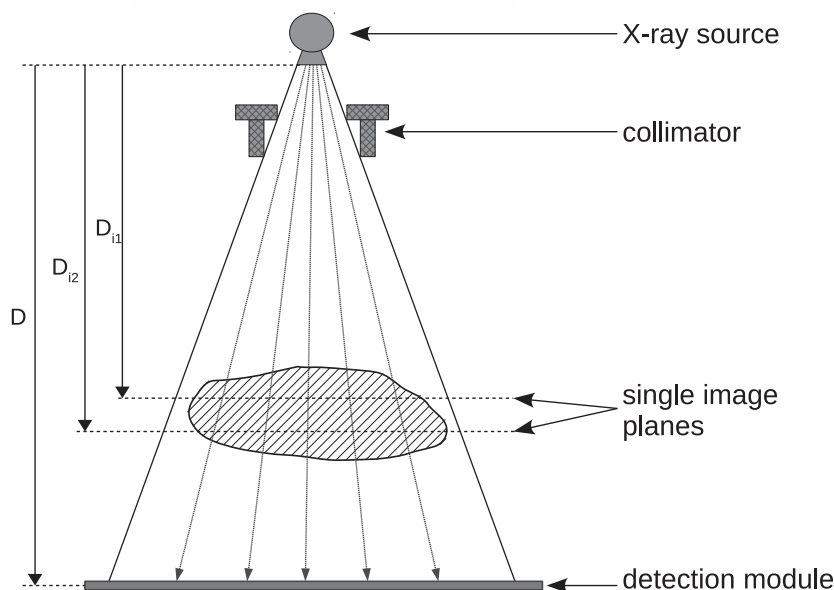

FIGURE 1.10: Principle of planar X-ray radiography.

1.2.1.1 Computed tomography

X-ray CT was invented by Godfrey N. Hounsfield, and the first CT scanner was built by him in 1972 at EMI Central Research Laboratories (*Electric and Musical*

Industries Ltd.). Later on, in 1979, he was awarded the Nobel Prize in Medicine jointly with Allen M. Cormack for the development of computer assisted tomography. Computed tomography is based on the acquisition of multiple 1D fan beam or 2D cone beam projections of thin slices of the object at different angles all around the object. In most common CT scanners, the X-ray source (X-ray tube) and the detector rotates around an object as depicted in figure 1.11. The reconstruction of CT slices makes it possible to visualize the object in different planes (e.g. axial, coronal or sagittal). However, a crucial limitation of CT scanning was the data collection time directly impacting the radiation dose absorbed by the patient. In order to reduce it and eventually the radiation dose, different architectures of scanners were studied and developed. Some of them are multi-slice scanners (to record a few slices at a time thanks to a small axial opening of the fan beam), spiral scanners (in which the object is linearly transported through the beam while the X-ray tube and the detector array are continuously rotated around the object) or scanners with multiple X-ray sources and a complete detector ring (to achieve simultaneous scans from different angles and/or at different energies).

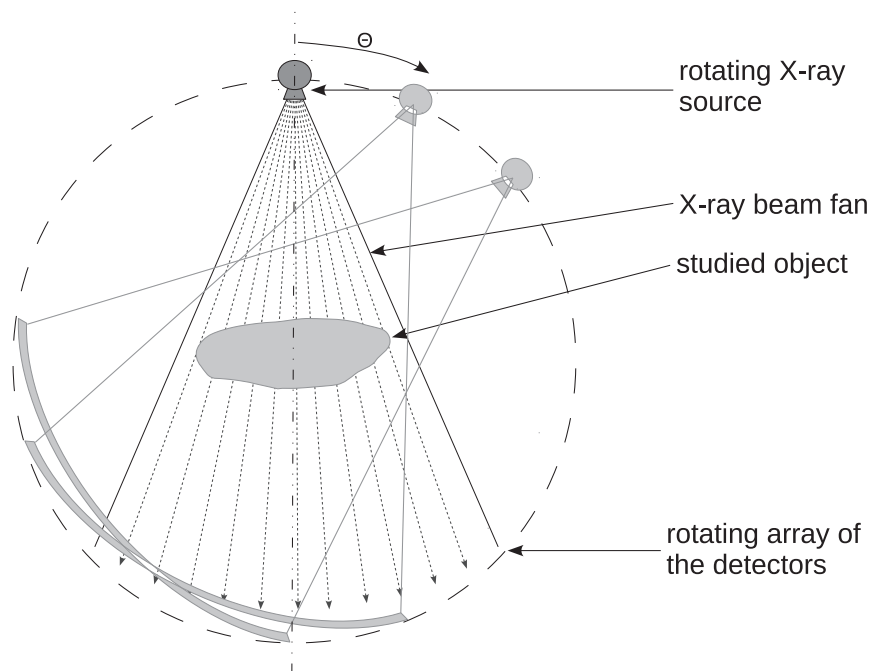

FIGURE 1.11: Slice view of the CT scanner.

One progress in CT imaging that is of particular interest for the work presented in this thesis is cone beam CT (CB-CT). In opposition to standard scanners, CB-CT uses a cone shaped X-ray beam with full opening as depicted in figure 1.12, which allows to scan the full volume of interest at once. The main technological

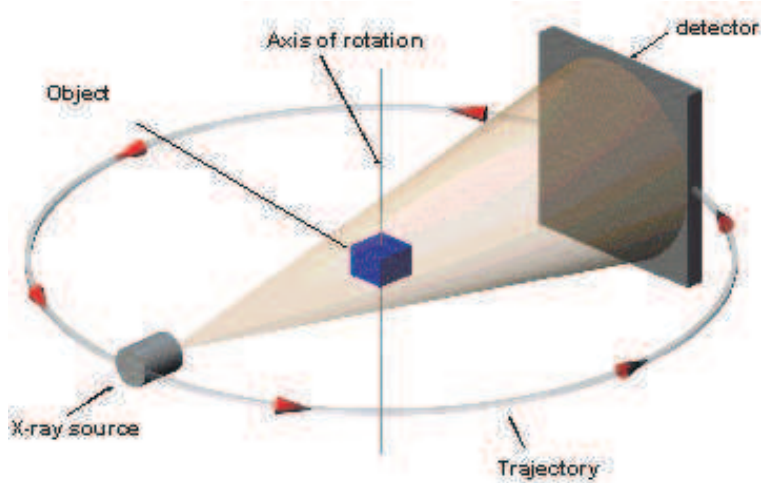

FIGURE 1.12: Schematic view of a CT scanner with cone shaped X-ray beam.

challenges in CB-CT are the big surface of the X-ray detector together with the very fast data readout. Since an image of a single projection is created at once, there is a huge amount of data emerging from the detector for each projection that has to be transferred to the computer as fast as possible in order to perform a full scan in a minimum time.

1.2.2 Crystallography

In crystallography, X-ray radiation is used to reconstruct the internal structure of a crystal. In opposition to radiography, elastic interaction between X-ray photons and molecules allows to detect the arrangement of atoms in a crystal lattice. The measurement of diffraction angle on the crystal sample provides information about the spacing of atomic planes in the crystal.

The diffraction of a monochromatic X-ray beam on the crystal atomic planes oriented at an angle θ respective to the beam is illustrated in figure 1.13. X-rays diffracted on the plane p_0 travel a distance which is shorter than those diffracted on the consecutive planes ($p_1 \dots p_n$). The difference in this distance between two consecutive planes is expressed by

$$\Delta x = \Delta x_1 + \Delta x_2 = 2d \sin\theta \quad (1.15)$$

If this distance Δx is a multiple of the incident beam wavelength, then a constructive interference of the diffracted waves occurs. In other cases, diffracted waves interfere with different phases and a destructive interference takes place. This

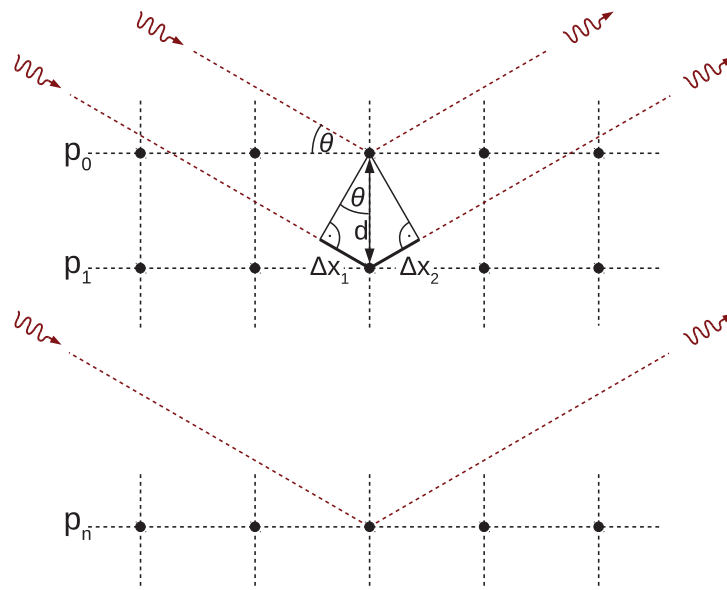

FIGURE 1.13: X-rays diffracted on a crystal lattice.

effect is known as the Bragg's law for X-ray diffraction

$$n\lambda = 2d \sin\theta \quad (1.16)$$

where d is the distance between the planes, λ is the wavelength of the X-rays and θ is the angle of diffraction. By changing the orientation of the crystal sample, it is possible to expose another diffraction plane of the crystal and hence to reconstruct finally the three-dimensional structure of the sample. Characteristic diffraction patterns comprise discrete spots (*Laue spots*) of high intensities created by coherent interference of X-rays diffracted on parallel planes. The only condition is that the distance between two planes has to be greater than half of the X-ray wavelength (for $d < \lambda/2 \Rightarrow \sin\theta > 1$). An example of X-ray diffraction on a protein sample is shown in figure 1.14.

1.2.2.1 Powder diffraction

By using a polycrystalline powder instead of a single crystal, the randomly organized small crystals of the powder provide every possible atomic plane orientation that fulfil the Bragg's condition. Each group of reflecting planes diffracts X-rays with the same angle, thus giving rise to a number of diffraction cones (Debye cones) as depicted in figure 1.15a. The resulting pattern is composed of diffraction rings

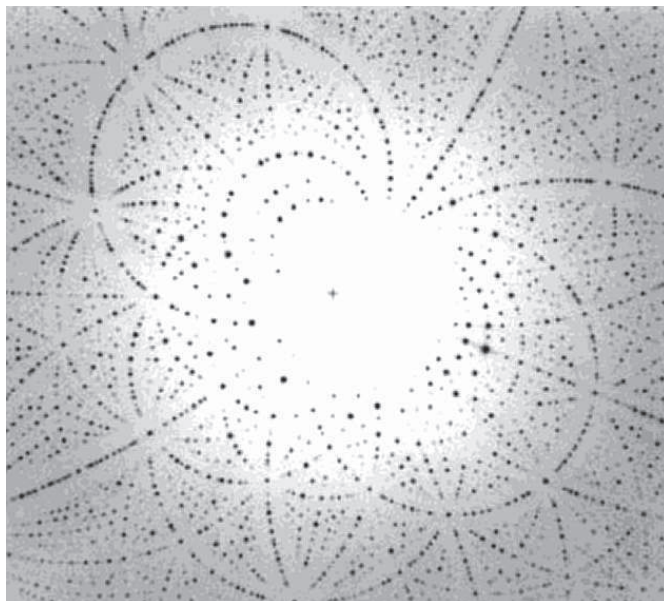
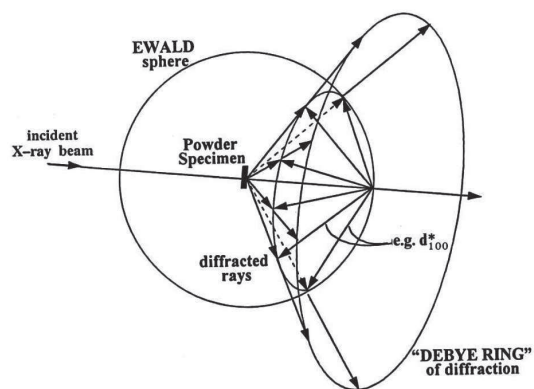
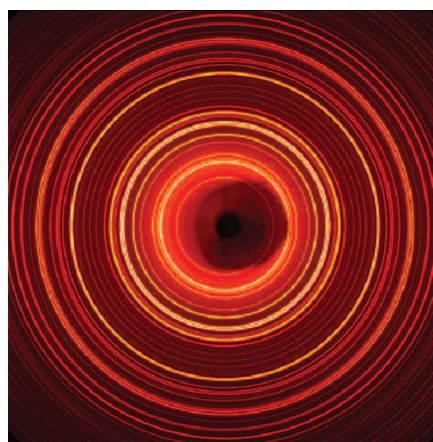

FIGURE 1.14: Laue spots as a result of X-ray diffraction on a protein sample (from [3]).

centred on the beam axis, each of them being composed of indistinguishable Laue spots that form a continuous line (figure 1.15b).



a)



b)

FIGURE 1.15: (a) View of the Debye cone resulting from X-ray diffraction on a polycrystalline sample and (b) the resulting diffraction pattern (from [49],[99]).

Chapter 2

Semiconductor pixel detectors

Position sensitive detector provide an information on the impact position of a particle. They have been intensively developed in the last decades and can be found presently in many applications related to radiation detection. Pixel detectors can offer high spatial resolution and thus are widely used in medical application, crystallography and tracking vertex detectors in High Energy Physics (HEP).

In the semiconductor radiation detectors, signal arises from a charge generated by an incoming particle. The collected charge is further processed by the frond-end electronics. The read-out electronics may be either a separated chip connected to the detector (strip or pixel hybrid detector), or it may be integrated on the same substrate as the detector (e.g. monolithic pixel detectors or charge coupled devices).

2.1 Principle of operation

2.1.1 Semiconductors physics

To understand the, principle of semiconductor detectors a primary knowledge on semiconductor physics is required. In this section, selected aspects necessary to comprehend operation of semiconductor pixel detectors will be discussed.

2.1.1.1 Energy band model

The electrical parameters of solid materials can be described using the energy band model. The band theory assumes that in a condensed materials, such as crystals, electrons can occupy energy levels grouped in *bands*. In a solid material composed of N closely spaced atoms, electrons of an adjacent atom are reciprocally influenced. The discrete energy levels of each individual atom do not remain, but become grouped in *bands* (formed by many closely spaced energy levels of single atoms). Allowed energy bands are separated by a *forbidden band*, which consists

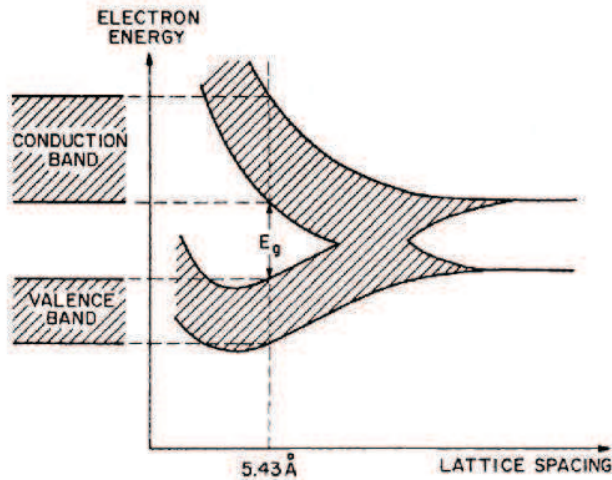

FIGURE 2.1: Energy levels of silicon atoms as a function of lattice spacing (from [64]).

in energy levels that are not available for electrons. Energy levels as a function of lattice spacing for silicon are shown in figure 2.1. At large distances, atoms have the same energy levels. As lattice spacing decreases, these levels start to form energy bands. Within a given material, two distinct energy bands are important to determine its electrical properties. The highest completely filled energy band at a temperature of 0 K is called *the valence band*. The band placed above, partially filled or empty, is called *the conduction band*. In order to bring the material into a conduction state, electrons needs to move by changing their quantum state. Therefore this movement is possible only towards the unfilled conduction band. In figure 2.2, three types of materials depending on their electrical properties are presented. In the case of a wide forbidden gap, electrons from the valence band cannot acquire enough energy to jump to the conduction band in order to contribute to conduction. Such material is an insulator. In the case of a conductor, the valence and conduction bands overlaps, or the conduction band is partially filled. In both cases, many vacant states are available for electrons. The third group

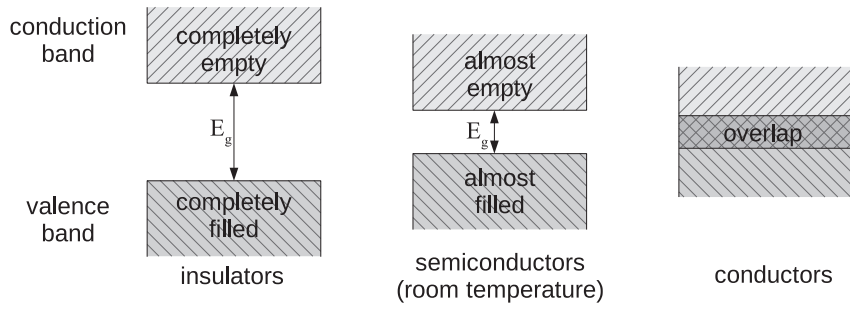

FIGURE 2.2: Different types of materials depending on the energy band structure (E_g - forbidden gap).

of materials in figure 2.2, the semiconductors, have a relatively small forbidden gap with an empty conductive band and a filled valence band at low temperature. However, thermal excitation at room temperature is sufficient to transfer a few electrons to the conduction band, thus leading to a weak conductivity. Two types of semiconductors depending on their band gap structure are recognized. These are the *direct-band* and the *indirect-band* semiconductors. When an electron, due to excitation, is promoted from the valence to the conduction band, one needs to care about momentum conservation. In the case of a direct-band semiconductor,

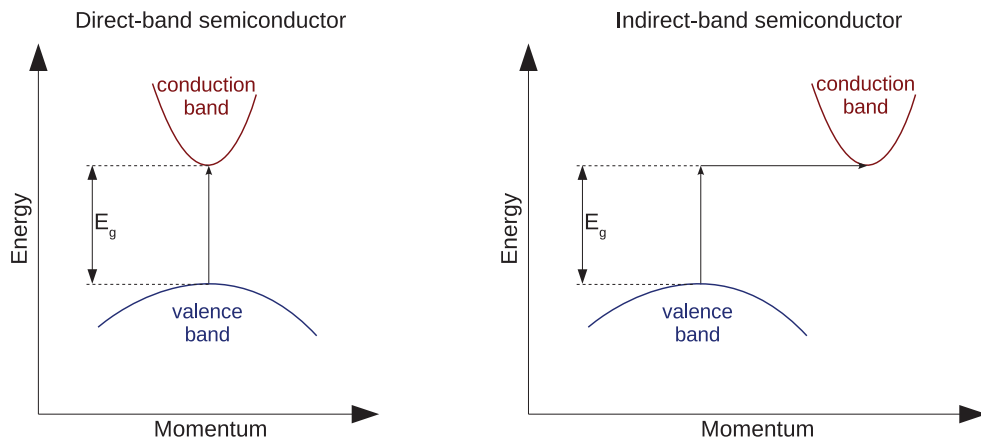

FIGURE 2.3: Direct-band and indirect-band types of semiconductors.

the highest state of the valence band and the lowest state of the conduction band have the same momentum (figure 2.3). For indirect-band semiconductors, besides energy, an electron needs to change its momentum in order to pass through the band gap. In most of the cases, this is done with phonon assistance.

2.1.1.2 Intrinsic and extrinsic semiconductors

Intrinsic semiconductors contain a negligible concentration of impurities compared to thermally generated electrons and holes. Each electron, thermally elevated from the valence band to the conduction band, leaves a hole behind it. In an intrinsic semiconductor, the numbers of generated holes and electrons are approximately the same. The density of free electrons, n , and of holes, p is given by

$$n = N_C e^{-\frac{E_C - E_F}{kT}} \quad (2.1)$$

$$p = N_V e^{-\frac{E_F - E_V}{kT}} \quad (2.2)$$

where N_C , N_V are the effective densities of energy states in the conduction and valence bands, E_C and E_V are the energy levels of the conduction and valence bands, k is the Boltzmann constant and T is the absolute temperature. E_F is the Fermi level, which corresponds to the energy at which the probability of occupation for an electronic state is one half. The product of electron and hole concentrations is given by

$$np = n_i^2 \quad (2.3)$$

where n_i is the intrinsic carrier density. The relation 2.3 is called the *mass action law*. For intrinsic semiconductors, the Fermi level is derived from the assumption that the numbers of electrons and holes are equal $n = p = n_i$ and expressed by

$$E_i = \frac{E_C + E_V}{2} + \frac{3kT}{4} \ln \left(\frac{m_p}{m_n} \right) \quad (2.4)$$

where m_p and m_n are the effective masses of holes and electrons. The intrinsic Fermi level E_i is located in the middle of the forbidden gap, since the deviation due to the second term of the sum is only of the order of 0.01 eV.

Intrinsic semiconductors are rather weak conductors, because this property depends strongly on the purity of the material and on its temperature. The improvement of the conductivity of a semiconductor is obtained by doping, which consists in adding small amounts of impurities to the material. Impurities replace crystal lattice atoms, thus introducing new energy levels in the forbidden gap of the material. Doped semiconductors are called *extrinsic*. The doping material is chosen in such a way that it has a different number of valence electrons than a semiconductor atom, thus adding new electrons or holes (figure 2.4). Dopants that bring extra electrons are called *donors* and those that bring extra holes *acceptors*. In case of donors, the introduced energy level is very close to the conduction

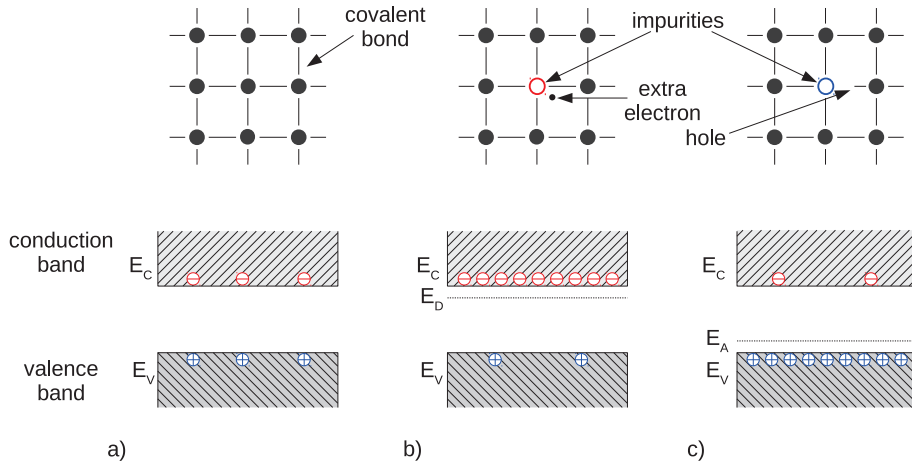

FIGURE 2.4: Crystal lattice bond structure (top) and energy band model (bottom) of (a) intrinsic, (b) n-type and (c) p-type semiconductors.

band. At room temperature, all donor states are ionized and all donor electrons are transported to the conduction band. Hence, the concentration of electrons, n , is equal to the concentration of donor atoms, N_D . Therefore, donor doped materials are called *n-type* semiconductors. Similar considerations can be made, for acceptor type dopants. In that case, an additional energy level is placed close to the valence band. In order to create a valence band with crystal atoms, acceptors will trap an electron from the valence band, thus leaving a hole behind them. The concentration of created holes, p , is equal to the concentration of acceptor atoms, N_A . Acceptor doped materials are called *p-type* semiconductors. In both cases, the intrinsic Fermi level is shifted towards the conduction or the valence bands for donors or acceptors, respectively. New energy levels are expressed by

$$E_F = \begin{cases} E_i + kT \ln \left(\frac{N_D}{n_i} \right), & \text{donor dopant} \\ E_i - kT \ln \left(\frac{N_A}{n_i} \right), & \text{acceptor dopant} \end{cases} \quad (2.5)$$

According to the *mass action law* (eq. 2.3), the increase of majority carriers (electrons in n-type materials and holes in p-type materials) is accompanied with a decrease of minority carriers.

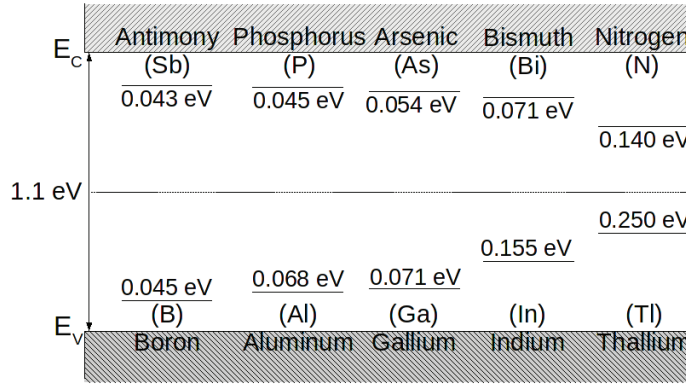

FIGURE 2.5: Change of the silicon band gap depending on the material used as a donor or an acceptor.

As an example, the band gap modulation of silicon with different types of dopant materials [64, 78] is shown in figure 2.5. Silicon have four valence electrons, hence acceptor materials from the boron group with three valence electrons are used, and materials from the nitrogen group with five valence electrons are used as a donors.

2.1.1.3 Charge generation and recombination

There are two main mechanisms of charge generation in a semiconductor: thermal excitation and charge particle interaction. The energy needed to promote an electron from the valence to the conduction band strongly depends on the type of semiconductor and on its energy gap (table 2.1). Thermal generation is often a parasitic process that leads to a rise of *leakage current* in radiation detectors,

	Si	CdTe	Ge	GaAs
Atomic Number Z	14	48 (<i>Cd</i>) 52 (<i>Te</i>)	32	31 (<i>Ga</i>) 33 (<i>As</i>)
Density [g/cm^3]	2.33	6.2	5.32	5.32
Energy gap [eV]	1.12	1.4	0.66	1.424
Energy/e-h pair [eV]	3.62	4.4	2.9	4.2
Intrinsic resistivity [Ωcm]	320000	$\approx 10^9$	50	3.3×10^8
Electron mobility [$cm^2/(Vs)$]	1450	1000	3900	8500
Hole mobility [$cm^2/(Vs)$]	450	80	1900	400
Electron lifetime [s]	10^{-4}	10^{-6}	10^{-4}	10^{-8}
Hole lifetime [s]	10^{-4}	10^{-6}	10^{-4}	10^{-8}

TABLE 2.1: Properties of different semiconductors at a temperature of 300 K (from [64],[83]).

and hence to signal degradation. Thus, for several materials with a small energy gap, such as germanium (Ge), it is necessary to operate them at low temperatures in order to decrease the influence of leakage current. In radiation detectors, the signal comes from the ionization by the impinging particle. Depending on the type of radiation, the shape of ionization paths are different, involving sometimes secondary processes. In case of X-rays, many electron-hole pairs are generated in a small spatial region around the interaction point. The number of electron-hole pairs, N , may be estimated from the energy needed to generate one electron-hole pair given by $N = E_{xray}/E_{e-h}$.

The thermal generation rate is independent from the concentration of donors and acceptors and is given by $G_{th} = n_i/\tau_g$, where τ_g is the generation lifetime. Under a thermal equilibrium, a continuous balance between generation and recombination of electron-hole pairs occurs, $G_{th} = R_{th}$, according to the mass action law (equation 2.3). Depending on the type of semiconductor, the thermal recombination rate is limited by the concentration of minority charge carriers, i.e. $R_{th} = p/\tau_{rn}$ for n-type semiconductors and $R_{th} = n/\tau_{rp}$ for p-type semiconductors. Factors τ_{rn} and τ_{rp} are recombination lifetimes in n- and p-type semiconductors. The excess of carriers created by radiation or injection disturbs this equilibrium. When the external stimulus is stopped, an equilibrium state will be eventually reached by the process of recombination regulated by the lifetime of excess minority carriers τ_r . On the other hand, if all charge carriers are removed from the semiconductor (e.g. by applying an external voltage), thermal generation will be the dominating process while the recombination rate will be very low. The equilibrium state will be reached again with a time constant determined by the generation lifetime τ_g . The above explanation is valid for direct semiconductors. In case of indirect materials, processes of generation and recombination are significantly different. The probability of direct band-to-band recombination in indirect semiconductors

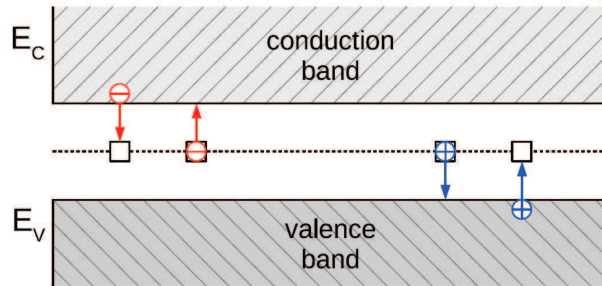

FIGURE 2.6: Mechanisms of generation and recombination through energy states in the forbidden gap.

is very small due to different crystal momentum between electrons of the conduction band and holes of the valence band (see figure 2.3). Recombination occurs as a step process that involves emission/capture of electrons/holes into intermediate energy states in the forbidden gap called *generation/recombination* centers. Generation/recombination centers consist of semiconductor defects or impurities. Mechanism of charge carrier trapping and emission are shown in figure 2.6.

2.1.1.4 Charge carriers transport

Motion of free charge carriers occurs through scattering on crystal lattices and impurities. This results in random direction movements. Hence, there are no net displacements at thermal equilibrium. In that case, we are dealing with a thermal motion defined by the mean free time between collisions τ_c , and by the velocity acquired between collisions v_{th} . The characteristic length of thermal motion is $l_{th} = v_{th}\tau_c$. Typically, at room temperature (300 K), $\tau_c \approx 10^{-13} - 10^{-12}$ s, $v_{th} \approx 10^7$ cm/s and $l_{th} \approx 100$ Å.

An electric field, E , applied to the semiconductor causes acceleration of the carriers in the direction defined by the electric field. The motion of charge carriers caused by the electric field is called *drift current*. During a mean free time, τ_c , carriers gain a velocity defined by

$$v_{drift} = \begin{cases} -\frac{qE}{m_n}\tau_c = -\mu_n E, & \text{for electrons} \\ \frac{qE}{m_p}\tau_c = \mu_p E, & \text{for holes} \end{cases} \quad (2.6)$$

where μ_n and μ_p are the mobility of electrons and holes. An increase of the electric field induces a saturation of the carriers velocity. These parameters strongly depend on the temperature and doping concentration. Carriers mobility for different materials are collected in table 2.1. The drift current density is given as follows

$$J_{drift} = \begin{cases} -qn v_{drift,n} = -qn\mu_n E, & \text{for electrons} \\ qp v_{drift,p} = qp\mu_p E, & \text{for holes} \end{cases} \quad (2.7)$$

The diffusion current arises in the presence of an inhomogeneous gradient distribution of free charge carriers. The diffusion current has a direction opposite to the concentration gradient, since the carriers move predominantly from the region of higher concentration towards the region of lower concentration. The diffusion

currents for the two types of carriers are given by

$$J_{diff} = \begin{cases} qD_n \nabla n, & \text{for electrons} \\ -qD_p \nabla p, & \text{for holes} \end{cases} \quad (2.8)$$

where D_n and D_p are the diffusion coefficients for electrons and holes. Diffusion coefficient and mobility are related through the *Einstein relationship*

$$\frac{D_n}{\mu_n} = \frac{D_p}{\mu_p} = \frac{kT}{q} \quad (2.9)$$

where the fraction kT/q is known as the thermal voltage and is equal to 25 mV at 300 K .

The total current for one type of carriers is the sum of the diffusion and drift currents:

$$\begin{aligned} J_n &= J_{drift,n} + J_{diff,n} = qn\mu_n E + qD_n \nabla n \\ J_p &= J_{drift,p} + J_{diff,p} = qp\mu_p E - qD_p \nabla p \end{aligned} \quad (2.10)$$

and the total current in the semiconductor is given by

$$J_{total} = J_n + J_p \quad (2.11)$$

2.1.2 Charge collection

The charge in a semiconductor detector originates from direct ionization caused by a traversing particle. The electron-hole pairs created during this process are separated by the presence of an electric field across the active volume. In order to limit the leakage current in the device, different sensor structures are implemented depending on the material. For low band gap materials, like silicon, a junction is required in order to limit leakage current at room temperature. A commonly used structure for this type of semiconductor is the reversed biased p-n junction with a depleted region acting as an active volume for signal detection. For other materials with inherent high resistivities, e.g. diamond, a simple ohmic contact is sufficient.

The p-n junction is formed when two adjacent regions of semiconductors are differently doped forming n- and p-type materials in one piece of material. Majority carriers from one side diffuse towards the other side (i.e. holes from the p-side towards the n-side and electrons from the n-side towards the p-side). Diffused charge carriers combine with dopant ions (i.e. extra electrons with acceptor holes

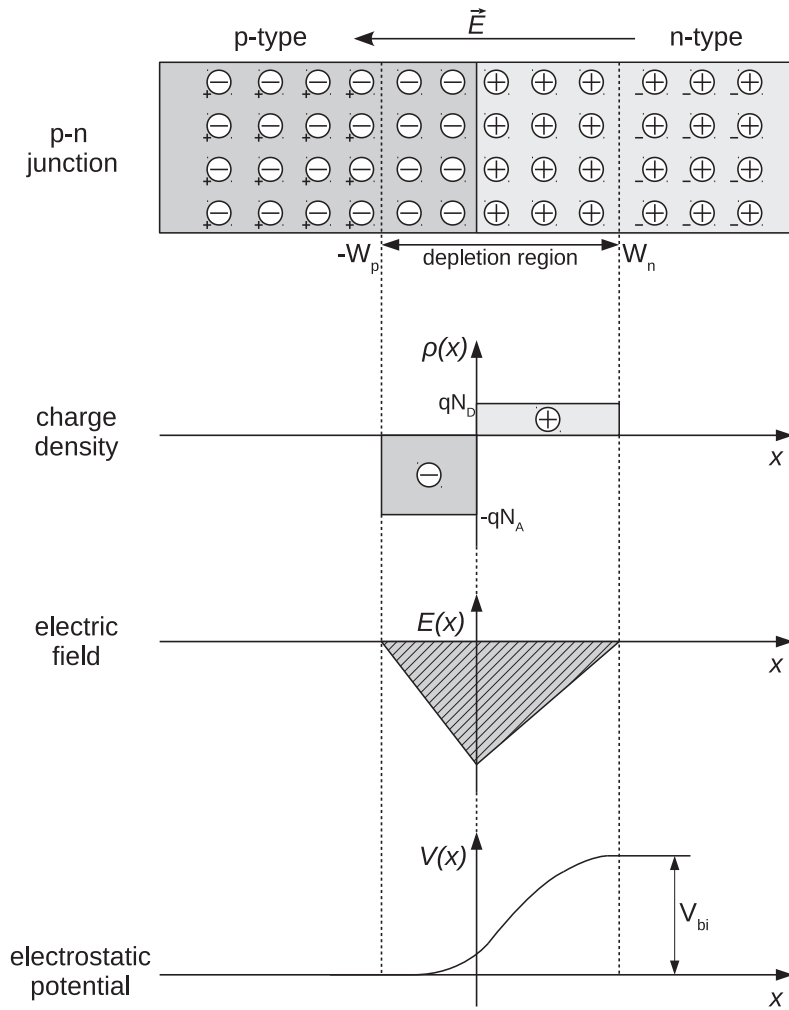

FIGURE 2.7: Electric characteristic functions of a typical abrupt p-n junction.

and extra holes with dopant electrons), which results in a space charge across the junction (positive in the n-side and negative in the p-side). These space charge prevent electron-hole pairs from recombination. In spite, they drift along the field lines. As a result, the region around the junction becomes free of mobile carriers and is called the *depleted region*. The potential difference across the depletion zone is called the *built-in potential* or the *junction potential*. The built-in potential, V_{bi} , is equal to the difference of the Fermi potential levels for p- and n-type materials (equation 2.5) and is given by

$$V_{bi} = \frac{kT}{q} \ln \left(\frac{N_D N_A}{n_i^2} \right) \quad (2.12)$$

At thermal equilibrium, the total negative charge in the n-type side is equal (in

absolute value) to the total positive charge in the p-type side of the depletion region, $N_A W_p = N_D W_n$, thus conserving the electrical neutrality of the device. In figure 2.7, the characteristic functions of an abrupt p-n junction are plotted. The width of the depleted region¹ at thermal equilibrium is given by

$$W = \sqrt{\frac{2\epsilon_s\epsilon_0}{q} \frac{N_A + N_D}{N_A N_D} V_{bi}} \quad (2.13)$$

In a typical detector diode, one side of the junction has a doping concentration a few orders of magnitude higher than the other, usually $N_A \gg N_D$. Therefore, the depletion region extends mainly into one side of the junction. The width of the depleted region can be now expressed by

$$W = \sqrt{\frac{2\epsilon_s\epsilon_0}{q} \frac{1}{N_D} V_{bi}} \quad (2.14)$$

The width of the depletion region can also be increased by applying an external voltage with the same polarity as the built-in potential. It increases proportionally to the square root of the applied voltage. The above equations (2.13 and 2.14) can be used to calculate the external voltage required to deplete completely a semiconductor of given thickness and doping concentrations.

A metal-semiconductor contact is created when a semiconductor is joined together with a metal layer. Its structure can be characterized by using the energy band model as it was done for p-n junctions. In order to induce the diffusion of the electron from the semiconductor to the metal, the Fermi energy level of the metal and the semiconductor has to be lined up, so that a voltage across the junction is created, which is equal to the difference between the potential functions² of the materials

$$V_{bi} = \Phi_{met} - \Phi_{sem} \quad (2.15)$$

The region around the junction on the semiconductor side becomes depleted from the electrons building up a positive space charge in the vicinity of the junction. In order to establish an equilibrium state, positive charges are compensated by a surface charge at the metal side. The height of the created barrier, called *the*

¹Obtained by solving the Poisson's equation for the electric potential ($\frac{d^2V}{dx^2} = \frac{\rho_s}{\epsilon_s\epsilon_0}$, where ϵ_s and ϵ_0 are the relative dielectric constant for the semiconductor and the permittivity of vacuum), with the assumption of an abrupt change of dopant concentrations

² Φ is the energy needed to move an electron from a solid (Fermi level) to the vacuum state. In order to obtain a rectifying metal-semiconductor contact, the condition $\Phi_{met} > \Phi_{sem}$ has to be fulfilled

Schottky barrier, is given by:

$$q\Phi_{Bn} = q(\Phi_{met} - \chi) \quad (2.16)$$

where $q\chi$ is the electron affinity³ of the semiconductor. The width of the depletion region can be modulated by applying an external potential and is expressed with the same equation as for p-n junctions (eq. 2.14).

In order to estimate the time needed to collect the charge created by an impinging particle, a parallel plate detector with a reversely biased silicon p-n junction will be considered (figure 2.8). In a partially depleted detector ($V_{bias} \leq V_{depl}$), the

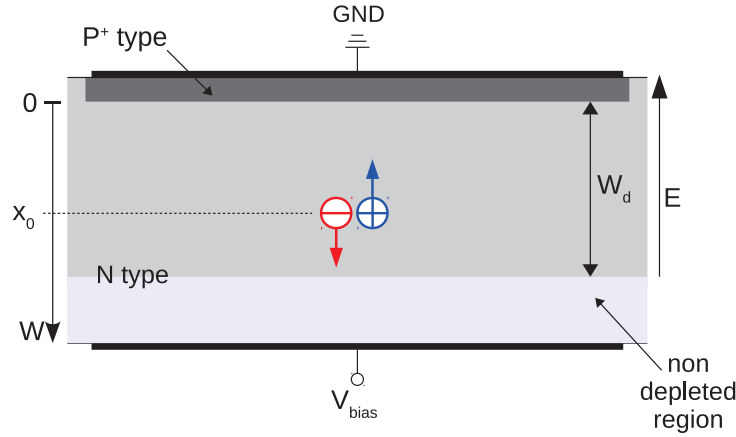

FIGURE 2.8: Charge collection with a partially depleted p-n junction.

electric field inside the bulk is expressed as a function of the depth x

$$E(x) = \begin{cases} \frac{2(V_{bias} + V_{bi})}{W_d} \left(1 - \frac{x}{W_d}\right), & \text{for } x \leq W_d \\ 0, & \text{for } x > W_d \end{cases} \quad (2.17)$$

The time needed for charge carriers created at a given point x_0 to reach the point x is given by

$$t(x) = \tau_c \ln\left(\frac{W - x}{W - x_0}\right), \quad \tau_c = \frac{\epsilon S_i}{\mu q N_D} \quad (2.18)$$

where τ_c is the collection time constant, which is independent of the applied voltage, but relates to the doping concentration and carriers mobility. Therefore, the

³The affinity is the energy needed to move an electron from the bottom of the conduction band to the vacuum state.

time required for carriers to reach the detector electrodes is expressed by

$$t = \tau_c \ln\left(\frac{W}{W - x_0}\right) \quad (2.19)$$

However, when the depletion region does not extend over the full width of the detector, the velocity of the electrons which are drifting towards the low field region will drop to zero around the boundary of the depletion zone. Most of the charges will be collected through diffusion. Some others may recombine in the non depleted region. Therefore, the charge collection time for a partially depleted detector is mainly determined by the diffusion across the non depleted region. Although, it should be said that the charge carriers generated in the non depleted region may not contribute to the total signal. In case they cannot reach the depletion region, they are lost due to recombination processes.

The charge collection time is reduced significantly when the detector is operating with a bias voltage exceeding the depletion voltage ($V_{bias} > V_{depl}$). In that case, a uniform electric field is added to the electric field distribution (eq. 2.17)

$$\begin{aligned} E(x) &= \frac{2(V_{depl} + V_{bi})}{W} \left(1 - \frac{x}{W}\right) + \frac{V_{bias} - V_{depl} - V_{bi}}{W} \\ E(x) &= E_0 \left(1 - \frac{x}{W}\right) + E_1 \end{aligned} \quad (2.20)$$

The time needed for charge carriers created at a given point x_0 to reach the point x is then given by

$$t(x) = \frac{W}{\mu E_0} \ln\left(\frac{E_0 + E_1 - E_0 \frac{x}{W}}{E_0 + E_1 - E_0 \frac{x_0}{W}}\right) \quad (2.21)$$

Hence the individual collection times for holes and electrons traversing the whole detector thickness are given by

$$\begin{aligned} t_{c,p} &= \frac{W}{\mu_p E_0} \ln\left(1 + \frac{E_0}{E_1}\right) \\ t_{c,n} &= \frac{W}{\mu_n E_0} \ln\left(1 + \frac{E_0}{E_1}\right) \end{aligned} \quad (2.22)$$

For example, a silicon detector of 300 μm thickness and 10 $k\Omega$ typical resistivity biased with 60 V have collection times of ~ 10 ns and ~ 35 ns for electrons and holes, respectively.

2.1.3 Signal formation

The signal current is generated on the collecting electrodes by the movement of the generated charges in the active volume of the detector. The electric charge induced on the given electrode can be calculated using the Ramo's theorem [76], which states that the amount of electric charge generated on the electrode is determined by the position of the drifting charges and the weighting potential, $\phi_w(x)$, of the electrode at this position. For a charge q drifting from the point x_1 to the point x_2 , the electric charge induced on the electrode is given by

$$Q = q [\phi_w(x_2) - \phi_w(x_1)] \quad (2.23)$$

The instantaneous current induced on the collecting electrode due to the charge motion is expressed by

$$i = E_w q v \quad (2.24)$$

where v is the instantaneous velocity of the electron and E_w is the *weighting field* of the given electrode. This is obtained by applying an unit potential to the electrode under consideration and by grounding all the others. The distribution of signal weighting potential depends on the geometry of the detector electrodes and is different than the electric field distribution (except for detectors with only two electrodes or pad detectors with electrodes significantly bigger than the thickness of the detector). In the case of a pixel detector, the weighting potential is highly concentrated in the region of the signal electrode. Thus, most of the current is generated while the moving charges get close to or directly on the signal electrode. Otherwise, if the charges will not end on the measurement electrode, the signal current induced on this electrode will be canceled. The induced electric charge, which is due to the motion of both types of charge carriers, electrons and holes, towards the opposite electrodes, has a net effect on the positive current of the negative electrode and on the negative current of the positive electrode. When a charge is not collected on the measurement electrode, it then induces a current on this electrode that will change the sign of the measured current and sets its integral to zero (figure 2.9).

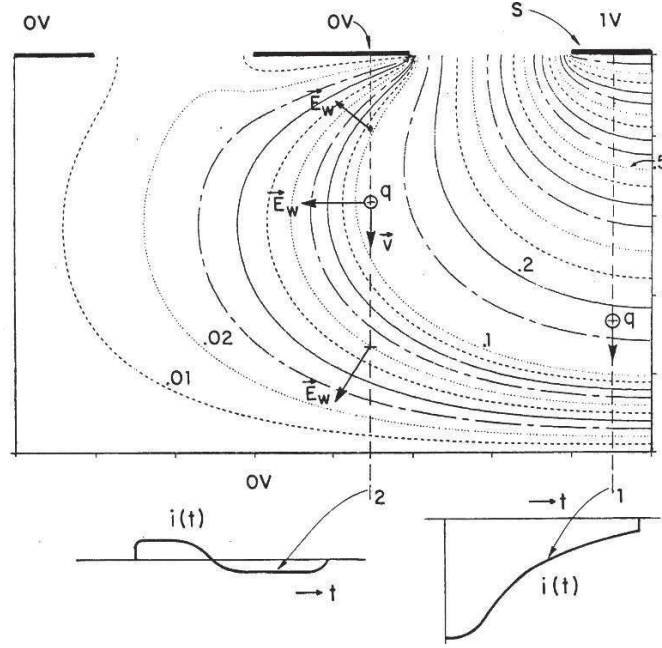

FIGURE 2.9: Plot of the weighting field in a segmented detector (from [75]).

2.1.4 Noise in semiconductor detectors

Noise optimization in a semiconductor detector is required in order to improve SNR (Signal-to-Noise Ratio) and consequently energy resolution of the detector. Detector noise and electronics noise cannot easily be treated separately. However, the ultimate achievable noise performance is limited by two physical phenomenons in the sensor itself, independently of the following electronics.

The first one is the variance of the number of charges produced by an incoming particle. As already stated, this number of charges is related to the impinging particle energy by

$$N = \frac{E}{E_{eh}} \quad (2.25)$$

If this energy transfer follows a Poisson law, the variance of N would simply be $V(N) = N$. Hopefully, this is not true and $V(N) = FN$, where F is the Fano factor, $F = 0.2$ in case of semiconductors. This means that, even with a perfect chain (detector and electronics), an incoming energy E will produce a gaussian shaped peak of variance

$$\sigma^2 = FN = F \frac{E}{E_{eh}} \quad (2.26)$$

As an example, the standard deviation of Gaussian peak produced by an incoming energy of 25 keV will be of $\sim 37 e^-$, corresponding to a FWHM⁴ of 370 eV .

⁴Full Width at Half Maximum

The second physical phenomenon limiting noise performance is related to the variance of the number of charges created by thermal generation in the sensor. This generation follows also a Poisson law and its variance is $V(N_{th}) = N_{th}$. In the case of a reverse bias diode, this is usually expressed in terms of a reverse current, I_r . Suppose that we integrate the signal from the sensor during a time period τ , we will then integrate also the reverse current during the same time period and therefore, the integrated charge due to this current will be $I_r\tau$. The variance of this charge is also $I_r\tau$ and, as before, this leads to a Gauss distribution of $\sigma^2 = I_r\tau$. This means that for slow systems (large τ), the reverse current is an crucial issue.

2.2 Semiconductor pixel detectors

In this section, selected architectures of pixel detectors for X-ray imaging in life sciences and for experiments in synchrotron radiation experiments will be discussed.

2.2.1 Charge Coupled Devices (CCD)

The Charge Coupled Device (CCD) is a matrix of Metal-Oxide-Semiconductor capacitors (MOS), each of them representing one pixel. The working principle of CCD is the displacement of charges collected in potential wells within the space charge region. A cross section of the device is shown in figure 2.10. The potential pockets where the charges generated by the radiation are collected, are created by operating the device in over-depletion mode and applying different potentials to adjacent gates of the capacitors. This creates a potential barrier under the neighboring gates that confines the charges collected in the region under the gate with the highest potential. Since all capacitors in one column have a common gate, the charges in one pixel are isolated against spreading in the direction of the gate by implanting channel stoppers (p strips implantations). In order to move charges in the shift-register manner, every third gate is kept on the same potentials Φ_1 , Φ_2 and Φ_3 . Appropriate clocking of these voltages will cause the displacement of the charges along the row in one direction towards the readout anode as depicted in figure 2.10.

A big advantage of CCD devices is the very high granularity and the possibility to build large scale devices. In addition they do not have any dead zones. However, the readout of this type of the detector is a relatively slow process, which becomes a real issue in the case of large surface detectors. Moreover, because charges need

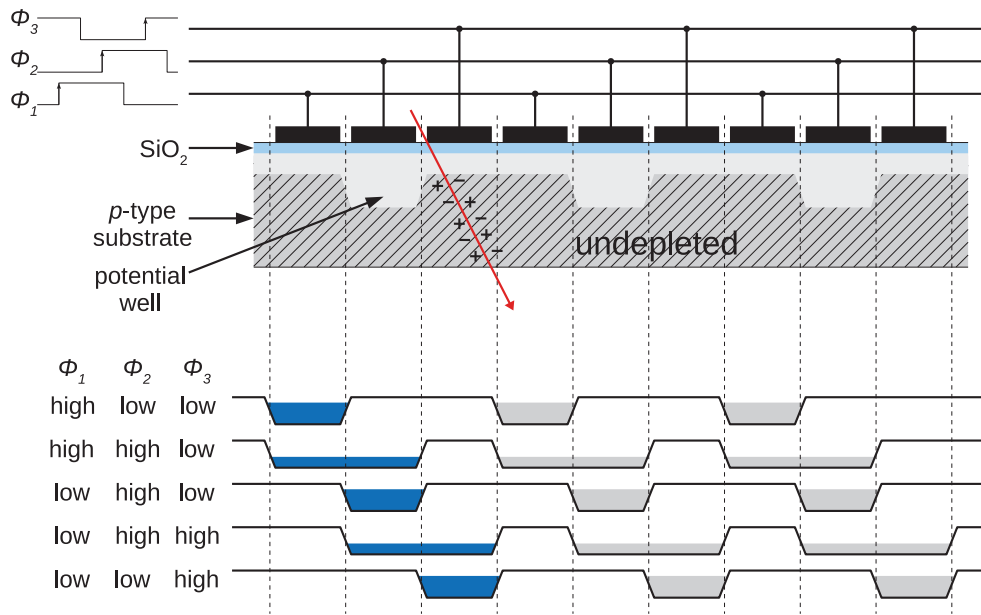

FIGURE 2.10: Cross section of a three phase CCD with a charge transfer diagram. Sequential change of the voltages applied to gates Φ_1 , Φ_2 and Φ_3 cause charge transfer from one cell to the other towards the readout anode located at the end of the row.

to be moved through a large number of elements, the transfer efficiency is a very important parameter of the CCD device. Another aspect is the weak radiation hardness, which affects the charge carriers lifetime and the charge trapping occurrences, and consequently results in a degradation of the charge transfer efficiency.

Different architectures of CCDs were studied in order to improve key parameters and to make them practical devices in various fields of use ([64],[102]). The buried-channel or two phase CCD was designed in order to improve the charge transfer efficiency and speed. Another example are pnCCDs with fully depleted silicon substrate and with enhanced sensitivity and fast readout for X-ray detection applications in astronomy, crystallography or medical imaging.

2.2.2 Monolithic pixel sensor

The architecture of a monolithic pixel detector assumes that the sensor is integrated in the same substrate with its readout electronics. Different approaches to developing these types of devices were studied and undertaken. They are mainly

driven by the needs for vertex tracking detectors for future colliders (e.g. International Linear Collider (ILC)). The most important (and most challenging) requirements for these detectors are the small size of pixels, the high rate data acquisition and the low material budget. In this section, Monolithic Active Pixel Sensors (MAPS) built in standard CMOS technology will be presented in more details. Indeed, these are the most advanced developments and are currently the only devices of this type that have the potential to build large area detectors. It should be noted, however, that there is ongoing research and development on different concepts of (semi-)monolithic pixel sensors (e.g. DEPFET⁵ detectors [2]), although these cannot offer yet a small pixel pitch or large surface detector.

2.2.2.1 Monolithic Active Pixel Sensor (MAPS)

A cross-section of MAPS built in standard CMOS technology is shown in figure 2.11a.

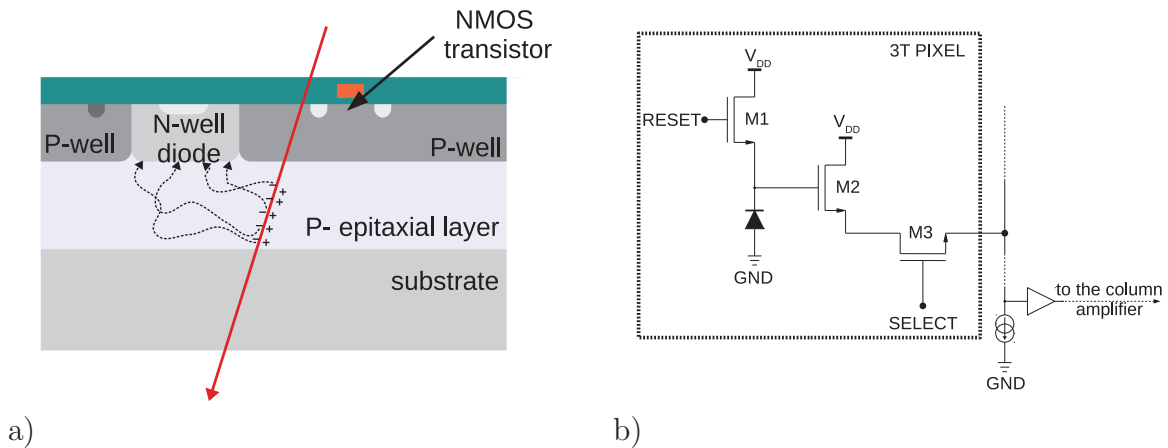

FIGURE 2.11: Monolithic Active Pixel Sensor built in standard CMOS technology: (a) cross section and principle of operation, (b) basic pixel architecture based on three N-MOS transistors and a collecting diode (3T pixel).

The availability of slightly doped epitaxial silicon layer in CMOS process is essential for MAPS design. It is grown on top of a low resistivity silicon bulk. The active element in this design is a n-well/p-epi diode. Only the region under the n-well is depleted. Charges liberated by a traversing particle are kept in this thin epitaxial layer (usual of a few to 15 μm thickness) by potentials of p-wells located at the border of the pixel and reach the region of the collection diode by thermal diffusion. Charge carriers generated in the substrate can contribute to the total

⁵Depleted Field Effect Transistor

signal charge only if they were generated at the border of the epitaxial layer. A big difference of doping levels between the substrate and the epitaxial layer results in a decrease of charge lifetime, since charges recombine in the substrate before they can be collected. The charge signal is usually very small. Therefore, low noise electronics is a critical issue in this development. A typical three transistors based pixel architecture (reset (M1), source follower (M2) and row select (M3)) is presented in figure 2.11b. One of the advantages of this design is its high granularity (a pixel pitch $< 15 \mu m$ is possible), due to a simple architecture of the single pixel and to the use of a commercial CMOS process. In addition to this, through thinning of the p-substrate and back-illumination, a 100% fill factor can be achieved.

The main disadvantage of MAPS devices in standard CMOS technology is that the electronics read-out must consist only of NMOS transistors. In a twin-tube standard process, a P-MOS transistor has to be embedded in a n-well in order to get the positive bias. Since the n-well is used as a collecting diode, any other implantation of n-well would decrease the collected charge signal. Different attempts have been undertaken to overcome this limitation. One of them is to use a non-standard Silicon on Insulator (SOI) technology, with a buried oxide layer (SiO_2) used to isolate the fully depleted substrate from the electronically active

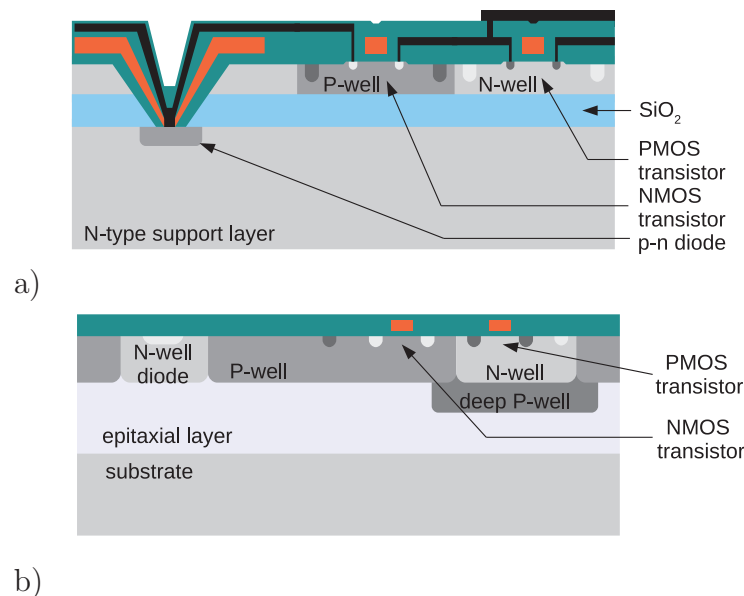

FIGURE 2.12: Different MAPS designs that allow use of both N- and P-MOS transistors in non-standard technologies: (a) in Silicon on Insulator (SOI) technology, (b) using INMAPS (Isolated N-well) process what allows deep p-well implants.

silicon on top of the insulator [57]. The charge collection is done by vias connecting the readout electronics with the substrate through the oxide. A schematic view of the device is shown in figure 2.12. Another approach is to use deep p-well implantation, which provides effective isolation (INMAPS process [5],[19]) of the n-well with P-MOS transistors (figure 2.12(b)).

2.2.3 Hybrid pixel detector

In the hybrid pixel detector architecture, the sensor and the electronics chips are fabricated on different substrates, thus ending with two separate chips. The development of this type of detector was initiated for vertex detectors for HEP experiments (e.g. LHC⁶ experiments ATLAS⁷, ALICE⁸, CMS⁹ and LHCb¹⁰ at CERN). The needs for these experiments was to achieve high spatial resolution, high timing precision (event time stamps) and high radiation tolerance. Hybrid pixel detectors have successfully fulfilled all these requirements and large surface detectors (e.g. $\sim 1.7 \text{ m}^2$ for ATLAS [105] and $\sim 1 \text{ m}^2$ for CMS [106]) were successfully built, thus empowering the reliability of the technology.

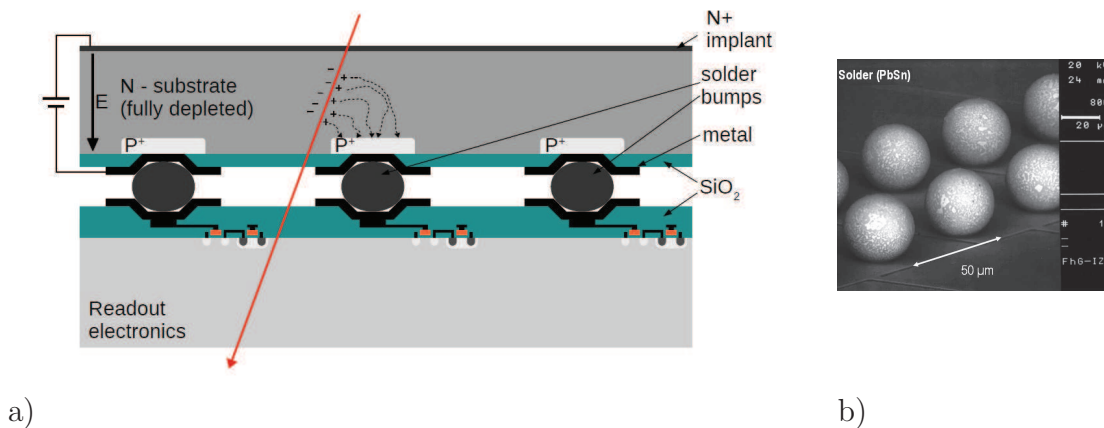

FIGURE 2.13: Hybrid pixel detector (a) cross-section and (b) SnPb bumps used for the sensor and electronics chip interconnection.

The separation between readout electronics and sensor electronics allows to optimize the sensor and readout parts independently. The two elements of the detector

⁶Large Hadron Collider

⁷A large Toroidal LHC ApparatuS

⁸A Large Ion Collider Experiment

⁹Compact Muon Solenoid

¹⁰Large Hadron Collider beauty

are connected together in the final stage of the production via the flip-chip technology (figure 2.13(b)). A cross-section through a hybrid pixel detector is shown in figure 2.13(a). A sensor of n-type high resistivity silicon with p^+ pixel implants is most often used, but it is also possible to use different materials with higher atomic number and higher efficiencies (e.g. CdTe, CdZnTe or GaAs). The readout electronics chip is designed in a standard, commercial CMOS process with a high density of transistors. Since the sensor part is completely separated from the readout part, this type of pixel does not suffer from any limitation and allows for various signal processing schemes that can be tuned for every given application. The front-end part is always built with a charge amplifier followed by a comparator. The basic pixel architecture of a hybrid pixel detector for X-ray detection is made of three main blocks: charge detection, signal selection and local hit memory. The charge detection block converts the charges generated in the sensor, which gives rise to the voltage (current) signal that is afterwards compared with a detection threshold. The comparison results are then stored in a local memory (counter).

The ability to detect and count individual radiation quanta, and thus to image selected energies extends the use of hybrid pixel detectors to different fields of imaging like medical imaging and synchrotron radiation experiments. However, integration of the entire amplifying, thresholding and signal processing electronics in each one of the pixels limits the granularity of the detector and hence spatial resolution. Additionally, the high complexity and the many production steps (chip and sensor production, bump-bonding and flip-chip) result in a lower production yield that makes these detectors quite expensive devices.

The hybrid pixel detectors have several advantages over the other detector architectures. The most important one is the significant suppression of the electronic noise, which must result in improved SNR and contrast in the image. Moreover, the adjustable threshold makes it possible to select the energy range of the photons. Especially, in the field of biomedical imaging, this feature can be used to optimize the detection of contrast agents while reducing the total exposure dose. In addition to all the foregoing, hybrid pixel detectors show high radiation tolerance and can achieve very fast readout.

In this thesis, the XPAD3 hybrid pixel detector will be discussed in details. But before we give a thorough description of the XPAD3 detector developed at CPPM, we will review some of the state-of-the-art hybrid pixel detectors that have already been developed elsewhere.

At present, the most mature designs that allow to build large surface detectors for imaging applications are the PILATUS, the MEDIPIX, and of course the XPAD designs. The first two designs are described in the next part of this section, whereas the detailed description of the XPAD detector is given in the next chapter. Last but not least, we also mention hybrid pixel detectors designed for vertex tracking detectors used in High Energy Physics, and a few other interesting specific developments and applications of hybrid pixel detectors.

2.2.3.1 Hybrid pixel detectors in High Energy Physics

As it was stated at the beginning of this chapter, the development of hybrid pixel detectors was initiated by the needs of High Energy Physics. The main requirements for charge particle tracking are very good spatial and timing resolutions, long term operation performance and high radiation tolerance to doses up to 500 kGy [93]. Hybrid pixels met all these requirements and are currently being used in the inner detector for several experiments of the LHC at CERN and of the Tevatron at Fermilab¹¹ close to the interaction point. The application to particle

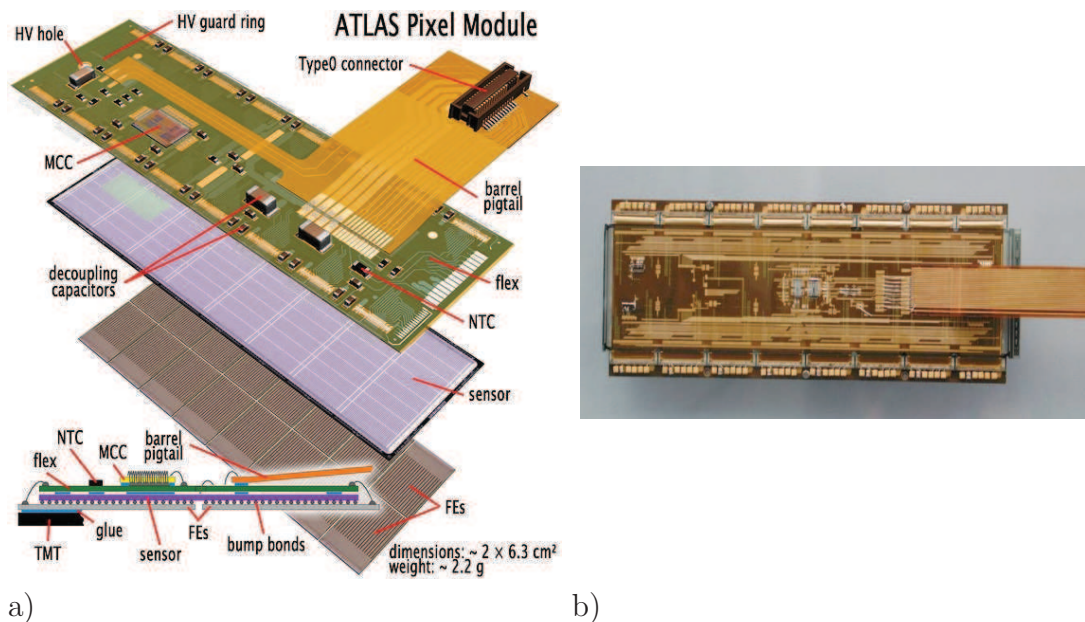

FIGURE 2.14: (a) Layered view of the ATLAS pixel detector module and (b) picture of a CMS pixel detector module.

tracking imposes a number of requirements for the pixel design such as low power consumption, low noise and low threshold dispersion, zero suppression in every

¹¹Fermi National Accelerator Laboratory: <http://www.fnal.gov/>

pixel or on-chip hit buffering. Every hit registered in the pixels is assigned to the corresponding collider bunch crossing. The main developments were carried out for the ATLAS and CMS experiments at CERN. The pixel sizes are $50 \times 400 \mu\text{m}^2$ for ATLAS and $100 \times 150 \mu\text{m}^2$ for CMS. For ATLAS and CMS, a detection module is composed of 16 readout chips bump bonded to a single silicon sensor. The chips are generally wire-bonded to a kapton flexible circuit that is glued atop the sensor (figure 2.14). The module is controlled via a Module Control Chip (the MCC) that is placed on the flexible circuit and is responsible for the front end trigger control and event building.

2.2.3.2 The PILATUS II and EIGER hybrid pixel detectors

2.2.3.2.1 PILATUS II

The PILATUS II¹² detector is a silicon hybrid pixel detector that was designed for crystallography experiments at the Swiss Light Source (SLS) of the Paul Scherrer Institute (PSI) [45],[103]. The PILATUS II detector is the successor of the PILATUS I [9], [44] detector with improved functionality and corrections for several shortcomings.

The PILATUS II readout chip (ROC) was designed in a standard $0.25 \mu\text{m}$ CMOS process using radiation tolerant layout techniques. The ROC is composed of 5820 pixels organized in a matrix of 60×97 pixels with a size of $172 \mu\text{m} \times 172 \mu\text{m}$. The main properties of the PILATUS II readout chip are presented in table 2.2. The pixel design comprises a charge sensitive preamplifier (CSA), an AC coupled shaper, a comparator and a 20-bit counter. The threshold level of the comparator is adjusted with a global threshold voltage and can be locally trimmed for each pixel with a 6-bit DAC. The digital output of the comparator feeds the 20-bit counter, in which the overall number of detected photons is stored. The architecture of the pixel cell is shown in figure 2.15.

Every pixel can be individually selected by addressing it with two signals, *ROWSEL* and *COLSEL*. These two registers allows for reading and writing the pixel counter and the 6-bit DAC, as well as for sending a calibration signal (CAL). The ROC can operate in two different modes: the *count mode* and the *readout mode*. During the count mode, no pixels are selected and, as long as the external enable signal is logic high, every pixel is counting photons. In the case of the readout mode,

¹²Pixel apparatus for the SLS

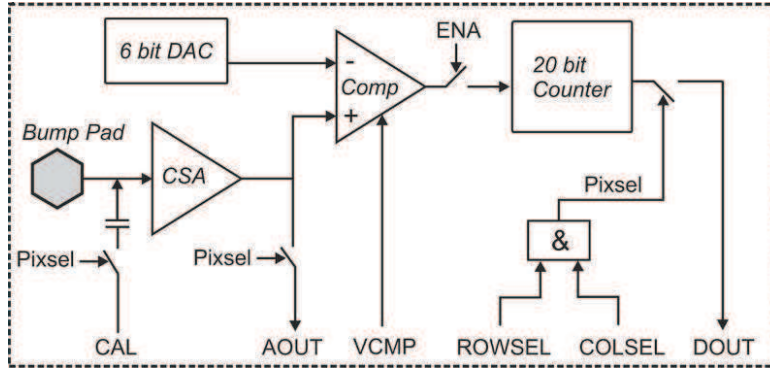

FIGURE 2.15: The pixel design of the PILATUS II readout chip (from [55]).

each pixel is sequentially selected in order to read its counter value via the digital output signal (DOUT).

A single PILATUS II detection module is formed by an array of 8×2 ROCs bump bonded to a single silicon sensor with a thickness of $320 \mu\text{m}$. The single module contains 94'965 pixels in an array of 487×195 pixels. In order to avoid dead areas between the chips, the sensor consists of two rows of pixels of size 1.5 times larger than a normal pixel ($258 \times 172 \mu\text{m}^2$). The counts of these pixels are distributed by the software into three pixels of normal size, thus introducing a virtual pixel. The same logic is applied to the corners of the chips. However, in this case, sensor pixels have a size that is 2.25 times larger than a normal pixel ($258 \times 258 \mu\text{m}^2$), thus introducing five virtual pixels. In total, this technique adds 1'845 virtual pixels to the matrix.

Every detection module is connected to its module control board (MCB). The MCB board is equipped with an electronics that provides all the necessary voltages and biasing as well as control signals distributed via an I²C¹³ interface. In order to have a fully operational detector system, one module have to be connected to a detector control board (DCB). The system requires a separate power supply and an acquisition computer.

The PILATUS II detector has a modular architecture, which means that a large surface detector of any size can be assembled, providing it consists in a multiple of 487×195 pixels. The PILATUS II modules were used to build a large hybrid pixel detector, the PILATUS 6M, which is currently in use at several synchrotron beamlines. The PILATUS 6M is built of 5×12 modules with $2436 \times 2527 = 6'155'772$ pixels. The total active area of this detector is $424 \times 435 \text{ mm}^2$. One

¹³Inter-Integrated Circuit

	Num. of pixels	Pixel size [μm^2]	Count rate [ph/px/s]	Counter depth	Readout time	Energy range [keV]	Power (analog.) μW	Thresh. dispers. (rms) e ⁻	Noise (rms) e ⁻	CMOS technology μm
PILATUS II	60 × 97 5'820	172 × 172	2 × 10 ⁶	20 bits	2.85 ms	3-30	-	50	125	0.25
EIGER	256 × 256 65'536	75 × 75	16 × 10 ⁶	12 bits (4, 8, 12 mode)	85 μs 8-bit mode	-	9	20	180	0.25
MEDIPIX2	256 × 256 65'536	55 × 55	10 ⁶	13 bits	8.5 ms in serial 266 μs in parallel	5-300	8	500	105	0.25
XPAD3	80 × 120 9'600	130 × 130	10 ⁶	12 bits + OVF	1 ms	5-35	40	50	130	0.25

TABLE 2.2: Technical specifications of the PILATUS II, EIGER, MEDIPIX2 and XPAD3 detectors (based on data from [97],[29],[35],[55]).

module of the PILATUS II detector is shown in figure 2.16 alongside with the PILATUS 6M detector system.

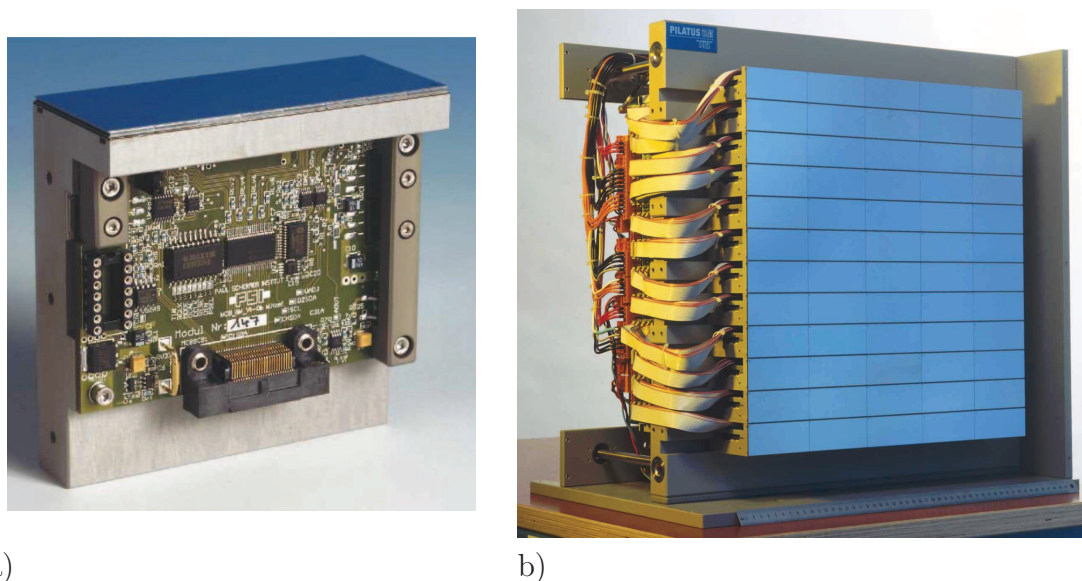

FIGURE 2.16: (a) PILATUS II single detector module and (b) PILATUS 6M detector system.

A spin-off company of PSI, named DECTRIS Ltd. was founded in 2006¹⁴ to commercialize hybrid pixel detector systems based on the PILATUS II chip. Comparison of the main parameters between some PILATUS detectors and the XPAD3 detector is shown in table 2.3.

2.2.3.2.2 EIGER

The EIGER¹⁵ detector is another hybrid pixel detector designed at PSI for the SLS. As a successor of the PILATUS II detector, its design has several improvements, including in particular a smaller pixel pitch and faster readout time. Similarly to its ancestor, the EIGER readout chip was designed in 0.25 μm technology using radiation tolerant layout techniques. The pixel size was scaled down to 75 μm \times 75 μm and a single chip contains 65'536 pixels organized in a matrix of 256 \times 256 pixels. The specification of the EIGER chip is presented in table 2.2. The threshold level of the comparator is globally set for all pixels and trimmed individually for each pixel with a 6-bit DAC. The output of the comparator feeds a double buffered 12-bit counter with overflow management. The counter can operate in three modes using 4, 8 or 12 bits. A single detector module is formed with eight chips (organized

¹⁴Dectris Ltd.: <http://www.dectris.ch>

¹⁵Extreme high frame rate detector

	PILATUS			XPAD3
	100K	300K	1M	
Area	$83.8 \times 33.5 \text{ mm}^2$	$83.8 \times 106.5 \text{ mm}^2$	$169 \times 179 \text{ mm}^2$	$75 \times 120 \text{ mm}^2$
Number of pixels	487×195 94'965	487×619 301'453	981×1043 1'023'183	560×960 537'600
Number of modules	1	3 (1 × 3)	10 (2 × 5)	8 (1 × 8)
Intermodule gap	none (one module)	5.5%	8.4%	none (tiling)
Framerate	300 Hz	200 Hz	30 Hz	240 Hz
Weight	~ 4 kg	~ 10 kg	~ 25 kg	~ 15 kg

TABLE 2.3: Comparison of the main parameters between some detectors of the PILATUS family and the XPAD3 detector (from [97],[16]).

in two rows of four chips) bump bonded to the sensor material. Each half-module (one row of four chips) is connected to a back-end board equipped with memory and processing electronics. The EIGER chip is currently undergoing tests at PSI to verify its design and functionality.

2.2.3.3 The MEDIPIX family of hybrid pixel detectors

The MEDIPIX family of hybrid pixel detectors includes the MEDIPIX1, MEDIPIX2, TimePix and MEDIPIX3 chips. These chips are being developed within a collaboration between many universities and research institutes, mainly from Europe. In this section, the MEDIPIX2, TimePix and MEDIPIX3 chips are introduced in more details.

2.2.3.3.1 MEDIPIX2

The MEDIPIX2 chip is designed in $0.25 \mu\text{m}$ technology. It consists of a matrix of 256×256 pixels, each of them having a size of $55 \times 55 \mu\text{m}^2$. Technical specifications of the MEDIPIX2 chip are shown in table 2.2.

The main components in the pixel design are the charge preamplifier with DC leakage current compensation, the double discrimination logic and the 13-bit counter.

The pixel cell is shown in figure 2.17. Changing of the bias conditions of the

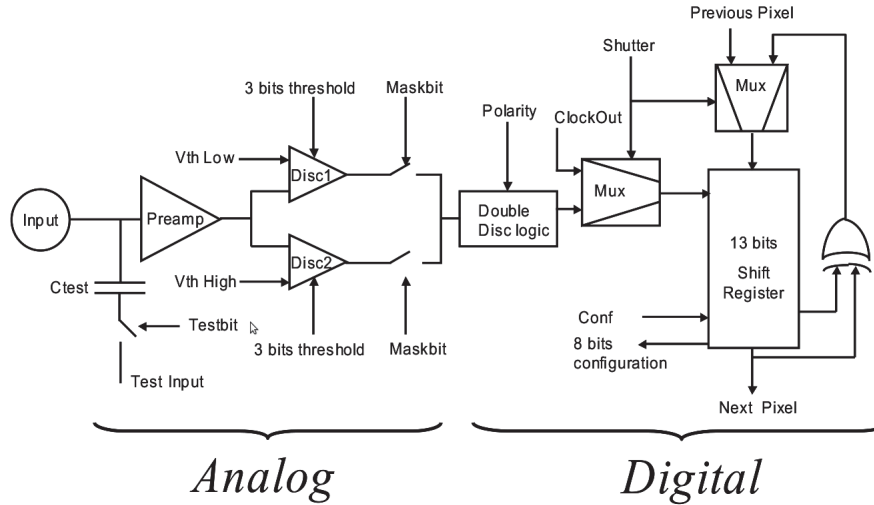

FIGURE 2.17: Pixel design of the MEDIPIX2 readout chip (from [63]).

preamplifier makes the chip sensitive for holes and electrons. The two comparators allow for energy windowing. Upper and lower energy settings are performed thanks three configuration bits per discriminator. Each pixel has two modes of operation that are selected with the input signal *shutter*: the *acquisition mode* and the *shift mode*. In the acquisition mode, the output of the double discrimination logic acts as the clock of the counter. In case of the shift mode, data are shifted from pixel to pixel in order to read out and write in the pixels. The MEDIPIX2 circuit can be read out in a serial mode using high speed LVDS signal or in a parallel mode via 32-bits.

The MEDIPIX2 circuit was successfully used to build a detector system with different sensor materials and architectures in order to fulfil requirements of experiments performed at synchrotron radiation sources and for biomedical imaging applications. Apart from silicon that is the classical sensor material used for charged particle detectors, the MEDIPIX2 chip was also hybridized with high-Z materials such as CdTe [17] and GaAs [54]. The circuit was also evaluated as a readout chip for a Time Projection Chamber (TPC) [12] gas detector, as well as for a novel 3D architecture of the sensor material [94].

Another interesting development is a neutron pixel detector based on the MEDIPIX2 chip [47]. In order to detect neutrons in the detector sensor, a dedicated layer of a neutron converter was deposited on the silicon sensor surface. Thermal neutrons are converted in this layer into secondary charged particles, which are detected by the MEDIPIX2 detector. In figure 2.18a, a single MEDIPIX2 chip wire bonded

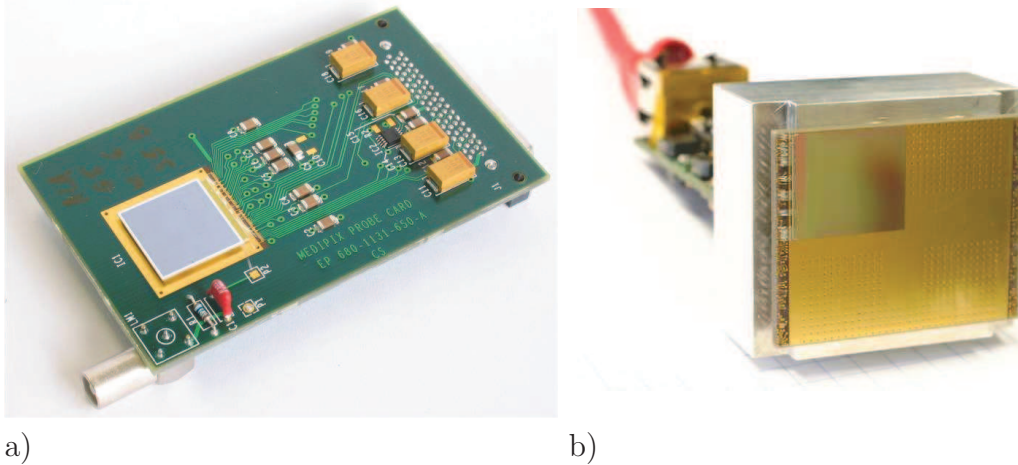

FIGURE 2.18: Pictures of (a) the MEDIPIX2 circuit with $300\ \mu\text{m}$ silicon sensor wire-bonded to the probe card and (b) of a four-chip module (quad) connected (in the figure only one chip is wire bonded without a sensor) to the Gigabyte Ethernet link (from [100]).

to the readout chip developed at CERN is shown. In figure 2.18b, four chips are connected to a high speed readout module that was developed in the framework of the RELAXD¹⁶ project [91]. The aim of this project is to build large area detector by tiling several modules like the one presented above. In order to minimize dead areas between the modules, it is planned to remove the wire bonding connection to the supporting PCB and replace it by a via through the MEDIPIX2 chip. The CAD visualisation of the RELAXD detector is shown in figure 2.19a and a cross section of the via interconnection in figure 2.19b.

2.2.3.3.2 TimePix

The TimePix chip [8] is a modified version of the MEDIPIX2 chip that has an extended functionality to determine the time of photon interaction and the total charge of an event. The motivation for the design of the TimePix chip was to evaluate its use for a Time Projection Chamber for High Energy Physics. This extended functionality was implemented at the expense of the high threshold setting. The implemented *TimePix synchronization logic* allows to synchronize the particle arrival time with a reference clock and to use the pixel counter as a timer. The time-stamp approximation has a tunable time resolution of 100 ns down to 10 ns. The total charge information is obtained from a time-over-threshold method. In that case, the counter is used as an ADC that allows for direct energy measurement in each pixel.

¹⁶High REsolution Large Area X-ray Detector

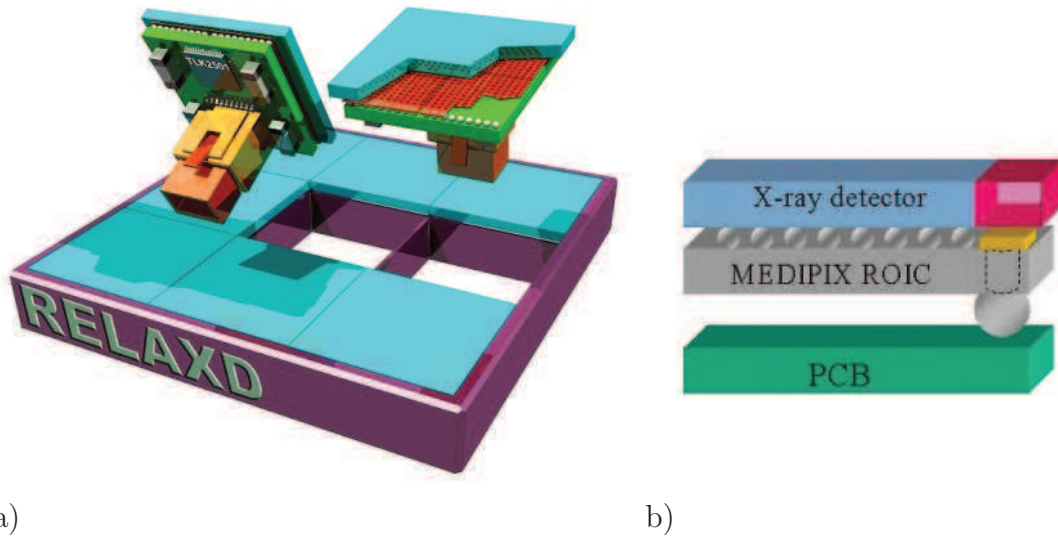

FIGURE 2.19: (a) CAD visualisation of the RELAXD detector and (b) a cross section of the via interconnection between the MEDIPIX2 and a supporting PCB.

2.2.3.3.3 MEDIPIX3

The MEDIPIX3 chip is the successor of the MEDIPIX2 circuit. It was designed in $0.13\ \mu\text{m}$ CMOS process and the chip has the same dimensions as the MEDIPIX2 chip, i.e. 256×256 pixels of $55 \times 55\ \mu\text{m}^2$ size. The main motivation to design this new chip was to reduce the problem of charge sharing between neighboring pixels. Indeed, this was a significant issue for the MEDIPIX2 detector [39],[4]. In the MEDIPIX3 architecture, four adjacent pixels are grouped into a cluster and information about charge deposition in the pixels is shared between the pixels belonging to a cluster. At the corner of each pixel, there is a summing circuit that adds the total charge deposited in sub-group of pixels and an arbitrary logic assigns a hit to the pixel hit with the highest charge. This mode of operation is referred to as the *charge summing mode*, but the circuit can also be configured in a *single pixel mode* to operate like a conventional detector system, without this charge reconstruction mechanism. In addition to this, each pixel consists of a preamplifier, a shaper and two threshold discriminators in the analogue front-end electronics. The digital processing circuitry includes a control logic, an arbitration logic for hit allocation, a double 12-bit counter and configuration registers. The low and high threshold levels of the discriminators are set via two 9-bit registers. Each one of the 12-bit pixel counters is registering hits that are associated with one threshold level. The counters can be configured to work with 1, 4 or 12-bits. In addition, both counters can be concatenated and used as a single 24-bit counter. However, only one discrimination level is used in this case. Furthermore, the chip

can be configured in such a way that either the size of the readout pixel matches the physical pixel pitch (the *fine pitch mode*) or is four times greater ($110 \times 110 \mu\text{m}^2$) by grouping four pixels in a cluster called a super-pixel (the *spectroscopic mode*). In either case, the charge summing and the single pixel modes are available.

2.2.3.4 Specific developments and applications of hybrid pixel detectors

Besides the above-mentioned hybrid pixel detection systems, several projects were launched in a number of research units worldwide. The most interesting ones are listed below.

2.2.3.4.1 CIX 0.2

The CIX detector [33][34] is a prototype of a simultaneously counting and integrating X-ray chip connected with a sensor material (the CIX chip was hybridized with Si, CdTe and CdZnTe sensors). The device is being developed jointly by the University of Bonn (Germany), the University of Heidelberg (Germany) and the Philips Research Laboratories Aachen (Germany). The CIX matrix is composed of 8×8 pixels with $250 \times 250 \mu\text{m}^2$ size. The technical characteristics of the chip are given in table 2.4. The main components of the photon counting part of the pixel design are a charge sensitive amplifier, a fast discriminator and a 16-bit counter. The charge integration circuitry consists again of a charge sensitive amplifier, a comparator and a current integrator. The double mode of photon detection allows for using the detector in a very high photon flux, where discrimination of the photon is no more possible.

2.2.3.4.2 DIXI

The DIXI (DIgital X-ray Imaging) detector [22][32] is a hybrid pixel device developed for dynamic medical X-ray imaging. The detector consists of a sensor bump bonded to the Angie readout chip. The Angie chip was developed in cooperation between the Radiation Science Department of the Uppsala University (Sweden) and the Norwegian ASIC design house Ideas ASA. The readout chip has 992 pixels organized in a matrix of 31 pixels with $270 \times 270 \mu\text{m}^2$ size. The pixel design consists of a preamplifier, a shaper, a discriminator and a two 16-bit counters. A double counter solution allows for acquiring two images from the detector every μs .

	CIX 0.2	Angie	Aladin1
Number of pixels	$8 \times 8 = 64$	$31 \times 32 = 992$	$64 \times 64 = 4096$ (<i>per chip</i>) $64 \times 448 = 28672$ (<i>per module</i>)
Pixel size	$500 \times 250 \mu\text{m}^2$	$270 \times 270 \mu\text{m}^2$	$150 \times 150 \mu\text{m}^2$
Counting rate	3×10^6 ph/pixel/s	$> 10^6$ ph/pixel/s	10^6 ph/pixel/s
Counter depth	16 bits	12 bits	15 bits
Features	photons counting and charge integration in one pixel	double counter	fast readout of 1 ms

TABLE 2.4: Technical specification of the CIX 0.2, Angie and Aladin chips.

2.2.3.4.3 LAD1

The LAD1 (Large Area Detector) detector [82][80] was developed for X-ray diffraction by a collaboration between the Imperial College in London (UK), the Glasgow University (UK) and the Rutherford Appleton Laboratory (UK). The detector has a modular structure with a maximum size of $300 \times 300 \text{ mm}^2$. Modules are built of seven Aladin readout chips bump bonded to a silicon sensor. The single Aladin chip consists of a 64×64 matrix with $150 \times 150 \mu\text{m}^2$ pixels. Each pixel contains a preamplifier, a shaper, a programmable discriminator and 15-bit counter. The maximum count rate per pixel is 10^6 photons/pixel/s. The readout speed of the module amounts up to 1000 frames/s and the readout speed of the multi-module detector is independent from the size.

Chapter 3

XPAD3 X-ray camera

3.1 Introduction

The XPAD3 detector is the third generation of hybrid pixel detectors developed by the imXgam¹ group at CPPM in collaboration with the group of Institut Néel in charge of the D2AM beam line at ESRF² and the detector group at SOLEIL³.

The design of the first photon counting chip of the XPAD family (XPAD1) was based on a development done at CPPM for the CERN experiment DELPHI⁴ [25]. The project was carried out in collaboration with the D2AM beamline group at ESRF. The first chip was designed to evaluate the ability of hybrid pixel detectors to be used in experiments for third generation synchrotron radiation sources. The very high brightness of these facilities makes it possible to perform new experiments that require a wide dynamic range and low noise detectors. The XPAD1 prototype demonstrated promising results that led to design a second prototype chip called XPAD2 [6]. A large surface detector ($70 \times 70 \text{ mm}^2$) was assembled and successfully used in experiments with synchrotron radiation. In addition to this, ability to image of small animals were investigated [24]. The SOLEIL detector group joined the collaboration for the design of the third prototype chip called XPAD3. The XPAD3 chip was designed in two different versions called XPAD3-S⁵

¹imaging techniques based on **X** and **gamma** radiation

²European Synchrotron Radiation Facility, address: Polygone Scientifique Louis Néel, 6 rue Jules Horowitz, 38000 Grenoble, France

³French national Synchrotron facility, address: L'Orme des Merisiers, Saint Aubin - BP 48, 91192 Gif sur Yvette cedex, France

⁴DEtector with Lepton, Photon and Hadron Identification

⁵S stands for Silicon

and the XPAD3-C⁶, which are working respectively in holes and electron collection modes. The main difference between both designs is the energy range that is 35 keV for the -S version and 60 keV for the -C version. Conceptually, the XPAD3-C circuit was designed for biomedical applications requiring high efficiency at high photon energies (which in turn means a sensor of high effective atomic number, usually working in e^- collection mode) and the XPAD3-S version for synchrotron radiation experiments.

The subject-matter of this chapter is the large surface camera built with the XPAD3-S chip.

3.2 XPAD3 photon counting chip

3.2.1 Global architecture

The XPAD3 chip was designed in deep sub-micron, radiation hard IBM 0.25 μm technology. Both versions of the chip (XPAD3-S and XPAD3-C) have the same global architecture and differ only in the pixel design. The main parameters of the XPAD3-S and the XPAD3-C chips are presented in table 3.1.

	XPAD3-S	XPAD3-C
Number of pixels	9600	
Pixel size	$130 \times 130 \mu\text{m}^2$	
Counting rate	$\leq 10^6$ photons/pixel/second	
Chip readout	< 1 ms	
Counter depth	12 bits + overflow	
Power	$< 70 \mu$ W/pixel	
Input polarity	holes collection	electrons collection
Selection mode	single threshold	double threshold
Nonlinearity	$< 10\%$ over 35 keV	$< 10\%$ over 60 keV
Electronic noise (rms)	$< 130 e^-$	
Threshold dispersion	$\sim 50 e^-$	

TABLE 3.1: XPAD3 characteristics.

The topology of the chip is shown in figure 3.1. The main blocks of the circuit are: a matrix of 9600 pixels organised in 80 columns of 120 cells each, readout/write-in shift registers and global configuration registers. In addition, the chip is equipped with a temperature sensor, a test pulse and a bias generator.

⁶C stands for Cadmium Telluride, CdTe

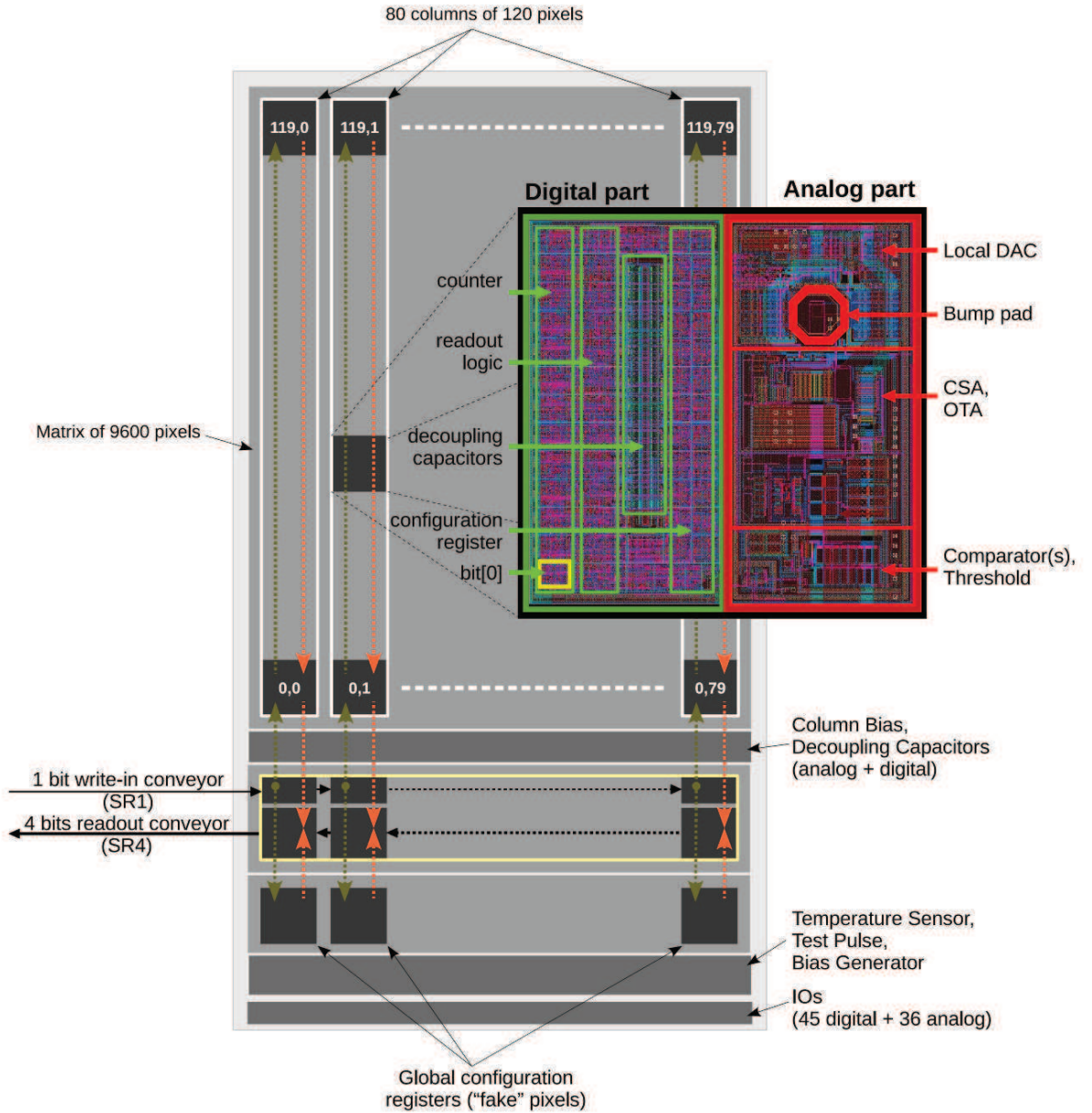

FIGURE 3.1: Global architecture of the XPAD3 chip.

3.2.2 Pixel details

The XPAD3 chip has pixels of $130 \times 130 \mu\text{m}^2$. The area of the pixel is vertically divided into two sub-cells of $65 \times 130 \mu\text{m}^2$, one for the analogue front-end electronics and the other one for the digital data processing and the readout. The XPAD3-S pixel chain is presented in figure 3.2. The analogue part of the

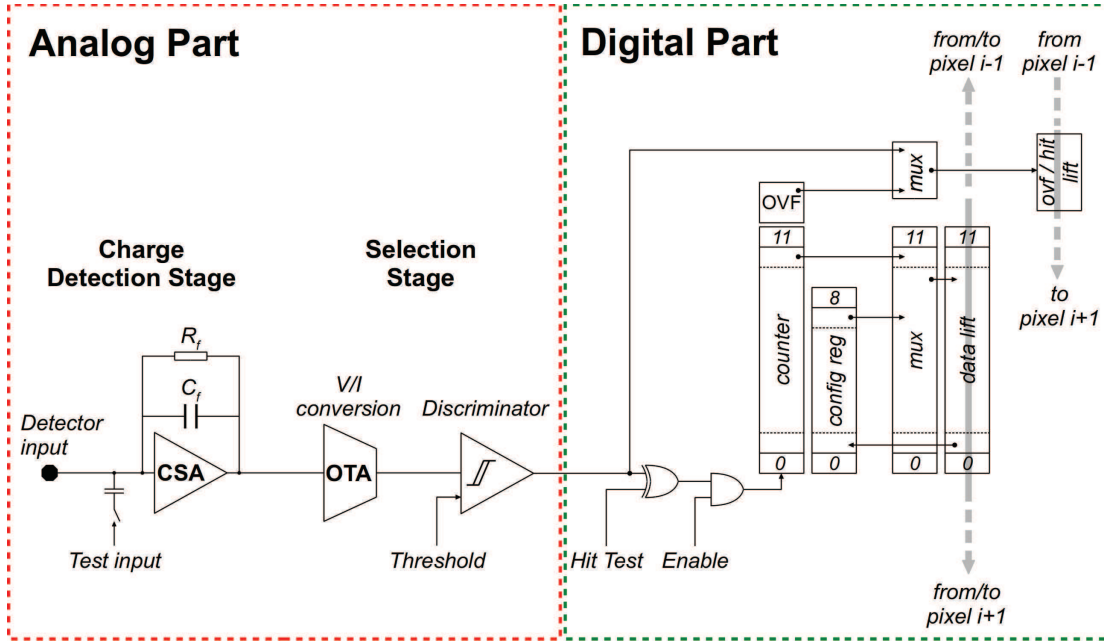

FIGURE 3.2: XPAD3-S pixel design.

pixel comprises a charge sensitive amplifier (CSA), an operational transconductance amplifier (OTA) and a current mode comparator⁷. The CSA is a low noise, folded cascode preamplifier that transforms the charges received from the detector through the bump pad into a voltage signal. The feedback resistor R_f that resets the 10 fF feedback capacitance is realized as a classical MOS transistor polarised in ohmic zone⁸. The output voltage signal is then converted to the proportional current signal by the second stage OTA. This allows for using a current mode comparator with a simple and compact design. The energy threshold value is set globally for all the pixels by a single 8-bit global DAC (section 3.2.4) and the dispersion of the offset is adjusted in every pixel with a 6-bit local DAC (DACL). The discriminator output feeds a 12-bit counter with an overflow bit (OVF). The depth of the counter was determined to permit on-the-fly readout with a photon counting rate up to 10^6 photons/pixel/s. Thus, reading an overflow bit at a frequency of 250 Hz allows the dynamic of the counter to be increased by the use of external electronics for processing and storage. The counter is enabled via a *Counter Enable Gate* signal (CEG). The 9-bit local configuration register, among other things, is used to store the DACL value. A detailed description of

⁷The XPAD3-C version consists in two separated discriminators for low and high energy thresholds

⁸The OTA design in used for the XPAD3-C version of the chip

the pixel configuration register in the XPAD3-S⁹ version is presented in table 3.2. The readout and write-in operations from and into the pixel are performed via a

Configuration bit	Description
[0]	Activate counter
[1]	Activate analogue and digital test
[2]	Deactivate preamplifier
[8:3]	Value of the local DAC

TABLE 3.2: Description of the XPAD3-S pixel configuration register.

shift-register called *lift*. This memory is a 12×120 -bit register per column that allow data to be transferred along the column in both directions. The source of the data for reading the counters or a configuration is selected with a 12-bit multiplexer. Data are copied to the lift and shifted “down” towards the direction to the readout conveyor placed at the bottom part of the circuit (figure 3.1). Beside the 12-bit data lift, there is also 1-bit lift that allows the readout of the overflow or of the output of the discriminator. Data input is done via a 80×1 -bit “horizontal” shift-register called *SR1*. In order to increase the transfer rate, data are carried out using a 80×4 -bit shift-register called *SR4*.

In addition, analogue and digital parts of the pixel are surrounded with guard rings in order to isolate each part from the other as well as adjacent pixels. The analogue part is surrounded with two, p^+ and n^+ diffusion rings, and the digital part is encircled with one p^+ ring. Moreover, in order to enhance the protection of the most sensitive analogue front-end part (the input of the detector) from the influence of the most noisy digital element part that consists in the least significant bit (lsb)¹⁰, the distance between these two parts was maximized (figure 3.1).

3.2.3 Modes of operation

Each of the three parts of the detector (the pixel matrix, the conveyors and the global configuration registers) is designed to perform different actions. The number of inputs in the chip are limited and do not allow to have a dedicated clock and data input for every section of the chip. Thus, a special logic has been designed that is able to decode and execute all operations needed to control the chip with

⁹The XPAD3-C version uses two 8-bit registers to set the low and high thresholds. Local dispersion correction is done with 5-bit and 2-bit DACs for low and high energy discriminators, respectively

¹⁰lsb - least significant bit, LSB - least significant byte.

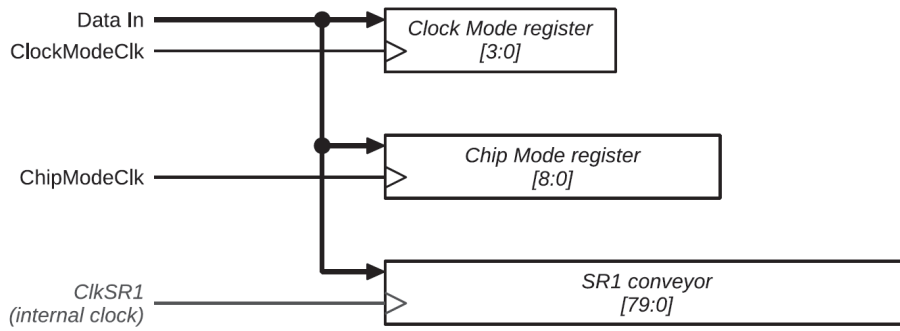

FIGURE 3.3: Programming of the XPAD3 chip modes and actions.

one data input and three clock sources (*DataIn*, *ChipModeClk*, *ClockModeClk* and *MasterClk*).

Key elements in that design are two configuration registers called *ChipMode* and *ClockMode* (figure 3.3). In this section, the available modes of operation depending on the value programmed in these registers are presented.

3.2.3.1 ChipMode register

The *ChipMode* is a 9-bit register that determines the current mode of operation of the different sections of the chip. In particular, it controls the data flow in the

Chip Mode	Value	Allowed operation
SR4 conveyor		
12 bits or 1 bit mode	reg[0]=0	connect SR4 input with pixel lift
	1	connect SR4 input with OVF lift
Conveyor mode	reg[1:2]=00	readout of SR4
	01	complete reset of SR4
	10	write pixels data to SR4
	11	write global registers values to SR4
Pixel		
Pixel data lift mode	reg[3:4]=00	read from SR1
	01	write to SR4
	10	load counter value to pixel lift
	11	load configuration register value to pixel lift
OVF or Hit mode	reg[5:6]=00	connect discriminator output with OVF/Hit lift
	01	connect counter OVF bit with OVF/Hit lift
	10	
	11	write to SR4

Global configuration		
ConfigG lift mode	reg[7:8]=00	read from SR1
	01	write to SR4
	10	not used
	11	load global configuration register value to the global configuration lift

TABLE 3.3: List of XPAD3 modes of operation.

chip. Available modes are listed in table 3.3.

3.2.3.2 ClockMode register

The *ClockMode* is a 4-bit register that routes one global clock of the circuit (*MasterClk*) to the selected block of the XPAD3 chip. Possible destinations of the *MasterClk* and subsequent triggered actions are listed in table 3.4.

Clock Mode	Action	Delay	Allowed operation
General			
0000	Reset Global Configuration	No	No
0001	Test Pulse	No	No
0010	Clk DAC TempSensor	No	No
0011	Clear DAC TempSensor	No	No
SR1/SR4 conveyors			
0100	Clk SR1	No	No
0101	Clk SR4	No	No
0110	Store Selcol	No	No
0111	N/A	N/A	N/A
1000	N/A	N/A	N/A
1001	N/A	N/A	N/A
Pixels			
1010	Clk DataLift	Yes	Yes
1011	Store Config	Yes	Yes
1100	Store OVF or Hit	Yes	Yes
1101	Counter clear	Yes	Yes
Global Configuration			
1110	Clk ConfigG Lift	Yes	Yes
1111	Store ConfigG	Yes	Yes

TABLE 3.4: List of XPAD3 actions triggered by the *ClockMode* register.

The operation that requires access to many pixels of the matrix may cause problem related to the noise generated by the high activity of the digital electronics. In order to minimize this effect, the global clock signal that synchronizes the readout and write-in processes of the pixels has been distributed in time and space across

the matrix. The mechanism called *tsunami* is based on delaying the *MasterClock* signal along 80 columns and 120 rows as depicted in figure 3.4. Hence, available actions listed in table 3.4 are divided into those that require the *MasterClock* signal delayed or not delayed.

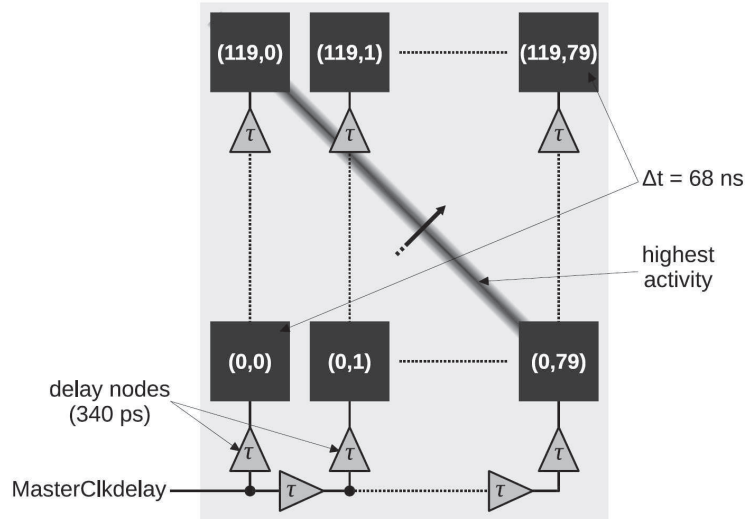

FIGURE 3.4: Distribution of the delayed clock signal.

3.2.4 Global configuration registers

The global configuration registers are placed at the bottom part of the circuit. Every global configuration register has the same design consisting in the digital part of one pixel. Thus, they are called *fake pixels* or *ConfigG*. Despite a similar design like for standard pixels, *fake pixels* have only 9-bit memories. They are organised in a single row that is read and written via the SR4 and SR1 conveyors. Global registers that are available in in the -S version¹¹ of the chip are listed in table 3.5.

However, some cells in a row are not only designed to store global configuration data, but have also extended or different functionalities.

- column 0: instead of *ConfigG*, there are cells called *IOinterface* and *Decoder*. These are responsible for the reception of the control signal from the IO ports and for the control of the digital part of the chip (registers *ChipMode* and *ClockMode*).

¹¹The XPAD3-C version has three more registers called I_{thH} , V_{ref} and V_{adj}

Register name	Column number	Used bits	Description
CMOS Disable[0]	5	ConfigG[1]	Deactivation of CMOS output
Data TestPulse[7:0]	50	ConfigG[8:1]	Injection pulse amplitude
Data I _{mfp} [7:0]	55	ConfigG[8:1]	R _f polarization
Data I _{ota} [7:0]	56	ConfigG[8:1]	OTA polarization
Data I _{pre} [7:0]	59	ConfigG[8:1]	CSA polarization
Data I _{thL} [7:0]	60	ConfigG[8:1]	Low threshold level
Data I _{tune} [7:0]	65	ConfigG[8:1]	DAC threshold and compensation
Data I _{buffer} [7:0]	66	ConfigG[8:1]	Polarization of output buffers
Disable MasterClock output[0]	78	ConfigG[1]	Deactivation of MasterClock output

TABLE 3.5: List of XPAD3-S global configuration registers.

- columns from 1 to 4 and 73 to 76: *ConfigTest* cells. They can probe some digital functionalities.
- columns 39 and 40: instead of *ConfigG*, these cells are temperature sensor control units.
- column 79: *Conveyor_ComeBack* block which is a termination of the SR1 and SR4 conveyors.

The *ConfigG* cells that are not used to store any global configuration can be used by the user as a general purpose memory.

3.2.5 Calibration

One important parameter in the pixel counting chain is the discriminator threshold, particularly with a polychromatic X-ray beam, in order to ensure that each pixel of the matrix is sensitive to the same energy range. As already described above, the global threshold of the matrix is adjusted by setting the I_{thL} parameter. However, the dispersion of the microelectronics process results in a wide pixel threshold distribution all over the matrix. In order to compensate these dispersions, a local 6-bit DAC has been implemented in each pixel. Changing the value of DACL allows to narrow the pixel threshold distribution.

Due to the fact that the signal amplitude value is lost after discrimination (figure 3.2), the value of the threshold has to be derived from the digital output of

the chip. The method that is used is based on the injection of a given number of pulses of known charge to the analogue front-end electronics. The response of the discriminator is then studied with different threshold settings. As a result, a curve that represents a pixel count rate versus its threshold setting is drawn. This curve has a characteristic *S* shape and the method of calibration is called *S-curve method* [30]. An example of an *S-curve* measured with the XPAD3-S chip is shown in figure 3.5b.

The XPAD3 chip is equipped with a charge injector generating a voltage with an amplitude determined by the *TestPulse* register. An injection pulse is distributed among a subset of pixels and charges the preamplifier of the pixels to permit the adjustment of thresholds. Unfortunately, with the first version of the XPAD3 chip, the injector is penalized by a slow rise time, which modifies the signal shape of the preamplifier. Therefore, the calibration of the detector to a desired energy level cannot be performed by the injection pulse, but requires the presence of an external monochromatic beam of known energy. This problem has been fixed for the second generation of the XPAD3 chip.

Another possibility is to calibrate the pixels just above the electronic noise without using an external physical signal, i.e. at the lowest practicable threshold.

The generic procedure of calibration is done with the following steps:

1. Setting of all the pixel DACL values to their middle value (DACL=32).
2. Determination of the global threshold value (register I_{thL}). For this, a loop process is started with the highest possible threshold, i.e. where almost no pixels are counting and the threshold is then gradually lowered. The value of the I_{thL} is then set when half of the pixels are counting.
3. Acquisition of 64 images, each one with a different DACL setting (from 0 to 63)¹².
4. For each pixel, the value of the count rate measured as a function of the DACL value creates a curve with the characteristic *S* shape. This curve allows for determining the best DACL value for the pixel. When a calibration is performed with an external beam, the DACL value is set by the inflection point of the curve that corresponds to one half of the maximum count rate. For the calibration just above the electronic noise, the DACL value is set to the last silent acquisition with the higher DACL value.

¹²By increasing the DACL value, the physical threshold is decreased

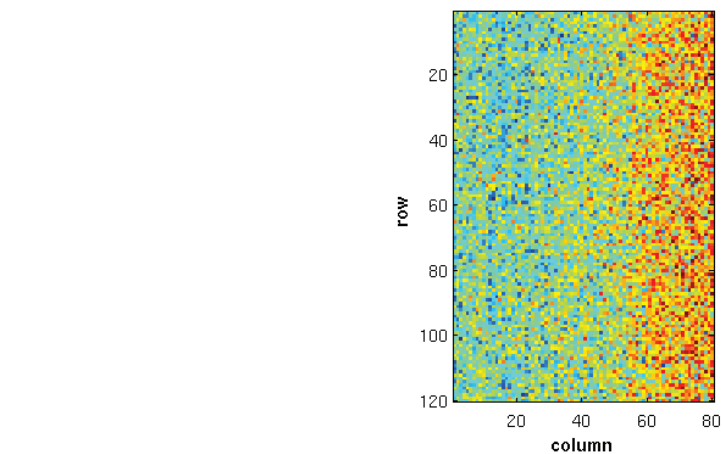
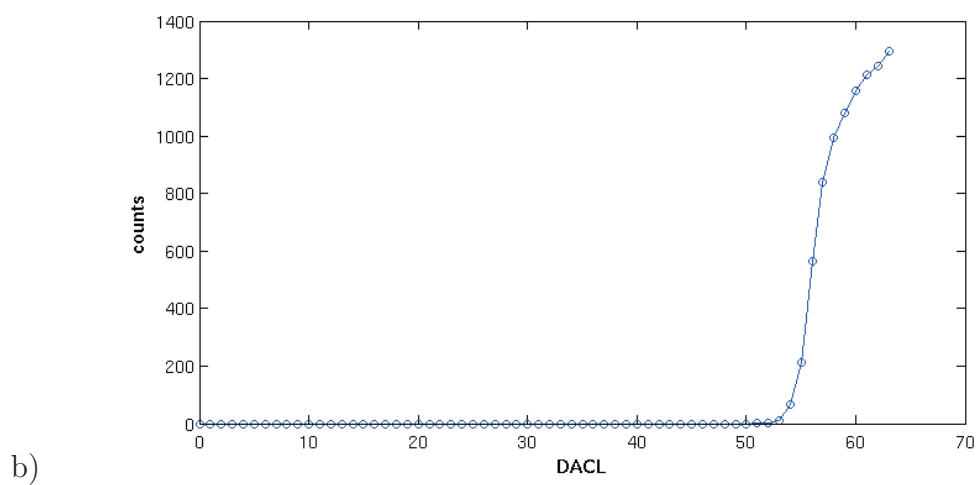
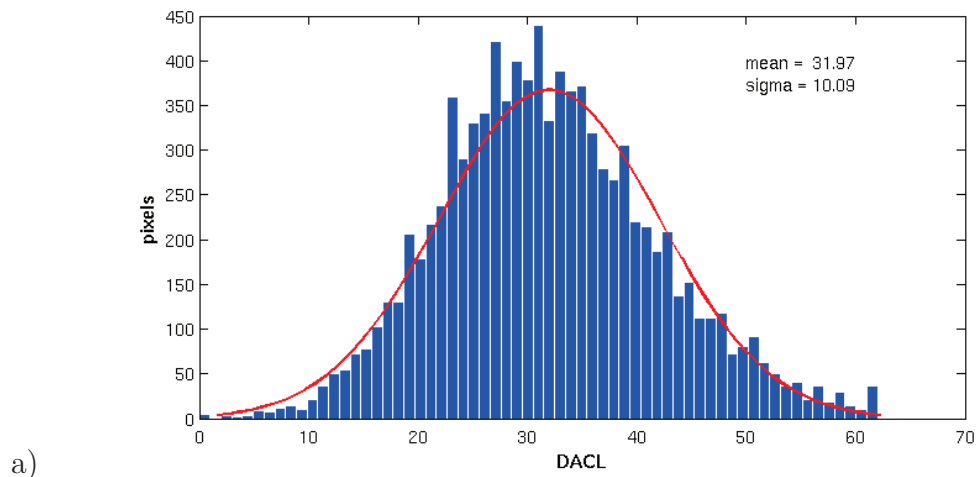

FIGURE 3.5: Result of the calibration with 10 keV monochromatic X-ray beam: (a) histogram of the DACL correction, (b) measured *S-curve* for one pixel and (c) map of the DACL in the matrix.

5. Uploading of the selected DACL values to the pixels.

The result of the calibration at the noise level is shown in figure 3.5. A lateral drift is clearly visible in the map of the DACL values in the chip. This parasitic effect results from the power supply track distribution on the bottom of the matrix [16].

3.2.6 Data transfer

The readout architecture of the XPAD3 is organised in columns that act as shift registers connected to the readout and write-in conveyors. This solution provides a fast and simple readout of the circuit that preserves the reliability of the transfer (in the worst case, only that column will be lost where there is one pixel is broken).

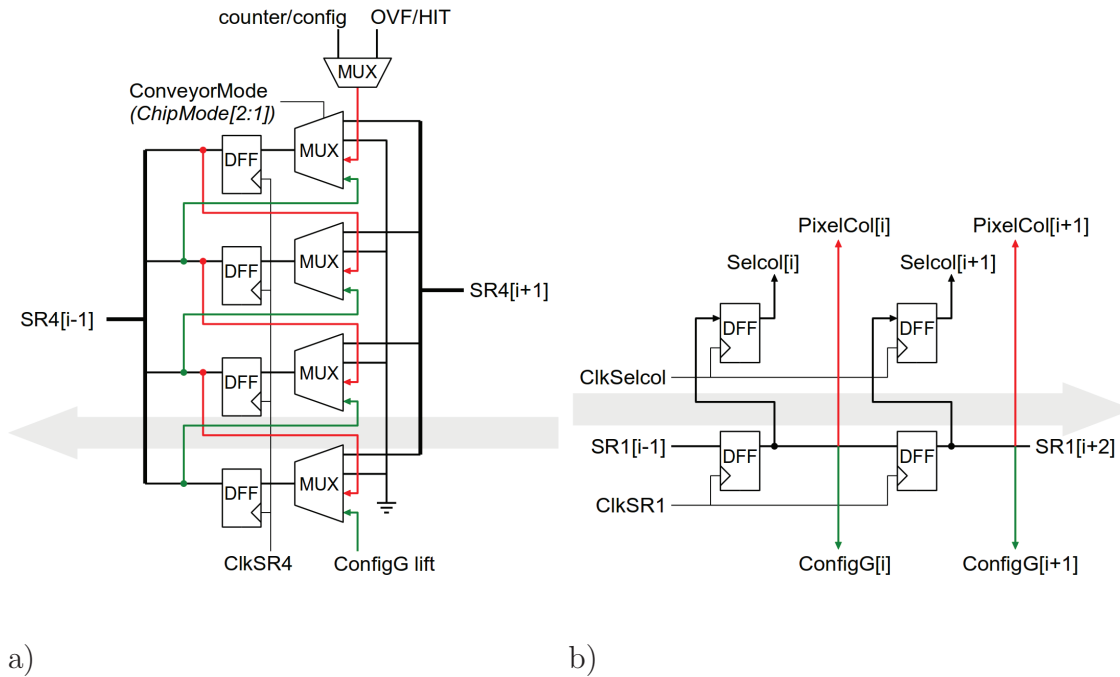

FIGURE 3.6: Architecture of a single cell (a) of the readout conveyor $SR4$ and (b) of the write-in conveyor $SR1$.

The readout of pixel and global registers is done via the 4-bit wide and 80-bit length readout conveyor ($SR4$). The mechanism is based on data shifts from pixel to pixel down to the $SR4$ register placed at the bottom of the matrix.

The following steps need to be taken in order to read the counters or the configuration register:

1. Enable the columns to be read (global operation)

2. Load the counter/configuration to the data lift (global operation)
3. Load the SR4 register using the 4-bits of the data lift (shift down)
4. Flush the SR4 register

Steps 1 and 2 need to be repeated 360 times in order to read the full matrix of pixels (1 column = 120 pixels \times 12 bits = 1440 bits). One has to remember that the *ChipMode* and *ClockMode* registers have to be correctly programmed before each readout step. The readout of the overflow bit of the counter is done the same way, except data are transferred via the 1-bit OVF/Hit lift. In that case, steps 1 and 2 have to be repeated 30 times for reading the pixel matrix (1 column = 120 pixels \times 1 bit).

Writing data to the chip is done in a similar way as reading. In that case, data are first loaded to the 1-bit wide and 80-bit length write-in conveyor (SR1), then copied to the data lift and finally shifted towards the pixel. When writing pixel data, the operation needs to be repeated 1440 times before the lift can be copied to the configuration register. It needs to be repeated only 9 times when writing a global configuration.

3.3 Architecture of the XPAD3 camera

3.3.1 Overview

The complete XPAD3 camera comprises eight detection modules, the HUB board and a PC equipped with a PCI Express board that is running the data acquisition software (DAQ). The global architecture of the readout electronics of the XPAD3 camera is presented in figure 3.7. Every module is connected to its own processing electronics, which is itself connected to the HUB board via a set of a copper cables. The role of the HUB board is to transfer the data sequentially from the modules to a PCI Express board embedded in a PC via two pairs of optical fibres. When writing from the DAQ, data are decoded and redirected to the correct module. Besides data management, an external gate signal is distributed to the modules via the HUB board in order to be able to perform time resolved experiments. Fast data transfer to the PC are ensured by using Direct Memory Access (DMA) transfer between the PCI Express interface and the PC memory.

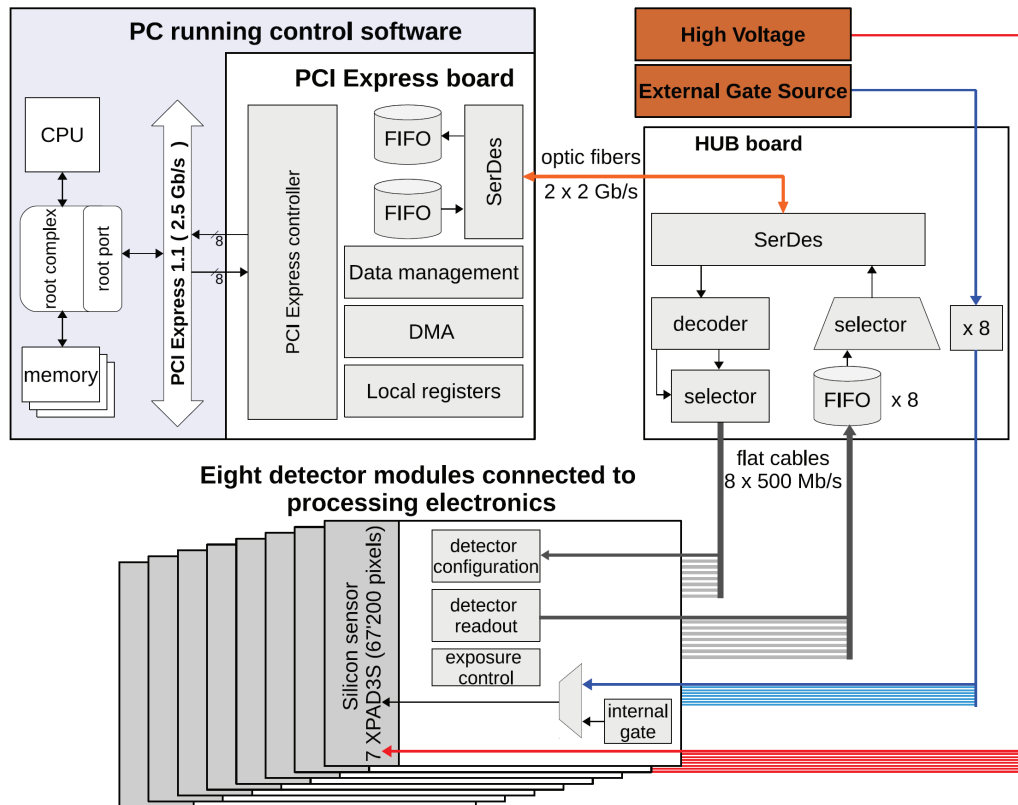

a)



b)

FIGURE 3.7: (a) Global architecture of the XPAD3 camera readout electronics and (b) picture of the complete camera enclosed in the box.

Within this project my contribution consisted in the design and implementation of the readout architecture of the camera. This work consisted in the development of the embedded firmware for every stage of the camera and of a first version of the software library. The firmware development process involved hardware components of the detector equipped with programmable logic (FPGA) such as: the detection modules, the HUB board and the PCI Express board. Communication between the abovementioned components is performed using custom protocols designed within this work. In order to validate the design architecture and to measure the performance of the camera, a preliminary version of the software library was developed.

The final device, especially its fast readout, was tested by conducting three experiments designed for this purpose. Moreover, I have participated in several experiments carried out at synchrotron radiation sources.

The following sections of this chapter include a description of the camera architecture developed specifically within the framework of this doctoral project.

3.3.2 Detection modules

3.3.2.1 Architecture

Every detection module is composed of seven XPAD3-S circuits placed side by side and bump bonded to a $500\ \mu\text{m}$ thick silicon sensor (figure 3.8a). The size of the module is $75.1 \times 15.6\ \text{mm}^2$ (560×120 pixels). In order to avoid dead areas between the chips, pixels at the border of the chip (left and right) have a bigger size of $320 \times 130\ \mu\text{m}^2$ (*long pixels*). This implies that the probability of photon detection in those pixels is 2.45 times higher than in a normal pixel. Therefore, their counter filling rate is proportionally higher.

The seven XPAD3-S chips are wire-bonded to a flexible printed circuit board (the *flex board*), as shown in figure figure 3.8b. The complete camera is formed by eight modules, each one being connected to its own readout electronics (the *Cyclone board*). Cyclone boards are positioned one above the other (figure 3.8c). Modules are assembled with a 7° tilt in order to avoid gaps between individual modules (tiled architecture) as shown in figure 3.8d.

The architecture of the design is shown in figure 3.9b. The programming system is based on a System On Programmable Chip (SOPC) of which most components

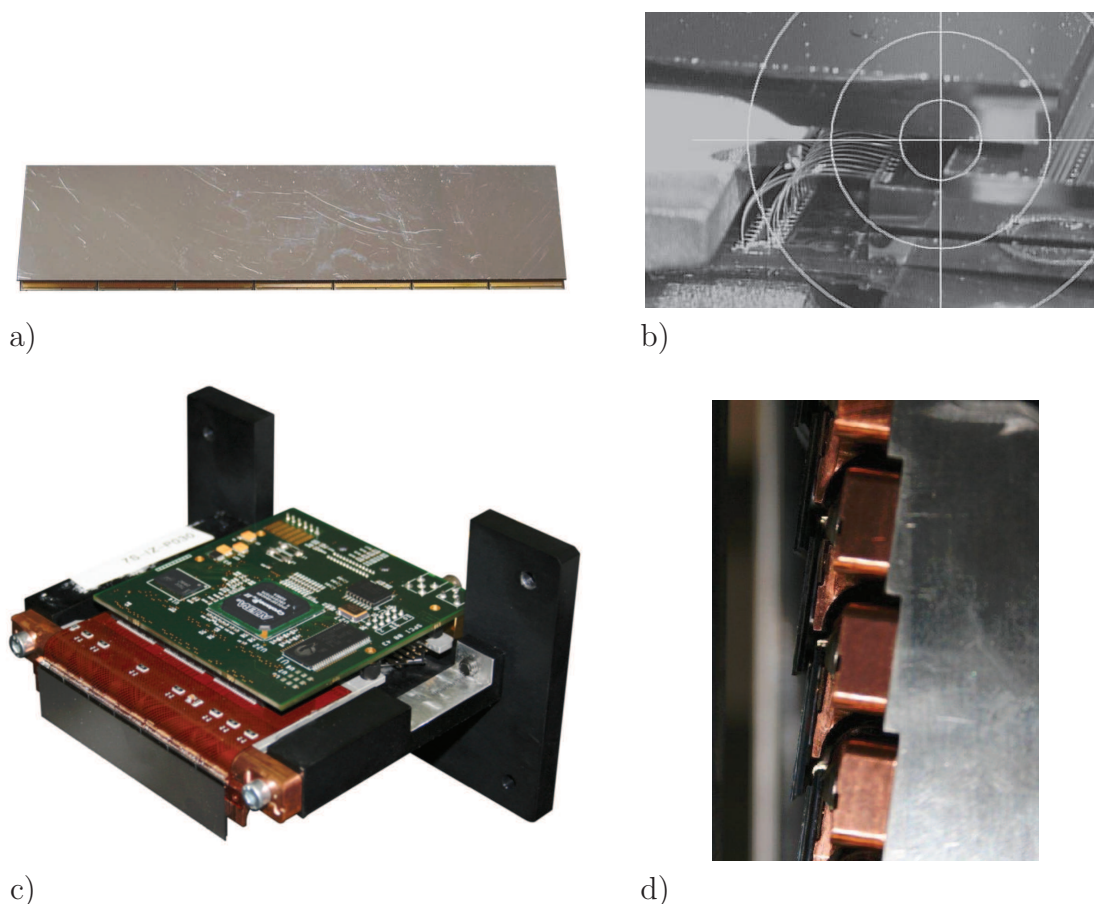

FIGURE 3.8: XPAD3 detector: (a) 7 XPAD3-S chips are bump-bonded to the silicon sensor and (b) wire-bonded to a *flex board* (c) that is connected to its processing board. Finally (d) 8 modules are tiled to form the complete camera.

are embedded in the FPGA circuit. The core of the design is a 32-bits Altera NIOS II soft processor [1]. The board comprises two memory chips, a 1 Gbit DDR2 SDRAM¹³ that works as a RAM memory of the NIOSII processor and a 16 Mbit asynchronous SRAM¹⁴ memory that is used as a temporary storage of the detector data. The configuration of the FPGA chip can be done through a JTAG¹⁵ connector by using an appropriate programming software or automatically after power-on from the serial programming device (EPCS64 flash memory). In addition, reprogramming of the device can be done from the HUB board by forcing to low (ground) a dedicated reconfiguration pin of the FPGA that is accessible through a connector. The board has two clock sources, a 125 MHz clock from

¹³Double Data Rate Synchronous Dynamic Random Access Memory. The Cyclone board is equipped with a Micron MT47H64M16HR-3:E memory (566 MT/s, 16-bit data bus)

¹⁴Static RAM memory. The Cyclone board is equipped with a Cypress CY7C1061AV33 memory

¹⁵Joint Test Action Group

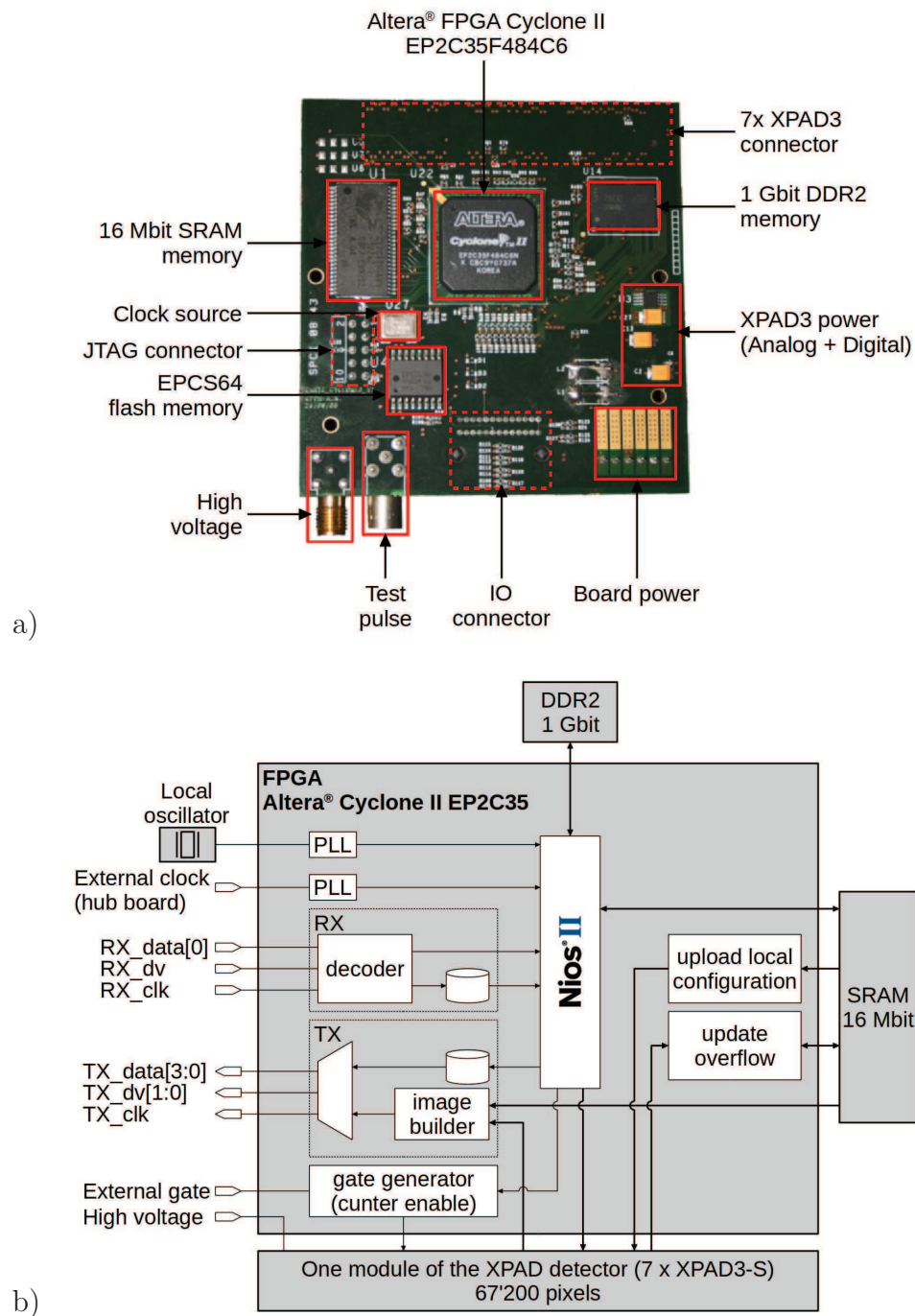

FIGURE 3.9: Cyclone board: (a) top view with description, (b) architecture of the embedded system.

a local oscillator and a 125 MHz signal provided by the HUB board, that feed PLLs¹⁶ implemented in the FPGA device. Several clocks with different frequencies and phases are generated and distributed within the implemented logic in the FPGA, to the DDR2 memory chip and to the seven XPAD3-S chips. The board

¹⁶Phase-Locked Loop

is supplied from an external alimentation that provide different voltages to supply the components placed on the board, the high voltage used to deplete the detector silicon sensor ($> 100\text{ V}$) and both the analogue and the digital voltages used for the XPAD3 chips. Communication with the HUB board is done via a 26-pin connector whose description is shown in the figure 3.10 below. Clocks and data are sent in LVDS¹⁷ standard.

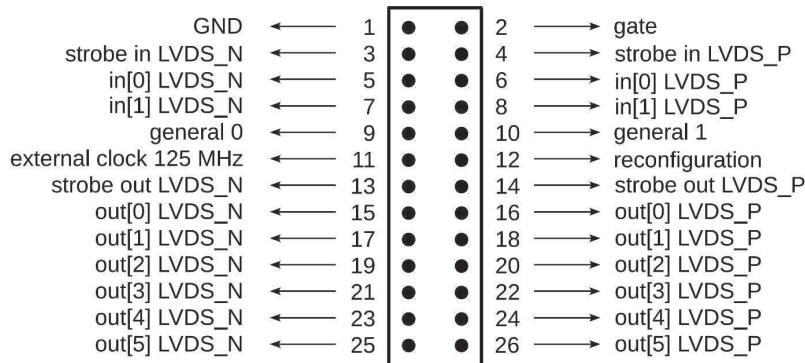

FIGURE 3.10: Description of the Cyclone board connector.

3.3.2.2 Data reception

To provide fast and simple communication between individual boards of the camera (i.e. between the HUB board and the Cyclone board) a custom communication protocol has been developed. A protocol message is built out of 16-bit words and its

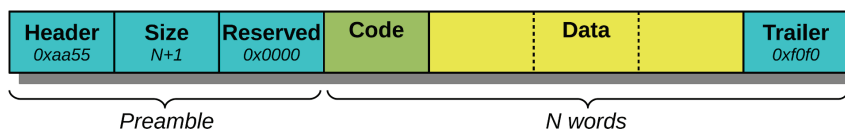

FIGURE 3.11: Format of the incoming messages.

description is shown in figure 3.11. A message consists of three words of preamble that always start with a constant word (*header*) of hexadecimal value 0xaa55, followed by the word representing the length of the message and a reserved word¹⁸. After the preamble message, a command word is placed to be detected by the NIOSII software. This word precedes the required number of data words. Finally,

¹⁷Low-Voltage Differential Signalling

¹⁸This reserved word is intended to be used as cyclic redundancy check (CRC) or checksum in case of transmission errors.

the message ends with a constant word (*trailer*) of hexadecimal value 0xf0f0. Furthermore, the designed system is able to receive special short messages (*ad hoc*¹⁹ commands) that are detected before being forwarded to the NIOSII processor. It allows to generate a software reset pulse, assign an identification number to the current module (from 1 to 8), and set and reset a HUB busy signal that indicates that the HUB board is not able to receive data from the module. Data from the HUB board are received from three inputs: clock, data and dv (data valid). The block diagram of the reception part is presented in figure 3.12. Incoming data

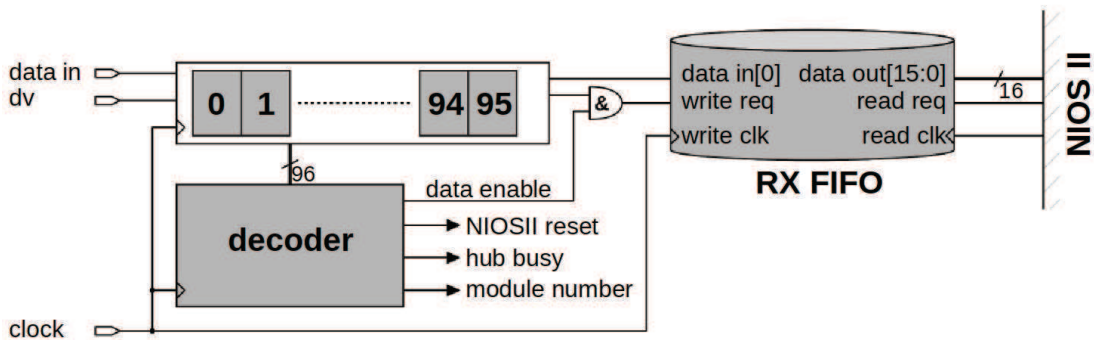

FIGURE 3.12: Architecture of the data reception block.

are first buffered in a 96-bit long register for detecting a valid data and the type of message (i.e. *ad hoc* or standard). In the case of a standard module message, data are deserialized and stored in the FIFO memory. The content of that FIFO is continuously checked by the NIOSII processor and a proper action is taken, according to the detected command word. Available commands and acknowledgement messages are listed in table 3.6.

3.3.2.3 Detector configuration

In order to upload the calibration data to the detector, both the global and the local configuration registers of the XPAD3 chip have to be programmed. The process is performed in two steps: data are first saved into the local storage and then uploaded to the detector. This allows to store several different calibration data sets and to modify these rapidly during an experiment. A single calibration of one chip includes 9600 values for local pixel configurations and 11 values for global registers. Local configuration data for the whole module (67200 bytes, one byte per pixel) are saved in the SRAM memory. In order to optimize the use of the

¹⁹*ad hoc* - designed for a specific task

memory, only DACL values of each pixels are saved (6-bits), while the remaining 3 bits of the 9-bit register are kept constant. The values of the global configuration registers are stored in the RAM memory of the NIOSII processor. The SRAM

Command name	Command code	Data	Ack code	Description
Ask ready	0x0101	N/A	0x1101	Diagnostic message, verify if a module responds
Auto test	0x0102	[0]-counter value	0x1102	Load known value to every pixel
ConfigG	0x0103	[0]-chip mask [1]-register [2]-value	0x1103	Configure selected register in a selected chip
All ConfigG	0x0203	[0]-chip mask [11:1]-values	0x1203	Configure every register of a selected chip
Flat config	0x0104	[0]-unsued [1]-chip mask [2]-value	0x1104	Load a known value of the local configuration register in a selected chip
Read img 2B	0x0182	N/A	N/A <i>image</i>	Read all pixel counters and send the data (image) to the PC. Each pixel value is stored on 2 bytes
Read img 4B	0x0183	N/A	N/A <i>image</i>	Read all pixel counters and send the data (image) to the PC. Each pixel value is stored on 4 bytes
Read config	0x01c0	N/A	N/A <i>image</i>	Read all pixel configurations and send data to the PC as an image
Save configL	0x0380	[0]-calib id [1]-chip [2]-row [82:3]-values	0x1380	Save local configuration data (80 values in a row) in the SRAM memory
Save configG	0x0381	[0]-calib id [1]-register [8:2]-values	0x1381	Save global configuration data for every chip in the RAM memory (DDR2)
Load calib	0x0480	[0]-calib id	0x1480	Upload previously saved data to the detector (local and global)
Expose	0x0140	[0]-mode [1]-length [2]-time unit	0x1140	Generation of a gate signal to enable pixel counters
Acquire N	0x0141	[0]-mode [1]-length [2]-time unit [3]-N loops	N/A <i>image</i>	Acquire and transmit N images

TABLE 3.6: List of NIOSII commands.

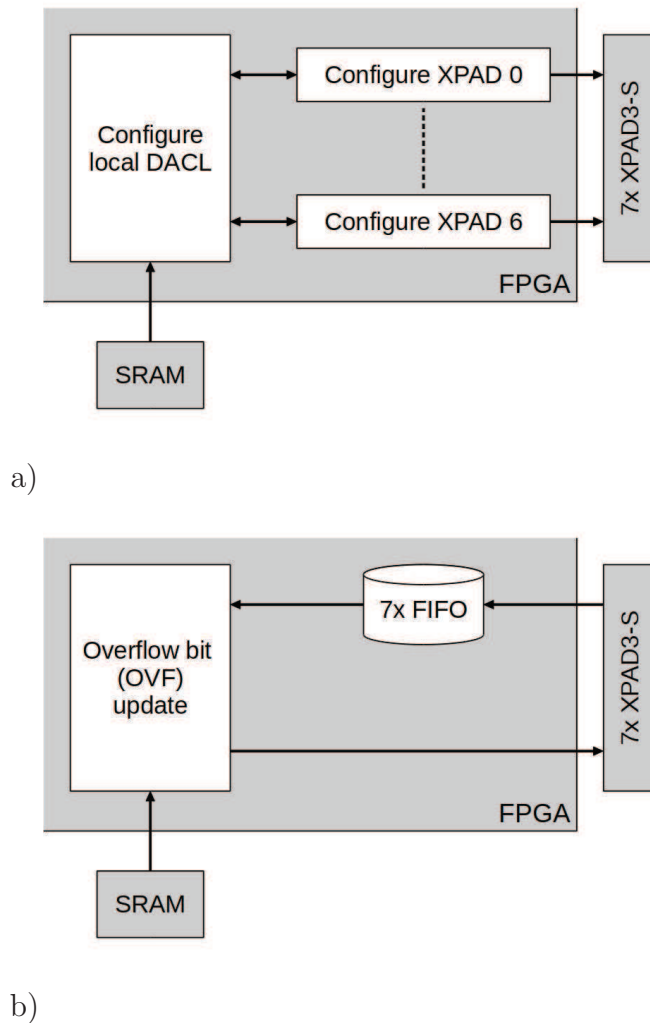

FIGURE 3.13: Block diagram that shows (a) uploading of the local DACL values to the detector pixels and (b) update if the overflow bit (OVF).

memory has three predefined regions where the local configuration data are saved. The module receives the local configuration data in a message that includes 80 words for one line in one chip. Therefore, transfer of data for seven chips is done with 840 messages. A single SRAM memory cell is 16-bit wide, which allows for saving the local DACL values for two pixels under one single 20-bit memory address (one pixel per byte). Programming of the detector registers is done in two consecutive processes: the configuration of the global registers by the soft processor and the configuration of the local register by the custom hardware logic implemented on the FPGA. The second process is done in parallel in every chip and takes less than 5 ms. The block diagram that shows uploading of the local DACL values is presented in figure 3.13a.

3.3.2.4 Readout of the overflow bits

To extend the dynamic range of the pixel counter, an overflow bit of the pixel counter can be read out periodically during irradiation. Due to the occupancy of the analogue chain, the maximum count rate of one pixel is limited to 10^6 photon/pixel/s. In order to handle such a count rate with a 12-bit counter, the frequency at which one must read the overflow bit cannot be lower than 250 Hz. Furthermore taking into account the fact that double pixels have a size approximately 2.3 times bigger than normal pixel, the frequency of the overflow bit readout should not be lower than 0.5 kHz. Reading the overflow bit of every pixel during an experiment at the highest affordable counting rate (10^6 counts/pixel/s) implies to disable the counters for $100 \mu\text{s}$ every 4 ms (2.5% dead time) because of the depth of the counter (12 bits). In the current design, every change of the overflow bit is used to increment a 15-bit counter located in the SRAM memory. This allows to extend the dynamic range of the counter to 27 bits (15 bits + 12 bits of the counter itself), which enables to store up to $\sim 134 \times 10^6$ counts. The architecture of the overflow updating logic is presented in figure 3.13b. For every chip, when the process is started, the overflow bits are stored separately in FIFO memories. After that, the overflow bits are processed within 67200 recurrent steps. The new value is then recorded in the SRAM memory. For each pixel this value is stored in one memory cell that has a size of 16-bits, the 15 least significant bits are used to store the actual value of the overflow and the most significant bit (msb)²⁰ is used to store the previous value of the overflow bit for the processed pixel. Actions that are taken in each one of the 67200 steps are shown in figure 3.14. The value of the processed overflow bit is compared with the msb of the SRAM word. If they are different, the overflow counter is incremented by one. The new values of the overflow counter and of the bit 15 are stored in the SRAM memory, before the memory address is incremented to process the next pixel.

3.3.2.5 Data transmission

The transfer of the data from the module is done via a 4-bit wide data bus, two data valid signals and a clock (all these signals being in LVDS standard). The block diagram of the data transmission part is shown in figure 3.15. There are three types of data that can be sent out from the module board. For each data type, the length of the message is predefined. Similarly to message reception, the

²⁰msb - most significant bit, MSB - most significant byte

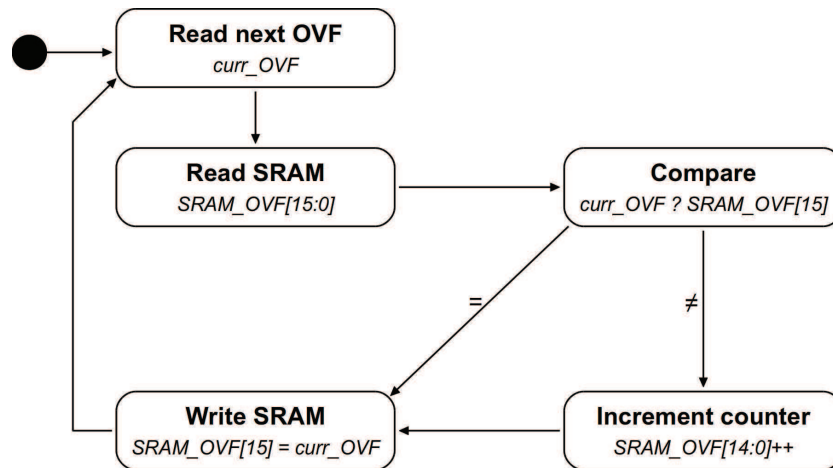

FIGURE 3.14: State machine representing one step of the overflow processing. The whole process consists in 67200 steps.

messages are built of 16-bit wide words. Therefore, since the output bus is 4-bit wide, every word has to be deserialized and sent in four cycles.

The first type of messages are *ad hoc* commands to the HUB board. The length of these messages is 8 bytes. Only one command of this type is implemented with the present design, but in principle there are no limitations from the system. The existing command is the request of the module ID that is sent to the HUB board after power-up or reset.

The second type of message is the acknowledgement for the commands received from the DAQ software and detected by the soft-core processor NIOSII. It has a fixed size of 16 words of 16 bits. The format of these messages is shown in figure 3.16a. Implemented acknowledgement messages are listed in table 3.6. In order to transfer the acknowledgement, the NIOSII processor stores the complete message in a dedicated FIFO memory. The FIFO is then read out with a 100 MHz clock, the data valid signal is assigned during the process and data are transferred to the HUB board.

The last type of message represents pixel data, counters or local configuration registers. These values are sent within 120 messages, each of them containing the data from one line of the detection module (560 values from seven XPAD3 chips). The format of these messages is shown in figure 3.16b and c. The transfer of data is started by copying the pixel counters or the configuration to the data lifts. Afterwards, two processes are started, one process reads data line by line from the detector and the second one creates data packets and sends them to the HUB board. Both processes are concurrent. As one line is read from the

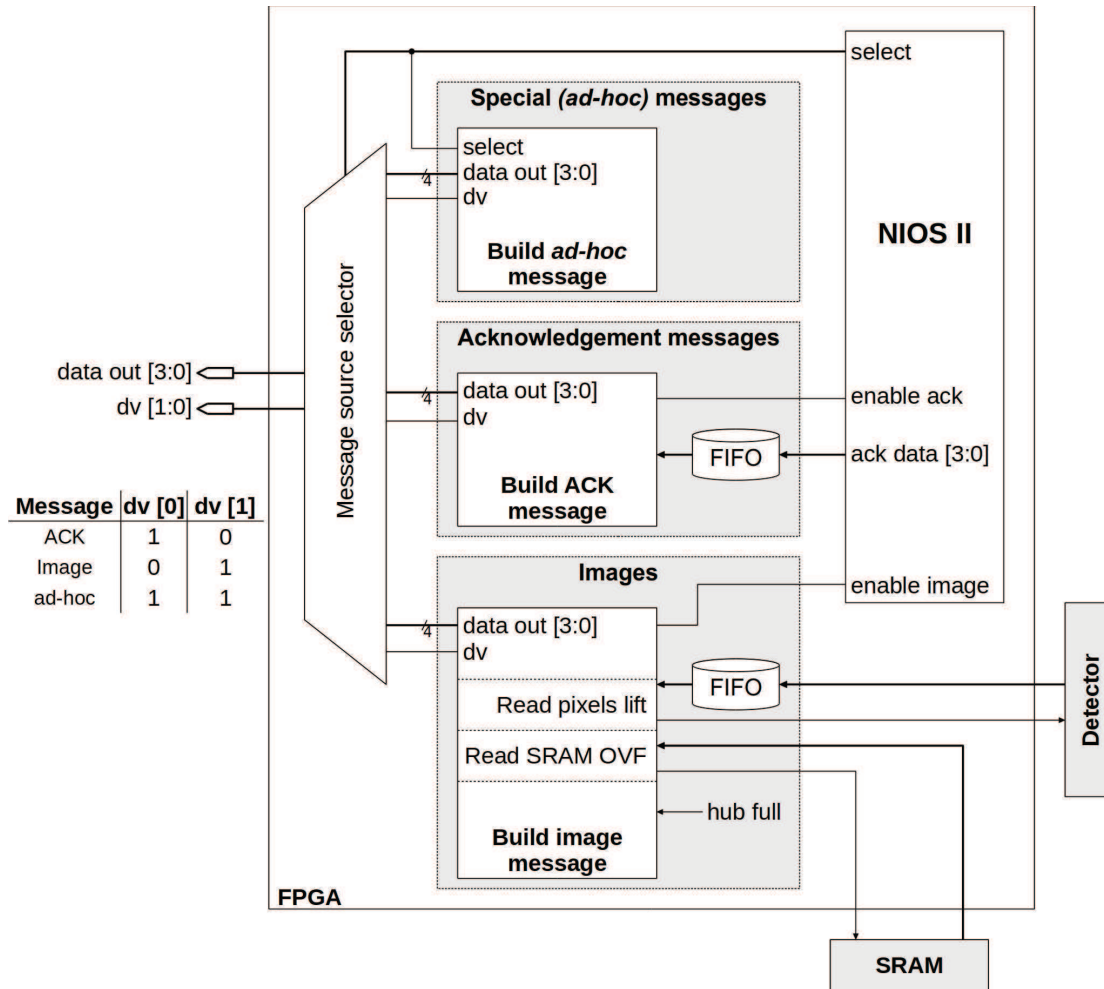

FIGURE 3.15: Block diagram of data transmission.

detector and stored in the temporary FIFO memory, the line that was previously read is transmitted to the HUB board. If the HUB board is not able to receive any more data from the module, the *HUB_full* signal is assigned and the readout process is paused until the *HUB_full* is cleared back. In case of reading the local configuration data, the value of each pixel is represented by 2 bytes, the 9 least significant bits containing the register value and the remaining 7 most significant bits are all being zeroed. When the counts of the pixels are sent, the read-out of the “in-pixel” value in order to be added to the counter that is stored in the SRAM memory. In that case, the value of one pixel can be represented either by 2 or 4 bytes. In the first case, the least significant 12 bits from the pixel counter and the 4 most significant bits form the 4 least significant bits of the overflow counter. In the second case, when a pixel value is represented by 4 bytes, the 12 bits of the pixel counter are combined with the 15 bits of the overflow counter, thus

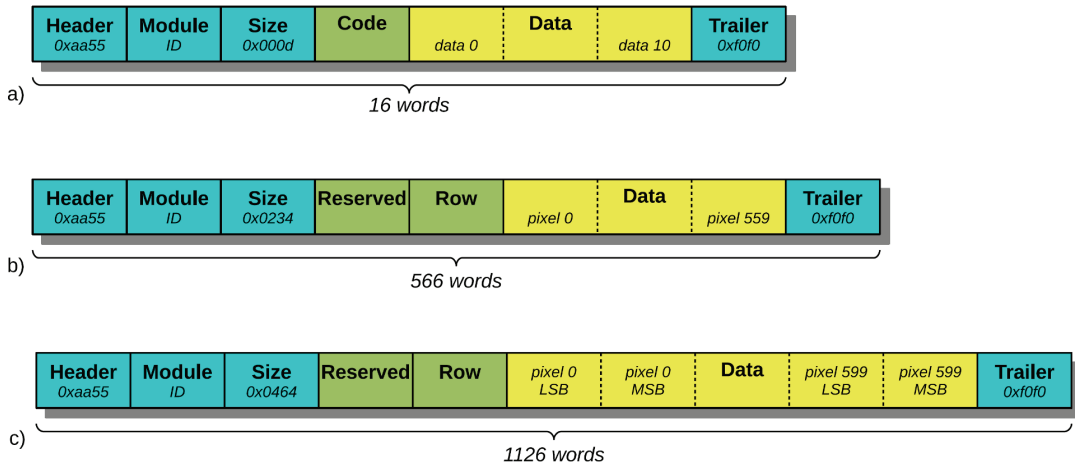

FIGURE 3.16: Format of the outgoing messages: (a) acknowledgement message and (b) image data with pixel counters stored on 2 bytes and (c) 4 bytes.

creating a 27-bit wide value that represents the number of the counts per pixel (the remaining most significant 5 bits being all zeroed). The transfer duration is determined by the time needed to send data to the HUB board via the 4-bit wide output bus and not by the readout of the detector itself.

		Configuration 2B	Counter 2B	Counter 4B
Transfer Time	100 MHz	2.71 ms	2.71 ms	5.88 ms
	125 MHz	2.17 ms	2.17 ms	4.71 ms
XPAD3 Readout Time	50 MHz	1.974 ms		

TABLE 3.7: Time of readout of the XPAD3 chip and data transfer depending on the format and readout clock frequency.

The transfer time versus data format are shown in table 3.7. The readout at a 125 MHz frequency is more than 0.5 ms faster than in the case of using a 100 MHz clock with 2 bytes data. Nevertheless, in the current camera design, the readout is implemented with a 100 MHz clock, because of the advantage of a faster clock in the module vanishes due to the limitation located in the hardware and software of the PCI Express board. This issue will be discussed later in this thesis.

3.3.2.6 Exposure

In the camera design, the signal (*gate*) that enables the counters of the pixels can be provided in two ways (see figure 3.2 for pixel details): either generated

internally or provided by an external source as shown in figure 3.17. These two

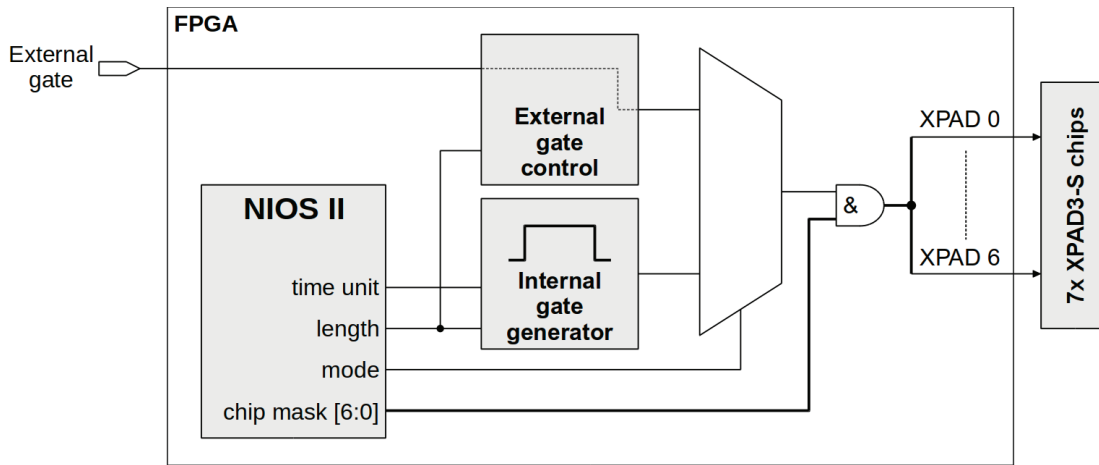

FIGURE 3.17: Generation and distribution of the gate signal to the pixels.

types of gate signals allow for carrying out an experiment with a very high time resolution (of the order of microseconds) and to synchronise it with an external apparatus. The mode and parameters of the gate are specified by the arguments of the *Expose* command received by the NIOSII processor (table 3.6). The function provides three parameters that control the gate signal generation, *gate mode*, *gate length* and *time unit*. Their description is given in the table 3.8.

Parameter	Description
gate mode	definition of the signal's source: <ul style="list-style-type: none"> · 0 - internal gate · 1 - external gate
gate length	depending on the mode of the gate parameter indicates: <ul style="list-style-type: none"> · internal - number of clocks cycles with frequency defined by time unit parameter · external - number of the external pulses
time unit	valid only for internal gate: <ul style="list-style-type: none"> · 1 - microseconds · 2 - milliseconds · 3 - seconds

TABLE 3.8: Description of the *Exposure* function parameters that are responsible for the gate signal generation and distribution.

Due to parasitic effects inside the chip, time resolved experiments cannot be carried out with a gate signal shorter than $1 \mu\text{s}$. All pixels along the columns are driven from one source, as it can be seen in figure 3.18. The parasitic capacitance of every column combined with the resistance between each column create different

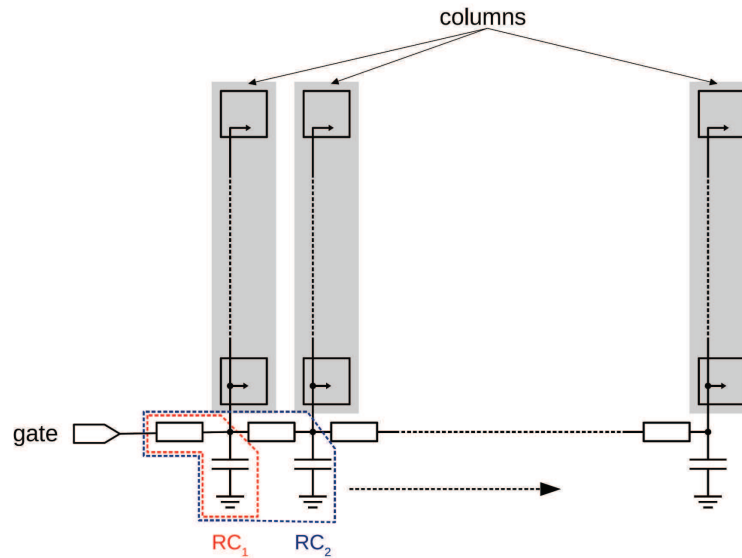

FIGURE 3.18: Distribution of the gate signal in the XPAD3-S chip.

RC circuits for every column. This leads to different time responses of given RC circuits to the gate signal and different slopes of the signal. In case of very short gates ($< 1 \mu\text{s}$), it may result in a situation where different columns are counting at different times.

3.3.3 The HUB board

3.3.3.1 Architecture

The core of the HUB board are two Altera Arria GX chips with eight embedded serial transceiver channels of maximum speed 3.125 Gbps. The board is shown in figure 3.19 together with its component description. Three optical transceivers are available on the board, two of them are connected directly to the FPGAs and one is connected to auxiliary external serializing/deserializing chips²¹. The board has eight connectors that allow to connect four modules per Arria GX chip. The external gate signal is entering the HUB via a SMA connector and is distributed to the modules via the FPGA chips. In addition, two spare signals can be provided to each one of the chips via SMA²² connectors. The board has a clock fanout buffer that multiplexes the 125 MHz clock signal between the Arria GX chips and the eight modules.

²¹A TLK2501 chip from Texas Instruments

²²SubMiniature version A connector

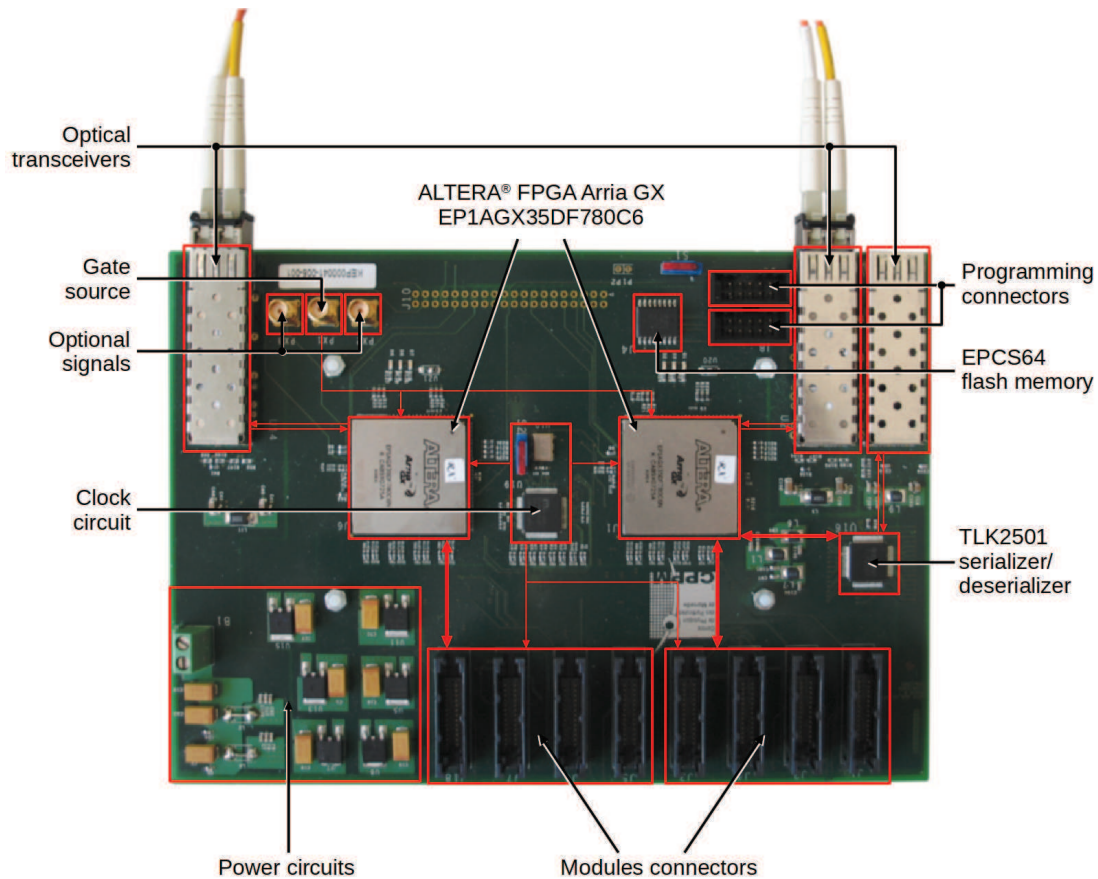

FIGURE 3.19: Picture of the HUB board with its component description.

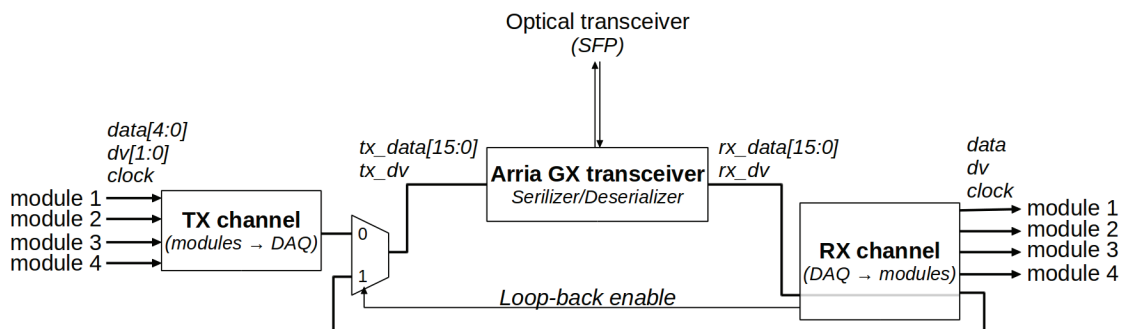

FIGURE 3.20: Picture and component description of the HUB board.

The global architecture of the design, which is implemented in the Arria GX chips, is shown in figure 3.20. The functionality of both chips is exactly the same and each chip is working independently from the other. The HUB board is composed of three main blocks: a transceiver, a data transmission downed towards from the DAQ to the module (RX channel) and another one from the modules to the DAQ (TX channel).

3.3.3.2 Arria GX transceiver

The Arria GX transceiver device used in the HUB board consists in two full duplex (transmitter and receiver) four-channel transceiver groups called *transceiver blocks*. Each transceiver block can be configured to work in one of the supported protocols [96]. The transceivers used in the HUB board design are configured to work at a speed of 2 Gbps in basic mode with 16-bit channels. The transceiver data path is shown in figure 3.21.

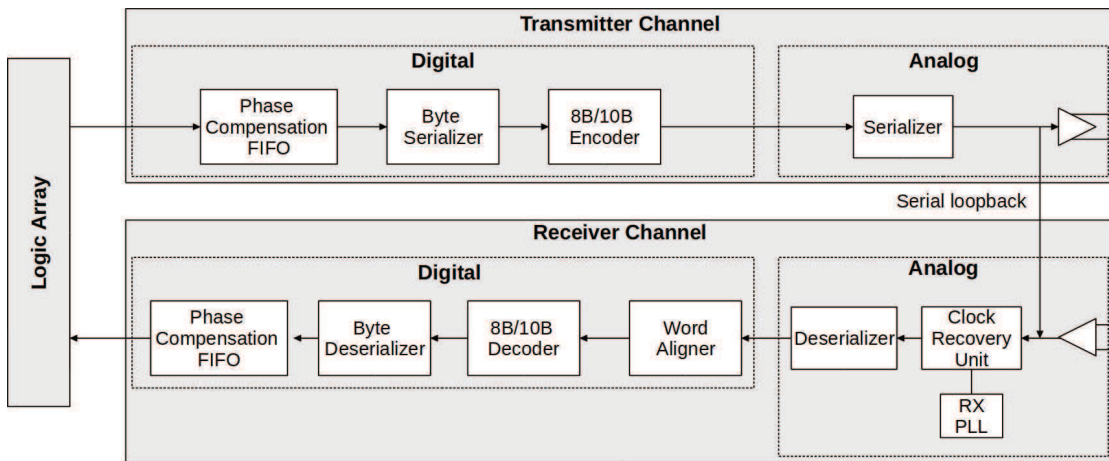

FIGURE 3.21: Transceiver data path.

The transmitter channel comprises a phase compensation FIFO, a byte serializer, an 8b/10b encoder, and a serializer. The byte serializer block takes 2-byte data from the compensation FIFO and serializes it into 1-byte data at twice the speed. Data are passed to the 8b/10b encoder block that generates a 10-bit data from the 1-byte word and the 1-bit control identifier. Depending on the control identifier bit, an 8-bit word is encoded as a data code group (Dx.y) or a control code group (Kx.y). Details of the 8b/10b encoding can be found in [11]. Encoded data are serialized with a high-speed serial clock (2 GHz) and transmitted to the output buffer.

The receiver channel consists of the following sub-blocks: a clock recovery unit, a deserializer (serial to parallel conversion), a word aligner, an 8b/10b decoder, a byte deserializer, and a phase compensation FIFO. The clock recovery unit (CRU) in conjunction with the receiver PLL generates two clocks: a high-speed serial recovered clock and a low-speed parallel clock for the digital part of the receiver logic. The receiver PLL and the CRU are operating in the *lock-to-data* mode, which means that these units are locked to the frequency and phase of the incoming

tx_dataout	1CBCh	0000h	0001h	0002h	0003h	0004h	0
tx_ctrldet	3h	0h					
rx_dataout	BC1Ch	001Ch	0100h	0200h	0300h	0400h	0
rx_ctrldet	3h	1h					0h
data_out	1CBCh	0000h	0001h	0			
ctrldet_out	3h	0h					

FIGURE 3.23: Byte reordering implemented in the camera design: transmitted data (top), detected byte swap in the received data (middle) and data correctly reordered by the implemented logic (bottom).

3.3.3.3 RX channel (from DAQ to modules)

The architecture of the receiving part of the HUB board is shown in figure 3.24. Data received from the byte reordering logic are queued in a 8-word deep shift

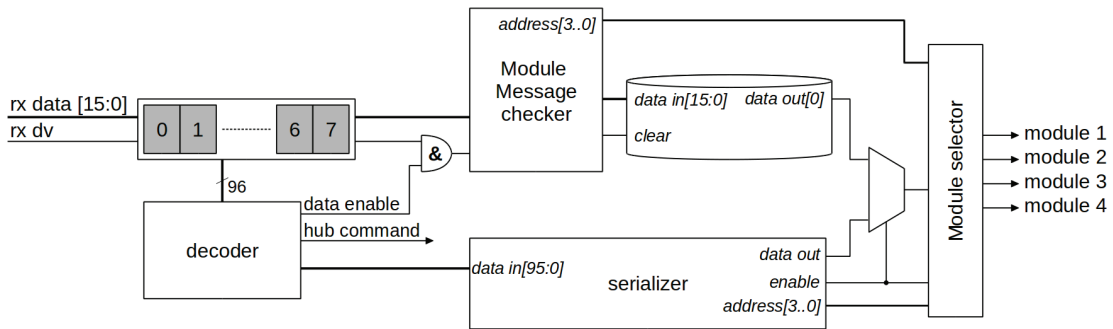

FIGURE 3.24: Architecture of the reception part of the HUB board.

register in order to recognize properly the type of message. Three types of messages are implemented in the HUB board: messages to the module(s) connected to the board, messages dedicated to the HUB board and special high priority messages to the modules. The formats of the module and HUB messages are shown in figure 3.25. The structures of the messages are similar to those described in the previous section. Data start with a constant header word (0xbb44), which is followed by the message type and the word size. The message type determines if the message is addressed either to the detection modules (0x3333) or to the HUB board (0xcccc), and the word size is the length of the message (number of words following the word size message). In the case of a HUB message, the next word is the command word followed by data words. In the case of a module message, the next word is the module mask followed by module message data. The module mask word is provided as an 8-bit word and each one of the FPGA of the HUB

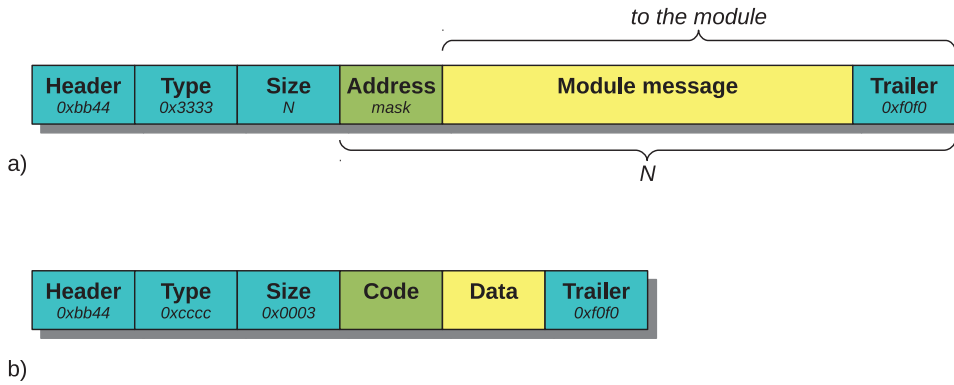

FIGURE 3.25: Format of the HUB board messages.

checks different 4 bit sections of this word (mask[3:0] in the case of first FPGA and mask[7:4] in the case of the second FPGA).

The detected module message is passed to the sub-block that extracts the address. The complete message is checked and saved in the FIFO. A message check consists in the verification of the length corresponding to the word size message word and in the verification of the last word. If the result is correct, the message is serialized into 1-bit data and sent to the modules that are enabled in the mask word. Some of the messages sent to the modules have a higher priority than standard messages. Hence they are sent directly and bypass the FIFO memory. This type of message has a fixed size of 12-bytes (6 words) and is copied to the serializer sub-block whenever detected. The serializer takes the complete 96-bit message and sends it to the selected modules in 1-bit format. High priority messages sent to the module are used to reset the module soft-core processor and assign an identification number to the module. All data are sent to the modules at a speed of 50 Mbps.

Another group of data are the commands dedicated for the HUB board. The HUB commands are listed in the table 3.9. The last two instructions in the table are used to perform a diagnostic test of the communication over the optical links between the HUB board and the PCI Express board. Once a loopback test is enabled, data that are received from the DAQ are sent back, as depicted in figure 3.20.

3.3.3.4 TX channel (from modules to DAQ)

Every Arria GX FPGA transmits data from four detection modules to one of the optical transceivers. The architecture of the transmitting part of the HUB board is shown in figure 3.26. Every module has its own data buffer implemented in

Name	Code	Data	Description
Reconfigure modules	0x03ff	mask	Generates a 20 μ s pulse to reconfigure the modules
Reset HUB	0x05ff	N/A	Reset of every HUB board FIFO and sub-block
2 byte image	0x0182	N/A	Image data from the module in 2 byte format
4 byte image	0x0183	N/A	Image data from the module in 4 byte format
Loopback enable	0x0001	N/A	Enable the HUB loopback mode
Loopback disable	0x0002	N/A	Disable the HUB loopback mode

TABLE 3.9: List of the implemented HUB board commands.

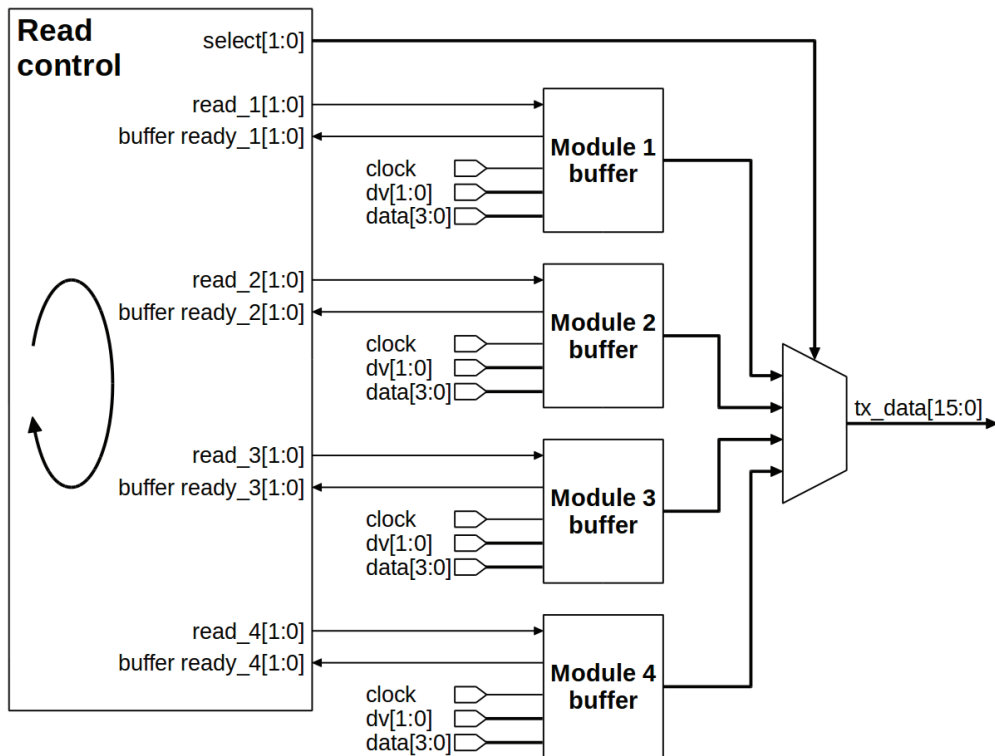

FIGURE 3.26: Architecture of the transmitting part of the HUB board.

the HUB. This buffer consists mainly in two FIFO memories (one for images and another one for commands), one ad-hoc command decoder and associated logics (see figure 3.27). Depending on the value of the data valid ($dv[1:0]$) signal, the module message is either written to one of these two available FIFO memories or a dedicated, ad-hoc type, command is detected. The module buffer has two signals to indicate that an image or a command FIFO is ready for being read

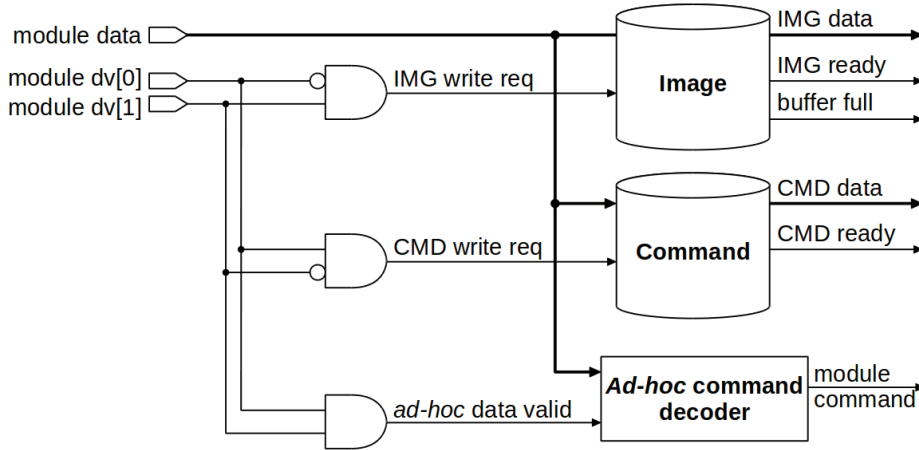

FIGURE 3.27: Architecture of the module buffer.

out. The image FIFO ready is asserted when it contains a number of words that corresponds to size of one line of the detector module (566 words when data are sent in the 2-byte format or 1226 words in the 4-byte format).

The command FIFO ready signal is asserted when at least 16 words (size of one acknowledgement message from the module) are in that FIFO. Reading out data from the four modules buffers is controlled by the higher-level state machine that continuously checks if any of the buffers is ready for reading. In each readout cycle, only one message from the buffer is transferred. It ensures that the modules will be evenly read out. The image FIFO has a size of 16384 bytes, which is enough to store 14 lines from the detectors in the 2-byte format or 7 lines in the 4-byte format. The command FIFO has a size of 64 bytes, which is enough to store 16 acknowledgement messages from the module. If for some reasons, modules are not read out on time and image buffers are almost full, the HUB busy signal is asserted to the module and kept high until there is a space in the FIFO to receive new data. Module buffers are read out with the 100 MHz clock and the width of the data bus is 16 bits. Due to the fact that modules are writing data via a 4-bit wide bus, the readout process is most efficient when all modules are writing data at the same time to the HUB board. The bandwidth of the HUB board is limited by the bandwidth of the optical transceivers (3.125 Gbps). The actual design is optimized to transfer data at a speed of 1.6 Gbps (2 Gbps after 8b/10b encoding by the transceiver), which matches the bandwidth of four modules connected to one Arria GX chip (one module is writing data at a speed of 400 Mbps).

3.3.4 The PCI Express[®] board

3.3.4.1 Architecture

The PCI Express board used in the camera design is the XpressGXII board of PLDA²⁴ shown in figure 3.28. The board is built around the Altera EP2SGX130

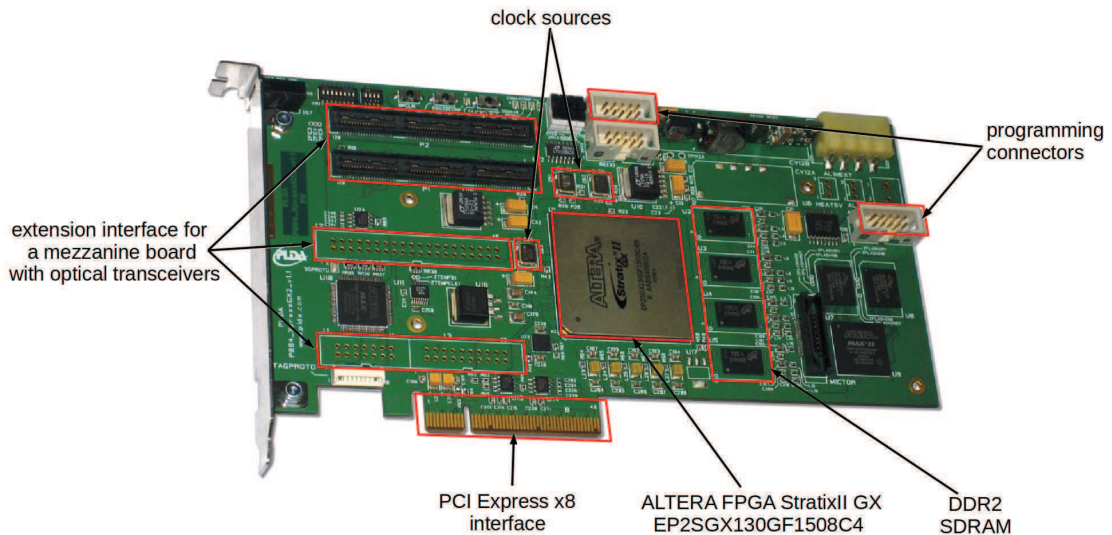

FIGURE 3.28: Picture and component description of the PLDA[®] XpressGXII board.

StartixII GX FPGA. It supports the PCI Express protocol configurations x1, x4 and x8. The optical transceivers are connected to the board via a high speed connector that provides up to eight transmitting and receiving gigabits links (up to 2.5 GHz). The XpressGXII development board is provided with the XpressLite2 PCI Express endpoint with DMA²⁵. The board is plugged to the PC and is connected with the detector acquisition system via two optical fibers. The optical transceivers are placed on a daughter mezzanine board that is attached to the high speed interface. The computer with the XpressGXII board and its daughter board with the optical interface is presented in figure 3.29.

The architecture of the design implemented in the PCI Express board is shown in figure 3.30. Its design includes four top-level blocks: the PCI Express endpoint with DMA (PLDA's Xpress Lite IP core), two transmitting and receiving channels, a slave management block that writes to the configuration registers or

²⁴PLD Applications: <http://www.plda.com>

²⁵Direct Memory Access

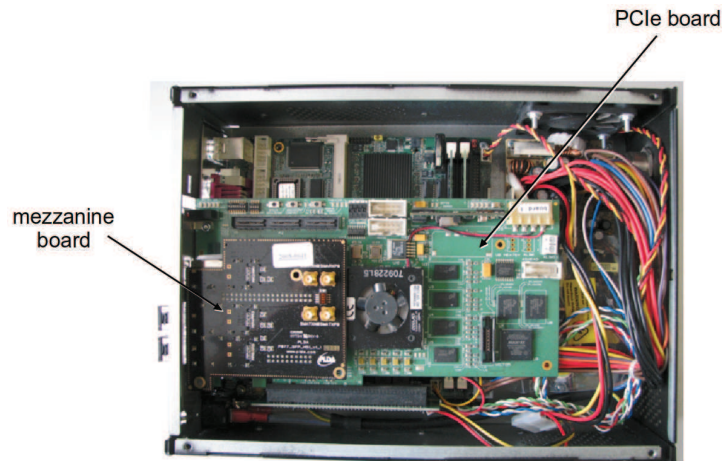

FIGURE 3.29: Picture of the PCI Express board plugged to the acquisition PC with its mezzanine daughter board containing optical transceivers.

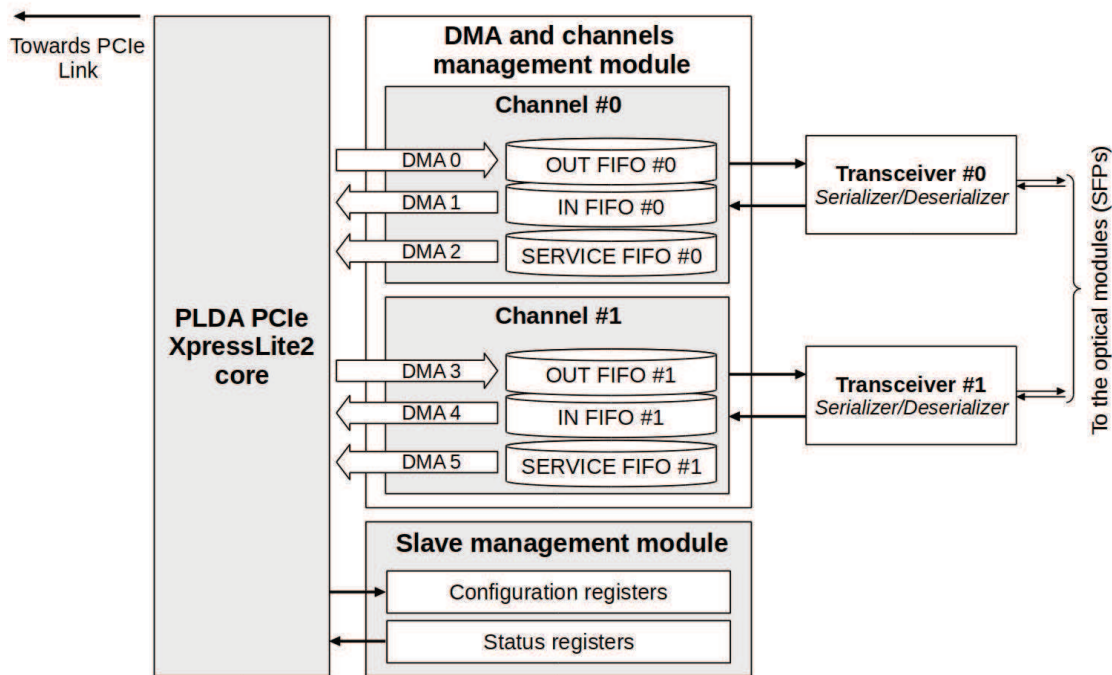

FIGURE 3.30: Top-level blocks of the PCI Express board design.

reads out status registers and two serializing and deserializing blocks for the optical transceivers. The individual blocks, as well as the principles of PCI Express transmission are described in the following sections.

3.3.4.2 PCI Express[®] fundamentals

PCI Express²⁶ (PCIe) is a high performance, serial point-to-point interconnection for a variety of computing and communication platforms [71][53]. It has been devised by the PSI-SIG²⁷ organisation as a successor of PCI and PCI-X standards. PCI Express peripheral devices are connected via a pair of differential signals

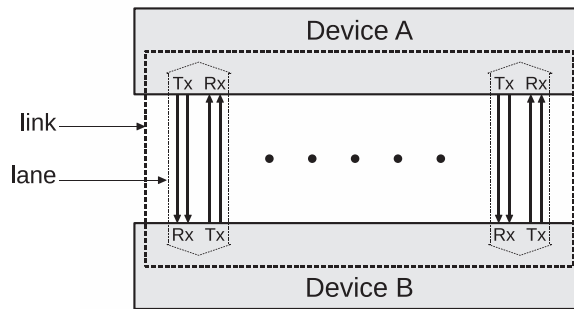

FIGURE 3.31: Scheme of a PCI Express link.

(LVDS), one for transmission and the other one for reception, as shown in figure 3.31. This link is called *lane* and ensures a full duplex transmission between the devices. The clock signal is embedded within the data using 8b/10b encoding. The bandwidth of the single lane depends on the generation of the implemented link. The first generation²⁸ PCIe has a throughput of 2.5 Gbps in one direction. The second generation²⁸ PCIe specifies a bandwidth of 5.0 Gbps. The latest one, the third generation of the standard²⁸, supports 8.0 Gbps. A link may aggregate multiple lanes to scale up the bandwidth. PCI Express specifications describe links with x1, x2, x4, x8, x12, x16 and x32 lanes. Due to 8b/10b encoding, 80% of the raw bandwidth is utilized. Effective aggregate bandwidths (simultaneous traffic in both directions) for different link widths are a multiplication of the single lane bandwidth (4 Gbps and 8 Gbps for first and second generation PCIe).

The PCI Express architecture is composed of point-to-point links that interconnect PCIe devices. A typical PCIe system topology (or fabric topology) that is composed of four different components (or functions), namely a root complex, endpoints, a switch and a bridge is shown in figure 3.32. PCI Express links interconnection are represented as dotted lines in the figure. A root complex initializes

²⁶Peripheral Component Interconnect Express

²⁷Peripheral Component Interconnect Special Interest Group

²⁸Successive generations of the standards were introduced in 2007 (Gen 1.0), January 2007 (Gen 2.0) and November 2010 (Gen 3.0)

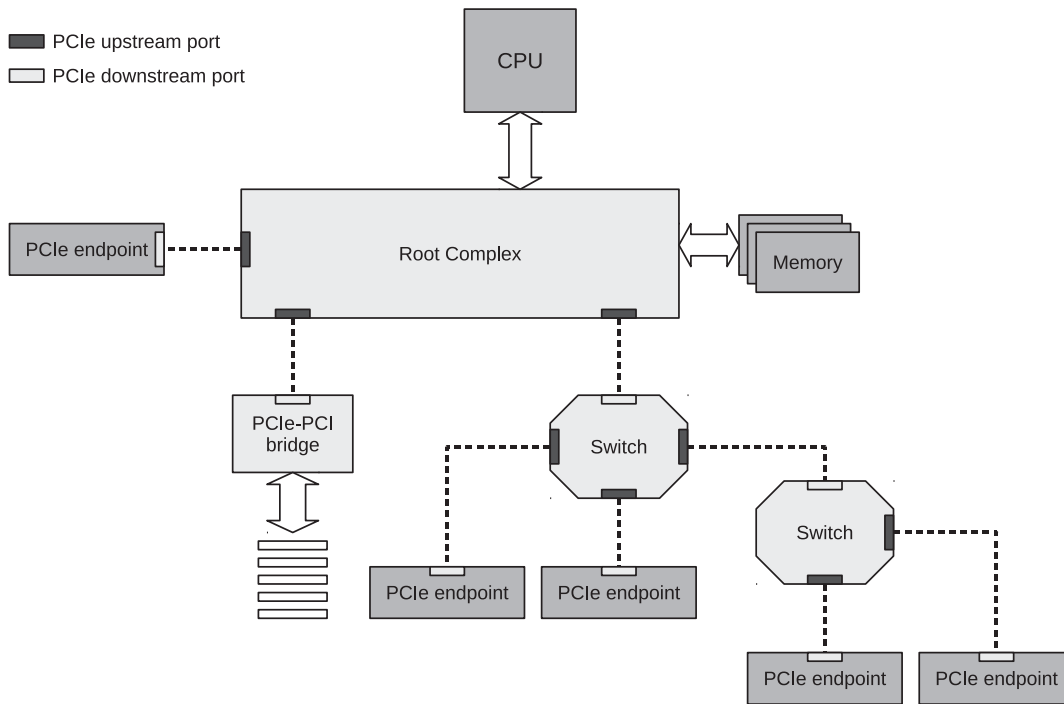

FIGURE 3.32: Example of a topology of the PCI Express system with four types of function: root complex, endpoints, switches and PCIe-PCI bridge.

a whole topology and configures links between PCIe devices. A root complex supports up to several PCIe ports, each one defined by different hierarchy domain (e.g. switch or bridge). Normally, it creates a link between the central processor unit (CPU) and one (or several) of the available functions: PCIe switches, endpoints or bridges to PCI devices. A PCIe switch allows to have multiple point-to-point connections between upstream (root complex) and downstream (endpoints) ports or between two downstream ports (peer-to-peer communication between two endpoints). Compatibility with other standards is ensured by the bridge functions, like the PCIe-PCI bridge shown in figure 3.32.

The architecture of the PCI Express is specified in three discrete logical layers: the transaction layer, the data link layer and the physical layer. Every layer is divided into two parts: one part is processing outbound information (TX) and the other one inbound information (RX). The PCI Express layered architecture shown in figure 3.33 comprises an application and a mechanical layer. The components that are connected via the PCIe link use packets to exchange information. A transaction is initiated by the application layer by sending the request to the transaction layer. An application request is converted into a PCIe transaction packet. While transmitted packets are sent through the following layers, they are

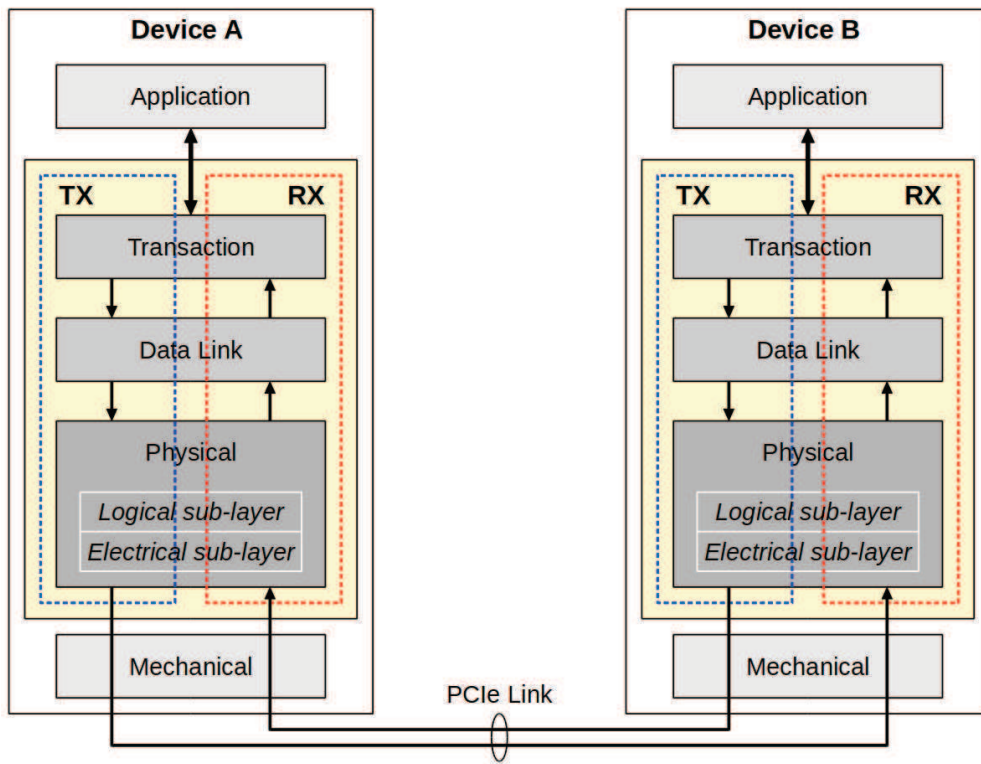

FIGURE 3.33: Example of a PCI Express layered architecture.

extended with additional information. A reverse process occurs when data are received and packet is transformed from its physical layer representation to the transaction layer packets. The format of the packets is shown in the figure 3.34. It has to be noted that two data link layers connected to the same link exchange a

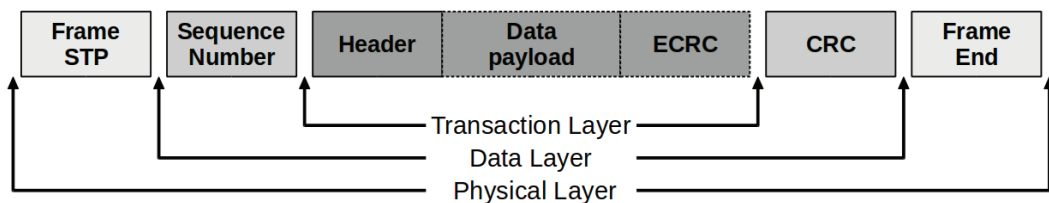

FIGURE 3.34: Building of a packet as it flows through the PCIe layers.

shorter version of the packets (a Data Link Layer Packet, DLLP) for the purpose of link management.

The physical layer is divided into two sub-layers: the electrical and logical layer. The electrical sub-layer implements analogue components like transceiver, analogue buffers, serializer and deserializer (SerDes). The power management of the

link is also implemented in this sub-layer. The functions implemented in the logical sub-layer are 8b/10b data encoding and decoding, clock tuning and alignment, link reset, initialization and configuration. However, the specification of the PCI

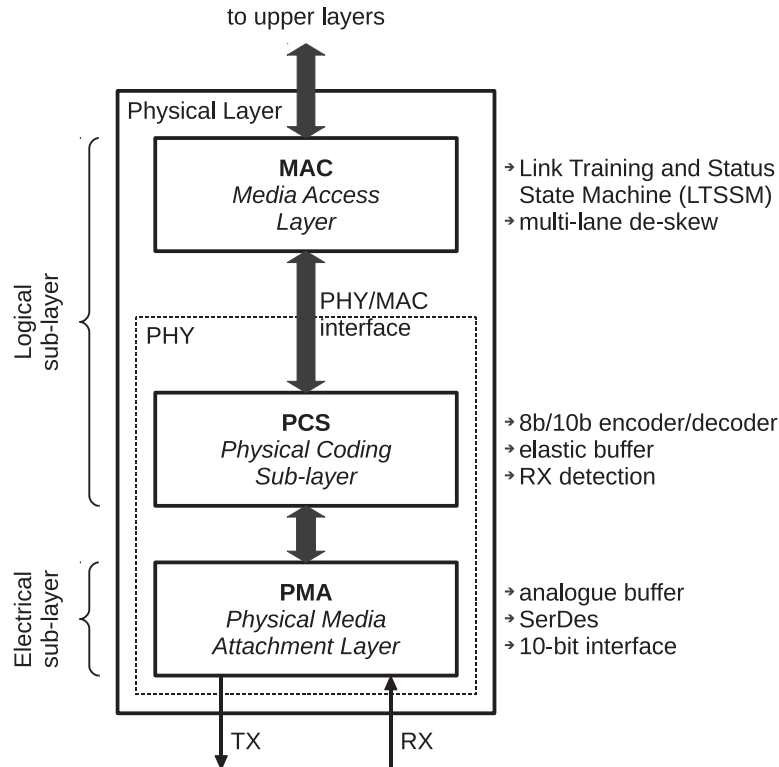

FIGURE 3.35: Scheme of a PIPE interface for a physical layer.

Express protocol does not define the interface between these two sub-layers. A number of vendors use for this an interface called PIPE²⁹ [46]. It implies three main sub-blocks in the physical layer, the Physical Media Attachment Layer (PMA), the Physical Coding Sub-layer (PMA) and the Media Access Layer (MAC). A diagram of the PIPE interface with a description of the functionality of each block is shown in figure 3.35. The future upgrades of the speed, or encoding techniques will affect only the Physical Layer of the PCI Express.

The data link layer is responsible for proper data exchange between its counterpart on the opposite side of the link. It includes initialization, reset and power services. Reliability is ensured by data protection (CRC generation and checking), error detection, retry and error reporting and logging.

The transaction layer creates outbound and receives inbound Transaction Layer Packets (TLP). There are two types of TLP, either a request type or a completion

²⁹Physical Interface for PCI Express Architecture

type (response to a request). Transactions where the requester expects to receive a completion are called *non-posted* transactions. Those where the requester does not expect and will not receive a completion packet are called *posted* transactions. In

Address Space	Type	Request handling	Notes
Memory	Read Write	Non-Posted Posted	Transfer data from or to a memory mapped location
I/O	Read Write	Non-Posted	Transfer data from or to an I/O location
Configuration	Read Write	Non-Posted	Device configuration and setup (device capabilities, program features, and check status stored in the 4KB PCI Express configuration space)
Message	Baseline	Posted	Event signalling and general purpose messaging

TABLE 3.10: Effective aggregate bandwidth for first and second generation of PCI Express standard.

the case of a non-posted read request, a completion packet includes either a data or an error status when the completer was not able to return a data. For non-posted write request, the completer returns a TLP without a data as an indication of reception. The types of transactions depending on the address and way of handling of the requests are shown in table 3.10. A TLP is made of a header, an optional data payload and an optional ECRC (End-to-End CRC). Information about the type of transaction, priority, address and packet characteristics are contained in the TLP header. The inbound transaction layer checks the TLP format and its header.

3.3.4.3 PLDA's PCI Express[®] *XpressLite2* module

The PCI Express XpressLite2 module is a fully configurable FPGA IP³⁰ core for interfacing the PCI Express protocol with Altera FPGA devices. This core supports both Gen1 and Gen2 protocols. The XPAD3 camera design utilizes the Gen1 protocol with a 2.5 Gbps bandwidth. The block diagram of the XpressLite2 core is shown in figure 3.36. The endpoint includes Physical, Data Link and Transaction Layers and supports x1, x4 and x8 PCIe lanes. The PCI Express configuration registers are implemented within a Transaction Layer. The functions implemented in this space generate completion messages during the device setup and configuration, and interrupt and error messages that are sent to the root

³⁰Intellectual Property

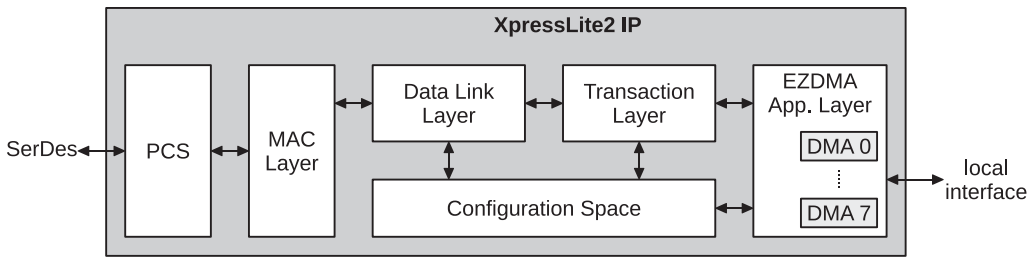

FIGURE 3.36: Block diagram of PLDA's PCI Express XpressLite2 core.

complex. Power management, PCI Express and device specific capabilities are also implemented in that space. The detailed structure of the configuration space is presented in Appendix A.

The Application Layer has integrated a DMA engine with up to eight channels for simultaneous data reading or writing. Each of the channels can be programmed, controlled and monitored independently from the others. It is done through a set of built-in registers programmed by the Application Layer. These registers include information about the type of the transaction (memory read/write, IO read/write or completion transaction), the size of the transferred data (up to 4 GB) and the source or destination address in the PC memory. Besides these features, the Application Layer also includes a structure to request an interrupt via a dedicated interrupt pin (INT A).

3.3.4.4 Slave and channel management modules

The design implemented in the FPGA of the PCI Express board is organized in two channels and a slave module. Every channel transfers data from the host memory (PC) to one of the two optical fibre interfaces and in the reverse direction. Two DMA per channel are configured to perform memory read and write. An additional third DMA is configured to write the status of the channel to the host memory. The description of the DMA implemented in the two channels is given in table 3.11. The table does not include the description of the seventh DMA that is implemented in the Application Layer, which is used for sending a completion transaction in response to I/O and memory read requests.

The Registers used to configure DMA0 - DMA5 are mapped in the Base Address Register spaces 0 and 1 of the configuration space (Appendix A). In the same region, one finds the status registers that reflects actual configuration of the DMAs and debugging information. Programming and reading of that registers is done via

DMA	Function	Channel	Description
DMA 0	Memory read	ch0	Read data from the PC memory and transfer it to the detector via optic fibre 0
DMA 1	Memory write	ch0	Read data from the optic fibre 0 and write it in the PC memory
DMA 2	Memory write	ch0	Write status of the previous DMA 0 or DMA 1 transaction in the PC memory
DMA 3	Memory read	ch1	Analogue functionality as for channel 0, except when optic fibre 1 is used instead of fibre 0
DMA 4	Memory write	ch1	
DMA 5	Memory write	ch1	

TABLE 3.11: List of the DMA channels implemented in the design and their functions.

the slave module of the design. The design has sixteen configuration and status registers that are described in the tables 3.12 and 3.13. Every register has 32 bits.

The block diagram that represents the structure of one channel is shown in figure 3.37. The transfer of data from the host memory to the detector and vice versa is done alternately on two channels. The communication with the modules from 1 to 4 is done via channel 0 and with the modules 5 to 8 via channel 1.

A DMA that makes a transfer from the host memory (DMA0 in channel 0 and DMA3 in channel 1) writes data to the outgoing FIFO OUT memory. To transfer data correctly, the address and size configuration registers (offsets 0 to 3) have to be programmed with correct values. The size of the outgoing transfer which is set to 2 kB is limited by the depth of the implemented FIFO memory in the PCI Express and HUB boards. Additionally, the FIFO memory takes care of deserializing 64-bit incoming data to 16-bit words compatible with the optical interface. The 64-bit datapath of the DMA imposes further requirements on the size of transferred data that have to be divisible by 8 bytes (to constitute 64-bit words). The transfer is started when value '1' is written to the least significant bit of the command register (offset 10 or 11). When the DMA transfer is finished, the number of words in the FIFO buffer is compared with the transfer size stored in the register. If both values are equal, the FIFO is flushed and a proper status is signalled to the service management. Otherwise, an error status is generated and the FIFO memory is cleared. Furthermore, simultaneously with a DMA transfer, a timeout counter is enabled. If the counter reaches the value specified in the timeout hardware configuration register (offset 12), the transfer is aborted, the FIFO buffer is cleared and an error status is generated.

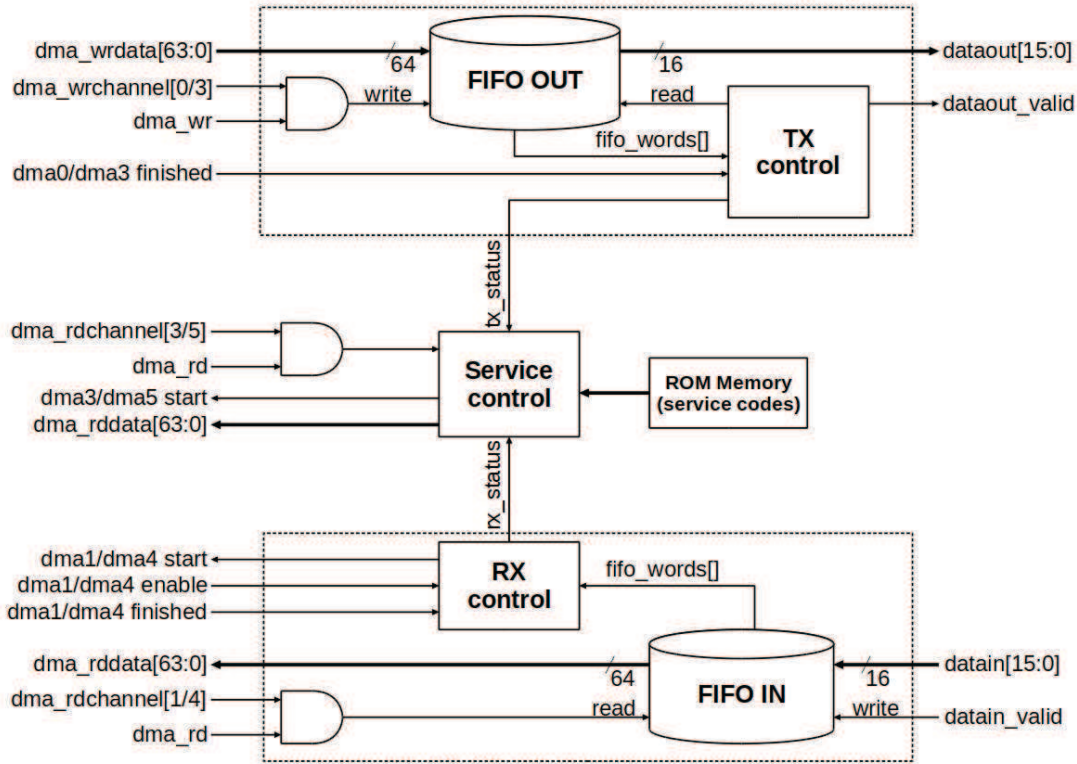

FIGURE 3.37: Architecture of the single channel implemented in the PCI-Express board.

The transfer of the data from the detector to the host memory is handled by DMA1 (channel 0) and DMA4 (channel 1). The transfer is initiated by writing '1' to the ninth bit of the command register. Data from the optical interface are written to the incoming FIFO IN buffer. As soon as the size of the data in that FIFO matches the value specified in the size configuration register (offset 6 or 7), a proper DMA channel is started and the data is moved to the host memory in the region specified by the address configuration register (offset 4 or 5). The maximum size of a transfer is 128 kB, which corresponds to 1/8 of the detector image size (in 2-byte format). If for some reasons, the FIFO IN is not read out by the host system and the buffer becomes full, a special message is generated towards the HUB board saying that the PCIe is not able to receive any data. As soon as the buffer is emptied, another message saying that the PCIe is able to receive data is sent to the HUB board. The end of the transfer is signalled with a success status generated towards the service management block. The waiting time for the data is limited by the value of the hardware timeout written in the configuration register. If this time is reached, the transfer is cancelled and finishes with an error status.

The *service management* block function is meant to indicate the end of any data

Register	Offset	Description
Address_TX_ch0	0 (0x00)	DMA0 32-bit address
Address_TX_ch1	1 (0x04)	DMA3 32-bit address
Size_TX_ch0	2 (0x08)	32-bit size of the transfer in bytes
Size_TX_ch1	3 (0x0c)	max. size 128 kB, rounded to 8 bytes
Address_RX_ch0	4 (0x10)	DMA1 32-bit address
Address_RX_ch1	5 (0x14)	DMA4 32-bit address
Size_RX_ch0	6 (0x18)	32-bit size of the transfer in bytes
Size_RX_ch1	7 (0x1c)	max. size 128 kB, rounded to 8 bytes
Address_SV_ch0	8 (0x20)	DMA2 32-bit address
Address_SV_ch1	9 (0x24)	DMA5 32-bit address
Command_ch0	10 (0x28)	Channel control reg[0] - start TX reg[1] - abort TX reg[2] - clear FIFO_OUT reg[7:3] - reserved reg[8] - start RX reg[9] - abort RX reg[10] - clear FIFO_IN reg[15:11] - reserved
Command_ch1	11 (0x2c)	
Hw_timeout	12 (0x30)	Value of the hardware timeout reg[7:0] = value n timeout $T = 2^{n-1}$ where $1 \leq n \leq 32$
Reserved	13 (0x34)	
Loopback/Reset	14 (0x38)	Enables/disables loopback test on both channels and resets local logic reg[0] - loopback test, enabled when '1' reg[1] - local reset, active when '1' reg[2] - clear status diode
Clear INT	15 (0x3c)	Restricted to interrupt handler use only

TABLE 3.12: Configuration and command registers implemented in the design.

transfer via a DMA in one channel. A DMA that performs services is configured to perform host memory writings with a size of the transfer fixed to 16 bytes. Different service codes are stored in the ROM memory and a status signal generated by the TX and RX blocks is nothing else but memory addresses of the word that has to be transferred to the host. The first byte of the service code indicates whether it is an error or a success message and the seven other bytes form an error message represented by its ASCII³¹ code values. The implemented service codes are listed in table 3.14. The transfer of the service DMA code always finishes with issuing an interrupt to the host system. In the PCI Express core, there is only one interrupt source that is shared between two channels. However, because there are no spontaneous messages from the detector, and also because only one channel

³¹American Standard Code for Information Interchange

Register	Offset	Description
Address_TX_ch0 Size_TX_ch0	0 (0x00) 1 (0x04)	32-bit address of the DMA 0 and transfer size in bytes
Address_TX_ch1 Size_TX_ch1	2 (0x08) 3 (0x0c)	32-bit address of the DMA 3 and transfer size in bytes
Address_RX_ch0 Size_RX_ch0	4 (0x10) 5 (0x14)	32-bit address of the DMA 1 and transfer size in bytes
Address_RX_ch1 Size_RX_ch1	6 (0x18) 7 (0x1c)	32-bit address of the DMA 4 and transfer size in bytes
Address_SV_ch0 Address_SV_ch1	8 (0x20) 9 (0x24)	32-bit address of the DMA 2 32-bit address of the DMA 5
RX_FIFO_status	10 (0x28)	Number of 8 bytes words in the RX_FIFO reg[15:0] - RX_FIFO_ch0 reg[31:16] - RX_FIFO_ch1
Firmware code	11 (0x34)	Date of last modification in hexadecimal format (e.g. 0x21062010 represents date 21 July 2010)
Hardware timeout	12 (0x34)	Value of the hardware timeout reg[7:0] = value n timeout $T = 2^{n-1}$ where $1 \leq n \leq 32$
Reserved	13 (0x34)	
Reserved	14 (0x38)	
INT status	15 (0x3c)	Interrupt status reg[0] - interrupt issued and pending when '1'

TABLE 3.13: Status registers implemented in the design.

can be used at a time, there are no risks that two interrupts would be generated at the same time and hence cause the lost of one of them.

Service Code		Description
First Byte	Error Message	
0x00	-	Success transfer of data
0x01	SIZEERR	TX error, mismatch between DMA size and number of words in the FIFO_OUT buffer
0x02	TIMEOUT	RX error, data from the detector not received within the time specified in the hardware timeout register
0x03	DMAERR	RX error, DMA started, but not finished in time
0x04	DMAERR	TX error, same as above

TABLE 3.14: Status codes sent by the service DMA.

Similarly to the HUB board, the PCI Express system has the ability to create a loopback channel. The option is enabled when value '1' is written to least significant bit of the Loopback/Reset configuration register (offset 14). The loop is created in the transceiver block by connecting the transmitter serializer with the

receiver part (figure 3.21). The loopback feature gives the possibility to verify the complete datapath in the PCI Express design without connecting detector parts.

3.3.4.5 Measurement of the performance of the PCIe with DMA transfer

The performance of the PCI Express with the DMA transfer was measured separately in each direction with the loopback mode enabled. The measurement was based on counting clock cycles while a transfer process was active. In case of sending data to the detector, copying data to the FIFO OUT, size verification, flushing FIFO, performing service DMA and generating an interrupt were also included. In the other direction, the measurement was started when complete data were in the FIFO IN and the DMA was activated. It was finished when an interrupt generated by the service DMA after copying data from the FIFO IN to the host memory was accepted. The resulting value was then written to one of the status registers. The measured bandwidths are presented in table 3.15. Keeping

Direction	Bandwidth
from the host memory to the PCIe	4 Gbps
from the PCIe to the host memory	8 Gbps

TABLE 3.15: Measured data rates over PCI Express with DMA transfer.

in mind that the size of one image from the detector is 1050 kBytes³², the bandwidth of 8 Gbps corresponds to an image frame rate of 950 images/s. However, in the current hardware configuration, this bandwidth cannot be utilized at 100%. Indeed, as it was explained in section 3.3.4.1, optical transceivers are placed on an auxiliary mezzanine board that is connected to the PCIe board via a high speed connector. Specification of that connector restricts the maximum bandwidth to 2 Gbps per optical fibre, and finally to an image rate of 490 images/s.

3.3.5 Software library

Access to the XPAD camera resources is provided by the software library. The library encapsulates all functions that are necessary to build a custom image acquisition software. The library utilizes a 32-bit driver from PLDA [72] that provides access to the XpressGXII PCI Express board resources. The library is compiled

³²Image size = 80 column * 120 rows * 7 chips * 8 modules = 537600 pixels = 1075200 Bytes

in standard gcc³³ and is compatible with a 32-bit SLC5³⁴ Linux[®] (Red Hat Enterprise 5). DMA channel management and system messages (e.g. *fifo_full* commands from to the HUB board and modules) are hidden in the library and a base set of functions is provided to the user. The acquisition function of the library allows to store detector images in the RAM memory of the PC. The number of images that can be stored in the memory depends on the format of the image (2 or 4 bytes per pixel) and on the size of the physical memory assembled in the computer. A sample software that acquires an image from the detector is shown in Appendix B.

3.3.5.1 Library functions

All the functions in the library return the value 0 (zero) in case of success and -1 in case of error. The list below is not exhaustive.

Initialization and status functions

```
⇒int xpci_init(int det, int sysType);
   input: det, sysType
```

This function opens the driver and checks if the PC has a PCI Express board with a detector design. Memory, interrupt and DMA resources are initialized making the board operational. The function is able to manage several different PCIe boards. However, in the current design, only one value *det* = 0 is recognized. This library is going to support upgraded version of detector that will be determined by the parameter *sysType*.

```
⇒int xpci_close(int det);
   input: det
```

This function deallocates all PC's resources used by the detector and closes the driver.

```
⇒int xpci_isPCIeOK();
```

This function enables a serial loop-back in the transceiver block of the FPGA by connecting the transmitter line with the receiver one (figure 3.21). Two loops are created, one on each channel. The function compares the transmitted pattern with the received one in order to test the full communication chain in the PCIe board.

```
⇒int xpci_isHubeOK();
```

³³GNU Compiler Collection

³⁴Scientific Linux CERN5

This function creates a loop-back in the HUB board by connecting the reception FIFO with the transmitting one (figure 3.20). This function allows to include the optical interface in the test as well as the reception logic in the HUB board.

```
⇒int xpci_dumpStatusRegsTable();
```

This function prints values of all the status registers defined in the PCIe board (table 3.13).

```
⇒int xpci_resetBoard();
```

This resets the PCIe resources (clears all the FIFO buffers, resets the configuration registers and aborts all DMA channels). The function does not reset PCIe core, which can be done only by rebooting the host PC.

```
⇒int xpci_HUBReset();
```

This function sends a reset message to the HUB board (table 3.9).

```
⇒int xpci_HUBModReconfFPGA(int modMask);
   input: modMask
```

This function sends a module reconfiguration message to the HUB board. The *mask* parameter indicates what modules are supposed to be reloaded (e.g. mask = 0x83 indicates that modules 1, 2 and 8 will be reloaded).

```
⇒int xpci_HUBModRebootNIOS(int modMask);
   input: modMask
```

This function sends a reset message to the selected modules.

```
⇒int xpci_modAskReady(unsigned *inMask);
   output: inMask
```

This function sends an identification request to each module sequentially. Depending on the reply from the detector, a mask of the connected modules is created and returned by the *inMask* parameter (e.g. inMask = 0xff means that all eight modules are connected and operational).

```
⇒int xpci_modLoadAutoTest(unsigned modMask, unsigned value);
   input: modMask, value
```

This function loads a known *value* of the pixel counters in the modules specified by the *modMask* value. Reading the pixels as an image allows to compare and detect non-working pixels (only failures in the digital part will be detected).

Modules configuration functions

```
⇒int xpci_modLoadConfigG(unsigned modMask, unsigned chipMask,
                        unsigned reg, unsigned regVal);
    input: modMask, chipMask, reg, regVal
```

This function configures the selected global register *reg* with the value *regVal* in the XPAD3 chips selected by the *chipMask* value in the modules enabled by the value *modMask*. The description of the global registers is given in the section 3.2.4 and the codes for register identification are given as follows

```
CMOS_Disable=0x01  TestPulse=0x32  I_mfp=0x37  I_ota=0x38
I_pre=0x3b        I_thL=0x3c      I_tune=0x41  I_buffer=0x42
```

```
⇒int xpci_modLoadAllConfigG(unsigned modMask, unsigned chipMask,
                            unsigned cmosVal, unsigned amtpVal,
                            unsigned ithhVal, unsigned vadjVal,
                            unsigned vrefVal, unsigned imfpVal,
                            unsigned iotaVal, unsigned ipreVal,
                            unsigned ithlVal, unsigned ituneVal);
    input: modMask, chipMask, cmosVal, amtpVal, ithhVal, vadjVal
          vrefVal, imfpVal, iotaVal, ipreVal, ithlVal, ituneVal
```

This function loads the values into every global register of the selected chips in the selected modules. The values of the registers are passed as function parameters in a predefined order.

```
⇒int xpci_modLoadFlatConfig(unsigned modMask, unsigned chipMask,
                           unsigned value);
    input: modMask, chipMask, value
```

This function loads every 9-bit local pixel registers with *value* in the enabled chips and modules.

```
⇒int xpci_modSaveConfigG(unsigned modMask, unsigned calibId,
                        unsigned reg, unsigned *values
    input: modMask, calibId, reg, values
```

This function sends the values to global configuration registers of every chip in selected module. The values are saved in the memory of the NIOSII soft-core processor with the index specified by parameter *CalibId*.

```
⇒int xpci_modSaveConfigL(unsigned modMask, unsigned calibId,
                        unsigned chipId, unsigned curRow,
                        unsigned *value);
    input: modMask, calibId, chipId, curRow, value
```

This function sends one line of local configuration data at the index *curRow* of the chip indicated by *chipId* of the module specified by *modMask*. Data are saved in the SRAM memory buffer identified by the parameter *CalibId*. In order to store a complete calibration of the detector, the function needs to be executed 960 times.

```
⇒int xpci_modDetLoadConfig((unsigned modMask, unsigned calibId);
    input: modMask, calibId
```

This function starts the configuration of the detector with the calibration data stored in the detector memory with index *CalibId*. The process comprises configuration of the global registers with the data saved in the processor memory and programming of the pixel local register with data stored in the SRAM memory buffer.

```
⇒int xpci_getModConfig(unsigned modMask, int chipMask, uint16_t *data);
    input: modMask, chipMask
    output: data
```

This function reads the values of the local configuration registers from the pixels of the chips selected through the *chipMask* and the modules enabled by the parameter *modMask*.

Acquisition functions

```
⇒int xpci_getImageInit(enum IMG_TYPE type, int modMask, int nbChips,
                      unsigned gateMod, unsigned gateLength,
                      unsigned timeUnit);
    input: type, modMask, nbChips, gateMod, gateLength, timeUnit
```

This function allocates the resources needed for the acquisition of the images. The parameters of the detector exposition are passed through *gateMode*, *gateLength* and *timeUnit*. The definition of these arguments is given in section 3.3.2.6. The function allocates the required memory for the size of the image defined by the *type* and number of the readout chips and modules. The *type* is an enumerator

that specifies if a one or two bytes per pixel are acquired and is defined as

```
enum IMG_TYPE {B2,B4};
```

```
=>int xpci_readOneImage(enum IMG_TYPE type, int modMask,
                       int chipMask, uint16_t *data);
```

input: type, modulesMask, chipMask, data

This function is meant to acquire one image from the modules specified by the *modMask* and from the XPAD chips defined by *chipMask*. The parameters of the acquisition has to be specified by the function *xpci_getImageInit()*. Image data are written in the PC memory, starting from the address indicated by the *data* pointer.

```
=>int xpci_getImgSeq(enum IMG_TYPE type, int modMask, int nbChips,
                   int gateMode, int gateLength, int timeUnit,
                   int imagesNb, void **pBuff);
```

input: type, modulesMask, nbChips, gateMode, gateLength,
timeUnit, imagesNb, pBuff

This function acquires sequences of images in a burst mode. The parameters of the exposition and acquisition are encapsulated in one function. In order to minimize the dead time between consecutive images, the detector is acquiring and sending one image after the other until it reaches the value specified in parameter *imagesNb*. Each of the received images is saved in the preallocated buffers, which are provided via an array of pointers, *pBuff*.

```
=>int xpci_readImageClose()
```

This function releases the resources that were allocated by a preceding *xpci_getImageInit()* function.

3.3.5.2 Software limitation of the readout speed

Despite the fact that the hardware can handle a bandwidth up to 490 images/s,³⁵ the achievable image rate is limited to 240 images/s at maximum. As it was explained in the section 3.3.4.4, an image in 2-byte format is received in the host memory as 16 consecutive transfers (8 per channel) and the end of every transfer is signaled by an interrupt sent by the PCIe system. In order to limit the time that is required to configure each DMA transfer, two buffers of half the size of a module are associated with each received DMA transmission and are configured at the

³⁵In 2 bytes format

beginning of the transmission. The data from the PCIe memory are always copied to the same location and only the start command must be sent before each DMA transmission. The two receiving DMA are activated alternately. While a transfer is being executed via one channel, data copied through the other channel are moved to a different location in the host memory. A simplified readout mechanism is shown in figure 3.38.

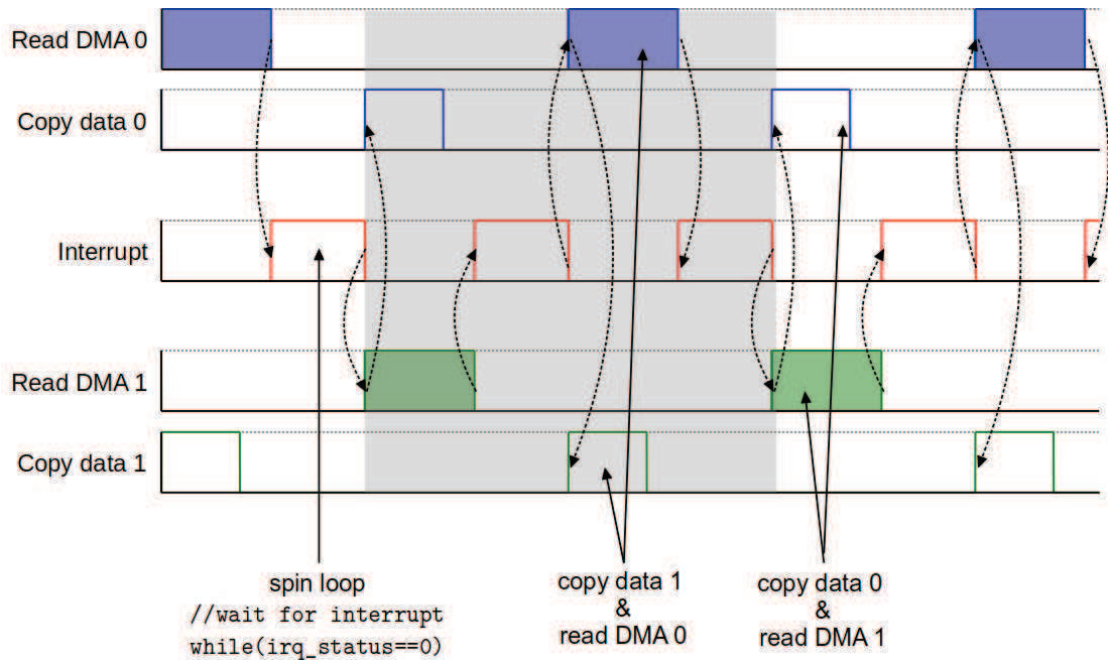

FIGURE 3.38: Chronogram that represents the readout mechanism implemented in the software library.

In order to achieve a high image rate, it is essential to start the subsequent transfer as soon as it is possible. This implies to detect the interrupt as soon as it was generated. We experienced that implementing the interrupt detection with a flag (*irq_status*) tested in a while spin loop, as it is shown in figure 3.38, causes to overload the CPU, which results in uncontrolled losses of interrupts. The PLDA's PCIe driver is a proprietary (closed) code. Therefore, it has not been possible to investigate further why interrupts are sometimes lost. In order to prevent this, a *µsleep* function was added to the loop, but it also slows down the readout process.

3.3.5.3 Structure of the image data

The image data are stored in the memory buffer in a structure that is presented in table 3.16. The size of the image depends on the format of the data (2 or 4

bytes) and on the number of modules that were readout. Data are received in the messages, in which each of them contains one line from one module. The format of the message was presented in the section 3.3.2.5. One image of the complete detector comprises 960 messages. Because the HUB board starts to transfer the data from the module that has first responded, and not with the first one in a row, data in the memory buffer are often scrambled as it can be seen in the table below. Moreover, the first half of the buffer contains only the data from modules 1-4 and the second half of the data from modules 5-8 due to the fact that data from both DMA channels are copied to different locations. For these reasons, data need to be reformatted and aligned after transmission.

header	module	size	reserved	line	560×data			trailer
↓	↓	↓	↓	↓	↙		↘	↓
0xAA55	0x0002	0x0234	0x0000	0x0001	data0	...	data559	0xF0F0
0xAA55	0x0003	0x0234	0x0000	0x0001	data0	...	data559	0xF0F0
0xAA55	0x0004	0x0234	0x0000	0x0001	data0	...	data559	0xF0F0
0xAA55	0x0001	0x0234	0x0000	0x0001	data0	...	data559	0xF0F0
0xAA55	0x0002	0x0234	0x0000	0x0002	data0	...	data559	0xF0F0
0xAA55	0x0003	0x0234	0x0000	0x0002	data0	...	data559	0xF0F0
0xAA55	0x0004	0x0234	0x0000	0x0002	data0	...	data559	0xF0F0
0xAA55	0x0001	0x0234	0x0000	0x0002	data0	...	data559	0xF0F0
⋮								
0xAA55	0x0002	0x0234	0x0000	0x0078	data0	...	data559	0xF0F0
0xAA55	0x0003	0x0234	0x0000	0x0078	data0	...	data559	0xF0F0
0xAA55	0x0004	0x0234	0x0000	0x0078	data0	...	data559	0xF0F0
0xAA55	0x0001	0x0234	0x0000	0x0078	data0	...	data559	0xF0F0
0xAA55	0x0007	0x0234	0x0000	0x0001	data0	...	data559	0xF0F0
0xAA55	0x0008	0x0234	0x0000	0x0001	data0	...	data559	0xF0F0
0xAA55	0x0005	0x0234	0x0000	0x0001	data0	...	data559	0xF0F0
0xAA55	0x0006	0x0234	0x0000	0x0001	data0	...	data559	0xF0F0
⋮								
0xAA55	0x0007	0x0234	0x0000	0x0078	data0	...	data559	0xF0F0
0xAA55	0x0008	0x0234	0x0000	0x0078	data0	...	data559	0xF0F0
0xAA55	0x0005	0x0234	0x0000	0x0078	data0	...	data559	0xF0F0
0xAA55	0x0006	0x0234	0x0000	0x0078	data0	...	data559	0xF0F0

TABLE 3.16: Structure of the memory buffer that contains detector image data in 2-byte mode.

The organization of the local configuration data read from the detector is exactly the same, except that register values are stored only on the 9 least significant bits of 2-byte word.

Chapter 4

Experimental results

In this chapter, experimental results obtained with the XPAD3 camera are described. The first part of this chapter describes results of selected experiments conducted at the SOLEIL synchrotron radiation source. In the second part, we present three experiments that were carried out to demonstrate and characterize the performance of the PCI Express based fast readout data acquisition.

4.1 Example of synchrotron source experiments

As an example of the use of the XPAD3 camera, we present two diffraction experiments performed at SOLEIL. The detector used to conduct these experiments was not equipped with the fast readout based on the PCI Express interface. Instead, data were transferred to the PC memory via a USB interface. This intermediate architecture of the detector was developed in order to be able to perform rapidly such types of experiment, which were not demanding a very fast readout. In order to achieve it, an auxiliary board, the USB-opto (figure 4.1b), was designed. Its role was to convert data received from the HUB board via an optical fiber to the USB 2.0 standard interface. Another significant difference in system architecture compared to the PCI Express based design is that it was utilizing only one optical fiber to transfer data between the HUB and the USB-opto boards. This version of the detector allowed to acquire images at the speed of 3 images/s.

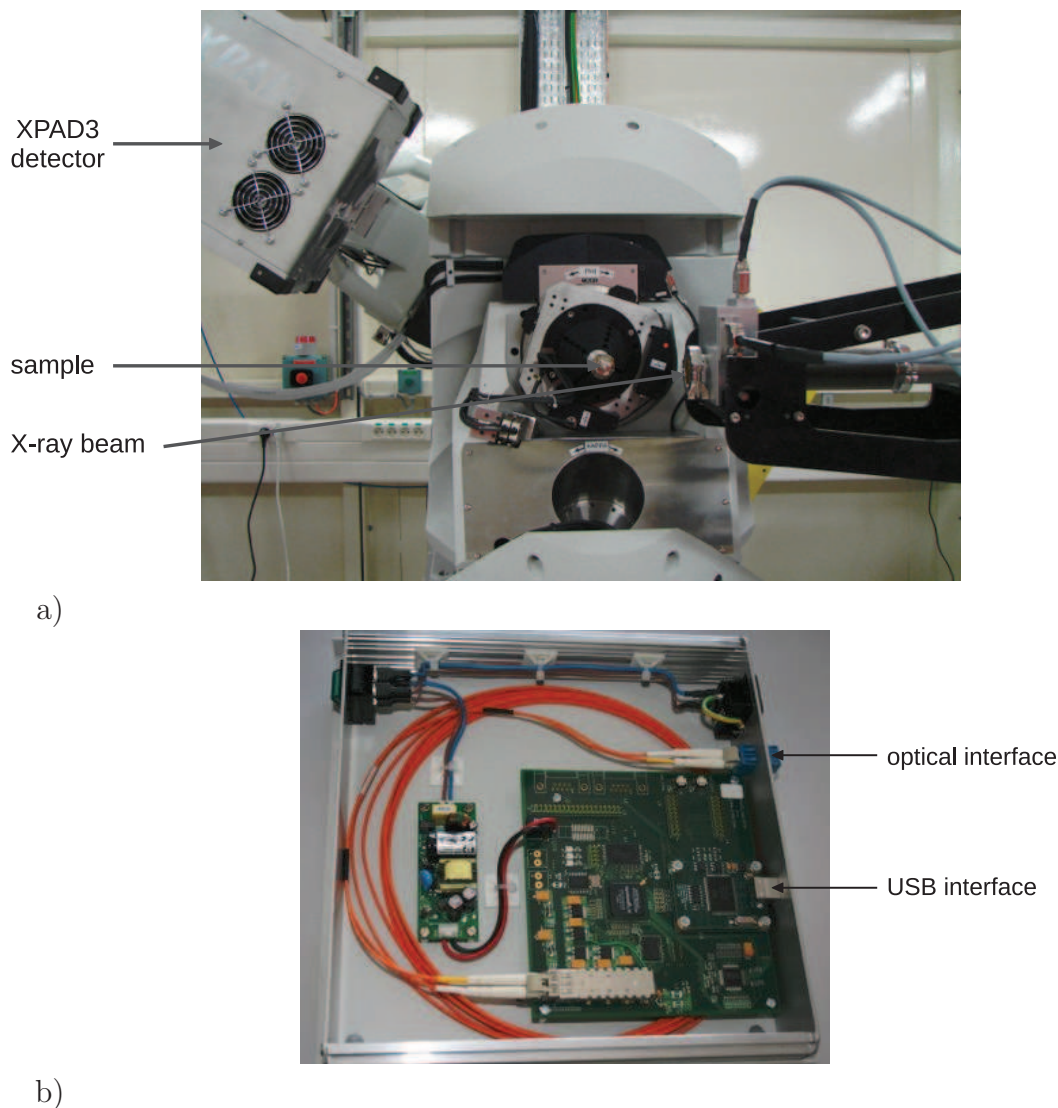

FIGURE 4.1: (a) The XPAD3 camera mounted on a diffractometer at the SOLEIL synchrotron facility and (b) picture of the intermediate USB-opto board.

4.1.1 Powder diffraction of a BaTiO_3 polycrystalline sample

Figure 4.2 shows a diffraction pattern of a BaTiO_3 polycrystalline sample. It was obtained using a 28 keV beam at the SOLEIL Cristal beamline. Raw data are presented, they do not take into account the geometrical correction for the tiling of the modules (vertical dark blue lines) and the broader edge pixels of the XPAD3 chips (horizontal white lines). In this measurement, the detector was mounted on the arm of the diffractometer, and 60 similar images were acquired, each one with a different Bragg-angle from 0° to 120° . In a polycrystalline sample, crystallites are randomly oriented, thus providing enough numbers (statistically relevant) of

crystallites for every crystal plane that diffract X-rays and produce continuous Debye-Scherrer rings, of which the firsts are visible in figure 4.2. Each one of the

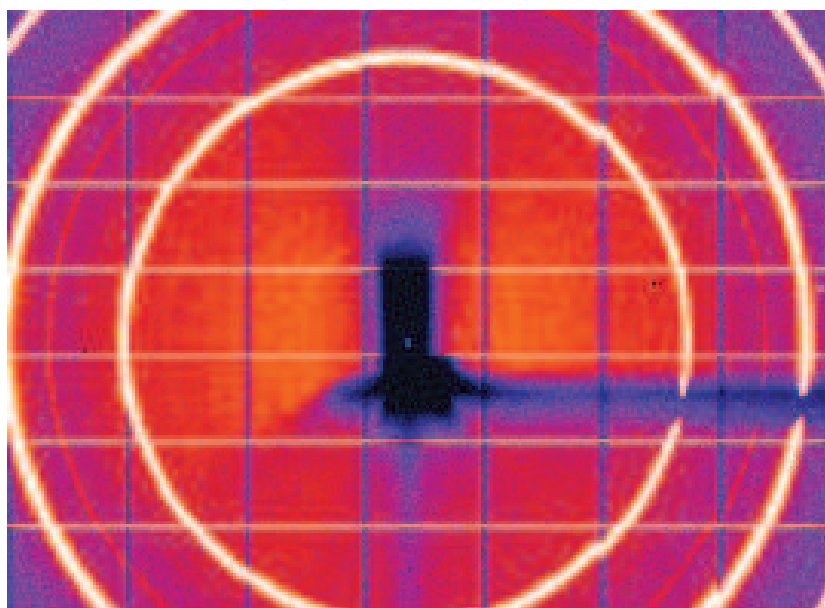

FIGURE 4.2: Diffraction pattern of a BaTiO₃ obtained with the XPAD3 detector at the Cristal beamline at SOLEIL. The image was recorded at 28 keV, close to the 0° Bragg-angle (from [67]).

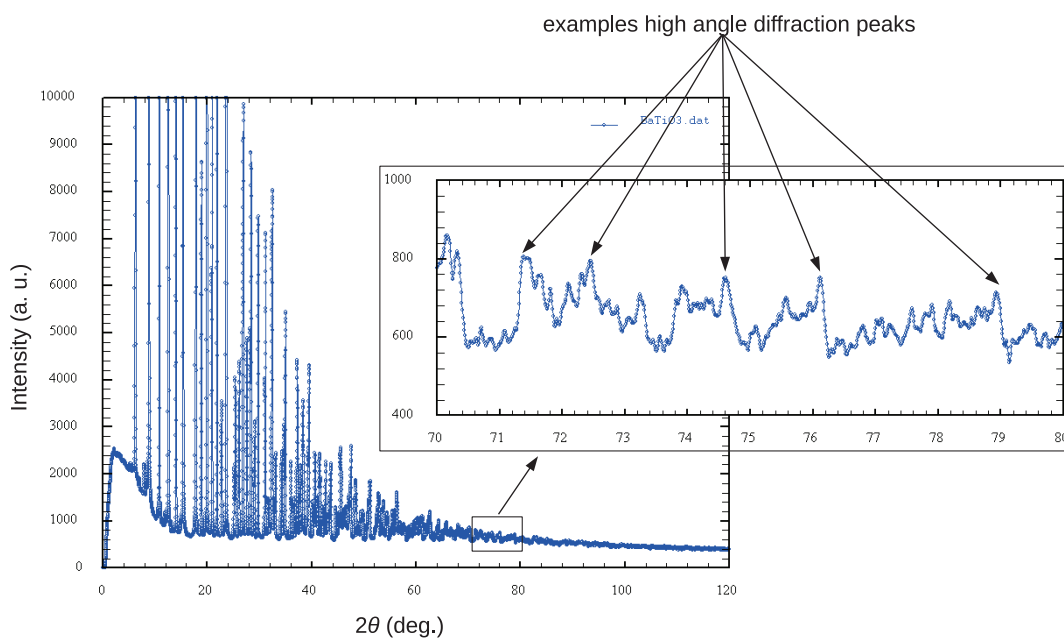

FIGURE 4.3: Linear (1D) diffraction scan pattern of a BaTiO₃ sample recorded with the XPAD3 detector at 28 keV (from [67]).

collected images was integrated to produce 60 linear (1D) scans of the intensity (in arbitrary units) versus the 2θ angle (the angle defined between the incident

beam and the detector). Afterwards, the produced 1D spectra were superposed to create a complete spectrum of 2θ angles from 0° to 120° that is shown in figure 4.3. Each one of the peaks visible in the figure corresponds to one family of crystal planes fulfilling the Bragg condition (eq. 1.16) so that constructive interference can occur. The position of the peaks is determined by the space between the diffraction planes (the peaks at low 2θ angles come from diffractions on the lattice planes of large d -spacing, contrarily to the peaks at high 2θ angles). The intensity of the peak depends on the arrangement of the atoms inside the diffraction plane. It is worth noticing that at high 2θ angles, the diffraction peaks are still visible and can be easily distinguished from the background noise (see magnification window in figure 4.3).

4.1.2 Diffraction on an epitaxial GaInAs film grown on GaAs substrate

Another example of research using synchrotron radiation is surface diffraction. The method refers to the diffraction that occurs from two dimensional adsorbed surface layers or from buried interfaces. Surface diffraction allows to determine the atomic structure of the studied layer. This kind of experiment entails high

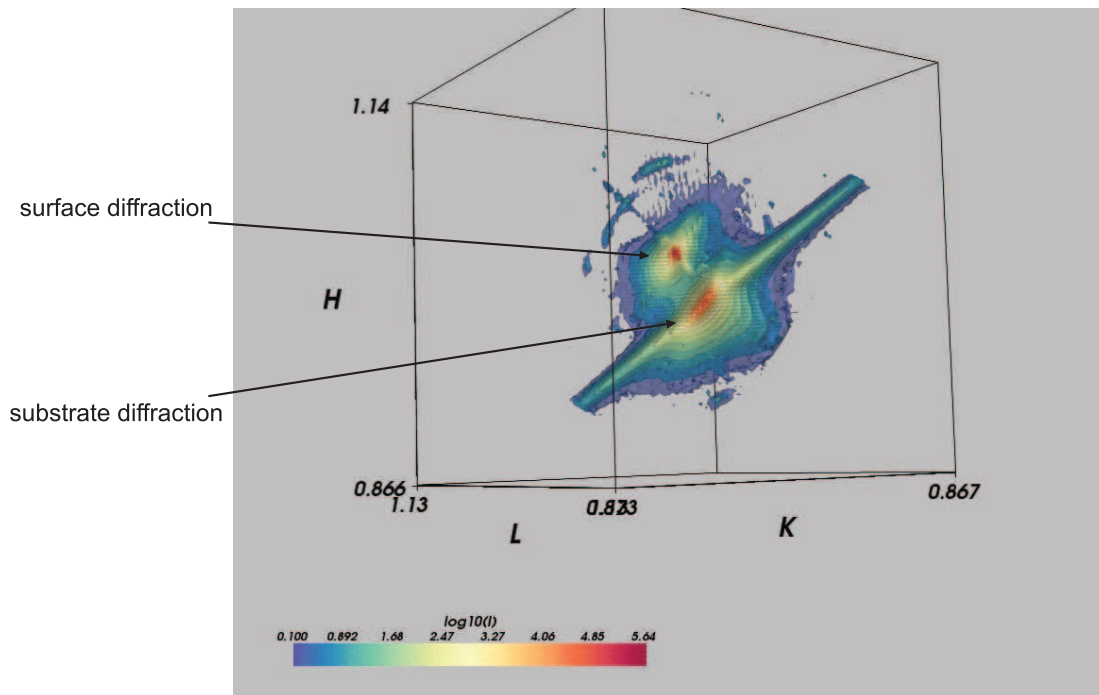

FIGURE 4.4: Surface diffraction on GaInAs epitaxial strains grown on a GaAs bulk shown in K -space, as recorded with the XPAD3 detector on the DIFFABS beamline at SOLEIL (from [7]).

experimental requirements. It is necessary to measure very weak scatterings that originate from the diffraction on the epitaxial layer which is located near the “high intensity” truncation rods associated with the surface of the AsGa single crystal. In figure 4.4, one of the images resulting from a surface diffraction is shown. It was recorded with a beam of 10 keV on the DIFFABS beamline at SOLEIL. The purpose of this experiment was to characterize the distortions of a GaInAs strained epitaxial film grown on GaAs substrate¹. In figure 4.4, small peaks from surface diffraction located close to the intense $\{111\}$ truncation rod are enlarged and hence made clearly visible.

4.2 Fast readout results

4.2.1 The PIXSCAN II demonstrator

Experiments that are presented in this section were carried out using the PIXSCAN II irradiation setup developed at CPPM. The PIXSCAN II setup is shown in figure 4.5. It combines an X-ray tube, the XPAD3 camera, and a rotating and sliding stage placed between the tube and the detector for mounting and positioning the object to be imaged. This rotating stage allows to move an object in the three directions in order to place it at the desired position. The PIXSCAN II components mentioned above are enclosed in a lead-shielded interlocked box controlled by a dedicated software application.

The X-ray tube mounted in the demonstrator is an UltraBright Microfocus X-ray tube from Oxford Instruments² with a tungsten target. Specifications of the tube are presented in table 4.1. The spectrum of the emitted photons is altered by changing the anode voltage and cathode current. The applied anode voltage changes the energy range of the emitted photons. It determines the end point of the spectrum whereas the cathode current fixes the intensity of the X-ray beam. Further changes can be applied to the spectrum by adding an external filter (see chapter 1).

The spectra that are presented in the next part of this section were measured with an Amptek³ XR-100T-CdTe γ /X-ray detector read out by an Amptek PX4 Digital

¹A GaInAs strain changes the electrical parameters of the semiconductor, particularly its band structure and low-field transport, making it an interesting material in high-frequency and low-noise field effect transistor application [48]

²Oxford Instruments, Tubney, Abingdon, Oxon OX13 5QX, UK, <http://www.oxinst.com/>

³Amptek Inc., 14 De Angelo Drive, Bedford, MA. 01730 U.S.A., <http://www.amptek.com/>

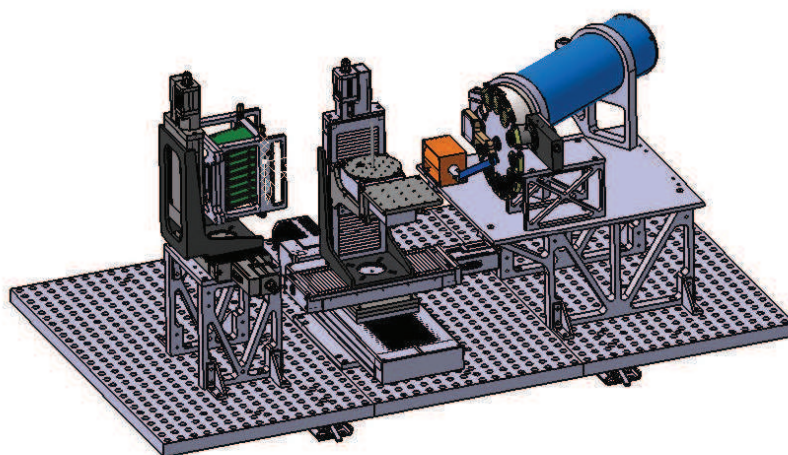

a)

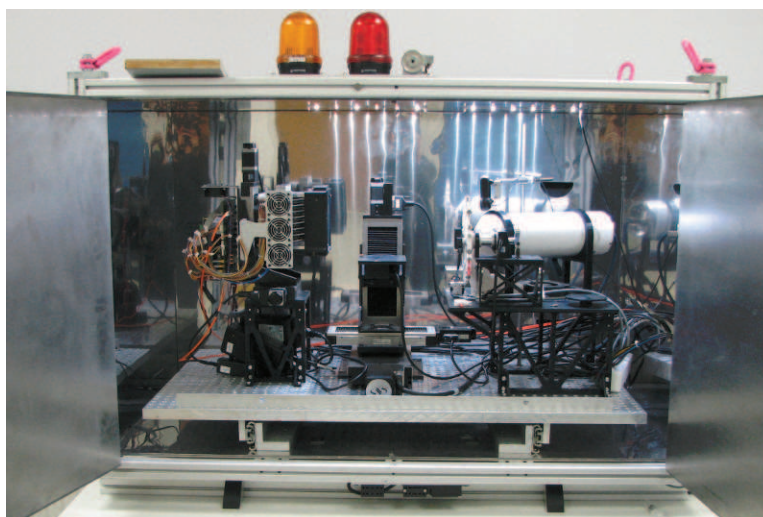

b)

FIGURE 4.5: (a) The CAD layout of The PIXSCAN II irradiation setup and (b) picture of the final device.

Voltage	10 to 90 kV
Current	10 to 80 W
Focal Spot Size	13 to 40 μm
Cone angle	33°
Target material	Tungsten (W)
Window material	Beryllium 245 μm

TABLE 4.1: Specifications of the Oxford Instruments UltraBright Microfocus X-ray tube.

Pulse Processor connected to a Multi-Channel Analyzer (MCA). Before processing with the measurements, the detector was calibrated using an ^{241}Am source with characteristic emission peaks at 13.9 keV, 26.3 keV and 59.5 keV. The spectrum

of the americium source obtained after calibration is shown in figure 4.6.

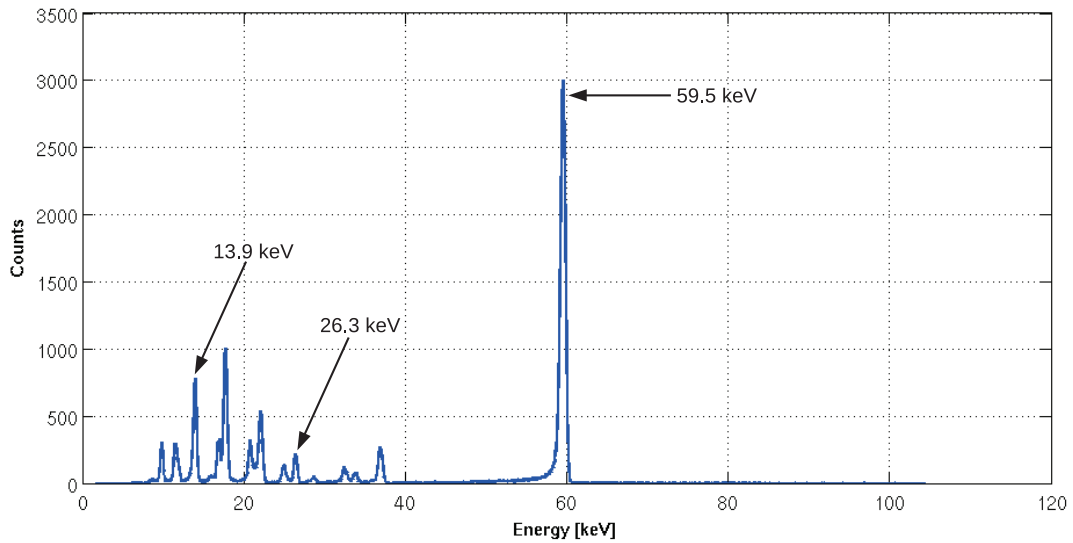

FIGURE 4.6: Spectrum of an ^{241}Am source obtained with XR-100T-CdTe detector and calibrated on the characteristic emission peaks at 13.9 keV, 26.3 keV and 59.5 keV.

The X-ray spectrum of tungsten consists of two main components: emission rays from the target material (appearing as three peaks) and a continuous background resulting from e^- bremsstrahlung (see chapter 1). The three characteristic peaks in the lower part of a tungsten spectrum corresponding to the L_α , L_β and L_γ emission rays, appears at 8.4 keV, 9.7 keV and 11.5 keV respectively. They correspond to transitions to the L shell ($n=2$) from the M, N, and O shells ($n=3,4,5$), respectively. Additionally, three peaks corresponding to the $K_{\alpha 1}$, $K_{\alpha 2}$ and $K_{\beta 1}$ emission rays are visible in the upper spectrum. These peaks correspond to transitions from the L and M shells to the K shell with energies of 59.3 keV, 58.0 keV and 67.2 keV, respectively [89].

Experiments that are described in this chapter were conducted in two configurations: without an external beam filter and with a 200 μm thick niobium filter. In both cases, 90 kV were applied to the tungsten anode. The corresponding spectra of the beam measured during 90 minutes are shown in figure 4.7. In the spectrum of the beam without an external filter (plotted in blue color), the three characteristic peaks of tungsten are positioned at the energies that are in accordance with the theoretical values introduced before.

The application of a filter absorbs predominantly photons with low energies (< 10 keV), which attenuates strongly the peaks in the lower part of the spectrum. Furthermore, the K-edge absorption of niobium is visible at ~ 19 keV.

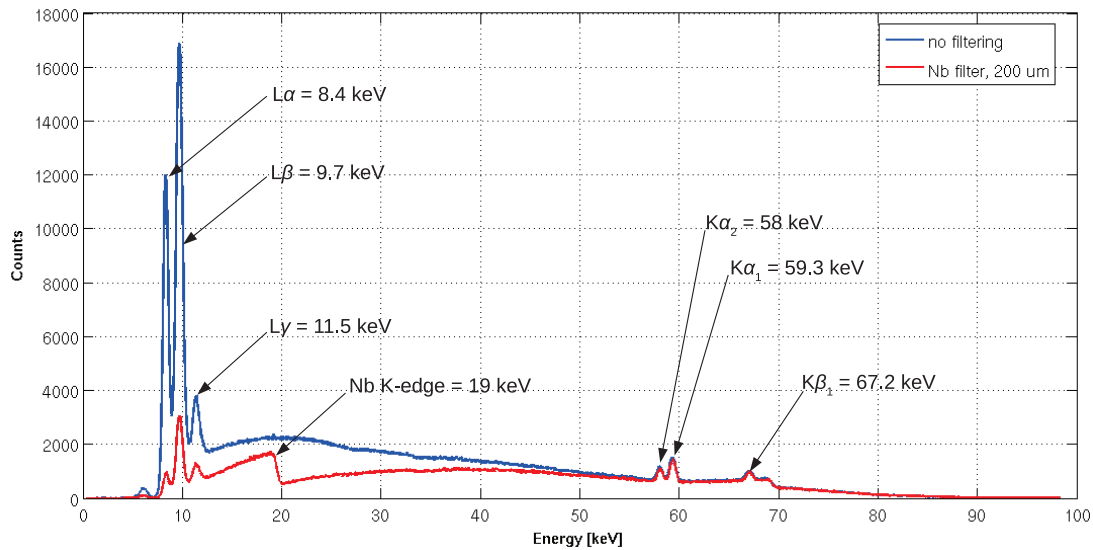

FIGURE 4.7: X-ray tube spectra measured at 90 kV and 10 W without and with external filtering using a 200 μm thick niobium filter.

The dose rate at the position of the XPAD3 detector was measured using a PTW DIADOS Diagnostic Dosimeter with a semiconductor detector DIADOS T60005⁴. The measurement was done at 90 kV and 80 W applied to the X-ray tube. The dose rates measured with and without an external 200 μm thick niobium filter were 1.15 mGy/s and 3.91 mGy/s, respectively.

4.2.2 Study of a free falling steel ball

The objective of this first experiment was to register the motion of a free falling steel ball. The steel ball was 6 mm in diameter. It was dropped inside a plastic tube. The tube was hidden in a foamed polyester that makes it opaque to visible light (figure 4.8). The ball was hold on the top of tube by a small electromagnet until acquisitions of the images were started.

In order to register accurately and completely the fall of the ball, one thousand images were acquired in a burst with an X-ray pose of 1 ms. To get a sufficient number of photons from the X-ray source in such a short exposition time, the tube was operated at maximum voltage and power corresponding to 90 kV and 80 W without additional filtering. In figure 4.9a, an image of flat raw data registered during 1 ms is shown. As it can be seen in figure 4.9a, the left-top corner of the detector is not covered by the beam. Also, on the profile plot (figure 4.9c) along the column through the eight modules, one can notice that the left-right

⁴PTW-Freiburg, Lörracher Strasse 7, 79115 Freiburg, Germany, <http://www.ptw.de/>

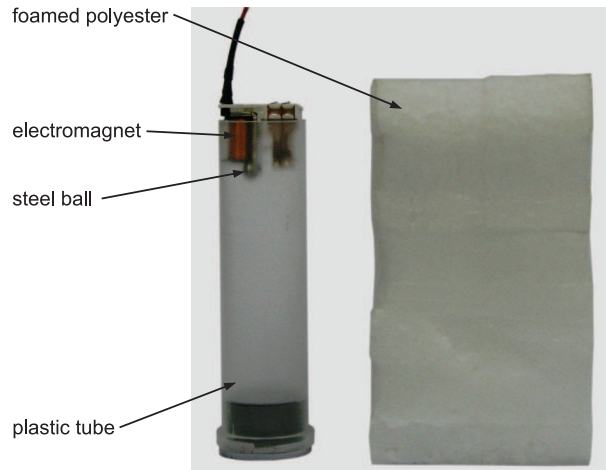

FIGURE 4.8: Picture of the setup used to study the motion of a free falling ball.

effect described in section 3.2.5 has been quite well corrected by the calibration but remains slightly visible. This is due to imperfect calibration of the detector.

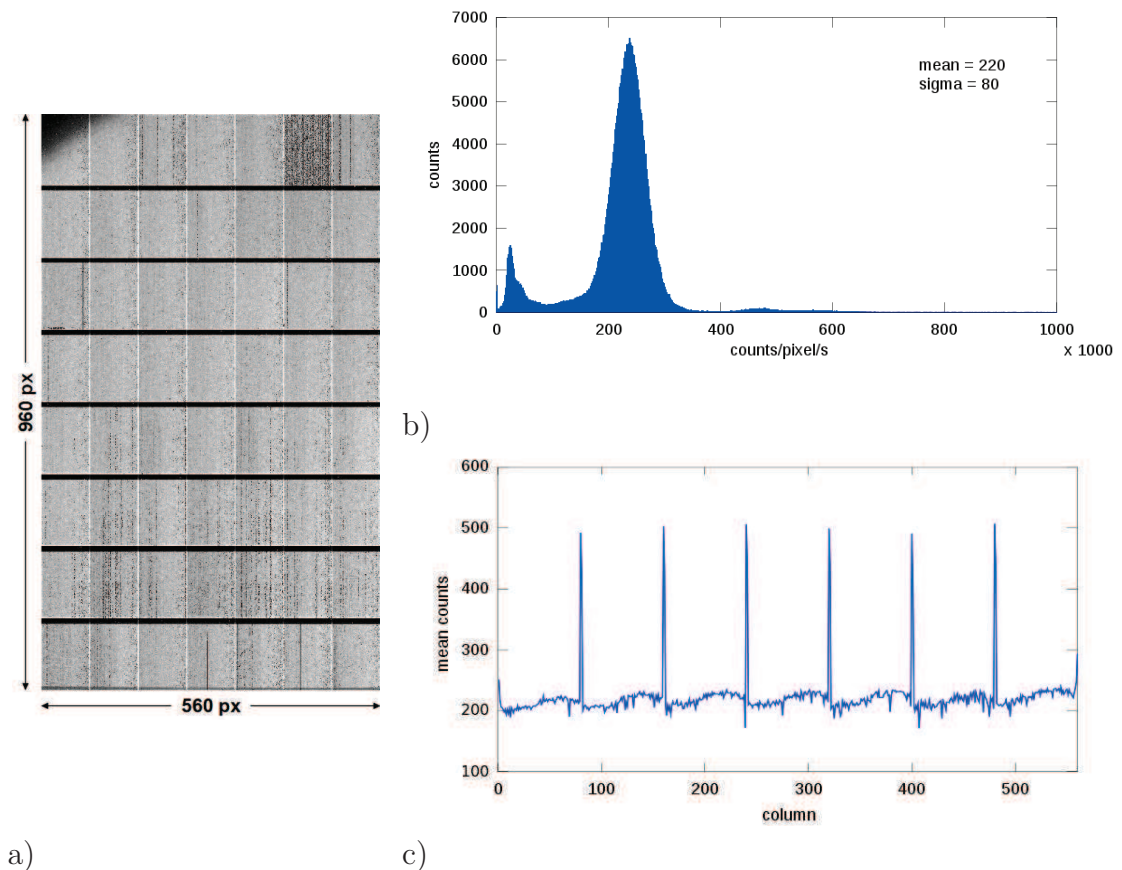

FIGURE 4.9: (a) Flat image of raw data acquired during 1 ms poses, (b) histogram of counts per pixel and (c) horizontal profile of mean counts per pixels.

However, this does not prevent us to perform the experiment. The distribution of

counts per pixel is shown in the histogram plot (figure 4.9b). The mean number of counts was approximately 220 photons/pixel. The principal parameters of the experiment are summarized in table 4.2.

Tube voltage	90 kV
Tube power	80 W
Filter	none
Pose duration	1 ms
Number of acquired images	1000
Overall duration of the acquisition	5524 ms
Frame rate	180 frames/s

TABLE 4.2: Principal parameters of the free falling ball experiment.

The first 500 ms of the fall of the ball are shown in figure 4.10 using 15 selected frames. The presented images have undergone several steps of post processing. This includes elimination of the masked pixels (pixels that are covered because of the tiling of the modules) and correction of the broader edge pixels between the chips, interpolation of the pixels that do not work properly (from a mask of the pixels determined from a long pose flat field image), division by the flat field image and geometrical correction for the 7° tiling of the modules (through projection on a flat grid). The initial fall and the two subsequent bounces of the ball are visible. We have repeated the experiment with poses of 2 ms instead of 1 ms. In order to evaluate the geometrical and timing precision of the detector, we have estimated the value of the acceleration due to gravity based on the acquired data. The obtained values are $(9.79 \pm 0.05) \text{ m/s}^2$ with 1 ms poses and $(9.84 \pm 0.06) \text{ m/s}^2$ with 2 ms poses. A detailed derivation of the acceleration with 2 ms pose data is described in the next section.

4.2.2.1 Estimation of the acceleration due to gravity

In this section, we describe the estimation of the acceleration due to gravity using data that were obtained from the free falling steel ball experiment. The calculations are related to the experiment performed with 2 ms poses.

A reference value of the acceleration due to gravity has been calculated for the latitude and altitude of Marseilles-Luminy, where the experiment has been carried out, using the *International Gravity Formula* [98].

$$g = 978.0495 \left[1 + 0.0052892 \sin^2(\phi) - 0.0000073 \sin^2(2\phi) \right] - 3h \cdot 10^6 \frac{m}{s^2} \quad (4.1)$$

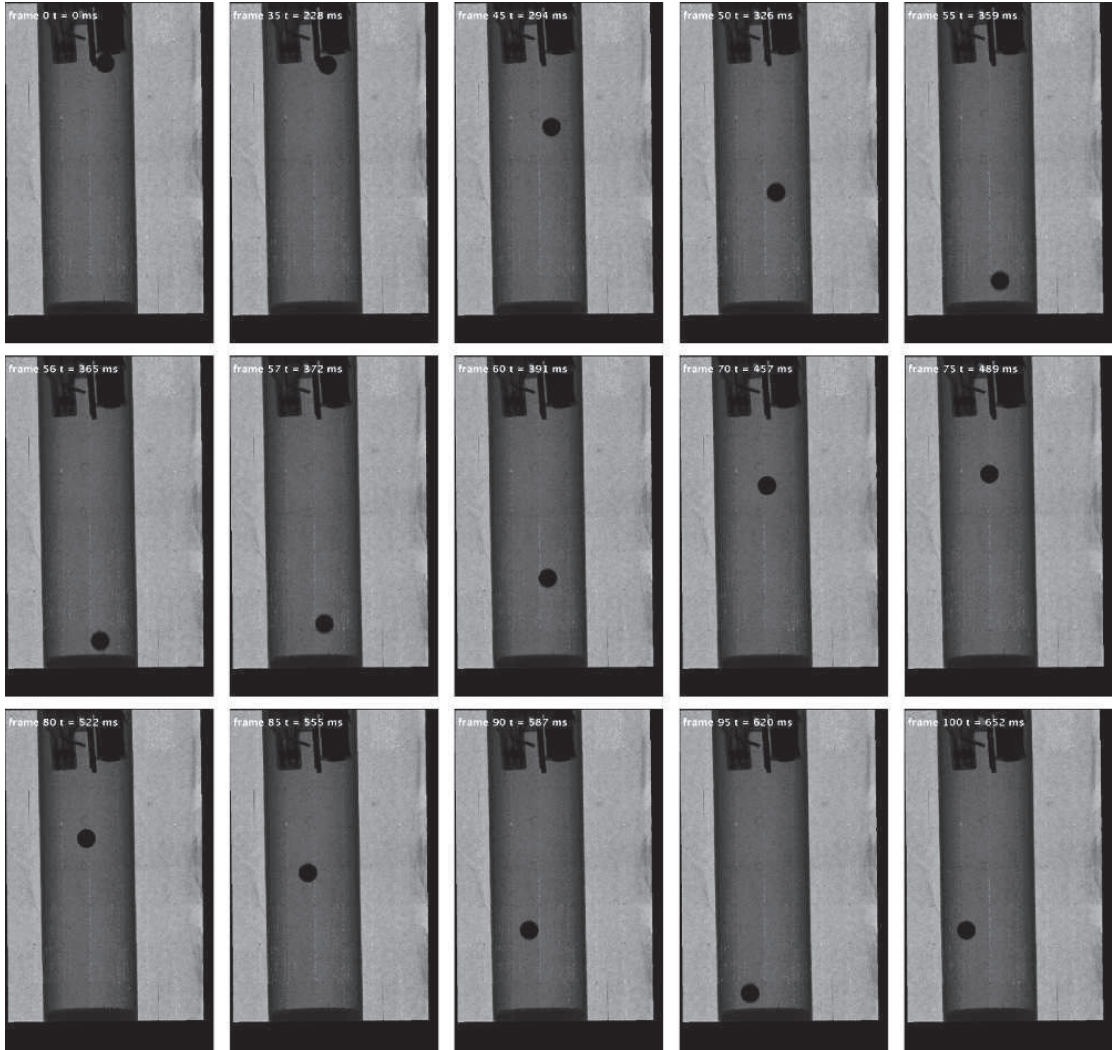

FIGURE 4.10: Motion of the steel ball during first 500 ms of the free fall.

where: $\phi = 43.23^\circ\text{N}$ and $h = 155$ m. This gives $g = \mathbf{9.804}$ m/s².

The motion of the ball after it is released is subject to the gravity force, to the Coriolis force, and to the Stokes' drag force. The Coriolis force does not affect the vertical movement of the ball, and the influence of the Stokes' force is five orders of magnitude smaller than the gravity as shown in Appendix C. Therefore, we can ignore both these forces in the following analysis.

A free falling object influenced only by gravity undergoes a constant vertical acceleration \mathbf{g} . The vertical distance as a function of time, with initial position and vertical speed equal to zero, is given by the kinematic equation

$$y(t) = \frac{1}{2}gt^2 \quad (4.2)$$

One method to estimate the acceleration of the ball is to plot its position versus time and fit a parabola through these points. The quadratic coefficient of the fit will correspond to $\frac{1}{2}g$ from equation 4.2.

In order to properly plot the trajectory of the ball, the acquired images have to be processed in order to find the vertical coordinate of the centre of the ball and to calculate the diameter of the ball in number of pixels.

The determination of the vertical coordinate of the centre of the ball was done as follows:

1. Make an average from all images (background)
2. Remove background from each image
3. Project image on the vertical axis and find the center of the ball

In the figures below, two images are shown: the original image (a), and the same image, but with removed background (b). Finally, the horizontal projection of the latter image is shown in (c). The horizontal red line indicates the maximum value of the profile, which corresponds to the centre of the ball.

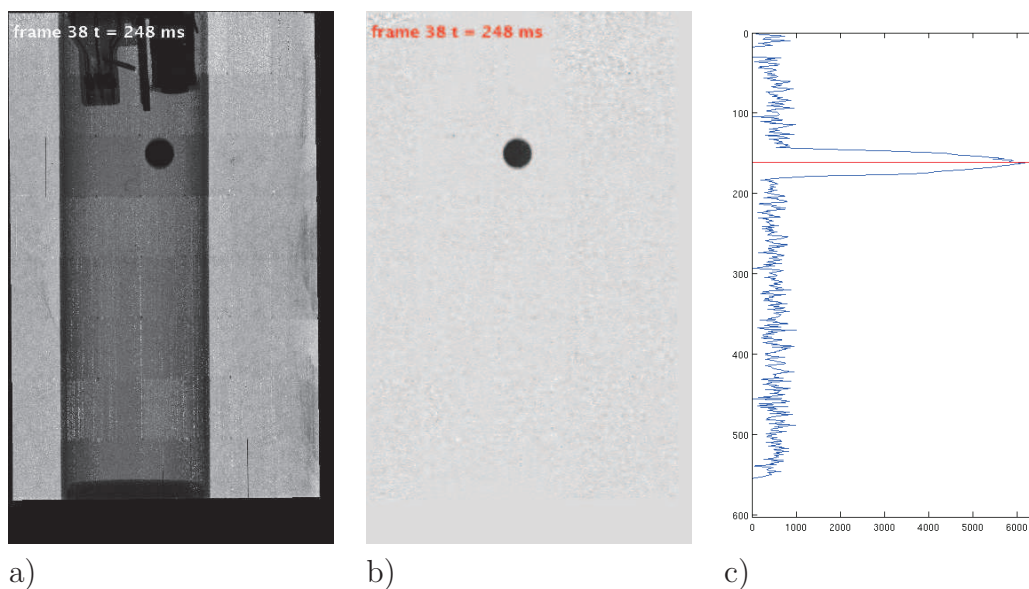

FIGURE 4.11: Subsequent steps of image processing to obtain the vertical coordinate of the centre of the ball: (a) original image, (b) background removed image and (c) horizontal projection.

In order to accurately estimate the diameter of the ball “seen” by the detector, we have used the relation between the ball diameter D and its RMS⁵ error given by $D/4$ (see appendix D). The RMS error was calculated on the horizontal profile of the ball (figure 4.11c). The histogram of the calculated diameter is shown in figure 4.12. The estimated diameter of the ball amounts to 53 ± 0.13 pixels.

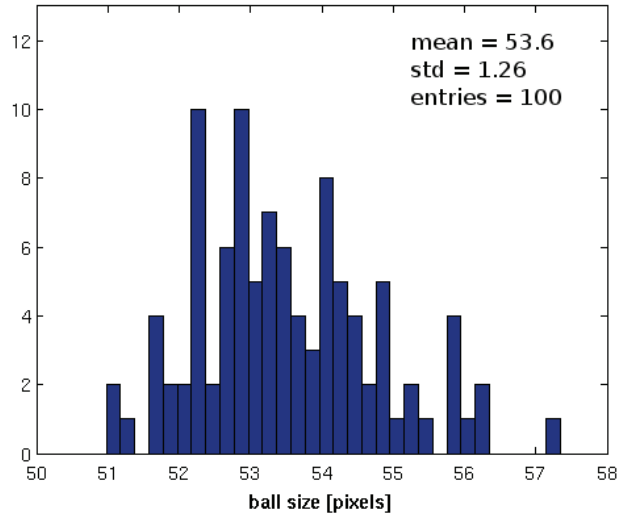

FIGURE 4.12: Histogram of the ball diameter values calculated from the RMS values.

The vertical position of the ball after its release is plotted versus elapsed time in figure 4.13. The two axis were rescaled in order to have a scaled representation of the vertical position (from the top of the detector) and of elapsed time. The vertical

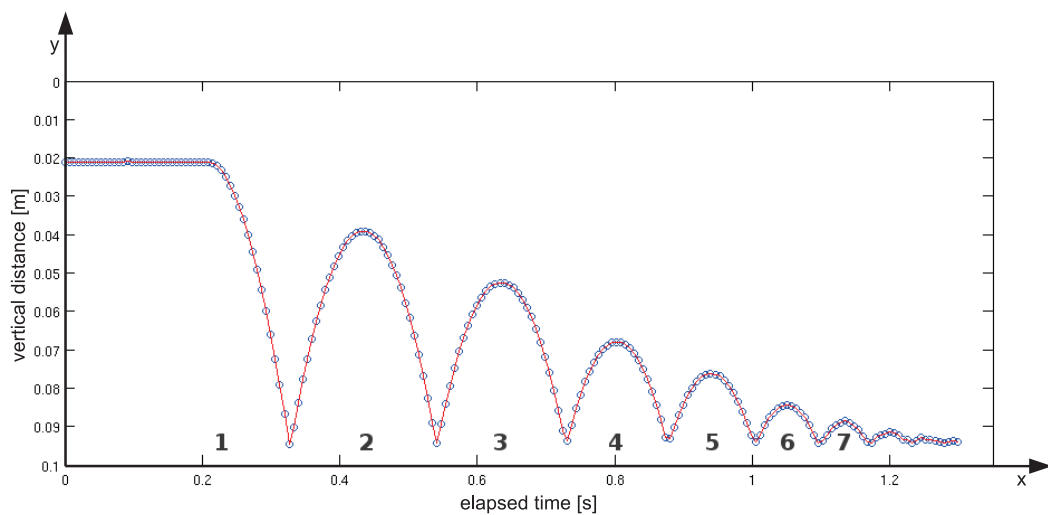

FIGURE 4.13: Plot of the ball trajectory. Both axis were rescaled in order to have real representation of the vertical ball position versus elapsed time.

⁵Root Mean Square

y axis was scaled accordingly to the size of the effective pixel that was estimated from the ratio between the ball diameter and its diameter in pixel counts. The horizontal x axis was scaled according to the elapsed time measured over 1000 acquired images. The estimations of the scaling factors for both the axis are given in equation 4.3.

$$\begin{aligned} Y_{scaling_factor} &= \frac{\varnothing_{real}}{\varnothing_{pixel}} = \frac{6 \cdot 10^{-3} \text{ m}}{53.6 \text{ pixels}} = 1.12 \cdot 10^{-4} \left[\frac{\text{m}}{\text{pixel}} \right] \\ X_{scaling_factor} &= \frac{T_{total}}{N_{images}} = \frac{6524 \cdot 10^3 \text{ s}}{1000 \text{ images}} = 6.524 \cdot 10^3 \left[\frac{\text{s}}{\text{images}} \right] \end{aligned} \quad (4.3)$$

where $Y_{scaling_factor}$ and $X_{scaling_factor}$ are multiplication factors for y and x axis, respectively.

The acceleration due to gravity was estimated from the parabolas labeled from 2 to 7 in figure 4.13. The initial fall of the ball was rejected due to the fact that only

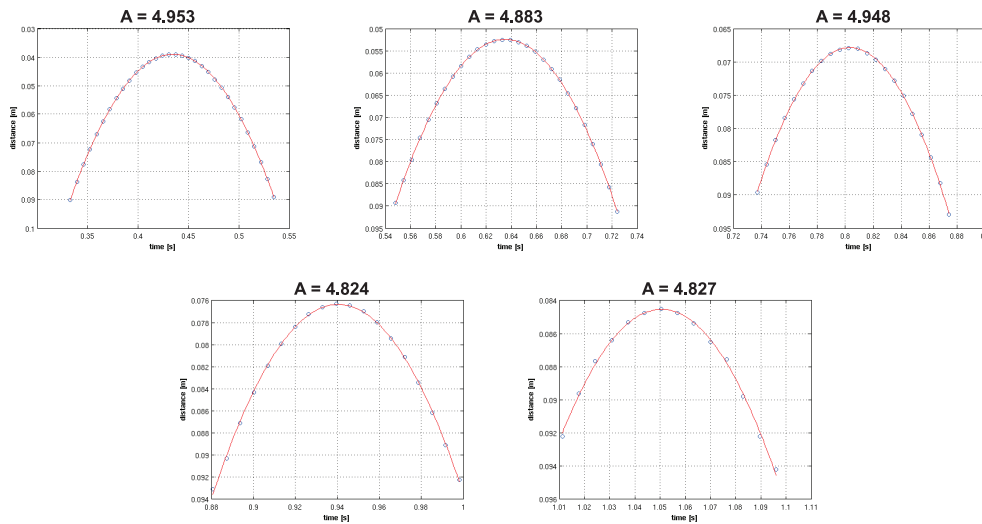

FIGURE 4.14: Polynomial fit to the experimental data.

half of the curve was plotted. The parabolas that represents the last few bounces were also rejected due to large errors introduced by the fact that the ball bounces near the edge of the tube and was touching the wall. Quadratic polynomial fits on

Parabola	Quadratic coef.	Acceleration g [m/s ²]	Mean g [m/s ²]
2	4.94	9.94	9.86 ± 0.05
3	4.88	9.84	
4	4.95	9.97	
5	4.82	9.72	
6	4.83	9.73	

TABLE 4.3: Values of the estimated gravitational acceleration.

these data with quadrature coefficients are shown in figure 4.14. The estimated values of the acceleration due to gravity for these data are shown in table 4.3.

The systematic error resulting from the estimation of the ball diameter is given by

$$0.13 \times 9.804/53.6 = 0.02$$

Thus, the final estimated value of the acceleration due to gravity is

$$g = (9.86 \pm 0.05 \pm 0.02) \frac{m}{s^2}$$

4.2.3 Mechanical Swiss watch

The second experiment was carried out to visualize the working mechanism of an analogue watch⁶ (figure 4.15). In this “exercise”, we have used a 200 μm

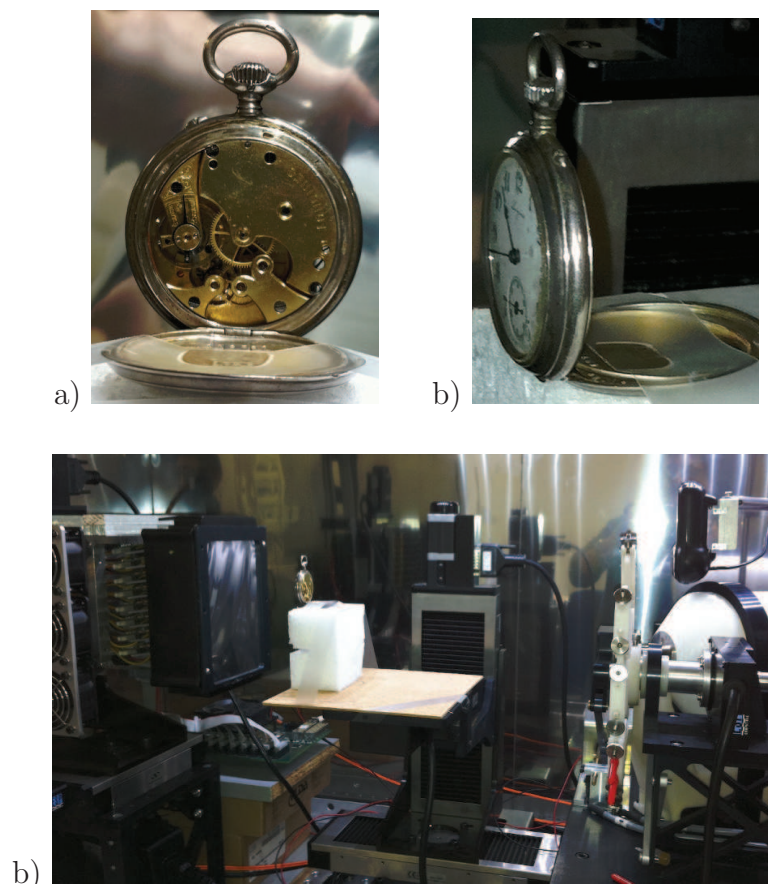

FIGURE 4.15: Pocket watch *Longines* used in the experiment.

niobium filter that makes the X-ray beam spectrum (see figure 4.7) harder and

⁶Longines, Grand Prix Paris 1889

helps to improve the contrast of the image. To get photon statistics that will allow to distinguish different components of the mechanism, the pose duration was extended to 50 ms. Nonetheless, most of the photons were absorbed by the rather thick metallic components of the clock.

Tube voltage	90 kV
Tube power	80 W
Filter	Nb 200 μm
Pose duration	50 ms
Number of acquired images	500
Overall duration of the acquisition	27262 ms
Frame rate	18 frames/s

TABLE 4.4: Parameters of the analogue pocket watch experiment.

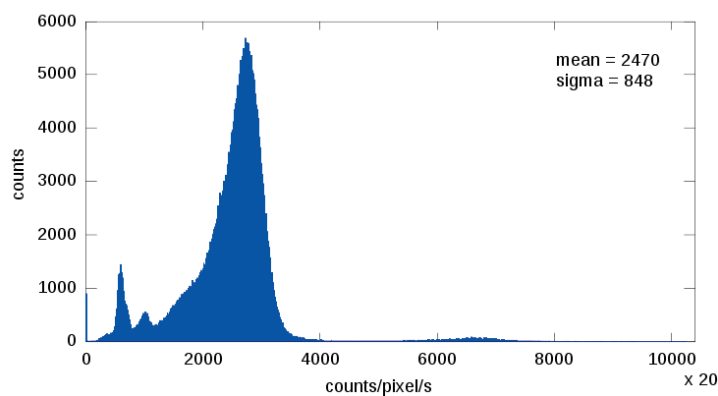

a)

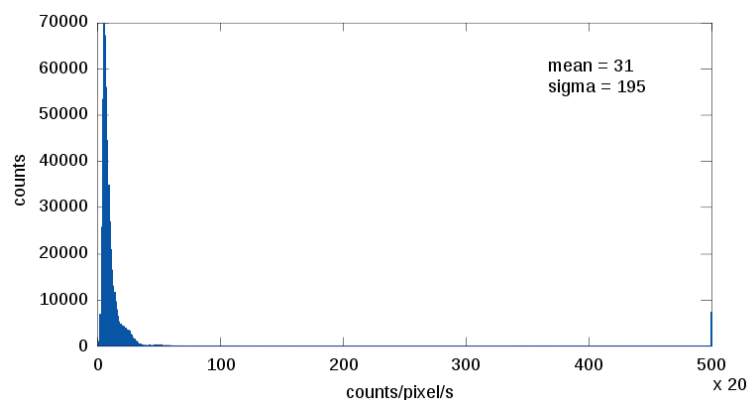

b)

FIGURE 4.16: Histograms of the pixel counts (a) in a flat image and (b) in an image of the pocket watch obtained with a 50 ms pose.

In figure 4.16, histograms of a flat image and of the pocket watch image with a 50 ms pose are shown. The mean values of counts shows that 99% of the photons were absorbed by the watch. Despite the very low statistics, it was possible to

observe the principal components of the watch mechanism in movement with a frame rate of 18 images/s.

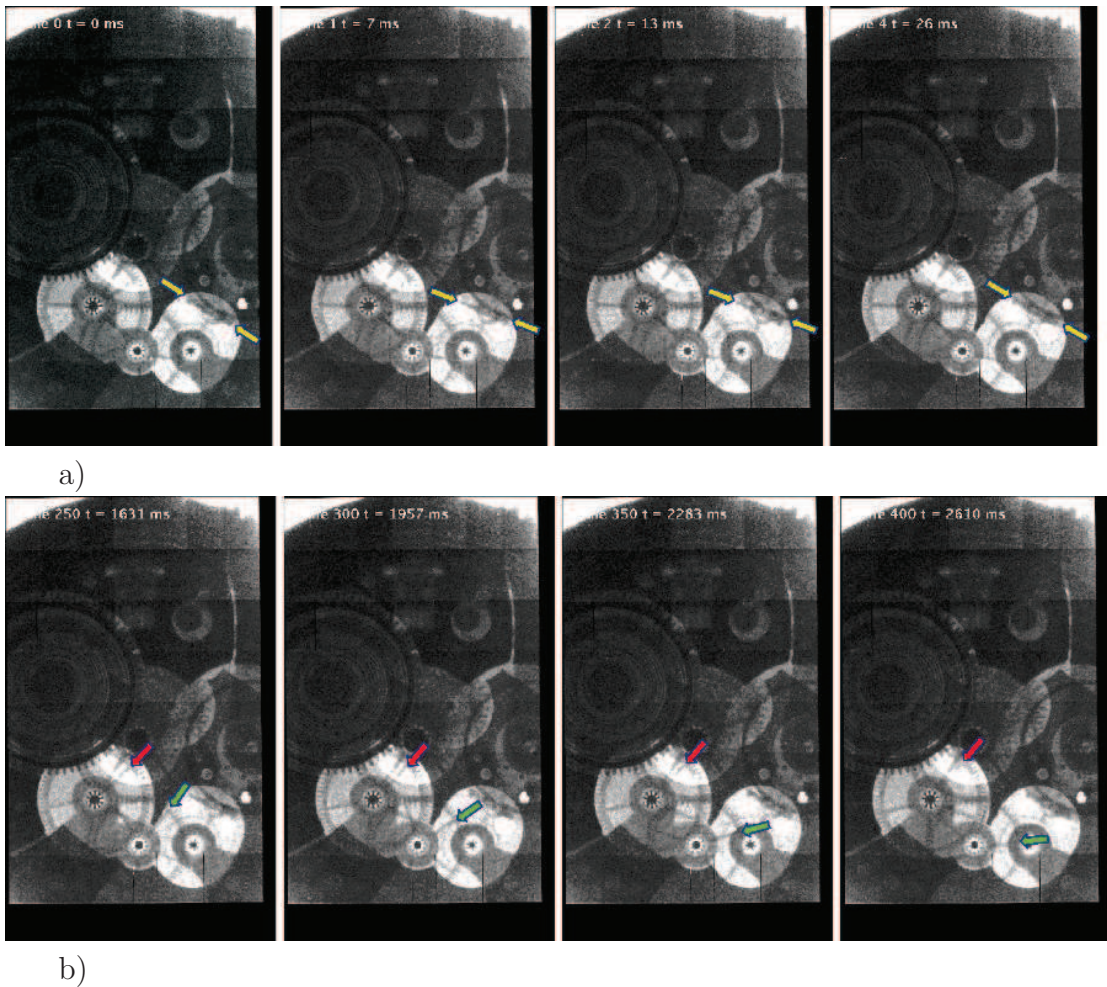

FIGURE 4.17: Movement of a selected part of the mechanism of the pocket watch shown (a) every 100 ms and (b) every 2500 ms.

In figure 4.17, the movement of a selected part of the pocket watch is shown in two series of five images. In the first series (figure 4.17a), the images show the position of the mechanism every 100 ms. One can see the movement of the *lever escapement* element of the watch (yellow arrows). In the second series (figure 4.17b), the images show the position of two wheels (*center* and *escape* wheels) indicated by red and green arrows every 2.5 s.

The analysis of selected regions of interest (ROI) in the images allowed to estimate the spinning speeds of one of the components of the lever escapement mechanism, the T-shaped *pallet fork*, and of the central wheel of the watch.

The ROIs that were used to estimate the frequency of the pallet fork are shown in figure 4.18a. These regions have a size of 24×24 pixels and cover sectors

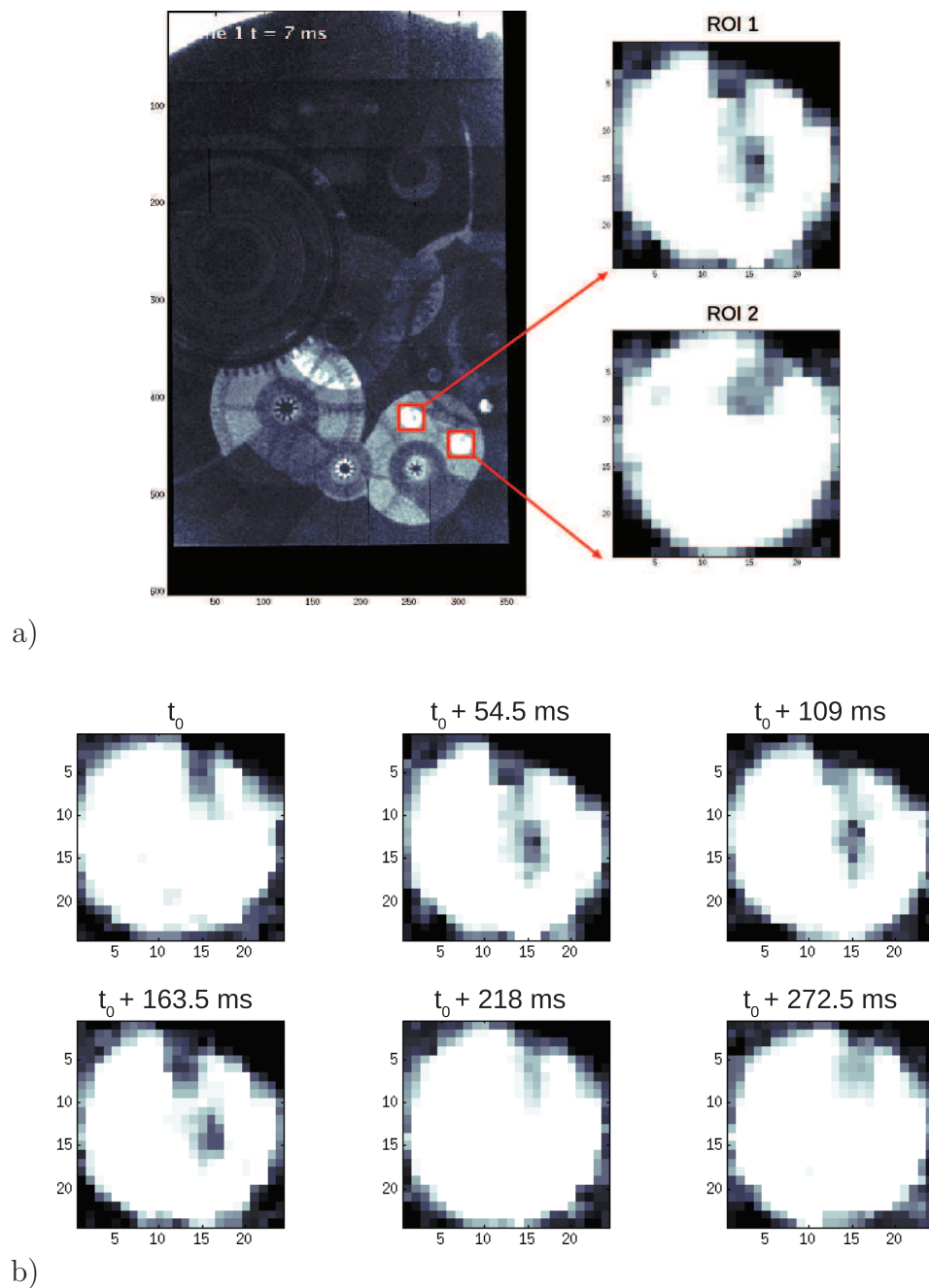
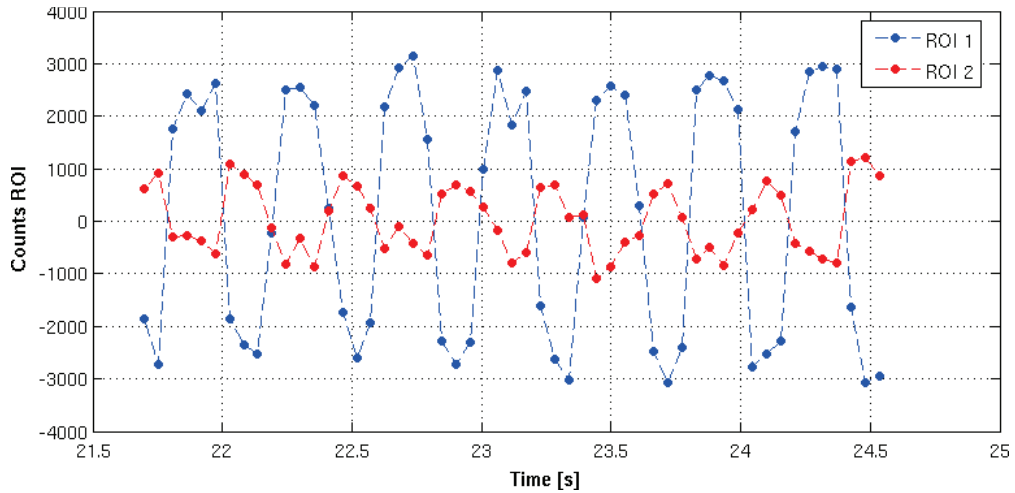
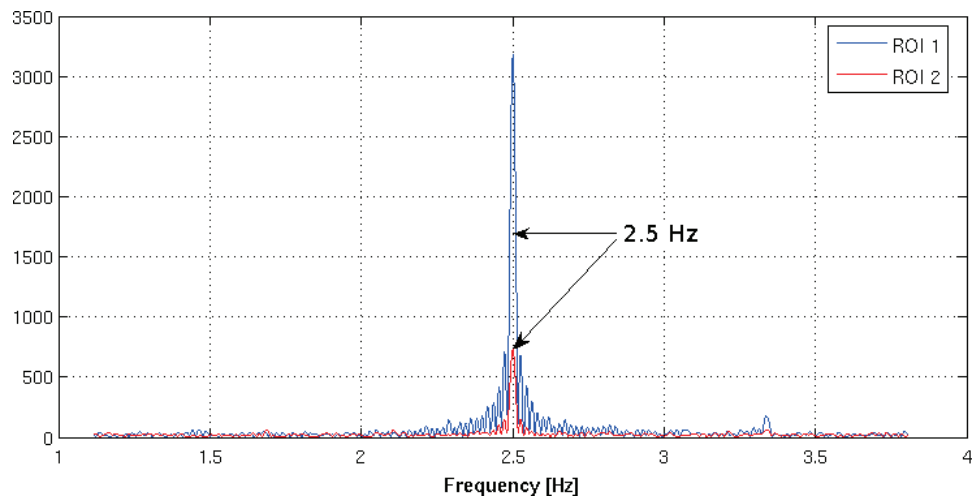

FIGURE 4.18: (a) The two regions of interest that were used to estimate the frequency of oscillations of the escapement element with (b) detailed view of its movement in ROI 1.

with a high photon statistics as compared to the neighbouring areas. The T-shaped element alternately enters and leaves these regions, thus changing the overall number of counts in the ROIs. The movement sequence in the upper ROI is shown in figure 4.18b. An analysis of the total number of counts in the ROIs allows for determining the frequency of oscillation of the pallet fork. Figure 4.19a shows the number of total counts in each one of the ROIs versus time. The lower



a)



a)

FIGURE 4.19: The total number of counts per ROI used for the estimation of the frequency oscillation of the pallet fork (a) as a function of time and (b) in the frequency domain.

amplitude of the second signal is due to the fact that the pallet fork does not leave this region completely. Consequently, there is a difference in total counts observed in ROI 2 that are smaller than in ROI 1. Performing an FFT⁷ on these data allows represent them in the frequency domain. The first harmonics of the frequency spectra of these two plots are shown in figure 4.19b. The frequency of the pallet fork oscillation read from these plots is 2.5 Hz, which is in agreement with the visual observations of the watch mechanism.

In order to estimate the rotation speed of the central wheel, the ROI presented in figure 4.20 was selected. Whenever one of the five spokes of the wheel is entering

⁷Fast Fourier Transform

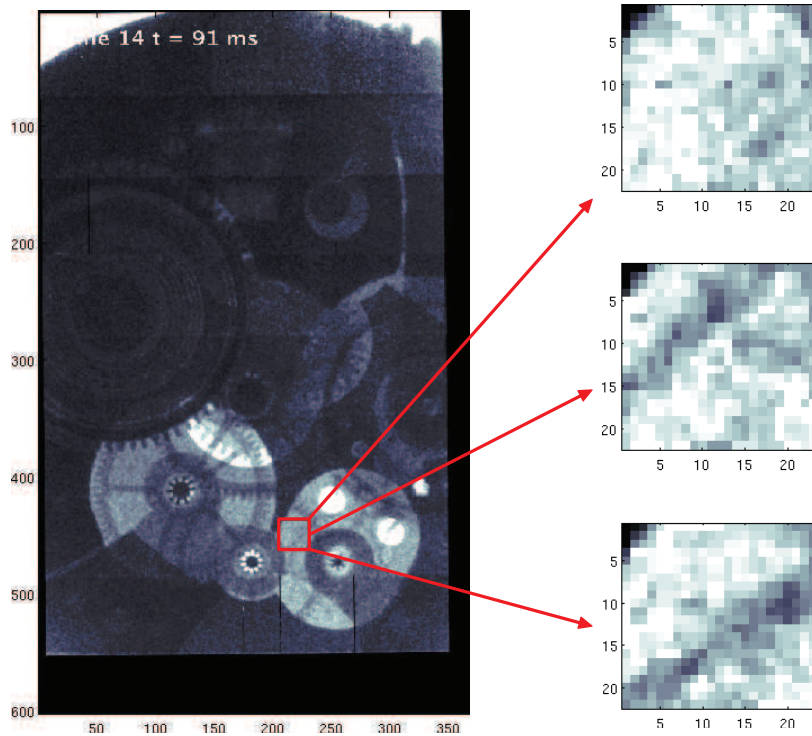

FIGURE 4.20: View on the ROI that was used to estimate the spinning speed of the central wheel.

this ROI, the number of detected photons decreases. Similarly to the previously described analysis, the total number of counts in the ROI is plotted against time. The resulting waveform is shown in figure 4.21a. A frequency spectrum resulting from an FFT is shown in figure 4.21b. The main frequency is 0.083 Hz and indicates the frequency of the entrance of the wheel spokes inside the ROI. Hence, the spinning frequency of the wheel is five times lower, since the wheel has five spokes and amounts to 16.6×10^{-3} Hz. This value corresponds to one turn every 60.2 s. Indeed, this wheel moves the second hand, which is visible at the bottom of the pocket watch in figure 4.15b.

4.2.4 Mouse angiography

The last type of experiments described in this chapter was carried out with the help of Franck Debarbieux, biologist at IBDML⁸. We performed imaging of a mouse with two different contrast agents (iodine and gadolinium). Mass attenuation coefficients for these contrast agents in the energy range of the X-ray spectrum is shown in figure 4.22. The K-edge (see section 1.1.1) of iodine at 33.2 keV is within

⁸Institute for Developmental Biology of Marseilles-Luminy

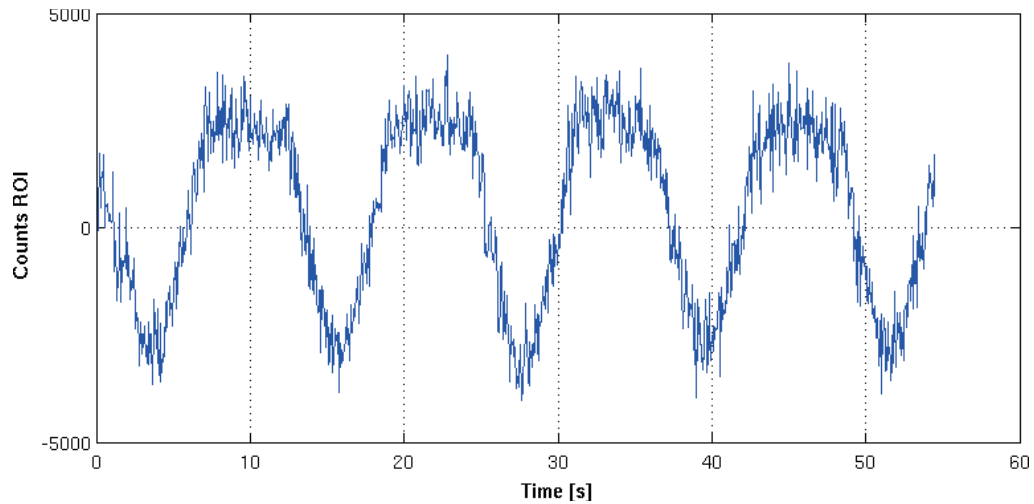

a)

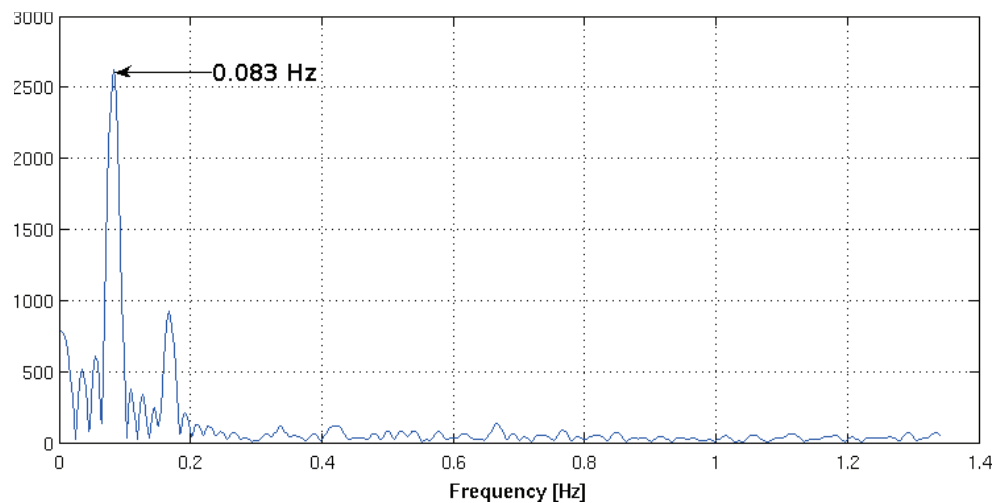

b)

FIGURE 4.21: Total number of counts in the ROI used for the estimation of the spinning speed of the central wheel (a) as a function of time and (b) in the frequency domain .

the energy range of the silicon sensor we use.

We have performed an angiography experiment with the detector calibrated on the electronic noise. We used iodine as contrast agent to distinguish blood vessels from the body by comparing the number of counts with an image that was taken before injection. 200 μL of iodine were injected retro-orbitally into the head of the animal. The injection was done during the first 3 s of the measurement. During this experiment, 1000 images were acquired with 10 ms pose at a frame rate of 69 images/s. Each one of the acquired images has been initially processed to correct for masked and broader edge pixels, as well as for geometrical correction due to the tiling of the modules. In addition, a median filter was applied to the images

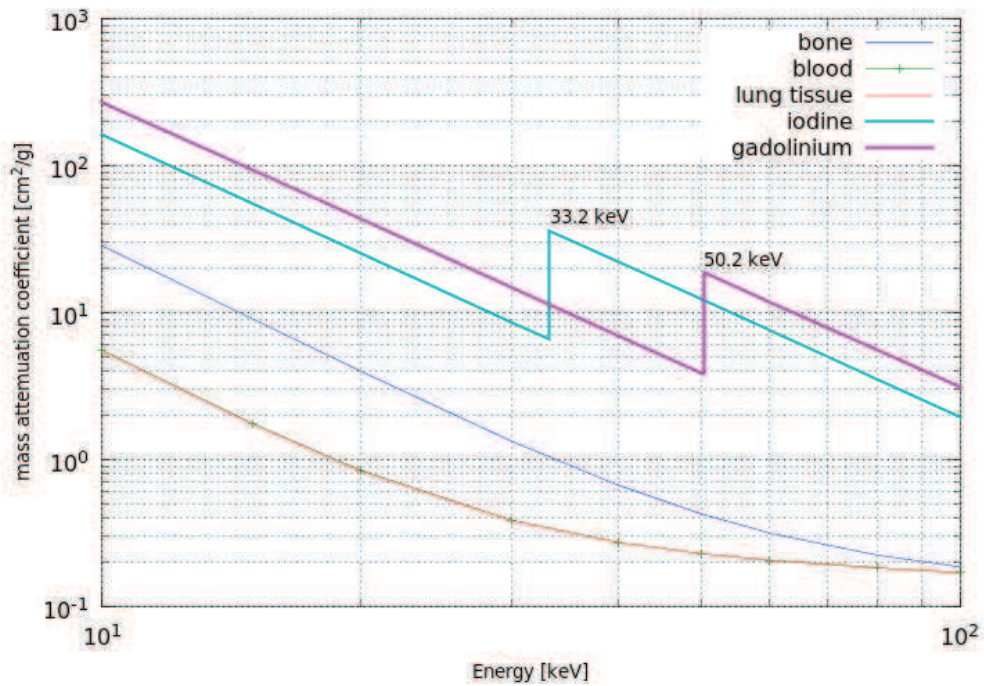

FIGURE 4.22: Mass attenuation coefficients for selected materials and compounds (data from [101]).

Tube voltage	90 kV
Tube power	70 W
Filter	Nb 200 μm
Pose duration	10 ms
Number of acquired images	1000
Overall duration of the acquisition	14524 ms
Frame rate	69 frame/s
Contrast agent	Iodine, 200 μL

TABLE 4.5: Parameters of the mouse angiography experiment using iodine contrast agent.

in order to smooth the noise. Further processing was done in order to enhance the contrast of the images. It includes dividing each one of the images by the one that was acquired before iodine was injected. In figure 4.23, the images before (a) and after injection (b) are shown. Dividing these two images improves the contrast between the iodine contained in the vessels and the body, as shown in figure 4.23c. The pixels from the region without iodine have values oscillating around one, while values of the pixels from the region containing iodine are much lower. Applying a threshold level to the resulting image allows to create a map of the pixels that represents the distribution of iodine in the body of the mouse. We have selected a threshold value of 0.9. The last step of the processing corresponds

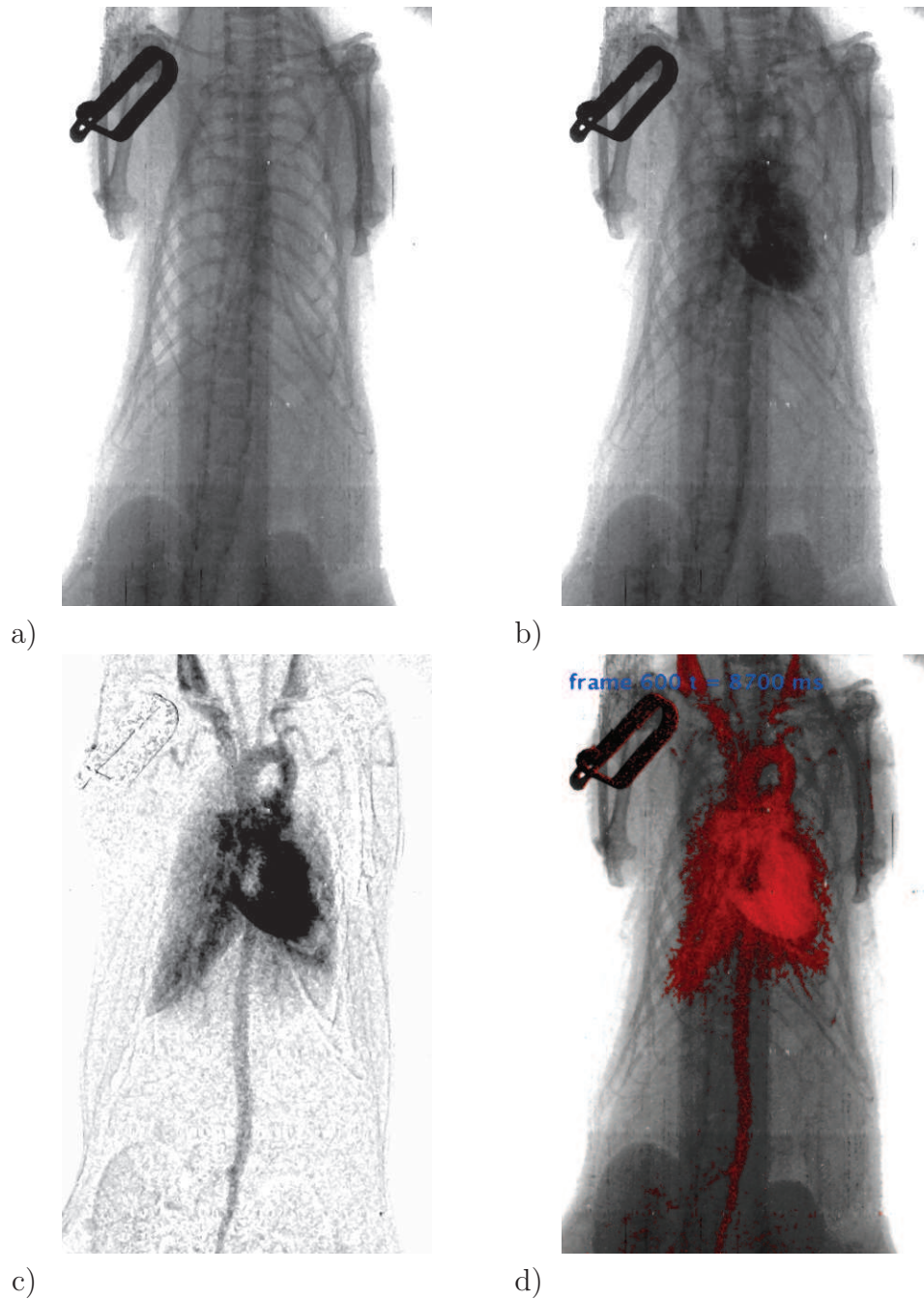

FIGURE 4.23: Image of the mouse (a) before injecting iodine, (b) after injection when iodine is well distributed, (c) result of the division $(b)/(a)$ of these two images and (d) image with colored pixels.

to the colorization of the pixels in the original image accordingly to the created map. The process of colorization was done by resetting values of the blue and green components of the RGB representation of the pixel value. An image obtained after all steps of processing is shown in figure 4.23d.

In figure 4.24, the first 6 seconds after injection of iodine into the mouse body

are shown in 25 images. In the presented images, it can be seen how iodine is transported with oxygen-poor blood via veins (i.e. *superior vena cava*) to the right atrium and then to the right ventricle of the heart. In the subsequent images, one can see how blood charged with iodine is circulated to the lungs via pulmonary veins and returns to the left atrium first, and then to the left ventricle of the heart. An oxygen-rich blood is then pumped towards the other organs via artery, as an aortic arch becomes clearly visible. The iodine then diffuses to the kidneys and is finally accumulated in the bladder (not visible in the picture).

The injection of iodine into the cardiovascular system of a mouse followed by dual-energy imaging with a threshold set below and above the K-edge of iodine can be used to perform a differential angiography experiment that would increase the contrast between parts of the body containing high iodine concentration (vessels) and the rest of the body. Dual-Energy Digital Subtraction Angiography (DEDSA [38][36][77]) is a technique that takes advantage of a very different attenuation coefficients between low atomic number biological compounds (e.g. soft tissue, blood, bone) and high atomic number elements used as contrast agents such as iodine, silver or gadolinium.

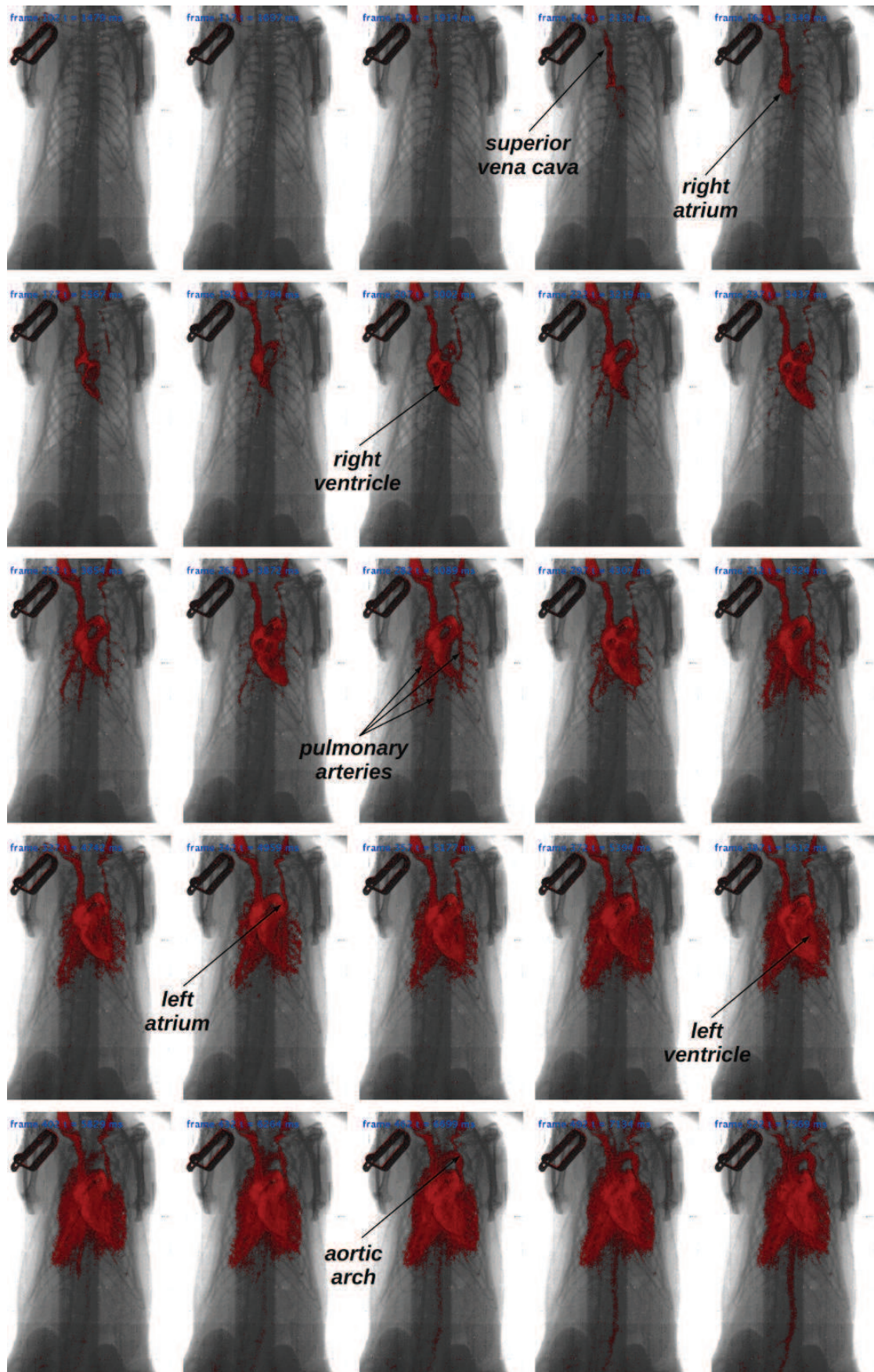

FIGURE 4.24: Mouse angiography.

Conclusions and prospects

The development of a high-speed data acquisition for the XPAD3 camera has been presented in this thesis. The architecture of the data acquisition system is based on a PCI Express interface. High frame rates are ensured by the use of DMA data transfer to the host PC. The complete detector is composed of eight independent modules, consisting of $560 \times 960 = 537\,600$ pixels which cover a total area of $75 \times 120 \text{ mm}^2$. Data acquisition developed for this work reaches a frame rate of 240 images/s. The number of images that can be downloaded is limited by the size of the RAM memory embedded in the acquisition PC. Three detectors were built within this project. Two of them are operated at the ESRF and SOLEIL synchrotron facilities for crystallography experiments and one is operated at CPPM for small animals imaging studies.

A new version of the XPAD3 photon counting chip has been developed to correct for malfunctions that were discovered in the first version of the circuit. This new chip has an improved design of the charge injection circuit that will allow to calibrate the detector on a given energy without using an external beam of known energy. The distribution of the power among the matrix has been modified to eliminate lateral drifts in bias values that were affecting the calibration process. Last but not least, the distribution of the “counter enable” signal has been modified so to be able to have pulse durations shorter than $1 \mu\text{s}$.

Besides tiling these known issues, the new version has been equipped with some further improvements. The most significant one is a 6-bit wide readout bus (instead of a 4-bit one) that will allow to read the chip even faster. The estimated speedup in the readout time of the chip will be around 30% as compared to XPAD3. Like for the former XPAD3 chip, the new version of the chip called XPAD3.2 has been designed in two versions called XPAD3.2-S and XPAD3.2-C. These latter will accept two different polarities of the input signal (version -S for hole and -C for electron collection). Furthermore, the linearity of the CSA has been extended up to 60 keV instead of 35 keV.

The upgraded architecture of the detector is designed so to benefit fully from the new readout of the XPAD3.2 chip and will get rid of the shortcomings of the current camera design. Most of the limitations of the current design results from the use of an intermediate HUB board. One of the main limiting issues involved by the use of this HUB board was the maximum achievable bandwidth, which in turn generates dead time between the readout of the image frames. The bandwidth of the HUB board was limited mainly by the optical transceivers implemented on the board and by the narrow data bus from the detector modules, which required data deserialization. As a result, a bandwidth of 2 Gbps only was achieved, which is equivalent to 2.1 ms to transfer one image through the HUB board, whereas the XPAD3 chip could be read out in less than 1 ms. It is then clear that the current hardware architecture configuration does not allow to exploit fully the potential of the detector modules.

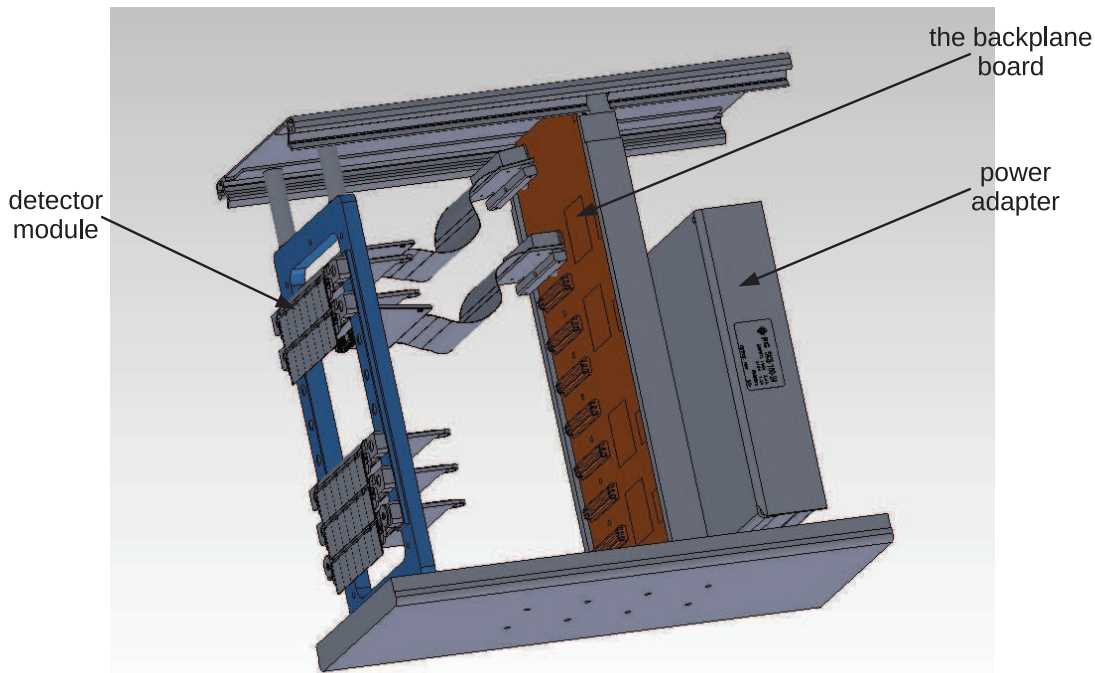

FIGURE 4.25: CAD view of the upgraded architecture of the camera.

For the new architecture of the XPAD3.2 camera, the HUB board and the eight Cyclone detector boards will be replaced by a single backplane that is going to undertake all their functionalities. In figure 4.25, a CAD visualization of the new detector design of the XPAD3.2 camera is presented. The eight detection modules will be connected directly to the backplane via flexible PCBs. The backplane will be equipped with four FPGAs for data processing (one FPGA per detector module pairs), each of them equipped with a dedicated optical channel that will allow to send data as fast as the XPAD3.2 circuits can afford.

The implementation of four optical channels implies to change the PCI Express design that was discussed in Section 3.3.4. One of the requirements that is imposed is to be compatible with the software library developed for the XPAD3 camera. Another demand is to get rid of the limitations on the readout speed that were introduced by the software management of interrupts, as it was explained in Section 3.3.5.2. A possible architecture of the PCI Express design that can manage

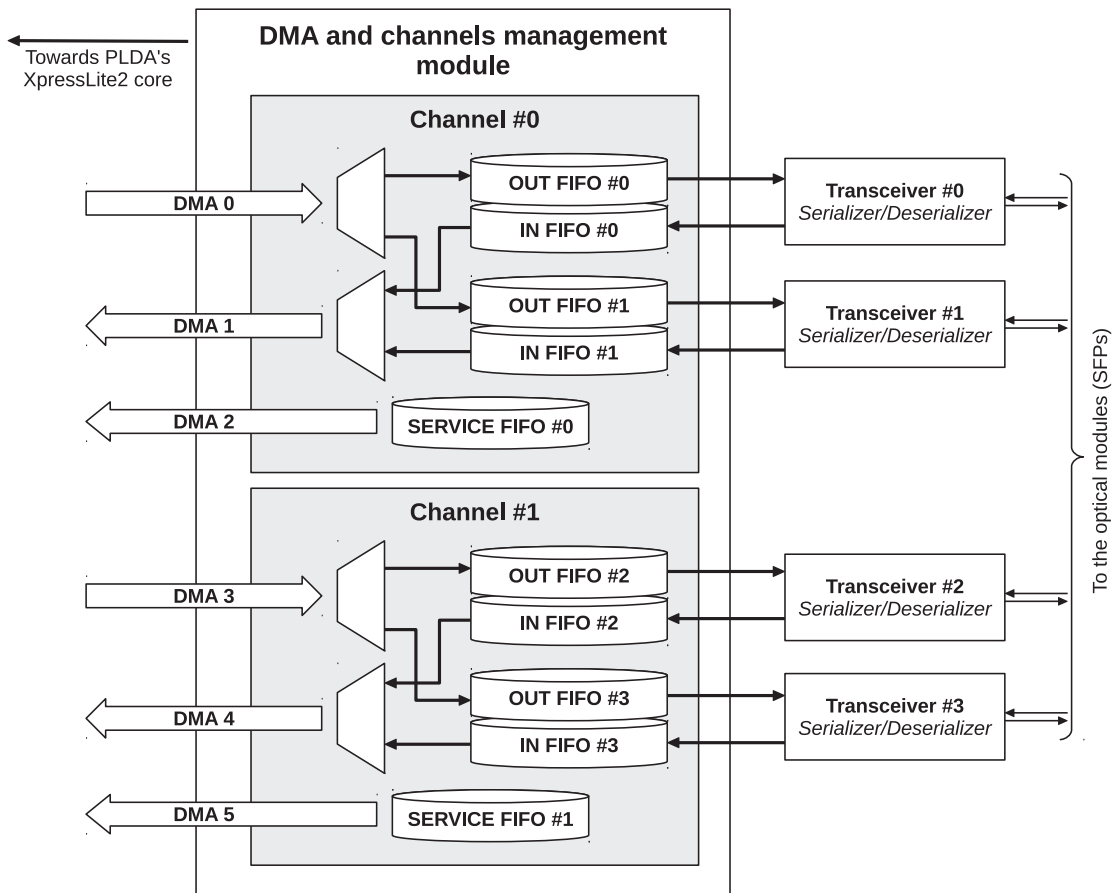

FIGURE 4.26: Proposed PCI-Express architecture for the upgraded design of the detector.

communication via four optical fibers is shown in figure 4.26. It is based on multiplexing/demultiplexing data between the optical interface and the DMA channels. This architecture preserves the organization of the DMA channels and minimizes the number of required changes in hardware and software. That solution would require additional configuration registers that would be used to control data flow via the multiplexers.

The solution for cancelling software limitations on the readout speed comes down to minimize the number of interrupts that are issued to complete the transfer of one image. As this was explained in the previous chapters, the transfer of one image

is done through sixteen DMA writing transactions, each one having a size of half a module image. One of the solutions to solve this problem is to allocate sixteen buffers and pass addresses to the PCI Express configuration registers. That would allow to perform DMA transactions one after the other and to issue an interrupt after the last DMA transfer (or before in case of error). This requires to implement additional registers that can be mapped in the Base Address Register spaces 2 to 5 of the configuration space (see Appendix A).

Although the XPAD3 chip was designed for small animal imaging and crystallography experiments, its unique features make it possible to use it in different applications than those presented in chapter 4. Especially, the selectable energy range and photon counting make it possible to use hybrid pixels for homeland security or waste management applications. Moreover, this technology has the capability to prefigure future 2-D energy spectrometers that will embed an ADC per pixel and bring “colour” to traditional X-ray CT, while opening spectral CT to the field of low dose intrinsic anatomic-functional imaging with X-rays. Additionally, the freedom in choosing a sensor material allows to build different types of detectors optimized for the foreseen applications, e.g. gas detector or neutron detector as mentioned in section 2.2.3.3.1. As an example, a neutron detector based on the XPAD3 chip was developed and used for neutron tomography [10].

All these fascinating application of hybrid pixel technology led a few engineers and physicist of CPPM to start the spin-off company imXPAD SAS⁹ in 2010 for commercializing hybrid pixel detectors based on the XPAD3 camera.

⁹imXPAD SAS, Parc Scientifique et Techno de Luminy, Zone Luminy Entreprises, CASE 922, 13288 MARSEILLE Cedex 09, France, <http://imxpad.com/>

Appendix A

PCI Express Configuration Space

In this appendix, the registers implemented in the configuration space of the XPressLite2 core are described. The structure of the *Common Configuration Space Header* and of the *Type 0 Configuration Settings* are presented in the subsequent tables. A description of the others registers can be found in the specification of the PCI Express protocol [71] or in the reference manual of the XPressLite2 core [73].

Common Configuration Space Header

31	0	
Type 0 Configuration Settings	000h	: 03Ch
Reserved	040h	
PLDA CSR	044h	
Reserved	048h	: 04Ch
MSI Capability Structure	050h	: 05Ch
Reserved	060h	: 064h
MSI-X Capability Structure	068h	: 070h
Power Manageent Capability Structure	078h	: 07Ch
PCI Express Capability Structure	080h	: 0B4h
Reserved	0B8h	: 0FCh

TABLE A.1: *Common Configuration Space Header.*

Type 0 Configuration Settings

31		16	15		0	
	Device ID			Vendor ID		000h
	Status			Command		004h
	Class Code			Revision ID		008h
				Cash Line Size		00Ch
Base Address Registers						010h
						014h
						018h
						01Ch
BAR0 - BAR5						020h
						024h
						028h
	Subsystem ID			Subsystem Vendor ID		02Ch
Expansion ROM base address						030h
				Capabilities PTR		034h
						038h
			Int. Pin	Int. Line		03Ch

TABLE A.2: *The Type 0 Configuration Settings.*

Appendix B

Example of a data acquisition program

A sample source-code that demonstrates an example of the implementation of a calibration data uploading to the detector and of a data acquisition of 1000 images in a burst mode is given below. All the functions that are used in this demonstration program are described in chapter 3.3.

```
1. int main(int argc, char *argv[]){
```

Initialize the PLDA[®]'s PCI-Express driver and all board resources.

```
2.     /* Initialization */
3.     if(xpci_init(0,0) != 0){
4.         printf("Error in PCI board Init ... Quitting...\n");
5.         return 0;
6.     }else{
7.         printf("PCIe successfully initialized \n");
8.     }
```

Diagnostic communication loop-mode test that includes the PCI-Express and HUB boards.

```
9.     /* Communication test */
10.    if(xpci_isPCIeOK()==1){
11.        printf("PCIe board check OK \n");
12.    }else{
13.        printf("PCIe board check FAILED \n");
```

```

14.     return 0;
15. }
16. if(xpci_isHubOK()==1){
17.     printf("HUB board check OK \n");
18. }else{
19.     printf("HUB board check FAILED \n");
20.     return 0;
21. }

```

Detect the number of available modules by sending the *AskReady* command to every module separately.

```

22.  \* Detect available modules *\
23.  if (xpci_modAskReady(&modMask)!=0)
24.      return 0;

```

Compute the size of the image data for the detected modules.

```

25.  \* Calculate size of the image from the available modules *\
26.  modNb = getModNb(modMask);
27.  imgSize = (120*566*2) * modNb;

```

Save values of global and local threshold configurations in the detector memory.

```

28.  \* Save global threshold data *\
29.  currMask = 0x01;
30.  for(currMod=0; currMod<MAX_MODULES; currMod++){
31.      if((modMask>>currMod)&1)
32.          xpci_modSaveConfigG(currMask, config_id, ITHL, IthlVal[currMod]);
33.      currMask=currMask<<1;
34.  }
35.  \* Save local threshold data (DACL values) *\
36.  currMask = 0x01;
37.  for(currMod=0; currMod<MAX_MODULES; currMod++){
38.      if((modMask>>currMod)&1){
39.          for(currLine=0; currLine<MAX_LINES; currLine++)
40.              xpci_modSaveConfigL(currMask, config_id, chip_nr,
41.                                  line_nr, DaclValues[currLine]);
42.          currMask=currMask<<1;
43.      }
44.  }

```

Configure the detector with the previously uploaded data.

```
45.  \* Load calibration data to the registers *\
46.  xpci_modDetLoadConfig(modMask, config_id, 0);
```

Allocate buffers to the PC memory for image acquisition.

```
47.  \* Allocate multiple buffers fir image acquisition *\
48.  images_nr = 1000;
49.  pImgBuff = malloc(images_nr*sizeof(uint16_t));
50.  for(i=0; i<images_nr; i++)
51.      pImgBuff[i] = malloc(imgSize);
```

Acquire 1000 images with 10 ms exposition time to the pre-allocated memory buffers.

```
34.  \* Acquisition of the images
34.  Exposure settings:
34.      - gate mode:  0 (internal gate)
34.      - gate length: 10
34.      - time unit:  1 (milliseconds) *\
34.  gate_mode = 0;
34.  gate_length = 10;
34.  time_unit = 1;
34.  xpci_timerStart(5);
35.  if(xpci_getImgSeq(B2, modMask, MAX_CHIP, gate_mode, gate_length,
35.      time_unit, images_nr, pBuff)!=0)
36.      printf(("Error in image acquisition \n"))
37.  xpci_timerStop(5);
```

Release resources and close program.

```
38.  \* Release all resources and close driver *\
39.  xpci_readImageClose();
40.  free(pBuff);
41.  xpci_close(0);
42. }
```

Appendix C

Influence of the Stokes force on a free falling ball

The motion equation of a ball with diameter r and mass m in a fluid of viscosity η is given with the equation

$$m\mathbf{v}'(t) = m\mathbf{g} - 6\pi\eta r\mathbf{v}(t) \quad (\text{C.1})$$

where the second term of the equation is the Stokes' drag force.

Assuming that the motion is purely vertical, the vector equation becomes a scalar first order linear differential equation with constant coefficients

$$v'(t) + \Gamma mv(t) = g \quad (\text{C.2})$$

where

$$\Gamma = \frac{6\pi\eta r}{m} \quad (\text{C.3})$$

Solving of the homogeneous equation ($g = 0$)

$$\frac{v'(t)}{v(t)} = -\Gamma \quad (\text{C.4})$$

gives

$$v(t) = v_0 e^{-\Gamma t} \quad (\text{C.5})$$

A particular solution of the non-homogeneous equation is given by the variation of the constant $v_0 = v_0(t)$:

$$\begin{aligned} v'(t) + \Gamma v(t) &= g \\ v'_0 e^{-\Gamma t} - \Gamma v_0 e^{\Gamma t} + \Gamma v_0 e^{-\Gamma t} &= g \\ v'_0 = g e^{\Gamma t} &\Rightarrow v_0 = \frac{g}{\Gamma} e^{\Gamma t} \end{aligned} \quad (\text{C.6})$$

The sum of the general solutions of the homogeneous equation and the particular solution of the non-homogeneous equation gives the general solution for equation C.2

$$v(t) = v_0 e^{-\Gamma t} + \frac{g}{\Gamma} e^{\Gamma t} e^{-\Gamma t} \quad (\text{C.7})$$

where v_0 can be determined from the initial condition

$$v(0) = 0 \Rightarrow v_0 = -\frac{g}{\Gamma} \quad (\text{C.8})$$

The solution then simplifies to

$$v(t) = \frac{g}{\Gamma} (1 - e^{-\Gamma t}) \quad (\text{C.9})$$

Replacing the exponential component with a Taylor series of second order, we obtain

$$v(t) \cong \frac{g}{\Gamma} \left(1 - \left(1 - \Gamma t + \frac{(\Gamma t)^2}{2} \right) \right) \quad (\text{C.10})$$

and hence

$$v(t) \cong gt - g\Gamma \frac{t^2}{2} \quad (\text{C.11})$$

The first term is determined by the gravitational acceleration and the second one corresponds to the Stokes drag force.

Substituting the real values to the equation:

$$\Gamma = \frac{6\pi\eta r}{m} \quad (\text{C.12})$$

with a viscosity for the air $\eta = 1.8 \times 10^{-5} \text{ kg/ms}$, the diameter of the ball $r = 3 \times 10^{-3} \text{ m}$ and mass of the ball $m = 0.9 \times 10^{-3} \text{ kg}$ we obtain the value

$$\Gamma = 113 \times 10^{-5} \frac{1}{\text{s}} \quad (\text{C.13})$$

After 100 ms corresponding to the initial fall of the ball before it bounces, we have:

$$gt = 9,81 \cdot 100 \times 10^{-3} \frac{m}{s^2} \cdot s \approx 1 \frac{m}{s} \quad (\text{C.14})$$

$$g\Gamma \frac{t^2}{2} = 9.81 \cdot 113 \times 10^{-5} \cdot \frac{(100 \times 10^{-3})^2}{2} \frac{m}{s^2} \cdot \frac{1}{s} \cdot s^2 \approx 5 \times 10^{-5} \frac{m}{s} \quad (\text{C.15})$$

Hence, it can be seen that the effect of the Stokes' drag force is five orders of magnitude smaller than gravitation and therefore can be neglected for $t < 100 \text{ ms}$.

Appendix D

Relation between the diameter of a circle and its RMS

The Root-Mean-Square (RMS) variance of a random variable x is given by

$$\sigma_{RMS}^2 = \langle x^2 \rangle - \langle x \rangle^2 \quad (\text{D.1})$$

When the random variable x is described by a distribution function $p(x)$,

$$\sigma_{RMS}^2 = E[x^2] - E^2[x] \quad (\text{D.2})$$

where E stands for the expectation.

If the expectation (the mean) $E[x] = 0$,

$$\sigma_{RMS}^2 = \int x^2 p(x) dx \quad (\text{D.3})$$

The estimation of the RMS error on the position of the center of the projection of a ball determined on one of its diameter is then given by the expectation of the square of the coordinate x of points of coordinate (x, y) evenly distributed on the surface of a disc circled by a great circle of the sphere corresponding to the surface of the ball

$$\langle x^2 \rangle = E[x^2] = \int \int x^2 p(x, y) dx dy \quad (\text{D.4})$$

with

$$p(x, y) = \frac{1}{\pi R^2} \quad \text{and} \quad x = r \cos \theta$$

Hence

$$\begin{aligned}\langle x^2 \rangle &= \int_0^{2\pi} \int_0^R (r \cos \theta)^2 \frac{r}{\pi R^2} dr d\theta \\ &= \frac{1}{\pi R^2} \int_0^{2\pi} (\cos \theta)^2 d\theta \int_0^R r^3 dr\end{aligned}\tag{D.5}$$

Solving for the first integral

$$\begin{aligned}\int_0^{2\pi} (\cos^2 \theta + \sin^2 \theta) d\theta &= \int_0^{2\pi} 1 d\theta = 2\pi \\ \int_0^{2\pi} (\cos^2 \theta + \sin^2 \theta) d\theta &= \int_0^{2\pi} \cos^2 \theta d\theta + \int_0^{2\pi} \sin^2 \theta d\theta \\ \int_0^{2\pi} \cos^2 \theta d\theta &= \int_0^{2\pi} \sin^2 \theta d\theta \implies 2 \int_0^{2\pi} \cos^2 \theta d\theta \\ \int_0^{2\pi} \cos^2 \theta d\theta &= \pi\end{aligned}\tag{D.6}$$

we obtain

$$\sigma_{RMS}^2 = \langle r^2 \cos^2 \theta \rangle = \frac{R^2}{4} = \frac{D^2}{16}$$

Therefore,

$$\sigma_{RMS} = \frac{D}{4}\tag{D.7}$$

Appendix E

Software design tools

E.1 Software tools

The camera design is based on several FPGA (8 CycloneII, 2 ArriaGX and 1 StratixIIGX), each of which being configured by a dedicated software provided by Altera Corporation, the FPGA vendor. The software tools Altera QuartusII (figure E.1), Altera SOPC¹ builder (figure E.2) and Altera NIOSII IDE (figure E.3) were used. The QuartusII is a complete design environment that allows for com-

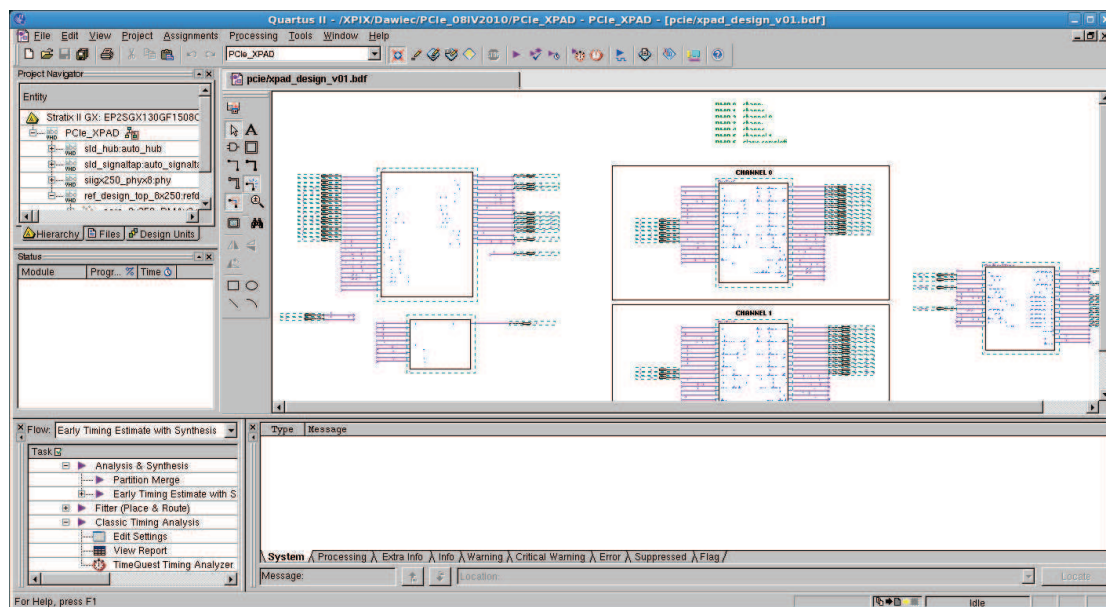

FIGURE E.1: Screen capture of the Altera QuartusII design software graphical use interface.

¹System On a Programmable Chip

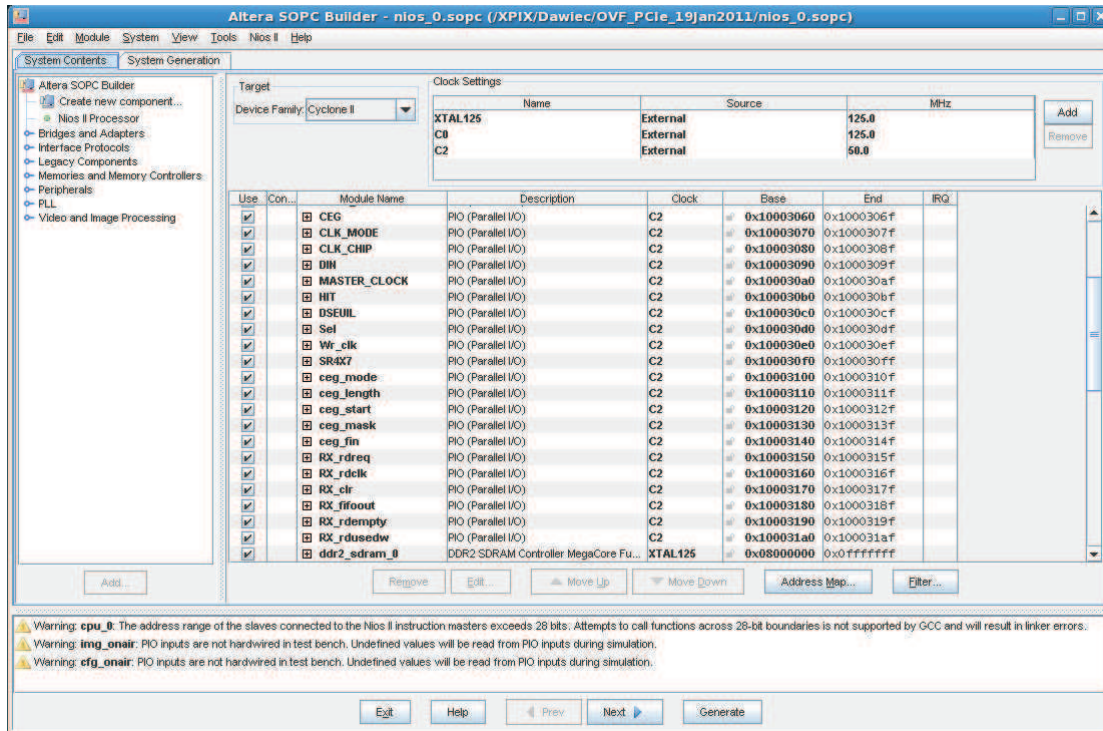

FIGURE E.2: Screen capture of the SOPC software interface.

pilation, verification, analysis and synthesis of a hardware design. The project development presented in this thesis was written entirely using the hardware description language, VHDL 1993². For the design of the Cyclone board, the version 7.2 of the QuartusII was used, whereas the version 9.1 was used for the HUB and PCI Express boards designs. The soft-core processor NIOSII embedded in the Cyclone FPGA was configured using the SOPC software. The SOPC builder automates connecting of components that are incorporated into the processor system (i.e. the processor core, memory controllers and peripherals). The software application running on the embedded processor was designed using another dedicated application from Altera, the NIOSII IDE. The NIOSII IDE includes C/C++ compilers based on the gcc Linux compiler.

E.2 Programming guidelines

Each FPGA is connected to a serial flash memory EPCS64 that contains a hardware image of the FPGA. The FPGA is automatically configured from the EPCS memory after power on. In the case of the Cyclone boards, the software of the NIOSII embedded processor is also stored in the EPCS memory, in addition to

²Very High Speed Integrated Circuit Hardware Description Language

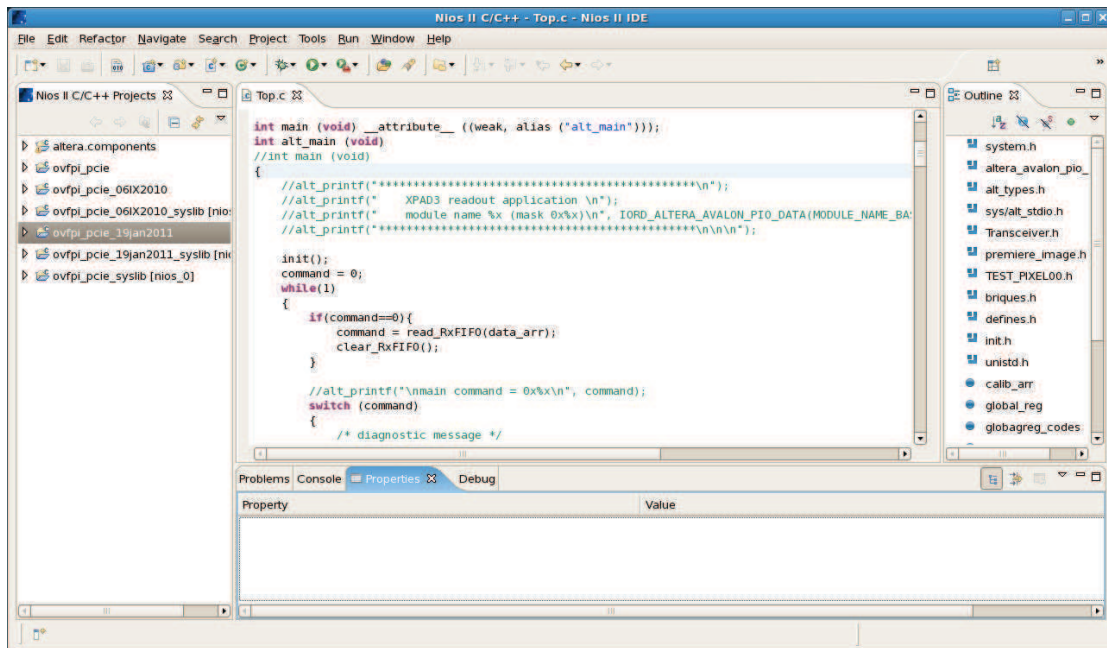

FIGURE E.3: Screen capture of the NIOSII IDE design suite.

the hardware image of the FPGA. In that case, the processor software is stored in the memory region with an offset equal to the size of the hardware image. The reset address of the embedded processor is pointing to the EPCS memory address where the software application is stored. Programming of the boards is done by using a dedicated programming cable, the Altera/Terasic USB-Blaster, which is shown in figure E.4.



FIGURE E.4: Picture of the USB-Blaster programming cable.

The programming procedure the Cyclone boards requires to program the FPGA with a hardware image using the QuartusII programmer in JTAG mode before uploading the processor software with the NIOSII IDE programmer. Since, the EPCS memory is physically connected to the NIOSII processor, its configuration is done via the NIOSII processor. The configuration panel of the NIOSII flash programmer is shown in figure E.5.

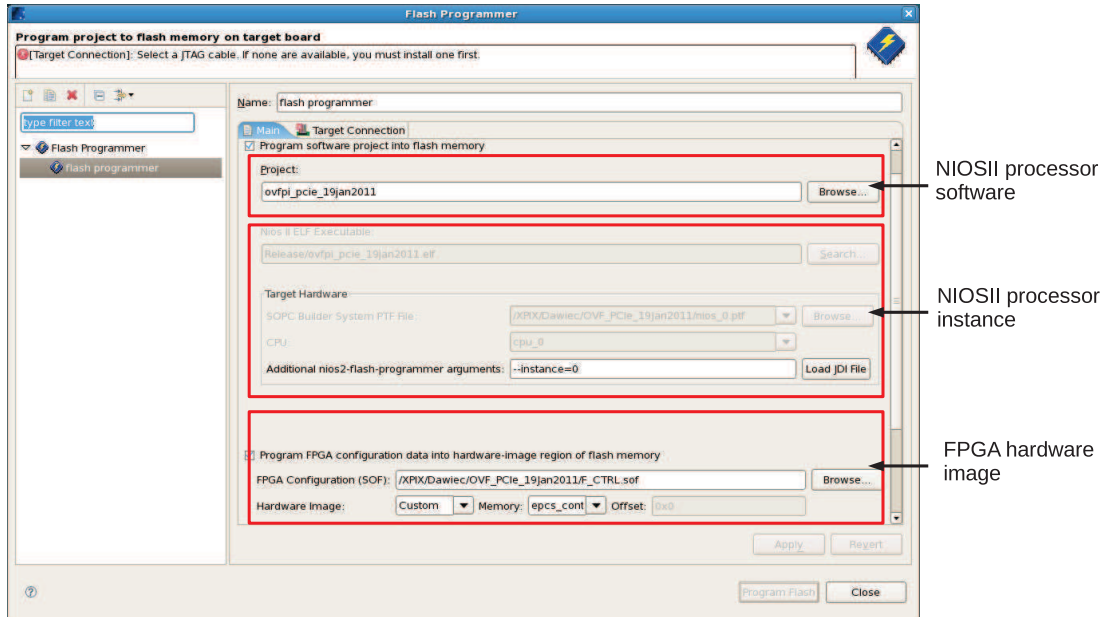

FIGURE E.5: Configuration panel of the NIOSII flash programmer.

In the HUB board and for the PCI Express board, the configuration of the flash memory is done via a dedicated board connector that allows for accessing it directly. In order to load the EPCS memory with a hardware image, a *SRAM object file* (*.sof*) corresponding to a standard output of the compilation process have to be converted into a *programmer object file* (*.pof*) as shown in figure E.6. Once the proper file is created, it has to be uploaded to the EPCS64 memory using the QuartusII programmer in the *active serial mode*. The configuration of the Quartus programmer is shown in figure E.7.

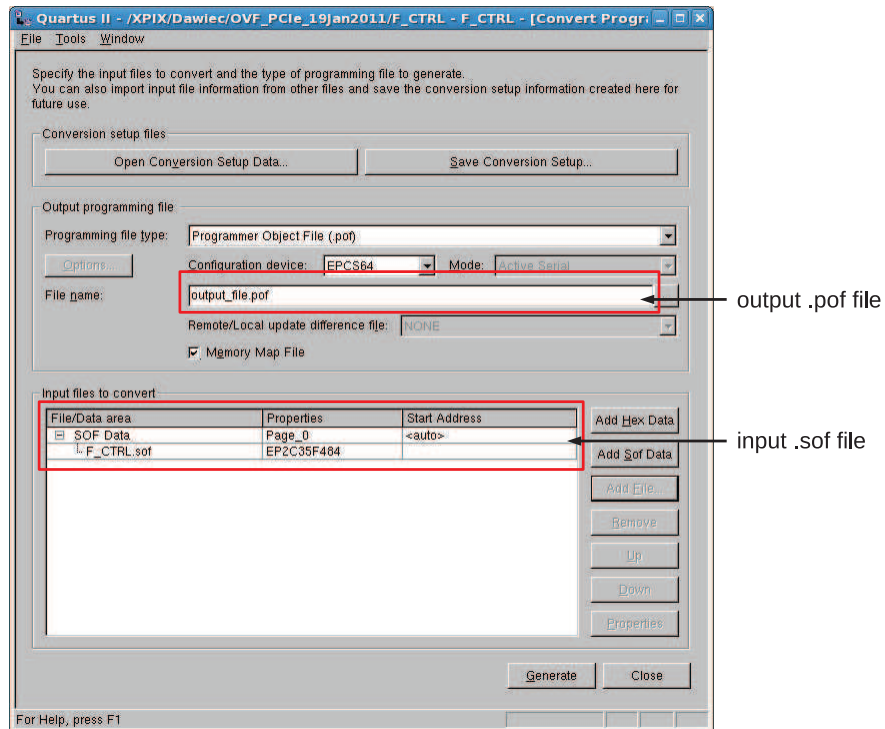

FIGURE E.6: Screen capture of the QuartusII programming files conversion tool.

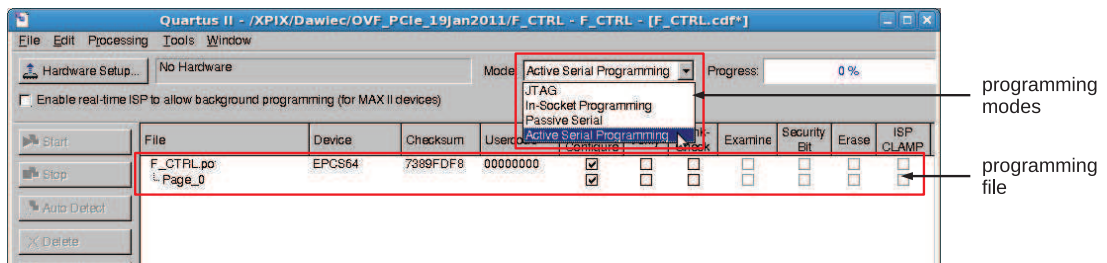

FIGURE E.7: Screen capture of the QuartusII programmer tool.

List of Figures

1.1	Classification of radiation [74].	3
1.2	Spectrum of electromagnetic radiation.	4
1.3	Photoelectric effect. An X-ray photon with energy E_{ph} interacts with a K shell electron that becomes a free photoelectron with a kinetic energy equals to the difference between E_{ph} and the binding energy of the K-shell electron $E_{binding}(K)$	6
1.4	Cross section of the photoelectric effect for various materials (from [74]).	7
1.5	Elastic scattering.	7
1.6	Compton scattering.	8
1.7	Relative percentages of photon interactions with water as a function of energy for three different processes: a) photoelectric effect, b) Compton scattering and c) Rayleigh scattering (from [15]).	11
1.8	X-ray spectra with (red) and without (black) 2 mm aluminium filtering.	11
1.9	Schematic drawing of the effects caused by ionizing radiation in MOS devices (from [65]).	13
1.10	Principle of planar X-ray radiography.	14
1.11	Slice view of the CT scanner.	15
1.12	Schematic view of a CT scanner with cone shaped X-ray beam.	16
1.13	X-rays diffracted on a crystal lattice.	17
1.14	Laue spots as a result of X-ray diffraction on a protein sample (from [3]).	18
1.15	(a) View of the Debye cone resulting from X-ray diffraction diffraction on a polycrystalline sample and (b) the resulting diffraction pattern (from [49],[99]).	18
2.1	Energy levels of silicon atoms as a function of lattice spacing (from [64]).	20
2.2	Different types of materials depending on the energy band structure (E_g - forbidden gap).	21
2.3	Direct-band and indirect-band types of semiconductors.	21
2.4	Crystal lattice bond structure (top) and energy band model (bottom) of (a) intrinsic, (b) n-type and (c) p-type semiconductors.	23
2.5	Change of the silicon band gap depending on the material used as a donor or an acceptor.	24
2.6	Mechanisms of generation and recombination trough energy states in the forbidden gap.	25
2.7	Electric characteristic functions of a typical abrupt p-n junction.	28
2.8	Charge collection with a partially depleted p-n junction.	30

2.9	Plot of the weighting field in a segmented detector (from [75]).	33
2.10	Cross section of a three phase CCD with a charge transfer diagram. Sequential change of the voltages applied to gates Φ_1 , Φ_2 and Φ_3 cause charge transfer from one cell to the other towards the readout anode located at the end of the row.	35
2.11	Monolithic Active Pixel Sensor built in standard CMOS technology: (a) cross section and principle of operation, (b) basic pixel architecture based on three N-MOS transistors and a collecting diode (3T pixel).	36
2.12	Different MAPS designs that allow use of both N- and P-MOS transistors in non-standard technologies: (a) in Silicon on Insulator (SOI) technology, (b) using INMAPS (Isolated N-well) process what allows deep p-well implants.	37
2.13	Hybrid pixel detector (a) cross-section and (b) SnPb bumps used for the sensor and electronics chip interconnection.	38
2.14	(a) Layered view of the ATLAS pixel detector module and (b) picture of a CMS pixel detector module.	40
2.15	The pixel design of the PILATUS II readout chip (from [55]).	42
2.16	(a) PILATUS II single detector module and (b) PILATUS 6M detector system.	44
2.17	Pixel design of the MEDIPIX2 readout chip (from [63]).	46
2.18	Pictures of (a) the MEDIPIX2 circuit with 300 μm silicon sensor wire-bonded to the probe card and (b) of a four-chip module (quad) connected (in the figure only one chip is wire bonded without a sensor) to the Gigabyte Ethernet link (from [100]).	47
2.19	(a) CAD visualisation of the RELAXD detector and (b) a cross section of the via interconnection between the MEDIPIX2 and a supporting PCB.	48
3.1	Global architecture of the XPAD3 chip.	53
3.2	XPAD3-S pixel design.	54
3.3	Programming of the XPAD3 chip modes and actions.	56
3.4	Distribution of the delayed clock signal.	58
3.5	Result of the calibration with 10 keV monochromatic X-ray beam: (a) histogram of the DACL correction, (b) measured <i>S-curve</i> for one pixel and (c) map of the DACL in the matrix.	61
3.6	Architecture of a single cell (a) of the readout conveyor <i>SR4</i> and (b) of the write-in conveyor <i>SR1</i>	62
3.7	(a) Global architecture of the XPAD3 camera readout electronics and (b) picture of the complete camera enclosed in the box.	64
3.8	XPAD3 detector: (a) 7 XPAD3-S chips are bump-bonded to the silicon sensor and (b) wire-bonded to a <i>flex board</i> (c) that is connected to its processing board. Finally (d) 8 modules are tiled to form the complete camera.	66
3.9	Cyclone board: (a) top view with description, (b) architecture of the embedded system.	67
3.10	Description of the Cyclone board connector.	68

3.11	Format of the incoming messages.	68
3.12	Architecture of the data reception block.	69
3.13	Block diagram that shows (a) uploading of the local DACL values to the detector pixels and (b) update if the overflow bit (OVF).	71
3.14	State machine representing one step of the overflow processing. The whole process consists in 67200 steps.	73
3.15	Block diagram of data transmission.	74
3.16	Format of the outgoing messages: (a) acknowledgement message and (b) image data with pixel counters stored on 2 bytes and (c) 4 bytes.	75
3.17	Generation and distribution of the gate signal to the pixels.	76
3.18	Distribution of the gate signal in the XPAD3-S chip.	77
3.19	Picture of the HUB board with its component description.	78
3.20	Picture and component description of the HUB board.	78
3.21	Transceiver data path.	79
3.22	Non-deterministic byte swap in the receiver channel: (a) the transmitted pattern is (b) received with wrong byte positions.	80
3.23	Byte reordering implemented in the camera design: transmitted data (top), detected byte swap in the received data (middle) and data correctly reordered by the implemented logic (bottom).	81
3.24	Architecture of the reception part of the HUB board.	81
3.25	Format of the HUB board messages.	82
3.26	Architecture of the transmitting part of the HUB board.	83
3.27	Architecture of the module buffer.	84
3.28	Picture and component description of the PLDA [®] XpressGXII board.	85
3.29	Picture of the PCI Express board plugged to the acquisition PC with its mezzanine daughter board containing optical transceivers.	86
3.30	Top-level blocks of the PCI Express board design.	86
3.31	Scheme of a PCI Express link.	87
3.32	Example of a topology of the PCI Express system with four types of function: root complex, endpoints, switches and PCIe-PCI bridge.	88
3.33	Example of a PCI Express layered architecture.	89
3.34	Building of a packet as it flows through the PCIe layers.	89
3.35	Scheme of a PIPE interface for a physical layer.	90
3.36	Block diagram of PLDA's PCI Express XpressLite2 core.	92
3.37	Architecture of the single channel implemented in the PCI-Express board.	94
3.38	Chronogram that represents the readout mechanism implemented in the software library.	103
4.1	(a) The XPAD3 camera mounted on a diffractometer at the SOLEIL synchrotron facility and (b) picture of the intermediate USB-opto board.	106
4.2	Diffraction pattern of a BaTiO ₃ obtained with the XPAD3 detector at the Cristal beamline at SOLEIL. The image was recorded at 28 keV, close to the 0° Bragg-angle (from [67]).	107

4.3	Linear (1D) diffraction scan pattern of a BaTiO ₃ sample recorded with the XPAD3 detector at 28 keV (from [67]).	107
4.4	Surface diffraction on GaInAs epitaxial strains grown on a GaAs bulk shown in $K-$ space, as recorded with the XPAD3 detector on the DIFFABS beamline at SOLEIL (from [7]).	108
4.5	(a) The CAD layout of The PIXSCAN II irradiation setup and (b) picture of the final device.	110
4.6	Spectrum of an ²⁴¹ Am source obtained with XR-100T-CdTe detector and calibrated on the characteristic emission peaks at 13.9 keV, 26.3 keV and 59.5 keV.	111
4.7	X-ray tube spectra measured at 90 kV and 10 W without and with external filtering using a 200 μ m thick niobium filter.	112
4.8	Picture of the setup used to study the motion of a free falling ball.	113
4.9	(a) Flat image of raw data acquired during 1 ms poses, (b) histogram of counts per pixel and (c) horizontal profile of mean counts per pixels.	113
4.10	Motion of the steel ball during first 500 ms of the free fall.	115
4.11	Subsequent steps of image processing to obtain the vertical coordinate of the centre of the ball: (a) original image, (b) background removed image and (c) horizontal projection.	116
4.12	Histogram of the ball diameter values calculated from the RMS values.	117
4.13	Plot of the ball trajectory. Both axis were rescaled in order to have real representation of the vertical ball position versus elapsed time.	117
4.14	Polynomial fit to the experimental data.	118
4.15	Pocket watch <i>Longines</i> used in the experiment.	119
4.16	Histograms of the pixel counts (a) in a flat image and (b) in an image of the pocket watch obtained with a 50 ms pose.	120
4.17	Movement of a selected part of the mechanism of the pocket watch shown (a) every 100 ms and (b) every 2500 ms.	121
4.18	(a) The two regions of interest that were used to estimate the frequency of oscillations of the escapement element with (b) detailed view of its movement in ROI 1.	122
4.19	The total number of counts per ROI used for the estimation of the frequency oscillation of the pallet fork (a) as a function of time and (b) in the frequency domain.	123
4.20	View on the ROI that was used to estimate the spinning speed of the central wheel.	124
4.21	Total number of counts in the ROI used for the estimation of the spinning speed of the central wheel (a) as a function of time and (b) in the frequency domain	125
4.22	Mass attenuation coefficients for selected materials and compounds (data from [101]).	126
4.23	Image of the mouse (a) before injecting iodine, (b) after injection when iodine is well distributed, (c) result of the division (b)/(a) of these two images and (d) image with colourized pixels.	127
4.24	Mouse angiography.	129
4.25	CAD view of the upgraded architecture of the camera.	132

4.26	Proposed PCI-Express architecture for the upgraded design of the detector.	133
E.1	Screen capture of the Altera QuartusII design software graphical use interface.	147
E.2	Screen capture of the SOPC software interface.	148
E.3	Screen capture of the NIOSII IDE design suite.	149
E.4	Picture of the USB-Blaster programming cable.	149
E.5	Configuration panel of the NIOSII flash programmer.	150
E.6	Screen capture of the QuartusII programming files conversion tool.	151
E.7	Screen capture of the QuartusII programmer tool.	151

List of Tables

2.1	Properties of different semiconductors at a temperature of 300 K (from [64],[83]).	24
2.2	Technical specifications of the PILATUS II, EIGER, MEDIPIX2 and XPAD3 detectors (based on data from [97],[29],[35],[55]).	43
2.3	Comparison of the main parameters between some detectors of the PILATUS family and the XPAD3 detector (from [97],[16]).	45
2.4	Technical specification of the CIX 0.2, Angie and Aladin chips.	50
3.1	XPAD3 characteristics.	52
3.2	Description of the XPAD3-S pixel configuration register.	55
3.3	List of XPAD3 modes of operation.	57
3.4	List of XPAD3 actions triggered by the <i>ClockMode</i> register.	57
3.5	List of XPAD3-S global configuration registers.	59
3.6	List of NIOSII commands.	70
3.7	Time of readout of the XPAD3 chip and data transfer depending on the format and readout clock frequency.	75
3.8	Description of the <i>Exposure</i> function parameters that are responsible for the gate signal generation and distribution.	76
3.9	List of the implemented HUB board commands.	83
3.10	Effective aggregate bandwidth for first and second generation of PCI Express standard.	91
3.11	List of the DMA channels implemented in the design and their functions.	93
3.12	Configuration and command registers implemented in the design.	95
3.13	Status registers implemented in the design.	96
3.14	Status codes sent by the service DMA.	96
3.15	Measured data rates over PCI Express with DMA transfer.	97
3.16	Structure of the memory buffer that contains detector image data in 2-byte mode.	104
4.1	Specifications of the Oxford Instruments UltraBright Microfocus X-ray tube.	110
4.2	Principal parameters of the free falling ball experiment.	114
4.3	Values of the estimated gravitational acceleration.	118
4.4	Parameters of the analogue pocket watch experiment.	120
4.5	Parameters of the mouse angiography experiment using iodine contrast agent.	126

A.1	<i>Common Configuration Space Header.</i>	135
A.2	<i>The Type 0 Configuration Settings.</i>	136

Books and papers

- [1] *Nios II Processor Reference. Handbook.* Altera Corporation, 2010.
- [2] L. Andricek et al. The active DEPFET pixel sensor for future e^+e^- linear collider experiments. In *Nuclear Science Symposium Conference Record, 2004 IEEE*, volume 2, pages 1087–1090, 2004.
- [3] A. Assmus. Early History of X Rays. *Beam Line. Stanford Linear Accelerator Center*, 25(2):10–21, 1995.
- [4] R. Ballabriga, M. Campbell, E. Heijne, X. Llopart, and L. Tlustos. The Medipix3 Prototype, a Pixel Readout Chip Working in Single Photon Counting Mode With Improved Spectrometric Performance. *IEEE Transactions on Nuclear Science*, 54(5):1824 –1829, 2007.
- [5] J. Ballin et al. Monolithic Active Pixel Sensors (MAPS) in a Quadruple Well Technology for Nearly 100% Fill Factor and Full CMOS Pixels. *Sensors*, 8(9):5336–5351, 2008.
- [6] S. Basolo et al. XPAD: pixel detector for material sciences. In *Nuclear Science Symposium Conference Record, 2004 IEEE*, volume 7, pages 4388–4391, 2004.
- [7] J.-F. Berar et al. XPAD3 hybrid pixel detector applications. *Nucl. Instr. and Meth. A*, 607(1):233–235, 2009.
- [8] M. Bohnel et al. Time resolved measurement of a pulsed X-ray source with the Timepix detector. In *Nuclear Science Symposium Conference Record, 2009 IEEE*, pages 1682–1684, 2009.
- [9] C. Brönnimann et al. A pixel read-out chip for the PILATUS project. *Nucl. Instr. and Meth. A*, 465(1):235–239, 2001.
- [10] F. C. Brunner, N. Kardjilov, J.-C. Clémens, and C. Morel. Neutron imaging with the XPAD3-S hybrid pixel detector. *Nucl. Instr. and Meth. A*, 634(1): 75–90, 2011.

- [11] R. Budruk, D. Anderson, and E. Solari. *PCI Express System Architecture*. Pearson Education, 2003.
- [12] M. Campbell et al. New gaseous detectors: the application of CMOS pixel chips as direct anode. In *Nuclear Science Symposium Conference Record, 2004 IEEE*, volume 2, pages 955–958, 2004.
- [13] M. Campbell, E. Heijne, G. Meddeler, E. Pernigotti, and W. Snoeys. A readout chip for a 64×64 pixel matrix with 15-bit single photon counting. *IEEE Transactions on Nuclear Science*, 45(3):751–753, 1998.
- [14] G. B. Cerati. Overview of the CMS pixel detector. In *Nuclear Science Symposium Conference Record, 2008 IEEE*, pages 2196–2199, 2008.
- [15] R. Cesareo. *Nuclear Analytical Techniques om Medicine*. Elsevier Science Publishers B.V., 1988.
- [16] B. Chantepie. *Étude et réalisation d'une électronique rapide à bas bruit pour un détecteur de rayons X à pixels hybrides destiné à l'imagerie du petit animal*. PhD thesis, Université de la Méditerranée Aix-Marseille II, Faculté des Sciences de Luminy, 2008.
- [17] M. Chmeissani et al. First experimental tests with a CdTe photon counting pixel detector hybridized with a Medipix2 readout chip. *IEEE Transactions on Nuclear Science*, 51(5):2379–2385, 2004.
- [18] J.-P. Colinge, and C. A. Colinge. *Physics of Semiconductor Devices*. Springer, 2006.
- [19] J. Crooks et al. A novel CMOS monolithic active pixel sensor with analog signal processing and 100% fill factor. In *Nuclear Science Symposium Conference Record, 2007 IEEE*, volume 2, pages 931–935, 2007.
- [20] B. Cullity. *Elements of X-ray Diffraction*. Addison-Wesley Publishing Company, 1956.
- [21] J. Daintith, editor. *Dictionary of Chemistry*. Oxford University Press, 2004.
- [22] L. del Risco Norrlid. *Modeling the Performance of a Hybrid Pixel Detector for Digital X-ray Imaging*. PhD thesis, Uppsala University, 2009.
- [23] P. Delpierre. Pixels detectors and silicon X-rays detectors. In *Journal de Physique IV European Symposium on Frontiers in Science and Technology with Synchrotron Radiation*, volume 4, pages C9.11–C9.18, 1994.

- [24] P. Delpierre et al. PIXSCAN: pixel detector CT-scanner for small animal imaging. In *Nuclear Science Symposium Conference Record, 2005 IEEE*, volume 4, pages 2381–2385, 2005.
- [25] P. Delpierre et al. Large surface X-ray pixel detector. In *Nuclear Science Symposium Conference Record, 2001 IEEE*, volume 2, pages 902–905, 2001.
- [26] G. Deptuch et al. Design and testing of monolithic active pixel sensors for charged particle tracking. *IEEE Transactions on Nuclear Science*, 49(2):601–610, 2002.
- [27] G. Deptuch, W. Dulinski, M. Caccia, and M. Winter. High-resolution, back-side illuminated monolithic active pixel sensor for low-energy electron imaging. *IEEE Transactions on Nuclear Science*, 52(5):1745–1754, 2005.
- [28] F. Dilmanian, X. Wu, and J. Kress. Dual energy iodine contrast CT with monochromatic X-rays. In *Nuclear Science Symposium and Medical Imaging Conference Record, 1995 IEEE*, volume 3, pages 1392–1396, 1995.
- [29] R. Dinapoli. EIGER: a New Generation of Pixel Detectors for HighFrame Rate X-Ray Applications. To appear in *Nuclear Science Symposium Conference Record, 2010 IEEE*.
- [30] R. Dinapoli. *A radiation tolerant pixel detector system for the Alice and LHCb experiments at CERN*. PhD thesis, Universite Montpellier II, 2004.
- [31] R. E. Dinnebier. *Powder diffraction: theory and practice*. Royal Society of Chemistry, 2008.
- [32] F. Edling et al. Performance of a chip for hybrid pixel detectors with two counters for X-ray imaging. *Nucl. Instr. and Meth. A*, 531(1-2):215–220, 2004.
- [33] J. Fink et al. Comparison of Pixelated CdZnTe, CdTe and Si Sensors With the Simultaneously Counting and Integrating CIX Chip. *IEEE Transactions on Nuclear Science*, 56(6):3819–3827, 2009.
- [34] J. Fink. *Characterization of the Imaging Performance of the Simultaneously Counting and Integrating X-ray Detector CIX*. PhD thesis, Rheinischen Friedrich-Wilhelms-Universität Bonn, 2009.
- [35] P. M. Frallicciardi. *Single Photon Counting X-Ray Micro-Imaging of Biological Samples*. PhD thesis, Università degli Studi di Napoli “Federico II”, 2009.

- [36] N. Freedman, R. Moreno, L. Le Meunier, and S. Bacharach. Identification of Contrast Media in PET/CT Using Dual Energy CT. *IEEE Transactions on Nuclear Science*, 54(3):523–527, 2007.
- [37] G. Gaycken et al. Monolithic active pixel sensors for fast and high resolution vertex detectors. *Nucl. Instr. and Meth. A*, 560(1):44–48, 2006.
- [38] J. C. Giacomini. K-Edge Subtraction Angiography with Synchrotron X-Rays. Technical report, Int. At. Energy Agency, 1996.
- [39] E. Gimenez et al. Characterization of MEDIPIX3 With Synchrotron Radiation. *IEEE Transactions on Nuclear Science*, 58(1):323–332, 2011.
- [40] C. Hamaguchi. *Basic Semiconductor Physics*. Springer, 2010.
- [41] B. B. He. *Two-dimensional X-ray Diffraction*. John Wiley & Sons, 2009.
- [42] W. R. Hendee, and E. R. Ritenour. *Medical Imaging Physics*. Willey-Liss, 2002.
- [43] R. K. Hobbie, and B. J. Roth. *Intermediate physics for medicine and biology*. Springer, 2007.
- [44] G. Hülsen-Bollier. *The PILATUS 1M Detector. A novel Large Area Pixel Detector*. PhD thesis, Swiss Federal Institute of Technology Zurich, 2005.
- [45] K. Iniewski, editor. *Semiconductor Radiation Detection Systems*. CRC Press, 2010.
- [46] *PHY Interface for the PCI Express Architecture*. Intel Corporation, 2003.
- [47] J. Jakubek et al. Properties of neutron pixel detector based on MEDIPIX2 device. In *Nuclear Science Symposium Conference Record, 2004 IEEE*, volume 2, pages 945–949, 2004.
- [48] A. Jasik, J. Sass, K. Mazur, and M. Wesolowski. Investigation of strained InGaAs layers on GaAs substrate. *Optica Applicata*, 37(3):237–242, 2007.
- [49] R. Jenkins, and R. L. Snyder. *Introduction to X-ray powder diffractometry*. John Wiley & Sons, 1996.
- [50] J. Jiří. *Medical Image Processing, Reconstruction and Restoration*. CRC Press, 2006.

- [51] M. Keil. Status and overview of the ATLAS pixel detector. In *Nuclear Science Symposium Conference Record, 2007 IEEE*, volume 3, pages 1766–1769, 2007.
- [52] G. F. Knoll. *Radiation Detection and Measurement*. John Wiley and Sons, 1989.
- [53] S. Knowlton. *Understanding the Fundamentals of PCI Express*. Synopsys, 2007.
- [54] P. Kostamo et al. GaAs MEDIPIX2 hybrid pixel detector. *Nucl. Instr. Meth. A*, 591(1):174–177, 2008.
- [55] P. Kraft et al. Characterization and Calibration of PILATUS Detectors. *IEEE Transactions on Nuclear Science*, 56(3):758–764, 2009.
- [56] H. Krüger. 2D detectors for particle physics and for imaging applications. *Nucl. Instr. and Meth. A*, 551(1):1–14, 2005.
- [57] W. Kucewicz et al. Fully depleted monolithic active pixel sensor in SOI technology. In *Nuclear Science Symposium Conference Record, 2004 IEEE*, volume 2, pages 1227–1230, 2004.
- [58] E. Lassner, and W.-D. Schubert. *Tungsten: properties, chemistry, technology of the element, alloys, and chemical compounds*. Springer, 1999.
- [59] Y. Lemoigne, A. Caner, and G. Rahal, editors. *Physics for Medical Imaging Application*. Springer, 2007.
- [60] W. R. Leo. *Techniques for nuclear and particle physics experiments: a how-to approach*. Springer, 1994.
- [61] C. Leroy, and P.-G. Rancoita. *Principles of Radiation Interaction in Matter and Detection*. World Scientific Publishing Co. Pte. Ltd., 2004.
- [62] D. R. Lide, editor. *Handbook of Chemistry and Physics*. CRC Press, 1999.
- [63] X. Llopart, M. Campbell, R. Dinapoli, D. San Segundo, and E. Pernigotti. MEDIPIX2: A 64-k pixel readout chip with 55- μm square elements working in single photon counting mode. *IEEE Transactions on Nuclear Science*, 49(5):2279–2283, 2002.
- [64] G. Lutz. *Semiconductor Radiation Detectors*. Springer, 1999.
- [65] T. P. Ma, and P. V. Dressendorfer. *Ionizing radiation effects in MOS devices and circuits*. John Wiley & Sons, 1989.

- [66] D. Marder et al. Noise in GaAs detectors after irradiation. *Nucl. Instr. and Meth. A*, 395(1):141–144, 1997.
- [67] K. Medjoubi et al. Performance and Applications of the CdTe- and Si-XPAD3 photon counting 2D detector. *JINST*, 6(01):C01080, 2011.
- [68] G. Mettivier, M. Montesi, and P. Russo. Digital autoradiography with a MEDIPIX2 hybrid silicon pixel detector. In *Nuclear Science Symposium Conference Record, 2003 IEEE*, volume 4, pages 2960–2963, 2003.
- [69] P. Pangaud et al. First results of XPAD3, a new photon counting chip for X-ray CT-scanner with energy discrimination. *Nuclear Science Symposium Conference Record, 2007 IEEE*, 1:14–18, 2007.
- [70] P. Pangaud, S. Basolo, M. Menouni, B. Dinkespiler, and B. Chantepie. Dossier de Conception XPAD3S/C. Technical report, Centre de Physique des Particules de Marseille, 2006.
- [71] *PCI Express Base Specification. Revision 1.0a*. PCI-SIG, 2003.
- [72] *Linux 32-Bit Compiled Driver. Reference Manual*. PLD Applications, 2009.
- [73] *PCI Express XpressLite2 Core. Reference Manual*. PLD Applications, 2009.
- [74] E. B. Podgoršak. *Radiation Physics for Medical Physicists*. Springer Berlin Heidelberg, 2006.
- [75] V. Radeka. Low-Noise Techniques in Detectors. *Annual Review of Nuclear and Particle Science*, 38:217–277, 1988.
- [76] S. Ramo. Currents Induced by Electron Motion. *Proceedings of the IRE*, 27(9):584–585, 1939.
- [77] J. Richardson, R. Petr, S. Theophanis, and L. Chapman. Dual-energy digital subtraction angiography using characteristic radiation and K-edge filtration. In *Nuclear Science Symposium Conference Record, 1996 IEEE*, volume 3, pages 1545–1546, 1996.
- [78] L. Rossi, P. Fisher, T. Rohe, and N. Wermes. *Pixel Detector. From Fundamentals to Applications*. Springer, 2006.
- [79] J.-J. Samuëli, J. Pigneret, and A. Sarazin. *Instrumentation électronique en physique nucléaire. Mesures de temps et d'énergie*. Masson & Cie, 1968.

- [80] P. Seller et al. Two approaches to hybrid x-ray pixel array readout. In *Society of Photo-Optical Instrumentation Engineers Conference Series*, volume 3774, pages 30–37, 1999.
- [81] P. Seller et al. Photon counting hybrid pixel detector for X-ray imaging. *Nucl. Instr. and Meth. A*, 455(3):715–720, 2000.
- [82] P. Seller et al. Photon counting silicon X-ray pixel detector modules. *Nucl. Instr. and Meth. A*, 466(1):174–177, 2001.
- [83] J. Singh. *Electronic and optoelectronic properties of semiconductor structures*. Cambridge University Press, 2003.
- [84] H. Spieler. *Semiconductor Detector Systems*. Oxford University Press, 2005.
- [85] S. Stergiopoulos. *Advanced Signal Processing Handbook: Theory and Implementation for Radar, Sonar, and Medical Imaging Real Time Systems*. CRC Press, 2002.
- [86] C. Suryanarayana, and M. G. Norton. *X-Ray diffraction: a practical approach*. Springer, 1998.
- [87] S. Sze, and K. K. Ng. *Physics of Semiconductor Devices*. Wiley-Interscience, 2007.
- [88] S. Tavernier. *Experimental Techniques in Nuclear and Particle Physics*. Springer, 2010.
- [89] A. Thompson et al. X-ray Data Booklet. Center for X-ray Optics and Advanced Light Source. Lawrence Berkeley National Laboratory, 2001.
- [90] R. Velazco, P. Fouillat, and R. Reis. *Radiation Effects on Embedded Systems*. Springer, 2007.
- [91] Z. Vykydal et al. The RELAXd project: Development of four-side tilable photon-counting imagers. *Nucl. Instr. and Meth. A*, 591(1):241–244, 2008.
- [92] A. Webb. *Introduction to Biomedical Imaging*. EMB, 2003.
- [93] N. Wermes. Pixel detectors for tracking and their spin-off in imaging applications. *Nucl. Instr. and Meth. A*, 541(1-2):150–165, 2005.
- [94] V. Wright et al. 3D MEDIPIX - a new generation of X-ray detectors. In *Nuclear Science Symposium Conference Record, 2004 IEEE*, volume 2, pages 1336–1343, 2004.

- [95] G. Zschornack. *Handbook of X-ray data*. Springer, 2007.

Web recourses

- [96] Altera. Arria GX Device Handbook.
<http://www.altera.com/literature/lit-agx.jsp>.
- [97] DECTRIS Ltd. The PILATUS 100K detector system.
<http://www.dectris.ch/>.
- [98] ESA. Gravity mission GOCE.
http://www.esa.int/esaLP/ESAK4XZK0TC_LPgoce_0.html.
- [99] European Synchrotron Radiation Facility.
<http://www.esrf.eu/>.
- [100] NIKHEF National Institute for Subatomic Physics.
<http://www.nikhef.nl/en/>.
- [101] NIST. Tables of X-ray Mass Attenuation Coefficients and Mass Energy-Absorption Coefficients from 1 keV to 20 MeV for Elements $Z = 1$ to 92 and 48 Additional Substances of Dosimetric Interest.
<http://www.nist.gov/pml/data/xraycoef/index.cfm>.
- [102] PNSensor. Detector Concept of pn-CCDs.
<http://www.pnsensor.de/Welcome/Detector/pn-CCD/index.html>.
- [103] SLS Detector Group. PILATUS Project.
<http://pilatus.web.psi.ch/sites/pilatus100k.html>.
- [104] SOLEIL synchrotron.
<http://www.synchrotron-soleil.fr/>.
- [105] The Atlas Experiment.
<http://atlas.ch/>.
- [106] The Compact Muon Solenoid Experiment.
<http://cms.web.cern.ch/cms/index.html>.

Arkadiusz DAWIEC

Personal information

Address:

Centre de Physique des Particules de Marseille
163, avenue de Luminy
Case 902
13288

Contact:

arkadiusz.dawiec@gmail.com
dawiec@cppm.in2p3.fr

Born on July 27th, 1982, Poland.
Polish citizenship.

Education

Ph.D. in Physics, specialty Instrumentation

May 2011

Université Méditerranéé Aix-Marseille II

Dissertation: Development of ultra-fast X-ray camera using hybrid pixels detector

M.Sc. in Electronics

September 2007

AGH University of Science and Technology in Krakow

Major: Electronic Equipment Design

Dissertation: Measurement of Ionizing Radiation Influence in Various Part of Monolithic Active Pixel Sensor

Internship: Diploma semester as an Erasmus Student at Université Louis Pasteur Strasbourg I, France

Experience

PhD student

Jan 2008 - Mar 2011

Centre de Physique des Particules de Marseille (CPPM)

Development of high speed X-ray camera based on PCI-Express board (hardware & software)

Junior Validation/Test Development Engineer

Sep 2007 - Jan 2008

Delphi Poland S.A., Technical Center Krakow

Development of test systems for car-audio parts

IC Tester - Intership

Feb 2007 - Aug 2007

Institut Pluridisciplinaire Hubert Curien (IPHC) - CNRS, Strasbourg

Testing CMOS vertex detectors in radiation environment, development of test setup (hardware & software) able to detect Single Events LatchUp & Upset

Publications

A. Dawiec, B. Dinkespiler, P. Breugnon, K. Arnaud, S. Godiot, S. Hustache, K. Medjoubi, J.-F Bérar, N. Boudet, C. Morel (2009). Development of the XPAD3 X-Ray Photon Counting Imager DAQ Electronics. *Advancements in Nuclear Instrumentation Measurement Methods and their Applications (ANIMMA), 2009 First International Conference on*, 1-3, 2009.

S. Nicol, S. Karkar, C. Hemmer, **A. Dawiec**, D. Benoit, P. Breugnon, B. Dinkespiler, F. Rivière, J.-P. Logier, M. Niclas, J. Royon, C. Messen, F. Cassol, J.-C. Clémens, A. Bonissent, F. Debarbieux, E. Vigeolas, P. Delpierre, C. Morel (2009). Design and construction of the Clear-PET/XPAD small animal PET/CT scanner. *Nuclear Science Symposium Conference Record (NSS/MIC), 2009 IEEE*, 3311-3314, 2009.

A. Dawiec, B. Dinkespiler, P. Breugnon, F. Bompard, K. Arnaud, P.-Y. Duval, S. Godiot, S. Hustache, K. Medjoubi, J.-F Bérar, N. Boudet, C. Morel (2010). Development of a PCI Express based readout electronics for the XPAD3 X-Ray Photon Counting Imager. *Real Time Conference (RT), 2010 17th IEEE-NPSS*, 1-3, 2010.

K. Medjoubi, S. Hustache, F. Picca, J.-F Bérar, N. Boudet, F. Bompard, P. Breugnon, J.-C. Clémens, **A. Dawiec**, P. Delpierre, B. Dinkespiler, S. Godiot, J.-P. Logier, M. Menouni, C. Morel, M. Niclas, P. Pangaud, E. Vigeolas (2010). Performance and Applications of the CdTe- and Si-XPAD3 photon counting 2D detector, *JINST*, 6(01):C01080, 2011.