



HAL
open science

Design and evaluation of wireless dense networks - Application to in-flight entertainment systems

Ahmed Akl

► **To cite this version:**

Ahmed Akl. Design and evaluation of wireless dense networks - Application to in-flight entertainment systems. Automatic Control Engineering. Université Paul Sabatier - Toulouse III, 2011. English. NNT: . tel-00660348

HAL Id: tel-00660348

<https://theses.hal.science/tel-00660348>

Submitted on 16 Jan 2012

HAL is a multi-disciplinary open access archive for the deposit and dissemination of scientific research documents, whether they are published or not. The documents may come from teaching and research institutions in France or abroad, or from public or private research centers.

L'archive ouverte pluridisciplinaire **HAL**, est destinée au dépôt et à la diffusion de documents scientifiques de niveau recherche, publiés ou non, émanant des établissements d'enseignement et de recherche français ou étrangers, des laboratoires publics ou privés.

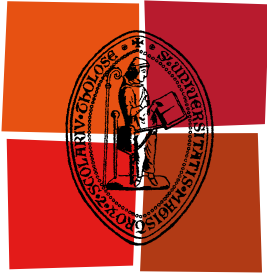

Université
de Toulouse

THÈSE

En vue de l'obtention du
DOCTORAT DE L'UNIVERSITÉ DE TOULOUSE

Délivré par :

Université Toulouse III Paul Sabatier (UT3 Paul Sabatier)

Discipline ou spécialité :

Systems Informatiques

Présentée et soutenue par :

Ahmed AKL

le: 17 Novembre 2011

Titre :

Design and Evaluation of Wireless Dense Networks - Application to In-Flight Entertainment Systems

Ecole doctorale :

Systemes (EDSYS)

Unité de recherche :

LAAS

Directeur(s) de Thèse :

Thierry GAYRAUD
Pascal BERTHOU

Rapporteurs :

Veronique VEQUE
Toufik AHMED

Membre(s) du jury :

Yacine GHAMRI DOUDANE
Jean CARLE
Thierry VILLEMUR

Therefore do thou hold Patience; a Patience of beautiful (contentment).
Quran (chapter 70 - verse 5)

There is no alternative for hard work
Thomas Edison (an inventor)

The business that only brings financial benefits is a weak business
Henry Ford (founder of ford company)

Acknowledgement

First of all i would like to thank the One who gave me every thing in this life. Praise be to Allah; praise be to You enough accordingly to what match with Your majesty, the greatness of Your suzerainty, and along the way that You like and agree.

I am sincerely and heartily grateful to my advisor, Prof. Thierry Gayraud, for the support and guidance he showed me throughout my dissertation writing. I am sure it would have not been possible without his help; and his fruitful discussions are unforgettable. Also, i would like to thank my co-advisor Dr. Pascal Berthou for his support especially in the last track of this thesis. And i would like to thank the jury of my thesis for their effort; especially Prof. Veronique Veque, Prof. Toufik Ahmed for their comments and constructive criticism, and Prof. Thierry Villemur for his support and encouragement.

My sweet wife Mai was "toooo" patient and helpful since the start of our life, and I want to thank her for her faithful support in every tiny thing. I would like to tell her that the best thing, to have in this world, is to have a wife like you; i am lucky to live with a unique person like you.

I owe my deepest gratitude to my wifes family. Her father who trusted me and allowed me to marry his daughter as well as his unlimited help. Her mother for her unbounded support in all matters of life. In fact, the title Mother-in-law does not match her, she is a real great mother. Her brother and sister who consider me as a brother in the family.

I would like to admit that mentioning my mother here, only enriches my acknowledgement through her presence without giving her what she really deserves. Just a hint about her, she succeeded in raising three successful young men, one of them is writing this dissertation. To feel her efforts, you have to be a father or a mother; even though, you will not know what this great woman had done. I would like to show my gratitude to my father for being my model of a real man during my childhood which had reflected on me

while growing up. I would like to thank my brothers for supporting me when ever i need them, and boosting me morally. I am truly indebted and thankful to my uncle Magdy for his real support and love.

Egypt, I would like to thank you for what you gave me; childhood memories, life experience, knowledge, warm feelings of your people, and many other things that shaped the personality of the writer of these words. I wish you the great future that you really deserve.

I owe sincere and earnest thankfulness to Mr. Mohammad Tatai whose speeches were the fuel for resisting daily life pressures.

I can not write this acknowledgement without mentioning the unforgettable couples Fernando Bender and his wife Rasha Hasan who practically showed me how a good person should be.

Part of my experimentation was held by cooperating with my friend Hassan Soubra. Thank you for the nice time we had spent working together. This dissertation would not have been possible without the emotional and daily support of my friends Akram Hakiri, Alaa Allouch, Ali, Ashraf Ez-Aldeen, Awady Attia, Denis Carvin, German Sancho, Hany Gamal, Hatem Arous, Ibrahim Al-Bluwi, Ihsan Tou, Ismaeel Bouassida, Jamal Dannora, Khaled Nasr, Khalil Al-Astal, Lionel Bertaux, Mahomoud Mohammad, Malek Masmoudi, Mohammad Almasry, Mohammad Askar, Nadim Nsreddin, Ossama Fawzi, Othman, Rami Al-Falaky, Riadh Ben Halima, Yamani. And i can not forget the members of ACCEPT association who gave me the time and effort to help me to learn the French language.

Behind any successful work there are people who work silently, but you can feel there efforts in the quality of work. I would like to thank Nathalie Romero, Camille Cazeneuve, Servan Arres, and Ahlem Moussaoui in the "Services Personnels", and Arlette Evrard, Emilie Marchand, Anne Bergez, and Sylvie Henry in the "Bibliothque".

I owe sincere and earnest thankfulness to Prof. Ismail TAG who eliminated the obstacles that was hindering my PhD studies. Dr Bassunni who showed

me how a real manager can overcome difficulties to achieve his targets. Dr Ali Abdelmoneam and Dr Sherif Al-Sharkawi who gave me a real push at the start of my career. Prof. Ahmed Fahmi, Prof. Taher Alsonni, and Prof. Ossama Badawi who taught me how to be a real engineer. All My colleagues in the Arab Academy for Science and Technology with whom i had spent a remarkable time.

Contents

List of Figures	v
List of Tables	vii
1 Introduction	1
1.1 Context of study	1
1.2 Problem description	4
1.3 Contribution and report structure	6
2 About wireless dense networks	9
2.1 Introduction	10
2.2 Wireless networking	11
2.2.1 Ad-hoc Networks	11
2.2.2 Wireless Sensor Networks	18
2.2.3 Discussion	28
2.3 Wireless network density and self-organization	29
2.3.1 Network density	30
2.3.2 Self-organization	32
2.4 IFE systems	38
2.4.1 The need for IFE systems	38
2.4.2 IFE system components and services	39
2.4.3 IFE as a self-organized dense network	40
2.5 Conclusion	41
3 On the Design of heterogeneous dense Wireless Network	43
3.1 Introduction	44
3.2 Measuring network density	45
3.2.1 A metric for evaluating network density	46
3.2.2 Simulation results and validation	47
3.2.3 Real life data	52
3.3 Case study: Building a Heterogeneous Network	54
3.3.1 Communication challenges	55
3.3.2 Proposed communication technologies	57

3.3.3	Evaluation of proposed technologies	64
3.3.4	The proposed architecture	75
3.4	Conclusion	76
4	Self-organization and IFE systems	79
4.1	Introduction	80
4.2	Self-organization	80
4.2.1	Self-organization Vs Self-configuration	81
4.2.2	The need for self-organization	83
4.3	Case study: A device identification protocol	84
4.3.1	Smart Antennas	84
4.3.2	Design of the proposed protocol	87
4.3.3	Protocol modeling	100
4.3.4	Protocol behavior and performance evaluation	104
4.4	Conclusion	110
5	Conclusion and future work	111
	Author's Publications	115
	References	116
	Glossary	131
	Index	133

List of Figures

2.1	Sensor node structure	19
3.1	Mean	49
3.2	Standard Deviation	50
3.3	Receiver Throughput	51
3.4	Effective Density	52
3.5	Effective Density, Throughput, and Nodes Vs time	53
3.6	UWB platform with WUSB	61
3.7	Flow rate of all flows	65
3.8	Packet count of the first flow	66
3.9	Loss Fraction	66
3.10	APs distribution	68
3.11	Packets sent by the transmitter	69
3.12	Average Throughput	70
3.13	Average Delay	70
3.14	WUSB test-bed	71
3.15	WUSB range Vs seat spacing	73
3.16	Heterogeneous network architecture	75
4.1	Omni antenna	85
4.2	Multi-element antenna	85
4.3	Communication using smart antennas	86
4.4	Smart antenna with K sectors	86
4.5	VDUs and PCUs distribution	89
4.6	Different scenarios for less than three valid PCUs	97
4.7	More than two PCUs within range	98
4.8	Negotiation cases	99
4.9	Failing PCUs scenarios	100
4.10	Model structure	102
4.11	VDU Class	102
4.12	Model signals	104
4.13	Threshold area	105

4.14 NS2 extra scenarios	106
4.15 Normal operation sequence diagram	106
4.16 Error operation sequence diagram	107
4.17 Negotiation operation sequence diagram	108
4.18 Convergence time	109

List of Tables

2.1	Ad-hoc Networks Vs WSN networks	28
3.1	802.11 standard	60
3.2	Rx threshold values	68
3.3	WUSB vs Wired USB	72
3.4	Transmission range	73
3.5	WUSB vs WiFi	73
4.1	Selection criteria	98
4.2	Messages list	106

Acronyms

AODV	Ad hoc On-Demand Distance Vector
AP	Access Point
APCM	Active Power Conservation Mechanism
CGPC	Coarse-Grain Power Conservation
CSMA	Carrier Sense Multiple Acces
DSDV	Destination Sequence Distance Vector
DSR	Dynamic Source Routing
ED	Effective Density
EMC	Electromagnetic Compatible
EME	Electromagnetic Emission
FGPC	Fine-Grain Power Conservation
FSR	Fisheye State Routing
IFE	In-Flight Entertainment
MAC	Medium Access Control
MLR	Maximum Lifetime Routing
OLSR	Optimized Link State Routing
PAR	Power Aware Routing
PED	Personal Electronic Device
PCU	Personal Control Unit
PLC	Power Line Communication
PLB	Power Line Box
PLHB	Power Line Head Box
PLPC	Physical Layer Power Conservation

PPCM Passive Power Control Mechanism
SEB Seat Electronic Box
TDMA Time Division Multiplexing Access
TORA Temporarily Ordered Routing Algorithm
UML Unified Modeling Language
VDU Visual Display Unit
WPAN Wireless Personal Area Network
WUSB Wireless Universal Serial Bus
WSN Wireless Sensor Network
ZRP Zone Routing Protocol
ZHLS Zone-based Hierarchical Link State

Chapter 1

Introduction

Contents

1.1	Context of study	1
1.2	Problem description	4
1.3	Contribution and report structure	6

1.1 Context of study

As a rule of thumb, the more technology advances, the more devices are involved in our life. Networking provides attractive solutions to efficiently utilize these devices. In a networking environment, resources can be shared, members can communicate and collaborate, and management is considered as an indispensable tool to organize these components.

In contrast to wired networks, wireless networks do not use cables to connect their components; this feature introduces vast amount of benefits as well as new challenges. By freeing the user from cables, anywhere/anytime mobility and communication becomes a reality, and causes fundamental changes in networking concepts. Different technologies can be used to support wire-

1.1. CONTEXT OF STUDY

less communication such as *Infrared (IrDA)*, *Bluetooth*, *WiFi*, *Wireless USB*... They can participate in different types of networking; a , for example, consists of several Access Points connected to the network backbone, and each wireless node entering the network is assigned to a certain Access Point. Another example is WPAN, where few number of nodes can communicate together within a very short distance. However, the requirements of some applications can not be satisfied with such charactersistics. Having a fixed backbone limits the network flexibility for installation and maintenance, as well as hindering node mobility. Moreover, some applications may require the coverage of large distances, and support large number of wireless nodes.

Specialized wireless networks such as ad hoc networks and wireless sensor networks can be used to overcome these drawbacks and fullfil the needed requirements. Herein a brief of these networks mentioning their main characteristics..

- ***Ad hoc networks:*** A collection of wireless nodes builds a temporary network without using any existing infrastructure. It can form a complex distributed system that comprises wireless mobile nodes that can freely and dynamically self-organize into arbitrary and temporary "ad-hoc" network topologies, allowing people and devices to seamlessly internet-work in areas with no pre-existing communication infrastructure
- ***Wireless Sensor Network (WSN):*** Its simplest form is a set of sensors for data capturing (i.e., temperature), and sending them to a base station. The extreme case is to have a heterogeneous network, which may contain base stations, different types of sensors, actuators, and processing elements [1]. The nodes (i.e., sensors) are characterized by being limited in resources (i.e., power, storage, processing, etc...), and small in size. They are powered by tiny batteries where the battery power is usually directly proportional to its size. Such power constraint has a great effect over node activities. The major power consuming activities

are mobility and communication. However, power consumption due to mobility is not a must; for example, when nodes are attached to a moving object, no power is consumed through mobility. On the contrary, power consumption due to communication is a must to perform the required task. It is also worthy to note that, a single hop communication can be more power consuming than a multiple hop communication [2] because more transmission power is required.

Ad hoc and Wireless Sensor Networks can introduce different solutions for wireless networking requirements. Ad hoc networks can be installed quickly, because they are not in need of pre-installed infrastructure; this speedy installation is important in some applications such as rescue missions and covering areas of natural disasters, where communication infrastructure may not exist or is not available. Also, it may help to minimize installation costs since less number of devices are involved, and allows nodes to move freely from one point to another. Moreover, wireless media can be utilized better because short communication links are used to connect node to node instead of node to a central base station. In addition, WSN allows wireless nodes to be used in environments and locations unaccessible by ad hoc nodes (i.e., underground pipes), also, it is characterized by having numerous number of nodes.

In-Flight Entertainment (IFE) is an application that inspires ideas from ad hoc networks and WSN, where different number of devices are willing to form a heterogeneous network. It is the entertainment available to aircraft passengers during flight. The passenger can experience different types of audio and video devices as well as using his own personal devices. Such environment can be considered as dense because many wireless devices exist inside a cabin of limited area, where the obstacles (i.e., seats) and the metallic tunnel structure of the cabin can affect the wireless signal. Moreover, a recent shift in the main concept of IFE systems introduced the usage of embedded sensors inside passenger's seat to provide the system with passenger's health status information to enhance the IFE services [3, 4, 5]. For instance, special embedded actuators

can also be used to provide massage for first class passengers [6].

1.2 Problem description

Wireless environment faces many challenges especially when new application requirements impose difficulties which were not previously under the spot. These difficulties range from the natural problems inherited by wireless media, to managerial and organizational problems.

Regardless of the differences between ad hoc networks and WSN, they are facing common challenges. Wireless nodes can not have simultaneous access to the wireless media, rather than that; they are sharing the media to achieve wireless connectivity. There are different sharing techniques to solve the situation, but the problem becomes worse when the number of nodes increase. Some applications (i.e., WSN applications) require the deployment of hundreds and even thousands of nodes in the area to be sensed, where the deployment scheme can be under either a controlled or random distribution. The same situation can exist if nodes are able to move and gather within a specific area. Such behavior may cause contention between nodes to use the shared media. Self-organization can be used to overcome these problems; it can provide solutions to save resources while keeping large number of nodes connected and managed [1].

In this section, we highlight some challenges such as network density, heterogeneity, and the importance of self-organization to the role played by wireless networks.

- **Network density:** Unattended node mobility or deployment can lead to different node densities within the same network. As the number of nodes increases, their connectivity increases; however, the nature of wireless media imposes some constrains over this rule. All nodes are sharing the same channel, so nodes within the same transmission range are not able to use it simultaneously. Moreover, nodes on high traffic

paths can deplete their power faster. Accordingly, network performance degrades when it becomes highly dense. On the other hand, sparse nodes do not suffer from high collision problems, but they may suffer from bad connectivity, and those without any connected neighbors are considered as isolated nodes.

Apparently, a dense network can raise different problems to MAC layer such as overhearing, communication grouping, over-provisioning, and neighbour state [7]. Moreover, the negative effect propagates to the Network layer [8, 9], and Application layer [10, 11], where it can not be over passed.

- **Network heterogeneity:** Nowadays, wireless communication spans a wide range of devices from satellite phones to wireless sensors. This diversity in devices and technologies leads to a heterogeneous environment. The heterogeneity and homogeneity of wireless environment can range from using different devices, to the various methods used in communication between identical devices. In other words, it is possible to say that the network is totally homogeneous only when all nodes are identical in all aspects. Otherwise, we have to mention the points of heterogeneity. For example, nodes, which play a special role in the network can be considered a factor of heterogeneity although they may have the same physical structure as the other nodes.

Regardless of heterogeneity type, a control scheme should exist to coordinate between different components. In this dissertation, we propose a heterogeneous networking architecture to be used inside the dense wireless environment of IFE systems to connect its different components.

- **Self-organization:** In some applications, centralized management does not offer good solutions especially when the system is too complex and needs to be scalable due to the overhead of control messaging especially when the system changes frequently, and decentralized techniques do

not satisfy all the needs of such systems because they lack the system global view and are still using control messages. On the other hand, self-organization techniques can provide new solutions for complex, autonomous, and scalable systems; where the system components can organize themselves independently without expensive coordination.

Many self-organizational techniques are inspired from natural systems such as in biology and physics [12]. However, these techniques should be thoroughly studied and adapted to match the technical systems. Self-organization greatly helps when a large number of subsystems needs to be managed while there is a lack of global state information; so that local information can be used to take the required decisions.

1.3 Contribution and report structure

The basic idea of finding network density is given by the number of direct neighboring nodes within the node transmission range. However, we believe that such metric is not enough; there are other factors that should be considered when judging the network as being dense or not. Thus, we propose a new metric that encompasses the number of direct neighbors and the network performance. In this way, the network response with respect to the increasing number of nodes is considered when deciding the density level.

Moreover, we defined two terms, self-organization and self-configuration (which are usually used interchangeably in the literature) through highlighting the difference between them. We believe that having a clear definition for terminology can eliminate a lot of ambiguity and help to present the research concepts more clearly.

Some applications, such as In-Flight Entertainment (IFE) systems inside the aircraft cabin, can be considered as wirelessly high dense even if relatively few nodes are present, so we propose a heterogeneous architecture of different technologies to overcome the inherited constraints inside the cabin, where each

component aims at solving a part of the problem. We held various experimentations and simulations to show the feasibility of the proposed architecture.

The experimentations and simulation results proved that such heterogeneous architecture can provide a solution for the constrained wireless communication inside the cabin.

Based on the self-organization concept, we introduce a new self-organizing identification protocol that utilizes smart antennas. The protocol was firstly designed and verified using UML language, then, a NS2 module was created to experiment with different scenarios.

In chapter 2, we introduce adhoc networks and discuss topics related to its communication capabilities, how it can utilize energy conservation techniques to overcome its limited power sources, and how to be identified through addressing schemes. Similar topics are discussed for WSN; showing similarities and differences between them. Finally, factors affecting network density are presented followed by a presentation for self-organization and IFE systems.

In chapter 3, we show how network density is usually measured in the literature, and how density calculation can be enhanced when network performance is considered as a parameter for calculating network density. We also propose a wireless heterogeneous network architecture as a solution for the dense wireless IFE systems.

In chapter 4, we explained our understanding to the terms self-organization and self-configuration, which are used interchangeably in the literature. We also introduce a device identification protocol for IFE systems, that practically shows the differences between the two terms. The protocol uses smart antennas to connect each display unit with its remote control without any previous configuration.

In chapter 5, we present the conclusion and future work of our contribution.

1.3. CONTRIBUTION AND REPORT STRUCTURE

Chapter 2

About wireless dense networks

Contents

2.1	Introduction	10
2.2	Wireless networking	11
2.2.1	Ad-hoc Networks	11
2.2.2	Wireless Sensor Networks	18
2.2.3	Discussion	28
2.3	Wireless network density and self-organization	29
2.3.1	Network density	30
2.3.2	Self-organization	32
2.4	IFE systems	38
2.4.1	The need for IFE systems	38
2.4.2	IFE system components and services	39
2.4.3	IFE as a self-organized dense network	40
2.5	Conclusion	41

2.1 Introduction

The rapid advance of portable wireless communication devices triggered the need of *ad-hoc networks* and *Wireless Sensor Networks (WSN)*, where certain applications require a wireless communication without the use of any infrastructure. These types of networks are usually characterized by being mobile, scalable, and numerous in numbers. This may lead to high node concentration in certain areas, where communication suffers from various difficulties such as signal interference. Thus, the term *network density* is used to describe nodes concentration in a certain location. Different research attempts were held to solve problems due to high density. However, the infrastructureless design of these networks makes them difficult to be managed, and the communicating nodes need to be cooperative and able to take their own decisions; this makes self-organization a valuable feature for this type of networks. We believe that self-organization techniques can provide solutions suitable for the special characteristics of these types of networks.

On the other hand, the solutions provided for ad-hoc and WSN networks can be helpful for other applications such as *In-Flight Entertainment (IFE)* systems. An IFE systems is a part of a complex avionic system where various constraints exist. They can be business constraints where minimizing costs is a paramount factor, or technical and safety constraints that affect the choice and usage of proposed solutions. Wiring complexity inside aircrafts increases weight which can be evaluated as more fuel consumption, increases testing difficulties to verify connection correctness, and makes maintenance and changing aircraft layout more difficult. These various constraints make the usage of a single technology insufficient to provide the expected service. Thus, IFE can use various networking techniques and technologies, where each technology solves part of the problem. The high number of wireless devices enclosed in a metallic tunnel filled with many obstacles (i.e., seats) initiates the same problems facing ad-hoc and WSN networks. Therefore, studying the features of these networks, the effect of network density, and the solutions provided by self-organization

techniques become a paramount need for designing such systems.

In this chapter, we discuss the features of ad-hoc networks and WSN showing their differences, and similarities; followed by a description of dense networks and self-organization. Then, we present IFE systems and showing their main features and how they can be treated as dense self-organized networks.

2.2 Wireless networking

Ad-hoc and WSN networks are characterized by special features that distinguish them from other types of wireless networks. In this section, we discuss their properties and the difficulties that they face.

2.2.1 Ad-hoc Networks

According to Merriam-Webster dictionary [13], the term “*Ad hoc*” means “*formed or used for specific or immediate problems or needs (i.e., ad hoc solutions)*”. This definition can show the sense of the term “*Ad-hoc networks*”.

Ad-hoc Networks are wireless networks where nodes can communicate wirelessly with each other without the need for a fixed infrastructure. This is the most distinguishing feature that differentiates between ad-hoc networks and traditional wireless networks (i.e., cellular networks). There is no centralized control; nodes are autonomous and can take their own actions depending on network’s situation [14]. In other words, they are responsible for determining the way they communicate, organizing themselves, and responding to changes that happen to the network due to external or internal factors.

The importance of ad-hoc networking concept is greatly recognized when the nodes are deployed over a large area where a single hop communication is not possible. This situation introduces a challenge to find techniques that provide appropriate multi-hop routing since nodes must be able to join or leave the network independently without causing the network to fail. To achieve this

functionality, the network should have an architecture capable of providing such behavior through its structure, methods of communication, topology.

2.2.1.1 Structure

Ordinary wireless networks usually depend on a fixed infrastructure to interconnect their nodes and connecting them to the external world. However, the contrary of this concept is applied in ad-hoc networks where there is no fixed infrastructure that allows direct communication between nodes. It is the responsibility of the individual nodes to recognize their surroundings and create their own communication network; they can work in a stand alone fashion or can be connected to another network.

To overcome the absence of infrastructure, the nodes can work in either single or multiple hop communication. *Wireless Personal Area Network (WPAN)* [15] is likely to use single hop since all nodes are within the transmission range of each other and no node is willing to act as a router. On the other hand, large ad-hoc networks use multiple hop communication to cover larger area. WSN nodes usually use the multihop scheme to connect to a central point that collects their data [16].

2.2.1.2 Communication

The main purpose of setting up an ad-hoc network is to communicate and exchange data between nodes. The wireless mobile environment has special characteristics that impose various constraints over the communication process. These characteristics are discussed below.

- **Wireless media:** According to its nature, a wireless network has inherited characteristics that distinguish it from wired networks leading to special kinds of problems. The spatial coexistence of multiple wireless nodes, which are using the same channel can cause interference problems leading to a degradation of network performance; the *Hidden Termi-*

nal problem [10, 17] and the *Exposed Terminal problem* [17] are a direct example of such effect. Moreover, the surrounding environment can impose fading effects [18] over the wireless signal such as *Shadowing*, which occurs due to surrounding obstacles that attenuate the signal, and *Multipath effect* where reflective objects in the environment reflect the signal causing it to arrive from different paths; these signals can add up either constructively or destructively to change the signal strength. This will be explained precisely in section 2.3.1.2).

- **Routing:** Multihop routing is a real challenge in wireless networks especially if nodes are mobile causing the network topology to change frequently and active routes to be no more available. Routing protocols are the mechanism through which nodes can communicate in such dynamic environment; they are usually categorized as *Proactive*, *Reactive*, and *Hybrid* protocols [19, 20]. *Proactive protocols* usually use periodic messaging to distribute information about the current network topology. Each node saves this information and tries to calculate a route for each destination; this helps to minimize the delay required to find routing information, but more resources must be allocated. Destination Sequence Distance Vector (**DSDV**) [21], Fisheye State Routing (**FSR**) [22], and Optimized Link State Routing (**OLSR**) [23] are classified as proactive protocols. *Reactive protocols* computes routes on demand, so when a node needs to send a packet it starts with an exploration phase to find the active available route through which the packets can be sent. This scheme saves a lot of resources especially energy and bandwidth since no periodic discovery packets are used. However, nodes need to wait before sending data until the routes are discovered. Many reactive protocols were introduced such as Ad hoc On-Demand Distance Vector (**AODV**) [21], Dynamic Source Routing (**DSR**) [24], and Temporarily Ordered Routing Algorithm (**TORA**) [25]. *Hybrid protocols* are a mix between the previous types where routes are kept proactively for nearby nodes and reactively

for far nodes (i.e., Zone Routing Protocol (ZRP) [26], and Zone-based Hierarchical Link State (ZHLS) [19]).

- **Link capacity:** In wired networks, capacity of the whole route is almost provided and can be calculated as the minimum of the capacities of its links. In a wireless environment, especially an ad-hoc network, the situation is different since the transmission media is shared between nodes within the same transmission range. Link capacity in wireless networks is not fixed and depends on many factors including transmission power over the link, interference caused by transmissions over other links in the network, and sharing the bandwidth between nodes so that throughput per node degrades as the number of nodes increases [27]. To overcome these constraints, different QoS protocols were introduced in the literature [27, 28, 29, 30].

2.2.1.3 Energy Saving

Among the various limited resources in ad-hoc networks (i.e., processing power, storage, etc...) energy is considered the most challenging resource to control; this is due to the complexity of trade-offs available to the design of energy-aware systems. It is difficult to say that a certain part of the system is responsible for energy conservation. In fact, it is a combination of physical elements, various layers of the protocol stack, and the environment in which the system operates.

The energy consumption behavior of *Network Interfaces (NI)* passes through known states, and the consumption values differ according to the interface type. There are three states for a wireless interface; *Sleep*, *Idle*, *Transmit*, and *Receive* states [31]. In the *Sleep* state, the *NI* doesn't transmit or receive. Thus, it must fire a transition to an *Idle* state to be able to transmit or receive. Consequently, an *Idle* state consumes more energy than *Sleep* state since more circuit elements are required to be active. As a result, it is recommended to keep the interface in *Sleep* mode more than in *Idle* mode

to save more power [31]; this can be achieved through power-saving protocols. Although this will enhance power consumption, but there will be a delay due to the wake-up period. Moreover, energy consumption can be further enhanced through power control techniques.

- **Power-Save protocols:** Their aim is to increase the *Sleep* duration and decrease the *Idle* duration while minimizing the impact on the network throughput and latency. These protocols may be either *Network Layer protocols* or *MAC Layer Protocols* [14].

Network Layer protocols usually follow the following strategies:

1. Synchronized operations where nodes periodically wakeup to listen and exchange data (i.e., IEEE 802.11 standard).
2. Asynchronous operations where nodes maintain independent Sleep / Awake schedules. The schedules are designed to guarantee that neighboring nodes have an overlapped awake states (i.e., BECA / AFECA [32])
3. A topological approach can be used to identify a set of nodes to topologically represent the network, so that the other nodes within their coverage area can spend most of the time in a *Sleep* state without highly affecting the network Throughput (i.e., Span [33], and GAF [34]).

MAC layer power-save protocols can be used to benefit of the fact that when a node is transmitting, its neighbors should remain silent to minimize interference. So that, a neighboring node can use the media access control information to go into a sleeping state (i.e., PAMAS [35])

- **Power Control techniques:** These techniques allow nodes to alter their transmission power to achieve more network capacity while reducing energy consumption since low-power transmission reduces contention and leads to an increase in network capacity [14]. This implies that a route

with a large number of low-power hops can be more energy efficient than a route with a fewer high power hops. This can be achieved through topology control and minimum energy routing. Topology control will be further explained in section 2.2.1.5.

The spirit of the minimum routing techniques is to minimize the total energy consumed in forwarding a packet from a source to a destination. Accordingly, the energy consumed at the transmitter and receiver sides must be counted. A transmission is considered successful at the receiver side if the power of the received signal is above certain threshold. Thus, the impact of adding a new hop to the route, in terms of energy consumption, should consider the overhead of the added transmit and receive operations [36].

2.2.1.4 Addressing Schemes

In ad hoc networks, there are three basic addressing schemes, *Centralized*, *Decentralized*, and *Neighbor-Base* [37, 38] schemes. The *Centralized scheme* is based on using at least one of the nodes, usually called *Leader*, as a DHCP server. The challenges facing this scheme are how to maintain a single server in an ad hoc environment in which mobile nodes are joining and leaving, and how to minimize the effect of the *Hot-Spot depletion* problem (further explanation in section 1) over the nearby nodes. The *Decentralized scheme* allows each node to independently configure its address, and then address uniqueness is evaluated through a global agreement from all other nodes. The *Neighbor-Based scheme* allows nodes to communicate locally in order to get their address. The key challenge is to guarantee address uniqueness without using global agreement or centralized control.

Addressing schemes have common features in between [39]:

- *Address uniqueness*: Each node must have its own unique address since duplicated address can cause severe routing problems.

- *Scalability*: The address pool must be able to handle large number of nodes. In addition, two factors can affect scalability; communication overhead and allocation latency. *Communication overhead* includes the number of packets and the packet size used to supply the node with its address. *Allocation latency* is the waiting time of a node to get its address.
- *Reusability*: Nodes may leave the network due to different reasons (i.e., mobility, power depletion, etc...). In this case, their address must return to the address pool to be reused. If there is no policy for such situation a scalability problem may exist.

2.2.1.5 Topology

Ad-hoc network topology control has a great effect over the network performance. Its main goal is to maintain network connectivity while improving routing performance, and reducing energy consumption and interference; when direct connection between a source and a destination is not feasible, a multi-hop communication can be a good solution. In this situation a topology control mechanism can be used. Two main approaches are usually used in the ad-hoc domain *Flat* or *Hierarchical* topology [40, 41]. In a *Flat* topology all nodes are considered equal and there is no preference between them. In *Hierarchical* topology, nodes can be gathered into clusters. In this approach, network nodes are divided into groups (i.e., clusters) where each cluster has a minimum of one *Clusterhead* node. *Clusterheads* are connected together, either directly or through gateways, to form the network backbone. They are characterized by having more resources (i.e., energy, transmission range, processing, storage, etc...) than ordinary nodes in order to be able to perform their tasks.

Topology control faces different challenges [39]. A *Flat* architecture can suffer from scalability problems in terms of throughput, delay, and communication overhead as the network size increases. On the other hand, clustering faces other types of challenges such as choosing the suitable clusterhead, which

can be a source of risk because its failure will affect connectivity with other clusterheads and between nodes within the cluster.

Topology control can introduce solutions for different ad-hoc challenges. Some applications require Fault-tolerant communication. Thallner [42] introduced a Fault-tolerant distributed topology control algorithm to provide a continuously maintained connections for energy efficient multi-hop communication. Roy [43] describes another algorithm that minimizes the amount of power needed to maintain bi-connectivity by preserving the minimum energy path between any pair of nodes.

2.2.2 Wireless Sensor Networks

During the recent years, great developments in electronics and wireless communication allowed researchers to implement miniature sensing devices with wireless communication capabilities. This modern technology satisfies the needs for special type of applications where *Wireless Sensor Network (WSN)* can play an important role. This type of networks is useful for applications where rapid deployment is required in areas that lack the appropriate infrastructure to setup the network. It is suitable for environmental measurements [44], communications in disaster areas [45], commercial [46], and military [47, 48] applications. A practical implementation is presented through the *Smart Dust* [49] application.

Wireless Sensor Network is a special type of networks where nodes are smart sensors with scarce resources. They are small in size, have limited computational power, short range communication capabilities, low energy, limited storage capacity, and usually numerous in number. They differ from the ordinary ad-hoc network nodes in that they are usually homogenous nodes unless different phenomena are going to be sensed [14]. Many challenges are facing WSN; the main challenges related to WSN implementation are energy conservation, low quality communication, and scalability. Self-organization can help in solving these problems or in the best case to minimize their drawbacks [50].

A WSN mainly consists of sensor nodes that measure certain phenomena and send the measured data to a sink node. A sink node is responsible for collecting the measured data and relaying it to an external entity (i.e., users, external network, etc...). Moreover, if required, it can make some processing over the collected data. A phenomenon is a measurable event or a value, which is sensed by a sensor node. A typical sensor node consists of four basic parts; a sensing subsystem to measure the targeted phenomena, a wireless communication subsystem, a processing subsystem for local data processing and storage, and a power source. Some extra subsystems can be included such as a positioning subsystem, and actuating subsystem (i.e., mobilizer) in case that the node is capable of performing some actions (see Figure 2.1).

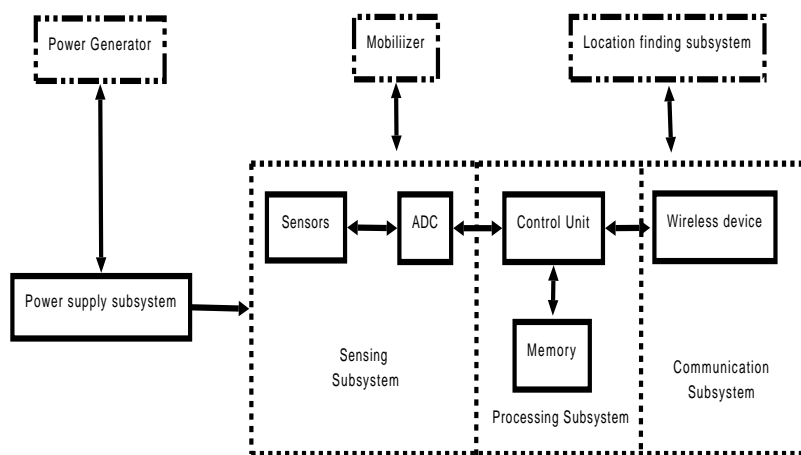

Figure 2.1: Sensor node structure

Having a quick look at old surveys can give a good image about the great developments that took place in this field. In 1986, T.G.Robertazzi [51] showed the new rising ad-hoc network technology. At that time they were interested in how to setup the connectivity between nodes, transmission scheduling, self-organization, etc... the concepts of traditional wireless networks were still in mind; using local hubs, backbone networks, gateway were thought to be part of the solution. Nowadays, it is totally different. Ad-hoc networking has its own concepts, which proved to be practical and reliable. Although connectivity

and transmission scheduling are still important issues, but it became the issue of their performance and reliability. Last but not least, more topics were introduced such as security, QoS...

Although ad-hoc networks and WSN have many similarities in between, but certain applications require especial characteristics (i.e., Connectivity, communication schemes) to cope with their requirements. So WSN is equipped with special capabilities, which allow it to work in environments, where ad-hoc networks can not satisfy the required needs.

2.2.2.1 Coverage and Connectivity

Two nodes are considered connected when they can exchange packets between each other. If they are within the transmission range of each other, then they are directly connected and identified as being one-hop neighbor; otherwise, they are connected indirectly through intermediate nodes to form a multi-hop connection. Unreachable nodes are called “*Disconnected*”. Factors that can affect connectivity are:

- Transmission range of nodes: this includes the transmission power and the receivers sensitivity;
- Surrounding noise and interference;
- Number of neighboring nodes (i.e., density);
- Routing protocols;

2.2.2.2 Communication Schemes

The aim of WSN is to setup a network of sensors that can measure data and transfer them to a location for further processing. During this process different types of messages are exchanged between WSN entities; this can include queries, data, commands, etc... Wu [14] mentioned three types of communica-

tion schemes; *Sink-to-Sensor*, *Sensor-to-Sink*, and *Sensor-to-Sensor* communication. They are described below.

1. ***Sink-to-Sensor communication:*** In this scheme, communication is initiated by the sink to allow sensors to perform certain tasks (i.e., sending their measured data). This scheme can be further sub-classified into *Sink-to-All*, *Sink-to-One*, *Sink-to-Region*, and *Sink-to-Subset* communications.
 - (a) *Sink-to-All Communication:* When a sink sends a query to all sensors, flooding is considered as the basic technique. However, blind flooding is not the best technique since it degrades the network performance and imposes many difficulties. Duplicate packets consume network resources and large number of them can cause undesirable congestion. A controlled flooding can introduce a solution [52] where hop counts will prevent the packets to circulate endlessly inside the network.
 - (b) *Sink-to-One communication:* In this scheme, the sink sends its query only to one sensor. In a way or another, this pattern can be utilized to implement all other patterns of Sink-to-Sensor communication. Different techniques and routing protocols [53] are used to implement this scheme. One advantage is that reliability can be introduced by using multiple paths to destination. On the other hand, a WSN environment imposes certain difficulties; the lack of global ID scheme to identify each individual node can make this scheme a difficult task.
 - (c) *Sink-to-Region communication:* When location information is available to WSN entities, nodes can be identified by their location. Therefore, a set of nodes occupying certain area can be identified by this region. This scheme is required when the application is interested in the data value existing within certain region rather than

the data sent by a certain node. However, some problems can occur; a WSN is deployed with a in numerous number of nodes that can have a high density within a specific area and the distance between nodes is considerably short. This leads to severe interference and packet collisions, so that receivers can get nothing but noise. Moreover, the short distance between nodes causes some nodes to exist continuously in the route between sink and required region; this leads to energy depletion of these nodes. This is called *Hot spot depletion* [54]. When the receiver receives multiple copies of the same packet; this is called *Response Implosion problem* [55]. Another cause of energy depletion is the usage of a multipath routing scheme to increase reliability where the transmitter selects the k shortest paths and divides the load among them [55]. Fortunately, data aggregation mechanisms [56] can be utilized to minimize these drawbacks.

(d) *Sink-to-Subset communication*: In this scheme, the sink sends its query to a group of nodes scattered through the whole field. When nodes can be uniquely identified, this scheme may not introduce serious difficulties. However, if there is no identification, finding the nodes will not be a trivial task.

2. ***Sensor-to-Sink communication***: In this scheme, the communication is started from the sensors towards the sink. It is usually used to send data or to respond for queries and commands sent by the sink. This scheme can be further sub-classified into *All-to-Sink*, *One-to-Sink*, *Region-to-Sink*, and *Subset-to-Sink* communications.

- *All-to-Sink communication*: When the sink wants to retrieve some information from all sensors, they reply with *All-to-Sink* scheme; this can be done periodically or upon certain requests by the sink. As a result, the *Hot-Spot* [54] and the *Response Implosion* [55] prob-

lems can exist, but within the nodes near to the sink, which may suffer from excessive workload.

- *One-To-Sink communication*: Simply, it is the communication originating from a single sensor towards the sink. It is much easier than *Sink-to-One* scheme since sink nodes already have their own identification while the transmitting sensor does not need to be uniquely identified.
 - *Region-to-Sink communication*: This is the most popular scheme, according to the WSN philosophy, large number of sensors are deployed in the field to sense certain phenomena. Consequently, an event can trigger multiple sensors within the same region (i.e., the temperature exceeds certain threshold). In this situation, high traffic can exist. Thus, aggregation techniques can be used to minimize this negative effect.
 - *Subset-to-Sink communication*: This scheme is used when information is needed from a group of sensors, which are sharing certain feature. Although it seems similar to *Region-to-Sink* communication, but it differs since it is not bounded by the location of sensors. In fact, it can be bounded by the type of sensor or the phenomena to be measured or any other criteria rather than location.
3. ***Sensor-to-Sensor communication***: *In-Network data processing* [57] and aggregation [56, 58] have great importance in WSN where data processing can enhance the network performance and overcome or minimize some of the WSN problems. For example, they can be used to reduce the number of packets transmitted by a node thereby saving energy, or sensed data can be gathered and transformed to a more abstract high level data before transmission. This requires the usage of processing power, storage, and wireless communication. Hence, *Sensor-to-Sensor* communication is indispensable to support these techniques.

2.2.2.3 Energy Conservation

To perform the required tasks, all sensor nodes have to be equipped with a power source. The type of power source may differ according to the application and the WSN architecture. For example a static WSN inside a building can have a fixed and/or rechargeable power source; however, this is an exceptional case. Sensor nodes are usually deployed in numerous numbers within harsh or unreachable environment. Moreover, their tiny size imposes constraints on using powerful energy source. Therefore, sensor nodes are usually equipped with batteries of limited power value. These batteries should have a lifetime long enough to perform the required task. That is why energy conservation is an important topic in WSN research.

For a typical sensor node (i.e., where there is neither a location finding nor actuating subsystems) energy consumption is cognizable in communication, and sensing subsystems. Pottie [59] mentioned that the cost of transmitting a single bit of information is approximately the same as the energy needed for processing a thousand operation in a typical sensor node.

Anastasi [31] proposed different approaches to minimize energy consumption such as *Duty Cycle*, and *Data-Driven* approaches. The *Duty Cycle* approach is concerned by putting sensor nodes into a sleeping mode when there is no need to transmit or receive. He defined the *Duty Cycle* approach as “*the fraction of time when nodes are active during their lifetime*“. However, such approach needs coordination between nodes to schedule their sleep and wakeup times. Thus *Duty Cycle* approach can be used to enhance energy consumption in communication subsystem. On the other hand, *Data-Driven* approach is concerned by reducing data sampling, while keeping an acceptable sensing accuracy, to save energy consumed by sensors, and to minimize transmitted data.

Another classification was introduced by Pantazis [60] and Zheng [61] where power control mechanisms were classified as either Active or Passive. An *Active Power Conservation Mechanism (APCM)* saves energy by using energy-

efficient network protocols; in other words, the communication subsystem doesn't go into sleeping mode. A *Passive Power Control Mechanism (PPCM)* saves energy by allowing the communication subsystem to enter a sleeping mode.

APCM can be distributed among different network layers. First, a MAC layer protocol can save power by reducing the number of collisions and thus decreasing energy consumption of retransmission. Second, network layer protocols can be further sub-classified into *Power Aware Routing (PAR)* [62, 63] and *Maximum Lifetime Routing (MLR)* [64, 65]. PAR protocols are concerned by finding routes that consumes least possible power. MLR protocols try to balance power dissipation among sensor nodes. Third, transport layer protocols are aiming at reducing unnecessary retransmissions to achieve minimum power consumption while preserving high Throughput.

PPCM can have different levels of control. First, *Physical Layer Power Conservation (PLPC)* where energy saving is achieved by minimizing energy consumption of the Central Processing Units of idle system. Second, *Fine-Grain Power Conservation (FGPC)* where MAC layer can take the decision to turn off the radio interface module for just one transmission frame [66]. Energy can be saved from every frame transmission if MAC layer can take this decision. Third, *Coarse-Grain Power Conservation (CGPC)* uses a dedicated application located higher than the MAC layer to control the radio interface. Therefore, it can be turned off for a longer period than the period of transmitting a single MAC frame.

2.2.2.4 Limited Resources

In the WSN context, resources can be organized by being everything that a node requires to survive and perform its required task. This includes processing power, memory, energy, communication capabilities, etc... The percentage of these resources within the system differs from one WSN to another according to the objective required to be satisfied. However, the common feature is that

these resources are limited either in quantity or value or both. The small size and limited resources structure limits sensor nodes to undertake too much complex tasks. Therefore, sensor nodes cooperate together to perform the required task. Such objective requires a resource management scheme to utilize the available resources. Any managing scheme will aim at maximizing some factors while minimizing others; for example, to maximize network life time and reliability, and minimize power usage and network traffic. Baarsma [67] showed general design issues of resource management in WSN; they include:

- *Lightweight management*: Traditional heavy-weight managing schemes are not suitable for WSN with limited resources, so that the managing architecture should be designed as light-weight in terms of computation and communication.
- *Localized management and coordination*: This managing scheme can reduce redundant activities of the network to save its resources. This can be achieved through inter-node coordination where neighboring nodes need only to coordinate with each other instead of propagating management messages through the whole network. Thus, network traffic is minimized and more energy is saved causing network life time to prolong.
- *Generic management functions*: WSN resource management encapsulates application requirements to carry out the required tasks. This may introduce compatibility problems when applying the same management scheme over different applications. So that, a degree of genericness is required to adapt the managing scheme.

2.2.2.5 Routing Protocols

Due to the large number of nodes deployed and the inherent characteristics of WSN, routing becomes a very challenging topic. Routing protocols should preserve active routes while considering energy limitations as well as node mobility. Different routing protocols were introduced in the literature, each to

overcome certain WSN challenge. Al-Karaki [41] organized WSN routing protocols according to network structure and protocol behavior. According to the network structure, routing can be classified as *Flat Network routing*, *Hierarchical Network routing*, and *Location Based routing*. In *Flat Network routing* all nodes play the same role and they cooperate together to accomplish the sensing task. In *Hierarchical Network routing*, nodes are usually divided into clusters where each cluster consists of a group of sensing nodes and cluster heads. Cluster heads are used to collect data and route them to a sink node; they are characterized by having higher energy level as well as more processing and communication capabilities. In *Location Based routing* protocols, nodes are addressed according to their location. Different techniques can be used to determine node's position; relative coordinates can be determined by exchanging data between neighbors or absolute coordinates can be obtained through GPS.

On the other hand, protocols can be classified according to their routing behavior. *Multipath routing* protocols [41, 68] use multiple paths instead of single path to increase network reliability and to be more resistive to route failure either due to mobility or energy depletion. However, such technique consumes more energy and introduces more overhead. *Query Based routing* [41, 69] are used where sink nodes send a query to get certain data; therefore, only the nodes having this data respond to the query. Certain techniques such as data aggregation can be used to minimize the effect of duplicate data. *Negotiation Base routing* [41, 69] uses negotiation messages to suppress duplicate and redundant data from being sent through the network. In *QoS-based routing* [41, 70], QoS metrics (i.e., delay, energy, etc...) are used to make a balance between energy consumption and required data quality.

From the first sight, Ad-hoc and Wireless Sensor networks seem the same. However, a detailed look can show basic differences between them. Table 2.1 shows some of their similarities and differences.

2.2. WIRELESS NETWORKING

Comparison	Ad-hoc network	WSN
Equipments	Relatively large with limited power	Tiny size with very limited energy level
Human Intervention	May exist	Does not exist in most applications
Traffic pattern	Usual pattern of Web, voice, applications	can exhibit periodic data transmission or long periods of inactivity followed by short periods of high activity
Scale	Usually few number of nodes	Can reach thousands of nodes
Self-Organization	Required	Required
QoS requirements	Traditional techniques can work	New techniques are required to consider the limited resources
Simplicity	Relatively complex architecture	Simple software and Hardware architecture
Mobility	Can exist	Can exist
Deployment	Random / Planned	Random / Planned

Table 2.1: Ad-hoc Networks Vs WSN networks

2.2.3 Discussion

Both ad-hoc and WSN networks have features that make them an appealing solution for many applications. Usually nodes are free to move either intentionally or unintentionally and nodes are able to adapt themselves to the changes resulting from movement (i.e., building new routes). Scalability is an important factor especially in WSN where numerous numbers of nodes are deployed. Although high number of nodes guarantees better connectivity, but raises an interference and congestion problems. Being reconfigurable, allows them to respond to surrounding changes. However, ad-hoc and WSN networks have some drawback such as limited energy sources which may shorten the networks life time, and limited transmission range which can be overcome by multihop routing.

Some applications can benefit from these advantages and cope with the advantages; while other applications can not. For example, IFE systems are applications of the second type where the surrounding environment is full of constraints especially those related to safety issues. In such environment, a failing node or high interference level are considered a severe situation that must not exist because their consequences are usually dangerous. Accordingly, IFE systems need to achieve the pros of ad-hoc and wireless networks, while avoiding their cons. They need to be mobile, reconfigurable, scalable, and infrastructureless (if possible); and at the same time, to be tolerant to interference, can avoid or recover from failure modes, and can keep the expected QoS level.

2.3 Wireless network density and self-organization

Wireless networks communication is based on sharing the wireless media between nodes through different sharing techniques. However, the existence of large number of wireless nodes makes it difficult for these techniques to sustain a good level of communication. Aside to the high concentration of nodes, other factors can have a noticeable effect over the communication link. In this section, we discuss these factors and show their impact over wireless communication.

Moreover, a self-organizational behavior can help wireless nodes to adapt themselves to overcome the effect of high network density. A wireless node is composed of different layers; each layer can participate in a part of the self-organizational behavior. Thus, we discuss the solutions mentioned in the literature to show how self-organization behavior is imbedded in these layers.

2.3.1 Network density

The term “*Dense networks*” is usually used to identify networks having large number of nodes within a small area while affecting the network performance. Starting from this concept, different networking solutions were proposed [71, 72, 14]. However, it seems that this view is very abstract and needs to be further investigated. In this section, we introduce the factors that have an influence over network density; some of them are controllable while the others are not. However, it is difficult to consider some factors as being absolutely controllable or uncontrollable (i.e., Mobility).

2.3.1.1 Mobility

Different performance aspects may benefit from mobility such as load balancing/life-time maximization [73], buffer overflow prevention [74], and coverage enhancement [75]. Moreover, mobility models [76] have an impact over traffic pattern [77], and can contribute to the role of bottleneck nodes (i.e., nodes close to sinks) where sink nodes can change their location to enhance performance [78].

On the other hand, mobility can have negative effect since frequent movements increase power consumption, and may result in performance degradation through dynamic link changes [79].

Mobility can be considered as a controllable factor if nodes have actuators to change their location according to a certain scheme [80]. For example, nodes can move toward coverage holes to enhance the quality of initial deployment [81]. On the other hand, if the node is deployed in a random way or attached to another moving object, then mobility is considered uncontrollable. In both cases, it has a great influence on nodes distribution and subsequently over their density [82].

2.3.1.2 Obstacles

Radio signals are highly affected by the surrounding obstacles. Two path loss models are usually considered in the context, the *Free Space* and the *Two-Ray* models [18]. The *Free Space* model assumes that there is a line of sight path between the transmitter and the receiver while reflections are neglected. A more realistic model is the *Two-Ray* model where two paths are considered, the line of sight path and the ground reflection [36]. In real life, path losses are not the only reason for signal fading. Surrounding obstacles can dramatically affect the radio signal through reflection and/or absorption. In addition, the signal value can vary through time due to the relative motion between the transmitter, the receiver, and the obstacle; this is called the *Shadowing Effect* [18]. In addition, the receiver can receive super-positioned signals due to reflections and/or scattering. These signals may add up constructively or destructively causing high signal variations. This is called the *Multipath Fading* [18] effect. So, a node, which is considered as near due to its location, can be considered out of transmission range due to the surrounding obstacles or, in the best case, connected through a weak link.

2.3.1.3 Transmission Power

The number of neighboring nodes is affected by transmission power. In case there are not enough neighbors, a node can extend its transmission range by increasing the transmission power to cover a larger area. However, such behavior should be governed by a power control scheme to reduce interference and to save energy [83]; instead of transmitting at the maximal power level, each node can choose a lower transmission power [84]. As a result, transmission power control can be another way to adjust a network topology as well as its population.

Moreover, a major interference source is the surrounding nodes. When two nodes within the range of each other are both transmitting at the same time and frequency, they are called to be interfering together and the arriving

signal is likely to be corrupted. In addition, two different channels with very near frequency band can interfere together due to spurious emissions especially at high speed transmissions [85]. A persistent problem always exists in spite of the different solutions proposed to overcome interference; it is hard for a transmitter to estimate the interference situation at the receiver, while only the channel status at the receiver side counts for successful transmission [1].

2.3.1.4 Deployment Scheme

In spite of the above factors, the deployment scheme [41, 54] is still considered the main factor. In a *Planned* scheme, usually the nodes locations are predefined according to a certain plan. This gives more control over the density and can manipulate node placement as one of the design parameters. Nevertheless, the initial distribution can be changed in some applications where nodes are attached to moving objects, but a good study of the mobility pattern [76] can minimize this effect. In contrast, a *Random* scheme is uncontrollable and different problems can arise; especially the existence of isolated nodes (i.e., where they are out of the transmission range of other nodes) or interference and collisions due to high population of nodes within certain area.

2.3.2 Self-organization

In WSN domain, the term self-organization is tightly coupled with routing protocols, so the term self-organizing may be confused with the term routing. Routing is the action of relaying data from one node to another through a communication path. Routing decision may be centralized or decentralized depending on the network architecture. Self-organization is the action of reorienting network nodes. This reorientation can be a result of a change in location, hardware or software configuration to alter the role that a node plays in the network. The decision of self-organizing is taken by the node itself in response to the surrounding environment.

Self-organization is of great importance to manage and save the node's scarce resources. Power consumption can be greatly reduced when transmission range is efficiently managed. In addition, node location can dramatically affect the choice of an efficient transmission range. Also, it has an influence on network traffic where it can reduce congestion in locations with high nodes density [1].

An important issue in WSN is that system requirements usually conflict with its physical limitations. A WSN is used for gathering and sending data. At the same time, WSN suffers from limited resources such as power source and hardware limitations [90], and limited computational capabilities that needs specific application structure [91]. Further more, WSN are used in different applications ranging from civil [92] and environmental [44] applications to military [48] ones. This wide range of applications needs different system architectural requirements. It is of a great importance to try to define a general basic architecture, and to find out its requirements. Different application requirements can be added to this generic architecture to obtain the desired outcome. We are trying to highlight the role of different networking layers that affect self-organization. Thus, we are interested in showing general structural requirements for MAC, Network, Transport, and Application layers that make them suitable for the WSN environment.

2.3.2.1 MAC Layer

According to the search done by Nait-Abdesselam [93], it was stated that MAC protocols can be categorized into *Time Division Multiplexing Access (TDMA)*, and *Carrier Sense Multiple Acces (CSMA)*. The former is basically a technique that allows nodes to share a communication media by synchronizing them to share available time slots. Its scheduling nature helps to reduce power losses due collisions. However, there still exists the non ignorable synchronization overhead. The later is dependent on an agreement between the sender and receiver to share the media instead of waiting for time slots. However, there

are losses due to collision, idle listening, and overhearing.

Areas with high density of nodes suffer from congestion due to sharing of same communication medium. Further more, recent improvements in hardware raised the importance of finding appropriate MAC protocols. Ilker Demirkol [94] introduced a survey for different MAC protocols where critical WSN properties for the design of MAC protocols were highlighted. They were also investigated to show their points of weakness and strength. It was mentioned that communication patterns can be categorized into four patterns, *broadcast*, *convergecast*, *local gossip*, and *multicast*. The differences between these patterns were discussed, and different attributes of a good MAC protocol were proposed. These attributes include energy efficiency, scalability, and adaptability to network changes. In spite of their importance, other attributes can be considered as secondary attributes when compared with the main goals of a MAC protocol, such as *Latency*, *Throughput*, and *Bandwidth Utilization*.

Furthermore, using certain technologies can improve MAC Layer performance. Ryoo [95] showed that using directional antennas can be used to reduce MAC level interference.

2.3.2.2 Network Layer

The way data are routed between nodes is of great importance. An efficient routing or placement algorithm can save a lot of lost energy. In a WSN environment, nodes are usually deployed randomly causing unintended node distribution. In such situation, it is usually impossible to establish a single hop communication link; this makes it very important to find out a way to transfer packets through multi-hop path(s) efficiently and accurately. This can minimize the energy lost due to packet losses, and sending packets in inappropriate or obsolete paths.

Most of the routing protocols, proposed for the wireless networks domain, do not consider limited resources constrain that exists in WSN environment. In addition, traditional addressing scheme doesn't work well in such dynamic

environment [41]. A well defined routing protocol can solve these issues, but it is impossible to have a single general design, so it is of great importance to identify different categories of protocols. Al-Karaki [41] proposed a good categorization of WSN routing protocols through different points of view according to network structure, and protocol operation. According to the former view, they can be categorized as flat, hierarchical, and location based routing. According to the latter, they can be categorized as negotiation, multi-path, query, QoS, and coherent based routing. In addition, Yazeed Al-Obaisat [96] showed that protocols can also be categorized according to routing discovery; they can be divided into proactive, reactive and hybrid protocols.

Different surveys agreed on common network layer challenges [41, 96, 97, 98], such as *Node placement*, *Energy saving*, *Scalability*, and *Mobility*. *Node placement*, sensors are deployed in either a deterministic or random way. In either case, the network must keep a communication link between nodes. *Energy saving*, routing protocols must try to increase the network life time by adopting an efficient algorithm to minimize energy required for routing. *Scalability*, node sensors are usually deployed in numerous numbers, the routing protocol must be able to handle extra nodes joining the network and preserve the required performance even if some nodes left the network (i.e., due to power depletion). *Mobility*, depending on the application, nodes can be either dynamic or static. These issues must be considered during the protocol design.

In addition, the role that the node plays in the network must be considered during the design. In a heterogeneous network environment specialized nodes can exist. A sensing node may be only able to communicate with a router node where there is no need to communicate with neighbouring sensing nodes. Router nodes can communicate with each other to relay data between different groups of sensing nodes. A sink node can be used to collect data sent by sensing nodes. On the other hand, a homogeneous network can exist where each node can play different roles; it can sense as well as route data.

2.3.2.3 Transport Layer

On the other hand, transport protocols have their own attributes of interest. Chonggang Wang [99] submitted a survey on transport protocols for WSN, where challenges in using transport protocols in sensor environment such as *Energy-efficiency*, *Quality of Service*, *Reliability*, and *Congestion Control* were mentioned. These challenges (which are due to the especial characteristics of WSN) raises the need to design either new transport protocols or to adapt the existing ones because ordinary transport protocols such as UDP or TCP, which do not behave well in WSN [53, 100]. A guideline for transport protocol design was proposed [99]. This guideline discusses common performance metrics (i.e., reliability, QoS, and fairness), and required functions of transport protocols (i.e., congestion control, and loss recovery) with respect to WSN environment. Chonggang Wangl [53] presented different design issues for transport layer in WSN. In [99] and [53] different types of transport protocols dedicated for WSN were discussed.

WSN are not an isolated network; for certain applications it is necessary to be connected to other types of networks such as internet or a database. Most of these networks, if not all, are dependent on the TCP protocol. Unfortunately, TCP does not behave well in WSN. So, if this type of connection is really needed, then adapting the transport layer should be considered to be able to establish this type of connection. Wangl [53] presented the disadvantages of using TCP and UDP, with respect to a WSN environment, which were originally designed for wired, or in the best cases for wireless networks. Kosanovic [100] proposed solutions to overcome this type of problems in order to connect WSN to other TCP networks. He discussed the *Proxy Architecture*, and the *Overlay Based Architecture*. The *Proxy Architecture* allows TCP users and sensor nodes to communicate through a proxy server. This allows free choice for communication protocol at the sensor side. This approach has two drawbacks. First, the proxy server represents a single point of failure. Second, the proxy implementation usually depends on a particular set of protocols

for the sensor side. The *Overlay Based architecture* implements the TCP/IP protocol to a microcomputer system with very poor resources (i.e., memory and processing).

2.3.2.4 Application Layer

From the first sight, it seems that self-organization is only dependent on the lower communication layers. In fact, a WSN application layer can have a considerable impact on self-organization and node performance. The basic software level is the *Operating System (OS)*. It is the responsibility of the OS to manage node resources such as, memory, CPU, and communication capabilities. Requirements for such OS were introduced by Ming-hai [101].

When the node structure is too complex, the applications may need a solution to hide this complexity for easier development process. In this case, intermediate software is required to handle the situation; this type of software is called middleware. Middleware was presented in a survey by Wang [102], where different issues were discussed including a study for the topic to determine the challenges, the services required, and provide a reference model for determining the required functionalities and services. In addition, he showed the current work related to this topic, as well as proposing a way to organize the relations between the middleware features to give a better understanding for the issue.

Although different programming models were introduced for the networking domain, but programming for WSN applications needs extra attention due to the different constraints that exist in WSN environment. Sugihara [103], introduced a comprehensive survey for representing the programming requirements, showing the challenges that arises due to limited resources, and introducing available programming models of WSN.

Another issue that shows the importance of application layer for self-organization is software update. When an environmental change occurs, such as the existence of new type of nodes, extra phenomena to be measured, and a

change in the node's task; a software update may be vital for the node to cope with these changes. Brown [104], introduced a survey for software update in WSN. It showed different issues such as the effect of update on performance, security, and energy saving, as well as known research categories for software update.

2.4 IFE systems

IFE systems are famous for their ability to provide video contents, audio tracks, and games. Actually, the entertainment service is just a single service of a grand set of services. The IFE system is capable of providing other services such as e-business, e-commerce, information services, and health monitoring. Achieving all these services in a single system requires the utilization of multiple technologies and techniques capable of being integrated together to form a single IFE system. As IFE designers are willing to use wireless communication; various problems arise, mainly the interference problem. Thus, an IFE system is considered as a high dense network due to the large number of short distance neighboring nodes; in addition to the cabin structure and the obstacles that affects wireless signal which can be added constructively in some parts and destructively in others. Moreover, it is difficult to have the luxury of on-board technical support when IFE system fails or need to be configured. That is why, IFE systems must be self-organized to be able to start automatically and reconfigure itself, when failure occurs, without any external intervention.

2.4.1 The need for IFE systems

The basic idea behind IFE systems was to provide passengers with comfortable-ness during their long range flights; especially with long transatlantic flights where passengers see nothing but a large blue surface, so that services were initially based on delivering food and drinks to passengers [87]. As passengers' demand for more services grows, accompanied with an increase in airlines

competition and technology advancement, more services were introduced and modern electronic devices played a remarkable role. This caused a change in the basic concept behind IFE systems; it becomes more than just giving physical comfortableness and providing food. It is extended to provide interactive services that allow passengers to participate as a part of the entertainment process as well as providing business oriented services through connectivity tools. Moreover, it can provide means of health monitoring [3, 4] and physiological comfort [5].

Hao [88] mentioned that the enclosed environment of the aircraft can cause discomfort or even problems to passengers. IFE systems can greatly reduce these negative effects. This can be done by using e-books, video/audio broadcasting, games, internet, and On Demand services. The fact that passengers from highly heterogeneous pools (i.e., age, gender, ethnicity, etc...) can impact the adaptive interface systems.

2.4.2 IFE system components and services

In fact, the entertainment starts from the passenger's seat design where most of the IFE system components are embedded. Wiring cables connect together all of the electronic devices in the seat as well as connecting them to the whole system in the cabin. They run through the cabin's walls, floor, and seats. Unfortunately, conveying signals and power to the seats with a connector for each seat would cause reliability and maintenance problems, and hinder cabin reconfiguration.

Nowadays, IFE systems are interactive systems, so a *Personal Control Unit (PCU)* is usually needed to control the surrounding devices. The PCU should be compact and easily held. Moreover, the pocket holding the PCU has to be placed in a way that makes it easily reached and not to affect the passenger's comfort.

A *Visual Display Unit (VDU)* is usually fixed to the back of the front seat. Depending on the required features of the system, ordinary displays can be

used to display the visual contents or touch screens can be installed to act as input devices. Another orientation is to be fixed in the ceiling as a shared display for a group of seats.

A *Seat Electronic Box (SEB)* can be used to connect the system's different components together. It is used to connect the passenger's devices and the IFE system instead of having a separate channel for each signal. For example, to transmit communication and video signals, two different networks should be available if the SEB is not used. When using the SEB, the communication and video devices are connected directly to it for conveying signals to the rest of the IFE system through one single network. Accordingly, it simplifies and facilitates maintenance procedure since malfunctioning devices can be easily replaced without affecting the IFE connections.

Halid [89] stated that *Power Line communication (PLC)* can provide a way of communication through power lines networks. Power lines and communication networks have different physical characteristics, so a PLC modem must be used as an interface between the two networks. They must be designed to provide accepted network operation under typical power lines transmission conditions. However, power lines are not designed as a good transmission media. It suffers from attenuation, fading, and noise. Nevertheless, the great advances in digital signal processing, error detection and correction, modulation, media access control techniques encourage the use of PLC in communication field.

2.4.3 IFE as a self-organized dense network

The cabin environment imposes various constraints on using IFE systems; ranging from technical to business constraints. For example, the long narrow metallic structure of the cabin, with many obstacles (i.e., seats and passengers bodies), makes wireless communication a real challenge. Wireless signals can be reflected in some areas to give a noticeable multipath effect, and may fade in other areas due to absorption or adding up destructively. In addition, airlines are willing to increase the number of seats per flight to increase their revenue,

so high number of wireless devices can exist in a very small area. The high density of passengers using their wireless devices causes wireless networking to be highly dense.

Furthermore, in avionic systems, failure mode is not accepted even for entertainment systems. A failing device can cause a severe un-satisfaction to passengers especially in long flights, causing airlines to lose their clients in a competitive business environment. In fact, there is not on-board technical support to configure or maintain a device. Accordingly, failing IFE equipments will not recover until the flight reaches its destination. Such situation can be avoided by having self-organized devices. This means that during startup or after replacing a failing device with a new one, the device is able to self-configure itself and join the IFE system. We believe that techniques inspired from ad-hoc and WSN can introduce solutions for IFE systems.

2.5 Conclusion

In this chapter, we presented the main characteristics of ad-hoc networking, showing its structure and the factors affecting node communication. Energy conservation is a paramount need which can be enhanced through power conservation techniques. WSN is characterized by its high number of nodes which can use different communication schemes. They also suffer from limited resources and energy conservation problems. Network density is affected by different factors such as mobility, surrounding obstacles, transmission power, and deployment scheme.

IFE systems exist in a constrained environment where wireless communication faces many challenges. An IFE system is capable of providing different services through its components. However, connecting these components together is not an easy task. Using wireless technology can solve part of the problem. However, traditional techniques are not enough for such environment, but infrastructureless wireless technologies can provide appealing solutions.

2.5. CONCLUSION

Chapter 3

On the Design of heterogeneous dense Wireless Network

Contents

3.1	Introduction	44
3.2	Measuring network density	45
3.2.1	A metric for evaluating network density	46
3.2.2	Simulation results and validation	47
3.2.3	Real life data	52
3.3	Case study: Building a Heterogeneous Network	54
3.3.1	Communication challenges	55
3.3.2	Proposed communication technologies	57
3.3.3	Evaluation of proposed technologies	64
3.3.4	The proposed architecture	75
3.4	Conclusion	76

3.1 Introduction

The term *Dense Network* is usually used in the ad-hoc networking context to represent high concentration of nodes within certain area. There are alternative terms (i.e., massively dense networks, and very large networks), other than “*Dense networks*”, used in the context, but the term “*Dense Networks*” is the most used one. However, this term can be misleading because it gives the impression that the population around all nodes is high, although it may be true for only some of them [105].

In other words, when nodes are randomly distributed, their concentration can be high in some regions and low in others, so we propose considering two different scopes of network densities; the *Global* and *Local* densities. The *Local* density represents the density of direct connected neighbors who are within the transmission range of the node. The *Global* density represents the distribution of nodes for the whole network. This means that the *Global* density consists of groups of *Local* densities.

In a dense ad-hoc network, too many communication links are detrimental for energy consumption, network throughput, and quality of service. In spite of the imposed difficulties, some WSN techniques prefer the usage of a dense network to obtain better performance since it encourages the cooperation between sensors. Scaglione [106] proposed a strategy to show that the efficient acquisition of correlated data mandates that nodes transmit cooperatively, instead of contending to report their local information. Toumpis [105] introduced different researches that investigated the concept of cooperative transmission; he mentioned that complexity is the price we have to pay for such cooperation.

In this chapter, we firstly examine the effect of network size over its performance, then introduce a metric to determine if a network is considered as a “dense network” or not. Thus, we apply our metric on experimental results

published in the CRAWDAD¹ dataset [107] site to verify our metric. Secondly, we present a case study to show how a wired network can be replaced by multiple networking technologies to form a heterogeneous network capable of eliminating the ordinary wired network and providing users with more services.

3.2 Measuring network density

Toumpis [105] surveyed different wireless networks solutions based on analogies with physics. He noted that, most of these solutions are based on the assumption that the network has high node density. However, few attempts were done to find a measure for density. Bulusu [71] proposed an equation to calculate the network density and many other publications had used it [14] [72]. He said that *Network Density* (μ) can be roughly calculated as $\mu = (N\pi R^2)/A$; Where N is the number of nodes in area A, and R is the radio transmission range for a disk communication model. A more precise equation was proposed by Toumpis [105] who defined the node density as $d(r) = \lim_{|A| \rightarrow 0} \frac{N(A)}{|A|}$, where density is measured as the number of nodes per m^2 .

These equations are derived from the idea that network density is the amount of certain quantity (i.e., number of nodes) within certain area, and that this quantity is only dependent on the node's transmission range. However, it seems to us that such assumption is very abstract, since there are other factors (i.e., mobility, obstacles, etc...), which are not considered in the equation and can affect the number of connected nodes. For example, a node can have 5 neighbors because they are located within its transmission range even if some of them are not really connected to it due to their short transmission range.

¹CRAWDAD is the Community Resource for Archiving Wireless Data At Dartmouth

3.2.1 A metric for evaluating network density

Although different solutions are based on the assumption of having a dense network, there is still a question that needs further investigations; Is the number of nodes per unit area considered the only required measure to identify a dense network? Furthermore, it seems to us that it is of great importance to be able to determine the level of network density. In other words, it is not only a matter of either dense or non-dense, but it may be also extended to degrees of densities.

To show the importance of defining a new metric, let us consider the following examples. First, an area containing x nodes, with data traffic y , and is considered as non-dense area due to the small value of x , can have a degradation of performance for different reasons other than the number of nodes. In this situation, x nodes can be considered as a part of dense network, because the network structure is not capable of handling this number of nodes. For example, a network using a Bluetooth technology can be considered as dense when having 8 nodes, in contrast to a WiFi network, which can be considered as a non-dense network for the same number of nodes. This is not only limited to the physical components of the network; a MAC protocol capable of handling a large number of nodes and keeping a good performance can preserve the network as non-dense. On the other hand, a low performance MAC protocol can change the network to be considered as a dense network. Second, a network layer with poor routing protocol can sense the surrounding environment as highly dense, even though, a MAC Layer beneath it is capable of preserving good performance.

According to the above examples, we can deduce the following:

- The number of nodes within the transmission range is not enough to measure network density.
- The minimum number of nodes to achieve a dense network depends on different factors in addition to the number of neighboring nodes.

- It may be necessary to have different degrees of density not only dense and non-dense in a network.

For these reasons, we need a metric that encompasses the network performance as well as the number of neighboring nodes within the transmission range. We propose the usage of *Effective Density (ED)* as an indication of the density level. The *ED* of a node is the ratio between the number of single hop connected nodes (N), and the node Throughput (th), where $ED = \frac{N}{th}$. In other words, we can consider *ED* as a measure to find out how much each additional node is going to participate in changing the Throughput.

When more nodes enter the transmission range of a node, the node's connectivity increases causing Throughput to increase, so that the enhancement of Throughput decreases the effect of increasing neighbors over the effective density. In other words, the increase of Throughput suppresses the effect of increasing N .

However, after a certain limit, the accumulated increase of direct connected neighbors imposes interference problems causing a degradation in Throughput. In this situation, the node will start to consider the network as being dense because the increasing number of neighbors started to affect its performance.

3.2.2 Simulation results and validation

The simulation was done by the NS2 simulator with two objectives? First, to study the effect of increasing the number of nodes over the receiver Throughput. Second, to show the *Effective Density* and how it is changed with respect to nodes number, and throughput.

The configuration of the simulated scenario is as follows; the network field is 500m x 500m with the Tx and Rx nodes located at (0, 0) and (500, 500), respectively. Node transmission range is adjusted so that the Tx and Rx are not directly connected, but they are connected through a group of single hop connected neighbors. The simulation is repeated 9 times where 10 randomly

3.2. MEASURING NETWORK DENSITY

distributed nodes are added to the network each time. CBR connection of 0.3 Mb is used to inject data traffic to the network, and Throughput was calculated at the Application Layer level. After many experimentations, the simulation duration was chosen to be 600 sec since longer duration would not give significant changes in results.

3.2.2.1 Simulation validation

Each simulation result is considered as a sample of the whole pool of expected results (i.e., population). Using the wrong sample can lead to wrong conclusions. Thus, the first step is to select a representative sample for the population. In other words, this sample should be unbiased to be a good representative for the targeted population. This means that the sample has the same characteristics of its parent population. This takes us to the second step which is selecting the matching parameters of the unbiased sample. An unbiased sample should have a mean ' \bar{X} ' (i.e., average) and standard deviation ' $\hat{\sigma}$ ' near to the mean ' μ ' and standard deviation ' σ ' of the population. Standard deviation is a way of saying how far typical values are from the mean. The smaller the standard deviation, the closer values are to the mean.

The simulation was repeated 10 times. The results of these simulations are considered as the source of our tested population; where *Throughput* is our targeted population, and its sampling unit is bits/sec. The sampling frame was selected as 10 nodes per sample where samples are taking when 10 nodes enters the simulation. The samples start with 10 nodes and end with 90 nodes. To get different results for each repetition, the seed of the simulator *Random Number Generator (RNG)* was changed with a constant interval. Each simulation is named after the value of its seed; for example, the simulation named 'seed 401' means that the seed of its RNG was 401.

First, the mean of each simulation was calculated and compared with the mean of the whole population. Figure 3.1 shows the difference between the mean of each sample and the mean of population. The selected samples are

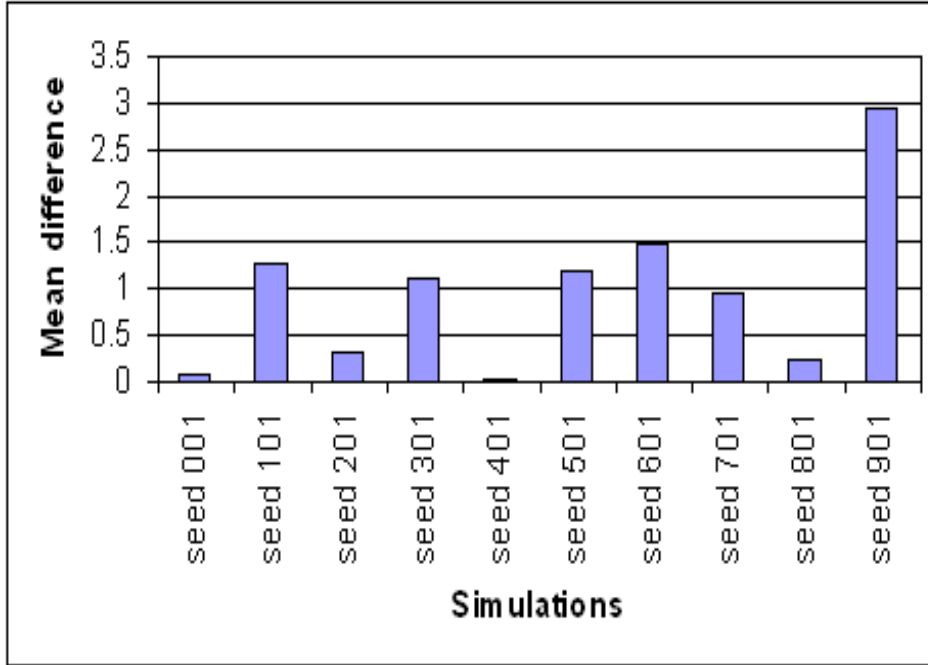

Figure 3.1: Mean

those which have the least difference with the population mean. This guarantees that these samples are good representatives to the population. This criterion allows us to extract three simulations (i.e., seed 001, seed 101, and seed 801).

Second, to minimize the variations that may exist in our sample, we select the sample with the least standard deviation. Figure 3.2 shows the standard deviation of selected samples; sample 'seed 801' represents the sample of least expected variations, so we will take it as the representative sample to extract our simulation results

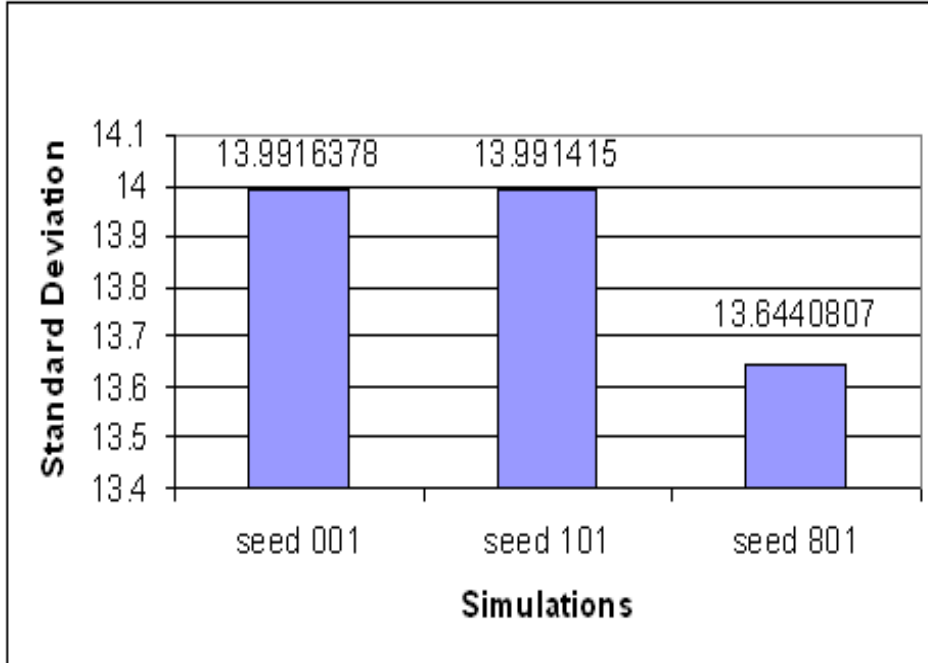

Figure 3.2: Standard Deviation

3.2.2.2 Simulation results

Gathering too many nodes within the same coverage area increases the interference level, and consequently the number of collisions, so we consider a network to become denser if its performance degrades due to the increase of nodes.

Figure 3.3 shows that for the first 40 nodes, the Throughput did not decrease too much. This means that the network is still capable of handling this number of nodes without a noticeable effect over its performance. However, as more nodes are injected, the Network is not able to perform efficiently since packets collisions and dropping increase. This causes a dramatic decrease in Throughput.

Figure 3.4 shows the change of *Effective Density* with respect to the number of nodes. It is noticeable that the rate of change had increased after adding

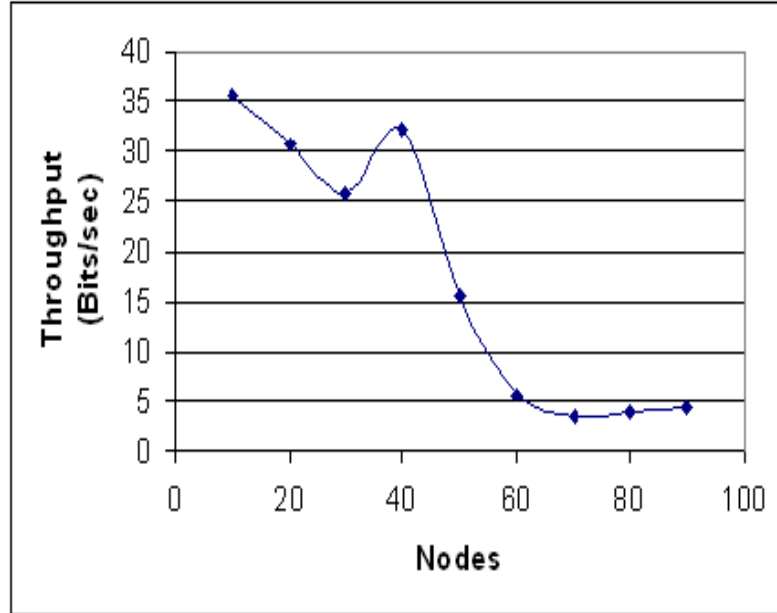

Figure 3.3: Receiver Throughput

40 nodes. This means that the network became crowded, so each additional node causes more collisions and Throughput degradation becomes obvious. Any protocol, which sets its behaviour according to the network density can utilize the ED value to determine if the network is becoming dense or not. However, there is still one more question, what is the value after which the network is considered dense. In fact, there is not an exact value; each protocol and application should determine its own threshold values. This helps to have different levels of densities. For example, an application can consider the network, represented in Figure 3.4, as a non-dense until it has 40 nodes, then semi-dense until 80 nodes, and finally highly dense for more than 80 nodes. On the other hand, another application can consider it as non-dense till 80 nodes, and highly dense after that.

To sum up, the number of nodes within a certain area does not determine if the network is dense or not, but the increasing number of nodes that increases the interference level, and number of collisions causing a degradation

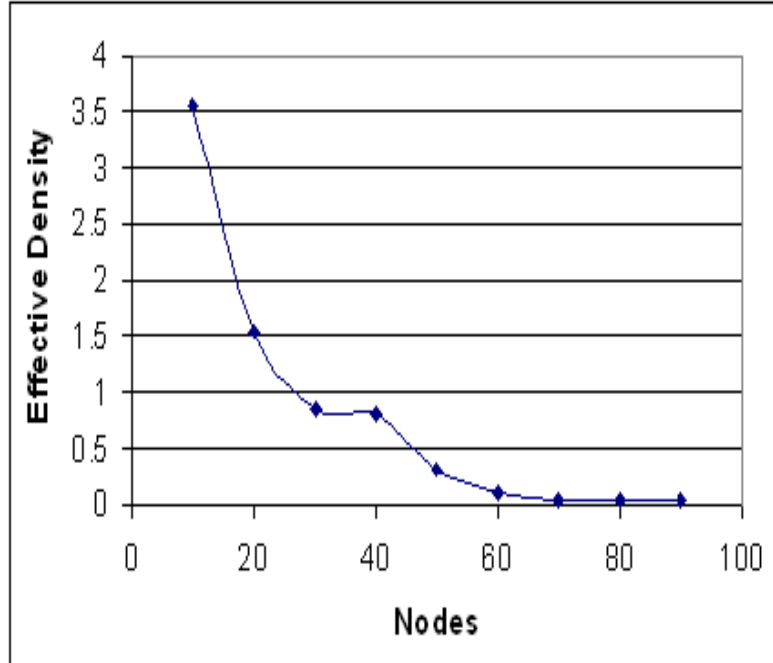

Figure 3.4: Effective Density

in performance makes the network more dense.

3.2.3 Real life data

CRAWDAD [107] provides rich datasets originating from different real experimentations in various networking domains; one of them was conducted by Liu [108]. He used a test bed to have a practical outdoor comparison between different ad-hoc protocols. The aim behind using a real life dataset is to show the applicability of the new metric over a real experimentation. The experimentation was held in an area of 225m x 365m where 40 laptops were moving randomly. They were divided into groups, of 10 laptops each, where each group was randomly distributed into one of the 4 areas in the terrain. The moving pattern is as follows; each device randomly chooses a location in a different area and moves straight toward it, then the process is repeated after reaching the destination. GPS location data and traffic data are located for

each device.

Four types of packets were recorded, $TOUT$, TIN , $SOUT$, and SIN where TIN represents the packets injected to the network by the transmitter, $TOUT$ represents the receivers' packets, which are received from the network, SIN shows the incoming packets to be forwarded, and $SOUT$ represents the outgoing forwarded packets. For example, if a packet is transmitted from node 1 and received by node 3, the following records are created; node 1 will have the values TIN and $SOUT$, intermediate nodes will have SIN and $SOUT$ and node 3 will have $TOUT$ and SIN

We used the dataset generated by Liu [108] to show the effect of changing the number of neighboring nodes over Throughput. As nodes move, the number of direct connected neighbors changes, and is calculated through the SIN values, so that inactive nodes are excluded from the calculations.

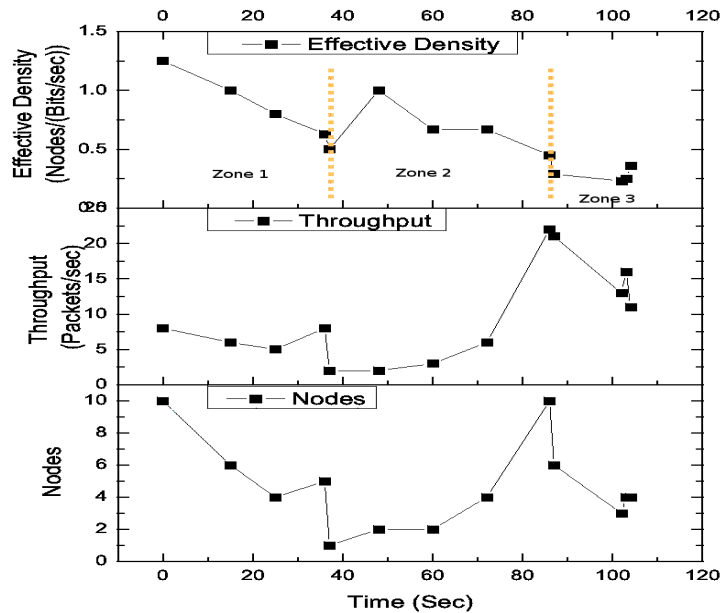

Figure 3.5: Effective Density, Throughput, and Nodes Vs time

Figure 3.5 shows The values of *Effective Density (ED)*, Throughput, and

number of nodes (N) as they change with time. It is noticeable that Throughput has the same pattern as the change of number of nodes. This is because almost all network parameters are kept constant and it is the number of neighboring nodes that changes due to mobility.

The graph is divided into three zones. In Zone1, ED started at its maximum, because N was high and Throughput was very low. This means that the large number of nodes did not enhance Throughput. However, ED decreased dramatically with decreasing N because Throughput did not change too much. This indicates that at this period, the current distribution of high number of nodes did not increase connectivity, but it affected Throughput negatively; this can be noticed in the trivial change of Throughput when compared to the large drop in number of nodes. Consequently, ED decreased quickly as N decreases.

In Zone2, the rate of change of nodes is almost the same as the rate of change of Throughput, so there was no great change in the ED . This means that when ED is constant, any change in N is accompanied with the same proportional change in Throughput. In other words, the new injected nodes are affecting the network positively and causing an increase in Throughput.

Zone3 has the same effect as Zone2, but in the opposite sense. ED is almost constant due to, approximately, the same decreasing rate of both N and Throughput.

We deduce that ED can be used as a measure for the effect of injected or leaving nodes over performance in terms of Throughput.

3.3 Case study: Building a Heterogeneous Network for IFE Systems

A primary difficulty when investigating communication requirements in an aircraft cabin is the diverse needs of passengers when compared to the strict constraints inside the cabin. It is recognized that there is an increasing need of

passengers to use their electronic devices as well as the need for entertainment during the flight. This case study aims at integrating heterogeneous available communication technologies, showing their pros and cons -within this context- while considering the imposed communication restrictions inside the aircraft cabin.

As stated by Niebla [109] users are becoming more and more familiar to personal equipments, such as mobile phones, laptops, and PDAs. This shows the importance of providing aircrafts with facilities that support these equipments.

In addition, usage of the wireless technology will help in decreasing the connecting wires; this is a valuable criterion in aircrafts design. However, using off-the-shelf technologies inside the cabin is usually not applicable when using them in the usual manner; the environment inside the cabin has very strict constraints since safety is a major requirement. Consequently, using just one technology can not give a feasible solution. In fact, using a combination of different technologies can provide a better service while overcoming the existing constraints. Allowing passengers to use their *Personal Electronic Device (PED)* (i.e., mobile phones, laptop, etc.) was usually done through specialized devices [109, 110]. Nevertheless, there is no current research to use a combination of off-the-shelf technologies inside the cabin.

Section 3.3.1 discusses the communication challenges that may hinder the usage of wireless communication inside the cabin. The proposed technologies that we suggest to overcome these challenges are mentioned in section 3.3.2. Finally, section 3.3.3 describes how each technology can be used inside the cabin.

3.3.1 Communication challenges

The recognized economics of wireless networks and communications systems have made them an attractive target for environments where individual wires are cumbersome. An airplane cabin is such an environment. Dwayne [111] said

3.3. CASE STUDY: BUILDING A HETEROGENEOUS NETWORK

that due to the need of rapidly reconfiguring the cabin seating, it is further assumed that wireless networking, rather than cable or fiber optics, must be used to interconnect passenger's entertainment equipment with other elements of the system.

The use of wireless communication technologies on board of an aircraft provides an opportunity to remove wiring and save weight on the aircraft. The weight savings can be directly measured in terms of fuel savings and improved operating economics over the life time of an aircraft.

Aircraft security may be seen as another burden due to its very strict requirements, but it is a mandatory parameter that should be included during the design of communication and data services. A major concern for using wireless devices in aircraft cabin is their interference with the aircraft communication and navigation system, especially unintended interference from the passenger's *Personal Electronic Device (PED)*. Holzbock [112] said that the installed navigation and communication systems on the aircraft are designed to be sensitive to electromagnetic signals, so they can be protected against passenger's emitters by means of frequency separation. In addition, Jahn [110] mentioned that there are two types of PEDs' interference, intentional and spurious. The former is the emissions used to transmit data over the PED's allocated frequency band. The latter is the emissions due to the RF noise level. Moreover, the existing systems suffer from bandwidth limitations; the trend toward bandwidth-consuming Internet services currently can not be satisfied [110]. The passengers number and categories can be considered as a factor that affects network scalability. For example, the network bandwidth should be increased if the number of the first class passengers was increased to support the increasing need for video stream.

It is stated by Holzbock [112] that existing indoor channel models mainly investigate office or home environments, thus these models may not be appropriate for modeling an aircraft cabin channel. Attenuation of walls and multi path effects in a 'normal' indoor environment are effects, which are not

expected to be comparable to the effect of the higher obstacle density in a metallic 'tunnel'. The elongated structure of a cabin causes smaller losses, than that expected in other type of room shapes. However, the power addition of local signal paths can lead to fading of the signal in particular points. In addition, small movements of the receiver can have a substantial effect on reception. The same opinion was emphasized by Diaz [113]. To overcome this problem, Youssef [114] used the commercial software package *Wireless Insite* to model the electromagnetic propagation of different wireless *Access Points (APs)* inside different types of aircrafts. Another challenge is that the cabin of an aircraft and the aeronautical environment in general define a very specific scenario that presents several constraints, which affect the coverage and capacity planning. This is due to the fact that the space is very limited in an aircraft cabin, and its design allows installing equipments only in specific locations, where the configuration of panels is easy to disassemble for maintenance [109]. Therefore, the replacement technique associated with the IFE system components, may affect the companies willingness to use them. Replacing time consuming parts can lead to a long aircraft downtime or flight delays. Also, a device that fails during the flight, and is difficult to be replaced, will cause the passenger to be unsatisfied. Consequently, it is advisable to design components that are easily replaced with the minimum required technical skill.

3.3.2 Proposed communication technologies

As mentioned by Holzbock [112], wireless cabin aims at developing a communication infrastructure consisting of heterogeneous wireless access networks to provide aircraft passengers and crew members with access to IFE system. Passengers are able to access different services through state-of-the-art wireless access technologies such as W-LAN IEEE 802.11, and Bluetooth.

3.3.2.1 Ethernet

The Ethernet standard is specified in the IEEE 802.3 standard. An Ethernet LAN typically uses coaxial cable or special grades of twisted pair wires. Ethernet is also used in wireless LANs. Ethernet uses the CSMA/CD access method to handle simultaneous demands. The most commonly installed Ethernet systems are called 10BASE-T and provide transmission speeds up to 10 Mbps. Devices are connected to the cable and compete for access using a *Carrier Sense Multiple Access with Collision Detection (CSMA/CD)* protocol. CSMA/CD enables devices to detect a collision when using data channel simultaneously. After detecting a collision, a device waits a random delay time and then attempts to re-transmit the message. If the device detects a collision again, it waits twice as long to try to re-transmit the message. Fast Ethernet or 100BASE-T provides transmission speeds up to 100 megabits per second and is typically used for LAN backbone systems, supporting workstations with 10BASE-T cards. Gigabit Ethernet provides an even higher level of backbone support at 1000 megabits per second.

Ethernet devices make use of a broad range of cable and connector specifications. Ethernet can use *Unshielded Twisted Pair (UTP)* copper cables and optical fiber to interconnect network devices via intermediary devices such as hubs and switches. Ethernet is currently the standard for wired communication in different fields. Haydn [115] showed that it is characterized by interesting features such as good communication performance, scalability, high availability, and resistance to external noise. However, Ethernet cabling is considered a burden for aircraft design because these cables impose more constraints on free spacedesign needed for cable routing, and reconfiguration of cabin layout becomes more difficult with larger number of cables.

3.3.2.2 WiFi

WiFi is used to connect devices together in one of two network configurations; *ad-hoc* and *infrastructure*. In an ad-hoc mode, wireless nodes communicate

with each other directly, without the need for any intermediary or central control. This means that when one WiFi node comes within range of another, a direct communication channel can be set up between them and allowing additional devices to join the network. In infrastructure mode, wireless nodes communicate with each other via a wireless *Access Point (AP)* which also acts as a connector between a wired network and the wireless network. The access point is effectively a base station that controls the communication between the other nodes.

A WiFi node determines whether it is in range of an AP by transmitting an enquiry and waiting for a response. If more than one AP responds, the station will choose to communicate with the one that has the strongest signal. Each node is uniquely identified by a MAC address. Every message data frame sent must contain the MAC address of the source, destination and access point, as well as other management data that enables the frames to be correctly sequenced and errors to be detected. It is based on the 802.11 standard; different version of this standard are presented in table 3.1

The 802.11 standard specifies a common *Medium Access Control (MAC) Layer*, which provides a variety of functions that support the operation of 802.11-based wireless LANs. In general, the MAC Layer manages and maintains communications between 802.11 nodes (radio network cards and access points) by coordinating access to a shared radio channel and utilizing protocols that enhance communications over a wireless medium. The 802.11 MAC Layer uses an 802.11 *Physical (PHY) Layer*, such as 802.11b or 802.11a, to perform the tasks of carrier sensing, transmission, and receiving of 802.11 frames. Before transmitting frames, a node must first gain access to the medium, which is a radio channel that nodes share. The 802.11 standard defines two forms of medium access, *Distributed Coordination Function (DCF)* and *Point Coordination Function (PCF)*. DCF is mandatory and based on the *Carrier Sense Multiple Access with Collision Avoidance (CSMA/CA)* protocol. With DCF, 802.11 nodes contend for access and attempt to send frames when there is no

3.3. CASE STUDY: BUILDING A HETEROGENEOUS NETWORK

Versions	characteristics
802.11	applies to wireless LANs and provides 1 or 2 Mbps transmission in the 2.4 GHz band
802.11a	an extension to 802.11 that applies to wireless LANs and provides up to 54 Mbps in the 5GHz band
802.11b	an extension to 802.11 that applies to wireless LANs and provides 11 Mbps transmission in the 2.4 GHz band
802.11d	Enhancement to 802.11a and 802.11b that allows for global roaming
802.11e	Enhancement to 802.11 that includes quality of service (QoS) features
802.11g	offers wireless transmission over relatively short distances at 20 - 54 Mbps in the 2.4 GHz band.
802.11n	builds upon previous 802.11 standards by adding MIMO (multiple-input multiple-output). IEEE 802.11n offers high throughput wireless transmission at 100Mbps - 200 Mbps

Table 3.1: 802.11 standard

other node transmitting. If another node is sending a frame, nodes are polite and wait until the channel is free.

There is no standard limit that defines the upper limit on the number of nodes that can join a network, though some particular equipment manufacturers may specify a limit. However, as the number of communicating nodes increases, the channel capacity available for each node decreases. A point will eventually be reached when the network becomes too congested to provide an adequate service.

WiFi are used in different commercial, industrial, and home devices, and can easily coexist with other technologies to form a heterogeneous network [109]. For example, Jim [116] stated that WiFi and Bluetooth technologies are two complementary not competing technologies. They can cooperate together to provide users with different connecting services.

3.3.2.3 Wireless USB

Wireless USB (WUSB) follows similar architecture as wired *Universal Serial Bus (USB)*, but *Ultra Wide Band (UWB)* radio is placed in place of wired connectivity medium. This enables almost seamless migration of USB applications over WUSB. WUSB provides adaptation to UWB through *Protocol Adaptation Layer (PAL)*. Figure 3.6 shows the WUSB protocol with UWB radio platform.

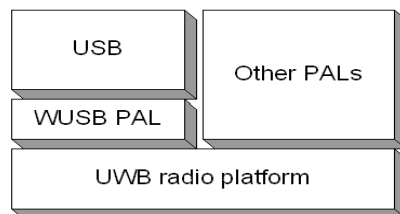

Figure 3.6: UWB platform with WUSB

Ultra Wide Band (UWB), short-range radio technology, complements other longer range radio technologies such as WiFi, and cellular wide area communications. UWB's combination of broader spectrum and lower power improves speed and reduces interference with other wireless spectra. It is used to relay data from a host device to other devices in the immediate area (up to 10 meters, or 30 feet). UWB radio transmissions can legally operate in the range from 3.1 GHz up to 10.6 GHz, at a limited transmission power. Consequently, UWB provides dramatic channel capacity at short range that limits interference.

Universal Serial Bus (USB) is the de facto standard in the personal computing industry. It allows different peripherals to be connected to the same PC more easily and efficiently than other technologies such as serial and parallel ports. However, cables are still needed to connect the devices. This raised the issue of *Wireless Universal Serial Bus (WUSB)* where devices can have the same connectivity through a wireless technology.

USB is based on centralized bus architecture, with host acting as master and device as slave entity. Host and devices are electrically connected to each

other. Similar to USB, WUSB is also classified in WUSB host and WUSB device. WUSB devices can be quickly connected to WUSB host, configured, used, and disconnected. The WUSB host and connected devices are called WUSB cluster. More than one cluster can coexist in overlapping spatial environment when using different channels. Thus, architectural changes due to evolving from USB to WUSB are minimal, so USB applications can seamlessly work on WUSB

Neal [117] stated that although it is difficult to achieve a wireless performance similar to wired USB, but the rapid improvements in radio communication can make WUSB a competitive rival. Although WUSB was designed to satisfy client needs, but it can also be used in a data centre environment. He discussed how WUSB characteristics can match such environment. This application can be of a great help in IFE systems, which strive to massive data communication to support multimedia services and minimizing the connection cables. Moreover, Jong [118] discussed the design issues related to WUSB. He stated that WUSB can support up to 480Mbps, but in real world it does not give the promised values; and he showed the effect of design parameters on the device performance.

3.3.2.4 Power Line Communication

In the *Power Line Communication (PLC)* communication systems, the powerline is not only used for energy transmission, but also is used as a medium for data communication. Powerline networking is an emerging home networking technology that allows the end-users or consumers to use their already existing electrical wiring systems to connect home appliances to each other and to the Internet. Home networks utilizing the high-speed powerline networking technology are able to control anything which plugs into the AC outlet This includes lights, television, thermostats, and alarms. To support data transmission over the power grid, a PLC modem is installed into the household power socket. It handles the up and down streams between the telecommunication

network and the powerline grid.

The commonly used technology for high speed LANs and data distribution is Ethernet. Classical non-optical Ethernet requires cables comprising several copper pairs, possibly additional shielding, and appropriate connectors. Cables and connectors must be mechanically robust to meet cabin environmental requirements. Regarding an onboard IFE network, an entire cabin seat-to-seat Ethernet installation may add significant weight, which can be avoided with a PLC-based system. Wiring complexity is an important issue since airline operations require frequent changes of cabin seat lay-out. A simple cabin seat wiring is therefore certainly advantageous.

A *Power Line Communication (PLC)* network can be used to convey data signals over cables dedicated to carry electrical power; where PLC modems are used to convert data from digital signal level to high power level; and vice versa. Using an existing wiring infrastructure can dramatically reduce costs and effort for setting up a communication network. Moreover, it can decrease the time needed for reconfiguring the cabin layout since less cables are going to be relocated.

However, such technology suffers from different problems. A power line cable works as an antenna that can produce *Electromagnetic Emission (EME)*. Thus, the PLC device must be *Electromagnetic Compatible (EMC)* to the surrounding environment. This means that it must not produce intolerable EME, and not to be susceptible to them. To overcome this problem, the transmission power should not be high in order not to disturb other communicating devices [89]. However, working on a limited power signal makes the system sensitive for external noise. In spite of this, the PLC devices can work without concerns of external interference due to two reasons. Firstly, the PLC is divided into segments; this minimizes signal attenuation. Secondly, all the cabin devices are designed according to strict rules that prevent EME high enough to interfere with the surrounding devices.

Yet, current design and implementation of electrical network inside the

cabin does not consider the usage of PLC networks in terms of cable routing and PLC segment distribution. Design companies have to consider these points in their future designs.

3.3.3 Evaluation of proposed technologies

IFE system is a field starving for unusual ideas. Passengers can be satisfied by receiving services dedicated to a single user, but it will be more interesting if they can be offered services for multiple users, where passengers of similar interests can share their time. Using a single communication technology inside the cabin can not yield satisfactory results, but a combination of different technologies can have a great impact on the provided services.

We mean by heterogeneity, the existence of different networking technologies cooperating together to achieve certain services. The network can be divided into *User Technology* and *System Technology*. A *User Technology* is the technology apparent and directly used by the user (i.e., Bluetooth, WiFi, etc...) to connect his devices to the system. A *System Technology* is the technology used by the system and is hidden from the user (i.e., PLC).

3.3.3.1 PLC

In this section, we introduce some experimentation results to show the applicability of using PLCs for a cabin IFE system. As shown in Figure 3.16, the PLC system consists of a *Power Line Head Box (PLHB)* and a *Power Line Box (PLB)*. The PLHB connects the two terminals of the power line to connect the data server with the seats. Each PLHB serves a group of seats, which are equipped with a PLB per seat. The PLB is responsible for distributing the signal received by the PLHB to the seat SEB. Each PLHB can support up to 20 PLBs at a rate of 3480 bit/sec. Both PLHB and PLB devices can be configured through their internal web interface to define their IP address and other configuration parameters.

The MGEN (version 4.2) [119] traffic generator was used to emulate the traffic produced by the data server, and a laptop was used as a substitute to the SEBs. The target of the test was to collect different statistics to study the behavior of the PLC system by injecting periodic traffic flows at constant intervals.

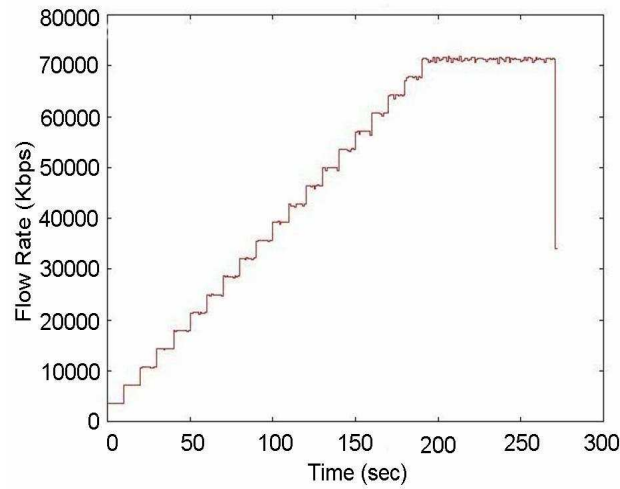

Figure 3.7: Flow rate of all flows

Figure 3.7 shows the sum of flows rates. The constant stepping of flow rate indicates that the PLC connection is able to carry the 20 flows. In addition, Figure 3.8 represents the packet count of the first flow. It is clear that the packet count stayed constant from the start to the end of the simulation without being affected by the injection of the subsequent flows. This emphasizes the same results derived from Figure 3.7

However, it is normal to have packet dropping during transmission; this is illustrated in Figure 3.9 showing the obtained loss fraction. It is less than 0.05, which can be considered as a good value. Such configuration can provide the IFE with a way to provide video services by using the existing power cabling.

3.3. CASE STUDY: BUILDING A HETEROGENEOUS NETWORK

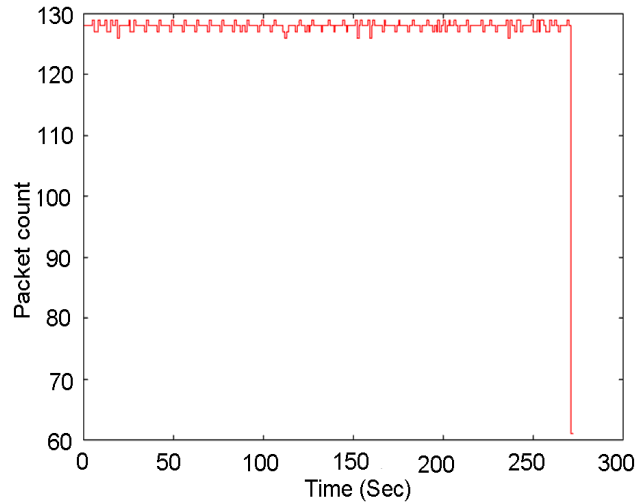

Figure 3.8: Packet count of the first flow

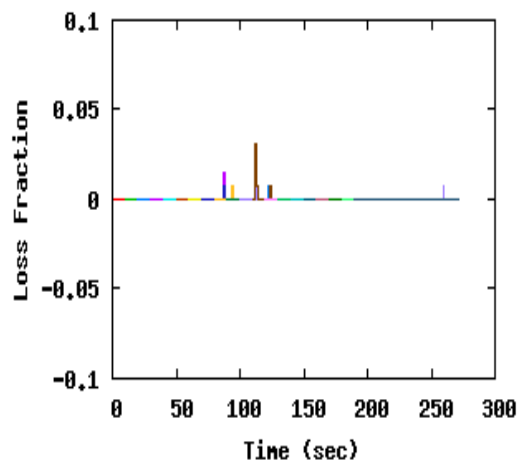

Figure 3.9: Loss Fraction

3.3.3.2 WiFi

We held different NS2 [120] simulations to propose a good distribution for the wireless *Access Point (AP)* inside the cabin. The objectives of this simulation is to verify the importance of using channel separation and transmission power

control in solving problems of dense wireless networks, and to identify the procedure to find the minimum possible number of APs.

We used the same cabin configuration used by Alexandaros [121]. The cabin consists of 26 rows with 6 seats each (3 on each side of the aisle); this gives a total of 156 seats. The cabin is 21m long and 3.54m wide. The rows separation distance is 81cm.

A wireless node - representing a passenger's device - is located at the position of each seat, and APs are used to connect them with the data server. Using large number of wireless devices in a very narrow metallic tunnel like the cabin has a dramatic effect on network performance. For this reason, we are studying the effect of using frequency separation between APs. However, we need to determine the minimum number of APs required to cover the whole cabin, and their distribution inside the cabin, so we experimented with three scenarios. In scenario 'A', all nodes (each has a transmission range covering the whole cabin) are using the same communication channel. Scenario 'B' uses nodes with short transmission range, which allows connection only to the nearest AP, while using the same channel. Scenario 'C' shows nodes with short transmission range and using channel separation. The channel separation in the third scenario is based on the fact that 802.11 only allows the usage of three non interfering channels (i.e., channels 1, 6, and 11). The impact of the three scenarios over average throughput, average delay, and number of transmitted packets is studied.

Each scenario was repeated several times while using different numbers of Aps located at the aisle. We started by using one AP and the number is incremented until we reached the maximum number of APs, which was determined according to the cabin dimensions. The AP transmission power was adjusted to minimize the transmission range, so the signal can travel a distance just enough to reach the seat beside the window in order to minimize the effect of its reflection. This allowed us to use a maximum number of 5 APs (Figure 3.10).

3.3. CASE STUDY: BUILDING A HETEROGENEOUS NETWORK

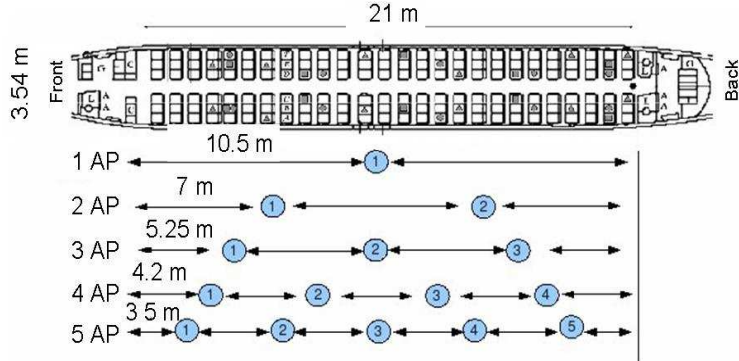

Figure 3.10: APs distribution

Number of APs	Transmission range (meters)	Rx threshold
1	10.5	8.97474e-9
2	5.25	3.58989e-8
3	3.5	8.07726e-8
4	2.625	1.43596e-7
5	2.1	2.24368e-7

Table 3.2: Rx threshold values

For all scenarios, the nodes (156 node + APs) were configured to have a large queue that can hold up to 1000 packets in order to prevent packet dropping. The transmission power was adjusted to 10mW as the minimum value defined in the 802.11 standard. In scenarios that use different channels, Channels 1, 6, and 11 were adjusted to their frequencies 2.412e9 GHz, 2.437e9 GHz, and 2.462e9 GHz respectively. The Rx threshold was determined according to the required transmission range. It was calculated by the "Threshold" tool, which is provided as a separate program with the NS2 simulator. Table 3.2 shows the values used with each number of APs. For each simulation, the APs were distributed evenly throughout the aisle to provide a full coverage for the cabin.

When comparing the three scenarios A, B, and C, we can find that using

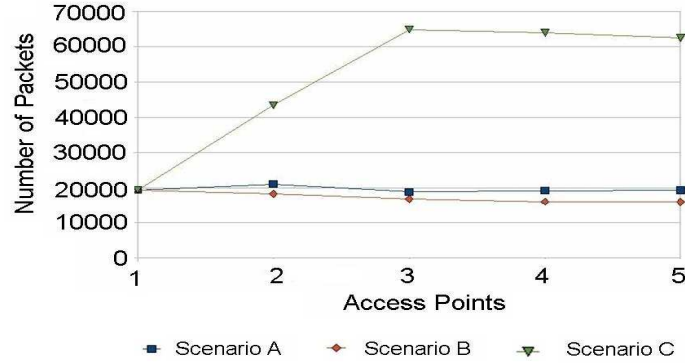

Figure 3.11: Packets sent by the transmitter

just different number of APs does not have a great impact on network performance, but when accompanied with channel separation the network performance is drastically enhanced. Figure 3.11, Figure 3.12, and Figure 3.13 combine the results of scenarios A, B, and C. It is noticeable that there is no great difference between scenario A and B; this is due to the existence of large number of nodes in a small area. In addition, there are many nodes in the shared zone between every two APs. In this zone, nodes are able to detect two APs, but they select just one of them. In other words, on the physical level signals are interfering, while on the logical level only one AP is seen. However, as the number of APs increase, the difference between scenario A and B starts to increase slightly; this is because the number of nodes in the shared zone becomes less, so the interference decreases. On the contrary, when using channel separation (i.e., scenario C) performance was drastically enhanced after using 3 APs.

It is worthy to note that the number of nodes assigned to each AP affects its performance; the fewer nodes we use, the higher performance we get. When using 1, 2, 3, 4, and 5 APs, each AP will have 156, 78, 52, 39, and 32 nodes respectively. However, the difference in the number of assigned nodes with 3, 4, and 5 APs is small. This justifies the reason for saturation after using more

3.3. CASE STUDY: BUILDING A HETEROGENEOUS NETWORK

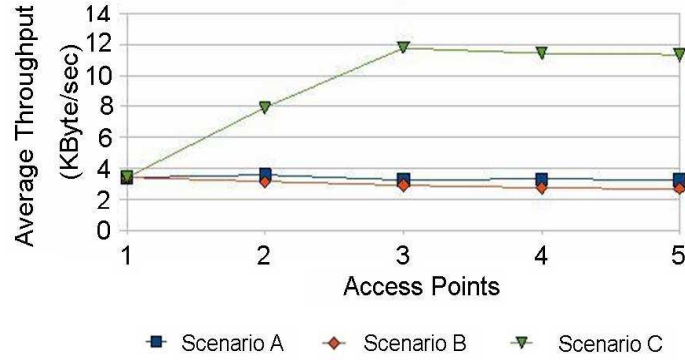

Figure 3.12: Average Throughput

than 3 APs; where APs almost handle the same amount of nodes.

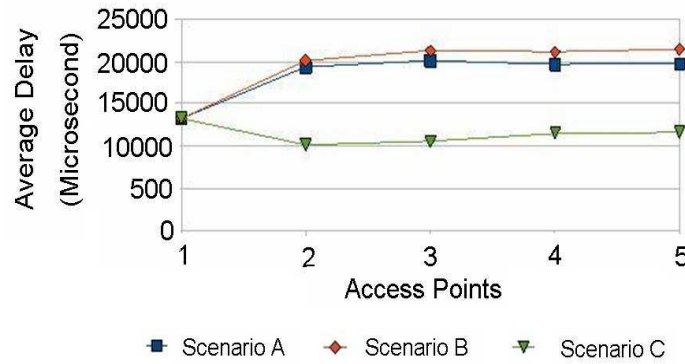

Figure 3.13: Average Delay

To sum up, interference between large number of wireless nodes can be minimized through using channel separation and controlled transmission power. Consequently, this can solve communication problems in a high density wireless environment

3.3.3.3 WUSB

Using WUSB to connect passenger’s devices seems to be an appealing solution since it does not require any additional adapters or connectors, and avoids interference with other wireless technologies (i.e., WiFi, Bluetooth, etc...) by using different bandwidth.

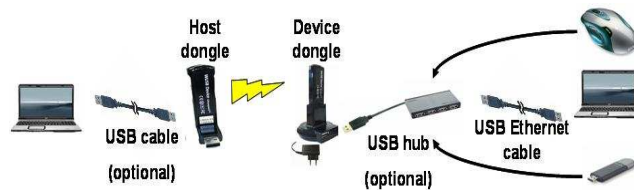

Figure 3.14: WUSB test-bed

Figure 3.14 shows our WUSB experimentations test-bed. WUSB Host and Device dongles were used to connect USB devices. The Host dongle is connected to the computer USB port, while the Device dongle connects the USB devices. The dongles driver allows changing of transmission power as well as transmission channel.

1. ***Connecting different USB devices:*** The objective of this test is to find the best way to connect multiple USB devices through WUSB dongles. Connecting multiple USB devices (i.e., mouse, and keyboard) was done in two different ways; firstly by using two Device dongles for each USB device, secondly by using a USB hub. The results of the first approach were not satisfactory because the two dongles were using the same channel causing interference between them. The Host dongle has the ability to choose between seven different channels. In other words, it is possible to use seven Hosts at the same transmission range without any interference between them. However, the channels are only allowed to be changed manually, and this is not allowed in the cabin environment. The second approach gave better performance. Moreover, a hub is much more economical than using a WUSB dongle dedicated for each device.

3.3. CASE STUDY: BUILDING A HETEROGENEOUS NETWORK

	Elapsed time	Delay ratio
WUSB	915secs	$((344/915) * 100) - 100 = 62.4\%$
Wired USB	344secs	

Table 3.3: WUSB vs Wired USB

2. ***File transfer:*** The objective of this test is to find the difference in performance between WUSB and Wired USB. It is important to know if WUSB is able to transfer large files, and to what extent it is comparable to wired USB, so 4064 files of size 892MB were transferred to a flash USB storage device using WUSB and wired USB. The results shown in Table 3.3 indicate that WUSB is slower by almost 60% than wired USB.
3. ***Transmission range with different power levels:*** The objective of this test is to find the transmission range capabilities of WUSB devices. The test started by putting the Host dongle and the Device dongle on the same line of sight; then the device dongle is moved away until it is disconnected. The same procedure was repeated while using two Device dongles. The two dongles are placed at the same horizontal level with a separation of few centimeters, and are moved together. The whole experiment was repeated while changing the dongles transmission power level (i.e., low, normal, and strong).

As shown in Table 3.4, the existence of two dongles at the same area, and working at the same channel has a dramatic effect on transmission range, so when considering that the distances between seats inside the cabin is considerably short when compared with the minimum transmission range, then it is highly recommended to use different channels for neighboring dongles.

Figure 3.15 shows the difference between the above transmission ranges with respect to seat spacing in the cabin model we are using. Since the seat distance is relatively short when compared with the transmission range; then

CHAPTER 3. ON THE DESIGN OF HETEROGENEOUS DENSE WIRELESS NETWORK

Transmission power	Max achieved distance in meters between Tx and Rxs	
	Single device	Dual device
Low	7	4.2
Normal	12	6.3
Strong	16	8.4

Table 3.4: Transmission range

it is highly recommended to use different channels for neighboring dongles.

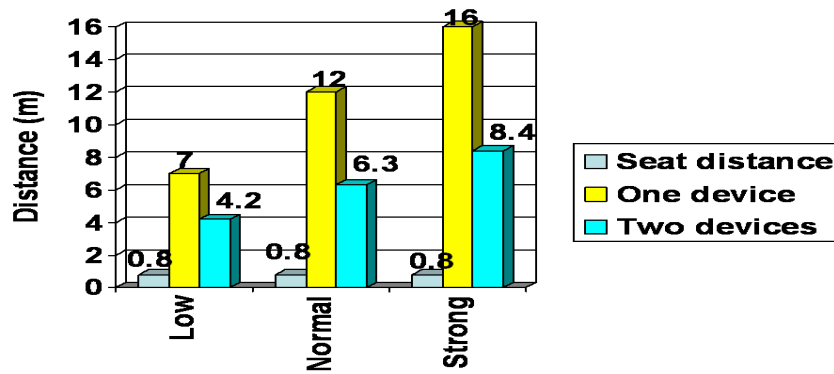

Figure 3.15: WUSB range Vs seat spacing

3.3.3.4 WUSB vs Wifi

Both WiFi and WUSB can provide wireless connectivity. However, each of them has its own characteristics (Table 3.5) that need to be studied and find out its applicability inside the cabine and what applications it can serve.

Specification	WUSB (ver1.1)	WiFi (802.11n)
Frequency Band	3.1 GHz/10.6 GHz	2.4 GHz/5 GHz
Bandwidth	53 - 480 Mbit/s	Max. 600 Mbit/s
Distance	3 - 10 m	100 m

Table 3.5: WUSB vs WiFi

3.3. CASE STUDY: BUILDING A HETEROGENEOUS NETWORK

WUSB utilizes the UWB technology. UWB is a new legalized frequency spectrum, which uses frequencies from 3.1 GHz to 10.6 GHz; a band more than 7 GHz wide. Each radio channel can have a bandwidth of more than 500 MHz, depending on its center frequency. To allow for such a large signal bandwidth, there are severe broadcast power restrictions. By doing so, UWB devices can make use of an extremely wide frequency band while not emitting enough energy to be noticed by narrower band devices nearby, such as 802.11a/b/g radios. This sharing of spectrum allows devices to obtain very high data throughput, but they must be within close proximity.

In terms of energy consumption, WiFi consumes more power to cover a larger area than WUSB which is designed to cover less area with low transmission power. UWB's low power requirements make it feasible to develop cost-effective CMOS implementations of UWB radios. With the characteristics of low power, low cost, and very high data rates at limited range, UWB is positioned to address the market for a high-speed WPAN.

In terms of distance, WUSB supports short distances (between 3 to 10 m) which is suitable for *Wireless Personal Networks (WPAN)*; WiFi can provide a larger distance up to 100 m, which makes it more feasible for *Wireless Local Area Network (WLAN)*. For an aircraft cabin of small area and large number of obstacles, using wireless devices of large transmission range can increase interference especially when we consider the larger number of IFE terminals, so WUSB can produce less interference than WiFi in such environment.

In terms of security, WiFi is a well known commercial technology that exists in almost all personal wireless devices. However, WUSB is a new technology that uses a different frequency spectrum, so more system security can be achieved when using WUSB rather than WiFi, because both intentional and non-intentional intrusion can be minimized.

3.3.4 The proposed architecture

In our proposed heterogeneous architecture (see Figure 3.16) are integrated together so that each of them solves a part of the networking problem. The objective of this architecture is to minimize wiring complexity while maintaining the same connectivity, performance, and allowing IFE system to enhance its services.

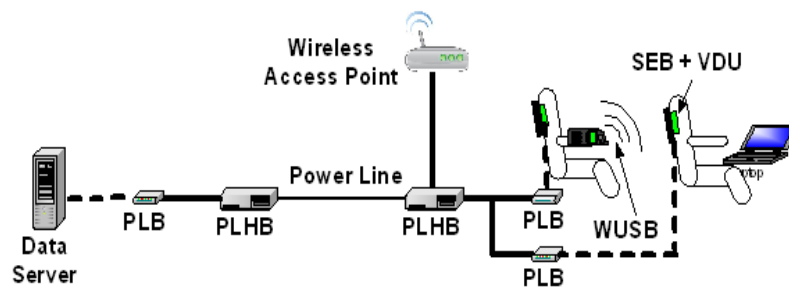

Figure 3.16: Heterogeneous network architecture

PLC system is proposed as the network backbone to convey data between a data server and the passenger's seat where he uses his PEDs. The evaluation results of using a PLC network showed that it is able to convey multimedia contents with up to 20 seats per PLC segment. This allows us to use the existing electrical network for data communication, so that no data dedicated cables need to be extended between seats and data server. All these features make PLC an appealing solution as part of the IFE system.

USB technology becomes a part of modern personal devices where it can provide an easy way to connect to other devices. WUSB can be used as an alternative to give USB devices wireless capabilities. Our experimentations showed that WUSB can be used to transfer simple data flows because its performance is much less than wired USB. However, using it will help to reduce traditional USB wiring between seats. It is enough to have the WUSB dongle

in the armrest and the other dongle to be the network backbone. This configuration (PLC and WUSB) was successfully implemented in Airbus-Hamburg site during the E-CAB [123] project.

Furthermore, controlling the transmission range and channels of wireless Access Points can help us to use them inside the cabin. the Access Points are connected to the PLC backbone, so that wireless devices can be connected to the system. However, good performance is not guaranteed for such high dense network, so passengers should expect to only have a best effort service.

The combination between these three technologies provides us with a heterogeneous architecture that can solve many of current problems such as the burden of using a dedicated communication network, connecting personal devices to the IFE system, and interface compatibility by using WUSB to connect USB devices.

3.4 Conclusion

In this chapter, we showed the effect of network density over its performance and how it is usually calculated in the literature. Generally, network density is usually measured according to the number of neighboring nodes, which we believe that it is not enough. So, we proposed the *Effective Density* metric. It considers both of the population surrounding the node and its performance. Encompassing throughput as a performance measure allows us to consider the effect of neighbors within the node transmission range. The metric feasibility was verified by using real experimental results from the CRAWDDAD data set.

An IFE system has a very special environment. The metallic tunnel structure of the cabin, the various obstacles (i.e., seats) within it, and safety constraints impose many difficulties on wireless communication inside the cabin. In such environment, *Effective Density* can be a measure to show the effect of additional wireless nodes over network performance. As a solution for such dense network, we proposed a heterogeneous networking architecture that uti-

CHAPTER 3. ON THE DESIGN OF HETEROGENEOUS DENSE WIRELESS NETWORK

lizes different technologies which are capable of working together as an integrated solution to overcome existing communication challenges.

3.4. CONCLUSION

Chapter 4

Self-organization and IFE systems

Contents

- 4.1 Introduction 80**
- 4.2 Self-organization 80**
 - 4.2.1 Self-organization Vs Self-configuration 81
 - 4.2.2 The need for self-organization 83
- 4.3 Case study: A device identification protocol 84**
 - 4.3.1 Smart Antennas 84
 - 4.3.2 Design of the proposed protocol 87
 - 4.3.3 Protocol modeling 100
 - 4.3.4 Protocol behavior and performance evaluation 104
- 4.4 Conclusion 110**

4.1 Introduction

In recent years, market surveys have revealed a surprising and growing trend in the importance of *In-Flight Entertainment (IFE)* with regard to choice of airline. With modern long range aircraft the need for "stop-over" has been reduced, so the duration of flights has also been increased. Air flights, especially long distance, may expose passengers to discomfort and even stress. IFE can provide stress reduction entertainment services to the passenger. The IFE system is an approach that can utilize the wireless technology for the purpose of exchanging data -in both directions- between passengers and the entertainment system. It can be also used to improve the passenger's service satisfaction level. When wireless technology is introduced to IFE systems, self-organization can provide solutions for many existing problems.

In this chapter, we present the importance of the self-organization concept and how it differs from self-configuration. Then we introduce a case study to present our proposed protocol that uses the capabilities of smart antennas to provide the PCU and VDU with self-organization capabilities.

4.2 Self-organized networks

Wireless Sensor Network (WSN) and ad-hoc networks have their own characteristics that differentiate them from other types of wireless networks. These differences raise new challenges to be overcome; one of them is self-organization. As in any rising domain, it is essential to specifically define the meaning of new terminologies. The terms self-organizing and self-configuring are an example of such terms that may have overlapping meaning. For example, in order not to degrade passenger satisfaction, any failing device must be fixed or replaced instantaneously. The crew members do not have the technical

background to install a failing device since it is beyond their assigned tasks. In other words, when a device fails the crew member has to replace it without performing any configuration; the device should identify itself and join the system.

In this section, we try to make a definition for both terms to determine their role, and stress on the differences between them. Consequently, we try to show the importance of self-organization in enhancing sensor network performance, and efficient usage of its resources.

4.2.1 Self-organization Vs Self-configuration

Self-organization is not a man made concept. Mills [12] showed that it is a natural phenomenon that exists in different natural systems. Most of artificial self-organization techniques were inspired from natural ones. For example, some anti-virus programming concepts were derived from the natural immune system. Natural systems are full of self-organizing mechanisms and concepts that can solve different WSN issues.

The terms self-organization and self-configuration are used interchangeably in the domain to express changes in the current network status to cope with certain environmental change or to enhance network and/or node performance [124], but the term self-organization is used more frequently. However, some contributions considered a difference between the two terms [125] to emphasize certain ideas, but there is still a need for a general definition to precisely specify the differences between the two terms. In this section, we will try to highlight the differences and propose a clear definition for both of them, so that they can be used unambiguously.

According to Merriam-Webster dictionary [13], “*Organization*” is derived from the verb “*Organize*”. It has different meanings; those we may be interested in are as follows:

- *To form into a coherent unity or functioning whole.*

4.2. SELF-ORGANIZATION

- *To set up an administrative structure.*
- *To persuade to associate in an organization.*
- *To arrange by systematic planning and united effort.*
- *To arrange elements into a whole of interdependent parts.*

From the above meanings we can deduce that the verb “*Organize*” means to arrange different independent entities into a single unity to cooperate together for performing a certain task. Applying the same meaning on the Wireless networking domain, we can define *Self-organization* as “*the changes that the node does in its behaviour to cooperate with its neighbours in the network to perform a certain task or achieve a certain goal*”.

On the other hand, “*Configure*” was defined as “*to set up for operation especially in a particular way*” [13]. Applying the same meaning on WSN domain, we can define *Self-configuration* as “*the changes that the node makes in its parameters to perform certain task*”.

To sum up, we can say that a node may perform self-configuration actions to achieve self-organization that helps the node to have certain behaviour. For example, if there is an environmental change that causes frames to collide frequently, then each node must be self-organized to overcome this problem in order to minimize power losses. To achieve this behaviour, the node starts to configure its MAC protocol to control the number of sent frames. In this case, we can say that self-configuration had lead to self-organization.

In other situations, self-organization can be achieved without self-configuration. If we considered the case when a node detects a weakness in the received signal due to moving in a certain direction, then it starts to change its direction to keep the signal. This happens without setting up any internal changes, so its behaviour (i.e., self-organization) was changed without any change in its internal parameters (i.e., self-configuration). This assumption is greatly dependent on the level of abstraction when considering self-configuring

parameters. In other words, do we consider changes in the values that cause alteration in direction as being changes in configuration or not.

4.2.2 The need for self-organization

A system can be defined as a group of entities that interact together to perform a certain task. The more entities and interactions we have, the more complex is the system. In complex systems, the system parts are usually coupled in a nonlinear fashion; when there is many nonlinearities, the system usually exhibits unpredictable actions. In such situation, individual components should be able to acquire, understand (i.e., process), and react probably with respect to the surrounding changes. In other words, components can perform individual changes that can give the overall system a new behavior or property. Such self-organizing activities can give the complex system more flexibility to respond to unpredicted phenomena, which it may face. However, if the environment changes too rapidly or if modifications are out of tolerance range, then instability may occur to the system.

Self-organizing systems usually show common characteristics such as:

- *Absence of external control*: Each component acts according to its individual decision.
- *Adaptation to changing condition*
- *Complexity*: It is an inherent characteristic due to the complex feature of the system, so that complex processing are usually required to react probably.
- *Dynamic operation*: Self-organization is a dynamic process that allows the system to react continuously to any surrounding changes over time.

4.3 Case study: A device identification protocol for IFE systems

As mentioned before, *In-Flight Entertainment (IFE)* systems are widely spread in modern flights. As forementioned, an IFE system usually consists of a *Seat Electronic Box (SEB)*, the passenger's terminal hardware, plus a *Passenger's Control Unit (PCU)*, the remote control to select the service, and a *Visual Display Unit (VDU)*, the screen. Using the wireless technology in these systems can increase the satisfaction level of both the passengers and the avionics companies. From that, we propose a new protocol, which utilizes the smart antennas technology to allow PCUs to be recognized and configured autonomously without any external intervention.

Section 4.3.1 introduces a brief description of smart antennas and how they can be used with the proposed protocol, which is discussed in section 4.3.2. Finally, the evaluation of the protocol is given in section 4.3.3

4.3.1 Smart Antennas

The traditional omni-directional antennas have a radiation pattern that is donut shaped (see Figure 4.1(b)) with the antenna at the center of the donut. In other words, it radiates radio wave power uniformly in all directions in one plane, with the radiated power decreasing with elevation angle above or below the plane, dropping to zero on the antenna's axis which is described as *doughnut shaped*. Note that this is different from an isotropic antenna, which radiates equal power in all directions and has a *spherical* radiation pattern. This means that with the omnidirectional antenna oriented vertically, the signal coverage is equal in all directions in the horizontal plane (see Figure 4.1(a)). Omnidirectional antennas are widely used for radio broadcasting antennas, and in mobile devices such as cell phones, and wireless computer networks. These antennas are not an effective technique to avoid interference (see Figure 4.1(c)).

On the other hand, a *Smart Antenna* is a multi-element antenna where each

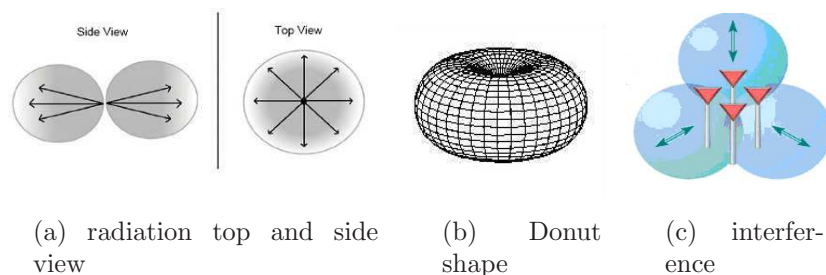

Figure 4.1: Omni antenna

element can be controlled separately, so that the antenna beam can be directed towards a certain direction as well as controlling the transmission power [126] (see figure 4.2). An antenna element is not smart by itself; it is a combination of antenna elements to form an array and the signal processing software used that make smart antennas effective. This shows that smart antennas are more than just the antenna, but rather a complete transceiver concept. This feature is of great importance for ad-hoc networks domain where interference and power saving are two major issues.

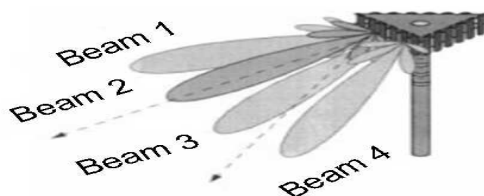

Figure 4.2: Multi-element antenna

Moreover, Okamoto [127] stated that smart antennas can provide the wireless environment with different advantages. First, it can significantly reduce the multi-path fading effect. Second, it minimizes the power consumption required for communication. Third, it can improve the system *Signal-to-Interference Ratio* (SIR). As shown in figure 4.3, when the nodes on route *ABCF* are communicating, other neighboring nodes (i.e., *D* and *G*) can not detect the signal. This minimize the interference problem and save energy of

retransmitted packets due to collision.

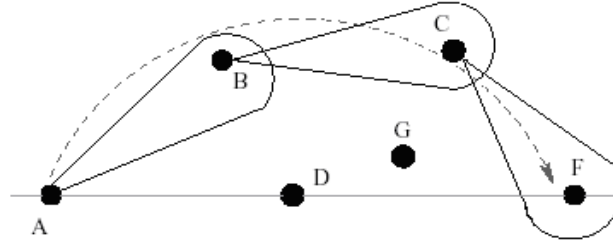

Figure 4.3: Communication using smart antennas

Smart antennas can be used for node localization. Zhuhong [128] mentioned two methods for determining node position, the range-based, and range-free methods. The first depends on the distance and angle information, while the later depends on estimating the location through the information of transmitted packets. He used an antenna with K elements can cover the surrounding region (i.e., 360°), see figure 4.4 . The more elements we have the more accuracy we get; for simplicity he used $k = 6$. Each element is capable of independently send messages in different power level to obtain approximate distance. At first, it starts by minimal power so that the near neighbors within the range will reply, then it increases its power. The process is repeated until it detects all neighboring nodes. Thus, this mechanism provides the distance information between the transmitter and the receiver, and the direction is determined by the segment performing the transmission. Such mechanism provides our proposed protocol with the information necessary to allow each VDU to determine the position of its own PCU.

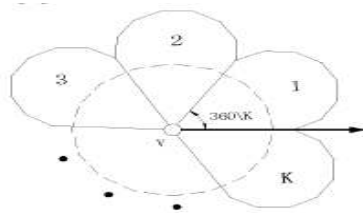

Figure 4.4: Smart antenna with K sectors

With respect to its usage in IFE systems, smart antenna location can be an issue for many arguments. One opinion is to fix the antenna in the seat's arm and to be directed towards the VDU, so the PCU will only act as a keyboard. Although this is an appealing solution, but it decreases the easiness of installation and reconfiguration of seats, and it may require physical changes to the seat arm design. In addition, any changes in the position of the front seat back, or the seat's arm itself (which can change its orientation in some types of seats) can affect the connection. For these reasons we propose to locate the antenna in the PCU itself.

4.3.2 Design of the proposed protocol

For every VDU in the IFE system, there is a dedicated PCU to allow the passenger to choose his selections. Thus, each VDU is surrounded by different number of PCUs. Selecting the appropriate comrade is not an easy task especially if we considered that PCUs are neither predefined nor pre-assigned for any VDU. Nevertheless, using non-configured PCUs makes the system more maintainable with respect to device failure where any failing device can be replaced instantaneously, and automatically recognized by the system. Accordingly, each VDU has to find its own PCU.

The smart antenna technology can provide a significant help in such environment. First, it can overcome the drawbacks of some physical hindrances such as interference, and multipath fading. Second, it can provide the system with the location information between each transmitter and receiver in terms of distance and angle.

This information can be used in the coupling process between VDUs and PCUs; when a VDU is able to know the location information of the surrounding PCUs, it will be possible to select the required partner. However, such process needs a selection mechanism able to differentiate between the targeted and the non-concerned neighboring devices. Accordingly, the proposed protocol can use this information to allow the VDU to select its PCU without being

confused by the large number of surrounding devices. The protocol is able to sense all the devices within range, identify the required device, and finally select it. Moreover, it is able to detect if the required device is out of service or not.

4.3.2.1 General requirements

Depending on the seats layout, each VDU is surrounded by one or more PCUs. When the system is started, these PCUs are not assigned to any VDU, so it is the task of each VDU to find its own PCU. The following problems may occur:

- A situation may exist where more than one PCU exist in the range of the same VDU. In this case, the protocol should be able to use the provided location information (i.e., angle, and distance) to determine the suitable PCU.
- When the link between a VDU and its PCU is broken, the protocol must be able to detect the situation.
- When a failing unit is replaced (either a VDU or a PCU), it must be self-configured to take its role in the network

Figure 4.5 shows a normal seat configuration where each VDU is fixed in its own seat and surrounded by different PCUs. The protocol has three phases, a configuration phase, a normal operation phase, and a re-configuration phase.

- *Configuration Phase:* This phase occurs during the system startup. It is responsible for determining the network topology. Each VDU checks the availability of its PCU and responds with its status.
- *Normal Operation phase:* In this phase, the protocol must be aware of the availability of its assigned PCU.
- *Re-configuration phase:* It occurs when a VDU fails to connect to its PCU or vice versa. After the failing unit had been replaced or re-operated, it should be able to join the network automatically.

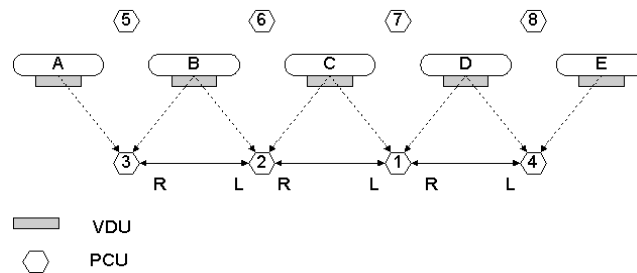

Figure 4.5: VDUs and PCUs distribution

4.3.2.2 Specifications

The protocol should be able to allow each VDU to find its own PCU and provide their connection status. In other words, it is not the protocol's responsibility to transfer data between nodes. Transferring data like audio or video streams can be accomplished by other protocols (i.e., TCP/IP).

The protocol should provide the running applications with information required to take certain actions (i.e., warnings due to a failing PCU). The following is a list of the proposed services:

- *Multiple PCUs awareness:* The protocol should be able to detect multiple PCUs that may exist in the VDU range and select the appropriate one.
- *ID assignment:* The protocol should automatically assign a unique ID to both of the PCU and the VDU so they can communicate with each other.
- *Failure reports:* A failing VDU or PCU should be detected and reported.
- *Self adaptation:* After replacing a failing device, it must be able to join the network automatically.
- *PCU out of range:* when a user moves or directs the PCU away of the VDU, the protocol should be able to identify this situation.

4.3.2.3 Functionality and selection mechanism

When the system is started, the *Configuration Phase* is initiated. The protocol is based on the idea that the required PCU is placed on the right hand side and have the shortest distance to the VDU. Algorithm 1 shows the main steps done by a VDU to detect its PCU. The VDU broadcasts a *QRY_search* request and waits for replies within a predetermined time interval to prevent indefinite wait states, then it creates a list of the surrounding PCUs containing their location information. The next step is to use the angle information to exclude the PCU(s) behind it (since it is only interested in the PCUs at its front side) and starts to handle the other PCU(s) of valid replies. Finally, the selection procedure starts.

Algorithm 1 VDU initialization

Require: startup or search signal**Ensure:** PCU search result

broadcast search request

while WaitPeriod not expired **do**

receive PCU replies

add responding PCU to PCU-List

end while**if** no replies received **then****return** no PCU found**else**

exclude PCUs behind the VDU

CALL selection procedure

return the selected PCU**end if**

Algorithm 2 shows how the selection procedure is implemented. The remaining PCUs are stored in two lists; a list for PCUs in the left zone (i.e., left-list) and another list of PCUs in the right zone (i.e., right-list). Each list is sorted in ascending order according to angle value. The number of PCUs at left and right zones are indicated as L and R , respectively. If $R = 0$, this means that the dedicated PCU is not present within the detection range, so

Algorithm 2 Selection procedure

Require: List of valid PCUs**Ensure:** selection result

create a list of all PCUs in the left zone

create a list of all PCUs in the right zone

arrange the two lists in ascending order according to the angle value

if $L \geq 0$ and $R = 0$ **then**

raise an error

return no PCU found**end if****if** $L = 0$ and $R = 1$ **then**

wait

if PCU is still available **then** **return** right PCU **else** **return** no PCU found **end if****end if****if** $L = 0$ and $R > 1$ **then**

entry-point = 1

CALL select according to angle

return selection result**end if****if** $L \geq 1$ and $R \geq 1$ **then**

wait

entry-point = 2

CALL select according to angle

return selection result**end if**

no PCU is selected and an error is initiated. This is done regardless of the value of L

If $L = 0$ and $R = 1$, then the PCU is selected after a period of time. This period is used to allow the PCU to be selected by another VDU if it belongs to it. In this case, an error is raised because no PCU will be detected.

If $R \geq 1$, then a selection according to angles is initiated. The entry points allow algorithm 3 to determine the actual state at the time it was called.

- *Angle selection:* When we mention the PCU angle we mean the angle that the PCU makes with the *vertical y axis* passing through the middle of the VDU. The angle value is between 0° and 90° for both left and right zones. Algorithm 3 presents how PCU angle can be used in selection.

When the entry point = 1, the values of the first and second right-PCU are assigned to θ_1 and θ_2 , respectively. If $\theta_1 < \theta_2$, then algorithm 4 is called to check the distance.

When the entry point = 2, the left-list enters the comparison. θ_1 is assigned the angle of 1st right-PCU, and θ_2 is assigned the angle of the 1st left-PCU. If there is only one PCU in the right zone and its angle is smaller, then it is selected.

If $\theta_1 > \theta_2$, this means that the PCU at the left side is nearer than the one at the right side; this indicates that the required PCU is not responding, so an error is raised. In either cases, when $\theta_1 = \theta_2$ or $\theta_1 < \theta_2$ with $R > 1$, the selection according to distance is initiated.

- *Distance selection:*

When a selection according to angle fails to find the correct PCU, a selection according to distance is performed. Algorithm 4 checks values of the entry points defined in algorithm 3. It also symbolizes the PCU distance as dx_y , where d means distance; x is equal to r or l to indicate right and left, respectively; y indicates the index of the PCU in the list.

Algorithm 3 Select according to angle

Require: Angles of PCUs, R **Ensure:** selection result

```
if entry-point = 1 then
   $\theta_1$  = angle of 1st right PCU
   $\theta_2$  = angle of 2nd right PCU
  if  $\theta_1 < \theta_2$  then
    return 1st right PCU selected
  else
    entry-point = 3
    CALL select according to distance
    return selection result
  end if
end if
if entry-point = 2 then
   $\theta_1$  = angle of 1st right PCU
   $\theta_2$  = angle of 1st left PCU
  if  $\theta_1 < \theta_2$  then
    if  $R = 1$  then
      return the first PCU in the right-list is selected
    else
      entry-point = 4
      CALL select according to distance
      return selection result
    end if
  end if
  if  $\theta_1 > \theta_2$  then
    raise an error
    return no PCU found
  end if
  if  $\theta_1 = \theta_2$  then
    entry-point = 5
    CALL select according to distance
    return selection result
  end if
end if
```

If the entry point = 3, this indicates that there is no PCUs at the left zone, so the distance of the first two PCUs in the right-list is compared. If they are equal, then the PCU is not able to find the difference in location between the two PCUs, so it asks them to initiate a negotiation session to elect one of them and inform the VDU with the election result. If the 1st PCU distance is shorter than the 2nd PCU, then it is selected since it has the smallest angle and shortest distance.

When the entry point is 4 or 5, the comparison is between PCUs in left and right lists. If $dr_1 < dl_1$, then the required PCU exist in the right-list, so the number of PCUs having the minimum angle and distance in the right-list are counted. If the count = 1, then the 1st PCU in the right-list is selected; otherwise, a negotiation procedure is initiated. If $dr_1 > dl_1$, then no PCU is selected and an error is raised. If $dr_1 = dl_1$, then a negotiation session starts.

- *Negotiation selection*: The negotiation session is shared between the VDU, which initiates the request, and the PCUs that participate in the negotiation. Firstly, the VDU creates a *Negotiation List* for all of the concerned PCUs, it then sends a negotiation message that includes the list to each of the participants, and waits for their reply (see algorithm 5). Each PCU receives the message and tries to find its position with respect to the others; considering that each PCU is already aware of the VDU position.

Algorithm 6 presents the negotiation procedure on the PCU side. When the PCU receives the negotiation list, it tries to retrieve the location information (i.e., angle and distance) of all PCUs in the list. Then, it compares its location and their locations with respect to the VDU position to see if it is the nearest one to the VDU or not. If it detects that it is the nearest PCU, it informs the other PCUs to see if they agree on the result according to their calculations. If they agree, the selected

Algorithm 4 Select according to distance

Require: distance (dr, dl) and angles (θ) of PCUs**Ensure:** selection result

```
if entry-point = 3 then
  if  $dr_1 = dr_2$  then
    CALL start negotiate
    return selection result
  end if
  if  $dr_1 < dr_2$  then
    return select first PCU in right-list
  else
    return no PCU is selected
  end if
end if
if (entry-point = 4) or (entry-point = 5) then
  if  $dr_1 < dl_1$  then
    search for PCU with minimum angle and distance in right-list
    if number of PCUs > 1 then
      CALL start negotiate
      return selection result
    else
      select 1st PCU in right-list
      return selection result
    end if
  end if
  if  $dr_1 > dl_1$  then
    raise an error
    return no PCU is selected
  else
    CALL start negotiate
    return selection result
  end if
end if
```

4.3. CASE STUDY: A DEVICE IDENTIFICATION PROTOCOL

PCU sends its index in the negotiation list to the VDU to indicate itself as the elected PCU. Otherwise, it sends no PCU is selected.

Algorithm 5 start negotiation

Require: PCU right-list

Ensure: negotiation result

 prepare negotiation list

 send negotiation-list to all participating PCUs

 wait for negotiation result

return negotiation result

Algorithm 6 PCU negotiation

Require: negotiation list

Ensure: negotiation result

 receive negotiation list

while not end of list **do**

 CALL retrieve distance and angle information of PCUs in the list

end while

 compare my location with other PCUs

 check if i'm the nearest PCU

 send the comparison results to other PCUs

 wait for their reply

if PCUs agree on selecting me **then**

return my index in the negotiation list

else

return no PCU is selected

end if

4.3.2.4 Use cases

The VDUs and PCUs distribution can have different forms according to the cabin layout; here we present some scenarios and show how the protocol can select the correct PCU or initiate an error signal.

1. *No PCU(s)*: When The VDU does not receive a reply for its search request, it raises an error to indicate that no PCU(s) are within its range, and enters a search state until a PCU is found. (i.e., seat 'A').

2. *Best case:* only one valid PCU is located in its correct position within the VDU range: The VDU sends a *QRY_join* request and the PCU replies with a *QRY_accept* to confirm the assignment (i.e., seat 'B' Figure 4.6).
3. *Two PCUs:* If the VDU received 2 valid replies within the time limit, then this indicates the presence of two PCUs within the range (i.e., seat 'C'). The PCU with the smallest angle with respect to the 'Y' axis is selected. If two PCUs are too close for the system to differentiate the difference in angle, then the PCU with the shortest distance is selected. If the difference in distance can not be determined, then the VDU sends a *QRY_negotiate* request to authorize the PCUs to elect one of them. The negotiation result is returned to the VDU to know its elected PCU. Seat 'D' illustrates the action of excluding PCUs behind the VDU and considering only those in front of it.

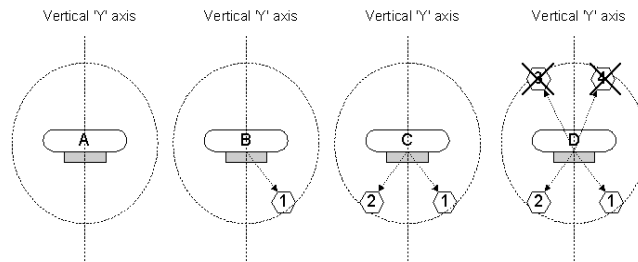

Figure 4.6: Different scenarios for less than three valid PCUs

4. *The worst case is the existence of more than two PCUs:* If the VDU received more than two valid replies, then it starts to sort them in ascending order firstly according to their angle to the 'Y' axis, secondly according to their distance. It is expected that the required PCU has the smallest angle and the shortest distance on the right of the 'Y' axis. There are different scenarios for this situation (see Figure 4.7). Table 4.1 shows how each situation can be handled.

- Seat 'E': PCU1 was selected because it has the smallest angle on the right side of the 'Y' axis.

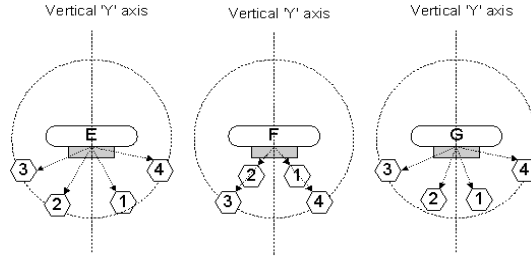

Figure 4.7: More than two PCUs within range

Seat	Situation	Selection according to		
		Angle	Distance	Negotiation
E	Small angle	PCU 1	-	-
F	Same angle	PCU 1&4	PCU 1	-
G	Too close (same angle & distance)	PCU 1&2	PCU 1&2	PCU 1

Table 4.1: Selection criteria

- Seat 'F': PCUs 1&4 are firstly selected since they are at the right side. However, they have equal angles, so their distance is checked. Finally, PCU1 is selected because it has a shorter distance.
 - Seat 'G': PCUs 1&2 were selected according to the angle and distance criteria. They are too close to each other to the extent that the VDU can not differentiate between their angles and distances, so the VDU initiates a negotiation session to elect one of them. During the election process, each PCU can detect the location of each other (i.e., either on the right or the left). After comparing their location with the VDU location, the PCU at the right side of the VDU is selected (i.e., PCU1).
5. *Negotiation*: Figure 4.8 shows different cases of negotiation. For seat "L" PCUs 1&2 are able to communicate with each other and to decide that PCU1 is nearer to the VDU. The same thing happens to seats "M & N". For seat "P", they will notice that PCU2 is the nearest but with

larger distance; this may be due to a failing PCU, so an error is raised.

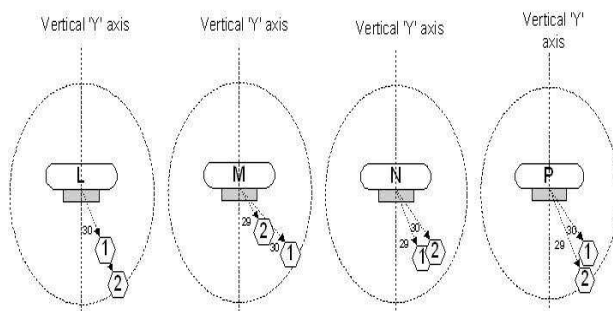

Figure 4.8: Negotiation cases

In fact, the real world is not that simple. If faults exist, then there will be exceptions in the above scenarios. For example, if the correct PCU is not functioning, then a wrong PCU can be chosen. This means that a PCU failure may affect its VDU as well as its neighboring VDU(s). To overcome this situation, the angle of the 1st PCU in the left quarter is always considered (i.e., PCU2). For instance, at seat 'H' (see Figure 4.9), if the angle of the recommended PCU for selection (i.e., PCU4) is greater than the angle of PCU2, this indicates that PCU1 is not working. This is due to the fact that the correct PCU must have the smallest angle and shortest distance to its VDU.

Unfortunately, this scheme does not solve the problem of seat 'I' where the angles and distances of PCU3 and PCU4 are equal, so they will enter a negotiation phase that ends up with electing PCU4 (which is not correct). Therefore, it is mandatory for PCUs to wait before starting negotiation to allow the wrong PCU (i.e., PCU4) to be chosen by its appropriate VDU (i.e., seat 'J'). In this case, seat 'I' can raise an error for not finding its PCU.

For seat 'K', PCU4 angle is equal to PCU2 angle, but with a greater distance, so PCU4 is not the correct PCU. In addition, each VDU has to inform all the PCUs in its range that it had found its comrade. On the other hand, a PCU, which knows that all the surrounding VDUs had found their own PCU will understand that its VDU is not functioning.

4.3.3 Protocol modeling

Fixing bugs in a protocol is an important and often the highest priority activity. Tracking down bugs, in non predefined protocol specifications, is a challenge to many designers. Checking protocol correctness is often done using verification techniques such as "Reachability Analysis" [129], which searches through all reachable states. It is almost impossible to do an exhaustive test, which often requires 100% of the reachable states. Another approach can be used, which is program proof. This requires an automated solution for analyzing and testing the design, so we used TAU version 3.1 [130] to build and verify our UML model. UML language is a formal language ensuring precision, consistency, and clarity in the design that is crucial for mission critical applications. It has a high degree of testability as a result of its formalization for parallelism, interfaces, communication, and time. After identifying the protocol functionality, NS2 simulator was used to apply more scenarios and show the protocol performance.

4.3.3.1 The UML model

The informal techniques used to design communication protocols (i.e., timing diagrams) yield a disturbing number of errors or unexpected and undesirable behavior in most protocols, so we are interested in formal techniques, which

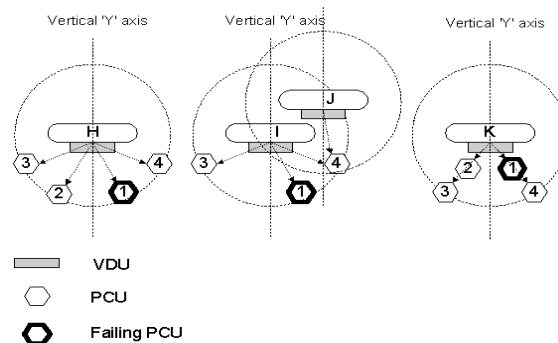

Figure 4.9: Failing PCUs scenarios

are being developed to facilitate design of correct protocols. It is accepted that the key to successfully develop a system is to produce a good system specification and design. This task requires a suitable specification language, satisfying the following needs:

- A well designed set of concepts.
- Unambiguous, clear, and precise specifications.
- A thorough and accurate basis for analyzing the specifications.
- A basis for determining whether or not an implementation conforms to the specifications.
- Computer support for generating applications without the need for the traditional coding phase.

UML language has been defined to meet these demands.

For our protocol, three different layers were modeled, *Upper Layer*, *Protocol Layer*, and *Lower* layers. The *Upper* layer initiates the session by a request to start the search phase and waits for the results; while the *Lower* layer provides the protocol layer with the distance "r" and the angle " θ ". The *Protocol* layer provides the necessary functionality that our protocol needs to work correctly. In addition, a model was used to represent the environment and determines the number of PCUs and their locations with respect to the VDU.

4.3.3.2 The model structure

The protocol model consists of three main classes; *VDU class*, *PCU class* (to represent the behavior of the VDU, and PCU), and the *Network* class (to determine the scenario parameters). Each scenario consists of a VDU, and a set of PCUs of different locations. The *Network* class is responsible for informing the working instances of the VDU and PCU(s) with their locations.

4.3. CASE STUDY: A DEVICE IDENTIFICATION PROTOCOL

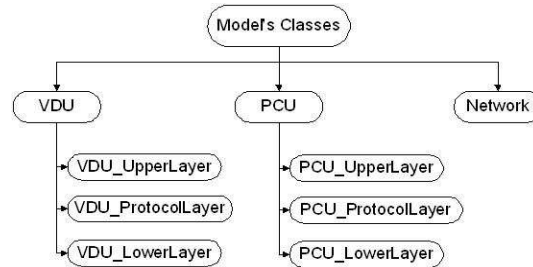

Figure 4.10: Model structure

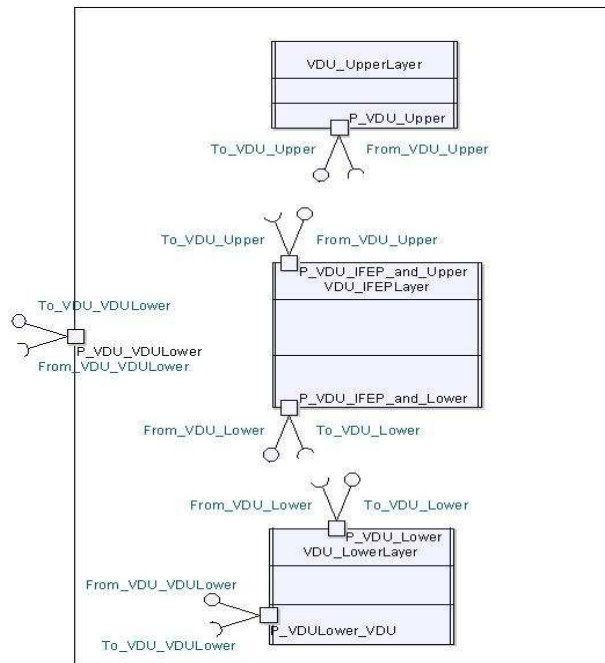

Figure 4.11: VDU Class

Both of the *VDU* and *PCU* classes consist of three internal classes, the *Upper Layer* class, the *Protocol Layer* class, and the *Lower Layer* class (see Figure 4.10). The *Protocol Layer* class represents the core of the protocol, while the other two layers are just assistances to provide the needed services. The connection between these layers and the surrounding environment takes place through the main class (i.e., *VDU* class, *PCU* class). Figure 4.11 represents the *VDU* class as an example of the implemented UML structures. Each internal class has input and output interfaces to communicate to each other.

The lower layer class has interfaces to the containing VDU class to allow it to communicate with external entities.

For example, to start a search request, the request is sent from the *Upper Layer* to the *Protocol Layer* where the correct decision is taken and the required action is determined. Now, the action should be sent to a corresponding instance (i.e., PCU). A signal is sent to the *Lower Layer* then to the containing class, which in turn sends the signal to the corresponding instance. When the corresponding instance receives the signal, the signal reaches the *Protocol Layer* of the instance through the same reversal internal path.

On the other hand, the *Network class* has a different structure since it is not concerned with the protocol's behavior. It determines the VDU and PCU instances, and provides the working instances with their location information in order to simulate the services provided by the smart antennas

4.3.3.3 The model behavior

An example for the model behavior is shown in Figure 4.12. As an initial preparation, the *Network* class sends the location information to the VDU and PCU(s) instances so that each instance knows its own location (signal 1). After the VDU had received its initialization data, its *Upper Layer* sends a search request to its protocol layer (signal 2). The *Protocol Layer* broadcasts this request to the neighboring PCU(s). When the *Protocol Layer* of a PCU instance receives the request, it replies with a signal that shows its presence (signal 3).

The VDU waits until it receives the replies to count the number of available PCUs. If no PCU had replied, then an error message is sent to the upper layer (signal 4). If one or more PCU had replied, then a selection procedure starts. The result of this selection is used to send a "Join" signal to the selected PCU (signal 5) and waits for its "Reply" signal to confirm its joining (signal 6). The confirmation is sent to the upper layer to inform it with the PCU that belongs to the PCU (signal 7).

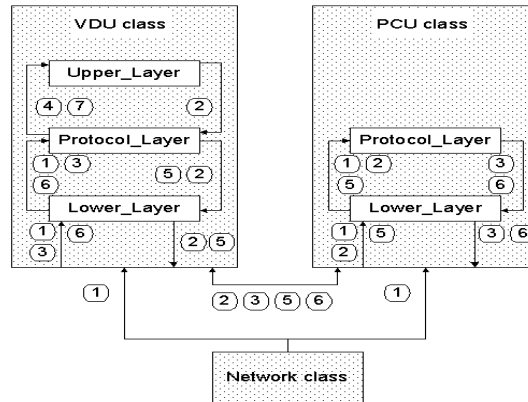

Figure 4.12: Model signals

4.3.4 Protocol behavior and performance evaluation

Obviously, TAU can provide us with a way to verify the correctness of the protocol through limited scenarios. It is difficult to use it to experiment with complicated scenarios, and determine performance issues. NS2 simulator [120] was used as the next step. It is a part of VINT (Virtual INternet Testbed) project [131]. It is an open source simulator that can be used to evaluate different issues for both wired and wireless networks. In the simulation part, we are trying to verify the written code for the NS2 as well as to find out the protocol points of weakness.

A problem that faced us was the unavailability of a smart antenna module embedded in NS2 because the protocol behavior is highly dependent on their presence. However, this was not a great issue because NS2 keeps track of the location of each node in the simulation through the class *MobileNode*. This means that the results of the simulation represents the actual performance of the protocol behavior.

The NS2 simulation is defined by TCL scripts, and C++ codes where the protocol module was implemented in C++ and linked to the TCL script for further configuration. For example, if we used the provided coordinates we will never be able to start a negotiation session, because the VDU will always see that the PCUs are of different angles and distances. In other words, to

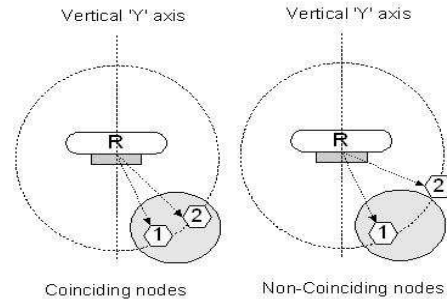

Figure 4.13: Threshold area

implement negotiation scenarios, the VDU must consider the PCUs as if they are coinciding. This was solved by using a *Threshold* variable (changed through the TCL script) through which two PCUs are coinciding if the distance between them is less than the *Threshold* value. The Threshold area is represented by dark circle in Figure 4.13, which represents two coinciding nodes, when they are located within a circle of radius equal to the *Threshold* value, and are considered non-coinciding if the distance between them is greater than the *Threshold*.

4.3.4.1 Use Case verification

In addition to the scenarios mentioned before (i.e., seats "A" to "P"), we implemented two extra scenarios (see Figure 4.14) Seat "Q" represents an error situation (because there is not any PCUs in the right area). Seat "R" represents a normal operation. They are almost like the situations of seat "A" and "B" respectively, but we used them just to prove that the existence of multiple PCUs within the same region does not affect the correctness of selection. Table 4.2 summarizes the types of messages exchanged between VDUs and PCUs instances. They are categorized according to the initiating device. The message sequence depends on the type of situation if it is a normal operation (Figure 4.15) or an error situation (Figure 4.16) or a negotiation operation (Figure 4.17).

4.3. CASE STUDY: A DEVICE IDENTIFICATION PROTOCOL

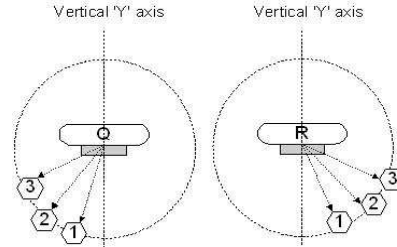

Figure 4.14: NS2 extra scenarios

Source	Message	Meaning
VDU	Search_Request	Starts the search phase
	Search_Join	Accepts its own PCU
	Negotiate	Starts a negotiation session
PCU	Search_Reply	A respond to <i>Search_Request</i>
	Search_Accept	A respond to <i>Search_Join</i>
	Negotiate_Request	Starts negotiation between PCUs
	Negotiate_Accept	Confirms acceptance of <i>Negotiate_Request</i>
	Negotiate_Reply	A respond to Negotiate

Table 4.2: Messages list

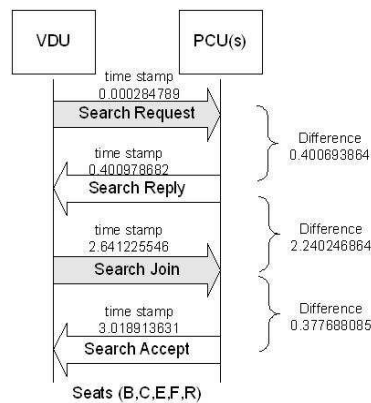

Figure 4.15: Normal operation sequence diagram

4.3.4.2 Performance evaluation

Figure 4.15, Figure 4.16, and Figure 4.17 show timing diagrams for three categories of scenarios, normal operation, error operation, and negotiation oper-

ation respectively. Each message is labeled by its transmission time stamp. When it happens that the same type of message is sent from different transmitters, we choose the time stamp of the latest one (maximum value). For example, when the VDU broadcasts a *Search_Request* message, it receives a *Search_Reply* message from all the neighboring PCUs. In this case, we choose the time stamp of the last received *Search_Reply*. At the right side of the figures, we calculated the time delay between each two successive messages. At the bottom of the figures we indicated the scenarios (i.e., seats), which match each operation.

Figure 4.15 shows the results of normal operation scenarios where the VDU broadcasts the request and the PCU(s) send their replies. The VDU decides, which PCU is the required one and sends a *Join_Request* for the chosen one, which in turn replies with its acceptance. It is obvious that the maximum delay in this operation is the wait period, which the VDU uses to wait for all available PCUs to respond. The delay was set to approximately 2 secs. The value was chosen to be relatively large to show its impact on the protocol performance; considering that the processing time of the requests is trivial when compared to the wait time.

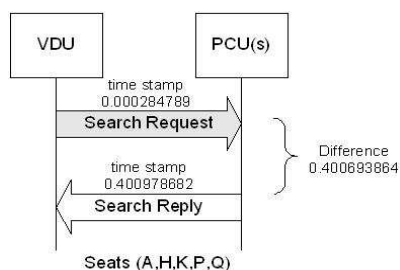

Figure 4.16: Error operation sequence diagram

Figure 4.16 shows the fastest operation, which took place when the required PCU is not detected. After waiting for the delay period (i.e., 2 secs) through which it receives all the *Search_Reply* messages (if any), the VDU raises an internal error to show the failure of finding the PCU.

Figure 4.17 shows the most time consuming operation, which takes place

4.3. CASE STUDY: A DEVICE IDENTIFICATION PROTOCOL

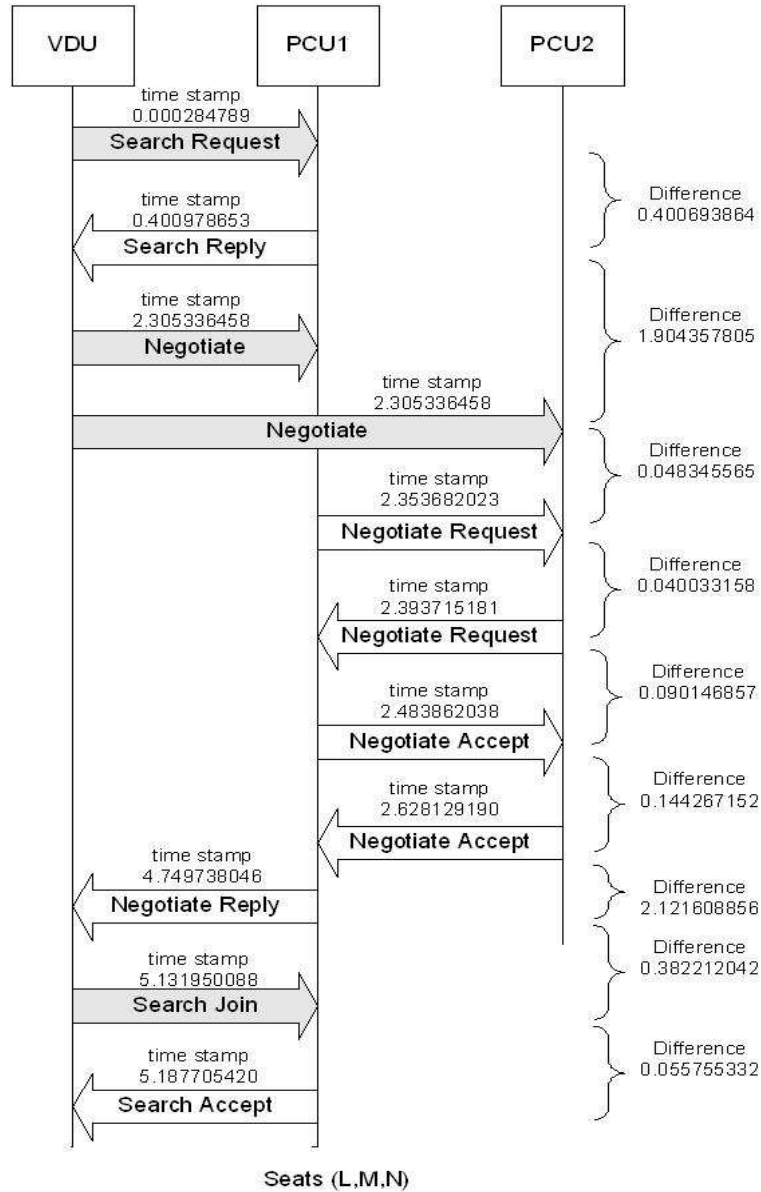

Figure 4.17: Negotiation operation sequence diagram

during negotiation between PCUs to elect one of them. The first part is the same as the start of a normal operation, but when the VDU fails to distinguish the location difference between two PCUs, where one of them is probably the required one, it asks them to start negotiation and elect one of them. The most time consuming parts are the waiting periods (mentioned above), and

the negotiation process between the PCUs. Each of them is about 2 sec.

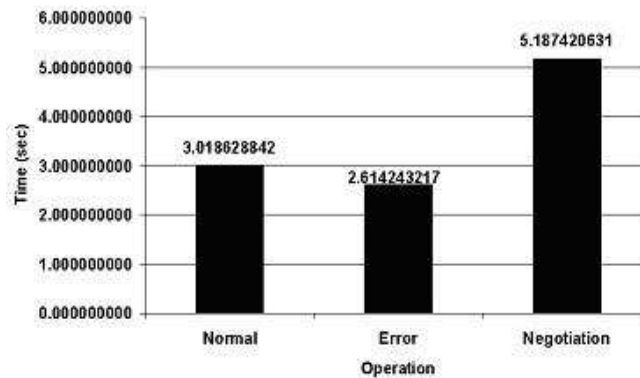

Figure 4.18: Convergence time

Figure 4.18 shows a comparison for the convergence time of each operation. It indicates that the negotiation operation is the slowest one, while the difference between a normal operation and an exception (error) is not large. However, the delay of the slowest case is still acceptable during the system startup. On the other hand, no significant comparison can be made to previous work since the wireless cabin environment is still under research investigation.

By recalling the self-organization and self-configuration concepts, we can say that the protocol performs self-organization actions to organize the whole network by coupling each VDU with its corresponding PCU. Although the protocol does not perform an explicit self-configuration actions, but it asks the lower layer (i.e., Physical Layer) to configure its smart antenna elements to scan the surrounding area, and provide the protocol with the required data. This behavior shows the importance of cooperation between different layers to achieve self-organization.

4.4 Conclusion

Self-organization and self-configuration are two terms that are usually used with autonomous systems. We highlighted the difference between the two terms and showed the importance of self-organization. Providing IFE systems with self-organization capabilities can decrease maintenance and cabin reconfiguration time. We proposed using smart antennas to minimize interference and benefit of their ability to determine distance and direction between transmitters and receivers. We introduced a new device identification protocol that allows IFE devices to be identified autonomously without any previous configuration. The protocol specifications and functionality were discussed. It is evaluated and verified through formal methods and simulations. The timing values were accepted in the E-CAB [123] project that match the requirements of airplane architecture.

Chapter 5

Conclusion and future work

Wireless networking is a wide-ranging and challenging domain. In this work, we tried to highlight some important topics as well as providing some solutions for existing challenges. Network density is one of the features that need a quantitative measure in order to be evaluated. It is highly affected not only by the number of nodes, but also by nodes performance. Consequently, the network density calculation, which is presented in the literature is not an enough metric to judge the network state as being dense or non-dense since it does not consider network performance. Thus, we propose the usage of *Effective Density* as a new measure, which allows us to study the dynamic effect of the neighbor's number. Moreover, It allows us to divide the network into areas of different densities, where each area can behave according to the influence of its current population.

Furthermore, we conducted a simulation as a proof of the concept, where we showed how the *Effective Density* is influenced by the changing number of node neighbors and its Throughput. Then, we showed the metric applicability over a data set extracted from a real experimentation.

A future step is to integrate our metric within a protocol that uses network density as its control parameter to show how our metric can enhance the protocol behavior.

Moreover, self-organization is a feature, which is inspired from natural systems. Natural systems had proven to be good competent, more reliable, and fault tolerant. These pre-tested natural systems give confidence in acquiring good results when inspiring techniques derived from them. One of their most interesting features is self-organization. Self-organization and self-configuration are two different terms, which are usually used interchangeably. We thoroughly identified them so that they can be used more precisely in the context of autonomus systems. One of the current features of WSN is that solutions tend to be application dependent, leading to different design concepts and approaches. We believe that, although each network layer can have a sole effect on self-organization, a better performance can be achieved if the global view of all layers were considered, so we show the role of each network layer to acquire self-organization in order to achieve better understanding as well as being able to evaluate different approaches.

From the application side, IFE systems are starving for new solutions where wireless communication can play a great role in improving as well as adding new services to them. However, the highly constrained environment inside the cabin imposes many difficulties, so that heterogeneous network architecture can be considered as a promising solution for such application. Through experimentation results and simulations, this work proves that it is possible to build a heterogeneous network, which contains different technologies; each to solve a certain part of the problem. Using PLC networks can be a competitive solution since it decreases the amount of cabling inside the cabin, and can be used to connect the APs (to support mobility) directly to the network system. Moreover, it overcomes the interference constrain, and can provide enough bandwidth to support heavy traffic required for multimedia services. When combined with WUSB, it becomes easier for passengers to connect their PEDs.

Moreover, IFE systems can utilize smart antennas to solve or minimize interference problems. However, new wireless technologies like smart anten-

nas require special mechanisms to fully utilize their capabilities. The proposed protocol is designed to use these capabilities to provide the IFE remote control with self-configurable wireless characteristics. Although the protocol procedures seems complicated, but in fact they are not, because it depends on comparing existing information without using excessive messaging. This behavior enhances convergence time and protocol performance.

An UML model and NS2 simulation were then used to prove that the proposed protocol is able to utilize the location information provided by the smart antennas to allow each VDU to detect its own PCU. Moreover, the protocol considered the probable failure situations, and was able to detect and handle them. However, the protocol point of weakness is its internal timer. The simulation results showed that the value of the timer has a great impact on convergence time. In addition, the usage of an UML model before creating a NS2 simulation had proved to be of great importance to the protocol design life time. Although designing the UML model seemed to be a time consuming part, but it saved the effort of tracking semantic errors during implementing the NS2 module.

In this phase of the work, we aimed at having a proof of the concept to show the feasibility of our proposed protocol. The next step is to enhance the written code by using better data structures to minimize the processing delay and improve the simulated convergence time. In addition, we are aiming at trying simulations that represent a real cabin configuration, and inject scenarios with randomly failing devices. It is also planned to investigate the scalability issues of WUSB.

Moreover, we believe that self-organization techniques can introduce solutions for different problems that are not well investigated yet in the WSN domain. For example, time critical applications where time of data transfer is a great issue, and they need to be zero tolerant for data loss; applications that need certain level of fault tolerance and reliability. Current WSN designs are mainly concerned with connectivity and power saving, so that these types of

applications need to be considered by researchers.

Furthermore, the relation between *Effective Density* and network QoS needs to be investigated because *Effective Density* can be a measure that shows the pattern of performance change with respect to number of single hop neighboring nodes.

Author's Publications

- [AGB₁] Ahmed Akl, Thierry Gayraud, and Pascal Berthou, *Investigating Several Wireless Technologies to Build a Heterogeneous Network for the In-Flight Entertainment System Inside an Aircraft Cabin*, The Sixth International Conference on Wireless and Mobile Communications (ICWMC) (2010), 532–537.
- [AGB₂] Ahmed AKL, Thierry GAYRAUD, and Pascal BERTHOU, *A Metric for Evaluating Density Level of Wireless Sensor Networks*, IFIP wireless days (2011).
- [AGB₃] Ahmed Akl, Thierry Gayraud, and Pascal Berthou, *A New Wireless Architecture for In-Flight Entertainment Systems Inside Aircraft Cabin*, International Journal on Advances in Networks and Services **4**, no. **1 & 2** (2011), no. ISSN 1942-2644, 159–175.
- [AGB₄] Ahmed Akl, Thierry Gayraud, and Pascal Berthou, *An investigation of self-organization in ad-hoc networks*, International Conference on Networking, Sensing and Control (ICNSC) (2011), no. April, 1–6.

AUTHOR'S PUBLICATIONS

References

- [1] F. Dressler, *Self-Organization in Sensor and Actor Networks*. WILEY Publishing, Inc., 1st ed., 2007.
- [2] J. Zhao and R. Govindan, “Understanding Packet Delivery Performance In Dense Wireless Sensor Networks,” *Proceedings of the 1st international conference on Embedded networked sensor systems*, pp. 1–13, 2003.
- [3] Y.-C. Chang and C.-F. Chen, “Identifying mobility service needs for disabled air passengers,” *Tourism Management*, vol. 32, pp. 1214–1217, Oct. 2011.
- [4] C. Tan, W. Chen, M. Verbunt, C. Bartneck, and M. Rauterberg, “Adaptive Posture Advisory System for Spinal Cord Injury Patient,” *Proceedings of the ASME International Design Engineering Technical Conferences & Computers and Information in Engineering Conference IDETC/CIE*, pp. 1–7, 2009.
- [5] J. Schumm, C. Setz, M. Bächlin, M. Bächler, B. Arnrich, and G. Tröster, “Unobtrusive physiological monitoring in an airplane seat,” *Personal and Ubiquitous Computing*, vol. 14, pp. 541–550, Feb. 2010.
- [6] C. F. Tan, W. Chen, and M. Rauterberg, “Intuitive thinking of design and redesign on innovative aircraft cabin simulator 3 . 0 Smart Technologies for Stress-free Air Travel,” *14th International Conference on Thinking*, pp. 122–132, 2009.
- [7] G. P. Halkes and K. G. Langendoen, “Crankshaft : An Energy-Efficient MAC-Protocol for Dense Wireless Sensor Networks,” *Proceedings of the 4th European conference on Wireless sensor networks*, pp. 228–244, 2007.
- [8] A. Silva, E. Altman, and G. Alfano, “Magnetworks : how mobility impacts the design of Mobile Networks,” *IEEE Proceedings INFOCOM*, pp. 1–9, 2010.

REFERENCES

- [9] D. Liarokapis, A. Shahrabi, A. Komninos, and A. Shahrabi, "DibA : An Adaptive Broadcasting Scheme in Mobile Ad Hoc Networks," *Proceedings of the 6th International Conference on Mobile Technology, Application, and Computing*, pp. 224–231, 2009.
- [10] S. Cho, H. Shin, S. Han, H. Cha, and R. Ha, "Density-adaptive network reprogramming protocol for wireless sensor networks," *Wireless Communication and Mobile Computing*, no. June 2009, pp. 857–874, 2010.
- [11] M. Haghpanahi, M. Kalantari, and M. Shayman, "Implementing Information Paths in a Dense Wireless Sensor Network," *IEEE Global Telecommunications Conference (GLOBECOM)*, pp. 1–7, 2009.
- [12] K. L. Mills, "A brief survey of self-organization in wireless sensor networks," *Wireless Communication and Mobile Computing*, vol. 7, 2007.
- [13] Meriam-webster, "<http://www.merriam-webster.com/dictionary>," *Last visit in 2011*.
- [14] S.-L. Wu and Y.-C. Tseng, *Wireless Ad Hoc Networks (Personal-Area, Local-Area, and the Sensory-Area Networks)*. Auerbach publications, 1st ed., 2007.
- [15] K. A. Ali and H. T. Mouftah, "Ad Hoc Networks Wireless personal area networks architecture and protocols for multimedia applications," *AD HOC NETWORKS*, pp. 1–12, 2010.
- [16] Y. Jiang, C.-h. Lung, and N. Goel, "A Tree-Based Multiple-Hop Clustering Protocol for," *Engineering*, vol. 49, pp. 371–383, 2010.
- [17] E. Care, *Bulletproof Wireless Security - GSM, UMTS, 802.11, And Ad Hoc Security*. Elsevier Inc., 2005.
- [18] Y.-W. P. Hong, W.-J. Huang, and C.-C. J. Kuo, *Cooperative Communications and Networking*. Springer, 2010.
- [19] P. K. Ponnappalli, R. B. Battula, P. K. Tummala, and S. Vemuru, *Wireless Mesh Networks: Routing Protocols and Challenges*, pp. 143–151. Springer Berlin Heidelberg, 2010.
- [20] A. Datta and S. Soundaralakshmi, *A Survey of State-of-the-Art Routing Protocols for Mobile Ad Hoc Networks*, ch. 1, pp. 3–24. John Wiley and Sons, 2010.

REFERENCES

- [21] D. Lim and J. Ghosh, "Performance Evaluation of DSDV and AODV Routing Protocols in Mobile Ad-hoc Networks," *4th International Conference on New Trends in Information Science and Service Science (NISS)*, pp. 399–403, 2010.
- [22] S. Mittal and P. Kaur, *Performance Comparison of FSR, LAR1 and LANMAR Routing Protocols in MANET*, pp. 396–400. Springer Berlin Heidelberg, 2010.
- [23] H. Park, "OLSR Protocol having a link reliability list in the MPR," *The 12th International Conference on Advanced Communication Technology (ICACT)*, pp. 1231–1234, 2010.
- [24] S. S. Rizvi, M. A. Jafri, K. Elleithy, and A. Riasat, "A Novel Optimization of the Distance Source Routing (DSR) Protocol for the Mobile Ad Hoc Networks (MANET)," in *Novel Algorithms and Techniques in Telecommunications and Networking*, pp. 269–274, Springer Netherlands, 2010.
- [25] V. R. P. Subbaiah, N. K. Rao, and N. S. Narayana, "Performance Comparison and Analysis of Preemptive-DSR and TORA," *International Journal of Ad hoc, Sensor & Ubiquitous Computing (IJASUC)*, vol. 1, no. 4, pp. 47–60, 2010.
- [26] B. Patel and S. Srivastava, "Performance Analysis of Zone Routing Protocols in Mobile Ad Hoc Networks," *National Conference on Communications (NCC)*, pp. 1–4, 2010.
- [27] H. Kaaniche, F. Louati, M. Frikha, and F. Kamoun, "A QoS Routing Protocol based on Available Bandwidth Estimation for Wireless Ad Hoc Networks," *A QoS Routing Protocol based on Available Bandwidth Estimation for Wireless Ad Hoc Networks*, vol. 3, no. 1, pp. 219–239, 2011.
- [28] D. Vidhate, A. Patil, and S. Sarkar, "Bandwidth Estimation Scheme for Mobile Adhoc Network," in *Information Processing and Management*, pp. 130–135, Springer Berlin Heidelberg, 2010.
- [29] R. Guimarães, J. M. Barceló, J. García, M. Voorhaen, and C. Blondia, "Ad Hoc Networks Quality of service through bandwidth reservation on multirate ad hoc wireless networks," *Ad Hoc Networks Journal*, vol. 7, pp. 388–400, 2009.
- [30] W. Yang, "Interference- and Bandwidth-based Multipath routing Protocol in Mobile Ad hoc Networks," *IEEE International Conference on*

REFERENCES

- Intelligent Computing and Intelligent Systems (ICIS)*., pp. 560 – 565, 2009.
- [31] G. Anastasi, M. Conti, M. Di Francesco, and A. Passarella, “Energy conservation in wireless sensor networks: A survey,” *Ad Hoc Networks Journal*, vol. 7, pp. 537–568, May 2009.
- [32] Y. Xu, “Adaptive energy-conservation routing for multihop adhoc networks,” tech. rep., USC/Information Sciences Institute, 2000.
- [33] B. Chen, K. Jamieson, H. Balakrishnan, and R. Morris, “Span : An Energy-Efficient Coordination Algorithm for Topology Maintenance in Ad Hoc Wireless Networks p P,” *ACM wireless Networks Journal*, pp. 481–494, 2002.
- [34] Y. Xu, J. Heidemann, and D. Estrin, “Geography-informed energy conservation for Ad Hoc routing,” *Proceedings of the 7th annual international conference on Mobile computing and networking*, pp. 70–84, 2001.
- [35] S. Singh and C. S. Raghavendra, “PAMAS: Power Aware Multi-Access protocol with Signalling for Ad Hoc Networks,” *ACM Computer Communication Review*, vol. 28, pp. 5–26, 1998.
- [36] H. Koivo and M. Elmusrati, *Systems engineering in wireless communications*. John Wiley & Sons Ltd., 2009.
- [37] S. Nesargi and R. Prakash, “MANETconf : Configuration of Hosts in a Mobile Ad Hoc Network,” *Twenty-First Annual Joint Conference of the IEEE Computer and Communications Societies INFOCOM*, vol. 2, pp. 1059 – 1068, 2002.
- [38] N. H. Vaidya, “Weak Duplicate Address Detection in Mobile Ad Hoc Networks,” *Proceedings of the 3rd ACM international symposium on Mobile ad hoc networking*, pp. 206–216, 2002.
- [39] H. Karl and A. Willig, *Protocols and Architectures for Wireless Sensor Networks*. Chichester, UK: John Wiley & Sons, Ltd, Apr. 2005.
- [40] A. Shrestha and L. Xing, “A Performance Comparison of Different Topologies for Wireless Sensor Networks,” *IEEE conference on Technologies for Homeland Security*, no. May, pp. 280–285, 2007.
- [41] J. N. Al-karaki and A. E. Kamal, “Routing Techniques in Wireless Sensor Networks : A Survey,” *IEEE wireless Communication*, vol. 11, no. 6, pp. 6–28, 2004.

REFERENCES

- [42] B. Thallner, H. Moser, and U. Schmid, "Topology control for fault-tolerant communication in wireless ad hoc networks," *Wireless Networks*, vol. 16, pp. 387–404, Oct. 2008.
- [43] H. Roy, S. K. De, and A. Rahman, *Fault-Tolerant Power-Aware Topology Control for Ad-Hoc Wireless Networks*, pp. 303–314. Springer Berlin / Heidelberg, 2010.
- [44] R. Behnke, F. Golatowski, K. Thurow, and D. Timmermann, "Wireless Sensor Networks for Life Science Automation," *In International Forum Life Science Automation*, 2007.
- [45] T. Miyazaki, D. Shitara, Y. Endo, Y. Tanno, H. Igari, and R. Kawano, "Die-hard Sensor Network : Robust Wireless Sensor Network Dedicated to Disaster Monitoring," *Proceedings of the 5th International Conference on Ubiquitous Information Management and Communication (ICUIMC)*, vol. 53, pp. 1–10, 2011.
- [46] J. Jung, B. Song, and S. Park, "The Possibility of Wireless Sensor Networks for Commercial Vehicle Load Monitoring," *10th International Workshop on Real-Time Networks*, pp. 29–34, 2011.
- [47] R. Ramanathan, R. Allan, P. Basu, J. Feinberg, G. Jakllari, V. Kawadia, S. Loos, J. Redi, C. Santivanez, and J. Freebersyser, "Scalability of Mobile Ad Hoc Networks : Theory vs Practice," *MILITARY COMMUNICATIONS CONFERENCE (MILCOM)*, pp. 493–498, 2010.
- [48] T. Bokareva, W. Hu, S. Kanhere, B. Ristic, and N. S. Wales, "Wireless Sensor Networks for Battlefield Surveillance," *Proceedings of the Land Warfare Conference*, no. October, 2006.
- [49] B. Warneke, B. Atwood, and K. S. J. Pister, "Smart dust mote forerunners," *The 14th IEEE International Conference on Micro Electro Mechanical Systems (M EMS)*, pp. 357–360, 2001.
- [50] M. M. Hasan and J. P. Jue, "Survivable Self-Organization for Prolonged Lifetime in Wireless Sensor Networks," *International Journal of Distributed Sensor Networks*, pp. 1–11, 2011.
- [51] T. G. Robertazzi and P. E. Sarachik, "Self-organizing Communication Networks," *IEEE Communications Magazine*, vol. 24, no. 1, pp. 28–33, 1986.

REFERENCES

- [52] P. S. Sausen, M. A. Spohn, and A. Perkusich, “Broadcast routing in Wireless Sensor Networks with Dynamic Power Management,” *IEEE Symposium on Computers and Communications*, pp. 1090–1095, July 2008.
- [53] C. Wangl, K. Sohraby, Y. Hu, B. Li, and W. Tang, “Issues of Transport Control Protocols for Wireless Sensor Networks,” *International Conference on Communications, Circuits, and systems*, pp. 422–426, 2005.
- [54] Y. Xu, L. Shen, and Q. Yang, “Dynamic deployment of wireless nodes for maximizing network lifetime in WSN,” *International Conference on Wireless Communications & Signal Processing*, pp. 1–5, Nov. 2009.
- [55] M. P. Singh and D. K. Singh, “Routing Protocols in Wireless Sensor Networks A survey,” *International Journal of Computer Science and Engineering Survey (IJCSES)*, vol. 1, no. 2, pp. 63–83, 2010.
- [56] R. Rajagopalan and P. K. Varshney, “Data aggregation techniques in sensor networks: A survey,” *IEEE Comm. Surveys & Tutorials*, vol. 8, pp. 48–63, 2006.
- [57] S. Eswaran, M. Johnson, A. Misra, and T. L. Porta, *Adaptive In-Network Processing for Bandwidth and Energy Constrained Mission-Oriented Multi-hop Wireless Networks*, pp. 87–102. Springer Berlin-Heidelberg, 2009.
- [58] E. Fasolo, M. Rossi, J. Widmer, and M. Zorzi, “In-network aggregation techniques for wireless sensor networks: a survey,” *IEEE Wireless Communications*, vol. 14, pp. 70–87, Apr. 2007.
- [59] G. J. Pottie and W. J. Kaiser, “Wireless integrated network sensors,” *Communications of the ACM*, vol. 43, no. 5, pp. 51–58, 2000.
- [60] N. A. PANTAZIS and D. D. VERGADOS, “A SURVEY ON POWER CONTROL ISSUES IN WIRELESS SENSOR NETWORKS,” *Communications Surveys & Tutorials, IEEE In Communications Surveys & Tutorials*, vol. 9, pp. 86–107, 2007.
- [61] J. Zheng and A. Jamalipour, *Wireless Sensor Networks: A Networking Perspective*. 2009.
- [62] D. Virmani and S. Jain, “Quality of Service On-demand Power Aware Routing,” in *Information Processing and Management*, pp. 281–289, 2010.

REFERENCES

- [63] C.-C. Weng, C.-W. Chen, C.-J. Ku, and S.-F. Hwang, "A Bandwidth-Based Power-Aware Routing Protocol with Low Route Discovery Overhead in Mobile Ad hoc Networks," *The Computer Journal*, vol. 53, pp. 969–990, Aug. 2009.
- [64] C. Hua and T. Peteryum, "Data aggregated maximum lifetime routing for wireless sensor networks," *Ad Hoc Networks*, vol. 6, pp. 380–392, May 2008.
- [65] T. Zhao, T.-d. Guo, W.-g. Yang, and G. Chen, "An Optimal Cross-Layer Model for Maximum Lifetime Routing in Wireless Sensor Networks," *Proceedings of the 2010 International Conference on Communications and Mobile Computing*, vol. 3, pp. 244–248, Apr. 2010.
- [66] C. Srisathapornphat and C.-C. Shen, "Coordinated power conservation for ad hoc networks," *IEEE International Conference on Communications (ICC)*, vol. 5, pp. 3330–3335, 2002.
- [67] H. E. Baarsma, M. G. C. Bosman, and J. L. Hurink, "Resource Management in Heterogeneous Wireless Sensor Networks," *Centre for Telematics and Information Technology, University of Twente*, pp. 1–19, 2008.
- [68] M. Tarique, K. E. Tepe, S. Adibi, and S. Erfani, "Survey of multipath routing protocols for mobile ad hoc networks," *Journal of Network and Computer Applications*, vol. 32, pp. 1125–1143, Nov. 2009.
- [69] A. K. Dwivedi, "Network Layer Protocols for Wireless Sensor Networks : Existing Classifications and Design Challenges," *International Journal of Computer Applications*, vol. 8, no. 12, pp. 30–34, 2010.
- [70] S. Sridhar, "A Survey on QoS Based Routing Protocols for MANET," *International Journal of Computer Applications*, vol. 8, no. 3, pp. 15–22, 2010.
- [71] N. Bulusu, D. Estrin, L. Girod, J. Heidemann, and U. S. C. Isi, "Scalable Coordination for Wireless Sensor Networks : Self-Configuring Localization Systems," *Proceedings of the Sixth International Symposium on Communication Theory and Applications (ISCTA)*, no. July, pp. 1–6, 2001.
- [72] I. F. Akyildiz, W. Su, Y. Sankarasubramaniam, and E. Cayirci, "A Survey on Sensor Networks," *IEEE Communications Magazine*, no. August, pp. 102–114, 2002.

REFERENCES

- [73] S. Basagni, A. Carosi, E. Melachrinoudis, C. Petrioli, and Z. M. Wang, “Controlled sink mobility for prolonging wireless sensor networks lifetime,” *Wireless Networks*, vol. 14, pp. 831–858, Feb. 2007.
- [74] A. Bari, F. Luo, W. Froese, and A. Jaekel, “Optimal Relay Node Placement and Trajectory Computation in Sensor Networks with Mobile Data Collector,” in *Ad Hoc Networks*, pp. 400–415, Springer Berlin Heidelberg, 2010.
- [75] J. H. Jun, B. Xie, and D. P. Agrawal, “Wireless Mobile Sensor Networks: Protocols and Mobility Strategies,” in *Guide to Wireless Sensor Networks*, Computer Communications and Networks, pp. 607–634, Springer London, 2009.
- [76] R. Ranjan, *Handbook of Mobile Ad Hoc Networks for Mobility Models*. Springer, 2001.
- [77] P. Wang and I. F. Akyildiz, “Effects of Different Mobility Models on Traffic Patterns in Wireless Sensor Networks,” *IEEE Global Telecommunications Conference (GLOBECOM)*, pp. 1–5, 2010.
- [78] M. Marta and M. Cardei, “Improved sensor network lifetime with multiple mobile sinks,” *Pervasive and Mobile Computing*, vol. 5, pp. 542–555, Oct. 2009.
- [79] G. S. Sara, R. Kalaiarasi, S. N. Pari, and D. Sridharan, “Energy Efficient Mobile Wireless Sensor Network Routing Protocol,” in *Recent Trends in Networks and Communications*, pp. 642–650, Springer Berlin Heidelberg, 2010.
- [80] S. Chellappan, S. Member, W. Gu, and X. Bai, “Deploying Wireless Sensor Networks under Limited Mobility Constraints,” *IEEE Transactions on Mobile Computing*, vol. 6, no. 10, pp. 1142–1157, 2007.
- [81] S. Yangy, M. Liz, and J. Wu, “Scan-Based Movement-Assisted Sensor Deployment Methods in Wireless Sensor Networks,” *IEEE Transactions on Parallel and Distributed Systems*, vol. 18, pp. 1108–1121, Aug. 2007.
- [82] S. Basagni, A. Carosi, and C. Petrioli, “Controlled Vs. Uncontrolled Mobility in Wireless Sensor Networks: Some Performance Insights,” *IEEE 66th Vehicular Technology Conference*, pp. 269–273, Sept. 2007.
- [83] N. Li, S. Member, J. C. Hou, and S. Member, “Localized Topology Control Algorithms for Heterogeneous Wireless Networks,” *IEEE/ACM Transaction Network*, vol. 13, no. 6, pp. 1313–1324, 2005.

REFERENCES

- [84] S.-l. Wu, Y.-c. Tseng, J.-p. Sheu, and S. Member, "Intelligent Medium Access for Mobile Ad Hoc Networks with Busy Tones and Power Control," *IEEE Journal on Selected Areas in Communications*, vol. 18, no. 9, pp. 1647–1657, 2000.
- [85] N. Humn, *Essentials of Short-Range Wireless*. Cambridge University Press, 2010.
- [86] F. Alamdari, "Airline in-flight entertainment: the passengers' perspective," *Journal of Air Transport Management*, vol. 5, pp. 203–209, Oct. 1999.
- [87] "http://www.airships.net."
- [88] H. Liu, "In-Flight Entertainment System: State of the Art and Research Directions," in *Second International Workshop on Semantic Media Adaptation and Personalization (SMAP)*, pp. 241–244, Second International Workshop on Semantic Media Adaptation and Personalization (SMAP 2007), 2007.
- [89] H. Hrasnica, A. Haidine, and R. Lehnert, *Broadband Powerline Communications Networks*. John Wiley & Sons, Ltd, 2004.
- [90] J. Li, M. Li, and L. Sun, "A Low Power Consumption Implementation for WSN Nodes in Lumber Drying Kiln," *IEEE International Conference on Mechatronics and Automation*, pp. 911–916, 2007.
- [91] M. Kuorilehto, M. MarkoHannikainen, and T. D. Hamalainen, "A Survey of Application Distribution," *EURASIP Journal on Wireless Communications and Networking*, vol. 5, pp. 774–788, 2005.
- [92] J. A. Stankovic, Q. Cao, T. Doan, L. Fang, Z. He, R. Kiran, S. Lin, S. Son, R. Stoleru, and A. Wood, "Wireless Sensor Networks for In-Home Healthcare : Potential and Challenges," in *High Confidence Medical Device Software and Systems (HCMDSS) Workshop*, 2005.
- [93] F. Nait-Abdesselam, B. Bensaou, T. Soete, and K.-L. Hung, "O-MAC : An Organized Energy-Aware MAC Protocol for Wireless Sensor Networks," *IEEE International Conference on Communications*, no. June, pp. 3648–3653, 2007.
- [94] I. Demirkol, C. Ersoy, and F. Alagoz, "MAC Protocols for Wireless Sensor Networks : A Survey," *IEEE Communications Magazine*, no. April, pp. 115–121, 2006.

REFERENCES

- [95] J. Ryoo and H. Kim, "Multi-sector multi-range control for self-organizing wireless networks," *Journal of Network and Computer Applications*, vol. 34, pp. 1848–1860, Nov. 2011.
- [96] Y. Al-obaisat and R. Braun, "On Wireless Sensor Networks : Architectures , Protocols , Applications , and Management," *In International Conference on Wireless Broadband and Ultra Wideband Communication (AusWireless)*, 2006.
- [97] M. A. Perillo and W. B. Heinzelman, "Wireless Sensor Network Protocols," *International Conference On Communication Technology*, 2006.
- [98] K. Akkaya and M. Younis, "A survey on routing protocols for wireless sensor networks," *Elsevier Ad Hoc Networks Journal*, vol. 3, pp. 325–349, 2005.
- [99] C. Wang, K. Sohraby, B. Li, M. Daneshmand, and Y. Hu, "A Survey of Transport Protocols for Wireless Sensor Networks," *IEEE Network Magazine*, no. June, pp. 34–40, 2006.
- [100] M. R. Kosanovic and M. K. Stojcev, "Implementation of TCP / IP Protocols in Wireless Sensor Networks," *Proceedings of the International Scientific Conference on Information, Communication and Energy Systems and Technologies (ICEST)*, pp. 143–146, 2007.
- [101] Y. Ming-Hai and Z. Xiao-Xiao, "Study and Transplant of Operating System for Wireless Sensor Network Node," *International Conference on Wireless Communication, Networking, and Mobile Computing*, pp. 2803–2807, 2007.
- [102] M.-m. Wang, J.-N. Cao, J. Li, and S. K. Das, "Middleware for Wireless Sensor Networks : A Survey," *Journal of Computer Science and Technology*, vol. 23, pp. 305–326, 2008.
- [103] R. Sugihara and R. K. Gupta, "Programming Models for Sensor Networks : A Survey," *ACM Transaction On Sensor Networks (TOSN)*, pp. 1–27, 2008.
- [104] S. Brown and C. Sreenan, "Updating Software in Wireless Sensor Networks : A Survey," *Technical Report UCC-CS-2006-13-07, National University of Ireland*, 2006.
- [105] S. Toumpis, "A survey of recent results on wireless networks based on analogies with physics," *Computer Networks*, vol. 52, pp. 360–383, 2008.

REFERENCES

- [106] A. Scaglione, Y. P. Hong, and B. S. Mergen, “Cooperative Strategies in Dense Sensor Networks,” *Signals and Communication Technology, Springer*, vol. 1, pp. 61–74, 2010.
- [107] R. S. Gray, D. Kotz, C. Newport, N. Dubrovsky, A. Fiske, J. Liu, C. Mason, S. McGrath, and Y. Yuan, “CRAWDAD data set dartmouth/outdoor (v. 2006-11-06),” 2006.
- [108] J. Liu, Y. Yuan, D. M. Nicol, R. S. Gray, C. C. Newport, D. Kotz, and L. F. Perrone, “Empirical Validation of Wireless Models in Simulations of Ad Hoc Routing Protocols,” *Simulation Journal*, vol. 81, pp. 307–323, 2005.
- [109] C. Niebla, “Coverage and capacity planning for aircraft in-cabin wireless heterogeneous networks,” *IEEE Vehicular Technology Conference*, pp. 1658–1662, 2003.
- [110] A. Jahn and M. Holzbock, “Evolution of aeronautical communications for personal and multimedia services,” *IEEE Communications Magazine*, vol. 41, pp. 36–43, 2003.
- [111] D. Folden, T. Jackson, M. Panique, R. Tiensvold, R. S. Wolff, T. Howard, E. Julian, L. Junkert, D. Lopez, and M. J. Oudshoorn, “An Aircraft Cabin Wireless System for Games and Video Entertainment,” *ACM Computer in Entertainment*, vol. 5, no. 1, pp. 1–17, 2007.
- [112] M. Holzbock, Y.-F. Hu, A. Jahn, and M. Werner, “Advances of aeronautical communications in the EU framework,” *International Journal of Satellite Communications and Networking*, vol. 22, no. 1, pp. 113–137, 2004.
- [113] N. R. Diaz and J. E. J. Esquitino, “Wideband Channel Characterization for Wireless Communications inside a short haul aircraft,” in *Vehicular Technology Conference*, pp. 223–228, 2004.
- [114] M. Youssef, L. Vahala, and J. Beggs, “Wireless network simulation in aircraft cabins,” *IEEE Antennas and Propagation Society Symposium*, vol. 3, pp. 2223–2226, 2004.
- [115] H. Thompson, “Wireless and Internet communications technologies for monitoring and control,” *Control Engineering Practice*, vol. 12, no. 6, pp. 781–791, 2004.

REFERENCES

- [116] J. Lansford, A. Stephens, and R. Nevo, "Wi-Fi (802.11b) and Bluetooth: Enabling Coexistence," *IEEE Communications Magazine*, pp. 20–27, 2001.
- [117] N. Leavitt, "For Wireless USB, the Future Starts Now," *IEEE Computer Society*, vol. 40, pp. 14–16, July 2007.
- [118] J. M. Sohn, S. H. Baek, and J. D. Huh, "Design issues towards a high performance wireless USB device," *IEEE International Conference on Ultra-Wideband*, vol. 3, pp. 109–112, Sept. 2008.
- [119] MGEN-site, "<http://pf.itd.nrl.navy.mil/mgen/mgen.html>," *Last visit in 2011*.
- [120] NS2-site:, "<http://www.isi.edu/nsnam/ns/>," *Last visit in 2011*.
- [121] A. Kaouris, M. Zaras, M. Revithi, N. Moraitis, and P. Constantinou, "Propagation Measurements inside a B737 Aircraft for In-Cabin Wireless Networks," in *VTC Spring 2008 - IEEE Vehicular Technology Conference*, pp. 2932–2936, IEEE, May 2008.
- [122] A. Akl, T. Gayraud, and P. Berthou, "Investigating Several Wireless Technologies to Build a Heterogeneous Network for the In-Flight Entertainment System Inside an Aircraft Cabin," *The Sixth International Conference on Wireless and Mobile Communications (ICWMC)*, pp. 532–537, 2010.
- [123] ECAB, "http://ec.europa.eu/research/transport/projects/items/e_cab_en.htm."
- [124] J. Ibriq and I. Mahgoub, "Cluster-Based Routing in Wireless Sensor Networks : Issues and Challenges," *Proceedings of the International Symposium on Performance Evaluation of Computer and Telecommunication Systems*, pp. 759–766, 2004.
- [125] J.-l. Lu, F. Valois, D. Barthel, and M. Dohler, "FISCO : a Fully Integrated Scheme of self-Configuration and self-Organization for WSN," *WCNC*, pp. 3372–3377, 2007.
- [126] J. H. WINTERS, "Smart Antenna Techniques and Their Application to Wireless ad hoc Networks," *IEEE Wireless Communications*, no. August, pp. 77–83, 2006.
- [127] G. T. Okamoto, *Smart antenna systems and wireless LANs*. Kluwer Academic Publishers, 1st ed., 2002.

REFERENCES

- [128] Z. You, M. Q.-H. Meng, H. Liang, S. Li, Y. Li, W. Chen, Y. Zhou, S. Miao, K. Jiang, and Q. Guo, “A Localization Algorithm in Wireless Sensor Networks Using a Mobile Beacon Node,” *Proceedings of the International Conference on Information Acquisition*, pp. 420–426, 2007.
- [129] F. J. Lin, P. M. Chu, and M. T. Liu, “Protocol Verification using reachability analysis,” *ACM Computer Communication Review*, pp. 126–135, 1988.
- [130] IBM Rational Tau site ;, “<http://www-01.ibm.com/software/awdtools/tau/>,” *Last visit in 2011*.
- [131] VINT-project_site:, “<http://www.isi.edu/nsnam/vint/>,” *Last visit in 2011*.

Glossary

Ad-hoc Network Ad-hoc network is a wireless network where nodes can communicate wirelessly with each other without the need for a fixed infrastructure.. [11](#)

Duty Cycle In terms of WSN energy conservation, it is the fraction of time when nodes are active during their lifetime. [24](#)

Effective Density (ED) of a node is the ratio between the number of single hop connected nodes (N), and the node Throughput (th), where $ED = \frac{N}{th}$. [45](#)

In-Flight Entertainment is the entertainment available to aircraft passengers during flight.. [3](#)

Personal Control Unit Is a remote control device used in IFE systems to allow passengers to select options or services of the system.. [32](#)

Seat Electronic Box Is an electronic device used to connect the devices used by passengers to the IFE system instead of having a separate connecting network for each device.. [33](#)

Self-configuration Is the changes that the node makes in its parameters to perform certain task.. [68](#)

Self-organization Is the changes that the node does in its behaviour to cooperate with its neighbours in the network to perform a certain task or achieve a certain goal.. [68](#)

Smart Antenna is a multi-element antenna where each element can be controlled separately, so that the antenna beam can be directed towards a certain direction as well as controlling the transmission power.. [70](#)

Visual Display Unit is a display unit usually fixed to the back of the front seat for individual use or is fixed in the ceiling as a shared display for a group of seats.. [32](#)

Wireless Sensor Network Is a special type of networks where nodes are smart sensors with scarce resources. They are small in size, have limited computational power, short range communication capabilities, low energy, limited and storage capacity, and usually numerous in number. [18](#)

Index

- Ad-hoc Networks, [2](#), [11](#)
 - Addressing schemes, [16](#)
 - Communication, [12](#)
 - Energy conservation, [14](#)
 - Topology, [17](#)
- Dense networks, [43](#)
 - Deployment scheme, [32](#)
 - Measurement, [45](#)
 - Mobility, [30](#)
 - Obstacles, [31](#)
 - Transmission power, [31](#)
- Effective Density, [47](#)
- Heterogeneous network, [54](#), [64](#)
- In-Flight Entertainment (IFE), [38](#), [54](#)
 - components, [39](#)
 - Device identification protocol, [84](#)
 - Seat Electronic Box, [40](#)
- Network density, *see* Dense networks
- Network heterogeneity, [5](#), *see* Heterogeneous network
- Personal Control Unit(PCU), [39](#)
- Power Line Communication (PLC), [62](#), [64](#), [112](#)
 - Power Line Box, [64](#)
 - Power Line Head Box, [64](#)
- Self-configuration, [81](#)
- Self-organization, [5](#), [32](#), [80](#), [81](#)
 - Application layer, [37](#)
 - MAC layer, [33](#)
 - Network layer, [34](#)
 - Transport layer, [36](#)
- Smart antenna, [84](#)
- Visual Display Unit(VDU), [39](#)
- WiFi, [58](#), [66](#)
- Wireless Sensor Networks, [2](#), [18](#)
 - Communication schemes, [20](#)
 - Energy conservation, [24](#)
 - Limited resources, [25](#)
 - Routing protocols, [26](#)
- Wireless USB, [61](#), [71](#)

INDEX
