



**HAL**  
open science

# New control schemes for bilateral teleoperation under asymmetric communication channels: stabilization and performance under variable time delays

Bo Zhang

► **To cite this version:**

Bo Zhang. New control schemes for bilateral teleoperation under asymmetric communication channels: stabilization and performance under variable time delays. Other. Ecole Centrale de Lille, 2012. English. NNT: 2012ECLI0014. tel-00733141

**HAL Id: tel-00733141**

**<https://theses.hal.science/tel-00733141>**

Submitted on 18 Sep 2012

**HAL** is a multi-disciplinary open access archive for the deposit and dissemination of scientific research documents, whether they are published or not. The documents may come from teaching and research institutions in France or abroad, or from public or private research centers.

L'archive ouverte pluridisciplinaire **HAL**, est destinée au dépôt et à la diffusion de documents scientifiques de niveau recherche, publiés ou non, émanant des établissements d'enseignement et de recherche français ou étrangers, des laboratoires publics ou privés.

N° d'ordre : 

1	9	0
---	---	---

ÉCOLE CENTRALE DE LILLE

THÈSE

présentée en vue  
d'obtenir le grade de

DOCTEUR

Spécialité : Automatique, Génie Informatique, Traitement du Signal et Images

par

ZHANG Bo

Doctorat délivré par l'École Centrale de Lille

Sur la commande à retour d'effort  
à travers des réseaux non dédiés:  
stabilisation et performance sous retards  
asymétriques et variables

Soutenue le 10 Juillet 2012 devant le jury :

Rapporteurs:	Prof. Emilia FRIDMAN	Université de Tel-Aviv - Israël
	Prof. Philippe FRAISSE	Université Montpellier 2
Président:	Prof. Michel DAMBRINE	Université de Valenciennes et du Hainaut-Cambrésis
Examineur:	Dr. Frédéric COLLEDANI	Commissariat à L'énergie Atomique
Directeur de Thèse:	Prof. Jean-Pierre RICHARD	EC Lille
Co-encadrant de Thèse:	Dr. Alexandre KRUSZEWSKI	EC Lille

Thèse préparée au Laboratoire d'Automatique, Génie Informatique et Signal  
L.A.G.I.S. - CNRS UMR 8219 - École Centrale de Lille  
Ecole Doctorale Sciences pour l'ingénieur ED 072  
PRES Université Lille Nord-de-France



Serial N° : | 1 | 9 | 0 |

**ECOLE CENTRALE DE LILLE**

**THESIS**

Presented to obtain  
the degree of

**DOCTOR**

Topic : Automatic Control and Industrial Data Processing

by

**Zhang Bo**

Ph.D. awarded by Ecole Centrale de Lille

**New control schemes for  
bilateral teleoperation  
under asymmetric communication channels:  
stabilization and performance  
under variable time delays**

Defended on July 10, 2012 in presence of the committee :

Rapporteurs:	Prof. Emilia Fridman	Tel-Aviv University - Israel
	Prof. Philippe Fraisse	University of Montpellier 2
President:	Prof. Michel Dambrine	University of Valenciennes and of Hainaut-Cambrésis
Examiner:	Dr. Frédéric Colledani	French Atomic Energy Commission
Thesis Supervisor:	Prof. Jean-Pierre Richard	EC Lille
Thesis Co-Advisor:	Dr. Alexandre Kruszewski	EC Lille

L.A.G.I.S. - CNRS UMR 8219 - Ecole Centrale de Lille  
Ecole Doctorale Sciences pour l'ingénieur ED 072  
PRES Université Lille Nord-de-France



## Acknowledgments

The PhD work presented in this thesis has been done at "Laboratoire d'Automatique, Génie Informatique et Signal" (LAGIS) in Ecole Centrale de Lille, from September 2009 to July 2012. This work is partly supported by the China Scholarship Council (CSC).

This thesis would not have been possible without the help and supports of so many people in so many ways. I would like to take the opportunity to express my gratitude to thank all friends and colleagues that have given me support and encouragement in my thesis work. First of all, my sincere thanks go to my supervisors, Prof. Jean-Pierre Richard and Dr. Alexandre Kruszewski, for their valuable guidance, continuous patience and encouragement and the share of their research experiences.

I would like to express my sincere gratitude to the members of my PhD Committee, Prof. Emilia Fridman, Prof. Philippe Fraisse, Dr. Frédéric Colledani and Prof. Michel Dambrine.

I also would like to express my sincere gratitude to all the members in the teams of "Equipe des Systèmes Non-linéaires et à Retard" (SyNeR) and "Non-Asymptotic Estimation for Online Systems" (NON-A), it has been a privilege to work together with the intelligent and friendly colleagues. I would especially like to mention the colleagues and friends in my office, Yang Tian, Christophe Fiter, Romain Delpoux, Hassan Omran, Emmanuel Bernuau, Laurentiu Hetel. Thanks to them, I have passed three agreeable years.

I would like to thank all the support staff. Throughout the years they have been very helpful. I first think of Philippe Vanheeghe, professor of Ecole Centrale de Lille and the chef of LAGIS. The secretariat has always been run with perfectionism, Virginie Leclercq, Vanessa Fleury, Christine Yvoz and Brigitte Foncez have relieved me of the administrative work. My thanks also go to Bernard, Hilaire, Gilles, Jacques, Patrick and Régine for their help, humor and hospitality.

I wish to express my special appreciation to Prof. Hélène Catsiapis, my French teacher. In her courses, I have learned not only the language but also the culture and history. Especially many trips organized by her, which enrich my life in France.

I would like to thank all my friends in Lille for their friendship and supports.

Finally, I want to thank all my family for always supporting and encouraging me.



# Contents

<b>List of Figures</b>	<b>7</b>
<b>List of Tables</b>	<b>9</b>
<b>Acronyms</b>	<b>11</b>
<b>Notations</b>	<b>13</b>
<b>Introduction and Outline of the Thesis</b>	<b>15</b>
<b>Chapter 1 Preliminaries</b>	<b>21</b>
1.1 Background and Challenges . . . . .	21
1.2 Overview of Teleoperation with Delays . . . . .	23
1.2.1 Types of Teleoperation . . . . .	24
1.2.2 Modeling of Time Delays . . . . .	26
1.2.2.1 Network Induced Delays . . . . .	26
1.2.2.2 Notations and Constraints for Delay Variations . . . . .	30
1.2.3 General Teleoperation Structure and Performance Objectives . . . . .	31
1.2.3.1 Performance Objective 1: Stability . . . . .	31
1.2.3.2 Performance Objective 2: Synchronization . . . . .	31
1.2.3.3 Performance Objective 3: Transparency . . . . .	31
1.2.3.4 General Teleoperation Structure . . . . .	31
1.2.4 Control Strategies in Teleoperation . . . . .	33
1.2.4.1 Passivity-Based Control . . . . .	34
1.2.4.2 Robust Control . . . . .	35
1.2.4.3 Frequential Methods . . . . .	36
1.2.4.4 Predictive Control . . . . .	37
1.2.4.5 Sliding Mode Control . . . . .	37



1.2.4.6	Adaptive Control . . . . .	38
1.2.4.7	Conclusions . . . . .	39
1.3	Outline of Time Delay Systems . . . . .	39
1.3.1	Modeling of Time Delay Systems . . . . .	40
1.3.2	Stability of Time Delay Systems . . . . .	41
1.3.3	Lyapunov Second Method and Extensions . . . . .	42
1.4	Conclusions . . . . .	44
<b>Chapter 2</b>	<b>Several Novel Control Schemes</b>	<b>47</b>
2.1	System Description and Assumptions . . . . .	47
2.2	Robust Stability Conditions . . . . .	50
2.2.1	Linear System with Time-Varying Delays . . . . .	50
2.2.2	$H_\infty$ Performance . . . . .	53
2.2.3	General Theorem on Rate-Independent Stability with $H_\infty$ Performance Index . . . . .	54
2.3	Bilateral State Feedback Control Scheme . . . . .	55
2.3.1	Controller Description . . . . .	56
2.3.2	Controller Design . . . . .	56
2.4	Force-Reflecting Proxy Control Scheme . . . . .	58
2.4.1	Slave Controller Description . . . . .	61
2.4.2	Controller Design . . . . .	62
2.4.2.1	Master-Proxy Synchronization . . . . .	62
2.4.2.2	Proxy-Slave Synchronization . . . . .	63
2.4.2.3	Global Performance Analysis . . . . .	64
2.5	Results and Analysis . . . . .	66
2.5.1	Abrupt Tracking Motion . . . . .	67
2.5.2	Wall Contact Motion . . . . .	68
2.5.3	Wall Contact Motion under Large Delays . . . . .	70
2.6	Conclusions . . . . .	72
<b>Chapter 3</b>	<b>Robustness Aspects</b>	<b>75</b>
3.1	Discrete-Time Approach . . . . .	76
3.1.1	Stability Analysis of Discrete-Time Delay System . . . . .	76
3.1.2	System Description and Problem Formulation . . . . .	79
3.1.3	Slave Controller Design . . . . .	81

---

3.1.4	Results and Analysis . . . . .	83
3.2	$H_\infty$ Robust Teleoperation under Time-Varying Model Uncertainties . . . .	86
3.2.1	$H_\infty$ Robust Control under Polytopic-Type Uncertainties . . . . .	87
3.2.1.1	Polytopic-Type $H_\infty$ Robust Stability . . . . .	87
3.2.1.2	Control Problem Formulation . . . . .	89
3.2.1.3	Problem 1: Local Controller Design . . . . .	90
3.2.1.4	Problem 2: Slave Controller Design . . . . .	90
3.2.1.5	Application to Euler-Lagrange Model . . . . .	94
3.2.2	$H_\infty$ Robust Control under Norm-Bounded Model Uncertainties . . . . .	95
3.2.2.1	Control Problem Formulation . . . . .	95
3.2.2.2	Problem 1: Local Controller Design . . . . .	96
3.2.2.3	Problem 2: Slave Controller Design . . . . .	96
3.2.3	Results and Analysis . . . . .	99
3.3	Conclusions . . . . .	101
 <b>Chapter 4 Implementation of Remote Haptic Cooperative System</b>		<b>103</b>
4.1	Experimental Test-Bench . . . . .	104
4.1.1	System Modeling . . . . .	105
4.2	Force Estimation . . . . .	105
4.3	Results and Analysis . . . . .	107
4.3.1	Abrupt Tracking Motion . . . . .	107
4.3.2	Wall Contact Motion . . . . .	107
4.4	Conclusion . . . . .	107
 <b>Conclusions and Perspectives</b>		<b>113</b>
 <b>Résumé étendu en français</b>		<b>119</b>
 <b>Appendix</b>		<b>131</b>
1	More Details about Passivity-Based Control . . . . .	131
2	Representations of Time Delay Systems . . . . .	135
3	Modeling of Time Delay Systems based on Functional Differential Equation	136
4	Design of Lyapunov-Krasovskii Functional . . . . .	139
5	Model Transformation of Time Delay Systems . . . . .	140
6	Controller Design based on Reciprocally Convex Approach of Lyapunov-Krasovskii Functional . . . . .	142

**Bibliography**

**147**

# List of Figures

1.1	Haptic interface cooperative system, LAGIS . . . . .	23
1.2	Two typical master/slave teleoperation schemes (upper: unilateral; lower: bilateral) . . . . .	25
1.3	Network delays composition . . . . .	27
1.4	Asynchronous sampling delay . . . . .	27
1.5	Data quantization error (borrowed from Wikipedia) . . . . .	28
1.6	General control scheme . . . . .	32
1.7	Predictive structure . . . . .	37
1.8	Sliding mode control structure . . . . .	38
1.9	Adaptive slave-side system structure . . . . .	39
2.1	General control scheme without auditive/visual signal . . . . .	47
2.2	Bilateral state feedback control scheme . . . . .	56
2.3	Force-reflecting control scheme . . . . .	59
2.4	Force-reflecting proxy control scheme . . . . .	61
2.5	Proxy of master . . . . .	61
2.6	An example of time-varying delays . . . . .	66
2.7	Position response in abrupt tracking motion (upper left: bilateral state feedback control scheme; upper right: force-reflecting proxy control scheme; lower left: from [Ye 2009c]; lower right: from [Hua 2010]) . . . . .	68
2.8	Position response in abrupt tracking motion (left: force-reflecting control scheme; right: force-reflecting proxy control scheme) . . . . .	69
2.9	Position scaling in abrupt tracking motion (left: bilateral state feedback control scheme; right: force-reflecting proxy control scheme) . . . . .	69
2.10	Position response in wall contact motion (upper left: bilateral state feedback control scheme; upper right: force-reflecting proxy control scheme; lower left: from [Ye 2009c]; lower right: from [Hua 2010]) . . . . .	70
2.11	Position response in wall contact motion (left: force-reflecting control scheme; right: force-reflecting proxy control scheme) . . . . .	71
2.12	Force response in wall contact motion ( $F_m(t)$ ; $\hat{F}_e(t)$ ) . . . . .	71
2.13	Position scaling in wall contact motion (left: bilateral state feedback control scheme; right: force-reflecting proxy control scheme) . . . . .	72
2.14	Position response with "large" delays in wall contact motion (left: bilateral state feedback control scheme; middle: force-reflecting proxy control scheme; right: from [Hua 2010]) . . . . .	72

2.15	Position response of force-reflecting proxy control scheme in wall contact motion (left: $h_2 = 0.2s$ ; right: $h_2 = 1.0s$ ) . . . . .	73
3.1	Discrete force-reflecting proxy control scheme . . . . .	79
3.2	Position response in abrupt tracking motion (left: our continuous-time force-reflecting proxy control scheme; right: our discrete-time result) . . . .	84
3.3	Performance in abrupt tracking motion (left: our continuous-time approach $\gamma^2(t)$ ; right: our discrete-time result $\gamma^2(k)$ ) . . . . .	85
3.4	Position response in wall contact motion (left: our continuous-time force-reflecting proxy control scheme; right: our discrete-time result) . . . . .	85
3.5	Force response in wall contact motion ( $F_m(k)$ ; $\hat{F}_e(k)$ ) . . . . .	86
3.6	Performance in wall contact motion (left: our continuous-time approach $\gamma^2(t)$ ; right: our discrete-time result $\gamma^2(k)$ ) . . . . .	86
3.7	Position response in abrupt tracking motion (left: polytopic-type; right: norm-bounded-type) . . . . .	101
3.8	Position response in wall contact motion (left: polytopic-type; right: norm-bounded-type) . . . . .	102
4.1	Master/slave experimental system structure . . . . .	104
4.2	Force estimation of $F_h(t)$ . . . . .	106
4.3	Position response in abrupt tracking motion (upper: bilateral state feedback control scheme; middle: force-reflecting control scheme; lower: force-reflecting proxy control scheme;) . . . . .	109
4.4	Position response in wall contact motion (upper: bilateral state feedback control scheme; middle: force-reflecting control scheme; lower: force-reflecting proxy control scheme;) . . . . .	110
4.5	Position response in wall contact motion (upper: bilateral state feedback control scheme; middle: force-reflecting control scheme; lower: force-reflecting proxy control scheme;) . . . . .	111
1	One master/multiple slaves teleoperation system . . . . .	116
1	La structure générale du contrôle . . . . .	122
2	Le schéma du contrôle bilatérale avec le retour de l'état . . . . .	123
3	Le schéma du contrôle avec le retour de la force . . . . .	124
4	Le schéma du contrôle avec le retour de la force et le 'Proxy' . . . . .	124
5	Le proxy du maître . . . . .	125
6	Le système de la téléopération avec un maître/multiples esclaves . . . . .	130
1	Two-port bilateral networked system . . . . .	131
2	Basic wave transformation . . . . .	132
3	Basic wave-based teleoperation . . . . .	133
4	Power-based time domain passivity control scheme . . . . .	134
5	Linear fractional transformation based on (29) and (30) . . . . .	138

# List of Tables

1.1	Main capabilities of the recent control strategies . . . . .	34
-----	--	----



# Acronyms

- CPU** - Central Processing Unit
- DOF** - Degree of Freedom
- GPS** - Global Position System
- IP** - Internet Protocol
- LKF** - Lyapunov-Krasovskii Functionals
- LMI** - Linear Matrix Inequality
- LPV** - Linear Parameter Varying
- LRF** - Lyapunov-Razumikhin Functions
- LTI** - Linear Time-Invariant
- LTV** - Linear Time-Varying
- NCS** - Network Control Systems
- QoS** - Quality of Service
- SMC** - Sliding Mode Control
- TCP** - Transfer Control Protocol
- TDS** - Time Delay System
- UDP** - User Data Protocol
- WSAN** - Wireless Sensor/Actuator Network
- WSN** - Wireless Sensor Network





# Notations

$\mathbb{N}$  - Set of positive integers

$\mathbb{R}$  - Set of real numbers

$\mathbb{R}_+$  - Set of positive real numbers or 0

$\bar{\mathbb{R}}_+$  - Set of positive real numbers

$\mathbb{R}^n$  - Set of real symmetric matrices of dimension  $n$

$\mathbb{R}^{m \times n}$  - Set of real matrices of dimension  $m \times n$

$\mathcal{C}([-h, 0], \mathbb{R}^n)$  - Set of continuous functions on  $[-h, 0]$  in  $\mathbb{R}^n$

$I$  - Identity matrix of appropriate dimension

$0$  - 0 or matrix of appropriate dimension with entries equal to 0

$M^T$  - Transpose matrix of  $M$

$M^{-1}$  - Inverse matrix of  $M$

$M^{-T}$  - Transpose matrix of the inverse of  $M$

$M > 0$  - Square symmetric positive definite matrix

$M < 0$  - Square symmetric negative definite matrix

$M < N$  -  $M - N$  matrix is a square symmetric negative definite matrix

$M = \begin{pmatrix} A & B \\ * & D \end{pmatrix}$  - Symmetric matrix  $M$ , where  $*$  means  $B^T$

$\|M\|_2$  - 2 Euclidean norm of  $M$

$col\{\alpha, \beta, \dots, \delta\}$  - Column vector with component  $\alpha, \beta, \dots, \delta$

$diag\{\alpha, \beta, \dots, \delta\}$  - Diagonal matrix with component  $\alpha, \beta, \dots, \delta$  on the main diagonal

$sup$  - Least upper bound of a partially ordered set

$min$  - Minimum of a set of values



# Introduction and Outline of the Thesis

## Context and general introduction of the thesis

This thesis is the fruit of a three years work (2009-2012) spent in "Laboratoire d'Automatique, Génie Informatique et Signal" (LAGIS) in Ecole Centrale de Lille, and in the team "Equipe des Systèmes Non-linéaires et à Retard" (SyNeR). Under the supervision of Prof. Jean-Pierre Richard and Asst. Prof. Alexandre Kruszewski, I worked on robust control of typical industrial teleoperation robots, which allows for handling very flexible tasks in collaboration with the human operator. Many international researches are devoted to the collaborative control, but few of them include the "network-in-the-loop" challenges.

More precisely on the thesis topic, we will consider a real experimental teleoperation test-bench as a type of closed-loop time delay control system, in which the time delays will be handled as in the most real cases, asymmetric and time-varying. The signals exchanged among the system's components are in the form of forward and backward information packets through an unreliable network, *e.g.* Internet or WiFi connections.

Based on the mathematical modeling of the real teleoperation test-bench, our work is devoted to the controller design for the whole system, which introduces some complexity since that firstly it reconstructs not only the past (delayed) state variables of the system, but also the present (predicted) state variables, secondly it needs to deal with several types of systems, minimize the modeling imperfections and uncertainties, eliminate the perturbations of the human operators and environment. Indeed, our challenge consists in guaranteeing several performances (the stability, the position/force tracking, the robustness) despite a variable Quality of Service of the communication link.

## Challenging points and motivations

Over the past 50 years, a plethora of research has been devoted to understand and overcome pertinent problems in teleoperation, in particular the bilateral teleoperation under

time delays [Hokayem 2006]. The prefix "tele" from Greek origin means at a distance and teleoperation naturally indicates operating at a distance. Thus, bilateral teleoperation is the extension of a person's sensing and manipulative capability to a remote environment.

Recently with the development of the control science, computer network and communication technologies (Internet, wireless network), the teleoperation becomes more and more popular and sophisticated, the design of which demands much higher performance. Real-time control over network delays becomes possible and has caught many research attentions (see *e.g.* [Jiang 2009], [Kruszewski 2011] and the references herein).

A great problem in the analysis of teleoperation systems is coming from the network constraints, caused by long-distance or wireless links [Tipsuwan 2003, Zampieri 2008]. More precisely, the bandwidth limitation, packet dropouts, sampling and delays belong to this problem. Several approaches have been developed to study these problems and have led to important results which have been applied successfully to handle challenging engineering teleoperation systems notably in the medical field<sup>1</sup>. Most of the network constraints, as it will be recalled, are related to time delay effects, that make the dynamical teleoperation system become a retarded one. In this area, stability analysis is still more complex than for Ordinary Differential Equations, and Lyapunov method has been developed from more simple cases through two celebrated tools, Lyapunov-Razumikhin Functions and Lyapunov-Krasovskii Functionals.

Another crucial problem is the robust stability analysis of the teleoperation feedback loops, since several constraints and requirements should be taken into consideration, *e.g.* the modeling uncertainties and the environment disturbances. The robust control algorithms and the recognition of environment are referred in the research working on teleoperation systems.

In this complex framework of delayed and perturbed systems, several performances are aimed at. Concerning teleoperation systems, the task performance is linked to the trajectory tracking and force feedback transparency. Many strategies have been studied to ensure these performances, but under the condition of time delays, guaranteeing these

---

<sup>1</sup>A famous example was the "Lindbergh operation", an intercontinental (New York - Strasbourg) surgical procedure directed by Prof. J. Marescaux in 2001. This operation used ATM network nodes through a high-speed terrestrial fiber-optics network. "This type of connection is very high quality with low transport delay and low packet loss ratio and is 99,9% reliable in terms of network outage, but come at a significant price that makes its everyday clinical use impracticable". Prof. J. Marescaux declared on 6th January, 2010 (Le Monde, [http://www.planete-plus-intelligente.lemonde.fr/sante/la-chirurgie-de-demain-c-est-la-chirurgie-assistee-par-un-robot\\_a-11-131.html](http://www.planete-plus-intelligente.lemonde.fr/sante/la-chirurgie-de-demain-c-est-la-chirurgie-assistee-par-un-robot_a-11-131.html)): "Le seul frein au développement de la télé chirurgie à grande distance demeure, aujourd'hui encore, son prix. Pour opérer à distance, il faut utiliser une ligne ATM en transcontinental, qu'il faut réserver pour six mois, et qui coûte environ 1 million de dollars." [Rosen 2010].

---

performances becomes much harder. Note that improving system performance and maintaining stability of the closed-loop system are usually conflicting: the compromise should be made in order to satisfy the requirements of real teleoperation.

Due to the particular system structure, the problems and challenging points, some modeling and control approaches have been generalized. In the point view of system modeling, the teleoperation system under time delays can be modeled as typical LTI/LPV/LTV systems, neutral/distributed delay systems,  $n$ -DOF nonlinear systems. Nonlinear system is closer to the real teleoperation, but note that, for the simplicity reasons, most of the research focused on linear systems based on the linearization of real teleoperation system. Furthermore, LPV/LTV systems can also be used to approximate nonlinear systems and hence the systematic and generic LPV/LTV systems can be applied to derive linear control laws for nonlinear systems.

As for control approaches (*e.g.* passivity-based control, Lyapunov method, robust control, predictive control, adaptive control, frequencial method, sliding mode control), they should be combined with the whole structure of the system, that is to say, different control methods for different system architectures meet different system performance objectives. Passivity-based control is more suitable for the teleoperation system with velocity/force information exchanged and without the trajectory tracking requirement [Nuño 2011]. In our thesis, our industrial teleoperation robots require that the control method adopted can handle time-varying delays, ensure robust stability under different working conditions, achieve the trajectory tracking and force feedback, at last be easily developed and implemented. Because each control strategy has its advantages, it is necessary for us to compare several control strategies and merge some of them in order to achieve the control objectives mentioned above.

## Outline of the thesis

**Chapter 1** is a literature survey, which provides an overview of problems and challenges, control objectives and structures, models of the various network effects, recent researches in the field of teleoperation, especially the delayed teleoperation. More precisely: the cooperative robotic control systems and delayed teleoperation are analyzed; based on different types of teleoperation systems and delays, a general control architecture meeting various control objectives is proposed; recent control methods are recalled in order to facilitate the choice of methods that we will use; an mathematical insight of time delay systems and Lyapunov method is given.

**Chapter 2** proposes three novel control architectures based on the general system architecture and the information exchanged between the master and the slave, which can be the positions, the velocities, and/or the forces (or their estimations). By applying the theories of Lyapunov-Krasovskii functionals and  $H_\infty$  control to the novel architectures, the stability conditions under asymmetric time-varying delays and perturbations of the human operator/environment are obtained, and then, the controllers ensuring stability and high-level performance are computed in terms of Linear Matrix Inequality (LMI) optimization. The simulations and comparisons with other results in different working conditions illustrate the merits of our methods. Note that, for simplicity reasons, linear time delay systems are considered in this chapter.

**Chapter 3** develops the results in Chapter 2 by handling various robustness aspects of the control scheme defined in 2. Firstly, considering the requirements of digital implementation on the experimental test-bench, the discrete-time approach of our stabilizing continuous-time bilateral teleoperation controllers is presented, based on a discrete Lyapunov-Krasovskii functional combined with  $H_\infty$  theory. Secondly, because LTI (linear, time-invariant) models may be quite unrealistic in concrete situations, we extend the results of Chapter 2 to systems with the time-varying polytopic-type and norm-bounded uncertainties. With this objective in mind, our design approaches can be summarized: the same control architecture can be used; the local controllers of subsystems are designed by Lyapunov functions and LMI; finally, the controllers reducing the impact of delays are obtained by Lyapunov-Krasovskii functional,  $H_\infty$  control and LMI. For each method mentioned above, the analyzed results are illustrated by various simulations.

**Chapter 4** achieves the system implementation on the experimental test-bench, based on the results of Chapter 2 and Chapter 3. Thanks to several proposed control schemes, a high degree of performance (the stability, the synchronization, the transparency) is guaranteed. In order to apply our theoretical results to the concrete test-bench, we introduce local linearizing controllers at the master and slave sides. Experimental results under different working conditions, *e.g.* abrupt tracking and wall contact motion, are performed to verify the correctness and effectiveness of the proposed methods.

## Main contributions

The main contributions in this thesis are as follows:

- Based on a large number of journal and conference papers, a general teleoperation

---

control architecture will be generalized, which can be tailored to fit many control strategies. The modeling of time delays and delayed teleoperation systems will be achieved, this is the basis of further works.

- Three novel teleoperation control schemes will be proposed to ensure the system stability and obtain a better system performance under asymmetric time-varying delays and the perturbations of the human operator and the environment, this will be illustrated by various simulations.

- The idea of merging Lyapunov method and  $H_\infty$  control theory is not new, but our works effectively combine the two methods with the teleoperation control architecture, and further apply them to design the controllers which make the teleoperation system meet the performance requirements. Several LMIs resolving the LKF and  $H_\infty$  control conditions will be derived in order to easily calculate the gains of the controllers.

- In addition to the ideal LTI time delay systems, some real cases in the control design of teleoperation system will also be considered. Discrete-time method will be proposed to facilitate the digital implementation on the experimental test-bench while ensuring the robustness with regard to input disturbances.  $H_\infty$  control will be applied to handle the time-varying polytopic-type and norm-bounded uncertainties. Generally, our proposed novel system architectures are suitable for a variety of real situations of teleoperation.

- Finally, note that most of the theoretical works dealing with control over networks limit their examples to simulation cases. From the beginning of this work, we had in mind to illustrate the feasibility of our results by proposing a validation on a experimental device. So, according to the obtained theoretical results, real experimental test-bench will be installed, and some analysis will be made.

Therefore, we can conclude a complete control design, which involves the establishment of control objectives, the modeling of control systems and subsystems, the design of control architecture, the calculation of controllers, the simulations and experimental tests with consideration of various real situations.





# Chapter 1

## Preliminaries

### 1.1 Background and Challenges

Multi-robot cooperation turns to be more and more significant for complex tasks in industry, the demands of which can not be achieved by a single robot. Cooperative robotics, as a rising cross-subject, integrates many theories, *e.g.* intelligent control, distributed artificial intelligence, sociology, management science, biology. It discusses many topics systematically, *e.g.* system architecture, integrated modeling and optimization, cooperative behaviors and evolution of robotic systems [Chong 2000]. However, cooperative robotics refers to many problems and challenges.

1. Wireless or long-distance, a key feature of remote cooperative control, requires stable communication channels, which introduce such problems as bandwidth limitation, packet dropouts, sampling and delays (in this case, cooperative robotics can be considered as Network Control Systems [Tipsuwan 2003, Zampieri 2008]). All these problems can be defined as the network constraints, which can deteriorate the system performance, even drive the global system unstable. Therefore, they should be considered in the design of cooperative robotic systems.
2. Besides, the design step has to take the complex environment changes into consideration: the robotic control algorithms should be considered as a typical hybrid control structure, and in the case of man-machine system, the operator should feel the visual or sensitive information that is interacted between the robot and the environment [Anderson 1989, Chopra 2006]. In [Park 2006, Cortesao 2006], the environmental contact force is handled by a position-force teleoperation structure and reproduced at the master side, but the time delays are supposed to be constant.

3. In many practical cases, there exist modeling uncertainties in multi-robot systems, and models are completed with some limit constraints such as energy limit, time requirement and communication range, which also have to be taken into account [Wei 2007].
4. Collaborative sensing (*e.g.* Wireless Sensor Network (WSN), Wireless Sensor/Actuator Network (WSAN)) is envisioned useful in a wide range of multi-robot cooperation for monitoring physical parameters and detecting objects or substances in an area. Some research considered the use of either fixedly deployed stationary sensors or sensors on mobile platforms traversing controlled paths [Clouqueur 2002, Santi 2003], and recently, the mobile sensing model utilizing mobile sensors arises, so as to handle the target detection, the field estimation and edge detection [Wang 2005].
5. In cooperating applications, the path planning and trajectory tracking is an important aspect. With this objective, in the intelligent multi-vehicle cooperative control system, a distributed approach called consensus tracking has been designed [Cao 2010]. [Defoort 2007] focused on the path planning, which is separated from the control algorithm and designed by an online optimization strategy.

In the consensus manipulative robots, the main requirement of haptic interface cooperative systems is the position/velocity/force tracking based on the system stability [Chopra 2008b, Nuño 2009]. In Fig. 1.1, a slave robot (the right part of Fig. 1.1) should perfectly follow the motion of a master robot (the left part of Fig. 1.1), which is maneuvered by a human operator. Accordingly, the environmental force acting on the slave, when it contacts the external environment, should be accurately and real-time transmitted to the master robot [Nuño 2008]. Fig. 1.1 corresponds to the real experimental test-bench of our laboratory LAGIS, on which the main theoretical results of this thesis have been illustrated.

This work focuses on bilateral teleoperation systems with unreliable communication links, and will consider most of these problems and challenges in this particular framework. Indeed, it will consider some particular aspects of *item 1* (wireless or long-distance communication links); *item 2* (human operator's force on the master robot and environment's force on the slave robot just as [Park 2006, Cortesao 2006]); *item 3* (parametric uncertainties and exogenous disturbances); *item 4* (will be limited to some force sensors); *item 5* (the position/force tracking).

Note that two papers [Park 2006, Cortesao 2006] present a good overview of the robotic challenges for bilateral teleoperation: the control architecture design; the position/force

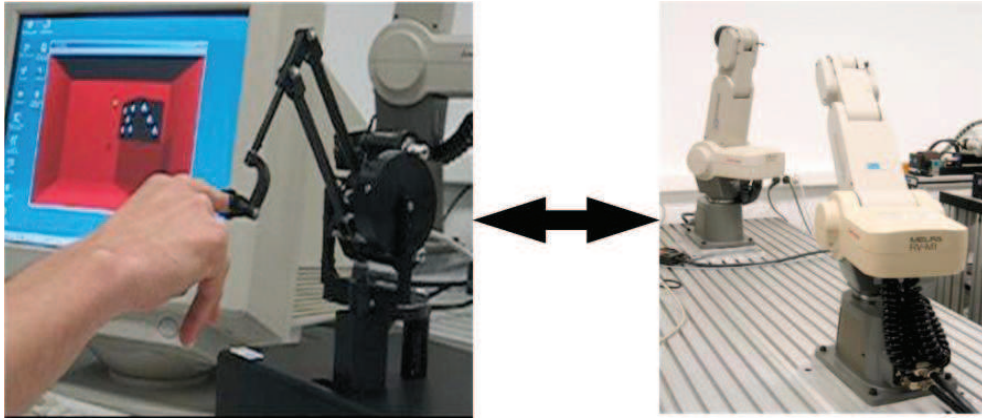

Figure 1.1: Haptic interface cooperative system, LAGIS

tracking; the robustness of the global system. These papers take into consideration constant communication delays. In our work, we consider similar challenges, while we extend the control techniques to asymmetric time-varying delays.

But before presenting our contribution in the next chapter, we will firstly introduce the delayed teleoperation and various types of delays, secondly the recent research in this area. At last, some theoretical methods of time delay systems, which are useful in our design approach, will be given.

## 1.2 Overview of Teleoperation with Delays

As an important aspect of cooperative robotics, the teleoperation systems extend the human manipulative capabilities to the remote environment. The first application of teleoperation system dated back in 1950's, when the force reflecting robotic manipulators were used in the nuclear industry [Kress 1997]. In the teleoperation development process, there are some keystone stages from understanding the interaction between the human and robots to a mostly theoretic control area [Hokayem 2006]. During 1960's, delay effects were introduced in [Ferrell 1965], and then supervisory control and a series of software languages were developed to address this problem for constant delays [Ferrell 1967, Fong 1986, Sato 1987]. Beginning in 1980's, more advanced control theoretic strategies started to appear *e.g.* Lyapunov-based and passivity-based stability analysis were presented [Miyazaki 1986, Anderson 1989], which are still prevalent research methods now in the design of teleoperation system under time-varying delays [Nuño 2011]. Besides, the impedance and hybrid representations to the virtual models appeared in the late 1980's and early 1990's, focusing at this stage on the teleoperation systems

without delays or with constant time delays [Hannaford 1988, Raju 1989]. During the 1990's, as the internet began to be used for communication, the variability of delays was considered [Yokokohji 1999]. At the same time, apart from the basic system stability, the transparency/synchronization became an important objective of teleoperation systems [Lawrence 1993]. With the change of objectives, earlier delay related results were adapted *e.g.*  $H_\infty$  control theory was utilized in teleoperation design [Leung 1994]. Note that in all these control methods, Lyapunov approach and  $H_\infty$  control are the main design strategies. In this thesis, we also consider these techniques, and complete them with the Lyapunov-Krasovskii approach.

As the technological evolution of teleoperation system design, teleoperation has been introduced in various application domains, *e.g.* hazardous research area, telemedicine, aerial/space/underwater application, industrial mining, real time gaming and nuclear industry [Hokayem 2006]. According to the different application areas, the next parts will present different types of delayed teleoperation, and their performance objectives, and then, control strategies to handle delayed teleoperation will be presented.

### 1.2.1 Types of Teleoperation

In typical application of teleoperation, a so-called master/slave teleoperation system (wired or wireless, dedicated or shared, short-distance or long-distance) is composed of five entities: the human operator, the haptic interface (master), the remote robot (slave), the environment and the communication network [Triden 2006]. Through the communication medium, various types of information can be transferred *e.g.* position/angular position, velocity/angular velocity, force/torque, video, voice and time [Hua 2010]. Based on the typical master/slave teleoperation, two different teleoperation systems as depicted in Fig. 1.2 have been considered. This classification depends on the exchange of information between the master side and the slave side.

In general, the teleoperation systems shown in Fig. 1.2 are classified as unilateral teleoperation (the upper part) and bilateral teleoperation (the lower part). Firstly, in unilateral teleoperation, the human operator drives the slave robot without the feedback information from slave to master, that is to say, the human operator is decoupled from the global system, and the operator impedance can not affect the system performance [Khan 2010]. The unilateral teleoperation is more reliable and much easier to implement than the bilateral one. The key technique is to make the slave track the human movements. Typical applications include digital control system and haptic tele-

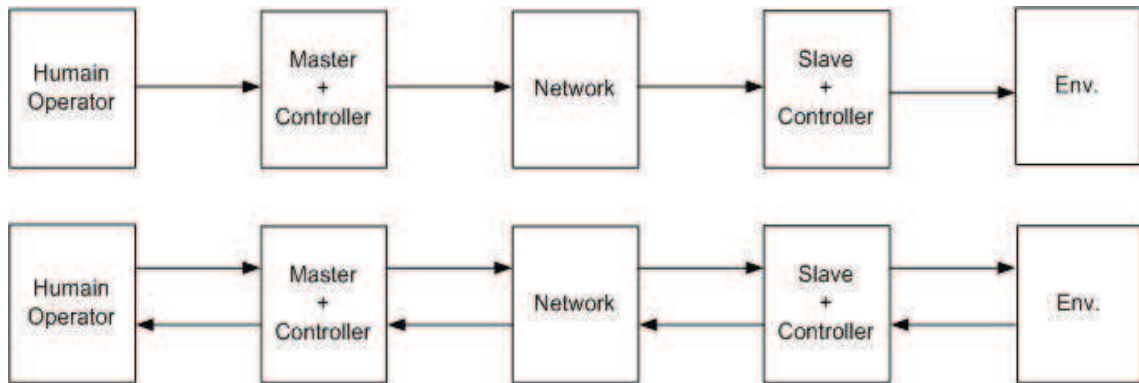

Figure 1.2: Two typical master/slave teleoperation schemes (upper: unilateral; lower: bilateral)

operation, the force and position information are only transferred from the operator to the remote side. [Rodriguez-Angeles 2010] implemented interfaces providing acceleration and turning rates of human operators, and then send these real-time information to the 3D display system.

In most cases of unilateral teleoperation, the slave system has a local closed-loop control system, which guarantees the system runs well. Supervisory control strategy can be used in the design, and in this case, the human operator acts as a supervisor, and the distant slave robot is given more 'intelligence' to complete the tasks autonomously [Hopper 1996]. However, like other approaches, the supervisory control in unilateral case can only provide rough system performance (the position/velocity tracking) without the information transferred from the slave to the master, which constrains the application of unilateral teleoperation.

Bilateral teleoperation involves an additional feedback from the slave side: if the communication delays are small, real-time feedback can be obtained [Anderson 1989]. Supervisory control strategy can also be applied in bilateral teleoperation, the supervisor receives the force or video feedback occasionally, and then adjusts control instructions to the slave robot. If there exist long delays in the system, "move and wait" policy can be adopted [Sheridan 1993]. Besides, collaborative control can make use of bilateral teleoperation, the human operator and the slave robot collaborate to perform tasks and achieve common goals. Instead of occasional supervisory instructions, the human operator and the robot engage in a frequent dialogue to exchange the information [Fong 2001].

More generally, there are different types in bilateral teleoperation defined with respect to the forward-backward information pair between the master and the slave.

- In velocity-force teleoperation, the velocity is the forward information from the

master to the slave, and the force is the backward information. The passivity-based teleoperation belongs to this structure [Anderson 1989, Niemeyer 1991, Ryu 2005b, Nuño 2009, Ye 2009c, Lee 2010a].

- The position-force *e.g.* an impedance-shaping term has been utilized to the generalized teleoperation control architecture, which guarantees the macro-micro effect [Son 2011]. [Park 2006] introduced a novel haptic teleoperation approach that integrates the contact force control with stiffness adaptation and a virtual spring to connect the master and the slave systems, many technique details *e.g.* Kalman active observers, online stiffness estimation can be found in this paper.

- The position-position: the impedance-shaping term can also be used in the position-position control architecture [Son 2011]. In fact, all the impedance-shaping based architectures in [Son 2011] derive from a four-channel control architecture [Lawrence 1993].

- It is possible that the mixed information are utilized *e.g.* the position/velocity/force-force [Zhang 2011b] or the position/velocity-position/velocity [Zhang 2011a] teleoperation, which will be presented in this thesis.

Although bilateral teleoperation has broader practical application, it asks more sophisticated design algorithms to ensure the global system stability and high level performance in presence of variable delays. This thesis will focus on these problems.

## 1.2.2 Modeling of Time Delays

### 1.2.2.1 Network Induced Delays

In order to facilitate the presentation of control performance objectives and control strategies, here we introduce the time delays.

Long-range or flexible communication links such as the Internet or Wireless 802.11 networks are extremely interesting in teleoperation. However, their unreliability [Chopra 2008a] hinders their use in bilateral teleoperation. More particularly, variations in the Quality of Service (QoS) introduce additional, complex dynamics [Zampieri 2008] represented by time-varying delays [Kruszewski 2011]. And because delays have a strong influence on the system performance [Richard 2003], they must be considered at the very stage of teleoperation control design. Their variability could be reduced by using buffers and waiting strategies [Khan 2010], however it is obvious that maximizing the delay up to its largest value is detrimental to the speed performance of the remote system.

In practical scenarios, the networked communication and wireless links do not offer zero delays and infinite bandwidth that can be neglected safely. Because of the very nature

of the communication networks, there exist many negative impacts, *e.g.* communication delays, data loss, asynchronous sampling, data quantization error [Zampieri 2008], which are shown in Fig. 1.3-1.5.

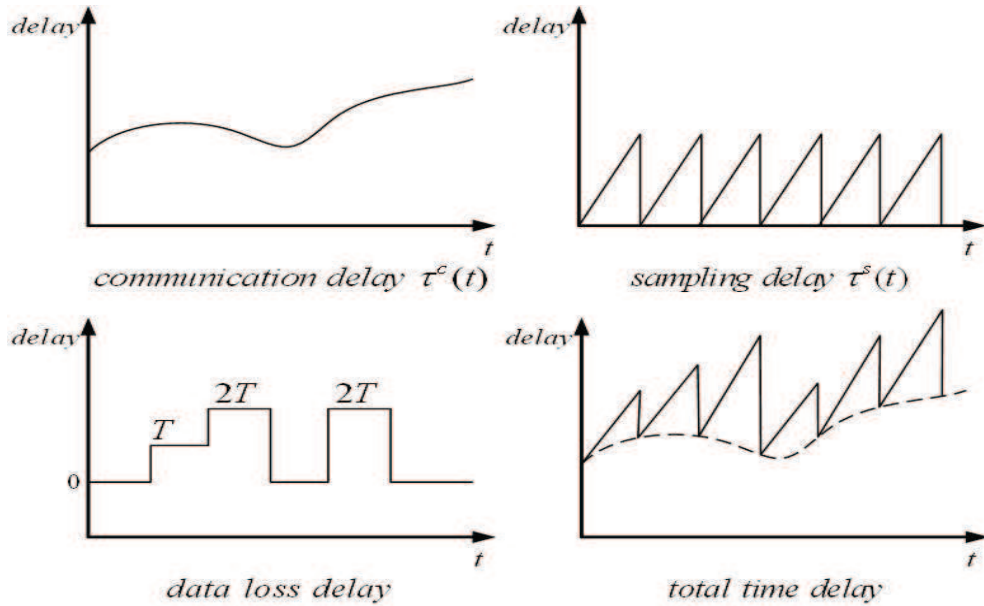

Figure 1.3: Network delays composition

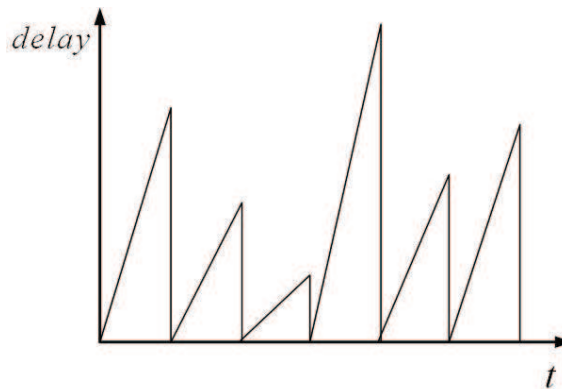

Figure 1.4: Asynchronous sampling delay

In Fig. 1.3, we can conclude various impacts (communication delays, data loss, sampling delays) as the total time delay. In the sequel, the superscript  $c$  denotes the communication delays *e.g.*  $\tau^c(t)$ , superscript  $s$  denotes the sampling delays *e.g.*  $\tau^s(t)$ . Here, we consider the case of constant sampling period, so the data loss delay is noted as  $NT$ ,  $N$  is a positive integer, but more realistically, the data sampling interval is also variable [Fiter 2012]: this synchronization can be considered in the same input delay



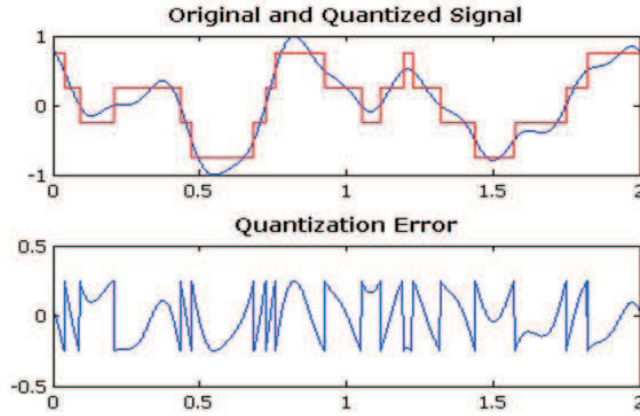

Figure 1.5: Data quantization error (borrowed from Wikipedia)

framework [Fridman 2004a], as well as hybrid switched models [Floquet 2009]. Here, we will only consider the first solution, this case is depicted on Fig. 1.4.

Overall, following [Seuret 2008, Jiang 2009, Khan 2010, Kruszewski 2011], this allows for making all various delays lump together (the addition of the three delays in Fig. 1.3) as one type of variable delay denoted as  $\tau(t)$ :

$$\tau(t) = \tau^c(t) + \tau^s(t) + NT. \quad (1.1)$$

Thus, in reality, communication delays are fast time-varying, and constant communication delays are rather theoretical approximation of practical situations. These various sources of delays are being detailed in the following.

1. Communication delays can be bounded or unbounded, which depend upon the types of network and should be treated in different ways at the control design stage. For instance, the token ring local area network introduces bounded communication delays, but the internet brings unbounded communication delays when packets are dropped out.
2. Another source of variable time delays comes from the sampling effect. Recently, modeling of continuous-time systems with digital control in the form of continuous-time systems with delayed control input was introduced by [Fridman 2004a], mainly for asymptotic approximations of small enough sampling intervals. Note that in [Fridman 2004a], the system input  $u(t)$  is given by:

$$u(t) = Kx(t_k) = Kx(t - \tau(t)). \quad (1.2)$$

Here,  $x(t)$  is the system state,  $t_k$  are the sampling instants, and we represent a piecewise constant control law as a continuous time control with a time-varying piecewise continuous delay:

$$\tau(t) = t - t_k, \quad t_k \leq t < t_{k+1}. \quad (1.3)$$

In the constant sampling, one has  $t_{k+1} - t_k = h$ , so  $\tau(t) < h$ . Some other sampling models have been raised by [Lee 2006, Flavia 2008] with periodic sampling and [Nešić 2004, Fridman 2005b] with variable sampling for hybrid or switched systems.

3. The information data may be lost while being transferred through the network (also called the packet dropouts or the packet loss) [Hespanha 2007], to evaluate this problem, the packet loss rate is introduced to indicate the number of packets that do not reach the destination in relation to all sent packets. It has mainly two causes, the transmission errors in physical network links and the buffer overflows resulting from the network congestions. Note that, in the application of wireless networks, the phenomenon of data loss is more frequent.
4. Bilateral communication relies on two communication channels, each of them introduces some delay. Asymmetry of the channel delays means that the delays of the forward and backward channels are not equal. For simplicity reasons, some authors consider the symmetric delays in two channels, but this does not hold in Internet or wireless networks, because the routers and the paths are not necessarily the same in the two ways.
5. An asynchronism of the master's and slave's clocks also constitutes a source of delay. However here, we do not detail this effect and prefer to assume the synchronism. Such clock synchronization of the master and the slave is achieved thanks to time-stamped data packet exchanges between them, using a network time protocol [Kruszewski 2011] or a GPS strategy [Jiang 2008]. When a packet arrives the master side or the slave side, its communication time delay can be calculated with that the time clock of the network is unique.
6. TCP vs. UDP (Time Control Protocol vs. User Data Protocol). Since we are in a control situation, our packets will contain the sampled values of the measured position/velocity/force. If a packet is lost we can choose to re-send it until it is

received, which corresponds to TCP. However, a more convenient solution to send the next sampled value without trying to re-send the discarded or lost one. This solution is supported by UDP with a re-ordering of the received packets with regard to their time of reception.

### 1.2.2.2 Notations and Constraints for Delay Variations

The above modeling of time delays is based on the digital communication properties, and the following will focus on the different modeling types of delays based on the mathematical properties of time delays [Seuret 2006], and the delay  $\tau(t)$  has the following form:

$$\tau(t) = h + \eta(t), \quad (1.4)$$

where  $h \geq 0$  is a nominal constant value and  $\eta(t)$  is a time-varying fluctuation.

- The constant delay:  $\eta(t) = 0$ ,  $h \neq 0$ . The constant delays, which can be known or unknown, and can be solved by many methods *e.g.* Linear Matrix Inequalities [Fridman 2002, Kharitonov 2003], frequency criterion stability analysis [Verriest 1993].

- The non-small time-varying delay:  $|\eta(t)| \leq \mu < h$ , so  $\tau(t) \in [h - \mu, h + \mu]$ . This is a practical delay condition in the internet-based teleoperation, because there are always delays in internet medium in any case. In [Jiang 2005], the time delay is assumed to be non-small time-varying, and a delay-dependent stability theorem without using model transformation is established based on  $H_\infty$  control.

- The interval time-varying delay:  $0 \leq \eta(t) \leq \mu$ , so  $\tau(t) \in [h, h + \mu]$ . As  $h = 0$ , the communication transfer is supposed as an instantaneous medium [Wu 2004], since the delay can be zero, this is different from the non-small time-varying delay mentioned above. Some additional delay conditions *e.g.* the delay with the constraint on the derivative can be utilized with this condition.

- The time delay with the constraint on the derivative:  $\dot{\tau}(t) \leq d < 1$ ,  $d > 0$ , or  $\dot{\tau}(t) \leq 1$  [Lien 2005a]. The former constraint means the delayed information arrive in the chronological order *e.g.* the time delayed function is defined as  $t - \tau(t)$ , the constraint on the derivative can ensure the time delayed function strictly increasing. The latter constraint has the similar meaning, but the derivative of delays can be 1, this is useful to model the sampling phenomena.

Generally, the real delays in the application can be modeled as a combination of the time delays mentioned above [Wu 2004, Lien 2005a], and as the real implementation, the

delays above will be discretized [Hetel 2008].

### 1.2.3 General Teleoperation Structure and Performance Objectives

#### 1.2.3.1 Performance Objective 1: Stability

The same as any other control systems, the stability of global system independently of the behavior of the human operator and the environment is the basic requirement of teleoperation systems under delays.

#### 1.2.3.2 Performance Objective 2: Synchronization

The synchronization of the master and the slave is being investigated in many linear/nonlinear teleoperation systems, where the slave robot should follow the motion of the master robot maneuvered by a human operator [Razi 2007], otherwise the two master and slave positions will have a drift. Specially because of excessive delays in bilateral teleoperation, the perfect synchronization is hard to maintain.

#### 1.2.3.3 Performance Objective 3: Transparency

The transparency (also called the telepresence) provides the human operator with a sense of real experience or impression of being present at the slave side (or makes the slave robot feels the human force). Implementation of transparency is usually performed through sound (auditive), video (visual) and touch (force) teleoperation [Lawrence 1993, Chopra 2006].

#### 1.2.3.4 General Teleoperation Structure

A general system structure is given in Fig. 1.6 to achieve these performance objectives [Arcara 2002].

- The general control scheme can be considered as a N-channel structure, in which N-channel represents various forward or backward information channels, *e.g.* the forward position channel, the backward velocity channel, the backward auditive channel [Lawrence 1993]. Many teleoperation control strategies involve the N-channel structure, we will introduce some of these methods in the following.

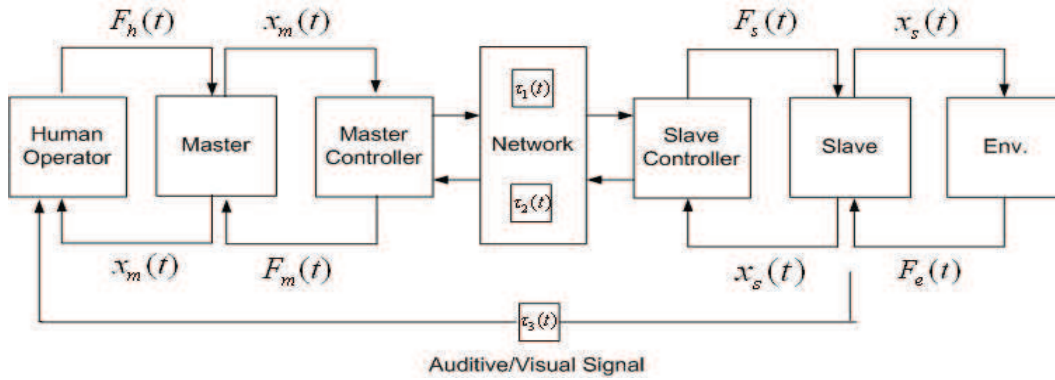

Figure 1.6: General control scheme

- Master controller and slave controller are the global controllers we should design so to ensure both the stability of the whole system and the synchronization/transparency between the master and the slave.

- $F_m(t)$  and  $F_s(t)$  are the actuated inputs of the master and of the slave, outputs of master and slave controllers.

- $F_h(t)$  and  $F_e(t)$  are the forces of the human operator and of the environment.

- $x_m(t)$  and  $x_s(t)$  are the states of the master and slave.

- $\tau_1(t)$  (from the master to the slave) and  $\tau_2(t)$ ,  $\tau_3(t)$  (from the slave to the master) are the delays that can be modeled as mentioned in previous section.

- The information transferred between the master and the slave can be divided into two categories: the auditive/visual signals; the mechanical properties of the system *e.g.* the position, the velocity or the estimated/measured forces of the human operator and the environment. This last category is more closely related with the system stability and synchronization. Both two categories contribute to the transparency, however in this work we only focus on "mechanical transparency".

This control structure is generic enough to represent most of the control schemes for master/slave bilateral teleoperation, and it is the basic structure of all novel control schemes proposed in this thesis. The control part (master/slave controllers) is designed so to reduce the consequences of the delays and ensure the system stability/performance. Based on this scheme, in the next chapter, three choices will be proposed according to the allowed complexity and performance requirements.

### 1.2.4 Control Strategies in Teleoperation

Generally, the high level stability and the synchronization/transparency are conflicting. As the communication medium (wired or wireless) introduces large delays, this conflict becomes more intense, and many control strategies have been involved to resolve this problem. At the beginning stage of teleoperation, a waiting strategy was used, whereby the human command is sent and the operator waits for the execution of the slave robot [Ferrell 1965, Khan 2010]. With the development in the communication and control technologies, real-time strategies arose: some recent approaches used in the control design of delayed teleoperation are presented in Table 1.1. The reader can refer to the following references for more details, while the following subsections will only recall their main characteristics, except for Lyapunov methods that will be more detailed in the context of delay systems.

- Passivity-based control (Passivity) [Anderson 1989, Niemeyer 1991, Kim 1992, Kosuge 1996, Yokokohji 2000, Zhu 2000, Hannaford 2001, Munir 2001, Lozano 2002, Ryu 2003, Lee 2003, Chopra 2004, Tanner 2004, Ryu 2004a, Ryu 2004b, Ryu 2005a, Ryu 2005b, Matidakis 2005, Iqbal 2006, Chopra 2006, Polushin 2006, Ryu 2007, Chopra 2008a, Chopra 2008b, Nuño 2008, Alise 2009, Kawashima 2009, Nuño 2009, Satler 2009, Ye 2009a, Ye 2009b, Ye 2009c, Lee 2010a, Natori 2010, Nuño 2011]. Within these references, the survey [Nuño 2011] is a recent and comprehensive presentation of this field.

- Robust control (Robust), *e.g.*  $H_\infty$  design,  $\mu$ -synthesis [Leung 1994, Lee 1994, Leung 1995, Yan 1996, Sano 1998, Tadmor 2000, Boukhnifer 2004, Sirouspour 2005, Zhang 2011a, Zhang 2011b].

- Frequential methods (Freq.) [Verriest 1993, Taoutaou 2003, Niculescu 2003b, Delgado 2009, Tian 2011].

- Predictive control (Predict.) [Smith 1957, Smith 1959, Sheng 2004, Smith 2005, Casavola 2006, Witrant 2007, Natori 2010].

- Sliding Mode Control (SMC) [Park 2000, Cho 2001, Garcia-Valdovinos 2007, Shahbazi 2010, Daly 2010].

- Adaptive control (Adapt.) [Hsu 2000, Leeraphan 2002, Nuño 2011].

- Lyapunov method and extensions (Lyapunov) [Miyazaki 1986, Niculescu 1999, Han 2001, Fridman 2001a, Rehm 2002, Han 2002, Fridman 2002, Gao 2003, Kharitonov 2003, Fridman 2004b, Fridman 2005a, Lien 2005b, Fridman 2006b, Xu 2006, Xu 2007, He 2007, Park 2007, Hetel 2008, Hou 2010, Hua 2011].

In Table 1.1, three main performance capabilities are given as the columns, the con-

Table 1.1: Main capabilities of the recent control strategies

Control Strategy	Time Delays		Position Tracking	Force Tracking
	Constant	Time-Varying		
Passivity	✓	✓	✓	
Robust	✓	✓	✓	✓
Freq.	✓		✓	
Predict.	✓	✓	✓	
SMC	✓	✓	✓	
Adapt.	✓		✓	
Lyapunov	✓	✓	✓	

trol strategies are introduced as the rows. Since the auditive or visual tracking are not considered in our experimental test-bench, they are omitted here.

Note that the main capabilities presented in Table 1.1 refer to the performance that each control strategy can achieve by itself, whereas in some cases, several control strategies are combined with each other, *e.g.* Lyapunov method and robust control, passivity-based control and adaptive control [Nuño 2011], or some control approaches are applied to some novel control structures: [Delgado 2009] synthesized the frequencial method and Lyapunov-Krasovskii functionals, and then applied them to a novel teleoperation scheme; frequencial method, passivity-based control and Lyapunov method have been applied to the generalized four-channel control architecture initially proposed by [Lawrence 1993]. By this way, the combined approaches can obtain a higher level of performance they can not achieve independently.

#### 1.2.4.1 Passivity-Based Control

Nonlinear control architectures are a prevalent research direction at the design stage of teleoperation, in which the passivity-based architectures play an important role. Generally, the passivity is more like a concept, in which one system that is passive is also stable. From the energy point of view, a system is passive, if it obeys the following properties [Niemeyer 1991, Niemeyer 1996, Matiakis 2005]:

- The system absorbs more energy than it produces.
- Considering  $P_{in}(t) = \frac{d}{dt}E_{store}(t) + P_{diss}(t)$ , where  $P_{in}(t)$  is the input energy,  $E_{store}(t)$  is the energy stored in the system, and  $P_{diss}(t) \geq 0$  is the dissipated energy, then at each time  $t \geq 0$ :  $\int_0^t P_{in}(\tau)d\tau = E_{store}(t) - E_{store}(0) + \int_0^t P_{diss}(\tau)d\tau \geq -E_{store}(0)$ .

As a major research direction of teleoperation, many control strategies have been pre-

sented based on the passivity concept, which include scattering-based, damping injection (which can achieve the position tracking), wave transformation and energy/power time domain passivity control, some of which are detailed in Appendix .1 [Nuño 2011]. These strategies also invoke various other control areas, *e.g.* frequencial method, adaptive control, Lyapunov method. Furthermore, most of the passivity strategies are independent of the delays (constant or time-varying) and of the system types, this is an important advantage of the passivity approach. However, in this thesis we support an alternative point of view: we will take into account the additional information on the delay values that are accessible to master and slave sides, distinctly. By this way, one can improve the system performance compared on independent-of-delay approaches.

Note that the simulation results of the passivity approaches [Ye 2009b, Ye 2009c] will be presented later in the thesis, and compared to our results under the same working conditions.

#### 1.2.4.2 Robust Control

Robust control is designed to minimize the effects of the modeling imperfections, uncertainties and input or measurement disturbances, in which  $H_\infty$  and  $\mu$ -synthesis control are the prevalent approaches, which are utilized to derive compensation algorithms for delay-free or delayed teleoperation. Taking the  $H_\infty$  control as an example firstly, the criterion is:

$$\sup_w \frac{\|z(t)\|_2}{\|w(t)\|_2} < \gamma, \quad (1.5)$$

where  $w(t)$  is defined as the exogenous disturbance signal, and  $z(t)$  is seen as the objective control output. The  $H_\infty$  control design objective is to minimize the norm of the closed-loop mapping  $w(t) \rightarrow z(t)$ . More precisely, we look for a minimum characterization of level  $\gamma$  by designing the appropriate controller.

Referring to  $\mu$ -synthesis control, the robust performance problem is also formulated based on the closed-loop mapping  $w(t) \rightarrow z(t)$ :

$$z(t) = \Upsilon(*, K)w(t), \quad (1.6)$$

where  $\Upsilon(*, K)$  contains the controller  $K$ , which is the solution to the following  $\mu$ -synthesis optimization where  $\mu_\Delta$  is the structured singular value:

$$\min_{K \text{ stabilizing}} \|\mu_\Delta(\Upsilon(*, K))\|_\infty < 1. \quad (1.7)$$



The main advantage of robust control is that the whole system remains stable despite variations and uncertainties in the dynamics of operator, master robot, communication channels, slave robot, and the environment.  $H_\infty$  control is utilized with Lyapunov methods as in [Shaked 1998, Tadmor 2000, Fridman 2001b, Fridman 2002, Gao 2003], and with frequencial method as [Leung 1995], in which  $H_\infty$  and  $\mu$ -synthesis are combined to design a controller for the free motion case (using  $H_\infty$ ) and delayed constrained motion case (using  $\mu$ -synthesis).

Note that many design structures have been presented, in which by robust control, the system stability/performance can be ensured. In [Sirouspour 2005], without delays, the force and position tracking are ensured by an  $\mu$ -synthesis control approach. [Sano 1998] introduced gain-scheduled compensation in the  $H_\infty$  controller design, that is to say, it designed and applied several controllers for the different values of constant delays, thus, the varied controllers are more suitable for delay variations on some values. In [Boukhnefer 2004], the force/position scaling and haptic feedback have been proposed based on the stability guarantee, a similar design procedure with [Leung 1995] was performed in the controller design. Besides, [Yan 1996] combined  $H_\infty$  control theory and 4-channel structure to handle time delays, disturbances, uncertainties and measurement noises. Smith predictor can also be applied with  $H_\infty$  control, the preliminary analysis can be found in [Lee 1994] under constant delays.

In this thesis,  $H_\infty$  control theory is an important approach, which will be applied with novel control schemes and Lyapunov-Krasovskii functionals.

### 1.2.4.3 Frequencial Methods

Frequencial approach is valuable for delay-dependent and delay-independent asymptotic stability analysis of linear teleoperation system. However, mostly of the available results only consider constant delays: in [Tian 2011], the wave variable method is analyzed in frequency domain to handle constant delays; [Delgado 2009] shows that the frequencial approach can deal with time-varying delays integrated with Lyapunov method or  $H_\infty$  control, but actually, it requires to extend the time-varying delays to their upper bound, and at last, the time-varying delays are treated as the constant delays. Besides, the 4-channel formulation was utilized usually with frequencial approach, in order to realize system transparency, this essential objective of teleoperation can be represented by  $Z_t = Z_e$ , here,  $Z_t$  is the input impedance of the human operator,  $Z_e$  is the impedance of the remote environment [Lawrence 1993].

However, the approach in [Niculescu 2003b, Taoutaou 2003] proposed closed-loop sta-

bility analysis of velocity-force delayed teleoperation under possible time-varying delays. By deriving system parameters that guarantee stability of the transfer function from the input force of human operator  $F_h(t)$  and the velocity of slave  $\dot{\theta}_s(t)$ , the delay-dependent and delay-independent asymptotic stability region can be obtained.

#### 1.2.4.4 Predictive Control

Since Smith's predictor in the late 1950's [Smith 1957, Smith 1959], the predictive control has been widely considered in the delay systems, especially under constant delays but also for variable, known delays [Witrant 2007]. The simple and basic predictive control strategy is given in Fig. 1.7 (note that this predictive scheme is a special case of the general structure in Fig. 1.6, and with constant delays  $\tau_1(t) = \tau_2(t) = \tau$ ) [Casavola 2006, Iqbal 2006].

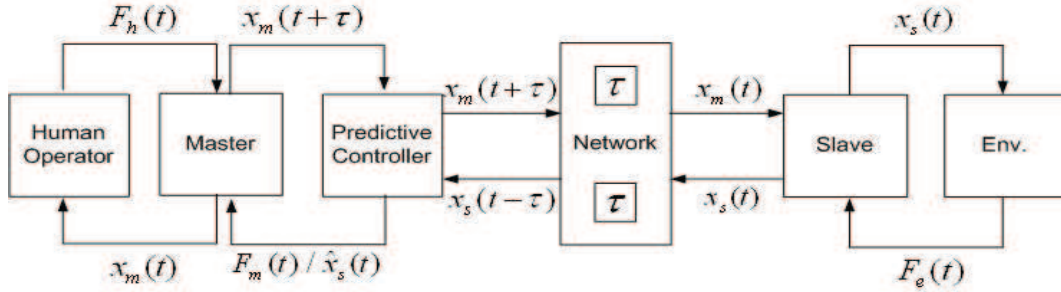

Figure 1.7: Predictive structure

The predictive controller is the design objective, which essentially contains a model of the slave robot and realizes so-called time desynchronization between the master and the slave in which the master works  $\tau$  time instants ahead of slave side (at each time instant  $t$ , a prediction  $\hat{x}_s(t)$  represents the remote slave state  $x_s(t)$ ).

Recently, a modified model predictive control technique was proposed, which adds restrictions on control inputs [Sheng 2004], and was based on both the current measurement information and a correction signal reflecting the difference between the measured information and its prediction. Here again, the delays were supposed to be equal and constant.

#### 1.2.4.5 Sliding Mode Control

Sliding mode control has been used extensively in teleoperation to cope with parametric uncertainties and hard nonlinearities. Based on Fig. 1.6, a typical system structure of

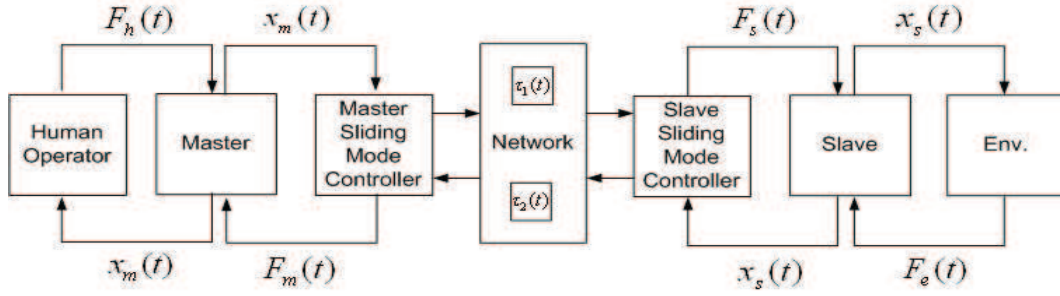

Figure 1.8: Sliding mode control structure

sliding mode control is shown in Fig. 1.8. In order to guarantee the stability and performance of the system, we select firstly the sliding surface  $s(t)$  comprised of the error between the positions and the velocities of the master and the slave:

$$s(t) = \dot{\tilde{x}}(t) + \lambda\tilde{x}(t), \quad (1.8)$$

where  $\tilde{x}(t) = \theta_s(t) - k_\theta\theta_m(t)$ ,  $k_\theta$  is a position scaling factor [Park 2000, Cho 2001],  $\lambda$  is a positive scalar. After that, one or two sliding mode controllers in Fig. 1.8 are designed to drive the system trajectories to the sliding surface in finite time and stay on it, *e.g.* for the sliding surface in (1.8), the sliding mode controllers are obtained by using  $\dot{s}(t) = s(t) = 0$ .

First order sliding mode controller is applied to teleoperation in presence of asymmetric variable communication delays [Shahbazi 2010], but can not handle the situation where the slave is in contact with a rigid environment. Thus, higher order sliding mode controller is proposed to guarantee the robust tracking [Garcia-Valdovinos 2007].

#### 1.2.4.6 Adaptive Control

Adaptive control design usually requires a reference model and identifies it during operation [Leeraphan 2002], and only focuses on the constant delays. This feature gets an advantage: the master and the slave are subject to the independent adaptive motion/force controllers at each side, thus, it can be applied in free as well as contact working conditions [Zhu 2000]. Recalling the general control architecture in Fig. 1.6 and taking the slave side as an example, we detail the slave controller in Fig. 1.9. Thus, we need to design the adjustment mechanism and the slave controller (we can consider these two modules as the slave controller of Fig. 1.6) so to reduce the impact of delays and improve the performance of system.

Lyapunov-based or passivity-based adaptive controllers are applicable to systems with dynamic environmental parameter variations [Niemeyer 1991, Hsu 2000, Nuño 2011]. Spe-

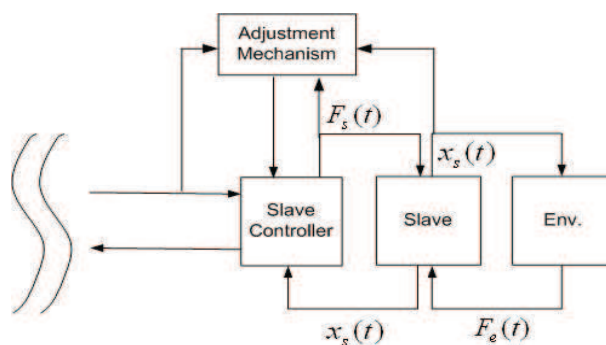

Figure 1.9: Adaptive slave-side system structure

cially in [Nuño 2011] and references therein, nonlinear teleoperation has been handled with a general Lyapunov-like function under passive environment, compared to other adaptive controllers, they can provide the stability and position tracking independent of delays.

#### 1.2.4.7 Conclusions

From the stability, system performance or real implementation view points, each control method mentioned above has some advantages and shortcomings. For instance, the robust control ( $H_\infty$  design) in teleoperation has better control performance compared to passivity-based control, but passivity-based control can ensure the stability of various types of system (linear, nonlinear, continuous-time, discrete-time, distributed, noncasual) even with large delays [Ye 2009c, Zhang 2011b]. Adaptive controllers can provide the position tracking independent of delays, but just the constant delays [Nuño 2011].

Therefore, the choice of control methods depends upon many factors *e.g.* the application objectives, software/hardware conditions, the delays (with or without delays, constant or variable delays), especially the performance of each control approach.

## 1.3 Outline of Time Delay Systems

Time delay systems are also called systems with aftereffect or dead-time, hereditary systems, equations with deviating argument or differential difference equations [Richard 2003]. Generally, various problems even for simple systems are caused by time delays. This section will briefly show the modeling and stability of time delay systems, and further introduce Lyapunov methods that allow for analyzing the stability of systems with variable delays.

### 1.3.1 Modeling of Time Delay Systems

There are various formalisms to represent time delay systems in the time domain, the frequency domain or the abstract space, some of which can deal with the constant delays, and some can be extended to handle time-varying delays [Dambrine 1998, Gu 2003]. Three different representations are commonly used: differential equation with coefficients in a ring of operators, differential equation on an infinite dimensional abstract linear space, functional differential equation for systems with variable delays, the last one is the most spread representation. We will detail it in the following, the other two representations are recalled in Appendix .2.

A Functional differential equation details an evolution over a finite Euclidian space or a functional space. A general system with time delays is given by:

$$\begin{cases} \dot{x}(t) = f(x(t), x_t, u(t), u_t), \\ x_t(\theta) = x(t + \theta), \quad x(t_0) = x_0, \\ u_t(\theta) = u(t + \theta), \quad u(t_0) = u_0, \\ x_{t_0} = \phi(\theta), \quad \theta \in [-h, 0]. \end{cases} \quad (1.9)$$

Based on (1.9), let us consider the system with piecewise time-varying delays acting on the state  $x(t)$  or input  $u(t)$  (more types of time delay systems are presented in Appendix .3 [Kolmanovskii 1999a, Seuret 2006]):

$$\begin{cases} \dot{x}(t) = f(x(t), x(t - \tau_1(t)), u(t), u(t - \tau_2(t))), \\ x(t_0 + \theta) = \phi(\theta), \quad \dot{x}(t_0 + \theta) = \dot{\phi}(\theta), \\ u(t_0 + \theta) = \zeta(\theta), \\ \theta \in [-h, 0], \end{cases} \quad (1.10)$$

where  $\phi(\theta)$  and  $\zeta(\theta)$  are the initial conditions,  $\tau_1(t)$ ,  $\tau_2(t) \in [0, h]$ ,  $h > 0$  are the time delays.

Recently, many authors consider linear system with several piecewise delays acting on the state  $x(t)$  or input  $u(t)$ :

$$\begin{cases} \dot{x}(t) = A_0 x(t) + \sum_{i=1}^n A_i x(t - \tau_{1i}(t)) + B_0 u(t) + \sum_{j=1}^m B_j u(t - \tau_{2j}(t)), \\ x(t_0 + \theta) = \phi(\theta), \quad \dot{x}(t_0 + \theta) = \dot{\phi}(\theta), \quad \theta \in [-h, 0], \end{cases} \quad (1.11)$$

where  $A_0$ ,  $A_i$ ,  $i = 1, 2, \dots, n$ ,  $B_0$  and  $B_j$ ,  $j = 1, 2, \dots, m$  are constant matrices. In this thesis, we study a particular class of such models (1.11), *e.g.* the case of two piecewise time-varying delays on state  $x(t)$ :

$$\begin{cases} \dot{x}(t) = A_0x(t) + A_1x(t - \tau_1(t)) + A_2x(t - \tau_2(t)) + B_0u(t), \\ x(t_0 + \theta) = \phi(\theta), \quad \dot{x}(t_0 + \theta) = \dot{\phi}(\theta), \quad \theta \in [-h, 0]. \end{cases} \quad (1.12)$$

This corresponds to our application: for fully actuated manipulative robots with a known Lagrangian model and measured state, it is possible to design a local linearizing controller so to obtain a linearized process. In the sequel, we also include possible parameter uncertainties as well as exogenous disturbances so to take more complex systems into consideration.

### 1.3.2 Stability of Time Delay Systems

Stability analysis is an open problem, which refers to two main directions: the frequency domain and the time domain analysis. The first one deals with the generalization of characteristic polynomial; the second one considers the state-space domain and matrices. Normally, the frequency domain approaches only consider the systems with constant delays, whereas the time domain approaches have a wide applicability to any type of systems. Taking the practical application into account, this thesis will focus on time domain approaches. Classical notions of stability in the sense of Lyapunov method can be found in [Kolmanovskii 1999a], that will not be recalled here. Some additional stability concepts are introduced as follows [Niculescu 2001, Briat 2008]:

**Definition 1.1 (*Delay-Independent Stability*)** *If a time-delay system is asymptotically stable for any delay values belonging to  $\mathbb{R}_+$ , the system is said to be delay-independent asymptotically stable.*

**Definition 1.2 (*Delay-Dependent Stability*)** *If a time-delay system is asymptotically stable for all delay values belonging to a compact subset  $D$  of  $\mathbb{R}_+$ , the system is said to be delay-dependent asymptotically stable.*

**Definition 1.3 (*Rate-Independent Stability*)** *For a delay-dependent asymptotically stable time delay system, if the stability does not depend on the variation rate of delays or on the time derivative of delays, the system is said to be rate-independent asymptotically stable.*

**Definition 1.4 (*Rate-Dependent Stability*)** *For a delay-dependent asymptotically stable time delay system, if the stability depends on the variation rate of delays or on the time derivative of delays, the system is said to be rate-dependent asymptotically stable.*

Of course, rate-independent/dependent stability focuses on the case of time-varying delays.

### 1.3.3 Lyapunov Second Method and Extensions

In the time domain, Lyapunov theory and its extensions are a prevalent approach to check the stability of time delay systems. This section is devoted to explain the principle and extensions of Lyapunov method.

In the absence of delay, Lyapunov second method is an efficient approach (the system stability is assured by the construction of Lyapunov function  $V(x(t))$  positive definite and its derivative  $\dot{V}(x(t))$  negative definite along the trajectories of (1.9)), but this method is only feasible to a very restricted class of delay systems: because the expression of  $\dot{V}(x(t))$  depends on both the present and past values of  $x(t)$ , checking its sign becomes impossible in general. We should extend Lyapunov second method, with a novel definition of Lyapunov function  $V(x_t)$ . Novel  $V(x_t)$  should depend on the delayed state  $x_t$  and similarly, the derivative  $\dot{V}(x_t)$  depends on  $\dot{x}_t$  along the trajectories of (1.10).

Two extensions have been proposed corresponding to the candidate functionals  $V(x_t)$  and  $V(x(t))$ , respectively Lyapunov-Krasovskii functionals (LKF) and Lyapunov-Razumikhin functions (LRF), which are the most famous results concerning the stability of time delay systems in the time domain. Briefly, the process of stability analysis can be summarized as follows:

- The search of suitable  $V(x_t)$  (LKF) or  $V(x(t))$  (LRF).
- The asymptotical stability condition, depending of the derivative of  $V(x_t)$  or  $V(x(t))$

along the system trajectories, writes:

*LKF*:  $V(x_t) > 0$ ,  $\dot{V}(x_t) < 0$ , for any  $x_t \neq 0$ , and  $V(x_0) = 0$ ,  $\dot{V}(x_0) = 0$ .

*LRF*:  $V(x(t)) > 0$ ,  $\dot{V}(x(t)) < 0$ , for any  $x(t) \neq 0$ , whenever  $V(x(t + \theta)) < \rho V(x(t))$ ,  $\rho > 1$ ,  $\theta \in [-h, 0]$ , and  $V(x(0)) = 0$ ,  $\dot{V}(x(0)) = 0$ .

In fact, the form of LRF is simpler than LKF, but it generally leads to nonlinear conditions and more conservative results. In the thesis, we focus on Lyapunov-Krasovskii functional stability with  $H_\infty$  performance. More details about Lyapunov-Razumikhin functions can be found in [Boyd 1994, Kolmanovskii 1999a, Kim 2001, Gu 2003, Seuret 2006, Briat 2008].

**Theorem 1.5 (Lyapunov-Krasovskii Stability Theorem)** *Suppose that  $x(0) = 0$  is an equilibrium of (1.9),  $f: \mathbb{R} \times \mathcal{C}([-h, 0], \mathbb{R}^n) \rightarrow \mathbb{R}^n$  maps  $\mathbb{R} \times$  (bounded sets of*

$\mathcal{C}([-h, 0], \mathbb{R}^n)$  into bounded sets of  $\mathbb{R}^n$ , and  $u, v, w: \bar{\mathbb{R}}_+ \rightarrow \bar{\mathbb{R}}_+$  are continuous non-decreasing functions,  $u(s)$  and  $v(s)$  are positive for  $s > 0$ , with  $u(0) = v(0) = 0$ . If there exists a continuous differentiable functional  $V: \mathbb{R} \times \mathcal{C} \rightarrow \mathbb{R}$  such that:

$$u(\|\phi(0)\|) \leq V(t, \phi) \leq v(\|\phi(0)\|), \quad (1.13)$$

and:

$$\dot{V}(t, \phi) \leq -w(\|\phi(0)\|), \quad (1.14)$$

then the zero solution of (1.9) is uniformly stable. If  $w(s) > 0$  for  $s > 0$ , then it is uniformly asymptotically stable.

According to the stability types (*Definition 1.1-1.4*) and the delay system types (linear/nonlinear system, piecewise/distributed delay system, neutral delay system), many different forms of LKF have been proposed, the readers can refer to Appendix .4 for more design details of Lyapunov-Krasovskii functionals. Taking a simple example for delay-independent and rate-independent stability of linear delay system  $\dot{x}(t) = Ax(t) + A_1x(t - h)$ ,  $h$  is the arbitrary constant delay, a possible Lyapunov-Krasovskii functional is given by:

$$V(x_t) = x^T(t)Px(t) + \int_{t-h}^t x^T(\theta)Qx(\theta)d\theta, \quad (1.15)$$

where symmetric matrices  $P > 0, Q > 0$ . Computing the derivative of  $V(x_t)$ :

$$\begin{aligned} \dot{V}(x_t) &= \dot{x}^T(t)Px(t) + x^T(t)P\dot{x}(t) + x^T(t)Qx(t) - x^T(t-h)Qx(t-h) \\ &= \begin{pmatrix} x(t) \\ x(t-h) \end{pmatrix}^T \begin{pmatrix} A^T P + P A + Q & P A_1 \\ * & -Q \end{pmatrix} \begin{pmatrix} x(t) \\ x(t-h) \end{pmatrix} = \zeta(t)^T \Pi \zeta(t). \end{aligned} \quad (1.16)$$

So  $\zeta(t) = \begin{pmatrix} x(t) \\ x(t-h) \end{pmatrix}$ ,  $\Pi$  is a symmetric matrix. From now on, we shall simplify the notation by using  $*$  to represent the symmetric terms in the matrix, e.g.  $\Pi$ . We then obtain the following result.

**Theorem 1.6 (Delay-Independent Stability Theorem)** Suppose there exist symmetric matrices  $P > 0, Q > 0$ , such that LMI condition (1.17) is feasible, then the system  $\dot{x}(t) = Ax(t) + A_1x(t - h)$  with delay  $h$  is delay-independent asymptotically stable:

$$\begin{pmatrix} A^T P + P A + Q & P A_1 \\ * & -Q \end{pmatrix} < 0. \quad (1.17)$$



Further, the delay-dependent stability of the same system is proposed by another Lyapunov-Krasovskii functional:

$$V(x_t) = x^T(t)Px(t) + \int_{t-h}^t x^T(\theta)Qx(\theta)d\theta + \int_{-h}^0 \int_{t+\theta}^t \dot{x}^T(s)Z\dot{x}(s)dsd\theta, \quad (1.18)$$

where symmetric matrices  $P > 0$ ,  $Q > 0$ ,  $Z > 0$ . Then,  $\dot{V}(x_t)$  along the system trajectories writes:

$$\begin{aligned} \dot{V}(x_t) &= x^T(t)[A^T P + PA + Q]x(t) + x^T(t)A_1^T Px(t) - x^T(t-h)Qx(t-h) \\ &\quad + \dot{x}^T(t)hZ\dot{x}(t) - \int_{t-h}^t \dot{x}^T(s)Z\dot{x}(s)ds. \end{aligned} \quad (1.19)$$

We should use Jensen's inequality [Gu 2003] to remove the integral part and get the upper bound of  $\dot{V}(x_t)$ :

$$- \int_{t-h}^t \dot{x}^T(s)Z\dot{x}(s)ds \leq -\frac{1}{h} \int_{t-h}^t \dot{x}^T(s)dsZ \int_{t-h}^t \dot{x}(s)ds. \quad (1.20)$$

Thus, the rate-independent stability theorem (the rate-independent stability implies the delay-dependent stability) is obtained.

**Theorem 1.7 (Rate-Independent Stability Theorem)** *Suppose there exist symmetric matrices  $P > 0$ ,  $Q > 0$ ,  $Z > 0$ , such that LMI condition (1.21) is feasible, then the system  $\dot{x}(t) = Ax(t) + A_1x(t-h)$  with delay  $h$  is rate-independent asymptotically stable:*

$$\begin{pmatrix} A^T P + PA + Q - \frac{1}{h}Z & PA_1 + \frac{1}{h}Z \\ * & -Q - \frac{1}{h}Z \end{pmatrix} < 0. \quad (1.21)$$

In fact, various model transformations of time delay systems are often utilized to get better stability conditions based on Lyapunov method, we detail these model transformations in Appendix .5. More details about Lyapunov-Krasovskii functionals of neutral/distributed delay systems or different types of stability can be found in [Park 1999, Han 2001, Fridman 2001a, Fridman 2002, Han 2002, Richard 2003, Fridman 2003, Xu 2003, Wu 2004, Fridman 2004a, Fridman 2004b, Jing 2004, Lien 2005a, Lien 2005b, Fridman 2006a, Xu 2007, Park 2007, He 2007, Gomes da Silva Jr 2011].

## 1.4 Conclusions

This chapter has given an overview of problems and challenges, control objectives and structures, recent researches in the field of teleoperation system, especially, the delayed

teleoperation system. The general teleoperation control scheme in Fig. 1.6 arises at meeting the main objectives *e.g.* the stability, the synchronization and the transparency. Several recent methods have been introduced in Table 1.1, in which passivity-based method will be compared with our approach, and  $H_\infty$  theory will be applied in this thesis. At last, time delay systems have been concisely presented, and the principles of the LKF-based stability approach have been introduced.

Generally speaking, some theories of this thesis are detailed as follows:

- Teleoperation system will be designed based on the proposed general control scheme in Fig. 1.6 to meet the control objectives mentioned above.
- The representation of our teleoperation system will use functional differential equation with different time-varying delays coming from the asymmetry of the communication channels.
- The master/slave controller design will be given by combining the theories of LKF and  $H_\infty$  performance so to be computable in terms of LMI optimization.



## Chapter 2

# Several Novel Control Schemes

This chapter is devoted to the controller design problem for bilateral teleoperation system under asymmetric and time-varying delays (in this area, many solutions have been presented, most of which have been introduced in previous chapter). With this motivation, some preliminary description and assumptions should be introduced before further works, which will constitute the first section. Then, this chapter will present the stability condition and three novel control schemes based on LKF,  $H_\infty$  control theory and LMI optimization. At last, the results of simulation and comparisons with other methods (*e.g.* passivity-based method [Ye 2009c], another Lyapunov-Krasovskii functional approach [Hua 2010]) will be presented.

### 2.1 System Description and Assumptions

Firstly, let us recall the general scheme as Fig. 1.6 in previous chapter. Here, according to our research focus, we do not consider the auditive/visual signals.

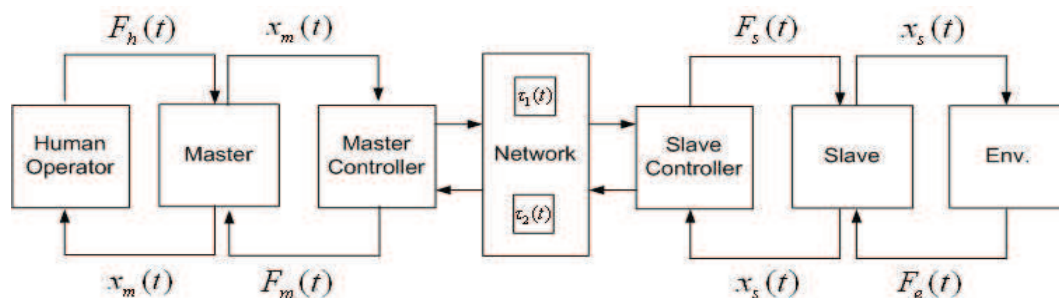

Figure 2.1: General control scheme without auditive/visual signal

Our following novel control schemes will be proposed with the design of different

master/slave controllers for bilateral teleoperation. Besides, in this thesis, the position, the velocity or the estimated/measured force will be transferred between the master and the slave. Note that we intend to reproduce or track, as much as possible, the present position/velocity/force, despite the transmission delays. This represents a "predictive" effect that will characterize our control schemes.

Several performance objectives should be achieved, above all it is the basic asymptotic stability of teleoperation systems under time-varying delays. And then, the synchronization/transparency should also be enhanced:

- Firstly, *position tracking* (or *position coordination*): the slave robot should follow the motion of the master robot driven by human operator [Razi 2007]. Especially when there are the time-varying delays in the communication lines, to achieve position tracking becomes more difficult.

- Secondly, *force tracking* (or *force coordination*): the environmental force acting on the slave (when it contacts the external environment) should be accurately and real-time reproduced to the master [Chopra 2006]. This can be achieved by the force-reflecting (the force feedback reproducing the environmental force at the side of human operator), in which the human operator feels haptic sensations as if he or she is actually present at the remote site [Lee 2010b].

Thus, our objective is to achieve these performance objectives by designing the master/slave controllers. The asymptotic stability of the closed-loop system is to be proved by Lyapunov approaches, especially Lyapunov-Krasovskii functionals that can be designed by LMI optimization (see [Fridman 2006a] and the references therein). For the performance consideration, the  $H_\infty$  control theory is used to make the position error (master/slave synchronization) converge to a small region [Fridman 2001b, Xu 2006, Zhang 2008], which can be defined as  $H_\infty$  region. And then, the force tracking is realized by the direct force-reflecting.

Besides, according to the general scheme and our experimental test-bench, the following assumptions are made.

**Assumption 1** *In our experimental test-bench, we will realize independently the control for each axis of master/slave robots (3-axis robots, one degree-of-freedom for each axis), and the nonlinear terms (e.g. the frictions) of master/slave robots can be linearized by internal feedback or controlled by  $H_\infty$  theory, thus the master and slave robots can be considered as linear dynamical systems (more details can be found in Chapter 4).*

*Thus, the master and the slave are reducible to the following models:*

$$\dot{x}_m(t) = (A_m - B_m K_0^m)x_m(t) + B_m(F_m(t) + F_h(t)), \quad (2.1)$$

$$\dot{x}_s(t) = (A_s - B_s K_0^s)x_s(t) + B_s(F_s(t) + F_e(t)), \quad (2.2)$$

where  $x_m(t) = \dot{\theta}_m(t) \in \mathbb{R}^n$ ,  $x_s(t) = \dot{\theta}_s(t) \in \mathbb{R}^n$  are the velocities of the master and the slave,  $K_0^s$  and  $K_0^m$  are local partial state feedbacks. They will be supposed to be known according to the following Assumption 4.  $A_m$ ,  $B_m$  and  $A_s$ ,  $B_s$  are constant matrices.  $F_m(t)$  and  $F_s(t)$  are the actuated force inputs of the master and of the slave.  $F_h(t)$  and  $F_e(t)$  are the uncontrolled forces of the human operator and of the environment on the master and on the slave respectively.

As mentioned above, each axis of master/slave robots will be designed respectively, so in this thesis,  $\dot{\theta}_m(t) \in \mathbb{R}^1$ ,  $\dot{\theta}_s(t) \in \mathbb{R}^1$ . In the following, the systems will also be considered as 1-DOF systems.

**Assumption 2** *The used long-range or flexible communication links (e.g. the Internet, Wireless 802.11 networks) introduce additional, complex dynamics that can be represented by delays [Zhang 2011b, Kruszewski 2011]. Furthermore, there exists a maximum delay value between two network terminations.*

Thus, in this thesis, the communication delays are time-varying, asymmetric and bounded, as  $\tau_1(t)$ ,  $\tau_2(t) \in [h_1, h_2]$ ,  $h_1 \geq 0$ . Here, the delays result from the communication, access time, and packet loss effects [Kruszewski 2011].

Note that this assumption is not very restrictive for some cases of real networks, we already explained in previous chapter that a finite number of successive lost packets under UDP protocol creates a bounded sampling delay. Besides, if the delay reaches the values that overpass the assumed maximum limit, then the bilateral control must be switched to another kind of controllers [Kruszewski 2011].

**Assumption 3** *Each data packet transferred between the master and the slave includes an added time-stamp. By this way, the master or slave side can calculate the delays affecting the received packets, as soon as it receives the packet.*

Besides, thanks to the time-stamped data packets, the master and slave clocks are synchronized by a network time protocol [Kruszewski 2011], or an alternative GPS strategy [Jiang 2008].

**Assumption 4** *The master and the slave systems have the local controllers ensuring the speed stability, respectively  $K_0^m$  and  $K_0^s$ .*

Note that *Assumption 1* and *Assumption 4* will be relaxed in the next chapter, where the robustness *w.r.t.* parameter variations and exogenous disturbances will be taken into account.

Thanks to these assumptions, we are now ready to present our control schemes.

## 2.2 Robust Stability Conditions

This section provides the theoretical results that will be useful in our stability and performance analysis. For simplicity reasons, the systems described in this section are modeled as linear time-invariant systems as *Assumption 1* but, for a use in more realistic situations, we will also consider additive perturbations.

The first theorem focuses on the asymptotical stability of time-varying delay systems, the second one considers the stability with the  $H_\infty$  performance index for perturbed systems without delay. The third one, in the final subsection, synthesizes these two subsections and gives a general stability condition with the  $H_\infty$  performance index for perturbed systems with time-varying delays.

### 2.2.1 Linear System with Time-Varying Delays

Consider the general time-varying delay system described by:

$$\begin{cases} \dot{x}(t) = A_0x(t) + \sum_{i=1}^q A_i x(t - \tau_i(t)), \\ x(t_0 + \theta) = \phi(\theta), \quad \dot{x}(t_0 + \theta) = \dot{\phi}(\theta), \quad \theta \in [-h_2, 0]. \end{cases} \quad (2.3)$$

Here,  $x(t) \in \mathbb{R}^n$  is the present system state,  $\phi(\theta)$  is the initial state function, which is supposed to be piecewise continuous with a finite number of bounded jumps, and continuously differentiable on each subinterval. Delays  $\tau_i(t) \in [h_1, h_2]$ ,  $h_1 \geq 0$ ,  $i = 1, 2, \dots, q$ , are time-varying. There is no particular assumption on  $\dot{\tau}_i(t)$ , that is to say, the delays can be fast-varying: our following results handle the rate-independent stability.  $A_0$  and  $A_i$ ,  $i = 1, 2, \dots, q$ , are constant matrices. We consider the following Lyapunov-Krasovskii functional [Fridman 2006a]:

$$\begin{aligned}
 V(x(t), \dot{x}(t)) &= \underbrace{x(t)^T P x(t)}_a \\
 &+ \underbrace{\int_{t-h_2}^t x(s)^T S_a x(s) ds + \int_{t-h_1}^t x(s)^T S x(s) ds}_b \\
 &+ \underbrace{h_1 \int_{-h_1}^0 \int_{t+\theta}^t \dot{x}(s)^T R \dot{x}(s) ds d\theta + \sum_{i=1}^q (h_2 - h_1) \int_{-h_2}^{-h_1} \int_{t+\theta}^t \dot{x}(s)^T R_{ai} \dot{x}(s) ds d\theta}_c.
 \end{aligned} \tag{2.4}$$

Roughly speaking, the part  $a$  in (2.4) represents Lyapunov function without considering the delays,  $b$  is the part for constant delays, and  $c$  is the one that handles time-varying delays.

**Theorem 2.1** *Suppose there exist  $n \times n$  symmetric matrices  $P > 0$ ,  $R > 0$ ,  $S > 0$ ,  $S_a > 0$ ,  $R_{ai} > 0$ , and some matrices  $P_2$ ,  $P_3$ ,  $Y_1$ ,  $Y_2$ ,  $i = 1, 2, \dots, q$ , such that LMI condition (2.5) with notations (2.6) is feasible. Then, the system (2.3) is rate-independent asymptotically stable for time-varying delays  $\tau_i(t) \in [h_1, h_2]$ ,  $i = 1, 2, \dots, q$ .*

$$\Gamma^1 = \begin{pmatrix} \Gamma_{11}^1 & \Gamma_{12}^1 & R + \sum_{i=1}^q P_2^T A_i - q Y_1^T & q Y_1^T & -P_2^T A_1 + Y_1^T & \dots & -P_2^T A_q + Y_1^T & Y_1^T & \dots & Y_1^T \\ * & \Gamma_{22}^1 & \sum_{i=1}^q P_3^T A_i - q Y_2^T & q Y_2^T & -P_3^T A_1 + Y_2^T & \dots & -P_3^T A_q + Y_2^T & Y_2^T & \dots & Y_2^T \\ * & * & -S - R & 0 & 0 & 0 & 0 & 0 & 0 & 0 \\ * & * & * & -S_a & 0 & 0 & 0 & 0 & 0 & 0 \\ * & * & * & * & -R_{a1} & 0 & 0 & 0 & 0 & 0 \\ * & * & * & * & * & \dots & 0 & 0 & 0 & 0 \\ * & * & * & * & * & * & -R_{aq} & 0 & 0 & 0 \\ * & * & * & * & * & * & * & -R_{a1} & 0 & 0 \\ * & * & * & * & * & * & * & * & \dots & 0 \\ * & * & * & * & * & * & * & * & * & -R_{aq} \end{pmatrix} < 0, \tag{2.5}$$

$$\begin{aligned}
 \Gamma_{11}^1 &= S + S_a - R + A_0^T P_2 + P_2^T A_0, & \Gamma_{12}^1 &= P - P_2^T + A_0^T P_3, \\
 \Gamma_{22}^1 &= -P_3 - P_3^T + h_1^2 R + (h_2 - h_1)^2 \sum_{i=1}^q R_{ai}.
 \end{aligned} \tag{2.6}$$

**Proof:** Differentiating  $V(x(t), \dot{x}(t))$ , one finds:

$$\begin{aligned}
 \dot{V}(x(t), \dot{x}(t)) &= x(t)^T (S + S_a) x(t) + \dot{x}(t)^T P x(t) + x(t)^T P \dot{x}(t) \\
 &- x(t - h_1)^T S x(t - h_1) - x(t - h_2)^T S_a x(t - h_2) \\
 &+ \dot{x}(t)^T [h_1^2 R + (h_2 - h_1)^2 \sum_{i=1}^q R_{ai}] \dot{x}(t) \\
 &- h_1 \int_{t-h_1}^t \dot{x}(s)^T R \dot{x}(s) ds - (h_2 - h_1) \int_{t-h_2}^{t-h_1} \dot{x}(s)^T \sum_{i=1}^q R_{ai} \dot{x}(s) ds.
 \end{aligned} \tag{2.7}$$



We decompose the last term into:

$$\begin{aligned}
 -(h_2 - h_1) \int_{t-h_2}^{t-h_1} \dot{x}(s)^T \sum_{i=1}^q R_{ai} \dot{x}(s) ds &= -(h_2 - h_1) \sum_{i=1}^q \int_{t-h_2}^{t-\tau_i(t)} \dot{x}(s)^T R_{ai} \dot{x}(s) ds \\
 &\quad - (h_2 - h_1) \sum_{i=1}^q \int_{t-\tau_i(t)}^{t-h_1} \dot{x}(s)^T R_{ai} \dot{x}(s) ds.
 \end{aligned} \tag{2.8}$$

Applying the Jensen's inequality [Gu 2003]:

$$\begin{aligned}
 -h_1 \int_{t-h_1}^t \dot{x}(s)^T R \dot{x}(s) ds &\leq - \int_{t-h_1}^t \dot{x}(s)^T ds R \int_{t-h_1}^t \dot{x}(s) ds, \\
 -(h_2 - h_1) \sum_{i=1}^q \int_{t-h_2}^{t-\tau_i(t)} \dot{x}(s)^T R_{ai} \dot{x}(s) ds &\leq - \sum_{i=1}^q \int_{t-h_2}^{t-\tau_i(t)} \dot{x}(s)^T ds R_{ai} \int_{t-h_2}^{t-\tau_i(t)} \dot{x}(s) ds, \\
 -(h_2 - h_1) \sum_{i=1}^q \int_{t-\tau_i(t)}^{t-h_1} \dot{x}(s)^T R_{ai} \dot{x}(s) ds &\leq - \sum_{i=1}^q \int_{t-\tau_i(t)}^{t-h_1} \dot{x}(s)^T ds R_{ai} \int_{t-\tau_i(t)}^{t-h_1} \dot{x}(s) ds,
 \end{aligned} \tag{2.9}$$

so we obtain:

$$\begin{aligned}
 \dot{V}(x(t), \dot{x}(t)) &\leq x(t)^T (S + S_a) x(t) + \dot{x}(t)^T P x(t) + x(t)^T P \dot{x}(t) \\
 &\quad - x(t-h_1)^T S x(t-h_1) - x(t-h_2)^T S_a x(t-h_2) \\
 &\quad + \dot{x}(t)^T [h_1^2 R + (h_2 - h_1)^2 \sum_{i=1}^q R_{ai}] \dot{x}(t) \\
 &\quad - [x(t)^T - x(t-h_1)^T] R [x(t) - x(t-h_1)] \\
 &\quad - \sum_{i=1}^q v_{1i}^T R_{ai} v_{1i} - \sum_{i=1}^q v_{2i}^T R_{ai} v_{2i},
 \end{aligned} \tag{2.10}$$

where:

$$v_{1i} = \int_{t-\tau_i(t)}^{t-h_1} \dot{x}(s) ds, \quad v_{2i} = \int_{t-h_2}^{t-\tau_i(t)} \dot{x}(s) ds, \quad i = 1, 2, \dots, q. \tag{2.11}$$

Introducing free weighting matrices  $P_2, P_3, Y_1, Y_2$ , the following expressions are added into  $\dot{V}(x(t), \dot{x}(t))$  [He 2004, Fridman 2006a]:

$$\begin{aligned}
 0 &= 2[x(t)^T P_2^T + \dot{x}(t)^T P_3^T] [A_0 x(t) + B w(t) + \sum_{i=1}^q A_i x(t-h_1) - \sum_{i=1}^q A_i v_{1i} - \dot{x}(t)], \\
 0 &= 2[x(t)^T Y_1^T + \dot{x}(t)^T Y_2^T] [q x(t-h_2) + \sum_{i=1}^q v_{1i} + \sum_{i=1}^q v_{2i} - q x(t-h_1)].
 \end{aligned} \tag{2.12}$$

Setting (the symbol  $col\{\}$  represents the column vector, which will also be used in the following):

$$\eta(t) = col\{x(t), \dot{x}(t), x(t - h_1), x(t - h_2), v_{11}, v_{12}, \dots, v_{1q}, v_{21}, v_{22}, \dots, v_{2q}, w(t)\}. \quad (2.13)$$

Finally, if the LMI in (2.5) is feasible, we obtain:

$$\dot{V}(x(t), \dot{x}(t)) \leq \eta(t)^T \Gamma^1 \eta(t) < 0. \quad (2.14)$$

### 2.2.2 $H_\infty$ Performance

$H_\infty$  control theory is introduced so to enhance the robustness performance. For the moment, we consider the delay-free linear system with perturbation:

$$\begin{cases} \dot{x}(t) &= Ax(t) + Bw(t), \\ z(t) &= Cx(t). \end{cases} \quad (2.15)$$

Here,  $w(t) \in \mathbb{R}^l$  is some exogenous disturbance signal, while  $z(t) \in \mathbb{R}^m$  is the objective control output.  $A$ ,  $B$  and  $C$  are constant matrices. According to  $H_\infty$  control theory, the performance will be studied by checking the criterion  $J(w) < 0$  for some  $H_\infty$  performance index  $\gamma$ :

$$J(w) = \int_0^\infty (z(t)^T z(t) - \gamma^2 w(t)^T w(t)) dt. \quad (2.16)$$

**Theorem 2.2** *Suppose there exist a  $n \times n$  symmetric matrix  $P > 0$ , some matrices  $P_2$ ,  $P_3$ , and a positive scalar  $\gamma$ , such that LMI condition (2.17) is feasible. Then, the system (2.15) is asymptotically stable with  $H_\infty$  performance  $J(w) < 0$  (2.16).*

$$\Gamma^2 = \begin{pmatrix} A^T P_2 + P_2^T A + C^T C & P - P_2^T + A^T P_3 & P_2^T B \\ * & -P_3 - P_3^T & P_3^T B \\ * & * & -\gamma^2 I \end{pmatrix} < 0. \quad (2.17)$$

**Proof:** Considering the quadratic Lyapunov function,  $V(x(t)) = x(t)^T P x(t)$  and the condition:

$$\dot{V}(x(t)) + z(t)^T z(t) - \gamma^2 w(t)^T w(t) < 0. \quad (2.18)$$

Integrating the resulting inequality *w.r.t.* in  $t$  from 0 to  $\infty$ , the condition yields:

$$\begin{aligned}
 & \int_0^\infty (\dot{V}(x(t)) + z(t)^T z(t) - \gamma^2 w(t)^T w(t)) dt \\
 & = V(x(\infty)) - V(x(0)) + \int_0^\infty (z(t)^T z(t) - \gamma^2 w(t)^T w(t)) dt \\
 & < 0.
 \end{aligned} \tag{2.19}$$

Because  $V(x(0)) = 0$  and  $V(x(\infty)) \geq 0$ ,  $J(w) < 0$  can be assured if (2.18) is negative. Now, substituting for  $z(t)$  leads to:

$$\begin{aligned}
 \dot{V}(x(t)) + z(t)^T z(t) - \gamma^2 w(t)^T w(t) & = x(t)^T C^T C x(t) + x(t)^T P \dot{x}(t) + \dot{x}(t)^T P x(t) \\
 & \quad - \gamma^2 w(t)^T w(t).
 \end{aligned} \tag{2.20}$$

Using the descriptor method and adding the free weighting matrices  $P_2$ ,  $P_3$  into  $\dot{V}(x(t)) + z(t)^T z(t) - \gamma^2 w(t)^T w(t)$ , one obtains:

$$0 = 2[x(t)^T P_2^T + \dot{x}(t)^T P_3^T][Ax(t) + Bw(t) - \dot{x}(t)]. \tag{2.21}$$

Setting  $\eta(t) = \text{col}\{x(t), \dot{x}(t), w(t)\}$ , then the LMI in (2.17) is equivalent to:

$$\dot{V}(x(t)) + z(t)^T z(t) - \gamma^2 w(t)^T w(t) \leq \eta(t)^T \Gamma^2 \eta(t) < 0. \tag{2.22}$$

### 2.2.3 General Theorem on Rate-Independent Stability with $H_\infty$ Performance Index

So far, we have a Lyapunov-Krasovskii functional stability condition with several time-varying delays *Theorem 2.1*, and the  $H_\infty$  performance improvement condition without time-varying delays *Theorem 2.2*. An integrated theorem will be given for the more general system:

$$\begin{cases} \dot{x}(t) = A_0 x(t) + \sum_{i=1}^q A_i x(t - \tau_i(t)) + Bw(t), \\ z(t) = Cx(t), \\ x(t_0 + \theta) = \phi(\theta), \quad \dot{x}(t_0 + \theta) = \dot{\phi}(\theta), \quad \theta \in [-h_2, 0]. \end{cases} \tag{2.23}$$

We consider the condition  $\dot{V}(x(t), \dot{x}(t)) + z(t)^T z(t) - \gamma^2 w(t)^T w(t) < 0$  ( $V(x(t), \dot{x}(t))$  has been defined in (2.4), and this inequality implies  $J(w) < 0$  defined in (2.16)), and substitute for  $z(t)$ . The similar proof with *Theorem 2.1* is utilized, at last, setting:

$$\eta(t) = \text{col}\{x(t), \dot{x}(t), x(t - h_1), x(t - h_2), v_{11}, v_{12}, \dots, v_{1q}, v_{21}, v_{22}, \dots, v_{2q}, w(t)\}. \tag{2.24}$$

The following LMI is obtained:

$$\dot{V}(x(t), \dot{x}(t)) + z(t)^T z(t) - \gamma^2 w(t)^T w(t) \leq \eta(t)^T \Gamma^3 \eta(t) < 0, \quad (2.25)$$

where:

$$\Gamma^3 = \begin{pmatrix} \Gamma_{11}^3 & \Gamma_{12}^3 & R + \sum_{i=1}^q P_2^T A_i - q Y_1^T & q Y_1^T & -P_2^T A_1 + Y_1^T & \dots & -P_2^T A_q + Y_1^T & Y_1^T & \dots & Y_1^T & P_2^T B \\ * & \Gamma_{22}^3 & \sum_{i=1}^q P_3^T A_i - q Y_2^T & q Y_2^T & -P_3^T A_1 + Y_2^T & \dots & -P_3^T A_q + Y_2^T & Y_2^T & \dots & Y_2^T & P_3^T B \\ * & * & -S - R & 0 & 0 & 0 & 0 & 0 & 0 & 0 & 0 \\ * & * & * & -S_a & 0 & 0 & 0 & 0 & 0 & 0 & 0 \\ * & * & * & * & -R_{a1} & 0 & 0 & 0 & 0 & 0 & 0 \\ * & * & * & * & * & \dots & 0 & 0 & 0 & 0 & 0 \\ * & * & * & * & * & * & -R_{aq} & 0 & 0 & 0 & 0 \\ * & * & * & * & * & * & * & -R_{a1} & 0 & 0 & 0 \\ * & * & * & * & * & * & * & * & \dots & 0 & 0 \\ * & * & * & * & * & * & * & * & * & -R_{aq} & 0 \\ * & * & * & * & * & * & * & * & * & * & -\gamma^2 I \end{pmatrix} < 0, \quad (2.26)$$

$$\begin{aligned} \Gamma_{11}^3 &= S + S_a - R + A_0^T P_2 + P_2^T A_0 + C^T C, & \Gamma_{12}^3 &= P - P_2^T + A_0^T P_3, \\ \Gamma_{22}^3 &= -P_3 - P_3^T + h_1^2 R + (h_2 - h_1)^2 \sum_{i=1}^q R_{ai}. \end{aligned} \quad (2.27)$$

**Theorem 2.3** Suppose there exist  $n \times n$  symmetric matrices  $P > 0$ ,  $R > 0$ ,  $S > 0$ ,  $S_a > 0$ ,  $R_{ai} > 0$ , some matrices  $P_2$ ,  $P_3$ ,  $Y_1$ ,  $Y_2$ ,  $i = 1, 2, \dots, q$ , and a positive scalar  $\gamma$ , such that LMI condition (2.26) with notations (2.27) is feasible. Then, the system (2.23) is rate-independent asymptotically stable with  $H_\infty$  performance  $J(w) < 0$  (2.16) for time-varying delays  $\tau_i(t) \in [h_1, h_2]$ ,  $i = 1, 2, \dots, q$ .

Our novel control architectures of bilateral teleoperation will be designed based on these theorems, under the assumptions presented in Section 2.1.

## 2.3 Bilateral State Feedback Control Scheme

Bilateral state feedback control scheme given in Fig. 2.2 ensures bilateral position tracking by state feedback, the master controller and the slave controller will be designed with details [Zhang 2011a]. In Fig. 2.2, the information transferred between the master and the slave are the velocities/positions of the master and the slave,  $\dot{\theta}_m(t)$ ,  $\theta_m(t)$  and  $\dot{\theta}_s(t)$ ,  $\theta_s(t)$ .  $C_1$  and  $C_2$  are the global controllers that we should design.

Note that  $\hat{\tau}_1(t)$  and  $\hat{\tau}_2(t)$  are estimated network delays between the master and the slave. From Assumption 3,  $\tau_1(t)$  is available at slave's side and  $\tau_2(t)$  is available at master's side:  $\hat{\tau}_1(t) = \tau_1(t)$ ,  $\hat{\tau}_2(t) = \tau_2(t)$ . Thanks to this additional knowledge,  $C_1$  and  $C_2$  will be linear state feedbacks of the delayed type.



$$\begin{cases} \dot{x}_{ms}(t) &= A_{ms}^0 x_{ms}(t) + A_{ms}^1 x_{ms}(t - \tau_1(t)) + A_{ms}^2 x_{ms}(t - \tau_2(t)) + B_{ms} w_{ms}(t), \\ z_{ms}(t) &= C_{ms} x_{ms}(t), \end{cases} \quad (2.32)$$

where the controlled output is  $z_{ms}(t) = (\theta_s(t) - \theta_m(t))$ . The definition of  $A_{ms}^0$ ,  $A_{ms}^1$ ,  $A_{ms}^2$ ,  $C$  is:

$$A_{ms}^0 = A_{ms} - B_{ms} K_0, \quad A_{ms}^1 = -B_{ms} K_{ms}^1, \quad A_{ms}^2 = -B_{ms} K_{ms}^2, \quad C_{ms} = \begin{pmatrix} 0 & 0 & 1 \end{pmatrix}. \quad (2.33)$$

Due to the particular form of  $B_{ms}$  (2.31), one has:

$$A_{ms}^1 = -B_{ms} K_{ms}^1 = -B_{ms}^1 K_1, \quad A_{ms}^2 = -B_{ms} K_{ms}^2 = -B_{ms}^2 K_2, \quad (2.34)$$

where  $i = 1, 2$ :

$$K_i = \begin{pmatrix} K_i^1 & K_i^2 & K_i^3 \end{pmatrix}. \quad (2.35)$$

Our objective is to minimize the impact of disturbances on  $z_{ms}(t)$  by using  $H_\infty$  control theory, that is to minimize the position deviation  $\theta_s(t) - \theta_m(t)$  between the master and the slave. Based on *Theorem 2.3*, the following result is proposed in form of LMI.

**Theorem 2.4** *Suppose there exist symmetric matrices  $P > 0$ ,  $R > 0$ ,  $S > 0$ ,  $S_a > 0$ ,  $R_{a1} > 0$ ,  $R_{a2} > 0$ , some matrices  $P_2$ ,  $W_1$ ,  $W_2$ ,  $Y_1$ ,  $Y_2$ , and positive scalars  $\gamma$  and  $\xi$ , such that LMI condition (2.37) with notations (2.38) is feasible. Then, the system (2.32) is rate-independent asymptotically stable with  $H_\infty$  performance  $J(w) < 0$  (2.16) for time-varying delays  $\tau_1(t)$ ,  $\tau_2(t) \in [h_1, h_2]$ , and the control gains:*

$$K_1 = W_1 P_2^{-1}, \quad K_2 = W_2 P_2^{-1}. \quad (2.36)$$

$$\Gamma^4 = \begin{pmatrix} \Gamma_{11}^4 & \Gamma_{12}^4 & \Gamma_{13}^4 & 2Y_1^T & Y_1^T + B_{ms}^1 W_1 & Y_1^T + B_{ms}^2 W_2 & Y_1^T & Y_1^T & B_{ms} & P_2^T C_{ms}^T \\ * & \Gamma_{22}^4 & \Gamma_{23}^4 & 2Y_2^T & Y_2^T + \xi B_{ms}^1 W_1 & Y_2^T + \xi B_{ms}^2 W_2 & Y_2^T & Y_2^T & \xi B_{ms} & 0 \\ * & * & -S - R & 0 & 0 & 0 & 0 & 0 & 0 & 0 \\ * & * & * & -S_a & 0 & 0 & 0 & 0 & 0 & 0 \\ * & * & * & * & -R_{a1} & 0 & 0 & 0 & 0 & 0 \\ * & * & * & * & * & -R_{a2} & 0 & 0 & 0 & 0 \\ * & * & * & * & * & * & -R_{a1} & 0 & 0 & 0 \\ * & * & * & * & * & * & * & -R_{a2} & 0 & 0 \\ * & * & * & * & * & * & * & * & -\gamma^2 I & 0 \\ * & * & * & * & * & * & * & * & * & -I \end{pmatrix} < 0, \quad (2.37)$$

$$\begin{aligned} \Gamma_{11}^4 &= S + S_a - R + P_2^T A_{ms}^T - P_2^T K_0^T B_{ms}^T + A_{ms} P_2 - B_{ms} K_0 P_2, \\ \Gamma_{12}^4 &= P - P_2 + \xi P_2^T A_{ms}^T - \xi P_2^T K_0^T B_{ms}^T, \quad \Gamma_{13}^4 = R - B_{ms}^1 W_1 - B_{ms}^2 W_2 - 2Y_1^T, \\ \Gamma_{22}^4 &= -\xi P_2 - \xi P_2^T + h_1^2 R + (h_2 - h_1)^2 (R_{a1} + R_{a2}), \quad \Gamma_{23}^4 = -\xi B_{ms}^1 W_1 - \xi B_{ms}^2 W_2 - 2Y_2^T. \end{aligned} \quad (2.38)$$

**Proof:** We use *Theorem 2.3* on system (2.32). Inspired from [Fridman 2001b], a series of steps is made to deal with the nonlinear matrix terms  $P_2^T BK_1$ ,  $P_2^T BK_2$ ,  $P_3^T BK_1$ ,  $P_3^T BK_2$ :

- multiplying  $\Gamma^3$  in (2.26) by  $diag\{P_2^{-T}, \dots, P_2^{-T}\}$  at the left side, by  $diag\{P_2^{-1}, \dots, P_2^{-1}\}$  at the right side;
- choosing  $P_3 = \xi P_2$ ;
- defining  $W_1 = K_1 P_2$  and  $W_2 = K_2 P_2$ ;
- applying the Schur formula [Briat 2008], and then, the theorem is obtained.

**Remark 2.5**  $K_1$  and  $K_2$  are fixed by  $W_1$  and  $W_2$  under the minimum value of  $\gamma$  that provides a feasible LMI (denoted as  $\gamma_{min}$ ). From [Tadmor 2000],  $sup_w(\|z_{ms}(t)\|_2 / \|w_{ms}(t)\|_2) < \gamma_{min}$  is achievable in the closed-loop system. Thus, the position deviation  $z_{ms}(t)$  can be minimized under exogenous disturbance input  $w_{ms}(t)$ . Besides, the performance of synchronization is proportional to the magnitude of  $\gamma_{min}$ : the smaller  $\gamma_{min}$ , the better  $H_\infty$  performance.

**Remark 2.6** In practical applications, the position scaling is also important [Son 2011]. Based on the position tracking, we redefine the system in (2.30):

$$x_{ms}(t) = \begin{pmatrix} \dot{\theta}_s(t) \\ \dot{\theta}_m(t) \\ \alpha_s \theta_s(t) - \alpha_m \theta_m(t) \end{pmatrix}, \quad z_{ms}(t) = \begin{pmatrix} \alpha_s \theta_s(t) - \alpha_m \theta_m(t) \end{pmatrix}, \quad (2.39)$$

where  $\alpha_s$ ,  $\alpha_m$  are the scaling gains. Therefore, the position scaling can be achieved by *Theorem 2.4*, and the scaling relation of the master and the slave is:

$$\frac{\theta_s(t)}{\theta_m(t)} = \frac{\alpha_m}{\alpha_s}. \quad (2.40)$$

## 2.4 Force-Reflecting Proxy Control Scheme

In order to improve the performance of system and achieve the force tracking between the master and the slave, the force feedback should be utilized based on the estimated/measured force of the human operator and environment. We firstly propose a force-reflecting control scheme Fig. 2.3 to illustrate the idea of the control and the theorem to be used later. And then, the slave controller will be redesigned by adding a proxy in the control scheme.

Note that the master controller has been discarded and, at slave side, the slave controller is designed. From master to slave, the information transferred are the velocity/position of the master. However, from slave to master, only the estimated/measured

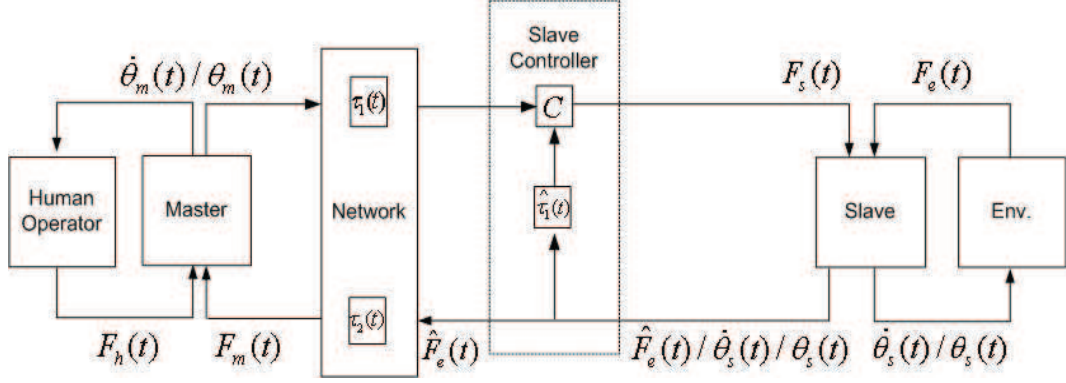

Figure 2.3: Force-reflecting control scheme

force  $\hat{F}_e(t)$  is transferred (the velocity/position of the slave is used to design the controller  $C$ ), so to realize the force tracking  $F_m(t) = \hat{F}_e(t - \tau_2(t))$ , which is based on the stability of the whole system. Technically,  $\hat{F}_e(t)$  can be either measured or estimated. In our experimental implementation, we prefer to introduce the additional sensors (to be presented in Chapter 4).

As mentioned above,  $\tau_1(t)$  is available at slave's side  $\hat{\tau}_1(t) = \tau_1(t)$ .

Again,  $C$  with controller gain  $K^i$ ,  $i = 1, 2, 3$  is given by:

$$C: \quad F_s(t) = -K^1 \dot{\theta}_s(t - \hat{\tau}_1(t)) - K^2 \dot{\theta}_m(t - \tau_1(t)) - K^3 (\theta_s(t - \hat{\tau}_1(t)) - \theta_m(t - \tau_1(t))). \quad (2.41)$$

The closed-loop system is described by:

$$\begin{cases} \dot{x}_{ms}(t) &= (A_{ms} - B_{ms}K_0)x_{ms}(t) + B_{ms}u_{ms}(t) + B_{ms}w_{ms}(t), \\ u_{ms}(t) &= -K_{ms}x_{ms}(t - \tau_1(t)), \end{cases} \quad (2.42)$$

where the description of  $x_{ms}(t)$ ,  $u_{ms}(t)$ ,  $w_{ms}(t)$  and  $A_{ms}$ ,  $B_{ms}$ ,  $K_0$  is the same as (2.30) and (2.31) of the bilateral state feedback control scheme, but:

$$K_{ms} = \begin{pmatrix} K^1 & K^2 & K^3 \\ 0 & 0 & 0 \end{pmatrix}. \quad (2.43)$$

Thus, the  $\tau_2(t)$ -delayed coming from the master controller is now suppressed. Applying the method for the controller design, we rewrite the system as:

$$\begin{cases} \dot{x}_{ms}(t) &= A_{ms}^0 x_{ms}(t) + A_{ms}^1 x_{ms}(t - \tau_1(t)) + B_{ms}w_{ms}(t), \\ z_{ms}(t) &= C_{ms}x_{ms}(t). \end{cases} \quad (2.44)$$

Here again,  $z_{ms}(t) = (\theta_s(t) - \theta_m(t))$ . Contrarily to the previous scheme, here only one delay  $\tau_1(t)$  is induced.  $A_{ms}^0$ ,  $C_{ms}$  can be found in previous subsection and, with



$K = \begin{pmatrix} K^1 & K^2 & K^3 \end{pmatrix}$ ,  $A_{ms}^1$  is:

$$A_{ms}^1 = -B_{ms}K_{ms} = -B_{ms}^1K. \quad (2.45)$$

An LMI condition under one delay can now be obtained.

**Theorem 2.7** *Suppose there exist symmetric matrices  $P > 0$ ,  $R > 0$ ,  $S > 0$ ,  $S_a > 0$ ,  $R_{a1} > 0$ , some matrices  $P_2$ ,  $W$ ,  $Y_1$ ,  $Y_2$ , and positive scalars  $\gamma$  and  $\xi$ , such that LMI condition (2.47) with notations (2.48) is feasible. Then, the system (2.42) is rate-independent asymptotically stable with  $H_\infty$  performance  $J(w) < 0$  (2.16) for the time-varying delay  $\tau_1(t) \in [h_1, h_2]$ , and the control gain:*

$$K = WP_2^{-1}. \quad (2.46)$$

$$\Gamma^5 = \begin{pmatrix} \Gamma_{11}^5 & \Gamma_{12}^5 & \Gamma_{13}^5 & Y_1^T & Y_1^T + B_{ms}^1 W & Y_1^T & B_{ms} & P_2^T C_{ms}^T \\ * & \Gamma_{22}^5 & \Gamma_{23}^5 & Y_2^T & Y_2^T + \xi B_{ms}^1 W & Y_2^T & \xi B_{ms} & 0 \\ * & * & -S - R & 0 & 0 & 0 & 0 & 0 \\ * & * & * & -S_a & 0 & 0 & 0 & 0 \\ * & * & * & * & -R_{a1} & 0 & 0 & 0 \\ * & * & * & * & * & -R_{a1} & 0 & 0 \\ * & * & * & * & * & * & -\gamma^2 I & 0 \\ * & * & * & * & * & * & * & -I \end{pmatrix} < 0, \quad (2.47)$$

$$\begin{aligned} \Gamma_{11}^5 &= S + S_a - R + P_2^T A_{ms}^T - P_2^T K_0^T B_{ms}^T + A_{ms} P_2 - B_{ms} K_0 P_2, \\ \Gamma_{12}^5 &= P - P_2 + \xi P_2^T A_{ms}^T - \xi P_2^T K_0^T B_{ms}^T, \quad \Gamma_{13}^5 = R - B_{ms}^1 W - Y_1^T \\ \Gamma_{22}^5 &= -\xi P_2 - \xi P_2^T + h_1^2 R + (h_2 - h_1)^2 R_{a1}, \quad \Gamma_{23}^5 = -\xi B_{ms}^1 W - Y_2^T. \end{aligned} \quad (2.48)$$

**Proof:** The proof is similar to *Theorem 2.4* and is omitted here.

This is a simpler control structure with the estimation of force, as mentioned above, only  $F_e(t)$  has been estimated/measured, next with the estimation of  $F_h(t)$  and a novel proxy scheme, a better system performance can be obtained.

A novel force-reflecting proxy control scheme is proposed in Fig. 2.4, which realized bilateral position and force tracking by adding a proxy of master into the slave controller (the term "proxy" is inspired by [Cheong 2008, Li 2009], and the "proxy of master" means the avatar of the master at the slave side). Here, the proxy of master provides an estimation of the master's present position and velocity despite the delay  $\tau_1(t)$ .

- From master to slave, the information transferred are the velocity/position of the master and the estimated/measured force  $\hat{F}_h(t)$ , these are used to achieve the position tracking.

- From slave to master, only the estimated/measured force  $\hat{F}_e(t)$  is transferred, so the force tracking  $F_m(t) = \hat{F}_e(t - \tau_2(t))$  is realized, if the stability of the whole system is verified.

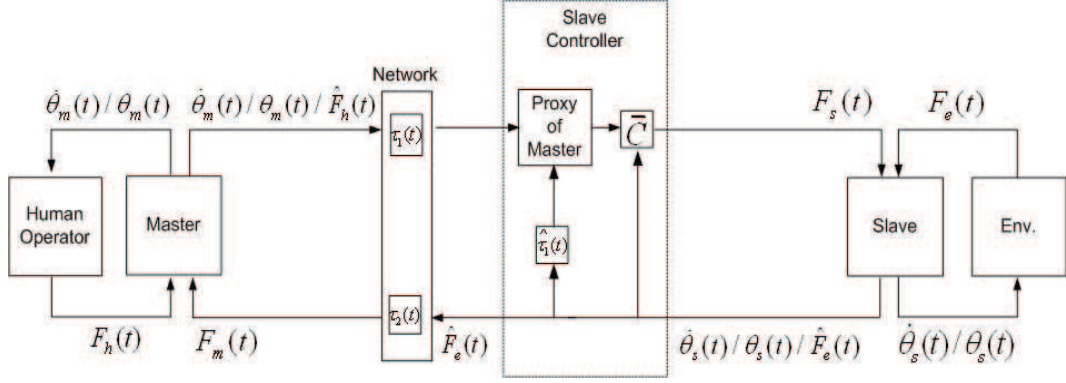

Figure 2.4: Force-reflecting proxy control scheme

Note that again, the proxy of master is like a remote and predictive observer of the master, which is used at the slave side to reduce the impact of the communication delays.

### 2.4.1 Slave Controller Description

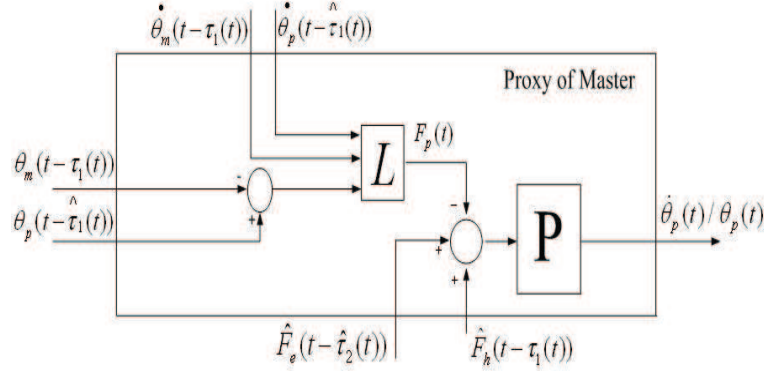

Figure 2.5: Proxy of master

Fig. 2.5 shows the scheme of the proxy of master. The block diagram "P" represents a model generating  $\dot{\theta}_p(t)/\theta_p(t)$  (the velocity/position of the proxy), which is designed so to reproduce the velocity/position of the master,  $\dot{\theta}_m(t)/\theta_m(t)$ .  $L$  is the gain to be designed. The model "P" is as follow:

$$\dot{x}_p(t) = (A_m - B_m K_0^m) x_p(t) - B_m F_p(t) + B_m (\hat{F}_e(t - \hat{\tau}_1(t)) + \hat{F}_h(t - \tau_1(t))). \quad (2.49)$$

Because the proxy acts as a remote observer of the master, the proxy parameters  $A_m$ ,  $B_m$  and  $K_0^m$  are the same as that of the master.  $x_p(t) = \dot{\theta}_p(t) \in \mathbb{R}^n$ , as mentioned above,

$\dot{\theta}_p(t) \in \mathbb{R}^1$  is considered in this thesis. The gain  $L = \begin{pmatrix} L_1 & L_2 & L_3 \end{pmatrix}$  is used to synchronize asymptotically the position between the master and the proxy of master:

$$F_p(t) = L \begin{pmatrix} \dot{\theta}_p(t-\hat{\tau}_1(t)) \\ \dot{\theta}_m(t-\tau_1(t)) \\ \theta_p(t-\hat{\tau}_1(t)) - \theta_m(t-\tau_1(t)) \end{pmatrix}. \quad (2.50)$$

Next,  $K = \begin{pmatrix} K_1 & K_2 & K_3 \end{pmatrix}$  is the gain of the controller  $\bar{C}$ :

$$F_s(t) = -K \begin{pmatrix} \dot{\theta}_s(t) \\ \dot{\theta}_p(t) \\ \theta_s(t) - \theta_p(t) \end{pmatrix}. \quad (2.51)$$

The main difference with a Luenberger observer is that the correction term  $F_p(t)$  acts as an input of the proxy. While, the proxy model still respects the dynamics of the master.

## 2.4.2 Controller Design

Our objective is to provide a controller design algorithm for the controller  $\bar{C}$  and the proxy, so to achieve the stability of the whole system with the position/force tracking under asymmetric time-varying delays.

### 2.4.2.1 Master-Proxy Synchronization

We design the proxy of master by Lyapunov-Krasovskii functionals,  $H_\infty$  control and LMI. we regroup the models of the master and proxy into the following linear system:

$$\begin{cases} \dot{x}_{mp}(t) &= A_{mp}^0 x_{mp}(t) + A_{mp}^1 x_{mp}(t - \tau_1(t)) + B_{mp} w_{mp}(t), \\ z_{mp}(t) &= C_{mp} x_{mp}(t), \end{cases} \quad (2.52)$$

where only one delay  $\tau_1(t)$  must be handled, and:

$$x_{mp}(t) = \begin{pmatrix} \dot{\theta}_p(t) \\ \dot{\theta}_m(t) \\ \theta_p(t) - \theta_m(t) \end{pmatrix}, \quad w_{mp}(t) = \begin{pmatrix} \hat{F}_e(t-\hat{\tau}_1(t)) + \hat{F}_h(t-\tau_1(t)) \\ F_m(t) + F_h(t) \end{pmatrix}, \quad z_{mp}(t) = \begin{pmatrix} \theta_p(t) - \theta_m(t) \end{pmatrix}. \quad (2.53)$$

Then:

$$\begin{aligned} A_{mp}^0 &= \begin{pmatrix} A_m - B_m K_0^m & 0 & 0 \\ 0 & A_m - B_m K_0^m & 0 \\ 1 & -1 & 0 \end{pmatrix}, \quad A_{mp}^1 = \begin{pmatrix} -B_m L_1 & -B_m L_2 & -B_m L_3 \\ 0 & 0 & 0 \\ 0 & 0 & 0 \end{pmatrix}, \\ B_{mp} &= \begin{pmatrix} B_m & 0 \\ 0 & B_m \end{pmatrix} = \begin{pmatrix} B_{mp}^1 & B_{mp}^2 \end{pmatrix}, \quad C_{mp} = \begin{pmatrix} 0 & 0 & 1 \end{pmatrix}. \end{aligned} \quad (2.54)$$

From (2.54) and  $L = \begin{pmatrix} L_1 & L_2 & L_3 \end{pmatrix}$ , one has:

$$A_{mp}^1 = -B_{mp}^1 L. \quad (2.55)$$

Then, the following theorem is obtained.

**Theorem 2.8** *Suppose there exist symmetric matrices  $P > 0$ ,  $R > 0$ ,  $S > 0$ ,  $S_a > 0$ ,  $R_{a1} > 0$ , some matrices  $P_2$ ,  $Y_1$ ,  $Y_2$ ,  $M$ , and positive scalars  $\gamma$  and  $\xi$ , such that LMI condition (2.57) with notations (2.58) is feasible. Then, the system (2.52) is rate-independent asymptotically stable with  $H_\infty$  performance  $J(w) < 0$  (2.16) for time-varying delay  $\tau_1(t) \in [h_1, h_2]$ , and the proxy control gain:*

$$L = MP_2^{-1}. \quad (2.56)$$

$$\Gamma^6 = \begin{pmatrix} \Gamma_{11}^6 & \Gamma_{12}^6 & R - B_{mp}^1 M - Y_1^T & Y_1^T & Y_1^T + B_{mp}^1 M & Y_1^T & B_{mp} & P_2^T C_{mp}^T \\ * & \Gamma_{22}^6 & -\xi B_{mp}^1 M - Y_2^T & Y_2^T & Y_2^T + \xi B_{mp}^1 M & Y_2^T & \xi B_{mp} & 0 \\ * & * & -S - R & 0 & 0 & 0 & 0 & 0 \\ * & * & * & -S_a & 0 & 0 & 0 & 0 \\ * & * & * & * & -R_{a1} & 0 & 0 & 0 \\ * & * & * & * & * & -R_{a1} & 0 & 0 \\ * & * & * & * & * & * & -\gamma^2 I & 0 \\ * & * & * & * & * & * & * & -I \end{pmatrix} < 0, \quad (2.57)$$

$$\begin{aligned} \Gamma_{11}^6 &= S + S_a - R + P_2^T A_{mp}^0{}^T + A_{mp}^0 P_2, & \Gamma_{12}^6 &= P - P_2 + \xi P_2^T A_{mp}^0{}^T, \\ \Gamma_{22}^6 &= -\xi P_2 - \xi P_2^T + h_1^2 R + (h_2 - h_1)^2 R_{a1}. \end{aligned} \quad (2.58)$$

**Proof:** The proof is similar to *Theorem 2.4* and is omitted here.

#### 2.4.2.2 Proxy-Slave Synchronization

The position tracking between the master and the proxy has been achieved. Then, the controller  $\bar{C}$  has to be designed so to assure the position tracking between the proxy and the slave. The system gathering the proxy, the controller  $\bar{C}$  and the slave, is given by:

$$\begin{cases} \dot{x}_{ps}(t) &= A_{ps} x_{ps}(t) + B_{ps} w_{ps}(t), \\ z_{ps}(t) &= C_{ps} x_{ps}(t), \end{cases} \quad (2.59)$$

$$x_{ps}(t) = \begin{pmatrix} \dot{\theta}_s(t) \\ \dot{\theta}_p(t) \\ \theta_s(t) - \theta_p(t) \end{pmatrix}, \quad z_{ps}(t) = \begin{pmatrix} \theta_s(t) - \theta_p(t) \end{pmatrix}. \quad (2.60)$$

Particularly, the input of the proxy,  $F_p(t)$ , is considered as the exogenous disturbance signal:

$$w_{ps}(t) = \begin{pmatrix} F_e(t) \\ \hat{F}_e(t - \hat{\tau}_1(t)) + \hat{F}_h(t - \tau_1(t)) - F_p(t) \end{pmatrix}. \quad (2.61)$$

So:

$$A_{ps} = \begin{pmatrix} A_s - B_s K_0^s - B_s K_1 & -B_s K_2 & -B_s K_3 \\ 0 & A_m - B_m K_0^m & 0 \\ 1 & -1 & 0 \end{pmatrix}, \quad B_{ps} = \begin{pmatrix} B_s & 0 \\ 0 & B_m \end{pmatrix} = \begin{pmatrix} B_{ps}^1 & B_{ps}^2 \end{pmatrix}, \quad C_{ps} = \begin{pmatrix} 0 & 0 & 1 \end{pmatrix}. \quad (2.62)$$

The following transformation is made:

$$\begin{aligned} A_{ps} &= \begin{pmatrix} A_s - B_s K_0^s & 0 & 0 \\ 0 & A_m - B_m K_0^m & 0 \\ 1 & -1 & 0 \end{pmatrix} + \begin{pmatrix} -B_s K_1 & -B_s K_2 & -B_s K_3 \\ 0 & 0 & 0 \\ 0 & 0 & 0 \end{pmatrix} \\ &= (A_{ps}^0 - B_{ps}^1 K). \end{aligned} \quad (2.63)$$

Then, we obtain the following theorem.

**Theorem 2.9** *Suppose there exist a symmetric matrix  $P > 0$ , some matrices  $P_2$ ,  $W$ , and positive scalars  $\gamma$  and  $\xi$ , such that LMI condition (2.65) with notations (2.66) is feasible. Then, the system (2.59) is asymptotically stable with  $H_\infty$  performance  $J(w) < 0$  (2.16), and the control gain of the controller  $\bar{C}$ :*

$$K = W P_2^{-1}. \quad (2.64)$$

$$\Gamma^7 = \begin{pmatrix} \Gamma_{11}^7 & \Gamma_{12}^7 & B_{ps} & P_2^T C_{ps}^T \\ * & -\xi P_2 - \xi P_2^T & \xi B_{ps} & 0 \\ * & * & -\gamma^2 I & 0 \\ * & * & * & -I \end{pmatrix} < 0, \quad (2.65)$$

$$\Gamma_{11}^7 = P_2^T A_{ps}^0{}^T + A_{ps}^0 P_2 - W^T B_{ps}^1{}^T - B_{ps}^1 W, \quad \Gamma_{12}^7 = P - P_2 + \xi P_2^T A_{ps}^0{}^T - \xi W^T B_{ps}^1{}^T. \quad (2.66)$$

**Proof:** *Theorem 2.9* is an extension of *Theorem 2.2*, similar with *Theorem 2.7*, multiplying  $\Gamma^2$  in (2.17) by  $\text{diag}\{P_2^{-T}, \dots, P_2^{-T}\}$  at the left side, by  $\text{diag}\{P_2^{-1}, \dots, P_2^{-1}\}$  at the right side. Choosing  $P_3 = \xi P_2$ , defining  $W = K P_2$ , and applying the Schur formula, conclude the proof.

### 2.4.2.3 Global Performance Analysis

By *Theorem 2.8* and *Theorem 2.9*, the position tracking between the master, the proxy and the slave is ensured. The next and final step is to ensure the stability of the global system. Note that a main advantage of our control scheme is that the position tracking combined with the global asymptotic stability will ensure the force tracking from the slave to the master as a consequence. The global system is described by:

$$\begin{cases} \dot{x}_{mps}(t) &= A_{mps}^0 x_{mps}(t) + A_{mps}^1 x_{mps}(t - \tau_1(t)) + B_{mps} w_{mps}(t), \\ z_{mps}(t) &= C_{mps} x_{mps}(t), \end{cases} \quad (2.67)$$

where:

$$x_{mps}(t) = \begin{pmatrix} \dot{\theta}_s(t) \\ \dot{\theta}_p(t) \\ \dot{\theta}_m(t) \\ \theta_s(t) - \theta_p(t) \\ \theta_p(t) - \theta_m(t) \end{pmatrix}, \quad w_{mps}(t) = \begin{pmatrix} F_e(t) \\ \hat{F}_e(t - \hat{\tau}_1(t)) + \hat{F}_h(t - \tau_1(t)) \\ F_m(t) + F_h(t) \end{pmatrix}, \quad z_{mps}(t) = \begin{pmatrix} \theta_s(t) - \theta_p(t) \\ \theta_p(t) - \theta_m(t) \end{pmatrix}. \quad (2.68)$$

So we can get:

$$A_{mps}^0 = \begin{pmatrix} A_s - B_s K_0^s - B_s K_1 & -B_s K_2 & 0 & -B_s K_3 & 0 \\ 0 & A_m - B_m K_0^m & 0 & 0 & 0 \\ 0 & 0 & A_m - B_m K_0^m & 0 & 0 \\ 1 & -1 & 0 & 0 & 0 \\ 0 & 1 & -1 & 0 & 0 \end{pmatrix}, \quad (2.69)$$

$$A_{mps}^1 = \begin{pmatrix} 0 & 0 & 0 & 0 & 0 \\ 0 & -B_m L_1 & -B_m L_2 & 0 & -B_m L_3 \\ 0 & 0 & 0 & 0 & 0 \\ 0 & 0 & 0 & 0 & 0 \\ 0 & 0 & 0 & 0 & 0 \end{pmatrix}, \quad B_{mps} = \begin{pmatrix} B_s & 0 & 0 \\ 0 & B_m & 0 \\ 0 & 0 & B_m \\ 0 & 0 & 0 \\ 0 & 0 & 0 \end{pmatrix}, \quad C_{mps} = \begin{pmatrix} 0 & 0 & 0 & 1 & 0 \\ 0 & 0 & 0 & 0 & 1 \end{pmatrix}.$$

By *Theorem 2.3*, we can verify the global stability of the system. That is to say, with the force tracking  $F_m(t) = \hat{F}_e(t - \tau_2(t))$ , the system is globally stable under the  $H_\infty$  constraint.

**Remark 2.10** *The global design of  $L$  and  $K$  from the terms  $A_{mps}^0$  and  $A_{mps}^1$  is impossible, because the  $L$  and  $K$  in (2.69) can not be calculated in the form of LMI, which normally requires the transformation as (2.45), (2.55), (2.63) (similarly to (2.34) in the previous bilateral state feedback control scheme).*

**Remark 2.11** *Comparing three architectures in Fig. 2.2, Fig. 2.3 and Fig. 2.4, all of them guaranty stability and position tracking thanks to the position/velocity information. Fig. 2.3 and Fig. 2.4, in addition, ensure the force tracking. Fig. 2.4 gets a better performance, however, it also introduces additional computation load and needs the human and environment force ( $F_h(t), F_e(t)$ ) to be estimated/measured. For these reasons (computing load, the implementation of the unknown input observers or external force sensors of  $F_h(t), F_e(t)$ ), one may prefer the simpler structure of Fig. 2.2 instead of the more performing one Fig. 2.4. This will be illustrated in next section (Simulations) or in the last chapter (Experiments).*

**Remark 2.12** *As in Remark 2.6, the position scaling can also be achieved here. This is realized not in the design of proxy of master, but in the design of controller  $\bar{C}$ . We redefine:*

$$x_{ps}(t) = \begin{pmatrix} \dot{\theta}_s(t) \\ \dot{\theta}_p(t) \\ \alpha_s \theta_s(t) - \alpha_p \theta_p(t) \end{pmatrix}, \quad z_{ps}(t) = \begin{pmatrix} \alpha_s \theta_s(t) - \alpha_p \theta_p(t) \end{pmatrix}. \quad (2.70)$$

where  $\alpha_s, \alpha_p$  are the scaling gains. Because the proxy follows the motion of the master, the scaling relation is achieved as:

$$\frac{\theta_s(t)}{\theta_p(t)} = \frac{\dot{\theta}_s(t)}{\dot{\theta}_p(t)} = \frac{\alpha_p}{\alpha_s}. \quad (2.71)$$

Besides, the force scaling can be achieved by adding the force scaling gain (e.g.  $\beta$ ) in the force-reflecting channel, as  $F_m(t) = \beta \hat{F}_e(t - \tau_2(t))$ .

## 2.5 Results and Analysis

In this subsection, simulations are performed in different working conditions so to evaluate the performance of the proposed approaches and compare it with other results from the literatures [Ye 2009c, Hua 2010]. The maximum amplitude of time-varying delays is taken as  $h_2 = 0.2s$  (greater allowable maximum delays can also be handled), which satisfies many network-based applications of teleoperation such as internet-based teleoperation. For the simulation of time-varying delays, we use a band-limited white noise, as in Fig. 2.6. Note that the time-varying delays in the two channels are asymmetric.

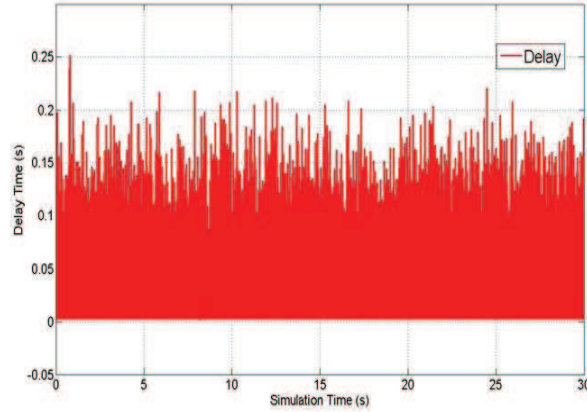

Figure 2.6: An example of time-varying delays

The master, the proxy and the slave models are described as simple integrators,  $m_m/s$ ,  $m_p/s$  and  $m_s/s$ . And for verifying the position tracking, the effective endpoint mass is chosen differently,  $m_m = m_p = 1kg$  and  $m_s = 2kg$  (more complex systems will be

introduced in Chapter 4). Besides, the poles of the master, the proxy and the slave are given as  $[-100.0]$ , then:  $K_0^m = 100$ ,  $K_0^s = 50$ .

For the bilateral state feedback control scheme, the following global controllers are obtained under  $\gamma_{min}^{C_1/C_2} = 0.0123$  (we choose  $\xi = 1$  in *Theorem 2.4*):

$$K_1 = \begin{pmatrix} -0.1870 & -0.0368 & 65.0846 \end{pmatrix}, \quad K_2 = \begin{pmatrix} 0.4419 & 0.0813 & -153.8704 \end{pmatrix}. \quad (2.72)$$

With the same models of master, proxy and slave, for the force-reflecting proxy control scheme, the gains  $L$  of the proxy and  $K$  of the controller  $\bar{C}$ , and the corresponding  $\gamma_{min}$ , are as follows (we choose  $\xi = 1$  in *Theorem 2.8* and *Theorem 2.9*):

$$\begin{aligned} L &= \begin{pmatrix} -1.4566 & 0.1420 & 282.482 \end{pmatrix}, \quad \gamma_{min}^L = 0.0081, \\ K &= \begin{pmatrix} -29.9635 & -3.6393 & 618.536 \end{pmatrix}, \quad \gamma_{min}^{\bar{C}} = 0.0075. \end{aligned} \quad (2.73)$$

From *Theorem 2.3*, the global rate-independent stability of the system is verified with  $\gamma_{min}^g = 0.0062$ .

### 2.5.1 Abrupt Tracking Motion

With the same simulation condition, our objective is to show the system stability and compare the position tracking and convergence performance between our bilateral state feedback control scheme, our force-reflecting proxy control scheme and the methods in [Ye 2009c, Hua 2010].

In Fig. 2.7, the passivity-based position tracking of [Ye 2009c] is shown in the lower left part, and the lower right part shows the result of [Hua 2010], which also used Lyapunov-Krasovskii functionals to design the controllers and analyze the stability. In [Hua 2010], the controller gains should be determined before, and then, the stability analysis and allowable maximum time delays will be checked by LKF theorems in form of LMI. We have resolved this problem in this paper, our controllers can be obtained directly by LKF theorems.

It is clear that our methods achieve the stability and the position tracking. Concerning [Ye 2009c, Hua 2010], the position convergence is ensured, but there is still a position deviation between master and slave. Besides, our force-reflecting proxy control scheme can get better position convergence than our bilateral state feedback control scheme. This can be seen on  $\gamma_{min}$ : the former's ( $\gamma_{min}^g = 0.0062$ ) is about 2 times smaller than the latter's ( $\gamma_{min}^{C_1/C_2} = 0.0123$ ).



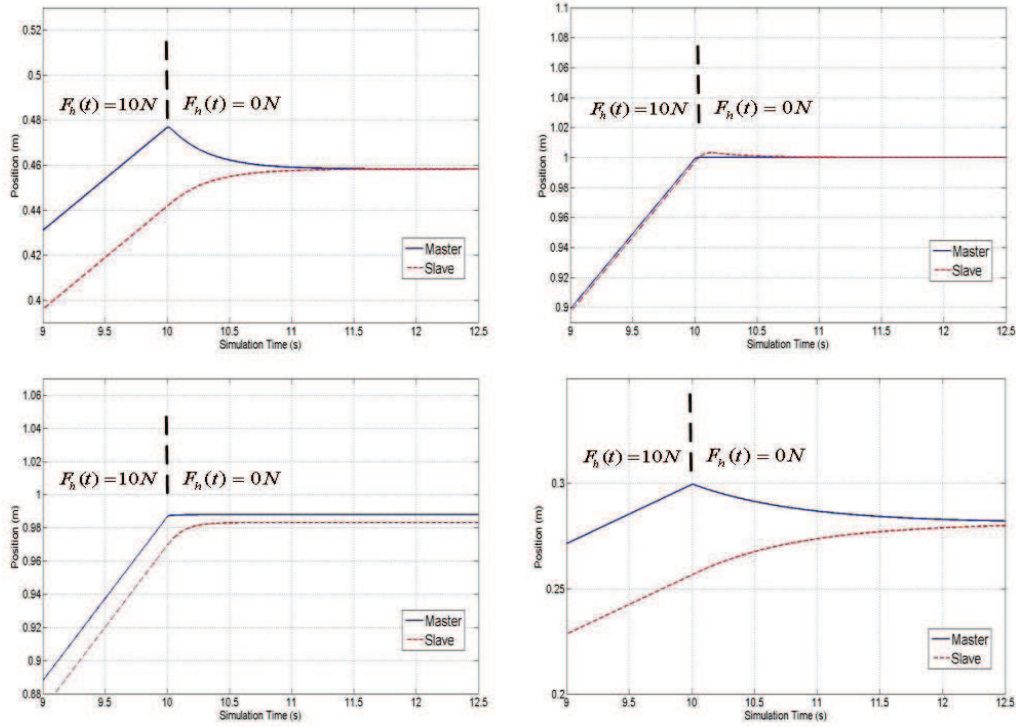

Figure 2.7: Position response in abrupt tracking motion (upper left: bilateral state feedback control scheme; upper right: force-reflecting proxy control scheme; lower left: from [Ye 2009c]; lower right: from [Hua 2010])

Furthermore, in order to show the effectiveness of the proxy in Fig. 2.8, we also compare the results of simulation between the force-reflecting control scheme (Fig. 2.3) and force-reflecting proxy control scheme (Fig. 2.4). We can see that the proxy of master can greatly improve the system performance.

Besides, as described in *Remark 2.6*, in Fig. 2.9 the position scaling is achieved for both the bilateral state feedback and force-reflecting proxy control schemes. Here,  $\alpha_m = 1$ ,  $\alpha_s = 2$ . Specially for the force-reflecting proxy control scheme, we make the position scaling at the design stage of the controller  $\tilde{C}$ , thus  $\alpha_p = 1$ ,  $\alpha_s = 2$ .

## 2.5.2 Wall Contact Motion

In this case, the slave robot is driven to the hard wall with a stiffness of  $K_e = 30kN/m$  located at  $x = 1.0m$ . Our aim is to show that, by our methods:

1. When the slave robot reaches the wall, the master robot can stop as quickly as possible.

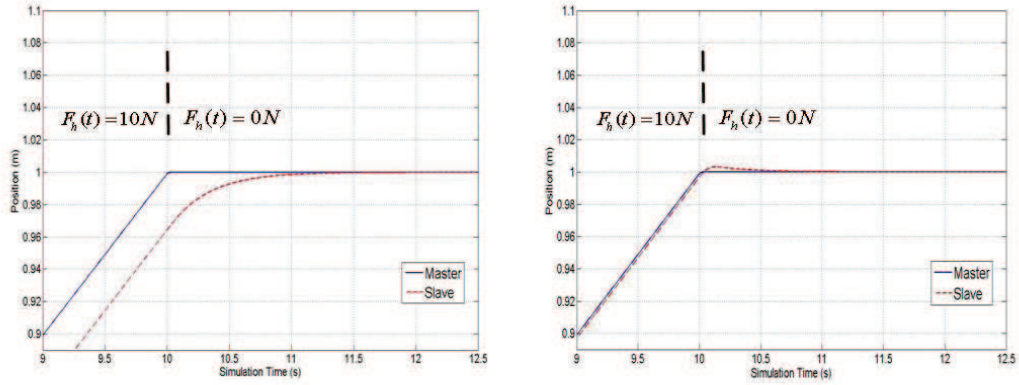

Figure 2.8: Position response in abrupt tracking motion (left: force-reflecting control scheme; right: force-reflecting proxy control scheme)

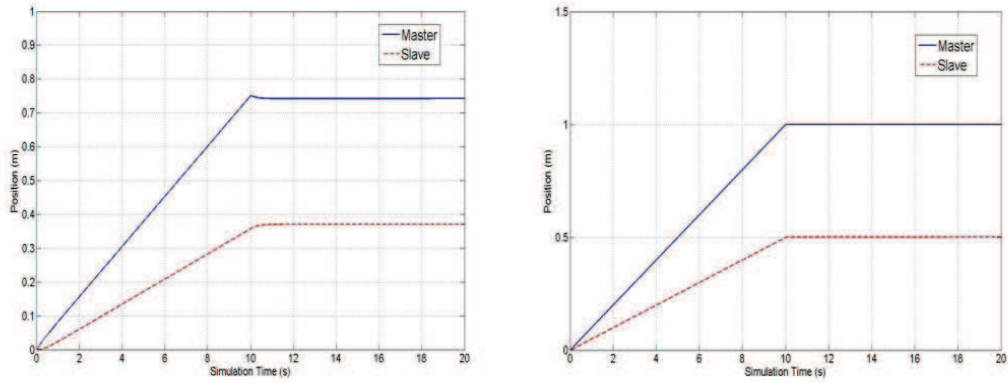

Figure 2.9: Position scaling in abrupt tracking motion (left: bilateral state feedback control scheme; right: force-reflecting proxy control scheme)

2. When the slave robot returns after hitting the wall ( $F_e(t) = 0$ ), the system can restore the position tracking between the master and the slave.
3. When the slave contacts the wall, the force tracking from the slave to the master can be assured.

Fig. 2.10 illustrates that our two schemes can ensure points 1) and 2). Moreover, our force-reflecting proxy control scheme can get a better position performance. By the approach in [Ye 2009c], the position deviation between the master and the slave is larger, and when the slave robot returns from the wall, the teleoperation system can not restore the position tracking. [Hua 2010] can also ensures points 1) and 2), but because we have introduced  $H_\infty$  control theory, our architectures can get better position tracking and faster position convergence than the one in [Hua 2010].

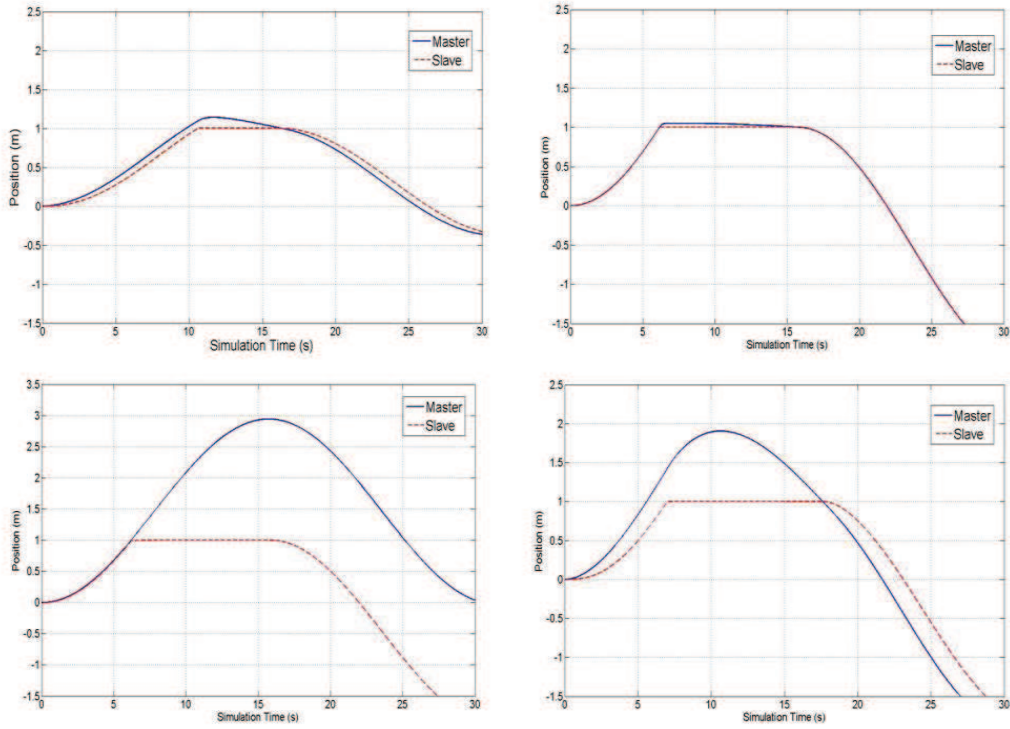

Figure 2.10: Position response in wall contact motion (upper left: bilateral state feedback control scheme; upper right: force-reflecting proxy control scheme; lower left: from [Ye 2009c]; lower right: from [Hua 2010])

Similarly, Fig. 2.11 compares the force-reflecting control scheme without the proxy and that with the proxy.

Fig. 2.12 shows the force tracking between the master and the slave,  $F_m(t)$  and  $\hat{F}_e(t)$ , which satisfies 3). We added a simple perturbation observer in SIMULINK (in real implementation of Chapter 4, the perturbation observer in SIMULINK will be replaced by the external force sensors) in the force-reflecting proxy control scheme so to estimate the unmeasured  $\hat{F}_e(t)$ .

Similarly with the abrupt tracking motion, the position scaling is achieved on Fig. 2.13. Besides, in the force-reflecting proxy control scheme, the force scaling is easy to realize by adding a scaling gain in the force feedback channel.

### 2.5.3 Wall Contact Motion under Large Delays

In the case of "large" delays, we suppose the allowable maximum time-varying delay,  $h_2 = 1.0s$ , by the theorems in the thesis, the controllers can be recalculated. The simulation results are presented in Fig. 2.14, we can see that, our methods (especially the force-

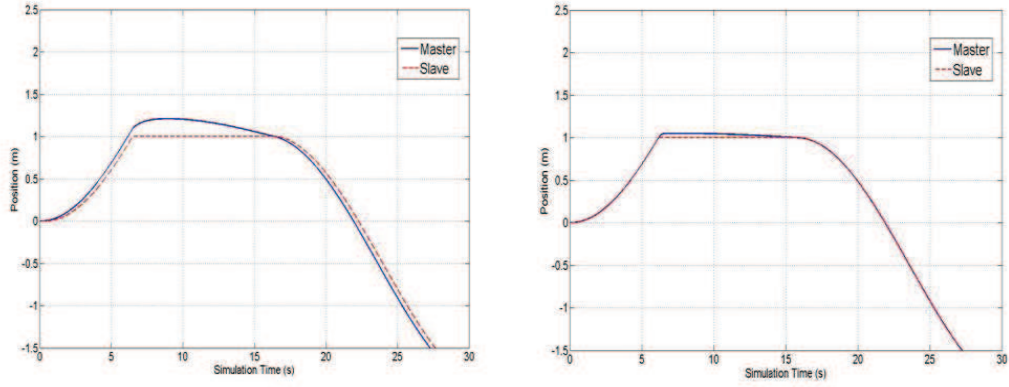

Figure 2.11: Position response in wall contact motion (left: force-reflecting control scheme; right: force-reflecting proxy control scheme)

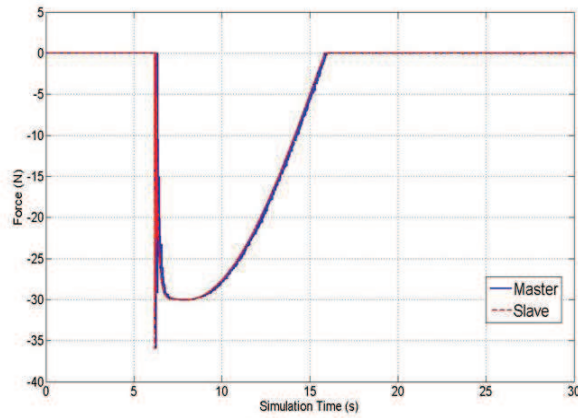

Figure 2.12: Force response in wall contact motion ( $F_m(t)$ ;  $\hat{F}_e(t)$ )

reflecting proxy control scheme) can support "large" delays, while ensuring stability and performance.

In order to present the influence of the time-varying delays, in Fig. 2.15 we zoom in the right part of Fig. 2.11 ( $h_2 = 0.2s$ ) and the middle part of Fig. 2.14 ( $h_2 = 1.0s$ ), which are both the results of the force-reflecting proxy control scheme. We can see that by our approach, the larger delay only enlarges the position gap between the master and the slave (this is inevitable), but does not introduce other dynamics and perturbations on the system performance.

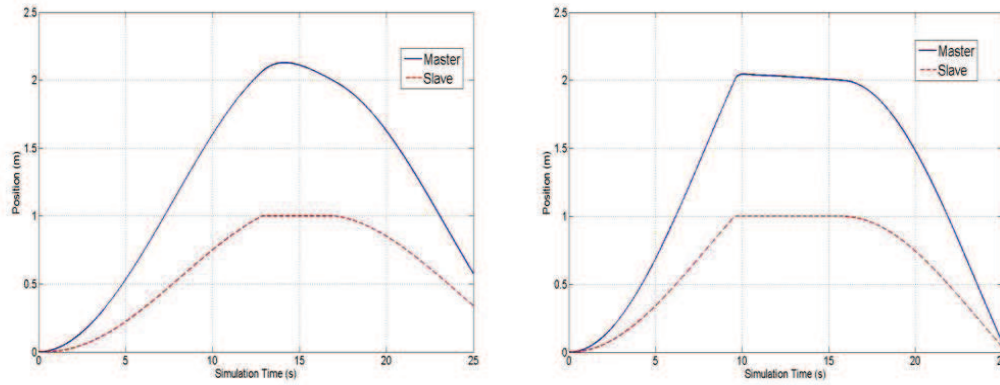

Figure 2.13: Position scaling in wall contact motion (left: bilateral state feedback control scheme; right: force-reflecting proxy control scheme)

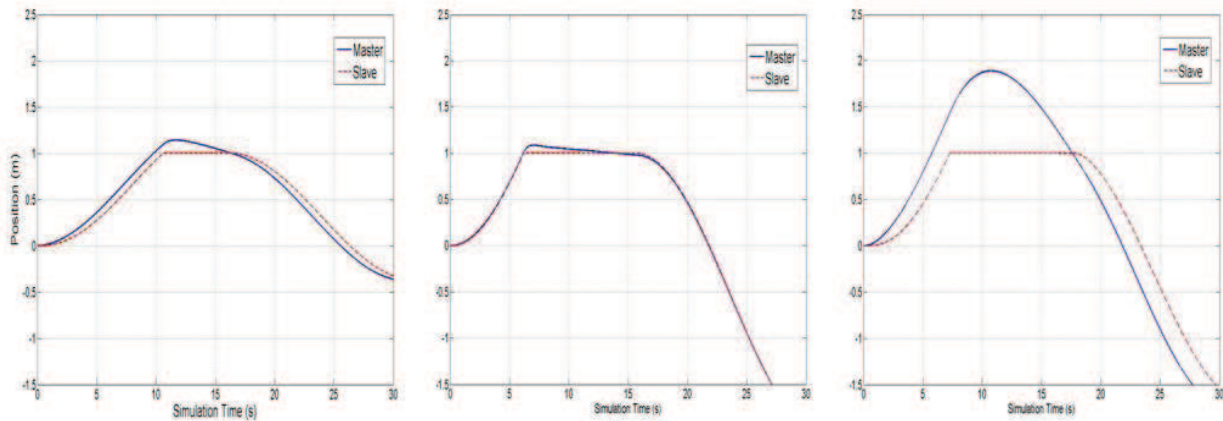

Figure 2.14: Position response with "large" delays in wall contact motion (left: bilateral state feedback control scheme; middle: force-reflecting proxy control scheme; right: from [Hua 2010])

## 2.6 Conclusions

Combining the theories of LKF and  $H_\infty$  allows us to propose a series of control schemes with asymptotic stability and guarantee performance under time-varying, asymmetric network delays. The controllers are computed in terms of LMI. The architectures are a comprehensive summary of the position-position and position-force schemes, especially the force-reflecting proxy control scheme, which pioneers the use of the proxy of master in the design of teleoperation. We think they present a quite flexible tool for the controller design in bilateral teleoperation.

The simulations, achieved under YALMIP and SIMULINK, demonstrate that the teleoperation system designed by our theory can run in different working conditions, even

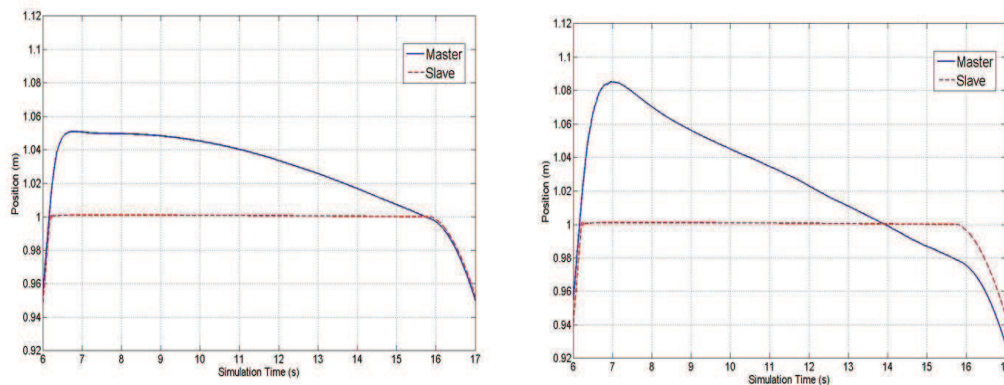

Figure 2.15: Position response of force-reflecting proxy control scheme in wall contact motion (left:  $h_2 = 0.2s$ ; right:  $h_2 = 1.0s$ )

under "large" delays. Besides, the comparison with other recent approaches has been achieved.

From now, some possible works are still open:

- The discrete-time approach of the teleoperation control scheme for digital implementation should be designed.
- This chapter supposed that the systems are modeled as linear time delay systems with perturbations, but in next chapter, the theory to be developed to cover a more general system with time-varying parametric uncertainties.
- Our results should be implemented in an experimental test-bench, and the real experimental results will prove the effectiveness of our approaches.



## Chapter 3

# Robustness Aspects

Till now, the stability, the synchronization and the transparency have been ensured by three bilateral teleoperation control schemes, especially by the force-reflecting proxy control scheme proposed in the previous chapter. Based on this, some extended research should be considered in order to resolve some particular aspects of robustness. It will be successively considered in the discrete-time domain, then in the continuous-time domain. In the discrete case, we only consider exogenous perturbations, while in the continuous-time domain, we also consider parametric uncertainties.

- Discrete-time approach: we will use a discrete-time approach to analyze the force-reflecting proxy control scheme and try to obtain a better system performance than the approach in continuous-time domain [Zhang 2012a]. Specifically, we present a rigorous development of the controllers in the form of LMI for discrete teleoperation by using discrete LKF and  $H_\infty$  control (the readers could refer to [Rehm 2002, Fridman 2005a, Hetel 2008, Meng 2010] for more details about the stability analysis of discrete-time delay systems by Lyapunov methods). The research in this subsection is valuable to the digital implementation on the experimental test-bench and switch controller design [Kruszewski 2011].

- Continuous-time: we should extend it to more general systems with time-varying uncertainties. There are two uncertainty cases proposed in this subsection: the teleoperation system with polytopic-type uncertainties [Zhang 2012b] and with norm-bounded model uncertainties [Zhang 2012c]. For these two cases, we use the same design steps: the force-reflecting proxy control scheme is utilized, but the models of master, proxy of master and slave are combined with time-varying uncertainties; local controllers of master, proxy and slave are designed by Lyapunov functions and LMI; the slave controller is obtained by LKF,  $H_\infty$  control and LMI. However, note that in each design step, design strategies are different from one case to another. At last, these two approaches will be compared



under the same working conditions.

In the following, a more detailed presentation of these research will be provided, and then in each subsection, some results and comparisons will be illustrated by simulations.

## 3.1 Discrete-Time Approach

### 3.1.1 Stability Analysis of Discrete-Time Delay System

Firstly, let us introduce a discrete-time stability theorem with  $H_\infty$  control performance index. The system can be modeled as follows:

$$\begin{cases} x(k+1) = \sum_{i=0}^q A_i x(k - \tau_i(k)) + Bw(k), \\ z(k) = Cx(k), \end{cases} \quad (3.1)$$

where  $x(k) \in \mathbb{R}^n$ ,  $w(k) \in \mathbb{R}^l$  is defined as the exogenous disturbance signal,  $z(k) \in \mathbb{R}^m$  is seen as the objective control output,  $A_i$ ,  $i = 1, 2, \dots, q$ ,  $B$  and  $C$  are constant matrices.  $\tau_0(k) \equiv 0$ , the time-varying delays  $\tau_i(k)$  are positive integers which can be modeled as  $\tau_i(k) \in [h_1, h_2] \cap \mathbb{N}$ ,  $i = 1, 2, \dots, q$ ,  $h_1, h_2$  are positive integers,  $h_2 \geq h_1 \geq 0$ . Consider the following discrete Lyapunov function<sup>2</sup> with the notation of  $y(k) = x(k+1) - x(k)$ :

$$\begin{aligned} V(x(k)) = & x(k)^T P x(k) + \sum_{i=k-h_2}^{k-1} x(i)^T S_a x(i) + \sum_{i=k-h_1}^{k-1} x(i)^T S x(i) \\ & + h_1 \sum_{i=-h_1}^{-1} \sum_{j=k+i}^{k-1} y(j)^T R y(j) + \sum_{i=1}^q (h_2 - h_1) \sum_{j=-h_2}^{-h_1-1} \sum_{l=k+j}^{k-1} y(l)^T R_{ai} y(l). \end{aligned} \quad (3.2)$$

In order to guarantee the improvement of the overall performance, we define the following  $H_\infty$  control performance criterion with a positive scalar  $\gamma$ :

$$J(w) = \sum_{i=0}^{\infty} [z(k)^T z(k) - \gamma^2 w(k)^T w(k)] < 0. \quad (3.3)$$

Then, we obtain the following theorem.

**Theorem 3.1** *Suppose there exist  $n \times n$  symmetric matrices  $P > 0$ ,  $R > 0$ ,  $S > 0$ ,  $S_a > 0$ ,  $R_{ai} > 0$ , some matrices  $P_2, P_3, Y_1, Y_2$ ,  $i = 1, 2, \dots, q$ , and a positive scalar  $\gamma$ , such*

---

<sup>2</sup>We do not call it Lyapunov-Krasovskii functional since in discrete-time domain, the delay system with an upper bound of the delays  $h_2$  has the finite dimension  $(h_2 + 1)$ . Indeed, it can be transformed into the switch model  $X(k+1) = \bar{A}(k)X(k) + \bar{B}w(k)$ , where  $X(k) = \text{col}\{x(k), x(k-1), \dots, x(k-h_2)\}$  and  $\bar{A}(k)$  takes a finite set of values, i.e.  $\bar{A}(k) = \bar{A}(\tau_i(k))$ ,  $i = 1, 2, \dots, q$  [Hetel 2008].

that LMI condition (3.4) with notations (3.5) is feasible, then the system (3.1) is rate-independent asymptotically stable and  $H_\infty$  performance  $J(w) < 0$  (3.3) for time-varying delays  $\tau_i(k) \in [h_1, h_2]$ ,  $h_2 \geq h_1 \geq 0$ ,  $i = 1, 2, \dots, q$ .

$$\Gamma^1 = \begin{pmatrix} \Gamma_{11}^1 & \Gamma_{12}^1 & R + \sum_{i=1}^q P_2^T A_i - q Y_1^T & q Y_1^T & -P_2^T A_1 + Y_1^T & \dots & -P_2^T A_q + Y_1^T & Y_1^T & \dots & Y_1^T & P_2^T B \\ * & \Gamma_{22}^1 & \sum_{i=1}^q P_3^T A_i - q Y_2^T & q Y_2^T & -P_3^T A_1 + Y_2^T & \dots & -P_3^T A_q + Y_2^T & Y_2^T & \dots & Y_2^T & P_3^T B \\ * & * & -S - R & 0 & 0 & 0 & 0 & 0 & 0 & 0 & 0 \\ * & * & * & -S_a & 0 & 0 & 0 & 0 & 0 & 0 & 0 \\ * & * & * & * & -R_{a1} & 0 & 0 & 0 & 0 & 0 & 0 \\ * & * & * & * & * & \dots & 0 & 0 & 0 & 0 & 0 \\ * & * & * & * & * & * & -R_{aq} & 0 & 0 & 0 & 0 \\ * & * & * & * & * & * & * & -R_{a1} & 0 & 0 & 0 \\ * & * & * & * & * & * & * & * & \dots & 0 & 0 \\ * & * & * & * & * & * & * & * & * & -R_{aq} & 0 \\ * & * & * & * & * & * & * & * & * & * & -\gamma^2 I \end{pmatrix} < 0, \quad (3.4)$$

$$\begin{aligned} \Gamma_{11}^1 &= S + S_a - R + A_0^T P_2 + P_2^T A_0 - P_2 - P_2^T + C^T C, & \Gamma_{12}^1 &= P - P_2^T - P_3^T + A_0^T P_3, \\ \Gamma_{22}^1 &= P - P_3 - P_3^T + h_1^2 R + (h_2 - h_1)^2 \sum_{i=1}^q R_{ai}. \end{aligned} \quad (3.5)$$

**Proof:** According to  $H_\infty$  control theory [Kapila 1998], we consider the condition:

$$\Delta V(x(k)) + z(k)^T z(k) - \gamma^2 w(k)^T w(k) < 0, \quad (3.6)$$

where  $\Delta V(x(k)) = V(x(k+1)) - V(x(k))$ . Similarly to *Theorem 2.3* in Chapter 2, we can see that  $J(w) < 0$  can be assured if inequality (3.6) holds. One obtains:

$$\begin{aligned} & \Delta V(x(k)) + z(k)^T z(k) - \gamma^2 w(k)^T w(k) \\ &= x(k)^T (S + S_a) x(k) + x(k+1)^T P x(k+1) - x(k)^T P x(k) \\ & \quad - x(k-h_1)^T S x(k-h_1) - x(k-h_2)^T S_a x(k-h_2) \\ & \quad + y(k)^T [h_1^2 R + (h_2 - h_1)^2 \sum_{i=1}^q R_{ai}] y(k) \\ & \quad - h_1 \sum_{i=k-h_1}^{k-1} y(i)^T R y(i) - (h_2 - h_1) \sum_{j=k-h_2}^{k-h_1-1} y(j)^T \sum_{i=1}^q R_{ai} y(j) \\ & \quad + z(k)^T z(k) - \gamma^2 w(k)^T w(k). \end{aligned} \quad (3.7)$$

Substituting for  $z(k)$  and applying the Jensen's inequality [Gu 2003] yield:

$$\begin{aligned}
 & \Delta V(x(k)) + z(k)^T z(k) - \gamma^2 w(k)^T w(k) \\
 & \leq x(k)^T (S + S_a) x(k) + x(k+1)^T P x(k+1) - x(k)^T P x(k) \\
 & \quad - x(k-h_1)^T S x(k-h_1) - x(k-h_2)^T S_a x(k-h_2) \\
 & \quad + y(k)^T [h_1^2 R + (h_2 - h_1)^2 \sum_{i=1}^q R_{ai}] y(k) \\
 & \quad - [x(k)^T - x(k-h_1)^T] R [x(k) - x(k-h_1)] \\
 & \quad - \sum_{i=1}^q v_{1i}^T R_{ai} v_{1i} - \sum_{i=1}^q v_{2i}^T R_{ai} v_{2i} \\
 & \quad + z(k)^T z(k) - \gamma^2 w(k)^T w(k),
 \end{aligned} \tag{3.8}$$

where:

$$v_{1i} = \sum_{i=k-\tau_i(k)}^{k-h_1-1} y(i), \quad v_{2i} = \sum_{i=k-h_2}^{k-\tau_i(k)-1} y(i), \quad i = 1, 2, \dots, q. \tag{3.9}$$

In  $\Delta V(x(k))$ ,  $x(k+1)^T P x(k+1) - x(k)^T P x(k)$  is replaced by  $y(k)^T P y(k) + x(k)^T P y(k) + y(k)^T P x(k)$ . We introduce free weighting matrices  $P_2, P_3, Y_1, Y_2$  as follows:

$$\begin{aligned}
 0 &= 2[x(k)^T P_2^T + y(k)^T P_3^T] [A_0 x(k) + B w(k) + \sum_{i=1}^q A_i x(k-h_1) - \sum_{i=1}^q A_i v_{1i} - y(k) - x(k)], \\
 0 &= 2[x(k)^T Y_1^T + \dot{x}(k)^T Y_2^T] [q x(k-h_2) + \sum_{i=1}^q v_{1i} + \sum_{i=1}^q v_{2i} - q x(k-h_1)],
 \end{aligned} \tag{3.10}$$

as well as the notation:

$$\eta(k) = \text{col}\{x(k), y(k), x(k-h_1), x(k-h_2), v_{11}, v_{12}, \dots, v_{1q}, v_{21}, v_{22}, \dots, v_{2q}, w(k)\}, \tag{3.11}$$

finally, if the LMI (3.4) is feasible, we obtain:

$$\Delta V(x(k)) + z(k)^T z(k) - \gamma^2 w(k)^T w(k) \leq \eta(k)^T \Gamma^1 \eta(k) < 0. \tag{3.12}$$

Specially in (3.1), when the system is delay-free ( $q = 0$ ) as follows:

$$\begin{cases} x(k+1) = A_0 x(k) + B w(k), \\ z(k) = C x(k), \end{cases} \tag{3.13}$$

we can get the following corollary of *Theorem 3.1*.

**Corollary 3.2** *Suppose there exist a  $n \times n$  symmetric matrix  $P > 0$ , some matrices  $P_2$ ,  $P_3$  and a positive scalar  $\gamma$ , such that LMI condition (3.14) with the notation (3.15) is feasible, then the delay-free system (3.13) is asymptotically stable and  $H_\infty$  performance  $J(w) < 0$  (3.3).*

$$\Gamma^2 = \begin{pmatrix} \Gamma_{11}^2 & P - P_2^T - P_3^T + A_0^T P_3 & P_2^T B \\ * & -P_3 - P_3^T & P_3^T B \\ * & * & -\gamma^2 I \end{pmatrix} < 0, \quad (3.14)$$

$$\Gamma_{11}^2 = A_0^T P_2 + P_2^T A_0 - P_2 - P_2^T + C^T C. \quad (3.15)$$

**Remark 3.3** *By  $H_\infty$  control in the discrete-time domain, we just guarantee the performance of the system at the sampling instances, but during the two sampling instances, we can hardly guarantee the performance of the system. However, in the real applications, we consider the sampling time is much smaller than the movements and the reactions of the robots, that is to say, if the sampling time is small enough, we can guarantee the performance of the robots in the continuous-time domain by guaranteeing  $H_\infty$  control at the sampling instances in the discrete-time domain.*

### 3.1.2 System Description and Problem Formulation

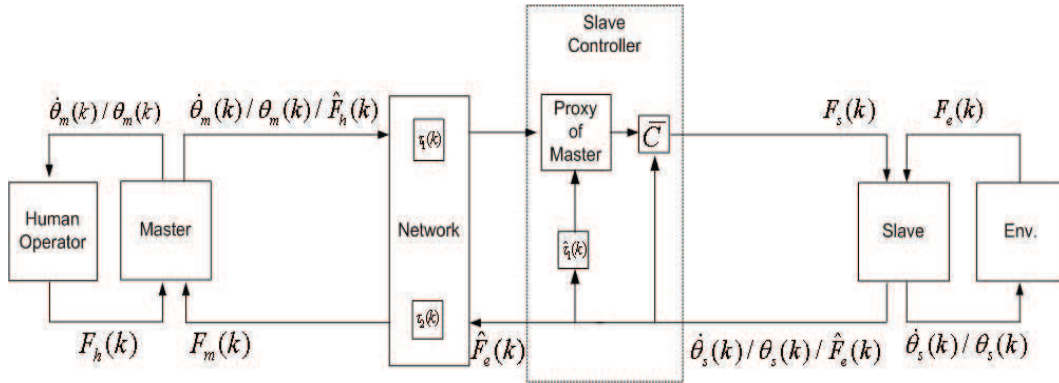

Figure 3.1: Discrete force-reflecting proxy control scheme

The discrete force-reflecting proxy control scheme is presented in Fig. 3.1, which is the discretization of the continuous force-reflecting proxy control scheme proposed in Chapter 2. Let us give a short recall of the system description:  $F_m(k)$  and  $F_s(k)$  are the actuated inputs of the master and of the slave at the  $k^{\text{th}}$  time sample;  $F_h(k)$  and  $F_e(k)$  are the forces of the human operator and of the environment on the system;  $\hat{F}_h(k)$  and

$\hat{F}_e(k)$  are the estimations of these two forces, which can be concretely obtained by adding perturbation observers in SIMULINK or external force sensors in real implementation.

$\tau_1(k)$  (from master to slave) and  $\tau_2(k)$  (from slave to master) are the time-varying delays, which are modeled as in the previous section:  $\tau_1(k), \tau_2(k) \in [h_1, h_2] \cap \mathbb{N}$ . Master and slave clocks are synchronized thanks to time-stamped data packet exchanges between them, by using a GPS strategy as in [Jiang 2008] or a network time protocol as in [Kruszewski 2011]. Therefore, the estimated network delay from the master to the slave,  $\hat{\tau}_1(k)$ , is available at slave's side:  $\hat{\tau}_1(k) = \tau_1(k)$ .

From master to slave, the information transferred are the velocity/position of the master and the estimated/measured force  $\hat{F}_h(k)$ . However, from slave to master, only the estimated/measured force  $\hat{F}_e(k)$  is transferred so that the force tracking  $F_m(k) = \hat{F}_e(k - \tau_2(k))$  is realized, provided that the stability of the whole system is verified.

$\dot{\theta}_m(k)/\theta_m(k)$  and  $\dot{\theta}_s(k)/\theta_s(k)$  are the velocities/positions of the master and the slave, and their models are described as follows:

$$(\Sigma_m^d) \quad x_m(k+1) = (A_{md} - B_{md}K_{md}^0)x_m(k) + B_{md}(F_m(k) + F_h(k)), \quad (3.16)$$

$$(\Sigma_s^d) \quad x_s(k+1) = (A_{sd} - B_{sd}K_{sd}^0)x_s(k) + B_{sd}(F_s(k) + F_e(k)), \quad (3.17)$$

where  $x_m(k) = \dot{\theta}_m(k) \in \mathbb{R}^1$ ,  $x_s(k) = \dot{\theta}_s(k) \in \mathbb{R}^1$ .  $K_{md}^0, K_{sd}^0$  are the local controllers ensuring the speed stability.

Here again, the proxy of master and the controller  $\bar{C}$  will be designed in sequential steps in the following. We consider the discrete-time model of proxy, where  $\dot{\theta}_p(k), \theta_p(k)$  is the velocity/position of the proxy:

$$(\Sigma_p^d) \quad x_p(k+1) = (A_{md} - B_{md}K_{md}^0)x_p(k) - B_{md}F_p(k) + B_{md}(\hat{F}_e(k - \hat{\tau}_1(k)) + \hat{F}_h(k - \tau_1(k))). \quad (3.18)$$

Because the proxy acts as a remote observer of the master, the proxy model is the same as that of the master,  $x_p(k) = \dot{\theta}_p(k) \in \mathbb{R}^1$ .  $L_d = \begin{pmatrix} L_{d1} & L_{d2} & L_{d3} \end{pmatrix}$  is the gain of proxy that will be designed so to synchronize the master and proxy positions:

$$F_p(k) = L_d \begin{pmatrix} \dot{\theta}_p(k - \hat{\tau}_1(k)) \\ \dot{\theta}_m(k - \tau_1(k)) \\ \theta_p(k - \hat{\tau}_1(k)) - \theta_m(k - \tau_1(k)) \end{pmatrix}. \quad (3.19)$$

$K_d = \begin{pmatrix} K_{d1} & K_{d2} & K_{d3} \end{pmatrix}$  is the gain of the controller  $\bar{C}$ :

$$F_s(k) = -K_d \begin{pmatrix} \dot{\theta}_s(k) \\ \dot{\theta}_p(k) \\ \theta_s(k) - \theta_p(k) \end{pmatrix}. \quad (3.20)$$

### 3.1.3 Slave Controller Design

We design the proxy of master and consider the whole system of master and proxy as follows:

$$(\Sigma_{mpd}^d) \begin{cases} x_{mp}(k+1) &= A_{mpd}^0 x_{mp}(k) + A_{mpd}^1 x_{mp}(k - \tau_1(k)) + B_{mpd} w_{mp}(k), \\ z_{mp}(k) &= C_{mpd} x_{mp}(k), \end{cases} \quad (3.21)$$

where:

$$x_{mp}(k) = \begin{pmatrix} \dot{\theta}_p(k) \\ \dot{\theta}_m(k) \\ \theta_p(k) - \theta_m(k) \end{pmatrix}, \quad w_{mp}(k) = \begin{pmatrix} \hat{F}_e(k - \hat{\tau}_1(k)) + \hat{F}_h(k - \tau_1(k)) \\ F_m(k) + F_h(k) \end{pmatrix}, \quad z_{mp}(k) = \begin{pmatrix} \theta_p(k) - \theta_m(k) \end{pmatrix}. \quad (3.22)$$

$A_{mpd}^0$ ,  $B_{mpd}$  are discretized from  $A_{mp}^0$ ,  $B_{mp}$  in Chapter 2,  $C_{mpd} = \begin{pmatrix} 0 & 0 & 1 \end{pmatrix}$  and:

$$A_{mpd}^1 = \begin{pmatrix} -B_{md}L_{d1} & -B_{md}L_{d2} & -B_{md}L_{d3} \\ 0 & 0 & 0 \end{pmatrix} = -B_L L_d, \quad (3.23)$$

where  $B_L = \begin{pmatrix} B_{md}^T & 0 & 0 \end{pmatrix}^T$ . Then, we design  $L_d$  by the following stability theorem.

**Theorem 3.4** *Suppose there exist symmetric matrices  $P > 0$ ,  $R > 0$ ,  $S > 0$ ,  $S_a > 0$ ,  $R_{a1} > 0$ , some matrices  $P_2$ ,  $Y_1$ ,  $Y_2$ ,  $M$ , and positive scalars  $\gamma$  and  $\xi$ , such that LMI condition (3.25) with notations (3.26) is feasible, then the system (3.21) is rate-independent asymptotically stable and  $H_\infty$  performance  $J(w) < 0$  (3.3) for time-varying delay  $\tau_1(k) \in [h_1, h_2]$ . The control gain of the proxy is given by:*

$$L_d = M P_2^{-1}. \quad (3.24)$$

$$\Gamma^3 = \begin{pmatrix} \Gamma_{11}^3 & \Gamma_{12}^3 & R - B_L M - Y_1^T & Y_1^T & Y_1^T + B_L M & Y_1^T & B_{mpd} & P_2^T C_{mpd}^T \\ * & \Gamma_{22}^3 & -\xi B_L M - Y_2^T & Y_2^T & Y_2^T + \xi B_L M & Y_2^T & \xi B_{mpd} & 0 \\ * & * & -S - R & 0 & 0 & 0 & 0 & 0 \\ * & * & * & -S_a & 0 & 0 & 0 & 0 \\ * & * & * & * & -R_{a1} & 0 & 0 & 0 \\ * & * & * & * & * & -R_{a1} & 0 & 0 \\ * & * & * & * & * & * & -\gamma^2 I & 0 \\ * & * & * & * & * & * & * & -I \end{pmatrix} < 0, \quad (3.25)$$

$$\begin{aligned} \Gamma_{11}^3 &= S + S_a - R + P_2^T A_{mpd}^0{}^T + A_{mpd}^0 P_2 - P_2 - P_2^T, & \Gamma_{12}^3 &= P - P_2 - \xi P_2 + \xi P_2^T A_{mpd}^0{}^T, \\ \Gamma_{22}^3 &= P - \xi P_2 - \xi P_2^T + h_1^2 R + (h_2 - h_1)^2 R_{a1}. \end{aligned} \quad (3.26)$$

**Proof:** We use *Theorem 3.1* on system (3.21). Inspired from [Fridman 2001b], a series of steps as follows is made to deal with nonlinear matrix terms,  $P_2^T B_L L_d$ ,  $P_3^T B_L L_d$ : multiplying  $\Gamma^1$  by  $\text{diag}\{P_2^{-T}, \dots, P_2^{-T}, I\}$  at the left side, by  $\text{diag}\{P_2^{-1}, \dots, P_2^{-1}, I\}$  at the right side; choosing  $P_3 = \xi P_2$ ; defining  $M = L_d P_2$ ; applying the Schur formula. This leads to LMI (3.25).

The position tracking between the master and the proxy has been achieved. Now, the position tracking between the proxy and the slave is to be achieved by the controller  $\bar{C}$ . The discrete-time model of the proxy, the controller  $\bar{C}$  and the slave is:

$$(\Sigma_{ps}^d) \begin{cases} x_{ps}(k+1) &= A_{psd} x_{ps}(k) + B_K F_s(k) + B_{psd} w_{ps}(k), \\ z_{ps}(k) &= C_{psd} x_{ps}(k), \end{cases} \quad (3.27)$$

where  $A_{psd}$ ,  $B_{psd}$  are transformed from  $A_{ps}^0$ ,  $B_{ps}$  in Chapter 2,  $B_K = \begin{pmatrix} B_{sd}^T & 0 & 0 \end{pmatrix}^T$ ,  $C_{psd} = \begin{pmatrix} 0 & 0 & 1 \end{pmatrix}$ , and:

$$x_{ps}(k) = \begin{pmatrix} \dot{\theta}_s(k) \\ \dot{\theta}_p(k) \\ \theta_s(k) - \theta_p(k) \end{pmatrix}, \quad z_{ps}(k) = \begin{pmatrix} \theta_s(k) - \theta_p(k) \end{pmatrix}, \quad w_{ps}(k) = \begin{pmatrix} F_e(k) \\ \hat{F}_e(k - \hat{\tau}_1(k)) + \hat{F}_h(k - \tau_1(k)) - F_p(k) \end{pmatrix}. \quad (3.28)$$

Thus, the system transformation is made so to apply LMI (3.14):

$$(\bar{\Sigma}_{ps}^d) \begin{cases} x_{ps}(k+1) &= (A_{psd} - B_K K_d) x_{ps}(k) + B_{psd} w_{ps}(k), \\ z_{ps}(k) &= C_{psd} x_{ps}(k). \end{cases} \quad (3.29)$$

**Theorem 3.5** *Suppose there exist a symmetric matrix  $P > 0$ , some matrices  $P_2$ ,  $W$ , and positive scalars  $\gamma$  and  $\xi$ , such that LMI condition (3.31) with notations (3.32) is feasible, then the system (3.27) is asymptotically stable and  $H_\infty$  performance  $J(w) < 0$  (3.3). The control gain of the controller  $\bar{C}$  is given by:*

$$K_d = W P_2^{-1}. \quad (3.30)$$

$$\Gamma^4 = \begin{pmatrix} \Gamma_{11}^4 & \Gamma_{12}^4 & B_{psd} & P_2^T C_{psd}^T \\ * & \Gamma_{22}^4 & \xi B_{psd} & 0 \\ * & * & -\gamma^2 I & 0 \\ * & * & * & -I \end{pmatrix} < 0, \quad (3.31)$$

$$\begin{aligned} \Gamma_{11}^4 &= P_2^T A_{psd}^T + A_{psd}^T P_2 - B_K W - W^T B_K^T - P_2 - P_2^T, \\ \Gamma_{12}^4 &= P - P_2 - \xi P_2 + \xi P_2^T A_{psd}^T - \xi W^T B_K^T, \quad \Gamma_{22}^4 = P - \xi P_2 - \xi P_2^T. \end{aligned} \quad (3.32)$$

**Proof:** *Corollary 3.2* is applied to (3.29), and  $K_d$  is obtained by the same process of *Theorem 3.4*.

The global system stability should be verified based on the position tracking between the master and the proxy, the proxy and the slave. The discrete-time whole system is:

$$(\Sigma_{mps}^d) \begin{cases} x(k+1) &= A_{mpsd}x(k) + B_{mpsd}^K F_s(k) - B_{mpsd}^L F_p(k) + B_{mpsd}w(k), \\ z(k) &= C_{mpsd}x(k). \end{cases} \quad (3.33)$$

Here,  $x(k)$ ,  $w(k)$ ,  $z(k)$  and  $A_{mpsd}$ ,  $B_{mpsd}$  are the discretization of the continuous system  $(x(t), w(t), z(t), A_0, B)$ . We redefine:

$$\begin{aligned} F_s(k) &= -\bar{K}_d x(k) = -\begin{pmatrix} K_{d1} & K_{d2} & 0 & K_{d3} & 0 \end{pmatrix} x(k), \\ F_p(k) &= \bar{L}_d x(k - \tau_1(k)) = \begin{pmatrix} 0 & L_{d1} & L_{d2} & 0 & L_{d3} \end{pmatrix} x(k - \tau_1(k)), \\ B_{mpsd}^K &= \begin{pmatrix} B_{sd} \\ 0 \\ 0 \\ 0 \end{pmatrix}, \quad B_{mpsd}^L = \begin{pmatrix} 0 \\ B_{md} \\ 0 \\ 0 \end{pmatrix}. \end{aligned} \quad (3.34)$$

Thus, we suppose  $A_0^d = A_{mpsd} - B_{mpsd}^K \bar{K}_d$ ,  $A_1^d = -B_{mpsd}^L \bar{L}_d$ , the whole system in (3.33) is transformed as follows:

$$(\bar{\Sigma}_{mps}^d) \begin{cases} x(k+1) &= A_0^d x(k) + A_1^d x(k - \tau_1(k)) + B_{mpsd}w(k), \\ z(k) &= C_{mpsd}x(k). \end{cases} \quad (3.35)$$

By *Theorem 3.1*, the global system stability is verified, and the force tracking  $F_m(k) = \hat{F}_e(k - \tau_2(k))$  is achieved on the basis of our control scheme.

### 3.1.4 Results and Analysis

The simulations are performed in different working conditions so to evaluate the performance of the proposed approach. Borrowing from the illustration of Chapter 2, the master, the proxy and the slave models are integrators,  $1/s$ ,  $1/s$  and  $2/s$ . Besides, the poles of the master, the proxy and the slave are given as  $[-100.0]$  in continuous-time domain.

The constant sampling time is  $T = 0.001s$ , and  $h_1 = 1$ ,  $h_2 = 100$  (*i.e.* in continuous-time domain,  $h_1 = 0.001s$  and  $h_2 = 0.1s$ ).  $L_d$ ,  $K_d$  with  $\gamma_{min}^{L_d}$ ,  $\gamma_{min}^{K_d}$  and the global system stability with  $\gamma_{min}^g$  are obtained:

$$\begin{aligned} L_d &= \begin{pmatrix} 4.6815 & -5.1390 & 540.7828 \end{pmatrix}, \quad \gamma_{min}^{L_d} = 0.0051, \\ K_d &= \begin{pmatrix} 273 & -127 & 10961 \end{pmatrix}, \quad \gamma_{min}^{K_d} = 2.9568 \times 10^{-4}, \\ \gamma_{min}^g &= 0.0327. \end{aligned} \quad (3.36)$$



Note that the  $\xi$  in the theorems mentioned above is an important tuning parameter, here we choose  $\xi = 1$  in *Theorem 3.4* and *Theorem 3.5*.

In abrupt tracking motion, the human operator ( $F_h(k)$ ) is modeled as a pulse generator. Fig. 3.2 compares the position tracking between the master and the slave, respectively for the continuous-time force-reflecting proxy control scheme of Chapter 2 and our result in this section.

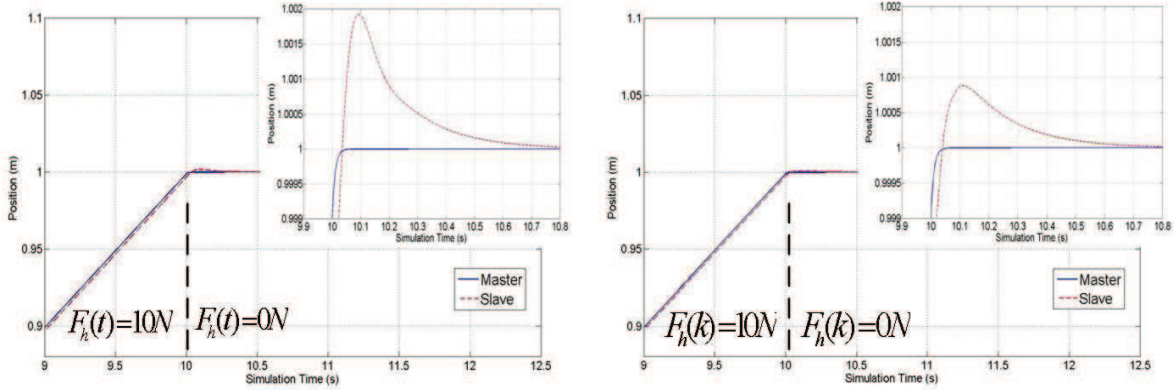

Figure 3.2: Position response in abrupt tracking motion (left: our continuous-time force-reflecting proxy control scheme; right: our discrete-time result)

Fig. 3.2 have zoomed in the changing point of the position, we can see that our discrete-time approach also ensures the system stability, and moreover achieves a better position tracking, which can be illustrated by  $\gamma_{min}$ , in (3.36),  $\gamma_{min}^{L_d}$ ,  $\gamma_{min}^{K_d}$  are smaller. Recall that the  $\gamma_{min}$  of continuous-time approach were:

$$\gamma_{min}^L = 0.0067, \quad \gamma_{min}^K = 0.0075, \quad (3.37)$$

where we have now  $\gamma_{min}^{L_d} = 0.0051$  and  $\gamma_{min}^{K_d} = 0.0003$ .

Actually,  $\gamma^2$  in  $H_\infty$  control (3.3) is a real-time performance scalar, which is denoted as  $\gamma^2(k)$  here (in continuous-time domain,  $\gamma^2$  in (2.16) of Chapter 2 is denoted as  $\gamma^2(t)$ ). We compare  $\gamma^2(k)$  and  $\gamma^2(t)$  as on Fig. 3.3.

**Remark 3.6** *The discrete-time approach obtains a better performance than the continuous-time one under the force-reflecting proxy control scheme. However, in discrete-time domain, when the upper bound of the delay  $h_2 \geq 300$  (the constant sampling time is  $T = 0.001s$ ), we hardly obtain the controllers by LMI conditions in Theorem 3.4 and Theorem 3.5, while in continuous-time domain, even  $h_2 = 1.0s$  as in Section 2.5.3 of Chapter 2, the controllers can be obtained.*

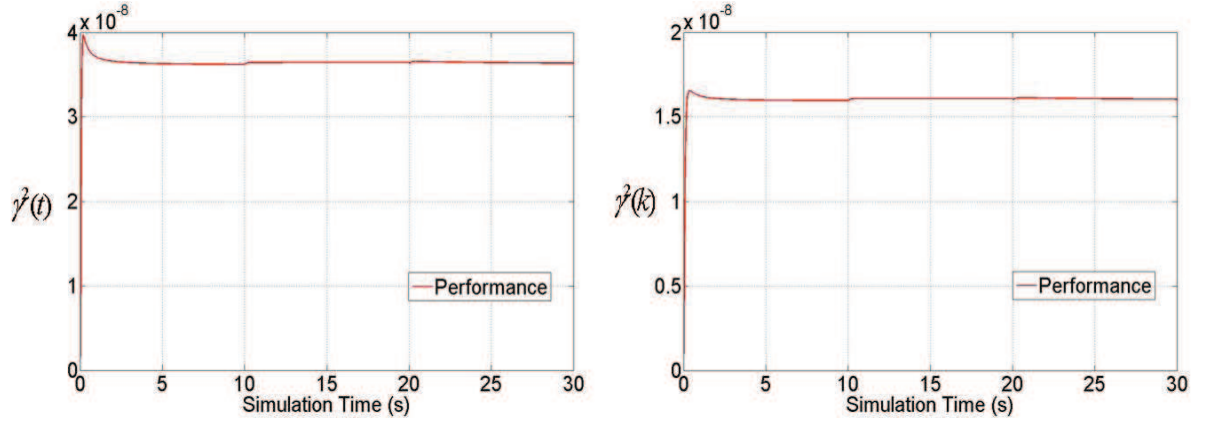

Figure 3.3: Performance in abrupt tracking motion (left: our continuous-time approach  $\dot{\gamma}^2(t)$ ; right: our discrete-time result  $\dot{\gamma}^2(k)$ )

Now, the position tracking of wall contact motion in discrete-time domain is presented in Figure 3.4. Here the slave is driven to the hard wall with a stiffness of  $K_e = 30kN/m$  located at the position  $x = 1.0m$ . Based on the characteristics of force-reflecting proxy control scheme, the force tracking  $F_m(k) = \hat{F}_e(k - \tau_2(k))$  can be seen in Figure 3.5.

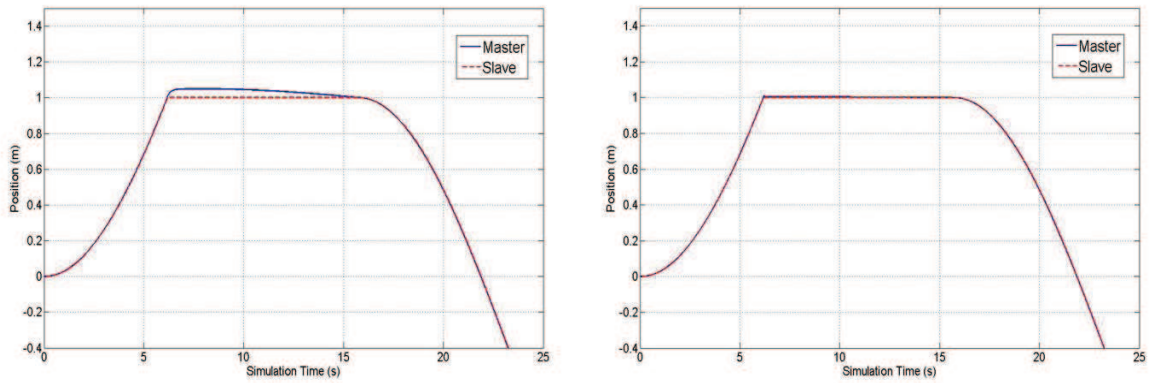

Figure 3.4: Position response in wall contact motion (left: our continuous-time force-reflecting proxy control scheme; right: our discrete-time result)

A comparison of  $\dot{\gamma}^2(t)$  and  $\dot{\gamma}^2(k)$  in the wall contact motion is also presented in Fig. 3.6. We can see that the discrete real-time performance index is about hundred times smaller than the continuous-time one.

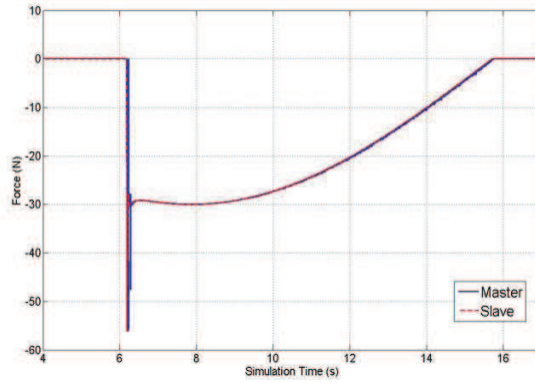

Figure 3.5: Force response in wall contact motion ( $F_m(k)$ ;  $\hat{F}_e(k)$ )

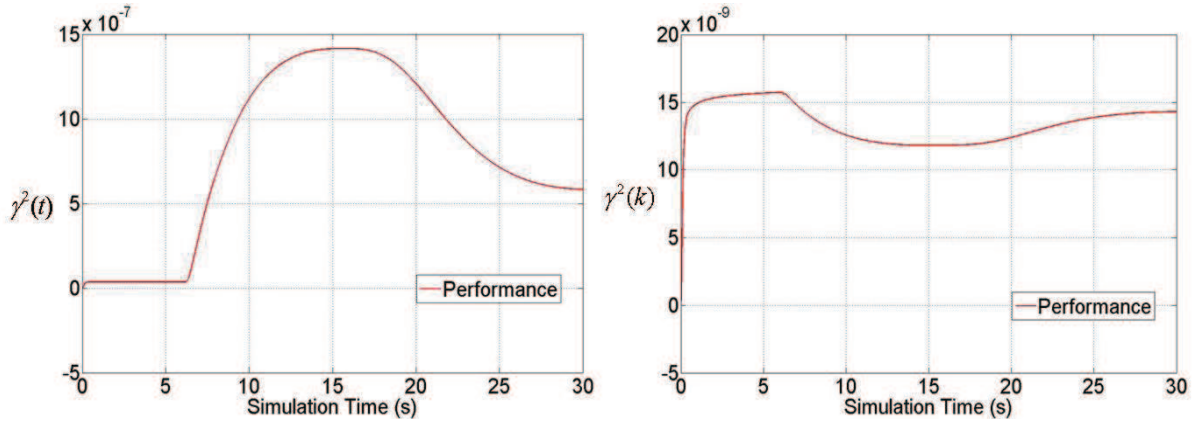

Figure 3.6: Performance in wall contact motion (left: our continuous-time approach  $\gamma^2(t)$ ; right: our discrete-time result  $\gamma^2(k)$ )

### 3.2 $H_\infty$ Robust Teleoperation under Time-Varying Model Uncertainties

This section considers the robustness with regard to parametric uncertainties of our time delay model. The first part concerns polytopic-type uncertainties, while the second part concerns norm-bounded ones. Note that both uncertainties are expressed under the form of time-varying parameters, but could also correspond to nonlinear effects. Thus, the methods we propose here can also handle nonlinear teleoperation control design.

### 3.2.1 $H_\infty$ Robust Control under Polytopic-Type Uncertainties

#### 3.2.1.1 Polytopic-Type $H_\infty$ Robust Stability

To start with, we propose a general stability analysis with the  $H_\infty$  performance index for uncertain time delay systems with time-varying polytopic-type uncertainties. It is considered by the following time-varying system:

$$\begin{cases} \dot{x}(t) = A_0(t)x(t) + \sum_{i=1}^q A_i(t)x(t - \tau_i(t)) + B(t)w(t), \\ z(t) = Cx(t), \\ x(t_0 + \theta) = \phi(\theta), \quad \dot{x}(t_0 + \theta) = \dot{\phi}(\theta), \quad \theta \in [-h_2, 0], \end{cases} \quad (3.38)$$

where  $x(t) \in \mathbb{R}^n$ ,  $w(t) \in \mathbb{R}^l$  is some exogenous disturbance signal,  $C \in \mathbb{R}^{m \times n}$  is a constant matrix and  $z(t) \in \mathbb{R}^m$  is the objective control output (here,  $C$  is defined by the users).  $\phi(\theta)$  is the initial state function, and  $\tau_i(t) \in [h_1, h_2]$ ,  $h_1 \geq 0$ ,  $i = 1, 2, \dots, q$ , are time-varying delays. There is no particular assumption on  $\dot{\tau}_i(t)$ .  $A_0(t)$ ,  $A_i(t)$ ,  $i = 1, 2, \dots, q$ ,  $B(t)$  are subject to the time variation  $\rho(t)$  and satisfy the real convex polytopic model:

$$\begin{aligned} [A_0(t), A_i(t), B(t)] &\in \Omega, \quad i = 1, 2, \dots, q, \\ \Omega &\triangleq [A_0(\rho(t)), A_i(\rho(t)), B(\rho(t))] = \sum_{j=1}^N \rho_j(t) [A_{0j}, A_{ij}, B_j], \quad \sum_{j=1}^N \rho_j(t) = 1, \quad \rho_j(t) \geq 0, \end{aligned} \quad (3.39)$$

where  $A_{0j}$ ,  $A_{ij}$ ,  $B_j$ ,  $i = 1, 2, \dots, q$ ,  $j = 1, 2, \dots, N$ , are constant matrices of appropriate dimension and  $\rho_j(t)$ ,  $j = 1, 2, \dots, N$ , are time-varying uncertainties.

Note that, in the following of this subsection, all systems mentioned satisfy the polytopic-type condition (3.39).

We recall Lyapunov-Krasovskii functional  $V(x(t), \dot{x}(t))$  and  $H_\infty$  performance  $J(w) < 0$ , (2.4) and (2.16) in Chapter 2:

$$\begin{aligned} V(x(t), \dot{x}(t)) &= x(t)^T P x(t) + \int_{t-h_2}^t x(s)^T S_a x(s) ds + \int_{t-h_1}^t x(s)^T S x(s) ds \\ &+ h_1 \int_{-h_1}^0 \int_{t+\theta}^t \dot{x}(s)^T R \dot{x}(s) ds d\theta + \sum_{i=1}^q (h_2 - h_1) \int_{-h_2}^{-h_1} \int_{t+\theta}^t \dot{x}(s)^T R_{ai} \dot{x}(s) ds d\theta, \end{aligned} \quad (3.40)$$

$$J(w) = \int_0^\infty (z(t)^T z(t) - \gamma^2 w(t)^T w(t)) dt < 0, \quad (3.41)$$

and then,  $J(w) < 0$  holds if:

$$\dot{V}(x(t), \dot{x}(t)) + z(t)^T z(t) - \gamma^2 w(t)^T w(t) < 0. \quad (3.42)$$

According to the polytopic method [He 2004, Fridman 2006a] and the same proof of *Theorem 2.3* in Chapter 2, the following theorem can be obtained.

**Theorem 3.7** *Suppose there exist symmetric matrices  $P > 0$ ,  $R > 0$ ,  $S > 0$ ,  $S_a > 0$ ,  $R_{ai} > 0$ , some matrices  $P_2, P_3, Y_1, Y_2$ ,  $i = 1, 2, \dots, q$ , and a positive scalar  $\gamma$ , such that LMI condition (3.43) with notations (3.44),  $j = 1, 2, \dots, N$ , is feasible. Then the system (3.38) is rate-independent asymptotically stable with  $H_\infty$  performance  $J(w) < 0$  (3.41) for time-varying delays  $\tau_i(t) \in [h_1, h_2]$ ,  $i = 1, 2, \dots, q$ .*

$$\Gamma^{5j} = \begin{pmatrix} \Gamma_{11}^{5j} & \Gamma_{12}^{5j} & R + \sum_{i=1}^q P_2^T A_{ij} - qY_1^T & qY_1^T & -P_2^T A_{1j} + Y_1^T & \dots & -P_2^T A_{qj} + Y_1^T & Y_1^T & \dots & Y_1^T & P_2^T B_j \\ * & \Gamma_{22}^{5j} & \sum_{i=1}^q P_3^T A_{ij} - qY_2^T & qY_2^T & -P_3^T A_{1j} + Y_2^T & \dots & -P_3^T A_{qj} + Y_2^T & Y_2^T & \dots & Y_2^T & P_3^T B_j \\ * & * & -S - R & 0 & 0 & 0 & 0 & 0 & 0 & 0 & 0 \\ * & * & * & -S_a & 0 & 0 & 0 & 0 & 0 & 0 & 0 \\ * & * & * & * & -R_{a1} & 0 & 0 & 0 & 0 & 0 & 0 \\ * & * & * & * & * & \dots & 0 & 0 & 0 & 0 & 0 \\ * & * & * & * & * & * & -R_{aq} & 0 & 0 & 0 & 0 \\ * & * & * & * & * & * & * & -R_{a1} & 0 & 0 & 0 \\ * & * & * & * & * & * & * & * & \dots & 0 & 0 \\ * & * & * & * & * & * & * & * & * & -R_{aq} & 0 \\ * & * & * & * & * & * & * & * & * & * & -\gamma^2 I \end{pmatrix} < 0, \quad (3.43)$$

$$\begin{aligned} \Gamma_{11}^{5j} &= S + S_a - R + A_{0j}^T P_2 + P_2^T A_{0j} + C^T C, & \Gamma_{12}^{5j} &= P - P_2^T + A_{0j}^T P_3, \\ \Gamma_{22}^{5j} &= -P_3 - P_3^T + h_1^2 R + (h_2 - h_1)^2 \sum_{i=1}^q R_{ai}. \end{aligned} \quad (3.44)$$

Similarly, a corollary can also be derived in the delay-free case (without  $\sum_{i=1}^q A_i x(t - \tau_i(t))$ ) as follows:

$$\begin{cases} \dot{x}(t) &= A_0 x(t) + Bw(t), \\ z(t) &= Cx(t). \end{cases} \quad (3.45)$$

**Corollary 3.8** *Suppose there exist symmetric matrices  $P > 0$ , some matrices  $P_2, P_3$ , and a positive scalar  $\gamma$ , such that LMI condition (3.46) with the notation (3.47),  $j = 1, 2, \dots, N$ , is feasible. Then the system (3.45) is asymptotically stable with  $H_\infty$  performance  $J(w) < 0$  (3.41).*

$$\Gamma^{6j} = \begin{pmatrix} \Gamma_{11}^{6j} & P - P_2^T + A_{0j}^T P_3 & P_2^T B_j \\ * & -P_3 - P_3^T & P_3^T B_j \\ * & * & -\gamma^2 I \end{pmatrix} < 0, \quad (3.46)$$

$$\Gamma_{11}^{6j} = A_{0j}^T P_2 + P_2^T A_{0j} + C^T C. \quad (3.47)$$

### 3.2.1.2 Control Problem Formulation

Our stability and performance analysis is based on the force-reflecting proxy control scheme [Zhang 2012b], and the difference is the model of each subsystem (the master, the proxy and the slave), which is combined with polytopic-type uncertainties. Considering the models of master and slave as follows:

$$\begin{aligned} (\Sigma_m) \quad \dot{x}_m(t) &= (A_m(\rho_m(t)) - B_m(\rho_m(t))K_m^0)x_m(t) + B_m(\rho_m(t))(F_m(t) + F_h(t)), \\ (\Sigma_s) \quad \dot{x}_s(t) &= (A_s(\rho_s(t)) - B_s(\rho_s(t))K_s^0)x_s(t) + B_s(\rho_s(t))(F_s(t) + F_e(t)), \end{aligned} \quad (3.48)$$

where  $x_m(t) = \dot{\theta}_m(t) \in \mathbb{R}^1$ ,  $x_s(t) = \dot{\theta}_s(t) \in \mathbb{R}^1$  are the state vectors of the master and slave and  $A_m(\rho_m(t))$ ,  $B_m(\rho_m(t))$ ,  $A_s(\rho_s(t))$ ,  $B_s(\rho_s(t))$  matrices are of polytopic-type:

$$\begin{aligned} [A_m(\rho_m(t)), B_m(\rho_m(t))] &= \sum_{j=1}^N \rho_{mj}(t)[A_{mj}, B_{mj}], \\ [A_s(\rho_s(t)), B_s(\rho_s(t))] &= \sum_{j=1}^N \rho_{sj}(t)[A_{sj}, B_{sj}]. \end{aligned} \quad (3.49)$$

As mentioned above, all uncertainties are assumed to satisfy the polytopic-type condition (3.39).  $K_m^0$ ,  $K_s^0$  are local controllers of the master and the slave ensuring the speed stability, which will be designed in the following.

Because the proxy acts as a remote observer of the master, the proxy model is the same as for the master, but under different polytopic-type uncertainties:

$$\begin{aligned} (\Sigma_p) \quad \dot{x}_p(t) &= (A_p(\rho_p(t)) - B_p(\rho_p(t))K_m^0)x_p(t) \\ &+ B_p(\rho_p(t))(\hat{F}_e(t - \hat{\tau}_1(t)) + \hat{F}_h(t - \tau_1(t)) - F_p(t)), \end{aligned} \quad (3.50)$$

$$[A_p(\rho_p(t)), B_p(\rho_p(t))] = \sum_{j=1}^N \rho_{pj}(t)[A_{mj}, B_{mj}], \quad (3.51)$$

where  $x_p(t) = \dot{\theta}_p(t) \in \mathbb{R}^1$  corresponds to the proxy,  $\dot{\theta}_p(t)/\theta_p(t)$  is the velocity/position. Let us recall the description of the proxy of master and the controller  $\bar{C}$ :

$$\begin{aligned} F_p(t) &= L \begin{pmatrix} \dot{\theta}_p(t - \hat{\tau}_1(t)) \\ \dot{\theta}_m(t - \tau_1(t)) \\ \theta_p(t - \hat{\tau}_1(t)) - \theta_m(t - \tau_1(t)) \end{pmatrix}, \quad L = \begin{pmatrix} L_1 & L_2 & L_3 \end{pmatrix}, \\ F_s(t) &= -K \begin{pmatrix} \dot{\theta}_s(t) \\ \dot{\theta}_p(t) \\ \theta_s(t) - \theta_p(t) \end{pmatrix}, \quad K = \begin{pmatrix} K_1 & K_2 & K_3 \end{pmatrix}. \end{aligned} \quad (3.52)$$

Now, the following works are being solved:

*Problem 1:* Design the local controllers of master, proxy and slave,  $K_m^0$  and  $K_s^0$ , so to make the master, proxy and slave robustly stable with respect to the polytopic-type uncertainties.

*Problem 2:* Design the slave controller  $L$ ,  $K$  so to provide the stability and performance guarantee for teleoperation system under time-varying delays and polytopic-type uncertainties.

### 3.2.1.3 Problem 1: Local Controller Design

Here again, the local controllers are designed from a Lyapunov function under LMI optimization. Consider the master for instance, and the Lyapunov function  $V(x_m(t)) = x_m(t)^T P x_m(t)$ ,  $P = P^T > 0$ . In order to apply LMI condition,  $\dot{V}(x_m(t)) < 0$  should be verified. We introduce free weighting matrices  $P_2, P_3$  into  $\dot{V}(x_m(t))$ ,  $j = 1, 2, \dots, N$  [He 2004]:

$$2[x_m(t)^T P_2^T + \dot{x}_m(t)^T P_3^T] \underbrace{[(A_{mj} - B_{mj} K_m^0)]}_{\bar{A}_{mj}} x_m(t) - \dot{x}_m(t) = 0. \quad (3.53)$$

We set  $\eta(t) = \text{col}\{x_m(t), \dot{x}_m(t)\}$  and get,  $j = 1, 2, \dots, N$ :

$$\begin{pmatrix} \bar{A}_{mj}^T P_2 + P_2^T \bar{A}_{mj} & P - P_2^T + \bar{A}_{mj}^T P_3 \\ * & -P_3 - P_3^T \end{pmatrix} < 0. \quad (3.54)$$

Multiplying (3.54) by  $\text{diag}\{P_2^{-T}, P_2^{-T}\}$  at the left side, by  $\text{diag}\{P_2^{-1}, P_2^{-1}\}$  at the right side, then  $K_m^0$  can be obtained by defining  $P_3 = \varepsilon P_2$  and  $N_m = K_m^0 P_2$ . The result  $K_m^0 = N_m P_2^{-1}$  follows,  $j = 1, 2, \dots, N$ :

$$\begin{pmatrix} A_{mj} P_2 - B_{mj} N_m + P_2^T A_{mj}^T - N_m^T B_{mj}^T & P - P_2 + \varepsilon P_2^T A_{mj}^T - \varepsilon N_m^T B_{mj}^T \\ * & -\varepsilon P_2 - \varepsilon P_2^T \end{pmatrix} < 0. \quad (3.55)$$

**Remark 3.9** *The proxy has the same local controller as the master ( $K_m^0$ ), and the local controller of slave ( $K_s^0$ ) can be obtained by the same procedure.*

### 3.2.1.4 Problem 2: Slave Controller Design

Secondly, we consider the design of the proxy of master by LKF and  $H_\infty$  control under LMI optimization. Consider the models of the master and the proxy:

$$\begin{cases} \dot{x}_{mp}(t) &= A_{mp}^0(\rho_{mp}(t))x_{mp}(t) + A_{mp}^1(\rho_{mp}(t))x_{mp}(t - \tau_1(t)) + B_{mp}(\rho_{mp}(t))w_{mp}(t), \\ z_{mp}(t) &= C_{mp}x_{mp}(t), \end{cases} \quad (3.56)$$

where:

$$x_{mp}(t) = \begin{pmatrix} \dot{\theta}_p(t) \\ \dot{\theta}_m(t) \\ \theta_p(t) - \theta_m(t) \end{pmatrix}, \quad w_{mp}(t) = \begin{pmatrix} \hat{F}_e(t - \hat{\tau}_1(t)) + \hat{F}_h(t - \tau_1(t)) \\ F_m(t) + F_h(t) \end{pmatrix}, \quad z_{mp}(t) = \begin{pmatrix} \theta_p(t) - \theta_m(t) \end{pmatrix}, \quad (3.57)$$

$$\begin{aligned} A_{mp}^0(\rho_{mp}(t)) &= \begin{pmatrix} A_p(\rho_p(t)) - B_p(\rho_p(t))K_m^0 & 0 \\ 0 & A_m(\rho_m(t)) - B_m(\rho_m(t))K_m^0 \\ 1 & -1 \end{pmatrix}, \\ A_{mp}^1(\rho_{mp}(t)) &= \begin{pmatrix} -B_p(\rho_p(t))L_1 & -B_p(\rho_p(t))L_2 & -B_p(\rho_p(t))L_3 \\ 0 & 0 & 0 \end{pmatrix}, \\ B_{mp}(\rho_{mp}(t)) &= \begin{pmatrix} B_p(\rho_p(t)) & 0 \\ 0 & B_m(\rho_m(t)) \\ 0 & 0 \end{pmatrix} = \begin{pmatrix} B_{mp}^1(\rho_{mp}(t)) & B_{mp}^2(\rho_{mp}(t)) \end{pmatrix}, \quad C_{mp} = \begin{pmatrix} 0 & 0 & 1 \end{pmatrix}. \end{aligned} \quad (3.58)$$

According to the force-reflecting proxy control scheme, considering any two subsystems in the master, proxy and slave, or the whole system, a polytopic-type model can be found. Thus, we get the parameter matrices satisfy the real convex polytopic models:

$$\begin{aligned} A_{mp}^0(\rho_{mp}(t)) &= \sum_{j=1}^N \rho_{mpj}(t) A_{mpj}^0, \\ B_{mp}(\rho_{mp}(t)) &= \sum_{j=1}^N \rho_{mpj}(t) B_{mpj} = \sum_{j=1}^N \rho_{mpj}(t) \begin{pmatrix} B_{mpj}^1 & B_{mpj}^2 \end{pmatrix}. \end{aligned} \quad (3.59)$$

**Theorem 3.10** *Suppose there exist symmetric matrices  $P > 0$ ,  $R > 0$ ,  $S > 0$ ,  $S_a > 0$ ,  $R_{a1} > 0$ , some matrices  $P_2$ ,  $Y_1$ ,  $Y_2$ ,  $M$ , and positive scalars  $\gamma$  and  $\xi$ , such that LMI condition (3.61) with notations (3.62),  $j = 1, 2, \dots, N$ , is feasible. Then the system (3.56) is rate-independent asymptotically stable with  $H_\infty$  performance  $J(w) < 0$  (3.41) for time-varying delay  $\tau_1(t) \in [h_1, h_2]$ , and with the following proxy control gain:*

$$L = MP_2^{-1}. \quad (3.60)$$

$$\Gamma^{7j} = \begin{pmatrix} \Gamma_{11}^{7j} & \Gamma_{12}^{7j} & R - B_{mpj}^1 M - Y_1^T & Y_1^T & Y_1^T + B_{mpj}^1 M & Y_1^T & B_{mpj} & P_2^T C_{mp}^T \\ * & \Gamma_{22}^{7j} & -\xi B_{mpj}^1 M - Y_2^T & Y_2^T & Y_2^T + \xi B_{mpj}^1 M & Y_2^T & \xi B_{mpj} & 0 \\ * & * & -S - R & 0 & 0 & 0 & 0 & 0 \\ * & * & * & -S_a & 0 & 0 & 0 & 0 \\ * & * & * & * & -R_{a1} & 0 & 0 & 0 \\ * & * & * & * & * & -R_{a1} & 0 & 0 \\ * & * & * & * & * & * & -\gamma^2 I & 0 \\ * & * & * & * & * & * & * & -I \end{pmatrix} < 0, \quad (3.61)$$

$$\begin{aligned} \Gamma_{11}^{7j} &= S + S_a - R + P_2^T A_{mpj}^0{}^T + A_{mpj}^0 P_2, \quad \Gamma_{12}^{7j} = P - P_2 + \xi P_2^T A_{mpj}^0{}^T, \\ \Gamma_{22}^{7j} &= -\xi P_2 - \xi P_2^T + h_1^2 R + (h_2 - h_1)^2 R_{a1}. \end{aligned} \quad (3.62)$$

**Proof:** Using *Theorem 3.7* on system (3.56), a series of steps is made to obtain the LMI condition [Fridman 2001b]. We define  $P_3 = \xi P_2$ ; multiply  $\Gamma^{5j}$ , by  $\text{diag}\{P_2^{-T}, \dots, P_2^{-T}, I\}$



at the left side, by  $\text{diag}\{P_2^{-1}, \dots, P_2^{-1}, I\}$  at the right side; then make the transformation  $A_{mp}^1(\rho_{mp}(t)) = -B_{mp}^1(\rho_{mp}(t))L$ , choose  $M = LP_2$ , apply Schur formula, finally the result follows.

The position tracking between the master and the proxy has been achieved. Then, the position tracking between the proxy and the slave is assured by the controller  $\bar{C}$ . The model of the system containing the proxy, the controller  $\bar{C}$  and the slave, is given as follows:

$$\begin{cases} \dot{x}_{ps}(t) = A_{ps}(\rho_{ps}(t))x_{ps}(t) + B_{ps}(\rho_{ps}(t))w_{ps}(t), \\ z_{ps}(t) = C_{ps}x_{ps}(t), \end{cases} \quad (3.63)$$

where:

$$x_{ps}(t) = \begin{pmatrix} \dot{\theta}_s(t) \\ \dot{\theta}_p(t) \\ \theta_s(t) - \theta_p(t) \end{pmatrix}, \quad w_{ps}(t) = \begin{pmatrix} F_e(t) \\ \hat{F}_e(t - \hat{\tau}_1(t)) + \hat{F}_h(t - \tau_1(t)) - F_p(t) \end{pmatrix}, \quad z_{ps}(t) = \begin{pmatrix} \theta_s(t) - \theta_p(t) \end{pmatrix}, \quad (3.64)$$

$$\begin{aligned} A_{ps}(\rho_{ps}(t)) &= \begin{pmatrix} A_s(\rho_s(t)) - B_s(\rho_s(t))K_s^0 - B_s(\rho_s(t))K_1 & -B_s(\rho_s(t))K_2 & -B_s(\rho_s(t))K_3 \\ 0 & A_p(\rho_p(t)) - B_p(\rho_p(t))K_m^0 & 0 \\ 1 & -1 & 0 \end{pmatrix}, \\ B_{ps}(\rho_{ps}(t)) &= \begin{pmatrix} B_s(\rho_s(t)) & 0 \\ 0 & B_p(\rho_p(t)) \\ 0 & 0 \end{pmatrix} = \begin{pmatrix} B_{ps}^1(\rho_{ps}(t)) & B_{ps}^2(\rho_{ps}(t)) \end{pmatrix}, \quad C_{ps} = \begin{pmatrix} 0 & 0 & 1 \end{pmatrix}. \end{aligned} \quad (3.65)$$

Thus, we get:

$$\begin{aligned} A_{ps}(\rho_{ps}(t)) &= A_{ps}^0(\rho_{ps}(t)) + A_{ps}^1(\rho_{ps}(t)) = \sum_{j=1}^N \rho_{psj}(t)(A_{psj}^0 + A_{psj}^1), \\ A_{psj}^0 &= \begin{pmatrix} A_{sj} - B_{sj}K_s^0 & 0 & 0 \\ 0 & A_{mj} - B_{mj}K_m^0 & 0 \\ 1 & -1 & 0 \end{pmatrix}, \quad A_{psj}^1 = \begin{pmatrix} -B_{sj}K_1 & -B_{sj}K_2 & -B_{sj}K_3 \\ 0 & 0 & 0 \\ 0 & 0 & 0 \end{pmatrix}, \\ B_{ps}(\rho_{ps}(t)) &= \sum_{j=1}^N \rho_{psj}(t)B_{psj} = \sum_{j=1}^N \rho_{psj}(t) \begin{pmatrix} B_{psj}^1 & B_{psj}^2 \end{pmatrix}. \end{aligned} \quad (3.66)$$

With the transformation  $A_{psj}^1 = -B_{psj}^1K$ ,  $j = 1, 2, \dots, N$ , we get the following theorem.

**Theorem 3.11** *Suppose there exist symmetric matrices  $P > 0$ , some matrices  $P_2, W$ , and positive scalars  $\gamma$  and  $\xi$ , such that LMI condition (3.68) with notations (3.69),  $j = 1, 2, \dots, N$ , is feasible. Then the system (3.63) is asymptotically stable with  $H_\infty$  performance  $J(w) < 0$  (3.41), and with the control gain of the controller  $\bar{C}$ :*

$$K = WP_2^{-1}. \quad (3.67)$$

$$\Gamma^{8j} = \begin{pmatrix} \Gamma_{11}^{8j} & \Gamma_{12}^{8j} & B_{psj} & P_2^T C_{ps}^T \\ * & \Gamma_{22}^{8j} & \xi B_{psj} & 0 \\ * & * & -\gamma^2 I & 0 \\ * & * & * & -I \end{pmatrix} < 0, \quad (3.68)$$

$$\begin{aligned} \Gamma_{11}^{8j} &= P_2^T A_{psj}^0{}^T + A_{psj}^0 P_2 - W^T B_{psj}^1{}^T - B_{psj}^1 W, & \Gamma_{12}^{8j} &= P - P_2 + \xi P_2^T A_{psj}^0{}^T - \xi W^T B_{psj}^1{}^T, \\ \Gamma_{22}^{8j} &= -\xi P_2 - \xi P_2^T. \end{aligned} \quad (3.69)$$

**Proof:** We apply the system (3.63) in *Corollary 3.8*, and from the proof of *Theorem 3.10*, the result is straightforward.

Till now, the position tracking between the master, the proxy and the slave is ensured. Finally, the objective is to ensure the global stability of the whole system described by:

$$\begin{cases} \dot{x}_{mps}(t) &= A_{mps}^0(\rho_{mps}(t))x_{mps}(t) + A_{mps}^1(\rho_{mps}(t))x_{mps}(t - \tau_1(t)) + B_{mps}(\rho_{mps}(t))w_{mps}(t), \\ z_{mps}(t) &= C_{mps}x_{mps}(t), \end{cases} \quad (3.70)$$

where:

$$x_{mps}(t) = \begin{pmatrix} \dot{\theta}_s(t) \\ \dot{\theta}_p(t) \\ \dot{\theta}_m(t) \\ \theta_s(t) - \theta_p(t) \\ \theta_p(t) - \theta_m(t) \end{pmatrix}, \quad w_{mps}(t) = \begin{pmatrix} F_e(t) \\ \hat{F}_e(t - \hat{\tau}_1(t)) + \hat{F}_h(t - \tau_1(t)) \\ F_m(t) + F_h(t) \end{pmatrix}, \quad z_{mps}(t) = \begin{pmatrix} \theta_s(t) - \theta_p(t) \\ \theta_p(t) - \theta_m(t) \end{pmatrix}. \quad (3.71)$$

Thus, we get,  $j = 1, 2, \dots, N$ :

$$\begin{aligned} A_{mps}^0(\rho_{mps}(t)) &= \sum_{j=1}^N \rho_{mps j}(t) A_{mps j}^0, \\ A_{mps j}^0 &= \begin{pmatrix} A_{sj} - B_{sj} K_s^0 - B_{sj} K_1 & -B_{sj} K_2 & 0 & -B_{sj} K_3 & 0 \\ 0 & A_{mj} - B_{mj} K_m^0 & 0 & 0 & 0 \\ 0 & 0 & A_{mj} - B_{mj} K_m^0 & 0 & 0 \\ 1 & -1 & 0 & 0 & 0 \\ 0 & 1 & -1 & 0 & 0 \end{pmatrix}, \\ A_{mps}^1(\rho_{mps}(t)) &= \sum_{j=1}^N \rho_{mps j}(t) A_{mps j}^1 = \sum_{j=1}^N \rho_{mps j}(t) \begin{pmatrix} 0 & 0 & 0 & 0 & 0 \\ 0 & -B_{mj} L_1 & -B_{mj} L_2 & 0 & -B_{mj} L_3 \\ 0 & 0 & 0 & 0 & 0 \\ 0 & 0 & 0 & 0 & 0 \\ 0 & 0 & 0 & 0 & 0 \end{pmatrix}, \\ B_{mps}(\rho_{mps}(t)) &= \sum_{j=1}^N \rho_{mps j}(t) B_{mps j} = \sum_{j=1}^N \rho_{mps j}(t) \begin{pmatrix} B_{sj} & 0 & 0 \\ 0 & B_{mj} & 0 \\ 0 & 0 & B_{mj} \\ 0 & 0 & 0 \\ 0 & 0 & 0 \end{pmatrix}, \quad C_{mps} = \begin{pmatrix} 0 & 0 & 0 & 1 & 0 \\ 0 & 0 & 0 & 0 & 1 \end{pmatrix}. \end{aligned} \quad (3.72)$$

Using *Theorem 3.7*, we can check the global stability of the system, which achieves the force tracking  $F_m(t) = \hat{F}_e(t - \tau_2(t))$ .

To evaluate the performance of the proposed approach, different working conditions will be simulated, and the results will be presented and compared to another approach in Section 3.2.2.

### 3.2.1.5 Application to Euler-Lagrange Model

This approach can be easily adopted so to handle nonlinear system. Using the same control scheme, we consider that the master, the proxy and the slave are described with the Euler-Lagrange equations for  $n$ -link systems:

$$\begin{aligned}
 (\Sigma_m) \quad & M_m(\theta_m)\ddot{\theta}_m(t) + C_m(\theta_m, \dot{\theta}_m)\dot{\theta}_m(t) + g_m(\theta_m) = F_h(t) + F_m(t), \\
 (\Sigma_p) \quad & M_m(\theta_p)\ddot{\theta}_p(t) + C_m(\theta_p, \dot{\theta}_p)\dot{\theta}_p(t) + g_m(\theta_p) = \hat{F}_e(t - \hat{\tau}_1(t)) + \hat{F}_h(t - \tau_1(t)) - F_p(t), \\
 (\Sigma_s) \quad & M_s(\theta_s)\ddot{\theta}_s(t) + C_s(\theta_s, \dot{\theta}_s)\dot{\theta}_s(t) + g_s(\theta_s) = F_e(t) + F_s(t),
 \end{aligned} \tag{3.73}$$

where  $M_m(\theta_m)$ ,  $M_m(\theta_p)$ ,  $M_s(\theta_s)$  are the positive definite inertia matrices,  $C_m(\theta_m, \dot{\theta}_m)$ ,  $C_m(\theta_p, \dot{\theta}_p)$ ,  $C_s(\theta_s, \dot{\theta}_s)$  are the matrices of Centripetal and Coriolis torques, and  $g_m(\theta_m)$ ,  $g_m(\theta_p)$ ,  $g_s(\theta_s)$  are the gravitational torques. The above equations exhibit certain fundamental properties due to their Lagrangian dynamic structure [Chopra 2008b].

Property 1: The inertia matrix  $M_i(\theta_j)$ ,  $i = \{m, s\}$ ,  $j = \{m, p, s\}$ , are symmetric positive definite and there exist the positive constants  $\mu(i1)$ ,  $\mu(i2)$  such that  $\mu(i1)I \leq M_i(\theta_j) \leq \mu(i2)I$ .

Property 2: Under an approximate definition of the matrix  $C_i(\theta_j, \dot{\theta}_j)$ , the matrix  $M_i(\theta_j) - 2C_i(\theta_j, \dot{\theta}_j)$  is a skew-symmetric.

Property 3: There exist positive scalars  $k_{ci}$  such that the Coriolis forces verify  $\|C_i(\theta_j, \dot{\theta}_j)\| \leq k_{ci} \|\dot{\theta}_j\|$ .

Then the model transformation is made and the following linear parameter-varying systems are obtained from (3.73):

$$\begin{aligned}
 (\bar{\Sigma}_m) \quad & \ddot{\theta}_m(t) = A_m(\theta_m, \dot{\theta}_m)\dot{\theta}_m(t) + B_m(\theta_m)(F_h(t) + F_m(t) - g_m(\theta_m)), \\
 (\bar{\Sigma}_p) \quad & \ddot{\theta}_p(t) = A_m(\theta_p, \dot{\theta}_p)\dot{\theta}_p(t) + B_m(\theta_p)(\hat{F}_e(t - \hat{\tau}_1(t)) + \hat{F}_h(t - \tau_1(t)) - F_p(t) - g_m(\theta_p)), \\
 (\bar{\Sigma}_s) \quad & \ddot{\theta}_s(t) = A_s(\theta_s, \dot{\theta}_s)\dot{\theta}_s(t) + B_s(\theta_s)(F_e(t) + F_s(t) - g_s(\theta_s)),
 \end{aligned} \tag{3.74}$$

where:

$$\begin{aligned}
 A_m(\theta_m, \dot{\theta}_m) &= -M_m^{-1}(\theta_m)C_m(\theta_m, \dot{\theta}_m), & B_m(\theta_m) &= M_m^{-1}(\theta_m), \\
 A_m(\theta_p, \dot{\theta}_p) &= -M_m^{-1}(\theta_p)C_m(\theta_p, \dot{\theta}_p), & B_m(\theta_p) &= M_m^{-1}(\theta_p), \\
 A_s(\theta_s, \dot{\theta}_s) &= -M_s^{-1}(\theta_s)C_s(\theta_s, \dot{\theta}_s), & B_s(\theta_s) &= M_s^{-1}(\theta_s).
 \end{aligned} \tag{3.75}$$

Because normally there are restrictions on the positions/velocites of the robots, these LPV systems are under the forms (3.48), (3.50), and can be resolved by the approach proposed in this section.

### 3.2.2 $H_\infty$ Robust Control under Norm-Bounded Model Uncertainties

Complementary to the polytopic-type approach, another model transformation with norm-bounded model uncertainties can also be utilized to solve the same problem.

#### 3.2.2.1 Control Problem Formulation

Noting that in master and slave, there exist norm-bounded and time-varying model uncertainties  $(\Delta A_m(t), \Delta B_m(t), \Delta A_s(t), \Delta B_s(t))$ , the model transformation is described as follows:

$$\begin{aligned}
 (\Sigma_m) \quad \dot{x}_m(t) &= ((A_m + \Delta A_m(t)) - (B_m + \Delta B_m(t))K_m^0)x_m(t) + (B_m + \Delta B_m(t))(F_m(t) + F_h(t)), \\
 (\Sigma_s) \quad \dot{x}_s(t) &= ((A_s + \Delta A_s(t)) - (B_s + \Delta B_s(t))K_s^0)x_s(t) + (B_s + \Delta B_s(t))(F_s(t) + F_e(t)),
 \end{aligned} \tag{3.76}$$

where  $x_m(t) = \dot{\theta}_m(t) \in \mathbb{R}^1$ ,  $x_s(t) = \dot{\theta}_s(t) \in \mathbb{R}^1$ .  $K_m^0$ ,  $K_s^0$  are the local controllers of the master and the slave ensuring the speed stability, which are to be designed later on. The model uncertainties satisfy,  $i = \{m, s\}$ :

$$\Delta A_i(t) = G_i \Delta(t) D_i, \quad \Delta B_i(t) = H_i \Delta(t) E_i, \tag{3.77}$$

where  $G_i$ ,  $D_i$ ,  $H_i$ ,  $E_i$  are constant matrices of appropriate dimension and  $\Delta(t)$  is a time-varying matrix,  $\Delta(t)^T \Delta(t) \leq I$ .

Again, the model of proxy, including the local controller, is the same as for the master, except for the model uncertainties:

$$\begin{aligned}
 (\Sigma_p) \quad \dot{x}_p(t) &= ((A_m + \Delta A_p(t)) - (B_m + \Delta B_p(t))K_m^0)x_p(t) - (B_m + \Delta B_p(t))F_p(t) \\
 &\quad + (B_m + \Delta B_p(t))(\hat{F}_e(t - \hat{\tau}_1(t)) + \hat{F}_h(t - \tau_1(t))),
 \end{aligned} \tag{3.78}$$

where  $x_p(t) = \dot{\theta}_p(t) \in \mathbb{R}^1$ ,  $\Delta A_p(t) = G_p \Delta(t) D_p$ ,  $\Delta B_p(t) = H_p \Delta(t) E_p$ .  $G_p$ ,  $D_p$ ,  $H_p$ ,  $E_p$  are constant matrices.

Here, we have to solve two problems as in the previous subsection:

*Problem 1:* Design the local controllers of master, proxy and slave,  $K_m^0$  and  $K_s^0$ .

*Problem 2:* Design the proxy of master and the controller  $\bar{C}$  so to make the whole system stable and achieve the position/force tracking.

### 3.2.2.2 Problem 1: Local Controller Design

Here we consider the design of the local controller of master  $K_m^0$ , while at the slave's side,  $K_s^0$  can be calculated by the same procedure. Considering the Lyapunov function  $V(x_m(t)) = x_m(t)^T P x_m(t)$ ,  $P = P^T > 0$ , we verify  $\dot{V}(x_m(t)) < 0$  by using *Lemma 1* in [Xu 2003]. Introducing scalar parameters  $\rho_A > 0$ ,  $\rho_B > 0$ , then applying Schur formula, lead to:

$$\begin{pmatrix} \Lambda & \rho_A^{-1} P G_m & \rho_B^{-1} P H_m & K_m^0{}^T E_m^T & D_m^T \\ * & -I & 0 & 0 & 0 \\ * & * & -I & 0 & 0 \\ * & * & * & -\rho_B^{-1} I & 0 \\ * & * & * & * & -\rho_A^{-1} I \end{pmatrix} < 0, \quad (3.79)$$

$$\Lambda = A_m^T P + P A_m - K_m^0{}^T B_m^T P - P B_m K_m^0.$$

Multiplying (3.79) by  $\text{diag}\{P^{-T}, \dots, P^{-T}, I\}$  at the left side, by  $\text{diag}\{P^{-1}, \dots, P^{-1}, I\}$  at the right side, defining  $N_m = K_m^0 P$ , then the result  $K_m^0 = N_m P^{-1}$  follows with:

$$\begin{pmatrix} \bar{\Lambda} & \rho_A^{-1} G_m P & \rho_B^{-1} H_m P & N_m^T E_m^T & P D_m^T \\ * & -I & 0 & 0 & 0 \\ * & * & -I & 0 & 0 \\ * & * & * & -\rho_B^{-1} I & 0 \\ * & * & * & * & -\rho_A^{-1} I \end{pmatrix} < 0, \quad (3.80)$$

$$\bar{\Lambda} = A_m P + P A_m^T - N_m^T B_m^T - B_m N_m.$$

### 3.2.2.3 Problem 2: Slave Controller Design

In order to provide the stability and performance analysis by designing the proxy of master and the controller  $\bar{C}$  under time-varying delays and uncertainties, our method is to firstly transform the time delay and norm-bounded uncertain system to the time delay system, and then apply the theorems proposed in Chapter 2. Firstly, we design the proxy of master,  $L$ , so to synchronize the position between the master and the proxy. The model of the master and proxy is:

$$\begin{cases} \dot{x}_{mp}(t) &= (A_{mp}^0 + \Delta A_{mp}^0(t))x_{mp}(t) + (A_{mp}^1 + \Delta A_{mp}^1(t))x_{mp}(t - \tau_1(t)) \\ &+ (B_{mp} + \Delta B_{mp}(t))w_{mp}(t), \\ z_{mp}(t) &= C_{mp}x_{mp}(t), \end{cases} \quad (3.81)$$

$$x_{mp}(t) = \begin{pmatrix} \hat{\theta}_p(t) \\ \hat{\theta}_m(t) \\ \theta_p(t) - \theta_m(t) \end{pmatrix}, \quad w_{mp}(t) = \begin{pmatrix} \hat{F}_e(t - \hat{\tau}_1(t)) + \hat{F}_h(t - \tau_1(t)) \\ F_m(t) + F_h(t) \end{pmatrix}, \quad z_{mp}(t) = \begin{pmatrix} \theta_p(t) - \theta_m(t) \end{pmatrix}, \quad (3.82)$$

$$\begin{aligned} A_{mp}^0 &= \begin{pmatrix} A_m - B_m K_m^0 & 0 & 0 \\ 0 & A_m - B_m K_m^0 & 0 \\ 1 & -1 & 0 \end{pmatrix}, \quad \Delta A_{mp}^0(t) = \begin{pmatrix} \Delta A_p(t) - \Delta B_p(t) K_m^0 & 0 & 0 \\ 0 & \Delta A_m(t) - \Delta B_m(t) K_m^0 & 0 \\ 0 & 0 & 0 \end{pmatrix}, \\ A_{mp}^1 &= \begin{pmatrix} -B_m L_1 & -B_m L_2 & -B_m L_3 \\ 0 & 0 & 0 \\ 0 & 0 & 0 \end{pmatrix}, \quad \Delta A_{mp}^1(t) = \begin{pmatrix} -\Delta B_p(t) L_1 & -\Delta B_p(t) L_2 & -\Delta B_p(t) L_3 \\ 0 & 0 & 0 \\ 0 & 0 & 0 \end{pmatrix}, \\ B_{mp} &= \begin{pmatrix} B_m & 0 \\ 0 & B_m \end{pmatrix} = \begin{pmatrix} B_{mp}^1 & B_{mp}^2 \end{pmatrix}, \quad \Delta B_{mp}(t) = \begin{pmatrix} \Delta B_p(t) & 0 \\ 0 & \Delta B_m(t) \\ 0 & 0 \end{pmatrix}, \quad C_{mp} = \begin{pmatrix} 0 & 0 & 1 \end{pmatrix}. \end{aligned} \quad (3.83)$$

Because  $H_\infty$  control theory aims at minimizing the modeling imperfections as well as uncertainties and expected disturbances, we consider the time-varying uncertainties in master and proxy as perturbations  $\varphi_p(t)$  and  $\varphi_m(t)$  defined by:

$$\begin{aligned} \varphi_p(t) &= (\Delta A_p(t) - \Delta B_p(t) K_m^0) \dot{\theta}_p(t) + \Delta B_p(t) (\hat{F}_e(t - \hat{\tau}_1(t)) + \hat{F}_h(t - \tau_1(t))), \\ \varphi_m(t) &= (\Delta A_m(t) - \Delta B_m(t) K_m^0) \dot{\theta}_m(t) + \Delta B_m(t) (F_m(t) + F_h(t)), \end{aligned} \quad (3.84)$$

and, at the proxy side:

$$\mu_p(t) = -\Delta B_p(t) L x_{mp}(t - \tau_1(t)). \quad (3.85)$$

We add uncertainties (3.84) and (3.85) into  $w_{mp}(t)$ . Thus, the system (3.81) is rewritten as:

$$\begin{cases} \dot{x}_{mp}(t) &= A_{mp}^0 x_{mp}(t) + A_{mp}^1 x_{mp}(t - \tau_1(t)) + \tilde{B}_{mp} \tilde{w}_{mp}(t), \\ z_{mp}(t) &= C_{mp} x_{mp}(t), \end{cases} \quad (3.86)$$

where:

$$\tilde{w}(t) = \begin{pmatrix} B_m \hat{F}_e(t - \hat{\tau}_1(t)) + B_m \hat{F}_h(t - \tau_1(t)) + \varphi_p(t) + \mu_p(t) \\ B_m F_m(t) + B_m F_h(t) + \varphi_m(t) \end{pmatrix}, \quad \tilde{B}_{mp} = \begin{pmatrix} 1 & 0 \\ 0 & 1 \\ 0 & 0 \end{pmatrix}. \quad (3.87)$$

By this way, the system (3.87) takes the form (2.52) in Chapter 2. *Theorem 2.8* in Chapter 2 can be utilized to compute  $L$ .

In order to design the controller  $\bar{C}$ , the model gathering the proxy, the controller  $\bar{C}$  and the slave, is given as follows:

$$\begin{cases} \dot{x}_{ps}(t) &= (A_{ps} + \Delta A_{ps}(t))x_{ps}(t) + (B_{ps} + \Delta B_{ps}(t))w_{ps}(t), \\ z_{ps}(t) &= C_{ps}x_{ps}(t). \end{cases} \quad (3.88)$$

Note that the input of the proxy,  $F_p(t)$ , is also considered as a perturbation:

$$x_{ps}(t) = \begin{pmatrix} \dot{\theta}_s(t) \\ \dot{\theta}_p(t) \\ \theta_s(t) - \theta_p(t) \end{pmatrix}, \quad w_{ps}(t) = \begin{pmatrix} F_e(t) \\ \hat{F}_e(t - \hat{\tau}_1(t)) + \hat{F}_h(t - \tau_1(t)) - F_p(t) \end{pmatrix}, \quad z_{ps}(t) = \begin{pmatrix} \theta_s(t) - \theta_p(t) \end{pmatrix}, \quad (3.89)$$

$$\begin{aligned} A_{ps} &= \begin{pmatrix} A_s - B_s K_s^0 - B_s K_1 & -B_s K_2 & -B_s K_3 \\ 0 & A_m - B_m K_m^0 & 0 \\ 1 & -1 & 0 \end{pmatrix}, \\ \Delta A_{ps}(t) &= \begin{pmatrix} \Delta A_s(t) - \Delta B_s(t) K_s^0 - \Delta B_s(t) K_1 & -\Delta B_s(t) K_2 & -\Delta B_s(t) K_3 \\ 0 & \Delta A_p(t) - \Delta B_p(t) K_m^0 & 0 \\ 0 & 0 & 0 \end{pmatrix}, \\ B_{ps} &= \begin{pmatrix} B_s & 0 \\ 0 & B_m \end{pmatrix} = \begin{pmatrix} B_{ps}^1 & B_{ps}^2 \end{pmatrix}, \quad \Delta B_{ps}(t) = \begin{pmatrix} \Delta B_s(t) & 0 \\ 0 & \Delta B_p(t) \end{pmatrix}, \quad C_{ps} = \begin{pmatrix} 0 & 0 & 1 \end{pmatrix}. \end{aligned} \quad (3.90)$$

Defining the perturbations at the slave side:

$$\begin{aligned} \varphi_s(t) &= (\Delta A_s(t) - \Delta B_s(t) K_s^0) \dot{\theta}_s(t) + \Delta B_s(t) F_e(t), \\ \mu_s(t) &= -\Delta B_{ps}^1(t) K x_{ps}(t). \end{aligned} \quad (3.91)$$

One gets:

$$\tilde{w}_{ps}(t) = \begin{pmatrix} B_s F_e(t) + \varphi_s(t) + \mu_s(t) \\ B_m \hat{F}_e(t - \hat{\tau}_1(t)) + B_m \hat{F}_h(t - \tau_1(t)) - B_m F_p(t) + \varphi_p(t) + \mu_p(t) \end{pmatrix}, \quad \tilde{B}_{ps} = \begin{pmatrix} 1 & 0 \\ 0 & 1 \end{pmatrix}, \quad (3.92)$$

and system (3.88) becomes:

$$\begin{cases} \dot{x}_{ps}(t) &= A_{ps} x_{ps}(t) + \tilde{B}_{ps} \tilde{w}_{ps}(t), \\ z_{ps}(t) &= C_{ps} x_{ps}(t). \end{cases} \quad (3.93)$$

The controller gain  $K$  can be obtained from *Theorem 2.9* in Chapter 2 that handles  $H_\infty$  controller design for the perturbed system without delays. Now, the position tracking between the master, the proxy and the slave is ensured. Finally, the objective is to ensure the global stability of the whole system described by:

$$\begin{cases} \dot{x}_{mps}(t) &= (A_{mps}^0 + \Delta A_{mps}^0(t))x_{mps}(t) + (A_{mps}^1 + \Delta A_{mps}^1(t))x_{mps}(t - \tau_1(t)) \\ &\quad + (B_{mps} + \Delta B_{mps}(t))w_{mps}(t), \\ z_{mps}(t) &= C_{mps}x_{mps}(t), \end{cases} \quad (3.94)$$

where:

$$x_{mps}(t) = \begin{pmatrix} \dot{\theta}_s(t) \\ \dot{\theta}_p(t) \\ \dot{\theta}_m(t) \\ \theta_s(t) - \theta_p(t) \\ \theta_p(t) - \theta_m(t) \end{pmatrix}, \quad w_{mps}(t) = \begin{pmatrix} F_e(t) \\ \hat{F}_e(t - \hat{\tau}_1(t)) + \hat{F}_h(t - \tau_1(t)) \\ F_m(t) + F_h(t) \end{pmatrix}, \quad z_{mps}(t) = \begin{pmatrix} \theta_s(t) - \theta_p(t) \\ \theta_p(t) - \theta_m(t) \end{pmatrix}. \quad (3.95)$$

So we get:

$$\begin{aligned} A_{mps}^0 &= \begin{pmatrix} A_s - B_s K_s^0 - B_s K_1 & -B_s K_2 & 0 & -B_s K_3 & 0 \\ 0 & A_m - B_m K_m^0 & 0 & 0 & 0 \\ 0 & 0 & A_m - B_m K_m^0 & 0 & 0 \\ 1 & -1 & 0 & 0 & 0 \\ 0 & 1 & -1 & 0 & 0 \end{pmatrix}, \\ \Delta A_{mps}^0(t) &= \begin{pmatrix} \Delta A_s(t) - \Delta B_s(t) K_s^0 - \Delta B_s(t) K_1 & -\Delta B_s(t) K_2 & 0 & -\Delta B_s(t) K_3 & 0 \\ 0 & \Delta A_p(t) - \Delta B_p(t) K_m^0 & 0 & 0 & 0 \\ 0 & 0 & \Delta A_m(t) - \Delta B_m(t) K_m^0 & 0 & 0 \\ 0 & 0 & 0 & 0 & 0 \\ 0 & 0 & 0 & 0 & 0 \end{pmatrix}, \\ A_{mps}^1 &= \begin{pmatrix} 0 & 0 & 0 & 0 & 0 \\ 0 & -B_m L_1 & -B_m L_2 & 0 & -B_m L_3 \\ 0 & 0 & 0 & 0 & 0 \\ 0 & 0 & 0 & 0 & 0 \end{pmatrix}, \quad \Delta A_{mps}^1(t) = \begin{pmatrix} 0 & 0 & 0 & 0 & 0 \\ 0 & -\Delta B_p(t) L_1 & -\Delta B_p(t) L_2 & 0 & -\Delta B_p(t) L_3 \\ 0 & 0 & 0 & 0 & 0 \\ 0 & 0 & 0 & 0 & 0 \end{pmatrix}, \\ B_{mps} &= \begin{pmatrix} B_s & 0 & 0 \\ 0 & B_m & 0 \\ 0 & 0 & B_m \\ 0 & 0 & 0 \\ 0 & 0 & 0 \end{pmatrix}, \quad \Delta B_{mps}(t) = \begin{pmatrix} \Delta B_s(t) & 0 & 0 \\ 0 & \Delta B_p(t) & 0 \\ 0 & 0 & \Delta B_m(t) \\ 0 & 0 & 0 \\ 0 & 0 & 0 \end{pmatrix}, \quad C_{mps} = \begin{pmatrix} 0 & 0 & 0 & 1 & 0 \\ 0 & 0 & 0 & 0 & 1 \end{pmatrix}. \end{aligned} \quad (3.96)$$

Considering the model uncertainties as perturbations, the whole system is described in the following form, involving a novel perturbation  $\tilde{w}_{mps}(t)$ :

$$\begin{cases} \dot{x}_{mps}(t) &= A_{mps}^0 x_{mps}(t) + A_{mps}^1 x_{mps}(t - \tau_1(t)) + \tilde{B}_{mps} \tilde{w}_{mps}(t), \\ z_{mps}(t) &= C_{mps} x_{mps}(t), \end{cases} \quad (3.97)$$

$$\tilde{w}_{mps}(t) = \begin{pmatrix} B_s F_e(t) + \varphi_s(t) \\ B_m \hat{F}_e(t - \hat{\tau}_1(t)) + B_m \hat{F}_h(t - \tau_1(t)) + \varphi_p(t) \\ B_m F_m(t) + B_m F_h(t) + \varphi_m(t) \end{pmatrix}, \quad \tilde{B}_{mps} = \begin{pmatrix} 1 & 0 & 0 \\ 0 & 1 & 0 \\ 0 & 0 & 1 \\ 0 & 0 & 0 \\ 0 & 0 & 0 \end{pmatrix}. \quad (3.98)$$

Using *Theorem 2.3* of Chapter 2, we can check the global stability of the system. This allows for achieving the force tracking  $F_m(t) = \hat{F}_e(t - \tau_2(t))$ .

**Remark 3.12** *An alternative LKF control theorem can also be derived so to obtain the slave controller, the details of which are introduced Appendix .6.*

### 3.2.3 Results and Analysis

In this subsection, we propose simulations that illustrate the two approaches proposed above (polytopic-type approach and norm-bounded model transformation). This will be



made under different working conditions, and then the performance will be analyzed and compared.

The maximum amplitude of time-varying delays is  $0.2s$  (greater amplitude of delays can also be handled). Note that the delays in the two channels are asymmetric. For simulation purpose, we sample by  $1kHz$ .

For simplicity reasons, the master, proxy and slave models are described by the following two forms (representing the same system):

$$\begin{aligned}
 \text{polytopic - type : } & A_m(\rho_m(t)) = A_s(\rho_s(t)) = 0, \\
 & B_m(\rho_m(t)) = B_s(\rho_s(t)) = \frac{1}{\rho(t)}, \quad \rho(t) \in [0.5, 1], \\
 \text{norm - bounded - type : } & A_m = A_s = 0, \quad G_i = D_i = 0, \\
 & B_m = B_s = 1.5, \quad H_i = 0.5, \quad E_i = 1, \quad i = \{m, p, s\}.
 \end{aligned} \tag{3.99}$$

Then, by the design procedure of local controllers, we get:

$$\begin{aligned}
 \text{polytopic - type : } & K_m^0 = 2.6585 \quad (\varepsilon = 100 \quad (3.55)), \\
 & K_s^0 = 2.6585 \quad (\varepsilon = 100 \quad (3.55)), \\
 \text{norm - bounded - type : } & K_m^0 = 9.5117 \quad (\rho_A = 0.1, \quad \rho_B = 0.1 \quad (3.80)), \\
 & K_s^0 = 3.3812 \quad (\rho_A = 0.2, \quad \rho_B = 0.2 \quad (3.80)).
 \end{aligned} \tag{3.100}$$

The obtained gains of the proxy and of the controller  $\bar{C}$ , the corresponding  $H_\infty$  performance index  $\gamma_{min}^L, \gamma_{min}^K$ , and the global stability with  $\gamma_{min}^g$  are presented as follows (note that in the two cases,  $\xi = 1$ ):

$$\begin{aligned}
 \text{polytopic - type : } & L = \begin{pmatrix} 1.3218 & -1.3219 & 6.3602 \end{pmatrix}, \quad \gamma_{min}^L = 0.4436, \\
 & K = \begin{pmatrix} 20.4799 & -21.2537 & 575.2051 \end{pmatrix}, \quad \gamma_{min}^K = 0.0164, \\
 & \gamma_{min}^g = 0.4595, \\
 \text{norm - bounded - type : } & L = \begin{pmatrix} 1.6218 & -1.6264 & 29.5012 \end{pmatrix}, \quad \gamma_{min}^L = 0.05, \\
 & K = \begin{pmatrix} 16.4993 & -12.0059 & 434.4988 \end{pmatrix}, \quad \gamma_{min}^K = 0.0072, \\
 & \gamma_{min}^g = 0.0376.
 \end{aligned} \tag{3.101}$$

So in this example, the model with norm-bounded uncertainties is more efficient, because the  $\gamma_{min}$  is about 10 times smaller.

In the simulation, two working conditions are utilized:

• Abrupt tracking motion: the human operator ( $F_h(t)$ ) is modeled as a pulse generator. Fig. 3.7 shows the position tracking between the master and the slave respectively for polytopic-type and norm-bounded approach presented in this section.

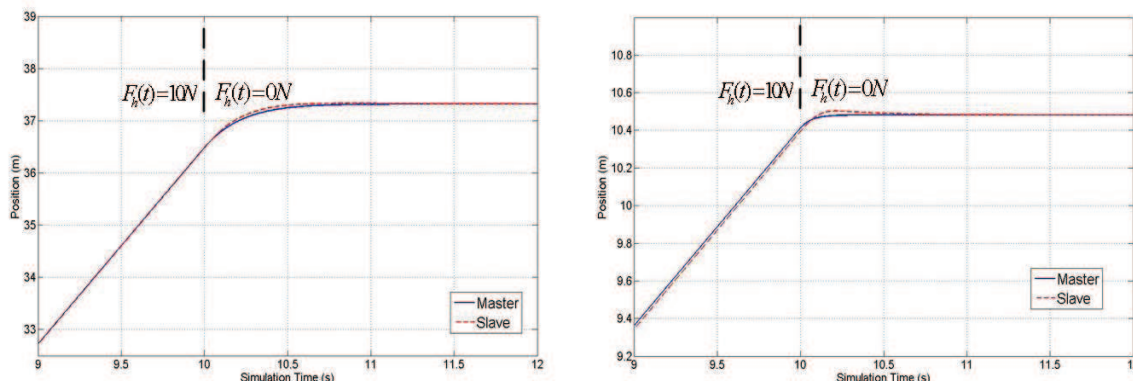

Figure 3.7: Position response in abrupt tracking motion (left: polytopic-type; right: norm-bounded-type)

**Remark 3.13** *The position range is different in two parts of Fig. 3.7, that is because the design strategies and values of the local controllers are different for the two approaches.*

On this figure, the two approaches achieve the position tracking: especially, at the changing point, both of them realize a good position convergence between the master and the slave.

• Wall contact motion: the slave is driven to the hard wall with a stiffness of  $K_e = 30kN/m$  located at the position  $x = 1.0m$ . The position tracking is presented in Fig. 3.8: the norm-bounded-type approach produces a more smooth position tracking between the master and the slave than the polytopic-type one; but the polytopic-type approach has faster convergence rate than the norm-bounded-type one, the arrows in Fig. 3.8 have marked the points where the slave's position converges to the master's.

Based on the characteristics of our force-reflecting proxy control scheme, the force tracking  $F_m(t) = \hat{F}_e(k - \tau_2(t))$  is straightforward.

### 3.3 Conclusions

Based on the force-reflecting proxy control scheme, two complementary studies have been carried out: firstly, a discrete-time approach has addressed the stability and performance problem of the delayed teleoperation, which is valuable to the digital implementations and

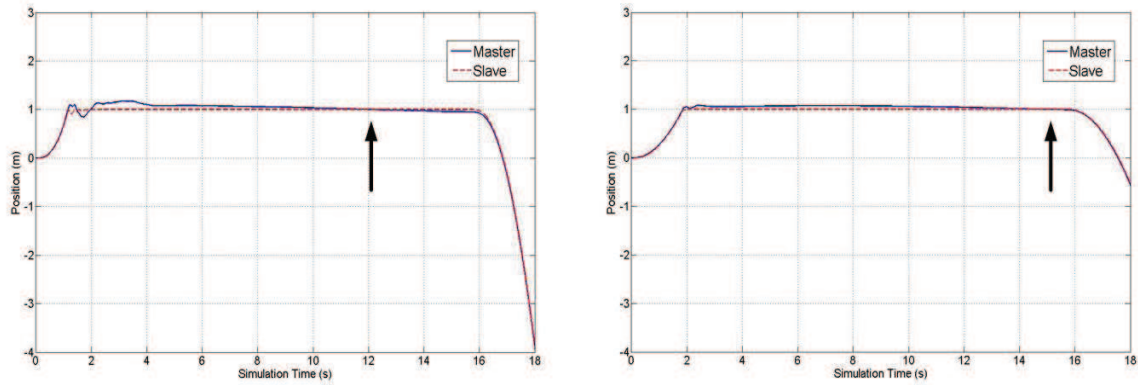

Figure 3.8: Position response in wall contact motion (left: polytopic-type; right: norm-bounded-type)

switch controller design; secondly, the controller design has been considered in the presence of time-varying model uncertainties. Two cases of model uncertainties (polytopic-type and norm-bounded-type) have been considered. In both two cases, the system stability and high-quality performance are formally guaranteed.

The design of the controller, here again, is obtained from LMI optimization algorithm, which is quite systematic. Besides, we also mentioned that such uncertainties allow for dealing with realistic nonlinear models of the Lagrange type.

For now, it is time to apply the results of our theoretical research to the real experimental test-bench. By the results of the experiments, the effectiveness of our approaches will be confirmed. This is the focus of the next chapter.

## Chapter 4

# Implementation of Remote Haptic Cooperative System

In this chapter, the experimental test-bench and the system implementation are described. Our system is implemented based on the master/slave control schemes proposed in Chapter 2. Considering high-quality performance objectives (the stability, the synchronization, the transparency), some techniques as follows will be used in the real implementation [Seuret 2006, Jiang 2009, Kruszewski 2011].

- The transmission protocol UDP is applied to communicate the data between the master and the slave.
- The time-stamps are added to each data packet, in order to know the instant of data-sent, synchronize master and slave, and estimate the delays.
- The multi-thread technique is used in the programs to get concurrent calculations within one CPU.
- In the case of the continuous-time implementation, the discretization period existing in the real controller implementation has to be sufficiently small.
- The data structure of list served as buffers is introduced for the program to search for the data of the right instance.
- The linearizing control of the slave model is utilized to eliminate the impact of the friction in real implementation [Henson 1997].
- At the slave side, the force of the environment  $\hat{F}_e(t)$  can be obtained with the force sensors; but at the master side, thanks to the precise system model of the master robot, the force of the human operator  $\hat{F}_h(t)$  can be obtained by adding a perturbation observer [Fu 2004, Chen 2006], which we will detail later (note that several alternative solutions are possible [Mboup 2009, Daly 2010]).

## 4.1 Experimental Test-Bench

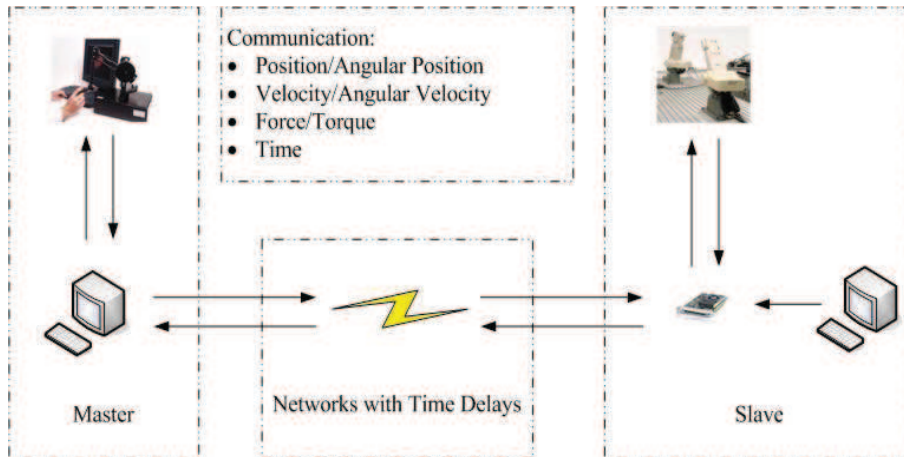

Figure 4.1: Master/slave experimental system structure

Based on the Fig. 1.1 in Chapter 1, we propose our master/slave experimental system structure in Fig. 4.1, which is composed of the Phantom Premium 1.0A (called Phantom in the following and linked with a computer that can send/receive the information and give the control law) at the master side, the network (Internet or Intranet), the slave robot (linked with another computer and a CRIO card (<http://en.wikipedia.org/wiki/CompactRIO>) that is used to send/receive the information and control the slave robot, the information about the robotic arms can be found at <http://www.mitsubishirobot.com/rv-m1.PDF>) at the slave side. Note that, through the network, the position/angular position, the velocity/angular velocity, the force/torque/motor power and the time can be transferred between the master and the slave, and this is followed by variable delays caused by the network physical feature and long distance.

- The Phantom at the master side is a device, in which one can place and move the finger. It is composed of 3 axis, one vertical axis and two horizontal axis, and sends/receives the real-time information with the high frequency (about  $4 \times 10^3 Hz$ ) between the master and the slave. Besides, as in Fig. 4.1, the Phantom is a haptic interface, so it can handle not only the position/velocity data, but also the force/torque information.

- The slave robot is a manipulative device with 5 axis of rotation, which transcribe the movements of the shoulder, the elbow and the wrist of the human arm. This is necessary to connect the slave robot to the CRIO card firstly, and then to the computer, in order to realize the control and information transmission.

Note that, because there exist 5 axis of rotation in the slave robot, but 3 axis in

Phantom, we only consider the 3 axis of the slave robot corresponding to the Phantom. Thus, there are two control design means: one-axis-by-one-axis design; 3 axis global design. In this thesis, we focus on the former.

- As the network protocol, we have two choices, the TCP/IP or UDP. Here, UDP is preferred to TCP/IP: although TCP/IP protocol provides more reliable transmissions of data packets, it checks (and re-sends if necessary) all the packet transmissions, which slows the transmission speed and degrades the communication capacity. In our control strategy, the outdated packets are not necessary to be remitted for the control system, moreover, the packet loss problem can be considered as communication delays, which is introduced in Chapter 1.

### 4.1.1 System Modeling

We take one axis in Phantom and slave robot as an example. Firstly, the Phantom model is a DAC motor supplied by the voltage, and the experiments show that the dry friction can be neglected here. Thus, a second order system is considered as follow:

$$\ddot{\theta}_m(t) = -\frac{\dot{\theta}_m(t)}{\tau_m} + \frac{K_m}{\tau_m}u_m(t), \quad (4.1)$$

where  $\dot{\theta}_m(t)$  is the Phantom velocity,  $u_m(t)$  is the control input,  $\tau_m$ ,  $K_m$  are the system parameters that have been identified,  $\tau_m = 0.448s$ ,  $K_m = 0.0176s/kg$ .

Similarly for the slave robot, a second order system is considered, but with the friction approximation  $sign(\dot{\theta}_s(t))$ :

$$\ddot{\theta}_s(t) = -\frac{\dot{\theta}_s(t)}{\tau_s} + \frac{K_s}{\tau_s}u_s(t) - F_s sign(\dot{\theta}_s(t)), \quad (4.2)$$

where  $\dot{\theta}_s(t)$  is the slave robot velocity,  $u_s(t)$  is the control input, and the system parameters,  $\tau_s = 0.32s$ ,  $K_s = 1.85s/kg$ ,  $F_s = 0.30m/s^2$ . Then, with a novel control input,  $v_s(t) = u_s(t) - F_s \frac{\tau_s}{K_s} sign(\dot{\theta}_s(t))$ , we realize the linearization of the slave model as:

$$\ddot{\theta}_s(t) = -\frac{\dot{\theta}_s(t)}{\tau_s} + \frac{K_s}{\tau_s}v_s(t). \quad (4.3)$$

## 4.2 Force Estimation

To cope with the absence of torque sensor at the master side, we consider a Luenberger observer to estimate the external forces of the human operator. Considering the force-

reflecting control scheme in Chapter 2 and the estimation of  $F_h(t)$ , we recall the corresponding LTI model of the master:

$$\dot{x}_m(t) = (A_m - B_m K_m^0)x_m(t) + B_m(F_m(t) + F_h(t)). \quad (4.4)$$

Now, limiting  $F_h(t)$  to a force with polynomial structure, one can make the assumption  $F_h^{(n+1)}(t) = 0$  for some  $n$ . Then, based on (4.4), we define:

$$\dot{\varepsilon}_h(t) = A_h \varepsilon_h(t) + B_h F_m(t), \quad (4.5)$$

where:

$$\varepsilon_h(t) = \begin{pmatrix} x_m(t) \\ F_h(t) \\ \dot{F}_h(t) \\ \vdots \\ F_h^{(n)}(t) \end{pmatrix}, \quad A_h = \begin{pmatrix} A_m - B_m K_m^0 & B_m & 0 & \cdots & 0 \\ 0 & 0 & I & \cdots & 0 \\ \vdots & \vdots & \vdots & \ddots & \vdots \\ 0 & 0 & 0 & \cdots & I \\ 0 & 0 & 0 & \cdots & 0 \end{pmatrix}, \quad B_h = \begin{pmatrix} B_m \\ 0 \\ \vdots \\ 0 \end{pmatrix}. \quad (4.6)$$

Then, we choose the Luenberger observer  $\hat{\varepsilon}_h(t)$ :

$$\dot{\hat{\varepsilon}}_h(t) = A_h \hat{\varepsilon}_h(t) + B_h F_m(t) + L_h(y_h(t) - \hat{y}_h(t)), \quad (4.7)$$

where  $y_h(t) = x_m(t) = C_h \varepsilon_h(t)$ ,  $C_h$  is a constant matrix. We define  $e_h(t) = \varepsilon_h(t) - \hat{\varepsilon}_h(t)$ :

$$\dot{e}_h(t) = (A_h - L_h C_h)e_h(t). \quad (4.8)$$

By choosing  $n$  and the eigenvalues of the Luenberger observer,  $L_h$  can be obtained, *e.g.* considering the system parameter in the illustrative example of Chapter 2,  $n = 1$  and the eigenvalues of Luenberger observer as  $[-11, -10, -9]$ , the estimation of  $F_h(t)$  is depicted as Fig. 4.2. Note that the increase of  $n$  can improve the estimation of force.

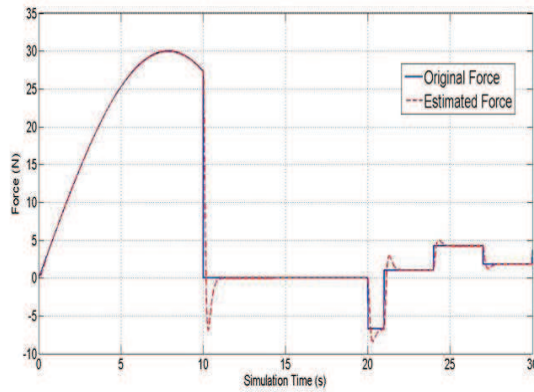

Figure 4.2: Force estimation of  $F_h(t)$

## 4.3 Results and Analysis

The experiments are performed using three architectures designed in Chapter 2 (bilateral state feedback control scheme, force-reflecting control scheme and force-reflecting proxy control scheme), in order to evaluate the performance of the proposed approaches. The maximum amplitude of time-varying delays is taken as  $h_2 = 0.3s$ .

### 4.3.1 Abrupt Tracking Motion

Fig. 4.3 shows the experimental results for the three control schemes. we can see that, all three control structures obtain a stable behavior and good position tracking performance. However, the force-reflecting proxy control scheme provides the smallest position gap between the master and slave robots.

### 4.3.2 Wall Contact Motion

The position tracking capabilities when interacting with the stiff wall environment are presented in Fig. 4.4. A steel wall has been located at about  $x = -0.2rad$  of the slave side, the human operator guides the remote manipulator to touch the steel wall. Because there are not the force-reflecting in the bilateral state feedback control scheme, the position gap between the master and the slave is much larger. Unluckily, the force feel ( $\hat{F}_e(t)$ ) at the master side in the force-reflecting control scheme with or without proxy can not be presented in the thesis, but the smaller position gap in Fig. 4.4 can illustrate that the force-reflecting is there.

For the three control schemes, when the slave robot returns after hitting the wall ( $F_e(t) = 0$ ), the system can restore the position tracking between the master and the slave.

By the program of LabVIEW (<http://www.ni.com/labview/>), we exert the 'artificial' forces  $F_h(t) = -20N * cm$  and  $F_h(t) = -40N * cm$  on the master robot, then the position gap between the master and the slave can be compared in Fig. 4.5.

## 4.4 Conclusion

This chapter was devoted to a technical presentation of the principles and approaches used for the implementation of our experimental test-bench based on our theoretical results in Chapter 2 and Chapter 3.



At last, the experiments, which are realized by LabVIEW, were performed based on different control architectures to verify the correctness and effectiveness of the proposed methods in the previous chapters.

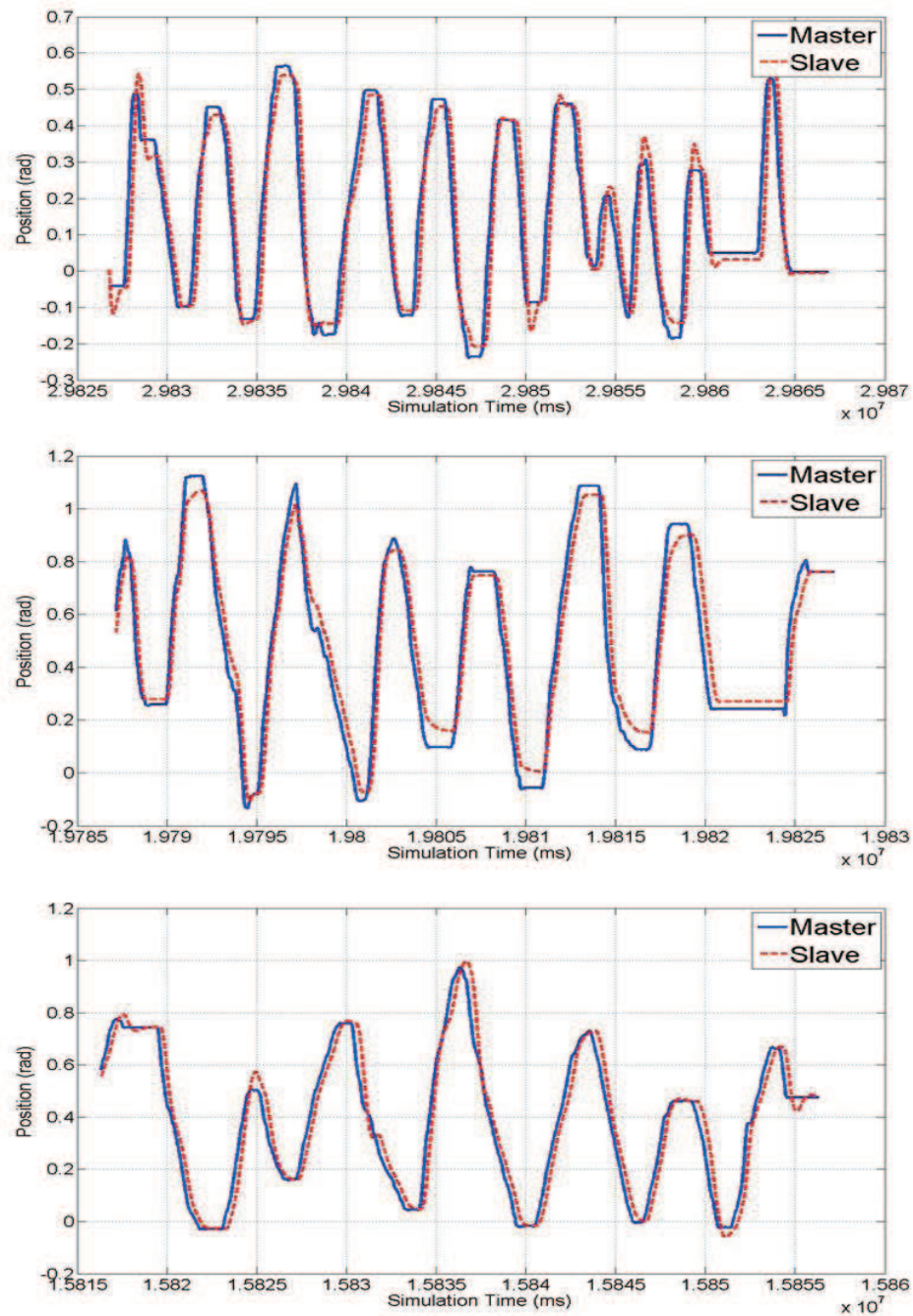

Figure 4.3: Position response in abrupt tracking motion (upper: bilateral state feedback control scheme; middle: force-reflecting control scheme; lower: force-reflecting proxy control scheme;)

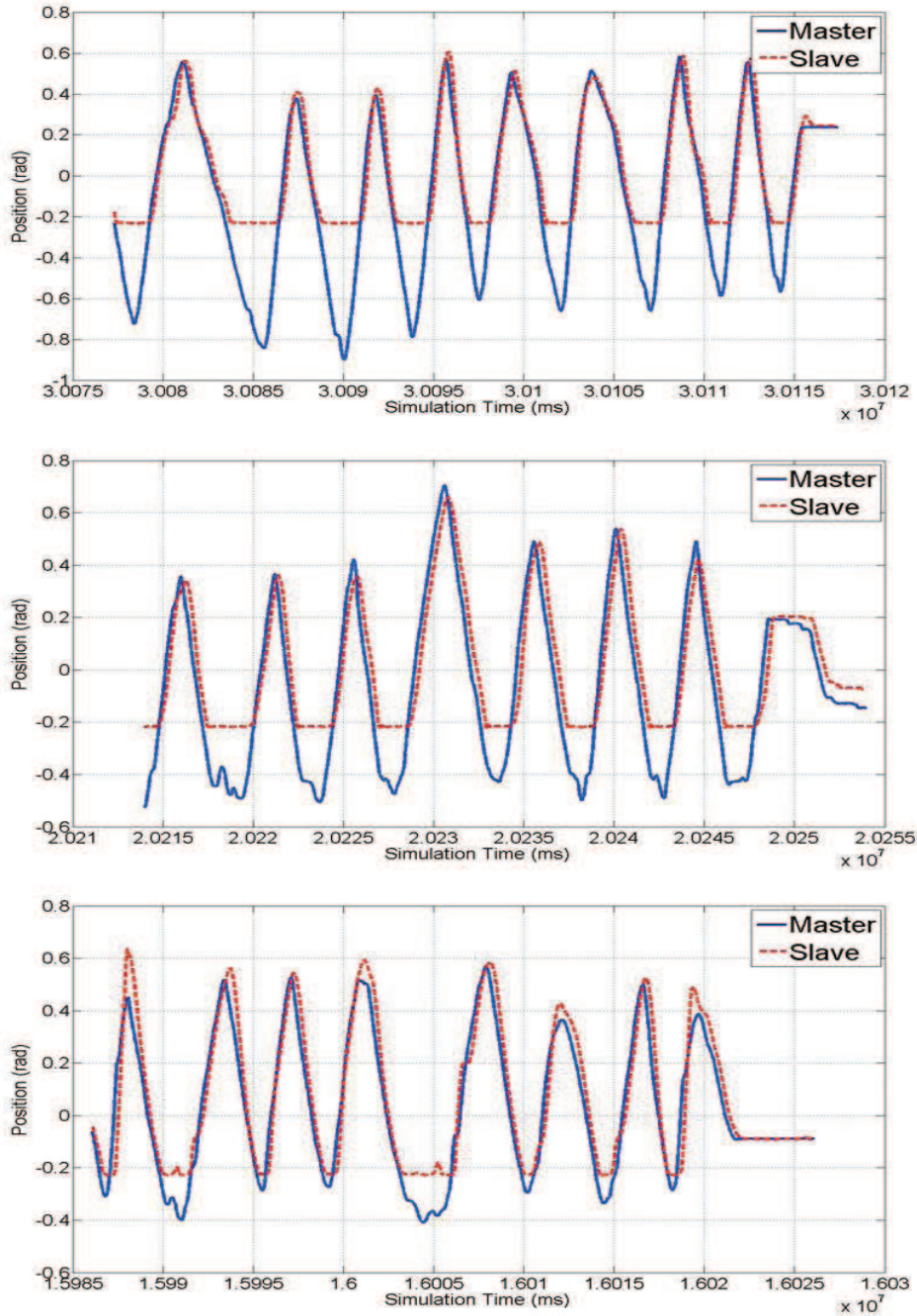

Figure 4.4: Position response in wall contact motion (upper: bilateral state feedback control scheme; middle: force-reflecting control scheme; lower: force-reflecting proxy control scheme;)

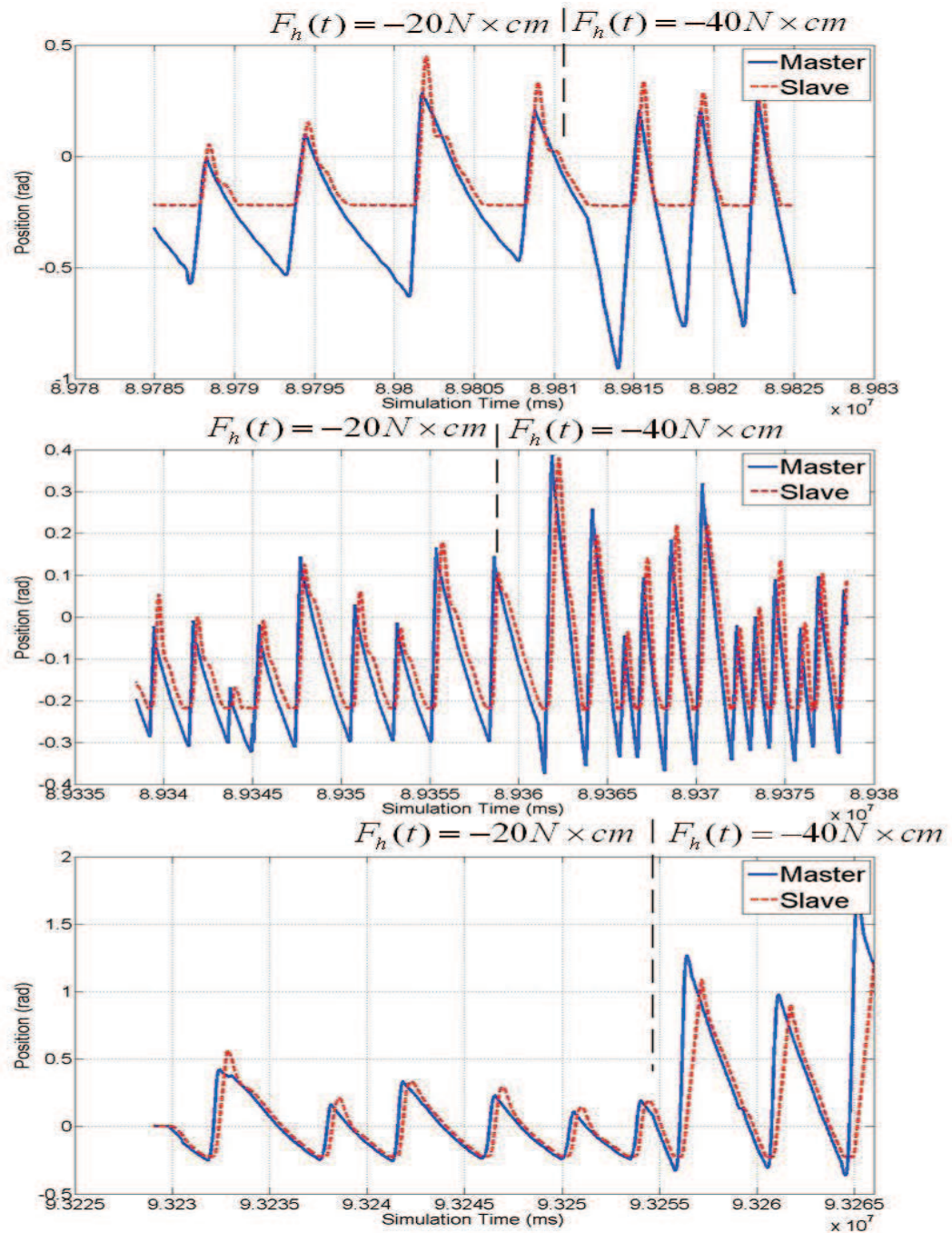

Figure 4.5: Position response in wall contact motion (upper: bilateral state feedback control scheme; middle: force-reflecting control scheme; lower: force-reflecting proxy control scheme;)



# Conclusions and Perspectives

## Conclusions

This thesis has considered the robust control of delayed teleoperation systems by using Lyapunov method together with  $H_\infty$  control theory, which is resolved in terms of LMI. The studied solution has focused on the controller design under asymmetric time-varying delays, based on three novel control architectures proposed in this thesis. Even if the problem remains open for several cases, the results presented in the thesis has brought several useful results in the domain of teleoperation control. The work has been presented as follows:

- The first chapter can be summarized in three parts: the first part has given an overview of problems and challenges of the cooperative robotics; the second part has firstly presented the delayed teleoperation and its control objectives (the stability, the synchronization, the transparency), secondly introduced the modeling of time delays depending upon two aspects (the digital communication properties and the mathematical properties), and then analyzed recent researches and their features in the field of teleoperation system; the third part has described time delay systems and the principles of the LKF-based stability approach, which constitutes a grounding for our work. In particular, we have proposed a general control architecture of teleoperation as in Fig. 1.6, which is generic enough to represent most of the control schemes for the master/slave teleoperation.

- The second chapter has gathered most theoretical contributions of this work. Three novel teleoperation control schemes ensuring the system stability and a high-level performance under asymmetric time-varying delays and the perturbations of the human operator and environment have been presented: the bilateral state feedback control scheme as in Fig. 2.2 ensured bilateral position tracking by state feedback, the master controller and the slave controller have been designed; the force-reflecting control scheme as in Fig. 2.3 used the estimated/measured force of the environment to achieve the position/force track-

ing, in this control scheme, we have discarded the master controller, and only designed the slave controller; with the estimated/measured force of the human operator, the force-reflecting proxy control scheme as in Fig. 2.4 has been proposed, in order to obtain a better system performance by adding a proxy of master into the slave controller. Comparing three architectures, all of them guaranteed the stability and the position tracking thanks to the position/velocity information. Fig. 2.3 and Fig. 2.4, in addition, ensured the force tracking. Fig. 2.4 can get a better performance, however, it also introduced additional computation load and needs the human and environment force to be estimated or measured.

A less conservative Lyapunov-Krasovskii functional with  $H_\infty$  control theory has been applied to linear time delay systems, and then the LMI theorems have been obtained in order to calculate the controllers in the control schemes. Finally, various simulations and comparisons with other methods in different working conditions, *e.g.* abrupt tracking and wall contact motion, have demonstrated the effectiveness and merits (the stability of the system, the position/force tracking between the master and the slave even under large delays) of our methods.

- The third chapter has extended the results obtained in Chapter 2. The force-reflecting proxy control scheme continued to be applied to the teleoperation system, and a discrete-time approach (a discrete LKF together with  $H_\infty$  control in the form of LMI) has been developed to analyze the control scheme and obtain a better system performance. Note that the discrete-time approach is valuable to the digital implementation on the experimental test-bench.

Based on the linear system handled in Chapter 2, a more general system with time-varying uncertainties has been considered in this chapter. According to the types of time-varying uncertainties (the polytopic-type uncertainties and the norm-bounded model uncertainties), different design strategies based on the the force-reflecting proxy control scheme have been applied to design the local controllers and the slave controller: in the case of the polytopic-type uncertainties, a polytopic-type LKF has been considered to obtain the LMI theorem; in the case of the norm-bounded model uncertainties, the norm-bounded uncertain system with the time delays has been transformed to the linear time delay system, and then the LMI theorems proposed in Chapter 2 have been applied to design the slave controller.

At last, for these extended research, some results and comparisons have been illustrated by simulations.

- The experimental test-bench and the real system implementation have been de-

---

scribed in the last chapter, the identification and linearizing control of the subsystems (the master/slave robots) have been introduced. At last, we have presented the analysis based on the experimental results.

On the theoretical side, our research principally focused on: firstly the introduction of the delayed teleoperation and the principal approaches in this domain; secondly the modeling and control scheme design of the teleoperation system; after that, in the framework of the control scheme, the controller design of linear time-varying delay systems with or without the model uncertainties, in the continuous-time or the discrete-time domain. The stability and performance problems (the position/force tracking) have been treated based on Lyapunov-Krasovskii functionals and  $H_\infty$  theory, all these control design theorems have been resolved in the form of LMI.

On the practical side, the results and comparisons of different simulations can totally present the merits of our theoretical approaches. Besides, based on the the theoretical results, the implementation of the experimental test-bench further illustrated the effectiveness of the approaches proposed in this thesis. This makes this PhD thesis more complete and convincing.

## Perspectives

As a perspective of the results developed in this thesis, we can mention:

- Nonlinear systems should be more completely studied, as the Euler-Lagrange equations of motion for  $n$ -link system:

$$M(\theta)\ddot{\theta}(t) + C(\theta, \dot{\theta})\dot{\theta}(t) + g(\theta) = F_h(t) + F_m(t), \quad (1)$$

where  $\theta(t)$  is the vector of joint displacements,  $\dot{\theta}(t)$  is the vector of joint velocity,  $F_m(t)$  is the vector of applied torque of master,  $F_h(t)$  is the vector of external input (the force of the human operator).  $M(\theta)$  is the positive definite inertia matrix,  $C(\theta, \dot{\theta})$  is the matrix of Centripetal and Coriolis torques, and  $g(\theta)$  is the gravitational torque.

Although this system can be transformed to LPV system and resolved as Section 3.2.1.5 of Chapter 3, this working axis-by-axis may induce some conservatism, that could be avoided by designing the master/slave controllers directly without the system transformation.

- Delay-scheduled state-feedback controller design for time delay systems is an excellent approach in order to reduce the conservatism and improve the system performance [Briat 2009a, Briat 2009b]. That is to say, we consider the following system and



controller:

$$\begin{cases} \dot{x}(t) = A_0x(t) + Bu(t) + Bw(t), \\ u(t) = -K(\tau(t))x(t - \tau(t)), \end{cases} \quad (2)$$

where  $K(\tau(t))$  is dependent to the time-varying delay  $\tau(t)$ ,  $\tau(t) \in [h_1, h_2]$ , *e.g.* one form of  $K(\tau(t))$  can be written as follow:

$$K(\tau(t)) = K_0 + K_1\tau(t) + K_2\tau^2(t) + \dots + K_h\tau^h(t) = \sum_{i=0}^h K_i\tau^i(t). \quad (3)$$

Here,  $K_i$ ,  $i = 1, \dots, h$ , should be calculated. Note that one problem for this approach is how to obtain the "real" correlation between the controller and the time-varying delay, otherwise, we will get the parameter-scheduled controller as  $K(\rho(t))$ ,  $\rho(t) \in [h_1, h_2]$  is the time-varying parameter (not the time-varying delay).

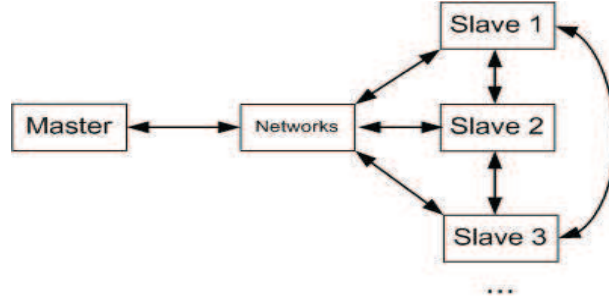

Figure 1: One master/multiple slaves teleoperation system

- Till now, the switch controller to improve the performance of whole system has been proposed in [Kruszewski 2011], but another switch control strategy can be applied to our system, the switch control between the passivity-based approach and the approach proposed in this thesis [Nuño 2011]. Taking the position tracking between the master and the slave as the control objective, there exists a small positive scalar  $\varsigma > 0$ , if the system runs under the condition of  $\theta_s(t) - \theta_m(t) < \varsigma$ , the passivity approach-based is applied to design the controllers, but when the  $\theta_s(t) - \theta_m(t) > \varsigma$  happens, our approach will be utilized to minimize the position gap. That is to say, the controller design strategies will switch according to the transient position gap, this leads to the different gains of controllers and system performances.

- In our work, the system is based on the master/slave structure with only one slave. The next step, we can consider several slave systems as Fig. 1.

The difficulty lies on: one should consider the share strategy of the bandwidth and the computation power; the control laws should include not only the strategy between

---

the master and the slaves, but also the strategy among multiple slaves.



# Résumé étendu en français

## Introduction générale

Ce travail propose de nouvelles structures de contrôle pour la téléopération bilatérale à travers des réseaux de communication non dédiés et présentant donc une qualité de service non maîtrisée.

La téléopération bilatérale permet de manipuler des objets par l'intermédiaire d'une interface haptique robotisée, qui renvoie à l'utilisateur la sensation des efforts subis par ces objets. Il s'agit donc typiquement d'une chaîne de rétroaction : dans un sens de la boucle, l'opérateur humain exerce un effort sur une interface robotisée, qui transmet ces efforts à un robot 'esclave' qui fait varier la position et la vitesse de l'objet. Dans l'autre sens de la boucle, l'environnement physique dans lequel se déplace l'objet manipulé exerce toute une gamme d'efforts sur lui (par exemple, lorsqu'il rencontre un obstacle) et ces efforts sont transmis en retour à l'opérateur humain, qui doit les ressentir le plus immédiatement possible, et de la façon la plus réaliste possible. Ce type d'opération existe depuis plusieurs décennies et fonctionne assez bien lorsque l'opérateur et l'objet sont proches et reliés par un réseau de communication ayant une qualité de service élevée (débit et rapidité suffisants) et garantie dans le temps (par exemple grâce à un réseau filaire réservé à cette seule application). Cependant, il est aujourd'hui très tentant de généraliser ces usages à des réseaux plus généralistes, comme par exemple l'Internet ou les réseaux sans fils.

Au delà d'un gain de flexibilité évident, ce type de situation introduit plusieurs difficultés :

- *Réseaux* : Ces réseaux introduisent dans les boucles de contrôle des retards dissymétriques et fortement variables, susceptibles de réduire les performances et même de déstabiliser le système global. Nous montrerons que, sous certaines hypothèses assez peu restrictives, ces effets se ramènent à deux 'retards de réseau'.
- *Performance* : De plus, la téléopération bilatérale est soumise à des entrées issues

des forces exercées par l'opérateur sur le robot maître et par l'environnement physique du robot esclave télé-opéré (un mur, par exemple). Ces efforts et sensations doivent être reproduits le plus fidèlement possible (transparence) et les variations de position doivent être suivies aussi rapidement que possible (suivi).

- *Robustesse* : Enfin, les systèmes robotiques correspondent le plus souvent à des modèles non linéaires ou non stationnaires (par exemple à cause de saturations d'énergie ou de poids d'objets différents). Bien qu'il soit possible de réaliser une commande locale linéarisante pour se ramener à des modèles nominaux linéaires, il faut pouvoir tenir compte des écarts par rapport à ce nominal en considérant des perturbations de modèles non négligeables.

Dans ces conditions très contraintes, l'enjeu est de concevoir et calculer des structures de commande garantissant à la fois la stabilisation et un bon degré de performance en termes de synchronisation (suivi des position et vitesse) et de transparence (ressenti des forces).

Concernant les objectifs de la synthèse des contrôleurs, on pourra selon le besoin considérer qu'une valeur supérieure des deux retards de réseau est connue (il s'agira alors d'optimiser la performance) ou que cette borne doit être calculée (pour garantir une performance minimale désirée). Nous verrons que, grâce aux modèles et techniques que nous introduirons, cette synthèse de contrôleur s'exprimera sous forme LMI (inégalités matricielles linéaires), donc optimisable par des solveurs algorithmiques classiques.

Une implantation sur une plate-forme expérimentale permettra d'illustrer plus concrètement notre approche théorique.

Le plan du travail est le suivant :

- Au chapitre 1, nous faisons tout d'abord un tour d'horizon des recherches récentes dans le domaine des systèmes de téléopération et de leurs caractéristiques. Puis, pour correspondre aux besoins de l'application, nous considérons des modèles linéaires à plusieurs retards variables pour lesquels nous proposons une approche d'analyse de stabilité par fonctionnelles de Lyapunov-Krasovskii, qui permettra par la suite de réduire le conservatisme des conditions de stabilisation, et qui est couplée avec une approche de contrôle robuste  $H_\infty$  pour tenir compte des aspects de performance. C'est cet ensemble qui permettra une synthèse par LMI.

- Dans le chapitre 2, trois structures de téléopération seront proposées en temps continu : un premier schéma de retour d'état bilatéral (positions/vitesses) ; un second intégrant un retour de force additionnel ; enfin un troisième avec un retour de force et un émulateur du maître placé du côté esclave, que nous nommons ici le 'Proxy'. La

---

comparaison de ces architectures montre que, pour un retard de réseau maximum donné ou calculé, toutes garantissent un suivi de position et vitesse. Les deux dernières, qui utilisent les forces mesurées ou estimées de l'opérateur humain et de l'environnement, garantissent de plus un suivi en force. Au final, la troisième structure (avec 'Proxy') présente la meilleure performance, même si elle demande un peu plus de calcul.

- Dans le chapitre 3, afin d'analyser et d'améliorer les performances de la troisième structure pour des modèles encore plus réalistes, une étude est menée en temps discret (modèle échantillonné traité, ici encore, par une approche combinant techniques de Lyapunov et contrôle  $H_\infty$ ), mais aussi sur un modèle non linéaire ou non stationnaire sous perturbations bornées en norme. Les perturbations de modèles sont considérées par l'intermédiaire d'une approche polytopique et l'ensemble conduit aussi à une synthèse par LMI.

- Dans le chapitre 4, l'implantation sur la plate-forme est décrite dans un quatrième et dernier chapitre. Chacun des deux sous-systèmes (robots Phantom côté maître, Mitsubishi côté esclave) est tout d'abord identifié puis linéarisé par retour d'état. Après avoir comparé les solutions par capteur ou par estimateur de force, la première est retenue. L'ensemble permet de valider les hypothèses de modélisation et de calculer les différentes structures. L'analyse des résultats expérimentaux est alors menée.

## Préliminaires

Le premier chapitre donne une vue générale des structures, des problèmes et recherches récents dans les domaines de la téléopération et de la stabilité des systèmes à retard. Basé sur les défis présentés avant, nous avons dans ce chapitre introduit ce qui suit :

- Un bref rappel sur l'histoire et les applications typiques de la téléopération depuis les années 1950.

- La distinction entre les différentes téléopérations, classés en unilatérale et bilatérale : en téléopération unilatérale, l'opérateur humain manœuvre le robot de l'esclave sans le retour des informations de l'esclave au maître, c'est-à-dire que l'opérateur humain est découplé du système global, et l'impédance de l'opérateur ne peut pas affecter la performance du système; la téléopération bilatérale implique un retour du côté d'esclave, si les retards de la communication sont petites, le retour en temps réel peut être obtenu. Pour ce qui concerne notre sujet, il existe différents types de téléopération bilatérale définis par rapport à la paire des informations de rétroaction entre maître et esclave, *e.g.* la téléopération en vitesse-force, la téléopération en position-force, la téléopération en

position-position, même la téléopération en informations mixtes.

- Afin de faciliter la présentation de la performance objective du contrôle et les stratégies du contrôle, nous avons présenté les diverses sources des retard variant en temps, qui sont détaillés comme suit : les retards de communication peuvent être bornés ou non bornés, ce qui dépend du type de réseau et doit être traitée par différentes manières lors de la phase de conception du contrôle; une autre source de retards variant en temps vient de l'échantillonnage; certaines données d'information peuvent être perdues lors de leur transfert par l'intermédiaire du réseau; l'asymétrie des retards signifie que les retards en sens aller (maître vers esclave) et en sens retour (esclave vers maître) ne sont pas égaux; la synchronisation des horloges entre le maître et l'esclave est réalisée ici grâce au datage sur horaire des paquets de données; enfin le type de protocole de communication (TCP vs UDP) est discuté.

- Basé sur l'objectif de performance (la stabilité, la synchronisation, la transparence) attendu de la téléopération, une structure générale du système est donnée dans la Fig. 1, qui est suffisamment générique pour représenter la plupart des cas de téléopération bilatérale avec retard. Ce sera la structure de base de tous les schémas de contrôle proposés dans cette thèse.

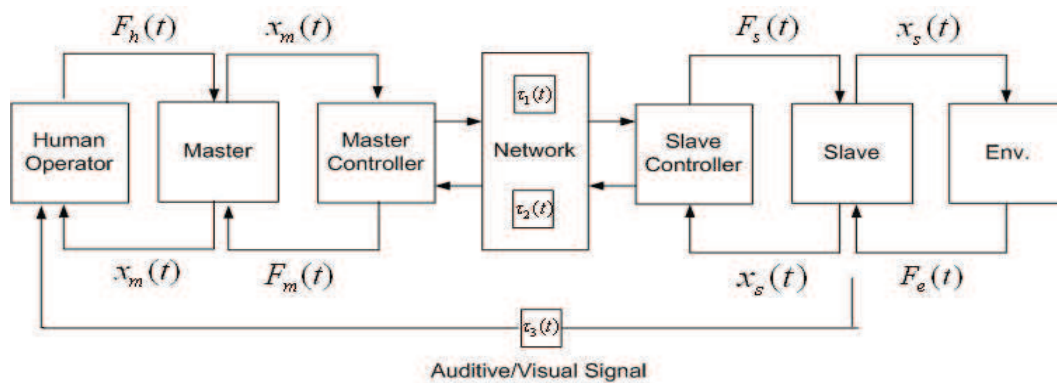

Figure 1: La structure générale du contrôle

- En général, les propriétés de stabilité et de synchronisation/transparence du système sont conflictuelles. Avec le développement des technologies de la communication et du contrôle, les stratégies en temps réel pour concevoir la téléopération bilatérale à retard sont apparues. Dans le premier chapitre, nous avons raconté les principes de ces méthodes.

Mathématiquement parlant, la téléopération bilatérale à retard variable sera traitée comme un système dynamique retardé, c'est pourquoi nous devons aussi présenter les systèmes à retards, le traitement de la stabilité de ces systèmes par la méthode de Lyapunov et ses extensions. En particulier, dans ce travail nous allons assurer la stabilité

et améliorer la performance du système linéaire à retard variable comme ci-dessous en utilisant les fonctionnelles de Lyapunov-Krasovskii et le contrôle de  $H_\infty$  :

$$\begin{cases} \dot{x}(t) = A_0x(t) + A_1x(t - \tau_1(t)) + A_2x(t - \tau_2(t)) + B_0u(t), \\ x(t_0 + \theta) = \phi(\theta), \quad \dot{x}(t_0 + \theta) = \dot{\phi}(\theta), \quad \theta \in [-h, 0]. \end{cases} \quad (1)$$

## Plusieurs schémas du contrôle de la téléopération

Basé sur la structure de la téléopération de la Fig. 1, nous proposons trois nouveaux schémas, qui devront permettre à la fois d'assurer la stabilité du système et de garantir la performance comme suit :

- Le suivi de position : le robot esclave doit suivre le mouvement du robot maître entraîné par l'opérateur humain.
- Le suivi de force : la force de l'environnement agissant sur l'esclave (quand il entre en contact avec un mûr rigide par exemple) devrait être reproduit sur maître précisément et immédiatement (en temps réel), grâce au retour de la force de l'esclave vers maître.

Avant de concevoir les contrôleurs correspondant à ces architectures, quelques descriptions préliminaires et hypothèses doivent être introduites. Elles visent l'utilisation des fonctionnelles de Lyapunov-Krasovskii et de la théorie  $H_\infty$ , et permettront une synthèse par optimisation LMI (inégalités matricielles linéaires). De plus, nous pouvons supposer que les retards variables sont bornés par une borne constante et connue, mais aussi que grâce aux marquages temporels de paquets, certains retards sont correctement estimés ( $\hat{\tau}_i(t)$  représentant l'estimé de  $\tau_i(t)$ ) par l'un des côtés, à savoir : le retard  $\tau_1(t)$  est connu du côté de l'esclave :  $\hat{\tau}_1(t) = \tau_1(t)$  ; et le retard  $\tau_2(t)$  est connu du côté du maître :  $\hat{\tau}_2(t) = \tau_2(t)$ .

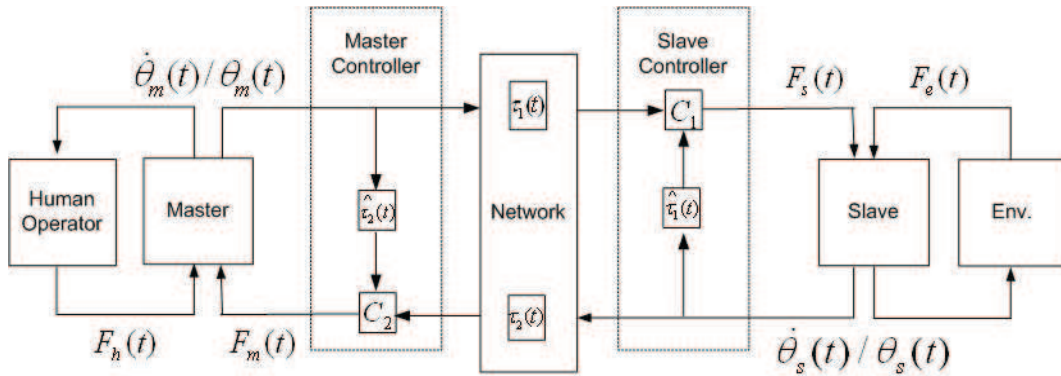

Figure 2: Le schéma du contrôle bilatérale avec le retour de l'état



Les trois schémas de téléopération présentés Fig. 2-4 requièrent des informations différentes :

- Contrôle bilatérale avec le retour d'état (Fig. 2) : les informations transmises entre le maître et l'esclave sont les vitesses et les positions du maître et de l'esclave,  $\dot{\theta}_m(t)$ ,  $\theta_m(t)$  et  $\dot{\theta}_s(t)$ ,  $\theta_s(t)$ . Ce schéma assure le suivi de position bilatérale et demande la synthèse des contrôleurs  $C_1$  du maître et  $C_2$  de l'esclave.

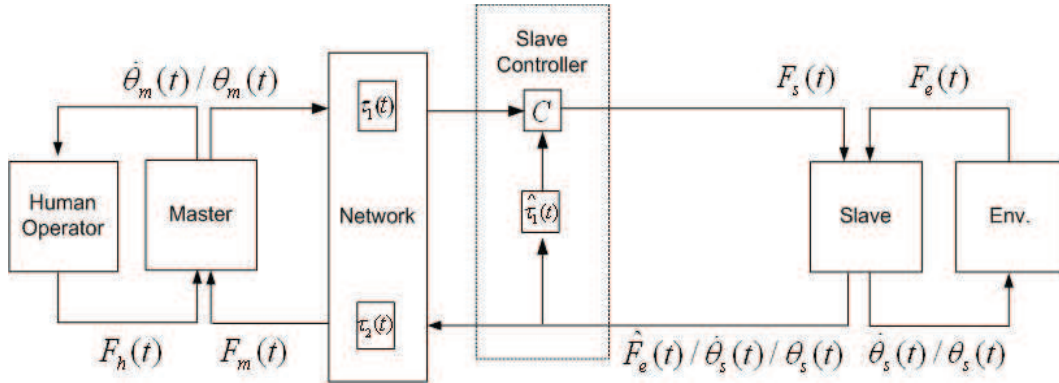

Figure 3: Le schéma du contrôle avec le retour de la force

- Contrôle avec le retour de la force (Fig. 3) : du maître à l'esclave, les informations transmises sont la vitesse/position du maître; cependant, de l'esclave vers le maître, seulement la force mesurée  $\hat{F}_e(t)$  est transférée. Ceci réalise le suivi de force  $F_m(t) = \hat{F}_e(t - \tau_2(t))$ , qui est basée sur la stabilité du système global. Dans ce schéma, la force de l'environnement (ou la force de l'opérateur humain, qui sera utilisé par le schéma suivant) peut être estimée ou mesurée. De plus, le contrôleur du maître a été supprimé : seulement le contrôleur du côté esclave  $C$  reste à concevoir.

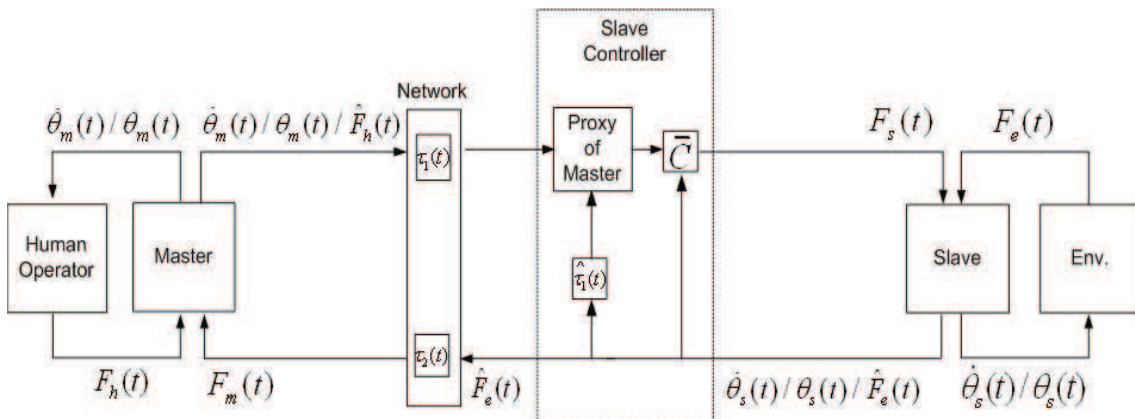

Figure 4: Le schéma du contrôle avec le retour de la force et le 'Proxy'

- Contrôle avec le retour de la force et le 'Proxy' (Fig. 4) : basé sur le schéma précédent

du contrôle avec le retour de la force, nous ajoutons un 'Proxy du Maître' (ou plus simplement 'Proxy') dans le contrôleur de l'esclave, qui émule le comportement du maître à proximité de l'esclave. Il permet de synchroniser la position entre le maître et l'esclave. Les informations transmises du maître vers l'esclave sont la vitesse/position du maître et la force mesurée  $\hat{F}_h(t)$  ; de l'esclave vers maître, seulement la force mesurée  $\hat{F}_e(t)$  est transmise pour réaliser le suivi de force  $F_m(t) = \hat{F}_e(t - \tau_2(t))$ .

Sur la Fig. 5, nous pouvons voir que le proxy du maître agit comme un observateur/prédicteur du maître. Il est utilisé du côté esclave pour réduire l'impact des retards de communication.

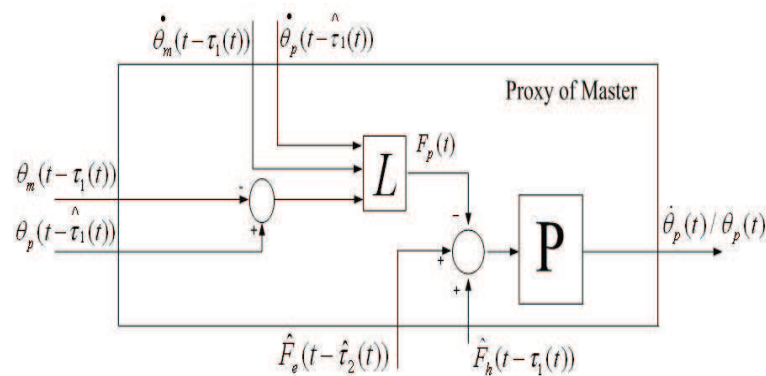

Figure 5: Le proxy du maître

Si l'on compare ces trois architectures,

- toutes garantissent la stabilité et le suivi de position grâce aux informations de vitesse/position.
- Celles des deux dernières figures Fig. 3 et Fig. 4 assurent en outre le suivi de force et nécessitent l'estimation ou la mesure des forces.
- Grâce à son proxy, la dernière, Fig. 4, donne une meilleure performance. Cependant, elle introduit également une charge de calcul supplémentaire.

Des simulations, obtenues par YALMIP et Simulink, montrent que le système de téléopération conçu par notre théorie peut fonctionner dans différentes conditions de travail, même sous des retards 'importants'. En outre, la comparaison avec les autres approches récentes a été réalisée et semble donner l'avantage à nos architectures et, en particulier, la troisième (avec proxy) semble très performante. Dans le dernier chapitre, nos résultats devront être mis en œuvre sur le dispositif expérimental, de façon à confirmer

l'efficacité de nos approches (notamment en termes de ressenti haptique par l'opérateur, qui est plus difficile à appréhender sur une simulation).

## Recherche étendue : prise en compte des effets de discrétisation temporelle et des perturbations variables

Le schéma de contrôle avec le retour de la force et le 'Proxy' (Fig. 4) semble le plus performant, nous avons choisi de l'approfondir et nous concentrons par la suite uniquement sur lui. Quelques recherches étendues ont été considérées en vue de résoudre certains points plus particuliers liés, notamment, à la robustesse.

Notre motivation est double : d'une part, la synthèse en temps discret est précieuse pour l'implémentation directe sur les robots. D'autre part, nous verrons qu'il est possible d'obtenir un meilleur résultat sur la performance, c'est en tous cas ce que les simulations montreront.

- Une approche en temps discret a été utilisé pour analyser le système de contrôle échnatilloné et essayer d'obtenir meilleure performance. Plus précisément, nous présentons un développement rigoureux des contrôleurs pour la téléopération en utilisant des fonctions de Lyapunov en temps discret ainsi que le contrôle  $H_\infty$ , conduisant ici encore à une optimisation par LMI. Dans le cas discret, les fonctionnelles de Lyapunov-Krasovskii (LKF) deviennent :

$$\begin{aligned}
 V(x(k)) = & x(k)^T P x(k) + \sum_{i=k-h_2}^{k-1} x(i)^T S_a x(i) + \sum_{i=k-h_1}^{k-1} x(i)^T S x(i) \\
 & + h_1 \sum_{i=-h_1}^{-1} \sum_{j=k+i}^{k-1} y(j)^T R y(j) + \sum_{i=1}^q (h_2 - h_1) \sum_{j=-h_2}^{-h_1-1} \sum_{l=k+j}^{k-1} y(l)^T R_{ai} y(l),
 \end{aligned} \tag{2}$$

où  $y(k) = x(k+1) - x(k)$ . Le critère  $J(w)$  de performance  $H_\infty$  est défini en lien avec un scalaire positif  $\gamma$  :

$$J(w) = \sum_{i=0}^{\infty} [z(k)^T z(k) - \gamma^2 w(k)^T w(k)] < 0. \tag{3}$$

Pour assurer la stabilité du système sous la performance  $J(w) < 0$ , nous considérons la condition :

$$\Delta V(x(k)) + z(k)^T z(k) - \gamma^2 w(k)^T w(k) < 0, \tag{4}$$

---

où  $\Delta V(x(k)) = V(x(k+1)) - V(x(k))$ . À partir de cette condition, nous concevons le proxy et le contrôleur  $\bar{C}$  en temps discret.

- Les systèmes linéaires stationnaires ont été traités précédemment, mais aucun système réel ne satisfait pleinement cette hypothèse de modélisation. Nous allons donc étendre notre approche à des modèles plus généraux, présentant des incertitudes variants en temps. Il y a deux cas d'incertitudes proposées :

- ★ le système de téléopération avec incertitudes polytopiques;
- ★ et celui avec incertitudes bornées en norme.

Pour ces deux cas, nous utiliserons les mêmes étapes de conception du schéma de contrôle avec le retour de la force et le 'Proxy', mais :

- ★ les modèles du maître, du proxy et de l'esclave sont combinés avec des incertitudes variant dans le temps ;
- ★ les contrôleurs locaux du maître, du proxy et de l'esclave sont conçus par fonctions de Lyapunov et LMI ;
- ★ le contrôleur de l'esclave est obtenu par LKF,  $H_\infty$  et LMI.

Toutefois, on notera que dans chaque étape de la conception, les stratégies de la conception sont différentes entre ces deux cas.

**Dans le cas des incertitudes polytopiques**, le système est sous la forme générale :

$$\begin{cases} \dot{x}(t) = A_0(t)x(t) + \sum_{i=1}^q A_i(t)x(t - \tau_i(t)) + B(t)w(t), \\ z(t) = Cx(t), \\ x(t_0 + \theta) = \phi(\theta), \quad \dot{x}(t_0 + \theta) = \dot{\phi}(\theta), \quad \theta \in [-h_2, 0], \end{cases} \quad (5)$$

où  $A_0(t)$ ,  $A_i(t)$ ,  $i = 1, 2, \dots, q$ ,  $B(t)$  sont soumises aux incertitudes variants en temps et satisfont le modèle convexe polytopique:

$$\begin{aligned} [A_0(t), A_i(t), B(t)] &\in \Omega, \quad i = 1, 2, \dots, q, \\ \Omega &\triangleq [A_0(\rho(t)), A_i(\rho(t)), B(\rho(t))] = \sum_{j=1}^N \rho_j(t) [A_{0j}, A_{ij}, B_j], \quad \sum_{j=1}^N \rho_j(t) = 1, \quad \rho_j(t) \geq 0. \end{aligned} \quad (6)$$

Pour traiter ce système, nous considérons le LKF  $V(x(t), \dot{x}(t))$  proposé dans Chapitre 2, par conséquent, la condition de la stabilité,  $\dot{V}(x(t), \dot{x}(t)) + z(t)^T z(t) - \gamma^2 w(t)^T w(t) < 0$ , peut être assouplie à un ensemble de  $N$  LMIs.

**Dans le cas des incertitudes bornées en norme**, nous considérons les incertitudes comme des perturbations. La théorie  $H_\infty$  permet alors de concevoir le contrôleur de l'esclave pour le système linéaire sans incertitudes, mais de façon robuste vis-à-vis de ces

perturbations. Dans ce cas, la clé est de faire la transformation entre le système linéaire avec incertitudes des normes bornées et le système linéaire sans incertitudes.

Nous avons comparé les deux cas par les simulations, qui montrent que chaque cas a ses avantages et ses inconvénients.

## Applications

Il est maintenant temps de confronter les résultats de notre recherche théorique avec l'expérimentation.

Ce chapitre réalise la mise en œuvre du système sur le banc d'essai expérimental, en fonction des résultats des Chapitre 2 et Chapitre 3. Grâce à nos trois schémas de contrôle, un degré élevé de performance (la stabilité, la synchronisation, la transparence) a été garanti. La conception du contrôleur est construite sur la base des forces mesurées/estimées par des capteurs/observateurs de couple. Les résultats expérimentaux dans différentes conditions de travail sont effectués pour vérifier l'exactitude et l'efficacité des méthodes proposées dans cette thèse.

## Conclusions et perspectives

Cette thèse a été consacrée à la définition et à l'étude de contrôleurs permettant la stabilisation et l'amélioration des performances en téléopération bilatérale à travers des réseaux non dédiés. La solution proposée est basée sur les fonctionnelles de Lyapunov-Krasovskii, la théorie du contrôle robuste  $H_\infty$ , et l'optimisation par LMI. Les simulations et les résultats expérimentaux ont confirmé l'efficacité de nos approches.

## Contributions

De notre point de vue, les contributions de ce travail sont les suivantes :

- Sur la base d'un grand nombre de références, une architecture générale de téléopération a été générée. La représentation des effets de réseau par des modèles à retards variables a été donnée.
- Trois nouveaux schémas de contrôle en téléopération ont été proposés pour assurer la stabilité du système et obtenir une meilleure performance malgré des retards variants dans le temps et des perturbations venant de l'opérateur humain et de l'environnement. Ceci a tout d'abord été illustré par diverses simulations.

---

- L'idée de l'utilisation de la méthode de Lyapunov et de la théorie  $H_\infty$  n'est pas nouvelle, mais nos travaux combinent efficacement ces deux méthodes avec l'architecture de contrôle de la téléopération. Plusieurs conditions LMI ont été établis afin de calculer facilement les gains des contrôleurs par des algorithmes d'optimisation convexe.

- Des points de réalisme supplémentaires ont été pris en considération dans la conception du contrôle du système de téléopération. Ainsi la méthode a été proposée en temps échantillonné pour faciliter la mise en œuvre numérique sur le vrai banc d'essai. Le contrôle  $H_\infty$  a été appliqué pour traiter des incertitudes de modèles variables dans le temps. Ainsi en général, nos architectures sont adaptées à une bonne variété des situations réelles de la téléopération.

- Enfin, selon les résultats théoriques obtenus, le vrai banc d'essai a été installé et une analyse a été présentée.

## Perspectives

On peut développer plusieurs points à la suite des résultats obtenus dans cette thèse :

- Les systèmes non linéaires devraient être étudiés plus profondément, comme les équations du mouvement de Euler-Lagrange pour  $n$  link-système :

$$M(\theta)\ddot{\theta}(t) + C(\theta, \dot{\theta})\dot{\theta}(t) + g(\theta) = F_h(t) + F_m(t), \quad (7)$$

où  $\theta(t)$  est le vecteur des déplacements communs,  $\dot{\theta}(t)$  est le vecteur des vitesses communes,  $F_m(t)$  est le vecteur du couple appliqué par le maître,  $F_h(t)$  est le vecteur de l'entrée externe, *e.g.* la force de l'opérateur humain,  $M(\theta)$  est la matrice définie positive inertie,  $C(\theta, \dot{\theta})$  est la matrice des couples centripètes et de Coriolis, et enfin  $g(\theta)$  est le couple gravitationnel.

- Le contrôleur dépendant du retard pour la téléopération à retard variable semble une excellente approche pour réduire le conservatisme et améliorer la performance du système. C'est-à-dire que nous pourrions considérer le système et le contrôleur suivants :

$$\begin{cases} \dot{x}(t) = A_0x(t) + Bu(t) + Bw(t), \\ u(t) = -K(\tau(t))x(t - \tau(t)), \end{cases} \quad (8)$$

où  $K(\tau(t))$  dépend du retard variant en temps  $\tau(t)$ ,  $\tau(t) \in [h_1, h_2]$ , une forme de  $K(\tau(t))$  peut être décrite comme:

$$K(\tau(t)) = K_0 + K_1\tau(t) + K_2\tau^2(t) + \dots + K_h\tau^h(t) = \sum_{i=0}^h K_i\tau^i(t). \quad (9)$$

Ici,  $K_i$ ,  $i = 1, \dots, h$ , doit être calculé. Notons que le problème de cette approche est d'obtenir la corrélation réelle entre le contrôleur et le retard variant en temps. Autrement, nous aurons le contrôleur dépendant du paramètre variable *e.g.*  $K(\rho(t))$ ,  $\rho(t) \in [h_1, h_2]$  est le paramètre variant en temps (et non pas le retard variant en temps).

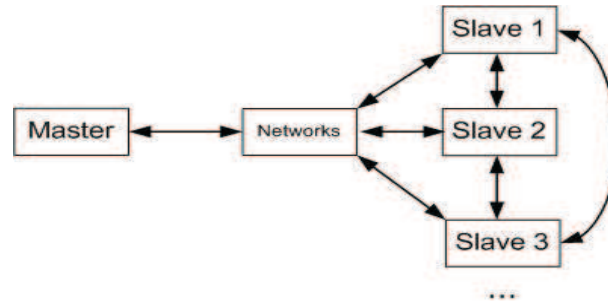

Figure 6: Le système de la téléopération avec un maître/multiples esclaves

- Jusqu'à maintenant, l'amélioration de la performance de téléopération du système a été proposée sur la base de contrôleurs à gains constants, mais une autre stratégie de commutation de commande peut être appliquée à notre système. Il serait intéressant d'envisager une commutation (*switched systems*) entre des contrôleurs issus des techniques de passivité et ceux issus de l'approche de cette thèse. En prenant pour objectif le suivi de position entre le maître et l'esclave, on peut imaginer un (petit) scalaire positif  $\varsigma > 0$ , tel que tant que le système fonctionne sous la condition  $\theta_s(t) - \theta_m(t) < \varsigma$ , l'approche de la passivité soit appliquée. Mais quand on atteint  $\theta_s(t) - \theta_m(t) > \varsigma$ , notre approche est utilisée pour réduire l'écart de position. Dans ce cas, il s'agit donc de concevoir une stratégie de commutation en fonction de l'écart de position transitoire.

- Dans notre travail, le système est basé sur une structure avec un seul esclave. Dans une prochaine étape, nous pouvons envisager l'utilisation de plusieurs sous-systèmes esclaves, comme sur Fig. 6. La difficulté réside alors dans la stratégie de compromis entre la bande passante et la puissance de calcul. La conception du contrôle devrait alors inclure non seulement la stratégie entre le maître et les esclaves, mais aussi la stratégie entre les esclaves eux-mêmes.

# Appendix

## 1 More Details about Passivity-Based Control

The first architecture proposed in [Anderson 1989] presented the conception of the scattering transformation. Considering a two-port bilateral networked system in Fig. 1, the relationship between the efforts  $F_1(t)$ ,  $F_2(t)$  (force, voltage) and the flows  $v_1(t)$ ,  $v_2(t)$  (velocity, current) is specified by hybrid matrix  $H(s)$ :



Figure 1: Two-port bilateral networked system

$$\begin{pmatrix} F_1(s) \\ -v_2(s) \end{pmatrix} = \begin{pmatrix} H_{11}(s) & H_{21}(s) \\ H_{12}(s) & H_{22}(s) \end{pmatrix} \begin{pmatrix} v_1(s) \\ F_2(s) \end{pmatrix} = H(s) \begin{pmatrix} v_1(s) \\ F_2(s) \end{pmatrix}, \quad (1)$$

where  $F_1(s)$ ,  $F_2(s)$ ,  $v_1(s)$ ,  $v_2(s)$  are the Laplace transforms of  $F_1(t)$ ,  $F_2(t)$ ,  $v_1(t)$ ,  $v_2(t)$ , and:

$$F(t) = \begin{pmatrix} F_1(t) \\ F_2(t) \end{pmatrix}, \quad v(t) = \begin{pmatrix} v_1(t) \\ -v_2(t) \end{pmatrix}. \quad (2)$$

Then, the time domain scattering operator can be defined.

**Definition .1 (Time Domain Scattering Operator)**  $S(t): L_2^n(\mathbb{R}_+) \rightarrow L_2^n(\mathbb{R}_+)$  is defined by:

$$F(t) - v(t) = S(t)(F(t) + v(t)). \quad (3)$$

$S(t)$  can be expressed in the frequency domain as a scattering matrix  $S(s)$ :



$$F(s) - v(s) = S(s)(F(s) + v(s)). \quad (4)$$

The relationship between the hybrid matrix  $H(s)$  and  $S(s)$  is obtained by:

$$\begin{pmatrix} F_1(s) - v_1(s) \\ F_2(s) + v_2(s) \end{pmatrix} = \begin{pmatrix} 1 & 0 \\ 0 & -1 \end{pmatrix} \left[ \begin{pmatrix} F_1(s) \\ -v_2(s) \end{pmatrix} - \begin{pmatrix} v_1(s) \\ F_2(s) \end{pmatrix} \right] = \begin{pmatrix} 1 & 0 \\ 0 & -1 \end{pmatrix} (H(s) - I) \begin{pmatrix} v_1(s) \\ F_2(s) \end{pmatrix}, \quad (5)$$

$$\begin{pmatrix} F_1(s) + v_1(s) \\ F_2(s) - v_2(s) \end{pmatrix} = \begin{pmatrix} F_1(s) \\ -v_2(s) \end{pmatrix} + \begin{pmatrix} v_1(s) \\ F_2(s) \end{pmatrix} = (H(s) + I) \begin{pmatrix} v_1(s) \\ F_2(s) \end{pmatrix},$$

$$S(s) = \begin{pmatrix} 1 & 0 \\ 0 & -1 \end{pmatrix} (H(s) - I)(H(s) + I)^{-1}. \quad (6)$$

Based on the scattering transformation and operator, we get some theorems that make the system passive (the proof details can be found in [Anderson 1989]). A system is passive:

- If and only if the norm of its scattering operator is less than or equal to one:

$$\|S(s)\| \leq 1. \quad (7)$$

- If and only if  $\sup_w \lambda^{1/2}(S^T(jw)S(jw)) \leq 1$ ,  $\lambda$  is the maximum eigenvalue.

After that, two directions are being studied recently, which are the passivity with or without the wave variable transformation. Let us consider the wave variable transformation firstly, the cornerstone paper is [Niemeyer 1991]. Fig. 2 shows the basic wave transformation related to the force  $F(t)$  and the velocity  $\dot{x}(t)$  [Niemeyer 1996]. Note that the force  $F(t)$  and the velocity  $\dot{x}(t)$  may be replaced by any other effort and flow pair.

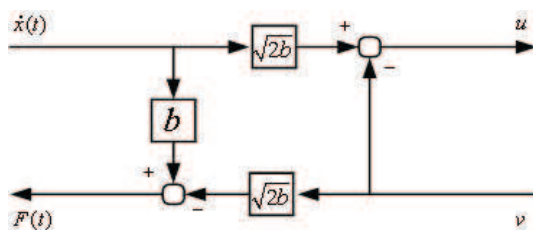

Figure 2: Basic wave transformation

In Fig. 2, the wave variables  $(u, v)$  and the power variables  $(F, \dot{x})$  have the relationships as follows:

$$u = \frac{b\dot{x} + F}{\sqrt{2b}}, \quad v = \frac{b\dot{x} - F}{\sqrt{2b}}, \quad b\dot{x} = \sqrt{\frac{b}{2}}(u + v), \quad F = \sqrt{\frac{b}{2}}(u - v), \quad (8)$$

where  $b$  is a positive constant or a symmetric positive definite matrix which represents the characteristic wave impedance. The system input  $(F, \dot{x})$  produces positive power flow as presented before, the input energy:

$$\begin{aligned}
 \int_0^t P_{in}(\tau)d\tau &= \int_0^t \dot{x}^T F d\tau = \int_0^t \frac{1}{2}u^T u - \frac{1}{2}v^T v d\tau \\
 &= E_{store}(t) - E_{store}(0) + \int_0^t P_{diss}(\tau)d\tau.
 \end{aligned} \tag{9}$$

Thus, we obtain the passivity condition in the power domain (the equality form and the inequality form):

$$\begin{aligned}
 \frac{1}{2}v^T v d\tau &= \int_0^t \frac{1}{2}u^T u - E_{store}(t) + E_{store}(0) - \int_0^t P_{diss}(\tau)d\tau, \\
 \frac{1}{2}v^T v d\tau &\leq \int_0^t \frac{1}{2}u^T u + E_{store}(0).
 \end{aligned} \tag{10}$$

The wave transformation is like the damping adjustment, by which the system power is controlled resulting in a stable operation. Fig. 3 shows basic wave-based teleoperation,  $B$  represents the wave transformation.

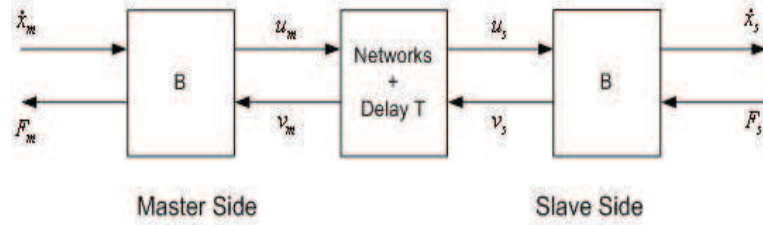

Figure 3: Basic wave-based teleoperation

Through the communication channel, only the wave variables are transmitted, we define the major direction from left to right, and vice versa:

$$u_s(t) = u_m(t - T), \quad v_m(t) = v_s(t - T). \tag{11}$$

Based on the wave transformation, we have already the relationship between the wave variables and the power variables, now the overall input power in the communication:

$$\begin{aligned}
 P_{in}(t) &= \dot{x}_m^T(t)F_m(t) - \dot{x}_s^T(t)F_s(t) \\
 &= \frac{1}{2}u_m^T(t)u_m(t) - \frac{1}{2}v_m^T(t)v_m(t) - \frac{1}{2}u_s^T(t)u_s(t) + \frac{1}{2}v_s^T(t)v_s(t) \\
 &= \frac{1}{2}u_m^T(t)u_m(t) - \frac{1}{2}u_m^T(t-T)u_m(t-T) + \frac{1}{2}v_s^T(t)v_s(t) - \frac{1}{2}v_s^T(t-T)v_s(t-T).
 \end{aligned} \tag{12}$$

We can find that the initial energy  $E_{store}(0) = 0$  and power dissipation  $P_{diss}(t) = 0$ , all input power is stored:



$$P_{diss}(t) = P_{in}(t) - \frac{d}{dt}E_{store}(t) = F_{mc}(t)V_m(t) - F_s(t)V_{sc}(t) - \frac{d}{dt}E_{store}(t) \geq 0. \quad (14)$$

With the definitions in [Niemeyer 1991, Ye 2009c],  $P_{in}(t)$  is written into:

$$\begin{aligned} P_{in}(t) &= \frac{1}{b}F_{mc}(t)^2 - \frac{1}{2b}(F_{mc}(t) - bV_m(t))^2 + bV_{sc}(t) - \frac{1}{2b}(F_s(t) + bV_{sc}(t))^2 \\ &+ \frac{d}{dt} \int_{t-T_2}^t \frac{1}{2b}F_s(\tau)^2 d\tau + \frac{d}{dt} \int_{t-T_1}^t \frac{b}{2}V_m(\tau)^2 d\tau, \end{aligned} \quad (15)$$

where  $b$  is an adjustable ratio, and the storage energy of the communication channel can be regarded as:

$$E_{store}(t) = \int_{t-T_2}^t \frac{1}{2b}F_s(\tau)^2 d\tau + \int_{t-T_1}^t \frac{b}{2}V_m(\tau)^2 d\tau. \quad (16)$$

Then, the power dissipation is derived as:

$$P_{diss}(t) = \frac{1}{b}F_{mc}(t)^2 - \frac{1}{2b}(F_{mc}(t) - bV_m(t))^2 + bV_{sc}(t) - \frac{1}{2b}(F_s(t) + bV_{sc}(t))^2. \quad (17)$$

The passive observers and controllers will be designed respectively, two passive observers ( $PO_{obsv}^m$  at the master side,  $PO_{obsv}^s$  at the slave side), which observe the excessive power leading to non-passivity of the system, are constructed as follows:

$$\begin{aligned} PO_{obsv}^m &= \frac{1}{b}F_{mc}(t)^2 - \frac{1}{2b}(F_{mc}(t) - bV_m(t))^2, \\ PO_{obsv}^s &= bV_{sc}(t) - \frac{1}{2b}(F_s(t) + bV_{sc}(t))^2. \end{aligned} \quad (18)$$

When  $PO_{obsv}^m$  or  $PO_{obsv}^s$  are less than zero, the corresponding passive controllers,  $PC_{ctr}^m$  at the master side and  $PC_{ctr}^s$  at the slave side, are activated to dissipate the excessive energy that the passive observers have observed:

$$PC_{ctr}^m = -PO_{obsv}^m, \quad PC_{ctr}^s = -PO_{obsv}^s. \quad (19)$$

This power-based time domain passivity control will be compared to our methods proposed in the thesis.

## 2 Representations of Time Delay Systems

Two different representations of time delay systems are introduced here.

- Differential equation with coefficients in a ring of operators. This topic is an early study about time delay systems, a linear time-delay system is governed by a following linear differential equation with coefficient in a module [Picard 1996, Perdon 1999]:

$$\dot{x}(t) = A(\nabla)x(t). \quad (20)$$

Generally,  $\nabla = \text{col}(\nabla_i)$ ,  $i = 1, 2, \dots$ , is the vector of delay operators such that *e.g.*  $x(t - h_i) = \nabla_i x(t)$ , the coefficient matrix of  $A$  is a multivariate polynomial in the variable  $\nabla$ , since the inverse of  $\nabla$  (the predictive operator  $x(t + h_i) = \nabla_i^{-1}x(t)$ ) is undefined from a causality point of view, the operators  $\nabla_i$  of the matrix  $A$  belong thus to a ring.

- Differential equation on an infinite dimensional abstract linear space. This type of representation stems from the application of infinite dimensional system theory to the case of time-delay systems. This type of system is completely characterized by the state:

$$\tilde{x} = \begin{pmatrix} x(t) \\ x_t(s) \end{pmatrix}. \quad (21)$$

For all  $s \in [-h, 0]$ ,  $x_t(s) = x(t + s)$  in the Hilbert space. One can easily see that the state of the system contains a point in an Euclidian space  $x(t)$  and a function of bounded energy  $x_t(s)$ , which belongs to an infinite dimensional linear space [Meinsma 2000, If-time 2005]. This motivates the denomination of infinite dimensional abstract linear space, in which the system rewrites:

$$\frac{d}{dx} \begin{pmatrix} y(t) \\ x_t(\cdot) \end{pmatrix} = \Lambda \begin{pmatrix} y(t) \\ x_t(\cdot) \end{pmatrix}. \quad (22)$$

$y(t)$  is the system output, and the operator  $\Lambda$  is given by:

$$\Lambda \begin{pmatrix} y(t) \\ x_t(\cdot) \end{pmatrix} = \begin{pmatrix} Ay(t) + A_h x_t(-h) \\ \frac{dx_t(\theta)}{d\theta} \end{pmatrix}. \quad (23)$$

The operator  $\Lambda$  is the infinite dimensional counterpart of the finite dimensional operator  $A$  in linear systems described by  $\dot{x} = Ax$ , and many tools involved in the theory of finite dimensional systems have been extended to infinite dimensional systems *e.g.* the exponential of matrix, eigenvalues and eigenfunctions, the fundamental matrix or also the explicit solution [Bensoussan 2006].

### 3 Modeling of Time Delay Systems based on Functional Differential Equation

Here, we will introduce several types of time delay systems widely considered in literatures based on functional differential equation.

• Based on the general system and a linear case with delays acting on the state  $x(t)$  or input  $u(t)$ , nonlinear parameter-varying systems are a generalization of the general class of linear time-varying systems, with considering the delays, *e.g.* [Gu 2003]:

$$\begin{cases} \dot{x}(t) &= A(t, x_t)x(t) + B(t, x_t)u(t) + A_1(t, x_t)x(t - \tau(t)) + B_1(t, x_t)u(t - \tau(t)), \\ y(t) &= C(t, x_t)x(t), \end{cases} \quad (24)$$

where  $x_t = x(t + \theta)$ ,  $\theta \in [-h, 0]$ . Three global formulations are commonly used to deal with this type of system. Firstly, the polytopic-type formulation, which is really spread in robust control, is governed by the following expressions [Oliveira 2007]:

$$\begin{cases} \dot{x}(t) = \sum_{i=0}^r \lambda_i(t, x_t)(A_i x(t) + B_i u(t) + A_{i,1} x(t - \tau(t)) + B_{i,1} u(t - \tau(t))), \\ y(t) = \sum_{i=0}^r \lambda_i(t, x_t) C_i x(t), \end{cases} \quad (25)$$

where:

$$\sum_{i=0}^r \lambda_i(t, x_t) = 1, \quad \forall i = 1, \dots, r, \quad \lambda_i(t, x_t) \geq 0. \quad (26)$$

Secondly, the parameter dependant formulation, in which, the system is considered in his primal form:

$$\begin{cases} \dot{x}(t) &= (A + \Delta A(t, x_t))x(t) + (B + \Delta B(t, x_t))u(t) \\ &\quad + (A_1 + \Delta A_1(t, x_t))x(t - \tau(t)) + (B_1 + \Delta B_1(t, x_t))u(t - \tau(t)), \\ y(t) &= (C + \Delta C(t, x_t))x(t), \end{cases} \quad (27)$$

where  $A, B, A_1, B_1, C$  are appropriate dimensional constant matrices, and the perturbation matrices are presented generally as follows:

$$\begin{aligned} \Delta A(t, x_t) &= G \Delta(t, x_t) D, & \Delta A_1(t, x_t) &= G_1 \Delta(t, x_t) D_1, \\ \Delta B(t, x_t) &= H \Delta(t, x_t) E, & \Delta B_1(t, x_t) &= H_1 \Delta(t, x_t) E_1, \\ \Delta C(t, x_t) &= J \Delta(t, x_t) F, & \forall t, \quad \Delta^T(t, x_t) \Delta(t, x_t) &\leq I. \end{aligned} \quad (28)$$

The matrix pairs,  $(G, D)$ ,  $(G_1, D_1)$ ,  $(H, E)$ ,  $(H_1, E_1)$ ,  $(J, F)$ , indicate the variation amplitude of perturbation [Dugard 1997].

The last formulation is called linear fractional transformation, the major idea of which is to split the original system into two parts: the parameter-varying part and the constant part, these two parts are connected closely [Scherer 2005]. Taking the following system as an introductory example:

$$\dot{x}(t) = A(t)x(t), \quad (29)$$

which can be rewritten into an interconnection of two systems:

$$\begin{cases} \dot{x}(t) = \tilde{A}x(t) + Bw(t), \\ z(t) = Cx(t) + Dw(t), \\ w(t) = \Theta(t)z(t). \end{cases} \quad (30)$$

As depicted in Fig. 5 ( $H(s) = C(sI - \tilde{A})^{-1}B + D$ ), the matrices  $\tilde{A}$ ,  $B$ ,  $C$ ,  $D$  in system 1 are constant, and all time-varying parts are located in the system 2.

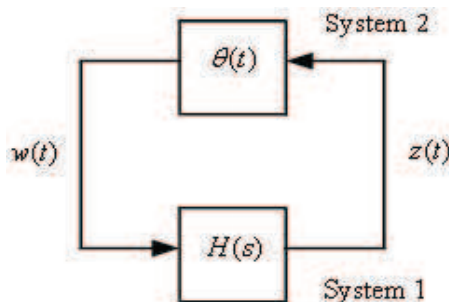

Figure 5: Linear fractional transformation based on (29) and (30)

- Distributed delay systems where the delay acts on state  $x(t)$  or inputs  $u(t)$  in a distributed fashion, *e.g.* in [Xie 2001], two models of linear systems with distributed time delays are given (the 'convolution-type' model in (31) and the 'summation-type' model in (32)):

$$\begin{cases} \dot{x}(t) = A_0x(t) + A_1x(t-h) + \int_{-d}^0 A_d(s)x(t+s)ds + Bw(t), \\ x(t) = 0, \quad \forall t \in [-\max\{h, d\}, 0], \\ z(t) = \text{col}\{C_0x(t), C_1x(t-h)\}, \end{cases} \quad (31)$$

$$\begin{cases} \dot{x}(t) = A_0x(t) + A_1x(t-h) + \int_{t-d}^t A_d(s)x(s)ds + Bw(t), \\ x(t) = 0, \quad \forall t \in [-\max\{h, d\}, 0], \\ z(t) = \text{col}\{C_0x(t), C_1x(t-h)\}, \end{cases} \quad (32)$$

where  $x(t)$  is the system state vector,  $w(t)$  is the exogenous disturbance signal and  $z(t)$  is the objective function signal.  $h$ ,  $d$  are constant delays,  $A_i$ ,  $B$ ,  $C_i$ ,  $i = 0, 1$ , are constant matrices of appropriate dimensions and  $A_d(t)$  is a continuous matrix on  $[-d, 0]$  (the 'convolution-type' model) or  $[-d, \infty]$  (the 'summation-type' model). Other results on systems with distributed delays can be found in [Münz 2007, Briat 2008, Münz 2008].

- Neutral delay systems where the delay acts on the higher-order state derivative, *e.g.* [Seuret 2006]:

$$\begin{cases} \dot{x}(t) = f(x(t), x(t - \tau(t)), \dot{x}(t - \tau(t)), u(t - \tau(t))), \\ x(t_0 + \theta) = \phi(\theta), \quad \dot{x}(t_0 + \theta) = \dot{\phi}(\theta), \\ u(t_0 + \theta) = \zeta(\theta), \\ \theta \in [-h, 0]. \end{cases} \quad (33)$$

Compared to the systems with delays acting on the state  $x(t)$  or input  $u(t)$ , neutral delay systems have one more term  $\dot{x}(t - \tau(t))$ , which makes the analysis of neutral delay systems more complex. For the linear case, *e.g.* [Gomes da Silva Jr 2011]:

$$\begin{cases} \dot{x}(t) - F\dot{x}(t - \tau(t)) = Ax(t) + A_1x(t - \tau(t)) + Bu(t), \\ x(t_0 + \theta) = \phi(\theta), \quad \dot{x}(t_0 + \theta) = \dot{\phi}(\theta), \quad \theta \in [-h, 0]. \end{cases} \quad (34)$$

For more details on neutral delay systems, the readers should refer to [Hale 1993, Verriest 2007].

## 4 Design of Lyapunov-Krasovskii Functional

As mentioned in Chapter 1, the main idea of Lyapunov-Krasovskii stability theorem is to determine a positive defined function  $V(x_t)$ , and the derivative of which along the system trajectories is negative. The main problem in the application of this theorem is the design of Lyapunov-Krasovskii functional  $V(x_t)$ . Taking a special case of linear time-varying delay systems as an example [Kharitonov 2003, Fridman 2006b]:

$$\begin{cases} \dot{x}(t) = A_0x(t) + A_1x(t - \tau(t)), \\ x_{t_0} = \phi(\theta), \quad \theta \in [-h - \mu, 0], \end{cases} \quad (35)$$

where  $\tau(t) = h + \eta(t)$  is the bilateral time-varying delay  $|\eta(t)| \leq \mu \leq h$ , so  $h - \mu \leq \tau(t) \leq h + \mu$ , we rewrite (35) by:

$$\dot{x}(t) = A_0x(t) + A_1x(t - h) + A_1[x(t - h - \eta(t)) - x(t - h)]. \quad (36)$$

According this system, we choose LKF  $V(x_t) = V_n(x(t)) + V_a(x_t)$ ,  $V_n(x(t))$  is a nominal LKF that corresponds to the part  $A_0x(t) + A_1x(t - h)$  (called nominal system) in (36).  $V_a(x_t)$  is a additional term corresponding to the time-varying delay part of system, in (36),  $V_a(x_t)$  depends on  $\mu$ . For nominal system, We focus on such a "complete" LKF  $V_n(x(t)) = V_{n0}(x(t)) + V_{n1}(x(t))$ , that along the system trajectories it has a form as follows:

$$\dot{V}_{n0}(x(t)) = -x^T(t)W_0x(t), \quad \dot{V}_{n1}(x(t)) = -\dot{x}^T(t)W_1\dot{x}(t). \quad (37)$$



$W_0, W_1$  are constant matrices, so  $V_n(x(t))$  can be constructed as follow:

$$\begin{aligned}
V_n(x(t)) &= V_{n0}(x(t)) + V_{n1}(x(t)) \\
&= \int_0^\infty x^T(t)W_0x(t)dt + \int_0^\infty \dot{x}^T(t)W_1\dot{x}(t)dt \\
&= x^T(t)U(0)x(t) + 2x^T(t) \int_{-h}^0 U(-h-\theta)A_1x(t+\theta)d\theta \\
&\quad + \int_{-h}^0 \int_{-h}^0 x^T(t+\theta_2)A_1^T U(\theta_2-\theta_1)A_1x(t+\theta_1)d\theta_1d\theta_2 \\
&\quad + \int_0^h x^T(t_0+t-h)A_1^T W_1[A_1x(t_0+t-h) + 2\dot{K}(t)x(t)]dt \\
&\quad + \int_0^h \int_{-h}^0 2x^T(t_0+t-h)A_1^T W_1\dot{K}(t-h-\theta)A_1x(t+\theta)d\theta dt.
\end{aligned} \tag{38}$$

More details about  $U(t)$ ,  $K(t)$  can be found in [Hale 1993, Fridman 2006b]. Many forms of  $V_a(x_t)$  are proposed, one of which is based on the model transformation of (35) as follow:

$$\dot{x}(t) = A_0x(t) + A_1x(t-h) - A_1 \int_{t-h-\eta(t)}^{t-h} \dot{x}(s)ds, \tag{39}$$

and with  $Q(h+\theta)$  in [Fridman 2006b], we have:

$$\begin{aligned}
V_a(x_t) &= \int_{-\mu}^\mu \int_{t+\theta-h}^t \dot{x}^T(s)A_1^T(R_1 + R_s)A_1\dot{x}(s)dsd\theta \\
&\quad + \mu \int_{-h}^0 \int_{t+\theta}^t \dot{x}^T(s)A_1^T Q(h+\theta)R_2Q^T(h+\theta)A_1\dot{x}(s)dsd\theta.
\end{aligned} \tag{40}$$

It is obvious that, the "complete" LKF is complex and its derivative is hard to handle, so some more "simple" LKF can be utilized to deal with time delay systems based on the "complete" one.

## 5 Model Transformation of Time Delay Systems

In LKF design, there are two points to which we should pay attention. Firstly, in order to get less conservative LMI-based stability theorem, several model transformations should be introduced to turn the system model into a more convenient form. Secondly, some integral parts or cross-terms (*e.g.* coupling  $x(t)$  and the integral part  $\int_{t-h}^t x(s)ds$  [Briat 2008]) introduce the conservatism into the LMI-based stability theorem, so some inequality techniques should be utilized to get better upper bound of  $\dot{V}(x_t)$ . [Briat 2008] has introduced

many useful inequality techniques to resolve the second one, so here we focus on the first one, the model transformation.

Model transformation introduces a new system, which is referred as a comparison system. In most cases, the comparison systems add additional dynamics into original systems, this means that if the comparison system is stable, then the original system is stable too, but the converse does not necessarily hold. This feature induces some conservatism, we continue to consider the system  $\dot{x}(t) = Ax(t) + A_1x(t - h)$ .

- Newton-Leibniz formula [Kolmanovskii 1999b]:

$$x(t - h) = x(t) - \int_{t-h}^t \dot{x}(\theta)d\theta. \quad (41)$$

It changes the original system into a novel form:

$$\dot{x}(t) = (A + A_1)x(t) - A_1 \int_{t-h}^t Ax(\theta) + A_1x(\theta - h)d\theta. \quad (42)$$

There are some developed forms based on basic Newton-Leibniz formula. Neutral type appears as the following form:

$$\frac{d}{dt}[x(t) + A_1 \int_{t-h}^t x(\theta)d\theta] = (A + A_1)x(t). \quad (43)$$

A Lyapunov-Krasovskii functional for this case can be found in [Niculescu 2003a]. Another developed form is the parameterized Newton-Leibniz formula [Niculescu 1999], by introducing a free matrix parameter  $C$ :

$$Cx(t - h) = Cx(t) - C \int_{t-h}^t \dot{x}(\theta)d\theta, \quad (44)$$

$$\dot{x}(t) = (A + C)x(t) + (A - C)x(t - h) - C \int_{t-h}^t Ax(\theta) + A_1x(\theta - h)d\theta. \quad (45)$$

(45) is flexible,  $C = 0$  recovers the original system,  $C = A_1$  obtains (42), further, an appropriate  $C$  allows to turn the original system into the descriptor form as follows.

- Descriptor form [Fridman 2001a] *e.g.*:

$$\dot{x}(t) = y(t), \quad y(t) = (A + A_1)x(t) - A_1 \int_{t-h}^t y(\theta)d\theta. \quad (46)$$

Note that (46) is equivalent with the original system, and it does not introduce any additional dynamics. A Lyapunov-Krasovskii functional for this case has the form [Fridman 2003]:

$$V(x_t) = \begin{pmatrix} x(t) \\ y(t) \end{pmatrix}^T EP \begin{pmatrix} x(t) \\ x(t-h) \end{pmatrix} + \int_{-h}^0 \int_{t+\theta}^t y^T(s) R y(s) ds d\theta, \quad (47)$$

where:

$$E = \begin{pmatrix} I & 0 \\ 0 & 0 \end{pmatrix}, \quad P = \begin{pmatrix} P_1 & 0 \\ P_2 & P_3 \end{pmatrix}, \quad P_1 > 0, \quad R > 0. \quad (48)$$

• Free weighting matrix approach adds free matrix variables into  $\dot{V}(x_t)$  in order to increase the freedom of LMI-based stability condition [He 2004]. In fact, free weighting matrix approach is not a typical model transformation, but it uses the following equalities/inequalities that contain the model transformation:

$$\begin{aligned} 2[x^T(t)N_1 + x^T(t-h)N_2 + \dot{x}^T(t)N_3][x(t) - x(t-h) - \int_{t-h}^t \dot{x}(\theta)d\theta] &= 0, \\ 2[x^T(t)T_1 + x^T(t-h)T_2 + \dot{x}^T(t)T_3][\dot{x}(t) - Ax(t) - A_1x(t-h)] &= 0, \\ h_{max} \begin{pmatrix} x(t) \\ x(t-h) \\ \dot{x}(t) \end{pmatrix}^T X \begin{pmatrix} x(t) \\ x(t-h) \\ \dot{x}(t) \end{pmatrix} - \int_{t-h}^t \begin{pmatrix} x(\theta) \\ x(\theta-h) \\ \dot{x}(\theta) \end{pmatrix}^T X \begin{pmatrix} x(\theta) \\ x(\theta-h) \\ \dot{x}(\theta) \end{pmatrix} d\theta &\geq 0, \end{aligned} \quad (49)$$

where the symmetric  $N_i > 0$ ,  $T_i > 0$ ,  $i = 1, 2, 3$ ,  $X > 0$ ,  $h_{max}$  is the upper bound of  $h$ . By this approach, we can obtain our LMI-based condition without substituting  $\dot{x}(t)$ .

• Reciprocally convex approach is proposed in [Park 2011]. We consider the time-varying delay system,  $\dot{x}(t) = Ax(t) + A_1x(t - \tau(t))$ ,  $0 \leq h_1 \leq \tau(t) \leq h_2$ , let us define:

$$\begin{aligned} \zeta(t) &= \begin{pmatrix} x^T(t) & x^T(t-\tau(t)) & x^T(t-h_1) & x^T(t-h_2) \end{pmatrix}^T, \\ e_1 &= \begin{pmatrix} I & 0 & 0 & 0 \end{pmatrix}^T, \quad e_2 = \begin{pmatrix} 0 & I & 0 & 0 \end{pmatrix}^T, \quad e_3 = \begin{pmatrix} 0 & 0 & I & 0 \end{pmatrix}^T, \quad e_4 = \begin{pmatrix} 0 & 0 & 0 & I \end{pmatrix}^T, \\ e_5 &= (Ae_1^T + A_1e_2^T)^T. \end{aligned} \quad (50)$$

Then the original system can be written as:

$$\dot{x}(t) = e_5^T \zeta(t). \quad (51)$$

This transformation introduces less conservatism, finally, the time derivative of  $V(x_t)$  is only a function of  $\zeta(t)$  *e.g.*  $\dot{V}(x_t) = \zeta^T(t)\Pi\zeta(t) < 0$ ,  $\Pi$  contains  $e_i$ ,  $i = 1, 2, 3, 4, 5$  and positive matrix variables.

## 6 Controller Design based on Reciprocally Convex Approach of Lyapunov-Krasovskii Functional

In Chapter 2 and Chapter 3, we have proposed a Lyapunov-Krasovskii functional as:

$$\begin{aligned}
 V(x(t), \dot{x}(t)) &= x(t)^T P x(t) \\
 &+ \int_{t-h_2}^t x(s)^T S_a x(s) ds + \int_{t-h_1}^t x(s)^T S x(s) ds \\
 &+ h_1 \int_{-h_1}^0 \int_{t+\theta}^t \dot{x}(s)^T R \dot{x}(s) ds d\theta + \sum_{i=1}^q (h_2 - h_1) \int_{-h_2}^{-h_1} \int_{t+\theta}^t \dot{x}(s)^T R_{ai} \dot{x}(s) ds d\theta.
 \end{aligned} \tag{52}$$

For comparison reasons, here we will present a transformation of the time delay system based on LKF in (52). For simplicity reasons, considering one delay in the system:

$$\begin{cases}
 \dot{x}(t) = A_0 x(t) + A_1 x(t - \tau(t)) + B w(t), \\
 z(t) = C x(t), \\
 x(t_0 + \theta) = \phi(\theta), \quad \dot{x}(t_0 + \theta) = \dot{\phi}(\theta), \quad \theta \in [-h_2, 0],
 \end{cases} \tag{53}$$

where  $x(t) \in \mathbf{R}^n$ ,  $w(t) \in \mathbf{R}^l$  is some exogenous disturbance signals, while  $z(t) \in \mathbf{R}^m$  is the objective control output.  $\phi(\theta)$  is the initial state function, and  $\tau(t) \in [h_1, h_2]$ ,  $h_1 \geq 0$  is the time-varying delay.  $A_0$ ,  $A_1$ ,  $B$  and  $C$  are constant matrices.

Let us define  $\chi(t) \triangleq \text{col}\{x(t), x(t - \tau(t)), x(t - h_1), x(t - h_2)\}$  and the corresponding block entry matrices [Park 2011]:

$$\begin{aligned}
 e_1 &= \text{col}\{I, 0, 0, 0\}, \quad e_2 = \text{col}\{0, I, 0, 0\}, \quad e_3 = \text{col}\{0, 0, I, 0\}, \quad e_4 = \text{col}\{0, 0, 0, I\}, \\
 e &= e_1 A_0^T + e_2 A_1^T.
 \end{aligned} \tag{54}$$

Thus, the system in (53) can be rewritten as:

$$\begin{cases}
 \dot{\chi}(t) = e^T \chi(t) + B w(t), \quad x(t) = e_1^T \chi(t), \\
 z(t) = C x(t) = C e_1^T \chi(t).
 \end{cases} \tag{55}$$

Considering the Lyapunov-Krasovskii functional in (52), according to  $H_\infty$  control theory, the performance will be studied by checking  $H_\infty$  performance condition  $J(w) < 0$  for a positive scalar  $\gamma$ , and then we obtain the following theorem.

**Theorem .2** *Suppose there exist symmetric matrices of appropriate dimension  $P > 0$ ,  $Q_i > 0$ ,  $R_i > 0$ , some matrices  $S$ ,  $P_2$ ,  $P_3$ ,  $i = 1, 2$ , and a positive scalar  $\gamma$ , such that LMI condition (56) with notations (57) is feasible, then the system (53) is rate-independent asymptotically stable and  $H_\infty$  performance  $J(w) < 0$  for time-varying delay  $\tau_1(t) \in [h_1, h_2]$ .*

$$\Gamma^1 = \begin{pmatrix} \Gamma_{11}^1 + e_1 C^T C e_1^T + e P_2 + P_2^T e^T & e_1 P - P_2^T + e P_3 & P_2^T B \\ * & \Gamma_{22}^1 - P_3^T - P_3 & P_3^T B \\ * & * & -\gamma^2 I \end{pmatrix} < 0, \quad \begin{pmatrix} R_2 & S \\ S^T & R_2 \end{pmatrix} \geq 0, \quad (56)$$

$$\begin{aligned} \Gamma_{11}^1 &= e_1 Q_1 e_1^T - e_3 Q_1 e_3^T + e_1 Q_2 e_1^T - e_4 Q_2 e_4^T - (e_1 - e_3) R_1 (e_1 - e_3)^T \\ &\quad - \begin{pmatrix} e_3 - e_2 & e_2 - e_4 \end{pmatrix} \begin{pmatrix} R_2 & S \\ S^T & R_2 \end{pmatrix} \begin{pmatrix} e_3^T - e_2^T \\ e_2^T - e_4^T \end{pmatrix}, \\ \Gamma_{22}^1 &= h_1^2 R_1 + (h_2 - h_1)^2 R_2. \end{aligned} \quad (57)$$

**Proof:**  $J(w) < 0$  holds if:

$$\dot{V}(x(t), \dot{x}(t)) + z(t)^T z(t) - \gamma^2 w(t)^T w(t) < 0. \quad (58)$$

By *Theorem 2* in [Park 2011], and substituting for  $z(t)$ , we get:

$$\begin{aligned} &\dot{V}(x(t), \dot{x}(t)) + z(t)^T z(t) - \gamma^2 w(t)^T w(t) \\ &\leq \chi(t)^T (\Gamma_{11}^3 + e_1 C^T C e_1^T) \chi(t) + \chi(t)^T (e_1 P + P e_1^T) \dot{x}(t) + \dot{x}(t)^T \Gamma_{22}^3 \dot{x}(t) - \gamma^2 w(t)^T w(t), \end{aligned} \quad (59)$$

and then introduce free weighting matrices  $P_2, P_3$ :

$$0 = 2[\chi(t)^T P_2^T + \dot{x}(t)^T P_3^T][e^T \chi(t) + B w(t) - \dot{x}(t)]. \quad (60)$$

The expression above is now added into  $\dot{V}(x(t), \dot{x}(t)) + z(t)^T z(t) - \gamma^2 w(t)^T w(t)$ , and using notation:

$$\eta(t) = \text{col}\{\chi(t), \dot{x}(t), w(t)\}, \quad (61)$$

leads to:

$$\dot{V}(x(t), \dot{x}(t)) + z(t)^T z(t) - \gamma^2 w(t)^T w(t) \leq \eta(t)^T \Gamma^3 \eta(t) < 0, \quad (62)$$

provides that the LMI (56) is feasible.

How to use this theorem to calculate the controller, we take the system in (53) as an example,  $A_1 = -BK$ , here  $K$  is the gain of the controller.

**Theorem .3** *Suppose there exist symmetric matrices of appropriate dimension  $P > 0, Q_i > 0, R_i > 0$ , some matrices  $S, \bar{P}_2, P_3, i = 1, 2$ , and positive scalars  $\gamma, \xi, \xi_i, i = 1, 2, 3$ , such that LMI condition (64) with notations (65) is feasible, then the system (53) is rate-independent asymptotically stable and  $H_\infty$  performance  $J(w) < 0$  for time-varying delay  $\tau_1(t) \in [h_1, h_2]$ , and the following proxy control gain:*

$$K = M \bar{P}_2^{-1}. \quad (63)$$

$$\Gamma^2 = \begin{pmatrix} \Gamma_{11}^1 + \Gamma_{11}^2 + \Gamma_{11}^2{}^T & \Gamma_{12}^4 & \Gamma_{13}^2 & e_1 \bar{P}_2^T C^T \\ * & \Gamma_{22}^1 - \xi \bar{P}_2 - \xi \bar{P}_2^T & \xi B & 0 \\ * & * & -\gamma^2 I & 0 \\ * & * & * & -I \end{pmatrix} < 0, \quad \begin{pmatrix} R_2 & S \\ S^T & R_2 \end{pmatrix} \geq 0, \quad (64)$$

$$\Gamma_{11}^2 = \begin{pmatrix} \bar{P}_2^T A^T & \xi_1 \bar{P}_2^T A^T & \xi_2 \bar{P}_2^T A^T & \xi_3 \bar{P}_2^T A^T \\ -M^T B^T & -\xi_1 M^T B^T & -\xi_2 M^T B^T & -\xi_3 M^T B^T \\ 0 & 0 & 0 & 0 \end{pmatrix}, \quad (65)$$

$$\Gamma_{12}^2 = e_1 P + \xi \begin{pmatrix} \bar{P}_2^T A^T \\ -M^T B^T \\ 0 \\ 0 \end{pmatrix} - \begin{pmatrix} \bar{P}_2 \\ \xi_1 \bar{P}_2 \\ \xi_2 \bar{P}_2 \\ \xi_3 \bar{P}_2 \end{pmatrix}, \quad \Gamma_{13}^2 = \begin{pmatrix} B \\ \xi_1 B \\ \xi_2 B \\ \xi_3 B \end{pmatrix}.$$

**Proof:** We use *Theorem .3* on system (53), a series of steps is made to deal with nonlinear matrix terms:

- supposing  $P_2 = \begin{pmatrix} \bar{P}_2 & \xi_1 \bar{P}_2 & \xi_2 \bar{P}_2 & \xi_3 \bar{P}_2 \end{pmatrix}$  and  $P_3 = \xi \bar{P}_2$  (the definition of  $P_2$  is for getting  $K$  by LMI, but it introduces the conservatism, till now, this is still an open problem);
- multiplying  $\Gamma^3$  by  $diag\{\bar{P}_2^{-T}, \dots, \bar{P}_2^{-T}, I\}$  at the left side, by  $diag\{\bar{P}_2^{-1}, \dots, \bar{P}_2^{-1}, I\}$  at the right side;
- defining  $M = K \bar{P}_2$ , applying Schur formula, then the result follows.



# Bibliography

- [Alise 2009] M. Alise, R.G. Roberts, D.W. Repperger, C.A. Moore and S. Tosunoglu. *On extending the wave variable method to multiple-DOF teleoperation systems*. IEEE/ASME Transactions on Mechatronics, vol. 14, no. 1, pages 55–63, 2009.
- [Anderson 1989] R.W. Anderson and M.W. Spong. *Bilateral control of teleoperators with time delay*. IEEE Transactions on Automatic Control, vol. 34, no. 5, pages 494–501, 1989.
- [Arcara 2002] P. Arcara and C. Melchiorri. *Control schemes for teleoperation with time delay: a comparative study*. Robotics and Autonomous Systems, vol. 38, no. 1, pages 49–64, 2002.
- [Bensoussan 2006] A. Bensoussan, G. Da Prato, M.C. Delfour and S.K. Mitter. Representation and control of infinite dimensional systems - 2<sup>nd</sup> edition. Birkhäuser, Boston, 2006.
- [Boukhniifer 2004] M. Boukhniifer, A. Ferreira and J.-G. Fontaine. *Scaled teleoperation controller design for micromanipulation over internet*. In Proceedings of 2004 IEEE International Conference on Robotics and Automation, pages 4577–4583, 2004.
- [Boyd 1994] S. Boyd, L. El Ghaoui, E. Feron and V. Balakrishnan. Linear matrix inequalities in systems and control theory. Society for Industrial and Applied Mathematics (SIAM), Philadelphia, USA, 1994.
- [Briat 2008] C. Briat. *Robust control and observation of LPV time-delay systems*. PhD thesis, Grenoble INP, 2008.
- [Briat 2009a] C. Briat, O. Sename and J.F. Lafay. *Delay-scheduled state-feedback design for time-delay systems with time-varying delays - a LPV approach*. Systems & Control Letters, vol. 58, no. 9, pages 664–671, 2009.
- [Briat 2009b] C. Briat, O. Sename and J.F. Lafay.  *$H_\infty$  Delay-scheduled control of linear systems with time-varying delays*. IEEE Transactions on Automatic Control, vol. 54, no. 9, pages 2255–2260, 2009.
- [Cao 2010] Y. Cao and W. Ren. *Distributed coordinated tracking with reduced interaction via a variable structure approach*. IEEE Transactions on Automatic Control, vol. 1, no. 99, pages 4744–4749, 2010.



- [Casavola 2006] A. Casavola, E. Mosca and M. Papini. *Predictive teleoperation of constrained dynamic systems via Internet-like channels*. IEEE Transactions on Control Systems Technology, vol. 14, no. 4, pages 681–694, 2006.
- [Chen 2006] W. Chen and M. Saif. *Fault detection and isolation based on novel unknown input observer design*. In Proceedings of 2006 American Control Conference, pages 5129–5134, Minneapolis, Minnesota, USA, 2006.
- [Cheong 2008] J. Cheong and S.-I. Niculescu. *Robust motion synchronization control for interconnected systems with human interaction*. In Proceedings of 2008 IFAC World Congress, pages 6347–6352, Seoul, South Korea, 2008.
- [Cho 2001] H.C. Cho, J.H. Park, K. Kim and J.-O. Park. *Sliding-mode-based impedance controller for bilateral teleoperation under varying time-delay*. In Proceedings of 2001 IEEE International Conference on Robotics and Automation, pages 1025–1030, Seoul, Korea, 2001.
- [Chong 2000] Nak Young Chong, T. Kotoku, K. Ohba, K. Komoriya, N. Matsuhira and K. Tanie. *Remote coordinated controls in multiple telerobot cooperation*. In 2000 IEEE International Conference on Robotics and Automation, pages 3138–3143, San Francisco, CA, USA, April 2000.
- [Chopra 2004] N. Chopra and M.W. Spong. *On position tracking in bilateral teleoperation*. In Proceedings of 2004 American Control Conference, pages 5244–5249, Boston, USA, June 2004.
- [Chopra 2006] N. Chopra, M.W. Spong, R. Ortega and N.E. Barabanov. *On tracking performance in bilateral teleoperation*. IEEE Transactions on Robotics, vol. 22, no. 4, pages 1047–1052, 2006.
- [Chopra 2008a] N. Chopra, P. Berestesky and M.W. Spong. *Bilateral teleoperation over unreliable communication networks*. IEEE Transactions on Control Systems Technology, vol. 16, no. 2, pages 304–313, 2008.
- [Chopra 2008b] N. Chopra, M.W. Spong and R. Lozano. *Synchronization of bilateral teleoperators with time delay*. Automatica, vol. 44, no. 8, pages 2142–2148, 2008.
- [Clouqueur 2002] T. Clouqueur, V. Phipatanasuphorn, P. Ramanathan and K. Saluja. *Sensor deployment strategy for target detection*. In Proceedings of 2002 ACM International Workshop on Wireless Sensor Networks and Applications, pages 42–48, New York, NY, USA, 2002.
- [Cortesaio 2006] R. Cortesaio, J. Park and O. Khatib. *Real-time adaptive control for haptic telemanipulation with Kalman active observers*. IEEE Transactions on Robotics, vol. 22, no. 5, pages 987–999, 2006.
- [Daly 2010] J.M. Daly and D.W.L. Wang. *Time-delayed bilateral teleoperation with force estimation for  $n$ -DOF nonlinear robot manipulators*. In Proceedings of 2007

- 
- IEEE/RSJ International Conference on Intelligent Robots and Systems, pages 3911–3918, Taipei, Taiwan, October 2010.
- [Dambrine 1998] M. Dambrine, F. Gouaisbaut, W. Perruquetti and J.-P. Richard. *Robustness of sliding mode control under delays effects: a case study*. In Proceedings of 1998 Conference IMACS-IEEE on Computational Engineering in Systems Applications, pages 817–821, Hammamet, Tunisie, April 1998.
- [Defoort 2007] M. Defoort, J. Palos, A. Kokosy, T. Floquet, W. Perruquetti and D. Boulinguez. *Experimental motion planning and control for an autonomous non-holonomic mobile robot*. In Proceedings of 2007 IEEE International Conference on Robotics and Automation, pages 2221–2226, Roma, Italy, 2007.
- [Delgado 2009] E. Delgado and A. Barreiro. *Stability of teleoperation systems for time-varying delays by Lyapunov-Krasovskii and frequencial techniques*. In Proceedings of 2009 Annual Conference of IEEE on Industrial Electronics, pages 1748–1753, Porto, Portugal, November 2009.
- [Dugard 1997] L. Dugard and E.I. Verriest. Lecture notes in control and information sciences. Springer, 1997.
- [Ferrell 1965] W.R. Ferrell. *Remote manipulative control with transmission delay*. IEEE Transactions on Human Factors in Electronics, vol. 6, pages 24–32, 1965.
- [Ferrell 1967] W.R. Ferrell and T.B. Sheridan. *Supervisory control of remote manipulation*. IEEE Spectrum, vol. 4, no. 10, pages 81–88, 1967.
- [Fiter 2012] C. Fiter, L. Hetel, W. Perruquetti and J.-P. Richard. *A state dependent sampling for linear state feedback*. Automatica, to appear, 2012.
- [Flavia 2008] F. Flavia, J. Ning, F. Simonot-Lion and Y.-Q. Song. *Optimal on-line  $(m,k)$ -firm constraint assignment for real-time control tasks based on plant state information*. In Proceedings of 2008 IEEE Conference on Emerging Technologies and Factory Automation, pages 908–915, Hamburg, Germany, 2008.
- [Floquet 2009] T. Floquet, L. Hetel and W. Perruquetti. *Stabilization of switched linear systems: a sliding mode approach*. In 2009 IFAC Conference on Analysis and Design of Hybrid Systems, Zaragoza, Spain, September 2009.
- [Fong 1986] C. Fong, R. Dotson and A. Bejczy. *Distributed microcomputer control system for advanced teleoperation*. In Proceedings of 1986 IEEE International Conference on Robotics and Automation, volume 3, pages 987–995, 1986.
- [Fong 2001] T. Fong. *Collaborative control: a robot centric model for vehicle teleoperation*. PhD thesis, Robotics Institute, Carnegie Mellon University, 2001.
- [Fridman 2001a] E. Fridman. *New Lyapunov-Krasovskii functionals for stability of linear retarded and neutral type systems*. Systems & Control Letters, vol. 43, no. 4, pages 309–319, 2001.

- [Fridman 2001b] E. Fridman and U. Shaked. *New bounded real lemma representations for time-delay systems and their applications*. IEEE Transactions on Automatic Control, vol. 46, no. 12, pages 1973–1979, 2001.
- [Fridman 2002] E. Fridman and U. Shaked. *An improved stabilization method for linear time-delay systems*. IEEE Transactions on Automatic Control, vol. 47, no. 11, pages 1931–1937, 2002.
- [Fridman 2003] E. Fridman. *Delay-dependent stability and  $H_\infty$  control: constant and time-varying delays*. International Journal of Control, vol. 76, no. 1, pages 48–60, 2003.
- [Fridman 2004a] E. Fridman, A. Seuret and J.-P. Richard. *Robust sampled-data stabilization of linear systems: an input delay approach*. Automatica, vol. 40, no. 8, pages 1441–1446, 2004.
- [Fridman 2004b] E. Fridman and U. Shaked. *Parameter dependent stability and stabilization of uncertain time-delay systems*. IEEE Transactions on Automatic Control, vol. 48, no. 5, pages 861–866, 2004.
- [Fridman 2005a] E. Fridman and U. Shaked. *Stability and guaranteed cost of uncertain discrete delay systems*. International Journal of Control, vol. 78, pages 235–246, 2005.
- [Fridman 2005b] E. Fridman, U. Shaked and V. Suplin. *Input/output delay approach to robust sampled-data  $H_\infty$  control*. Systems & Control Letters, vol. 54, no. 3, pages 271–282, 2005.
- [Fridman 2006a] E. Fridman. *A new Lyapunov technique for robust control of systems with uncertain non-small delays*. IMA Journal of Mathematical Control and Information, vol. 23, no. 2, pages 165–179, 2006.
- [Fridman 2006b] E. Fridman. *Stability of systems with uncertain delays: a new 'complete' Lyapunov-Krasovskii functional*. IEEE Transactions on Automatic Control, vol. 51, no. 5, pages 885–890, 2006.
- [Fu 2004] Y.-M. Fu, G.-R. Duan and S.-M. Song. *Design of unknown input observer for linear time-delay systems*. International Journal of Control, Automation, and Systems, vol. 2, no. 4, pages 530–535, 2004.
- [Gao 2003] H. Gao and C. Wang. *Comments and further results on "A descriptor system approach to control of linear time-delay systems"*. IEEE Transactions on Automatic Control, vol. 48, no. 3, pages 520–525, 2003.
- [Garcia-Valdovinos 2007] L.G. Garcia-Valdovinos, V. Parra-Vega and M.A. Arteaga. *Observer-based sliding mode impedance control of bilateral teleoperation under constant unknown time delay*. Robotics and Autonomous Systems, vol. 55, no. 8, pages 609–617, 2007.

- 
- [Gomes da Silva Jr 2011] J.M. Gomes da Silva Jr, A. Seuret, E. Fridman and J.-P. Richard. *Stabilisation of neutral systems with saturating control inputs*. International Journal of Systems Science, vol. 42, no. 7, pages 1093–1103, 2011.
- [Gu 2003] K. Gu, V.L. Kharitonov and J. Chen. *Stability of time-delay systems*. Birkhäuser, Boston, Basel, Berlin, 2003.
- [Hale 1993] J.K. Hale and S.M.V. Lunel. *Introduction to functional differential equations*. Springer-Verlag, New York, USA, 1993.
- [Han 2001] Q.-L. Han and K. Gu. *Stability of linear systems with time-varying delay: a generalized discretized lyapunov functional approach*. Asian Journal of Control, vol. 3, no. 3, pages 170–180, 2001.
- [Han 2002] Q.-L. Han. *Robust stability of uncertain delay-differential systems of neutral type*. Automatica, vol. 38, no. 4, pages 719–723, 2002.
- [Hannaford 1988] B. Hannaford and P. Fiorini. *A detailed model of bi-lateral teleoperation*. In Proceedings of 1988 IEEE International Conference on Systems, Man and Cybernetics, volume 1, pages 117–121, 1988.
- [Hannaford 2001] B. Hannaford and J.-H. Ryu. *Time domain passivity control of haptic interfaces*. In Proceedings of 2001 IEEE International Conference on Robotics and Automation, pages 1863–1869, Seoul, Korea, May 2001.
- [He 2004] Y. He, M. Wu, J.H. She and G.P. Liu. *Parameter-dependent Lyapunov functional for stability of time-delay systems with polytopic-type uncertainties*. IEEE Transactions on Automatic Control, vol. 49, no. 5, pages 828–832, 2004.
- [He 2007] Y. He, Q.-G. Wang, C. Lin and M. Wu. *Delay-range-dependent stability for systems with time-varying delay*. Automatica, vol. 43, no. 2, pages 371–376, 2007.
- [Henson 1997] M.A. Henson and D.E. Seborg. *Nonlinear process control*. Prentice Hall PTR, 1997.
- [Hespanha 2007] J.P. Hespanha, P. Naghshtabrizi and Y. Xu. *A survey of recent results in networked control systems*. Proceedings of the IEEE, vol. 95, no. 1, pages 138–162, 2007.
- [Hetel 2007] L. Hetel, J. Daafouz and C. Iung. *LMI control design for a class of exponential uncertain systems with application to network controlled switched systems*. In Proceedings of 2007 American Control Conference, pages 1401–1406, New York City, USA, 2007.
- [Hetel 2008] L. Hetel, J. Daafouz and C. Iung. *Equivalence between the Lyapunov-Krasovskii functionals approach for discrete delay systems and that of the stability conditions for switched systems*. Nonlinear Analysis: Hybrid Systems, vol. 2, no. 3, pages 697–705, 2008.

- [Hokayem 2006] P.F. Hokayem and M.W. Spong. *Bilateral teleoperation: an historical survey*. Automatica, vol. 42, no. 12, pages 2035–2057, 2006.
- [Hopper 1996] D. Hopper, C. Boddy and D. Reilly. *Advanced teleoperation testbed: a system you can see through*. Robotica, vol. 14, pages 457–461, 1996.
- [Hou 2010] Z.-L. Hou, Q. Wei, F. Li and D.-P. Han. *Design on a half closed-loop bilateral teleoperation system*. In Proceedings of 2010 Chinese Control Conference, pages 3432–3436, Beijing, China, July 2010.
- [Hsu 2000] L. Hsu, R.R. Costa and F. Lizarralde. *Lyapunov/passivity-based adaptive control of relative degree two MIMO systems with an application to visual servoing*. In Proceedings of 2000 American Control Conference, pages 2682–2687, Minneapolis, Minnesota, USA, June 2000.
- [Hua 2010] C.-C. Hua and X.P. Liu. *Delay-dependent stability criteria of teleoperation systems with asymmetric time-varying delays*. IEEE Transactions on Robotics, vol. 26, no. 5, pages 925–932, 2010.
- [Hua 2011] C.-C. Hua and X.P. Liu. *Teleoperation over the internet with/without velocity signal*. IEEE Transactions on Instrumentation and Measurement, vol. 60, no. 1, pages 4–13, 2011.
- [Iftime 2005] O.V. Iftime, H.J. Zwart and R.F. Curtain. *A representation of all solutions of the control algebraic Riccati equations for infinite-dimensional systems*. International Journal of Control, vol. 78, no. 7, pages 505–502, 2005.
- [Iqbal 2006] A. Iqbal and H. Roth. *Predictive time domain passivity control for delayed teleoperation using energy derivatives*. In Proceedings of 2006 International Conference on Control, Automation, Robotics and Vision, pages 1–6, Singapore, Singapore, December 2006.
- [Jiang 2005] X. Jiang and Q.-L. Han. *On  $H_\infty$  control for linear systems with interval time-varying delay*. Automatica, vol. 41, no. 12, pages 2099–2106, 2005.
- [Jiang 2008] W.-J. Jiang, A. Kruszewski, J.-P. Richard and A. Togyeni. *A gain scheduling strategy for the control and estimation of a remote robot via internet*. In Proceedings of 2008 Chinese Control Conference, pages 793–799, Kunming, China, July 2008.
- [Jiang 2009] W.-J. Jiang. *A contribution to control and observation of networked control systems*. PhD thesis, Ecole Central de Lille, 2009.
- [Jing 2004] X.-J. Jing, D.-L. Tan and Y.-C. Wang. *An LMI approach to stability of systems with severe time-delay*. IEEE Transactions on Automatic Control, vol. 19, no. 7, pages 1192–1195, 2004.
- [Kapila 1998] V. Kapila and W.M. Haddad. *Memoryless  $H_\infty$  controllers for discrete-time systems with time delay*. Automatica, vol. 34, no. 9, pages 1141–1144, 1998.

- 
- [Kawashima 2009] K. Kawashima, K. Tadano, C. Wang, G. Sankaranarayanan and B. Hannaford. *Bilateral teleoperation with time delay using modified wave variable based controller*. In Proceedings of 2009 IEEE International Conference on Robotics and Automation, pages 4326–4331, Kobe, Japan, May 2009.
- [Khan 2010] Z.H. Khan. *Wireless network architecture for long range teleoperation of an autonomous system*. PhD thesis, Université de Grenoble, 2010.
- [Kharitonov 2003] V. Kharitonov and A.P. Zhabko. *Lyapunov-Krasovskii approach to the robust stability analysis of time-delay systems*. Automatica, vol. 39, no. 1, pages 15–20, 2003.
- [Kim 1992] W.S. Kim, B. Hannaford and A.K. Bejczy. *Force-reflection and shared compliant control in operating telemanipulators with time delay*. IEEE Transactions on Robotics and Automation, vol. 8, no. 2, pages 176–185, 1992.
- [Kim 2001] J.-H. Kim. *Delay and its time-derivative dependent robust stability of time-delayed linear systems with uncertainty*. IEEE Transactions on Automatic Control, vol. 46, no. 5, pages 789–792, 2001.
- [Kolmanovskii 1999a] V.B. Kolmanovskii and A. Myshkis. Introduction to the theory and applications of functional differential equations. Kluwer Academic Publishers, Dordrecht, Netherlands, 1999.
- [Kolmanovskii 1999b] V.B. Kolmanovskii and J.-P. Richard. *Stability of some linear systems with delays*. IEEE Transactions on Automatic Control, vol. 44, no. 5, pages 984–989, 1999.
- [Kosuge 1996] K. Kosuge, H. Murayama and K. Takeo. *Bilateral feedback control of telemanipulators via computer network*. In Proceedings of 1996 IEEE/RSJ International Conference on Intelligent Robots and Systems, pages 1380–1385, Osaka, Japan, November 1996.
- [Kress 1997] R.L. Kress, J.F. Jansen, M.W. Noakes and J.N. Herndon. *The evolution of teleoperated manipulators at ornl*. Technical report, Oak Ridge National Laboratory, 1997.
- [Kruszewski 2011] A. Kruszewski, W.-J. Jiang, E. Fridman, J.-P. Richard and A. Toguyeni. *A switched system approach to exponential stabilization through communication network*. IEEE Transactions on Control Systems Technology, to appear, 2011.
- [Lawrence 1993] D.A. Lawrence. *Stability and transparency in bilateral teleoperation*. IEEE Transactions on Robotics and Automation, vol. 9, no. 5, pages 624–637, 1993.
- [Lee 1994] S. Lee and K. Jeong. *Design of robust time delayed teleoperator control system*. In Proceedings of 1994 IEEE/RSJ International Conference on Intelligent Robots and Systems, pages 1413–1420, 1994.

- [Lee 2003] D. Lee and P.Y. Li. *Passive bilateral feedforward control of linear dynamically similar teleoperated manipulators*. IEEE Transactions on Robotics and Automation, vol. 19, no. 3, pages 443–456, 2003.
- [Lee 2006] J.-W. Lee and G.-E. Dullerud. *Uniform stabilization of discrete-time switched and markovian jump linear systems*. Automatica, vol. 45, no. 2, pages 205–218, 2006.
- [Lee 2010a] D. Lee and K. Huang. *Passive-set-position-modulation framework for interactive robotic systems*. IEEE Transactions on Robotics, vol. 26, no. 2, pages 354–369, 2010.
- [Lee 2010b] S. Lee, J.-W. Kim and Y. Ishibashi. *Transparency improvement of force-reflecting teleoperation over time-varying network delays*. In Proceedings of IEEE International Conference on Multimedia and Expo, pages 1010–1015, Suntec City, Singapore, July 2010.
- [Leeraphan 2002] S. Leeraphan, T. Maneewarn and D. Laowattana. *Stable adaptive bilateral control of transparent teleoperation through time varying delay*. In Proceedings of 2002 IEEE/RSJ International Conference on Intelligent Robots and Systems, pages 2979–2984, Lausanne, Swiss, October 2002.
- [Leung 1994] G.M.H. Leung and B.A. Francis. *Robust nonlinear control of bilateral teleoperators*. In Proceedings of 1994 American Control Conference, volume 2, pages 2119–2123, 1994.
- [Leung 1995] G.M.H. Leung, B.A. Francis and J. Apkarian. *Bilateral controller for with time delay via teleoperators via  $\mu$ -synthesis*. IEEE Transactions on Robotics and Automation, vol. 11, no. 1, pages 105–116, 1995.
- [Li 2009] Z. Li and D. Constantinescu. *Remote dynamic proxies for wave-based peer-to-peer haptic interaction*. In Proceedings of 2009 Third Joint Eurohaptics Conference and Symposium on Haptic Interfaces for Virtual Environment and Teleoperator Systems, pages 553–558, Salt Lake City, UT, USA, 2009.
- [Lien 2005a] C.H. Lien. *Delay-dependent stability criteria for uncertain neutral systems with multiple time-varying delays via LMI approach*. IEE Proceedings - Control Theory and Applications, vol. 152, no. 6, pages 707–714, 2005.
- [Lien 2005b] C.H. Lien. *Stability and stabilization criteria for a class of uncertain neutral systems with time-varying delays*. Journal of Optimization Theory and Applications, vol. 124, no. 3, pages 637–657, 2005.
- [Lozano 2002] R. Lozano, N. Chopra and M.W. Spong. *Passivation of force reflecting bilateral teleoperators with time varying delay*. In Proceedings of 2002 Mechatronics Forum, Drexel Institute for Mechatronic of the University of Twente, Netherlands, June 2002.

- 
- [Matiakis 2005] T. Matiakis, S. Hirche and M. Buss. *The scattering transformation for networked control systems*. In Proceedings of 2005 IEEE Conference on Control Applications, pages 705–710, Toronto, Canada, August 2005.
- [Mboup 2009] M. Mboup, C. Join and M. Fliess. *Numerical differentiation with annihilators in noisy environment*. Numerical Algorithms, vol. 50, no. 4, pages 439–467, 2009.
- [Meinsma 2000] G. Meinsma and H. Zwart. *On  $H_\infty$  control for dead-time systems*. IEEE Transactions on Automatic Control, vol. 45, no. 2, pages 272–285, 2000.
- [Meng 2010] X. Meng, J. Lamb, B. Du and H. Gao. *A delay-partitioning approach to the stability analysis of discrete-time systems*. Automatica, vol. 46, no. 3, pages 610–614, 2010.
- [Miyazaki 1986] F. Miyazaki, S. Matsubayashi, T. Yoshimi and S. Arimoto. *A new control methodology toward advanced teleoperation of master-slave robot systems*. In Proceedings of 1986 IEEE International Conference on Robotics and Automation, volume 3, pages 997–1002, 1986.
- [Munir 2001] S. Munir and W.J. Book. *Internet based teleoperation using wave variables with prediction*. In Proceedings of 2001 IEEE/ASME International Conference on Advanced Intelligent Mechatronics, pages 43–50, Como, Italy, July 2001.
- [Münz 2007] U. Münz and F. Allgöwer.  *$L_2$  gain-based controller design for linear systems with distributed input delay*. In 2007 IFAC Workshop on Time-Delay Systems, Nantes, France, September 2007.
- [Münz 2008] U. Münz, M. Rieber and F. Allgöwer. *Robust stability of distributed delay systems*. In 2008 IFAC World Congress, Seoul, South Korea, November 2008.
- [Natori 2010] K. Natori, T. Tsuji, K. Ohnishi, A. Hase and K. Jezernik. *Time-delay compensation by communication disturbance observer for bilateral teleoperation under time-varying delay*. IEEE Transactions on Industrial Electronics, vol. 57, no. 3, pages 1050–1062, 2010.
- [Nešić 2004] D. Nešić and A. Teel. *Input-output stability properties of networked control systems*. IEEE Transactions on Automatic Control, vol. 49, no. 10, pages 1650–1667, 2004.
- [Niculescu 1999] S.-I. Niculescu and J. Chen. *Frequency sweeping tests for asymptotic stability: a model transformation for multiple delays*. In Proceedings of 1999 IEEE Conference on Decision and Control, pages 4678–4683, Phoenix, AZ, USA, 1999.
- [Niculescu 2001] S.-I. Niculescu. Delay effects on stability: a robust control approach. Springer-Verlag, Heidelberg, 2001.



- [Niculescu 2003a] S.-I. Niculescu. *On delay-dependent stability under model transformations of some neutral linear systems*. International Journal of Control, vol. 74, no. 6, pages 609–617, 2003.
- [Niculescu 2003b] S.-I. Niculescu, D. Taoutaou and R. Lozano. *Bilateral teleoperation with communication delays*. International Journal of Robust and Nonlinear Control, vol. 13, no. 9, pages 873–883, 2003.
- [Niemeyer 1991] G. Niemeyer and J.-J. E. Slotine. *Stable adaptive teleoperation*. IEEE Journal of Oceanic Engineering, vol. 16, no. 1, pages 152–162, 1991.
- [Niemeyer 1996] G. Niemeyer. *Using wave variables in time delayed force reflecting teleoperation*. PhD thesis, Massachusetts Institute of Technology, 1996.
- [Nuño 2008] E. Nuño, R. Ortega, N. Barabanov and L. Basañez. *A globally stable PD controller for bilateral teleoperators*. IEEE Transactions on Robotics, vol. 24, no. 3, pages 753–758, 2008.
- [Nuño 2009] E. Nuño, L. Basañez, R. Ortega and M.W. Spong. *Position tracking for non-linear teleoperators with variable time delay*. International Journal of Robotics Research, vol. 28, no. 7, pages 895–901, 2009.
- [Nuño 2011] E. Nuño, L. Basañez and R. Ortega. *Passivity-based control for bilateral teleoperation: a tutorial*. Automatica, vol. 47, no. 3, pages 485–495, 2011.
- [Oliveira 2007] R.C.L.F. Oliveira, V.F. Montagner, P.L.D. Peres and P.-A. Bliman. *LMI relaxations for  $H_\infty$  control of time-varying polytopic systems by means of parameter-dependent quadratically stabilizing gains*. In 2007 IFAC Symposium on System, Structure and Control, Foz do Iguassu, Brasil, October 2007.
- [Park 1999] P. Park. *A delay-dependent stability criterion for systems with uncertain time-invariant delays*. IEEE Transactions on Automatic Control, vol. 44, no. 4, pages 876–877, 1999.
- [Park 2000] J.H. Park and H.C. Cho. *Sliding mode control of bilateral teleoperation systems with force-reflection on the internet*. In Proceedings of 2000 IEEE/RSJ International Conference on Intelligent Robots and Systems, pages 1187–1192, Takamatsu, Japan, October 2000.
- [Park 2006] J. Park and O. Khatib. *A haptic teleoperation approach based on contact force control*. The International Journal of Robotics Research, vol. 25, no. 5-6, pages 575–591, 2006.
- [Park 2007] P. Park and J. Ko. *Stability and robust stability for systems with a time-varying delay*. Automatica, vol. 43, no. 10, pages 1855–1858, 2007.
- [Park 2011] P. Park, J.W. Kob and C. Jeong. *Reciprocally convex approach to stability of systems with time-varying delays*. Automatica, vol. 47, no. 1, pages 235–238, 2011.

- 
- [Perdon 1999] A.M. Perdon and G. Conte. *Invited session: algebraic and ring-theoretic methods in the study of time-delay systems*. In 1999 IEEE Conference on Decision and Control, Phoenix, Arizona, USA, December 1999.
- [Picard 1996] P. Picard, O. Sename and J.F. Lafay. *Observers and observability indices for linear systems with delays*. In 1996 IEEE Conference on Computational Engineering in Systems Applications, Lille, France, July 1996.
- [Polushin 2006] I.G. Polushin, P.X. Liu and C.-H. Lung. *A control scheme for stable force-reflecting teleoperation over IP networks*. IEEE Transactions on Systems, Man, and Cybernetics, vol. 36, no. 4, pages 930–939, 2006.
- [Raju 1989] G.J. Raju, G.C. Verghese and T.B. Sheridan. *Design issues in 2-port network models of bilateral remote manipulation*. In Proceedings of 1989 IEEE International Conference on Robotics and Automation, volume 3, pages 1316–1321, 1989.
- [Razi 2007] K. Razi, M.J. Yazdanpanah, S.S. Ghidary, H.H. Najafabadi, M. Zareinejad, R. Seifabadi and S.M. Rezaei. *Position coordination of a linear teleoperation system with constant time delay*. In Proceedings of 2007 IEEE/RSJ International Conference on Intelligent Robots and Systems, pages 2673–2678, San Diego, CA, USA, October 2007.
- [Rehm 2002] A. Rehm and F. Allgower. *An LMI approach towards  $H_\infty$  control of discrete-time descriptor systems*. In Proceedings of 2002 American Control Conference (ACC'02), pages 614–619, Alaska, USA, May 2002.
- [Richard 2003] J.-P. Richard. *Time delay systems: an overview of some recent advances and open problems*. Automatica, vol. 39, no. 10, pages 1667–1694, 2003.
- [Rodriguez-Angeles 2010] A. Rodriguez-Angeles, J.L. Guzman-Gutierrez and C. Cruz-Villar. *User wearable interface based on inertial sensors for unilateral master-slave robot teleoperation*. In 2010 International Conference on Electrical Engineering Computing Science and Automatic Control, Chiapas, Mexico, September 2010.
- [Rosen 2010] J. Rosen, B. Hannaford and R.M. Satava. *Surgical robotics: systems applications and visions*. Springer, 2010.
- [Ryu 2003] J.-H. Ryu, Y.S. Kim and B. Hannaford. *Sampled and continuous time passivity and stability of virtual environments*. In Proceedings of 2003 IEEE International Conference on Robotics and Automation, pages 822–827, Taipei, Taiwan, September 2003.
- [Ryu 2004a] J.-H. Ryu, D.-S. Kwon and B. Hannaford. *Stability guaranteed control: time domain passivity approach*. IEEE Transactions on Control Systems Technology, vol. 12, no. 6, pages 860–868, 2004.
- [Ryu 2004b] J.-H. Ryu, D.-S. Kwon and B. Hannaford. *Stable teleoperation with time-domain passivity control*. IEEE Transactions on Robotics and Automation, vol. 20, no. 2, pages 365–373, 2004.

- [Ryu 2005a] J.-H. Ryu and J.-H. Kim. *Stable and high performance teleoperation with time domain passivity control: reference energy following scheme*. In Proceedings of 2005 International Conference on Advanced Robotics, pages 782–787, Seattle, Washington, USA, July 2005.
- [Ryu 2005b] J.-H. Ryu, C. Preusche, B. Hannaford and G. Hirzinger. *Time domain passivity control with reference energy following*. IEEE Transactions on Control Systems Technology, vol. 13, no. 5, pages 737–742, 2005.
- [Ryu 2007] J.-H. Ryu and C. Preusche. *Stable bilateral control of teleoperators under time-varying communication delay: time domain passivity approach*. In Proceedings of 2007 IEEE International Conference on Robotics and Automation, pages 3508–3513, Roma, Italy, April 2007.
- [Sano 1998] A. Sano, H. Fujimoto and M. Tanaka. *Gain-scheduled compensation for time delay of bilateral teleoperation systems*. In Proceedings of 1998 IEEE International Conference on Robotics and Automation, pages 1916–1923, 1998.
- [Santi 2003] P. Santi and D.-M. Blough. *The critical transmitting range for connectivity in sparse wireless ad hoc networks*. IEEE Transactions on Mobile Computing, vol. 2, no. 1, pages 25–39, 2003.
- [Satler 2009] M. Satler, C.A. Avizzano, A. Frisoli, P. Tripicchio and M. Bergamasco. *Bilateral teleoperation under time-varying delay using wave variables*. In Proceedings of 2009 IEEE/RSJ International Conference on Intelligent Robots and Systems, pages 4596–4602, St. Louis, USA, October 2009.
- [Sato 1987] T. Sato and S. Hirai. *Language-aided robotic teleoperation system (LARTS) for advanced teleoperation*. IEEE Journal of Robotics and Automation, vol. 3, no. 5, pages 476–481, 1987.
- [Scherer 2005] C.W. Scherer and S. Weiland. *Linear matrix inequalities in control*. Technical report, Delft Center for Systems and Control, Delft University of Technology and Department of Electrical Engineering, Eindhoven University of Technology, Netherlands, 2005.
- [Seuret 2006] A. Seuret. *Commande et observation du systèmes à retards variables: théorie et applications*. PhD thesis, Ecole Central de Lille & Université de Sciences et Technologies de Lille, 2006.
- [Seuret 2008] A. Seuret and J.-P. Richard. *Control of a remote system over network including delays and packet dropout*. In Proceedings of 2008 IFAC World Congress, pages 1191–1196, Seoul, South Korea, 2008.
- [Shahbazi 2010] M. Shahbazi, H.A. Talebi and M.J. Yazdanpanah. *A control architecture for dual user teleoperation with unknown time delays: a sliding mode approach*. In Proceedings of 2010 IEEE/ASME International Conference on Advanced Intelligent Mechatronics, pages 1221–1226, Montreal, Canada, July 2010.

- 
- [Shaked 1998] U. Shaked, I. Yaesh and C.E. de Souza. *Bounded real criteria for linear time-delay systems*. IEEE Transactions on Automatic Control, vol. 43, no. 7, pages 1016–1022, 1998.
- [Sheng 2004] J. Sheng and M.W. Spong. *Model predictive control for bilateral teleoperation systems with time delays*. In 2004 Canadian Conference on Electrical and Computer Engineering, Ontario, Canada, May 2004.
- [Sheridan 1993] T. Sheridan. *Space teleoperation through time delay: review and prognosis*. IEEE Transactions on Robotics and Automation, vol. 9, no. 5, pages 592–606, 1993.
- [Sirouspour 2005] S. Sirouspour. *Robust Control Design for Cooperative Teleoperation*. In Proceedings of 2005 IEEE International Conference on Robotics and Automation, pages 1133–1138, Barcelona, Spain, April 2005.
- [Smith 1957] O.J.M. Smith. *Posicast control of damped oscillatory systems*. Proceedings of the IRE, vol. 45, no. 9, pages 1249–1255, 1957.
- [Smith 1959] O.J.M. Smith. *A controller to overcome dead time*. ISA Journal of Instrument Society of America, vol. 6, pages 28–33, 1959.
- [Smith 2005] A.C. Smith and K. Hashtrudi-Zaad. *Neural network-based teleoperation using smith predictors*. In Proceedings of 2005 IEEE International Conference on Mechatronics & Automation, pages 1654–1659, Niagara Falls, Canada, July 2005.
- [Son 2011] H.I. Son, T. Bhattacharjee and H. Hashimoto. *Effect of impedance-shaping on perception of soft tissues in macro-micro teleoperation*. IEEE Transactions on Industrial Electronics, to appear, 2011.
- [Tadmor 2000] G. Tadmor. *The standard  $H_\infty$  problem in systems with a single input delay*. IEEE Transactions on Automatic Control, vol. 45, no. 3, pages 382–396, 2000.
- [Tanner 2004] N.A. Tanner and G. Niemeyer. *Online tuning of wave impedance in telerobotics*. In Proceedings of 2004 IEEE Conference on Robotics, Automation and Mechatronics, pages 7–12, Singapore, Singapore, December 2004.
- [Taoutaou 2003] D. Taoutaou, S.-I. Niculescu and K. Gu. *Robust stability of teleoperation schemes subject to constant and time-varying communication delays*. In Proceedings of 2003 IEEE Conference on Decision and Control, pages 5579–5584, 2003.
- [Tian 2011] D. Tian, D. Yashiro and K. Ohnishi. *Frequency-domain analysis of wave variable based teleoperation and its equivalent implementation*. In Proceedings of 2011 International Symposium on Access Spaces, pages 41–46, Yokohama, Japan, June 2011.
- [Tipsuwan 2003] Y. Tipsuwan and M.-Y. Chow. *Control methodologies in networked control systems*. Proceedings of the IEEE, vol. 11, no. 10, pages 1099–1111, 2003.

- [Triden 2006] B. Triden, S. Mantri, K. Schroeder, A. Thomas, J. Moyne and D. Tilbury. *Dedicated vs. shared networks for safety and controls: an analysis of the trade-offs involved*. In Proceedings of 2006 IEEE Conference on Emerging Technologies and Factory Automation, pages 341–347, Prague, Czech Republic, 2006.
- [Verriest 1993] E.I. Verriest, M.K.H. Fan and J. Kullstam. *Frequency domain robust stability criteria for linear delay systems*. In Proceedings of 1993 IEEE Conference on Decision and Control, pages 3473–3478, San Antonio, TX, USA, December 1993.
- [Verriest 2007] E.I. Verriest and P. Pepe. *Time optimal and optimal impulsive control for coupled differential difference point delay systems with an application in forestry*. In 2007 IFAC Workshop on Time-Delay Systems, Nantes, France, September 2007.
- [Wang 2005] K.-C. Wang and P. Ramanathan. *Collaborative sensing using sensors of uncoordinated mobility*. In Proceedings of 2005 International Conference on Distributed Computing in Sensor Systems, pages 293–306, 2005.
- [Wei 2007] L. Wei, D.Y. Xue and D.-Z. E. *Some basic issues in networked control systems*. In Proceedings of 2007 IEEE Conference on Industrial Electronics and Applications, pages 2098–2102, Harbin, China, May 2007.
- [Witrant 2007] E. Witrant, C. Canudas-De-Wit, D. Georges and M. Alamir. *Remote stabilization via communication networks with a distributed control law*. IEEE Transactions on Automatic Control, vol. 52, no. 8, pages 1480–1485, 2007.
- [Wu 2004] M. Wu, Y. He, J.-H. She and G.-P. Liu. *Delay-dependent criteria for robust stability of time-varying delay systems*. Automatica, vol. 40, no. 8, pages 2099–2106, 2004.
- [Xie 2001] L. Xie, E. Fridman and U. Shaked. *Robust  $H_\infty$  control of distributed delay systems with application to combustion control*. IEEE Transactions on Automatic Control, vol. 46, no. 12, pages 1930–1935, 2001.
- [Xu 2003] B. Xu and Y.-H. Liu. *Delay-dependent/delay-independent stability of linear systems with multiple time-varying delays*. IEEE Transactions on Automatic Control, vol. 48, no. 4, pages 697–701, 2003.
- [Xu 2006] S.-Y. Xu, J. Lam and Y. Zou. *New results on delay-dependent robust  $H_\infty$  control for systems with time-varying delays*. Automatica, vol. 42, no. 2, pages 343–348, 2006.
- [Xu 2007] S. Xu and J. Lam. *On equivalence and efficiency of certain stability criteria for time-delay systems*. IEEE Transactions on Automatic Control, vol. 52, no. 1, pages 95–101, 2007.
- [Yan 1996] J. Yan and S.E. Salcudean. *Teleoperation controller design using  $H_\infty$ -optimization with application to motion-scaling*. IEEE Transactions on Control Systems Technology, vol. 4, no. 3, pages 244–258, 1996.

- 
- [Ye 2009a] Y. Ye and P.X. Liu. *Improving haptic feedback fidelity in wave-variable-based teleoperation orientated to telemedical applications*. IEEE Transactions on Instrumentation and Measurement, vol. 58, no. 8, pages 2847–2855, 2009.
- [Ye 2009b] Y.-Q. Ye, Y.-J. Pan and Y. Gupta. *A power based time domain passivity control for haptic interfaces*. In Proceedings of 2009 IEEE Conference on Decision and Control, and Chinese Control Conference, pages 7521–7526, Shanghai, China, December 2009.
- [Ye 2009c] Y.-Q. Ye, Y.-J. Pan and Y. Gupta. *Time domain passivity control of teleoperation systems with random asymmetric time delays*. In Proceedings of 2009 IEEE Conference on Decision and Control, and Chinese Control Conference, pages 7533–7538, Shanghai, China, December 2009.
- [Yokokohji 1999] Y. Yokokohji, T. Imaida and T. Yoshikawa. *Bilateral teleoperation under time-varying communication delay*. In Proceedings of 1999 IEEE/RSJ International Conference on Intelligent Robots and Systems, pages 1854–1859, Vilamoura-Algarve, Portugal, October 1999.
- [Yokokohji 2000] Y. Yokokohji, T. Imaida and T. Yoshikawa. *Bilateral control with energy balance monitoring under time-varying communication delay*. In Proceedings of 1999 IEEE/RSJ International Conference on Intelligent Robots and Systems, pages 2684–2689, San Francisco, CA, USA, April 2000.
- [Zampieri 2008] S. Zampieri. *Trends in networked control systems*. In 2008 IFAC World Congress, pages 2886–2894, Seoul, Korea, July 2008.
- [Zhang 2008] X.-M. Zhang and Q.-L. Han. *Robust  $H_\infty$  filtering for a class of uncertain linear systems with time-varying delay*. Automatica, vol. 44, no. 1, pages 157–166, 2008.
- [Zhang 2011a] B. Zhang, A. Kruszewski and J.-P. Richard. *A novel control scheme for teleoperation with guaranteed performance under time-varying delays*. In 2011 Chinese Control and Decision Conference, Mianyang, China, May 2011.
- [Zhang 2011b] B. Zhang, A. Kruszewski and J.-P. Richard. *Tracking improvement based on the proxy control scheme for bilateral teleoperation system under time-varying delays*. In 2011 IEEE International Conference on Emerging Technologies and Factory Automation, Toulouse, France, September 2011.
- [Zhang 2012a] B. Zhang, A. Kruszewski and J.-P. Richard.  *$H_\infty$  Control Design for Novel Teleoperation System Scheme: a Discrete Approach*. In 2012 IFAC Workshop on Time Delay Systems, to appear, Boston, USA, June 2012.
- [Zhang 2012b] B. Zhang, A. Kruszewski and J.-P. Richard.  *$H_\infty$  Control of Delayed Teleoperation Systems under Polytopic-Type Uncertainties*. In 2012 Mediterranean Conference on Control and Automation, Barcelona, Spain, July 2012.

- [Zhang 2012c] B. Zhang, A. Kruszewski and J.-P. Richard. *H<sub>∞</sub> Robust Control Design for Teleoperation Systems*. In 2012 IFAC Symposium on Robust Control Design, to appear, Aalborg, Denmark, June 2012.
- [Zhu 2000] W.-H. Zhu and S.E. Salcudean. *Stability guaranteed teleoperation: an adaptive motion/force control approach*. IEEE Transactions on Automatic Control, vol. 45, no. 11, pages 1951–1969, 2000.

# Sur la commande à retour d'effort à travers des réseaux non dédiés: stabilisation et performance sous retards asymétriques et variables

## Résumé

Ce travail propose de nouvelles structures de contrôle pour la téléopération bilatérale à travers des réseaux de communication non dédiés (par exemple Wifi ou Internet) et présentant donc une qualité de service non maîtrisée. On montrera que ce type de réseau introduit dans les boucles de contrôle des retards dissymétriques et fortement variables, susceptibles de réduire les performances et même de déstabiliser le système global. Ces effets se résument ainsi à deux "retards de réseau". De plus, la téléopération bilatérale est soumise à des entrées et perturbations issues des forces exercées par l'opérateur sur le robot maître et par l'environnement physique du robot esclave télé-opéré (un mur, par exemple).

L'enjeu est donc de concevoir et calculer des structures de commande garantissant, dans ces conditions, la stabilisation et un bon degré de performance en termes de synchronisation (suivi des positions et vitesse) et de transparence (ressenti des forces). Une implantation sur une plate-forme expérimentale permettra d'illustrer plus concrètement notre approche théorique.

Concernant les objectifs de la synthèse de contrôleurs, on pourra selon le besoin considérer qu'une valeur supérieure des deux retards de réseau est connue (il s'agira alors d'optimiser la performance) ou que cette borne doit être calculée (pour garantir une performance minimale désirée). Nous verrons que, grace aux modèles et techniques que nous introduirons, cette synthèse de contrôleur s'exprimera sous forme LMI (inégalités matricielles linéaires), donc optimisable par des solveurs algorithmiques classiques.

Nous faisons tout d'abord un tour d'horizon des recherches récentes dans le domaine des systèmes de téléopération et de leurs caractéristiques. Puis, pour correspondre aux besoins de l'application, nous considérons des modèles linéaires à plusieurs retards variables pour lesquels nous proposons une approche d'analyse de stabilité par fonctionnelles de Lyapunov-Krasovskii, qui permettra par la suite de réduire le conservatisme des conditions de stabilisation, et qui est couplée avec une approche de contrôle robuste  $H_\infty$  pour tenir compte des aspects de performance. C'est cet ensemble qui permettra une synthèse par LMI.

Trois structures de téléopération seront proposées en temps continu : un premier schéma de retour d'état bilatéral (positions/vitesses); un second intégrant un retour de force additionnel; enfin un troisième avec un retour de force et un émulateur du maître placé du côté esclave, que nous nommons ici le "proxy". La comparaison de ces architectures montre que, pour un retard de réseau maximum donné ou calculé, toutes garantissent un suivi de position et vitesse. Les deux dernières, qui utilisent les forces mesurées ou estimées de l'opérateur humain et de l'environnement, garantissent de plus un suivi en force. Au final, la troisième structure (avec proxy) présente la meilleure performance, même si elle demande un peu plus de calcul.

Puis, afin d'analyser et d'améliorer les performances de la troisième structure pour des modèles encore plus réalistes, une étude est menée en temps discret (modèle échantillonné traité, ici encore, par une approche combinant techniques de Lyapunov et contrôle  $H_\infty$ ), mais aussi sur un modèle non linéaire ou non stationnaire sous perturbations bornées en norme. Les perturbations de modèles sont considérées par l'intermédiaire d'une approche polytopique et l'ensemble conduit aussi à une synthèse par LMI.

L'implantation sur la plate-forme est décrite dans un quatrième et dernier chapitre. Chacun des deux sous-systèmes (robots Phantom côté maître, Mitsubishi côté esclave) est tout d'abord identifié puis linéarisé par retour d'état. Après avoir comparé les solutions par capteur ou par estimateur de force, la première est retenue. L'ensemble permet de valider les hypothèses de modélisation et de calculer les différentes structures. L'analyse des résultats expérimentaux est alors menée.



**Mots-clés:** Téléopération, Retard variable, Fonctionnelle de Lyapunov-Krasovskii, Commande robuste  $H_\infty$ , Robotique, Retour d'effort, Modèle polytopique

# New control schemes for bilateral teleoperation under asymmetric communication channels: stabilization and performance under variable time delays

## Abstract

This PhD thesis is dedicated to the control scheme design of the bilateral teleoperation under asymmetric communication channels: the stabilization and a high-level performance (the synchronization/transparency) under asymmetric time-varying delays and the perturbations of the human operator and environment. After a review of the recent researches and their features in the field of teleoperation system, a less conservative Lyapunov-Krasovskii functional together with  $H_\infty$  control theory has been applied to linear time delay systems, and then the LMI theorems have been obtained in order to calculate the controllers in the control schemes.

Firstly, three novel teleoperation control schemes (bilateral state feedback control scheme, force-reflecting control scheme without or with proxy) have been presented. Comparing three architectures, all of them guaranteed the stability and the position tracking thanks to the position/velocity information. Force-reflecting control scheme without or with proxy, in addition, ensured the force tracking by using the estimated/measured force of the human operator and the environment. Here, the control scheme with the proxy got a better performance.

Secondly, a discrete-time approach (a discrete LKF together with  $H_\infty$  control in the form of LMI) has been developed to analyze the force-reflecting control scheme with proxy and obtain a better system performance. Besides, more general systems with time-varying uncertainties (the polytopic-type uncertainties and the norm-bounded model uncertainties) have been considered.

Finally, the experimental test-bench and the real system implementation have been designed, which involved the identification and linearizing control of the subsystems (the master/slave robots). The experimental results have illustrated the effectiveness of the approaches proposed in this thesis.

**Keywords:** Teleoperation, Asymmetric time-varying delays, Lyapunov-Krasovskii functionals,  $H_\infty$  robust control, Robotics, Force feedback, Polytopic model

