



**HAL**  
open science

# Virtual reality platform design & development for intelligent vehicles control

Minzhi Luo

► **To cite this version:**

Minzhi Luo. Virtual reality platform design & development for intelligent vehicles control. Other. Ecole Centrale de Lille, 2012. English. NNT : 2012ECLI0016 . tel-00741938

**HAL Id: tel-00741938**

**<https://theses.hal.science/tel-00741938>**

Submitted on 15 Oct 2012

**HAL** is a multi-disciplinary open access archive for the deposit and dissemination of scientific research documents, whether they are published or not. The documents may come from teaching and research institutions in France or abroad, or from public or private research centers.

L'archive ouverte pluridisciplinaire **HAL**, est destinée au dépôt et à la diffusion de documents scientifiques de niveau recherche, publiés ou non, émanant des établissements d'enseignement et de recherche français ou étrangers, des laboratoires publics ou privés.

N° d'ordre : 

1	9	4
---	---	---

**ÉCOLE CENTRALE DE LILLE**

**THÈSE**

présentée en vue  
d'obtenir le grade de

**DOCTEUR**

Spécialité : Automatique, génie informatique, traitement du signal et des images

par

**LUO Minzhi**

Master of Engineering of Beijing University of Aeronautics and Astronautics (BUAA)

Doctorat délivré par l'École Centrale de Lille

# Conception & Développement d'une Plateforme en Réalité Virtuelle de Pilotage de Véhicules Intelligents

Soutenue le 21 septembre 2012 devant le jury :

M. Pierre BORNE	Ecole Centrale de Lille	Président
M. Nouredine ELLOUZE	Ecole Nationale d'Ingénieurs de Tunis	Rapporteur
M. Abdellah EL-MOUDNI	Université de technologie de Belfort-Montbéliard	Rapporteur
Mme. Guanghong GONG	Beijing University of Aeronautics and Astronautics	Examineur
M. Abdelkader EL KAMEL	Ecole Centrale de Lille	Directeur de Thèse
M. Khaled MELLOULI	Institut des Hautes Etudes Commerciales de Carthage	Examineur
M. Dumitru POPESCU	Université Politehnica de Bucarest	Examineur

Thèse préparée au Laboratoire d'Automatique, Génie Informatique et Signal  
L.A.G.I.S. - UMR 8219 - École Centrale de Lille  
École Doctorale Sciences pour l'ingénieur - 072  
PRES Université Lille Nord-de-France



Serial N° : 

1	9	4
---	---	---

**ECOLE CENTRALE DE LILLE**

**THESIS**

Presented to obtain  
the degree of

**DOCTOR**

Topic : Automatic Control, Computer Engineering, signal and image processing  
by

**LUO Minzhi**

Master of Engineering of Beijing University of Aeronautics and Astronautics (BUAA)

**Ph.D. awarded by Ecole Centrale de Lille**

## **Virtual Reality Platform Design & Development for Intelligent Vehicles Control**

Defended on September 21, 2012 in presence of the committee :

Mr Pierre BORNE	Ecole Centrale de Lille	President
Mr Nouredine ELLOUZE	Ecole Nationale d'Ingénieurs de Tunis	Reporter
Mr Abdellah EL-MOUDNI	Université de technologie de Belfort-Montbéliard	Reporter
Mrs. Guanghong GONG	Beijing University of Aeronautics and Astronautics	Examiner
Mr Abdelkader EL KAMEL	Ecole Centrale de Lille	Supervisor
Mr Khaled MELLOULI	Institut des Hautes Etudes Commerciales de Carthage	Examiner
Mr Dumitru POPESCU	Université Politehnica de Bucarest	Examiner

Thèse préparée au Laboratoire d'Automatique, Génie Informatique et Signal  
L.A.G.I.S. - UMR 8219 - École Centrale de Lille  
École Doctorale Sciences pour l'ingénieur - 072  
PRES Université Lille Nord-de-France



---

## Acknowledgments

The PhD work presented in this thesis has been carried out at "Laboratoire d'Automatique, Génie Informatique et Signal" (LAGIS) in Ecole Centrale de Lille, from September 2009 to September 2012.

This thesis would not have been possible without the help and support of so many people in so many ways. I would like to take the opportunity to express my gratitude to all those who contributed to this work.

First of all, my sincere thanks go to my supervisor, Prof. Abdelkader EL KAMEL, for his valuable guidance, continuous encouragement and the share of his research experience.

A special acknowledgement should be shown to Prof. Guanghong GONG, who always support my thesis work during these three years with her helpful suggestions and discussions. My gratitude to both Prof. GONG and Prof. EL KAMEL for having involved me in their research cooperation project and giving me the opportunity to come to France.

I would like to thank Prof. Pierre BORNE for his generous helps. I would also like to express my sincere gratitude to Prof. Nouredine ELLOUZE and Prof. Abdellah EL MOUDNI, who have kindly accepted the invitation to be the reviewers of my PhD thesis. My heartfelt thanks go to Prof. Khaked MELLOULI and Prof. Dumitru POPESCU, for their kind acceptance to be the members of my PhD Committee.

I am also very grateful to the staff in EC Lille. Vanessa Fleury, Christine YVOZ, and Brigitte FONCEZ have helped me in the administrative works. Many thanks go also to Bernard SZUKALA, Hilaire ROSSI, Gilles MARGUERITE, Jacques LASUE, Patrick GALLAIS and Régine DUPLOUICH, for their kind help and hospitality.

I wish to express my special appreciation to Prof. Hélène CATSIAPIS, my French teacher. In her courses, I learned not only the language but also the culture, history, especially the many trips, which enrich my life in France.

I would like also to thank all my colleagues and friends, Yue, Daji, Tian, Jin, Yahong, Yongliang, Huarong, Jian, Wenhua, Bo, Guoguang... for their friendship and supports.

Finally, Thanks to my boyfriend, Ye, for his love and helps on my life and work. Thanks to my family for always supporting and encouraging me.



# Contents

<b>List of Figures</b>	<b>9</b>
<b>List of tables</b>	<b>11</b>
<b>General Introduction</b>	<b>15</b>
<b>Acronyms</b>	<b>14</b>
<b>1 Background</b>	<b>19</b>
1.1 Introduction . . . . .	20
1.2 "Driver-Vehicle-Environment" framework . . . . .	22
1.2.1 The Environment . . . . .	22
1.2.2 The Driver . . . . .	23
1.2.3 The Vehicle . . . . .	24
1.3 Advanced Driver Assistance Systems (ADAS) . . . . .	25
1.3.1 Intelligent Transportation Systems/Automated Highway Sys- tems . . . . .	25
1.3.2 ADAS architecture . . . . .	26
1.3.3 ADAS classification . . . . .	30
1.3.4 ADAS simulation and verification . . . . .	33
1.3.5 Previous works . . . . .	34
1.4 Virtual Reality (VR) . . . . .	35
1.4.1 Brief history . . . . .	35
1.4.2 Definition . . . . .	37
1.4.3 Applications . . . . .	40
1.4.4 Previous works of VR in transportation systems . . . . .	43
1.5 Conclusion . . . . .	46
<b>2 Intelligent Vehicles Virtual Reality Platform</b>	<b>47</b>
2.1 Introduction . . . . .	47
2.2 IVVR platform design in Unified Modeling Language . . . . .	51
2.2.1 Use-case diagram for IVVR platform . . . . .	52
2.2.2 Class diagram for IVVR platform . . . . .	53
2.2.3 Activity diagram for IVVR platform . . . . .	56
2.3 IVVR platform realization . . . . .	57
2.3.1 Vehicle Intelligent Control Subsystem . . . . .	57
2.3.2 Visualization Subsystem . . . . .	59
2.3.3 Virtual Wireless Subsystem . . . . .	63
2.3.4 Features and application structure . . . . .	65
2.4 IVVR platform simulation . . . . .	66
2.5 Conclusion . . . . .	68



---

<b>3</b>	<b>Natural Environment Modeling and Simulation</b>	<b>71</b>
3.1	Introduction . . . . .	71
3.2	Natural Environment (NE) concept . . . . .	73
3.2.1	NE conceptual model . . . . .	74
3.2.2	NE M&S features . . . . .	74
3.2.3	NE M&S applications . . . . .	76
3.3	NE modeling for intelligent vehicle system . . . . .	78
3.3.1	NE conceptual model for intelligent vehicles . . . . .	78
3.3.2	Virtual Sensor Data . . . . .	79
3.3.3	Transmitters of Virtual Sensor Data . . . . .	81
3.3.4	Receivers of Virtual Sensor Data . . . . .	81
3.3.5	Summary . . . . .	91
3.4	NE Simulation for intelligent vehicle system . . . . .	92
3.4.1	Simulation 1: stable weather . . . . .	94
3.4.2	Simulation 2: variable weather . . . . .	95
3.5	Conclusion . . . . .	96
<b>4</b>	<b>CACC Design and Simulation Involving NE Impacts</b>	<b>97</b>
4.1	Introduction . . . . .	97
4.2	ACC/CACC systems . . . . .	99
4.2.1	ACC/CACC system design . . . . .	99
4.2.2	Previous works on ACC/CACC algorithms . . . . .	100
4.3	NECACC algorithm design . . . . .	102
4.3.1	Basic NECACC algorithm . . . . .	103
4.3.2	Adaptive NE driving strategy . . . . .	105
4.3.3	String stability and traffic flow stability . . . . .	107
4.4	NECACC simulations . . . . .	115
4.4.1	Multi-track mode . . . . .	116
4.4.2	Simulation architecture . . . . .	116
4.4.3	Simulations under fixed NE condition . . . . .	118
4.4.4	Simulations with user-in-the-loop . . . . .	127
4.5	Conclusion . . . . .	127
<b>5</b>	<b>Integrated Vehicle Control under Complex NE Conditions</b>	<b>129</b>
5.1	Introduction . . . . .	129
5.2	Lane tracking/lane following . . . . .	130
5.2.1	Simulation architecture . . . . .	131
5.2.2	Longitudinal control . . . . .	132
5.2.3	Lateral control . . . . .	133
5.2.4	Simulation results . . . . .	135
5.3	Lane changing/Overtaking . . . . .	139
5.3.1	Simulation architecture . . . . .	141
5.3.2	Longitudinal control . . . . .	142
5.3.3	Lateral control . . . . .	145

## Contents

---

5.3.4 Simulation results . . . . .	145
5.4 Conclusion . . . . .	150
<b>Conclusions and Perspectives</b>	<b>151</b>
<b>Bibliography</b>	<b>155</b>
<b>Résumé étendu</b>	<b>167</b>



# List of Figures

1.1	Road safety ranking among OECD member countries . . . . .	21
1.2	Congestion Growth Trend . . . . .	21
1.3	"Driver-Vehicle-Environment" framework . . . . .	22
1.4	Drive style in terms of vehicle potential limit and road type . . . . .	24
1.5	Intelligent Transportation System illustration . . . . .	25
1.6	General architecture of ADAS . . . . .	27
1.7	Basic structure of ADAS . . . . .	28
1.8	ACC system architecture . . . . .	32
1.9	ITS development chronology in the world [Zhao 2010] . . . . .	35
1.10	Virtual reality systems: left, the <i>Sensorama</i> (1965), right, the <i>Ultimate Display</i> (1968) . . . . .	36
1.11	Virtual reality systems: left, the <i>Videoplace</i> (1970), right, description of HMD of project <i>VIVED</i> (1981) . . . . .	36
1.12	The continuum of "real - virtual" . . . . .	37
1.13	Virtual reality triangle . . . . .	39
1.14	The mediation of reality . . . . .	39
1.15	Left: Data visualization concerning earthquake [Frohlich 1999]; right: Visualization of molecules inside of a catalyst [Lourdeaux 2001] . . . . .	41
1.16	Left: the video game <i>The sims</i> ; right: the virtual tour of Nantes in 1757 . . . . .	41
1.17	Left: the training application <i>SecuReVi</i> [Querrec 2003]; right: risk analysis in a mine [Lourdeaux 2001] . . . . .	42
1.18	Left: A dynamic simulation. The pendulum-like part rotates about the shaft and translates along the shaft axis [Jayaram 1999]; right: the study of impacts of the integration of tram in a urban landscape of Nantes [Donikian 1999] . . . . .	43
1.19	Images from the virtual traffic jam scenario [Sewall 2011] . . . . .	44
1.20	Simulation under normal operation (left) and fire condition (right) [hongke 2007] . . . . .	45
1.21	Examples of driving simulator . . . . .	45
1.22	Virtual scenes of distributed virtual reality system [Lehner 1997] . . . . .	46
2.1	Vehicle platoon in the NAHSC demonstration . . . . .	48
2.2	The i3Drive application's structure [Ambroz 2010] . . . . .	49
2.3	Modular structure of the software environment [Ambroz 2005] . . . . .	50
2.4	Related basic UML notions . . . . .	52
2.5	Use-case diagram of IVVR platform . . . . .	54
2.6	Class diagram of IVVR platform . . . . .	55
2.7	Activity diagram of IVVR platform . . . . .	56
2.8	Vehicle dynamic modeling structure . . . . .	58

2.9	Integrated control system [Zhao 2010] . . . . .	59
2.10	Virtual world structure . . . . .	60
2.11	Virtual vehicle measurements . . . . .	61
2.12	The SkyDome . . . . .	62
2.13	Various virtual world scenes: top mode with snow (a); follow mode with cloud (b); driver mode with rain (c); follow mode with fog (d) .	62
2.14	The graphical man-machine interface . . . . .	63
2.15	Integration with COM technology . . . . .	64
2.16	Block diagram of S-Function in IVVR platform . . . . .	65
2.17	Application structure of IVVR platform . . . . .	66
2.18	Simulation results in curves . . . . .	67
2.19	Screenshots of animation: 1 (0s), 2 (40s), 3 (45s), 4 (60s) . . . . .	68
3.1	A basic NE conceptual model . . . . .	74
3.2	Natural Environment conceptual model . . . . .	75
3.3	Different aspects in natural environment . . . . .	76
3.4	Military applications supported by NE M&S . . . . .	77
3.5	NE conceptual model for intelligent vehicle system . . . . .	78
3.6	Wireless Traffic Service Platform structure [Sukuvaara 2009] . . . . .	80
3.7	Communication structure of IVVR platform . . . . .	80
3.8	Longitudinal forces acting on a vehicle moving on an inclined road [Rajamani 2006] . . . . .	82
3.9	Curve produced by the original Magic Formula . . . . .	86
3.10	Typical longitudinal friction characteristics. a) Sunny/Cloudy: dry, b) Rainy: wet, c) Snowy: snow, d) Icy: ice . . . . .	86
3.11	Bicycle model for lateral vehicle dynamics [Zhao 2010] . . . . .	87
3.12	Lateral vehicle dynamics [Rajamani 2006] . . . . .	89
3.13	From body fixed to global coordinates [Rajamani 2006] . . . . .	90
3.14	VSD delivery system . . . . .	92
3.15	Road structure . . . . .	93
3.16	Stable weather impacts on intelligent vehicle system . . . . .	94
3.17	Variable weather impacts on intelligent vehicle system . . . . .	95
4.1	Dual-loop structure of an ACC/CACC system . . . . .	100
4.2	Microscopic traffic model . . . . .	103
4.3	Structure of NECACC driving strategy . . . . .	105
4.4	Comparison of CACC and NECACC in case of rainy . . . . .	106
4.5	Comparison of CACC and NECACC in case of snowy . . . . .	108
4.6	Comparison of CACC and NECACC in case of icy . . . . .	109
4.7	Macroscopic traffic flow model . . . . .	110
4.8	$Q - \rho$ curves of NECACC/NEACC . . . . .	115
4.9	Simulation architecture . . . . .	117
4.10	The pre-designed velocity of leading vehicle . . . . .	119
4.11	Simulation results under fixed NE condition: Cloudy to Rainy . . . . .	120

## List of Figures

---

4.12	Simulation results under fixed NE condition: Cloudy to Snowy . . .	121
4.13	Simulation results under fixed NE condition: Road partially frozen .	122
4.14	Virtual 3D scenes under fixed NE condition: Cloudy to Rainy. (a): 2s, (b): 10s, (c): 20s . . . . .	124
4.15	Virtual 3D scenes under fixed NE condition: Cloudy to Snowy. (a): 2s, (b): 10s, (c): 19s . . . . .	125
4.16	Virtual 3D scenes under fixed NE condition: Road partially frozen. (a): 2s, (b): 15s, (c): 18s . . . . .	126
4.17	Simulation results in the way of user-in-the-loop . . . . .	128
5.1	Simulation architecture of lane tracking/lane following . . . . .	132
5.2	Illustration of input variables . . . . .	133
5.3	Fuzzy-variable membership functions . . . . .	134
5.4	Scenes of lane tracking/lane following in case of rainy . . . . .	136
5.5	Simulation results of lane tracking/lane following in case of rainy . .	137
5.6	Scenes of lane tracking/lane following in case of cloudy to snowy . .	137
5.7	Simulation results of lane tracking/lane following in case of cloudy to snowy . . . . .	138
5.8	Scenes of lane tracking/lane following in case of icy . . . . .	139
5.9	Simulation results of lane tracking/lane following in case of icy . . .	140
5.10	Simulation architecture of lane changing/overtaking . . . . .	142
5.11	Matrix of transition from one ACC state to another [Pauwelussen 2010]	144
5.12	Decomposition of operating regimes . . . . .	146
5.13	Scenes of lane changing in case of cloudy to snowy . . . . .	147
5.14	Simulation results of lane changing in case of cloudy to snowy . . . .	148
5.15	Scenes of overtaking in case of icy . . . . .	149
5.16	Simulation results of overtaking in case of icy . . . . .	149
1	Le processus "environnement-véhicule-conducteur" . . . . .	167
2	Systèmes de transport intelligents . . . . .	168
3	modèle conceptuel de l'environnement naturel pour le système de véhicules intelligents . . . . .	170
4	Système de transmission VSD . . . . .	171
5	Modèle de trafic microscopique . . . . .	172
6	La stratégie de commande pour l'algorithme NECACC . . . . .	173
7	$Q - \rho$ courbes pour NECACC/NEACC . . . . .	174
8	Architecture de la simulation . . . . .	175
9	Architecture de la simulation pour le suivi de voie . . . . .	176
10	l'architecture de la Simulation pour changement de voie/dépassement	177



# List of Tables

1.1	Related focuses towards different stakeholder [Xiao 2010] . . . . .	32
3.1	Some representative longitudinal tire/road friction models . . . . .	85
3.2	Pacejka Coefficients . . . . .	85
3.3	Vehicle parameters and their typical values . . . . .	91
3.4	Basic weather types . . . . .	93





# Acronyms

**ITS** - Intelligent Transportation Systems

**AHS** - Automated Highway System

**ADAS** - Advanced Driver Assistance Systems

**VR** - Virtual Reality

**NE** - Natural Environment

**ACC** - Adaptive Cruise Control

**CACC** - Cooperative Adaptive Cruise Control

**IVVR** - Intelligent Vehicles Virtual Reality platform

**VICS** - Vehicle Intelligent Control Subsystem

**VS** - Visualization Subsystem

**VWS** - Virtual Wireless Subsystem

**NECACC** - Natural Environment based CACC

**VSD** - Virtual Sensor Data



# General Introduction

As the backbone of civilization, transportation is actually the reason for the economic prosperity for the past 50-plus years. There is serious money in the transportation infrastructure, research, policy, data collection, and software or other IT systems - not only to update the current backlog but also to meet the growing public demand and to ensure safety. However, things accompanying this massive transportation system are not just significant challenges or opportunities but also serious risk: each year, approximately 1.3 million people die on the world's road as well as between 20 and 50 million sustain nonfatal injuries.

When driving a car, the dynamic system can be composed of three elements: Driver, Vehicle, and Environment. Studies show that the Driver behavior takes most of the responsibilities which can achieve 90% in traffic accidents. Hence, facing to the increasing accidents brought by driver-related human errors, the Advanced Driver Assistance Systems (ADAS) in the field of Intelligent Transportation systems/Automatic Highway System (ITS/AHS) have been widely studied to assist drivers by either providing warning to reduce crashes or performing some of the control tasks to relieve a driver from repetitive and boring tasks. For instance, Adaptive Cruise Control or Cooperative Adaptive Cruise Control (ACC/CACC) systems, Collision Warning or Collision Avoidance (CW/CA) systems, etc. For the purpose of proving the validity of these ADAS, several tests or demonstrations were carried out by researchers over the world in terms of software or with real test vehicles. However, the experiments with real cars cost lots of money and time and even dangerous when it comes to analysis of complex situation in road traffic, for example, under some adverse environment conditions, like rainy, snowy or icy or in a traffic with abundant vehicles.

Fortunately, the Virtual Reality (VR) simulation allows to get rid of some of these limitations thanks to its powerful technical supports in terms of software as well as hardware. As a young discipline that lies at the crossing of several areas such as computer graphics, computer aided design, simulation, teleoperation, audiovisual, collaboration, etc., VR technology attempts to attract our attentions and change our way of perceiving and analyzing the world around us. It allows man to be an actor who is able to change the course of events in a synthetic environment and interact with virtual entities. The applications of virtual reality can be found in multiple domains, such as education and training, information visualization and exploration, prototyping and demonstrations, entertainment and so on.

Here, we concentrate on three VR features, visualization, simulation and interaction, for ADAS design and simulation. Natural Environment (NE) is also integrated into VR technology to provide us an intelligent virtual environment involving various weather or terrain conditions that is capable of impacting on the behaviors of virtual vehicles just like the way in the real world. This method can help us carrying out the ADAS tests under complex NE conditions and this kind of tests cost much

less money or time, avoid dangerous brought by real car experiments, and provide us simulation results in terms of data, figures, and realist virtual demonstrations with real-time feedbacks of natural environment impacts in a designed scene.

Thus, in this thesis, the Intelligent Vehicles Virtual Reality (IVVR) platform is designed and developed for simulating and verifying ADAS algorithms in the way of software. It includes three subsystems: Vehicle Intelligent Control Subsystem (VICS) which is in charge of vehicle control and dynamic modeling, Visualization Subsystem (VS) that provides a man-machine interface and ITS virtual traffic scenes, and Virtual Wireless Subsystem (VWS) which establishes the real-time communication between VICS and VS. Then, several simulations of ACC/CACC (one kind of ADAS) equipped traffic are executed in the IVVR platform and the simulation results show that normal ACC/CACC system fails to keep a safe inter-vehicle space when the natural environment condition is variable or adverse especially in stiff conditions.

For solving this problem, we propose a new control algorithm called NECACC (Natural Environment based CACC) for longitudinal vehicle control in maintaining a safe inter-vehicle distance as well as guaranteeing an appropriate traffic capacity even under complex environmental conditions (snowy weather, icy road, etc.). This algorithm is then simulated or verified in IVVR platform as a "proof of concept". Finally, some virtual traffic demonstrations performing common traffic maneuvers (e.g. lane following, lane changing, or overtaking) are presented in IVVR platform under various environmental conditions. The vehicle platoon is controlled by proposed integrated control system and the safety can be ensured all the time.

## Outline of the thesis

This thesis is divided into 5 chapters.

**Chapter 1** introduces the basic research background of our researches. Starting from the description of prosperity of the modern transport system as well as some drawbacks it brings, such as car accidents and congestion, we analyze firstly the framework "Driver-Vehicle-Environment" in discussing its three factors' responsibilities in a traffic accident. Then, in the field of ITS/AHS, the ADAS aiming to assist drivers in driving the vehicle with more safety or comfort are introduced in terms of architecture, classification, test and verification and previous works. For the purpose of avoiding the disadvantages brought by the traditional research methods of ADAS, VR has been considered as a powerful tool in the process of ADAS design and production. Its brief history, definition, main applications and contributions in transportation systems are also discussed in this chapter.

**Chapter 2** presents a virtual reality platform for intelligent vehicles control called IVVR platform, which is a software application that simulates an automatic or semi-automatic traffic in an intelligent virtual 3D environment. First of all, the conceptual design of IVVR platform in Unified Modeling Language (UML) is realized by use-case diagram, class diagram and activity diagram. Then, the soft-

---

ware implementation of the IVVR platform is introduced precisely in software and technology selection and subsystems (VICS, VS, and VWS) description. Finally, a simple experiment with user-in-the-loop for a two-vehicle platoon is carried out to show the performance of the IVVR platform.

**Chapter 3** concentrates on modeling and simulation of NE for intelligent vehicle system based on the IVVR platform. The conceptual model, features and applications of NE are introduced at first, and then, we establish a link between the NE impacts and the intelligent vehicle system by realizing a Virtual Sensor Data (VSD) delivery system which includes several transmitters and receivers of VSD. At last, two experiments of intelligent vehicle system control with environmental impacts are performed and the results indicate that if the weather condition is adominable, automatic vehicle platoon is difficult to maintain a safe inter-vehicle distance all the time with current ACC system.

**Chapter 4** is then devoted to the presentation of a new spacing policy called NECACC which is supposed to be capable of keeping the automatic vehicle platoon running with safe inter-vehicle space even though the NE condition is complex and variable. The basic knowledge of ACC/CACC systems design and their previous works are introduced firstly. Next, the NECACC algorithm design is executed in three steps: deduction of basic NECACC algorithm, proposition of an adaptive NE driving strategy, and analysis of the string stability and traffic flow stability. Finally, this new algorithm is simulated and analyzed in the proposed IVVR platform and a comparison with another classical spacing policy is also realized. Experiments are carried out under fixed NE conditions as well as variable NE conditions controlled by users in a 3D virtual environment.

**Chapter 5** focuses on integrated vehicle control design and performance analysis for common traffic manoeuvres, lane following/lane tracking and lane changing/overtaking, based on the IVVR platform under different NE conditions. These 3D animations are called in this thesis virtual traffic demonstrations and they are described through the simulation architecture design, the integrated intelligent control system introduction, and finally the discusses of simulation results.



# Background

---

## Contents

---

<b>1.1</b>	<b>Introduction</b>	<b>20</b>
<b>1.2</b>	<b>"Driver-Vehicle-Environment" framework</b>	<b>22</b>
1.2.1	The Environment	22
1.2.1.1	Road context	22
1.2.1.2	Weather conditions	23
1.2.2	The Driver	23
1.2.3	The Vehicle	24
<b>1.3</b>	<b>Advanced Driver Assistance Systems (ADAS)</b>	<b>25</b>
1.3.1	Intelligent Transportation Systems/Automated Highway Systems	25
1.3.2	ADAS architecture	26
1.3.2.1	Longitudinal control	28
1.3.2.2	Lateral control	29
1.3.3	ADAS classification	30
1.3.4	ADAS simulation and verification	33
1.3.5	Previous works	34
<b>1.4</b>	<b>Virtual Reality (VR)</b>	<b>35</b>
1.4.1	Brief history	35
1.4.2	Definition	37
1.4.3	Applications	40
1.4.3.1	VR for visualization	40
1.4.3.2	VR for education/training	42
1.4.3.3	VR for virtual prototyping/virtual demonstrations	42
1.4.4	Previous works of VR in transportation systems	43
1.4.4.1	Transportation data visualization	43
1.4.4.2	Simulator/visualization of traffic	44
1.4.4.3	Virtual vehicle design	44
<b>1.5</b>	<b>Conclusion</b>	<b>46</b>

---



## 1.1 Introduction

As the backbone of civilization, transportation is the reason for the economic prosperity for the past 50-plus years. There is serious money in the transportation infrastructure, research, policy, data collection, and software or other IT systems. According to the report "2012: State of the Public Transportation Industry" from the American Public Transportation Association (APTA), \$78 billion is needed to address existing public transit infrastructure needs and even more investment in public transportation infrastructure - not only to update the current backlog, but to meet the growing public demand, and to ensure safety. Fortunately, this investment provides access to jobs and is itself a proven job creator. Every \$1 billion invested in public transportation creates and supports 36,000 jobs, and finally, the public transportation industry is a \$55 billion industry supporting 1.9 million jobs [Melaniphy 2012].

However, things accompanying this massive transportation system are not only significant challenges and opportunities but also serious risk. Statistics on traffic fatalities show that every year, over 40,000 cases are reported in Western Europe, a similar number in the U.S., over 6,000 in Japan, and over a million worldwide. As a matter of fact, approximately one out of three people will be injured in a traffic accident at some point in their lives. Up to the age 55, traffic accidents are the most common causes of hospitalization. Fig. 1.1 shows in 2008 the road safety ranking among the member countries of Organization for Economic Cooperation and Development (OECD) in terms of fatalities per billion vehicle kilometers traveled . It could be deduced that traffic collisions would become one of the major causes of death since forecasts have indicated that this global road toll would likely increase by as much as 50% in the next 20 years, particularly in low and middle income countries, if action is not taken [Government 2011].

A theoretical model of road safety was presented in [Tony Churchill 2010] in which the external influences of road safety are classified into 7 types: Economy, Population health, Technology, Social/Cultural, Mobility, Spatial planning/policy and Weather. Serval road safety measures are also proposed in terms of infrastructure, vehicle and enforcement/education.

Besides, another serious traffic problem is the congestion which incurs further economic loss. For instance, the Texas Transportation Institute [Schrank 2011] estimated that, in 2010, congestion caused urban Americans to travel 4.8 billion hours more and to purchase an extra 1.9 billion gallons of fuel for a congestion cost of \$101 billion. The congestion decreases also air quality by increasing vehicle idling time and emissions and it is not just a big city problem. The growing delays also hit residents of smaller cities (Fig. 1.2). Regions of all sizes have problems of implementing enough projects, programs and policies to meet the demand of growing population and jobs. Generally speaking, traffic jams can occur at any daylight hour, many nighttime hours and on weekends, and the reasons could be work zones, smaller urban areas with a major interstate highway, tourism, geographic constraints and so on. In order to ameliorate the actual situation, the congestion solutions are widely

## 1.1. Introduction

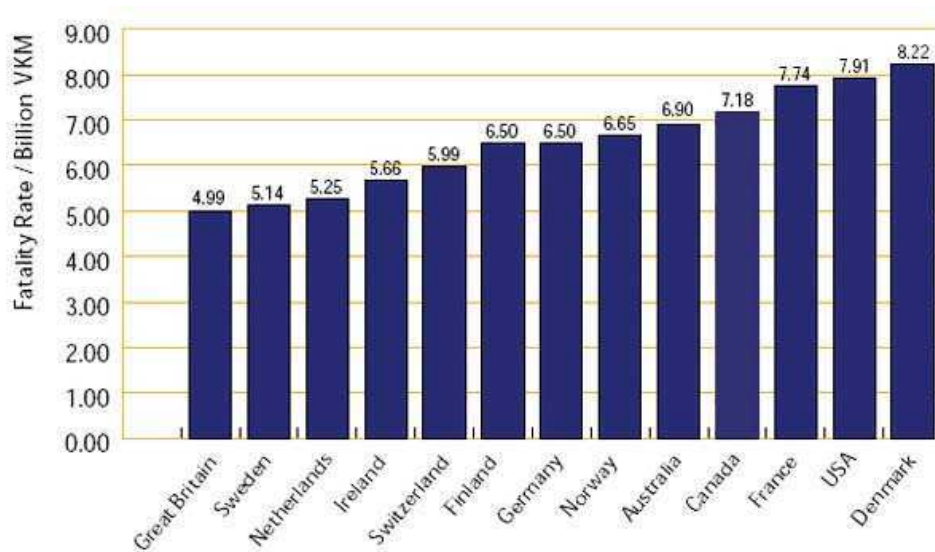

Figure 1.1: Road safety ranking among OECD member countries

studied to provide more public transportation service, improve traffic flow efficiency, and increase traffic capacity.

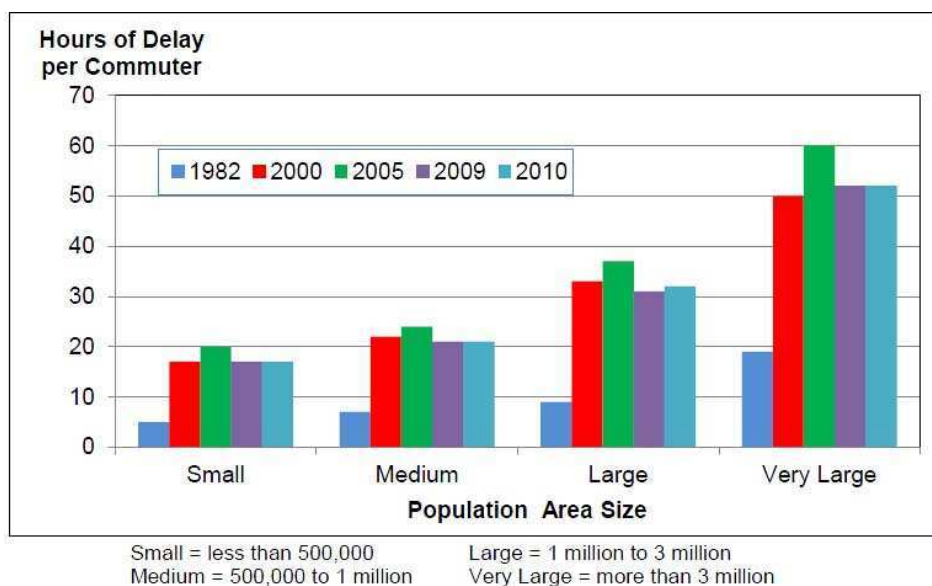

Figure 1.2: Congestion Growth Trend

With all these truths, numerous research studies are underway for the purpose of reducing the traffic accidents, ameliorating the problem of traffic jams and meanwhile increasing the traffic efficiency. A great number of approaches that depend on the level of control objectives (stability, performance, etc), the software/hardware

applications (environment and system specifications), the driver training, the infrastructure constructions, etc. have been described in the past few years. Among them, the presentation of Intelligent Transportation System/Automatic Highway System (ITS/AHS) has attracted many researchers and has been greatly developed in the past of 20 years. Simultaneously, the increasing contributions of Virtual Reality (VR) technology for transportation system have also been paid much more attention to.

This chapter is dedicated to the presentation of this scientific context. This includes firstly the description of the relationships existing among driver, vehicle and environment when driving on the road. After introducing some Advance Driver Assistance Systems (ADAS) in the field of ITS/AHS, the VR technology is imported for resolving some transportation woes in software and the definition and main contributions of VR will be discussed in detail. Finally, previous researches concerning ITS/AHS and VR are expatiated.

## 1.2 "Driver-Vehicle-Environment" framework

When driving a car, the dynamic system can be composed of three elements which involve, in a closed loop, as presented in Fig. 1.3 the framework "driver-vehicle-environment": the Environment, the Vehicle and the Driver. According to Alain Priez [Priez 2000], these factors have different responsibility in traffic accidents. The Vehicle occupies from 10% to 12%, the Environment is between 25% and 30%, and the Driver behavior takes most of the responsibility which can achieve 90%.

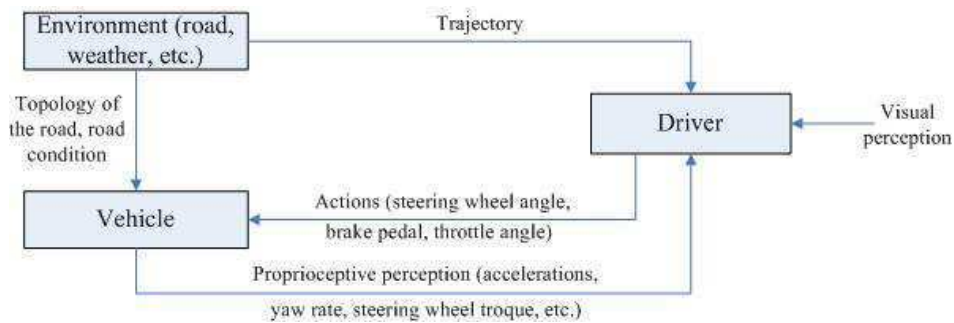

Figure 1.3: "Driver-Vehicle-Environment" framework

### 1.2.1 The Environment

#### 1.2.1.1 Road context

The road context is the most important component of the Environment and is also one of the most discriminating criterions for the accidents or the severity of accidents. Actually, the accident rate depends on the location in a great measure, studies show that about 2/3 traffic accidents happened in the city with less severity

## 1.2. "Driver-Vehicle-Environment" framework

---

than the ones occurred on the highway which bring much more injuries and deaths. The road context can be decomposed into three elements.

- The infrastructure geometry. Roads are physical elements built to provide a convenient infrastructure for vehicle-based travels and they represent the fixed trajectories that drivers must respect. Hence, driving on the road, the geometry can be seen as the source of constraints, as drivers have to take account of the geometric composition of the road (limited width, bends, inclines, etc.) to ensure the security of Vehicles.
- The driving rules. These rules may be of different natures (related to the Vehicle, to the road configuration, etc.) and they may be different according to the transportation laws in different countries. Usually, they are expressed using the signboards, for example, the speed limit sign, the one-way traffic sign, and so on.
- The traffic. It represents the dynamic environment for the Drivers and depends on the location. It is obvious that the urban traffic is much more complicated than the rural traffic. In fact, it can be seen as the integration of static obstacles and moving obstacles (the other vehicles) which have to be considered as constraints by Driver to avoid accidents.

### 1.2.1.2 Weather conditions

The influences of weather conditions reflect on the quality of road surface, the Vehicle dynamics and the Driver behaviors. Under a atrocious weather, in the driver's point of view, an accident can be aroused by poor visibility, poor evaluation of the potential of the vehicle, or inappropriate reaction when facing a new situation.

Fig. 1.4 [Gissinger 1997] describes the risk that a driver may take in terms of the quality of road surface (dry, wet and icy) and the potential of his vehicle. It is clear that when the road surface is dry, very few drivers drive their car over the vehicle potential limit. However, the situation is just opposite under the icy condition.

### 1.2.2 The Driver

To avoid hazardous situations, Drivers are most likely to stay in a vehicle configuration which is considered as safe. The measurements of the different vehicle speeds and accelerations can then help to determine the Driver's level of comfort. Actually, the comfort usually refers to the vehicle accelerations and more precisely to the lateral acceleration. These related accelerations should not exceed a predefined value.

There are several elements that must be mentioned when talking about the Drivers:

- Their activities. Generally speaking, the driver activities can be seen as the transformation of energy or information sampling and precessing system, and they can be divided into four types:

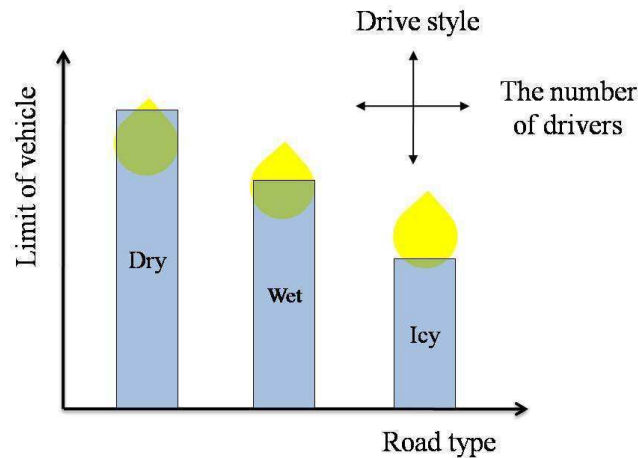

Figure 1.4: Drive style in terms of vehicle potential limit and road type

- Collection activities: searching, acquiring and distinguishing various information, like respecting signboards, signals, etc.
  - Interpretation activities: information processing, problem solving, and decision making.
  - Physical activities: actions like navigation, speed control, lane following and so on.
  - Communication activities: exchange of information with other vehicles or infrastructures.
- Their memories. Driver's memory plays an important role in the complex road driving task, as it allows the drivers to anticipate certain actions according to their similar experiences, helps them to design the drive strategies based on some basic knowledge and also makes them being capable to predict the influence of some operations.

### 1.2.3 The Vehicle

The Vehicle is the system which evolves in the Environment and which is controlled by the Driver. In normal driving, the Vehicle plays a significant role. Regarding to the actions of driver, Vehicle has a reaction which is sensed by the Driver such as visual indicators, accelerations, sound, etc. This helps the driver in his evaluation task, thus allowing him to adapt his actions on the Vehicle. On the other hand, the driver reacts differently in respecting the differences among Vehicles in their characters, their relative comfort or their mechanism. For example, with regard to the number of accidents caused by power/weight problems, it increases significantly among young drivers according to different vehicle performance, while this situation is not suitable for the old drivers.

### 1.3. Advanced Driver Assistance Systems (ADAS)

---

Nowadays, with the development of the automobile industry, the world vehicle production rose significantly during the past decades and simultaneously, modern vehicle integrates more and more technologies to help the Driver driving in security and also with comfort. With the assistant systems and technologies, the future intelligent vehicle is supposed to help drivers to better understand and interpret their environment and assist in the decision making instead of shirking. It will have a set of features that could enhance and extend the capabilities of drivers or palliate their deficiencies.

## 1.3 Advanced Driver Assistance Systems (ADAS)

### 1.3.1 Intelligent Transportation Systems/Automated Highway Systems

As mentioned before, in the real traffic, an accident could be brought by errors in driver behavior, a bad environment condition, or the malfunctions of vehicle. For this, the concept of Intelligent Transportation Systems (ITS) has been promoted as a way to enhance transportation system performance through application of advanced technology to the planning, management and operation of transportation services and infrastructure. These systems bring together users, vehicles and infrastructure into a dynamic relationship of information exchange, reduce the risk from individual driving behaviors or visibility problems, etc. and finally result in better management strategies and more efficient use of available resources, as described in Fig 1.5.

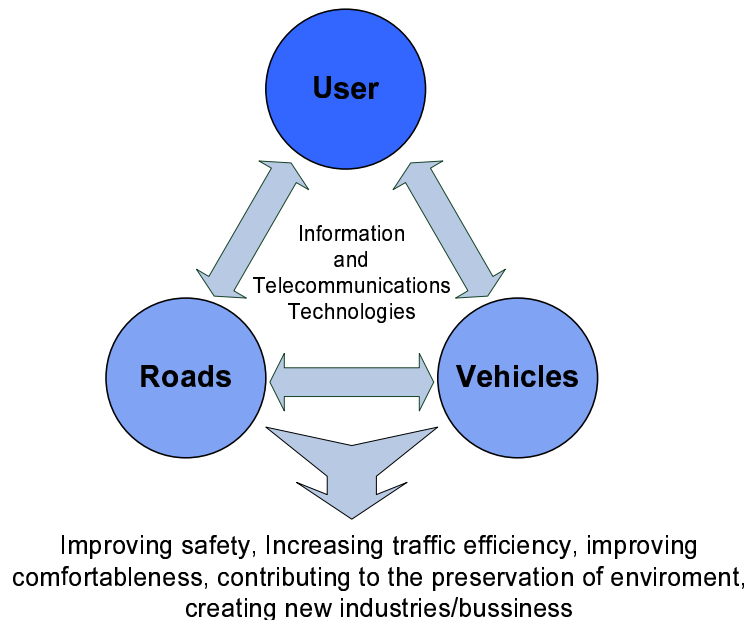

Figure 1.5: Intelligent Transportation System illustration

The Automated Highway System (AHS) is one of the most important items among the diverse topics in ITS research. The full automated highway systems assume the existence of dedicated highway lanes, where all the vehicles are fully automated, with steering, brakes and throttle being controlled by a computer [Tomizula 1993]. In brief, the AHS concept combines on-board vehicle intelligence with a range of intelligent technologies installed onto existing highway infrastructure and communication technologies that connect vehicles to highway infrastructure [Cheon 2002].

Clearly, technology and technology integration are key aspects of ITS/AHS. They have supported the development of a wealth of ITS/AHS user services for better transportation performance. Examples include [Canada 1999]:

- Traveler information & route guidance
- Incident management
- Traffic control (including transit priority strategies)
- Commercial vehicle electronic clearance
- Collision avoidance systems
- Electronic payment services
- Fleet management

As studies have shown that over 90% of highway accidents occur due to driver-related human errors, especially under bad road conditions, such as failing to keep safe distance, overtaking when there was poor visibility, or by not giving way to an overtaking vehicle, etc. Nowadays, for improving this situation, most of the related researches in the field of ITS/AHS focus on the ADAS design which can bear part of the driver's works. ADAS aim for reducing congestion, promoting more sustainable travel modes, and increasing the efficiency and safety of the transportation and the level of service afforded to travelers. Actually, these embedded electronics (ADAS) contribute to the revolution of automobile since few years. They account for about 20% of the manufacturing cost of a vehicle and reach 35% of the top grade vehicles equipped with a guidance system. These devices play different roles, from the low level functions for controlling the operation of mechanical parts to the highest level functions which could improve the traffic safety and driver comfort [Merie-Agnes 2002].

### 1.3.2 ADAS architecture

The general architecture of an advanced driving assistance system can be represented by a pyramidal form (see Fig. 1.6). This pyramidal form describes the evolution of information flow: the raw data are extremely numerous, the symbolic information are less, and the pertinent information for drivers are very few [Merie-Agnes 2002].

The information concerning Environment, Vehicle and Driver are collected through sensors and this results in a number of raw data as inputs to the electronic co-driver.

### 1.3. Advanced Driver Assistance Systems (ADAS)

---

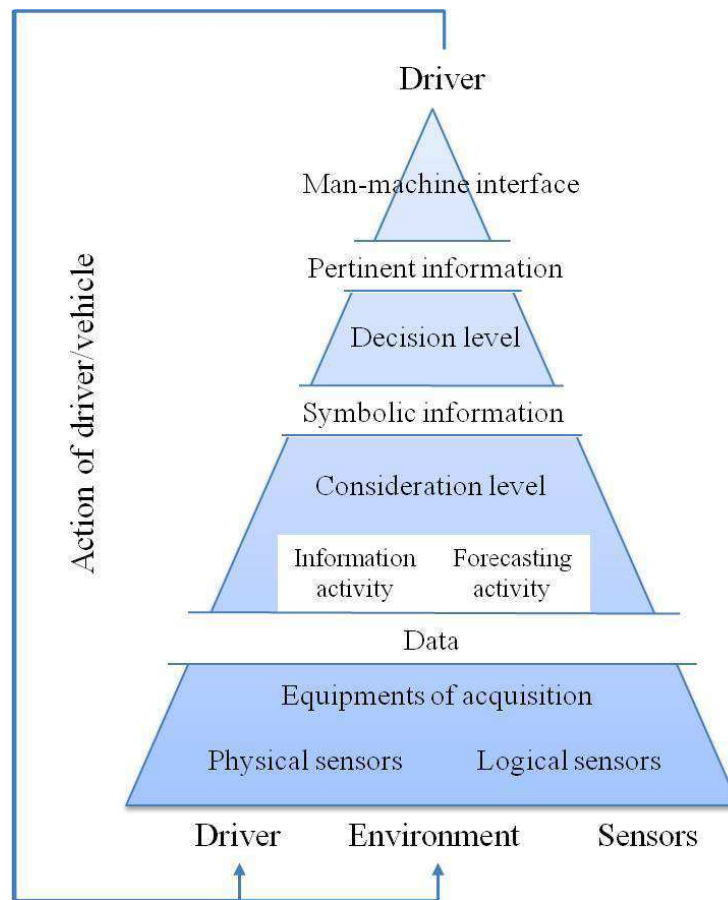

Figure 1.6: General architecture of ADAS



These data are then analyzed and transmitted as Symbolic information by Information activity. Next, These Symbolic information are analyzed by the Decision level in refining and completing them. As outputs, the Decision level elaborates the Pertinent information for Driver, such as warning signals or action propositions.

The Consideration level is in charge of generating the decision signals for the Decision level. It is made up of two activities: the Information activity which translates the raw or heterogeneous data to be in the symbolic form and the Forecasting activity which analyzes the corresponding assumptions and forecasts possible future situations by using the rest of the data.

The Decision level is responsible for providing Pertinent information according to the requirement of driver via the Man-machine interface. It also consists of two activities, one is elaboration activity which analyzes the decision signals from Consideration level to propose possible vehicle actions and the other is execution activity which controls and guides the driver when carrying out an action.

Actually, the objective of these driving assistance systems is acting as approximately as possible to the driver style during a driving task, as shown in Fig. 1.7. The driver is kept in the control loop by receiving the information from co-driver (e.g. ADAS) but still being responsible of the driving decision-making.

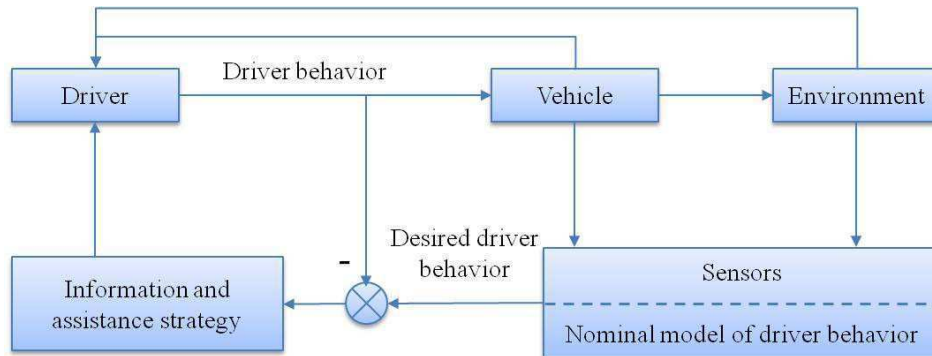

Figure 1.7: Basic structure of ADAS

Driving on the highway, the high-speed as well as the monotone driving style could generate several specific hazards. In order to overcome these problems, different types of ADAS are studied in terms of longitudinal control and lateral control.

### 1.3.2.1 Longitudinal control

As a central task of intelligent vehicle guidance, the longitudinal control relates to monitoring and controlling the vehicle speed in taking account of road trajectory and preceding vehicles or obstacles. Driver should always pay attention to the actual traffic situation and then make decision of the vehicle’s velocity, inter-vehicle distance with the preceding vehicle and relative velocities with sufficient accuracy and frequency. These decision-makings require a high level of vigilance and focused

### 1.3. Advanced Driver Assistance Systems (ADAS)

---

attention of the driver.

Fortunately, the sensors equipped on the ADAS can help drivers to control the inter-vehicle space as well as the speed by providing useful information, such as vehicle acceleration, vehicle rotational speed, wheel rotational speed, steering angle and so on. Usually, we use infrared lasers or radars with a range of 150m to 200m, which are combined with sophisticated tracking algorithm and obstacle classification. The technologies of image processing are also developed for intelligent longitudinal control.

Generally, longitudinal control system contains a high-level controller which aims to calculate the desired acceleration and a low level controller to achieve this acceleration by controlling throttle and brake. Several challenges must be handled in the longitudinal control system design, such as nonlinear vehicle dynamics, spacing policy and its associated control law design, string stability and traffic flow stability, as well as operation at all speed: from high-speed to a complete stop [Rajamani 2000] [Santhanakrishnan 2003].

#### 1.3.2.2 Lateral control

Among driving tasks, maintaining the vehicle on its desired trajectory requires the most efforts and time. With lateral control, the vehicle's trajectory can then be controlled. In order to carry out the lateral guidance, detecting the relative position of vehicle in comparing with the center line of the road is necessary. The localization can be realized by the following methods:

- Detection of labels situated on the surface of inter-lane or road edge.
- Reading magnetic band that is glued on the road.
- Differential GPS.
- Detection of non-magnetic and non-inductive ferrous wire.

The detection of horizontal labels seems very suitable to the localization of vehicle when the visibility is good and the road surface is dry, but it works not very well when it is rainy. The magnetic band can output interesting results but there exist several filter problems. The differential GPS is capable of providing a vehicle's precise location and the detection by ferrous wire could be feasible with some simple algorithms.

In addition, lateral controllers for lane departure, lane keeping, lane changing or overtaking should be designed to provide the corresponding strategies for the above lateral actions. Normally, the lateral controller is composed of two levels of controllers, one for the design of desired lateral trajectory, and the other is for executing the desired strategy. Regarding the modeling of vehicle lateral dynamics, the model often used for practical purposes is the well-know Bicycle model [Rajamani 2006].

### 1.3.3 ADAS classification

In the field of ADAS, there are three levels of solution, from the simplest system used to provide information only to more complex system which is responsible for all the driving tasks [Merie-Agnes 2002]. The descriptions of the above three levels of system are listed as follows:

- The informative systems which do not attach themselves directly to the vehicle but can handle the malfunctions which would lead to the risk for driver or vehicle. At present, the researches of this kind of system concentrate on the developments of the following applications or functions:
  - Rear vision for detection in the blind angle.
  - Detection of driver vigilance: deducted from driver behaviors or measured by eye tracking.
  - Detection of obstacles.
  - Predictive detection of vehicle departure.
  - Parking assistance system.
  - Vehicle-to-vehicle or vehicle-to-infrastructure communication.

These devices are all possible to help avoiding traffic accidents.

- The active systems which are used in case of detection of dangers. A typical system of this kind is Anti-lock Braking System (ABS) which becomes active only when the wheels lock. ABS improves the traffic management and efficiency in case of emergency braking. Other active systems being developed are:
  - Predictive air-bag.
  - Path stability control.
  - Longitudinal collision avoidance system.
- The automatic control systems which aim to the improvement of security and comfort of drivers. Several topics of this kind of system are listed as follows:
  - Inter-vehicle distance control together with collision avoiding and communication.
  - Urban longitudinal control.
  - Transverse highway control.

Actually, these ADAS can also be classified by their functions of supporting: in longitudinal vehicle control or in lateral vehicle control. They are supposed to assist drivers by either providing warning to reduce crashes or performing some of the control tasks to relieve a driver from repetitive and boring tasks. Some examples of ADAS are described in details as follows.

### 1.3. Advanced Driver Assistance Systems (ADAS)

---

Lane keeping Support (LKS) (the third level of ADAS classification), Lane Departure Warning (LDW) (the first level of ADAS classification) and Lane Change Decision Aid (LCDA) systems (the third level of ADAS classification) are designed for the lateral vehicle control. The LKS system is supposed to help drivers in lane keeping, especially on the curved road. The LDW system will warn the driver if his or her vehicle leaves its lane unintentionally, while a LCDA system will check for obstacles in a vehicle's course when the driver intends to change lanes.

Collision Warning (CW) and Collision Avoidance (CA) systems (belong to the second level of ADAS classification) are designed concerning the longitudinal vehicle control to warn drivers the possibility of collision once the inter-vehicle space is below the standard one. It maintains a constant desired speed in the absence of preceding vehicles. If a preceding vehicle appears, the CW/CA system will judge the operation speed is safe or not, if not, the CW/CA will reduce the throttle and/or apply brake so as to slow the vehicle down, and at the same time a warning is provided to the driver.

With respect to Adaptive Cruise Control or Cooperative Adaptive Cruise Control (ACC/CACC) (belong to the third level of ADAS classification), they are presented for the longitudinal vehicle control in keeping a safe inter-vehicle distance as well as guaranteeing an appropriate traffic capacity on the highway and will be introduced precisely in this section.

Actually, ACC/CACC systems are now commercially available in a wide range of passenger vehicles and are the focus of researchers, automakers, governments and consumers across the world. The first generation of ACC systems was included in some luxury vehicles by automakers and their suppliers primarily from the viewpoint of enhancing driving comfort and convenience with some additional potential increase in safety [Vahidi 2003].

Furthermore, several related key issues have been concerned by the researchers, automakers, governments and consumers across the world from theoretical research, system development, component implementation, product manufacturing to market deployment, as shown in Table 1.1. These issues can primarily be categorized into three types: human issues (driver-behaviour, user-acceptance and human-machine), traffic issues (safety, capacity and stability) and social issues (environment, market and law).

According to the signal flow and operating process of an ACC system, the system's architecture can be split into four major parts, which are illustrated in Fig. 1.8: signal collecting (SC), signal processing (SP), signal actuating (SA) and signal displaying (SD) parts [Xiao 2010].

The difference between ACC and CACC is the SC part. For CACC, the motion signals of the preceding vehicle should also be collected as inputs of SP. The operating process of ACC can be described as follows. The switch control module always detects the ON/OFF signal during driving. If the switch button is pressed to the ON position and the velocity and time headway have been set by the driver, the switch control module activates the ACC system. The range sensor starts to detect the preceding objects. If the preceding objects are not available or are far away and

Table 1.1: Related focuses towards different stakeholder [Xiao 2010]

Focuses	Researcher	Automaker	Consumer	Government
Driver-behaviour	✓	✓	✓	
User-acceptance		✓	✓	
Human-machine		✓	✓	
safety	✓	✓	✓	✓
Capacity	✓			✓
Stability	✓			
Environment	✓	✓		✓
Market				
Law				✓

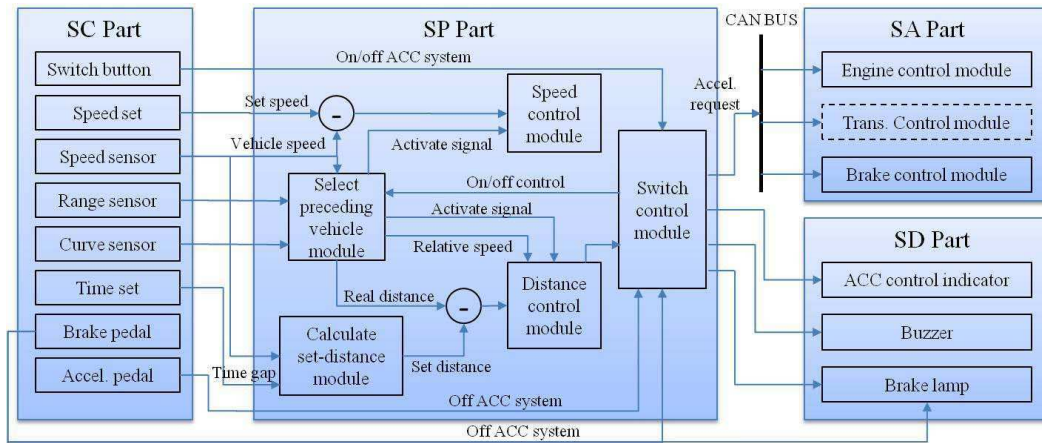

Figure 1.8: ACC system architecture

### 1.3. Advanced Driver Assistance Systems (ADAS)

---

running fast, the speed control module is activated by selecting the preceding vehicle module; then the vehicle automatically operates in the velocity control state with the user-set velocity of the speed control module, which controls the engine control module (transmission control module is an option). If the preceding objects are available and too close or running slowly, the distance control module is activated by selecting the preceding vehicle module; then the vehicle automatically operates in the spacing control state with the user-set time headway of the distance control module, which controls the engine control and brake control modules. If the switch button is pressed to the OFF position or either the brake pedal or the acceleration pedal is pressed by driver, the switch control module turns off the ACC system.

#### 1.3.4 ADAS simulation and verification

As the last step of ADAS design, the simulation and verification must be performed in ways of hardware-in-the-loop or software-in-the-loop before being used in a real traffic.

If using hardware-in-the-loop, the test car is fundamentally necessary to validate the researches from laboratories, such as certain new subsystems or some new concepts. This kind of car should be the one whose characteristics and basic behaviors are well known and when trying to test one of its subsystems, it is preferable to add just the subsystem which is intended to be tested and not change any other things so as to clearly identify what advantages this new subsystem could bring.

Thanks to sensors, the wiring, and the data acquisition systems (like GPS), now almost all of the necessary measurement could be obtained and processed for the test vehicle [Bouafif 2012], for example, the state of the vehicle including velocity, acceleration, position, steering angle, etc., the state of static environment like the number of lanes, the road type, etc. and the state of dynamic environment which means the velocity or acceleration of the other vehicles, the inter-vehicle space, etc. Besides, there are also some measurements inside the vehicle, such as forces or moments. The above data can be transmitted by wiring inside the vehicle and by wireless communication between vehicle and other vehicles or infrastructures. In fact, some of these equipments are very expensive and should be chosen carefully.

The reliability of this kind of vehicle test can possibly be affected by vibration, temperature, humidity, etc. and this means when choosing the related materials for a test, we should pay much attention to their quality. Concerning the highway for testing, normally, the road being protected are used to held the experiment for the purpose of security.

It is obvious that the test with real vehicles is very complex. It costs lots of money for purchasing necessary devices (e.g. vehicles, sensors, etc.) and loses a lot of time in organizing and performing. If it fails, ADAS must be improved and another experiment must be carried out. Additionally, several unforeseen dangers may exist if driving in bad road or weather condition. Therefore, we propose the simulation and verification of ADAS being realized in software supported by some powerful calculating software like Matlab/Simulink or contemporary simulation technology,

like Virtual Reality which will be described precisely in the next section.

### 1.3.5 Previous works

With respect to the ITS projects in the world, in USA, the program PATH (Partners for Advanced Transit and Highways) is one of the most fruitful organization in transportation researches and it was created by the Caltrans (California Department of Transportation) and ITSUC (Institute of Transportation Studies of the University of California) in Berkeley in 1986 [PATH]. Its current research projects are mainly in fields of transportation safety, traffic operations and modal applications. In 1997, the project IVI (Intelligent Vehicle Initiative) programme was also carried out, which is a government-industry partnership to accelerate the development and commercialization of safety and driver assistance systems.

In France, PREDIT is a programme of research, experimentation and innovation in land transport, started and implemented by the ministries in charge of research, transport, environment and industry, the ADEME (Agence gouvernementale De l'environnement et de la Maîtrise de l'Energie) and the ANVAR (Agence National de Valorisation de la Recherche) [PREDIT]. Since 1990, the PREDIT has past three phases, the first phase PREDIT 1 (1990-1994) was mainly devoted to technological innovations in vehicles. PREDIT 2 (1996-2000) covered a wider field including the aspects of human and society sciences and transport services organization, etc. PREDIT 3 (2002-2006) aimed at the goods transportation and energy and environment issues, as well as a diversified research on safety. Now, the PREDIT 4 (2008-) is currently implemented, and its objective is to improve 20% of energy efficiency in 2020, priority the other transportation methods (no-road), develop the ecological tax, etc.

In China, the ITSC (National Intelligent Transport System Center of Engineering and Technology) was established in 1999 and supported by the Ministry of Science and Technology. It aims at improving traffic safety and efficiency by using the communication and information technologies.

A brief chronology of the ITS development in the world is shown in Fig. 1.9 and more details can be found in [Zhao 2010].

Along with these projects, ADAS were widely studied by researchers in the whole world. Various aspects are taken into account, such as the traffic maneuvers (lane tracking, lane following, lane changing and overtaking) [Amditis 2010] [Naranjo 2008], the driver behavior analysis [Viti 2008] [Pauwelussen 2010] and the string stability or traffic flow stability analysis of ADAS equipped vehicle platoon [Swaroop 1996] [Xiao 2011].

The latest news concerning the ADAS development should be the Google self-driving car which has just gotten a driving licence approved in Nevada in May 2012. The car uses video cameras mounted on the roof, radar sensors and a laser range finder to "see" other traffic. It has covered 140,000 miles with no accidents, other than a bump at traffic lights from a car behind. Google maintains that the technology is not supposed to replace drivers, but rather help them. Humans can

## 1.4. Virtual Reality (VR)

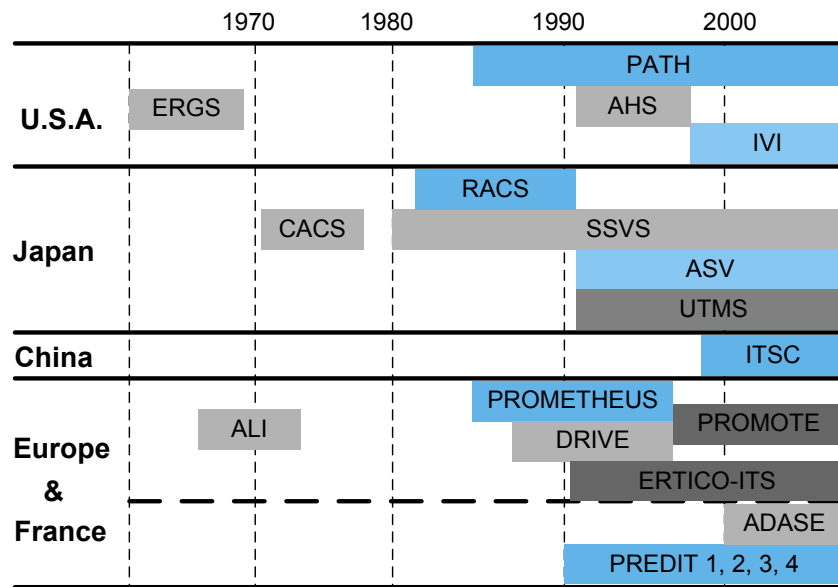

Figure 1.9: ITS development chronology in the world [Zhao 2010]

always gain control of the car by taking hold of the wheel or stepping on the brake [BBCNews].

## 1.4 Virtual Reality (VR)

### 1.4.1 Brief history

Virtual reality systems actually appeared earlier than the term of virtual reality. The first famous application is the *Sensorama* of Morton Heiling [Fuchs 2006], which was constructed in 1965 (see Fig. 1.10 left). It allowed a user being in a previously filmed real scene with visual and auditory immersion. In the 1960s, Ivan Sutherland proposed *Sketchpad* (see Fig. 1.10 right), which was the first system to use a graphical interface and considered as the ancestor of Computer Assistance Design (CAD) systems. He later proposed one of the first virtual reality helmet systems *Ultimate Display* with his student Bob Sproull [Fuchs 2006].

In 1970, the artist Myron Krueger created a multimedia interactive installation called *videoplace* [Krueger 1985] to illustrate his concept of "artificial reality". This system consists of a screen and a camera and it allows users to interact with various 2D virtual environments which are able to interpret and react to user gestures (Fig. 1.11 (left)). Next, in 1981, a NASA (National Aeronautics and Space Agency) created a prototype HMD (Head Mounted Display) containing mini LCD screens, called *VIVED* (*Virtual Visual Environment Display*) [Fisher 1987]. The objective of this project is to develop new interfaces that allow improving the simulators for astronauts (see Fig. 1.11 (right)).



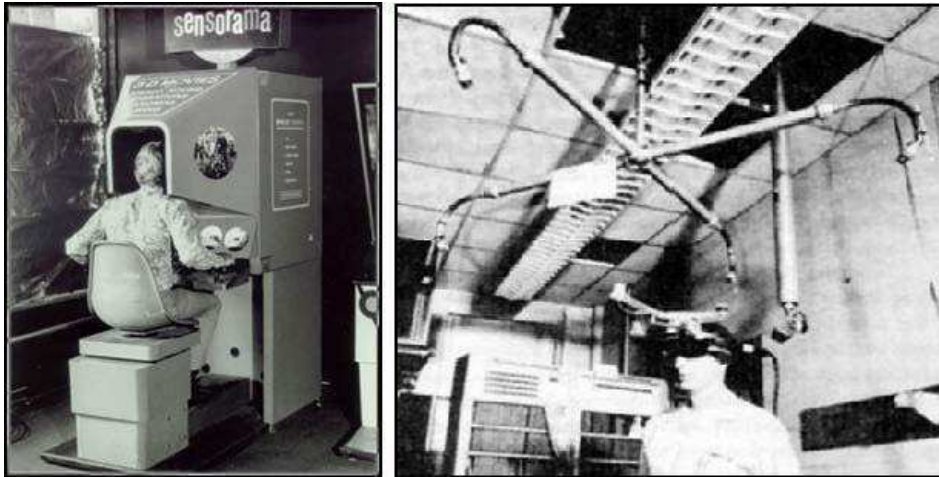

Figure 1.10: Virtual reality systems: left, the *Sensorama* (1965), right, the *Ultimate Display* (1968)

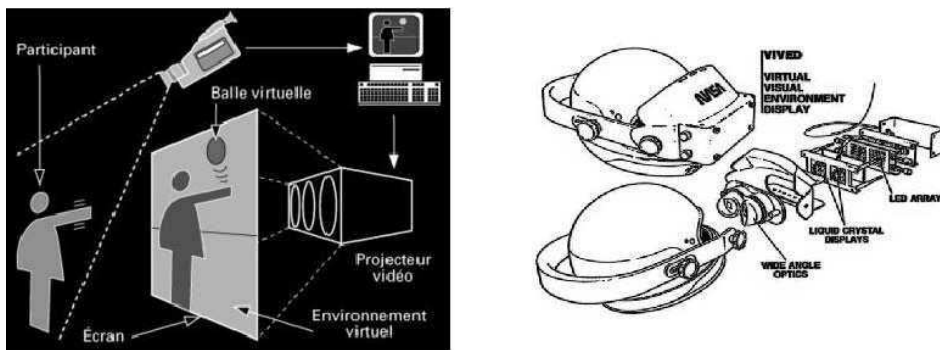

Figure 1.11: Virtual reality systems: left, the *Videoplace* (1970), right, description of HMD of project *VIVED* (1981)

## 1.4. Virtual Reality (VR)

---

Although the devices being capable of reproducing an image in 3D have appeared in the middle of 19th century, the term of Virtual Reality (VR) was introduced the first time in 1988 by Jaron Lanier. He invented this expression in connection with the marketing strategy and advertising for his company. He describes the VR as a technology that uses computer to create synthesized realities, which could be shareable by multiple people and be felt through five senses of human being [Ouramdane 2008]:

*"We are speaking about a technology that uses computerized clothing to synthesise shared reality. It recreates our relationship with the physical world in a new plane, no more, no less. It does not affect the subjective world; it does not have anything to do directly with what is going on inside your brain. It only has to do with what your sense organs perceive (Lanier, 1988)."*

Since the presentation of the above description, VR has been defined in several ways, like from its purpose, its applications, its features or its technologies and so on. These different definitions divide the researchers into several areas according to their scientific community and their own definition of "virtual". Paul Milgram [Milgram 1994] presented a unification of concepts by considering a linear continuum that goes from real to virtual. It defines Mixed Reality as the interval between the real and the virtual, as illustrated in Fig. 1.12.

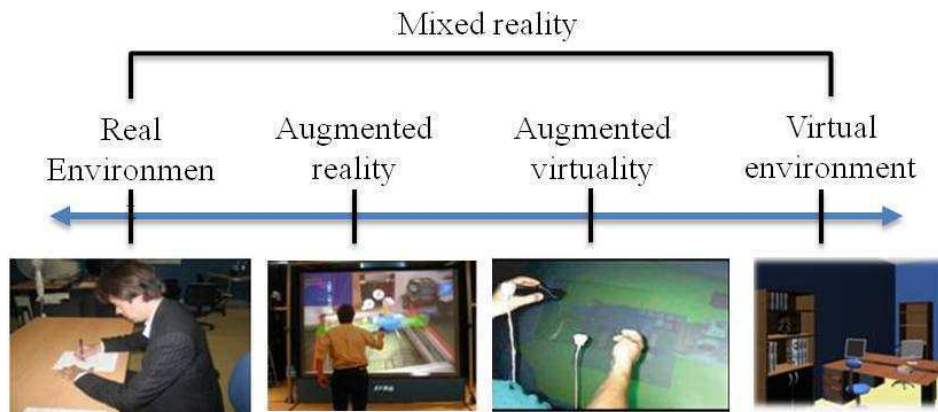

Figure 1.12: The continuum of "real - virtual"

### 1.4.2 Definition

As a matter of fact, a precise definition of VR is difficult because of the following three reasons [Chellali 2009]:

- Firstly, being a recent concept, its definition is evolving quite rapidly

- Secondly, the VR is at the intersection of several areas such as robotics, computer graphics, man-machine interface, real-time computing, ergonomics, physical and physiological and more recently psychology and cognitive ergonomics. Although VR is most often related to computer science, the contribution of other disciplines in recent years can not be overlooked. The VR has taken this multidisciplinary approach to construct itself as a research field.
- Thirdly, the impact of VR on the general public through the mass media has led to numerous interpretations and this impact is sometimes inconsistent in terms of issue.

Thus, we offer here a brief review of key definitions to extract and define the key concepts necessary for our researches in this thesis.

Recently, the definition of VR is not single, and it was designated by several terms that we can find in the literature such as *Virtual Environment*, *Virtual Space*, *Artificial World*, *Synthetic Reality* and so on. Each of the above terms traverses several research areas and researchers in a field does not necessarily give the same definition as those of another field for the same term. For example, the VR studies of a mathematician or a philosopher will not be the same as the ones of a computer scientist.

Aukstakalnis and Blatner [Aukstakalnis 1992] have developed a general definition of VR. They think that VR is a way that allows humans to visualize, manipulate and interact with computers and extremely complex data.

Burdera et Coiffet [Burdea 1993] introduced three basic components for VR: *Immersion*, *Interaction* and *Imagination* (see Fig. 1.13). *Immersion* is related to the perception of user in the 3D virtual world which is directly accessible by different senses of user. There exist several levels of immersion according to the number of human senses that the VR system focuses on. Indeed, some applications permit the immersion performance with a single computer screen. *Interaction* represents the communication language between human and machine. This language permits the user to change the virtual world and to get feedbacks from it through sensory interfaces. It is easy for most of people to understand that VR is both immersive and interactive, however, the *Imagination* may need more explanations. In fact, VR is not just a medium or a high-end user interface, it also has applications that involve solutions to real problems in engineering, medicine, military, etc. These applications are designed by virtual reality developers. The extent to which an application is able to solve a particular problem, that is, the extent to which a simulation performs well, depends therefore very much on the human *imagination*. Actually, we can also find out that the third "I" *Imagination* is replaced by *Presence* or *Real-time* in some other similar definitions.

Tisseau [Tisseau 2001] defined the VR as a universe of models in which everything happens as if the models were real because they offer the same triple mediation of senses, action and spirit (see Fig. 1.14). The mediation of senses permit the perception of reality, the mediation of actions can conduct experiments while the mediation of spirit allows the mental representation of reality.

#### 1.4. Virtual Reality (VR)

---

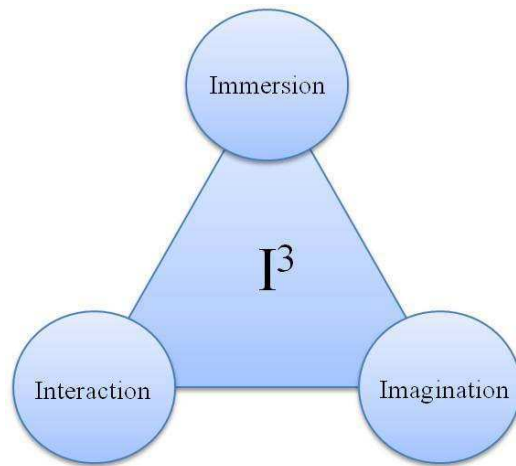

Figure 1.13: Virtual reality triangle

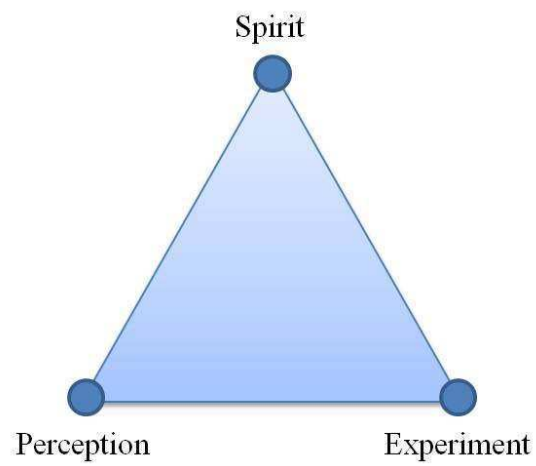

Figure 1.14: The mediation of reality

Other researchers consider this new technology as the extension of classic man-machine interface that simulates a 3D realistic environment and allow participants to interact with it [Chellali 2009] [Ellis 1994].

According to the above different definitions, three key concepts appear to be essential to define a virtual reality system: real-time interaction, real-time immersion and the use of a 3D realistic environment.

### 1.4.3 Applications

The applications of VR exist in many different domains and can be classified by several criterions, like their objective, their supporting technology, their features and so on. In our research work, we focus on the VR applications in terms of visualization, simulation and interaction which are important features of VR.

#### 1.4.3.1 VR for visualization

As mentioned before, VR can provide us a 3D virtual environment with realistic objects and this function allows us to visualize some real-world phenomena that can not been seen by humans directly and make them easier being understood. For example, some VR applications can do exploratory analysis of abstract data (information visualization) such as the multidimensional complex digital data. The data can be materialized visually by showing some of their invisible features so as to do some further researches. Fig. 1.15 (left) shows a data visualization concerning earthquake [Frohlich 1999]. Besides, VR are also used to do the scientific visualization which can visualize certain physical phenomena that are too small to be seen (e.g. radioactivity, nano technology, inside of human body, etc.) by displaying them on a larger scale or in symbolic form. Fig. 1.15 (right) shows the visualization of molecules represented by atoms in spherical models, and this method can make us better understanding their properties [Lourdeaux 2001]. Besides, the visualization of natural environment scenes is also an important application of VR. This kind of natural environment simulation contains the visualization of environmental images generated by sensors as well as the visualization of all visible information (such as, road, river, etc.) or non-visible information (such as, temperate, wind distribution, etc.) in the natural environment.

The VR visualization can also been found in the 3D video games which significantly contribute to the development of computer graphics. An example called *The Sims* is presented in Fig. 1.16 (left), which is a simulation of daily activities of one or more virtual characters. And we can also find some VR demonstrations in museums which are used to attract visitors. Fig. 1.16 (right) shows the virtual theater of the museum called *Musée Canadien de la Civilisation à Hull ou du Musée d'Histoire* in the city Nantes in France. It offers visitors the opportunity to take a virtual tour of Nantes in the 18th century with its panoramic photos in 2007 [Chellali 2009].

## 1.4. Virtual Reality (VR)

---

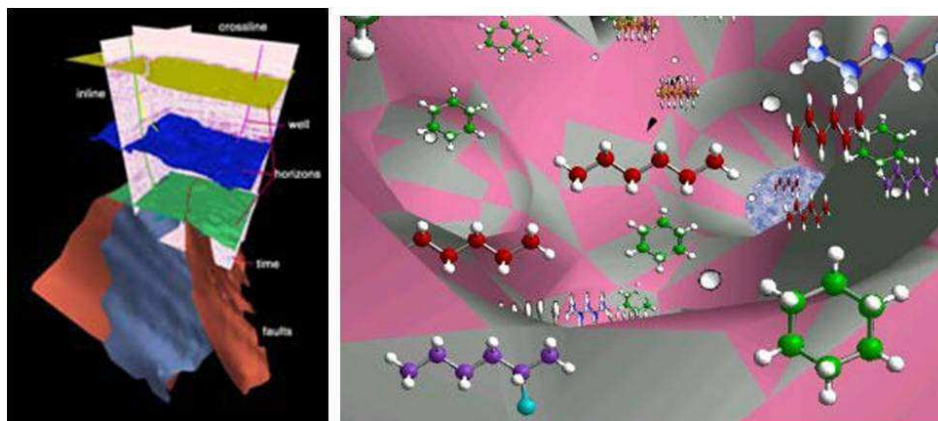

Figure 1.15: Left: Data visualization concerning earthquake [Frohlich 1999]; right: Visualization of molecules inside of a catalyst [Lourdeaux 2001]



Figure 1.16: Left: the video game *The Sims*; right: the virtual tour of Nantes in 1757

### 1.4.3.2 VR for education/training

In many cases, the classical education and training show their limits and it seems more appropriate to use the VR technology, which is capable to avoid certain risks relating to the training in real situations (e.g. maintenance of a nuclear plant), to reduce the cost or time in a real situation (e.g. the trainings to fly a plane) or to make the trainings more accessible in some rare real situations (e.g. the trainings for disaster management). The designers then try their best to make the virtual situation being as close as possible to the real situation, although this is generally constrained by the limits of technology. But this aspect should not be considered as a restriction. Indeed, it is absurd to use a simulation to have exactly the same behaviors as that of the real world. Instead, some aspects must be disregarded (e.g. educational needs), the designer must first define the aspects to be reproduced as needed for the application [Chellali 2009]. This kind of VR applications can be classified by domain (like military, medical, etc.) or the aims of education or training (like gesture learning, knowledge learning, etc.). Fig. 1.17 (left) shows the application *SecuReVi* used to train firefighters for operational management and command [Querrec 2003]. Fig. 1.17 (right) shows an application in the mining field [Lourdeaux 2001].

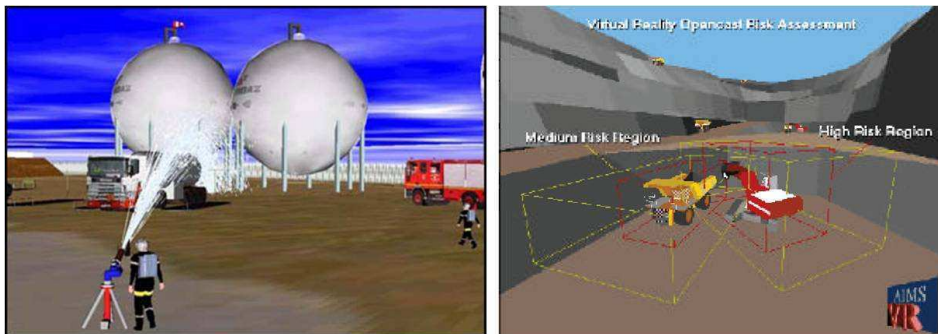

Figure 1.17: Left: the training application *SecuReVi* [Querrec 2003]; right: risk analysis in a mine [Lourdeaux 2001]

### 1.4.3.3 VR for virtual prototyping/virtual demonstrations

Recently, VR is also applied for virtual prototyping to verify assembly of mechanical systems and maintenance processes. Sankar Jayaram [Jayaram 1999] presented the Virtual Assembly Design Environment (VADE), which is a VR-based engineering application that allows engineers to plan, evaluate, and verify the assembly of mechanical systems. The main purpose of this project was to explore the potential and the technical challenges in using VR technologies for design and manufacturing by creating a virtual environment for assembly planning and evaluation (see Fig. 1.18 (left)). Besides, some virtual demonstrations have also been studied to describe

## 1.4. Virtual Reality (VR)

---

a product design or city planning before their realizations. Fig. 1.18 (right) is a scene of the project which studies the impacts of the integration of tram in an urban landscape of the city Nantes (France) [Donikian 1999].

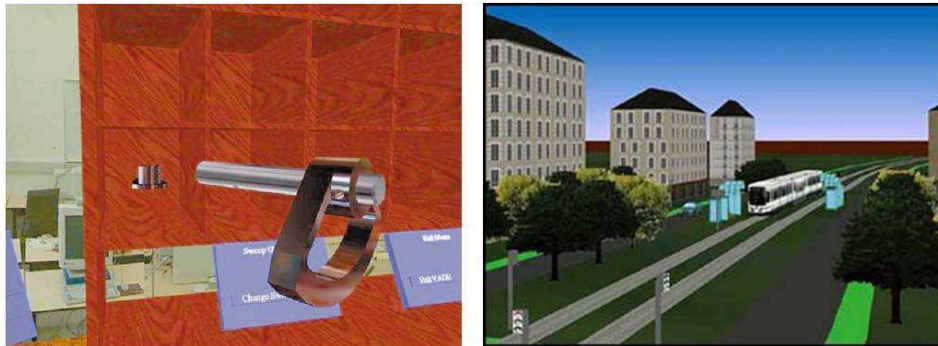

Figure 1.18: Left: A dynamic simulation. The pendulum-like part rotates about the shaft and translates along the shaft axis [Jayaram 1999]; right: the study of impacts of the integration of tram in a urban landscape of Nantes [Donikian 1999]

### 1.4.4 Previous works of VR in transportation systems

Recently, more and more VR applications are applied into the studies of transportation systems to obtain some specific and important advantages that we can not get from the real world directly. Previous work can be divided into three categories: transportation data visualization, simulator/visualization of traffic, and virtual vehicle design.

#### 1.4.4.1 Transportation data visualization

Today, a huge amount of traffic data could be collected (through GPS, sensors, etc.) in the world's road and stored in devices such as tape, disk and CD. It is known that statistics from this data has great potential to improve the traffic performance and traffic data visualization can provide an easy accessible approach for reducing complex and tedious statistical data to simple but powerful information that can benefit non-professional and professional users alike. Such information visualization tools have already been studied and developed, for example, the Incident Cluster Explorer (ICE) in CATT (Center for Advance Transportation Technology Laboratory) lab of University of Maryland lets users easily analyze data related to Virginia, D.C., and Maryland accident reports [Pack 2010]. ICE integrates an array of information visualization widgets that work together to drive the user toward discovery and understanding that were previously difficult to obtain. [Shekhar 2002] also constructs the *CubeView* visualization system which presents information in various formats to assist transportation managers, traffic engineers, travellers and



commuters, and researchers and planners to observe and analyze traffic trends. Besides, [Sewall 2011] visualized the vehicle trajectory data containing samples for the position, velocity, and acceleration of each vehicle at regular intervals each separated by 1/10th of a second and also the length, width, and type of each vehicle in a 3D virtual environment (see Fig. 1.19).

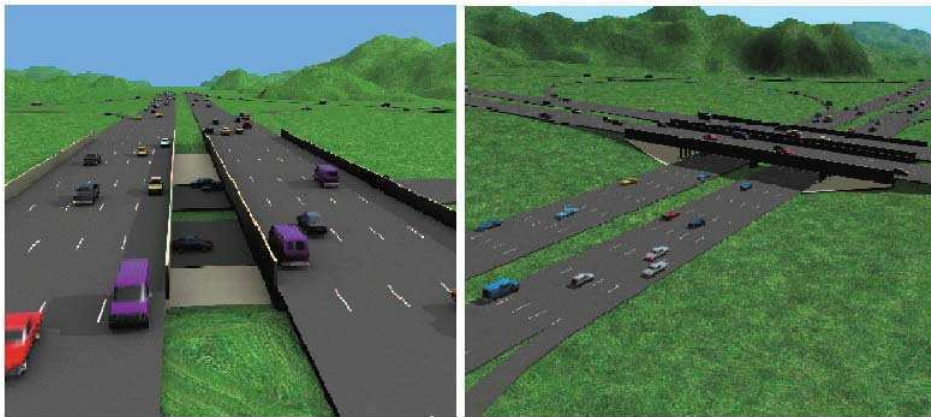

Figure 1.19: Images from the virtual traffic jam scenario [Sewall 2011]

### 1.4.4.2 Simulator/visualization of traffic

Many researches in simulation or visualization of a designed ITS system have been done in the past of few years. Abdullah Cavusoglu [Cavusoglu 2011] developed a parameterized driver Traffic Training Simulator (TTS) with intelligent synthetic agents or actors for training driver candidates. These intelligent actors in traffic are capable of moving according to the traffic signs and lights. Parametric values such as duration of traffic lights, weather conditions, seasons and sunlight can be fed to the simulator as inputs. Xu Hongke [hongke 2007] realized the simulation system about highway tunnel traffic control and guidance based on virtual reality technology and MultiGen Creator/Vega [MULTIGEN]. This system can serve as a train flat on which people can learn about the operation management in highway tunnel traffic under normal condition and it can simulate the process of the strategy in highway tunnel operation management. Fig. 1.20 shows some virtual scenes of the simulation results of highway tunnel. Examples of driving simulator are also illustrated in Fig. 1.21.

### 1.4.4.3 Virtual vehicle design

Virtual prototyping decreases the time between the design phase and the market introduction of the new product, at the same time allowing for improved quality. This technology can reduce the costs and satisfy users' requests in a more precise way: presenting them with something more concrete other than plans. Lehner

#### 1.4. Virtual Reality (VR)

---

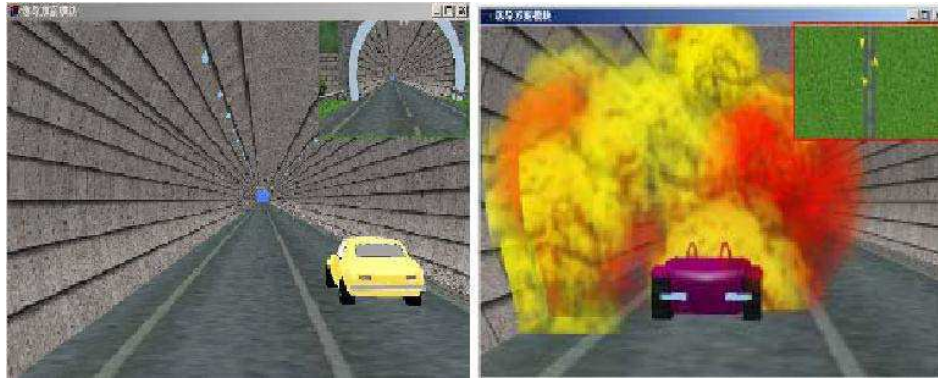

Figure 1.20: Simulation under normal operation (left) and fire condition (right) [hongke 2007]



Figure 1.21: Examples of driving simulator

[Lehner 1997] presented a distributed virtual reality system for gathering a group of remotely located engineers to design a vehicle. Any number of participants can share a virtual environment and see each other's video transmissions at the position and orientation of the corresponding viewpoint. Fig. 1.22 shows the virtual environment of this system and the scene of operator in the CAVE (Cave Automatic Virtual Environment).



Figure 1.22: Virtual scenes of distributed virtual reality system [Lehner 1997]

## 1.5 Conclusion

Up to now, the related knowledge with regard to road traffic system, ITS/AHS, ADAS, and VR technologies have been introduced precisely and they strongly support our researches as the basic background.

The aim of this thesis is to introduce the VR technologies to solve some of our transportation woes, especially in the subject of ADAS design, simulation and analysis. As mentioned before, VR applications are capable of realizing the simulations in a virtual environment which can be modeled as closely as possible to the real situation so as to avoid certain dangers and simultaneously reduce the cost and shorten the development time. Some experiments of ADAS in a abominable weather or with bad road condition could then be proposed to be carried out in a virtual environment which can provide us such a complex natural environment like icy road, snowy weather, etc. In this way, some existing control algorithms can be tested or simulated and more appropriate intelligent control system can be designed to promote the development of ADAS field. This method lies on the interdisciplinary area of transportation systems and virtual reality technologies and will be described more precisely in the next chapters.

# Intelligent Vehicles Virtual Reality Platform

---

## Contents

---

<b>2.1</b>	<b>Introduction</b>	<b>47</b>
<b>2.2</b>	<b>IVVR platform design in Unified Modeling Language</b>	<b>51</b>
2.2.1	Use-case diagram for IVVR platform	52
2.2.2	Class diagram for IVVR platform	53
2.2.3	Activity diagram for IVVR platform	56
<b>2.3</b>	<b>IVVR platform realization</b>	<b>57</b>
2.3.1	Vehicle Intelligent Control Subsystem	57
2.3.1.1	Modeling of vehicle dynamics	57
2.3.1.2	Control architecture	58
2.3.2	Visualization Subsystem	59
2.3.2.1	Virtual world structure	60
2.3.2.2	Virtual vehicles	60
2.3.2.3	Virtual environment	60
2.3.2.4	Virtual Observer	61
2.3.2.5	Graphical Man-Machine Interface	63
2.3.3	Virtual Wireless Subsystem	63
2.3.4	Features and application structure	65
<b>2.4</b>	<b>IVVR platform simulation</b>	<b>66</b>
<b>2.5</b>	<b>Conclusion</b>	<b>68</b>

---

## 2.1 Introduction

Since the proposition of ITS/AHS concept, studies on this topic have attracted more and more researchers. Besides the researches in communication technologies and driver behavior models, most of researchers contribute to the design of ADAS, for example, ACC/CACC systems, CW/CA systems for the longitudinal vehicle control; LKS (Lane keeping support), LDW (Lane departure warning) and LCDA (Lane change decision aid) systems for the lateral vehicle control, and so on (see Section 1.3.3).

To establish feasibility of these academic controllers or systems, plenty of real vehicle applications have been developed which are capable of autonomous steering management and performing human-like actions. Rajesh Rajamani [Rajamani 2000] presented an integrated longitudinal and lateral controller which is experimented by the NAHSC demonstration of automated highways conducted in August 1997 at San Diego, CA. This demonstration shows eight fully automated cars traveling together in a tightly spaced platoon guided by the magnetic plots fixed on the center of the road, as shown in Fig. 2.1.



Figure 2.1: Vehicle platoon in the NAHSC demonstration

Another demonstration, called "Demo 2000 cooperative driving" [Kato 2002], was held with a platoon of five automated vehicles on the oval-shaped test track of 3.2 km long of Mechanical Engineering Laboratory in Tsukuba, Japan. All these vehicles can autonomously drive under the longitudinal and lateral controls with the help of GPS and laser radar.

However, it has become obvious that experimental test with real vehicles not only costs lots of time and money, but also would be difficult to perform or even dangerous when it comes to analysis of complex situations in road traffic, and it is more difficult to reproduce in setups with real vehicles and targets. Although some simulation systems with hardware-in-the-loop have already been developed for testing the control strategies of ADAS with low cost [El Kamel 2006] [Jianqiang 2010], the computer simulation is still proposed and inducted into the development, test, and presentation of ADAS for more benefits. Fortunately, several VR applications are proposed to replace the real implementation with low cost and meanwhile present visually comprehensible simulation results and improve the experimental efficiency. Currently, there are already some contributions concerning the resolution of traffic problems with VR approaches.

In the University of Maryland's Center for Advanced Transportation Technology (CATT) Laboratory [Pack 2010], Virtual Incident Management, a 3D massively multi-player training environment is being developed. This environment could be a

## 2.1. Introduction

comprehensive tool with that the coalition can train traffic management personnel and first responders to better respond to an array of incident scenarios. Moreover, the CATT lab has also developed a 4D, wide-area traffic visualization tool to help incident management personnel, emergency management personnel, and the general public achieve situational awareness in as close to a real-world setting as possible. The prototype system interacts with real-time traffic databases to show animations of traffic, incident, and weather data. Users can travel through the region to inspect conditions from different angles, at different distances with a virtual helicopter, and can also monitor and interact with traffic control devices. FEMA (the US Federal Emergency Management Agency) used it during President Obama’s inauguration to manage traffic in and out of the Washington, D.C. and to monitor the parade route and security zones in real time.

i3Drive, is a 3D interactive driving simulator developed by Miha Ambroz and Ivan Prebil [Ambroz 2010]. This software application provides interactive simulation of a wheeled vehicle on an arbitrary terrain. Fig. 2.2 shows its application structure. It presents real-time motion displays in a virtual 3D environment and lets users export data in various formats for offline display or future analysis. The input data for vehicle properties and geometry, terrain properties and geometry, and objects in the environment are stored in text files. i3Drive offers two simulation modes: in interactive mode, users deliver the vehicle’s control data in real time to the driving-dynamics model, while in non-interactive mode, the application reads the data from an input data file.

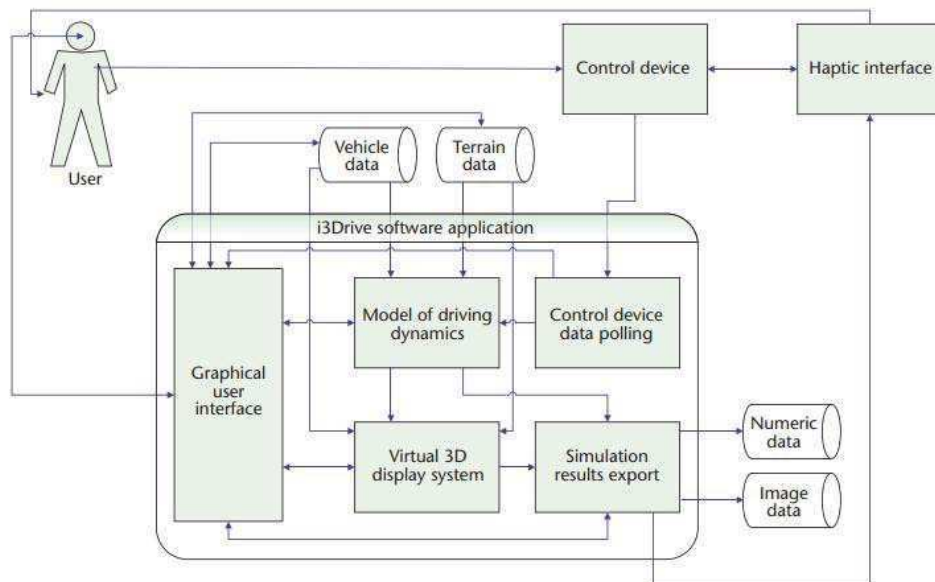

Figure 2.2: The i3Drive application’s structure [Ambroz 2010]

A 3D road traffic situation simulation system, called VRMLPathm, which could be considered as an integrated software product [Ambroz 2005], has been developed

for integrating intelligent vehicles and virtual reality. Fig. 2.3 illustrates its modular structure. This system can be used to simulate and analyze vehicle and its occupant behavior under different road conditions and different driving regimes with pre-prepared databases and appropriate default values. It has a great control module as the user interface and the results of simulations are available as numerical data as well as animations in virtual 3D environment.

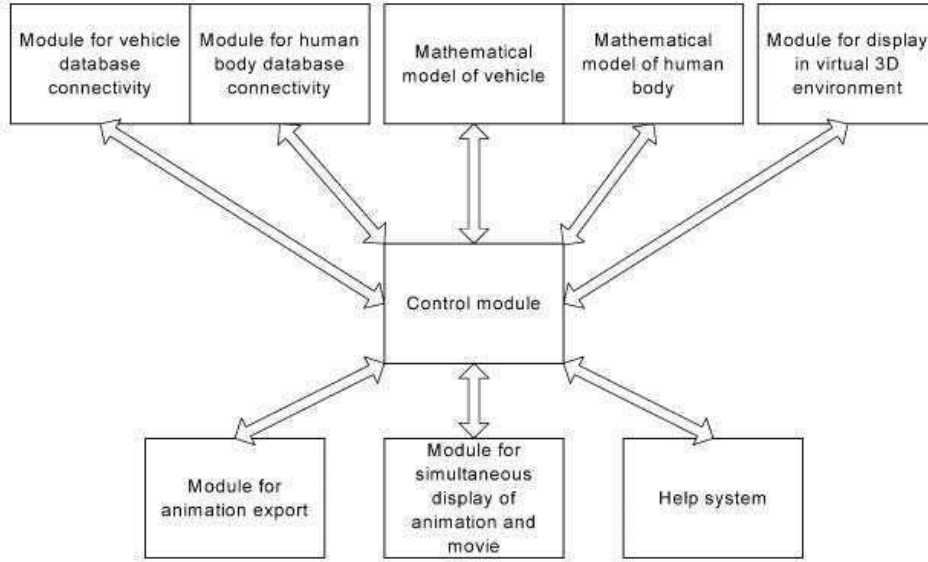

Figure 2.3: Modular structure of the software environment [Ambroz 2005]

In addition, Yvonne Laschinsky [Laschinsky 2010] presented a tool called Vehicle in the Loop (VIL), which is a virtual reality application and simulation setup that allows for testing driver assistance systems in critical driving situations while driving a real car, but without the risk of collisions with real objects. Abdullah [Cavusoglu 2011] introduced a driver Traffic Training Simulator (TTS) that utilizes intelligent synthetic actors. And Arne Kesting [Kesting 2008] used a traffic simulator to verify their new adaptive cruise control strategy.

There are also many other similar virtual reality systems that have been developed for simulations and meanwhile visualizing the simulation results. However, some limitations can be found in previous researches, for example, for i3Drive, its virtual environment is always passive and not active as it can only receive the data or signals but can not generate or sent back some useful information to controllers. And for VRMLPathm, data can not be transmitted to VRMLPathm in real-time and its virtual environment is also passive (can not output feedbacks).

Inspired by the existent VR systems with regard to transportation as well as their limitations, in this chapter, we present an intelligent vehicles virtual reality (IVVR) platform which combines Vehicle Intelligent Control Subsystem (VICS), Visualization Subsystem (VS), and Virtual Wireless Subsystem (VWS) [Luo 2011b].

## 2.2. IVVR platform design in Unified Modeling Language

---

It is a software application that simulates an automatic or semi-automatic traffic and also provides a real-time 3D interactive simulation environment, in which most of the input data are not needed to be pre-prepared or stored in the text files, but to be delivered in real time by VICS or users. At the same time, the VS can output useful information (e.g. weather information) as feedbacks to VICS through VWS.

The objective of IVVR platform is to assist the users in, for one thing, designing the vehicle control algorithms which are dedicated to resolve the spreading problems such as traffic congestion, safety, pollution and fuel consumption, etc. for another, simulating and analyzing the control algorithms through not only classical simple simulations (figures or data) but also comprehensible simulation results presented visually by a virtual 3D display system, which is a good performance for the observers.

This chapter shows firstly the IVVR platform conceptual design based on the Unified Modeling Language(UML), and next, the software construction of this platform is introduced through detailed description of each component, and the features and application structure are summarized at the end of this section. Finally, a simulation is carried out in the IVVR platform to show us the platform performance.

## 2.2 IVVR platform design in Unified Modeling Language

To establish the IVVR platform, conceptual design based on UML is proposed firstly to work at a higher level of abstraction. UML is a specification defining a graphical language for visualizing, specifying, constructing and documenting the artifacts of distributed object systems. It is widely accepted by industry and it has become the standard for object-oriented modeling and design [UML] [El Kamel 2005].

UML 2 defines thirteen basic diagram types, divided into two general sets:

- Structural Modeling Diagrams, which define the static architecture of a model. They are used to model the "things" that make up a model - the classes, objects, interfaces and physical components. In addition, they are used to model the relationships and dependencies between elements. They include package diagrams, class or structural diagrams, object diagrams, composite structure diagrams, component diagrams and deployment diagrams.
- Behavioral Modeling Diagrams, which capture the varieties of interaction and instantaneous states within a model as it "executes" over time; tracking how the system will act in a real-world environment, and observing the effects of an operation or event, including its results. They include use-case diagrams, activity diagrams, state machine diagrams, communication diagrams, sequence diagrams, timing diagrams and interaction overview diagrams.

Ideally, with UML, the system designer should be able to 1) define the system as one program, in form of a set of interacting functional objects that implement the processing algorithms that the system is expected to perform and 2) specify



many deployment schemes that represent as many ways of running the program on different network topologies.

In this section, a use-case diagram, a class diagram as well as an activity diagram have been created to describe the IVVR platform via both static and dynamic aspects. The related basic notions of the above three diagrams and their representations are listed in the following figure (see Fig. 2.4).

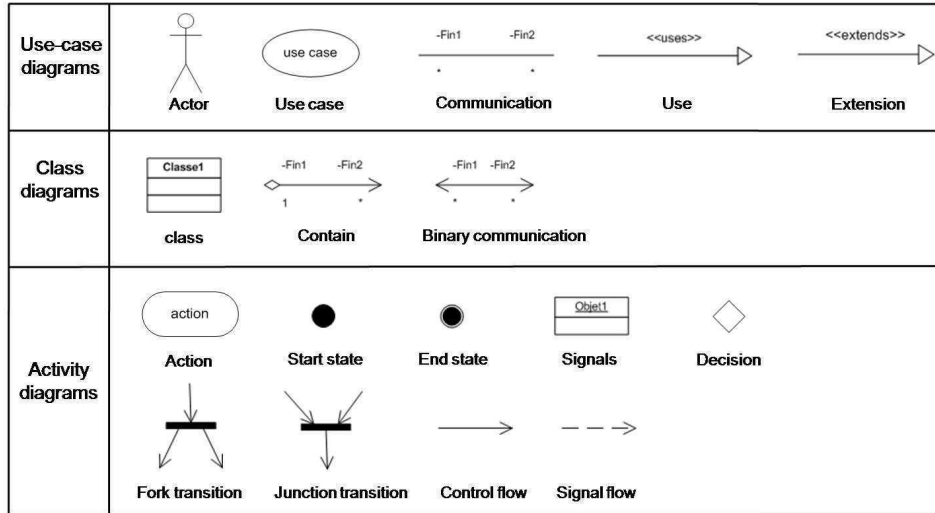

Figure 2.4: Related basic UML notions

### 2.2.1 Use-case diagram for IVVR platform

A use case describes a sequence of actions that provide something of measurable value to an actor, and a use case diagram displays the relationship among actors and use cases. It helps to clarify exactly what the system is supposed to do.

The IVVR platform is designed to face two kinds of actors, Fig. 2.5 shows its use-case diagram. The first one is the normal user who could also be called as evaluator. We have defined seven use cases related to the evaluator activity in the platform. There are:

- Set the parameters of virtual vehicles.
- Start/stop the simulation.
- Watch the virtual scene.
- Choose terrain type. Several terrain types should be listed to be chosen by users before beginning the simulation.
- Change climate. Several climate types should be created and users could switch them manually from one to another even when the simulation is running.

## 2.2. IVVR platform design in Unified Modeling Language

---

- Change the position of camera. To observe the virtual scene from different viewpoints, controlled by mouse or keyboard.
- Get information of virtual world.

The second actor defined in this platform is the designer, who succeeds to the normal user. Besides the use case of normal user, it has also two additional related use cases, there are:

- Design intelligent vehicle controller. Designer could improve the existing controllers by adjusting the parameters or adding new controllers into the IVVR platform.
- Observe and analyze the simulation results. The simulation results could be obtained and analyzed in the forms of numerical data as well as 3D virtual animation.

### 2.2.2 Class diagram for IVVR platform

The Class diagram defines the basic building blocks of a model: the types, classes and general materials used to construct a full model. Fig. 2.6 shows the static structure of IVVR platform.

In Vehicle Intelligent Control Subsystem (VICS), several intelligent vehicle models can be created and each intelligent vehicle contains two vehicle controllers (longitudinal & lateral) and two dynamic vehicle models (longitudinal & lateral). Consisting of an upper level controller and a lower level controller, the longitudinal/lateral controller sends control signals to the corresponding vehicle dynamic model and receives the feedback as corrections. The vehicle's longitudinal velocity could be used to provide some of the initial information in the lateral controller to make the VICS as a coupled system. In addition, the information of the preceding vehicle is also available to the following vehicle.

The Visualization Subsystem (VS) embraces two components: virtual world and man-machine interface. The virtual world is supposed to display a virtual environment with a highway on which a virtual vehicle platoon is running under a proposed appropriate driving strategy. This strategy is chosen according to different traffic situation or natural environment situation. Virtual GPS or some virtual sensors are placed into the virtual world to collect the real-time information of natural environment or vehicles. The Man-machine interface has some menu bars and a display window that can display the virtual scene and the GPS/Sensors data. Meanwhile, the modification of several related parameters in the simulation is feasible via key-board or mouse, such as the climate, the view point, etc.

Thanks to the Virtual Wireless Subsystem (VWS), various data could be exchanged bidirectionally between VICS and VS. For instance, vehicle states (like velocity, acceleration, etc.) sent by vehicle models can be transferred to the virtual vehicles in 3D virtual world. On the contrary, virtual GPS/Sensors data from virtual world can also be sent back to the vehicle controllers and vehicle dynamic models.



Figure 2.5: Use-case diagram of IVVR platform

## 2.2. IVVR platform design in Unified Modeling Language

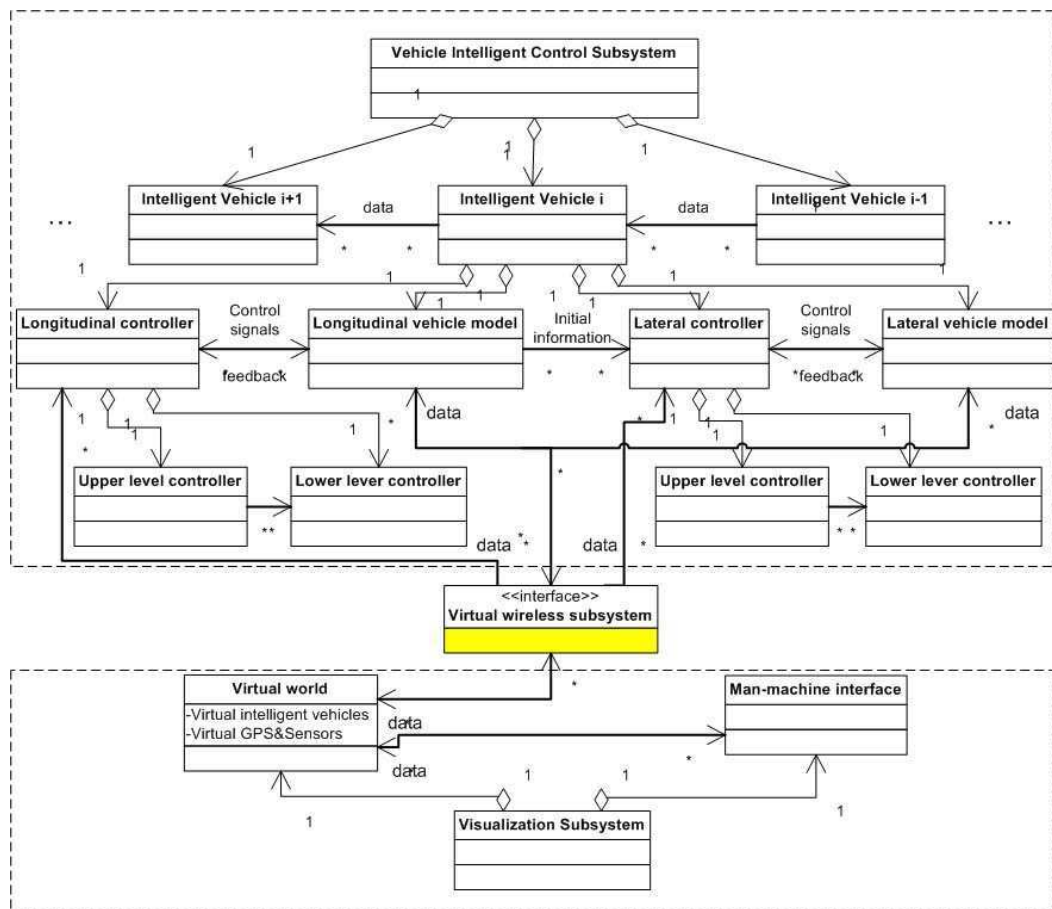

Figure 2.6: Class diagram of IVVR platform

### 2.2.3 Activity diagram for IVVR platform

Activity diagrams inherit from behavior diagrams and have a wide number of uses, from defining basic program flow, to capturing the decision points and actions within any generalized process. Here, we have drawn the activity diagram (Fig. 2.7) with two parallel swim lanes: VICS swim lane and VS swim lane.

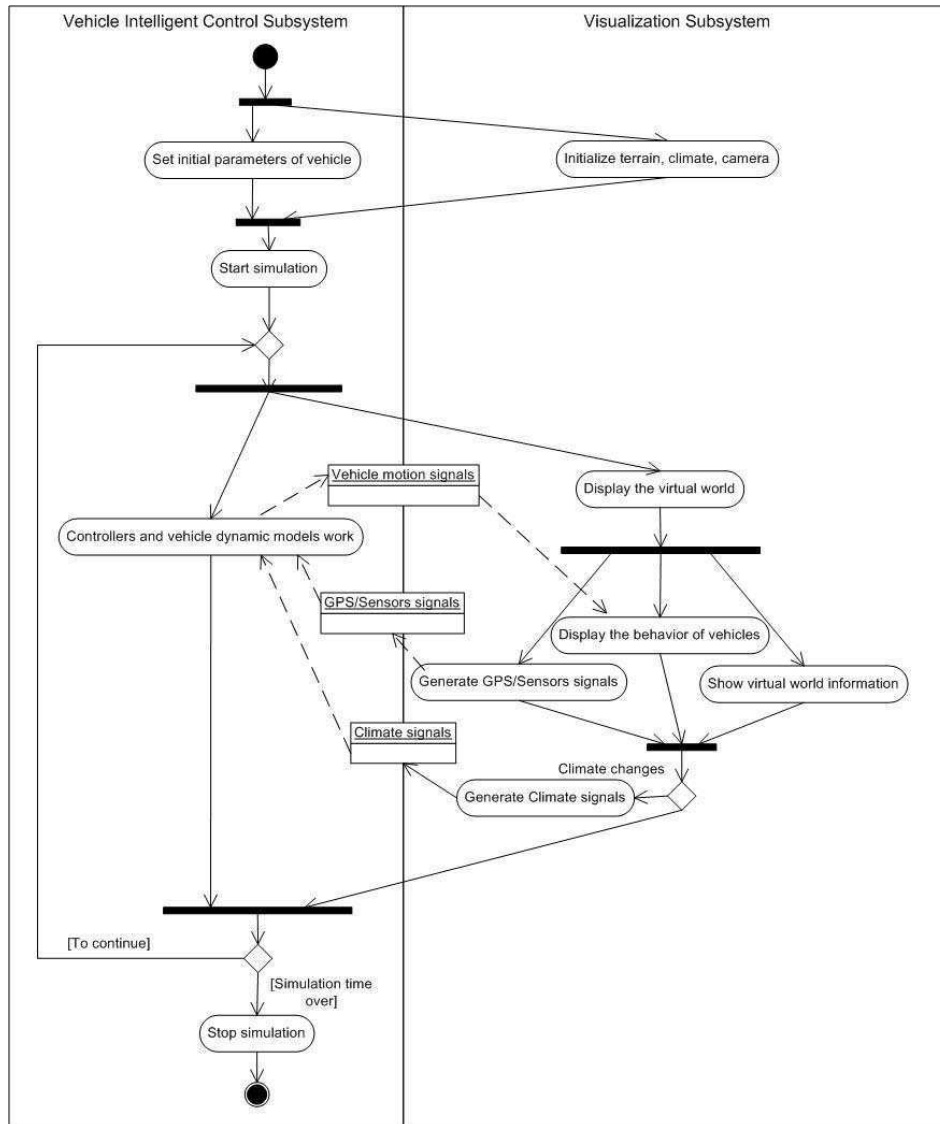

Figure 2.7: Activity diagram of IVVR platform

First, in VICS, we set initial parameters of vehicle, the experimental vehicle could be a car or a truck with different mass, size, etc. and in VS, we initialize the terrain type, the climate type and the position of virtual camera. After that, the simulation begins. We describe this simulation as a cycle under the condition

### 2.3. IVVR platform realization

---

that the simulation time is not over. In the cycle, the intelligent vehicle controllers and corresponding vehicle dynamic models in VICS work together and send out the vehicles' motion data to VS. In VS, the man-machine interface displays the virtual world and focuses on the behavior of virtual vehicles, and at the same time, the information of the virtual world is shown and the related GPS/Sensors signals are generated and sent back to VICS. If the climate changes according to the internal climate model or users, the weather signals will also be sent back to VICS as the references of controllers and vehicle models.

## 2.3 IVVR platform realization

Since the IVVR platform has been defined as a software application, to realize this platform, the software selection should be taken seriously. We need to consider a number of factors of the software, such as the cost, the features, the hardware requirements, etc. and each factor should be suitable to make the whole system has the best performance.

### 2.3.1 Vehicle Intelligent Control Subsystem

Matlab/Simulink was chosen to be in charge of the vehicle intelligent control algorithms realization as well as the vehicle dynamic modeling due to its superiorities comparing to the other softwares in the field of algorithm development, numeric computation, model-based design for dynamic and embedded systems, etc. It provides an interactive graphical environment and a customizable set of block libraries that help us design, simulate, implement, and test the vehicle control systems.

Actually, the VICS is supposed to be a workplace for the intelligent vehicle controller designers (see Section 2.2.1). Hence, we built the basic control architecture and then designers could improve or change the original controllers to achieve better performance for the intelligent vehicles control.

#### 2.3.1.1 Modeling of vehicle dynamics

Modeling of the vehicle dynamics is the first step for vehicle control system design. It is known that the vehicle system dynamic is normally a complex system where always exists nonlinear parts (tyre, clutch, etc.) and parameter variations (mass, tyre-road friction coefficient, etc.). Basically, the modeling of vehicle dynamics is essentially dependent on the forces created at the tyre/road interface and the different mechanical parts of the vehicle.

The modeling of vehicle dynamic have been pursued at many different levels by researchers and automotive manufactures. Generally, the complexity and accuracy of the vehicle model is always dependent on the final purpose of implementation. Although it has been proved that there must exist some relationship between the lateral and longitudinal forces via "friction ellipse" [Gillespie 1992], we still can decouple the dynamics of the longitudinal and lateral movements, under the assumption of

small varying velocity and steering angle, and this method has been tested on automated vehicle prototypes as well as in vehicle platoon operations [Kodagoda 2002]. Thus, the control problem can also be simplified into two separate tasks: longitudinal control and lateral control. And it is a good strategy specially when soft computing techniques (such as fuzzy, neural, multi-control, etc.) are introduced.

Fig. 2.8 shows the vehicle dynamic modeling structure. The longitudinal vehicle model contains two major elements: the powertrain dynamics and the vehicle dynamics and lateral vehicle dynamics are described by "Bicycle model" with two degrees of freedom. Corresponding detailed descriptions were presented in [Zhao 2010]. It should be noted that this vehicle dynamic model did not consider the slip influence, as it has a supposition that the tyre-road interface is dry and the normal force is a constant.

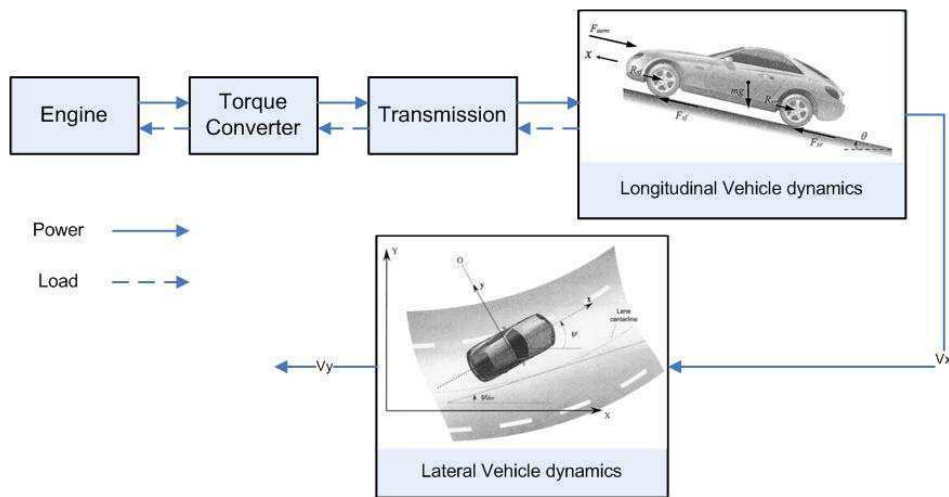

Figure 2.8: Vehicle dynamic modeling structure

### 2.3.1.2 Control architecture

Here, an integrated longitudinal and lateral controllers for autonomous vehicles has been designed with Matlab/Simulink (see Fig. 2.9).

The longitudinal controller concentrates on the design of spacing policy that also called ACC/CACC algorithm and its associated control law, thus, a sliding mode controller as well as the coordinate throttle and break fuzzy controller have been designed. For the vehicle lateral control, a multi-model fuzzy controller is proposed. This multi-model fuzzy controller contains four local fuzzy controllers which correspond to four velocity intervals [Zhao 2010].

### 2.3. IVVR platform realization

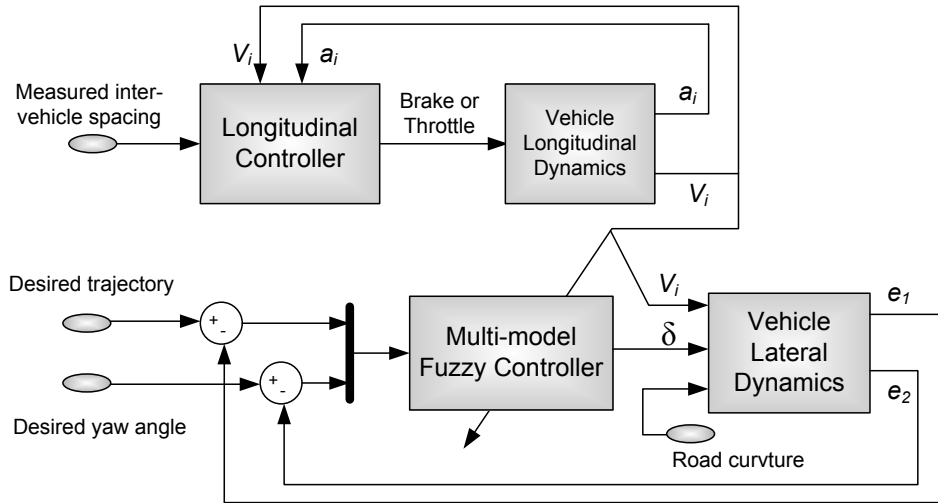

Figure 2.9: Integrated control system [Zhao 2010]

#### 2.3.2 Visualization Subsystem

Concerning the software choice of VS, at the beginning, the Matlab's Virtual Reality Toolbox (VRT) was considered in respect of its great visualization power and its superiority in connecting with the Matlab/Simulink models. Nevertheless, it has a drawback that it does not meet the bidirectional requirements of our system design, which means that the VRT could only receive and visualize data but could not generate or send out data.

Fortunately, the outstanding Integrated Development Environment - Microsoft Visual Studio provides us the opportunities to develop a graphical user interface applications with individual requirements. We have chosen C++ as the programming language and MFC as the user interface style that offers the convenient operation and a classic style user interface to make the application more user-friendly.

To create a virtual world, a 3D engine is necessary. OGRE (Object-oriented Graphics Rendering Engine) is an open source graphics rendering engine [Team 2008]. It is written in C++ and designed to make the developers easier and more intuitive to produce applications utilizing hardware-accelerated 3D graphics. Its class library abstracts all the details of using the underlying system libraries like Direct3D or OpenGL. Every feature that goes into OGRE is considered thoroughly and slotted into the overall design as elegantly as possible and is always fully documented. Another reason for us to chose OGRE is because that it is a flexible 3D engine that can be used not only for games but also for simulations, business applications, anything at all.

It should be noted that there exist many methods for integrating C++ applications with Matlab/Simulink, and these will be introduced precisely in the next section (Virtual Wireless Subsystem).

Thus, the VS is intended to be developed using Microsoft visual C++ as in-



egrated development environment, MFC as user interface style and OGRE as 3D engine. In this way, the visualization would be no longer passive but active.

**2.3.2.1 Virtual world structure**

As the virtual world is supposed to receive control signals from the VICS, the regulation of unified units between VS and VICS should be defined. Matlab/Simulink output data are set to meet the international standard unit and with regard to the virtual world, we have defined 10 units equal to 1 meter.

To set up a virtual world for intelligent vehicles, three components are required, they are virtual vehicles, virtual environment, and virtual observer. Fig. 2.10 shows detailedly the structure of virtual world using a UML class diagram.

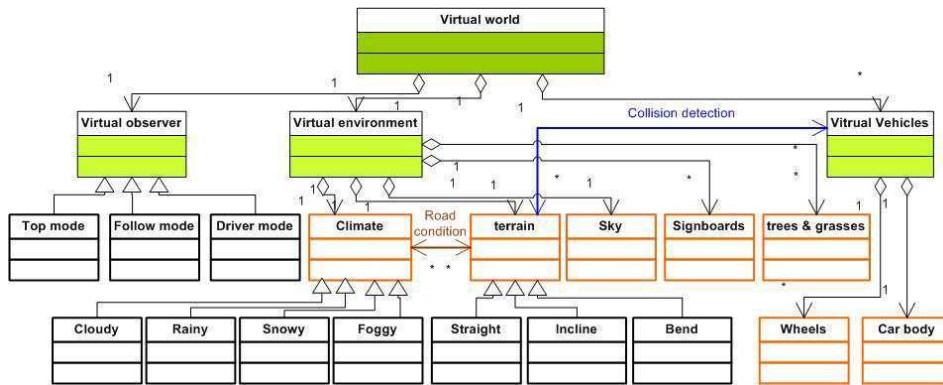

Figure 2.10: Virtual world structure

**2.3.2.2 Virtual vehicles**

The virtual vehicle has been designed to be a multi-object model. It consists of four individual wheels and a car body in which the seats and steering wheel have also been created. Each of the five parts has 6 degrees of freedom. A proposed virtual vehicle has been shown in Fig. 2.11. The diameter of wheel is set to be 6 units, the length of the vehicle is 40 units and the width is 15 units.

**2.3.2.3 Virtual environment**

We have created a realistic natural outdoor environment that includes the static part, such as sky, terrain, plants, signboards, etc. and the animation part of four climatic effects: cloudy, rainy, snowy and foggy. Each component will be described as follows.

- The sky is added into the scene as a SkyDome. The SkyDome is actually a simple sphere that representing virtual sky and the observer is usually located inside the dome and seeing the inside wall of the dome. Fig. 2.12 shows a terrain surrounded by a sky dome drawn as lines viewed from the outside.

### 2.3. IVVR platform realization

---

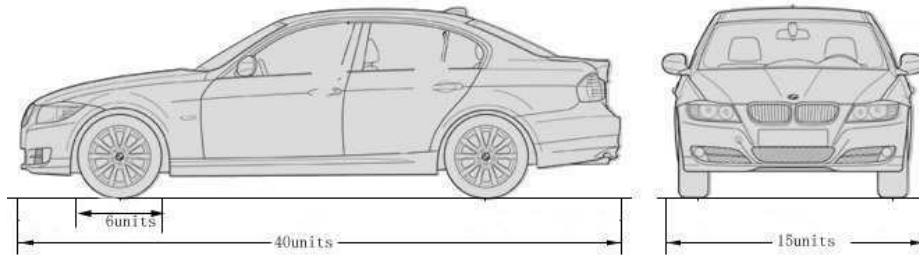

Figure 2.11: Virtual vehicle measurements

- The terrain, with a size of  $10260 \times 10260$  units, is constructed via a high-resolution texture and a height map in the application. As a part of the terrain, the highway with two lanes, with each lane 40 units, has been created with the help of texture mapping technique, and it has three different road types: straight, inclined and curved. Note that the collision detection between virtual vehicles and road surface also has been taken into account to avoid the phenomenon that virtual vehicles run into the terrain or hang in the air.
- Vegetation such as trees or grasses, are plentifully rendered in the environment with high-performance. The plants rendering takes advantage of the Level of Detail (LOD) technology, which involves decreasing the complexity of a 3D object representation as it moves away from the viewer or according other metrics such as object importance or position.
- The signboards of highway are also added to increase the fidelity of the virtual environment.
- Rendering climatic effects into a virtual outdoor environment could greatly improve the immersion and realism. Rainy and snowy animations are realized by the technology of particle system that has been defined in OGRE in the form of script.

#### 2.3.2.4 Virtual Observer

A camera, which also can be accounted as virtual observer, can represent the user's eye in the simulation. In the three dimensional virtual world, scene scheduling can be done by changing the position or orientation of camera. In our platform, three observe modes have been set, which are:

- Top mode: oversee the vehicles from the top, and move as the vehicles move.
- Follow mode: follow the vehicles in the same horizontal plane.
- Driver mode: as a driver in one of the vehicles.

The virtual world scenes with different observe modes and climatic effects have been shown in Fig. 2.13.

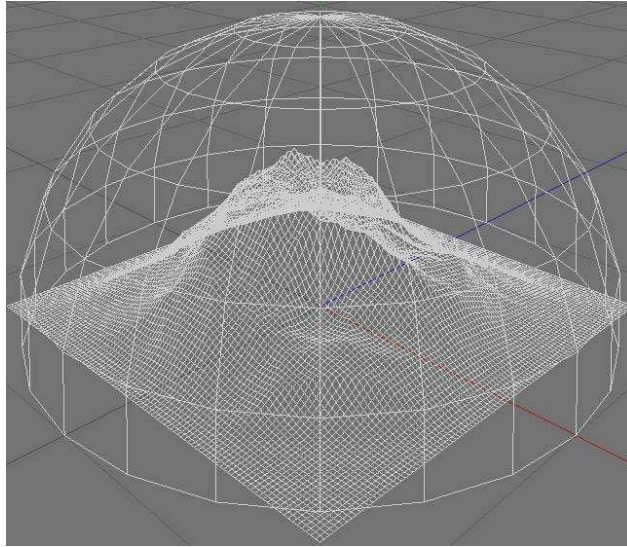

Figure 2.12: The SkyDome



Figure 2.13: Various virtual world scenes: top mode with snow (a); follow mode with cloud (b); driver mode with rain (c); follow mode with fog (d)

## 2.3. IVVR platform realization

---

### 2.3.2.5 Graphical Man-Machine Interface

A man-machine interface allows users to be a part of the simulation. In addition to observing visible information (such as the virtual scenes) as well as non-visible information (such as the current velocity of vehicles), we could also send out our orders to the virtual world to get a desired simulation with this interface.

Here, the graphical man-machine interface is made up of a 3D display window, a menu bar in which several parameters could be set, and a translucent panel that is used to show real-time information of the virtual world, like the velocity or acceleration of vehicles, the temperature, and so on. See Fig. 2.14.

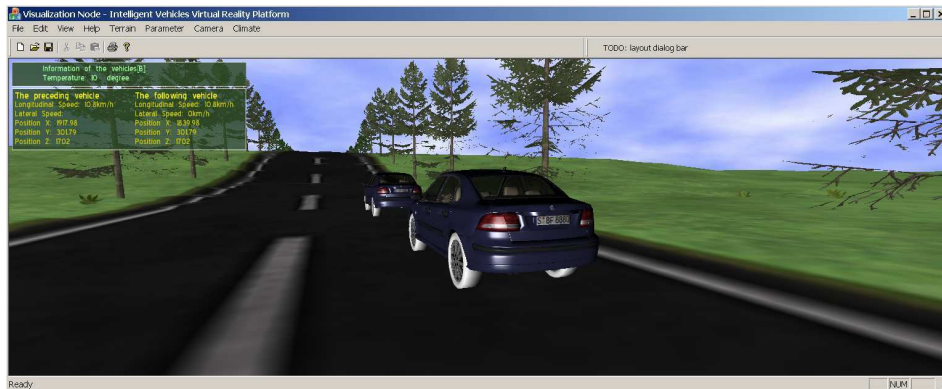

Figure 2.14: The graphical man-machine interface

The terrain types, observer modes, and different climates can be selected by users via the mouse, and moreover, the key-board could also control the position and the orientation of viewpoint.

### 2.3.3 Virtual Wireless Subsystem

Using metaphor, we consider that the VICS can be treated as the "brain" and VS is similar to the "body", then the VWS could be the "nervous system". According to the requirements of platform design in Section 2.2, the VWS should be provided with several properties:

1. The data exchange must be bidirectional and in real-time.
2. Redundant conversion processes ought to be averted if the vehicle control algorithms change.
3. A Client/Server mode should be constructed to make VICS and VS run in separate processes. The VICS, as the workspace of algorithm design, is better to be the "Client" to make simulations more convenient for designers.

In fact, the methods of linking Matlab/Simulink model with VC++ applications are quite a bit. Real-Time Workshop (RTW) in Matlab/Simulink could generate

C/C++ code and executables for discrete, continuous, or hybrid Simulink models. The resulting code can be used for many real-time or non-real-time applications outside the Matlab/Simulink environment. However, it is not acceptable because it does not accord with the second and the third properties listed above. While the Matlab Engine, which contains routines that permits to call Matlab commands from C++ programs, has also been rejected due to its unsuitability to the third property.

Finally, the Microsoft Component Object Model (COM) technology was chosen to carry out this task by reason of its powerful ability of communication. The COM technology enables application-specific components produced by different vendors to communicate. It provides a framework for integrating reusable, binary software components into an application. The source code could be written in any programming languages that support COM, such as C++. Moreover, Matlab has the feature of supporting COM, thus the communication can be realized fairly straightforward by integrating COM objects into Matlab/Simulink models through IDispatch interface. COM objects are discrete components, each with a unique identity, which expose interfaces that allow applications and other components to access their feature. A COM client is a program that makes use of COM objects and COM objects that expose functionality for use are called COM servers. Fig. 2.15 shows more details.

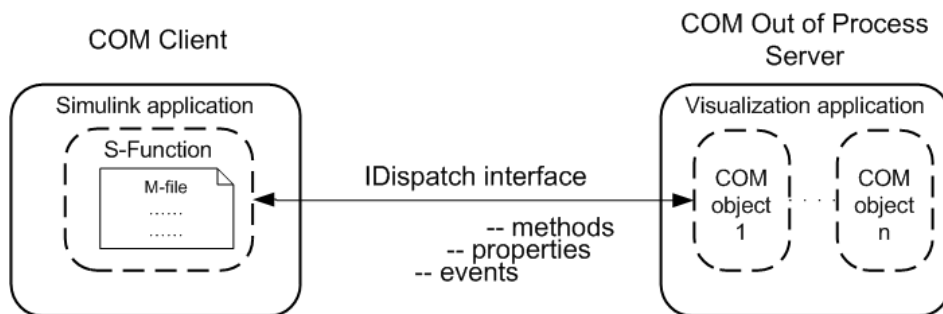

Figure 2.15: Integration with COM technology

The COM server exposes their objects via the IDispatch interface which exposes the objects' functionality through a set of public methods, properties, and events. Here, COM objects were created in VS by Microsoft Active Template Library programming.

The S-Function module used in the Simulink application plays a role of intervening, and it includes a level-2 m-file in which several Matlab command lines were written to communicate with the COM objects placed in the COM Server. At each time step, the Simulink engine calls these commands to updates the S-Function's inputs, outputs and also its states. The S-Function takes the normal Matlab/Simulink modules' outputs as the inputs, after the exchange of data with the VS (COM server), it outputs the signals from the virtual world as the references or corrections for vehicle controllers or vehicle dynamic models in Simulink. An

### 2.3. IVVR platform realization

---

example of the S-Function is shown in Fig. 2.16. The numbers and the types of the inputs and outputs could be further modified by users according to the specific requirements. It is worth mentioning that, the COM Server should be registered in the local computer for the purpose of being found by the COM Client.

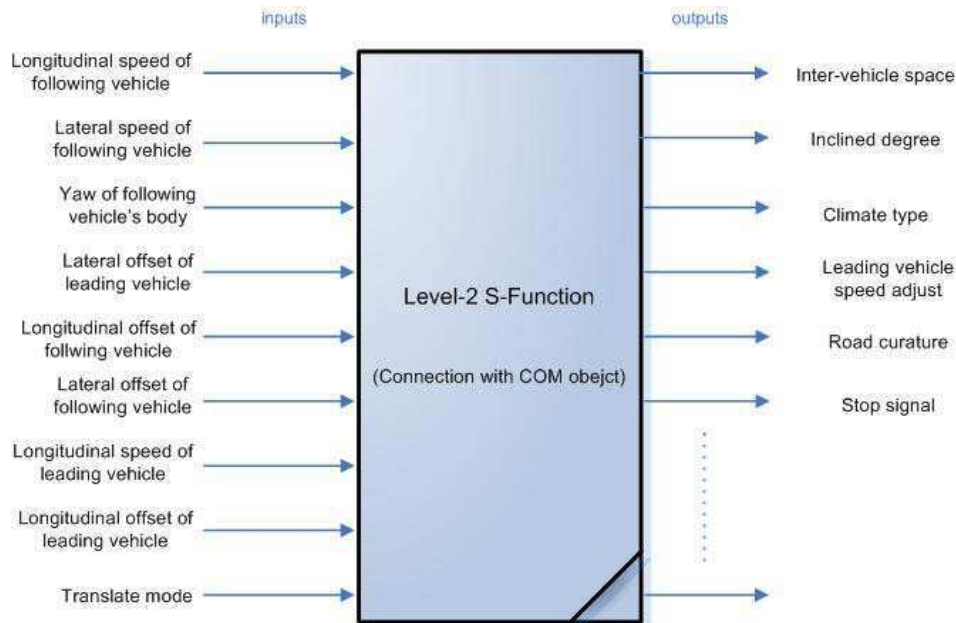

Figure 2.16: Block diagram of S-Function in IVVR platform

In this way, the VWS had been established with real-time and bidirectional communication. In case of the change of intelligent control algorithm, no redundant work needed to be done and the communication is immediate.

#### 2.3.4 Features and application structure

As a summary, The features of IVVR platform are listed as follows:

- Support for Matlab/Simulink models
- Data exchange in real-time
- Built-in vehicle dynamics model
- Support for different vehicle dynamics models
- Display in virtual 3D
- View analysis from arbitrary point inside or outside vehicle
- Interactive driving simulation
- Visual comparison of experiment and simulation

- Active visualization

In addition, the application structure of IVVR platform is shown in Fig. 2.17. In the Matlab/Simulink, the intelligent vehicle controllers send out the signals of throttle, break, and steering angle to the vehicle dynamic models. Sending back the motion data to controllers as references, the vehicle dynamic models also output the positions or velocities to the virtual reality system via COM interface. With these kinematic data, the animation of virtual vehicles is performed in the virtual world and at the same time, some NE signals from NE models can be send back to the vehicle dynamic models. Besides, NE signals as well as traffic information can also be sent back to intelligent vehicle controllers as corrections or references.

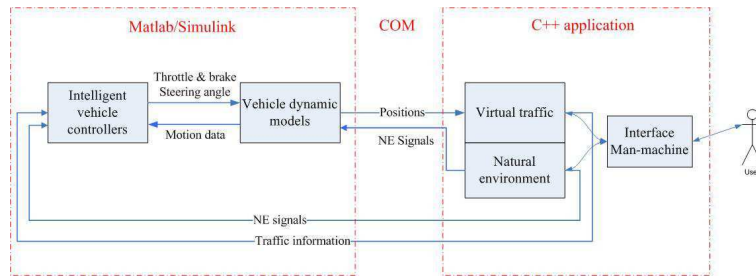

Figure 2.17: Application structure of IVVR platform

The module natural environment is considered as an important component in IVVR platform. It impacts not only the visualization of virtual world via the animations of natural phenomenon like rainy, snowy, etc. but also the movements of vehicles via the driver behavior or the tire/road dynamics, etc.

## 2.4 IVVR platform simulation

A simple experiment for a two-vehicle platoon had been realized in the IVVR platform. The following vehicle was treated as the automatic vehicle controlled by our integrated longitudinal and lateral controller. The leading vehicle was supposed to be driven by a driver. It is apparent that the velocity of the preceding vehicle is unforeseen, thus, instead of pre-preparing the value of the preceding vehicle's velocity as done in the traditional intelligent vehicle simulation, the IVVR platform allows the user to modify the value via key-board thanks to the Man-machine interface and the feedbacks "Leading vehicle speed adjust" (see Fig. 2.16) from VS to VICS. This is just like that the user is the driver of the preceding vehicle and this brings the simulation more immersion and entertainment.

Fig. 2.18 shows the simulation results in terms of curves. The following vehicle performs the behaviors of lane following and lane changing automatically. From the Fig. 2.18(a), we can see that the longitudinal speed of the posterior vehicle succeeded in following the one of the preceding vehicle and therefore, the inter-vehicle spacing was always normal and safety (Fig. 2.18(b)). With regard to the

## 2.4. IVVR platform simulation

---

lane changing, Fig. 2.18(c)(d) show the lateral displacement of posterior vehicle and the corresponding steering angle.

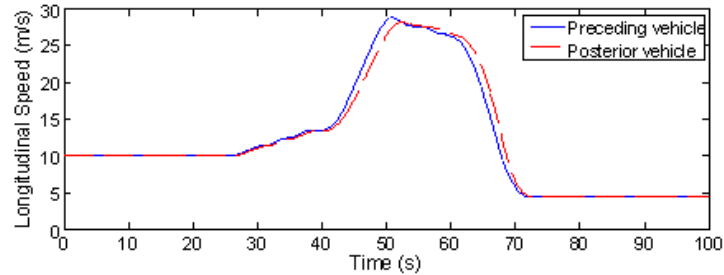

(a) Preceding vehicle and posterior vehicle speed

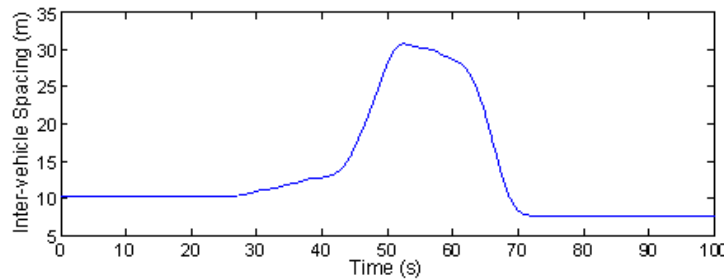

(b) Inter-vehicle spacing

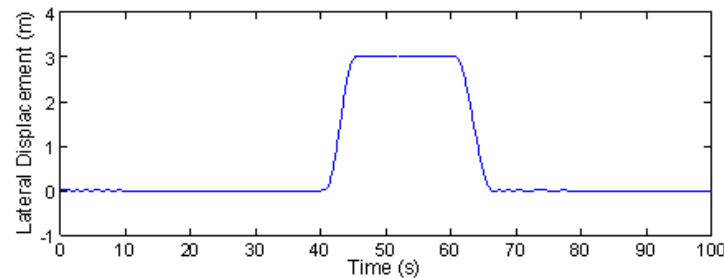

(c) Lateral displacement of posterior vehicle

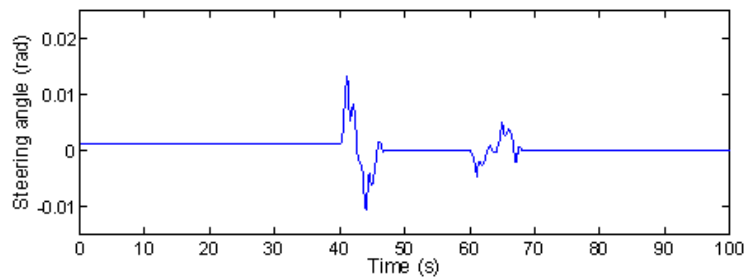

(d) Steering angle of posterior vehicle

Figure 2.18: Simulation results in curves

Simultaneously, after the transmission of vehicles' motion data from VICS to VS, the animation was displayed in VS. Fig. 2.19 shows four screenshots at different



simulation time. At the beginning, two vehicles are running on the road and the posterior vehicle is controlled to keep a safe distance from the preceding one (Fig. 2.19(1)). At the time of 40s, the posterior vehicle receives a lane changing signal from the lateral controller, so, it makes a turn the the left lane (Fig. 2.19(2)). At 60s, it changes back to the right lane (Fig. 2.19(4)). During the simulation, two vehicles always keep a safe distance and the animation is stable and smooth.

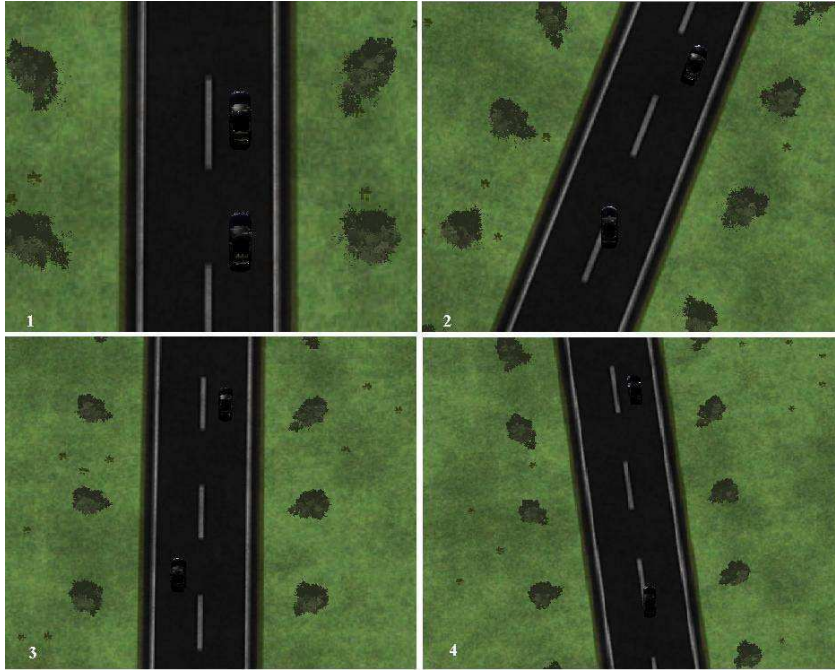

Figure 2.19: Screenshots of animation: 1 (0s), 2 (40s), 3 (45s), 4 (60s)

## 2.5 Conclusion

Nowadays, many opportunities exist for the computer graphics community to help solve some of our transportation woes. There are already several traffic simulation virtual reality platforms developed for various objectives, such as visualizing the simulation results, visualizing the recorded real transportation data in 3D animation, training the drivers in a driving simulator, etc. Even though, some research gaps still exist in this area and they are needed to be further studied, for example, the visualization is always passive which means the virtual world could only receive data but could not generate any data, the internal data transmission is offline, etc.

For the purpose of filling the research gaps mentioned before and concentrate our attention on the verification of vehicle control algorithm, we present the IVVR platform in this chapter to do the simulations of intelligent vehicles controller test in a 3D virtual world, as the experimenting with real vehicles would be dangerous, expensive and also would waste lots of time. The IVVR platform provides

## 2.5. Conclusion

---

users a workspace to design, analyze, and verify the vehicle control algorithm and meanwhile, it demonstrates the control algorithm with vivid 3D animation and the interaction with users is also supported so as to improve the simulation's immersion and entertainment. The internal data exchange is real-time, and there will be no supernumerary process if the control algorithm is modified by users. The virtual world in IVVR platform is no longer passive but active as it can send out various signals as feedbacks, for example, the feedback of natural environment information which can make the virtual simulation environment more realistic and further make the experiment more creditable.



# Natural Environment Modeling and Simulation

---

## Contents

---

<b>3.1 Introduction</b> . . . . .	<b>71</b>
<b>3.2 Natural Environment (NE) concept</b> . . . . .	<b>73</b>
3.2.1 NE conceptual model . . . . .	74
3.2.2 NE M&S features . . . . .	74
3.2.3 NE M&S applications . . . . .	76
<b>3.3 NE modeling for intelligent vehicle system</b> . . . . .	<b>78</b>
3.3.1 NE conceptual model for intelligent vehicles . . . . .	78
3.3.2 Virtual Sensor Data . . . . .	79
3.3.3 Transmitters of Virtual Sensor Data . . . . .	81
3.3.4 Receivers of Virtual Sensor Data . . . . .	81
3.3.4.1 Longitudinal vehicle dynamics . . . . .	81
3.3.4.2 Lateral vehicle dynamics . . . . .	87
3.3.4.3 Longitudinal leading vehicle controller . . . . .	90
3.3.4.4 Longitudinal/Lateral following vehicle controller . . . . .	91
3.3.5 Summary . . . . .	91
3.3.5.1 Glossary . . . . .	91
3.3.5.2 VSD delivery system . . . . .	91
<b>3.4 NE Simulation for intelligent vehicle system</b> . . . . .	<b>92</b>
3.4.1 Simulation 1: stable weather . . . . .	94
3.4.2 Simulation 2: variable weather . . . . .	95
<b>3.5 Conclusion</b> . . . . .	<b>96</b>

---

## 3.1 Introduction

According to the research of Alain Priez [Priez 2000], among the three factors, which are environment, human behavior and vehicle, involved in a traffic accident, the environment has an estimated responsibility of between 25% and 30%. In recent years, the ITS/AHS has been proposed to improve the situation that approximately 1.3 million people die each year on the world's road in view of the accidents caused

by human errors. Simultaneously, the presentation of ITS/AHS could also ameliorate the traffic's adaptability of the impacts from some weather and environment conditions which relate to the driver visibility, such as, the fog, darkness, etc.

Nevertheless, the dependence reduction on the clear vision as driving brought by ITS technology is not enough. As we know, the other environment factors like snow, rain, wind, etc. can still bring us great risk of augmenting the collision rates. In North Europe, data analysis from Road Traffic Directorate Accident-Database have shown that a considerable portion of road accidents has adverse weather (e.g. strong winds, snow and ice) as a primary or a contributing case ([Thordarson 2008]). In Canada, it is estimated that approximately 7 percent of injury collisions and 12 percent of property damage collisions are directly attributable to inclement weather and this translates into a conservative estimate of \$1 billion per year ([Andrey 2001b]). According to Mark [Koetse 2009], although fog and wind may have an increasing effect on the accidents, the most important variable is precipitation. [Andrey 2001a] shows that on average, precipitation increase the number of accidents by 75% and the number of related injuries by 45%, with snowfall having a more substantial effect than rainfall. [Edwards 1996] concludes that in most counties of England and Wales, 4% of road collisions occurred in high winds, 1 to 2% in fog, and less than 1% in snowfall and [Mercer 1986] had gotten the result that weather related traffic accidents constituted 11.1% of total accidents. Of these, it was raining 42% of the time and snowing 19% of the time.

Apparently, the Natural Environment (NE, including weather, terrain, etc.) has great impacts on road traffic. Comparing to the complex and individual human errors in traffic accidents, weather-related hazards are valued to be further researched by reason of their potential rules according to the limited types of weather. Hence, besides the researches pointing at automatic driving, the consideration of NE impacts on automatic vehicles should also be added into the ITS/AHS researches.

Actually, there are already some contributions in the related areas of NE and ITS/AHS. Jeannette and Robyn [Montufar 2006] has done some researches about the potential climate change impacts on seasonal truck weight limits. They discussed the types of technologies that are currently being adopted to allow more aggressive real-time knowledge-based harmonization and rationalization of seasonal weight limits in the prairie region, where changing climatic conditions are imminent. R.G. Hoogendoorn [Hoogendoorn 2010] studied on the longitudinal driving behavior under adverse weather conditions, the adaptation effects, model performance and freeway capacity in case of fog. The results from the experiments with the driving simulator showed a significant decrease in speed and a significant increase in distance to the lead vehicle. And based on the results from a micro-simulation traffic model, a reduction in capacity could be observed of 37% in case of fog. Moreover, a crash-likelihood prediction model was developed by Mohamed A. Abdel-Aty [Abdel-Aty 2006] using real-time traffic-flow variables (measured through series of underground sensors) and rain data (collected at weather stations) potentially associated with crash occurrence. The impacts from ITS to natural environment has also been studied in [Armstrong 2006] in which the results were promising, suggest-

### 3.2. Natural Environment (NE) concept

---

ing that ITS measures may be an effective way to reduce greenhouse gas emissions from transportation. However, as our objective is to reduce the collision rate on the world's road, and the above researches are not exactly in this area, thus, the studies related to the influences of natural environment on vehicle behaviors or road transport for the aim of improving the road security are waiting to be enriched.

Fortunately, virtual reality technology can help us to do the ITS/AHS applications involving the NE impacts. Actually, in the laboratory of Advanced Simulation Technologies in Beijing University of Aeronautics and Astronautics (BUAA), related researches concerning Natural Environment (NE) Modeling and Simulation (M&S) have been studied in depth, such as the visualization of natural environment (ocean, terrain, atmosphere, etc.) [Luo 2010] [Luo 2011a], the conceptual model of NE [Liu 2004], the NE M&S in the flight control system and so on.

Based on the proposed IVVR platform [Luo 2011b] as well as our basic knowledge and experiences in NE, in this chapter, we introduce the NE M&S into the intelligent vehicle system to help designers proposing more appropriate intelligent vehicle controllers under different NE conditions and even with variable weathers. What's more, our IVVR platform together with NE M&S can provide excellent participation experience for users in the simulation thanks to the Human-Machine Interface and the 3D virtual scene that integrates environment data as well as objects' motion data. And this virtual scene could also reflect simulation results in real-time automatically and visually according to the environmental change that can also be dominated by users.

This chapter is organized as follows: Section 3.2 introduces the concept of NE including its conceptual model, its features and its applications. Based on the IVVR platform, Section 3.3 introduces the NE modeling for intelligent vehicle system and Section 3.4 shows the NE simulation for intelligent vehicle system with different environmental models.

## 3.2 Natural Environment (NE) concept

Recently, with the development of Modeling and Simulation technology, several physical systems are preferred to be numerically modeled and simulated in distributed simulation environment before their realization in real world. It is not only by reason of that this method can help us saving money and time, but also because it can eliminate some potential dangers if the system performance is dangerous, like military manoeuvre or some related activities. To know that human or physical object behaviors can not be independent of natural environment, the modeling and simulation of natural environment then must be payed attention to in this kind of simulation systems.

Under this context, NE M&S is proposed for the distributed simulation researches. It aims to provide integrated and authoritative representation of natural environment including terrain, ocean, atmosphere and space for the modeling and simulation community.

### 3.2.1 NE conceptual model

In 1998, Brikel [Birkel 1998] presented a basic NE conceptual model, which has been depicted in Fig. 3.1. This conceptual model provides a brief description of its components and the interaction relationships between them. It is divided into two main parts, Environmental Ground Truth and Physical System.

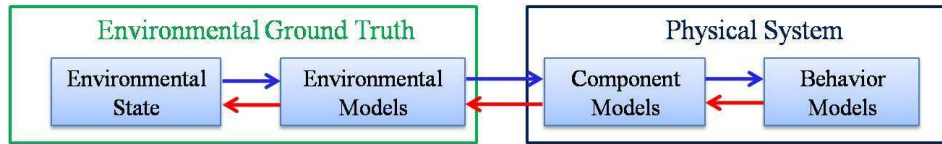

Figure 3.1: A basic NE conceptual model

In Environmental Ground Truth, the environmental state means various measurable parameters of natural environment at one moment, such as temperature, pressure, etc. while the environmental models is supposed to be the way to generate continuous environment data, for example, a road trajectory. In Physical System, the component models indicate the physical models, such as a plane model, a tank model, etc. And the behavior models are used to simulate the algorithms of different entity behaviors. The former provides the simulated natural environment data to affect the later by changing its states, behaviors, etc., and on the contrary, the later could also affect the former by some actions like exploration, collision and also the CO2 emission which could cause the greenhouse effect.

Further refining the above basic NE model, a more precise conceptual model is described in Fig. 3.2. In the Environmental Ground Truth, which also can be called Synthetic Environment, the Environmental Data is composed of the data from terrain, atmosphere, ocean, space, civilian and military. The Environmental Models includes environment effects, environmental internal dynamics and environment impacts and all these things can be treated as physical entities. With regard to the Physical System that includes several Players Entities in the environment, the passive sensors, active sensors, weapons & countermeasures, and unit/plaforms are treated as Component Models and the Behavior Models have also been listed, such as scout, march, occupy, target, fire, search, localize, track, etc.

### 3.2.2 NE M&S features

The features of NE M&S had been summarized by [Liu 2004] as follows:

1. NE is three-dimensional with rich and dynamic content. For instance, the terrain field contains the land cover, the structures, the road, the bridge, etc. The atmosphere field includes the air temperature, rain rate, wind speed/direction, solar flares, sensible & latent heat, etc. The ocean field has beach profile, swell/wave refraction, temperature of ocean water, etc. And the space field

### 3.2. Natural Environment (NE) concept

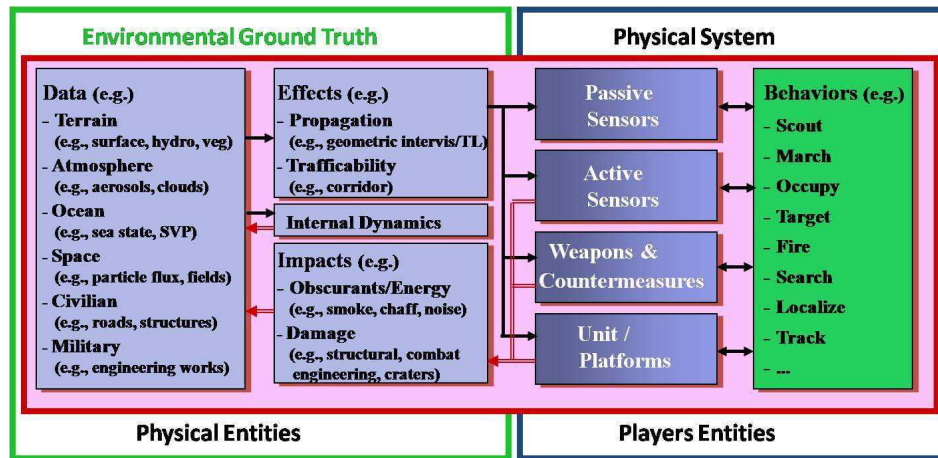

Figure 3.2: Natural Environment conceptual model

consists of electro-optics, electro-magnetics, etc. See Fig. 3.3 for details. Furthermore, the natural environment is spatiotemporally dynamic. For example, the temperate and the wind power or direction are always changing. Although the changes of terrain is very slow, it could still be affected by some physical behaviors, such as an explosion. And the smoke generated by an explosion could also influence the atmospheric visibility.

2. The objective of NE M&S research is not to study the problem itself but its impacts on the physical models. As a matter of fact, physical objects modeling just needs the environmental data that can affect their behavior or state, and only when these objects act in such a circumstance, the effects would work. Thus, in the NE M&S, we should select the indispensable environmental factors rather than all of them.
3. Different applications of NE M&S require different environmental data or the data in different scales and resolutions. We could simulate just a microscopic traffic model or a battlefield that covers navy, army, and air force, and obviously, their demand for environmental data would not be the same.
4. In a distributed simulation, the representation of NE information should be consistent and relevant. Since we have lots of physical models influenced by corresponding environmental factors, the manifestations of these factors for each physical model could be different, and in addition they should have Lexical Consistency, Syntactic Consistency and Semantic Consistency so as to make sure that they are trying to describe a same natural environment.



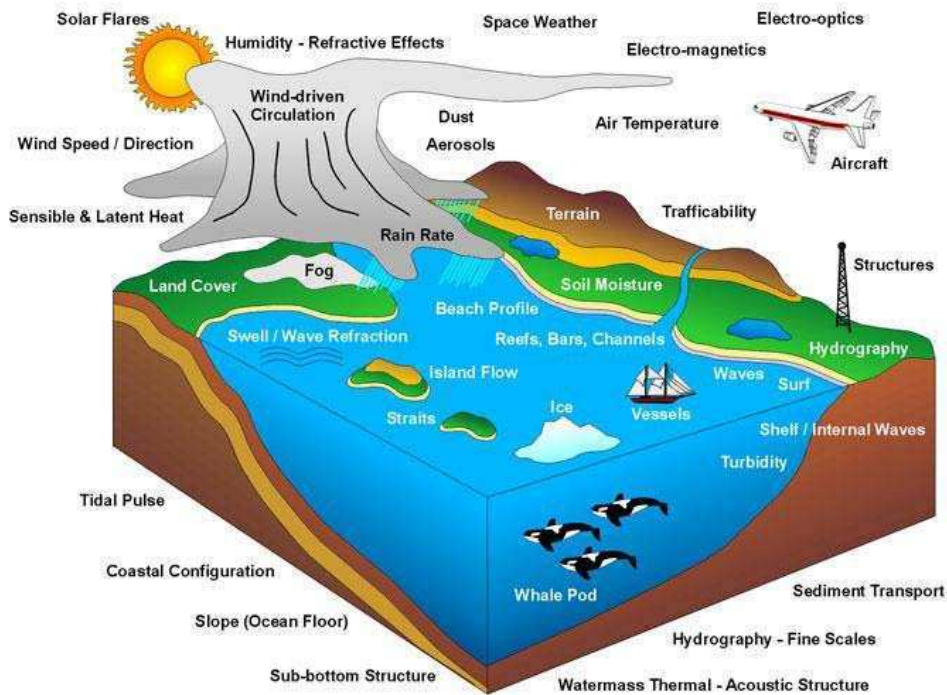

Figure 3.3: Different aspects in natural environment

### 3.2.3 NE M&S applications

Nowadays, NE M&S has been widely applied in nation defense and military fields for the aims of concept proof of advanced tactic, military training and weapons development (see Fig. 3.4). For instance, in United States, the INE Strategy was presented for the purpose of providing integrated authoritative representation of physical environment (terrain, ocean, air and space) for military manoeuvre or training. It focuses on the following three technology areas: environmental requirements/interchange, environmental common services and environmental integration/experiments [Liu 2004].

However, the application of NE M&S could be more extensive and significant. It could be applied not only in the military simulation but also in the civil simulation such as the driving simulator for car, bus, subway, train, the intelligent transportation simulation, etc.

In 1996, John H. Christiansen [Christiansen 1996] presented a sophisticated software architecture named Dynamic Environmental Effects Model (DEEM), which is used to determine the environmental impacts on military and also civilian operations. It provides a flexible framework for multidisciplinary modeling of terrestrial, aquatic, and atmospheric processes. The DEEM has already taken effect in the USAF Air Weather Service, the South Florida Water Management District and also the Forces Command.

### 3.2. Natural Environment (NE) concept

---

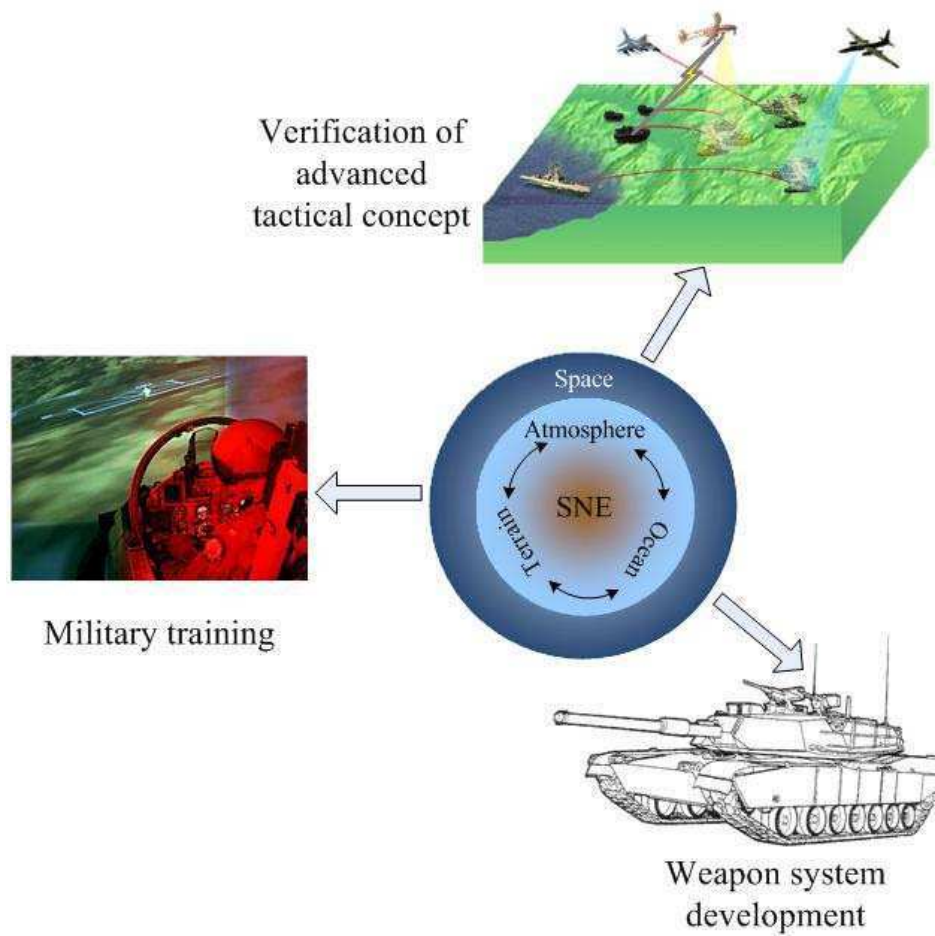

Figure 3.4: Military applications supported by NE M&S

Similar to the above software architecture DEEM, the NE impacts on intelligent vehicle system can also be modeled and simulated in IVVR platform, which has already provided the NE module where there are various weather animations as well as the corresponding environmental data.

As mentioned before, NE M&S aims to simulate the NE effects on physical models, thus, the relationship between environmental factors and physical models should be taken into account. In IVVR platform, we solve this problem by making the component models in intelligent vehicle system as functions of environmental conditions (terrain and weather) and transmitting environmental signals in real-time to affect the virtual vehicles' behavior via the VWS in the simulation.

In the following sections, we will concentrate the attention on NE M&S for intelligent vehicle system. Hence, according to Fig. 3.2, the physical system studied will be replaced by intelligent vehicle system and the players entities will be automatic vehicles or normal vehicles driven by drivers.

### 3.3 NE modeling for intelligent vehicle system

#### 3.3.1 NE conceptual model for intelligent vehicles

In order to make definite the natural environment impacts on intelligent vehicles, a NE conceptual model in allusion to intelligent vehicle system has been proposed [Luo 2011c] and described in Fig. 3.5. Since the intelligent vehicle system studied here has been defined as a microscopic one, the related environmental data are not necessary to be too precise or too complete according to the NE M&S features.

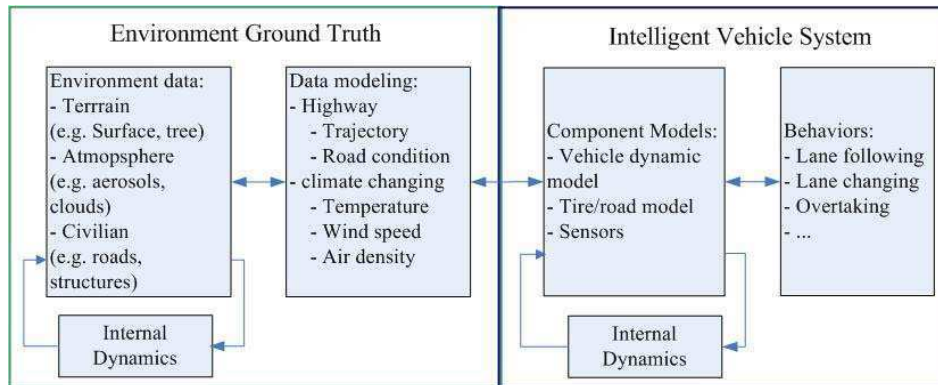

Figure 3.5: NE conceptual model for intelligent vehicle system

The related environmental information are selected from the terrain field, atmosphere field as well as civilian field. With these data, we can propose the environmental model, such as the road trajectory and the rules of highway or the climate changing strategy. With regard to the intelligent vehicle system, various component models of each intelligent vehicle should be modeled involving the corresponding

### 3.3. NE modeling for intelligent vehicle system

---

environmental factors, like vehicle longitudinal/lateral dynamic model, tire/road model, sensor model, etc. The effects from natural environment can act on the component models and this influence can be further extended to vehicles' behaviors, such as lane following, lane changing, overtaking and so on. Certainly, intelligent vehicle behaviors could also affect the natural environment, but this subject will not be discussed in this chapter.

#### 3.3.2 Virtual Sensor Data

In a ITS/AHS system, vehicular wireless communications and vehicular ad hoc networks are widely identified enablers for improving traffic safety and efficiency. The focus is typically on bilateral communication between two vehicles or on broadcasting information from one vehicle or infrastructure to other vehicles in the surrounding area. Timo Sukuvaara [Sukuvaara 2009] proposed a Wireless Traffic Service Platform for combined vehicle-to-vehicle (V2V) and vehicle-to-infrastructure (V2I) communications supported by roadside wireless base stations. It is designed to provide an infrastructure to a wide community of commercial and governmental traffic and safety services. The platform is divided into three parts: the traffic service central unit (TSCU), the base station network with traffic service base stations (TSBSs), and mobile end users (MEUs) with ad hoc connectivity and (non-continuous) backbone network connectivity. Fig. 3.6 shows the structure of this platform, which consists of MEU units embedded in vehicles, TSBSs beside the road, and the host system TSCU beyond the BS network. More details can be found in [Sukuvaara 2009].

In IVVR platform, similarly, the creation of VWS is exactly for the aim of simulating the V2V and V2I communications existed in real world. Fig. 3.7 describes the internal communication structure of IVVR platform, in which the natural environment impacts are emphasized. The arrows that are inside the circle indicate the direction of internal signaling, while the arrows that come from Users mean the participation of users by manually modifying the environmental conditions or parameters of certain component models in virtual vehicles. Acting as the "bridge" in IVVR platform, VWS can connect VICS, VS and SNE module in real-time information exchange. This function permits firstly the reflection of NE influences on the vehicle component models and secondly the automatic adjustments of intelligent vehicle control algorithms according to different environmental conditions. Both of the above two actions will eventually leading to vehicle behavior change, and the scene can be observed visually through VS. The information transmitted by VWS include control signals inside VICS, motion signals from VICS to VS and also feedbacks from VS to VICS. The feedbacks here are called Virtual Sensor Data (VSD) as they resemble the signals sent by real sensors equipped on vehicles, GPS or some other infrastructures like weather station.

The VSD play a key role in our simulation on account of that they represent almost all information from virtual environment including static environment and dynamic environment. Here, a microscopic traffic model in which there are two vehi-

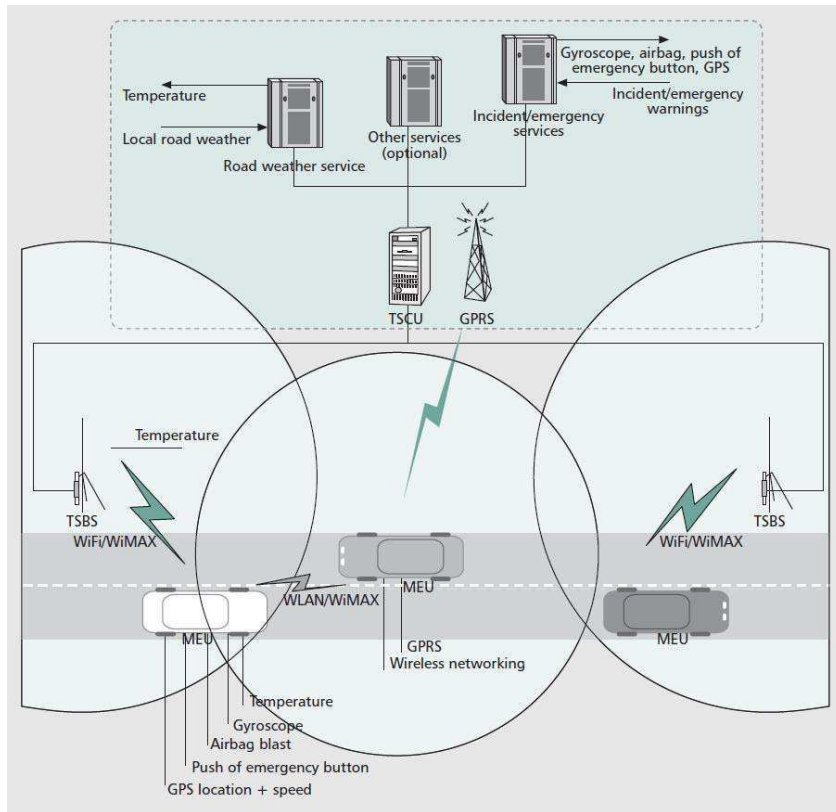

Figure 3.6: Wireless Traffic Service Platform structure [Sukuvaara 2009]

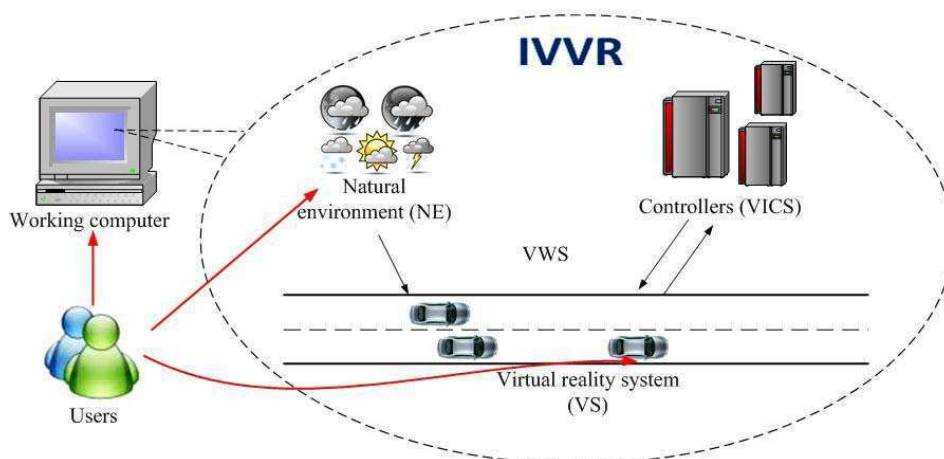

Figure 3.7: Communication structure of IVVR platform

### 3.3. NE modeling for intelligent vehicle system

---

cles (the following one is automatic, while the leading one is manual) is established. We focus on the maintenance of a safe distance between these two vehicles in lane following simulation. Several transmitters of VSD are set in the virtual world to provide real-time environmental information (as we concentrate on the NE M&S in this chapter) and some component models such as dynamic models or controllers are defined as the receivers of VSD so as to make them being functions of environmental conditions.

#### 3.3.3 Transmitters of Virtual Sensor Data

The transmitters defined here aim to simulate sensors, GPS, or weather station in real world to send out real-time useful information. We have considered two kinds of transmitters: firstly the climate VSD transmitters, which consist of weather/road condition, temperature, air density and wind speed and secondly the terrain VSD transmitters, which include slope, road type (straight or curved), and road curvature.

#### 3.3.4 Receivers of Virtual Sensor Data

It should be noted that the leading vehicle is treated as a particle and it is controlled only by longitudinal speed, while the following vehicle is modeled in dynamics. Thus, the receivers defined in this microscopic traffic model are longitudinal vehicle dynamics and controller as well as lateral vehicle dynamics and controller for the following vehicle, and longitudinal vehicle controller for the leading vehicle. These receivers will be described at length in the following.

##### 3.3.4.1 Longitudinal vehicle dynamics

For a simulation of longitudinal vehicle dynamic performance, two levels of dynamics must be considered. One level is the dynamics of the vehicle as a whole, and the other is the dynamics of the wheels. These can both be captured by simplified lumped mass models, and may consist of single-wheel versions, two-wheel versions, or full four-wheel models for cornering as well as acceleration/braking analysis [Gillespie 1992]. Passenger vehicles of the type under simulation here are generally built to be as possible with a center of gravity as close to the center of the car as possible, thus, a simplified two-wheel dynamic model is best suited to describe the dynamics, Fig. 3.8 shows a vehicle moving on an inclined road [Rajamani 2006].

A force balance along the vehicle longitudinal axis yields

$$m\ddot{x} = F_{xf} + F_{xr} - F_{aero} - R_{xf} - R_{xr} - mg \sin(\theta) \quad (3.1)$$

where

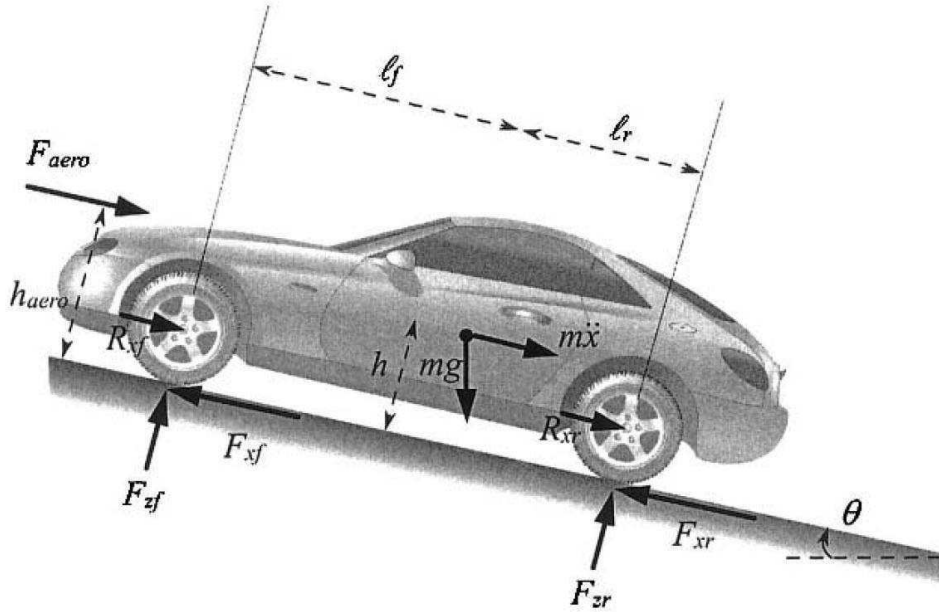

Figure 3.8: Longitudinal forces acting on a vehicle moving on an inclined road [Rajamani 2006]

- $F_{xf}$  is the longitudinal tyre force at the front tyres
- $F_{xr}$  is the longitudinal tyre force at the rear tyres
- $F_{aero}$  is the equivalent longitudinal aerodynamic drag force
- $R_{xf}$  is the force due to rolling resistance at the front tyres
- $R_{xr}$  is the force due to rolling resistance at the rear tyres
- $m$  is the mass of the vehicle
- $g$  is the gravitational acceleration
- $\alpha$  is the angle of inclination of the road

The equivalent aerodynamic drag force on a vehicle can be represented as

$$F_{aero} = \frac{1}{2} \rho C_d A_F (V_x + V_{wind})^2 \quad (3.2)$$

where

- $\rho$  is the mass density of air
- $C_d$  is the aerodynamic drag coefficient
- $A_F$  is the frontal area of the vehicle
- $V_x$  is the longitudinal vehicle velocity
- $V_{wind}$  is the wind velocity (It should be noted that wind force can be divided into 3 components: lift force, drag force and side force. Here, we consider only the wind drag force)

Clearly, longitudinal dynamics relate to the road slope and the aerodynamic drag force and the  $F_{aero}$  is the function of wind speed and air density that influenced by temperature.

### 3.3. NE modeling for intelligent vehicle system

---

With regard to the wheel dynamics, the longitudinal fire force  $F_{xf}$  and  $F_{xr}$  are friction forces from the ground that act on the tires. Experimental results have established that the longitudinal tire force generated by each tire depends on the normal load on the tire and the slip ratio.

Generally speaking, the relationship between longitudinal tyre force  $F_x$  and normalized force  $F_z$  can be described as

$$F_x = \mu_x F_z \quad (3.3)$$

Where the  $\mu_x$  means the longitudinal tire/road friction coefficient and it can be calculated by the slip ratio  $S_x$ . Normally,  $\mu_x$  increases when vehicle velocity decreases or the road surface becomes rougher.

The normal tire forces  $F_{zf}$  and  $F_{zr}$  (see fig. 3.8) are influenced by the total weight of the vehicle, the fore-aft location of the c.g., the longitudinal acceleration of the vehicle, the aerodynamic drag forces on the vehicle and the grade of the road. They are represented as follows:

$$F_{zr} = \frac{F_{aero}h_{aero} + m\ddot{x}h + mgh \sin(\alpha) + mgl_f \cos(\theta)}{l_f + l_r} \quad (3.4)$$

$$F_{zf} = \frac{mgl_r \cos(\alpha) - f_{aero}h_{aero} - m\ddot{x}h - mgh \sin(\theta)}{l_f + l_r} \quad (3.5)$$

In agreement with intuition, whilst the vehicle is accelerating the load is transferred to the rear wheels, and during braking it is transferred to the front wheels.

The longitudinal slip ratio  $S_x$  means the difference between the actual longitudinal velocity at the axle of the wheel  $V_x$  and the equivalent rotational velocity  $R\omega$  of the tyre. The value of slip ration varies according to the vehicle movement: for traction ( $V_x < R\omega$ ,  $\omega \neq 0$ ):

$$S_x = 1 - \frac{V_x}{R\omega} \quad (3.6)$$

for braking ( $V_x > R\omega$ ,  $V_x \neq 0$ ):

$$S_x = 1 - \frac{R\omega}{V_x} \quad (3.7)$$

where,  $R$  is the effective radius of the wheel,  $\omega$  represents the angular velocity, and  $V_x$  represents the longitudinal velocity.  $S_x$  is defined on the unit interval  $I = [0, 1]$ , taking on the limiting value of  $S_x = 0$  for free rolling ( $V_x = R\omega$ ), which implies the absence of either engine or brake torque and  $S_x = 1$  for wheel lockup ( $R\omega = 0$ ) or "spinning" with the vehicle at zero speed ( $V_x = 0$ ).

Experimental studies have produced several clearly defined friction/slip characteristics between the tyre and road surface for a variety of different driving surfaces and conditions. For the purposes of simulation, four types of road condition that accord to four types of weather are to be modeled [Short 2004]:

- Dry (Sunny/Cloudy): The maximum traction is theoretically possible.



- Wet (Rainy): Overall traction is reduced by about 20%.
- Snow (Snowy): Un-packed snow lies on the road surface. Maximum traction reduced by 65%.
- Ice (icy): Packed frozen snow and black ice lie on the road surface. Highly dangerous - maximum traction reduced by 85%.

For a given set of tyre test data, several models exist to analyze and simulate the relationship between  $\mu_x$  and  $S_x$ , and these models can be classified into two types: empirical (semi-empirical) models and analytical models. The empirical (semi-empirical) models are based on curve-fitting techniques, which usually formulate the  $\mu_x - S_x$  curve into a complex function of  $S_x$ . And they can accurately catch the steady-state characteristics of tire/road friction phenomena. However, empirical (semi-empirical) models cannot describe several significant dynamic behaviors such as hysteresis. Moreover, they lack physical interpretations and cannot directly reflect the effects of some special factors such as humidity of the road or tire pressure. For this, the analytical models are presented to interpret dynamic tire/road phenomena, and they usually use differential equations to describe tire/road friction properties. Some representative longitudinal tire/road friction models have been listed in Table 3.1 (see [Li 2006] for more details).

Among the above models, Pacejka Magic Formula [Bakker 1989] received successive modifications in the last two decades and has now become the most important semi-empirical tire friction model. It is defined mathematically as follows:

$$\mu_x(S_x) = D \sin(C \arctan(BS_x - E(BS_x - \arctan(BS_x)))) \quad (3.8)$$

Fig. 3.9 shows a curve produced by the original Magic Formula, and it illustrates the meaning of some of the factors. Obviously, coefficient  $D$  represents the peak value (for  $C \geq 1$ ) and the product  $BCD$  corresponds to the slope at the origin. The shape factor  $C$  controls the limits of the range of the sine function. Thereby it determines the shape of resulting curve as also the height of the horizontal asymptote  $Y_a$ . The factor  $B$  is left to determine the slope at the origin and is called the stiffness factor. The factor  $E$  is introduced to control the curvature at the peak and at the same time the horizontal position of the peak,  $X_m$  [Versteden 2005].

Actually, this model defines in excess of 40 constants that are determined from the given set of experimental data, and the overall model coefficients  $B$ ,  $C$ ,  $D$  and  $E$  are then calculated from a combination of these constants. Table 3.2 shows the model coefficients according to the above four types of road conditions. And with these coefficients, the corresponding slip/friction relationships under different weather conditions are shown in Fig. 3.10. This way, the NE impacts are successfully transmitted from  $\mu_x - S_x$  relationship to the dynamics of wheels.

Till now, the longitudinal following vehicle dynamics has become a function of environmental factors, which are weather/road condition, temperature/air density, wind speed, and slope of road.

### 3.3. NE modeling for intelligent vehicle system

---

Table 3.1: Some representative longitudinal tire/road friction models

Year	Model Name	Model Properties	Features
	Piecewise Linear Model	Empirical	1). Cannot accurately fit curves 2). Easy to identify
1993	Burckhardt Model	Semi-Empirical	1). Can accurately fit curves 2). Has some revised formula
1994	Rill Model	Semi-Empirical	Easy to identify
1987	Magic Formula	Semi-Empirical	1). Can accurately fit curves 2). Has lots of revised formula 3). Can employ different factors
1977	Dahl Model	Analytical	1). Can describe Coulomb friction 2). Can produces smooth transition around zero velocity
1991	Bliman-Sorine Model	Analytical	Can capture the Stribeck effect in addition to Dahl Model
1995	LuGre Model	Analytical	Can combine pre-sliding & sliding in addition to Bliman-Sorine Model

Table 3.2: Pacejka Coefficients

Surface	B	C	D	E
Dry Tarmac	10	1.9	1	0.97
Wet Tarmac	12	2.3	0.82	1
Snow	5	2	0.3	1
Ice	4	2	0.1	1

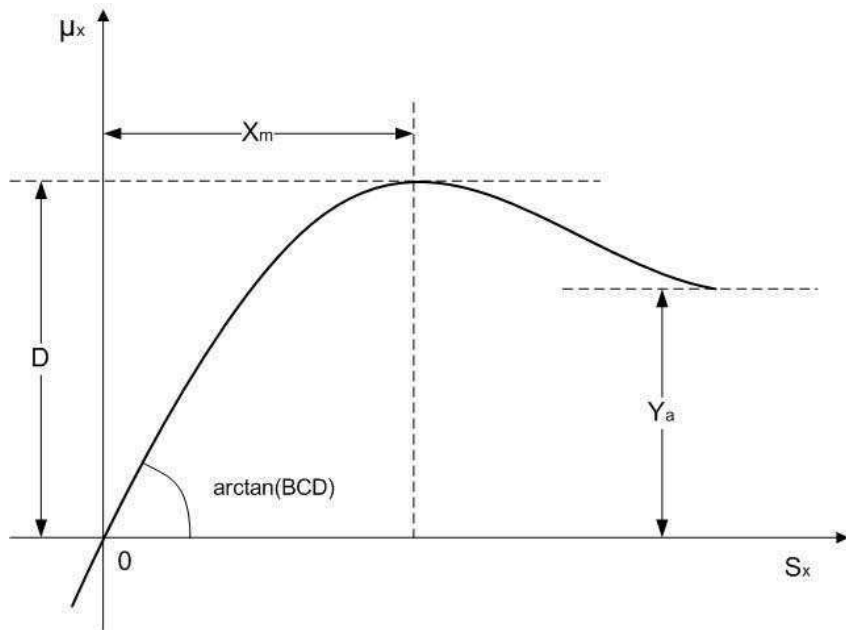

Figure 3.9: Curve produced by the original Magic Formula

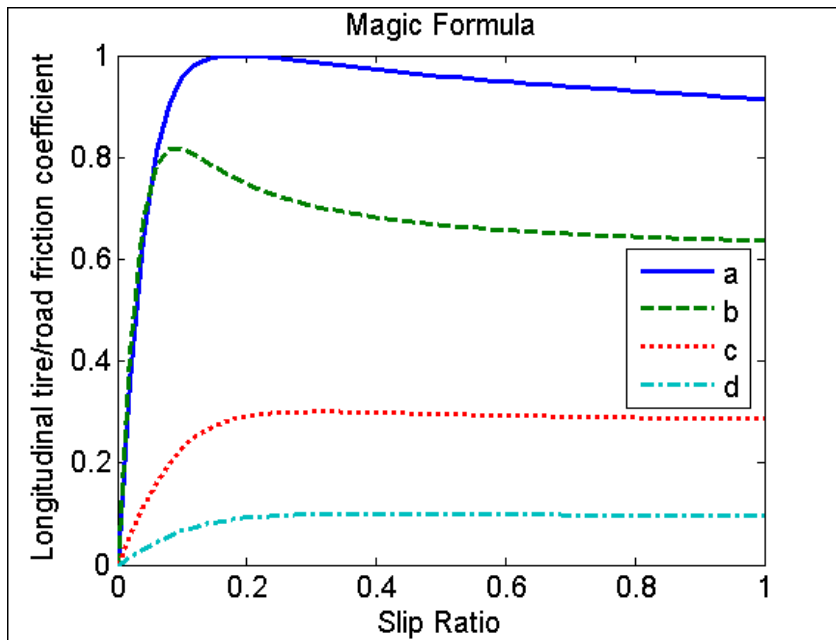

Figure 3.10: Typical longitudinal friction characteristics. a) Sunny/Cloudy: dry, b) Rainy: wet, c) Snowy: snow, d) Icy: ice

### 3.3. NE modeling for intelligent vehicle system

#### 3.3.4.2 Lateral vehicle dynamics

As the most frequently used model for vehicle lateral-motion studies, the "bicycle model" that has two degrees of freedom is considered here for the following vehicle (Fig. 3.11). The two degrees of freedom are represented by the vehicle lateral position  $y$  and the vehicle yaw angle  $\psi$ . The vehicle lateral position is measured along the lateral axis of the vehicle to the point  $O$  which is the center of rotation of the vehicle. The vehicle yaw angle  $\psi$  is measured with respect to the global  $X$  axis. The longitudinal velocity of the vehicle at the c.g. (point  $c$ ) is denoted by  $V_x$  [Rajamani 2006] [Zhao 2010].

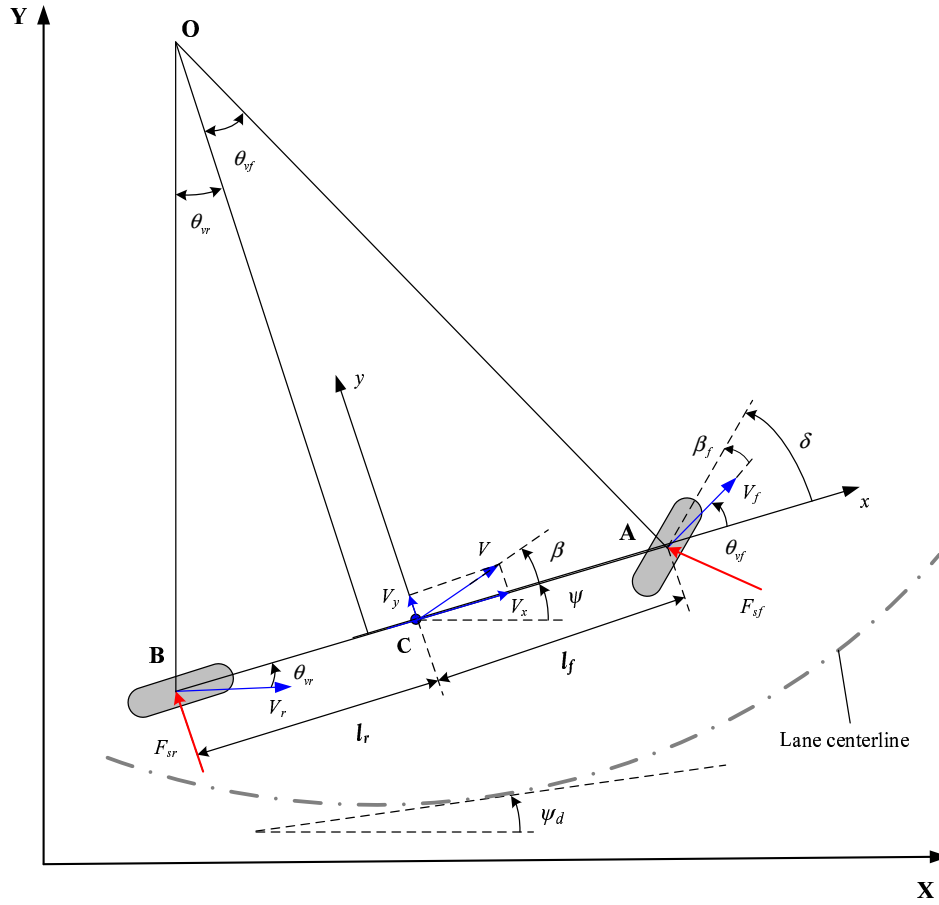

Figure 3.11: Bicycle model for lateral vehicle dynamics [Zhao 2010]

Assuming that vehicle has a constant velocity and ignoring road bank angle, the front-steering model can finally be described by the following differential equation

$$\dot{X} = AX + B\delta \quad (3.9)$$

where,  $X$  is the state variable,  $X = [y, \dot{y}, \psi, \dot{\psi}]^T$ ,  $\delta$  is the front wheel steering angle and

$$A = \begin{bmatrix} 0 & 1 & 0 & 0 \\ 0 & -\frac{2C_{af} + 2C_{ar}}{mV_x} & 0 & -V_x - \frac{2C_{af}l_f - 2C_{ar}l_r}{mV_x} \\ 0 & 0 & 0 & 1 \\ 0 & -\frac{2l_f C_{af} - 2l_r C_{ar}}{I_z V_x} & 0 & -\frac{2l_f^2 C_{af} + 2l_r^2 C_{ar}}{I_z V_x} \end{bmatrix}$$

$$B = \begin{bmatrix} 0 \\ \frac{2C_{af}}{m} \\ 0 \\ \frac{2l_f C_{af}}{I_z} \end{bmatrix}$$

in which the  $C_{af}$  is called the cornering stiffness of each front tire,  $C_{ar}$  is the cornering stiffness of each rear tire,  $\delta$  is the front wheel steering angle, and  $I_z$  is the moment balance about the  $z$  axis.

As our objective is to develop a steering control system for automatic lane following, it is practical to utilize a dynamic model in which the state variables are in terms of position and orientation error with respect to the road. Thus, the lateral model developed before can be redefined in terms of the following error variables:

- $e_1$ , the distance of the c.g. of the vehicle from the center line of the lane, see Fig. 3.12
- $e_2$ , the orientation error of the vehicle with respect to the road, see Fig. 3.12

After some algebraic reductions [Rajamani 2006], the state space model in tracking error variables is given by

$$\dot{X} = AX + B_1\delta + B_2\rho \quad (3.10)$$

where,  $X$  is the state variable,  $X = [e_1, \dot{e}_1, e_2, \dot{e}_2]^T$ , and

$$A = \begin{bmatrix} 0 & 1 & 0 & 0 \\ 0 & -\frac{2C_{af} + 2C_{ar}}{mV_x} & \frac{2C_{af} + 2C_{ar}}{m} & -\frac{2C_{af}l_f + 2C_{ar}l_r}{mV_x} \\ 0 & 0 & 0 & 1 \\ 0 & -\frac{2C_{af}l_f - 2C_{ar}l_r}{I_z V_x} & \frac{2C_{af}l_f - 2C_{ar}l_r}{I_z} & -\frac{2C_{af}l_f^2 + 2C_{ar}l_r^2}{I_z V_x} \end{bmatrix},$$

$$B_1 = \begin{bmatrix} 0 & \frac{2C_{af}}{m} & 0 & \frac{2C_{af}l_f}{I_z} \end{bmatrix}^T,$$

$$B_2 = \begin{bmatrix} 0 & -\frac{2C_{af}l_f - 2C_{ar}l_r}{m} - V_x^2 & 0 & -\frac{2C_{af}l_f^2 + 2C_{ar}l_r^2}{I_z} \end{bmatrix}^T.$$

Therefore, the tracking objective of the steering control problem can be expressed as a problem of stabilizing the dynamics given by equation (3.10). In fact, this dynamic model is described based on body fixed coordinates. It is suitable for control system design, since a lane following controller must utilize body fixed measurements

### 3.3. NE modeling for intelligent vehicle system

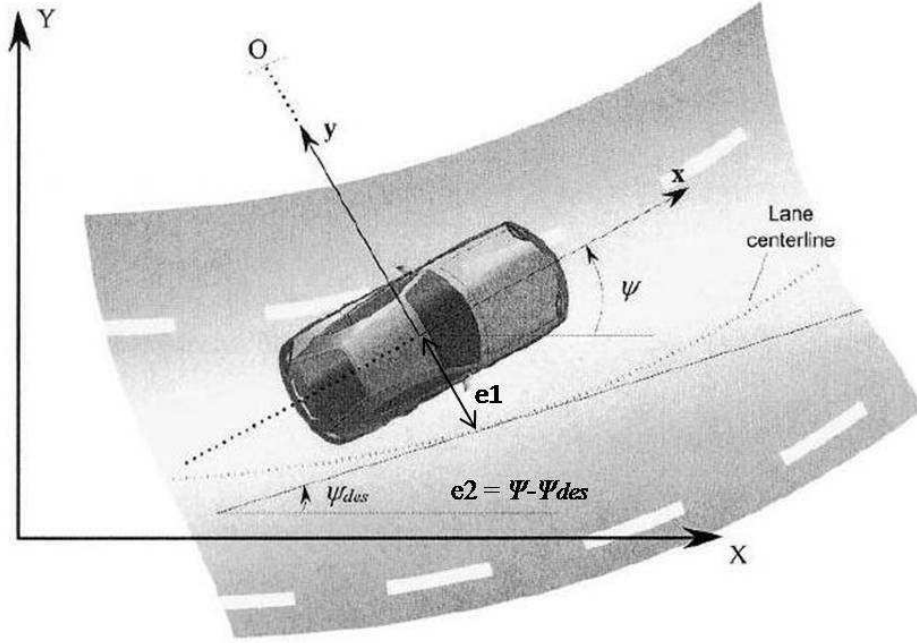

Figure 3.12: Lateral vehicle dynamics [Rajamani 2006]

of position error with respect to road. To simulate a global scene of the trajectory traversed by the vehicle, the body-fixed coordinates should be converted into global coordinates.

As shown in Fig. 3.13, the lateral distance between the c.g. of the vehicle and the road centerline is  $e_1$ . The position of the vehicle in global coordinates is then given by

$$X = X_{des} - e_1 \sin(\psi) \quad (3.11)$$

$$Y = Y_{des} + e_1 \cos(\psi) \quad (3.12)$$

where  $(X_{des}, Y_{des})$  are the global coordinates of the point on the road centerline which lies on a line along the lateral axis of the vehicle.

Using  $X_{des} = \int_0^t V \cos(\psi_{des}) dt$ ,  $Y_{des} = \int_0^t V \sin(\psi_{des}) dt$  and replacing  $\psi$  by  $\psi = e_2 + \psi_{des}$  in equations (3.11) and (3.12), the global coordinates of the vehicle are obtained as

$$X = \int_0^t V \cos(\psi_{des}) dt - e_1 \sin(e_2 + \psi_{des}) \quad (3.13)$$

$$Y = \int_0^t V \sin(\psi_{des}) dt + e_1 \cos(e_2 + \psi_{des}) \quad (3.14)$$

Up to now, lateral dynamics has been established by "bicycle model" and the next task is linking this model to the environmental factors. Fortunately, according to [Li 2006], the "bicycle model" can also be viewed as a certain analytical lateral tire/road friction model, in which the friction situation is described by two stiffness

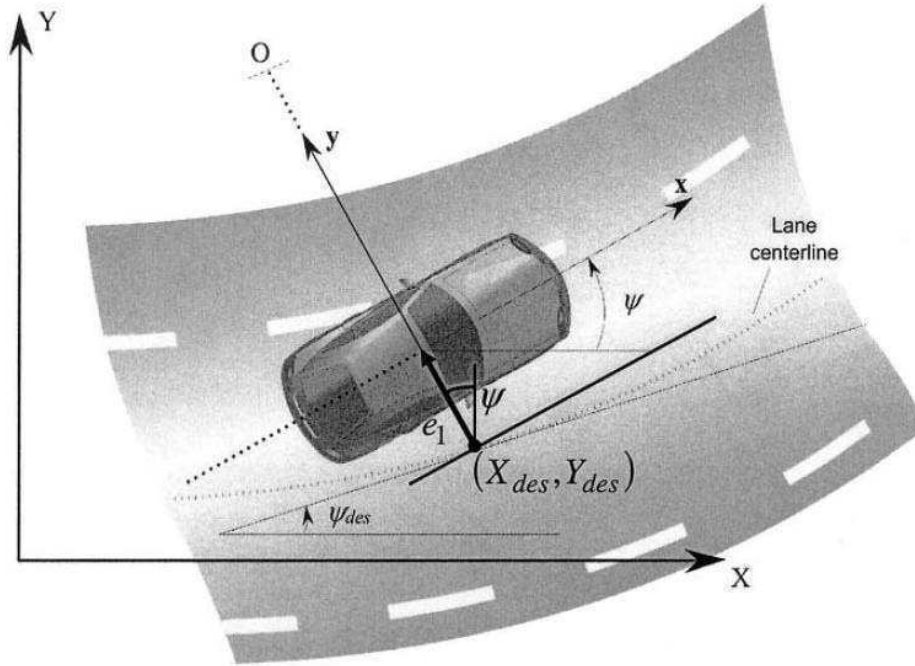

Figure 3.13: From body fixed to global coordinates [Rajamani 2006]

coefficients  $C_{af}$  and  $C_{ar}$ , the mass of the vehicle  $m$  and the yaw moment of inertia  $I_z$ .

In terms of the environmental impacts on the lateral dynamic model,  $C_{af}$  and  $C_{ar}$  would become smaller if the road condition is not dry. Hence, a controllable parameter  $\lambda$  is introduced into the equation (3.10) so as to replace the  $C_{af}$  and  $C_{ar}$  with  $\lambda C_{af}$  and  $\lambda C_{ar}$ .  $\lambda = 1$  is used for a dry road,  $\lambda = 0.5$  for a wet road or a snowy road, and  $\lambda = 0.4$  for a icy road [Li 2006].

Thus, the connection between lateral dynamic model and natural environment has been established and the main environmental factor is the weather/road condition.

### 3.3.4.3 Longitudinal leading vehicle controller

For the leading vehicle, a longitudinal vehicle controller has been designed to control its behaviors. Since it is supposed to be driven by a driver, the recognition of the signboards or the road types must be simulated in the virtual reality platform. Therefore, the longitudinal velocity of the leading vehicle must be controllable in the simulation.

As we know, each country has its own laws concerning speed limits on the highway for the purpose of improving traffic security and traffic efficiency. Various speed ranges have been defined according to different situations. These situations could be that the vehicle is a car or a truck, the highway is rural or urban, it is

### 3.3. NE modeling for intelligent vehicle system

---

Table 3.3: Vehicle parameters and their typical values

Symbols	Typical values
Mass of the vehicle $m$	$[1200, 1300]kg$
Inertia moment around z-axis $I_z$	$2872kg \cdot m^2$
Distance between c.g. and the front wheels $l_f$	$1.1m$
Distance between c.g. and the rear wheels $l_r$	$1.58m$
Wheel moment of inertia	$1.048kg \cdot m^2$
Wheel effective rolling radius $R$	$0.344m$
Stiffness coefficients of front/rear tire $C_{af}$ and $C_{ar}$	$42000N/rad$
Aerodynamic drag coefficient $C_d$	$0.4$
Acceleration of gravity force $g$	$9.8m/s^2$

day or night, the road is straight or curved or inclined, etc., and all of them ask for different criterions of speed limit.

As described in Chapter 2, the virtual highway modeled in IVVR platform is rural and contains three road types. Thus, the road type has been considered as a environmental factor to affect the longitudinal leading vehicle controller to simulate the driver-behavior of respecting the speed limits on the highway.

#### 3.3.4.4 Longitudinal/Lateral following vehicle controller

For the following vehicle, we also define the longitudinal and lateral controllers as the environmental VSD receivers by reason of hoping these controllers can ensure traffic security or efficiency under various natural environment conditions, even with bad weather situation. For example, once receiving a weather change signal, the desired inter-vehicle space would be adjusted, or once detecting the change of road curvature, the lateral higher controller would chose a appropriate lower controller.

Actually, these definitions help users to design some more advanced intelligent vehicle controllers to adapt to different natural environment conditions. And this topic will be studied in detail in the following two chapters.

### 3.3.5 Summary

#### 3.3.5.1 Glossary

Vehicle parameters used in the vehicle dynamic modeling and their typical values have been listed in Table 3.3.

#### 3.3.5.2 VSD delivery system

With the above VSD transmitters and receivers, users can observe ont only real-time vehicle dynamic reaction under different natural environment conditions but



also some artificial intelligent vehicle behaviors which make the simulation more reasonable. For instance, if it starts to rain suddenly or the road condition changes from a straight road to a curved road, the VSD transmitters would send out the signals corresponding to these changes and then certain VSD receivers would receive the signals and synchronously make the virtual vehicles act in security and reasonable just like what the real vehicles do in the homologous real environment.

Fig. 3.14 shows the environmental information exchange system in IVVR platform in which the VSD transmitters, the VSDs, and the VSD receivers have been listed.

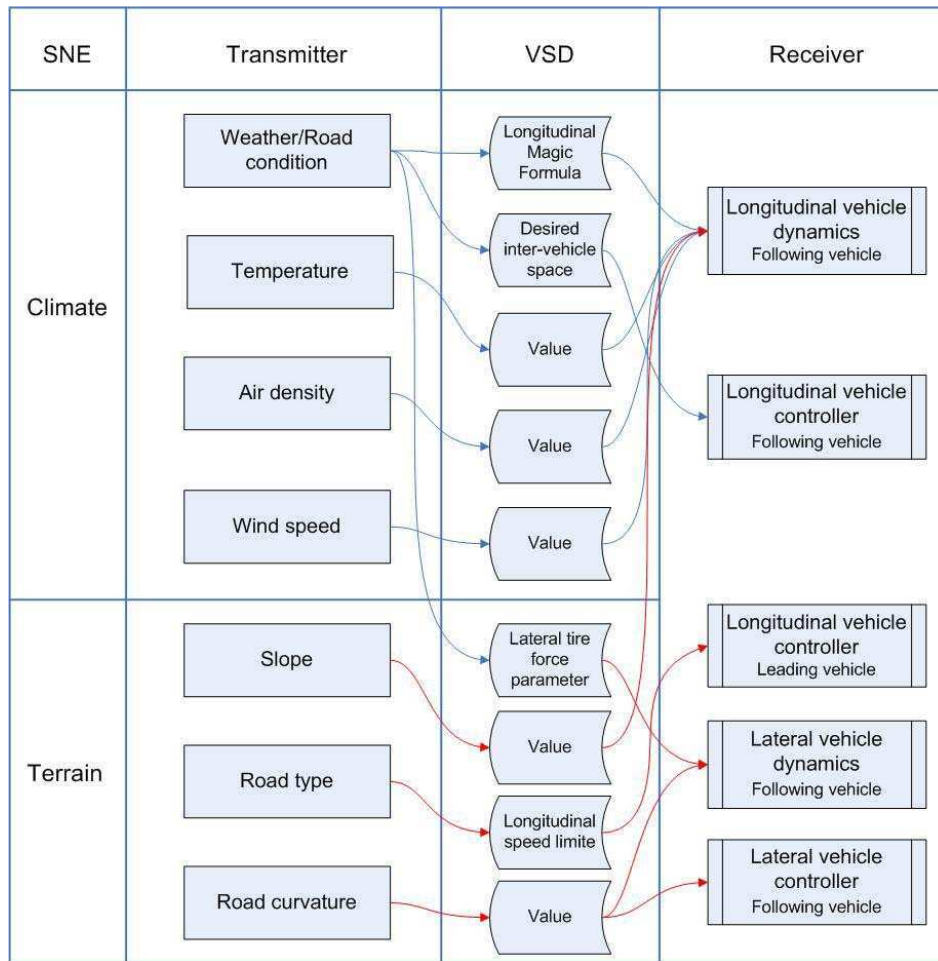

Figure 3.14: VSD delivery system

### 3.4 NE Simulation for intelligent vehicle system

In lane following simulation, the comfort of drivers and the safe distance between vehicles must be taken into account. Here, we propose the simulation of a two-

### 3.4. NE Simulation for intelligent vehicle system

Table 3.4: Basic weather types

Weather	cloudy	rainy	snowy	icy
Temperature ( $^{\circ}C$ )	20	10	0	-5
Air density ( $kg/m^3$ )	1.205	1.247	1.293	1.293
Tire/road type	dry	wet	snowy	icy
Wind speed ( $m/s$ )	0	0.3	0.5	1.0

vehicle platoon under complex natural environment conditions, and we aim to test if a secure inter-vehicular distance can be maintained or not in the whole time. The leading vehicle has been designed to simulate the driver behaviors, like keeping the vehicle on the trajectory, respecting to the signboards, etc. The following vehicle is equipped with a hierarchical longitudinal controller including an ACC system and a fuzzy lower controller [Zhao 2010].

The terrain in virtual world is constructed with pre-prepared database and the trajectory consists of three types of road: the straight road, the curved road and the inclined road, as seen in Fig. 3.15. The related speed limit of each road type has also been defined.

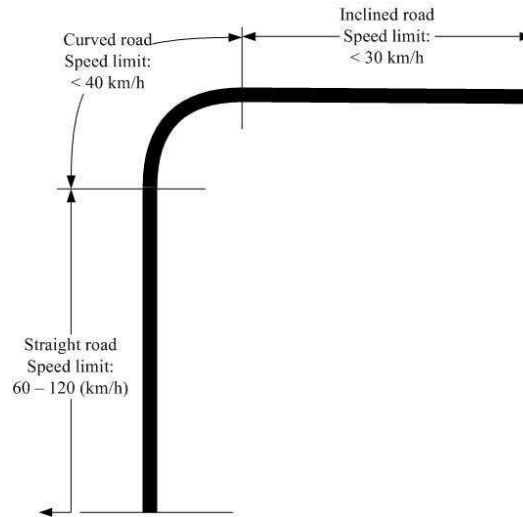

Figure 3.15: Road structure

Concerning the weather condition, IVVR platform can provide different atmosphere environments with stable or variable weather condition, and the weather multiplicity makes our experimental environment more realistic. Table 3.4 shows us four basic weather types as well as their corresponding parameter values.

### 3.4.1 Simulation 1: stable weather

Cloudy and Icy have been chosen as two stable weather conditions in this simulation to simulate their impacts on intelligent vehicle system.

Under the above two weather conditions, the two-vehicle platoon moves from straight road to curved road and finally enters inclined road. The initial speed is set to  $61.2\text{km/h}$  ( $17\text{m/s}$ ). The following vehicle is supposed to maintain a safe distance from the leading vehicle, which complies with speed limits of different road types. The simulation times is set as  $40\text{s}$  and if the collision happens, the simulation stops automatically.

The simulation results are represented by curves of two-vehicle platoon's velocity as well as inter-vehicle distance, and also virtual 3D animations (see Fig. 3.16).

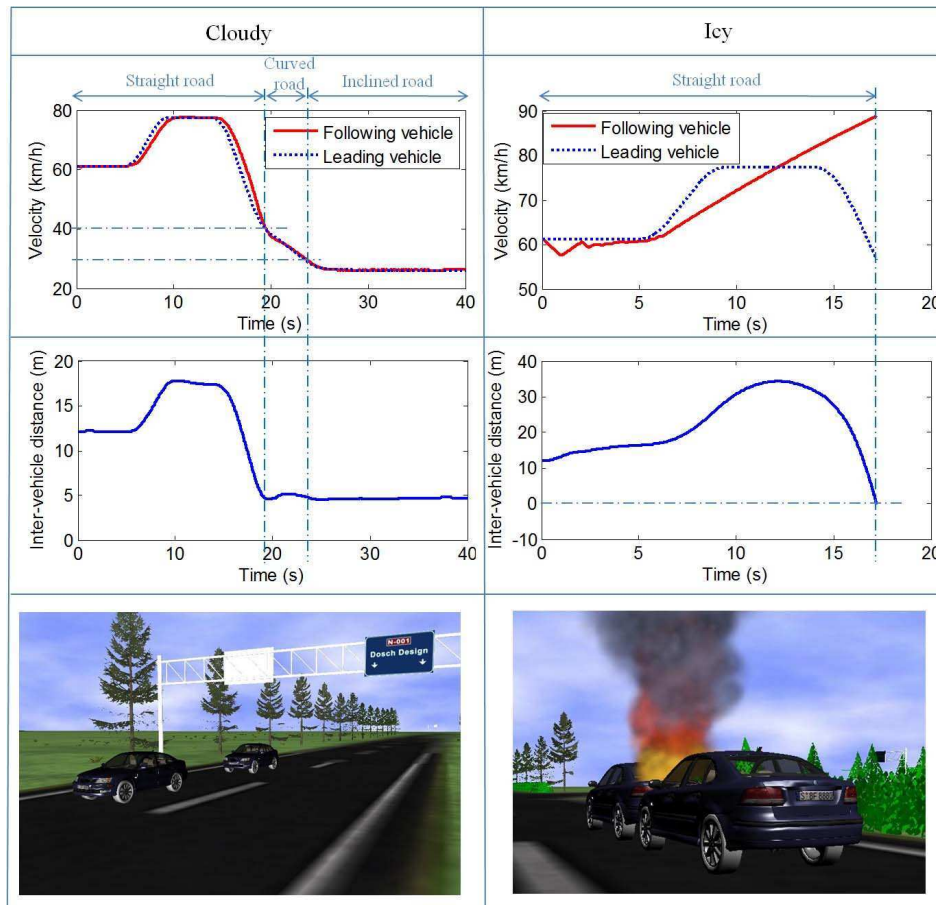

Figure 3.16: Stable weather impacts on intelligent vehicle system

It is obvious that when it is cloudy the longitudinal controller works well and the two-vehicle platoon can always maintain a safe distance during simulation. However, when the road surface is icy, the following vehicle failed to decelerate while the leading vehicle had slowed down to respect to the speed limit of curved road, as

### 3.4. NE Simulation for intelligent vehicle system

the tire force on the icy road has greatly reduced. Thus, the collision happened inevitably at the end of the straight road.

From this simulation, we can compare the two different weather effects on intelligent vehicle system through curve parameters and also vivid 3D animations. Furthermore, designers could improve the adaptability of controllers for adverse weather condition by testing the effectiveness of new controllers according to this type of simulation.

#### 3.4.2 Simulation 2: variable weather

The simulation of variable weather impacts on intelligent vehicle can be realized in IVVR platform in two ways. Firstly the automatic weather changing through environmental model and secondly the manual weather changing through man-machine interface. It should be noted that as the weather changes the corresponding parameters (e.g. temperature, air density, etc.) also change. Fig. 3.17 shows two examples of variable weather influences on vehicles.

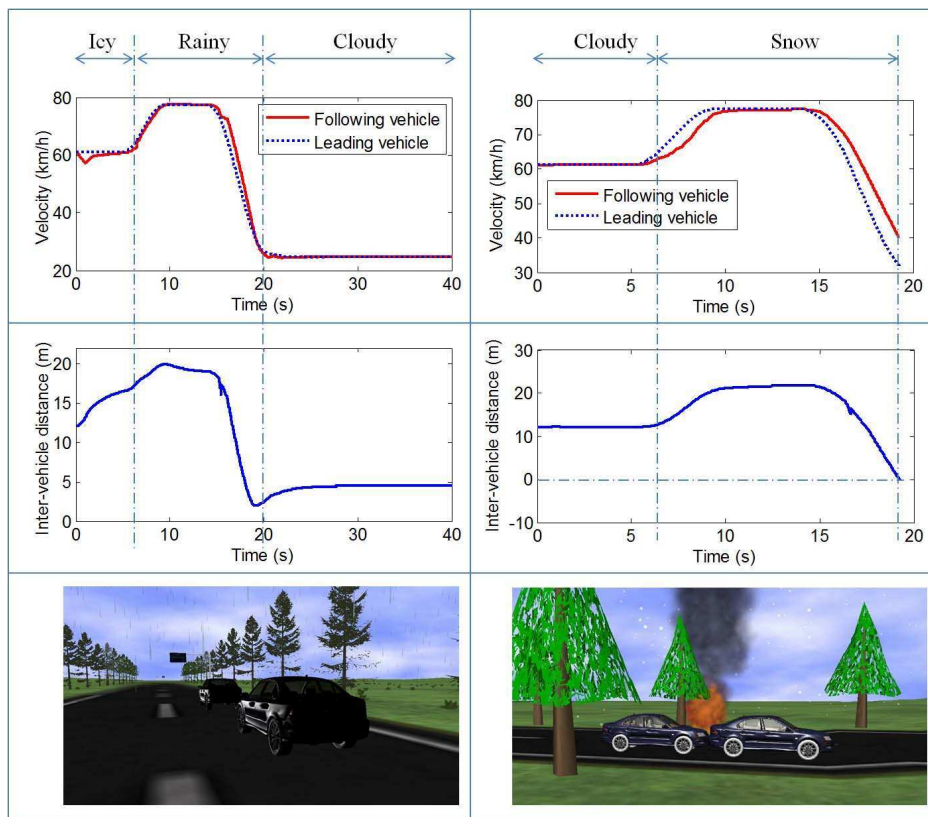

Figure 3.17: Variable weather impacts on intelligent vehicle system

In the left column, the road condition changes from icy road to wet road and finally to dry road. The curve of inter-vehicle distance indicates that it is very dan-

gerous at around 20s, and this phenomenon could be considered as the consequences of low traction when it was icy and rainy. The second simulation in the right column displays two different weathers, cloudy and snowy. It is because of the snow, the two vehicles collide on the inclined road at around 20s.

Actually, more experiments can be followed up to deduce the detailed influence of each weather condition to help the researchers designing more suitable intelligent vehicle controllers which take into account the natural environment impacts. In addition, the way of user-in-the-loop improves the entertainment of the simulation.

### 3.5 Conclusion

NE M&S have become a indispensable part in various (distributed) simulation systems that rely on the natural environment, such as military manoeuvre, maritime training, driving simulator, etc. In this chapter, we realized the NE M&S for intelligent vehicle system based on the IVVR platform presented in Chapter 2 by linking the components of intelligent vehicle system to natural environment impacts. Thus, vehicle dynamic models and controllers have been created as the functions of various environmental factors. In this way, the simulation results from IVVR platform can truly reflect the NE impacts on the intelligent vehicle system.

At present, the following conclusions can be deduced by the above NE simulation results in IVVR platform:

- With the current intelligent vehicle controllers, a two-vehicle platoon can not keep a safe inter-vehicle distance under an abominable weather or a changeable climate.
- The improvements in intelligent control including both longitudinal and lateral aspects are worth doing to make the intelligent vehicle system being more adaptive to the complex natural environment.

# Cooperative Adaptive Cruise Control Design and Simulation Involving Natural Environment Impacts

---

## Contents

---

<b>4.1 Introduction</b> . . . . .	<b>97</b>
<b>4.2 ACC/CACC systems</b> . . . . .	<b>99</b>
4.2.1 ACC/CACC system design . . . . .	99
4.2.2 Previous works on ACC/CACC algorithms . . . . .	100
<b>4.3 NECACC algorithm design</b> . . . . .	<b>102</b>
4.3.1 Basic NECACC algorithm . . . . .	103
4.3.2 Adaptive NE driving strategy . . . . .	105
4.3.3 String stability and traffic flow stability . . . . .	107
4.3.3.1 String stability . . . . .	110
4.3.3.2 Traffic flow stability . . . . .	112
<b>4.4 NECACC simulations</b> . . . . .	<b>115</b>
4.4.1 Multi-track mode . . . . .	116
4.4.2 Simulation architecture . . . . .	116
4.4.3 Simulations under fixed NE condition . . . . .	118
4.4.4 Simulations with user-in-the-loop . . . . .	127
<b>4.5 Conclusion</b> . . . . .	<b>127</b>

---

## 4.1 Introduction

As concluded in Chapter 3, it is necessary to improve the actual intelligent vehicle control algorithms in order to make the intelligent vehicle system more adaptive to the complex natural environment. In this chapter, we concentrate on the longitudinal vehicle control as it exists throughout the entire auto-driving process.

Currently, although fully automated vehicle control which needs special infrastructure and dedicated lanes is difficult to be realized all over the world, partly

automated driving have already been commercially available for basic driving tasks such as accelerating and braking by means of ACC systems relating to the longitudinal vehicle control.

While regular Cruise-Control (CC) systems track a desired vehicle speed, ACC systems relieve a driver from manually adjusting his/her control to achieve a safe cruise. It focuses on the equilibrium between traffic capacity (minimum inter-vehicle space) and security (avoidance of rear-end collision) whilst retaining driving comfort. Being improved through vehicle-to-vehicle communication, where the current speed and acceleration of a vehicle can be transmitted to the following vehicle by inter-vehicle communication, the standard ACC systems can be extended to Cooperative ACC (CACC) systems, which provide us better traffic-flow performance in reducing time gaps and improving string stability [Arem 2006].

The present ACC/CACC systems equipped on the vehicle accept as input the velocity or acceleration of itself or its preceding vehicle and their deceleration capabilities and returns the minimum spacing needed to guarantee that the two vehicles do not collide. If well designed, the ACC/CACC systems can lead to traffic flows with desirable characteristics and can significantly ease congestion. Besides, for these systems, two kinds of stability which are string stability (or car-following stability) and traffic flow stability must be considered. Actually, the flow stability and critical capacity of any section of a highway is dependent not only on the vehicle following control laws and the information used in their synthesis, but also on the spacing policy provided by the ACC/CACC control system [Swaroop 1999].

Recently, researches with regard to ACC/CACC design are prosperous as we have made great progresses in sensing, communicating, and computing technologies [Desjardins 2011]. However, throughout the previous studies concerning ACC/CACC systems [Xiao 2010], the Natural Environment (NE)(e.g. weather, terrain, etc.) impacts on the road-vehicle relationship have totally been ignored, and the ACC system used in the IVVR platform is also not an exception. According to Chapter 3, it is clear that the NE condition is actually one risk factor to affect collision rates. Hence, here, a new CACC algorithm, called NECACC (Natural Environment based CACC algorithm), is presented to act as the upper controller under our hierarchical ACC/CACC architecture in which a lower fuzzy controller has been designed to decide the throttle and brake commands required to track the desired acceleration. This algorithm establishes a link between CACC and NE and tries to achieve the balance of traffic capacity and security under various NE conditions.

It should be noted that once an algorithm is presented, the simulation or verification is important and necessary. Thanks to the IVVR platform as well as its NE M&S that brings together users, virtual intelligent vehicles, and virtual environment into a dynamic relationship of information exchange, the simulations under different NE conditions can be carried out in a virtual world without any dangerous and with lower cost and less time. This kind of verification can be considered as a "proof of concept".

Hence, the presentation of the new CACC algorithm as well as its conceptual proof will be emphasized in this chapter and the contents are organized as follows:

## 4.2. ACC/CACC systems

---

Section 4.2 introduces the ACC/CACC system structure and previous works on ACC/CACC algorithms. In Section 4.3, the NECACC algorithm is firstly presented together with its driving strategy and the analysis relating to string stability and traffic flow stability will be shown next. In Section 4.4, the simulations of NECACC are performed under several fixed NE conditions and also some changeable NE conditions controlled by users. A multi-track mode for synchronized performance of multiple animations is proposed for the comparison of NECACC algorithm with other ACC/CACC algorithms.

## 4.2 ACC/CACC systems

### 4.2.1 ACC/CACC system design

The ACC/CACC systems are one kind of Advanced Driver Assistance Systems (ADAS) with the potential to influence traffic flow characteristics. Some ACC systems are already available on several production cars, including the Nissan Q45 and FX45, the Mercedes Sclass, the Lexus 330 and 430, the Audi A8, and select Jaguar and Cadillac models [Girard 2005]. It concerns maximizing the traffic capacity and meanwhile avoiding the longitudinal collision address rear-end collisions, which are usually due to the difficulty for the driver to react to a sudden braking by the leading vehicle. If the leading car slows down, the inter-vehicle space will decrease, the ACC/CACC system then detects the changes through sensors or wireless communication link and sends signals to the engine or braking system of the following car to decelerate. On the contrary, when the road is clear, the ACC/CACC system will re-accelerate the vehicle to augment the traffic capacity.

The overall design of ACC/CACC system involves the following steps:

- Design of an ACC/CACC algorithm (spacing policy). A spacing policy or an ACC/CACC algorithm is a rule that dictates how the speed of an automatically controlled vehicle must be regulated as a function of the following distance.
- Design of a control system for the servo-loop to regulate the vehicle velocity according to the designed spacing policy. Normally, it is composed by a throttle controller and a brake controller which can be realized for instance by PID method or Fuzzy logic method.

The ACC/CACC system is assumed to have a dual-loop structure, see Fig. 4.1. A main loop ACC/CACC controller determines the proper acceleration based on measured interspace, interspace rate, speed and acceleration of itself or the neighboring vehicles. A sub-loop controller then manipulates the engine and brake actuators to achieve the desired acceleration or deceleration. In this chapter, the emphasis of our study is on the ACC/CACC algorithm design and the outer loop controller, while the servo-loop is ignored.

When designing an ACC/CACC algorithm, several attributes should be satisfied and they have been listed as follows:



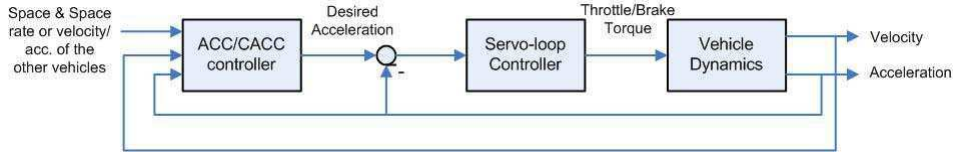

Figure 4.1: Dual-loop structure of an ACC/CACC system

1. The proposed algorithm leads to increased traffic capacity and stable traffic flow up to a higher characteristic density.
2. It should have a companion servo (lower level) controller that ensures string stability without communicating with neighboring vehicles or the infrastructure.
3. It should close to the human drivers' range behavior, at least during the early implementation stage.
4. The control effort should be within the vehicle's traction/braking capability.
5. The spacing policy should be adaptive according to different traffic situations or natural environment conditions.

#### 4.2.2 Previous works on ACC/CACC algorithms

The most common ACC algorithm is the constant time-gap (CTG) policy [Wang 2004a], and the desired inter-vehicle spacing  $D_s$  can be given by:

$$D_s = L + h\dot{x}_F(t) \tag{4.1}$$

where  $L$  is a constant that means the minimum inter-vehicle spacing,  $h$  is the headway time, and  $\dot{x}_F(t)$  is the velocity of the following vehicle.

However, it has already been proved by Swaroop [Swaroop 1999] and Junmin Wang [Wang 2004b] that the traffic flow is unstable when all vehicles on the highway use the CTG policy. Thus, [Wang 2004b] presented a new spacing policy named variable time-gap (VTG) policy. The VTG policy is a nonlinear function of vehicle velocity, and the desired spacing  $D_s$  under the proposed policy is given by:

$$D_s = \frac{1}{\rho_m(1 - \dot{x}_F(t)/v_f)} \tag{4.2}$$

where  $\rho_m$  is a density parameter and  $v_f$  is a speed parameter. Values of  $\rho_m = 1/L$ ,  $L = 5$  and  $v_f = 28.89m/s$  were used in the paper.

The comparison between CTG and VTG was followed up in terms of the inter-vehicle spacing as a function of velocity, the traffic follow and density characteristic curves and also the total travel (TT) and total travel time (TTT). Finally, [Wang 2004b] proved that the VTG gives better traffic behavior than does the CTG.

## 4.2. ACC/CACC systems

---

Besides, Lydie Nouveliere [Nouveliere 2002] had also presented two types of safety spacing policy, the first one faces to the situation when detecting a static preceding vehicle, the desired spacing  $D_s$  can be described as a parabolic function of vehicle velocity:

$$D_s = \bar{a} + \bar{b}\dot{x}_F(t) + \bar{c}\dot{x}_F(t)^2 \quad (4.3)$$

where  $\bar{a} = 5.0201m$  means the minimum distance as two vehicles are static,  $\bar{b} = 0.7723s$  means the reaction time of driver, and  $\bar{c} = -\frac{1}{2a_F} = 0.0644m^{-1}s^2$ . The  $\bar{c}\dot{x}_F(t)^2$  means the stopping distance of following vehicle with the comfortable deceleration  $a_F (< 0)$ .

As detecting a mobile preceding vehicle, the expression is also presented as a parabolic function but the parameters change:

$$D_s = \tilde{a} + \tilde{b}\dot{x}_F(t) + \tilde{c}\dot{x}_F(t)^2 \quad (4.4)$$

where  $\tilde{a} = 2.74m$  denotes the inter-vehicle space when two vehicles' velocity is zero,  $\tilde{b} = 1.0939s$  denotes the driver's reaction time, and  $\tilde{c} = \frac{1}{2a_L} - \frac{1}{2a_F} = -0.0878$ , in which  $a_L (< 0)$  is the maximum deceleration of leading vehicle. The  $\tilde{c}\dot{x}_F(t)^2$  signifies the relative distance between two vehicles traveled between when the driver begins to brake by pressing the brake pedal and when it stops. What's more, the adjustment of the above three parameters also has been mentioned in [Nouveliere 2002] according to the conditions of circulation, road, vehicle and climate.

Also being a parabolic function with different parameters, the SSP (Safety Spacing Policy) presented by Jin Zhao [Zhao 2010] is supposed to improve traffic capacity and at the same time ensure string stability and traffic flow stability.

With the purpose of adapting to different traffic situations, like moving in free traffic or passing infrastructure bottleneck sections, etc., Arne Kesting [Kesting 2008] has designed a cooperative adaptive cruise control strategy based on the intelligent driver model (IDM) [Treiber 2000]. The effective desired minimum gap in IDM is:

$$D_s = s_0 + T\dot{x}_F(t) + \frac{\dot{x}_F(t)(\dot{x}_L(t) - \dot{x}_F(t))}{2\sqrt{a_F a_L}} \quad (4.5)$$

where  $\dot{x}_L(t)$  means the velocity of the leading vehicle,  $s_0 (= 2m)$  is the jam distance, and  $t (= 1.5s)$  is the safe time gap. Three additional parameters  $\lambda_T, \lambda_a, \lambda_b \in [0, 1]$  have been added and multiplied by  $T, a_F, a_L$  in the algorithm to modify automatically the CACC parameters depending on the detected traffic situation.

It should be noted that the original ACC controller applied in IVVR platform is the algorithm (4.4) with different parameter values, which is called LNACC in this chapter.

As a matter of fact, several collision warning/avoidance algorithms in the area of driver-assistance systems also have been studied to define a desired distance between two vehicles to avoid rear-end collision and in particular the two main types are based on kinematic and perceptual approach.

The algorithms based on kinematic trigger alerts use the fundamental laws of motion. Combining the hypothesis of the deceleration and reaction time with the

current state of a vehicle, the algorithm determines a minimum distance required to stop safely. When the vehicle is at a distance minor or equal to the safe distance from another vehicle, an alarm is triggered. One of the typical algorithms is the Mazda Algorithm [Bella 2011][Seiler 1998], see (4.6).

$$D_{warning} = 0.5\left(\frac{\dot{x}_F(t)^2}{a_F} - \frac{\dot{x}_L(t)^2}{a_L}\right) + \dot{x}_F(t)\tau_1 + (\dot{x}_L(t) - \dot{x}_F(t))\tau_2 + D_{min} \quad (4.6)$$

here, the scenario assumes that initially the two vehicles maintain constant speeds:  $\dot{x}_L(t)$  and  $\dot{x}_F(t)$ . Subsequently, the lead vehicle starts to brake after time  $\tau_2 = 0.6s$  with a deceleration rate  $a_L = 8m/s^2$ , while the following vehicle costs time  $\tau_1 = 0.1s$  to detect this situation and begins to brake at deceleration rate  $a_F = 6m/s^2$ . This process continues until both vehicles come to a full stop. And the  $D_{min} = 5m$  is the minimum range.

With algorithms based on the perceptual approach, an alarm is triggered based on thresholds of perception. Once exceeding the human perceptual threshold, a signal is activated to alert the driver. This approach is based on thresholds of Time to Collision (TTC), which is defined as the time until a collision between two vehicles would have occurred if the collision course and speed difference were maintained. For instance, in the Honda Algorithm [Seiler 1998][Bella 2011], a warning is issued when the TTC is equal to 2.2 seconds. The distance is calculated by means of:

$$D_{warning} = 2.2(\dot{x}_L(t) - \dot{x}_F(t)) + 6.2 \quad (4.7)$$

where 6.2 is an additional safety value.

Furthermore, Ararat [Ararat 2006] presented a new Collision Warning algorithm for ACC vehicles to avoid the unnecessary warnings and once there is a warning, it means that there is a need for emergency braking. In this way, the time delay is related also to ACC delay and system delay.

It is obvious that the contributions relating to the ACC/CACC algorithm are numerous and active in the past of few years. Nevertheless, the aspect of natural environment has been ignored in the algorithm design and that is the reason that we present the NECACC algorithm here.

### 4.3 NECACC algorithm design

The NECACC algorithm design is executed in three steps. The first step is the deduction of the basic NECACC algorithm in terms of a microscopic traffic model. The second step is the proposition of a adaptive NE driving strategy that used to help this basic algorithm being adaptive to various natural environment. And in the third step, the string stability and traffic flow stability of NECACC are proved theoretically.

### 4.3. NECACC algorithm design

#### 4.3.1 Basic NECACC algorithm

Fig. 4.2 shows the microscopic traffic model with a leading vehicle and a following vehicle and some parameters most frequently used, in which  $X_L(t)$  and  $D_L(a_L, t)$  is the leading vehicle's current position and braking distance with the maximum deceleration  $a_L$ , and  $X_F(t)$  and  $D_F(a_F, t)$  is the following vehicle's current position and braking distance with a comfortable deceleration  $a_F$ .

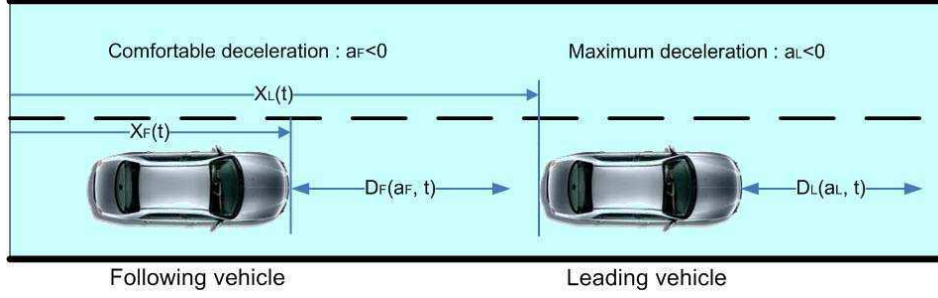

Figure 4.2: Microscopic traffic model

As our aim is making sure that with the current inter-vehicle space  $X_L(t) - X_F(t)$ , two vehicles will not collide even if the leading vehicle brakes suddenly with its maximum deceleration  $a_L$ . If we have

$$X_F(t) + D_F(a_F, t) \geq X_L(t) + D_L(a_L, t) \quad (4.8)$$

Then, a risk of collision between two vehicles exists. Thus, defining a safety space  $\sigma (> 0)$ , to avoid a collision, the following expression must be satisfied:

$$X_L(t) + D_L(a_L, t) - (X_F(t) + D_F(a_F, t)) \geq \sigma \quad (4.9)$$

Knowing that the stopping distance  $D_L(a_L, t) = -\frac{1}{2a_L}\dot{x}_L(t)^2$  and  $D_F(a_F, t) = -\frac{1}{2a_F}\dot{x}_F(t)^2$ , then (4.9) can be transformed to:

$$X_L(t) - X_F(t) \geq \sigma + \frac{1}{2a_L}\dot{x}_L(t)^2 - \frac{1}{2a_F}\dot{x}_F(t)^2 \quad (4.10)$$

where  $\sigma$  relates to the minimum range  $D_{min}$  when two vehicles stop and the reaction time  $t_r$  of ACC/CACC system. It can be described as:

$$\sigma = D_{min} + t_r\dot{x}_F(t) \quad (4.11)$$

Further considering the maximization of traffic capacity, the optimized inter-vehicle distance  $D_s(t)$  can be obtained by combining (4.10) and (4.11).

$$D_s(t) = D_{min} + t_r\dot{x}_F(t) + \frac{1}{2a_L}\dot{x}_L(t)^2 - \frac{1}{2a_F}\dot{x}_F(t)^2 \quad (4.12)$$

Till now, we have gotten the initial expression of desired inter-vehicle distance in NECACC algorithm in which the wireless communication with the nearest preceding

vehicle has been considered. Nevertheless, the practical result usually could not accord with the desired value by reason of various factors according to the real environment. For example, if the road is wet or icy, the slip between road and tire cannot be ignored any more, under this situation, the real distance between vehicles is usually smaller than the desired one because of the vehicle's tire force is much smaller than the value expected, hence, the possibility of collision is much higher.

In this case, for the sake of improving the NE adaptability of CACC algorithm, the system parameters need to be changed in a way that preserves the individual settings and driving characteristics under various weather conditions. Thus, three variables  $\lambda_T$ ,  $\lambda_{aF}$ ,  $\lambda_{aL}$  are imported as the NE adjustment parameters in NECACC, which can be defined by the following relations:

$$t_{r_{NE}} = \lambda_T t_r, a_{F_{NE}} = \lambda_{aF} a_F, a_{L_{NE}} = \lambda_{aL} a_L \quad (4.13)$$

where the subscript  $_{NE}$  denotes one of the NE conditions to which the respective value applies. Applying (4.13) into (4.12), we can finally get the NECACC algorithm in terms of desired inter-vehicle space:

$$D_{s_{NE}}(t) = D_{min} + \lambda_T t_r \dot{x}_F(t) + \frac{1}{2\lambda_{aL} a_L} \dot{x}_L(t)^2 - \frac{1}{2\lambda_{aF} a_F} \dot{x}_F(t)^2 \quad (4.14)$$

Defining  $\varepsilon(t) = X_F(t) - X_L(t)$  as the current real inter-vehicle space, the spacing error is given by:

$$\delta(t) = \varepsilon(t) + D_{min} + \lambda_T t_r \dot{x}_F(t) + \frac{1}{2\lambda_{aL} a_L} \dot{x}_L(t)^2 - \frac{1}{2\lambda_{aF} a_F} \dot{x}_F(t)^2 \quad (4.15)$$

Setting  $\dot{\delta}(t) = -\lambda\delta(t)$  by differentiating (4.15), the desired acceleration of the following vehicle  $\ddot{x}_{dF}(t)$  with the NECACC algorithm can be obtained as:

$$\ddot{x}_{dF}(t) = -(\dot{\varepsilon}(t) + \lambda\delta(t) + \frac{\dot{x}_L(t)}{\lambda_{aL} a_L} \ddot{x}_L(t)) / (\lambda_T t_r - \frac{\dot{x}_F(t)}{\lambda_{aF} a_F}) \quad (4.16)$$

One thing should be underlined is that, in case of the invalidation of vehicle-to-vehicle communication, the NECACC algorithm can degrade to NEACC algorithm, which means (4.14) and (4.16) would be changed to (4.17) and (4.18) with the hypothesis of  $\dot{x}_L(0) = \dot{x}_F(0)$ , here,  $\dot{x}_L(0)$  and  $\dot{x}_F(0)$  denote the initial velocity of leading vehicle and following vehicle.

$$D_{s_{NE}}(t) = D_{min} + \lambda_T t_r \dot{x}_F(t) + \left(\frac{1}{2\lambda_{aL} a_L} - \frac{1}{2\lambda_{aF} a_F}\right) \dot{x}_F(t)^2 \quad (4.17)$$

$$\ddot{x}_{dF}(t) = -(\dot{\varepsilon}(t) + \lambda\delta(t)) / (\lambda_T t_r + \frac{\dot{x}_F(t)}{\lambda_{aL} a_L} - \frac{\dot{x}_F(t)}{\lambda_{aF} a_F}) \quad (4.18)$$

Assuming that the type of two vehicles is fixed, so the values of  $a_L$  and  $a_F$  are fixed. Here we set  $a_L = -11.772m/s^2$ ,  $a_F = -7.848m/s^2$ ,  $D_{min} = 2.5m$ ,  $\lambda = 0.4$  and  $t_r = 0.1s$ . The values of NE adjustment parameters  $\lambda_T$ ,  $\lambda_{aF}$ ,  $\lambda_{aL}$  will be presented in the next paragraph. This algorithm is supposed to work together with a lower fuzzy controller [Zhao 2010] which can output the throttle and brake commands to track the desired acceleration.

### 4.3. NECACC algorithm design

#### 4.3.2 Adaptive NE driving strategy

As accounted above, the parameters  $\lambda_T$ ,  $\lambda_{aF}$ ,  $\lambda_{aL}$  are supposed to change automatically according to different NE situations, thus, we propose in this section a driving strategy that adapts them to the local NE situation. Since Chapter 3 has defined four NE situations which are Sunny/Cloudy, Rainy, Snowy and Icy (see Table 3.4), the driving strategy will be designed based on the above four climate types.

Fig. 4.3 shows the strategy which consists of three components: Detection model, Driving strategy matrix and NECACC operating mode. The Detection model is presumed to receive the NE signals and then select the most appropriate NE situation model. Next, in the Driving strategy matrix, the corresponding NE adjustment parameters will be chosen depending on the detected NE situation and then be sent out to the operating mode. Finally, NECACC algorithm calculates the desired acceleration according to the proposed values of  $\lambda_T$ ,  $\lambda_{aF}$ ,  $\lambda_{aL}$  and the value of desired acceleration will be sent to the lower control system.

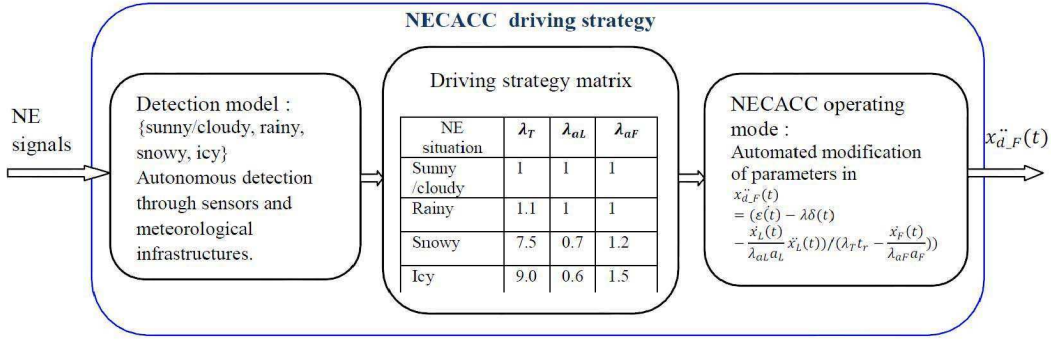

Figure 4.3: Structure of NECACC driving strategy

Basically, as the natural environment condition becomes worse and worse, the desired inter-vehicle space should augmented step by step. Hence, we define the NE adjustment parameters with different values under four NE conditions so as to make the final control algorithm being appropriate to the local NE condition. The choice of these values has been carried out by lots of experiments in IVVR platform and the final results have been listed in Fig. 4.3.

To prove the effectiveness of the NE adjustment parameters, some experiments have been taken place to compare the control effects between the situation with NE driving strategy (denoted by NECACC) and the one without NE driving strategy (denoted by CACC), which means the three NE adjustment parameters are always 1. We have selected the two vehicles' velocity, the inter-vehicle space and the desired acceleration of the following vehicle as the elements of comparison.

When it is rainy, the road surface becomes damp, the traction is reduced by about 20%. So,  $\lambda_T = 1.1$ ,  $\lambda_{aF} = 1.0$  and  $\lambda_{aL} = 1.0$  were chosen in the control algorithm. Fig. 4.4 shows the experiments results which indicate that under the rainy condition, a safe inter-vehicle space can always been maintained in the simulation. There are

not many differences between CACC and NECACC with the rain.

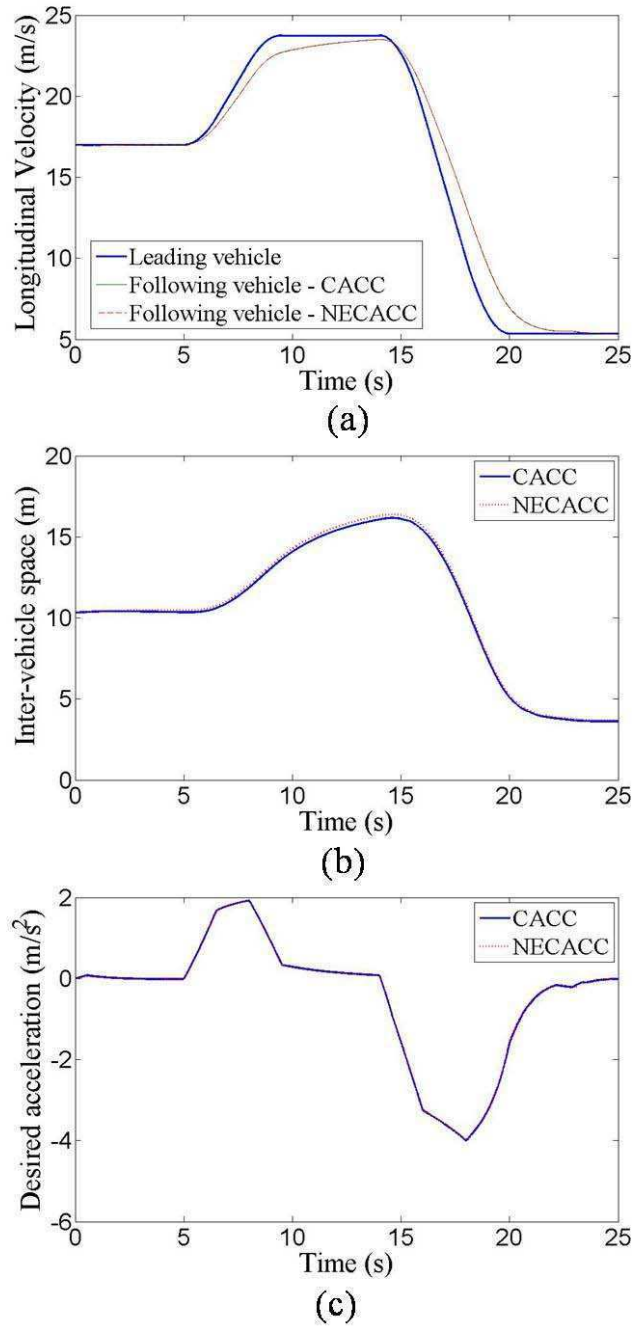

Figure 4.4: Comparison of CACC and NECACC in case of rainy

It must be admitted that, this simulation result can not explain all the traffic situations under the rainy condition, as we know that the heavy rain is a important reason for the increasing accidents in the world's road recently by reason of its

### 4.3. NECACC algorithm design

---

influence on the visibility of drivers. However, as we focus on the automatic traffic system, the impact of visibility problem has been reduced to the maximum extent and the friction of road surface is only slightly reduced, it is then reasonable to obtain the above result that the rainy condition will not affect much on the automatic traffic behavior.

When it is snowy, un-packed snow lies on the road surface and the traction can be reduced by 65%. In this case,  $\lambda_T = 7.5$ ,  $\lambda_{aF} = 0.7$  and  $\lambda_{aL} = 1.2$  have been chosen. Fig. 4.5 shows us the simulation results.

Concerning the following vehicle's velocity, NECACC chose to decelerate a little at the beginning in order to gain more inter-vehicle space, and when the leading vehicle starts a hard break, it decelerates smoothly which results also a larger inter-vehicle distance. This means that NECACC tends to sacrifice the efficiency of traffic flow to obtain more security. From the curves of inter-vehicle space, we can see that for the vehicle equipped with CACC algorithm, a collision happens around of 20s when the following vehicle decelerates hardly and tries to get more traffic capacity. While for the vehicle equipped with NECACC, the inter-vehicle space is always positive. With regard to the desired acceleration of the following vehicle, NECACC provides a more smooth curve of acceleration and this represents a better performance in ensuring the driver's comfort.

From the above simulation result, it is clear that with the three NE adjustment parameters, under the snowy situation, NECACC gives us more security and comfortable feelings by immolating some traffic efficiency.

When it is icy, there are packed frozen snow and black ice lie on the road surface, and the maximum traction can be reduced by 85%. This situation is very dangerous for driving and normally driving behaviors are forbidden under such a abominable road condition. Fortunately, with the help of virtual reality technology, the experiment can be executed in IVVR platform and Fig. 5.9 shows the results. Although the collision can not be avoided with both algorithms, the results still reflect the superiority of NECACC. We can see that with NECACC, the collision time is put off, and the acceleration curve is also more smooth.

Actually, we chose to do this kind of experiment for the purpose of proving that NECACC algorithm could work well when there exists only a short part of icy road on the highway which can be observed in winter.

#### 4.3.3 String stability and traffic flow stability

As two important performance indicators concerning the Intelligent Transportation System, string stability and traffic flow stability are going to be discussed in this subsection as both of them are influenced by the proposed CACC algorithm. For this, a macroscopic flow model has been described in Fig. 4.7, where all the vehicles are equipped with a NEACC/NECACC system.

In fact, as mentioned in Section 4.2.1, the ACC/CACC algorithm design should ensure string stability without communicating with neighboring vehicles and according to [Arem 2006][Desjardins 2011][Naus 2010], it has been proven that the



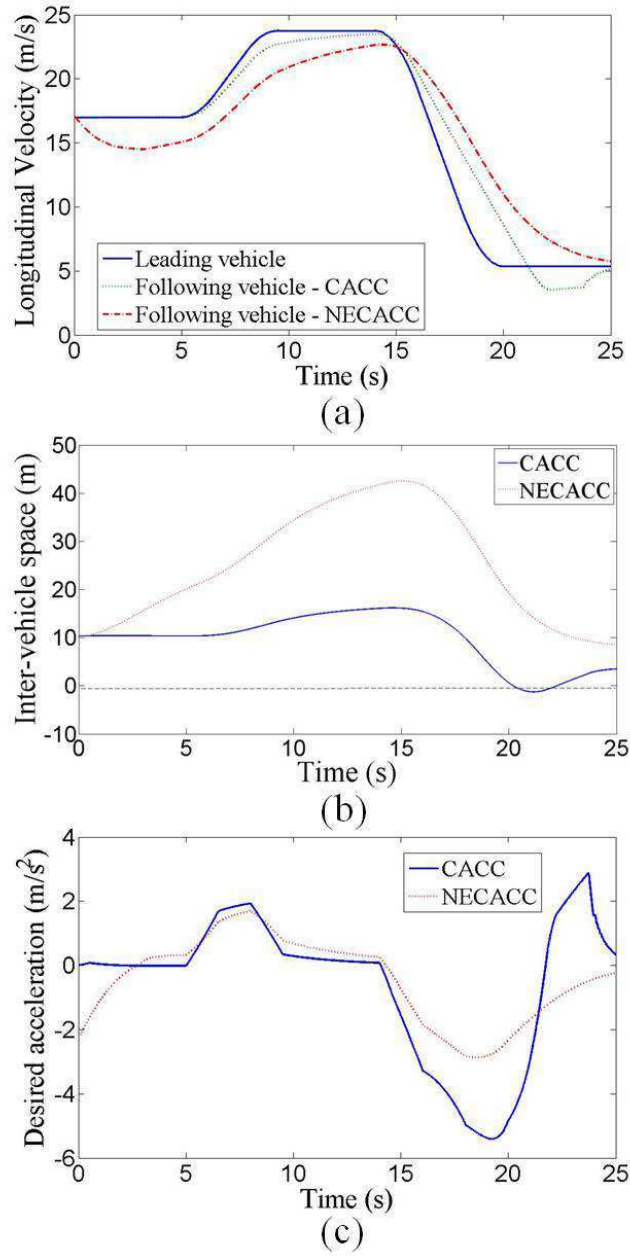

Figure 4.5: Comparison of CACC and NECACC in case of snowy

### 4.3. NECACC algorithm design

---

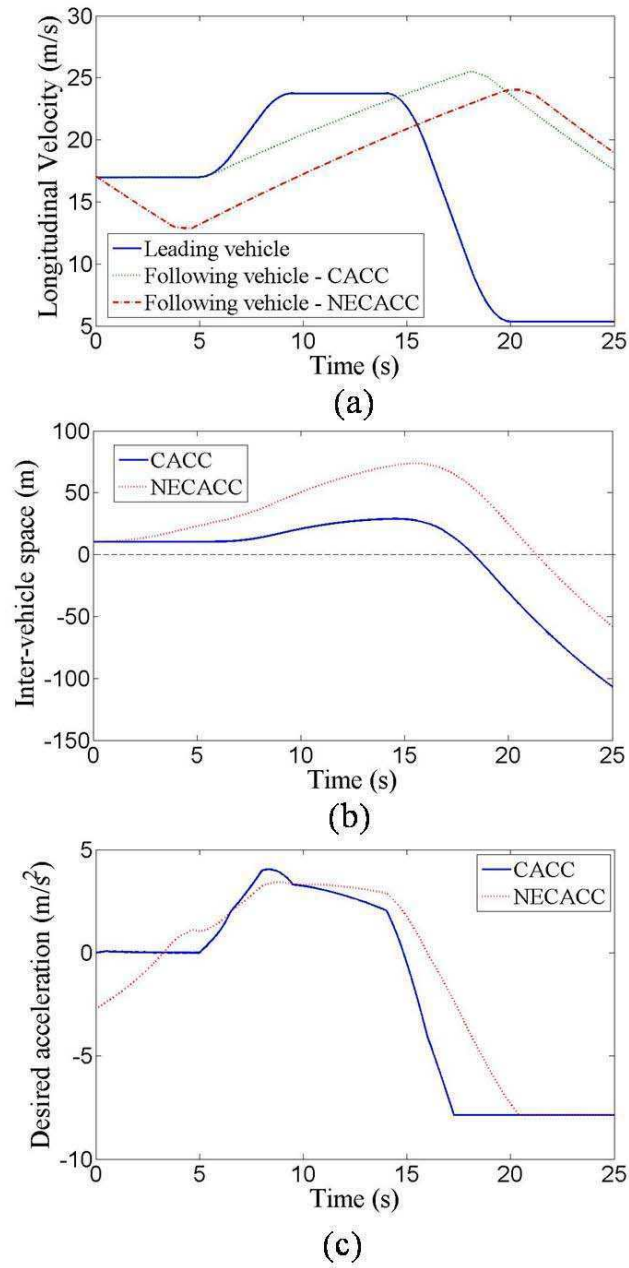

Figure 4.6: Comparison of CACC and NECACC in case of icy

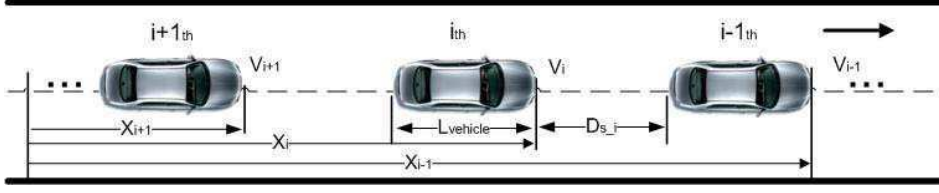

Figure 4.7: Macroscopic traffic flow model

CACC systems which use the wireless communicated data in a feedforward setting have better performance in terms of traffic stability when comparing to the ACC systems. That is to say, if the NEACC equipped vehicles are stable then the traffic stability can be sure guaranteed after adding the inter-vehicle communication. Hence, here, we analyze the string stability and traffic flow stability without considering the communication with neighboring vehicles. The corresponding results could be considered as the minimum stability that the NECACC can get.

#### 4.3.3.1 String stability

**Definition** The string stability problem of a vehicle platoon has been studied since the late 1970s [Caudill 1977]. The term "string stability" refers to the non-amplifying upstream propagation of vehicle speed perturbation through a string of vehicles. String stability is stability with respect to inter-vehicle space and it is an important characteristic of a good longitudinal control strategy. Intuitively, it ensures the knowledge of the position and velocity of every vehicle in the traffic, within reasonable bounds of error, from the knowledge of the position and velocity of a vehicle in the traffic. String stability is analyzed without adding vehicles to or removing vehicles from the traffic [Zhao 2010].

A traffic is said to be string stable when any disturbance to the motion is attenuated as it propagates along the vehicles convoy: the range errors decrease as the pass along the vehicle stream. Defining  $\varepsilon_i(t) = x_i(t) - x_{i-1}(t)$ , then we get the spacing error  $\delta_i(t) = \varepsilon_i(t) + D_{s,i}(t) + L_{vehicle}$ . D. Swaroop [Swaroop 1999] had defined the string stability of a platoon of vehicles in temporal area.

**definition 1** (*String stability*). A string of automated vehicles is stable if give  $\zeta > 0$ , there exists a  $\gamma > 0$  such that

$$\sup_i \max \{|\delta_i(0)|, |\dot{\varepsilon}_i(0)|\} < \gamma \Rightarrow \sup_i \sup_{t \geq 0} \max \{|\delta_i(t)|, |\dot{\varepsilon}_i(t)|\} < \zeta$$

**definition 2** (*Asymptotic string stability*). A string of automated vehicle is asymptotically stable if it is stable and if

$$\lim_{t \rightarrow \infty} \sup_i \max \{|\delta_i(t)|, |\dot{\varepsilon}_i(t)|\} = 0$$

In which the  $\dot{\varepsilon}_i(t)$  denote the rate of change of the following distance of an automated vehicle.

### 4.3. NECACC algorithm design

---

**String stability of NECACC/NEACC** With the proposed spacing policy, we think that it is string stable if the following condition is satisfied [Swaroop 1996] [Swaroop 1994]:

$$\|\hat{H}(s)\|_\infty \leq 1 \quad (4.19)$$

Where,  $\hat{H}(s)$  is the transfer function relating the spacing errors of consecutive vehicles,  $\hat{H}(s) = \delta_i(s)/\delta_{i-1}(s)$ . In order to investigate the string stability characteristics of the proposed algorithm, the ACC system is linearized around a nominal vehicle speed  $v_i(0) = v_{i-1}(0) = v_0$  and the corresponding space  $D_{s_i}(0) = D_{s_{i-1}} = D_0$  with  $D_0 = D_s(v_0)$ . At a certain moment, the leading vehicle speed is perturbed, thus introducing disturbance to the trailing vehicles. Let  $v_i = v_0 + \Delta v_i$ ,  $\dot{v}_i = \Delta \dot{v}_i$ , and  $D_{s_i} = D_0 + \Delta D_{s_i}$ ,  $\dot{D}_{s_i} = \Delta \dot{D}_{s_i}$ . It can be shown that for linearized systems the transfer function of the spacing error propagation is the same as that of the speed variation [Zhou 2005]:

$$\hat{H}(s) = \frac{\delta_i(s)}{\delta_{i-1}(s)} = \frac{\Delta v_i(s)}{\Delta v_{i-1}(s)} \quad (4.20)$$

We assume that the vehicle dynamic could be approximated by a first-order system [Zhou 2005][Xiao 2011]:

$$\tau \dot{a}_i(t) + a_i(t) = a_{ides}(t - \Omega) \quad (4.21)$$

where  $a_i(t)$  is the vehicle's actual acceleration,  $a_{ides}$  is the desired acceleration,  $\tau$  is the parasitic time lag and  $\Omega$  is the parasitic time delay. Combining (4.18) and (4.21), we get

$$\tau \dot{a}_i(t) + a_i(t) = -\frac{\dot{\varepsilon}_i(t - \Omega) + \lambda \delta_i(t - \Omega)}{T_v} \quad (4.22)$$

Here,  $T_v = \lambda_T t_r + (\frac{1}{\lambda_{aL} a_L} - \frac{1}{\lambda_{aF} a_F}) v_i$ . Differentiating both sides of (4.22) and using the relation  $\dot{v}_i = \Delta \dot{v}_i$ , we obtain

$$\Delta \dot{v}_{i-1}(t - \Omega) + \lambda v_{i-1}(t - \Omega) = T_v \tau \Delta \ddot{v}_i(t) + T_v \Delta \dot{v}_i(t) + (1 + T_v \lambda) \Delta \dot{v}_i(t - \Omega) + \lambda \Delta v_i(t - \Omega) \quad (4.23)$$

Taking the Laplace transformation of (4.23), we obtain

$$\hat{H}(s) = \frac{\Delta v_i(s)}{\Delta v_{i-1}(s)} = \frac{(s + \lambda)e^{-\Omega s}}{T_v \tau s^3 + T_v s^2 + (1 + T_v \lambda) s e^{-\Omega s} + \lambda e^{-\Omega s}} \quad (4.24)$$

According to (4.19) and substituting  $s = jw$  in (4.24), to ensure the string stability, we must have

$$\left\| \frac{\Delta v_i}{\Delta v_{i-1}}(jw) \right\| \leq 1, \text{ for } \forall w > 0 \quad (4.25)$$

After some algebraic reductions [Xiao 2011], it is found that this inequality constraint is always satisfied if holding

$$T_v > 2(\tau + \Omega) \quad (4.26)$$

which means

$$\lambda_T t_r + \left( \frac{1}{\lambda_{aL} a_L} - \frac{1}{\lambda_{aF} a_F} \right) v_i > 2(\tau + \Omega) \quad (4.27)$$

Since our object of study is ACC/CACC equipped vehicles,  $\tau + \Omega = 0.1$  is then chosen to describe the parasitic time lag and delay. For the NECACC/NEACC algorithm, the string stability of every NE condition must be considered. After setting corresponding parameters' value into (4.27), we finally get the range of  $v_i$  to ensure the string stability for each NE condition:

- For Sunny/Cloudy, the range of  $v_i$  to ensure the string stability is  $v_i \geq 2.35m/s$
- For Rainy, the range of  $v_i$  to ensure the string stability is  $v_i \geq 2.12m/s$
- For Snowy, the range of  $v_i$  to ensure the string stability is  $v_i \leq 36m/s$
- For Icy, the range of  $v_i$  to ensure the string stability is  $v_i \leq 12.37m/s$

By reason of the dangers brought by bad weather conditions such as snowy or icy, to make sure the string stability, the velocity of vehicles on the road should be smaller than a threshold, just as the results shown above.

#### 4.3.3.2 Traffic flow stability

**Definition** Traffic flow stability was proposed to evaluate the traffic flow dynamics and it is different from the conception of string stability. Normally, in the study of string stability, the situation of that vehicle enters or leaves the string is not considered. However, traffic flow stability deals with the evolution of aggregate velocity and density in response to addition or removal of vehicles from the flow. Traffic flow stability can be guaranteed only if the velocity and density solutions of the coupled set of equations is stable or only if stability with respect to automatic vehicle following and stability with respect to density evolution is guaranteed [Zhao 2010].

As described in Fig. 4.7, let  $x$  denote the position of a vehicle at time  $t$ , i.e.,  $x = x(X, t)$ , where  $X$  is the state of the vehicle at some initial time,  $t_0$ . The velocity of the vehicle be given by  $v(x(t), t)$  or simply,  $v(x, t)$ . The traffic density is represented by  $\rho(x, t) = \frac{1}{\varepsilon(x, t) + L_{vehicle}}$ . Then the traffic flow stability can be defined as follows [Swaroop 1999]:

**definition 3** (*Traffic flow stability*). Let  $v_0(x, t)$ ,  $\rho_0(x, t)$  denote the nominal state of traffic. Let  $v_p(x, t)$ ,  $\rho_p(x, t)$  be the velocity and density perturbations to the traffic, consistent with the boundary conditions and are such that  $v_p(x, 0) \equiv 0$ ,  $\rho_p(x, 0) \equiv 0 \forall x \geq x_u$ . The traffic flow is stable, if

1. given  $\zeta > 0$ , there exists a  $\gamma > 0$  such that
$$\sup_{x \leq x_u} \{|v_p(x, 0)|, |\rho_p(x, 0)|\} < \gamma \Rightarrow \sup_{t \geq 0} \sup_{x \leq x_u} \{|v_p(x, t)|, |\rho_p(x, t)|\} < \zeta$$

and
2.  $\lim_{t \rightarrow \infty} \sup_{x \leq x_u} \{|v_p(x, t)|, |\rho_p(x, t)|\} = 0$

### 4.3. NECACC algorithm design

---

When we say that a traffic flow is unstable, we mean that a traffic flow is not stable according to the above definition. For the purpose of analyzing the influences brought by the ACC/CACC algorithm (spacing policy) which regulates the inter-vehicle distance with respect to the speed of the vehicle, the inverse of density is then given by:

$$\frac{1}{\rho} = g(v) \Rightarrow v = h(\rho) := g^{-1}\left(\frac{1}{\rho}\right) \quad (4.28)$$

Analogous to the flow of a fluid, traffic volume at any point is defined as  $Q = \rho v$ . The evolution of traffic density is determined by the conservation of mass equation:

$$\frac{\partial \rho}{\partial t} + \frac{\partial Q}{\partial x} = 0 \quad (4.29)$$

With the assumption of ideal cruise control system, the conservation of mass equation becomes:

$$\frac{\partial \rho}{\partial t} + \frac{\partial(\rho h(\rho))}{\partial x} = 0 \quad (4.30)$$

Let  $\rho_0$  be a base solution for the density and considering small density perturbations,  $\zeta \rho_p$  to the base solution. Neglecting second-order terms in  $\zeta$  and defining the characteristic wave velocity,  $c$  at a density  $\rho_0$  as:

$$c := h(\rho_0) + \rho_0 \frac{\partial h}{\partial \rho}(\rho_0) \quad (4.31)$$

we get:

$$\frac{\partial \rho_p}{\partial t} + c \frac{\partial \rho_p}{\partial x} = 0, c = \frac{\partial Q}{\partial \rho} \quad (4.32)$$

Clearly, the sign of  $c$  depends on the density of base flow  $\rho_0$ . The behavior of the solution to the above linear partial differential equation that describes the evolution of a density disturbance relies on the sign of  $c$ . The solution of (4.32) is a traveling wave, i.e.,  $\rho_p = F(x - ct)$ . If  $c > 0$ , the solution is a forward traveling wave and if  $c < 0$ , the solution is a backward traveling wave. Applying on an ideal cruise control system dynamics, when  $c < 0$ , arbitrarily small density disturbances are propagated upstream without any attenuation. However, there should be no spacing errors or density disturbance propagate upstream and unattenuated when  $c < 0$  at any time for an ideal cruise control system. Thus,  $c = \frac{\partial Q}{\partial \rho} < 0$  is definitely an undesired feature of automated vehicle traffic on a highway.

Taking the CTG policy as an example, its desired inter-vehicle distance is linearly proportional to the vehicle velocity  $v$ , see (4.1). The density of a CTG traffic can then be described as follows:

$$\rho = \frac{1}{L + hv} \quad (4.33)$$

Solving  $v$  in terms of  $\rho$  from (4.33), we get  $v = (1 - \rho L)/(\rho h)$ , and the traffic flow is:

$$Q = \rho v = \frac{1 - \rho L}{h} \quad (4.34)$$

and

$$c = \frac{\partial Q}{\partial \rho} = -\frac{L}{h} \quad (4.35)$$

Obviously, with a CTG algorithm,  $c$  is always negative for positive values of  $h$ . Since  $c$  is independent of  $\rho_0$ , the governing differential equation is a linear partial differential equation and the result holds at all operating traffic densities.

Concerning the traffic flow which is completely artificial, based on the experiment results from Intelligent Cruise Control Field Operational Test (ICCFOT) database [Fancher 2002], it can be deduced that the vehicle strings formed by human drivers are "more unstable" than the ACC vehicles using the CTG range policy [Zhou 2005].

In addition, it should be clear that no matter what spacing policy is chosen, there will be a certain critical density beyond which the traffic flow will be unstable. This conclusion is derived from the assumption that the traffic flow has to fall to zero at maximum density (jam density). For this reason, there will be some part of the  $(\rho, Q(\rho))$  curve where  $\partial Q/\partial \rho < 0$ . Hence, it is not possible to achieve traffic-flow stability for all  $\rho$  [Wang 2004b].

**Traffic flow stability of NECACC/NEACC** As described before, the traffic flow is stable if the gradient of the traffic flow volume  $Q$  with respect to traffic density  $\rho$  is positive:

$$\partial Q/\partial \rho > 0 \quad (4.36)$$

The traffic flow characteristics of NEACC/NECACC algorithm are analyzed below. At steady state, the traffic density is  $\rho = 1/(L_{vehicle} + D_{s_{NE}})$ . Flow rate can then be formulated as a function of  $\rho$ :

$$Q = \rho v = \rho \frac{-\lambda_T t_r + \sqrt{\lambda_t^2 t_r^2 - 2\left(\frac{1}{\lambda_{aL} a_L} - \frac{1}{\lambda_{aF} a_F}\right)(L_{vehicle} + D_{min} - 1/\rho)}}{\frac{1}{\lambda_{aL} a_L} - \frac{1}{\lambda_{aF} a_F}} \quad (4.37)$$

We use  $\frac{1}{\lambda_{aL} a_L} - \frac{1}{\lambda_{aF} a_F} = \gamma$  and differentiate the expression (4.37), then we get:

$$\frac{\partial Q}{\partial \rho} = \frac{-\lambda_T t_r}{\gamma} + \frac{\rho[\lambda_T^2 t_r^2 + 2\gamma(1/\rho - D_{min})] - \gamma}{\gamma \rho \sqrt{\lambda_T^2 t_r^2 + 2\gamma(1/\rho - D_{min})}} \quad (4.38)$$

Applying the values of parameters into (4.37), we can get the curves of  $Q - \rho$  under four different NE conditions, see Fig. 4.8, in which the traffic flow stable parts have been marked.

One can find that, under different NE conditions, the proposed algorithm holds a stable traffic flow when the density is below a critical density  $\rho_c$  which has been listed as follows:

#### 4.4. NECACC simulations

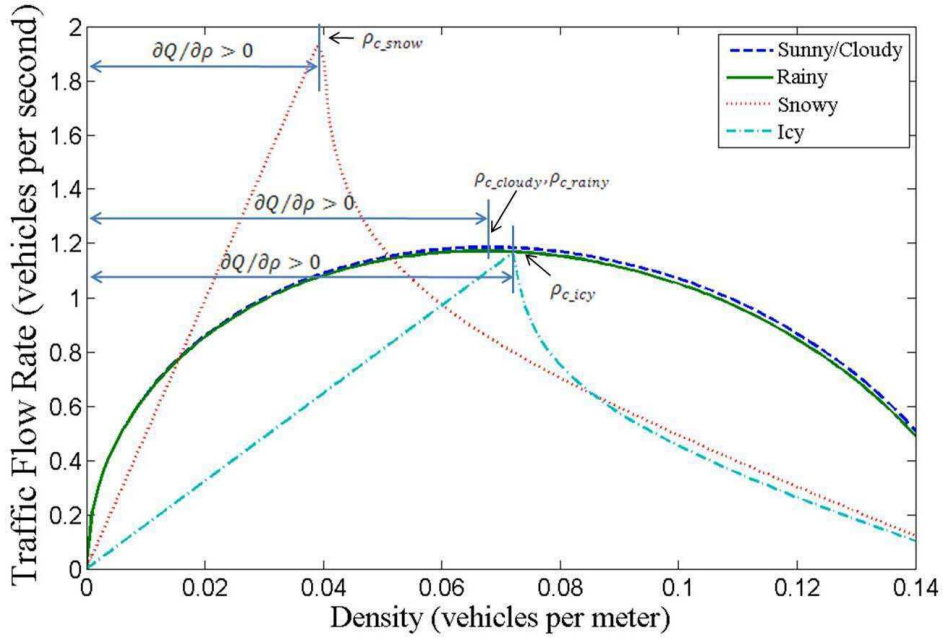

Figure 4.8:  $Q - \rho$  curves of NECACC/NEACC

- For Sunny/Cloudy and Rainy,  $\rho_{c\_cloudy} \approx \rho_{c\_rainy} \approx 0.068 \text{ vehicle/m}$ .
- For Snowy,  $\rho_{c\_snowy} \approx 0.039 \text{ vehicle/m}$ .
- For Icy,  $\rho_{c\_icy} \approx 0.072 \text{ vehicle/m}$ .

The similar stability range between Sunny/Cloudy and Rainy shows once again that wet road condition affects few on automatic traffic. While the stability range of Icy is bigger than the others by reason of that this traffic flow stability is approved by respecting the speed limit (in the situation of Icy, drivers are supposed to drive with a very low speed) which ensures the string stability. This result shows that NECACC/NEACC algorithm succeeds in proving traffic flow stability within a certain range which is obviously better than CTG policy equipped traffic and the traffic without any ACC/CACC systems.

#### 4.4 NECACC simulations

Based on the IVVR platform described in Chapter 2 and the method of natural environment simulation for intelligent vehicles presented in Chapter 3, the simulation and verification of NECACC in the level of "proof of concept" can now be carried out and shown to users through vivid and interational 3D virtual reality animation instead of the real vehicles test which costs much more money and risks.

The algorithm (4.4), called LNACC, represents the classical ACC algorithm in the form of a quadratic curve. And it had been proven to be a good longitudinal



vehicle control strategy in practice as well as in theory [Nouveliere 2002][Zhou 2005]. Thus, in our experiments, LNACC has been chosen as the comparative algorithm for NECACC.

Assuming that vehicles are driving on the straight section of a rural highway, and they are trying to maintain a safe inter-vehicle distance from each other under various weather conditions.

### 4.4.1 Multi-track mode

Multi-track mode is proposed as a way of visualizing simulation in the IVVR platform. Several simulations that correspond to different ACC/CACC algorithms can be integrated in one single animation and each simulation can be overlaid by means of rendering techniques. This method is ideal for reference comparisons and in all cases where strategies for a particular maneuver need to be assessed. This is also an ideal form of documenting results visually [DSpace 2006].

In this simulation, besides the leading virtual vehicle, we use two virtual following vehicles which have the same initial condition but in different color to perform two ACC/CACC algorithms in the meantime.

### 4.4.2 Simulation architecture

The simulation architecture for verifying conceptually the new algorithm NECACC has been described in Fig. 4.9, in which the structure of control system, the contents of virtual reality system and also the flow of information exchange have been shown in detail.

In the part of Intelligent control system, a longitudinal controller has been created for the leading vehicle to receive the signals from virtual world or users and further output its longitudinal velocity. While with regard to the two following vehicles which equipped with NECACC system and LNACC system respectively, a hierarchical longitudinal controller (contains an upper level ACC/CACC controller and a lower level fuzzy controller) and the corresponding vehicle longitudinal dynamic model have been designed for each of them. For more information about the lower level fuzzy controller used in the simulation, see [Zhao 2010].

For the purpose of comparing the performance of NECACC and LNACC, these two following vehicles have exactly the same initial conditions, like the initial longitudinal position, and the same fuzzy lower controller as well as the same longitudinal dynamic model. And obviously, they act in the same natural environment which means they have the same environmental conditions.

In the simulation, the above three car models output their longitudinal motion data to the virtual world to drive the corresponding virtual cars and simultaneously, they receive various NE signals which can effect their behaviors from the virtual environment and the control signals from their two-level controllers.

In the part of Virtual Reality system, it contains static environment, weather animation, vehicle animation and virtual observer. The vehicle animation is con-

#### 4.4. NECACC simulations

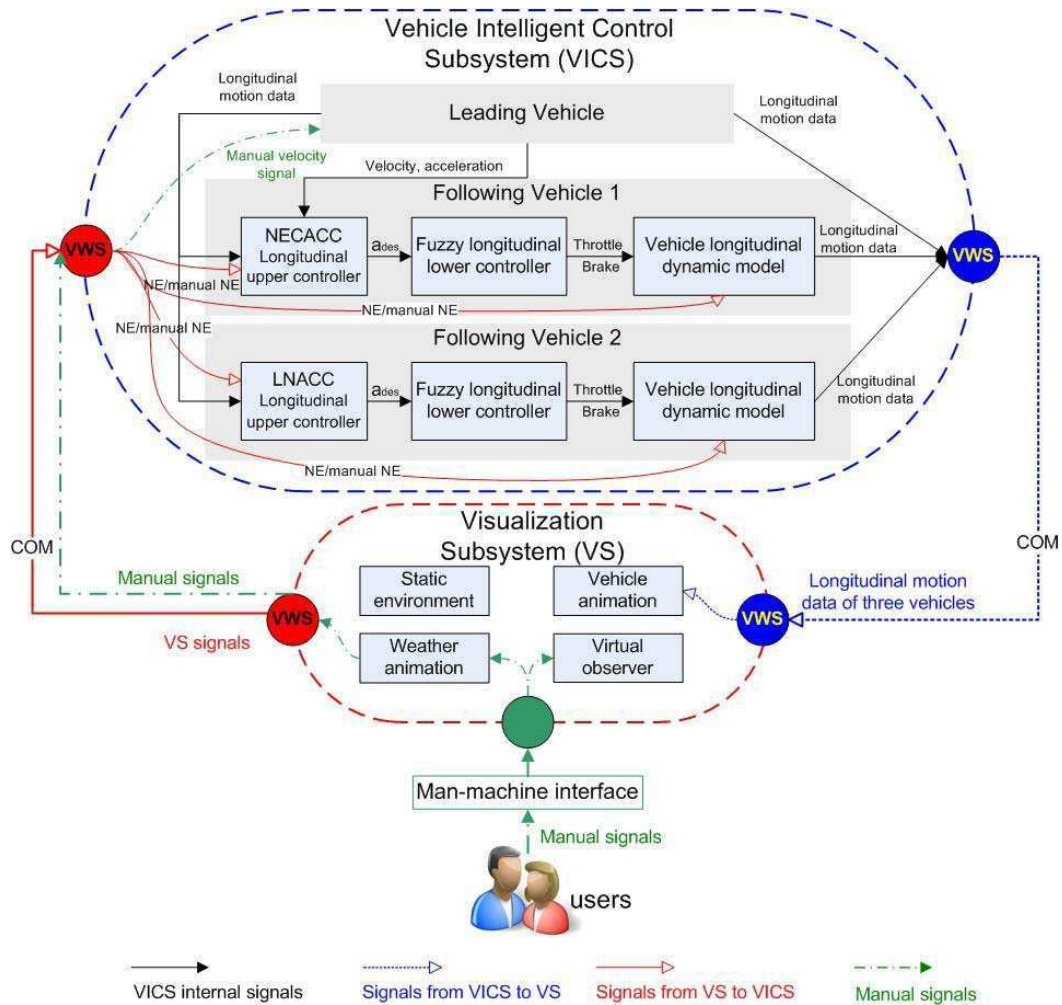

Figure 4.9: Simulation architecture

trolled by the longitudinal motion data from the Intelligent control system. And the display of weather animation can be dominated by the internal environmental models or by the users via the man-machine interface. The position or orientation of the virtual observer can also be controlled by users via the mouse or keyboard.

The signals exchanging in the simulation have also been described in Fig. 4.9. They are summarized as follows:

- Internal signals. For example, the throttle and brake signals, the desired acceleration signals for the two following vehicles.
- Signals from VICS to VS. As we concentrate on the longitudinal control in the simulation, the VICS outputs only the longitudinal motion data for the three vehicles.
- Signals from VS to VICS. This kind of signals are also called VSD according to the Chapter 3. Here, the principal VSD is the climate signals which can be generated by the environmental models or changed by the users.
- Manual signals. Users can control the virtual observer, change the weather type, and also change the velocity of the leading vehicle through the Man-machine interface.

### 4.4.3 Simulations under fixed NE condition

Here, three automatic micro-NE modules are created for the experiment:

- From Sunny/Cloudy to Rainy
- From Sunny/Cloudy to Snowy
- Road partially frozen

It should be noted that the start point of our experiment is a balance point in the middle of traffic. Hence, the initial conditions of virtual vehicles are set as follows:

$$X_L(0) = X_F(0) = 17m/s, X_L''(0) = X_F''(0) = 0m/s^2, D_s(0) = 10.34m \quad (4.39)$$

where the  $D_s(0)$  is actually the desired inter-vehicle space of NECACC algorithm when the road surface is dry.

The longitudinal motion of leading vehicle has been pre-designed. It runs with  $17m/s$  in a few seconds, and then accelerates to  $23.75m/s$  in  $5s$ . After keeping the new velocity a few moments, it starts to decelerate to  $5.35m/s$  in  $6s$ . The deceleration can reach to  $-4.6m/s^2$ , see Fig. 4.10.

In the simulation, two virtual vehicles equipped with LNACC and NECACC respectively are following the leading car to see if they could avoid the collision all the time and ensure the maximum traffic capacity at the same time under various natural environment conditions.

#### 4.4. NECACC simulations

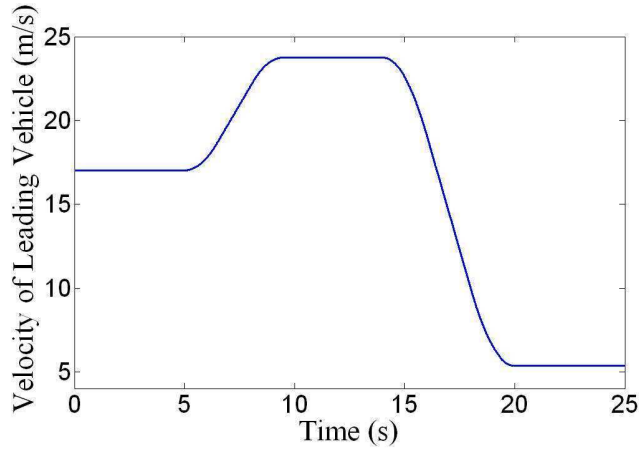

Figure 4.10: The pre-designed velocity of leading vehicle

With respect to the traffic capacity, considering a highway pipe, a single lane highway without entrances and exits, we estimate the maximum possible steady state flow in vehicles per lane per hour through such a pipe, and this is called the AHS pipeline capacity. If the traffic volume exceeds this limit, traffic flow stops, as is often experienced on congested road. Here, the traffic capacity  $C$  is calculated by:

$$C = \frac{3600v}{L_{vehicle} + D_{sreal}} \quad (4.40)$$

where  $L_{vehicle} = 4m$  denotes the length of vehicle,  $v$  means the velocity of vehicle, and  $D_{sreal}$  is the actual inter-vehicle space in the virtual world.

Concerning the climate type, 0 stands for cloudy, 1 stands for rainy, 2 means snowy and 3 means the road partially frozen.

The simulation curves of inter-vehicle space and traffic capacity of the two following vehicles have been recorded under the above three micro-NE modules.

Firstly, with the module from Cloudy to Rainy, the change time is about 15s. From beginning to the time 15s, the inter-vehicle space with NECACC is smaller than the one with LNACC to augmenter the traffic capacity, while after the time 15s, as the wet road surface increases the risk of collision, the NECACC chooses decelerating a little to make sure the traffic safety by sacrificing certain traffic capacity (see Fig. 4.11). At the time of 20s, the LNACC equipped vehicle is very close to the leading vehicle which indicates a dangerous situation for driving.

Secondly, with the module that changes from Cloudy to Snowy at the time 15s, the NECACC assures the safety of vehicles in the entire simulation. Before 15s, its traffic capacity is bigger than the one of LNACC and smaller relatively after 15s for the purpose of ensuring the safety. For the simulation with LNACC controller, the vehicles collide round 19s (we make the traffic capacity being zero when the collision happens), which means it filed to keep a safe inter-distance when the weather becomes worse (see Fig. 4.12).

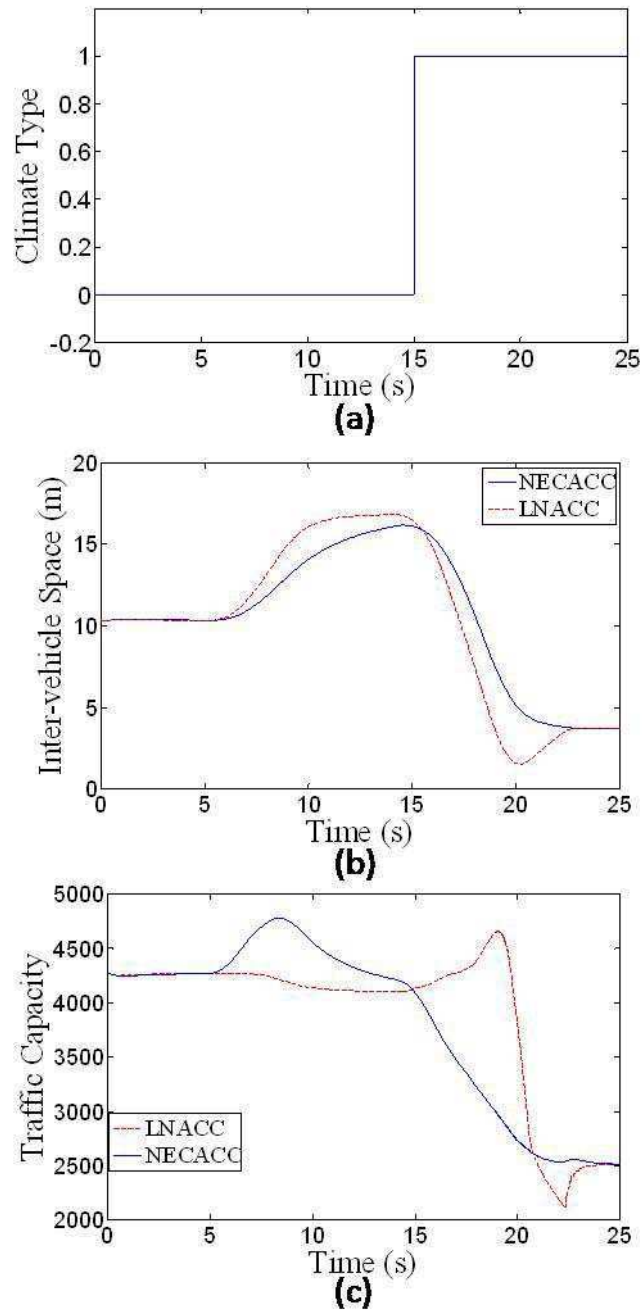

Figure 4.11: Simulation results under fixed NE condition: Cloudy to Rainy

#### 4.4. NECACC simulations

---

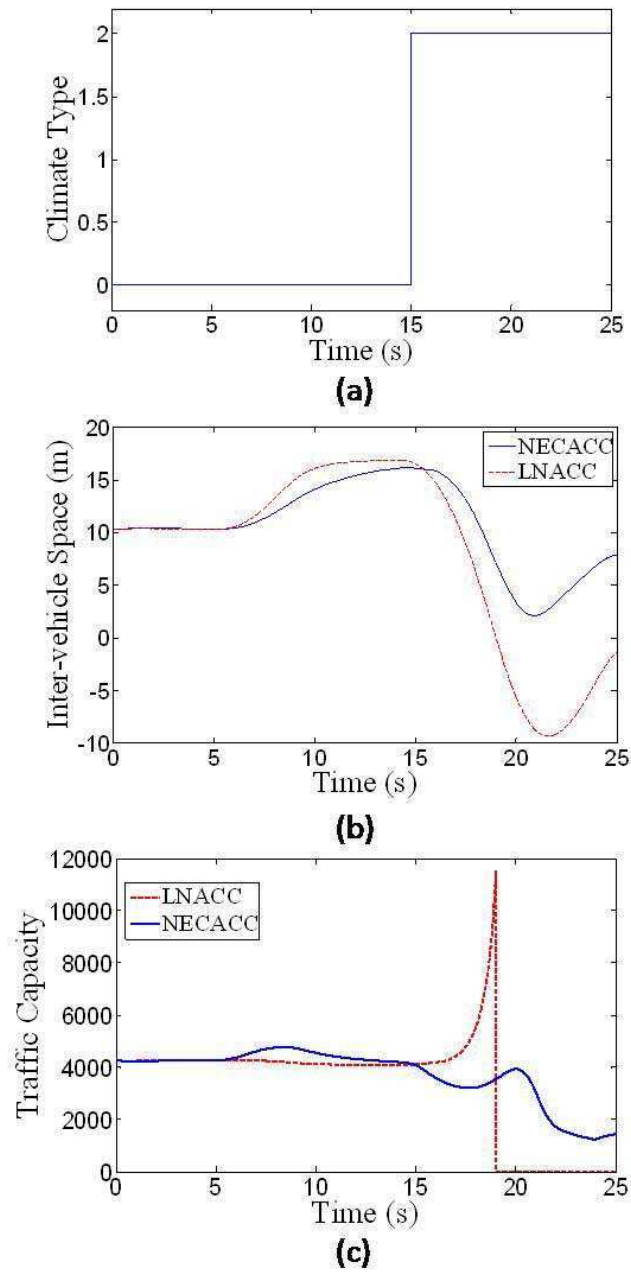

Figure 4.12: Simulation results under fixed NE condition: Cloudy to Snowy

Finally, if there is one part of the highway covered by ice, the LNACC fails again to guarantee the security of road round 18s, whereas the NECACC provides stable inter-vehicle space and appropriate traffic capacity by intelligent and adaptive controlling (see Fig. 4.13).

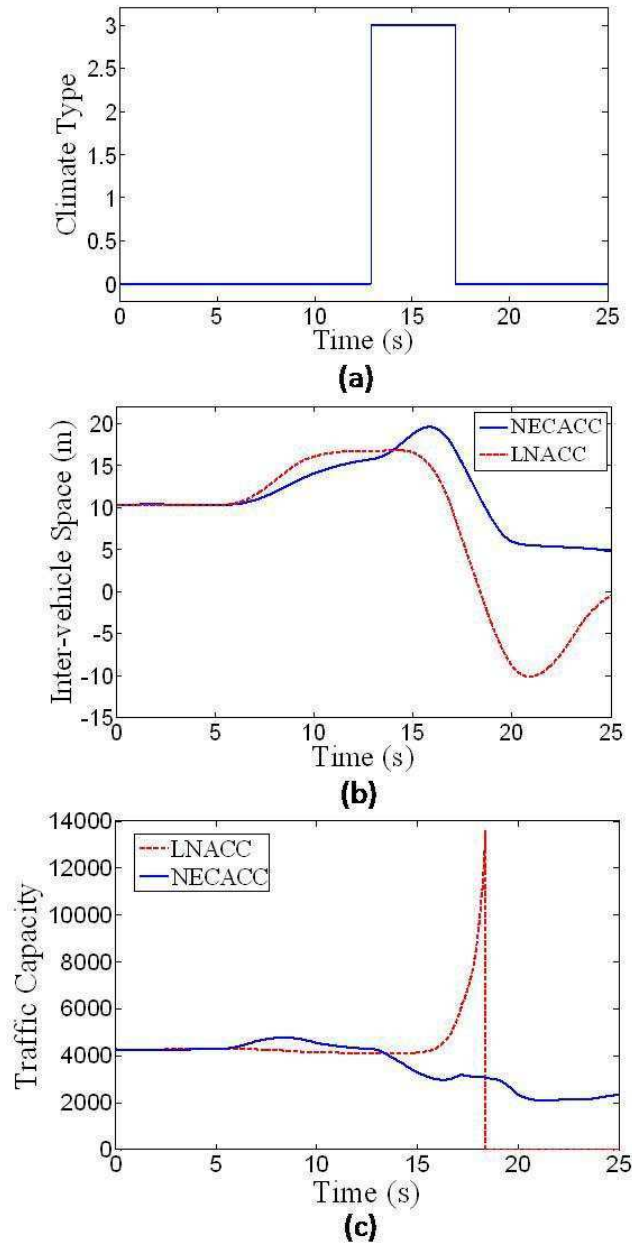

Figure 4.13: Simulation results under fixed NE condition: Road partially frozen

According to these simulation results, the advantage of NECACC under complex weather condition is then distinct. On the premise of security, NECACC succeeds in increasing the traffic efficiency by reducing the inter-vehicle space. And when the

#### 4.4. NECACC simulations

---

environmental condition becomes worse, it chose to augment the distance between vehicles to ensure the safety. Generally speaking, NECACC brings us a better balance between traffic safety and traffic capacity.

In addition to the above "proofs" in terms of curves, the virtual 3D animations together with the multi-track mode in IVVR platform show us the simulation results in a more comprehensible and intuitive way. We color the NECACC equipped virtual following vehicle in red (situated slightly left) and the LNACC equipped vehicle in yellow (situated slightly right). At the beginning, they are situated at the same place and start with the same speed. For each experiment, three scenes in different observation mode have been chosen to represent three important moments in the simulation.

With the climate from cloudy to rainy, the three screenshots are selected at 2s, 10s, and 20s, see Fig. 4.14. In the simulation, the transparent information board in the upper left corner of the first scene displays the real-time information of virtual world, including the NE conditions and the motion parameters of three virtual cars and this board could be hidden if necessary. The second scene shows the moment before the weather changes from cloudy to rainy and the longitudinal displacements of the two following vehicles start to be different on the dry road. We can see that under the premise of safety, the red car maintains a smaller inter-vehicle space to obtain more traffic efficiency. After 15s (see Fig. 4.11), it begins to rain which makes the red car changing its strategy to keep a bigger inter-vehicle space to ensure the security. However, the yellow car fails to react to this weather changing, thus, in the third scene that represents the moment of 20s, the yellow car is driven very near to the white car, and the inter-vehicle distance is obviously lower than the safe distance. However, the red car is much safer by keeping a normal space with the preceding car.

Fig. 4.15 shows three virtual scenes chosen from the second simulation (cloudy to snowy) at 2s, 10s, and 19s. Similar to the above animation screenshots, the first scene means the beginning state and the second scene represents the moment when the red car begins to maintain a closer distance with the preceding car on the dry road to get more traffic capacity. While in the last scene at 20S, the weather has been changed to snowy. As the snowy road is much more danger than the wet road, being powerless for the bad road condition, the yellow car finally hits the preceding car (indicated by smoke effect). While the red car which equips with NECACC is always safe in keeping a safe inter-vehicle distance.

Fig. 4.16 shows three scenes of animation assuming that there exist some ice on one section of road. These scenes are selected at 2s, 15s, 18s, and the icy road exists between the 13s and 17s (see fig. 4.13). The first scene is the same with the one of the above two animations. The second scene shows the two following cars running on the icy road and the yellow car starts to lose control. Hence, in the end, shown by the third scene, the yellow car and the leading collide with a high speed, while the red car (NECACC) is much safer by increasing the inter-vehicle space in advance.





(a)



(b)



(c)

Figure 4.14: Virtual 3D scenes under fixed NE condition: Cloudy to Rainy. (a): 2s, (b): 10s, (c): 20s

#### 4.4. NECACC simulations

---



(a)



(b)



(c)

Figure 4.15: Virtual 3D scenes under fixed NE condition: Cloudy to Snowy. (a): 2s, (b): 10s, (c): 19s



(a)



(b)



(c)

Figure 4.16: Virtual 3D scenes under fixed NE condition: Road partially frozen. (a): 2s, (b): 15s, (c): 18s

## 4.5. Conclusion

---

In the above three animations, the viewpoint can be controlled by users via mouse and keyboard in real-time and the simulation will continue until the simulation time (25s) is over.

### 4.4.4 Simulations with user-in-the-loop

In IVVR platform, the man-machine interface in VS can involve users in simulation in the way of being the driver of the leading vehicle or changing the weather condition manually. This kind of experiment augments the randomness of traffic and NE situation, and could be considered as an effective way to further validate the feasibility of NECACC algorithm.

With the same initial conditions as the experiment under fixed NE condition, Fig. 4.17 shows the simulation results in the way of user-in-the-loop, in which the velocity of leading vehicle (Fig. 4.17(a)) and the changing of NE condition (Fig. 4.17(b)) are all controlled optionally by users in real-time in the simulation. It is obvious that the curves of the above two factors are much more stochastic.

Even under such stochastic traffic and NE conditions, the Fig. 4.17(c)(d) show us that equipping with NECACC algorithm, the inter-vehicle space is stable and the traffic capacity can adjust in time according to the current situation, whereas the performance under LNACC algorithm is not so good in comparing to the NECACC. For instance, concerning the inter-vehicle space, at about 19s, the LNACC equipped vehicle has a very dangerous distance with the preceding vehicle, and for the curve of traffic capacity, it is incapable of auto-adjusting its speed in time to obtain the best traffic efficiency at every moment.

## 4.5 Conclusion

Actually, ACC/CACC systems have been widely studied in the past of few years, and some of them are already available on the market. Nevertheless, perhaps for the reason of that the duration of the inclement weather is not long in each year, the consideration of natural environment impacts on ACC/CACC system has been approximately ignored even though many of the traffic accidents or congestions are caused by abominable weather or bad terrain condition every year according to previous related researches.

Hence, aiming to fill this research gap, based on the IVVR platform developed in Chapter 2 and the method of SNE simulation for intelligent vehicles presented in Chapter 3, we proposed in this chapter a NE based CACC algorithm, named NECACC, accompanying with a NE driving strategy to intelligentize the traffic in adapting to different NE conditions. Equipped with NECACC system, the vehicles could choose automatically a specific driving strategy according to the actual NE situation to keep a safe distance to the preceding vehicle and simultaneously affirm the maximum traffic capacity all the while.

To prove the feasibility of NECACC algorithm, some measures were carried out. Firstly, the string stability and the traffic flow stability had been analyzed under

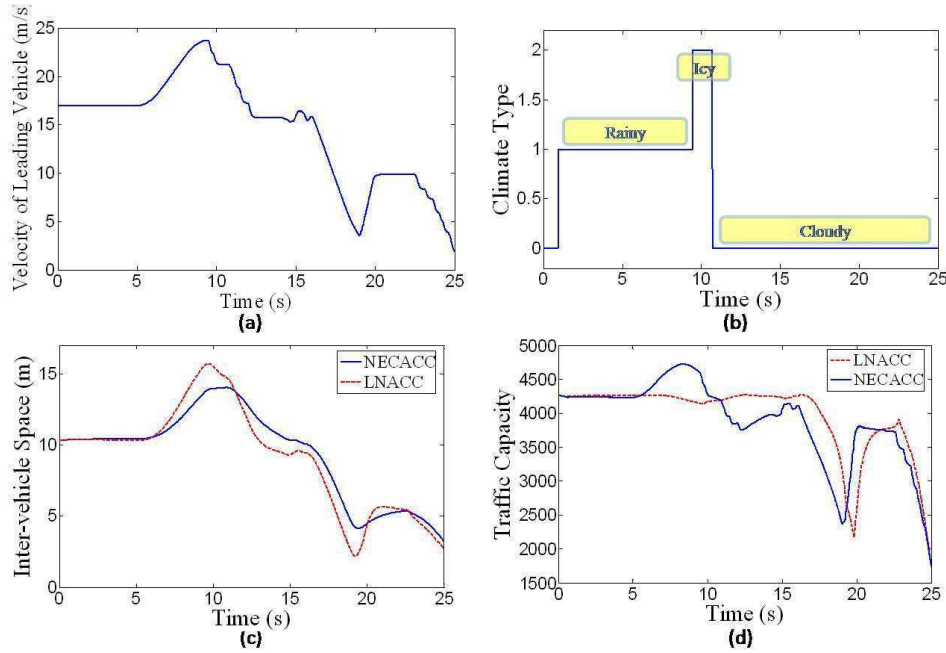

Figure 4.17: Simulation results in the way of user-in-the-loop

different NE conditions. Some limitations of the following vehicle’s velocity have been given out in proving the string stability. The traffic flow stability has also been certified to be superior comparing to the traffic composed by CTG policy equipped vehicles or the manual traffic. Secondly, the corresponding simulations were implemented in the IVVR platform. These simulations provide users the results in vivid 3D virtual scene and the man-machine interactive experiences. Meanwhile, in this way, we avoid risk and redundant time or money cost by real vehicle testing. In the simulation, the internal communication system succeeds in exchanging the virtual sensor data (VSD) concerning to NE or traffic and it makes our simulation being closer to the one in real world. Thus, this kind of simulation can be thought as the "concept testing".

These simulations are carried out in multi-track mode in the IVVR platform. The traffic and NE condition were set in two ways: automatic and user in the loop. We had chosen LNACC to do the comparison with NECACC, and the simulation results show obviously the superiority of NECACC in both road safety and traffic capacity, especially under bad weather condition.

With the help of the new CACC algorithm, some traditional traffic operations can then be simulated under different NE conditions in IVVR platform. In the next chapter, the demonstrations of lane tracking/lane following and lane changing/overtaking will be shown.

# Integrated Vehicle Control under Complex NE Conditions

---

## Contents

---

<b>5.1</b>	<b>Introduction</b>	<b>129</b>
<b>5.2</b>	<b>Lane tracking/lane following</b>	<b>130</b>
5.2.1	Simulation architecture	131
5.2.2	Longitudinal control	132
5.2.3	Lateral control	133
5.2.4	Simulation results	135
5.2.4.1	Rainy	135
5.2.4.2	Cloudy to snowy	136
5.2.4.3	Icy	138
<b>5.3</b>	<b>Lane changing/Overtaking</b>	<b>139</b>
5.3.1	Simulation architecture	141
5.3.2	Longitudinal control	142
5.3.3	Lateral control	145
5.3.4	Simulation results	145
5.3.4.1	Cloudy to snowy	146
5.3.4.2	Icy	148
<b>5.4</b>	<b>Conclusion</b>	<b>150</b>

---

## 5.1 Introduction

Recently, the concept of ITS/AHS has become an attractive area of research motivated by both the increasing need for solutions to traffic problems and the developments in the hardware/software technology enabling the design of low cost and reliable communication and control systems. Hence, a considerable number of research projects relating to the cooperative driving and control of automated vehicles have been carried out in the past decades, such as the California PATH project [Rajamani 2000], Demo 2000 in Japan [Kato 2002], and the ARCOS project in France [Blosseville 2006]. Most of these research projects focus on the operation

of the vehicle platoon, such as stop&go, splitting, merging, lane changing, etc. besides, the corresponding experiments with real vehicles were also carried out to prove the validity of the designed intelligent control systems. Of course, real vehicle tests are usually implemented on the dry road for the purpose of reducing risks. However, driving in the rain or snow is not rare in our daily life and if we hope that the cars of tomorrow will increasingly be equipped with advanced driver-assistance systems to support the driver in the driving task to improve traffic safety, throughput and/or the environment even in bad weather conditions, the corresponding demonstrations then should be implemented.

For filling this research gap and simultaneously ensuring the security, in this chapter, the integrated vehicle control demonstrations of lane tracking/lane following and lane changing/overtaking are performed on the IVVR platform together with NE simulation. It concentrates on avoiding possible collision when the road condition is not so good, such as wet, covered by snow or icy.

### 5.2 Lane tracking/lane following

A lane tracking/lane following system automatically controls the steering angle to keep the vehicles in its lane (straight or curved lane) and also maintaining a safe inter-vehicle space. In ITS/AHS field, the lane tracking/lane following for automatic vehicles that aims to reduce the traffic accidents caused by human error is actually a complex operation as it needs the integrated longitudinal and lateral control.

The challenges handled in the design of longitudinal control system include non-linear vehicle dynamics, string-stable operation with very small inter-vehicle spacing, operation at all speeds from a complete stop to high-speed cruising and the execution of longitudinal split and join maneuvers in the presence of communication constraints. Recently, we have seen significant advances in research in this area, with several applications to commercial vehicles. The most important advances are Adaptive cruise control/Cooperative Adaptive cruise control [Arem 2006], antilock brakes (ABS) [Lin 2007], pedestrian detection with night-vision system [Bi 2009], collision avoidance [Gehrig 2007], and warning system [Bella 2011]. In this chapter, we concentrate on the cooperative adaptive cruise control for the longitudinal control of lane following.

With regard to the lateral control, the lane following operation focuses on the steering wheel system. Konur A. [Unyelioglu 1997] presented a constant steering controller, whose objective is to steer a ground vehicle along a reference line located in the middle of the lane to be followed. An arbitrary look-ahead point located on the local longitudinal axis of the vehicle was defined and the deviation of the look-ahead point from the reference could be measured by a radar-based or a vision-based sensor in practice. The controller is a function of the longitudinal speed, the cornering stiffness values of the tires, the location of CG, as well as the mass of the vehicle. And the stability of the closed-loop system is analytically proven. It is shown that there exists a sufficiently large look-ahead distance guaranteeing stability

## 5.2. Lane tracking/lane following

---

for all longitudinal speeds in that interval. The controller was successfully tested at the Transportation Research Center, Marysville, OH, in May 1995. Jose E. Naranjo [Naranjo 2005] designed a two-layer control architecture for automatically moving the steering wheel of a mass-produced vehicle. The first layer is designed to calculate the target position of the steering wheel at any time and is based on fuzzy logic. The second is a classic control layer that moves the steering bar by means of an actuator to achieve the position targeted by the first layer. Real-time kinematic differential global positioning system equipment is the main sensor input for positioning. It is accurate to about 1 cm and can finely locate the vehicle trajectory. These developed systems have been tested on a Citroën Berlingo van. More researches could be found on the efficient approaches that propose fusion techniques to complement the yaw-rate-based road geometry, and estimate and predict changes in the curvature of the road ahead using a digital map and Global Positioning System (GPS) receivers, video cameras and tracks from the radar or stationary obstacles that represent guardrails or posts [Administration 2003] [Schwartz 2003].

Nevertheless, we have found that all the existing demonstrations of lane following have ignored one important factor: natural environment (weather, terrain) impacts. To know that the weather or terrain is actually environmental risk factor to affect collision rates which has been described in Chapter 3. Here, we focus on the lane following simulation involving NE impacts and propose an integrated control architecture to simulate this maneuver in IVVR platform. The trajectory has been defined in Fig. 3.15. It contains a straight road, a right turn curved road and finally a straight inclined road.

### 5.2.1 Simulation architecture

Fig. 5.1 shows the simulation architecture of lane tracking/lane following experiment in IVVR platform. It describes in detail the internal operating principle and the information transmission.

In Vehicle Intelligent Control Subsystem (VICS), a two-vehicle platoon is studied. The leading vehicle is treated as a kinematic model and its longitudinal motion data can be controlled by auto-adjust velocity signals from the virtual traffic module in Visualization Subsystem (VS).

The following vehicle model is established through vehicle longitudinal dynamic modeling and lateral dynamic modeling. An integrated longitudinal and lateral controller is designed to make the following vehicle following a pre-defined trajectory and at the same time keeping a safe distance with the leading vehicle under various weather conditions. The natural environment module in VS outputs the climate VSD and terrain VSD to the integrated controller as references or corrections. For example, the road curvature is sent to the decision-making module to be an important reference.

In addition, users can participate in the simulation through the man-machine interface by changing the visual angle, the climate, etc.



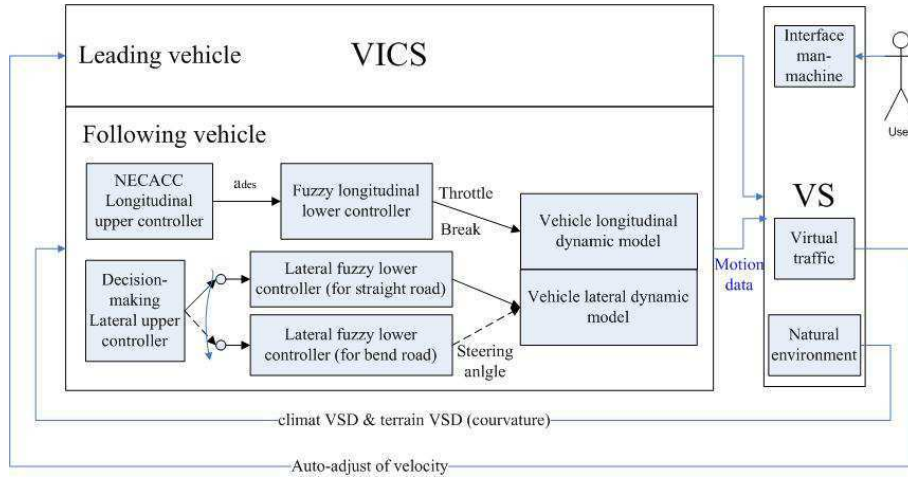

Figure 5.1: Simulation architecture of lane tracking/lane following

### 5.2.2 Longitudinal control

Simply to say, longitudinal control is the integration of brake pedal control and throttle angle control. From the perspective of kinematics, we can assume that it is constituted by a series of acceleration and deceleration. As described in the system "driver-vehicle-environment" in Chapter 1, the driver is the one who decides when to accelerate and when to slow down after collecting all kinds of information. In a real traffic, the signboard is one of the most important sources of visual information, as it shows the road speed limits for different road conditions or indications of turning, no entry and so on. In IVVR platform, various road types have been designed and several virtual signboards have been placed in the virtual world, and the intelligent controllers take the place of the driver's role and are responsible for the actions of deceleration or acceleration according to different road conditions. Here, Related driver-like behavior has been applied to the leading vehicle to do the auto-adjustment of its longitudinal velocity to respect to the local road condition as its longitudinal control, for example, from straight road to curved road, the deceleration of the leading vehicle acts automatically when it detects the virtual signboard in front of it, and it is the same when driving from curved road to inclined road.

For the following vehicle, the longitudinal control is carried out by a two-layer hierarchical controller, in which the upper controller is called NECACC (which has been presented in the Chapter 4) and it aims at the maximizing of traffic capacity under the premise of safety even with bad natural environment conditions. The lower controller is realized by fuzzy logic and it takes the desired longitudinal acceleration as input and then outputs the commands of throttle and break to the vehicle longitudinal dynamic model to generate the longitudinal motion data for the following vehicle.

## 5.2. Lane tracking/lane following

### 5.2.3 Lateral control

The lateral controller of the following vehicle is composed by a decision-making module and two lateral fuzzy lower controllers in which one for keeping on the straight road and the other for following the bend road. The decision-making module is used to decide the occasion to switch the above two lateral lower controllers and send out the right steering angle signal to the following vehicle's lateral dynamic model. Finally, the lateral motion data can be generated.

Road curvature is inducted as the judgment condition in the decision-making module. Normally, on the straight road, the road curvature is set to be zero, while on the curved road, the value of road curvature becomes positive and this change will trigger the switch between the two lateral fuzzy lower controllers.

Fuzzy controller performs three basic tasks known as fuzzification, inference, and defuzzification. Fuzzification is the stage in which the input crisp values are transformed into fuzzy data. Inference is the procedure whereby the values of the fuzzy variables are inferred from a rule base, generating a fuzzy value for the output variable: the target steering-wheel angle. The final stage, defuzzification, transforms this output fuzzy value into crisp data that can be sent to an actuator (vehicle lateral dynamic model). The design of our two lateral fuzzy controllers are described in the following.

**Input and output variables** Whether straight road or bend road, two parameters are set as the input variables: the lateral error and the angular error. The lateral error is the deviation, in meters, of the front of the car from the reference trajectory, measured perpendicularly from it. The angular error is the angular deviation, in degrees, of the vehicle from the reference trajectory and is represented by a director vector. Fig. 5.2 illustrates these variables.

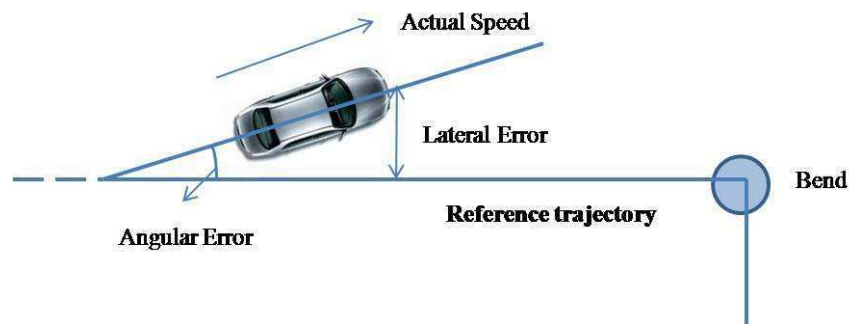

Figure 5.2: Illustration of input variables

The output of the fuzzy controller here is the steering angle, which will be sent to the vehicle lateral dynamic model to control the lateral motion.

The input values are transformed and interpreted as fuzzy data in the fuzzification stage processes and the fuzzy output variable is treated in the defuzzification

operation. Each fuzzy variable is defined by a membership function which is associated with three linguistic labels: Left, Center, Right. The definition of these fuzzy variables is shown in Fig. 5.3.

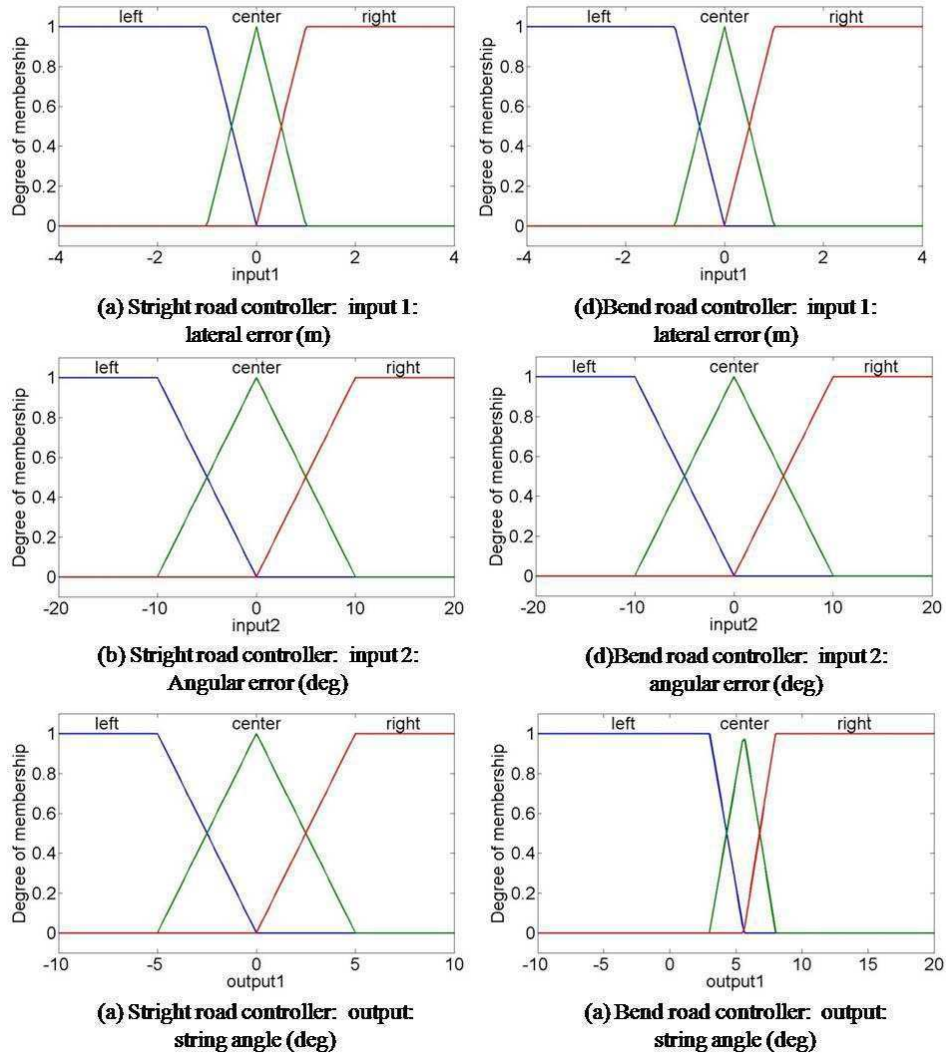

Figure 5.3: Fuzzy-variable membership functions

Two operating modes are contemplated in the steering control, i.e., straight-road driving and bend-road driving. These modes influence the membership-function definition of the output variable, see the bottom row of Fig. 5.3.

Driving on the straight road, the aim is making the string angle being zero, thus, the limit range of the output is set to be  $(-5, 5)$  and in the center, the desired value is zero. If a disturbance happens which means the lateral or angular errors augment, the fuzzy controller will change the output value to eliminate this interference and finally re-maintain at zero.

In the bend-road mode, it should be noted that when we are driving in the

## 5.2. Lane tracking/lane following

---

right-hand lane of a road, taking a bend to the left is different from taking a turning to the right. Here, according to the road structure designed in IVVR platform, we focus on the situation of turning to the right. In the fuzzy controller for the bend road, the output value settings is different from the one for the straight road, as the desired value of string angle is not zero any more. We set it as 5.6 degree which is related to the value of road curvature and the limit range of string angle is (3, 8) degree. Once entering into the turning area, the vehicle detect the value change of the road curvature, then the target of the control is maintaining the string angle not being zero any more but being 5.6 degree which is suitable for the 90 degree right turn. When the curved road finishes, the road curvature comes back to be zero, and then the decision-making module makes the desired string angle backing to be zero.

**Fuzzy rules** When driving, we move the steering wheel to the right to correct a trajectory deviation to the left and vice versa when the deviation is to the right. Fuzzy rules are then supposed to represent this human driving experience. In this case, we have defined four intuitive rules that perfectly describe the behavior of people when maneuvering a car:

- R1 If **Angular error** *Left* then **Steering** *Right*
- R2 If **Angular error** *Right* then **Steering** *Left*
- R3 If **Lateral error** *Left* then **Steering** *Right*
- R4 If **Lateral error** *Right* then **Steering** *Left*

where fuzzy variables are in bold and the linguistic labels in italics. These rules are appropriate for both straight and bend driving situations.

**Fuzzy reasoning process** In this work, we use triangle shaped membership function for the fuzzification process. And the Mamdani's inference method is employed to solve the fuzzy implication as its results have been widely tested in control systems. Finally, we use centroid method for the defuzzification process.

With regard to the leading vehicle, the turning maneuver is realized by a kinematic controller which also takes the road curvature signal as the basis to turn.

### 5.2.4 Simulation results

Simulations of lane tracking/lane following operation under unitary or variational weather conditions are carried out in IVVR platform by a two-vehicle platoon. We assume that these two vehicles always aim to keep a safe inter-vehicle space even when they turn. The simulation results in terms of curves and animations will be displayed in this section.

#### 5.2.4.1 Rainy

Driving in the rain is actually a common drive state especially in the rain season. When it is rainy, road surface is wet and this can cause slightly the tire slippage.

Fig. 5.4 shows three selected scenes from the corresponding animation. The left scene indicates the beginning of this experiment in which the yellow car following the white car with a safe inter-vehicle space. The middle picture shows the moment of turning right and the right one is the scene of two vehicles running on the inclined road after turning.



Figure 5.4: Scenes of lane tracking/lane following in case of rainy

In addition, the simulation results in form of curves are also displayed in Fig. 5.5, including the longitudinal velocities of two vehicles, the steering angle, the inter-vehicle space, the interspace error, the lateral displacement and lateral displacement error.

From the longitudinal velocity curves, it is clear to see the speed auto-adjustment of two vehicles facing to different road types. At about 20s, the longitudinal speed has decreased to about  $10m/s(36km/h < 40km/h)$  to turn right, and at the time 33s, the two-vehicle platoon slows down once again to about  $7m/s(25.2km/s < 30km/s)$  to adapt to the speed limit of inclined road. The inter-vehicle space is safe and the space error is always less than  $0.3m$  which denotes a good control effect. For the lateral control, the curves of steering angle and lateral displacement are normal and the lateral error when turning is less than  $0.07m$ , which is acceptable.

### 5.2.4.2 Cloudy to snowy

Concerning the variational weather condition, we have chosen the climate that changes from cloudy to snowy. In fact, this climate can be often observed in winter and an assumption like this makes our simulation more meaningful.

Three scenes have been chosen from this animation (see Fig. 5.6). They describe the start state with cloudy weather condition, the turning moment in the snow and finally the state of running on the inclined road. In the whole process, these two vehicles succeed in maintaining a safe inter-vehicle distance and following the road trajectory (including bend road).

The related parameters' curves are shown in Fig. 5.7. Similar to the last experiment, the curves of longitudinal velocities of two vehicles show the driver-like behavior of leading vehicle as well as the behavior of NECACC system controlled following vehicle which respect to the speed limits for different road types as designed. The curves of steering angle and lateral displacement are normal and the lateral error is within the normal range. We focus on the curves of inter-vehicle space and space error in this simulation as they are very different from the ones in

## 5.2. Lane tracking/lane following

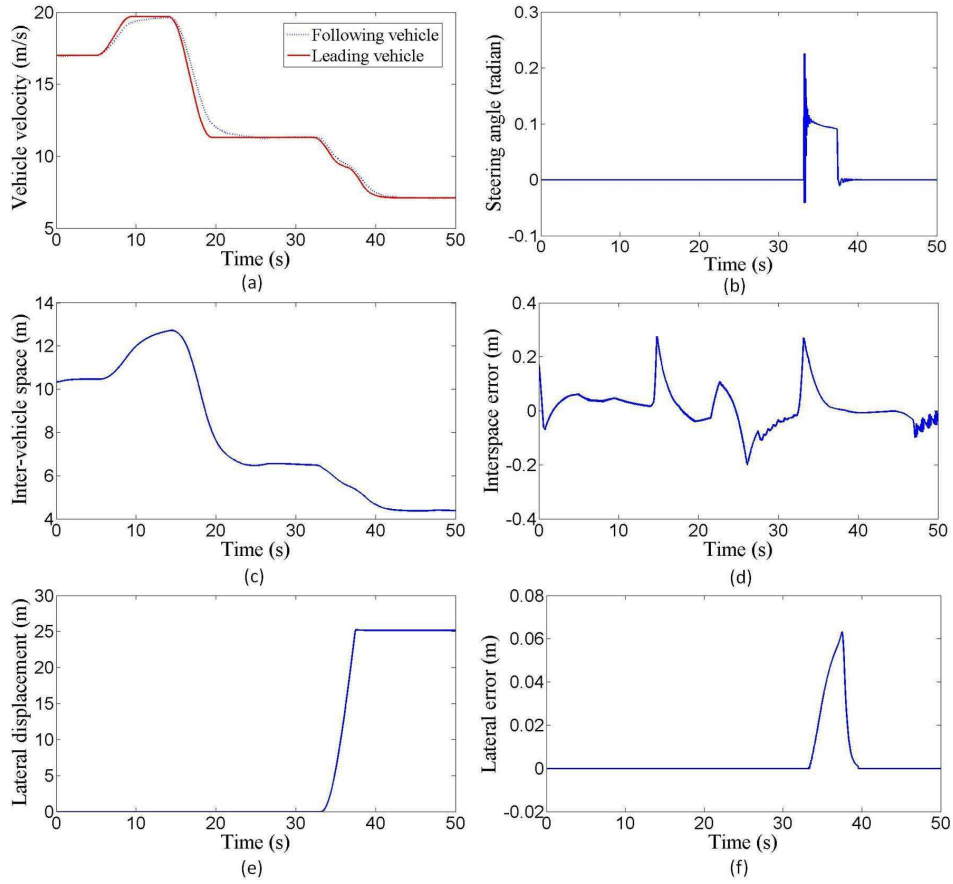

Figure 5.5: Simulation results of lane tracking/lane following in case of rainy



Figure 5.6: Scenes of lane tracking/lane following in case of cloudy to snowy

the last simulation. The difference happens at the moment when it starts to snow, when the NECACC system adjusts its NE parameters to adapt to the snow weather condition which leads to the augmentation of the desired inter-vehicle and that is why the space error increases suddenly at the time of 18s. Therefore, the following vehicle decreases its speed to obtain more inter-vehicle space until it archives the desired value under snow weather condition. Finally, the simulation results prove the security of lane following maneuver under variable weather condition with the help of NECACC system.

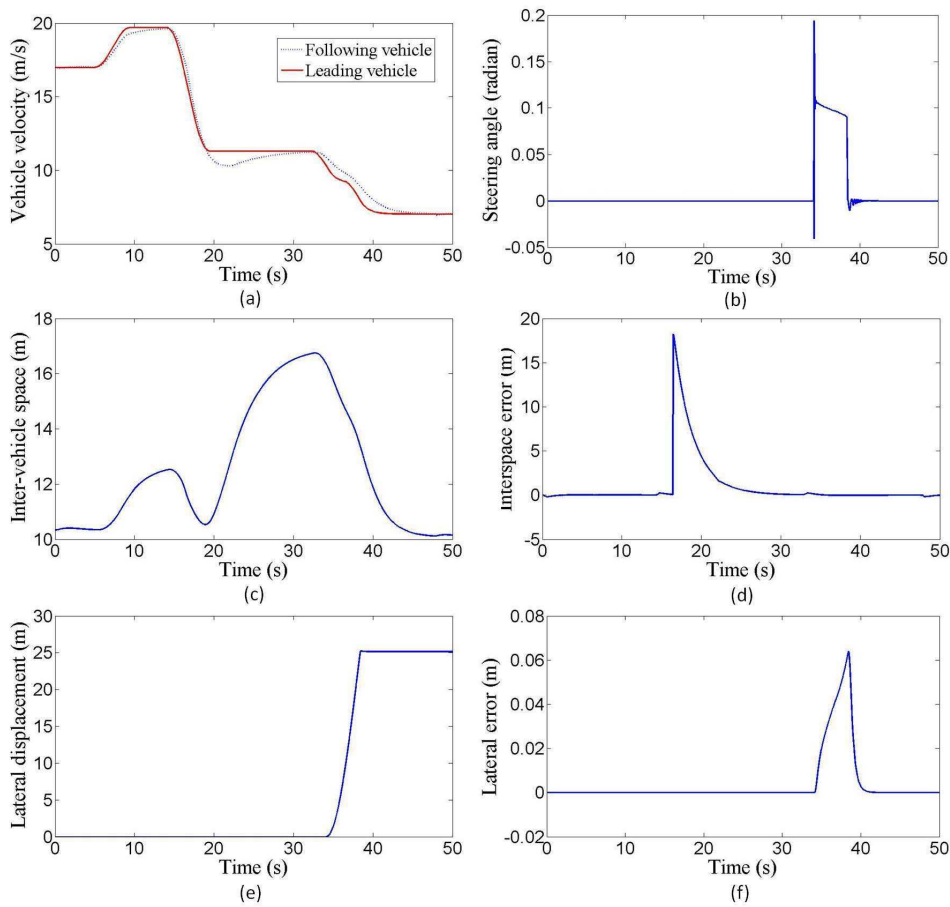

Figure 5.7: Simulation results of lane tracking/lane following in case of cloudy to snowy

### 5.2.4.3 Icy

In case of icy road, we assume that only a section of road is covered by ice, and the other road sections are dry. Fig. 5.8 shows two scenes selected from this virtual demonstration. The first one shows the moment when these two vehicles are running on the icy road and the second one is the turning moment.

### 5.3. Lane changing/Overtaking



Figure 5.8: Scenes of lane tracking/lane following in case of icy

Curves of related parameters have been shown in Fig. 5.9. The turning right control can be proved to be successful by the curves of steering angle and lateral error. Then, we pay more attention to the longitudinal control in case of icy road. It could be noted that once the following vehicle enters the icy road section, the NECACC system adapts its NE parameters to the icy situation and when the icy road section comes to an end, it turns back to the dry road situation. This process can be observed from the curve of interspace error and this error converges to zero eventually. The curve of inter-vehicle space shows that the two-vehicle platoon maintained a long inter-vehicle distance when running on the icy road in order to prevent possible collision and the curves of longitudinal speed also show that the following vehicle reduces its speed immediately once entering the icy road section to obtain more interspace. Finally, the simulation results prove that the traffic operation lane following work well under this road condition with the proposed intelligent controllers.

### 5.3 Lane changing/Overtaking

As a matter of fact, the lane changing maneuver is one of the most thoroughly investigated automatic driving operations for autonomous vehicles after trajectory tracking (lane following). There is a lot of literature as well as research projects, related to the lane-change issue. For example, [Jula 2000] studied the situation concerning the merging and lane changing maneuver. After analyzing the kinematics of the vehicles involved in a lane changing/merging maneuver, for a given scenario, it calculated the minimum longitudinal spacing which the vehicles involved should initially have so that no collision of any type takes place during the maneuver. Besides, it also defines the four situations in which a lane change is safe or unsafe when circulating on freeways. Consider that the overtaking vehicle is vehicle 1, and vehicle 2 is circulating in the contiguous lane.

- Case 1: Vehicle 1 is moving at a lower speed than the other vehicle; vehicle 1 performs a lane change without modifying its speed and pulls in behind vehicle 2.



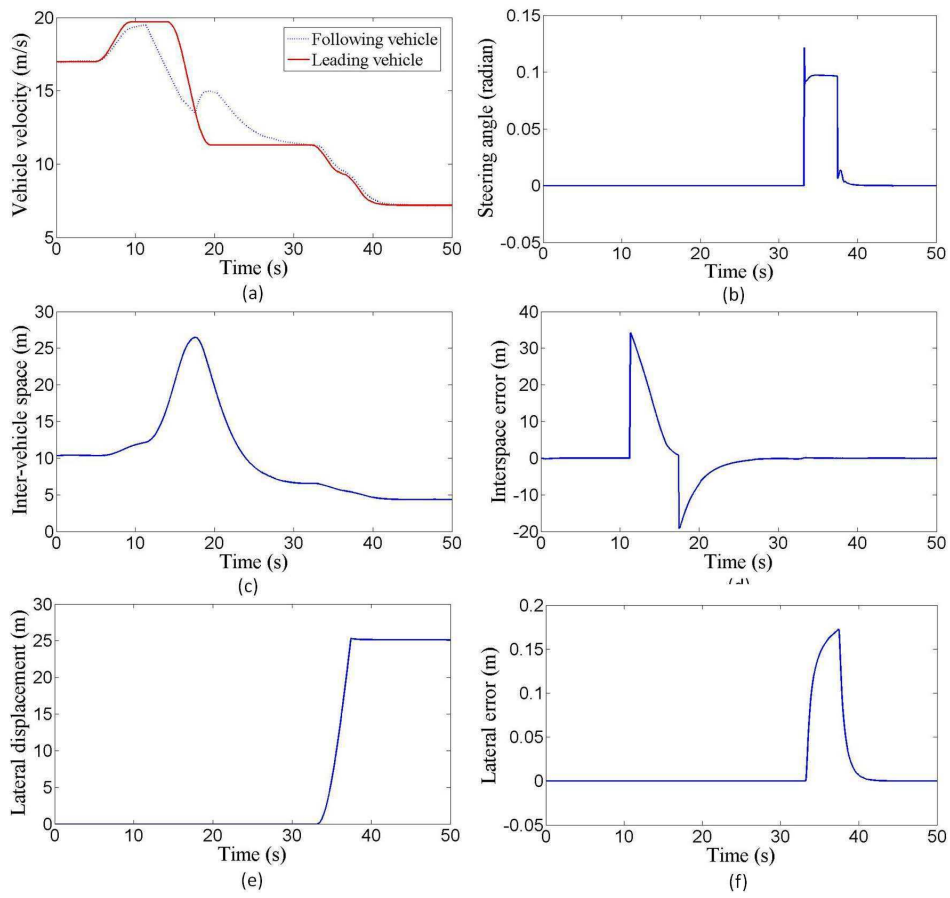

Figure 5.9: Simulation results of lane tracking/lane following in case of icy

### 5.3. Lane changing/Overtaking

---

- Case 2: Vehicle 1 is driving slower than vehicle 2 and makes a lane change, constantly accelerating to pull into the lane in front of vehicle 2.
- Case 3: Vehicle 1 is driving faster than vehicle 2 and makes a lane change at a constant speed to pull into the lane in front of vehicle 2.
- Case 4: Vehicle 1 is moving at a higher speed than vehicle 2 and makes a lane change, constantly decelerating to pull in behind vehicle 2.

In [Rajamani 2000], the lane change is used to get an autonomous vehicle to automatically leave or join a platoon of unmanned vehicles circulating in a different lane. This lane change is carried out by defining the estimated lane-change trajectory and then using onboard sensors to track the path.

Concerning the overtaking, it can be considered as the combination of two lane changing maneuvers: one is departing from the current lane and passing the overtaken vehicle and the other is returning to the original lane. Generally speaking, overtaking performed by an intelligent vehicle is related to a variety of decision-making and control technologies. Some researches have presented certain control methods for the overtaking maneuver. For instance, [Wang 2009] propose an overtaking control method based on the estimation of the conflict probability. This method uses the conflict probability as the safety indicator and completes overtaking by tracking a safe conflict probability. Besides, [Naranjo 2008] presented an overtaking system for autonomous vehicles equipped with path-tracking and lane-change capabilities. The system uses fuzzy controllers that mimic human behavior and reactions during overtaking maneuvers and it is based on the information that is supplied by a high-precision Global Positioning System and a wireless network environment.

In a microscopic perspective, overtaking can keep the velocity of the high-speed vehicle and in a macroscopic perspective, overtaking can improve the traffic flow rate by reducing the negative impact generated by low-speed vehicles. In addition to the above two significations, in this chapter, a new level of meaning will be given to the overtaking or lane changing, which is safety. As we know, when the preceding vehicle decelerates, the following vehicle has to come up with a program to avoid the possible collision between them. Normally, there are two solutions for the following vehicle: the first one is decelerating to keep a safe distance with the preceding vehicle, and the second one is choosing lane changing/overtaking instead of slowing down. This kind of lane changing/overtaking could be seen as a way to get rid of certain dangerous for automatic vehicles especially under adverse weather conditions.

#### 5.3.1 Simulation architecture

A simulation architecture has been designed in Fig. 5.10 for describing the process of the lane changing/overtaking simulation.

A two-vehicle platoon was modeled and controlled in VICS. The leading vehicle was treated as a particle and its longitudinal velocity has been pre-prepared. For

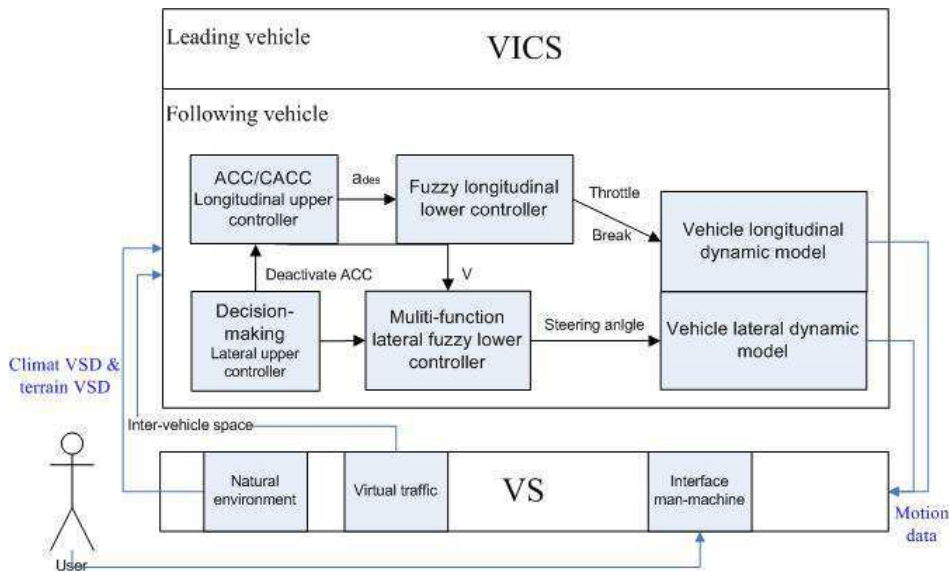

Figure 5.10: Simulation architecture of lane changing/overtaking

the following vehicle, besides the vehicle dynamic modeling, a intelligent control structure was designed for it, which includes a two-level longitudinal controller for maintenance of a safe inter-vehicle space and a two-level lateral controller for the overtaking operation, in which the decision-making part is used to decide when to initiate overtaking and how to complete overtaking and the lower fuzzy controller contributes in the steering angle control for its two lane changing behaviors.

In VS, the virtual traffic module outputs the actual inter-vehicle space to decision-making module and natural environment module also exports climate VSD and terrain VSD to VICS for the following vehicle control. Besides, users can be involved in the simulation via man-machine interface.

### 5.3.2 Longitudinal control

As mentioned before, avoidance of collision can be realized in two ways: deceleration and lane changing/overtaking. The deceleration is normally implemented by ACC/CACC system, such as the NECACC system presented in Chapter 4, it has been proved in concept by several simulations in IVVR platform that it is capable of keeping a safe inter-vehicle distance under various environmental conditions. However, if we still use the spacing policy without the NE adaptive strategy, the deceleration of ACC/CACC is then not sufficient to avoid a collision under some bad weather conditions, thus carrying out the lane changing/overtaking would be a good choice.

Once deciding to overtaking, the maintenance of a safe distance between the two vehicles will be canceled as the following vehicle is not behind the leading one any more. An algorithm for deciding the moment of deactivation of ACC/CACC

### 5.3. Lane changing/Overtaking

---

system should then be designed in function of inter-vehicle space before realizing the operation of lane changing/overtaking. Actually, the driver behavior analysis during ACC/CACC activation and deactivation has been studied by many researchers. [Hoogendoorn 2007] shows that ACC was often used during free driving and busy traffic and was hardly used during slow traffic. And [Viti 2008] investigated the effect of ACC on behavioral adaptation, which was focused on traffic throughput. According to this study, the ACC was often deactivated under dense traffic conditions. It turned out that drivers tend to overrule the ACC and make it inactive under densities ranging from 20 to 40 vehicles/km/lane. Besides, [Pauwelussen 2010] analyzed real traffic data to investigate real driver behavior and the drivers' motives for the transition between ACC/CACC activation and deactivation. These real traffic data were collected during the Dutch full-traffic field operational test (FOT) "The Assisted driver", which was part of the "Road to the Future" project in which 19 participants drove with an instrumented vehicle for six months [Hoogendoorn 2007]. The final conclusions of this research had been drawn in Fig. 5.11.

There are three ACC states in this schema: ACC Inactive, ACC Active and ACC Active & Accelerate. From one ACC state to another, the motive and result after transition have been described clearly in terms of texts and pictures. The participants overruled the system by pressing the gas pedal to drive closer to the leading vehicle than the set distance of the ACC, but in most cases, the driver approached the leading vehicle to overtake the leading vehicle. One can resume the ACC by activating the system or by releasing the throttle after overruling the system resulted in a larger gap between participant and leading vehicle.

We present a simple algorithm here to decide the moment of lane changing. As the real inter-vehicle space is smaller than the desired safe inter-vehicle space, the first lane changing will be triggered. At that moment, ACC/CACC system still works and the lane changing could be considered as a method to avoid the collision. After that, two following situations are listed as follows:

1. If the following vehicle succeeds in deceleration on the neighboring lane, when the inter-vehicle distance re-achieves the desired one, the second lane changing will be triggered for the following vehicle to let it return to the original lane behind the leading vehicle.
2. But if after the first lane changing, the following vehicle still accelerates and finally overtakes the leading vehicle, the deactivation of ACC/CACC will then be carried out, and meanwhile the second lane changing will be triggered. After that, the sequence of this two-vehicle platoon changes and the longitudinal velocity of the overtaking vehicle will be set as the same as the overtaken vehicle.

Hence, the longitudinal control in the lane changing/overtaking simulation could be described as the alteration of activation and deactivation of ACC/CACC system.

## Chapter 5. Integrated Vehicle Control under Complex NE Conditions

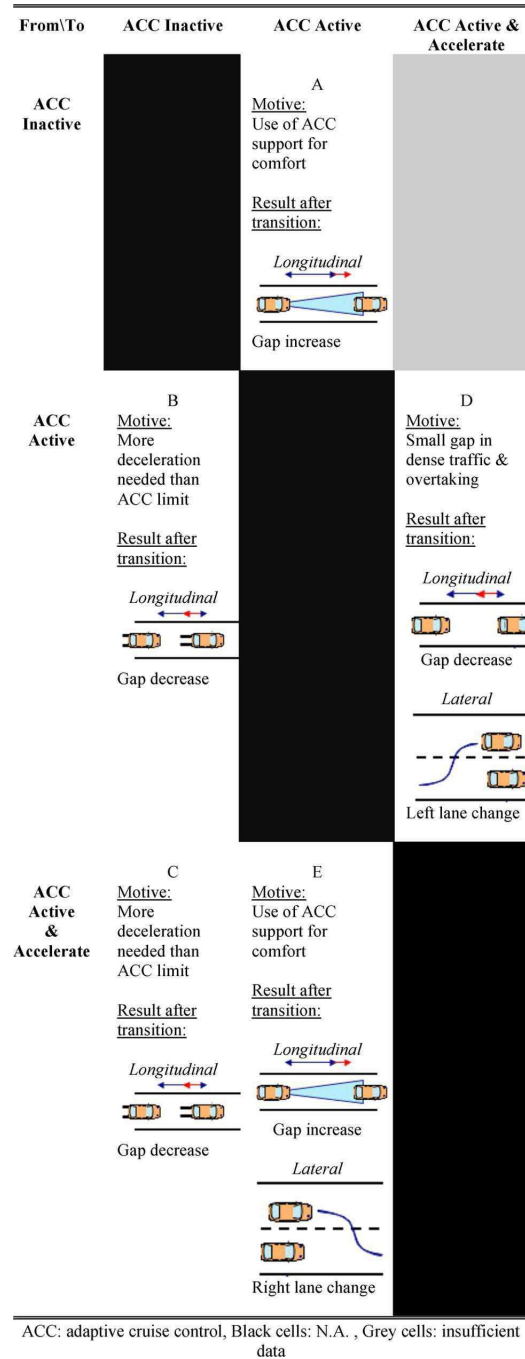

Figure 5.11: Matrix of transition from one ACC state to another [Pauwelussen 2010]

### 5.3. Lane changing/Overtaking

---

#### 5.3.3 Lateral control

A decision-making module and a multi-function lateral fuzzy controller have been created as lateral controller for the following vehicle. The decision-making module is in charge of sending the signals of when to implement the departure from the original lane, when to deactivate the ACC/CACC system and when to turn back to the original lane. It takes the inter-vehicle space measured from virtual world as the input and outputs desired lateral offset, desired vehicle yaw as well as ACC/CACC deactivation signal.

Supposing that a two-vehicle platoon is running on the highway with a safe inter-vehicle space, then, as the acceleration of the following vehicle, the real inter-vehicle space decreases until less than the desired distance. The decision-making module detects this change and after the internal logic operation, it outputs a lane changing trajectory (represented by lateral offset signal and vehicle yaw signal) to the lower-level lateral controller to perform the lane changing from original lane to neighboring lane. Then, if the inter-vehicle space achieves the desired value again (no matter which vehicle is in front of the other), the decision-making module will output another lane changing trajectory (represented by lateral offset signal and vehicle yaw signal) to make the following vehicle backing to the original lane. In this case, if the leading vehicle has been overtaken, then the deactivation signal of ACC/CACC system will also be sent out, otherwise, the following vehicle will back to follow the leading vehicle with ACC/CACC system control.

Multi-function lateral fuzzy controller can be considered as the manipulator who realizes the two above desired lane changing actions: from original lane to adjacent lane and from adjacent lane back to original lane. It receives desired lateral offset signal and desired vehicle yaw signal as inputs, and then sends out the correct steering angle signals to support these two lane changing actions. The low level lateral controller contains 4 fuzzy controllers which are classified by their responsibility for different ranges of longitudinal speed (see Fig. 5.12), as the longitudinal speed variations influence the lateral control effect. Four operating regimes have been proposed: Low [0, 35], Medium-Low [25, 65], Medium-High [55, 95], and High [85, 120], in which the 120km/h is the highest speed allowed on the highway. Besides, a fusion block has also been designed to combine the four independent local controllers into a global one. This fusion block determines the weighting functions for each local controller. It is designed based on a fuzzy type strategy to ensure a smooth and accurate transition between the working points. A more detailed description of the multi-function lateral fuzzy controller can be found in [Zhao 2010] and related knowledge are in [El Kamel 2000] [Hennequin 2001].

#### 5.3.4 Simulation results

The integrated vehicle control demonstrations of lane changing/overtaking under two variable weather conditions have been performed in IVVR platform. Animations as well as curves of related parameters are described in this section. We assume that

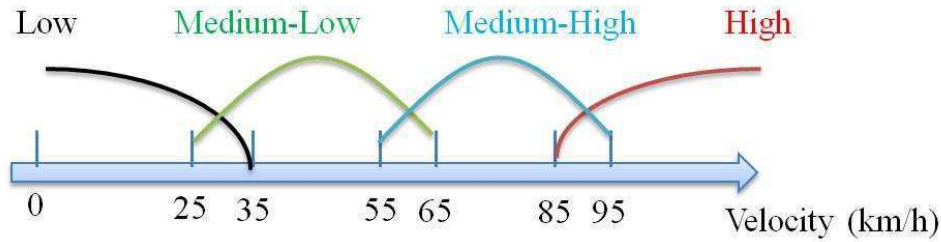

Figure 5.12: Decomposition of operating regimes

the leading vehicle runs with its pre-prepared longitudinal velocity in the simulation.

#### 5.3.4.1 Cloudy to snowy

Weather condition that changing from cloudy to snowy has been chosen for the lane changing simulation. Four scenes were selected from this animation and shown in Fig. 5.13. At the beginning, the yellow vehicle follows the white vehicle with the help of ACC/CACC system (see Fig. 5.13(a)) and then when it starts to snow and the ACC/CACC system being incapable of adapting to the changing weather, the yellow vehicle gets closer and closer to the white vehicle until less than the safe distance, so in this situation, our control system decides to change lane (see Fig. 5.13(b)) to avoid the possible collision. Then, after changing to the neighboring lane, the following vehicle still tries to decelerate and it succeeds. When the white vehicle overtakes the yellow vehicle again and their inter-vehicle space achieve the safe distance, the yellow vehicle decides to turn back to the original lane to keep following the white vehicle (see Fig. 5.13(c) and see Fig. 5.13(d)).

Some representative parameters have been studied by their curve, which are longitudinal velocities of these two vehicles, inter-vehicle space, and lateral displacement as well as yaw angle for the following vehicle, see Fig. 5.14. From Fig. 5.14(c), we can see that the first lane changing happens at about 17s, when the leading vehicle is slowing down and the following vehicle can not decelerate as soon as possible as the road surface covered by snows is too slip. From 17s to 24s, the following vehicle finishes the lane changing, and running with the leading vehicle side by side for a while (which can be deduced by Fig. 5.14(b) where the inter-vehicle space is zero from 20s to 22s). The second lane changing takes place at about 24s, when the yellow car is behind of the white car again with a safe distance. Concerning the lateral control performance for the following vehicle, Fig. 5.14(c)(d) show us the comparisons between the desired one and the real one in terms of lateral displacement and vehicle yaw angle and it is obvious that the lateral control errors are very small and reasonable. All the above simulation results prove that the intergraded control system proposed for the lane changing experiment works well.

### 5.3. Lane changing/Overtaking

---

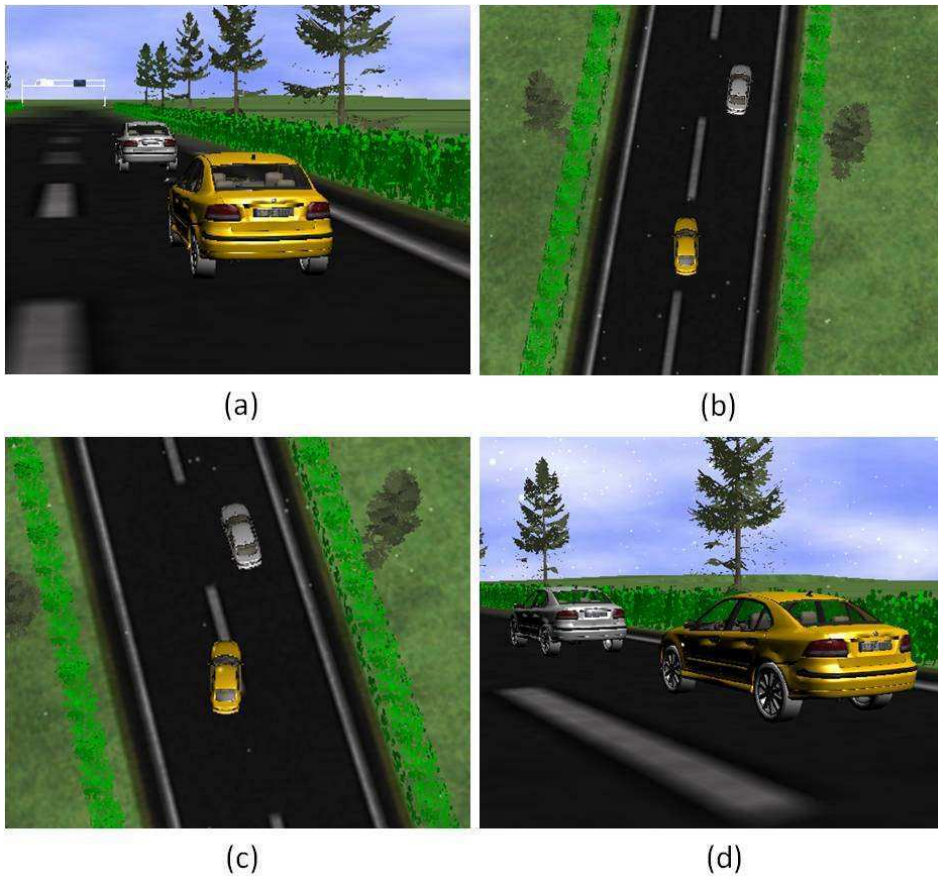

Figure 5.13: Scenes of lane changing in case of cloudy to snowy



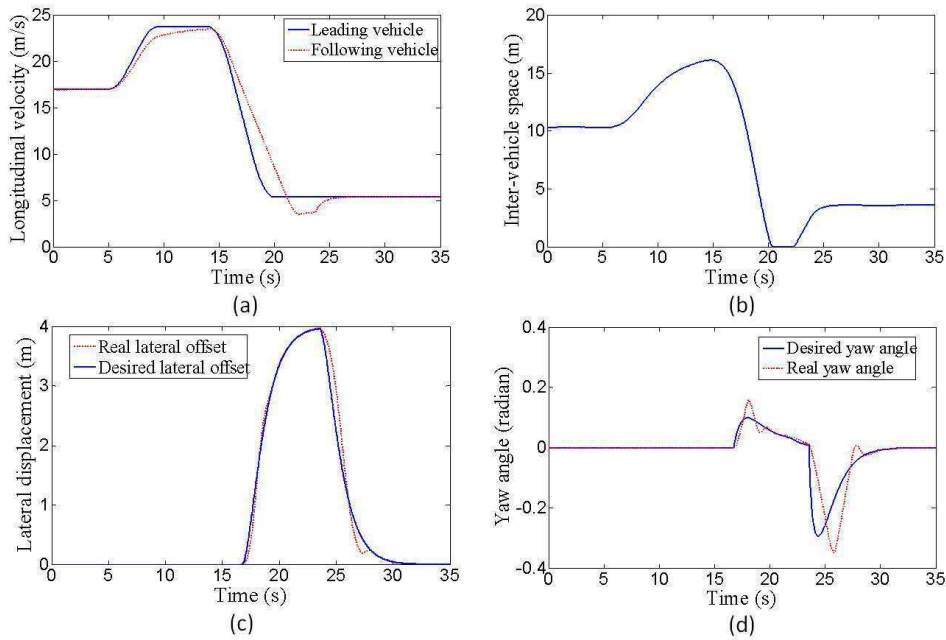

Figure 5.14: Simulation results of lane changing in case of cloudy to snowy

### 5.3.4.2 Icy

We have chosen the icy road condition to do the simulation of overtaking. Four scenes from the animation have been shown in Fig. 5.15. The first one displays the start state on the dry road, and when this two-vehicle platoon enters the icy road section, it becomes very dangerous. Thus, after detecting the unsafe inter-vehicle space, our control system makes the following car to change lane (see Fig. 5.15(b)). The longitudinal speed of the yellow car keeps being high for a moment even that it has departed from the icy road section. After overtaking the white car, the yellow car carries out another lane changing to back to the original lane and be in front of the white car (see Fig. 5.15(c)(d)).

The corresponding parameter also have been described in Fig. 5.16. From the curves describing longitudinal speeds of these two vehicles (see Fig. 5.16(a)), we can see that the following vehicle's longitudinal speed can not follow well with the one of leading vehicle after they enter the icy road section. And this results in the decreasing inter-vehicle distance until getting over the safe distance range (see Fig. 5.16(b)). Hence, at about 15s, the yellow car begins to change lane, and then it quickly overtaking the white car on the neighboring lane. When the yellow car finally slow down, it has been far before the white car. In this situation, our control system deactivates the ACC/CACC system that equipped on the yellow vehicle, activates another lane changing movement that happened at about 21s, and makes the longitudinal speed of the yellow car being closer to the white car. The errors between real and desired lateral displacement is small and reasonable (see

### 5.3. Lane changing/Overtaking

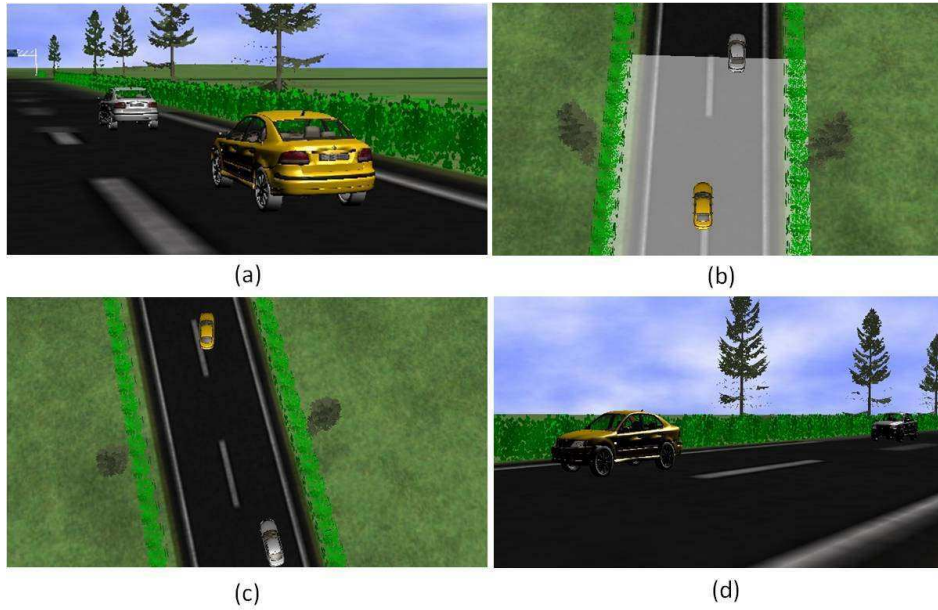

Figure 5.15: Scenes of overtaking in case of icy

Fig. 5.16(c)) and it is the same situation for the yaw angle parameter (see Fig. 5.16(d)).

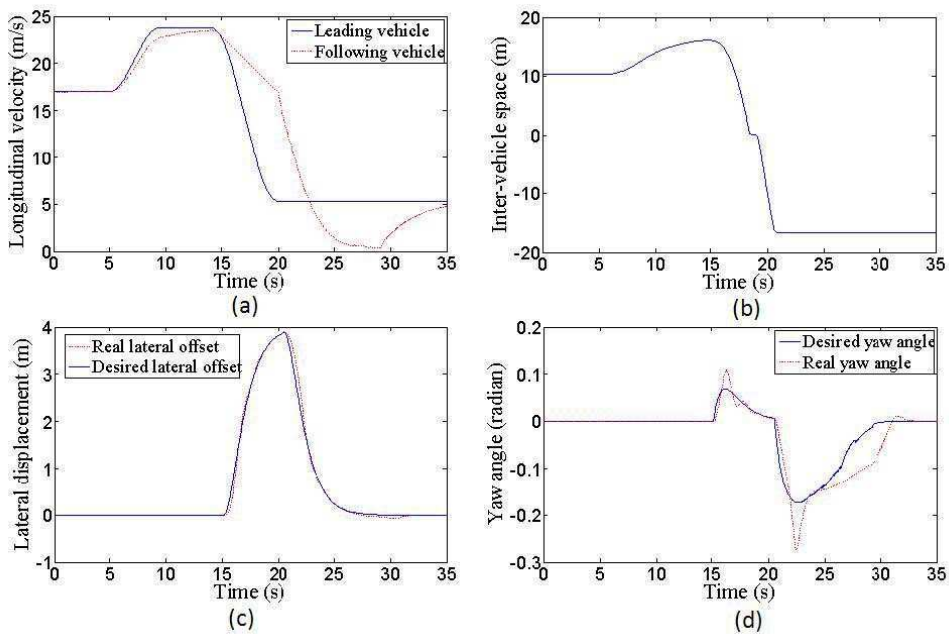

Figure 5.16: Simulation results of overtaking in case of icy

## **5.4 Conclusion**

Usually, in a real road traffic, lane tracking, lane following, lane changing as well as overtaking are considered as the most common traffic maneuvers. With the proposition of concept ITS/AHS, several automatic control systems are studied by researchers to make the intelligent vehicles finishing these operations of themselves. Then, for the purpose of testing these intelligent vehicles, experiments of the above traffic maneuvers are usually carried out to verify the effectiveness of the designed automatic control systems. Those experiments always take place on the dry road condition which means in a good weather situation to ensure the security. Nevertheless, the climate condition is changing all the time, the simulations of traffic operations for intelligent vehicles should also be performed under various climate conditions but not just in the good weather, like in the rain, in the snow or even running on the dangerous icy road.

In this chapter, with the help of IVVR platform which is a virtual reality platform for intelligent vehicles, we have succeeded in performing these three most frequent traffic maneuvers (lane following, lane changing and overtaking) under some complex weather conditions as the virtual traffic demonstrations. For each demonstration, the simulation architecture and the corresponding intergraded control system were firstly introduced, then the simulation results were shown in terms of animation as well as related parameter curves.

These virtual traffic demonstrations prove the feasibility of our proposed intergraded control system or control strategy by showing us a safe traffic situation in a virtual world even under bad climate conditions.

# Conclusions and Perspectives

## Conclusions

This thesis is dedicated to the interdisciplinary area of ITS (Intelligent Transportation Systems) and VR (Virtual Reality) technologies. It concentrates on the improvement of intelligent vehicles control strategies by considering the NE (Natural Environment) impacts as well as the visualization, the verification and performance analysis of proposed control algorithms on the proposed IVVR (Intelligent Vehicles Virtual Reality) platform.

## Main contributions

The main contributions of this thesis are summarized as follows:

- **Design and development of a virtual reality platform for intelligent vehicles control, called IVVR platform.** This platform provides a software work place, where designers can design the vehicle control algorithms which are dedicated to resolve the spreading problems such as traffic congestion, safety, pollution and fuel consumption, etc. and simultaneously analyze and verify the control algorithms through not only classical simple simulations (figures and data) but also comprehensible simulation results presented visually by a virtual 3D display system. Three main advantages of the proposed IVVR platform in comparison to previous similar platforms are: (1) with IVVR platform, design and verification of the vehicle control strategies can be realized at the same time, which means no redundant tasks have to be done between the two above activities as data exchange between them is real-time; (2) the virtual environment is intelligent by reason of that it does not just receive vehicle control and motion data to perform 3D traffic animations, but also outputs feedbacks as references or corrections for vehicle controllers or models; (3) users can be involved in the virtual traffic demonstrations performed by IVVR platform to make the simulations much less boring and more interactive. The corresponding results are published in [Luo 2011b].
- **NE (Natural Environment) modeling and simulation for intelligent vehicle system.** Inspired by NE applications in nation defense and military fields, in which we already have some contributions concerning the NE visualization [Luo 2010] [Luo 2011a], we propose here to introduce the NE modeling and simulation into the field of intelligent vehicle system for the sake of making the traditional intelligent vehicle simulations more believable by considering the NE impacts on vehicles. The link between NE impacts and intelligent vehicles are established by VSD (Virtual Sensor Data) system based on the IVVR platform. This new method can help designers to design more

appropriate intelligent vehicle controllers under different NE conditions, even variable or adverse weather conditions. The corresponding contributions are published in "IEEE Conference on Computational Engineering and Scientific Applications" and "Informatica Economica Journal" [Luo 2011c].

- Based on the above two research results, **A NE based CACC (Cooperative Adaptive Cruise Control) algorithm, called NECACC algorithm** is then presented as the control strategy for maintaining a safe inter-vehicle space for intelligent vehicle platoon under complex or variable NE conditions. This new algorithm has been verified "in concept" in the IVVR platform and the simulation results (figures, data, and 3D animations) show its advantages in comparison to the other algorithms in terms of the balance between security and traffic capacity especially in stiff conditions. The detailed results can be found in [Luo 2012a].
- **Virtual traffic demonstrations with proposed control strategies are realized for performance analysis.** Here, two kinds of traffic maneuvers are simulated in IVVR platform: lane tracking/lane following and lane changing/overtaking. For lane tracking/lane following, the simulation architecture is presented firstly and then a lateral controller is presented for lane tracking (from straight road to curved road). Together with the proposed NECACC system for longitudinal control, simulations of lane tracking/lane following as well as its performance analysis are then realized under various NE conditions. For lane changing/overtaking, its simulation architecture is also proposed and a decision-making module has been presented to control the activation or deactivation of ACC/CACC system so as to make the actions of lane changing/overtaking being automatic. The corresponding simulations and performance analysis have also been carried out in IVVR platform. Safety can be ensured all the time during the above two simulations. Part of the results have been published in [Luo 2012b].

### Limits

Two limits of our researches have been listed as follows:

- In a real traffic, drivers are actually forbidden driving under some extreme NE conditions like totally icy road, snowstorm, etc. in certain countries. In this thesis, some experiments are still implemented under such extreme weather conditions by reason of that this method can help us to approve the superiorities of proposed control strategies in adapting to the variable environment.
- Although VR technology has been more and more used as a verification tool in different sectors, it should be noted that because of the limitations in simulator fidelity and the richness of variety in real world situations, the test with real vehicles for our proposed vehicle control strategies is always necessary.

---

## Perspectives

Based on the contributions and limits of our researches in this thesis, several perspectives should be considered:

### Short-term

- In NE modeling and simulation, more environmental information would be provided and considered in the intelligent vehicle system simulations. For instance, the wind could be a more complex factor in influencing the security of traffic as its power and orientation are discretionary.
- With respect to the virtual traffic demonstrations, the proposed lateral controller for lane tracking is suitable only for the pre-designed trajectory, thus, some improvements on the lateral controller would be done to make it more intelligent to adapt to the trajectory in real-time. Besides, its fuzzy control effect could also be ameliorated by adding other variables as inputs in addition to lateral error and angular error, such as the variation of lateral error or angular error.
- Concerning the simulation of overtaking, the control strategy design should be more precise especially after the overtaking action performed by the following vehicle.

### Long-term

- In this thesis, a virtual reality platform for intelligent vehicles control has been designed and developed. Obviously, all tasks being carried out on one single computer lead to low performance and inefficiency. For solving this problem, in the future, a distributed intelligent vehicle virtual reality system should be developed, in which tasks could be solved in parallel by several computers. For example, in our system, the agents like intelligent controllers, vehicle dynamic models, visualization system and communication system could be separated and performed in parallel on 4 or more different computers so as to obtain a more fluency simulation even with abundant virtual vehicles.
- Augmented reality that links the VR (Virtual Reality) to the real world is also considered as a very important future work since the reason has been explained clearly in the second limit point.
- Either in a distributed virtual reality system or in an augmented reality system, the communication system between software agents or between computer and real devices (e.g. sensors) should be studied seriously in terms of data reliability, like the error protection, data delay or losses, etc.



# Bibliography

- [Abdel-Aty 2006] Mohamed A. Abdel-Aty and Rajashekar Pemmanaboina. *Calibrating a real-time traffic crash-prediction model using archived weather and ITS traffic data*. IEEE Transactions on Intelligent Transportation Systems, vol. 7, no. 2, pages 192–210, 2006. (Cited on page 72.)
- [Administration 2003] National Highway Traffic Safety Administration. *Automotive collision avoidance system field operational test/third annual report*. U.S. Department of Transportation, 2003. (Cited on page 131.)
- [Ambroz 2005] M. Ambroz, S. Krasna and I. Prebil. *3D road traffic situation simulation system*. Advances in Engineering Software, vol. 36, pages 77–86, 2005. (Cited on pages 7, 49 and 50.)
- [Ambroz 2010] Miha Ambroz and Ivan Prebil. *i3Drive, a 3D interactive driving simulator*. IEEE Computer Graphics & Applications, pages 86–92, 2010. (Cited on pages 7 and 49.)
- [Amditis 2010] Angelos Amditis, Matthaios Bimpas and George Thomaidis. *A situation-adaptive lane-keeping support system: Overview of the SAFELANE approach*. IEEE Transactions on Intelligent Transportation Systems, vol. 11, no. 3, pages 617–629, 2010. (Cited on page 34.)
- [Andrey 2001a] J. Andrey, J. Suggett, B. Mills and M. Leahy. *Weather-related road accident risks in mid-sized Canadian cities*. Canadian Multidisciplinary Road Safety Conference XII Proceedings, 2001. (Cited on page 72.)
- [Andrey 2001b] Jean Andrey. *Weather information and road safety*. 2001. (Cited on page 72.)
- [Ararat 2006] Oncu Ararat, Emre Kural and Bilin Aksum Guvenc. *Development of a Collision Warning system for adaptive cruise control vehicles using a comparison analysis of recent algorithms*. Intelligent Vehicles Symposium, 2006. (Cited on page 102.)
- [Arem 2006] Bart Van Arem, Cornelia J. G. van Driel and Ruben Visser. *The impact of cooperative adaptive cruise control on traffic-flow characteristics*. IEEE Transactions on Intelligent Transportation Systems, vol. 7, no. 4, pages 429–436, 2006. (Cited on pages 98, 107 and 130.)
- [Armstrong 2006] Jennifer Armstrong and Ata Khan. *Modelling intelligent transportation systems and their implications for climate change*. IEEE EIC Climate Change Technology, pages 1–10, 2006. (Cited on page 72.)



- [Aukstakalnis 1992] Steve Aukstakalnis and David Blatner. *Silicon mirage: the art and science of virtual reality*. Peachpit Press, Berkeley, USA, 1992. (Cited on pages 38 and 169.)
- [Bakker 1989] E. Bakker, H. Pacejka and L. Lidner. *A new tire model with application in vehicle dynamic studies*. Society of Automotive Engineers (SAE), no. 890087, pages 101–113, 1989. (Cited on page 84.)
- [BBCNews ] BBCNews. *Google gets Nevada driving licence for self-drive car*. "<http://www.bbc.co.uk/news/technology-17989553>". Online; accessed 04-July-2012. (Cited on page 35.)
- [Bella 2011] Francesco Bella and Roberta Russo. *A Collision Warning system for rear-end collision: A driving simulator study*. *Procedia Social and Behavioral Sciences*, vol. 20, pages 676–686, 2011. (Cited on pages 102 and 130.)
- [Bi 2009] L. Bi, O. Tsimhoni and Y. Liu. *Using image-based metrics to model pedestrian detection performance with night-vision systems*. *IEEE Transactions on Intelligent Transportation Systems*, vol. 10, no. 1, pages 155–164, 2009. (Cited on page 130.)
- [Birkel 1998] Paul A. Birkel. *SNE (Synthetic Natural Environment) conceptual reference model*. In *Proceedings of the Fall Simulation Interoperability Workshop*, 1998. (Cited on page 74.)
- [Blosseville 2006] Jean Marc Blosseville. *Driver assistance systems, a long way to AHS*. In *Proceedings of Intelligent Vehicles Symposium*, page 237, 2006. (Cited on page 129.)
- [Bouaff 2012] Lamia Bouaff, Kais Ouni and Noureddine Ellouze. *A speech tool software for signal processing applications*. In *Proceedings of Conference Sciences of Electronics, Technologies of Information and Telecommunications*, Tunisia, March 2012. (Cited on page 33.)
- [Burdea 1993] G. Burdea and P. Coiffet. *La réalité virtuelle, chapitre 2*. Hermes Sciences Publication, Paris, 1993. (Cited on pages 38 and 169.)
- [Canada 1999] Transport Canada. *An Intelligent Transportation Systems (ITS) plan for Canada: En route to intelligent mobility*. 1999. (Cited on page 26.)
- [Caudill 1977] R.J. Caudill and W.L. Garrard. *Vehicle-follower longitudinal control for automated transit vehicles*. *ASME J. Dyn. Syst. Meas. Control*, vol. 99, no. 4, pages 241–248, 1977. (Cited on page 110.)
- [Cavusoglu 2011] Abdullah Cavusoglu and Ismail Kurnaz. *Developing a parameterized simulation platform with intelligent synthetic agents for training driver candidates*. *Procedia Computer Science*, vol. 3, pages 727–731, 2011. (Cited on pages 44 and 50.)

## Bibliography

---

- [Chellali 2009] Mohamed-EL-Amine Chellali. *Etude des interactions homme-homme pour l'élaboration du référentiel commun dans les environnements virtuels collaboratifs*. PhD thesis, l'Université d'Nantes UFR Sciences et Techniques, France, 2009. (Cited on pages 37, 40 and 42.)
- [Cheon 2002] S. Cheon. *An overview of Automated Highway System (AHS) and the social and institutional challenges they face*. Rapport technique, Report 624, University of California Transportation Center, 2002. (Cited on page 26.)
- [Christiansen 1996] John H. Christiansen, A. Peter Campbell and John R. Hummel. *The Dynamic environmental effects model: a high-fidelity simulation system with dynamic environmental effects*. SPIE, vol. 2740, pages 164–175, 1996. (Cited on page 76.)
- [Desjardins 2011] Charles Desjardins and Brahim Chaib-draa. *Cooperative adaptive cruise control: A reinforcement learning approach*. IEEE Transactions on Intelligent Transportation Systems, vol. 12, no. 4, pages 1248–1260, 2011. (Cited on pages 98 and 107.)
- [Donikian 1999] S. Donikian, G. Moreau and G. Thomas. *Progress in system and robot analysis and control design*. Springer, 1999. (Cited on pages 7 and 43.)
- [DSpace 2006] Group DSpace. *Catalogue 2006 solution for control*. dSPACE, 2006. (Cited on page 116.)
- [Edwards 1996] J. Edwards. *Weather-related road accidents in England and Wales: A special analysis*. Journal of Transport Geography, vol. 4, pages 201–212, 1996. (Cited on page 72.)
- [El Kamel 2000] A. El Kamel, F. Bouslama and P. Borne. *Multimodel multicontrol of vehicles in automated highways*. In Proceedings of 4th World Automation Congress, Hawaii, USA, June 2000. (Cited on page 145.)
- [El Kamel 2005] A. El Kamel and J.P. Bourey. *UML-based and design and fuzzy control of automated vehicles*. Lecture notes in Artificial Intelligence, vol. 3613, pages 1025–1033, 2005. (Cited on page 51.)
- [El Kamel 2006] A. El Kamel, Q. Hembise, S. Olive and K. Mellouli. *Intelligent Transportation System Design and Monitoring*. In Proceedings of IEEE International Conference on Industrial Technology, pages 3020–3025, 2006. (Cited on page 48.)
- [Ellis 1994] S.R. Ellis. *What are Virtual Environment?* In Proceedings of IEEE Computer Graphics et Applications, pages 17–22, 1994. (Cited on page 40.)
- [Fancher 2002] P. Fancher. *Research on desirable adaptive cruise control behavior in traffic streams*. MI: University of Michigan Transportation Research Institute, 2002. (Cited on page 114.)

- [Fisher 1987] Scott S. Fisher, M. Mcgreevy, J. Humphries and W. Robinett. *Virtual environment display system*. In SI3D'86: Proceedings of the 1986 workshop on Interactive 3D graphics, pages 77–87, 1987. (Cited on page 35.)
- [Frohlich 1999] B. Frohlich, S. Barrass and B. Zehner. *Exploring geo-scientific data in virtual environment*. In Proceedings of IEEE Conference on Visualization, pages 169–173, 1999. (Cited on pages 7, 40 and 41.)
- [Fuchs 2006] P. Fuchs, G. Moreau, A. Berthoz and J. Vercher. *Le traité de la réalité virtuelle*. Presses de l'Ecole des Mines de Paris, 2006. (Cited on page 35.)
- [Gehrig 2007] S. Gehrig and F. Stein. *Collision avoidance for vehicle-following systems*. IEEE Transactions on Intelligent Transportation Systems, vol. 8, no. 2, pages 233–244, 2007. (Cited on page 130.)
- [Gillespie 1992] T. D. Gillespie. *Fundamentals of vehicle dynamics*. Society of Automotive Engineers Warrendale, 1992. (Cited on pages 57 and 81.)
- [Girard 2005] Anouck R. Girard, Stephen Spry and J. Karl Hedrick. *Intelligent cruise control applications*. IEEE Robotics & Automation Magazine, pages 22–28, 2005. (Cited on page 99.)
- [Gissinger 1997] G.L. Gissinger and W. Kortum. *Simulation of vehicle system dynamics, state of the art and ongoing developments*. Transportation Systems' 97, vol. 1, pages 215–222, 1997. (Cited on page 23.)
- [Government 2011] Canada Government. *Road Safety in Canada*. 2011. (Cited on page 20.)
- [Hennequin 2001] S. Hennequin, D. Lefebvre and A. EL Moudni. *Fuzzy multimodel of timed Petri nets*. IEEE Transactions on Systems, Man, and Cybernetics, Part B: Cybernetics, vol. 31, no. 2, pages 245–251, 2001. (Cited on page 145.)
- [hongke 2007] Xu hongke, Chuai Jinhua, Chen Dashan and Xu Na. *Simulation of highway tunnel traffic control and guidance*. In Proceedings of the Eighth International Conference on Electronic Measurement and Instruments, pages 644–647, 2007. (Cited on pages 7, 44 and 45.)
- [Hoogendoorn 2007] S. P. Hoogendoorn, F. Viti, S. J. L. Ossen, W. Van Nifterick and M. Doelman. *Full Traffic Research Report*. Delft Univ. Technol., 2007. (Cited on page 143.)
- [Hoogendoorn 2010] R.G. Hoogendoorn, G. Tamminga, S.P. Hoogendoorn and W.Daamen. *Longitudinal driving behavior under adverse weather conditions: Adaptation effects, model performance and freeway capacity in case of fog*. In Proceedings of 13th International IEEE Annual Conference on Intelligent Transportation Systems, pages 450–455, 2010. (Cited on page 72.)

## Bibliography

---

- [Jayaram 1999] Sankar Jayaram, Uma Jayaram, Yong Wang and Hrishikesh Tirumali. *VADE: a Virtual Assembly Design Environment*. IEEE Computer Graphics and Applications, vol. 19, no. 6, pages 44–50, 1999. (Cited on pages 7, 42 and 43.)
- [Jianqiang 2010] W. Jianqiang, L. Shengbo, H. Xiaoyu and L. Keqiang. *Driving simulation platform applied to develop driving assistance systems*. IET Intelligent Transport Systems, vol. 4, no. 2, pages 121–127, 2010. (Cited on page 48.)
- [Jula 2000] Hossein Jula, Elias B. Kosmatopoulos and Petros A. Ioannou. *Collision Avoidance Analysis for Lane Changing and Merging*. IEEE Transactions on Vehicular Technology, vol. 49, no. 6, pages 2295–2308, 2000. (Cited on page 139.)
- [Kato 2002] Shin Kato and Sadayuki Tsugawa. *Vehicle control algorithms for cooperative driving with automated vehicles and intervehicle communications*. IEEE Transactions on Intelligent Transportation Systems, vol. 3, no. 3, pages 155–161, 2002. (Cited on pages 48 and 129.)
- [Kesting 2008] Arne Kesting, Martin Treiber and Martin Schonhof. *Average brain models: A convergence study*. Transportation Research Part C, vol. 16, pages 668–683, 2008. (Cited on pages 50 and 101.)
- [Kodagoda 2002] KRS Kodagoda. *Fuzzy speed and steering control of an AGV*. IEEE Transactions on control systems technology, vol. 10, no. 1, pages 112–120, 2002. (Cited on page 58.)
- [Koetse 2009] Mark J. Koetse and Piet Rietveld. *The impact of climate change and weather on transport: An overview of empirical findings*. Transportation Research Part D, vol. 14, pages 205–221, 2009. (Cited on page 72.)
- [Krueger 1985] Myron W. Krueger, Thomas Gionfriddo and Katrin Hinrichsen. *Videoplace - an artificial reality*. SIGCHI Bull, vol. 16, no. 4, pages 35–40, 1985. (Cited on page 35.)
- [Laschinsky 2010] Y. Laschinsky, K. von Neumann-Cosel and M. gontler. *Evaluation of an active safety light using virtual test drive within vehicle in the loop*. In Proceedings of IEEE International Conference on Industrial Technology (ICIT), pages 1119–1112, 2010. (Cited on page 50.)
- [Lehner 1997] Valerie D. Lehner and Thomas A. Defanti. *Distributed virtual reality: Supporting remote collaboration in vehicle design*. IEEE Computer Graphics and Applications, vol. 17, no. 2, pages 13–17, 1997. (Cited on pages 7 and 46.)
- [Li 2006] Li Li, Feiyue Wang and Qunzhi Zhou. *Integrated longitudinal and lateral tire/road friction modeling and monitoring for vehicle motion control*. IEEE

- 
- Transactions on Intelligent Transportation Systems, vol. 7, no. 1, pages 1–19, 2006. (Cited on pages 84, 89 and 90.)
- [Lin 2007] J.S. Lin and W.E. Ting. *Nonlinear control design of anti-lock braking systems with assistance of active suspension*. IET Control Theory Application, vol. 1, no. 1, pages 343–348, 2007. (Cited on page 130.)
- [Liu 2004] Weihua Liu. *Researche on key technologies of Synthetic Natural Environment (SNE)*. PhD thesis, Beijing University of Aeronautics and Astronautics (BUAA), China, 2004. (Cited on pages 73, 74 and 76.)
- [Lourdeaux 2001] Domitile Lourdeaux. *Réalité virtuelle et formation: conception d'environnements virtuels pédagogiques*. PhD thesis, Ecole des mines de Paris, 2001. (Cited on pages 7, 40, 41 and 42.)
- [Luo 2010] Minzhi Luo, Guanghong Gong and Abdelkader El Kamel. *GPU-Based real-time virtual reality modeling and simulation of seashore*. In Proceedings of 10th IEEE International Conference on Intelligent Systems Design and Applications, pages 1036–1041, Cairo, Egypt, 2010. (Cited on pages 73 and 151.)
- [Luo 2011a] Minzhi Luo, Guanghong Gong and Abdelkader El Kamel. *GPU-based real-time virtual reality modeling and simulation of seashore*. In Tauseef Gulrez and Aboul Ella Hassaniien, editors, *Advances in Robotics and Virtual Reality*, chapitre 13, pages 307–332. Springer, 2011. (Cited on pages 73 and 151.)
- [Luo 2011b] Minzhi Luo, Abdelkader El Kamel and Guanghong Gong. *UML-based design of intelligent vehicles virtual reality platform*. In Proceedings of IEEE International Conference on Systems, Man, and Cybernetics, pages 115–120, Alaska, USA, 2011. (Cited on pages 50, 73 and 151.)
- [Luo 2011c] Minzhi Luo, Abdelkader El Kamel and Guanghong Gong. *VR-based real-time simulation of natural environment impacts on intelligent vehicle*. In Proceedings of IEEE International Conference on Computational Engineering and Scientific Applications, pages 115–120, Chile, 2011. Selected by Informatica Economica Journal. (Cited on pages 78 and 152.)
- [Luo 2012a] Minzhi Luo, Abdelkader El Kamel and Guanghong Gong. *Cooperative adaptive cruise control design and simulation involving natural environment*. Submitted to IEEE Transactions on Intelligent Transportation Systems, 2012. (Cited on page 152.)
- [Luo 2012b] Minzhi Luo, Abdelkader El Kamel and Guanghong Gong. *Simulaiton of natural environment impacts on intelligent vehicle based on a virtual reality platform*. In Proceedings of 13th IFAC Symposium on Control in Transportation Systems, Sofia, Bulgaria, September 12 - 14 2012. (Cited on page 152.)

## Bibliography

---

- [Melaniphy 2012] Michael P. Melaniphy. *2012: State of the Public Transportation Industry*. 2012. (Cited on page 20.)
- [Mercer 1986] G. Mercer. *Aspects of weather-related casualty traffic accidents, British Columbia, 1984*. British Columbia Ministry of Attorney General, Police Services Branch, 1986. (Cited on page 72.)
- [Merie-Agnes 2002] Merie-Agnes, Dillies-Peltier and Nadine le Fort-Piat. *Les systèmes d'aide à la conduite, chapitre 4*. Lavoisier, Paris, 2002. (Cited on pages 26 and 30.)
- [Milgram 1994] P. Milgram and F. Kishino. *A taxonomy of mixed reality visual displays*. IEICE Transactions on Information and Systems (Special Issue on Networked Reality), pages 1321–1329, 1994. (Cited on page 37.)
- [Montufar 2006] Jeannette Montufar and Robyn McGregor. *Using intelligent transportation system to adapt to potential climate change impacts on seasonal truck weight limits*. IEEE EIC Climate Change Technology, pages 1–8, 2006. (Cited on page 72.)
- [MULTIGEN ] MULTIGEN. *Multigen-paradigm vega prime homepage*. "[http://www.presagis.com/about\\_us/press\\_room/releases/multigen-paradigm\\_announces\\_availability\\_of\\_vega\\_prime\\_v20/](http://www.presagis.com/about_us/press_room/releases/multigen-paradigm_announces_availability_of_vega_prime_v20/)". Online; accessed 04-July-2012. (Cited on page 44.)
- [Naranjo 2005] Jose E. Naranjo, Carlos Gonzalez and Ricardo Garcia. *Power-steering control architecture for automatic driving*. IEEE Transactions on Intelligent Transportation Systems, vol. 6, no. 4, pages 406–415, 2005. (Cited on page 131.)
- [Naranjo 2008] Jose E. Naranjo, Carlos Gonzalez, Ricardo Garcia and Teresa de pedro. *Lane-change fuzzy control in autonomous vehicles for the overtaking maneuver*. IEEE Transactions on Intelligent Transportation Systems, vol. 9, no. 3, pages 438–450, 2008. (Cited on pages 34 and 141.)
- [Naus 2010] Gerrit J. L. Naus, Rene P. A. Vugts and Jeroen Ploeg. *String-stable CACC design and experimental validation: A frequency-domain approach*. IEEE Transactions on Vehicular Technology, vol. 59, no. 9, pages 4268–4279, 2010. (Cited on page 107.)
- [Nouveliere 2002] Lydie Nouveliere. *Commandes robustes appliquées au contrôle assisté d'un véhicule à basse vitesse*. PhD thesis, l'Université de Versailles-Saint Quentin en Yvelines, France, 2002. (Cited on pages 101 and 116.)
- [Ouramdane 2008] Nassima Ouramdane. *Ver un système d'assistance à l'interaction 3D pour le travail et le télétravail collaboratif dans les environnements de réalité virtuelle et augmentée*. PhD thesis, l'Université d'Evry-Val d'Essonne, France, 2008. (Cited on page 37.)

- [Pack 2010] Michael L. Pack. *Visualization in transportation: challenges and opportunities for everyone*. IEEE Computer Graphics & Applications, pages 90–96, 2010. (Cited on pages 43 and 48.)
- [PATH ] PATH. *California PATH homepage*. "<http://www.path.berkeley.edu/>". Online; accessed 04-July-2012. (Cited on page 34.)
- [Pauwelussen 2010] Jasper Pauwelussen and Philip J. Feenstra. *Driver behavior analysis during ACC activation and deactivation in a real traffic environment*. IEEE Transactions on Intelligent Transportation Systems, vol. 11, no. 2, pages 329–338, 2010. (Cited on pages 9, 34, 143 and 144.)
- [PREDIT ] PREDIT. *PREDIT homepage*. "<http://www.predit.prd.fr/predit3/menu.fo?cmd=englishVersion>". Online; accessed 04-July-2012. (Cited on page 34.)
- [Priez 2000] Alain Priez. *Attention, chercheurs à bord R & D*. La route de l'innovation, no. 15, pages 15–19, 2000. (Cited on pages 22 and 71.)
- [Querrec 2003] R. Querrec, C. Buche, E. Maffre and P. Chevallier. *SecuReVi: Virtual environments for fire fighting training*. In Proceedings of VRIC 2003 (Colloque Laval Virtual 2003 Cinquième Conférence Internationale sur la Réalité Virtuelle), pages 169–175, 2003. (Cited on pages 7 and 42.)
- [Rajamani 2000] Rajesh Rajamani and Han-Shue Tan. *Demonstration of integrated longitudinal and lateral control for the operation of automated vehicles in platoons*. IEEE Transactions on Control System Technology, vol. 8, no. 4, pages 695–708, 2000. (Cited on pages 29, 48, 129 and 141.)
- [Rajamani 2006] Rajesh Rajamani. *Vehicle dynamics and control*. Springer, USA, 2006. (Cited on pages 8, 29, 81, 82, 87, 88, 89 and 90.)
- [Santhanakrishnan 2003] K. Santhanakrishnan and R. Rajamani. *On spacing policies for highway vehicle automation*. IEEE Transactions on Intelligent Transportation Systems, vol. 4, no. 4, pages 198–204, 2003. (Cited on page 29.)
- [Schrank 2011] David Schrank, Tim Lomax and Bill Eisele. *TTI 2011 URBAN MOBILITY REPORT Powered by INRIX Traffic Data*. vol. Texas Transportation Institute, 2011. (Cited on page 20.)
- [Schwartz 2003] D. Schwartz. *Clothoid road geometry unsuitable for sensor fusion*. In Proceedings of IEEE Intelligent Vehicles Symposium, pages 484–488, 2003. (Cited on page 131.)
- [Seiler 1998] Peter Seiler, Bongsob Song and J. Karl Hendrick. *Development of a Collision Avoidance System*. SAE Special Publications, ITS Advanced Controls and Vehicle Navigation Systems, vol. 1332, pages 97–103, 1998. (Cited on page 102.)

## Bibliography

---

- [Sewall 2011] Jason Sewall, Jur van den Berg, Ming Lin and Dinesh Manocha. *Virtualized Traffic: Reconstructing traffic flows from discrete spatio-temporal data*. IEEE Transactions on Visualization and Computer Graphics, vol. 17, no. 1, pages 26–37, 2011. (Cited on pages 7 and 44.)
- [Shekhar 2002] S. Shekhar, C. T. Lu, R. Liu and C. Zhou. *CubeView: a system for traffic data visualization*. In Proceedings of IEEE 5th International Conference on Intelligent Transportation Systems, 2002. (Cited on page 43.)
- [Short 2004] Michael Short, Michael J. Pont and Qiang Huang. *Simulation of vehicle longitudinal dynamics*. Technical Report, 2004. (Cited on page 83.)
- [Sukuvaara 2009] Timo Sukuvaara, Pertti nurmi and Finnish Meteorological Institute. *Wireless traffic service platform for combined vehicle-to-vehicle and vehicle-to-infrastructure communications*. IEEE Wireless Communications, pages 54–61, 2009. (Cited on pages 8, 79 and 80.)
- [Swaroop 1994] D. Swaroop. *String stability of interconnected systems: An application to platooning in automated highway systems*. PhD thesis, University of California at Berkeley, 1994. (Cited on page 111.)
- [Swaroop 1996] D. Swaroop and J.K. Hedrick. *String stability of interconnected systems*. IEEE Transactions on Automatic Control, vol. 41, no. 3, pages 349–357, 1996. (Cited on pages 34 and 111.)
- [Swaroop 1999] D. Swaroop and K.R. Rajagopal. *Intelligent cruise control systems and traffic flow stability*. Transportation Research, Part C, vol. 7, no. 6, pages 329–352, 1999. (Cited on pages 98, 100, 110 and 112.)
- [Team 2008] The OGRE Team. *OGRE Manual Version 1.6*. 2008. (Cited on page 59.)
- [Thordarson 2008] Skuli Thordarson and Bjorn Olafsson. *Weather induced road accidents, winter maintenance and user information*. Transport Research Arena Europe 2008, 2008. (Cited on page 72.)
- [Tisseau 2001] J. Tisseau. *Réalité virtuelle: autonomie in virtuo*. PhD thesis, l’Université de Rennes 1, France, 2001. (Cited on pages 38 and 169.)
- [Tomizula 1993] M. Tomizula and JK Hedrick. *Automated vehicle control for IVHS systems*. In Proceedings of IFAC Conference, pages 109–112, Sydney, Australia, 1993. (Cited on page 26.)
- [Tony Churchill 2010] MSc Tony Churchill and dr. Yvette van Norden. *Relationships between road safety, safety measures and external factors*. 2010. (Cited on page 20.)



- [Treiber 2000] M. Treiber, A. Hennecke and D. Helbing. *Congested traffic states in empirical observations and microscopic simulations*. Physical Review E, vol. 62, pages 1805–1824, 2000. (Cited on page 101.)
- [UML ] UML. *UML homepage*. "<http://www.uml.org/>". Online; accessed 11-July-2012. (Cited on page 51.)
- [Unyelioglu 1997] Konur A. Unyelioglu, Cem Hatipoglu and Umit Ozguner. *Design and stability analysis of a lane following controller*. IEEE Transactions on Control Systems Technology, vol. 5, no. 1, pages 127–134, 1997. (Cited on page 130.)
- [Vahidi 2003] A. Vahidi and A. Eskandarian. *Research advances in intelligent collision avoidance and adaptive cruise control*. IEEE Transactions on Intelligent Transportation Systems, vol. 4, pages 143–152, 2003. (Cited on page 31.)
- [Versteden 2005] W. Versteden. *Improving a tyre model for motorcycle simulations*. Master’s thesis, Eindhoven University of Technology Department Mechanical Engineering Dynamics and Control Group, 2005. (Cited on page 84.)
- [Viti 2008] F. Viti, S. P. Hoogendoorn and T. P. Alkim. *Driving behavior interaction with ACC: Results from a field operational test in the netherlands*. In Proceedings of IEEE IV Symp, pages 745–750, 2008. (Cited on pages 34 and 143.)
- [Wang 2004a] J. Wang and R. Rajamani. *The impact of adaptive cruise control systems on highway safety and traffic flow*. Institution of Mechanical Engineers, Part D: Journal of Automobile Engineering, vol. 218, no. 2, pages 111–130, 2004. (Cited on page 100.)
- [Wang 2004b] J. Wang and R. Rajamani. *Should adaptive cruise-control systems be designed to maintain a constant time gap between vehicles?* IEEE Transactions on Vehicular Technology, vol. 53, no. 5, pages 1480–1490, 2004. (Cited on pages 100 and 114.)
- [Wang 2009] Fenghui Wang, Ming Yang and Ruqing Yang. *Conflict-probability-estimation-based overtaking for intelligent vehicles*. IEEE Transactions on Intelligent Transportation Systems, vol. 10, no. 2, pages 366–370, 2009. (Cited on page 141.)
- [Xiao 2010] Lingyun Xiao and Feng Gao. *A comprehensive review of the development of adaptive cruise control systems*. Vehicle System Dynamics, vol. 48, no. 10, pages 1167–1192, 2010. (Cited on pages 11, 31, 32 and 98.)
- [Xiao 2011] Lingyun Xiao and Feng gao. *Practical string stability of platoon of adaptive cruise control vehicles*. IEEE Transactions on Intelligent Transportation Systems, vol. 12, no. 4, pages 1184–1194, 2011. (Cited on pages 34 and 111.)

## Bibliography

---

- [Zhao 2010] Jin Zhao. *Contribution to intelligent vehicle platoon control*. PhD thesis, Ecole Centrale de Lille, France, 2010. (Cited on pages 7, 8, 34, 35, 58, 59, 87, 93, 101, 104, 110, 112, 116 and 145.)
- [Zhou 2005] Jing Zhou and Hui Peng. *Range policy of adaptive cruise control vehicles for improved flow stability and string stability*. IEEE Transactions on Intelligent Transportation Systems, vol. 6, no. 2, pages 229–237, 2005. (Cited on pages 111, 114 and 116.)



# Résumé étendu

Le transport a beaucoup contribué à la prospérité économique des 50 dernières années. Afin de répondre à la demande croissante du public et assurer la sécurité, beaucoup d'argent a donc été investi dans plusieurs domaines liés au transport, tels que l'infrastructure, la recherche, la politique, la collecte de données et les systèmes informatiques. Toutefois, le développement de transport s'accompagne également avec des risques : environ 1,3 million personnes dans le monde meurent sur les routes chaque année et entre 20 et 50 millions personnes subissent des blessures non mortelles. En même temps, le problème de congestion routière conduit à la perte du temps et de l'énergie et à la pollution environnementale, donc entraîne une perte économique non négligeable.

Pour améliorer la sécurité du transport et soulager la congestion routière, de nombreuses recherches ont été consacrées à ce domaine. En effet, comme montré dans Fig. 1, pendant la conduite, le conducteur se trouve intégré dans le processus "environnement-véhicule-conducteur". L'environnement routier comprend les infrastructures routières et les conditions météorologiques. En effet, sur ces trois facteurs intervenant dans un accident, le véhicule joue à hauteur de 10% à 12% souvent à cause du problème de performance ; l'environnement a, quant à lui, une responsabilité estimée entre 25% et 30% dû principalement aux mauvais temps ; et le comportement humain jusqu'à 90% qui est impacté par la vitesse de réaction, l'âge, l'expérience du conducteur, etc.

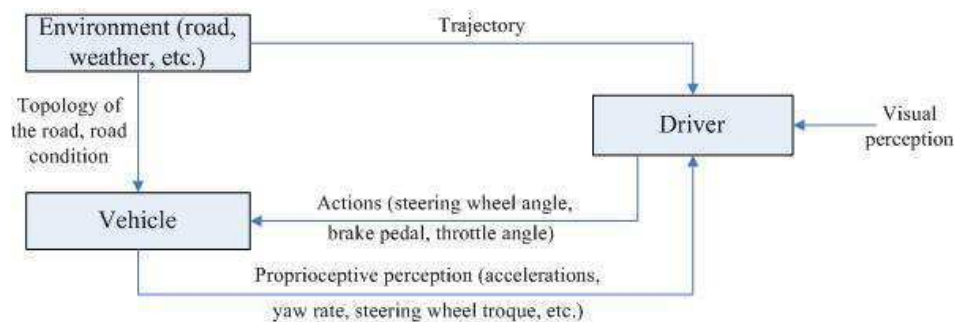

Figure 1: Le processus "environnement-véhicule-conducteur"

Il est clair que la raison principale dans les accidents routiers est le comportement humain, pour résoudre ce problème, les systèmes d'aide à la conduite ont été étudiés depuis quelque années par les chercheurs. Les systèmes d'aide à la conduite est un sujet de recherche très important dans le domaine des systèmes de transport intelligents (ITS), qui rassemblent les conducteurs, les véhicules et l'infrastructure dans une relation dynamique. L'objectif de l'ITS est de réduire le risque venant du comportement humain et finalement contribuer à la sécurité, l'efficacité du trafic et la préservation de l'environnement (voir Fig. 2). Le système d'aide à la conduite

est conçu pour agir de façon très approchée de celle du conducteur durant une tâche spécifique. Le conducteur obtient des informations du système d'aide à la conduite mais reste responsable des décisions de conduite.

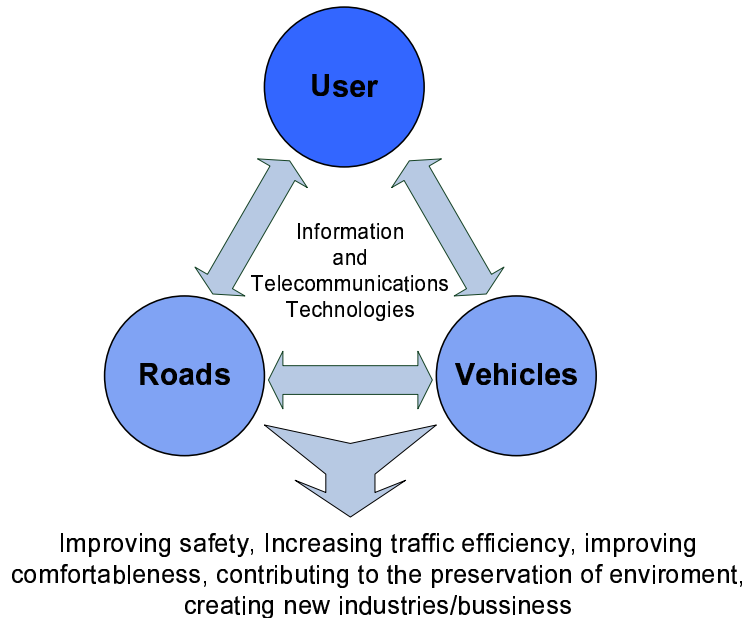

Figure 2: Systèmes de transport intelligents

Dans le domaine des systèmes d'aide à la conduite (ADAS), on peut distinguer trois niveaux de solution, du système le plus simple, uniquement informatif, au système plus complexe de prise en charge complète. Les systèmes du premier niveau s'appellent les systèmes informatifs qui peuvent sortir des signaux d'alerte, par exemple, le signal de détection d'obstacles. Les systèmes du deuxième niveau sont les systèmes actifs qui interviennent uniquement en cas de détection de danger, e.g. ABS (Anti-lock Braking System), il fonctionne dans la situation de freinage rapide. Et les systèmes du niveau le plus haut signifient les systèmes de contrôle automatique qui contribuent à la sécurité et le confort du conducteur, e.g. les régulateurs de vitesse adaptative. Quant à la vérification et la simulation des systèmes ADAS, d'après une bibliographie concernant ce domaine, on trouve qu'il existe deux moyens : premièrement la méthode de matériel, comme l'expérimentation avec une voiture d'essais et deuxièmement la méthode de logiciel, comme la simulation numérique ou la technologie de réalité virtuelle. Dans notre travail, on se concentre sur le deuxième moyen, la technologie de réalité virtuelle pour nous aider à résoudre certains problèmes de transport.

En effet, plusieurs définitions de réalité virtuelle ont été proposées par les chercheurs et on cite trois définitions classiques suivantes:

- 
1. *"VR is a way that allows humans to visualize, manipulate and interact with computers and extremely complex data [Aukstakalnis 1992]."*
  2. *"There are three basic components for VR: Immersion, Interaction and Imagination [Burdea 1993]."*
  3. *"VR is a universe of models in which everything happens as if the models were real because they offer the same triple mediation of senses, action and spirit [Tisseau 2001]."*

Selon les trois définitions précédents, il peut être résumé que la réalité virtuelle est une méthode qui nous permet d'interagir avec les objets dans un environnement virtuel en 3D avec le sentiment d'immersion.

Maintenant, la technologie de réalité virtuelle a beaucoup d'applications dans plusieurs domaines. Elle contribue à la visualisation des données et des phénomènes physiques. Elle peut aussi servir de formation, de prototypage virtuel et de démonstration virtuelle.

Inspiré par ce contexte scientifique, on propose donc une plateforme de réalité virtuelle pour les véhicules intelligents. Cette plateforme est conçue pour aider les utilisateurs sur deux aspects. Premièrement la conception des stratégies de commande et deuxièmement on peut simuler et analyser des algorithmes de commande proposés via non seulement des simulations classiques mais aussi des animations 3D dans un système de visualisation. En comparaison avec des expérimentations dans des véhicules d'essais, la plateforme proposée a plusieurs avantages, par exemple, elle permet de gagner du temps et de l'argent, elle a moins de danger, moins de pollution et elle montre les résultats en animation 3D comme dans le monde réel.

Après une phase de spécification du besoin, basé sur la méthode UML (Unified Modeling language), le diagramme des cas d'utilisation, le diagramme de classes, et le diagramme d'activité sont proposés pour décrire cette plateforme. La plateforme est divisée en trois sous-systèmes, un sous-système de commande de véhicules intelligents, qui comprend des contrôleurs et des modèles dynamiques de véhicules intelligents, un sous-système de visualisation qui nous montre des scénarios virtuels en 3D et un sous-système virtuel sans fil qui contribue à l'échange d'information en temps réel entre les deux sous-systèmes précédents.

La commande et la modélisation dynamique du véhicule intelligent sont réalisées sous le logiciel Matlab/Simulink. Le système de visualisation est développé en C++. On a réalisé l'échange d'informatique entre Matlab/Simulink et l'application C++ par la technologie COM. Par ailleurs, les utilisateurs peuvent communiquer avec le monde virtuel grâce à l'Interface Homme-Machine. En comparaison avec les autres plateformes similaires, la plateforme proposée a trois caractéristiques : elle est compatible avec un modèle Simulink, elle permet d'échanger des informations en temps réel, et elle permet de réaliser une simulation de conduite interactive.

Basé sur la plateforme IVVR, on intègre la modélisation et la simulation de l'environnement naturel pour qu'on puisse concevoir et simuler des algorithmes de commande sous différentes conditions environnementales. Un modèle conceptuel

de l'environnement naturel pour le système de véhicules intelligents est proposé et montré dans Fig. 3.

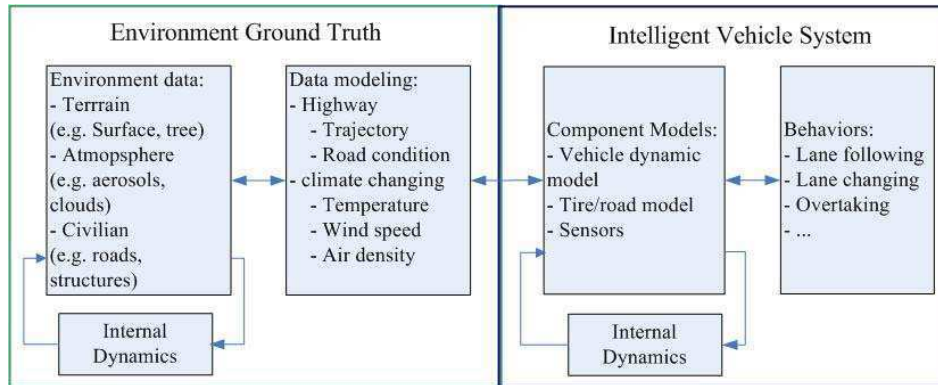

Figure 3: modèle conceptuel de l'environnement naturel pour le système de véhicules intelligents

Ensuite, basé sur le modèle conceptuel proposé, on établit un lien entre l'environnement naturel et les véhicules intelligents dans la plateforme IVVR: d'abord, on définit les feed-backs de VS à VICs comme les données de capteurs virtuels dans le monde virtuel. Et puis deux types de capteurs sont proposés, le capteur climatique et le capteur de relief. Les récepteurs sont les modèles dynamiques du véhicule ou les systèmes d'aide à la conduite. Dans notre travail, les modèles dynamiques du véhicule sont réalisés en prenant en compte des impacts environnementaux. Autrement dit, les récepteurs sont définis comme les fonctions des paramètres environnementaux, tels que, la température, la vitesse du vent, etc. Grâce au système de communication de la plateforme IVVR, les capteurs virtuels peuvent envoyer des informations environnementales aux récepteurs dans la simulation. Dans ce cas là, le comportement dynamique du véhicule sera impacté par la météo ou le relief.

Fig. 4 nous montre les capteurs virtuels, les récepteurs et les données de capteur virtuel qu'on réalise dans une simulation avec deux véhicules intelligents. On a défini 5 récepteurs et 7 capteurs virtuels.

La simulation de l'environnement naturel avec deux véhicules intelligents est effectuée dans la plateforme IVVR. L'objectif est de confirmer que les deux véhicules peuvent garder une distance sécuritaire même dans les conditions environnementales défavorables. Nous avons 4 types de météos: nuageux, pluvieux, neigeux et glacial. La trajectoire est composée de trois types de route : la route droite, la route courbe et la route inclinée. La vitesse du véhicule précédent varie en respectant la limite de la vitesse pour chaque type de route et le véhicule suivant est contrôlé par un système d'aide à la conduite. Selon les résultats, Nous pouvons savoir quand il fait beau, l'état de la route est bon, les deux véhicules ont réussi à garder une distance sécuritaire. Cependant, quand la route est glaciale, une collision a eu lieu entre les deux véhicules. D'après les résultats de la météo variée, nous pouvons savoir que la

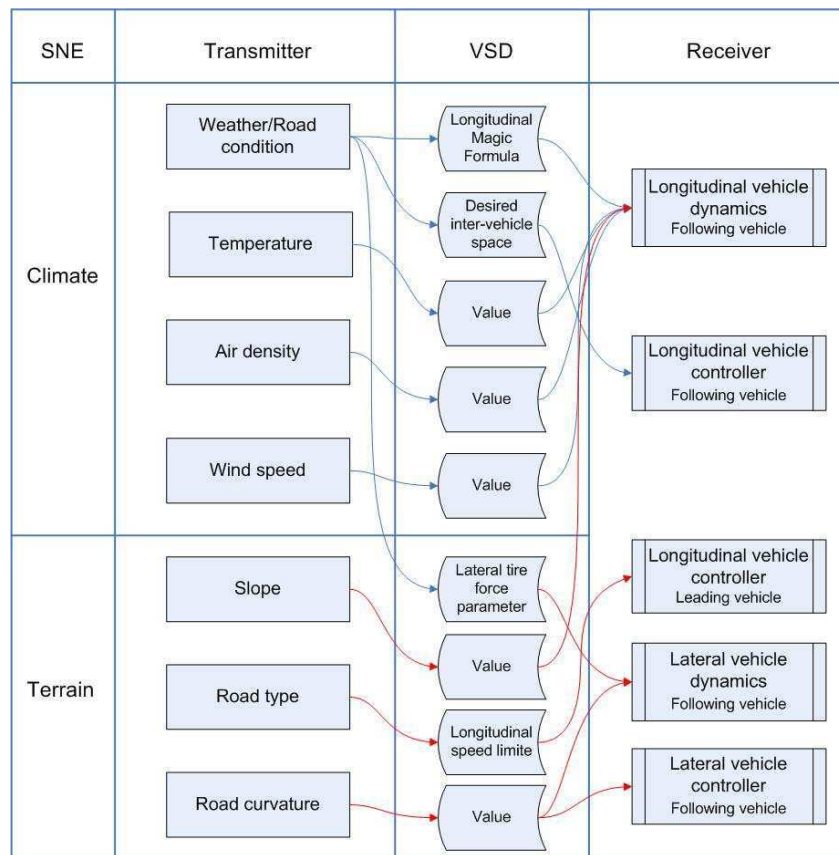

Figure 4: Système de transmission VSD



neige pourrait conduire à un accident imprévu.

Donc, pour résoudre ce problème, on propose un algorithme de commande innovant du régulateur de vitesse adaptative coopérative qui prend en compte les impacts de l'environnement naturel basé sur un modèle de trafic microscopique (Fig. 5).

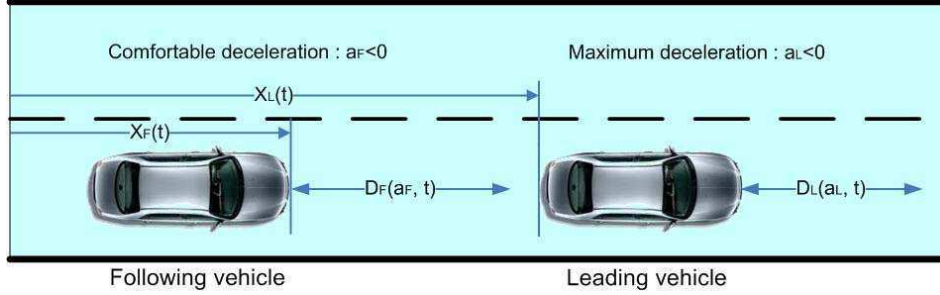

Figure 5: Modèle de trafic microscopique

Après avoir introduit trois paramètres environnementaux  $\lambda_T$ ,  $\lambda_{aF}$ ,  $\lambda_{aL}$ , le nouvel algorithme NECACC (natural environment based algorithm of cooperative adaptive cruise control) peut être exprimé par l'expression suivante ( $D_{s_{NE}}(t)$  est la distance inter-véhiculaire désirée;  $D_{min}$  est l'espace inter-véhiculaire minimum ;  $t_r$  est le temps de réaction du système CACC):

$$D_{s_{NE}}(t) = D_{min} + \lambda_T t_r \dot{x}_F(t) + \frac{1}{2\lambda_{aL} a_L} \dot{x}_L(t)^2 - \frac{1}{2\lambda_{aF} a_F} \dot{x}_F(t)^2$$

Quand on perd la communication avec le véhicule précédent, l'algorithme NECACC peut se dégrader à l'algorithme NEACC (dans ce cas là, on suppose que la vitesse des deux véhicules est la même):

$$D_{s_{NE}}(t) = D_{min} + \lambda_T t_r \dot{x}_F(t) + \left( \frac{1}{2\lambda_{aL} a_L} - \frac{1}{2\lambda_{aF} a_F} \right) \dot{x}_F(t)^2$$

La stratégie de commande pour l'algorithme NECACC est montrée dans Fig. 6. Les signaux environnementaux sont détectés premièrement pour savoir le type de la météo, et puis les trois paramètres prennent des valeurs différentes. Finalement, l'algorithme fonctionne et sort la décélération désirée. Les valeurs des trois paramètres ont été simulées dans la plateforme IVVR.

Pour appliquer la méthode proposée, il faut d'abord assurer la stabilité de la chaîne et la stabilité des flux de trafic. La stabilité de la chaîne signifie que les erreurs d'espacement n'amplifient pas quand ils se propagent vers la queue de la chaîne. Elle peut être exprimée par l'équation:

$$\left\| \hat{H}(s) = \delta_i(s) / \delta_{i-1}(s) \right\|_{\infty} \leq 1$$

Après le processus algébrique, nous pouvons avoir l'équation suivante ( $\tau$  est le décalage dans le temps et  $\Omega$  est le retard):

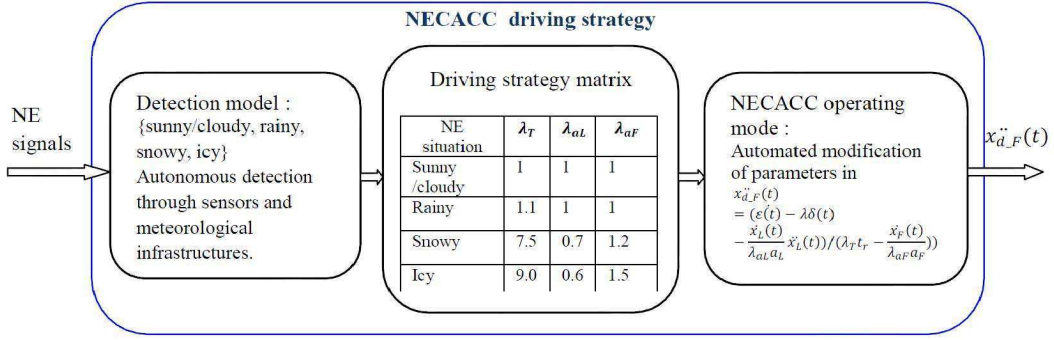

Figure 6: La stratégie de commande pour l’algorithme NECACC

$$\lambda_T t_r + \left( \frac{1}{\lambda_{aL} a_L} - \frac{1}{\lambda_{aF} a_F} \right) v_i > 2(\tau + \Omega)$$

Cette équation nous permet de déduire la limite de la vitesse pour chaque condition météorologique donnée tout en assurant la stabilité de la chaîne:

- Pour nuageux, la limite de  $v_i$  en assurant la stabilité de la chaîne est  $v_i \geq 2.35m/s$
- Pour pluvieux, la limite de  $v_i$  en assurant la stabilité de la chaîne est  $v_i \geq 2.12m/s$
- Pour neigeux, la limite de  $v_i$  en assurant la stabilité de la chaîne est  $v_i \leq 36m/s$
- Pour glacial, la limite de  $v_i$  en assurant la stabilité de la chaîne est  $v_i \leq 12.37m/s$

En ce qui concerne la stabilité de flux de trafic, elle signifie que les erreurs d’espacement n’amplifient pas quand ils se propagent vers la queue de la chaîne. On dit que le flux de trafic est stable, si l’équation  $\partial Q / \partial \rho > 0$  est soutenable.  $Q$  est le flux de trafic et  $\rho$  est la densité de trafic. Pour l’algorithme proposé NECACC, nous pouvons avoir l’expression de  $Q$  et  $\rho$ :

$$\rho = 1 / (L_{vehicle} + D_{sNE})$$

$$Q = \rho v = \rho \frac{-\lambda_T t_r + \sqrt{\lambda_t^2 t_r^2 - 2 \left( \frac{1}{\lambda_{aL} a_L} - \frac{1}{\lambda_{aF} a_F} \right) (L_{vehicle} + D_{min} - 1/\rho)}}{\frac{1}{\lambda_{aL} a_L} - \frac{1}{\lambda_{aF} a_F}}$$

Fig. 7 nous montre la région stable pour chaque type de météo et la valeur seuil de densité des véhicules sont remarquables

Pour mettre en évidence les avantages du nouvel algorithme NECACC, une simulation est effectuée en comparant avec l’algorithme classique LNACC en termes

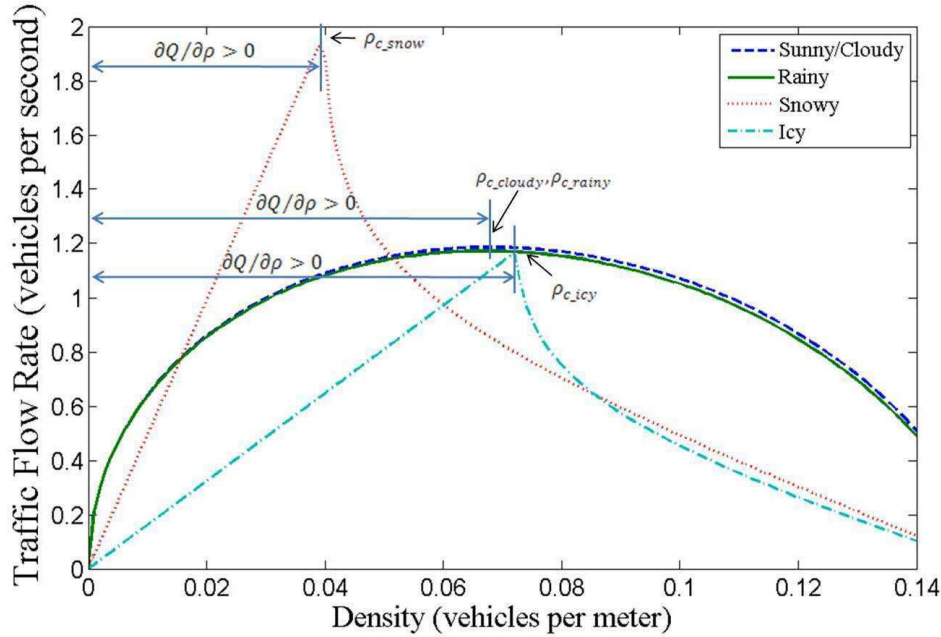

Figure 7:  $Q - \rho$  courbes pour NECACC/NEACC

de la sécurité et de capacité de trafic. La capacité de trafic est définie comme le nombre de véhicules qui peuvent circuler sur la même voie pendant une heure.

Dans la simulation, à part le véhicule précédent, il y a deux véhicules suivants qui ont les mêmes conditions initiales. L'un est équipé du système NECACC et l'autre est équipé du système LNACC. La structure de la simulation est décrite par Fig. 8. La vitesse du véhicule précédent est fixée à l'avance. Les deux véhicules suivants de différentes couleurs ont le même modèle dynamique et le même servo-contrôleur. Les trois véhicules envoient des données de mouvement au système de visualisation et les signaux environnementaux sont renvoyés au système de véhicules intelligents. Les utilisateurs peuvent contacter avec la simulation via l'Interface Homme-Machine.

D'abord, nous utilisons trois conditions environnementales fixées dans la simulation: de nuageux à pluvieux, de nuageux à neigeux et une partie de la route est gelé. Les résultats nous montrent que d'un point de vue de la sécurité, l'algorithme NECACC est plus sécuritaire pour le véhicule intelligent et d'un point de vue de la capacité de trafic, la circulation équipée du système NECACC est optimale.

Nous avons également fait une simulation avec l'utilisateur dans la boucle. C'est-à-dire, la condition environnementale ainsi que la vitesse du véhicule précédent sont contrôlés en temps réel par l'utilisateur. Dans ce cas là, l'environnement de la conduite est stochastique. Selon les résultats de la simulation, nous pouvons savoir que, dans les conditions environnementales complexes, l'algorithme proposé est meilleur que l'algorithme classique que ce soit en termes de sécurité ou de capacité de trafic.

Après des travaux dans le domaine du contrôle longitudinal, nous étudions égale-

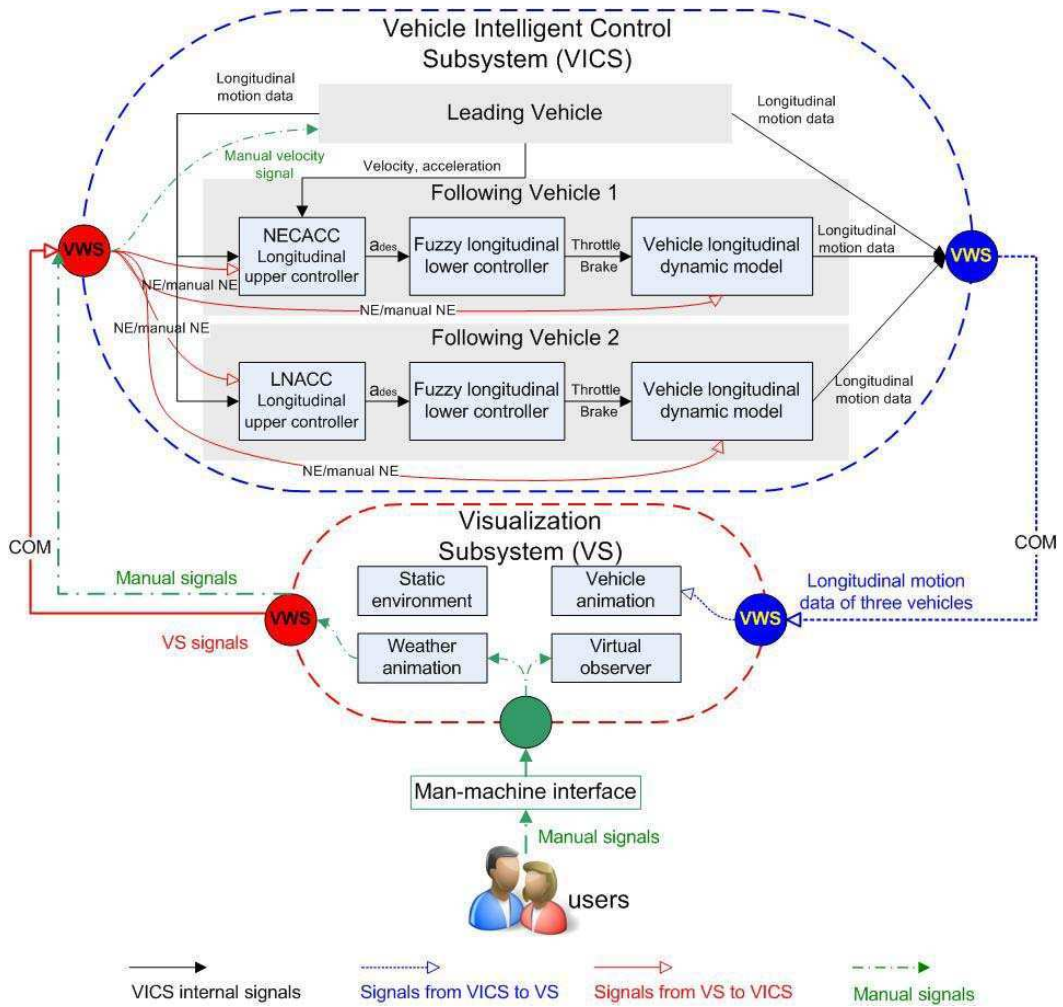

Figure 8: Architecture de la simulation

ment le contrôle latéral. Les démonstrations de trafic contrôlés par les systèmes de commande intégrés seront présentés sous diverses conditions environnementales.

Sur le manœuvre de circulation: le suivi de voie, on propose une stratégie de commande pour adapter aux diverses conditions environnementales. Cette stratégie a été simulée dans la plateforme IVVR. L'architecture de la simulation est illustrée dans Fig. 9.

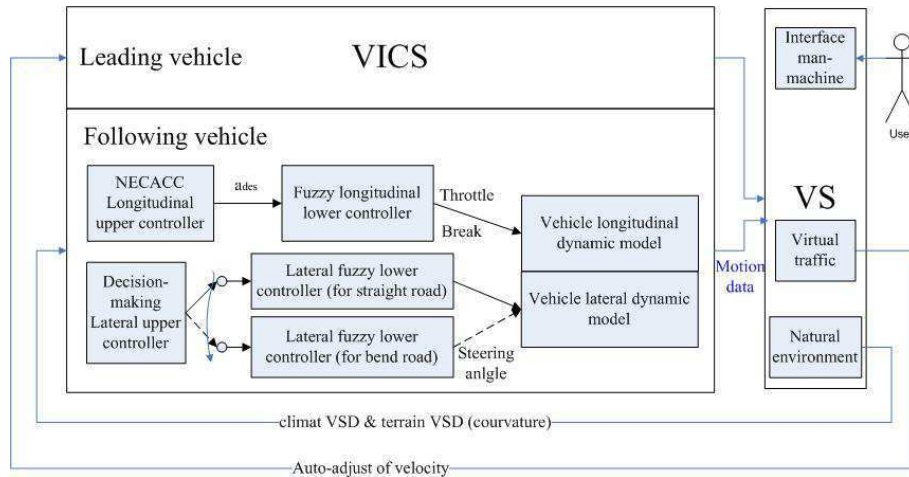

Figure 9: Architecture de la simulation pour le suivi de voie

Le contrôle longitudinal est réalisé par le système NECACC, on se concentre donc sur le contrôle latéral. On a un modèle de décision qui est en charge de choisir un contrôleur flou pertinent pour garder la voiture dans la voie droite ou dans la voie courbe. Son entrée est la courbure de la voie. Quand la courbure est supérieure à zéro, le modèle de décision choisit le contrôleur flou conçu pour la voie courbe, sinon, il choisit le contrôleur flou conçu pour la voie droite.

En ce qui concerne les contrôleurs flous, deux entrées et une sortie ont été définies: l'erreur latérale et l'erreur angulaire comme entrées et l'angle volant comme sortie. La différence entre le contrôleur flou conçu pour la voie rectiligne et le contrôleur flou conçu pour la voie courbe est la valeur désirée de l'angle volant. Pour la voie courbe, la valeur désirée de l'angle volant est 5,6 degrés mais pas zéro. Il faut noter que cette valeur est valable seulement dans l'environnement donné.

Les simulations concernant deux véhicules intelligents sur le suivi de voie sont effectués sous diverses conditions environnementales. La circulation est fluide et la sécurité entre les deux véhicules intelligents est toujours assurée.

Sur le changement de voie et le dépassement, 4 situations de changement de voie sont considérées. On suppose que le véhicule 1 et le véhicule 2 roulent sur deux voies différentes. Dans la première situation, le véhicule 1 a une vitesse inférieure, il effectue un changement de voie sans modifier sa vitesse et puis entre à l'arrière du véhicule 2. Dans la deuxième situation, le véhicule 1 a aussi une vitesse inférieure, mais il accélère pendant le changement de voie et puis il entre à l'avant du véhicule 2. Dans le

troisième cas, le véhicule 1 a une vitesse supérieure, et il garde sa vitesse pendant le changement de voie et puis entre à l'avant du véhicule 2. Dans le dernier cas, le véhicule 1 a une vitesse supérieure, mais il décélère quand il change de voie et il entre finalement à l'arrière du véhicule 2. Le dépassement peut être considéré comme une combinaison des deux changement de voie. Quand on effectue le dépassement, l'objectif peut être le maintien de la haute vitesse du véhicule, ou l'amélioration de la capacité de trafic. Dans notre travail, on se concentre sur la sécurité que le dépassement ou le changement de voie peut nous apporter. En effet, pour éviter une collision sur la route, il y a deux moyens. Premièrement, on peut diminuer la vitesse du véhicule suivant, et deuxièmement, on peut choisir le dépassement.

L'architecture de la simulation pour le changement de voie et le dépassement est illustrée dans Fig. 10.

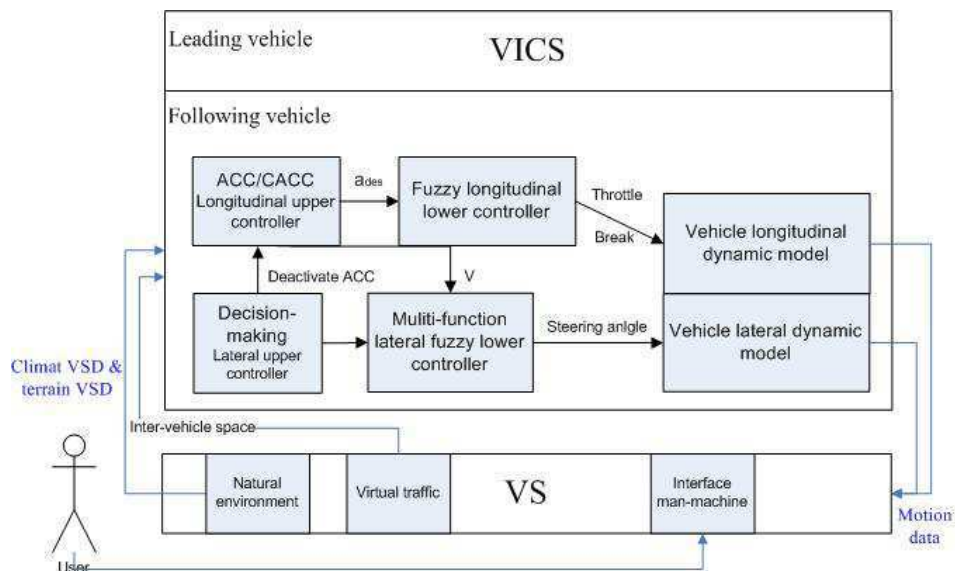

Figure 10: l'architecture de la Simulation pour changement de voie/dépassement

Sur le contrôle longitudinal du véhicule suivant, on utilise le système ACC classique. Dans ce cas là, si la condition météorologique est défavorable, le véhicule suivant ne pourrait pas toujours garder une distance sécuritaire avec le véhicule précédent. Dans ce cas, le dépassement ou le changement de voie pourrait être un bon choix pour éviter une collision imprévue. Sur le contrôle latéral pour le dépassement, un modèle de décision est en charge de décider le moment du changement de voie et un contrôleur flou effectue le comportement sont réalisés. Si la distance inter-véhiculaire est inférieure à la distance désirée, le véhicule suivant effectue le premier changement de voie pour quitter la voie original et continue à diminuer la vitesse. Ensuite, si l'espace inter-véhiculaire augmente et revient à la distance désirée, le véhicule suivant réalise encore une fois le changement de voie pour rentrer à la voie original à l'arrière du véhicule précédent, comme dans le quatrième cas du

changement de voie. Si la distance inter-véhiculaire continue à diminuer, le système ACC du véhicule suiveur serait arrêté et le véhicule suiveur va rentrer sur la voie originale à l'avant du véhicule précédent, comme dans le troisième cas.

Les simulations concernant le changement de voie et le dépassement sont exécutées dans la plateforme IVVR. Avec le météo de nuageux à neigeux, sur la route droite, le véhicule suiveur a effectué deux fois le changement de voie et finalement entre à l'arrière du véhicule précédent pour éviter un accident imprévu. D'après les résultats, nous pouvons savoir que le comportement des deux véhicules intelligents est stable. Quand il y a une partie de la route gelée, le véhicule suiveur a dépassé le véhicule précédent pour la sécurité grâce à la stratégie de commande proposée.

En conclusion, dans les travaux de thèse, premièrement, nous avons conçu et développé une plateforme de réalité virtuelle pour le pilotage de véhicules intelligents. Deuxièmement, nous avons réalisé la modélisation et la simulation de l'environnement naturel pour le système de véhicules intelligents basé sur la plateforme proposée. Troisièmement, un algorithme de commande innovant pour le régulateur de vitesse adaptative coopérative est présenté. Cet algorithme proposé peut aider les conducteurs à garder une distance inter-véhiculaire de sécurité même dans les conditions environnementales complexes ou défavorables. Enfin, les démonstrations du système de véhicules intelligents contrôlé par la commande intégrée proposée ont été réalisées sous diverses conditions environnementales.

En perspective, à court terme, on ira considérer plus d'éléments environnementaux pour améliorer la modélisation et la simulation de l'environnement naturel. Et puis, la stabilité sur la transition entre deux conditions environnementales dans l'algorithme proposé devrait être attestée. Enfin, les stratégies de commande sur la simulation du suivi de voie et du dépassement seraient également améliorées. A long terme, une plateforme distribuée de réalité virtuelle dans le domaine de transport intelligent serait développée et puis une plateforme de réalité augmentée serait aussi réalisée. Par ailleurs, le système de la communication parmi les ordinateurs ou entre l'ordinateur et les autres dispositifs seront très importants pour les plateformes futures.

## Virtual Reality Platform Design & Development for Intelligent Vehicles Control

**Abstract:** This thesis is dedicated to the interdisciplinary area of Intelligent Transportation Systems and Virtual Reality technologies. It focuses on the improvement of intelligent vehicles control strategies by considering the natural environment impacts as well as the visualization, the verification and performance analysis of proposed control algorithms on the proposed Intelligent Vehicles Virtual Reality (IVVR) platform.

The IVVR platform includes three subsystems: Vehicle Intelligent Control Subsystem, Visualization Subsystem and Virtual Wireless Subsystem. For realizing the control strategy simulation and performance analysis under complex natural environment conditions, Synthetic Natural Environment has been modeled and simulated in this IVVR platform. Therefore, experiments of Adaptive Cruise Control (ACC) or Cooperative ACC system equipped traffic are executed and show that normal ACC/CACC system fails to keep a safe inter-vehicle space when the natural environment condition is variable or adverse especially in stiff conditions. For solving this problem, we propose a new control algorithm called NECACC (Natural Environment based CACC) for longitudinal vehicle control in maintaining a safe inter-vehicle distance as well as guaranteeing an appropriate traffic capacity even under complex environmental conditions. This algorithm is then simulated and verified in IVVR platform as a "proof of concept". Finally, some virtual traffic demonstrations performing common traffic maneuvers are presented in IVVR platform under various environmental conditions. The vehicle platoon is controlled by proposed integrated control system and the safety can be ensured all the time.

**Keywords:** Intelligent transportation systems, Virtual reality, Synthetic natural environment, Cooperative adaptive cruise control, Intelligent control, Performance analysis.

## Conception & Développement d'une Plateforme en Réalité Virtuelle de Pilotage de Véhicules Intelligents

**Résumé:** Cette thèse est consacrée au domaine interdisciplinaire des Systèmes de Transport Intelligents et des technologies de Réalité Virtuelle. Elle se concentre sur l'amélioration des stratégies de commande des véhicules intelligents en tenant compte des impacts de l'environnement naturel ainsi que sur l'analyse de performance, la visualisation et la vérification de la validité des algorithmes de commande sur la plateforme de véhicules intelligents réalité virtuelle (IVVR).

La plateforme IVVR comprend trois sous-systèmes : un sous-système de commande de véhicules intelligents, un sous-système de visualisation et un sous-système virtuel sans fil. Le synthétique environnement naturel a été modélisé et simulé pour l'analyse de performance des stratégies de commande sous conditions environnementales complexes. Ensuite, les expérimentations concernant le trafic équipé du régulateur de vitesses adaptatives (ou coopératives) sont exécutés et ils montrent que les systèmes existants ont échoué à maintenir un espace inter-véhiculaire de sécurité lorsque les conditions d'environnement naturel sont défavorables. Dans ce cas, nous proposons un nouvel algorithme de commande appelé NECACC pour le contrôle longitudinal du véhicule en maintenant un espace inter-véhiculaire de sécurité et garantissant une capacité de circulation optimisée même dans des conditions environnementales complexes. Cet algorithme est ensuite simulé, vérifié et validé sur la plateforme IVVR. Enfin, les démonstrations de trafic virtuel effectuant des manœuvres communes de circulation contrôlées par les systèmes de commande intégrés proposées sont présentées sous diverses conditions environnementales.

**Mots-clés:** Systèmes de transport intelligents, Réalité virtuelle, Synthétique environnement naturel, Régulateur de vitesses adaptatives coopératives, Contrôle intelligent, Analyse de performances