



HAL
open science

Combinatorial methods in Teichmüller theory

Valentina Disarlo

► **To cite this version:**

Valentina Disarlo. Combinatorial methods in Teichmüller theory. Geometric Topology [math.GT]. Scuola Normale Superiore; Université de Strasbourg, 2013. English. ⟨NNT : 2013STRAD017⟩. ⟨tel-00875029⟩

HAL Id: tel-00875029

<https://theses.hal.science/tel-00875029v1>

Submitted on 20 Oct 2013

HAL is a multi-disciplinary open access archive for the deposit and dissemination of scientific research documents, whether they are published or not. The documents may come from teaching and research institutions in France or abroad, or from public or private research centers.

L'archive ouverte pluridisciplinaire **HAL**, est destinée au dépôt et à la diffusion de documents scientifiques de niveau recherche, publiés ou non, émanant des établissements d'enseignement et de recherche français ou étrangers, des laboratoires publics ou privés.



HAL Authorization

SCUOLA NORMALE SUPERIORE DI PISA
I.R.M.A. - UNIVERSITÉ DE STRASBOURG

PHD. THESIS
Combinatorial methods in Teichmüller theory

PHD. CANDIDATE:
Valentina Disarlo

ADVISOR:
Prof. Athanase Papadopoulos

CO-ADVISOR:
Prof. Carlo Petronio

2012/2013

Alla memoria di nonno 'Luccio (Lizzano, 1923–2007)
Ai lavoratori dell'industria pesante di Taranto.
A chi non si è venduto, a chi ha denunciato.

Aqua chètta caccia vierme.
L'acqua che stagna
imputridisce.

Detto popolare del Sud Italia

Achras - O mais c'est que, voyez-vous bien, je n'ai point sujet d'être mécontent de mes polyèdres, ils font des petits toutes les six semaines, c'est pire que des lapins. Et il est bien vrai de dire que les polyèdres réguliers sont les plus fidèles et les plus attachés à leur maître; sauf que l'Isocaèdre s'est révolté ce matin et que j'ai été forcé, voyez-vous bien, de lui flanquer une gifle sur chacune de ses faces. Et comme ça c'était compris. Et mon traité, voyez-vous bien, sur les mœurs des polyèdres qui s'avance: n'y a plus que vingt-cinq volumes à faire.

A. Jarry, *Ubu cocu*

Contents

Introduction	v
Version française abrégée	xv
Acknowledgements	xxi
1 Generalities	1
1.1 The mapping class group of a surface	1
1.2 Teichmüller and moduli spaces	4
1.3 Coarse geometry of metric spaces	5
2 Combinatorial rigidity of arc complexes	9
2.1 Introduction	9
2.2 Combinatorics of arc complexes	11
2.2.1 The arc complexes $A(S, \mathbf{p})$ and $A_{\mathbb{H}}(S, \mathbf{p})$	13
2.2.2 Intersection numbers	15
2.3 Proof of Theorem A	17
2.4 Proof of Theorem B	25
2.4.1 Examples in genus 0	25
2.4.2 Surfaces with one boundary component	28
2.4.3 The general case	39
2.5 Proof of Theorem C	40
3 The arc complex through the complex of domains	45
3.1 Introduction	45
3.2 The subcomplexes of $D(S)$	47
3.2.1 Subcomplexes of $D(S)$ containing $C(S)$	49
3.3 The arc complex $A(S)$	51
3.3.1 The boundary graph complex $A_B(S)$	51
3.3.2 $A_B(S)$ is quasi-isometric to $P_{\partial}(S)$	56
3.4 Application: the arc and curve complex	60

4	On the geometry of the ideal triangulation graph	63
4.1	Introduction	63
4.2	Generalities on $\mathcal{F}(S_{g,b}^n, \mathbf{p})$	66
4.2.1	The geometry of strata	68
4.3	Large-scale results on \mathcal{F}_g^n	73
4.3.1	The growth of $\text{diam. } \mathcal{M}\mathcal{F}_g^n$	73
4.3.2	On the coarse geometry of \mathcal{F}_g^n	76
4.4	The Thurston metric on $\text{Teich}(S_{g,b})$	79
4.4.1	Bounding distances	81
4.4.2	Regular surfaces and ideal triangulation graphs	84

List of Figures

1.1	$S_{g,b}^n$	1
1.2	A pants decomposition	2
1.3	The action of a Dehn twist	4
1.4	A δ -slim triangle	7
2.1	A 3-simplex in $A(S, \mathbf{p})$	13
2.2	Surfaces (upper line) and their arc complexes (lower line)	15
2.3	Remark 2.2.4	15
2.4	Cutting along v on S	18
2.5	A 3-leaf, a 3-petal and a 4-petal	19
2.6	Two edge-drops	19
2.7	An edge-bridge	20
2.8	Fans and chords	26
2.9	Annulus	27
2.10	$(S_{0,2}, (1, 2))$ and $A(S_{0,2}, (1, 2))$	28
2.11	a^-, a^+	29
2.12	Lemma 2.4.9	30
2.13	Lemma 2.4.9: case 1	30
2.14	Lemma 2.4.9: case 2	31
2.15	Lemma 2.4.9: case 3	31
2.16	Simplicial relations between $f^{-1}([b])$ and $f^{-1}([c])$	32
2.17	Lemma 2.4.10	34
2.18	Theorem 2.4.15	36
2.19	Lemma 2.4.16: two ways of flipping v in $\mu'_{\phi(c)}$	38
2.20	Step 1	41
2.21	Lemma 2.5.1	41
2.22	Lemma 2.5.2	42
2.23	Definition of $\tilde{\phi}_{\mathcal{E}}(\gamma)$	42
2.24	Definition of $\tilde{\phi}_{\mathcal{E}}(\delta)$	43
3.1	$C(S)$	48

3.2	$A(S)$	48
3.3	$A_B(S)$	52
3.4	Lemma 3.3.2 (a)	53
3.5	Lemma 3.3.2 (b)	54
3.6	Lemma 3.3.2	54
3.7	Lemma 3.3.2 (a)	54
3.8	Lemma 3.3.2 (b)	54
3.9	Lemma 3.3.2 (c)	55
3.10	Lemma 3.3.2 (a)	55
3.11	Lemma 3.3.2 (b)	55
3.12	Lemma 3.3.2 (c)	55
3.13	Lemma 3.3.2	56
3.14	P biperipheral	56
3.15	Theorem 3.3.6	59
4.1	A flip movement in S_g^n	67
4.2	A flip movement in $S_{g,b}$	67
4.3	Triangulations of S_1^1 and the Farey tessellation of \mathbb{H}^2	68
4.4	comb_α and cut_α	70
4.5	Lemma 4.2.11	72
4.6	Lemma 4.2.11	72
4.7	Lemma 4.2.11	72
4.8	Example	74
4.9	$\mathcal{C}(T)$	75
4.10	Example	77
4.11	A marked right-angled geodesic hexagon	81
4.12	O^W and O^T	86

Introduction

Teichmüller and moduli spaces of a surface S are deformation spaces of hyperbolic metrics on S . The *moduli space* of S is the space of all the isometry classes of complete hyperbolic metrics on S . The *Teichmüller space* of S is the space of all *marked* hyperbolic structures on S . The moduli space is the quotient of Teichmüller space under the *mapping class group*, the group of orientation-preserving homeomorphisms of the surface up to isotopy. Teichmüller space can be endowed with several metrics invariant under the action of the mapping class group, that naturally descend to the moduli space and measure deformation in different ways.

An interesting trend of research is the study and the comparison of different geometric features of Teichmüller and moduli space of S through suitable combinatorial models, built from topological objects on S . In this thesis we will study the geometric properties of some models built from the combinatorics of arcs on a surface with boundary S and their relation with the Teichmüller space of S .

Historical overview

The parametrization of the complex structures on a given topological surface of finite type is a problem that dates back to Riemann. The *Teichmüller space* of a surface of finite type was defined by Oswald Teichmüller in the 1940's, and the study of its complex and real-analytic structure was further developed by the Alfhors-Bers school in the subsequent two decades. By the uniformization theorem, Teichmüller space can be equivalently defined as the space of the marked hyperbolic/conformal/complex structures on the surface up to homotopy. Forgetting the marking one defines a map from Teichmüller space to Riemann's moduli space, and the latter can be equivalently defined as the quotient of Teichmüller space under the action of the *mapping class group* of the surface.

From the topological point of view, Teichmüller space is an open cell whose dimension depends on the topological data of the base surface. It has

a real-analytic and a complex structure. In the 1980's Thurston enriched the theory by importing in it beautiful techniques from low-dimensional topology and hyperbolic geometry. He provided new coordinates and a compactification on which the mapping class group acts continuously. This action proves also crucial in the so-called *Nielsen-Thurston classification* of the elements of the mapping class group.

Teichmüller space can be endowed with many natural different metrics that descend to the moduli space. Many open problems deal with the geometric properties of these metrics, the geometry of the subgroups of the mapping class group and their interplay.

Combinatorics of essential curves and arcs is crucial in the hyperbolic approach to this theory, in particular in the definition of Thurston's boundary of Teichmüller space.

The combinatorics of arcs and curves has also proved useful in the study of the mapping class group from the homological and coarse point of view. In fact, one can encode the combinatorics of arcs or curves into appropriate infinite simplicial complexes, and it turns out that the mapping class group naturally acts by automorphisms on these complexes. In the 1980's the study of this action lead to important results concerning the homological properties of the mapping class group (Harer) and to the first explicit finite presentation of the group, the so-called *Hatcher-Thurston presentation*. In the last decade, research has been more concerned with the coarse geometric properties of the mapping class group and its subgroups, which was again investigated by means of the action on some complex. In many cases, the coarse geometry type of the complexes used is considered itself of independent interest: this is the case of the curve and the pants graphs, built respectively from the combinatorics of curves and pants decompositions. By a result of Masur-Minsky in 2000, the curve complex "mimics" Teichmüller space equipped with the Teichmüller metric. By a result of Brock in 2007, the pants graph is quasi-isometric to Teichmüller space equipped with the Weil-Peterson metric. Research on the coarse modeling of Teichmüller space with its distances is still on-going.

In the setting of punctured/bordered surfaces it is natural to deal with arcs instead of curves. The *arc complex* of a punctured/bordered surface is a simplicial complex whose k -simplices correspond to the collections of $(k + 1)$ homotopy classes of arcs that can be realized in a disjoint fashion on the surface. The arc complex was introduced by Harer in the 1970's as tool to study the homology of the mapping class group. In the 1980's Bowditch-Epstein and Penner used an appropriate quotient of this complex in order to define a combinatorial compactification of the moduli space. Combinatorics of arcs and triangulations on a surface proves also crucial in Penner's

decorated Teichmüller theory, developed in the 1990's. The coarse geometry of the arc complex and some of its subcomplexes has been investigated by Masur-Schleimer in 2013.

Overview of the main results

In this thesis we will deal with combinatorial and geometric properties of arc complexes and triangulation graphs, and we will provide some applications to the Teichmüller theory of a bordered surface equipped with Thurston's distance.

In this section we will give a quick overview of the main results we have obtained. The thesis is divided into two parts. In the former we deal with the problem of combinatorial rigidity of arc complexes. In the latter we study some large-scale properties of the arc complex and the 1-skeleton of its dual, called the *ideal triangulation graph*.

Combinatorial rigidity of arc complexes

The *arc complex* of a surface with marked points is a simplicial complex whose vertices are the homotopy classes of essential arcs based on the marked points, and n vertices span a $n + 1$ simplex if they can be simultaneously realized in a disjoint fashion.

It was introduced by Harer [27; 28]. Its topology and simplicial structure proves crucial for the definition of a combinatorial compactification of the moduli space (see Bowditch-Epstein [7] and Penner [55; 57]) and for Penner's decorated Teichmüller theory [61].

In Chapter 2 we deal with the arc complex of a surface with marked points on their boundary and in their interior. Surfaces of this type were first studied in the founding paper by Oswald Teichmüller [66; 65]. They are also called *ciliated surfaces* in the works of Fock-Goncharov [22; 21]. Hatcher [30] studied some of their basic topological features, *i.e.*, their connectedness and homotopy type. Penner [60; 58] studied their quotient under the action of the mapping class group and their relation with the (decorated) moduli space of a surface with boundary.

We will be concerned with the problem of *combinatorial rigidity* of the arc complex of a surface with boundary and marked points on the boundary and in the interior: the mapping class group naturally acts on it by simplicial automorphisms, and we say that the arc complex is *rigid* if this action is rigid, that is, it has no other automorphism besides those coming from the mapping class group of the surface.

We denote by $(S_{g,b}^s, \mathbf{p})$ an orientable surface of genus g with $b > 0$ boundary components, $p_i \geq 1$ marked points on the i -th boundary component with $\mathbf{p} = (p_1, \dots, p_b)$, and $s \geq 0$ marked points in the interior, it has finite dimension $6g + 3b + 3s + |\mathbf{p}| - 7$. The *arc complex* $A(S_{g,b}^s, \mathbf{p})$ is the simplicial complex whose vertices are the homotopy classes of essential arcs based at the marked points, and $n + 1$ vertices span a n simplex if they can be simultaneously realized in a disjoint fashion, its dimension is finite and equal to $6g + 3b + 2s + \mathbf{p} - 7$. The *pure arc complex* $A_{\#}(S_{g,b}^s, \mathbf{p})$ is the subcomplex spanned by the arcs based only at the marked points on the boundary of the surface. The mapping class group $\text{MCG}(S_{g,b}^s, \mathbf{p})$ acts on $A(S_{g,b}^s, \mathbf{p})$ and $A_{\#}(S_{g,b}^s, \mathbf{p})$ simplicially. We denote by $\text{Aut}(A_{\#}(S_{g,b}^s, \mathbf{p}))$, $\text{Aut}(A(S_{g,b}^s, \mathbf{p}))$ their simplicial automorphism groups of the complexes. The main results we will prove are the following:

Theorem. *If $\dim A(S_{g,b}^s, \mathbf{p}) \geq 2$ and $A(S_{g,b}^s, \mathbf{p})$ is isomorphic to $A(S_{g',b'}^{s'}, \mathbf{p}')$ then $s = s'$, $b = b'$, $g = g'$ and $p_i = p'_i$ for all i (up to reordering).*

Theorem. *If $\dim A(S_{g,b}^s, \mathbf{p}) \geq 2$ then $A(S_{g,b}^s, \mathbf{p})$ is rigid.*

Theorem. *If $\dim A_{\#}(S_{g,b}^s, \mathbf{p}) \geq 2$ then $A_{\#}(S_{g,b}^s, \mathbf{p})$ is rigid.*

We will also list and study the cases not satisfying the assumptions of these results. A rigidity theorem for the curve complex of a punctured surface similar to our results was first stated by Ivanov [34] for surfaces of genus greater than 1, then proved in genus 0 and 1 (except for the 2-punctured torus) by Korkmaz [36], and finally reproved in full generality by Luo [42]. Applications of the result include a new proof of Royden's theorem on the isometries of the Teichmüller space of a punctured surface and the study of finite-index subgroups of the mapping class group (see for instance [34; 33]).

More rigidity properties of natural simplicial complexes associated to a surface have been investigated in the past by many different authors; a survey of known results and their applications can be found in [48]. Most of the proofs are based on a (non-trivial) reduction to the rigidity theorem of the curve complex. Our proof for arc complexes does not employ any previously known rigidity result.

Large-scale properties of arc complexes

In the second part of the thesis we will deal with the large-scale behaviour of the arc complex by putting it in relation with the coarse geometry of the so-called *complex of domains*, and we will study the geometry of the *ideal triangulation graph* and its connection with the *Thurston metric* on the Teichmüller space of a surface with boundary.

On the coarse geometry of the complex of domains Let $S_{g,b}$ an orientable surface of genus g with b boundary components. The *curve complex* $C(S_{g,b})$ is the simplicial complex whose vertices are the homotopy classes of essential simple closed curves, and n vertices span a $n+1$ simplex if they can be simultaneously realized in a disjoint fashion. It was introduced by Harvey [29] as a tool for the study of the boundary of Teichmüller space. When $b > 0$, one can similarly define the *arc complex* $A(S_{g,b})$, *i.e.*, the simplicial complex whose vertices are the homotopy classes of essential arcs based on $\partial S_{g,b}$, and n vertices span a $n+1$ simplex if they can be simultaneously realized in a disjoint fashion. This complex was introduced by Harer [27; 28] in his works on the homological properties of the mapping class group. The *arc and curve complex* $AC(S_{g,b})$ is defined similarly, its vertices are those of $C(S_{g,b})$ union those of $A(S_{g,b})$, and the n -simplices are the collections of $n+1$ vertices that can be realized in a disjoint fashion. The complex $AC(S_{g,b})$ was studied by Hatcher [30], who proved that it contractible.

All the complexes just defined and those introduced below will be endowed with the length metric such that every simplex is Euclidean with edges of length 1. The coarse geometric properties of the curve complex were first studied by Masur-Minsky [46; 47], who proved that $C(S_{g,b})$ has infinite diameter, it is Gromov-hyperbolic and “mimics” Teichmüller space with the Teichmüller distance. Klarreich [35] proved that the Gromov-boundary of $C(S_{g,b})$ is the space of the ending laminations. Korkmaz-Papadopoulos [37] and Masur-Schleimer [45] proved that $AC(S_{g,b})$ is quasi-isometric to $C(S_{g,b})$. Masur-Schleimer [45] also studied the coarse type of some subcomplexes of $AC(S_{g,b})$, proving that $A(S_{g,b})$ is Gromov-hyperbolic as well.

In Chapter 3 we will deal with the coarse geometry of some sort of “generalized” curve complex, the so-called *complex of domains* $D(S_{g,b})$. A *domain* D in $S_{g,b}$ is a connected subsurface of $S_{g,b}$ such that each boundary component of ∂D is a boundary component of $S_{g,b}$ or an essential curve in $S_{g,b}$. Pairs of pants and essential annuli are examples of domains. The complex of domains $D(S_{g,b})$, introduced by McCarthy-Papadopoulos [48], is defined as usual: for $n \geq 0$, a n -simplex is a collection of $n+1$ non-homotopic domains in $S_{g,b}$. By identifying the homotopy class of a curve with its regular neighborhood, $C(S_{g,b})$ can be naturally considered a subcomplex of $D(S_{g,b})$. We will prove the following results:

Theorem. *If Δ is a connected subcomplex of $D(S_{g,b})$ that contains $C(S_{g,b})$ then the inclusion $C(S_{g,b}) \hookrightarrow \Delta$ is an isometric embedding and a quasi-isometry.*

Theorem. *If $b \geq 3$ and $(g,b) \neq (0,4)$, the following holds:*

1. $A(S_{g,b})$ is quasi-isometric to the subcomplex $P_\delta(S_{g,b})$ of $D(S_{g,b})$, whose vertices are the peripheral pairs of pants.
2. if $g = 0$ then the inclusion $P_\delta(S_{g,b}) \hookrightarrow D(S_{g,b})$ is an isometric embedding and a quasi-isometry.
3. if $g \geq 1$ then the inclusion $P_\delta(S_{g,b}) \hookrightarrow D(S_{g,b})$ has a 2-dense image in $D(S_{g,b})$, but it is not a quasi-isometric embedding.

From the theorem just stated we deduce a new proof of the following result, contained in [37] and [45]:

Corollary. *If $b \geq 3$ and $(g, b) \neq (0, 3)$ then the following holds:*

1. $AC(S_{g,b})$ is quasi-isometric to $C(S_{g,b})$.
2. for $g = 0$ the inclusion $A(S_{g,b}) \hookrightarrow AC(S_{g,b})$ is a quasi-isometry, while for $g \geq 1$ it is not a quasi-isometric embedding.

The geometry of ideal triangulation graphs Ideal triangulations are used in the work of Thurston [68], and in particular they prove crucial for the construction of the Thurston-Bonahon-Fock-Penner *shear coordinates* [68; 22; 4; 55] on the Teichmüller space of a punctured surface. In Chapter 4 we will describe the results of a joint project with Hugo Parlier concerning the *ideal triangulation graph* and its geometry.

Let S_g^n be an orientable surface of genus g with $n > 0$ marked points. The *ideal triangulation graph* \mathcal{F}_g^n of S_g^n is the 1-skeleton of the dual of the arc complex $A(S_g^n)$. In practice, it can be defined as follows: each ideal triangulation of S_g^n defines a vertex of \mathcal{F}_g^n , and two vertices are joined by an edge if the two corresponding triangulations differ by a *flip*, *i.e.*, by the replacement of one diagonal of a quadrilateral by the other diagonal. We consider the graph endowed with the length metric where edges have length 1. This definition can be adapted with little effort to a surface with boundary $S_{g,b}$, using hexagonal decompositions instead of triangulations, and the resulting graph $\mathcal{F}_{g,b}$ is naturally isomorphic to \mathcal{F}_g^b .

The ideal triangulation graph \mathcal{F}_g^n has a natural stratification, where each stratum \mathcal{F}_σ is associated to a simplex σ of $A(S_{g,b}^n, \mathbf{p})$, and \mathcal{F}_σ is the subgraph of \mathcal{F}_g^n whose vertices are the triangulations of S_g^n that contain all the arcs in σ . Our first result about the ideal triangulation graph concerns the geometry of these strata:

Theorem. *For every simplex σ in $A(S_g^n)$, the stratum \mathcal{F}_σ is convex in \mathcal{F}_g^n .*

Turning to our next topic, we recall that the action of the mapping class group on \mathcal{F}_g^n is cocompact, and we denote by $\mathcal{M}\mathcal{F}_g^n$ the quotient. We will there determine the growth rate of $\mathcal{M}\mathcal{F}_g^n$ with respect to n by showing the following result in the same spirit of Sleator-Tarjan-Thurston [63] for planar surfaces:

Theorem.

$$\limsup_{n \rightarrow +\infty} \frac{\text{diam. } \mathcal{M}\mathcal{F}_g^n}{|\chi(S_g^n)| \log |\chi(S_g^n)|} < +\infty.$$

It is worth mentioning that the results of Sleator-Tarjan-Thurston on the triangulations of planar surfaces [63; 64] motivated a wealth of research in theoretical computer science and computational geometry. In these fields the ideal triangulation graph is called *flip graph* (see [25]). The algorithmic description of a geodesic, the exact computation of the flip distance between two vertices of the flip graph or some closely related graphs remain open problems (see the surveys [5; 6]).

The ideal triangulation graph can be viewed as the analogue for a surface with marked points of the pants graph for a closed surface. The large scale properties of this last graph are themselves of independent interest, since Brock [11] proved that it is quasi-isometric to the Teichmüller space with the Weil-Petersson distance. Results on the geometric properties of its subgraphs were obtained by Aramayona-Parlier-Shackleton [1; 2]. Some results on the diameter of the quotient of the pants graph under the action of the mapping class group and of some slight modifications were first obtained by Cavendish [12] and they were crucial in the work of Cavendish-Parlier [13] on the growth of the Weil-Petersson diameter of the moduli space. The study of the growth of the pants graph, completed by Rafi-Tao [62], has also proved useful in their study of the growth of the Teichmüller and the Thurston diameter of the thick part of the moduli space of a punctured surface.

The coarse geometry type of the ideal triangulation graph \mathcal{F}_g^n is itself of independent interest. Korkmaz-Papadopoulos [37] studied its automorphism group and they also proved that the action of the mapping class group on \mathcal{F}_g^n is proper and cocompact, hence this graph naturally gives a coarse model for the mapping class group. Different coarse models were provided by Masur-Minsky [47] and Hamenstädt [26]. We refine the result of Korkmaz-Papadopoulos [37] as follows:

Theorem. *If $\chi(S_g^n) < 0$ and $(g, n) \neq (0, 3)$ then the following holds:*

1. *For every vertex T of \mathcal{F}_g^n the map*

$$\begin{aligned} q_{g,n} : \text{MCG}(S_g^n) &\rightarrow \mathcal{F}_g^n \\ g &\mapsto gT \end{aligned}$$

is a $(k_{qg,n}, 1)$ -quasi-isometry for some $k_{qg,n}$, with $k_{qg,n} \leq C \cdot |\chi(S_g^n)| \log |\chi(S_g^n)|$ as n tends to $+\infty$.

2. For every simplex σ in $A(S_g^n)$ and for every vertex T of \mathcal{F}_σ , if $\text{Stab}(\sigma)$ denotes the stabilizer of σ in $\text{MCG}(S_g^n)$, the map

$$\begin{aligned} \text{Stab}(\sigma) &\rightarrow \mathcal{F}_\sigma \\ g &\mapsto gT \end{aligned}$$

is a quasi-isometry, and $\text{Stab}(\sigma)$ is an undistorted subgroup of $\text{MCG}(S_g^n)$.

An assertion analogous to the second one of the previous statement was proved for the stabilizers of the simplices in the curve complex by Masur-Minsky [47] and Hamenstädt [26].

We will also deal with some application of the ideal triangulation graph to the Teichmüller theory of surfaces with boundary. In our study, we will endow $\text{Teich}(S_{g,b})$ with the *Thurston asymmetric distance*. This distance was introduced by Thurston [67] in the context of closed and punctured surfaces as the “hyperbolic analogue” of the Teichmüller distance. Its topology was studied by Papadopoulos-Théret [52]. A first comparison between the Teichmüller and the Thurston distance on the Teichmüller space of a punctured surface is due to Choi-Rafi [14]. A study of the asymptotic growth of the Thurston diameter of the moduli space is due to Rafi-Tao [62]. The generalization of Thurston’s distance to the setting of surfaces with boundary has been studied by Papadopoulos-Théret-Liu-Su (see for instance [54; 53; 41; 40; 39]).

Let $H = (t_1, \dots, t_{6g+3b-6})$ be a maximal set of disjoint essential arcs on $S_{g,b}$, i.e. a hexagonal decomposition of $S_{g,b}$. It is well-known that for all $\mathcal{A} \in \mathbb{R}_{>0}^{6g+3b-6}$ there exists a unique hyperbolic metric $X_{(H,\mathcal{A})}$ on $S_{g,b}$ such that the length of t_i with respect to $X_{(H,\mathcal{A})}$ is \mathcal{A}_i . Moreover, $\mathbb{R}_{>0} \ni \mathcal{A} \rightarrow X_{(H,\mathcal{A})} \in \text{Teich}(S_{g,b})$ is a bijection (i.e., a parametrization of Teichmüller space). We will prove the following:

Proposition. *Assume $L > 0$ and $k > 1$. Set $\mathcal{A}_1 = (L, \dots, L) \in \mathbb{R}^{6g+3b-6}$ and $\mathcal{A}_k = k\mathcal{A}_1 = (kL, \dots, kL) \in \mathbb{R}^{6g+3b-6}$. For any vertex T of $\mathcal{F}_{g,b}$ we have:*

$$d(X_{(T,\mathcal{A}_1)}, X_{(T,\mathcal{A}_k)}) = \log k.$$

In other words, the line $\mathbb{R} \ni t \mapsto X_{(T,e^t\mathcal{A}_1)} \in \text{Teich}(S_{g,b})$ is a forward geodesic with respect to the Thurston metric.

We say that a hyperbolic metric X on $S_{g,b}$ is *L-regular* if there exists a hexagonal decomposition H of $S_{g,b}$ such that $X = X_{(H,(L,\dots,L))}$. Let $\mathcal{R}_{g,b}^L$ be the set of the *L-regular* metrics on $S_{g,b}$ and $\mathcal{M}\mathcal{R}_{g,b}^L$ be its quotient under the

action of the mapping class group. We will use \mathcal{F}_g^b in order to give a bound with respect to b on the growth of the diameter of $\mathcal{MR}_{g,b}^L$ in the moduli space $\mathcal{M}(S_{g,b})$ with respect to b :

Theorem. *For all $L > 0$, the surjective map:*

$$\begin{aligned} \mathcal{F}_{g,b}^{(0)} &\rightarrow \mathcal{R}_{g,b}^L \subseteq \text{Teich}(S_{g,b}) \\ T &\mapsto X_{(T,(L,\dots,L))} \end{aligned}$$

is a Lipschitz map with constant $K(L)$ that does not depend on g and b . Furthermore

$$\limsup_{b \rightarrow +\infty} \frac{\text{diam}(\mathcal{MR}_{g,b}^L)}{|\chi(S_{g,b})| \log |\chi(S_{g,b})|} \leq K(L).$$

Structure of the thesis

This thesis is organized as follows:

- in Chapter 1 we recall some well-known results about the Teichmüller space, the moduli space, and the mapping class group;
- in Chapter 2 we deal with the combinatorial rigidity of arc complexes;
- in Chapter 3 we deal with the coarse geometry of the complex of domains;
- in Chapter 4 we study the geometry of the ideal triangulation graphs.

Version française abrégée

Les espaces de Teichmüller et de modules d'une surface de type fini peuvent être décrits comme des espaces de paramètres (ou des espaces de déformations) des métriques hyperboliques dont on peut munir une surface.

L'*espace de modules* d'une surface de type fini est l'espace des ses classes d'isométries de ses métriques hyperboliques. L'espace de Teichmüller est l'espace des ses structures hyperboliques *marquées*.

Il s'agit de deux espaces topologiques dont la topologie décrit les déformations. L'espace de modules d'une surface est le quotient de l'espace de Teichmüller sous l'action du groupe modulaire, c'est-à-dire le groupe des homéomorphismes de la surface à isotopie près.

L'espace de Teichmüller admet plusieurs métriques invariantes sous l'action du groupe modulaire; celles-ci descendent naturellement à l'espace des modules et offrent plusieurs manières de mesurer les déformations. Une tendance intéressante dans ce domaine de recherche est d'étudier ou de comparer les différentes propriétés géométriques des espaces de modules et de Teichmüller grâce à des modèles combinatoires adaptés, construits à partir d'objets topologiques sur la surface de base.

Dans cette thèse, nous étudions les *complexes des arcs*, c'est-à-dire des modèles provenant de la combinatoire des arcs sur la surface ainsi que leurs relations avec l'espace de Teichmüller des surfaces à bords.

Survol des résultats principaux

Nous donnons ici un rapide survol des résultats principaux obtenus dans cette thèse. Elle se compose de deux parties, correspondant à nos deux axes principaux de recherche. La première partie traite du problème de la rigidité combinatoire d'une certaine famille des complexes d'arcs. La deuxième partie traite des propriétés à grande échelle du complexe des arcs.

Rigidité combinatoire du complexe des arcs

L'un des résultats les plus intéressants à propos du complexe des courbes est la rigidité de l'action du groupe modulaire sur ce complexe. Elle signifie que, mis à part pour quelques surfaces exceptionnelles, le groupe des automorphismes de ce complexe est précisément le groupe modulaire. Ce résultat a été dégagé par Ivanov en genre ≥ 2 , démontré en genre 0 et 1 par Korkmaz, puis de nouveau en toute généralité par Luo. Un tel résultat a en particulier été utilisé par Ivanov pour donner une nouvelle démonstration de l'important résultat de Royden qui énonce que le groupe modulaire est le groupe des isométries de l'espace de Teichmüller pour la métrique de Teichmüller. Il existe une vaste littérature de résultats de rigidité pour des complexes simpliciaux similaires construits à partir de surfaces (un premier survol de ces résultats et leurs applications est due à McCarthy-Papadopoulos).

Dans la première partie de cette thèse, nous traitons du problème de la rigidité combinatoire du complexe des arcs dans le contexte général des surfaces orientables à points marqués à l'intérieur et sur le bord.

Soit $(S_{g,b}^s, \mathbf{p})$ une surface orientable de genre g à s points marqués, et b composantes de bord numérotées, où $\mathbf{p} = (p_1, \dots, p_b)$ est un vecteur représentant le nombre de points marqués par composante connexe. Dans ce contexte, le *groupe modulaire* $\text{MCG}(S_{g,b}^s, \mathbf{p})$ de $S_{g,b}^s$ est le groupe des classes d'isotopie d'homéomorphismes qui préserve globalement les points marqués et les points marqués du bord. Le *complexe des arcs* $A(S_{g,b}^s, \mathbf{p})$ est le complexe simplicial dont les n -simplexes sont les ensembles de $n+1$ classes d'homotopie d'arcs essentiels dont les extrémités sont sur les points marqués à l'intérieur sur le bord de S . Le *complexe des arcs pur* $A_{\sharp}(S_{g,b}^s, \mathbf{p})$ est le sous-complexe engendré par les arcs sur les seuls points marqués sur le bord de S . Le groupe modulaire $\text{MCG}(S_{g,b}^s, \mathbf{p})$ opère sur ces deux complexes de façon simpliciale.

Ces complexes apparaissent naturellement lors de l'étude des liens de sommets dans $A(S_g^s)$ et dans la compactification combinatoire de l'espace des modules par Bowditch-Epstein-Penner. Harer a employé ces complexes dans ses travaux sur les propriétés homologiques du groupe modulaire. Hatcher a montré que, sauf pour quelques cas exceptionnels, ces complexes sont contractiles. Penner a étudié la topologie de certains de ces quotients et esquisse certaines relations entre la topologie de leurs espaces de modules et la topologie de l'espace de modules de surfaces de Riemann décorées.

Nous montrons les résultats suivants:

Théorème. *Si $\dim A(S_{g,b}^s, \mathbf{p}) \geq 2$ et $A(S_{g,b}^s, \mathbf{p})$ est isomorphe à $A(S_{g',b'}^{s'}, \mathbf{p}')$, alors $s = s'$, $g = g'$, $b = b'$, et $p_i = p'_i$ pour tout $i = 1, \dots, b$ (à ordre près).*

Théorème. *Si $\dim A(S_{g,b}^s, \mathbf{p}) \geq 2$, alors $A(S_{g,b}^s, \mathbf{p})$ est rigide.*

Théorème. *Si $\dim A_{\sharp}(S_{g,b}^s, \mathbf{p}) \geq 2$, alors $A_{\sharp}(S_{g,b}^s, \mathbf{p})$ est rigide.*

Nous retrouvons comme cas particulier de notre démonstration un résultat de rigidité du complexe des arcs $A(S_{g,b})$, d'abord démontré par Irmak-McCarthy. La démonstration que nous donnons est indépendante de tous les autres résultats de rigidité obtenus jusqu'ici, en particulier du célèbre résultat de rigidité pour le complexe des courbes. Notre résultat est aussi utile pour la démonstration d'un analogue du théorème de Royden qui concerne les isométries de Teichmüller pour les surfaces à bord.

Propriétés à grande échelle des complexes d'arcs

Dans cette deuxième partie de la thèse, nous étudions certaines propriétés à grande échelle des complexes d'arcs. Nous établissons une comparaison entre la géométrie grossière du complexe des arcs et celle du complexe des courbes à travers le complexe des domaines, et nous étudions la géométrie du graphe des triangulations idéales et sa relation avec la métrique de Thurston de l'espace de Teichmüller.

Complexes d'arcs par le complexe des domaines Soit $S_{g,b}$ une surface orientable. Le *complexe des courbes* de $S_{g,b}$, que nous notons $C(S_{g,b})$, est le complexe simplicial dont les n -simplexes sont les ensembles de $n + 1$ classes d'homotopie de lacets simples (non-périphériques) sur $S_{g,b}$. Lorsque $b > 0$, il est naturel de considérer le *complexe des arcs* $A(S_{g,b})$. Les premières définitions des complexes des arcs et des courbes proviennent de la topologie algébrique. Harer a défini et utilisé ces deux objets dans son étude des propriétés homologiques du groupe modulaire.

Si nous munissons chaque simplexe de la structure euclidienne avec arêtes de longueur 1, les deux complexes héritent naturellement d'une métrique. Du point de vue de la géométrie de grande échelle, le complexe des courbes est un objet très intéressant. La première étude du complexe des courbes $C(S_{g,b})$ en tant qu'espace métrique a été conduite par Masur-Minsky. Ils ont montré que son diamètre est infini, qu'il est Gromov-hyperbolique et que sa géométrie à grande échelle capte le défaut d'hyperbolicité de l'espace de Teichmüller pour la métrique de Teichmüller.

Du point de vue de la géométrie grossière, le complexe des arcs est en revanche encore un objet mystérieux.

La première partie de notre travail traite de la comparaison entre la géométrie grossière de $A(S_{g,b})$ et celle de $C(S_{g,b})$ par l'étude du type grossier

d'un complexe combinatoire similaire, appelé *complexe des domaines* $D(S_{g,b})$. Un *domaine* D sur $S_{g,b}$ est une sous-surface connexe de $S_{g,b}$ qui est distincte de $S_{g,b}$ et telle que toute composante de bord de ∂D est soit une composante de bord de $S_{g,b}$ ou bien une courbe essentielle sur $S_{g,b}$.

Les “pantalons” ou les anneaux essentiels sont également des domaines. Le complexe des domaines $D(S_{g,b})$, introduit par McCarthy-Papadopoulos, est défini comme suit. Pour $k \geq 0$, ses k -simplexes sont les collections de $k+1$ classes d'isotopie distinctes de domaines qui peuvent être réalisés d'une manière disjointe dans $S_{g,b}$. D'après cette définition, $C(S_{g,b})$ est naturellement un sous-complexe de $D(S_{g,b})$.

Dans cette partie, nous montrons les résultats suivants:

Théorème. *Soit $\Delta(S_{g,b})$ un sous-complexe de $D(S_{g,b})$ qui contient $C(S_{g,b})$. L'inclusion $\iota : C(S_{g,b}) \rightarrow \Delta(S_{g,b})$ est un plongement isométrique et une quasi-isométrie.*

Théorème. *Si $b \geq 3$ et $(g, b) \neq (0, 4)$, les propositions suivantes sont vraies:*

1. *$A(S_{g,b})$ est quasi-isométrique au sous-complexe $P_\delta(S_{g,b})$ de $D(S_{g,b})$ où les sommets sont donnés par des pantalons périphériques,*
2. *Si $g = 0$, alors l'inclusion simpliciale $P_\delta(S_{g,b}) \rightarrow D(S_{g,b})$ est un plongement isométrique et une quasi-isométrie.*
3. *Si $g \geq 1$ l'image de l'inclusion $k : P_\delta(S_{g,b}) \rightarrow D(S_{g,b})$ est 2-dense dans $D(S_{g,b})$, mais k n'est pas un plongement quasi-isométrique.*

Géométrie du graphe des triangulations idéales Le *graphe des triangulations idéales* est un graphe qui peut être identifié au 1-squelette du dual du complexe des arcs $A(S_g^n)$. En pratique, on peut définir ce graphe comme suit. Étant donné un ensemble de points marqués sur une surface, nous considérons des triangulations (à isotopie près) de la surface dont les sommets sont des points marqués. Chaque triangulation forme un sommet de ce graphe, et deux sommets sont reliés si les deux triangulations sous-jacentes diffèrent d'un *flip* i.e. le remplacement d'une arête par une autre dans un quadrilatère.

Il convient de mentionner que le graphe des triangulations idéales a fait l'objet d'investigations de différents points de vue, dont ceux de la géométrie computationnelle et l'informatique théorique. Sleator-Tarjan-Thurston fournissent des bornes pour la croissance du diamètre du graphe des triangulations idéales dans le cas où la surface est plane. Leurs résultats ont motivé un pléthore de recherches concernant la géométrie du graphe des transpositions des surfaces planes et certaines variantes proches. La description

explicite des géodésiques demeure un problème ouvert, ainsi qu'une méthode de calcul de la distance exacte entre deux triangulations.

Dans cette partie de la thèse, nous utilisons des graphes de triangulations idéales afin de paramétrer des sous-espaces naturels de l'espace de Teichmüller et d'estimer la croissance de leurs diamètres dans l'espace des modules relativement à la métrique de Thurston.

La croissance du diamètre de l'espace des modules pour la métrique de Weil-Petersson a été étudiée par Cavendish-Parlier. La croissance du diamètre du graphe des pantalons et la partie épaisse de l'espace des modules a été établie par Rafi-Tao.

Soit $S_{g,b}$ une surface orientable de genre g à b composantes de bord. Soit $N = 6g + 3b - 6$ et $H = (t_1, \dots, t_N)$ un ensemble maximal d'arcs disjoints essentiels, *i.e.* une décomposition de $S_{g,b}$ en hexagones à côtés alternés dans $\partial S_{g,b}$. Pour toute métrique hyperbolique X sur $S_{g,b}$, il existe un unique représentant géodésique de chaque arc de H qui décompose $S_{g,b}$ en hexagones à angles droits de longueurs $(L_X(t_1), \dots, L_X(t_N)) \in \mathbb{R}_{>0}^N$. Réciproquement, étant donné un vecteur $\mathcal{A} = (a_1, \dots, a_N) \in \mathbb{R}_{>0}^N$, il existe une unique métrique hyperbolique $X_{(H, \mathcal{A})}$ qui induit la longueur a_i sur le représentant géodésique de t_i pour tout i . Cette correspondance bijective entre $\text{Teich}(S_{g,b})$ et l'ensemble des attributions de longueurs $\mathcal{A} \in \mathbb{R}_{>0}^N$ sur les côtés de H définissent des coordonnées sur $\text{Teich}(S_{g,b})$.

Le graphe des triangulations idéales $\mathcal{F}(S_{g,b})$ de la surface est construit en prenant un sommet pour chaque décomposition en hexagones et en joignant deux sommets si et seulement si ils sont liés par un *flip*. Ce graphe peut être muni d'une métrique naturelle en déclarant ses arêtes de longueur 1.

En collaboration avec Hugo Parlier, nous avons obtenus les résultats suivants :

Théorème. *Soit $\chi_{g,b}$ la caractéristique d'Euler de $S_{g,b}$. On a alors :*

$$\limsup_{b \rightarrow +\infty} \frac{\text{diam. } \mathcal{M} \mathcal{F}_{g,b}}{|\chi_{g,b}| \log |\chi_{g,b}|} < +\infty$$

Proposition. *Si $\chi_{g,n} < 0$ et $(g,n) \neq (0,3)$, alors les énoncés suivants sont vrais :*

1. *pour toutes sommets $T \in \mathcal{F}_g^n$, l'application*

$$q_{g,n} : \text{MCG}(S_g^n) \rightarrow \mathcal{F}_g^n \\ g \mapsto gT$$

est une $(k_{q_{g,n}}, 1)$ -quasi-isométrie et la croissance des constantes $k_{q_{g,n}}$ est bornée par $C \cdot |\chi_g^n| \log |\chi_g^n|$ par rapport à n .

2. pour tous simplexes σ dans $A(S_g^n)$ et pour tous sommets $T \in \mathcal{F}_g^n$, l'application

$$\begin{aligned} \text{Stab}(\sigma) &\rightarrow \mathcal{F}_\sigma \\ g &\mapsto gT \end{aligned}$$

est une quasi-isométrie et $\text{Stab}(\sigma)$ est non tordue dans $\text{MCG}(S_g^n)$.

Proposition. Soit $L > 0$ et $k > 1$. Soient $\mathcal{A}_1 = (L, \dots, L) \in \mathbb{R}^N$ et $\mathcal{A}_k = k\mathcal{A}_1 = (kL, \dots, kL) \in \mathbb{R}^N$. Si $T \in \mathcal{F}_{g,b}$ est un sommet, on a :

$$d(X_{(T, \mathcal{A}_1)}, X_{(T, \mathcal{A}_k)}) = \log k$$

De plus, la droite $\mathbb{R} \ni t \mapsto X_{(T, e^{t\mathcal{A}_1})} \in \text{Teich}(S)$ est une géodésique (dans le sens positif) de la métrique de Thurston.

On dit qu'une métrique hyperbolique X est L -régulière s'il existe une hexagonalisation H telle que $X = X_{(H, (L, \dots, L))}$. Soit $\mathcal{R}_{g,b}^L$ l'ensemble des surfaces régulières et $\mathcal{M}\mathcal{R}_{g,b}^L$ son quotient par l'action du groupe modulaire.

Proposition. Pour tout $L > 0$, il existe une application Lipschitzienne

$$\begin{aligned} \mathcal{F}_{g,b}^{(0)} &\rightarrow \mathcal{R}_{g,b}^L \subseteq \text{Teich}(S_{g,b}) \\ T &\mapsto X_{(T, (L, \dots, L))} \end{aligned}$$

de constante de Lipschitz $K(L)$ qui ne dépend pas de g ou de b . De plus,

$$\limsup_{b \rightarrow +\infty} \frac{\text{diam. } \mathcal{M}\mathcal{R}_{g,b}^L}{|\chi_{g,b}| \log |\chi_{g,b}|} \leq K(L).$$

Acknowledgements

My first and sincere appreciation goes to my advisor Athanase Papadopoulos for all I have learned from him and for his constant support and encouragement in all stages of this thesis. I would also like to express my gratitude and respect to my co-supervisor Carlo Petronio for his valuable remarks on part of this thesis.

I am greatly indebted to Hugo Parlier for his interest in my work, for our joint results contained in the last chapter of this thesis and for inviting me to visit Université de Fribourg. I would like to thank Daniele Alessandrini for the many useful conversations we had during this years, for his comments on a part of this thesis and for our future collaboration.

I would like to express my gratitude to Mustafa Korkmaz, Bob Penner and Olivier Guichard, for their long travel to Italy to be my committee members, for their many useful comments on my work, and for their encouragement.

I would like to thank Institute de Recherche Mathématiques Avancée de Strasbourg for the hospitality in the last three years. A special thank is due to the Geometry and Topology group, in particular Charles Boubel, Francesco Costantino, Thomas Delzant, Vladimir Fock, Nicolas Juillet, Gwénaél Massey, Alexandre Martin, Fabien Bouschbacher for the useful conversations we had during my staying in Strasbourg.

I also thank Bruno Duchesne, Jean-Marc Schlenker, Anna Wienhard and Luis Paris for their interest in my work and for inviting me to give a talk in their universities.

In addition, I would like to thank Marco Abate, Riccardo Benedetti, Roberto Frigerio, Giovanni Gaiffi, Fulvio Lazzeri, Paolo Lisca, Bruno Martelli for introducing me to the beautiful world of geometry and topology with their beautiful and exciting classes during my undergraduate years. I would also

like to thank Francesca Acquistapace, Francesco Bonsante, Fabrizio Broglia, Stefano Francaviglia, Stefano Galatolo, Paolo Ghiggini and Gabriele Mondello for their friendly and warm encouraging whenever we meet.

A special thank goes to the math freshmen I mentored in 2008/09 at Università di Pisa for their enthusiasm and encouragement, even in the later years. I also thank my students in 2011/12 and 2012/13 at Université de Strasbourg and Ecole CESI for the beautiful experience I had as their instructor. Many thanks go to Josiane Gasparini-Nervi, Claude Mitschi and Pietro Di Martino for their helpful advices and encouragement on teaching.

Another special thank goes to my "baby" geometric topology group in Pisa in 2009/10, that is, all the students attending "I seminari dei Baby-geometri". I would like to thank the co-organizers, Abramo Bertucco and Cristina Pagliantini, and all the speakers/partecipants for the funny afternoons lost into geometric/topological daydreaming: Fionntan Roukema, Michele Tocchet, Alessandro Sisto, Nicolas Matte Bon, Francesca Iezzi, Antonio De Capua, Marco Golla, Maria Beatrice Pozzetti, Claudio Tamburrino, Eleonora Bardelli, Mario Scarascia, Daniele Angella, Paolo Aceto, Francesco Lin, Lorenzo Losa, Daniele Celoria, Gilberto Spano, John Calabrese, Giacomo D'Antonio, Leone Slavich... (random order. if I skipped somebody, shame on me!!)

Back to my mathematics "childhood" as undergrad student, I would like to express my deepest appreciation and gratitude to the PhD. students in the "Aula Studenti" in Pisa years 2004-2009. Thank for always being there whenever one of us "kids" had some math problem, in particular thank you for sharing my maths questions and excitements: Abramo Bertucco, Luca Caputo, Tiziano Casavecchia, Marco Illengo, Ana G. Lecuona, Isaia Nisoli, Marco Mazzucchelli, Demdah Mady, Francesca Mori, Jasmin Raissy, Marco Strambi.

Finally I would like to acknowledge all the funding bodies that have given me the opportunity to continue my education from the high school up to a doctoral level. First I would like to thank INdAM for their undergraduate fellowships that encourage me to study mathematics, then I acknowledge Scuola Normale Superiore, Collège Doctoral Européen, GNSAGA-INdAM, FIRB "Geometry and topology of low-dimensional manifolds", the Italian Ministry for Foreign Affairs-Campus France for the financial support provided during my PhD. studies, in particular for financing this joint PhD. program with IRMA. A special thank goes to Collège Doctoral Européen,

IRMA and Scuola Normale Superiore di Pisa for the facilities provided during these years.

Je tiens aussi à remercier mes collègues doctorants à Strasbourg pour les beaux moments que l'on a passé ensemble: merci mes co-bureau pour la patience (!) Ambroise, Ranine et André, puis merci à Cédric, Olivier, Alex, Enrica, Nicolas, Florian, Romain, Camille, Fabien, Jean, Mikhael, Aurélien, Simon, Vincent, Alain...

Je remercie aussi mes pots au CDE: Alice, Benoit, Laura, Daniela C., Daniela D., Marco, Marta, Nadia, Lan Xi, Diego, Denise, Farouk, Francesco, Giovanna, Prudence, Valérie, Vulca pour les belles soirées ensemble.

Ringrazio i miei genitori, mio fratello per il sostegno in tutti questi anni di studio. Un grazie speciale a Gianna per le conversazioni su Pier Paolo Pasolini, ispiratore occulto di questo lavoro. Grazie Enrica, LAB, Marko, Roberta, Annalisa, Davide, Carla, Lisa, Michele, Leonardo, Mattia, Filippo, Gangi, Lorenzo, Guendalina, Eleonora, Chiara, Sara, Giulia, OT, MEF, Marco, Vins, Martina, Alesandra, Jack, Raffaele, Diego, Andrea, Gianfilippo, Gabriella, Biagio, Maurizio, Eva, Ilario, Marcella, il Sardo, Giacomo per aver condiviso insieme almeno una (o forse mille) indimenticabile vacanza, paranoia, risata fino alle lacrime, serata tanghera, birra, manifestazione, preoccupazione, tavola imbandita, serena giornata casalinga, incazzatura, serata al cinema, comoda poltrona in ufficio, pesantissimo scatolone da traslocare...

Nell'anno dello scandalo ILVA, non posso non dedicare un pensiero di profonda gratitudine ai lavoratori dell'industria pesante tarantina (*in primis* mio nonno e i "maschi" della mia famiglia Sabatelli) fra i quali sono cresciuta e che, fin da piccolissima, tanto mi hanno sostenuto e incoraggiato negli studi. A loro dedico questo lavoro.

Chapter 1

Generalities

The goal of this chapter is to provide a quick overview of some basic notions and classical results about the mapping class group, Teichmüller space, the moduli space and large scale geometry. The reader will find in the book of Farb-Margalit [18] detailed proofs of all the statements given in Section 1 and 2. We shall refer to the book of Bridson-Haefliger [11] for Section 3.

1.1 The mapping class group of a surface

A surface (with boundary) is a 2-dimensional topological manifold (with boundary). We shall always assume surfaces to be orientable and of finite type. A surface of finite type $S_{g,b}^n$ is determined up to homeomorphism by its genus g , its number of boundary components b and its number of punctures n . The genus, the number of boundary components and the punctures are related by the Euler characteristic formula $\chi(S_{g,b}^n) = 2 - 2g - b - n$.

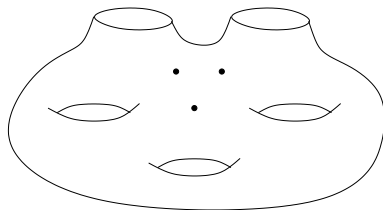

Figure 1.1: $S_{g,b}^n$

A *pair of pants* is $S_{0,3}$, namely the surface homeomorphic to a disk with 2 holes. A well-known result about surfaces with boundary is the following.

Theorem 1.1.1. *If $n = 0$ and $\chi(S_{g,b}) < 0$, then there is a maximal set \mathcal{C} of pairwise disjoint non-homotopic simple closed loops on S such that the surface obtained by cutting along \mathcal{C} is a disjoint union of pairs of pants.*

A *hyperbolic structure* on a surface S is a diffeomorphism $\phi : S \rightarrow X$ where X is a surface with a complete, finite-area hyperbolic metric and totally geodesic boundary. We can record the hyperbolic structure $\phi : S \rightarrow X$ by the pair (S, ϕ) . The following result is well-known:

Theorem 1.1.2. *If $\chi(S_{g,b}^n) < 0$, then $S_{g,b}^n$ admits a hyperbolic structure.*

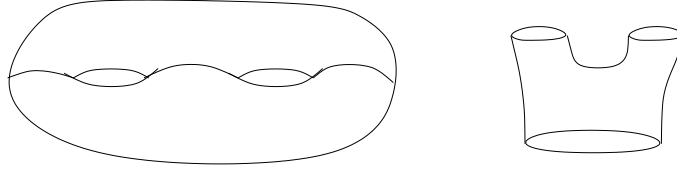

Figure 1.2: A pants decomposition

In the rest of this thesis we shall deal with combinatorics of arcs and curves. By a *simple closed curve* in $S_{g,b}^n$ we will mean an embedding $S^1 \rightarrow S_{g,b}^n$, though we usually identify a simple closed curve with its image in $S_{g,b}^n$. By a *proper arc* in $S_{g,b}^n$ we will mean an embedding $[0, 1] \rightarrow S_{g,b}^n$ whose endpoints are ideal vertices or on the boundary of $S_{g,b}^n$. An arc or a curve is *essential* if it is homotopic neither to a boundary component of S (with a homotopy with endpoints fixed in the case of arcs) nor to a puncture of $S_{g,b}^n$.

Definition 1.1.3. *The geometric intersection number between free homotopy classes a and b of essential simple closed curves in a surface $S_{g,b}^n$ is the minimal number of intersection points between a representative curve in the class a and a representative curve in the class b :*

$$i(a, b) = \min\{|\alpha \cap \beta| : \alpha \in a, \beta \in b\}.$$

Similarly, the geometric intersection number between two homotopy classes a and b of essential arcs in $S_{g,b}^n$ is the minimal number of intersection points between the interior of a representative arc in the class a and the interior of a representative arc in the class b .

We say that two curves are in minimal position if they realize the intersection number of their homotopy classes. Moreover, the following holds (a proof can be found for instance in [18]).

Theorem 1.1.4. *Let $S_{g,b}^n$ be a hyperbolic surface. If α is an essential closed curve in $S_{g,b}^n$, then α is homotopic to a unique geodesic closed curve g_α . Distinct simple closed geodesics on $S_{g,b}^n$ are in minimal position with each other.*

The same result holds for arcs.

Generating the mapping class group Let $\text{Homeo}(S_{g,b}^n)$ be the group of homeomorphisms of $S_{g,b}^n$ endowed with the compact-open topology, and denote by $\text{Homeo}_0(S_{g,b}^n)$ the connected component of the identity $\text{Id} : S_{g,b}^n \rightarrow S_{g,b}^n$. It is well-known that $\text{Homeo}_0(S_{g,b}^n)$ consists of homeomorphisms isotopic to Id .

Definition 1.1.5. *The (extended) mapping class group of $S_{g,b}^n$ is the group $\text{MCG}^*(S_{g,b}^n) = \text{Homeo}(S_{g,b}^n)/\text{Homeo}_0(S_{g,b}^n)$, that is, the group of isotopy classes of elements of $\text{Homeo}(S_{g,b}^n)$.*

The elements of $\text{MCG}^*(S_{g,b}^n)$ are called *mapping classes*. We denote by $\text{MCG}(S_{g,b}^n)$ the subgroup generated by orientation-preserving mapping classes. The *pure mapping class group* $\text{PMCG}(S_{g,b}^n)$ is the subgroup of $\text{MCG}(S_{g,b}^n)$ generated by the mapping classes fixing the boundary and each puncture of $S_{g,b}^n$ pointwise. There is a short exact sequence:

$$1 \rightarrow \mathbb{Z}^b \rightarrow \text{PMCG}(S_{g,b}^n) \rightarrow \text{MCG}^*(S_{g,b}^n) \rightarrow \mathbb{Z}_2 \oplus \mathfrak{S}_b \oplus \mathfrak{S}_n \rightarrow 1,$$

where \mathfrak{S}_s is the permutation group of the set with s elements.

We will now introduce the so-called *Dehn twist*, that provides a special example of an infinite-order mapping class.

Let us first consider the annulus $A = S^1 \times [0, 1]$, equipped with the embedding into the Euclidean plane given by polar coordinates. Consider on the boundary of A the orientation induced by the orientation of the plane. Let $T : A \rightarrow A$ be the map defined by $T(\theta, t) = (\theta + 2\pi t, t)$. T is an orientation-preserving homeomorphism that fixes ∂A pointwise.

Let α be a simple closed curve not homotopic to a boundary in S and N be a regular neighborhood of α in S . Choose an orientation-preserving homeomorphism $\phi : A \rightarrow N$. The homeomorphism $T_\alpha : S \rightarrow S$ defined by

$$T_\alpha(x) = \begin{cases} (\phi \circ T \circ \phi^{-1})(x) & \text{if } x \in N \\ x & \text{if } x \notin N \end{cases}$$

depends on the choice of N and of the homeomorphism ϕ . By the uniqueness of regular neighborhoods, the isotopy class of T_α does not depend on either of

these choices. Furthermore, T_α does not depend on the choice of the simple closed curve α within its isotopy class. If a is the isotopy class of α , then T_a is a well-defined element of $\text{MCG}(S_{g,b}^n)$. If α is not homotopic to a point or to a boundary, then T_a is a non-trivial element of $\text{MCG}(S_{g,b}^n)$.

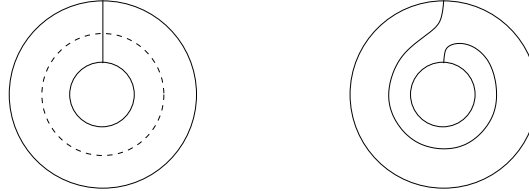

Figure 1.3: The action of a Dehn twist

Theorem 1.1.6 (Dehn-Lickorish). $\text{MCG}(S_{g,b}^n)$ is finitely generated.

Moreover, the following holds:

Theorem 1.1.7 (McCool). $\text{MCG}(S_{g,b}^n)$ is finitely presented.

The first explicit presentation was written by Hatcher-Thurston [31] and many others were built in later years (for a survey see Chapter 5 of [18]).

1.2 Teichmüller and moduli spaces

Let S be an orientable surface of finite type as above. Two hyperbolic structures (X_1, ϕ_1) and (X_2, ϕ_2) on S are *homotopic* if there is an isometry $I : X_1 \rightarrow X_2$ such that $I \circ \phi_1 : S \rightarrow X_2$ and $\phi_2 : S \rightarrow X_2$ are homotopic, *i.e.*, the following diagram commutes up to homotopy:

$$\begin{array}{ccc} S & & \\ \phi_1 \downarrow & \searrow \phi_2 & \\ X_1 & \xrightarrow{I} & X_2. \end{array}$$

Definition 1.2.1. The Teichmüller space of S is the set $\text{Teich}(S)$ of homotopy classes of hyperbolic structures on S .

A marking (ϕ, X) gives rise to a hyperbolic metric on S by pullback. So, one can describe Teichmüller space also as the set of isotopy classes of complete finite-area hyperbolic metrics with totally geodesic boundary on S . The following is a well-known result.

Theorem 1.2.2. *If $\chi_{g,b}^n < 0$, then $\text{Teich}(S_{g,b}^n)$ is homeomorphic to $\mathbb{R}^{6g-6+2n+3b}$.*

The so-called *Fenchel-Nielsen* coordinates, associated to the lengths of the curves in a pair of pants decomposition (see [18] for a precise definition), define a real-analytic structure on $\text{Teich}(S_{g,b}^n)$.

Definition 1.2.3. *The moduli space $\mathcal{M}(S)$ is the quotient of $\text{Teich}(S)$ under the action of the mapping class group $\text{MCG}(S)$.*

Theorem 1.2.4. *The action of $\text{MCG}(S)$ on $\text{Teich}(S)$ is properly discontinuous. Every metric on $\text{Teich}(S)$ that is invariant under the mapping class group descends to one on $\mathcal{M}(S)$.*

A celebrated distance on Teichmüller space is the so-called *Teichmüller distance*, which measures the deformations of two conformal structures on the same surface.

Definition 1.2.5. *The Teichmüller distance between two points $X, Y \in \text{Teich}(S)$ of Teichmüller space is defined as*

$$d_T(X, Y) = \frac{1}{2} \inf_{\phi \sim \text{id}} \log K(\phi),$$

where $\phi : X \rightarrow Y$ is a quasi-conformal homeomorphism isotopic to the identity and $K(\phi)$ is its quasi-conformal constant.

Theorem 1.2.6 (Teichmüller). *The Teichmüller space $(\text{Teich}(S_g^n), d_T)$ with respect to the Teichmüller metric is a complete and uniquely geodesic metric space.*

The distance d_T descends to an infinite-diameter distance on the moduli space $\mathcal{M}(S_g^n)$.

Theorem 1.2.7 (Royden). *If S is closed and $g \geq 2$, then the isometry group of $(\text{Teich}(S_g), d_T)$ is isomorphic to $\text{MCG}(S_g)$.*

1.3 Coarse geometry of metric spaces

Here we recall a few basic notions of large scale geometry that we will use in the forthcoming chapters. We refer the reader to the book of Bridson-Haefliger [11] for proofs, examples and further references.

Definition 1.3.1. *Let (X, d) be a metric space. The distance d is a length distance if the distance between every pair of points $x, y \in X$ is equal to the infimum of the length of rectifiable curves joining them. If d is a length distance, then (X, d) is called a length space.*

Theorem 1.3.2 (Hopf-Rinow). *Let X be a length space. If X is complete and locally compact, then:*

1. *every closed bounded subset of X is compact;*
2. *X is a geodesic space.*

Definition 1.3.3. *Let (X_1, d_1) and (X_2, d_2) be metric spaces. A (not necessarily continuous) map $f : X_1 \rightarrow X_2$ is called a (k, h) -quasi-isometric embedding if there exist constants $k \geq 1$ and $h \geq 0$ such that for all $x, y \in X_1$ we have:*

$$\frac{1}{k} \cdot d_1(x, y) - h \leq d_2(f(x), f(y)) \leq k \cdot d_1(x, y) + h.$$

If there exists $C \geq 0$ such that $f(X_1)$ is C -dense in X_2 , then f is a (k, h) -quasi-isometry. When such a map exists, X_1 and X_2 are said to be quasi-isometric.

Every finitely generated group can be turned into a metric space, as follows.

Definition 1.3.4. *Let G be a finitely generated group and S a generating set for G . For every $g \in G$, we denote by $|g|$ the length of the shortest word representing g in the generators S . The word distance between $g_1, g_2 \in G$ is defined as $d_{(G,S)}(g_1, g_2) = |g_1^{-1}g_2|$.*

It is not difficult to see that the word metrics associated to two finite generating sets S and S' are bilipschitz equivalent, and the word metric on G is well-defined up to quasi-isometry.

Definition 1.3.5. *Let G be a finitely generated group, and S a finite and symmetric generating set. The Cayley graph $\mathcal{C}_S(G)$ is a graph constructed as follows:*

- *we assign a vertex to each element g of G : the vertex set $V(G)$ of $\mathcal{C}_S(G)$ is identified with G ;*
- *for every $g \in G$, $s \in S$ the vertices corresponding to the elements g and gs and are joined by an edge. Thus the edge set $E(G)$ consists of pairs of the form (g, gs) with $s \in S$*

The definition of the Cayley graph $\mathcal{C}_S(G)$ depends on the choice of the set S of generators, but its coarse geometry does not.

Theorem 1.3.6 (Svarc-Milnor Lemma). *Let X be a length space. If G acts properly and cocompactly by isometries on X , then G is finitely generated and for every $x_0 \in X$, the map $G \ni g \mapsto g.x_0 \in X$ is a quasi-isometry.*

The following notion is due to Gromov. It generalizes the usual definition of hyperbolicity to the setting of geodesic metric spaces.

Definition 1.3.7. *Assume $\delta > 0$. A geodesic triangle in a metric space is δ -slim if each of its edges is contained in the δ -neighbourhood of the union of the other two edges. A geodesic metric space X is δ -hyperbolic (or Gromov-hyperbolic) if every geodesic triangle in X is δ -slim.*

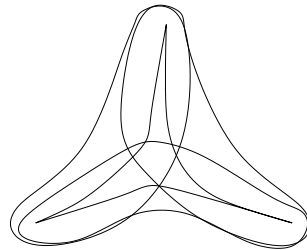

Figure 1.4: A δ -slim triangle

Gromov-hyperbolicity is a quasi-isometric invariant.

Chapter 2

Combinatorial rigidity of arc complexes

We study arc complexes of surfaces in the most general setting of surfaces with marked points in the interior and on the boundary. Among other things, we prove that except in a few cases every automorphism is induced by a homeomorphism of the surface that fixes the marked points setwise. Moreover we show that the isomorphism type of the arc complex determines the topological data of the underlying surface. Our proofs are based on a combinatorial approach that yields new information on the geometry of these objects. We do not employ any other known combinatorial rigidity result. This chapter is based on the author's paper [16].

2.1 Introduction

The *arc complex* of a surface with marked points is a simplicial complex whose vertices are the homotopy classes of essential arcs based on the marked points, and n vertices span a $n + 1$ simplex if they can be simultaneously realized in a disjoint fashion.

It was introduced by Harer [27; 28]. Its topology and simplicial structure is crucial for the definition of a combinatorial compactification of the moduli space (see Bowditch-Epstein [7] and Penner [55; 57]) and for Penner's decorated Teichmüller theory [61].

In this chapter we deal with the arc complex of a surface with marked points on their boundary and in their interior. Surfaces of this type were first studied in the founding paper by Oswald Teichmüller [66; 65]. They are also called *ciliated surfaces* in the works of Fock-Goncharov [22; 21]. The arc complexes of ciliated surfaces were studied in the works of Fomin-

Shapiro-Thurston [23; 24]. Hatcher [30] studied some of their basic topological features, *i.e.*, their connectedness and homotopy type. Penner [60; 58; 59] studied their quotient under the action of the mapping class group and their relation with the (decorated) moduli space of a surface with boundary.

We will be concerned with the problem of *combinatorial rigidity* of the arc complex of a surface with boundary and marked points on the boundary and in the interior: the mapping class group naturally acts on it by simplicial automorphisms. We say that the arc complex is *rigid* if this action is rigid, that is, if the automorphism group of this complex is isomorphic to the mapping class group of the surface.

We denote by $(S_{g,b}^s, \mathbf{p})$ an orientable surface of genus g with $b > 0$ boundary components, $p_i \geq 1$ marked points on the i -th boundary component with $\mathbf{p} = (p_1, \dots, p_b)$, and $s \geq 0$ marked points in the interior. The *arc complex* $A(S_{g,b}^s, \mathbf{p})$ is the simplicial complex whose vertices are the homotopy classes of essential arcs based at the marked points, and n vertices span a $n + 1$ simplex if they can be simultaneously realized in a disjoint fashion. Its dimension is finite and equal to $6g + 3b + 3s + |\mathbf{p}| - 7$. The *pure arc complex* $A_{\#}(S_{g,b}^s, \mathbf{p})$ is the subcomplex spanned by the arcs based only at the marked points on the boundary of the surface. The mapping class group $\text{MCG}(S_{g,b}^s, \mathbf{p})$ acts on $A(S_{g,b}^s, \mathbf{p})$ and $A_{\#}(S_{g,b}^s, \mathbf{p})$ simplicially. Its dimension is finite and $6g + 3b + 2s + |\mathbf{p}| - 7$. We denote by $\text{Aut}(A_{\#}(S_{g,b}^s, \mathbf{p}))$, $\text{Aut}(A(S_{g,b}^s, \mathbf{p}))$ their simplicial automorphism groups of the complexes. The main results we will prove are the following:

Theorem A. *If $\dim(A(S_{g,b}^s, \mathbf{p})) \geq 2$ and $A(S_{g,b}^s, \mathbf{p})$ is isomorphic to $A(S_{g',b'}^{s'}, \mathbf{p}')$ then $s = s'$, $b = b'$, $g = g'$ and $p_i = p'_i$ for all i (up to reordering).*

Theorem B. *If $\dim(A(S_{g,b}^s, \mathbf{p})) \geq 2$ then $A(S_{g,b}^s, \mathbf{p})$ is rigid.*

Theorem C. *If $\dim(A_{\#}(S_{g,b}^s, \mathbf{p})) \geq 2$ then $A_{\#}(S_{g,b}^s, \mathbf{p})$ is rigid.*

We will also list and study the cases not satisfying the assumptions of these results. A rigidity theorem for the curve complex of a punctured surface similar to our results was first stated by Ivanov [34] for surfaces of genus greater than 1, then proved in genus 0 and 1 (except for the 2-punctured torus) by Korkmaz [36], and finally reproved in full generality by Luo [42]. Applications of the result include a new proof of Royden's theorem on the isometries of the Teichmüller space of a punctured surface and the study of finite-index subgroups of the mapping class group (see for instance [34; 33]). A similar rigidity result for the so-called *pants graph* was proved by Margalit [44]. Brock-Margalit [10] used this result in order to provide a new proof of the Masur-Wolf theorem on the isometries of the Weil-Petersson metric.

More rigidity properties of natural simplicial complexes associated to a surface have been investigated in the past by many different authors; a survey of known results and their applications can be found in [48]. Most of the proofs are based on a (non-trivial) reduction to the rigidity theorem of the curve complex. Our proof for arc complexes does not employ any previously known rigidity result.

Structure of the chapter The structure of the chapter is the following. In Section 2.2 we introduce the notation, we list exceptional cases and study and present the main results. We also discuss some new results about the combinatorics of arc complexes, including some invariance lemmas that will be used throughout the chapter. Finally we prove Theorem A in Section 2.3. In Section 2.4 we discuss examples and give a proof of Theorem B. Section 2.5 is devoted to the proof of Theorem C.

2.2 Combinatorics of arc complexes

Let us fix the notation. Let $S_{g,b}^s$ be a compact orientable surface of genus $g \geq 0$, with $b \geq 0$ ordered boundary components $\mathcal{B}_1, \dots, \mathcal{B}_b$ and a set \mathcal{S} of s marked points in the interior of the surface. When $b > 0$ we will fix a finite set \mathcal{P} of distinguished points on ∂S and denote by $\mathbf{p} = (p_1, \dots, p_b)$ the vector whose component p_i is the number of distinguished points on the i -th boundary component of S .

The mapping class group $\text{MCG}^*(S, \mathbf{p})$ We recall the definition of mapping class group of the pair $(S_{g,b}^s, \mathbf{p})$, (S, \mathbf{p}) for short. Let $\text{Homeo}(S, \mathbf{p})$ be the group of homeomorphisms of S fixing $\mathcal{P} \cup \mathcal{S}$ as a set. Let $\text{Homeo}_0(S, \mathbf{p}) \subseteq \text{Homeo}(S, \mathbf{p})$ be the normal subgroup consisting of homeomorphisms isotopic to the identity through isotopy fixing $\mathcal{P} \cup \mathcal{S}$. The *extended mapping class group of the pair (S, \mathbf{p})* is the group $\text{MCG}^*(S, \mathbf{p}) = \text{Homeo}(S, \mathbf{p}) / \text{Homeo}_0(S, \mathbf{p})$. The *pure mapping class group of the pair (S, \mathbf{p})* is the subgroup $\text{PMCG}^*(S, \mathbf{p}) < \text{MCG}^*(S, \mathbf{p})$ generated by the homeomorphisms fixing $\mathcal{P} \cup \mathcal{S}$ pointwise. We will also denote by $\text{MCG}(S, \mathbf{p})$, $\text{PMCG}(S, \mathbf{p})$ the subgroups generated by orientation-preserving homeomorphisms.

Let \mathcal{B}_i be the i -th boundary component of S with p_i marked points on it. We introduce the definition of $\frac{2\pi}{p_i}$ -rotation around \mathcal{B}_i . First consider the annulus $A = S^1 \times [0, 1]$ in \mathbb{R}^2 (equipped with polar coordinates (θ, r)) with marked points $\{(\frac{2\pi}{p_i}j, 1)\}_{j=0, \dots, p_i-1}$. The $\frac{2\pi}{p_i}$ -rotation map of A is the map $R : A \rightarrow A$ defined as $R(\theta, r) = (\theta + \frac{2\pi}{p_i}t, t)$. Remark that R is orientation-

preserving, the restriction $R|_1 : S^1 \times \{1\} \rightarrow S^1 \times \{1\}$ is a rotation of angle $\frac{2\pi}{p_i}$, the restriction of R to $S^1 \times \{0\}$ is the identity and the power R^{p_i} is the right Dehn-twist around the core curve of the annulus.

Let $\{P_j\}_{j=0, \dots, p_i-1}$ be the set of marked points on \mathcal{B}_i . Let N be the closure of a regular neighborhood of \mathcal{B}_i , and choose a homeomorphism $\phi : N \rightarrow A$ such that $\phi(P_j) = (\frac{2\pi j}{p_i}, 1)$ for all $j = 0, \dots, p_i - 1$ (up to reordering). We consider the homeomorphism $\tilde{R}_i : (S, \mathbf{p}) \rightarrow (S, \mathbf{p})$ defined as follows:

$$\tilde{R}_i(x) = \begin{cases} (\phi^{-1} \circ R \circ \phi)(x) & \text{if } x \in N \\ x & \text{if } x \notin N . \end{cases}$$

The map \tilde{R}_i depends on the choices of N and ϕ , but the equivalence class modulo isotopy fixing \mathcal{P} pointwise does not depend on such choices and gives a well-defined non-trivial element $\rho_{\frac{2\pi}{p_i}} = [\tilde{R}_i]$ in $\text{MCG}^*(S, \mathbf{p})$. We call this element the $\frac{2\pi}{p_i}$ -rotation around the i -th boundary component \mathcal{B}_i .

We remark that the group $R_{\mathbf{p}} = \langle \rho_{\frac{2\pi}{p_1}}, \dots, \rho_{\frac{2\pi}{p_b}} \rangle$, generated by all the rotations around the boundary components of S is Abelian of rank b .

Let us denote by \mathfrak{S}_n be the symmetric group on n elements. For every $i = 1, \dots, b$, let r_i be the number of boundary components having exactly p_i marked points. The following two propositions are not difficult to prove.

Proposition 2.2.1. *There is a short exact sequence:*

$$0 \rightarrow \text{PMCG}(S, \mathbf{p}) \rightarrow \text{MCG}(S, \mathbf{p}) \rightarrow \bigoplus_{i=1}^b (\mathfrak{S}_{r_i} \times \mathbb{Z}_{p_i}) \oplus \mathfrak{S}_s \rightarrow 0.$$

If $s = 0$ and the p_i 's are all distinct, then $\text{MCG}(S, \mathbf{p})$ is generated by $R_{\mathbf{p}}$ and the Dehn twists about simple closed curves not parallel to ∂S .

Finally we denote by $\text{PMCG}(S)$ the subgroup of $\text{MCG}^*(S, \mathbf{p})$ generated by mapping classes fixing pointwise $\mathcal{S} \cup \partial S$. It is not difficult to see the following.

Proposition 2.2.2. *The following holds:*

1. *If there exists p_i such that $p_i \geq 3$, then $\text{PMCG}^*(S, \mathbf{p}) = \text{PMCG}(S, \mathbf{p})$.*
2. *If $s = 0$ and for all $i = 1, \dots, b$ we have $p_i \leq 2$, then $\text{PMCG}^*(S, \mathbf{p})$ is generated by $\langle \text{PMCG}(S), i \rangle$, where i is an involution which fixes every point in \mathbf{p} .*
3. *In all the other cases, $\text{PMCG}^*(S, \mathbf{p})$ is isomorphic to $\text{PMCG}(S)$.*

2.2.1 The arc complexes $A(S, \mathbf{p})$ and $A_{\sharp}(S, \mathbf{p})$

In this section we will define arc complexes and give some examples in low dimensions.

We denote by $A(S, \mathbf{p})$ the simplicial complex whose vertices are the equivalence classes of arcs with endpoints in $\mathcal{P} \cup \mathcal{S}$ modulo isotopy fixing $\mathcal{P} \cup \mathcal{S}$ pointwise. We consider arcs as simple and not homotopic to a piece of boundary between two consecutive points of \mathbf{p} . A set of vertices $\langle a_1, \dots, a_k \rangle$ spans a $(k-1)$ -simplex if and only if a_1, \dots, a_k can be realized simultaneously as arcs that are disjoint in the interior. We will denote by $A_{\sharp}(S, \mathbf{p})$ the subcomplex of $A(S, \mathbf{p})$ spanned by isotopy classes of arcs with both endpoints on \mathcal{P} . If $s = 0$ we have $A_{\sharp}(S, \mathbf{p}) = A(S, \mathbf{p})$.

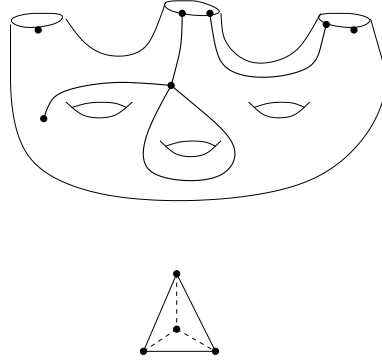

Figure 2.1: A 3-simplex in $A(S, \mathbf{p})$

By an elementary Euler characteristic argument, we find that the dimension of simplices in the complexes is bounded from above, in particular $A(S, \mathbf{p})$ and $A_{\sharp}(S, \mathbf{p})$ have dimension respectively $6g + 3b + 3s + |\mathbf{p}| - 7$ and $6g + 3b + 2s + |\mathbf{p}| - 7$. We remark that in both $A(S, \mathbf{p})$ and $A_{\sharp}(S, \mathbf{p})$ each simplex of maximal dimension corresponds to a collection of disjoint non-homotopic arcs that is maximal with respect to inclusion on the surface. Indeed, a maximal simplex in $A(S, \mathbf{p})$ corresponds to a triangulation of S with vertices in $\mathcal{P} \cup \mathcal{S}$, and the complement on (S, \mathbf{p}) of a maximal simplex in $A_{\sharp}(S, \mathbf{p})$ corresponds to a union of once-punctured discs (with punctures in \mathcal{S}) and (immersed) triangles with vertices in \mathcal{P} . It is easy to see that $A_{\sharp}(S, \mathbf{p})$ has codimension s in $A(S, \mathbf{p})$. The definitions here also make sense when $\mathcal{P} = \emptyset$. In this case we will use the notation $A(S_g^s)$ instead of $A(S_{g,0}^s, \emptyset)$.

The following remarks are not difficult to prove and describe some basic properties of the complexes.

Remark 2.2.3. *If $g, s \geq 0$, $b \geq 1$ and $\mathbf{p} = (p_1, \dots, p_b) \in \mathbb{N}^b \setminus (0, \dots, 0)$, the following holds:*

1. $A(S, \mathbf{p}) = \emptyset$ if and only if $(g, b, s) = (0, 1, 0)$ and $p_1 \in \{1, 2, 3\}$.
2. $A(S, \mathbf{p})$ has a finite number of vertices if and only if $g = 0$, $b = 1$ and $s \leq 1$. In particular, $A(S, \mathbf{p})$ is a single point if and only if $g = 0$, $b = 1$, $s = 1$ and $p_1 = 1$.

Remark 2.2.4. *If $b = 0$, $g \geq 0$ and $s \geq 1$, the following holds:*

1. $A(S_g^s) = \emptyset$ if and only if $(g, s) = (0, 1)$;
2. $A(S_g^s)$ has a finite number of vertices if and only if $g = 0$, $s \leq 3$. In particular, $A(S_g^s)$ is a single point if and only if $g = 0$ and $s = 2$, and $A(S_0^3)$ is homeomorphic to a disk having 6 vertices and 4 2-simplices (see Figure 2.3).
3. $A(S_1^1)$ is isomorphic to the Farey graph.

Remark 2.2.5 (Low dimensional cases). *Suppose $g, s \geq 0$, $b \geq 1$ and $\mathbf{p} = (p_1, \dots, p_b) \in \mathbb{N}^b \setminus (0, \dots, 0)$. The following holds:*

1. The arc complex $A(S, \mathbf{p})$ has dimension 0 if and only if $(g, b, s, \mathbf{p}) \in \{(0, 1, 0; (4)), (0, 1, 1; (1))\}$. In particular, $A(S_{0,1}^1; (1))$ is a single vertex and $A(S_{0,1}^0; (4))$ consists of two disjoint vertices (see Figure 2.2).
2. The arc complex $A(S, \mathbf{p})$ has dimension 1 if and only if $(g, b, s, \mathbf{p}) \in \{(0, 2, 0; (1, 1)), (0, 1, 0; (5)), (0, 1, 1; (2))\}$. In particular, $A(S_{0,2}^0; (1, 1))$ is isomorphic to \mathbb{R} , $A(S_{0,1}^0; (5))$ has diameter 2 and $A(S_{0,1}^1; (2))$ has diameter 3.
3. The arc complex $A(S, \mathbf{p})$ has dimension 2 if and only if $(g, b, s, \mathbf{p}) \in \{(0, 1, 0; (6)), (0, 1, 1; (3)), (0, 2, 0; (1, 2))\}$.

Proposition 2.2.6. *If $A(S, \mathbf{p})$ has dimension at least 1, then it is arcwise connected. Moreover, except when S is a disk or an annulus with $s = 0$, $A(S, \mathbf{p})$ is contractible. In the exceptional cases, $A(S, \mathbf{p})$ is homeomorphic to a sphere.*

Proof. See Hatcher [30]. □

It is immediate to see that $\text{MCG}^*(S, \mathbf{p})$ and its subgroups acts naturally on $A(S, \mathbf{p})$ by automorphisms, and the same holds for $A_{\sharp}(S, \mathbf{p})$. In [60] Penner studied the topology of quotients of these arc complexes under the action of the pure mapping class group, suggesting a deep connection with the topology of the moduli space. In particular he proved the following result:

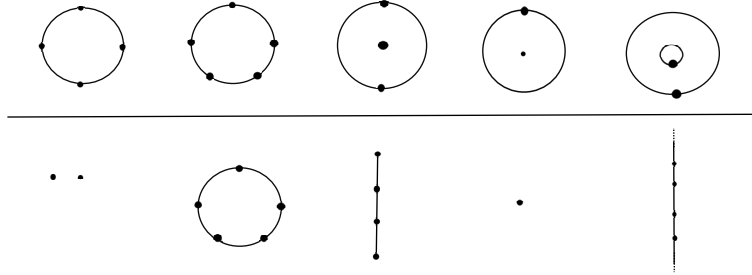

Figure 2.2: Surfaces (upper line) and their arc complexes (lower line)

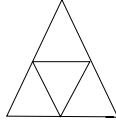

Figure 2.3: Remark 2.2.4

Theorem 2.2.7 (Penner [60]). *Let $(S_{g,b}^s, \mathbf{p})$ be a compact orientable surface with genus g , $b \geq 1$ boundary components, s marked points in the interior and $\mathbf{p} = (p_1, \dots, p_b)$ marked points on the boundary, with $p_i \geq 1$ for all i . The quotient $Q(S_{g,b}^s, \mathbf{p})$ of $A_{\#}(S_{g,b}^s, \mathbf{p})$ by the action of the pure mapping class group $\text{PMCG}(S_{g,b}^s, \mathbf{p})$ is a sphere only in the cases*

$$\begin{aligned} & Q(S_{0,1}^s, \mathbf{p}) \text{ for } s \geq 0; & Q(S_{0,2}^1, \mathbf{p}) \text{ for } p_1 + p_2 \geq 2; \\ & Q(S_{1,1}^1, \mathbf{p}) \text{ for } p_1 \geq 1; & Q(S_{0,2}^0, \mathbf{p}) \text{ for } p_1 + p_2 \geq 2; \\ & Q(S_{0,1}^1, \mathbf{p}) \text{ for } p_1 \geq 1; & Q(S_{0,3}^0, \mathbf{p}) \text{ for } p_1 + p_2 + p_3 \geq 3. \end{aligned}$$

Furthermore, $Q(S_{g,b}^s, \mathbf{p})$ is a PL-manifold but not a sphere if and only if $p_i = 1$ for all i and $(g, b, s) \in \{(0, 2, 2), (0, 3, 1), (1, 3, 1), (1, 2, 0)\}$. In all other cases the quotient $Q(S_{g,b}^s, \mathbf{p})$ is not a PL-manifold.

We remark that $A_{\#}(S_{g,b}^s, \mathbf{p})$ and $A(S_{g,b}^s, \mathbf{p})$ coincide when $s = 0$. The topology of the non-spherical quotients is still unknown.

2.2.2 Intersection numbers

Let v_1, v_2 be two vertices in $A(S, \mathbf{p})$. We define their *intersection number* $i(v_1, v_2)$ as follows:

$$i(v_1, v_2) = \min|\dot{\alpha} \cap \dot{\beta}|,$$

where α is an essential arc in the homotopy class v_1 ($\mathring{\alpha}$ is its interior) and β is an essential arc in the homotopy class v_2 ($\mathring{\beta}$ is its interior).

Definition 2.2.8. Let τ and σ be two simplices in $A(S, \mathbf{p})$ with the same dimension. We say that σ and τ are obtained from each other by a flip if there exist vertices $v_1 \in \tau$ and $v_2 \in \sigma$ (called flippable) such that the following properties hold:

- $i(v_1, v_2) = 1$;
- $i(v_1, w) = 0$ for every $w \in \sigma \setminus v_2$;
- $i(v_2, z) = 0$ for every $z \in \tau \setminus v_1$.

Lemma 2.2.9. If α, β are two maximal simplices in $A(S, \mathbf{p})$, then there exists a finite sequence τ_0, \dots, τ_n of maximal simplices such that $\tau_0 = \alpha$, $\tau_n = \beta$ and τ_{i+1} is obtained by τ_i by a flip for every $i = 0, \dots, n-1$.

Proof. See Thurston [19], Hatcher [30] or Penner [56]. □

The following lemma can be easily adapted from Ivanov [33].

Invariance Lemma 2.2.10 (Intersection number). Assume $\dim A(S, \mathbf{p}) \geq 1$. Let $\phi : A(S, \mathbf{p}) \rightarrow A(S', \mathbf{p}')$ be an isomorphism. For every $\alpha_1, \alpha_2 \in A(S, \mathbf{p})$ such that $i(\alpha_1, \alpha_2) = 1$, we have $i(\phi(\alpha_1), \phi(\alpha_2)) = 1$. The same result holds for $A_{\#}(S, \mathbf{p})$.

Proof. Let us first consider the case when $\mathcal{A} = A$. Since ϕ is an isomorphism, $\dim A(S, \mathbf{p}) = \dim A(S', \mathbf{p}')$ and ϕ sends maximal simplices (that is, triangulations of (S, \mathbf{p})) into maximal simplices (that is, triangulations of (S', \mathbf{p}')). Let α and β be arcs intersecting exactly once, we can extend α to a triangulation τ_α such that the set of arcs $\tau_\beta := (\tau_\alpha \setminus \{\alpha\}) \cup \beta$ is also a triangulation of S . Let τ be the simplex of $A(S, \mathbf{p})$ defined as $\tau = \tau_\alpha \cap \tau_\beta = \tau_\alpha \setminus \alpha = \tau_\beta \setminus \beta$, it has codimension 1. Now $\phi(\tau_\alpha)$ and $\phi(\tau_\beta)$ are triangulations of (S', \mathbf{p}') , and $\phi(\tau) = \phi(\tau_\alpha) \cap \phi(\tau_\beta) = \phi(\tau_\alpha) \setminus \phi(\alpha) = \phi(\tau_\beta) \setminus \phi(\beta)$ has codimension 1. Hence, one can pass from $\phi(\tau_\alpha)$ to $\phi(\tau_\beta)$ with one elementary move. We have necessarily $i(\phi(\alpha), \phi(\beta)) = 1$.

Let us adapt the argument for $A_{\#}(S, \mathbf{p})$. Let \mathcal{V} be the set of all vertices of $A_{\#}(S, \mathbf{p})$ which correspond to simple closed loops around exactly one point in \mathcal{S} . It is easy to see that any maximal simplex σ of $A_{\#}(S, \mathbf{p})$ contains exactly s disjoint elements of \mathcal{V} . Now let $\alpha_1, \alpha_2 \in A_{\#}(S, \mathbf{p})$ be such that $i(\alpha_1, \alpha_2) = 1$. Notice that for each $v \in \mathcal{V}$ we have $i(v, \alpha) \neq 1$ for all $\alpha \in A_{\#}(S, \mathbf{p})$, so nor α_1 nor α_2 are elements in \mathcal{V} . Let us extend α_1, α_2 to maximal simplices $\sigma_{\alpha_1}, \sigma_{\alpha_2}$ such that $\sigma_{\alpha_2} = \langle \sigma_{\alpha_1} \setminus \alpha_1, \alpha_2 \rangle$ is the simplex spanned by $\sigma_{\alpha_1} \setminus \alpha_1$

and α_2 . Let us define $\sigma_0 = \sigma_{\alpha_1} \cap \sigma_{\alpha_2}$, it is a simplex of codimension 1. Both $\phi(\sigma_{\alpha_1}) = \langle \phi(\sigma_{\alpha_0}), \phi(\alpha_1) \rangle$ and $\phi(\sigma_{\alpha_2}) = \langle \phi(\sigma_{\alpha_0}), \phi(\alpha_2) \rangle$ are maximal simplices in $A_{\sharp}(S, \mathbf{p})$. Now let us realize $\phi(\sigma_0)$ and look at its complement on S . Since $\phi(\sigma_0)$ has codimension 1, its complement contains at most one element of \mathcal{V} . If the complement contains exactly one element $v \in \mathcal{V}$, then we would have $v = \phi(\alpha_1) = \phi(\alpha_2)$, in contradiction with the injectivity: in fact the simplices $\phi(\sigma_{\alpha_1}), \phi(\sigma_{\alpha_2})$ being both maximal simplices, both of them have the same number s of elements of \mathcal{V} . Thus all the complementary regions of $\phi(\sigma_0)$ are open triangles except one open square which should contain both $\phi(\alpha_1)$ and $\phi(\alpha_2)$. We then conclude that $i(\phi(\alpha_1), \phi(\alpha_2)) = 1$. \square

The following lemma, which gives a useful criterion to establish whether two automorphisms coincide or not, follows easily from the Invariance Lemma above.

Lemma 2.2.11. *Fix $\phi_1, \phi_2 \in \text{Aut } A(S, \mathbf{p})$. If there exists a maximal simplex $\sigma = \langle a_1, \dots, a_M \rangle$ in $A(S, \mathbf{p})$ such that $\phi_1(a_i) = \phi_2(a_i)$ for all $i = 1, \dots, M$, then $\phi_1(v) = \phi_2(v)$ for all $v \in A(S, \mathbf{p})$.*

2.3 Proof of Theorem A

The purpose of this section is to state and prove Theorem A and some Invariance Lemmas that will be used throughout the chapter.

Let us first recall some well-known definitions (a classical reference for simplicial topology is [51]). Let K be a nonempty simplicial complex and let σ be one of its simplices. The *link* $\text{Lk}(\sigma, K)$ of σ is the subcomplex of K whose simplices are the simplices τ such that $\sigma \cap \tau = \emptyset$ and $\sigma \cup \tau$ is a simplex of K . Let K_1 and K_2 be two simplicial complexes whose vertex sets V_1 and V_2 are disjoint. The *join of K_1 and K_2* is a simplicial complex $K_1 \star K_2$ with vertex set $V_1 \cup V_2$; a subset of $V_1 \cup V_2$ is a simplex of $K_1 \star K_2$ if and only if it is a simplex of K_1 , a simplex of K_2 or the union of a simplex of K_1 and a simplex of K_2 . We have $\dim(K_1 \star K_2) = \dim K_1 + \dim K_2 + 1$. A *cone* $C(K)$ over K is a simplicial complex isomorphic to $K \star \{w_0\}$.

It is important to remark that the link of a simplex in the arc complex of a surface can be described in term of the arc complex of "simpler" surfaces. In fact, according to the topological properties of the base arcs (separating, non-separating, etc) the link of a simplex is the join of the arc complexes of the surfaces obtained by cutting along the arcs in the simplex. In Figure 2.4 we show the surfaces obtained cutting along the arc v , in particular how to add marked points on the boundary components created by v .

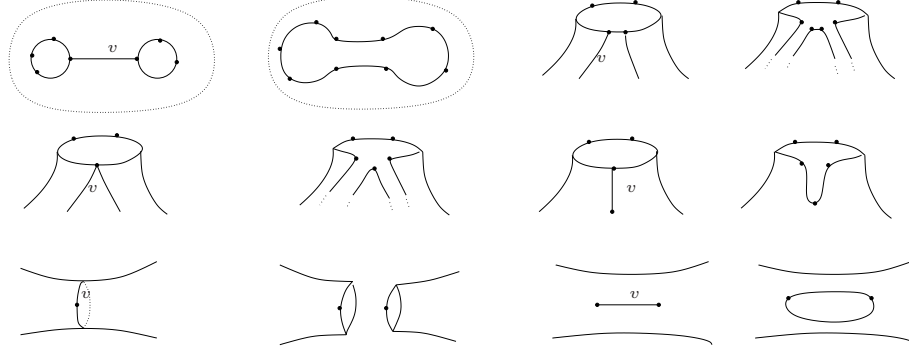
Figure 2.4: Cutting along v on S

According to the vocabulary above, we deduce from Lemma 2.2.11 the following:

Lemma 2.3.1. *Let $v \in A(S_{g,b}^s, \mathbf{p})$ be a vertex. If $\phi, \psi \in \text{Aut } A(S_{g,b}^s, \mathbf{p})$ fix v and coincide on each vertex of $\text{Lk}(v)$, then $\phi = \psi$.*

The following remarks are immediate and very useful.

Remark 2.3.2. *The following holds:*

1. $\text{Lk}(v, A(S, \mathbf{p})) = \emptyset$ if and only if $(g, s, b, \mathbf{p}) \in \{(0, 1, 0, (4)), (0, 1, 1, (1))\}$.
2. $\text{Lk}(v, A(S, \mathbf{p}))$ consists of two disjoint vertices if and only if $(g, s, b, \mathbf{p}) \in \{(0, 1, 0, (5)), (0, 1, 1, (2)), (0, 2, 0, (1, 1))\}$.
3. Assume $\dim A(S, \mathbf{p}) \geq 1$, and let v_1, v_2 be two vertices in $A(S, \mathbf{p})$. $\text{Lk}(v_1) = \text{Lk}(v_2)$ as subsets of $A(S, \mathbf{p})$ if and only if $v_1 = v_2$. The same statement holds for $A_{\#}(S, \mathbf{p})$.
4. $A(S, \mathbf{p})$ is a cone if and only if $(g, s, b, \mathbf{p}) = (0, 1, 1, (1))$, i.e. if and only if $A(S, \mathbf{p})$ is a single point.
5. The join of two arc complexes is a cone if and only if one of the two arc complexes is $A(S_{0,1}^1, (1))$.

Remark 2.3.3. *The following holds:*

1. $\text{diam} A_{\#}(S_{g,b}^s, (1_b)) \geq \text{diam} A(S_{g,b}^s, (1_b)) \geq \text{diam} A(S_{g,b+s})$. In particular, if $\text{diam} A(S_{g,b+s})$ is infinite, $\text{diam} A_{\#}(S_{g,b}^s, (1_b))$ and $\text{diam} A(S_{g,b}^s, (1_b))$ are infinite as well.

2. If $\text{diam}A(S_{g,b+s}) = \infty$, then $A(S_{g,b}^s, \mathbf{p})$ has infinite diameter or it contains a simplex σ where $\text{Lk}(\sigma) \cong A(S_{g,b}^s, (1_b))$ has infinite diameter. The same statement holds for $A_{\sharp}(S_{g,b}^s, \mathbf{p})$.
3. If there exists i such that $p_i \geq 5$ then $\text{diam}A(S_{g,b}^s, \mathbf{p}) = 2$.

Some vocabulary The purpose of this paragraph is to introduce some useful definitions we will use throughout the chapter.

Definition 2.3.4. If $p_i \geq 2$, a p_i -leaf is a simple loop on (S, \mathbf{p}) based at one marked point on \mathcal{B}_i and running parallel to \mathcal{B}_i . If $3 \leq j \leq p_i$, a j -petal is an arc on (S, \mathbf{p}) that runs parallel to \mathcal{B}_i , bounding a disk with j marked points on the boundary (see Figure 2.5).

It is immediate to see that if l is a p_1 -leaf on \mathcal{B}_1 , then $\text{Lk}(l) = A(S_{0,1}^0, (p_1 + 1)) \star A(S_{g,b}^s, (1, p_2, \dots, p_b))$. Similarly if m is a j -petal on \mathcal{B}_1 , then $\text{Lk}(m) = A(S_{0,1}^0, (j)) \star A(S_{g,b}^s, (p_1 - j + 2, p_2, \dots, p_b))$.

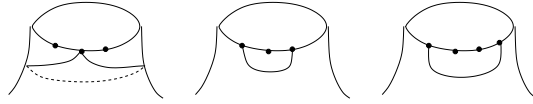

Figure 2.5: A 3-leaf, a 3-petal and a 4-petal

Definition 2.3.5. An arc l on (S, \mathbf{p}) is a drop if it is a simple loop based on a point bounding a disc with a marked point in the interior (see Figure 2.6). An edge $\langle l, v \rangle$ in $A(S, \mathbf{p})$ is an edge-drop if l is a drop and v joins the endpoint of l to the marked point as in Figure 2.6.

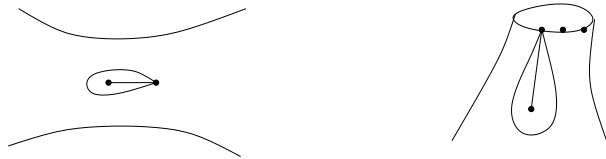

Figure 2.6: Two edge-drops

Definition 2.3.6. An arc on (S, \mathbf{p}) is properly separating if it is separating and is not a 3-petal, a 2-leaf or a drop. A non-separating arc on S is an arc that does not disconnect the surface.

Let $(S_{g,b}^s, \mathbf{p})$ be a surface and assume $b \geq 2$. We denote by $\beta^1(\mathbf{p})$ the number of boundary components of S with exactly 1 marked point on it.

Definition 2.3.7. Assume $\beta^1(\mathbf{p}) \geq 1$. We say that an edge $\langle l, w \rangle$ of $A(S_{g,b}^s, \mathbf{p})$ is an edge-bridge if l and w are as in Figure 2.7, that is, w is a non-separating arc connecting two distinct boundary components (at least one with $p = 1$) and l is a separating loop surrounding the boundary component with $p = 1$.

We remark that $Lk(l) \cong A(S_{0,2}^0, (1,1)) \star A(S_{g,b}^s, \mathbf{p}') \cong \mathbb{R} \star A(S_{g,b-1}^s, \mathbf{p}')$ for a suitable \mathbf{p}' , where w is a vertex of $A(S_{0,2}^0, (1,1))$.

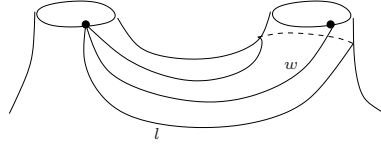

Figure 2.7: An edge-bridge

The following remark directly follows from these definitions and easily implies the invariance lemma below.

Remark 2.3.8. The following holds:

1. an arc v is properly separating if and only if $Lk(v, A(S, \mathbf{p})) = A_1 \star A_2$ where A_1 and A_2 are two arc complexes both with more than one vertex.
2. an arc l is a drop if and only if $Lk(l, A(S, \mathbf{p}))$ in $A(S_{g,b}^s, \mathbf{p})$ is a cone.
3. an arc v is a 4-petal or a 3-leaf if and only if $Lk(v, A(S, \mathbf{p})) = A_1 \star A_2$, with A_1 consisting of two disjoint vertices, and A_2 the arc complex of the surface obtained cutting along v .

Lemma 2.3.9. The following holds:

1. Set $K_1 = A(S_{0,1}^0, (4))$, i.e. the simplicial complex given by two disjoint vertices. Set $K_2 = A(S, \mathbf{p})$ of dimension at least 1. If K'_1 and K'_2 are non-empty arc complexes such that $K_1 \star K_2$ is isomorphic to $K'_1 \star K'_2$, then K'_1 is isomorphic K_1 and K'_2 is isomorphic K_2 (up to reordering).
2. Set $K_1 = A(S_{0,2}^0, (1,1))$, i.e. the simplicial complex isomorphic to \mathbb{R} and set $K_2 = A(S, \mathbf{p})$ of dimension at least 1 and infinite diameter. If K'_1 and K'_2 are non-empty arc complexes such that $K_1 \star K_2$ is isomorphic $K'_1 \star K'_2$, then K'_1 is isomorphic K_1 and K'_2 is isomorphic to K_2 (up to reordering).

Proof. 1. We write $K_1 = \{a, b\}$. It is immediate to remark that the pair $\{a, b\}$ is the unique pair of vertices in $K_1 \star K_2$ whose links are equal as subsets of $K_1 \star K_2$. If $\phi : K_1 \star K_2 \rightarrow K'_1 \star K'_2$ is an isomorphism, then $\phi(a)$ and $\phi(b)$ are necessarily in the same K'_i (otherwise they would be connected by an edge). Since K'_i is an arc complex as well, it contains two vertices with the same link if and only if it is isomorphic to K_1 (Proposition 2.3.2).

2. Let $v \in K_1 = A(S_{0,2}^0, (1, 1)) \cong \mathbb{R}$ be a vertex, and let $\phi : K_1 \star K_2 \rightarrow K'_1 \star K'_2$ be an isomorphism. Assume $\phi(v) \in K'_1$, we have:

$$\{a, b\} \star K_2 = Lk(v, K_1) \star K_2 = Lk(v, K_1 \star K_2) \cong Lk(\phi(v), K'_1 \star K'_2) = Lk(\phi(v), K'_1) \star K'_2.$$

Now $Lk(\phi(v), K'_1)$ is either isomorphic to an arc complex A or to a join of arc complexes $A_1 \star A_2$. In the first case we conclude by a straightforward application of (1). In the second case, by the argument used in (1) we have that one among A_1, A_2, K'_2 is isomorphic to $\{a, b\}$. If $K'_2 \cong \{a, b\}$, we conclude by (1). If $A_1 \cong \{a, b\}$, we deduce $K_2 \cong A_2 \star K'_2$, in contradiction with the hypothesis on the diameter of K_2 . \square

Invariance lemmas The purpose of this paragraph is to prove that the types of arcs above defined are simplicial invariant. The invariance lemmas we prove here will be used throughout the paper.

Invariance Lemma 2.3.10 (Separating arcs). *Assume $\dim A(S_{g,b}^s, \mathbf{p}) \geq 2$. Let $\phi : A(S_{g,b}^s, \mathbf{p}) \rightarrow A(S_{g',b'}^{s'}, \mathbf{p}')$ be an isomorphism. The following holds:*

1. *If l is a properly separating arc, then $\phi(l)$ is a properly separating arc. The same statement holds for $A_{\#}(S, \mathbf{p})$.*
2. *If l is a drop, then $\phi(l)$ is a drop.*
3. *If $\langle l, v \rangle$ is an edge-drop, then $\langle \phi(l), \phi(v) \rangle$ is an edge-drop.*

We will see later that (2) also holds for $A_{\#}(S, \mathbf{p})$ and that separating arcs are ϕ -invariant as well.

Proposition 2.3.11. *Let $\phi : A(S_{g,b}^s, \mathbf{p}) \rightarrow A(S_{g',b'}^{s'}, \mathbf{p}')$ be an isomorphism. Denote by \mathcal{S} and \mathcal{S}' be the set of marked points in the interior of S and S' . We have:*

1. $s' = s$.
2. *If α is a non-separating arc with 1 or 2 endpoints on \mathcal{S} , then $\phi(\alpha)$ is a non-separating arc with 1 or 2 endpoints on \mathcal{S}' .*

Proof. By Remark 2.3.10, drops are simplicial invariants. Since the maximal dimension of a simplex spanned by a set of disjoint drops is s , isomorphic arc complexes have the same number of marked points in the interior, and we deduce (1). Statement (2) follows from (1) by passing to the link of α (and $\phi(\alpha)$). \square

Invariance Lemma 2.3.12 (Petals). *Assume $\dim A(S_{g,b}^s, \mathbf{p}) \geq 2$, and let $\phi : A(S_{g,b}^s, \mathbf{p}) \rightarrow A(S_{g',b'}^{s'}, \mathbf{p}')$ be an isomorphism. The following holds:*

1. *If l_1 is a 3-leaf, then $\phi(l_1)$ is a 3-leaf.*
2. *If l_2 is a 4-petal, then $\phi(l_2)$ is a 4-petal.*
3. *If l_3 is a 3-petal, then $\phi(l_3)$ is a 3-petal.*
4. *Set $\beta^{\geq 3}(\mathbf{p}) := \sum_{p_i \geq 3} p_i$. We have $\beta^{\geq 3}(\mathbf{p}) = \beta^{\geq 3}(\mathbf{p}')$.*

The same result holds for $A_{\sharp}(S_{g,b}^s, \mathbf{p})$.

Proof. 1. and 2. By Remark 2.3.8 (3), $\phi(l_1)$ and $\phi(l_2)$ are 3-leaves or 4-petals. It suffices to prove that if $A(S_{g,b}^s, \mathbf{p})$ contains both a 3-leaf l_1 and a 4-petal l_2 , then $\phi(l_1)$ cannot be a 4-petal and $\phi(l_2)$ cannot be a 3-leaf of $A(S_{g',b'}^{s'}, \mathbf{p}')$.

Without loss of generality, we assume $p_1 = 3$, $p_2 \geq 4$, l_1 based on \mathcal{B}_1 , and l_2 based on \mathcal{B}_2 . Under this assumption, we have:

$$\begin{aligned} \text{Lk}(l_1, A(S_{g,b}^s, \mathbf{p})) &\cong A(S_{0,1}^0, (4)) \star A(S_{g,b}^s, (1, p_2, \dots, p_b)) \\ \text{Lk}(l_2, A(S_{g,b}^s, \mathbf{p})) &\cong A(S_{0,1}^0, (4)) \star A(S_{g,b}^s, (3, p_2 - 2, \dots, p_b)). \end{aligned}$$

Let ρ_1, ρ_2 be respectively the $\frac{2\pi}{3}$ -rotation around \mathcal{B}_1 and the $\frac{2\pi}{p_2}$ -rotation around \mathcal{B}_2 . We remark that for every $i = 0, 1, 2$ the $\rho_1^i(l_1)$'s are 3-leaves and the $\rho_2^i(l_2)$'s are 4-petals. Their intersection pattern is $i(\rho_1^i(l_1), \rho_1^{j\pm 1}(l_1)) = 2\delta_{ij}$ for $i, j = 0, 1, 2$, and $i(\rho_2^h(l_2), \rho_2^{k\pm 1}(l_2)) = \delta_{hk}$ for $h, k = 0, \dots, p_2 - 1$.

By Invariance Lemma 2.2.10, the arcs $\{\phi(\rho_2^j(l_2))\}_{j=0, \dots, p_2-1}$ are all based on the same boundary component of S' , and they are all of the same type (*i.e.*, either they are all 3-leaves or they are all 4-petals). Since $p_2 \geq 4$, they are necessarily 4-petals, hence $\phi(l_1)$ is necessarily a 3-leaf.

3. Remark that if l_3 is a 3-petal based on \mathcal{B}_i , there exists a 4-petal (or a 3-leaf, in the case $p_i = 3$) l_4 based on \mathcal{B}_i such that $\text{Lk}(l_4, A(S, \mathbf{p})) = \{l_3, \rho_i(l_3)\} \star A(S_{g',b'}^{s'}, \mathbf{p}') \cong A(S_{0,1}^0, (4)) \star A(S_{g',b'}^{s'}, \mathbf{p}')$. By Lemma 2.3.9 and the previous case, $\phi(l_4)$ is also a 4-petal (or a 3-leaf when $p_i = 3$), and the same holds for the $\rho_i^j(l_4)$'s as well. Remark that the number p_i of points on the i -th boundary component of S is equal to the number of 3-petals based on it.

Since $i(\rho^j(l_3), \rho^{j+1}(l_3)) = 1$ for all $j = 0, \dots, p_i - 1$, our conclusion follows by simpliciality as in the previous case.

The last statement follows directly from the arguments used here. It is also immediate to see that this proof works for $A_{\#}(S, \mathbf{p})$ as well. \square

The arguments in Lemma 2.3.12 easily prove the following:

Corollary 2.3.13. *Let $\phi \in \text{Aut } A(S, \mathbf{p})$ be an automorphism. The following holds:*

1. *For every boundary component \mathcal{B} of S there exists $f \in \text{MCG}^*(S, \mathbf{p})$ such that $f_* \circ \phi$ fixes every 3-petal (or every 2-leaf) on \mathcal{B} .*
2. *If $f \in \text{MCG}^*(S, \mathbf{p})$ fixes two intersecting 3-petal (or 2-leaves), then ϕ fixes every 3-petal (or 2-leaf).*

Invariance Lemma 2.3.14 (Edge-bridges). *Assume $\dim A(S_{g,b}^s, \mathbf{p}) \geq 2$. Let $\phi : A(S_{g,b}^s, \mathbf{p}) \rightarrow A(S_{g',b'}^s, \mathbf{p})$ be an isomorphism. The following holds:*

1. *if v joins two distinct boundary components of S , then $\phi(v)$ is an arc of the same type.*
2. *if v joins a point in \mathcal{P} and a point in \mathcal{S} , then $\phi(v)$ is an arc of the same type on S' .*
3. *If $\langle l, w \rangle$ is an edge-bridge, then $\langle \phi(l), \phi(w) \rangle$ is an edge-bridge. Moreover, $\phi(l)$ is an arc of the same type of l , $\phi(w)$ is an arc of the same type of w and $\beta^1(\mathbf{p}) = \beta^1(\mathbf{p}')$.*

The results in (1) and (3) also hold for $A_{\#}(S_{g,b}^s, \mathbf{p})$.

Proof. 1. Assume v joining \mathcal{B}_1 and \mathcal{B}_2 . Let (S'', \mathbf{p}'') be the surface obtained cutting along v . We have $Lk(v, A(S, \mathbf{p})) = A(S'', \mathbf{p}'')$, and $\beta^{\geq 3}(\mathbf{p}'') = p_1 + p_2 + 2 + \sum_{p_{h+3} \geq 3} p_{h+3} > \beta^{\geq 3}(\mathbf{p})$.

It is not difficult to see that by Invariance Lemmas 2.3.10, 2.3.12, 2.3.11, either $\phi(v)$ is a non-separating arc with both endpoints in \mathcal{P} or it is a 2-leaf. By contradiction, assume $\phi(v)$ is a 2-leaf. Let (S''', \mathbf{p}''') be the surface obtained cutting (S', \mathbf{p}') along $\phi(v)$, by Lemma 2.3.12 we have:

$$\beta^{\geq 3}(\mathbf{p}''') = \beta^{\geq 3}(\mathbf{p}') = \beta^{\geq 3}(\mathbf{p}).$$

Moreover, we have $Lk(\phi(v), A(S', \mathbf{p}')) = A(S''', \mathbf{p}''') \cong A(S'', \mathbf{p}'') = Lk(v, A(S, \mathbf{p}))$. Again by Lemma 2.3.12, we have $\beta^{\geq 3}(\mathbf{p}''') = \beta^{\geq 3}(\mathbf{p}'')$, in contradiction with the above calculations.

2. By Lemma 2.3.11 it is not difficult to prove that $\phi(v)$ is either an arc of the same type or a loop based in \mathcal{S} . The latter case can be excluded as in (1).

3. It follows easily from Lemma 2.3.9 and the statements (1), (2). \square

Invariance Lemma 2.3.15 (Non-separating arcs). *Assume $\dim A(S_{g,b}^s, \mathbf{p}) \geq 2$. Let $\phi : A(S_{g,b}^s, \mathbf{p}) \rightarrow A(S_{g',b'}^{s'}, \mathbf{p}')$ be an isomorphism. The following holds:*

1. *if v is a non-separating arc, then $\phi(v)$ is a non-separating arc;*
2. *if v is a 2-leaf, then $\phi(v)$ is a 2-leaf.*

The same result holds for $A_{\sharp}(S_{g,b}^s, \mathbf{p})$.

Proof. 1. We first remark that if v is a loop based in \mathcal{S} , then $\phi(v)$ is an arc of the same type (it follows easily from Lemma 2.3.11-(2), 2.3.14 and Lemma 2.3.10). Now let v be a 2-leaf, and recall $Lk(v) = A(S, (1, p_2, \dots, p_b))$ (up to reordering the \mathcal{B}_i 's). By Lemma 2.3.10 either $\phi(v)$ is a 2-leaf or $\phi(v)$ is a non-separating arc.

By contradiction, assume $\phi(v)$ is a non-separating arc. From Lemma 2.3.14 and the above remark, it follows that $\phi(v)$ is a loop based on a point in \mathcal{P}' on some boundary component, say \mathcal{B}'_1 (up to reordering). We have:

$$Lk(\phi(v)) = A(S_{g',b'+1}^s, (1, p'_1+1, \dots, p'_b)) \cong A(S_{g,b}^s, (1, p_2, \dots, p_b)) = Lk(v, A(S, \mathbf{p})).$$

Now if $p'_1 \geq 2$, by Lemma 2.3.12 we have:

$$\beta^{\geq 3}((1, p'_1+1, \dots, p'_b)) > \beta^{\geq 3}(\mathbf{p}') = \beta^{\geq 3}(\mathbf{p}) = \beta^{\geq 3}(1, p_2, \dots, p_b),$$

and we get to a contradiction.

It $p'_1 = 1$, by Invariance Lemma 2.3.12 $\beta^1(1, p'_1+1, \dots, p'_b) = \beta^1(1, p_2, \dots, p_b)$, but it is immediate to see that $\beta^1(1, p'_1+1, \dots, p'_b) = \beta^1(\mathbf{p}') = \beta^1(\mathbf{p})$ and $\beta^1(1, p_2, \dots, p_b) = \beta(\mathbf{p}) + 1$. Hence, we get to a contradiction.

2. It follows easily by Invariance Lemma 2.3.11 and (2). \square

Invariance Lemma 2.3.16 (Leaves). *Assume $\dim A(S_{g,b}^s, \mathbf{p}) \geq 2$. Let $\phi : A(S_{g,b}^s, \mathbf{p}) \rightarrow A(S_{g',b'}^{s'}, \mathbf{p}')$ be an isomorphism. If $p_i \geq 2$ and l is a p_i -leaf, then $\phi(l)$ is a p_i -leaf. The same result holds for $A_{\sharp}(S_{g,b}^s, \mathbf{p})$.*

Proof. By Lemma 2.3.15 and Lemma 2.3.12 of 3-petals and 2-leaves, it follows that if α is an arc with both endpoints on the same boundary component on S , then $\phi(\alpha)$ is an arc of the same type on S' . Moreover, if the endpoints of α are distinct, the endpoints of $\phi(\alpha)$ are distinct as well.

By contradiction suppose $\phi(l)$ is not a leaf. By the above discussion $\phi(l)$ is a separating loop based on some \mathcal{B}'_i with $p'_i = p_i$, and $\phi(l)$ is not homotopic to \mathcal{B}'_i . Hence, there exists k a non-separating arc with 2 different endpoints on \mathcal{B}' such that $\iota(k, \phi(l)) = 0$. By the above discussion k is an arc with the same property and we get to the contradiction $\iota(\phi^{-1}(k), l) = 0$. \square

It is now immediate to deduce Theorem A.

Theorem A. *If $\dim A(S_{g,b}^s, \mathbf{p}) \geq 2$ and $A(S_{g,b}^s, \mathbf{p})$ is isomorphic to $A(S_{g',b'}^{s'}, \mathbf{p}')$, then $s = s'$, $b = b'$, $g = g'$ and $p_i = p'_i$ for all i (up to reordering).*

Proof. The equality $s = s'$ was proved in Lemma 2.3.11. The equality $p_i = p'_i$ for all i (up to reordering) is an immediate consequence of Lemma 2.3.16. The equality $b = b'$ follows from Lemma 2.3.14-(3). Finally $g = g'$ follows from all the above and $\dim A(S_{g,b}^s, \mathbf{p}) = \dim A(S_{g',b'}^{s'}, \mathbf{p}')$. \square

2.4 Proof of Theorem B

In this section we deal with the proof of Theorem B. The main idea is to prove directly the low-dimensional cases and then use invariance lemmas to reduce the problem to "smaller" surfaces.

The structure of the section is the following: in Subsection 2.4.1 we deal with the case $g = 0$, in Subsection 2.4.2 we deal with the cases $b = 0$ and $b = 1$, and in Subsection 2.4.3 we prove the reduction lemmas and complete the proof of Theorem B.

We denote by $\text{Aut} A(S_{g,b}^s, \mathbf{p})$ the automorphism group of $A(S_{g,b}^s, \mathbf{p})$. We recall that $\text{MCG}^*(S_{g,b}^s, \mathbf{p})$ acts naturally by simplicial automorphisms on $A(S_{g,b}^s, \mathbf{p})$.

Definition 2.4.1. *Let $(S_{g,b}^s, \mathbf{p})$ be a surface such that its arc complex $A(S_{g,b}^s, \mathbf{p})$ is not empty. We say that $A(S_{g,b}^s, \mathbf{p})$ is rigid if its automorphism group $\text{Aut} A(S_{g,b}^s, \mathbf{p})$ is isomorphic to the mapping class group $\text{MCG}^*(S_{g,b}^s, \mathbf{p})$.*

$A(S_{g,b}^s, \mathbf{p})$ is weakly rigid if the natural homomorphism $\text{MCG}^(S_{g,b}^s, \mathbf{p}) \rightarrow \text{Aut} A(S_{g,b}^s, \mathbf{p})$ is surjective.*

We will prove later that except a few cases the two notions of rigidity and weak rigidity are equivalent.

2.4.1 Examples in genus 0

The purpose of this section is to prove Theorem B for some genus 0 surfaces.

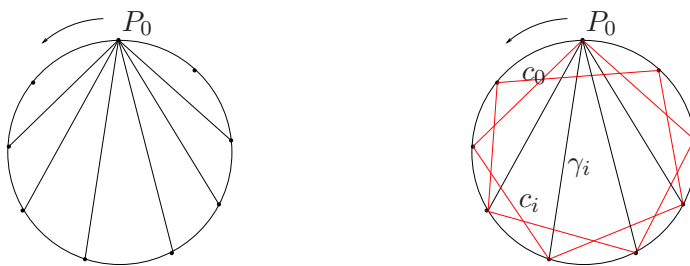

Figure 2.8: Fans and chords

The disk $(S_{0,1}^0, (n))$ Let $(S_{0,1}^0, (n))$ be a disk with a set $\mathcal{P} = \{P_0, \dots, P_{n-1}\}$ of $n \geq 4$ marked points on its boundary (enumerated with respect to the order induced by the orientation of ∂S). We denote by $\rho_{\frac{2\pi}{n}}$ the $\frac{2\pi}{n}$ -rotation around the boundary. The following is a well-known result.

Theorem 2.4.2. $A(S_{0,1}^0, (n))$ is PL-homeomorphic to \mathbb{S}^{n-4} .

Proof. See for instance [8] or [57]. □

For every $P \in \mathcal{P}$, the P -fan F_P is the triangulation as in Figure 2.8. The P -chord c_P is the 3-petal joining the two marked points adjacent to P . If $P = P_i$, we will write c_i and F_i for short.

It is immediate to see that a triangulation T of the surface is a fan if and only if there exists $P \in \mathcal{P}$ such that $Lk(c_P, A(S, (n))) \cap T = \emptyset$. Moreover, any 3-petal is a chord with respect to a unique point $P \in \mathcal{P}$.

Let $\mathcal{C} = \{c_i\}_{i=0, \dots, n-1}$ be the set of all the chords in $(S_{0,1}^0, (n))$. According to our notation, we remark that $\iota(c_i, c_{i\pm 1}) = 1$ for $i = 0, \dots, n-1$ and $\iota(c_i, c_j) = 0$ for $|i - j| \neq 1$.

Let $F_0 = \{\gamma_i\}_{i=2, \dots, n-2}$ be the P_0 -fan, and γ_i the arc joining P_0 to P_i . According to our notation, we have $\iota(c_0, \gamma_i) = 1$ for all $i = 2, \dots, n-2$, and $\iota(c_i, \gamma_i) = 1$ for all $i = 2, \dots, n-2$. In all the other cases, we have $\iota(c_i, \gamma_j) = 0$.

The following lemma can be easily deduced from Lemma 2.2.10:

Lemma 2.4.3. Let $\phi : A(S_{0,1}^0, (n)) \rightarrow A(S_{0,1}^0, (n))$ be an automorphism. The following holds:

1. If \mathcal{C} is the all set of chords of S , then $\phi(\mathcal{C}) = \mathcal{C}$, and ϕ either preserves or reverses the order of arcs in \mathcal{C} .
2. Let $F_P = \{\gamma_i\}$ be the P -fan in the above notation. There exists $P' \in \mathcal{P}$ such that $\phi(F_P) = \{\phi(\gamma_i)\}$ is a fan triangulation $F_{P'}$. The map ϕ either preserves or reverses the order of arcs in F_P .

The following holds:

Theorem 2.4.4 (Weak rigidity of $A(S_{0,1},(n))$). *For $n \geq 4$, $A(S_{0,1}^0,(n))$ is weakly rigid.*

Proof. By Lemma 2.2.11 it suffices to prove that if F_P is a fan and $\phi \in \text{Aut}A(S_{0,1}^0,(n))$, then there exists a homeomorphism $\tilde{\phi}$ of the base disk such that $\tilde{\phi}_*$ agrees with ϕ on each arc of F_P .

Up to precomposition with an automorphism induced by a rotation $\rho_{\frac{2\pi}{n}}^j$, we assume $\phi(F_P) = F_P$. By Lemma 2.4.3, the order of arcs in F_P is either preserved or reversed. Up to precomposition with an automorphism induced by a reflection, we can assume that ϕ preserves the order of arcs in F_P . Up to isotopy, we can also assume that ϕ fixes each arc pointwise. By Lemma 2.3.1, we can conclude by extending ϕ to a homeomorphism of the disc by the identity on the inner triangles. \square

Annuli In this paragraph we study the annulus $(S_{0,2}^0,(p_1,p_2))$. We denote by ρ_1 and ρ_2 the two rotations (respectively of $\frac{2\pi}{p_1}$ and $\frac{2\pi}{p_2}$) around the two boundary components of S , and by i the inversion that exchanges the two boundary components of the surface.

Example 2.4.5 (Annulus $(S_{0,2}^0,(1,1))$).

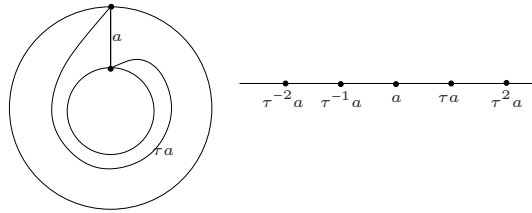
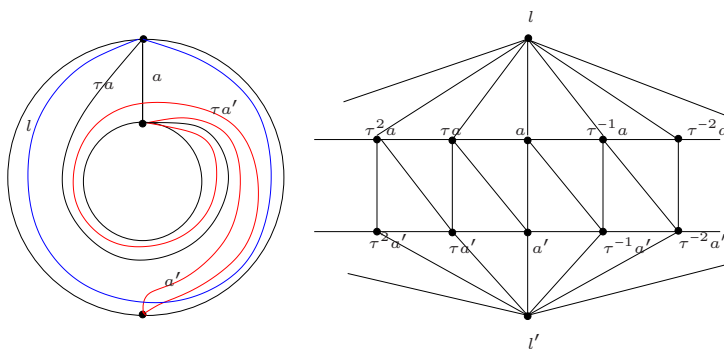

Figure 2.9: Annulus

If a is an arc as in Figure 2.9, then $\text{MCG}^*(S_{0,2}^0,(1,1))$ is generated by $\langle \tau, r, i \rangle$, where τ is the Dehn twist along the core curve of the annulus, r is the reflection with respect to a , and i is the inversion that exchanges the two boundary components of S . For every arc α in $A(S_{0,2}^0,(1,1))$ we have $i(\alpha, \tau\alpha) = 0$, hence $A(S_{0,2}^0,(1,1))$ is isomorphic to the real line.

Notice that the natural homomorphism $\text{MCG}^*(S_{0,2}^0,(1,1)) \rightarrow \text{Aut} A(S_{0,2}^0,(1,1))$ is surjective but not injective: r and i have the same image.

Figure 2.10: $(S_{0,2}, (1, 2))$ and $A(S_{0,2}, (1, 2))$

Example 2.4.6 (Annulus $(S_{0,2}^0, (1, 2))$).

Let τ be the Dehn twist around the core of the annulus, let ρ be the π -rotation that exchanges the two marked points and let r be the reflection that fixes the three marked points. It is easy to see that the group $\text{MCG}^*(S_{0,2}^0, (1, 2))$ is generated by the elements τ, ρ, r .

Theorem 2.4.7 (Annuli). *For every $p_1, p_2 \in \mathbb{N} \setminus \{0\}$, $A(S_{0,2}^0, (p_1, p_2))$ is weakly rigid. If $p_1 = p_2 = 1$, $A(S_{0,2}^0, (p_1, p_2))$ is not rigid.*

Proof. Assume $p_1 \geq 2$. Let a be an arc joining the two boundary components. Let ϕ be an automorphism of $A(S_{0,2}^s, (p_1, p_2))$. By Lemma 2.3.15, we can assume $\phi(a) = a$ and by Lemma 2.3.13 we can assume that ϕ fixes every 3-petal (or 2-leaf) in the first boundary component. Cutting the surface along a , we find a new surface $(S_{0,1}^s, (p_1 + p_2 + 2))$. The map ϕ induces by restriction an automorphism $\phi|$ that fixes at least two intersecting 3-petals. By Lemma 2.3.13, $\phi|$ fixes any other 3-petal. By Theorem 2.4.4, $\phi|$ is induced by a homeomorphism of the surface that restricts to the identity on the boundary. We can glue back the two pieces of the boundary coming from the cut along a in order to get a homeomorphism of the annulus that induces ϕ by Lemma 2.3.1.

To conclude, just notice that if $p_1 = p_2 = 1$, then r and i have the same image. \square

2.4.2 Surfaces with one boundary component

The purpose of this section is to prove Theorem B for surfaces with one boundary component. This subsection is structured as follows: in the first paragraph we study the properties of a natural forgetful map between $A(S_{g,1}^0, (1))$

and $A(S_g^1)$; in the second paragraph we introduce a useful reduction lemma and prove Theorem B for surface with $b = 1$; in the third paragraph we deal with the case $b = 0$, providing a new proof of a result by Irmak-McCarthy.

We will first work on the pair $(S_{g,1}^0, (1)) = (S_{g,1}^0, P)$ and we denote by P the unique marked point on the boundary of S . We will assume $g \geq 1$.

The forgetful map Recall that the Dehn-twist τ around the boundary of S is not the identity in $\text{MCG}^*(S_{g,1}^s, P)$. Let a be a simple loop based at P on S , and let $a^-, a^+ = \tau a^-$ be the arcs obtained from a twisting only one of its two endpoints (see Figure 2.11). The natural inclusion $(S_{g,1}^s, P) \hookrightarrow S_{g,1}^s$, which "forgets" about P , induces a natural *forgetful map* as follows

$$\begin{aligned} f : A(S_{g,1}^s, P) &\rightarrow A(S_{g,1}^s) \cong A(S_g^{s+1}) \\ [a]_P &\mapsto [a] \end{aligned}$$

where the vertex $[a]_P \in A(S, P)$, that corresponds to a , is mapped to the vertex $[a] \in A(S_{g,1}^s)$ forgetting about P . We remark that $f([\tau^n a]_P) = f([\tau^n a^-]_P) = f([\tau^n a^+]_P)$.

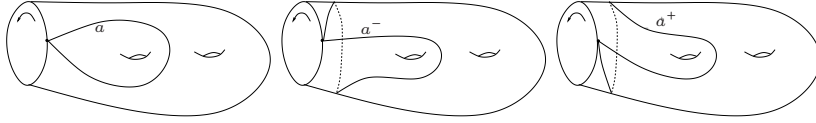

Figure 2.11: a^-, a^+

The following lemma is not difficult to prove.

Lemma 2.4.8. *Let f as above. The following holds:*

1. f is well-defined, simplicial and surjective, and for every vertex $[a] \in A(S)$, $f^{-1}([a])$ is a 1-dimensional simplicial complex isomorphic to \mathbb{R} .
2. If $\phi \in \text{Aut}(A(S, P))$ is an automorphism induced by an element of $\text{MCG}^*(S, P)$, then for every $[a] \in A(S, P)$ the restriction of ϕ is an isomorphism: $\phi|_1 : f^{-1}([a]) \rightarrow f^{-1}([\phi(a)])$. Moreover, there is a well-defined simplicial map $f(\phi) : A(S, \mathbf{p}) \ni [a] \mapsto A(S) \ni f([\phi(a)])$ that is also an automorphism.
3. If $\tau : (S, P) \rightarrow (S, P)$ is the Dehn twist around ∂S , then $\tau_* : A(S, P) \rightarrow A(S, P)$ is a 2-translation on the fiber $f^{-1}([a])$ for each $[a] \in A(S)$, and $f(\tau) : A(S) \rightarrow A(S)$ is the identity.

Lemma 2.4.9. *If $\sigma : A(S, P) \rightarrow A(S, P)$ is an automorphism such that $f(\sigma) : A(S) \rightarrow A(S)$ is well-defined and $f(\sigma) = id_{A(S)}$, then $\sigma = id_{A(S, P)}$ or there exists $k \in \mathbb{Z}$ such that $\sigma = \tau_*^k$, where τ is a twist around ∂S .*

Proof. Claim 1: there exists a vertex $[a] \in A(S)$ such that the restriction $\sigma| : f^{-1}([a]) \rightarrow f^{-1}([a])$ is not a 1-translation.

By contradiction, suppose that for all vertices $[a] \in A(S)$, $\sigma| : f^{-1}([a]) \rightarrow f^{-1}([a])$ is a 1-translation. Let us fix a hyperbolic metric with geodesic boundary on S . Recall that any vertex of $A(S)$ has exactly one shortest geodesic representative in its isotopy class; geodesic representatives intersect each other minimally and are orthogonal to the boundary. Let \bar{a} be this geodesic representative for $[a]$.

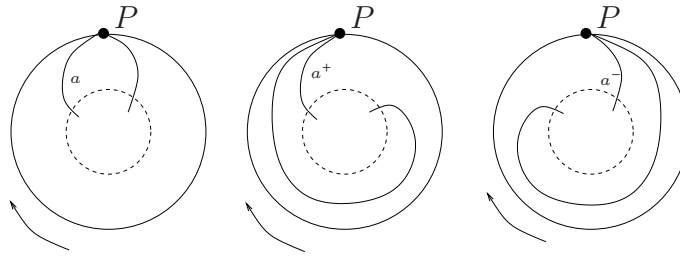

Figure 2.12: Lemma 2.4.9

We define $a, a^+, a^- \in A(S, P)$ to be the classes of the loops obtained joining the endpoints of \bar{a} to P as in Figure 2.12. Remark that $\tau a^- = a^+$. Similarly for every vertex $[b] \in Lk([a], A(S))$ define $b, b^-, b^+ \in f^{-1}([b])$. The connections between the fibers $f^{-1}([a])$ and $f^{-1}([b])$ are described in Figures 2.13, 2.14, 2.15 (up to exchange $[a]$ and $[b]$). It is not difficult to see that the three configurations can be realized by suitable choices of $\langle [a], [b] \rangle$ in $A(S)$.

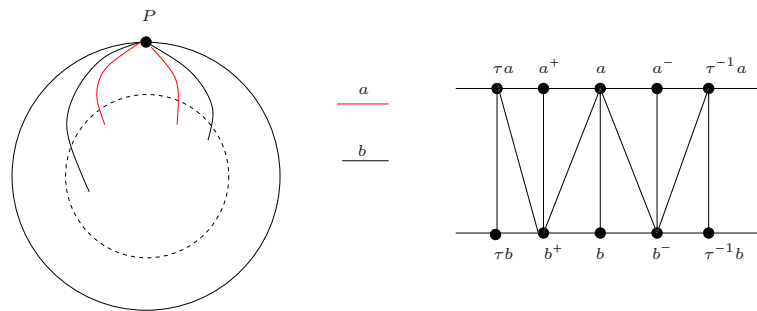

Figure 2.13: Lemma 2.4.9: case 1

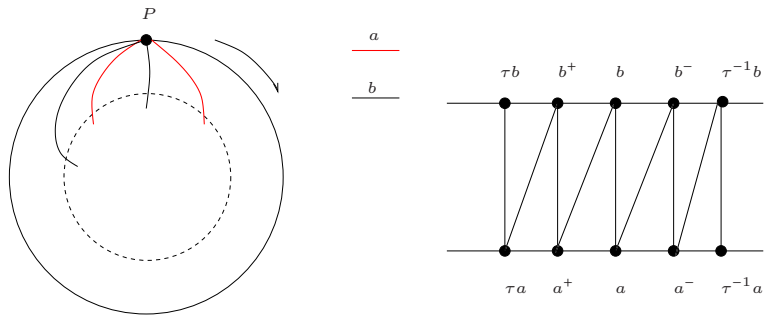

Figure 2.14: Lemma 2.4.9: case 2

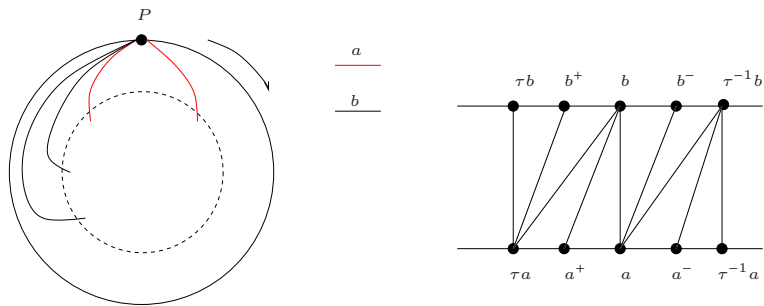

Figure 2.15: Lemma 2.4.9: case 3

In particular, in Case 3 we have $|Lk(a, A(S, P)) \cap f^{-1}([b])| = 1$ and $|Lk(a^\pm, A(S, P)) \cap f^{-1}([b])| = 3$, in contradiction with the assumption $\sigma(a) = a^\pm$ and $\sigma(f^{-1}([b]) = f^{-1}([b])$.

Claim 2: there exists a vertex $[a] \in A(S)$ such that $\sigma_1 : f^{-1}([a]) \rightarrow f^{-1}([a])$ is not a reflection.

We will prove the claim by contradiction. Assume that $\sigma_1 : f^{-1}([a]) \rightarrow f^{-1}([a])$ is a reflection on the fiber for every $[a] \in A(S)$ vertex. In the same setting of the previous claim, the reflection of $f^{-1}([a])$ is defined as follows:

$$\rho_a : \begin{cases} a & \mapsto a \\ a^- & \mapsto \tau^{-1}a^- \\ \tau^k a & \mapsto \tau^{-k}a & \text{for } k \in \mathbb{Z} \\ \tau^k a^- & \mapsto \tau^{-k-1}a^- & \text{for } k \in \mathbb{N} \end{cases}$$

Now assume that $\sigma : A(S, P) \rightarrow A(S, P)$ extends $\rho_a : f^{-1}([a]) \rightarrow f^{-1}([a])$. Recall from the proof of the previous claim that for every $[b] \in Lk([a], A(S, P))$ the fibers $f^{-1}([a])$ and $f^{-1}([b])$ are linked in three possible ways (Figures 2.13, 2.14, 2.15). By a direct calculation, it is not difficult to verify that:

- $\sigma_1 = \rho_b : f^{-1}([b]) \rightarrow f^{-1}([b])$ in Case 1;
- $\sigma_1 = \sigma_b \circ \rho_b : f^{-1}([b]) \rightarrow f^{-1}([b])$ in Case 2;
- $\sigma_1 = \sigma_b \circ \rho_b \circ \sigma_b^{-1} : f^{-1}([b]) \rightarrow f^{-1}([b])$ in Case 3.

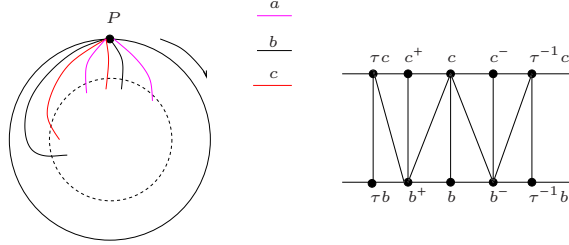

Figure 2.16: Simplicial relations between $f^{-1}([b])$ and $f^{-1}([c])$

Now assume that $[b], [c] \in A(S)$ are vertices such that $\langle [a], [b], [c] \rangle$ is a 2-simplex in $A(S)$ and they are both in Case 2. It is easy to see that the simplicial relations between $f^{-1}([b])$ and $f^{-1}([c])$ in Figure 2.16 are not compatible with the definitions of $\sigma_1 : f^{-1}([b]) \rightarrow f^{-1}([b])$ and $\sigma_1 : f^{-1}([c]) \rightarrow f^{-1}([c])$, and we get to a contradiction.

By Claim 1 and 2, σ agrees with some τ^{k_a} on each fiber $f^{-1}([a])$. Looking at the configurations in Figure 2.13 2.14, 2.15 we easily deduce that k_a is a constant that does not depend on $[a]$. \square

Lemma 2.4.10. *If $\phi : A(S, P) \rightarrow A(S, P)$ is an automorphism, then $f(\phi) : A(S) \ni [a] \mapsto f([\phi(a)]) \in A(S)$ is well-defined and it is an automorphism.*

Proof. Remark that if $\langle a, b \rangle$ is an edge of $A(S, P)$, then either $\langle f(a), f(b) \rangle$ is an edge in $A(S)$ or $f(a) = f(b)$ and $b = a^\pm \in f^{-1}([a])$ according to the above description of the fiber of $[a] \in A(S)$. Moreover, if $\langle a_1, \dots, a_M \rangle$ is a maximal simplex in $A(S, P)$, then the set $\{f(a_1), \dots, f(a_M)\}$ spans a maximal simplex in $A(S)$, and there are exactly two indices $i \neq j$ such that $f(a_i) = f(a_j)$ (that is $a_j = a_i^\pm$).

By contradiction assume that there exists $\phi \in \text{Aut } A(S, P)$ such $f(\phi)$ is not well-defined or simplicial. There are two cases:

1. there exists an edge $\langle a, b \rangle \in A(S, P)$ such that $\langle f(a), f(b) \rangle$ is an edge in $A(S)$, but $f(\phi(a)) = f(\phi(b)) \in A(S)$;
2. there exists an edge $\langle a, a^\pm \rangle \in A(S, P)$ such that $f(a) = f(a^\pm)$, $f(\phi(a^\pm)) \neq f(\phi(a))$ and $\langle f(\phi(a^\pm)), f(\phi(a)) \rangle$ is an edge in $A(S)$.

Claim 1: If $\langle a, b \rangle$ is an edge of $A(S, P)$ as in the case 1, then there does not exist $c \in A(S, P)$ such that $\langle a, b, c \rangle$ is a 2-simplex in $A(S, P)$, $\langle f(a), f(b), f(c) \rangle$ is a 2-simplex in $A(S)$ and $f(\phi(a)) = f(\phi(b)) = f(\phi(c))$.

By contradiction, let c be such a vertex, and let δ_{abc} be a maximal simplex in $A(S, P)$ that extends the 2-simplex $\langle a, b, c \rangle$. By simpliciality $\phi(\delta_{abc})$ is a maximal simplex in $A(S, P)$ that contains the simplex $\langle \phi(a), \phi(b), \phi(c) \rangle$, and $f(\phi(\delta_{abc}))$ spans a maximal simplex in $A(S)$. By the previous remark, at most two elements in the set $\{f(\phi(a)), f(\phi(b)), f(\phi(c))\}$ coincide.

Claim 2: If $\langle a, b \rangle$ be an edge as in the case 1, then $\langle a, a^\pm \rangle$ spans an edge of $A(S, P)$ as in the case 2.

Consider the 2-simplex $\langle a, a^\pm, b \rangle$ and extend it to a maximal simplex $\delta_{aa^\pm b}$ of $A(S, P)$. Notice that $\phi(\delta_{aa^\pm b})$ is a maximal simplex of $A(S, P)$, and by the above remark exactly two of its vertices have the same image through f . Now it follows from the hypothesis that if $f(\phi(a)) = f(\phi(b))$, then necessarily $f(\phi(a)) \neq f(\phi(a^\pm))$, and $\langle a, a^\pm \rangle$ is an edge of $A(S, P)$ in the case 2.

Claim 3: Let $\langle a, a^\pm \rangle$ be an edge as in the case 2, and let δ_{aa^\pm} be a maximal simplex of $A(S, P)$ extending it. δ_{aa^\pm} contains a unique vertex b^δ such that $\langle a, b^\delta \rangle$ is an edge as in the case 1.

By simpliciality $\phi(\delta_{aa^\pm})$ is a maximal simplex in $A(S, P)$. It follows from the hypothesis that $f(\phi(a)) \neq f(\phi(a^\pm))$. By the above remark there exists $b \in \delta_{aa^\pm}$ such that $f(\phi(b)) = f(\phi(a))$. Now $f(a) = f(a^\pm)$, and by Claim 1 necessarily $f(b) \neq f(a)$. The uniqueness of b follows from the same argument.

Without loss of generality we can assume that $\langle a, a^+ \rangle$ is an edge as in the case 2 (Claim 2 guarantees that such an edge exists).

In genus 1, the proof is direct. Remark that in $(S_{1,1}^0, (1))$ there is only one orbit of arcs under the action of the mapping class group. Up to pre-composition with a simplicial automorphism induced by a mapping class, we can assume $\phi(a) = a$. The map ϕ restricts to a simplicial automorphism of the annulus $(S_{0,2}^0, (1,2))$ obtained by cutting S along a . We remark that the two arcs a^+ and a^- correspond to the two 2-leaves of the annulus. By Lemma 2.3.15, ϕ preserves the set of 2-leaves, hence $\phi(a^+) \in \{a^+, a^-\}$ and $f(\phi(a^+)) = f(a)$, we get to a contradiction.

Let us now focus on the case $g \geq 2$. Let $\delta_{aa^+}^1$ be a maximal simplex of $A(S, P)$ containing $\langle a, a^+ \rangle$. Let b^1 be the unique vertex in $\delta_{aa^+}^1$ as in Claim 3. Now flip $\delta_{aa^+}^1$ on b^1 , and let $\delta_{aa^+}^2$ be the new triangulation and b^2 be the new edge. By Claims 1 and 3 the edge $\langle a, b^2 \rangle$ is necessarily as in the case 1. Now

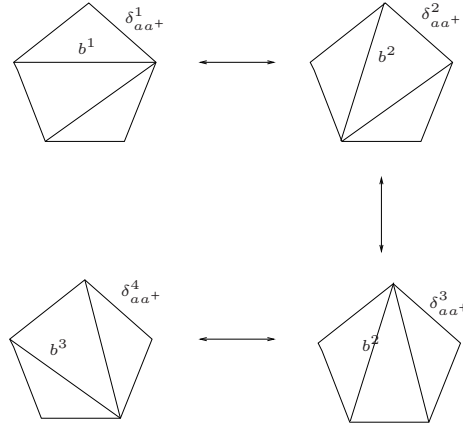

Figure 2.17: Lemma 2.4.10

since $g \geq 2$ the situation looks like in Figure 2.17 and b^2 bounds a triangle on (S, P) where at least one of the other two edges is different from both a and a^+ . Performing another flip on this edge, we find another maximal simplex $\delta_{aa^+}^3$ still containing a, a^+ and b^2 . Now flipping again on b^2 , we obtain a new maximal simplex $\delta_{aa^+}^4$ containing a, a^+ and a new edge b^3 (not contained in $\delta_{aa^+}^3$). By Claim 1 and 3, the edge $\langle a, b^3 \rangle$ is in the case 1, and $\langle b^1, a, b^3 \rangle$ spans a 2-simplex (see again 2.17), but this contradicts Claim 1. \square

A straightforward application of the previous lemmas proves the following proposition.

Proposition 2.4.11. *The forgetful map $f : A(S, P) \rightarrow A(S)$ is a simplicial*

map and it induces a homomorphism $f_* : \text{Aut } A(S, P) \rightarrow \text{Aut } A(S)$ whose kernel is generated by Dehn twists around ∂S .

Proof of Theorem B for $b = 1$ Let us now complete the proof of Theorem B for surfaces with one boundary component.

Lemma 2.4.12. *Let $S_{g,1}^0$ be a surface of genus $g \geq 1$ with one boundary component. If $A(S_{g,1}^0)$ is weakly rigid, then also $A(S_{g,1}^0, P)$ is weakly rigid.*

Proof. Let $\phi \in \text{Aut } A(S_{g,1}^0, P)$ be an automorphism. By Lemma 2.4.10 $f(\phi) \in \text{Aut } A(S_{g,1}^0)$, and it follows from the hypothesis that there exists a mapping class $\text{MCG}^*(S_{g,1}^0)$ that induces ϕ . Let $\bar{\phi} : (S, P) \rightarrow (S, P)$ be a homeomorphism in this class and let $\bar{\phi}_* : A(S, P) \rightarrow A(S, P)$ be the induced map. We have $\text{id} = f(\bar{\phi}_*^{-1} \circ \phi) : A(S_{g,1}^0) \rightarrow A(S_{g,1}^0)$. It follows that there exists $k \in \mathbb{Z}$ such that $\bar{\phi}_*^{-1} \circ \phi = \tau_*^k$, hence ϕ is induced by $\phi \circ \tau^k$. \square

The following proposition is a particular case of a theorem of Irmak and McCarthy [32]. We postpone our proof to the next section.

Proposition 2.4.13. *If $S_{g,1}^0$ is a surface of genus $g \geq 2$ with one boundary component, then the natural homomorphism $\text{MCG}^*(S_{g,1}^0) \rightarrow \text{Aut } A(S_{g,1}^0)$ is surjective.*

By an application of Lemma 2.4.12 and the previous proposition we have:

Proposition 2.4.14. *If $(S_{g,1}^0, (n))$ is a surface of genus $g \geq 1$ with one boundary component and n marked points on it, then $A(S_{g,1}^0, (n))$ is weakly rigid.*

Proof. The case $n = 1$ was studied in Lemma 2.4.12.

We will use an inductive argument. By Lemma 2.3.13, up to precomposition with an automorphism induced by a mapping class, we can assume that ϕ fixes every 3-petal or 2-leaf on the boundary of S . Let v be a 3-petal (or 2-leaf), cutting S along v we find two surfaces $(S_{g,1}^0, (1))$ and $(S_{0,1}^0, (3))$, and ϕ induces an automorphism ϕ_1 of the arc complex of $(S_{g,1}^0, (n-1))$. By induction ϕ_1 is induced by a homeomorphism ϕ_1 of $(S_{g,1}^0, (n-1))$ that fixes every point on the boundary. Lemma 2.3.1 ensures that the homeomorphism obtained by glueing ϕ_1 to a suitable homeomorphism of $(S_{0,1}^0, (3))$ induces ϕ on the whole $A(S_{g,1}^0, (n))$. \square

Theorem 2.4.15 ($b = 1$). *If $(S_{g,1}^s, (1))$ is a surface of genus $g \geq 1$, then $A(S_{g,1}^s, (1))$ is weakly rigid.*

Proof. Let $\phi \in \text{Aut } A(S_{g,1}^s, (1))$ be an automorphism. For every $i = 1, \dots, s$, let $\langle l_i, v_i \rangle$ be an edge-drop as in Lemma 2.3.10 (3). Without loss of generality we assume that the set of all edges $\{\langle l_i, v_i \rangle\}_i$ spans a simplex σ on $A(S_{g,1}^s, (1))$, and by Lemma 2.3.10, $\phi(l_i) = l_i$ and $\phi(v_i) = v_i$ for all $i = 1, \dots, s$. By restriction ϕ induces an automorphism $\phi|$ on $Lk(\sigma) = A(S_{g,1}^0, (s+1))$. It follows from Proposition 2.4.14 that $\phi|$ is induced by a homeomorphism $\tilde{\phi} : (S_{g,1}^0, (s+1)) \rightarrow (S_{g,1}^0, (s+1))$. We claim that $\tilde{\phi}$ restricts to the identity on the boundary of $(S_{g,1}^0, (s+1))$, or equivalently $\tilde{\phi}$ fixes every 3-petal on $(S_{g,1}^0, (s+1))$. Let us denote by l_{ii+1} the 3-petal of $(S_{g,1}^0, (s+1))$ that joins the i -th and the $i+1$ -th marked point on the boundary of $(S_{g,1}^0, (s+1))$. Let a_{ii+1} be the arc joining the i -th and the $i+1$ -th marked point in the interior of $(S_{g,1}^s, (1))$ as it is shown in the Figure 2.18. The intersection pattern of the a_{ii+1} 's, l_j 's and l_{ii+1} 's is the following:

$$\begin{cases} i(a_{i,i+1}, l_i) = i(a_{i,i+1}, l_{i+1}) = 1 & \text{for all } i \\ i(a_{ii+1}, l_k) = 0 & \text{for } k \neq i, i+1 \\ i(a_{i,i+1}, l_{i+1,i+2}) = i(l_{i+1,i+2}, a_{i+2,i+3}) = 1 & \text{for all } i \\ i(a_{h,h+1}, l_{k+1,k+2}) = i(l_{k+1,k+2}, a_{h+2,h+3}) = 0 & \text{for } h < k. \end{cases}$$

Using Lemmas 2.3.11-(2), 2.3.12 and the simplicial invariance of this intersection pattern, we immediately deduce $\phi(l_{ii+1}) = l_{ii+1}$ for all i . We deduce that $\tilde{\phi}$ fixes each 3-petal, and it is the identity on the boundary of $(S_{g,1}^0, (s+1))$. We can glue back the punctured disks bounded by the l_i 's and extend $\tilde{\phi}$ to a homeomorphism of the surface inducing ϕ . \square



Figure 2.18: Theorem 2.4.15

Proof of Proposition 2.4.13 In this section we will use Lemma 2.4.12 to provide a new proof of Proposition 2.4.13. Our proof does not employ Irmak-McCarthy's theorem.

Lemma 2.4.16. *Let S_g^1 be a surface of genus $g \geq 2$ with one marked point P . Let $c \in A(S_g^1)$ be an arc that separates $S = S'_c \cup S''_c$.*

For every $\phi \in \text{Aut } A(S_g^1)$, the arc $\phi(c)$ separates S in two connected components $S = S'_{\phi(c)} \cup S''_{\phi(c)}$, with $S'_{\phi(c)}$ homeomorphic to S'_c and $S''_{\phi(c)}$ homeomorphic to S''_c . Moreover, ϕ restricts to isomorphisms $\phi|_1 : A(S'_c, P) \rightarrow A(S'_{\phi(c)}, P)$ and $\phi|_2 : A(S''_c, P) \rightarrow A(S''_{\phi(c)}, P)$.

Proof. By simpliciality, $Lk(c, A(S_g^1)) = A(S'_c, P) \star A(S''_c, P) \cong Lk(\phi(c), A(S_g^1))$ has diameter 2. If $\phi(c)$ is non-separating, then $Lk(\phi(c), A(S_g^1)) \cong A(S_{g-1,2}^0, (1, 1))$ has infinite diameter (Remark 2.3.3). It follows that $\phi(c)$ separates S into two connected components $S'_{\phi(c)}$ and $S''_{\phi(c)}$.

Denote by $g(S)$ the genus of S . Recall that the following conditions are equivalent:

1. $S'_{\phi(c)}$ is homeomorphic to S'_c and $S''_{\phi(c)}$ is homeomorphic to S''_c ;
2. $(g(S'_{\phi(c)}), g(S''_{\phi(c)})) = (g(S'_c), g(S''_c))$;
3. $\dim A(S'_c, P) = \dim A(S'_{\phi(c)}, P)$;
4. the number of arcs of a triangulation of S'_c is equal to the number of arcs of a triangulation of $S'_{\phi(c)}$.

Without loss of generality we assume that S'_c has the maximum genus, that is, $g(S'_c) = \max\{g(S'_c), g(S''_c), g(S'_{\phi(c)}), g(S''_{\phi(c)})\}$.

If μ_c is a maximal simplex in $A(S_c, P)$, then $\dim \mu_c = \dim A(S_c, P)$. Let $\mathcal{J}(\mu_c)$ be the set of simplices of $Lk(c, A(S))$ obtained from μ_c by a flip. Since μ_c corresponds to a triangulation of S_c , we have:

$$|\mathcal{J}(\mu_c)| = \dim \mu_c + 1 = \dim A(S'_c, P) + 1.$$

By simpliciality, the set $\phi(\mathcal{J}(\mu_c))$ is exactly the set of simplices in $Lk(\phi(c), A(S))$ obtained from $\phi(\mu_c)$ by one flip, and $|\phi(\mathcal{J}(\mu_c))| = |\mathcal{J}(\mu_c)|$. We have that $\phi(\mu_c) = \langle \mu'_{\phi(c)}, \mu''_{\phi(c)} \rangle$, where $\mu'_{\phi(c)}$ is the empty set or a simplex in $A(S'_{\phi(c)}, P)$, and the same holds for $\mu''_{\phi(c)}$ in $A(S''_{\phi(c)}, P)$. We remark:

$$\begin{aligned} \dim \mu'_{\phi(c)} + \dim \mu''_{\phi(c)} + 2 &= \dim \phi(\mu_c) + 1 = \dim \mu_c + 1 \\ &= \dim A(S'_c, P) + 1 = |\mathcal{J}(\mu_c)| \end{aligned}$$

By contradiction, assume $0 \leq \dim \mu'_{\phi(c)} < \dim A(S'_{\phi(c)}, P)$, that is, $\mu'_{\phi(c)}$ is not empty nor a triangulation of $(S'_{\phi(c)}, P)$. Since $g \geq 2$, there are at least two different ways to extend $\mu'_{\phi(c)}$ to a triangulation of $S'_{\phi(c)}$. Since $(S'_{\phi(c)}, P)$ has only one boundary component, there exists at least one vertex of $\mu'_{\phi(c)}$ flippable in at least two different ways (see Figure 2.19). It follows:

$$|\mathcal{J}(\phi(\mu_c))| \geq \dim \mu''_{\phi(c)} + 1 + \dim \mu'_{\phi(c)} + 2 > |\mathcal{J}(\mu_c)|,$$



Figure 2.19: Lemma 2.4.16: two ways of flipping v in $\mu'_{\phi(c)}$

and we get to a contradiction. The same holds if $0 \leq \dim \mu''_{\phi(c)} < \dim A(S'_{\phi(c)}, P)$.

We deduce that either $\dim \mu'_{\phi(c)} = \dim A(S'_{\phi(c)}, P)$ (and $\mu''_{\phi(c)} = \emptyset$) or $\dim \mu''_{\phi(c)} = \dim A(S''_{\phi(c)}, P)$ (and $\mu'_{\phi(c)} = \emptyset$). In the first case $\phi(\mu_c) = \phi(\mu'_c) \subset A(S'_c, P)$ has maximal dimension. Similarly, in the second case, $\phi(\mu_c) = \phi(\mu''_c) \subset A(S''_c, P)$ has maximal dimension. The conclusion easily follows from the equivalence of the conditions 1 and 3 above. \square

This lemma proves Proposition 2.4.13:

Proposition 2.4.17. *If S_g^1 is a surface of genus $g \geq 1$ with one marked point P , then the natural homomorphism $\text{MCG}^*(S_g^1) \rightarrow \text{Aut } A(S_g^1)$ is surjective.*

Proof. Since the result is well-known for $g = 1$, we will assume $g \geq 2$.

Let $\phi \in \text{Aut } A(S_g^1)$ be a simplicial automorphism, and let $c \in A(S_g^1)$ be an arc that separates S in two subsurfaces $(S_{1,1}^0, P)$ of genus 1 and $(S_{g_2,1}^0, P)$ of genus $g_2 \geq 1$. Up to precomposing ϕ with an automorphism induced by $\text{MCG}^*(S_g^1)$, we can assume $\phi(c) = c$, and ϕ restricts to automorphisms ϕ_1 and ϕ_2 , respectively of $A(S_{1,1}^0, P)$ and $A(S_{g_2,1}^0, P)$. By the genus 1 case, ϕ_1 is induced by a homeomorphism $f_1 : (S_{1,1}^0, P) \rightarrow (S_{1,1}^0, P)$.

If $g_2 = 1$, let $f_2 : (S_{1,1}^0, P) \rightarrow (S_{1,1}^0, P)$ be the homeomorphism that induces ϕ_2 , then we can glue f_2 to f_1 so that the resulting homeomorphism $f : S_1^1 \rightarrow S_1^1$ induces ϕ (Lemma 2.3.1). By Lemma 2.4.12, induction on g_2 concludes the proof. \square

Remarks on the case $b = 0$ Irmak-McCarthy [32] proved that any injective simplicial map of the arc complex is induced by a mapping class. Their proof is direct and they list and study extensively all the possible configurations of quintuplets of disjoint arcs on S . By sake of completeness, we prove here that our indirect approach leads to a new (and shorter) proof that each simplicial automorphism of $A(S_g^s)$ is induced by a mapping class.

The following lemma can be proved with the same argument as Proposition 2.4.16.

Lemma 2.4.18. *Let S_g^{s+1} be a surface of genus $g \geq 2$ with $s+1$ marked points. Let $c_1 \in A(S_g^{s+1})$ be an arc that separates $S = S'_{c_1} \cup S''_{c_1}$ where $S'_{c_1} = (S_{g'+1,1}^0, (1))$ and $S''_{c_1} = (S_{g''+1,1}^s, (1))$.*

For every $\phi \in \text{Aut } A(S_g^{s+1})$, $\phi(c_1)$ is an arc that separates $S = S'_{\phi(c_1)} \cup S''_{\phi(c_1)}$, with $S'_{\phi(c_1)}$ homeomorphic to S'_{c_1} and $S''_{\phi(c_1)}$ homeomorphic to S''_{c_1} . Moreover, ϕ restricts to isomorphisms $\phi| : A(S'_{c_1}, P) \rightarrow A(S'_{\phi(c_1)}, P)$ and $\phi| : A(S''_{c_1}, P) \rightarrow A(S''_{\phi(c_1)}, P)$.

Theorem 2.4.19. *If S_g^s be a surface of genus $g \geq 2$ with $s \geq 1$ marked points, then the natural homomorphism $\text{MCG}^*(S_g^s) \rightarrow \text{Aut } A(S_g^s)$ is surjective.*

Proof. Let $\phi \in \text{Aut } A(S_g^s)$ and let c be a separating loop based at the point $P \in \mathcal{S}$. Assume that c separates into $(S_{1,1}^{s-1}, P)$ (of genus 1) and $(S_{g_2,1}^0, P)$ (of genus $g_2 \geq 1$). By Lemma 2.4.18, up to precomposition with an automorphism induced by $\text{MCG}^*(S_g^s)$, ϕ restricts to an automorphism of $A(S_{1,1}^{s-1}, P)$ and one of $A(S_{g_2,1}^0, P)$. By Proposition 2.4.14 in the genus 1 case, Proposition 2.4.17 and Lemma 2.4.12 each one is induced by a homeomorphism of the respective surface. By Lemma 2.3.1, we can glue them both in order to get a homeomorphism of S inducing ϕ . \square

2.4.3 The general case

The purpose of this section is to complete the proof of Theorem B.

Reduction Lemma 2.4.20 (Reducing \mathbf{p}). *Assume $\dim A(S_{g,b}^s, \mathbf{p}) \geq 2$. If $A(S_{g,b}^s, \mathbf{1})$ is weakly rigid, then $A(S_{g,b}^s, \mathbf{p})$ is weakly rigid.*

Proof. By an inductive argument it suffices to prove the following claim.

Claim: If $p_1 \geq 2$ and $A(S_{g,b}^s, (p_1 - 1, p_2, \dots, p_b))$ is weakly rigid, then $A(S_{g,b}^s, \mathbf{p})$ is weakly rigid.

Assume $\phi \in \text{Aut } A(S_{g,b}^s, \mathbf{p})$. By Corollary 2.3.13 we can assume that ϕ fixes all the 3-petals (or 2-leaves) on \mathcal{B} . Let v be a 3-petal (or 2-leaf), ϕ induces an automorphism $\phi|$ of the arc complex of the surface $(S_{g,b}^s, (p_1 - 1, \dots, p_b))$ obtained cutting along v . By the hypothesis of the claim, $\phi|$ is induced by a homeomorphism $\tilde{\phi}|$ of $(S_{g,b}^s, (p_1 - 1, \dots, p_b))$ that fixes \mathcal{B}_1 . We can then glue back the disk $(S_{0,1}^0, (3))$ bounded by v and get to a homeomorphism of $(S_{g,b}^s, \mathbf{p})$ that agrees with ϕ . \square

Reduction Lemma 2.4.21 (Reducing b). *Assume $\dim A(S_{g,b}^s, \mathbf{p}) \geq 2$ and $b \geq 2$. If $A(S_{g,b-1}^s, \mathbf{1})$ is weakly rigid, then $A(S_{g,b}^s, \mathbf{1})$ is weakly rigid.*

Proof. Let $\langle l, v \rangle$ be an edge-bridge as in Lemma 2.3.14. Without loss of generality, we assume l based on \mathcal{B}_1 and v joining \mathcal{B}_1 and \mathcal{B}_2 . Assume $\phi \in \text{Aut } A(S_{g,b}^s, \mathbf{1})$. By Lemma 2.3.14, we can assume $\phi(l) = l$ and $\phi(v) = v$, up to precomposition with an automorphism induced by a mapping class. Moreover, ϕ restricts to an automorphism $\phi|_l$ of the arc complex of the surface $(S_{g,b-1}^s, (4, 1_{b-2}))$, obtained cutting along v . By Lemma 2.4.20 and the hypothesis, there exists a homeomorphism $\tilde{\phi}|_l$ of $(S_{g,b-1}^s, (4, 1_{b-2}))$ inducing $\phi|_l$, and $\tilde{\phi}|_l$ fixes the arc l . It follows that ϕ preserves the segments coming from the cut along v on the boundary of $(S_{g,b-1}^s, (4, 1_{b-2}))$. We can thus glue back to get a homeomorphism of $(S_{g,b}^s, \mathbf{1})$ that induces ϕ . \square

Proposition 2.4.22. *Assume $\dim A(S_{g,b}^s, \mathbf{p}) \geq 2$. If $f \in \text{MCG}^*(S_{g,b}^s, \mathbf{p})$ induces the identity $id = f_* : A(S_{g,b}^s, \mathbf{p}) \rightarrow A(S_{g,b}^s, \mathbf{p})$, then f is homotopic to the identity. Equivalently, if $A(S_{g,b}^s, \mathbf{p})$ is weakly rigid, then it is also rigid.*

Proof. It suffices to recall that if $\dim A(S_{g,b}^s, \mathbf{p}) \geq 2$, i.e. any triangulation of $(S_{g,b}^s, \mathbf{p})$ has at least 3 essential arcs, then a homeomorphism of (S, \mathbf{p}) that fixes every arc is necessarily isotopic to the identity. \square

We finally deduce Theorem B:

Theorem B. *If $\dim A(S_{g,b}^s, \mathbf{p}) \geq 2$ then $A(S_{g,b}^s, \mathbf{p})$ is rigid.*

Proof. Reduction Lemmas 2.4.20 2.4.21 allow us to reduce to the two basic cases of surfaces with $g = 0$, and surfaces with $b = 1$ and $g \geq 1$. The first case has been proven in Theorems 2.4.4 and 2.4.7, the second case has been proven in Theorem 2.4.15. \square

2.5 Proof of Theorem C

Since no ambiguity occurs, in this section we will use the notation A_{\sharp} for $A_{\sharp}(S_{g,b}^s, \mathbf{p})$ and A for $A(S_{g,b}^s, \mathbf{p})$. Recall that \mathcal{P} denotes the set of all marked points on the boundary of S , and \mathcal{S} denotes the set of marked points in the interior of S . The purpose of this section is to prove the following result:

Theorem C. *If $\dim A_{\sharp}(S_{g,b}^s, \mathbf{p}) \geq 2$ then $A_{\sharp}(S_{g,b}^s, \mathbf{p})$ is rigid.*

We will first prove that any automorphism $\phi : A_{\sharp} \rightarrow A_{\sharp}$ extends to an automorphism $\tilde{\phi} : A \rightarrow A$.

Step 1: Extending ϕ on the vertices of $A \setminus A_{\#}$ We classify the vertices of $A \setminus A_{\#}$ in 4 types, as in Figure 2.20 (in all the figures below points in \mathcal{P} are represented as filled circles, points in \mathcal{S} are represented as non-filled circles):

1. arcs α joining a point in \mathcal{P} to a point in \mathcal{S} ;
2. arcs β joining two points in \mathcal{S} ;
3. drops γ based at a point on \mathcal{S} ;
4. loops (non-drops) δ based on a point on \mathcal{S} .

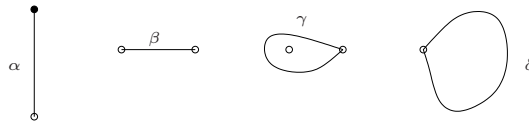

Figure 2.20: Step 1

Definition of $\tilde{\phi}(\alpha)$ Let α be an arc joining a point in \mathcal{P} to a point in \mathcal{S} , and complete α to the edge-drop $\langle \alpha, l_\alpha \rangle$ (we can do it in a unique way). By Lemma 2.3.10, $\phi(l_\alpha)$ is an arc of the same type. We define $\tilde{\phi}(\alpha)$ as the unique arc that completes $\phi(l_\alpha)$ to an edge-drop in A . We remark that $\tilde{\phi}(\alpha)$ is well-defined and it is an arc of type (1) and $\tilde{\phi}$ is bijection on arcs on type (1). The following lemma follows from invariance lemmas in Section 2.3 and Lemma 2.3.9.

Lemma 2.5.1. *Let $\langle v_1, v_2, v_3, v_4 \rangle$ be a simplex in A , which spans a square on S as in Figure 2.21. We assume $\langle v_1, v_2 \rangle$ and $\langle v_3, v_4 \rangle$ are edges where each v_i joins a point in \mathcal{S} to a point in \mathcal{P} .*

According to the above definition, $\tilde{\phi}$ preserves the configuration of arcs as in Figure 2.21.



Figure 2.21: Lemma 2.5.1

Definition of $\tilde{\phi}(\beta)$. Let $\beta \in A$ be an arc joining two points in \mathcal{S} . Choose a simplex $\langle v_1^\beta, \dots, v_4^\beta \rangle \in A$ spanned by disjoint arcs of type (1), bounding a

square on S whose diagonal is β (as in Figure 2.21-right). We denote by β^* the other diagonal of this square, and we remark $\beta^* \in A_{\#}$. By Lemma 2.5.1, the arcs $\langle \tilde{\phi}(v_1^\beta), \dots, \tilde{\phi}(v_4^\beta) \rangle$ bound a square with diagonal $\phi(\beta^*)$. Finally we define $\tilde{\phi}(\beta) := \phi(\beta^*)^*$, that is, the other diagonal of this new square. We remark that this definition depends only on $\langle v_1^\beta, \dots, v_4^\beta \rangle$, and the vertex $\tilde{\phi}(\beta)$ is of type (2). Denote by $\mathcal{C} = \{ \langle v_1^\beta, \dots, v_4^\beta \rangle \}_\beta$ the union of all the simplices chosen as above, we denote $\tilde{\phi}_{\mathcal{C}}$ the extension of $\tilde{\phi}$ on vertices of type (2), defined as above. We will see later that $\tilde{\phi}_{\mathcal{C}}$ does not depend on the choice of \mathcal{C} . The proof of the following lemma follows easily from invariance lemmas in Section 2.3 and Lemma 2.3.9.

Lemma 2.5.2. *Let $\langle v_1, v_2, v_3, v_4 \rangle$ be a simplex in A spanning a square on S as in Figure 2.22. The configuration of arcs in Figure 2.22 is $\tilde{\phi}_{\mathcal{C}}$ -invariant.*

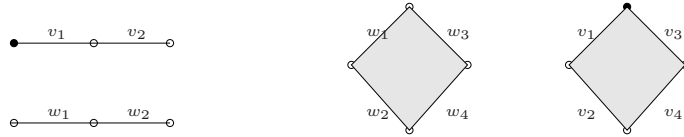

Figure 2.22: Lemma 2.5.2

Definition of $\tilde{\phi}_{\mathcal{C}}(\gamma)$. Let γ be a loop around β , and let α be one of the arcs used in the definition of $\tilde{\phi}_{\mathcal{C}}(\beta)$ (see Figure 2.23). By definition, $\tilde{\phi}_{\mathcal{C}}(\beta)$ is an arc of the same type of β , and $\tilde{\phi}(\alpha)$ is an arc of the same type of α . By invariance lemmas $\tilde{\phi}(\alpha)$ and $\tilde{\phi}_{\mathcal{C}}(\beta)$ share a (unique) common endpoint. We can thus define $\tilde{\phi}_{\mathcal{C}}(\gamma)$ as the loop based at this end and running close

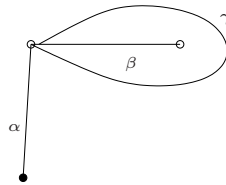

Figure 2.23: Definition of $\tilde{\phi}_{\mathcal{C}}(\gamma)$

around $\tilde{\phi}_{\mathcal{C}}(\beta)$. We remark that this definition depends only on the definition of $\tilde{\phi}_{\mathcal{C}}(\beta)$, hence on the choice of \mathcal{C} . We remark that $\tilde{\phi}_{\mathcal{C}}(\gamma)$ is an arc of type (3).

Definition of $\tilde{\phi}_{\mathcal{C}}(\delta)$. Let δ be a loop based at a point in \mathcal{S} . Let us choose α_δ an arc disjoint from δ that connects this point in \mathcal{S} to a point in

\mathcal{P} , and let l_δ be the loop boundary of $\alpha_\delta \cup \delta$ as in Figure 2.24. As in the above lemmas, it is not difficult to prove that the configuration of $\alpha_\delta \cup l_\delta$ is invariant under the action of $\tilde{\phi}_\mathcal{C}$. We can then define $\tilde{\phi}_\mathcal{C}(\delta)$ as the loop parallel to $\phi_\mathcal{C}(l_\delta)$ based at the same point of $\tilde{\phi}_\mathcal{C}(\alpha_\delta)$. This definition depends only on the choice of α_δ .

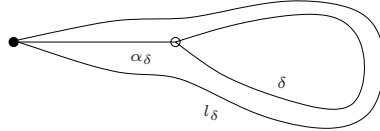

Figure 2.24: Definition of $\tilde{\phi}_\mathcal{C}(\delta)$

Step 2: $\tilde{\phi}_\mathcal{C}$ is simplicial It suffices to prove that for every maximal simplex T in A , $\tilde{\phi}_\mathcal{C}(T)$ is a maximal simplex. For every T_\sharp maximal simplex in A_\sharp , there is a natural way to extend T_\sharp to a maximal simplex \tilde{T}_\sharp by arcs of type α . By definition of $\tilde{\phi}_\mathcal{C}$, the simultaneous disjointness of arcs in \tilde{T}_\sharp is preserved, and $\tilde{\phi}_\mathcal{C}(\tilde{T}_\sharp)$ is a maximal simplex in A . By Lemmas 2.5.2, 2.5.1 and 2.2.10 $\tilde{\phi}_\mathcal{C}$ preserves squares and arcs intersecting once. The conclusion follows easily from this remark and Lemma 2.2.9.

Step 3: $\tilde{\phi}_\mathcal{C}$ is bijective By construction $\tilde{\phi}_\mathcal{C}$ is bijective on arcs of type (1) and on A_\sharp . By an application of Lemmas 2.5.2, $\tilde{\phi}_\mathcal{C}$ is surjective on arcs of type (2) (hence, on arcs of type (3)). Surjectivity on arcs of type (4) follows from the surjectivity of all the above. Again, by contradiction and the above remarks one proves that $\tilde{\phi}_\mathcal{C}$ is injective on each type of arc.

Step 4: $\tilde{\phi}_\mathcal{C}$ does not depend on \mathcal{C} By the above steps, the map $\tilde{\phi}_\mathcal{C}$ is an automorphism of A for every \mathcal{C} . By the above remarks, for every \mathcal{C} the maps $\tilde{\phi}_\mathcal{C}$ coincide on a triangulation \tilde{T}_\sharp as in Step 2. Hence, by Lemma 2.2.11, they coincide on A and the definition of $\tilde{\phi}$ does not depend on \mathcal{C} .

To conclude the proof of Theorem C, remark that the restriction map $\beta : \text{Aut } A \rightarrow \text{Aut } A_\sharp$ defined as $\beta(\phi) := \phi|$ is well-defined and it is a group homomorphism, and so it is $\alpha : \text{Aut } A_\sharp \rightarrow \text{Aut } A$ defined as $\alpha(\phi) := \tilde{\phi}$. Moreover, we have $\alpha \circ \beta = id_{\text{Aut } A}$ and $\beta \circ \alpha = id_{\text{Aut } A_\sharp}$, hence $\text{Aut } A_\sharp \cong \text{Aut } A$. We conclude by Theorem C.

Chapter 3

The arc complex through the complex of domains

The complex of domains is a geometric tool with a very rich simplicial structure. It contains the curve complex as a subcomplex. In this chapter we will consider it as a metric space, endowed with the metric that makes each simplex Euclidean with edges of length 1. We will discuss its coarse geometry and its relation with the geometries of the curve and the arc complexes. The results of this chapter are based on the author's paper [15].

3.1 Introduction

Let $S_{g,b}$ an orientable surface of genus g with b boundary components. The *curve complex* $C(S_{g,b})$ is the simplicial complex whose vertices are the homotopy classes of essential simple closed curves, and n vertices span a $n + 1$ simplex if they can be simultaneously realized in a disjoint fashion. It was introduced by Harvey [29] as a tool for the study of the boundary of Teichmüller space. When $b > 0$, one can similarly define the *arc complex* $A(S_{g,b})$, *i.e.*, the simplicial complex whose vertices are the homotopy classes of essential arcs based on $\partial S_{g,b}$, and n vertices span a $n + 1$ simplex if they can be simultaneously realized in a disjoint fashion. This complex was introduced by Harer [27; 28] in his works on the homological properties of the mapping class group. The *arc and curve complex* $AC(S_{g,b})$ is defined similarly, its vertices are those of $C(S_{g,b})$ union those of $A(S_{g,b})$, and the n -simplices are the collections of $n + 1$ vertices that can be realized in a disjoint fashion. The complex $AC(S_{g,b})$ was studied by Hatcher [30], who proved that it contractible.

All the complexes just defined and those introduced below will be endowed with the length metric such that every simplex is Euclidean with

edges of length 1. The coarse geometric properties of the curve complex were first studied by Masur-Minsky [46; 47], who proved that $C(S_{g,b})$ has infinite diameter, it is Gromov-hyperbolic and “mimics” Teichmüller space with the Teichmüller distance. Klarreich [35] proved that the Gromov-boundary of $C(S_{g,b})$ is the space of the ending laminations. Korkmaz-Papadopoulos [37] and Masur-Schleimer [45] proved that $AC(S_{g,b})$ is quasi-isometric to $C(S_{g,b})$. Masur-Schleimer [45] also studied the coarse type of some subcomplexes of $AC(S_{g,b})$, proving that $A(S_{g,b})$ is Gromov-hyperbolic as well.

In this chapter we will deal with the coarse geometry of some sort of “generalized” curve complex, the so-called *complex of domains* $D(S_{g,b})$. A *domain* D in $S_{g,b}$ is a connected subsurface of $S_{g,b}$ such that each boundary component of ∂D is a boundary component of $S_{g,b}$ or an essential curve in $S_{g,b}$. Pairs of pants and essential annuli are examples of domains. The complex of domains $D(S_{g,b})$, introduced by McCarthy-Papadopoulos [48], is defined as usual: for $n \geq 0$, a n -simplex is a collection of $n + 1$ disjoint non-homotopic domains in $S_{g,b}$. By identifying the homotopy class of a curve with its regular neighborhood, $C(S_{g,b})$ can be naturally considered a subcomplex of $D(S_{g,b})$. We will prove the following results:

Theorem. *If Δ is a connected subcomplex of $D(S_{g,b})$ that contains $C(S_{g,b})$ then the inclusion $C(S_{g,b}) \hookrightarrow \Delta$ is an isometric embedding and a quasi-isometry.*

Theorem. *If $b \geq 3$ and $(g, b) \neq (0, 4)$, the following holds:*

1. $A(S_{g,b})$ is quasi-isometric to the subcomplex $P_\delta(S_{g,b})$ of $D(S_{g,b})$, whose vertices are the peripheral pairs of pants.
2. if $g = 0$ then the inclusion $P_\delta(S_{g,b}) \hookrightarrow D(S_{g,b})$ is an isometric embedding and a quasi-isometry.
3. if $g \geq 1$ then the inclusion $P_\delta(S_{g,b}) \hookrightarrow D(S_{g,b})$ has a 2-dense image in $D(S_{g,b})$, but it is not a quasi-isometric embedding.

From the theorem just stated we deduce a new proof of the following result, contained in [37] and [45]:

Corollary. *If $b \geq 3$ and $(g, b) \neq (0, 3)$ then the following holds:*

1. $AC(S_{g,b})$ is quasi-isometric to $C(S_{g,b})$.
2. for $g = 0$ the inclusion $A(S_{g,b}) \hookrightarrow AC(S_{g,b})$ is a quasi-isometry, while for $g \geq 1$ it is not a quasi-isometric embedding.

Structure of the chapter The chapter is organized as follows: Section 3.2 contains some generalities about the complex of domains and the proof that the inclusion of $C(S)$ in a subcomplex $\Delta(S)$ of $D(S)$ induces a quasi-isometry $C(S) \hookrightarrow \Delta(S)$. In Section 3.3 we describe a quasi-isometry between $A(S)$ and the subcomplex $P_\partial(S)$ of $D(S)$ spanned by peripheral pairs of pants, and we prove that the inclusion $P_\partial(S) \hookrightarrow D(S)$ is a quasi-isometric embedding if and only if S has genus 0. In Section 3.4 we combine the previous results to prove that $AC(S)$ is quasi-isometric to $C(S)$ and to show that the inclusion $A(S) \hookrightarrow AC(S)$ is a quasi-isometric embedding if and only if S has genus 0.

3.2 The complex of domains $D(S)$ and its subcomplexes

Let $S_{g,b}$ (or S for short) be a connected, orientable surface of genus g and $b > 0$ boundary components. Its *complexity* is defined as $c(S) = 3g + b - 4$. Here and in the rest of this chapter we will always assume $c(S) > 0$. It is immediate to see that $c(S) \leq 0$ if and only if $(g, b) \in \{(0, 1), (0, 2), (0, 3), (0, 4), (1, 1)\}$.

A simple closed curve on S is *essential* if it is not null-homotopic or homotopic to a boundary component. An *essential arc* on S is a properly embedded arc with endpoints on the boundary of S not homotopic to a piece of boundary of S . An *essential annulus* on S is a regular neighbourhood of an essential curve.

Definition 3.2.1. *The curve complex $C(S)$ of S is the simplicial complex whose n -simplices are the collections of $n+1$ pairwise disjoint non-homotopic essential curves on S (see Figure 3.1).*

A maximal simplex of $C(S)$ induces a pants decomposition of S , so we have $\dim C(S) = 3g + b - 4$. If $(g, b) \in \{(0, 0), (0, 1), (0, 2), (0, 3)\}$, then $C(S) = \emptyset$. If $(g, b) \in \{(0, 4), (1, 1)\}$, then $C(S)$ is an infinite set of vertices and it is disconnected. In all the other cases (that is, $c(S) > 0$) $C(S)$ is arcwise connected (see Harvey [29]).

Definition 3.2.2. *The arc complex $A(S)$ is the simplicial complex whose n -simplices are the collections of $n+1$ pairwise disjoint non-homotopic essential arcs on S (see Figure 3.2).*

If S is a closed surface or a sphere with one hole, then $A(S)$ is empty. If S is a sphere with two holes, then $A(S)$ is a single point. In all other cases, all maximal simplices of $A(S)$ have the same dimension, that is $6g +$

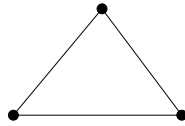
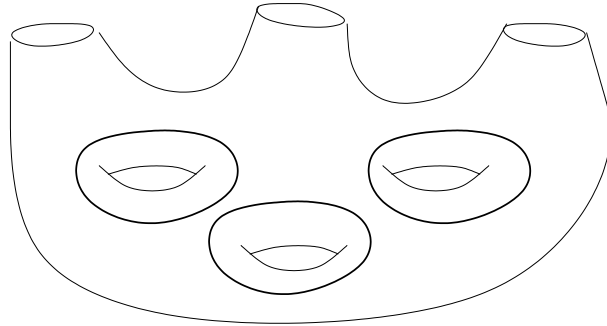
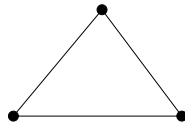
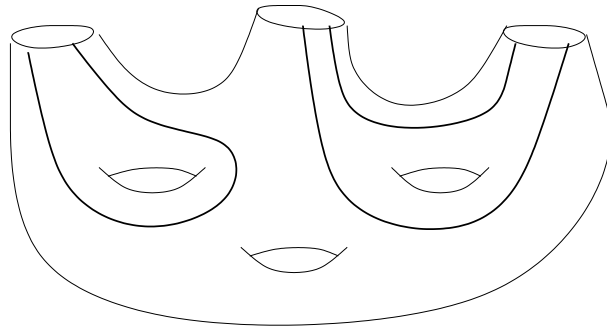
Figure 3.1: $C(S)$ Figure 3.2: $A(S)$

3b – 7. A *domain* X in S is a proper connected subsurface of S such that every boundary component of X is either a boundary component of S or an essential curve on S . Examples of domains are annuli or pairs of pants.

Definition 3.2.3. *The complex of domains $D(S)$ is the simplicial complex such that for all $k \geq 0$ its k -simplices are the collections of $k + 1$ pairwise disjoint non-homotopic domains on S .*

The identification of an annulus with its core curve induces a natural simplicial inclusion $C(S) \hookrightarrow D(S)$. We remark that $A(S)$ is not a natural subcomplex of $D(S)$.

3.2.1 Subcomplexes of $D(S)$ containing $C(S)$

For $h, k \in \mathbb{R}^+$ a (h, k) -*quasi-isometric embedding* between two metric spaces (X, d_X) and (Y, d_Y) is a map $f : X \rightarrow Y$ such that for every $x, y \in X$ the following holds:

$$\frac{1}{h}d_X(x, y) - k \leq d_Y(f(x), f(y)) \leq hd_X(x, y) + k .$$

A *bilipschitz map* is a $(h, 0)$ -quasi-isometric embedding. A quasi-isometric embedding is a *quasi-isometry* if there exists $c > 0$ such that $f(X)$ is c -dense in Y .

In this section we discuss metric properties of some natural map between subcomplexes of $D(S)$. In the rest of the chapter, we will assume that subcomplexes are arcwise connected, and we will endow every complex with the natural length metric such that every simplex is a Euclidean simplex with edges of length 1. It is not difficult to prove that every complex here mentioned is quasi-isometric to its 1-skeleton.

Theorem 3.2.4. *Let $\Delta(S)$ be a subcomplex of $D(S)$ that contains $C(S)$. The inclusion $i : C(S) \hookrightarrow \Delta(S)$ is an isometric embedding and a quasi-isometry.*

Proof. Let us first prove the theorem in the case $\Delta(S) = D(S)$.

For every c_1 and c_2 in $C(S)$, we have $d_{D(S)}(i(c_1), i(c_2)) \leq d_{C(S)}(c_1, c_2)$. Indeed, let σ be a geodesic path on $C(S)$ joining c_1 and c_2 , namely σ is given by an edge path $c_1 = x_0 \cdots x_n = c_2$. By definition x_i and x_{i+1} are represented by two disjoint non-homotopic annuli on S , hence $d_{D(S)}(i(x_i), i(x_{i+1})) = 1$, and $i(\sigma)$ is a path on $D(S)$ with the same length as σ . It is easy to see the following:

$$d_{D(S)}(i(c_1), i(c_2)) \leq \text{Length}_{D(S)}(i(\sigma)) = \text{Length}_{C(S)}(\sigma) = d_{C(S)}(c_1, c_2) .$$

Let us now prove the reverse inequality. Let Σ be a geodesic segment in $D(S)$ joining $i(c_1)$ and $i(c_2)$, that is, Σ is given by the edge path $i(c_1) = X_0 \cdots X_{k+1} = i(c_2)$. Choose for every vertex X_i a curve x_i^b among the essential boundary components of X_i . Since $X_i \cap X_{i+1} = \emptyset$, we have that either x_i^b is homotopic to x_{i+1}^b , or x_i^b and x_{i+1}^b are disjoint. In the first case x_i^b and x_{i+1}^b are represented by the same vertex in the curve complex $C(S)$, in the second case these x_i^b and x_{i+1}^b are represented by two different vertices joined by an edge in $C(S)$. Then, we can consider the path in $C(S)$ given by the x_i^b 's, namely $\Sigma^b : c_1 x_1^b \cdots x_k^b c_2$, and notice that its length is not greater than the length of Σ in $D(S)$. We conclude $d_{C(S)}(c_1, c_2) \leq \text{Length}_{C(S)}(\Sigma^b) \leq \text{Length}_{D(S)}(\Sigma) = d_{D(S)}(i(c_1), i(c_2))$.

Now we notice that for an arbitrary $\Delta(S)$, by the above case, for every pair of vertices $c_1, c_2 \in C(S)$ the following holds:

$$d_{C(S)}(c_1, c_2) = d_{D(S)}(i(c_1), i(c_2)) \leq d_{\Delta(S)}(i(c_1), i(c_2)) \leq d_{C(S)}(c_1, c_2) .$$

The image of i is 1-dense in $\Delta(S)$: every domain X in $\Delta(S)$ admits an essential boundary component x^b , that is, an element of $i(C(S))$ at distance 1. Hence, i is a quasi-isometry. \square

Corollary 3.2.5. *The following holds:*

1. *If $\Delta(S)$ is a subcomplex of $D(S)$ that contains $C(S)$, then the inclusion $\Delta(S) \hookrightarrow D(S)$ is a quasi-isometry.*
2. *Let $\Lambda(S)$ be a subcomplex of $D(S)$ and $\Lambda C(S)$ be the subcomplex of $D(S)$ spanned by the vertices of $\Lambda(S)$ and the vertices of $C(S)$. The inclusion $\Lambda(S) \hookrightarrow \Lambda C(S)$ is a quasi-isometric embedding if and only if the inclusion $\Lambda(S) \hookrightarrow D(S)$ is a quasi-isometric embedding.*

We can exhibit an uncountable family of right-inverse maps to i that are quasi-isometries between $C(S)$ and $\Delta(S)$. For every domain X , we choose one of its essential boundary components, say x^b . Given any such choice, we define a *coarse projection* $\pi : \Delta(S) \rightarrow C(S)$ as the map $X \mapsto \pi(X) = x^b$. By our definition, we have $\pi \circ i = id_{C(S)}$, and there exist infinitely many such coarse projections. We also notice that for every such coarse projection π and for every $X \in \Delta(S)$, we have $d_{\Delta(S)}(i \circ \pi(X), X) \leq 1$.

Theorem 3.2.6. *The following holds:*

1. *If $\pi_1, \pi_2 : \Delta(S) \rightarrow C(S)$ are coarse projections, then we have:*

$$d_{C(S)}(\pi_2(X), \pi_2(Y)) - 2 \leq d_{C(S)}(\pi_1(X), \pi_1(Y)) \leq d_{C(S)}(\pi_2(X), \pi_2(Y)) + 2$$

for every $X, Y \in \Delta(S)$.

2. A coarse projection $\pi : \Delta(S) \rightarrow C(S)$ is a $(1, 2)$ -quasi isometric embedding and a quasi-isometry.

Proof. Let us prove (1). We notice that if $\pi_1(X) \neq \pi_2(X)$, they are joined by an edge in $C(S)$, for they are different boundary components of X . We get a path in $C(S)$ of vertices $\pi_1(X)\pi_2(X)\pi_2(Y)\pi_1(Y)$, and we can conclude what follows:

$$\begin{aligned} d_{C(S)}(\pi_1(X), \pi_1(Y)) &\leq d_{C(S)}(\pi_1(X), \pi_2(X)) + d_{C(S)}(\pi_2(X), \pi_2(Y)) \\ &\quad + d_{C(S)}(\pi_2(Y), \pi_1(Y)) \\ &= d_{C(S)}(\pi_2(X), \pi_2(Y)) + 2 . \end{aligned}$$

Furthermore, we have the following:

$$\begin{aligned} d_{C(S)}(\pi_2(X), \pi_2(Y)) &\leq d_{C(S)}(\pi_2(X), \pi_1(X)) + d_{C(S)}(\pi_1(X), \pi_1(Y)) \\ &\quad + d_{C(S)}(\pi_1(Y), \pi_2(Y)) \\ &= d_{C(S)}(\pi_1(X), \pi_1(Y)) + 2 . \end{aligned}$$

Now we prove (2). Consider the path given by $i(\pi(X))XYi(\pi(Y))$ in $\Delta(S)$ and remark that $d_{\Delta(S)}(i(\pi(X)), X), d_{\Delta(S)}(i(\pi(Y)), Y) \leq 1$. By Theorem 3.2.4, the inclusion $i : C(S) \rightarrow \Delta(S)$ is an isometric embedding:

$$\begin{aligned} d_{C(S)}(\pi(X), \pi(Y)) &= d_{\Delta(S)}(i(\pi(X)), i(\pi(Y))) \leq d_{\Delta(S)}(X, Y) + 2 \\ d_{\Delta(S)}(X, Y) &\leq d_{\Delta(S)}(i(\pi(X)), i(\pi(Y))) + 2 = d_{C(S)}(\pi(X), \pi(Y)) + 2 . \end{aligned}$$

□

3.3 The arc complex $A(S)$ as a coarse subcomplex of $D(S)$

In this section we prove that if $b \geq 3$, then the arc complex is quasi-isometric to the subcomplex $P_\delta(S)$ of the complex of domains, whose vertices are pair of pants in S with at least one boundary component on ∂S .

3.3.1 The boundary graph complex $A_B(S)$

Given an essential arc α on S , its *boundary graph* G_α is the graph obtained as the union of α and the boundary components of S that contain its endpoints (see McCarthy-Papadopoulos [48]).

Definition 3.3.1. The complex of boundary graphs $A_B(S)$ is the simplicial complex whose k -simplices, for each $k \geq 0$, are collections of $k + 1$ distinct isotopy classes of disjoint boundary graphs on S .

We will always assume $b \geq 3$ and $S \neq S_{0,4}$, otherwise $A_B(S)$ is not arcwise connected. Up to identify G_α with α , $A_B(S)$ and $A(S)$ have the same set of vertices, and $A_B(S)$ is a subcomplex of $A(S)$. Indeed, disjoint arcs with endpoints on the same boundary components span an edge in $A(S)$, but not in $A_B(S)$. We consider $A_B(S)$ as a metric space with the shortest-path distance $d_{A_B(S)}$.

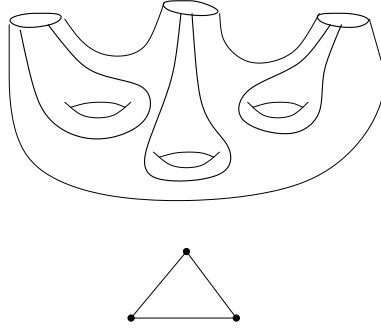

Figure 3.3: $A_B(S)$

Lemma 3.3.2. If $\langle a, b \rangle$ is a 1-simplex of $A(S)$ then $d_{A_B(S)}(a, b) \leq 4$.

Proof. By the assumption on S , either the genus g of S is 0 and S has more than 5 boundary components, or the genus of S is at least 1 and S has at least 3 boundary components. Now, let a, b be distinct vertices in $A(S)$, and assume they are not connected by an edge in $A_B(S)$.

In the case $g = 0$, since $b \geq 5$, for every pair of vertices $a, b \in A(S)$ there exists a connected component of $S \setminus a \cup b$ that contains at least two different boundary components of S , and we can find a boundary graph disjoint from a and b . Hence, the distance in $A_B(S)$ between a and b is 2.

For $g \geq 1$, we prove the case $b = 3$. The cases $b = 1$ and $b = 2$ will follow with a slight modification. We have different cases, depending on the configurations of a and b (here and in the rest of this proof, we will consider the boundary components as marked points. This will simplify the figures below):

1. $a \cup b$ is a simple closed curve.

It bounds a disc or not: in both cases $d_{A_B(S)}(a, b) \leq 4$ (see Figures 3.4 and 3.5, subcases (a) and (b)).

2. $a \cup b$ is a simple arc with two different endpoints.
In this case we have $d_{A_B(S)}(a, b) \leq 3$ (see Figure 3.6).
3. a bounds a disc, and b is not a closed curve.
In this case we have $d_{A_B(S)}(a, b) \leq 4$ (see Figure 3.7, 3.8, 3.9 subcases (a), (b), (c)).
4. Both a and b are closed simple curves, and a bounds a disc.
In this case we have $d_{A_B(S)}(a, b) \leq 4$ (see Figure 3.10, 3.11, 3.12).
5. a and b are closed curves, but none of them bounds a disc.
Since a and b have an endpoint on a common component of ∂S , and $a \cup b$ disconnect S in at most 3 connected subsurfaces. Each of them contains a simple arc joining the other two boundary components of S , or there is a non-disc component of $S \setminus a \cup b$ that contains an essential arc with both endpoints on the same boundary component of ∂S , disjoint from a and b (see Figure 3.13), and we have $d_{A_B(S)}(a, b) = 2$.
6. a is a closed curve and it does not bound a disc and b is not a closed curve.
We conclude by the same argument as in 5.

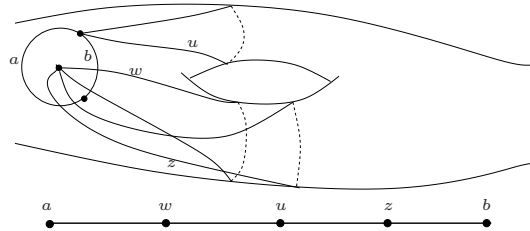

Figure 3.4: Lemma 3.3.2 (a)

□

Proposition 3.3.3. *The inclusion $j : A_B(S) \rightarrow A(S)$ is a bilipschitz equivalence between $(A_B(S), d_{A_B(S)})$ and $(A(S), d_{A(S)})$.*

Proof. First notice that for every pair of vertices $a_1, a_2 \in A(S)$, we have $d_{A(S)}(a_1, a_2) \leq d_{A_B(S)}(a_1, a_2)$.

Let σ be a geodesic path in $A(S)$, assume $\sigma : a_1 = x_0 x_1 \cdots x_n x_{n+1} = a_2$, where x_0, \dots, x_{n+1} are vertices in $A(S)$. Let σ^\sharp be a path in $A_B(S)$ defined as follows: $\sigma^\sharp : [x_0, x_1] * \cdots * [x_n, x_{n+1}]$, where the $[x_i, x_{i+1}]$'s are geodesic segments in $A_B(S)$.

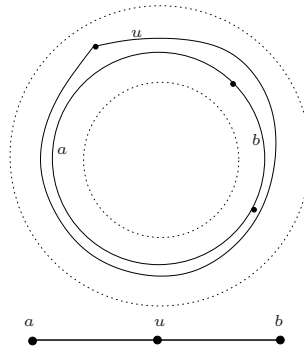

Figure 3.5: Lemma 3.3.2 (b)

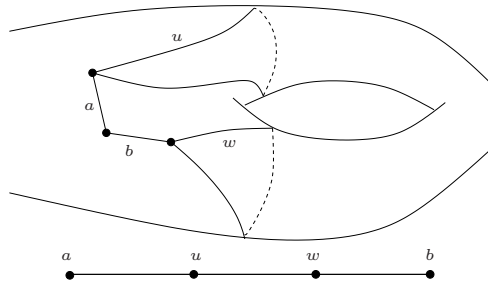

Figure 3.6: Lemma 3.3.2

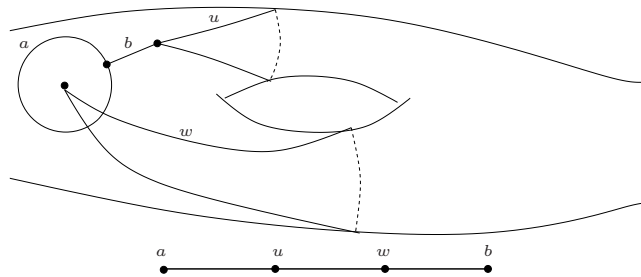

Figure 3.7: Lemma 3.3.2 (a)

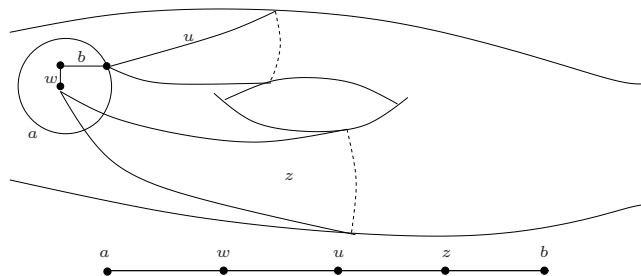

Figure 3.8: Lemma 3.3.2 (b)

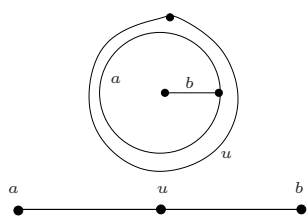

Figure 3.9: Lemma 3.3.2 (c)

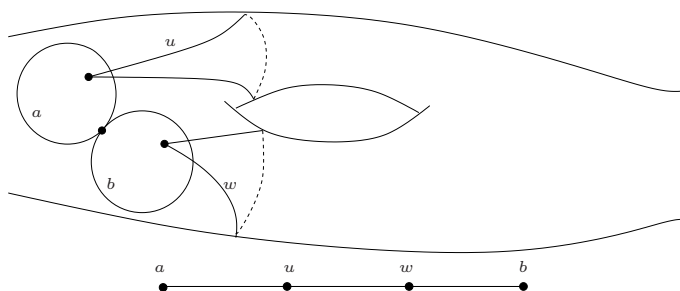

Figure 3.10: Lemma 3.3.2 (a)

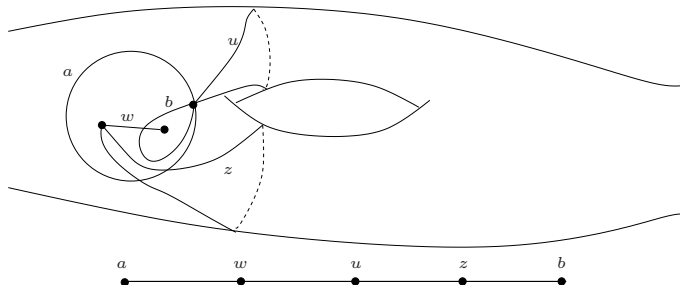

Figure 3.11: Lemma 3.3.2 (b)

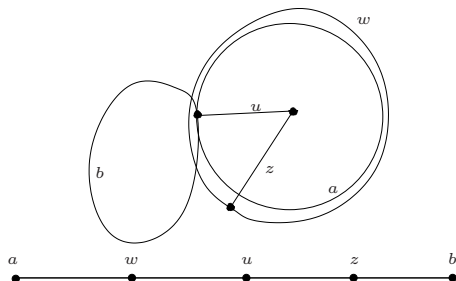

Figure 3.12: Lemma 3.3.2 (c)

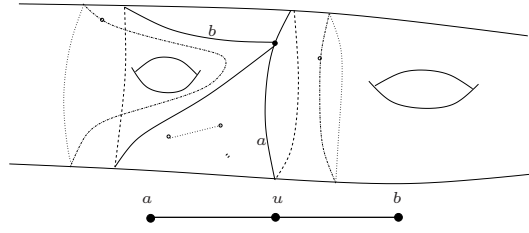

Figure 3.13: Lemma 3.3.2

By Lemma 3.3.2, we have $L_{A_B(S)}(\sigma^\sharp) \leq 4L_{A(S)}(\sigma)$. It follows:

$$d_{A_B(S)}(a_1, a_2) \leq L_{A_B(S)}(\sigma^\sharp) \leq 4L_{A(S)}(\sigma) = 4d_{A(S)}(a_1, a_2) .$$

We conclude $d_{A(S)}(a_1, a_2) \leq d_{A_B(S)}(a_1, a_2) \leq 4d_{A(S)}(a_1, a_2)$. □

3.3.2 $A_B(S)$ is quasi-isometric to $P_\partial(S)$

A *peripheral pair of pants* on S is a pair of pants with at least one boundary component on ∂S . A peripheral pair of pants is *monoperipheral* if exactly one of its boundary components belongs to ∂S , otherwise it is *biperipheral*. A regular neighborhood of a boundary graph is a peripheral pair of pants. The *complex of peripheral pair of pants* $P_\partial(S)$ is the subcomplex of $D(S)$ spanned by the vertices that are peripheral pairs of pants.

We choose for every peripheral pair of pants P an essential arc whose boundary graph has a regular neighbourhood isotopic to P . This choice determines an embedding $i : P_\partial(S) \rightarrow A_B(S)$. If P is a monoperipheral pair of pants in S , there exists only one essential arc in P whose boundary graph has a regular neighborhood isotopic to P . If P is biperipheral, then there are 3 essential arcs (see Figure 3.14). The path determined by the concatenation of these vertices has length 2 in $A(S)$ (see Figure 3.14) and length at most 8 in $A_B(S)$ (by Lemma 3.3.2).

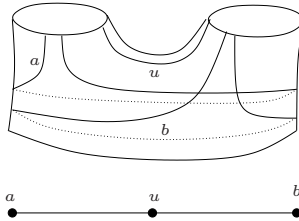

Figure 3.14: P biperipheral

Proposition 3.3.4. *The following holds:*

1. Let $i_1, i_2 : P_\partial(S) \rightarrow A_B(S)$ be as above, we have:

$$d_{A_B(S)}(i_2(a), i_2(b)) - 16 \leq d_{A_B(S)}(i_1(a), i_1(b)) \leq d_{A_B(S)}(i_2(a), i_2(b)) + 16$$

for every $a, b \in P_\partial(S)$.

2. $i : P_\partial(S) \rightarrow A_B(S)$ as above is an isometric embedding and a quasi-isometry.

Proof. 1. Let a, b be two peripheral pairs of pants. By Lemma 3.3.2 we have $d_{A_B(S)}(i_1(a), i_2(a)) \leq 8$ and $d_{A_B(S)}(i_1(b), i_2(b)) \leq 8$. By the triangle inequality on a quadrilateral with vertices $i_2(a), i_1(a), i_1(b), i_2(b)$, we have:

$$d_{A_B(S)}(i_2(a), i_2(b)) - 16 \leq d_{A_B(S)}(i_1(a), i_1(b)) \leq d_{A_B(S)}(i_2(a), i_2(b)) + 16 .$$

2. By definition, i is injective. We prove that it is an isometric embedding. If P_1, P_2 are disjoint peripheral pairs of pants, then their images are disjoint boundary graphs, and we have $d_{A_B(S)}(i(P_1), i(P_2)) \leq d_{P_\partial(S)}(P_1, P_2)$. Now, let us consider the geodesic σ in $A_B(S)$ given by the edge path $\sigma : i(P_1) = b_0 \cdots b_n = i(P_2)$. In a similar fashion, σ projects to a curve σ^\sharp on $A_B(S)$ given by isotopy classes of regular neighborhoods of the b_i 's, with endpoints P_1 and P_2 . We have: $d_{P_\partial(S)}(P_1, P_2) \leq L(\sigma^\sharp) \leq L(\sigma) = d_{A_B(S)}(i(P_1), i(P_2))$. \square

Let us now consider the natural surjective map $\pi : A_B(S) \rightarrow P_\partial(S)$ that assigns to a boundary graph a in $A_B(S)$ the isotopy class of the peripheral pair of pants of a regular neighbourhood of a in S . We notice that the map π is not injective: any two vertices as in Figure 3.14 have the same image. By Lemma 3.3.2 we have that if $d_{P_\partial(S)}(\pi b_1, \pi b_2) = 0$, then $d_{A_B(S)}(b_1, b_2) \leq 8$. For every map i as in Proposition 3.3.4, we have $\pi \circ i = id_{P_\partial(S)}$ and $d_{A_B(S)}(i \circ \pi(x), x) \leq 4d_{A(S)}(i \circ \pi(x), x) \leq 8$. We have the following:

Proposition 3.3.5. *The map $\pi : A_B(S) \rightarrow P_\partial(S)$ is a $(1, 8)$ -quasi-isometric embedding and a quasi-isometry.*

Proof. If b_1 and b_2 are disjoint boundary graphs, then their regular neighborhoods are disjoint peripheral pairs of pants. Furthermore, if P_1, P_2 are disjoint pairs of pants, then one can realize disjointly every pair of boundary graphs b_1, b_2 , with regular neighbourhoods P_1, P_2 . Thus, we have $d_{P_\partial(S)}(\pi b_1, \pi b_2) \leq d_{A_B(S)}(b_1, b_2)$.

If $\pi b_1 \neq \pi b_2$, let σ be a geodesic in $P_\partial(S)$ defined by the concatenation of vertices $\sigma : \pi b_1 = P_1 \cdots P_n = \pi b_2$, with $P_i \cap P_{i+1} = \emptyset$. Choose for every P_i a boundary graph b_i . We get a curve σ^\sharp in $A_B(S)$ given by the edge path

$\sigma^\sharp : b_1 \cdots b_n$, with $d_{AB(S)}(b_i, b_{i+1}) = 1$. Hence, we have $d_{AB(S)}(b_1, b_n) \leq L(\sigma^\sharp) = d_{P_\partial(S)}(\pi b_1, \pi b_2)$. We conclude:

$$d_{P_\partial(S)}(\pi b_1, \pi b_2) - 8 \leq d_{P_\partial(S)}(\pi b_1, \pi b_2) \leq d_{P_\partial(S)}(\pi b_1, \pi b_2) + 8 .$$

□

Theorem 3.3.6. *If $b \geq 3$, the following holds:*

1. $A(S)$ is quasi-isometric to $P_\partial(S)$.
2. If $g = 0$, then the inclusion $k : P_\partial(S) \hookrightarrow D(S)$ is an isometric embedding and a quasi-isometry.
3. If $g \geq 1$, the inclusion k is 2-dense in $D(S)$, but k is not a quasi-isometric embedding.

Proof. The proof of (1) follows from the consideration that both the compositions $j \circ i$, $j \circ \pi : A(S) \rightarrow P_\partial(S)$ of the maps in Lemma 3.3.2, Proposition 3.3.4 and Proposition 3.3.5 are quasi-isometries.

Let us prove (2). Let X be a domain. As a vertex of $D(S)$, X is at distance 1 from each of the vertices representing its essential boundary components, and each essential boundary component of X is at distance 1 from a pair of pants in $P_\partial(S)$. This proves that the image of the inclusion $P_\partial(S) \hookrightarrow D(S)$ is 2-dense. By hypothesis on S if $g = 0$, then $b \geq 5$. Since $g = 0$, each domain X of S is a sphere with holes, and each simple closed curve on S disconnects the surface into two connected components, and each of them has at least one boundary component on ∂S . Let P_1, P_2 be peripheral pairs of pants of S , and γ be a geodesic in $D(S)$ joining them, say $\gamma : P_1 X_1 \cdots X_{n-1} P_2$. Let $\pi : D(S) \rightarrow C(S)$ be a coarse projection and $i : C(S) \hookrightarrow D(S)$ the inclusion. For every X_1 , we have that $i(\pi(X_1))$ is a curve and it is disjoint from both P_1 and X_2 . Moreover, $i(\pi(X_1))$ is also distinct from X_2 (otherwise we could shorten γ). Up to replacing X_1 with $i(\pi(X_1))$ and X_{n-1} with $i(\pi(X_{n-1}))$, we can assume that both X_1 and X_{n-1} are represented by simple closed curves. Similarly, up to replacing the segment of γ given by $X_1 \cdots X_{n-1}$ with the geodesic in $C(S)$ that joins X_1 and X_{n-1} (see Theorem 3.2.4), we can assume that each X_i is a curve, say C_i .

If γ has length 2, it is represented by a path $P_1 C P_2$. Since γ is geodesic, P_1 and P_2 belong to the same connected component of $S \setminus C$. Hence, there is a peripheral pair of pants P^* in the other one, and we find a new geodesic of length 2 connecting P_1, P_2 contained in $P_\partial(S)$, namely $P_1 P^* P_2$.

If γ has length greater than 2, we focus on the initial segment of γ given by $P_1 C_1 C_2$. With the same argument, we can find a peripheral pair of pants

P^{c_1} disjoint from both P_1 and C_2 , which replace C_1 in γ . Notice that the curve $P_1P^{c_1}C_2\cdots C_{n-1}P_2$ has the same length as γ , hence is a geodesic. In this way, we get a path $\gamma^* : P_1P^{c_1}\cdots P^{c_{n-1}}P_2$ with all vertices in $P_\partial(S)$ with the same length as γ . Finally, we have what follows:

$$d_{D(S)}(P_1, P_2) \leq d_{P_\partial(S)}(P_1, P_2) \leq L_{P_\partial(S)}(\gamma^*) = L_{D(S)}(\gamma^*) = d_{D(S)}(P_1, P_2) .$$

Let us prove (3). As in the previous case, it is easy to see that the image of k is 2-dense. Let c be a simple closed loop on S surrounding all the boundary components of S as in Figure 3.15. Since S is not a sphere, c is essential, and it disconnects the surface in two domains: one of them is the sphere $B = B_{0,b+1} \subset S$ that contains all the boundary components of S , the other is the subsurface $C = C_{g,1}$ that has c as unique boundary component (see Figure 3.15). First, we claim that for every pair of peripheral pair of

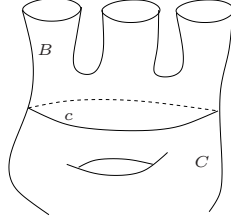

Figure 3.15: Theorem 3.3.6

pants P_1, P_2 we have $d_{P_\partial(S)}(P_1, P_2) \geq d_{P_\partial(B)}(P_1, P_2)$. Let γ be a geodesic in $P_\partial(S)$ joining P_1, P_2 . If Q is a vertex of γ , but not a peripheral pair of pants of B , then Q crosses transverse a regular neighborhood of the curve c and $Q \cap C$ is a strip. We can then replace this strip with one of the two strips of the neighborhood of c in order to get a new peripheral pair of pants $Q' \in P_\partial(B)$ that replaces Q in γ . The curve obtained from γ after all these replacements may be shorter than γ , but each of its vertices belongs to $P_\partial(B)$. Hence, we have $d_{P_\partial(S)}(P_1, P_2) \geq d_{P_\partial(B)}(P_1, P_2)$. Now, by the hypothesis B has at least 4 boundary components, hence by statement (2) we have $\text{diam } P_\partial(B) = \text{diam } D(B) = +\infty$. Hence, there exist P_0, P_n peripheral pair of pants on B such that $d_{P_\partial(B)}(P_0, P_n) \geq n$. Without loss of generality, we assume that all the boundary components of P_0, P_n are boundary components of S . By our claim, we have $d_{A_\partial(S)}(P_0, P_n) \geq n$. Moreover, since both P_0 and P_n are disjoint from C , we have $d_{D(S)}(P_0, P_n) = 2$, and this concludes the proof. \square

As an immediate consequence of Theorem 3.3.6 and Theorem 3.2.4, we have:

Corollary 3.3.7. *If $g = 0$ and $b \geq 5$, then $A(S)$ is quasi-isometric to $C(S)$.*

3.4 Application: the arc and curve complex

The *arc and curve complex* $AC(S)$ is the simplicial complex whose k -simplices are the collections of $k + 1$ pairwise disjoint non-homotopic essential arcs or curves on S . Except a few cases, it is contractible (see Hatcher [30]). Korkmaz-Papadopoulos [37] proved that its automorphism group is the extended mapping class group. As an application of Theorem 3.3.6 and Theorem 3.2.4, we give a simple proof of the quasi-isometry between $C(S)$ and $AC(S)$ in the case $b \geq 3$. This result was proved by Korkmaz-Papadopoulos [37] and Masur-Schleimer [45]. We also give necessary and sufficient conditions on S for the inclusion $A(S) \hookrightarrow AC(S)$ to be a quasi-isometry. A statement of the latter result and a detailed study of the subcomplexes of $AC(S)$ can be found in Masur-Schleimer [45].

Theorem 3.4.1. *If $b \geq 3$, then the following holds:*

1. $AC(S)$ is quasi-isometric to $C(S)$.
2. If $g = 0$, the inclusion $A(S) \hookrightarrow AC(S)$ is a quasi-isometry. In the other cases, the inclusion is not a quasi-isometric embedding.

Proof. Let us prove (1). We consider the subcomplex of $D(S)$ spanned by the vertices of $C(S)$ and $P_\partial(S)$, say $P_\partial C(S)$, and the subcomplex of $AC(S)$ spanned by the vertices of $A_B(S)$ and $C(S)$, say $A_B C(S)$. We remark that:

- i. $AC(S)$ is quasi-isometric to $A_B C(S)$, by a quasi-isometry given by the inclusion of $A_B(S)$ in $A(S)$ as in Lemma 3.3.2;
- ii. $A_B C(S)$ is quasi-isometric to $P_\partial C(S)$, by a quasi-isometry induced by the natural isometric embedding $i : P_\partial(S) \hookrightarrow A_B(S)$ as in Proposition 3.3.4.

By Theorem 3.2.4 the complex $P_\partial C(S)$ is quasi-isometric to $C(S)$, and we conclude.

Let us prove (2). By Corollary 3.2.5 the inclusion $P_\partial C(S) \hookrightarrow D(S)$ is a quasi-isometry. In the diagram below the horizontal rows are given by inclusions, and the vertical rows are the above mentioned quasi-isometries. The diagram commutes, hence the inclusion $A(S) \hookrightarrow AC(S)$ is a quasi-isometric embedding if and only if the inclusion $P_\partial(S) \hookrightarrow P_\partial C(S)$ is a quasi-isometric embedding. Moreover, the latter holds if and only if the map $P_\partial(S) \hookrightarrow D(S)$

is a quasi-isometric embedding. We conclude using Theorem 3.3.6.

$$\begin{array}{ccccc} A(S) & \longrightarrow & AC(S) & & \\ \uparrow \text{q.i.} & & \uparrow \text{q.i.} & & \\ A_B(S) & \longrightarrow & A_B C(S) & & \\ \uparrow \text{q.i.} & & \uparrow \text{q.i.} & & \\ P_\partial(S) & \longrightarrow & P_\partial C(S) & \xleftrightarrow{\text{q.i.}} & D(S) \end{array}$$

□

Chapter 4

On the geometry of the ideal triangulation graph

In this chapter we deal with the geometry of the ideal triangulation graph and its quotient under the action of the mapping class group. Results obtained include upper and lower bounds for the growth of the diameter of the quotient, and we will provide some application on the geometry of the mapping class group. We will also deal with the Thurston metric on Teichmüller space of a surface with boundary. We will use the ideal triangulation graph to parametrize a natural subspace of Teichmüller space, and we will provide an upper bound for the growth of its diameter in the moduli space. The results we present here are based on a joint work with Hugo Parlier.

4.1 Introduction

Ideal triangulations are used in the work of Thurston [68], and in particular they prove crucial for the construction of the Thurston-Bonahon-Fock-Penner *shear coordinates* [68; 22; 4; 55] on the Teichmüller space of a punctured surface. In this chapter we will describe the results of a joint project with Hugo Parlier concerning the *ideal triangulation graph* and its geometry.

Let S_g^n be an orientable surface of genus g with $n > 0$ marked points. The *ideal triangulation graph* \mathcal{F}_g^n of S_g^n is the 1-skeleton of the dual of the arc complex $A(S_g^n)$. In practice, it can be defined as follows: each ideal triangulation of S_g^n defines a vertex of \mathcal{F}_g^n , and two vertices are joined by an edge if the two corresponding triangulations differ by a *flip*, *i.e.*, by the replacement of one diagonal of a quadrilateral by the other diagonal. We consider the graph endowed with the length metric where edges have length 1. This definition can be adapted with little effort to a surface with boundary $S_{g,b}$,

using hexagonal decompositions instead of triangulations, and the resulting graph $\mathcal{F}_{g,b}$ is naturally isomorphic to \mathcal{F}_g^b .

The ideal triangulation graph \mathcal{F}_g^n has a natural stratification, where each stratum \mathcal{F}_σ is associated to a simplex σ of $A(S_{g,b}^n, \mathbf{p})$, and \mathcal{F}_σ is the subgraph of \mathcal{F}_g^n whose vertices are the triangulations of S_g^n that contain all the arcs in σ . Our first result about the ideal triangulation graph concerns the geometry of these strata:

Theorem. *For every simplex σ in $A(S_g^n)$, the stratum \mathcal{F}_σ is convex in \mathcal{F}_g^n .*

Turning to our next topic, we recall that the action of the mapping class group on \mathcal{F}_g^n is cocompact, and we denote by $\mathcal{M}\mathcal{F}_g^n$ the quotient. We will there determine the growth rate of $\mathcal{M}\mathcal{F}_g^n$ with respect to n by showing the following result in the same spirit of Sleator-Tarjan-Thurston [63] for planar surfaces:

Theorem.

$$\limsup_{n \rightarrow +\infty} \frac{\text{diam. } \mathcal{M}\mathcal{F}_g^n}{|\chi(S_g^n)| \log |\chi(S_g^n)|} < +\infty.$$

It is worth mentioning that the results of Sleator-Tarjan-Thurston on the triangulations of planar surfaces [63; 64] motivated a wealth of research in theoretical computer science and computational geometry. In these fields the ideal triangulation graph is called *flip graph* (see [25]). The algorithmic description of a geodesic, the exact computation of the flip distance between two vertices of the flip graph or some closely related graphs remain open problems (see the surveys [5; 6]).

The ideal triangulation graph can be viewed as the analogue for a surface with marked points of the pants graph for a closed surface. The large scale properties of this last graph are themselves of independent interest, since Brock [11] proved that it is quasi-isometric to the Teichmüller space with the Weil-Petersson distance. Results on the geometric properties of its subgraphs were obtained by Aramayona-Parlier-Shackleton [1; 2]. Some results on the diameter of the quotient of the pants graph under the action of the mapping class group and of some slight modifications were first obtained by Cavendish [12] and they were crucial in the work of Cavendish-Parlier [13] on the growth of the Weil-Petersson diameter of the moduli space. The study of the growth of the pants graph, completed by Rafi-Tao [62], has also proved useful in their study of the growth of the Teichmüller and the Thurston diameter of the thick part of the moduli space of a punctured surface.

The coarse geometry type of the ideal triangulation graph \mathcal{F}_g^n is itself of independent interest. Korkmaz-Papadopoulos [37] studied its automorphism group and they also proved that the action of the mapping class group

on \mathcal{F}_g^n is proper and cocompact, hence this graph naturally gives a coarse model for the mapping class group. Different coarse models were provided by Masur-Minsky [47] and Hamenstädt [26]. We refine the result of Korkmaz-Papadopoulos [37] as follows:

Proposition. *If $\chi(S_g^n) < 0$ and $(g, n) \neq (0, 3)$ then the following holds:*

1. *For every vertex T of \mathcal{F}_g^n the map*

$$\begin{aligned} q_{g,n} : \text{MCG}(S_g^n) &\rightarrow \mathcal{F}_g^n \\ g &\mapsto gT \end{aligned}$$

is a $(k_{q_{g,n}}, 1)$ -quasi-isometry for some $k_{q_{g,n}}$, with $k_{q_{g,n}} \leq \chi(S_g^n) \log \chi(S_g^n)$ as n tends to $+\infty$.

2. *For every simplex σ in $A(S_g^n)$ and for every vertex T of \mathcal{F}_σ , if $\text{Stab}(\sigma)$ denotes the stabilizer of σ in $\text{MCG}(S_g^n)$, the map*

$$\begin{aligned} \text{Stab}(\sigma) &\rightarrow \mathcal{F}_\sigma \\ g &\mapsto gT \end{aligned}$$

is a quasi-isometry, and $\text{Stab}(\sigma)$ is an undistorted subgroup of $\text{MCG}(S_g^n)$.

An assertion analogous to the second one of the previous statement was proved for the stabilizers of the simplices in the curve complex by Masur-Minsky [47] and Hamenstädt [26].

We will also deal with some application of the ideal triangulation graph to the Teichmüller theory of surfaces with boundary. In our study, we will endow $\text{Teich}(S_{g,b})$ with the *Thurston asymmetric distance*. This distance was introduced by Thurston [67] in the context of closed and punctured surfaces as the “hyperbolic analogue” of the Teichmüller distance. Its topology was studied by Papadopoulos-Théret [52]. A first comparison between the Teichmüller and the Thurston distance on the Teichmüller space of a punctured surface is due to Choi-Rafi [14]. A study of the asymptotic growth of the Thurston diameter of the moduli space is due to Rafi-Tao [62]. The generalization of Thurston’s distance to the setting of surfaces with boundary has been studied by Papadopoulos-Théret-Liu-Su (see for instance [54; 53; 41; 40; 39]).

Let $H = (t_1, \dots, t_{6g+3b-6})$ be a maximal set of disjoint essential arcs on $S_{g,b}$, *i.e.* a hexagonal decomposition of $S_{g,b}$. It is well-known that for all $\mathcal{A} \in \mathbb{R}_{>0}^{6g+3b-6}$ there exists a unique hyperbolic metric $X_{(H,\mathcal{A})}$ on $S_{g,b}$ such that the length of t_i with respect to $X_{(H,\mathcal{A})}$ is \mathcal{A}_i . Moreover, $\mathbb{R}_{>0} \ni \mathcal{A} \rightarrow X_{(H,\mathcal{A})} \in \text{Teich}(S_{g,b})$ is a bijection (*i.e.*, a parametrization of Teichmüller space). We will prove the following:

Proposition. Assume $L > 0$ and $k > 1$. Set $\mathcal{A}_1 = (L, \dots, L) \in \mathbb{R}^{6g+3b-6}$ and $\mathcal{A}_k = k\mathcal{A}_1 = (kL, \dots, kL) \in \mathbb{R}^{6g+3b-6}$. For any vertex T of $\mathcal{F}_{g,b}$ we have:

$$d(X_{(T, \mathcal{A}_1)}, X_{(T, \mathcal{A}_k)}) = \log k.$$

Furthermore, the line $\mathbb{R} \ni t \mapsto X_{(T, e^t \mathcal{A}_1)} \in \text{Teich}(S_{g,b})$ is a forward geodesic with respect to the Thurston metric.

We say that a hyperbolic metric X on $S_{g,b}$ is L -regular if there exists a hexagonal decomposition H of $S_{g,b}$ such that $X = X_{(H, (L, \dots, L))}$. Let $\mathcal{R}_{g,b}^L$ be the set of the L -regular metrics on $S_{g,b}$ and $\mathcal{M}\mathcal{R}_{g,b}^L$ be its quotient under the action of the mapping class group. We will use \mathcal{F}_g^n in order to give a bound with respect to b on the growth of the diameter of $\mathcal{M}\mathcal{R}_{g,b}^L$ in the moduli space $\mathcal{M}(S_{g,b})$ with respect to b :

Theorem. For all $L > 0$, the surjective map:

$$\begin{aligned} \mathcal{F}_{g,b}^{(0)} &\rightarrow \mathcal{R}_{g,b}^L \subseteq \text{Teich}(S_{g,b}) \\ T &\mapsto X_{(T, (L, \dots, L))} \end{aligned}$$

is a Lipschitz map with constant $K(L)$ that does not depend on g and b . Furthermore

$$\limsup_{b \rightarrow +\infty} \frac{\text{diam}(\mathcal{M}\mathcal{R}_{g,b}^L)}{|\mathcal{X}(S_{g,b})| \log |\mathcal{X}(S_{g,b})|} \leq K(L).$$

Structure of the chapter This chapter is organized as follows. In Section 4.2 we deal with generalities on $\mathcal{F}_{g,b,\mathbf{p}}^n$ and the geometry of its strata. In Section 4.3 we deal with some result on the large-scale geometry of \mathcal{F}_g^n , we establish the growth rate of of $\mathcal{M}\mathcal{F}_g^n$ and its strata. In Section 4.4 we recall some properties of Thurston's metric on Teichmüller space, and we define a Lipschitz map between the flip graph and the subspace of regular surfaces. We also provide an upper bound for the growth of the diameter of this subspace in the moduli space.

4.2 Generalities on $\mathcal{F}(S_{g,b}^n, \mathbf{p})$

Let $(S_{g,b}^n, \mathbf{p})$ (or (S, \mathbf{p}) for short) be a surface with $n > 0$ marked points in the interior, $b > 0$ boundary components and $p_i \geq 0$ marked points on each boundary component, and we set $\mathbf{p} = (p_1, \dots, p_b) \in \mathbb{N}_+^b$.

Definition 4.2.1. The ideal triangulation graph $\mathcal{F}(S_{g,b}^n, \mathbf{p})$ (or $\mathcal{F}_{g,b,\mathbf{p}}^n$) is the 1-skeleton of the dual CW-complex of $A(S, \mathbf{p})$.

This is equivalent to say that $\mathcal{F}_{g,b,\mathbf{p}}^n$ is the graph that has one vertex for each triangulation of (S, \mathbf{p}) , and where two vertices are joined by one edge if and only if the triangulations they represent are related by a flip (see Figure 4.1).

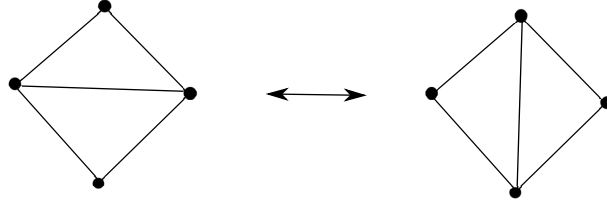

Figure 4.1: A flip movement in S_g^n

When $b = 0$, we will write \mathcal{F}_g^n for short. The following is a well-known result.

Theorem 4.2.2. $\mathcal{F}_{g,b,\mathbf{p}}^n$ is arcwise connected.

Proof. A proof can be found for instance in papers by Penner [56], Hatcher [30]. \square

Here and in the following we will always consider that $\mathcal{F}_{g,b,\mathbf{p}}^n$ as a length space with edges of length 1, endowed with its shortest-path distance.

If $n = 0$ and $\mathbf{p} = (0, \dots, 0)$, that is, $S_{g,b}$ is a surface with boundary, the ideal triangulation graph $\mathcal{F}_{g,b}$ is naturally isomorphic to \mathcal{F}_g^b as above. We remark that in this setting a vertex of $\mathcal{F}_{g,b}$ corresponds to a decomposition of $S_{g,b}$ into topological hexagons, whose edges are either essential arcs on the surface or they lie on $\partial S_{g,b}$, and no two consecutive edges are of the same type. Flips between hexagons are contained into topological octagons with edges in the same fashion (see Figure 4.2).

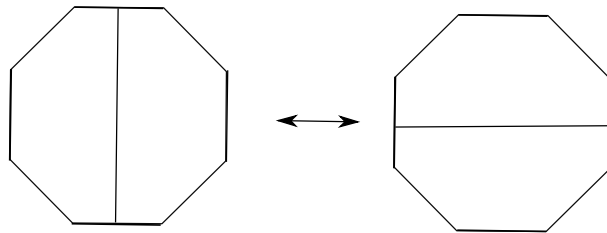

Figure 4.2: A flip movement in $S_{g,b}$

We recall some well-known facts.

Remark 4.2.3. *The following holds:*

1. \mathcal{F}_0^3 has 4 vertices and is isomorphic to a tripod;
2. \mathcal{F}_1^1 is isomorphic to the graph dual to the Farey tessellation of \mathbb{H}^2 .

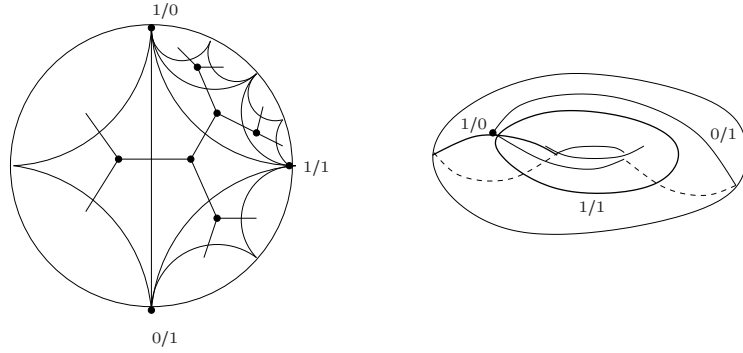

Figure 4.3: Triangulations of S_1^1 and the Farey tessellation of \mathbb{H}^2

4.2.1 The geometry of strata

It is natural to define a stratification of the ideal triangulation graph, where each stratum is associated to a simplex of $A(S_{g,b}^n, \mathbf{p})$.

Definition 4.2.4. *Let σ be a simplex in $A(S_{g,b}^n, \mathbf{p})$. The stratum \mathcal{F}_σ of σ in $\mathcal{F}_{g,b,\mathbf{p}}^n$ is the subgraph spanned by the triangulations of the surface that contain the arcs in σ .*

In this section we prove some results about the geometry of these strata. Among other things, we will prove that the strata of \mathcal{F}_g^n are connected and convex.

Connectdness of strata in \mathcal{F}_g^n Let V and W the two triangulations of S_g^n . We will denote by $V \cap W$ the set of arcs common to V and W . In this paragraph we recall a direct construction of a path joining two vertices on the ideal triangulation graph. The detailed proofs of the claims below, refinements and applications in different settings can be found in papers of Penner [56] and Mosher [50].

Theorem 4.2.5. *There exists a finite sequence $\{T_i\}_{i=1,\dots,N}$ of triangulations of S such that $T_1 = V$, $T_N = W$, T_i and T_{i+1} differ by a flip, and each T_i contains all the arcs in $V \cap W$.*

Let $T = (t_1, \dots, t_N)$ be a triangulation and α be an essential oriented arc on S . Without loss of generality, we assume that T and α intersect efficiently, that is, for each $t_i \in T$ we have $i(t_i, \alpha) = |t_i \cap \alpha|$. The *intersection number* between α and T is defined as $\iota(\alpha, T) := \sum_{t_i \in T} \iota(\alpha, t_i)$.

If $\alpha \cap T \neq \emptyset$, we denote by x_0 the “first” point (with respect to the orientation of α) in $T \cap \alpha$, and we denote by τ_α^T the unique arc of T that intersects α in x_0 .

Claim 4.2.6. *If $\alpha \notin T$ then τ_α^T is a flippable arc in T .*

Define a function f on the 0-skeleton of $A(S_g^n) \times \mathcal{F}_g^n$ as follows:

$$f(\alpha, T) = \begin{cases} 0 & \text{if } \alpha \in T \\ \sum_{t \in T \setminus \tau_\alpha^T} i(\alpha, t) & \text{if } \alpha \notin T. \end{cases}$$

We remark that $f(\alpha, T) \leq \iota(\alpha, T) - 1$ when $\alpha \notin T$.

Claim 4.2.7. *For every vertex $T \in \mathcal{F}_g^n$ and for every vertex $\alpha \in A(S_g^n)$, $f(\alpha, T) = 0$ if and only if $\alpha \in T$ or α is obtained performing one flip on T .*

Claim 4.2.8. *If $f(\alpha, T) \neq 0$ and T' is the triangulation obtained from T performing one flip on τ_α^T , then $f(\alpha, T') < f(\alpha, T)$.*

From the above discussion, it follows immediately:

Proposition 4.2.9. *For every simplex σ in $A(S_g^n)$ \mathcal{F}_σ is arcwise connected.*

Moreover, for every vertex $T \in \mathcal{F}_g^n$, for every vertex $\alpha \in A(S_g^n)$ we have $d_{\mathcal{F}}(T, \mathcal{F}_\alpha) \leq \iota(\alpha, T)$.

Proof. Let us first consider a 0-dimensional simplex $\sigma = \langle \alpha \rangle$ in $A(S)$. It follows by Claim 4.2.6 and Claim 4.2.8 that after at most $f(\alpha, T)$ flips on arcs $\tau_\alpha^{T'}$ transverse to α , we get to a triangulation \bar{T} such that $f(\alpha, \bar{T}) = 0$. By Claim 4.2.7 after at most one flip on $\tau_\alpha^{\bar{T}}$, we get to a triangulation which contains α . Hence $d_{\mathcal{F}}(T, \mathcal{F}_\alpha) \leq f(\alpha, T) + 1 \leq \iota(\alpha, T)$.

Let σ be a simplex of positive dimension in $A(S_g^n)$, and let $U, W \in \mathcal{F}_\sigma$ be vertices. In the construction of the path between U and W given above, none of the arcs in $U \cap W$ is flipped. Hence, this path is contained in \mathcal{F}_σ . \square

We will denote by d_σ the shortest-path distance on \mathcal{F}_σ .

Remark 4.2.10. *The following holds:*

1. *If $\sigma = \langle \alpha_1, \dots, \alpha_k \rangle$ then $\mathcal{F}_\sigma = \mathcal{F}_{\alpha_1} \cap \dots \cap \mathcal{F}_{\alpha_k}$.*
2. *If α is a separating arc and $S \setminus \alpha = S_1 \cup S_2$, then \mathcal{F}_α is isomorphic to $\mathcal{F}(S_1) \times \mathcal{F}(S_2)$ with $d_\alpha = d_{\mathcal{F}(S_1)} + d_{\mathcal{F}(S_2)}$.*

Projections on strata Let α, ν be two essential arcs in S , and consider α as oriented. We denote by $\text{cut}_\alpha(\nu)$ the set of connected components of $\nu \setminus \alpha \cap \nu$. If $\iota(\alpha, \nu) = 0$ then $\text{cut}_\alpha(\nu) = \nu$, otherwise each arc in $\text{cut}_\alpha(\nu)$ is an arc (not necessarily essential) based on the boundary component of $S \setminus \alpha$ created by α . If $T = (t_1, \dots, t_N)$ is a triangulation of $S \setminus \alpha$, we will denote $\text{cut}_\alpha(T) := (\text{cut}_\alpha(t_1), \dots, \text{cut}_\alpha(t_N))$.

We denote by $\text{comb}_\alpha(\text{cut}_\alpha(\nu))$ the set of arcs on $S \setminus \alpha$ obtained "combing" each connected component of $\nu \setminus \alpha \cap \nu$ in the direction of α (see Figure 4.4). We remark that $|\text{comb}_\alpha(\text{cut}_\alpha(\nu))| \leq |\text{cut}_\alpha(\nu)|$.

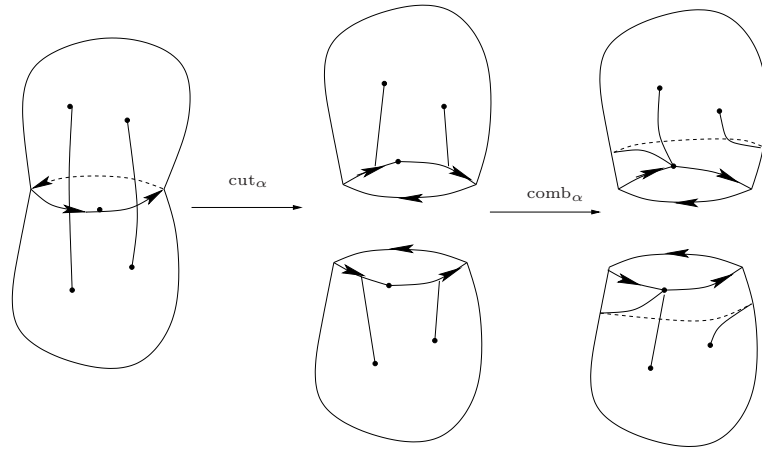

Figure 4.4: comb_α and cut_α

Lemma 4.2.11. *The map comb_α defined as follows is simplicial, surjective and it is 1-Lipschitz.*

$$\begin{aligned} \text{comb}_\alpha : \mathcal{F}_g^n &\rightarrow \mathcal{F}(S \setminus \alpha) \\ T &\mapsto \text{comb}_\alpha(\text{cut}_\alpha(T)) \end{aligned}$$

Proof. We will first prove that for every triangulation T of S_g^n , $\text{comb}_\alpha(\text{cut}_\alpha(T))$ is a triangulation in $S_g^n \setminus \alpha$. Let Δ be a triangle in $S_g^n \setminus T$. If α does not visit Δ , we have $\text{comb}_\alpha(\text{cut}_\alpha(\Delta)) = \Delta$, hence it gives a triangle in $S_g^n \setminus \alpha$.

Now assume that α visits Δ . In Figure 4.5, 4.6, 4.7 we exhibit in gray all the possible shapes of a connected component in $\Delta \setminus \alpha$. If Δ is the "first" or the "last" triangle visited by α , we are in the case of Figure 4.5. Otherwise, $\Delta \setminus \alpha$ has exactly one connected component as in Figure 4.6 and at least one as in Figure 4.7. When we comb in the direction of α , any connected component as in Figure 4.7 contracts to an edge and any connected

component as in Figure 4.6 gives a triangle in $S_g^n \setminus \alpha$. Similarly, in Figure 4.5 the "first" triangle visited by α gives two triangles in $S_g^n \setminus \alpha$, and the last one contracts to an edge. Finally, we conclude that $\text{comb}_\alpha(\text{cut}_\alpha(T))$ decompose $S_g^n \setminus \alpha$ into the same number of triangles of $S_g^n \setminus T$ and $\text{comb}_\alpha(T)$ is a triangulation of $S_g^n \setminus \alpha$.

It is easy to see that combing along α does not create new intersections between arcs, hence $\iota(\text{comb}_\alpha(t_i), \text{comb}_\alpha(t_j)) \leq \iota(t_i, t_j)$. In particular, if $T_1, T_2 \in \mathcal{F}_g^s$ differ by a flip, then either $\text{comb}_\alpha(\text{cut}_\alpha(T_1))$ and $\text{comb}_\alpha(\text{cut}_\alpha(T_2))$ differ by a flip or $\text{comb}_\alpha(\text{cut}_\alpha(T_1)) = \text{comb}_\alpha(\text{cut}_\alpha(T_2))$.

It is also clear that the restriction of comb_α to \mathcal{F}_α is the identity. Now, let $U, W \in \mathcal{F}$ and let $\gamma : U = T_0 \dots T_m = W$ a geodesic path in \mathcal{F}_g^n joining them. By the above argument, $\text{comb}_\alpha(\gamma) : \text{comb}_\alpha(U) \dots \text{comb}_\alpha(T_i) \dots \text{comb}_\alpha(W)$ is a path in $\mathcal{F}(S \setminus \alpha)$ of length at most m . Hence, we have

$$d_{\mathcal{F}(S \setminus \alpha)}(\text{comb}_\alpha(U), \text{comb}_\alpha(W)) \leq L(\text{comb}_\alpha(\gamma)) \leq m = d_{\mathcal{F}}(U, W),$$

and comb_α is 1-Lipschitz. \square

Remark 4.2.12. *If $\langle \alpha_i, \alpha_j \rangle$ is an edge in $A(S_g^n)$, then $\text{comb}_{\alpha_j}(\mathcal{F}_{\alpha_i}) = \mathcal{F}_{\langle \alpha_i, \alpha_j \rangle}$*

Theorem 4.2.13. *For every simplex σ in $A(S_g^n)$, the stratum \mathcal{F}_σ is arcwise connected and convex.*

Proof. If $U, W \in \mathcal{F}_\alpha \subseteq \mathcal{F}_g^n$ then $\text{comb}_\alpha(\text{cut}_\alpha(U)) = U$, $\text{comb}_\alpha(\text{cut}_\alpha(W)) = W$ and $d_{\mathcal{F}}(U, W) = d_{\mathcal{F}_\alpha}(U, W)$ by Lemma 4.2.11.

We recall that if $\sigma = \langle \alpha_1, \dots, \alpha_k \rangle$, then $\mathcal{F}_\sigma = \mathcal{F}_{\alpha_1} \cap \dots \cap \mathcal{F}_{\alpha_k}$. We also remark that $\text{comb}_{\alpha_j}(\mathcal{F}_{\alpha_i}) = \mathcal{F}_{\langle \alpha_i, \alpha_j \rangle}$. Let $U, W \in \mathcal{F}_\sigma$ be vertices. It is immediate to see that the path described in Section 4.2.1 is entirely contained in \mathcal{F}_σ . Indeed, none of the common arcs between U and W is flipped. The proof of the total geodesity for \mathcal{F}_σ follows from Lemma 4.2.11 by induction on k . \square

Let $f : A(S_{g,b}^n, \mathbf{1}) \rightarrow A(S_{g,b-1}^{n+1}, \mathbf{1})$ be the "forgetful" map defined between arc complexes, that is, the map that "forgets" the marked point on some boundary component of the surface, as seen in Section 2.4.2. It is immediate that f is simplicial and surjective. The argument in 4.2.11 also proves the following:

Lemma 4.2.14. *The forgetful map $f : A(S_{g,b}^n, \mathbf{1}) \rightarrow A(S_{g,b-1}^{n+1}, \mathbf{1})$ descends to a map*

$$f : \mathcal{F}_{g,b,1}^n \rightarrow \mathcal{F}_{g,b-1,1}^{n+1}$$

that is simplicial, surjective and 1-Lipschitz.

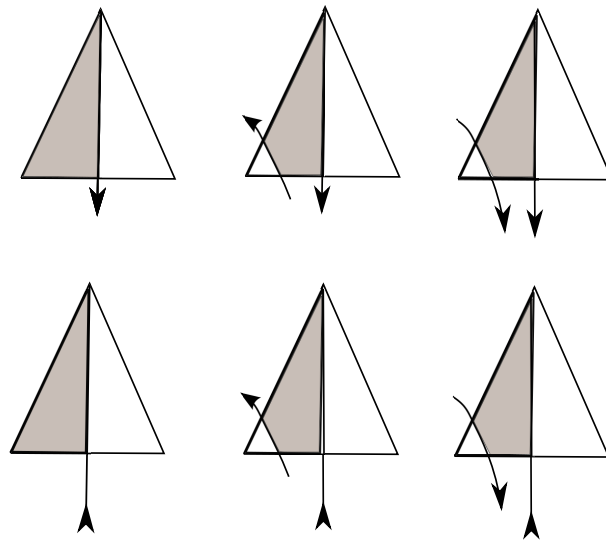

Figure 4.5: Lemma 4.2.11

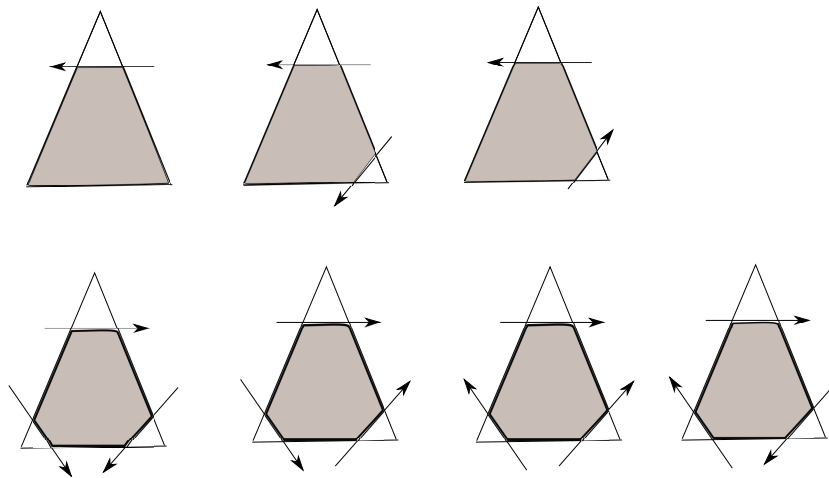

Figure 4.6: Lemma 4.2.11

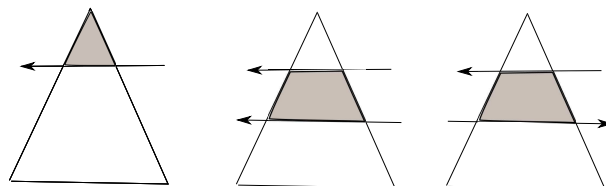

Figure 4.7: Lemma 4.2.11

4.3 Large-scale results on \mathcal{F}_g^n

The mapping class group $\text{MCG}(S_g^n)$ is the group of the orientation preserving homeomorphisms of S_g^n modulo isotopy. The pure mapping class group $\text{PMCG}(S_g^n)$ is the subgroup of the orientation preserving homeomorphisms of S_g^n fixing the marked points of S_g^n pointwise. Both groups acts on \mathcal{F}_g^n simplicially by isometries. We denote by \mathcal{MF}_g^n and \mathcal{PMF}_g^n the moduli space of this action, that is, respectively the quotients $\mathcal{F}_g^n/\text{MCG}(S_g^n)$ and $\mathcal{F}_g^n/\text{PMCG}(S_g^n)$. It is immediate to see that both \mathcal{MF}_g^n and \mathcal{PMF}_g^n are finite graphs.

The graph \mathcal{F}_g^n is locally finite, it is easy to see that a ball of radius 1 around a vertex contains at most $6g + 3n - 6$ vertices. The following lemma bounds the number of vertices in a ball of arbitrary radius in \mathcal{F}_g^n . Its proof follows from the discussion in Thurston-Sleator-Tarjan [Section 5, [64]].

Lemma 4.3.1. *For every vertex $T_0 \in \mathcal{F}_g^n$, for every $R \in \mathbb{N}$, the ball $B(T_0, R) := \{T \in \mathcal{F}_g^n | d(T, T_0) \leq R\}$ contains at most $3^{4g+2n-48R}$ vertices.*

In this section we will deal with the growth of the diameter of \mathcal{MF}_g^n with respect to n and the coarse geometry of \mathcal{F}_g^n .

4.3.1 The growth of $\text{diam} \mathcal{MF}_g^n$

We endow \mathcal{MF}_g^n and \mathcal{PMF}_g^n with the distances inherited from \mathcal{F}_g^n as follows:

$$d_{\mathcal{MF}}([T_1], [T_2]) := \min_{f_1, f_2 \in \text{MCG}(S)} d_{\mathcal{F}}(f_1(T_1), f_2(T_2)) = \min_{f \in \text{MCG}(S)} d(T_1, f(T_2))$$

$$d_{\mathcal{PMF}}([T_1], [T_2]) := \min_{f_1, f_2 \in \text{PMCG}(S)} d_{\mathcal{F}}(f_1(T_1), f_2(T_2)) = \min_{f \in \text{PMCG}(S)} d(T_1, f(T_2)).$$

It is immediate to see that $\text{diam} \mathcal{MF}_g^n \leq \text{diam} \mathcal{PMF}_g^n$. In Figure 4.3.1 we exhibit an example of two triangulations that have distance 2 in \mathcal{F}_g^n and \mathcal{PMF}_g^n but they coincide in \mathcal{MF}_g^n .

Let σ be a simplex in $A(S_g^n)$, we denote

$$\mathcal{MF}_\sigma = \left(\bigcup_{f \in \text{MCG}(S_g^n)} \mathcal{F}_{f\sigma} \right) / \text{MCG}(S_g^n)$$

$$\mathcal{PMF}_\sigma = \left(\bigcup_{f \in \text{PMCG}(S_g^n)} \mathcal{F}_{f\sigma} \right) / \text{PMCG}(S_g^n).$$

It is immediate to see that $\mathcal{MF}_\sigma = \mathcal{MF}_{f\sigma}$ for every $f \in \text{MCG}(S_g^n)$ and $\mathcal{PMF}_\sigma = \mathcal{PMF}_{f\sigma}$ for every $f \in \text{PMCG}(S_g^n)$.

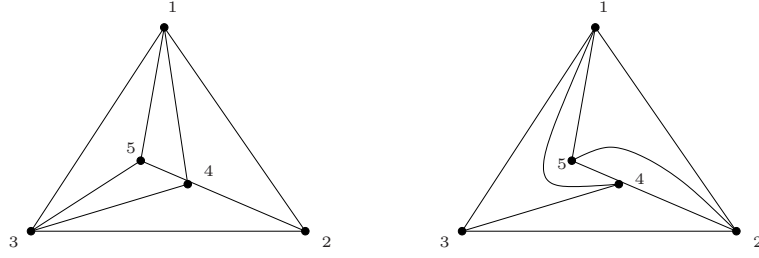

Figure 4.8: Example

In this section we prove that the diameter of \mathcal{MF}_g^n is roughly bounded above by $n \log n$.

We recall the following result of Sleator-Tarjan-Thurston [64] for $g = 0$.

Theorem 4.3.2 (Sleator-Tarjan-Thurston [64]). *The following holds:*

$$\liminf_{n \rightarrow +\infty} \frac{\text{diam } \mathcal{PMF}_0^n}{n \log n} > 0, \quad \limsup_{n \rightarrow +\infty} \frac{\text{diam } \mathcal{MF}_0^n}{n \log n} < +\infty.$$

Lemma 4.3.1 provides easily the following results.

Proposition 4.3.3. *Let $PT(g, n)$ and $T(g, n)$ be the number of equivalence classes of triangulations of S_g^n modulo the actions of $\text{PMCG}(S_g^n)$ and $\text{MCG}(S_g^n)$ respectively. The following holds:*

$$\liminf_{n \rightarrow +\infty} \frac{\text{diam } \mathcal{PMF}_g^n}{\log PT(g, n)} > 0 \text{ and } \liminf_{n \rightarrow +\infty} \frac{\text{diam } \mathcal{MF}_g^n}{\log T(g, n)} > 0.$$

Lemma 4.3.4 (Inequalities). *The following holds:*

1. for every α essential arc on S_g^n , $\text{diam } \mathcal{MF}_\alpha \leq \text{diam } \mathcal{MF}(S_g^n \setminus \alpha)$;
2. if α is a separating arc such that $S_g^n \setminus \alpha = S_{g',1,1}^{m'} \cup S_{g'',1,1}^{m''}$, then

$$\text{diam } \mathcal{MF}(S_g^n \setminus \alpha) = \text{diam } \mathcal{MF}(S_{g',1,1}^{m'}) + \text{diam } \mathcal{MF}(S_{g'',1,1}^{m''});$$

3. $\text{diam } \mathcal{MF}_{g,b,1}^{n+1} \leq \text{diam } \mathcal{MF}_{g,b+1,1}^n$;
4. for $n \rightarrow +\infty$, $\text{diam } \mathcal{MF}_{0,1,(1)}^n \leq \text{diam } \mathcal{MF}_{0,2n+1}$.

Proof. 1. It follows from the definitions of distance and from the fact that $\text{MCG}(S \setminus \alpha) \cong \text{Stab}(\alpha)$.

2. It follows from the equivariance of Remark 4.2.10-(2) with respect to the

action of $\text{Stab}(\alpha)$.

3. It follows from the equivariance of Lemma 4.2.14.

4. Every triangulation of $S_{0,1,(m)}^n$ has at least one arc α connecting an inner point with a point on the boundary. Hence $\mathcal{MF}(S_{0,1,(m)}^n) = \mathcal{MF}_\alpha$. From (1) it follows $\text{diam} \mathcal{MF}(S_{0,1,(m)}^n) \leq \text{diam} \mathcal{MF}(S_{0,1,(m)}^n \setminus \alpha) = \text{diam} \mathcal{MF}(S_{0,1,(m+2)}^{n-1})$. By induction, one concludes $\text{diam} \mathcal{MF}(S_{0,1,(m)}^n) \leq \text{diam} \mathcal{MF}(S_{0,1,(m+2n)}^0)$. By Thurston-Sleator-Tarjan's results on the planar cases [63; 64] one have $\text{diam} \mathcal{MF}(S_{0,1,(m+2n)}^0) \leq \text{diam} \mathcal{MF}(S_0^{m+2n})$ for n large. \square

Theorem 4.3.5. *The following holds:*

$$\limsup_{n \rightarrow +\infty} \frac{\text{diam} \mathcal{MF}_g^n}{|\chi_g^n| \log |\chi_g^n|} < +\infty.$$

Proof. Denote by \mathcal{S} the set of marked points on S_g^n . Let $T \in \mathcal{F}_g^n$ be a vertex, that is, a triangulation of S_g^n . We define a graph $\mathcal{G}(T)$ embedded in S_g^n as follows. For each triangle in $S \setminus T$, choose one point c in its interior. Denote by $\mathcal{C}(S)$ the set of all the c 's. The set of vertices of $\mathcal{G}(T)$ is $\mathcal{S} \cup \mathcal{C}(T)$. The edges of $\mathcal{G}(T)$ are defined as follows (see the dotted graph in Figure 4.9):

- join each $c \in \mathcal{C}(T)$ to the vertices of the triangle it belongs to;
- $c, c' \in \mathcal{C}(T)$ are joined by an edge if they belong to adjacent triangles in $S \setminus T$.

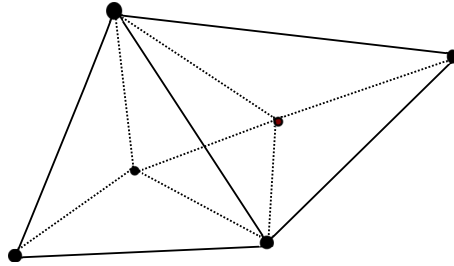

Figure 4.9: $\mathcal{G}(T)$

Let $\mathcal{G}'(T)$ be a spanning tree for $\mathcal{G}(T)$ and γ be a simple closed curve in a regular neighborhood of $\mathcal{G}'(T)$. By construction we have $\iota(\gamma, t_i) \leq 2$ for all $t_i \in T$. Join this curve to one point in \mathcal{S} , and let α_γ be the essential arc obtained. We have $\iota(\alpha_\gamma, t_i) \leq 2$ for all $t_i \in T$, and by Proposition 4.2.9, we have $d_{\mathcal{F}}(T, \mathcal{F}_{\alpha_\gamma}) \leq \iota(\alpha_\gamma, T) = 2|T|$. By construction, α_γ is an arc based on one point in \mathcal{S} , and it surrounds all the other points in \mathcal{S} . Hence, its

orbit under the action of $\text{MCG}(S_g^n)$ does not depend on T , and the stratum $\mathcal{MF}_{\alpha_\gamma}$ does not depend on T .

By the above remark, we have $d_{\mathcal{MF}}([T_1], \mathcal{MF}_{\alpha_\gamma}) \leq 2|T|$. By the triangular inequality, it follows:

$$\begin{aligned} d_{\mathcal{MF}}([T_1], [T_2]) &\leq d_{\mathcal{MF}}([T_1], \mathcal{MF}_{\alpha_\gamma}) + d_{\mathcal{MF}}([T_2], \mathcal{MF}_{\alpha_\gamma}) + \text{diam}(\mathcal{MF}_{\alpha_\gamma}) \\ &\leq 4|T| + \text{diam}(\mathcal{MF}_{\alpha_\gamma}) \end{aligned}$$

Since α_γ is separating, by Lemma 4.3.4 we have:

$$\begin{aligned} \text{diam} \mathcal{MF}_{\alpha_\gamma} &\leq \text{diam} \mathcal{MF}(S \setminus \alpha) = \text{diam} \mathcal{MF}_{0,1,(1)}^{n-1} + c(g) \\ \text{diam} \mathcal{MF}_0^n &\leq \text{diam} \mathcal{MF}_{0,1,(1)}^{n-1} \leq \text{diam} \mathcal{MF}_0^{n+1}. \end{aligned}$$

The proof follows from Lemma 4.3.2. □

4.3.2 On the coarse geometry of \mathcal{F}_g^n

We recall some basic definition on coarse geometry. For further readings on this topic, we address the reader to [9].

Definition 4.3.6. *Let (X_1, d_1) and (X_2, d_2) be metric spaces. A map $f : X_1 \rightarrow X_2$ is a (k_f, l_f) -quasi-isometric embedding if there exist constants $k_f \geq 1$ and $l_f \geq 0$ such that for all $x, y \in X_1$*

$$\frac{1}{k_f} \cdot d_1(x, y) - l_f \leq d_2(f(x), f(y)) \leq k_f \cdot d_1(x, y) + l_f.$$

If the image of f is l_f -dense in X_2 , f is called a (k_f, l_f) -quasi isometry.

If G is finitely generated, any generating set on G induces a *word metric* on the group. Denote by $|g|$ the length of the shortest word in the generators representing $g \in G$, the distance between $g_1, g_2 \in G$ is defined as $d_G(g_1, g_2) = |g_1^{-1}g_2|$. The metrics associated to any two finite generating sets are bilipschitz equivalent. If H is a finitely generated subgroup of G , we say that H is *undistorted* in G if the inclusion $H \hookrightarrow G$ is a quasi-isometric embedding.

We recall that a group G acts *properly* on a geodesic metric space X if for every $x \in X$ there exists $r > 0$ such that $|\{g \in G | gB(x, r) \cap B(x, r) \neq \emptyset\}| < +\infty$. The *(pointwise) stabilizer* of a subset $Y \subseteq X$ is the subgroup $\text{Stab}(Y)$ generated by the elements $g \in G$ such that $g(y) = y$ for every $y \in Y$. A proof of the following version of Svarc-Milnor Lemma can be found for instance in [9].

Theorem 4.3.7 (Svarc-Milnor Lemma). *Let X be a proper geodesic metric space. If G acts cocompactly and properly on X , then G is finitely generated, and for every $x \in X$ the orbit map*

$$\begin{aligned} \psi^x : G &\rightarrow X \\ \gamma &\mapsto \gamma.x \end{aligned}$$

is a $(3 \cdot \text{diam}X/G, 1)$ -quasi-isometry.

We first recall the following well-known fact, whose proof is based on Alexander's trick.

Remark 4.3.8. *Assume $\chi_g^n < 0$ and $(g, n) \neq (0, 3)$ and let T be a triangulation of S_g^n . If $\phi : S_g^n \rightarrow S_g^n$ is an homeomorphism that fixes T arcwise, then ϕ is isotopic to the identity.*

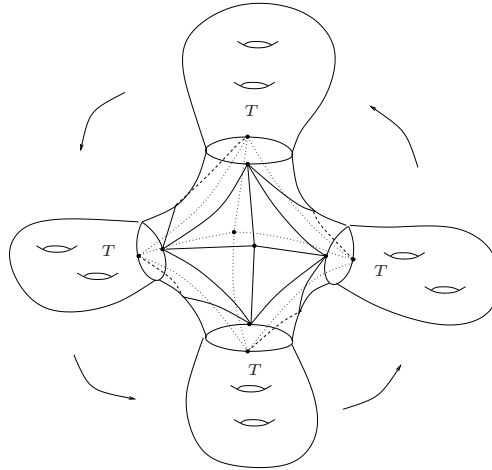

Figure 4.10: Example

It is well-known that the action of $\text{MCG}(S_g^n)$ on \mathcal{F}_g^n is not free. In Figure 4.10 we provide an example of a triangulation of a surface with a non-trivial stabilizer. We start with a “symmetric” triangulation of $(S_{0,4}^2, \mathbf{2})$, and then we extend it to the other four subsurfaces by the same triangulation T . The rotation as in the figure is a non-trivial element in the stabilizer of the resulting triangulation of a surface.

In [38] Korkmaz-Papadopoulos proved that, except for a few cases, the automorphism group of \mathcal{F}_g^n is isomorphic to $\text{MCG}^*(S_g^n)$. Furthermore, they proved that \mathcal{F}_g^n is not Gromov-hyperbolic. From their argument, the version of the Svarc-Milnor Lemma above and Theorem 4.3.5, it follows:

Proposition. *If $\chi(S_g^n) < 0$ and $(g, n) \neq (0, 3)$ then the following holds:*

1. *For every vertex T of \mathcal{F}_g^n the map*

$$\begin{aligned} \psi^T : \text{MCG}(S_g^n) &\rightarrow \mathcal{F}_g^n \\ g &\mapsto gT \end{aligned}$$

is a $(k_{\psi^T}, 1)$ -quasi-isometry for some k_{ψ^T} , with $k_{\psi^T} \leq C \cdot |\chi(S_g^n)| \log |\chi(S_g^n)|$ as n tends to $+\infty$.

2. *For every simplex σ in $A(S_g^n)$ and for every vertex T of \mathcal{F}_σ , the map*

$$\begin{aligned} \psi^T : \text{Stab}(\sigma) &\rightarrow \mathcal{F}_\sigma \\ g &\mapsto gT \end{aligned}$$

is a quasi-isometry.

3. *$\text{Stab}(\sigma)$ is an undistorted subgroup of $\text{MCG}(S_g^n)$.*

Proof. 1. We recall the main argument in [Theorem 1.4, [38]]. Let T be a vertex of \mathcal{F}_g^n and $g \in \text{Stab}(T)$. By definition g induces a permutation of the edges of T . If g_1 and g_2 induce the same permutation, then $g_1 g_2^{-1}$ fixes every arc of T , hence, by Remark 4.3.8, it is isotopic to the identity. This proves $\text{Stab}(T) \leq (6g+3n-6)!$. The set $\{g \in \text{MCG}(S) \mid gB(T, \frac{1}{2}) \cap B(T, \frac{1}{2}) \neq \emptyset\}$ coincides with $\text{Stab}(T)$, hence it is finite. and the action of the mapping class group is proper. It is well-known that $\mathcal{F}_g^n / \text{MCG}(S_g^n)$ is compact. The Svarc-Milnor Lemma 4.3.7 concludes. By Theorem 4.3.5 we deduce the assertion about the quasi-isometry constants.

2. By Theorem 4.2.13 \mathcal{F}_σ is arcwise connected. Similarly, the action of $\text{Stab}(\sigma)$ on $\mathcal{F}_\sigma = \mathcal{F}(S \setminus \sigma)$ is proper. Now $\text{PMCG}(S \setminus \sigma) \cong \text{Stab}(\sigma)$ and $\mathcal{F}(S \setminus \sigma) \cong \mathcal{F}_\sigma$, and the action is also cocompact.

3. For every vertex $T \in \mathcal{F}_\sigma$, there is a commutative diagram:

$$\begin{array}{ccc} \mathcal{F}_\sigma & \xrightarrow{\iota} & \mathcal{F}_g^n \\ \psi_\uparrow^T \uparrow & & \uparrow \psi^T \\ \text{Stab}(\sigma) & \xrightarrow{j} & \text{MCG}(S_g^n) \end{array}$$

where the inclusion $\iota : \mathcal{F}_\sigma \hookrightarrow \mathcal{F}_g^n$ is an isometry by Theorem 4.2.13, and the orbit maps ψ^T and ψ_\uparrow^T are quasi-isometries. It follows that $\text{Stab}(\sigma)$ is undistorted. \square

The assertion (2) was proved by Masur-Minsky [47] and Hamenstädt [26] for the stabilizers of the curve complex. Masur-Minsky [46] built a quasi-isometric model for $\text{MCG}(S_g^n)$ through an appropriate modification of the curve complex, which they called the *marking complex*. Another coarse model for the mapping class group is the *train track complex*, defined by Hamenstädt [26]. The coarse geometry of the mapping class group and its relation with the one of Teichmüller space has been studied by several different authors, for further readings see for instance Hamenstädt [26], Masur-Minsky [46; 47], Farb [17] or Behrstock [3].

4.4 The Thurston metric on $\text{Teich}(S_{g,b})$

In this section we deal with Teichmüller space of a surface with boundary $S_{g,b}$, and we point out some relation between its geometry with respect to Thurston's metric and the geometry of the ideal triangulation graph.

Natural coordinates on $\text{Teich}(S_{g,b})$ Set $N = 6g + 3b - 6$ and let $H = (t_1, \dots, t_N)$ be a maximal set of disjoint essential arcs on S , *i.e.* a decomposition of $S_{g,b}$ into hexagons where edges are either essential arcs on the surface or they lie on $\partial S_{g,b}$ and no two consecutive edges of the same type.

We recall that for a fixed a hyperbolic metric X on $S_{g,b}$ each $t_i \in H$ admits a unique shortest geodesic representative in its homotopy class. This geodesic is orthogonal to $\partial S_{g,b}$. All the arcs in H can be realized simultaneously as disjoint (shortest) geodesics on $S_{g,b}$. By a little abuse of notation, we denote by $(L_X(t_1), \dots, L_X(t_N)) \in \mathbb{R}_{>0}^N$ the vector of lengths of these representatives, and H induces a (geodesic hyperbolic right-angled) hexagonal decomposition of $(S_{g,b}, X)$. Conversely, for every vector $\mathcal{A} = (a_1, \dots, a_N) \in \mathbb{R}_{>0}^N$ there exists a unique hyperbolic metric $X_{(H, \mathcal{A})}$ such that $L_{X_{(H, \mathcal{A})}}(t_i) = a_i$ for all $i = 1, \dots, N$. This bijective correspondence defines some natural coordinates on $\text{Teich}(S_{g,b})$. Refinements of these coordinates can be found in papers by Ushijima [69], Mondello [49] and Luo [43].

$$\begin{aligned} \text{Teich}(S_{g,b}) &\longrightarrow \mathbb{R}_{>0}^N \\ X &\mapsto (l_X(t_1), \dots, l_X(t_N)) \end{aligned}$$

$$\begin{aligned} \mathbb{R}_{>0}^N &\longrightarrow \text{Teich}(S_{g,b}) \\ \mathcal{A} &\mapsto X_{(T, \mathcal{A})} \end{aligned}$$

The Thurston distance In the preprint [67] Thurston introduced an *asymmetric distance* on Teichmüller space of closed and punctured surfaces

that is “natural” with respect to the hyperbolic approach to Teichmüller theory.

Definition 4.4.1. Let (X, d) be a metric space. A function $d : X \times X \rightarrow [0, +\infty[$ is an asymmetric distance if d satisfies:

- $d \geq 0$ and $d(x, y) = 0$ iff $x = y$;
- $d(x, y) \leq d(x, z) + d(z, y)$ for all $x, y, z \in X$.

We remark that in general $d(x, y)$ and $d(y, x)$ may differ. We recall another well-known definition.

Definition 4.4.2. Let (X, d_X) and (Y, d_Y) metric spaces. Assume $k \in \mathbb{R}^+$. The map $f : (X, d_X) \rightarrow (Y, d_Y)$ is k -Lipschitz if $d_Y(f(x), f(y)) \leq k \cdot d_X(x, y)$ for all $x, y \in X$. The Lipschitz constant $K(f)$ of f is defined as

$$K(f) = \sup_{x \neq y} \frac{d_Y(f(x), f(y))}{d_X(x, y)}.$$

Definition 4.4.3. The Thurston distance between two points $X, Y \in \text{Teich}(S_g^n)$ is defined as follows

$$d(X, Y) = \inf_{\phi \sim id} \log K(\phi)$$

with $\phi : (S_g^n, X) \rightarrow (S_g^n, Y)$ homeomorphism isotopic to the identity and $K(\phi)$ its Lipschitz constant.

Thurston [67] defined a family of “natural” geodesics with respect to this distance, the so-called *stretch-lines*. He also proved that this distance can be calculated in terms of length spectra of simple closed geodesics as follows:

Theorem 4.4.4. For every $X, Y \in \text{Teich}(S_g^n)$, we have:

$$d(X, Y) = \sup \left\{ \log \frac{L_X(\alpha)}{L_Y(\alpha)} \mid \alpha \text{ essential closed curve on } S \right\}.$$

Teichmüller distance naturally provides an upper bound for Thurston’s distance. Choi-Rafi [14] compared the properties of these two distances on Teichmüller space of a punctured surface. Papadopoulos-Théret [52] proved that the topology induced actually coincide with the usual topology on $\text{Teich}(S_{g,b})$ and d is complete.

In a series of papers [54; 53; 41; 40; 39] Papadopoulos, Théret, Liu and Su dealt with the generalization of the Thurston distance in the case of a bordered surface. Among other things, Papadopoulos-Théret [54] proved that in the case of a surface with boundary the following (analogous to Definition 4.4.3) is well-defined and it provides an asymmetric distance as well, though Theorem 4.4.4 does not hold anymore.

Definition 4.4.5. *The Thurston distance between $X, Y \in \text{Teich}(S_{g,b})$ is defined by*

$$d(X, Y) = \inf_{\phi \sim id} \log K(\phi)$$

with $\phi : (S_{g,b}, X) \rightarrow (S_{g,b}, Y)$ is a homeomorphism isotopic to the identity and $K(\phi)$ is its Lipschitz constant.

Since the action of the mapping class group on Teichmüller space is properly discontinuous, this (asymmetric) distance naturally induces a (asymmetric) distance on the moduli space $\mathcal{M}_{g,b}$.

4.4.1 Bounding distances

In this section we will use the above coordinates in order to bound distances in Thurston's metric on $\text{Teich}(S_{g,b})$. We will first recall some well-known formulae for hyperbolic geodesic right-angled hexagons and we apply them in order to provide bounds on distances between two points in Teichmüller space.

Geodesic right-angled hexagons in \mathbb{H}^2 Let H be a geodesic right-angled hexagon in \mathbb{H}^2 , with enumerated edges \mathcal{S}_i of length s_i as in Figure 4.11. We will say that H is a *marked* hexagon.

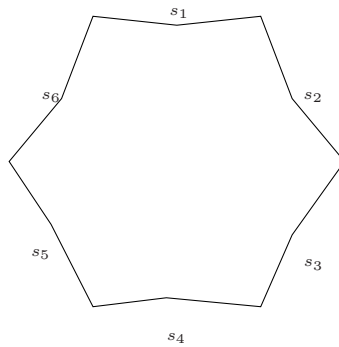

Figure 4.11: A marked right-angled geodesic hexagon

The following theorem is a classical result. A proof can be found for instance in [20].

Theorem 4.4.6. *The following holds:*

$$\cosh s_4 \sinh s_5 \sinh s_3 = \cosh s_1 + \cosh s_5 \cosh s_3; \quad (4.4.1)$$

$$\frac{\sinh s_1}{\sinh s_4} = \frac{\sinh s_5}{\sinh s_2} = \frac{\sinh s_3}{\sinh s_6}. \quad (4.4.2)$$

It follows that the lengths of the six edges of H are determined by the triple (s_1, s_3, s_5) (or (s_2, s_4, s_6)).

Definition 4.4.7. *Let $H(s_1, s_2, s_3), H'(s'_1, s'_3, s'_5)$ be two marked geodesic right-angled hexagons in \mathbb{H}^2 . We define:*

$$K(H, H') = \inf_f K(f),$$

where $f : H(s_1, s_3, s_5) \rightarrow H(s'_1, s'_3, s'_5)$ is a marking-preserving homeomorphism, that is, $f(\mathcal{S}_i) = \mathcal{S}'_i$ for $i = 1, \dots, 6$, and $K(f)$ is its Lipschitz constant.

It is immediate to see that $K(H, H') \geq \min_{i=1, \dots, 6} \frac{s'_i}{s_i}$.

Lemma 4.4.8 (Papadopoulos-Th  ret [54]). *Assume $s > 0$ and $k > 1$. Let $H_1 = H(s, s, s)$ and $H_k = H(ks, ks, ks)$ be two marked hexagons as above.*

We have $K(H_1, H_k) = k$, and there exists a marking-preserving homeomorphism $f : H_1 \rightarrow H_k$ such that $K(f) = k$ and the restriction of $f|_1$ on the edges of H_1 is affine.

Some bounds It is easy to see that in a geodesic metric space the Lipschitz constant of a homeomorphism can be calculated as follows. Its proof is immediate.

Lemma 4.4.9. *Let (X, d) be a geodesic metric space and $f : X \rightarrow X$ be a homeomorphism. Assume $X = \bigcup_\alpha U_\alpha$, with every $U_\alpha \neq \emptyset$ and $f|_1 : U_\alpha \rightarrow X$ is K_α -Lipschitz for some $K_\alpha \in \mathbb{R}^+$.*

If $\sup_\alpha K_\alpha < +\infty$ then f is $(\sup_\alpha K_\alpha)$ -Lipschitz.

Let $T \in \mathcal{F}_{g,b}$ be a vertex, $\mathcal{A} \in \mathbb{R}_+^N$ and $X_{(T, \mathcal{A})}$ their corresponding point in $\text{Teich}(S_{g,b})$. T induces a decomposition of $X_{(T, \mathcal{A})}$ into $4g + 2b - 4$ hyperbolic geodesic right-angled hexagons E_i . We denote this decomposition by $\mathcal{E}^\mathcal{A} = \{E_i\}_{i=1, \dots, 4g+2b-4}$, and we mark each E_i with the lengths of its three edges $s_{i,1}, s_{i,2}, s_{i,3}$ belonging to T . By the above lemma, we can bound the Thurston distance on $\text{Teich}(S_{g,b})$ as follows.

Proposition 4.4.10. *Let $T \in \mathcal{F}_{g,b}$ be a vertex, and $\mathcal{A}_1 = (a_1^i), \mathcal{A}_2 = (a_2^i) \in \mathbb{R}_{>0}^N$ with $\mathcal{A}_1 \neq \mathcal{A}_2$. The following holds:*

1. $d(X_{(T, \mathcal{A}_1)}, X_{(T, \mathcal{A}_2)}) \leq \log \max_{E_1, E_2} K(E_1, E_2);$
2. $d(X_{(T, \mathcal{A}_2)}, X_{(T, \mathcal{A}_1)}) \leq \log \max_{E_1, E_2} K(E_2, E_1);$
3. if $\max_i \frac{a_2^i}{a_1^i} > 1$ then we have:

$$\log \max_{i=1, \dots, N} \frac{a_2^i}{a_1^i} \leq d(X_{(T, \mathcal{A}_1)}, X_{(T, \mathcal{A}_2)}) \leq \log \max_{E_1, E_2} K(E_1, E_2);$$

4. if $\max_i \frac{a_1^i}{a_2^i} > 1$ then we have:

$$\log \max_{i=1, \dots, N} \frac{a_1^i}{a_2^i} \leq d(X_{(T, \mathcal{A}_2)}, X_{(T, \mathcal{A}_1)}) \leq \log \max_{E_1, E_2} K(E_2, E_1);$$

where $E_1 \in \mathcal{E}^{\mathcal{A}_1}$ and $E_2 \in \mathcal{E}^{\mathcal{A}_2}$.

Proof. 1. and 3. Let $\mathcal{E}^{\mathcal{A}_1} = \{E_i^{\mathcal{A}_1}\}$ and $\mathcal{E}^{\mathcal{A}_2} = \{E_i^{\mathcal{A}_2}\}$ be respectively the hexagonal decompositions of $(S, X_{(T, \mathcal{A}_1)})$ and $(S, X_{(T, \mathcal{A}_2)})$ associated to T as above. Without loss of generality, we assume that $E_i^{\mathcal{A}_1}$ and $E_i^{\mathcal{A}_2}$ are isotopic on S for all $i = 1, \dots, 4g + 2b - 4$.

If $\phi : (S, X_{(T, \mathcal{A}_1)}) \rightarrow (S, X_{(T, \mathcal{A}_2)})$ is a homeomorphism homotopic to the identity on S , we have the following:

$$K(\phi) \geq \max_{i=1, \dots, N} \frac{L_{X_{(T, \mathcal{A}_2)}}(\phi(t_i))}{a_1^i} \geq \max_{i=1, \dots, N} \frac{a_2^i}{a_1^i}.$$

We conclude $d(X_{(T, \mathcal{A}_1)}, X_{(T, \mathcal{A}_2)}) \geq \log \max_{i=1, \dots, N} \frac{a_2^i}{a_1^i}$.

For every $i = 1, \dots, 4g + 2b - 4$, set $\kappa_i = K(E_i^{\mathcal{A}_1}, E_i^{\mathcal{A}_2})$, and remark that $\max_i \kappa_i \geq \max_i \frac{a_2^i}{a_1^i} > 1$. Fix $\epsilon > 0$, and let $f_i^\epsilon : E_1^{\mathcal{A}_1} \rightarrow E_2^{\mathcal{A}_2}$ be a homeomorphism affine on the edges such that $|K(f_i^\epsilon) - \kappa_i| \leq \epsilon$. Set $K^\epsilon = \max_i K(f_i^\epsilon)$. We have $|K^\epsilon - \max_i \kappa_i| \leq \epsilon$. We glue the f_i^ϵ 's, and we get a homeomorphism $f^\epsilon : (S, X_{(T, \mathcal{A}_1)}) \rightarrow (S, X_{(T, \mathcal{A}_2)})$. By Lemma 4.4.9, we have $K(f^\epsilon) = K^\epsilon$. Since f^ϵ preserves the homotopy class of each arc in T , f^ϵ is homotopic to the identity $id : S \rightarrow S$. We conclude:

$$d(X_{(T, \mathcal{A}_1)}, X_{(T, \mathcal{A}_2)}) \leq \log K(f^\epsilon) = \log K^\epsilon \leq \log(\max_i \kappa_i + \epsilon).$$

For $\epsilon \rightarrow 0$, we conclude:

$$d(X_{(T, \mathcal{A}_1)}, X_{(T, \mathcal{A}_2)}) \leq \log \max_{E_1, E_2} K(E_1, E_2).$$

2. and 4. The conclusion follows by the same argument. \square

Definition 4.4.11. Assume $L > 0$. A hyperbolic surface $X \in \text{Teich}(S_{g,b})$ is L -regular if there exists a vertex $T \in \mathcal{F}_{g,b}$ such that $l_X(t_i) = L$ for each arc $t_i \in T$. We denote the set of L -regular surfaces by $\mathcal{R}_{g,b}^L$.

The following proposition proves that for every vertex $T \in \mathcal{F}_{g,b}$ the set of all T -regular surfaces lies on the image of a (forward) geodesic with respect to Thurston's metric.

Proposition 4.4.12. Fix $k \geq 1$ and $L > 0$. Set $\mathcal{A}_1 = (L, \dots, L) \in \mathbb{R}^N$ and $\mathcal{A}_k = k\mathcal{A}_1 = (kL, \dots, kL) \in \mathbb{R}^N$. For every vertex $T \in \mathcal{F}_{g,b}$, we have:

$$d(X_{(T, \mathcal{A}_1)}, X_{(T, \mathcal{A}_k)}) = \log k.$$

Furthermore, the line $\mathbb{R} \ni t \mapsto X_{(T, e^t \mathcal{A}_1)} \in \text{Teich}(S_{g,b})$ is (forward) geodesic with respect to the Thurston metric on $\text{Teich}(S_{g,b})$.

Proof. Let $\mathcal{E}^{\mathcal{A}_1} = \{E_i^{\mathcal{A}_1}\}$ and $\mathcal{E}^{\mathcal{A}_k} = \{E_i^{\mathcal{A}_k}\}$ be respectively the hexagonal decompositions of $(S, X_{(T, \mathcal{A}_1)})$ and $(S, X_{(T, \mathcal{A}_k)})$ associated to T described above. Without loss of generality, assume that $E_i^{\mathcal{A}_1}$ and $E_i^{\mathcal{A}_k}$ are homotopic in S for all $i = 1, \dots, 4g + 2b - 4$.

By Lemma 4.4.8, for all $i = 1, \dots, 4g + 2b - 4$ there exists a homeomorphism $f_i : E_i^{\mathcal{A}_1} \rightarrow E_i^{\mathcal{A}_k}$ that realizes the smallest Lipschitz constant, this constant is equal to k and $f_i|_1$ is affine on the edges of the hexagons. Let $f : (S, X_{(T, \mathcal{A}_1)}) \rightarrow (S, X_{(T, \mathcal{A}_k)})$ be the homeomorphism obtained by glueing all the f_i 's. By Lemma 4.4.9, we have $K(f) = k$. By Lemma 4.3.8, f is isotopic to the identity $id : S \rightarrow S$. We have:

$$d(X_{(T, \mathcal{A}_1)}, X_{(T, \mathcal{A}_k)}) \leq \log k.$$

By Proposition 4.4.10, we have $d(X_{(T, \mathcal{A}_1)}, X_{(T, \mathcal{A}_k)}) \geq \log k$, and we conclude $d(X_{(T, \mathcal{A}_1)}, X_{(T, \mathcal{A}_k)}) = \log k$. □

4.4.2 Regular surfaces and ideal triangulation graphs

We recall that $\mathcal{R}_{g,b}^L$ is the set of L -regular surfaces in $\text{Teich}(S_{g,b})$. By definition this set is $\text{MCG}(S_{g,b})$ -invariant. We denote by $\mathcal{M}\mathcal{R}_{g,b}^L$ its quotient under the action of the mapping class group. Let $\delta : \text{Teich}(S_{g,b}) \times \text{Teich}(S_{g,b}) \rightarrow \mathbb{R}^+$ be the distance defined as follows:

$$\delta(X_{(T, \mathcal{A}_1)}, X_{(T, \mathcal{A}_2)}) = \max\{d(X_{(T, \mathcal{A}_1)}, X_{(T, \mathcal{A}_2)}), d(X_{(T, \mathcal{A}_2)}, X_{(T, \mathcal{A}_1)})\}.$$

Proposition 4.4.13. *For every $g \geq 0$, $L > 0$, the map defined on the 0-skeleton of $\mathcal{F}_{g,b}$*

$$\begin{aligned} f_L : \mathcal{F}_{g,b}^{(0)} &\rightarrow (\mathcal{R}_{g,b}^L, \delta) \\ T &\mapsto X_{(T,(L,\dots,L))} \end{aligned}$$

is Lipschitz, with a Lipschitz constant $K(L)$ that does not depend on g and b . Furthermore,

$$\limsup_{b \rightarrow +\infty} \frac{\text{diam. } \mathcal{M} \mathcal{R}_{g,b}^L}{|\chi(S_{g,b})| \log |\chi(S_{g,b})|} \leq K(L).$$

Proof. We prove that if $T, W \in \mathcal{F}_{g,b}$ are vertices at distance 1, that is, they differ by a flip, then there exists two constants $0 < C_1 \leq C_2$ independent by g, b, T, W such that

$$C_1 \leq d(f_L(W), f_L(T)) \leq C_2.$$

Set $X_W = f_L(W) = X_{(W,(L,\dots,L))}$, $X_T = f_L(T) = X_{(T,(L,\dots,L))}$ and denote by $T \cap W$ the set of arcs in common between T and W .

The arcs in $T \cap W$ decompose $S_{g,b}$ into one topological octagon O containing the flip, and $4g + 2b - 6$ topological hexagons H_i . For each H_i , we denote by H_i^W and H_i^T its (hyperbolic geodesic right-angled) realizations in X_W and X_T . Recall that H_i^W and H_i^T are isometric to $H(L, L, L) \subseteq \mathbb{H}^2$ for all i . Similarly, denote by O^W, O^T its (hyperbolic geodesic right-angled) realizations in X_W and X_T . Denote by a_1^W, a_2^W respectively the horizontal and vertical axes of O^W . By construction, a_1^W has length L . The length $2c$ of a_2^W and the length A of the edges of O^W can be calculated by the formulae in Theorem 4.4.6 :

$$\begin{aligned} \cosh(L) \sin A^2 &= \cosh A + \cosh^2 A \\ \cosh(c) \sinh^2 \left(\frac{A}{2} \right) &= \cosh(2A) \cosh^2 \left(\frac{A}{2} \right). \end{aligned}$$

By a straightforward calculation, we have:

$$\begin{aligned} \cosh A &= \frac{1}{\cosh(L) - 1} + 1 \\ \cosh(c) &= \frac{(2 \cosh(L) - 1) \cosh(L) \sqrt{2 \cosh(L) - 1}}{(\cosh(L) - 1)^2}. \end{aligned}$$

We remark that O^W is isometric to the union of two hexagons $H(L, L, L) \subseteq \mathbb{H}^2$ sharing the edge a_1^W . Similarly, O^T is isometric to the union of two

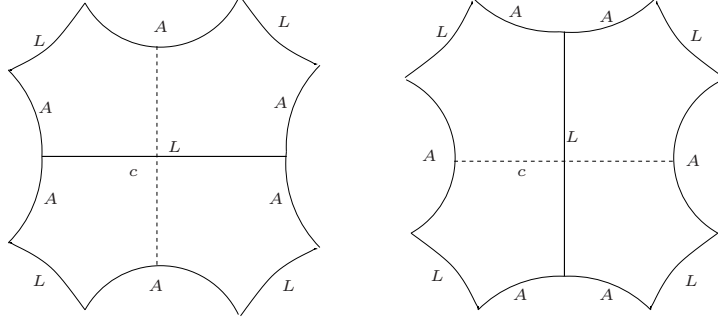
Figure 4.12: O^W and O^T

hexagons $H(L, 2c, L) \subseteq \mathbb{H}^2$ sharing the edge a_1^T (see Figure 4.12).

Any $\phi : (S, X_W) \rightarrow (S, X_T)$ homotopic to the identity preserves the homotopy class of the arcs $W \cup T$. Consider the embedding $\phi|_O : O^W \rightarrow \phi(O^W) \subset X_T$, induced by restriction. By construction, $\phi(a_1^W)$ is homotopic to a geodesic of length $2c$ on X_T . We have:

$$K(\phi|_O) \geq \frac{L_{X_T}(\phi(a_1^W))}{L_W(a_1^W)} \geq \frac{\min_{\tilde{a} \in [\phi(a_1^W)]} L_{X_T}(\tilde{a})}{L} = \frac{2c}{L}.$$

Similarly, consider the embedding $\phi|_H^i : H_i^W \rightarrow \phi(H_i^W) \subset X_T$, induced by restriction. If s_i is an edge of H_i of length L , then $\phi(s_i)$ is isotopic to a geodesic of length L on (S, X_T) . We have:

$$K(\phi|_H^i) \geq \frac{L_{X_T}(\phi(s_i))}{L_W(s_i)} \geq \frac{\min_{\tilde{s} \in [\phi(s_i)]} L_{X_T}(\tilde{s})}{L} = \frac{L}{L} = 1.$$

By Lemma 4.4.9, we have $K(\phi) = \max_i \{K(\phi|_O), K(\phi|_H^i)\} \geq \frac{2c}{L}$ and we conclude $d(X_W, X_L) = \inf_\phi \log K(\phi) \geq \frac{2c}{L}$, so $C_1 = \log \frac{2c}{L}$.

Set $e^{C_2} = K(H(L, L, L), H(L, 2c, L))$, and we remark $C_2 \geq \log \frac{2c}{L} = C_1$. Fix $\epsilon > 0$. Let $f_O^\epsilon : O^W \rightarrow O^T$ be a marking-preserving homeomorphism, that is, f_O^ϵ preserves the homotopy class on S of $W \cap O^W$. Assume $|K(f_O^\epsilon) - C_2| \leq \epsilon$. Let $f_i : H_i^W \rightarrow H_i^T$ be the marking-preserving isometry. We have $K(f_i) = 1$. Finally, glue all these homeomorphisms together and let $f^\epsilon : (S, X_W) \rightarrow (S, X_T)$ be the resulting homeomorphism. By Lemma 4.3.8, f^ϵ is homotopic to the identity. By Lemma 4.4.9, we have:

$$K(f^\epsilon) = \max_i \{K(f_O^\epsilon), K(f_i)\} = K(f_O^\epsilon) \leq e^{C_2} + \epsilon.$$

For $\epsilon \rightarrow 0$, we easily conclude:

$$d(X_W, X_T) \leq \log C_2.$$

By the same argument $d(X_T, X_W) \leq \log K(H(L, 2c, L), H(L, L, L))$, and $K(L) = \max\{\log K(H(L, 2c, L), H(L, L, L)), \log K(H(L, L, L), H(L, 2c, L))\}$. \square

Tous les évènements sont enchainés dans le meilleur des mondes possibles : car enfin si vous n'aviez pas été chassé d'un beau château à grands coups de pieds dans le derrière pour l'amour de mademoiselle Cunégonde, si vous n'aviez pas été mis à l'Inquisition, si vous n'aviez pas couru l'Amérique à pied, si vous n'aviez pas donné un bon coup d'épée au baron, si vous n'aviez pas perdu tous vos moutons du bon pays d'Eldorado, vous ne mangeriez pas ici des cédrats confits et des pistaches.

— Cela est bien dit, répondit Candide, mais il faut cultiver notre jardin.

Voltaire, *Candide*

Bibliography

- [1] Javier Aramayona, Hugo Parlier, and Kenneth J. Shackleton. Totally geodesic subgraphs of the pants complex. *Math. Res. Lett.*, 15(2):309–320, 2008.
- [2] Javier Aramayona, Hugo Parlier, and Kenneth J. Shackleton. Constructing convex planes in the pants complex. *Proc. Amer. Math. Soc.*, 137(10):3523–3531, 2009.
- [3] Jason A. Behrstock. Asymptotic geometry of the mapping class group and Teichmüller space. *Geom. Topol.*, 10:1523–1578, 2006.
- [4] Francis Bonahon. Shearing hyperbolic surfaces, bending pleated surfaces and Thurston’s symplectic form. *Ann. Fac. Sci. Toulouse Math. (6)*, 5(2):233–297, 1996.
- [5] Prosenjit Bose and Ferran Hurtado. Flips in planar graphs. *Comput. Geom.*, 42(1):60–80, 2009.
- [6] Prosenjit Bose and A. Verdonchot. A history of combinatorial flips. *Lect. Not. Comp. Sc.*, to appear.
- [7] B. H. Bowditch and D. B. A. Epstein. Natural triangulations associated to a surface. *Topology*, 27(1):91–117, 1988.
- [8] Benjamin Braun and Richard Ehrenborg. The complex of non-crossing diagonals of a polygon. *J. Combin. Theory Ser. A*, 117(6):642–649, 2010.
- [9] Martin R. Bridson and André Haefliger. *Metric spaces of non-positive curvature*, volume 319 of *Grundlehren der Mathematischen Wissenschaften [Fundamental Principles of Mathematical Sciences]*. Springer-Verlag, Berlin, 1999.
- [10] Jeffrey Brock and Dan Margalit. Weil-Petersson isometries via the pants complex. *Proc. Amer. Math. Soc.*, 135(3):795–803 (electronic), 2007.

-
- [11] Jeffrey F. Brock. The Weil-Petersson metric and volumes of 3-dimensional hyperbolic convex cores. *J. Amer. Math. Soc.*, 16(3):495–535 (electronic), 2003.
- [12] William Cavendish. Growth of the diameter of the pants graph modulo the mapping class group. <https://web.math.princeton.edu/wcavendi/PantsModMCG.pdf>.
- [13] William Cavendish and Hugo Parlier. Growth of the Weil-Petersson diameter of moduli space. *Duke Math. J.*, 161(1):139–171, 2012.
- [14] Young-Eun Choi and Kasra Rafi. Comparison between Teichmüller and Lipschitz metrics. *J. Lond. Math. Soc. (2)*, 76(3):739–756, 2007.
- [15] Valentina Disarlo. On the coarse geometry of the complex of domains. In *Handbook of Teichmüller theory. Volume III*, volume 17 of *IRMA Lect. Math. Theor. Phys.*, pages 425–439. Eur. Math. Soc., Zürich, 2012.
- [16] Valentina Disarlo. Combinatorial rigidity of arc complexes. <http://hal.archives-ouvertes.fr/hal-00771195/>, 2013.
- [17] Benson Farb, editor. *Problems on mapping class groups and related topics*, volume 74 of *Proceedings of Symposia in Pure Mathematics*. American Mathematical Society, Providence, RI, 2006.
- [18] Benson Farb and Dan Margalit. *A primer on mapping class groups*, volume 49 of *Princeton Mathematical Series*. Princeton University Press, Princeton, NJ, 2012.
- [19] Albert Fathi, François Laudenbach, and Valentin Poénaru. *Thurston’s work on surfaces. Transl. from the French by Djun Kim and Dan Margalit*. Mathematical Notes 48. Princeton, NJ: Princeton University Press. xiii, 255 p., 2012.
- [20] Werner Fenchel and Jakob Nielsen. *Discontinuous groups of isometries in the hyperbolic plane*, volume 29 of *de Gruyter Studies in Mathematics*. Walter de Gruyter & Co., Berlin, 2003.
- [21] Vladimir Fock and Alexander Goncharov. Moduli spaces of local systems and higher Teichmüller theory. *Publ. Math. Inst. Hautes Études Sci.*, (103):1–211, 2006.
- [22] Vladimir V. Fock and Alexander B. Goncharov. Cluster ensembles, quantization and the dilogarithm. *Ann. Sci. Éc. Norm. Supér. (4)*, 42(6):865–930, 2009.

-
- [23] Sergey Fomin, Michael Shapiro, and Dylan Thurston. Cluster algebras and triangulated surfaces. I. Cluster complexes. *Acta Math.*, 201(1):83–146, 2008.
- [24] Sergey Fomin and Dylan Thurston. Cluster algebras and triangulated surfaces. part ii: Lambda lengths, 10 2012.
- [25] Clara I. Grima and Alberto Márquez. *Computational geometry on surfaces*. Kluwer Academic Publishers, Dordrecht, 2001.
- [26] Ursula Hamenstädt. Geometric properties of the mapping class group. In *Problems on mapping class groups and related topics*, volume 74 of *Proc. Sympos. Pure Math.*, pages 215–232. Amer. Math. Soc., Providence, RI, 2006.
- [27] John L. Harer. Stability of the homology of the mapping class groups of orientable surfaces. *Ann. of Math. (2)*, 121(2):215–249, 1985.
- [28] John L. Harer. The virtual cohomological dimension of the mapping class group of an orientable surface. *Invent. Math.*, 84(1):157–176, 1986.
- [29] William J. Harvey. Boundary structure of the modular group. In *Riemann surfaces and related topics: Proceedings of the 1978 Stony Brook Conference (State Univ. New York, Stony Brook, N.Y., 1978)*, volume 97 of *Ann. of Math. Stud.*, pages 245–251. Princeton Univ. Press, Princeton, N.J., 1981.
- [30] Allen Hatcher. On triangulations of surfaces. *Topology Appl.*, 40(2):189–194, 1991.
- [31] Allen Hatcher and William P. Thurston. A presentation for the mapping class group of a closed orientable surface. *Topology*, 19(3):221–237, 1980.
- [32] Elmas Irmak and John D. McCarthy. Injective simplicial maps of the arc complex. *Turkish J. Math.*, 34(3):339–354, 2010.
- [33] Nikolai V. Ivanov. Automorphism of complexes of curves and of Teichmüller spaces. *Internat. Math. Res. Notices*, (14):651–666, 1997.
- [34] Nikolai V. Ivanov. Mapping class groups. In *Handbook of geometric topology*, pages 523–633. North-Holland, Amsterdam, 2002.
- [35] Erica Klarreich. The boundary at infinity of the curve complex. <http://ericaklarreich.com/curvecomplex.pdf>.

-
- [36] Mustafa Korkmaz. Automorphisms of complexes of curves on punctured spheres and on punctured tori. *Topology Appl.*, 95(2):85–111, 1999.
- [37] Mustafa Korkmaz and Athanase Papadopoulos. On the arc and curve complex of a surface. *Math. Proc. Cambridge Philos. Soc.*, 148(3):473–483, 2010.
- [38] Mustafa Korkmaz and Athanase Papadopoulos. On the ideal triangulation graph of a punctured surface. *Ann. Inst. Fourier*, 4(62), 2012.
- [39] Lixin Liu, Athanase Papadopoulos, Weixu Su, and Guillaume Théret. Length spectra and the Teichmüller metric for surfaces with boundary. *Monatsh. Math.*, 161(3):295–311, 2010.
- [40] Lixin Liu, Athanase Papadopoulos, Weixu Su, and Guillaume Théret. On length spectrum metrics and weak metrics on Teichmüller spaces of surfaces with boundary. *Ann. Acad. Sci. Fenn. Math.*, 35(1):255–274, 2010.
- [41] Lixin Liu, Athanase Papadopoulos, Weixu Su, and Guillaume Théret. On the classification of mapping class actions on thurston’s asymmetric metric. <http://arxiv.org/abs/1110.3601>, 10 2011.
- [42] Feng Luo. Automorphisms of the complex of curves. *Topology*, 39(2):283–298, 2000.
- [43] Feng Luo. On Teichmüller spaces of surfaces with boundary. *Duke Math. J.*, 139(3):463–482, 2007.
- [44] Dan Margalit. Automorphisms of the pants complex. *Duke Math. J.*, 121(3):457–479, 2004.
- [45] Howard Masur and Saul Schleimer. The geometry of the disk complex. *J. Amer. Math. Soc.*, 26(1):1–62, 2013.
- [46] Howard A. Masur and Yair N. Minsky. Geometry of the complex of curves. I. Hyperbolicity. *Invent. Math.*, 138(1):103–149, 1999.
- [47] Howard A. Masur and Yair N. Minsky. Geometry of the complex of curves. II. Hierarchical structure. *Geom. Funct. Anal.*, 10(4):902–974, 2000.
- [48] John D. McCarthy and Athanase Papadopoulos. Simplicial actions of mapping class groups. In *Handbook of Teichmüller theory. Volume III*, volume 17 of *IRMA Lect. Math. Theor. Phys.*, pages 297–423. Eur. Math. Soc., Zürich, 2012.

-
- [49] Gabriele Mondello. Riemann surfaces with boundary and natural triangulations of the Teichmüller space. *J. Eur. Math. Soc. (JEMS)*, 13(3):635–684, 2011.
- [50] Lee Mosher. Tiling the projective foliation space of a punctured surface. *Trans. Amer. Math. Soc.*, 306(1):1–70, 1988.
- [51] James R. Munkres. *Elements of algebraic topology*. Addison-Wesley Publishing Company, Menlo Park, CA, 1984.
- [52] Athanase Papadopoulos and Guillaume Théret. On the topology defined by Thurston’s asymmetric metric. *Math. Proc. Cambridge Philos. Soc.*, 142(3):487–496, 2007.
- [53] Athanase Papadopoulos and Guillaume Théret. Shortening all the simple closed geodesics on surfaces with boundary. *Proc. Amer. Math. Soc.*, 138(5):1775–1784, 2010.
- [54] Athanase Papadopoulos and Guillaume Théret. Some Lipschitz maps between hyperbolic surfaces with applications to Teichmüller theory. *Geom. Dedicata*, 161:63–83, 2012.
- [55] Robert C. Penner. The decorated Teichmüller space of punctured surfaces. *Comm. Math. Phys.*, 113(2):299–339, 1987.
- [56] Robert C. Penner. Universal constructions in Teichmüller theory. *Adv. Math.*, 98(2):143–215, 1993.
- [57] Robert C. Penner. The simplicial compactification of Riemann’s moduli space. In *Topology and Teichmüller spaces (Katinkulta, 1995)*, pages 237–252. World Sci. Publ., River Edge, NJ, 1996.
- [58] Robert C. Penner. Decorated Teichmüller theory of bordered surfaces. *Comm. Anal. Geom.*, 12(4):793–820, 2004.
- [59] Robert C. Penner. Probing mapping class groups using arcs. In *Problems on mapping class groups and related topics*, volume 74 of *Proc. Sympos. Pure Math.*, pages 97–114. Amer. Math. Soc., Providence, RI, 2006.
- [60] Robert C. Penner. The structure and singularities of quotient arc complexes. *J. Topol.*, 1(3):527–550, 2008.
- [61] Robert C. Penner. *Decorated Teichmüller theory*. Eur. Math. Soc., Zürich, 2012.

-
- [62] Kasra Rafi and Jing Tao. Diameter of the thick part of moduli space and simultaneous whitehead moves. <http://arxiv.org/abs/1108.4150>, 08 2011.
- [63] Daniel D. Sleator, Robert E. Tarjan, and William P. Thurston. Rotation distance, triangulations, and hyperbolic geometry. *J. Amer. Math. Soc.*, 1(3):647–681, 1988.
- [64] Daniel D. Sleator, Robert E. Tarjan, and William P. Thurston. Short encodings of evolving structures. *SIAM J. Discrete Math.*, 5(3):428–450, 1992.
- [65] Oswald Teichmüller. Vollständige Lösung einer Extremalaufgabe der quasikonformen Abbildung. *Abh. Preuss. Akad. Wiss. Math.-Nat. Kl.*, 1941(5):18, 1941.
- [66] Oswald Teichmüller. Bestimmung der extremalen quasikonformen Abbildungen bei geschlossenen orientierten Riemannschen Flächen. *Abh. Preuss. Akad. Wiss. Math.-Nat. Kl.*, 1943(4):42, 1943.
- [67] William P. Thurston. Minimal stretch maps between hyperbolic surfaces. <http://arxiv.org/abs/math/9801039>.
- [68] William P. Thurston. *Three-dimensional geometry and topology. Vol. 1*, volume 35 of *Princeton Mathematical Series*. Princeton University Press, Princeton, NJ, 1997. Edited by Silvio Levy.
- [69] Akira Ushijima. A canonical cellular decomposition of the Teichmüller space of compact surfaces with boundary. *Comm. Math. Phys.*, 201(2):305–326, 1999.