



HAL
open science

Joint Network / Channel Decoding over Noisy Wireless Networks

Xuan Thang Vu

► **To cite this version:**

Xuan Thang Vu. Joint Network / Channel Decoding over Noisy Wireless Networks. Other [cond-mat.other]. Université Paris Sud - Paris XI, 2014. English. NNT: 2014PA112005 . tel-01060330v2

HAL Id: tel-01060330

<https://theses.hal.science/tel-01060330v2>

Submitted on 4 Jan 2016

HAL is a multi-disciplinary open access archive for the deposit and dissemination of scientific research documents, whether they are published or not. The documents may come from teaching and research institutions in France or abroad, or from public or private research centers.

L'archive ouverte pluridisciplinaire **HAL**, est destinée au dépôt et à la diffusion de documents scientifiques de niveau recherche, publiés ou non, émanant des établissements d'enseignement et de recherche français ou étrangers, des laboratoires publics ou privés.

UNIVERSITE PARIS-SUD

ÉCOLE DOCTORALE : STITS

Laboratoire de Signaux et Systèmes, École Supérieure d'Électricité

DISCIPLINE ELECTRICAL ENGINEERING

THÈSE DE DOCTORAT

soutenue le 14/01/2014
par

Xuan-Thang VU (VŨ Xuân Thắng)

Joint Network/Channel Decoding over Noisy Wireless Networks

Directeur de thèse : Marco DI RENZO Chargé de Recherche, CNRS, France
Co-directeur de thèse : Pierre DUHAMEL Directeur de Recherche, CNRS, France

Composition du jury :

Rapporteurs: Charly POULLAIT, Professor, ENP-ENSEEIH Toulouse, France
Erdal ARIKAN, Professor, Bilkent University, Turkey
Examineurs: Bernard Henri FLEURY, Professor, Aalborg University, Denmark
Luc VANDENDORPE, Professor, UCL, Belgium

January 2014

Abstract

Network coding (NC) has gained much research attention as a potential candidate to solve the demand for higher spectral efficiency of modern wireless communications. Many research papers have investigated the performance of NC-aided networks such as throughput and outage capacity. However, the analysis of NC in practical systems where NC is combined with other techniques such as channel coding is still immature to fully understand its potential performance. In this thesis, we aim to design high performance receivers and analyze its performance for network-coded cooperative networks in practical scenarios.

Firstly, we propose two Iterative Network/Channel Decoding (INCD) algorithms for the Multiple-Access Relay Channel (MARC) with two notable relaying schemes named Decode-and-Forward (DF) and Demodulate-and-Forward (DMF). The INCD algorithm operates based on turbo-like decoding methods and reduces the impact of the error propagation problem with the aid of a channel-aware receiver design. Both perfect Channel State Information (CSI) and imperfect CSI at the receiver side are investigated. We propose a practical method that forwards the quantized version of the relay decoding errors to the destination. It is shown that the proposed algorithms achieve full diversity gain and significantly outperforms solutions which do not take care of error propagation. We also show that the number of pilot symbols affects only the coding gain but has a negligible impact on the diversity order, while the quantization level affects both the diversity and coding gain.

Secondly, we propose a Near Optimal Joint Network/Channel Decoding (NOJNCD) algorithm for the MARC that allows to analyze the system Bit Error Rate (BER). The NOJNCD algorithm performs network decoding and channel decoding in one decoding step of the *super code*, which comprises of all trellis states of individual code at the sources via NC. Furthermore, NC combined with Relay Selection (RS) is considered and the achievable diversity order is studied with the aid of outage analysis. We analytically show that Single Relay Selection (SRS) always achieves a diversity order two and Multiple Relay Selection (MRS) can achieve full diversity gain only when the number of selected relays exceeds the number of the

sources.

Last but not least, we propose a so-called *partial relaying* protocol to improve the spectral efficiency for channel coding assisted relay networks. Closed-form expression of the BER and the system diversity order are computed for partial relaying. We show, by analysis and simulations, that with a proper Convolutional Code (CC), partial relaying can achieve full diversity gain and same coding gain as the classical (full) relaying protocol in finite signal-to-noise ratio region while it obtains a better spectrum usage. Moreover, we propose a new protocol based on partial relaying in opportunistic relaying cooperative networks and show that this protocol significantly outperforms the NC-based cooperation in some circumstances.

Dedication

To my parents, my sisters, my beloved wife Ly and my dear son Huy Alex.

Acknowledgments

First of all, I would like to sincerely thank my advisors, Prof. Marco Di Renzo and, especially, Prof. Pierre Duhamel, who provided me the opportunity to be the researcher. Despite often and often very busy, Dr. Duhamel regularly spent his valuable time for discussion. More importantly, Dr. Duhamel patiently taught me to be an autonomic researcher like I am today. I would like to thank the other members in my dissertation committee for agreeing to serve in my thesis committee.

I would like to thank every member in our Laboratory of Signal and Systems for giving a warm atmosphere, which is very important to my first time in my P.h.D. study.

Last but not least, I would like to deeply thank my parents, my sisters and my dear wife for their endless support and love. Without you, I would not have been able to accomplish this achievement. Greatly thank for always being with me.

Table of Contents

Dedication	iii
Acknowledgments	iv
List of Figures	viii
List of Tables	xi
List of Acronyms	xii
Chapter 1	
Introduction	1
Chapter 2	
Iterative Network/Channel Decoding algorithm for MARC	9
2.1 System Model	10
2.2 Channel Estimation and Modulation Metric Computation	13
2.2.1 Perfect CSI scenario	13
2.2.2 Imperfect CSI scenario	14
2.3 Error Probability Estimation and Quantization	17
2.3.1 Error Estimation with Perfect CSI: Computation of Pe_{code}^{F1} , Pe_{code}^{F4} and Pe_{code}^{Full}	19
2.3.1.1 Block Rayleigh Fading $F = 1$	19
2.3.1.2 Block Rayleigh Fading $F = 4$	20
2.3.1.3 Fully-Interleaved Rayleigh Fading	20
2.3.2 Error Estimation with Perfect CSI: Computation of Pe_{bit}^{F1} , Pe_{bit}^{F4} and Pe_{bit}^{Full}	20
2.3.2.1 Block Rayleigh Fading channel with $F = 1$	21
2.3.2.2 Block Rayleigh Fading channel with $F = 4$	21
2.3.2.3 Fully-Interleaved Rayleigh Fading	22
2.3.3 Error Estimation with Imperfect Perfect CSI	22

2.3.4	Error Quantization	23
2.4	Proposed Algorithm 1: Turbo-like Iterative Network/Channel Decoding algorithm	23
2.5	Proposed Algorithm 2: Low Complexity Iterative Network/Channel Decoding algorithm	27
2.6	Numerical Results	30
2.6.1	Perfect CSI Scenario	30
2.6.2	Numerical Results: Imperfect CSI case	34
2.6.2.1	Effect of Iterations with Imperfect CSI	34
2.6.2.2	Effects of Quantization	36
2.6.2.3	Effects of Pilot Length	36
2.7	Conclusions	42

Chapter 3

	Near Optimal Joint Network/Channel Decoding for the MARC	43
3.1	System Model	44
3.1.1	Processing at the sources	44
3.1.2	Processing at the relay	45
3.2	Decoding at the destination	46
3.3	Distance Spectrum of the Compound Code	50
3.4	Pair-Wise Error Probability Analysis	52
3.5	Bit Error Rate Analysis	54
3.5.1	Upper Bound of the BER	54
3.5.2	Asymptotic expression of the BER	55
3.6	Diversity gain and Coding gain	56
3.6.1	Simulation Results	57
3.7	Conclusions	62

Chapter 4

	Network Coding Cooperation in Multiple-Relay Networks	63
4.1	System Model	64
4.2	Relay Selection in Network Coding Cooperation	67
4.2.1	Single Relay Selection	67
4.2.2	Multiple Relay Selection	68
4.3	Outage Analysis for SRS	69
4.3.1	Exact OP of SRS	70
4.3.2	Asymptotic OP of SRS	71
4.4	Outage Analysis for MRS	72
4.4.1	Exact OP of MRS	72
4.4.2	Asymptotic OP of MRS	74
4.5	Comparison between NCC and Conventional Relaying Protocol	76
4.6	Numerical Results	78
4.7	Conclusions	81

Chapter 5	
Partial Relaying in Cooperative Relay Networks	82
5.1 Partial Relaying for Single-Relay Networks	83
5.1.1 System Model	84
5.1.2 Equivalent Channel	86
5.1.3 Bit Error Probability Analysis	86
5.1.4 Diversity Analysis	90
5.1.5 Design a Diversity-achieved Relay Network in Low SNR Re-	
gion	91
5.1.6 Simulation Results	93
5.2 Partial Relaying for Multiple Relay Networks	97
5.2.1 System Model	97
5.2.2 Relay Selection	99
5.2.3 Bit Error Rate Analysis	100
5.2.4 Diversity analysis for DACP	103
5.2.5 Simulation Results	106
5.3 Conclusions	108
Chapter 6	
Conclusions and Future work	109
6.1 Conclusions	109
6.2 Further work	111
Bibliography	113

List of Figures

1.1	Three cooperative networks under consideration: i). Relay channel; ii). Multiple-access relay channel and iii). Multiple-access multiple-relay channel.	5
2.1	Block diagram of two relaying protocols at the relays.	11
2.2	Packet structure for imperfect CSI case: a) $F = 1$ block fading channel, b) $F = 3$ block fading channel.	15
2.3	Diagram of the proposed Turbo-like INCD algorithm.	24
2.4	Diagram of the proposed Low complexity INCD algorithm.	28
2.5	Performance of the proposed INCD algorithms in fully-interleaved Rayleigh fading scenarios with full CSI at receivers.	31
2.6	Performance of the proposed INCD algorithms in $F = 4$ block Rayleigh fading scenarios with full CSI at receivers.	32
2.7	Performance of the proposed INCD algorithms in quasi-static block Rayleigh fading scenarios with full CSI at receivers.	33
2.8	Effect of iterations on performance of the proposed algorithm 1 and 2 in block fading $F = 1$ vs knowledge of decoding error at the relay. The total number of overhead symbol $Lr_p + L_q = 5$	35
2.9	Effects of quantization level L_q on performance of the proposed algorithm 1 and 2 in block fading $F = 1$, Full CSI scenario.	37
2.10	Effects of quantization level L_q on performance of the proposed algorithm 1 and 2 in block fading $F = 1$. Imperfect CSI scenario with 5 pilot symbols.	38
2.11	Effects of quantization level L_q on performance of the proposed algorithm 1 and 2 in block fading $F = 4$, Full CSI at receivers . . .	39
2.12	Effects of pilots on performance of the proposed algorithm 1 and 2 in block fading $F = 1$. The destination has full knowledge of possible decoding error at the relay	40
2.13	Effects of pilots on performance of the proposed algorithm 1 and 2 in block fading $F = 1$. Possible decoding error at relay is 3-bit quantized	40
2.14	Effects of pilots on performance of the proposed algorithm 1 and 2 in block fading $F = 4$. The destination has full knowledge of possible decoding error at the relay	41

3.1	Network coding cooperative network with single relay.	45
3.2	Performance of Coded-NCC in $N_s = 3$ sources network under BPSK and QPSK modulation. a) Setup 1: The relay locates close to the sources and b) Setup 2: The relay locates at the middle between the sources and the destination.	58
3.3	Performance of Coded-NCC in $N_s = 3$ sources network under 16-QAM modulation and the channel code [13 15] is used. a) Setup 1: The relay locates close to the sources and b) Setup 2: The relay locates at the middle between the sources and the destination.	59
3.4	Performance comparison of Coded-NCC with P2P and Uncoded-NCC in $N_s = 2$ sources network and BPSK modulation. P2P is a non cooperation with channel code, Uncoded-NCC is a cooperative network without channel code.	60
3.5	Coding gain of the Coded-NCC over P2P and Uncoded-NCC for the $N_s = 2$ sources network and BPSK modulation. The relay locates at the middle of the sources and the destination.	61
4.1	Multiple-source multiple-relay NCC networks with multiple relay selection.	64
4.2	Time allocation comparison between NCC and Conventional relaying protocol for a network consisting of $N_s = 3$ sources, $N_r = 3$ relays and $L = 2$ selected relays.	77
4.3	Outage probability of SRS in $N_s = 3$ sources v.s different number of relays, the threshold $\gamma_{th} = 1$. Left sub figure shows <i>Setup 1</i> : $\bar{\gamma}_{SD} = \bar{\gamma}_{SD}$. Right sub figure shows <i>Setup 2</i> : $(\bar{\gamma}_{SD}, \bar{\gamma}_{SD}, \bar{\gamma}_{SD}) = (\bar{\gamma}, \bar{\gamma} + 9dB, \bar{\gamma} + 9dB)$	78
4.4	Outage probability of MRS in $N_s = 3$ sources, $N = 5$ relays v.s different number of selected relays L , the threshold $\gamma_{th} = 1$. Left sub figure shows <i>Setup 1</i> : $\bar{\gamma}_{SD} = \bar{\gamma}_{SD} = \bar{\gamma}_{SD}$. Right sub figure shows <i>Setup 2</i> : $(\bar{\gamma}_{SD}, \bar{\gamma}_{SD}, \bar{\gamma}_{SD}) = (\bar{\gamma}, \bar{\gamma} + 9dB, \bar{\gamma} + 9dB)$	79
4.5	Outage probability comparison between NCC with conventional relaying protocol in $N_s = 3$ sources, $N = 3$ relays network with $L = 2$ selected relays. The system rate $\mathcal{R} = 3/10$ bpcu. Case 1: $\bar{\gamma}_{SR} = \bar{\gamma}_{RD} = \bar{\gamma}_{SD}$. Case 2: $\bar{\gamma}_{SR} = \bar{\gamma}_{SD}, \bar{\gamma}_{RD} = \bar{\gamma}_{SD} - 20dB$. Case 3: $\bar{\gamma}_{SR} = \bar{\gamma}_{SD} + 20dB, \bar{\gamma}_{RD} = \bar{\gamma}_{SD}$. Case 4: $\bar{\gamma}_{SR} = \bar{\gamma}_{SD} + 20dB, \bar{\gamma}_{RD} = \bar{\gamma}_{SD} - 20dB$	80
5.1	The three-node relay channel with partial relaying.	84
5.2	Instantaneous diversity order vs. δ when average SNR is fixed	94
5.3	Instantaneous diversity order vs. average SNR when δ is fixed	95

5.4	The performance of the proposed network for different channel codes and different δ in block Rayleigh fading channels. Total power consumption is fixed. Solid marked cures: simulation results, dotted curves: the bound. The curve $\delta = 0$ corresponds to <i>No Cooperation</i> and has spectrum efficiency 1 (coded bit per channel use). The curve $\delta = 1$ corresponds to <i>Classical relay</i> and has spectrum efficiency 0.5. The curves $\delta = 1/2$ and $\delta = 2/3$ have respectively spectrum efficiency 0.67 and 0.6.	96
5.5	Diagram of partial relaying in two-source multiple-relay networks. In DACP, two relays are selected to help the sources. Each relay helps one source by forwarding half of the codeword to the destination.	98
5.6	Performance comparison between DACP and NCCP when the CC [25 33 37] with the minimum distance $d_H = 12$ and the rate $1/3$ is used.	106
5.7	Performance comparison between DACP and NCCP when the CC [133 165 171] with the minimum distance $d_H = 15$ and the rate $1/3$ is used.	107

List of Tables

3.1 Extended distance spectrum of \mathbf{G} in (3.9) with $N_s = 3$ sources and $\mathbf{g} = [13, 15]$ 52

List of Acronyms

Acronym	Explanation
AF	Amplify and Forward
ANC	Analog Network Coding
AWGN	Additive White Gaussian Noise
BCJR	Bahl-Cocke-Jelinek-Raviv algorithm
BER	Bit Error Rate
BPSK	Binary Phase-Shift Keying
BRC	Broadcast Relay Channel
CC	Convolutional Code
CDF	Cumulative Density Function
CF	Compress and Forward
C-MRC	Cooperative Maximum Ratio Combining
CoF	Compute and Forward
CPEP	Conditioned Pair-wise Error Probability
CSI	Channel State Information
DACP	Diversity-Achieving Cooperative Protocol
DEC	Decoder
DF	Decode and Forward
DMF	Demodulate and Forward
DMT	Diversity Multiplexing Tradeoff
ENC	Encoder
FDMA	Frequency Division Multiple Access
G-MF	Generalized Maximum Function
INCD	Iterative Network Channel Decoding
JNCC	Joint Network Channel Coding

Acronym	Explanation
JNCD	Joint Network Channel Decoding
LDPC	Low Density Parity Check
LLR	Log-Likelihood Ratio
MAMRC	Multiple Access Multiple Relay Channel
MAP	Maximum A Posteriori
MARC	Multiple Access Relay Channel
MIMO	Multiple-Input Multiple-Output
ML	Maximum Likelihood
MRC	Maximum Ratio Combining
MRS	Multiple Relay Selection
NC	Network Coding
NCC	Network Coding Cooperation
NCCP	Network-Coded Cooperative Protocol
NO-JNCD	Near Optimal Joint Network Channel Decoding
OJNCD	Optimal Joint Network Channel Decoding
OP	Outage Probability
P2P	Point to Point
PDF	Probability Density Function
PEP	Pair-wise Error Probability
PNC	Physical-layer Network Coding
QAM	Quadrature Amplitude Modulation
QPSK	Quadrature Phase-Shift Keying
RNC	Random Network Coding
RS	Relay Selection
RSC	Recursive Systematic Convolutional
SIHO	Soft Input Hard Output
SISO	Soft Input Soft Output
SNR	Signal-to-Noise Ratio
SRS	Single Relay Selection
TDMA	Time Division Multiple Access
TWRC	Two-Way Relay Channel
UPEP	Unconditioned Pair-wise Error Probability

Introduction

Wireless communication has become more and more important in our modern life. With the development of technology and the increasingly demand of rate for wireless applications, today wireless terminals not only provide classical voice connection but also big data services. For example, a smart phone can support a video call or can provide weather, stock information any time, any where. This requires wireless links to provide high rate, high reliability and larger coverage. Cooperation is an effective technique to satisfy those requirements. The most notable cooperation form was first introduced by [1] as the three-node relay channel which consists of one source, one destination and one relay node. The destination receives signal from both the source and the relay and then combines them to decode the source data. Since the source-relay and relay-destination channels are potentially independent of the source-destination link, the destination is able to decode the source data even when the direct source-destination link is very poor. Hence cooperation offers better coverage and reliability (diversity gain).

Cooperative Relaying

Since its introduction in [1], the relay channel has gained much attention, especially in the realm of information theory. In [2], capacity bounds and two fundamental relaying strategies named Decode-and-Forward (DF) and Compress-and-Forward (CF) have been studied for the three-node relay network. In the first case, the relay decodes the signal from the source and forwards it to the destination. In the

later case, the relay transmits an estimated (or quantized) version of the observed signal based on the idea of source coding with side information [3]. The capacity bounds of both relaying schemes have been derived for both degraded and reversely degraded relay channels. In [4], lower bounds and upper bounds of outage capacity have been computed for the three-node relay channel in fading environment. Another relaying technique named Amplify-and-Forward (AF), in which the relay simply retransmits the source signal to the destination, has been analyzed in [5, 4, 6, 7, 8]. As for multiple relay networks, in which more than one relay aid one source to communicate with destination, capacity and achievable rate region have been computed for DF and CF relaying in [9]. In addition, various coding schemes are also proposed and characterized including repetition coding [10, 11] and space time coding [12]. Multiple-Access Relay Channel (MARC), which consists of multiple sources and a single destination, has been widely investigated as an extension of the relay channels. Among those, rate regions of MARC with DF and AF have been derived in [13, 14, 15] and capacity bounds have been investigated in [16]. Recent results on capacity bounds and rate regions for Broadcast Relay Channels (BRC) [13, 17] and Two-way Relay Channels (TWRC) with both half-duplex and full-duplex have been studied, providing an insight to the potential benefits of cooperative relaying.

Network Coding

In multi-source wireless networks, conventional relaying techniques require the relay to aid each source by using orthogonal time slots, resulting in a large loss in spectrum efficiency. In order to improve the system throughput, one relay might serve multiple sources simultaneously with the aid of Network Coding (NC). NC was first introduced in information theory by Yeung et al. [18] and has attracted significant interest from the community for both theoretical and practical sides. In contrast to classical routing technique, in which intermediate nodes simply store and forward packets, NC allows the intermediate nodes to operate on the received data: input packets can be linearly combined onto one or several new packets. Resources in term of power and bandwidth efficiency and robustness to network topology changes are some of potential advantages of NC over classical routing

technique [19]. It has been shown in [18] that the use of NC could achieve the min-cut max-flow capacity in multicast where one source sends data to multiple receivers. The authors of [20, 21] generalized these results to any type of networks using an algebraic framework which establishes a very useful connection between a NC problem and the solution of polynomial equations. However, these solutions require a complete knowledge of the whole network, which is in general not available. Random Network Coding (RNC) was introduced to overcome this problem. In RNC, the network encoding process at the intermediate nodes is performed randomly and independently [19, 22]. It has been shown in [22] that RNC can achieve asymptotically the maximum capacity with a sufficiently long enough codeword's length. Further contributions in [23, 24, 25] have demonstrated the advantages of RNC over a network with correlated sources. Recently, a decentralized scheme has been proposed by the authors in [26, 27], allowing network coding principle to be performed in practical networks. The idea of this solution is to let the routers add in front of data packets the global network coding vector. So that the destination can completely decode from the received packets themselves. These NC schemes so far are based on *digital* NC and orthogonal channels in which the relay decodes and then applies NC on individual source message. Another possibility of applying NC based on the broadcast property of wireless channels has been developed for TWRC [28, 29, 30, 31], which is known under the name Physical-layer Network Coding (PNC) or Analog Network Coding (ANC). In ANC, the relay receives signals from the sources. Unlike digital NC, which considers interference as a destructive signal, ANC takes advantage from the interference. Instead of decoding individual source message, ANC only recovers a combination of the source signals. In general, ANC can be seen as a special case of Compute-and-Forward (CoF) protocol [32, 33] which is usually used along with lattice decoding [34, 35, 36]. Compared to digital NC, ANC results in a better spectral efficiency. However, time synchronization may be challenging in ANC.

Problem Formulation and Contributions

Beside many potential advantages of NC over classical routing technique, NC is not without limitation. When applied to noisy networks (e.g. wireless networks), NC

is challenged by a fundamental problem which is so-called *error propagation*: Due to packet combining operations at the intermediate nodes, the injection of a single corrupted packet may render impossible packet demodulation at the destination. Error propagation can result in significant degradation of diversity and coding gain. In the attempt to reduce the impact of error propagation, Joint Network Channel Decoding (JNCD) has gained much attention. JNCD was first introduced in [37, 38] for the MARC, in which a distributed turbo-like decoder is proposed. The central idea behind JNCD is the exploitation of the inherent redundancy of network and channel codes. However, these results assume that only correct packets are forwarded from the relay to the destination. Even in some typical topologies where the relay is very close to the source, there are still some errors introduced by the source-relay channel since the channel code is never perfect. From the diversity gain standpoint, this solution is not optimal. In order to assure full diversity, Joint Network Channel Coding (JNCC) has been recently proposed in [39] for LDPC codes. However, error-free source-relay links are assumed to leverage the performance analysis. The authors in [40] has proposed a JNCD algorithm using a sliding-window message passing algorithm for half-orthogonal MARC. In [41], JNCD algorithms have been studied for various non-orthogonal channels for the MARC. Other solutions dealing with error propagation include soft relaying [42, 43, 44]. In soft-relaying, the relay does not take any hard decision of the input signals. Instead, the relay computes the Log-Likelihood Ratio (LLR) value of network coded bits and re-encodes them using a soft encoder. The relay then forwards encoded soft bits to the destination. The disadvantage of this method is that it requires a high computational complexity at the relay, as well as a large bandwidth since soft values are transmitted to the destination instead of binary estimates. Another strategy is threshold-based relaying [45, 46, 47] where only decoded bits with the reliability above a given threshold are forwarded to the destination. Opportunistic relaying, which is known as Relay Selection (RS), is also useful to combat the error propagation [48]. Opportunistic relaying takes advantage of the many potential relay nodes in the network. The relay with the best end-to-end link is chosen to forward the received data to the destination. Further contributions to the achievable performance and benefits of RS have been reported in [49, 50, 51].

It is well-known that error-aware relaying provides better performance than error-unaware relaying protocols. The idea is that, if the destination has access to the Channel State Information (CSI) of the source-relay links, it can exploit it to counteract the error propagation problem. It has been shown in [52, 53] that channel-aware receivers can significantly improve the performance of NC. However, no channel coding is considered in [52, 53]. Other channel-aware designs were proposed for a turbo-like decoder [54] and for multiple-input multiple-output (MIMO) systems [55]. A similar approach has been proposed in [56] without performing channel decoding at the relay.

In this thesis, we focus on three cooperative networks as depicted in Fig. 1.1: i) Relay networks; ii) MARC which consists of a single relay and iii) Multiple-Access Multiple-Relay Channel (MAMRC). The system under consideration operates in orthogonal mode in order to avoid multiple-access interference at the receiver side. For MAMRC, in order to improve the spectrum efficiency, we consider opportunistic relaying with both Single Relay Selection (SRS) and Multiple Relay Selection (MRS). The contribution and organization of the thesis are as follows.

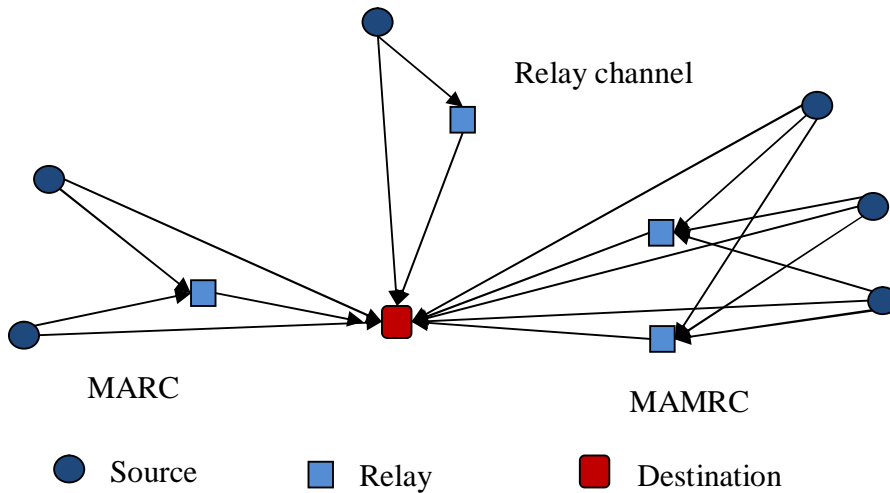

Figure 1.1. Three cooperative networks under consideration: i). Relay channel; ii). Multiple-access relay channel and iii). Multiple-access multiple-relay channel.

In **CHAPTER 2**, we investigate the four-node MARC in which two source nodes try to communicate with one destination with the aid of one relay. The relay can operate in either DF or DMF mode. Unlike [46], in which the relay

only be activated if it successfully decodes source messages, the relay in our model is always forwarding the estimated signal in addition to the source-relay CSI to the destination. We proposed two Iterative Network Channel Decoding (INCD) algorithms. The first INCD algorithm is developed based on the idea of distributed turbo-like decoding: the channel decoders, which decode each received signal from the sources and relay, exchange information with the network decoder. Network decoding in the first algorithm is performed on *information bits*. The second INCD algorithm is derived thanks to the linear probability of network coding: network coding on information bits can be seen as network coding on coded bits. As a result, this algorithm does not need to apply channel decoding on the relayed signal, leading the algorithm to be less complex. In addition, we study impact of imperfect CSI at the destination and propose a practical mechanism that quantized the source-relay CSI and forward to the destination.

This chapter has partly been presented in the following publications:

- [57]: X.-T. Vu, M. DiRenzo and P. Duhamel, "Multiple-Access Relaying with Network Coding: Iterative Network/Channel Decoding with Imperfect CSI", *EURASIP Journal on Advances in Signal Processing*, 2013:170.
- [58]: X.-T. Vu, M. Di Renzo, and P. Duhamel, "Iterative Network/Channel Decoding for the Noisy Multiple-Access Relay Channel (MARC)", in *Acoustics, Speech and Signal Processing (ICASSP), 2012 IEEE International Conference on*, 2012, pp. 2901-2904.
- [59]: X.-T. Vu, M. DiRenzo and P. Duhamel, "Improved Receiver for Cooperative Wireless Communication Systems using QAM and Galois Field Network Coding," in *Advanced Technologies for Communications (ATC), 2012 International Conference on*, 2012, pp. 203-206.
- [60]: X.-T. Vu, M. Di Renzo and P. Duhamel, " Optimal and Low-Complexity Iterative Joint Network/Channel Decoding for the Multiple-Access Relay Channel," in *Acoustics, Speech and Signal Processing (ICASSP), 2011 IEEE International Conference on*, 2011, pp. 3312-3315.

The solutions in Chapter 2 was developed based on iterative decoding principle, which might breaks the optimality since channel decoding and network decoding

are treated separately. In addition, iterative decoding leads the performance evaluation be very complicated and in general impossible. In **CHAPTER 3**, we propose a new JNCD algorithm, which is called Near Optimal JNCD (NO-JNCD) for the MARC. The new proposal approaches the optimal decoder design and allows to analyze the system performance. The key idea behind this design is to consider the relayed signal as part of a super code whose trellis consists of all possible states in individual code at the sources. That way, the relayed signal is treated as an additional parity (redundancy) to the super code and the network decoding and channel decoding are involved in one process. The upper bound and asymptotic BER closed-form are derived for all sources. Consequently, the coding gain and diversity gain are provided.

This chapter has partly been presented in [60] and the following publications:

- [61]: X.-T. Vu, M. DiRenzo and P. Duhamel, "BER analysis of Joint Network Channel Decoding in Block Rayleigh fading channels", *Personal Indoor and Mobile Radio Communications (PIMRC), 2013 IEEE 24rd International Symposium on*, pp. 698-702, 2013.
- [62]: Vu, X.-T., P. Duhamel, and M. Di Renzo (2013), "Performance analysis for Network Coding Cooperation with Channel coding and Selection DF in Rayleigh Fading channels", *Communications, IEEE Letters on*, to be submitted.

In **CHAPTER 4**, we study Network Coding Cooperation (NCC) in multiple-relay networks. In order to improve the spectrum efficiency, RS might be used together with NC. In such scenarios, we prove that, for quasi-static block fading channels, utilizing NC along with RS does not exploit full potential diversity gain (which comes from available relays), unless the number of selected relays exceeds the number of the sources. For SRS, the diversity gain is only equal to diversity order of non cooperative communication (point-to-point communication) even when the total number of relays goes infinity.

This chapter has lead to the following publication:

- [63]: X.-T. Vu, M. DiRenzo and P. Duhamel, "Outage and Diversity Analysis of Network Coding with Single and Multiple Relay Selection", *IEEE Transactions on Communications*, to be submitted.

In **CHAPTER 5**, we propose a new relaying protocol named *partial relaying* for channel-coded relay networks. In order to improve the spectrum efficiency, the relay might forward a part of the estimated codeword to the destination during cooperative phase. First, we develop the BER upper bound of the proposed scheme. The upper bound shows that the diversity gain depends on both the amount of information the relay forwards and the minimum distance of the channel code. Much forwarded information results in better diversity gain, and stronger code (larger minimum distance) brings a better diversity gain. Interestingly, with a strong channel code, the proposed scheme could achieve full diversity gain while it offers a higher spectrum efficiency than classical relaying in finite SNR region (which is usually operating SNR in practical networks). Secondly, we develop a criteria based on the BER upper bound to design the relay network which simultaneously achieves full diversity gain and improve the system spectrum efficiency in the SNR region of interest. When applied to multiple-source multiple-relay networks, we propose a novel Diversity-Achieving Cooperative Protocol (DACP) scheme based on partial relaying and relay selection. The proposed scheme shows a significant performance improvement over the Network-Coded Cooperative Protocol (NCCP) in some circumstances.

This chapter has partly been presented in the following publications:

- [64]: Vu, X.-T., N. Vo, M. Di Renzo, and P. Duhamel (2013) "Performance Analysis of Relay Networks with Channel code in Low SNR Regime," in *2013 IEEE 14th International Workshop on Signal Processing Advances in Wireless Communications (SPAWC)*, pp. 575-579, 2013.
- [65]: X.-T. Vu, P. Duhamel, V.N.Q. Bao and M. DiRenzo, "Partial Relaying in Channel-coded Relay Networks with Relay Selection," *IEEE Transactions on Communications*, to be submitted.

Finally, **CHAPTER 6** concludes the thesis and brings out some discussions and future work.

Iterative Network/Channel Decoding algorithm for MARC

In this chapter, we proposed two Iterative Network/Channel Decoding (INCD) algorithms for the MARC. Conventional JNCD algorithms for MARC either avoid forwarding erroneous packets to the destination or assume that relayed packets are errorless, resulting in a loss of coding gain or diversity gain. In contrast, in the proposed algorithms, the relay always forwards the estimated packets along with source-relay CSIs to the destination. The idea is that, if the destination has access to the CSI of the source-relay links, it can exploit it to counteract the error propagation problem. Various channel-aware receiver designs have been proposed showing a significant performance improvement of NC for both uncoded systems [52] and channel-coded systems [54, 55, 56]. All these solutions assume that CSI and decoding error probability at the relay are available at the destination, which might not be the case in practical wireless systems. It is shown in [66], [67] that imperfect CSI can significantly degrade the performance of cooperative systems.

Beside the new proposed receiver design, we study the impact of both CSI and decoding error probability at the relay on the performance of MARC. It is assumed that CSI at the receivers is acquired via the transmission of pilot symbols. The decoding error probability at the relay is not assumed to be available for free at the destination but we propose a practical way of transmitting a quantized version of it. We study the performance of two notable relaying protocols: DF relaying and DMF relaying. In the first case, channel decoding is performed at the relay before

NC and forwarding. On the other hand, in the second case, only demodulation is performed at the relay. As such, DMF has less computational complexity than DF but it is more prone to decoding errors at the relay. For each protocol, we develop a new channel-aware INCD algorithm. We show that INCD algorithms provide better performance than Separate Network Channel Decoding (SNCD) only if the destination has enough knowledge of the decoding error probability at the relay. In addition, this gain will be larger as the number of fading blocks per codeword increases. Also, it is shown that the number of pilot symbols mostly affects the coding gain of the system with a negligible impact on the diversity order, at least for the SNR range of interest. Finally, it is shown that CSI quantization errors affect both coding gain and diversity order. Additionally, it is shown that, in general, 3-bit quantization is sufficient for DMF relaying and 6-bit quantization is needed for DF relaying.

2.1 System Model

The system model under analysis is given by the canonical multiple-access relay channel, where two mobile stations, S_1 and S_2 , communicate to a base station D with the help of a relay R [38]. We study the realistic situation where all the channels are subject to Rayleigh fading and additive white Gaussian noise (AWGN). In order to avoid mutual interference, we consider that transmissions are scheduled in orthogonal channels (TDMA or FDMA). We study both perfect CSI and imperfect CSI at the receiver. Three fading scenarios are investigated: fully-interleaved, block fading with F blocks per codeword, and quasi-static fading, *i.e.*, $F = 1$.

The source node S_j with $j \in \{1, 2\}$, emits a K -length information message \mathbf{u}_j , where K is the number of information bits in \mathbf{u}_j . At each source, the information message \mathbf{u}_j is processed as follows: i) first, it is encoded using a Recursive Systematic Convolutional code (RSC), which produces a N -length codeword \mathbf{c}_j , with $R = K/N$ being the code rate; ii) then, \mathbf{c}_j is interleaved and mapped into a 2^M constellation point using Gray mapping. This operation provides the modulated signal \mathbf{x}_j . The modulated signal \mathbf{x}_j , of length N/M is transmitted to the relay and destination over a Rayleigh fading channel [68] with AWGN. Note that this

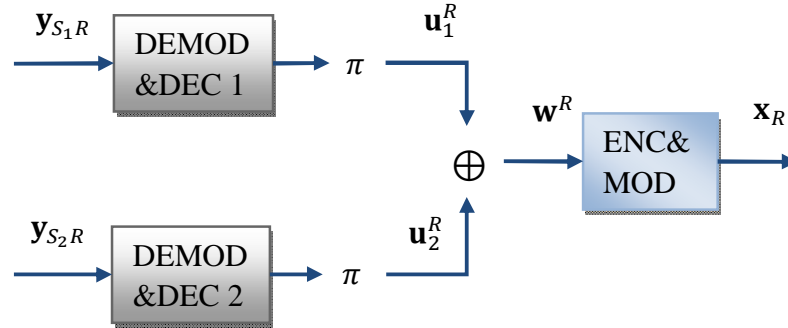

a) DF relaying protocol

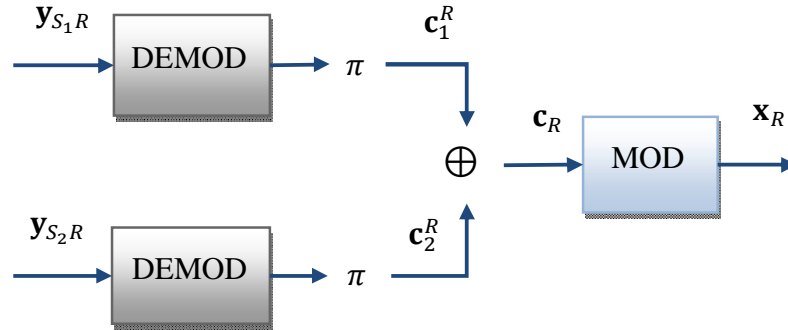

b) DMF relaying protocol

Figure 2.1. Block diagram of two relaying protocols at the relays.

description involves only the data part. In the imperfect CSI case we consider that channel estimates are obtained via the use of pilot symbols, and the description will be refined accordingly. These details are provided in the next sections.

We study two relaying protocols: DMF relaying and DF relaying as shown in Figure 2.1. In DMF relaying, two receivers first demodulate the corresponding signals $\mathbf{y}_{S_1R}, \mathbf{y}_{S_2R}$ to get the estimated codewords $\mathbf{c}_1^r, \mathbf{c}_2^r$. Then the estimated codewords are interleaved before being network encoded to get $\mathbf{c}_r = \pi(\mathbf{c}_1^r) \oplus \pi(\mathbf{c}_2^r)$, where $\pi(\cdot)$ denotes interleaving operations, \oplus denotes bit-wise XOR operations. In DF relaying, two soft-input hard-output (SIHO) decoders decode $\mathbf{y}_{S_1R}, \mathbf{y}_{S_2R}$ to

get the estimated information messages $\mathbf{u}_1^r, \mathbf{u}_2^r$. Note that errors may occur during the decoding process at the relay, *i.e.*, the estimated messages are different from the messages transmitted from the sources. Unlike [45], which relies on forwarding the estimated bits only if their reliability is above a certain threshold, we always forward the estimated bits with or without decoding errors (error channel model). However, the receiver will make use of the knowledge of the error probability at the relay. A network encoder encodes the interleaved estimated bits $\pi(\mathbf{u}_1^r), \pi(\mathbf{u}_2^r)$ to get the network coded information messages $\mathbf{w}^r = \pi(\mathbf{u}_1^r) \oplus \pi(\mathbf{u}_2^r)$. Then, a channel encoder encodes \mathbf{w}^r to get the codeword \mathbf{c}_r , which is then mapped into the modulated signal \mathbf{x}_r . The signal received at D from the sources, at R from the sources, and at D from R are given, respectively, as follows:

$$\begin{cases} \mathbf{y}_{S_j D} &= \sqrt{P_{S_j D}} \mathbf{h}_{S_j D} \mathbf{x}_j + \mathbf{n}, \quad j = 1, 2 \\ \mathbf{y}_{S_j R} &= \sqrt{P_{S_j R}} \mathbf{h}_{S_j R} \mathbf{x}_j + \mathbf{n}, \quad j = 1, 2 \\ \mathbf{y}_{RD} &= \sqrt{P_R} \mathbf{h}_{RD} \mathbf{x}_r + \mathbf{n}, \end{cases} \quad (2.1)$$

where $P_{S_j D}$ is the energy of the signal received at the destination from S_j , $P_{S_j R}$ is the energy of the signal received at the relay from the S_j , P_r is the energy of the signal received at the destination from the relay. These quantities include the pathloss effect; $\mathbf{h}_{S_j D}$, $\mathbf{h}_{S_j R}$ and \mathbf{h}_{RD} are Rayleigh fading coefficient vectors of source-to-relay channels and relay-to-destination channels, respectively, with $\mathbb{E}\{|\|\mathbf{h}_{(\cdot)}\|^2\} = 1$. For the sake of simplicity, we use vector notation $\mathbf{h}_{(\cdot)}$ for all fading scenarios considered in this paper. Therefore, the size of the vector $\mathbf{h}_{(\cdot)}$ depends on the fading scenario. Three fading channel scenarios are investigated: i) fully-interleaved fading, where the number of components of $\mathbf{h}_{(\cdot)}$ is equal to the length of $\mathbf{x}_{(\cdot)}$; ii) F -block fading, where the number of components of $\mathbf{h}_{(\cdot)}$ is F , that is the number of channel gains in one codeword; and iii) quasi-static fading where $\mathbf{h}_{(\cdot)}$ is a scalar since $F = 1$. Furthermore, \mathbf{n} (index is ignored for simplicity) is the noise vector whose components are circularly-symmetric zero-mean complex Gaussian random variables with power spectrum density equal to σ_n^2 , $n_k \sim \mathcal{CN}(0, \sigma_n^2)$.

2.2 Channel Estimation and Modulation Metric Computation

This section describes the computation of modulation metrics for both perfect and imperfect CSI, as well as how channel estimation for imperfect CSI is performed. These metrics will be used in the next sub-sections to implement the proposed decoders.

2.2.1 Perfect CSI scenario

For simplicity, we drop the channel indexes in our notation. Let \mathbf{x} and $\mathbf{y} = \mathbf{h}\mathbf{x} + \mathbf{n}$ be transmitted and received signals of a generic channel link. The demodulation metric of the k -th symbol is computed, given the channel gain h_k , as follows:

$$D_{FC SI}(x_k, y_k | h_k) = \log(\sigma_n^2) + \frac{|y_k - \sqrt{E_{S_{(\cdot)}}} h_k x_k|^2}{\sigma_n^2},$$

where $P_{(\cdot)}$ is the received signal energy at the destination from the sources or from the relay.

Let $C_k = \{c_{k1}, c_{k2}, \dots, c_{kM}\}$ be the k -th coded symbol, which contains M coded bits, associated to symbol x_k , belonging to the constellation set Θ . The cardinality of Θ is equal to 2^M . The a posteriori probability (APP) of the l -th bit, $l = 1, \dots, M$ in the k -th symbol after demodulating is as follows:

$$\Pr_{FC SI}\{c_{kl} = 1\} = \lambda \sum_{x_k \in \Theta, c_{kl}=1} \exp(-D_{FC SI}(x_k, y_k | h_k)),$$

where λ is a normalization factor that satisfies the condition $\Pr_{FC SI}(c_{kl} = 1) + \Pr_{FC SI}(c_{kl} = 0) = 1$. Then, the LLR of the coded bit c_{kl} , $L_{C_{kl}}$, is given by:

$$\begin{aligned} L_{C_{kl}} &= \log \frac{\Pr_{FC SI}\{c_{kl} = 1\}}{\Pr_{FC SI}\{c_{kl} = 0\}} \\ &= \log \frac{\sum_{x_k \in \Theta, c_{kl}=1} \exp(-D_{FC SI}(x_k, y_k | h_k))}{\sum_{x_k \in \Theta, c_{kl}=0} \exp(-D_{FC SI}(x_k, y_k | h_k))}. \end{aligned} \quad (2.2)$$

$L_{C_{kl}}$ is sent to the JNCD decoder and is processed as described in the next sections.

2.2.2 Imperfect CSI scenario

As far as the imperfect CSI case is concerned, we restrict our attention to only block fading channels with F blocks and quasi-static fading ($F = 1$). The reason is that channel estimation is assumed to be obtained via a pilot-based approach [69], which is clearly not compatible with fully interleaved Rayleigh fading. The channel gain is assumed to be constant over one block and is assumed to change independently from block to block. In our setting, a codeword covers F blocks, and the relay estimates the error probability of the whole codeword based on the knowledge of the channel gains of all blocks (see Section 2.3 below). These channel gains are estimated via a pilot message, which is inserted at the beginning of each block, and transmitted via BPSK modulation.

Let L_d be the length in bits of the coded data part and L_p the length of the overhead. As far as the source-relay links and the source-destination links are concerned, each block consists of L_d/M data symbols and L_p pilot symbols. As far as the relay-destination link is concerned, the relay also transmits to the destination a quantized version of its decoding error probability which is transmitted in the same way as the pilot bits. In this case the overhead of length L_p consists in the number of symbols L_q used for transmitting this error probability (quantization precision), plus the pilot sequence which is thus reduced to $Lr_p = L_p - L_q$. In block fading environment with $F > 1$, the error probability is concerned with the whole codeword, thus only one block of R \rightarrow D channel is used to transmit this quantized error probability. The packet structure is sketched in Figure 2.2. Note that pilot and quantization bits are assumed to be binary modulated in order to make the decoding process more robust.

Define a *channel rate* R_c as the ratio of the information bits over the packet length in one channel use (in contrast with standard definition, we include the overhead bits). If $F = 1$ and $L_d = N$, we have:

$$R_c = \frac{RL_d}{L_d + ML_p} = \frac{NR}{N + ML_p}.$$

If $F > 1$ and $L_d = N/F$, we have:

$$R_c = \frac{FRL_d}{FL_d + MFL_p} = \frac{RN}{N + MFL_p},$$

where R is the rate of the channel code and N is the codeword's length. The

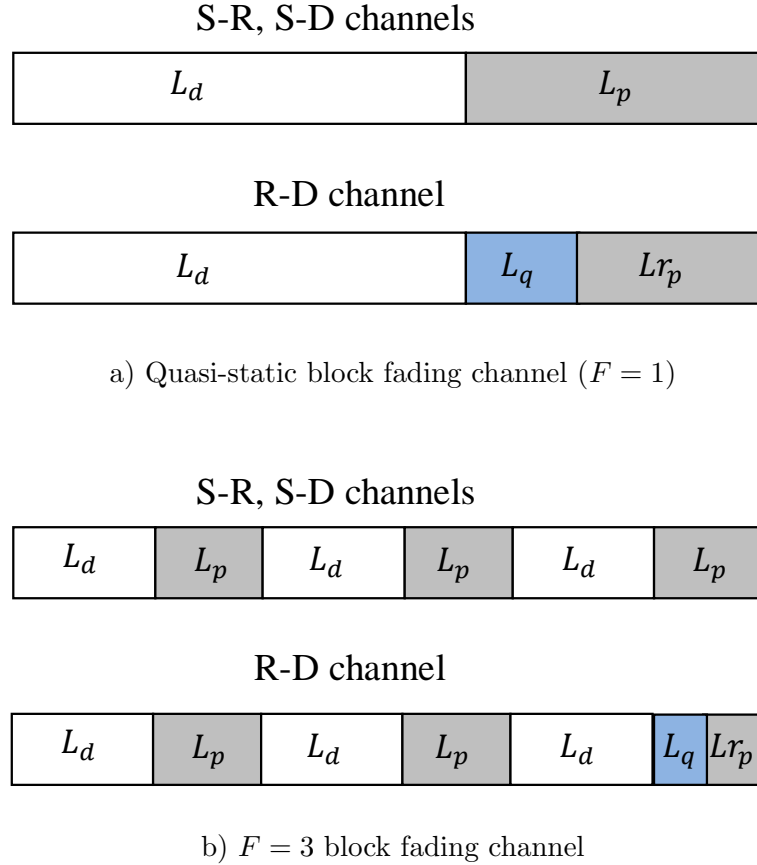

Figure 2.2. Packet structure for imperfect CSI case: a) $F = 1$ block fading channel, b) $F = 3$ block fading channel.

difference of the channel rates for $F = 1$ and $F > 1$ is negligible and can be ignored in practice. For example, for the parameters used in the simulation section the actual rates for $F = 1$ and $F = 4$ are respectively 0.476 and 0.417. In this paper, block fading channels with $F > 4$ are not considered.

For simplicity, we drop S and R indexes in our notation. The channel estimation of the generic link works as follows. Each transmission block first consists in the

pilot message \mathbf{x}_p followed by the data message \mathbf{x}_d . The corresponding received signals are as follows:

$$\begin{cases} \mathbf{y}_p &= \sqrt{P_{(.)}}h\mathbf{x}_p + \mathbf{n}_p, \\ \mathbf{y}_d &= \sqrt{P_{(.)}}h\mathbf{x}_d + \mathbf{n}_d, \end{cases} \quad (2.3)$$

where $P_{(.)}$ is the energy of the received signal at the destination (the power of the pilot and the data are assumed the same); $h \sim \mathcal{CN}(0, \sigma_h^2)$ is a complex Gaussian random variable; and \mathbf{n}_p is a L_p -long noise vector whose components are circularly-symmetric zero-mean complex Gaussian random variables with power spectrum density σ_n^2 . A maximum likelihood (ML) estimator is employed. The estimated channel gain is [69]: $\hat{h} = \mathbf{x}_p^* \mathbf{y}_p (\mathbf{x}_p^* \mathbf{x}_p)^{-1}$, where $(.)^*$ denotes the transpose conjugate operator, and $(.)^{-1}$ denotes the matrix inverse operator. The modulation metric is computed as follows:

$$D_{PCSI}(x_k, y_k | \hat{h}) = \log(\sigma_n^2) + \frac{|y_k - \sqrt{Es_{(.)}}\hat{h}x_k|^2}{\sigma_n^2}.$$

Let $C_k = \{c_{k1}, c_{k2}, \dots, c_{kM}\}$ be the k -th data symbol associated to symbol x_k . The *a posteriori* probability of the l th bit, $l = 1, \dots, M$ in the k -th symbol, c_{kl} , after demodulation can be computed as follows:

$$\Pr_{PCSI}\{c_{kl} = 1\} = \lambda \sum_{x_k \in \Theta, c_{kl}=1} \exp\left(-D_{PCSI}(x_k, y_k | \hat{h})\right),$$

where λ is a normalization factor such that $P_{PCSI}(c_{kl} = 1) + P_{PCSI}(c_{kl} = 0) = 1$. The LLR demodulation output of the coded bit c_{kl} , Lc_{kl} thus reads:

$$\begin{aligned} Lc_{kl} &= \log \frac{\Pr_{PCSI}\{c_{kl} = 1\}}{\Pr_{PCSI}\{c_{kl} = 0\}} \\ &= \log \frac{\sum_{x_k \in \Theta, c_{kl}=1} \exp\left(-D_{PCSI}(x_k, y_k | \hat{h})\right)}{\sum_{x_k \in \Theta, c_{kl}=0} \exp\left(-D_{PCSI}(x_k, y_k | \hat{h})\right)}, \end{aligned} \quad (2.4)$$

which used by the JNCD decoder for further processing as described in the next sections.

2.3 Error Probability Estimation and Quantization

This section describes how possible errors at the relay are computed and forwarded to the destination. In order to take into account these errors, the destination must estimate $Pe_{bit} = \Pr\{w^r \neq u_1 \oplus u_2\}$ and $Pe_{code} = \Pr\{c^r \neq c_1 \oplus c_2\}$. In this section, we compute these probabilities. Let $Pe_{bit}(j) = \Pr\{u_j^r \neq u_j\}$ and $Pe_{code}(j) = \Pr\{c_j^r \neq c_j\}$, $j = 1, 2$ be the decoding error probability of information bits and coded bits, respectively, of the link from S_j to the relay. We assume, for simplicity, that the network encoded information bits and network encoded coded bits are independent (a reasonable assumption if interleavers are used at the relay).

The decoding error probability at the relay, Pe_{bit} , can be computed as follows:

$$\begin{aligned} Pe_{bit} &= \Pr\{w^r \neq u_1 \oplus u_2\} \\ &= \frac{1}{2}\Pr\{w^r = 1|u_1 \oplus u_2 = 0\} + \frac{1}{2}\Pr\{w^r = 0|u_1 \oplus u_2 = 1\}. \end{aligned} \quad (2.5)$$

The first factor in (2.5) can be computed as follows:

$$\begin{aligned} &\Pr\{w^r = 1|u_1 \oplus u_2 = 0\} \\ &= \frac{1}{2}\Pr\{w^r = 1|u_1 = 0, u_2 = 0\} + \frac{1}{2}\Pr\{w^r = 1|u_1 = 1, u_2 = 1\} \\ &= \frac{1}{2}\Pr\{u_1^r = 0, u_2^r = 1|u_1 = 0, u_2 = 0\} + \frac{1}{2}\Pr\{u_1^r = 1, u_2^r = 0|u_1 = 0, u_2 = 0\} \\ &\quad + \frac{1}{2}\Pr\{u_1^r = 0, u_2^r = 1|u_1 = 1, u_2 = 1\} + \frac{1}{2}\Pr\{u_1^r = 1, u_2^r = 0|u_1 = 1, u_2 = 1\} \\ &= \frac{1}{2}\Pr\{u_1^r = 0|u_1 = 0\}\Pr\{u_2^r = 1|u_2 = 0\} + \frac{1}{2}\Pr\{u_1^r = 1|u_1 = 0\}\Pr\{u_2^r = 0|u_2 = 0\} \\ &\quad + \frac{1}{2}\Pr\{u_1^r = 0|u_1 = 1\}\Pr\{u_2^r = 1|u_2 = 1\} + \frac{1}{2}\Pr\{u_1^r = 1|u_1 = 1\}\Pr\{u_2^r = 0|u_2 = 1\} \\ &= (1 - Pe_{bit}(1))Pe_{bit}(2) + (1 - Pe_{bit}(2))Pe_{bit}(1), \end{aligned} \quad (2.6)$$

where the expression in (2.6) is given by the definition of XOR network coding.

Likewise, we have:

$$\Pr\{w^r = 0|u_1 \oplus u_2 = 1\} = (1 - Pe_{bit}(1))Pe_{bit}(2) + (1 - Pe_{bit}(2))Pe_{bit}(1). \quad (2.7)$$

From (2.5)–(2.7) we have:

$$Pe_{bit} = Pe_{bit}(1) + Pe_{bit}(2) - 2Pe_{bit}(1)Pe_{bit}(2). \quad (2.8)$$

The decoding error probability at the relay, Pe_{code} , can be computed using similar steps as follows:

$$\begin{aligned} Pe_{code} &= \Pr\{c^r \neq c_1 \oplus c_2\} \\ &= \frac{1}{2}\Pr\{c^r = 1|c_1 \oplus c_2 = 0\} + \frac{1}{2}\Pr\{c^r = 0|c_1 \oplus c_2 = 1\}. \end{aligned} \quad (2.9)$$

The first factor can be computed as follows:

$$\begin{aligned} &\Pr\{c^r = 1|c_1 \oplus c_2 = 0\} \\ &= \frac{1}{2}\Pr\{c^r = 1|c_1 = 0, c_2 = 0\} + \frac{1}{2}\Pr\{c^r = 1|c_1 = 1, c_2 = 1\} \\ &= \frac{1}{2}\Pr\{c_1^r = 0, c_2^r = 1|c_1 = 0, c_2 = 0\} + \frac{1}{2}\Pr\{c_1^r = 1, c_2^r = 0|c_1 = 0, c_2 = 0\} \\ &\quad + \frac{1}{2}\Pr\{c_1^r = 0, c_2^r = 1|c_1 = 1, c_2 = 1\} + \frac{1}{2}\Pr\{c_1^r = 1, c_2^r = 0|c_1 = 1, c_2 = 1\} \\ &= \frac{1}{2}\Pr\{c_1^r = 0|c_1 = 0\}\Pr\{c_2^r = 1|c_2 = 0\} + \frac{1}{2}\Pr\{c_1^r = 1|c_1 = 0\}\Pr\{c_2^r = 0|c_2 = 0\} \\ &\quad + \frac{1}{2}\Pr\{c_1^r = 0|c_1 = 1\}\Pr\{c_2^r = 1|c_2 = 1\} + \frac{1}{2}\Pr\{c_1^r = 1|c_1 = 1\}\Pr\{c_2^r = 0|c_2 = 1\} \\ &= (1 - Pe_{code}(1))Pe_{code}(2) + (1 - Pe_{code}(2))Pe_{code}(1). \end{aligned} \quad (2.10)$$

Likewise, we have:

$$\Pr\{c^r = 0|c_1 \oplus c_2 = 1\} = (1 - Pe_{code}(1))Pe_{code}(2) + (1 - Pe_{code}(2))Pe_{code}(1). \quad (2.11)$$

From (2.9)–(2.11) we have:

$$Pe_{code} = Pe_{code}(1) + Pe_{code}(2) - 2Pe_{code}(1)Pe_{code}(2). \quad (2.12)$$

In the next subsections, $Pe_{bit}(j) = \Pr\{u_j^r \neq u_j\}$ and $Pe_{code}(j) = \Pr\{c_j^r \neq c_j\}$, $j = 1, 2$ are computed for different fading scenarios. In our analysis we assume Gray mapping. Also, the nearest neighbor approximation is used. This

corresponds to the assumption that if an error occurs, then the transmitted symbol can only be one of the symbols closest to the estimated one. Therefore, due to Gray mapping, one symbol error causes a single coded bit error. As illustrative examples, three cases are considered: $F = 1$, $F = 4$, and fully-interleaved fading. $Pe_{bit}^{F1,F4,Full}$ ($Pe_{code}^{F1,F4,Full}$) denotes the decoding error probability of information bits (coded bits) for each case study, respectively. For simplicity, we focus our attention on 16-QAM modulation, as used in our numerical examples.

2.3.1 Error Estimation with Perfect CSI: Computation of

$$Pe_{code}^{F1}, Pe_{code}^{F4} \text{ and } Pe_{code}^{Full}$$

2.3.1.1 Block Rayleigh Fading $F = 1$

In this case, the channels $S_j \rightarrow R$, $j = 1, 2$ are Gaussian distributed conditioned on h_j . The symbol error probability of the $S_j \rightarrow R$ link for M -QAM modulation is [70, eq 5-2-79]:

$$Psym_M(j) = 1 - (1 - Psym_{\sqrt{M}})^2,$$

with

$$Psym_{\sqrt{M}} = 2 \left(1 - \frac{1}{\sqrt{M}} \right) Q \left(\sqrt{\frac{3}{M-1} \frac{|h_j|^2 Es}{\sigma_n^2}} \right),$$

where $Q(\cdot)$ denotes the Q-function, h_j is the channel coefficient and Es is the symbol energy. Because each symbol error causes one coded bit error (Gray mapping and nearest neighbor approximation), then the error probability of coded bits of, for example, 16-QAM modulation can be estimated as follows:

$$\begin{aligned} Pe_{code}^{F1}(j) &= Psym_M(j) / \sqrt{M} \\ &\approx \frac{3}{8} \operatorname{erfc} \left(\sqrt{\frac{|h_j|^2 Es}{10\sigma_n^2}} \right), \end{aligned} \quad (2.13)$$

where $\operatorname{erfc}(\cdot)$ is related to the Q-function.

2.3.1.2 Block Rayleigh Fading $F = 4$

Let $h_j = [h_{j1}, h_{j2}, h_{j3}, h_{j4}]$ be the channel gain vector of link $S_j \rightarrow R$, $j = 1, 2$. Because the components of h_j are independent, the error probability $Pe_{code}^{F4}(j)$ of 16-QAM modulation is estimated as the average over the vector h_j :

$$Pe_{code}^{F4}(j) = \frac{1}{4} \sum_{k=1}^4 \left[\frac{3}{8} \operatorname{erfc} \left(\sqrt{\frac{|h_{jk}|^2 Es}{10\sigma_n^2}} \right) \right]. \quad (2.14)$$

2.3.1.3 Fully-Interleaved Rayleigh Fading

The error probability of coded bits of link $S_j \rightarrow R$ over fully-interleaved Rayleigh fading channel is computed by integrating over the distribution of the channel gains. Let h_j be channel gain, then $\gamma = |h_j|^2$ is exponentially distributed with mean equal to $E[|h_j|^2] = 1$. Therefore, the symbol error rate of link $S_j \rightarrow R$ with M-QAM modulation is:

$$\begin{aligned} P_{sym_M}^{Full}(j) &= \int_0^\infty \frac{\sqrt{M} - 1}{M} e^{-\gamma} \operatorname{erfc} \left(\sqrt{\frac{3Es}{2(M-1)\sigma_n^2} \gamma} \right) d\gamma \\ &= 2 \left(1 - \frac{1}{\sqrt{M}} \right) \left(1 - \sqrt{\frac{3Es}{3Es + 2(M-1)\sigma_n^2}} \right), \quad j = 1, 2. \end{aligned} \quad (2.15)$$

The coded bit error probability of 16-QAM modulation is thus equal to:

$$\begin{aligned} Pe_{code}^{Full}(j) &= P_{sym_M}^{Full}(j) / \sqrt{M} \\ &= \frac{3}{8} \left(1 - \sqrt{\frac{Es}{Es + 10\sigma_n^2}} \right). \end{aligned} \quad (2.16)$$

2.3.2 Error Estimation with Perfect CSI: Computation of

$$Pe_{bit}^{F1}, Pe_{bit}^{F4} \text{ and } Pe_{bit}^{Full}$$

The information bit error probability of convolutional codes conditioned on the channel vector can be computed as follows [71, eq.3.175]:

$$Pe_{bit} \approx \sum_{d=d_H}^{\infty} \beta(d) P_c(d), \quad (2.17)$$

where d_H is the minimum distance, $\beta(d)$ is the distance spectrum of the convolutional code, and $P_c(d)$ is the probability of choosing a wrong path in the trellis with distance d from the correct path (usually the all-zero path). $P_c(d)$ depends on the channel gains and is computed as follows.

2.3.2.1 Block Rayleigh Fading channel with $F = 1$

Lets $P_c^j(d)$ be the conditional pairwise error probability related to the $S_j \rightarrow R$ channel. Since Gray mapping is used and the nearest neighbor approximation is assumed, each symbol error only causes one error on the coded bits. In addition, the coded bits are interleaved before being mapped into the constellation. Thus, the conditional pairwise error probability of the $S_j \rightarrow R$ link is:

$$P_c^j(d) = \frac{3}{4} \operatorname{erfc} \left(\sqrt{\frac{d|h_j|^2 Es}{10\sigma_n^2}} \right). \quad (2.18)$$

By substituting (2.18) in (2.17), the bit error probability of the $S_j \rightarrow R$ link is estimated as follows:

$$P_{e_{bit}}^{F1}(j) \approx \frac{3}{4} \sum_{d=d_H}^{\infty} \beta(d) \operatorname{erfc} \left(\sqrt{\frac{d|h_j|^2 Es}{10\sigma_n^2}} \right). \quad (2.19)$$

In our simulation results, $d_H = 6$ for the RSC code [1 15/13] and only two values of d are used.

2.3.2.2 Block Rayleigh Fading channel with $F = 4$

The conditional pairwise error probability $P_c^j(d)$ on the $S_j \rightarrow R$ link depends on the channel vector $\mathbf{h}_j = \{h_{jf}\}_{f=1}^4$ and the distribution of the weight d over the F blocks. Denote by d_f the number of weights in block f , $f = 1, 2, \dots, F$ subject to $0 \leq d_f \leq d$ and $\sum_{f=1}^F d_f = d$. Then the distribution of the weight d over the F blocks is given by the weight pattern $\mathbf{D} = \{d_f\}_{f=1}^F$. The conditional pairwise error probability is estimated by averaging over all the weight patterns \mathbf{D} :

$$P_c^j(d) = \sum_{\mathbf{D}} P_c^j(d|\mathbf{D}) p(\mathbf{D}), \quad (2.20)$$

where the pairwise error probability given the weight pattern \mathbf{D} is computed as [68]:

$$P_c^j(d|\mathbf{D}) = \frac{3}{4} \operatorname{erfc} \left(\sqrt{\frac{E_s}{10\sigma_n^2} \sum_{f=1}^F d_f |h_{jf}|^2} \right), \quad (2.21)$$

and the distribution of the pattern \mathbf{D} is computed using combinatorial analysis:

$$p(\mathbf{D}) = \frac{\prod_{f=1}^F \mathcal{C}_{d_f}^m}{\mathcal{C}_d^{N_s}},$$

where $\mathcal{C}_k^n = \frac{n!}{k!(n-k)!}$ denotes the binomial coefficients; $N_s = N/\log_2(M)$ is the length of a signal; $m = N_s/F$ is the block's length.

From (2.17), (2.20) and (2.21), the error probability reduces to:

$$P e_{bit}^{F4}(j) \approx \frac{3}{4} \sum_{d=d_H}^{\infty} \beta(d) \sum_{\mathbf{D}} \operatorname{erfc} \left(\sqrt{\frac{E_s}{10\sigma_n^2} \sum_{f=1}^F d_f |h_{jf}|^2} \right) p(\mathbf{D}). \quad (2.22)$$

2.3.2.3 Fully-Interleaved Rayleigh Fading

The error probability of coded bits does not depend on the instantaneous channel gain but on the noise variance only. The pairwise error probability in fully-interleaved fading channel can be obtained by integrating over the distribution of channel gains. Using [71], we get:

$$P e_{bit}^{Full}(j) = \frac{3\beta(d_H)}{2} \mathcal{C}_{d_H}^{2d_H-1} \left(\frac{2E_s}{5\sigma_n^2} \right)^{-d_H}. \quad (2.23)$$

2.3.3 Error Estimation with Imperfect Perfect CSI

In the imperfect CSI case, we consider $F = 1$ and $F = 4$. The error probabilities at the relay can be computed as in the perfect CSI case, except that the estimated channel gain \hat{h}_j , $j = 1, 2$ is used instead of correct one h_j .

2.3.4 Error Quantization

To inform the destination about the decoding error probability at the relay, the relay quantizes and sends it to the destination. Let \bar{v} be a q -bit quantized value of v using uniform quantization function $Q_q(\cdot)$:

$$\bar{v} = Q_q(v) = \frac{kM_v}{2^q}, \text{ if } \frac{(k-1)M_v}{2^{q+1}} \leq v < \frac{(k+1)M_v}{2^{q+1}}, \quad k = 1, 2, \dots, 2^q \quad (2.24)$$

where $M_v = \max(v) - \min(v)$. The quantization error by $Q_q(\cdot)$ is given by $\varepsilon_q = M_v/2^{q+1}$. The quantized \bar{v} is transmitted over fading plus Gaussian noise to the destination. At the end of the channel estimation phase, the destination recovers the decoding error probability at the relay from the noisy version of the transmitted quantized signal.

2.4 Proposed Algorithm 1: Turbo-like Iterative Network/Channel Decoding algorithm

The first algorithm is developed based on turbo-like decoding methods. To fully exploit the potential of distributed diversity provided by the relay, the destination needs to know the decoding error probability at the relay, which is estimated and transmitted by the relay as described in the previous section. After receiving three channel observations from the two sources and from the relay, along with the decoding error probability at the relay, the destination runs the algorithm as follows.

First, maximum a posteriori probability (MAP) decoding is applied. Let $\hat{\mathbf{c}}_1, \hat{\mathbf{c}}_2$ and $\hat{\mathbf{c}}_r$ be the soft outputs of the demodulators associated to S_1, S_2 and R, respectively. At the destination, the maximum a posteriori probability decision rule is:

$$\hat{u}_{1k}, \hat{u}_{2k} = \arg \max_{u_{1k}, u_{2k}} \Pr\{u_{1k}, u_{2k} | \hat{\mathbf{c}}_1, \hat{\mathbf{c}}_2, \hat{\mathbf{c}}_r\}, \quad (2.25)$$

where $\Pr\{\cdot\}$ denotes probability and $\Pr\{a|b\}$ denotes probability of a conditioned on b .

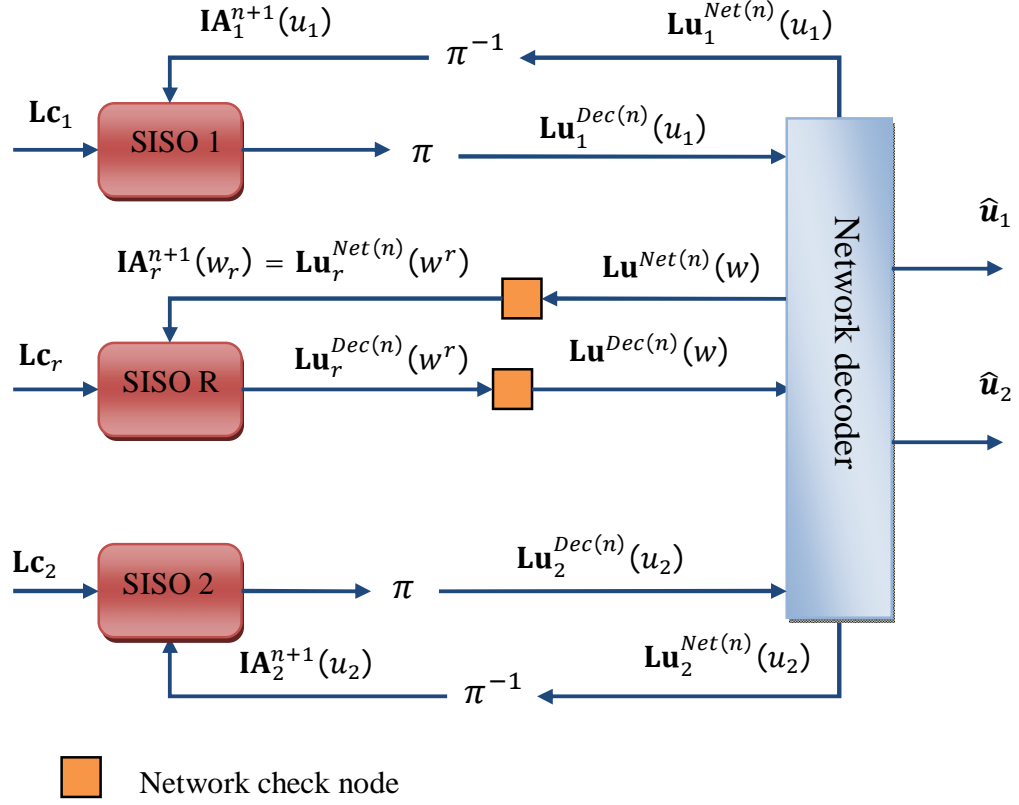

Figure 2.3. Diagram of the proposed Turbo-like INCD algorithm.

The probability in (2.25) is the marginal probability of the whole codeword. With some algebra, (2.25) can be re-written as follows:

$$\begin{aligned}
 \hat{u}_{1k}, \hat{u}_{2k} &= \arg \max_{u_{1k}, u_{2k}} \sum_{\substack{\mathbf{u}_2 \sim \{u_{2k}\} \\ \mathbf{u}_1 \sim \{u_{1k}\}}} \Pr \{ \hat{\mathbf{c}}_1, \hat{\mathbf{c}}_2, \hat{\mathbf{c}}_r | \mathbf{u}_1, \mathbf{u}_2 \} \\
 &= \arg \max_{u_{1k}, u_{2k}} \sum_{\substack{\mathbf{u}_2 \sim \{u_{2k}\} \\ \mathbf{u}_1 \sim \{u_{1k}\}, \mathbf{w}^r}} \Pr \{ \hat{\mathbf{c}}_1, \hat{\mathbf{c}}_2, \hat{\mathbf{c}}_r | \mathbf{u}_1, \mathbf{u}_2, \mathbf{w}^r \} \times \Pr \{ \mathbf{w}^r | \mathbf{u}_1, \mathbf{u}_2 \}, \quad (2.26)
 \end{aligned}$$

where $\sum_{\mathbf{u}_1 \sim \{u_{1k}\}, \mathbf{u}_2 \sim \{u_{2k}\}, \mathbf{w}^r} (\cdot)$ denotes the sum over all bits of $\mathbf{u}_1, \mathbf{u}_2, \mathbf{w}^r$ except bits $\{u_{1k}, u_{2k}\}$. From (2.26), we note that, given the information messages, the

received signals are independent. Thus, the righthand side of (2.26) simplifies to:

$$\sum_{\substack{\mathbf{u}_2 \sim \{u_{2k}\} \\ \mathbf{u}_1 \sim \{u_{2k}\}, \mathbf{w}^r}} \Pr\{\hat{\mathbf{c}}_1|\mathbf{u}_1\}\Pr\{\hat{\mathbf{c}}_2|\mathbf{u}_2\}\Pr\{\hat{\mathbf{c}}_r|\mathbf{w}^r\}\Pr\{\mathbf{w}^r|\mathbf{u}_1, \mathbf{u}_2\}. \quad (2.27)$$

The last term in (2.27) accounts for possible decoding errors at the relay. We note that this decoding error is on the information bits. The related error probability is denoted by $P_{e_{bit}}$ and it is computed in the next section. We assume, for tractability, that the network coded information bits are independent (a reasonable assumptions when interleavers at the relay are used). Thus, we have: $\Pr\{\mathbf{w}^r\} = \prod_{k=1}^K \Pr\{w_k^r\}$. This assumption leads to a suboptimal JNCD algorithm. In addition, since the transmitted information bits are independent we have: $\Pr\{\mathbf{w}^r|\mathbf{u}_1, \mathbf{u}_2\} = \prod_{k=1}^K \Pr\{w_k^r|u_{1k}, u_{2k}\}$. Let $w_k = u_{1k} \oplus u_{2k}$ be the correct network coded bit. We note that \mathbf{w} is based on the codebook while \mathbf{w}^r is based on the actual estimate at the relay. As a result, the decoding error at the relay is determined by $Pr[w_k^r|w_k]$. The decision rule in (2.27) becomes:

$$\hat{u}_{1k}, \hat{u}_{2k} = \arg \max_{u_{1k}, u_{2k}} \left\{ \sum_{\mathbf{u}_1 \sim \{u_{1k}\}} \Pr\{\hat{\mathbf{c}}_1|\mathbf{u}_1\} \times \sum_{\mathbf{u}_2 \sim \{u_{2k}\}} \Pr\{\hat{\mathbf{c}}_2|\mathbf{u}_2\} \times \sum_{\mathbf{w}^r} \Pr\{\hat{\mathbf{c}}_r|\mathbf{w}^r\} \times \prod_{l=1}^K \Pr\{w_l^r|w_l = u_{1l} \oplus u_{2l}\} \right\}. \quad (2.28)$$

The block diagram of the proposed JNCD algorithm is illustrated in Figure 2.3. The algorithm consists of three SISO decoders for the two sources and the single relay, as well as one network decoder. There is also a decoding check node between the SISO decoder for the relay and the network decoder, which controls the uncertainty of the decoding process at the relay. Let $\mathbf{L}\mathbf{u}_1^{Net}(\cdot)$, $\mathbf{L}\mathbf{u}_2^{Net}(\cdot)$ and $\mathbf{L}\mathbf{u}^{Net}(\cdot)$ be the extrinsic LLRs of the information bits sent by the network decoder to SISO decoder 1, SISO decoder 2 and SISO decoder R, respectively. Also, let $\mathbf{L}\mathbf{u}_1^{Dec}(\cdot)$, $\mathbf{L}\mathbf{u}_2^{Dec}(\cdot)$ and $\mathbf{L}\mathbf{u}^{Dec}(\cdot)$ be the extrinsic LLRs of the information bits that reach the network decoder from SISO decoder 1, SISO decoder 2 and SISO decoder R, respectively. Furthermore, let $\mathbf{L}\mathbf{u}_r^{Dec}(\cdot)$ be the extrinsic LLRs of the information bits sent from SISO decoder R to the decoding check node, and $\mathbf{L}\mathbf{u}_r^{Net}(\cdot)$ be the

extrinsic LLRs of the information bits that reach the SISO decoder R from the decoding check node.

The proposed iterative decoding algorithm works by exchanging extrinsic information between the SISO decoders and the network decoder. It consists in the following steps:

Step 0. (Setup) Let $\mathbf{Lc}_1, \mathbf{Lc}_2, \mathbf{Lc}_r$ be the LLRs of codewords $\hat{\mathbf{c}}_1, \hat{\mathbf{c}}_2$ and $\hat{\mathbf{c}}_r$, respectively, which are the outputs of the demodulators described in Section 2.2. The k -th element of \mathbf{Lc}_j , $j = 1, 2, r$ is computed as in (2.2) and (2.4).

Step 1. (Channel decoding) At the n -th iteration, the SISO decoder j , $j = 1, 2$ and SISO decoder R run the BCJR algorithm [72], as follows. **Input:** extrinsic of coded bits \mathbf{Lc}_j , $j = 1, 2, r$ and apriori information \mathbf{IA}_j^n . **Output:** extrinsic of information bits $\mathbf{Lu}_j^{Dec(n)}(u_j)$, $j = 1, 2$ and $\mathbf{Lu}_r^{Dec(n)}(w^r)$. The upper index (n) indicates the index iteration. In the first iteration, there is no a priori information for SISO decoders 1,2, R.

Step 2. (Decoding errors are taken into account). The decoding check node updates the extrinsic of the estimated network-coded information bits $\mathbf{Lu}_r^{Dec(n)}(w^r)$ to get the extrinsic of correct network-coded information bits $\mathbf{Lu}^{Dec(n)}(w)$ by taking into account the decoding error probability Pe_{bit} . Let $Lu_r^{Dec(n)}(w_k^r)$, $Lu^{Dec(n)}(w_k)$ be the k -th elements of $\mathbf{Lu}_r^{Dec(n)}(w^r)$ and $\mathbf{Lu}^{Dec(n)}(w)$, respectively, then:

$$Lu^{Dec(n)}(w_k) = \log \frac{(1 - Pe_{bit}) \exp \left(Lu_r^{Dec(n)}(w_k^r) \right) + Pe_{bit}}{Pe_{bit} \exp \left(Lu_r^{Dec(n)}(w_k^r) \right) + 1 - Pe_{bit}}.$$

Step 3. (Network decoding) The extrinsic of information bits $\mathbf{Lu}_1^{Dec(n)}(u_1)$, $\mathbf{Lu}_2^{Dec(n)}(u_2)$, $\mathbf{Lu}^{Dec(n)}(w)$ are input to the network decoder to output $\mathbf{Lu}_1^{Net(n)}(u_1)$, $\mathbf{Lu}_2^{Dec(n)}(u_2)$, $\mathbf{Lu}^{Net(n)}(w)$. Let $Lu_1^{Net(n)}(u_{1k})$, $Lu_2^{Net(n)}(u_{2k})$, $Lu^{Net(n)}(w_k)$ be the k -th element of $\mathbf{Lu}_1^{Net(n)}(u_1)$, $\mathbf{Lu}_2^{Dec(n)}(u_2)$, $\mathbf{Lu}^{Net(n)}(w)$, respectively.

The outputs of the network decoder are computed as follows:

$$\begin{aligned}
Lu_1^{Net(n)}(u_{1k}) &= \log \frac{1 + \exp \left(Lu_2^{Dec(n)}(u_{2k}) + Lu^{Dec(n)}(w_k) \right)}{\exp \left(Lu_2^{Dec(n)}(u_{2k}) \right) + \exp \left(Lu^{Dec(n)}(w_k) \right)}, \\
Lu_2^{Net(n)}(u_{2k}) &= \log \frac{1 + \exp \left(Lu_1^{Dec(n)}(u_{1k}) + Lu^{Dec(n)}(w_k) \right)}{\exp \left(Lu_1^{Dec(n)}(u_{1k}) \right) + \exp \left(Lu^{Dec(n)}(w_k) \right)}, \\
Lu^{Net(n)}(w_k) &= \log \frac{1 + \exp \left(Lu_1^{Dec(n)}(u_{1k}) + Lu_2^{Dec(n)}(u_{2k}) \right)}{\exp \left(Lu_1^{Dec(n)}(u_{1k}) \right) + \exp \left(Lu_2^{Dec(n)}(u_{2k}) \right)}.
\end{aligned}$$

Step 4. (Decoding errors are taken into account) The decoding check node update $\mathbf{Lu}^{Net(n)}(w)$ to get $\mathbf{Lu}_r^{Net(n)}(w^r)$ by taking into account the decoding error probability:

$$Lu_r^{Net(n)}(w_k^r) = \log \frac{(1 - Pe_{bit}) \exp \left(Lu^{Net(n)}(w_k) \right) + Pe_{bit}}{Pe_{bit} \exp \left(Lu^{Net(n)}(w_k) \right) + 1 - Pe_{bit}}.$$

Step 5. (Feedback) The extrinsic of information bits $\mathbf{Lu}_1^{Net(n)}(u_1)$, $\mathbf{Lu}_2^{Net(n)}(u_2)$, $\mathbf{Lu}^{Net(n)}(w)$ are feedback to SISO decoders 1,2, and R as a priori information for the next iteration, as follows: $\mathbf{IA}_1^{n+1}(u_1) = \mathbf{Lu}_1^{Net(n)}(u_1)$; $\mathbf{IA}_2^{n+1}(u_2) = \mathbf{Lu}_2^{Net(n)}(u_2)$; $\mathbf{IA}_r^{n+1}(w^r) = \mathbf{Lu}_r^{Net(n)}(w^r)$.

Step 6. Repeat from Step 1.

2.5 Proposed Algorithm 2: Low Complexity Iterative Network/Channel Decoding algorithm

Algorithm 1 performs channel decoding first and utilizes the decoding error probability of the information bits Pe_{bit} . On the other hand, the second proposed INCD algorithm exploits the decoding error probability of the coded bits Pe_{code} and performs network decoding first. After receiving three channel observations from the two sources and the single relay, along with the decoding error probability Pe_{code} ,

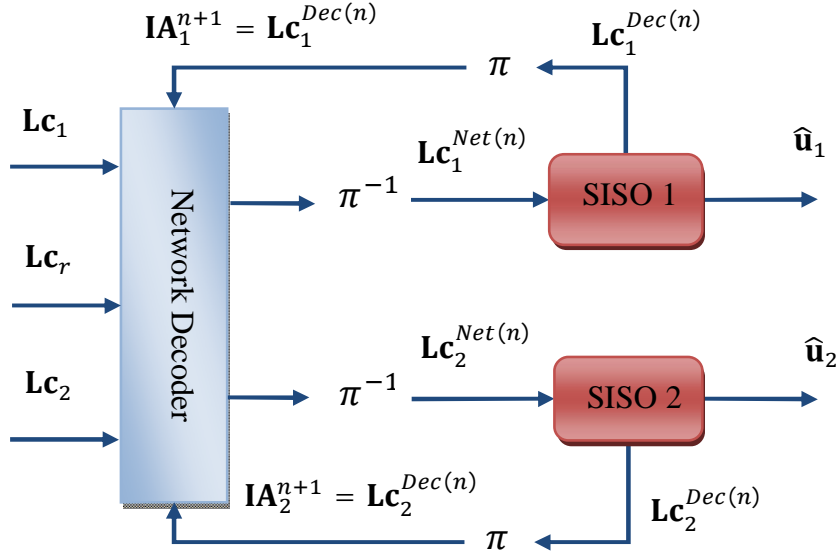

Figure 2.4. Diagram of the proposed Low complexity INCD algorithm.

the destination applies the MAP decoding rule as follows:

$$\begin{aligned}
\hat{\mathbf{u}}_1, \hat{\mathbf{u}}_2 &= \arg \max_{\mathbf{u}_1, \mathbf{u}_2} \Pr\{\mathbf{u}_1, \mathbf{u}_2 | \hat{\mathbf{c}}_1, \hat{\mathbf{c}}_2, \hat{\mathbf{c}}_r\} \\
&\sim \arg \max_{\mathbf{u}_1, \mathbf{u}_2} \sum_{\mathbf{c}_1, \mathbf{c}_2} \Pr\{\mathbf{u}_1 | \mathbf{c}_1\} \Pr\{\mathbf{u}_2 | \mathbf{c}_2\} \times \Pr\{\hat{\mathbf{c}}_1, \hat{\mathbf{c}}_2, \hat{\mathbf{c}}_r | \mathbf{c}_1, \mathbf{c}_2\} \\
&\sim \arg \max_{\mathbf{u}_1, \mathbf{u}_2} \sum_{\mathbf{c}_1, \mathbf{c}_2} \Pr\{\mathbf{u}_1 | \mathbf{c}_1\} \Pr\{\mathbf{u}_2 | \mathbf{c}_2\} \times \Pr\{\hat{\mathbf{c}}_1 | \mathbf{c}_1\} \Pr\{\hat{\mathbf{c}}_2 | \mathbf{c}_2\} \\
&\quad \times \sum_{\mathbf{c}^r} \Pr\{\hat{\mathbf{c}}_r | \mathbf{c}^r\} \Pr\{\mathbf{c}^r | \mathbf{c}_r \triangleq \mathbf{c}_1 \oplus \mathbf{c}_2\}, \tag{2.29}
\end{aligned}$$

where \mathbf{c}_j , $j = 1, 2$ is the codeword generated from the information message \mathbf{u}_j ; \mathbf{c}^r is the network coded codeword; $\mathbf{c}_r \triangleq \mathbf{c}_1 \oplus \mathbf{c}_2$ is the *correct* network coded codeword; $\hat{\mathbf{c}}_{1,2,r}$ is the soft output of the demodulator related to source 1,2 and relay R. We note that the correct network coded codeword \mathbf{c}_r is computed from the codebook, while the network coded codeword $\mathbf{c}^r = \pi(\mathbf{c}_1^r) \oplus \pi(\mathbf{c}_2^r)$ is computed from the estimated codeword $\mathbf{c}_1^r, \mathbf{c}_2^r$ at the relay. The two first factors in (2.29) account for two channel decoders, and the other terms account for the network decoder. The last factor in (2.29) shows how error decoding on the coded bits at the relay, whose probability is Pe_{code} , is taken into account by the decoder. The

block diagram of this algorithm is sketched in Figure 2.4. The main difference between algorithm 1 and algorithm 2 is that in the latter case network decoding is performed first. As a result, one channel decoder can be avoided in algorithm 2, which makes the receiver simpler to implement.

Let $\mathbf{Lc}_1, \mathbf{Lc}_2$ and \mathbf{Lc}_r be LLR inputs for source 1, 2 and relay R, respectively. Let $\mathbf{Lc}_1^{Net}, \mathbf{Lc}_2^{Net}$ be the extrinsic information output of network decoder, and $\mathbf{Lc}_1^{Dec}, \mathbf{Lc}_2^{Dec}$ be extrinsic information output of the coded bits of SISO decoder 1 and SISO decoder 2. Finally, let $\mathbf{IA}_1, \mathbf{IA}_2$ be the a priori information (on coded bits) of the network decoder.

Algorithm 2 consists of following steps.

Step 0. (Setup) The three demodulators process the received signal to output $\mathbf{Lc}_1, \mathbf{Lc}_2, \mathbf{Lc}_r$. The k -th element of \mathbf{Lc}_j , $j = 1, 2, r$ is computed as in (2.2) and (2.4).

A decoding check node updates \mathbf{Lc}_r by taking into account the decoding error probability at the relay, Pe_{code} , to get $\widetilde{\mathbf{Lc}}_r$:

$$\widetilde{Lc}_{rk} = \log \frac{(1 - Pe_{code}) \exp(Lc_{rk}) + Pe_{code}}{Pe_{code} \exp(Lc_{rk}) + 1 - Pe_{code}}, \quad (2.30)$$

where $Lc_{rk}, \widetilde{Lc}_{rk}$ are the k th element of \mathbf{Lc}_r and $\widetilde{\mathbf{Lc}}_r$, respectively.

Step 1. (Network decoding) At the n th iteration, the network decoder decodes $\mathbf{Lc}_1, \mathbf{Lc}_2, \widetilde{\mathbf{Lc}}_r$, with a priori information \mathbf{IA}_1^n and \mathbf{IA}_2^n to output the extrinsic information of coded bits $\mathbf{Lc}_1^{Net(n)}$ and $\mathbf{Lc}_2^{Net(n)}$. Let $Lc_{1k}, Lc_{2k}, Lc_{rk}$ be the k th element of $\mathbf{Lc}_1, \mathbf{Lc}_2, \widetilde{\mathbf{Lc}}_r$, respectively; $Lc_{1k}^{Net(n)}, Lc_{2k}^{Net(n)}$ be the k th element of $\mathbf{Lc}_1^{Net(n)}$ and $\mathbf{Lc}_2^{Net(n)}$, respectively; and IA_{1k}^n, IA_{2k}^n be the k th element of \mathbf{IA}_1^n and \mathbf{IA}_2^n , respectively. Then:

$$Lc_{1k}^{Net(n)} = Lc_{1k} + \log \frac{\exp(\widetilde{Lc}_{rk}) + \exp(Lc_{2k} + IA_{2k}^n)}{1 + \exp(\widetilde{Lc}_{rk} + Lc_{2k} + IA_{2k}^n)},$$

$$Lc_{2k}^{Net(n)} = Lc_{2k} + \log \frac{\exp(\widetilde{Lc}_{rk}) + \exp(Lc_{1k} + IA_{1k}^n)}{1 + \exp(\widetilde{Lc}_{rk} + Lc_{1k} + IA_{1k}^n)}.$$

At the first iteration, $\mathbf{IA}_1^1 = \mathbf{IA}_2^1 = 0$.

Step 2. (Channel decoding) The SISO decoder j , $j = 1, 2$, run the BCJR algorithm [72] as follows. **Input:** extrinsic information of coded bits $\mathbf{Lc}_j^{Net(n)}$; the a priori extrinsic of information bits is equal to 0. **Output:** extrinsic information of coded bits $\mathbf{Lc}_j^{Dec(n)}$.

Step 3. (Feedback) The extrinsic information of coded bits \mathbf{Lc}_1^{Dec} , \mathbf{Lc}_2^{Dec} is feedback to the network decoder as a priori (of coded bits) information for the next iteration: $\mathbf{IA}_j^{n+1} = \mathbf{Lc}_j^{Dec(n)}$, $j = 1, 2$.

Step 4. Repeat from Step 1.

2.6 Numerical Results

2.6.1 Perfect CSI Scenario

In this section, we study the performance of the proposed INCD algorithms in various fading scenarios. For this perfect CSI case, assume that the receivers have perfect knowledge of the one-hop links CSI. In addition, the destination is assumed to have full knowledge of the decoding error probability at the relay, Pe_{bit} and Pe_{code} , which are estimated as described in the previous sections. We assume a symmetric network topology in which the distance from the sources to the destination is the same. The relay is located at mid distance between sources and destination. The path loss has been chosen equal to 2. A recursive systematic convolutional (RSC) code with rate $R = 1/2$ and polynomial generator $G=[1\ 15/13]$ is used to transmit an information block of $K = 197$ bits, which corresponds to $N = 400$ coded bits with tailing decoding. 16-QAM is used as the modulation scheme. The number of iterations used to obtain our results is 4, since we have observed that the algorithms converge to the best performance in 4 iterations.

Both DF and DMF relaying protocols are studied. In particular, three schemes are studied: i) DF relaying with the proposed algorithm 1, named *DF, Algo 1* in the figure; ii) DF relaying with the proposed algorithm 2, named *DF, Algo 2* in the figure; iii) DMF relaying with the proposed algorithm 2, named *DMF, Algo 2* in the figure. We note that algorithm 1 cannot be used with the DMF protocol

because it performs network coding on the information bits. We also compare our algorithms with [56], which is denoted by *Ref. [Yune]* in the figure. In addition, we denote by *Blind* the scenario where the receiver has no information about the decoding error probability at the relay (it assumes perfect decoding at the relay) and by *No Cooperation* the conventional point-to-point communication scenario.

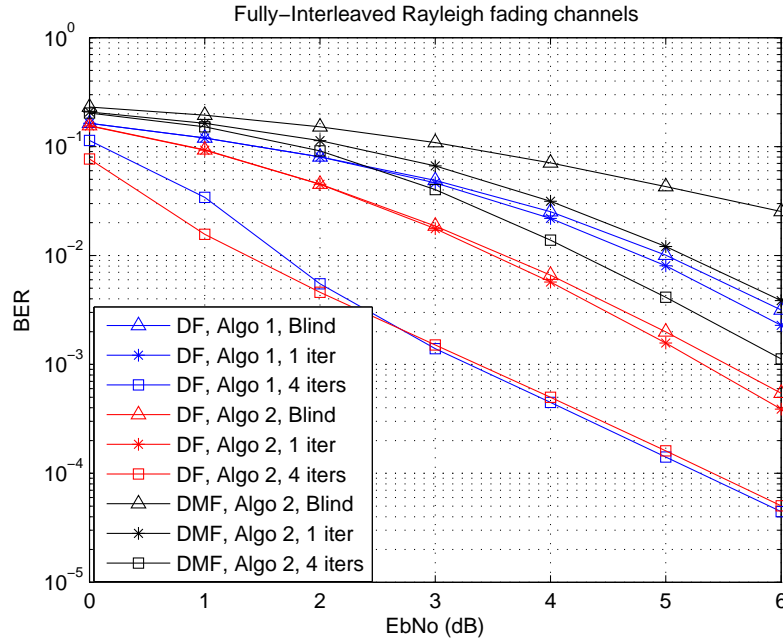

Figure 2.5. Performance of the proposed INCD algorithms in fully-interleaved Rayleigh fading scenarios with full CSI at receivers.

Figure 2.5 shows the simulation results for fully-interleaved fading channels. It is shown in the figure that: i) Iterative network/channel decoding significantly improves the performance of both proposed algorithms using the DF protocol. More specifically, with 4 iterations, compared with separate decoding (1 iteration), the proposed algorithm 1 gains 3dB at a BER equal to 10^{-3} . On the other hand, the proposed algorithm 2 gains 2dB. If the DMF protocol is considered, the proposed algorithm 2 with 4 iterations gains about 1dB at a BER equal to 10^{-3} compared with 1 iteration decoding. ii) If the DF protocol is considered, the algorithm 2 is about 1dB better than the algorithm 1 after 1 iteration. After 4 iterations, the two algorithms have almost the same performance. iii) Compared to [56], the two proposed algorithms with 4 iterations and DF protocol perform 3.5dB better. The

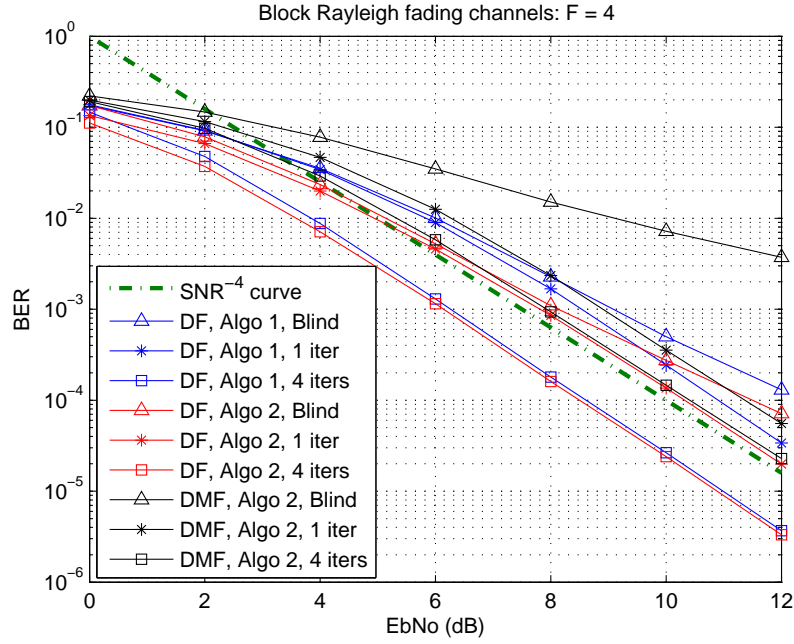

Figure 2.6. Performance of the proposed INCD algorithms in $F = 4$ block Rayleigh fading scenarios with full CSI at receivers.

proposed algorithm 2 with DMF protocol performs 1dB better than [56].

Figure 2.6 shows the simulation results for block fading channel with $F = 4$. In addition, the theoretical curve SNR^{-4} is plotted to provide some information about the achievable diversity order. i) Iterative decoding improves performance for both DF and DMF relaying. With 4 iterations, DF relaying with the proposed algorithm 1 gains about 2dB and with the proposed algorithm 2 it gains about 1.5dB at a BER equal to 10^{-4} compared to the single iteration case. DMF relaying with algorithm 2 gains about 1dB. ii) Compared to [56], after 4 iterations, algorithm 1 and algorithm 2 with DF relaying both gain about 3dB at a BER equal to 10^{-4} . With DMF relaying, the algorithm 2 with 4 iterations gains about 1dB at a BER equal to 10^{-4} . iii) For both DF and DMF relaying, the receiver loses the diversity order if it has no information about the decoding error probability.

We note that in Figure 2.6 the proposed algorithms have diversity order equal to 4 if $F = 4$. The reason is as follows. The diversity gain d^H of a convolutional code in a F -block fading channel with M -QAM modulation is upper bound by

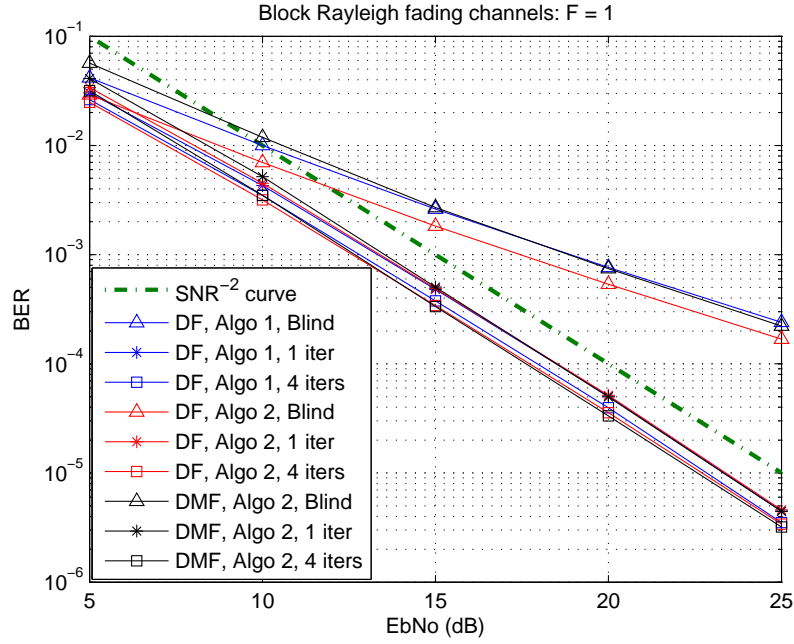

Figure 2.7. Performance of the proposed INCD algorithms in quasi-static block Rayleigh fading scenarios with full CSI at receivers.

[68]:

$$d^H \leq \lfloor F(1 - \frac{R}{\log_2(M)}) \rfloor + 1,$$

where $\lfloor x \rfloor$ denotes the largest integer no greater than x , R is the code rate in bits/symbol. In our setup, we have $R = 2$ bits/symbol and 16-QAM. Thus, we get $d^H \leq 3$. It is shown from the simulation that the actual diversity order of the code [1 15/13] is 2 in the SNR range of interest. Therefore, it is reasonable that in the MARC, the relay provides a better diversity gain.

Figure 2.7 shows simulation results for the quasi-static fading channel with $F = 1$. In addition, the theoretical curve SNR^{-2} is plotted as a diversity reference. It is shown in the figure that: i) if the receiver is not informed about the decoding error probability at the relay, the performance is dramatically decreased and it loses diversity order; ii) iterative decoding brings a little gain in both algorithms. Algorithm 2 with 4 iterations gains about 0.8dB over the 1 iteration case, while algorithm 1 with 4 iterations gains about 0.5dB over the 1 iteration case; and iii)

both algorithm 1 and algorithm 2 with 4 iterations have almost same performance.

2.6.2 Numerical Results: Imperfect CSI case

This section evaluates the impact of imperfect CSI and quantization error on the performance of the proposed algorithms. The two case studies with $F = 1$ and $F = 4$ are investigated. The channel code is chosen as in the previous section and 16-QAM is used. The ML estimator is used for channel estimation. Because the performance of algorithm 2 with DF and DMF relaying is almost the same, we only study algorithm 2 with DMF relaying in this section. Then, in this section, algorithm 1 is linked to DF relaying and algorithm 2 is linked to DMF relaying. In the figures, *Full CSI* denotes the case when the receivers (relay and destination) have perfect channel state information of the one-hop links. On the other hand, *Full Pe* denotes the case when the destination has full knowledge of the decoding error probability at the relay. Finally, the case study *No Pe* denotes the setup when the destination assumes that the relay perfectly decodes.

2.6.2.1 Effect of Iterations with Imperfect CSI

Figure 2.8 shows results for $F = 1$ by considering separate (1 iteration) and joint/iterative decoding (4 iterations) of algorithm 1 and algorithm 2 with imperfect CSI scenario and different quantization levels. In this figure, the total number of overhead symbols (pilots + BER value) is assumed to be equal to 5. For both proposed algorithms, joint decoding gives about 0.7dB gain compared with separate decoding (1 iteration) if the *Full Pe* scenario is considered and gives a little gain if $L_q = 4$ bits used for transmitting decoding errors at the relay. If the quantization level L_q decreases, joint decoding does not perform better or even worse than separate decoding. It is because the total number of overhead symbols is limited to 5. Obviously, if we use more number of overhead symbols, joint decoding gives a larger gain compared with separate decoding. However, concerning realistic imperfect CSI systems where the total number of overhead symbols is not too large, we focus on only separate decoding (1 iteration) for block fadings ($F = 1$ and $F = 4$) in what follows.

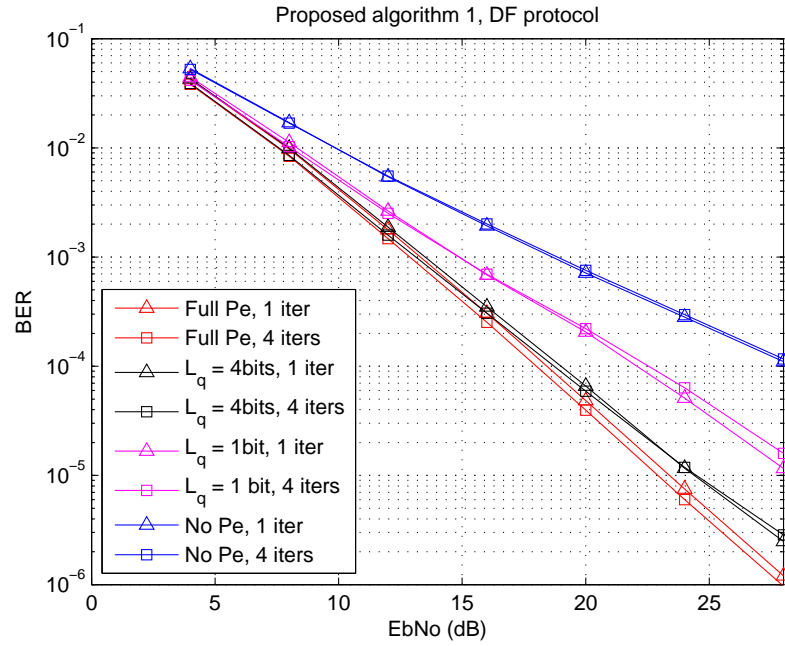

a) The proposed Algorithm 1

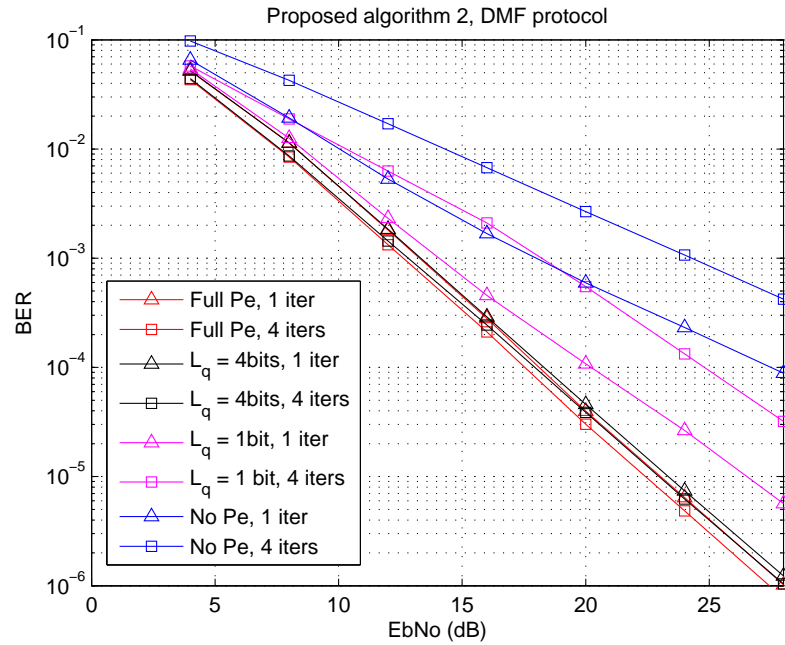

b) The proposed Algorithm 2

Figure 2.8. Effect of iterations on performance of the proposed algorithm 1 and 2 in block fading $F = 1$ vs knowledge of decoding error at the relay. The total number of overhead symbol $Lr_p + L_q = 5$

2.6.2.2 Effects of Quantization

We study effect of quantization level in two cases: perfect CSI and imperfect CSI. In the latter, the total number of overhead symbols (pilots + BER value) is assumed to be equal to 5.

Figure 2.9 illustrates the effect of quantization by assuming perfect CSI and $F = 1$. It is observed that if the BER at the relay is not taken into account by the decoder at destination, it loses both coding gain and diversity order. Furthermore, the quantization level, L_q , affects both performance and diversity order. In algorithm 2, 3-bit quantization is sufficient at a BER equal to 10^{-5} . While in algorithm 1, 6-bit quantization level is required.

Figure 2.10 shows results for imperfect CSI with 5 pilot symbols. We note that the 4-bits quantization is still far from the Full-Pe curve because the more quantized bits are transmitted by the relay, the less pilot symbols are available for the relay to destination link. The constraint of a common number of overhead symbols in all links which seems to be necessary in a practical scheme makes iterative algorithms of little practical use.

Figure 2.11 shows the effect of quantization with perfect CSI and $F = 4$. Similar conclusions as above are derived. The quantization level affects both diversity order and coding gain. In addition, if the destination has no information on possible decoding error at the relay or not too much (1 bit quantization), cooperation even degrades performance, compared with non-cooperative schemes. This is because with DMF relaying the error probability at the relay has a significant impact on the performance.

2.6.2.3 Effects of Pilot Length

Figure 2.12 shows the effect of pilot length assuming Full-Pe and $F = 1$. Both algorithms have the same performance trend as a function of number of pilot symbols. It is shown that pilot length only affects the coding gain, and it does not change the diversity order of the system in the SNR range of interest. In addition, 16-symbol pilot curve is about 1dB worse than the full CSI curve (at a BER equal to 10^{-4}).

Figure 2.13 shows results when decoding error at the relay is quantized on 3-

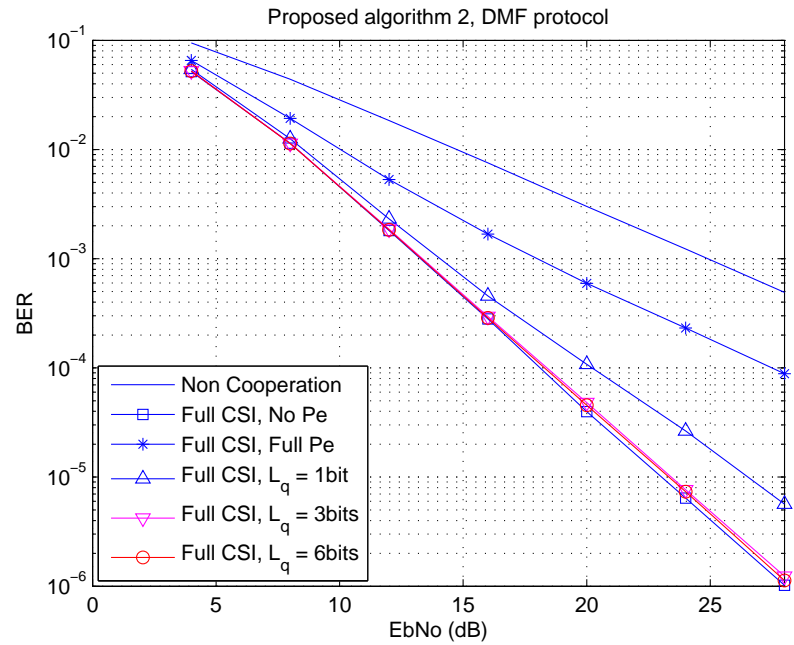
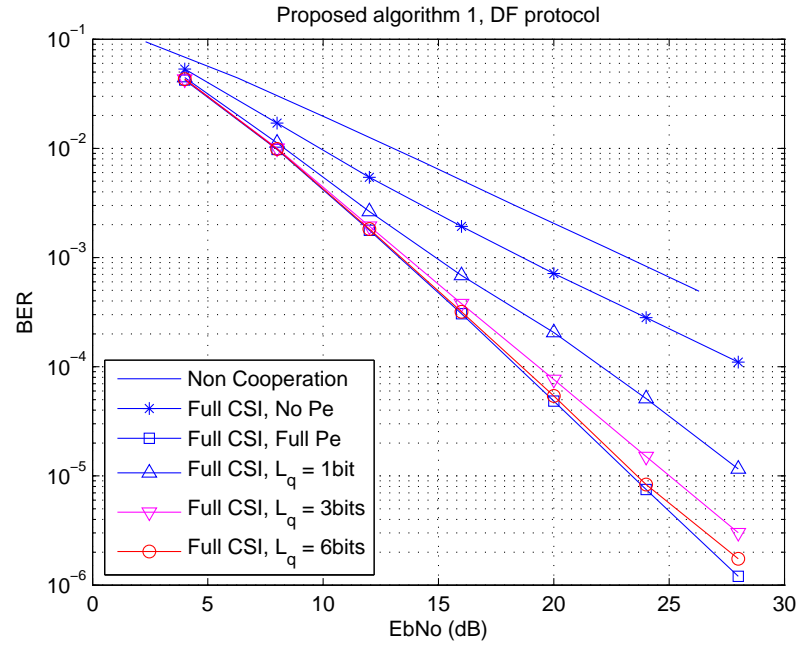
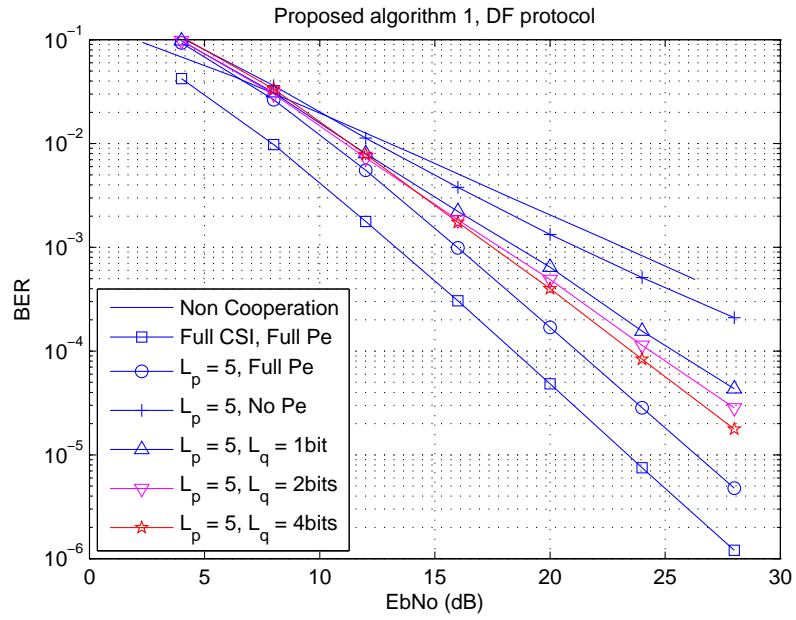
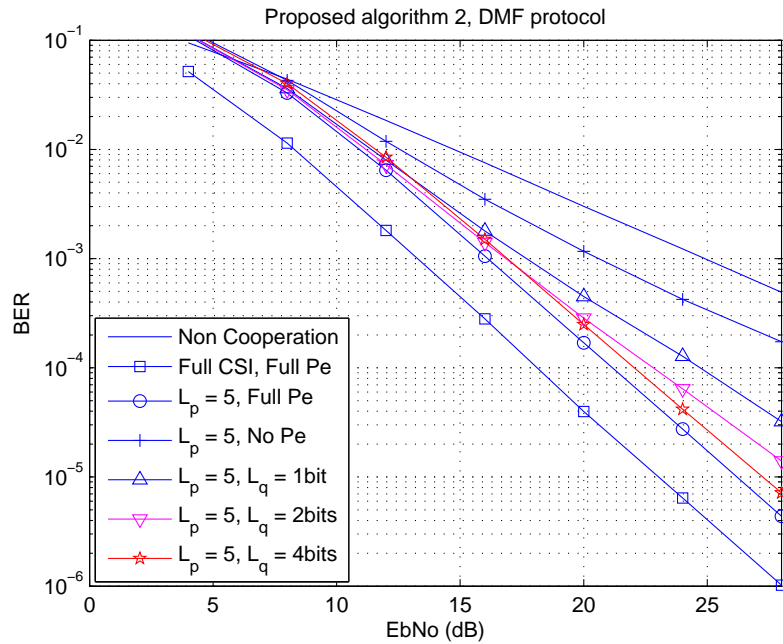

Figure 2.9. Effects of quantization level L_q on performance of the proposed algorithm 1 and 2 in block fading $F = 1$, Full CSI scenario.



a) The proposed Algorithm 1



b) The proposed Algorithm 2

Figure 2.10. Effects of quantization level L_q on performance of the proposed algorithm 1 and 2 in block fading $F = 1$. Imperfect CSI scenario with 5 pilot symbols.

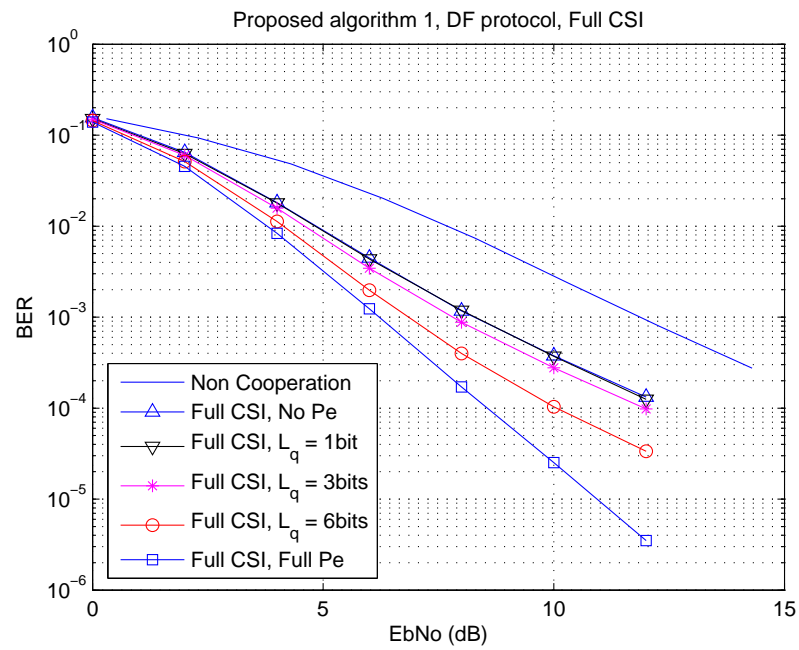

a) The proposed Algorithm 1

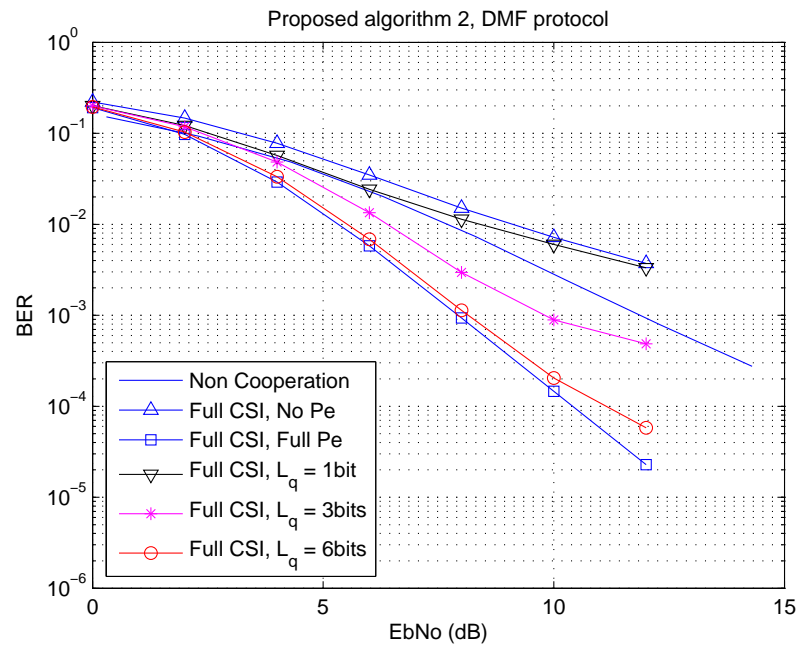

b) The proposed Algorithm 2

Figure 2.11. Effects of quantization level L_q on performance of the proposed algorithm 1 and 2 in block fading $F = 4$, Full CSI at receivers

bits. With DMF relaying and algorithm 2, the pilot length only affects the coding gain. In addition, the 16-symbol pilot curve is 1.5dB worse than the perfect CSI curve. On the other hand, the pilot length affects both coding gain and diversity order when algorithm 1 and DF relaying are used.

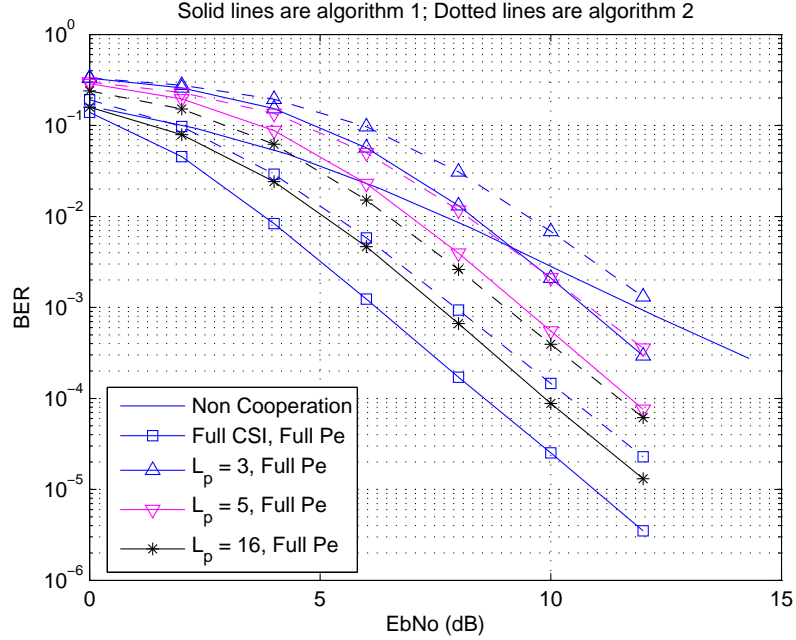

Figure 2.14. Effects of pilots on performance of the proposed algorithm 1 and 2 in block fading $F = 4$. The destination has full knowledge of possible decoding error at the relay

Figure 2.14 shows the effect of pilot length by assuming Full-Pe and $F = 4$. In this case, the pilot length only affects the coding gain, but it does not change the diversity order of the system. It is shown that algorithm 1 with DF relaying outperforms algorithm 2 with DMF relaying by about 1.2dB.

In conclusion: i) If $F = 1$, algorithm 2 has the same performance as algorithm 1 and it is less complex than algorithm 1. However, if $F = 4$, algorithm 1 outperforms algorithm 2. ii) If the destination is enough aware of the decoding error probability at the relay, pilot length does not change that diversity order of the system. iii) The number of quantization bits for reporting decoding errors from the relay affects both coding gain and diversity order. iv) 6-bit quantization is enough in most analyzed scenarios.

2.7 Conclusions

We have studied the performance of the multiple access relay channel with binary Network Coding and INCD algorithms at the destination in practical situations. Decode and Forward and Demodulate and Forward relaying strategies have been investigated. Our results show that iterative Joint Network and Channel Decoding provides better performance than separate network channel decoding only if the destination has enough CSI and knowledge of the decoding error probability at the relay. This gain increases with the number of fading blocks per codeword. It is also shown that the number of pilot symbols mostly affects the coding gain of the system with a negligible impact on the diversity order, at least for the SNR range of interest. Finally, it is shown that CSI quantization errors affect both coding gain and diversity order. In general, representing the BER at the relay using 3-bit quantization is sufficient for DMF relaying while 6-bit quantization is needed for DF relaying.

Near Optimal Joint Network/Channel Decoding for the MARC

The iterative decoding algorithms proposed in the previous chapter have an advantage that the computational complexity linearly increases with the number of iterations. Unfortunately, the mathematical performance analysis of iterative decoding is in general very difficult, *e.g.*, coding gain and diversity gain. However, any good iterative decoding scheme should, in theory, approach the performance of ML-optimum decoding, which may serve as a benchmark in order to understand the best achievable performance by avoiding extensive numerical simulations. In addition, although the information is exchanged through the iterative process, channel decoding and network decoding are still performed in different steps, which might not optimally exploit the inherent redundancy conveyed by network-coded signal. In this chapter, we propose a novel Near Optimal Joint Network/Channel Decoding (NO-JNCD) algorithm for the MARC. The key idea of our proposal is that we consider the relayed signal as an *internal* redundancy of the channel codes instead as an external redundancy, which is, on the other hand, typically assumed by iterative decoding algorithms. From the system point of view, the relayed signal can be seen as an additional parity bits of a super code whose super trellis contains all combinations of single trellis states at the sources. The destination may then apply the well-known BCJR algorithm on the super code to decode source data.

Because network decoding and channel decoding are processed in one single decoding step of the super code, the NO-JNCD algorithm exploits the network-coded redundancy more effectively and provides a near-optimal solution.

We analyze the coding gain and diversity gain of Network Coding Cooperation with channel coding (Coded-NCC). The performance of NCC without channel coding (Uncoded-NCC) has recently been addressed by [73, 53] in which accurate asymptotic BER was derived to provide an insightful analysis of NCC. Concerning Coded-NCC, [40, 74] proposed iterative decoding algorithms for either convolutional code or Low Density Parity Check (LDPC) code for MARC while [75] investigated on TWRC and Physical-layer Network Coding (PNC). However, these papers did not provide analytical results due to the difficulty of characterizing information among iterations or high complexity of LDPC code.

3.1 System Model

We consider the cooperative network composed of N_s channel-coded sources S_i with $i = 1, \dots, N_s$, one relay R and one destination D, as depicted in Figure 3.1. All nodes are equipped with half-duplex single antennas. In order to avoid mutual interference, the system is assumed to operate with orthogonal channels. As a result, a cooperation phase consists of $N_s + 1$ timeslots. In the first N_s timeslots, each source consecutively broadcasts a data message to the relay and to the destination. In the $(N_s + 1)$ -th timeslot, the relay forwards a network-coded signal to the destination (XOR in our study). All channels are subject to fully-interleaved Rayleigh fading (*i.e.*, channel coefficients independently change symbol to symbol), plus AWGN noise. The relay employs DF relaying protocol.

3.1.1 Processing at the sources

Let \mathbf{u}_i with $1 \leq i \leq N_s$ denote a length K data message generated by source S_i . The data message \mathbf{u}_i is then encoded by a convolutional code (CC) with generator polynomial \mathbf{g} . This code has rate K/N and provides codewords $\mathbf{c}_i = \{c_{i,1}, \dots, c_{i,N}\}$, corresponding to N coded symbols. The codeword \mathbf{c}_i is then mapped (using Gray mapping) into a signal \mathbf{x}_i which contains $L = N/\log_2 M$ signal symbols belonging

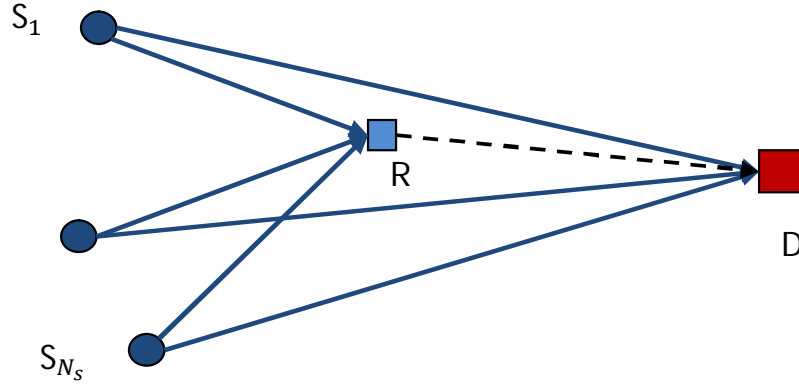

Figure 3.1. Network coding cooperative network with single relay.

to an M quadrature amplitude modulation (M -QAM). The codeword \mathbf{x}_i is then transmitted to the relay and the destination. Let $\mathbf{h}_{S_i R} = \{h_{S_i R,1}, \dots, h_{S_i R,L}\}$ and $\mathbf{h}_{S_i D} = \{h_{S_i D,1}, \dots, h_{S_i D,L}\}$ be channel coefficient vectors of links $S_i \rightarrow R$ and $S_i \rightarrow D$, respectively. The received signal at the relay and destination from source S_i with $1 \leq i \leq N_s$ is given as follows:

$$\begin{cases} y_{S_i R,k} = \sqrt{P_{S_i R}} h_{S_i R,k} x_{i,k} + n, & k = 1, \dots, L \\ y_{S_i D,k} = \sqrt{P_{S_i D}} h_{S_i D,k} x_{i,k} + n, & k = 1, \dots, L \end{cases} \quad (3.1)$$

where P_{XY} with $X \in \{S_1, \dots, S_{N_s}\}$, $Y \in \{R, D\}$ is power of the received signal at node Y from node X including the path loss; $h_{XY,k}$ is the channel coefficient of the $X \rightarrow Y$ channel at time k -th, which is a complex Gaussian random variable with zero mean and unit variance, *i.e.*, $\mathbb{E}\{|h_{XY,k}|^2\} = 1$ and is mutual statistically independent along time; n (index is ignored for convenience) is a Gaussian random noise with mean zero and variance σ^2 .

3.1.2 Processing at the relay

When receiving N_s packets from the sources, the relay applies the BCJR algorithm [72] to get the estimated codeword \mathbf{c}_i^R from $\mathbf{y}_{S_i R}$. Next, the relay performs network

encoding to get the network-coded codeword $\widehat{\mathbf{c}}_R = \{\widehat{c}_{R,1}, \dots, \widehat{c}_{R,N}\}$ with

$$\widehat{c}_{R,k} = c_{1,k}^R \oplus c_{2,k}^R \oplus \dots \oplus c_{N_s,k}^R.$$

After network encoding, the relay M -QAM modulates $\widehat{\mathbf{c}}_R$ into signal \mathbf{x}_R and forwards it to the destination. The received signal at the destination in $(N_s + 1)$ -th timeslot is give by

$$y_{RD,k} = \sqrt{P_{RD}} h_{RD,k} x_{R,k} + n, \quad k = 1, \dots, L, \quad (3.2)$$

where P_{RD} is power of the received signal at the destination from the relay that includes the path loss; $h_{RD,k}$ is the channel coefficient of link $R \rightarrow D$ at time index k -th, which is a complex Gaussian random variable with zero mean and unit variance, *i.e.*, $\mathbb{E}\{|h_{XY,k}|^2\} = 1$ and is mutual statistically independent from time to time; n is a Gaussian random noise with mean zero and variance σ^2 .

When received $N_s + 1$ signal from the sources and the relay, the destination starts perform joint decoding algorithm.

3.2 Decoding at the destination

This subsection describes the proposed joint decoding algorithm at the destination. After receiving $N_s + 1$ packets from the sources and from the relay, the destination performs joint network/channel decoding. Assuming the CSI of incoming links, *i.e.*, $S_i \rightarrow D$ and $R \rightarrow D$ links is available at the destination, the MAP decoding rule reads

$$[\hat{u}_{1,k}, \dots, \hat{u}_{N_s,k}] = \arg \max_{u_{1,k}, \dots, u_{N_s,k}} \Pr \{u_{1,k}, \dots, u_{N_s,k} | \mathbf{y}_{S_1D}, \dots, \mathbf{y}_{S_{N_s}D}, \mathbf{y}_{RD}\}, \quad (3.3)$$

where $u_{j,k}$ denotes the k -th element of vector \mathbf{u}_j .

Existing solution of (3.3) might includes iterative network/channel decoding algorithm [60] in which the extrinsic information is exchanged between the network decoder and the channel decoders. However, the iterative decoding algorithm does not lead to mathematically tractable performance analysis due to the difficulty of characterizing the extrinsic information among iterations.

To overcome this difficulty, we look at (3.3) from the system point of view. Denote by $\mathbf{U} = [\mathbf{u}_1, \dots, \mathbf{u}_{N_s}]$ the collection of data messages and by $\mathbf{Y} = [\mathbf{y}_{S_1D}, \dots, \mathbf{y}_{S_{N_s}D}, \mathbf{y}_{RD}]$ the set of received signal at destination. In addition, $U_k \triangleq (u_{1,k}, \dots, u_{N_s,k})$ denotes the k -th "element" of \mathbf{U} . Then the problem in (3.3) can be rewritten as follows:

$$\begin{aligned} [\widehat{U}_k] &= \arg \max_{U_k} \Pr \{U_k | \mathbf{Y}\} \\ &\propto \arg \max_{U_k} \Pr \{U_k, \mathbf{Y}\}. \end{aligned} \quad (3.4)$$

The MAP decoding rule in (3.4) can be seen as a decoding problem of the so-called "super code" with the data input \mathbf{U} and channel output \mathbf{Y} whose trellis contains all possible states of single trellises at the source combined by the network code. The key idea in our proposal is to consider the relayed signal as an additional parity bits (redundancy) belonging to the super code. Therefore, network decoding and channel decoding are involved in a single decoding process of the super code. In particular, denote by \mathbf{g} the channel code generator polynomial of the sources, the generator polynomial of the super code at destination, \mathbf{G} , is given by

$$\mathbf{G} = \begin{bmatrix} \mathbf{g} & 0 & \dots & 0 & \mathbf{g} \\ 0 & \mathbf{g} & \dots & 0 & \mathbf{g} \\ \dots & & & & \\ 0 & 0 & \dots & \mathbf{g} & \mathbf{g} \end{bmatrix}. \quad (3.5)$$

In (3.5), \mathbf{G} is a generator polynomial of the super code of rate of $\frac{KN_s}{N(N_s+1)} < \frac{K}{N}$. The problem formulated in (3.4) can be solved by applying the BCJR algorithm [72] to the super code \mathbf{G} , with the compound codeword $\mathbf{C} = [\mathbf{c}_1, \dots, \mathbf{c}_{N_s}, \mathbf{c}_R]$ where $\mathbf{c}_R = \{c_{R,k}\}_{k=1}^N$, and $c_{R,k} = c_{1,k} \oplus \dots \oplus c_{N_s,k}$.

In particular, denote by $\mathbf{Y}_{<k} = (Y_1, \dots, Y_{k-1})$ and $\mathbf{Y}_{>k} = (Y_{k+1}, \dots, Y_N)$ the collections of received signal after and before time k -th, respectively. Let S_i^n with $1 \leq i \leq N_s$ by the state of the trellis at source S_i at time index n -th; $d_i(S_i^{n-1}, S_i^n)$ be data input and $c_i(S_i^{n-1}, S_i^n)$ by output bits when the trellis at source S_i , $i = 1, \dots, N_s$, move from state S_i^{n-1} to state S_i^n . The joint probability in (3.4) can be

expressed as follows:

$$\Pr \{U_k, \mathbf{Y}\} = \sum_{\substack{S_i^{n-1}, S_i^n \forall 1 \leq i \leq N_s \\ \text{such as } d_i(S_i^{n-1}, S_i^n) = u_{i,n}}} \Pr \{S_1^{n-1}, \dots, S_{N_s}^{n-1}, S_1^n, \dots, S_{N_s}^n, \mathbf{Y}\}. \quad (3.6)$$

The probability in (3.6) can be further expressed as following:

$$\begin{aligned} \Pr \{S_1^{n-1}, \dots, S_{N_s}^{n-1}, S_1^n, \dots, S_{N_s}^n, \mathbf{Y}\} &= \Pr \{S_1^{n-1}, \dots, S_{N_s}^{n-1}, S_1^n, \dots, S_{N_s}^n, \mathbf{Y}_{<n}, Y_k, \mathbf{Y}_{>n}\} \\ &= \Pr \{ \mathbf{Y}_{>n} | S_1^{n-1}, \dots, S_{N_s}^{n-1}, S_1^n, \dots, S_{N_s}^n, \mathbf{Y}_{<n}, Y_k \} \\ &\quad \times \Pr \{ S_1^n, \dots, S_{N_s}^n, Y_k | S_1^{n-1}, \dots, S_{N_s}^{n-1}, \mathbf{Y}_{<n} \} \times \Pr \{ S_1^{n-1}, \dots, S_{N_s}^{n-1}, \mathbf{Y}_{<n} \} \\ &= \Pr \{ \mathbf{Y}_{>n} | S_1^n, \dots, S_{N_s}^n \} \times \Pr \{ S_1^n, \dots, S_{N_s}^n, Y_k | S_1^{n-1}, \dots, S_{N_s}^{n-1} \} \\ &\quad \times \Pr \{ S_1^{n-1}, \dots, S_{N_s}^{n-1}, \mathbf{Y}_{<n} \} \\ &\triangleq \beta_{n+1}(S_1^n, \dots, S_{N_s}^n) \times \chi_n(S_1^{n-1}, \dots, S_{N_s}^{n-1}, S_1^n, \dots, S_{N_s}^n) \times \alpha_n(S_1^{n-1}, \dots, S_{N_s}^{n-1}), \end{aligned} \quad (3.7)$$

where $\alpha_n(S_1^{n-1}, \dots, S_{N_s}^{n-1})$, $\beta_{n+1}(S_1^n, \dots, S_{N_s}^n)$ and $\chi_n(S_1^{n-1}, \dots, S_{N_s}^{n-1}, S_1^n, \dots, S_{N_s}^n)$ are the *forward prediction*, *backward prediction* and *metric* of the super code [60]. The forward and backward predictions can be recursively computed from the global metric as follows:

$$\begin{aligned} \alpha_{n+1}(S_1^n, \dots, S_{N_s}^n) &= \sum_{S_1^{n-1}/S_1^{n-1} \rightarrow S_1^n} \dots \sum_{S_{N_s}^{n-1}/S_{N_s}^{n-1} \rightarrow S_{N_s}^n} \Pr \{ S_1^{n-1}, \dots, S_{N_s}^{n-1}, S_1^n, \dots, S_{N_s}^n, \mathbf{Y}_{<n}, Y_n \} \\ &= \sum_{S_1^{n-1}/S_1^{n-1} \rightarrow S_1^n} \dots \sum_{S_{N_s}^{n-1}/S_{N_s}^{n-1} \rightarrow S_{N_s}^n} \Pr \{ S_1^n, \dots, S_{N_s}^n, Y_k | S_1^{n-1}, \dots, S_{N_s}^{n-1}, \mathbf{Y}_{<n} \} \\ &\quad \times \Pr \{ S_1^{n-1}, \dots, S_{N_s}^{n-1}, \mathbf{Y}_{<n} \} \\ &= \sum_{S_1^{n-1}/S_1^{n-1} \rightarrow S_1^n} \dots \sum_{S_{N_s}^{n-1}/S_{N_s}^{n-1} \rightarrow S_{N_s}^n} \Pr \{ S_1^n, \dots, S_{N_s}^n, Y_k | S_1^{n-1}, \dots, S_{N_s}^{n-1} \} \\ &\quad \times \Pr \{ S_1^{n-1}, \dots, S_{N_s}^{n-1}, \mathbf{Y}_{<n} \} \\ &= \sum_{S_1^{n-1}/S_1^{n-1} \rightarrow S_1^n} \dots \sum_{S_{N_s}^{n-1}/S_{N_s}^{n-1} \rightarrow S_{N_s}^n} \chi_n(S_1^{n-1}, \dots, S_{N_s}^{n-1}, S_1^n, \dots, S_{N_s}^n) \times \alpha_n(S_1^{n-1}, \dots, S_{N_s}^{n-1}). \end{aligned}$$

and

$$\begin{aligned}
\beta_n(S_1^{n-1}, \dots, S_{N_s}^{n-1}) &= \sum_{S_1^n/S_1^{n-1} \rightarrow S_1^n} \dots \sum_{S_{N_s}^n/S_{N_s}^{n-1} \rightarrow S_{N_s}^n} \Pr\{S_1^n, \dots, S_{N_s}^n, \mathbf{Y}_{>n}, Y_n | S_1^{n-1}, \dots, S_{N_s}^{n-1}\} \\
&= \sum_{S_1^n/S_1^{n-1} \rightarrow S_1^n} \dots \sum_{S_{N_s}^n/S_{N_s}^{n-1} \rightarrow S_{N_s}^n} \Pr\{\mathbf{Y}_{>n} | S_1^n, \dots, S_{N_s}^n, S_1^{n-1}, \dots, S_{N_s}^{n-1}, Y_k\} \\
&\quad \times \Pr\{S_1^n, \dots, S_{N_s}^n, Y_k | S_1^{n-1}, \dots, S_{N_s}^{n-1}\} \\
&= \sum_{S_1^n/S_1^{n-1} \rightarrow S_1^n} \dots \sum_{S_{N_s}^n/S_{N_s}^{n-1} \rightarrow S_{N_s}^n} \Pr\{\mathbf{Y}_{>n} | S_1^n, \dots, S_{N_s}^n\} \times \Pr\{S_1^n, \dots, S_{N_s}^n, Y_k | S_1^{n-1}, \dots, S_{N_s}^{n-1}\} \\
&= \sum_{S_1^n/S_1^{n-1} \rightarrow S_1^n} \dots \sum_{S_{N_s}^n/S_{N_s}^{n-1} \rightarrow S_{N_s}^n} \beta_{n+1}(S_1^n, \dots, S_{N_s}^n) \times \chi_n(S_1^{n-1}, \dots, S_{N_s}^{n-1}, S_1^n, \dots, S_{N_s}^n).
\end{aligned}$$

The metric $\chi_n(S_1^{n-1}, \dots, S_{N_s}^{n-1}, S_1^n, \dots, S_{N_s}^n)$ is computed as:

$$\chi_n(S_1^{n-1}, \dots, S_{N_s}^{n-1}, S_1^n, \dots, S_{N_s}^n) = \sum_{k=\frac{N}{K}n+1}^{\frac{N}{K}(n+1)} \left(\sum_{l=1}^{N_s} \mathcal{M}_l(c_{l,k}) + \mathcal{M}_R(c_{R,k}) \right), \quad (3.8)$$

with $\mathcal{M}_l(c_{l,k})$ and $\mathcal{M}_R(c_{R,k})$ are metrics of the source signal and the relayed signal given by

$$\begin{aligned}
\mathcal{M}_l(c_{l,k}) &= \log \left[\sum_{\sim c_{l,k}} \exp \left\{ - \left| y_{S_l D, k} - \sqrt{P_{S_l D}} h_{S_l D, k} x(c_{l,k}) \right|^2 / \sigma^2 \right\} \right], \\
\mathcal{M}_R(c_{R,k}) &= \log \left[\sum_{\sim c_{R,k}} \exp \left\{ - \left| y_{R D, k} - \sqrt{P_{R D}} h_{R D, k} x(c_{R,k}) \right|^2 / \sigma^2 \right\} \right],
\end{aligned}$$

where $x(c_{(\cdot)})$ being the symbols associated to the coded bit $c_{(\cdot)}$ and $\sim c_{(\cdot)}$ denotes all coded bits that belong to the symbol $x(c_{(\cdot)})$, except bit $c_{(\cdot)}$.

The redundancy $\mathcal{M}_R(c_{R,k})$ in (3.8) is computed under the assumption that the relayed signal is a linear combination of the sources signal, *i.e.*, the relay decodes all the source signals without any error. Therefore, the proposed scheme is a suboptimal solution of (3.3). However, in channel-coded cooperative network with DF relaying under fully-interleaved Rayleigh channels, the possible decoding errors at the relay is usually negligible under the assumption that the source-relay

average SNR is better than the source-destination average SNR. In addition, we have observed in our previous work [57] that if the BER at the relay is less than 10^{-3} , it does not affect the system diversity gain, at least in the operating (finite) SNR region.

The complexity of the proposed decoder exponentially increases with the number of the sources N_s . Although being more complex than the iterative decoding algorithm [38, 60], the proposed algorithm allows to analyze the performance of Coded-NCC system by serving as a benchmark for practical and low-complexity decoding algorithms.

3.3 Distance Spectrum of the Compound Code

The distance spectrum is an important parameter to evaluate the performance of a convolutional code. The distance spectrum provides the distribution of input weights (Number of non-zero input bits corresponding to a path different from the all-zero path) and output weights (Number of non-zero coded bits corresponding to a non-zero path) [71]. When applied to the super code \mathbf{G} , since the input weights are computed over N_s single inputs \mathbf{u}_i , $i = 1, \dots, N_s$ and the output weights are distributed on $N_s + 1$ channels, *i.e.*, $S_i \rightarrow D$ links and $R \rightarrow D$ link, we derive an extended distance spectrum of the super code [61]. This is used to analyze the performance in the next section. The final result is as follows:

$$\Gamma(w, d) = \sum_{\substack{w_1 + \dots + w_{N_s} = w \\ d_1 + \dots + d_{N_s} + d_R = d}} \Gamma_{w_1 \dots w_{N_s} d_1 \dots d_{N_s} d_R} W_1^{w_1} \dots W_{N_s}^{w_{N_s}} N_1^{d_1} \dots N_{N_s}^{d_{N_s}} N_R^{d_R}, \quad (3.9)$$

where W_i with $i = 1, \dots, N_s$ is a placeholder for input \mathbf{u}_i ; N_j with $j \in \{1, \dots, N_s, R\}$ is a placeholder for (coded) output propagating via channel $S_j \rightarrow D$ and $R \rightarrow D$, respectively; w_i is the input weights of data message \mathbf{u}_i ; d_j is the output weights locating on channel $S_j \rightarrow D$ and $R \rightarrow D$; and $\Gamma_{w_1 \dots w_{N_s} d_1 \dots d_{N_s} d_R}$ is the number of non-zero paths with parameters $w_1 \dots w_{N_s} d_1 \dots d_{N_s} d_R$. For example, $2W_1^2W_2N_1N_2^3N_3^2$ stands for a distance spectrum of a two-source network that there are $\Gamma_{21132} = 2$ non-zero paths with input weight 3 including weight 2 for \mathbf{u}_1 and weight 2 for \mathbf{u}_2 ;

output weight 6 consisting of weight 1 for channel $S_1 \rightarrow D$, weight 3 for channel $S_2 \rightarrow D$ and weight 2 for channel $R \rightarrow D$. The computation of the extended distance spectrum in (3.9) can easily be done with the well-known algorithm in [76].

Define $\mathbf{D}_d \triangleq \{d_1, \dots, d_{N_s}, d_R\}$ with $d_1 + \dots + d_{N_s} + d_R = d$ as a weight pattern (pattern) corresponding to the output weight d . Obviously, \mathbf{D}_d defines how the d output weights are distributed among the $N_s + 1$ channels.

An important question now is how the properties of the distance spectrum in (3.9) relates to the properties of the individual codes \mathbf{g} at each source. Let f be the minimum distance (free distance) of the single code \mathbf{g} and d_F be the minimum distance of the super code \mathbf{G} . The following lemma is important to further estimate BER of the Coded-NCC.

Lemma 1. *The minimum distance F of the super code \mathbf{G} is given as follows:*

$$F = 2f,$$

and the pattern $\mathbf{D}_F = \{d_1, \dots, d_{N_s}, d_R\}$ corresponding to the minimum distance path of the super code only has two non-zero elements as

$$d_{i_1} = d_{i_2} = f, \quad d_{j \neq i_1, i_2} = 0, \quad \text{with } i_1, i_2, j \in \{1, \dots, N_s, R\}. \quad (3.10)$$

For example, in the 2-source NCC ($N_s = 2$), \mathbf{D}_F has one of three values $\{f, f, 0\}$, $\{f, 0, f\}$ and $\{0, f, f\}$.

Proof. Denote $\mathcal{H}(\mathbf{c})$ as the weight of a codeword \mathbf{c} , *i.e.*, total number of non-zero coded bits and $\mathbf{C} = [\mathbf{c}_1, \dots, \mathbf{c}_{N_s}, \mathbf{c}_R]$ as a minimum-distance super codeword. Obviously, we have $\mathcal{H}(\mathbf{C}) = \mathcal{H}(\mathbf{c}_1) + \dots + \mathcal{H}(\mathbf{c}_R) = 2f$. Because \mathbf{C} is the minimum-distance super codeword, each codeword $\mathbf{c}_i, 1 \leq i \leq N_s$ is also the minimum-distance single codeword. In the following, we will show that there are one or two codewords \mathbf{c}_i are non-zero. Indeed, without loss of generality, we assume that $\mathbf{c}_1 \neq \mathbf{0}$, or $d_1 = \mathcal{H}(\mathbf{c}_1) = f$. If $\mathbf{c}_i = \mathbf{0}$ with $2 \leq i \leq N_s$, we have $\mathbf{c}_R = \mathbf{c}_1$, or $d_R = d_1 = f$. Then the weight of the super codeword is $\mathcal{H}(\mathbf{C}) = d_1 + d_R = F$. If there is only another non-zero codeword, namely \mathbf{c}_2 , we have $\mathbf{c}_R = \mathbf{0}$ because $c_{R,k} = c_{1,k} \oplus c_{2,k} = 0$ with $0 \leq k \leq N$. In this case we obtain $\mathcal{H}(\mathbf{C}) = d_1 + d_2 =$

F . Now if there are more than 2 non-zero codeword, namely $\mathbf{c}_1, \mathbf{c}_2$ and \mathbf{c}_3 , then $\mathcal{H}(\mathbf{C}) \geq d_1 + d_2 + d_3 = 3f > F$. It means that those codewords do not depend on the minimum-distance super codeword \mathbf{C} . \square

Lemma 1 provides an important information about the output weights corresponding to the minimum distance F : the F weights always distribute on two out of $N_s + 1$ total channels, each one having a weight of $f = F/2$. Table. 3.1 shows an example extended distance spectrum of a network with $N_s = 3$ sources and channel code $\mathbf{g} = [13 \ 15]$ with the minimum distance $f = 6$. As a results, the minimum distance of the super code is $F = 12$.

Table 3.1. Extended distance spectrum of \mathbf{G} in (3.9) with $N_s = 3$ sources and $\mathbf{g} = [13, 15]$

$\Gamma_{(\dots)}$	w_1	w_2	w_3	d_1	d_2	d_3	d_R
1	0	0	4	0	0	6	6
1	0	4	0	0	6	0	6
1	4	0	0	6	0	0	6
1	4	0	4	6	0	6	0
1	4	4	0	6	6	0	0
1	0	4	4	0	6	6	0

3.4 Pair-Wise Error Probability Analysis

In this subsection, we compute the pairwise error probability (PEP) of compound codewords \mathbf{X} , which is then used to evaluate the system BER. The PEP is computed as the probability that the transmitted codeword \mathbf{X} is received as another codeword $\bar{\mathbf{X}}$ supposed that $\bar{\mathbf{X}}$ is the only candidate in addition to \mathbf{X} . The average PEP is estimated by averaging all possible codewords $\bar{\mathbf{X}}$. For convolutional codes, it has been shown in [71] that their performance does not depend on the individual pair \mathbf{X} and $\bar{\mathbf{X}}$ but depends on the Hamming distance between two codewords which is defined by $\mathcal{H}(\mathbf{X}, \bar{\mathbf{X}})$. Therefore, without loss of generality, it is assumed that the all-zeros codeword \mathbf{X} was transmitted. Denote by $P_c(d)$ the conditioned

pair-wise error probability¹ (CPEP), which is given as

$$\begin{aligned} P_c(d) &= \Pr \{ \mathbf{X} \rightarrow \bar{\mathbf{X}} | \mathcal{H}(\mathbf{X}, \bar{\mathbf{X}}) = d \} \\ &= \sum_{\mathbf{D}_d} \underbrace{\Pr \{ \mathbf{X} \rightarrow \bar{\mathbf{X}} | \mathcal{H}(\mathbf{X}, \bar{\mathbf{X}}) = d, \mathbf{D}_d \}}_{P_c(d|\mathbf{D}_d)}. \end{aligned} \quad (3.11)$$

Given the pattern \mathbf{D}_d , there are d_i different symbols between \mathbf{x}_i and $\bar{\mathbf{x}}_i$ with $i \in \{1, \dots, N_s, R\}$. We assume that the erroneous detected symbol could only be one of the nearest neighbour symbols. Using the Gray mapping, each closest symbol error only causes one coded bit error. Without loss of generality, assume that those d_i symbols are located at the beginning of the codewords \mathbf{x}_i and $\bar{\mathbf{x}}_i$. Therefore, the CPEP $P_c(d|\mathbf{D}_d)$ is given by

$$P_c(d|\mathbf{D}_d) = \beta Q \left(\sqrt{2\alpha\chi} \right), \quad (3.12)$$

where

$$\chi = \sum_{i=1}^{N_s} \sum_{k=1}^{d_i} \gamma_{S_i D, k} + \sum_{k=1}^{d_R} \gamma_{RD, k},$$

and β is a constant that depends on the relation between symbol error probability and coded bit error probability in M -QAM, $\alpha = l_{min}^2/4$ with l_{min} is equal to the minimum separation of M -QAM constellation. For example in BPSK we have $\beta = \alpha = 1$, while in 16-QAM $\beta = 3/4$, $\alpha = 2/5$.

The unconditioned pair-wise error probability (UPEP) $P_u(d)$ is the expectation over the fading channels of the CPEP $P_c(d)$:

$$P_u(d) = \mathbb{E}\{P_c(d)\}, \quad (3.13)$$

with $\mathbb{E}\{\cdot\}$ denote the expectation operator over fading channels.

Substituting (3.11) into (3.13) we obtain

$$P_u(d) = \sum_{\mathbf{D}_d} \underbrace{\mathbb{E}\{P_c(d|\mathbf{D}_d)\}}_{P_u(d|\mathbf{D}_d)}. \quad (3.14)$$

In (3.12), χ is a Chi-Square random variable with $d_1 + \dots + d_{N_s} + d_R = d$ degrees of

¹The CPEP depends on fading channels

freedom. In order to obtain the UPEP $P_u(d|\mathbf{D}_d)$, one may use the Chernoff bound of the Q-funtion [68]. However, it has been shown in [68] that Chernoff bound is not very tight for Rayleigh channels. Therefore, we use a tighter approximation of Q-funtion [77, eq. 14]:

$$Q(x) \simeq \frac{1}{12} \exp\left(-\frac{x^2}{2}\right) + \frac{1}{4} \exp\left(-\frac{2x^2}{3}\right). \quad (3.15)$$

Now we can compute the UPEP $P_u(d|\mathbf{D}_d)$ using (3.15) and (3.12) as follows:

$$\begin{aligned} P_u(d|\mathbf{D}_d) &= \frac{\beta}{12} \mathbb{E} \{ \exp(-\alpha\chi) \} + \frac{\beta}{4} \mathbb{E} \{ \exp(-4\alpha\chi/3) \} \\ &= \frac{\beta}{12} (\alpha\bar{\gamma}_{RD} + 1)^{-d_R} \prod_{i=1}^{N_s} (\alpha\bar{\gamma}_{S_iD} + 1)^{-d_i} \\ &\quad + \frac{\beta}{4} \left(\frac{4\alpha\bar{\gamma}_{RD}}{3} + 1 \right)^{-d_R} \prod_{i=1}^{N_s} \left(\frac{4\alpha\bar{\gamma}_{S_iD}}{3} + 1 \right)^{-d_i}. \end{aligned} \quad (3.16)$$

The result in (3.16) is obtained from the fact that the fading coefficients are independent. Hence the complex integral of χ can be factorized into a product of simple integrals (of $\gamma_{XY,k}$), which results in (3.16).

One can see from (3.16) that the UPEP $P_u(d|\mathbf{D}_d)$ corresponds to a diversity order of $d_1 + \dots + d_{N_s} + d_R = d$. As an example, the UPEP for the BPSK is given by

$$\begin{aligned} P_u(d|\mathbf{D}_d) &= \frac{1}{12} (\bar{\gamma}_{RD} + 1)^{-d_R} \prod_{i=1}^{N_s} (\bar{\gamma}_{S_iD} + 1)^{-d_i} \\ &\quad + \frac{1}{4} \left(\frac{4\bar{\gamma}_{RD}}{3} + 1 \right)^{-d_R} \prod_{i=1}^{N_s} \left(\frac{4\bar{\gamma}_{S_iD}}{3} + 1 \right)^{-d_i}. \end{aligned}$$

3.5 Bit Error Rate Analysis

3.5.1 Upper Bound of the BER

Let us recall the reader that the destination applies the BCJR algorithm on the super code to decode the data messages simultaneously. Denote $w(\mathbf{D}_d) = \Gamma_{w_1 \dots d_L d_R} \sum_{i=1}^{N_s} w_i$ as total input weights (number of errors on data input caused by

one pair-wise error of the codeword) associated to pattern \mathbf{D}_d , which is computed from the extended distance spectrum in (3.9). Each non-zero path associated with the pattern \mathbf{D}_d results in $w(\mathbf{D}_d)$ errors in input data. Therefore, the BER of the super code is calculated as follows [71]:

$$\text{Pe} = \sum_{d=F}^{+\infty} \sum_{\mathbf{D}_d} w(\mathbf{D}_d) P_u(d|\mathbf{D}_d), \quad (3.17)$$

where F is the minimum distance of the super code which is computed in Lemma 1 and $P_u(d|\mathbf{D}_d)$ is the UPEP given in (3.16).

Note that the BER in (3.17) is the average BER over all sources. In order to obtain the BER of each source S_i with $i = 1, \dots, N_s$, we further exploit the extended distance spectrum in (3.9). Let $w_i(\mathbf{D}_d) = w_i \Gamma_{w_1 \dots d_L d_R}$ be the input weights of source S_i corresponding to the pattern \mathbf{D}_d . The BER of each source can be then computed as follows:

$$\text{Pe}(S_i) = \sum_{d=F}^{+\infty} \sum_{\mathbf{D}_d} w_i(\mathbf{D}_d) P_u(d|\mathbf{D}_d), \quad \text{with } i = 1, \dots, N_s. \quad (3.18)$$

It is worth noticing that in (3.18) the BER of each source is a linear combination of UPEP $P_u(d|\mathbf{D}_d)$ weighted by the input weights $w_i(\mathbf{D}_d)$. Both F and $w_i(\mathbf{D}_d)$ are strictly defined by the generator polynomial \mathbf{G} . Although the weight d in (3.18) can range from F to infinity, the BER $\text{Pe}(S_i)$ is usually determined by the first values of d . This can be explained by the fact that the UPEP $P_u(d|\mathbf{D}_d)$ decodes with the rate d (diversity order of d), hence it becomes negligible as d increases.

3.5.2 Asymptotic expression of the BER

The asymptotic of BER is computed as the lowest diversity order term $P_u(d|\mathbf{D}_F)$ as follows:

$$\overrightarrow{\text{Pe}}(S_i) = \sum_{\mathbf{D}_F} w_i(f) P_u(d|\mathbf{D}_F), \quad i = 1, \dots, N_s, \quad (3.19)$$

where $w_i(f)$ is equal to the input weights of the single code \mathbf{g} at the minimum distance f .

Taking into account the pattern \mathbf{D}_F given in Lemma 1, the asymptotic of BER of source S_i is given as follows:

$$\begin{aligned} \overset{\rightarrow}{\text{Pe}}(S_i) &= \frac{\beta w_i(f)}{12} (\alpha \bar{\gamma}_{S_i D} + 1)^{-f} \left[\sum_{j=1, j \neq i}^{N_s} (\alpha \bar{\gamma}_{S_j D} + 1)^{-f} + (\alpha \bar{\gamma}_{RD} + 1)^{-f} \right] \\ &+ \frac{\beta w_i(f)}{4} \left(\frac{4\alpha}{3} \bar{\gamma}_{S_i D} + 1 \right)^{-f} \left[\sum_{j=1, j \neq i}^{N_s} \left(\frac{4\alpha}{3} \bar{\gamma}_{S_j D} + 1 \right)^{-f} + \left(\frac{4\alpha}{3} \bar{\gamma}_{RD} + 1 \right)^{-f} \right]. \end{aligned} \quad (3.20)$$

From (3.20) we can see that the BER of each source achieves a diversity order equal to $2f$.

3.6 Diversity gain and Coding gain

In this subsection, we compute the coding gain and diversity gain of the Coded-NCC for the Point-to-Point (P2P) and the Uncoded-NCC [73] system setups. As a study case, only BPSK is considered in this subsection. P2P is a non cooperative protocol using only channel coding. The asymptotic BER of the P2P, $\overset{\rightarrow}{\text{Pe}}_1$, is computed as in (3.17) as follows:

$$\overset{\rightarrow}{\text{Pe}}_1(S_i) = \frac{w_i(f)}{12} (\bar{\gamma}_{S_i D} + 1)^{-f} + \frac{w_i(f)}{4} \left(\frac{4}{3} \bar{\gamma}_{S_i D} + 1 \right)^{-f}. \quad (3.21)$$

And the asymptotic BER of the Uncoded-NCC is given by [73, eq. (25)]:

$$\overset{\rightarrow}{\text{Pe}}_2(S_i) = \frac{1}{\bar{\gamma}_{S_i D}} \left(\frac{45 + \sqrt{5}}{160} \sum_{j=1}^{N_s} \frac{1}{\bar{\gamma}_{S_j R}} + \frac{3}{16} \left(\sum_{j=1, j \neq i}^{N_s} \frac{1}{\bar{\gamma}_{S_j D}} + \frac{1}{\bar{\gamma}_{RD}} \right) \right). \quad (3.22)$$

The SNR gain of the Coded-NCC over the P2P and Uncoded-NCC, denoted by CG_1, CG_2 , is defined as an additional SNR the P2P or Uncoded-NCC need to obtain the same BER as Coded-NCC communication. Let $\bar{\gamma}(\text{BER}), \bar{\gamma}_1(\text{BER})$ and $\bar{\gamma}_2(\text{BER})$ be average SNR for Coded-NCC, P2P and Uncoded-NCC to achieve same BER, respectively. Then the coding gain CG_i in dB is computed as follows:

$$\text{CG}_i \triangleq 10 \log_{10} \frac{\bar{\gamma}(\text{BER})}{\bar{\gamma}_i(\text{BER})}, \quad i = 1, 2. \quad (3.23)$$

We note that $\bar{\gamma}(\text{BER})$, $\bar{\gamma}_1(\text{BER})$ and $\bar{\gamma}_2(\text{BER})$ can be easily computed from (3.20), (3.21) and (3.22) by inverse function. We note that the definition of CG_i includes both coding gain and diversity gain. As we will show later the CG_i increases with the average SNR. This confirms that Coded-NCC outperforms P2P and Uncoded-NCC in term of both coding gain and diversity gain.

3.6.1 Simulation Results

The system under study consists of N_s sources, one relay and one destination. Assuming ideal interleavers, all channels are subject fully-interleaved Rayleigh fading plus Gaussian noise. Gray mapping and M -QAM modulation are employed. The relay utilizes binary network coding. Two convolutional code of the rate $1/2$ are considered: Code [2 3] with the minimum distance $f = 3$ and Code [13 15] with the minimum distance $f = 6$. The data packet length is equal to 1024bits. The first 6 value of the weights d is used to compute the upper bound BER. We assume that all sources are closely-located, resulting in $\bar{\gamma}_{S_1D} = \dots = \bar{\gamma}_{S_LD} = \bar{\gamma}_{SD}$ and $\bar{\gamma}_{S_1R} = \dots = \bar{\gamma}_{S_LR} = \bar{\gamma}_{SR}$. Two setups are studied: i) Setup 1: the relay is located close to the source $(\bar{\gamma}_{SD}, \bar{\gamma}_{SR}, \bar{\gamma}_{RD}) = (\bar{\gamma}, \bar{\gamma} + 20dB, \bar{\gamma})$ and ii) Setup 2: the relay is located at the middle between sources and the destination $(\bar{\gamma}_{SD}, \bar{\gamma}_{SR}, \bar{\gamma}_{RD}) = (\bar{\gamma}, \bar{\gamma} + 12dB, \bar{\gamma} + 12dB)$.

Fig. 3.2 shows performance of the Coded-NCC for two setups with $N_s = 3$ sources. First, it is shown that the simulation perfectly matches the analytical results when the average SNR is high enough for both BPSK and QPSK modulation (BPSK and QPSK have the same performance, since the two constellations have equal minimum distance). Second, the upper bound and the asymptotic BER are overlapped at high SNR. This confirms that the impact of the UPEP $P_u(d|\mathbf{D}_d)$ for large d is negligible. In addition, the performance of Setup 2 (relay is at the middle of sources and the destination) is better than the performance of Setup 1 (relay is close to the sources). This is because the relay-destination channel of Setup 2 is better than that of Setup 1.

Fig. 3.3 shows the performance of the 3-source Coded-NCC when 16-QAM is used. In this case, the analytical framework is approximately 1dB worse than the simulation, but achieves the same diversity gain as the simulation results.

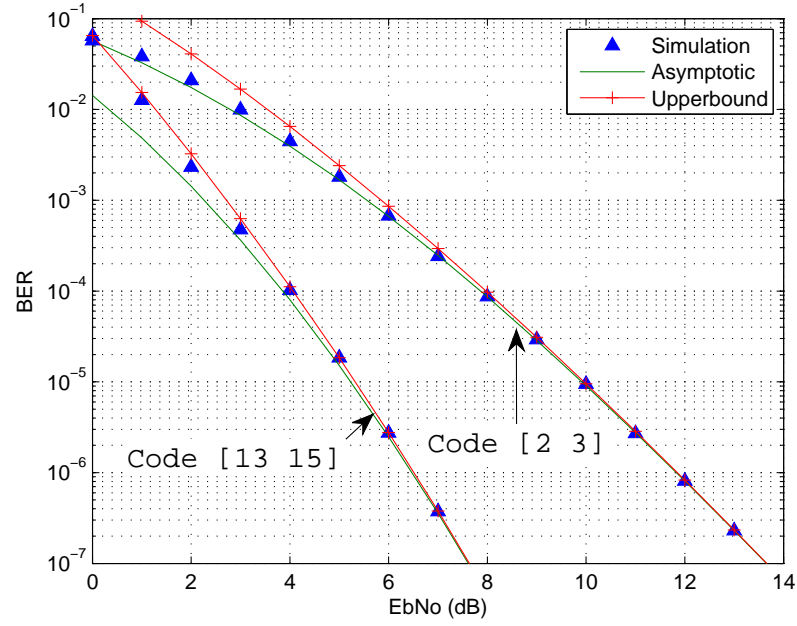

a) Setup 1: $(\bar{\gamma}_{SD}, \bar{\gamma}_{SR}, \bar{\gamma}_{RD}) = (\bar{\gamma}, \bar{\gamma} + 20dB, \bar{\gamma})$.

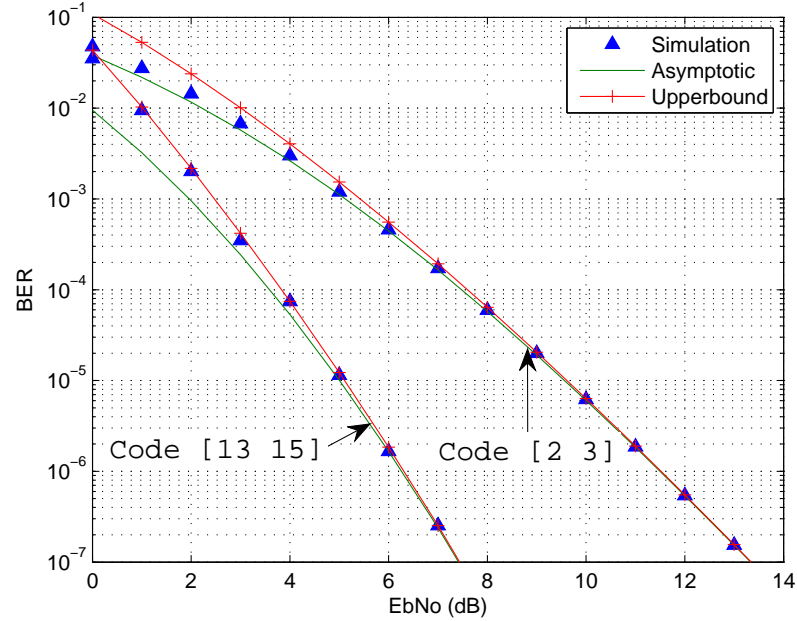

b) Setup 2: $(\bar{\gamma}_{SD}, \bar{\gamma}_{SR}, \bar{\gamma}_{RD}) = (\bar{\gamma}, \bar{\gamma} + 12dB, \bar{\gamma} + 12dB)$

Figure 3.2. Performance of Coded-NCC in $N_s = 3$ sources network under BPSK and QPSK modulation. a) Setup 1: The relay locates close to the sources and b) Setup 2: The relay locates at the middle between the sources and the destination.

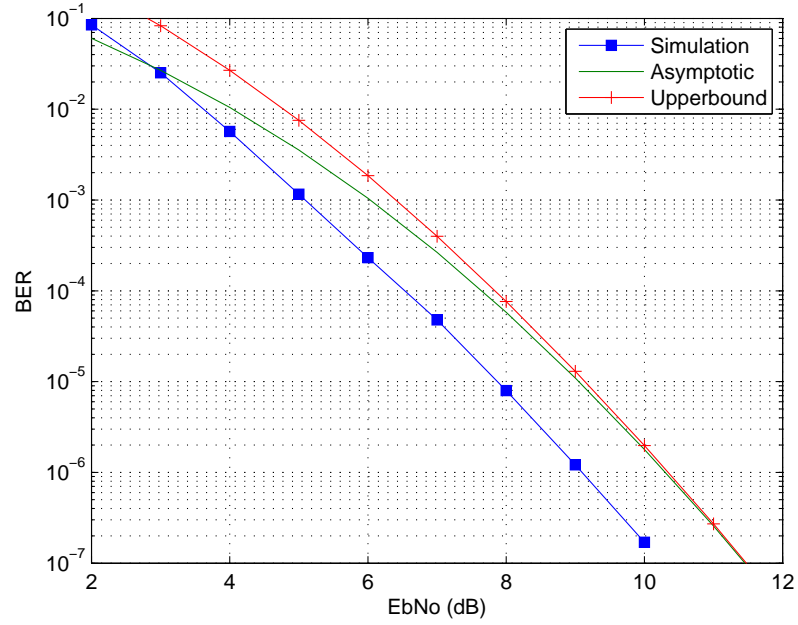

$$a) (\bar{\gamma}_{SD}, \bar{\gamma}_{SR}, \bar{\gamma}_{RD}) = (\bar{\gamma}, \bar{\gamma} + 20dB, \bar{\gamma}).$$

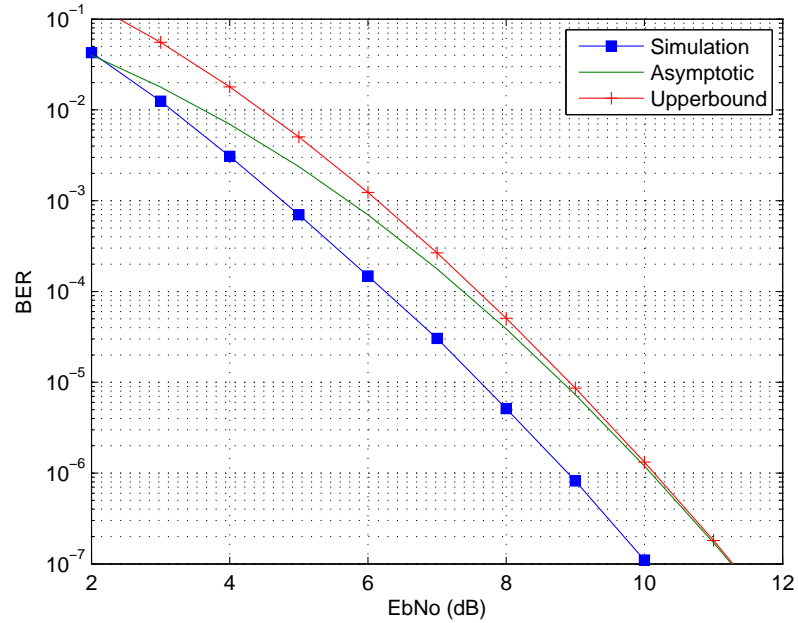

$$b) (\bar{\gamma}_{SD}, \bar{\gamma}_{SR}, \bar{\gamma}_{RD}) = (\bar{\gamma}, \bar{\gamma} + 12dB, \bar{\gamma} + 12dB)$$

Figure 3.3. Performance of Coded-NCC in $N_s = 3$ sources network under 16-QAM modulation and the channel code [13 15] is used. a) Setup 1: The relay locates close to the sources and b) Setup 2: The relay locates at the middle between the sources and the destination.

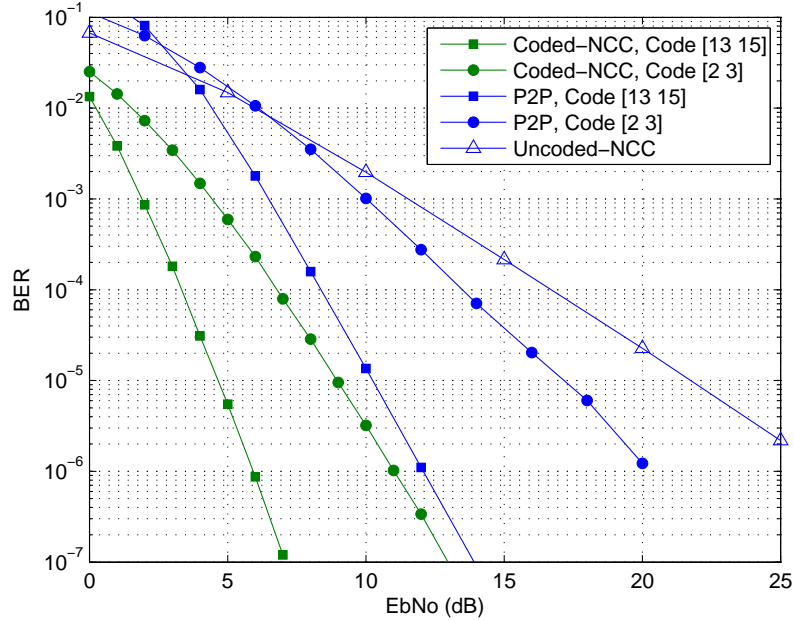
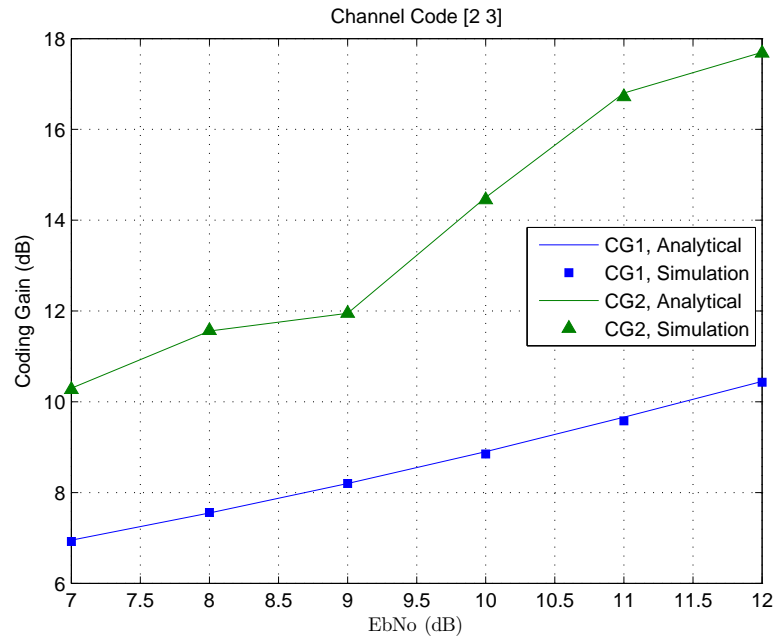

Figure 3.4. Performance comparison of Coded-NCC with P2P and Uncoded-NCC in $N_s = 2$ sources network and BPSK modulation. P2P is a non cooperation with channel code, Uncoded-NCC is a cooperative network without channel code.

Fig. 3.4 shows the performance comparison of Coded-NCC with P2P and Uncoded-NCC. Obviously, Coded-NCC brings a significant diversity gain and coding gain compared to the two references. We note that the curve of Coded-NCC with the CC [2 3] has the same slope as the curve of P2P with the CC [13 15]. This is because the minimum distance of the code [2 3] is 3, resulting in a diversity of Coded-NCC with the code [2 3] equal to 6. While the minimum distance of the channel code [13 15] is 6.

Fig. 3.5 presents the coding gain of Coded-NCC over two references for the 2-source network with different channel codes. The coding gain obtained by analysis tightly matches with simulations. We can see that the coding gain increases along with the average SNR. This is because the coded cooperation has both diversity gain and coding gain over the two references.



a) Channel code [2 3].

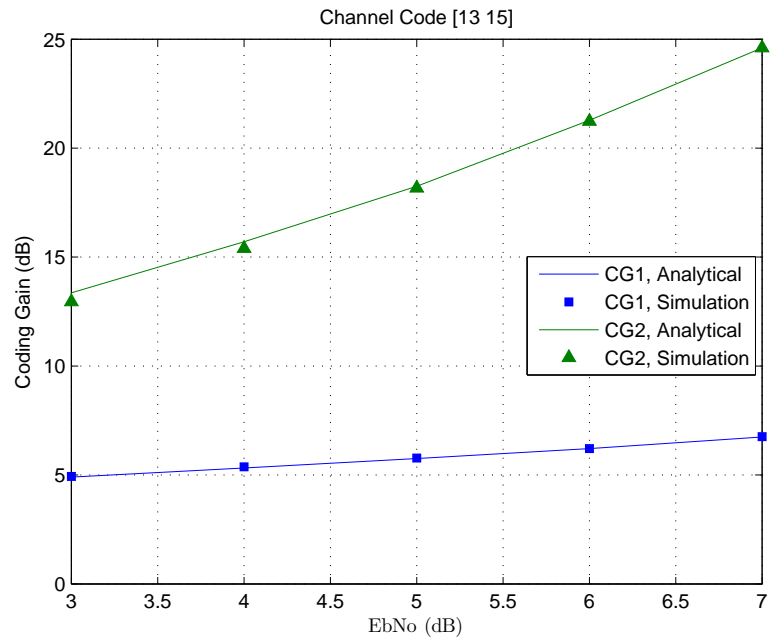

b) Channel code [13 15].

Figure 3.5. Coding gain of the Coded-NCC over P2P and Uncoded-NCC for the $N_s = 2$ sources network and BPSK modulation. The relay locates at the middle of the sources and the destination.

3.7 Conclusions

In conclusion, we have proposed a framework to analyze the performance of network-coded cooperative networks when convolutional code is employed with fully-interleaved Rayleigh fading channels, which is the best situation in fading models. The key idea in our work is to consider the relayed signal as a parity bits of the super code at the destination. The upper bound and lower bound BER of each source is derived. In addition, we computed the coding gain of the studied system over the channel coded point-2-point and cooperation without channel code.

Network Coding Cooperation in Multiple-Relay Networks

In this chapter, we consider Network Coding Cooperation (NCC) in multiple-relay networks context [53]. In order to reduce the rate loss in multiple relays cooperative networks, only a few relays communicate with the destination, which is referred to as Relay Selection (RS) [48]. It has been shown in [48] that the best relay selection can achieve full diversity for single-source multiple-relay networks. The combination of NC and RS has recently been addressed for both Single Relay Selection (SRS) [49] and Multiple Relay Selection (MRS) [50], mostly focusing on the Two-Way Relay Channel (TWRC) system model. A special property of TWRC is that one source node already knows its transmitted data, and therefore, only has to decode network-coded messages from the relay. In [49], the authors proposed a joint design of NC with SRS and dual RS based on Max-Min criteria in order to maximize the worse SNR of two users in two-way DF relay networks. In [50], a SNR-suboptimal based on relay ordering is proposed for MRS in two-way AF relay networks. A similar method is applied in [78] to derive the system Outage Probability (OP), BER and diversity order. As for unidirectional relay networks, [51] studied Diversity Multiplexing Tradeoff (DMT) of NCC and showed that full diversity is achieved with the best relay selection. However, [51] is based on an optimistic assumption that unintended packets are available at any destination, pushing unidirectional NCC to be similar to TWRC. By removing this assumption, the authors in [79] generalized the DMT for both SRS and MRS.

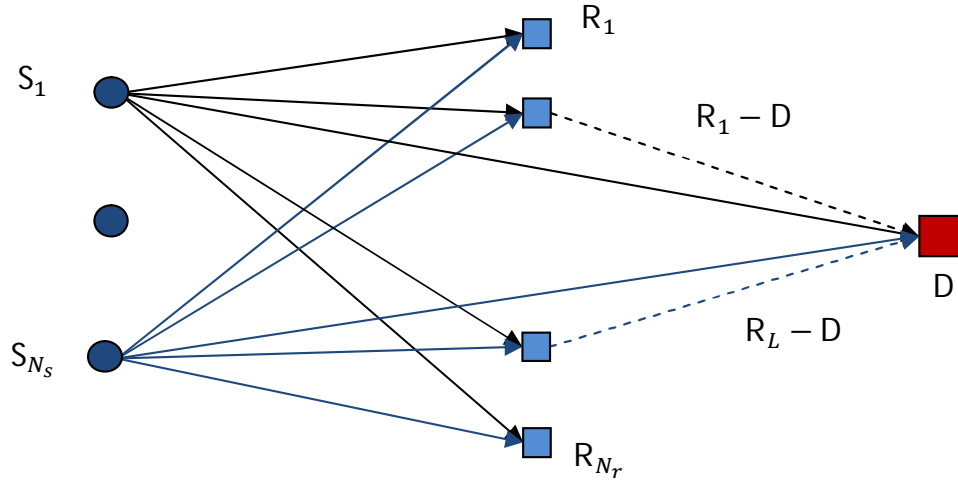

Figure 4.1. Multiple-source multiple-relay NCC networks with multiple relay selection.

We study the diversity order of NCC with RS using system outage probability analysis. Different from [80] that considered AF relaying and Analog Network Coding (ANC), we investigate DF relaying and digital network coding, *e.g.*, XOR. First, we derive the so-called *generalized maximum function* (G-MF) that takes the n -th largest value of a set. Using G-MF, we derive the exact OP and asymptotic OP for both SRS and MRS. Then we analytically show that in our system: i) SRS only achieves diversity order 2 regardless total number of relays; ii) MRS achieves diversity order $L + 1$ if the number of selected relays L is strictly less than N_s and full diversity order $N_r + 1$ if $L \geq N_s$.

4.1 System Model

The system under consideration considers N_s sources denoted by S_m , N_r relays denoted by R_n with $1 \leq m \leq N_s, 1 \leq n \leq N_r$ and one destination D, as depicted in Figure 4.1. All channels are assumed to be quasi-static Rayleigh fading plus AWGN. All nodes are equipped with half-duplex (*i.e.*, not receive and transmit at the same time) single antennas. As a result, one cooperation period is divided into two phases: broadcast phase and relay phase. In the broadcast phase, each source sequentially broadcasts a data message to the relays and the destination. Let b_m be a data symbol which contains q data bit emitted by source S_m . A 2^q -order

modulation maps b_m into a signal symbol x_m . At the end of the broadcast phase, the received signal at relay R_n with $1 \leq n \leq N_r$ and at the destination are as follows:

$$\begin{cases} y_{S_m R_n} &= \sqrt{P_{S_m R_n}} h_{S_m R_n} x_m + z, \quad 1 \leq m \leq N_s \\ y_{S_m D} &= \sqrt{P_{S_m D}} h_{S_m D} x_m + z, \quad 1 \leq m \leq N_s, \end{cases} \quad (4.1)$$

where h_{XY} with $X \in \{S_m\}$, $Y \in \{R_n, D\}$ denotes the channel coefficient of link $X \rightarrow Y$, which is a complex Gaussian variable with zero mean and unit variance, *i.e.*, $\mathbb{E}\{|h_{XY}|^2\} = 1$; P_{XY} denotes the received signal power at node Y from node X , including the path loss; and z (subscript is ignored for simple representation) denote a Gaussian noise with zero mean and variance σ^2 .

In the relay phase, after relay selection, the selected relay(s): i) decodes all source data by a Maximum Likelihood (ML) decoder:

$$\hat{b}_{S_m R_n} = \arg \max_{\tilde{b}_m} \Pr\{\tilde{b}_m | y_{S_m R_n}\},$$

where \tilde{b}_m denotes a trial data symbol transmitted at source S_m ; ii) performs network encoding to get the estimated network-coded symbol: $\hat{b}_{R_n} = \hat{b}_{S_1 R_n} \boxplus \dots \boxplus \hat{b}_{S_{N_s} R_n}$, where \boxplus stands for an additive sum in $\text{GF}(2^q)$; and iii) modulates the network-coded data symbol \hat{b}_{R_n} into a signal symbol \hat{x}_{R_n} and then forwards it to the destination. Unlike [79] where only error-free symbols are network-encoded at the relay, we always perform network encoding on all estimated symbols. Possible errors injected at the relays will be mitigated at the destination thanks to Cooperative Maximum Ratio Combining (C-MRC) decoder [73]. Denote $\{i_1, \dots, i_L\}$ as the index set of L selected relays. The received signal at the destination from L active relays are as follows:

$$y_{R_n D} = \sqrt{P_{R_n D}} h_{R_n D} \hat{x}_{R_n} + z, \quad n \in \{i_1, \dots, i_L\}, \quad (4.2)$$

where $h_{R_n D}$ denotes complex Gaussian channel coefficient of link $R_n \rightarrow D$ and $P_{R_n D}$ denotes the received signal power at D from R_n .

Upon receiving all signal from N_s sources and L active relays, the destination

decodes the source data as following:

$$[\hat{b}_1, \dots, \hat{b}_{N_s}] = \arg \max_{[\tilde{b}_1, \dots, \tilde{b}_{N_s}]} \Pr\{\tilde{b}_1, \dots, \tilde{b}_{N_s} | y_{S_1 D}, \dots, y_{S_{N_s} D}, y_{R_{i_1} D}, \dots, y_{R_{i_L} D}\}. \quad (4.3)$$

Assuming that the destination has full channel state information (CSI) of all incoming channels, *i.e.*, $S \rightarrow D$, $R_n \rightarrow D$ channels, and CSI of channels from the sources to the active relays, the destination applies the C-MRC decoder [73] in order to reduce the receiver's complexity. Then the decision rule in (4.3) becomes:

$$[\hat{b}_1, \dots, \hat{b}_{N_s}] = \arg \max_{[\tilde{b}_1, \dots, \tilde{b}_{N_s}]} \left\{ \sum_{m=1}^{N_s} \mathcal{M}(S_m) + \sum_{n=i_1}^{i_L} \mathcal{M}(R_n) \right\}, \quad (4.4)$$

where

$$\mathcal{M}(S_m) = -\frac{|y_{S_m D} - \sqrt{P_{S_m D}} h_{S_m D} x_m|^2}{\sigma^2},$$

and

$$\mathcal{M}(R_n) = -\lambda_{R_n} \frac{|y_{R_n D} - \sqrt{P_{R_n D}} h_{R_n D} x_{R_n}|^2}{\sigma^2}, \quad (4.5)$$

with x_{R_n} being a modulated symbol from the correct network-coded data symbol $b_{R_n} \triangleq b_1 \boxplus \dots \boxplus b_{N_s}$ and λ_{R_n} being the C-MRC factor that moderates possible errors introduced at the relays. Denote by γ_{XY} the instantaneous SNR of $X \rightarrow Y$ channel: $\gamma_{XY} = \frac{P_{XY} |h_{XY}|^2}{\sigma^2}$. Then the C-MRC factor is given as follows [73]:

$$\lambda_{R_n} = \frac{\min \{\gamma_{S_1 R_n}, \dots, \gamma_{S_m R_n}, \gamma_{R_n D}\}}{\gamma_{R_n D}}. \quad (4.6)$$

If the relay decodes all source data without any error, *i.e.*, $\lambda_{R_n} = 1$, the solution in (4.4) becomes an optimal solution of (4.3). Otherwise, $\lambda_{R_n} < 1$ and it reduces the impact of erroneous relayed symbols on the decision in (4.4).

Since all channels are subject to Rayleigh fading channels, the instantaneous SNR is exponentially distributed with which Probability Density Function (PDF) and Cumulate Density Function (CDF) are respectively $f_{\gamma_{XY}}(x) = \frac{1}{\bar{\gamma}_{XY}} e^{-\frac{x}{\bar{\gamma}_{XY}}}$ and $F_{\gamma_{XY}}(x) = 1 - e^{-\frac{x}{\bar{\gamma}_{XY}}}$, where $\bar{\gamma}_{XY} = \mathbb{E}\{\gamma_{XY}\} = \frac{P_{XY}}{\sigma^2}$ denotes average SNR of $X \rightarrow Y$ channel.

For ease of notation, we denote $\sum_{\substack{i_1=1, \dots, i_k=1 \\ i_1 \neq \dots \neq i_k}}^n \left(\prod_{j=i_1}^{i_k} x_j \right) = \sum_{i_1=1}^{n-k+1} \sum_{i_2=i_1+1}^{n-k+2} \dots \sum_{i_k=i_{k-1}+1}^n (x_{i_1} x_{i_2} \dots x_{i_k})$ as a summation of \mathcal{C}_k^n terms in which each term is a product of k elements, with $\mathcal{C}_k^n = \frac{n!}{(n-k)! \times k!}$ denotes the binomial coefficients. For example, $\sum_{\substack{i_1=1, i_2=1 \\ i_1 \neq i_2}}^3 \left(\prod_{j=i_1}^{i_2} x_j \right) = x_1 x_2 + x_1 x_3 + x_2 x_3$.

4.2 Relay Selection in Network Coding Cooperation

In this section, two selective relay schemes namely SRS and MRS are presented. In order to reduce the system complexity, we employ a suboptimal max-min selection criteria [51] that maximizes the worse end-to-end SNR.

4.2.1 Single Relay Selection

Since the C-MRC is employed at the destination, the two-hop channel of network-coded symbols can be modeled as an *equivalent* single-hop channel with an instantaneous SNR that is tightly approximated as follows [73]:

$$\gamma_n = \min\{\gamma_{S_1 R_n}, \dots, \gamma_{S_{N_s} R_n}, \gamma_{R_n D}\}. \quad (4.7)$$

Because the instantaneous SNR γ_{XY} in (4.7) are mutually independent, and thanks to the Min function in [81] we could easily obtain that the equivalent SNR γ_n is also an exponential random variable with the CDF is given by:

$$F_{\gamma_n}(x) = 1 - e^{-\frac{x}{\bar{\gamma}_n}},$$

where

$$\frac{1}{\bar{\gamma}_n} = \frac{1}{\bar{\gamma}_{S_1 R_n}} + \dots + \frac{1}{\bar{\gamma}_{S_{N_s} R_n}} + \frac{1}{\bar{\gamma}_{R_n D}}. \quad (4.8)$$

In SRS, the relay with the largest equivalent SNR is selected in order to minimize end-to-end error probability of network-coded symbols. The instantaneous selected

SNR, denote by g_{SRS} , is given as:

$$g_{SRS} = \max\{\gamma_1, \dots, \gamma_{N_r}\}. \quad (4.9)$$

The CDF of g_{SRS} , $F_{g_{SRS}}(x)$, is computed thanks to the Max function [81] as follows:

$$F_{g_{SRS}}(x) = \prod_{n=1}^{N_r} F_{\gamma_n}(x) = \prod_{n=1}^{N_r} \left(1 - e^{-\frac{x}{\gamma_n}}\right). \quad (4.10)$$

After SRS, the best selected relay forwards network-coded symbols to the destination.

4.2.2 Multiple Relay Selection

In order to further improve the performance of NCC, we propose MRS in which more than one relay will participate in the cooperation. In MRS, a set of $L > 1$ relays which have the largest equivalent SNR are chosen to forward the network-coded symbols to the destination. The MRS can be implemented using a distributed manner as in [48] in which the relays transmit a timer signal that is inversely proportional to their channel quality.

Before going into the details of the MRS protocol, we first introduce the so-called *generalized maximum function* (G-MF) to help the analysis. The G-MF on a set is defined as follows: The l^{th} -maximum of a set $\{\gamma_1, \dots, \gamma_N\}$, denoted by $g_l \triangleq \max^l\{\gamma_1, \dots, \gamma_{N_r}\}$, is defined by

$$\Pr\{g_l \leq x\} = \Pr\{(N_r - l + 1 \text{ values } \gamma_n \leq x) \&\& (l - 1 \text{ values } \gamma_n > x)\}. \quad (4.11)$$

Using the G-MF, we can write $\mathbf{g}_{MRS} \triangleq \{g_1, \dots, g_L\}$ as the selected channels in MRS. In what following, we show some properties of \mathbf{g}_{MRS} which will be used to analyze the system OP in the next sections.

Lemma 2. *The CDF $F_{g_l}(x)$ of the l^{th} largest g_l with $1 \leq l \leq N_r$ in (4.11) is given as follows:*

$$F_{g_l}(x) = \sum_{k=1}^l (-1)^{k-1} \binom{N_r - l + 1}{N_r - l + k} \Gamma_l(k, x), \quad (4.12)$$

with

$$\Gamma_l(k, x) = \sum_{\substack{i_1=1, \dots, i_{N_r-l+k}=1 \\ i_1 \neq \dots \neq i_{N_r-l+k}}}^{N_r} \prod_{n=i_1}^{i_{N_r-l+k}} F_{\gamma_n}(x).$$

Proof: The CDF of g_l is equal to the probability that there are $N_r - l + 1$ SNRs less than the threshold while $l - 1$ other SNRs are above the threshold. Denote $i_1, \dots, i_{N_r-l+1}, \dots, i_{N_r}$ as an index set satisfying (4.11), that is $\gamma_n < x$ with $i_1 \leq n \leq i_{N_r-l+1}$ and $\gamma_n > x$ with $i_{N_r-l+1} \leq n \leq i_{N_r}$. The probability of this event is given by $\prod_{n=i_1}^{i_{N_r-l+1}} F_{\gamma_n}(x) \times \prod_{n'=i_{N_r-l+1}}^{i_{N_r}} (1 - F_{\gamma_{n'}}(x))$. Because all the SNRs γ_n are mutual independent, there are $\mathcal{C}_{l-1}^{N_r}$ index sets satisfying (4.11). By performing polynomial factorization the probability corresponding to each index set and then summing over all index sets we obtain (4.12). \square

Lemma 3. *The l^{th} maximum g_l in G-MF achieves a diversity order of $N_r - l + 1$.*

The outline proof of Lemma 3 is sketched as follows. It is easy to see that $F_{\gamma_n}(x) = 1 - e^{-\frac{x}{\bar{\gamma}_n}}$ corresponds to a diversity order one for all n . Therefore, $\Gamma_l(k, x)$ achieves diversity order of $N - l + k$. From Lemma 2 we understand that the CDF of g_l is a combination of $\Gamma_l(k, x)$ with $1 \leq k \leq l$, which corresponds to a factor of diversity order from $N - l + 1$ to N . Consequently, $\Gamma_l(1, x)$ is the smallest power factor in (4.12) and it determines the diversity order of g_l . Considering i.i.d case where $\bar{\gamma}_1 = \dots = \bar{\gamma}_N = \bar{\gamma}$, we obtain $\Gamma_l(1, x) = \mathcal{C}_{N-l+1}^N (F_{\gamma_n}(x))^{N-l+1}$. In high SNR, $F_{\gamma_n}(x) \rightarrow \frac{1}{\bar{\gamma}}$, leading to $\Gamma_l(1, x) \rightarrow \mathcal{C}_{N-l+1}^N \frac{1}{\bar{\gamma}^{N-l+1}}$. This proves Lemma 3

Lemma 2 and Lemma 3 provide the key information about the selected SNR in MRS. In our setup, MRS selects L different relays in order to optimally exploit spatial gain among the relays, hence to maximize the diversity gain of the relayed signal. This relay selection mechanism differs from that in [79] in which one relay might be selected several times.

After MRS, the L active relays forward network-coded signal to the destination.

4.3 Outage Analysis for SRS

In this section, we analyze outage probability for SRS of the network described in subsection 4.1.

4.3.1 Exact OP of SRS

In SRS, after two phases, the destination receives $N_s + 1$ packets from N_s sources and from the best relay. An outage event occurs when the destination can only be able to decode less than N_s packets (those channel are above the threshold γ_{th}). In other words, the system is not in outage if there is not more than 1 link falling below the threshold. The OP of SRS can be described as: $OP_{SRS} = 1 - \overline{OP}$, with \overline{OP} being the probability that the system is not in outage:

$$\overline{OP} = \Pr\{0 \text{ link} < \gamma_{th}\} + \Pr\{1 \text{ link} < \gamma_{th}\}.$$

Theorem 1. *Consider a network consisting of N_s sources, N_r relays and 1 destination with network coding is applied at the relays. The SRS selects the best relay to cooperate with the destination. The exact OP of SRS is given as follows:*

$$\begin{aligned} OP_{SRS} = 1 - & \prod_{m=1}^{N_s} (1 - F_{\gamma_{S_m D}}(\gamma_{th})) + (1 - F_{g_{SRS}}(\gamma_{th})) \\ & \times \sum_{m=1}^{N_s} \left(F_{\gamma_{S_m D}}(\gamma_{th}) \prod_{m'=1, m' \neq m}^{N_s} (1 - F_{\gamma_{S_{m'} D}}(\gamma_{th})) \right), \end{aligned} \quad (4.13)$$

where $F_{S_m D}(x) = 1 - e^{-\frac{x}{\bar{\gamma}_{S_m D}}}$ and $F_{g_{SRS}}(x)$ is given in (4.10).

The outline proof of Theorem 1 is as follows. Thanks to independency of $N_s + 1$ channels, we can factorize joint probability into a product of terms, *e.g.*, $\Pr\{\gamma_{S_1 D} \leq \gamma_{th}, \gamma_{SRS} \leq \gamma_{th}\} = \Pr\{\gamma_{S_1 D} \leq \gamma_{th}\} \times \Pr\{\gamma_{SRS} \leq \gamma_{th}\}$. Then we can compute two probabilities in \overline{OP} and grouping same common terms we obtain (4.13).

The exact OP of SRS in Theorem 1 is a complex function of all average SNRs in the network and it is not trivial to see the system diversity via the exact OP. In the next subsection, we derive the asymptotic OP through which it could reveal the system diversity order.

4.3.2 Asymptotic OP of SRS

This subsection computes the asymptotic OP for SRS through which it could derive the system diversity order.

Theorem 2. *Consider a network consisting of N_s sources, N_r relays and 1 destination with network coding applied at the relays. The SRS selects the best relays to cooperate with the destination. The asymptotic OP of SRS is given as follows:*

$$OP_{SRS}^{Asym} = \sum_{\substack{m=1, m'=1 \\ m \neq m'}}^{N_s} \frac{\gamma_{th}^2}{\bar{\gamma}_{S_m D} \bar{\gamma}_{S_{m'} D}}.$$

Proof: We start the proof with the second-order approximation of function e^{-x} , $\forall x > 0$, which is given as follows:

$$e^{-x} \simeq 1 - x + \frac{x^2}{2} + \mathcal{O}[x^3]. \quad (4.14)$$

Define $a_m = \frac{\gamma_{th}}{\bar{\gamma}_{S_m D}} > 0$, $A = \sum_{m=1}^{N_s} a_m$ and $A_{\sim m} = \sum_{m \neq m'=1}^{N_s} a_{m'}$, then we have

$$\begin{aligned} \prod_{m=1}^{N_s} (1 - F_{\gamma_{S_m D}}(\gamma_{th})) &= \prod_{m=1}^{N_s} e^{-a_m} \\ &= e^{-A} \simeq 1 - A + \frac{A^2}{2}, \end{aligned} \quad (4.15)$$

and

$$\begin{aligned} \sum_{m=1}^{N_s} F_{\gamma_{S_m D}}(\gamma_{th}) \prod_{m'=1, m' \neq m}^{N_s} (1 - F_{\gamma_{S_{j'} D}}(\gamma_{th})) &= \sum_{m=1}^{N_s} \left(a_m - \frac{a_m^2}{2} \right) \left(1 - A_{\sim m} + \frac{A_{\sim m}^2}{2} \right) \\ &= \sum_{m=1}^{N_s} a_m - \frac{1}{2} \sum_{m=1}^{N_s} a_m^2 - \sum_{m=1}^{N_s} a_m A_{\sim m} \\ &= A - \frac{A^2}{2} - \sum_{\substack{m=1, m'=1 \\ m \neq m'}}^{N_s} a_m a_{m'}. \end{aligned} \quad (4.16)$$

Define $b_n = \frac{\gamma_{th}}{\bar{\gamma}_n}$ with $1 \leq n \leq N$ and $B = \prod_{n=1}^N b_n$. Applying the approximation

of e^{-x} on the CDF of g_{SRS} it yields:

$$\begin{aligned} F_{g_{SRS}}(\gamma_{th}) &\simeq \prod_{n=1}^N \left(b_n - \frac{b_n^2}{2} \right) \\ &\simeq B. \end{aligned} \tag{4.17}$$

Substituting (4.15), (4.16), (4.17) into (4.13) and keeping the smallest power elements we obtain the Theorem 2. \square

We can conclude from Theorem 2 that SRS achieves diversity order of 2 regardless how many relays are available. And the asymptotic OP only depends on direct source-destination channels. This conclusion is different from that obtained in best relay selection in single-source relay networks or TWRC in which full diversity order is achieved. The loss in diversity is because although the network-coded signal achieves full diversity order, it is not sufficient to guarantee for the destination to recover all source data. The destination also requires direct source-destination signal, which is of single diversity order, in order to decode. In fact, if it breaks the optimistic assumption that unintended packets are available at destination nodes in [51], the system diversity order drops to two.

4.4 Outage Analysis for MRS

In this subsection, we analyze the outage probability of NCC with MRS. Assuming that all encoding vectors of selected relays satisfy MDS code [82], the destination can recover all source data if it receives at least N_s error-free packets from the sources or the active relays.

4.4.1 Exact OP of MRS

In MRS, after two phases, the destination receives $N_s + L$ packets composed of N_s packets from the sources and L packets from the selected relays. An outage event happens when the destination is only able to decode less than N_s packets out of $N_s + L$ packets from the channels $\{\gamma_{S_1D}, \dots, \gamma_{S_{N_s}D}, g_1, \dots, g_L\}$. In other words, the

system is in outage if there are less than N_s channels above the threshold γ_{th} :

$$OP = \Pr\{0 \text{ link} > \gamma_{th}\} + \Pr\{1 \text{ link} > \gamma_{th}\} + \dots + \Pr\{N_s - 1 \text{ links} > \gamma_{th}\}. \quad (4.18)$$

Theorem 3. *Consider a network consisting of N_s sources, N_r relays and 1 destination with network coding applied at the relays. The MRS selects L best relays to cooperate with the destination. The exact OP of MRS is given by*

$$OP_{MRS}^1 = \left(\sum_{m=0}^{N_s-L-1} \Psi(m) \right) \left(1 + \sum_{l=1}^{L-1} F_{g_l}(\gamma_{th}) \right) + \sum_{k=1}^L \left(\Psi(N_s - k) \sum_{l=1}^k F_{g_l}(\gamma_{th}) \right), \quad (4.19)$$

if $L \leq N_s$. Otherwise, the OP is given by

$$OP_{MRS}^2 = \sum_{k=1}^{N_s} \left(\Psi(N_s - k) \sum_{l=1}^k F_{g_l}(\gamma_{th}) \right), \quad (4.20)$$

where $F_{g_l}(\gamma_{th})$ is given in Lemma 3 and

$$\Psi(k) = \sum_{\substack{i_1=1, \dots, i_k=1 \\ i_1 \neq \dots \neq i_k}}^{N_s} \left\{ \prod_{m=i_1}^{i_k} (1 - F_{\gamma_{S_m D}}(\gamma_{th})) \times \prod_{\substack{m'=1 \\ m' \neq \{i_1, \dots, i_k\}}}^{N_s} F_{\gamma_{S_{m'} D}}(\gamma_{th}) \right\}. \quad (4.21)$$

Proof. Divide the received packets at the destination into two groups: i) the first group consisting of N_s packets from the sources and ii) the second group consisting of L packets from the selected relays. The probability of that the destination can be able to decode P packets is equal to probability of that there are P links above the threshold γ_{th} . Those P links are uniformly distributed over two groups. Therefore, the probability that P links are above the threshold is a sum of \mathcal{C}_2^P terms, each is corresponding to one distribution of P over two groups. Denote $\Psi(k)$ as the probability that there are k source-destination channels are above the threshold while $N_s - k$ other links are below the threshold. Taking into account the independency of all channels, we can easily obtain (4.21).

The probability that $l < L$ links in \mathbf{g}_{MRS} are above the threshold is given in Lemma 3, that is equal to $F_{g_{l+1}}(\gamma_{th})$. The probability that all L channels in \mathbf{g}_{MRS}

are above the threshold is equal to $1 - F_{g_L}(\gamma_{th})$.

By stacking all probabilities in (4.18) we obtain a lower matrix of size $(N_s + 1) \times (L + 1)$ in (4.22) for $N_s > L$, which is shown on top of the next page. When $L \geq N_s$ we obtain (4.23). As a result, elements in one diagonal have same $\Psi(k)$.

$$\begin{bmatrix} \Psi(0) F_{g_1}(\gamma_{th}) & & & & & & \\ \Psi(1) F_{g_1}(\gamma_{th}) & & \Psi(0) F_{g_2}(\gamma_{th}) & & & & \\ \dots & & & & & & \\ \Psi(L-1) F_{g_1}(\gamma_{th}) & \dots & & \Psi(0) F_{g_L}(\gamma_{th}) & & & \\ \Psi(L) F_{g_1}(\gamma_{th}) & \dots & & \Psi(1) F_{g_L}(\gamma_{th}) & \Psi(0) (1 - F_{g_L}(\gamma_{th})) & & \\ \dots & & & & & & \\ \Psi(N_s-1) F_{g_1}(\gamma_{th}) & \dots & & \Psi(N_s-L) F_{g_L}(\gamma_{th}) & \Psi(N_s-L-1) (1 - F_{g_L}(\gamma_{th})) & & \end{bmatrix}. \quad (4.22)$$

$$\begin{bmatrix} \Psi(0) F_{g_1}(\gamma_{th}) & & & & & & \\ \Psi(1) F_{g_1}(\gamma_{th}) & & \Psi(0) F_{g_2}(\gamma_{th}) & & & & \\ \dots & & & & & & \\ \Psi(N_s-1) F_{g_1}(\gamma_{th}) & \dots & & \dots & \Psi(0) F_{g_{N_s}}(\gamma_{th}) & & \end{bmatrix}. \quad (4.23)$$

Summing up the first L diagonals in (4.22) we obtain the first factor in (4.19). Summing up the rest in (4.22) gives the second factor in (4.19). When $L \geq N_s$, summing up (4.23) and grouping same elements yields (4.20). \square

Similar conclusion as in SRS is conducted, the exact OP of MRS depends on the whole network protocol. In order to further understand the system behavior, one needs to study the asymptotic of the OP.

4.4.2 Asymptotic OP of MRS

Theorem 4. *Consider a network consisting of N_s sources, N_r relays and 1 destination with network coding applied at the relays. The MRS selects L best relays to*

cooperate with the destination. The asymptotic OP of MRS is given as follows:

$$OP_{MRS}^{1-Asym} = \sum_{\substack{i_1=1, \dots, i_{L+1}=1 \\ i_1 \neq \dots \neq i_{L+1}}}^{N_s} \left(\prod_{m=i_1}^{i_{L+1}} \frac{\gamma_{th}}{\bar{\gamma}_{S_m D}} \right) \quad (4.24)$$

if $L < N_s$. Otherwise, the asymptotic OP is given by

$$OP_{MRS}^{2-Asym} = \sum_{k=1}^{N_s} \Omega_S(k) \Omega_R(N_r - k + 1), \quad (4.25)$$

$$\text{with } \Omega_S(k) = \sum_{\substack{i_1=1, \dots, i_k=1 \\ i_1 \neq \dots \neq i_k}}^{N_s} \left(\prod_{m=i_1}^{i_k} \frac{\gamma_{th}}{\bar{\gamma}_{S_m D}} \right), \text{ and } \Omega_R(k) = \sum_{\substack{i_1=1, \dots, i_k=1 \\ i_1 \neq \dots \neq i_k}}^{N_r} \left(\prod_{n=i_1}^{i_k} \frac{\gamma_{th}}{\bar{\gamma}_n} \right).$$

Proof. Obviously, $\Psi(k)$ has diversity order $N_s - k$ and $F_{g_l}(\gamma_{th})$ has diversity order $N_r - l + 1$ (see Lemma 3). Let us first consider the case $L < N_s$. In this case, the OP is given in (4.19). When SNR tends to infinity, the first factor $\left(\sum_{m=0}^{N_s-L-1} \Psi(m) \right) \left(1 + \sum_{l=1}^{L-1} F_{g_l}(\gamma_{th}) \right)$ in (4.19) reduces to $\Psi(N_s - L - 1)$. Using the second-order approximation (4.14) and keeping the smallest power elements we obtain (4.24).

For the case $L \geq N_s$, we note that $\Omega_S(k) \Omega_R(N_r - k + 1)$ achieves diversity order $N_r + 1$ for all k . Applying again approximation (4.14) we obtain (4.25). This completes the prove of Theorem 4. \square

Theorem 4 states that MRS achieves diversity order of $L + 1$ if $L < N_s$ and full diversity order $N_r + 1$ when $L \geq N_s$. The asymptotic OP does not depend on the relay channels for $L < N_s$ case. It means that for a given number of selected relays, MRS achieves the same asymptotic OP for whatever total number of relays N_r is and their locations. This conclusion suggests an interesting result in homogenous relay networks where the relays are randomly generated according to some random processes, *e.g.*, Poisson point process. In such case, if the average number of relays is larger than the selected relays L , it is high probable that the total number of available relays is larger than L . Then the asymptotic performance of MRS does not rely on how the available relays are distributed in the network.

When $L \geq N_s$, both exact and asymptotic OP depend on the whole network.

In this case, selecting more relay does not improve any performance gain. When $L = 1$, Theorem 3 and 4 collapse to Theorem 1 and 2 of SRS, respectively.

4.5 Comparison between NCC and Conventional Relaying Protocol

In this section, we compare MRS with conventional relaying scheme which does not utilize NC. In the conventional relaying protocol, one relay is selected to support one source during the cooperative phase. Consequently, it requires $2N_r$ time slots to complete the cooperation. In addition, the relay selection phase in the conventional relaying protocol is more complex and more time consuming than that in NCC. Let T be a time duration of one cooperation phase, a time slot duration τ_{CON} in the conventional relaying protocol is given by $\tau_{CON} = \frac{T}{2N_s}$. In NCC, since there are only $N_s + L$ time slots, a time slot duration τ_{NC} in NCC is given by $\tau_{NC} = \frac{T}{N_s + L}$, as shown in Figure 4.2. Then the system rate \mathcal{R} (bit per channel use) is related to code rate $\mathcal{R}_{NC}, \mathcal{R}_{CON}$ of NCC and conventional relaying protocol as following [83]:

$$\mathcal{R} = \frac{\mathcal{R}_{NC}}{N_s + L} = \frac{\mathcal{R}_{CON}}{2N_s} \text{ (bpcu)}.$$

Denote γ_{th}^{CON} and γ_{th}^{NC} are respective the threshold in conventional relaying scheme and NCC. The threshold is related to the rate as follows: $\gamma_{th}^{CON} = 2^{\mathcal{R}_{CON}} - 1$ and $\gamma_{th}^{NC} = 2^{\mathcal{R}_{NC}} - 1$.

In conventional relaying scheme, the best relay selection is performed for each relay. The best selected relay channel for source S_m is chosen as follows:

$$g_m^{CON} = \max_{n=1, \dots, N_r} \{\gamma_n^{CON}\}, \quad (4.26)$$

with

$$\gamma_n^{CON} = \min\{\gamma_{S_m R_n}, \gamma_{R_n D}\}.$$

Source S_m is in outage if both $\gamma_{S_m D}$ and g_m^{CON} are below the threshold γ_{th}^{CON} :

$$OP_m = \Pr\{\gamma_{S_m D} \leq \gamma_{th}^{CON}, g_m^{CON} \leq \gamma_{th}^{CON}\}$$

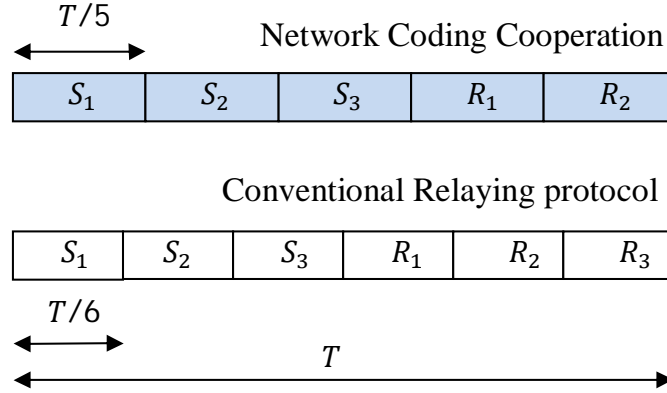

Figure 4.2. Time allocation comparison between NCC and Conventional relaying protocol for a network consisting of $N_s = 3$ sources, $N_r = 3$ relays and $L = 2$ selected relays.

$$= \left(1 - e^{-\frac{\gamma_{th}^{CON}}{\bar{\gamma}_{S_m D}}} \right) \prod_{n=1}^N \left(1 - e^{-\frac{\gamma_{th}^{CON}}{\bar{\gamma}_n^{CON}}} \right), \quad (4.27)$$

where $\frac{1}{\bar{\gamma}_{th}^{CON}} = \frac{1}{\bar{\gamma}_{S_m R_n}} + \frac{1}{\bar{\gamma}_{R_n D}}$.

The conventional relaying scheme is said to be in outage if at least one of N_s sources are in outage. Denote $\overline{OP}_m = 1 - OP_m$ as the probability that source S_m is not in outage. The outage probability of conventional relaying scheme is given as follows:

$$\begin{aligned}
 OP_{CON} &= 1 - \prod_{m=1}^{N_s} \overline{OP}_m \\
 &= 1 - \prod_{m=1}^{N_s} (1 - OP_m),
 \end{aligned} \quad (4.28)$$

with OP_m is given in (4.27).

By following same method in the proof of Theorem 2, we obtain the asymptotic OP of conventional relaying protocol as follows:

$$OP_{CON}^{Asym} = \sum_{m=1}^{N_s} \left(\frac{(\gamma_{th}^{CON})^{N_r+1}}{\bar{\gamma}_{S_m D}} \prod_{n=1}^{N_r} \left(\frac{1}{\bar{\gamma}_{S_m R_n}} + \frac{1}{\bar{\gamma}_{R_n D}} \right) \right). \quad (4.29)$$

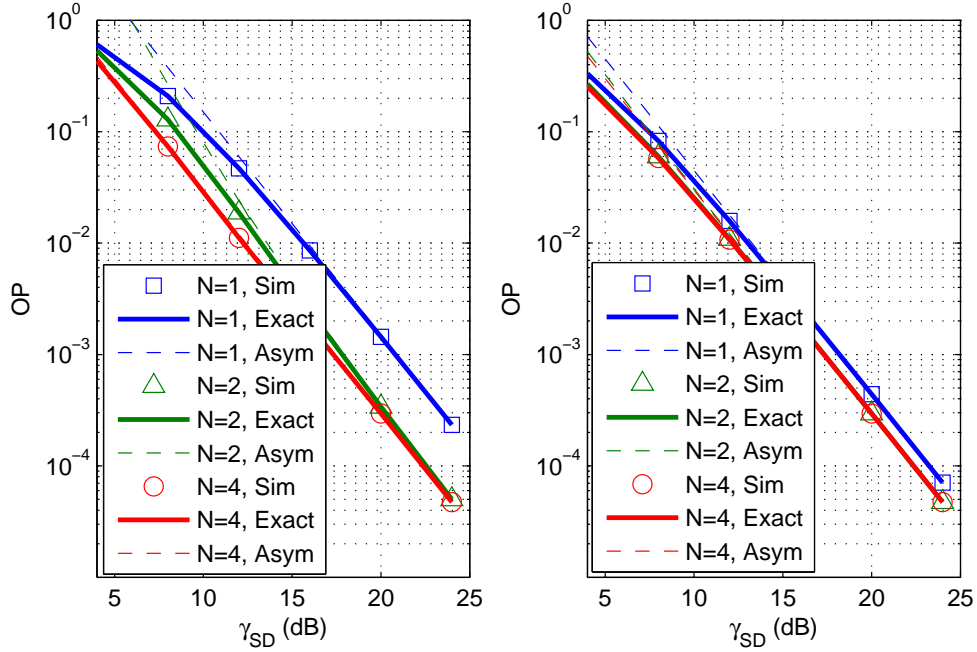

Figure 4.3. Outage probability of SRS in $N_s = 3$ sources v.s different number of relays, the threshold $\gamma_{th} = 1$. Left sub figure shows *Setup 1*: $\bar{\gamma}_{SD} = \bar{\gamma}_{SD} = \bar{\gamma}_{SD}$. Right sub figure shows *Setup 2*: $(\bar{\gamma}_{SD}, \bar{\gamma}_{SD}, \bar{\gamma}_{SD}) = (\bar{\gamma}, \bar{\gamma} + 9dB, \bar{\gamma} + 9dB)$.

From (4.29) we can see that the conventional relaying protocol always achieves full diversity order $N_r + 1$. However, full diversity order does not guarantee for the conventional relaying scheme to be always better than NCC because of difference between γ_{th}^{CON} and γ_{th}^{NC} , which affects the system coding gain. In fact, depending on network protocol and number of sources and relays, the performance of NCC can be better than that of conventional relaying scheme or not.

4.6 Numerical Results

This section presents numerical results for the system described in Section 4.1 to verify our analysis. For ease of presentation, a symmetric system model is considered but our analysis holds for any network topology, *i.e.*, $\bar{\gamma}_{S_m D} = \bar{\gamma}_{SD}, \forall m$, $\bar{\gamma}_{R_n D} = \bar{\gamma}_{RD}, \forall n$ and $\bar{\gamma}_{S_m R_n} = \bar{\gamma}_{SR}, \forall m$ and n .

Figure 4.3 shows the performance of SRS for different number of relays N . The curve $N = 1$ corresponds to non relay selection. It is shown that the sim-

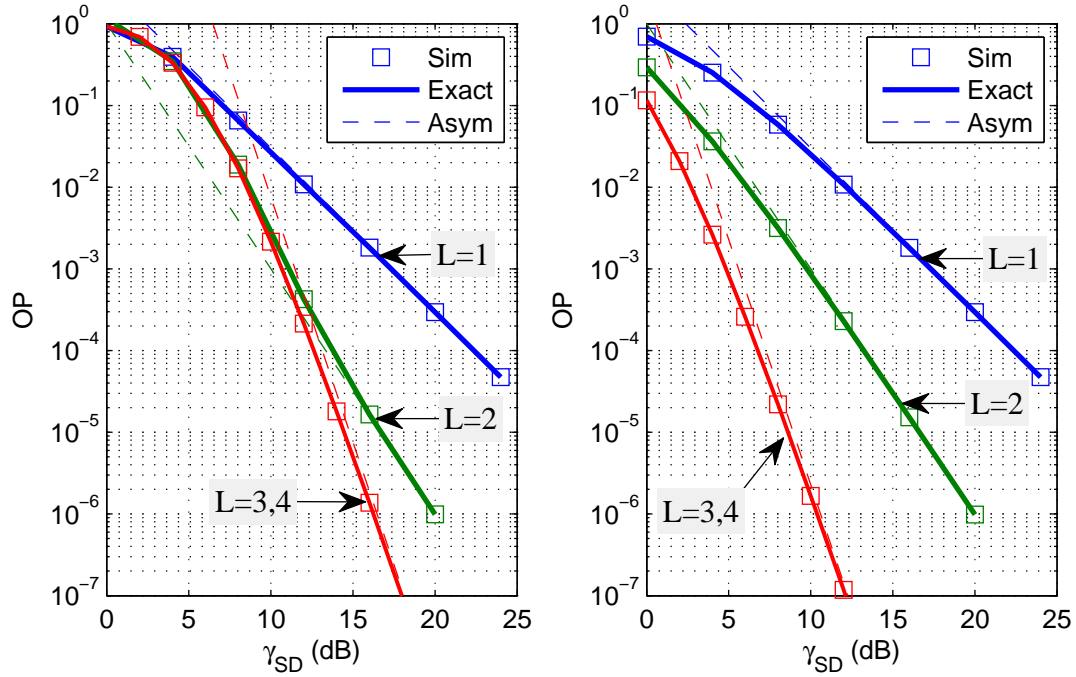

Figure 4.4. Outage probability of MRS in $N_s = 3$ sources, $N = 5$ relays v.s different number of selected relays L , the threshold $\gamma_{th} = 1$. Left sub figure shows *Setup 1*: $\bar{\gamma}_{SD} = \bar{\gamma}_{SD}$. Right sub figure shows *Setup 2*: $(\bar{\gamma}_{SD}, \bar{\gamma}_{SD}, \bar{\gamma}_{SD}) = (\bar{\gamma}, \bar{\gamma} + 9\text{dB}, \bar{\gamma} + 9\text{dB})$.

ulation perfectly matches our analysis and SRS always achieve second diversity order. When the available relays N increases, SRS provides little coding gain but same asymptotic OP. Compare with non relay selection ($N = 1$), SRS obtains a coding gain of 3dB in setup 1 and 1dB in setup 2. We note that the asymptotic performance in both setups is the same. This can be explained from Theorem 2 that the asymptotic of SRS does not depend on relay channels.

Figure 4.4 shows the performance of MRS with different number of selected relays. When the number of selected relays L is smaller than the number of sources N_s , more relays selected provides better diversity gain and coding gain. Those coding gains are clearer when the relay channels ($S \rightarrow R$, $R \rightarrow D$) are better than $S \rightarrow D$ channels. However, if the selected relays is equal to the number of sources, selecting more relays does not bring any more performance gain, which results from Theorem 3. Furthermore, the performance of $L = 1$ in two setups are the same since it is equivalent to SRS scenario.

Figure 4.5 compares performance between MRS and conventional relaying pro-

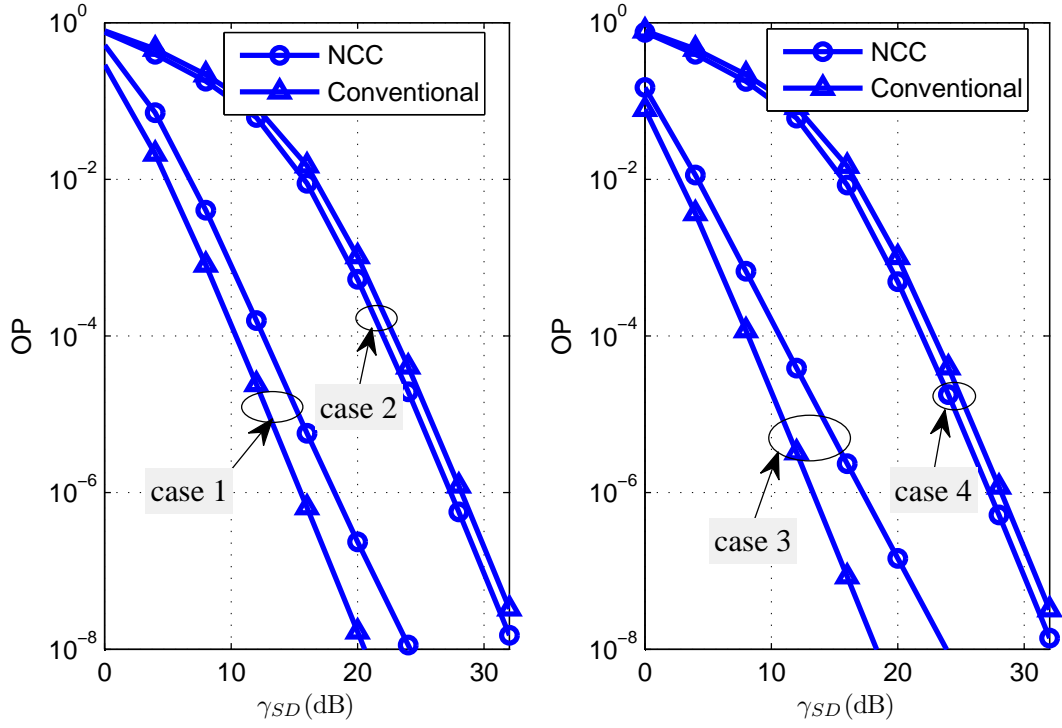

Figure 4.5. Outage probability comparison between NCC with conventional relaying protocol in $N_s = 3$ sources, $N = 3$ relays network with $L = 2$ selected relays. The system rate $\mathcal{R} = 3/10$ bpcu. Case 1: $\bar{\gamma}_{SR} = \bar{\gamma}_{RD} = \bar{\gamma}_{SD}$. Case 2: $\bar{\gamma}_{SR} = \bar{\gamma}_{SD}, \bar{\gamma}_{RD} = \bar{\gamma}_{SD} - 20\text{dB}$. Case 3: $\bar{\gamma}_{SR} = \bar{\gamma}_{SD} + 20\text{dB}, \bar{\gamma}_{RD} = \bar{\gamma}_{SD}$. Case 4: $\bar{\gamma}_{SR} = \bar{\gamma}_{SD} + 20\text{dB}, \bar{\gamma}_{RD} = \bar{\gamma}_{SD} - 20\text{dB}$.

tolcol when relay channels are either better or worse than the direct $S \rightarrow D$ channels and $L = 2$ relays are selected for cooperation. When $R \rightarrow D$ channels have same average SNR as direct channels, conventional relaying outperforms over NCC. When direct channels are better than $R \rightarrow D$ channels, NCC provides a better coding gain than conventional relaying in the analyzed SNR region. In this case, NCC has same diversity order as conventional relaying. However, when SNR tends to infinity, the conventional relaying scheme still outperforms NCC since it achieves full diversity order 4 while NCC achieves diversity order 3.

4.7 Conclusions

In conclusion, we have analyzed the performance of cooperative wireless networks with both single relay selection and multiple relay selection. Exact outage probability and asymptotic outage probability of SRS and MRS are provided. We show that combining network coding and relay selection in such networks can only achieve full diversity if the number of selected relay are equal or greater than the number of sources.

Partial Relaying in Cooperative Relay Networks

Conventional relaying techniques take advantage from the independency between the relay channel and the direct source-destination channel. In conventional relaying, the relay usually forwards the whole estimated packet it receives from the source to the destination. At the receiver side, the destination first combines received packets (from the source and from the relay) and then performs channel decoding. It is well known that the three-node relay network achieves a diversity order two compared with the single diversity order of the direct transmission under quasi-static block Rayleigh fading scenario. This diversity gain comes with a loss in the spectrum efficiency since each symbol costs two time slots. In order to improve the spectrum efficiency, we propose a so-called *partial relaying* protocol in which the relay only forwards a part of the estimated codeword to the destination. In our proposal, the destination receives two different versions of the source message: one full-rate codeword from the source and one truncated codeword from the relay. Interestingly, the analytical results show that partial relaying can achieve full diversity gain in a low and medium SNR regime when a proper channel code is used while it provides a better spectrum usage than conventional relaying techniques. Those results are important to practical systems where the operating SNR region is usually finite.

In the first part of this chapter, we analyze the partial relaying in the simplest cooperation form of a three-node relay network. Analytical results including the

system BER and diversity order are presented. In the second part, we consider the partial relaying in a general multiple-relay networks and show that partial relaying significantly outperforms NC-based cooperation in some circumstances.

5.1 Partial Relaying for Single-Relay Networks

In this section, we study the performance of partial relaying scheme in the three-node relay network. This network was realized as the simplest cooperation form where one relay helps one source to communicate with one destination [1]. It is shown that relay networks achieve better performance and diversity gain as compared with the non-cooperative counterpart [1]. However, the disadvantage of cooperative communications is the loss in spectral efficiency since at least two orthogonal channels are used. To increase the spectrum efficiency, the relay might not transmit the whole codeword during the relaying phase. In particular, the relay can either forward the whole or a part of the estimated codeword to the destination. At the destination, a Cooperative Maximum Ratio Combining (C-MRC) detector [84] is used in priority to channel decoding.

First, we derive the upper bound for the BER of the proposed scheme. The upper bound shows that the diversity gain depends on both the amount of information the relay forwards and the minimum distance of the channel code. Much forwarded information results in better diversity gain, and stronger code (larger minimum distance) brings a better diversity gain. Both analytical and simulated results show that for a standard CC $\{5\ 7\ 5\}$ with the minimum distance equal to 7, the system could achieve diversity order of 2 and save 20% spectrum efficiency over the conventional relay network in SNR region of the until $\text{BER} = 10^{-6}$. The spectrum efficiency gain is 32% when a strong code $\{123\ 135\ 157\}$ [85] is utilized. Second, we develop a criteria based on the BER upper bound to design the relay network which simultaneously achieves full diversity gain and improve the system spectrum efficiency in the SNR region of interest. This can be accomplished by optimizing the minimum distance of the code and the amount of information the relay conveys. The optimal amount of forwarded information is a function of the minimum distance and the maximum SNR.

5.1.1 System Model

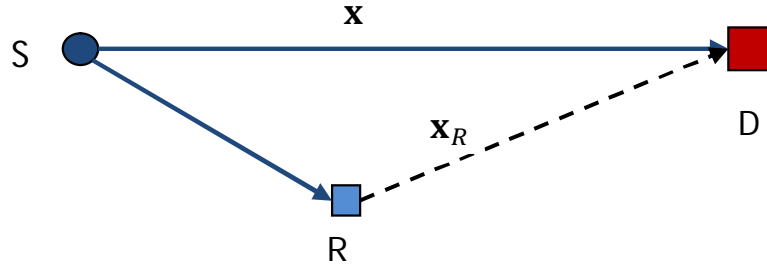

Figure 5.1. The three-node relay channel with partial relaying.

Fig. 5.1 depicts the three-node relay networks consisting of a source S, a destination D and a relay R. All nodes are equipped with half-duplex single antennas. The system is assumed to operate with orthogonal channels in order to avoid mutual interference. Therefore, one cooperation phase comprises of two frames. In the first frame, S broadcasts a codeword to R and D. In the second frame, R forwards (a part of) the estimated codeword to D. All channels are subject to quasi-static block Rayleigh fading plus AWGN. The relay employs the DMF protocol [2]. More specifically, S encodes a data message \mathbf{u} of length K into a codeword \mathbf{c} of length N via a convolutional code (CC) code with rate K/N . The codeword \mathbf{c} is then BPSK modulated into a signal \mathbf{x} as $x_k = 2c_k - 1$, where x_k is the k -th element of \mathbf{x} , before being transmitted to the relay and the destination. The received signals at R and D are modelled respectively as follows:

$$\begin{cases} \mathbf{y}_{SD} = \sqrt{P_{SD}}h_{SD}\mathbf{x} + \mathbf{n}_{SD}, \\ \mathbf{y}_{SR} = \sqrt{P_{SR}}h_{SR}\mathbf{x} + \mathbf{n}_{SR}, \end{cases} \quad (5.1)$$

where P_{XY} with $X \in \{S\}, Y \in \{R, D\}$ is power of the received signal at node Y from node X including the path loss; h_{XY} is the channel coefficient of $X \rightarrow Y$ channel, which is a complex Gaussian random variable with zero mean and unit variance, *i.e.*, $\mathbb{E}\{|h_{XY}|^2\} = 1$ and is mutual statistically independent among channels; \mathbf{n}_{XY} is a noise vectors of $X \rightarrow Y$ channels whose elements are Gaussian random noises with mean zero and variance σ^2 .

At the end of the first frame, the relay first estimates $L = \delta N$ coded symbols with $0 \leq \delta \leq 1$ to form an estimated (punctured) codeword $\hat{\mathbf{c}}_R = \{\hat{c}_{R,k_l}\}_{l=1}^L$ with

$\Theta = \{k_1, k_2, \dots, k_L\}$ being a set of data indexes which are retransmitted by the relay. Estimated by a ML detector, the data symbols at the relay are as follows:

$$\hat{c}_{R,l} = \arg \min_{\tilde{c}_{k_l} \in \{0,1\}} \{|y_{SR,k_l} - \sqrt{P_{SR}}h_{SR}x_{k_l}|^2\}.$$

where \tilde{c}_{k_l} being a trial code bit transmitted by the source.

Next, the relay modulates $\hat{\mathbf{c}}_R$ into a signal $\hat{\mathbf{x}}_R$ and then forwards it along with the index set Θ to the destination. Different with [86], where only estimated symbols with reliability above a certain threshold are forwarded, the relay always forward the estimated symbols regardless of its decoding status. Possible decoding errors at the relay are eliminated by the C-MRC receiver at the destination. The received signal at the destination from the relay is given by:

$$\mathbf{y}_{RD} = \sqrt{P_{RD}}h_{RD}\hat{\mathbf{x}}_R + \mathbf{n}_{RD}, \quad (5.2)$$

where P_{RD} is the power of the received signal at D from R including the path loss; h_{RD} is the channel coefficient R \rightarrow D link with $\mathbb{E}\{|h_{RD}|^2\} = 1$; and \mathbf{n}_{RD} is a noise vector whose components are Gaussian random variable with zero mean and variance σ^2 .

After receiving two signal from the source and the relay, the destination starts the decoding process with two consecutive steps: demodulating and decoding. Assume that the CSI of all channels, *i.e.*, S \rightarrow D, S \rightarrow R and R \rightarrow D channels, are available at the destination, the destination first applies the C-MRC detector [84] to demodulate the coded bits as follows:

$$\hat{c}_k = \arg \min_{c_k \in \{0,1\}} \mathcal{M}(x_k),$$

where the metric $\mathcal{M}(x_k)$ is of the form

$$\mathcal{M}(x_k) = \begin{cases} |y_{SD,k} - \sqrt{P_{SD}}h_{SD}x_k|^2, & \text{if } k \notin \Theta \\ |y_{SD,k} - \sqrt{P_{SD}}h_{SD}x_k|^2 + \lambda_R |y_{RD,k} - \sqrt{P_{RD}}h_{RD}x_{R,k}|^2, & \text{if } k \in \Theta \end{cases}. \quad (5.3)$$

In (5.3), λ_R is the parameter of the C-MRC detector and is defined as $\lambda_R \triangleq$

$\min(\gamma_{SR}, \gamma_{RD})/\gamma_{RD}$, where $\gamma_{XY} = P_{XY}|h_{XY}|^2/\sigma^2$ being the instantaneous SNR of the $X \rightarrow Y$ channel. Since all channels are Rayleigh fading, the instantaneous SNR γ_{XY} is an exponential random variable with the parameter $\bar{\gamma}_{XY} = P_{XY}/\sigma^2$.

The C-MRC detector then computes the log-likelihood ratio (LLR) value of the coded bits $\{\hat{c}_k\}_{k=1}^N$ and sends them to the channel decoder. Finally, the channel decoder applies the BCJR algorithm [72] to decode the transmitted data.

5.1.2 Equivalent Channel

In this subsection, we compute the equivalent channel for the relayed signal in C-MRC detector. The equivalent channel is then used to study the system performance. Using the C-MRC detector, the two-hop relay channel is equivalent to a single-hop channel whose equivalent instantaneous SNR, denoted by γ_{eq} , is tightly modeled as follows [84]:

$$\gamma_{eq} = \min\{\gamma_{SR}, \gamma_{RD}\}. \quad (5.4)$$

Because γ_{SR} and γ_{RD} are exponentially distributed, it is easy to show that γ_{eq} is also an exponential random variable with the parameter $\bar{\gamma}_{eq}$, such as:

$$\frac{1}{\bar{\gamma}_{eq}} = \frac{1}{\bar{\gamma}_{SR}} + \frac{1}{\bar{\gamma}_{RD}}.$$

Using the equivalent channel γ_{eq} , the destination considers the estimated signal $\hat{\mathbf{x}}$ transmitted via the $R \rightarrow D$ channel γ_{RD} as the correct one \mathbf{x} transmitted via the equivalent channel γ_{eq} .

5.1.3 Bit Error Probability Analysis

The received signal at the destination comprises of two blocks, *i.e.*, one is directly transmitted from the source which consists of $N-L$ symbols and the other includes L symbols which see two $S \rightarrow D$ channel and $R \rightarrow D$ channel. Define by $P_u(d)$ the unconditional pair-wise error probability¹ (UPEP) of receiving a codeword with weight (number of non-zero coded bits) d assumed that the all-zero codeword was

¹The UPEP does not depend on the fading channels

transmitted, the system BER with the convolutional code is upper-bounded as follows: [71, eq. (3.175)]:

$$\text{Pe} \leq \sum_{d=d_H}^{\infty} w(d)P_u(d), \quad (5.5)$$

where d_H is the minimum distance (free distance) of the channel code and $w(d)$ is the number of non-zero input bits corresponding to the codeword with weight d . Note that $w(d)$ is computed directly from the structure of the code. The UPEP is the expectation over fading channels of the conditioned pair wise error probability (CPEP) $P_c(d)$ as follows:

$$P_u(d) \triangleq \mathbb{E}\{P_c(d)\}, \quad (5.6)$$

where $\mathbb{E}\{.\}$ denotes the expectation operator over fading channels.

The CPEP $P_c(d)$ depends on $S \rightarrow D, S \rightarrow R$ and $R \rightarrow D$ channels and how d weights are distributed on two blocks. Introducing $\mathbf{D}_d = \{d_1, d_2\}$ as a weight pattern in which there are d_1 weights on the block 1 (directly from S) and d_2 weights on the block 2 (from both S and R), with $d_1 + d_2 = d$. The CPEP $P_c(d)$ is computed by averaging over all distributions of the pattern \mathbf{D}_d as

$$P_c(d) = \sum_{\mathbf{D}_d} P_c(d|\mathbf{D}_d) \times p(\mathbf{D}_d). \quad (5.7)$$

In (5.7), $p(\mathbf{D}_d)$ is the probability of the pattern \mathbf{D}_d computed by combinatoric computation as

$$p(\mathbf{D}_d) = \frac{\mathcal{C}_{d_1}^{N-L} \times \mathcal{C}_{d_2}^L}{\mathcal{C}_d^N}, \quad (5.8)$$

where $\mathcal{C}_k^n = \frac{n!}{k!(n-k)!}$ denotes the binomial coefficients.

Substituting (5.8) and (5.7) into (5.6) yields:

$$P_u(d) = \sum_{\mathbf{D}_d} \underbrace{\mathbb{E}\{P_c(d|\mathbf{D}_d)\}}_{P_u(d|\mathbf{D}_d)} p(\mathbf{D}_d). \quad (5.9)$$

In (5.9), $P_c(d|\mathbf{D}_d)$ is the probability of receiving codeword $\tilde{\mathbf{x}}$ when the all-zero codeword \mathbf{x} was transmitted. In addition, given the pattern \mathbf{D}_d , there are d_1 weights see a single channel $S \rightarrow D$ and d_2 weights see both $S \rightarrow D$ and $R \rightarrow D$ channels. Therefore, the CPEP $P_c(d|\mathbf{D}_d)$ is given as follows [68]:

$$\begin{aligned} P_c(d|\mathbf{D}_d) &= Q\left(\sqrt{2((d_1 + d_2)\gamma_{SD} + d_2\gamma_{eq})}\right) \\ &= Q\left(\sqrt{2d\gamma_{SD} + 2d_2\gamma_{eq}}\right), \end{aligned} \quad (5.10)$$

where $Q(\cdot)$ denotes the Q-function.

Denote by $D_1 = \{d, 0\}$ the pattern that all d weights are located on block 1 (only see the channel γ_{SD}). The UPEP $P_u(d|\mathbf{D}_d)$ is given as in the following theorem.

Theorem 5. *The UPEP $P_u(d|\mathbf{D}_d)$ of the partial relaying system is upper bounded as follows:*

$$P_u(d|\mathbf{D}_d) \leq \begin{cases} \frac{1}{2d\bar{\gamma}_{SD}} & \text{if } \mathbf{D}_d = D_1 \\ \frac{1}{2dd_2\bar{\gamma}_{SD}} \left(\frac{1}{\bar{\gamma}_{SR}} + \frac{1}{\bar{\gamma}_{RD}} \right) & \text{if } \mathbf{D}_d \neq D_1 \end{cases} \quad (5.11)$$

Proof: We start the proof with the pattern $D_1 = \{d, 0\}$. The CPEP corresponding to the pattern D_1 is given by $P_c(d|D_1) = Q(\sqrt{d\gamma_{SD}})$. Using the Chernoff bound of the Q-function we obtain:

$$\begin{aligned} P_u(d|D_1) &= \mathbb{E} \left\{ Q\left(\sqrt{2d\gamma_{SD}}\right) \right\} \\ &\leq \mathbb{E} \left\{ \frac{1}{2} \exp(-d\gamma_{SD}) \right\} \\ &\leq \int_0^\infty \frac{1}{2\bar{\gamma}_{SD}} e^{-\gamma_{SD}\left(d + \frac{1}{\bar{\gamma}_{SD}}\right)} d\gamma_{SD} \\ &< \frac{1}{2d\bar{\gamma}_{SD}}. \end{aligned} \quad (5.12)$$

For any $\mathbf{D}_d \neq D_1$, there are two channels γ_{SD} and γ_{eq} in the Q-function. Following the same argument above we obtain

$$P_u(d|\mathbf{D}_d \neq D_1) = \mathbb{E} \left\{ Q\left(\sqrt{2d\gamma_{SD} + 2d_2\gamma_{eq}}\right) \right\}$$

$$\begin{aligned}
&\leq \mathbb{E} \left\{ \frac{1}{2} \exp(-d\gamma_{SD} - d_2\gamma_{eq}) \right\} \\
&\leq \int_0^\infty \int_0^\infty \frac{1}{2\bar{\gamma}_{SD}\bar{\gamma}_{eq}} e^{-\gamma_{SD}(d+\frac{1}{\bar{\gamma}_{SD}})} e^{-\gamma_{eq}(d_2+\frac{1}{\bar{\gamma}_{eq}})} d\gamma_{SD}d\gamma_{eq} \\
&< \frac{1}{2dd_2\bar{\gamma}_{SD}\bar{\gamma}_{eq}} \\
&= \frac{1}{2dd_2\bar{\gamma}_{SD}} \left(\frac{1}{\bar{\gamma}_{SR}} + \frac{1}{\bar{\gamma}_{RD}} \right). \tag{5.13}
\end{aligned}$$

From (5.12) and (5.13) we get Theorem 5 proved. \square

Making use of Theorem 5 and (5.9) we can derive the BER of the partial relaying as follows:

$$\text{Pe} \leq \sum_{d=d_H}^{\infty} w(d) \underbrace{\left[\frac{p(\mathbf{D}_1)}{2d\bar{\gamma}_{SD}} + \frac{1}{2d\bar{\gamma}_{SD}} \left(\frac{1}{\bar{\gamma}_{SR}} + \frac{1}{\bar{\gamma}_{RD}} \right) \sum_{\mathbf{D}_d \neq \mathbf{D}_1} \frac{p(\mathbf{D}_d)}{d_2} \right]}_{P_u(d)}. \tag{5.14}$$

The system BER in (5.14) is a linear combination of the UPEP $P_u(d)$ weighted by the input weight $w(d)$. Note that the input weight $w(d)$ is strictly defined from the structure of the channel code. Therefore, the diversity order of the system BER is decided by the diversity order of the UPEP $P_u(d)$. We further note that the infinity of d in (5.14) was primitively given for Gaussian channels. In block fading channels, d is usually limited by some first values [68].

It is worth noticing that $P_u(d)$ in (5.14) is a sum of two terms: one has diversity order one weighted by $p(\mathbf{D}_1)/(2d)$ and the other has diversity order two. As such, the overall performance will depend on the ratio between the weights of two terms. The probability of the diversity one term is given by

$$\begin{aligned}
p(\mathbf{D}_1) &= \frac{\mathcal{C}_d^{N-L}}{\mathcal{C}_d^N} = \frac{(N-L)!(N-d)!}{(N-L-d)!N!} \\
&= \prod_{k=0}^{d-1} \frac{N(1-\delta) - k}{N - k}.
\end{aligned}$$

In practice, the length of codeword, N , is usually much larger than d . For example, $d = 5$ for the RSC [5 7] code and N is usually several hundreds of symbols. Then

$p(D_1)$ can be well-approximated as

$$p(D_1) \simeq (1 - \delta)^d. \quad (5.15)$$

Since $p(D_1)$ is a function of d and δ , we can observe that the larger values of δ and d are, the smaller contribution of diversity order one factor is and vice versa. In the next subsection, we will study in details the system diversity order.

5.1.4 Diversity Analysis

The classical definition of diversity order is defined as negative exponent of the average BER in log-log scale in the infinity SNR region [87] as $\zeta = -\lim_{\gamma \rightarrow \infty} \frac{\log[\text{Pe}(\gamma)]}{\log(\gamma)}$, where γ is the average SNR. Stated another way, the diversity order is a slope of the plot of BER as a function of average SNR when SNR tends to infinity. In this paper, we are interested in the diversity order at low and medium SNR regions. To facilitate the analysis, we re-define the diversity order at a certain range of average SNRs γ as follows:

$$\zeta(\gamma) \triangleq -\lim_{\Delta \rightarrow 1} \frac{\log[\text{Pe}(\Delta\gamma)] - \log[\text{Pe}(\gamma)]}{\log(\Delta\gamma) - \log(\gamma)}, \quad (5.16)$$

which perfectly coincides with the classical definition of diversity order when SNR tends to infinity. Here, we refer $\zeta(\gamma)$ as *instantaneous diversity order* (also denoted by instantaneous diversity). The key idea behind the definition is that it allows us to study the system behaviour at any SNR region. Generally speaking, the instantaneous diversity order is the slope when we plot $\text{Pe}(\gamma)$ as a function of γ in log-log scale. Mathematically speaking, the instantaneous diversity at γ_0 is equal to the derivative of $\log[\text{Pe}(\gamma)]$ in log scale

$$\zeta(\gamma_0) = -\left. \frac{\partial \log [\text{Pe}(\gamma)]}{\partial \log \gamma} \right|_{\gamma=\gamma_0} = -\gamma \left. \frac{\partial \log [\text{Pe}(\gamma)]}{\partial \gamma} \right|_{\gamma=\gamma_0}. \quad (5.17)$$

Using instantaneous diversity definition, the diversity order of the proposed network in low and medium SNR regions is provided in Theorem 6.

Theorem 6. *The instantaneous diversity order of $P_u(d)$ at average SNR γ_0 is*

given by

$$\zeta(\gamma_0) = 1 + \frac{B}{B + A\gamma_0} \quad (5.18)$$

where $A = (1 - \delta)^d$ and $B = \left(\frac{1}{g_{SR}} + \frac{1}{g_{RD}}\right) \sum_{\mathbf{D}_d \neq \mathbf{D}_1} \frac{p(\mathbf{D}_d)}{d_2}$, with $g_{SR} = \frac{\bar{\gamma}_{SR}}{\bar{\gamma}_{SD}}$, $g_{RD} = \frac{\bar{\gamma}_{RD}}{\bar{\gamma}_{SD}}$ denote the distance gain of $S \rightarrow D, R \rightarrow D$ channels over $S \rightarrow D$ channel.

Proof. : Denote $A = (1 - \delta)^d$ and $B = \left(\frac{1}{g_{RD}} + \frac{1}{g_{SR}}\right) \sum_{\mathbf{D}_d \setminus \mathbf{D}_1} \frac{p(\mathbf{D}_d)}{d_2}$, the instantaneous diversity order at γ_0 is obtained by making use the definition of instantaneous diversity order in (5.17), *i.e.*, taking the derivative of $\log(P_u(d))$ with respect to γ and then setting $\gamma = \gamma_0$ as follows:

$$\begin{aligned} \zeta(\gamma_0) &= -\gamma \frac{\partial}{\partial \gamma} \left[\log \left(\frac{A\gamma^{-1}}{2d} + \frac{B\gamma^{-2}}{2d} \right) \right] \Big|_{\gamma=\gamma_0} \\ &= 1 + \frac{B}{B + A\gamma_0}. \end{aligned} \quad (5.19)$$

□

Theorem 6 states that the instantaneous diversity order depends on δ , d and γ_0 . If d and δ are large enough such as $(1 - \delta)^d \gamma_0 \ll B$, the proposed scheme could achieve diversity order of 2 in the $[0, \gamma_0]$ SNR region. Especially, if the relay keeps silent, *e.g.*, $\delta = 0$ then $B = 0$, the diversity order is equal to 1 and if the relay forwards all the codeword, *e.g.*, $\delta = 1$, $\zeta(\gamma) = 2 \forall \gamma_0$.

Lets $R = 1/(1 + \delta)$ as the spectrum efficiency in (coded) bits per channel use. There is a trade-off between the instantaneous diversity order and the spectrum efficiency. The relation between $\zeta(\gamma, R)$ and R is similar to Diversity-Multiplexing Trade-off (DMT) [88]. The only difference is that $\zeta(\gamma, R) - R$ depends on average SNR in low and medium SNR region.

5.1.5 Design a Diversity-achieved Relay Network in Low SNR Region

It has been shown in the previous section that the BER of the proposed scheme comprises of one factor of diversity order 1 and one factor of diversity order 2 with different weights. The distribution of the weights would affect the coding gain and

the diversity gain of the system. And this distribution depends on the minimum distance of the code and the amount of information that the relay forwards. In this section, we develop a criteria to efficiently design relay networks with channel coding providing full diversity gain in the SNR region of interest while keeping the relay transmission as less information as possible. Stated another way, relay networks achieve full diversity gain with the highest spectrum efficiency. The theorems presented below will show the design criteria.

Theorem 7. *For a fixed channel code with the minimum distance d_H , the proposed relay scheme achieves full diversity gain in the SNR region $[0, \gamma^*]$ if and only if the relay forwards at least an amount information $M = \delta N$ to the destination with*

$$\delta = 1 - \left(\frac{\varepsilon K}{\gamma^* + \varepsilon K} \right)^{1/d_H}, \quad (5.20)$$

where $\varepsilon \ll 1$ and $K = 1/g_{RD} + 1/g_{SR}$.

Proof. : Starting from (5.20) and recognizing that $d \geq d_H$ and $\varepsilon K/(\gamma^* + \varepsilon K) < 1$, we have

$$(1 - \delta)^d \leq \frac{\varepsilon K}{\gamma^* + \varepsilon K}. \quad (5.21)$$

Recalling that $p(\mathbf{D}_1) = (1 - \delta)^d$, (5.21) is rewritten as follows:

$$\gamma^* p(\mathbf{D}_1) < \varepsilon K (1 - p(\mathbf{D}_1)) \quad (5.22)$$

Since $p(\mathbf{D}_1) = 1 - \sum_{\mathbf{D}_d \neq \mathbf{D}_1} p(\mathbf{D}_d)$, we have

$$\gamma^* p(\mathbf{D}_1) \stackrel{(a)}{\ll} K \sum_{\mathbf{D}_d \neq \mathbf{D}_1} \frac{p(\mathbf{D}_d)}{d} \quad (5.23)$$

$$\stackrel{(b)}{<} K \sum_{\mathbf{D}_d \neq \mathbf{D}_1} \frac{p(\mathbf{D}_d)}{d_2}, \quad (5.24)$$

where (a) results from the fact that $d\varepsilon \ll 1$ since $\varepsilon \ll 1$ and (b) is because $d_2 \leq d$

for all the pattern $\mathbf{D}_d \neq \mathbf{D}_1$. For any value of SNR $\bar{\gamma}_{SD} \leq \gamma^*$, we have

$$\bar{\gamma}_{SD}(1 - \delta)^d \leq \gamma^* p(\mathbf{D}_1) \ll K \sum_{\mathbf{D}_d \neq \mathbf{D}_1} \frac{p(\mathbf{D}_d)}{d_2} = \left(\frac{1}{1g_{RD}} + \frac{1}{g_{SR}} \right) \sum_{\mathbf{D}_d \neq \mathbf{D}_1} \frac{p(\mathbf{D}_d)}{d_2}. \quad (5.25)$$

When the condition in Theorem 6 is satisfied, dividing both sides by $d\bar{\gamma}_{SD}^2$, we get

$$\frac{p(\mathbf{D}_1)}{2d\bar{\gamma}_{SD}} \ll \left(\frac{1}{2d\bar{\gamma}_{SD}\bar{\gamma}_{RD}} + \frac{1}{2d\bar{\gamma}_{SD}\bar{\gamma}_{SR}} \right) \sum_{\mathbf{D}_d \neq \mathbf{D}_1} \frac{p(\mathbf{D}_d)}{d_2}. \quad (5.26)$$

From (5.14), we get $P_u(d) \simeq \left(\frac{1}{2d\bar{\gamma}_{SD}\bar{\gamma}_{RD}} + \frac{1}{2d\bar{\gamma}_{SD}\bar{\gamma}_{SR}} \right) \sum_{\mathbf{D}_d \neq \mathbf{D}_1} \frac{p(\mathbf{D}_d)}{d_2}$ proving that the BER is proportional to $1/\text{SNR}^2$, which also completes the proof. \square

At this point, a natural question arises for a fixed value of δ : what is the required condition of d_H for which the proposed system achieves full diversity? The corresponding answer is given by the following theorem.

Theorem 8. *For a given δ , the proposed network will achieve full diversity gain in the SNR region of $[0, \gamma^*]$ if the minimum distance of the channel d_H satisfies*

$$d_H \geq \left\lceil \log \frac{\gamma^* + \varepsilon K}{\varepsilon K(1 - \delta)} \right\rceil + 1 \quad (5.27)$$

where $\varepsilon \ll 1$ and $K = 1/g_{RD} + 1/g_{SR}$.

Consider the average BER $P_u[d|\mathbf{D}_D]$, from (5.20), we have $d \geq d_H > \log \frac{\gamma^* + \varepsilon K}{\varepsilon K(1 - \delta)}$. Following the same steps as for Theorem 6, we have the desired result as (5.27), which also completes the proof.

5.1.6 Simulation Results

The system and channel settings are set as follows: data message of 1024 bit length, BPSK modulation. The total power consumption is fixed and equal to P_{tot} . This assumption ensures a fair comparison between different values of δ with constraint P_{tot} [89], *i.e.*, the transmitted power symbol $P_0(\delta) = \frac{P_{\text{tot}}}{(1+\delta)N}$. The symbol power at the relay is set equal to that one of the source. Three channel codes with rate 1/3 are examined [85]: i) CC [3 2 3] with $d_H = 5$, ii) CC [5 7 5] with $d_H = 7$,

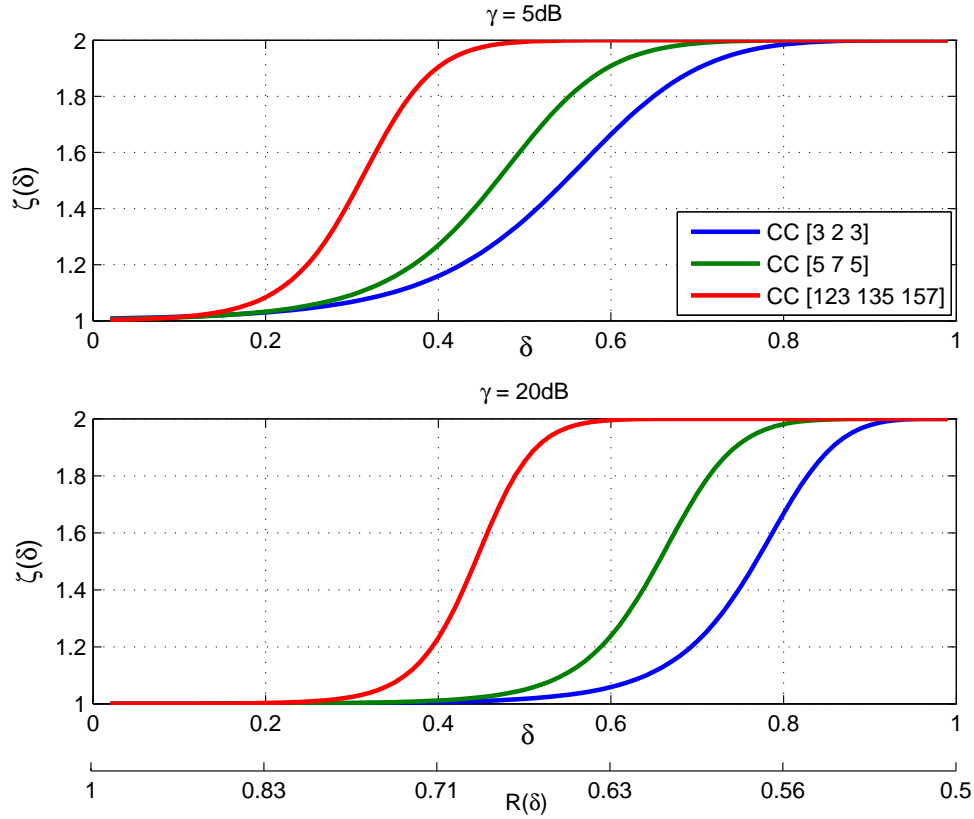

Figure 5.2. Instantaneous diversity order vs. δ when average SNR is fixed

and iii) CC [123 135 157] with $d_H = 15$. As a baseline, we also plot the curves corresponding to special values of δ , *i.e.*, $\delta = 0$ corresponding to *No Cooperation* and $\delta = 1$ corresponding to *Classical relay*.

Fig. 5.2 shows the analysis of the diversity-spectrum efficiency tradeoff for three channel codes. We can see that the stronger the channel code is (larger minimum distance), the higher spectrum efficiency (smaller δ) the network achieves. At $\bar{\gamma}_{SD} = 5$ dB, the code [3 2 3] achieves full diversity order of 2 when the relay forwards 2/3 of the estimated codeword, while the relay needs to forward only $\delta = 0.4$ for CC [123 135 157] and $\delta = 0.6$ for CC [5 7 5], respectively. At $\bar{\gamma}_{SD} = 20$ dB (or BER = 10^{-5}), the weak code [3 2 3] can only achieve diversity of 2 if the relay forwards all the codeword. While the strong code [123 135 157] only needs to forward a half of the codeword to gain full spatial diversity gain. It is equivalent to 32% spectrum efficiency better than classical relay network, in which the relay retransmits the whole estimated codeword. The gain is 20% for the code [5 7 5].

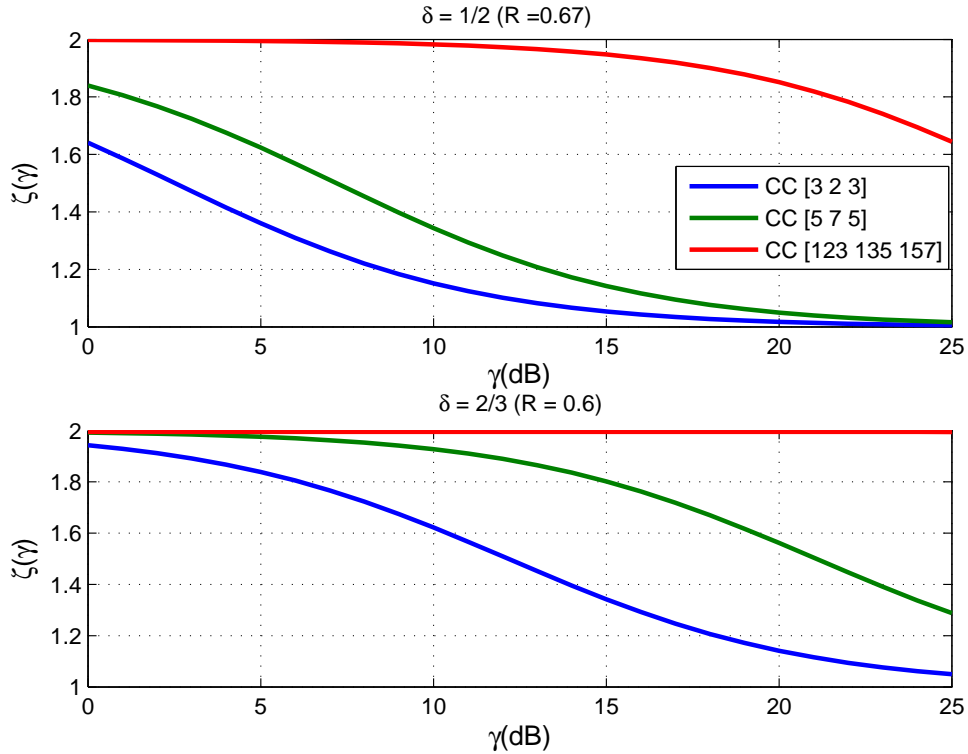

Figure 5.3. Instantaneous diversity order vs. average SNR when δ is fixed

Fig. 5.3 shows the relation of diversity order with average SNRs for a fixed number $\delta = 1/2$ and $\delta = 2/3$. The strong code [123 135 157] achieves full diversity gain in [0, 20] dB SNR region, while the code [5 7 5] only gains full diversity in [0, 15] dB and $\delta = 2/3$. The weak code [3 2 3] loses diversity very soon.

Fig. 5.4 shows the upper bound and simulation of the proposed network for three channel codes when the total power consumption P_{tot} is fixed and the relay is located in the middle of the source and the destination. The solid marked curves show the simulation results and the dotted curves show the upper bound in (5.14). Three first weights in d are used to compute the bound. It is shown in the figure that the weak code does not provide diversity gain. This agrees with the analysis of diversity-spectrum efficiency tradeoff. Interestingly, the strong code with $\delta = 1/2$ achieves full diversity gain in (BER = 10^{-5}) SNR region and same performance as classical relaying ($\delta = 1$) while it can save 32% spectrum efficiency.

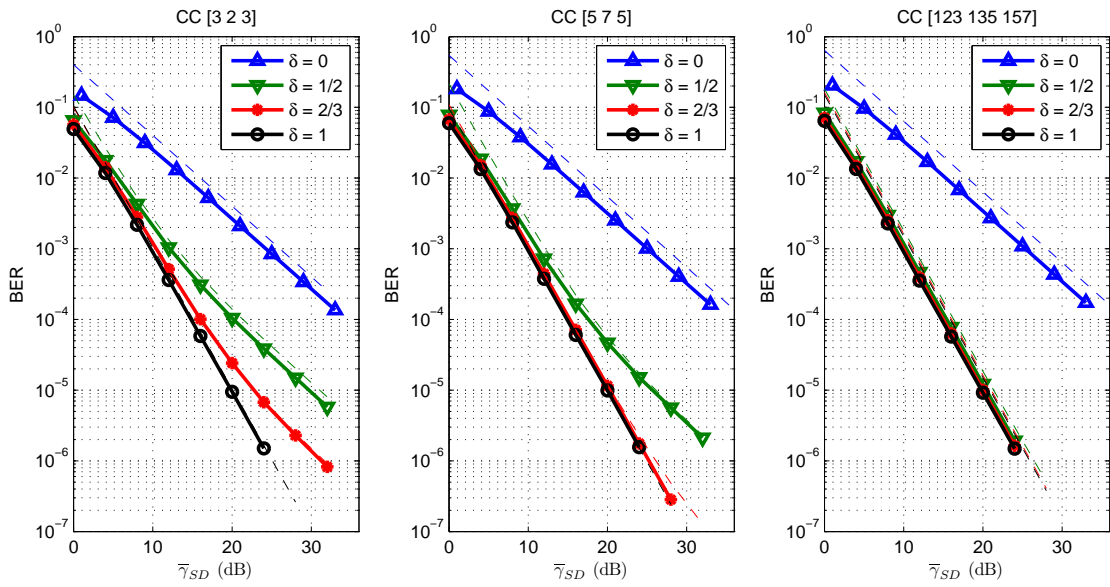

Figure 5.4. The performance of the proposed network for different channel codes and different δ in block Rayleigh fading channels. Total power consumption is fixed. Solid marked cures: simulation results, dotted curves: the bound. The curve $\delta = 0$ corresponds to *No Cooperation* and has spectrum efficiency 1 (coded bit per channel use). The curve $\delta = 1$ corresponds to *Classical relay* and has spectrum efficiency 0.5. The curves $\delta = 1/2$ and $\delta = 2/3$ have respectively spectrum efficiency 0.67 and 0.6.

5.2 Partial Relaying for Multiple Relay Networks

The previous section studied the performance of the partial relaying scheme and showed the potential spectrum improvement over the classical relaying scheme. In this section, we consider the partial relaying in two-source multiple-relay networks. In such networks, in order to increase the spectrum usage, relay selection [48] will be used to select a few active relays for cooperation. In Network-Coded Cooperative Protocol (NCCP), which is studied in Section 4 of Chapter 3, the best relay is chosen to forward the network-coded symbols to the destination. However, it has been shown in Section 4 that NCCP only achieves single diversity gain whatever how many relays are available. This loss in diversity gain results from the fact that the selected relay is only optimal for the network-coded symbols. To recover this diversity loss, we propose a novel Diversity-Achieving Cooperative Protocol (DACP). In DACP, two relays will be selected for cooperation, each relay will help one source. In order to maintain the spectrum usage, the selected relay can only forward half of the estimated codeword to the destination. We derive the upper bound of BER as well as analyze the diversity order of DACP. The analytical results show that DACP can achieve full diversity order and significantly outperforms NCCP in finite SNR region when a strong code is used.

5.2.1 System Model

Figure 5.5 depicts the system under consideration consisting of two sources (S_1, S_2), a destination D and N_r relays R_i with $1 \leq i \leq N_r$. All nodes are equipped with half-duplex single antennas. The system is assumed to operate with orthogonal channels. As a result, a cooperation period is divided into two phases: in the first phase, two sources consecutively broadcast a codeword to the destination and the relays; in the second phase, after relay selection, the selected relays forward the estimated codewords to the destination. All the channels are subjected to quasi-static block Rayleigh fading plus AWGN. The relays employ DMF protocol. We note that DACP does not use NC. Since the operation at two sources is similar, we drop the index for each source and use subscript $(.)_S$ to denote the source signal.

First, the source encodes a length K data message \mathbf{u}_S into a codeword \mathbf{c}_S which contains KN coded symbols by a convolutional code with rate $1/N$. The codeword

\mathbf{c}_S is then BPSK modulated into a signal \mathbf{x}_S . Next, the signal \mathbf{x}_S is broadcasted to the relays and the destination. Without loss of generality, denote by R (without subscript) the selected relay in DACP. The received signal at the destination and the selected relay at the end of first frame are given as follows:

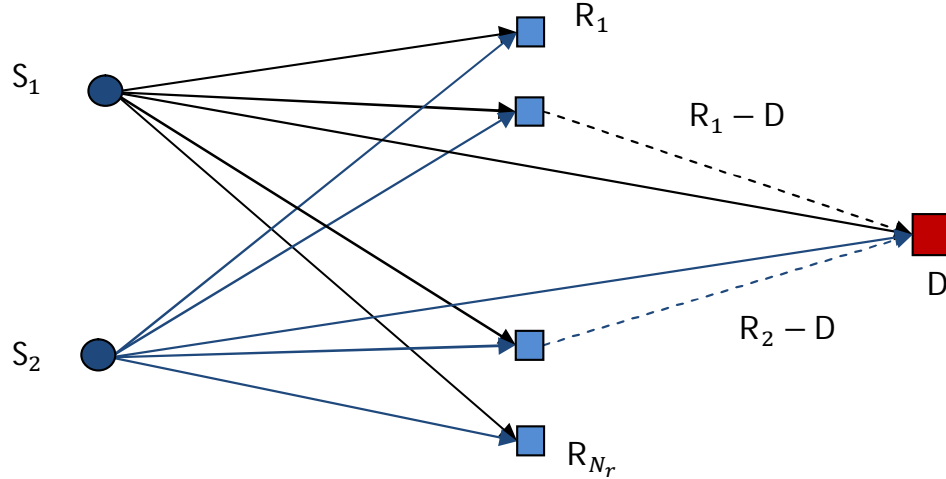

Figure 5.5. Diagram of partial relaying in two-source multiple-relay networks. In DACP, two relays are selected to help the sources. Each relay helps one source by forwarding half of the codeword to the destination.

$$\begin{cases} \mathbf{y}_{SR} = \sqrt{P_{SR}}h_{SR}\mathbf{x}_S + \mathbf{n}, \\ \mathbf{y}_{SD} = \sqrt{P_{SD}}h_{SD}\mathbf{x}_S + \mathbf{n}, \end{cases} \quad (5.28)$$

where P_{XY} with $X \in \{S_1, S_2\}, Y \in \{R, D\}$ is power of the received signal at node Y from node X , including the path loss; h_{XY} is channel coefficient of the channel $X \rightarrow Y$, which is a complex Gaussian random variable with zero mean and unit variance, *i.e.*, $\mathbb{E}\{|h_{XY}|^2\} = 1$ and is mutual statistically independent among $X \rightarrow Y$ channels; \mathbf{n} (index is ignored for convenience) is a noise vector whose components are Gaussian random variables with mean zero and variance σ^2 .

Once received signal from the source, the selected relay R first estimates $L = KN/2$ data symbols to form an estimated punctured codeword $\hat{\mathbf{c}}_R = \{\hat{c}_{R,k_l}\}_{l=1}^L$ with $\Theta = \{k_1, k_2, \dots, k_L\}$ being a set of data indexes which is retransmitted by

the relay. Estimated by the ML detector, the data symbols at the relay are as follows:

$$\hat{c}_{R,l} = \arg \min_{c_{k_l} \in \{0,1\}} \{|y_{SR,k_l} - \sqrt{P_{SR}}h_{SR}x_{S,k_l}|^2\}.$$

Next, R modulates $\{\hat{c}_{R,k_l}\}_{l=1}^L$ into signal symbols $\hat{x}_{R,l} = 2\hat{c}_{R,l} - 1$ before forwarding it along with the index set Θ to the destination. The received signal at the destination transmitted from the relay is given by

$$\mathbf{y}_{RD} = \sqrt{P_{RD}}h_{RD}\hat{\mathbf{x}}_R + \mathbf{n}, \quad (5.29)$$

where P_{RD} is the power of the received signal at D from R; h_{RD} is the channel coefficient from R \rightarrow D and \mathbf{n} is a noise vector whose components are Gaussian random variable with zero mean and variance σ^2 .

Upon receiving signal from the source and from the selected relay, the destination starts the decoding process in the same manner as in (5.3) in Section 5.1.

Note that in DACP, the destination applies the BCJR algorithm for each source separately. In contrast, the NCCP jointly decodes both source messages at the same time.

5.2.2 Relay Selection

In this section, we describe in details the relay selection in DACP. Reminding that $\gamma_{XY} = P_{XY}|h_{XY}|^2/\sigma^2$ denotes the instantaneous SNR of the channel X \rightarrow Y. The average SNR is given by $\bar{\gamma}_{XY} = P_{XY}/\sigma^2$.

In DACP, the relay selection phase is divided into two sub-phases. Each sub-phase is used for one source. Because the system is symmetric, we avoid source index and use $(\cdot)_S$ as subscript for the source signal. The two-hop source-relay-destination channel for relayed symbols can be tightly modeled as a single-hop channel $\gamma_j = \min\{\gamma_{SR_j}, \gamma_{R_jD}\}$ with $1 \leq j \leq N_r$. Because γ_{SR_j} and γ_{R_jD} are exponential random variables, it is easy to show that γ_j is also an exponent random

variable with parameter $\bar{\gamma}_j$, which is given as follows:

$$\frac{1}{\bar{\gamma}_j} = \frac{1}{\bar{\gamma}_{SR_j}} + \frac{1}{\bar{\gamma}_{R_jD}}. \quad (5.30)$$

The relay whose equivalent channel is largest will be selected for cooperation. Without loss of generality, denote by R (since the relay selection process for two source is similar, we drop the subscript of the selected relay for convenience) the selected relay whose equivalent SNR is chosen as follows:

$$\gamma_{Sel} = \max\{\gamma_1, \dots, \gamma_{N_r}\}. \quad (5.31)$$

Thanks to the Max function in [81], the PDF of γ_{Sel} is given in a shorten form as follows [90]:

$$f_{\gamma_{Sel}}(\gamma) = \sum_{j=1}^{N_r} \left((-1)^{j-1} \sum_{\substack{n_1=1, n_2=1, \dots, n_j=1 \\ n_1 < n_2 < \dots < n_j}}^{N_r} \frac{1}{\bar{\gamma}_{Sel,j}} \exp\left(-\frac{\gamma}{\bar{\gamma}_{Sel,j}}\right) \right), \quad (5.32)$$

with

$$\frac{1}{\bar{\gamma}_{Sel,j}} = \sum_{k=1}^j \left(\frac{1}{\bar{\gamma}_{SR_{n_k}}} + \frac{1}{\bar{\gamma}_{R_{n_k}D}} \right). \quad (5.33)$$

The MGF of γ_{Sel} is given by

$$\Psi_{\gamma_{Sel}}(s) = \sum_{j=1}^{N_r} \left((-1)^{j-1} \sum_{\substack{n_1=1, n_2=1, \dots, n_j=1 \\ n_1 < n_2 < \dots < n_j}}^{N_r} \frac{1}{1 + \bar{\gamma}_{Sel,j}s} \right). \quad (5.34)$$

Knowing the distribution and the MGF of the equivalent selected SNR allows us to derive the performance of the proposed scheme.

5.2.3 Bit Error Rate Analysis

In this subsection, we study the BER for DACP. Remind that the system is symmetric, hence the performance analysis for two sources is analogous. For conve-

nience, we avoid sub index for the source. In addition, we also use equivalent channel as in Section 5.1 to derive the system BER.

After two frames, the destination receives two signal from the source and from the selected relay. Because the selected relay only forwards half of the estimated codeword, the received signal at the destination, after C-MRC demodulating, can be seen as an output of block fading channel with 2 blocks: one block consisting of $N/2$ symbols only sees the channel γ_{SD} , and the other one which contains $N/2$ symbols sees both channel γ_{SD} and channel γ_{Sel} . Therefore, the BER of DACP becomes similar to the BER of partial relaying in Section 5.1 when the relaying factor $\delta = 1/2$. The only difference between DACP and Section 5.1 is that the equivalent SNR of the relay channel γ_{Sel} in DACP is an output of the Max function and has the PDF given in (5.32).

Let $P_u(d)$ be the UPEP that the destination receives a codeword with the Hamming distance d when the all-zero codeword was transmitted, the BER in DACP is upper-bounded as follows [71, eq. (3.175)]:

$$Pe \leq \sum_{d=d_H}^{\infty} w(d)P_u(d), \quad (5.35)$$

where d_H is the minimum distance of the channel code at sources and $w(d)$ is the input weights computed directly from structure of the code at the sources.

Denote by $P_c(d)$ the conditional pairwise error probability (CPEP) and $\mathbf{D}_d = \{d_1, d_2\}$ with $d_1 + d_2 = d$ the weight pattern that presents how d weights are distributed on two blocks. Following same steps as in Section 5.1 we obtain:

$$P_u(d) = \sum_{\mathbf{D}_d} \underbrace{\mathbb{E} \{P_c(d|\mathbf{D}_d)\}}_{P_u(d|\mathbf{D}_d)} p(\mathbf{D}_d). \quad (5.36)$$

In (5.36), $p(\mathbf{D}_d)$ is the probability of pattern \mathbf{D}_d which is computed by combinatoric computation as

$$p(\mathbf{D}_d) = \frac{\mathcal{C}_{d_1}^{N/2} \times \mathcal{C}_{d_2}^{N/2}}{\mathcal{C}_d^N}. \quad (5.37)$$

The CPEP $P_c(d|\mathbf{D}_d)$ is given as follows:

$$P_c(d|\mathbf{D}_d) = Q(\sqrt{\gamma_\Sigma}), \quad (5.38)$$

with $\gamma_\Sigma = 2d\gamma_{SD} + 2d_2\gamma_{Sel}$ and $Q(\cdot)$ denotes the Q-function.

Taking into account the independency between γ_{SD} and γ_{Sel} as well as their distribution, we can obtain the UPEP $P_u(d|\mathbf{D}_d)$ as in the following theorem.

Theorem 9. *Given the weight pattern $\mathbf{D}_d = \{d_1, d_2\}$ with $d = d_1 + d_2$, the UPEP $P_u(d|\mathbf{D}_d)$ of DACP is given as follows:*

$$P_u(d|\mathbf{D}_d) = \begin{cases} \frac{1}{2} \left(1 - \sqrt{\frac{d\bar{\gamma}_{SD}}{1+d\bar{\gamma}_{SD}}} \right), & \text{if } d_2 = 0 \\ \sum_{j=1}^{N_r} \left((-1)^{j-1} \sum_{\substack{n_1=1, n_2=1, \dots, n_j=1 \\ n_1 < n_2 < \dots < n_j}}^{N_r} \mathcal{I}(d\bar{\gamma}_{SD}, d_2\bar{\gamma}_{Sel, j}) \right), & \text{if } d_2 > 0 \end{cases}, \quad (5.39)$$

with

$$\mathcal{I}(a, b) = \frac{1}{2} \left(1 - \frac{a}{a-b} \sqrt{\frac{a}{a+1}} - \frac{b}{b-a} \sqrt{\frac{b}{b+1}} \right).$$

Proof. : Because the relayed symbols are randomly distributed on the codeword, the weight on relayed block d_2 can have any value in $[0, d]$. Define $D_1 = \{d, 0\}$ as the weight pattern where all d weights are not relayed. Then the weight pattern in DACP has one of two forms, $D_1 = \{d, 0\}$ and $\mathbf{D}_d \neq D_1$.

- **Case 1:** $\mathbf{D}_d = D_1$. In this case, all d weights locate in source-destination block, resulting in $\gamma_\Sigma = d\gamma_{SD}$ and $\Psi_{\gamma_\Sigma}(s) = \Psi_{\gamma_{SD}}(ds)$. The UPEP is given by

$$\begin{aligned} P_u(d|D_1) &= \frac{1}{\pi} \int_0^{\pi/2} \Psi_{\gamma_\Sigma} \left(\frac{1}{\sin^2 \theta} \right) d\theta \\ &= \frac{1}{\pi} \int_0^{\pi/2} \frac{\sin^2 \theta}{\sin^2 \theta + d\bar{\gamma}_{SD}} d\theta \\ &= \frac{1}{2} \left(1 - \sqrt{\frac{d\bar{\gamma}_{SD}}{1+d\bar{\gamma}_{SD}}} \right). \end{aligned} \quad (5.40)$$

- **Case 2: $\mathbf{D}_d \neq \mathbf{D}_1$.** The d weights always distribute on two blocks, resulting in $\Psi_{\gamma_\Sigma}(s) = \Psi_{\gamma_{SD}}(ds) \times \Psi_{\gamma_\Sigma}(d_2s)$.

$$\begin{aligned}
P_u(d|\mathbf{D}_d) &= \frac{1}{\pi} \int_0^{\pi/2} \Psi_{\gamma_\Sigma} \left(\frac{1}{\sin \theta^2} \right) d\theta \\
&= \sum_{j=1}^{N_r} \left((-1)^{j-1} \sum_{\substack{n_1=1, n_2=1, \dots, n_j=1 \\ n_1 < n_2 < \dots < n_j}}^{N_r} \frac{1}{\pi} \int_0^{\pi/2} \frac{\sin \theta^4}{(\sin \theta^2 + d\bar{\gamma}_{SD})(\sin \theta^2 + d_2\bar{\gamma}_{Sel,j})} d\theta \right) \\
&= \sum_{j=1}^{N_r} \left((-1)^{j-1} \sum_{\substack{n_1=1, n_2=1, \dots, n_j=1 \\ n_1 < n_2 < \dots < n_j}}^{N_r} \mathcal{I}(d\bar{\gamma}_{SD}, d_2\bar{\gamma}_{Sel,j}) \right), \quad (5.41)
\end{aligned}$$

where

$$\mathcal{I}(a, b) = \frac{1}{2} \left(1 - \frac{a}{a-b} \sqrt{\frac{a}{1+a}} - \frac{b}{b-a} \sqrt{\frac{b}{1+b}} \right).$$

□

From Theorem 9 and (5.35) one can see that the BER of DACP is a combination of two terms: the first term with single diversity order weighted by $p(\mathbf{D}_1)$ and the other one weighted by $p(\mathbf{D}_d)$ with $\mathbf{D}_d \neq \mathbf{D}_1$. The contribution of the diversity order 1 term is given by

$$p(\mathbf{D}_1) = \frac{\mathcal{C}_d^{N/2}}{\mathcal{C}_d^N}. \quad (5.42)$$

Depending on the minimum distance of the channel code, the effect of diversity order 1 factor on the system BER varies accordingly. The next subsection study in details the diversity order of DACP.

5.2.4 Diversity analysis for DACP

As showed earlier, the BER of DACP is a sum of a diversity one term and the other term. The diversity order of DACP is given in Theorem 10.

Theorem 10. *Given the weight pattern $\mathbf{D}_d = \{d_1, d_2\}$ with $d = d_1 + d_2$, the UPEP $P_u(d|\mathbf{D}_d)$ in DACP is given as follows:*

$$P_u(d|\mathbf{D}_d) \doteq \begin{cases} SNR^{-1}, & \text{if } d_2 = 0 \\ SNR^{-(N_r+1)}, & \text{if } d_2 > 0 \end{cases}. \quad (5.43)$$

Proof. The diversity order is defined as the negative exponent of UPEP in log-scale when the average SNR $\bar{\gamma}$ tends to infinity

$$\tau_d = - \lim_{\bar{\gamma} \rightarrow \infty} \left(\frac{\log P_u(d|\mathbf{D}_d)}{\log \bar{\gamma}} \right). \quad (5.44)$$

Using the upper bound of UPEP [81] as $P_u(d|\mathbf{D}_d) \leq \frac{1}{2} \Psi_{\gamma_\Sigma}(1/2) < \Psi_{\gamma_\Sigma}(1/2)$ and recall (5.44) we have

$$\tau_d \geq - \lim_{\bar{\gamma} \rightarrow \infty} \left(\frac{\log \Psi_{\gamma_\Sigma}(1/2)}{\log \bar{\gamma}} \right). \quad (5.45)$$

As in Theorem 9, we consider two cases.

- **Case 1:** $\mathbf{D}_d = \mathbf{D}_1$. In this case, all weights locate in the γ_{SD} channel, resulting in $\Psi_{\gamma_\Sigma}(1/2) = \Psi_{\gamma_{SD}}(d/2)$. The diversity order in this case is given by

$$\begin{aligned} \tau_d &\geq - \lim_{\bar{\gamma} \rightarrow \infty} \frac{\log \Psi_{\gamma_{SD}}(d/2)}{\log \bar{\gamma}} \\ &\geq - \lim_{\bar{\gamma} \rightarrow \infty} \left(\frac{(1 + d\bar{\gamma}_{SD}/2)^{-1}}{\log \bar{\gamma}} \right) \\ &= 1. \end{aligned} \quad (5.46)$$

Then the UPEP has diversity order of 1 when $d_2 = 0$ and we can write $P_u(d|\mathbf{D}_1) \doteq (\bar{\gamma})^{-1}$.

- **Case 2:** $\mathbf{D}_d \neq \mathbf{D}_1$. The MGF of the γ_Σ in this case has a form of $\Psi_{\gamma_\Sigma}(1/2) = \Psi_{\gamma_{SD}}(d/2) \times \Psi_{\gamma_{sel}}(d_2/2)$. Consequently, the diversity order is given as fol-

lows:

$$\begin{aligned} \tau_d &\geq - \lim_{\bar{\gamma} \rightarrow \infty} \frac{\log \Psi_{\gamma_{SD}}(d/2)}{\log \bar{\gamma}} - \underbrace{\lim_{\bar{\gamma} \rightarrow \infty} \frac{\log \Psi_{\gamma_{Sel}}(d_2/2)}{\log \bar{\gamma}}}_{\tau_{Sel}} \\ &= 1 + \tau_{Sel}, \end{aligned} \quad (5.47)$$

where τ_{Sel} is the diversity order of the best selective relay signal (without direct link). It has shown in [48] that the best selected relay achieves diversity order is equal to the total number of available relays, $\tau_{Sel} = N_r$. Therefore we have the system diversity order in this case is equal to $N_r + 1$. In other words, we have $P_u(d | \mathbf{D}_d \neq \mathbf{D}_1) \stackrel{\circ}{=} (\bar{\gamma})^{-(N_r+1)}$.

From two cases above, we get Theorem 10 proved. \square

The system BER in (5.35) is a linear combination of the UPEP $P_u(d)$ weighted by the input weight $w(d)$, which is a constant and is directly computed from the structure of the channel code. Therefore, the diversity order of DACP is decided by diversity order of the UPEP $P_u(d)$. From Theorem 10 we can conclude that the UPEP $P_u(d)$ is a sum of one single diversity order and one diversity order of $N_r + 1$. The contribution of the single diversity order factor is given in (5.42). In practical systems, the codeword length N is usually much larger than d , then $p(D_1)$ can be well-approximated as

$$p(D_1) \simeq \left(\frac{1}{2}\right)^d. \quad (5.48)$$

Since $p(D_1)$ is a function of d , we observe that the larger d is, the less impact of diversity one factor on the BER in DACP is. For a strong code where the minimum distance d_H is large enough, the impact of diversity one is negligible compared with the diversity order $N_r + 1$ factor, resulting the system can achieve full diversity of $N_r + 1$ in the finite SNR region [61]. It is important to practical networks because the operating SNR region is usually finite. When the average SNR tends to be infinity, the diversity order of DACP approaches to one.

5.2.5 Simulation Results

The system under study consists of two sources, N_r relays and one destination. All channels are subject to quasi-static block Rayleigh fading plus Gaussian noise. BPSK modulation and binary network coding are employed. The data packet length is equal to 1024bits. All relays locate at the middle of the sources and the destination. The channel code is chosen as the one that optimizes both the minimum distance and distance spectrum in block Rayleigh fading channels [91].

We compare the proposed DACP with NCCP, which is described in the Chapter 3.

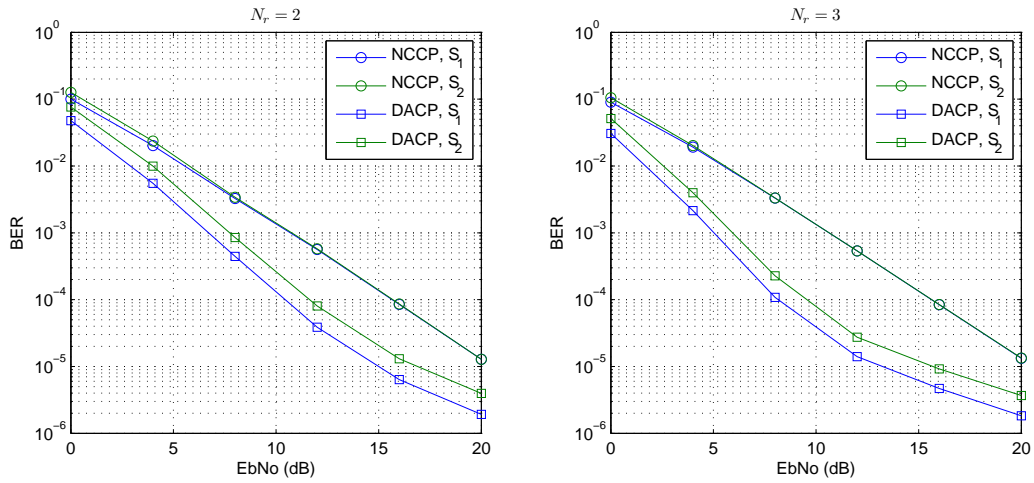

Figure 5.6. Performance comparison between DACP and NCCP when the CC [25 33 37] with the minimum distance $d_H = 12$ and the rate $1/3$ is used.

Figure 5.6 shows the performance comparison between DACP and NCCP when the channel code [25 33 37] with rate $1/3$ is used. The minimum distance of this code is $d_H = 12$. We observe that NCCP always achieve a diversity order of 2 for both case $N_r = 2$ or $N_r = 3$ available relays in the network. In addition, the performance of NCCP in both cases is similar. When $N_r = 2$ relays, DACP achieves full diversity order of 3 at low SNR region. Similarly, DACP achieves a diversity order of 4 when the total available relays is $N_r = 3$. This is consistent with our analysis. Moving toward to the high SNR region, the diversity order of DACP decodes. However, DACP significantly outperforms NCCP in term of coding gain at finite SNR regime. Particularly, DACP provides about 5dB coding

gain over NCCP at BER of 10^{-4} for the case $N_r = 2$ relays. When the total number of relays is 3, this coding gain becomes more significant at about 7dB. If the SNR tends to infinity, the diversity order of DACP collapses to one and there will be a crossing-point between DACP and NCCP. From the practical system point of view, that crossing-point might not affect the fact that DACP outperforms NCCP because the system usually operates at finite SNR region.

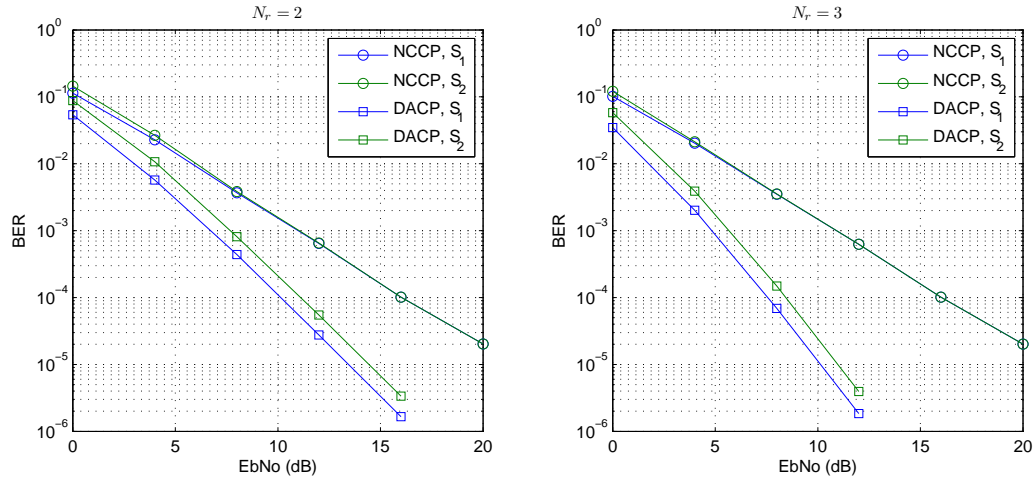

Figure 5.7. Performance comparison between DACP and NCCP when the CC [133 165 171] with the minimum distance $d_H = 15$ and the rate $1/3$ is used.

Figure 5.7 compares the performance of DACP and NCCP when the strong code [133 165 171] with the rate $1/3$ and the minimum distance $d_H = 15$ is used. In this case, a similar conclusion for NCCP is given that NCCP always achieves a diversity order of 2. In contrast, DACP gains full diversity order of 3 and 4 in the observing SNR region when the total number of relays are respectively 2 and 3. This can be explained that in this case, the impact of diversity order 1 factor is negligible and equal to $p(D_1) = (1/2)^{d_H} \simeq 3 \cdot 10^{-5}$. Therefore, DACP can gain diversity in the observing SNR region, that is equivalent to $\text{BER} = 10^{-6}$ in this case. Compare with NCCP, DACP significantly outperforms with about 6dB and 10dB at $\text{BER} = 10^{-4}$ for the case $N_r = 2$ and $N_r = 3$, respectively. When SNR tends to infinity, NCCP may outperform DACP because DACP's diversity decreases to one while NCCP still has diversity order of 2.

5.3 Conclusions

We proposed a new partial relaying protocol applied in practical networks. Unlike classical relay scheme, which forwards entire codewords to the destination, the proposed scheme only retransmits a part of the estimated codeword in order to gain a higher spectrum efficiency. When applied in the relay networks under quasi-static block Rayleigh fading conditions, we analytical show that the proposed relay scheme can gain a full diversity order in finite SNR region. The relation between the diversity order and the fraction of relay signal is deeply understood via some optimal system design criteria. In practical systems, while the number of possible choices of channel code (the minimum distance) is usually limited, the proposed scheme provides a more flexible solution to design a cooperative network which gains a full diversity order in some finite SNR regimes. Furthermore, based on partial relaying protocol, we proposed a diversity-achieved cooperative protocol for a multiple-relay network with relay selection. Compared with the Network Coding based cooperative protocol, which only corresponds to diversity order of 2, the DACP achieves full diversity gain that is equal to the total number of available relays at low SNR region. Therefore, although the eventual diversity order of DACP is one (at infinity SNR), DACP significantly outperforms NCCP in finite SNR region.

Conclusions and Future work

6.1 Conclusions

We have investigated robust receiver design and its performance analysis for a cooperative network with both single-relay and multiple-relay networks. The network is studied under realistic conditions with channel coding. Our design is based on joint network/channel decoding in order to achieve full diversity and high coding gain. The contributions of the thesis can be summarized as follows:

- Iterative Network/Channel Decoding algorithm. In Chapter 2, we have studied the four-node MARC under realistic conditions where all links are subject to block Rayleigh fading channels. Two relaying techniques named Decode-and-Forward and Demodulate-and-Forward have been considered. In the DF, the relay first decodes the source messages and then performs network-encoding. In the DMF, no channel decoding is performed at the relay. Instead, the relay only estimates the encoded bits. As a matter of fact, network coding is performed on information bits in DF and on encoded bits in DMF. We have developed two INCD algorithms at the destination, each algorithm for one relaying protocol. The proposed algorithms operates based on turbo-decoding method: soft information (of information bits or encoded bits) is exchanged between the channel decoders and the network decoder. In order to achieve full diversity, possible errors at the relay are eliminated at the destination thanks to the channel-aware receiver design. It is well known

that the possible decoding errors at the relay is inversely proportional to the quality of source-relay links. In our design, the source-relay CSI is conveyed to the destination via a practical mechanism: the relay quantizes the possible decoding errors and then forwards them to the destination. The impact of the pilots was also studied. The simulation results have shown that the proposed algorithms achieved full diversity gain and better coding compared with classical JNCD design. The number of pilot symbols only affects the system coding gain but not the diversity gain while the quantization accuracy takes effect on both coding gain and diversity order.

- Near Optimal Joint Network/Channel Decoding algorithm. In Chapter 3, we have proposed a new decoding algorithm called NO-JNCD. Although INCD algorithm achieves full diversity order, it is difficult to derive the BER in closed-form due to the difficulty of characterizing information among iterations. Moreover, network decoding and channel decoding are performed in separate steps, which results in a sub-optimal solution. To overcome this problem, we considered the network from the system point of view: the received signal at the destination is parts of a super code. From this point, the relayed signal can be seen as an additional redundancy to the super code. Therefore, network decoding and channel decoding are completed in one decoding step of the super code. Although being more complex than iterative decoding solutions, NO-JNCD algorithm approaches the optimal solution and allows us to analyze the system performance, *e.g.*, BER and diversity order. In particular, we have proposed a framework to analyze the performance of NCC under fully-interleaved Rayleigh fading channels. We have derived the accurate BER closed-form for NCC and have analytically shown that NCC achieves a diversity gain that is equal the minimum distance of the channel code used at the sources.
- Network Coding with Relay Selection. In Chapter 4 we have considered cooperative networks where NC is exploited together with SRS and MRS. Particularly, we have studied the diversity order of multiple-source multiple-relay networks under flat Rayleigh fading channels. The exact and asymptotic outage probability of NC with MRS were provided. From the asymptotic of

outage probability, we have derived the diversity gain of relay selection. It has been shown that SRS only achieves a single diversity gain regardless of the number of relays. On the other hand, MRS can achieve full diversity gain if the number of selected relays is equal or larger than the number of sources.

- **Partial Relaying in Cooperative Networks.** In Chapter 5, we have proposed a new relaying scheme called *partial relaying* applied for channel-coded relay networks in order to improve the spectrum efficiency. First for the single relay network, we have derived the closed-form expressions of BER and diversity order. We have shown, by both simulation and analysis, that the system diversity order depends on the channel code and the amount of information the relay forwards. For a convolutional code with the minimum distance equal to 15, partial relaying can achieve full diversity and almost the same coding gain as the classical relay technique, while it provides 32% spectrum efficiency over classical relaying. Based on this framework, we developed a criteria to design a relay network to gain full diversity and better spectrum usage. Furthermore, we have proposed a new cooperative scheme based on partial relaying in two-source multiple-relay networks with relay selection. The proposed scheme has shown significant improvement over a network-coding based scheme in finite SNR region when a strong convolutive code is used. In particular, the partial relaying based scheme could achieve full diversity in low and medium SNR regime, while the NC-based scheme only achieves a diversity order of two.

6.2 Further work

Several possible further research directions originate from this thesis:

- The proposed NO-JNCD algorithm was only analyzed for fully-interleaved and quasi-static block Rayleigh fading. In practical systems, the fading model can be different. Some different fading models, *e.g.*, general block Rayleigh fading, can be considered with NO-JNCD. In this thesis, we only considered NO-JNCD algorithm when one relay is active. Another extension is to study

the network with more than one active relay. In this case, each relayed signal plays as an addition parity bits to the super code.

- Consider NC combined with RS, the interesting result in Chapter 3 is that the asymptotic outage probability of MRS does not depend on the relay channels. This result can be extended to study different aspects, for example, effects of the number of relays and their location. In homogeneous relay networks, the relays are randomly generated according to some random processes, *e.g.*, Poisson point process and their location is uniform distributed over the surface.

Bibliography

- [1] MEULEN, E. V. (1971) “Three-Terminal Communication Channels,” *Advances in Applied Probability*, **3**(1), pp. 120–154.
- [2] COVER, T. and A. GAMAL (1979) “Capacity theorems for the relay channel,” **25**(5), pp. 572–584.
- [3] WYNER, A. (1975) “On source coding with side information at the decoder,” *Information Theory, IEEE Transactions on*, **21**(3), pp. 294–300.
- [4] HOST-MADSEN, A. and J. ZHANG (2005) “Capacity bounds and power allocation for wireless relay channels,” *Information Theory, IEEE Transactions on*, **51**(6), pp. 2020–2040.
- [5] NABAR, R., H. BOLCSKEI, and F. KNEUBUHLER (2004) “Fading relay channels: performance limits and space-time signal design,” *Selected Areas in Communications, IEEE Journal on*, **22**(6), pp. 1099–1109.
- [6] EL GAMAL, A. and S. ZAHEDI (2005) “Capacity of a class of relay channels with orthogonal components,” *Information Theory, IEEE Transactions on*, **51**(5), pp. 1815–1817.
- [7] LIANG, Y. and V. VEERAVALLI (2005) “Gaussian Orthogonal Relay Channels: Optimal Resource Allocation and Capacity,” *Information Theory, IEEE Transactions on*, **51**(9), pp. 3284–3289.

- [8] EL GAMAL, A., M. MOHSENI, and S. ZAHEDI (2006) “Bounds on capacity and minimum energy-per-bit for AWGN relay channels,” *Information Theory, IEEE Transactions on*, **52**(4), pp. 1545–1561.
- [9] DANA, A. and B. HASSIBI (2006) “On the power efficiency of sensory and ad hoc wireless networks,” *Information Theory, IEEE Transactions on*, **52**(7), pp. 2890–2914.
- [10] NOSRATINIA, A., T. HUNTER, and A. HEDAYAT (2004) “Cooperative communication in wireless networks,” *Communications Magazine, IEEE*, **42**(10), pp. 74–80.
- [11] HUNTER, T. and A. NOSRATINIA (2006) “Diversity through coded cooperation,” *Wireless Communications, IEEE Transactions on*, **5**(2), pp. 283–289.
- [12] JANANI, M., A. HEDAYAT, T. E. HUNTER, and A. NOSRATINIA (2004) “Coded cooperation in wireless communications: space-time transmission and iterative decoding,” *Signal Processing, IEEE Transactions on*, **52**(2), pp. 362–371.
- [13] KRAMER, G., M. GASTPAR, and P. GUPTA (2005) “Cooperative Strategies and Capacity Theorems for Relay Networks,” *Information Theory, IEEE Transactions on*, **51**(9), pp. 3037–3063, 0018-9448.
- [14] KRAMER, G. and A. VAN WIJNGAARDEN (2000) “On the white Gaussian multiple-access relay channel,” in *Information Theory, 2000. Proceedings. IEEE International Symposium on*, pp. 40–.
- [15] SANKARANARAYANAN, L., G. KRAMER, and N. B. MANDAYAM (2004) “Hierarchical sensor networks: capacity bounds and cooperative strategies using the multiple-access relay channel model,” in *Sensor and Ad Hoc Communications and Networks, 2004. IEEE SECON 2004. 2004 First Annual IEEE Communications Society Conference on*, pp. 191–199.
- [16] CHEN, D., K. AZARIAN, and J. LANEMAN (2008) “A Case for Amplify-and-Forward Relaying in the Block-Fading Multiple-Access Channel,” *Information Theory, IEEE Transactions on*, **54**(8), pp. 3728–3733.

- [17] LIANG, Y. and G. KRAMER (2007) “Rate Regions for Relay Broadcast Channels,” *Information Theory, IEEE Transactions on*, **53**(10), pp. 3517–3535.
- [18] AHLWEDE, R., C. NING, S. Y. R. LI, and R. W. YEUNG (2000) “Network information flow,” *Information Theory, IEEE Transactions on*, **46**(4), pp. 1204–1216.
- [19] HO, T., R. KOETTER, M. MEDARD, D. KARGER, and M. EFFROS (2003) “The benefits of coding over routing in a randomized setting,” in *Information Theory, 2003. Proceedings. IEEE International Symposium on*, pp. 442–.
- [20] KOETTER, R. and M. MEDARD (2003) “An algebraic approach to network coding,” *Networking, IEEE/ACM Transactions on*, **11**(5), pp. 782–795.
- [21] JAGGI, S., P. SANDERS, P. CHOU, M. EFFROS, S. EGNER, K. JAIN, and L. M. G. M. TOLHUIZEN (2005) “Polynomial time algorithms for multicast network code construction,” *Information Theory, IEEE Transactions on*, **51**(6), pp. 1973–1982.
- [22] HO, T., M. MEDARD, R. KOETTER, D. KARGER, M. EFFROS, J. SHI, and B. LEONG (2006) “A Random Linear Network Coding Approach to Multicast,” *Information Theory, IEEE Transactions on*, **52**(10), pp. 4413–4430.
- [23] HO, T., M. MDARD, M. EFFROS, and R. KOETTER (2004) “Network Coding for Correlated Sources,” in *in CISS*.
- [24] BARROS, J. and S. SERVETTO (2006) “Network information flow with correlated sources,” *Information Theory, IEEE Transactions on*, **52**(1), pp. 155–170.
- [25] ZHANG, X., G. NEGLIA, J. KUROSE, and D. TOWSLEY (2006) “On the Benefits of Random Linear Coding for Unicast Applications in Disruption Tolerant Networks,” in *Modeling and Optimization in Mobile, Ad Hoc and Wireless Networks, 2006 4th International Symposium on*, pp. 1–7.
- [26] CHOU, P. A., Y. WU, and K. JAIN (2003), “Practical Network Coding,” .

- [27] KATTI, S., H. RAHUL, W. HU, D. KATABI, M. MEDARD, and J. CROWCROFT (2008) “XORs in the Air: Practical Wireless Network Coding,” *Networking, IEEE/ACM Transactions on*, **16**(3), pp. 497–510.
- [28] ZHANG, S., S. C. LIEW, and P. P. LAM (2006) “Hot topic: physical-layer network coding,” in *Proceedings of the 12th annual international conference on Mobile computing and networking*, MobiCom '06, ACM, pp. 358–365.
- [29] POPOVSKI, P. and H. YOMO (2006) “Bi-directional Amplification of Throughput in a Wireless Multi-Hop Network,” in *Vehicular Technology Conference, 2006. VTC 2006-Spring. IEEE 63rd*, vol. 2, pp. 588–593.
- [30] KATTI, S., S. GOLLAKOTA, and D. KATABI (2007) “Embracing wireless interference: analog network coding,” *SIGCOMM Comput. Commun. Rev.*, **37**(4), pp. 397–408.
- [31] NAZER, B. and M. GASTPAR (2006) “Computing over Multiple-Access Channels with Connections to Wireless Network Coding,” in *Proceedings of the 2006 International Symposium on Information Theory (ISIT 2006)*, Seattle, WA.
- [32] ——— (2007) “Lattice coding increases multicast rates for gaussian multiple-access networks,” in *Pro. Annual Allerton Conf. '07*, pp. 1089–1096.
- [33] WILSON, M., K. NARAYANAN, H. PFISTER, and A. SPRINTSON (2010) “Joint Physical Layer Coding and Network Coding for Bidirectional Relaying,” *Information Theory, IEEE Transactions on*, **56**(11), pp. 5641–5654.
- [34] DUC, T. and C. JINHO (2010) “Convolutional Codes in Two-Way Relay Networks with Physical-Layer Network Coding,” *Wireless Communications, IEEE Transactions on*, **9**(9), pp. 2724–2729.
- [35] CASTRO, M. C., B. F. UCHOA-FILHO, T. T. V. VINHOZA, M. NORONHANELO, and J. BARROS “Improved joint turbo decoding and physical-layer network coding,” in *Information Theory Workshop (ITW), 2012 IEEE*, pp. 532–536.

- [36] LIU, J., T. MEIXIA, and X. YOUYUN (2012) “Pairwise Check Decoding for LDPC Coded Two-Way Relay Block Fading Channels,” *Communications, IEEE Transactions on*, **60**(8), pp. 2065–2076.
- [37] HAUSL, C., F. SCHRECKENBACH, I. OIKONOMIDIS, and G. BAUCH (2005) “Iterative network and channel decoding on a tanner graph,” *Proc. Allerton Conf. on Commun., Control and Computing*.
- [38] HAUSL, C. and P. DUPRAZ (2006) “Joint Network-Channel Coding for the Multiple-Access Relay Channel,” in *Sensor and Ad Hoc Communications and Networks, 2006. SECON '06. 2006 3rd Annual IEEE Communications Society on*, vol. 3, pp. 817–822.
- [39] DUYCK, D., D. CAPIRONE, J. BOUTROS, and M. MOENECLAHEY (2010) “Analysis and Construction of Full-Diversity Joint Network-LDPC Codes for Cooperative Communications,” *EURASIP Journal on Wireless Communications and Networking*, **2010**(1), p. 805216.
- [40] XIAOYAN, X., M. F. FLANAGAN, N. GOERTZ, and J. THOMPSON (2010) “Joint Channel and Network Coding for Cooperative Diversity in a Shared-Relay Environment,” *Wireless Communications, IEEE Transactions on*, **9**(8), pp. 2420–2423.
- [41] HATEFI, A. (2012) *Distributed coding for Wireless Cooperative Networks*, Phd dissertation, Supelec.
- [42] LI, Y., B. VUCETIC, T. WONG, and M. DOHLER (2006) “Distributed Turbo Coding With Soft Information Relaying in Multihop Relay Networks,” *Selected Areas in Communications, IEEE Journal on*, **24**(11), pp. 2040–2050.
- [43] WEITKEMPER, P., D. WUEBBEN, V. KUEHN, and K.-D. KAMMEYER (2008) “Soft Information Relaying for Wireless Networks with Error- Prone Source-Relay Link,” in *Source and Channel Coding (SCC), 2008 7th International ITG Conference on*, pp. 1–6.
- [44] SNEESEENS, H. H. and L. VANDENDORPE (2005) “Soft decode and forward improves cooperative communications,” in *Computational Advances in Multi-*

Sensor Adaptive Processing, 2005 1st IEEE International Workshop on, pp. 157–160.

- [45] AL-HABIAN, G., A. GHAYEB, and M. HASNA (2009) “Controlling Error Propagation in Network-Coded Cooperative Wireless Systems,” in *Communications, 2009. ICC '09. IEEE International Conference on*, pp. 1–6.
- [46] SINH LE HONG, N., A. GHAYEB, G. AL-HABIAN, and M. HASNA (2010) “Mitigating Error Propagation in Two-Way Relay Channels with Network Coding,” *Wireless Communications, IEEE Transactions on*, **9**(11), pp. 3380–3390.
- [47] YING, L., S. GUANGHUI, and W. LILI (2010) “Analysis of the joint network LDPC codes over orthogonal multi-access relay channel,” *Communications Letters, IEEE*, **14**(2), pp. 184–186.
- [48] BLETSAS, A., A. KHISTI, D. P. REED, and A. LIPPMAN (2006) “A Simple Cooperative Diversity Method Based on Network Path Selection,” *IEEE Journal on Select Areas in Communications*, **24**(3), pp. 659–672.
- [49] LI, Y., R. H. Y. LOUIE, and B. VUCETIC (2010) “Relay Selection With Network Coding in Two-Way Relay Channels,” *Vehicular Technology, IEEE Transactions on*, **59**(9), pp. 4489–4499.
- [50] JING, Y. and H. JAFARKHANI (2009) “Single and multiple relay selection schemes and their achievable diversity orders,” *Wireless Communications, IEEE Transactions on*, **8**(3), pp. 1414–1423.
- [51] PENG, C., Q. ZHANG, M. ZHAO, Y. YAO, and W. JIA (2008) “On the Performance Analysis of Network-Coded Cooperation in Wireless Networks,” *Wireless Communications, IEEE Transactions on*, **7**(8), pp. 3090–3097.
- [52] MING, X. and T. AULIN (2009) “Optimal Decoding and Performance Analysis of a Noisy Channel Network with Network Coding,” *Communications, IEEE Transactions on*, **57**(5), pp. 1402–1412.

- [53] RENZO, M. D., M. IEZZI, and F. GRAZIOSI (2013) “Error Performance and Diversity Analysis of Multi-Source Multi-Relay Wireless Networks with Binary Network Coding and Cooperative MRC,” *CoRR*, **abs/1303.5310**.
- [54] SNEESSENS, H. H., J. LOUVEAUX, and L. VANDENDORPE (2008) “Turbo-coded decode-and-forward strategy resilient to relay errors,” in *Acoustics, Speech and Signal Processing, 2008. ICASSP 2008. IEEE International Conference on*, pp. 3213–3216.
- [55] SUNGEUN, L., H. MYEONGSU, and H. DAESIK (2009) “Average SNR and Ergodic Capacity Analysis for Proactive and Reactive DF Relaying over Rayleigh Fading Channels,” in *Vehicular Technology Conference, 2009. VTC Spring 2009. IEEE 69th*, pp. 1–5.
- [56] YUNE, T., D. KIM, and G. IM (2011) “Opportunistic Network-Coded Cooperative Transmission with Demodulate-and-Forward Protocol in Wireless Channels,” *Communications, IEEE Transactions on*, **PP(99)**, pp. 1–5.
- [57] VU, X.-T., M. DIRENZO, and P. DUHAMEL (2013) “Multiple-Access Relaying with Network Coding: Iterative Network/Channel Decoding with Imperfect CSI,” *EURASIP Journal on Advances in Signal Processing*, (170).
- [58] VU, X.-T., M. DI RENZO, and P. DUHAMEL (2012) “Iterative network/channel decoding for the noisy multiple-access relay channel (MARC),” in *Acoustics, Speech and Signal Processing (ICASSP), 2012 IEEE International Conference on*, pp. 2901–2904.
- [59] VU, X.-T., M. DIRENZO, , and P. DUHAMEL (2012) “Improved receiver for cooperative wireless communication systems using QAM and Galois Field network coding,” in *Advanced Technologies for Communications (ATC), 2012 International Conference on*, pp. 203–206.
- [60] VU, X.-T., M. DI RENZO, and P. DUHAMEL (2011) “Optimal and low-complexity iterative joint network/channel decoding for the multiple-access relay channel,” in *Acoustics, Speech and Signal Processing (ICASSP), 2011 IEEE International Conference on*, pp. 3312–3315.

- [61] VU, X.-T., M. DI RENZO, and P. DUHAMEL (2013) “BER Analysis of Joint Network/Channel decoding in Block Rayleigh fading channels,” in *Personal, Indoor and Mobile Radio Communications, 2013. PIMRC’13., 24th IEEE International Symposium on*, pp. 698–702.
- [62] VU, X.-T., P. DUHAMEL, and M. DI RENZO (2013) “Performance analysis for Network Coding Cooperation with Channel coding and Selection DF in Rayleigh Fading channels,” *Communications, IEEE Letters on*, to be submitted.
- [63] VU, X.-T., M. DI RENZO, and P. DUHAMEL “Outage and Diversity analysis of Network Coding with Single and Multiple Relay Selection,” *IEEE Transactions on Communications*, to be submitted.
- [64] VU, X.-T., N. VO, M. DI RENZO, and P. DUHAMEL (2013) “Performance Analysis of Relay Networks with Channel code in Low SNR Regime,” in *Signal Processing Advances in Wireless Communications (SPAWC), 2013 IEEE 14th Workshop on*, pp. 575–579.
- [65] VU, X.-T., P. DUHAMEL, V. N. Q. BAO, and M. DI RENZO “Partial Relaying in Channel-coded Relay Networks with Relay Selection,” *IEEE Transactions on Communications*, to be submitted.
- [66] KIM, T. T., G. CAIRE, and M. SKOGLUND (2008) “Decode-and-Forward Relaying With Quantized Channel State Feedback: An Outage Exponent Analysis,” *Information Theory, IEEE Transactions on*, **54**(10), pp. 4548–4564.
- [67] ZHIGUO, D. and K. K. LEUNG (2011) “Impact of Imperfect Channel State Information on Bi-Directional Communications With Relay Selection,” *Signal Processing, IEEE Transactions on*, **59**(11), pp. 5657–5662.
- [68] KNOPP, R. and P. A. HUMBLET (2000) “On coding for block fading channels,” *Information Theory, IEEE Transactions on*, **46**(1), pp. 189–205.
- [69] CAVERS, J. K. (1991) “An analysis of pilot symbol assisted modulation for Rayleigh fading channels [mobile radio],” *Vehicular Technology, IEEE Transactions on*, **40**(4), pp. 686–693.

- [70] PROAKIS, J. G. (2001) *Digital communications*, McGraw-Hill series in electrical and computer engineering, 4th ed., McGraw-Hill, Boston.
- [71] GLAVIEUX, A. (2007) *Channel Coding in Communication Networks: From Theory to Turbo Codes*, Wiley & Sons Ltd.
- [72] BAHL, L., J. COCKE, F. JELINEK, and J. RAVIV (1974) “Optimal decoding of linear codes for minimizing symbol error rate (Corresp.),” *Information Theory, IEEE Transactions on*, **20**(2), pp. 284–287.
- [73] NASRI, A., R. SCHÖBER, and M. UYSAL (2013) “Performance and Optimization of Network-Coded Cooperative Diversity Systems,” *Communications, IEEE Transactions on*, **PP**(99), pp. 1–12.
- [74] ZHENG, G., H. JIE, W. BING, Z. SHENGLI, C. JUN-HONG, and P. WILLETT (2012) “A Practical Joint Network-Channel Coding Scheme for Reliable Communication in Wireless Networks,” *Wireless Communications, IEEE Transactions on*, **11**(6), pp. 2084–2094.
- [75] LI, Y., R. H. Y. LOUIE, and B. VUCETIC (2010) “Relay Selection With Network Coding in Two-Way Relay Channels,” *Vehicular Technology, IEEE Transactions on*, **59**(9), pp. 4489–4499.
- [76] CEDERVALL, M. L. and R. JOHANNESSON (1989) “A fast algorithm for computing distance spectrum of convolutional codes,” *Information Theory, IEEE Transactions on*, **35**(6), pp. 1146–1159.
- [77] CHIARI, M., D. DARDARI, and M. K. SIMON (2003) “New exponential bounds and approximations for the computation of error probability in fading channels,” *Wireless Communications, IEEE Transactions on*, **2**(4), pp. 840–845.
- [78] ATAPATTU, S., Y. JING, H. JIANG, and C. TELLAMBURA (2013) “Relay Selection Schemes and Performance Analysis Approximations for Two-Way Networks,” *Communications, IEEE Transactions on*, **61**(3), pp. 987–998.

- [79] TOPAKKAYA, H. and W. ZHENGDAO (2011) “Wireless Network Code Design and Performance Analysis Using Diversity-Multiplexing Tradeoff,” *Communications, IEEE Transactions on*, **59**(2), pp. 488–496.
- [80] GUAN, W. and K. LIU (2013) “Diversity Analysis of Analog Network Coding with Multi-User Interferences,” *Wireless Communications, IEEE Transactions on*, **12**(2), pp. 668–679.
- [81] SIMON, M. K. and M.-S. ALOUINI (2005) *Digital communication over fading channels*, Wiley series in telecommunications and signal processing, 2nd ed., John Wiley & Sons, Hoboken, N.J.
- [82] SINGLETON, R. C. (1964) “Maximum distance q -nary codes,” *Information Theory, IEEE Transactions on*, **10**(2), pp. 116–118.
- [83] WOLDEGEBREAL, D. H. and H. KARL (2007) “Multiple-Access Relay Channel with Network Coding and Non-Ideal Source-Relay Channels,” in *Wireless Communication Systems, 2007. ISWCS 2007. 4th International Symposium on*, pp. 732–736.
- [84] WANG, T., A. CANO, G. B. GIANNAKIS, and J. N. LANEMAN (2007) “High-Performance Cooperative Demodulation With Decode-and-Forward Relays,” *IEEE Transactions on Communications*, **55**(7), pp. 1427–1438.
- [85] BENEDETTO, S., R. GARELLO, and G. MONTORSI (1998) “A search for good convolutional codes to be used in the construction of turbo codes,” *Communications, IEEE Transactions on*, **46**(9), pp. 1101–1105.
- [86] NGUYEN, S. L. H., A. GHAYEB, G. AL-HABIAN, and M. HASNA (2010) “Mitigating Error Propagation in Two-Way Relay Channels with Network Coding,” *Wireless Communications, IEEE Transactions on*, **9**(11), pp. 3380–3390.
- [87] UYSAL, M. (2006) “Diversity analysis of space-time coding in cascaded Rayleigh fading channels,” *Communications Letters, IEEE*, **10**(3), pp. 165–167, 1089-7798.

- [88] ZHENG, L. and D. TSE (2003) “Diversity and multiplexing: A fundamental tradeoff in multiple-antenna channels,” *Information Theory, IEEE Transactions on*, **49**(5), pp. 1073–1096.
- [89] MARK GRAYSON, S. W., KEVIN SHATZKAMER (2009) *IP design for Mobile Networks*, Cisco Press.
- [90] DUONG, T. and V. N. Q. BAO (2008) “Performance analysis of selection decode-and-forward relay networks,” *Electronics Letters*, **44**(20), pp. 1206–1207.
- [91] FRENGER, P., P. ORTEN, and T. OTTOSSON (1999) “Convolutional codes with optimum distance spectrum,” *Communications Letters, IEEE*, **3**(11), pp. 317–319.