



HAL
open science

Analysis of the roles of Interleukin 15 and CD4+ T cells specific of a dietary antigen in a mouse model of celiac-like enteropathy

Natalia Korneychuk

► To cite this version:

Natalia Korneychuk. Analysis of the roles of Interleukin 15 and CD4+ T cells specific of a dietary antigen in a mouse model of celiac-like enteropathy. Immunology. Université René Descartes - Paris V, 2014. English. NNT : 2014PA05T037 . tel-01127195

HAL Id: tel-01127195

<https://theses.hal.science/tel-01127195>

Submitted on 7 Mar 2015

HAL is a multi-disciplinary open access archive for the deposit and dissemination of scientific research documents, whether they are published or not. The documents may come from teaching and research institutions in France or abroad, or from public or private research centers.

L'archive ouverte pluridisciplinaire **HAL**, est destinée au dépôt et à la diffusion de documents scientifiques de niveau recherche, publiés ou non, émanant des établissements d'enseignement et de recherche français ou étrangers, des laboratoires publics ou privés.

Université Paris Descartes

Doctorate school Gc2iD

INSERM U1163 (ex-U989)

Laboratory of intestinal immunity

Analysis of the roles of Interleukin 15 and CD4⁺ T cells specific of a dietary antigen in a mouse model of celiac-like enteropathy

Natalia Korneychuk

PhD dissertation in Immunology

Directed by Nadine Cerf-Bensussan

Presented and publicly defended on July 9, 2014

Before a jury panel composed of:

Prof. SIX Adrien	President of Jury
Dr. VERHASSELT Valérie	Rapporteur
Prof. PABST Oliver	Rapporteur
Dr. LANTZ Olivier	Examiner
Dr. EBERL Gérard	Examiner
Dr. CERF-BENSUSSAN Nadine	Thesis Supervisor

 Except where otherwise noted, this work is licensed under <http://creativecommons.org/licenses/by-nc-nd/3.0/>

Abstract

In physiological conditions, robust immunological mechanisms avoid adverse responses to food antigens. In contrast, in celiac disease that affects about 1% of Western populations, exposure to dietary gluten of genetically predisposed HLA-DQ2.5/ DQ8 individuals triggers a chronic small intestinal enteropathy. Previous studies in humans have established the crucial role of HLA-DQ2/DQ8 restricted gluten-specific intestinal CD4 T cell response. This CD4 T cell response is necessary but is however not sufficient to induce tissue damage. Other studies have pointed to the role of interleukin 15 (IL-15). Thus, IL-15 over-expressed in the mucosa of celiac patients can interfere with immunoregulatory mechanisms and stimulate the activation of cytotoxic CD8 T intraepithelial lymphocytes, thought to induce epithelial lesions. Whether and how gluten-specific CD4 T cells and IL-15 interact to activate CD8 T intraepithelial lymphocytes and to drive intestinal tissue damage has not been however established.

To address this question, we have set up a mouse model based on the breeding of OTII mice possessing CD4 T cells specific of a model antigen, ovalbumin, with heterozygous transgenic mice overexpressing a secreted form of human IL-15 in intestinal epithelium (hIL-15Tge mice). Resulting OTII^{+/-} B6 and OTII^{+/-} hIL-15Tge^{+/-} mice were exposed to dietary ovalbumin from the prenatal period until 3 months of age. Upon chronic exposure to ovalbumin, OTII^{+/-} hIL-15Tge⁺ mice, contrary to their OTII^{+/-} B6 littermates, developed growth retardation, and villous atrophy associated with expansion of intestinal cytotoxic CD8 T cells, as in celiac disease. Moreover, we showed that IL-15 impaired immunoregulation by FoxP3⁺ T cells and cooperated with IL-2 produced by OVA-activated CD4 T cells to stimulate the expansion of non-cognate cytotoxic CD8 T cells. We suggest that a comparable scenario can operate in celiac disease.

During this study, I observed that chronic overexpression of IL-15 was associated with an expansion of CD103⁺CD11c⁺CD11b⁻ mononuclear cells. In the Supplementary results, I have shown that this effect depends on the production of GM-CSF secreted by IL-15-activated NK cells and that CD11c⁺ DCs differentiated in mice overexpressing IL-15 were enriched in CD103⁺ cells and displayed enhanced cross-presentation abilities *in vitro*. The latter results illustrate how IL-15, by orchestrating a crosstalk between NK cells and mononuclear phagocytes, can modulate adaptive immune responses.

Keywords: Celiac disease, Interleukin 15, mouse model, cytotoxic CD8 T cells, CD4 T cell help, regulatory T cells, GM-CSF, CD103⁺ dendritic cells, cross-presentation

I dedicate this thesis to my family that accompanied me throughout this long journey.

To my parents, thank you for your great affection, your help to realize my dreams, and for having taught me working hardly.

To my mom, thank you for your tenderness, devotion, support and all your love.

To my dad, thank you for sharing with me your passion for science.

To my lovely sister Olga, thank you for your confidence in me and all your help and encouragement.

To my dear husband Jonathan, thank you for your limitless optimism and love, for your patience and support.

To my little monster Eneko, you are my little sunshine and my daily source of joy!

Acknowledgements

This thesis has been a hard work during three years and a half, and it would have never been realized without the support of a great number of persons. I would like to express my sincere thanks to many people who were instrumental in the creation and realization of this project and who supported me in one way or another during my PhD study.

*First of all, I would like to express my special thanks to my PhD advisor **Dr Nadine Cerf-Bensussan** who took me to her lab despite my 6-months pregnancy. I would like to thank you for your presence and availability in spite of your tight schedule, for all regular meetings and discussions that we had. Thank you for having given me a large autonomy and your precious advice at moments when I particularly needed it. Thanks for the time you devoted for improving of our manuscripts and correction of this thesis during long (and sometimes very long..) evenings in the office ;). To work by your side during this time allowed me to particularly appreciate your skilled guidance, commitment, perfectionism, and hard working.*

*Many thanks to **Dr Bertrand Meresse**, who directly participated in the designing and initiation of this study and co-supervised this PhD work, for your precious suggestions and comments throughout of three years. I will not forget your jokes about Russians...*

*I would like to thank **Dr Valérie Verhasselt** and **Prof. Oliver Pabst** for having accepted to judge this work and **Dr Olivier Lantz** and **Dr Gérard Eberl** for having accepted to be part of the jury. I also thank **Prof. Adrien Six** for having accepted to preside this jury, you probably do not know but without your agreement to take me on Master 1 in the Université Pierre Marie Curie in 2008 I would have been never able to obtain Eiffel Fellowship that allowed me to come from a faraway Vladivostok to France for Master studies.*

*I would also like to thank **Doctoral School ED157 (Gc2iD)** of Université Paris Descartes for having attributed me a doctoral fellowship for three years, as well as **Fondation pour la Recherche Médicale** for their financial support during the last six months.*

*My special thanks to all present and past members of Nadine's lab. Particular thanks to **Emma** who spent three years optimizing all conditions in order to set up the OTII/IL-15Tge mouse model of celiac-like enteropathy. I am deeply grateful to you for initiating me to isolation of those famous intestinal lymphocytes and of all other state-of-the-art techniques that I needed to continue the project. Thanks to **Julie** for teaching me doing intravenous injections, gavage, and other manipulations. Huge thanks to **Julien** for assuming a heavy burden of doing breeding of OTII and IL-15Tge mice, since I was occupied with obtaining of TCR/HLA-DQ2/MHCIIKO mice. I appreciated so much your help during so many early and very early mornings for sacrifices of tones of mice. Many thanks to **Grand Nico** who so often joined us for*

those early experiments and shared his “wonderful” music playlist with us! **Petit Nico**, thanks for your help for some rare times when you succeeded in waking up sufficiently early in the morning (I know it was too much early for you). Guys, you made it so nice to come to the lab, thank you for all your endless jokes, crazy birthday presents and so on! Overall, I doubt I will find another team like you.

Huge thanks to all the members who shared with me the everyday lab life and work, I can't not mention you, my dear girls, **Juliette** and **Swellen**, with whom we had so many mad laughs, discussions, and simply nice meals. Thanks for your so helpful presence in hard times especially in the beginning of this thesis! Ma chère **Bernadette** (!! non non pas vieille, ne les écoute pas ;))), je te remercie beaucoup pour ton soutien, pour avoir été ma voisine préférée pendant tout ce temps, malgré tes problèmes informatiques sans arrêt et tes demandes de massages, ça a été un vrai plaisir de t'aider et de masser ton (vieux;) dos pendant tout ce temps ! Particular thanks to **Martin**, for sharing your optimism and for all our endless scientific and non-scientific discussions and laughs! Thank you, guys, for all chocolate bars that you shared with me and that I have finished!!

Special thanks to the “SFB team”: **Valérie** (for your kindness), **Sabine** (for your notable baking skills), **Emelyne** (for your diplomatic skills and perseverance), **Hélène**, **Marion** (for your courage and straightness) and **Marine** (for your determination and excellence), thank you girls for sharing your passion for microbiota with “celiac disease” part of the lab. I would also like to thank the “CD71-IgA” team: **Corinne** (“la pro de la microscopie confocale”), **Georgia** (The Gastroenterologist), **Benoît** and **Simon** (the best duo of the lab), as well as the “exome sequencing” team: **Frank**, **Bernadette**, **Fabienne** (for you determination), **Anaïs** (for your always good mood). **Mirette** (formidable pour son caractère), merci d'avoir assuré sans faille pendant tout ce temps le fonctionnement du labo, sans toi on n'aurait pas pu travailler! **Manoëlla**, thank you for assuring the purchase of all lab goods and for your availability. Overall, I particularly appreciated the solidarity and the cohesion in the lab, events, and cakes that we shared. Finally, I would like to wish best of luck to younger and new PhD students, interns, and members in pursuit of your studies: **Marion**, **Fabienne**, **Marine**, **Benoît**, **Anaïs**, **Pierre**, and **Nouara**.

I would also like to thank all those who provided mice and technical advice for this project including **Hiroshi Kiyono**, **Lars Fugger**, **Olivier Lantz**, **Jim Di Santo**, and **Sebastian Amigorena**.

I would like to acknowledge my outside-lab friends and all talented people with whom I had a luck to work on different associative projects (Commission de la Recherche de Paris V, Forum BioTechno, BioDocs, UNESCO, etc.): **Natalia**, **Aygul**, **Cécile**, **Marianna**, **Zhenia**, **Alexandre**, **Nour**, **Shimeen**, **Tarek** and many others, thank you for your support and for sharing your enthusiasm.

Finally, huge thanks go to my family. **My mom and dad**, I would like so much that you would be able to assist personally to my thesis defence and share this event with me. I thank you so much for your continual encouragements and I believe that you will be so proud of me. **My dear sister** (with your bad temper), thank you for all the help and your availability. I am sorry that I was not able to tell you more about my PhD studies, as I needed to change the subject of conversation out of the lab.

My dearest Jonathan, thank you for your immeasurable patience, for your easy-going character, for all nights and week-ends that you took care of **Eneko** alone when I was doing my experiments and writing this manuscript, for your tolerance of my bad moods and for your efforts to join me (and Eneko) for jogging on Saturday and Sunday mornings. I know I was not very easy the latter time, but I appreciate so much that you were with me all this time. I love you, my boys.

Natalia

Table of contents

LIST OF FIGURES AND TABLES.....	6
LIST OF PUBLICATIONS.....	8
LIST OF ABBREVIATIONS	9
GENERAL INTRODUCTION	11
I. CHAPTER 1: ORAL TOLERANCE.....	12
1.1 INTRODUCTION	12
1.2 GUT IMMUNE SYSTEM.....	13
1.3 MECHANISMS OF UPTAKE OF INTRALUMINAL SOLUBLE ANTIGENS.....	20
1.3.1. ROLE OF M CELLS.....	20
1.3.2. ROLE OF ENTEROCYTES.....	22
1.3.3 GOBLET CELLS	26
1.3.4 GUT MONONUCLEAR PHAGOCYTES	27
1.4 ROLE OF MONONUCLEAR PHAGOCYTES IN THE PRESENTATION OF SOLUBLE DIETARY ANTIGENS	29
1.4.1 COMPARISON OF THE ROLES OF CX3CR1 ⁺ AND CD103 ⁺ MNP IN ANTIGEN PRIMING	29
1.4.2 INFLUENCE OF DISTINCT SUBSETS OF INTESTINAL MNP ON PRIMING AND OUTCOME OF INTESTINAL IMMUNE RESPONSES TO DIETARY ANTIGENS	32
1.5 SYSTEMIC DISSEMINATION OF INTESTINAL ANTIGENS.....	34
1.6 MECHANISMS OF ORAL TOLERANCE	35
1.6.1 CLONAL ANERGY AND DELETION	35
1.6.2 REGULATORY CD4 T CELLS	36
1.6.3 CD8 T CELLS	40
1.7 OPEN ISSUES: FACTORS INFLUENCING ORAL TOLERANCE INDUCTION	40
II. CHAPTER 2: ABNORMAL RESPONSE TO FOOD GLUTEN IN CELIAC DISEASE	43
2.1 INTRODUCTION	43
2.2 ADAPTIVE RESPONSE	45
2.2.1 GLUTEN-SPECIFIC CD4 T CELL RESPONSE	45
2.2.2 B CELL RESPONSE	50
2.3 ACTIVATION OF INTRAEPITHELIAL LYMPHOCYTES.....	53
2.3.1 ROLE OF IL-15	54
2.3.2 ROLE OF TCR AND NK RECEPTORS IN TRIGGERING OF IEL CYTOTOXICITY AGAINST EPITHELIUM.....	58
2.4 OPEN ISSUES: FACTORS TRIGGERING THE BREAK OF TOLERANCE TO GLUTEN	59
2.4.1 SUPPLEMENTAL GENETIC FACTORS (IL2/IL21).....	59
2.4.2 FROM GLUTEN-SPECIFIC CD4 T CELL RESPONSE TO IEL ACTIVATION.....	62
2.4.3 ROLE OF NEONATAL INFECTIONS IN ACTIVATION OF INNATE IMMUNE RESPONSE	63
2.4.4 ACTIVATION OF TG2	64
2.4.5 INDUCTION OF IL-15	65
2.4.6 INTRODUCTION OF GLUTEN.....	65

2.5 CONCLUSION AND PERSPECTIVES	66
<u>III. CHAPTER 3: ANIMAL MODELS OF CELIAC DISEASE</u>	<u>67</u>
3.1 MODELS USING WILD TYPE ANIMALS.....	67
3.1.1 GLIADIN INDUCES ORAL TOLERANCE IN WILD TYPE MICE.....	67
3.1.2 GLUTEN-INDUCED ENTEROPATHY IN NEWBORN RATS	68
3.1.3 ENTEROPATHY MODEL USING IMMUNODEFICIENT MICE	69
3.2 MODELS USING HLA-DQ TRANSGENIC MICE	71
3.2.1 GENERATION OF HUMANIZED TRANSGENIC MICE	71
3.2.2 USE OF HLA-DQ2.5/8 TRANSGENIC MICE TO STUDY ADAPTIVE IMMUNE RESPONSE TO GLUTEN	73
3.3 LESSONS LEARNED FROM MOUSE MODELS AND PERSPECTIVES	85
3.3.1 IMPORTANCE OF AGE OF GLUTEN INTRODUCTION AND DURATION OF EXPOSURE	86
3.3.2 CD4 T GLIADIN-SPECIFIC RESPONSE IS NECESSARY BUT NOT SUFFICIENT.....	86
3.3.3 NEED FOR SUPPLEMENTAL TRIGGERS FOR DISEASE ONSET	87
<u>EXPERIMENTAL WORK.....</u>	<u>89</u>
<u>A. THESIS AIMS AND EXPERIMENTAL APPROACH.....</u>	<u>90</u>
<u>B. MAIN RESULTS: COOPERATION BETWEEN ANTIGEN-SPECIFIC CD4 T CELLS AND IL-15 IN THE MOUSE MODEL OF CELIAC-LIKE SMALL INTESTINAL ENTEROPATHY INDUCED BY DIETARY ANTIGEN 94</u>	
B.1 RESULTS.....	94
B.2 ARTICLE	94
B.3 DISCUSSION	95
<u>C. SUPPLEMENTARY RESULTS: IL-15-ACTIVATED NK CELLS TRIGGER CD103 EXPRESSION ON MONONUCLEAR PHAGOCYTES AND ENHANCE THEIR CROSS-PRIMING ACTIVITY</u>	<u>105</u>
C.1 INTRODUCTION	105
C.2 MATERIALS AND METHODS.....	106
C.3 RESULTS	108
C.4 DISCUSSION	119
<u>CONCLUSION</u>	<u>125</u>
<u>REFERENCES</u>	<u>126</u>

List of Figures and Tables

Figure I.1: Anatomy of gastrointestinal tract	14
Figure I.2: Organisation of small intestinal mucosa	14
Figure I.3: Types of intestinal epithelial cells.....	15
Figure I.4: Structural organisation of intestinal mucosa	15
Figure I.5: Schematic representation of lymphoid elements of the intestinal immune system	17
Figure I.6: Antigen uptake and priming of effector T and B cells	19
Figure I.7: Mechanisms of antigen uptake in gut-associated lymphoid tissue (GALT) and lamina propria	21
Figure I.8: Paracellular and transcellular transport pathways	22
Figure I.9: Immunoglobulin-mediated retrotransport of luminal antigens.....	25
Figure I.10: The emerging intestinal lamina propria dendritic cell compartment	28
Figure I.11: Transfer of antigen from lamina propria macrophages to DCs through gap junctions	30
Figure I.12: Conditioning of CD103 ⁺ DCs by the intestinal microenvironment	33
Figure I.13: Routes of systemic dissemination of antigen.....	35
Figure I.14: A multistep model of oral tolerance to soluble antigens	39
Figure II.1: Normal and celiac-disease small intestinal mucosae	43
Figure II.2: Overlap of genetic risk factors for celiac disease with autoimmune and inflammatory diseases.....	44
Figure II.3: Human leukocyte antigen (HLA) associations in celiac disease (CD).....	46
Figure II.4: Posttranslational modification of gluten.....	48
Figure II.5: Activation of gluten-specific CD4 T cells responses by HLA-DQ2.5 molecule	50
Figure II.6: B cell response in celiac disease	52
Figure II.7: T cell response in celiac disease	57
Figure II.8: History of celiac disease genetics.....	60
Figure II.9: Location and effect of CD risk single nucleotide polymorphisms (SNPs)	61
Figure II.10: Hypothetical role of non-HLA genes in celiac immune responses	62
Figure III.1: Effect of feeding mothers gluten-containing diet (ND) during pregnancy and/or breastfeeding on the immune response of their offspring in (Troncone and Ferguson, 1988)	68
Figure III.2: Experimental protocol of gluten-sensitization used in (Freitag et al., 2009)	70
Figure III.3: Schematic illustration of the generation of HLA-DQ8 ⁺ . H-2Ab ⁰ mice.....	75
Figure III.4: Schematic illustration of HLA-DQ8.hCD4.β ⁰ .mCD4 ⁰ mice generation and gluten-sensitization protocol used in (Black et al., 2002)	76
Figure III.5: Schematic illustration of gluten-sensitization protocol used in (Marietta et al., 2004)	77
Figure III.6: Regulated expression of the HLA-DR3-DQ2 haplotype encoded by yeast artificial chromosome.	78
Figure III.7: Schematic illustration of gluten-sensitization protocol used in (de Kauwe et al., 2009).....	79
Figure III.8: Structure of the D ^d -IL-15 transgene.	82
Figure III.9: Schematic illustration of experimental protocol used in (Abed et al., 2014)	85
Figure A.1: Experimental hypothesis.....	91
Figure A.2: Experimental mouse model (1).....	92
Figure A.3: Experimental mouse model (2).....	93
Figure B.1: Tetracycline on/off system.....	97
Figure B.2: Scheme depicting cooperation between IL-15 and diet-activated CD4 T cells in the activation of intestinal cytotoxic CD8 T cells	101
Figure C.1: Gating strategy for identification of small intestinal lamina propria mononuclear phagocytes (SI LP MNP)	109

Figure C.2: Comparative analysis of frequency and numbers of CD11c ⁺ CD11b ⁻ and CD11c ⁺ CD11b ⁺ MNP in WT B6, hIL-15Tge and IL-15KO mice	110
Figure C.3: Significant increase in frequency of CD103 ⁺ cells among CD11c ⁺ CD11b ⁻ but not CD11c ⁺ CD11b ⁺ MNP in hIL-15Tge mice.....	111
Figure C.4: Strong increase of intensity of CD103 expression by CD11c ⁺ CD11b ⁻ cells but not CD11c ⁺ CD11b ⁺ of.....	111
Figure C.5: Strong expansion of CD103 ⁺ CD11c ⁺ CD11b ⁻ and CD103 ⁺ CD11c ⁺ CD11b ⁺ cells in hIL-15Tge mice.....	112
Figure C.6: Increased CD86 expression by lamina propria CD11c ⁺ CD11b ⁻ and CD11c ⁺ CD11b ⁺ mononuclear phagocytes in hIL-15Tge mice.	112
Figure C.7: No changes in CD40 and MHC class II expression by MNP in hIL-15Tge mice	113
Figure C.8: Increased CD103 expression on bone marrow differentiated dendritic cells in the presence of Flt3L and IL-15 accompanied by emergence of NK cells.....	114
Figure C.9: CD103 expression on DCs is not directly triggered by IL-15 but is mediated by IL-15-activated NK cells.....	115
Figure C.10: CD103 induction on DCs does not require cell-cell contact between DCs and NK cells ...	116
Figure C.11: GM-CSF can recapitulate the effect of IL-15-activated NK cells on the CD103 induction on DCs	117
Figure C.12: <i>Csf-2</i> transcripts in duodenum of CD patients and controls	118
Figure C.13: Cross-presentation of OVA by DCs subsets from B6 and hIL-15Tge mice to OTI CD8 T cells	119
Table I-1: Routes of uptake of soluble and particulate antigens in the small intestine (SI) of mice.....	27
Table I-2: Intestinal lamina propria mononuclear phagocyte subsets in the mouse	31
Table II-1: List of celiac disease relevant T cell epitopes recognized by CD4 T cells	49

List of Publications

Korneychuk, N., Ramiro-Puig, E., Ettersperger, J., Schulthess, J., Montcuquet, N., Kiyono, H., Meresse, B., and Cerf-Bensussan, N. (2014). Interleukin 15 and CD4(+) T cells cooperate to promote small intestinal enteropathy in response to dietary antigen. *Gastroenterology* *146*, 1017-1027.

Korneychuk, N. (2014). [Innate lymphoid cells control the intestinal commensal bacteria adaptive response]. *Medecine sciences : M/S* *30*, 253-257.

List of Abbreviations

ARA	Anti-reticulin antibody
APC	Antigen-presenting cell
BM	Bone marrow
CD	Celiac disease
CFA	Complete Freund's adjuvant
CFSE	Carboxyfluorescein succinimidyl ester
CX3CR1	CX3C chemokine receptor 1
DC	Dendritic cell
DH	Dermatitis herpetiformis
DT	Diphtheria toxin
DTH	Delayed type hypersensitivity
EAE	Experimental autoimmune encephalitis
ELISA	Enzyme-linked immunosorbent assay
EmA	Anti-endomysium antibody
FACS	Fluorescence activated cell sorting
FAE	Follicle-associated epithelium
Flt3L	FMS-like tyrosine kinase 3 ligand
Foxp3	Forkhead box P3
GALT	Gut-associated lymphoid tissue
GAP	Goblet-cell-associated antigen passage
GFD	Gluten-free diet
GFP	Green fluorescent protein
GM-CSF	Granulocyte-macrophage colony-stimulating factor
GvHR	Graft versus host reaction
GWAS	Genome-wide association study
HEV	High endothelial venule
HLA	Human leukocyte antigen
HRP	Horseradish peroxidase
IEC	Intestinal epithelial cell
IEL	Intraepithelial lymphocyte
IFN	Interferon
Ig	Immunoglobulin
ILF	Isolated lymphoid follicle
iTreg	Induced regulatory T cell
LP	Lamina propria
LPL	Lamina propria lymphocyte
M cell	Microfold cell
MBP	Myelin basic protein
MHC	Major histocompatibility complex
MLN	Mesenteric lymph node

MNP	Mononuclear phagocyte
MIIC	MHC class II-enriched compartment
nTreg	Natural regulatory T cell
OVA	Ovalbumin
PBL	Peripheral blood lymphocytes
PCR	Polymerase chain reaction
pDC	Plasmacytoid dendritic cell
PI3K	Phosphoinositide 3 kinase
Poly I:C	Polyinosinic:polycytidylic acid
PP	Peyer's patches
RA	Retinoic acid
SED	Subepithelial dome
SI	Small intestine
SIgA	Secretory IgA
SNP	Single nucleotide polymorphism
TED	Transepithelial dendrite
TGF β	Transforming growth factor β
TG2	Transglutaminase 2
Th	T helper cell
Treg	Regulatory T cell
TSLP	Thymic stromal lymphopoietin
T1D	Type 1 diabetes
Zbtb46	Zinc finger and BTB containing 46

General Introduction

In physiological conditions, robust immunological mechanisms avoid adverse responses to food antigens. Loss of tolerance to dietary antigens can cause different inflammatory diseases. In my thesis, I have focused on the pathogenesis of celiac disease, an autoimmune-like disease, in which loss of tolerance to dietary gluten leads to severe epithelial damage. CD pathogenesis has been studied in depth in humans. A first set of studies demonstrated that gluten-specific CD4 T cells were necessary but insufficient to trigger tissue damage. A second set of studies suggested that IL-15 over-produced in the intestine of CD patients was necessary to drive the expansion of cytotoxic CD8 T cells. It remains however unclear how these two mechanisms cooperate and whether they are sufficient to induce tissue damage. The largest part of the experimental work performed during my thesis addresses this question with the use of a mouse model. In the introduction of this manuscript, I review the data currently available in literature that have helped us to design experimental approaches and to interpret our results. In Chapter 1: Oral Tolerance, I discuss the mechanisms that control the uptake of soluble antigens in the gut and the mechanisms that allow the establishment and the maintenance of tolerance to dietary proteins in and beyond the intestine. In Chapter 2: Abnormal response to food gluten in Celiac disease, I summarize the advancements in the study of celiac disease pathogenesis and address the issues that remain unknown or uncertain to date. Finally, in Chapter 3: Animal models of Celiac disease, I analyze the previous attempts to set up a relevant mouse model of celiac disease, notably using HLA-DQ2.5 or HLA-DQ8 humanized mice, and discuss why they have remained largely unsuccessful. I notably address the question of the missing elements required to trigger tissue damage.

I. Chapter 1: Oral Tolerance

1.1 Introduction

Oral tolerance is defined as the specific suppression of humoral and/or cellular systemic immune responses to non-replicative antigens by administration of the same antigen through the oral route (Faria and Weiner, 2005). The hyporesponsive state observed after challenges with the same antigen can be demonstrated by the down-modulation of cellular responses, including delayed-type hypersensitivity (DTH) *in vivo* and lymphocyte proliferation *in vitro*, as well as by the inhibition of humoral IgE and IgG responses (Faria and Weiner, 1999). The fact that systemic tolerance to soluble dietary antigens is initiated in gut-associated lymphoid organs and avoids inadvertent T cell responses in the intestinal mucosa allows extending the concept of oral tolerance to the local immune response. Importantly, the local regulatory T cell response does not inhibit the production of intestinal IgA against dietary proteins, an important mechanism preventing absorption of non-digested immunogenic proteins. Of note, the immune response to dietary soluble antigens differs from the response to microbiota by the outcome of peripheral responses after systemic injection of the antigen. In contrast to the systemic tolerance observed upon challenge with a soluble antigen initially given orally, systemic administration of a commensal bacterium triggers activation of spleen CD4 T cells and production of serum IgG (Slack et al., 2009). Oral tolerance therefore represents a major continuous immune process guaranteeing local and systemic tolerance to exogenous soluble (or non-replicative) antigens, by analogy with central tolerance assuring the unresponsiveness to self-antigens.

Since the pioneer experiments demonstrating active tolerance to orally ingested proteins performed over a century ago by Wells and then Besredka in guinea pigs, which became protected from anaphylaxis to hen's egg or milk proteins by prior feeding of these proteins (Faria and Weiner, 1999), immunological mechanisms of oral tolerance have been progressively unknotted. Depending on dose of ingested antigen, nature of the antigen, duration of exposure and timing of administration, multiple mechanisms were shown to contribute to the establishment of oral tolerance, including anergy and deletion of antigen-specific T cells and induction of various types of regulatory T cells (Weiner et al., 2011). Regulatory T cells are now viewed as absolutely crucial in preventing systemic and local intestinal immune responses to dietary antigens (Pabst and Mowat, 2012), a view substantiated by the onset of severe food

allergy in patients lacking FoxP3 or in mice deficient for CNS1 unable to develop peripherally induced Tregs (Josefowicz et al., 2012; Torgerson et al., 2007) (see 1.6.2 Regulatory CD4 T cells). Loss of tolerance to dietary antigens can cause different diseases. The best characterized are IgE-dependent food allergies and celiac disease (CD). CD was defined in the past as type IV allergy and today is generally considered as an autoimmune-like disease induced by dietary gluten (see Chapter 2: Abnormal response to food gluten in Celiac disease).

In addition to an important protective role in physiology, oral tolerance may have a therapeutic potential. Indeed, simplicity and non-toxicity of this method based on oral administration of a specific antigen are particularly attractive (Wang et al., 2013). This approach has been successfully tested in multiple mouse models of autoimmune diseases (EAE, diabetes, arthritis, colitis, etc) but mainly as a preventive approach. It has however demonstrated only limited success in clinical trials for diabetes, multiple sclerosis, and rheumatoid arthritis, likely because it is more difficult to induce tolerance once a proinflammatory immune response has been initiated (Faria and Weiner, 2006). Better defining immunological processes implicated in oral tolerance might help for developing of therapeutic applications. Indeed, oral administration of antigen is currently tested for desensitization of IgE-dependent food allergies

Herein, I will present mechanisms that drive oral tolerance to dietary proteins. Since digestion and absorption of food proteins takes place in small intestine (SI), I will more particularly describe this part of the gastrointestinal tract, which contains the largest number of immune cells.

1.2 Gut immune system

The gut is anatomically divided into small intestine and colon (Figure I.1). The human intestine (Figure I.1) with a surface of more than 300 m² (Moog, 1981) is the main physical barrier between internal and external environments. Food digestion largely takes place in the duodenum (Figure I.1), the short proximal part of the small intestine. Partially digested in the stomach, the food is further broken down by enzymes delivered with pancreatic juice into the duodenum. Bile and pancreatic juice secreted into the duodenum also neutralize the acidic pH of gastric content. The enzymes located in the brush border of epithelial layer throughout the small intestine participate in further protein degradation, which is completed into the lysosomal compartment of epithelial cells. The formation of villi considerably increases the absorptive and digestive surface of the SI (Figure I.2). This surface is further increased through the formation of folds, called Kerckring's valves, and the development of microvilli at the apical

surface of enterocytes that form the brush border and harbour digestive enzymes. It is estimated that the intestinal surface can be thus multiplied by 600 fold (Figure I.2).

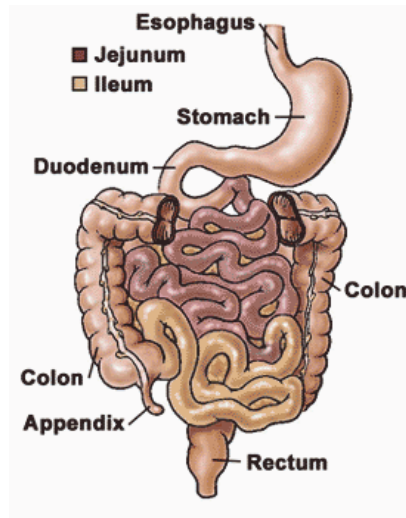

Figure I.1: Anatomy of gastrointestinal tract

Small intestine is located after the stomach and the colon. Small intestine consists of three segments: duodenum, jejunum and ileum. http://missinglink.ucsf.edu/lm/ids_106_lowergi/lower%20gi/mainpages/smallintestine.htm

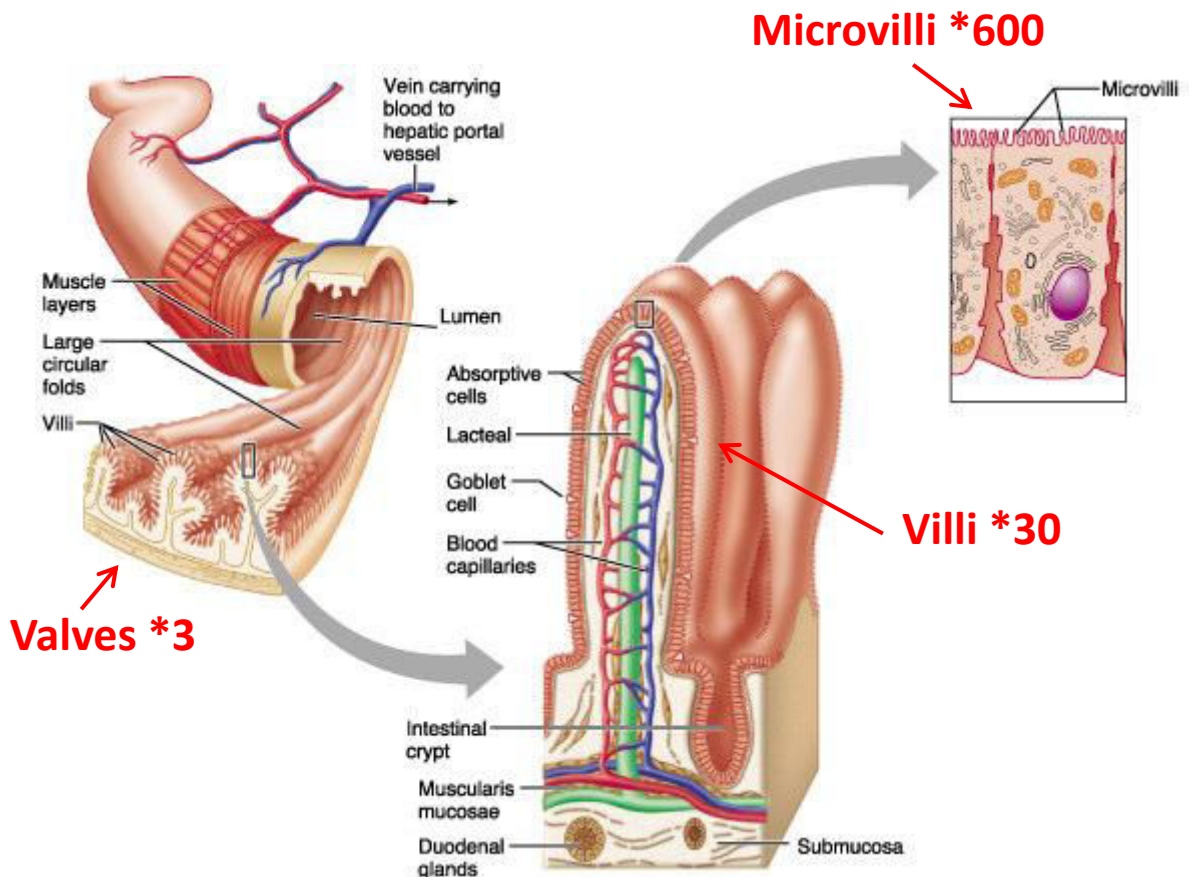

Figure I.2: Organisation of small intestinal mucosa
http://physiologie.envt.fr/spip/IMG/pdf/Phys_digest_14.pdf

The SI epithelium is made of a monolayer of intestinal epithelial cells (IECs) comprising four cell types: absorptive enterocytes representing approximately 80% of SI

epithelial cells, mucus-secreting goblet cells, hormone-secreting enteroendocrine cells and Paneth cells secreting antimicrobial molecules (van der Flier and Clevers, 2009) (Figure I.3, Figure I.4). All epithelial cells arise from stem cells in the crypts but, while Paneth cells remain at the bottom of the crypts, the three other cell types migrate up and form villi that are supported by an axis made of connective tissue, lamina propria (LP). LP contains blood vessels and lymphatics and remains separated from the epithelial layer by the basal membrane (Figure I.4).

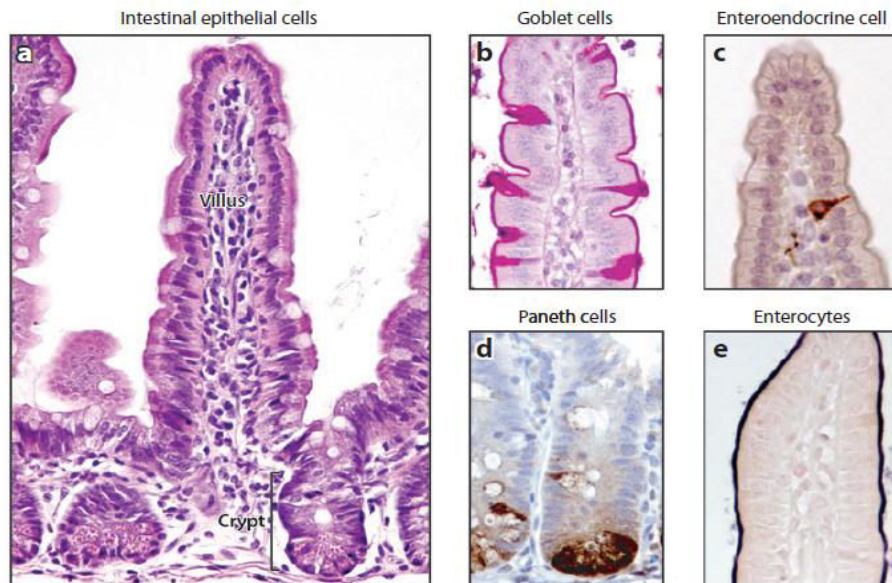

Figure I.3: Types of intestinal epithelial cells

a. H&E staining showing the morphology of the mouse intestine. Single layer of epithelial cells is organized into crypts and villi. Immunohistochemical analysis for main four differentiated cell types present in the intestinal epithelium: b, periodic acid-Schiff (PAS) to stain goblet cells; c, anti-synaptophysin to stain enteroendocrine cells; d, lysozyme to stain Paneth cells; e, alkaline phosphatase to stain enterocytes (van der Flier and Clevers, 2009).

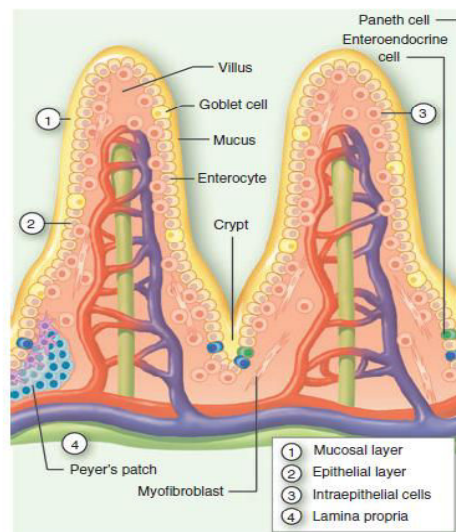

Figure I.4: Structural organisation of intestinal mucosa

Schematic representation of the small intestinal barrier consisting of a mucosal layer (1) and gradients of IgA and microbial factors, epithelial cells (2) made up by enterocytes, Paneth cells, goblet cells and enterocrine cells, intraepithelial lymphocytes (3), and the lamina propria (4). Secondary lymphoid structures, such as Peyer's patches are present in the lamina propria (Moens and Veldhoen, 2012).

Digested peptides and nutrients are mainly absorbed in duodenum and jejunum (Figure I.1). The distal part of SI, is however indispensable for the absorption of bile salts and the concomitant absorption of liposoluble vitamins. Of note, due to the higher pH and to the lesser concentration in bile salts, the number of bacteria increases considerably in the ileum (about 10^8 organisms per gram of luminal content), compared to stomach and proximal portion of SI (10^3 - 10^5 per ml of luminal content respectively) but remains less than in colon (10^{10} - 10^{12} per ml) (Macpherson and Harris, 2004). In contrast to the large intestine, which is protected by two mucus layers, notably by a thick inner layer almost deprived of bacteria, the small intestine is protected only by a single partially discontinuous layer of mucus permeable to bacteria (Hansson, 2012). Interactions between bacteria and epithelial cells can thus become intimate in the ileum, notably with segmented filamentous bacteria. These interactions are thought to play an important role in the development of the lymphoid structures that are more particularly abundant in this part of the intestine. However, up to now it remains poorly understood to which extent the responses to microbiota overlap with the responses to dietary antigen, even if recent data suggest that some bacterial species can induce regulatory responses promoting tolerance to food proteins (Atarashi et al., 2013).

The intestine has evolved an elaborated defence system in order to cope with the vast spectrum of intraluminal antigens and to ensure its integrity and homeostasis. It is estimated that the gut contains 10^{12} immune cells, mostly lymphocytes (Mestecky and McGhee, 1987) that represents about 70% of all immune cells in mammals. These immune cells are organized within a complex gut-associated immune system comprising inductive and effector sites (Brandtzaeg et al., 2008) (Figure I.5). Inductive sites comprise gut-associated lymphoid tissue (GALT) composed of Peyer's patches (PP) scattered along the mesenteric side of the SI and isolated lymphoid follicles (ILF) distributed throughout the mucosa of the small and large intestine (Mowat, 2003), but also gut-draining mesenteric lymph nodes (MLN) (Figure I.5). PP, ILF and MLN are sites where gut adaptive immune response can be initiated through the priming of naïve T and B cells by mucosal antigens processed by antigen-presenting cells (APC). Lymphocytes primed in gut-associated inductive sites follow a hemolymphatic cycle that allows them to colonize the whole intestinal length of the intestine, where they become mature effector cells, and to distribute in lamina propria and epithelium, effector sites of the gut immune system.

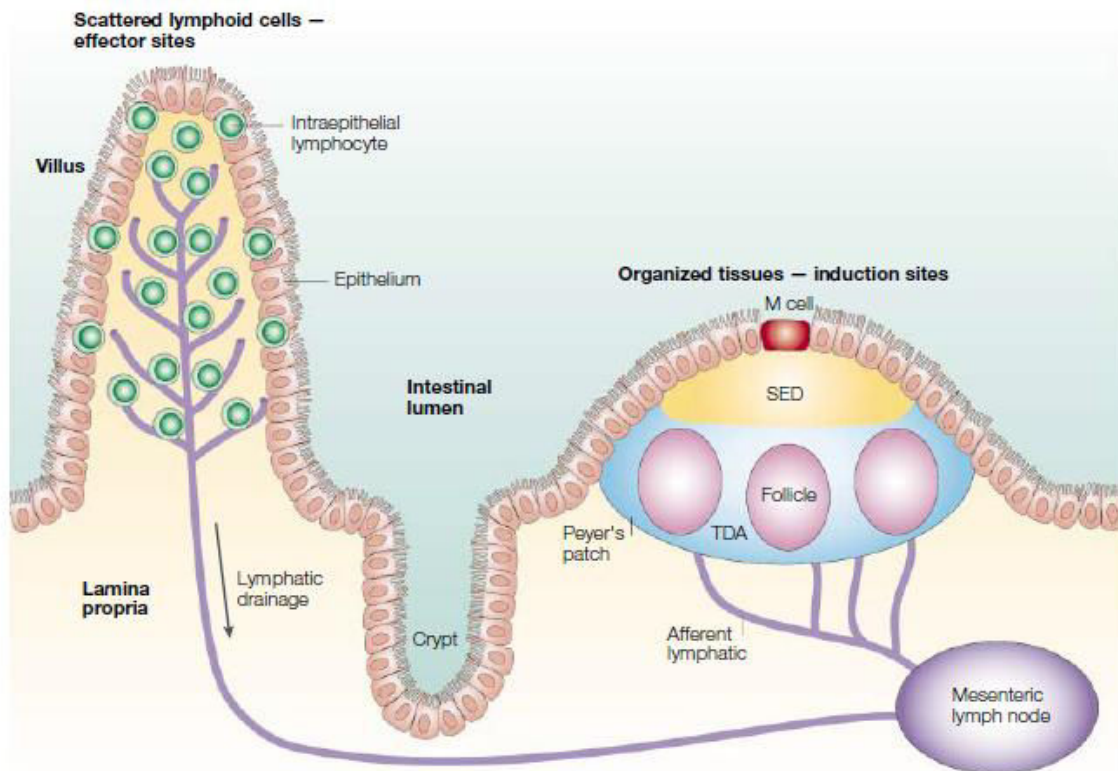

Figure I.5: Schematic representation of lymphoid elements of the intestinal immune system

The organized tissues of the Peyer's patches and mesenteric lymph nodes (MLN) are involved in the induction of immunity and tolerance, whereas the effector sites are scattered throughout the lamina propria and the epithelium of the mucosa. Both Peyer's patches and lamina propria are drained by afferent lymphatics that go to the MLN. SED, subepithelial dome; TDA-thymus-dependent area (Mowat, 2003).

Besides GALT, intraepithelial and lamina propria lymphocytes are distributed all over the intestine. The intestinal epithelium contains several subsets of intraepithelial lymphocytes (IELs) (Figure I.4), the origin of which remains still debated. IEL are heterogenous, and adults comprise mainly effector CD8 T cells displaying TCR $\alpha\beta$ or TCR $\gamma\delta$ receptors. Due to their proximity to the gut lumen, IELs form a first line of defence. Thus, they are enriched in cytotoxic T cells that can be activated both via their TCR and/or via innate receptors. IELs can also secrete cytokines and may even exert regulatory functions (Cheroutre et al., 2011). Lamina propria contains much more diverse immune cell populations including resident macrophages, dendritic cells (DCs), and effector T cells, mainly CD4⁺ TCR $\alpha\beta$ ⁺, plasma cells, innate lymphoid cells, eosinophils and mast cells.

Peyer's patches and isolated lymphoid follicles. Peyer's patches are macroscopic lymphoid aggregates located in LP and submucosa of small intestine. They are regularly scattered across the SI but are more particularly abundant in the ileum. Mature PP consist of B-cell follicles separated by T-cell zones (Figure I.6) (Mowat, 2003). B follicles are overlaid by the dome covered by the follicle-associated epithelium (FAE) that contains a specialized cell type, microfold cells (M cells), which lack microvillous brush border and basement membrane

(Figure I.6). M cells that differentiate under the influence of adjacent B cells are characterized by their capacity to capture and rapidly transport soluble and particular antigens under intact form from gut lumen into the subepithelial dome (SED) of PP where they can be taken up by APC (Figure I.6). The mechanism of the transepithelial antigen transport across M cells remains not fully delineated (Mowat, 2003). Dendritic cells loaded with antigens in the SED were shown to migrate to the T zone where they can present antigen to naïve B and T cells (Iwasaki and Kelsall, 2000). They are also likely to migrate to MLN through the efferent lymphatics. ILF resemble PP and notably possess an SED, but consist of only one or two B cell follicles, with no distinct T cell zone (Eberl and Lochner, 2009). As PP, ILF develop as a consequence of a genetically determined programme. In contrast to PP that develop *in utero*, ILF appear only during the post-natal period as cryptopatches. The full development of PP and ILF is triggered by intestinal bacterial colonization (Eberl and Lochner, 2009). Of note, some bacteria and notably segmented filamentous bacteria, but also inflammation, can stimulate *de novo* development of tertiary lymphoid follicles well beyond the neonatal period (Lecuyer et al., 2014; Lochner et al., 2011).

Mesenteric lymph nodes. Mesenteric lymph nodes are the largest lymph nodes of the body. They acquire antigen-loaded dendritic cells migrating in a CCR7-dependent manner from the gut through the afferent lymphatics draining the intestinal mucosa and PP (Jang et al., 2006; Worbs et al., 2006). They can also acquire soluble proteins from the bloodstream captured by DCs numerous in the paracortex (Sixt et al., 2005). These DCs can prime naïve T and B cells entering MLN via high endothelial venules (HEV). Similarly to PP DCs, they can stimulate expression of the gut homing receptors $\alpha 4\beta 7$ and CCR9 and thereby imprint lymphocytes for homing back into the gut mucosa (Agace, 2008) (Figure I.6).

T and B cells that are primed in gut associated lymphoid tissues (PP and ILF) and in MLN can indeed leave the gut wall and MLN via efferent lymphatics, circulate in the thoracic duct and home into mucosa due to their expression of gut-homing receptors. Primed lymphocytes may also localize in the spleen, which possesses a terminal circulation and can thereby collect all circulating lymphocytes (Figure I.6).

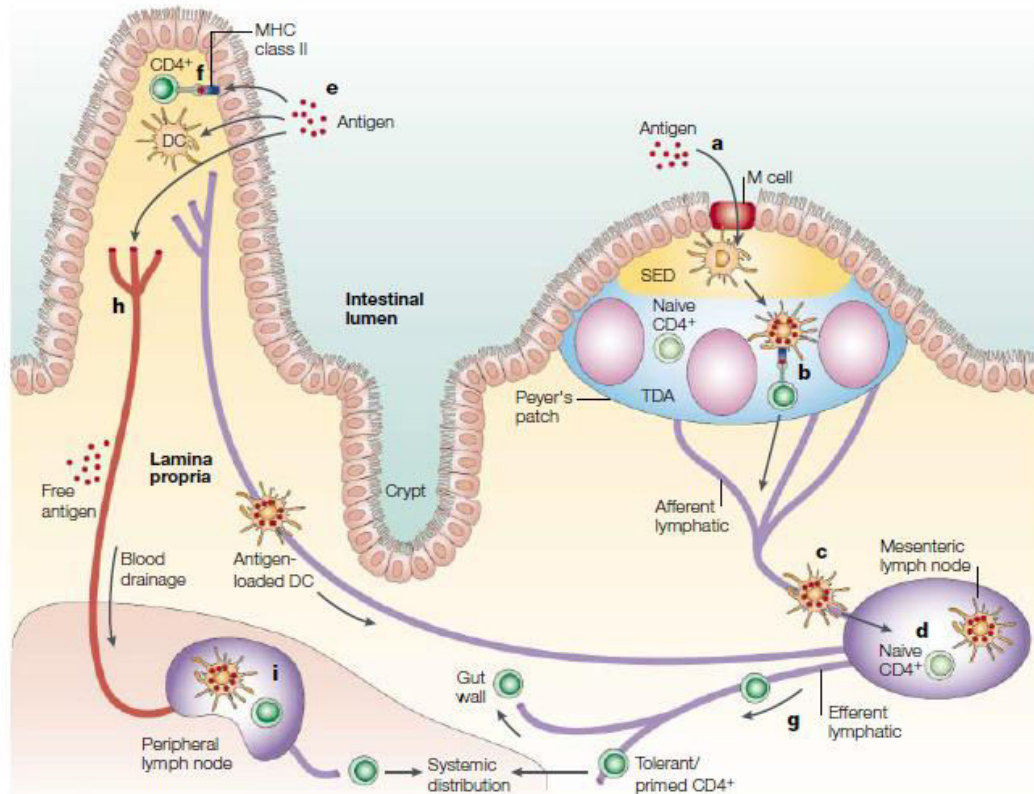

Figure I.6: Antigen uptake and priming of effector T and B cells

Antigen might enter through the microfold (M) cells in the follicle-associated epithelium (FAE) (a), and after transfer to local dendritic cells (DCs), might then be presented directly to T cells in the Peyer's patch (PP) (b). Alternatively, antigen or antigen-loaded DCs from PP might gain access to draining lymph (c), with subsequent T-cell recognition in the mesenteric lymph nodes (MLN) (d). A similar process of antigen or antigen-presenting cell (APC) dissemination to MLN might occur if antigen enters through the epithelium covering the villus lamina propria (e), but in this case, there is the further possibility that MHC class II⁺ enterocytes might act as local APC (f). In all cases, the antigen-responsive CD4 T cells acquire expression of the $\alpha_4\beta_7$ integrin and the chemokine receptor CCR9, leave the MLN in the efferent lymph (g) and after entering the bloodstream through the thoracic duct, exit into the mucosa through vessels in the lamina propria. T cells, which have recognized antigen first in the MLN, might also disseminate from the bloodstream throughout the peripheral immune system. Antigen might also gain direct access to the bloodstream from the gut (h) and interact with T cells in the peripheral lymphoid tissues (i) (Mowat, 2003).

What are the respective roles of MLN, PP and ILF in oral tolerance? As highlighted by recent work from our laboratory, PP partially relayed by ILF play a crucial role for development of IgA and specific Th17 gut immune responses against the microbiota (Lecuyer et al., 2014). In contrast, several studies indicate that MLN, but not PP, are indispensable for inducing tolerance to the soluble antigens present in the intestinal lumen. Thus, H.L. Weiner's group has demonstrated that $LT\alpha^{-/-}$ mice lacking both PP and MLN could not develop oral tolerance, while $LT\beta^{-/-}$ or $LT\alpha/LT\beta^{+/-}$ mice lacking only PP were orally tolerized (Spahn et al., 2001). Along the same line it was shown that mice prenatally treated with $LT\beta R$ -IgG that blocked PP development readily developed oral tolerance contrary to mice treated with TNFR I-IgG, which lacked both PP and MLN (Spahn et al., 2002). Similar conclusions were done in another study that introduced a soluble antigen in the lumen of ligated small bowel loops containing or not PP (Kraus et al., 2005). The impossibility to induce systemic tolerance (as

reflected by DTH) after surgical removal of MLN further emphasized the key role of MLN in oral tolerance (Worbs et al., 2006). Discrepant results were however obtained by another group that observed impaired systemic tolerance in mice lacking PP after prenatal treatment with LT β R-IgG (Fujihashi et al., 2001). Moreover, they observed that M cell-dependent delivery of antigen favoured the increase in regulatory cells in both systemic and mucosal lymphoid tissues (Suzuki et al., 2008). Overall, it seems clear that MLN play a crucial role in oral tolerance. A complementary role of PP and perhaps of ILF is possible but may not be sufficient for the induction of oral tolerance.

1.3 Mechanisms of uptake of intraluminal soluble antigens

1.3.1. Role of M cells

M cells represent particular absorptive columnar enterocytes lacking surface microvilli that makes easier the uptake of large antigens. M cells are mainly found in follicle-associated epithelium of PP and ILF, but some cells similar to M cells are dispersed throughout of the epithelium, although their numbers remain low (Jang et al., 2004). Unlike enterocytes, M cells deliver luminal antigens to the SED via a transepithelial vesicular pathway largely protected from lysosomal degradation, thus allowing the transport of antigens under an intact form (Neutra et al., 2001). The lack of microvilli, but also the expression of specific receptors may favour adherence of bacteria and viruses to M cells (Schulz and Pabst, 2013). DCs located in SED may then capture luminal antigens transported by M cells and then participate in priming of naïve B and T cells locally in PP or after migrating to MLN (Iwasaki and Kelsall, 2000; Kelsall and Strober, 1996; Ruedl et al., 1996).

In contrast to well studied role of M cells in transport and initiation of immune responses to some bacteria and viruses (Schulz and Pabst, 2013), the exact role of M cells in the transport of protein macromolecules is less well delineated. A very ancient study showed that M cells may quickly take up horseradish peroxidase injected into normal mouse intestine (Owen, 1977). Furthermore, it has been shown that M cells may mediate the transport of immune complexes of secretory IgA (SIgA) bound to bacteria through a non-identified IgA receptor (Kadaoui and Corthesy, 2007). It is thus not excluded that this mechanism can participate to the transport of large proteins, for example gluten presented bound to SIgA.

As discussed above, PP are not likely to be obligatory for oral tolerance induction. Thus, one hour after intragastric administration, OVA was detected not only in PP but also in lamina propria dendritic cells, indicating that PP cannot be the exclusive site of entry of soluble proteins (Chirido et al., 2005). Yet, villous M cells present at distance from PP in the villous

epithelium may perhaps allow the entry of proteins. Several other routes of entry and sampling have been suggested for soluble antigens, including paracellular diffusion between epithelial cells or transcellular transport across enterocytes, goblet-cell-associated antigen passages (GAPs) and uptake by intestinal mononuclear phagocytes (MNP) (Figure I.7). Their respective contribution, either in physiological or pathological situations, remains poorly delineated. We will examine below the different routes of entry of soluble antigens and how they may influence the onset or, on the contrary, the loss of tolerance to dietary antigens.

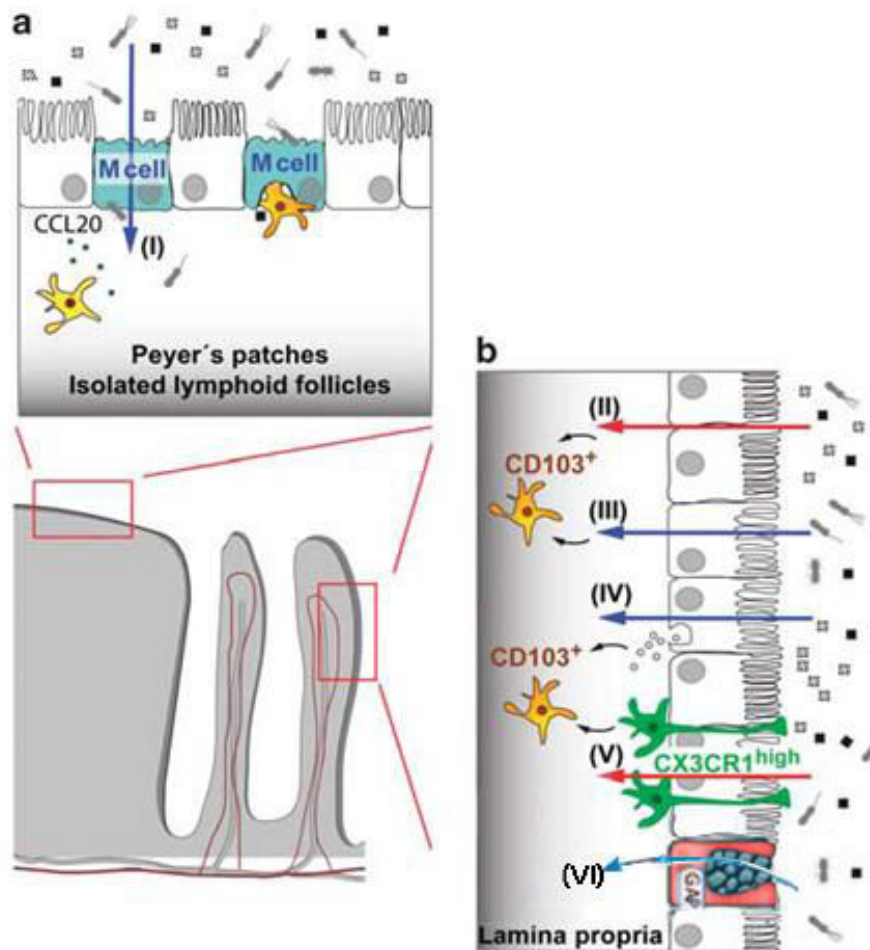

Figure I.7: Mechanisms of antigen uptake in gut-associated lymphoid tissue (GALT) and lamina propria

(a) In organized tissues of the GALT such as Peyer's patches and isolated lymphoid follicles, specialized microfold cells (M cells) in the epithelium overlying the lymphoid follicles mediate transcellular transport of particulate material notably intestinal microbiota (I). This antigen is then passed onto dendritic cells that lie either below the epithelium or in the basolateral pocket of M cell. Production of CCL20 by surrounding epithelial cells can attract further DCs via their expression of CCR6. (b) CD103⁺ DCs in the lamina propria underlying normal villus epithelium also play a critical role in presenting antigen for the induction of tolerance. They may acquire soluble antigens that have diffused through epithelial tight junctions (II), or that have been transferred across epithelial cells by transcellular routes (III). Exosomes containing antigen derived from MHCII⁺ enterocytes may be taken up by DCs (IV). CX3CR1^{high} macrophages have also been reported to capture luminal antigens by extending processes through the epithelial layer and they may pass this onto neighbouring CD103⁺ DCs, probably via gap junction transfer (V). Soluble antigen may also be taken up by Goblet cells via goblet-cells-associated antigen passages (GAPs). CD103⁺CD11c⁺DCs can then acquire antigen from GAPs (VI). Adapted from (Pabst and Mowat, 2012).

1.3.2. Role of enterocytes

Enterocytes play a major role in the absorption of nutrients. The absorption of various molecules of different sizes by enterocytes is termed intestinal permeability (Menard et al., 2010). Several mechanisms have been established, globally separated in two groups: *paracellular diffusion* of small molecules (<600 Da, (Watson et al., 2001) through tight junctions between adjacent intestinal epithelial cells (IECs) (Figure I.8A) and *transcellular transport* of macromolecules from apical to basolateral surface of IECs known as transcytosis (Figure I.8B) (Menard et al., 2010). Dietary proteins are largely degraded within intestinal lumen into small non-immunogenic peptides. Yet, some proteins or peptides can reach the epithelial surface in intact form, notably allergenic proteins and gluten-derived peptides that are characterized by their resistance to enzymatic digestion (Faria and Weiner, 1999).

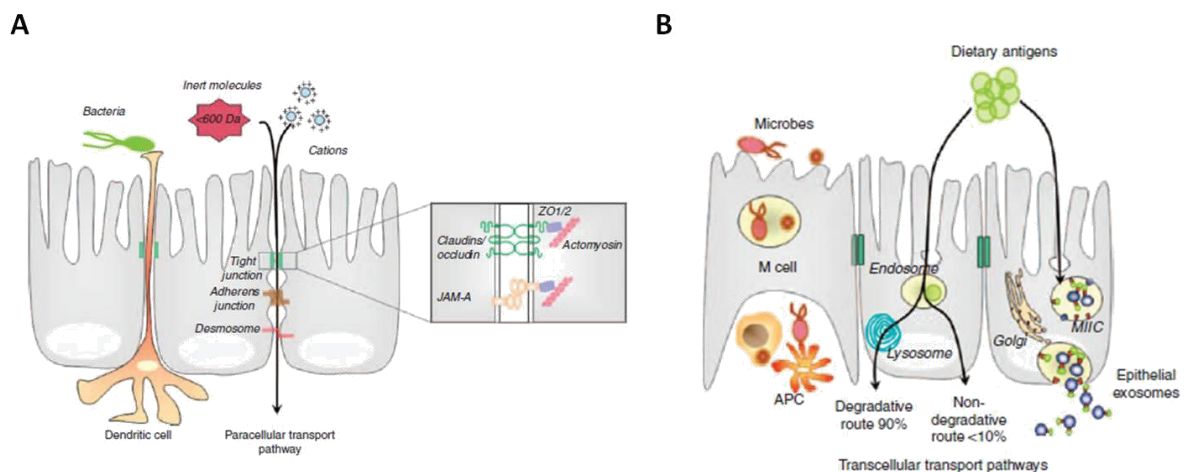

Figure I.8: Paracellular and transcellular transport pathways

A. The paracellular pathway relates to structures joining adjacent intestinal epithelial cells and is delineated by tight junction, adherent junctions and desmosomes. Paracellular diffusion of molecules is mainly restricted by tight junctions, network of transmembrane proteins. Under steady-state condition, these highly regulated structures allow the diffusion of ions and inert molecules of small size <600 Da and can be increased in pathological situation. B. Transcellular transport pathways. Under steady-state condition, molecules of MW>600 Da, such as food antigens, peptides, are sampled by the epithelial cells by endocytosis at the apical membrane and transcytosis toward the lamina propria. During transcytosis, full-length peptides or proteins are partly degraded in acidic and lysosomal compartments and released in the form of amino acids (total degradation) or breakdown products (partial degradation) at the basolateral pole of enterocytes. Early endosomes containing partially degraded food antigens meet the major histocompatibility complex class II-enriched compartment (MIIC) where exogenous peptides are loaded on MHC class II molecules. Inward invagination of MIIC compartment leads to the formation of exosomes, small membrane vesicles (40-90nm) bearing MHC classII/peptide complexes at their surface. Exosomes can diffuse in the basement membrane and interact with local immune cells (Menard et al., 2010).

Paracellular pathway. The role of the paracellular pathway in the intestinal entry of immunogenic peptides has been suggested notably in inflamed gut. This pathway that depends on the very narrow pores formed by tight junction proteins allows the passage of ions and very small molecules across epithelium. It has been advocated notably by A. Fasano that in celiac disease immunogenic gluten peptides can however pass by paracellular diffusion through tight junctions (Fasano et al., 2000; Lammers et al., 2008; Tripathi et al., 2009). While there is ample

evidence that paracellular permeability is increased and that tight junctions are modified during intestinal inflammation, notably due to the action of inflammatory cytokines, there is as yet no formal demonstration that immunogenic peptides can pass through this pathway (Heyman et al., 2012; Menard et al., 2012). I will therefore focus on the role of transcellular pathways in the intestinal entry of dietary proteins.

Transcellular pathway. Internalisation of luminal macromolecules within enterocytes can be divided into two main mechanisms depending or not on the implication of a receptor at the apical cell surface.

Non-receptor mediated transcellular pathway. Large particles with size of 200nm up to 2µm can be endocytosed by IECs, and detected in LP within 5-30 min and in MLN within 30min-1h after oral administration (Hodges et al., 1995; Snoeck et al., 2005). Internalization of macromolecules by enterocytes involves clathrin- or caveolae-mediated or independent endocytosis, but is unlikely to be mediated by macropinocytosis or phagocytosis (Conner and Schmid, 2003). Most proteins or peptides internalized by passive endocytosis undergo strong degradation within IECs. *In vitro* analysis of transcellular transport of HRP molecules by HT29 epithelial cells using Ussing chambers has shown that only 0.1% of native proteins resisted to the degradation while the largest part was degraded into small peptides with average molecular weight of about 1,500 Da (Terpend et al., 1998). Interestingly, this molecular size is close to that of immunogenic peptides that can be uploaded to MHC class II molecules (Terpend et al., 1998). Further analysis by high-performance liquid radiochromatography (HPLC) demonstrated that about 40% of proteins applied at the mucosal surface of biopsies mounted in Ussing chambers were transformed by IECs into peptides of size compatible with MHC pockets, while over 50% were completely degraded into amino acids (Figure I.8B) (Menard et al., 2010). The fact that peptides processed by enterocytes had a size close to the size of immunogenic peptides led to suggest that the peptides may be protected from degradation through the binding to MHC class II molecules expressed by enterocytes. In keeping with this hypothesis, it was shown that enterocyte cell lines could present soluble proteins to CD4 T cell hybridoma (Brandeis et al., 1994; Hershberg et al., 1997; Kaiserlian et al., 1989). The *in vivo* relevance of direct presentation is however uncertain, knowing that IECs are separated from CD4 T cells by the basement membrane, but may perhaps occur in recall responses of the small subset of CD4⁺ IELs. Alternatively, experimental work performed in our laboratory has shown that IECs can release endocytosed antigens within exosomes, small membrane vesicles of 30-90nm size formed through the fusion of early endosomes and MHC class II-enriched compartments (MIICs) (van Niel et al., 2001) (Figure I.8B). Following this fusion, exosomes

may be formed by the inward invagination of MIIC membrane, thus leading to the formation of highly immunogenic peptide/MHC class II complexes on their surface. Exosomes released at the basal side of enterocytes (Figure I.8B) may then be captured by LP mononuclear phagocytes and thereby promote the antigen presentation. This mechanism can be probably enhanced in inflamed gut due to the increased expression of MCH class II molecules on epithelial cells, notably under the influence of IFN γ released by activated T cells.

Receptor-mediated transcellular transport of immune complexes. Small intestine harbors great numbers of antibody secreting cells. 80% of the plasmocytes are IgA-producing cells, 15-20% - polymeric IgM-secreting cells and 3-4% - IgG-secreting. IgE-secreting cells can be found only in food allergy or helminth infection (Brandtzaeg and Johansen, 2005). Polymeric IgA and IgM are transported from the basal to apical side of enterocytes by the polymeric IgA receptor and released in the lumen as secretory IgA (SIgA) or IgM bound to the extracellular part of the receptor (secretory component). The primary function of these antibodies is to neutralize bacterial and food antigens and to limit their entry to the mucosa. However, it has been suggested that these immune complexes may play a role in protected transport of dietary antigens via receptor-mediated route. The impact of this protected transport on the induction of consequent tolerogenic or proinflammatory response remains poorly understood. Three receptors have been respectively implicated in the transport of IgA, IgG or IgE immune complexes.

Studies performed in our laboratory have shown that in the pathological situation of coeliac disease SIgA may play a role in the retrotransport of large gluten peptides. In fact, the cross-linking of secretory IgA by poorly digested gluten peptides may lead to the formation of large complexes able to bind CD71. CD71 was first described as a high avidity receptor for transferrin, but can also serve as a weak-affinity receptor for IgA (Moura et al., 2001). CD71 expression is restricted to the basolateral surface of IECs in healthy individuals, but in celiac disease it can be induced also at the apical surface. It has been therefore shown that SIgA complexes could bind to apically expressed CD71 and allow the retrotransport of intact gluten peptides from the lumen into LP (Lebreton et al., 2012; Matysiak-Budnik et al., 2008) (Figure I.9A). *In vivo* study using mice that had upregulated CD71 apical expression and bore hybridomas secreting ovalbumin (OVA)-specific IgA suggested that OVA/IgA complexes could be transported via CD71 across the epithelium and favour the appearance of IFN γ -producing T cells in MLN in response to OVA (Abed et al., 2014). Moreover, the group of I. Moura has shown that binding of IgA1 to CD71 can induce the activation of proinflammatory MAPK/ERK-mediated signalling in mesangial cells associated with glomerular damage in IgA

nephropathy (Tamouza et al., 2012). It should be therefore verified if the binding of gluten peptide/IgA complexes to CD71 in enterocytes could also induce proinflammatory pathways.

The neonatal Fc receptor (FcRn) was initially reported to play a role in protective immunity in suckling rats by allowing the absorption of IgG from maternal milk (Brambell, 1966; Jones and Waldmann, 1972). In humans, this receptor was also found at the apical and basolateral poles of adult intestinal enterocytes where it was shown to favour the bidirectional transport of IgG (Israel et al., 1997; Shah et al., 2003). As determined by *in vitro* and *in vivo* studies, FcRn-mediated transport of IgG bound to ovalbumin may protect the antigen from degradation (Figure I.9B) and favour the presentation of the antigen by CD11c⁺ DCs to OVA-specific CD4 T cells (Yoshida et al., 2004). Other data in newborn mice have suggested that the apico-to-basal transport of IgG/OVA immune complexes from maternal milk may participate in the establishment of oral tolerance (see 1.7 Open issues: Factors influencing oral tolerance induction) (Matson et al., 2010; Mosconi et al., 2010). The relevance of IgG-mediated transport in humans is unclear, given the very low concentration of IgG in human maternal milk and in intestinal secretion, but it is not excluded that it can have a pathogenic function during inflammatory bowel disease associated with a marked increase in intestinal IgG plasma cells.

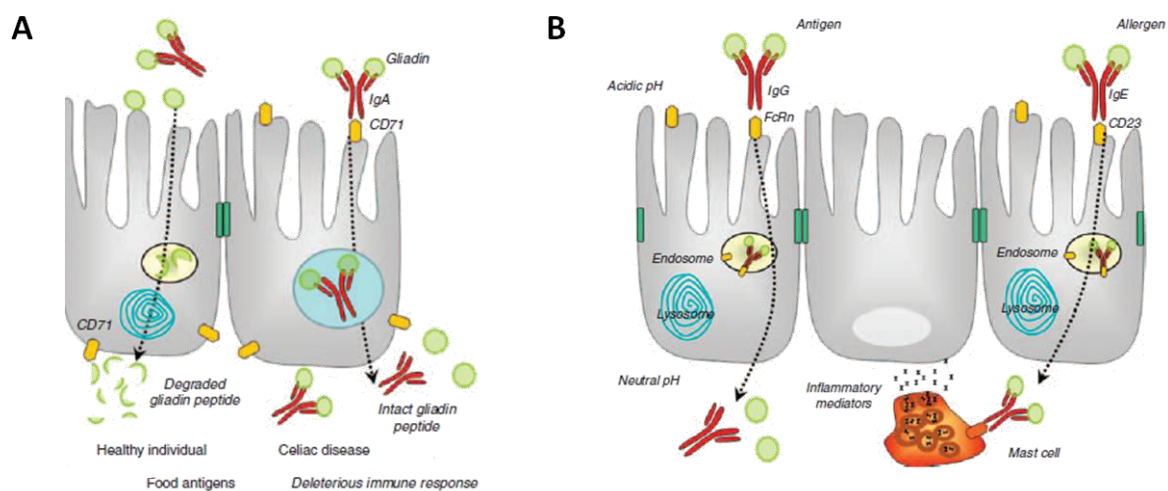

Figure I.9: Immunoglobulin-mediated retrotransport of luminal antigens

A. In healthy individuals, undigested gliadin peptides are taken up by non-specific endocytosis in enterocytes and entirely degraded during transepithelial transport. In some pathological situations, notably in celiac disease, secretory IgA allow the protected transcytosis of gliadin peptides. The ectopic expression of CD71 at the apical membrane of epithelial cells favors the retrotransport of IgA immune complexes and inappropriate immune responses. B. IgG have been shown to bind the neonatal Fc receptor expressed on intestinal epithelial cells (FcRn). This receptor-mediated transcytosis allows a protected transport of IgG and their release on the basal side of enterocytes. IgG immune complexes can also be shuttled from basal to apical pole of the enterocytes. In food allergy, an overexpression of CD23 at the apical side of enterocytes can drive the transport of intact IgE/allergen immune complexes from the intestinal lumen to the lamina propria, a phenomenon triggering mast cell degranulation and allergic inflammatory cascade (Menard et al., 2010).

Finally, IgE induced in food allergy may also play a role in the protected transport of dietary antigens and thus promote gut allergic responses. It has been shown that CD23 (FcεRII), the low-affinity receptor for IgE (Bonney et al., 1987), can be up-regulated by IL-4

in rats (Yang et al., 2000; Yu et al., 2001) and overexpressed on IEC apical and basolateral surfaces in human cow's milk allergy (Kaiserlian et al., 1993). Moreover, this receptor was shown to promote the translocation of IgE bound to HRP in sensitized rats and thereby to stimulate the degranulation of intestinal mast cells (Bevilacqua et al., 2004) (Figure I.9).

Contrary to pathways discussed below, the protected transport of dietary antigens mediated by IgA/peptide and IgE/peptide immune complexes is likely to be specifically induced in pathological situations, although the role of IgG/peptide complexes in induction of tolerance or inflammation remains unclear.

1.3.3 Goblet cells

One group has recently shown using a minimally disruptive *in vivo* imaging that small intestinal goblet cells (Figure I.3, Figure I.4) may deliver intraluminal fluorescent proteins ($M_w < 70\text{kDa}$), like dextran or OVA, into lamina propria, a process that they termed goblet-cell associated antigen passages (GAPs) (McDole et al., 2012). Presence of goblet cells throughout the intestine makes this mechanism of potential interest. *In vivo* imaging suggested that the uptake of orally administered or intraluminally injected large molecules such as fluorescent OVA, dextran or LPS, occurred via GAPs throughout the epithelium and via PP within 30min-1h after antigen administration, while IECs internalized only nanoparticles ($< 40\text{nm}$) during this time lapse (Table I-1) (Howe et al., 2014). Imaging also suggested that antigens delivered through GAPs were captured by CD103^+ LP DCs found in close contact with goblet cells, while CX3CR1^+ DCs were much less efficient in this process (McDole et al., 2012). The factors that determine the preferential capture of soluble antigen by CD103^+ DCs remain to be identified. Providing further support to the role of this pathway in loading LP DCs, it was observed that LP DCs isolated from $\text{Math1}^{-/-}$ mice specifically lacking goblet cells were not able to present OVA to OVA-specific CD8 (OTI) T cells. Yet, the molecular basis of this pathway needs to be further investigated. Although GAPs seem to be implicated in transport of antigen in physiological conditions, it remains unknown whether this pathway may amplify the antigen entry in pathological situations.

Table I-1: Routes of uptake of soluble and particulate antigens in the small intestine (SI) of mice
 Analysis performed in living mice by *in vivo* imaging one hour after intraluminal injection of fluorescent molecules
 (Howe et al., 2014)

	Mode of administration	Routes of antigen uptake in the SI		
		GAPs	IECs	Peyer's patches
Ova	PO, IL	+	-	+
Dextran	PO, IL	+	-	+
LPS	IL	+	-	N/E
NPs<40 nm	PO, IL	N/E	+	+
NPs>100 nm	PO, IL	-	-	+

Abbreviations: PO: Per-oral; IL: Intraluminal (injected in the lumen of the SI); N/E: Not evaluated. GAPs (Goblet Cell Associated Passageways); IECs (Intestinal Epithelial Cells).

1.3.4 Gut mononuclear phagocytes

Different studies have suggested that lamina propria CD11c⁺ mononuclear phagocytes (MNP) can directly take up bacterial antigen by extending dendrites inbetween epithelial cell tight junctions into the lumen (transepithelial dendrites, TEDs) (Chieppa et al., 2006; Niess et al., 2005; Rescigno et al., 2001) (Figure I.10). The dissemination of *Salmonella enterica* has thus been associated with CX3CR1⁺ DCs able to send dendrites into the lumen, while CX3CR1^{GFP/GFP} mice, which were unable to send such dendrites, were protected from *Salmonella* invasion (Hapfelmeier et al., 2008; Niess et al., 2005). One recent study (Farache et al., 2013) suggested that CD103⁺ DCs could also extend TEDs for sampling luminal bacteria, but this mechanism did not allow an efficient uptake of soluble antigens. It is therefore likely that TED-dependent mechanism is irrelevant to the uptake of proteins, probably because of the lack of proinflammatory signals required for the recruitment of DCs to the epithelium.

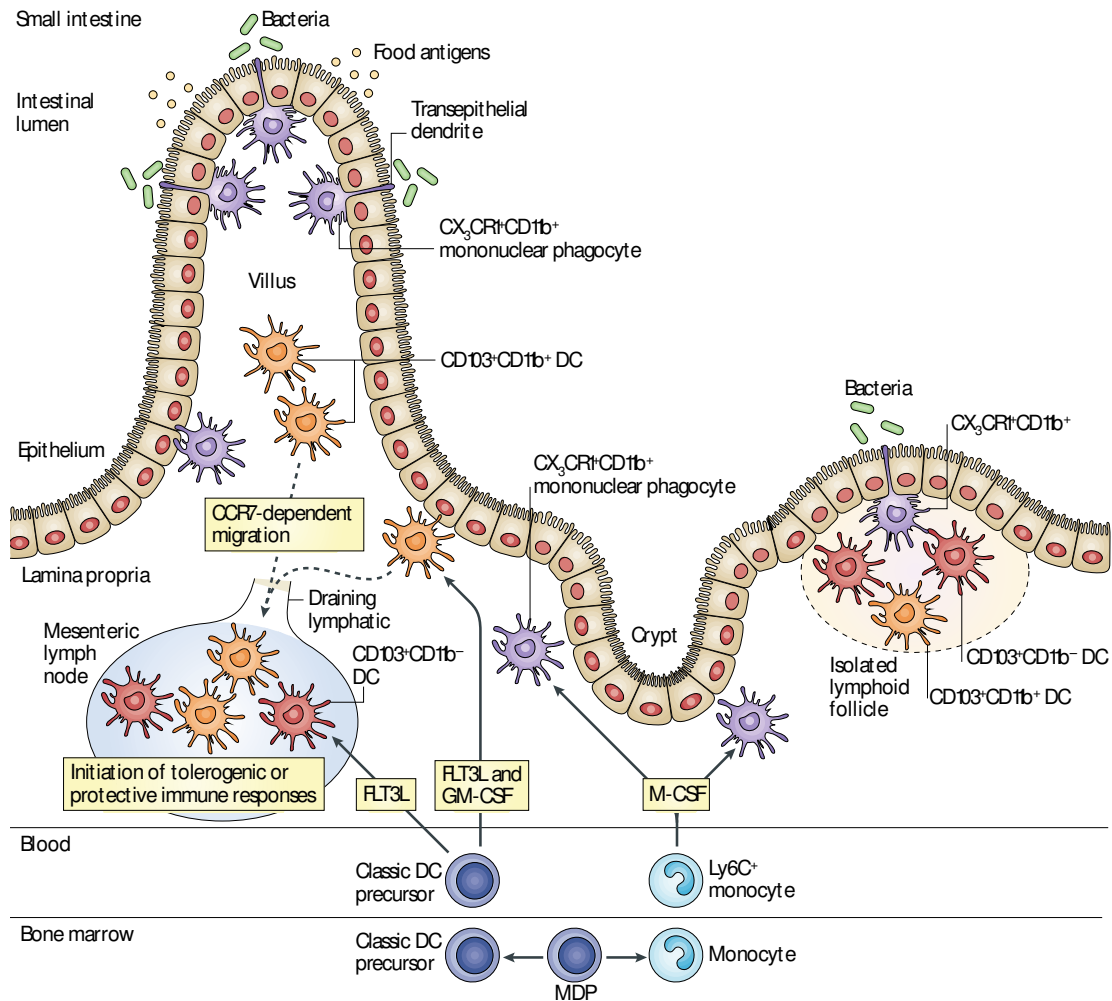

Figure 1.10: The emerging intestinal lamina propria dendritic cell compartment

A common precursor, the macrophage-dendritic cell precursor (MDP), gives rise to classical DC precursor and monocytes in the bone marrow, which enter the circulation and home to the gut. Locally, classical DC precursor give rise to CD103⁺ lamina propria DCs that can be subdivided into a CD11b⁻ and a CD11b⁺ population, which reside in the gut-associated lymphoid tissue (GALT) and lamina propria. Differentiation of CD11b⁺ lamina propria DCs requires FMS-related tyrosine kinase 3 ligand (Flt3L) and granulocyte-macrophage colony-stimulating factor (GM-CSF). Following antigenic challenge, CD11b⁺CD103⁺ lamina propria DCs migrate in a CC-chemokine receptor 7 (CCR7)-dependent manner to the mesenteric lymph nodes and promote antigen-specific tolerance or protective immunity. Ly6C⁺ monocytes differentiate locally into CX3CR1⁺ lamina propria mononuclear phagocytes that can penetrate epithelium by extending transepithelial dendrites. It remains controversial whether CX3CR1⁺ lamina propria mononuclear phagocytes are able to migrate to lymph nodes but seem to have pro and anti-inflammatory functions locally (Varol et al., 2010).

However, CX3CR1⁺ MNP may play an indirect role in the uptake of soluble antigens. One hour after injection of fluorescent ovalbumin into the gut lumen of anaesthetized CX3CR1^{+/GFP} mice, a small part (about 10%) of lamina propria CX3CR1⁺ MNP, but not CD103⁺ MNP, took up the fluorescent dye (Farache et al., 2013; Schulz et al., 2009). Of note, a recent study has suggested that CX3CR1⁺ lamina propria MNP may not only participate in the capture of luminal antigens but may also in the uptake of blood-derived soluble antigens circulating in fenestrated capillaries located just beneath intestinal epithelium (Chang et al., 2013).

1.4 Role of mononuclear phagocytes in the presentation of soluble dietary antigens

1.4.1 Comparison of the roles of CX3CR1⁺ and CD103⁺ MNP in antigen priming

Despite the ability to take up fluorescent ovalbumin, CX3CR1⁺ MNP were suggested to have only poor *in vitro* and *in vivo* priming capacities and failed to induce gut-homing receptors on T cells (Schulz et al., 2009). In contrast, CD103⁺ MNP demonstrated much superior ability to prime and to induce CCR9 and $\alpha 4\beta 7$ gut-homing receptors on T cells (Annacker et al., 2005; Jaensson et al., 2008; Johansson-Lindbom et al., 2005; Schulz et al., 2009). Moreover, due to their intrinsic capacity to produce retinoic acid (RA) and transforming growth factor β (TGF β), CD103⁺ DCs were shown to be very efficient in inducing Foxp3⁺ CD4 regulatory T cell from naïve T cells (Coombes et al., 2007; Scott et al., 2011; Sun et al., 2007a). On the basis of these results, it has been suggested that CX3CR1⁺ cells are resident antigen-capturing macrophages, while CD103⁺ MNP represent DCs able to migrate to MLN and to prime antigen-specific cells (Persson et al., 2010; Persson et al., 2013a; Varol et al., 2010). This concept was reinforced by the data suggesting that two subsets may have distinct ontogenic origins, CX3CR1⁺ cells may derive from circulating Ly6C^{hi} monocytes and depend on M-CSF for their differentiation, while CD103⁺ cells may derive from *bona fide* DC precursors and depend on FMS-like tyrosine kinase 3 ligand (Flt3L) and granulocyte-macrophage colony-stimulating factor (GM-CSF) (Bogunovic et al., 2009; Varol et al., 2009). Although this concept seems to be generally accepted, several questions persist. First, it is unclear by which mechanisms CX3CR1⁺ MNP specifically take up fluorescent antigens. As TED-dependent mechanism is unlikely to contribute for the uptake of soluble proteins, other mechanisms should exist. It has been speculated that some CX3CR1⁺ cells are found close to IECs may capture antigens delivered to lamina propria, but this hypothesis has not been formally demonstrated. Second, since CD103⁺ DCs do not directly capture luminal antigens but are critical for the antigen transfer to MLN, it is unclear how and from which cells they receive the antigen. A recent study suggests that CX3CR1⁺ macrophages may deliver ovalbumin to CD103⁺ DCs through connexin 43-dependent gap junctions (Mazzini et al., 2014) (Figure I.11), but the *in vivo* relevance of this mechanism remains unknown. Third, two groups have shown that CX3CR1⁺ phagocytes may efficiently deliver at least bacterial antigens to MLN and promote tolerogenic or inflammatory immune responses (Cerovic et al., 2013; Diehl et al., 2013). CX3CR1⁺ CD11c^{high} LP MNP were also shown to efficiently cross-present OVA to CD8 T cells, which produced IL-10 and *in*

in vitro exerted a suppressive effect on activated CD4 T cells (Chang et al., 2013). Overall, these recent data put into question the distribution of roles suggested for CD103⁺ and CX3CR1⁺ LP MNP cells. Of note, phenotypic markers used to define CX3CR1⁺ or CD103⁺ subsets of MNP largely differed between authors. Moreover, the two subsets share overlapping phenotypic characteristics, which complicate their functional analysis (Table I-2) (Geissmann et al., 2010). Further studies are needed to define how factors present in the intestinal microenvironment influence the phenotype and functions of CX3CR1⁺ or CD103⁺ subsets of MNP. Finally, it is also unclear whether CX3CR1 and CD103 are molecules that can influence the function of these two subsets of MNP.

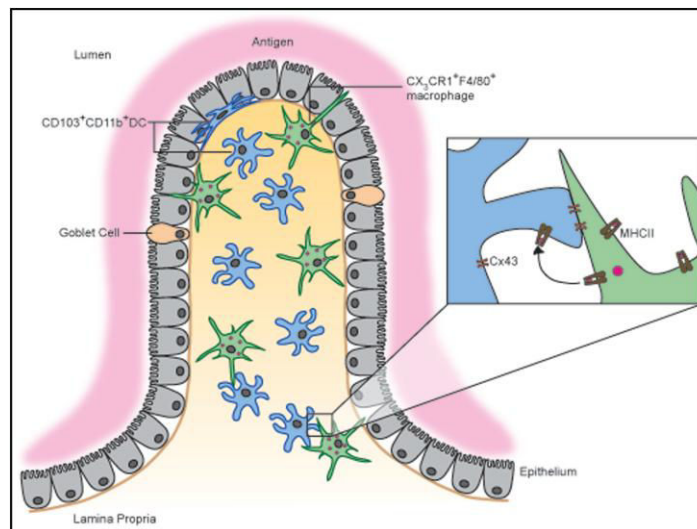

Figure I.11: Transfer of antigen from lamina propria macrophages to DCs through gap junctions

To collect soluble antigen from the gut lumen, intestinal CX3CR1⁺F4/80⁺ macrophages residing in the lamina propria send dendrites through the intestinal epithelium. Alternatively, goblet cells in the epithelium flow the antigen into the lamina propria. Rather than collecting this antigen themselves, CD103⁺CD11b⁺ DCs present in the lamina propria receive it from the macrophages. The transfer of antigen depends on the gap junction molecules connexin 43 (Cx43). Surprisingly, connexin seems to relay the antigenic peptides already complexed to MHCII molecules in a process involving transfer of cell membrane. DCs would subsequently migrate into draining lymph nodes, present the antigen to T cells, and, under noninflammatory conditions, induce oral tolerance (Shakhar and Kolesnikov, 2014).

CD103 is known as a αE component of integrin complex $\alpha E\beta 7$ that binds to E-cadherin expressed on epithelial cells and can be induced by TGF β . CD103 expression is not limited to mucosal DCs, and also found on intraepithelial lymphocytes, on some Tregs and on some cytotoxic CD8 T cells (Agace et al., 2000; Allakhverdi et al., 2006; Hadley et al., 1997). It has been suggested that the interaction of E-cadherin with its ligand αE (CD103) $\beta 7$ leads to the retention of CD103⁺ cells in the epithelium and that expression of CD103 by LP DC may reflect their conditioning by TGF β produced in large amounts in the intestine at steady state (Van den Bossche et al., 2012).

Table I-2: Intestinal lamina propria mononuclear phagocyte subsets in the mouse
(Varol *et al.*, 2010)

Subset	Phenotype	Precursor cell (growth factor requirements)	Functions described in the small intestine*	Functions described in the large intestine*
CX ₃ CR1 ⁺ mononuclear phagocytes	CD11c ^{mid} CD103 ^{low} F4/80 ⁺ CD11b ⁺ CD14 ⁻ CD70 ⁻ CD172a ⁻ MHC class II ⁺ M-CSF ⁺ CD80 ⁻ CD86 ⁻	Ly6C ^{hi} monocytes (M-CSF)	<ul style="list-style-type: none"> • Sense or sample lumen with transepithelial dendrites^{14,16,24-27} • Do not migrate to mesenteric lymph nodes¹⁷ • Poorly stimulate naive T cells¹⁷ • Induce T_H1 and T_H17 cells <i>in vitro</i>¹⁰ • Regulate T cell-independent IgA class-switching⁵⁴ • Mediate IL-23-dependent granuloma formation¹⁰² 	<ul style="list-style-type: none"> • Maintain local FOXP3⁺ T_{Reg} cell pool³⁵ • Induce colonic T_H17 cells following activation by commensal-derived ATP³⁶ • Promote TNF-dependent colitis¹⁴ • Selectively express CD172a and are reduced in colitis-resistant CD47-deficient mice³⁴ • Mediate IL-23-dependent granuloma formation¹⁰²
CD103 ⁺ CD11b ⁺ DCs	CD11c ^{hi} CD14 ⁻ CX ₃ CR1 ⁻ CD70 ⁻ MHC class II ⁺ M-CSF ⁺ ^{sw} F4/80 ^{low} CD80 ⁻ CD86 ⁻ TLF6 ⁺ CCR7 ⁻ CD172a ⁻	Classic DC precursor (FLT3L and GM-CSF)	<ul style="list-style-type: none"> • Carry antigen to mesenteric lymph nodes in a CCR7-dependent manner^{11,15,17,30,31} • Promote generation of functional T_{Reg} cells¹³ • Induce tolerance to orally administered antigens³⁰ • Imprint gut tropism (expression of CCR9 and α4β7 integrin on T cells)^{13,18,32} • Induce T_H17 cells (TLF5-dependent)¹² • Promote T cell-independent IgA class-switching (TLF5-dependent)¹² 	• Not described
CD103 ⁺ CD11b ⁻ DCs	CD11c ^{hi} CX ₃ CR1 ⁻ CD14 ⁻ CD8 ⁺ MHC class II ⁺ CD80 ⁻ CD86 ⁻ F4/80 ⁻ M-CSF ⁺	Classic DC precursor (FLT3L)	<ul style="list-style-type: none"> • Show phenotypic and ontogenic characteristics of lymphoid organ classic DCs^{14,15} • Most prevalent in Peyer's patches and isolated lymphoid follicles^{15,22} • Absent in IRF8^{-/-}, ID2^{-/-} and BATF3^{-/-} mice (as are CD8⁺ classic DCs)^{15,22,23} 	• Show phenotypic and ontogenic characteristics of lymphoid organ classic DCs ¹⁴
CD11b ⁺ F4/80 ⁺ macrophages	CD11c ^{low} CX ₃ CR1 ^{-/+} MHC class II ⁺ CD80 ⁻ CD86 ^{sw} CD103 ⁻ PDL1 ⁺	Unknown	<ul style="list-style-type: none"> • Secrete IL-10 spontaneously and promote the differentiation of FOXP3⁺ T_{Reg} cells¹⁰ 	<ul style="list-style-type: none"> • Phagocytose and eradicate bacteria but are refractory to TLR stimulation⁴⁷⁻⁴⁹ • Promote colonic wound healing⁴¹ • TREM2⁺ macrophages promote colonic epithelial regeneration⁴²

BATF3, basic leucine zipper transcription factor; ATF-like 3; CCR, CC-chemokine receptor; CX₃CR1, CX₃C-chemokine receptor 1; DC, dendritic cell; FLT3L, FMS-related tyrosine kinase 3 ligand; FOXP3, forkhead box P3; GM-CSF, granulocyte-macrophage colony stimulating factor; ID2, inhibitor of DNA-binding 2; IL, interleukin; IPF8, interferon regulatory factor 8; M-CSF, macrophage colony-stimulating factor; PDL1, programmed cell death ligand 1; R, receptor; T_H1, T helper; TLR, Toll-like receptor; TNF, tumour necrosis factor; T_{Reg} cell, regulator T cell; TREM2, triggering receptor expressed on myeloid cells 2. * There is currently no evidence for distinct functions of the different mononuclear phagocyte subsets in the two tissue compartments. Classifications of the subsets have in some cases been deduced by the authors according to the provided data.

CX3CR1 is the receptor for the chemokine CX3CL1 (fractalkine). Soluble CX3CL1 acts as a chemoattractant for T cells and monocytes, while cell-bound CX3CL1 expressed on endothelium promotes the strong adhesion of leukocytes to activated endothelial cells (Bazan *et al.*, 1997). CX3CL1 was shown to be produced by epithelial cells in the mouse ileum and thereby to promote TEDs. In mouse model of skin hypersensitivity and soluble CX3CL1 induced in inflamed lymphatic endothelium could stimulate the trafficking of cutaneous DCs to draining lymph nodes. Indeed, *in vivo* blocking of CX3CL1 or deletion of its receptor in CX3CR1^{-/-} DCs led to markedly delayed DC trafficking through lymphatics (Johnson and Jackson, 2013). Accordingly, if soluble CX3CL1 can be released during intestinal inflammation, it could allow the trafficking of intestinal CX3CR1⁺ MNP to MLN. This hypothesis remains to be verified. Moreover, CX3CL1 can modulate cytokine production. Thus, low doses of CX3CL1 decreased TNFα production, while high doses led to the upregulation of proinflammatory IL-23 (Mizutani *et al.*, 2007).

1.4.2 Influence of distinct subsets of intestinal MNP on priming and outcome of intestinal immune responses to dietary antigens

Priming of naïve T cells to dietary antigens occurs in PP or in MLN. Most studies have focused on the role of CD103⁺ DCs that presumably transport antigens from LP to MLN loaded with antigens. At steady state, CD103⁺ DCs can efficiently induce the conversion of naïve T cells into gut-homing Foxp3⁺ CD4 regulatory T cells (Tregs) (Coombes et al., 2007; Sun et al., 2007a). In contrast, CD103⁺ DCs isolated from colitic Rag^{-/-} mice rather induced proinflammatory IFN γ - and IL-17-secreting T cells and were less capable to induce Treg differentiation (Laffont et al., 2010). Reconciling these observations, another study showed that depending on the context, CD103⁺ DCs promote tolerance or immunity (Semmrich et al., 2012). In this study, OVA coupled to CD103 antibody M290 was used to specifically track the role of CD103⁺ DCs *in vivo* (Semmrich et al., 2012). In the presence of proinflammatory stimuli, CD40 antibody or polyinosinic:polycytidylic acid (Poly I:C), administration of M290.OVA led to the generation of OVA-specific IgG and activated cytotoxic OTI CD8 T cells able to kill OVA-pulsed targets (Semmrich et al., 2012). In contrast, targeting mucosal CD103⁺ DCs by intratracheal administration of M290.OVA stimulated T cell proliferation but led to the development of regulatory response that inhibited subsequent induction of allergic response to inhaled OVA (Semmrich et al., 2012). These data indicate that the capacity of CD103⁺ DCs to stimulate tolerogenic versus immunogenic responses to soluble antigens is not intrinsic to these cells but also depends on environmental cues.

If the role of CD103⁺ DC in the priming of naïve T cells in MLN has been well established, other studies indicate that LP macrophages (defined by their expression of CD11b and F4/80, enriched in CX3CR1) might promote tolerance. Thus, they could induce *in vitro* conversion of naïve T cells into Foxp3 Tregs via IL-10 secretion in the presence of TGF β (Denning et al., 2007). Another study suggested that mucosal CD11c⁺CD11b⁺F4/80⁺ (expressing high levels of CX3CR1) cells maintained Foxp3 expression in Tregs through the secretion of IL-10 (Murai et al., 2009). A role of LP macrophages in *in vivo* generation of Foxp3⁺ Treg cells seems rather unlikely given the lack of naïve T cells in LP. Nevertheless, secreted IL-10 and TGF β may play a role in maintenance and probably local expansion of Tregs. Indeed, a recent work has suggested that CX3CR1⁺ macrophages mediate the expansion of LP Foxp3⁺ Treg cells through IL-10 secretion (Hadis et al., 2011).

Which factors modulate the capacity of intestinal MNP to induce proinflammatory or tolerogenic response? Signals that may change maturation state of DCs seem to be crucial for

the modulation of their tolerogenic or inflammatory state (Laffont et al., 2010; Semmrich et al., 2012). Thus, signals received from surrounding cells may largely condition DCs. It has been suggested that factors such as TSLP produced by epithelial cells, TGFβ1 produced by multiple mucosal cell types, RA, IL-4, GM-CSF produced by immune cells, but also TLR signalling, may play a role in DC conditioning (Figure I.12) (Rescigno, 2010; Scott et al., 2011). Therefore, bacteria signalling but also dietary components may tune DC function (Scott et al., 2011).

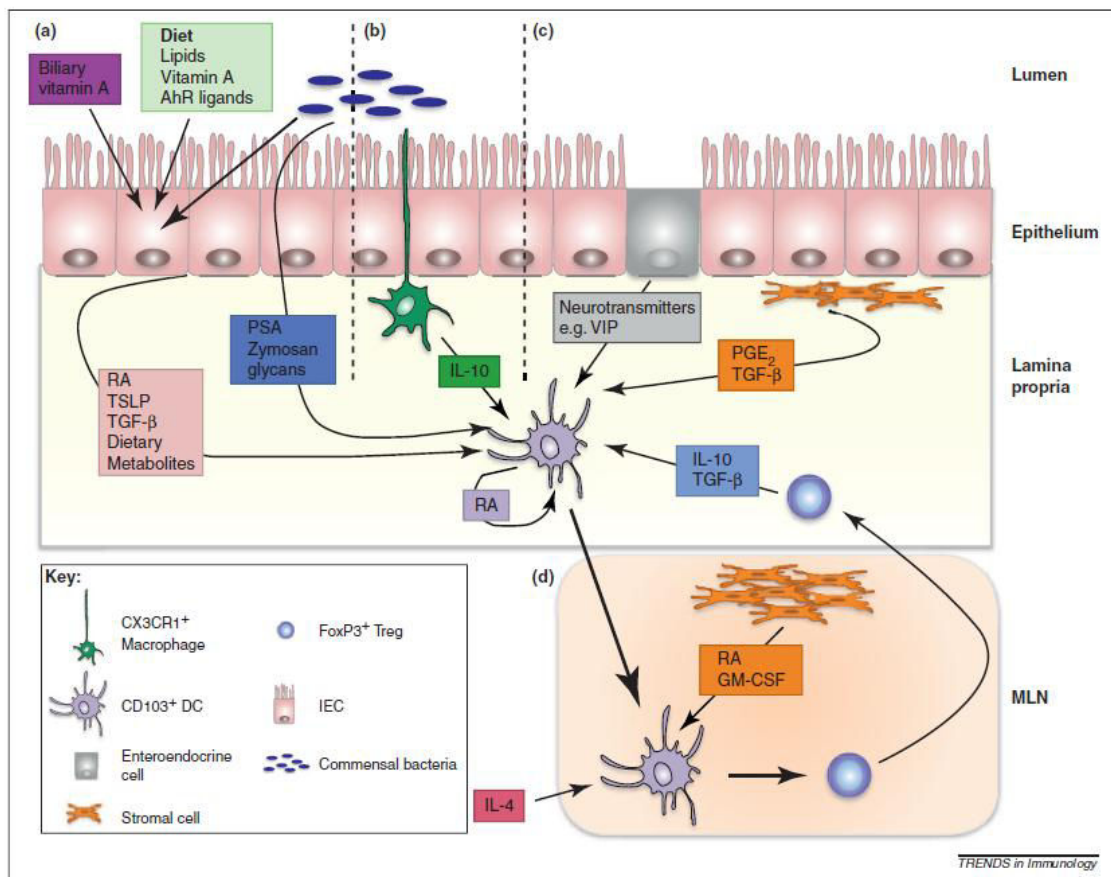

Figure I.12: Conditioning of CD103⁺ DCs by the intestinal microenvironment

A number of different factors might act in a concert to condition mucosal CD103⁺ LP DCs with their unique physiological properties. These include (a) dietary components such as vitamin A or lipid ligands of PPARγ or AhR, as well as components of local commensal bacteria and yeast. The bile is a further source of vitamin A, which has been stored in the liver. Epithelial cells can produce factors such as TGFβ, TSLP, or RA, either constitutively or under the influence of exogenous signals from the diet or the microbiota. The exact role of these individual mediators might be species-dependent, with TSLP appearing to be more important in humans than in mice. (b) Intestinal bacteria might gain access to mucosal DCs after being taken up by resident CX3CR1⁺ macrophages. These macrophages also produce IL-10 that is required for the survival of Foxp3⁺ Treg cells, which in turn might be additional sources of IL-10 and TGFβ. (c) Neurotransmitters, such as VIP, are produced by enteroendocrine cells in the epithelium, whereas mucosal stromal cells can produce IL-10, TGFβ, RA or PGE2. (d) Initial conditioning of CD103⁺ DCs in the mucosa might be further reinforced after their migration to the MLN by GM-CSF and RA produced by stromal cells, as well as IL-4 from unknown sources (Scott et al., 2011).

1.5 Systemic dissemination of intestinal antigens

We have discussed above how the uptake of soluble protein and their capture by dendritic cells allow the presentation of antigen to immune cells in MLN or PP. It was suggested that antigens derived from dietary proteins can also pass into the blood under free form. Thus, intact or partially degraded antigen derived from ovalbumin or β -lactoglobulin can be detected in serum of healthy humans or mice within one to several hours after oral feeding (Bruce and Ferguson, 1986; Husby et al., 1985; Swarbrick et al., 1979). Within 6 hours after oral administration of cytochrome C, activated CD69⁺ antigen-specific cells were detected in spleen and MLN (Gutgemann et al., 1998). Moreover, transfer of serum from OVA-fed mice one hour after OVA feeding to naïve mice could efficiently suppress DTH responses to OVA (Bruce and Ferguson, 1986; Strobel et al., 1983). Intraluminal antigens may therefore enter the bloodstream and via the portal vein reach the liver (Figure I.13).

Antigen delivery to the liver has been suggested to participate in oral tolerance. Indeed, portacaval shunting prevented the induction of oral tolerance (Callery et al., 1989). Moreover, transfer of liver cells from OVA-fed mice 24 hours after feeding protected naïve recipients from the development of DTH response (Li et al., 2004). Several liver populations were suggested to act as antigen-presenting cells (APC), including conventional liver DCs, plasmacytoid DCs (pDCs), Kupffler and sinusoidal endothelial cells, and to promote tolerance rather than immunity (Thomson and Knolle, 2010). It was notably shown that pDCs are particularly numerous in the liver (up to 30% of all DCs) and can actively participate in tolerance through induction of anergy and/or deletion of 70-80% of antigen-specific CD4 and CD8 T cells (Goubier et al., 2008). Contrary to liver, pDCs from spleen were weakly suppressive, probably because of the limited amount of dietary antigens reaching the spleen (Goubier et al., 2008). The tolerogenic properties of liver and spleen can be probably explained by the immature state of liver APC, the absence of costimulatory molecules and the tolerogenic environment of liver (Goubier et al., 2008; Thomson and Knolle, 2010). Although the role of the liver in the induction of oral tolerance is likely, other mechanisms described below play a crucial role in maintaining local and systemic tolerance to dietary proteins.

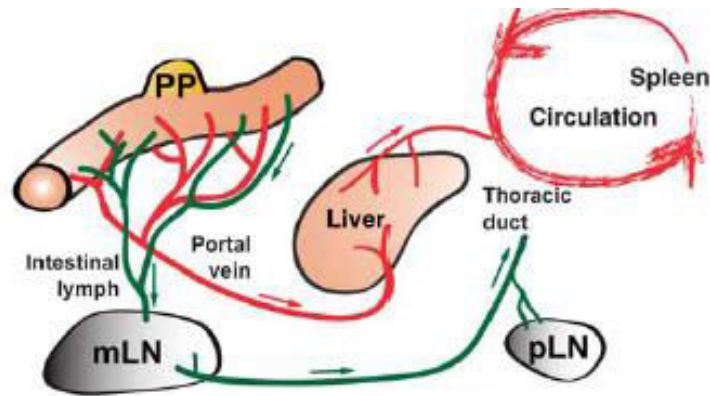

Figure 1.13: Routes of systemic dissemination of antigen

Antigen taken up into Peyer's patches (PP) or lamina propria may enter the bloodstream via the portal vein, first reaching the liver before it becomes distributed into the wider circulation. Systemic tolerance may then occur because of antigen presentation in the liver by sinusoidal endothelial cells, tolerogenic conventional DCs or plasmacytoid DCs, or because antigen reaching peripheral lymph nodes (pLN) will be presented by resident DCs in the absence of costimulation. Free antigen taken up into afferent intestinal lymph will pass through the mesenteric lymph nodes (MLN) and eventually enter the bloodstream via the thoracic duct (*Pabst and Mowat, 2012*).

1.6 Mechanisms of oral tolerance

Mechanisms implicated in the establishment of oral tolerance have been progressively unravelled and comprise anergy or clonal deletion of antigen-specific T cells, induction of different populations of regulatory CD4 T cells (Tr1, Th3, Foxp3⁺ Tregs) and suppressive effect of some CD8 T cells (Faria and Weiner, 2005). It has been initially suggested that the dose of antigen may determine the mechanism of tolerance induction (Faria and Weiner, 2005). Low dose of antigen favoured the generation of Treg cells, while high dose rather induced anergy and deletion of antigen-specific cells (Friedman and Weiner, 1994; Mowat and Ferguson, 1982). Later work has however shown that Foxp3⁺ Treg cells were also induced in response to high dose of antigen, and even in higher proportion than at low doses (Siewert et al., 2008). Moreover, accumulating evidence points out to the central role of regulatory T cells. Notably, the early onset of both dramatic autoimmunity and severe food allergy in patients who lack functional Tregs due to X-linked inactivating mutations of the FOXP3 gene (Torgerson et al., 2007) demonstrated the importance of the latter cells in preventing adverse responses not only to self antigens but also food-derived antigens in humans.

1.6.1 Clonal anergy and deletion

Several studies performed in 1990s have suggested that anergy and deletion of antigen-specific T cells contribute to oral tolerance. Oral administration of myelin basic protein (MBP) readily suppressed experimental autoimmune encephalomyelitis (Whitacre et al., 1991). In this study, lymphoid cells from tolerized mice did not transfer tolerance to naïve mice, and

proliferation of effector cells was not inhibited by lymphoid cells from tolerant donors. Based on the fact that MBP-reactive cells neither proliferated nor secreted IL-2, unresponsiveness of MBP-fed animals was explained by the state of clonal anergy. Another study has shown that feeding wild-type animals with high dose (but not low doses) of egg white lysozyme or guinea pig MBP decreased secretion of TGF β and increased that of IL-4 (Friedman and Weiner, 1994). Cells from tolerized mice did not respond to MBP even in the presence of anti-TGF β , but proliferated in response to recombinant IL-2 *in vitro*. Thus, anergy has been defined by two criteria, absence of transferrable suppression and responsiveness to *in vitro* IL-2 stimulation. In my view, these studies need to be reevaluated using updated techniques, notably multicolor flow cytometry, in order to better characterize the phenotype of anergic cells and also to eliminate the hypothesis that analyzed cells may contain a small percentage of Foxp3 Treg cells not proliferating *in vitro* except in the presence of IL-2. It would be also interesting to verify whether these cells undergo apoptosis with time or, if not, determine the factors that maintain their survival *in vivo*.

Y. Chen and colleagues, for their part, have reported that high-dose, contrary to low-dose, feeding with ovalbumin led to deletion of antigen-reactive T cells in PP of mice transgenic for OVA-specific TCR (Chen et al., 1995a). In fact, they have observed a significant decrease in the frequency of OVA-specific T cells through the apoptosis of activated cells. These results are consistent with our own experimental work that showed a decrease in the absolute numbers of OVA-specific CD4 T cells in all compartments of OTII transgenic mice upon prolonged exposure to high doses of ovalbumin (Korneychuk et al., 2014) (see B.2 Article).

1.6.2 Regulatory CD4 T cells

Different suppressive CD4 T cell populations playing a role in oral tolerance have been described since 1990s, among which IL-10-(Tr1) and TGF β -(Th3) secreting regulatory cells (Chen et al., 1994; Groux et al., 1997). CD4⁺CD25⁺ regulatory T cells were described by Sakaguchi and colleagues (Sakaguchi et al., 1995) and subsequently shown to express the Foxp3 transcription factor (Brunkow et al., 2001; Fontenot et al., 2003; Hori et al., 2003; Khattri et al., 2003). Alike Tr1 and Th3 populations, CD4⁺ CD25⁺ Foxp3⁺ Treg cells can produce IL-10 and TGF β (Shevach, 2009), suggesting a possible overlap between these populations. Indeed, three distinct subsets of Tregs have been described using mice in which the coding sequence of IL-10 was replaced with that of Thy1.1 crossed with FoxP3 reporter mice in which GFP was knocked-in the gene encoding FoxP3 (Maynard et al., 2007). Foxp3⁺

IL-10⁺ were more frequent in lymph nodes and spleen, Foxp3⁺ IL10⁺ predominated in large intestine, while Foxp3⁺IL-10⁺ Tregs in small intestine and PP. The latter cells resembled Tr1 by their cytokine profile, proliferative and suppressive responses (Maynard et al., 2007). The lack of surface markers specific for Tr1 and Th3 regulatory cells complicates the discrimination of these populations.

Transfer of CD25⁺ CD4 T cells enriched in Foxp3⁺ Tregs (about 90% expressing Foxp3) demonstrated the role of Treg cells role in the establishment of oral tolerance. The transfer of such cells from orally tolerized animals into naïve mice promoted the unresponsiveness in recipients to subsequent challenge with the same antigen. Conversely, depletion of CD4 T cells by CD4 antibody or of CD25⁺ CD4 T cells by CD25 antibody abrogated oral tolerance indicating that CD25⁺ CD4 Treg cells play a critical role in oral tolerance (Dubois et al., 2003).

What are the respective roles of natural and induced Tregs in oral toleranced? Two populations of Tregs have been described, natural Tregs (nTreg) that develop in thymus (also called now thymus-derived Tregs) and Treg cells induced in periphery from naïve T cells (iTreg or peripherally-induced Tregs). The role of thymus-induced Tregs in the prevention of autoimmunity was firmly established by experiments of neonatal thymectomy (Asano et al., 1996; Sakaguchi et al., 1985; Sakaguchi et al., 1982). In contrast, studies in TCR transgenic RAG-deficient mice, deficient in nTregs, showed that iTregs were generated upon the exposure to dietary antigen and efficiently drove oral tolerance (Mucida et al., 2005). Oral administration of antigen was efficient in preventing allergy and asthma reactions, pointing out to a critical role of iTregs in oral tolerance; however, a complementary effect of nTreg was not excluded. The recent study using mice deficient for conserved non-coding sequence 1 (CNS1) in the *Foxp3* promoter, which controls the differentiation of iTregs but not that of nTregs, has provided evidence that iTregs are necessary to suppress mucosal Th2 responses to food antigens and to prevent the appearance of IgE antibodies against food antigens (Josefowicz et al., 2012).

How can the generation of induced Foxp3⁺ Treg cells be induced? As dicussed above, gut-imprinted antigen-presenting CD103⁺ DCs are likely to play an essential role in the generation of Foxp3⁺ Treg cells in MLN of orally challenged animals (Coombes et al., 2007). Such capacity of CD103⁺ DCs largely depends on their ability to synthesize RA and TGFβ necessary for conversion of naive T cells into gut-homing Foxp3⁺ Tregs (Coombes et al., 2007; Sun et al., 2007a).

What is the respective role of Foxp3⁺ Tregs in the induction of local and systemic tolerance? U. Hadis and colleagues have precisely dissected the sequence of events explaining the suppressive role of Foxp3⁺ Tregs in oral tolerance (Hadis et al., 2011). This work showed that Foxp3⁺ Treg cells must migrate into the mucosa and expand within the gut for the induction of oral tolerance (Figure I.14). Elimination of Foxp3⁺ Treg cells in DEREK mice (mice expressing diphtheria toxin receptor under control of the Foxp3 promoter) by diphtheria toxin (DT) administration abrogated the induction of both local and systemic oral tolerance. Thus, DEREK mice treated with DT and orally challenged with OVA developed allergic diarrhea associated with increased titres of OVA-specific IgE and IgG1 and DTH responses. In keeping with previous data, Foxp3⁺ Treg cells differentiated, acquired gut-homing receptors and underwent expansion in MLN within 5 days and (Figure I.14). This step seems however to be critical for the establishment of oral tolerance, since mice deficient in $\alpha 4\beta 7$ integrin (ITGB7-knockout mice) or its ligand MADCAM1, both necessary for gut homing, had an impaired systemic tolerance. Finally, U. Hadis and colleagues showed that, once recruited into LP, Foxp3⁺ Tregs underwent massive expansion between day 5 and day 12, several times more important than that observed in MLN. This Treg expansion was abrogated in CX3CR1^{-/-} mice that lack CX3CR1⁺ LP macrophages, known to produce high levels of IL-10, a cytokine that promotes or Foxp3⁺ Treg expansion as indicated above (Denning et al., 2007; Murai et al., 2009) (Figure I.14). However, the generation of Tregs in MLN of CX3CR1-deficient mice was not compromised. These data provide a supplementary argument that IL-10-producing CX3CR1⁺ LP cells do not participate in Treg differentiation in MLN, as their numbers were not altered, but rather play a role in the local expansion of regulatory T cells (Figure I.14). It would be interesting to explore whether other mucosal cells may produce IL-10 or TGF β , another factor that sustains Treg expansion. It is unclear whether CD103⁺ DCs, known to produce RA and TGF β (Coombes et al., 2007), can also enhance the mucosal Foxp3⁺ Treg expansion in the intestinal mucosa.

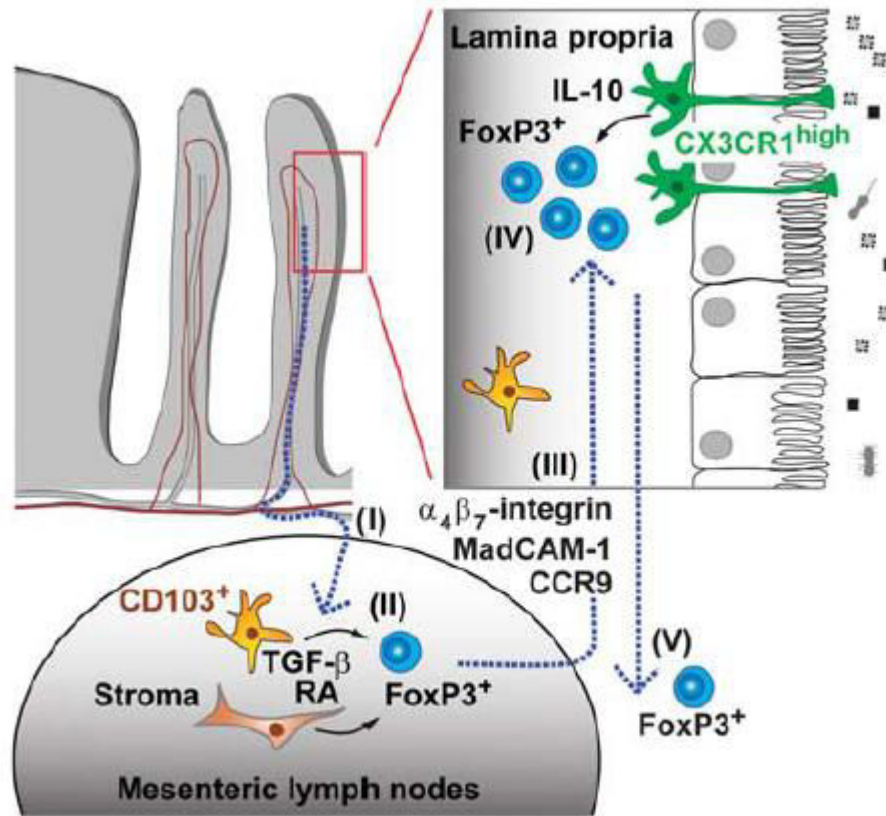

Figure I.14: A multistep model of oral tolerance to soluble antigens

Oral tolerance is initiated by the migration of antigen-loaded CD103⁺ DCs from the lamina propria into the draining mesenteric lymph nodes (MLN) (I). In the MLN, retinoic acid (RA) produced by DCs and local stromal cells induces the expression of gut-homing receptors $\alpha_4\beta_7$ integrin and CCR9 on antigen-specific T cells and favors the TGF β -dependent differentiation of Foxp3 induced regulatory T cells (iTreg) (II). These committed Treg cells home back to the intestinal lamina propria (III), where they undergo secondary expansion under the influence of IL-10 produced by CX3CR1^{high} macrophages in the lamina propria (IV). In a putative fifth step (V), some of Treg cells may exit from the mucosa via lymph and/or blood, disseminating throughout the immune system, and promoting the systemic consequences of oral tolerance (Pabst and Mowat, 2012).

How Foxp3⁺ Treg cells generated in response to intestinal antigen migrate to peripheral organs to suppress systemic responses is also not fully elucidated. Blocking T cell migration into the gut abrogated systemic tolerance. It was therefore proposed that Foxp3⁺ Tregs recruited and expanded in intestinal mucosa recirculated to the periphery via the bloodstream (Figure I.14). However, it cannot be excluded that Foxp3⁺ Treg may directly migrate from MLN into the bloodstream. The exact kinetics of systemic tolerance induction should be thus further investigated.

Overall, these recent studies have provided evidence that Foxp3⁺ Treg cells play a crucial and non-redundant role in oral tolerance, both at the systemic and mucosal levels. Nevertheless, complementary role of other regulatory populations is not excluded.

1.6.3 CD8 T cells

CD8 T suppressive cells have been described in 1980-90s (Bland and Warren, 1986; Mayer and Shlien, 1987; Miller et al., 1992; Richman et al., 1978), but remain poorly characterized and their impact on oral tolerance is unclear. Knowing that CD8 T cells can be cross-primed by gut-derived DCs (Johansson-Lindbom et al., 2005; Kim et al., 1998), such cells have been suggested to participate in oral tolerance induction. In fact, primed effector CD8 T cells can migrate into the mucosa and contribute to the tolerance by exerting cytotoxicity against antigen-presenting epithelial cells or mononuclear phagocytes, thus limiting the propagation of the immune response (Chang et al., 2013; Miller et al., 1998). A recent study proposed that lamina propria CD8 T cells might suppress activated CD4 T cells (Chang et al., 2013). However, CD8 T cells seem dispensable for oral tolerance, since $\beta 2m$ -deficient mice or mice treated with anti-CD8 antibodies show normal induction of oral tolerance (Barone et al., 1995; Chen et al., 1995b; Grdic et al., 1998; Vistica et al., 1996).

Otherwise, intraepithelial CD8 T cells expressing TCR $\gamma\delta$ were also shown to contribute to oral tolerance. Mice treated by a depleting anti- δ chain antibody or TCR δ -deficient mice displayed impaired induction of oral tolerance to OVA on both humoral and cellular responses (Ke et al., 1997; Mengel et al., 1995). Adoptive splenocyte transfer from OVA-tolerized mice inhibited IgE response in recipients to aerosolized OVA. Depletion of $\gamma\delta$ T cells abolished tolerance while transfer of very small numbers of $\gamma\delta$ T cells was sufficient to restore it (McMenamin et al., 1994). It was suggested that $\gamma\delta$ T cells may directly suppress Th2-dependent IgE responses, but the exact mechanism remains unknown.

1.7 Open issues: Factors influencing oral tolerance induction

Factors as dose, nature of antigen, time framework, and frequency of antigen administration seem to play an important role in oral tolerance induction (Strobel et al., 1983). The majority of basic studies on these issues have been performed several decades ago, when modern performant immunological techniques were not yet available. Thus, a reevaluation of these studies using more precise methods, notably flow cytometry and imaging, is needed in order to better characterize those processes. Moreover, it would be of great interest to better define the time framework of oral tolerance induction and outcoming immune responses when the antigen is given in prenatal, neonatal periods or after weaning. Several studies performed in 1980s suggested that exposure to oral antigen within the neonatal period resulted in priming of humoral and cell-mediated immune responses, contrary to adults developing oral tolerance (Hanson, 1981; Strobel and Ferguson, 1984). The immune responses were even stronger when

mice were exposed to the dietary antigen in the prenatal period (Strobel and Ferguson, 1984). A temporarily loss of oral tolerance was also observed during the weaning period. Thus, oral administration of myelin basic protein before 4 weeks of age in mice could induce priming of encephalitogenic T cells and enhance experimental autoimmune encephalomyelitis upon systemic immunization in adult mice (Miller et al., 1994). Susceptibility of rodents and humans during prenatal and early postnatal periods may be linked to the immature state of gut immune system and its increased permeability. Gut maturation, which takes place at the time of weaning in rodents and during the first days after birth for humans, leads to reduced gut permeability (Verhasselt, 2010b). The exact mechanisms remain to be better delineated.

Breast-feeding was proposed to contribute to the development of oral tolerance in suckling animals. Small concentrations of dietary antigens are detected in maternal milk (Verhasselt, 2010a). Secretory IgA present in breast milk (SIgA being the predominant Ig class in human breast milk), might play a protective role to prevent inadvertent entry of dietary antigen across the neonate mucosa and avoid the sensitisation to dietary antigens (Levinsky, 1985). Indeed, partially degraded gliadin, cow ovalbumin or food allergen ovomucoid were found to be bound to maternal milk IgA (Chirido et al., 1998; Hirose et al., 2001; Juto and Holm, 1992). Whether SIgA can play, alike IgG in mice, an active role in induction of tolerance has not yet been tested. In mouse breast milk, OVA was found within immune complexes with IgG and IgG/OVA could be transported via the neonatal FcR across the neonatal epithelium (Mosconi et al., 2010). Such transport could induce Treg cells able to prevent the development of allergic asthma (Matson et al., 2010; Mosconi et al., 2010). In contrast to mouse breast milk that contains high concentrations of IgG (Mosconi et al., 2010), IgG concentration in human milk is very low; therefore it is unclear whether the latter mechanism can operate in humans. However, other components present in maternal milk, such as TGF β and epidermal growth factors, may promote oral tolerance in neonates and enhance protection from allergic asthma (Verhasselt et al., 2008). The mechanisms contributing to the tolerance induction in fetus and neonates should be further explored, as well as the factors preventing tolerance development at this age.

Other factors, notably intestinal microbiota, might promote tolerance. Indeed, some *Clostridium* species could promote Foxp3⁺ Treg accumulation in the colon through induction of TGF β or production of short chain fatty acids (Arpaia et al., 2013; Atarashi et al., 2013; Atarashi et al., 2011). Oral administration of these species early in life or in adult mice could prevent or attenuate colitis and allergic diarrhea induced by OVA (Atarashi et al., 2013;

Atarashi et al., 2011). *Bacteroides fragilis* could also direct the development of IL-10 expressing Foxp3⁺ Treg cells in monocolonized mice, an effect that was mediated by the capsule polysaccharide A characteristic of this species (Round and Mazmanian, 2010). It is thus plausible that some bacterial strains contribute to the local expansion/maintenance of the Treg pool. It is however unclear how colonic Treg cells induced by bacteria may contribute to tolerance to food proteins. Do they differentiate in PP and/or MLN and then disperse to small intestine and periphery? How are Tregs activated to suppress immune responses to dietary antigens, through TGFβ/IL-10 mechanism or via TCR? It is perhaps possible that Tregs activated by microbial antigens may exert a bystander effect on T cell responses to dietary antigens. Yet, it is unclear how activation of colonic Tregs can protect against responses taking place in the upper small intestine.

II. Chapter 2: Abnormal response to food gluten in Celiac disease

2.1 Introduction

Celiac disease (CD) is defined as a chronic small intestinal immune-mediated enteropathy precipitated by the exposure to dietary gluten in genetically predisposed individuals (Ludvigsson et al., 2013). Celiac disease affects about 1% of Western populations (Rubio-Tapia and Murray, 2010) and can occur at any age following the introduction of gluten in the diet. Nevertheless, onset of CD is more frequent in early childhood or in young women (Meresse et al., 2012). CD patients develop typical lesions of small intestinal villous atrophy and crypt hyperplasia associated with intraepithelial lymphocyte infiltration, lymphoplasmocytic infiltration of lamina propria (Figure II.1) and appearance of IgA antibodies specific of gliadin or of a self antigen, transglutaminase 2 (TG2). As a result of epithelial damage, active CD patients present signs and symptoms of malabsorption, such as diarrhoea and steatorrhoea, leading to weight loss in adults or growth failure in children (Ludvigsson et al., 2013).

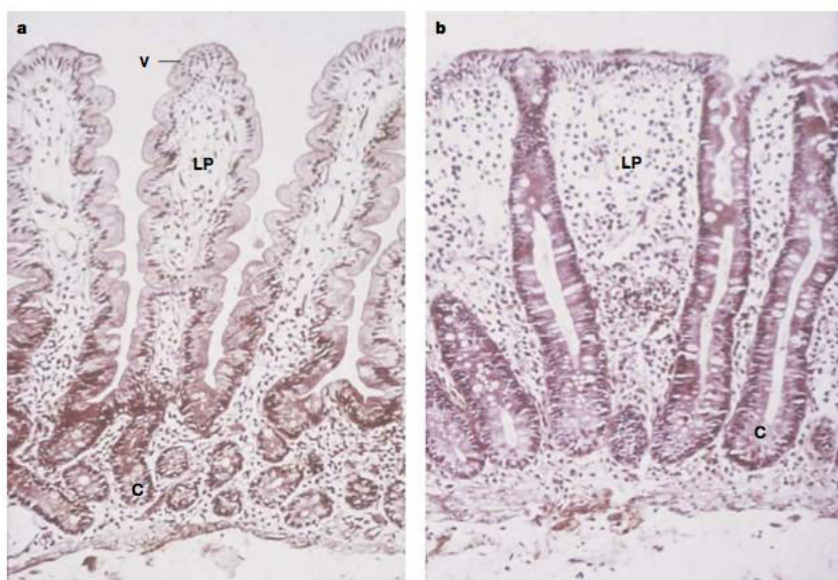

Figure II.1: Normal and celiac-disease small intestinal mucosae

a. Histology of a normal small intestine showing villi (V) and crypts (C). b. Celiac mucosa characterized by total villous atrophy, enlarged hyperplastic crypts and increased infiltration of lymphoid cells in the lamina propria (LP) and epithelium (Sollid, 2002).

The disease is precipitated in susceptible individuals by ingestion of gluten, the triggering environmental factor. A primary genetic factor of CD susceptibility, HLA-DQ2.5 or

HLA-DQ8 genes coding for MHC class II molecules, was identified by familial genetic studies (Houlston and Ford, 1996). The interactions between these two factors lead to the development of adaptive CD4 T and B cell responses (Sollid, 2002), the first keystone of CD pathogenesis. The second keystone relies on the activation of intestinal intraepithelial lymphocytes (IELs) that are considered to drive small intestinal tissue damage (Abadie et al., 2012; Meresse et al., 2012). Furthermore, CD pathogenesis has an important autoimmune-like component since CD patients develop autoantibodies against TG2 and 7-18% of CD patients develop autoimmune diseases (Cosnes et al., 2008). A strong overlap was as well identified by genome-wide association studies (GWAS) (Dubois et al., 2010; Hunt et al., 2008; Trynka et al., 2011; Trynka et al., 2009; van Heel et al., 2007) between genetic factors predisposing to CD and to autoimmune disease, and with a lesser extent to inflammatory disease (Parkes et al., 2013) (Figure II.2).

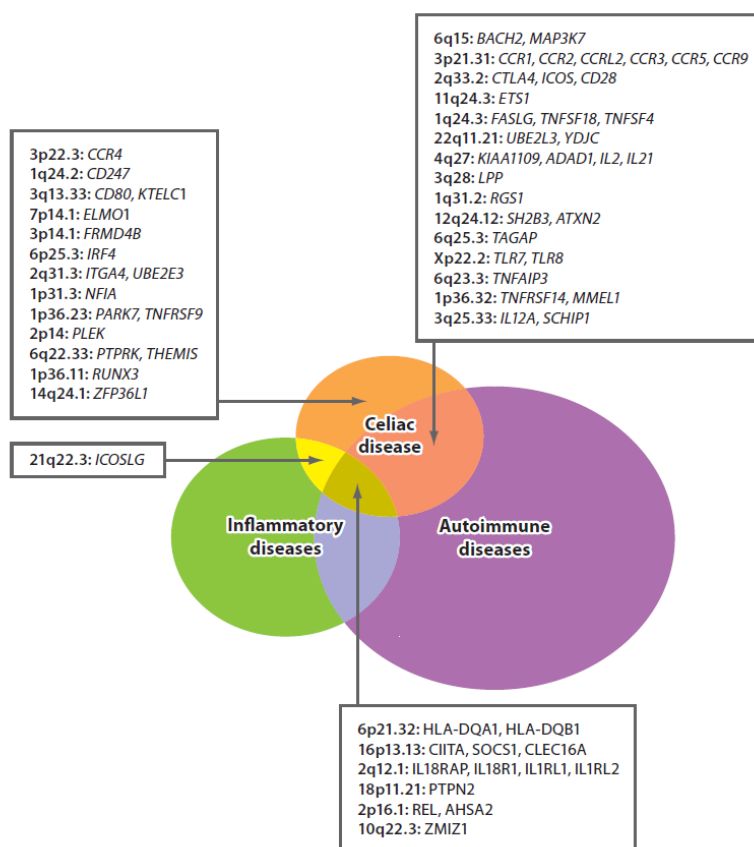

Figure II.2: Overlap of genetic risk factors for celiac disease with autoimmune and inflammatory diseases
 Shown the overlaps between the regions identified by genome-wide association studies (GWAS) as associated with CD and the regions identified by GWAS as associated with autoimmune diseases or inflammatory disorders. The set of autoimmune diseases includes rheumatoid arthritis, systemic lupus erythematosus, type 1 diabetes, multiple sclerosis, and psoriasis. The set of inflammatory disorders includes Crohn’s disease and ulcerative colitis (Abadie et al., 2012).

In this chapter, I summarize the advancements in the study of celiac disease pathogenesis and address the issues that remain unknown or uncertain to date.

2.2 Adaptive response

It is now well established that celiac disease is caused by an inappropriate immune response to dietary gluten. Herein, I give insight into mechanisms leading to the instauration of adaptive immune response perceived as a trigger of immunological cascade orchestrating small intestinal lesions in CD.

2.2.1 Gluten-specific CD4 T cell response

2.2.1.1 Gluten, triggering environmental factor

The causal role of environmental factor, gluten, in CD was first put in evidence in 1950s by a Dutch paediatrician W. Dicke that associated the onset of clinical symptoms with the consumption of wheat and related cereals. On this basis, he proposed a strict life-long gluten-free diet (GFD) that proved its efficiency in paediatric patients leading to the withdrawal of clinical symptoms and the recover of a normal growth curve in these patients (van Berge-Henegouwen and Mulder, 1993; Van De Kamer et al., 1953). Till now GFD still remains the unique but very constraining method of treatment.

Gluten is a composite of several hundred grain storage proteins from wheat, barley and rye, composed of soluble gliadins and insoluble glutenins. High number of repetitive proline- and glutamine-rich sequences and multiple disulphide bonds result in the formation of large aggregates (500-1000 kDa) with poor aqueous solubility that explains the resistance of gluten to proteolytic digestion by gastrointestinal enzymes (Hausch et al., 2002; Shan et al., 2002). These properties of gluten may in part explain its immunogenicity and toxicity in susceptible individuals.

2.2.1.2 HLA-DQ molecules, genetic factor

Family studies performed since early 1960s have provided evidence that genetic factors influence the susceptibility to the disease (Houlston and Ford, 1996). Several studies suggested the existence of association of CD with HLA class II region (Houlston and Ford, 1996). Genotyping of unrelated CD patients revealed a primary association of CD with HLA-DQ locus (Sollid et al., 1989). Most (90-95%) of CD patients carry HLA-DQ2 variant DQ2.5 encoded in *cis* by the DQA1*0501 and the DQB1*0201 genes of DR3-DQ2 haplotype (Figure II.3 *cis*) or *in trans*, where HLA2.5 molecules are encoded by DQA1*05 and DQB1*02 chains located on different haplotypes, DR5-DQ7 and DR7-DQ2 (Lundin et al., 1990; Sollid et al.,

1989) (Figure II.3 *trans*). Most of remaining (5-10%) patients bears DR4-DQ8 haplotype (Sollid et al., 1989; Spurkland et al., 1992) (Figure II.3). Interestingly, HLA-DQ2/8 transdimers formed in individuals carrying DR4-DQ8 and DR3-DQ2 haplotypes are able to selectively present β -islet autoantigens (van Lummel et al., 2012) and thus, in addition to CD, confer a high risk of type 1 diabetes (T1D) development (Tollefsen et al., 2012; van Lummel et al., 2012) (Figure II.3). These transdimers are formed either by α chain of HLA-DQ2 (HLA-DQA1*0501) and β chain of HLA-DQ8 (HLA-DQB1*0302) or by α chain of HLA-DQ8 (HLA-DQA1*0301) and β chain of HLA-DQ2 (HLA-DQB1*0201).

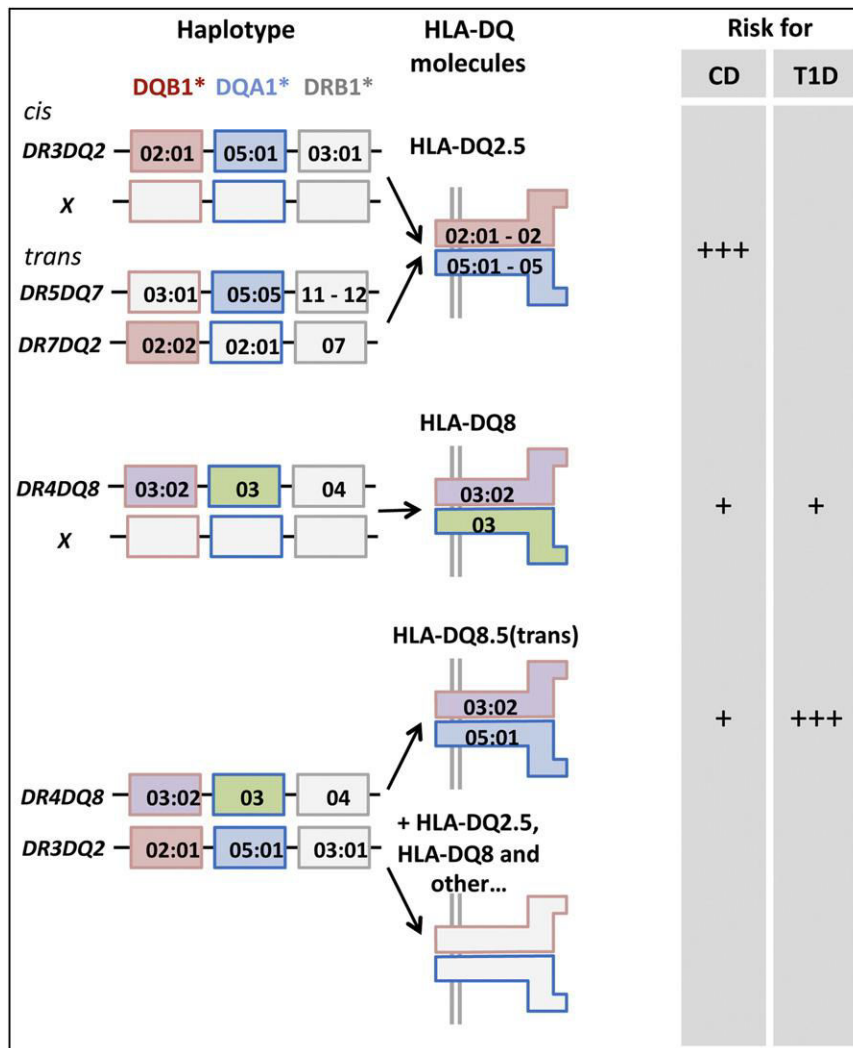

Figure II.3: Human leukocyte antigen (HLA) associations in celiac disease (CD)

The majority of CD patients express HLA-DQ2.5 heterodimer encoded by the HLA-DQA1*05 (α -chain) and HLA-DQB1*02 (β -chain) alleles. These two alleles are carried either in *cis* on the DR3-DQ2.5 haplotype or in *trans* in individuals who are DR5-DQ7 and DR7-DQ2.2 heterozygous. HLA-DQ8 is encoded by DR4-DQ8 haplotype and confers a lesser risk of CD. In individuals who are DR3-DQ2.5 and DR4-DQ8 heterozygous, transdimers DQ8.5 can form and confer high susceptibility to type 1 diabetes (T1D) (Meresse et al., 2012).

2.2.1.3 Pathogenic role of gluten-specific CD4 T cells

The link between main environmental factor, gluten, and main genetic factor, HLA-DQ2.5 or -DQ8, was established by the work of the group of L. Sollid. The presence of gliadin-specific CD4 T cells recognizing gluten in the context of HLA-DQ2.5 or HLA-DQ8 molecules in small intestinal biopsies from CD patients was therefore demonstrated (Lundin et al., 1994; Lundin et al., 1993; Molberg et al., 1997). Gliadin-specific T cells were not detected in biopsies from healthy individuals contrary to CD patients. HLA-DQ2.5 molecules encoded either in *cis* or in *trans* could both efficiently present gluten to T cells (Gjertsen et al., 1994).

Nevertheless, it remained unclear how positively charged HLA-DQ molecules with preference for negatively charged peptides could bind gluten peptides, known to be enriched in uncharged proline and glutamine but not in negatively charged amino acids. This question was resolved with the discovery of posttranslational modifications of gluten peptides carried out by transglutaminase 2 conferring them negative charge (Molberg et al., 1998; van de Wal et al., 1998a). Indeed, increased activity of tissue TG2 has been observed in small intestinal biopsies of CD patients (Bruce et al., 1985) and activated TG2 was capable to efficiently convert specific non-charged glutamine residues (in glutamine-X-proline sequences) into glutamic acid residues bearing negative charge (van de Wal et al., 1998a) termed deamidation (Figure II.4). As a consequence, HLA-DQ2/8 molecules have a strong preference for deamidated gliadin peptides over native gliadin peptides (Figure II.4). Even though, one study indicates that HLA-DQ8 molecules can efficiently present a particular native gluten peptide (van de Wal et al., 1998b), but its chemical basis remains unclear. Overall, activated tissue TG2 enhances the binding of gluten peptides to MHC class II molecules, thus conferring them a greater capacity to activate CD4 T cells.

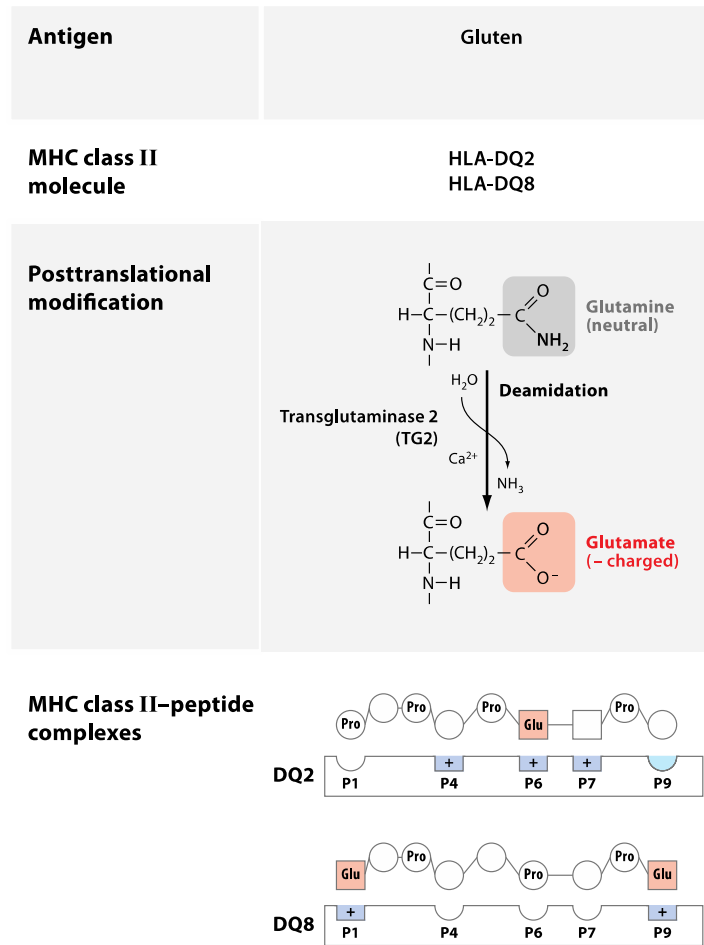

Figure II.4: Posttranslational modification of gluten

Gluten is a very good substrate for transglutaminase 2 (TG2), which converts glutamine residues to glutamate. This process, known as deamidation, generates peptides with negatively charged amino acid residues that bind with higher affinity to the disease-associated HLA-DQ2 or HLA-DQ8 molecules. P4, P6 and P7 pockets in HLA-DQ2 and P1 and P9 pockets in HLA-DQ8 have a preference for negatively charged anchor residues (*Abadie et al., 2012*).

Multiple gluten epitopes preferentially recognized in the context of HLA-DQ2.5 or HLA-DQ8 have been listed by Sollid and colleagues (Sollid et al., 2012) (Table II-1). Although polyclonal T cell responses are found in CD patients, some dominant epitopes demonstrating a high avidity for particular TCR was documented that may foster the clonal expansion of CD4 T cells (Meresse et al., 2012) (Figure II.5). Recent studies have provided molecular basis of interactions between TCR and HLA-DQ2 or DQ8/peptide complexes (Broughton et al., 2012b; Petersen et al., 2014).

Table II-1: List of celiac disease relevant T cell epitopes recognized by CD4 T cells
 (Sollid et al., 2012)

Epitope ^a	Previous names	Peptide-binding register ^b									Reference
		1	2	3	4	5	6	7	8	9	
DQ2.5 restricted epitopes											
DQ2.5-glia-α1a	DQ2-α-I, α9	P	F	P	Q	P	E	L	P	Y	(Arentz-Hansen et al. 2000)
DQ2.5-glia-α1b	DQ2-α-III	P	Y	P	Q	P	E	L	P	Y	(Arentz-Hansen et al. 2002)
DQ2.5-glia-α2	DQ2-α-II, α2	P	Q	P	E	L	P	Y	P	Q	(Arentz-Hansen et al. 2000)
DQ2.5-glia-α3	glia-α20	F	R	P	E	Q	P	Y	P	Q	(Vader et al. 2002b)
DQ2.5-glia-γ1	DQ2-γ-I	P	Q	Q	S	F	P	E	Q	<u>Q</u>	(Sjöström et al. 1998)
DQ2.5-glia-γ2	DQ2-γ-II, γ30	I	Q	P	E	Q	P	A	Q	L	(Qiao et al. 2005; Vader et al. 2002b)
DQ2.5-glia-γ3	DQ2-γ-III	<u>Q</u>	Q	P	E	Q	P	Y	P	<u>Q</u>	(Arentz-Hansen et al. 2002)
DQ2.5-glia-γ4a	DQ2-γ-IV	S	Q	P	E	Q	E	F	P	Q	(Arentz-Hansen et al. 2002)
DQ2.5-glia-γ4b	DQ2-γ-VIIc	P	Q	P	E	Q	E	F	P	Q	(Qiao et al. 2005)
DQ2.5-glia-γ4c	DQ2-γ-VIIa	<u>Q</u>	Q	P	E	Q	P	F	P	Q	(Arentz-Hansen et al. 2002)
DQ2.5-glia-γ4d	DQ2-γ-VIIIb	P	Q	P	E	Q	P	F	C	<u>Q</u>	(Qiao, unpublished)
DQ2.5-glia-γ5	DQ2-γ-VI	Q	Q	P	F	P	E	Q	P	Q	(Arentz-Hansen et al. 2002)
DQ2.5-glia-ω1	DQ2-ω-I	P	F	P	Q	P	E	Q	P	F	(Tye-Din et al. 2010)
DQ2.5-glia-ω2	DQ2-ω-II	P	Q	P	E	Q	P	F	P	W	(Tye-Din et al. 2010)
DQ2.5-glut-L1	glutenin-17	P	F	S	E	Q	E	Q	P	V	(Vader et al. 2002b)
DQ2.5-glut-L2	glutenin-156	F	S	<u>Q</u>	Q	Q	E	S	P	F	(Stepniak et al. 2005; Vader et al. 2002b)
DQ2.5-hor-1	Hor-α9, Hα9	P	F	P	Q	P	E	Q	P	F	(Tye-Din et al. 2010; Vader et al. 2003a)
DQ2.5-hor-2	Hor-α2, Hα2	P	Q	P	E	Q	P	F	P	Q	(Vader et al. 2003a)
DQ2.5-hor-3	hor-I-DQ2	P	I	P	E	Q	P	Q	P	Y	(Tye-Din et al. 2010)
DQ2.5-sec-1	Sec-α9, Sα9	P	F	P	Q	P	E	Q	P	F	(Tye-Din et al. 2010; Vader et al. 2003a)
DQ2.5-sec-2	Sec-α2, Sα2	P	Q	P	E	Q	P	F	P	Q	(Vader et al. 2003a)
DQ2.5-ave-1a	Av-α9A	P	Y	P	E	Q	E	E	P	F	(Arentz-Hansen et al. 2004; Vader et al. 2003a)
DQ2.5-ave-1b	Av-α9B, 1490	P	Y	P	E	Q	E	Q	P	F	(Arentz-Hansen et al. 2004; Vader et al. 2003a)
DQ2.2 restricted epitopes											
DQ2.2-glut-L1	glutenin-17	P	F	S	E	Q	E	Q	P	V	(Bodd et al. 2012)
DQ8 restricted epitopes											
DQ8-glia-α1	DQ8-α-I	E	G	S	F	Q	P	S	Q	E	(van de Wal et al. 1998b)
DQ8-glia-γ1a	DQ8-γ-Ia	E	Q	P	<u>Q</u>	Q	P	F	P	Q	(Tollefsen et al. 2006)
DQ8-glia-γ1b	DQ8-γ-Ib	E	Q	P	<u>Q</u>	Q	P	Y	P	E	(Tollefsen et al. 2006)
DQ8-glut-H1	HMW-glutenin	<u>Q</u>	G	Y	Y	P	T	S	P	<u>Q</u>	(van de Wal et al. 1999)
DQ8.5 restricted epitopes											
DQ8.5-glia-α1	DQ8-α-I	E	G	S	F	Q	P	S	Q	E	(Kooy-Winkelaar et al. 2011)
DQ8.5-glia-γ1		P	Q	Q	S	F	P	E	Q	E	(Kooy-Winkelaar et al. 2011)
DQ8.5-glut-H1	HMW-glutenin	<u>Q</u>	G	Y	Y	P	T	S	P	<u>Q</u>	(Kooy-Winkelaar et al. 2011)

^a In the epitope names, these short terms are used to denote the type of proteins that the epitopes derive from: 'glia-α' denotes α-gliadin, 'glia-γ' denotes γ-gliadin, 'glia-ω' denotes ω-gliadin, 'glut-L' denotes low molecular weight glutenin, 'glut-H' denotes high molecular weight glutenin, 'hor' denotes hordein, 'sec' denotes secalin and 'ave' denotes avenin

^b Glutamate residues (E) formed by TG2-mediated deamidation which are important for recognition by T cells are shown in bold. Additional glutamine residues also targeted by TG2 are underlined

Overall, these findings suggest that gluten-specific CD4 T cells activated by gluten presented in the context of HLA-DQ2.5 or DQ8 molecules trigger the immunological cascade leading to intestinal damage in CD. However, studies in HLA-DQ2.5 or HLA-DQ8 transgenic mice exposed to gluten have demonstrated that adaptive CD4 T cell response is necessary but not sufficient to provoke intestinal lesions (Black et al., 2002; de Kauwe et al., 2009; Du Pre et al., 2011). Despite production of proinflammatory cytokines, like IFNγ and IL-21, also observed in CD patients (van Leeuwen et al., 2013b), mice mounted a regulatory response, and no villous atrophy was found (Black et al., 2002; de Kauwe et al., 2009; Du Pre et al., 2011). These findings indicate that supplemental factors are needed to provoke intestinal damage.

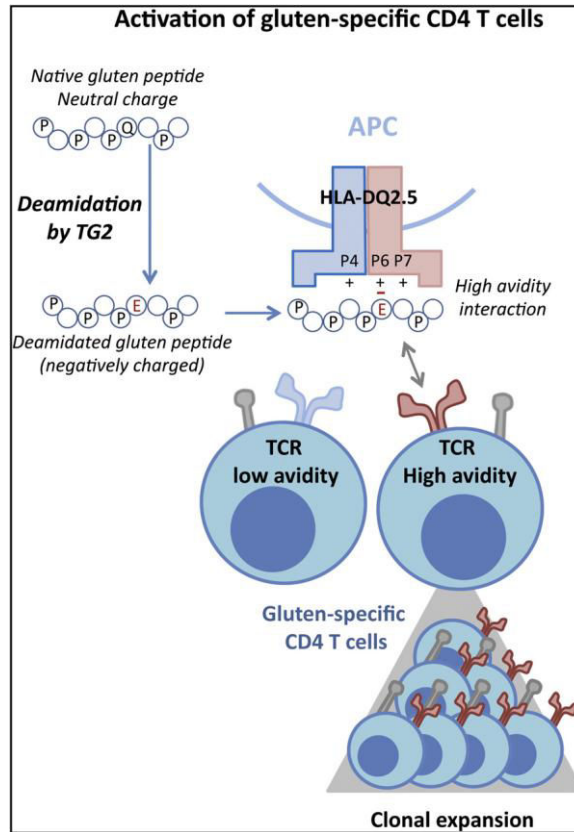

Figure II.5: Activation of gluten-specific CD4 T cells responses by HLA-DQ2.5 molecule

Complexes formed between deamidated gluten peptides and HLA-DQ2.5 molecules expressed on antigen-presenting cells (APC) can prime gluten-specific CD4 T cells. As for other dietary antigens, priming may occur in Peyer's patches or in mesenteric lymph nodes after migration of CD103⁺ dendritic cells loaded with gluten peptides in lamina propria. Priming is followed by selection and clonal expansion of T cells displaying high-avidity TCR (Meresse *et al.*, 2012).

2.2.2 B cell response

2.2.2.1 Anti-gliadin and anti-TG2 antibodies

In addition to the establishment of gluten-specific CD4 T response, active CD patients are characterized by the appearance of particular serum and intestinal IgA triggered by exposure to gluten. The work of Shiner and Ballard in the early 1970s was the first to reveal the presence of extracellular deposits of immunoglobulins, principally IgA, in jejunal mucosa of CD paediatric patients challenged with gluten (Shiner and Ballard, 1972). A massive plasmacytosis, due to the increase in immunoglobulin-containing plasma cells of all three major classes (IgA, IgM, IgG) with prevalence of IgA plasma cells in celiac lesions, has been shown (Baklien *et al.*, 1977; Lancaster-Smith *et al.*, 1976). Heavy IgA deposits were found only in CD patients and not in healthy individuals, principally located in basement membrane of surface epithelial cells, crypt epithelium and in the walls of blood vessels in small intestinal mucosa (Jos *et al.*, 1979).

Moreover, IgA deposits disappear during GFD and reappear when gluten is reintroduced to the diet of CD patients (Lancaster-Smith et al., 1976). These findings indicate that IgA induction is dependent on the exposure to gluten. Therefore, it has been supposed that these antibodies are gluten-specific. However, further studies revealed the detection of anti-gliadin IgG antibodies (AGA), but also of IgA autoantibodies directed against reticulin R1 (ARA) (Eterman and Feltkamp, 1978) and endomysium (EmA) (Chorzelski et al., 1984), components of connective tissue. The latter antibodies were found both in intestine and in serum of CD patients. Contrary to AGA and ARA also found in genetically-non-predisposed healthy individuals and individuals having other gastrointestinal diseases, EmA IgA antibodies appear to be strictly correlated with the development of CD and never present in disease control patients (Beutner et al., 1986; Chorzelski et al., 1984). On this basis the dosage of EmA IgA is now used for the specific diagnosis of CD.

These data suggested that endomysium may contain one or several target autoantigens implicated in the disease, conferring to CD an autoimmune-like status. The precise triggering antigen was identified only 10 years later as tissue transglutaminase (TG2) (Dieterich et al., 1997). The exact mechanism leading to specific production of anti-TG2 antibodies upon exposure to gluten and their disappearance following GFD remain to be defined. Nevertheless, it has been suggested that TG2 cross-linked to gluten may be recognized as hapten, explaining the appearance of gliadin- and TG2-specific antibodies upon exposure to gluten and their disappearance during GFD (Sollid et al., 1997). This hypothesis has not been however formally confirmed. T cells stimulated by deamidated gluten probably provide help to gliadin- and TG2-specific B cells, thus leading to the appearance of anti-gliadin and anti-TG2 antibodies. Moreover, TG2 IgA antibodies may participate in TG2 activation (Esposito et al., 2003), indicating the existence of positive feedback loop.

2.2.2.2 Pathogenic role of IgA

Recently a mechanism explaining a possible pathogenic role of IgA in CD has been suggested. CD71, a receptor of weak affinity for IgA, was identified by I. Moura and colleagues (Moura et al., 2001). Known to be a high avidity receptor for transferrin, it may also bind polymeric IgA. In physiological conditions CD71 is expressed only at basal surface of small intestinal enterocytes, while in CD patients it is also induced at the apical surface of IECs (Matysiak-Budnik et al., 2008). Experimental data from our laboratory suggest that luminal secretory IgA/gluten complexes can bind to CD71 expressed on apical surface and be transported from the gut into the lamina propria (Lebreton et al., 2012; Matysiak-Budnik et al.,

2008) (Figure II.6). The retransport of immune complexes probably occur through the recycling pathway thus avoiding lysosomal degradation of peptides. This process allows an apical-to-basal protected retrotransport of large gluten peptides, which remain probably more immunogenic. Moreover, TG2 seems to facilitate this mechanism, but its exact role is still unknown. A recent study has shown that abnormal apical-to-basal transport of a dietary ovalbumin in mice strongly expressing CD71, notably on apical surface of enterocytes, and grafted with OVA-secreting humanized IgA-secreting hybridoma favoured the activation of OVA-specific CD4 Th1 response (Abed et al., 2014). Poor digestion of gluten peptides and their crosslinking properties likely promote the formation of large gluten/SIgA complexes that can bind CD71 more efficiently (I. Moura, personal communication, and B. Clément, unpublished results).

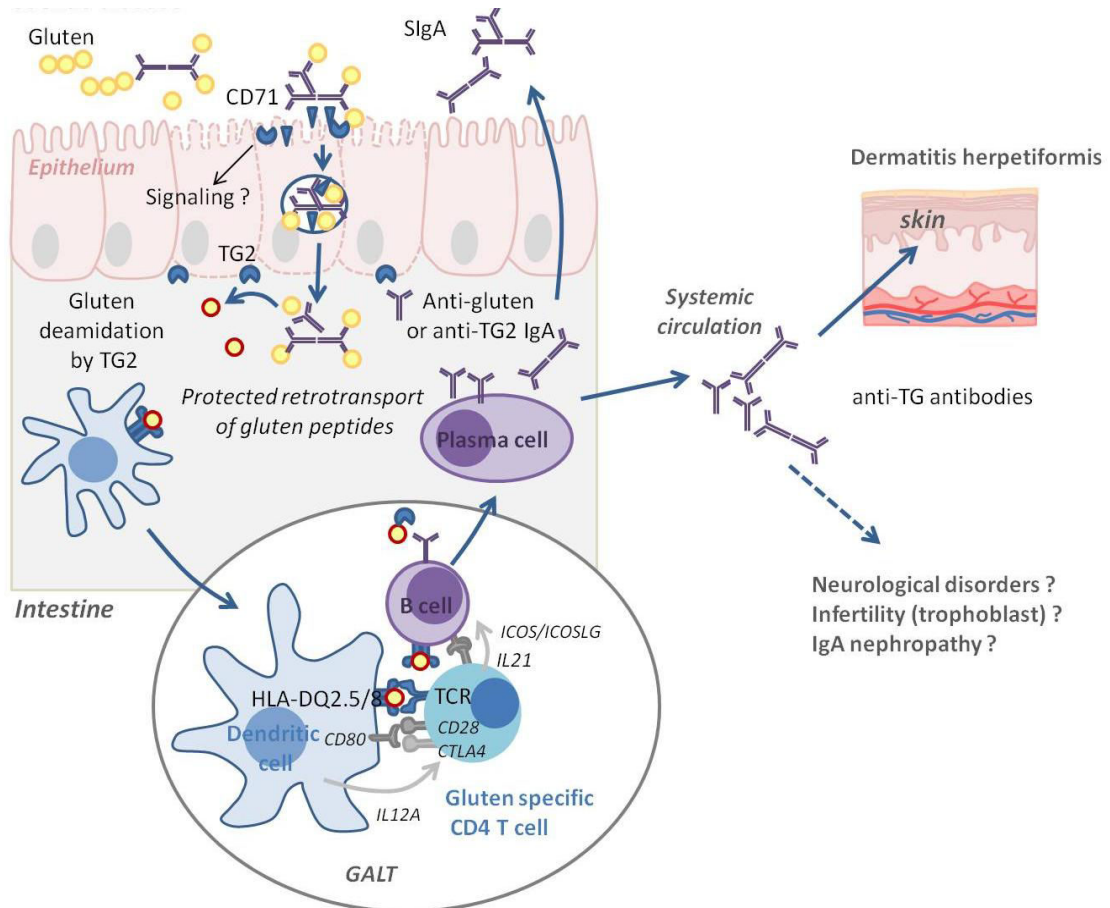

Figure II.6: B cell response in celiac disease

IgA-producing B cells primed in gut-associated lymphoid tissue (GALT) migrate into lamina propria (LP) and differentiate into plasma cells, which produce dimeric IgA released into the intestinal lumen as secretory IgA. In active CD, SIgA-gluten complexes formed in the intestinal lumen can bind the CD71 receptor up-regulated at the apical surface of enterocytes, resulting in their rapid retro-transport into LP. Binding of sIgA to CD71 may also activate signal transduction into epithelial cells. These mechanisms may exacerbate immune responses. *Adapted from (Merese et al., 2012).*

Moreover, a recent work has shown that binding of large polymeric IgA/peptide complexes to CD71 in mesangial cells in patients with IgA nephropathy can lead to the activation of MAPK and ERK-mediated signalling resulting in increased IL-6 secretion

(Tamouza et al., 2012). The activation of MAPK/ERK pathway correlated with glomerular damage in these patients (Tamouza et al., 2012). This finding indicates that the engagement of CD71 by IgA/gluten immune complexes may also lead to the activation of proinflammatory signalling pathways. This hypothesis is currently studied in our laboratory.

Although a pathogenic role of secretory IgA is evoked, it seems that they are not indispensable for CD development, as IgA-deficient patients may also develop CD. Interestingly, IgA-deficient patients develop IgM deposits (Borrelli et al., 2010) and produce serum IgG antibodies instead of IgA. In these patients, IgM may also trigger the inflammation by activating classical pathway of complement (Borrelli et al., 2010; Halstensen et al., 1992). It has been also supposed that the absence of efficient barrier formed by secretory IgA may facilitate transepithelial entry of gliadin peptides (Wang et al., 2011).

The role played by anti-TG2 autoantibodies is poorly understood. It has been shown that TG2 antibodies *in vitro* may contribute to increased activation of TG2 in CD patients (Klock et al., 2012). The presence of IgA deposits was also detected in latent CD patients that do not have any villous atrophy (Kaukinen et al., 2005). These anti-TG2 IgA may thus play a role early in the disease development, but it is uncertain if they are sufficient to provoke the disease.

Nevertheless, IgA deposits are likely to play a central role in extraintestinal autoimmune manifestations of intolerance to gluten, notably in dermatitis herpetiformis (DH), a gluten-dependent blistering skin disease. In this disorder, no T cells are detected in skin lesions, but they are either associated with deposits of IgA specific for TG3, an epithelial analogue of TG2, and neutrophil infiltrates (Sardy et al., 2002). HLA-DQ8 transgenic mice on NOD background sensitized with gluten developed blistering pathology similar to DH, characterized by IgA deposits and neutrophil infiltration (Marietta et al., 2004). Interestingly, skin blistering was completely reverted when mice were switched to GFD, like in DH patients. Serum IgA in these mice were not specific of TG2, neither TG3 nor gluten; gluten-specific serum IgG have been however detected (Marietta et al., 2004). The injection of serum from CD or DH patients or anti-human TG3 antibody into SCID mice grafted with human skin induced blistering lesions in the grafted skin (Zone et al., 2011).

2.3 Activation of intraepithelial lymphocytes

Along with adaptive immune response, one of the main features of CD is a massive expansion of intraepithelial lymphocytes, a heterogeneous population of T cells composed

mainly of cytotoxic CD8 T cells residing within the intestinal epithelium. In active CD patients, IELs are mainly constituted by TCR $\alpha\beta^+$ and TCR $\gamma\delta^+$ massively increased in comparison to control individuals (Halstensen et al., 1989; Kutlu et al., 1993; Savilahti et al., 1997; Troncone et al., 1996). The expansion and increased activation of IELs are largely reverted in patients on GFD, indicating the causal effect of gluten on IEL activation. The resorption of symptoms in CD patients following GFD has been mostly associated with the decrease of TCR $\alpha\beta^+$ CD8 T IEL number indicating their key role in intestinal tissue damage (Kutlu et al., 1993). Contrary to latter cells, the number of TCR $\gamma\delta^+$ IELs persists despite epithelial recovery during a prolonged period on GFD, suggesting that they are not directly involved in tissue damage. Their activation may reflect chronic epithelial stress induced by exposure to gluten (Kutlu et al., 1993). Up to now, the role of the latter cells remains largely unknown.

Several elements point out to a direct role of TCR $\alpha\beta^+$ CD8 T IELs in the epithelial attack in active CD patients. First, CD8 T cells among IELs and lamina propria lymphocytes (LPLs) contain significantly increased amounts of cytolytic granule proteins, granzyme B and perforin, in comparison to controls (Di Sabatino et al., 2006; Oberhuber et al., 1996). Second, CD8 T IELs is the main cell population secreting IFN γ , a cytokine suggested to be implicated in tissue damage (Olaussen et al., 2002). Third, CD8 T IELs from untreated CD patients upregulate the expression of NK-like receptors, such as NKG2D and CD94, NKp44, NKp46 (Hue et al., 2004; Jabri et al., 2000; Meresse et al., 2004; Meresse et al., 2006) and can exert enhanced *in vitro* cytotoxicity against different targets including epithelial cell lines compared to control IELs (Di Sabatino et al., 2006; Meresse et al., 2004; Meresse et al., 2006). The mechanisms that drive the abnormal activation of IELs and LPLs are not completely understood. Nevertheless, IL-15, a cytokine overexpressed in the intestinal mucosa of active CD patients, seems to play an important role in this process (Maiuri et al., 2000; Mention et al., 2003).

2.3.1 Role of IL-15

It was shown that IL-15 expression was increased in the epithelium and the lamina propria of active CD patients and tended to decrease in CD patients on GFD, but remained higher than in controls (Di Sabatino et al., 2006; Maiuri et al., 2000; Mention et al., 2003). This observation indicates that IL-15 increase is at least in part induced in response to gluten exposure. Moreover, it has been suggested that the level of IL-15 expression correlates with the degree of mucosal damage (Di Sabatino et al., 2006). The exact mechanisms of its induction and its cellular sources remain to be fully explored.

Only small amounts of IL-15 were detected by enzyme-linked immunosorbent assay (ELISA) in supernatants of CD intestinal biopsies (Mention et al., 2003) in keeping with previous observations indicating that this cytokine can be synthesized by many cell types including intestinal epithelial cells but remains poorly secreted (Musso et al., 1999). The detection of IL-15 is yet complicated by the fact that IL-15 is generally expressed linked to the α -chain of its receptor, IL-15R α , which is expressed by the same cells. Surface IL-15R α can then trans-present IL-15 to nearby lymphocytes bearing the signalling module IL-15R β/γ c. The increased expression of IL-15R α , demonstrated in CD intestine (Di Sabatino et al., 2006), may thus lead to the increased presentation of IL-15 at the surface of producing cells, notably epithelial cells (Bernardo et al., 2008). In addition, IL-15 can be released attached to IL-15R α further complicating the detection by anti-IL-15 antibodies, which can fail to recognize these complexes. Thus, the generally low expression levels of IL-15 as well as the formation of IL-15/IL-15R α complexes impair the precise quantification of IL-15 and complicate the definition of the cellular source of IL-15. Nevertheless, immunohistochemical staining of CD mucosa with IL-15 antibody has shown an intense cytoplasmic staining of epithelial cells from the top of villi to the bottom of crypts, contrary to healthy individuals where it is detected only in the upper half of villi, suggesting that these cells have up-regulated IL-15 synthesis in CD (Mention et al., 2003). Strong staining was also detected on lamina propria mononuclear cells, suggesting that they may also produce and/or transpresent IL-15 (Mention et al., 2003). Furthermore, immunoblot analysis also showed increased amounts of IL-15 in enterocytes and lamina propria mononuclear monocytes isolated from untreated CD patients, contrary to treated CD patients and controls (Di Sabatino et al., 2006).

Ex vivo studies have shown that IELs from CD patients respond more strongly to IL-15 than control IELs; they notably proliferate more efficiently, produce more IFN γ and TNF α and display stronger cytotoxicity against epithelial cells when stimulated by IL-15 (Di Sabatino et al., 2006). In keeping with a role of IL-15 in CD, it has been shown that the expression of the NK-receptors CD94 and NKG2D markedly increased on CD IELs is mediated by IL-15 (Jabri et al., 2000; Roberts et al., 2001). Increased expression of NK receptors was also found in mice overexpressing human IL-15 transgene in intestinal epithelium (T3^b-hIL-15Tge mice) (Ohta et al., 2002). The latter mice develop a small intestinal enteropathy that progresses with age due to the dramatic expansion of activated CD8 T cells that upregulate the NK receptor NK1.1 (Ohta et al., 2002) and NKG2D (lab data). These changes can be reverted by the administration of anti-IL15 antibody (Yokoyama et al., 2009). Overall, these findings indicate that

overexpression of IL-15 largely recapitulates the abnormal changes in IELs of CD patients (Figure II.7).

Other studies have provided a complementary insight in the abnormal CD8 T cell activation observed in CD patients. In addition to its effect on CD8 T survival, IL-15 was shown to interfere with immunoregulatory pathways controlling effector response. Thus, IL-15 interfered with the mechanisms controlling the activation of human effector T cells, notably CD8 T cells. On the one hand, IL-15 can inhibit the regulatory Smad3 pathway of TGF β via activation of JNK and induction of phospho-c-jun that impairs the binding of Smad3 to the promoters of TGF β target genes in effector cells, notably CD8 T cells (Benahmed et al., 2007). On the other hand, IL-15 can impair the response of human effector T cells to immune suppression by Foxp3⁺ regulatory T cells (Treg) by a mechanism dependent on the activation of phosphoinositide 3 kinase (PI3K) in effector T cells (Ben Ahmed et al., 2009) (Figure II.7). Accordingly, LPLs and IELs, as well as peripheral blood lymphocytes from active CD patients remained unresponsive to suppressive effect of autologous or heterologous Treg, thus explaining their increased IFN γ secretion and proliferation (Hmida et al., 2012; Zanzi et al., 2011). One study in mice has suggested that IL-15 in synergy with retinoic acid may impair the generation of induced Treg cells (DePaolo et al., 2011). Nevertheless, contrary to decrease in Treg cells described in these mice, CD patients are characterized by an increase in functional Treg cells in the periphery and intestine (Hmida et al., 2012; van Leeuwen et al., 2013a; Zanzi et al., 2011), suggesting that these data are not relevant to the situation in CD. One may argue that the increased accumulation of Foxp3⁺ Tregs in CD patients may due to the expansion of thymus-derived Tregs that may hide the lack of induction of Tregs in response to gluten. The absence of reliable markers of natural or induced Treg cells complicates the response to this question.

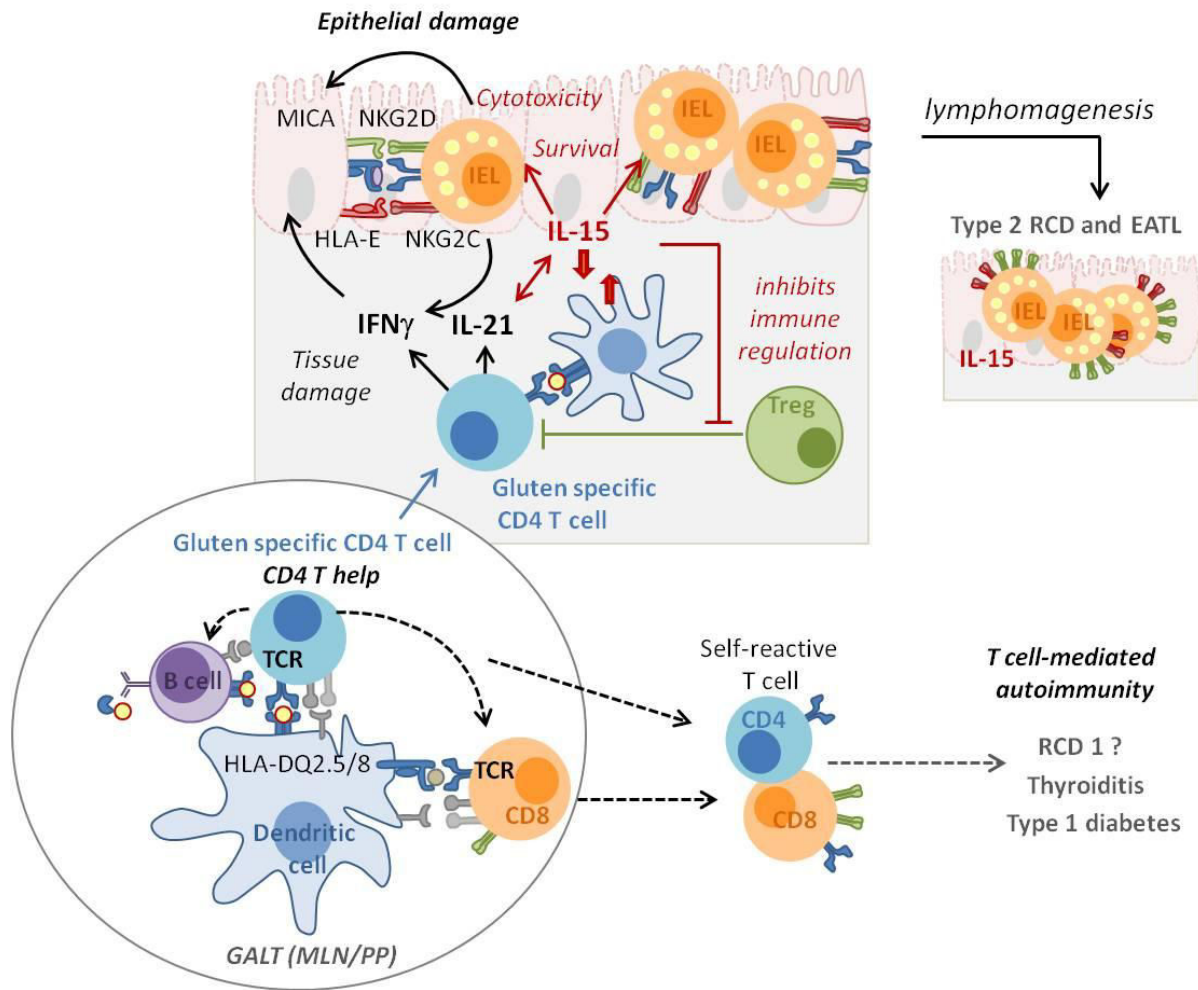

Figure II.7: T cell response in celiac disease

In active CD, IL-15 produced by enterocytes and intestinal mononuclear phagocytes favours the activation of IFN γ -producing and cytotoxic CD8 IELs harboring NK cell receptors. Gluten-specific CD4 T cells may participate in IEL activation via cross-priming. IEL cytotoxic activation can be also triggered via interactions of their NK receptors NKG2D and NKG2C with respective ligands MICA and HLA-E upregulated on enterocytes. IL-15 and IL-21 may also cooperate and enable autoreactive CD8 T cells to respond to weakly agonistic TCR self-ligands. IL-15 then favours the accumulation of activated CD8 T cells by stimulating their survival and inhibiting their responses to immunoregulatory mechanisms, further increasing the risk of developing T-dependent autoimmune diseases (T1D), thyroiditis, and perhaps type I refractory celiac disease (RCD I). Finally, IL-15 can promote the emergence of unusual IEL-derived T lymphomas sharing characteristics of both NK and T cells and able to drive epithelial lesions. Onset of lymphoma is revealed by refractoriness of the gluten-free diet. In a majority of patients, the lymphoma is the first intraepithelial (type II) refractory celiac disease (RCD II) and can secondarily transform into overt enteropathy-associated type T lymphoma (EATL). *Adapted from (Meresse et al., 2012).*

Moreover, one study suggests that IL-15 may also have an effect on B cell response. Apparently, T3^b-hIL-15Tge mice display increased numbers of B cells, plasmoblasts and plasma cells, notably in small intestinal lamina propria, but also in spleen, and elevated levels of IgG, IgM and also IgA in serum. They also detected anti-TG2 antibodies in serum of these mice (Yokoyama et al., 2011). The reliability of these results should be verified. It is unclear how IL-15 can activate B cells.

2.3.2 Role of TCR and NK receptors in triggering of IEL cytotoxicity against epithelium

Despite activated profile of IELs, factors that unleash the attack of IELs of epithelium remain unclear. It has been suggested that the release of cytotoxic granules by CD8 T IELs may be triggered either via TCR-dependent activation, or via NK-dependent activation, or both (Meresse et al., 2012).

Since intestinal lesions and TCR $\alpha\beta^+$ CD8 T IEL activation subside simultaneously in CD patients on GFD, it has been suggested that the latter cells are activated via TCR by cross-presented gluten peptides. Indeed, one study showed that CD8 T cells specific of A-gliadin₁₂₃₋₁₃₂ (pA2) peptide could be generated from the mucosa of active CD patients challenged with gluten (Gianfrani et al., 2003; Mazzarella et al., 2008). Furthermore, these authors showed that CD8 T cells put in culture with pA2-pulsed epithelial cells produced granzyme B and IFN γ and triggered the apoptosis of epithelial cells (Mazzarella et al., 2008). This study therefore suggested that enterocyte apoptosis may be induced by gluten-specific CD8 T cells through TCR/HLA I interaction. Nevertheless, no association with HLA class I molecules was identified in CD arguing against HLA I-dependent activation of CD8 T cells (Gravano and Hoyer, 2013).

Some studies suggest that epithelial damage can also be mediated by activating NK receptors alone or in addition to TCR-mediated activation (Hue et al., 2004; Meresse et al., 2004; Meresse et al., 2006; Roberts et al., 2001). Knowing that NKG2D is constitutively expressed by activated IELs and that CD94 can be induced on IELs of CD mucosa by IL-15 (Jabri et al., 2000; Roberts et al., 2001), it has been suggested that interaction of these receptors with their ligands might be sufficient to provoke the release of cytotoxic granules and cause epithelial damage (Meresse et al., 2004; Meresse et al., 2006). This hypothesis is supported by observations that CD enterocytes strongly upregulate MICA and HLA-E, two nonclassical MHC class I molecules representing respective ligands of NKG2D and CD94/NKG2C, and that these receptors are sufficient to trigger the cytotoxicity of CD8 T IELs at least *in vitro* in the presence of IL-15 (Meresse et al., 2004; Meresse et al., 2006) (Figure II.7). Other studies suggest that NKG2D functions more as a costimulatory signal amplifying antigen-specific signals provided by the TCR in CD8 T cells (Hue et al., 2004). Therefore NKG2D-mediated signal may contribute to increased activation of gluten-specific CD8 T cells or of CD8 T cells specific of viral, bacterial or self-antigens.

NKG2D-mediated cytotoxicity may also play a role in other diseases. In NOD mouse model of T1D, autoreactive CD8 T cells infiltrating the pancreas were shown to express NKG2D. Moreover, its ligand RAE-1, the mouse analogue of MICA, is present in prediabetic islets of NOD mice (Ogasawara et al., 2004), suggesting that NKG2D may mediate CD8 T cell cytotoxicity. Treatment with a non-depleting NKG2D antibody was efficient in preventing the progression of diabetes in NOD mice by impairing the expansion and function of autoreactive CD8 T cells (Ogasawara et al., 2004). Another report showed that RAE1 ϵ expressed by pancreatic β islet cells could stimulate the recruitment of CD8 T cells independently of their antigenic specificity and induce insulinitis (Markiewicz et al., 2012).

These controversial results indicate that further studies are required to better define the mechanisms of cytotoxic attack of epithelium by CD8 T cells.

2.4 Open issues: factors triggering the break of tolerance to gluten

Despite important progress in identifying mechanisms implicated in CD pathogenesis, several questions persist. First of all, only a small part (about 4%) of genetically predisposed individuals bearing HLA-DQ2/8 genes develops CD (Silano et al., 2010), indicating the involvement of other genetic and environmental factors in the disease onset. Second, it is likely that activation of IEL cytotoxicity against epithelial cells requires several signals, one from gluten-specific HLA-DQ2/8-primed CD4 T cells and another from IL-15, overexpressed in the epithelium. The exact nature of interactions between CD4 T cells, CD8 T IELs and IL-15 remain to be fully determined. Moreover, the antigenic specificity of intestinal CD8 T cells causing tissue damage is not unclear. Third, the mechanisms leading to IL-15 overexpression and TG2 activation in the intestine are not fully explored. Neonatal gastrointestinal infections as well as some toxic gluten peptides were suggested to be involved in activation of innate immunity probably leading to increase in IL-15 expression and TG2 activation. However, the precise role of these factors remains to be determined. Finally, several epidemiological studies suggested that the timing of introduction of gluten to diet as well as its amount might play a role in triggering CD onset. These open issues are discussed in this chapter.

2.4.1 Supplemental genetic factors (IL2/IL21)

HLA-identical siblings and dizygotic twins have 30% and 10% concordance rates for CD, respectively, whereas the concordance rate achieves 75% in monozygotic twins (Nistico et al., 2006). These facts indicate that susceptibility to CD has a strong genetic basis outside the

HLA locus. Over the last ten years, genome-wide association (GWAS) studies and ImmunoChip analysis have identified in total 40 risk loci of genome-wide significance ($P < 5 \times 10^{-8}$) resulting in 57 independent celiac disease associated signals (Figure II.8) (Dubois et al., 2010; Hunt et al., 2008; Trynka et al., 2011; Trynka et al., 2009; van Heel et al., 2007). It became clear that HLA locus has the most important effect (odds ratio 6.23), whereas the non-HLA loci have only limited effects with odds ratios between 0.7 and 1.3. The 39 non-HLA loci account for nearly 14% of the genetic variance in CD, while HLA is by far the strongest susceptibility locus counting for about 40% (Bevan et al., 1999; Trynka et al., 2011). Advanced analysis demonstrated that thousands of non-significant single nucleotide polymorphisms (SNPs) from CD GWAS may explain additional 46% of the disease risk (Lundin and Sollid, 2014). SNPs associated with CD often locate to non-coding gene regions as regulatory DNA marked by DNase I hypersensitive sites (Maurano et al., 2012) (Figure II.9). They may affect the recognition of gene enhancers by transcription factors thus resulting in differences of gene expression. These transcription factors remain a part of the regulatory networks shared between CD and other autoimmune diseases (Figure II.10).

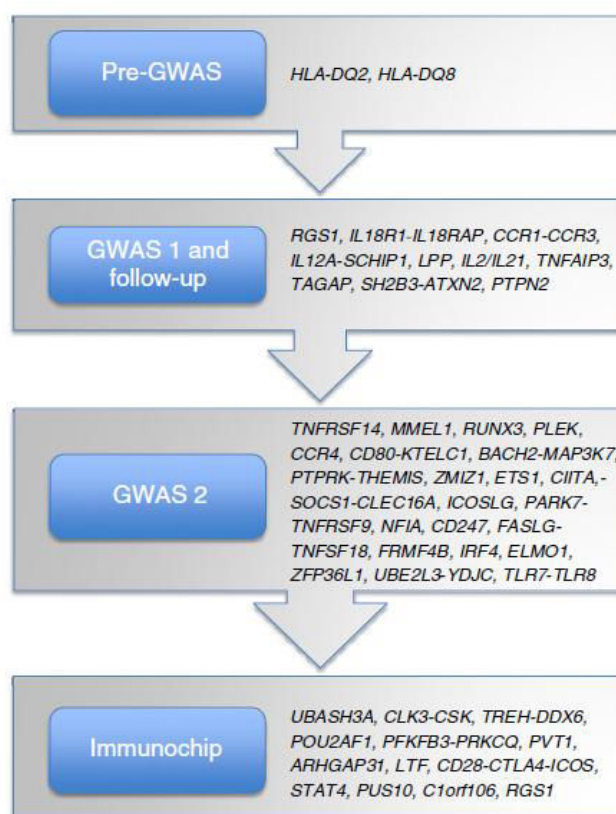

Figure II.8: History of celiac disease genetics

Pre-GWAS studies have identified risk factors in HLA-DQ locus (Bevan Gen Med 1999). The first GWAS 1 (Hunt et al., 2008; Trynka et al., 2009; van Heel et al., 2007) was performed in UK on cohort of 778 CD patients and 1442 controls and identified 13 non-HLA regions associated to CD. GWAS 2 (Dubois et al., 2010) included more than 4500 CD patients and nearly 11000 controls from UK, Italy, Finland, the Netherlands, and pointed to 13 new risk loci. Finally, the number of loci was raised to 40 using ImmunoChip analysis (Trynka et al., 2011). (Kumar et al., 2012).

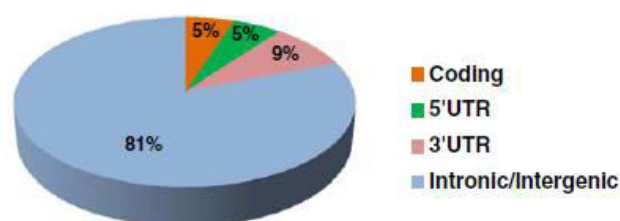

Figure II.9: Location and effect of CD risk single nucleotide polymorphisms (SNPs)

A genomic location of the SNPs. 57 CD top SNPs were extracted using 1000 Genomes Project CEU population. Only three (5%) of the 57 SNPs were in linkage with coding variants. About 5 and 9% are located in the 5'-UTR and the 3'-UTR regions, respectively. This leaves 81% of the variants to be located in non-coding regions of the genome (intergenic or intronic). The latter SNPs could be involved in the regulation of gene expression or they could affect non-coding RNA species (Kumar *et al.*, 2012).

Among the multiple pathways involved in CD pathogenesis (Figure II.10), linkage disequilibrium within IL-2/IL-21 locus is of particular interest. It is unclear whether and how this polymorphism affects IL-2 production. Interestingly, IL-21 produced by gluten-specific CD4 T cells was shown to be strongly increased in biopsies of active patients. No increase was observed in patients on gluten free diet or in the biopsies of patients with latent CD that have antibodies against TG2 but have not yet developed intestinal lesions (Fina *et al.*, 2008; Sperandio *et al.*, 2011). However, a very modest but comparable increase of IL-21 was observed in the serum of CD patients independently of their diet (Einarsdottir *et al.*, 2011), suggesting that the variant may influence IL21 expression. It is notably possible that regulatory elements at considerable distance from the IL21 gene itself may affect the levels of IL21. CD-associated variants were also found in the region encoding IRF4, a transcription factor that is activated in response to TCR stimulation and controls IL-21 production by CD4 T cells (Biswas *et al.*, 2010). Interestingly, IL-21 is able to synergize with IL-15 in the expansion of cytotoxic CD8 T cells (Zeng *et al.*, 2005) (Figure II.7). It has been also suggested that IL-15 can positively regulate IL-21 production in intestinal CD4 T cells through Akt-dependent signalling (Sarraf *et al.*, 2013). This interaction may at least in part explain the synergy between CD4 T cells and IL-15 in activation of IEL cytotoxicity in CD patients (see also B.3 Discussion of thesis results).

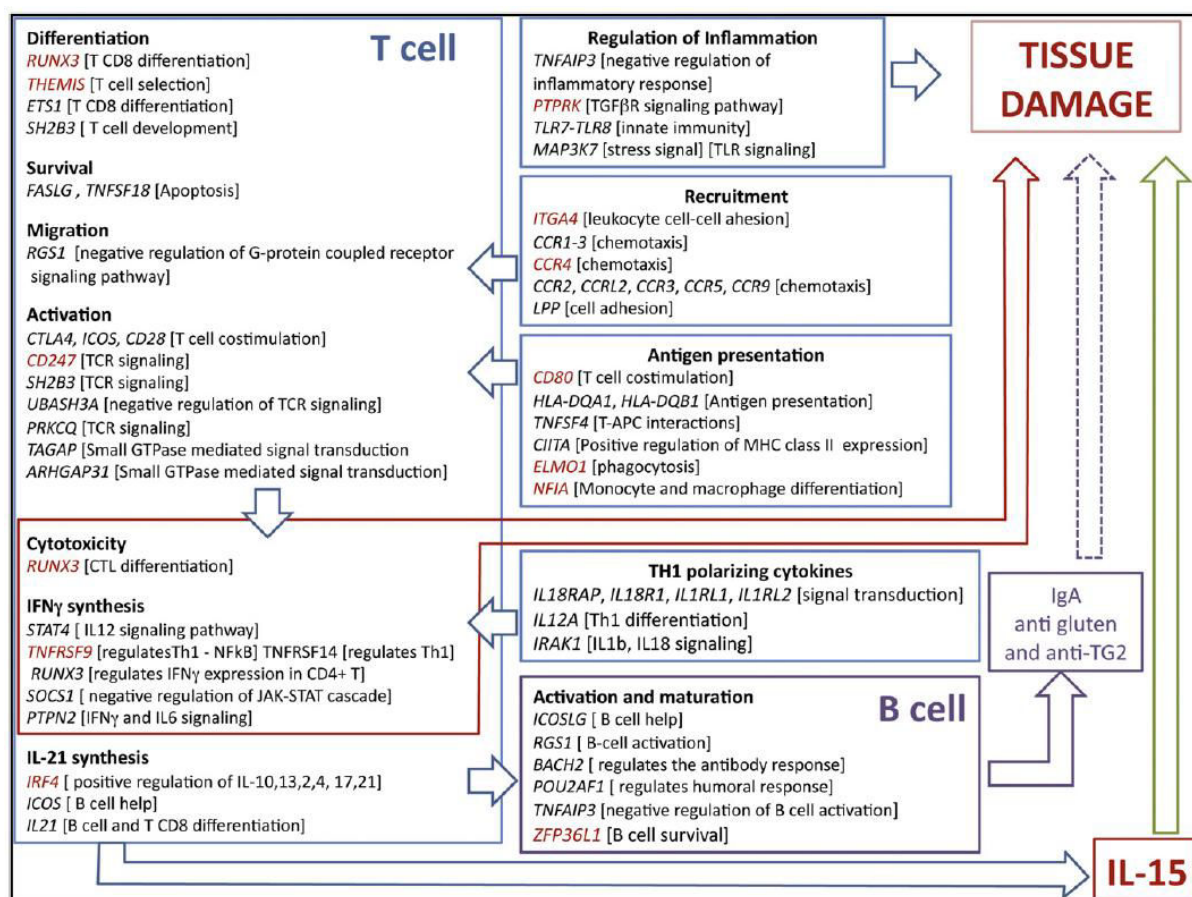

Figure II.10: Hypothetical role of non-HLA genes in celiac immune responses

Non-HLA loci associated with CD are enriched in genes predicted to control T cell activation (TCR signaling, antigen presentation, recruitment and differentiation into effector cells), activation of B cells, and NK cells (not shown). Loci specific for CD are in red. Those shared with other autoimmune diseases (including T1D) are in black. Hypothetical groups of genes that may participate in T cell activation, T cell cytotoxicity, IL-21 production, and IgA response are shown. The possible interplay between IL-21 and IL-15 in tissue damage is suggested (*Meresse et al., 2012*).

2.4.2 From gluten-specific CD4 T cell response to IEL activation

The key role of gluten-specific CD4 T cell response is now well demonstrated. Several studies have provided a better understanding of the mechanisms that promote the activation of CD8 T IELs. Nevertheless, little is known about the cascade of events linking the CD4 T and CD8 T cell responses in CD.

It has been recently shown that CD8 T cell activation takes place at the same time as that of CD4 T cells, arguing against sequential activation of these populations (Han et al., 2013). It is documented that CD4 T cells emerge in blood on day 6 after oral gluten challenge of CD patients on gluten-free diet. Interestingly, activated CD8 T cells with TCR $\alpha\beta$ as well as TCR $\gamma\delta$ T cells emerge in parallel and have highly focused and converging TCR repertoires (Han et al., 2013). These data suggest that those cells are specific of gluten and thereby activated upon reintroduction of gluten in the diet perhaps with the help of gluten-specific CD4 T cells. Alternatively, the expanded CD8 T cells may be memory cells directed against

microbial or even self antigens and, due to their phenotype, may be easily activated by IL-15 overproduced in CD (Han et al., 2013). Only little evidence has been provided to substantiate the hypothesis that intestinal CD8 T cells are specific of gluten (Gianfrani et al., 2003; Mazzarella et al., 2008). The role of CD4 T cell help for the priming and activation of intestinal CD8 cytotoxic T cells also needs to be precisely addressed in CD.

IL-21, a cytokine strongly upregulated in CD biopsies (Fina et al., 2008) and produced by gluten-specific CD4 T cells upon exposure to gluten (Bodd et al., 2010), may provide a link between CD4 T cell response and CD8 T IEL activation. It has been suggested that IL-21 may cooperate with IL-15 in CD8 T IEL activation in CD patients (Zeng et al., 2005) (Figure II.7). Thus, the combination of IL-15 and IL-21 enables autoreactive CD8 T cells bearing weak-affinity TCR to respond to self-antigens, while each cytokine separately has only little effect (Ramanathan et al., 2010). Such stimulation of CD8 T cells results in their increased proliferation, cytokine secretion and cytotoxic activity *in vitro*. These cytokine-preactivated CD8 T cells were also able to induce diabetes in mice, but only in the continuous availability of IL-15 (Ramanathan et al., 2010). Nevertheless, the mechanisms of synergy between these two cytokines, whose receptors share γ c chain, are not well understood.

The specificity of activated CD8 T cells and the role of cognate and non-cognate CD4 T cell help are issues that I have addressed in the experimental part of the thesis.

2.4.3 Role of neonatal infections in activation of innate immune response

It has long been suggested that gastrointestinal infections may trigger the onset of CD. One hypothesis concerned a possible molecular mimicry between gluten and bacterial or viral proteins. Indeed, sequence homology was noted between A-gliadin, a major α -gliadin component, and the early region E1b protein of human adenovirus 12, isolated from the human intestinal tract (Kagnoff et al., 1987), notably based on the observation that the majority of untreated CD patients had undergone previous adenovirus 12 infection. However, the role of this virus in triggering CD has not been confirmed (Vesny et al., 1993). A strong homology was also noticed between one virulence factor of *Candida albicans*, hyphal wall protein 1 (HWP1), and α - and γ -gliadin T cell epitopes (Nieuwenhuizen et al., 2003). This hypothesis is interesting as HWP1 is a TG2 substrate and this interaction may induce the production of TG2 and endomysium autoreactive antibodies. Yet, no definitive demonstration has been provided. The presence of rod-shaped bacteria was also noted in the intestinal biopsies of some CD children in Sweden. Nevertheless, it remains unknown whether the specific adherence of these bacteria is the consequence or the trigger of intestinal inflammation (Forsberg et al., 2004; Ou et al.,

2009). The onset of CD was as well observed in patients treated with IFN α for hepatitis C virus (Bourliere et al., 2001) pointing out to the possible implication of viral infections in triggering CD onset. This hypothesis is attractive, as activation of TLR3 by PolyI:C was associated with TG2 activation in mice and also with production of IL-15 that may then promote CD8 IEL activation (Dafik et al., 2012; Siegel et al., 2008). Moreover, several epidemiological studies indicate that children who experienced three or more infectious episodes before six months of age have increased risk of CD development before two years of age (Ivarsson, 2005; Sandberg-Bennich et al., 2002; Stene et al., 2006). Besides a possible role of viral infections via the induction of type I IFN that may foster inflammatory responses, repeated infectious episodes may probably increase gut permeability and thereby stimulate the activation of innate immune responses and antigen penetration. Increased paracellular leakage of gluten peptides as a consequence of increased production of inflammatory cytokines has been suggested (Fasano et al., 2000; Lammers et al., 2008; Tripathi et al., 2009), but was not confirmed by permeability studies performed in our laboratory using patients' biopsies mounted in Ussing chambers (Matysiak-Budnik et al., 2003). Conversely, studies in the laboratory have propounded that a specific retrotransport of immunogenic peptides may be mediated by the CD71 receptor overexpressed at the apical enterocyte surface (Lebreton et al., 2012; Matysiak-Budnik et al., 2003; Matysiak-Budnik et al., 2008). It should be verified whether CD71 up-regulation can be induced during intestinal infections.

2.4.4 Activation of TG2

The important role of TG2 in CD pathogenesis is now well demonstrated. TG2 is not only the target of TG2 autoantibodies but is necessary for the deamidation of gluten peptides that thereby trigger CD4 T cell activation. In physiological conditions TG2 is highly expressed in the intestine but remains inactive. The mechanisms of TG2 activation in the celiac mucosa remain largely undetermined.

It has been suggested that TG2 may be activated subsequent to tissue damage. Thus, administration of polyinosinic-polycytidylic acid (Poly I:C), a synthetic analogue of double-stranded RNA activating Toll-like receptor 3 (TLR3) known to provoke small intestinal damage, induced a transitory activation of TG2 in mice (Dafik et al., 2012; Siegel et al., 2008).

Moreover, the proinflammatory cytokine IFN γ , produced by activated gluten-reactive CD4 T cells and strongly upregulated in CD mucosa, can activate TG2 expression in intestinal cell lines in a dose-dependent manner mediated by PI3K (Diraimondo et al., 2012) and in CD small intestinal mucosa (Bayardo et al., 2012). *In vitro* results suggest that IFN γ stimulates

monocytes to release thioredoxin (Trx), a small protein able to specifically recognize and activate TG2 via reduction of disulfide bond, which in turn can activate extracellular TG2 (Jin et al., 2011).

A feedback loop of TG2 activation may probably exist. TG2 antibodies (Esposito et al., 2003) and IFN γ produced by activated CD4 T cells in turn may amplify TG2 activation (Jin et al., 2011).

2.4.5 Induction of IL-15

The mechanisms triggering the expression of IL-15 in CD remain poorly understood. IL-15 can be produced by different cell types (epithelial cells, macrophages, dendritic cells, etc), but in physiological situations its expression is tightly controlled (Fehniger and Caligiuri, 2001). In CD, cytoplasmic IL-15 was detected in enterocytes and surface IL-15 was detected on lamina propria mononuclear cells (Mention et al., 2003). Nevertheless, the exact source remains unknown, as surface IL-15 may be a result of IL-15 binding to the latter cells. More reliable methods are needed to definitely solve this issue.

The events leading to overexpression of IL-15 in CD mucosa remain also unknown. The production of IL-15 tends to decrease in CD patients on GFD (Mention et al., 2003) pointing out that IL-15 increase is at least in part induced in response to gluten exposure. Accordingly, it has been demonstrated using intestinal organ cultures that non-dominant gluten peptide p31-49 can enhance IL-15 synthesis in CD3⁺ intestinal cells (Hue et al., 2004; Maiuri et al., 2000). Another plausible hypothesis for IL-15 overexpression is its induction following viral infection leading to innate cell activation in the intestine (Dafik et al., 2012; Siegel et al., 2008).

2.4.6 Introduction of gluten

It has been largely speculated that there is a time window conferring tolerance to gluten (4-6 months of age) (Silano et al., 2010; Strobel and Ferguson, 1984). Therefore, earlier or later introduction of gluten and its greater amounts in the early non-breast milk diet may trigger more symptoms in predisposed to CD children (Ivarsson et al., 2002; Norris et al., 2005). However, the results of different epidemiological studies remain controversial. One study performed on small size cohorts of infants showed that early introduction of gluten at the age of 1-3 months or later introduction after the age of 6 months conferred an increased risk of CD (Norris et al., 2005), while two large Swedish studies (Ivarsson et al., 2002; Welander et al., 2010) failed to demonstrate any association between timing of gluten introduction and CD risk (Ludvigsson and Fasano, 2012; Szajewska et al., 2012). Furthermore, a larger consumption of

wheat gluten in Sweden and Italy was associated with a higher prevalence of CD than in Finland, Denmark, and Estonia (Ludvigsson and Fasano, 2012). A dose-related effect on small intestinal mucosa was documented when the individuals were given increasing amounts of dietary gluten (Catassi et al., 1993; Doherty and Barry, 1981; Ferguson et al., 1987).

Another long lasting hypothesis concerns protective effect of breast-feeding. H. Szajewska and colleagues have analyzed multiple studies on the role of breast-feeding on CD onset within the framework of the international project PREVENTCD launched in 2007 aiming to investigate the induction of tolerance to gluten in genetically predisposed children (Szajewska et al., 2012). The results of those studies are controversial and different methodological biases prevent to draw firm conclusions. However, it seems that breast-feeding has no long-term preventive effect (Szajewska et al., 2012). The exact mechanism underlying its supposed protective effect is not fully understood. Work in mice has shown that small amount of dietary proteins in milk can promote the acquisition of oral tolerance in the breast-fed offspring. Suggested mechanisms include the activation of pups Tregs by TGF β present in milk (Verhasselt et al., 2008) or a role of IgG/antigen complexes translocated across the mucosa (Matson et al., 2010; Mosconi et al., 2010). Small quantities of gluten contained in human milk (Chirido et al., 1998) as well as TGF β may thus promote tolerance establishment. Secretory IgA antibodies (sIgA), lactoferrin, lysozyme, and EGF may also shape the development of immune response and reduce the frequency of gastrointestinal infections. Waiting for clear evidence of breast-feeding, timing and amount of gluten introduction on risk of CD onset, international committees on nutrition recommend the introduction of gluten at 4-6 months of age and preferably while children are still being breast-fed.

2.5 Conclusion and perspectives

The case of celiac disease is particularly interesting for the study of tolerance versus loss of tolerance to dietary antigens in humans. The strong HLA-DQ genetic predisposition of CD patients alone does not explain the onset of intestinal lesions. Further studies are therefore needed to complete the understanding of this pathology. Pertinent animal models are strongly required to determine the respective role of each putative player and establish the cascade of events leading to the tissue damage. Relevant animal models would then be useful to test novel therapeutic strategies.

III. Chapter 3: Animal models of Celiac disease

A. Ferguson was the first to suggest in the mid-1970s that mucosal cell-mediated immunity could play a major role in CD pathogenesis based on the observation that villous flattening with increased crypt height was observed in mouse models of intestinal allograft rejection and graft versus host reaction, both T cell-mediated diseases. Since the late 1980s several attempts were performed to obtain a *bona fide* animal model of celiac disease that might allow the investigation of CD pathogenesis and the analysis of novel treatment strategies. As main features, an animal model of celiac-like enteropathy should display gluten-induced lesions of intestinal mucosa characterized by villous flattening, crypt hyperplasia, lymphocyte infiltration of the gut epithelium, associated with appearance of anti-gliadin and anti-TG2 IgA.

3.1 Models using wild type animals

3.1.1 Gliadin induces oral tolerance in wild type mice

Anne Ferguson, a pioneer and emblematic researcher in intestinal immunology, was the first to initiate studies aiming at defining gluten immunogenicity. Since gliadins are complex proteins with lectin properties and knowing that lectins may efficiently prime immune response, Anne Ferguson together with Riccardo Troncone investigated the immune response of BALB/c mice to dietary gluten (Troncone and Ferguson, 1988). Gavage with commercial gliadin or feeding with gluten-containing normal chow induced oral tolerance in 3-week old weaned mice indicating that this protective state can be acquired in the early adult life. Thus, mice fed with dietary gluten during one week and then immunized with gliadin in complete Freund's adjuvant (CFA) into rear footpad displayed a marked suppression of humoral and cellular (evaluated by delayed-type hypersensitivity, DTH) responses (Troncone and Ferguson, 1988). These findings demonstrated that despite their lectin-like properties “gliadins are not a particular class of proteins abnormally handled by the gut, and can induce oral tolerance similarly to other dietary proteins such as soluble egg or milk proteins” (Troncone and Ferguson, 1988).

In another work, the same authors investigated the importance of age of gluten introduction (Troncone and Ferguson, 1988). Several groups of female mice maintained on gluten-free diet were formed including mice fed with gliadin only prior to pregnancy, mice fed before and during pregnancy, and mice fed only during lactation (Figure III.1). All pups were

weaned on gluten-free diet and immunized i.p. with gliadin emulsified in CFA at 4-weeks of age. Three weeks later, they were tested for DTH and gliadin-specific IgG response. Although the introduction of gluten during pregnancy rendered pups tolerant, gluten in maternal diet during lactation period specifically primed the systemic immune responses of the offspring (Figure III.1) (Troncone and Ferguson, 1988). This study emphasizes the critical role of time frame of gluten introduction for the subsequent immune status of animals. This result may seem at odds with recent works, which suggested that suckling pups of OVA-fed mothers were protected against the subsequent induction of OVA-induced asthma (Matson et al., 2010; Mosconi et al., 2010).

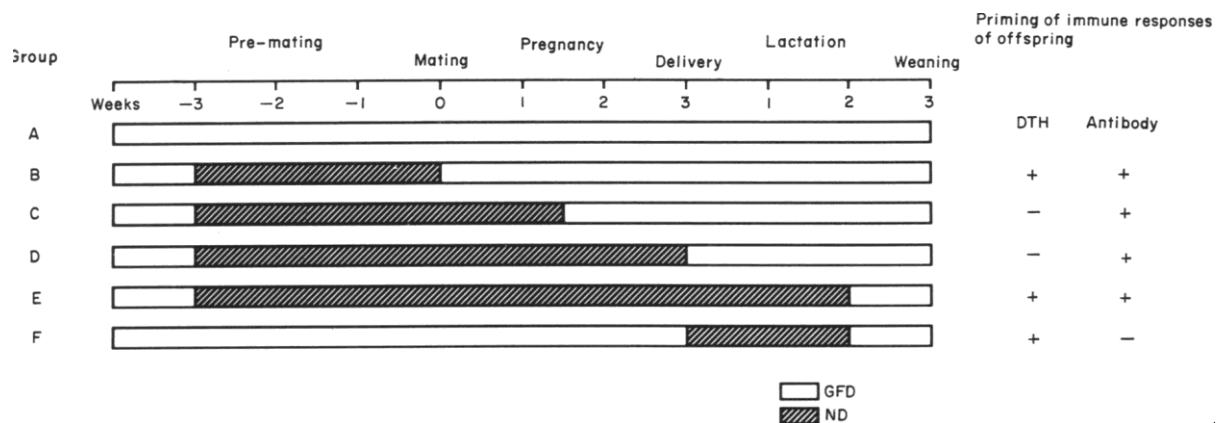

Figure III.1: Effect of feeding mothers gluten-containing diet (ND) during pregnancy and/or breast-feeding on the immune response of their offspring in (Troncone and Ferguson, 1988)

Control mothers (group A) were maintained throughout on GFD. Mothers from gluten-free diet (GFD) colony were switched to the gluten-containing diet (ND) 3 weeks before mating and returned to the GFD at different times (groups B-E). Group F mice fed ND only for the first 2 weeks of lactation. All pups were weaned on GFD and parentally immunized with gliadin at the age of 4 weeks. The systemic immune response was assessed 3 weeks later. Signs + and - indicate presence or absence of priming for DTH and/or gliadin-specific IgG response in the offspring (Troncone and Ferguson, 1988).

Yet, attempts to induce mucosal cellular immune response to gluten in weaned mice by systemic immunization and subsequent feeding with gliadin did not provoke any intestinal lesions (Troncone and Ferguson, 1991), indicating that priming against gliadin was not a sufficient condition for induction of T cell-mediated intestinal lesions. Either the frequency of gliadin-specific T cells was not sufficient or an additional factor was needed to break tolerance. The susceptibility to gluten-mediated intestinal damage was then evaluated in mice with graft versus host reaction (GvHR) (Troncone et al., 1994). Feeding of GvHR mice with normal gluten-containing or gluten-enriched (15.8% gluten) chow did not cause additional tissue damage in comparison to GvHR mice on gluten-free chow (Troncone et al., 1994).

3.1.2 Gluten-induced enteropathy in newborn rats

In one study, enteropathy has been induced in newborn rats exposed to gluten for a prolonged period (Stepankova et al., 1996). Inbred AVN Wistar germfree rats were gavaged

intragastrically with gliadin from birth until day 63 (0.5-5mg of gliadin per day). This prolonged exposure to gliadin led to shortening of jejunal villi, crypt hyperplasia, and increased numbers of TCR $\alpha\beta^+$ CD8 IELs. Transfer of IELs from gliadin-fed rats into the jejunal loops of untreated rats led to the mucosal damage, suggesting a critical role of IELs in tissue damage. Yet, the mechanism by which IELs placed in the lumen could induce tissue damage is unknown and remains difficult to apprehend. Of note, administration of gliadin after weaning failed to alter intestinal mucosa.

In another study (Stepankova et al., 2003) unsuckled artificially reared rats received IFN γ (1000 U per animal) after birth and were gavaged with gliadin in the neonatal period as following: 0.5 mg of gliadin on day 0, 3 mg of gliadin on day 3 and 30 mg of gliadin 24 hours before sacrifice at 21 days of age. Those rats developed chronic diarrhea with vomiting and dehydration symptoms within one week, and nine out of 25 died on day 9. Surviving animals improved when switched to gluten-free diet. Gluten-fed and IFN γ -treated rats had decreased growth rate compared to all other groups of rats also treated with IFN γ : artificially reared rats that did not receive gliadin, mother-reared rats on GFD, and mother-reared rats that received gliadin. Gluten-fed and IFN γ -treated unsuckled rats displayed subtotal villous atrophy in jejunum and strong infiltration of lamina propria by inflammatory cells. Other groups of mice had normal villous architecture (Stepankova et al., 2003). This study highlights the importance of age of gluten introduction and breast-feeding for the onset of tolerance. Early exposure to gluten just after birth in the absence of breast-feeding render animals much more susceptible to the development of intestinal lesions comparable to those observed in CD patients. Thus, the role of breast-feeding remains unknown, taking in account the conflicting results obtained in this model and in the model developed by A. Ferguson (Stepankova et al., 2003; Troncone and Ferguson, 1988).

3.1.3 Enteropathy model using immunodeficient mice

T.L. Freitag and colleagues have described a model of gluten-induced small intestinal enteropathy adapted from the model of microbiota-dependent colonic inflammation induced by the transfer of Treg-depleted T cells into immunodeficient SCID or Rag $^{-/-}$ mice (Freitag et al., 2009). To induce gluten-specific CD4 T cells, C57BL/6 mice were immunized twice with gliadin (or as a control with ovalbumin) in CFA. Spleen memory CD4 $^+$ CD45RB low CD25 $^-$ T cells deprived of regulatory T cells were next sorted and intraperitoneally injected into T and B cell-deficient RAG1 $^{-/-}$ or into T cell-deficient nude mice. Recipients were fed with gluten-rich diet containing 2.5g of wheat gluten per kg or with gluten-free diet for 8.5 weeks (Figure III.2).

Injection of gluten-sensitized T cells into gluten-fed nude mice induced serum anti-gliadin IgG and IgA antibodies but failed to induce enteropathy. It is unclear why no enteropathy developed in nude mice injected with gliadin-sensitized T cells. Given the strong antibody response, one may suggest a protective role of intestinal IgA in this model but this hypothesis was not addressed. In this regard, it is noticeable that polymeric mouse IgA do not bind CD71, and therefore cannot mediate the protected transport of SIgA/gluten peptides described in human CD.

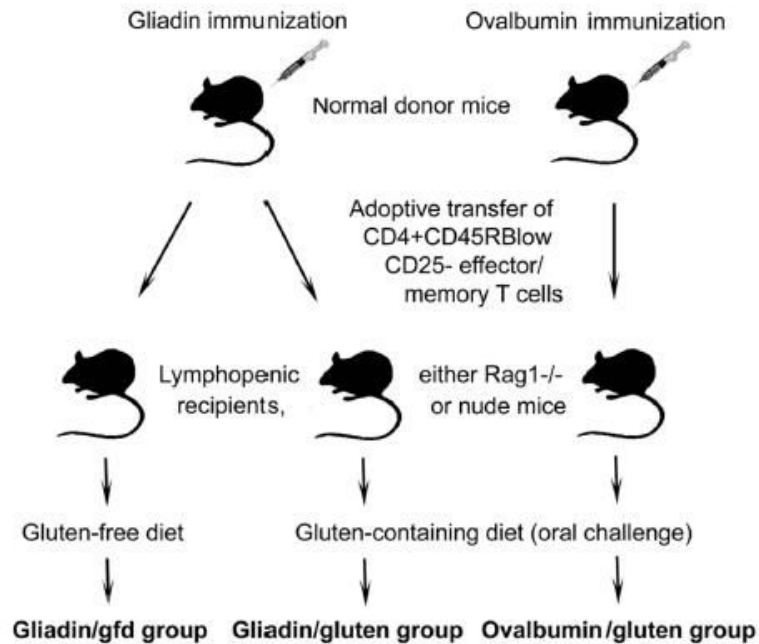

Figure III.2: Experimental protocol of gluten-sensitization used in (Freitag et al., 2009)

Splenic CD3⁺ T cell subsets from immunized donor mice were stained with fluorescent antibodies. Rag1^{-/-} or nude mice were injected i.p. with 4.5×10^5 CD4⁺ CD45RB^{low} CD25⁻ T cells from gliadin-immunized donors, or from ovalbumin (control)-immunized donors. After T cell transfer, recipients were either maintained on gluten-free diet (gliadin/gfd), or challenged with gluten (gliadin/gluten, ovalbumin/gluten) (Freitag et al., 2009).

Supporting a protecting role of IgA antibodies in this model, RAG1^{-/-} recipients of gluten-sensitized CD4 T cells unable to mount humoral responses developed mild to severe duodenitis in response to gluten-containing but not to OVA-containing diet. Duodenitis resulted in significant weight loss and was accompanied by an increase in IFN γ and IL-17 transcripts that subsided after gluten free diet. The authors concluded that CD4 T immunity against gluten was sufficient to trigger an enteropathy in lymphopenic mice. Yet, the mucosal infiltrate was not characterized and the activation of other populations, such as NK-like granzyme B-containing IELs present in RAG^{-/-} mice that might participate in intestinal damage, was not analyzed. The relevance of this study to the physiological situation, where Treg cells are known to be present, is not clear. Moreover, no comparison was performed between mice injected with sensitized T cells not depleted in CD25⁺ Tregs, preventing to demonstrate clearly the immunoregulatory role of the later cells.

3.2 Models using HLA-DQ transgenic mice

It is now well established that almost all human autoimmune diseases are linked to HLA genes, mostly HLA class II. Three haplotypes are associated to almost 90% of autoimmune diseases: HLA-DQ2/DR3, HLA-DQ6/DR2, and HLA-DQ8/DR4 (Mangalam et al., 2008). Humanized mice expressing HLA class II molecules in the absence of endogenous mouse class II molecules have been largely used to explore disease mechanisms, including rheumatoid arthritis and multiple sclerosis (Gregersen et al., 2004; Mangalam et al., 2008). As T cell repertoire is shaped in these mice by HLA class II molecules, it shall display the same HLA restriction as in humans, and may thus potentially participate in disease triggering. Humanized disease models have allowed major progress in understanding the pathogenesis of immune-mediated diseases.

3.2.1 Generation of humanized transgenic mice

Humanized mouse models have been continually improved since the early 1990s, when the transgenic technology was at an early stage of development. In this subchapter, I will highlight the steps of establishment of HLA class II humanized mice that might be helpful in understanding possible difficulties met in using such models.

MHC class II molecules play a central role in shaping the T cell repertoire in thymus and in presenting peptide fragments to CD4 T cells in the periphery. MHC class II molecules are surface proteins that comprise an almost invariant α chain and a highly polymorphic β chain. The main problem in constructing humanized mice is a species barrier due to the inability of transgenic HLA molecules to efficiently interact with mouse CD4 molecules (Vignali et al., 1992). To bypass this obstacle, several attempts were performed to generate chimeric mice in which the α chain was derived from mouse endogenous class II molecule while the β chain was derived from human class II molecule mice lacking the corresponding endogenous gene (Taneja and David, 1998). Alternately, chimeric mice with the human α chain and endogenous mouse β chain were produced. Several studies identified a species-specific region on the β 2 domain of human class II molecules responsible for binding to human CD4 (Cammara et al., 1992; Vignali et al., 1992). These studies further showed that human class II α chains could interact with mouse class II β chain and form functional molecules that bound mouse CD4 molecules. An anticipated risk for such chimeric MHC class II heterodimers comprising a human α chain and amouse β chain is however to select for a T cell repertoire distinct from that developed by humans expressing an entirely human class II molecule.

Two teams showed that it was possible to generate HLA-restricted CD4 T cell responses in the absence of a human CD4 transgene in mice bearing chimeric or fully human HLA-DR or DQ molecules (Woods et al., 1994; Yamamoto et al., 1994). Nevertheless, it remained unclear how interactions between mouse CD4 and human class II molecules could influence the *in vivo* generation of immune responses (Schwartz, 1994). One study suggested that, for some responses, the requirement for species-matched CD4 might not be absolute (Altmann et al., 1995). Other laboratories performed efforts in generating double transgenic mice simultaneously expressing the predisposing HLA-DR or DQ allele and human CD4 to facilitate interactions between murine T cells and transgenic HLA. Thus, L. Fugger and colleagues (Fugger et al., 1994) obtained mice expressing the HLA-DR4 chains α and β under the promoter of murine I-E α gene and human CD4 transgene under the murine CD3 δ promoter. Efficient negative selection was observed in the latter mice. Moreover, challenge with influenza A immunogenic peptide, which induces a strong HLA-DR4-restricted CD4 T cell response in humans, also led to HLA-DR4-dependent CD4 T cell response in the double transgenic mice. It was therefore concluded that the transgenes were functional *in vivo*. In another study, in order to minimize cross-species molecular interactions, R. Yeung et al. (Yeung et al., 1994) introduced human CD4 and human HLA-DQ6 in a mouse strain deficient for endogenous CD4 and CD8 (Schilham et al., 1993). This model allowed the full restoration of phenotype and function of both transgenes and effective interaction between human CD4 and human MHC class II molecules resulting in the generation of efficient immune responses. Upon challenge by vesicular stomatitis virus, the reconstituted mature T cell population provided efficient CD4 T cell help to B cells for immunoglobulin class switching from IgM to specific IgG-neutralizing antibodies, as well as to cytotoxic T cells. Nevertheless, the functional role of HLA molecules can be masked by the dominant expression of endogenous mouse class II molecules.

A complementary approach has therefore been to generate human class II-restricted responses in mice rendered deficient for mouse class II expression (Cosgrove et al., 1991), in order to promote the preferential selection of HLA-restricted T cells (Nabozny et al., 1996). In numerous studies, a combination of the methods described above has been used to establish mouse models of autoimmune diseases (Gregersen et al., 2004; Mangalam et al., 2008). Mice humanized for human HLA molecules have notably allowed recapitulating the induction of some human diseases, such as rheumatoid arthritis and multiple sclerosis (Gregersen et al., 2004). A similar approach was therefore developed to analyse the role of HLA-DQ restricted CD4 T cells in the development of CD.

3.2.2 Use of HLA-DQ2.5/8 transgenic mice to study adaptive immune response to gluten

Over the past ten years, several attempts to obtain a model of celiac disease were performed using HLA-DQ2.5 or HLA-DQ8 transgenic mice. Yet, they did not succeed in the establishment of a mouse model recapitulating human pathology. Notably celiac-like intestinal lesions were not observed until now in HLA-DQ2.5 or -DQ8 humanized mice sensitized with gluten (Black et al., 2002; de Kauwe et al., 2009; Du Pre et al., 2011). In this chapter, I sum up lessons learned from these studies.

3.2.2.1 Generation of HLA-DQ8 transgenic mice

The team of Chella S. David from Mayo Clinic (Rochester, MN) was the first to test whether HLA-DQ8 transgenic mice sensitized or immunized by gluten or individual peptides were able to mount an efficient T cell response and whether the exposure to gluten led to CD-like symptoms (Black et al., 2002).

Since the early 1990s, the team of CS Davis extensively worked on elaborating humanized HLA class II transgenic mice. They succeeded in generating transgenic mice expressing HLA-DQ6 and DQ8 α and β genes. As HLA-DQ8 is an MHC class II molecule commonly linked to numerous autoimmune diseases (juvenile diabetes, rheumatoid arthritis and celiac disease), the generation of HLA-DQ8 transgenic mice was expected to be useful to delineate the role of this molecule in disease and to develop autoimmune mouse models recapitulating human diseases (Taneja and David, 1998). HLA-DQ6 transgenic mice were used as controls, since HLA-DQ6 does not confer any known predisposition to autoimmune diseases. The HLA-DQA1*0301 and HLA-DQB1*0302 (HLA-DQ8 α and β) genes were isolated from cosmids containing a 30 kb DNA fragment and a 38 kb DNA fragment from the PRIES cell line (Okada et al., 1985). Digested and purified cosmid inserts were microinjected into F1 mice. Transgene-positive founders were identified by Southern blot analysis of tail DNA and subsequently mated to B10 mice for the generation of transgenic lines expressing HLA-DQ8 α and β genes (Cheng et al., 1996). Flow cytometric analysis of peripheral blood lymphocytes (PBL) using anti-HLA-DQ specific monoclonal antibodies revealed the expression of HLA-DQ molecules in 20-30% of spleen and lymph node cells (Mangalam et al., 2008). In order to determine whether HLA-DQ molecules bind to self-antigens and positively select for HLA-DQ restricted T cells capable to migrate to the periphery, transgenic mice were immunized with several antigens implicated in autoimmune diseases, such as type II collagen

in arthritis, myelin basic protein in multiple sclerosis and glutamic acid decarboxylase in diabetes. Strikingly, mice efficiently generated T cell response to almost all tested antigens. However, T cell responses were not restricted by the DQ molecules, as they were not blocked by anti-DQ antibodies. In contrast, antibodies against endogenous mouse class II molecules H2-A blocked T cell proliferation. Consistent with these results, it was observed that DQ-restricted peptides did not generate peripheral T cell response, indicating that CD4 T cells ignored human DQ molecules in thymus and rather interacted with endogenous class II molecules for generating the T cell repertoire (Mangalam et al., 2008). Nevertheless, DQ molecules participated in thymic clonal deletion of T cells expressing specific TCR V β genes, which recognize antigens from mammary tumor viruses. Thus, T cells expressing TCR V β 5, V β 6, V β 8, and V β 11 were eliminated in DQ-transgenic mice, while present in negative littermates.

To favour the generation of HLA-DQ restricted T cell responses, the only possible option was to eliminate mouse class II molecules (H2-A β° mice). Mice deficient in class II molecules were successfully obtained by the team of D. Mathis and C. Benoist, in Strasbourg, who introduced an inactivating mutation in the A β gene in mice of the H2^b haplotype, in which E α is naturally non-functional (Cosgrove et al., 1991). As a result, mice do not express surface class II molecules. The need to remove endogenous class II molecules is clearly a disadvantage of HLA humanized models, as this does not reflect the physiological situation where multiple HLA molecules are co-expressed and participate in T cell selection and priming.

DQ8.A β° mice were next obtained by crossing of HLA-DQ8 transgenic mice with H2-A β° mice (Figure III.3). Mice expressed the DQ8 molecule in up to 25% of PBL, while no surface expression of endogenous mouse class II A and E molecules was detected. In comparison to H2-A β° mice that contain less than 3% of CD4 T cells within lymph nodes (mostly CD44⁺), mice expressing transgenic DQ α and β genes showed 10-15% CD4 T cells suggesting positive selection of CD4 T cells in the context of HLA-DQ molecules. These CD4 T cells expressed a variety of V β TCRs, different from DQ8- negative mice suggesting their positive and negative selection (Nabozny et al., 1996). The HLA-DQ8.A β° mice were first used to test the possible implication of HLA-DQ8 molecules in rheumatoid arthritis (Nabozny et al., 1996). G.H. Nabozny et al. showed that immunization of HLA-DQ8.A β° mice expressing HLA-DQ8 on 15-30% PBL and 10-13% of CD4 T cells with bovine collagen CII was sufficient to induce symptoms of arthritis. They demonstrated a strong *in vitro* collagen-specific CD4 T cell proliferation, as well as a strong serum antibody response against CII. Moreover, these responses were efficiently blocked *in vitro* by anti-HLA-DQ mAb. This study

demonstrated that, in the context of an HLA-DQ8 transgene, collagen antigen was efficiently presented to mouse CD4 T cells that could induce an inflammatory reaction.

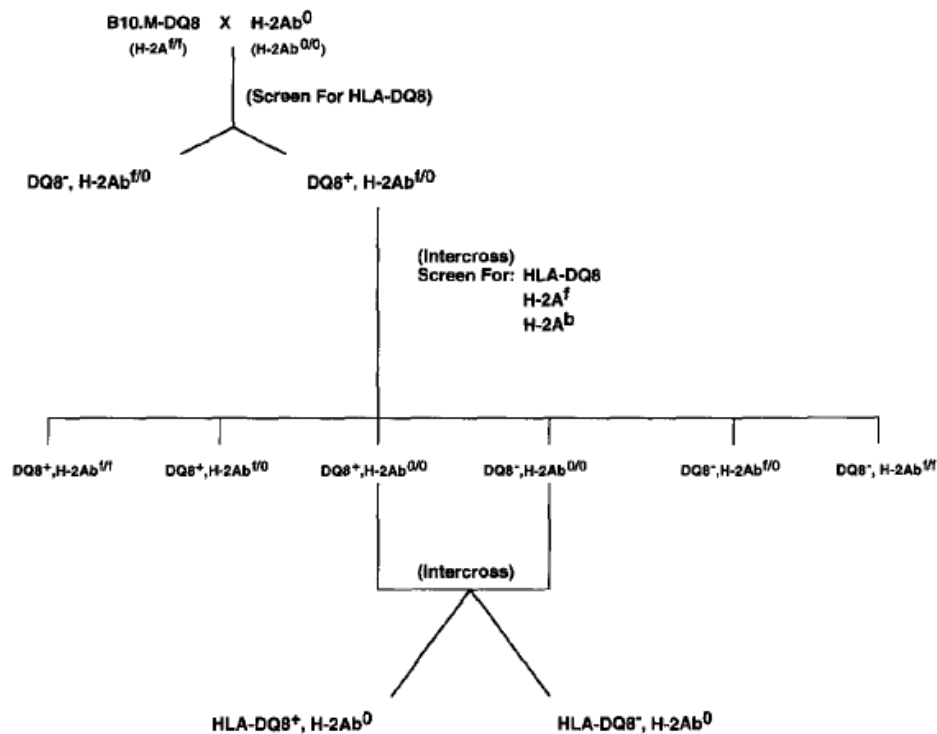

Figure III.3: Schematic illustration of the generation of HLA-DQ8⁺ H-2Ab⁰ mice

Detection of the HLA-DQ8 transgene was monitored by flow cytometric analysis of the PBL using the HLA-DQ-specific mAb. Detection of the mutant H-2A⁰ gene was evaluated by the flow cytometry by monitoring the expression of the H-2A^f and H-2A^b molecules using the mAbs (Nabozny *et al.*, 1996).

3.2.2.2 Response of HLA-DQ8 humanized mice to gluten

Since HLA-DQ8 transgenic mice develop arthritis in response to collagen, it was logical to test their response to gluten. Curiously, such data were never published. It is unknown whether this question was addressed. It is likely that the low percentage of mouse CD4 T cells observed in HLA-DQ8 transgenic mice led the researchers to develop another strategy by crossing those mice with mice expressing human CD4 (Black *et al.*, 2002). DQ8.A⁰ or DQ6.A⁰ were crossed with mice transgenic for human CD4 and lacking mouse CD4 (Law *et al.*, 1994). Resulting double transgenic mice expressed both human class II molecules and human CD4 on PBL. In order to test the proliferative responses, mice were immunized with 20µg of crude gluten emulsified in complete Freund's adjuvant in tail and hind footpad. The draining lymph nodes were harvested seven days later and restimulated *in vitro* with gluten. T cells isolated from draining lymph nodes of hCD4/DQ8 mice showed a rather good proliferative response to gluten, while T cells from hCD4/DQ6 mice were also able to respond to gluten but to a much lesser extent. T cell proliferation was DQ8-restricted as was inhibited

both by anti-DQ and anti-CD4 (using an antibody directed against mouse CD4, which may perhaps cross react with human CD4, although this was not indicated). Proliferative response to a variety of synthetic gliadin peptides was screened. Peptides corresponding to 1-20 and 20-30 amino acid residues induced the most significant T cell response. Another peptide 206-217, produced by pepsin digestion of gliadin and known to be particularly antigenic for DQ8-restricted gluten-specific CD4 T cell lines from CD patients (van de Wal et al., 1998b), was also tested, as well as its deamidated analogue that possesses increased immunogenicity for CD patients (van de Wal et al., 1998a). As expected, gliadin peptide 206-217 induced a strong *in vitro* proliferative response and the deamidation of residues Q208 or Q216 resulted in further increased response of T cells from hCD4/DQ8 mice.

Another experimental protocol was used in order to assess cytokine production by intestinal cells. Seven days after the first immunization with 500µg crude gluten with CFA in i.p. (or rice as a negative control), mice were gavaged with 2mg of gluten (or rice) in order to stimulate intestinal T cells. Intestinal T cells were isolated 7 days later and *in vitro* restimulated with gluten (Figure III.4). Gluten stimulation induced the production of regulatory cytokines TGFβ and IL-10, but also of pro-inflammatory IL-6. Several of gluten-fed hCD4/DQ8 mice showed poor growth (results not shown in the paper). However, the mice did not develop any gross signs of intestinal pathology or inflammation. High levels of gliadin-specific IgG were found in serum of hCD4/DQ8 mice immunized with gluten, but no gliadin-specific IgA or endomysial IgA were detected in mouse serum.

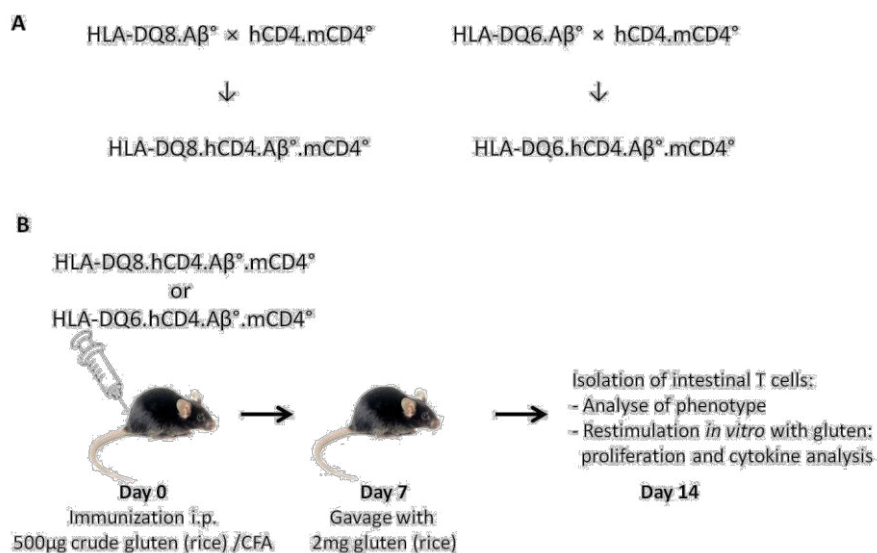

Figure III.4: Schematic illustration of HLA-DQ8.hCD4.Aβ⁰.mCD4⁰ mice generation and gluten-sensitization protocol used in (Black et al., 2002)

A. HLA-DQ transgenic mice on MHC class II-deficient background were crossed to mice transgenic for human CD4 and deficient for mouse CD4. B. Resulted mice were i.p. immunized with 500µg crude gluten or rice (negative control) in CFA on Day 1, then challenged on Day 7 with 2mg gluten or rice by gavage. On day 14, intestinal T cells were analyzed and restimulated *in vitro* with gluten for proliferation and cytokine analysis (Black et al., 2002).

This study raised several questions. First, whether DQ8 is able to present non-deamidated peptides or whether there is an activation of TG2 in this experimental protocol. The efficient *in vitro* restimulation with total gluten suggests that those mice mounted a T cell response to non-deamidated peptide(s). Indeed, these results confirm the data produced by Van de Wal and colleagues who had identified a naturally occurred pepsin fragment of gliadin 206-216 that efficiently stimulated DQ8⁺ but not DQ2.5⁺ cell lines derived from CD patients (van de Wal et al., 1998b), the response that was further increased by deamidation of residues Q208 and Q216 (van de Wal et al., 1998a). Second, the absence of any inflammatory signs in mice humanized for HLA-DQ8 and CD4 fed with gluten indicates that mice mounted rather tolerogenic response. Several hypotheses explaining the absence of inflammation can be considered: insufficient duration of exposure to gluten, lack of TG2 activation for gluten deamidation and thereby inefficient T cell priming and low frequency of gluten-specific T cells. Alternatively, the need of additional genetic or environmental factor for enteropathy onset should be considered.

Interestingly, when HLA-DQ8.Aβ° mice were backcrossed on the autoimmune-prone NOD background and immunized with gluten and adjuvant pertussis toxin (Figure III.5), they developed blistering cutaneous lesions reminiscent of dermatitis herpetiformis, a gluten-induced cutaneous disease linked to CD (Marietta et al., 2004). Despite the development of dermatitis herpetiformis-like symptoms and the presence of IgA dermal deposits in 17% of mice, neither enteropathy nor anti-TG3 (epidermal analogue of TG2) IgA were detected in any of these animals. Only gluten-specific IgG antibodies were found in the sera of blistering mice. Spectacularly, the switch to gluten-free diet led to the resorption of blisters after 1-3 weeks of diet. The mechanisms of observed lesions still remain unknown.

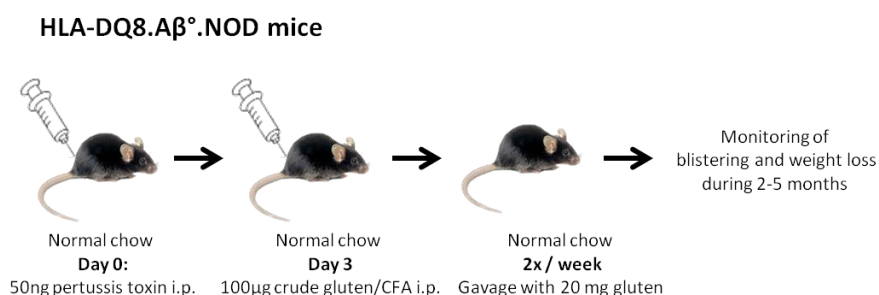

Figure III.5: Schematic illustration of gluten-sensitization protocol used in (Marietta et al., 2004)
HLA-DQ transgenic mice deficient for mouse MHC class II molecules on NOD background were sensitized i.p. by pertussis toxin, and 3 days later immunized i.p. with crude gluten in CFA. During 2-5 months mice were gavaged with 20mg gluten twice per week. Weight loss and signs of blistering were monitored (Marietta et al., 2004).

3.2.2.3 Generation of HLA-DQ2.5 transgenic mice

HLA-DQ2.5 gene is the main predisposing HLA molecule present in 90% of CD patients. Several HLA-DQ2.5 transgenic models were obtained. One of them was described by Z. Chen and colleagues (Chen et al., 2002). Transgenic HLA-DR3-DQ2 mice expressing a 320-kb region of the HLA-DR3-DQ2.5 haplotype (HLA DRB1*0301-DRB3*0101-DRA*0101-DQB1*0201-DQA*0501) were derived from a yeast artificial chromosome (YAC) containing seven HLA class II genes from DRA to DQB2 including authentic flanking and intervening sequences as shown in Figure III.6. The founder line was selected following multiple blastocyst injections performed with transfected ES cells and expanded by breeding with C57BL/6 mice deficient for mouse class II molecules ($A\beta^\circ$). In HLA-DR3-DQ2. $A\beta^\circ$ mice, the human HLA transgene was expressed on dendritic cells, B cells and on a fraction of macrophages. In HLA^{+/+} $A\beta^\circ$ mice only 13% of splenic lymphocytes expressed the murine CD4 molecule (de Kauwe et al., 2009) suggesting that inefficient interaction between HLA-DQ2 and murine CD4 impaired the selection of CD4 T cells. HLA^{+/+} $A\beta^\circ$ mice had however fully functional CD4 T cells. Indeed, mice immunized with a DQ2-restricted α -gliadin peptide 57-73 were able to mount a recall peptide-specific T cell *in vitro* response, even if not very strong. However no pathology was detected in these mice.

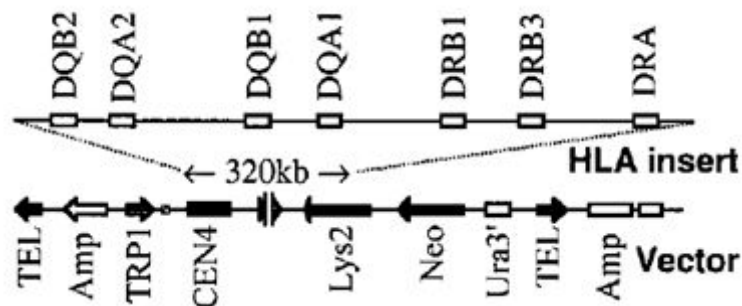

Figure III.6: Regulated expression of the HLA-DR3-DQ2 haplotype encoded by yeast artificial chromosome. The yeast artificial chromosome R1B1D12 of ~320kb size contains seven genes from HLA-DR3-DQ2 haplotype from DRA to DQB2, a vector arm on each end, and the neo-resistant gene in the right arm (Chen et al., 2002).

In order to favour the interactions between HLA and murine T cells, a human CD4 transgene was introduced into HLA-DR3-DQ2 transgenic mice (de Kauwe et al., 2009). This increased CD4 T cell frequency up to 18%. Moreover T cells from hCD4.DR3-DQ2.MHCII^{ΔΔ} mice immunized with deamidated α -gliadin 57-73 Q65E peptide specifically responded to *in vitro* recall with the same peptide, while non-deamidated version of α -gliadin 57-73 peptide triggered only a very weak T cell response. These results are relevant to the situation in humans, in whom deamidated gluten peptides prime much more efficiently specific T cell responses (Meresse et al., 2012).

In order to increase the frequency of gluten-specific T cells in hCD4.DR3-DQ2.MHCII^{Δ/Δ} mice that might favour the development of disease, a gliadin-specific CD4 T cell hybridoma (HH8) coexpressing TCR Vα8.3 and TCR Vβ8.2 was obtained from animals immunized with α-gliadin 57-73 Q65E peptide. As T cells can be easily tracked using mAbs against TCR Vα8.3 and TCR Vβ8.2 chains, this hybridoma was selected to generate TCR tg mice. In TCR tg mice generated on hCD4.DR3-DQ2.MHCII^{Δ/Δ} background, CD4 T cells had normal development and peripheral export, since 97% of peripheral CD4 T cells expressed the transgene-encoded TCR, while CD8 T cells were dramatically reduced in the periphery and thymus (de Kauwe et al., 2009).

3.2.2.4 Response of HLA-DQ2.5 humanized mice to gluten

HCD4.DR3-DQ2.MHCII^{Δ/Δ} mice remained healthy. Neither weight loss nor alterations of intestinal histology were detected upon exposure to gluten, even after prior immunization with deamidated chymotrypsin-digested gliadin or various preparations of α-gliadin 57-73 Q65E peptide (experimental scheme on Figure III.7). Neither immunization with gluten in the presence of pertussis toxin nor the backcross of mice onto NOD background provoked any changes in villous structure or body weight (de Kauwe et al., 2009).

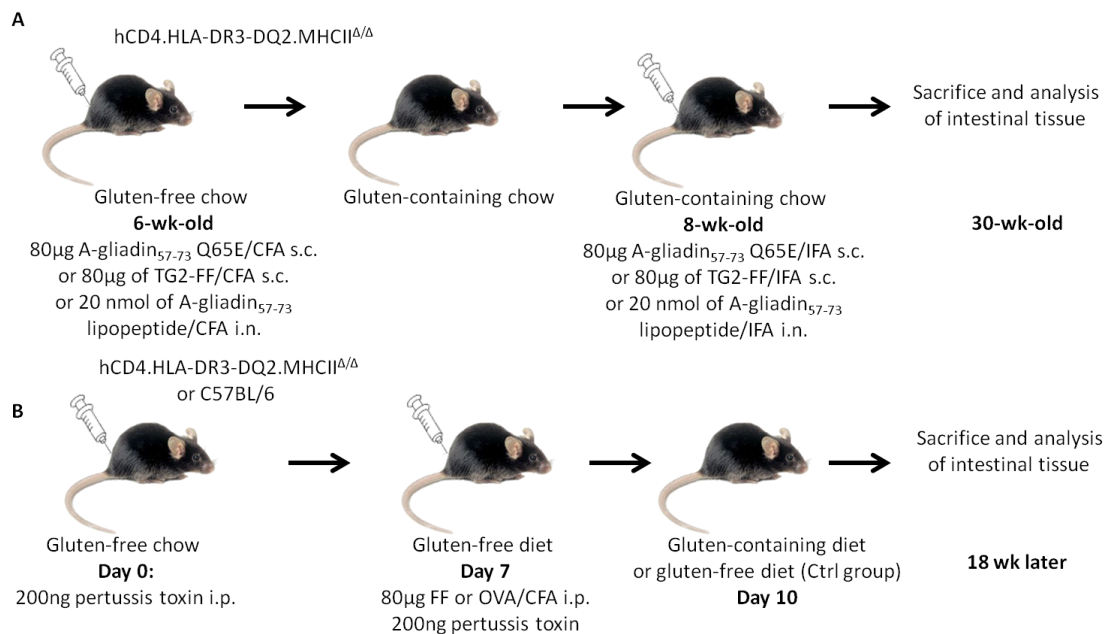

Figure III.7: Schematic illustration of gluten-sensitization protocol used in (de Kauwe et al., 2009)

A. 6-week old mice transgenic for HLA-DR3-DQ2 and human CD4 mice on MHC class II-deficient background maintained on gluten-free chow were immunized with indicated peptide together with CFA, then the chow was switched to gluten-containing one and mice received a second challenge of the peptide on Day 14. 30-week old mice were sacrificed and intestinal tissue was analyzed. B. hCD4.HLA-DR3-DQ2.MHCII^{Δ/Δ} or C57BL/6 mice maintained on gluten-free chow were sensitized with pertussis toxin, then seven days later immunized with trypsin-chymotrypsin-digested gliadin (FF) or OVA in CFA together with

pertussis toxin. Three days later one group of mice was switched to gluten-containing diet. Mice were sacrificed 18 weeks later for the analysis of intestinal tissue (*de Kauwe et al., 2009*).

CD4 TCR transgenic cells transferred into hCD4.DR3-DQ2.MHCII^{Δ/Δ} mice immunized with α-gliadin 57-73 Q65E peptide or gavaged daily with the same peptide proliferated in an antigen-specific manner. Nevertheless, hCD4.DR3-DQ2.MHCII^{Δ/Δ} mice possessing CD4 TCR transgenic cells did not develop any sign of intestinal pathology nor autoantibodies specific for TG2 or gliadin upon exposure to dietary gluten. Interestingly, *in vitro* restimulation of TCR transgenic T cells with a specific epitope DQ2-α-II led to the production of mainly IL-2 and IFN γ cytokines. These mice were analyzed for the induction of Foxp3⁺ CD4 T cells, a main mechanism of tolerance to food antigens. No expansion of Foxp3⁺ CD4 T cells was detected in MLN or in spleen after 10 days of exposure to dietary gluten (*de Kauwe et al., 2009*). Nevertheless, it cannot be excluded that Foxp3⁺ Treg cells might have been induced and had already migrated from MLN to the lamina propria (according to observations made in (*Hadis et al., 2011*)). Overall, these findings indicate that exposure to dietary gluten of mice expressing HLA-DQ2.5 and possessing substantial amount of CD4 T cells specific for gluten was not sufficient to break local tolerance and provoke intestinal lesions. Time window of gluten introduction and the duration of exposure to some immunogenic peptides may play a role in the disease onset. Moreover, additional factors may also be required.

Another study was performed several years later (*Du Pre et al., 2011*) in distinct HLA-DQ2.5 transgenic mice, in which the transgene is a smaller 68kb fragment. This fragment included DQA*0501 and DQB1*0201 genes together with promoters and regulatory elements. It was purified from bacteriophage clone p797a11 and used for microinjection. HLA-DQ2.5 mice were crossed with transgenic mice expressing a chimeric TCR construct, in which the variable domains were derived from a human γ 1-gliadin-specific T cell clone and constant regions and regulatory elements were of mouse origin (*Sjostrom et al., 1998*). All mouse lines were backcrossed to MHCII^{Δ/Δ} mice. Splenocytes from HLA-DQ2.gliadin-TCR.MHCII^{Δ/Δ} double transgenic mice efficiently responded to deamidated gliadin *in vitro* and this response was accompanied by a strong production of IL-2 as well as of inflammatory cytokines such as IFN γ , IL-17, and IL-21 and IL-4, whereas the response to non-deamidated gliadin was very low. This study showed that gavage with deamidated (TG2-gliadin) induced strong proliferation of gliadin-specific V β 1 CD4 T cells transferred into HLA-DQ2.5.MHCII^{Δ/Δ} animals. Strikingly and in contrast to the response observed in WT mice gavaged with ovalbumin detected in MLN, the response to gluten predominated in spleen. Gavage with non-deamidated gliadin did not induce any T cell proliferation indicating that, in homeostatic

conditions, TG2 was inactive and could not promote efficient deamidation of gluten. Proliferating cells produced large amounts of IFN γ , which was probably controlled by IL-10 also strongly secreted by responding spleen cells. This observation and the absence of Foxp3 T cells induction led the authors to suggest that systemic tolerance induced upon gavage with deamidated gliadin resulted from the development of Tr1-like T cells rather than of Foxp3⁺ regulatory T cells. Yet, this study did not analyze mucosal T cell response in response to gliadin challenge. Moreover, this result is not consistent with the expansion of Foxp3⁺ Treg cells observed in the intestinal mucosa of celiac patients (Hmida et al., 2012; Zanzi et al., 2011).

Interestingly, the authors also observed that immunization with native (non-deamidated) gliadin by the intramuscular route efficiently induced CD4 V β 1 T cell proliferation, contrary to feeding with non-deamidated gliadin. This result was interpreted as an indication that tissue damage caused by intramuscular injection was sufficient for TG2 activation. It was therefore assessed whether tissue damage induced by chemical agents might promote the activation of TG2. For this purpose Poly I:C that can induce transient intestinal damage and TG2 activation (Siegel et al., 2008) or the cytostatic drug methotrexate (MTX) that induces prolonged severe intestinal damage (de Koning et al., 2006) were used. These treatments stimulated TG2 activation in the small intestine. Yet, no increase in T cell response was observed in MLN and spleen after 3 days of gavage with native non-deamidated gliadin in mice administered with Poly I:C or MTX. Even if unlikely, one cannot formally exclude insufficient activation of TG2 or delayed migration of immunogenic peptides to MLN following their deamidation locally in the intestine and thereby delayed T cell priming. To address the latter hypothesis, analysis of T cell responses and notably of mucosal T cell response at later time points, for example on day 12, as described by U. Hadis and colleagues in response to OVA, might have been useful (Hadis et al., 2011).

3.2.2.5 Critical role of IL-15 in gluten intolerance

Several studies have suggested the implication of IL-15, a cytokine upregulated in the celiac mucosa, in the loss of tolerance to gluten in CD patients (Di Sabatino et al., 2006; Mention et al., 2003; Meresse et al., 2004). R.W. DePaolo and colleagues have therefore examined whether mice transgenic for human HLA-DQ8 and IL-15 could develop intestinal enteropathy in response to dietary gluten (DePaolo et al., 2011). Humanized HLA-DQ8.MHCII Δ/Δ mice (Black et al., 2002) were crossed to mice expressing mouse IL-15 under the minimal MHC class I H2-D^d promoter (Fehniger et al., 2001).

IL-15 is a cytokine tightly controlled on the posttranscriptional level and poorly secreted (Fehniger et al., 2001). Therefore, to create IL-15 transgenic mice, T.A. Fehniger and colleagues designed a construct lacking three primary posttranscriptional checkpoints controlling IL-15 translation and secretion and replaced the leader peptide of IL-15 by that of IL-2 resulting in overexpression of an efficiently translated and secreted murine IL-15 (scheme of IL-15 construct on Figure III.8). In D^d-IL-15 transgenic mice, IL-15 expression was observed in LP and MLN, but not in IECs, likely because mouse IECs do not express H2-D molecules. This model thus differs from the situation in celiac disease patients, where IL-15 is strongly detected both in LP and in epithelium (Di Sabatino et al., 2006; Mention et al., 2003). D^d-IL-15 transgenic mice showed early expansion of peripheral blood lymphocytes, notably of natural killer (NK) and CD8 T lymphocytes of memory phenotype. Between 12 and 30 weeks of age most of mice developed fatal lymphocytic leukemia revealed by decreased activity and body weight, progressive alopecia, and characterized by massive multiorgan lymphocytic infiltration, composed mainly by CD3⁺ TCRαβ⁺ and NK cells (Fehniger et al., 2001).

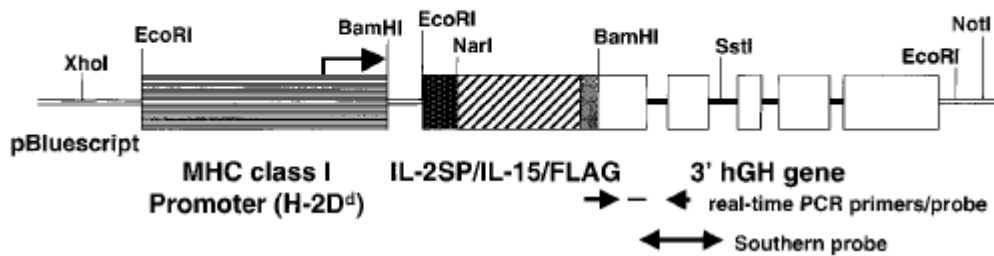

Figure III.8: Structure of the D^d-IL-15 transgene.

Three primary posttranscriptional checkpoints were eliminated: 5' AUGs, the inefficient IL-15 signal peptide, and a COOH terminus retention sequence. Near global overexpression was achieved by the MHC class I promoter, efficient translation and secretion by the use of the IL-2 signal peptide, and stabilization of COOH terminus by the addition of the FLAG epitope. The 3' portion of the hGH gene is fused out of frame for straightforward identification of the transgene by Southern blot and to optimize transgene expression *in vivo* (Fehniger et al., 2001).

HLA-DQ8.D^d-IL-15Tg mice fed recombinant α-gliadin or crude gluten for ten days did not develop any intestinal damage or villous atrophy (DePaolo et al., 2011). However, increased frequency of IFNγ-producing T cells in MLN, mainly CD8⁺, increased IEL numbers and serum anti-gliadin and anti-TG2 antibodies were observed. *In vitro* restimulation of LP or MLN cells isolated from HLA-DQ8 mice coexpressing IL-15 by gliadin led to the increased production of IFNγ and also IL-17, detected by ELISA, in comparison to IL-15 negative siblings. These results indicate the presence of gliadin-specific proinflammatory cells. LP and MLN cells from mice gavaged with gliadin complemented with retinoic acid (RA) produced even more IFNγ and IL-17 in response to gliadin restimulation. The authors supposed that this

enhanced T cell activation observed in the presence of IL-15 might be due to the impaired Treg induction. Thus, they observed that IL-15 together with retinoic acid reduced the ability of dendritic cells to *in vitro* convert naïve T cells into Treg cells. Moreover, they showed that naïve OVA-specific T cells failed to convert into Tregs when transferred into OVA-fed D^d-IL-15 transgenic mice receiving a dietary supplement in retinoic acid. Therefore, they concluded that IL-15 impaired the generation of induced Treg cells, thus leading to increased inflammatory T cell response.

Nevertheless, neither weight loss nor intestinal damage was observed in HLA-DQ8.D^d-IL-15Tg mice indicating that increased T cell activation was not sufficient to promote intestinal lesions. The authors suggested therefore that this model might correspond to latent CD, a situation defined by the appearance of anti-TG2 antibodies and increased numbers of IEL in genetically predisposed individuals that might precede the onset of villous atrophy and active CD.

It is tempting to suggest that different parameters should be modified to better mimic the situation in CD, including notably the use of mice overexpressing IL-15 in the intestinal epithelium, a more prolonged exposure to gliadin, the use of deamidated trypsin-chymotrypsin-digested gliadin for gavage. Crossing of HLA-DQ8.D^d-IL-15Tg mice with mice transgenic for a TCR recognizing gliadin in the context of DQ8 can be considered in order to amplify gluten-specific CD4 T cell response. Furthermore, no comparison in this study was performed between HLA-DQ8.D^d-IL-15Tg and D^d-IL-15Tg mice, thus preventing to delineate the importance of HLA-DQ8 in the development of proinflammatory CD8 T cell responses to gluten, knowing that IL-15 alone may largely promote such responses. This comparison might also be useful to exclude activation of innate responses by gluten that may foster inflammatory responses independently of DQ8.

3.2.2.6 Role of IgA-dependent transport of dietary antigen

In basal condition, dimeric IgA produced by lamina propria plasma cells are transported by the receptor for polymeric immunoglobulins (pIgR) from lamina propria into the lumen where they are released as SIgA bound to the extracellular part of this receptor or secretory component. SIgA can then form complexes with luminal antigens and prevent their absorption. *Ex vivo* and *in vitro* studies performed in our laboratory have suggested that CD71-mediated transport of gliadin-specific secretory IgA can jeopardize the protective role of SIgA and allow the apico-to-basal transport of gliadin peptides, resulting in enhanced antigen-specific T cell immune response (Abed et al., 2014; Lebreton et al., 2012; Matysiak-Budnik et al., 2008). As

already discussed above (see 2.2.2.2 Pathogenic role of IgA), CD71, initially known as a high avidity receptor for transferrin, can function in humans as a receptor of weak affinity for polymeric IgA (Moura et al., 2001). In active CD, this receptor is strongly upregulated in small intestinal enterocytes and becomes expressed at the apical surface, allowing the binding of intraluminal sIgA complexed to immunogenic p31-49 and 33-mer gliadin peptides and their subsequent retrotransport into lamina propria via the recycling endocytic pathway (Lebreton et al., 2012; Matysiak-Budnik et al., 2008). During this process gliadin peptides remain protected from degradation in lysosomes and may thus foster immune responses.

To substantiate this hypothesis, J. Abed and colleagues in our laboratory (Abed et al., 2014) have designed a mouse model to analyze the contribution of CD71 to the transport of ovalbumin (used as a model antigen) bound to OVA-specific SIgA in activation of antigen-specific T cells. To stimulate CD71 expression at the apical surface of enterocytes, BALB/c mice were treated with tyrphostin A8 (Tyr A8), known to enhance CD71-mediated apical-to-basal transcytosis of insulin-transferrin complexes in Caco-2 cells and diabetic rats (Norouziyan et al., 2008; Xia and Shen, 2001). An apical CD71 expression was observed in the intestine of mice treated with Tyr A8 for 48h. Biphoton analysis of intestinal fragments demonstrated that up-regulation of CD71 allowed the apical to basal transport of transferrin and human SIgA1. Of note, mouse CD71 unlike human IgA2 lack a hinge region and in contrast to human SIgA1 do not bind to CD71. Therefore, to test the *in vivo* function of SIgA-CD71 mediated transport, mice were grafted with hybridoma cells secreting chimeric hzIgA (made of human $\alpha 1$ heavy and murine light chains) specific for OVA or for control antigen β -lactoglobulin. Mice bearing hybridomas showed increased titres of specific hzIgA in serum and intestinal fluid. Moreover, analysis of biopsies mounted in Ussing chambers showed a ten-fold increase in the fraction of OVA transported in intact form across the mucosa in mice bearing the hybridoma secreting OVA-specific IgA and treated by Tyr A8 compared to control mice. Notably, total OVA fluxes were unchanged pleading against any non-specific leakage and pointing to the protected transport of the dietary antigen (Abed et al., 2014).

To assess how CD71-SIgA mediated transport of OVA might influence mucosal immune response, OVA-secreting hybridoma cells were grafted on Day 0 onto DO11.10 mice possessing CD4 T cells specific of OVA. Mice were treated with Tyr A8 on days 13 and 14 and gavaged with OVA on days 14, 15, and 16 (Figure III.9). On day 20, a significant increase in the proportion of activated CD69⁺ OVA-specific CD4 T cells was observed in the MLN of OVA-gavaged mice treated with Tyr A8. Moreover, T cells from MLN stimulated by OVA showed a significant increase in IFN γ secretion in OVA-fed DO11.10 mice bearing OVA-

specific tumor and treated with Tyr A8 in comparison to other groups of mice (not treated with Tyr A8 or bearing irrelevant β -globulin specific tumor). These results provided evidence that protected transport of intact dietary antigen via apical CD71 and SIgA enhanced the activation and might skew antigen-specific mucosal CD4 T cells toward a Th1 response (Abed et al., 2014). Together with previous *ex vivo* and *in vitro* studies (Lebreton et al., 2012; Matysiak-Budnik et al., 2008), this study emphasized a possible pathogenic role of retransport of immune IgA/peptide complexes (Abed et al., 2014).

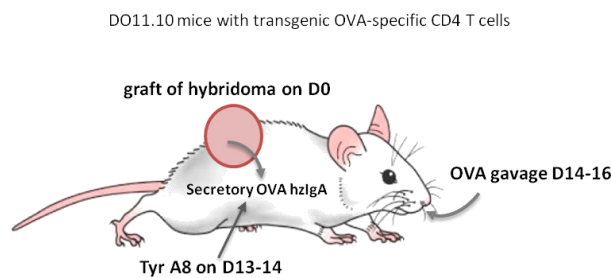

Figure III.9: Schematic illustration of experimental protocol used in (Abed et al., 2014)

DO11.10 mice possessing CD4 T cells specific of OVA were grafted with OVA-secreting hybridoma cells on Day 0. Mice were then treated with Tyr A8 on days 13 and 14 and gavaged with OVA on days 14, 15, and 16, and sacrificed on day 20.

It would however be useful to confirm these results in the gliadin-specific model, and to use a model that does use tumor grafts to avoid a possible proinflammatory host response toward the tumor. It would also be interesting to induce ectopic CD71 expression not by a pharmacological agent but by a mechanism closer to the one susceptible to operate in CD, notably iron deprivation known to induce overexpression of CD71 in enterocytes (Zamani et al., 2008) and M. Heyman, personal communication). As discussed above, IgA-mediated protected transport of gliadin peptides may be one of the mechanisms participating in the development of enteropathy. The fact that IgA-deficient patients are prone to develop CD suggests that this mechanism is dispensable for the development of intestinal lesions. Yet, in the latter patients, the lack of SIgA may be sufficient to facilitate the entry of intact peptides and may also result in the excessive activation of epithelial cells by bacterial products (Meresse et al., 2012).

3.3 Lessons learned from mouse models and perspectives

Overall, multiple efforts in order to establish a mouse model of celiac-like enteropathy have been largely unsuccessful. Several conclusions can however be made from these studies. Herein, I discuss the hypotheses that remain to be tested henceforward.

3.3.1 Importance of age of gluten introduction and duration of exposure

As shown by early studies in wild type mice and rats, the time window of gluten introduction may play an important role in settling on tolerance or immunity (Stepankova et al., 2003; Stepankova et al., 1996; Troncone et al., 1994; Troncone and Ferguson, 1988, 1991). As in humans, too early introduction of gluten seems to be a risk factor for CD development. Introduction during gestation or early after the birth before weaning provokes an enteropathy in newborn rats that is favoured by the absence of breast-feeding (Stepankova et al., 2003; Stepankova et al., 1996). Exposure to gluten after weaning did not provoke any pathological changes in rat intestine. Studies performed in HLA-transgenic mice did not include the setting of early introduction of gluten. Experimental protocol should probably also be revised by extending exposure to gluten knowing that celiac disease is induced after its prolonged consumption. Introduction of gluten early in life or even during prenatal period to pregnant mice should also be tested.

3.3.2 CD4 T gliadin-specific response is necessary but not sufficient

Several attempts to induce an enteropathy in gluten-fed HLA-DQ2.5 or DQ8 transgenic mice were not successful. Despite the activation of gluten-specific CD4 T cells and the secretion of proinflammatory cytokines, such as IFN γ , no significant changes in intestinal morphology were detected (Black et al., 2002; de Kauwe et al., 2009; DePaolo et al., 2011; Du Pre et al., 2011). The activation of gluten-specific cells was probably efficiently counterbalanced by a regulatory response. An insufficient frequency of gluten-specific T cells may perhaps explain the difficulties encountered to induce the enteropathy. Indeed, HLA-DQ2.5 or DQ8 transgenic mice on MHC class II deficient background have only small frequency of naturally primed T cells. In order to increase gluten-specific response, it would be necessary to systematically use mice co-expressing human CD4 transgene to favour the interaction between HLA-DQ and CD4 T cells, or even more use gliadin-specific human TCR transgene. As multiple immunogenic gliadin peptides were described, it is not clear whether some of them may induce more harmful T cell response than others. Therefore, a particular attention should be paid to the choice of the TCR transgene.

Furthermore, contrary to HLA-DQ8 molecules that may efficiently present a non-deamidated 206-217 gluten peptide (van de Wal et al., 1998b), HLA-DQ2.5 molecules present only deamidated gliadin peptides. Of note, the majority of tested experimental protocols

comprised the immunization or gavage with non-deamidated gliadin without testing the activation of TG2 in these conditions. The use of deamidated gluten peptides should therefore be considered. Alternatively, the *in vivo* induction of TG2 activation should be triggered. It would permit to avoid the deamidation of gluten prior its administration, a very costly step. Yet, achieving of *in vivo* activation of TG2 seems difficult in mice and may represent a limiting step in the design of a mouse CD model.

3.3.3 Need for supplemental triggers for disease onset

Even if the number of DQ-restricted CD4 T cells that can be stimulated in humanized mouse models may not be very high, it is likely that the frequency of gluten-specific T cells is also not very high in human CD. Indeed, detection of gluten-specific T cells with DQ2 tetramers revealed only very small frequencies of gluten-specific CD4 T cells in the blood and intestinal mucosa of the patients. Therefore, results observed in humanized models strongly support the hypothesis that CD4 T cells are necessary but not sufficient to induce villous atrophy.

Strikingly, one important characteristic of CD is the activation of intestinal CD8 T intraepithelial lymphocytes. Studies performed by Mazzarella and colleagues have suggested that CD8 T cells can be activated via cross-presentation of gluten peptides (Mazzarella et al., 2008). Decrease in CD8 T IEL activation after gluten free diet was taken as a support for this hypothesis. Alternatively, T cell help from gluten-activated CD4 T cells might be necessary for CD8 T cell activation. Strikingly, no CD8 T cell activation was documented in gluten-fed HLA-DQ2.5 or -DQ8 transgenic mice (Black et al., 2002; de Kauwe et al., 2009) indicating that cross-presentation does not occur in the latter mice and/or another factor is required to foster CD8 T cell activation.

Overall, analyses in humanized mouse models indicate that additional factors besides HLA predisposing haplotypes are necessary to break tolerance to gluten and to drive tissue damage. Non-HLA susceptibility variants associated with the risk of developing CD patients might be one missing factor. They seem however to account overall for less than 13% of CD genetic susceptibility. Second, CD71-SIgA interactions may be important in human CD but cannot operate in mice due to the lack of binding of mouse SIgA to mouse CD71. As discussed in chapter 2 (2.4.4 Activation of TG2), additional factors may be necessary to trigger TG2 activation, notably environmental factors, such as viral infections, that may trigger tissue damage (Dafik et al., 2012). It was also suggested that components of gluten might activate innate inflammatory responses and thereby favour the loss of tolerance. Thus, amylase/trypsin

inhibitors in wheat were found to be strong activators of TLR4-dependent innate immune responses in monocytes, macrophages, and dendritic cells (Junker et al., 2012). This mechanism is however expected to operate in mice as well as humans. Finally, one key factor missing in humanized HLA-DQ models may be IL-15. Of note, a moderate expansion of CD8 T IELs was observed in mice humanized for HLA-DQ8 (DePaolo et al., 2011). No enteropathy was observed in this model. Yet, one major difference with CD was that IL-15 was predominantly expressed outside the gut. Our own work described in the results section demonstrates how IL-15 produced in large amounts in the intestine can cooperate with CD4 T cells specific for a dietary antigen and drive the activation of cytotoxic intestinal CD8 T cells (Korneychuk et al., 2014) (MAIN RESULTS: Cooperation between antigen-specific CD4 T cells and IL-15 in the mouse model of celiac-like small intestinal enteropathy induced by dietary antigen).

Experimental Work

A. Thesis aims and experimental approach

The main purpose of my work has been to set up a mouse model in order to validate hypotheses suggested by human *ex vivo* and *in vitro* studies (reviewed in Chapter 2: Abnormal response to food gluten in Celiac disease and Chapter 3: Animal models of Celiac disease). One set of data that account for the strong genetic link of CD with MHC class II genes indicates that CD enteropathy depends on the activation of CD4 T lamina propria lymphocytes by gluten peptides efficiently presented by human MHC class II molecules HLA-DQ2.5 or -DQ8 (Meresse et al., 2012). However, it is now established that the adaptive gluten-specific CD4 T cell response is necessary but not sufficient to induce tissue damage. Only a small fraction (<5%) of HLA-DQ2 or -DQ8-positive individuals develop CD, and HLA-DQ2 and -DQ8 transgenic mice challenged with gluten do not develop any signs of enteropathy or intestinal inflammation and remain tolerant to gluten (Black et al., 2002; de Kauwe et al., 2009; Du Pre et al., 2011; Silano et al., 2010) (discussed in Chapter 3: Animal models of Celiac disease). A second data set points out to the role of IL-15, a cytokine overproduced in the small intestinal mucosa of active CD patients. On the one hand, IL-15 favours accumulation and cytotoxic activation of intraepithelial CD8 T lymphocytes (Di Sabatino et al., 2006; Maiuri et al., 2000; Malamut et al., 2010; Mention et al., 2003) and their increased expression of activating NK receptors (Jabri et al., 2000; Meresse et al., 2004; Meresse et al., 2006). On the other hand, IL-15 impairs *in vitro* response of human effector T cells, notably CD8 T cells, to immune suppression by Foxp3⁺ Treg cells and to immunoregulation by TGFβ (Ben Ahmed et al., 2009; Benahmed et al., 2007; Hmida et al., 2012; Zanzi et al., 2011), two complementary mechanisms important for preserving tolerance to dietary antigens. The goal of my project has thus been to establish whether activation of CD4 T cells by dietary antigen in the context of intestinal overexpression of IL-15 could impair the establishment of tolerance to the dietary antigen and lead to epithelial damage and villous atrophy (Figure A.1). To verify this hypothesis, it was necessary to set up an animal model allowing the dissection of interactions between IL-15 and gluten-specific CD4 T cells in the activation of cytotoxic intestinal CD8 T cells.

Hypothesis: gluten-specific CD4 T cells and IL-15 expressed in intestinal mucosa may trigger the break of tolerance to gluten and tissue damage

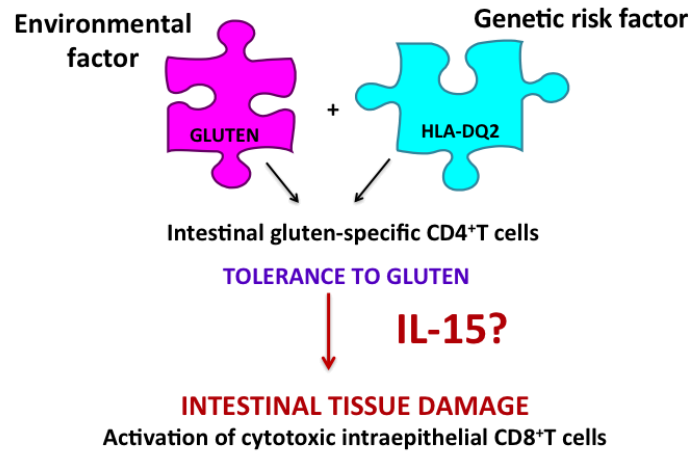

Figure A.1: Experimental hypothesis

To this end, two complementary approaches were considered. First, I initiated the breeding of humanized mice in order to create a mouse model close to celiac disease combining expression of the human HLA-DQ2.5 transgene, expression of a human TCR specific for a γ -gliadin peptide and overexpression of human IL-15 under the control of intestinal epithelial T3b promoter. Mouse lines separately expressing HLA-DQ2.5 (HLA-DQ2.5^{+/-} mice), gliadin-specific TCR (TCRgli^{+/-} mice; generously offered by L. Fugger) and human IL-15Tge (generously offered by H. Kyiono) backcrossed on a B6 background were available in the laboratory. In order to favour gluten presentation by human HLA-DQ2.5 molecules, each mouse line was crossed with mice deficient in mouse endogenous MHC class II molecules (MHCII^{-/-}). Sequential breeding of HLA-DQ2.5^{+/+} MHCII^{-/-} and TCRgli^{+/+} MHCII^{-/-} was planned to obtain HLA-DQ2.5^{+/+} TCRgli^{+/+} MHCII^{-/-} and then to cross them with hIL-15Tg^{+/-} MHCII^{-/-} in order to get HLA-DQ2^{+/-}TCR^{+/-}hIL-15^{+/-} (50%) and HLA-DQ2^{+/-}TCR^{+/-}hIL15⁻ (50%) on MHCII^{-/-} background (Figure A.2). The goal was to expose these animals to gluten-free or gluten-rich diet and to test whether inflammatory conditions created by IL-15 might lead to the deamidation of gluten peptides. As this breeding process needed a considerable delay, I have used in parallel another model previously elaborated by a post-doc, Emma Ramiro-Puig.

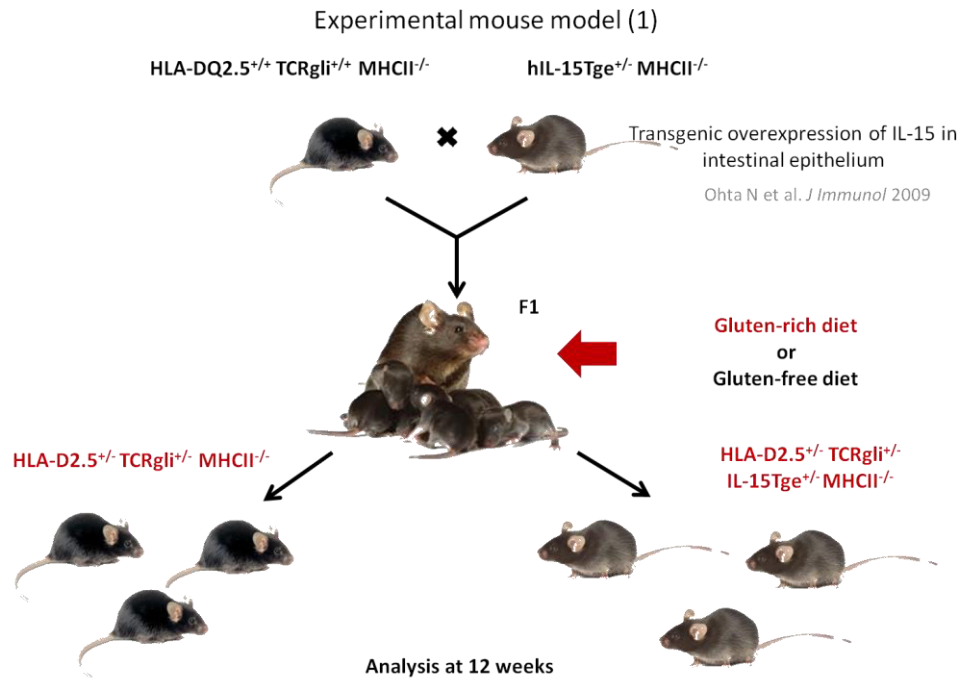

Figure A.2: Experimental mouse model (1)

HLA-DQ2^{+/-}TCR^{+/-}hIL-15^{+/-} (50%) and HLA-DQ2^{+/-}TCR^{+/-}hIL15⁻ (50%) mice would be obtained from breeding of HLA-DQ2.5^{+/-}TCRgli^{+/+} MHCII^{-/-} and hIL-15Tg^{+/-} MHCII^{-/-} and then exposed to gluten-rich or gluten-free diet for prolonged period of time (until 12 weeks of age).

The second model is based on the use of OTII mice possessing CD4 T cells specific of OVA₃₂₃₋₃₃₉ peptide and allows the mimicking of the CD4 T cell response to gluten developing in CD patients by a CD4 T cell response against the model dietary antigen OVA. Homozygous OTII mice were crossed with heterozygous mice overexpressing IL-15 in intestinal epithelium in order to obtain OTII^{+/-} hIL-15Tge⁻ (OTII/B6) and OTII^{+/-} hIL-15Tge^{+/-} pups (Figure A.3). Prior to my arrival, E. Ramiro-Puig had tested different protocols to provoke an enteropathy by exposing the latter mice to dietary OVA. Among different protocols that were tested, one was efficient in the induction of an enteropathy. It consisted in the exposure to dietary OVA of pregnant mothers before the birth of pups and during the lactation period and then prolonged exposure of the offspring from weaning until 12 weeks of age. OVA was administered in the form of pellets containing 10% of OVA (isoproteic/isocaloric diet). Upon prolonged exposure to dietary OVA, OTII^{+/-} hIL-15Tge^{+/-} but not in OTII^{+/-} hIL-15Tge⁻ animals developed growth retardation and small intestinal macroscopic and microscopic lesions, affecting mainly if not exclusively the duodenum. In our colony, a fraction of hIL-15Tge mice developed an early onset disease that likely corresponds to the onset of a fulminate lymphoma lethal within the first 6 weeks of life. The latter mice did not however show any enteropathy. Mice that were not affected by this early disease developed normally but displayed after 10 months of age an enteropathy comparable to that described by Ohta and colleagues (Ohta et al., 2002). The

reason for the delayed onset of enteropathy in our colony is unclear, but may be explained by a difference in the microbiota since our hIL-15Tge mice were rederived from frozen embryos provided by the Japanese group. This delayed onset was instrumental in analysis of mechanisms of cooperation between CD4 T cells and IL-15 that led to the development of enteropathy in Ova-fed OTII^{+/-} hIL-15Tge^{+/-} mice. The purpose of my study has therefore been to dissect the cellular mechanisms the break of tolerance to dietary OVA n OTII^{+/-} hIL-15Tge^{+/-} mice and to determine how antigen-specific CD4 T cells might cooperate with IL-15 in driving the cytotoxic activation of CD8 T cells.

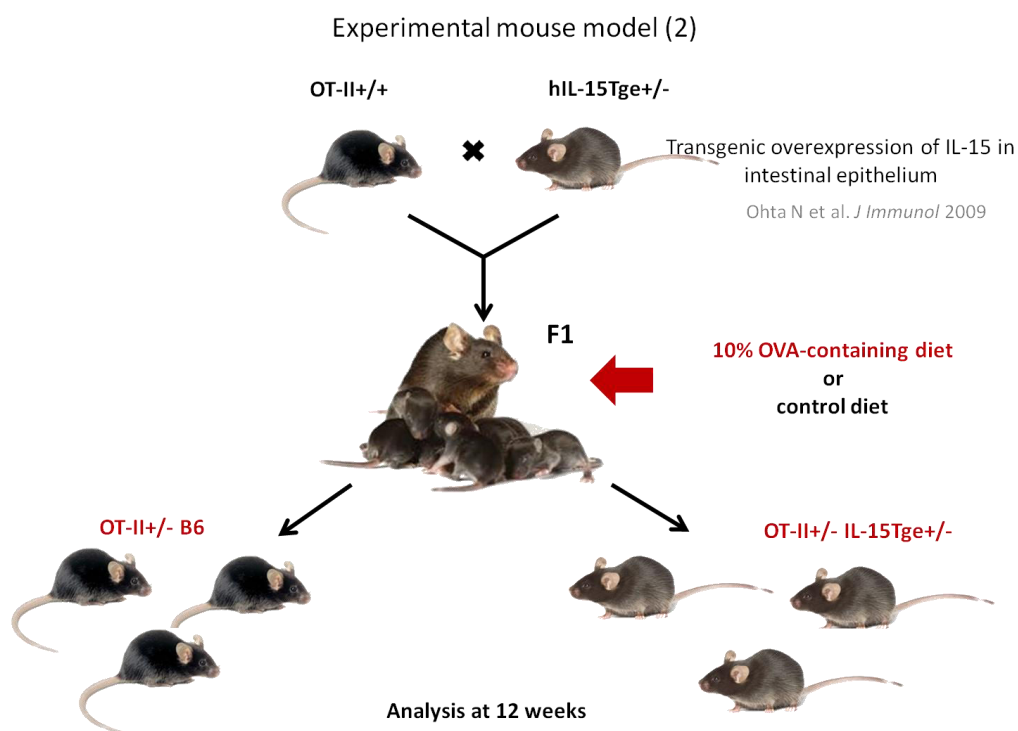

Figure A.3: Experimental mouse model (2)

Homozygous OTII mice were crossed with heterozygous mice overexpressing IL-15 in intestinal epithelium in order to obtain OTII^{+/-} hIL-15Tge⁻ (OTII/B6) and OTII^{+/-} hIL-15Tge^{+/-} offspring. Pregnant mothers were exposed to 10% OVA-containing diet before birth of pups and during lactation period. The offspring was then chronically exposed to dietary OVA from weaning until 12 weeks of age.

B. MAIN RESULTS: Cooperation between antigen-specific CD4 T cells and IL-15 in the mouse model of celiac-like small intestinal enteropathy induced by dietary antigen

B.1 Results

Breeding of HLA-DQ2.5, TCR and IL-15Tge mice allowed me to obtain HLA-DQ2^{+/+} MHCII^{-/-}, TCR^{+/+} MHCII^{-/-} mice. hIL-15Tge MHCII^{-/-} mice have been obtained but are very difficult to maintain as a stable colony. Indeed, the latter mice are very fragile likely due to the strong CD8 T cell expansion and the lack of CD4 Tregs. One additional difficulty that we face in this model is the necessity either to use deamidated gliadin or deamidated γ -gliadin peptide for feeding, which will be excessively costly, or to activate TG2 in order to allow *in situ* deamidation of gluten peptides indispensable for CD4 T cell activation. As TG2 can be activated by tissue damage, we have examined whether up-regulation of IL-15 may be sufficient to stimulate TG2. Preliminary results using an ELISA that specifically detects the activated form of TG2 suggested that TG2 was not activated in hIL-15Tge mice (not shown). The use of Poly I:C reported to activate TG2 is a possible approach (Dafik et al., 2012; Siegel et al., 2008). Yet, in our hands, poly I:C induced severe but rapidly resorbed intestinal lesions that may be insufficient to durably activate TG2.

B.2 Article

Results obtained in Ova-fed OTII/hIL-15Tge mice are presented below in the form of the article published in *Gastroenterology* (Korneychuk et al., 2014).

Interleukin 15 and CD4⁺ T Cells Cooperate to Promote Small Intestinal Enteropathy in Response to Dietary Antigen

Natalia Korneychuk,^{1,2,*} Emma Ramiro-Puig,^{1,2,*} Julien Ettersperger,^{1,2} Julie Schulthess,^{1,2} Nicolas Montcuquet,^{1,2} Hiroshi Kiyono,³ Bertrand Meresse,^{1,2,§} and Nadine Cerf-Bensussan^{1,2,§}

¹INSERM UMR1163, Laboratory of Intestinal Immunity, Paris, France; ²Université Paris Descartes-Sorbonne Paris Cité and Institut IMAGINE, Paris, France; ³Division of Mucosal Immunology, Institute of Medical Science, The University of Tokyo, Tokyo, Japan

BACKGROUND & AIMS: CD4⁺ T cells specific for dietary gluten and interleukin 15 (IL15) contribute to the pathogenesis of celiac disease. We investigated whether and how they interact to damage the intestine using mice that overexpress human IL15 in the intestinal epithelium and have CD4⁺ T cells specific for ovalbumin, a dietary antigen. **METHODS:** We crossed mice with CD4⁺ T cells specific for ovalbumin (OTII) with mice that overexpress human IL15 under an intestine-specific promoter (B6 × IL15Tge). The offspring (OTII × IL15Tge mice) received control or ovalbumin-containing diets until 3 months of age. Enteropathy was monitored by weight, ratio of villous:crypt length, and the number of intestinal lymphocytes. Phenotype, cytokine production, and degranulation of mucosal and spleen lymphocytes were analyzed by multicolor flow cytometry or enzyme-linked immunosorbent assay. Regulatory T-cell function and CD8⁺ T-cell activation were analyzed in co-culture assays. **RESULTS:** Exposure to ovalbumin reduced growth and led to enteropathy in OTII × IL15Tge mice but not in control OTII × B6 littermates. Enteropathy was associated with expansion of mucosal granzyme B⁺ CD8⁺ T cells, and developed despite increased frequency of functional ovalbumin-specific regulatory T cells. Ovalbumin-activated CD4⁺ T cells secreted IL2, which along with IL15 stimulated expansion of noncognate intestinal cytotoxic CD8⁺ T cells, which did not respond to regulatory T cells and induced epithelial damage. **CONCLUSIONS:** We observed that in mice given food antigen, cooperation between IL15 and CD4⁺ T cells is necessary and sufficient to activate CD8⁺ T cells and damage the small intestine. We propose that this process is involved in the development of celiac disease.

Keywords: Gluten Allergy; Treg Cells; Immune Regulation; Mouse Model.

In physiologic conditions, robust immunologic mechanisms avoid adverse responses to food antigens.¹ In contrast, in celiac disease (CD), abnormal activation of intestinal lymphocytes by dietary gluten leads to severe small intestinal enteropathy. In CD, intestinal lesions depend on the activation of lamina propria (LP) CD4⁺ T lymphocytes (TLs) by gluten peptides selectively presented by HLA-DQ2/8 molecules, the main genetic risk factor.² This mechanism is necessary, however, it is not sufficient to break tolerance to the dietary antigen and to induce

tissue damage.² Previous studies, including ours, also have implicated interleukin 15 (IL15), a cytokine up-regulated in the CD intestine. IL15 promotes the survival, accumulation, and activation of cytotoxic CD8⁺ intraepithelial lymphocytes (IEL), which can induce epithelial lesions.^{3–6} IL15 also might impair local immune regulation, either by making TLs resistant to suppression by transforming growth factor- β and Forkhead box P3 (FOXP3⁺) regulatory T cells (Tregs),^{7–9} or by hampering the generation of Tregs.¹⁰ Whether and how gluten-specific CD4⁺ TLs and IL15 interact to activate CD8⁺ IELs and to drive tissue damage, however, is unknown.

To address this question, we have developed a mouse model. Transgenic CD4⁺ T cells specific for ovalbumin (OTII) mice with CD4⁺ TL specific for an epitope of ovalbumin (OVA) were crossed with heterozygous B6 × IL15Tge mice, which express a secreted form of human IL15 in the intestinal epithelium.¹¹ We next compared the consequences of OVA-containing diet in the created OTII × IL15Tge mice and in OTII × B6 littermates, which also possess OVA-specific CD4⁺ TL but do not overexpress IL15. In OTII × IL15Tge mice, but not in OTII × B6 mice, early and chronic exposure to dietary OVA led to growth retardation, and to an enteropathy associated, as in CD, with expansion of Granzyme B⁺ CD8⁺ TL in LP and epithelium. We further show that IL15 cooperates with IL2 produced by OVA-activated CD4⁺ TLs to stimulate the expansion of cytotoxic CD8⁺ TL.

Materials and Methods

Mouse Models

B6 (C57BL/6j) mice, OTII mice, b2m^{-/-} mice, and major histocompatibility complex (MHC)II^{-/-} mice were purchased from

*Authors share co-first authorship; §Authors share co-senior authorship.

Abbreviations used in this paper: CD, celiac disease; DC, dendritic cell; IEL, intraepithelial lymphocyte; IFN, interferon; IL, interleukin; iTreg, regulatory T cell induced in the periphery in response to exogenous antigens; LP, lamina propria; mAb, monoclonal antibody; MLN, mesenteric lymph nodes; nTreg, natural regulatory T cell generated in the thymus; OTII, CD4⁺ T cells specific for ovalbumin; OVA, ovalbumin (albumin from chicken egg white); PBS, phosphate-buffered saline; rhIL, recombinant human interleukin; TL, T lymphocyte; TCR, T-cell receptor; Treg, regulatory T cell; WT, wild type.

© 2014 by the AGA Institute
0016-5085/\$36.00

<http://dx.doi.org/10.1053/j.gastro.2013.12.023>

Charles River (L'Arbresle, France). OTII RAG2^{-/-} Thy1.1 mice and OTI RAG2^{-/-} mice were a gift from O. Lantz (Institut Curie, Paris, France). Heterozygous B6 × IL15Tge male mice, which express human IL15 under control of the intestine-specific T3b promoter, were crossed with female OTII or B6 mice.¹¹ A diet containing 10% OVA or an isoprotein/isocaloric control diet (Genestil, Royaucourt, France) was given to OTII or B6 mice during the last week of gestation, and to their offspring until 3 months of age. Daily intake of OVA was approximately 17 mg/g of mouse body weight. Animals were bred under specific pathogen-free conditions in accordance with European Guidelines. Experiments were approved by the local ethics committee.

Histology and Immunohistochemistry

Sections (5 μm) from formal-fixed, paraffin-embedded duodenum were stained with H&E. Granzyme B was detected using antimouse Granzyme B goat IgG (AF1865; R&D Systems, Lille, France), biotinylated rabbit antigoat IgG (E0466; Dako, Les Ulis, France), and streptavidin peroxidase (P0397; Dako).

Cell Isolation and Flow Cytometry

Isolation of LP, mesenteric lymph nodes (MLNs), and spleen cells, and staining for surface markers and intracellular Foxp3, Granzyme B, and cytokines, were performed as described.¹² Antibodies are listed in the [Supplementary Materials and Methods section](#). Cells were analyzed on a FACS Canto II using BD FACSDiva software (BD Biosciences, Le Pont-de Claix, France).

Cell Subset Purification and Functional Assays

T-cell subsets were enriched by an AutoMACS Pro Separator (Miltenyi Biotec, Paris, France) and further purified using a FACS Aria cell sorter II (BD Biosciences). To test Treg activity, 5 × 10⁴ OVA-specific responder T cells (Vβ5⁺CD25⁺CD4⁺) were co-cultured at a 1:1 ratio with OVA-specific Tregs (Vβ5⁺CD25⁺CD4⁺), or, as a control, with OVA-nonspecific Tregs (Vβ5⁺CD4⁺CD25⁻), in 96-well, round-bottom plates with 0.5 μg/mL OVA₃₂₃₋₃₃₉ peptide (Covalab, Villeurbanne, France) and 5 × 10⁴ irradiated spleen cells from OTII mice fed the control diet. Proliferative responses were assessed in triplicate cultures by [³H] thymidine incorporation. To test T-cell response to Tregs, 5 × 10⁴ CD45⁺CD25⁻ B6 spleen cells were labeled using the Cell Trace Violet cell proliferation kit (Life Technologies, Saint Aubin, France) and co-cultured at a 1:1 ratio with unlabeled CD45⁺CD25⁺ cells or, as a control, with unlabeled CD45⁺CD25⁻ cells. To assess proliferation, cells were stimulated for 48–72 hours with 0.2 μg/mL CD3 monoclonal antibodies (mAbs) (145-2C11; BD Biosciences), and then analyzed by flow cytometry. To assess induction of interferon (IFN)-γ and Granzyme B, cells were stimulated with CD3 mAbs and 0.2 μg/mL CD28 mAbs (37.51; BD Biosciences), in the presence or absence of 20 ng/mL human IL15 (Miltenyi Biotec), and then analyzed by enzyme-linked immunosorbent assay (R&D Systems).

To analyze interactions between CD8⁺ and CD4⁺ Tregs, CD8⁺ and CD4⁺ Tregs purified from indicated sources were stained using Cell Trace Violet, added with spleen CD11c⁺ dendritic cells (DCs) (DC/T ratio, 1:10), and stimulated with OVA₂₅₃₋₂₆₇, OVA₃₂₃₋₃₃₉ (2 μg/mL), or OVA protein (400 μg/mL) plus 20 ng/mL IL15. After 4 days, proliferation and activation

markers were assessed by flow cytometry. Degranulation of CD8⁺ Tregs was analyzed by stimulating cells for 4 hours with 1 μg/mL CD3 mAb, and then staining for CD107a-PE (1D4B; eBioscience, Paris, France).

Adoptive Cell Transfer

Spleen and MLN cells from OTII RAG2^{-/-} Thy1.1 transgenic mice (2 × 10⁶ cells in 100 μL phosphate-buffered saline [PBS]) were injected intravenously into B6 or B6 × IL15Tge mice. On days 1 and 2 after transfer, mice were gavaged with 50 mg OVA in 100 μL PBS, or with PBS alone. CD25⁺Foxp3⁺Thy1.1⁺ Tregs were assessed by flow cytometry in spleen and MLN on day 5.

Western Blot

Detection of Granzyme B in duodenal tissue was performed as described,⁷ using goat anti-Granzyme B (AF1865; R&D Systems). Granzyme B was quantified relative to actin, using a LAS-1000 CCD camera and Image Gauge software (Fujifilm Lifesciences, Bois d'Arcy, France).

Messenger RNA Expression

RNA was purified from duodenal biopsy specimens using an RNeasy Mini kit (Qiagen France S.A.S., Courtaboeuf, France) and reverse-transcribed.¹² Quantitative polymerase chain reaction was performed using TaqMan gene expression assays (Life Technologies). Data were normalized to Hypoxanthine-guanine phosphoribosyltransferase.

IL2 Treatment

B6 and B6 × IL15Tge mice were treated for 5 days by daily intraperitoneal injections of 200,000 IU recombinant human IL2 (rhIL2) (Proleukin, Novartis, France), generously provided by D. Klatzmann (CHU Pitié-Salpêtrière, Paris, France).

Statistical Analysis

Statistical analysis was performed with GraphPad Prism version 6.00 (GraphPad Software, Inc., La Jolla). Weight curves were compared using repeated analysis of variance followed by the Tukey post hoc test. Other comparisons used the Mann-Whitney *U* test. A *P* value less than .05 was considered statistically significant.

Results

Chronic Oral Exposure to OVA Causes Small Intestinal Lesions in OTII × IL15Tge Mice

Whether fed with control diet or OVA diet, OTII × B6 mice showed similar weight gain and a similar villous/crypt length ratio ([Figure 1A and B](#)), indicating that the presence of many CD4⁺ Tregs specific for the dietary antigen ([Supplementary Figure 1A](#)) is not sufficient to induce an enteropathy. In contrast, 3-month-old OTII × IL15Tge mice fed the OVA diet showed slower growth; increased cellularity in LP, epithelium, and submucosa; villous blunting; and crypt elongation in the proximal duodenum ([Figure 1A–F](#) and [Supplementary Figure 2A](#)). Epithelial lesions were patchy and their intensity varied. They were particularly severe in 7 of 11 OVA-fed

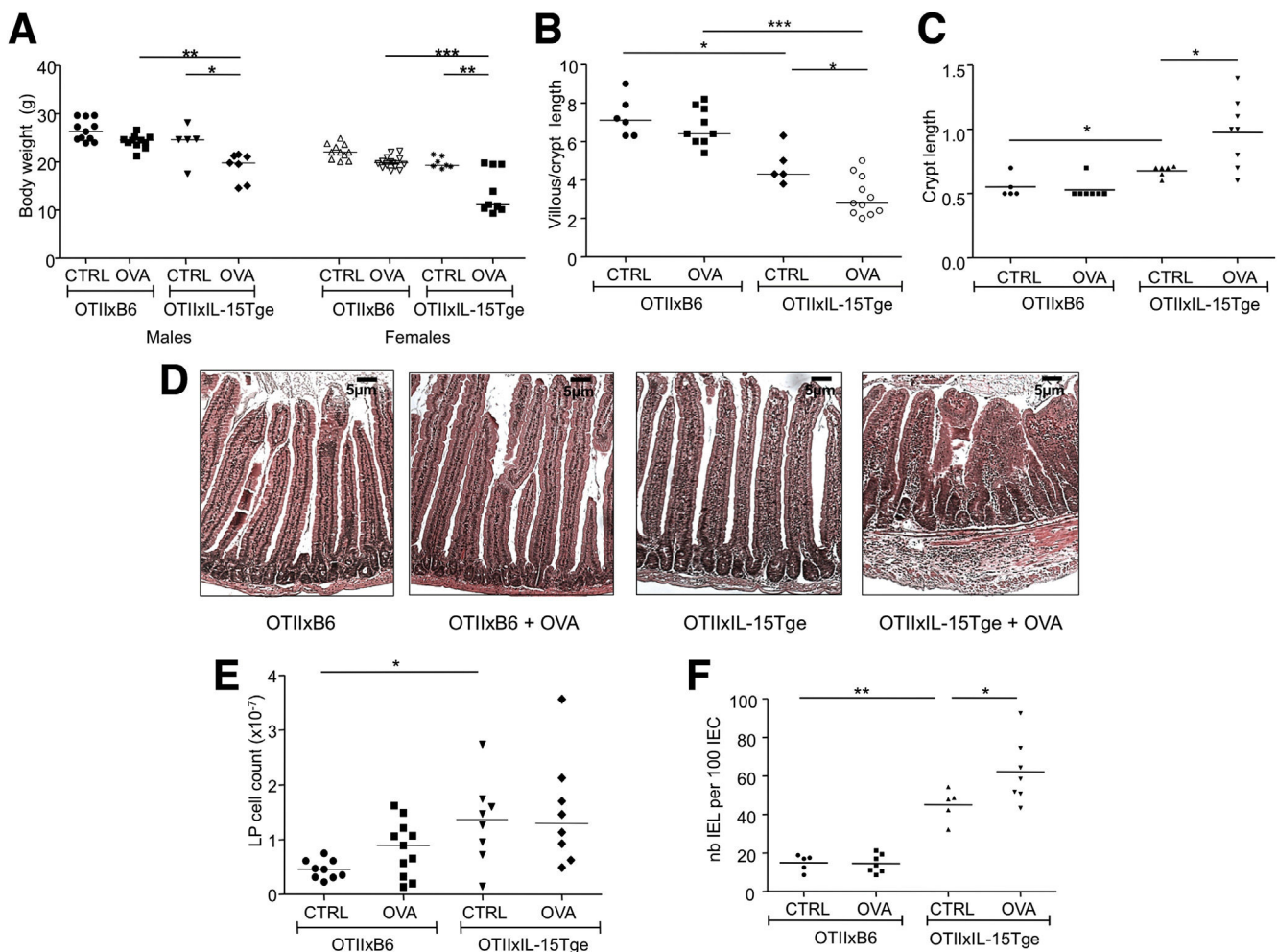

Figure 1. Enteropathy development in OVA-fed OTII \times IL15Tge mice. (A) Comparison of body weight of 3-month-old OTII \times B6 and OTII \times IL15Tge mice fed OVA-containing (OVA) or control (CTRL) diets. Males and females were analyzed separately. (B, C, E, and F) Comparison of (B) villous/crypt length ratio, (C) crypt length, (E) absolute numbers of small intestinal LP cells, and (F) numbers of IELs per 100 intestinal epithelial cells (IECs) between indicated groups of mice. (D) Representative H&E-stained duodenal sections at 3 months in each group. Scale bars: 5 μ m. * P < .05, ** P < .01, *** P < .001.

OTII \times IL15Tge mice, which displayed a hypotonic and enlarged duodenum and severe growth retardation (Figure 1A and Supplementary Figure 2A). Some changes were observed in 3-month-old OTII \times IL15Tge mice on the control diet (Figure 1B, C, E, and F). However, epithelial lesions were mild, and growth was comparable with that of OTII \times B6 littermates. Indeed, in our colony, the spontaneous enteropathy described in B6 \times IL15Tge mice¹¹ was observed only in some mice after 10 months (Supplementary Figure 2B). Overall, these data indicated that IL15 and CD4⁺ T cells activated by the dietary antigen cooperated to induce tissue damage.

Enteropathy Develops in OVA-Fed OTII \times IL15Tge Mice Despite Expansion of Functional OVA-Specific Tregs

Exposure to dietary OVA increased the frequency of activated (CD44^{hi}CD62L^{lo}) OVA-specific V β 5⁺V α 2⁺CD4⁺ T cells in LP, MLN, and spleen (Supplementary Figure 1B), and that of memory (CD44^{hi}CD62L^{hi}) OVA-CD4⁺ T cells in MLN and spleen (Supplementary Figure 1C). There was more increase in OTII \times

IL15Tge mice than in OTII \times B6 mice, indicating that IL15 bolsters the response of CD4⁺ T cells to OVA. T-cell activation, however, was associated with significantly fewer OVA-CD4⁺ T cells in spleen and MLN, likely reflecting activation-induced deletion¹³ (Supplementary Figure 1A). IFN- γ -producing CD4⁺ T cells were increased in OTII \times IL15Tge mice on the control diet compared with OTII \times B6 mice on the control diet. After OVA feeding, they did not increase further except in the spleen of OTII \times IL15Tge mice (Supplementary Figure 3A and B). In contrast, many OVA-CD4⁺ T cells displayed a regulatory phenotype (CD4⁺CD25⁺Foxp3⁺), particularly in OVA-fed OTII \times IL15Tge mice. In these mice, approximately 80% of OVA-CD4⁺ T cells in LP and 20% in MLN and spleen were CD25⁺Foxp3⁺ (Figure 2A). This was surprising because IL15 reportedly impaired the conversion of naive T cells into Tregs.¹⁰ Tregs comprise both natural Tregs generated in the thymus (nTregs) and Tregs induced in the periphery in response to exogenous antigens (iTregs).¹⁴ In OVA-fed OTII \times B6 mice and OTII \times IL15Tge mice, most OVA-specific Tregs in LP showed intracellular expression of Helios, a suggested but equivocal marker of nTregs^{15,16} (Supplementary Figure 4).

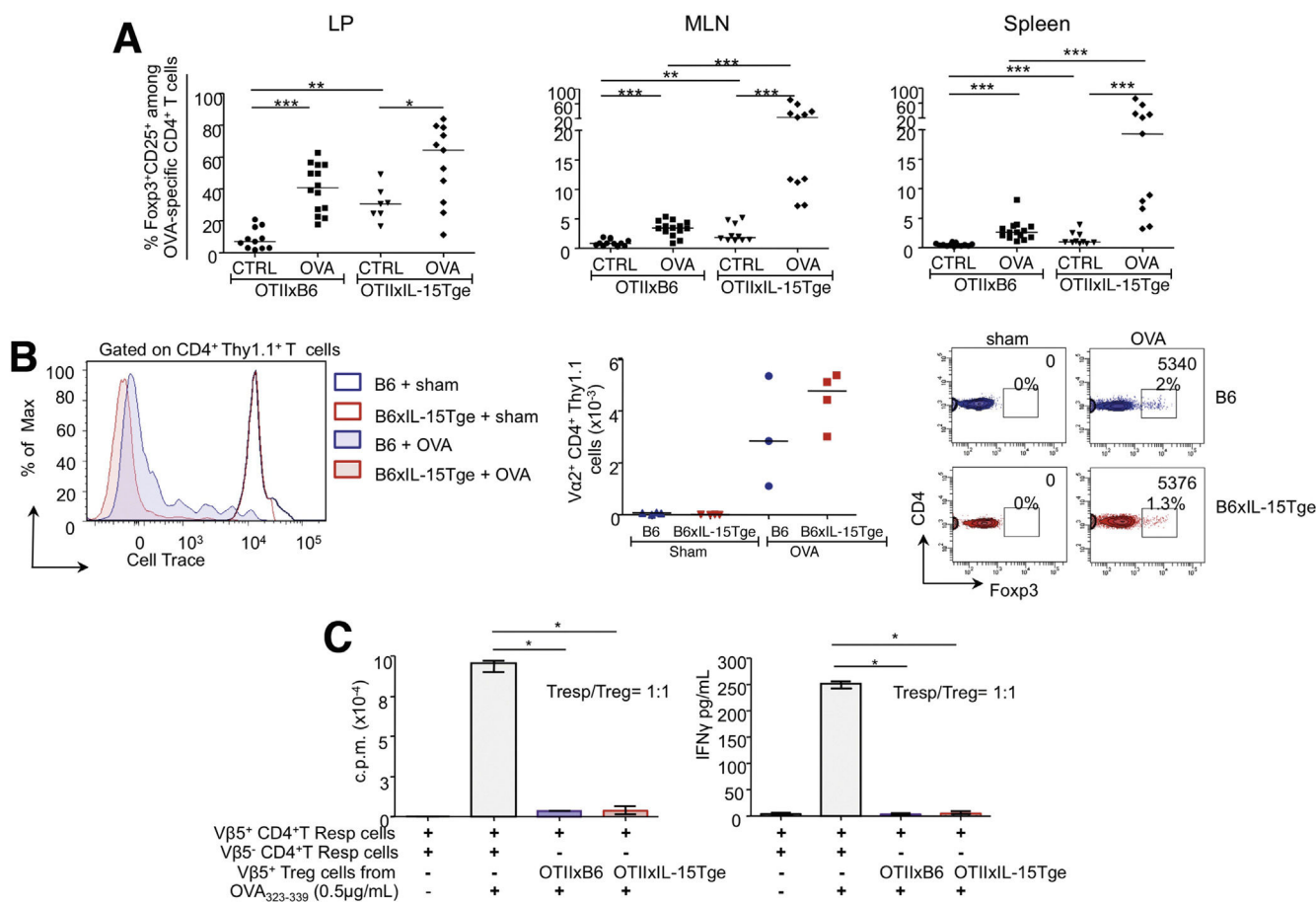

Figure 2. Expansion of functional Tregs in OVA-fed OTII \times IL15Tge mice. (A) Frequencies of Foxp3⁺CD25⁺ cells (Tregs) among OVA-CD4⁺ T cells in LP, MLN, and spleen of OTII \times B6 and OTII \times IL15Tge mice fed with OVA or CTRL diets. (B) *Left panel:* proliferation of OVA-CD4⁺ T cells of donor origin assessed 5 days after adoptive transfer of 8×10^6 Cell Trace-labeled cells from OTII RAG2^{-/-} Thy1.1⁺ mice. Recipient mice were gavaged with 50 mg OVA or PBS (sham) on days 1 and 2 after transfer. *Middle panel:* numbers of induced Foxp3⁺ Tregs among OVA-CD4⁺ T cells of donor origin (Thy1.1) in MLN of B6 or IL15Tge recipients (Thy1.2). Pooled results from 2 independent experiments. *Right panel:* representative dot plots showing percentages and numbers of induced Foxp3⁺ Tregs among OVA-CD4⁺ T cells of donor origin (Thy1.1) in MLN of B6, or of B6 \times IL15Tge recipients (Thy1.2) as indicated. (C) Inhibition of proliferation (*left graph*) and of IFN- γ secretion (*right graph*) of OVA-CD4⁺ responder T cells (V β 5⁺CD4⁺CD25⁺) isolated from control OTII mice by OVA-specific Tregs (V β 5⁺CD4⁺CD25⁺) purified from OVA-fed OTII \times B6 and OTII \times IL15Tge mice. Pooled results from 3 to 4 independent experiments performed in triplicate. Bar graphs show medians \pm range. * $P < .05$, ** $P < .01$, and *** $P < .001$.

Conversion of naive OVA-CD4⁺ T cells into iTreg was therefore tested by transferring CD4⁺ T cells from OTII RAG2^{-/-} Thy1.1 mice (which lack nTregs) into wild-type (WT) B6 or into IL15Tge (Thy1.2) recipient mice. On days 1 and 2 after transfer, mice were gavaged with 50 mg OVA, or with PBS alone. On day 5, OVA-CD4⁺ donor T cells strongly proliferated in OVA-fed mice, but not in sham-fed mice (Figure 2B). OVA-CD4⁺ T cells, of donor origin (Thy1.1⁺V α 2⁺), and with a Treg phenotype, were observed in comparable numbers in MLN of OVA-fed WT mice and OVA-fed IL15Tge mice, but were undetectable in sham-fed mice. Therefore, in OVA-fed OTII \times IL15Tge mice, the increase in Treg numbers may result from expansion of nTregs and also from conversion of naive T cells into iTregs.

In OVA-fed OTII \times IL15Tge mice, the massive expansion of OVA-CD4⁺ T cells with a Treg phenotype contrasted with early onset enteropathy, suggesting that Tregs were not functional. V β 5⁺CD25⁺CD4⁺ T cells therefore were purified from MLN and spleen and their immunosuppressive function

was tested against spleen V β 5⁺CD25⁺CD4⁺ responder T cell (Tresp) stimulated with OVA₃₂₃₋₃₃₉ peptide. As shown in Figure 2C, V β 5⁺CD25⁺ Tregs from OVA-fed OTII \times B6 mice and from OVA-fed OTII \times IL15Tge mice, at a 1:1 Tresp/Treg ratio, completely blocked proliferation and IFN- γ production. At a 2:1 Tresp/Treg ratio, inhibition of proliferation by Tregs from OTII \times IL15Tge mice was more potent than inhibition by Tregs from OTII \times B6 controls, indicating that IL15 does not impair but stimulates Treg function (Supplementary Figure 5).

In OTII \times IL15Tge Mice, the OVA Diet Promotes a Massive Expansion of CD8⁺ T Cells Expressing Granzyme B

In OTII \times IL15Tge mice, in duodenum, interferon gamma transcripts were strongly up-regulated (not shown) and there were more IFN- γ -producing CD8⁺ T cells in LP, MLN,

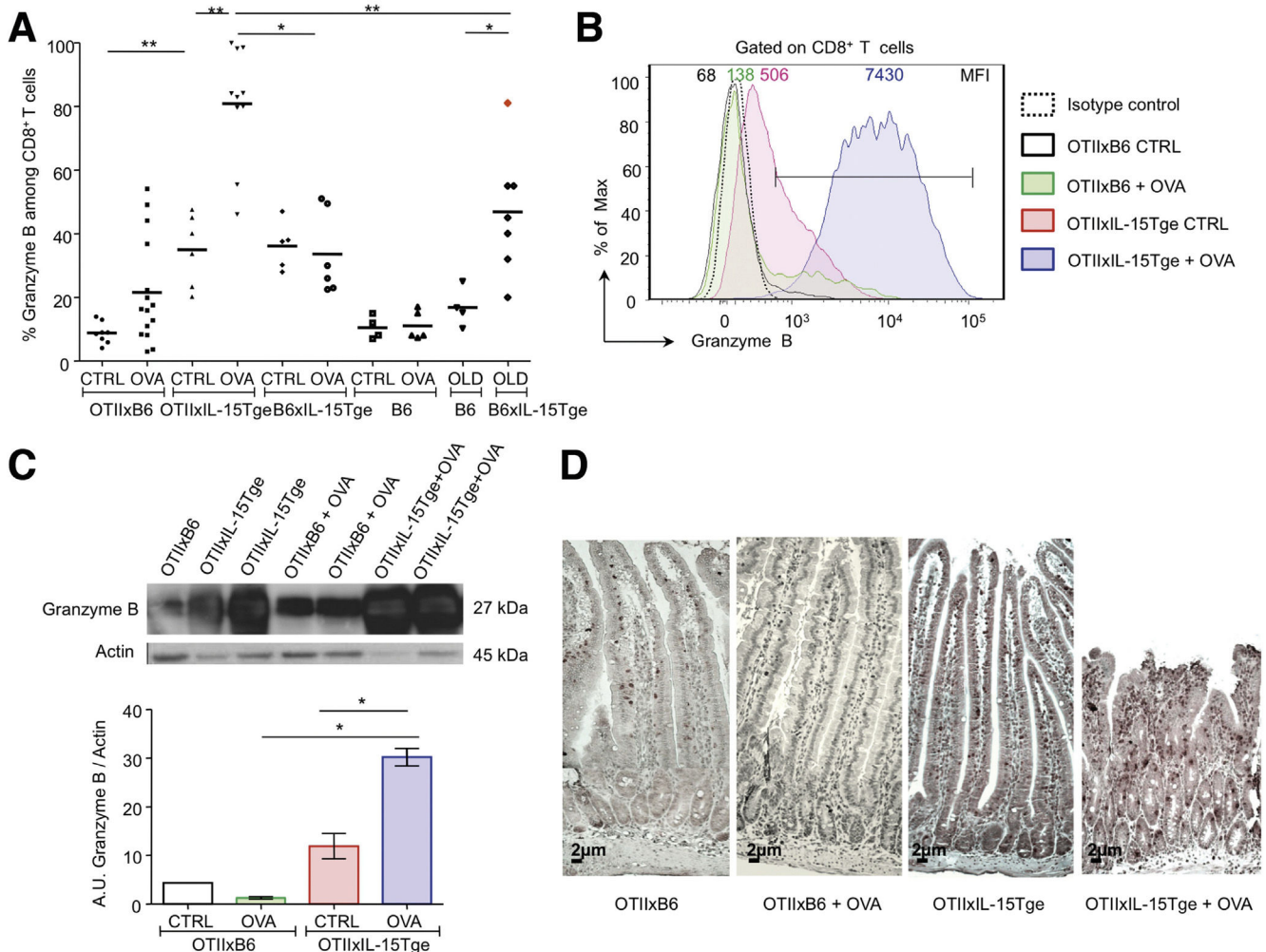

Figure 3. Expansion of Granzyme B⁺ CD8⁺ T cells in OVA-fed OTII × IL15Tge mice. (A) Frequency of LP Granzyme B–producing CD8⁺ T cells in 3-month-old OTII × B6, OTII × IL15Tge, B6, and B6 × IL15Tge mice fed with OVA or control (CTRL) diets and in old B6 or B6 × IL15Tge mice (≥10 mo) on a CTRL diet. Red dot indicates the old B6 × IL15Tge mouse with enteropathy. (B) Granzyme B intracellular staining of LP CD8⁺ T cells in 1 representative experiment of 3 experiments. Mean fluorescent intensities are shown. (C) Western blot detection of Granzyme B in duodenal biopsy specimens of indicated mice. Granzyme B/actin ratios (arbitrary units [AU]) are shown. (D) Immunohistochemical staining of Granzyme B on paraffin duodenal sections of indicated mice. Scale bar: 2 μm. **P* < .05, ***P* < .01, and ****P* < .001.

and spleen than in OTII × B6 controls. Absolute numbers of natural killer cells also were increased in spleen, LP, and epithelium of OTII × IL15Tge mice compared with OTII × B6 littermates. These changes, however, were independent of diet (Supplementary Figures 6 and 7). In contrast, CD8⁺ T cells expressing Granzyme B were not only more numerous in LP of control diet OTII × IL15Tge mice than of OTII × B6 mice, but they increased further after OVA feeding (Figure 3A), and flow cytometry showed their enhanced content in Granzyme B (Figure 3B). These results were confirmed in duodenal biopsy specimens by Western blot (Figure 3C). In addition, immunohistochemistry showed many Granzyme B⁺ cells close to epithelial lesions in OVA-fed OTII × IL15Tge mice (Figure 3D). Granzyme-B⁺ CD8⁺ T cells were more numerous in the LP of 3-month-old B6 × IL15Tge mice than of B6 littermates, but frequency was comparable in mice fed control or OVA-containing diet (Figure 3A). Overall, these results suggested that IL15 and

activated OVA-CD4⁺ T cells cooperated to expand intestinal cytotoxic CD8⁺ T cells. In B6 × IL15Tge mice, the frequency of LP Granzyme B⁺ CD8⁺ T cells was the same at 3 months and 10 months, except in 1 old mouse displaying duodenal epithelial lesions and massive IEL infiltration, further implying a link between Granzyme B⁺ cells and enteropathy (Figure 3A and not shown).

IL15 Renders CD8⁺ T Cells Less Sensitive to Immunosuppression by Tregs

In OVA-fed OTII × IL15Tge mice, the up-regulation of Granzyme B in LP CD8⁺ T cells after OVA feeding, and the expansion of functional OVA-specific Tregs, seemed contradictory. This result, together with the expansion of effector CD4⁺ and CD8⁺ T cells observed in the same mice regardless of diet, suggested that effector cells exposed to IL15 might escape Treg control. This hypothesis was consistent with our

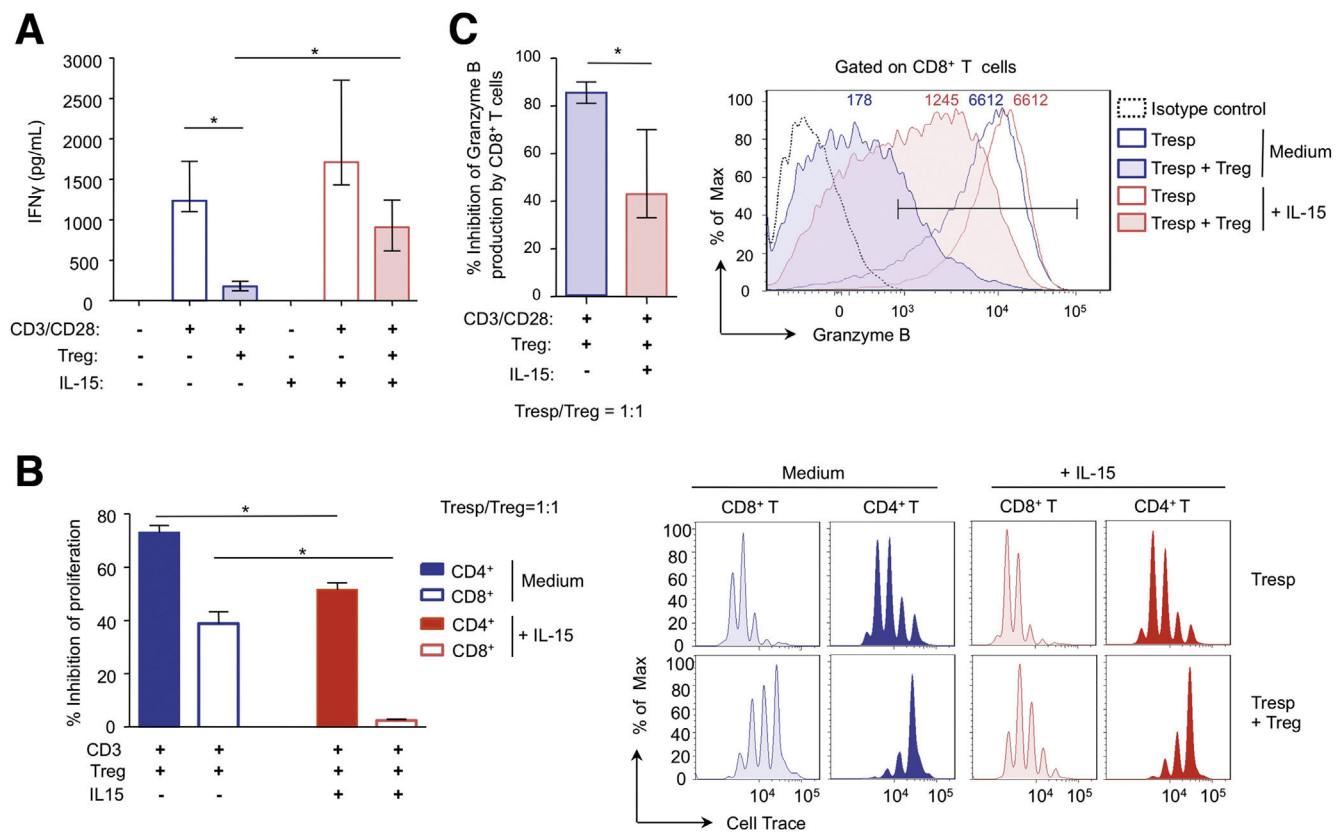

Figure 4. Impaired response of CD8⁺ T effector cells to Tregs in the presence of IL15. (A–C) Cell Trace–labeled CD45⁺CD25⁻ spleen cells from B6 mice (responder cells [Tresp]) were co-cultured at a 1:1 ratio with unlabeled CD45⁺CD25⁺ B6 spleen cells (>90% CD4⁺, Tregs) or unlabeled CD45⁺CD25⁻ spleen cells for control and stimulated with 0.2 μ g/mL (A and C) soluble anti-CD3/CD28 or (B) anti-CD3 alone in the presence or absence of 20 ng/mL human IL15. (A) Inhibition of IFN- γ secretion by Tregs determined by enzyme-linked immunosorbent assay in culture supernatants after 48 hours. (B) Proliferation was determined by dilution of Cell Trace in CD4⁺ and CD8⁺ TL cells after 48 hours. *Left panel*: percentage of inhibition of proliferation of responder cells in the presence of Tregs compared with control co-cultures. Results are pooled from 4 independent experiments. *Right panel*: analysis of proliferation in 1 representative experiment. (C) Granzyme B staining of Cell Trace–labeled responder CD8⁺ TLs after a 48-hour culture. *Left graph*: percentages of inhibition of Granzyme B expression in CD8⁺ TL by Tregs. *Right graph*: Granzyme B staining in indicated conditions in 1 representative experiment. Bar graphs show medians \pm range. Results are pooled from 4 independent experiments. * $P < .05$.

in vitro observations showing that, IL15 partially reversed Treg-mediated inhibition of proliferation and IFN- γ production (Figure 4A and B). In keeping with the known selective effect of IL15 on CD8⁺ TLs, and with the preferential in vivo expansion of activated CD8⁺ TLs in OTII \times IL15Tge mice, reversal of Treg-mediated inhibition by IL15 was more efficacious in CD8⁺ than in CD4⁺ TLs. IL15 also weakened the inhibition exerted by Tregs on Granzyme B induction in spleen CD8⁺ TLs stimulated by CD3 mAb (Figure 4C), further suggesting that cytotoxic CD8⁺ TLs can escape Treg control in OTII \times IL15Tge mice.

IL15 and OVA-Specific CD4⁺ T Cells Synergize to Stimulate T-Cell Receptor–Independent Activation of Granzyme B⁺ Cytotoxic CD8⁺ T Cells

In B6 mice, OVA immunization can stimulate specific CD8⁺ TLs directed against a dominant OVA_{257–263} epitope presented by MHC class I H2-K^b.¹⁷ However, we observed that the presence of OVA in the diet did not change

the numbers of CD8⁺ TLs stained with high-avidity H2-K^b/OVA_{257–263} dextramers in the epithelium, LP, MLN, and spleen of OTII \times B6 or OTII \times IL15Tge mice (Supplementary Figure 8). In addition, LP lymphocytes from OVA-fed OTII \times B6 or OTII \times IL15Tge mice also failed to proliferate when stimulated by the dominant MHC class I OVA_{257–263} peptide, even in the presence of IL15 (Figure 5A). In contrast, both CD4⁺ and CD8⁺ LP TLs proliferated in response to OVA protein and, strikingly, even more in response to the MHC class II restricted OVA_{323–339} peptide, the cognate target of OVA-CD4⁺ TLs (Figure 5A). Of note, CD4⁺ TLs proliferated in response to OVA and OVA_{323–339} peptide, without IL15 (data not shown), whereas CD8⁺ TLs only proliferated when OVA-CD4⁺ TLs and IL15 were added to the cultures (Figure 5A). Overall, these results suggested that IL15 and OVA-CD4⁺ TLs synergized to activate non-cognate LP CD8⁺ TLs.

To further confirm these results, CD8⁺ TLs expressing a single T-cell receptor (TCR) specific for the MHC class I-restricted OVA_{257–263} epitope were purified from OTI RAG2^{-/-} mice and cultured with B6 DCs and IL15 with or

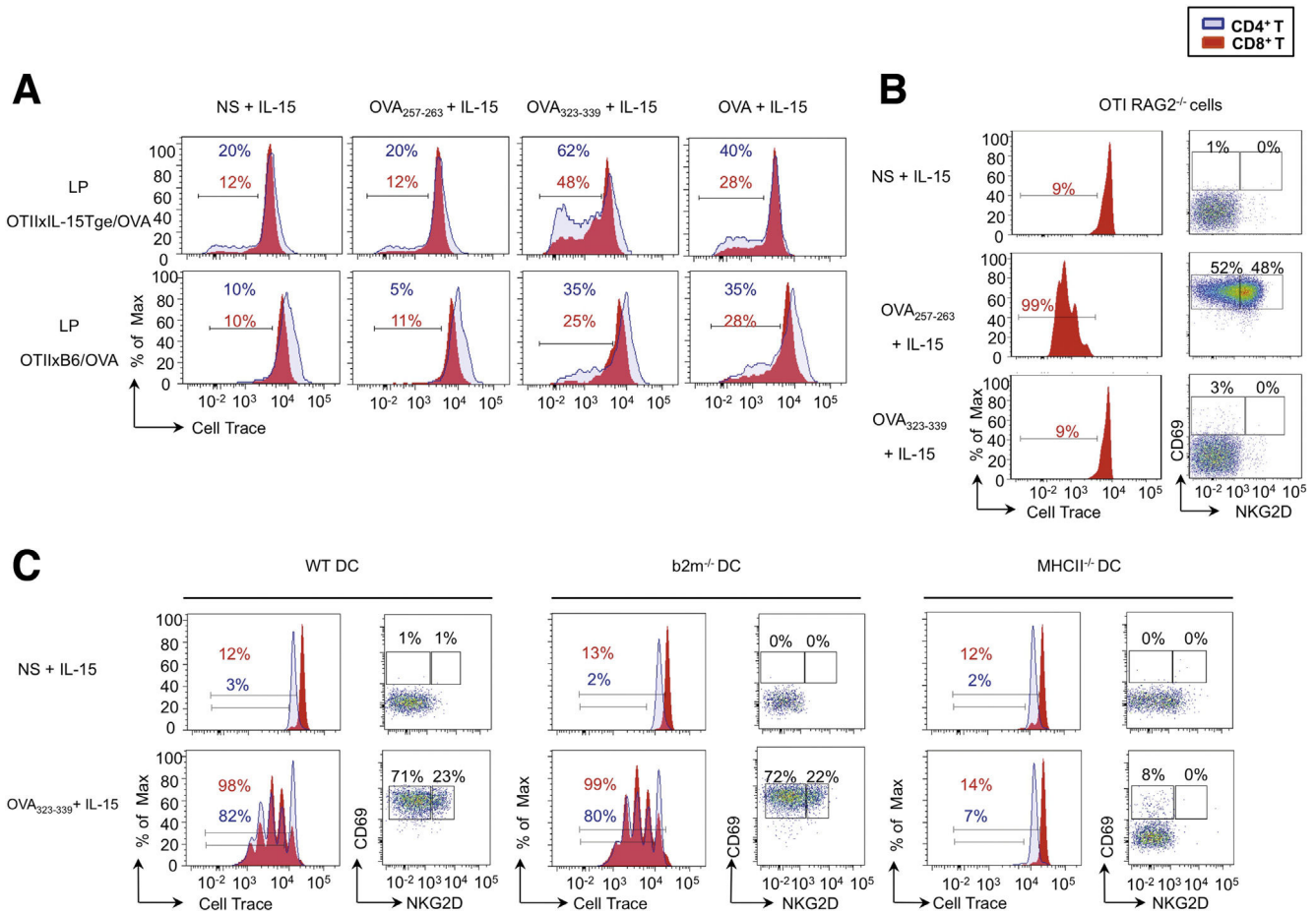

Figure 5. Activation of noncognate CD8⁺ T cells through cooperation between OVA-CD4⁺ T cells and IL15. (A) Flow cytometry analysis of Cell Trace–stained LP cells from OVA-fed OTII × IL15Tge mice or OTII × B6 mice, stimulated with OVA₂₅₇₋₂₆₃ (2 μg/mL) peptide, OVA₃₂₃₋₃₃₉ (2 μg/mL) peptide, or OVA protein (400 μg/mL) in the presence of IL15 (20 ng/mL) for 96 hours. (B) Proliferation (left panel) and CD69 and NKG2D expression (right panel) of Cell Trace–stained CD8⁺ TLs from OTI RAG2^{-/-} mice after a 72-hour stimulation with OVA₂₅₇₋₂₆₃ peptide (2 μg/mL) or OVA₃₂₃₋₃₃₉ (2 μg/mL) peptide, in the presence of IL15 (20 ng/mL). (C) Proliferation of CD4⁺ and CD8⁺ TLs and CD69 and NKG2D expression by CD8⁺ TLs after 72 hours co-culture of Cell Trace–stained CD4⁺ TLs from OTII RAG2^{-/-} mice, and CD8⁺ TLs from OTI RAG2^{-/-} mice, stimulated by OVA₃₂₃₋₃₃₉ peptide (2 μg/mL) plus IL15 (20 ng/mL); and either WT, major histocompatibility complex class I-deficient (b2m^{-/-}), or major histocompatibility complex class II-deficient (MHCII^{-/-}) DCs. One representative experiment of 3–4 independent experiments is shown. Blue histograms, CD4⁺ TLs; red full histograms, CD8⁺ TLs.

without CD4⁺ TLs from OTII RAG2^{-/-} mice. These mice have a single TCR specific for the MHC class II–restricted OVA₃₂₃₋₃₃₉ epitope. OTI-derived CD8⁺ TL alone did not respond to the OVA₃₂₃₋₃₃₉ peptide (Figure 5B), but they did respond when added with OVA-CD4⁺ TLs (Figure 5C). Furthermore, activation of OTI-derived CD8⁺ TLs was comparable in the presence of DCs from WT mice, or from MHC class I-deficient (b2m^{-/-}) mice, but was abolished when DCs derived from MHC class II-deficient mice. This confirmed that, in the presence of IL15, CD4⁺ TLs stimulated by their cognate antigen could activate CD8⁺ TLs without engaging their TCR (Figure 5C).

To extend these results to normal CD8⁺ TLs with a polyclonal repertoire, naive (CD62^{hi}CD44^{lo}) CD8⁺ TLs were purified from spleen and effector/memory (CD62^{lo}CD44^{hi}) CD8⁺ TLs from small intestinal LP and epithelium of B6 mice that had never been exposed to OVA. Then the CD8⁺ TLs were mixed with B6 DCs and OVA-specific CD4⁺ TLs

from OTII RAG2^{-/-} mice, and stimulated with OVA₃₂₃₋₃₃₉ peptide or with OVA protein. No proliferation was observed in spleen CD8⁺ TLs (Supplementary Figure 9). In contrast CD8⁺ TLs derived from LP (not shown) and from epithelium (Figure 6A), proliferated when co-cultured with activated OVA-CD4⁺ TLs and IL15. Such in vitro-activated intestinal CD8⁺ TLs showed a moderate increase in the expression of the Natural killer group 2, member D (NKG2D) expression, but they strongly up-regulated intracellular Granzyme B (Figure 6A and not shown). Accordingly, they showed more degranulation in response to CD3 stimulation than CD8⁺ TLs cultured without CD4⁺ TLs (Figure 6B and not shown). Overall, these results indicated that, in the presence of IL15, OVA-CD4⁺ TLs can provide noncognate help to intestinal CD8⁺ TLs that stimulates their expansion and cytotoxicity, irrespective of their specificity. These in vitro results were in keeping with vivo observations in OVA-fed OTII × IL15Tge mice, in which LP CD8⁺ TLs lacking any reactivity

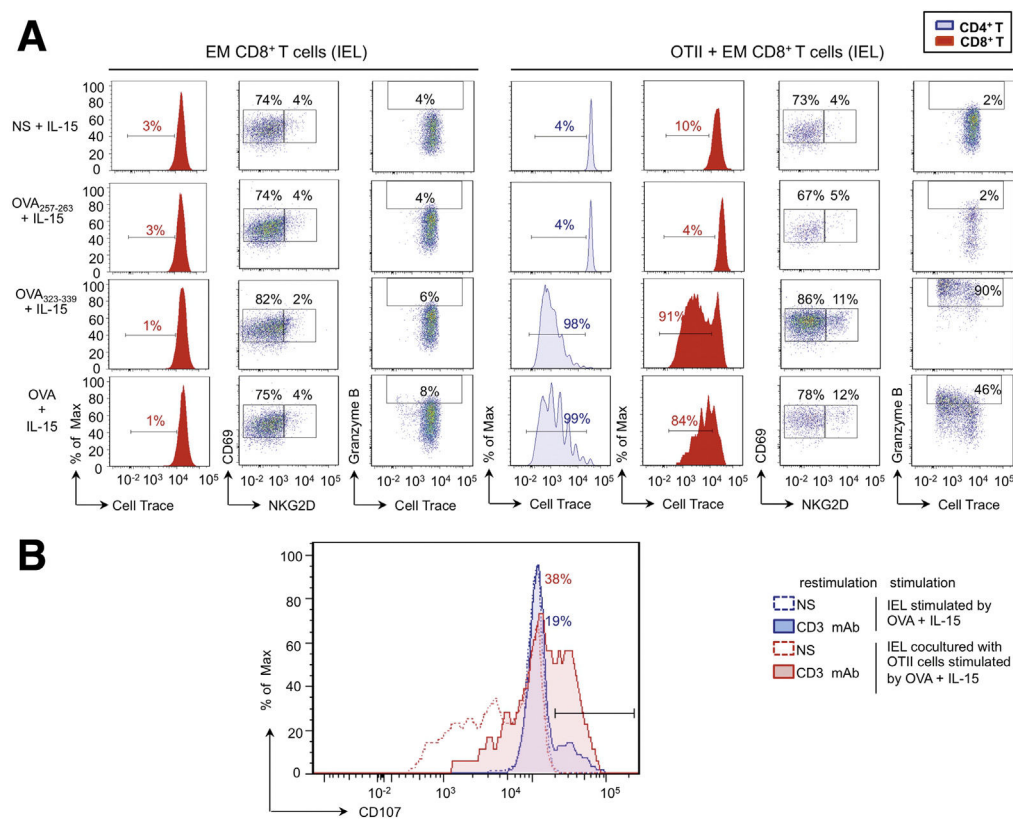

Figure 6. Activation of cytotoxic CD8⁺ T-IELs through cooperation between OVA-CD4⁺ T cells and IL15. Proliferation and expression of Granzyme B, CD69, and NKG2D in B6-derived CD8⁺ T-IELs after 96 hours of stimulation with OVA₂₅₇₋₂₆₃ peptide (2 μg/mL), OVA₃₂₃₋₃₃₉ (2 μg/mL) peptide, or OVA protein (400 μg/mL), and 20 ng/mL IL15 in the absence (*left panel*) or presence of CD4⁺ T cells from OTII RAG2^{-/-} mice (*right panel*). The threshold for Granzyme B staining was set on nonstimulated cells. (*B*) CD107a staining of IELs activated as in panel A and stimulated by CD3 mAb (1 μg/mL) for 4 hours. One representative of 3 independent experiments is shown.

against OVA showed moderate NKG2D expression, but massive amounts of Granzyme B (Figure 3A and Supplementary Figures 8 and 10).

CD4 Help to Cytotoxic CD8⁺ T Cells Depends on OVA-Induced IL2 Secretion

We next examined the mechanism of CD4 help. Suggesting the role of a soluble factor, Granzyme B⁺ CD8⁺ T cells (from OTI RAG2^{-/-} mice) were comparably activated whether cultured in contact with OVA-stimulated CD4⁺ T cells or cultured separately with the latter cells by a Transwell membrane (Corning Costar, Sigma Aldrich, Lyon, France) (Supplementary Figure 11). In addition, supernatants of OVA₃₂₃₋₃₃₉-stimulated CD4⁺ T cells from OTII RAG2^{-/-} mice activated both OTI Rag^{-/-}-derived CD8⁺ T cells and B6-derived IELs (Figure 7A and Supplementary Figure 12). Finally, help delivered by supernatants depended, as did CD4 help, on the presence of IL15 (not shown). One soluble factor that can mediate CD4 help is IL2.¹⁸ Consistent with this hypothesis, proliferation and up-regulation of CD69 and Granzyme B in CD8⁺ T cells were abrogated when supernatants were depleted of IL2 (Figure 7A and Supplementary Figure 12), and induced when supernatants were replaced by rhIL2 (not shown).

The hypothesis that IL2 mediates CD4 help and synergizes with IL15 *in vivo* in our model was supported by 2 pieces of evidence. First, *Il2* transcripts were increased significantly in the duodenum of OTII × IL15Tge mice on the

OVA diet, compared with mice on a control diet (Figure 7B). Second, in 4-month-old B6 × IL15Tge mice but not in age-matched B6 mice, intraperitoneal injections of rhIL2 for 5 days reduced the villous/crypt length ratio and increased the number of Granzyme B⁺ IELs (Figure 7C-E). Intestinal changes occurred despite expansion of Tregs, confirming that IL15 interferes with Treg-mediated suppression (Supplementary Figure 13). Interestingly, *Il2* messenger RNA tended to increase with age in the duodenum of B6 × IL15Tge mice. It was particularly increased in a 10-month-old B6 × IL15Tge mouse that developed epithelial damage (Figure 7B), suggesting that, in these mice, accumulation of IL2-producing CD4⁺ T cells also participates in enteropathy.

Discussion

Herein we show that, when mice are chronically exposed to OVA in their diet, IL15 and OVA-specific CD4⁺ T cells cooperate to induce gut damage. Confirming that the presence of numerous cognate CD4⁺ T cells cannot by itself break immune tolerance to a food protein,¹⁹ feeding large doses of OVA to OTII × B6 mice with transgenic OVA-CD4⁺ T cells did not induce enteropathy. In contrast, in OTII × IL15Tge mice, chronic exposure to OVA diet led to growth retardation and enteropathy, which was characterized, as in CD, by patchy lesions of villous blunting in the duodenum. The spontaneous enteropathy previously described in mice overexpressing IL15 in the gut epithelium¹¹ did not develop in our colony before 10 months. Thus, at 3 months of age,

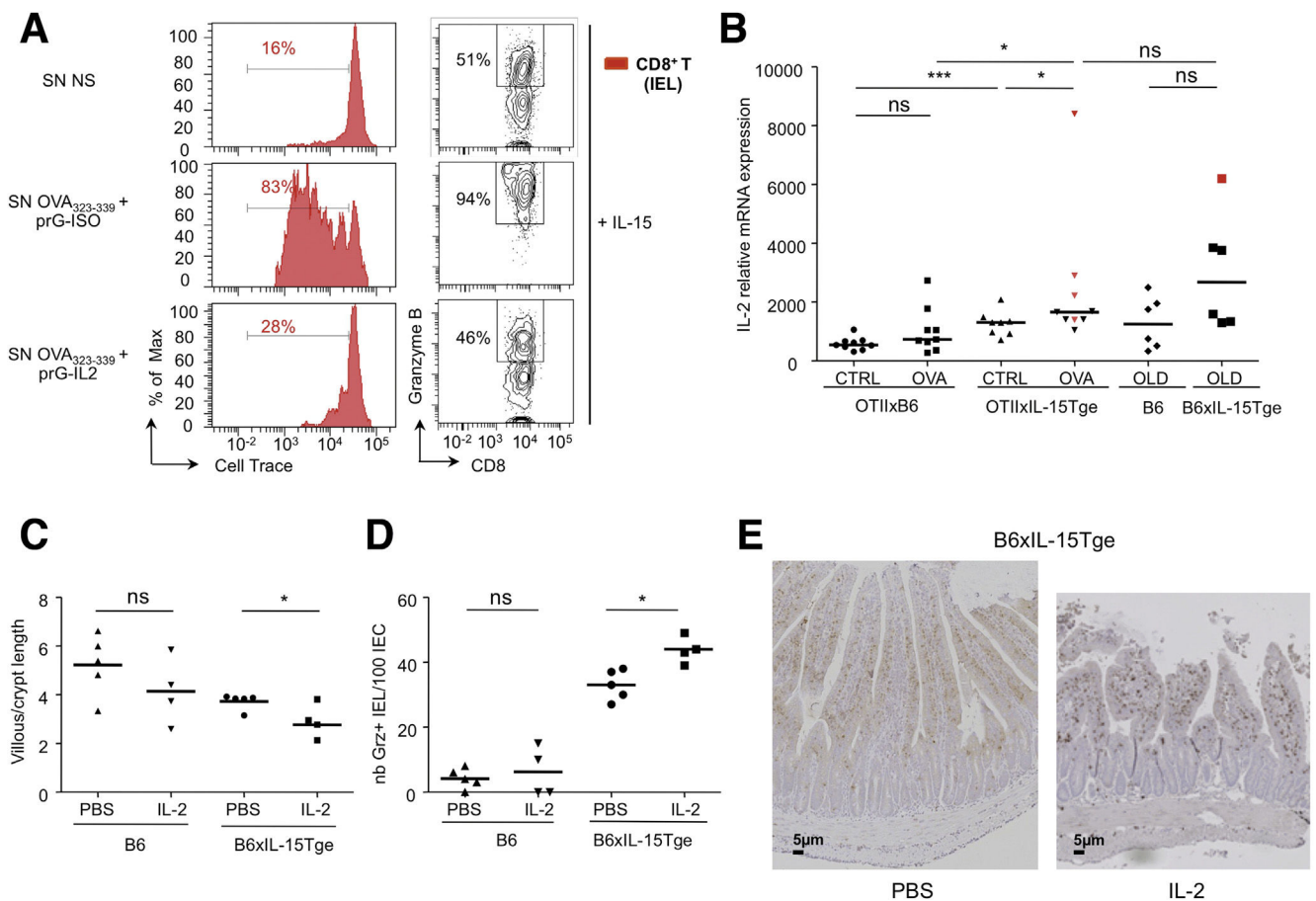

Figure 7. Expansion of cytotoxic CD8⁺ T cells through synergy between IL2 and IL15. (A) Proliferation and Granzyme B expression of CD8⁺ T-IELs after 96 hours of culture with IL15 (20 ng/mL), and supernatants of OVA-CD4⁺ TLs stimulated by OVA₃₂₃₋₃₃₉ (2 μg/mL), with or without IL2 depletion. One representative experiment of 3 independent experiments is shown. (B) *Ii2* messenger RNA (mRNA) expression normalized to *Hrpt1* mRNA in 3-month-old OTII × B6 and OTII × IL15Tge mice fed OVA or CTRL diets; and in old B6 or B6 × IL15Tge mice (≥10 mo) on a CTRL diet. Red dots indicate mice with enteropathy. (C and D) Comparison of (C) villous/crypt length ratios and (D) number of IELs per 100 intestinal epithelial cells (IECs) in B6 and B6 × IL15Tge mice after intraperitoneal injections of rhIL2 (200,000 IU/day) or PBS for 5 days. (E) Immunohistochemical staining of Granzyme B in paraffin duodenal sections of B6 × IL15Tge mice treated with rhIL2 or PBS. **P* < .05, ****P* < .001

epithelial lesions remained very mild, both in OTII × IL15Tge mice fed a control diet, and in B6 × IL15Tge mice fed an OVA diet. This indicates that IL15 and activated CD4⁺ TLs must interact to break local immune tolerance and to induce intestinal tissue damage. In OTII × IL15Tge mice, OVA diet accelerates the accumulation of intestinal activated CD4⁺ TLs and, thereby, the onset of enteropathy.

In OVA-fed OTII × IL15Tge mice, epithelial damage was associated with an increase in Granzyme B⁺ CD8⁺ TLs, in both epithelium and LP, despite a massive expansion in functional OVA-specific Tregs. This situation resembles CD, in which epithelial lesions are thought to depend on cytotoxic CD8⁺ TLs and also occur despite the presence of many Tregs in LP.^{9,20} Consistent with previous results in human beings,^{8,9} IL15 reduced the in vitro immunosuppression of effector T cells by Tregs, resulting in impaired control of IFN-γ and Granzyme B production. In vivo, more IFN-γ-producing CD4⁺ and CD8⁺ TLs were seen in the intestine and in the periphery of OTII × IL15Tge mice, regardless of diet. OVA feeding significantly increased IFN-γ-producing OVA-specific TLs in spleen, but not in MLN and intestine.

These results are consistent with the loss of peripheral tolerance already described in mice overexpressing IL15,¹¹ but suggest that IFN-γ-producing OVA-specific TL cells are not sufficient to cause epithelial damage. In contrast, Granzyme B⁺ CD8⁺ TLs, already increased in mice fed a control diet, further increased in OVA-fed mice.

The intestinal CD8⁺ TLs, which expanded in response to OVA feeding, were not directed against the dietary antigen. Thus, no reactivity could be shown against the dominant H2-K^b-restricted epitope OVA₂₅₇₋₂₆₃, using either high-avidity dextramers or proliferation tests. In CD, whether CD8⁺ TLs react against gluten-derived peptides is debated (reviewed by Meresse et al²). Results in this mouse model may not be directly translatable to CD. Nevertheless, they show that intestinal cytotoxic CD8⁺ TLs can expand independently of cognate TCR recognition of antigen in the diet. Moreover, our in vitro data indicate that cooperation between IL15 and IL2 released by CD4⁺ TLs activated by the dietary antigen is necessary and sufficient to stimulate cytotoxic CD8⁺ TLs independently of their antigen specificity. The synergistic effect of IL2 and IL15 was

restricted to memory/effector CD8⁺ T_H1s and was not observed in naive CD8⁺ T_H1s. This mechanism is thus not sufficient to activate naive CD8⁺ T_H1s, but may rapidly mobilize many effector CD8⁺ T_H1s at tissue sites independently of their specificity. Suggesting that this mechanism may operate in vivo in our model, *Il2* messenger RNA was enhanced significantly in the duodenum of OVA-fed OTII × IL15Tge compared with mice fed a control diet. Moreover, injection of IL2 into B6 × IL15Tge but not into WT B6 mice increased Granzyme B⁺ CD8⁺ IELs, and resulted in villous shortening. As expected, in vivo injection of IL2 induced an expansion of Tregs.²¹ However, as discussed earlier, IL15 may stop Tregs from controlling effector T cells, notably CD8⁺. The molecular mechanism(s) underlying the synergistic effects of IL2 and IL15 remain to be deciphered. Signals delivered to lymphocytes by IL2 and IL15 are overlapping because their receptors share 2 chains, which form a signaling module. However, differences in downstream signaling events have been reported both in vitro^{22,23} and in vivo.²⁴ Interestingly, a polymorphism in the *IL2/IL21* locus²⁵ conferred increased risk for CD and type I diabetes in human beings and in non-obese diabetic mice.²⁶ How this polymorphism affects the expression of either cytokine remains unclear in human beings. In human CD, IL21 is produced by gluten-activated CD4⁺ T_H1s (reviewed by Meresse et al²). In our mice, we did not observe any significant IL21 production (not shown). IL21, able to synergize with IL15 to expand cytotoxic CD8⁺ T_H1s,²⁷ may play a similar or complementary role to IL2 in human CD.

In CD, cytotoxic CD8⁺ T_H1s are thought to induce epithelial lesions, although the exact mechanism that triggers their cytotoxicity remains under discussion. Signals via activating natural killer receptors such as NKG2D were notably shown to stimulate the degranulation of human CD8⁺ T IELs independently of their specificity.⁶ In contrast with human CD8⁺ T_H1s, mouse CD8⁺ T_H1s do not constitutively express NKG2D and only 10%–20% of intestinal CD8⁺ T_H1s expressed NKG2D in OVA-fed OTII × B6 or OTII × IL15Tge mice. Similarly, 10%–20% of intestinal CD8⁺ T_H1s stimulated in vitro by OVA-stimulated CD4⁺ T_H1s and IL15 expressed NKG2D. In the latter CD8⁺ T_H1s, degranulation could be induced by a CD3 antibody used to mimic TCR stimulation (Figure 7) but not by an NKG2D antibody (data not shown). We do not exclude that in vitro conditions were not adequate to show activation via NKG2D and that this receptor plays a role in vivo. Thus, its ligand Rae-1e was detected by Western blot in intestinal tissue in all groups of mice (Supplementary Figure 14). Alternatively, degranulation of intestinal cytotoxic CD8⁺ T_H1s might be triggered via their TCR. In our model, intestinal memory/effector CD8⁺ T_H1s expanded and acquired Granzyme B regardless of their specificity. However, effector T_H1s migrate into the intestine only after a step of activation by cognate antigens in gut-associated lymphoid organs. A re-encounter with the same exogenous or perhaps also self-antigens in the small intestine might trigger their degranulation and induce tissue damage. This hypothesis, however, needs to be substantiated by further studies.

In conclusion, this study in a mouse model shows that interactions between IL15, produced in excess in the intestine, and CD4⁺ T_H1s, chronically activated by a dietary antigen, are necessary and sufficient to stimulate the expansion of intestinal cytotoxic effector CD8⁺ T_H1s, and to induce intestinal damage. A comparable scenario, illustrated in Supplementary Figure 15, may operate in celiac disease. Deciphering the mechanisms that control intestinal expression of IL15 in celiac patients may help to prevent disease in HLA-DQ2/8 individuals who are predisposed to develop gluten-specific CD4⁺ T_H1s.

Supplementary Material

Note: To access the supplementary material accompanying this article, visit the online version of *Gastroenterology* at www.gastrojournal.org, and at <http://dx.doi.org/10.1053/j.gastro.2013.12.023>.

References

1. Pabst O, Mowat AM. Oral tolerance to food protein. *Mucosal Immunol* 2012;5:232–239.
2. Meresse B, Malamut G, Cerf-Bensussan N. Celiac disease: an immunological jigsaw. *Immunity* 2012;36:907–919.
3. Di Sabatino A, Ciccocioppo R, Cupelli F, et al. Epithelium derived interleukin 15 regulates intraepithelial lymphocyte Th1 cytokine production, cytotoxicity, and survival in coeliac disease. *Gut* 2006;55:469–477.
4. Hue S, Mention JJ, Monteiro RC, et al. A direct role for NKG2D/MICA interaction in villous atrophy during celiac disease. *Immunity* 2004;21:367–377.
5. Mention JJ, Ben Ahmed M, Begue B, et al. Interleukin 15: a key to disrupted intraepithelial lymphocyte homeostasis and lymphomagenesis in celiac disease. *Gastroenterology* 2003;125:730–745.
6. Meresse B, Chen Z, Ciszewski C, et al. Coordinated induction by IL15 of a TCR-independent NKG2D signaling pathway converts CTL into lymphokine-activated killer cells in celiac disease. *Immunity* 2004;21:357–366.
7. Benahmed M, Meresse B, Arnulf B, et al. Inhibition of TGF-beta signaling by IL-15: a new role for IL-15 in the loss of immune homeostasis in celiac disease. *Gastroenterology* 2007;132:994–1008.
8. Ben Ahmed M, Belhadj Hmidia N, Moes N, et al. IL-15 renders conventional lymphocytes resistant to suppressive functions of regulatory T cells through activation of the phosphatidylinositol 3-kinase pathway. *J Immunol* 2009;182:6763–6770.
9. Zanzi D, Stefanile R, Santagata S, et al. IL-15 interferes with suppressive activity of intestinal regulatory T cells expanded in celiac disease. *Am J Gastroenterol* 2011;106:1308–1317.
10. DePaolo RW, Abadie V, Tang F, et al. Co-adjuvant effects of retinoic acid and IL-15 induce inflammatory immunity to dietary antigens. *Nature* 2011;471:220–224.
11. Ohta N, Hiroi T, Kweon MN, et al. IL-15-dependent activation-induced cell death-resistant Th1 type CD8 alpha beta+ NK1.1+ T cells for the development of small intestinal inflammation. *J Immunol* 2002;169:460–468.

12. Gaboriau-Routhiau V, Rakotobe S, Lecuyer E, et al. The key role of segmented filamentous bacteria in the coordinated maturation of gut helper T cell responses. *Immunity* 2009;31:677–689.
13. Chen Y, Inobe J, Marks R, et al. Peripheral deletion of antigen-reactive T cells in oral tolerance. *Nature* 1995;376:177–180.
14. Bilate AM, Lafaille JJ. Induced CD4⁺Foxp3⁺ regulatory T cells in immune tolerance. *Annu Rev Immunol* 2012;30:733–758.
15. Akimova T, Beier UH, Wang L, et al. Helios expression is a marker of T cell activation and proliferation. *PLoS One* 2011;6:e24226.
16. Thornton AM, Korty PE, Tran DQ, et al. Expression of Helios, an Ikaros transcription factor family member, differentiates thymic-derived from peripherally induced Foxp3⁺ T regulatory cells. *J Immunol* 2010;184:3433–3441.
17. Plumlee CR, Sheridan BS, Cicek BB, et al. Environmental cues dictate the fate of individual CD8⁺ T cells responding to infection. *Immunity* 2013;39:347–356.
18. Keene JA, Forman J. Helper activity is required for the *in vivo* generation of cytotoxic T lymphocytes. *J Exp Med* 1982;155:768–782.
19. Newberry RD, Stenson WF, Lorenz RG. Cyclooxygenase-2-dependent arachidonic acid metabolites are essential modulators of the intestinal immune response to dietary antigen. *Nat Med* 1999;5:900–906.
20. Hmida NB, Ben Ahmed M, Moussa A, et al. Impaired control of effector T cells by regulatory T cells: a clue to loss of oral tolerance and autoimmunity in celiac disease? *Am J Gastroenterol* 2012;107:604–611.
21. **Grinberg-Bleyer Y, Baeyens A, You S, et al.** IL-2 reverses established type 1 diabetes in NOD mice by a local effect on pancreatic regulatory T cells. *J Exp Med* 2010;207:1871–1878.
22. Dubois S, Shou W, Haneline LS, et al. Distinct pathways involving the FK506-binding proteins 12 and 12.6 underlie IL-2-versus IL-15-mediated proliferation of T cells. *Proc Natl Acad Sci U S A* 2003;100:14169–14174.
23. Cornish GH, Sinclair LV, Cantrell DA. Differential regulation of T-cell growth by IL-2 and IL-15. *Blood* 2006;108:600–608.
24. **Marks-Konczalik J, Dubois S, Losi JM, et al.** IL-2-induced activation-induced cell death is inhibited in IL-15 transgenic mice. *Proc Natl Acad Sci U S A* 2000;97:11445–11450.
25. van Heel DA, Franke L, Hunt KA, et al. A genome-wide association study for celiac disease identifies risk variants in the region harboring IL2 and IL21. *Nat Genet* 2007;39:827–829.
26. Yamanouchi J, Rainbow D, Serra P, et al. Interleukin-2 gene variation impairs regulatory T cell function and causes autoimmunity. *Nat Genet* 2007;39:329–337.
27. Zeng R, Spolski R, Finkelstein SE, et al. Synergy of IL-21 and IL-15 in regulating CD8⁺ T cell expansion and function. *J Exp Med* 2005;201:139–148.

Author names in bold designate shared co-first authorship.

Received February 27, 2013. Accepted December 11, 2013.

Reprint requests

Address requests for reprints to: Nadine Cerf-Bensussan, MD, PhD or Bertrand Meresse, PhD, INSERM UMR1163, Laboratory of Intestinal Immunity, 24 boulevard du Montparnasse, 75015 Paris, France. e-mail: nadine.cerf-bensussan@inserm.fr or bertrand.meresse@inserm.fr; fax: (33) 1-72-60-64-21.

Acknowledgments

The authors are grateful to the flow cytometry and histology platforms of IFR94.

Conflicts of interest

The authors disclose no conflicts.

Funding

This work was supported by institutional funding from INSERM and by grants from the Agence Nationale pour la Recherche and the Fondation pour la Recherche Medicale; by postdoctoral fellowships from the Fundació Española para la Ciencia y la Tecnología, the Fundació Pedró i Pons, and from the Fondation pour la Recherche Medicale (E.R.-P.); by doctoral fellowships from the Ministère de la Recherche (N.K.) and the Cancéropole Ile-de-France (J.E.); and by postdoctoral fellowships from the Ligue Nationale Contre le Cancer and the French Association of Patients With Gluten Intolerance (N.M.).

SUPPLEMENTARY MATERIALS AND METHODS

Surface and intracellular staining. For membrane staining, 10^5 cells were incubated with FcRII/III mAb (Fc block, 2.4G2) and then with various mixes of directly coupled mouse mAbs: V β 5-FITC (MR9-4), V α 2-PE (MR5-2), CD4-PerCP (RM4-5), CD4-APCH7 (GK1.5), CD8 α -PerCP (53-6.7), CD8 α -APC-H7 (53-6.7), CD44-PE (IM7), CD62L-APC (MEL-14), CD25-PE (PC61), CD25-APC (PC61), NK1.1-PE (PK136) (BD Biosciences); CD3-PE-Cy7 (145-2C11), NKG2D-APC (CX5), CD45-eFluor450 (30-F11), CD45-PerCP (30-F11), CD107a-PE (1D4B) (eBioscience); dextramer H2-Kb/SIINFEKL-PE (Immudex, Copenhagen, Denmark). Dead cells were excluded using Aqua dead (Life Technologies). For intracellular staining of Foxp3, 10^6 cells were membrane labelled, fixed, permeabilized using a Foxp3 Staining Buffer Set (eBioscience) and then labelled with Foxp3-PE-Cy5 (FJK-16s) or rat IgG2a-PE-Cy5 isotype (eBioscience). In some experiments, cells were simultaneously labelled with Helios-Alexa-Fluor647 Ab (22F6) or control Armenian Hamster IgG-Alexa-Fluor-647 (eBioscience). For intracellular staining of Granzyme B, membrane-labelled cells were fixed with 2% paraformaldehyde (Euromedex, Soffelweyersheim, France), permeabilized with 0.5% saponin (Sigma-Aldrich, Saint-Quentin Fallavier, France) in PBS with 1% FCS, and then stained with GzB-APC mAb (GB12) or control mouse IgG1 (Caltag Laboratories, Buckingham, UK). For Intracellular detection of cytokines, 10^6 cells were stimulated with 100 ng/mL phorbol 12-myristate 13-acetate (PMA) and 1 μ g/mL ionomycin in the presence of 10 μ g/mL brefeldin A (Sigma-Aldrich) for 4h. After membrane staining, cells were fixed and permeabilized as for Granzyme B staining, and labelled with IFN- γ -APC (XMG1.2), and IL-17A-PE (TC11-18H10) rat mAbs or rat IgG1 isotype (BD Biosciences). Cells were analyzed on a FACS Canto II using BD FACSDiva software (BD Biosciences).

Transwell experiments. CD8⁺ T cells from OTI RAG2^{-/-} mice were placed on 0.4 μ m polycarbonate membrane inserts in the upper chambers of 12-well plates (Corning Costar, Sigma Aldrich, Lyon, France) and CD4⁺ T cells from OTII RAG2^{-/-} mice in the lower

chambers. Cells were stimulated or not with OVA₃₂₃₋₃₃₉ peptide (2µg/mL) in the presence of 20 ng/mL IL-15 for 3 days.

SUPPLEMENTARY FIGURE LEGENDS

Supplementary Figure 1: Impact of OVA diet on OVA-CD4⁺ T cells

(A) Frequency of OVA-specific ($V\beta 5^+V\alpha 2^+$) T cells among CD4⁺ T cells in LP, MLN and spleen of OTIIxB6 and OTIIxIL-15Tge mice fed OVA-containing (OVA) or control (CTR) diets. **(B, C)** Frequencies of activated CD44^{hi}CD62L⁻ cells **(B)** and memory CD44^{hi}CD62L^{hi} cells **(C)** among OVA-CD4⁺ TL, in LP, MLN and spleen of indicated mice as in A. * $P < 0.05$, ** $P < 0.01$ and *** $P < 0.001$.

Supplementary Figure 2: Enteropathy development in OTIIxIL-15Tge mice

(A) Representative pictures of 3 month-old OTIIxB6 mice and OTIIxIL-15Tge mice fed OVA- or CTR diets. **(B)** H&E-stained duodenal sections of 1-year-old B6 or B6xIL-15Tge mice. Scale bar, 5 μm .

Supplementary Figure 3: Expansion of IFN- γ -producing T-cells in OTIIxIL-15Tge mice

(A, B) Frequencies of IFN- γ -producing cells among OVA-specific ($V\beta 5^+$) CD4⁺ TL **(A)** or OVA-non-specific ($V\beta 5^-$) CD4⁺ TL **(B)** in LP, MLN and spleen of OTIIxB6 and OTIIxIL-15Tge mice, fed OVA or CTR diets * $P < 0.05$, ** $P < 0.01$ and *** $P < 0.001$.

Supplementary Figure 4: High Helios expression in OVA-specific regulatory T cells in OVA-fed mice

Frequency of Helios⁺ cells among OVA-specific CD25⁺Foxp3⁺CD4⁺ Tregs from LP, MLN and spleen of OVA-fed OTIIxB6 and OTIIxIL-15Tge. Dot plots in one out of 2 independent experiments.

Supplementary Figure 5: Potent immunosuppressive effect of OVA-specific regulatory T cells from OVA-fed OTIIxIL-15Tge mice

OVA-specific Tregs ($V\beta 5^+CD25^+CD4^+$) were purified from MLN and spleen of OVA-fed OTIIxB6 and OTIIxIL-15Tge mice as in Figure 4. Their immunosuppressive functions were tested by co-culture (1:2 ratio) with OVA- $CD4^+$ responder TL ($V\beta 5^+CD25^-CD4^+$) from control OTII mice and stimulation with $0.5\mu\text{g/mL}$ OVA₃₂₃₋₃₃₉ peptide. Proliferative responses were assessed by the uptake of [^3H] thymidine after 72h. Results are pooled from 3 independent experiments. * $P < 0.05$, ** $P < 0.01$.

Supplementary Figure 6: Expansion of IFN- γ -producing $CD8^+$ T cells in OTIIxIL-15Tge mice

Frequencies of IFN- γ -producing cells among $CD8^+$ TL, in LP, MLN and spleen in indicated mice as in Fig S1. ** $P < 0.01$ and *** $P < 0.001$.

Supplementary Figure 7: Expansion of NK cells in OTIIxIL-15Tge mice

Absolute numbers of NK cells in spleen, MLN, LP and IEL of indicated mice as in Figure S1. * $P < 0.05$, ** $P < 0.01$.

Supplementary Figure 8: $CD8^+$ T cells from OVA-fed mice are not specific for dietary ovalbumin

Frequency of H2-K^b/SIINFEKL dextramer-positive cells among $CD8^+$ TL, in LP, epithelium, MLN and spleen, of OTIIxB6, OTIIxIL-15Tge, B6 and B6xIL-15Tge mice, fed with OVA or CTRL diets. Results from 3 independent experiments are pooled.

Supplementary Figure 9: Activated OVA-specific $CD4^+$ T cells do not stimulate naïve $CD8^+$ T cells

Naïve $CD8^+$ TL were sorted from spleen of B6 mice, labeled with Cell Trace Violet, added with spleen $CD11c^+$ dendritic cells (DC) (DC:T ratio1:10), and then co-cultured or not with $CD4^+$ TL from OTII RAG2^{-/-} mice. Cells were stimulated for 96h with OVA₂₅₇₋₂₆₃ ($2\mu\text{g/mL}$), OVA₃₂₃₋₃₃₉

(2µg/mL) peptides or OVA protein (400µg/mL) and cultured in the presence of 20ng/mL IL-15. One representative out of 3 independent experiments is shown.

Supplementary Figure 10: NKG2D upregulation in lamina propria CD8⁺ T cells in OVA-fed mice

Frequencies of NKG2D⁺ cells among CD8⁺ LP T cells of indicated mice as in Fig S1. * $P < 0.05$, ** $P < 0.01$.

Supplementary Figure 11: CD4⁺ T cell help for cytotoxic activation of CD8⁺ TL depends on a soluble factor

CD8⁺ TL were sorted from the spleen of OTI RAG2^{-/-} mice, labeled with Cell Trace Violet, added with spleen CD11c⁺ DC (DC/T ratio 1:10), and were cultured with OVA-stimulated CD4⁺ TL (sorted from the spleen of OTII RAG2^{-/-} mice), with cells either in direct contact, or separated by a Transwell membrane. Cells stimulated with OVA₃₂₃₋₃₃₉ (2µg/mL) peptide and cultured in the presence of 20ng/mL IL-15. Proliferation, surface expression of CD69 and NKG2D and intracellular expression of Granzyme B of CD8⁺TL were assessed by flow cytometry on day 3. One representative out of 3 independent experiments is shown.

Supplementary Figure 12: CD4⁺ T cell help to cytotoxic CD8⁺ TL depends on OVA-induced IL-2 secretion

OVA-CD4⁺ T cells were sorted from the spleen of OTII RAG2^{-/-} mice, added with spleen CD11c⁺ DC (DC/T ratio 1:10) and then stimulated by OVA₃₂₃₋₃₃₉ (2µg/mL) for 3 days. Supernatants were harvested and depleted with IL-2 antibody coupled to protein G or mock treated by control isotype. IL-2 depleted and isotype treated supernatants were then added to CD8⁺ TL sorted from the spleen of OTI RAG2^{-/-} mice and labeled with Cell Trace Violet. Cells were cultured in the presence of 20ng/mL IL-15. Proliferation, surface expression of CD69 and intracellular expression of Granzyme B of CD8⁺ TL were assessed by flow cytometry on day 3. One representative out of 3 independent experiments-is shown.

Supplementary Figure 13: CD25⁺Foxp3⁺ Tregs expand in B6 and B6xIL-15Tge mice treated by IL-2

Frequencies of Foxp3⁺CD25⁺ Tregs among CD4⁺ TL in LP, MLN and spleen of B6 and B6xIL-15Tge mice, treated by intraperitoneal injections of rhIL-2 (200,000 IU/day) or of PBS for 5 days. **P*<0.05, ***P*<0.01.

Supplementary Figure 14: Intestinal Rae1 expression

Western blot detection of NKG2D ligand Rae1 in duodenal biopsies of mice as indicated.

Supplementary Figure 15: Schematic depicting cooperation between IL-15 and diet-activated CD4⁺ T cells in the activation of intestinal cytotoxic CD8⁺ T cells

Chronic oral exposure to a food protein activates antigen-specific effector and regulatory CD4⁺ TL, which migrate into the intestinal mucosa. When restimulated in the intestinal mucosa by the dietary antigen, mucosal effector CD4⁺ T cells produce IL-2, which promotes the survival and expansion of regulatory FOXP3⁺CD25⁺ T cells (Tregs). In turn Tregs suppress local immune activation and maintain homeostasis. When IL-15 is produced in excess in the intestine, IL-2 acts in concert with IL-15 on intestinal effector/memory CD8⁺ TL regardless of their antigenic specificity, and stimulates their expansion and differentiation into cytotoxic Granzyme B⁺ cells. IL-15 then renders CD8⁺ TL resistant to immunosuppression by Tregs and activates potent anti-apoptotic signals, which drive their progressive accumulation. Degranulation of cytotoxic CD8⁺ TL may then cause tissue damage. Mechanisms susceptible to trigger degranulation are discussed in the text.

FIGURE S1

FIGURE S1

A



OTIxB6

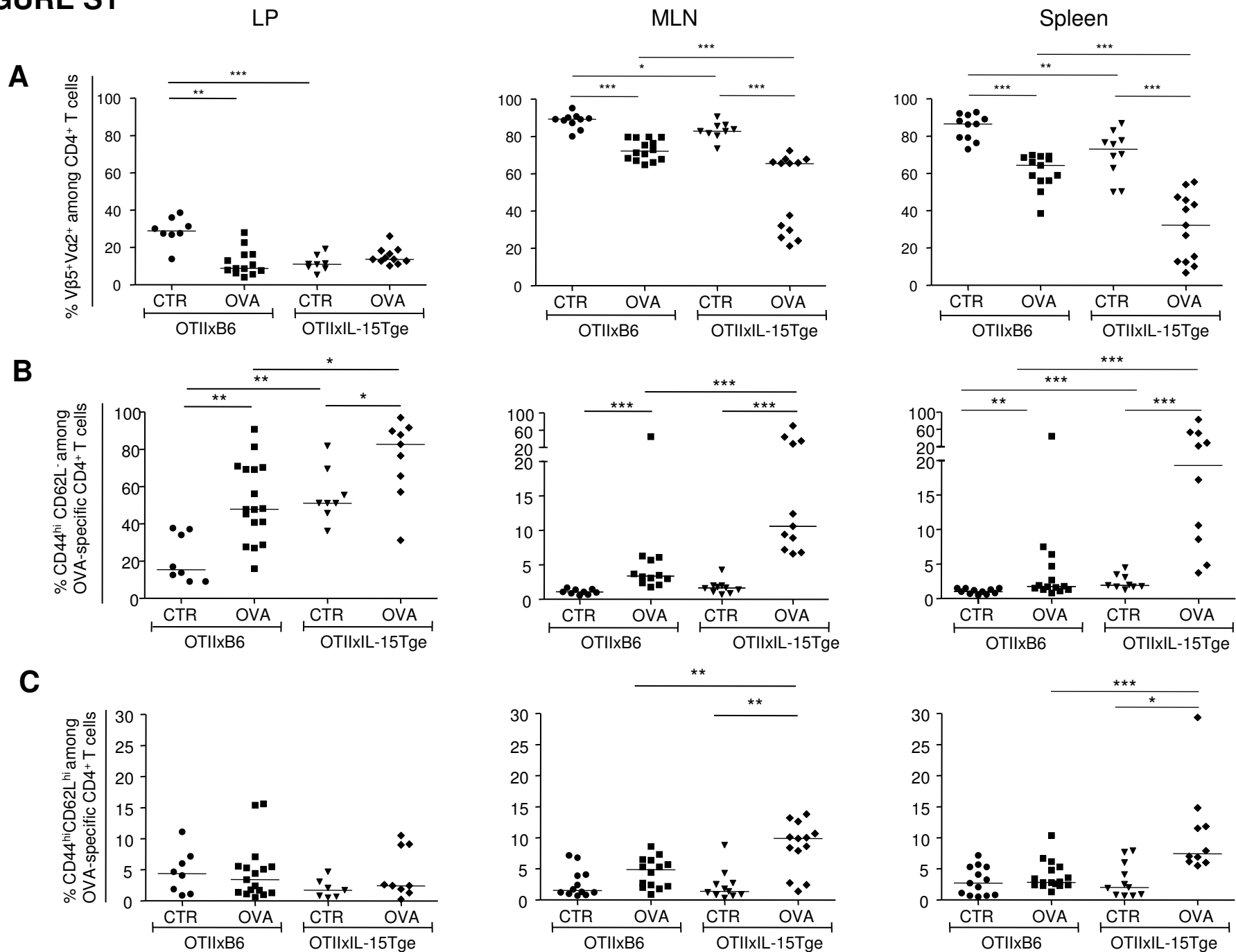

OTIxB6 + OVA



OTIxB6 + IL-15



OTIxB6 + IL-15 + OVA

B

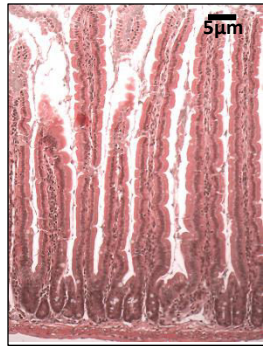

B6 OLD

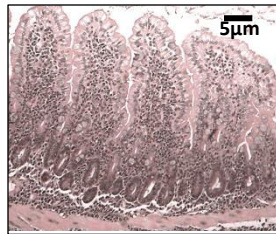

B6xIL-15Tge OLD

FIGURE S3

A

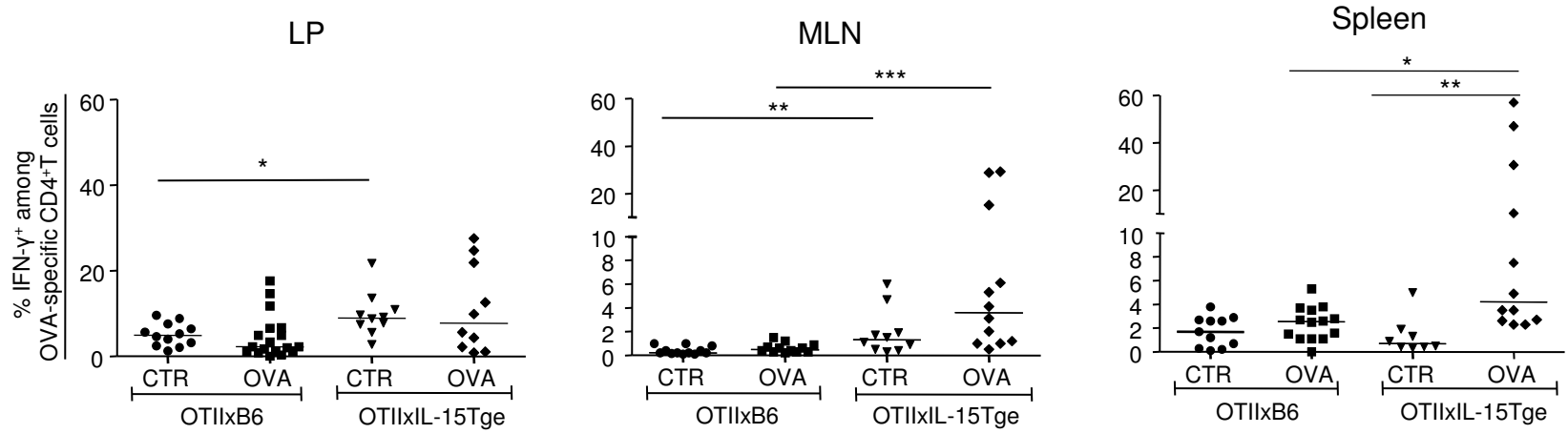

B

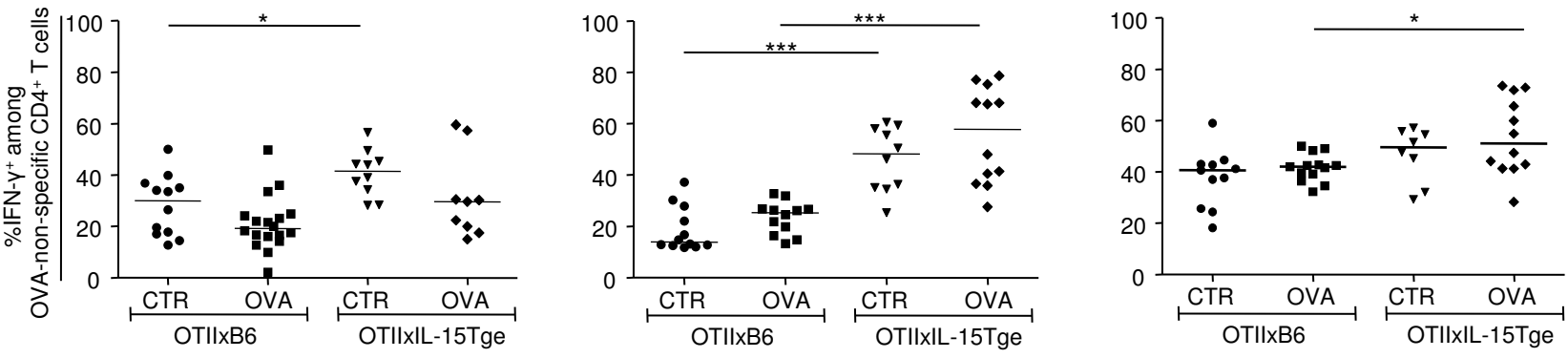

FIGURE S4

Gated on OVA-specific CD25⁺ Foxp3⁺ Tregs

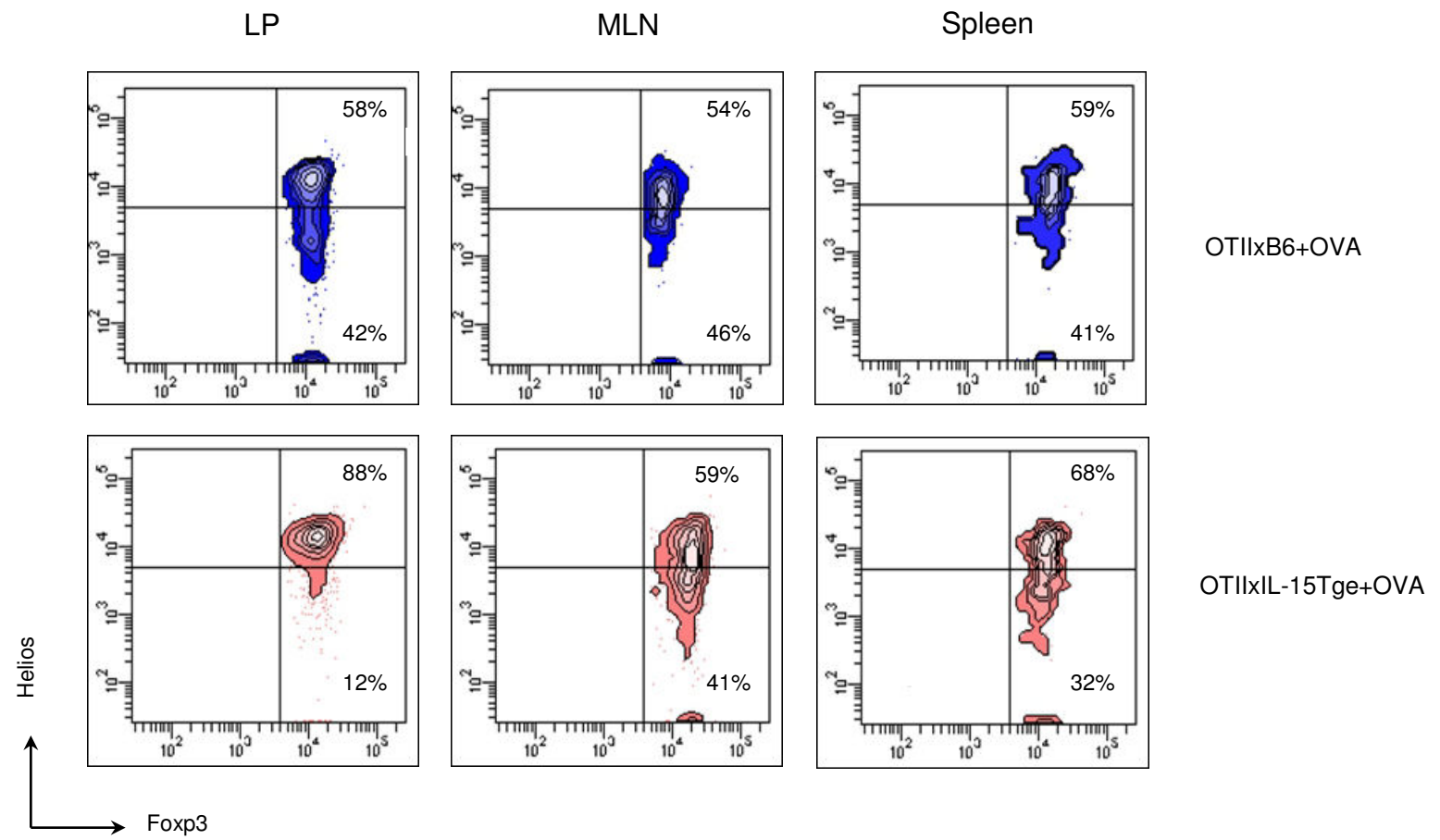

FIGURE S5

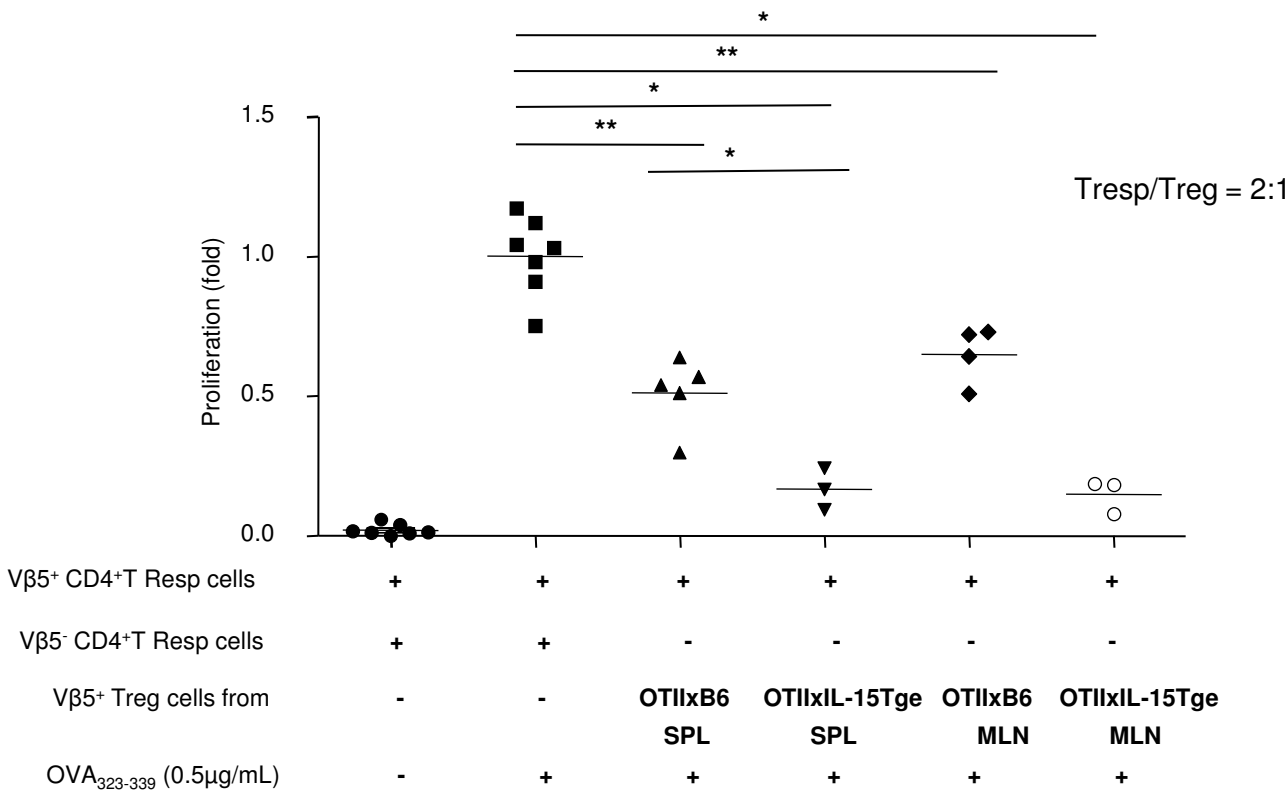

FIGURE S6

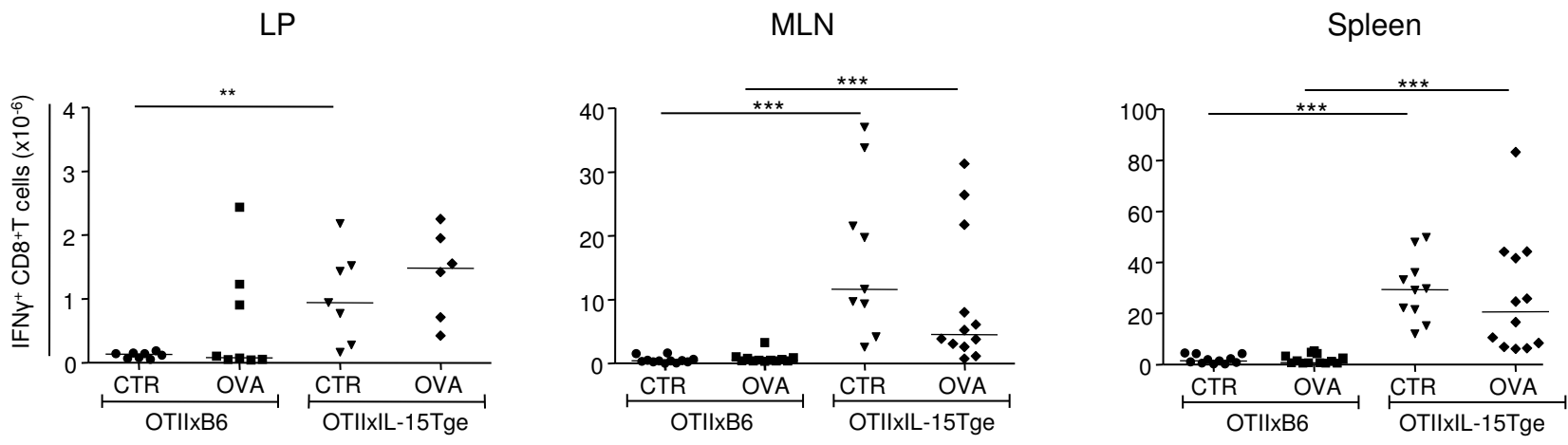

FIGURE S7

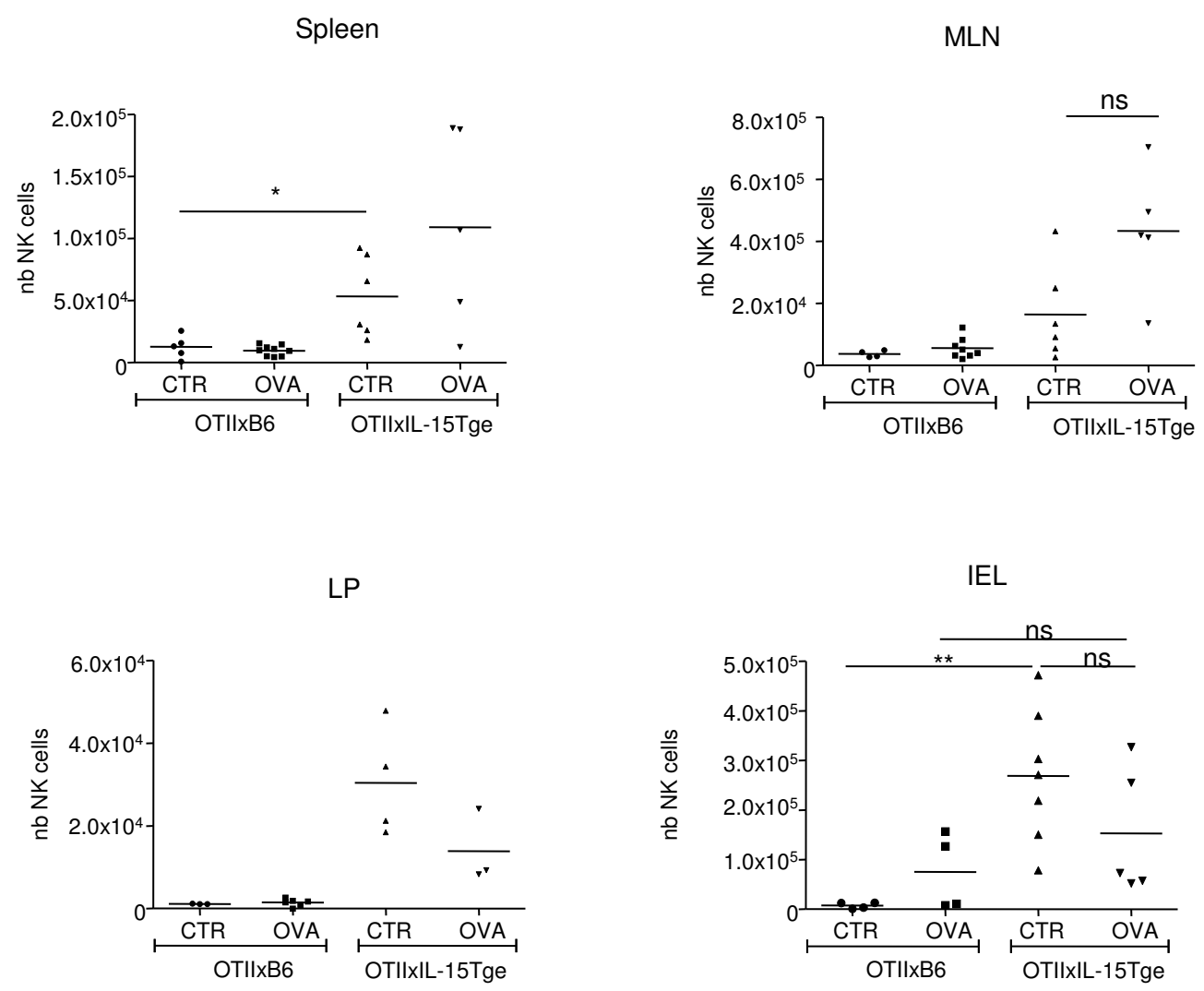

FIGURE S8

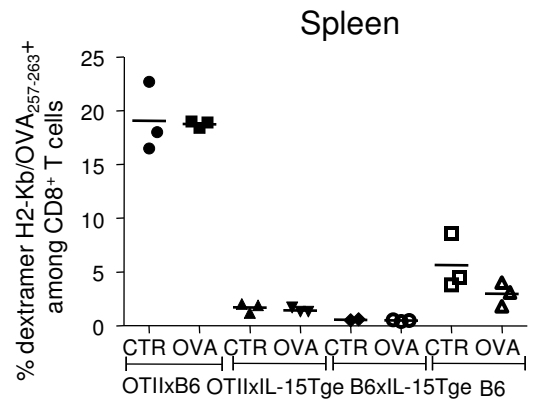
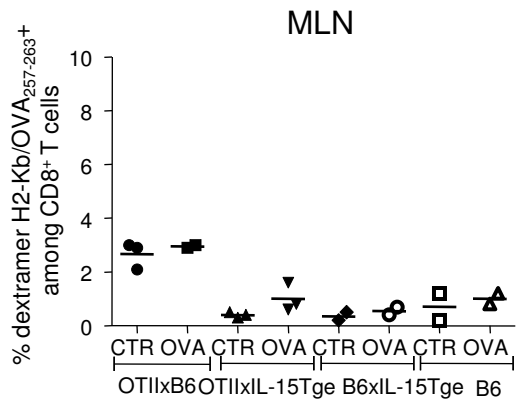
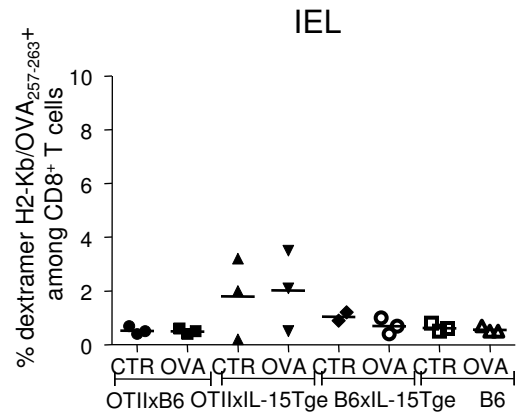
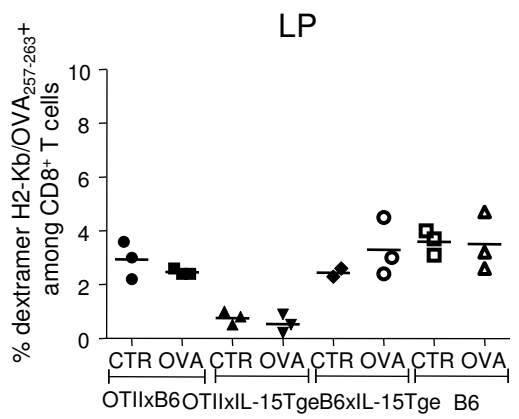

FIGURE S9

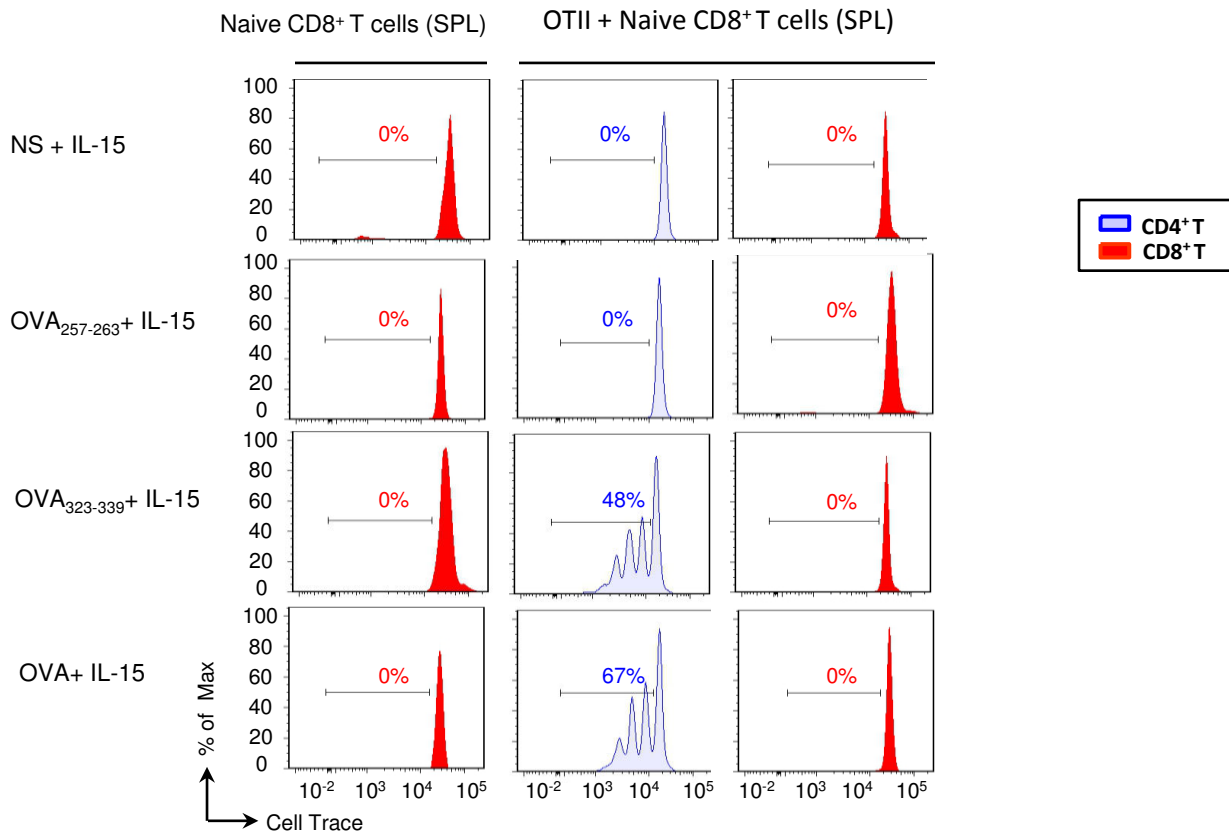

FIGURE S10

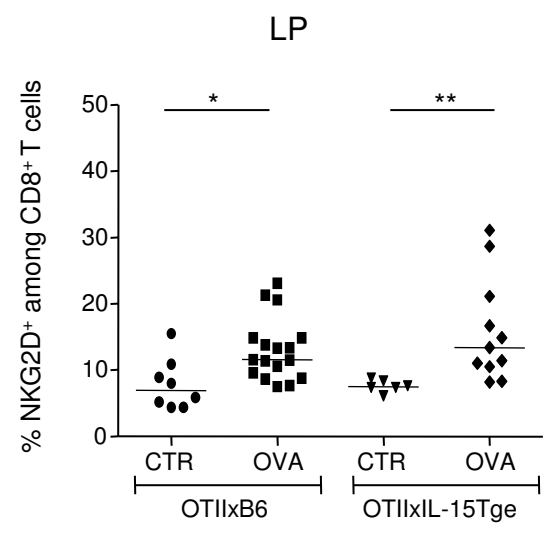

FIGURE S11

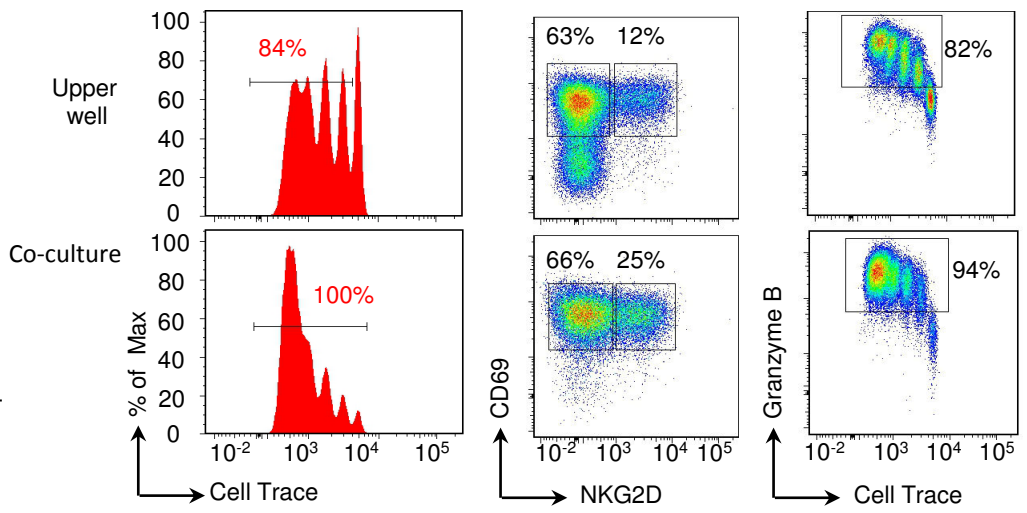
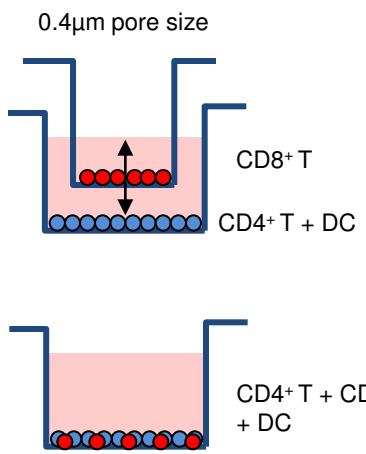

FIGURE S12

CD8⁺T (from OTI Rag^{-/-} mice)

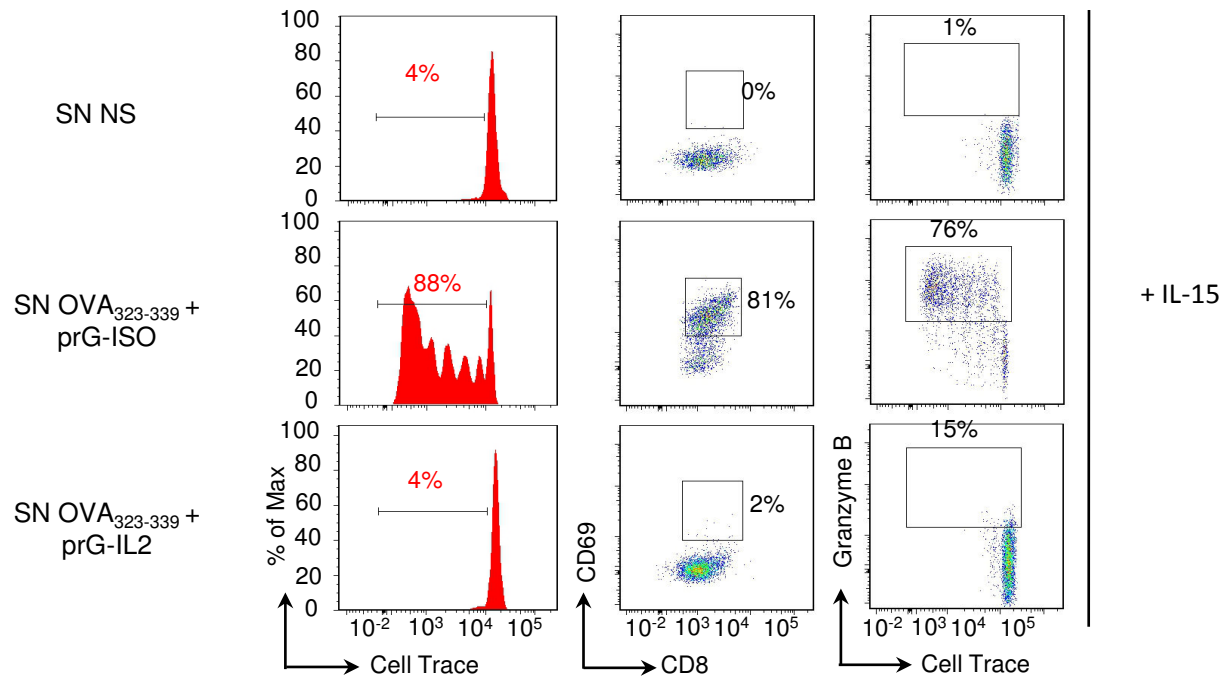

FIGURE S13

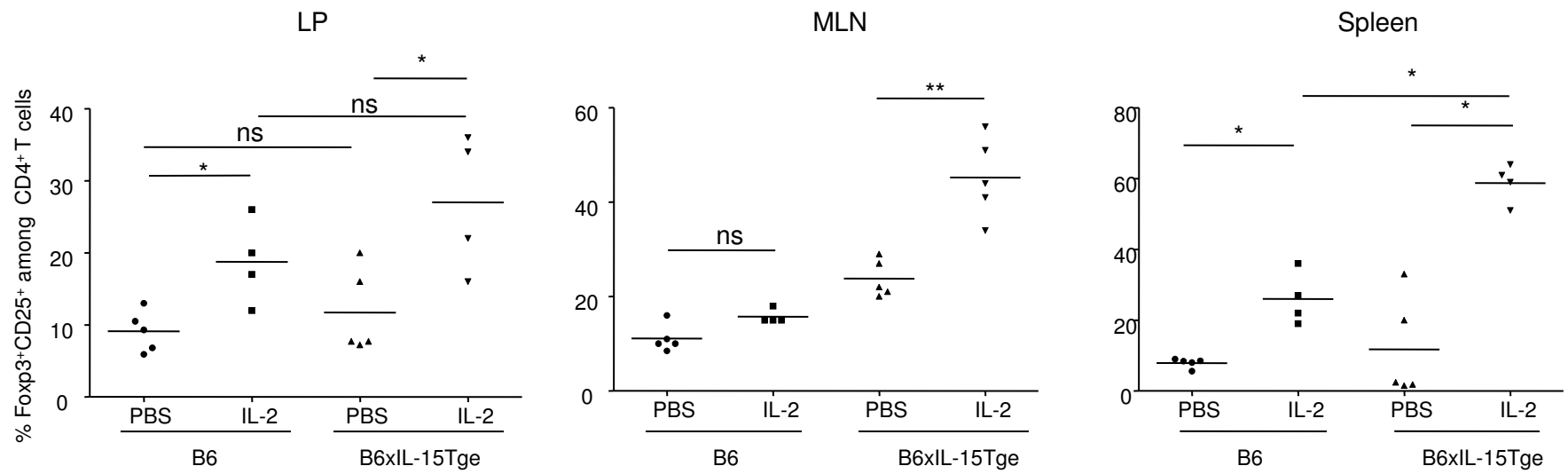

FIGURE S14

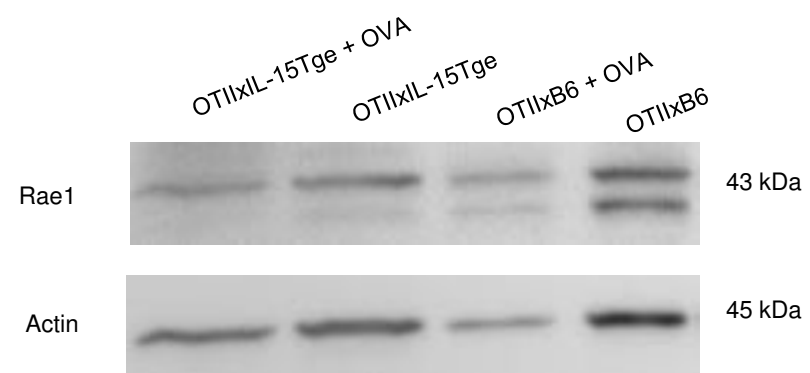
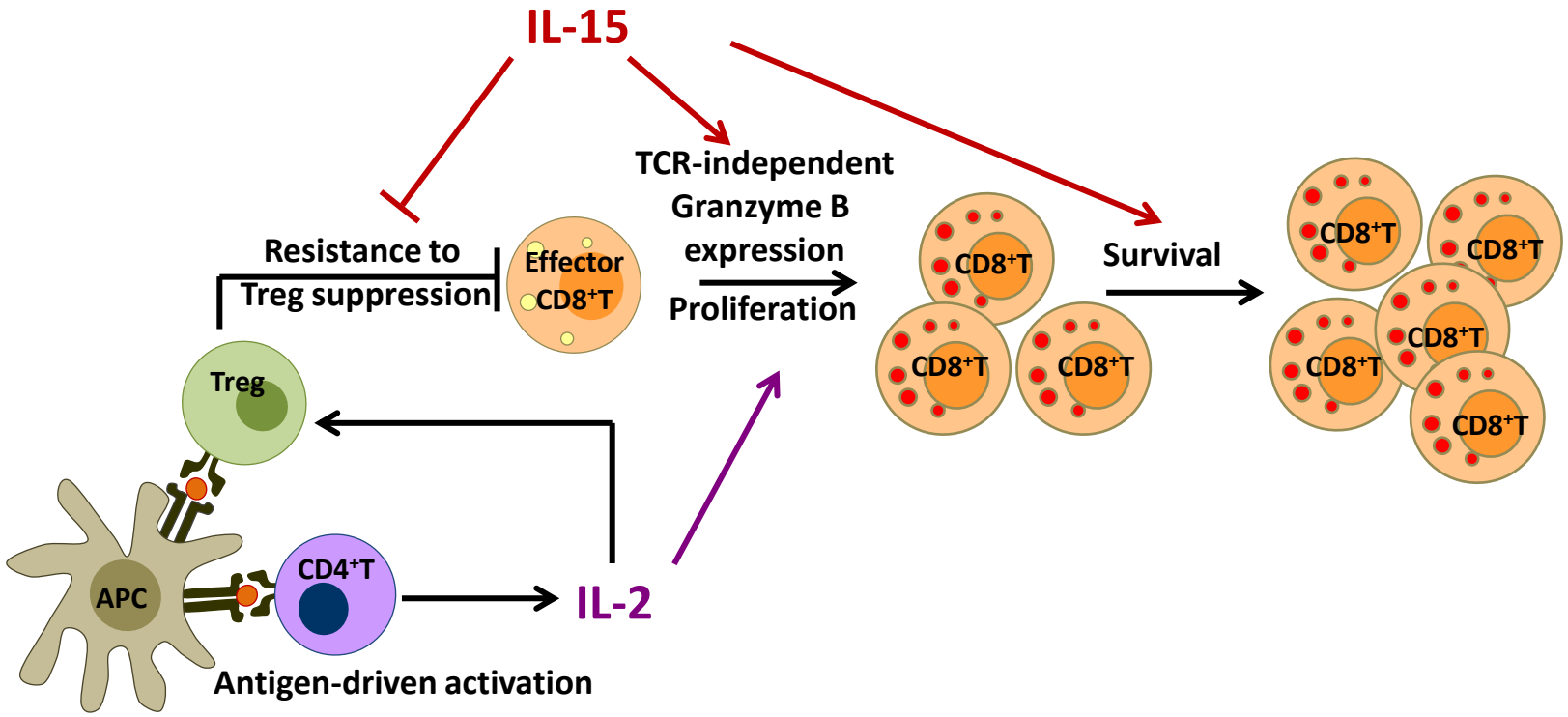

FIGURE S15



B.3 Discussion

Different questions have been addressed while setting up the mouse model and characterising the mechanisms of tolerance break to dietary OVA observed in OTII/hIL-15Tge mice.

Is the enteropathy observed in OVA-fed OTII/hIL-15Tge mice similar to celiac disease enteropathy?

Macroscopic tissue lesions observed in our mouse model were, as in CD patients, mostly limited to duodenum, the proximal small intestinal part, where protein digestion largely takes place. Intestinal lesions were characterised by significant villous shortening, crypt hyperplasia and increased number of IELs, signs reminiscent of CD enteropathy. Lamina propria infiltration by CD8 T cells was however more important than in CD, probably due to the fact that IL-15 produced by epithelial cells in this model is secreted in large amounts. In some mice, the infiltration also affected deeper submucosa and muscle layers, which is not observed in most CD patients. Production of anti-gliadin and anti-TG2 IgA is a characteristic sign of CD. We have not addressed this issue thoroughly. An increase in serum OVA IgG was observed but no OVA-IgA were detected in the feces (not shown). We have not attempted to check for anti-TG2 antibodies. Indeed, TG2 IgA antibodies are detected only in active CD patients consuming gluten but not during GFD; it is therefore thought that the production of anti-TG2 IgA autoantibodies is induced by TG2/gluten hapten complexes formed exclusively upon gluten feeding (Sollid et al., 1997). Nevertheless, this issue remains to be addressed as J. Yokoyama and colleagues have reported that hIL-15Tge mice displayed increased serum levels of anti-TG2 IgA and lamina propria plasmacytosis (Yokoyama et al., 2011), suggesting that the formation of anti-TG2 IgA is not directly triggered by gluten but can be mediated by IL-15.

Overall and despite uncharacterized IgA production, macroscopic and microscopic lesions observed in OVA-fed OTII/hIL-15Tge mice are largely reminiscent of CD lesions. Moreover, obtained results allow us to conclude that antigen-specific CD4 T cell response and epithelium-derived IL-15 are sufficient to induce intestinal lesions. The production of IL-15 in intestinal epithelium or least in the intestinal mucosa is a critical factor. HLA-DQ8 transgenic mice on MHC class II-deficient background that overexpressed IL-15 under the H2-D^d promoter (HLA-DQ8/D^d-IL-15Tge mice) did not develop any enteropathy in response to dietary gluten. In the latter mice, it seems that IL-15 was overexpressed in MLN but its expression in LP was only very mildly affected (DePaolo et al., 2011). These observations are in keeping with our data. Indeed, the cooperation between IL-2 produced by CD4 T cells activated by the dietary antigen

MAIN RESULTS: Cooperation between antigen-specific CD4 T cells and IL-15 in the mouse model of celiac-like small intestinal enteropathy induced by dietary antigen and IL-15 drove the expansion of cytotoxic CD8 T cells and this mechanism operated only in memory/effector CD8 T cells known to be present in intestinal tissue but not in naïve CD8 T cells predominant in MLN.

Can the observed enteropathy be reverted by removing of dietary ovalbumin?

Gluten-free diet is the unique therapeutic strategy for active CD patients allowing histological recovery and reversion of clinical symptoms. Thus, to definitely conclude that a mouse model is entirely relevant to CD, the enteropathy should be reversible upon removal of the triggering dietary antigen. Yet, in CD IL-15 is overexpressed in active CD patients but tends to decrease in patients following gluten-free diet, except in a subset of refractory patients who become resistant to the diet and display persistence of IL-15 overexpression that is thought to participate in sustaining epithelial damage (Di Sabatino et al., 2006; Maiuri et al., 2000; Mention et al., 2003). In our model hIL-15 is permanently expressed and cannot be switched off upon removal of dietary OVA. Accordingly, aging hIL-15Tge mice develop spontaneous enteropathy (in our colony by the age of 9-12 months). Moreover, a few very old hIL-15Tge mice have developed an intraepithelial expansion of clonal IELs lacking surface CD3 (J. Ettersperger, B. Meresse unpublished observations) reminiscent of the population of malignant IELs that define clonal refractory CD in a the small subset of CD patients (Malamut et al., 2012).

The permanent expression of IL-15 is thus one limit of this model. Moreover, it must be indicated that IL-15 is expressed in a secreted form and is therefore found in large amounts in the serum resulting in a strong expansion of CD8 T cells not only in the intestine but also in the periphery of hIL-15tge mice. Of note, small amounts of IL-15 have been detected in serum of CD patients that often display an inversion of the CD4:CD8 ratio. Nevertheless, mouse models in which IL-15 overexpression could be switched on upon exposure to an antigen and switched off upon its removal are strongly required. Alternatively, mice with inducible IL-15 expression using for example tetracycline-inducible expression system should be considered (Figure B.1).

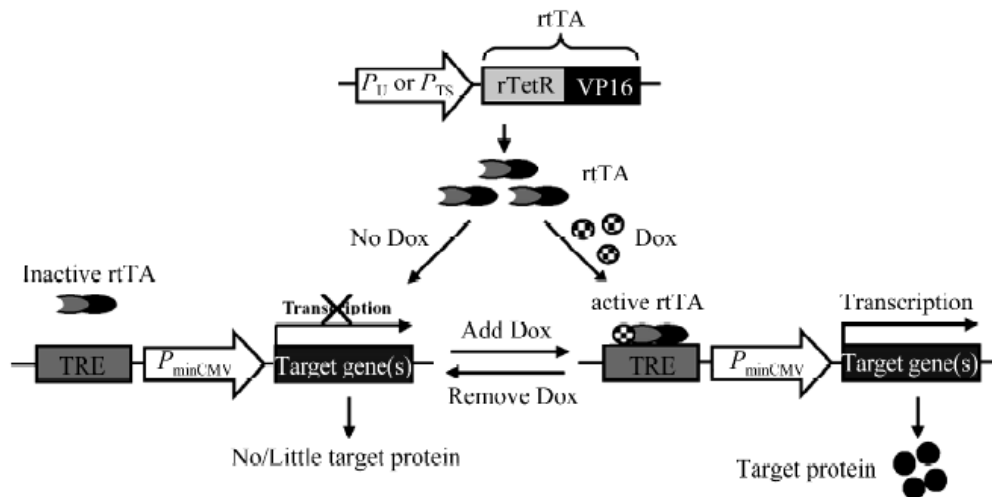

Figure B.1: Tetracycline on/off system

Breeding of transactivator transgenic mice, in which regulatory protein reverse tetracycline-controlled transcriptional activation (rtTA) is constitutively produced under the control of a ubiquitous promoter (P_U) or tissue-specific promoter (P_{TS}), and responder mice, in which the expression of cDNA(s) of interest is under the regulation of the rtTA-dependent promoter. In double transgenic mice, addition of Dox to Tet-on system results in transcriptional induction of the gene(s) of interest, whereas in the absence of Dox, inactive rtTA cannot bind its target or dissociates from tetracycline response elements (TRE), and subsequently terminates the transcription of downstream target gene(s) (Sun et al., 2007b).

Does early and prolonged exposure to dietary antigen contribute to tolerance break?

Celiac disease frequently develops in early childhood (Namatovu et al., 2014). It has been largely speculated that earlier (<4 months of age) or later (>6 months of age) introduction of gluten to the diet may trigger the onset of CD (Ivarsson et al., 2002; Norris et al., 2005). Previous data (Hanson, 1981; Strobel and Ferguson, 1984) suggested the existence of a time frame during prenatal and early postnatal development when the exposure to a food antigen may rather lead to immune priming than to tolerance. Of note, gut permeability is increased in the immature intestine, as observed in rodents up to 7 days after birth and in humans during the first days after birth. Thus, large molecules, such as proteins, may probably reach the intestine of pups before birth through umbilical cord and through breast mother milk after the birth (Verhasselt, 2010a) contributing to the priming of antigen-specific cells.

Accordingly, different protocols were tested by Emma Ramiro-Puig in order to provoke tissues lesions in OTII/hIL-15Tge and OTII/B6 offspring. Strikingly, only prenatal introduction of OVA to pregnant mothers and prolonged exposure of pups to high dose of OVA (10% OVA-containing pellets) provoked growth retardation and small intestinal enteropathy in OTII/hIL-15Tge mice, but not in OTII/B6 mice. In contrast, introduction of OVA at the time of weaning and prolonged exposure until 12 weeks of age did not induce any enteropathy in young OTII/hIL-15Tge mice (unpublished data). These results indicate that the mechanisms of tolerance in weaned animals are sufficiently robust to preserve tolerance even in the presence

MAIN RESULTS: Cooperation between antigen-specific CD4 T cells and IL-15 in the mouse model of celiac-like small intestinal enteropathy induced by dietary antigen of IL-15. Several factors probably contribute to the loss of local tolerance to dietary OVA in OVA-fed OTII/hIL-15Tge mice, including early and prolonged exposure, high dose, and increased gut permeability during prenatal and early postnatal periods, and IL-15 overexpression.

Does IL-15 interfere with tolerance mechanisms? Does it prevent the generation and function of Treg cells?

In OVA-fed OTII/B6 mice, the striking decrease in OVA-specific CD4 T cells suggested their deletion in response to activation by OVA. As discussed in chapter 1, deletion of activated T cells can contribute to oral tolerance (Chen et al., 1995a). This protective mechanism may be altered in OVA-fed OTII/hIL-15Tge mice in which the decrease in OVA-specific CD4 T cells after feeding was much less obvious. A plausible hypothesis is that IL-15 can exert anti-apoptotic effect on activated CD4 T cells.

Foxp3 Treg cells are believed to be crucial for tolerance to food antigens (Hadis et al., 2011; Torgerson et al., 2007). In our model, we observed a striking increase in the frequency of CD25⁺ Foxp3⁺ OVA-specific CD4 T cells notably in the intestinal lamina propria of OVA-fed OTII/hIL-15Tge mice. This result appears at odds with a previous report suggesting that IL-15 together with retinoic acid impairs the generation of induced Treg cells (DePaolo et al., 2011). In our OTII transgenic mouse model, OVA-specific T cells can express a second T cell receptor and can therefore be selected in the thymus as thymus-derived Tregs. Therefore, many OVA-specific T cells with a Treg phenotype that expand in the intestine of OVA-fed OTII/hIL-15Tge mice may be thymus-derived OVA-specific Tregs. In keeping with this, a large proportion of the latter cells expressed Helios, a marker that is preferentially expressed on thymus-derived Tregs. Yet, experiments from the laboratory performed *in vitro* using human T cells have failed to demonstrate any inhibitory effect of IL-15 on the conversion of naïve T cells into Tregs. Moreover, herein we observed that naïve OVA-specific CD4 T cells obtained from OTIIxRag1^{-/-} that do not contain thymus-derived T cells could convert into Tregs in the MLN of both B6 and hIL-15Tge mice upon oral exposure to OVA. Thus, we did not observe any evidence that IL-15 might impair peripheral conversion of OVA-specific T cells into Tregs.

Furthermore and similarly to results obtained in human CD studies (Ben Ahmed et al., 2009; Hmida et al., 2012; Zanzi et al., 2011), we observed that Treg cells remained fully functional in *in vitro* assays. In contrast, and as previously shown in humans, effector cells, notably CD8 T

MAIN RESULTS: Cooperation between antigen-specific CD4 T cells and IL-15 in the mouse model of celiac-like small intestinal enteropathy induced by dietary antigen cells, were much less responsive to *in vitro* suppression by Tregs in the presence of IL-15. Thus, proliferation, IFN γ production, as well as Granzyme B production by effector CD8 T cells were less well controlled by Tregs in the presence of IL-15. Overall, these data are in keeping with observations made *ex vivo* in CD patients, showing the lack of response of their effector intestinal and peripheral T cells to suppression by autologous or heterologous Tregs (Hmida et al., 2012).

Consistent with the study of de Paolo and colleagues in HLA-DQ8/D^d-IL-15Tge mice (DePaolo et al., 2011), we have observed an increase in the frequency of IFN γ -producing cells in spleen of hIL-15Tge mice, suggesting a loss of peripheral tolerance. Of note, this effect was not restricted to OVA-specific CD4 T cells but was also observed in spleen non-OVA-specific CD4 T cells and in CD8 T cells, pointing out to a generalized loss of response of T cells to immunoregulation, also reminiscent of observations made in CD patients (Hmida et al., 2012). No significant increase in IFN γ -producing OVA-specific CD4 T cells was however observed in lamina propria, probably due to the strong expansion of Tregs in the intestine of OVA-fed OTII/hIL-15Tge mice (in some mice, up to 90% of OVA-specific CD4 T cells were Foxp3⁺CD25⁺).

In vivo results pointed out to a loss of intestinal tolerance associated with an increase in granzyme B expression by intestinal CD8 T cells in OTII/hIL-15Tge mice, yet more important after OVA feeding. Moreover, Granzyme-positive CD8 T cells in OVA-fed OTII/hIL-15Tge mice were found in close proximity to epithelial lesions, suggesting their participation in epithelial damage. As discussed below, expansion of Granzyme B⁺ CD8 T cells depends on the interaction between IL-15 and IL-2 produced by OVA-specific CD4 T cells. Up-regulation of Granzyme B was seen only in intestine, probably due to the fact that IL-2 was produced by OVA-specific CD4 T cells restimulated by the antigen locally in the intestine.

Are the expanded cytotoxic CD8 T cells specific of dietary ovalbumin? How are they activated?

Cytotoxic CD8 T cells are thought to be central for epithelial damage in CD. However, it still remains unclear whether these cells are specific or not of gluten (Gianfrani et al., 2003; Mazzarella et al., 2008). In our mouse model, we could easily address this question since it is known that in B6 mice OVA-specific CD8 T cells are directed against OVA₂₅₇₋₂₆₃ dominant peptide. Taking advantage of commercialized dextramers H2-Kb/OVA₂₅₇₋₂₆₃ and *in vitro* restimulation, we have demonstrated that expanded CD8 T cells are not OVA-specific. In

MAIN RESULTS: Cooperation between antigen-specific CD4 T cells and IL-15 in the mouse model of celiac-like small intestinal enteropathy induced by dietary antigen addition, *in vitro* studies have provided evidence that CD8 T cells proliferated and up-regulated Granzyme B in non-cognate manner when co-cultured with activated CD4 T cells.

How CD4 and IL15 interact in activation of cytotoxic CD8 T cells?

We have shown that *in vitro* CD8 T cell proliferation and Granzyme B up-regulation were independent of their TCR specificity and were mediated by cooperation between IL-15 and IL-2, released by OVA-specific CD4 T cells in response to cognate activation by dietary antigen. However, this synergistic effect of IL-15 and IL-2 was limited only to effector/memory CD8 T cells and was not observed in naive CD8 T cells. Indicating that this mechanism observed *in vitro* could also operate *in vivo*, PCR analysis demonstrated an increase in *IL-2* mRNA in duodenum of OVA-fed OTII/hIL-15Tge mice. Moreover, IL-2 injection into hIL-15Tge^{+/-} mice increased the numbers of Granzyme B-containing CD8 T cells and resulted in villous shortening despite a marked expansion in Treg cells. Contrary to hIL-15Tge mice, B6 mice injected with IL-2 have not displayed any mucosal changes, confirming the synergistic effect between IL-15 and IL-2.

What is the molecular basis of the synergy between IL-15 and IL-2 for cytotoxic activation of CD8 T cells?

The two cytokines have very similar signalling pathways as their receptors share the β and γ chains responsible for downstream signalling. Some differences in downstream signals between IL-2 and IL-15 have been reported (Cornish et al., 2006; Dubois et al., 2003; Marks-Konczalik et al., 2000). It is however unclear to which extent the synergistic effects result from activation of distinct signalling pathways or from a dose effect of these two cytokines.

Where do the expansion and cytotoxic activation of CD8T cells take place?

Since the mechanism that we have described operate only in effector/memory CD8 T cells, it likely takes place only in effector intestinal site and not in MLN where T cells are mainly naive. Overall, we propose the following scheme (Figure B.2). CD4 T cells primed by the dietary antigen in MLN migrate into lamina propria. Locally reactivated by the cognate antigen, CD4 T cells produce IL-2 that together with epithelium-derived IL-15 acts onto nearby effector/memory CD8 T cells leading to their expansion and their cytotoxic activation. This process likely needs close proximity of CD4 and CD8 T cells. Moreover, in the presence of IL-15, effector CD8 T cells become resistant to Treg cell suppression that further sustains their

MAIN RESULTS: Cooperation between antigen-specific CD4 T cells and IL-15 in the mouse model of celiac-like small intestinal enteropathy induced by dietary antigen expansion and Granzyme B up-regulation. Finally, IL-15 may favour the survival and accumulation of granzyme B CD8 T cells due to its anti-apoptotic properties.

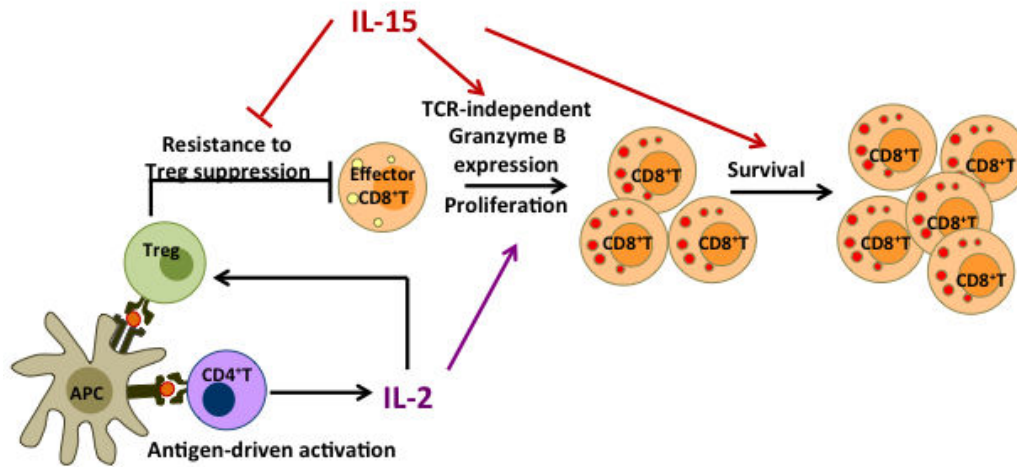

Figure B.2: Scheme depicting the cooperation between IL-15 and diet-activated CD4 T cells in cytotoxic activation of intestinal CD8 T cells

CD4 T cells primed by dietary antigen in MLN migrate into lamina propria. Locally reactivated by the cognate dietary antigen, CD4 T cells produce IL-2 that together with epithelium-derived IL-15 acts onto neighboring effector/memory CD8 T cells leading to their expansion and cytotoxic activation. This process likely needs close proximity of CD4 and CD8 T cells. Moreover, in the presence of IL-15, effector CD8 T cells become resistant to Treg cell suppression that further sustains their expansion and Granzyme B up-regulation. Finally, IL-15 may favour the survival and accumulation of Granzyme B CD8 T cells due to its anti-apoptotic properties.

What is the mechanism triggering cytotoxicity of CD8 T cells against epithelial cells?

Different studies have suggested that intestinal CD8 T cells may damage epithelial cells via NK-receptor-dependent and/or TCR-dependent mechanisms (Hue et al., 2004; Mazzarella et al., 2008; Meresse et al., 2004; Meresse et al., 2006; Roberts et al., 2001).

In our mouse model, we have tried to establish whether CD8 T cells could degranulate in response to TCR and/or NKG2D-receptor stimulation. Polyclonal stimulation with antibodies against CD3 but not against NKG2D could induce the degranulation of CD8 T cells derived from *in vitro* coculture with OVA-stimulated OTII CD4 T cells and IL-15. Since the cytotoxic CD8 T cells that expanded in OVA-fed OTII/hIL-15Tge mice were not specific of OVA, their degranulation can probably be triggered in the intestine upon encounter with their cognate antigens, such as bacterial or viral antigens, or even self-antigens. In human CD, an important role has been suggested for NKG2D and NKG2C, both receptors expressed in IELs from CD patients while their ligands are up-regulated in the gut epithelium (Hue et al., 2004; Jabri et al., 2000; Mazzarella et al., 2008; Meresse et al., 2004; Meresse et al., 2006; Roberts et al., 2001). NKG2C does not exist in mice. NKG2D is an NK receptor constitutively expressed by human CD8 T cells including IELs but in mice NKG2D expression depends on TCR stimulation and was observed only on 10-20% of intestinal CD8 T cells in OVA-fed OTII/B6 or OTII/hIL-

MAIN RESULTS: Cooperation between antigen-specific CD4 T cells and IL-15 in the mouse model of celiac-like small intestinal enteropathy induced by dietary antigen 15Tge mice. The role of NKG2D in CD8 T cells is thus likely different in mice and in humans. Yet, the NKG2D mouse ligand, Rae-1 was strongly expressed in the duodenum of all groups of mice. Therefore, we cannot exclude that NKG2D-mediated degranulation of Granzyme-positive CD8 T cells takes place, even if this mechanism is likely much less efficient than in humans.

To which extent can this mechanism be translatable to CD?

This study has demonstrated that cooperation between CD4 T cells, chronically activated by a dietary antigen, and IL-15, overexpressed in intestinal epithelium, is necessary and sufficient to induce tissue lesions, evocative of CD enteropathy associated with the expansion of intestinal cytotoxic effector CD8 T cells. A similar scenario may operate in CD (Figure B.2). Thus, chronic exposure to gluten in individuals bearing MHC class II antigens enabling gluten presentation should allow the generation of antigen-specific CD4 T cells. In healthy HLA-DQ2/8 individuals, gluten-specific Tregs are likely generated and IL-2 produced by activated effector CD4 T cells may sustain expansion and function of antigen-specific Foxp3 T cells that, in turn, can keep in check both CD4 and CD8 effector T cells. However, in the presence of IL-15, effector cells, notably CD8 T cells, become unresponsive to Treg immuno-suppression. Moreover, IL-2 and IL-15 produced by epithelial cells can synergize to stimulate the cytotoxic activation and proliferation of non-cognate effector CD8 T cells. Finally, IL-15, due to its potent anti-apoptotic properties, may promote the survival and accumulation of such cytotoxic CD8 T cells. Degranulation of CD8 T cells may then be triggered by TCR and/or NK-receptor stimulation.

It remains unknown whether IL-2 plays a similar role in CD patients. Of note, a polymorphism in the IL-2/IL-21 locus confers an increased risk for CD (van Heel et al., 2007). It is unclear how this polymorphism affects the expression of IL-2 and IL-21. IL-2 transcripts are not increased in the biopsies of active CD. Yet, IL-2 can be detected in the supernatant of organ cultures from CD biopsies in response to stimulation by gluten peptides. It is therefore possible that small amounts of IL-2 released within the intestinal tissue by activated CD4 T cells might synergize with IL-15. IL-21 might perhaps play a role comparable or complementary to IL-2 in human CD. Thus, IL-21 transcripts were upregulated in CD biopsies, and IL-21 was produced by gluten-specific CD4 T cells (Fina et al., 2008; Sperandeo et al., 2011). Interestingly, IL-21 is necessary for development and survival of memory CD8 T cells after viral infection (Barker et al., 2010; Cui et al., 2011; Novy et al., 2011). IL-21 may synergize with IL-15 in human CD

MAIN RESULTS: Cooperation between antigen-specific CD4 T cells and IL-15 in the mouse model of celiac-like small intestinal enteropathy induced by dietary antigen intestine to foster the expansion of cytotoxic CD8 T cells (Zeng et al., 2005). It was suggested that *in vitro* incubation of intestinal CD4 T cells with IL-15 enhanced their production of IL-21 pointing to a possible feedback loop (Sarra et al., 2013).

A recent study has shown that gluten challenge of CD patients on GFD induced the appearance of activated gut-homing CD8 TCR $\alpha\beta$ and TCR $\gamma\delta$ in their peripheral blood (Han et al., 2013). Activated CD8 T cells were detected simultaneously to gluten-specific CD4 T cells and displayed a focused TCR repertoire similar between different patients. The authors of this study speculated that gluten-specific CD4 T cells might license CD8 T cells specific for self or common infectious antigens (Han et al., 2013). Overall, this hypothesis is in keeping with our results suggesting that CD4 T cells specific of the dietary antigen provide, in the presence of IL-15, non-cognate T cell help to CD8 T cells and drive their expansion and cytotoxic differentiation. This mechanism as well as the blocking effect of IL-15 on Foxp3-mediated immunosuppression may participate in the onset of autoimmune diseases that frequently complicate CD (Cosnes et al., 2008).

May this non-cognate activation of CD8 T cells operate in other MHC class II-dependent autoimmune diseases?

Despite the strong association of most autoimmune diseases with MHC class II alleles (T1D, multiple sclerosis, rheumatoid arthritis and others), numerous reports provide an evidence that CD4 T cells remain initiators of the diseases, while CD8 T cells play an effector role in tissue damage (Gravano and Hoyer, 2013). Indeed, CD8 T cells often dominate in the inflammatory infiltrate accompanying lesions in different autoimmune diseases, including diabetes, multiple sclerosis, rheumatoid arthritis, and autoimmune hepatitis (Babbe et al., 2000; Lucchinetti et al., 2011; Malmstrom et al., 2008; Nakao et al., 1990; Willcox et al., 2009; Wong et al., 2007). Depletion of CD8 T cells reduces or prevents the development of insulin-dependent diabetes in NOD mice (Wang et al., 1996; Wong et al., 1996), experimental rheumatoid arthritis (Larsson et al., 1989; Raposo et al., 2010), experimental autoimmune glomerulonephritis (Reynolds et al., 2002) or myasthenia gravis (Zhang et al., 1995). Contradictory data are available about the specificity of CD8 T cells indicating that they can be specific of tissue self-antigens or not. IL-15 is produced by many tissues and elevated IL-15 levels have been found in several autoimmune diseases, including rheumatoid disease and multiple sclerosis (Carroll et al., 2008; Correale and Villa, 2008; McInnes and Schett, 2007; Vaknin-Dembinsky et al., 2008). Therefore, the cytotoxic activation of CD8 T cells in these pathologies may result from the cooperation between IL-15 produced locally in the tissues and activated CD4 T cells.

May IL-15 contribute to the activation/maturation of dendritic cells therefore contributing to the initiation of inflammatory response?

This issue is studied and discussed in the following chapter of complementary results p. 105.

Perspectives: gluten-induced model of celiac-like enteropathy?

In addition to the presence of human HLA-DQ2/8 transgenes and probably of human transgenic TCR in mice, two main issues remain to be addressed in order to create a gluten-induced mouse model of celiac-like enteropathy: activation of TG2 and reversible up-regulation of IL-15 in the intestinal epithelium. In CD patients, these two events depend on exposure to gluten. However, to establish mouse model, in which IL-15 induction and TG2 activation depend on gluten exposure, will probably be difficult. Models based on tetracycline-dependent (Figure B.1) induction of IL-15 may allow the reversible expression of IL-15. To stimulate prolonged but reversible activation of TG2 activation may be more difficult. Of note, preliminary results in the laboratory suggest that interactions of CD71 with IgA/gluten peptides immune complexes may trigger a Ca²⁺ signal and activate TG2. Strikingly, this mechanism cannot operate in mice since CD71 does not fix mouse IgA. If this result is confirmed, the use of mice expressing a humanized version of IgA may therefore be necessary to recapitulate CD. Production of a pertinent mouse model of CD may thus require complicated breeding to combine at risk HLA, responsive CD4 T cells, IL-15 and human IgA able to bind mouse CD71.

C. SUPPLEMENTARY RESULTS: IL-15-activated NK cells trigger CD103 expression on mononuclear phagocytes and enhance their cross-priming activity

C.1 Introduction

IL-15 is a cytokine synthesized by many cell types, including epithelial cells, tissue mononuclear phagocytes (MNP) and dendritic cells (DCs). IL-15 is generally expressed bound to the alpha chain of IL-15 receptor (IL-15R α) that allows its trans-presentation to immune cells, notably CD8 T cells and NK cells. Indeed, the latter cells express a signaling module comprising a β chain (CD122) common to IL-2 and IL-15 receptors and the γ_c chain (CD132) common to γ_c cytokines (IL-2, IL-4, IL-7, IL-9, IL-15, IL-21) (Fehniger and Caligiuri, 2001). IL-15 is up-regulated during viral and bacterial infections, such as human immunodeficiency virus type 1 (HIV-1), herpes simplex virus 2 (HSV-2), hepatitis C virus (HCV), *Listeria monocytogenes*, and *Toxoplasma gondii*, and may thus contribute to the development of protective innate and adaptive immune responses (Di Sabatino et al., 2011). Conversely, chronic IL-15 up-regulation has been reported in several diseases, notably in celiac disease, rheumatoid arthritis, inflammatory bowel diseases and multiple sclerosis, where it is thought to participate in tissue damage (Di Sabatino et al., 2011). We have recently shown in a mouse model mimicking CD how IL-15 may cooperate with CD4 T cells activated by a dietary antigen to stimulate the expansion of cytotoxic CD8 T cells and foster intestinal tissue damage (Korneychuk et al., 2014). Another work from our laboratory has also shown how an IL-15-dependent population of NK-like innate lymphoid cells present in the intestinal lamina propria can amplify intestinal inflammation by secreting the chemokine CCL3 that recruits inflammatory monocytes into the intestine (Schulthess et al., 2012). Herein, we have examined how chronic up-regulation of IL-15 might influence dendritic cell activation or maturation and thereby perhaps participate in inflammation. Indeed, several reports have indicated that IL-15 might enhance the maturation of dendritic cells differentiated from bone marrow or from blood monocytes (Anguille et al., 2009; Dubsky et al., 2007; Kuwajima et al., 2006; Ohteki et al., 2001; Regamey et al., 2007). Dendritic cells were also suggested to prime more efficiently naïve T cells, when differentiated in the presence of IL-15 (Anguille et al., 2009; Dubsky et al.,

SUPPLEMENTARY RESULTS: IL-15-activated NK cells trigger CD103 expression on mononuclear phagocytes and enhance their cross-priming activity (2007; Ohteki et al., 2001). To address this issue, we have taken advantage of mice chronically overexpressing a soluble form of human IL-15 in intestinal epithelium (hIL-15Tge mice) (Ohta et al., 2002). Herein, we show that overexpression of IL-15 stimulates the expansion of a subset of dendritic cells expressing CD103 and that this effect depends on GM-CSF secretion by IL-15-activated NK cells. DCs differentiated in mice overexpressing IL-15 were enriched in CD103⁺ DCs and displayed enhanced cross-presentation abilities *in vitro*. These results illustrate how IL-15, by orchestrating a crosstalk between NK cells and mononuclear phagocytes, can modulate adaptive immune responses.

C.2 Materials and Methods

Mice

B6 (C57BL/6j) and B6 Ly5.1 mice were purchased from Charles River (L'Arbresle, France). OTI RAG2^{-/-} mice were a gift from O. Lantz (Institut Curie, Paris, France). RAG^{-/-} γ c^{-/-} Ly-5.2, CD122^{-/-} RAG^{-/-} Ly-5.2 and RAG^{-/-} Ly5.1 mice were a gift from J. Di Santo (Institut Pasteur, Paris, France). Bone marrows of Csf-2R β ^{-/-} mice were a gift from F. Powrie (University of Oxford, UK). Heterozygous mice expressing human IL-15 under control of intestine-specific T3b promoter (hIL-15Tge mice) (Ohta et al., 2002) and IL-15^{-/-} mice were maintained and bred under specific pathogen-free conditions in accordance with European Guidelines. Experiments were approved by the local ethics committee.

Cell isolation and flow cytometry

Isolation of lamina propria (LP), spleen and mesenteric lymph nodes (MLN) cells was performed as described (Gaboriau-Routhiau et al., 2009). For isolation of dendritic cells, spleen and MLN tissues were cut in small pieces and digested with 100U/mL Collagenase D (Roche, France) and 50U/mL DNase I (Sigma, France) for 40 minutes at 37°C prior to collecting cell suspensions. For membrane staining, 10⁵ cells were incubated with FcRII/III mAb (Fc block, 2.4G2) and then with various mixes of directly coupled mouse mAbs: I-A/I-E-FITC (2G9), CD11c-PE-Cy7 (HL3), CD11b-APC (M1/70), CD3e-APC (145-2C11), CD19-APC (1D3), CD45R (B220)-Alexa Fluor 647 (RA3-6B2), NK1.1-APC (PK136), V β 5-FITC (MR9-4), CD8-APC-H7 (PC61), CD4-FITC (H129.19) from BD Biosciences (Le Pont-de Claix, France); CD11-PerCP-Cy5.5 (N418), NKG2D-APC (CX5), CD80-FITC (16-10A1), CD86-PE-Cy5 (GL1), CD40-PE-Cy5 (1C10), CD45-eFluor 450 (20-F11) from eBioscience (Paris, France). Dead cells were excluded using Aqua dead (Life Technologies, Saint-Aubin, France). Cells

SUPPLEMENTARY RESULTS: IL-15-activated NK cells trigger CD103 expression on mononuclear phagocytes and enhance their cross-priming activity were analyzed on a FACS Canto II using BD FACSDiva software (BD Biosciences, Le Pont-de Claix, France) or FlowJo software (Treestar Inc., USA).

Bone-marrow dendritic cell cultures

Bone marrow (BM) was flushed out from femurs and tibiae using PBS 1X. Red blood cells were lysed and washed with RPMI/2% FCS. Cells were resuspended at 2×10^6 cells/mL in RPMI 1640 added with 10% FCS and Flt3L (200ng/mL, Miltenyi Biotec SAS) in 6-well plates (3mL of cell suspension/per well) for 9-12 days at 37°C. In some conditions, mouse IL-15 (100ng/mL, Miltenyi Biotec SAS) and/or mouse GM-CSF (1ng/mL, Miltenyi Biotec SAS) were added to the culture on day 0 or day 6. In co-culture experiments BM from RAG^{-/-} γ c^{-/-} Ly-5.2 or CD122^{-/-} RAG^{-/-} Ly-5.2 mice and BM cells from B6 Ly5.1 or RAG^{-/-} Ly5.1 mice were put into culture at a 1:1 ratio. In Transwell experiments, RAG^{-/-} γ c^{-/-} Ly-5.2 BM cells were placed on 0.4 μ m polycarbonate membrane inserts in the upper chambers of 6-well plates (Corning Costar, Sigma Aldrich, Lyon, France) while RAG^{-/-} Ly5.1 BM cells were added into the lower chambers.

Enzyme-linked immunosorbent assay (ELISA)

GM-CSF concentration was analyzed by ELISA (DY415, R&D Systems, Lille, France).

Quantification of messenger RNA expression

RNA was purified from duodenal biopsy specimens using RNeasy Mini kit (Qiagen France SAS, Courtaboeuf, France) and reverse-transcribed as described (Gaboriau-Routhiau et al., 2009). Quantitative polymerase chain reaction was performed using Taqman gene expression assays (Life Technologies).

Cross-presentation assay

Spleen DCs from WT B6 or hIL-15Tge mice were enriched by an AutoMACS Pro Separator using CD11c magnetic beads (Miltenyi Biotec) and distinct DC subsets were FACS-sorted as MHCII⁺Lin⁻CD11c⁺CD11b⁻ or CD11b⁺ (Lin included CD3, CD19, NK1.1, NKG2D and B220) using a FACS Aria cell sorter (BD Biosciences). OVA-specific CD8 (OTI) T cells were isolated from the spleen of OTI RAG^{-/-} mice and negatively sorted by an AutoMACS Pro Separator and then by a FACS Aria cell sorter as CD8⁺NKG2D⁻NK1.1⁻CD11c⁻ cells. OVA-specific CD8 T cells (>99% purity) were then labeled using Cell Trace Violet cell proliferation kit (Life Technologies). To assess the ability of DCs to cross-present OVA protein to Cell

Trace Violet-stained CD8 OTI T cells, APC were first pulsed with different concentrations of OVA protein (from 10mg/mL to lesser concentrations obtained by two-fold serial dilutions) for 4 hours at 37°C, washed several times with RPMI/10% FCS and co-cultured with OVA-specific CD8 T cells in 1:10 ratio for 3 days at 37°C with 5% CO₂ in 96-well round-bottom plates. After 3 days, proliferation and cell counts were determined by flow cytometry using cell count beads (BD Biosciences).

Statistical analysis

Statistical analysis was performed with GraphPad Prism version 6.00 (GraphPad Software Inc., La Jolla, USA) using non-parametric Mann-Whitney U test. A P value less than .05 was considered statistically significant.

C.3 Results

Striking expansion of CD103⁺CD11c⁺CD11b⁻ DCs in hIL-15Tge mice

Comparative analysis of mononuclear phagocytes (MNP) purified from small intestinal lamina propria, MLN and spleen of WT B6 and hIL-15Tge mice was performed using traditional surface markers. A simple gating strategy was adopted (Figure C.1). Total mononuclear phagocytes were identified among live leukocytes (CD45⁺ Aqua dead⁻) as CD11c⁺ MHCII⁺ Lin⁻ cells (Lin included CD3, CD19, NK1.1, B220 markers). Then, two populations were distinguished as CD11c⁺CD11b⁻ and CD11c⁺CD11b⁺ cells and the latter two subsets were analyzed for CD103 expression. The lack of functional CX3CR1 antibody and of hIL-15Tge mice crossed to CX3CR1^{+/GFP} prevented the simultaneous analysis of CX3CR1 and CD103 expression.

SUPPLEMENTARY RESULTS: IL-15-activated NK cells trigger CD103 expression on mononuclear phagocytes and enhance their cross-priming activity

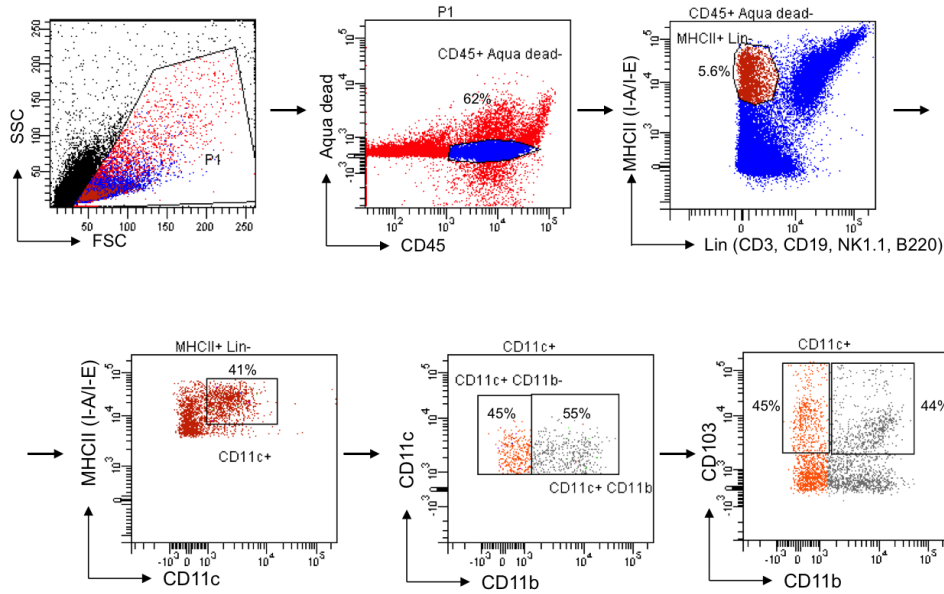

Figure C.1: Gating strategy for identification of small intestinal lamina propria mononuclear phagocytes (SI LP MNP)
 Representative dot plots showing the identification of SI LP MNP in WT B6 mouse. Based on SSC/FSC profiles, live leukocytes were identified as CD45⁺ Aqua-dead⁻ cells. MNP were then identified as CD11c⁺ MHCII⁺ Lin⁻ (Lin containing CD3, CD19, NK1.1 and B220). Two MNP subsets were distinguished based on their expression of CD11b: CD11c⁺CD11b⁻ (orange) and CD11c⁺CD11b⁺ (gray). The expression of CD103 was analyzed in both subsets.

Except in MLN, which contained increased frequency of CD11c⁺CD11b⁻ cells, frequencies of CD11c⁺CD11b⁻ and CD11c⁺CD11b⁺ cells were comparable in hIL-15Tge mice and WT B6 mice (Figure C.2 A, B). However, absolute numbers of both populations were strongly increased in all tested compartments of hIL-15Tge mice (Figure C.2 C). In contrast, no difference was observed in frequencies or numbers of CD11c⁺CD11b⁻ and CD11c⁺CD11b⁺ MNP between IL-15^{-/-} and WT B6 mice (Figure C.2 B, C). Overall, these data indicate that IL-15 is dispensable for the differentiation or survival of MNP cell subsets, but chronic IL-15 overexpression can drive their expansion.

SUPPLEMENTARY RESULTS: IL-15-activated NK cells trigger CD103 expression on mononuclear phagocytes and enhance their cross-priming activity

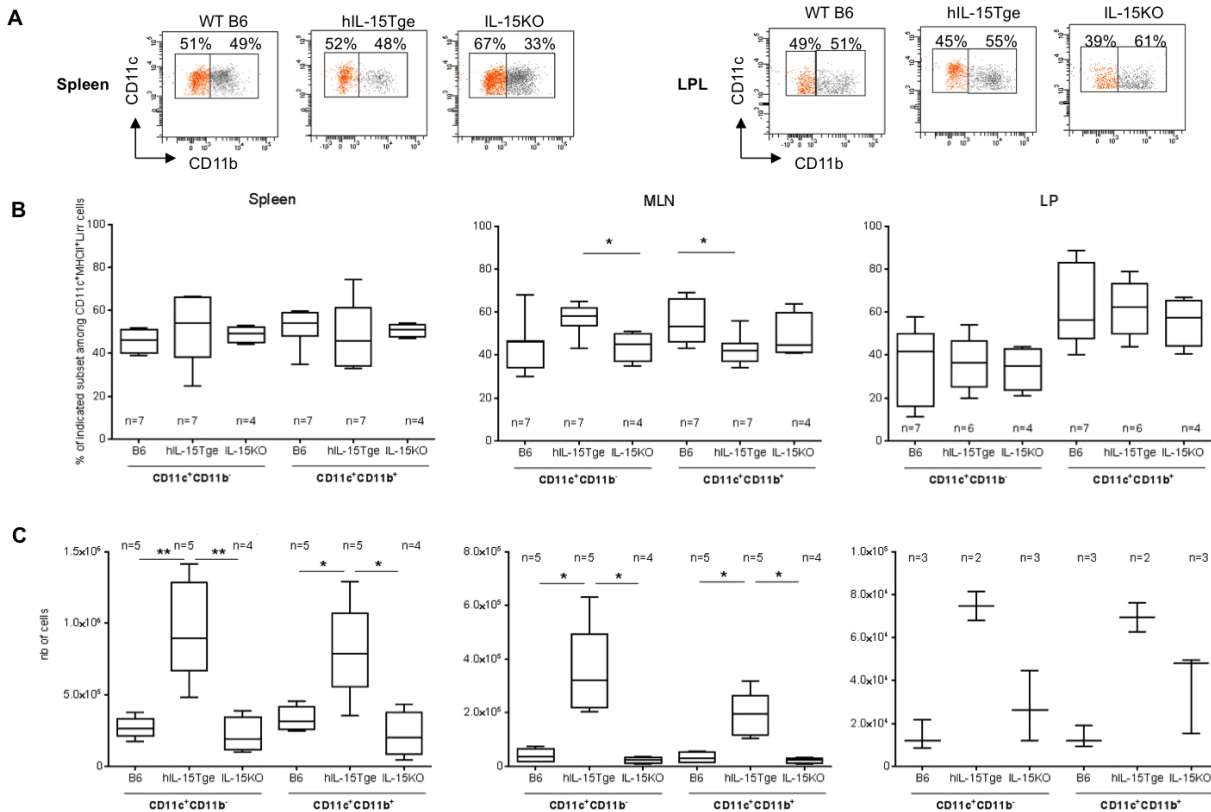

Figure C.2: Comparative analysis of frequency and numbers of CD11c⁺CD11b⁻ and CD11c⁺CD11b⁺ MNP in WT B6, hIL-15Tge and IL-15KO mice

A. Representative dot plots showing distribution of CD11c⁺CD11b⁻ and CD11c⁺CD11b⁺ subsets among CD11c⁺MHCII⁺Lin⁻ cells in spleen and lamina propria (LP) of WT B6, hIL-15Tge and IL-15KO mice. B, C. Frequency (B) and absolute numbers (C) of two populations among CD11c⁺MHCII⁺Lin⁻ in spleen, mesenteric lymph nodes (MLN) and lamina propria (LP) of WT B6, hIL-15Tge and IL-15KO mice. *P < 0.05, **P < 0.01.

Further analysis revealed a striking increase in the frequency of CD103⁺ cells among CD11c⁺CD11b⁻ but not among CD11c⁺CD11b⁺ MNP in all analyzed compartments (small intestinal LP, MLN and spleen) of hIL-15Tge mice compared with WT B6 mice (Figure C.3 A, B, and Figure C.4 A, B). Given the strong increase in total numbers of MNP cells in hIL-15Tge mice, the latter mice demonstrated a 8-fold increase in CD103⁺CD11c⁺CD11b⁻ cells in lamina propria and a 10-fold increase in MLN and spleen compared with WT B6 and IL-15^{-/-} mice (Figure C.5). These findings indicated that IL-15 stimulated CD103 expression by CD11c⁺CD11b⁻ MNP but also promoted their expansion.

SUPPLEMENTARY RESULTS: IL-15-activated NK cells trigger CD103 expression on mononuclear phagocytes and enhance their cross-priming activity

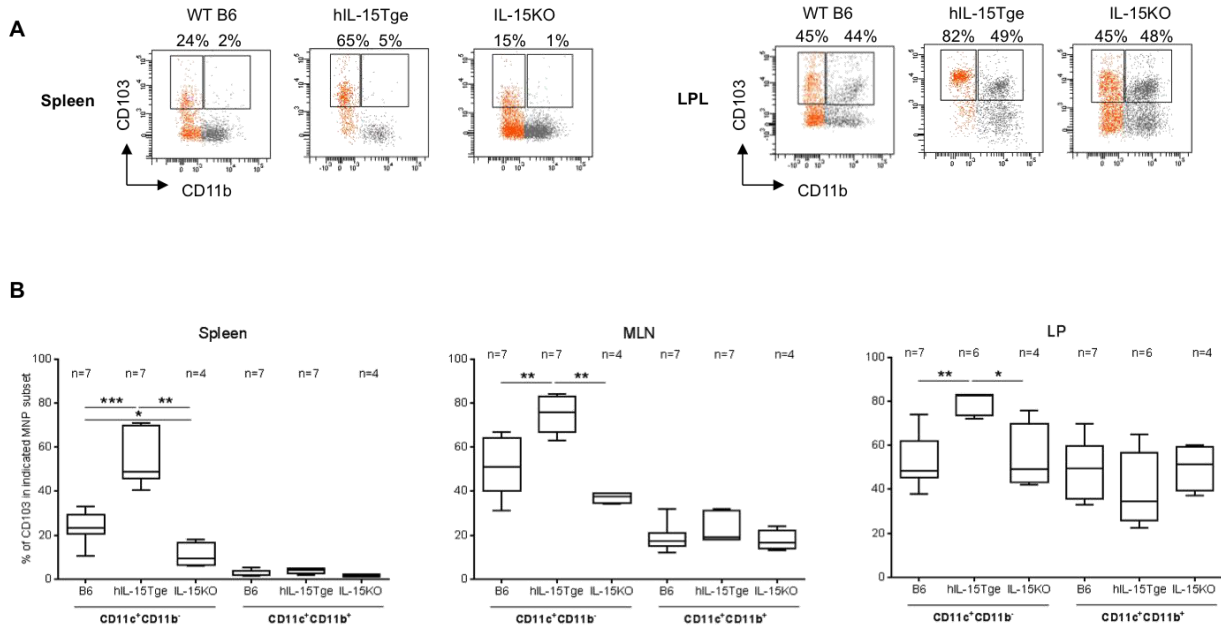

Figure C.3: Significant increase in frequency of CD103⁺ cells among CD11c⁺CD11b⁻ but not CD11c⁺CD11b⁺ MNP in hIL-15Tge mice

A. Representative dot plots of CD103 staining of CD11c⁺CD11b⁻ (orange) and CD11c⁺CD11b⁺ (gray) MNP subsets of spleen and lamina propria (LP) lymphocytes of WT B6, hIL-15Tge and IL-15KO mice. B. Frequency of CD103⁺ cells among CD11c⁺CD11b⁻ and CD11c⁺CD11b⁺ MNP subsets in spleen, mesenteric lymph nodes (MLN) and LP of WT B6, hIL-15Tge and IL-15KO mice. *P<.05, **P<.01; ***P<.001.

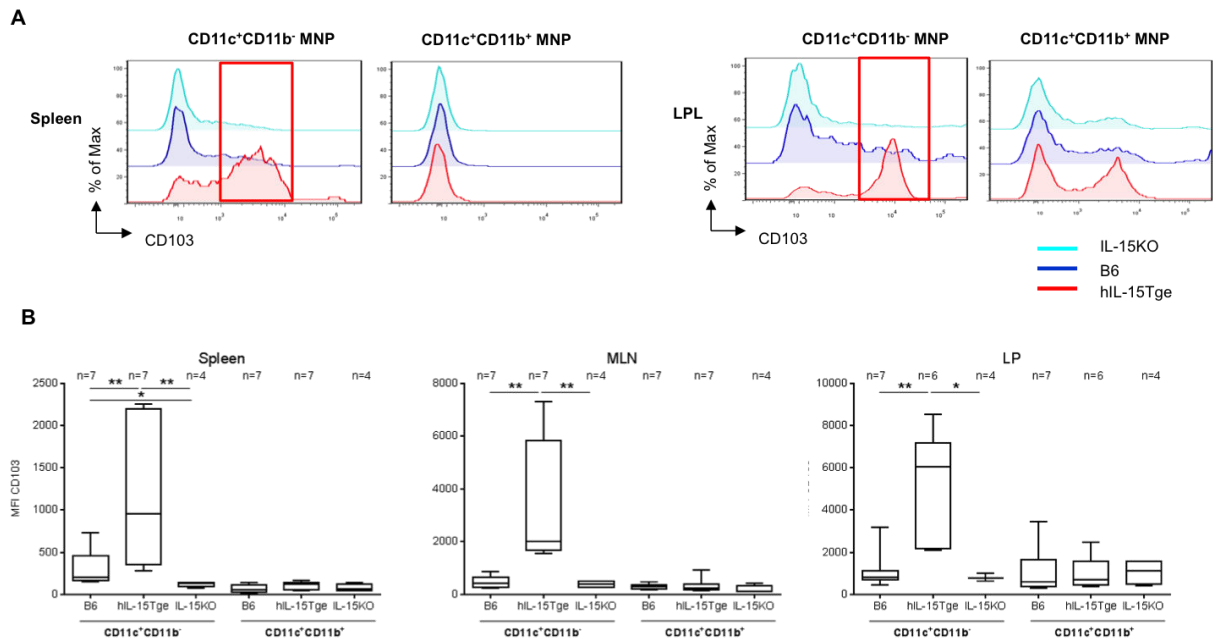

Figure C.4: Strong increase of intensity of CD103 expression by CD11c⁺CD11b⁻ cells but not CD11c⁺CD11b⁺ of hIL-15Tge mice

A. Mean fluorescent intensities of CD103 staining of CD11c⁺CD11b⁻ and CD11c⁺CD11b⁺ MHCII⁺ Lin⁻ splenocytes and lamina propria lymphocytes (LPL) from representative WT B6, hIL-15Tge and IL-15KO mice. B. MFI for CD103 expression by CD11c⁺CD11b⁻ and CD11c⁺CD11b⁺ MNP from spleen, mesenteric lymph nodes (MLN) and LP of WT B6, hIL-15Tge and IL-15KO mice. *P<.05, **P<.01.

SUPPLEMENTARY RESULTS: IL-15-activated NK cells trigger CD103 expression on mononuclear phagocytes and enhance their cross-priming activity

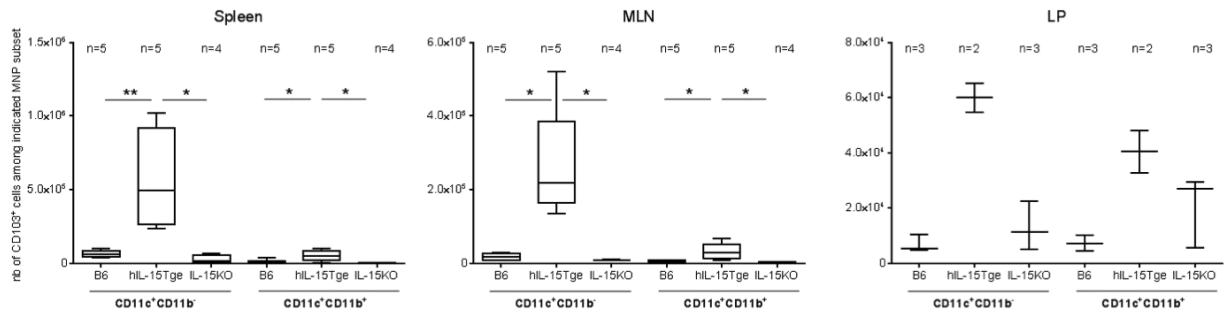

Figure C.5: Strong expansion of CD103⁺CD11c⁺CD11b⁻ and CD103⁺CD11c⁺CD11b⁺ cells in hIL-15Tge mice

Absolute numbers of CD103⁺CD11c⁺CD11b⁻ and CD103⁺CD11c⁺CD11b⁺ in spleen, mesenteric lymph nodes (MLN) and lamina propria (LP) of WT B6, hIL-15Tge and IL-15KO mice. *P<.05, **P<.01.

Increased CD86 expression by lamina propria mononuclear cells in hIL-15Tge mice

A long-lasting hypothesis suggests that IL-15 can foster MNP maturation (Anguille et al., 2009; Dubsky et al., 2007; Kuwajima et al., 2006; Ohteki et al., 2001; Regamey et al., 2007). Staining for costimulatory molecules revealed a significant increase in CD86 expression in CD11c⁺CD11b⁻ and CD11c⁺CD11b⁺ MNP in the small intestine but not in MLN or spleen (Figure C.6). In contrast, expression of CD40 or MHC class II was unchanged in CD11c⁺ MNP from hIL-15Tge mice compared with B6 mice (Figure C.7) and CD80 was not detected in any tested MNP subsets (not shown). Overall, these data suggest that IL-15 overexpression may not be sufficient to induce the complete maturation of CD11c DCs.

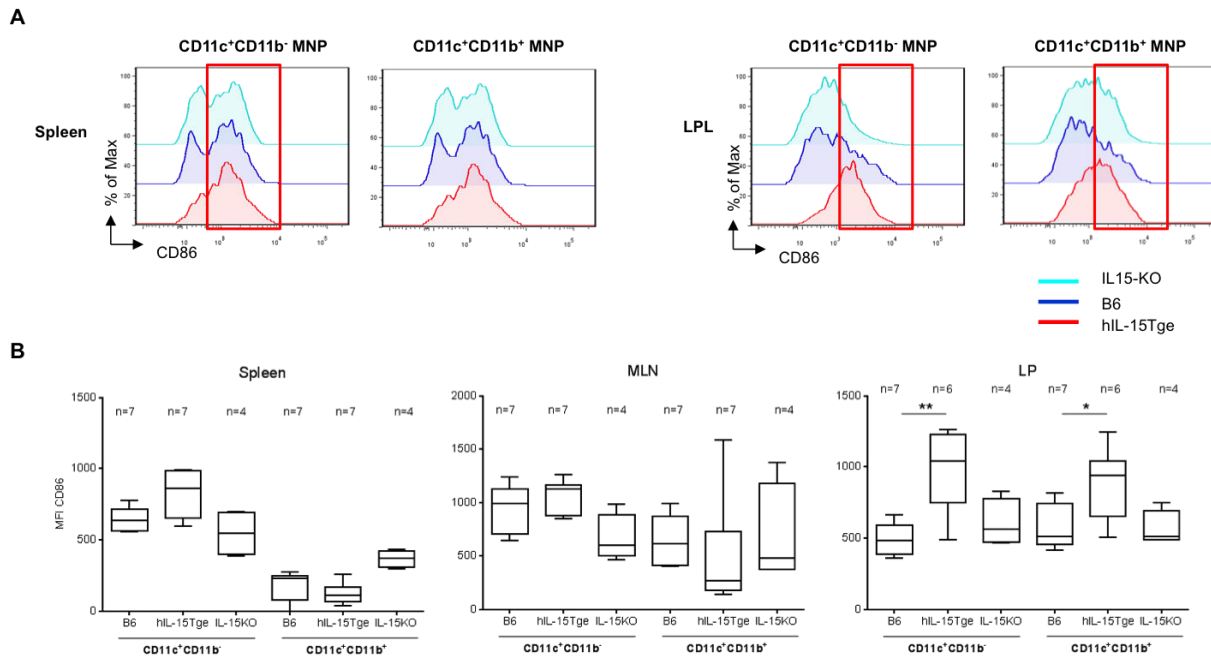

Figure C.6: Increased CD86 expression by lamina propria CD11c⁺CD11b⁻ and CD11c⁺CD11b⁺ mononuclear phagocytes in hIL-15Tge mice.

A. Mean fluorescent intensities of CD86 staining of CD11c⁺CD11b⁻ and CD11c⁺CD11b⁺ MHCII⁺ Lin⁻ splenocytes and lamina propria lymphocytes (LPL) from representative WT B6, hIL-15Tge and IL-15KO mice. B. MFI for CD86 expression by CD11c⁺CD11b⁻ and CD11c⁺CD11b⁺ MNP from spleen, mesenteric lymph nodes (MLN) and LP of WT B6, hIL-15Tge and IL-15KO mice. *P<.05, **P<.01.

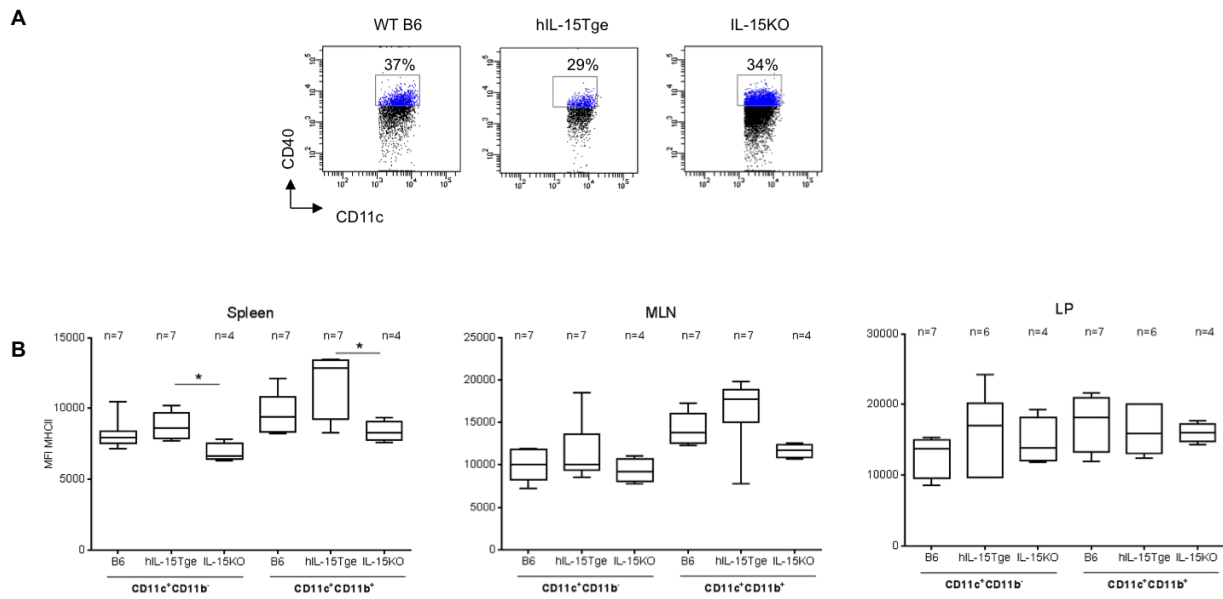

Figure C.7: No changes in CD40 and MHC class II expression by MNP in hIL-15Tge mice

A. Representative dot plots of CD40 staining of CD11c⁺ MHCII⁺ Lin⁻ lamina propria lymphocytes from representative WT B6, hIL-15Tge and IL-15KO mice. B. Mean fluorescent intensity (MFI) of MHCII (I-A/I-E) staining of CD11c⁺CD11b⁻ and CD11c⁺CD11b⁺ MHCII⁺ Lin⁻ cells from spleen, mesenteric lymph nodes (MLN) and lamina propria (LP) from WT B6, hIL-15Tge and IL-15KO mice. *P<.05.

IL-15 upregulates CD103 expression on bone marrow-derived dendritic cells

To analyze how IL-15 could promote the expansion of CD103⁺CD11c⁺ DCs, DCs from WT B6 bone marrow (BM) were differentiated in the presence or not of IL-15. Knowing that the development of CD103⁺ CD11c⁺ DCs from non-lymphoid tissues requires Flt3L (Ginhoux et al., 2009; Varol et al., 2009), differentiation of BM DCs was performed in the presence of Flt3L. On day 9, the majority of cells differentiated in the presence of Flt3L displayed an MHCII⁺Lin⁻CD11c⁺CD11b^{int/+} phenotype but only about 10% expressed CD103 (Figure C.8A). When differentiation was performed in the presence of IL-15 (added from day 0), numbers of MHCII⁺Lin⁻CD11c⁺CD11b^{int/+} cells were more than two fold increased on day 9 and 50-90% of the latter cells expressed CD103 (Figure C.8B). Strikingly, the expansion of CD103⁺CD11c⁺CD11b^{int/+} DCs in IL-15-containing cultures was associated with the appearance of a distinct cell population that was identified as CD3⁻CD19⁻NK1.1⁺ NK cells. NK cells are known to differentiate from BM precursors in the presence of IL-15 and, accordingly, were absent in BM cells differentiated in the absence of IL-15 (Figure C.8B). Of note, adding IL-15 to Flt3L-BM cultures on day 6 was sufficient to simultaneously induce by day 12 increased expression of CD103 on CD11c⁺ CD11b^{int/+} cells DCs and NK cell expansion (Fig.8C). In contrast, when IL-15 was removed (by washing) on day 6 from the BM cell culture, no CD103 expression was anymore detected on DCs on day 12 and no NK cells were found in the culture (Figure C.8D). These results suggested that IL-15 could either directly or,

SUPPLEMENTARY RESULTS: IL-15-activated NK cells trigger CD103 expression on mononuclear phagocytes and enhance their cross-priming activity indirectly via NK cells, trigger CD103 expression on DCs and promote expansion of DCs, notably of those expressing CD103.

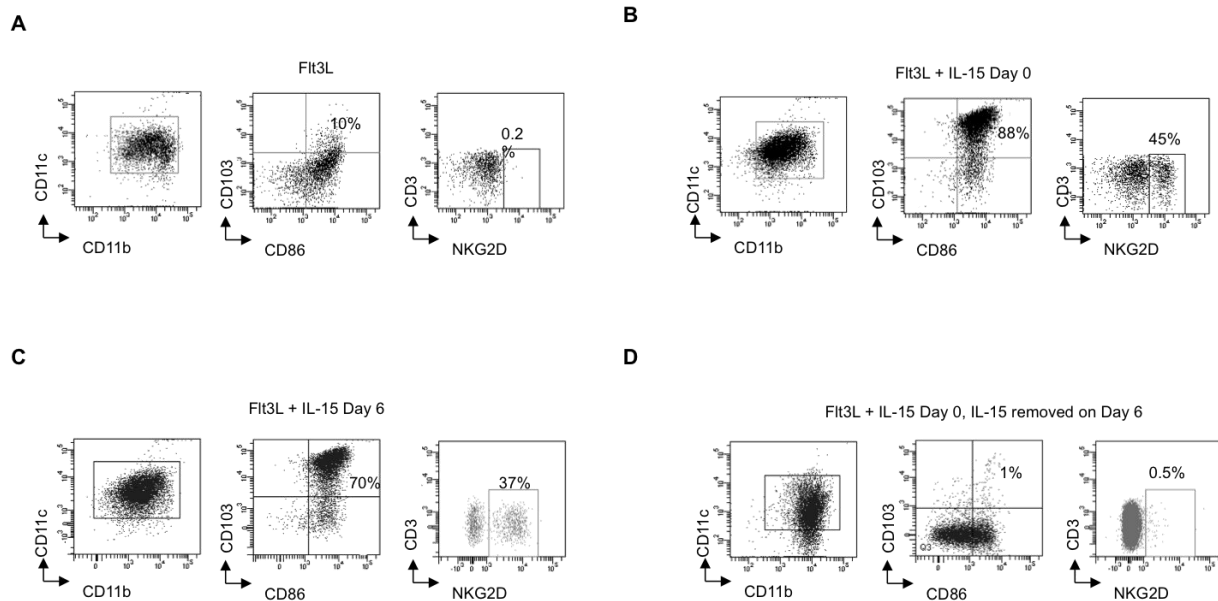

Figure C.8: Increased CD103 expression on bone marrow differentiated dendritic cells in the presence of Flt3L and IL-15 accompanied by emergence of NK cells.

A-D. Flow cytometry of bone marrow cells cultured for 9 (A, B) or 12 (C, D) days with Flt3L. Mouse IL-15 was added to the culture on day 0 (B) or on day 6 (C). The effect of removal of IL-15 from the culture on day 6 by washing of cells with RPMI was assessed in D. CD11c⁺MHCII⁺Lin⁻ dendritic cells were analyzed for the expression of CD103 and CD86. The differentiation of NK cells in the culture was assessed by NKG2D staining as CD3⁺NKG2D⁺.

CD103 expression on DCs is not directly triggered by IL-15 but is mediated by IL-15-activated NK cells

Confirming that CD103 expression on DCs depends on IL-15 signaling, DCs differentiated from BM of RAG^{-/-} γ c^{-/-} or CD122^{-/-} RAG^{-/-} mice lacking functional signaling of IL-15 receptor, failed to express CD103 (Figure C.9A, B). Yet, NK differentiation and homeostasis depend on IL-15 signals, so mice lacking γ c or IL15-R β (CD122) chains have no NK cells (Fehniger and Caligiuri, 2001). Therefore, in order to distinguish whether IL-15 acted directly on DCs or indirectly via NK cells that expanded in IL-15-containing cultures, CD103 expression was compared in DCs derived from co-cultures between RAG^{-/-} Ly-5.1 or B6 Ly-5.1 BM cells with normal IL-15 signaling and CD122^{-/-} RAG^{-/-} Ly-5.2 or RAG^{-/-} γ c^{-/-} Ly-5.2 BM cells, which do not respond to IL-15 (Figure C.9C, D). Strikingly, in the presence of IL-15, Ly-5.2⁺ DCs from either CD122^{-/-} RAG^{-/-} Ly-5.2 or RAG^{-/-} γ c^{-/-} Ly-5.2 BM cells up-regulated CD103 expression as efficiently as RAG^{-/-} Ly-5.1 DCs, indicating that CD103 expression does not depend on direct IL-15 signalling in DCs but rather on a signal provided by IL-15-dependent cells (Figure C.9C, D). No difference in the expression of CD103 was observed between DCs differentiated in the presence of B6 Ly-5.1 BM cells or RAG^{-/-} Ly-5.1, indicating that the IL-15-dependent cells

SUPPLEMENTARY RESULTS: IL-15-activated NK cells trigger CD103 expression on mononuclear phagocytes and enhance their cross-priming activity necessary for inducing CD103 could not be contaminating T or B lymphocytes and were NK cells or NK-like innate lymphoid cells.

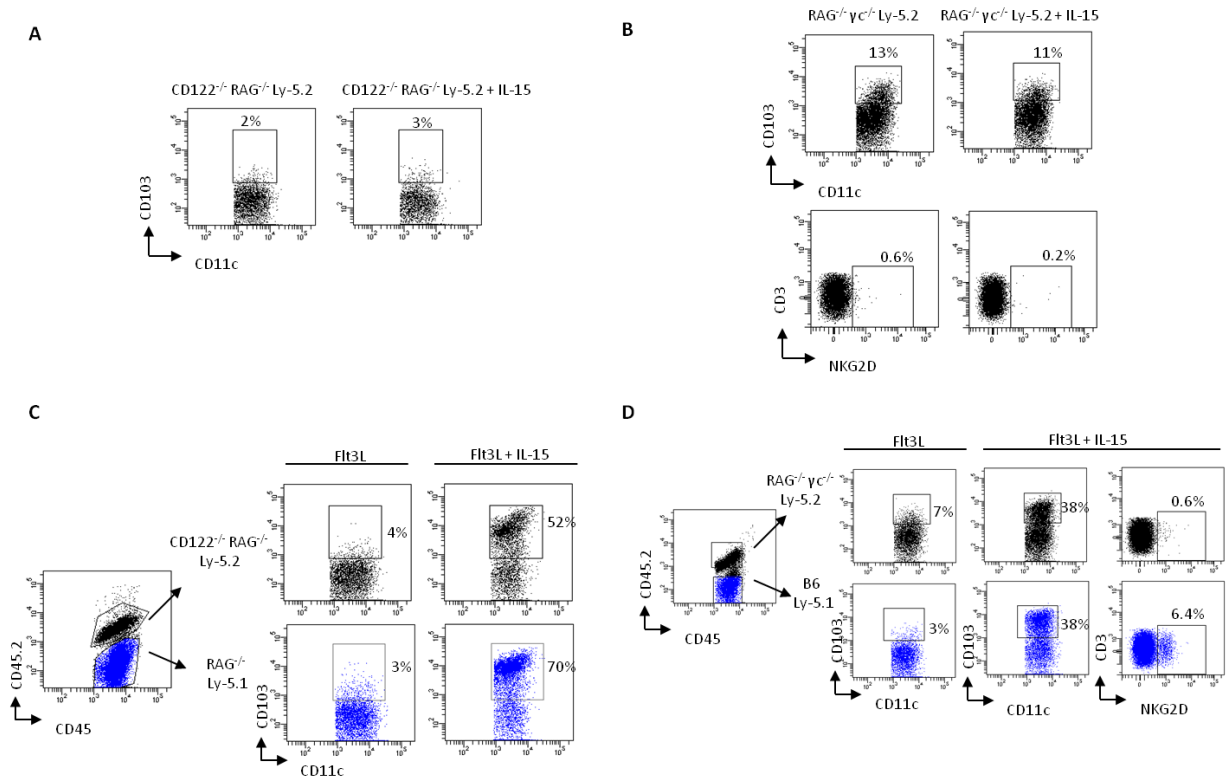

Figure C.9: CD103 expression on DCs is not directly triggered by IL-15 but is mediated by IL-15-activated NK cells
 A-D. Flow cytometry of bone marrow (BM) cells from CD122^{-/-} RAG^{-/-} Ly-5.2 or RAG^{-/-} γ C^{-/-} Ly-5.2 mice cultured alone with Flt3L in the presence or not of mouse IL-15 (A, B) or together with RAG^{-/-} Ly-5.1 or B6 Ly-5.1 BM respectively in 1:1 ratio (C, D) for 9 days in the presence or not of IL-15. CD103 expression by CD11c⁺MHCII⁺Lin⁻ dendritic cells of Ly-5.1 or Ly-5.2 origin was analyzed on day 9. The differentiation of NK cells was determined as CD3⁺NKG2D⁺.

CD103 induction on DCs does not require cell-cell contact between DCs and NK cells

In order to define whether CD103 induction on DCs required or not cell-cell contact between DCs, RAG^{-/-} γ C^{-/-} Ly-5.2 were co-cultured with RAG^{-/-} Ly-5.1 BM cells across a Transwell membrane in the presence of IL-15 (Figure C.10). Expression of CD103 on day 9 was similar in DCs differentiated from RAG^{-/-} γ C^{-/-} Ly-5.2 and from RAG^{-/-} Ly-5.1 DCs (Figure C.10). Taken together, these data indicate that CD103 induction on DCs depended on a soluble factor released by NK cells.

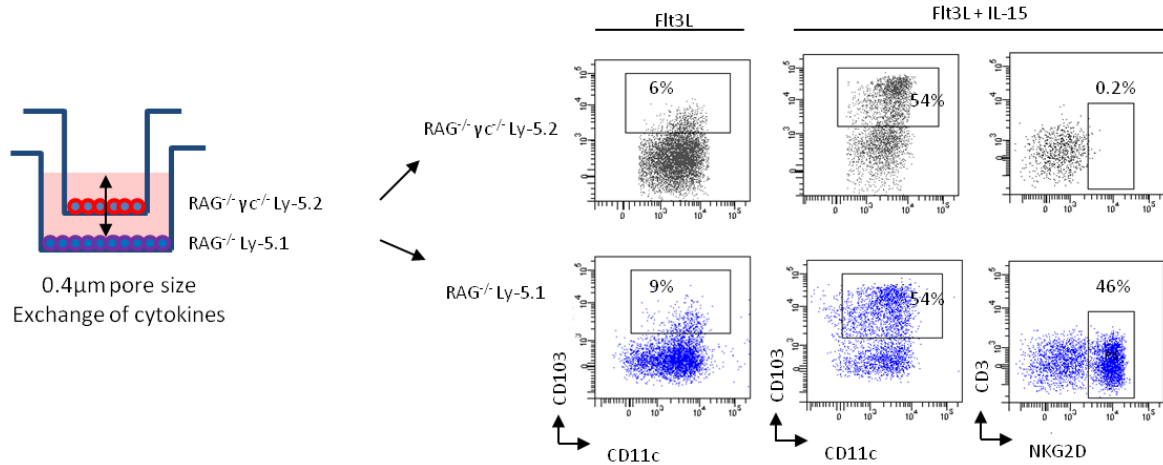

Figure C.10: CD103 induction on DCs does not require cell-cell contact between DCs and NK cells

Co-culture of $RAG^{-/-} \gamma c^{-/-} Ly-5.2$ and $Rag^{-/-} Ly-5.1$ bone marrow cells (1:1 ratio) separated by transwell membrane was performed for 9 days with mouse Flt3L in the presence or not of mouse IL-15. Flow cytometry analysis of CD103 expression by Ly-5.1 and Ly-5.2 CD11c⁺MHCII⁺Lin⁻ cells was performed on day 9. Differentiated NK cells were determined as CD3⁻NKG2D⁺.

GM-CSF can recapitulate the inducing effect of IL-15-activated NK cells on CD103 expression by DCs

A possible role of GM-CSF was suggested by previous evidence that this cytokine can be produced by NK cells (Zhang et al., 2007) and may regulate the development of lamina propria CD103⁺ MNP or merely control CD103 expression (Bogunovic et al., 2009; Greter et al., 2012). Consistent with this hypothesis, GM-CSF progressively accumulated between day 3 and day 8 in the supernatant of WT B6 BM cell cultures performed in the presence but not in the absence of IL-15 (Figure C.11A). Moreover, adding GM-CSF to WT B6 BM differentiation culture on day 6 strongly stimulated CD103 expression on DCs harvested on day 9 compared to cultures without IL-15 and GM-CSF (Figure C.11B). That GM-CSF signaling was indispensable for CD103 induction on DCs was further confirmed using BM cells from mice deficient for the *Csf-2Rβ* chain (Broughton et al., 2012a). Although *Csf-2Rβ*^{-/-} BM cells could differentiate into CD11c⁺CD11B^{+/+} DCs in cultures containing Flt3L, the latter cells did not express CD103 when IL-15 was added to the culture, despite a high frequency of NK cells (Figure C.11C) and conspicuous production of GM-CSF (Figure C.11A). In addition, the numbers of CD11c⁺ DCs differentiated from *Csf-2Rβ*^{-/-} BM cells were greatly reduced compared to those differentiated from B6 BM (not shown).

SUPPLEMENTARY RESULTS: IL-15-activated NK cells trigger CD103 expression on mononuclear phagocytes and enhance their cross-priming activity

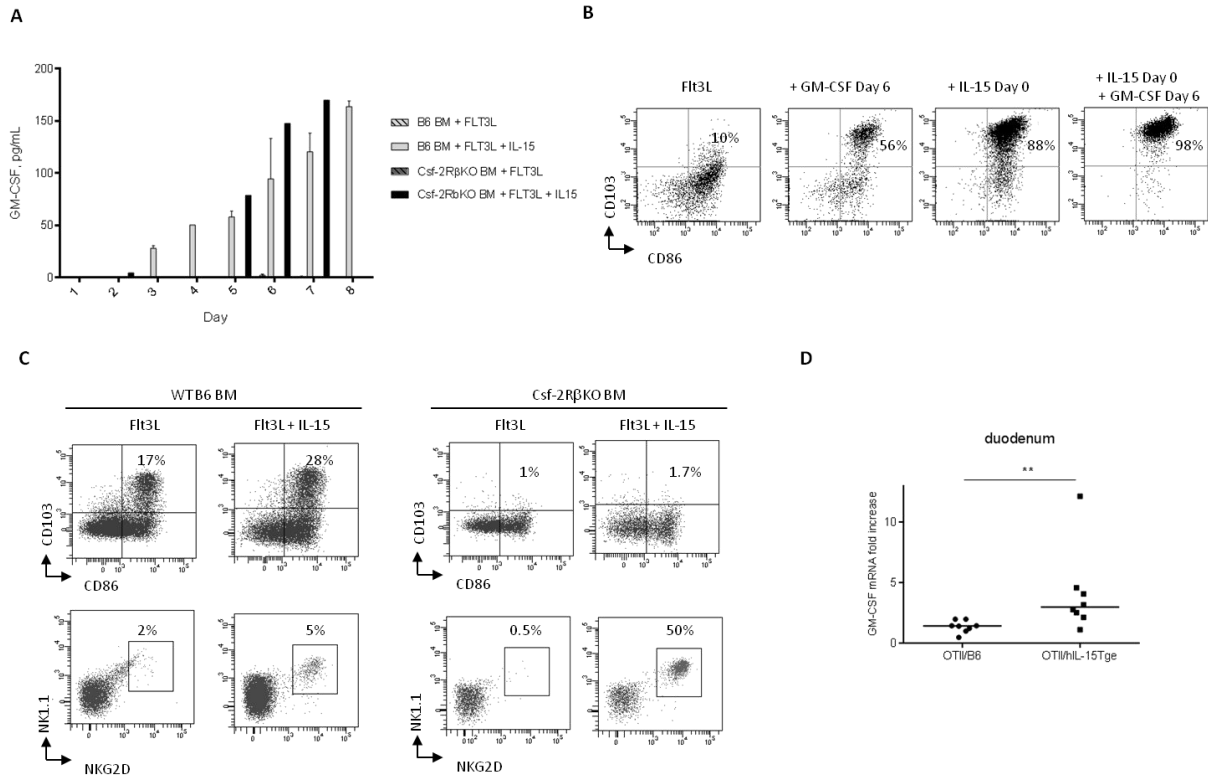

Figure C.11: GM-CSF can recapitulate the effect of IL-15-activated NK cells on the CD103 induction on DCs

A-C. The differentiation of bone marrow cells from WT B6 or *Csf-2Rβ*KO mice was induced by mouse Flt3L in the presence or not of mouse IL-15. A. GM-CSF production was analyzed by ELISA in supernatant collected during the culture (Day 1-8). B. GM-CSF was added on day 6 to the culture of WT B6 BM differentiated in the presence of Flt3L and/or IL-15. The expression of CD103 by CD11c⁺MHCII⁺Lin⁻ cells was analyzed on day 9. C. Flow cytometry analysis of CD103 and CD86 expression was assessed after 9 days of or *Csf-2Rβ*KO BM cells cultured in the presence or not of IL-15. NK cells were detected as CD3⁺NKG2D⁺NK1.1⁺. D. Relative expression of *Csf-2* (*GM-CSF*) mRNA transcripts normalized to *Hprt1* in duodenum of OTII/B6 and OTII/hIL-15Tge mice.

In order to determine whether these *in vitro* findings were translatable to the *in vivo* situation, when IL-15 is chronically overexpressed in the intestine, *Csf-2* transcripts was assessed by qPCR in duodenal biopsies of B6 and hIL-15Tge mice. A significant increase in *Csf-2* transcripts was observed in the duodenum of hIL-15Tge mice compared to B6 mice (Figure C.11D). *Csf-2* transcripts were also assessed in duodenal biopsies of celiac patients either active or on GFD, patients with type II refractory sprue patients and controls (Figure C.12). No significant increase was detected in CD patients compared to controls, but *Csf-2* transcripts tended to increase in patients with type II refractory sprue that develop a population of clonal IELs displaying NK-like features (Malamut et al., 2012). Analysis of supplemental individuals in each group is however needed to reach definitive conclusion.

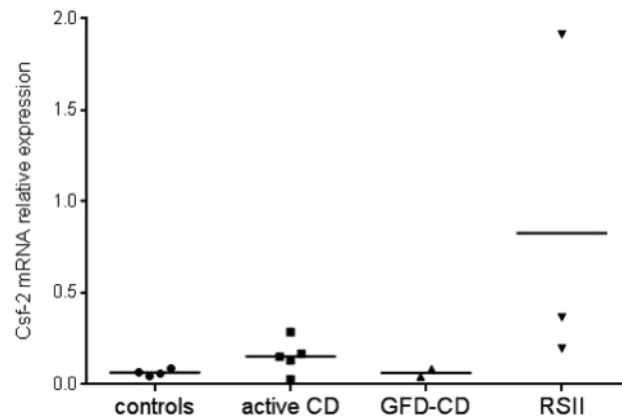

Figure C.12: *Csf-2* transcripts in duodenum of CD patients and controls

Csf-2 messenger (mRNA) expression normalized to *Rpl10* mRNA in duodenum of controls, active celiac disease (CD) patients, CD patients following gluten-free diet (GFD-CD), and type II refractory patients.

Functional significance of GM-CSF-dependent CD103 increase on DCs

CD103⁺DCs were suggested to efficiently present antigens to naïve T cells and notably to have cross-priming capacities (Greter et al., 2012; Sathe et al., 2011; Zhan et al., 2011). In order to test whether DCs from hIL-15Tge mice enriched in CD103⁺ cells may have enhanced cross-presenting activity (Figure C.13A), MHCII⁺Lin⁻CD11c⁺CD11b⁻ and MHCII⁺Lin⁻CD11c⁺CD11b⁺ DCs were FACS-sorted from spleens of B6 and hIL-15Tge mice, pulsed with different concentrations of OVA protein and then co-cultured with purified OVA-specific TCR transgenic CD8 (OTI) T cells (99% pure). Both subsets of CD11c⁺CD11b⁺ or CD11c⁺CD11b⁻ DCs could cross-present OVA to OTI CD8 T cells but, as expected, CD11c⁺CD11b⁻ cells were more efficient. Thus, at all tested OVA concentrations the numbers of proliferating OTI cells were higher upon co-culture with CD11c⁺CD11b⁻ than with CD11c⁺CD11b⁺ DCs. Moreover, the numbers of proliferating OTI cells were higher when co-cultured with MHCII⁺Lin⁻CD11c⁺CD11b⁻ DCs from hIL-15Tge than from B6 mice, while no difference was noted for MHCII⁺Lin⁻CD11c⁺CD11b⁺ DCs except at the two higher tested concentrations of OVA (Figure C.13B). Overall, these data indicate that CD11c⁺CD11b⁻ DCs from hIL-15Tge mice not only expressed more CD103 but also displayed enhanced *in vitro* capacities for cross-presentation.

SUPPLEMENTARY RESULTS: IL-15-activated NK cells trigger CD103 expression on mononuclear phagocytes and enhance their cross-priming activity

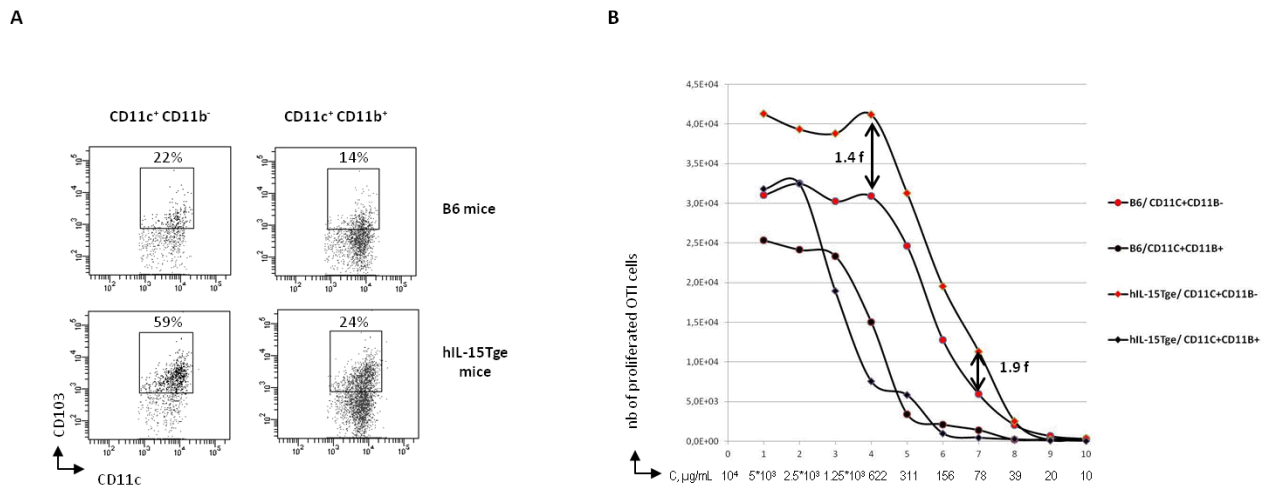

Figure C.13: Cross-presentation of OVA by DCs subsets from B6 and hIL-15Tge mice to OTI CD8 T cells

A. CD103 expression on CD11c⁺CD11b⁺ or CD11b⁻ DCs sorted spleen of WT B6 or hIL-15Tge mice. B. MHCII⁺ Lin⁻ CD11c⁺CD11b⁺ or CD11b⁻ DCs sorted from spleen of WT B6 or hIL-15Tge mice were pulsed for 4 hours with OVA protein at different concentrations, washed and then co-cultured with OTI (CD8) RAG^{-/-} T cells for 3 days. The graph represents the numbers of proliferated OTI cells.

C.4 Discussion

Overall, our data indicate that IL-15 is not necessary for the differentiation of MNP but chronic IL-15 overexpression can result in a considerable expansion of CD11c⁺ MNP expressing or not CD11b. Prolonged exposure of CD11c⁺CD11b⁻ MNP to IL-15 can more specifically induce the expansion of CD11c⁺CD11b⁻ expressing CD103 and displaying enhanced cross-presenting capacities. Our data further show that IL-15 does not act directly on DCs but rather via a relay implicating the production of GM-CSF by IL-15-dependent NK cells. These results provide a novel example of the cross-talk that can exist between NK cells and MNP under the influence of IL-15 and suggest a new mechanism by which IL-15 may modulate adaptive T cell responses. Several unanswered questions are discussed below.

Does IL-15 favor the emergence of particular MNP subsets?

Both CD11c⁺CD11b⁻ and CD11c⁺CD11b⁺ MNP expanded in hIL-15Tge mice compared to B6 but a preferential expansion of CD11c⁺CD11b⁻ MNP was observed in MLN (although not in spleen nor in small intestinal lamina propria). Moreover, frequency and absolute numbers of CD11c⁺CD11b⁻ MNP expressing CD103 increased in all tested organs of hIL-15Tge mice, and CD11c⁺CD11b⁻ spleen cells from hIL-15Tge mice exhibited stronger cross-presentation capacities. Overall, these data suggest that IL-15 may either exert a preferential effect on the subset of CD103⁺CD11c⁺CD11b⁻ cells or induce a specific state of differentiation reflected by the expression of CD103. CD11c⁺CD11b⁻ cells expressing CD103 are largely considered to

SUPPLEMENTARY RESULTS: IL-15-activated NK cells trigger CD103 expression on mononuclear phagocytes and enhance their cross-priming activity

derive from classical dendritic cell precursors and, similarly to CD8⁺CD11c⁺CD11b⁻ DCs, depend on IRF8, ID2 and BATF3 transcription factors (Bogunovic et al., 2009; Edelson et al., 2010; Ginhoux et al., 2009). A more complete phenotype analysis using these markers as well as other surface markers, such as CD64, F4/80 and CX3CR1 characterizing intestinal macrophages (Bogunovic et al., 2009; De Calisto et al., 2012; Langlet et al., 2012; Schulz et al., 2009; Zigmond and Jung, 2013), or transcription factors, such as Zbtb46 restricted to classical DC-derived cells (Meredith et al., 2012; Satpathy et al., 2012), or IRF4 specific of CD11b⁺ DCs (Persson et al., 2013b; Vander Lugt et al., 2014) might have allowed to better delineate the characteristics of MNP that expand or differentiate in response to IL-15. Of note, GM-CSF may regulate *in vivo* development of intestinal CD103⁺CD11c⁺ DCs (Bogunovic et al., 2009; Greter et al., 2012), and our own results show that the preferential effect of IL-15 on the differentiation of CD103⁺CD11c⁺CD11b⁻ from BM precursors depends on GM-CSF. Better analysis of GM-CSF receptor expression on the various subsets of MNP, as well as the analysis of hIL-15Tge mice crossed with Csf-2R-deficient (Csf-2Rβ^{-/-} Csf-2Rβ2^{-/-}) mice might help to better delineate the subsets of MNP affected by IL-15 up-regulation.

Can IL-15 modulate the maturation status of some MNP subset?

Increased expression of costimulatory signals and MHCII molecules is largely associated with DC maturation. Several studies have suggested that IL-15 produced by DCs and macrophages may favour their maturation, and DCs generated from blood CD14⁺ monocytes in the presence of IL-15 had increased expression of CD40, CD86, CD80 or MHCII molecules depending on studies (Anguille et al., 2009; Dubsky et al., 2007; Kuwajima et al., 2006; Ohteki et al., 2001; Regamey et al., 2007). Moreover, one study showed that IL-15 produced by airway epithelial cells could promote the differentiation of monocytes into partially matured DCs (Regamey et al., 2007). Herein, we observed increased CD86 expression on intestinal MNP but not on MLN and spleen cells. Moreover, no change in CD40, CD80 or MHCII was observed in hIL-15Tge mice compared with WT B6 mice. These data suggest that IL-15 does not induce *per se* pro-inflammatory phenotype in MNP, a result in keeping with our previous observations in peritoneal mouse monocytes/macrophages (Schulthess et al., 2012).

Is the up-regulation of CD103 by CD11c⁺CD11b⁻ cells induced directly by IL-15?

Our *in vitro* data of BM cell differentiation confirmed and completed our *in vivo* data showing that IL-15 promoted differentiation of CD11c⁺CD11b^{+/-} DCs expressing CD103 from BM precursors. In keeping with our *in vivo* data, the numbers of CD11c⁺ cells differentiated from

BM precursors were significantly higher in the presence of IL-15. Moreover, frequency of CD103⁺ cells and intensity of CD103 expression were considerably increased. IL-15 activates a signaling cascade via a module comprising CD122 (β chain) and CD132 (γ_c chain). Accordingly, BM cells cultured in the presence of IL-15 but deficient in either CD122 or CD132 did not differentiate in CD103⁺ CD11c⁺CD11b⁺ DCs. In contrast, CD122^{-/-} or CD132^{-/-} BM cells differentiated into CD103⁺CD11c⁺ DCs when co-cultured with WT B6 or RAG^{-/-} BM cells in the presence of IL-15, indicating that CD103 expression on DCs did not depend on IL-15 signaling in DCs, but rather on IL-15 signals to another cell type. All data pointed to the role of NK cells as a key relay between IL-15 and DCs. NK cells are known to differentiate from BM cells in the presence of IL-15, which is necessary for their differentiation and survival (Fehniger and Caligiuri, 2001). Accordingly, they became abundant in BM cultures performed in the presence of IL-15 that contained CD103⁺ DCs, but were absent in BM cultures performed without IL-15 or with Ly5.2 CD122^{-/-}RAG^{-/-} or RAG^{-/-} γ_c ^{-/-} BM cells, which do not give rise to Ly5.2 CD103⁺ DCs. In contrast, mixing Ly5.1 WT or RAG^{-/-} BM cells to the latter cells restored both NK cell expansion from Ly5.1 cells and differentiation of both Ly5.1 and Ly5.2 CD103⁺ DCs, confirming that a subset of IL-15-dependent Ly5.1 cells, likely NK cells or NK-like innate lymphoid cells, relays the effect of IL-15 to promote differentiation of CD103⁺CD11c⁺ DCs. Moreover, the differentiation of the latter cells could be entirely recapitulated by a soluble factor produced by IL-15-dependent Ly5.1 cells independently of any contact with Ly5.2 DC precursors. TGF β , IL-3 and GM-CSF were shown to induce CD103 (Edelson et al., 2011; Jackson et al., 2011; Sathe et al., 2011) and GM-CSF is known to be produced by activated NK cells (Huntington et al., 2007; Souza-Fonseca-Guimaraes et al., 2013; Zhang et al., 2007). Pleading for a role of GM-CSF at least *in vitro*, GM-CSF recapitulated the effect of IL-15 on CD103 expression in BM-derived DCs while conversely IL-15 failed to induce differentiation of Csf-2R β ^{-/-} BM cells into CD103 expressing CD11c⁺ cells, despite marked expansion of NK cells and release of conspicuous amounts of GM-CSF. These data exclude the role of TGF β but not of IL-3, the receptor of which also uses Csf-2R β . Neutralizing IL-3 would thus be important to ascertain an exclusive role for GM-CSF *in vitro*. Moreover, *in vivo* role of TGF β in inducing CD103 in lamina propria DCs has been suggested at least at steady state. Increased expression of Csf-2 transcripts in the intestinal biopsies of hIL-15Tge mice compared to B6 mice supports an idea of the role of GM-CSF. Further demonstration of the presence of GM-CSF in the serum of hIL-15tge mice as well as in the supernatants of spleen, MLN and lamina propria cells stimulated or not with IL-15, and analysis of IL-3 would be useful. Moreover, to prove that GM-CSF is solely responsible for the

SUPPLEMENTARY RESULTS: IL-15-activated NK cells trigger CD103 expression on mononuclear phagocytes and enhance their cross-priming activity

expansion of CD103⁺ CD11c⁺ DCs observed *in vivo* in IL-15Tge mice, it will be necessary to block GM-CSF either with a neutralizing antibody or by analyzing hIL-15Tge mice crossed with Csf-2^{-/-} or Csf-2Rβ^{-/-} Csf-2Rβ2^{-/-} mice.

What is the in vivo source of GM-CSF in hIL-15Tge mice? Do NK cells overproduce GM-CSF in hIL-15Tge mice and/or CD patients?

Many different cell types can produce GM-CSF *in vivo* including epithelial cells, fibroblasts, monocytes/macrophages, mast cells, activated T cells, NK cells and ILC (Spits et al., 2013; Zhan et al., 2012). A recent report suggests that, at steady-state, the main producers of GM-CSF in small and large intestine are RORγt⁺ innate lymphoid cells type 3 (ILC3), but not the RORγt⁻ NKp46⁺ NK or NK-like innate lymphoid subsets (Mortha et al., 2014), which are dependent on IL-15 (Klose et al., 2014). HIL-15Tge mice have increased numbers of NK cells in various compartments. In addition, the continuous presence of IL-15 may stimulate the production of GM-CSF by the latter cells. Further work is needed to ascertain whether NK cells are the main source of GM-CSF in hIL-15Tge mice. Given our previous work showing chronic overexpression of IL-15 in CD, we tested whether GM-CSF transcripts were increased in biopsies. No increase was noted in active CD patients in whom CD8 T IELs expressing NK receptors expanded but not NK cells. Yet, increased production of GM-CSF by the small population of NK cells present in lamina propria is not excluded and needs to be analyzed by more sensitive methods and, notably in lymphocytes isolated from biopsies rather than on whole biopsies. Interestingly, preliminary data suggest increased GM-CSF transcription in biopsies of RCD II patients who develop massive intraepithelial expansion of clonal IELs likely derived from a subset of IL-15-dependent intraepithelial innate lymphoid cells. The latter cells resemble the induced-T to NK cells (ITNK) that differentiate from Bcl11b^{-/-} thymic precursors (Di Santo, 2010; Li et al., 2010). They share overlapping features between NK and T cells and depend on IL-15 for their differentiation (Montcuquet *et al* in preparation). It will be interesting to define whether ITNK IEL from controls or from patients with refractory sprue can produce GM-CSF.

What is the functional outcome of CD103 increase and increased maturation of lamina propria CD103⁺CD11c⁺CD11b⁻ DCs?

Several studies have suggested that CD103⁺ but not CD103⁻ DCs have cross-presenting properties. Expression of CD103 *per se* is not sufficient since DCs induced to express CD103 by TGFβ lacked cross-presenting activity (Sathe et al., 2011). In contrast, DCs responding to

GM-CSF by an increase in CD103 expression acquired in parallel increased cross-presentation capacities (Sathe et al., 2011; Semmrich et al., 2012; Zhan et al., 2011). Accordingly, DCs isolated from GM-CSF transgenic mice are better at cross-presenting OVA and *listeria* (Sathe et al., 2011; Zhan et al., 2011), while $Csf-2R\beta^{-/-}$ $Csf-2R\beta 2^{-/-}$ mice lack CD103⁺DCs and cannot mount airway CD8 T cell response to OVA after immunization with OVA beads and Poly I:C (Greter et al., 2012). In keeping with the hypothesis that IL-15-driven expansion of CD103⁺CD11c⁺ DCs in hIL-15Tge mice largely depends on GM-SCF, we observed that spleen CD11c⁺CD11b⁻ DCs from hIL-15Tge mice highly enriched in CD103⁺ cells compared to CD11c⁺CD11b⁻ DCs from B6 mice also demonstrated enhanced capacity to present OVA to OT1 CD8 T cells. It is therefore possible that overexpression of IL-15 might selectively promote the expansion of cross-presenting CD103⁺ DCs and thereby perhaps favour the activation of the memory/effector CD8 T cells that accumulate in tissues of the latter mice. We could not demonstrate any OVA-reactivity in the intestinal Granzyme B⁺ CD8 T cells that expanded in OVA-fed OTII/hIL-15Tge mice (Korneychuk et al., 2014). We have rather shown that expansion of the latter cells is driven independently of any cognate recognition by synergistic signals provided by IL-15 and by IL-2 secreted by intestinal OVA-specific CD4 T cells. Yet, IL-15 and IL-2 could only exert this effect on memory/effector T cells. The latter cells are thus likely directed against either against intraluminal bacteria or perhaps self-antigens, the cross-presentation of which may be facilitated by CD103⁺ CD11c⁺ DCs (Korneychuk et al., 2014). This hypothesis needs however to be substantiated.

The polarization of CD4 T cells by CD103⁺DCs induced in the presence of IL-15 should also be examined knowing that, at steady state, MLN CD103⁺DCs can exert tolerogenic functions and notably stimulate generation of Foxp3⁺ T cells from naïve T cells (Coombes et al., 2007; Matteoli et al., 2010; Sun et al., 2007a), while conversely the same cells can, in the presence of proinflammatory signals, promote Th1 responses (Laffont et al., 2010). This question will be further addressed first *in vitro* by co-cultures of FACS-sorted DC populations of hIL-15Tge mice and OVA-specific TCR transgenic CD4 (OTII) T cells. It is not excluded that the CD103⁺DCs that expand in hIL-15Tge may stimulate the massive expansion of OVA-specific Tregs observed in OVA-fed OTII/hIL-15Tge mice (Korneychuk et al., 2014).

What is the in vivo role of IL-15-dependent/GM-CSF-mediated CD103 increase on DCs? Do latter cells polarize T cell response?

This issue should be further studied. CD103 expression is not *per se* predictive of the immune response induced by CD103⁺CD11c⁺ DCs (Laffont et al., 2010; Semmrich et al., 2012). Thus and as already eluded above, CD103⁺DCs can stimulate the generation of Foxp3⁺ Treg cells both at steady state and in inflammatory conditions (Coombes et al., 2007; Laffont et al., 2010; Semmrich et al., 2012; Sun et al., 2007a). However, CD103⁺DCs can also, in inflammatory conditions, induce Th1 CD4 T cells and CD8 cytotoxic T cell responses (Laffont et al., 2010; Semmrich et al., 2012). Therefore, the context influences the outcome of the immune responses induced by CD103⁺CD11c⁺ DCs. Dosage of GM-CSF may be one key factor. Indeed, low levels of GM-SCF seem to promote homeostasis and induction of Tregs. A recent article notably shows how GM-CSF produced by ILC3 in response to microbiota-induced IL-1 β could control homeostatic expansion of MNP and Tregs in the colon (Mortha et al., 2014). In contrast, excessive secretion of GM-CSF can promote severe inflammation and tissue damage, as in mouse models of experimental encephalitis (Codarri et al., 2011; El-Behi et al., 2011; King et al., 2010; Ponomarev et al., 2007) or of colitis in Rag^{-/-} mice (Griseri et al., 2012). In the latter model, excessive GM-CSF production in the gut could deregulate hematopoiesis and foster differentiation and subsequent intestinal migration of granulocytes and inflammatory monocytes that, in turn, aggravate intestinal inflammation (Griseri et al., 2012). Further studies are therefore needed to define how CD103⁺CD11c⁺CD11b⁻ DCs induced by IL-15 might modulate CD4 and CD8 T cell responses, notably in the intestine.

Conclusion

My thesis work based on a mouse model has allowed dissecting the mechanisms of cooperation between gluten-specific CD4 T cells and IL-15, over-produced by intestinal epithelium in CD patients. This work demonstrates how the synergy between IL-2 produced by activated gluten-specific CD4 T cells and IL-15 can promote the expansion of cytotoxic CD8 T cells that become, due to the presence of IL-15, unresponsive to Tregs. The mechanism that triggers the release of cytotoxic granules by CD8 T cells against intestinal epithelial cells remains however to be further investigated.

The second and as yet incomplete part of my work has shown that besides an effect on T cells, IL-15 produced by intestinal epithelium may modulate the function of intestinal mononuclear cells. We show that CD103⁺ dendritic cells expand in mice chronically over-expressing IL-15. Through *in vitro* studies using bone marrow-derived dendritic cells (DCs), we provide evidence that activated NK or NK-like innate lymphoid cells can enhance the expansion of CD103-expressing DCs via the production of GM-CSF. Furthermore, we show that DCs differentiated in mice overexpressing IL-15 are enriched in CD103⁺ DCs and display enhanced cross-presentation abilities *in vitro*. Further work is required to determine the *in vivo* source of GM-CSF and to confirm its production by intestinal NK or NK-like lymphoid cells. The role of CD103⁺ DCs differentiated in the presence of GM-SCF on the polarization of CD4 T cell response also needs to be better delineated.

Overall, obtained results illustrate how IL-15 may modulate adaptive immune responses, notably in celiac disease, but perhaps more generally in autoimmune or inflammatory diseases associated with prolonged production of IL-15. Deciphering the mechanisms that control intestinal expression of IL-15 in celiac patients may help to prevent disease in predisposed individuals.

References

- Abadie, V., Discepolo, V., and Jabri, B. (2012). Intraepithelial lymphocytes in celiac disease immunopathology. *Seminars in immunopathology* 34, 551-566.
- Abed, J., Lebreton, C., Champier, G., Cuvillier, A., Cogne, M., Meresse, B., Dugave, C., Garfa-Traore, M., Corthesy, B., Cerf-Bensussan, N., *et al.* (2014). Abnormal apical-to-basal transport of dietary ovalbumin by secretory IgA stimulates a mucosal Th1 response. *Mucosal immunology* 7, 315-324.
- Agace, W.W. (2008). T-cell recruitment to the intestinal mucosa. *Trends in immunology* 29, 514-522.
- Agace, W.W., Higgins, J.M., Sadasivan, B., Brenner, M.B., and Parker, C.M. (2000). T-lymphocyte-epithelial-cell interactions: integrin alpha(E)(CD103)beta(7), LEEP-CAM and chemokines. *Current opinion in cell biology* 12, 563-568.
- Allakhverdi, Z., Fitzpatrick, D., Boisvert, A., Baba, N., Bouguermouh, S., Sarfati, M., and Delespesse, G. (2006). Expression of CD103 identifies human regulatory T-cell subsets. *The Journal of allergy and clinical immunology* 118, 1342-1349.
- Altmann, D.M., Douek, D.C., Frater, A.J., Hetherington, C.M., Inoko, H., and Elliott, J.I. (1995). The T cell response of HLA-DR transgenic mice to human myelin basic protein and other antigens in the presence and absence of human CD4. *The Journal of experimental medicine* 181, 867-875.
- Anguille, S., Smits, E.L., Cools, N., Goossens, H., Berneman, Z.N., and Van Tendeloo, V.F. (2009). Short-term cultured, interleukin-15 differentiated dendritic cells have potent immunostimulatory properties. *Journal of translational medicine* 7, 109.
- Annacker, O., Coombes, J.L., Malmstrom, V., Uhlig, H.H., Bourne, T., Johansson-Lindbom, B., Agace, W.W., Parker, C.M., and Powrie, F. (2005). Essential role for CD103 in the T cell-mediated regulation of experimental colitis. *The Journal of experimental medicine* 202, 1051-1061.
- Arpaia, N., Campbell, C., Fan, X., Dikiy, S., van der Veeken, J., deRoos, P., Liu, H., Cross, J.R., Pfeffer, K., Coffey, P.J., *et al.* (2013). Metabolites produced by commensal bacteria promote peripheral regulatory T-cell generation. *Nature* 504, 451-455.
- Asano, M., Toda, M., Sakaguchi, N., and Sakaguchi, S. (1996). Autoimmune disease as a consequence of developmental abnormality of a T cell subpopulation. *The Journal of experimental medicine* 184, 387-396.

- Atarashi, K., Tanoue, T., Oshima, K., Suda, W., Nagano, Y., Nishikawa, H., Fukuda, S., Saito, T., Narushima, S., Hase, K., *et al.* (2013). Treg induction by a rationally selected mixture of Clostridia strains from the human microbiota. *Nature* *500*, 232-236.
- Atarashi, K., Tanoue, T., Shima, T., Imaoka, A., Kuwahara, T., Momose, Y., Cheng, G., Yamasaki, S., Saito, T., Ohba, Y., *et al.* (2011). Induction of colonic regulatory T cells by indigenous Clostridium species. *Science* *331*, 337-341.
- Babbe, H., Roers, A., Waisman, A., Lassmann, H., Goebels, N., Hohlfield, R., Friese, M., Schroder, R., Deckert, M., Schmidt, S., *et al.* (2000). Clonal expansions of CD8(+) T cells dominate the T cell infiltrate in active multiple sclerosis lesions as shown by micromanipulation and single cell polymerase chain reaction. *The Journal of experimental medicine* *192*, 393-404.
- Baklien, K., Brandtzaeg, P., and Fausa, O. (1977). Immunoglobulins in jejunal mucosa and serum from patients with adult coeliac disease. *Scandinavian journal of gastroenterology* *12*, 149-159.
- Barker, B.R., Gladstone, M.N., Gillard, G.O., Panas, M.W., and Letvin, N.L. (2010). Critical role for IL-21 in both primary and memory anti-viral CD8+ T-cell responses. *European journal of immunology* *40*, 3085-3096.
- Barone, K.S., Jain, S.L., and Michael, J.G. (1995). Effect of in vivo depletion of CD4+ and CD8+ cells on the induction and maintenance of oral tolerance. *Cellular immunology* *163*, 19-29.
- Bayardo, M., Punzi, F., Bondar, C., Chopita, N., and Chirido, F. (2012). Transglutaminase 2 expression is enhanced synergistically by interferon-gamma and tumour necrosis factor-alpha in human small intestine. *Clinical and experimental immunology* *168*, 95-104.
- Bazan, J.F., Bacon, K.B., Hardiman, G., Wang, W., Soo, K., Rossi, D., Greaves, D.R., Zlotnik, A., and Schall, T.J. (1997). A new class of membrane-bound chemokine with a CX3C motif. *Nature* *385*, 640-644.
- Ben Ahmed, M., Belhadj Hmida, N., Moes, N., Buyse, S., Abdeladhim, M., Louzir, H., and Cerf-Bensussan, N. (2009). IL-15 renders conventional lymphocytes resistant to suppressive functions of regulatory T cells through activation of the phosphatidylinositol 3-kinase pathway. *Journal of immunology* *182*, 6763-6770.
- Benahmed, M., Meresse, B., Arnulf, B., Barbe, U., Mention, J.J., Verkarre, V., Allez, M., Cellier, C., Hermine, O., and Cerf-Bensussan, N. (2007). Inhibition of TGF-beta signaling by IL-15: a new role for IL-15 in the loss of immune homeostasis in celiac disease. *Gastroenterology* *132*, 994-1008.

- Bernardo, D., Garrote, J.A., Allegretti, Y., Leon, A., Gomez, E., Bermejo-Martin, J.F., Calvo, C., Riestra, S., Fernandez-Salazar, L., Blanco-Quiros, A., *et al.* (2008). Higher constitutive IL15R alpha expression and lower IL-15 response threshold in coeliac disease patients. *Clinical and experimental immunology* 154, 64-73.
- Beutner, E.H., Chorzelski, T.P., Kumar, V., Leonard, J., and Krasny, S. (1986). Sensitivity and specificity of IgA-class antiendomysial antibodies for dermatitis herpetiformis and findings relevant to their pathogenic significance. *Journal of the American Academy of Dermatology* 15, 464-473.
- Bevan, S., Popat, S., Braegger, C.P., Busch, A., O'Donoghue, D., Falth-Magnusson, K., Ferguson, A., Godkin, A., Hogberg, L., Holmes, G., *et al.* (1999). Contribution of the MHC region to the familial risk of coeliac disease. *Journal of medical genetics* 36, 687-690.
- Bevilacqua, C., Montagnac, G., Benmerah, A., Candalh, C., Brousse, N., Cerf-Bensussan, N., Perdue, M.H., and Heyman, M. (2004). Food allergens are protected from degradation during CD23-mediated transepithelial transport. *International archives of allergy and immunology* 135, 108-116.
- Biswas, P.S., Bhagat, G., and Pernis, A.B. (2010). IRF4 and its regulators: evolving insights into the pathogenesis of inflammatory arthritis? *Immunological reviews* 233, 79-96.
- Black, K.E., Murray, J.A., and David, C.S. (2002). HLA-DQ determines the response to exogenous wheat proteins: a model of gluten sensitivity in transgenic knockout mice. *Journal of immunology* 169, 5595-5600.
- Bland, P.W., and Warren, L.G. (1986). Antigen presentation by epithelial cells of the rat small intestine. II. Selective induction of suppressor T cells. *Immunology* 58, 9-14.
- Bodd, M., Raki, M., Tollefsen, S., Fallang, L.E., Bergseng, E., Lundin, K.E., and Sollid, L.M. (2010). HLA-DQ2-restricted gluten-reactive T cells produce IL-21 but not IL-17 or IL-22. *Mucosal immunology* 3, 594-601.
- Bogunovic, M., Ginhoux, F., Helft, J., Shang, L., Hashimoto, D., Greter, M., Liu, K., Jakubzick, C., Ingersoll, M.A., Leboeuf, M., *et al.* (2009). Origin of the lamina propria dendritic cell network. *Immunity* 31, 513-525.
- Bonnefoy, J.Y., Aubry, J.P., Peronne, C., Wijdenes, J., and Banchereau, J. (1987). Production and characterization of a monoclonal antibody specific for the human lymphocyte low affinity receptor for IgE: CD 23 is a low affinity receptor for IgE. *Journal of immunology* 138, 2970-2978.
- Borrelli, M., Maglio, M., Agnese, M., Paparo, F., Gentile, S., Colicchio, B., Tosco, A., Auricchio, R., and Troncone, R. (2010). High density of intraepithelial gammadelta

- lymphocytes and deposits of immunoglobulin (Ig)M anti-tissue transglutaminase antibodies in the jejunum of coeliac patients with IgA deficiency. *Clinical and experimental immunology* 160, 199-206.
- Bourliere, M., Oules, V., Perrier, H., and Mengotti, C. (2001). Onset of coeliac disease and interferon treatment. *Lancet* 357, 803-804.
- Brambell, F.W. (1966). The transmission of immunity from mother to young and the catabolism of immunoglobulins. *Lancet* 2, 1087-1093.
- Brandeis, J.M., Sayegh, M.H., Gallon, L., Blumberg, R.S., and Carpenter, C.B. (1994). Rat intestinal epithelial cells present major histocompatibility complex allopeptides to primed T cells. *Gastroenterology* 107, 1537-1542.
- Brandtzaeg, P., and Johansen, F.E. (2005). Mucosal B cells: phenotypic characteristics, transcriptional regulation, and homing properties. *Immunological reviews* 206, 32-63.
- Brandtzaeg, P., Kiyono, H., Pabst, R., and Russell, M.W. (2008). Terminology: nomenclature of mucosa-associated lymphoid tissue. *Mucosal immunology* 1, 31-37.
- Broughton, S.E., Dhagat, U., Hercus, T.R., Nero, T.L., Grimbaldston, M.A., Bonder, C.S., Lopez, A.F., and Parker, M.W. (2012a). The GM-CSF/IL-3/IL-5 cytokine receptor family: from ligand recognition to initiation of signaling. *Immunological reviews* 250, 277-302.
- Broughton, S.E., Petersen, J., Theodossis, A., Scally, S.W., Loh, K.L., Thompson, A., van Bergen, J., Kooy-Winkelaar, Y., Henderson, K.N., Beddoe, T., *et al.* (2012b). Biased T cell receptor usage directed against human leukocyte antigen DQ8-restricted gliadin peptides is associated with celiac disease. *Immunity* 37, 611-621.
- Bruce, M.G., and Ferguson, A. (1986). Oral tolerance to ovalbumin in mice: studies of chemically modified and 'biologically filtered' antigen. *Immunology* 57, 627-630.
- Bruce, S.E., Bjarnason, I., and Peters, T.J. (1985). Human jejunal transglutaminase: demonstration of activity, enzyme kinetics and substrate specificity with special relation to gliadin and coeliac disease. *Clinical science* 68, 573-579.
- Brunkow, M.E., Jeffery, E.W., Hjerrild, K.A., Paepker, B., Clark, L.B., Yasayko, S.A., Wilkinson, J.E., Galas, D., Ziegler, S.F., and Ramsdell, F. (2001). Disruption of a new forkhead/winged-helix protein, scurfy, results in the fatal lymphoproliferative disorder of the scurfy mouse. *Nature genetics* 27, 68-73.
- Callery, M.P., Kamei, T., and Flye, M.W. (1989). The effect of portacaval shunt on delayed-hypersensitivity responses following antigen feeding. *The Journal of surgical research* 46, 391-394.

- Cammarota, G., Scheirle, A., Takacs, B., Doran, D.M., Knorr, R., Bannwarth, W., Guardiola, J., and Sinigaglia, F. (1992). Identification of a CD4 binding site on the beta 2 domain of HLA-DR molecules. *Nature* 356, 799-801.
- Carroll, H.P., Paunovic, V., and Gadina, M. (2008). Signalling, inflammation and arthritis: Crossed signals: the role of interleukin-15 and -18 in autoimmunity. *Rheumatology* 47, 1269-1277.
- Catassi, C., Rossini, M., Ratsch, I.M., Bearzi, I., Santinelli, A., Castagnani, R., Pisani, E., Coppa, G.V., and Giorgi, P.L. (1993). Dose dependent effects of protracted ingestion of small amounts of gliadin in coeliac disease children: a clinical and jejunal morphometric study. *Gut* 34, 1515-1519.
- Cerovic, V., Houston, S.A., Scott, C.L., Aumeunier, A., Yrlid, U., Mowat, A.M., and Milling, S.W. (2013). Intestinal CD103(-) dendritic cells migrate in lymph and prime effector T cells. *Mucosal immunology* 6, 104-113.
- Chang, S.Y., Song, J.H., Guleng, B., Cotoner, C.A., Arihiro, S., Zhao, Y., Chiang, H.S., O'Keeffe, M., Liao, G., Karp, C.L., *et al.* (2013). Circulatory antigen processing by mucosal dendritic cells controls CD8(+) T cell activation. *Immunity* 38, 153-165.
- Chen, Y., Inobe, J., Marks, R., Gonnella, P., Kuchroo, V.K., and Weiner, H.L. (1995a). Peripheral deletion of antigen-reactive T cells in oral tolerance. *Nature* 376, 177-180.
- Chen, Y., Inobe, J., and Weiner, H.L. (1995b). Induction of oral tolerance to myelin basic protein in CD8-depleted mice: both CD4+ and CD8+ cells mediate active suppression. *Journal of immunology* 155, 910-916.
- Chen, Y., Kuchroo, V.K., Inobe, J., Hafler, D.A., and Weiner, H.L. (1994). Regulatory T cell clones induced by oral tolerance: suppression of autoimmune encephalomyelitis. *Science* 265, 1237-1240.
- Chen, Z., Dudek, N., Wijburg, O., Strugnell, R., Brown, L., Deliyannis, G., Jackson, D., Koentgen, F., Gordon, T., and McCluskey, J. (2002). A 320-kilobase artificial chromosome encoding the human HLA DR3-DQ2 MHC haplotype confers HLA restriction in transgenic mice. *Journal of immunology* 168, 3050-3056.
- Cheng, S., Baisch, J., Krco, C., Savarirayan, S., Hanson, J., Hodgson, K., Smart, M., and David, C. (1996). Expression and function of HLA-DQ8 (DQA1*0301/DQB1*0302) genes in transgenic mice. *European journal of immunogenetics : official journal of the British Society for Histocompatibility and Immunogenetics* 23, 15-20.
- Cheroutre, H., Lambolez, F., and Mucida, D. (2011). The light and dark sides of intestinal intraepithelial lymphocytes. *Nature reviews Immunology* 11, 445-456.

- Chieppa, M., Rescigno, M., Huang, A.Y., and Germain, R.N. (2006). Dynamic imaging of dendritic cell extension into the small bowel lumen in response to epithelial cell TLR engagement. *The Journal of experimental medicine* 203, 2841-2852.
- Chirido, F.G., Millington, O.R., Beacock-Sharp, H., and Mowat, A.M. (2005). Immunomodulatory dendritic cells in intestinal lamina propria. *European journal of immunology* 35, 1831-1840.
- Chirido, F.G., Rumbo, M., Anon, M.C., and Fossati, C.A. (1998). Presence of high levels of non-degraded gliadin in breast milk from healthy mothers. *Scandinavian journal of gastroenterology* 33, 1186-1192.
- Chorzelski, T.P., Beutner, E.H., Sulej, J., Tchorzewska, H., Jablonska, S., Kumar, V., and Kapuscinska, A. (1984). IgA anti-endomysium antibody. A new immunological marker of dermatitis herpetiformis and coeliac disease. *The British journal of dermatology* 111, 395-402.
- Codarri, L., Gyulveszi, G., Tosevski, V., Hesske, L., Fontana, A., Magnenat, L., Suter, T., and Becher, B. (2011). ROR γ drives production of the cytokine GM-CSF in helper T cells, which is essential for the effector phase of autoimmune neuroinflammation. *Nature immunology* 12, 560-567.
- Conner, S.D., and Schmid, S.L. (2003). Regulated portals of entry into the cell. *Nature* 422, 37-44.
- Coombes, J.L., Siddiqui, K.R., Arancibia-Carcamo, C.V., Hall, J., Sun, C.M., Belkaid, Y., and Powrie, F. (2007). A functionally specialized population of mucosal CD103⁺ DCs induces Foxp3⁺ regulatory T cells via a TGF- β and retinoic acid-dependent mechanism. *The Journal of experimental medicine* 204, 1757-1764.
- Cornish, G.H., Sinclair, L.V., and Cantrell, D.A. (2006). Differential regulation of T-cell growth by IL-2 and IL-15. *Blood* 108, 600-608.
- Correale, J., and Villa, A. (2008). Isolation and characterization of CD8⁺ regulatory T cells in multiple sclerosis. *Journal of neuroimmunology* 195, 121-134.
- Cosgrove, D., Gray, D., Dierich, A., Kaufman, J., Lemeur, M., Benoist, C., and Mathis, D. (1991). Mice lacking MHC class II molecules. *Cell* 66, 1051-1066.
- Cosnes, J., Cellier, C., Viola, S., Colombel, J.F., Michaud, L., Sarles, J., Hugot, J.P., Ginies, J.L., Dabadie, A., Mouterde, O., *et al.* (2008). Incidence of autoimmune diseases in celiac disease: protective effect of the gluten-free diet. *Clinical gastroenterology and hepatology : the official clinical practice journal of the American Gastroenterological Association* 6, 753-758.

- Cui, W., Liu, Y., Weinstein, J.S., Craft, J., and Kaech, S.M. (2011). An interleukin-21-interleukin-10-STAT3 pathway is critical for functional maturation of memory CD8⁺ T cells. *Immunity* 35, 792-805.
- Dafik, L., Albertelli, M., Stammaes, J., Sollid, L.M., and Khosla, C. (2012). Activation and inhibition of transglutaminase 2 in mice. *PloS one* 7, e30642.
- De Calisto, J., Villablanca, E.J., and Mora, J.R. (2012). FcγRI (CD64): an identity card for intestinal macrophages. *European journal of immunology* 42, 3136-3140.
- de Kauwe, A.L., Chen, Z., Anderson, R.P., Keech, C.L., Price, J.D., Wijburg, O., Jackson, D.C., Ladhams, J., Allison, J., and McCluskey, J. (2009). Resistance to celiac disease in humanized HLA-DR3-DQ2-transgenic mice expressing specific anti-gliadin CD4⁺ T cells. *Journal of immunology* 182, 7440-7450.
- de Koning, B.A., van Dieren, J.M., Lindenbergh-Kortleve, D.J., van der Sluis, M., Matsumoto, T., Yamaguchi, K., Einerhand, A.W., Samsom, J.N., Pieters, R., and Nieuwenhuis, E.E. (2006). Contributions of mucosal immune cells to methotrexate-induced mucositis. *International immunology* 18, 941-949.
- Denning, T.L., Wang, Y.C., Patel, S.R., Williams, I.R., and Pulendran, B. (2007). Lamina propria macrophages and dendritic cells differentially induce regulatory and interleukin 17-producing T cell responses. *Nature immunology* 8, 1086-1094.
- DePaolo, R.W., Abadie, V., Tang, F., Fehlner-Peach, H., Hall, J.A., Wang, W., Marietta, E.V., Kasarda, D.D., Waldmann, T.A., Murray, J.A., *et al.* (2011). Co-adjuvant effects of retinoic acid and IL-15 induce inflammatory immunity to dietary antigens. *Nature* 471, 220-224.
- Di Sabatino, A., Calarota, S.A., Vidali, F., Macdonald, T.T., and Corazza, G.R. (2011). Role of IL-15 in immune-mediated and infectious diseases. *Cytokine & growth factor reviews* 22, 19-33.
- Di Sabatino, A., Ciccocioppo, R., Cupelli, F., Cinque, B., Millimaggi, D., Clarkson, M.M., Paulli, M., Cifone, M.G., and Corazza, G.R. (2006). Epithelium derived interleukin 15 regulates intraepithelial lymphocyte Th1 cytokine production, cytotoxicity, and survival in coeliac disease. *Gut* 55, 469-477.
- Di Santo, J.P. (2010). Immunology. A guardian of T cell fate. *Science* 329, 44-45.
- Diehl, G.E., Longman, R.S., Zhang, J.X., Breart, B., Galan, C., Cuesta, A., Schwab, S.R., and Littman, D.R. (2013). Microbiota restricts trafficking of bacteria to mesenteric lymph nodes by CX(3)CR1(hi) cells. *Nature* 494, 116-120.

- Dieterich, W., Ehnis, T., Bauer, M., Donner, P., Volta, U., Riecken, E.O., and Schuppan, D. (1997). Identification of tissue transglutaminase as the autoantigen of celiac disease. *Nature medicine* 3, 797-801.
- Diraimondo, T.R., Klock, C., and Khosla, C. (2012). Interferon-gamma activates transglutaminase 2 via a phosphatidylinositol-3-kinase-dependent pathway: implications for celiac sprue therapy. *The Journal of pharmacology and experimental therapeutics* 341, 104-114.
- Doherty, M., and Barry, R.E. (1981). Gluten-induced mucosal changes in subjects without overt small-bowel disease. *Lancet* 1, 517-520.
- Du Pre, M.F., Kozijn, A.E., van Berkel, L.A., ter Borg, M.N., Lindenbergh-Kortleve, D., Jensen, L.T., Kooy-Winkelaar, Y., Koning, F., Boon, L., Nieuwenhuis, E.E., *et al.* (2011). Tolerance to ingested deamidated gliadin in mice is maintained by splenic, type 1 regulatory T cells. *Gastroenterology* 141, 610-620, 620 e611-612.
- Dubois, B., Chapat, L., Goubier, A., Papiernik, M., Nicolas, J.F., and Kaiserlian, D. (2003). Innate CD4+CD25+ regulatory T cells are required for oral tolerance and inhibition of CD8+ T cells mediating skin inflammation. *Blood* 102, 3295-3301.
- Dubois, P.C., Trynka, G., Franke, L., Hunt, K.A., Romanos, J., Curtotti, A., Zhernakova, A., Heap, G.A., Adany, R., Aromaa, A., *et al.* (2010). Multiple common variants for celiac disease influencing immune gene expression. *Nature genetics* 42, 295-302.
- Dubsky, P., Saito, H., Leogier, M., Dantin, C., Connolly, J.E., Banchereau, J., and Palucka, A.K. (2007). IL-15-induced human DC efficiently prime melanoma-specific naive CD8+ T cells to differentiate into CTL. *European journal of immunology* 37, 1678-1690.
- Eberl, G., and Lochner, M. (2009). The development of intestinal lymphoid tissues at the interface of self and microbiota. *Mucosal immunology* 2, 478-485.
- Edelson, B.T., Bradstreet, T.R., Kc, W., Hildner, K., Herzog, J.W., Sim, J., Russell, J.H., Murphy, T.L., Unanue, E.R., and Murphy, K.M. (2011). Batf3-dependent CD11b(low/-) peripheral dendritic cells are GM-CSF-independent and are not required for Th cell priming after subcutaneous immunization. *PloS one* 6, e25660.
- Edelson, B.T., Kc, W., Juang, R., Kohyama, M., Benoit, L.A., Klekotka, P.A., Moon, C., Albring, J.C., Ise, W., Michael, D.G., *et al.* (2010). Peripheral CD103+ dendritic cells form a unified subset developmentally related to CD8alpha+ conventional dendritic cells. *The Journal of experimental medicine* 207, 823-836.
- Einarsdottir, E., Koskinen, L.L., de Kauwe, A.L., Dukes, E., Mustalahti, K., Balogh, M., Korponay-Szabo, I.R., Kaukinen, K., Kurppa, K., Adany, R., *et al.* (2011). Genome-wide

analysis of extended pedigrees confirms IL2-IL21 linkage and shows additional regions of interest potentially influencing coeliac disease risk. *Tissue antigens* 78, 428-437.

El-Behi, M., Ciric, B., Dai, H., Yan, Y., Cullimore, M., Safavi, F., Zhang, G.X., Dittel, B.N., and Rostami, A. (2011). The encephalitogenicity of T(H)17 cells is dependent on IL-1- and IL-23-induced production of the cytokine GM-CSF. *Nature immunology* 12, 568-575.

Esposito, C., Paparo, F., Caputo, I., Porta, R., Salvati, V.M., Mazzarella, G., Auricchio, S., and Troncone, R. (2003). Expression and enzymatic activity of small intestinal tissue transglutaminase in celiac disease. *The American journal of gastroenterology* 98, 1813-1820.

Eterman, K.P., and Feltkamp, T.E. (1978). Antibodies to gluten and reticulin in gastrointestinal diseases. *Clinical and experimental immunology* 31, 92-99.

Farache, J., Koren, I., Milo, I., Gurevich, I., Kim, K.W., Zigmond, E., Furtado, G.C., Lira, S.A., and Shakhar, G. (2013). Luminal bacteria recruit CD103+ dendritic cells into the intestinal epithelium to sample bacterial antigens for presentation. *Immunity* 38, 581-595.

Faria, A.M., and Weiner, H.L. (1999). Oral tolerance: mechanisms and therapeutic applications. *Advances in immunology* 73, 153-264.

Faria, A.M., and Weiner, H.L. (2005). Oral tolerance. *Immunological reviews* 206, 232-259.

Faria, A.M., and Weiner, H.L. (2006). Oral tolerance: therapeutic implications for autoimmune diseases. *Clinical & developmental immunology* 13, 143-157.

Fasano, A., Not, T., Wang, W., Uzzau, S., Berti, I., Tommasini, A., and Goldblum, S.E. (2000). Zonulin, a newly discovered modulator of intestinal permeability, and its expression in coeliac disease. *Lancet* 355, 1518-1519.

Fehniger, T.A., and Caligiuri, M.A. (2001). Interleukin 15: biology and relevance to human disease. *Blood* 97, 14-32.

Fehniger, T.A., Suzuki, K., Ponnappan, A., VanDeusen, J.B., Cooper, M.A., Florea, S.M., Freud, A.G., Robinson, M.L., Durbin, J., and Caligiuri, M.A. (2001). Fatal leukemia in interleukin 15 transgenic mice follows early expansions in natural killer and memory phenotype CD8+ T cells. *The Journal of experimental medicine* 193, 219-231.

Ferguson, A., Blackwell, J.N., and Barnetson, R.S. (1987). Effects of additional dietary gluten on the small-intestinal mucosa of volunteers and of patients with dermatitis herpetiformis. *Scandinavian journal of gastroenterology* 22, 543-549.

Fina, D., Sarra, M., Caruso, R., Del Vecchio Blanco, G., Pallone, F., MacDonald, T.T., and Monteleone, G. (2008). Interleukin 21 contributes to the mucosal T helper cell type 1 response in coeliac disease. *Gut* 57, 887-892.

- Fontenot, J.D., Gavin, M.A., and Rudensky, A.Y. (2003). Foxp3 programs the development and function of CD4+CD25+ regulatory T cells. *Nature immunology* 4, 330-336.
- Forsberg, G., Fahlgren, A., Horstedt, P., Hammarstrom, S., Hernell, O., and Hammarstrom, M.L. (2004). Presence of bacteria and innate immunity of intestinal epithelium in childhood celiac disease. *The American journal of gastroenterology* 99, 894-904.
- Freitag, T.L., Rietdijk, S., Junker, Y., Popov, Y., Bhan, A.K., Kelly, C.P., Terhorst, C., and Schuppan, D. (2009). Gliadin-primed CD4+CD45RB^{low}CD25⁻ T cells drive gluten-dependent small intestinal damage after adoptive transfer into lymphopenic mice. *Gut* 58, 1597-1605.
- Friedman, A., and Weiner, H.L. (1994). Induction of anergy or active suppression following oral tolerance is determined by antigen dosage. *Proceedings of the National Academy of Sciences of the United States of America* 91, 6688-6692.
- Fugger, L., Michie, S.A., Rulifson, I., Lock, C.B., and McDevitt, G.S. (1994). Expression of HLA-DR4 and human CD4 transgenes in mice determines the variable region beta-chain T-cell repertoire and mediates an HLA-DR-restricted immune response. *Proceedings of the National Academy of Sciences of the United States of America* 91, 6151-6155.
- Fujihashi, K., Dohi, T., Rennert, P.D., Yamamoto, M., Koga, T., Kiyono, H., and McGhee, J.R. (2001). Peyer's patches are required for oral tolerance to proteins. *Proceedings of the National Academy of Sciences of the United States of America* 98, 3310-3315.
- Gaboriau-Routhiau, V., Rakotobe, S., Lecuyer, E., Mulder, I., Lan, A., Bridonneau, C., Rochet, V., Pisi, A., De Paepe, M., Brandi, G., *et al.* (2009). The key role of segmented filamentous bacteria in the coordinated maturation of gut helper T cell responses. *Immunity* 31, 677-689.
- Geissmann, F., Gordon, S., Hume, D.A., Mowat, A.M., and Randolph, G.J. (2010). Unravelling mononuclear phagocyte heterogeneity. *Nature reviews Immunology* 10, 453-460.
- Gianfrani, C., Troncone, R., Mugione, P., Cosentini, E., De Pascale, M., Faruolo, C., Senger, S., Terrazzano, G., Southwood, S., Auricchio, S., *et al.* (2003). Celiac disease association with CD8+ T cell responses: identification of a novel gliadin-derived HLA-A2-restricted epitope. *Journal of immunology* 170, 2719-2726.
- Ginhoux, F., Liu, K., Helft, J., Bogunovic, M., Greter, M., Hashimoto, D., Price, J., Yin, N., Bromberg, J., Lira, S.A., *et al.* (2009). The origin and development of nonlymphoid tissue CD103+ DCs. *The Journal of experimental medicine* 206, 3115-3130.
- Gjertsen, H.A., Lundin, K.E., Sollid, L.M., Eriksen, J.A., and Thorsby, E. (1994). T cells recognize a peptide derived from alpha-gliadin presented by the celiac disease-associated HLA-DQ (alpha 1*0501, beta 1*0201) heterodimer. *Human immunology* 39, 243-252.

- Goubier, A., Dubois, B., Gheit, H., Joubert, G., Villard-Truc, F., Asselin-Paturel, C., Trinchieri, G., and Kaiserlian, D. (2008). Plasmacytoid dendritic cells mediate oral tolerance. *Immunity* 29, 464-475.
- Gravano, D.M., and Hoyer, K.K. (2013). Promotion and prevention of autoimmune disease by CD8+ T cells. *Journal of autoimmunity* 45, 68-79.
- Grdic, D., Hornquist, E., Kjerrulf, M., and Lycke, N.Y. (1998). Lack of local suppression in orally tolerant CD8-deficient mice reveals a critical regulatory role of CD8+ T cells in the normal gut mucosa. *Journal of immunology* 160, 754-762.
- Gregersen, J.W., Holmes, S., and Fugger, L. (2004). Humanized animal models for autoimmune diseases. *Tissue antigens* 63, 383-394.
- Greter, M., Helft, J., Chow, A., Hashimoto, D., Mortha, A., Agudo-Cantero, J., Bogunovic, M., Gautier, E.L., Miller, J., Leboeuf, M., *et al.* (2012). GM-CSF controls nonlymphoid tissue dendritic cell homeostasis but is dispensable for the differentiation of inflammatory dendritic cells. *Immunity* 36, 1031-1046.
- Griseri, T., McKenzie, B.S., Schiering, C., and Powrie, F. (2012). Dysregulated hematopoietic stem and progenitor cell activity promotes interleukin-23-driven chronic intestinal inflammation. *Immunity* 37, 1116-1129.
- Groux, H., O'Garra, A., Bigler, M., Rouleau, M., Antonenko, S., de Vries, J.E., and Roncarolo, M.G. (1997). A CD4+ T-cell subset inhibits antigen-specific T-cell responses and prevents colitis. *Nature* 389, 737-742.
- Gutgemann, I., Fahrner, A.M., Altman, J.D., Davis, M.M., and Chien, Y.H. (1998). Induction of rapid T cell activation and tolerance by systemic presentation of an orally administered antigen. *Immunity* 8, 667-673.
- Hadis, U., Wahl, B., Schulz, O., Hardtke-Wolenski, M., Schippers, A., Wagner, N., Muller, W., Sparwasser, T., Forster, R., and Pabst, O. (2011). Intestinal tolerance requires gut homing and expansion of FoxP3+ regulatory T cells in the lamina propria. *Immunity* 34, 237-246.
- Hadley, G.A., Bartlett, S.T., Via, C.S., Rostapshova, E.A., and Moainie, S. (1997). The epithelial cell-specific integrin, CD103 (alpha E integrin), defines a novel subset of alloreactive CD8+ CTL. *Journal of immunology* 159, 3748-3756.
- Halstensen, T.S., Hvatum, M., Scott, H., Fausa, O., and Brandtzaeg, P. (1992). Association of subepithelial deposition of activated complement and immunoglobulin G and M response to gluten in celiac disease. *Gastroenterology* 102, 751-759.

- Halstensen, T.S., Scott, H., and Brandtzaeg, P. (1989). Intraepithelial T cells of the TcR gamma/delta+ CD8- and V delta 1/J delta 1+ phenotypes are increased in coeliac disease. *Scandinavian journal of immunology* 30, 665-672.
- Han, A., Newell, E.W., Glanville, J., Fernandez-Becker, N., Khosla, C., Chien, Y.H., and Davis, M.M. (2013). Dietary gluten triggers concomitant activation of CD4+ and CD8+ alphabeta T cells and gammadelta T cells in celiac disease. *Proceedings of the National Academy of Sciences of the United States of America* 110, 13073-13078.
- Hanson, D.G. (1981). Ontogeny of orally induced tolerance to soluble proteins in mice. I. Priming and tolerance in newborns. *Journal of immunology* 127, 1518-1524.
- Hansson, G.C. (2012). Role of mucus layers in gut infection and inflammation. *Current opinion in microbiology* 15, 57-62.
- Hapfelmeier, S., Muller, A.J., Stecher, B., Kaiser, P., Barthel, M., Endt, K., Eberhard, M., Robbiani, R., Jacobi, C.A., Heikenwalder, M., *et al.* (2008). Microbe sampling by mucosal dendritic cells is a discrete, MyD88-independent step in DeltainvG S. Typhimurium colitis. *The Journal of experimental medicine* 205, 437-450.
- Hausch, F., Shan, L., Santiago, N.A., Gray, G.M., and Khosla, C. (2002). Intestinal digestive resistance of immunodominant gliadin peptides. *American journal of physiology Gastrointestinal and liver physiology* 283, G996-G1003.
- Hershberg, R.M., Framson, P.E., Cho, D.H., Lee, L.Y., Kovats, S., Beitz, J., Blum, J.S., and Nepom, G.T. (1997). Intestinal epithelial cells use two distinct pathways for HLA class II antigen processing. *The Journal of clinical investigation* 100, 204-215.
- Heyman, M., Abed, J., Lebreton, C., and Cerf-Bensussan, N. (2012). Intestinal permeability in coeliac disease: insight into mechanisms and relevance to pathogenesis. *Gut* 61, 1355-1364.
- Hirose, J., Ito, S., Hirata, N., Kido, S., Kitabatake, N., and Narita, H. (2001). Occurrence of the major food allergen, ovomucoid, in human breast milk as an immune complex. *Bioscience, biotechnology, and biochemistry* 65, 1438-1440.
- Hmida, N.B., Ben Ahmed, M., Moussa, A., Rejeb, M.B., Said, Y., Kourda, N., Meresse, B., Abdeladhim, M., Louzir, H., and Cerf-Bensussan, N. (2012). Impaired control of effector T cells by regulatory T cells: a clue to loss of oral tolerance and autoimmunity in celiac disease? *The American journal of gastroenterology* 107, 604-611.
- Hodges, G.M., Carr, E.A., Hazzard, R.A., and Carr, K.E. (1995). Uptake and translocation of microparticles in small intestine. Morphology and quantification of particle distribution. *Digestive diseases and sciences* 40, 967-975.

- Hori, S., Nomura, T., and Sakaguchi, S. (2003). Control of regulatory T cell development by the transcription factor Foxp3. *Science* 299, 1057-1061.
- Houlston, R.S., and Ford, D. (1996). Genetics of coeliac disease. *QJM : monthly journal of the Association of Physicians* 89, 737-743.
- Howe, S.E., Lickteig, D.J., Plunkett, K.N., Ryerse, J.S., and Konjufca, V. (2014). The uptake of soluble and particulate antigens by epithelial cells in the mouse small intestine. *PloS one* 9, e86656.
- Hue, S., Mention, J.J., Monteiro, R.C., Zhang, S., Cellier, C., Schmitz, J., Verkarre, V., Fodil, N., Bahram, S., Cerf-Bensussan, N., *et al.* (2004). A direct role for NKG2D/MICA interaction in villous atrophy during celiac disease. *Immunity* 21, 367-377.
- Hunt, K.A., Zhernakova, A., Turner, G., Heap, G.A., Franke, L., Bruinenberg, M., Romanos, J., Dinesen, L.C., Ryan, A.W., Panesar, D., *et al.* (2008). Newly identified genetic risk variants for celiac disease related to the immune response. *Nature genetics* 40, 395-402.
- Huntington, N.D., Puthalakath, H., Gunn, P., Naik, E., Michalak, E.M., Smyth, M.J., Tabarias, H., Degli-Esposti, M.A., Dewson, G., Willis, S.N., *et al.* (2007). Interleukin 15-mediated survival of natural killer cells is determined by interactions among Bim, Noxa and Mcl-1. *Nature immunology* 8, 856-863.
- Husby, S., Jensenius, J.C., and Svehag, S.E. (1985). Passage of undegraded dietary antigen into the blood of healthy adults. Quantification, estimation of size distribution, and relation of uptake to levels of specific antibodies. *Scandinavian journal of immunology* 22, 83-92.
- Israel, E.J., Taylor, S., Wu, Z., Mizoguchi, E., Blumberg, R.S., Bhan, A., and Simister, N.E. (1997). Expression of the neonatal Fc receptor, FcRn, on human intestinal epithelial cells. *Immunology* 92, 69-74.
- Ivarsson, A. (2005). The Swedish epidemic of coeliac disease explored using an epidemiological approach--some lessons to be learnt. *Best practice & research Clinical gastroenterology* 19, 425-440.
- Ivarsson, A., Hernell, O., Stenlund, H., and Persson, L.A. (2002). Breast-feeding protects against celiac disease. *The American journal of clinical nutrition* 75, 914-921.
- Iwasaki, A., and Kelsall, B.L. (2000). Localization of distinct Peyer's patch dendritic cell subsets and their recruitment by chemokines macrophage inflammatory protein (MIP)-3alpha, MIP-3beta, and secondary lymphoid organ chemokine. *The Journal of experimental medicine* 191, 1381-1394.
- Jabri, B., de Serre, N.P., Cellier, C., Evans, K., Gache, C., Carvalho, C., Mougnot, J.F., Allez, M., Jian, R., Desreumaux, P., *et al.* (2000). Selective expansion of intraepithelial lymphocytes

expressing the HLA-E-specific natural killer receptor CD94 in celiac disease. *Gastroenterology* 118, 867-879.

Jackson, J.T., Hu, Y., Liu, R., Masson, F., D'Amico, A., Carotta, S., Xin, A., Camilleri, M.J., Mount, A.M., Kallies, A., *et al.* (2011). Id2 expression delineates differential checkpoints in the genetic program of CD8alpha+ and CD103+ dendritic cell lineages. *The EMBO journal* 30, 2690-2704.

Jaensson, E., Uronen-Hansson, H., Pabst, O., Eksteen, B., Tian, J., Coombes, J.L., Berg, P.L., Davidsson, T., Powrie, F., Johansson-Lindbom, B., *et al.* (2008). Small intestinal CD103+ dendritic cells display unique functional properties that are conserved between mice and humans. *The Journal of experimental medicine* 205, 2139-2149.

Jang, M.H., Kweon, M.N., Iwatani, K., Yamamoto, M., Terahara, K., Sasakawa, C., Suzuki, T., Nochi, T., Yokota, Y., Rennert, P.D., *et al.* (2004). Intestinal villous M cells: an antigen entry site in the mucosal epithelium. *Proceedings of the National Academy of Sciences of the United States of America* 101, 6110-6115.

Jang, M.H., Sougawa, N., Tanaka, T., Hirata, T., Hiroi, T., Tohya, K., Guo, Z., Umemoto, E., Ebisuno, Y., Yang, B.G., *et al.* (2006). CCR7 is critically important for migration of dendritic cells in intestinal lamina propria to mesenteric lymph nodes. *Journal of immunology* 176, 803-810.

Jin, X., Stammaes, J., Klock, C., DiRaimondo, T.R., Sollid, L.M., and Khosla, C. (2011). Activation of extracellular transglutaminase 2 by thioredoxin. *The Journal of biological chemistry* 286, 37866-37873.

Johansson-Lindbom, B., Svensson, M., Pabst, O., Palmqvist, C., Marquez, G., Forster, R., and Agace, W.W. (2005). Functional specialization of gut CD103+ dendritic cells in the regulation of tissue-selective T cell homing. *The Journal of experimental medicine* 202, 1063-1073.

Johnson, L.A., and Jackson, D.G. (2013). The chemokine CX3CL1 promotes trafficking of dendritic cells through inflamed lymphatics. *Journal of cell science* 126, 5259-5270.

Jones, E.A., and Waldmann, T.A. (1972). The mechanism of intestinal uptake and transcellular transport of IgG in the neonatal rat. *The Journal of clinical investigation* 51, 2916-2927.

Jos, J., Labbe, F., Geny, B., and Griscelli, C. (1979). Immunoelectron-microscopic localization of immunoglobulin A and secretory component in jejunal mucosa from children with coeliac disease. *Scandinavian journal of immunology* 9, 441-450.

Josefowicz, S.Z., Niec, R.E., Kim, H.Y., Treuting, P., Chinen, T., Zheng, Y., Umetsu, D.T., and Rudensky, A.Y. (2012). Extrathymically generated regulatory T cells control mucosal TH2 inflammation. *Nature* 482, 395-399.

- Junker, Y., Zeissig, S., Kim, S.J., Barisani, D., Wieser, H., Leffler, D.A., Zevallos, V., Libermann, T.A., Dillon, S., Freitag, T.L., *et al.* (2012). Wheat amylase trypsin inhibitors drive intestinal inflammation via activation of toll-like receptor 4. *The Journal of experimental medicine* 209, 2395-2408.
- Juto, P., and Holm, S. (1992). Gliadin-specific and cow's milk protein-specific IgA in human milk. *Journal of pediatric gastroenterology and nutrition* 15, 159-162.
- Kadaoui, K.A., and Corthesy, B. (2007). Secretory IgA mediates bacterial translocation to dendritic cells in mouse Peyer's patches with restriction to mucosal compartment. *Journal of immunology* 179, 7751-7757.
- Kagnoff, M.F., Paterson, Y.J., Kumar, P.J., Kasarda, D.D., Carbone, F.R., Unsworth, D.J., and Austin, R.K. (1987). Evidence for the role of a human intestinal adenovirus in the pathogenesis of coeliac disease. *Gut* 28, 995-1001.
- Kaiserlian, D., Lachaux, A., Grosjean, I., Graber, P., and Bonnefoy, J.Y. (1993). Intestinal epithelial cells express the CD23/Fc epsilon RII molecule: enhanced expression in enteropathies. *Immunology* 80, 90-95.
- Kaiserlian, D., Vidal, K., and Revillard, J.P. (1989). Murine enterocytes can present soluble antigen to specific class II-restricted CD4+ T cells. *European journal of immunology* 19, 1513-1516.
- Kaukinen, K., Peraaho, M., Collin, P., Partanen, J., Woolley, N., Kaartinen, T., Nuutinen, T., Halttunen, T., Maki, M., and Korponay-Szabo, I. (2005). Small-bowel mucosal transglutaminase 2-specific IgA deposits in coeliac disease without villous atrophy: a prospective and randomized clinical study. *Scandinavian journal of gastroenterology* 40, 564-572.
- Ke, Y., Pearce, K., Lake, J.P., Ziegler, H.K., and Kapp, J.A. (1997). Gamma delta T lymphocytes regulate the induction and maintenance of oral tolerance. *Journal of immunology* 158, 3610-3618.
- Kelsall, B.L., and Strober, W. (1996). Distinct populations of dendritic cells are present in the subepithelial dome and T cell regions of the murine Peyer's patch. *The Journal of experimental medicine* 183, 237-247.
- Khattari, R., Cox, T., Yasayko, S.A., and Ramsdell, F. (2003). An essential role for Scurfin in CD4+CD25+ T regulatory cells. *Nature immunology* 4, 337-342.
- Kim, S.K., Reed, D.S., Olson, S., Schnell, M.J., Rose, J.K., Morton, P.A., and Lefrancois, L. (1998). Generation of mucosal cytotoxic T cells against soluble protein by tissue-specific

environmental and costimulatory signals. *Proceedings of the National Academy of Sciences of the United States of America* 95, 10814-10819.

King, I.L., Kroenke, M.A., and Segal, B.M. (2010). GM-CSF-dependent, CD103+ dermal dendritic cells play a critical role in Th effector cell differentiation after subcutaneous immunization. *The Journal of experimental medicine* 207, 953-961.

Klock, C., Diraimondo, T.R., and Khosla, C. (2012). Role of transglutaminase 2 in celiac disease pathogenesis. *Seminars in immunopathology* 34, 513-522.

Klose, C.S., Flach, M., Mohle, L., Rogell, L., Hoyler, T., Ebert, K., Fabiunke, C., Pfeifer, D., Sexl, V., Fonseca-Pereira, D., *et al.* (2014). Differentiation of Type 1 ILCs from a Common Progenitor to All Helper-like Innate Lymphoid Cell Lineages. *Cell* 157, 340-356.

Korneychuk, N., Ramiro-Puig, E., Ettersperger, J., Schulthess, J., Montcuquet, N., Kiyono, H., Meresse, B., and Cerf-Bensussan, N. (2014). Interleukin 15 and CD4(+) T cells cooperate to promote small intestinal enteropathy in response to dietary antigen. *Gastroenterology* 146, 1017-1027.

Kraus, T.A., Brimnes, J., Muong, C., Liu, J.H., Moran, T.M., Tappenden, K.A., Boros, P., and Mayer, L. (2005). Induction of mucosal tolerance in Peyer's patch-deficient, ligated small bowel loops. *The Journal of clinical investigation* 115, 2234-2243.

Kumar, V., Wijmenga, C., and Withoff, S. (2012). From genome-wide association studies to disease mechanisms: celiac disease as a model for autoimmune diseases. *Seminars in immunopathology* 34, 567-580.

Kutlu, T., Brousse, N., Rambaud, C., Le Deist, F., Schmitz, J., and Cerf-Bensussan, N. (1993). Numbers of T cell receptor (TCR) alpha beta+ but not of TcR gamma delta+ intraepithelial lymphocytes correlate with the grade of villous atrophy in coeliac patients on a long term normal diet. *Gut* 34, 208-214.

Kuwajima, S., Sato, T., Ishida, K., Tada, H., Tezuka, H., and Ohteki, T. (2006). Interleukin 15-dependent crosstalk between conventional and plasmacytoid dendritic cells is essential for CpG-induced immune activation. *Nature immunology* 7, 740-746.

Laffont, S., Siddiqui, K.R., and Powrie, F. (2010). Intestinal inflammation abrogates the tolerogenic properties of MLN CD103+ dendritic cells. *European journal of immunology* 40, 1877-1883.

Lammers, K.M., Lu, R., Brownley, J., Lu, B., Gerard, C., Thomas, K., Rallabhandi, P., Shear-Donohue, T., Tamiz, A., Alkan, S., *et al.* (2008). Gliadin induces an increase in intestinal permeability and zonulin release by binding to the chemokine receptor CXCR3. *Gastroenterology* 135, 194-204 e193.

- Lancaster-Smith, M., Packer, S., Kumar, P.J., and Harries, J.T. (1976). Immunological phenomena in the jejunum and serum after reintroduction of dietary gluten in children with treated coeliac disease. *Journal of clinical pathology* 29, 592-597.
- Langlet, C., Tamoutounour, S., Henri, S., Luche, H., Ardouin, L., Gregoire, C., Malissen, B., and Williams, M. (2012). CD64 expression distinguishes monocyte-derived and conventional dendritic cells and reveals their distinct role during intramuscular immunization. *Journal of immunology* 188, 1751-1760.
- Larsson, P., Holmdahl, R., and Klareskog, L. (1989). In vivo treatment with anti-CD8 and anti-CD5 monoclonal antibodies alters induced tolerance to adjuvant arthritis. *Journal of cellular biochemistry* 40, 49-56.
- Law, Y.M., Yeung, R.S., Mamalaki, C., Kioussis, D., Mak, T.W., and Flavell, R.A. (1994). Human CD4 restores normal T cell development and function in mice deficient in murine CD4. *The Journal of experimental medicine* 179, 1233-1242.
- Lebreton, C., Menard, S., Abed, J., Moura, I.C., Coppo, R., Dugave, C., Monteiro, R.C., Fricot, A., Traore, M.G., Griffin, M., *et al.* (2012). Interactions among secretory immunoglobulin A, CD71, and transglutaminase-2 affect permeability of intestinal epithelial cells to gliadin peptides. *Gastroenterology* 143, 698-707 e691-694.
- Lecuyer, E., Rakotobe, S., Lengline-Garnier, H., Lebreton, C., Picard, M., Juste, C., Fritzen, R., Eberl, G., McCoy, K.D., Macpherson, A.J., *et al.* (2014). Segmented filamentous bacterium uses secondary and tertiary lymphoid tissues to induce gut IgA and specific T helper 17 cell responses. *Immunity* 40, 608-620.
- Levinsky, R.J. (1985). Factors influencing intestinal uptake of food antigens. *The Proceedings of the Nutrition Society* 44, 81-86.
- Li, P., Burke, S., Wang, J., Chen, X., Ortiz, M., Lee, S.C., Lu, D., Campos, L., Goulding, D., Ng, B.L., *et al.* (2010). Reprogramming of T cells to natural killer-like cells upon Bcl11b deletion. *Science* 329, 85-89.
- Li, W., Chou, S.T., Wang, C., Kuhr, C.S., and Perkins, J.D. (2004). Role of the liver in peripheral tolerance: induction through oral antigen feeding. *American journal of transplantation : official journal of the American Society of Transplantation and the American Society of Transplant Surgeons* 4, 1574-1582.
- Lochner, M., Ohnmacht, C., Presley, L., Bruhns, P., Si-Tahar, M., Sawa, S., and Eberl, G. (2011). Microbiota-induced tertiary lymphoid tissues aggravate inflammatory disease in the absence of RORgamma t and LTi cells. *The Journal of experimental medicine* 208, 125-134.

- Lucchinetti, C.F., Popescu, B.F., Bunyan, R.F., Moll, N.M., Roemer, S.F., Lassmann, H., Bruck, W., Parisi, J.E., Scheithauer, B.W., Giannini, C., *et al.* (2011). Inflammatory cortical demyelination in early multiple sclerosis. *The New England journal of medicine* *365*, 2188-2197.
- Ludvigsson, J.F., and Fasano, A. (2012). Timing of introduction of gluten and celiac disease risk. *Annals of nutrition & metabolism* *60 Suppl 2*, 22-29.
- Ludvigsson, J.F., Leffler, D.A., Bai, J.C., Biagi, F., Fasano, A., Green, P.H., Hadjivassiliou, M., Kaukinen, K., Kelly, C.P., Leonard, J.N., *et al.* (2013). The Oslo definitions for coeliac disease and related terms. *Gut* *62*, 43-52.
- Lundin, K.E., Scott, H., Fausa, O., Thorsby, E., and Sollid, L.M. (1994). T cells from the small intestinal mucosa of a DR4, DQ7/DR4, DQ8 celiac disease patient preferentially recognize gliadin when presented by DQ8. *Human immunology* *41*, 285-291.
- Lundin, K.E., Scott, H., Hansen, T., Paulsen, G., Halstensen, T.S., Fausa, O., Thorsby, E., and Sollid, L.M. (1993). Gliadin-specific, HLA-DQ(alpha 1*0501,beta 1*0201) restricted T cells isolated from the small intestinal mucosa of celiac disease patients. *The Journal of experimental medicine* *178*, 187-196.
- Lundin, K.E., and Sollid, L.M. (2014). Advances in coeliac disease. *Current opinion in gastroenterology* *30*, 154-162.
- Lundin, K.E., Sollid, L.M., Qvigstad, E., Markussen, G., Gjertsen, H.A., Ek, J., and Thorsby, E. (1990). T lymphocyte recognition of a celiac disease-associated cis- or trans-encoded HLA-DQ alpha/beta-heterodimer. *Journal of immunology* *145*, 136-139.
- Macpherson, A.J., and Harris, N.L. (2004). Interactions between commensal intestinal bacteria and the immune system. *Nature reviews Immunology* *4*, 478-485.
- Maiuri, L., Ciacci, C., Auricchio, S., Brown, V., Quarantino, S., and Londei, M. (2000). Interleukin 15 mediates epithelial changes in celiac disease. *Gastroenterology* *119*, 996-1006.
- Malamut, G., El Machhour, R., Montcuquet, N., Martin-Lanneree, S., Dusanter-Fourt, I., Verkarre, V., Mention, J.J., Rahmi, G., Kiyono, H., Butz, E.A., *et al.* (2010). IL-15 triggers an antiapoptotic pathway in human intraepithelial lymphocytes that is a potential new target in celiac disease-associated inflammation and lymphomagenesis. *The Journal of clinical investigation* *120*, 2131-2143.
- Malamut, G., Meresse, B., Cellier, C., and Cerf-Bensussan, N. (2012). Refractory celiac disease: from bench to bedside. *Seminars in immunopathology* *34*, 601-613.

- Malmestrom, C., Lycke, J., Haghghi, S., Andersen, O., Carlsson, L., Wadenvik, H., and Olsson, B. (2008). Relapses in multiple sclerosis are associated with increased CD8+ T-cell mediated cytotoxicity in CSF. *Journal of neuroimmunology* *196*, 159-165.
- Mangalam, A.K., Rajagopalan, G., Taneja, V., and David, C.S. (2008). HLA class II transgenic mice mimic human inflammatory diseases. *Advances in immunology* *97*, 65-147.
- Marietta, E., Black, K., Camilleri, M., Krause, P., Rogers, R.S., 3rd, David, C., Pittelkow, M.R., and Murray, J.A. (2004). A new model for dermatitis herpetiformis that uses HLA-DQ8 transgenic NOD mice. *The Journal of clinical investigation* *114*, 1090-1097.
- Markiewicz, M.A., Wise, E.L., Buchwald, Z.S., Pinto, A.K., Zafirova, B., Polic, B., and Shaw, A.S. (2012). RAE1epsilon ligand expressed on pancreatic islets recruits NKG2D receptor-expressing cytotoxic T cells independent of T cell receptor recognition. *Immunity* *36*, 132-141.
- Marks-Konczalik, J., Dubois, S., Losi, J.M., Sabzevari, H., Yamada, N., Feigenbaum, L., Waldmann, T.A., and Tagaya, Y. (2000). IL-2-induced activation-induced cell death is inhibited in IL-15 transgenic mice. *Proceedings of the National Academy of Sciences of the United States of America* *97*, 11445-11450.
- Matson, A.P., Thrall, R.S., Rafti, E., Lingenheld, E.G., and Puddington, L. (2010). IgG transmitted from allergic mothers decreases allergic sensitization in breastfed offspring. *Clinical and molecular allergy : CMA* *8*, 9.
- Matteoli, G., Mazzini, E., Iliev, I.D., Mileti, E., Fallarino, F., Puccetti, P., Chieppa, M., and Rescigno, M. (2010). Gut CD103+ dendritic cells express indoleamine 2,3-dioxygenase which influences T regulatory/T effector cell balance and oral tolerance induction. *Gut* *59*, 595-604.
- Matysiak-Budnik, T., Candalh, C., Dugave, C., Namane, A., Cellier, C., Cerf-Bensussan, N., and Heyman, M. (2003). Alterations of the intestinal transport and processing of gliadin peptides in celiac disease. *Gastroenterology* *125*, 696-707.
- Matysiak-Budnik, T., Moura, I.C., Arcos-Fajardo, M., Lebreton, C., Menard, S., Candalh, C., Ben-Khalifa, K., Dugave, C., Tamouza, H., van Niel, G., *et al.* (2008). Secretory IgA mediates retrotranscytosis of intact gliadin peptides via the transferrin receptor in celiac disease. *The Journal of experimental medicine* *205*, 143-154.
- Maurano, M.T., Humbert, R., Rynes, E., Thurman, R.E., Haugen, E., Wang, H., Reynolds, A.P., Sandstrom, R., Qu, H., Brody, J., *et al.* (2012). Systematic localization of common disease-associated variation in regulatory DNA. *Science* *337*, 1190-1195.
- Mayer, L., and Shlien, R. (1987). Evidence for function of Ia molecules on gut epithelial cells in man. *The Journal of experimental medicine* *166*, 1471-1483.

- Maynard, C.L., Harrington, L.E., Janowski, K.M., Oliver, J.R., Zindl, C.L., Rudensky, A.Y., and Weaver, C.T. (2007). Regulatory T cells expressing interleukin 10 develop from Foxp3⁺ and Foxp3⁻ precursor cells in the absence of interleukin 10. *Nature immunology* 8, 931-941.
- Mazzarella, G., Stefanile, R., Camarca, A., Giliberti, P., Cosentini, E., Marano, C., Iaquinto, G., Giardullo, N., Auricchio, S., Sette, A., *et al.* (2008). Gliadin activates HLA class I-restricted CD8⁺ T cells in celiac disease intestinal mucosa and induces the enterocyte apoptosis. *Gastroenterology* 134, 1017-1027.
- Mazzini, E., Massimiliano, L., Penna, G., and Rescigno, M. (2014). Oral tolerance can be established via gap junction transfer of fed antigens from CX3CR1(+) macrophages to CD103(+) dendritic cells. *Immunity* 40, 248-261.
- McDole, J.R., Wheeler, L.W., McDonald, K.G., Wang, B., Konjufca, V., Knoop, K.A., Newberry, R.D., and Miller, M.J. (2012). Goblet cells deliver luminal antigen to CD103⁺ dendritic cells in the small intestine. *Nature* 483, 345-349.
- McInnes, I.B., and Schett, G. (2007). Cytokines in the pathogenesis of rheumatoid arthritis. *Nature reviews Immunology* 7, 429-442.
- McMenamin, C., Pimm, C., McKersey, M., and Holt, P.G. (1994). Regulation of IgE responses to inhaled antigen in mice by antigen-specific gamma delta T cells. *Science* 265, 1869-1871.
- Menard, S., Cerf-Bensussan, N., and Heyman, M. (2010). Multiple facets of intestinal permeability and epithelial handling of dietary antigens. *Mucosal immunology* 3, 247-259.
- Menard, S., Lebreton, C., Schumann, M., Matysiak-Budnik, T., Dugave, C., Bouhnik, Y., Malamut, G., Cellier, C., Allez, M., Crenn, P., *et al.* (2012). Paracellular versus transcellular intestinal permeability to gliadin peptides in active celiac disease. *The American journal of pathology* 180, 608-615.
- Mengel, J., Cardillo, F., Aroeira, L.S., Williams, O., Russo, M., and Vaz, N.M. (1995). Anti-gamma delta T cell antibody blocks the induction and maintenance of oral tolerance to ovalbumin in mice. *Immunology letters* 48, 97-102.
- Mention, J.J., Ben Ahmed, M., Begue, B., Barbe, U., Verkarre, V., Asnafi, V., Colombel, J.F., Cugnenc, P.H., Ruemmele, F.M., McIntyre, E., *et al.* (2003). Interleukin 15: a key to disrupted intraepithelial lymphocyte homeostasis and lymphomagenesis in celiac disease. *Gastroenterology* 125, 730-745.
- Meredith, M.M., Liu, K., Kamphorst, A.O., Idoyaga, J., Yamane, A., Guermonprez, P., Rihn, S., Yao, K.H., Silva, I.T., Oliveira, T.Y., *et al.* (2012). Zinc finger transcription factor zDC is a negative regulator required to prevent activation of classical dendritic cells in the steady state. *The Journal of experimental medicine* 209, 1583-1593.

- Meresse, B., Chen, Z., Ciszewski, C., Tretiakova, M., Bhagat, G., Krausz, T.N., Raulet, D.H., Lanier, L.L., Groh, V., Spies, T., *et al.* (2004). Coordinated induction by IL15 of a TCR-independent NKG2D signaling pathway converts CTL into lymphokine-activated killer cells in celiac disease. *Immunity* 21, 357-366.
- Meresse, B., Curran, S.A., Ciszewski, C., Orbelyan, G., Setty, M., Bhagat, G., Lee, L., Tretiakova, M., Semrad, C., Kistner, E., *et al.* (2006). Reprogramming of CTLs into natural killer-like cells in celiac disease. *The Journal of experimental medicine* 203, 1343-1355.
- Meresse, B., Malamut, G., and Cerf-Bensussan, N. (2012). Celiac disease: an immunological jigsaw. *Immunity* 36, 907-919.
- Mestecky, J., and McGhee, J.R. (1987). Immunoglobulin A (IgA): molecular and cellular interactions involved in IgA biosynthesis and immune response. *Advances in immunology* 40, 153-245.
- Miller, A., Lider, O., Abramsky, O., and Weiner, H.L. (1994). Orally administered myelin basic protein in neonates primes for immune responses and enhances experimental autoimmune encephalomyelitis in adult animals. *European journal of immunology* 24, 1026-1032.
- Miller, A., Lider, O., al-Sabbagh, A., and Weiner, H.L. (1992). Suppression of experimental autoimmune encephalomyelitis by oral administration of myelin basic protein. V. Hierarchy of suppression by myelin basic protein from different species. *Journal of neuroimmunology* 39, 243-250.
- Miller, J.F., Kurts, C., Allison, J., Kosaka, H., Carbone, F., and Heath, W.R. (1998). Induction of peripheral CD8+ T-cell tolerance by cross-presentation of self antigens. *Immunological reviews* 165, 267-277.
- Mizutani, N., Sakurai, T., Shibata, T., Uchida, K., Fujita, J., Kawashima, R., Kawamura, Y.I., Toyama-Sorimachi, N., Imai, T., and Dohi, T. (2007). Dose-dependent differential regulation of cytokine secretion from macrophages by fractalkine. *Journal of immunology* 179, 7478-7487.
- Moens, E., and Veldhoen, M. (2012). Epithelial barrier biology: good fences make good neighbours. *Immunology* 135, 1-8.
- Molberg, O., Kett, K., Scott, H., Thorsby, E., Sollid, L.M., and Lundin, K.E. (1997). Gliadin specific, HLA DQ2-restricted T cells are commonly found in small intestinal biopsies from coeliac disease patients, but not from controls. *Scandinavian journal of immunology* 46, 103-109.
- Molberg, O., McAdam, S.N., Korner, R., Quarsten, H., Kristiansen, C., Madsen, L., Fugger, L., Scott, H., Noren, O., Roepstorff, P., *et al.* (1998). Tissue transglutaminase selectively modifies

- gliadin peptides that are recognized by gut-derived T cells in celiac disease. *Nature medicine* 4, 713-717.
- Moog, F. (1981). The lining of the small intestine. *Scientific American* 245, 154-158, 160, 162 et passiom.
- Mortha, A., Chudnovskiy, A., Hashimoto, D., Bogunovic, M., Spencer, S.P., Belkaid, Y., and Merad, M. (2014). Microbiota-dependent crosstalk between macrophages and ILC3 promotes intestinal homeostasis. *Science* 343, 1249288.
- Mosconi, E., Rekima, A., Seitz-Polski, B., Kanda, A., Fleury, S., Tissandie, E., Monteiro, R., Dombrowicz, D.D., Julia, V., Glaichenhaus, N., *et al.* (2010). Breast milk immune complexes are potent inducers of oral tolerance in neonates and prevent asthma development. *Mucosal immunology* 3, 461-474.
- Moura, I.C., Centelles, M.N., Arcos-Fajardo, M., Malheiros, D.M., Collawn, J.F., Cooper, M.D., and Monteiro, R.C. (2001). Identification of the transferrin receptor as a novel immunoglobulin (Ig)A1 receptor and its enhanced expression on mesangial cells in IgA nephropathy. *The Journal of experimental medicine* 194, 417-425.
- Mowat, A.M. (2003). Anatomical basis of tolerance and immunity to intestinal antigens. *Nature reviews Immunology* 3, 331-341.
- Mowat, A.M., and Ferguson, A. (1982). Migration inhibition of lymph node lymphocytes as an assay for regional cell-mediated immunity in the intestinal lymphoid tissues of mice immunized orally with ovalbumin. *Immunology* 47, 365-370.
- Mucida, D., Kutchukhidze, N., Erazo, A., Russo, M., Lafaille, J.J., and Curotto de Lafaille, M.A. (2005). Oral tolerance in the absence of naturally occurring Tregs. *The Journal of clinical investigation* 115, 1923-1933.
- Murai, M., Turovskaya, O., Kim, G., Madan, R., Karp, C.L., Cheroutre, H., and Kronenberg, M. (2009). Interleukin 10 acts on regulatory T cells to maintain expression of the transcription factor Foxp3 and suppressive function in mice with colitis. *Nature immunology* 10, 1178-1184.
- Musso, T., Calosso, L., Zucca, M., Millesimo, M., Ravarino, D., Giovarelli, M., Malavasi, F., Ponzi, A.N., Paus, R., and Bulfone-Paus, S. (1999). Human monocytes constitutively express membrane-bound, biologically active, and interferon-gamma-upregulated interleukin-15. *Blood* 93, 3531-3539.
- Nabozny, G.H., Baisch, J.M., Cheng, S., Cosgrove, D., Griffiths, M.M., Luthra, H.S., and David, C.S. (1996). HLA-DQ8 transgenic mice are highly susceptible to collagen-induced arthritis: a novel model for human polyarthritis. *The Journal of experimental medicine* 183, 27-37.

- Nakao, H., Eguchi, K., Kawakami, A., Migita, K., Otsubo, T., Ueki, Y., Shimomura, C., Tezuka, H., Matsunaga, M., Maeda, K., *et al.* (1990). Phenotypic characterization of lymphocytes infiltrating synovial tissue from patients with rheumatoid arthritis: analysis of lymphocytes isolated from minced synovial tissue by dual immunofluorescent staining. *The Journal of rheumatology* *17*, 142-148.
- Namatovu, F., Sandstrom, O., Olsson, C., Lindkvist, M., and Ivarsson, A. (2014). Celiac disease risk varies between birth cohorts, generating hypotheses about causality: evidence from 36 years of population-based follow-up. *BMC gastroenterology* *14*, 59.
- Neutra, M.R., Mantis, N.J., and Kraehenbuhl, J.P. (2001). Collaboration of epithelial cells with organized mucosal lymphoid tissues. *Nature immunology* *2*, 1004-1009.
- Niess, J.H., Brand, S., Gu, X., Landsman, L., Jung, S., McCormick, B.A., Vyas, J.M., Boes, M., Ploegh, H.L., Fox, J.G., *et al.* (2005). CX3CR1-mediated dendritic cell access to the intestinal lumen and bacterial clearance. *Science* *307*, 254-258.
- Nieuwenhuizen, W.F., Pieters, R.H., Knippels, L.M., Jansen, M.C., and Koppelman, S.J. (2003). Is *Candida albicans* a trigger in the onset of coeliac disease? *Lancet* *361*, 2152-2154.
- Nistico, L., Fagnani, C., Coto, I., Percopo, S., Cotichini, R., Limongelli, M.G., Paparo, F., D'Alfonso, S., Giordano, M., Sferlazzas, C., *et al.* (2006). Concordance, disease progression, and heritability of coeliac disease in Italian twins. *Gut* *55*, 803-808.
- Norouziyan, F., Shen, W.C., and Hamm-Alvarez, S.F. (2008). Tyrphostin A8 stimulates a novel trafficking pathway of apically endocytosed transferrin through Rab11-enriched compartments in Caco-2 cells. *American journal of physiology Cell physiology* *294*, C7-21.
- Norris, J.M., Barriga, K., Hoffenberg, E.J., Taki, I., Miao, D., Haas, J.E., Emery, L.M., Sokol, R.J., Erlich, H.A., Eisenbarth, G.S., *et al.* (2005). Risk of celiac disease autoimmunity and timing of gluten introduction in the diet of infants at increased risk of disease. *JAMA : the journal of the American Medical Association* *293*, 2343-2351.
- Novy, P., Huang, X., Leonard, W.J., and Yang, Y. (2011). Intrinsic IL-21 signaling is critical for CD8 T cell survival and memory formation in response to vaccinia viral infection. *Journal of immunology* *186*, 2729-2738.
- Oberhuber, G., Vogelsang, H., Stolte, M., Muthenthaler, S., Kummer, J.A., and Radaszkiewicz, T. (1996). Evidence that intestinal intraepithelial lymphocytes are activated cytotoxic T cells in celiac disease but not in giardiasis. *The American journal of pathology* *148*, 1351-1357.
- Ogasawara, K., Hamerman, J.A., Ehrlich, L.R., Bour-Jordan, H., Santamaria, P., Bluestone, J.A., and Lanier, L.L. (2004). NKG2D blockade prevents autoimmune diabetes in NOD mice. *Immunity* *20*, 757-767.

- Ohta, N., Hiroi, T., Kweon, M.N., Kinoshita, N., Jang, M.H., Mashimo, T., Miyazaki, J., and Kiyono, H. (2002). IL-15-dependent activation-induced cell death-resistant Th1 type CD8 alpha beta+ NK1.1+ T cells for the development of small intestinal inflammation. *Journal of immunology* 169, 460-468.
- Ohteki, T., Suzue, K., Maki, C., Ota, T., and Koyasu, S. (2001). Critical role of IL-15-IL-15R for antigen-presenting cell functions in the innate immune response. *Nature immunology* 2, 1138-1143.
- Okada, K., Prentice, H.L., Boss, J.M., Levy, D.J., Kappes, D., Spies, T., Raghupathy, R., Mengler, R.A., Auffray, C., and Strominger, J.L. (1985). SB subregion of the human major histocompatibility complex: gene organization, allelic polymorphism and expression in transformed cells. *The EMBO journal* 4, 739-748.
- Olaussen, R.W., Johansen, F.E., Lundin, K.E., Jahnsen, J., Brandtzaeg, P., and Farstad, I.N. (2002). Interferon-gamma-secreting T cells localize to the epithelium in coeliac disease. *Scandinavian journal of immunology* 56, 652-664.
- Ou, G., Hedberg, M., Horstedt, P., Baranov, V., Forsberg, G., Drobni, M., Sandstrom, O., Wai, S.N., Johansson, I., Hammarstrom, M.L., *et al.* (2009). Proximal small intestinal microbiota and identification of rod-shaped bacteria associated with childhood celiac disease. *The American journal of gastroenterology* 104, 3058-3067.
- Owen, R.L. (1977). Sequential uptake of horseradish peroxidase by lymphoid follicle epithelium of Peyer's patches in the normal unobstructed mouse intestine: an ultrastructural study. *Gastroenterology* 72, 440-451.
- Pabst, O., and Mowat, A.M. (2012). Oral tolerance to food protein. *Mucosal immunology* 5, 232-239.
- Parkes, M., Cortes, A., van Heel, D.A., and Brown, M.A. (2013). Genetic insights into common pathways and complex relationships among immune-mediated diseases. *Nature reviews Genetics* 14, 661-673.
- Persson, E.K., Jaensson, E., and Agace, W.W. (2010). The diverse ontogeny and function of murine small intestinal dendritic cell/macrophage subsets. *Immunobiology* 215, 692-697.
- Persson, E.K., Scott, C.L., Mowat, A.M., and Agace, W.W. (2013a). Dendritic cell subsets in the intestinal lamina propria: ontogeny and function. *European journal of immunology* 43, 3098-3107.
- Persson, E.K., Uronen-Hansson, H., Semmrich, M., Rivollier, A., Hagerbrand, K., Marsal, J., Gudjonsson, S., Hakansson, U., Reizis, B., Kotarsky, K., *et al.* (2013b). IRF4 transcription-

factor-dependent CD103(+)CD11b(+) dendritic cells drive mucosal T helper 17 cell differentiation. *Immunity* 38, 958-969.

Petersen, J., Montserrat, V., Mujico, J.R., Loh, K.L., Beringer, D.X., van Lummel, M., Thompson, A., Mearin, M.L., Schweizer, J., Kooy-Winkelaar, Y., *et al.* (2014). T-cell receptor recognition of HLA-DQ2-gliadin complexes associated with celiac disease. *Nature structural & molecular biology* 21, 480-488.

Ponomarev, E.D., Shriver, L.P., Maresz, K., Pedras-Vasconcelos, J., Verthelyi, D., and Dittel, B.N. (2007). GM-CSF production by autoreactive T cells is required for the activation of microglial cells and the onset of experimental autoimmune encephalomyelitis. *Journal of immunology* 178, 39-48.

Ramanathan, S., Dubois, S., Gagnon, J., Leblanc, C., Mariathasan, S., Ferbeyre, G., Rottapel, R., Ohashi, P.S., and Ilangumaran, S. (2010). Regulation of cytokine-driven functional differentiation of CD8 T cells by suppressor of cytokine signaling 1 controls autoimmunity and preserves their proliferative capacity toward foreign antigens. *Journal of immunology* 185, 357-366.

Raposo, B.R., Rodrigues-Santos, P., Carneiro, H., Agua-Doce, A.M., Carvalho, L., Pereira da Silva, J.A., Graca, L., and Souto-Carneiro, M.M. (2010). Monoclonal anti-CD8 therapy induces disease amelioration in the K/BxN mouse model of spontaneous chronic polyarthritis. *Arthritis and rheumatism* 62, 2953-2962.

Regamey, N., Obregon, C., Ferrari-Lacraz, S., van Leer, C., Chanson, M., Nicod, L.P., and Geiser, T. (2007). Airway epithelial IL-15 transforms monocytes into dendritic cells. *American journal of respiratory cell and molecular biology* 37, 75-84.

Rescigno, M. (2010). Intestinal dendritic cells. *Advances in immunology* 107, 109-138.

Rescigno, M., Urbano, M., Valzasina, B., Francolini, M., Rotta, G., Bonasio, R., Granucci, F., Kraehenbuhl, J.P., and Ricciardi-Castagnoli, P. (2001). Dendritic cells express tight junction proteins and penetrate gut epithelial monolayers to sample bacteria. *Nature immunology* 2, 361-367.

Reynolds, J., Norgan, V.A., Bhambra, U., Smith, J., Cook, H.T., and Pusey, C.D. (2002). Anti-CD8 monoclonal antibody therapy is effective in the prevention and treatment of experimental autoimmune glomerulonephritis. *Journal of the American Society of Nephrology : JASN* 13, 359-369.

Richman, L.K., Chiller, J.M., Brown, W.R., Hanson, D.G., and Vaz, N.M. (1978). Enterically induced immunologic tolerance. I. Induction of suppressor T lymphocytes by intragastric administration of soluble proteins. *Journal of immunology* 121, 2429-2434.

- Roberts, A.I., Lee, L., Schwarz, E., Groh, V., Spies, T., Ebert, E.C., and Jabri, B. (2001). NKG2D receptors induced by IL-15 costimulate CD28-negative effector CTL in the tissue microenvironment. *Journal of immunology* *167*, 5527-5530.
- Round, J.L., and Mazmanian, S.K. (2010). Inducible Foxp3+ regulatory T-cell development by a commensal bacterium of the intestinal microbiota. *Proceedings of the National Academy of Sciences of the United States of America* *107*, 12204-12209.
- Rubio-Tapia, A., and Murray, J.A. (2010). Celiac disease. *Current opinion in gastroenterology* *26*, 116-122.
- Ruedl, C., Rieser, C., Bock, G., Wick, G., and Wolf, H. (1996). Phenotypic and functional characterization of CD11c+ dendritic cell population in mouse Peyer's patches. *European journal of immunology* *26*, 1801-1806.
- Sakaguchi, S., Fukuma, K., Kuribayashi, K., and Masuda, T. (1985). Organ-specific autoimmune diseases induced in mice by elimination of T cell subset. I. Evidence for the active participation of T cells in natural self-tolerance; deficit of a T cell subset as a possible cause of autoimmune disease. *The Journal of experimental medicine* *161*, 72-87.
- Sakaguchi, S., Sakaguchi, N., Asano, M., Itoh, M., and Toda, M. (1995). Immunologic self-tolerance maintained by activated T cells expressing IL-2 receptor alpha-chains (CD25). Breakdown of a single mechanism of self-tolerance causes various autoimmune diseases. *Journal of immunology* *155*, 1151-1164.
- Sakaguchi, S., Takahashi, T., and Nishizuka, Y. (1982). Study on cellular events in postthymectomy autoimmune oophoritis in mice. I. Requirement of Lyt-1 effector cells for oocytes damage after adoptive transfer. *The Journal of experimental medicine* *156*, 1565-1576.
- Sandberg-Bennich, S., Dahlquist, G., and Kallen, B. (2002). Coeliac disease is associated with intrauterine growth and neonatal infections. *Acta paediatrica* *91*, 30-33.
- Sardy, M., Karpati, S., Merkl, B., Paulsson, M., and Smyth, N. (2002). Epidermal transglutaminase (TGase 3) is the autoantigen of dermatitis herpetiformis. *The Journal of experimental medicine* *195*, 747-757.
- Sarra, M., Cupi, M.L., Monteleone, I., Franze, E., Ronchetti, G., Di Sabatino, A., Gentileschi, P., Franceschilli, L., Sileri, P., Sica, G., *et al.* (2013). IL-15 positively regulates IL-21 production in celiac disease mucosa. *Mucosal immunology* *6*, 244-255.
- Sathe, P., Pooley, J., Vremec, D., Mintern, J., Jin, J.O., Wu, L., Kwak, J.Y., Villadangos, J.A., and Shortman, K. (2011). The acquisition of antigen cross-presentation function by newly formed dendritic cells. *Journal of immunology* *186*, 5184-5192.

- Satpathy, A.T., Kc, W., Albring, J.C., Edelson, B.T., Kretzer, N.M., Bhattacharya, D., Murphy, T.L., and Murphy, K.M. (2012). Zbtb46 expression distinguishes classical dendritic cells and their committed progenitors from other immune lineages. *The Journal of experimental medicine* 209, 1135-1152.
- Savilahti, E., Ormala, T., Arato, A., Hacesek, G., Holm, K., Klemola, T., Nemeth, A., Maki, M., and Reunala, T. (1997). Density of gamma/delta+ T cells in the jejunal epithelium of patients with coeliac disease and dermatitis herpetiformis is increased with age. *Clinical and experimental immunology* 109, 464-467.
- Schilham, M.W., Fung-Leung, W.P., Rahemtulla, A., Kuendig, T., Zhang, L., Potter, J., Miller, R.G., Hengartner, H., and Mak, T.W. (1993). Alloreactive cytotoxic T cells can develop and function in mice lacking both CD4 and CD8. *European journal of immunology* 23, 1299-1304.
- Schulthess, J., Meresse, B., Ramiro-Puig, E., Montcuquet, N., Darche, S., Begue, B., Ruummele, F., Combadiere, C., Di Santo, J.P., Buzoni-Gatel, D., *et al.* (2012). Interleukin-15-dependent NKp46+ innate lymphoid cells control intestinal inflammation by recruiting inflammatory monocytes. *Immunity* 37, 108-121.
- Schulz, O., Jaensson, E., Persson, E.K., Liu, X., Worbs, T., Agace, W.W., and Pabst, O. (2009). Intestinal CD103+, but not CX3CR1+, antigen sampling cells migrate in lymph and serve classical dendritic cell functions. *The Journal of experimental medicine* 206, 3101-3114.
- Schulz, O., and Pabst, O. (2013). Antigen sampling in the small intestine. *Trends in immunology* 34, 155-161.
- Schwartz, B.D. (1994). HLA class II transgenic mice: the chance to unravel the basis of HLA class II associations with disease. *The Journal of experimental medicine* 180, 11-13.
- Scott, C.L., Aumeunier, A.M., and Mowat, A.M. (2011). Intestinal CD103+ dendritic cells: master regulators of tolerance? *Trends in immunology* 32, 412-419.
- Semrich, M., Plantinga, M., Svensson-Frej, M., Uronen-Hansson, H., Gustafsson, T., Mowat, A.M., Yrlid, U., Lambrecht, B.N., and Agace, W.W. (2012). Directed antigen targeting in vivo identifies a role for CD103+ dendritic cells in both tolerogenic and immunogenic T-cell responses. *Mucosal immunology* 5, 150-160.
- Shah, U., Dickinson, B.L., Blumberg, R.S., Simister, N.E., Lencer, W.I., and Walker, W.A. (2003). Distribution of the IgG Fc receptor, FcRn, in the human fetal intestine. *Pediatric research* 53, 295-301.
- Shakhar, G., and Kolesnikov, M. (2014). Intestinal macrophages and DCs close the gap on tolerance. *Immunity* 40, 171-173.

- Shan, L., Molberg, O., Parrot, I., Hausch, F., Filiz, F., Gray, G.M., Sollid, L.M., and Khosla, C. (2002). Structural basis for gluten intolerance in celiac sprue. *Science* 297, 2275-2279.
- Shevach, E.M. (2009). Mechanisms of foxp3+ T regulatory cell-mediated suppression. *Immunity* 30, 636-645.
- Shiner, M., and Ballard, J. (1972). Antigen-antibody reactions in jejunal mucosa in childhood coeliac disease after gluten challenge. *Lancet* 1, 1202-1205.
- Siegel, M., Strnad, P., Watts, R.E., Choi, K., Jabri, B., Omary, M.B., and Khosla, C. (2008). Extracellular transglutaminase 2 is catalytically inactive, but is transiently activated upon tissue injury. *PloS one* 3, e1861.
- Siewert, C., Lauer, U., Cording, S., Bopp, T., Schmitt, E., Hamann, A., and Huehn, J. (2008). Experience-driven development: effector/memory-like alphaE+Foxp3+ regulatory T cells originate from both naive T cells and naturally occurring naive-like regulatory T cells. *Journal of immunology* 180, 146-155.
- Silano, M., Agostoni, C., and Guandalini, S. (2010). Effect of the timing of gluten introduction on the development of celiac disease. *World journal of gastroenterology : WJG* 16, 1939-1942.
- Sixt, M., Kanazawa, N., Selg, M., Samson, T., Roos, G., Reinhardt, D.P., Pabst, R., Lutz, M.B., and Sorokin, L. (2005). The conduit system transports soluble antigens from the afferent lymph to resident dendritic cells in the T cell area of the lymph node. *Immunity* 22, 19-29.
- Sjostrom, H., Lundin, K.E., Molberg, O., Korner, R., McAdam, S.N., Anthonsen, D., Quarsten, H., Noren, O., Roepstorff, P., Thorsby, E., *et al.* (1998). Identification of a gliadin T-cell epitope in coeliac disease: general importance of gliadin deamidation for intestinal T-cell recognition. *Scandinavian journal of immunology* 48, 111-115.
- Slack, E., Hapfelmeier, S., Stecher, B., Velykoredko, Y., Stiel, M., Lawson, M.A., Geuking, M.B., Beutler, B., Tedder, T.F., Hardt, W.D., *et al.* (2009). Innate and adaptive immunity cooperate flexibly to maintain host-microbiota mutualism. *Science* 325, 617-620.
- Snoeck, V., Goddeeris, B., and Cox, E. (2005). The role of enterocytes in the intestinal barrier function and antigen uptake. *Microbes and infection / Institut Pasteur* 7, 997-1004.
- Sollid, L.M. (2002). Coeliac disease: dissecting a complex inflammatory disorder. *Nature reviews Immunology* 2, 647-655.
- Sollid, L.M., Markussen, G., Ek, J., Gjerde, H., Vartdal, F., and Thorsby, E. (1989). Evidence for a primary association of celiac disease to a particular HLA-DQ alpha/beta heterodimer. *The Journal of experimental medicine* 169, 345-350.
- Sollid, L.M., Molberg, O., McAdam, S., and Lundin, K.E. (1997). Autoantibodies in coeliac disease: tissue transglutaminase--guilt by association? *Gut* 41, 851-852.

- Sollid, L.M., Qiao, S.W., Anderson, R.P., Gianfrani, C., and Koning, F. (2012). Nomenclature and listing of celiac disease relevant gluten T-cell epitopes restricted by HLA-DQ molecules. *Immunogenetics* 64, 455-460.
- Souza-Fonseca-Guimaraes, F., Parlato, M., de Oliveira, R.B., Golenbock, D., Fitzgerald, K., Shalova, I.N., Biswas, S.K., Cavaillon, J.M., and Adib-Conquy, M. (2013). Interferon-gamma and granulocyte/monocyte colony-stimulating factor production by natural killer cells involves different signaling pathways and the adaptor stimulator of interferon genes (STING). *The Journal of biological chemistry* 288, 10715-10721.
- Spahn, T.W., Fontana, A., Faria, A.M., Slavin, A.J., Eugster, H.P., Zhang, X., Koni, P.A., Ruddle, N.H., Flavell, R.A., Rennert, P.D., *et al.* (2001). Induction of oral tolerance to cellular immune responses in the absence of Peyer's patches. *European journal of immunology* 31, 1278-1287.
- Spahn, T.W., Weiner, H.L., Rennert, P.D., Lugerling, N., Fontana, A., Domschke, W., and Kucharzik, T. (2002). Mesenteric lymph nodes are critical for the induction of high-dose oral tolerance in the absence of Peyer's patches. *European journal of immunology* 32, 1109-1113.
- Sperandeo, M.P., Tosco, A., Izzo, V., Tucci, F., Troncone, R., Auricchio, R., Romanos, J., Trynka, G., Auricchio, S., Jabri, B., *et al.* (2011). Potential celiac patients: a model of celiac disease pathogenesis. *PloS one* 6, e21281.
- Spits, H., Artis, D., Colonna, M., Diefenbach, A., Di Santo, J.P., Eberl, G., Koyasu, S., Locksley, R.M., McKenzie, A.N., Mebius, R.E., *et al.* (2013). Innate lymphoid cells--a proposal for uniform nomenclature. *Nature reviews Immunology* 13, 145-149.
- Spurkland, A., Sollid, L.M., Polanco, I., Vartdal, F., and Thorsby, E. (1992). HLA-DR and -DQ genotypes of celiac disease patients serologically typed to be non-DR3 or non-DR5/7. *Human immunology* 35, 188-192.
- Stene, L.C., Honeyman, M.C., Hoffenberg, E.J., Haas, J.E., Sokol, R.J., Emery, L., Taki, I., Norris, J.M., Erlich, H.A., Eisenbarth, G.S., *et al.* (2006). Rotavirus infection frequency and risk of celiac disease autoimmunity in early childhood: a longitudinal study. *The American journal of gastroenterology* 101, 2333-2340.
- Stepankova, R., Kofronova, O., Tuckova, L., Kozakova, H., Cebra, J.J., and Tlaskalova-Hogenova, H. (2003). Experimentally induced gluten enteropathy and protective effect of epidermal growth factor in artificially fed neonatal rats. *Journal of pediatric gastroenterology and nutrition* 36, 96-104.

- Stepankova, R., Tlaskalova-Hogenova, H., Sinkora, J., Jodl, J., and Fric, P. (1996). Changes in jejunal mucosa after long-term feeding of germfree rats with gluten. *Scandinavian journal of gastroenterology* 31, 551-557.
- Strobel, S., and Ferguson, A. (1984). Immune responses to fed protein antigens in mice. 3. Systemic tolerance or priming is related to age at which antigen is first encountered. *Pediatric research* 18, 588-594.
- Strobel, S., Mowat, A.M., Drummond, H.E., Pickering, M.G., and Ferguson, A. (1983). Immunological responses to fed protein antigens in mice. II. Oral tolerance for CMI is due to activation of cyclophosphamide-sensitive cells by gut-processed antigen. *Immunology* 49, 451-456.
- Sun, C.M., Hall, J.A., Blank, R.B., Bouladoux, N., Oukka, M., Mora, J.R., and Belkaid, Y. (2007a). Small intestine lamina propria dendritic cells promote de novo generation of Foxp3 T reg cells via retinoic acid. *The Journal of experimental medicine* 204, 1775-1785.
- Sun, Y., Chen, X., and Xiao, D. (2007b). Tetracycline-inducible expression systems: new strategies and practices in the transgenic mouse modeling. *Acta biochimica et biophysica Sinica* 39, 235-246.
- Suzuki, H., Sekine, S., Kataoka, K., Pascual, D.W., Maddaloni, M., Kobayashi, R., Fujihashi, K., Kozono, H., McGhee, J.R., and Fujihashi, K. (2008). Ovalbumin-protein sigma 1 M-cell targeting facilitates oral tolerance with reduction of antigen-specific CD4+ T cells. *Gastroenterology* 135, 917-925.
- Swarbrick, E.T., Stokes, C.R., and Soothill, J.F. (1979). Absorption of antigens after oral immunisation and the simultaneous induction of specific systemic tolerance. *Gut* 20, 121-125.
- Szajewska, H., Chmielewska, A., Piescik-Lech, M., Ivarsson, A., Kolacek, S., Koletzko, S., Mearin, M.L., Shamir, R., Auricchio, R., Troncone, R., *et al.* (2012). Systematic review: early infant feeding and the prevention of coeliac disease. *Alimentary pharmacology & therapeutics* 36, 607-618.
- Tamouza, H., Chemouny, J.M., Raskova Kafkova, L., Berthelot, L., Flamant, M., Demion, M., Mesnard, L., Paubelle, E., Walker, F., Julian, B.A., *et al.* (2012). The IgA1 immune complex-mediated activation of the MAPK/ERK kinase pathway in mesangial cells is associated with glomerular damage in IgA nephropathy. *Kidney international* 82, 1284-1296.
- Taneja, V., and David, C.S. (1998). HLA transgenic mice as humanized mouse models of disease and immunity. *The Journal of clinical investigation* 101, 921-926.

- Terpend, K., Boisgerault, F., Blaton, M.A., Desjeux, J.F., and Heyman, M. (1998). Protein transport and processing by human HT29-19A intestinal cells: effect of interferon gamma. *Gut* 42, 538-545.
- Thomson, A.W., and Knolle, P.A. (2010). Antigen-presenting cell function in the tolerogenic liver environment. *Nature reviews Immunology* 10, 753-766.
- Tollefsen, S., Hotta, K., Chen, X., Simonsen, B., Swaminathan, K., Mathews, II, Sollid, L.M., and Kim, C.Y. (2012). Structural and functional studies of trans-encoded HLA-DQ2.3 (DQA1*03:01/DQB1*02:01) protein molecule. *The Journal of biological chemistry* 287, 13611-13619.
- Torgerson, T.R., Linane, A., Moes, N., Anover, S., Mateo, V., Rieux-Laucat, F., Hermine, O., Vijay, S., Gambineri, E., Cerf-Bensussan, N., *et al.* (2007). Severe food allergy as a variant of IPEX syndrome caused by a deletion in a noncoding region of the FOXP3 gene. *Gastroenterology* 132, 1705-1717.
- Tripathi, A., Lammers, K.M., Goldblum, S., Shea-Donohue, T., Netzel-Arnett, S., Buzza, M.S., Antalis, T.M., Vogel, S.N., Zhao, A., Yang, S., *et al.* (2009). Identification of human zonulin, a physiological modulator of tight junctions, as prehaptoglobin-2. *Proceedings of the National Academy of Sciences of the United States of America* 106, 16799-16804.
- Troncone, R., Caputo, N., Zibella, A., Moliterno, G., Maiuri, L., and Auricchio, S. (1994). Effects of gluten enriched diet on the small intestinal mucosa of normal mice and mice with graft versus host reaction. *Gut* 35, 779-782.
- Troncone, R., and Ferguson, A. (1988). Gliadin presented via the gut induces oral tolerance in mice. *Clinical and experimental immunology* 72, 284-287.
- Troncone, R., and Ferguson, A. (1991). Animal model of gluten induced enteropathy in mice. *Gut* 32, 871-875.
- Troncone, R., Greco, L., Mayer, M., Mazzarella, G., Maiuri, L., Congia, M., Frau, F., De Virgiliis, S., and Auricchio, S. (1996). In siblings of celiac children, rectal gluten challenge reveals gluten sensitization not restricted to celiac HLA. *Gastroenterology* 111, 318-324.
- Trynka, G., Hunt, K.A., Bockett, N.A., Romanos, J., Mistry, V., Szperl, A., Bakker, S.F., Bardella, M.T., Bhaw-Rosun, L., Castillejo, G., *et al.* (2011). Dense genotyping identifies and localizes multiple common and rare variant association signals in celiac disease. *Nature genetics* 43, 1193-1201.
- Trynka, G., Zhernakova, A., Romanos, J., Franke, L., Hunt, K.A., Turner, G., Bruinenberg, M., Heap, G.A., Platteel, M., Ryan, A.W., *et al.* (2009). Coeliac disease-associated risk variants in TNFAIP3 and REL implicate altered NF-kappaB signalling. *Gut* 58, 1078-1083.

- Vaknin-Dembinsky, A., Brass, S.D., Gandhi, R., and Weiner, H.L. (2008). Membrane bound IL-15 is increased on CD14 monocytes in early stages of MS. *Journal of neuroimmunology* 195, 135-139.
- van Berge-Henegouwen, G.P., and Mulder, C.J. (1993). Pioneer in the gluten free diet: Willem-Karel Dicke 1905-1962, over 50 years of gluten free diet. *Gut* 34, 1473-1475.
- Van De Kamer, J.H., Weijers, H.A., and Dicke, W.K. (1953). Coeliac disease. IV. An investigation into the injurious constituents of wheat in connection with their action on patients with coeliac disease. *Acta paediatrica* 42, 223-231.
- van de Wal, Y., Kooy, Y., van Veelen, P., Pena, S., Mearin, L., Papadopoulos, G., and Koning, F. (1998a). Selective deamidation by tissue transglutaminase strongly enhances gliadin-specific T cell reactivity. *Journal of immunology* 161, 1585-1588.
- van de Wal, Y., Kooy, Y.M., van Veelen, P.A., Pena, S.A., Mearin, L.M., Molberg, O., Lundin, K.E., Sollid, L.M., Mutis, T., Benckhuijsen, W.E., *et al.* (1998b). Small intestinal T cells of celiac disease patients recognize a natural pepsin fragment of gliadin. *Proceedings of the National Academy of Sciences of the United States of America* 95, 10050-10054.
- Van den Bossche, J., Malissen, B., Mantovani, A., De Baetselier, P., and Van Ginderachter, J.A. (2012). Regulation and function of the E-cadherin/catenin complex in cells of the monocyte-macrophage lineage and DCs. *Blood* 119, 1623-1633.
- van der Flier, L.G., and Clevers, H. (2009). Stem cells, self-renewal, and differentiation in the intestinal epithelium. *Annual review of physiology* 71, 241-260.
- van Heel, D.A., Franke, L., Hunt, K.A., Gwilliam, R., Zhernakova, A., Inouye, M., Wapenaar, M.C., Barnardo, M.C., Bethel, G., Holmes, G.K., *et al.* (2007). A genome-wide association study for celiac disease identifies risk variants in the region harboring IL2 and IL21. *Nature genetics* 39, 827-829.
- van Leeuwen, M.A., du Pre, M.F., van Wanrooij, R.L., de Ruiter, L.F., Raatgeep, H.R., Lindenbergh-Kortleve, D.J., Mulder, C.J., de Ridder, L., Escher, J.C., and Samsom, J.N. (2013a). Changes in natural Foxp3(+)Treg but not mucosally-imprinted CD62L(neg)CD38(+)Foxp3(+)Treg in the circulation of celiac disease patients. *PloS one* 8, e68432.
- van Leeuwen, M.A., Lindenbergh-Kortleve, D.J., Raatgeep, H.C., de Ruiter, L.F., de Krijger, R.R., Groeneweg, M., Escher, J.C., and Samsom, J.N. (2013b). Increased production of interleukin-21, but not interleukin-17A, in the small intestine characterizes pediatric celiac disease. *Mucosal immunology* 6, 1202-1213.

- van Lummel, M., van Veelen, P.A., Zaldumbide, A., de Ru, A., Janssen, G.M., Moustakas, A.K., Papadopoulos, G.K., Drijfhout, J.W., Roep, B.O., and Koning, F. (2012). Type 1 diabetes-associated HLA-DQ8 transdimer accommodates a unique peptide repertoire. *The Journal of biological chemistry* 287, 9514-9524.
- van Niel, G., Raposo, G., Candalh, C., Boussac, M., Hershberg, R., Cerf-Bensussan, N., and Heyman, M. (2001). Intestinal epithelial cells secrete exosome-like vesicles. *Gastroenterology* 121, 337-349.
- Vander Lugt, B., Khan, A.A., Hackney, J.A., Agrawal, S., Lesch, J., Zhou, M., Lee, W.P., Park, S., Xu, M., DeVoss, J., *et al.* (2014). Transcriptional programming of dendritic cells for enhanced MHC class II antigen presentation. *Nature immunology* 15, 161-167.
- Varol, C., Vallon-Eberhard, A., Elinav, E., Aychek, T., Shapira, Y., Luche, H., Fehling, H.J., Hardt, W.D., Shakhar, G., and Jung, S. (2009). Intestinal lamina propria dendritic cell subsets have different origin and functions. *Immunity* 31, 502-512.
- Varol, C., Zigmond, E., and Jung, S. (2010). Securing the immune tightrope: mononuclear phagocytes in the intestinal lamina propria. *Nature reviews Immunology* 10, 415-426.
- Verhasselt, V. (2010a). Neonatal tolerance under breastfeeding influence. *Current opinion in immunology* 22, 623-630.
- Verhasselt, V. (2010b). Oral tolerance in neonates: from basics to potential prevention of allergic disease. *Mucosal immunology* 3, 326-333.
- Verhasselt, V., Milcent, V., Cazareth, J., Kanda, A., Fleury, S., Dombrowicz, D., Glaichenhaus, N., and Julia, V. (2008). Breast milk-mediated transfer of an antigen induces tolerance and protection from allergic asthma. *Nature medicine* 14, 170-175.
- Vesy, C.J., Greenon, J.K., Papp, A.C., Snyder, P.J., Qualman, S.J., and Prior, T.W. (1993). Evaluation of celiac disease biopsies for adenovirus 12 DNA using a multiplex polymerase chain reaction. *Modern pathology : an official journal of the United States and Canadian Academy of Pathology, Inc* 6, 61-64.
- Vignali, D.A., Moreno, J., Schiller, D., and Hammerling, G.J. (1992). Species-specific binding of CD4 to the beta 2 domain of major histocompatibility complex class II molecules. *The Journal of experimental medicine* 175, 925-932.
- Vistica, B.P., Chanaud, N.P., 3rd, Felix, N., Caspi, R.R., Rizzo, L.V., Nussenblatt, R.B., and Gery, I. (1996). CD8 T-cells are not essential for the induction of "low-dose" oral tolerance. *Clinical immunology and immunopathology* 78, 196-202.

- Wang, B., Gonzalez, A., Benoist, C., and Mathis, D. (1996). The role of CD8+ T cells in the initiation of insulin-dependent diabetes mellitus. *European journal of immunology* 26, 1762-1769.
- Wang, N., Shen, N., Vyse, T.J., Anand, V., Gunnarson, I., Sturfelt, G., Rantapaa-Dahlqvist, S., Elvin, K., Truedsson, L., Andersson, B.A., *et al.* (2011). Selective IgA deficiency in autoimmune diseases. *Molecular medicine* 17, 1383-1396.
- Wang, X., Sherman, A., Liao, G., Leong, K.W., Daniell, H., Terhorst, C., and Herzog, R.W. (2013). Mechanism of oral tolerance induction to therapeutic proteins. *Advanced drug delivery reviews* 65, 759-773.
- Watson, C.J., Rowland, M., and Warhurst, G. (2001). Functional modeling of tight junctions in intestinal cell monolayers using polyethylene glycol oligomers. *American journal of physiology Cell physiology* 281, C388-397.
- Weiner, H.L., da Cunha, A.P., Quintana, F., and Wu, H. (2011). Oral tolerance. *Immunological reviews* 241, 241-259.
- Welander, A., Tjernberg, A.R., Montgomery, S.M., Ludvigsson, J., and Ludvigsson, J.F. (2010). Infectious disease and risk of later celiac disease in childhood. *Pediatrics* 125, e530-536.
- Whitacre, C.C., Gienapp, I.E., Orosz, C.G., and Bitar, D.M. (1991). Oral tolerance in experimental autoimmune encephalomyelitis. III. Evidence for clonal anergy. *Journal of immunology* 147, 2155-2163.
- Willcox, A., Richardson, S.J., Bone, A.J., Foulis, A.K., and Morgan, N.G. (2009). Analysis of islet inflammation in human type 1 diabetes. *Clinical and experimental immunology* 155, 173-181.
- Wong, C.P., Stevens, R., Long, B., Li, L., Wang, Y., Wallet, M.A., Goudy, K.S., Frelinger, J.A., and Tisch, R. (2007). Identical beta cell-specific CD8(+) T cell clonotypes typically reside in both peripheral blood lymphocyte and pancreatic islets. *Journal of immunology* 178, 1388-1395.
- Wong, F.S., Visintin, I., Wen, L., Flavell, R.A., and Janeway, C.A., Jr. (1996). CD8 T cell clones from young nonobese diabetic (NOD) islets can transfer rapid onset of diabetes in NOD mice in the absence of CD4 cells. *The Journal of experimental medicine* 183, 67-76.
- Woods, A., Chen, H.Y., Trumbauer, M.E., Sirotna, A., Cummings, R., and Zaller, D.M. (1994). Human major histocompatibility complex class II-restricted T cell responses in transgenic mice. *The Journal of experimental medicine* 180, 173-181.

- Worbs, T., Bode, U., Yan, S., Hoffmann, M.W., Hintzen, G., Bernhardt, G., Forster, R., and Pabst, O. (2006). Oral tolerance originates in the intestinal immune system and relies on antigen carriage by dendritic cells. *The Journal of experimental medicine* *203*, 519-527.
- Xia, C.Q., and Shen, W.C. (2001). Tyrphostin-8 enhances transferrin receptor-mediated transcytosis in Caco-2- cells and increases hypoglycemic effect of orally administered insulin-transferrin conjugate in diabetic rats. *Pharmaceutical research* *18*, 191-195.
- Yamamoto, K., Fukui, Y., Esaki, Y., Inamitsu, T., Sudo, T., Yamane, K., Kamikawaji, N., Kimura, A., and Sasazuki, T. (1994). Functional interaction between human histocompatibility leukocyte antigen (HLA) class II and mouse CD4 molecule in antigen recognition by T cells in HLA-DR and DQ transgenic mice. *The Journal of experimental medicine* *180*, 165-171.
- Yang, P.C., Berin, M.C., Yu, L.C., Conrad, D.H., and Perdue, M.H. (2000). Enhanced intestinal transepithelial antigen transport in allergic rats is mediated by IgE and CD23 (FcepsilonRII). *The Journal of clinical investigation* *106*, 879-886.
- Yeung, R.S., Penninger, J.M., Kundig, T.M., Law, Y., Yamamoto, K., Kamikawaji, N., Burkly, L., Sasazuki, T., Flavell, R., Ohashi, P.S., *et al.* (1994). Human CD4-major histocompatibility complex class II (DQw6) transgenic mice in an endogenous CD4/CD8-deficient background: reconstitution of phenotype and human-restricted function. *The Journal of experimental medicine* *180*, 1911-1920.
- Yokoyama, S., Takada, K., Hirasawa, M., Perera, L.P., and Hiroi, T. (2011). Transgenic mice that overexpress human IL-15 in enterocytes recapitulate both B and T cell-mediated pathologic manifestations of celiac disease. *Journal of clinical immunology* *31*, 1038-1044.
- Yokoyama, S., Watanabe, N., Sato, N., Perera, P.Y., Filkoski, L., Tanaka, T., Miyasaka, M., Waldmann, T.A., Hiroi, T., and Perera, L.P. (2009). Antibody-mediated blockade of IL-15 reverses the autoimmune intestinal damage in transgenic mice that overexpress IL-15 in enterocytes. *Proceedings of the National Academy of Sciences of the United States of America* *106*, 15849-15854.
- Yoshida, M., Claypool, S.M., Wagner, J.S., Mizoguchi, E., Mizoguchi, A., Roopenian, D.C., Lencer, W.I., and Blumberg, R.S. (2004). Human neonatal Fc receptor mediates transport of IgG into luminal secretions for delivery of antigens to mucosal dendritic cells. *Immunity* *20*, 769-783.
- Yu, L.C., Yang, P.C., Berin, M.C., Di Leo, V., Conrad, D.H., McKay, D.M., Satoskar, A.R., and Perdue, M.H. (2001). Enhanced transepithelial antigen transport in intestine of allergic mice is mediated by IgE/CD23 and regulated by interleukin-4. *Gastroenterology* *121*, 370-381.

- Zamani, F., Mohamadnejad, M., Shakeri, R., Amiri, A., Najafi, S., Alimohamadi, S.M., Tavangar, S.M., Ghavamzadeh, A., and Malekzadeh, R. (2008). Gluten sensitive enteropathy in patients with iron deficiency anemia of unknown origin. *World journal of gastroenterology : WJG* 14, 7381-7385.
- Zanzi, D., Stefanile, R., Santagata, S., Iaffaldano, L., Iaquinto, G., Giardullo, N., Lania, G., Vigliano, I., Vera, A.R., Ferrara, K., *et al.* (2011). IL-15 interferes with suppressive activity of intestinal regulatory T cells expanded in Celiac disease. *The American journal of gastroenterology* 106, 1308-1317.
- Zeng, R., Spolski, R., Finkelstein, S.E., Oh, S., Kovanen, P.E., Hinrichs, C.S., Pise-Masison, C.A., Radonovich, M.F., Brady, J.N., Restifo, N.P., *et al.* (2005). Synergy of IL-21 and IL-15 in regulating CD8+ T cell expansion and function. *The Journal of experimental medicine* 201, 139-148.
- Zhan, Y., Carrington, E.M., van Nieuwenhuijze, A., Bedoui, S., Seah, S., Xu, Y., Wang, N., Mintern, J.D., Villadangos, J.A., Wicks, I.P., *et al.* (2011). GM-CSF increases cross-presentation and CD103 expression by mouse CD8(+) spleen dendritic cells. *European journal of immunology* 41, 2585-2595.
- Zhan, Y., Xu, Y., and Lew, A.M. (2012). The regulation of the development and function of dendritic cell subsets by GM-CSF: more than a hematopoietic growth factor. *Molecular immunology* 52, 30-37.
- Zhang, A.L., Colmenero, P., Purath, U., Teixeira de Matos, C., Hueber, W., Klareskog, L., Tarner, I.H., Engleman, E.G., and Soderstrom, K. (2007). Natural killer cells trigger differentiation of monocytes into dendritic cells. *Blood* 110, 2484-2493.
- Zhang, G.X., Ma, C.G., Xiao, B.G., Bakhiet, M., Link, H., and Olsson, T. (1995). Depletion of CD8+ T cells suppresses the development of experimental autoimmune myasthenia gravis in Lewis rats. *European journal of immunology* 25, 1191-1198.
- Zigmond, E., and Jung, S. (2013). Intestinal macrophages: well educated exceptions from the rule. *Trends in immunology* 34, 162-168.
- Zone, J.J., Schmidt, L.A., Taylor, T.B., Hull, C.M., Sotiriou, M.C., Jaskowski, T.D., Hill, H.R., and Meyer, L.J. (2011). Dermatitis herpetiformis sera or goat anti-transglutaminase-3 transferred to human skin-grafted mice mimics dermatitis herpetiformis immunopathology. *Journal of immunology* 186, 4474-4480.

Abstract

In physiological conditions, robust immunological mechanisms avoid adverse responses to food antigens. In contrast, in celiac disease that affects about 1% of Western populations, exposure to dietary gluten of genetically predisposed HLA-DQ2.5/ DQ8 individuals triggers a chronic small intestinal enteropathy. Previous studies in humans have established the crucial role of HLA-DQ2/DQ8 restricted gluten-specific intestinal CD4 T cell response. This CD4 T cell response is necessary but is however not sufficient to induce tissue damage. Other studies have pointed to the role of interleukin 15 (IL-15). Thus, IL-15 over-expressed in the mucosa of celiac patients can interfere with immunoregulatory mechanisms and stimulate the activation of cytotoxic CD8 T intraepithelial lymphocytes, thought to induce epithelial lesions. Whether and how gluten-specific CD4 T cells and IL-15 interact to activate CD8 T intraepithelial lymphocytes and to drive intestinal tissue damage has not been however established.

To address this question, we have set up a mouse model based on the breeding of OTII mice possessing CD4 T cells specific of a model antigen, ovalbumin, with heterozygous transgenic mice overexpressing a secreted form of human IL-15 in intestinal epithelium (hIL-15Tge mice). Resulting OTII^{+/-} B6 and OTII^{+/-} hIL-15Tge^{+/-} mice were exposed to dietary ovalbumin from the prenatal period until 3 months of age. Upon chronic exposure to ovalbumin, OTII^{+/-} hIL-15Tge⁺ mice, contrary to their OTII^{+/-} B6 littermates, developed growth retardation, and villous atrophy associated with expansion of intestinal cytotoxic CD8 T cells, as in celiac disease. Moreover, we showed that IL-15 impaired immunoregulation by FoxP3⁺ T cells and cooperated with IL-2 produced by OVA-activated CD4 T cells to stimulate the expansion of non-cognate cytotoxic CD8 T cells. We suggest that a comparable scenario can operate in celiac disease.

During this study, I observed that chronic overexpression of IL-15 was associated with an expansion of CD103⁺CD11c⁺CD11b⁻ mononuclear cells. In the Supplementary results, I have shown that this effect depends on the production of GM-CSF secreted by IL-15-activated NK cells and that CD11c⁺ DCs differentiated in mice overexpressing IL-15 were enriched in CD103⁺ cells and displayed enhanced cross-presentation abilities *in vitro*. The latter results illustrate how IL-15, by orchestrating a crosstalk between NK cells and mononuclear phagocytes, can modulate adaptive immune responses.

Keywords: Celiac disease, Interleukin 15, mouse model, cytotoxic CD8 T cells, CD4 T cell help, regulatory T cells, GM-CSF, CD103⁺ dendritic cells, cross-presentation