



**HAL**  
open science

## Contribution to the study of weighted Petri nets

Thomas Hujsa

► **To cite this version:**

Thomas Hujsa. Contribution to the study of weighted Petri nets. Modeling and Simulation. Université Pierre et Marie Curie - Paris VI, 2014. English. NNT : 2014PA066342 . tel-01127406

**HAL Id: tel-01127406**

**<https://theses.hal.science/tel-01127406v1>**

Submitted on 7 Mar 2015

**HAL** is a multi-disciplinary open access archive for the deposit and dissemination of scientific research documents, whether they are published or not. The documents may come from teaching and research institutions in France or abroad, or from public or private research centers.

L'archive ouverte pluridisciplinaire **HAL**, est destinée au dépôt et à la diffusion de documents scientifiques de niveau recherche, publiés ou non, émanant des établissements d'enseignement et de recherche français ou étrangers, des laboratoires publics ou privés.



**THÈSE DE DOCTORAT DE  
L'UNIVERSITÉ PIERRE ET MARIE CURIE**

Spécialité

**Informatique**

École doctorale Informatique, Télécommunications et Électronique (Paris)

Présentée par

**M. Thomas HUJSA**

Pour obtenir le grade de

**DOCTEUR de L'UNIVERSITÉ PIERRE ET MARIE CURIE**

Sujet de la thèse :

**Contribution à l'étude des réseaux de Petri généralisés**

**soutenue le 29 octobre 2014**

devant le jury composé de :

M. Ahmed BOUAJJANI	Rapporteur	LIAFA, Paris
M. José-Manuel COLOM	Rapporteur	DIIS, GISED, Saragosse, Espagne
Mme. Anne BOUILLARD	Examinatrice	DI, ENS Paris
Mme. Béatrice BÉRARD	Examinatrice	LIP6, Paris
M. Serge HADDAD	Examineur	LSV, ENS Cachan
Mme. Alix MUNIER-KORDON	Directrice de thèse	LIP6, Paris
M. Jean-Marc DELOSME	Directeur de thèse	IBISC, Evry



---

## Remerciements

Tout d'abord, je remercie chaleureusement Alix et Jean-Marc pour la qualité de leur encadrement, tant du point de vue scientifique qu'humain. Leur vision et pratique de la recherche et de l'enseignement m'ont influencé très positivement. Je suis très heureux de les avoir rencontrés et d'avoir travaillé avec eux pendant trois années qui ont passé très vite.

Je tiens à remercier tous les membres du jury pour l'intérêt accordé à mon travail de recherche.

Ma thèse s'est déroulée en majeure partie au LIP6 au sein du département SOC, dans l'équipe ALSOC. Par ailleurs, j'ai eu l'occasion de rencontrer certains membres d'autres équipes et de découvrir le laboratoire IBISC de l'université d'Evry-Val d'Essonne par l'intermédiaire de Jean-Marc. Je souhaite remercier de nombreuses personnes du LIP6 et d'IBISC pour leurs conseils précieux et les conversations passionnantes que nous avons partagées sur des sujets très variés. J'ai apprécié la compagnie, voire l'amitié, de chacune des personnes rencontrées pendant cette période.

De manière non-exhaustive et sans ordre précis, je pense tout particulièrement à Karine Heydemann, Youen Lesparre, Andi Drebes, Bruno Bodin, Mohamed Benazouz, Lucien Goubet, Liliana Andrade, Benoit Vernay, Olivier Marchetti, Jean-Lou Desbarbieux, Roselyne Chotin-Avot, Emmanuelle Encrenaz et Shahin Mahmoodian.

Concernant l'équipe MoVe du département Systèmes Complexes, je remercie Fabrice Kordon, Béatrice Bérard, Claude Girault et Yann Thierry-Mieg.

Je réserve de même une pensée chaleureuse pour Hanna Klaudel et Cinzia Di Giusto, de l'IBISC, et pour Raymond Devillers de l'Université Libre de Bruxelles.

Les personnes non citées ici et que j'apprécie font bien entendu partie de mes pensées reconnaissantes et amicales.



---

## Résumé

### Contexte et objectifs

La théorie des systèmes dynamiques à événement discret a été développée de manière conséquente au cours de la deuxième moitié du siècle passé. Le formalisme des réseaux de Petri en fait partie et est encore activement étudié aujourd'hui.

Dans sa thèse présentée en 1962, Carl Adam Petri introduit les réseaux de Petri de manière à obtenir un modèle général de systèmes discrets, concurrents et distribués. Ces réseaux sont des graphes bipartis dynamiques dont le nombre d'états est potentiellement infini. Tout état du système est défini par un ensemble d'états locaux, chaque état local étant représenté par une *place* accueillant des jetons. Le système change d'état via les tirs de *transitions*. Ces réseaux permettent de modéliser les phénomènes de concurrence, conflit et synchronisation.

Le formalisme très expressif des réseaux de Petri n'est pas Turing-complet et bénéficie de la décidabilité de nombreux problèmes importants. Il existe de nombreuses extensions de ce modèle, prenant en compte le temps ou encore des processus stochastiques, ce qui autorise notamment l'évaluation de performances et les techniques d'ordonnancement. De tels avantages justifient l'utilisation des réseaux de Petri pour la spécification et la vérification, avec de nombreuses applications à l'ingénierie des protocoles, la modélisation de systèmes biologiques, systèmes embarqués et ateliers flexibles, la conception de circuits ...

Les systèmes embarqués doivent préserver toutes leurs fonctionnalités sur de longues périodes tout en utilisant une quantité de mémoire limitée. De telles garanties sont fondamentales pour les applications. Les propriétés associées dans les réseaux de Petri sont appelées *vivacité* (ou *liveness*), et *mémoire bornée* (ou *boundedness*). De plus, les systèmes réels ont souvent besoin d'éviter une phase d'initialisation généralement coûteuse, et doivent avoir la possibilité de retourner à leur état initial à partir de tout état accessible. La propriété correspondante dans les réseaux de Petri est appelée *réversibilité* (ou *reversibility*).

Dans les réseaux de Petri, les jetons représentent les données locales de manière abstraite, non évaluée. De manière similaire, les valeurs de l'état global du système sont abstraites par un vecteur de jetons, le *marquage*. Les propriétés de ces réseaux dépendent des évolutions possibles de leurs marquages.

En représentant les buffers par des places, les sous-programmes par des transitions et les interactions de sous-programmes par des arcs à poids, les réseaux de Petri sont adaptés à la modélisation d'applications embarquées, permettant de garantir les propriétés com-

---

portementales requises dès la phase de conception. Cette approche évite les simulations coûteuses qui sont généralement effectuées a posteriori.

Cependant, la grande expressivité des réseaux de Petri induit en contrepartie une forte complexité d'analyse. Notamment, les problèmes de l'accessibilité et de la vivacité sont EXPSPACE-hard. De sorte à contourner ce problème, un compromis entre expressivité et complexité est souvent privilégié et limite l'étude à des sous-classes de réseaux. Des heuristiques sont aussi fréquemment employées.

L'objectif principal de cette thèse est de fournir les premières méthodes efficaces qui assurent la vivacité et la réversibilité de plusieurs sous-classes de réseaux de Petri pondérés (aussi appelés *généralisés*), dans l'optique de la conception de systèmes embarqués.

## Des modèles connus d'applications

Nous rappelons ci-après différents modèles connus d'applications, à savoir les graphes de Kahn et les graphes Synchronous Data Flow (SDF). Leurs principaux avantages et inconvénients sont exposés, ainsi que leur lien avec les réseaux de Petri, et nous motivons notre choix du modèle réseau de Petri dans cette thèse.

**Les graphes de Kahn.** Ces graphes, aussi appelés *Kahn Process Networks* [Kahn 74], ont une très forte expressivité et peuvent modéliser des applications dataflow (à flux de données). Cependant, ils ne fournissent pas de méthodes d'analyse raisonnables : la vivacité d'un graphe de Kahn est indécidable et il n'est pas possible de trouver une borne sur la capacité des buffers. De telles difficultés motivent l'utilisation de nouveaux modèles qui combinent une expressivité suffisante avec une complexité d'analyse faible, de sorte à concevoir des applications embarquées fonctionnelles.

Dans un graphe de Kahn, les sous-programmes sont appelés *acteurs* et envoient des données aux autres acteurs via des buffers FIFO infinis. Chaque buffer possède au maximum un écrivain et un lecteur. Chaque acteur peut bloquer en lecture sur l'un de ses canaux d'entrées, en attente de nouvelles données. De plus, deux exécutions basées sur des entrées identiques mènent au même résultat, induisant une forme de déterminisme.

Sur la Figure 1, l'acteur  $A_1$  envoie des données à  $A_2$  si  $x = 0$ , auquel cas elles sont stockées dans le buffer  $(A_1, A_2)$ , sinon l'acteur les envoie à  $A_3$ , auquel cas elles sont stockées dans le buffer  $(A_1, A_3)$ .

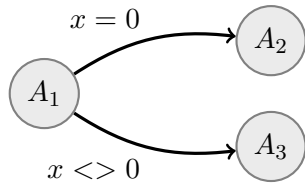

Acteur  $A_1$   
 si ( $x = 0$ ) alors  
     envoyer une donnée à  $A_2$   
 sinon  
     envoyer une donnée à  $A_3$

Figure 1: Un graphe de Kahn et le pseudo-code de l'acteur  $A_1$ .

**Les graphes Synchronous Data Flow (SDF) et Cyclo-Static Data Flow (CSDF).** Le formalisme Synchronous Data Flow, introduit en 1987 par Lee et Messerschmidt, ainsi que son extension par des phases, nommée Cyclo-Static Data Flow (CSDF) [Engels 1994], sont des modèles dataflow pour des applications concurrentes exécutées sur des architectures parallèles. Ils ont été utilisés dans de nombreuses applications, souvent multimédia.

De manière similaire aux graphes de Kahn, les graphes SDF peuvent bloquer en attente de la lecture de nouvelles données en entrée. De plus, chaque buffer possède au maximum un écrivain et un lecteur. Cependant, contrairement aux graphes de Kahn, les SDF ont une expressivité très réduite : les sous-programmes lisent et écrivent une quantité fixe de données de manière inconditionnelle. En conséquence, le système a un comportement régulier, malgré l'existence possible de blocages, appelés *deadlocks*.

La faible expressivité de ce modèle a l'avantage d'autoriser des méthodes efficaces (en temps polynomial) pour assurer la vivacité d'un SDF et évaluer les tailles de buffers nécessaires à son exécution [Marchetti 2009].

La Figure 2 représente un graphe SDF avec 3 acteurs qui communiquent via des buffers intermédiaires. Ils lisent et écrivent des quantités fixes de données —indiquées par les poids sur les arcs—dans ces buffers. Quand l'acteur  $A_1$  termine, il envoie 2 données dans le buffer ( $A_1, A_2$ ) et l'acteur  $A_2$  est autorisé à démarrer lorsqu'au moins 3 données sont présentes dans ce buffer.

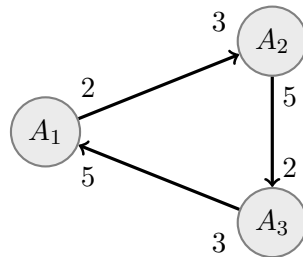

Figure 2: Un graphe Synchronous DataFlow avec 3 acteurs.



---

**Lien avec les réseaux de Petri.** Les réseaux de Petri s'avèrent très utiles pour modéliser les systèmes à événements discrets avec conflits, synchronisations et concurrence. Ils ont un fort pouvoir expressif et leurs principales propriétés comportementales sont décidables, contrairement aux graphes de Kahn, ce qui en fait un modèle attractif. Par ailleurs, ils peuvent modéliser les graphes SDF en remplaçant les acteurs par des transitions et les buffers par des places, ce qui est illustré par la Figure 3. La sous-classe des réseaux de Petri pondérés correspondant à la structure des graphes SDF est celle des T-systèmes à poids.

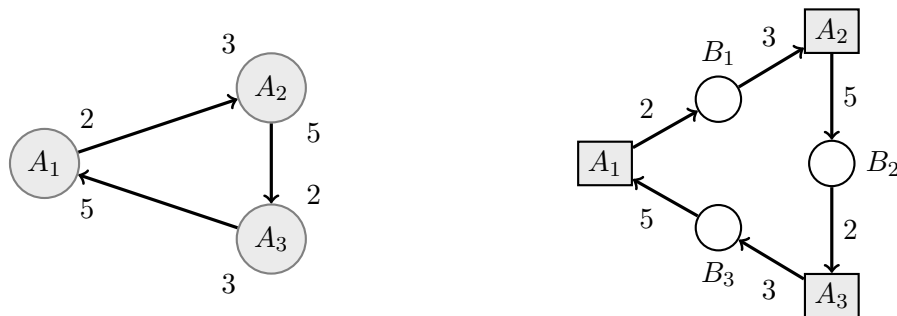

Figure 3: Le graphe SDF sur la gauche est représenté par un réseau de Petri sur la droite.

## Des applications importantes

Les réseaux de Petri à poids sont connus pour modéliser les ateliers flexibles ainsi que les systèmes embarqués. Les poids rendent possible la modélisation de consommation et production de ressources par paquets, des situations qui apparaissent fréquemment dans ces systèmes [Teruel 97, Lee 87b]. De plus, en comparaison avec les réseaux non pondérés, les poids permettent une représentation beaucoup plus compacte du système.

**Les ateliers flexibles.** Un atelier flexible est une usine qui manipule des matériaux composés d'entités discrètes et qui peut gérer une grande variété de produits en parallèle, ainsi que de nouvelles familles de produits. Un atelier flexible est généralement constitué de trois éléments : un ensemble de machines flexibles (des stations de travail), un système de transport automatique et un système de décision. Un processus de travail est une séquence d'opérations effectuée pour la fabrication d'un produit. Une ressource est une partie de l'usine qui peut manipuler des produits, par exemple pour leur transport.

Les processus de travail d'un atelier flexible entrent en compétition pour un même ensemble de ressources, créant éventuellement des blocages des commandes de production.

Pour un atelier flexible, la propriété de vivacité assure la terminaison de chaque processus de production et préserve la possibilité d'ajout de nouveaux produits à fabriquer. La propriété de réversibilité garantit l'existence d'un comportement cyclique.

Pour plus de détails, les ateliers sont présentés dans [Silva 90, Ezpeleta 95, Teruel 97], en faisant l'usage de poids.

---

**Les systèmes embarqués.** Ces systèmes doivent préserver toutes leurs fonctionnalités au fil du temps avec une mémoire bornée. De plus, ils doivent le plus souvent éviter une phase d’initialisation coûteuse et toujours avoir la possibilité de retourner à leur configuration initiale ; en effet, cette propriété autorise des ordonnancements périodiques et peut faciliter la récupération du système après une erreur, ainsi que l’étude du comportement du système et l’évaluation de ses performances.

Les fonctionnalités peuvent intuitivement être modélisées par des transitions, et leurs interactions par des places et arcs à poids. Ces poids représentent des quantités de données lues ou écrites. La préservation de toutes les fonctionnalités est une exigence comportementale qui est formalisée par la propriété de vivacité. La possibilité de retour à l’état initial à partir de tout état accessible, autorisant ainsi une réinitialisation du système, définit la réversibilité.

Les graphes SDF ont été utilisés pendant de nombreuses années dans le domaine des systèmes embarqués pour modéliser des applications diverses, notamment des programmes embarqués de traitement du signal [Lee87a, Pino 95, Sriram 09].

Les graphes CSDF étendent les graphes SDF en affinant les acteurs avec des phases, permettant ainsi la description d’applications dont le comportement change cycliquement. Ils ont été introduits dans [Bilsen 94, Engels 95] où ils sont utilisés pour modéliser un encodeur vidéo. Ils se sont avérés utiles pour modéliser des applications de lecture MP3 [Wiggers 07b] ainsi qu’un programme de décodage Reed-Solomon [Benazouz 10]. De tels exemples montrent l’importance de ce modèle dans le domaine du traitement de signal. Ces graphes sont aussi utilisés dans le compilateur dataflow conçu pour répartir un graphe CSDF sur la grille de 256 processeurs parallèles de la société Kalray<sup>1</sup>.

Plusieurs méthodes efficaces d’évaluation de la vivacité ont été proposées pour les graphes SDF [Marchetti 09] et CSDF [Benazouz 13], en opposition avec la plupart des méthodes connues qui utilisent une exécution symbolique (généralement exponentielle) du graphe, telles celles présentées dans [Anapalli 09].

Cependant, dans ces systèmes, la propriété de réversibilité est induite par la vivacité et la mémoire bornée [Lee 87b, Teruel 92, Bilsen 95], ce qui n’est plus le cas pour les classes plus larges [Teruel 97]. Cette constatation motive l’étude de la propriété de réversibilité sous l’hypothèse de vivacité dans des classes plus expressives.

---

<sup>1</sup>Kalray. Manycore processors for embedded computing. [www.kalray.eu](http://www.kalray.eu).

---

## Des sous-classes de réseaux de Petri importantes pour les applications

Dans cette thèse, nous présentons des résultats originaux concernant le comportement de plusieurs sous-classes expressives des réseaux de Petri généralisés, qui autorisent plusieurs écrivains et plusieurs lecteurs de mêmes buffers, permettant une forme d'indéterminisme.

Nous nous focalisons notamment sur la classe des systèmes Equal-Conflict, qui contient les systèmes Choice-Free, Fork-Attribution et les T-systèmes. Celle classe généralise largement celle des T-systèmes, et donc aussi les graphes SDF. Nous étudions par ailleurs la classe des systèmes Join-Free, qui n'est pas une sous-classe des systèmes Equal-Conflict.

**Les systèmes Equal-Conflict.** Cette classe est définie en tant que restriction structurelle de la classe entière des réseaux de Petri pondérés. Elle impose en effet que les transitions ayant une entrée commune possèdent les mêmes entrées, et que tous les poids en sortie d'une même place soient égaux, et ce, pour chaque place. Cette contrainte d'égalité des poids en sortie des places est appelée *homogénéité*.

**Les systèmes Choice-Free et les T-systèmes.** Ces systèmes forment une sous-classe des systèmes Equal-Conflict dans laquelle chaque place du système possède au plus une sortie. Les places des T-systèmes possèdent au plus une entrée et une sortie. Les T-systèmes forment donc une sous-classe des systèmes Choice-Free.

**Les systèmes Join-Free.** Dans tout système de cette classe, chaque transition possède au plus une entrée.

**Les systèmes Fork-Attribution.** Dans tout système de cette classe, chaque transition possède au plus une entrée et chaque place possède au plus une sortie. Il s'agit donc de l'intersection des classes Choice-Free et Join-Free.

Ces différentes classes sont illustrées en Figures 4 et 5.

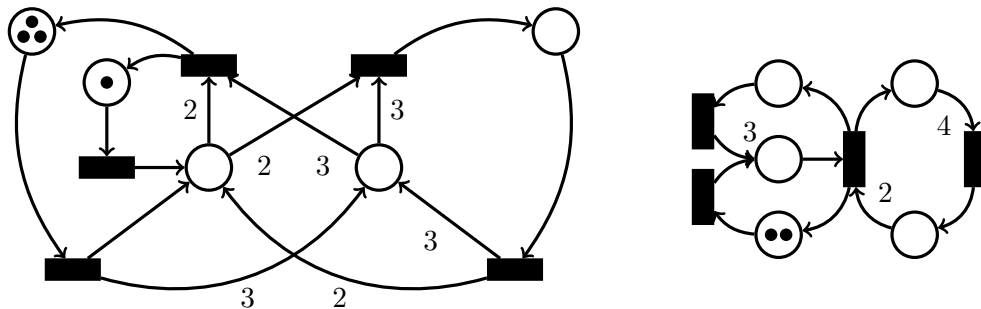

Figure 4: Le système à gauche est Equal-Conflict. A droite, le système est Choice-Free.

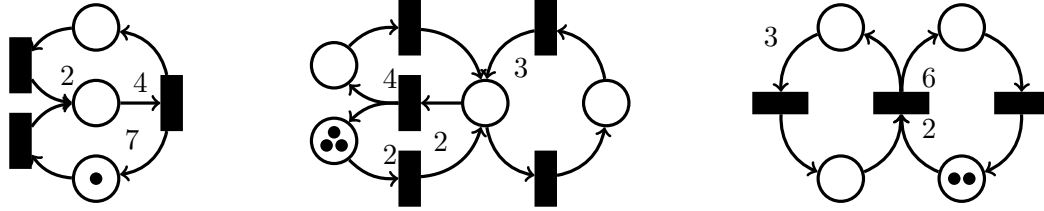

Figure 5: Le réseau sur la gauche est un système Fork-Attribution. Le réseau du milieu est un Join-Free. Le réseau sur la droite est un T-système.

### Nos contributions à l'étude des réseaux de Petri généralisés

Les SDF, ou T-systèmes, ont été largement utilisés pour modéliser des applications embarquées. Cependant, de nos jours, les fonctionnalités deviennent de plus en plus sophistiquées et l'expressivité des modèles doit alors être étendue. Un objectif est de généraliser des résultats communs aux SDF et T-systèmes de manière à traiter des applications plus complexes autorisant des choix, dans l'optique d'obtenir des méthodes d'analyse efficaces.

Plus précisément, nous nous focalisons sur des extensions des T-systèmes et SDF qui :

- sont strictement plus expressives structurellement, telles que la classe Choice-Free qui autorise plusieurs sous-programmes à écrire dans un même buffer;
- permettent une forme de non-déterminisme, tels que les systèmes Join-Free et Equal-Conflict, dans lesquels les choix effectués lors des exécutions successives ne sont pas fixés et dépendent des données.

Le chapitre 1 forme l'introduction de cette thèse, tandis que le chapitre 2 définit le formalisme des réseaux de Petri à poids, ainsi que les sous-classes étudiées dans cette thèse et des rappels de résultats importants associés. Le plus souvent, nous nous focalisons sur l'étude de réseaux dont la structure assure l'existence d'un marquage initial vivant et garantit la mémoire bornée pour tout marquage initial ; une telle structure est dite *bien formée*, ou *well-formed*.

Nos contributions sont ensuite réparties dans les chapitres 3, 4 et 5.

Dans le chapitre 3, nous présentons de nouvelles transformations de réseaux de Petri. L'étude de la propriété de vivacité est détaillée dans le chapitre 4. Finalement, les résultats sur la propriété de réversibilité forment le sujet du chapitre 5. Le chapitre 6 constitue notre conclusion et plusieurs perspectives.

Nous détaillons ci-après nos contributions, qui ont fait l'objet de trois publications indexées (1), (3) et (4) en annexe. La publication (2) est un travail non détaillé dans cette

---

thèse mais dont le sujet est connexe et qui étudie la vivacité des CSDF.

### **De nouvelles transformations polynomiales (Chapitre 3) - Publications (1), (3) et (4)**

De nombreuses propriétés comportementales des réseaux de Petri induisent un coût d'analyse élevé [Cheng 1993, Esparza 1994]. Dans cette thèse, nous nous focalisons sur les problèmes de la vivacité et de la réversibilité, connus comme décidables [Hack 1976, Araki 1977, Mayr 1984]. Cependant, le problème de la vivacité est EXSPACE-hard [Hack 1974, Lipton 1976], tandis que la complexité du problème de la réversibilité n'est pas connue.

De manière à simplifier l'étude du comportement, le système peut être transformé efficacement tout en préservant des propriétés fortes. L'analyse est ensuite effectuée sur le système transformé. De nombreuses transformations existent [Berthelot 1986, 87, Murata 1989, Colom 2003] et sont généralement définies comme des règles qui s'appliquent à des motifs spécifiques et locaux du graphe, ce qui réduit souvent la taille du graphe et mène à des conditions suffisantes efficaces. Cependant, dans de nombreuses situations, ces règles ne réduisent pas la complexité d'analyse.

Nous présentons plusieurs nouvelles transformations polynomiales en temps pour les réseaux de Petri pondérés (généralisés) qui préservent de fortes propriétés structurelles et comportementales, simplifiant l'analyse des propriétés de ces systèmes.

Premièrement, nous généralisons des méthodes qui furent précédemment développées dans le contexte des T-systèmes généralisés [Marchetti 2009].

Nous introduisons le *scaling* des réseaux de Petri par un vecteur, une transformation qui s'applique à tous les réseaux de Petri et modifie uniquement les poids et le marquage initial. L'idée est de multiplier ces valeurs localement au niveau de chaque place par certains rationnels strictement positifs. Cette opération préserve le langage et la structure bien formée, et en conséquence, les propriétés de vivacité et réversibilité.

Nous étendons la notion de jetons utiles, permettant de réduire le marquage initial de tout réseau de Petri tout en préservant le langage. Nous montrons que les jetons utiles au système, à savoir ceux qui vont servir à effectuer des tirs de transitions, doivent constituer dans chaque place un multiple du plus grand commun diviseur des poids entourant cette place.

Nous définissons l'opération d'équilibrage, nommée *balancing*, qui est un cas particulier du *scaling* s'appliquant à tout système conservatif et menant à un système *token-conservative*, dont le nombre total de jetons est invariant. Lorsque le nombre de jetons est constant dans un système, l'étude de propriétés comportementales est grandement simplifiée. Cette méthode s'applique en particulier à tous les réseaux de Petri bien formés, car ils sont conservatifs [Sifakis 78, Memmi 80].

Nous rappelons ensuite la normalisation des T-systèmes et la comparons avec l'opération

---

d'équilibrage. L'opération de normalisation fut introduite dans [Marchetti 2009] de sorte à ce que le T-système normalisé obtenu possède un nombre invariant de jetons dans chacun de ses circuits, simplifiant ainsi l'étude de sa vivacité.

Ces transformations sont présentées dans notre publication (1).

Par la suite, nous présentons une transformation de tout réseau de Petri pondéré en système Free-Choice pondéré (une classe qui généralise les Equal-Conflict), préservant le langage et la structure bien formée. L'idée est de compléter les arcs manquants entre places et transitions de manière adéquate en utilisant le scaling, de sorte à ce que le comportement soit préservé. Il devient ainsi possible d'étudier des propriétés du nouveau système, dont la structure est plus simple que celle du système initial, pour déduire des propriétés du système initial.

Enfin, nous introduisons la transformation *place-splitting*, qui s'applique à tout système Choice-Free bien formé pour obtenir un T-système bien formé qui préserve de fortes propriétés structurelles et comportementales. L'ensemble des T-semiflows est notamment préservé. Nous montrons par ailleurs l'inclusion du langage du T-système obtenu dans celui du système Choice-Free initial. Cette transformation permettra la simplification de l'étude du comportement des Choice-Free dans les chapitres suivants, et est présentée dans notre publication (4).

### Une étude de la vivacité (Chapitre 4) - Publications (1) et (3)

Dans ce chapitre, nous nous focalisons sur les systèmes Join-Free et Equal-Conflict pondérés bien formés (*well-formed*), ainsi que sur certaines de leurs sous-classes, comprenant notamment les systèmes Choice-Free, Fork-Attribution et les T-systèmes. Des caractérisations de *well-formedness* polynomiales en temps existent pour toutes ces classes [Teruel 1994, 96, 97, Recalde 95, 96, Silva 98, Amer-Yahia 99a]. Ainsi, le problème de décision de la *well-formedness* de tels modèles d'applications est résolu efficacement.

Une fois qu'un réseau bien formé a été conçu, le défi est de construire un marquage initial vivant. L'hypothèse de *well-formedness* implique l'existence d'un tel marquage.

Cependant, seules des caractérisations exponentielles en temps de vivacité sont connues pour les circuits bien formés à poids. La complexité de décision de la vivacité d'un circuit pondéré est une question ouverte fortement liée au problème de Frobenius, qui est connu pour être difficile [Chrzaszowski-Wachtel 93, Ramirez-Alfonsin 96]. En conséquence, cette difficulté se propage à toutes les classes plus larges et nous cherchons des marquages initiaux *polynomiaux* pour plusieurs classes expressives. Un marquage *polynomial* possède un nombre polynomial de jetons et est calculé en temps polynomial.

À ce jour, il existe des méthodes qui construisent des marquages initiaux vivants pour les systèmes Equal-Conflict et la plupart de leurs sous-classes, avec un nombre exponentiel

---

de jetons initiaux ou en temps exponentiel [Teruel 1993, 96, 97]. Dans le cas des T-systèmes pondérés, il existe des conditions suffisantes polynomiales [Marchetti 2009]. Concernant les systèmes Join-Free bien formés, il n’existait jusqu’à présent aucune méthode dédiée.

Nous utilisons les transformations du chapitre 2 pour obtenir les premières conditions *polynomiales* suffisantes de vivacité pour les Join-Free et Equal-Conflict bien formés, contrastant avec les précédentes méthodes exponentielles de la littérature. Ces résultats originaux permettent de construire des systèmes vivants bornés efficacement avec une taille raisonnable de configuration initiale.

Nous obtenons tout d’abord la première condition suffisante polynomiale de vivacité qui s’applique aux Join-Free équilibrés, dans lesquels la quantité totale de jetons reste invariante. Nous en déduisons des marquages polynomiaux vivants pour tous les Join-Free bien formés.

Nous rappelons ensuite des théorèmes connus concernant la vivacité des Equal-Conflict bien formés. Nous utilisons alors un théorème de décomposition pour construire les premiers marquages polynomiaux de cette classe, qui inclut les systèmes Choice-Free.

De plus, nous utilisons la transformation de place-splitting pour déduire une autre condition suffisante de vivacité pour les Choice-Free bien formés, ainsi qu’une version polynomiale en temps de cette condition, et nous comparons ces nouvelles méthodes.

Finalement, nous montrons que ces conditions ne sont pas nécessaires dans le cas pondéré.

Ces résultats sont en partie présentés dans nos publications (1) et (3).

### **Une étude de la réversibilité (chapitre 5) - Publications (1) et (4)**

Dans ce chapitre, nous étudions la propriété de réversibilité sous l’hypothèse de vivacité dans les systèmes fortement connexes bien formés Equal-Conflict et Join-Free. Dans certains cas, nous étudions aussi les systèmes Equal-Conflict qui ne sont pas nécessairement bien formés.

Dans le chapitre 4, nous avons déterminé des conditions suffisantes polynomiales de vivacité pour les systèmes Equal-Conflict et Join-Free bien formés, permettant de construire efficacement des systèmes expressifs à la fois vivants et bornés. Une fois que les propriétés fondamentales de vivacité et mémoire bornée sont assurées, la réversibilité est la prochaine propriété à être considérée car elle est souvent requise par les applications réelles. De plus, une fois qu’un système est connu comme étant vivant réversible, l’étude de son graphe d’accessibilité peut être grandement simplifiée.

Les propriétés de vivacité et réversibilité ne sont pas intimement liées : il existe des systèmes vivants qui ne sont pas réversibles et des systèmes réversibles qui ne sont pas vivants [Murata 1989]. La réversibilité a déjà été étudiée sous l’hypothèse de vivacité et

---

mémoire bornée dans plusieurs sous-classes de réseaux de Petri pondérés. Dans le cas des T-systèmes, la réversibilité est induite par la vivacité et la mémoire bornée. Cette implication n'est plus vraie pour les systèmes Fork-Attribution [Teruel 1997] car il existe des systèmes Fork-Attribution vivant bornés qui ne sont pas réversibles.

Des méthodes polynomiales construisent des marquages vivants pour les T-systèmes [Marchetti 2009] et la réversibilité est ainsi efficacement assurée pour cette classe. Les marquages réversibles, ainsi qu'une caractérisation de réversibilité, existent pour les systèmes Choice-Free vivants bornés [Teruel 1997] ; cependant, de tels marquages vivants réversibles sont construits en temps exponentiel ou en temps polynomial avec un nombre exponentiel de jetons initiaux.

L'existence de marquages réversibles a été prouvée dans les systèmes Equal-Conflict vivants bornés [Teruel 1993] bien qu'aucune caractérisation de réversibilité et aucune méthode dédiée pour construire des marquages réversibles ne soient données.

Premièrement, nous présentons les premiers marquages initiaux polynomiaux à la fois vivants et réversibles pour la classe des systèmes Fork-Attribution bien formés. Ce résultat est détaillé dans notre publication (1).

Ensuite, nous étudions la classe plus générale des systèmes Choice-Free, pour laquelle nous présentons une nouvelle caractérisation de réversibilité par décomposition et déduisons les premiers marquages polynomiaux vivants réversibles, en utilisant les marquages trouvés pour la sous-classe Fork-Attribution. Nous donnons aussi une autre condition suffisante polynomiale originale de vivacité et réversibilité, ainsi qu'une version polynomiale en temps de cette condition, avec l'aide de la transformation place-splitting. Nous comparons finalement ces nouvelles conditions. Ces résultats sont explicités dans notre publication (4).

Par la suite, nous étudions la réversibilité des systèmes Equal-Conflict vivants consistants. Avec l'aide d'un contre-exemple, nous montrons tout d'abord que notre méthode de décomposition développée pour les systèmes Choice-Free ne peut être étendue à la classe des systèmes Equal-Conflict. Ce fait nous motive à développer la première caractérisation non-triviale de réversibilité pour les systèmes Equal-Conflict supposés vivants consistants, incluant les systèmes Choice-Free and Join-Free homogènes. Cette caractérisation étend une condition qui fut développée pour le cas particulier des systèmes Choice-Free [Teruel 1997]. De plus, ce résultat mène aux premiers marquages polynomiaux vivants réversibles pour les systèmes Equal-Conflict bien formés.

Finalement, nous utilisons ces nouvelles méthodes pour obtenir les premiers marquages polynomiaux vivants réversibles pour les Join-Free well-formed, dans lesquels la contrainte d'homogénéité n'est pas imposée.

Ainsi, nous étendons l'expressivité des modèles utilisables dans les applications réelles, dont la vivacité, mémoire bornée et réversibilité peuvent être assurées efficacement.



---

## Les perspectives de cette thèse

**Questions ouvertes.** Deux questions fondamentales restent ouvertes.

Premièrement, la complexité du problème de la vivacité du circuit pondéré n'est pas connue et est liée au problème diophantien de Frobenius, qui est connu pour être difficile [Chrzaszowski-Wachtel 93, Ramirez-Alfonsin 96]. On se pose la question d'une éventuelle amélioration de nos conditions suffisantes polynomiales de vivacité et réversibilité.

Deuxièmement, des caractérisations non-triviales de réversibilité pour les Join-Free pondérés non-homogènes n'existent pas encore. Cette classe retire la primitive de synchronisation des réseaux de Petri. En l'absence de cette primitive, les transitions qui attendent que toutes leurs conditions en entrée soient satisfaites ne sont pas permises; la contrainte d'avoir au plus une place en entrée des transitions rend les conditions indistingables. Bien que cette classe soit définie comme le dual de la classe Choice-Free, et que la structure et le comportement des systèmes Choice-Free soient bien compris, seuls des résultats structurels peuvent être déduits via dualité, et le comportement des systèmes Join-Free n'est pas complètement maîtrisé.

**Des méthodes polynomiales dans des classes plus grandes.** Des caractérisations polynomiales de well-formedness n'ont pas encore été trouvées pour tous les réseaux de Petri pondérés. Une telle caractérisation existe pour les réseaux Equal-Conflict ; cependant aucun résultat similaire n'a été obtenu pour les Free-Choice à poids. Dorénavant, cette question devrait être étudiée. Par la suite, la vivacité et la réversibilité peuvent être étudiées dans cette classe plus expressive, pour obtenir d'éventuelles conditions suffisantes polynomiales. De plus, notre transformation de réseaux de Petri pondérés en Free-Choice pondérés pourrait autoriser la propagation et la généralisation des propriétés de cette sous-classe à tous les réseaux de Petri.

**Propriétés des réseaux de Petri temporisés.** Les applications réelles ont besoin de la notion de temps, qui est modélisée dans certaines extensions des réseaux de Petri. Quand le temps est décrit dans le modèle, une évaluation des performances du système peut être établie. Des bornes polynomiales du débit du système existent pour les T-systèmes à poids [Benabid-Najjar 2012] et peuvent être étendues à des classes plus larges que nous avons identifiées, incluant les systèmes Choice-Free.

Dans les classes qui modélisent des choix, les politiques de routage doivent être étudiées, de manière similaire au travail de [Bouillard 05a]. L'évaluation des performances peut aussi suivre la piste des réseaux de Petri stochastiques [Bouillard 05b].

**La modularité.** Beaucoup de systèmes réels peuvent être vus comme l'assemblage de plusieurs modules. De telles méthodes compositionnelles ont été explorées dans le domaine des réseaux de Petri, composant des modules adéquats tout en préservant les propriétés désirées, définissant des classes pondérées qui sont plus expressives que le modèle T-système à poids [Recalde 1996, Recalde 98].

Dans la communauté Dataflow, de telles méthodes existent aussi. Les SDF déterministes

---

avec mémoires FIFO partagées [Tripakis 2013] et les SDF basés sur une interface [Piat 2009] sont des généralisations compositionnelles des graphes SDF.

Plusieurs techniques d'affinement furent développées par ailleurs, qui consistent à remplacer des noeuds particuliers par un réseau, selon des règles spéciales qui préservent les propriétés voulues. Par exemple, les graphes CSDF étendent le modèle SDF en affinant les acteurs avec plusieurs phases [Bilsen 1995]. Les techniques d'affinement furent de même étudiées dans le contexte des réseaux de Petri [Suzuki 1993, Brauer 1990].

Une unification de toutes ces techniques de synthèse et d'affinement devrait être possible, liant ainsi les différentes communautés.

## Liste des publications

### Revue internationale avec comité de lecture :

(1) Thomas Hujsa, Jean-Marc Delosme, and Alix Munier-Kordon. *Polynomial sufficient conditions of well-behavedness and home markings in subclasses of weighted Petri nets*. Transactions on Embedded Computing Systems (TECS), Vol. 13, No. 141, pages 1–25, July 2014. ACM New York, NY, USA.

Cette publication est une extension de (3), détaillant les transformations (Chapitre 3 de cette thèse), améliorant les marquages vivants polynomiaux (Chapitre 4) et fournissant les premiers marquages vivants réversibles polynomiaux pour les systèmes bien formés Fork-Attribution (Chapitre 5).

### Conférences internationales avec comité de lecture :

(2) Mohamed Benazouz, Alix Munier-Kordon, Thomas Hujsa, and Bruno Bodin. *Liveness evaluation of a cyclo-static DataFlow graph*. In proceedings of the 50th Annual Design Automation Conference (DAC'13), pages 1–7, Austin, Texas, June 2013. ACM New York, NY, USA / EDAC / IEEE.

Cette publication fournit les premières conditions suffisantes polynomiales de vivacité pour les graphes CSDF, qui affinent les graphes SDF avec l'ajout de phases. Une méthode originale de calcul des capacités quasi-optimales assurant la vivacité est aussi présentée.

(3) Jean-Marc Delosme, Thomas Hujsa, and Alix Munier-Kordon. *Polynomial Sufficient Conditions of Well-Behavedness for Weighted Join-Free and Choice-Free Systems*. In proceedings of the 13th International Conference on Application of Concurrency to System

---

Design (ACSD'13), pages 90–99, Barcelona, Spain, July 2013. IEEE.

Cette publication présente de nouvelles transformations à temps polynomial des réseaux de Petri à poids, préservant des propriétés fortes (Chapitre 3 de cette thèse), et fournit les premières conditions suffisantes polynomiales de vivacité pour les systèmes Choice-Free et Join-Free bien formés (Chapitre 4).

(4) Thomas Hujsa, Jean-Marc Delosme, and Alix Munier-Kordon. *On the Reversibility of Well-Behaved Weighted Choice-Free Systems*. In proceedings of the 35th International Conference on (Petri Nets'14), pages 334–353, Barcelona, June 2014. Springer, LNCS.

Cette publication étudie la propriété de réversibilité des systèmes vivants Choice-Free bien formés. Pour cette classe, une nouvelle caractérisation de réversibilité et les premières conditions suffisantes de vivacité et réversibilité sont présentées (Chapitre 5 de cette thèse). Une transformation originale des systèmes Choice-Free bien formés en T-systèmes bien formés éclaire leur comportement (Chapitre 3).





---

## Abstract

Many real systems and applications, including flexible manufacturing systems and embedded systems, may be modeled by weighted Petri nets. The behavior of these systems can be checked on their model early on at the design phase, thus avoiding costly simulations on the designed systems. Usually, the models should exhibit three basic properties: liveness, which states the possibility of keeping all the functionalities active over time; boundedness, which ensures that the system can perform all operations with a bounded amount of resources; and reversibility, which avoids a costly initialization phase.

The analysis of these properties has however been proved difficult since most existing methods have an exponential time complexity. By focusing on several expressive subclasses of weighted Petri nets, the first polynomial algorithms that ensure liveness, boundedness and reversibility for these classes have been developed in this thesis. By *polynomial*, we mean in polynomial time with a polynomial number of initial tokens.

First, we provide several polynomial time transformations that preserve structural and behavioral properties of weighted Petri nets, while simplifying the study of their behavior. These transformations allow to delineate several subclasses of weighted Petri nets that are important for applications, encompassing the *well-formed* Petri nets, whose structure ensures the existence of a live and bounded initial marking.

Second, we use these transformations to study the liveness of Join-Free and Equal-Conflict systems. We propose the first polynomial sufficient condition for token-conservative Join-Free systems, whose overall number of tokens is constant. We also present several polynomial sufficient conditions of liveness for well-formed Join-Free and Equal-Conflict systems, which include Choice-Free systems. Moreover, we compare these different conditions.

Finally, the transformations also prove useful for the study of the reversibility property under the liveness assumption. We propose the first polynomial live and reversible markings for well-formed Fork-Attribution systems. Then, we prove a new characterization of reversibility for well-formed Choice-Free systems and derive original polynomial live and reversible initial markings for this class, as well as a polynomial time sufficient condition of liveness and reversibility. We also provide the first characterization of reversibility for live consistent Equal-Conflict systems, deduce the first polynomial live and reversible initial markings for well-formed Equal-Conflict systems, and construct such polynomial markings for well-formed Join-Free systems.

This thesis highlights several expressive subclasses of weighted Petri nets that are useful for the modeling of applications. For all these classes, we provided the first polynomial initial conditions that ensure the liveness and reversibility properties. Moreover, these conditions are scalable and can be easily implemented in real systems.



# Contents

<b>1</b>	<b>Introduction</b>	<b>1</b>
1.1	Context and main objective . . . . .	3
1.2	State of the art . . . . .	4
1.2.1	Existing models . . . . .	4
1.2.2	Applications of weighted Petri nets . . . . .	6
1.2.3	Overview of relevant results on Petri nets . . . . .	8
1.3	Contributions and thesis organization . . . . .	10
<b>2</b>	<b>Weighted Petri nets</b>	<b>13</b>
2.1	The model . . . . .	15
2.1.1	Weighted and ordinary nets . . . . .	15
2.1.2	Markings, systems, firing sequences and reachability graphs . . . . .	16
2.2	Structural and behavioral properties . . . . .	17
2.2.1	Deadlocks, liveness and boundedness . . . . .	17
2.2.2	Well-formedness . . . . .	19
2.2.3	Home markings and reversibility . . . . .	19
2.2.4	Semiflows, consistency and conservativeness . . . . .	20
2.3	Additional definitions and notations . . . . .	21
2.3.1	Conflicts and choice-places, synchronizations and join-transitions . . . . .	21
2.3.2	P-(T-)subnets, P-(T-)subsystems and subsequences . . . . .	21
2.3.3	The notations $max_p$ and $gcd_p$ . . . . .	23
2.3.4	Homogeneity . . . . .	23
2.3.5	Source places . . . . .	23
2.3.6	Well-connectedness . . . . .	23
2.4	Particular subclasses . . . . .	24
2.4.1	Asymmetric-Choice nets . . . . .	24
2.4.2	Free-Choice nets . . . . .	24
2.4.3	Equal-Conflict nets and sets . . . . .	24
2.4.4	Choice-Free nets and T-nets . . . . .	25
2.4.5	Join-Free nets and S-nets . . . . .	25
2.4.6	Fork-Attribution nets . . . . .	26
2.4.7	Inclusion relation of the main subclasses . . . . .	27
2.5	Duality . . . . .	28
2.6	Expressiveness and applications . . . . .	28
2.6.1	Join-Free systems . . . . .	28
2.6.2	Equal-Conflict systems and subclasses . . . . .	29



## Contents

---

2.7	Polynomial time characterizations of well-formedness . . . . .	29
2.7.1	Choice-Free and Join-Free nets . . . . .	29
2.7.2	Equal-Conflict nets . . . . .	30
2.8	Structure of well-formed EC and Join-Free nets . . . . .	30
2.9	Conclusion . . . . .	33
<b>3</b>	<b>Polynomial time transformations of weighted Petri nets</b>	<b>35</b>
3.1	Scaling of systems . . . . .	37
3.1.1	Definition . . . . .	38
3.1.2	Properties . . . . .	38
3.2	Balancing and token-conservation . . . . .	41
3.2.1	Definition . . . . .	41
3.2.2	Properties . . . . .	42
3.2.3	Polynomial complexity . . . . .	43
3.3	Normalization and its relation to balancing . . . . .	43
3.4	Useful tokens . . . . .	46
3.5	Transformation into weighted Free-Choice systems . . . . .	47
3.6	The place-splitting transformation . . . . .	50
3.6.1	Definition . . . . .	50
3.6.2	Properties . . . . .	52
3.7	Conclusion . . . . .	54
<b>4</b>	<b>Polynomial sufficient conditions of liveness for well-formed Join-Free and Equal-Conflict systems</b>	<b>57</b>
4.1	Polynomial sufficient conditions of liveness for well-formed Join-Free systems	60
4.1.1	Well-formedness and balancing . . . . .	60
4.1.2	A polynomial sufficient condition for balanced Join-Free systems . .	60
4.1.3	The special case of ordinary Join-Free systems . . . . .	63
4.1.4	Polynomial live markings for well-formed Join-Free systems . . . . .	63
4.2	Previous results on the liveness of Equal-Conflict systems . . . . .	65
4.2.1	A characterization of liveness for well-formed systems . . . . .	65
4.2.2	Liveness monotonicity of bounded systems . . . . .	65
4.3	Polynomial live markings for well-formed Equal-Conflict systems . . . . .	65
4.3.1	Polynomial live markings . . . . .	66
4.3.2	Special case of normalized T-systems . . . . .	68
4.4	Sufficient conditions of liveness for Choice-Free systems . . . . .	69
4.4.1	Known results on the liveness . . . . .	69
4.4.2	A sufficient condition of liveness by place-splitting . . . . .	69
4.4.3	Deduction of a polynomial time sufficient condition . . . . .	69
4.5	A comparison of the liveness conditions . . . . .	71
4.6	The sufficient conditions are not necessary . . . . .	72
4.7	Conclusion . . . . .	74

<b>5</b>	<b>Reversibility of live Equal-Conflict and Join-Free systems</b>	<b>75</b>
5.1	Reversibility of well-behaved Choice-Free systems . . . . .	78
5.1.1	Previous results . . . . .	78
5.1.2	Preliminary definitions and results . . . . .	80
5.1.3	Polynomial markings for well-formed Fork-Attribution systems . . . . .	82
5.1.4	A result about subsequences and P-subsystems . . . . .	85
5.1.5	A necessary condition of reversibility for Choice-Free systems . . . . .	86
5.1.6	A new characterization of reversibility for Choice-Free systems . . . . .	87
5.1.7	Polynomial markings for well-formed Choice-Free systems . . . . .	93
5.1.8	A sufficient condition of liveness and reversibility . . . . .	94
5.2	Reversibility of live consistent Equal-Conflict systems . . . . .	96
5.2.1	Reversibility is not induced by reversible P-components . . . . .	97
5.2.2	T-sequences and reversibility . . . . .	98
5.2.3	A well-behaved homogeneous S-system that is not reversible . . . . .	99
5.2.4	Feasible T-sequences do not imply liveness . . . . .	99
5.2.5	A characterization of reversibility . . . . .	99
5.2.6	Monotonicity of reversibility in well-behaved systems . . . . .	106
5.2.7	Polynomial live home markings for well-formed systems . . . . .	106
5.3	Reversibility of well-behaved Join-Free systems . . . . .	110
5.3.1	Polynomial live home markings . . . . .	110
5.4	Reversibility and T-sequences for other classes . . . . .	113
5.5	Conclusion . . . . .	118
<b>6</b>	<b>Conclusion and perspectives</b>	<b>119</b>
<b>Bibliography</b>		<b>128</b>



# Chapter 1

## Introduction

### Contents

---

<b>1.1</b>	<b>Context and main objective</b>	<b>3</b>
<b>1.2</b>	<b>State of the art</b>	<b>4</b>
1.2.1	Existing models	4
1.2.1.1	Kahn graphs	4
1.2.1.2	Synchronous DataFlow (SDF) and Cyclo-Static DataFlow (CSDF)	5
1.2.1.3	Relationship with Petri nets	5
1.2.2	Applications of weighted Petri nets	6
1.2.2.1	Flexible Manufacturing Systems (FMS)	6
1.2.2.2	Embedded systems	7
1.2.3	Overview of relevant results on Petri nets	8
<b>1.3</b>	<b>Contributions and thesis organization</b>	<b>10</b>

---

### 1.1 Context and main objective

A large part of the theory of Discrete Event Dynamic Systems (DEDS) has developed in the second half of the past century. Automata and Petri net formalisms, among others, belong to this theory and are still flourishing today.

In his PhD thesis, presented in 1962, Carl Adam Petri introduced the places/transitions nets (Petri nets) in order to obtain a general model for discrete concurrent and distributed systems. These nets are directed bipartite graphs with local states, described by *places* containing *tokens*, and state modifiers, called *transitions*, that allow for the modeling of concurrency, conflicts and synchronizations, as well as an infinite number of states. This highly expressive formalism is not Turing-complete and benefits from the decidability of many interesting problems. There exist many extensions of Petri nets, some of which add a notion of time or consider stochastic processes, allowing for performance evaluation and scheduling, non-exhaustively. Such advantages justify the use of Petri nets for specification and verification, with many applications to software and protocol engineering, biological systems, the design of circuits, embedded systems and flexible manufacturing systems...

Embedded systems must be kept fully functioning over long periods of time. They have to preserve over time the entirety of their functions and use a limited amount of memory. Such guarantees are fundamental for applications. The corresponding properties in Petri nets are *liveness* and *boundedness*. Moreover, real systems often need to avoid costly initialization phases and to have the possibility to return to their initial state from any reachable state. The associated property in Petri nets is called *reversibility*. In Petri nets data is abstracted through the use of tokens, indicating the presence of data items while leaving out their values. Likewise, the values of a system's state are left out in the Petri net model, which uses only the bare bones of the state under the form of a vector of tokens, the marking. Properties of Petri nets relate to the possible evolutions of their markings. Representing buffers by places, subprograms by transitions and interactions of subprograms by arcs, Petri nets are well suited to model embedded applications, making sure that useful behavioral properties are satisfied at the design phase. This approach avoids the costly simulations that usually occur afterwards.

However, the particularly appealing expressiveness of Petri nets comes at the cost of a high analysis complexity. The reachability and liveness problems, among others, are EXPSPACE-hard. In order to alleviate this problem, a trade-off between expressiveness and complexity is often considered by restricting to proper subclasses. Heuristics are also commonly used in many cases.

The main objective of this thesis is to provide the first efficient methods that ensure the liveness and the reversibility of several expressive subclasses of weighted Petri nets with a view toward the design of embedded systems.

This introductory chapter is organized as follows. In Section 1.2, we present the state of the art regarding some well-known models and we motivate our choice of the Petri net model. We highlight applications of weighted Petri nets. We also review the main results on Petri nets that deal with our issue. In Section 1.3, we detail our contribution and the organization of the thesis.

## 1.2 State of the art

### 1.2.1 Existing models

We briefly review the formalisms of Kahn graphs and Synchronous Data Flow graphs (SDF). We relate the SDF model, which has been widely used for the modeling of embedded applications, to a well-known subclass of weighted Petri nets, namely the T-systems. We finally motivate our preference for the Petri net formalism.

#### 1.2.1.1 Kahn graphs

Kahn graphs [Kahn 1974] have a strong expressive power and can model dataflow applications. However, they do not provide reasonable analysis possibilities: the liveness of a Kahn graph is undecidable and it is not possible to find a bound on the capacity of the buffers [Parks 1995]. Such difficulties motivate the use of new models that combine sufficient expressiveness with tractability, in order to build functional embedded applications.

In a Kahn graph or “Kahn Process Network”, the subprograms are named “actors” and send data items to other actors under certain conditions. Since two executions that are based on identical inputs lead to the same results, these systems benefit from a kind of determinism.

Data items move from one actor to another via an infinite FIFO buffer, which is represented by an arc. Each actor may block when reading one of its input channels, waiting for new data items. In Figure 1.1, the actor  $A_1$  sends data items to  $A_2$  if  $x = 0$ , in which case they are stored in the buffer  $(A_1, A_2)$ , and otherwise it sends them to  $A_3$ , in which case they are stored in the buffer  $(A_1, A_3)$ .



Figure 1.1: A Kahn graph and the pseudo-code of the actor  $A_1$ .

### 1.2.1.2 Synchronous DataFlow (SDF) and Cyclo-Static DataFlow (CSDF)

The formalism of Synchronous Data Flow (SDF) [Lee 1987a, Lee 1987b] and its extension to Cyclo-Static Data Flow (CSDF) by adding phases [Engels 1994, Bilsen 1995] are special data flow models for concurrent applications to be executed on parallel architectures. They have been used in many—often multimedia—applications, such as MP3 playback [Wiggers 2007a].

In contrast with Kahn graphs, SDFs have a very restricted expressiveness: subprograms read and write a fixed amount of data unconditionally. They can wait for data on their input channels. Moreover, each buffer has at most one writer and one reader. Consequently, the system has a regular behavior, although blocking (deadlock) may occur. Figure 1.2 represents an SDF with 3 actors that communicate through intermediate buffers. They read and write fixed amounts of data—indicated by weights on the arcs—into these buffers. When actor  $A_1$  terminates, it sends 2 data items to the buffer  $(A_1, A_2)$  and actor  $A_2$  is enabled for starting when at least 3 data items are present in that buffer.

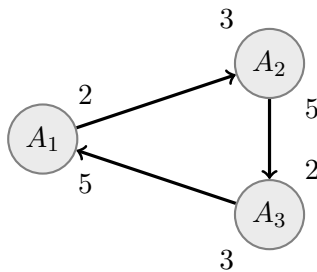

Figure 1.2: A Synchronous DataFlow with 3 actors.

The low expressiveness of this model has the advantage of inducing efficient methods—typically in polynomial time—to ensure the liveness of an SDF and evaluate the buffer sizes necessary for its execution [Marchetti 2009].

### 1.2.1.3 Relationship with Petri nets

Petri nets have proved useful to model discrete event systems possibly with conflicts, synchronization and concurrency. They have a great modeling power while, in contrast with Kahn graphs, many of their properties are decidable [Murata 1989, Esparza 1998]. In particular, they can model an SDF by replacing actors with transitions and buffers with places. Figure 1.3 illustrates this property.

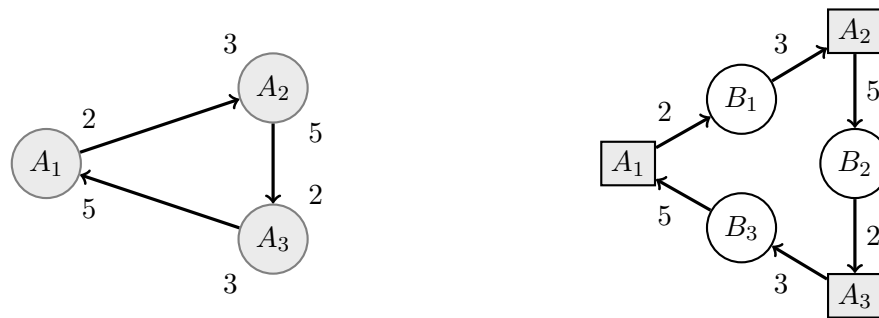

Figure 1.3: The SDF on the left is represented by the Petri net on the right.

Petri nets such that each place has at most one input and one output are called (weighted) *T-systems*, or (generalized) *event graphs*. The modeling power of T-systems subsumes that of the SDF. Consequently, studying extensions of T-systems amounts to doing the same for SDFs.

In this thesis, we study the Petri net formalism. Our choice has been determined by the existence of a large Petri net community and of a very rich literature on the structure and behavior of these nets.

## 1.2.2 Applications of weighted Petri nets

Weighted Petri nets are a well-known model for Flexible Manufacturing Systems (FMS) and embedded systems. The weights make possible the modeling of bulk consumption or production of resources, situations that appear frequently in these systems [Teruel 1997, Lee 1987b]. Moreover, comparing with ordinary (non-weighted) nets, the weights allow a more compact representation of the system.

### 1.2.2.1 Flexible Manufacturing Systems (FMS)

A *manufacturing system*, also called *discrete production system*, is a factory that handles materials made of discrete entities.

A *flexible manufacturing system* can handle concurrently a large variety of product families at a given time, and can easily manage new product families. An FMS is generally composed of three parts: a set of flexible machines (workstations), an automatic transport system and a decision making system.

A *working process* (WP) is a sequence of operations performed in order to manufacture a product.

A *system resource* is an element of the system that is able to hold a product, e.g. for transport.



## Chapter 1. Introduction

---

The concurrent working processes of an FMS compete for a same set of resources, inducing possible deadlocks that block production orders. For FMS, the liveness property ensures the termination of every production process and preserves over time the possibility to add new products to be manufactured. The reversibility property ensures the existence of a cyclic behavior.

For further reading, manufacturing systems are studied in [Silva 1990, Ezpeleta 1995, Teruel 1997], making use of weights.

### 1.2.2.2 Embedded systems

Embedded systems have to preserve all their functionalities over time within bounded memory. Moreover, they often need to avoid a costly initialization phase and to have the possibility of returning to their initial configuration, since this property allows periodic schedules, may facilitate error recovery, behavior analysis and performance evaluation.

Functionalities can intuitively be modeled by transitions, and their interactions by places and weighted arcs. The weights on the arcs represent amounts of read or written data. The preservation of all functionalities is a behavioral requirement that is formalized as the liveness property. The possibility to return to the initial state from every reachable state (a reset of the system) is called reversibility.

SDF graphs have been used for many years in the domain of embedded system design for modeling numerous applications, including embedded Digital Signal Processing (DSP) applications [Lee 1987a, Pino 1995, Sriram 2009].

CSDF graphs extend SDFs by adding phases, allowing for the description of applications with a cyclically changing behavior. They have been introduced in [Engels 1994, Bilsen 1995], where they are used for modeling a video encoder. They have proved useful to model MP3 playback applications [Wiggers 2007b] and a Reed-Solomon Decoder application [Benazouz 2010]. Such examples show the importance of this model in the context of DSP systems. These graphs also prove useful in the dataflow compiler designed to map a CSDF graph on the Massively Parallel Processor Array (MPPA, 256 processors) developed by Kalray company<sup>1</sup>.

Several efficient methods for liveness evaluation have been proposed for SDF graphs [Marchetti 2009] and CSDF graphs [Benazouz 2013], in contrast with most of the known methods which use a costly symbolic execution of the graph [Benazouz 2013, Anapalli 2009].

However, in these systems, the reversibility property is implied by the liveness and boundedness properties [Lee 1987b, Teruel 1992, Bilsen 1995], which is not the case for larger classes [Teruel 1997]. This fact motivates the study of the reversibility property in more expressive classes under the liveness assumption.

---

<sup>1</sup>Kalray. Manycore processors for embedded computing. [www.kalray.eu](http://www.kalray.eu).

### 1.2.3 Overview of relevant results on Petri nets

We present here the state of the art regarding our issue and motivating our work. We first review classical decidable problems, with some of their (high) complexity lower bounds. We depict informally some well-studied subclasses of weighted Petri nets that are more expressive than the T-systems, thus more expressive than the SDF graphs. We then focus on the structural and behavioral properties related to liveness and boundedness, as well as the reversibility and the associated results. Finally, we recall classical methods for the study of the behavior in Petri nets.

**Some classical problems in Petri nets.** The deadlock problem consists in deciding whether there exists a reachable state—a marking—that is a deadlock, meaning a state not allowing any action—the firing of a transition. The liveness problem consists in deciding if a Petri net is live, meaning that all transitions can be fired after a finite number of steps from any reachable marking.

Deciding the attainability of a given marking starting from a particular initial marking defines the reachability problem. A home marking is a marking that is reachable from every reachable marking. Deciding if a particular reachable marking is a home marking defines the home marking problem, or home state problem. Deciding if the initial marking is a home marking solves the reversibility problem, a particular case of the home marking problem.

Many Petri nets problems are decidable, although not tractable. As a matter of fact, the deadlock, liveness and reachability problems are EXPSPACE-hard [Lipton 1976, Cheng 1993]. The home marking and reversibility problems are decidable [Araki 1977, de Frutos Escrig 1989] although their complexity remains open.

**Expressive subclasses.** In order to alleviate the high complexity of most interesting problems, proper subclasses have been studied. Weighted S-systems can be viewed as dual of T-systems; while in a T-system a place cannot have more than one input and one output, the same is true for a transition in an S-system. These S-systems model choices since their places may have several outputs, thus inducing a form of non-determinism.

Weighted Choice-Free systems augment the expressiveness of T-systems by allowing places to have several inputs. Weighted Join-Free systems expand the modeling power of S-systems as they do not constrain the number of transition outputs. The systems belonging to both of these larger classes, hence inheriting their structural properties, are called Fork-Attribution (FA) systems.

Equal-Conflict systems extend the Choice-Free class by allowing restricted choices and do not include all the Join-Free systems.

**Well-formedness.** Well-formedness ensures that there exists at least one initialization of the net yielding a system whose functionalities are preserved—the liveness property—while a limited use of memory is ensured—the boundedness property. The structural notions of consistency and conservativeness are known necessary conditions for well-formedness [Sifakis 1978, Memmi 1980].

Well-formedness is characterized in polynomial time for several subclasses of weighted and ordinary (non-weighted) Petri nets. The well-formedness of ordinary Free-Choice nets, which are structurally more permissive than weighted Choice-Free nets but lacking weights, can be decided in polynomial time [Desel 1995]. This is also the case for Equal-Conflict nets, which generalize weighted Choice-Free nets [Teruel 1996] and ordinary Free-Choice nets. For several other weighted classes, there exist polynomial time necessary or sufficient conditions of well-formedness and sometimes complete characterizations [Recalde 1995, Recalde 1996, Silva 1998]. For the classes studied in this thesis, namely weighted Join-Free and Equal-Conflict nets with their subclasses, well-formedness is decided in polynomial time [Teruel 1994, Recalde 1996, Teruel 1997, Amer-Yahia 1999a].

**Well-behavedness.** The next challenge is to find efficiently an initialization ensuring liveness and boundedness, a combination of properties called “well-behavedness”. Polynomial time characterizations of well-behavedness are not known for weighted classes, even for weighted circuits, and may not exist. This problem is related to the diophantine problem of Frobenius [Chrastowski-Wachtel 1993]. Thus, finding sufficient—although not necessary—conditions of well-behavedness that are polynomial in time and initial number of tokens would constitute a significant advance. In this thesis, we shall simply qualify such conditions as “polynomial”. However, even such relaxed conditions are not easy to discover. One has been found recently for T-systems [Marchetti 2009]. In weighted Choice-Free systems and some larger classes, only costly conditions have been proposed [Recalde 1996, Teruel 1997], using exponential time algorithms or an exponential number of initial tokens, forbidding application to real systems. Necessary but not sufficient conditions for liveness and boundedness also exist [Amer-Yahia 1999b]. Other results encompass polynomial characterizations of liveness for several ordinary classes [Barkaoui 1992, Chao 2001, Alimonti 2011] and non-polynomial ones if weights are allowed with some restrictions [Barkaoui 1996, Jiao 2004]. Well-behavedness is also not fully understood for weighted Join-Free systems.

**Home markings and reversibility.** Home markings are markings that can be reached from any reachable marking; they reflect a kind of cyclicity. Used as an initial data distribution in the system, they avoid a transient phase. This reversibility property is often required in embedded applications that need a steady behavior. Besides, such markings simplify the study of the reachability graph. They may also be useful in protocol validation. However, reversible markings are not necessarily live and live markings are not always reversible [Murata 1989], even in non-weighted Petri nets, witnessing to the difficulty

### 1.3. Contributions and thesis organization

---

of designing live and reversible systems. Under the liveness and boundedness hypothesis, weighted T-systems are known to be reversible [Teruel 1992] while some other particular weighted classes, such as the well-behaved Equal-Conflict systems, always have home markings [Teruel 1993, Teruel 1996, Recalde 1998, Silva 1998]. Their existence is stated, and even completely characterized for Choice-Free systems [Teruel 1997]. However, polynomial time algorithms that build live home markings with a polynomial number of initial tokens do not exist for most weighted classes, including Fork-Attribution systems.

**Well-known methods.** A common approach to the study of the behavior considers particular subclasses of nets. However, even in the very restricted class of the well-formed weighted circuits, the complexity of the liveness problem is not known and the size of the state space is exponential. Therefore, several methods were developed that avoid naive enumerations, namely transformations and structural techniques.

Transformations aim at modifying the net efficiently while preserving behavior or other strong properties, so that the analysis cost is lower on the transformed net. Many transformations are defined as rules that apply to special local graph patterns and often reduce the size of the net, leading to efficient sufficient conditions [Berthelot 1986, Berthelot 1987, Murata 1989, Colom 2003].

Structural techniques study to what extent the structure and the initial marking impact on the behavior. Such methods are useful notably for structurally defined subclasses. Net decomposition theories have been developed for particular classes of nets and improve the understanding of their dynamics.

### 1.3 Contributions and thesis organization

The SDFs, or the T-systems, have been widely used to model embedded applications. However, as functionalities become more sophisticated, model expressiveness has to be extended. An objective is thus to generalize results common to SDFs and T-systems in order to treat more complex applications involving choices, with a view to offering efficient analysis methods. More precisely, we focus on extensions of the T-systems and SDFs that

- are strictly more expressive structurally, as are the Choice-Free and Equal-Conflict classes, which allow several subprograms to write in the same buffer, with optional (restricted) choices;
- permit a kind of non-determinism, as are the Join-Free and Equal-Conflict systems, in which the choices that are made during successive executions are not fixed and depend on the data items.

Our contributions are described next.

## Chapter 1. Introduction

---

**Transformations.** We present several new polynomial time transformations for weighted Petri nets that will prove useful for the study of behavioral properties.

First, we generalize methods that were developed in the context of weighted T-systems in [Marchetti 2009]. The scaling transformation applies to all Petri nets and modifies only the weights and the initial marking while preserving language and well-formedness. We also extend the notion of useful tokens, allowing to reduce the initial marking while preserving the feasible sequences.

We define the balancing transformation, a particular scaling that allows the number of tokens to remain constant in the entire system, simplifying the study of behavioral properties.

Then, we show that every weighted Petri net can be transformed into a weighted Free-Choice system, while retaining the behavior and the well-formedness.

Finally, we present the place-splitting transformation that applies to a well-formed Choice-Free system to obtain a well-formed T-system with strong properties.

**Study of the liveness property.** We use the new transformations to obtain the first polynomial sufficient conditions of liveness for well-formed Join-Free and Equal-Conflict systems, which are particular markings with a polynomial number of tokens determined in polynomial time.

To find these conditions, we first obtain a polynomial sufficient condition that applies to balanced Join-Free systems. We deduce from it polynomial live markings for all well-formed Join-Free systems. We use a known decomposition theorem for well-formed Equal-Conflict systems to build the first polynomial markings for this class, which includes the Choice-Free systems. Moreover, we use the place-splitting transformation to deduce another sufficient condition of liveness for Choice-Free systems, as well as a polynomial time version of the condition, and we compare the different methods.

These new results allow to build well-behaved systems efficiently with a reasonably sized initial data distribution, and contrast with the prior exponential algorithms of the literature.

**Study of the reversibility property.** We present the first polynomial live and reversible initial markings for the class of Fork-Attributions systems. We then study the class of well-formed Choice-Free systems, for which we present a new characterization of reversibility and deduce the first polynomial live and home markings, using the marking found for the Fork-Attribution subclass.

We also provide another original sufficient condition of liveness and reversibility for well-formed Choice-Free systems, as well as a polynomial one, with the help of the place-splitting transformation. We compare all these conditions.

Thereafter, we study the reversibility of live consistent Equal-Conflict systems. We show that our methods dedicated to Choice-Free systems do not apply to this more expressive class. This fact motivates us to develop the first non-trivial characterization of reversibility

### 1.3. Contributions and thesis organization

---

for live consistent Equal-Conflict systems, encompassing Choice-Free systems and homogeneous Join-Free systems. This new condition generalizes a characterization of reversibility that was known for Choice-Free systems. This result leads to the first polynomial live and home markings for well-formed Equal-Conflict systems.

Finally, we use these new methods to obtain the first polynomial live and reversible markings for well-formed Join-Free systems, in which the homogeneity constraint is removed.

Thus, we extend the expressiveness of the models usable in real applications, whose well-behavedness and reversibility can be ensured efficiently.

**Thesis organization.** First, in Chapter 2, we recall the formalism of weighted Petri nets, with definitions and examples. We also recall important results regarding the subclasses studied in this thesis. The transformations form the subject of Chapter 3. The study of the liveness property is detailed in Chapter 4. Finally, the results on the reversibility property are presented in Chapter 5. Chapter 6 forms our conclusion and several perspectives.



# Weighted Petri nets

## Contents

---

<b>2.1</b>	<b>The model . . . . .</b>	<b>15</b>
2.1.1	Weighted and ordinary nets . . . . .	15
2.1.2	Markings, systems, firing sequences and reachability graphs . . . . .	16
<b>2.2</b>	<b>Structural and behavioral properties . . . . .</b>	<b>17</b>
2.2.1	Deadlocks, liveness and boundedness . . . . .	17
2.2.2	Well-formedness . . . . .	19
2.2.3	Home markings and reversibility . . . . .	19
2.2.4	Semiflows, consistency and conservativeness . . . . .	20
<b>2.3</b>	<b>Additional definitions and notations . . . . .</b>	<b>21</b>
2.3.1	Conflicts and choice-places, synchronizations and join-transitions . . . . .	21
2.3.2	P-(T-)subnets, P-(T-)subsystems and subsequences . . . . .	21
2.3.3	The notations $max_p$ and $gcd_p$ . . . . .	23
2.3.4	Homogeneity . . . . .	23
2.3.5	Source places . . . . .	23
2.3.6	Well-connectedness . . . . .	23
<b>2.4</b>	<b>Particular subclasses . . . . .</b>	<b>24</b>
2.4.1	Asymmetric-Choice nets . . . . .	24
2.4.2	Free-Choice nets . . . . .	24
2.4.3	Equal-Conflict nets and sets . . . . .	24
2.4.4	Choice-Free nets and T-nets . . . . .	25
2.4.5	Join-Free nets and S-nets . . . . .	25
2.4.6	Fork-Attribution nets . . . . .	26
2.4.7	Inclusion relation of the main subclasses . . . . .	27
<b>2.5</b>	<b>Duality . . . . .</b>	<b>28</b>
<b>2.6</b>	<b>Expressiveness and applications . . . . .</b>	<b>28</b>
2.6.1	Join-Free systems . . . . .	28
2.6.1.1	S-systems . . . . .	28
2.6.2	Equal-Conflict systems and subclasses . . . . .	29
<b>2.7</b>	<b>Polynomial time characterizations of well-formedness . . . . .</b>	<b>29</b>
2.7.1	Choice-Free and Join-Free nets . . . . .	29
2.7.2	Equal-Conflict nets . . . . .	30
<b>2.8</b>	<b>Structure of well-formed EC and Join-Free nets . . . . .</b>	<b>30</b>
<b>2.9</b>	<b>Conclusion . . . . .</b>	<b>33</b>

---



In this chapter, we recall the formalism of weighted Petri nets and classical definitions regarding their structure and behavior. We also provide additional definitions and notations that may be less common. Then we present the main classes of Petri nets investigated in this thesis, namely Equal-Conflict and Join-Free nets, as well as some of their subclasses and their relationships. Finally, we recall known theorems of well-formedness for these nets and the covering of well-formed Equal-Conflict and Join-Free nets by components.

### 2.1 The model

In this section, we present the formalism of weighted Petri nets. After an overview of notations for weighted nets and their subclass of ordinary nets, we provide definitions relevant to markings and firing sequences, and their relationships.

#### 2.1.1 Weighted and ordinary nets

A (*weighted*) *net* is a triple  $N = (P, T, W)$  where:

- the sets  $P$  and  $T$  are finite and disjoint,  $T$  contains only transitions and  $P$  only places,
- $W : (P \times T) \cup (T \times P) \mapsto \mathbb{N}$  is a weight function.

$P \cup T$  is the set of the elements of the net.

An arc is present from a place  $p$  to a transition  $t$  (respectively a transition  $t$  to a place  $p$ ) if  $W(p, t) > 0$  (respectively  $W(t, p) > 0$ ). An *ordinary* net is a net whose weight function  $W$  takes values in  $\{0, 1\}$ .

The *incidence matrix* of a net  $N = (P, T, W)$  is a place-transition matrix  $C$  defined as

$$\forall p \in P \quad \forall t \in T, \quad C[p, t] = W(t, p) - W(p, t)$$

where the weight of each non-existing arc is 0. The weight function  $W$  can be represented by two place-transition matrices  $Pre$  and  $Post$  defined as follows:  $\forall p \in P, \forall t \in T, Pre[p, t] = W(p, t)$  and  $Post[p, t] = W(t, p)$ . Consequently, the incidence matrix can be defined as  $C = Post - Pre$ . Regarding notations for matrices, if  $C$  denotes a matrix,  $\alpha$  a subset of rows and  $\beta$  a subset of columns, we note  $C[\alpha, \beta]$  the largest submatrix of  $C$  whose each element belongs to a row of  $\alpha$  and to a column of  $\beta$ .

The *pre-set* of the element  $x$  of  $P \cup T$  is the set  $\{w | W(w, x) > 0\}$ , denoted by  $\bullet x$ . By extension, for any subset  $E$  of  $P$  or  $T$ ,  $\bullet E = \bigcup_{x \in E} \bullet x$ .

The *post-set* of the element  $x$  of  $P \cup T$  is the set  $\{y | W(x, y) > 0\}$ , denoted by  $x \bullet$ . Similarly,  $E \bullet = \bigcup_{x \in E} x \bullet$ .

Figure 2.1 presents a weighted net with its incidence matrix, with notations.

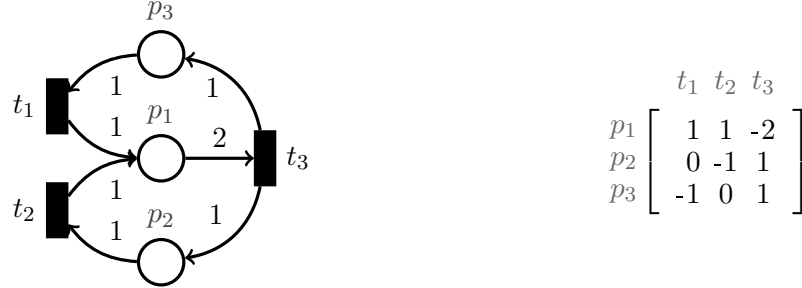

Figure 2.1: A weighted net and its incidence matrix. The pre-set of  $p_1$  is  $\{t_1, t_2\}$  and its post-set is  $\{t_3\}$ .

### 2.1.2 Markings, systems, firing sequences and reachability graphs

A *marking*  $M$  of a net  $N$  is a mapping  $M : P \rightarrow \mathbb{N}$ . We shall also denote by  $M$  the column vector whose components are the values  $M(p)$  for  $p \in P$ .

A *system* is a couple  $(N, M_0)$  where  $N$  is a net and  $M_0$  its initial marking. Figure 2.2 pictures a weighted system.

A marking  $M$  of a net  $N$  *enables* a transition  $t \in T$  if  $\forall p \in \bullet t, M(p) \geq W(p, t)$ . Generalizing to sets, a set  $A$  of transitions is enabled by  $M$  if every transition of  $A$  is enabled by  $M$ . A marking  $M$  *enables* a place  $p \in P$  if  $\forall t \in p^\bullet, M(p) \geq W(p, t)$ . Generalizing to sets, a set  $A$  of places is enabled by  $M$  if every place of  $A$  is enabled by  $M$ . The marking  $M'$  obtained from  $M$  by the firing of an enabled transition  $t$ , noted  $M \xrightarrow{t} M'$ , is defined by  $\forall p \in P, M'(p) = M(p) - W(p, t) + W(t, p)$ .

A *firing sequence*  $\sigma$  of length  $n \geq 1$  on the set of transitions  $T$  is a mapping  $\{1, \dots, n\} \rightarrow T$ , written  $\sigma = t_1 t_2 \dots t_n$ . A sequence is *infinite* if its domain is countably infinite. A firing sequence  $\sigma = t_1 t_2 \dots t_n$  is *feasible* in the system  $(N, M_0)$  if the successive markings obtained,  $M_0 \xrightarrow{t_1} M_1 \xrightarrow{t_2} M_2 \dots \xrightarrow{t_n} M_n$ , are such that  $M_{i-1}$  enables the transition  $t_i$  for each  $i \in \{1, \dots, n\}$ . We note  $M_0 \xrightarrow{\sigma} M_n$ . The *language* of a system is the set of all its finite feasible sequences.

A marking  $M'$  is said to be *reachable* from the marking  $M$  if there exists a feasible firing sequence  $\sigma$  such that  $M \xrightarrow{\sigma} M'$ . The set of reachable markings from  $M$  is denoted by  $[M]$ .

The *Parikh vector*  $\vec{\sigma} : T \rightarrow \mathbb{N}$  associated with a finite sequence of transitions  $\sigma$  maps every transition  $t$  of  $T$  to the number of occurrences of  $t$  in  $\sigma$ .

The *reachability set* of a system  $S = (N, M_0)$ , noted  $R(S)$ , is the set of all the markings reachable in  $S$ . The *reachability graph* of a system  $S = (N, M_0)$ , noted  $RG(S)$ , is a rooted and labeled directed graph  $(V, E, v_0)$ , where  $V$  is the set of the markings of  $R(S)$ , the root  $v_0$  is the initial marking  $M_0$  and  $E = \{(M, t, M') \mid M, M' \in V \text{ and } M \xrightarrow{t} M'\}$  is the set of labeled arcs connecting every reachable marking to each of its successor markings. A reachability graph is pictured on the right of Figure 2.2.

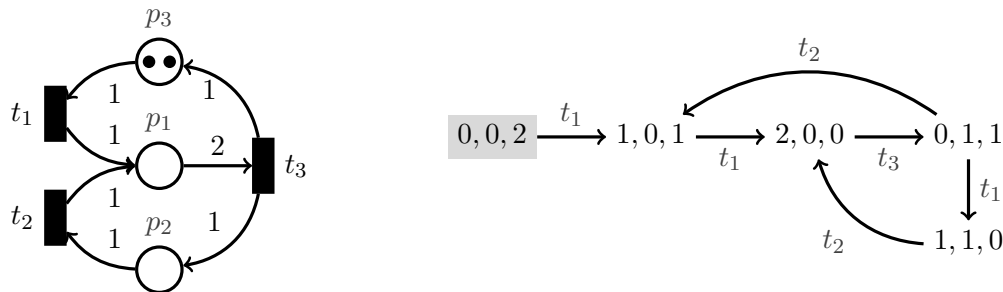

Figure 2.2: A weighted system  $S = (N, M_0)$  whose initial marking  $M_0$  equals  $(0, 0, 2)$ . The transition  $t_1$  is initially enabled whereas  $t_2$  and  $t_3$  are not. The sequence  $\sigma = t_1 t_1$ , whose Parikh vector is  $\vec{\sigma} = (2, 0, 0)$ , is feasible in  $S$  and leads to the reachable marking  $(2, 0, 0)$ . The reachability graph of  $S$  is pictured on the right.

## 2.2 Structural and behavioral properties

In this section, we present fundamental properties of Petri nets that will be used throughout this thesis.

### 2.2.1 Deadlocks, liveness and boundedness

A *deadlock* is a situation in which no transition is enabled in the system. A marking that causes a deadlock is often called a *dead marking*. A system is *deadlock-free* if no reachable marking is dead.

Intuitively, liveness and boundedness are two properties ensuring that all transitions of a system can always be fired and that the overall number of tokens remains bounded. These properties are described formally next.

A system  $S = (N, M_0)$  is *live* if for every marking  $M$  in  $[M_0)$  and for every transition  $t$ , there exists a marking  $M'$  in  $[M)$  enabling  $t$ .

## 2.2. Structural and behavioral properties

---

$S$  is *bounded* if there exists an integer  $k$  such that the number of tokens in each place never exceeds  $k$ . Formally,  $\exists k \in \mathbb{N} \ \forall M \in [M_0] \ \forall p \in P, M(p) \leq k$ .

$S$  is *k-bounded* if, for each place  $p \in P$ ,  $k \geq \max\{M(p) | M \in [M_0]\}$ .

A marking  $M$  is *live* for a net  $N$  if the system  $(N, M)$  is live. The same definition applies to boundedness and any other behavioral property.

A system  $S$  is *well-behaved* if it is live and bounded.

These properties are presented in Figure 2.3. Liveness implies absence of deadlock, however the converse does not hold in general, as pictured in Figure 2.4.

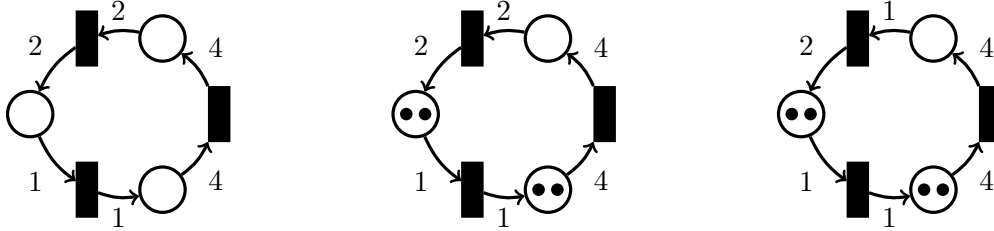

Figure 2.3: The circuit on the left is bounded, not live, and with a dead marking. The circuit in the middle is live, bounded and 4-bounded in particular, hence it is well-behaved. The last circuit is live and not bounded.

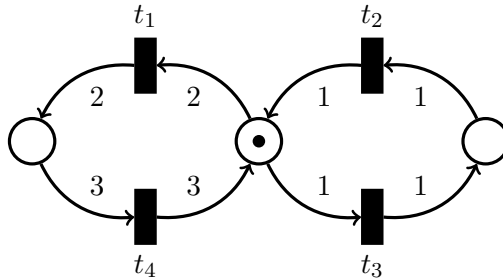

Figure 2.4: This system is deadlock-free, since every reachable marking enables a transition. However, it is not live, since no reachable marking enables the transitions  $t_1$  and  $t_4$ .

### 2.2.2 Well-formedness

The structure of a net  $N$  may be studied to ensure the existence of an initial marking  $M_0$  such that  $(N, M_0)$  is live and bounded:

- $N$  is *structurally live* if a marking  $M_0$  exists such that  $(N, M_0)$  is live.
- $N$  is *structurally bounded* if the system  $(N, M_0)$  is bounded for each  $M_0$ .
- $N$  is *well-formed* if it is structurally live and structurally bounded.

The leftmost circuit in Figure 2.5 is well-formed: it is structurally live, since there exists a live marking for this net in the second circuit, and it is structurally bounded since its number of tokens remains constant for every initial marking after every feasible firing sequence.

### 2.2.3 Home markings and reversibility

A *home marking* is a marking that can be reached from any reachable marking. Formally,  $M$  is a home marking in the system  $(N, M_0)$  if  $\forall M' \in [M_0], M \in [M']$ . A system is *reversible* if its initial marking is a home marking. A consequence of this definition is that a system is reversible if and only if its reachability graph is strongly connected. In the particular case of a dead initial marking, the system is reversible since the reachability graph contains only one element and is thus strongly connected.

The marked circuit in the middle of Figure 2.5 is well-behaved and reversible, while the circuit on the left is deadlocked and reversible. The system of Figure 2.4 is reversible, deadlock-free and not live.

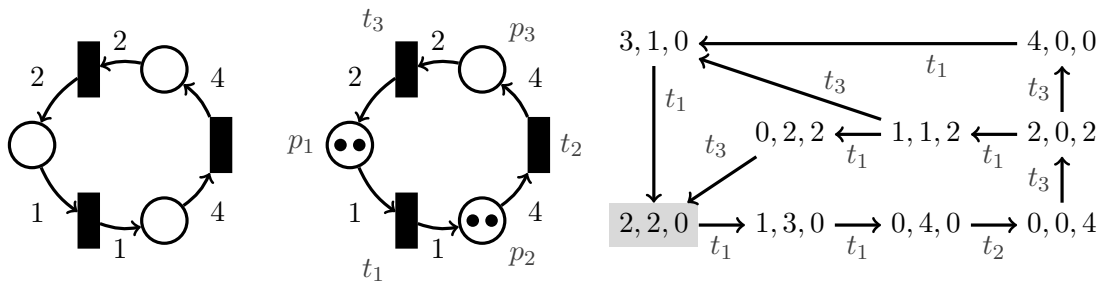

Figure 2.5: The leftmost circuit is well-formed and marked with the empty marking, thus its reachability graph contains only the empty marking and is strongly connected, implying reversibility. The second circuit is well-behaved and reversible, since its reachability graph, depicted on the right with the grey initial state, is strongly connected.

2.2.4 Semiflows, consistency and conservativeness

In the following, we denote by  $P$  the set of places and  $T$  the set of transitions of the net considered. We will denote by  $\mathcal{I}(V)$  the set of the indices of the vector  $V$ . The *support* of a vector  $V$ , noted  $|V|$ , is defined as the largest subset of  $\mathcal{I}(V)$  being associated to non-zero components of  $V$ , meaning that  $\forall i \in |V|, V[i] \neq 0$  and  $\forall i \in \mathcal{I}(V) \setminus |V|, V[i] = 0$ .

Semiflows are particular left or right annulers of the incidence matrix  $C$  that is supposed to be non-empty:

- A *P-semiflow* is a non-null vector  $X \in \mathbb{N}^{|P|}$  such that  ${}^tX \cdot C = 0$ .
- A *T-semiflow* is a non-null vector  $Y \in \mathbb{N}^{|T|}$  such that  $C \cdot Y = 0$ .

A P-semiflow is *minimal* if the greatest common divisor of its components is equal to 1 and its support is not a proper superset of the support of any other P-semiflow. The same definition applies to T-semiflows.

We denote by  $\mathbb{1}^n$  the column vector of size  $n$  whose components are all equal to 1.

The conservativeness and consistency properties are defined as follows using the incidence matrix  $C$  of a net  $N$  and particular semiflows:

- $N$  is *conservative* if a P-semiflow  $X \in \mathbb{N}^{|P|}$  exists for  $C$  such that  $X \geq \mathbb{1}^{|P|}$ .
- $N$  is *consistent* if a T-semiflow  $Y \in \mathbb{N}^{|T|}$  exists for  $C$  such that  $Y \geq \mathbb{1}^{|T|}$ .

The net on Figure 2.6 is conservative and consistent.

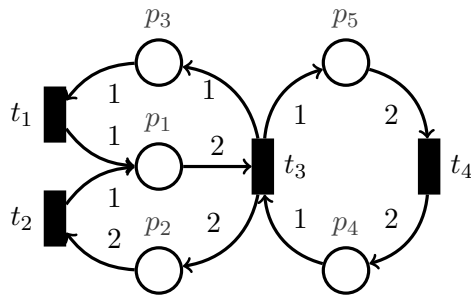

$${}^t \begin{bmatrix} 2 \\ 1 \\ 2 \\ 1 \\ 1 \end{bmatrix} \begin{bmatrix} 1 & 1 & -2 & 0 \\ 0 & -2 & 2 & 0 \\ -1 & 0 & 1 & 0 \\ 0 & 0 & -1 & 2 \\ 0 & 0 & 1 & -2 \end{bmatrix} = {}^t \begin{bmatrix} 0 \\ 0 \\ 0 \\ 0 \\ 0 \end{bmatrix}$$

$$\begin{bmatrix} 1 & 1 & -2 & 0 \\ 0 & -2 & 2 & 0 \\ -1 & 0 & 1 & 0 \\ 0 & 0 & -1 & 2 \\ 0 & 0 & 1 & -2 \end{bmatrix} \begin{bmatrix} 2 \\ 2 \\ 2 \\ 1 \end{bmatrix} = \begin{bmatrix} 0 \\ 0 \\ 0 \\ 0 \\ 0 \end{bmatrix}$$

Figure 2.6: This weighted net is conservative (the left vector  $(2, 1, 2, 1, 1)$  is a P-semiflow and its components are  $\geq 1$ ) and consistent (the right vector  ${}^t(2, 2, 2, 1)$  is a T-semiflow and its components are  $\geq 1$ ).

## 2.3 Additional definitions and notations

In this section, we present supplementary definitions and notations for weighted Petri nets. First we focus on some keywords in relation with the expressiveness of the model, such as choice-places and join-transitions. Then we define subsequences, as well as particular subnets and, by extension, particular subsystems defined by subsets of places or transitions. We provide notations regarding the weights and present the homogeneity property, a restriction on the output weights of choice-places. Finally, we define source places and a particular notion of graph connectedness.

### 2.3.1 Conflicts and choice-places, synchronizations and join-transitions

The expressiveness of Petri nets allows *conflicts*, characterizing a situation in which two transitions  $t_1$  and  $t_2$  share a common input place such that the firing of  $t_1$  disables  $t_2$ . The purely structural counterpart of a conflict is a *choice*, meaning that some transitions have a common input place. Formally, two transitions  $t$  and  $t'$  are in *choice relation*, if  $\bullet t \cap \bullet t' \neq \emptyset$ . A *choice-place* is a place with at least two output transitions, thus modeling a choice.

Petri nets allow the modeling of *synchronizations*, meaning that some places have a common output transition. A *join-transition* is a transition with at least two input places, which thus models a synchronization.

These definitions are illustrated in Figure 2.7.



Figure 2.7: On the left, transitions  $t_1$  and  $t_2$  are in conflict and  $p$  is a choice-place. On the right,  $t$  is a join-transition, modeling a synchronization of its input places  $p_1$  and  $p_2$ .

### 2.3.2 P-(T-)subnets, P-(T-)subsystems and subsequences

The sequence  $\sigma'$  is a *subsequence* of the sequence  $\sigma$  if  $\sigma'$  is obtained from  $\sigma$  by removing some transitions of  $\sigma$ . The *restriction of  $\sigma$  to the set  $T' \subseteq T$  of transitions* is the maximum subsequence of  $\sigma$  whose transitions belong to  $T'$ , noted  $\sigma|_{T'}$ . For example, the restriction of the sequence  $\sigma = t_1 t_2 t_3 t_2$  to the set  $\{t_1, t_2\}$  is the sequence  $t_1 t_2 t_2$ .

### 2.3. Additional definitions and notations

The net  $N' = (P', T', W')$  is a *P-subnet* of  $N = (P, T, W)$  if  $P'$  is a subset of  $P$ ,  $T' = \bullet P' \cup P' \bullet$  and  $W'$  is the restriction of  $W$  to  $P'$  and  $T'$ .

Similarly, the net  $N' = (P', T', W')$  is a *T-subnet* of  $N = (P, T, W)$  if  $T'$  is a subset of  $T$ ,  $P' = \bullet T' \cup T' \bullet$  and  $W'$  is the restriction of  $W$  to  $P'$  and  $T'$ .

The system  $S' = (N', M'_0)$ , with  $N' = (P', T', W')$ , is a *P-subsystem* of  $S = (N, M_0)$  if  $N'$  is a P-subnet of  $N$  and its initial marking  $M'_0$  is the restriction of  $M_0$  to  $P'$ , *i.e.*  $M'_0 = M_0|_{P'}$ . Figure 2.8 displays two P-subsystems of a system.

Similarly, the system  $S' = (N', M'_0)$ , with  $N' = (P', T', W')$ , is a *T-subsystem* of  $S = (N, M_0)$  if  $N'$  is a T-subnet of  $N$  and its initial marking  $M'_0$  is the restriction of  $M_0$  to  $P'$ , *i.e.*  $M'_0 = M_0|_{P'}$ . Figure 2.9 shows two T-subsystems of a system.

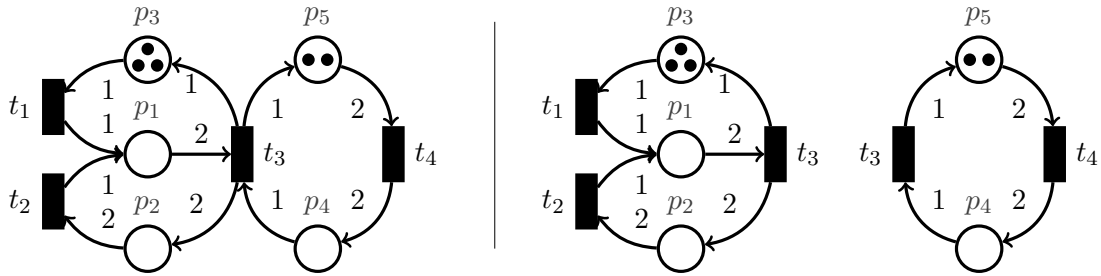

Figure 2.8: Two P-subsystems of the system on the left are pictured on the right. The leftmost P-subsystem is defined by the subset of places  $\{p_1, p_2, p_3\}$ . The rightmost P-subsystem is defined by the subset of places  $\{p_4, p_5\}$ .

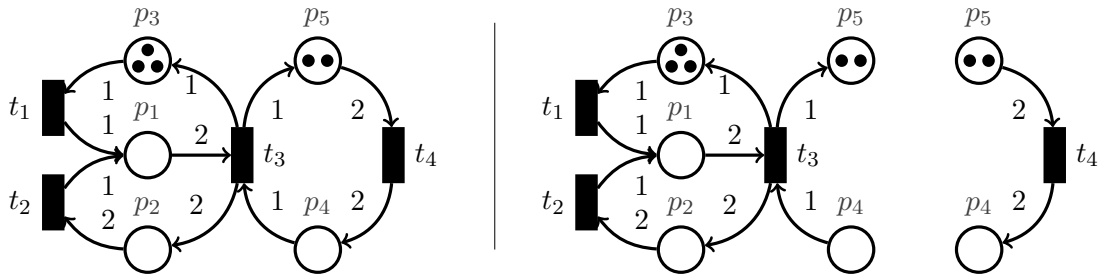

Figure 2.9: Two T-subsystems of the system on the left are shown on the right. The leftmost T-subsystem is defined by the subset of transitions  $\{t_1, t_2, t_3\}$ . The rightmost T-subsystem is defined by the subset of transitions  $\{t_4\}$ .



### 2.3.3 The notations $max_p$ and $gcd_p$

We denote by  $max_p^N$  the maximum output weight of  $p$  in the net  $N$  and by  $gcd_p^N$  the greatest common divisor of all input and output weights of  $p$  in the net  $N$ . The simpler notations  $max_p$  and  $gcd_p$  are used when no confusion is possible. In Figure 2.9 on the facing page,  $max_{p_1} = 2$  and  $gcd_{p_1} = 1$ .

### 2.3.4 Homogeneity

A place  $p$  is called *homogeneous* if all its output weights are equal, meaning  $\forall t, t' \in p^\bullet$ ,  $W(p, t) = W(p, t')$ . A net  $N$  is *homogeneous* if every place  $p$  of  $N$  is homogeneous. Figure 2.10 pictures a homogeneous net.

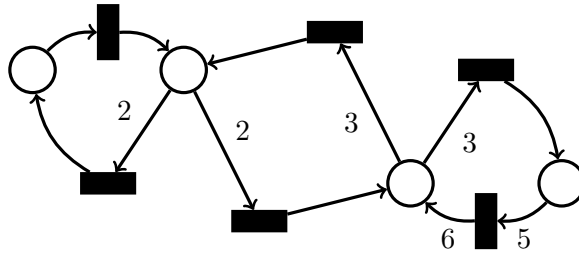

Figure 2.10: All the places of the net are homogeneous, hence the net is homogeneous.

### 2.3.5 Source places

A *source place* is defined as a place with at least one output transition and without input transition. Figure 2.11 pictures a source place.

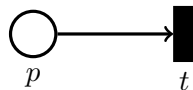

Figure 2.11: The place  $p$  is a source place.

### 2.3.6 Well-connectedness

A net is *well-connected* if it is connected and every place and transition has at least one input.

## 2.4 Particular subclasses

In this section, we present the main subclasses of weighted Petri nets studied in this thesis.

### 2.4.1 Asymmetric-Choice nets

A net  $N = (P, T, W)$  is *Asymmetric-Choice* if  $\forall p_1, p_2 \in P, p_1^\bullet \cap p_2^\bullet \neq \emptyset \Rightarrow p_1^\bullet \subseteq p_2^\bullet$  or  $p_2^\bullet \subseteq p_1^\bullet$ .

Figure 2.12 on the next page depicts three Asymmetric-Choice nets.

### 2.4.2 Free-Choice nets

A net  $N = (P, T, W)$  is *Free-Choice* if  $\forall t_1, t_2 \in T, \bullet t_1 \cap \bullet t_2 \neq \emptyset \Rightarrow \bullet t_1 = \bullet t_2$ . Equivalently, the net is Free-Choice if  $\forall p_1, p_2 \in P, p_1^\bullet \cap p_2^\bullet \neq \emptyset \Rightarrow p_1^\bullet = p_2^\bullet$ .

In general, Free-Choice nets are considered as ordinary nets. There exist other definitions of Free-Choice nets, as the *Extended Free-Choice* nets. We have presented here the most general of these definitions, the same as in [Desel 1995], encompassing Extended Free-Choice nets. In this thesis, we consider weighted Free-Choice nets, defined by the same structure and arbitrary weights. Other names for the class of weighted Free-Choice nets can be found, such as Topologically Extended Free-Choice [Teruel 1996].

Free-Choice nets constitute a proper subclass of Asymmetric-Choice nets.

Figure 2.12 pictures two weighted Free-Choice nets, on the left and right sides.

### 2.4.3 Equal-Conflict nets and sets

A net  $N = (P, T, W)$  is an *Equal-Conflict* (EC) net if for all transitions  $t$  and  $t'$  of  $N$ , the following implication is true:  $\bullet t \cap \bullet t' \neq \emptyset \Rightarrow \forall p \in P, W(p, t) = W(p, t')$ .

A consequence of this definition is that Equal-Conflict nets are homogeneous weighted Free-Choice nets.

Figure 2.12 contains an Equal-Conflict net.

**Definition 1** (Equivalence relation, equivalence classes). *A binary relation  $\sim$  on a set  $X$  is called an equivalence relation if and only if it is reflexive, symmetric and transitive. Equivalently,  $\forall a, b, c \in X, a \sim a$  (reflexivity), if  $a \sim b$  then  $b \sim a$  (symmetry), if  $a \sim b$  and  $b \sim c$ , then  $a \sim c$  (transitivity). The equivalence class of  $x$  under  $\sim$ , denoted by  $[x]$ , is defined as  $[x] = \{y \in X \mid x \sim y\}$ .*

The following definition presents an equivalence relation on the transitions of a net.

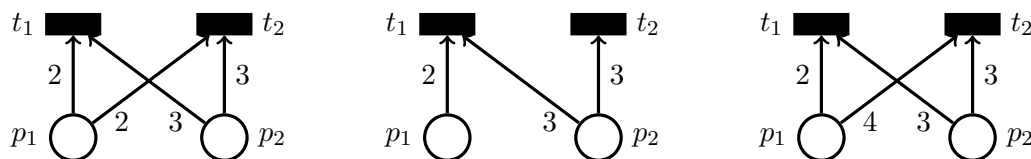

Figure 2.12: The net on the left is an Equal-Conflict net. In the middle,  $\bullet t_1 = \{p_1, p_2\} \neq \{p_2\} = \bullet t_2$ , hence the net is not Equal-Conflict, however it is a homogeneous Asymmetric-Choice net. On the right, the pre-sets of both transitions are equal, thus the net is weighted Free-Choice, however it is not Equal-Conflict since it is not homogeneous: the output weights of  $p_1$  are not all equal.

**Definition 2** (Equal conflict relation [Teruel 1996]). *Consider a net  $N = (P, T, W)$ . Two transitions  $t$  and  $t'$  of  $T$  are in equal conflict relation if  $Pre[P, t] = Pre[P, t'] \neq \emptyset^{|P|}$ . It is an equivalence relation on the set of transitions, and each equivalence class is an equal conflict set. The set of all equal conflict sets of a net  $N$  is noted  $\mathcal{E}(N)$ .*

We deduce that an equal conflict set is enabled by  $M$  if and only if at least one transition of this set is enabled by  $M$ .

#### 2.4.4 Choice-Free nets and T-nets

A net  $N = (P, T, W)$  is a (weighted) *Choice-Free net* if each place has at most one output transition, meaning that  $\forall p \in P, |p^\bullet| \leq 1$ .

Choice-Free nets form a proper subclass of Equal-Conflict nets.

A *T-net* is a Choice-Free net  $N = (P, T, W)$  such that each place has at most one input transition, meaning that  $\forall p \in P, |\bullet p| \leq 1$  and  $|p^\bullet| \leq 1$ .

Hence, T-nets form a proper subclass of Choice-Free nets. Figure 2.13 shows a Choice-Free net and a T-net.

#### 2.4.5 Join-Free nets and S-nets

A net  $N = (P, T, W)$  is a (weighted) *Join-Free net* if each transition has at most one input place, meaning that  $\forall t \in T, |\bullet t| \leq 1$ .

Thus, Join-Free nets form a proper subclass of (weighted) Free-Choice nets: they can be defined as Free-Choice nets in which synchronizations are not allowed. Homogeneous



Figure 2.13: On the left, a Choice-Free net that is not a T-net. The net on the right is a T-net.

Join-Free nets are particular Equal-Conflict nets.

An *S-net* is a Join-Free net  $N = (P, T, W)$  such that each transition has at most one output place, meaning that  $\forall t \in T, |t^\bullet| \leq 1$  and  $|\bullet t| \leq 1$ .

Hence, S-nets form a proper subclass of Join-Free nets.

Figure 2.14 pictures an S-net and a Join-Free net.



Figure 2.14: On the left, a Join-Free net that is not an S-net. The net on the right is an S-net.

### 2.4.6 Fork-Attribution nets

A *Fork-Attribution* net (or FA net) is both a Join-Free and a Choice-Free net.

Hence, in these systems, synchronizations and choices are not allowed.

Since a transition of a T-net may have several input places, T-nets are not included in FA nets. Similarly, since a place of an S-net may have several output transitions, S-nets are not included in FA nets. Conversely, FA nets allow transitions having several outputs, also known as *splits* or *forks*, and are thus not included in S-nets. FA nets allow places having several inputs, also known as *attributions*, a construction that is not possible in T-nets.

Figure 2.15 pictures a Fork-Attribution net.

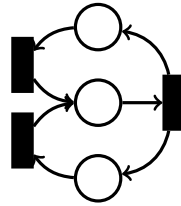

Figure 2.15: A Fork-Attribution net, in which a place may have several inputs and a transition may have several outputs.

### 2.4.7 Inclusion relation of the main subclasses

Figure 2.16 represents the inclusion relations between the special classes of weighted Petri nets considered in this thesis.

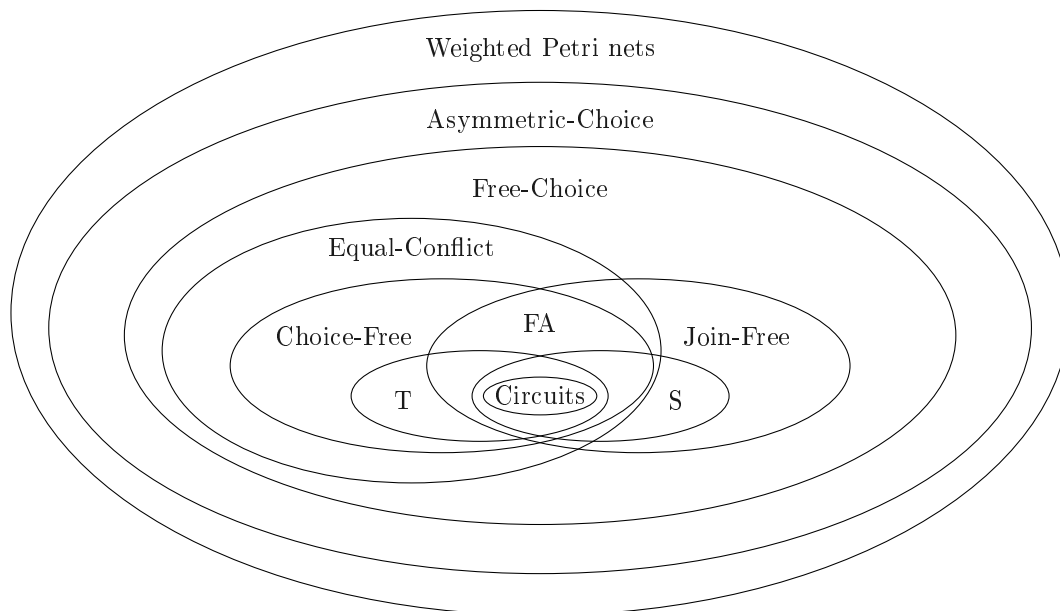

Figure 2.16: Some classes and subclasses of weighted systems.

## 2.5 Duality

The *dual* of a net is defined by reversing the arcs and transforming places into transitions and transitions into places. This transformation amounts to transposing the incidence matrix.

The Choice-Free and Join-Free classes are dual. The S and T classes are also dual; while in a T-system a place cannot have more than one input and one output, the same is true for a transition in an S-system. The duals of the nets in Figure 2.14 are pictured in Figure 2.13 on page 26.

## 2.6 Expressiveness and applications

Equal-Conflict and Join-Free systems are appealing not only from a theoretical point of view but also because they can model a variety of useful applications.

### 2.6.1 Join-Free systems

Such systems model choices since their places may have several outputs, thus inducing a form of non-determinism. They are closely related to Basic Parallel Processes (BPPs, context-free multiset rewrite systems, commutative context-free processes) [Mayr 2000]. Results on Join-Free systems with a weight restriction, named communication-free, have served to gain insight into commutative context-free grammars and BPPs [Esparza 1997].

#### 2.6.1.1 S-systems

They are a simple subclass of weighted Petri nets, in which programs read or write in a single memory, while memories can be shared between programs. They allow to model asynchronous parallel algorithms on several processors. Asynchronous methods cut down the number of synchronization points between processors, eliminating idle time at the expense of extra computations, yet they may perform better than their synchronous counterparts. Computational models as well as an associated convergence theory have been developed [Frommer 2000]. A powerful and simple model reads data from a shared memory, computes a function and overwrites data in the common memory with the corresponding updated values. This computational model applies to a wide range of problems, including solving nonsingular linear systems, and is represented by a Petri net in Figure 2.17.

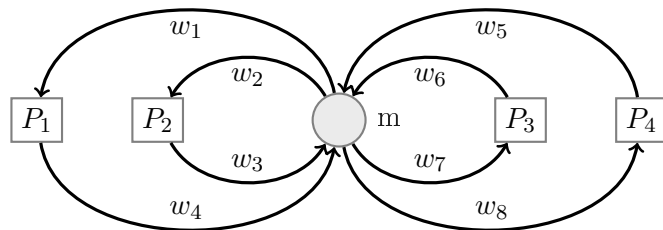

Figure 2.17: The S-net models one shared memory as the place  $m$ , in which four asynchronous parallel processors read and write to compute an asynchronous iteration. Weights denote amounts of read or written data.

### 2.6.2 Equal-Conflict systems and subclasses

Flow applications are usually modeled with weighted T-systems (or with SDFs) [Lee 1987b]. The weighted Choice-Free model adds the possibility to write asynchronously in a memory, thus is strictly more powerful than the T-system model. The weighted Equal-Conflict model adds restricted choices to the Choice-Free model.

## 2.7 Polynomial time characterizations of well-formedness

In this section, we recall polynomial time characterizations of well-formedness for the subclasses of weighted Petri nets studied in this thesis. We first present a characterization of well-formedness dedicated to Choice-Free and Join-Free nets. Then, we give another condition for Equal-Conflict nets, which generalize Choice-Free nets and homogeneous Join-Free nets.

### 2.7.1 Choice-Free and Join-Free nets

The next theorem expresses a necessary and sufficient condition of well-formedness for Choice-Free and Join-Free nets. Moreover, this property can be checked in polynomial time.

**Proposition 1** (Well-formedness [Recalde 1996, Teruel 1997]). *Suppose that  $N$  is a weighted strongly connected Choice-Free or Join-Free net. The properties*

1.  $N$  is consistent and conservative
2.  $N$  is well-formed

*are equivalent. Moreover, consistency implies conservativeness in strongly connected Choice-Free nets and conservativeness implies consistency in strongly connected Join-Free nets.*

Figure 2.6 on page 20 shows a well-formed Choice-Free net.

### 2.7.2 Equal-Conflict nets

A polynomial time characterization of well-formedness for Equal-Conflict nets is recalled next.

**Proposition 2** (Well-formedness ([Teruel 1996])). *Let  $N$  be a strongly connected Equal-Conflict net. The following propositions are equivalent.*

- $N$  is well-formed;
- $N$  is consistent and conservative, and the rank of its incidence matrix is equal to  $|\mathcal{E}(N)| - 1$ .

Figure 2.18 pictures a well-formed Equal-Conflict net illustrating this proposition.

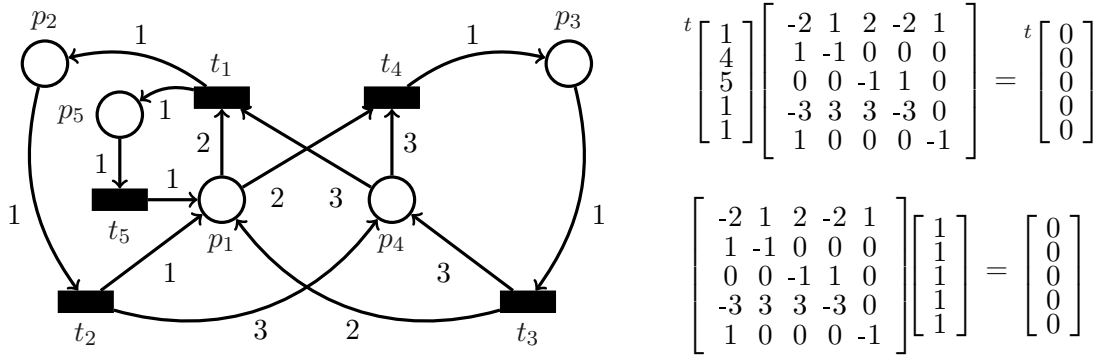

Figure 2.18: This Equal-Conflict net  $N$  is consistent (bottom equality) and conservative (top equality). The equal conflict sets are  $\{t_1, t_4\}$ ,  $\{t_2\}$ ,  $\{t_3\}$  and  $\{t_5\}$ , thus  $|\mathcal{E}(N)| = 4$ . Moreover, the rank of its incidence matrix equals  $3 = |\mathcal{E}(N)| - 1$ . Thus,  $N$  is well-formed.

The following proposition recalls that well-formedness is a necessary condition of well-behavedness for Equal-Conflict systems.

**Proposition 3** ([Teruel 1993]). *A well-behaved Equal-Conflict system is well-formed.*

## 2.8 Structure of well-formed EC and Join-Free nets

In this section, we recall properties regarding the structure of well-formed Equal-Conflict nets and their Choice-Free subclass, as well as well-formed Join-Free nets.

The next proposition states the existence of a unique minimal T-semiflow in well-formed Choice-Free nets and is illustrated in Figure 2.19.



**Proposition 4** (Unique minimal T-semiflow [Teruel 1997]). *If  $N = (P, T, W)$  is a well-formed strongly connected Choice-Free net, then  $N$  has a unique minimal T-semiflow  $Y$ . Moreover, the support of  $Y$  is the set  $T$ .*

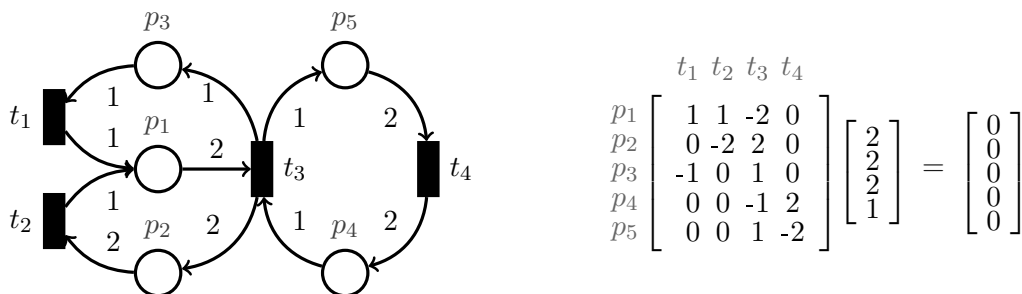

Figure 2.19: This weighted Choice-Free net is strongly connected and consistent, thus well-formed (Proposition 1 on page 29). The minimal T-semiflow is  ${}^t(2, 2, 2, 1)$ .

We present next the union of subnets of a net and the covering of a nets by subnets.

**Definition 3** (Union of subnets and covering). *Consider two nets  $N_1$  and  $N_2$  that are subnets of a net  $N$ . The union of  $N_1 = (P_1, T_1, W_1)$  with  $N_2 = (P_2, T_2, W_2)$  is the net  $N' = (P', T', W')$  such that  $P' = P_1 \cup P_2$ ,  $T' = T_1 \cup T_2$ , and the new weight function  $W'$  inherits the weights of the arcs defined by  $W_1$  or  $W_2$ . Generalizing inductively to a set  $C$  of subnets, the union of  $C = \{C_1, \dots, C_k\}$  is the union of  $C_1$  with the result of the union of  $C \setminus \{C_1\}$ . A net  $N$  is covered by a set  $C$  of subnets if  $N$  is the union of  $C$ .*

A decomposition theory has been developed for Equal-Conflict systems [Teruel 1996] and specialized for Choice-Free systems [Teruel 1997], allowing to gain insight into their structure and behavior by studying particular subsystems. The next result shows the relevance of FA P-subnets to the study of well-formedness in Choice-Free nets.

**Proposition 5** (Structure and FA P-subnets [Teruel 1997]). *Consider a strongly connected well-formed Choice-Free net  $N$  with unique minimal T-semiflow  $Y$ . If  $N_* = (P_*, T_*, W_*)$  is a strongly connected FA P-subnet of  $N$  then  $N_*$  is well-formed, with a unique minimal T-semiflow  $Y_*$ , and  $Y|_{T_*}$  is a multiple of  $Y_*$ . Moreover,  $N$  is covered by such FA P-subnets.*

This proposition is illustrated on Figure 2.20.

For weighted Petri nets, we define next some particular subnets named components.

**Definition 4** (Components [Teruel 1996]). *A (weighted) P-component  $N'$  of a net  $N$  is a strongly connected and conservative Join-Free P-subnet of  $N$ . A (weighted) T-component  $N'$  of a net  $N$  is a strongly connected and consistent Choice-Free T-subnet of  $N$ .*

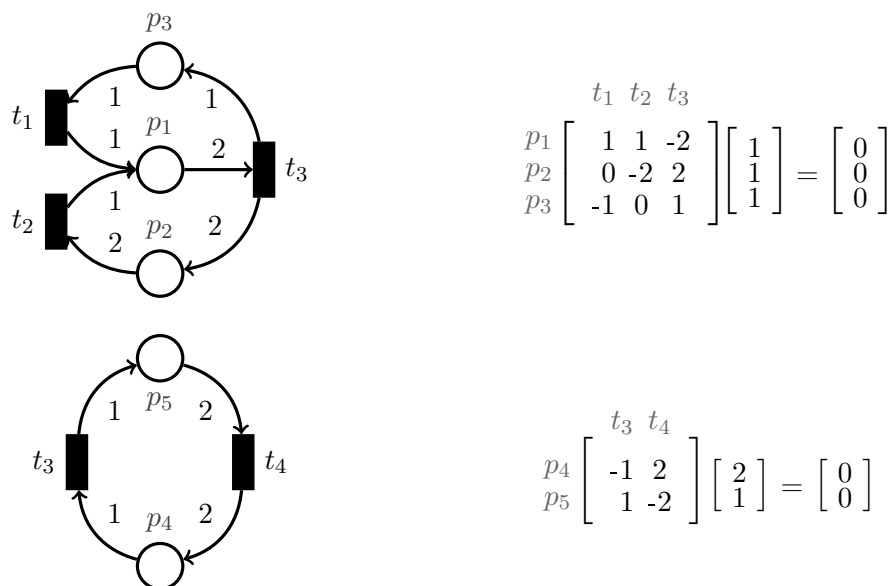

Figure 2.20: Two well-formed strongly connected FA P-subnets of the well-formed Choice-Free net of Figure 2.19 whose minimal T-semiflow is  $Y = {}^t(2, 2, 2, 1)$ . Their minimal T-semiflow is pictured on the right of their incidence matrix. The restriction of  $Y$  to the set  $\{t_1, t_2, t_3\}$  is  $Y_1 = {}^t(2, 2, 2)$ , which is a multiple of  $(1, 1, 1)$ , the minimal T-semiflow of the first P-subnet. The restriction of  $Y$  to the set  $\{t_3, t_4\}$  is  $Y_2 = {}^t(2, 1)$ , which is equal to the minimal T-semiflow of the second P-subnet.

It follows from this definition that each P-component of an Equal-Conflict net is a homogeneous Join-Free net.

The next proposition states that well-formed Equal-Conflict nets are covered by P-components and T-components, and indicates their relationship with minimal semiflows.

**Proposition 6** (Coverings of Equal-Conflict nets [Teruel 1993]). *Consider a well-formed Equal-Conflict net  $N$ .  $N$  is covered both by a set of T-components, each of them inducing the support of the associated unique minimal T-semiflow, and by a set of P-components, each of them inducing the support of the associated unique minimal P-semiflow.*

We deduce from the previous proposition that every well-formed Choice-Free net  $N$  is covered by P-components which are FA nets.

A similar kind of result is deduced from [Teruel 1997], where structural properties of well-formed Join-Free nets are deduced from the properties of well-formed Choice-Free nets by duality. The covering of well-formed Join-Free nets by components is stated next.

**Proposition 7** (Coverings of Join-Free nets [Teruel 1997]). *Consider a well-formed strongly connected Join-Free net  $N$ .  $N$  is covered by a set of FA  $T$ -components, each of them inducing the support of the associated unique minimal  $T$ -semiflow. Moreover, the unique  $P$ -component of the net  $N$  is  $N$  itself, inducing the support of the unique minimal  $P$ -semiflow of  $N$ .*

## 2.9 Conclusion

In this chapter, we presented the model used throughout this thesis, the weighted Petri nets. We recalled the main structural and behavioral properties, as well as definitions and notations regarding these nets. We defined the main subclasses investigated in this thesis and showed their inclusion relationships. We noted that the structural notion of duality applies for example to Choice-Free and Join-Free nets. We gave insight into the expressiveness of the subclasses and some possible applications. Finally, we recalled the existence of polynomial time characterizations of well-formedness for Equal-Conflict, Join-Free and Choice-Free nets. We also highlighted results regarding the semiflows and components of Equal-Conflict nets and Join-Free nets.





# Chapter 3

## Polynomial time transformations of weighted Petri nets

### Contents

---

<b>3.1</b>	<b>Scaling of systems</b>	<b>37</b>
3.1.1	Definition	38
3.1.2	Properties	38
<b>3.2</b>	<b>Balancing and token-conservation</b>	<b>41</b>
3.2.1	Definition	41
3.2.2	Properties	42
3.2.3	Polynomial complexity	43
<b>3.3</b>	<b>Normalization and its relation to balancing</b>	<b>43</b>
<b>3.4</b>	<b>Useful tokens</b>	<b>46</b>
<b>3.5</b>	<b>Transformation into weighted Free-Choice systems</b>	<b>47</b>
<b>3.6</b>	<b>The place-splitting transformation</b>	<b>50</b>
3.6.1	Definition	50
3.6.2	Properties	52
<b>3.7</b>	<b>Conclusion</b>	<b>54</b>

---

## Chapter 3. Polynomial time transformations of weighted Petri nets

---

Many behavioral properties of Petri nets are intractable [Cheng 1993, Esparza 1994]. In this thesis, we focus on the liveness and reversibility problems, which are known to be decidable [Hack 1976, Araki 1977, Mayr 1984]. The liveness problem is EXPSPACE-hard [Hack 1974, Lipton 1976], while the complexity of the reversibility problem is not known.

In order to simplify the study of the behavior, the system may be efficiently transformed while preserving the behavior or other strong properties. The analysis of behavioral properties is then achieved on the transformed system. Many transformations exist [Berthelot 1986, Berthelot 1987, Murata 1989, Colom 2003]. They are generally defined as rules that apply to special local graph patterns and often reduce the size of the net, leading to efficient sufficient conditions. However, in many situations, these rules do not reduce the analysis complexity.

In this chapter, we present several new polynomial time transformations for weighted Petri nets. One of them applies to a particular subclass of weighted Petri nets, the well-formed Choice-Free systems, leading to a well-formed T-system while preserving strong structural properties. The other transformations apply to either all Petri nets or conservative ones and preserve the feasible firing sequences and the well-formedness, generalizing methods that were developed in the context of weighted T-systems in [Marchetti 2009]. These transformations will prove useful in the sequel as they will greatly simplify the study of behavioral properties.

This chapter is organized as follows. First, in Section 3.1, we define the *scaling* of a Petri net by a vector. We show that this polynomial time transformation preserves the language of the system and consequently the liveness and reversibility properties. Moreover, the well-formedness is also preserved. Then, we introduce in Section 3.2 a particular scaling, called a *balancing* transformation, that can be applied to a system when it is conservative to obtain what we call a *token-conservative* system, whose total number of tokens is invariant. This method applies in particular to all well-formed weighted Petri nets, since they are conservative [Sifakis 1978, Memmi 1980]. In Section 3.3, we recall the *normalization* of T-systems and compare it to balancing. We present in Section 3.4 the *useful tokens* property, which allows to reduce the initial number of tokens of any Petri net while preserving the language. In Section 3.5, using the previous transformations, we obtain a polynomial transformation of any Petri net into a weighted Free-Choice system which preserves language and well-formedness. Finally, Section 3.6 provides a polynomial time transformation of a well-formed Choice-Free system into a well-formed T-system that preserves the set of T-semiflows and induces a language inclusion. Section 3.7 concludes.

### 3.1 Scaling of systems

In this section, we present the *scaling* transformation, which may be applied in polynomial time to any weighted Petri net. This transformation modifies only the weights and the

initial marking. We then show that the language is preserved by the transformation and study the repercussions on the liveness and reversibility properties, as well as on T-semiflows and reachable markings. We also show that well-formedness is preserved.

### 3.1.1 Definition

We define the *scaling*, which multiplies weights and initial markings by positive (meaning  $> 0$ ) rational numbers.

**Definition 5.** *The multiplication of all input and output weights of a place  $p$  together with its marking by a positive rational  $\alpha_p$  is a scaling of the place  $p$  if the resulting input and output weights and marking are integers. If each place  $p$  of a system is scaled by a positive rational  $\alpha_p$ , the system is said to be scaled by the vector  $\alpha$  whose components are the scaling factors  $\alpha_p$ .*

Figure 3.1 shows the scaling of a marked place by 2.



Figure 3.1: The marked place on the left is scaled by 2, yielding the place on the right.

### 3.1.2 Properties

We study below several properties of the transformation.

**Theorem 1** (Language preservation). *Let  $S = ((P, T, W), M_0)$  be a system and  $\alpha$  a vector of  $|P|$  positive rational components. Scaling  $S$  by  $\alpha$  preserves the feasible sequences of firings.*

*Proof.* Let  $S' = ((P, T, W'), M'_0)$  be the system obtained when scaling the system  $S = ((P, T, W), M_0)$  by  $\alpha$ . Let  $\sigma = \sigma_1 t$  be a finite sequence of firings. We prove by induction on the size of  $\sigma$  that  $\sigma$  is equivalently feasible in  $S$  and  $S'$ .

The property is true if  $\sigma$  is empty. Now suppose that  $\sigma_1$  is feasible in both  $S$  and  $S'$ . The firing sequence  $\sigma$  is feasible in  $S$  if and only if

$$\forall p \in \bullet t, M_0(p) + \sum_{t_i \in \bullet p} W(t_i, p) \cdot \vec{\sigma}_1(t_i) - \sum_{t_i \in p \bullet} W(p, t_i) \cdot \vec{\sigma}_1(t_i) \geq W(p, t)$$



### Chapter 3. Polynomial time transformations of weighted Petri nets

---

which gives after scaling

$$\forall p \in \bullet t, \alpha_p \cdot M_0(p) + \sum_{t_i \in \bullet p} \alpha_p \cdot W(t_i, p) \cdot \vec{\sigma}_1(t_i) - \sum_{t_i \in p \bullet} \alpha_p \cdot W(p, t_i) \cdot \vec{\sigma}_1(t_i) \geq \alpha_p \cdot W(p, t)$$

and is equivalent to

$$\forall p \in \bullet t, M'_0(p) + \sum_{t_i \in \bullet p} W'(t_i, p) \cdot \vec{\sigma}_1(t_i) - \sum_{t_i \in p \bullet} W'(p, t_i) \cdot \vec{\sigma}_1(t_i) \geq W'(p, t).$$

Thus,  $t$  is equivalently enabled in  $S'$ .  $\square$

As shown in the previous theorem, the operation of scaling does not change the language of the system. We deduce easily that the liveness property is preserved as stated by the following corollary.

**Corollary 1** (Liveness preservation). *A system is live if and only if its scalings are live.*

The next result shows that the transformation preserves some strong algebraic properties of the incidence matrix of the system.

**Theorem 2** (T-semiflows preservation). *Scaling preserves the set of T-semiflows.*

*Proof.* Consider a system with incidence matrix  $C$  and a scaling vector  $\alpha$ . When the system is scaled by  $\alpha$ , the incidence matrix  $C'$  is obtained which satisfies  $C'[p] = \alpha_p \cdot C[p]$  for every place  $p$ . These multiplications of rows by *non-zero* coefficients  $\alpha_p$  preserve the kernel (or null space) of the matrix.  $\square$

The following result shows that the system obtained by firing a feasible sequence  $\sigma$  and then scaling it by a vector  $\alpha$ , is the same as the system obtained by first scaling the initial system by  $\alpha$  and then firing  $\sigma$ . Thus, firing and scaling commute (see Figure 3.2).

**Theorem 3** (Commutativity). *Consider a system  $S$  with initial marking  $M_0$  and a feasible sequence  $\sigma$ . Call  $M$  the reachable marking such that  $M_0 \xrightarrow{\sigma} M$ . Let  $\alpha$  be a scaling vector for  $S$  and  $S'$  be the associated scaled system with initial marking  $M'_0 = \alpha \circ M_0$ , where  $\circ$  is the component-wise product (Hadamard product). The reachable marking  $M'$  in  $S'$  such that  $M'_0 \xrightarrow{\sigma} M'$  satisfies  $M' = \alpha \circ M$ .*

*Proof.* The vector  $\alpha$  scales  $S = ((P, T, W), M_0)$  to  $S' = ((P, T, W'), M'_0)$  while preserving the sequences of firings (Theorem 1). Let  $\sigma$  be a sequence feasible in both  $S$  and  $S'$ , then for every place  $p$  and rational scaling coefficient  $\alpha_p > 0$ ,

$$\begin{aligned} M'(p) &= M'_0(p) + \sum_{t_i \in \bullet p} W'(t_i, p) \cdot \vec{\sigma}(t_i) - \sum_{t_i \in p \bullet} W'(p, t_i) \cdot \vec{\sigma}(t_i) \\ &= \alpha_p \cdot \left( M_0(p) + \sum_{t_i \in \bullet p} W(t_i, p) \cdot \vec{\sigma}(t_i) - \sum_{t_i \in p \bullet} W(p, t_i) \cdot \vec{\sigma}(t_i) \right). \end{aligned}$$

$$\begin{array}{ccc}
 M_0 & \xrightarrow{\sigma} & M \\
 \downarrow \alpha & & \downarrow \alpha \\
 M'_0 & \xrightarrow{\sigma} & M'
 \end{array}$$

Figure 3.2: Scaling and firing commute:  $M'_0 = \alpha \circ M_0$  and  $M' = \alpha \circ M$ .

Since

$$M(p) = M_0(p) + \sum_{t_i \in \bullet p} W(t_i, p) \cdot \bar{\sigma}(t_i) - \sum_{t_i \in p \bullet} W(p, t_i) \cdot \bar{\sigma}(t_i),$$

it follows that  $M'(p) = \alpha_p \cdot M(p)$ .  $\square$

We deduce from the previous theorem the preservation of the reversibility.

**Corollary 2** (Reversibility preservation). *A system is reversible if and only if its scalings are reversible.*

*Proof.* Consider a system  $S = (N, M_0)$  and the system  $S' = (N, M'_0)$  obtained when scaling  $S$  by a vector  $v$ . By Theorem 1 on page 38, any sequence  $\sigma$  that is feasible in  $S$  is feasible in  $S'$ . We note  $M_0 \xrightarrow{\sigma} M$  in  $S$  and  $M'_0 \xrightarrow{\sigma} M'$  in  $S'$ . Hence, suppose that  $S$  is reversible: there exists a sequence  $\sigma'$  that is feasible in  $(N, M)$  such that  $M \xrightarrow{\sigma'} M_0$ . The sequence  $\sigma'$  is then feasible in  $(N', M')$ , with  $M' \xrightarrow{\sigma'} M''$ . We note  $\sigma_r = \sigma \sigma'$ . By Theorem 3,  $M''$  is equal to the result of scaling  $M_0$  by  $v$ , which is  $M'_0$ , implying the reversibility of  $S'$ .  $\square$

**Corollary 3** (Boundedness preservation). *A system is bounded if and only if its scalings are bounded.*

*Proof.* Consider a system  $S = (N, M_0)$  that is bounded and  $S' = (N', M'_0)$  the scaling of  $S$  by a vector  $v$  such that  $S'$  is not bounded. Thus, there exists a place  $p$  which is not bounded in  $S'$ . Denote by  $k$  the maximum marking of  $p$  over all reachable markings in  $S$ . There exists a marking  $M'$  reachable in  $S'$  such that  $M'(p) > v(p) \cdot k \cdot 2$ , thus a marking  $M$  is reachable in  $S$  such that  $M' = v \circ M$  (Theorem 3) thus  $M'(p) = v(p) \cdot M(p)$ , implying that  $M(p) > k \cdot 2$ , a contradiction with the upper bound  $k$  of  $p$ .  $\square$

We deduce next the preservation of structural liveness and boundedness, which may be used for example when scaling a system having an empty marking, thus scaling the underlying net.

**Corollary 4** (Structural liveness and boundedness preservation). *A system is structurally live if and only if its scalings are structurally live. A system is structurally bounded if and only if its scalings are structurally bounded. As a consequence, a system is well-formed if and only if its scalings are well-formed.*

*Proof.* By Corollary 1 on page 39, the liveness property is preserved by the scaling operation, thus if a live marking  $M_0$  exists for a net  $N$ , every scaling of  $(N, M_0)$  leads to a live system  $(N', M'_0)$ , which is therefore structurally live.

Suppose there exists a structurally bounded system  $S = (N, M_0)$ ,  $M_0$  being the empty marking, and  $S' = (N', M'_0)$  is a not structurally bounded scaling of  $S$ . Denote the scaling vector transforming  $S$  into  $S'$  by  $v$  and the inverse vector transforming  $S'$  into  $S$  by  $v^{-1}$ . There exists a marking  $M'_1$  such that  $S'_1 = (N', M'_1)$  is not bounded. Hence, for every marking larger than  $M'_1$ , the system obtained is not bounded; in particular, a marking  $M''_1$  exists such that  $S''_1 = (N', M''_1)$  is not bounded and can be scaled by  $v^{-1}$  (multiply  $M''_1$  by the least common multiple of the denominators of  $v^{-1}$ ), leading to the system  $S_1 = (N, M_1)$ . Since  $N$  is structurally bounded,  $S_1$  is bounded, a contradiction with Corollary 3 on the preceding page. The preservation of the well-formedness follows by definition.  $\square$

We presented a general polynomial time transformation, namely the *scaling*, that preserves several structural and behavioral properties of weighted Petri nets. In the next section, we present a particular scaling, the *balancing* operation.

### 3.2 Balancing and token-conservation

When the total number of tokens in a system is preserved when its transitions are fired, the study of its behavioral properties is greatly simplified. This property, which is a special case of conservativeness, has been introduced under the name *1-conservativeness* in [Jones 1977]. It is also sometimes called strict conservativeness, and, in this thesis, we shall call it *token-conservativeness* or, even better, *token-conservation*, since its meaning is then readily understood. In the following, balancing is defined as a scaling that yields token-conservative systems. We highlight the correspondence between conservative systems and balanceable systems by means of simple linear algebra arguments.

#### 3.2.1 Definition

We define below token-conservative transitions and nets, as well as the balancing transformation.

**Definition 6.** *A transition  $t$  is token-conservative if*

$$\sum_{p \in \bullet t} W(p, t) = \sum_{p \in t \bullet} W(t, p).$$

*If all the transitions of a net are token-conservative, the net is said to be token-conservative.*

This definition is illustrated on Figure 3.3.

Now we define *balancing*, which transforms a system into a token-conservative system. This definition is illustrated in Figure 3.4.



Figure 3.3: On the left, a token-conservative transition  $t$ . On the right, a non token-conservative transition  $t$ .

**Definition 7.** Balancing a system  $S$  consists in scaling  $S$  by a vector of positive rational numbers such that the resulting system is token-conservative.

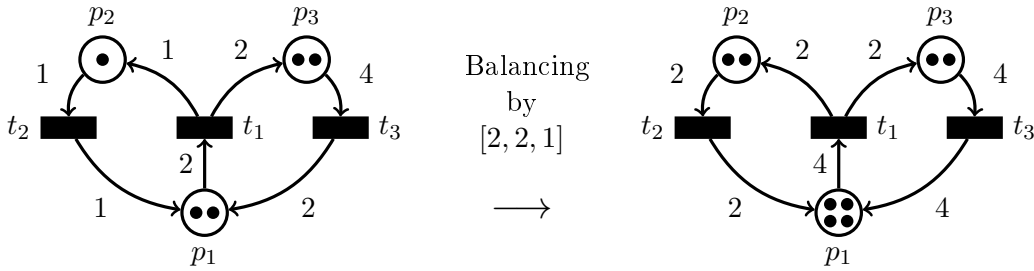

Figure 3.4: The system on the left is not token-conservative, since the transition  $t_3$  is not token-conservative. The token-conservative system on the right is obtained by an appropriate system scaling.

### 3.2.2 Properties

The balancing transformation can help gain insight into conservative systems as shown by the next theorem.

**Theorem 4.** A system is conservative if and only if it can be balanced.

*Proof.* Consider a conservative system with incidence matrix  $C$ , then by definition there exists a vector  $X \geq \mathbb{1}^{|P|}$  of natural numbers such that  ${}^tX \cdot C = 0$ . Multiplying every component  $C[p, t]$  by  $X_p$  yields an incidence matrix  $C'$ , whose elements are integers, satisfying for every transition  $t$ ,  ${}^t\mathbb{1}^{|P|} \cdot C'[t] = 0$ . The new initial marking contains only natural numbers and the new system is balanced.

Conversely, if a system can be balanced, there exists a vector  $X$  of positive rational numbers that annuls every column of its incidence matrix. The multiplication of  $X$  by the least common multiple of the denominators of its components gives a conservative vector, hence the system is conservative.  $\square$

The balancing operation is a particular scaling, thus inherits its properties, including liveness and reversibility preservation.

**Corollary 5.** *A conservative system is live if and only if its balancings are live.*

**Corollary 6.** *A conservative system is reversible if and only if its balancings are reversible.*

### 3.2.3 Polynomial complexity

The balancing transformation applies to all conservative weighted Petri nets. Since conservativeness is a known necessary condition for well-formedness [Sifakis 1978, Memmi 1980], balancing applies to all well-formed weighted Petri nets, which constitute a wide range of models for real applications, including embedded systems.

Finding an adequate (conservative) balancing vector for a conservative net with incidence matrix  $C$  consists in finding a solution to  ${}^tX \cdot C = 0, X \geq \mathbb{1}^{|P|}$ , or  ${}^tC \cdot X = 0, X \geq \mathbb{1}^{|P|}$  where the entries of  $C$  are integers and those of  $X$  are natural numbers. A Petri net modeling an application is very likely to be conservative. In a conservative system, a positive rational solution  $X$  can be found with a linear program in weakly polynomial time [Megiddo 1987]. Multiplying the components of  $X$  by the product of their denominators leads to a solution whose components are positive natural numbers with a polynomial increase of the number of bits. However, the values obtained and thus the number of tokens can grow exponentially, inducing an exponential increase of the buffer sizes. Consequently, the transformed system should not be used by itself for the design of an application, but only to deduce properties of the original system.

## 3.3 Normalization and its relation to balancing

Normalization was introduced in the context of weighted T-systems to obtain a polynomial time sufficient condition of liveness in [Marchetti 2009]. By applying this transformation, the number of tokens remains constant in every circuit of the T-system, simplifying the study of its behavior. Normalization can be performed in polynomial time with the Bellman-Ford algorithm [Marchetti 2009]. Here this transformation is explicated in a different way, starting from the notion of consistency of a well-formed T-system. It is then compared to balancing in S-systems. We finally present the properties of liveness and reversibility preservation through normalization.

The following definition is illustrated in Figure 3.5.

**Definition 8.** *A transition  $t$  is normalized if all the input and output weights of  $t$  are equal. A net, or a system, is normalized if all its transitions are normalized. Normalization transforms a system into a normalized one by means of an appropriate system scaling.*

The next theorem shows that normalization can be performed on consistent T-systems.

**Theorem 5** ([Marchetti 2009]). *If a weighted T-system is consistent, then it can be normalized.*

### 3.3. Normalization and its relation to balancing



Figure 3.5: The transition  $t$  on the left is normalized. On the right,  $t$  is not normalized.

*Proof.* Suppose that  $S = (N, M_0)$  is a weighted consistent T-system with incidence matrix  $C$ . There exists by definition a vector  $Y \geq \mathbb{1}^{|T|}$  of integers such that  $C \cdot Y = 0$ .

Since  $S$  is consistent, its places either have one input and one output transition or are isolated. Only non isolated places need be considered for normalization.

Denote by  $K$  the least common multiple of the values  $Y[t]$ ,  $t \in T$ . We observe that, since any place  $p$  has exactly one input transition  $t'$  and one output transition  $t$ ,

$$W(t', p) \cdot Y[t'] = W(p, t) \cdot Y[t]$$

and we set

$$\alpha_p = \frac{K}{W(t', p) \cdot Y[t']} = \frac{K}{W(p, t) \cdot Y[t]}.$$

Now we prove that the weighted T-system  $S' = (N', M'_0)$  obtained by scaling  $S$  with  $(\alpha_1, \dots, \alpha_{|P|})$  is normalized.

Consider a transition  $t$ , then for every place  $p \in \bullet t$

$$W'(p, t) = \alpha_p \cdot W(p, t) = \frac{K}{Y[t]}.$$

Similarly, for any place  $p \in t^\bullet$ ,

$$W'(t, p) = \alpha_p \cdot W(t, p) = \frac{W(t, p) \cdot K}{W(t, p) \cdot Y[t]} = \frac{K}{Y[t]}.$$

Thus every transition  $t$  is normalized and  $S'$  is normalized.  $\square$

Well-formed strongly connected T-systems are consistent and conservative (Proposition 1 on page 29), thus they can be either normalized or balanced. When a system is normalized, the number of tokens is invariant in every circuit while, when it is balanced, its total number of tokens is kept constant. Figure 3.6 shows the difference between a normalized T-system and a balanced T-system.

S-systems constitute a subclass of Join-Free systems. As shown next, the normalization that was developed for T-systems coincides for S-systems with balancing.

**Theorem 6.** *A strongly connected S-system is balanced if and only if it is normalized.*

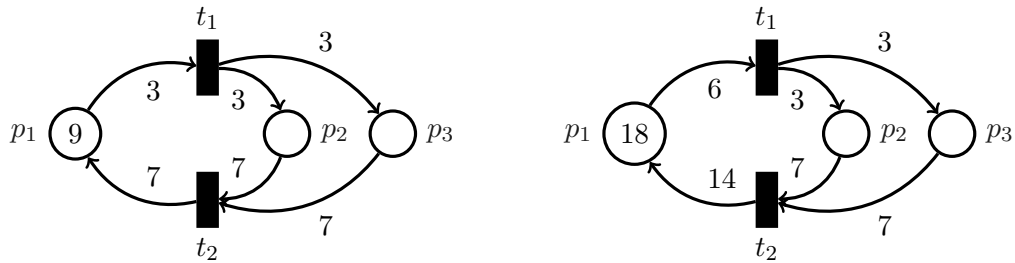

Figure 3.6: Consistent T-systems can be normalized. Since they are also conservative they can be balanced as well. The T-system on the left is normalized but not balanced and all circuits preserve their number of tokens when firing, take e.g. the circuit  $p_1 t_1 p_2 t_2$ . The equivalent T-system on the right is obtained by multiplying  $p_1$  by 2: it is balanced but not normalized and the total number of tokens remains constant after any sequence of firings.

*Proof.* As each of its transitions has just one input and one output place, the system is balanced if and only if each transition's unique input weight equals its unique output weight, characterizing a normalized system.  $\square$

However, the outcomes of balancing and normalization differ in other weighted classes, even if the considered systems are well-formed, consistent and conservative. Figure 3.7 depicts a normalized and balanced S-system on the left, and, on the right, a Fork-Attribution system, that is balanced but neither normalized nor even normalizable.

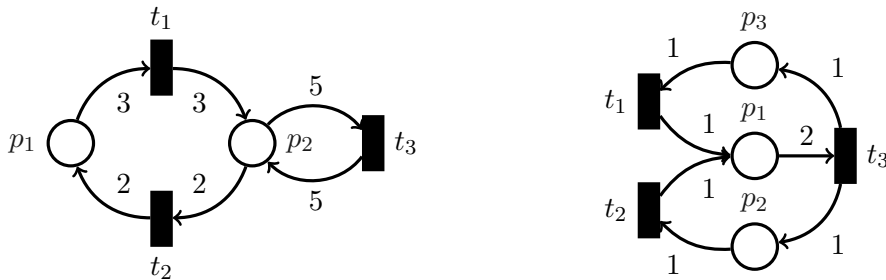

Figure 3.7: Ability to normalize or balance a system depends on its structure. Conservative systems can be balanced, hence all well-formed systems can be balanced. A well-formed balanced FA system may not be normalized nor normalizable.

As normalization is a particular scaling, corollary 1 on page 39 and corollary 2 on page 40 induce the following ones for the preservation of liveness and reversibility.

**Corollary 7.** *A system is live if and only if its normalizations are live.*

**Corollary 8.** *A system is reversible if and only if its normalizations are reversible.*

### 3.4 Useful tokens

We show that some tokens do not impact the behavior of a system and hence can be removed without modifying the language of the system. The idea of *useful tokens* was first introduced in [Marchetti 2009]. We generalize this approach to all weighted Petri nets.

**Definition 9.** *A weighted Petri net is said to satisfy the useful tokens condition if every place  $p$  is initially marked with a multiple of  $\text{gcd}_p$ .*

The following theorem shows that any initial marking can be modified to satisfy this condition in such a way that the set of feasible sequences is not modified.

**Theorem 7.** *The marking  $M_0(p)$  of every place  $p$  of a system  $S = (N, M_0)$  can be replaced by*

$$\left\lfloor \frac{M_0(p)}{\text{gcd}_p} \right\rfloor \cdot \text{gcd}_p$$

*without modifying the feasible firing sequences of  $S$ .*

*Proof.* From the initial marking  $M_0$  of the net  $N$  we construct a marking  $M'_0$  according to

$$\forall p \in P, M'_0(p) = \left\lfloor \frac{M_0(p)}{\text{gcd}_p} \right\rfloor \cdot \text{gcd}_p.$$

Let  $r_p$  be the remainder of the division of  $M_0(p)$  by  $\text{gcd}_p$ , hence  $M_0(p) = M'_0(p) + r_p$ . We prove by induction on the size of a firing sequence  $\sigma$  that  $\sigma$  is feasible for  $M_0$  if and only if  $\sigma$  is feasible for  $M'_0$ .

The property is true if  $\sigma$  is empty. Otherwise, suppose  $\sigma_1$  is feasible in both systems, with  $M_0 \xrightarrow{\sigma_1} M$  and  $M'_0 \xrightarrow{\sigma_1} M'$ , and consider  $\sigma = \sigma_1 t$ . Denote

$$v_p = \sum_{t_i \in \bullet p} W(t_i, p) \cdot \bar{\sigma}_1(t_i) - \sum_{t_i \in p \bullet} W(p, t_i) \cdot \bar{\sigma}_1(t_i).$$

Since all input and output weights of  $p$  are multiples of  $\text{gcd}_p$ ,  $v_p$  is a multiple of  $\text{gcd}_p$ . By definition of  $M_0$ , we have the following equivalence on the possibility to fire  $t$  in both systems after the firing of  $\sigma_1$ :

$$\forall p \in \bullet t, M_0(p) + v_p \geq W(p, t) \iff \forall p \in \bullet t, M'_0(p) + r_p + v_p \geq W(p, t).$$

Since  $M'_0(p)$ ,  $v_p$  and  $W(p, t)$  are multiples of  $\text{gcd}_p$  for every place  $p$ , while  $r_p$  is strictly smaller than  $\text{gcd}_p$ , we deduce

$$\forall p \in \bullet t, M'_0(p) + v_p \geq W(p, t).$$

Therefore  $t$  can equivalently be fired at  $M'$ , which completes the proof.  $\square$

This theorem is illustrated on Figure 3.8.





Figure 3.8: The  $\gcd$  of the places equals 2. The marking on the left does not fulfill the useful tokens condition, hence it can be reduced while preserving the language. On the right, the place fulfills the condition and induces the same language.

### 3.5 Transformation into weighted Free-Choice systems

In this section, we present a method which transforms any weighted Petri net into a weighted Free-Choice system while preserving the language and the well-formedness. For that purpose, we use the scaling transformation, and introduce new arcs and new tokens, in order to complete the input sets of transitions and satisfy the Free-Choice structure.

We first prove the next theorem, illustrated in Figures 3.9 and 3.10, which presents a simple transformation that preserves strong properties. The idea consists in completing the missing arcs between a set  $A$  of transitions and a place  $p$ .

**Theorem 8** (A local transformation). *Consider a system  $S = (N, M_0)$ , with  $N = (P, T, W)$ , such that  $M_0$  contains only useful tokens and there exists a place whose output set is not  $T$ . Consider the following transformation of  $S$  that leads to a new system  $S'$ . Select a non-empty subset of transitions  $A$  and a place  $p$  such that  $A$  contains only transitions that are not outputs of  $p$ :*

1. if  $\gcd_p = 1$ , then scale  $p$  by 2;
2. For every transition  $t$  in  $A$ :  
 add an arc with weight 1 from  $p$  to  $t$ ; if an arc with weight  $w > 0$  exists from  $t$  to  $p$ , then replace  $w$  by  $w + 1$ , otherwise add an arc with weight 1 from  $t$  to  $p$ ;
3. add one token to  $p$ .

*Then,  $S$  and  $S'$  have the same language. Moreover, if  $S$  is well-formed, then  $S'$  is well-formed.*

*Proof.* The first step may scale a place, an operation that has been shown to preserve the language of the system (Theorem 1 on page 38) and the well-formedness (Corollary 4 on page 40). Moreover, scaling preserves the useful tokens condition, supposed to be satisfied by the initial marking  $M_0$ . After the potential scaling of  $p$  and before adding new arcs, the place  $p$  satisfies  $\gcd_p \geq 2$ . Hence, the token added becomes a useful token only when the

### 3.5. Transformation into weighted Free-Choice systems

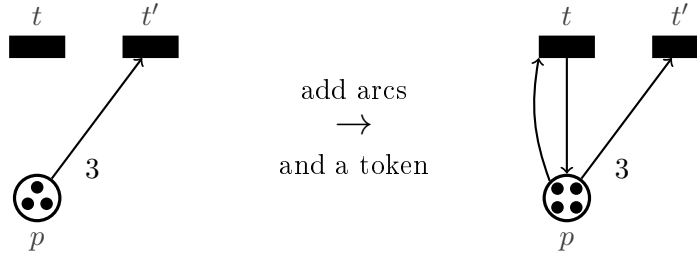

Figure 3.9: A first example of the transformation, with  $A = \{t\}$ . On the left, the initial system to be transformed. Since  $\gcd_p = 3$ , the place  $p$  needs not be scaled. Finally, arcs are added between  $p$  and  $t$  and a token is added to  $p$ .

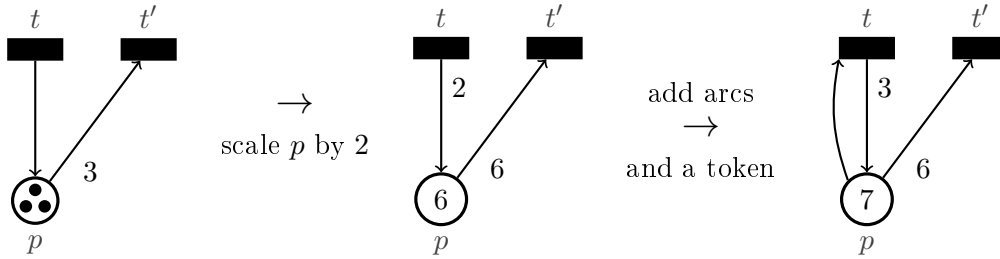

Figure 3.10: A second example of the transformation, with  $A = \{t\}$ . On the left, the initial system to be transformed. Since  $\gcd_p = 1$ , the place  $p$  is scaled by 2, leading to the second system. Finally, arcs are added between  $p$  and  $t$  and a token is added to  $p$ . Since an arc already linked  $t$  to  $p$ , 1 is added to its weight 2, leading to the new weight 3.

output arcs of  $p$  with weight 1 are added. Moreover, in the final transformed system, any firing of an output transition removing the new token sends this token back to the place. Thus, for every marking  $M$  reachable in the new system,  $M(p)$  is of the form  $k \cdot c + 1$ , where  $k$  and  $c$  are natural numbers such that  $c \geq 2$ , and the output arcs with weight 1 are the new output arcs. We deduce the language preservation.

Finally, by the properties of the scaling operation, if the initial system is well-formed, then the scaled system is also well-formed. The new arcs only check for the presence of a token, restricting the firing possibilities in the new system. Thus, structural boundedness is preserved. The preservation of structural liveness comes from the language preservation. It follows that well-formedness is preserved.  $\square$

We are now able to deduce a polynomial time transformation of weighted systems into weighted Free-Choice systems which preserves the language and the well-formedness. The algorithm follows, supposing that the initial marking contains only useful tokens, otherwise it must first be reduced.

### Chapter 3. Polynomial time transformations of weighted Petri nets

**Corollary 9** (Transformation into a weighted Free-Choice system). *Consider a system  $S = (N, M_0)$ , with  $N = (P, T, W)$ , such that  $M_0$  contains only useful tokens. Consider the following transformation of  $S$  that leads to a new system  $S'$ : For every place  $p$  whose post-set is not the set  $T$  of all the transitions:*

1. if  $\gcd_p = 1$ , scale by 2 the place  $p$ ;
2. For every transition  $t$  that is not an output of  $p$  then add the arc  $(p, t)$  (with weight 1). Then, if an arc with weight  $w$  from  $t$  to  $p$  already exists, replace  $w$  by  $w + 1$ , otherwise, add one arc  $(t, p)$  with weight 1.
3. add one token to  $p$ .

Then,  $S$  and  $S'$  have the same language, and  $S'$  is a weighted Free-Choice system. Moreover, if  $S$  is well-formed, then  $S'$  is well-formed.

*Proof.* The algorithm iterates the transformation of Theorem 8 on page 47 on every place  $p$  whose output set is not  $T$ . We deduce that the language and well-formedness are preserved. After the transformation, the input set of every transition is the set of all places  $P$ . Thus, all transitions, and in particular the transitions sharing an input place, have the same input set. Consequently, the transformed system is a weighted Free-Choice system.  $\square$

Figure 3.11 pictures the transformation.

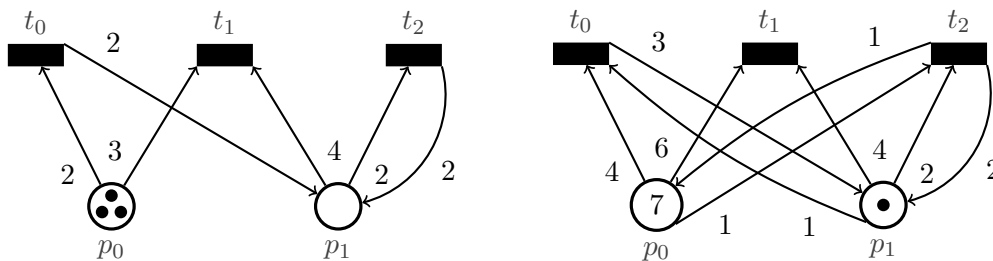

Figure 3.11: The system on the left is not even Asymmetric-Choice:  $p_0$  and  $p_1$  have a common output transition  $t_1$  while  $p_0^\bullet \not\subseteq p_1^\bullet$  and  $p_1^\bullet \not\subseteq p_0^\bullet$ . The transformation leads to the weighted Free-Choice system on the right with the same language. On the left,  $\gcd_{p_0} = 1$  and  $p_0$  is not an input of all the transitions, hence it is scaled by 2 and a token is added. We then build the two arcs between  $p_0$  and  $t_2$ . On the left,  $\gcd_{p_1} = 2$ , thus on the right  $p_1$  is not scaled. We then add a token and an arc from  $p_1$  to  $t_0$ . We finally add 1 to the weight of the arc from  $t_0$  to  $p_1$ .

We deduce the next corollary.

**Corollary 10** (Liveness and reversibility preservation). *The transformation into a weighted Free-Choice system preserves the liveness and reversibility properties: the initial system is live (resp. reversible) if and only if the transformed system is live (resp. reversible).*

*Proof.* The liveness preservation comes from the language preservation. Then, by Corollary 2, the scaling operation preserves reversibility. Finally, firings of transitions having new input arcs with weight 1 put the new added tokens back in their initial place.  $\square$

## 3.6 The place-splitting transformation

In this section, we propose a polynomial time transformation of a well-formed Choice-Free system into a well-formed T-system with the same set of T-semiflows. The idea is to deduce behavioral properties of the Choice-Free system from the study of the T-system obtained, with the benefits of polynomial time methods that exist already for T-systems.

First, we present the transformation. We then show several important properties of this transformation that will prove useful when studying the behavior of well-formed Choice-Free systems in the next chapters.

### 3.6.1 Definition

We present here the place-splitting transformation. In order to obtain a T-system from a Choice-Free system, one has to get rid of the situations in which places exist that have several inputs, since this pattern is not allowed in T-systems. For that purpose, we propose a local transformation that consists in splitting such places into several ones, meaning that we add places to the system and modify the arcs such that each new place has at most one input and one output. Moreover, in order to relate the properties of one system to those of the other, we provide a formula that computes the new weights surrounding the new places and takes into account the minimal T-semiflow of the initial well-formed Choice-Free system. An objective is to maintain the structure from the T-semiflow point of view. Finally, we compute a new marking based on the new weights.

In the following, we define the transformation on a strongly connected and well-formed Choice-Free system  $S = ((P, T, W), M_0)$ . By Proposition 4 on page 31,  $S$  has a unique minimal T-semiflow  $Y$  whose support is  $T$ . We denote by  $U$  the least common multiple of the components of  $Y$ . The system  $S' = ((P', T, W'), M'_0)$  has the same set of transitions and is obtained from  $S$  as follows.

**Splitting of particular places.** Every place  $p$  having at least two input transitions  $t_1 \dots t_k$  and an output  $t$  is replaced by  $k$  places  $p_1 \dots p_k$  in  $P'$  such that, for every  $i \in 1 \dots k$ ,  $p_i$  is an output of  $t_i$  and an input of  $t$ . This operation is illustrated in Figure 3.12.

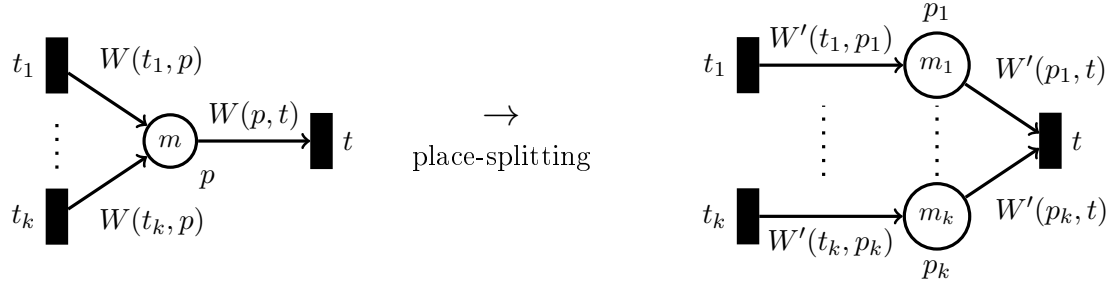

Figure 3.12: The place  $p$  on the left has  $k$  input transitions. The splitting of place  $p$  leads to  $k$  places on the right.

**New weights.** For every place  $p$  split into  $k$  places  $p_1 \dots p_k$ , for every  $i \in 1 \dots k$ , all the weights surrounding the place  $p_i$  are determined as follows:

$$W'(t_i, p_i) = U \cdot W(t_i, p)$$

$$W'(p_i, t) = W'(t_i, p_i) \cdot \frac{Y(t_i)}{Y(t)}.$$

Since the support of  $Y$  is  $T$ , the division by  $Y(t) \geq 1$  is allowed. Moreover, by definition of  $U$ ,  $\frac{U}{Y(t)} \in \mathbb{N}$ , thus  $W'(p_i, t) \in \mathbb{N}$ . All other weights are kept identical.

The idea is to separate the flows of tokens that go through the place  $p$ , hence preserving some kind of proportionality between the old weights and the new ones. To preserve the minimal T-semiflow, we have to satisfy the equality  $W'(p_i, t) \cdot Y(t) = W'(t_i, p_i) \cdot Y(t_i)$  for every place  $p_i$  resulting from the splitting operation. For example, in Figure 3.12, the equality  $W'(p_1, t) \cdot Y(t) = W'(t_1, p_1) \cdot Y(t_1)$  has to be satisfied.

**New marking.** The initial marking  $M'_0$  is computed from the marking  $M_0$  according to:

$$M'_0(p_i) = \left\lfloor \frac{M_0(p) \cdot U \cdot W(t_i, p) \cdot Y(t_i)}{\gcd_{p_i} \cdot W(p, t) \cdot Y(t)} \right\rfloor \cdot \gcd_{p_i}.$$

This equality can be written equivalently as follows:

$$M'_0(p_i) = \left\lfloor \frac{M_0(p) \cdot W'(p_i, t)}{\gcd_{p_i} \cdot W(p, t)} \right\rfloor \cdot \gcd_{p_i}.$$

The new initial marking of a new place  $p_i$  is obtained from the old marking by applying the ratio of the new output weight to the initial output weight. The idea is to preserve

### 3.6. The place-splitting transformation

a kind of firing potential of the output transition  $t$  relatively to the initial marking. Finally, the value is rounded down to a multiple of  $gcd_{p_i}$ , since we consider only useful tokens.

The whole place-splitting transformation is illustrated in Figure 3.13.

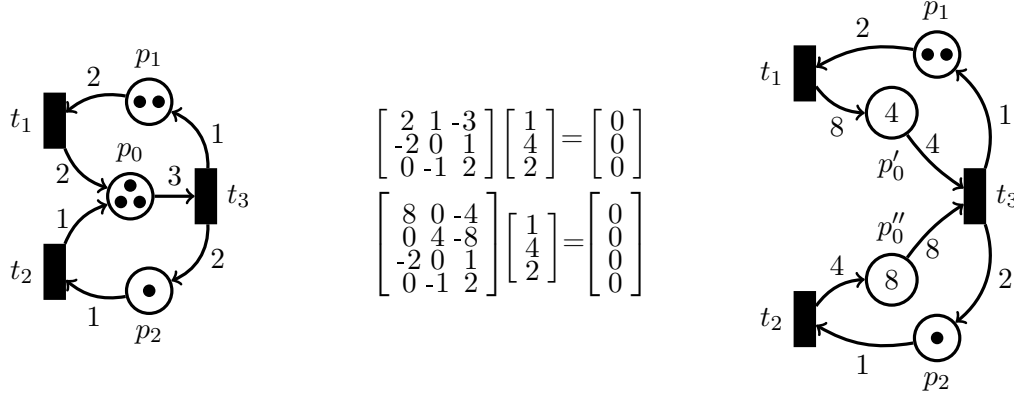

Figure 3.13: The Choice-Free system on the left has the minimal T-semiflow  $(1, 4, 2)$ , thus  $U = 4$ . Applying the transformation,  $W'(t_1, p'_0) = 2 \cdot 4$ ,  $W'(t_2, p''_0) = 1 \cdot 4$ ,  $W'(p'_0, t_3) = 8 \cdot 1/2$  and  $W'(p''_0, t_3) = 4 \cdot 4/2$ . The marking of  $p_1$  and  $p_2$  does not change. Since  $gcd_{p'_0} = 4$ ,  $W(t_2, p_0) = 1$ ,  $gcd_{p''_0} = 4$  and  $W(t_1, p_0) = 2$ , we get  $M'_0(p'_0) = 4$  and  $M'_0(p''_0) = 8$ . We obtain the T-system on the right with the same minimal T-semiflow.

#### 3.6.2 Properties

The transformation clearly preserves strong connectedness. As shown next, it also preserves the set of T-semiflows and well-formedness.

**Theorem 9** (T-semiflow preservation). *Consider the well-formed strongly connected Choice-Free system  $S$  and the transformed T-system  $S'$ . Both systems have the same set of T-semiflows and  $S'$  is well-formed.*

*Proof.*  $S$  and  $S'$  have the same set of transitions  $T$ . The system  $S$ , being well-formed, has a unique minimal T-semiflow  $Y$ , whose support is  $T$  (Proposition 4 on page 31). For every transition  $t_i$ ,  $Y(t) \cdot W'(p_i, t) = Y(t_i) \cdot W'(t_i, p_i)$ , thus  $Y$  is a T-semiflow of  $S'$ . We deduce that  $S'$  is consistent and strongly connected, thus well-formed (Proposition 1 on page 29) and it has a unique minimal T-semiflow with support  $T$  (Proposition 4 on page 31). Since  $Y$  is a T-semiflow of  $S'$  and the gcd of its components is 1, there is no smaller T-semiflow in  $S'$ , thus  $Y$  is the unique minimal T-semiflow of  $S'$ . As each T-semiflow is a multiple of  $Y$ , the set of T-semiflows is preserved.  $\square$

This property is illustrated by Figure 3.13, where both systems are well-formed and have the same set of T-semiflows, including the unique minimal one.

### Chapter 3. Polynomial time transformations of weighted Petri nets

---

The next property compares the number of initial tokens in both systems.

**Theorem 10** (Marking bound property). *Consider a well-formed strongly connected Choice-Free system  $(N, M_0)$  and its transformation  $(N', M'_0)$ . The following inequality is satisfied for each place  $p$  transformed into  $k$  places  $p_1 \dots p_k$ :*

$$\sum_{i=1}^k M'_0(p_i) \leq M_0(p) \cdot U.$$

*Proof.* By definition of  $M'_0$ , we obtain:

$$\begin{aligned} \sum_{i=1 \dots k} M'_0(p_i) &= \sum_{i=1 \dots k} \left\lfloor \frac{M_0(p) \cdot U \cdot W(t_i, p) \cdot Y(t_i)}{\gcd_{p_i} \cdot W(p, t) \cdot Y(t)} \right\rfloor \cdot \gcd_{p_i} \\ &\leq \sum_{i=1 \dots k} \frac{M_0(p) \cdot U \cdot W(t_i, p) \cdot Y(t_i)}{W(p, t) \cdot Y(t)} \\ &\leq \frac{U \cdot M_0(p)}{W(p, t) \cdot Y(t)} \cdot \sum_{i=1 \dots k} W(t_i, p) \cdot Y(t_i) \end{aligned}$$

Since  $\sum_{i=1}^k W(t_i, p) \cdot Y(t_i) = W(p, t) \cdot Y(t)$ , the claim is proved.  $\square$

On Figure 3.13 on the preceding page,  $M'_0(p'_0) + M'_0(p''_0) = 12$  while  $M_0(p) \cdot U = 3 \cdot 4 = 12$ .

The inclusion of the language of  $S'$  in the language of  $S$  is shown below.

**Theorem 11** (Language inclusion). *Every sequence that is feasible in  $S'$  is feasible in  $S$ .*

*Proof.* We prove the claim by induction on the size of a sequence  $\sigma$  that is feasible in  $S' = (N', M'_0)$ .

If  $\sigma$  is empty, then it is also feasible in  $S = (N, M_0)$ . Hence suppose that  $\sigma = \sigma_1 t$  has size  $k \geq 1$  and the property is true for  $\sigma_1$ , thus  $\sigma_1$  is also feasible in  $S$ . We note  $M_0 \xrightarrow{\sigma_1} M_1$  and  $M'_0 \xrightarrow{\sigma_1} M'_1 \xrightarrow{t} M'$ .

If no input of  $t$  has been modified by the transformation, then for each of its input places  $p$ , the weights surrounding  $p$  have not been modified and the corresponding transitions have been fired the same number of times, thus  $M'_1(p) = M_1(p)$  and  $t$  is enabled by  $M_1$  in  $S$ . Otherwise, the same argument applies to any non-modified input place of  $t$ , and for every input place  $p$  of  $t$  that has been transformed into places  $p_1 \dots p_k$ , we show that if the places  $p_i$ ,  $i = 1 \dots k$ , are enabled by  $M'_1$  in  $S'$  then  $p$  is enabled by  $M_1$  in  $S$ . It is equivalent to show that  $M'(p_i) \geq 0$ ,  $\forall i \in \{p_1, \dots, p_k\}$ , implies  $M(p) \geq 0$  where  $M_1 \xrightarrow{t} M$ . For every such place  $p_i$ ,  $i \in \{1, \dots, k\}$ ,

$$M'_0(p_i) + W'(t_i, p_i) \cdot \vec{\sigma}(t_i) - W'(p_i, t) \cdot \vec{\sigma}(t) \geq 0.$$

From the definition of  $W'$ , we get

$$M'_0(p_i) + U \cdot W(t_i, p) \cdot \vec{\sigma}(t_i) - U \cdot W(t_i, p) \cdot \frac{Y(t_i)}{Y(t)} \cdot \vec{\sigma}(t) \geq 0.$$

By summing the preceding inequality over places  $p_1 \dots p_k$ , we obtain

$$\sum_{i=1\dots k} M'_0(p_i) + U \cdot \left( \sum_{i=1\dots k} W(t_i, p) \cdot \vec{\sigma}(t_i) - \left( \sum_{i=1\dots k} W(t_i, p) \cdot Y(t_i) \right) \cdot \frac{\vec{\sigma}(t)}{Y(t)} \right) \geq 0$$

Since  $\sum_{i=1\dots k} W(t_i, p) \cdot Y(t_i) = W(p, t) \cdot Y(t)$ ,

$$\sum_{i=1\dots k} M'_0(p_i) + U \cdot \left( \sum_{i=1\dots k} W(t_i, p) \cdot \vec{\sigma}(t_i) - W(p, t) \cdot \vec{\sigma}(t) \right) \geq 0$$

From the marking bound property (Theorem 10 on the preceding page), it follows that

$$U \cdot \left( M_0(p) + \sum_{i=1\dots k} W(t_i, p) \cdot \vec{\sigma}(t_i) - W(p, t) \cdot \vec{\sigma}(t) \right) \geq 0$$

thus  $U \cdot (M_1(p) - W(p, t)) \geq 0$  and  $\sigma$  is feasible in  $S$ .  $\square$

In Figure 3.13 on page 52, the sequence  $t_3 t_1 t_2 t_2 t_3$  is feasible in the T-system and also in the Choice-Free system. However, the sequence  $t_3 t_1 t_2 t_3$  is feasible in the Choice-Free system whereas it is not feasible in the T-system.

The language inclusion property will prove useful in studying behavioral properties of Choice-Free systems in the next chapters. Indeed, this property intuitively states that what can be done in the T-system can also be done in the Choice-Free system, which thus inherits a more constrained underlying behavior. We will benefit from the lower expressiveness of T-systems to study the properties of Choice-Free systems.

## 3.7 Conclusion

We generalized to all weighted Petri nets several polynomial time transformations that were developed for weighted T-systems [Marchetti 2009].

We showed several important properties of the scaling transformation, namely the preservation of the language, the T-semiflows as well as the liveness and reversibility properties, and the well-formedness.

We introduced a particular scaling, namely balancing, which transforms every conservative system into a token-conservative system, inheriting the properties of the scaling while the number of tokens is invariant over the set of reachable markings. As the conservativeness property is known to be necessary for well-formedness, the balancing transformation applies to all well-formed weighted Petri nets.



### Chapter 3. Polynomial time transformations of weighted Petri nets

---

We also presented a transformation of any weighted Petri net into a weighted Free-Choice Petri net preserving the language and the well-formedness.

Finally, the polynomial place-splitting transformation applies to well-formed Choice-Free systems and benefits from strong properties, namely the preservation of the T-semiflows and well-formedness, as well as the inclusion of the language of the transformed system into the language of the initial system.





# Polynomial sufficient conditions of liveness for well-formed Join-Free and Equal-Conflict systems

## Contents

---

<b>4.1 Polynomial sufficient conditions of liveness for well-formed Join-Free systems . . . . .</b>	<b>60</b>
4.1.1 Well-formedness and balancing . . . . .	60
4.1.2 A polynomial sufficient condition for balanced Join-Free systems . . . . .	60
4.1.3 The special case of ordinary Join-Free systems . . . . .	63
4.1.4 Polynomial live markings for well-formed Join-Free systems . . . . .	63
<b>4.2 Previous results on the liveness of Equal-Conflict systems . . . . .</b>	<b>65</b>
4.2.1 A characterization of liveness for well-formed systems . . . . .	65
4.2.2 Liveness monotonicity of bounded systems . . . . .	65
<b>4.3 Polynomial live markings for well-formed Equal-Conflict systems . . . . .</b>	<b>65</b>
4.3.1 Polynomial live markings . . . . .	66
4.3.2 Special case of normalized T-systems . . . . .	68
<b>4.4 Sufficient conditions of liveness for Choice-Free systems . . . . .</b>	<b>69</b>
4.4.1 Known results on the liveness . . . . .	69
4.4.2 A sufficient condition of liveness by place-splitting . . . . .	69
4.4.3 Deduction of a polynomial time sufficient condition . . . . .	69
<b>4.5 A comparison of the liveness conditions . . . . .</b>	<b>71</b>
<b>4.6 The sufficient conditions are not necessary . . . . .</b>	<b>72</b>
<b>4.7 Conclusion . . . . .</b>	<b>74</b>

---

## Chapter 4. Polynomial sufficient conditions of liveness for well-formed Join-Free and Equal-Conflict systems

---

In this chapter, we focus on well-formed and weighted Join-Free and Equal-Conflict systems, and also on some of their subclasses: Choice-Free systems, T-systems, S-systems and Fork-Attribution systems. Polynomial time characterizations of well-formedness exist for all these classes [Teruel 1994, Recalde 1995, Recalde 1996, Teruel 1996, Teruel 1997, Silva 1998, Amer-Yahia 1999a]. Consequently, the problem of deciding the well-formedness of such models of applications is tractable.

Once a well-formed net has been designed, a challenging question is to build a live initial marking. The well-formedness assumption implies the existence of such a marking. Only exponential time characterizations of liveness are known for well-formed weighted circuits. The complexity of deciding the liveness of a weighted circuit is an open question and is strongly related to the Frobenius problem, which is known to be difficult [Chrastowski-Wachtel 1993, Ramirez-Alfonsin 1996]. Consequently, this difficulty propagates to all larger classes and we are interested in finding *polynomial*, meaning in polynomial time with a polynomial number of initial tokens, live initial markings for several expressive classes.

To date, methods exist that build live initial markings for Equal-Conflict systems and most of their subclasses, either with an exponential number of initial tokens or in exponential time [Teruel 1993, Teruel 1996, Teruel 1997], except in the case of weighted T-systems, for which polynomial sufficient conditions are known [Marchetti 2009]. In the case of well-formed Join-Free systems, dedicated methods have not been developed until now.

In this chapter, we use the transformations of Chapter 2 to obtain the first polynomial sufficient conditions of liveness for well-formed Join-Free and Equal-Conflict systems. This allows to build well-behaved systems efficiently with a reasonably sized initial data distribution. These new results contrast with the prior exponential methods of the literature.

This chapter is organized as follows. First, in Section 4.1, we provide the first sufficient condition of liveness for token-conservative Join-Free systems, in which the total amount of tokens remains invariant. We deduce from this result another sufficient condition for the more general class of all well-formed Join-Free systems. In Section 4.3, we recall known theorems concerning the liveness of well-formed Equal-Conflict systems. Then, we exploit these results to provide the first polynomial sufficient conditions for well-formed Equal-Conflict systems. In Section 4.4, with the help of the place-splitting transformation, we present another polynomial time sufficient condition of liveness for the special case of well-formed Choice-Free systems. We compare all these liveness conditions in Section 4.5. Finally, we show in Section 4.6 that these conditions are not necessary in the weighted case.

## 4.1 Polynomial sufficient conditions of liveness for well-formed Join-Free systems

Observing that a well-formed Join-Free system is necessarily balanceable, we express a first sufficient condition of liveness on a balanced version of the system. Then we examine the special case of ordinary well-formed Join-Free systems for which we derive a simple necessary and sufficient condition of liveness. We then propose a live marking that imposes a distribution of the initial tokens among all places. Moreover, every larger marking is also live.

### 4.1.1 Well-formedness and balancing

We consider in this section conservative Join-Free systems, which are well-formed by Theorem 1 on page 29. According to Theorem 4 on page 42 these systems may also be balanced, which can be done in polynomial time. Hence we shall restrict our study to Join-Free balanceable systems.

### 4.1.2 A polynomial sufficient condition for balanced Join-Free systems

The following technical lemma expresses a simple sufficient condition for the existence of enabled places.

**Lemma 1.** *Let  $S = ((P, T, W), M_0)$  be a balanced strongly connected Join-Free system satisfying the useful tokens condition and the inequality*

$$\sum_{p \in P} M_0(p) > \sum_{p \in P} (\max_p - \gcd_p). \quad (4.1)$$

*Then for every marking  $M$  in  $[M_0]$ , there exists a place  $p \in P$  which is enabled by  $M$ .*

*Proof.* As  $M_0$  fulfills the useful tokens condition, it follows that for every place  $p$ ,  $M_0(p)$  is a multiple of  $\gcd_p$ . Since the input and output weights of every place  $p$  are also multiples of  $\gcd_p$ ,  $M(p)$  is a multiple of  $\gcd_p$  for every reachable marking  $M$  and every place  $p$ .

Now suppose, by contradiction, that  $M$  is a fixed reachable marking that does not enable any place. Then

$$\forall p \in P, M(p) \leq \max_p - \gcd_p,$$

hence

$$\sum_{p \in P} M(p) \leq \sum_{p \in P} (\max_p - \gcd_p). \quad (4.2)$$

Since  $S$  is balanced, every transition firing maintains the number of tokens in the system, implying that

$$\sum_{p \in P} M(p) = \sum_{p \in P} M_0(p).$$

## Chapter 4. Polynomial sufficient conditions of liveness for well-formed Join-Free and Equal-Conflict systems

---

Inequality (4.2) is therefore equivalent to

$$\sum_{p \in P} M_0(p) \leq \sum_{p \in P} (max_p - gcd_p),$$

contradicting inequality (4.1). □

We are now able to prove that inequality (4.1) provides a sufficient condition of liveness.

**Theorem 12.** *A balanced strongly connected Join-Free system  $S = (N, M_0)$  satisfying the useful tokens condition is live if*

$$\sum_{p \in P} M_0(p) > \sum_{p \in P} (max_p - gcd_p).$$

*Proof.* Let  $S$  be a Join-Free system meeting the conditions of the theorem. We show that  $S$  is live, that is, for every reachable marking  $M$  and every transition  $t$ , there exists a finite and feasible firing sequence starting at  $M$  that leads to a marking  $M'$  enabling  $t$ . For that purpose, we prove that Algorithm 1 on the following page computes such a sequence and terminates. Tokens are arbitrarily numbered to ensure its convergence.

If  $M(p) \geq W(p, t)$  then  $t$  is enabled. The algorithm terminates and  $\sigma$  is the requested firing sequence.

Now consider the alternative. The place  $p$  is not enabled.  $L$  is not empty by Lemma 1 on the preceding page and thus,  $p'$  exists. Moreover  $p \neq p'$  since  $p \notin L$ .

At every step of the loop, a firing occurs so as to reduce the minimal distance between the mobile token with smallest number and the place  $p$ . Note that a firing can move several tokens at once on different paths, taking some of them away from  $p$ . Such a firing is always possible when  $p$  is not enabled, since by Lemma 1 there exists at least one enabled place at any reachable marking. In so doing, a new marking  $M'$  is reached, inducing the new shortest distances of  $d^{M'}$ . We prove that  $d^M >_{lex} d^{M'}$ , following the lexical order on  $\mathbb{N}^\delta$ . The firing of  $t'$  ensures that  $d_i^{M'} < d_i^M$ . At this step, as the numbers of the other displaced tokens are greater than  $i$ , the inequality  $d^M >_{lex} d^{M'}$  is true, even though  $d_j^M$  may increase for  $j > i$ . Now, as the lexical order is well-founded over  $\mathbb{N}^\delta$ , the algorithm terminates,  $\sigma$  is finite and  $t$  is enabled. □

Figure 4.1 on page 63 shows the application of this theorem to a balanced Join-Free system. The system represented satisfies  $\sum_p (max_p - gcd_p) = 1 + 1 + 0 = 2$ . The inequality becomes  $\sum_p M_0(p) > 2$  and is satisfied by the marking on the figure.

The sufficient condition of Theorem 12 obtained for balanced FA systems is the same as the one developed for weighted balanced circuits in [Marchetti 2009]. Consequently, the condition of Theorem 12 cannot be improved while preserving a polynomial time complexity unless the complexity for the circuit can be improved.

#### 4.1. Polynomial sufficient conditions of liveness for well-formed Join-Free systems

---



---

**Algorithm 1:** The algorithm computes a feasible firing sequence starting at  $M$  so as to enable any fixed transition  $t$ .

---

**Data:**

- The current reached marking  $M$ , which contains  $\delta$  tokens arbitrarily numbered  $1, \dots, \delta$ ;
- The unique input place  $p$  of  $t$ ;
- The  $\delta$ -tuple  $d^M = (d_1^M, \dots, d_\delta^M)$ , which associates the shortest distance  $d_i^M$  from token  $i$  to the place  $p$  according to the marking  $M$ ;

**Result:** A finite firing sequence  $\sigma$  such that  $M \xrightarrow{\sigma} M'$  and  $M'$  enables  $t$ .

```

1  $\sigma := \epsilon$ , the empty sequence;
2 while  $M(p) < W(p, t)$  do
3   | Let  $L$  be the set of the places enabled by  $M$  and  $J = \{i_1 \dots i_k\}$  the set of the
   | numbers of the tokens in the places of  $L$  at  $M$ ;
4   | Let  $p'$  be the place of  $L$  containing token  $i$  where  $i$  is the smallest value in  $J$ ;
5   | Let  $\mu = p', t', p'', \dots, p$  be a shortest path from  $p'$  to  $p$ ;
6   | Fire  $t'$  such that token  $i$  is sent to  $p''$ ;
7   | Update  $M$  and  $d^M$ ;
8   |  $\sigma := \sigma t'$ 
9 end

```

---



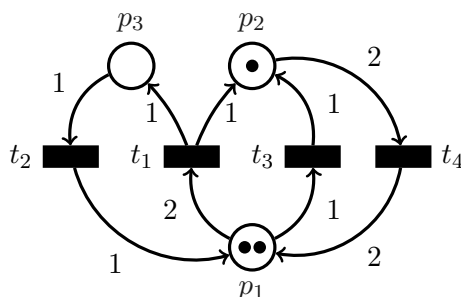

Figure 4.1: The initial marking of this balanced Join-Free system fulfills the conditions of Theorem 12 and is thus well-behaved.

### 4.1.3 The special case of ordinary Join-Free systems

We show that the sufficient condition of liveness for well-formed Join-Free systems becomes a necessary and sufficient condition of liveness for ordinary well-formed Join-Free systems, which are S-systems.

**Theorem 13.** *An ordinary strongly connected well-formed Join-Free net is an S-net.*

*Proof.* By contradiction, suppose that there exists an ordinary well-formed strongly connected Join-Free net  $N$  and a transition  $t$  with  $|t^\bullet| > 1$ .  $N$  is strongly connected, thus there exists a circuit  $c = tp_1t_1p_2t_2 \dots p_k t_k$  passing through  $t$  with  $t_k = t$ . As  $N$  is conservative by Theorem 1 on page 29, there exists  $X \geq \mathbb{1}^{|P|}$  such that  ${}^t X \cdot C = 0$ , where  $C$  is the incidence matrix of  $N$ . Since by assumption  $|t^\bullet| > 1$ , there is at least another place  $p' \in t^\bullet$  with  $p' \neq p_1$ . Thus

$$X[p_k] = \sum_{p \in t^\bullet} X[p] > X[p_1].$$

Generalizing over  $i \in \{1, \dots, k-1\}$ ,  $X[p_i] \geq X[p_{i+1}]$ , implying  $X[p_1] \geq X[p_k]$ , which contradicts  $X[p_k] > X[p_1]$ .  $\square$

This result and the inequality of Theorem 12 on page 61 taken together induce the following simple necessary and sufficient condition of liveness for ordinary well-formed strongly connected Join-Free systems, which are S-systems.

**Corollary 11.** *An ordinary, well-formed and strongly connected Join-Free system (S-system)  $S = ((P, T, W), M_0)$  having at least one place and one transition is live if and only if  $\sum_{p \in P} M_0(p) \geq 1$ .*

### 4.1.4 Polynomial live markings for well-formed Join-Free systems

The next theorem, illustrated by Figure 4.2, is a specialization of the previous sufficient condition for all well-formed and weighted Join-Free systems. This theorem gives a construction of a class of live markings  $\mathcal{M}_{\text{JF}}$ , a live marking for each choice of place  $p_0$ .

#### 4.1. Polynomial sufficient conditions of liveness for well-formed Join-Free systems

---

Moreover, every marking that is larger than a marking of this class is also live, inducing an associated sufficient condition. This condition is pictured on Figure 4.2.

**Theorem 14** (The set of polynomial live markings  $\mathcal{M}_{\text{JF}}$ ). *Let  $S = (N, M_0)$  be a weighted, strongly connected and conservative (well-formed) Join-Free system.  $S$  is live if the following conditions hold:*

- for a place  $p_0$ ,  $M_0(p_0) = \max_{p_0}$
- for every place  $p$  in  $P - \{p_0\}$ ,  $M_0(p) = \max_p - \gcd_p$ .

Moreover, every larger marking is also live.

*Proof.* By Theorem 4 on page 42, there exists a balancing vector  $\alpha \geq \mathbf{1}^{|P|}$  for  $S$  such that  $\alpha$  contains only positive natural numbers. Scaling  $S$  by  $\alpha$  yields the balanced system  $S' = (N', M'_0)$ . Consequently,

$$\forall p \in P, \max'_p - \gcd'_p = \alpha_p \cdot (\max_p - \gcd_p)$$

with  $\max'_p - \gcd'_p \in \mathbb{N}$ . We deduce that

$$\sum_{p \in P} M'_0(p) \geq \sum_{p \in P - \{p_0\}} (\max'_p - \gcd'_p) + \max'_{p_0} > \sum_{p \in P} (\max'_p - \gcd'_p).$$

Moreover, for every place  $p$ ,  $\max_p$  is a multiple of  $\gcd_p$ . Thus  $M'_0$  fulfills the useful tokens condition and by Theorem 12 on page 61 the balanced Join-Free system  $S'$  is live. According to Corollary 5 on page 43, balancing a system preserves the property of liveness, thus  $S$  is live. Larger markings are also live since their balanced version also satisfies the above inequalities.  $\square$

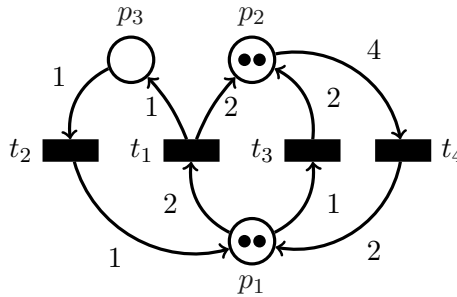

Figure 4.2: Since the initial marking of this well-formed, unbalanced, Join-Free system fulfills the conditions of Theorem 14, the system is well-behaved.

## 4.2 Previous results on the liveness of Equal-Conflict systems

In this section, we recall a known characterization of liveness and its monotonicity for well-formed Equal-Conflict systems. As a consequence, if a live marking is found for this class, any larger marking is also live.

### 4.2.1 A characterization of liveness for well-formed systems

By Proposition 1 on page 29 and Proposition 6 on page 32, every well-formed Equal-Conflict system is covered by a set of well-formed P-components, which are strongly connected and conservative homogeneous Join-Free P-subsystems. The next theorem states the liveness of a well-formed Equal-Conflict system by observing the liveness of its P-components.

**Proposition 8** ([Teruel 1996]). *Consider a strongly connected well-formed Equal-Conflict system  $S = (N, M_0)$ .  $S$  is live if and only if for every (well-formed) P-component  $N' = (P', T', W')$  of  $N$ , the system  $(N', M_0|_{P'})$  is live.*

This characterization of liveness in terms of subsystems does not trivially lead to an efficient algorithm for checking liveness, as one may have to check an exponential number of subsystems.

### 4.2.2 Liveness monotonicity of bounded systems

The liveness property is not always monotonous, even in well-formed classes, as pictured in Figure 4.3, which is taken from [Heiner 2010]. However, the structure of the well-formed Equal-Conflict systems ensures this monotonicity, as recalled by the next theorem.

**Theorem 15** ([Teruel 1996]). *Let  $(N, M_0)$  be a bounded Equal-Conflict system. Consider a marking  $M'_0$  such that  $M'_0 \geq M_0$ . If  $(N, M_0)$  is live then  $(N, M'_0)$  is live.*

Hence, if a polynomial live marking is provided for a well-formed Equal-Conflict net, then every larger marking is also live.

## 4.3 Polynomial live markings for well-formed Equal-Conflict systems

In this section, we exploit the properties and the results obtained in previous sections to deduce the first polynomial live initial marking for well-formed Equal-Conflict systems. Moreover, by the liveness monotonicity of Theorem 15, every larger marking is also live. We also deduce from these new results a sufficient condition of liveness that was formerly developed for T-systems [Marchetti 2009].

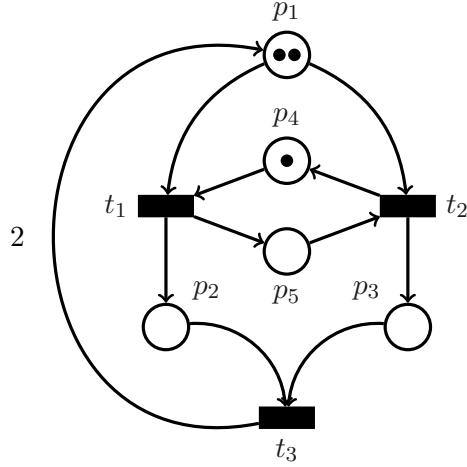

Figure 4.3: This Asymmetric-Choice Petri net is live and does not benefit from liveness monotonicity: adding a token in place  $p_4$  allows firing of the sequence  $t_1 t_1$ , which leads to a deadlock.

### 4.3.1 Polynomial live markings

The subclass of Equal-Conflict nets allows transitions with several input places. The firing of such transitions may occur only when all their input places are enabled. We build on the previous results on Join-Free P-subnets to construct a polynomial live marking for well-formed Equal-Conflict systems.

When an Equal-Conflict net has no join-transition, it is an homogeneous Join-Free net and the live marking of Theorem 14 on page 64 applies. The interesting case deals with at least one join-transition.

We first prove a technical lemma on the structure of the strongly connected Join-Free P-subnets of well-formed Equal-Conflict nets.

**Lemma 2.** *Let  $N$  be a strongly connected and well-formed Equal-Conflict net with at least one join-transition. Every strongly connected Join-Free P-subnet of  $N$  contains at least one input place of a join-transition.*

*Proof.* Suppose there exists a strongly connected Join-Free P-subnet  $N_{JF}$  containing only transitions having a unique input place in  $N$ . Then, either  $N_{JF}$  is equal to  $N$  which would then be a Join-Free net, a contradiction, or  $N_{JF}$  is a proper subnet and there exists a node  $n$  in  $N_{JF}$  and a node  $n'$  in  $N - N_{JF}$ , such that  $n'$  is an input of  $n$ , since  $N$  is strongly connected. The node  $n$  cannot be a place, otherwise  $N_{JF}$  would not be a P-subnet. Hence  $n$  is a transition with at least two input places: the one in  $N_{JF}$ ,  $N_{JF}$  being strongly connected, and  $n'$ . Thus  $N_{JF}$  contains a transition that is a join-transition of  $N$ , a contradiction.  $\square$

## Chapter 4. Polynomial sufficient conditions of liveness for well-formed Join-Free and Equal-Conflict systems

---

We are now able to provide the first polynomial live marking for well-formed Equal-Conflict systems, as described by the following theorem. The systems studied in this theorem are not Join-Free, since this case has been considered in Theorem 14 on page 64.

**Theorem 16** (Polynomial live marking  $M_{EC}$ ). *Let  $S = (N, M_0)$  be a well-formed Equal-Conflict system that is not a Join-Free system.  $S$  is well-behaved if for all input places  $p_i$  of all join-transitions,  $M_0(p_i) = \max_{p_i}$  and for all other places  $p$ ,  $M_0(p) = \max_p - \gcd_p$ . Moreover, any larger marking also provides well-behavedness.*

*Proof.* Let  $S_{JF} = (N_{JF}, M_0^{JF})$  be any of the P-components of  $N$ , where  $N_{JF} = (P_{JF}, T_{JF}, W_{JF})$  and  $M_0^{JF}$  is the restriction of  $M_0$  to  $P_{JF}$ . By definition of P-components and by Proposition 1 on page 29,  $S_{JF}$  is a conservative well-formed Join-Free P-subsystem of  $N$ . Moreover, by Lemma 2, every strongly connected Join-Free P-subnet of  $N$  contains at least an input place of a join-transition, hence contains at least a place  $p$  such that  $M_0(p) = \max_p$ . Thus, by Theorem 14 on page 64,  $S_{JF}$  is live. We deduce that  $M_0$  makes every P-component live and  $S$  is well-behaved by Proposition 8 on page 65. Moreover, by Theorem 15, any larger marking makes the system well-behaved.  $\square$

Figure 4.4 depicts a well-behaved Equal-Conflict system. Indeed, this system is well-formed (see Figure 2.18 on page 30), each input place  $p_i$  of a join-transition has a marking equal to  $\max_{p_i}$  and all the other places  $p$  contain  $\max_p - \gcd_p$  tokens. Figure 4.5 shows all the well-behaved P-components of this system.

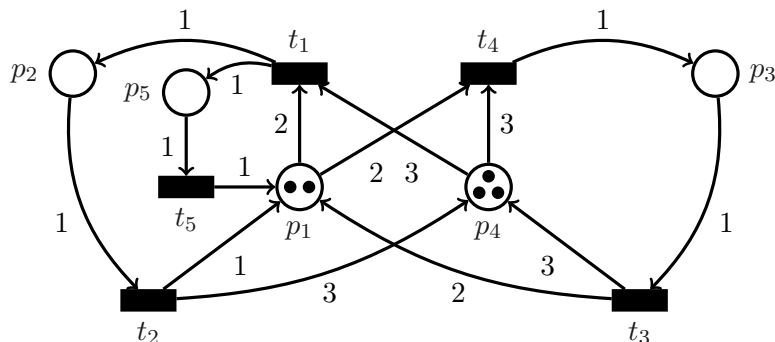

Figure 4.4: The Equal-Conflict system is well-formed, thus the live initial marking of Theorem 16 makes the system well-behaved. In order to construct this live initialization, notice that  $t_1$  and  $t_4$  are the only join-transitions, thus their input places  $p_1$  and  $p_4$  are initially marked by  $\max_{p_1} = 2$  and  $\max_{p_4} = 3$  tokens. It is then sufficient to mark every other place  $p$  with  $\max_p - \gcd_p$  tokens: in this example, no other place needs to be marked. Moreover, adding tokens does not destroy its well-behavedness.

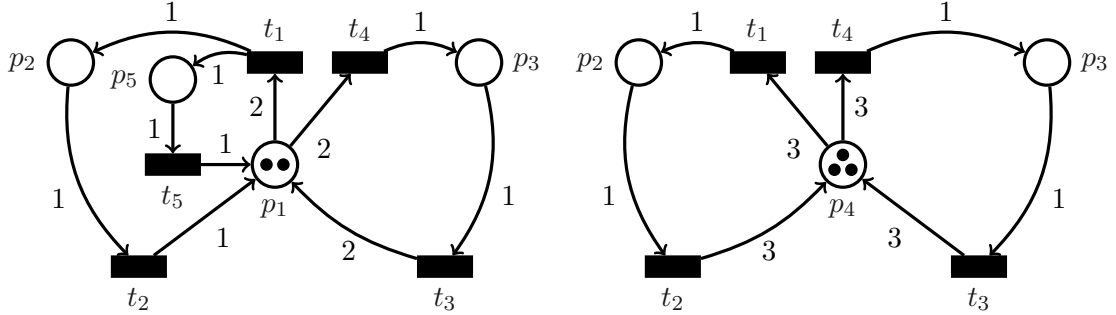

Figure 4.5: The well-behaved P-components of the Equal-Conflict system of Figure 4.4.

### 4.3.2 Special case of normalized T-systems

For T-systems, a sufficient condition of liveness was expressed in [Marchetti 2009]. We show that this result can be viewed as a consequence of Theorem 12 on page 61 and Proposition 8 on page 65.

We need the following simple lemma on the structure of T-nets.

**Lemma 3.** *All strongly connected Join-Free P-subnets of a strongly connected T-net are circuits.*

*Proof.* Consider a strongly connected Join-Free P-subnet  $N$  of a strongly connected T-net and suppose by contradiction that a transition  $t$  of  $N$  has at least two output places  $p_1$  and  $p_2$ . Let  $p$  be the unique input place of  $t$ . Places  $p_1$  and  $p_2$  belong to two different paths leading to  $p$  since the net is strongly connected. These paths are not allowed to merge as two inputs of a place since the net is a T-net. They cannot merge as two inputs of a transition either, since the subnet  $N$  is Join-Free, and  $N$  is not strongly connected, a contradiction.  $\square$

We recall a known sufficient condition of liveness for T-systems that we prove now, differently from [Marchetti 2009].

**Theorem 17** ([Marchetti 2009]). *Let  $S = ((P, T, W), M_0)$  be a strongly connected and normalized T-system that fulfills the useful-token condition.  $S$  is live if every circuit  $S_C$  of  $S$  satisfies*

$$\sum_{p \in P_C} M_0(p) > \sum_{p \in P_C} (\max_p - \gcd_p),$$

where  $P_C$  is the set of places of the circuit  $S_C$ .

*Proof.* By definition of the normalization, if  $(P, T, W)$  is a normalized T-net then its circuits are balanced. Moreover, balanced circuits are strongly connected balanced Join-Free nets, thus Theorem 12 on page 61 applies. T-nets are Equal-Conflict nets and  $S$  is strongly connected. By Lemma 3 and Proposition 8 on page 65, the claim is proved.  $\square$

## 4.4 Sufficient conditions of liveness for Choice-Free systems

In this section, we recall properties regarding the liveness of Choice-Free systems and T-systems. We provide a new sufficient condition of liveness for the particular subclass of well-formed Choice-Free systems with the help of the place-splitting transformation of Chapter 3. We deduce a polynomial time version of this condition by using a sufficient condition of liveness developed in the context of weighted T-systems [Marchetti 2009].

### 4.4.1 Known results on the liveness

We recall the two following propositions related to the liveness property.

**Proposition 9** (Characterization of liveness for Choice-Free systems [Teruel 1997]). *Consider a Choice-Free system  $S = (N, M_0)$ , its set of transitions  $T$  and the incidence matrix  $C$  of  $N$ .  $S$  is live if and only if there exist a reachable marking  $M \in [M_0]$  and a sequence  $\sigma$  that is feasible in  $(N, M)$  such that  $\vec{\sigma} \geq \mathbb{1}^{|T|}$  and  $C \cdot \vec{\sigma} \geq 0$ .*

**Proposition 10** (Necessary condition of liveness for T-systems [Teruel 1992]). *Consider a T-system  $S = (N, M_0)$ , with set of transitions  $T$  and incidence matrix  $C$  of  $N$ . If  $S$  is live then for all  $Y \geq \mathbb{1}^{|T|}$  such that  $C \cdot Y \geq 0$  there exists a sequence  $\sigma_Y$  that is feasible in  $S$  such that  $\vec{\sigma}_Y = Y$ .*

### 4.4.2 A sufficient condition of liveness by place-splitting

We show that the place-splitting transformation induces a sufficient condition of liveness for strongly connected well-formed Choice-Free systems.

**Theorem 18** (Sufficient condition of liveness). *Consider a strongly connected well-formed Choice-Free system  $S$ . Denote by  $S'$  the T-system obtained by applying the place-splitting transformation to  $S$ . If  $S'$  is live, then  $S$  is live.*

*Proof.* By definition of the place-splitting transformation, both systems have the same set of transitions  $T$ . By the preservation of T-semiflows (Theorem 9 on page 52) and Proposition 4 on page 31,  $S$  and  $S'$  have a common T-semiflow  $Y \geq \mathbb{1}^{|T|}$ .  $S'$  is live, thus a sequence  $\sigma_Y$  such that  $\vec{\sigma}_Y = Y$  is feasible (Proposition 10). By the language inclusion (Theorem 11 on page 53),  $\sigma_Y$  is also feasible in  $S$ , which is consequently live (take  $M = M_0$  and  $\sigma = \sigma_Y$  in Proposition 9).  $\square$

This sufficient condition of liveness is illustrated in Figure 4.6.

### 4.4.3 Deduction of a polynomial time sufficient condition

The polynomial sufficient condition of liveness of Theorem 17 for well-formed T-systems, whose checking complexity is  $\mathcal{O}(\max\{|P| \cdot |T|, |P| \cdot \log(\min_{p \in P} \max_p)\})$  [Marchetti 2009], leads to a polynomial time sufficient condition of liveness for well-formed Choice-Free systems.

#### 4.4. Sufficient conditions of liveness for Choice-Free systems

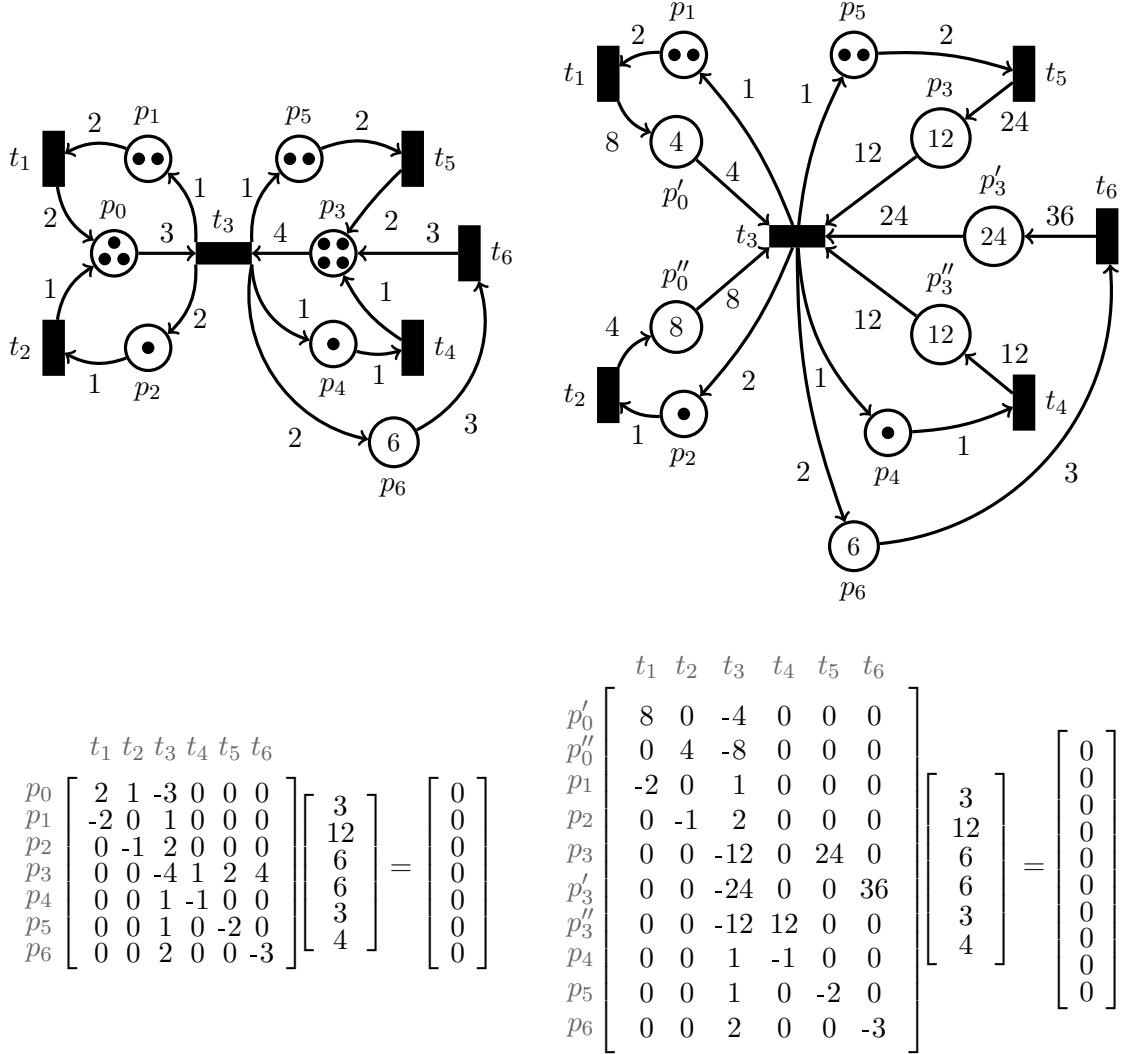

Figure 4.6: The place-splitting transformation is applied to the Choice-Free system on the left, leading to the T-system on the right with the same set of transitions. Since this T-system is live, the Choice-Free system is live.

**Theorem 19** (Polynomial time sufficient condition of liveness). *Consider a strongly connected and well-formed Choice-Free system  $S$ . Denote by  $S'$  the T-system obtained by applying the place-splitting transformation to  $S$ . Then  $S'$  can be normalized, leading to a normalized system  $S''$ . Moreover, if  $S''$  satisfies the liveness condition of Theorem 17 on page 68 for T-systems, then  $S$  is live.*

*Proof.* Since  $S$  is well-formed,  $S'$  is well-formed by Theorem 9 on page 52, thus consistent and conservative by Theorem 1 on page 29. Consequently,  $S'$  can be normalized (Theorem



## Chapter 4. Polynomial sufficient conditions of liveness for well-formed Join-Free and Equal-Conflict systems

---

5) in polynomial time while preserving the liveness property (Corollary 7). We deduce that the liveness of  $S''$  implies the liveness of  $S'$ , which induces the liveness of  $S$  by Theorem 18 on page 69. Finally, the condition of Theorem 17 on page 68 applies to  $S''$  and leads a polynomial time sufficient condition of liveness for  $S$ .  $\square$

This theorem is illustrated on Figure 4.7.

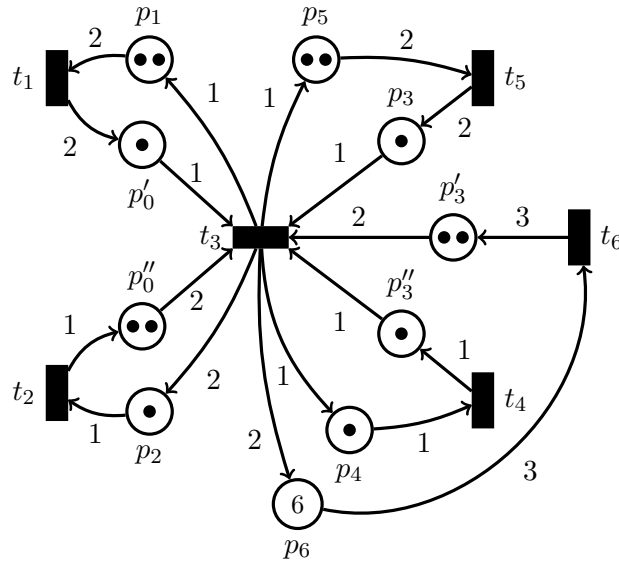

Figure 4.7: This normalized T-system is obtained from the system on the right of Figure 4.6 on the preceding page and satisfies the sufficient condition of Theorem 17 on page 68, which can be checked in polynomial time, implying the liveness of the Choice-Free system on the left of Figure 4.6 on the preceding page.

### 4.5 A comparison of the liveness conditions

For balanced FA systems, we compare the polynomial time sufficient conditions of liveness of Theorem 12 on page 61 and Theorem 19 on the preceding page. We show that neither one of these sufficient conditions subsumes the others.

Indeed, Figure 4.8 shows a live balanced FA system whose liveness is detected by the condition of Theorem 12 on page 61 but not detected when checking the condition of Theorem 19 on the preceding page.

Figure 4.9 shows a live balanced FA system that does not fulfill the condition of Theorem 12 on page 61, while the condition of Theorem 19 is satisfied.

#### 4.6. The sufficient conditions are not necessary

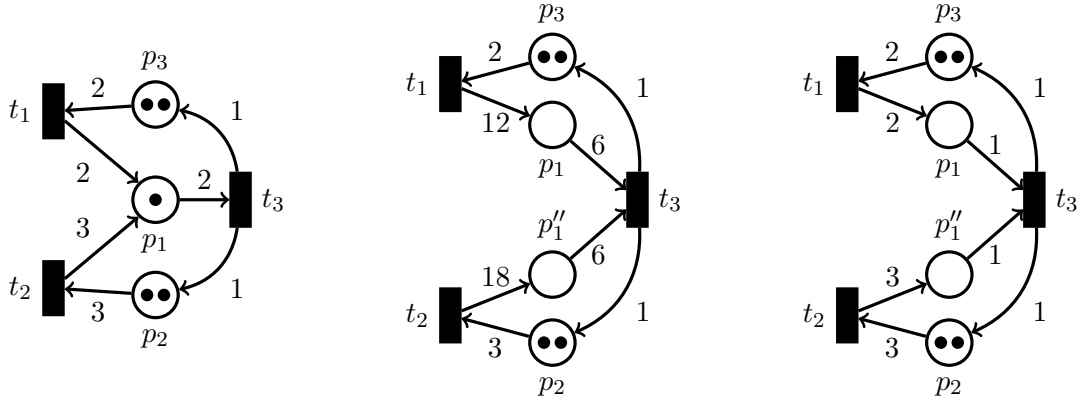

Figure 4.8: The balanced FA system on the left satisfies the condition of Theorem 12 on page 61 ( $\sum_{p \in P} M_0(p) = 5 > \sum_{p \in P} (\max_p - \gcd_p) = 4$ ), while the place-splitting transformation results in the non-live normalized T-system on the right. Hence, the condition of Theorem 19 on page 70 does not subsume the condition of Theorem 12 on page 61.

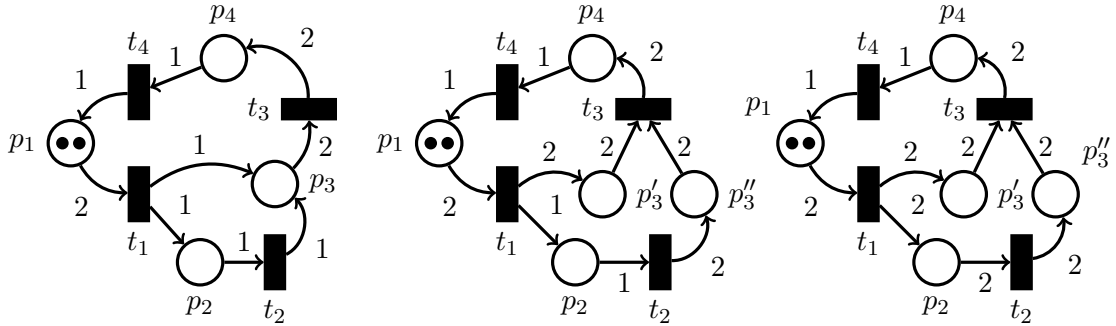

Figure 4.9: On the left, the live and balanced Fork-Attribution system does not satisfy the condition of Theorem 12 on page 61:  $\sum_{p \in P} (\max_p - \gcd_p) = 2$ , the condition requires three tokens whereas two tokens are sufficient for liveness. The system in the center is the well-formed unnormalized T-system obtained by the place-splitting transformation. On the right, the normalized version of the T-system is obtained from it upon scaling the place  $p_2$  by 2. Since two tokens are present on every circuit  $C$  of the normalized T-system while  $\sum_{p \in C} (\max_p - \gcd_p) = 1$ , the liveness condition of Theorem 17 on page 68 is fulfilled and the condition of Theorem 12 on page 61 does not subsume the condition of Theorem 19 on page 70.

#### 4.6 The sufficient conditions are not necessary

The comparison of the polynomial sufficient conditions in the previous section shows that the T-system obtained by the place-splitting transformation needs not be live to ensure

## Chapter 4. Polynomial sufficient conditions of liveness for well-formed Join-Free and Equal-Conflict systems

---

the liveness of the Choice-Free system (see Figure 4.8 on the preceding page). Thus, this sufficient condition is not necessary.

The other sufficient conditions of liveness are based on Theorem 12 on page 61, which is not necessary, as shown on the counter example of Figure 4.10, which has been developed in the context of T-systems [Marchetti 2009]. A live circuit is pictured that does not fulfill the sufficient condition of Theorem 12 on page 61. Indeed,

$$\sum_p (max_p - gcd_p) = (14 - 2) + (21 - 7) + (6 - 3) = 29.$$

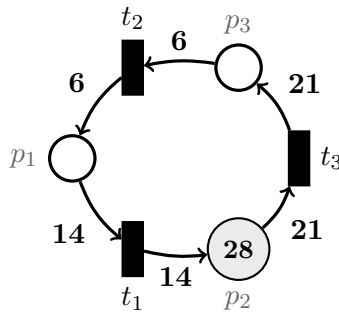

Figure 4.10: This circuit is live but does not fulfill the polynomial sufficient conditions of the previous sections.

The reachability graph of Figure 4.11 shows that every transition can be fired from any reachable marking after a finite firing sequence, thus the circuit of Figure 4.10 is live.

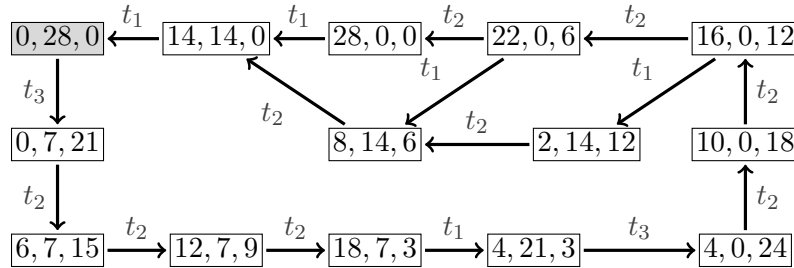

Figure 4.11: The reachability graph of the circuit shows all the feasible sequences. Starting from any reachable marking, there exists a finite feasible sequence containing every transition, thus implying liveness.

## **4.7 Conclusion**

We applied the balancing transformation to the well-formed Join-Free nets. For this class, and for well-formed Equal-Conflict nets, we obtained the first polynomial sufficient conditions of liveness. All these conditions and markings have a polynomial time complexity, and require only a linear number of initial tokens, whereas prior methods used exponential time algorithms or an exponential number of initial tokens.

We also exploited the place-splitting transformation to provide another polynomial time sufficient condition of liveness for well-formed Choice-Free systems, which constitute a subclass of Equal-Conflict systems.

Finally, we compared these conditions and showed that neither one of them subsumes the others, making all of them worthy of interest.



# Reversibility of live Equal-Conflict and Join-Free systems

## Contents

---

<b>5.1</b>	<b>Reversibility of well-behaved Choice-Free systems . . . . .</b>	<b>78</b>
5.1.1	Previous results . . . . .	78
5.1.2	Preliminary definitions and results . . . . .	80
5.1.3	Polynomial markings for well-formed Fork-Attribution systems . . . . .	82
5.1.4	A result about subsequences and P-subsystems . . . . .	85
5.1.5	A necessary condition of reversibility for Choice-Free systems . . . . .	86
5.1.6	A new characterization of reversibility for Choice-Free systems . . . . .	87
5.1.7	Polynomial markings for well-formed Choice-Free systems . . . . .	93
5.1.8	A sufficient condition of liveness and reversibility . . . . .	94
5.1.8.1	Deduction of a polynomial time sufficient condition . . . . .	95
5.1.8.2	The sufficient condition is not necessary . . . . .	95
5.1.8.3	Comparison with the polynomial live home markings . . . . .	96
<b>5.2</b>	<b>Reversibility of live consistent Equal-Conflict systems . . . . .</b>	<b>96</b>
5.2.1	Reversibility is not induced by reversible P-components . . . . .	97
5.2.2	T-sequences and reversibility . . . . .	98
5.2.3	A well-behaved homogeneous S-system that is not reversible . . . . .	99
5.2.4	Feasible T-sequences do not imply liveness . . . . .	99
5.2.5	A characterization of reversibility . . . . .	99
5.2.6	Monotonicity of reversibility in well-behaved systems . . . . .	106
5.2.7	Polynomial live home markings for well-formed systems . . . . .	106
<b>5.3</b>	<b>Reversibility of well-behaved Join-Free systems . . . . .</b>	<b>110</b>
5.3.1	Polynomial live home markings . . . . .	110
<b>5.4</b>	<b>Reversibility and T-sequences for other classes . . . . .</b>	<b>113</b>
<b>5.5</b>	<b>Conclusion . . . . .</b>	<b>118</b>

---

## Chapter 5. Reversibility of live Equal-Conflict and Join-Free systems

---

In this chapter, we study the reversibility property under the liveness hypothesis in strongly connected well-formed Equal-Conflict and Join-Free systems. In some cases, we also study Equal-Conflict systems that are not necessarily well-formed.

In the previous chapter, we provided polynomial sufficient conditions of liveness for well-formed Equal-Conflict and Join-Free systems, allowing to build well-behaved expressive systems efficiently. Once the fundamental properties of liveness and boundedness are ensured, reversibility is the next property to be considered since it is often needed by real applications. Moreover, once a system is known to be live and reversible, the study of the reachability graph may be greatly simplified.

The liveness and reversibility properties are not tightly related: there exist live systems that are not reversible, and reversible systems that are not live [Murata 1989]. Reversibility has already been investigated under the well-behavedness hypothesis in several subclasses of weighted Petri nets. In the case of T-systems, reversibility is induced by well-behavedness. This implication is no longer true for Fork-Attribution systems [Teruel 1997], since there exist well-behaved Fork-Attribution systems that are not reversible. Polynomial methods exist that build live markings for T-systems [Marchetti 2009], hence reversibility is also efficiently ensured for this class. Home markings, as well as a characterization of reversibility, exist for well-behaved Choice-Free systems [Teruel 1997]; however, such live home markings are built either in exponential time or in polynomial time with an exponential number of initial tokens. The existence of home markings in well-behaved Equal-Conflict systems has been proved [Teruel 1993], although no characterization of reversibility and no dedicated method to build home markings are given.

Our contributions are organized as follows. First, in Section 5.1, we present the first polynomial live and reversible initial marking for the class of Fork-Attribution systems. Then, we study the more general class of Choice-Free systems, for which we present a new characterization of reversibility and deduce the first polynomial live home markings, using the marking found for the Fork-Attribution subclass. We also provide another original sufficient condition of liveness and reversibility, as well as a polynomial one, with the help of the place-splitting transformation. We then compare all these conditions.

Thereafter, in Section 5.2, we study the reversibility of live consistent Equal-Conflict systems. With the help of a counterexample, we first show that our decomposition method for Choice-Free systems cannot be extended to the Equal-Conflict class. We also show that well-behavedness of a homogeneous S-system does not imply its reversibility, giving insight into which supplementary assumption should be made to ensure the reversibility of this class. We consequently obtain the first non-trivial characterization of reversibility for live consistent Equal-Conflict systems, encompassing Choice-Free systems and homogeneous Join-Free systems. We compare this characterization with a known one in the particular case of Choice-Free systems. This result leads to the first polynomial live home markings for well-formed Equal-Conflict systems.

## 5.1. Reversibility of well-behaved Choice-Free systems

---

In Section 5.3, we use these new methods to obtain the first polynomial live reversible markings for well-formed Join-Free systems, in which the homogeneity constraint is removed.

Finally, in Section 5.4, we test our characterization of reversibility for Equal-Conflict systems in larger classes.

### 5.1 Reversibility of well-behaved Choice-Free systems

In this section, we first recall several properties of Choice-Free systems, that obviously apply to their Fork-Attribution subclass. Building on these results, we provide a polynomial live and reversible initial marking for the Fork-Attribution class.

Then, under the well-behavedness hypothesis, we provide for Choice-Free systems a new necessary and sufficient condition of reversibility that is expressed in terms of the reversibility of particular subsystems, namely strongly connected FA P-subsystems. This result extends a known liveness condition for well-formed Choice-Free systems, improving our understanding of their behavior from the decomposition point of view. To prove this condition, we exploit a known characterization of reversibility as well as a property of the sequences that are feasible in P-subsystems. Moreover, this approach allows to construct, for these systems, a *polynomial*, meaning in polynomial time with a polynomial number of tokens, live and reversible initial marking, whereas the older characterization gives no direct solution to this problem. We compare our result to the liveness and reversibility of the T-system subclass, in which the interesting P-subnets are circuits.

Finally, we provide a sufficient condition of liveness and reversibility that is based on the place-splitting transformation. We deduce a polynomial time sufficient condition of liveness and reversibility that we compare with the previous polynomial markings, which can also be seen as polynomial sufficient conditions since every larger marking is also live and reversible.

#### 5.1.1 Previous results

We recall properties of Choice-Free systems that arise from their absence of conflicts and deal with liveness, reversibility and languages.

**Liveness by decomposition.** A decomposition theory has been developed for Equal-Conflict systems [Teruel 1996] and specialized for Choice-Free systems [Teruel 1997], allowing to get insight into their structure and behavior by studying particular subsystems. The next result shows the relevance of FA P-subsystems to the study the liveness in Choice-Free systems.

**Proposition 11** (Characterization of liveness [Teruel 1997]). *Consider a Choice-Free system  $S = (N, M_0)$  without source places.  $S$  is live if and only if all the strongly connected FA P-subsystems  $S_* = ((P_*, T_*, W_*), M_0|_{P_*})$  of  $S$  are live.*



## Chapter 5. Reversibility of live Equal-Conflict and Join-Free systems

---

Proposition 11 on the preceding page may be partly seen as a specialization of Proposition 8 on page 65 for Equal-Conflict systems when restricted to Choice-Free systems, in which case the well-formed Join-Free P-subsystems become well-formed Fork-Attribution P-subsystems.

**Reversibility under the well-behavedness hypothesis.** A characterization of reversibility for well-behaved Choice-Free systems, presented in [Teruel 1997], is recalled below. This statement relies on the feasibility of a sequence whose Parikh vector is equal to the minimal T-semiflow.

**Proposition 12** (Characterization of reversibility [Teruel 1997]). *Consider a well-behaved and strongly connected Choice-Free system  $S = (N, M_0)$  with unique minimal T-semiflow  $Y$ .  $S$  is reversible if and only if a sequence  $\sigma_Y$  such that  $\vec{\sigma}_Y = Y$  is feasible at  $M_0$ .*

**Persistent systems and confluence.** A system is persistent if every reachable marking  $M$  that enables two transitions  $t_1$  and  $t_2$  enables the sequence  $t_1 t_2$ . Persistent systems encompass the structurally persistent Choice-Free systems and have a *confluent* language [Keller 1975, Lien 1976, Teruel 1997, Best 2008]. This property is also known as the *Church-Rosser* property in the context of rewriting systems. A constructive theorem of confluence for persistent systems exists [Best 2008], however, we only need the following one, illustrated in Figure 5.1.

**Proposition 13** (Confluence ([Teruel 1997])). *Consider a Choice-Free system  $(N, M_0)$ . If  $M_1$  and  $M_2$  are reachable markings such that  $M_0 \xrightarrow{\sigma} M_1$  and  $M_0 \xrightarrow{\tau} M_2$  then a marking  $M_3$  exists such that  $M_1 \xrightarrow{\alpha} M_3$  and  $M_2 \xrightarrow{\beta} M_3$ , where the feasible sequences  $\alpha$  and  $\beta$  satisfy the following conditions for every transition  $t$ :*

$$\begin{aligned}\vec{\alpha}(t) &= \max\{\vec{\sigma}(t), \vec{\tau}(t)\} - \vec{\sigma}(t) \\ \vec{\beta}(t) &= \max\{\vec{\sigma}(t), \vec{\tau}(t)\} - \vec{\tau}(t).\end{aligned}$$

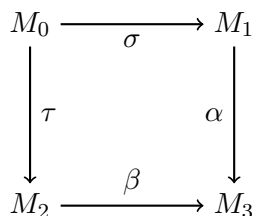

Figure 5.1: If the sequences  $\sigma$  and  $\tau$  are feasible in the Choice-Free system, then the feasible sequences  $\alpha$  and  $\beta$  exist and reach the same marking  $M_3$ .

5.1.2 Preliminary definitions and results

Sequences whose Parikh vector equals a T-semiflow are strongly related to the reversibility property, since such sequences return to the same marking. Starting from this fact, we study particular sequences that are smaller than some T-semiflows. We provide below definitions that will simplify our study of reversibility and deal with such sequences, as well as technical lemmas.

**Definition 10** (Transient sequences and systems). *Let  $S = (N, M_0)$  be a system having a T-semiflow  $Y$ . A sequence  $\sigma$  is transient relative to  $Y$  if its Parikh vector is smaller but not equal to  $Y$ , that is  $\vec{\sigma}(t) \leq Y(t)$  for every transition  $t$  and  $\vec{\sigma}(t') < Y(t')$  for at least one transition  $t'$ , noted  $\vec{\sigma} \not\leq Y$ . The firing of  $\sigma$  in  $S$ , when feasible and leading to a marking  $M$ , induces a transient system denoted by the quadruple  $(N, M, \sigma, Y)$ .*

This definition is illustrated in Figure 5.2.

In order to simplify our study of transient sequences and systems, we partition the places and transitions into *ready* and *frozen* ones, as specified below.

**Definition 11** (Ready or frozen). *Consider a transient system  $S = (N, M, \sigma, Y)$ . A transition  $t$  is ready in  $S$  if  $\vec{\sigma}(t) < Y(t)$ , otherwise the transition is frozen in  $S$ , in which case  $\vec{\sigma}(t) = Y(t)$ . A place is ready in  $S$  if it is an input of a transition that is ready in  $S$ , otherwise it is frozen in  $S$ .*

Figure 5.2 pictures ready and frozen nodes.

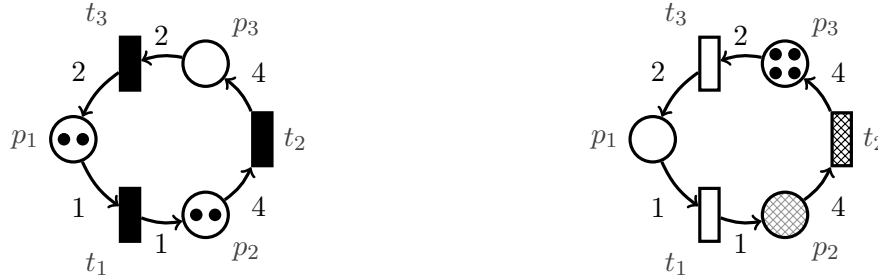

Figure 5.2: These circuits have the unique minimal T-semiflow  $Y = (4, 1, 2)$ . The feasible sequence  $\sigma = t_1 t_1 t_2$  is transient relative to  $Y$  since  $\vec{\sigma} = (2, 1, 0) \not\leq (4, 1, 2) = Y$ . Thus, the firing of  $\sigma$  in the system on the left leads to the system on the right, which is transient relative to  $Y$ . All transitions on the left are initially ready relative to  $Y$ . On the right, the transition  $t_2$  is frozen since  $\vec{\sigma}(t_2) = 1 = Y(t_2)$ . Consequently, all the input places of  $t_2$  are frozen, namely the place  $p_2$ .

**Remark.** Applying the previous definitions, all input places of a ready transition are always ready in any Petri net, even if these places have some output transitions that are

## Chapter 5. Reversibility of live Equal-Conflict and Join-Free systems

frozen. Thus, in the general case, places that are inputs of a frozen transition may not always be frozen. However, in the particular case of (strongly connected) Choice-Free systems, the type of a place is defined by the type of its unique output transition: all output transitions of the ready places are ready, all output transitions of the frozen places are frozen. These facts are pictured in Figure 5.3.

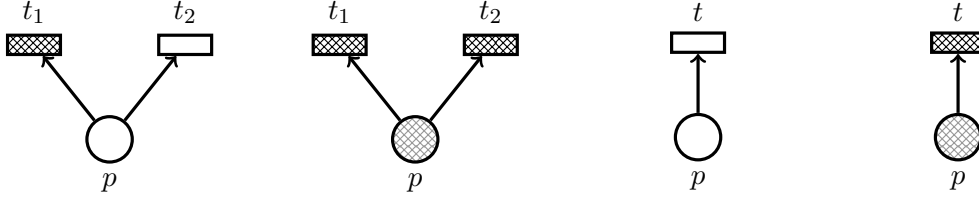

Figure 5.3: Starting from the left, the first system shows a place having a ready output and a frozen output, thus the place is ready. The second system shows a place with only frozen outputs, thus the place is frozen. The other two systems represent the particular case of places having only one output: the place has the same type as its output.

As the following lemma shows, a frozen place in a transient system cannot contain more than its initial number of tokens.

**Lemma 4.** *Consider a system  $S = (N, M_0)$  with  $N = (P, T, W)$  and a transient sequence  $\sigma$  such that  $M_0 \xrightarrow{\sigma} M$  and there exists a frozen place  $p$  in  $S' = (N, M, \sigma, Y)$ . If all input transitions of  $p$  are frozen in  $S'$ , then  $M(p) = M_0(p)$ , otherwise  $M(p) < M_0(p)$ .*

*Proof.* The sequence  $\sigma$  is transient thus  $\vec{\sigma}(t) \leq Y(t)$  for every transition  $t$ . Besides,  $p$  is frozen thus every output transition  $t$  of  $p$  has fired exactly  $Y(t)$  times:  $\forall t \in p^\bullet, \vec{\sigma}(t) = Y(t)$ , and every input transition  $t_i$  of  $p$  has fired at most  $Y(t_i)$  times.

We deduce that

$$\begin{aligned} M(p) &= M_0(p) + \sum_{t_i \in \bullet p} W(t_i, p) \cdot \vec{\sigma}(t_i) - \sum_{t_i \in p^\bullet} W(p, t_i) \cdot \vec{\sigma}(t_i) \\ &\leq M_0(p) + \sum_{t_i \in \bullet p} W(t_i, p) \cdot Y(t_i) - \sum_{t_i \in p^\bullet} W(p, t_i) \cdot Y(t_i) = M_0(p). \end{aligned}$$

The equality  $M(p) = M_0(p)$  is obtained when all input transitions  $t_i$  are frozen and thus have been fired  $Y(t_i)$  times. The inequality is strict when at least one of them has been fired a strictly smaller number of times.  $\square$

An example is pictured on the right of Figure 5.2:  $p_2$  is frozen and cannot contain more than 2 tokens ; moreover, its input transition  $t_1$  is ready, thus  $p_2$  must contain strictly fewer than 2 tokens. Indeed, it does not contain any token in this example.

## 5.1. Reversibility of well-behaved Choice-Free systems

---

The following technical lemma deals with the inputs of particular frozen places in transient Choice-Free systems.

**Lemma 5.** *Consider a strongly connected and transient Choice-Free system  $S = (N, M, \sigma, Y)$ . If  $S$  contains at least one frozen place, then it contains a frozen place with at least one ready input in  $S$ .*

*Proof.* Since  $S$  is transient, it contains a ready place. As  $S$  is strongly connected, there exists an elementary path from a ready place to a frozen place. Moreover, the unique output transition of any ready place is ready. Consequently, a frozen place on the path has at least one ready input transition.  $\square$

The transient system on the right of Figure 5.2 contains the frozen place  $p_2$ , which has a ready input  $t_1$ .

### 5.1.3 Polynomial markings for well-formed Fork-Attribution systems

Fork-Attribution systems form a subclass of Choice-Free systems from which they inherit their properties. Strongly connected well-formed Choice-Free nets are shown in [Teruel 1997] to have exactly one minimal T-semiflow whose support is the set of all transitions (Proposition 4 on page 31); it follows that such a T-semiflow also exists for strongly connected well-formed Fork-Attribution nets. Moreover, a live initial marking is a home marking if and only if it enables a firing sequence whose Parikh vector is equal to the minimal T-semiflow (Proposition 12 on page 79).

We use previous properties on transient sequences, as well as a new technical lemma about enabled places, to show that the live markings of Theorem 14 on page 64 (for well-formed Join-Free systems) allow to fire a sequence whose Parikh vector is equal to this minimal T-semiflow in well-formed FA systems. We deduce that these live markings, denoted by  $\mathcal{M}_{\text{FA}}$ , are also home markings for these FA systems. Finally, we note that this proof cannot be trivially extended to Choice-Free or Join-Free systems, due to the existence of synchronizations or choices, respectively.

We show next that for a well-formed FA net initially marked by  $\widehat{M}_0$ , which represents any of the live markings of the set  $\mathcal{M}_{\text{FA}}$ , there is at least one enabled ready place after any transient sequence.

**Lemma 6** (Enabled ready place). *Consider a strongly connected and well-formed FA system  $S_{\text{FA}} = (N, \widehat{M}_0)$  with  $N = (P, T, W)$  and a sequence  $\sigma$  that is transient relative to a T-semiflow  $Y$  such that  $\widehat{M}_0 \xrightarrow{\sigma} \widehat{M}$ . Then there exists at least one enabled ready place in  $(N, \widehat{M}, \sigma, Y)$ .*

*Proof.* Let  $S_\sigma = (N, \widehat{M}, \sigma, Y)$ . On one hand, since  $\sigma$  is transient, there exists at least one ready place in  $S_\sigma$ . On the other hand, since the system  $S_{\text{FA}}$  is live by Theorem 14 on page 64 and places have exactly one output transition, there exists at least one enabled place in  $S_\sigma$ .

## Chapter 5. Reversibility of live Equal-Conflict and Join-Free systems

The claim of the theorem is clearly true if all places are ready in  $S_\sigma$ . The remainder of the proof deals with the case where some places are not ready in  $S_\sigma$ .

The system  $S_{FA}$  is conservative hence, according to Theorem 4 on page 42, it can be balanced. Let  $S'_{FA} = (N', \widehat{M}'_0)$ , with  $N' = (P, T, W')$ , be a balancing of  $S_{FA}$ . The sequence  $\sigma$  is feasible in  $S'_{FA}$  by Theorem 1 on page 38, hence there exists  $\widehat{M}'$  such that  $\widehat{M}'_0 \xrightarrow{\sigma} \widehat{M}'$ . By Theorem 2 on page 39,  $S_{FA}$  and  $S'_{FA}$  have the same unique minimal T-semiflow  $Y$ , hence  $\sigma$  is transient in both systems and, consequently,  $\widehat{M}$  and  $\widehat{M}'$  have the same sets of ready and frozen places.

Thus, there is at least one ready place in  $S'_\sigma = (N', \widehat{M}', \sigma, Y)$ .

Considering the transient sequence  $\sigma$ , the set of frozen places having only frozen inputs (potentially empty) is denoted by  $P_f$ , the set of the frozen places having at least one ready input (not empty by assumption and by Lemma 5) by  $P_{fr}$  and the set of ready places (not empty by assumption) by  $P_r$ . As depicted in Figure 5.4,  $P_f$ ,  $P_{fr}$  and  $P_r$  form a tri-partition of the places of  $S_{FA}$  and  $S'_{FA}$ :

$$\sum_{p \in P} \widehat{M}'(p) = \sum_{p \in P_f} \widehat{M}'(p) + \sum_{p \in P_{fr}} \widehat{M}'(p) + \sum_{p \in P_r} \widehat{M}'(p),$$

hence

$$\sum_{p \in P_r} \widehat{M}'(p) = \sum_{p \in P} \widehat{M}'(p) - \sum_{p \in P_f \cup P_{fr}} \widehat{M}'(p). \quad (5.1)$$

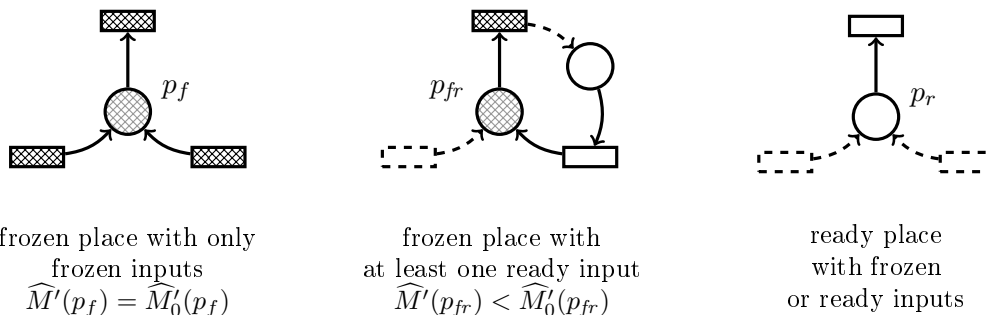

Figure 5.4: The frozen nodes are shaded, while the ready nodes are white. The dashed nodes can be either frozen or ready. The places of the transient system are tri-partitioned into frozen places having only frozen inputs (the set  $P_f$ ), frozen places having at least one ready input (the set  $P_{fr}$ ) and ready places (the set  $P_r$ ). The number of tokens in a frozen place  $p$  is bounded above by  $\widehat{M}'_0(p)$ . As the number of tokens in the system remains constant, this tri-partition provides a lower bound of the total number of tokens in ready places.

## 5.1. Reversibility of well-behaved Choice-Free systems

---

This is also true for the initial marking:

$$\sum_{p \in P_r} \widehat{M}'_0(p) = \sum_{p \in P} \widehat{M}'_0(p) - \sum_{p \in P_f \cup P_{fr}} \widehat{M}'_0(p). \quad (5.2)$$

Since the number of tokens remains constant in  $S'_{FA}$ ,  $\sum_{p \in P} \widehat{M}'_0(p) = \sum_{p \in P} \widehat{M}'(p)$ , and the first terms on the right-hand side of the above two equations are equal.

By Lemma 4 on page 81,

$$\sum_{p \in P_f} \widehat{M}'(p) = \sum_{p \in P_f} \widehat{M}'_0(p)$$

and, since  $P_{fr}$  is not empty,

$$\sum_{p \in P_{fr}} \widehat{M}'(p) < \sum_{p \in P_{fr}} \widehat{M}'_0(p),$$

hence the last terms on the right-hand side of the equations satisfy

$$\sum_{p \in P_f \cup P_{fr}} \widehat{M}'(p) < \sum_{p \in P_f \cup P_{fr}} \widehat{M}'_0(p).$$

Thus the right-hand side of eqn. (5.2) is strictly smaller than the right-hand side of eqn. (5.1) and

$$\sum_{p \in P_r} \widehat{M}'(p) > \sum_{p \in P_r} \widehat{M}'_0(p) \geq \sum_{p \in P_r} (\max'_p - \gcd'_p),$$

where the last inequality follows from the definition of  $\widehat{M}'_0$ .

Recall that the tokens of  $\widehat{M}'$  are all useful tokens, since  $\widehat{M}'_0$  contains only useful tokens. Thus, at least one place of  $P_r$  is then enabled by  $\widehat{M}'$ , having  $\max'_p$  or more tokens in  $\widehat{M}'$ . The language of the system is preserved (Theorem 1 on page 38) and every feasible sequence is transient relatively to the same minimal T-semiflow (Theorem 2 on page 39), thus ready places enabled in  $S'_\sigma$  are also ready and enabled in  $S_\sigma$ .  $\square$

The following result states that the polynomial live markings of the set  $\mathcal{M}_{FA}$  (Theorem 14 on page 64 when restricted to FA nets) are also home markings for every strongly connected and well-formed FA net. We denote by  $\widehat{M}_0$  any of the live markings of  $\mathcal{M}_{FA}$ .

**Theorem 20** (The set of polynomial live home markings  $\mathcal{M}_{FA}$ ). *If  $N_{FA}$  is a weighted, strongly connected and conservative FA net, then the system  $S_{FA} = (N_{FA}, \widehat{M}_0)$  is live and reversible. Moreover, every larger initial marking is also live and reversible.*

## Chapter 5. Reversibility of live Equal-Conflict and Join-Free systems

---

*Proof.* The system is live by Theorem 14 on page 64. According to Lemma 6 on page 82, for any transient sequence  $\sigma$  with  $\widehat{M}_0 \xrightarrow{\sigma} \widehat{M}$ , at least one ready place is enabled by  $\widehat{M}$ . Moreover, every transition has only one input place. Thus, a ready transition is enabled by  $\widehat{M}$  and a sequence  $\sigma_Y$  whose Parikh vector equals the minimal T-semiflow of  $S_{FA}$  can be fired exactly. By Proposition 12 on page 79, the claim is proved. By Theorem 15 on page 65, liveness is monotonous in well-formed FA systems. Moreover, any larger marking also enables  $\sigma_Y$ , and hence preserves the reversibility.  $\square$

**An extension to more expressive classes is not trivial.** An extension of this proof to all well-formed Choice-Free nets would show that after any transient sequence, a ready transition is enabled, even if only join-transitions are ready. However, it is not clear that the coverability of the Choice-Free net by live and reversible strongly connected FA P-subnets induces the existence, after any transient sequence, of a ready transition whose input places are all enabled. Thus, the proof cannot be easily extended to well-formed Choice-Free nets.

Well-formed Join-Free nets do not benefit from a characterization of home markings such as the one given in Proposition 12 on page 79 for Choice-Free nets. Thus, the proof cannot be applied to Join-Free nets either.

**Towards a generalization.** In later sections, we develop original methods to study the reversibility of larger classes of nets. In this section, we focus on well-formed Choice-Free nets, which are covered by well-formed FA P-subnets (Proposition 5 on page 31), and we provide the first polynomial live home markings for FA systems. The idea is therefore to express the reversibility of a Choice-Free system in terms of the reversibility of FA P-subsystems. For that purpose, we need to study first the relationship between the sequences feasible in a system and the subsequences feasible in its subsystems.

### 5.1.4 A result about subsequences and P-subsystems

We present a general technical result about the restriction of sequences to P-subsystems. Such subsequences have been used in [Teruel 1996].

**Lemma 7.** *Consider a system  $S = (N, M_0)$ , where  $N = (P, T, W)$ , together with one of its P-subsystems  $S' = (N', M_0|_{P'})$ , where  $N' = (P', T', W')$ . For every feasible sequence  $\sigma$  in  $S$ , the subsequence  $\sigma|_{T'}$  is feasible in  $S'$ . Moreover, if  $M_0 \xrightarrow{\sigma} M$  in  $S$  and  $M_0|_{P'} \xrightarrow{\sigma|_{T'}} M'$  in  $S'$ , then  $M|_{P'} = M'$ .*

*Proof.* We prove the claim by induction on the size of a feasible sequence of size  $k$  in  $S$ . If  $\sigma$  is empty, it is feasible in both systems and the marking is unchanged.

Hence, suppose that  $\sigma = \sigma_1 t$  is feasible in  $S$ , where  $\sigma_1$  has size  $k - 1$ , and that the claim is true when the size of the sequence is strictly smaller than  $k$ . We note  $M_0 \xrightarrow{\sigma_1} M_1 \xrightarrow{t} M_2$  in  $S$ . By the induction hypothesis,  $\sigma_1|_{T'}$  is feasible in  $S'$ , we note  $M_0|_{P'} \xrightarrow{\sigma_1|_{T'}} M'_1$  in  $S'$ , and for every place  $p$  in  $P'$ ,  $M_1(p) = M'_1(p)$ .

## 5.1. Reversibility of well-behaved Choice-Free systems

---

As  $S'$  is a P-subsystem of  $S$ , a transition belongs to  $T'$  if and only if it is an input or output of at least one place of  $P'$ .

If  $t$  is not in  $T'$  then  $\sigma_{1|T'}$  equals  $\sigma_{|T'}$ , which is thus feasible in  $S'$ . Moreover,  $t$  does not modify the marking of places in  $P'$ , thus  $M'_1 = M_{2|P'}$ .

Otherwise  $t$  belongs to  $T'$  and is enabled in  $(N, M_1)$ . Moreover,  $M_{1|P'} = M'_1$ , implying that the input places of  $t$  that belong to  $P'$  are enabled in  $(N', M'_1)$ , thus  $t$  is enabled in  $(N', M'_1)$ . We note  $M'_1 \xrightarrow{t} M'_2$ . Finally, a place  $p$  in  $P'$  is an input or output of  $t$  in  $N$  if and only if it is one or the other in  $N'$  thus  $M_{2|P'} = M'_2$ .  $\square$

This lemma is illustrated in Figure 5.5.

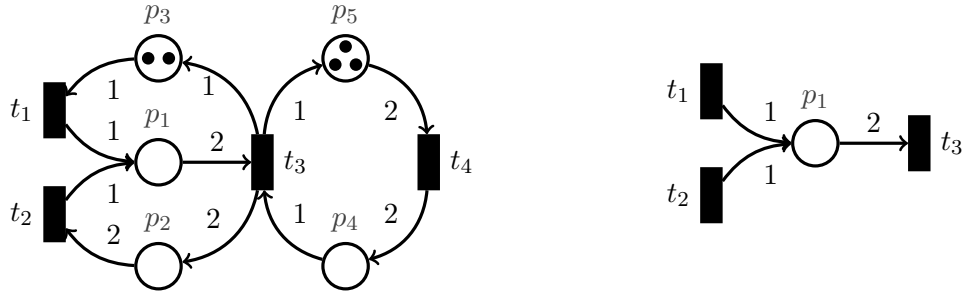

Figure 5.5: The P-subsystem on the right is obtained from the system on the left by considering only the place  $p_1$ . The sequence  $\sigma = t_4 t_1 t_1 t_3 t_4$  is feasible in the system on the left. Consequently, the subsequence  $\sigma'$  obtained by restricting  $\sigma$  to the set of transitions  $\{t_1 t_2 t_3\}$ , that is  $t_1 t_1 t_3$ , is feasible in the P-subsystem on the right.

### 5.1.5 A necessary condition of reversibility for Choice-Free systems

As mentioned earlier, we focus on strongly connected well-behaved Choice-Free systems. We present here the necessity part of our characterization of reversibility. For that purpose, we need the following lemma, deduced from [Teruel 1997].

**Lemma 8** (Sequence reordering [Teruel 1997]). *Consider a strongly connected and well-formed Choice-Free system  $S = (N, M_0)$  with minimal T-semiflow  $Y$ . If there exists a positive integer  $k$ ,  $k \geq 1$ , and a feasible sequence  $\sigma$  in  $S$  such that  $\vec{\sigma} = k \cdot Y$ , then there exists a feasible sequence  $\sigma_Y$  in  $S$  such that  $\vec{\sigma}_Y = Y$ . Consequently, the sequence  $(\sigma_Y)^k$  is feasible in  $S$ .*

The name *reordering* in the lemma comes from the existence of another feasible sequence,  $\sigma_Y$  concatenated  $k$  times, with Parikh vector obviously equal to the Parikh vector of  $\sigma$ , leading therefore to the same marking as  $\sigma$ .



We are now able to prove the necessary condition of reversibility.

**Theorem 21** (Necessary condition of reversibility). *Consider a strongly connected well-behaved Choice-Free system  $S = ((P, T, W), M_0)$ . The reversibility of  $S$  implies the reversibility of each of its strongly connected FA P-subsystems.*

*Proof.* By Propositions 1 on page 29 and 4 on page 31,  $S$  is well-formed and has a unique minimal T-semiflow  $Y$ , whose support is the whole set  $T$ .  $S$  is reversible, thus by Proposition 12 on page 79, there exists a sequence  $\sigma_Y$  that is feasible in  $S$  and whose Parikh vector is equal to  $Y$ . Consider  $S_* = ((P_*, T_*, W_*), M_0|_{P_*})$  a strongly connected FA P-subsystem of  $S$ , with minimal T-semiflow  $Y_*$ . The sequence  $\sigma_Y|_{T_*}$  is feasible in  $S_*$  by Lemma 7 on page 85. Moreover  $\vec{\sigma}_Y|_{T_*} = Y|_{T_*}$  and  $Y|_{T_*}$  is a multiple of  $Y_*$  by Proposition 5 on page 31. We deduce that  $\vec{\sigma}_Y|_{T_*}$  is a multiple of  $Y_*$ . Thus, by Lemma 8, there exists a sequence  $\sigma_{Y_*}$  feasible in  $S_*$  and with Parikh vector equal to  $Y_*$ . By Proposition 12 on page 79,  $S_*$  is reversible.  $\square$

### 5.1.6 A new characterization of reversibility for Choice-Free systems

We prove the sufficiency part of the characterization, stating that the non-reversibility of the whole system implies the existence of a non-reversible FA P-subsystem. For that purpose, we provide an intermediate characterization of reversibility which involves firing sequences. Then, using decomposition arguments, we prove the main characterization of reversibility.

In a system which is transient relative to a T-semiflow  $Y$ , the firing of a ready transition reduces the number of steps to attain  $Y$ . However, ready transitions may not be enabled, in which case the possibility to reach again the initial marking may be compromised. We formalize next the notion of blocking system, whose ready transitions cannot be fired.

**Definition 12** (Blocking system). *A transient system is blocking if it contains no enabled ready transition.*

Figure 5.6 pictures an FA system and an associated blocking system.

Therefore, we focus on strongly connected well-behaved Choice-Free systems, which are well-formed (Proposition 1 on page 29) and have a unique minimal T-semiflow, whose support contains all transitions (Proposition 4 on page 31). Thus, the Parikh vector of any feasible sequence is smaller than some multiple of the minimal T-semiflow  $Y$ . If such a system  $S = (N, M, \sigma, Y')$  is blocking then liveness induces the existence of an enabled frozen transition in  $S$  and  $Y'$  is the smallest multiple of  $Y$  greater than  $\vec{\sigma}$ . For these systems, the following characterization of reversibility is an alternative to Proposition 12 on page 79 using the notion of blocking system.

**Theorem 22** (Intermediate characterization of reversibility). *Consider a strongly connected well-behaved Choice-Free system  $S$ .  $S$  is reversible if and only if no feasible sequence in  $S$  leads to a blocking system.*

## 5.1. Reversibility of well-behaved Choice-Free systems

---



Figure 5.6: Two well-formed FA systems with minimal T-semiflow  $(1, 1, 1)$ . Relatively to this T-semiflow, the transient FA system on the right, obtained by firing the sequence  $t_1$  in the system on the left, does not contain any enabled ready transition (white transitions) since the only enabled one is  $t_1$ , which is frozen (dashed transition). Consequently, this transient system is blocking.

*Proof.* To prove that the system is reversible, it suffices to consider the empty sequence, which is transient relative to the unique minimal T-semiflow  $Y$  (Propositions 1 on page 29 and 4 on page 31). The corresponding transient system is not blocking, thus a ready transition is enabled. Firing only ready transitions, every reached marking enables a ready transition until a sequence with Parikh vector equal to  $Y$  is fired. By Proposition 12 on page 79, the system is reversible.

If  $S = (N, M_0)$  is well-behaved and reversible, there exists a feasible sequence  $\sigma_Y$  with Parikh vector equal to the minimal T-semiflow  $Y$  such that  $M_0 \xrightarrow{\sigma_Y} M_0$  (Proposition 12 on page 79). Thus, for every  $k \geq 1$ , the sequence  $\sigma_{kY} = (\sigma_Y)^k$  is feasible.

Consider a feasible sequence  $\sigma$  and the smallest integer  $k$  such that  $\sigma$  is transient relative to the T-semiflow  $Y_k = k \cdot Y$  with  $M_0 \xrightarrow{\sigma} M$ . The confluence property (Proposition 13 on page 79) states the existence of two feasible sequences  $\alpha$  and  $\beta$  such that  $M_0 \xrightarrow{\alpha} M_0$  and  $M \xrightarrow{\beta} M_0$ , satisfying, for every transition  $t$ ,

$$\begin{aligned} \vec{\alpha}(t) &= \max\{\vec{\sigma}_{kY}(t), \vec{\sigma}(t)\} - \vec{\sigma}_{kY}(t) = \vec{\sigma}_{kY}(t) - \vec{\sigma}_{kY}(t) = 0 \\ \vec{\beta}(t) &= \max\{\vec{\sigma}_{kY}(t), \vec{\sigma}(t)\} - \vec{\sigma}(t) = \vec{\sigma}_{kY}(t) - \vec{\sigma}(t). \end{aligned}$$

The feasible sequence  $\beta$  completes the transient sequence  $\sigma$  up to the T-semiflow  $Y_k$ , *i.e.*  $\vec{\sigma} + \vec{\beta} = k \cdot Y$  and we note  $M_0 \xrightarrow{\sigma \cdot \beta} M_0$ . This particular use of confluence is illustrated in Figure 5.7. We deduce that the transient system  $(N, M, \sigma, Y_k)$  contains an enabled ready transition, hence is not blocking.  $\square$

The following lemma shows the existence of a blocking FA P-subsystem in a blocking Choice-Free system with the help of graph-theoretic arguments and without considering the liveness property.

$$\begin{array}{ccc}
 M_0 & \xrightarrow{\sigma_{kY}} & M_0 \\
 \sigma \searrow & & \nearrow \beta \\
 & M &
 \end{array}$$

Figure 5.7: If both sequences  $\sigma_{kY}$  and  $\sigma$  are feasible, then there exists a sequence  $\beta$  such that  $\sigma.\beta$  is feasible and  $\vec{\sigma}_{kY} = \vec{\sigma} + \vec{\beta}$ .

**Lemma 9** (Existence of a blocking subsystem). *Consider a strongly connected transient Choice-Free system  $S = (N, M, \sigma, Y)$ . If  $S$  is blocking then it contains a non-empty strongly connected FA  $P$ -subsystem  $(N_*, M|_{P_*})$  with  $N_* = (P_*, T_*, W_*)$  such that the transient system  $(N_*, M|_{P_*}, \sigma|_{T_*}, Y|_{T_*})$  is blocking.*

*Proof.* To illustrate the proof, we depict in Figure 5.8 a Choice-Free system and the associated blocking system obtained by firing a particular feasible sequence. The same system will be used in the rest of the proof to highlight the key points.

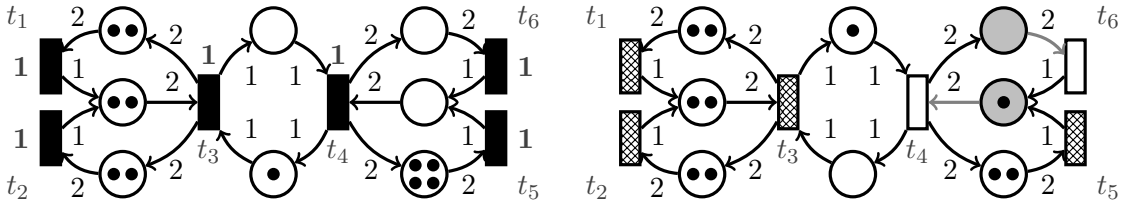

Figure 5.8: The well-behaved Choice-Free system on the left is not reversible. The firing of the sequence  $t_1 t_2 t_3 t_5$  in this system leads to the blocking system on the right, in which ready transitions are white and frozen transitions are trellised. No ready transition is enabled since the grey places are not enabled. The minimal T-semiflow, whose components are all equal to 1, is indicated on the left.

We prove the claim by induction on the number  $n$  of join-transitions. If  $n = 0$ ,  $S$  is an FA system and we are done.

Otherwise, let  $t$  be a join-transition. Either  $t$  is ready or it is frozen. If it is ready, denote by  $p$  one of its non-enabled input places; such a place exists since the whole system is blocking. Otherwise,  $t$  is frozen. Since  $S$  is strongly connected and blocking, thus transient, there exists in  $S$  an elementary path (*i.e.* that does not contain two occurrences of the same node) from a ready transition to  $t$  containing an input place  $p$  of  $t$ . Figure 5.9 pictures such an elementary path, where  $t = t_3$ , whose input place to be preserved is  $p = p_4$ .

A new system  $S'$  is obtained by deleting all input places of  $t$  except  $p$ . Denote by  $R$  the reduced graph of  $S'$ , *i.e.* the directed acyclic graph in which each node is obtained by contracting all the nodes of a maximal strongly connected component of  $S'$  into one node and each arc  $(u, v)$ ,  $u$  and  $v$  being two nodes of  $R$ , corresponds to an arc  $(a, b)$  of  $S'$  such that  $a$  belongs to  $u$  and  $b$  belongs to  $v$ . Let  $G$  be a node of  $R$  without input.

### 5.1. Reversibility of well-behaved Choice-Free systems

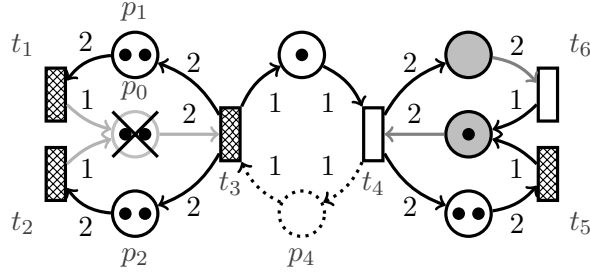

Figure 5.9: The elementary path  $t_4 p_4 t_3$  starts from the ready transition  $t_4$  and leads to the frozen transition  $t_3$ . The place  $p_4$  is preserved and the other inputs of  $t_3$ , namely  $p_0$ , are deleted.

Denoting by  $N_G = (P_G, T_G, W_G)$  the subnet of  $S'$  corresponding to  $G$ , we show that  $G = (N_G, M|_{P_G}, \sigma|_{T_G}, Y|_{T_G})$ , which is strongly connected, is a non-empty blocking P-subsystem of  $S$ . An example is depicted in Figure 5.10.

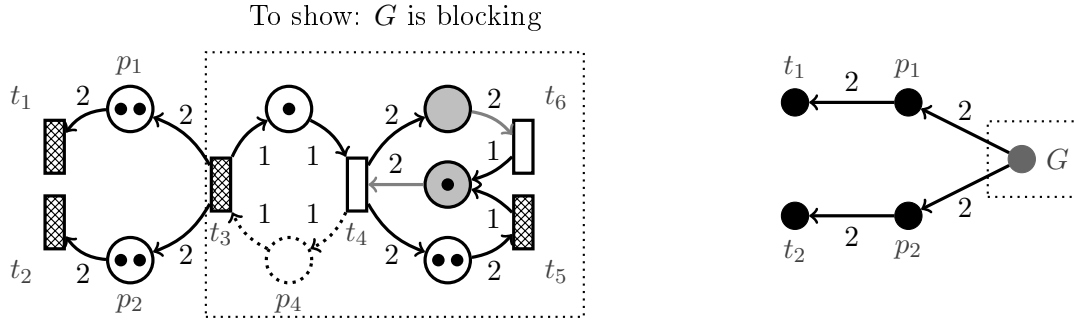

Figure 5.10: On the left, the transient system in which an input place of the frozen transition  $t_3$  has been deleted. On the right, the reduced graph represents the system on the left.  $G$  is shown to be blocking.

**$G$  is a non-empty P-subsystem of  $S$ .** Since  $S$  has a T-semiflow, it contains at least one place and one transition. Moreover,  $S$  is strongly connected and the only inputs of nodes that have been deleted are inputs of the transition  $t$ , which has one input after the deletion. Thus, every node of  $S'$  has at least one input so that  $S'$  is well-connected. We deduce that  $G$  contains at least one place and one transition. For every place  $p$  of  $G$  in  $S'$ , all inputs of  $p$  in  $S'$  belong to  $G$  since  $G$  has no input in  $R$ , while the unique output of  $p$  in  $S'$  belongs to  $G$  since  $G$  is strongly connected. Thus,  $G$  is a P-subsystem of  $S'$ , which is a P-subsystem of  $S$  since only places were removed. Hence  $G$  is a non-empty P-subsystem of  $S$ .

## Chapter 5. Reversibility of live Equal-Conflict and Join-Free systems

**$G$  is blocking.** Assume that  $S$  is obtained from  $S_0 = (N, M_0)$  by firing  $\sigma$ . Since  $G$  is a non-empty P-subsystem of  $S$ ,  $Y|_{T_G}$  is a T-semiflow of  $G$  and  $\sigma|_{T_G}$  is feasible in  $G_0 = ((P_G, T_G, W_G), M_0|_{P_G})$  by Lemma 7 on page 85. Moreover, for every transition  $t$  of  $T_G$ ,  $\vec{\sigma}|_{T_G}(t) = \vec{\sigma}(t)$ , thus if  $t$  is ready in  $S$ , it is ready in  $G$ . We show first that  $G$  contains a ready transition.

Suppose that  $G$  contains only frozen transitions, and consider a frozen transition  $t_f$  in  $G$ . Since  $S$  is strongly connected, an elementary path  $c$  from a ready transition  $t_r$  to  $t_f$  exists in  $S$ . This path does not exist in  $S'$  since  $G$  has no input, thus  $c$  contains a deleted input place of  $t$ . We note  $c = c_1 t c_2 t_f$ . The elementary path  $t c_2 t_f$  exists in  $S'$  and belongs to  $G$  since  $G$  has no input in  $R$ . If  $t$  is ready, we have a contradiction. Otherwise  $t$  is frozen, and by the choice of its deleted input places, there exists an elementary path  $c'_1$  from a ready transition  $t'_r$  to  $t$  in  $S'$ . The path  $t'_r c'_1 t c_2$  belongs to  $G$ , which thus contains a ready transition, a contradiction. Figure 5.11 depicts this case.

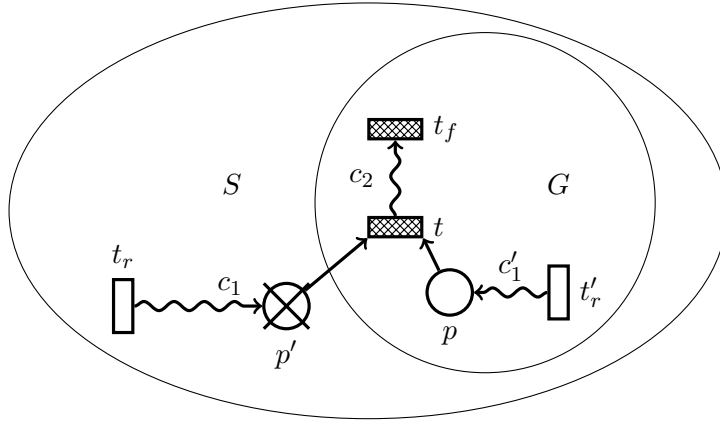

Figure 5.11: The system  $S'$  is obtained by deleting the crossed place  $p'$ . Since  $t_f$  and  $t$  are frozen, the elementary path  $t'_r c'_1 t$  belongs to  $G$ , thus  $G$  contains the ready transition  $t'_r$ .

We deduce that  $G$  contains at least one ready transition and  $\sigma|_{T_G}$  is transient relative to  $Y|_{T_G}$  in  $G_0$ . Moreover, all the transitions of  $G$  have the same inputs in  $G$  as in  $S'$ . Thus, if  $t$  belongs to  $G$  and is ready then its input place was chosen to be non-enabled, which is the case in  $G$ . The other ready transitions of  $S'$  are not enabled either, thus no ready transition of  $G$  is enabled and  $G$  is blocking. Figure 5.10 shows an example of a blocking P-subsystem  $G$ .

Finally,  $G$  is a strongly connected blocking Choice-Free P-subsystem of  $S$  containing strictly fewer join-transitions than  $S$ . Applying the induction hypothesis on  $G$ , a non-empty FA P-subsystem  $F = ((P_*, T_*, W_*), (M|_{P_G})|_{P_*}, (\sigma|_{T_G})|_{T_*}, (Y|_{T_G})|_{T_*})$  which is strongly connected and blocking exists in  $G$ , thus exists in  $S$  such that  $(M|_{P_G})|_{P_*} = M|_{P_*}$ ,  $(\sigma|_{T_G})|_{T_*} = \sigma|_{T_*}$  and  $(Y|_{T_G})|_{T_*} = Y|_{T_*}$ . Figure 5.12 shows a blocking FA P-subsystem  $F$ .  $\square$

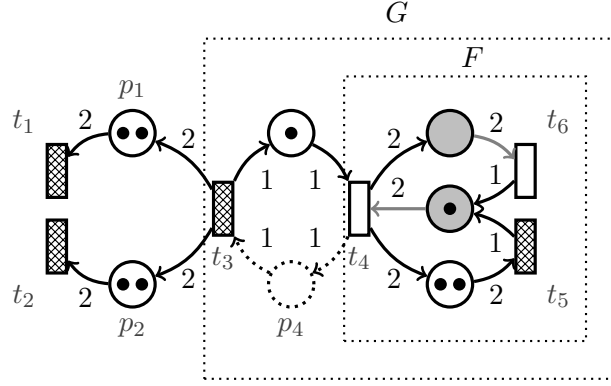

Figure 5.12: The strongly connected FA P-subsystem  $F$  is blocking.

We are now able to prove the characterization of reversibility.

**Theorem 23** (Characterization of reversibility). *Consider a strongly connected well-behaved Choice-Free system  $S = ((P, T, W), M_0)$ .  $S$  is reversible if and only if each of its strongly connected FA P-subsystems  $S_* = ((P_*, T_*, W_*), M_0|_{P_*})$  is reversible.*

*Proof.* The necessity comes from Theorem 21 on page 87. We prove the sufficiency next.

If  $S$  is empty or contains a unique place or transition, then the claim is true. Hence we suppose that  $S$  has a place and a transition. Suppose that  $S$  is not reversible, then by Theorem 22 on page 87 a sequence  $\sigma$  is feasible in  $S$  such that  $M_0 \xrightarrow{\sigma} M$ , leading to the blocking system  $S^b = ((P, T, W), M, \sigma, Y)$ , where  $Y$  is a T-semiflow of  $S$ . Besides, Lemma 9 on page 89 applies and  $S^b$  contains a non-empty strongly connected blocking FA P-subsystem  $S_*^b = ((P_*, T_*, W_*), M|_{P_*}, \sigma|_{T_*}, Y|_{T_*})$ , obtained by firing  $\sigma|_{T_*}$  in  $S_* = ((P_*, T_*, W_*), M_0|_{P_*})$ . By Propositions 5 on page 31 and 11 on page 78,  $S_*$  is well-behaved. Applying Theorem 22 on page 87,  $S_*$  is not reversible. Figure 5.13 gives examples of such subsystems.  $\square$

**Comparison with the special case of weighted T-systems.** T-systems form a proper subclass of Choice-Free systems. When strongly connected and well-formed, their liveness is equivalent to the liveness of all their circuit P-subsystems [Teruel 1992]. A characterization of reversibility for these systems is recalled next.

**Theorem 24** (Reversibility of T-systems [Teruel 1992]). *If a weighted strongly connected T-system is well-behaved, then it is reversible.*

We deduce that a well-behaved T-system is reversible if and only if all its circuit P-subsystems are live, thus reversible, constituting a particular case of Theorem 23. In the general case of Choice-Free systems, the well-behavedness of the whole system ensures the well-behavedness of all its FA P-subsystems, which may however not be reversible. This contrast is illustrated in Figure 5.14.

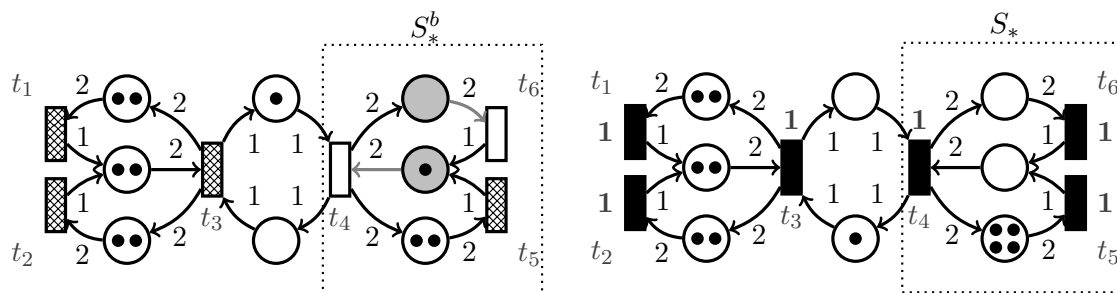

Figure 5.13: The blocking system  $S^b$  on the left is obtained by firing the sequence  $t_1 t_2 t_3 t_5$  in the initial system  $S$  on the right and contains the blocking FA P-subsystem  $S_*^b$ . The initial system  $S$  on the right contains the associated FA P-subsystem  $S_*$ . The restriction of  $t_1 t_2 t_3 t_5$  set  $T_* = \{t_4, t_5, t_6\}$  is the sequence  $t_5$ , which is feasible in  $S_*$  and leads to  $S_*^b$ .

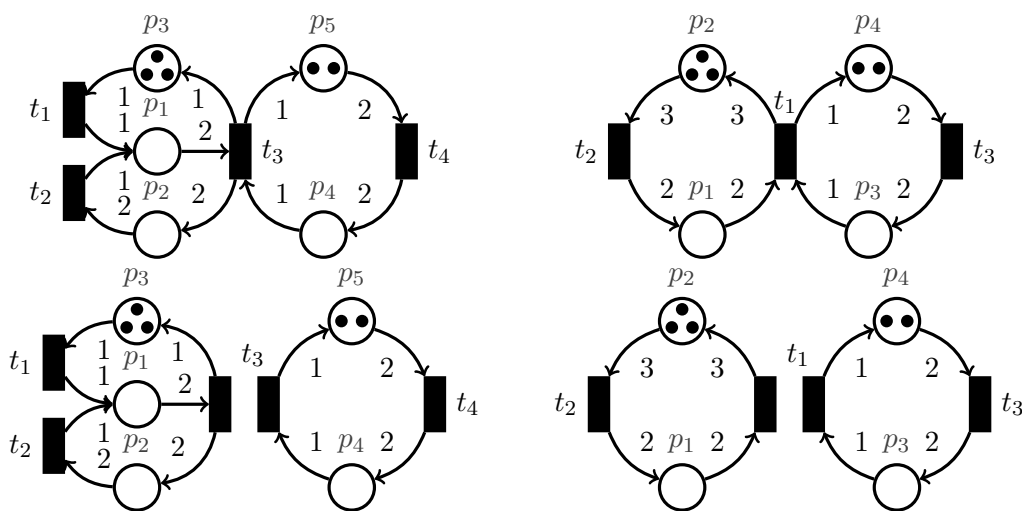

Figure 5.14: On the left, the well-behaved Choice-Free system is not reversible and contains an FA P-subsystem that is well-behaved and not reversible (bottom left). On the right, the well-formed T-system is well-behaved and reversible, as well as all its circuit P-subsystems.

### 5.1.7 Polynomial markings for well-formed Choice-Free systems

We provide the first *polynomial* live and reversible initial marking for strongly connected well-formed Choice-Free systems. To achieve this construction, we use the set of polynomial live home markings  $\mathcal{M}_{\text{FA}}$  of Theorem 20 on page 84 (for well-formed FA systems).

We denote by  $M_{\text{CF}}$  the polynomial live marking  $M_{\text{EC}}$  of Theorem 16 on page 67 when applied to the well-formed Choice-Free systems which are not FA. We show that  $M_{\text{CF}}$  is also reversible.

## 5.1. Reversibility of well-behaved Choice-Free systems

**Theorem 25** (The live home marking  $M_{CF}$ ). *Consider a strongly connected and well-formed Choice-Free net  $N$  that is not an FA. The system  $S = (N, M_{CF})$  is well-behaved and reversible. Moreover, any larger initial marking makes the system well-behaved and reversible.*

*Proof.* Every non-empty strongly connected FA P-subsystem  $S_* = (N_*, M_*)$  of  $S$  contains at least one input of a join-transition, by Lemma 2 on page 66. Since  $M_*$  is the restriction of  $M_{CF}$  to the places of  $N_*$ , we deduce that a place  $p$  in  $S_*$  contains  $max_p$  tokens, while all other places  $p'$  of  $S_*$  are assigned at least  $max_{p'} - gcd_{p'}$  tokens. Thus,  $M_*$  is greater than or equal to a marking of  $\mathcal{M}_{FA}$  and by Theorem 20 on page 84,  $S_*$  is live and reversible. Thus, all strongly connected FA P-subsystems of  $S$  are live and reversible. Applying the characterization of Theorem 23 on page 92, the Choice-Free system  $S$  is live and reversible. Besides, since well-formed Choice-Free systems constitute a particular case of bounded Equal-Conflict systems, Theorem 15 on page 65 applies and liveness is monotonous in these systems. Since  $S$  is well-formed, it has a unique minimal T-semiflow  $Y$  (Proposition 4 on page 31) and there exists a feasible sequence  $\sigma_Y$  such that  $\vec{\sigma}_Y = Y$  (Proposition 12 on page 79). Any larger initial marking enables the sequence  $\sigma_Y$ , thus preserves the reversibility property (Proposition 12 on page 79).  $\square$

This theorem is illustrated on Figure 5.15, where a well-behaved and reversible Choice-Free system is pictured, along with its two well-behaved and reversible strongly connected P-subsystems.

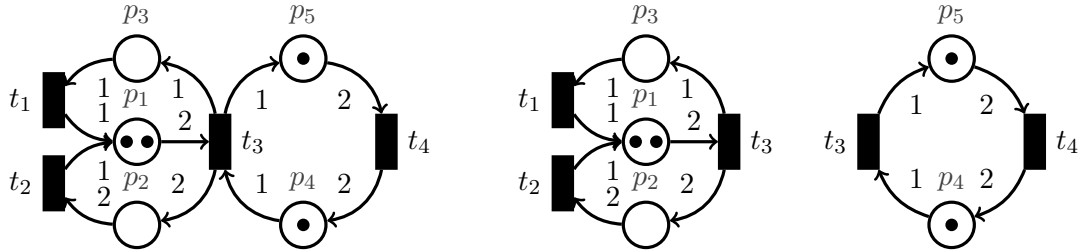

Figure 5.15: On the left, a well-behaved and reversible Choice-Free system satisfying the condition of Theorem 25. On the right, its well-behaved and reversible strongly connected FA P-subsystems.

### 5.1.8 A sufficient condition of liveness and reversibility

Previously, we presented two new necessary and sufficient conditions of reversibility for well-behaved strongly connected Choice-Free systems. For this class, the decomposition into FA P-subsystems induces polynomial markings which are reversible. However, these markings impose a distribution of the initial tokens over the entire system. In particular, initially empty places may not exist, which may cause difficulties in designing specific systems.



## Chapter 5. Reversibility of live Equal-Conflict and Join-Free systems

---

We show next that the place-splitting transformation induces a sufficient condition of liveness and reversibility for strongly connected well-formed Choice-Free systems, allowing more flexibility in the initial distribution of the tokens.

**Theorem 26.** *Consider a strongly connected and well-formed Choice-Free system  $S$ . Denote by  $S'$  the T-system obtained by applying the place-splitting transformation to  $S$ . If  $S'$  is live, then  $S$  is live and reversible.*

*Proof.* Both systems have the same unique minimal T-semiflow  $Y$  and  $S'$  is well-formed (Proposition 4 on page 31 and the T-semiflow preservation of Theorem 9 on page 52). If  $S'$  is live, then it is reversible (Theorem 24 on page 92) and a sequence  $\sigma_Y$ , with Parikh vector equal to the minimal T-semiflow  $Y$  of both systems, is feasible in  $S'$  (Proposition 12 on page 79). By the language inclusion (Theorem 11 on page 53),  $\sigma_Y$  is also feasible in  $S$ , which is consequently live (take  $M = M_0$  and  $\sigma = \sigma_Y$  in Proposition 9 on page 69) and reversible (Proposition 12 on page 79).  $\square$

### 5.1.8.1 Deduction of a polynomial time sufficient condition

The polynomial time sufficient condition of liveness of Theorem 17 on page 68 for normalized T-systems leads to the following polynomial time sufficient condition of liveness and reversibility for well-formed Choice-Free systems.

**Theorem 27** (Polynomial time sufficient condition of liveness and reversibility). *Consider a strongly connected and well-formed Choice-Free system  $S$ . Denote by  $S'$  the T-system obtained by applying the place-splitting transformation to  $S$ . Then  $S'$  can be normalized, leading to a normalized system  $S''$ . Moreover, if  $S''$  satisfies the liveness condition of Theorem 17 on page 68 for T-systems, then  $S$  is live and reversible.*

*Proof.* Since  $S$  is well-formed,  $S'$  is well-formed by Theorem 9 on page 52, thus consistent and conservative by Theorem 1 on page 29. Consequently,  $S'$  can be normalized (Theorem 5 on page 43) in polynomial time while preserving the liveness property (Corollary 7 on page 45). We deduce that the liveness of  $S''$  implies the liveness of  $S'$ , which induces both liveness and reversibility of  $S$  by Theorem 26. Finally, the condition of Theorem 17 on page 68 applies to  $S''$  and we obtain a polynomial time sufficient condition of liveness and reversibility for  $S$ .  $\square$

This theorem is illustrated on the right of Figure 5.16, where the normalized T-system obtained is live, implying that the FA system (resp. Choice-Free system when considering the place  $p_4$ ) is live and reversible.

### 5.1.8.2 The sufficient condition is not necessary

The liveness of the T-system is not necessary for the liveness and reversibility of the Choice-Free system, since that was already the case for the single property of liveness in the previous section. Another counter-example is highlighted on the left in Figure 5.16.

5.2. Reversibility of live consistent Equal-Conflict systems

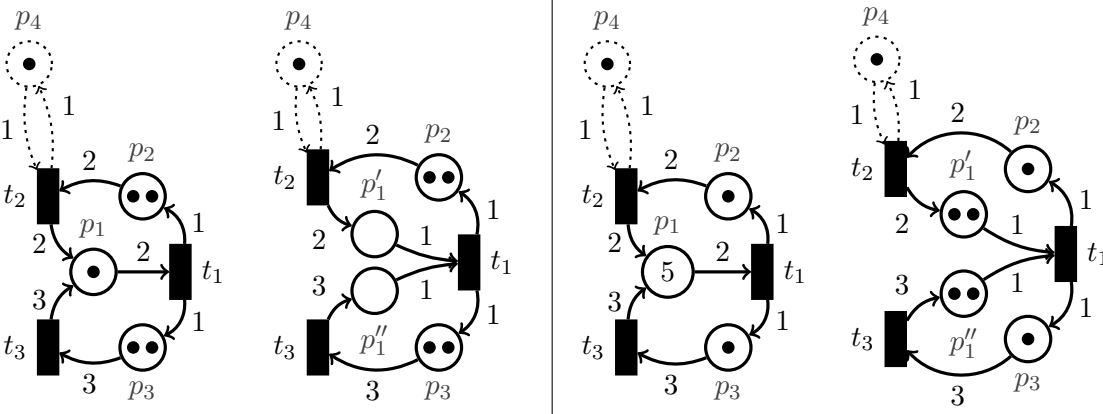

Figure 5.16: On the left, the well-formed FA system (resp. Choice-Free, with the *dotted part*), marked with a marking of  $\mathcal{M}_{FA}$  (resp. the marking  $M_{CF}$ ) hence live and reversible, is transformed into a non-live T-system. On the right, the initial marking of the FA (resp. Choice-Free) system is not greater than or equal to any marking in  $\mathcal{M}_{FA}$  (resp. the marking  $M_{CF}$ ), since  $\max_{p_3} - \gcd_{p_3} = 3 - 1 = 2$ . However, the transformation leads to a well-behaved T-system, satisfying the sufficient condition, and the FA (resp. Choice-Free) system is live and reversible. Notice that the T-systems have been normalized.

5.1.8.3 Comparison with the polynomial live home markings

The example on the left in Figure 5.16 shows that the live and reversible markings of  $\mathcal{M}_{FA}$  for FA systems are not always detected by the sufficient condition. The same holds for Choice-Free systems that are marked with  $M_{CF}$ , as pictured on the left when considering the dotted place  $p_4$ . Moreover, there exist markings that are live and reversible without being greater than or equal to some marking of  $\mathcal{M}_{FA}$ , while detected by the polynomial sufficient condition, as pictured on the right in Figure 5.16. This is also the case for the marking  $M_{CF}$ , when the dotted place  $p_4$  is added.

Thus, the set of markings detected by one method neither is included in the other set nor includes it, considering either the polynomial version of the second condition or the non-polynomial one.

5.2 Reversibility of live consistent Equal-Conflict systems

The well-formedness, liveness and reversibility properties of Equal-Conflict systems have been studied in [Teruel 1993, Teruel 1996], where it is proved that the well-behavedness assumption induces the existence of reachable home markings, although no non-trivial characterization of such markings is proposed. Similar results have been found for larger classes of weighted Petri nets [Recalde 1998, Silva 1998].

## Chapter 5. Reversibility of live Equal-Conflict and Join-Free systems

---

In the absence of reversibility characterizations, a naive exponential algorithm testing the reversibility of a well-behaved system, whose reachability graph is finite by boundedness, would build the whole state space and check if it is strongly connected.

In this section, we improve our understanding of the reversibility property for live consistent Equal-Conflict systems in order to obtain, at the end, efficient constructive methods for home markings. In some cases, we focus on well-formed Equal-Conflict systems, which are consistent by Proposition 2 on page 30.

In a previous section, we developed a new characterization of reversibility for well-behaved Choice-Free systems by means of a decomposition into FA P-subsystems.

We first show through a counter-example that this kind of decomposition cannot be extended to well-formed Equal-Conflict systems.

We then define T-sequences and provide an example of a well-behaved homogeneous S-system which is not reversible and does not enable any T-sequence, giving insight into the relationship between T-sequences and reversibility.

In the context of Choice-Free systems [Teruel 1997], T-sequences were implicitly used and shown to imply both liveness and reversibility. We show with a counterexample that it is not the case anymore in homogeneous S-systems, emphasizing the importance of the liveness assumption when studying the reversibility property of Equal-Conflict systems.

Thereafter, we derive, using feasible T-sequences, the first non-trivial characterization of reversibility for live consistent Equal-Conflict systems. This new condition extends a characterization of reversibility for Choice-Free systems.

Finally, using our characterization of reversibility for Equal-Conflict systems as well as particular Choice-Free T-subsystems, we obtain the first polynomial live home marking for well-formed Equal-Conflict systems, which encompass homogeneous Join-Free systems.

### 5.2.1 Reversibility is not induced by reversible P-components

As recalled in Proposition 6 on page 32, well-formed Equal-Conflict systems are covered by well-formed P-components, namely conservative homogeneous Join-Free P-subsystems. In a previous section, we provided a new characterization of reversibility for well-behaved Choice-Free systems, stating their reversibility in terms of the reversibility of all their strongly connected FA P-subsystems, which are actually their P-components. We already know, by Proposition 8 on page 65, that a well-formed Equal-Conflict system is live if and only if all its P-components are live. An intuitive generalization would state that a well-behaved strongly connected Equal-Conflict system is reversible if and only if all its P-components are reversible. However, we highlight in Figure 5.17 an example of a well-behaved and non-reversible Equal-Conflict system whose P-components are all live and reversible.

## 5.2. Reversibility of live consistent Equal-Conflict systems

---

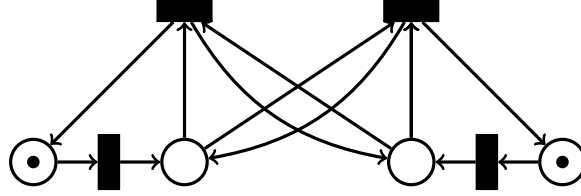

Figure 5.17: This well-behaved Equal-Conflict system is not reversible.



Figure 5.18: The two P-components of the well-behaved Equal-Conflict system of Figure 5.17 are well-behaved and reversible.

### 5.2.2 T-sequences and reversibility

We introduce next the notion of *T-sequences*, which will prove useful in our study of reversibility.

**Definition 13** (T-sequences, partial T-sequences). *Consider a Petri net with set of transitions  $T$ . A T-sequence is a sequence whose Parikh vector is equal to a T-semiflow whose support is  $T$ . A partial T-sequence is a sequence whose Parikh vector is equal to a T-semiflow whose support is different from  $T$ .*

The feasible (partial or not) T-sequences can be found under the names of *feasible / realizable T-semiflows / T-invariants*. The existence of a (partial or not) T-sequence that is feasible at the initial marking defines *weak reversibility* in [Teruel 1992]. We introduce the name *T-sequence* to emphasize the fact that it denotes a firing sequence associated to a T-semiflow.

If a system  $S$  is live, then there exists a finite feasible sequence that fires every transition at least once. Consequently, if this system  $S$  is reversible, it enables a T-sequence. Thus, under the liveness hypothesis, the existence of a feasible T-sequence is a necessary condition for reversibility. We also deduce that the live and reversible Petri nets are necessarily consistent.

It is more difficult to determine if the existence of a feasible T-sequence, under the liveness hypothesis, implies reversibility for all weighted Petri nets. It is known to be true for well-formed Choice-Free [Teruel 1997] and ordinary Free-Choice systems [Desel 1995]. However, similar results have not been found for larger classes. Other particular classes

have been studied in [Lopez-Grao 2013], which investigates the relationship between the reversibility property and the existence of reachable markings that enable a partial T-sequence associated to a minimal T-semiflow.

In the rest of this section, we show that the existence of a feasible T-sequence implies the reversibility of live consistent Equal-Conflict systems. We show moreover that this condition is no longer sufficient when considering all weighted Petri nets, even if they are well-behaved.

### 5.2.3 A well-behaved homogeneous S-system that is not reversible

A well-behaved and non-reversible homogeneous S-system, hence a particular Equal-Conflict system, is pictured in Figure 5.19. Note that there exists a feasible sequence,  $t_1 t_6$ , with Parikh vector equal to a T-semiflow, while no feasible T-sequence exists.

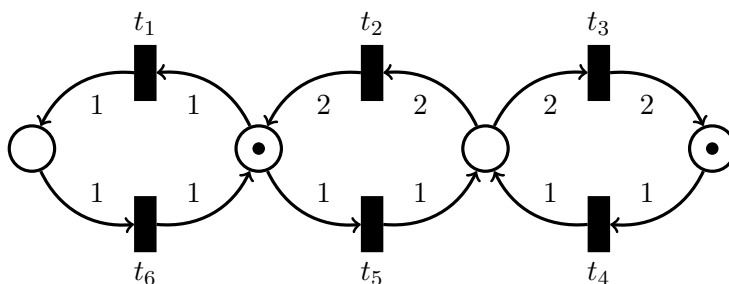

Figure 5.19: This homogeneous S-system is well-behaved and non-reversible.

### 5.2.4 Feasible T-sequences do not imply liveness

While in consistent Choice-Free systems, all the feasible sequences whose Parikh vector is equal to a T-semiflow are T-sequences [Teruel 1997], this is no longer the case in Equal-Conflict systems (see Figure 5.19). In a well-formed Choice-Free system, the fireability of a T-semiflow, hence the existence of a feasible T-sequence, implies both liveness and reversibility ([Teruel 1997]). However this is not the case in homogeneous S-systems, as shown in Figure 5.20, where a T-sequence is feasible in the well-formed S-system but not live.

### 5.2.5 A characterization of reversibility

Using feasible T-sequences, we present the first non-trivial characterization of reversibility for live consistent Equal-Conflict systems. We first need to prove a theorem regarding the *fairness* property, defined next, then we introduce new notations and prove a lemma.

## 5.2. Reversibility of live consistent Equal-Conflict systems

---

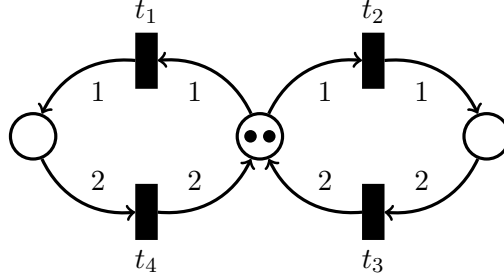

Figure 5.20: This homogeneous S-system is not live (fire  $t_1 t_2$ ) although a T-sequence is feasible (fire  $t_1 t_1 t_4 t_2 t_2 t_3$ ).

Taking inspiration from [Teruel 1996], we define a *fairness* property dedicated to the Equal-Conflict class.

**Definition 14** (Fairness in Equal-Conflict systems). *An infinite firing sequence is globally fair if it fires every transition of the system an infinite number of times. An infinite firing sequence is locally fair if every time an equal conflict set is enabled, one of its transitions is fired after a finite number of firings, and if all the transitions of the equal conflict sets containing a transition that fires an infinite number of times are fired an infinite number of times.*

The following theorem is similar to a result of [Teruel 1996] that deals with a slightly different definition of fairness and uses the boundedness and strong connectedness assumptions instead of our liveness assumption.

**Theorem 28** (Fairness in live Equal-Conflict systems). *Let  $S$  be a live Equal-Conflict system. A sequence  $\sigma$  that is feasible in  $S$  is globally fair if and only if it is locally fair.*

*Proof.* If  $\sigma$  is globally fair, it is easy to see that  $\sigma$  is locally fair. Let us prove the converse. Denote by  $Q$  the set of the equal conflict sets containing a transition that occurs infinitely often in  $\sigma$  and by  $\bar{Q}$  the set of the other equal conflict sets. The set  $Q$  is non-empty since there is only a finite number of equal conflict sets and  $\sigma$  is infinite.

Now suppose that  $\sigma$  is locally fair and  $\bar{Q}$  is non-empty. By definition, all the transitions of the sets in  $Q$  are fired an infinite number of times in  $\sigma$ , while all the transitions of the sets in  $\bar{Q}$  are fired a finite number of times and become forever non-enabled after the firing of a sufficiently large finite prefix sequence  $\sigma_0$  of  $\sigma$ . Denote by  $M$  the marking reached by firing  $\sigma_0$  in  $S$  and by  $\sigma'$  the infinite suffix sequence of  $\sigma$  satisfying  $\sigma = \sigma_0 \sigma'$ . By the liveness assumption, there exists a transition  $t$  in  $\bar{Q}$  and a finite sequence  $\sigma_1$  feasible at  $M$  such that  $\sigma_1$  contains only transitions of  $Q$  and enables  $t$ . Moreover, only transitions of  $\bar{Q}$  are structurally allowed to remove tokens from the inputs of  $t$ . We deduce that a sufficiently large finite prefix sequence  $\sigma_2$  of  $\sigma'$  exists such that  $\bar{\sigma}_2 > \bar{\sigma}_1$ . Consequently,  $t$  becomes enabled after the firing of the finite sequence  $\sigma_0 \sigma_2$ , contradicting the fact that

## Chapter 5. Reversibility of live Equal-Conflict and Join-Free systems

---

every transition of  $\overline{Q}$  stays forever non-enabled after the firing of  $\sigma_0$ . Thus,  $\overline{Q}$  is empty and  $\sigma$  is globally fair.  $\square$

**Notations.** For any transition  $t$ , we denote by  $E^t$  the equal conflict set containing  $t$ . We introduce  $\sigma^\infty$  to denote the infinite concatenation of the sequence  $\sigma$ . The notation  $K_{t_x}^n(\sigma)$ ,  $n \geq 1$ , or more simply  $K_x^n(\sigma)$ , denotes the largest prefix sequence of  $\sigma$  preceding the  $n$ -th occurrence of  $t_x$  in  $\sigma$ , thus containing  $n - 1$  occurrences of  $t_x$ . For example, considering the sequence  $\sigma = t_1 t_2 t_1 t_3 t_1 t_2 t_3$ ,  $K_{t_1}^3(\sigma) = t_1 t_2 t_1 t_3$  and  $K_{t_3}^1(\sigma) = t_1 t_2 t_1$ .

Before proving the characterization of reversibility, we show the following lemma, which is illustrated in Figure 5.21.

**Lemma 10.** *Consider a live Equal-Conflict system  $S = (N, M_0)$ , with  $N = (P, T, W)$ . Suppose there exists a feasible  $T$ -sequence  $\sigma_r$  in  $S$ . For every transition  $t$  enabled by  $M_0$  such that  $M_0 \xrightarrow{t} M$ , there exists a sequence  $\sigma_c$  that is feasible at  $M$  with  $\sigma = t \sigma_c$  and an integer  $k \geq 1$  such that  $\sigma$  is a  $T$ -sequence satisfying  $\vec{\sigma} = k \cdot \vec{\sigma}_r$ .*

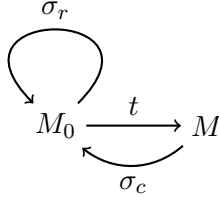

Figure 5.21: If the sequence  $\sigma_r$  is supposed to be feasible, then one can build the sequence  $\sigma_c$  feasible at  $M$ .

*Proof.* In the rest of the proof, we note  $K^1 = K_t^1(\sigma_r)$  the largest prefix sequence of  $\sigma_r$  preceding the first occurrence of  $t$ , meaning that  $\sigma_r$  is of the form  $K^1 t \sigma_2$ , while the sequence  $K^1$  does not contain any occurrence of  $t$ . This sequence is well-defined since the support of  $\vec{\sigma}_r$  is  $T$ .

If  $t$  is the first transition of  $E^t$  to be fired following the order of  $\sigma_r$ , meaning that  $K^1$  does not contain any occurrence of transitions in  $E^t$ , then the sequence  $K^1$  does not use any token from the input places of  $t$ , thus one can execute  $K^1$  after the firing of the first occurrence of  $t$  and the sequence  $t K^1 \sigma_2$  is feasible at  $M_0$ . Hence,  $\sigma_c = K^1 \sigma_2$ .

Otherwise,  $t$  is not the first transition in  $E^t$  to be fired following the order of  $\sigma_r$ , meaning that  $K^1$  contains at least one occurrence of another transition of  $E^t$ . We show next that Algorithm 2 builds the sequence  $\sigma_c$  that returns to the initial marking. We illustrate the proof on a example in Figures 5.22 and 5.23.

**Study of the first loop.** This loop aims at firing the transitions different from  $t$  in  $E^t$  until the number of their occurrences in  $\tau$  equals that in  $K^1$ . Intuitively, the transition  $t$  has been initially fired whereas other transitions of  $E^t$  should have been fired first if one

## 5.2. Reversibility of live consistent Equal-Conflict systems

---



---

**Algorithm 2:** Computation of the feasible sequence  $\sigma_c$

---

**Data:** The system  $(N, M)$  obtained by firing  $t$  in  $S$ , the feasible sequence  $\sigma_r$ .

**Result:** A sequence  $\sigma_c$  that is feasible in  $(N, M)$  such that  $M \xrightarrow{\sigma_c} M_0$ .

```

1  $\tau := t$ ;
2 while  $\exists t' \in E^t \setminus \{t\}, \vec{K}^1(t') > \vec{\tau}(t')$  do
3   while the equal conflict set  $E^t$  is not enabled do
4     Among the transitions that belong to enabled equal conflict sets, fire the
     transition  $t_x$  whose  $(\vec{\tau}(t_x) + 1)$ -th occurrence appears at the smallest position
     in  $(\sigma_r)^\infty$ ;
5      $\tau := \tau t_x$ ;
6   end
7   Among the transitions of  $E^t$  different from  $t$ , fire the transition  $t_y$  satisfying
    $\vec{K}^1(t_y) > \vec{\tau}(t_y)$  and whose  $(\vec{\tau}(t_y) + 1)$ -th occurrence appears at the smallest
   position in  $K^1$  ;
8    $\tau := \tau t_y$ ;
9 end
10 Let  $\alpha$  be the smallest natural number such that  $\vec{\tau} \leq \alpha \cdot \vec{\sigma}_r$ ;
11 We denote by  $\kappa$  the sequence  $(\sigma_r)^\alpha$ ;
12 while  $\vec{\tau} \neq \vec{\kappa}$  do
13   Fire the transition  $t_x$  whose  $(\vec{\tau}(t_x) + 1)$ -th occurrence appears at the smallest
   position in  $\kappa$ ;
14    $\tau := \tau t_x$ ;
15 end
16  $\tau$  is of the form  $t\sigma_c$ ;
17 return  $\sigma_c$ 

```

---



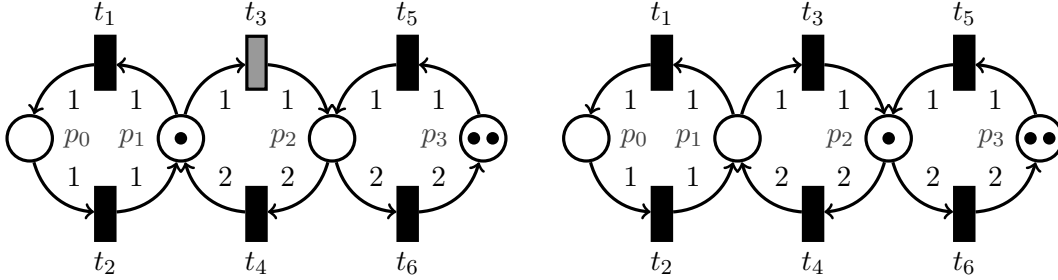

Figure 5.22: The homogeneous S-system on the left is well-behaved and enables the T-sequence  $\sigma_r = t_1 t_2 t_3 t_5 t_5 t_4 t_3 t_6$ . As first action,  $t = t_3$  is fired, leading to the system on the right. Since the first output transition of  $p_1$  to be fired in  $\sigma_r$  is  $t_1 \neq t_3$ , the algorithm constructs the sequence  $\sigma_c$  returning to  $M_0$ , starting from the system on the right. Thus, before the first loop,  $\tau = t_3$  and  $K^1 = K_{t_3}^1(\sigma_r) = t_1 t_2$ .

wanted to follow the order of  $\sigma_r$ . In this algorithm, every time  $E^t$  is enabled, a firing occurs in this set that follows the order of  $K^1$  until completion. The inner loop aims at firing transitions that do not belong to  $E^t$  by following the associated order in  $(\sigma_r)^\infty$  so as to enable  $E^t$ . Let us show that the inner loop always terminates and enables  $E^t$ . First, by the liveness assumption, every reachable marking enables at least one equal conflict set. Now suppose that the inner loop does not terminate. Consequently, an infinite feasible sequence  $\nu$  is fired that never enables  $E^t$ . Since the firings in the loop follow the order of  $(\sigma_r)^\infty$  and the support of  $\sigma_r$  is  $T$ , the sequence  $\nu$  is locally fair, thus globally fair by Theorem 28 on page 100, contradicting the fact that  $E^t$  never becomes enabled. We deduce that  $E^t$  becomes enabled and the inner loop terminates.

We now prove the termination of the complete first loop. Since the inner loop always terminates, a transition  $t_y$  is fired at the end of every iteration of the outer loop such that  $\vec{K}^1(t_y) > \vec{\tau}(t_y)$  and  $t_y$  is concatenated to the current  $\tau$ , decreasing the number of remaining steps to attain  $\vec{K}^1(t_y)$ . Hence the outer loop terminates.

**Study of the second loop.** We show that after the termination of the first loop, the current sequence  $\tau$  can be completed up to  $\kappa$  by following the order of the remaining unfired occurrences in  $\kappa$ . We first introduce the function  $\text{MinPos}(E^t, \tau, \kappa)$  defined only if the largest subset  $A$  of  $E^t$  such that every transition  $t' \in A$  satisfies  $\vec{\tau}(t') < \vec{\kappa}(t')$  is not empty and  $\vec{\tau} \leq \vec{\kappa}$ :  $\text{MinPos}(E^t, \tau, \kappa)$  returns the transition  $t'$  of  $A$  whose  $(\vec{\tau}(t') + 1)$ -th occurrence appears at the smallest position in  $\kappa$ .

We prove the following loop invariant  $I(k)$  to be true for  $k \geq 0$ :  
 $I(k)$ : "at the end of iteration  $k$ , for every transition  $t_u$  such that  $\vec{\tau}(t_u) < \vec{\kappa}(t_u)$  and  $t_u = \text{MinPos}(E^{t_u}, \tau, \kappa)$ , then for every transition  $t_y$  of  $E^{t_u}$ ,  $\vec{\tau}(t_y) = \vec{K}(t_y)$ , where  $K$  denotes the sequence  $K_u^m(\kappa)$  and  $m$  is the value  $\vec{\tau}(t_u) + 1$ ".

Before starting the loop,  $k = 0$ . We consider two cases for every  $t_u$  satisfying  $\vec{\tau}(t_u) < \vec{\kappa}(t_u)$  and  $t_u = \text{MinPos}(E^{t_u}, \tau, \kappa)$ . If  $t_u$  does not belong to  $E^t$ , then all firings of  $E^{t_u}$

## 5.2. Reversibility of live consistent Equal-Conflict systems

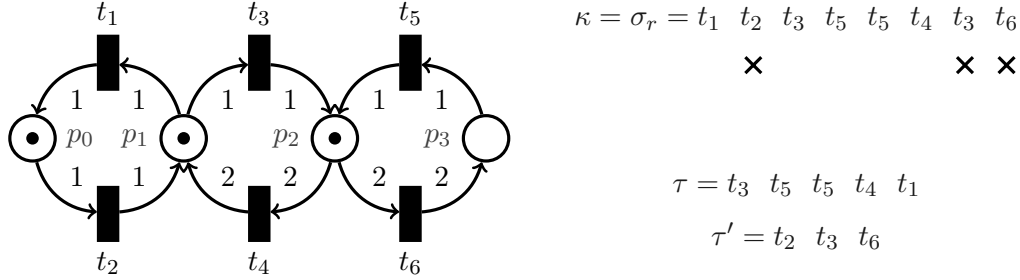

Figure 5.23: On the left, the system obtained at the end of the first loop and the corresponding value of  $\tau$  on the right. The crosses denote the occurrences of transitions  $\kappa$  that have not yet been fired in  $\tau$ . Before starting the first loop,  $K^1 = t_1 t_2$  and the output transitions of  $p_1$  represented in  $K^1$  are  $t_1$ . Consequently, the first loop fires the output transitions of  $p_1$  that should have been fired before the first occurrence of  $t_3$ , meaning one occurrence of  $t_1$ , and terminates. However, the loop starts on the right system in Figure 5.22 where the only enabled equal conflict set is  $\{t_5\}$ . Thus, the first loop terminates when  $\tau$  equals  $t_3 t_5 t_5 t_4 t_1$ , leading to the system on the left. After the first loop,  $\alpha = 1$ ,  $\kappa = \sigma_r$ . The second loop fires the subsequence of  $\kappa$  made of the occurrences that have not yet been fired in  $\tau$  following the order of  $\kappa$ . Thus, the second loop has to fire the sequence  $\tau' = t_2 t_3 t_6$ . On the right, the sequences  $\tau$  and  $\kappa$  are represented as computed after the first loop and before starting the second loop. The sequence  $\tau'$  is fired in the second loop. Finally,  $\sigma_c = t_5 t_5 t_4 t_1 t_2 t_3 t_6$ .

appeared in the same order and are as many in  $\tau$  as in  $K$  in the inner loop. We deduce that every transition  $t_y$  of  $E^{t_u}$  satisfies  $\vec{\tau}(t_y) = \vec{K}(t_y)$ . Otherwise,  $t_u$  belongs to  $E^t$  and the first loop fired precisely all the occurrences of  $E^t$  that belong to  $K^1$ , in addition to the first unique firing of  $t$ . Thus, every transition  $t_y$  of  $E^t$  satisfies  $\vec{\tau}(t_y) = \vec{K}(t_y)$ .

Now assume that  $k$  iterations of the loop occurred and  $I(k)$  is true. During iteration  $k + 1$ , a new transition  $t_x$  is fired following the order of  $\kappa$ . At the end of iteration  $k + 1$ , for every transition  $t_u$  such that  $\vec{\tau}(t_u) < \vec{\kappa}(t_u)$  and  $t_u = \text{MinPos}(E^{t_u}, \tau, \kappa)$ , denoting by  $K'$  the sequence  $K_u^{m'}(\kappa)$  where  $m' = \vec{\tau}(t_u) + 1$ , we consider two cases. First, if  $t_u$  does not belong to  $E^{t_x}$ , then  $K'$  is the same sequence as in the previous iteration and for every transition  $t_y$  of  $E^{t_u}$ ,  $\vec{\tau}(t_y)$  has not changed either, thus  $\vec{\tau}(t_y) = \vec{K}'(t_y)$ . Otherwise, if  $t_u$  belongs to  $E^{t_x}$ , implying  $E^{t_x} = E^{t_u}$ , then  $K'$  contains the same number of occurrences of every transition  $t_y$  of  $E^{t_x}$  as in the  $K$  associated to  $t_x$  in the previous iteration, except for  $t_x$  whose number has been incremented by one. Besides, the only transition whose number of occurrences in  $\tau$  has been incremented by one is  $t_x$ . Consequently, for every transition  $t_y$  of  $E^{t_u}$ ,  $\vec{\tau}(t_y) = \vec{K}'(t_y)$ . We deduce finally that all the equalities that are supposed to be true at the end of iteration  $k$  remain true at the end of iteration  $k + 1$ .

Hence, the invariant is true at every iteration of the loop. Moreover, by definition of the  $t_x$  chosen at every step, for which we define the current value  $m = \vec{\tau}(t_x) + 1$  and the sequence  $K = K_x^m(\kappa)$ , all the occurrences in  $K$  are already present in the sequence  $\tau$  of the current iteration. Thus, at the beginning of every iteration, for every transition  $t_y \in T$ ,

## Chapter 5. Reversibility of live Equal-Conflict and Join-Free systems

---

$$\vec{\tau}(t_y) \geq \vec{K}(t_y).$$

Moreover, the sequence  $K$  is feasible at  $M_0$  and leads to a marking that enables  $t_x$ , by definition of the feasible sequence  $\kappa$ . Thus,  $\tau$  fired the input transitions of the input places of  $t_x$  at least as many times as in  $K$ . Then, the invariant implies that the transitions of  $E^{t_x}$  fired exactly as many times in  $K$  as in  $\tau$ . Thus, the input places of  $t_x$  received at least the number of tokens they would receive by firing  $K$  from  $M_0$ , implying that  $t_x$  is enabled. We deduce that the loop completes  $\vec{\tau}$  up to  $\vec{\kappa}$  and terminates. As an example, in Figure 5.23, the second loop fires the crossed transitions following the order of  $\kappa$ : initially,  $t_x = t_2$ ,  $m = \vec{\tau}(t_2) + 1 = 1$ ,  $K = K_{t_2}^1(\kappa) = t_1$  and  $\tau$  has already fired an occurrence of  $t_1$ , while no occurrence of  $t_2$  was fired in  $\tau$ , thus  $t_2$  is enabled. After the firing of  $t_2$ , in the next iteration,  $t_x = t_3$ ,  $\tau = t_3 t_5 t_5 t_4 t_1 t_2$ ,  $\tau' = t_3 t_6$ ,  $m = \vec{\tau}(t_3) + 1 = 2$ ,  $K = K_{t_3}^2(\kappa) = t_1 t_2 t_3 t_5 t_5 t_4$  and  $\tau$  has already fired all the occurrences of  $K$ . Moreover,  $\vec{\tau}(t_1) = 1 = \vec{K}(t_1)$  and  $\vec{\tau}(t_3) = 1 = \vec{K}(t_3)$ , thus  $t_3$  is enabled.

Finally, since  $\kappa$  is of the form  $(\sigma_r)^\alpha$  for an integer  $\alpha > 0$ , the feasible sequence  $t\sigma_c$  is a T-sequence.  $\square$

We use this lemma to deduce the next characterization of reversibility for live Equal-Conflict systems.

**Theorem 29.** *Consider a live Equal-Conflict system  $S = (N, M_0)$  such that  $N = (P, T, W)$ . The system  $S$  is reversible if and only if it enables a T-sequence.*

*Proof.* The simple case is the necessity. Suppose that  $S$  is live and reversible. By the liveness assumption, there exists a feasible sequence  $\sigma_0$  whose support is the set of all transitions. By the reversibility assumption, there exists a feasible sequence  $\sigma_1$  returning to  $M_0$ . Thus, the feasible sequence  $\sigma_0\sigma_1$  is a feasible T-sequence.

We prove the sufficiency next. Suppose there exists a feasible T-sequence  $\sigma_r$  in the live system  $S$ . We show that after the firing of any feasible sequence  $\sigma$ , with  $M_0 \xrightarrow{\sigma} M$ , there exists a feasible sequence  $\sigma^*$  that leads to the initial marking. For that purpose, we show by induction on the length  $n$  of  $\sigma$  the property  $P(n)$ :

“If a sequence  $\sigma$  of length  $n$  is feasible in a live Equal-Conflict system  $S = (N, M_0)$  and a feasible T-sequence, noted  $\sigma_r$ , exists in  $S$ , then there exists a feasible sequence  $\sigma^*$  such that  $M_0 \xrightarrow{\sigma\sigma^*} M_0$ .”

If  $n = 0$ ,  $\sigma$  and  $\sigma^*$  are empty sequences and the initial marking is reached.

Otherwise, suppose  $n > 0$ , with  $\sigma = t\sigma'$ , note  $M_0 \xrightarrow{t} M \xrightarrow{\sigma'} M'$ , and assume the property  $P(n-1)$  to be true. Applying Lemma 10 on page 101, there exists a sequence  $\sigma_c$  that is feasible at  $M$  such that  $M \xrightarrow{\sigma_c} M_0$  and the sequence  $t\sigma_c$  is a T-sequence. Thus, the T-sequence  $\sigma_c t$  is feasible at  $M$ . Applying the induction hypothesis on the sequence  $\sigma'$  of size  $n-1$ , which is feasible in the live system  $(N, M)$ , we obtain a sequence  $\sigma_d$  that is feasible at  $M'$  and returns to  $M$ . Thus, the sequence  $\sigma^* = \sigma_d\sigma_c$  is feasible at  $M'$  and leads to  $M_0$ .

## 5.2. Reversibility of live consistent Equal-Conflict systems

---

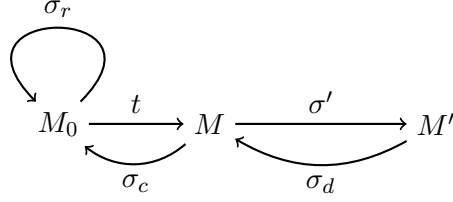

We deduce that after the firing of any feasible sequence in  $S$ , there exists a feasible sequence that returns to the initial marking. We conclude that  $S$  is reversible.  $\square$

### 5.2.6 Monotonicity of reversibility in well-behaved systems

The new characterization of reversibility of Theorem 29 on the preceding page implies the monotonicity of the reversibility property in the case of well-behaved Equal-Conflict systems, as stated by the following theorem.

**Theorem 30** (Reversibility monotonicity). *Consider a well-behaved Equal-Conflict system  $S = (N, M_0)$  that is reversible. Then, for any marking  $M'_0 \geq M_0$ , the system  $(N, M'_0)$  is also well-behaved and reversible.*

*Proof.* By Proposition 15 on page 65,  $(N, M'_0)$  is also well-behaved. Moreover, Theorem 29 on the preceding page applies, meaning that a T-sequence  $\sigma$  is feasible in  $S$ . The system  $(N, M'_0)$  clearly enables  $\sigma$  and is consequently reversible by Theorem 29.  $\square$

### 5.2.7 Polynomial live home markings for well-formed systems

We use the new characterization of reversibility for live Equal-Conflict systems to show that the polynomial live marking  $M_{EC}$  of Theorem 16 on page 67 is also reversible for well-formed Equal-Conflict systems.

We will need the next simple technical lemma, illustrated in Figure 5.24, when considering T-subsystems, in which places may have fewer surrounding weights than in the complete system.

**Lemma 11.** *Consider a Petri net containing a place  $p$  having at least one output. Let  $S'$  be any subsystem (subgraph) containing  $p$  and at least one of its inputs or outputs. Denote by  $max_p$  the maximum output weight of  $p$  in  $S$ , by  $max'_p$  the maximum output weight of  $p$  in  $S'$ , by  $gcd_p$  the gcd of  $p$  in  $S$  and by  $gcd'_p$  the gcd of  $p$  in  $S'$ . Then  $max_p \geq max'_p$ ,  $gcd_p \leq gcd'_p$ , and  $max_p - gcd_p \geq max'_p - gcd'_p$ .*

*Proof.* Since the place  $p$  may have fewer outputs in  $S'$  than in  $S$ ,  $max_p \geq max'_p$ . If there is no more output, then  $max'_p = 0$ . Since the place  $p$  may have fewer outputs or inputs in  $S'$  than in  $S$ , the gcd of a non-empty subset of the weights surrounding the place may only be larger or equal, thus  $gcd_p \leq gcd'_p$ . We deduce easily the last inequality.  $\square$

## Chapter 5. Reversibility of live Equal-Conflict and Join-Free systems



Figure 5.24: On the left,  $gcd_p = 1$ ,  $max_p = 6$  and  $max_p - gcd_p = 5$ . In the T-subsystem on the right,  $gcd_p = 2$ ,  $max_p = 4$  and  $max_p - gcd_p = 2$ .

We prove the following result that deals with the previous polynomial markings  $M_{EC}$  and  $M_{JF}$ , as well as T-components.

**Theorem 31.** *Consider a strongly connected system  $S = (N, M_0)$  that is covered by T-components. If  $S$  is not Join-Free, suppose that  $M_0$  is greater than or equal to the marking  $M_{EC}$ . Otherwise, if  $S$  is Join-Free, suppose that  $M_0$  is greater than or equal to a marking of  $M_{JF}$ . Then,  $S$  enables a T-sequence.*

*Proof.* We illustrate the ideas by examples throughout the proof.

If no T-component of  $S$  is an FA T-subsystem of  $S$ , then all T-components are initially marked by  $M_{CF}$  or a larger marking by definition of  $M_{EC}$  and by Lemma 11 on the facing page, thus they are made well-behaved and reversible by Theorem 25 on page 93. Denote by  $C_1 \dots C_k$  all the  $k$  T-components covering the system. Since every sequence which is feasible in a T-subsystem is also feasible in the whole system, and every T-component  $C_i$ ,  $i = 1 \dots k$ , enables in  $S$  a partial T-sequence  $\sigma_i$  whose Parikh vector is equal to the minimal T-semiflow of  $C_i$  (Theorem 12 on page 79), the sequence  $\sigma = \sigma_1 \dots \sigma_k$  is a T-sequence that is feasible in  $S$ . An example is pictured in Figure 5.25.

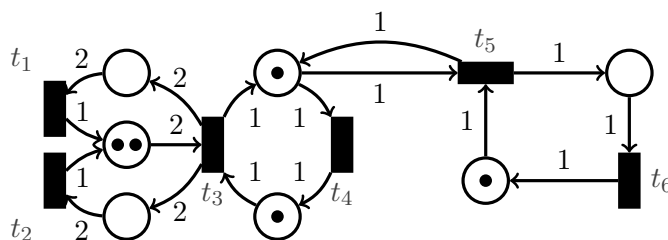

Figure 5.25: This (Equal-Conflict) system is marked by  $M_{EC}$ , and its two T-components  $C_1$  and  $C_2$ , defined respectively by  $\{t_1, t_2, t_3, t_4\}$  and  $\{t_5, t_6\}$ , have each an initial marking obtained by projection that is larger than or equal to  $M_{CF}$ , thus are live and reversible. Consider the (partial) T-sequence  $\sigma_1 = t_3 t_1 t_2 t_4$  that is feasible in  $C_1$  and the (partial) T-sequence  $\sigma_2 = t_5 t_6$  that is feasible in  $C_2$ . Then, the sequence  $\sigma = \sigma_1 \sigma_2$  is a feasible T-sequence for the whole system.

Now consider that some T-components are FA T-subsystems. If the system is not Join-Free, then it contains a Choice-Free T-component that is not FA,  $M_0$  is equal to or

## 5.2. Reversibility of live consistent Equal-Conflict systems

greater than  $M_{EC}$  and every Choice-Free T-component that is not FA is live and reversible. Otherwise the system is Join-Free,  $M_0$  is equal to or greater than a marking of  $\mathcal{M}_{JF}$ , at least one place  $p$  satisfies  $M_0(p) \geq \max_p$  and the system contains an FA T-component whose initial marking, obtained by projecting  $M_0$  on its places, is greater than or equal to a marking of  $\mathcal{M}_{JF}$ , and is thus live and reversible (Theorem 20 on page 84). Consequently, in all cases, we can suppose that  $S$  contains at least one well-behaved reversible T-component.

As seen before, one can fire a partial T-sequence by concatenating smaller partial T-sequences over all the T-components that are initially live and reversible. However, there may exist FA T-components that are not initially live and reversible, meaning that they do not contain any place enabled by projection. We prove next that, for every such T-component  $C$ , there exists a sequence that is feasible at  $M_0$ , fires all the transitions of  $C$  and returns to  $M_0$ . Figure 5.26 illustrates this fact with the feasible sequence  $t_3 t_5 t_7 t_8 t_6 t_4 t_1 t_2$ , where  $C_3$  the FA T-component defined by  $\{t_7, t_8\}$  plays the role of  $C$ .

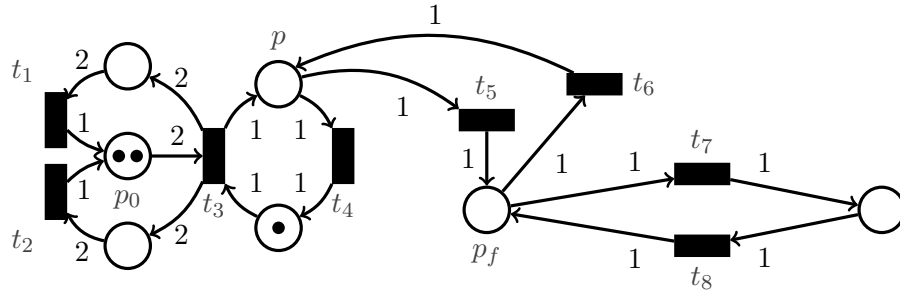

Figure 5.26: The Choice-Free T-component  $C_1$  that is not FA, defined by  $\{t_1, t_2, t_3, t_4\}$ , is made initially live and reversible by projection. The two FA T-components  $C_2$  and  $C_3$  defined respectively by  $\{t_5, t_6\}$  and  $\{t_7, t_8\}$  are non-live. However, firing the transition  $t_3$  adds a token to the place  $p$ , making  $C_2$  live and reversible, while the firing of the sequence  $t_3 t_5$  makes  $C_3$  live and reversible.

By hypothesis, there exists in  $S$  at least one enabled place that is an input of an enabled transition. Select an elementary path  $\mu$  of the form  $p_0 t_0 \dots p_f$  where  $p_0$  is an enabled place,  $t_0$  is the only transition of  $\mu$  enabled by  $M_0$  and  $p_f$  belongs to  $C$ . Such a path exists by strong connectedness and the previous assumptions. For example, consider the path  $p_0 t_3 p t_5 p_f$  in Figure 5.26.

Since  $\mu$  is an elementary path, each of its places and transitions are visited once. Denote by  $\sigma$  the sequence made of the successive transitions following the order of  $\mu$ , thus starting by  $t_0$ . Among all the possible sets of T-components whose union contains the path  $\mu$ , select a set  $D$  of minimum cardinality  $u$  and containing  $C$ , implying that every transition of  $\mu$  belongs to at most two elements of  $D$ . Define the elements of  $D$  ordered following the path  $\mu$  as the sequence  $D_i, i = 1..u$ , with  $D_u = C$ . In our example,  $D_1 = C_1, D_2 = C_2$  and  $D_u = C_3$ . Now the path  $\mu$  can be rewritten as  $d_1 \dots d_{u-1} p_f$  where, for every  $i = 1 \dots u - 1$ ,  $d_i$  starts with a place and ends with a transition,  $d_1$  starting with  $p_0, p_f = d_u$  is the only non-empty subpath of  $\mu$  that belongs to  $C$ , and  $d_i$  is the longest subpath of  $\mu$  that belongs

## Chapter 5. Reversibility of live Equal-Conflict and Join-Free systems

---

to  $D_i$  but contains no node that belongs to  $D_{i+1}$ . In our example,  $d_1 = p_0 t_3$ ,  $d_2 = p t_5$ ,  $d_u = d_3 = p_f$ .

We first show that  $\sigma$  is feasible in  $S$ . By definition of  $\sigma$ , its first transition  $t_0$  is enabled. Moreover, every place  $p_i$  of  $\mu$  contains at least  $\max_{p_i} - \gcd_{p_i}$  tokens in  $S$ . Suppose that  $\sigma$  is not feasible, meaning that it is of the form  $\tau t \tau_1$ , where  $\tau$  can be fired in  $S$  and contains  $t_0$ , leading to a marking  $M$  that does not enable  $t$ . Since the path is elementary,  $t$  has not been fired previously. We have two cases. If  $t$  is a join-transition, then it was enabled by  $M_0$ , which is impossible by the choice of  $\mu$ , which contains only one initially enabled transition, the transition  $t_0$ . Thus  $t$  has a unique input place  $p$ . If  $t$  is the unique output of  $p$ , then no transition of  $\tau$  removed tokens from  $p$ , thus  $p$  contained at least  $\max_p - \gcd_p$  tokens at  $M_0$  and is thus enabled by  $M$  because of the firing of one of its input transitions in  $\tau$ , and  $t$  is enabled, a contradiction. Now suppose that another output  $t'$  of  $p$  exists in  $S$ . If  $t'$  is a join-transition, then  $p$  and  $t$  were initially enabled, contradicting the definition of  $\mu$ . Thus, every output of  $p$  has  $p$  as its unique input. If an output  $t'$  of  $p$  has been fired in  $\tau$ , then its unique input place  $p$  has already been visited, a contradiction with the fact that  $\mu$  is an elementary path. Thus, no output of  $p$  has been fired in  $\tau$ . We deduce that  $t$  is feasible.

Thus, in all cases,  $t$  is enabled by  $M$ . We deduce that  $\sigma$  is enabled.

Now, we prove by induction on  $u$  that the marking  $M_c$  reached by firing  $\sigma$  makes  $C$  live and reversible, and that it enables a sequence  $\sigma^*$  whose transitions all belong to the components  $D_1 \dots D_{u-1}$  and which returns to  $M_0$ .

If  $u = 2$ , then  $\sigma$  fires a sequence in  $D_1$ , which is live and reversible, leading to a marking  $M$  that enables the place  $p_f$ . The projection of  $M$  on the T-component  $C$  is greater than or equal to a marking of  $\mathcal{M}_{FA}$ , implying its liveness and reversibility. Then, a sequence  $\sigma^*$  is enabled by  $M$  completing the sequence  $\sigma$  up to the minimal T-semiflow of  $D_1$ . In Figure 5.26, if  $C = C_2$ , the firing of  $\sigma = t_3$  enables  $p$ , making  $C_2$  live and reversible, and the sequence  $\sigma^* = t_4 t_1 t_2$  is feasible that leads to  $M_0$ .

If  $u > 2$ , suppose that the property is true for  $u - 1$ . The prefix sequence  $\nu$  of  $\sigma$  corresponding to  $\mu_1 = d_1 \dots d_{u-2}$  is feasible at  $M_0$ — $\mu_1$  being an elementary path from an enabled place to a place of  $D_{u-1}$  and in which the only transition enabled by  $M_0$  is  $t_0$ —and it leads to a marking  $M$  that makes  $D_{u-1}$  live and reversible. Moreover, the sequence  $\nu'$  associated to  $d_{u-1}$  is feasible at  $M$  and enables  $p_f$ , making  $C$  live and reversible at a marking  $M'$ . Then, since  $D_{u-1}$  is live and reversible, a sequence  $\nu''$  is feasible at  $M'$  such that  $\nu' \nu''$  is a partial T-sequence whose Parikh vector is equal to the minimal T-semiflow of  $D_{u-1}$  and thus leads to  $M$ . Applying the induction hypothesis, a sequence  $\gamma$ , whose transitions all belong to the components  $D_1 \dots D_{u-2}$ , is enabled by  $M$  that leads to  $M_0$ . Consequently, the sequence  $\nu'' \gamma$  is feasible at  $M'$ , leads to  $M_0$  and contains only transitions of the components  $D_1 \dots D_{u-1}$ .

We deduce that the property is true for every  $u \geq 2$ . Finally, from this property we deduce that, for every T-component  $C_i$  that is not initially live and reversible, there exists a sequence  $\sigma$  feasible at  $M_0$  leading to a marking  $M_c$  that makes  $C_i$  live and reversible, hence there exists a sequence  $\sigma_i$  whose Parikh vector is equal to the minimal T-semiflow of  $C_i$  and

### 5.3. Reversibility of well-behaved Join-Free systems

---

is feasible at  $M_c$  that returns to  $M_c$ . Then, a sequence  $\sigma^*$  is feasible at  $M_c$ , returning to  $M_0$ . Denote the concatenation of such sequences by  $\gamma_i = \sigma \sigma_i \sigma^*$ . Since the system is strongly connected, covered by T-components with at least one of them initially live and reversible, then by concatenating all such partial T-sequences  $\gamma_i$ , for every T-component  $C_i$  that is not initially live and reversible, together with those that initially fire partial T-sequences in the reversible T-components, we obtain a feasible T-sequence for the complete system.  $\square$

We deduce next that the polynomial live markings  $M_{EC}$  and  $\mathcal{M}_{JF}$  are reversible for well-formed Equal-Conflict and homogeneous Join-Free systems, respectively.

**Theorem 32** (Polynomial live home markings). *Let  $S = (N, M_0)$  be a strongly connected well-formed Equal-Conflict system. If  $S$  is not Join-Free, suppose that  $M_0$  is equal to the marking  $M_{EC}$ . Otherwise, if  $S$  is Join-Free, suppose that  $M_0$  belongs to  $\mathcal{M}_{JF}$ . Then, in both cases,  $S$  is well-behaved and reversible. Moreover, any larger marking also leads to well-behavedness and reversibility.*

*Proof.* Every well-formed Equal-Conflict net is covered by T-components by Proposition 6 on page 32. Since the marking  $M_0$  satisfies the conditions of Theorem 31, it enables a T-sequence. Applying the characterization of reversibility for Equal-Conflict systems of Theorem 29 on page 105, the system  $S$  is reversible. Moreover, liveness of well-formed Equal-Conflict systems is monotonous (Proposition 15 on page 65) and the same applies to reversibility (Theorem 30 on page 106).  $\square$

### 5.3 Reversibility of well-behaved Join-Free systems

There exists no non-trivial characterization of reversibility for well-formed Join-Free systems. This class extends the expressiveness of homogeneous Join-Free systems by removing the homogeneity constraint. Thus, Join-Free systems do not constitute a proper subclass of the Equal-Conflict class. However, we are able to construct next the first polynomial live home markings for this class without any new characterization.

#### 5.3.1 Polynomial live home markings

We show that the polynomial live markings  $\mathcal{M}_{JF}$  of Theorem 14 on page 64 for well-formed Join-Free systems are also reversible. As shown in the study of the liveness property of Chapter 4, balanced Join-Free systems that meet the conditions of Lemma 1 on page 60 have the property that every reachable marking enables a place. Since the language of a system is preserved by the balancing operation, the markings  $\mathcal{M}_{JF}$  also satisfy this property. All the output transitions of an enabled place being enabled in a Join-Free system, the choices that follow the order of a T-sequence intuitively lead to reversibility, the enabled places playing the role of enabled equal conflict sets. We prove this fact by adapting the results found for Equal-Conflict systems. In order to avoid redundancy, we only prove the parts that need new arguments.



## Chapter 5. Reversibility of live Equal-Conflict and Join-Free systems

---

We first need the following lemma, illustrated on Figure 5.27. This is a counterpart of Lemma 10 on page 101 for the live well-formed Join-Free systems whose every reachable marking enables a place.

**Lemma 12.** *Consider a strongly connected, live and well-formed Join-Free system  $S = (N, M_0)$ , with  $N = (P, T, W)$  and such that every reachable marking enables a place. Suppose there exists a feasible T-sequence  $\sigma_r$  in  $S$ . For every transition  $t$  enabled by  $M_0$  such that  $M_0 \xrightarrow{t} M$ , there exists a sequence  $\sigma_c$  that is feasible at  $M$  with  $\sigma = t\sigma_c$  and an integer  $k \geq 1$  such that  $\sigma$  is a T-sequence satisfying  $\vec{\sigma} = k \cdot \vec{\sigma}_r$ .*

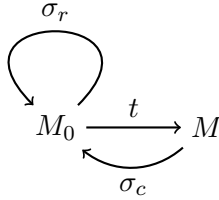

Figure 5.27: If the sequence  $\sigma_r$  is supposed to be feasible, then one can build the sequence  $\sigma_c$  feasible at  $M$ .

*Proof.* We adopt the same notations as in the Equal-Conflict case. We note  $K^1 = K_t^1(\sigma_r)$  the largest prefix sequence of  $\sigma_r$  preceding the first occurrence of  $t$ , meaning that  $\sigma_r$  is of the form  $K^1 t \sigma_2$ , where  $K^1$  does not contain any occurrence of  $t$ . This sequence is well-defined since the support of  $\vec{\sigma}_r$  is  $T$ . We note  $p$  the unique input place of  $t$ .

If  $t$  is the first transition in  $p^\bullet$  to be fired following the order of  $\sigma_r$ , meaning that  $K^1$  does not contain any occurrence of transitions in  $p^\bullet$ , then the sequence  $K^1$  does not use any token of the input place of  $t$ , thus one can execute  $K^1$  after the firing of the first occurrence of  $t$  and the sequence  $t K^1 \sigma_2$  is feasible at  $M_0$ . Hence,  $\sigma_c = K^1 \sigma_2$ .

Otherwise,  $t$  is not the first transition in  $p^\bullet$  to be fired following the order of  $\sigma_r$ , meaning that  $K^1$  contains at least one occurrence of another transition of  $p^\bullet$ . We show next that Algorithm 3 builds the sequence  $\sigma_c$  that returns to the initial marking. This is Algorithm 2 on page 102 in which enabled equal-conflict sets are replaced with enabled places.

We show that the inner loop always terminates and enables  $p$ . By assumption, every reachable marking enables a place. Now suppose that the inner loop does not terminate. Consequently, an infinite feasible sequence  $\nu$  is fired that never enables  $p$ . This means that all the input transitions of  $p$  are fired a finite number of times in  $\nu$ . Since the firings in the loop follow the order of  $(\sigma_r)^\infty$  and the support of  $\sigma_r$  is  $T$ , and the system is bounded, then for every place  $p'$  having an output transition fired a finite number of times, all the outputs and inputs of  $p'$  are fired a finite number of times. By strong connectedness, we deduce that no transition is fired an infinite number of times, a contradiction. Thus,  $p$  becomes enabled and the loop terminates.

The rest of the proof is deduced from the proof of Lemma 10 on page 101. Finally, since  $\kappa$  is of the form  $(\sigma_r)^\alpha$  for an integer  $\alpha > 0$ , the feasible sequence  $t\sigma_c$  is a T-sequence.  $\square$

### 5.3. Reversibility of well-behaved Join-Free systems

---



---

**Algorithm 3:** Computation of the feasible sequence  $\sigma_c$ .

---

**Data:** The system  $(N, M)$  obtained by firing  $t$  in  $S$ , the feasible sequence  $\sigma_r$ .

**Result:** A sequence  $\sigma_c$  that is feasible in  $(N, M)$  such that  $M \xrightarrow{\sigma_c} M_0$ .

```

1  $\tau := t$ ;
2 while  $\exists t' \in p^\bullet \setminus \{t\}, \vec{K}^1(t') > \vec{\tau}(t')$  do
3   while the input place  $p$  of  $t$  is not enabled do
4     Among the transitions that are outputs of enabled places, fire the transition
5      $t_x$  whose  $(\vec{\tau}(t_x) + 1)$ -th occurrence appears at the smallest position in  $(\sigma_r)^\infty$ ;
6      $\tau := \tau t_x$ ;
7   end
8   Among the transitions of  $p^\bullet$  different from  $t$ , fire the transition  $t_y$  satisfying
9    $\vec{K}^1(t_y) > \vec{\tau}(t_y)$  and whose  $(\vec{\tau}(t_y) + 1)$ -th occurrence appears at the smallest
10  position in  $K^1$ ;
11   $\tau := \tau t_y$ ;
12 end
13 Let  $\alpha$  be the smallest natural number such that  $\vec{\tau} \leq \alpha \cdot \vec{\sigma}_r$ ;
14 Denote by  $\kappa$  the sequence  $(\sigma_r)^\alpha$ ;
15 while  $\vec{\tau} \neq \vec{\kappa}$  do
16   Fire the transition  $t_x$  whose  $(\vec{\tau}(t_x) + 1)$ -th occurrence appears at the smallest
17   position in  $\kappa$ ;
18    $\tau := \tau t_x$ ;
19 end
20  $\tau$  is of the form  $t \sigma_c$ ;
21 return  $\sigma_c$ 

```

---

## Chapter 5. Reversibility of live Equal-Conflict and Join-Free systems

---

We use this lemma to deduce the next characterization of reversibility for the well-formed Join-Free systems whose every reachable marking enables a place.

**Theorem 33.** *Consider a live, well-formed strongly connected Join-Free system  $S = (N, M_0)$  such that  $N = (P, T, W)$  and every reachable marking enables a place. The system  $S$  is reversible if and only if it enables a T-sequence.*

*Proof.* The proof is similar to the proof of Theorem 29. In the inductive case, denoting by  $M$  the marking reached by firing  $t$ , we notice that every marking reachable from  $M$  enables a place. Finally, Lemma 12 applies.  $\square$

We deduce that the well-formed Join-Free systems whose initial marking belongs to  $\mathcal{M}_{\text{JF}}$  are live and reversible.

**Theorem 34** (Polynomial live home markings  $\mathcal{M}_{\text{JF}}$ ). *Let  $S = (N, M_0)$  be a strongly connected well-formed Join-Free system whose initial marking  $M_0$  belongs to  $\mathcal{M}_{\text{JF}}$ . Then,  $S$  is live and reversible. Moreover, every larger initial marking is also live and reversible.*

*Proof.* The existence of a feasible T-sequence has been recalled previously to be a necessary condition of reversibility for the live Petri nets. We prove next the sufficiency.

We show that  $S$  enables a T-sequence. The system  $S$  is covered by well-formed FA T-components by Proposition 7 on page 32. Moreover, it is strongly connected, and Theorem 31 on page 107 applies. Thus,  $S$  enables a T-sequence. Besides, by Lemma 1 on page 60, every reachable marking enables a place. Theorem 33 applies and  $S$  is reversible. Every larger marking is live (Theorem 14 on page 64), makes every reachable marking enable a place (Lemma 1 on page 60) and enables a T-sequence. Thus Theorem 33 also applies and every larger marking is live and reversible.  $\square$

### 5.4 Reversibility and T-sequences for other classes

We construct several examples of Petri nets whose expressiveness is not far from the Equal-Conflict class and which are live and non-reversible while enabling a T-sequence. We will also show that a well-behaved Petri net enabling a T-sequence is not necessarily reversible.

Figure 5.28 pictures ordinary strongly connected live systems that allow the firing of a T-sequence. The example on the left, which is taken from [Desel 1998], is bounded when  $M_0(p_4) = 0$ . If initial tokens are present in  $p_4$ , then the system becomes unbounded. In all cases, if we modify only the tokens of the place  $p_4$ , the system remains live and reversible. We obtain the system on the right by deleting the two "checking" arcs between  $t_3$  and  $p_4$ , and fixing  $M_0(p_4) = 0$ . This system is live, not bounded, not reversible and allows a T-sequence which is also feasible in the system on the left for any initial number in  $p_4$ .

#### 5.4. Reversibility and T-sequences for other classes

---

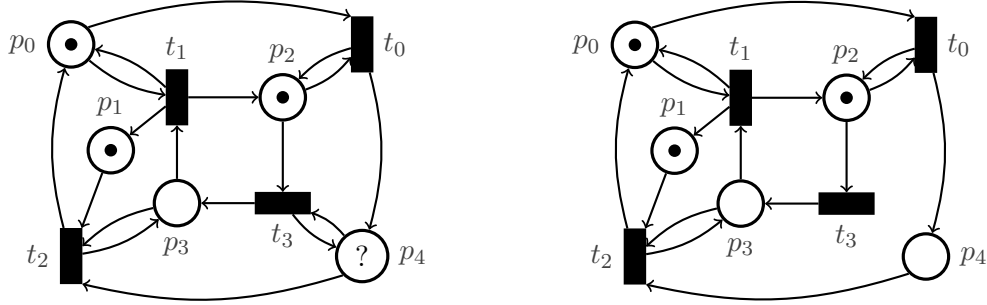

Figure 5.28: In the system on the left, changing the number of initial tokens in the place  $p_4$  modifies its behavior: if  $M_0(p_4) = 0$ , then it is live, bounded and reversible ; if  $M_0(p_4) \geq 1$ , then it is live, not bounded and reversible. On the right, we fix  $M_0(p_4) = 0$ , and delete the arcs between  $t_3$  and  $p_4$  ; the system obtained is live, not bounded, not reversible and allows the T-sequence  $t_0 t_3 t_2 t_1$ .

In these systems, when they are not bounded, the place  $p_1$  is the only unbounded place. The firing of  $t_0$  is necessary to enable  $t_2$ , but one can fire  $t_3$  without firing  $t_2$ . Firings of  $t_3$  enable  $t_1$  which generates tokens in  $p_1$ . Thus, if  $M_0(p_4) = 1$ , one can fire the sequence  $(t_3 t_1)^k$  for any positive integer  $k$ , which implies the unboundedness of  $p_1$ . On the left, if  $M_0(p_4) = 1$ , then there is a way to decrease the number of tokens in  $p_1$ : one can fire  $t_2$  twice as often as  $t_1$ , leading to the initial marking.

We propose in Figure 5.29 a modification of the net on the right of Figure 5.28. We add the place  $p_5$ , with one initial token, whose role is to bound the firings of  $t_1$  and thus to bound the place  $p_1$ . We scale the place  $p_0$  by 2 in order to balance the net, which is consequently structurally bounded. We obtain a well-formed, well-behaved, non-reversible system that still allows the firing of a T-sequence.

However, the system in Figure 5.29 does not belong to the Asymmetric-Choice class since  $p_0$  and  $p_2$  are both inputs of  $t_0$ ,  $p_0^\bullet = \{t_0, t_1\}$ ,  $p_2^\bullet = \{t_0, t_3\}$ , thus  $p_0^\bullet \not\subseteq p_2^\bullet$  and  $p_2^\bullet \not\subseteq p_0^\bullet$ . We picture in Figure 5.30 an ordinary Asymmetric-Choice net that is live, non-bounded, non-reversible and enables a T-sequence. This example is obtained by deleting the arcs between  $p_0$  and  $t_1$  in the system on the right of Figure 5.28.

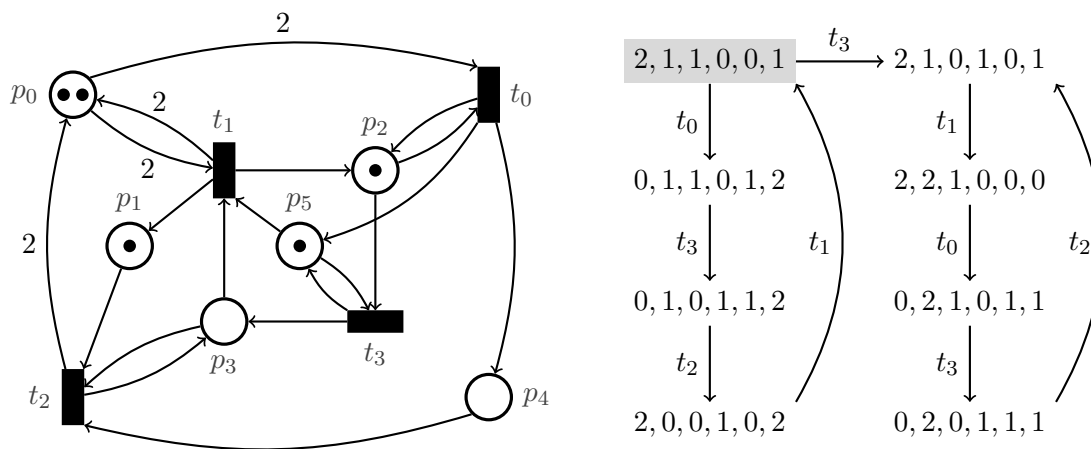

Figure 5.29: The balanced system on the left is well-formed, well-behaved, non-reversible and allows the T-sequence  $t_0 t_3 t_2 t_1$ . Its reachability graph is given on the right. We can see that every reachable marking enables a T-sequence.

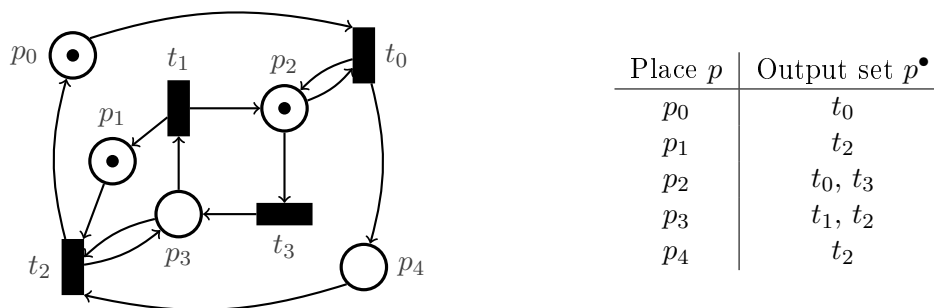

Figure 5.30: This ordinary Asymmetric-Choice system is live, not bounded, not reversible and allows the T-sequence  $t_0 t_3 t_2 t_1$ .

Figure 5.31 contains another example<sup>1</sup> of a Petri net that is live, not reversible and enables a T-sequence. In addition, it is well-behaved. The idea is to allow for the number of tokens of the place  $p_0$  to decrease so that it becomes impossible to get the tokens back. For example, the sequence  $t_3 t_1$  leads to the marking  $(1, 1, 0, 1, 0)$  from which it is impossible to reach the initial marking. However, the T-sequence  $t_3 t_2 t_1 t_0$  returns to the initial marking.

<sup>1</sup>This example, with a different layout, is taken from a Petri net course of Pr. Javier Campos, Universidad de Zaragoza, Spain.

#### 5.4. Reversibility and T-sequences for other classes

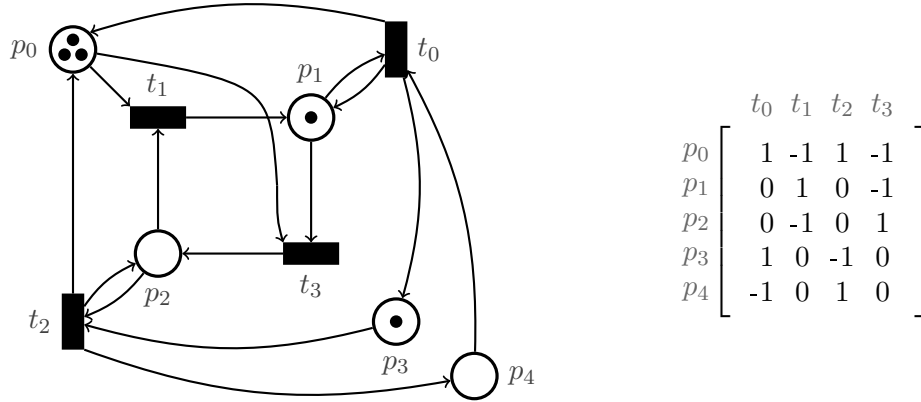

Figure 5.31: This Petri net is well-behaved, not reversible and enables the T-sequence  $t_3 t_2 t_1 t_0$ . Its incidence matrix, on the right, shows that it is not conservative (add column  $t_0$  to  $t_2$ ), thus not well-formed. However, it is consistent (the vector  $(1, 1, 1, 1)$  being the Parikh vector of the T-sequence).

We do not know yet if live Join-Free systems that allow the firing of a T-sequence are necessarily reversible. We propose, in Figure 5.32 an example of a weighted Free-Choice system that contains only one join-transition, with only two inputs. Thus, the structure of this net may be considered as not far from the structure of a Join-Free net. However, it may be difficult, if not impossible, to express the two conditions of the synchronization by means of weights without synchronization.

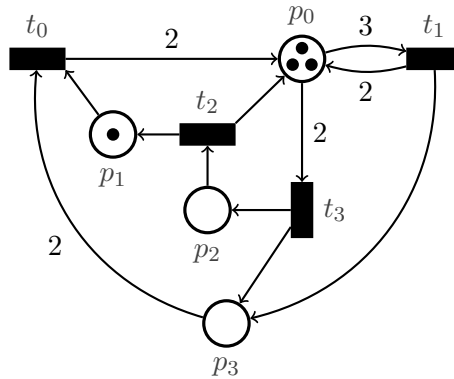

Figure 5.32: This Free-Choice Petri net is live, not bounded, not reversible and enables the T-sequence  $t_1 t_3 t_2 t_0$ . Moreover, it contains only one join-transition  $t_0$ , which has only two inputs. The place  $p_1$  is not bounded while the place  $p_0$  is 3-bounded. Thus, two consecutive firings of  $t_1$  are not possible, and  $t_0$  is either enabled by a firing of  $t_1$  followed by a firing of  $t_3$ , or by two firings of  $t_3$ .

## Chapter 5. Reversibility of live Equal-Conflict and Join-Free systems

---

Finally, Figure 5.33 highlights several subclasses for which we have presented counter-examples. The crosses represent systems appearing in previous figures. An L indicates that the system considered in the example is live, a B states its boundedness and an R its reversibility. Finally, the letter T indicates that there exists a T-sequence that is feasible at the initial marking. The negation of these properties is expressed by overlining the corresponding letters.

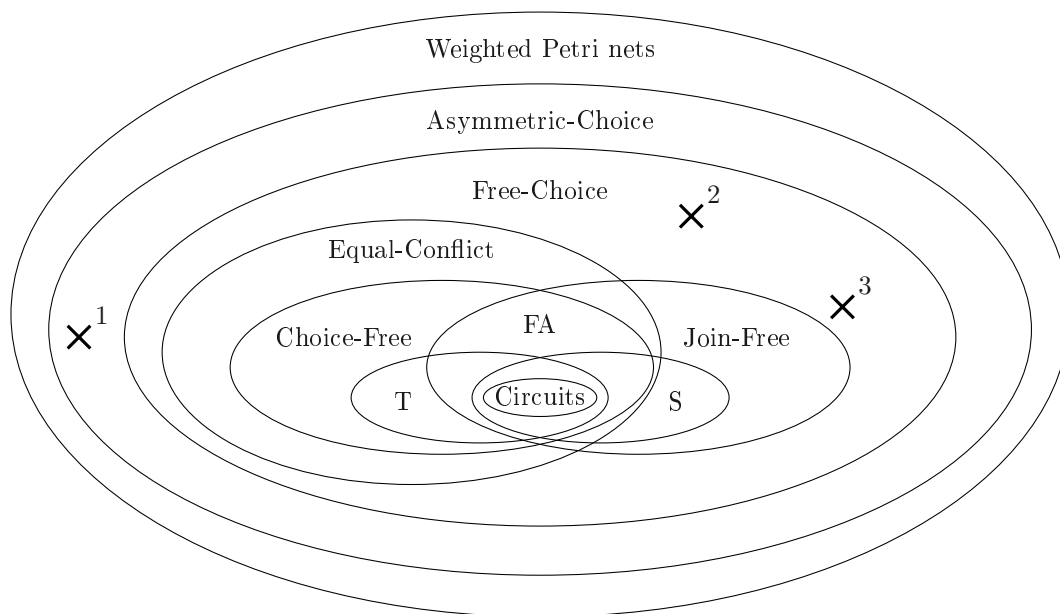

Figure 5.33: The cross 1 represents the counter-example of Figure 5.30, which is an ordinary Asymmetric-Choice system satisfying:  $L \bar{B} \bar{R} T$ . The cross 2 represents the transformation of the counter-example of Figure 5.29 into a Free-Choice system, which is consequently a well-formed weighted system satisfying:  $L B \bar{R} T$  (by Corollary 9 on page 48 and Corollary 10 on page 49). The cross 3 represents the counter-example of Figure 5.32, which is a weighted Free-Choice system having only one join-transition and satisfying:  $L \bar{B} \bar{R} T$ .

## 5.5 Conclusion

In this chapter, we studied the reversibility property in several expressive subclasses of weighted Petri nets under the liveness hypothesis. The reversibility property has many applications. It is required for the design of systems having a steady behavior, can simplify the analysis of the reachability graph and avoids a costly transient phase. It may also be used to check protocols that need to be reversible.

We provided the first polynomial live and reversible markings for the class of well-formed Fork-Attributions systems. We then obtained a new characterization of reversibility for well-behaved Choice-Free systems, extending a condition developed for T-systems by means of a decomposition into smaller subsystems. We used this characterization to build the first polynomial live and reversible markings for this class, whereas prior methods were exponential in time or in the number of initial tokens.

Using the place-splitting transformation, we also found another sufficient condition for liveness and reversibility, from which we deduced another polynomial time sufficient condition.

We compared all these methods and concluded that they are all worthy of interest for the checking of initial markings.

Later on, we focused on the more general class of live consistent Equal-Conflict systems, for which we presented the first non-trivial characterization of reversibility. Using this result, we showed that our polynomial live markings developed for well-formed Equal-Conflict systems are also reversible. We then deduced that our polynomial live markings developed in the previous chapter for well-formed Join-Free systems, which may not be homogeneous, are also reversible for this class.

Finally, we investigated the relationship between T-sequences and reversibility in larger classes of weighted Petri nets. We provided counter-examples showing that the existence of a feasible T-sequence in a live Petri net is not always sufficient to ensure reversibility, even in systems that are well-behaved. Thus, our characterization is tightly related to the Equal-Conflict structure.

We proposed polynomial monotonous markings that ensure the reversibility of several expressive well-behaved classes, providing starting conditions for complex systems that need to be live, bounded and reversible.





Chapter **6**

Conclusion and perspectives

## Chapter 6. Conclusion and perspectives

---

In this thesis, we investigated the liveness and reversibility properties of several expressive classes of weighted Petri nets. The structure and the behavior of a Petri net are strongly related, and we developed several general transformations that allow to simplify the study of the behavioral properties.

In Chapter 3, we presented the scaling operation and the notion of useful tokens, generalizing previous results developed in the context of weighted T-systems. We introduced the balancing transformation, a particular scaling that applies to conservative systems and leads to a token-conservative system, whose total number of tokens is constant over the whole set of reachable markings. We compared this transformation to the normalization of T-systems, which makes constant the number of tokens in every circuit.

We also presented a transformation of weighted Petri nets into weighted Free-Choice Petri nets.

All these transformations preserve strong properties, including the associated language and the well-formedness.

Furthermore, we introduced a place-splitting transformation that applies to a well-formed Choice-Free system to obtain a more constrained well-formed T-system, whose language is included in the language of the initial system.

In Chapter 4, we focused on the liveness property. We used the balancing operation to study the liveness of Join-Free systems, leading to the first polynomial sufficient condition of liveness for balanced well-formed Join-Free systems. We deduced polynomial live markings for the well-formed Join-Free systems that are not necessarily balanced.

Using these new markings as well as a known decomposition result for well-formed Equal-Conflict systems, we found the first polynomial live markings for this class.

We also obtained another sufficient condition of liveness for the subclass of Choice-Free systems, using the place-splitting transformation, that we compared with the other sufficient conditions.

We concluded that all the conditions are worthy of interest.

In Chapter 5, we studied the reversibility property under the liveness assumption. We proposed the first polynomial live and reversible markings for the well-formed Fork-Attribution systems.

We gave a new characterization of reversibility for the well-behaved Choice-Free systems by means of a decomposition into particular Fork-Attribution subsystems. We deduced the first polynomial live and reversible markings for well-formed Choice-Free systems.

We also used the place-splitting transformation to build new sufficient conditions of liveness and reversibility for this class, one of them benefiting from a polynomial time complexity, by studying the more constrained resulting T-system.

We compared the different sufficient conditions and proved that neither one of them subsumes the others.

Afterwards, we showed that our characterization of reversibility for Choice-Free sys-

---

tems cannot be trivially extended to the Equal-Conflict class. To overcome this problem, we introduced the notion of feasible T-sequences and showed that such sequences play a fundamental role in reversibility under the liveness assumption for this class. We obtained the first non-trivial characterization of reversibility for live consistent Equal-Conflict systems, which may be unbounded, stating both the necessity and sufficiency of the existence of a feasible T-sequence to ensure reversibility.

Using these results, we determined the first polynomial live and reversible markings for well-formed Equal-Conflict systems, as well as for well-formed Join-Free systems that are not necessarily homogeneous.

Finally, we showed that the existence of a feasible T-sequence is not sufficient anymore in larger classes of live weighted Petri nets, and even in well-behaved weighted Free-Choice systems, using our transformation into Free-Choice systems. Thus, our characterization is tightly related to the Equal-Conflict structure.

These results allow to ensure efficiently the liveness and reversibility of several expressive subclasses of weighted Petri nets, whereas prior methods were either exponential or did not exist. Since our transformations are general and apply to classes that are more expressive than Equal-Conflict and Join-Free systems, we hope they will be used for the study of other properties or other classes.

The following tables summarize the main results of the thesis.

Table 6.1 presents the main properties preserved or induced by the transformations: in most cases, the property can be studied equivalently in the initial system or in the transformed system.

Table 6.1: Properties of the transformations

	Language	Live and/or reversible	T-semiflows	Well-formedness
Scaling	$\Leftrightarrow$	$\Leftrightarrow$	$\Leftrightarrow$	$\Leftrightarrow$
Balancing	$\Leftrightarrow$	$\Leftrightarrow$	$\Leftrightarrow$	$\Leftrightarrow$
Useful tokens	$\Leftrightarrow$	$\Leftrightarrow$	$\Leftrightarrow$	$\Leftrightarrow$
Free-Choice	$\Leftrightarrow$	$\Leftrightarrow$	$\Leftrightarrow$	$\Leftrightarrow$
Place-splitting	$\supseteq$	$\Leftarrow$	$\Leftrightarrow$	$\Leftrightarrow$

## Chapter 6. Conclusion and perspectives

---

Table 6.2 recalls the new polynomial markings and sufficient conditions ensuring or checking the liveness property. A checkmark denotes a new result while a checkmark in brackets denotes previous results.

Table 6.2: Polynomial sufficient methods for liveness

	Monotonous polynomial markings	Polynomial sufficient conditions
T-systems	✓	(✓)
Choice-Free	✓	✓
Join-Free	✓	✓(balanced)
Equal-Conflict	✓	

Table 6.3 summarizes the new polynomial markings and sufficient conditions for reversibility, together with the new characterizations. A checkmark denotes a new result while a checkmark in brackets denotes previous results.

Table 6.3: New characterizations and polynomial sufficient methods for the liveness and reversibility properties

	Monotonous polynomial markings	Polynomial sufficient conditions	Characterizations
T-systems	✓	(✓)	(✓)
Choice-Free	✓	✓	(✓) + ✓
Join-Free	✓		
Equal-Conflict	✓		✓

---

## Perspectives

**Open questions.** Two fundamental questions remain open.

First, the complexity of the liveness problem in the weighted circuit remains open and is related to the Diophantine problem of Frobenius, which is known to be difficult [Chrzaszowski-Wachtel 1993, Ramirez-Alfonsin 1996]. A question arises of an improvement of our polynomial sufficient conditions of liveness and reversibility.

Second, non-trivial characterizations of reversibility for non-homogeneous weighted Join-Free systems have not been found either. This class removes the synchronization primitive of Petri nets. In the absence of this primitive, transitions that wait for all their input conditions to be satisfied are not permitted; the existence of at most one input place for transitions makes the conditions indistinguishable. Although this class is defined as the dual of the Choice-Free class, and the structure and behavior of Choice-Free systems are well understood, only structural results can be deduced by duality, and the behavior of Join-Free systems is not totally mastered.

**Polynomial methods in larger classes.** Polynomial time characterizations of well-formedness have not been found for all weighted Petri nets. Such a characterization exists for Equal-Conflict nets, however no similar result has been obtained for weighted Free-Choice nets. Hence, this question should be investigated. Later on, the liveness and reversibility properties could be studied in this more expressive class, looking for polynomial sufficient conditions. Moreover, our transformation of weighted Petri nets into weighted Free-Choice nets may allow for propagating and generalizing the properties of this subclass to all weighted Petri nets.

**Properties of timed Petri nets.** Real applications need the notion of time, which is modeled in well-known extensions of Petri nets. When time is included in the model, an evaluation of the performance of the system can be performed. Polynomial time bounds on the throughput of a system exist for weighted T-systems [Benabid-Najjar 2012] and may be extended to larger classes that we have identified, including Choice-Free systems.

In the classes that model choices, routing policies have to be investigated, similarly to the work of [Bouillard 2005a]. Performance evaluation of Petri nets can also be studied using stochastic Petri nets, as in [Bouillard 2005b].

**Modularity.** Many real systems can be seen as the assembly of several modules. Such compositional methods have been extensively explored in the domain of Petri nets, composing adequate modules while preserving desired properties, defining weighted classes that are more expressive than the weighted T-systems [Recalde 1996, Recalde 1998].

In the dataflow community, such methods also exist. Deterministic SDF with shared FIFOs (DSSF) [Tripakis 2013] and Interface-Based SDF (IBSDF) [Piat 2009] are compositional generalizations of the SDF graphs.

## Chapter 6. Conclusion and perspectives

---

Several refinement techniques also exist, which consist in replacing particular nodes by a net, according to particular rules, while preserving properties. For example, CSDF graphs extend the SDF model by refining actors with several phases [Bilsen 1995]. Refinement techniques were also studied in the context of Petri nets, as in [Suzuki 1983, Brauer 1990].

A unification of all these synthesis and refinement techniques may be possible, bridging the gap between different communities.

---



## Chapter 6. Conclusion and perspectives

---

# Bibliography

- [Alimonti 2011] Paola Alimonti, Esteban Feuerstein, Luigi Laura and Umberto Nanni. *Linear time analysis of properties of Conflict-Free and general Petri nets*. Theoretical Computer Science, vol. 412, no. 4-5, pages 320–38, 2011.
- [Amer-Yahia 1999a] Chérif Amer-Yahia and Nouredine Zerhouni. *Structure theory of Choice-Free Petri nets based on eigenvalues*. Journal of the Franklin Institute, vol. 336, no. 5, pages 833–849, 1999.
- [Amer-Yahia 1999b] Chérif Amer-Yahia, Nouredine Zerhouni, Abdellah El Moudni and Michel Ferney. *Some subclasses of Petri nets and the analysis of their structural properties: a new approach*. IEEE Transactions on Systems, Man and Cybernetics, Part A, vol. 29, no. 2, pages 164–172, 1999.
- [Anapalli 2009] Sukumar Reddy Anapalli, Krishna Chaithanya Chakilam and Timothy W. O’Neil. *Static Scheduling for Cyclo Static Data Flow Graphs*. In Proceedings of the International Conference on Parallel and Distributed Processing Techniques and Applications (PDPTA’09), pages 302–306, 2009.
- [Araki 1977] Toshiro Araki and Tadao Kasami. *Decidable problems on the strong connectivity of Petri net reachability sets*. Theoretical Computer Science, vol. 4, no. 1, pages 99–119, 1977.
- [Barkaoui 1992] Kamel Barkaoui and Michel Minoux. *A polynomial-time graph algorithm to decide liveness of some basic classes of bounded Petri nets*. In K. Jensen, editor, Application and Theory of Petri Nets, volume 616 of *Lecture Notes in Computer Science*, pages 62–75. Springer Berlin Heidelberg, 1992.
- [Barkaoui 1996] Kamel Barkaoui and Jean-François Pradat-Peyre. *On liveness and controlled siphons in Petri nets*. In J. Billington and W. Reisig, editors, Application and Theory of Petri Nets 1996, volume 1091 of *Lecture Notes in Computer Science*, pages 57–72. Springer Berlin Heidelberg, 1996.
- [Benabid-Najjar 2012] Abir Benabid-Najjar, Claire Hanen, Olivier Marchetti and Alix Munier-Kordon. *Periodic schedules for bounded timed weighted Event Graphs*. IEEE Transactions on Automatic Control, vol. 57, no. 5, pages 1222–1232, May 2012.
- [Benazouz 2010] Mohamed Benazouz, Olivier Marchetti, Alix Munier-Kordon and Thierry Michel. *A new method for minimizing buffer sizes for Cyclo-Static Dataflow graphs*. In 8th IEEE Workshop on Embedded Systems for Real-Time Multimedia (ESTI-Media’10), pages 11–20, Oct 2010.

## Bibliography

---

- [Benazouz 2013] Mohamed Benazouz, Alix Munier-Kordon, Thomas Hujsa and Bruno Bodin. *Liveness evaluation of a cyclo-static dataflow graph*. In Proceedings of the 50th Annual Design Automation Conference (DAC'13), pages 1–7, New York, NY, USA, 2013. ACM.
- [Berthelot 1986] Gérard Berthelot. *Checking properties of nets using transformations*. In G. Rozenberg, editor, Advances in Petri Nets 1985, volume 222 of *LNCS*, pages 19–40. Springer, Heidelberg, 1986.
- [Berthelot 1987] Gérard Berthelot. *Transformations and decompositions of nets*. In W. Brauer, W. Reisig and G. Rozenberg, editors, Petri Nets: Central Models and Their Properties, volume 254 of *LNCS*, pages 359–376. Springer, Heidelberg, 1987.
- [Best 2008] Eike Best and Philippe Darondeau. *Decomposition Theorems for Bounded Persistent Petri Nets*. In Heidelberg Springer, editor, Applications and Theory of Petri Nets, volume 5062 of *LNCS*, pages 33–51, 2008.
- [Bilsen 1995] Greet Bilsen, Marc Engels, Rudy Lauwereins and Jean A. Peperstraete. *Cyclo-static data flow*. In International conference on Acoustics, Speech and Signal Processing (ICASSP '95), volume 5, pages 3255–3258, May 1995.
- [Bouillard 2005a] Anne Bouillard, Bruno Gaujal and Jean Mairesse. *Extremal Throughputs in Free-Choice Nets*. In Gianfranco Ciardo and Philippe Darondeau, editors, Applications and Theory of Petri Nets '05, volume 3536 of *Lecture Notes in Computer Science*, pages 108–127. Springer Berlin Heidelberg, 2005.
- [Bouillard 2005b] Anne Bouillard, Bruno Gaujal and Jean Mairesse. *Throughput in stochastic free-choice nets under various policies*. In 44th IEEE Conference on Decision and control, and European Control Conference (CDC-ECC '05), pages 2131–2136, Dec. 2005.
- [Brauer 1990] Wilfried Brauer, Robert Gold and Walter Vogler. *A survey of behavior and equivalence preserving refinements of Petri nets*. In Grzegorz Rozenberg, editor, Advances in Petri nets, volume 483 of *Lecture Notes in Computer Science*, pages 1–46. Springer Berlin Heidelberg, 1990.
- [Chao 2001] Daniel Y. Chao and Jose A. Nicdao. *Liveness for Synchronized Choice Petri nets*. The Computer Journal, vol. 44, no. 2, pages 124–136, 2001.
- [Cheng 1993] Allan Cheng, Javier Esparza and Jens Palsberg. *Complexity results for 1-safe nets*. In RudrapatnaK. Shyamasundar, editor, Foundations of Software Technology and Theoretical Computer Science, volume 761 of *Lecture Notes in Computer Science*, pages 326–337. Springer Berlin Heidelberg, 1993.
- [Chrzastowski-Wachtel 1993] Piotr Chrzastowski-Wachtel and Marek Raczunas. *Liveness of weighted circuits and the diophantine problem of Frobenius*. In Zoltán Ésik, editor,

- Fundamentals of Computation Theory, volume 710 of *Lecture Notes in Computer Science*, pages 171–180. Springer Berlin Heidelberg, 1993.
- [Colom 2003] J.M. Colom, E. Teruel, M. Silva and S. Haddad. *Structural Methods*. In Petri Nets for Systems Engineering, pages 277–316. Springer, Heidelberg, 2003.
- [de Frutos Escrig 1989] David de Frutos Escrig and Colette Johnen. *Decidability of Home Space Property*. Technical report LRI-503, Univ. de Paris-Sud, Centre d’Orsay, LRI, 1989.
- [Desel 1995] Jörg Desel and Javier Esparza. Free Choice Petri Nets, volume 40 of *Cambridge Tracts in Theoretical Computer Science*. Cambridge University Press, New York, NY, USA, 1995.
- [Desel 1998] Jörg Desel and Wolfgang Reisig. *Place/Transition Petri Nets*. In Wolfgang Reisig and Grzegorz Rozenberg, editors, Lectures on Petri Nets I: Basic Models, volume 1491 of *Lecture Notes in Computer Science*, pages 122–173. Springer Berlin Heidelberg, 1998.
- [Engels 1994] Marc Engels, Greet Bilsen, Rudy Lauwereins and Jean A. Peperstraete. *Cycle-static dataflow: model and implementation*. In Proceedings of the 20th Asilomar Conference on Signals, Systems and Computers, pages 503–507, 1994.
- [Esparza 1994] Javier Esparza and Mogens Nielsen. *Decidability issues for Petri nets*. Petri nets newsletter, vol. 94, pages 5–23, 1994.
- [Esparza 1997] Javier Esparza. *Petri nets, commutative context-free grammars, and Basic Parallel Processes*. Fundamenta Informaticae, vol. 31, no. 1, pages 13–26, 1997.
- [Esparza 1998] Javier Esparza. *Decidability and complexity of Petri net problems - an introduction*. In W. Reisig and G. Rozenberg, editors, Lectures on Petri Nets I: Basic Models, volume 1491 of *Lecture Notes in Computer Science*, pages 374–428. Springer Berlin Heidelberg, 1998.
- [Ezpeleta 1995] J. Ezpeleta, J.-M. Colom and J. Martinez. *A Petri net based deadlock prevention policy for flexible manufacturing systems*. IEEE Transactions on Robotics and Automation, vol. 11, no. 2, pages 173–184, Apr 1995.
- [Frommer 2000] Andreas Frommer and Daniel B. Szyld. *On Asynchronous Iterations*. Journal of Computational and Applied Mathematics, vol. 123, no. 1-2, pages 201–216, 2000.
- [Hack 1974] Michel Hack. *The recursive equivalence of the reachability problem and the liveness problem for Petri nets and vector addition systems*. In IEEE Conference Record of 15th Annual Symposium on Switching and Automata Theory, pages 156–164, Oct 1974.

## Bibliography

---

- [Hack 1976] Michel Hack. *Decidability questions for Petri nets*. Technical report 161, MIT, Laboratory for Computer Science, 1976.
- [Heiner 2010] Monika Heiner, Cristian Mahulea and Manuel Silva. *On the Importance of the Deadlock Trap Property for Monotonic Liveness*. In International Workshop on Biological Processes and Petri nets (BioPPN), A satellite event of Petri Nets 2010, Braga, Portugal, June 2010.
- [Jiao 2004] Li Jiao, To-Yat Cheung and Weiming Lu. *On liveness and boundedness of Asymmetric Choice nets*. Theoretical Computer Science, vol. 311, no. 1-3, pages 165–197, 2004.
- [Jones 1977] Neil D. Jones, Lawrence H. Landweber and Y. Edmund Lien. *Complexity of some problems in Petri nets*. Theoretical Computer Science, vol. 4, no. 3, pages 277–299, 1977.
- [Kahn 1974] Gilles Kahn. *The semantics of simple language for parallel programming*. In Proceedings of IFIP 74 Conference, pages 471–475, 1974.
- [Keller 1975] Robert M. Keller. *A fundamental theorem of asynchronous parallel computation*. In Tse-yun Feng, editor, Parallel Processing, volume 24 of *LNCS*, pages 102–112. Springer, Heidelberg, 1975.
- [Lee 1987a] E.A. Lee and D.G. Messerschmidt. *Static scheduling of synchronous data flow programs for digital signal processing*. In IEEE Transaction on Computers, C-36(1):24-35, 1987.
- [Lee 1987b] Edward A. Lee and David G. Messerschmitt. *Synchronous Data Flow*. Proceedings of the IEEE, vol. 75, no. 9, pages 1235–1245, 1987.
- [Lien 1976] Y. Edmund Lien. *Termination Properties of Generalized Petri Nets*. SIAM Journal on Computing, vol. 5, no. 2, pages 251–265, 1976.
- [Lipton 1976] R. Lipton. *The reachability problem requires exponential space*. Technical report 62, Department of Computer Science, Yale University, 1976.
- [Lopez-Grao 2013] Juan-Pablo Lopez-Grao and José-Manuel Colom. *Structural Methods for the Control of Discrete Event Dynamic Systems - The case of the Resource Allocation Problem*. In Carla Seatzu, Manuel Silva and Jan H. van Schuppen, editors, Control of Discrete-Event Systems, volume 433 of *Lecture Notes in Control and Information Sciences*, pages 257–278. Springer London, 2013.
- [Marchetti 2009] Olivier Marchetti and Alix Munier-Kordon. *A sufficient condition for the liveness of Weighted Event Graphs*. European Journal of Operational Research, vol. 197, no. 2, pages 532–540, 2009.

- 
- [Mayr 1984] Ernst W Mayr. *An algorithm for the general Petri net reachability problem*. SIAM Journal on computing, vol. 13, no. 3, pages 441–460, 1984.
- [Mayr 2000] Richard Mayr. *Process rewrite systems*. Information and Computation, vol. 156, no. 1-2, pages 264–286, 2000.
- [Megiddo 1987] Nimrod Megiddo. *On the complexity of linear programming*. In Proceedings of the Fifth World Congress on Advances in Economic Theory, pages 225–268, 1987.
- [Memmi 1980] Gérard Memmi and Gérard Roucairol. *Linear algebra in net theory*. In W. Brauer, editor, Net Theory and Applications, volume 84 of *LNCS*, pages 213–223. Springer, Heidelberg, 1980.
- [Murata 1989] Tadao Murata. *Petri nets : properties, analysis and applications*. Proceedings of the IEEE, vol. 77, no. 4, pages 541–580, 1989.
- [Parks 1995] Thomas M. Parks. *Bounded Scheduling of Process Networks*. PhD thesis, EECS Department, University of California, Berkeley, 1995.
- [Piat 2009] J. Piat, S.S. Bhattacharyya and M. Raullet. *Interface-based hierarchy for synchronous data-flow graphs*. In IEEE Workshop on Signal Processing Systems (SiPS '09), pages 145–150, Oct 2009.
- [Pino 1995] Jose Luis Pino, Shuvra S. Bhattacharyya and Edward A. Lee. *A hierarchical multiprocessor scheduling framework for synchronous dataflow graphs*. Technical report, University of California, Berkeley, May 1995.
- [Ramirez-Alfonsin 1996] J.L. Ramirez-Alfonsin. *Complexity of the Frobenius problem*. Combinatorica, vol. 16, no. 1, pages 143–147, 1996.
- [Recalde 1995] Laura Recalde, Enrique Teruel and Manuel Silva. *On well-formedness analysis: the case of Deterministic Systems of Sequential Processes*. In J. Desel, editor, Structures in Concurrency Theory, Workshops in Computing, pages 279–293. Springer London, 1995.
- [Recalde 1996] Laura Recalde, Enrique Teruel and Manuel Silva. *SC\*ECS: a class of modular and hierarchical cooperating systems*. In J. Billington and W. Reisig, editors, Application and Theory of Petri Nets 1996, volume 1091 of *Lecture Notes in Computer Science*, pages 440–459. Springer Berlin Heidelberg, 1996.
- [Recalde 1998] Laura Recalde, Enrique Teruel and Manuel Silva. *Modeling and analysis of sequential processes that cooperate through buffers*. IEEE Transactions on Robotics and Automation, vol. 14, no. 2, pages 267–277, 1998.
- [Sifakis 1978] Joseph Sifakis. *Structural properties of Petri nets*. In J. Winkowski, editor, Mathematical Foundations of Computer Science, volume 64 of *LNCS*, pages 474–483. Springer, Heidelberg, 1978.

## Bibliography

---

- [Silva 1990] Manuel Silva and Robert Valette. *Petri Nets and Flexible Manufacturing*. In Advances in Petri nets 1989, pages 374–417, London, UK, UK, 1990. Springer-Verlag.
- [Silva 1998] Manuel Silva, Enrique Teruel and José Manuel Colom. *Linear algebraic and linear programming techniques for the analysis of place/transition net systems*. In W. Reisig and G. Rozenberg, editors, Lectures on Petri Nets I: Basic Models, volume 1491 of *Lecture Notes in Computer Science*, pages 309–373. Springer Berlin Heidelberg, 1998.
- [Sriram 2009] Sundararajan Sriram and Shuvra S. Bhattacharyya. *Embedded multiprocessors: scheduling and synchronization*. Signal Processing and Communications. CRC Press, 2009.
- [Suzuki 1983] Ichiro Suzuki and Tadao Murata. *A method for stepwise refinement and abstraction of Petri nets*. Journal of Computer and System Sciences, vol. 27, no. 1, pages 51–76, 1983.
- [Teruel 1992] Enrique Teruel, Piotr Chrzastowski-Wachtel, José Manuel Colom and Manuel Silva. *On weighted T-systems*. In K. Jensen, editor, Application and Theory of Petri Nets 1992, volume 616 of *LNCS*, pages 348–367. Springer, Heidelberg, 1992.
- [Teruel 1993] Enrique Teruel and Manuel Silva. *Liveness and home states in Equal Conflict systems*. In M. Ajmone Marsan, editor, Application and Theory of Petri Nets 1993, volume 691 of *LNCS*, pages 415–432. Springer, Heidelberg, 1993.
- [Teruel 1994] Enrique Teruel and Manuel Silva. *Well-formedness of Equal Conflict systems*. In Robert Valette, editor, Application and Theory of Petri Nets, volume 815 of *Lecture Notes in Computer Science*, pages 491–510. Springer Berlin Heidelberg, 1994.
- [Teruel 1996] Enrique Teruel and Manuel Silva. *Structure theory of Equal Conflict systems*. Theoretical Computer Science, vol. 153, no. 1&2, pages 271–300, 1996.
- [Teruel 1997] Enrique Teruel, José Manuel Colom and Manuel Silva. *Choice-Free Petri nets: a model for deterministic concurrent systems with bulk services and arrivals*. IEEE Transactions on Systems, Man and Cybernetics, Part A, vol. 27, no. 1, pages 73–83, 1997.
- [Tripakis 2013] Stavros Tripakis, Dai Bui, Marc Geilen, Bert Rodiers and Edward A. Lee. *Compositionality in Synchronous DataFlow: Modular Code Generation from Hierarchical SDF graphs*. ACM Transactions on Embedded Computing Systems, vol. 12, no. 3, pages 1–26, apr 2013.
- [Wiggers 2007a] Maarten Wiggers, Marco Jan Gerrit Bekooij, Pierre G. Jansen and Gerard J. M. Smit. *Efficient computation of buffer capacities for Cyclo-Static DataFlow*

*graphs*. In Proceedings of the 44th Design Automation Conference, pages 658–663, 2007.

[Wiggers 2007b] Maarten Wiggers, Marco Jan Gerrit Bekooij, Pierre G. Jansen and Gerard J. M. Smit. *Efficient computation of buffer capacities for cyclo-static real-time systems with back-pressure*. In 13th IEEE Real Time and embedded technology and Applications Symposium (RTAS'07), pages 281–292, Apr 2007.





## List of publications

### International journal with peer review:

(1) Thomas Hujsa, Jean-Marc Delosme, and Alix Munier-Kordon. *Polynomial sufficient conditions of well-behavedness and home markings in subclasses of weighted Petri nets*. Transactions on Embedded Computing Systems (TECS), Vol. 13, No. 141, pages 1–25, July 2014. ACM New York, NY, USA.

This publication is an extension of (3), detailing the transformations (Chapter 3 of this thesis), improving the polynomial live markings (Chap. 4) and providing the first polynomial live and reversible markings for well-formed Fork-Attribution systems (Chap. 5).

### International conferences with peer review:

(2) Mohamed Benazouz, Alix Munier-Kordon, Thomas Hujsa, and Bruno Bodin. *Liveness evaluation of a cyclo-static DataFlow graph*. In proceedings of the 50th Annual Design Automation Conference (DAC'13), pages 1–7, Austin, Texas, June 2013. ACM New York, NY, USA / EDAC / IEEE.

This publication provides polynomial sufficient conditions of liveness for CSDF graphs, which refine SDF graphs with phases. An original method to compute close-to-optimal buffer capacities ensuring liveness is also presented.

(3) Jean-Marc Delosme, Thomas Hujsa, and Alix Munier-Kordon. *Polynomial Sufficient Conditions of Well-Behavedness for Weighted Join-Free and Choice-Free Systems*. In proceedings of the 13th International Conference on Application of Concurrency to System Design (ACSD'13), pages 90–99, Barcelona, Spain, July 2013. IEEE.

This publication presents new polynomial time transformations of weighted Petri nets preserving strong properties (Chapter 3 of this thesis), and provides the first polynomial sufficient conditions of liveness for well-formed Choice-Free and Join-Free systems (Chap. 4).

(4) Thomas Hujsa, Jean-Marc Delosme, and Alix Munier-Kordon. *On the Reversibility of Well-Behaved Weighted Choice-Free Systems*. In proceedings of the 35th International Conference on (Petri Nets'14), pages 334–353, Barcelona, June 2014. Springer, LNCS.

This publication studies the reversibility property in well-formed live Choice-Free systems. For this class, a new characterization of reversibility and the first polynomial sufficient conditions of liveness and reversibility are presented (Chapter 5 of this thesis). An original transformation of well-formed Choice-Free systems into well-formed T-systems gives insight into their behavior (Chap. 3).

