



HAL
open science

Collaboration des équipements du réseau domestique pour une meilleure efficacité énergétique globale

Han Yan

► **To cite this version:**

Han Yan. Collaboration des équipements du réseau domestique pour une meilleure efficacité énergétique globale. Autre [cs.OH]. Université de Rennes, 2014. Français. NNT : 2014REN1S122 . tel-01147623

HAL Id: tel-01147623

<https://theses.hal.science/tel-01147623>

Submitted on 30 Apr 2015

HAL is a multi-disciplinary open access archive for the deposit and dissemination of scientific research documents, whether they are published or not. The documents may come from teaching and research institutions in France or abroad, or from public or private research centers.

L'archive ouverte pluridisciplinaire **HAL**, est destinée au dépôt et à la diffusion de documents scientifiques de niveau recherche, publiés ou non, émanant des établissements d'enseignement et de recherche français ou étrangers, des laboratoires publics ou privés.



THÈSE / UNIVERSITÉ DE RENNES 1
sous le sceau de l'Université Européenne de Bretagne

pour le grade de
DOCTEUR DE L'UNIVERSITÉ DE RENNES 1

Mention : Informatique

Ecole doctorale MATISSE

présentée par

Han YAN

Préparée à l'unité de recherche IRISA (UMR 6074)
Institut de Recherche en Informatique et Systèmes Aléatoires

**Smart Devices
Collaboration
for Energy Saving
in Home Networks**

**Thèse soutenue à Rennes
le 19/12/2014**

devant le jury composé de :

Ye-Qiong SONG

Professeur, Université de Lorraine / *rapporteur*

Mohamed Yacine GHAMRI DOUDANE

Professeur, Université de La Rochelle / *rapporteur*

Stéphane LOHIER

Maître de conférence, Université Paris Est /
examineur

Bernard COUSIN

Professeur, Université de Rennes 1 /
directeur de thèse

Cédric GUEGUEN

Maître de conférence, Université de Rennes 1 /
examineur

Jean-Paul VUICHARD

Responsable unité de recherche, Orange Labs /
co-directeur de thèse

Remerciements

Je tiens avant tout à remercier le Professeur Ye-Qiong Song ainsi que le Professeur Mohamed Yacine Ghamri-Doudane d'avoir accepté d'être les rapporteurs et membres du jury de ma thèse. Je remercie également Stéphane Lohier d'avoir accepté le rôle d'examineur de cette thèse.

Je tiens à exprimer ma profonde reconnaissance à mes encadrants qui ont contribué à ces travaux avec la pédagogie précieuse de mon directeur de thèse Bernard Cousin, mon encadrant de thèse Cédric Gueguen et mon co-directeur de thèse et manager Jean-Paul Vuichard qui depuis le tout début de ma thèse m'ont conseillée, épaulée, et soutenue, jusqu'à l'aboutissement de cette thèse. Je vous remercie tous pour vos corrections et vos commentaires pertinents lors de chaque rédaction d'article et lors de la rédaction de ma thèse. J'ai beaucoup apprécié nos discussions régulières sur les travaux de la thèse ainsi que sur les autres sujets variés.

Cette thèse s'est déroulée au sein du laboratoire "Smart Access in Digital Home" à Orange Labs et de l'équipe "Advanced Technology in NETworking" à l'Irisa. Je tiens à remercier généralement les membres de ces deux équipes pour le cadre de travail stimulant et la bonne ambiance. Je remercie particulièrement Fabrice Fontaine avec qui j'ai collaboré sur plusieurs dépôts de brevet. Je remercie Gil Mardon qui m'as encadrée pour que je puisse commencer ma thèse dans de bonnes conditions. Je salue les membres de l'URD HDMI et HEAD qui m'ont accueillie chaleureusement. J'exprime également ma sympathie aux membres de l'équipe ATNET qui m'ont accueilli 3 ans et plusieurs semaines jusqu'à la fin de ma thèse.

J'adresse une pensée forte à mon mari Romain pour son soutien et son accompagnement quotidien durant cette thèse. Je remercie ma famille, ma belle famille et mes amis de toutes nationalités pour leurs soutiens qui m'ont énormément encouragé pour mener à bien ma thèse.

Abstract

In recent years, Information and Communications Technology (ICT) has totally changed the people daily life in the Digital Home. Meanwhile, not only the amount of CO₂ emission of ICT, so called “footprint”, is increasing without cease, but also the price of electricity is constantly rising. Thus, it is quite important to reduce energy consumption in the home network and home devices for the environmental and economic reasons.

In order to cope with this context, the thesis concerns the design, the evaluation, and the implementation of a novel set of mechanisms with the purpose of responding to home network energy consumption problems. We proposed firstly an Overlay Energy Control Network which is formed by the overlay energy control nodes. Each node is connected to one device which forms an overlay control network to coordinate the power states of the device. Then, a testbed for HOme Power Efficiency system (HOPE) is implemented to demonstrate the technical solution for energy control in a real home network environment with several frequently used scenarios. After analyzing user’s way of use of their home network equipment, we propose a power management which controls the devices based on the analysis of the collaborative services. These frequently used collaborative services require different functional blocks in different devices. This model provides the possibility to turn on the right requested functional blocks in the right device at the right moment. Finally, based on the former contribution, the collaborative overlay power management offers several possible tradeoffs between the power consumption and the waiting delay in the home network.

Abstract

Key words: *Home network, collaborative service, overlay network, power management, user behaviors, low power network*

Résumé

Au cours des dernières années, la révolution numérique a continué sa progression. Les technologies de l'information et des communications (TIC) ont totalement changé la vie quotidienne des gens à leur domicile (concept de « maison numérique »). Pendant ce temps, non seulement le volume des émissions de CO₂ produit par les TIC, ce qu'on appelle l'empreinte carbone, est sans cesse en croissance mais elle s'accompagne également d'une hausse du prix de l'électricité, augmentant fortement la part des équipements numériques dans la budget global des ménages. Ainsi, pour des raisons environnementales et économiques, réduire la consommation d'énergie dans les nombreux équipements du réseau domestique est devenu un enjeu majeur.

Dans ce contexte, la thèse porte sur la conception, l'évaluation et la mise en œuvre d'un ensemble de mécanismes dans le but de répondre aux problèmes de consommation d'énergie sur les réseaux locaux rassemblant les équipements numériques domestiques. Nous proposons un réseau de contrôle qui est formé par des noeuds de contrôle de l'énergie placés au-dessus du réseau traditionnel. Chaque noeud de contrôle est relié à un dispositif en vue de coordonner les états d'alimentation de l'équipement domestique associé. Un démonstrateur pour un système HOme Power Efficiency (HOPE) a également été mis en œuvre. Il démontre la faisabilité de la solution technique que nous proposons pour le contrôle de l'énergie dans un réseau domestique réel avec des scénarios réels qui sont souvent utilisées par utilisateur. Après avoir analysé le mode d'utilisation des équipements du réseau domestique, nous proposons un système de gestion d'énergie qui contrôle ces équipements minimisant ainsi que leur consommation. Le système

Résumé

est basé sur l'analyse des services collaboratifs, chaque service est découpé en blocs fonctionnels atomiques, distribués dans les différents équipements. Cela permet de gérer avec plus de précision les besoins énergétiques de chaque équipement de manière à n'alimenter que les composants nécessaires au service demandé. Pour conclure ces travaux, nous avons également cherché à minimiser les impacts de l'économie d'énergie sur la qualité d'expérience perçue par l'utilisateur (notamment le délai d'activation des services). Nous proposons un système de gestion d'énergie pour des services collaboratifs offrant plusieurs compromis possibles entre la consommation d'énergie et le délai d'activation des services dans un réseau domestique. Il est complété par un algorithme d'apprentissage du comportement des utilisateurs domestiques.

Mots clés: *Réseau domestique, service collaboratif, réseau overlay, système de gestion d'énergie, comportements des utilisateurs, réseau à basse consommation*

Résumé de la thèse en Français

Au cours des dernières années, la révolution numérique a continué sa progression. Les technologies de l'information et des communications (TIC) ont totalement changé la vie quotidienne des gens à leur domicile (concept de « maison numérique »). Pendant ce temps, non seulement le volume des émissions de CO₂ produit par les TIC, ce qu'on appelle l'empreinte carbone, est sans cesse en croissance mais elle s'accompagne également d'une hausse du prix de l'électricité, augmentant fortement la part des équipements numériques dans la budget global des ménages. Ainsi, pour des raisons environnementales et économiques, réduire la consommation d'énergie dans les nombreux équipements du réseau domestique est devenu un enjeu majeur.

Problèmes étudiés

Maison numérique est appelé grâce "numérique" pour les dispositifs qui peuvent être connectés par différentes technologies de communication. Les équipements connectés peuvent être une passerelle domestique, un Set-Top Box, un ordinateur personnel, une tablette, ou capteurs de maison, etc. Dans cette section, nous allons présenter les principaux problèmes que nous avons étudiés dans cette thèse.

Les connectivités dans la maison deviennent omniprésentes. Être connecté est devenu un caractère important pour les équipements de la maison. Ils ont besoin de fournir divers services pour les utilisateurs du réseau de la maison, comme les achats en ligne, le partage multimédia, vidéoconférence, etc. Technologies de connexion comme le WiFi, Ethernet, Courant Porteur en Ligne sont nécessaires pour fournir un réseau pratique et de confort pour l'utilisation du service. Bien que parfois les équipements connectés ne sont pas toujours en cours d'utilisation,

Résumé de la thèse en Français

Le WiFi, Ethernet ou les communications Courant Porteur en Ligne (CPL) sont maintenus afin de préserver un réseau toujours actif à l'exigence de l'utilisateur. Pour faire partie du réseau, des dispositifs tels que la passerelle domestique, ou des plugs CPL sont toujours tous les jours allumées afin d'assurer un réseau toujours actif. Et ce n'est pas nécessaire. Par exemple, si il n'y a pas d'équipement se connecte aux plugs CPL, il n'est donc pas nécessaire de garder ce lien toujours allumée juste pour l'entretien du réseau. On pourrait résumer que les connexions réseau a la maison ne sont pas utilisés de manière efficace de l'énergie.

Comme mentionné précédemment, avec la connexion omniprésente du réseau, les dispositifs ne travaillent plus individuellement. Ils travaillent ensemble pour fournir un service collaboratif. Le service collaboratif plus simple pourrait être à télécharger un fichier sur un ordinateur portable. Ce service nécessite la passerelle domestique fournit la connexion WiFi pour établir la connexion réseau d'ordinateur portable afin de effectuer le téléchargement. Dans cet exemple, nous avons au moins deux dispositifs fonctionnent ensemble pour le service collaboratif de téléchargement. Si nous prenons un cas d'utilisation plus complexe: UPnP audio vidéo. L'utilisateur contrôle les équipements de la maison avec un point de contrôle UPnP (smart-phone, iPad ou autre tablette). Il veut regarder un film sur son UPnP multimédia render (STB). Ce film est enregistré sur son serveur de médias (PC). Pour effectuer le service UPnP audio video, il est nécessaire d'avoir smart-phone, STB et PC qui collaborent ensemble. Ceci est un autre service collaboratif qui nous montre qu'il est intéressant de trouver la relation entre les dispositifs.

Un autre problème est les équipements connectés ne sont pas utilisés de manière efficace en terme d'énergie. Dans la plupart de famille, la Set-Top Box et la télévision sont de plus en plus indispensable. L'étude de NRDC montre que deux-tiers de l'électricité consommée par les Set-Top Box et la télévision est utilisé quand ils sont inactifs [16]. Alors que les équipements sont en état d'inactifs, cela signifie que les équipements ne sont pas nécessaires par les services. Bien qu'il est certain que l'énergie consommée dans l'état d'inactif est un gaspillage d'énergie réel, les utilisateurs ne se passent pas toujours de leurs équipements. Il y a deux raisons: d'abord, pas chaque utilisateur a la conscience d'économiser de l'énergie. Et aussi il y a des utilisateurs qui veulent pas éteindre leurs équipements, car

ils doivent attendre pendant le temps de démarrage tandis que ils ont besoin pour profiter immédiatement du service. Ainsi, les équipements consomment de l'énergie inutilement alors qu'ils ne sont pas utilisés.

L'utilisateur joue un rôle important dans l'environnement de réseau domestique, parce que les services de réseau domestique sont utilisés par l'utilisateur et la qualité de l'expérience utilisateur peut directement impacts les choix si l'utilisateur continuera à utiliser ce service. Il est important de fournir un environnement de réseau domestique plus efficace en énergie pour les utilisateurs sans affecter l'expérience utilisateur. Concrètement, le comportement de l'utilisateur est la manière dont l'utilisateur se sert de ses équipements, à quel moment, dans quelle occasion etc. Ceci est une information importante pour la maîtrise de l'énergie de l'équipement. Ainsi, la maîtrise de l'énergie devrait utiliser cette information pour devenir plus souple et transparente pour l'utilisateur sans changer leur comportement quotidien. Pour la plupart des utilisateurs, ils choisiront d'utiliser la gestion d'alimentation seulement dans le cas où leur expérience ne sera pas affectée par la gestion de la maîtrise de l'énergie mis en œuvre.

Contributions

Dans ce contexte, la thèse porte sur la conception, l'évaluation et la mise en œuvre d'un ensemble de mécanismes dans le but de répondre aux problèmes de consommation d'énergie sur les réseaux locaux rassemblant les équipements numériques domestiques.

Nous proposons tout à bord un réseau de contrôle (Overlay Energy Control Network: OECN) qui est formé par des nœuds de contrôle de l'énergie placés au-dessus du réseau traditionnel. Chaque nœud de contrôle est relié à un dispositif en vue de coordonner les états d'alimentation de l'équipement domestique associé. Avec notre solution proposée, les équipements peuvent changer de l'état d'inactive à l'état veille profond beaucoup plus rapidement et de l'état d'inactive à l'état soft-off automatiquement. Le OECN peut être adaptatif à nos équipements de réseau domestique et il est développé de deux façons:

1. Tous les nœuds de contrôle de l'énergie de superposition dans le réseau de

Résumé de la thèse en Français

la maison sont des nœuds ZigBee. Ceci est une ZigBee obligatoire Solution OECN (ZMS).

2. Un ou plusieurs dispositifs deviennent les nœuds de contrôle de l'énergie où il n'y a pas de modules ZigBee sur ce dispositif. Ceci est une option ZigBee Solution OECN (ZOS).

Ces deux façons de déploiement sont illustrée dans la Figure 1 et la Figure 2.

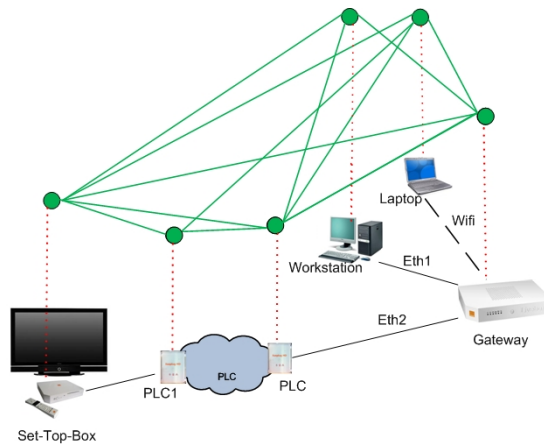

Figure 1: ZigBee Mandatory energy-saving Solution

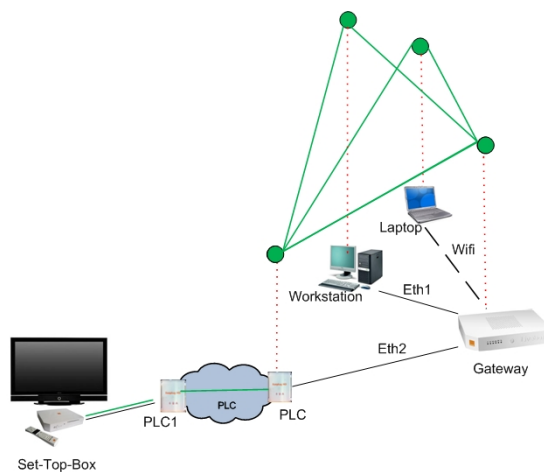

Figure 2: ZigBee Optional energy-saving Solution

Ces deux propositions: ZMS et ZOS, basés sur le réseau de contrôle vise à réduire la consommation d'énergie des équipements de réseau domestique. Notre simulations prouvent que deux solutions sont efficace tous les deux pour l'économie de l'énergie. Le ZMS, qui est basé sur un OECN complet, est encore plus efficace en termes d'économies d'énergie par rapport ZOS, mais il a un délai relativement élevé par rapport à le ZOS. Le ZOS, qui est basé sur un OECN partielle, est un bon compromis entre le gain d'énergie et le délai. Le ZOS a en même efficacité énergétique de temps et peu de retard.

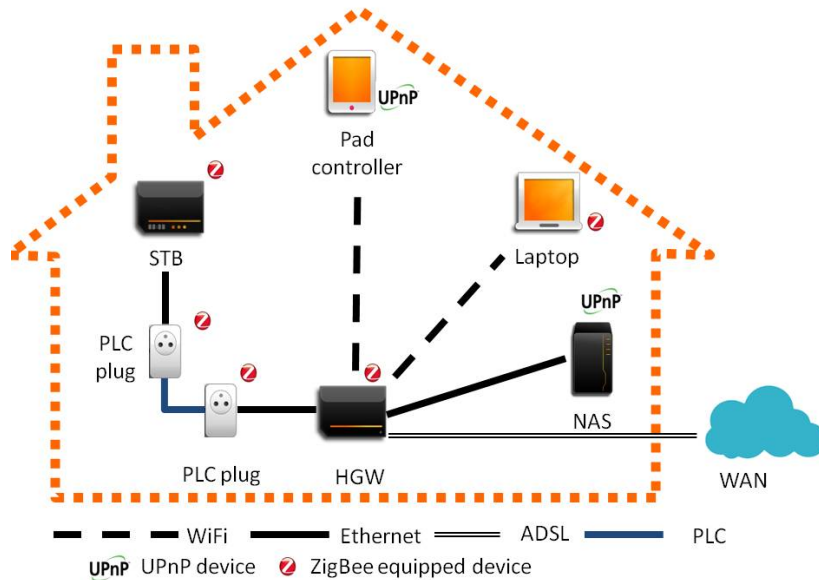

Figure 3: L'architecture HOPE Power Efficiency System

Cette conception est mise en oeuvre dans un démonstrateur pour un système Home Power Efficiency (HOPE). Il démontre la faisabilité de la solution technique que nous proposons pour le contrôle de l'énergie dans un réseau domestique réel avec des scénarios réels qui sont souvent utilisées par utilisateur. Système HOPE allume que les équipements dans le but d'établir le service à l'aide d'un réseau de contrôle de faible consommation, illustrée dans la Figure 3. A la fin des services, le HOPE système vérifie la possibilité de désactiver les équipements afin d'éviter la consommation inutile d'énergie. Le démonstrateur mis en oeuvre montre que le système HOPE pourrait réduire significativement la consommation de

Résumé de la thèse en Français

réseaux domestiques. Les utilisateurs peuvent bénéficier des services multimédia enrichissant et gérer efficacement leur consommation d'énergie. En mettant en œuvre le démonstrateur sur les cas d'utilisation, nous avons réalisé que de plus en plus de services demandent plusieurs équipements différents à collaborer ensemble. Nous avons également réalisé que les différents blocs fonctionnels collaborent dans les dispositifs pour fournir le services. Nous avons décidé d'étudier sur l'économie d'énergie des services collaboratifs.

Après avoir analysé le mode d'utilisation des équipements du réseau domestique, nous proposons un système de gestion d'énergie qui contrôle ces équipements minimisant ainsi que leur consommation. Le système est basé sur l'analyse des services collaboratifs, chaque service est découpé en blocs fonctionnels atomiques, distribués dans les différents équipements. Cela permet de gérer avec plus de précision les besoins énergétiques de chaque équipement de manière à n'alimenter que les composants nécessaires au service demandé. Pour conclure ces travaux, nous avons également cherché à minimiser les impacts de l'économie d'énergie sur la qualité d'expérience perçue par l'utilisateur (notamment le délai d'activation des services). Nous proposons un système de gestion d'énergie pour des services collaboratifs offrant plusieurs compromis possibles entre la consommation d'énergie et le délai d'activation des services dans un réseau domestique. Il est complété par un algorithme d'apprentissage du comportement des utilisateurs domestiques. Grâce à ces travaux, nos solutions atteindre en même temps une très bonne efficacité énergétique et un faible délai d'attente de la demande de l'utilisateur.

Contents

| | |
|--|-----------|
| Remerciements | i |
| Abstract | iii |
| Résumé | v |
| Résumé de la thèse en Français | vii |
| Contents | xiii |
| List of Figures | xvii |
| List of Tables | xxi |
| List of Abbreviations | xxiii |
| 1 Introduction | 1 |
| 1.1 The context and motivations | 1 |
| 1.2 Problems studied in this thesis | 4 |
| 1.3 Main contributions | 7 |
| 1.4 Thesis outline | 8 |
| 2 Evolution toward green home network environment | 11 |
| 2.1 Introduction | 12 |
| 2.2 Understand the home network environment | 12 |
| 2.3 Wired and wireless network technologies | 14 |
| 2.3.1 Power Line Communication | 14 |

CONTENTS

| | | |
|----------|---|-----------|
| 2.3.2 | IEEE 1905.1 | 15 |
| 2.4 | Low power technologies | 17 |
| 2.4.1 | Bluetooth Low Energy | 17 |
| 2.4.2 | ZigBee and IEEE 802.15.4 | 18 |
| 2.4.3 | 6LoWPAN | 20 |
| 2.5 | UPnP protocol | 21 |
| 2.5.1 | UPnP Audio Video | 23 |
| 2.5.2 | UPnP Low Power | 25 |
| 2.5.3 | UPnP Energy Management | 25 |
| 2.6 | Conclusion | 26 |
| 3 | Existing power management solutions | 27 |
| 3.1 | Introduction | 28 |
| 3.2 | Device level power management | 28 |
| 3.2.1 | Advanced configuration and power interfaces | 28 |
| 3.2.2 | Dynamic Power management | 29 |
| 3.2.3 | Device element energy reduction | 30 |
| 3.3 | The network level proposed solutions | 32 |
| 3.3.1 | Home Automation Energy Management | 32 |
| 3.3.2 | Network connection power control | 33 |
| 3.3.3 | Home connected devices power consumption management | 34 |
| 3.4 | Conclusion | 35 |
| 4 | An Overlay Network for energy control | 37 |
| 4.1 | Introduction | 38 |
| 4.2 | The proposed Overlay Energy Control Network | 39 |
| 4.2.1 | Overlay Energy Control Network system | 39 |
| 4.2.2 | Proposed solutions based on Overlay Energy Control Network system | 42 |
| 4.3 | Simulation and analysis of results | 44 |
| 4.3.1 | Simulation methodology | 44 |
| 4.3.2 | Simulation of one device analysis of results | 53 |
| 4.3.3 | Analysis of results | 58 |

| | | |
|----------|--|-----------|
| 4.4 | Conclusion | 62 |
| 5 | A testbed for H0me Power Efficiency System for a Green Network | 63 |
| 5.1 | Introduction | 63 |
| 5.2 | The testbed of H0me Power Efficiency system | 64 |
| 5.2.1 | The architecture of H0me Power Efficiency System | 64 |
| 5.2.2 | The procedure of H0me Power Efficiency system | 67 |
| 5.3 | Implementation of the H0me Power Efficiency System | 70 |
| 5.3.1 | The software of H0me Power Efficiency system | 70 |
| 5.3.2 | Use cases shown in the home network | 72 |
| 5.4 | Conclusion | 75 |
| 6 | Collaborative power management | 77 |
| 6.1 | Introduction | 77 |
| 6.2 | Architecture of the collaborative power management | 78 |
| 6.2.1 | Power management | 78 |
| 6.2.2 | Home network connected devices | 80 |
| 6.2.3 | Low energy communication overlay network | 81 |
| 6.3 | Energy and delay models | 81 |
| 6.4 | Conclusion | 83 |
| 7 | Collaborative power management with refined overlay algorithms | 85 |
| 7.1 | Introduction | 86 |
| 7.2 | Refined Overlay Power Management & Refined Overlay Auto-Learning Power management | 87 |
| 7.3 | Power Management Modeling | 88 |
| 7.3.1 | User control power management | 88 |
| 7.3.2 | PCE power management | 89 |
| 7.3.3 | ROPM & ROAL power management | 90 |
| 7.4 | Setup of Simulations and Analysis of Results | 92 |
| 7.4.1 | Setup of simulations | 92 |
| 7.4.2 | Analysis of results | 93 |
| 7.5 | Conclusion | 102 |

CONTENTS

| | |
|---|------------|
| 8 Collaborative power management with delay-power tradeoffs | 103 |
| 8.1 Introduction | 103 |
| 8.2 Proposed collaborative overlay power management power-delay trade-off algorithm | 104 |
| 8.3 Setup of simulations and analysis of results | 106 |
| 8.3.1 Simulation setup | 106 |
| 8.3.2 Simulation Results | 108 |
| 8.4 Conclusion | 112 |
| 9 Conclusions and Future Perspective | 115 |
| 9.1 Conclusion | 115 |
| 9.1.1 The challenges of the complex home network environment | 116 |
| 9.1.2 Our responses to the challenges | 116 |
| 9.2 Perspective | 118 |
| Appendix A - Patent1261565: Economiser l'énergie du réseau domestique tout en maintenant la QoE de l'utilisateur | 121 |
| Appendix B - Patent1352881: Système de gestion intelligente de la consommation à haut niveau de granularité en analysant des services collaboratifs | 127 |
| Appendix C - Patent1359446: Mécanisme de gestion intelligente et transparente des connexions réseau IPv4/IPv6 par l'intermédiaire d'un réseau en overlay 6loWPAN | 133 |
| Personal publications | 139 |
| Bibliography | 143 |

List of Figures

| | | |
|-----|---|----|
| 1 | ZigBee Mandatory energy-saving Solution | x |
| 2 | ZigBee Optional energy-saving Solution | x |
| 3 | L'architecture H0me Power Efficiency System | xi |
| 1.1 | Global energy footprint of information and communication technologies | 2 |
| 1.2 | Global energy consumption in France from 1970 to 2010 | 3 |
| 1.3 | French energy residential consumption | 4 |
| 2.1 | OSI model including 1905.1 | 16 |
| 2.2 | Three ZigBee topologies | 19 |
| 2.3 | 6LoWPAN Protocol stack | 21 |
| 2.4 | UPnP operation phases | 22 |
| 2.5 | UPnP Audio Video architecture | 24 |
| 3.1 | Power states defined by the ACPI for a personal computer | 28 |
| 3.2 | Network-level inter-MAC architecture | 33 |
| 4.1 | OECN Management | 40 |
| 4.2 | OECN Protocol Stack | 42 |
| 4.3 | ZigBee Mandatory energy-saving Solution | 43 |
| 4.4 | ZigBee Optional energy-saving Solution | 44 |
| 4.5 | Device model from the user's perspective | 46 |
| 4.6 | Set-top Box utilization ratio on working day | 48 |
| 4.7 | Self-controlled Energy Saving Solution | 50 |
| 4.8 | ZigBee Mandatory Energy Saving Solution | 51 |

LIST OF FIGURES

| | | |
|------|---|-----|
| 4.9 | ZigBee Optional Energy Saving Solution | 52 |
| 4.10 | 3 energy saving solutions apply on Laptop during Weekend | 54 |
| 4.11 | 3 energy saving solutions apply on Laptop during Wednesday | 56 |
| 4.12 | Home network total energy consumption result | 59 |
| 4.13 | Home network energy consumption result | 59 |
| 4.14 | Home network delay result | 60 |
| 4.15 | Home network cost result | 61 |
| | | |
| 5.1 | Home network environment | 65 |
| 5.2 | Architecture of HOme Power Efficiency System | 66 |
| 5.3 | The procedure of the HOme Power Efficiency System | 67 |
| 5.4 | The algorithm of the HOme Power Efficiency system | 68 |
| 5.5 | The exchanged messages of the IPTV service | 69 |
| 5.6 | The software components of HOme Power Efficiency System | 70 |
| 5.7 | The testbed of the HOme Power Energy system | 72 |
| | | |
| 6.1 | Collaborative home network service management | 78 |
| 6.2 | A service pattern example | 80 |
| 6.3 | Functional block is turned on (a) in advance (b) by the service request | 81 |
| | | |
| 7.1 | A service pattern example | 89 |
| 7.2 | ROAL progress the user habits knowledge by increasing the simulation time | 94 |
| 7.3 | Energy consumption per service by increasing simulation duration | 95 |
| 7.4 | Delay per service by increasing simulation duration | 96 |
| 7.5 | Energy consumption while changing request time | 98 |
| 7.6 | Delay while changing request time | 99 |
| 7.7 | Energy consumption when standard deviation is changed | 101 |
| 7.8 | Delay when standard deviation is changed | 102 |
| | | |
| 8.1 | Algorithm of COPM-PDT | 105 |
| 8.2 | Energy while varying the request of Functional Block(FB) | 109 |
| 8.3 | Delay while varying the request of Functional Block(FB) | 110 |
| 8.4 | Energy consumption and delay while the request at 1000 seconds | 110 |

LIST OF FIGURES

| | | |
|-----|---|-----|
| 8.5 | Energy consumption while varying the request of tradeoff coefficient | 111 |
| 8.6 | Delay while varying the request of tradeoff coefficient | 112 |
| 1 | Architecture d'un réseau domestique avec son power management | 124 |
| 2 | Comparaison des consommations avec ou sans la solution proposée | 125 |
| 3 | Architecture d'un réseau domestique avec son power management | 129 |
| 4 | Apprentissage (Processus d'apprentissage) | 130 |
| 5 | Apprentissage (Processus d'exploration) | 131 |
| 6 | Relation entre équipements DLNA avec un Media Server | 134 |
| 7 | Diagramme de séquence de gestion de la mise en veille transparenter | 138 |

LIST OF FIGURES

List of Tables

| | | |
|-----|---|-----|
| 4.1 | Home network devices power consumption | 47 |
| 4.2 | An overlay network for energy control notation summary | 49 |
| 4.3 | Device transition time (inactive to active) | 57 |
| 4.4 | Expense on electricity and ZigBee module | 57 |
| 5.1 | Power consumption (Watt hour), Service Time: ST (hours) and Number of startups parameters of our testbed devices | 75 |
| 6.1 | Collaboration power management notation summary | 82 |
| 7.1 | Refined overlay algorithms simulation setup | 93 |
| 8.1 | Delay-power tradeoffs algorithm simulation setup | 107 |
| 8.2 | Delay-power tradeoffs algorithm simulation energy and waiting de- lay results | 111 |

LIST OF TABLES

List of Abbreviations

| | |
|---------|---|
| 6LoWPAN | IPv6 over Low power Wireless Personal Area Networks |
| ACPI | Advanced Configuration and Power Interface |
| BLE | Bluetooth Low Energy |
| CMOS | Complementary Metal–Oxide–Semiconductor |
| COPM | Collaborative Overlay Power Management |
| DELS | Dynamic Ethernet Link Shutdown |
| DHCP | Dynamic Host Configuration Protocol |
| DLNA | Digital Living Network Alliance |
| EMD | Energy Monitoring Device |
| FFD | Full Function Device |
| HGW | Home GateWay |
| HDD | Hard Disk Driver |
| HOPE | HOme Power Efficiency System |
| IEEE | Institute of Electrical and Electronics Engineers |
| HTTP | Hypertext Transfer Protocol |
| IoT | Internet of Things |
| IP | Internet Protocol |
| LAN | Local Area Network |
| MAC | Media Access Control |
| MoCA | Multimedia over CoAx |
| NAS | Network Access Storage |

List of Abbreviations

| | |
|---------|--|
| OECN | Overlay Energy Control Network |
| PAN | Personal Area Network |
| PC | Personal Computer |
| PDT | Power Delay Tradeoff |
| PCE | Power Control Element |
| PLL | Phase-locked loop |
| PLC | Power Line Communication |
| RFD | Reduced Function Device |
| ROPM | Refined Overlay Power Management |
| ROAL | Refined Overlay Auto-Learning Power management |
| SHEMS | Smart Home Energy Management System |
| SIG | Special Interest Group |
| SOAP | Simple Object Access protocol |
| SSDP | Simple Service Discovery Protocol |
| STB | Set-Top Box |
| TV | Television |
| UPnP | Universal Plug and Play |
| UPnP AV | Universal Plug and Play Audio Video |
| WAN | Wide Area Network |
| WSN | Wireless Sensor Network |
| XML | Extensible Markup Language |
| ZMS | ZigBee Mandatory energy saving Solution |
| ZOS | ZigBee Optional energy saving Solution |

Chapter 1

Introduction

Contents

| | | |
|-----|---|---|
| 1.1 | The context and motivations | 1 |
| 1.2 | Problems studied in this thesis | 4 |
| 1.3 | Main contributions | 7 |
| 1.4 | Thesis outline | 8 |

1.1 The context and motivations

In recent years, Information and Communications Technology (ICT) has totally changed the people daily life. ICT services provide facilities for multimedia, communications, entertainment and so on. Meanwhile, the amount of CO_2 emission of ICT, so called “carbon footprint” [91], is increasing without cease. Technology analysts estimate that ICT represents around 2% of global emissions of CO_2 [33]. This amount of carbon emission is the same as aviation industry. However, with rising demand for communication services, devices become more and more powerful. It is also estimated that ICT global emissions could increase to 3% of global emission by 2020 [70]. If nothing is done, the ICT contribution to global greenhouse gas emissions is projected to nearly double to about 4% by 2020. [32]

Although there are many reasons that cause the climate change, for example the solar radiation and volcanic activity. However, that human activities are one

Introduction

of the main causes of climate change. This man made CO_2 generation is the main cause of the global warming which is already becoming a severe issue. As we continue to increase the amount of CO_2 in the atmosphere, the warming effect of this gas is continuing to increase [82]. And the rate of this increase is becoming more and more rapidly according to the IPCC report 2013 [45]. This landmark

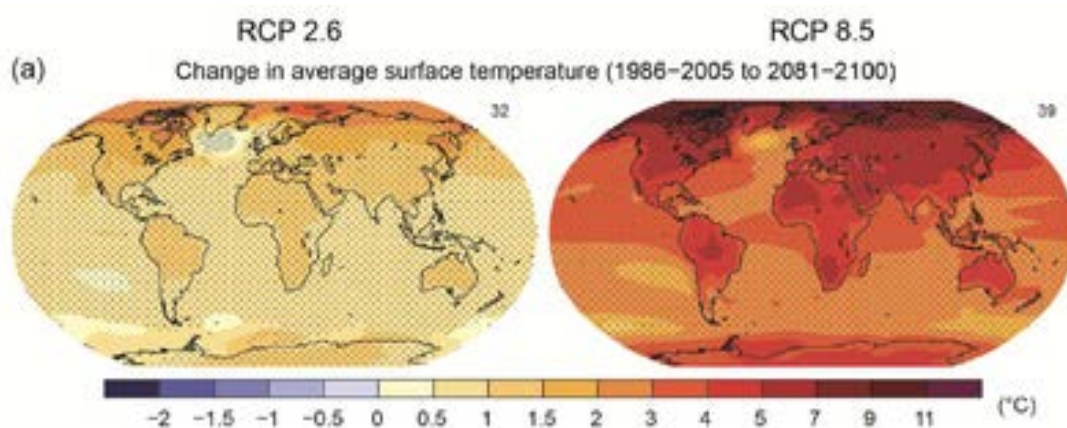

Figure 1.1: Global energy footprint of information and communication technologies [45]

report by the United Nations climate panel details the physical evidence behind climate change in different scenarios. These scenarios are ranging from “business as usual/no actions taken” to “aggressive actions taken”. In Figure 1.1, we could see based on the scenario RCP 8.5, “business as usual/no actions taken”, average global surface temperatures will likely rise by an additional 1.1 to 4.8 degrees by 2100. This temperature increase is largely above the 1986-2005 average. And this temperature change will be accompanied by other environmental changes such as an increase in global sea level by up to 1–2 feet [45].

It means that the impact is affecting all the continents [22]. For example, in Europe it is estimated that will be multiple stresses and systemic failures due to climate change in the Mediterranean. This will increase energy costs and damage tourism from 2050. And the result, now as then, is a vicious circle of energy consumption and greenhouse gas emissions.

Accordingly, reducing global greenhouse gas emissions and reducing the global energy consumption have become a crucial issue for protecting our earth. In

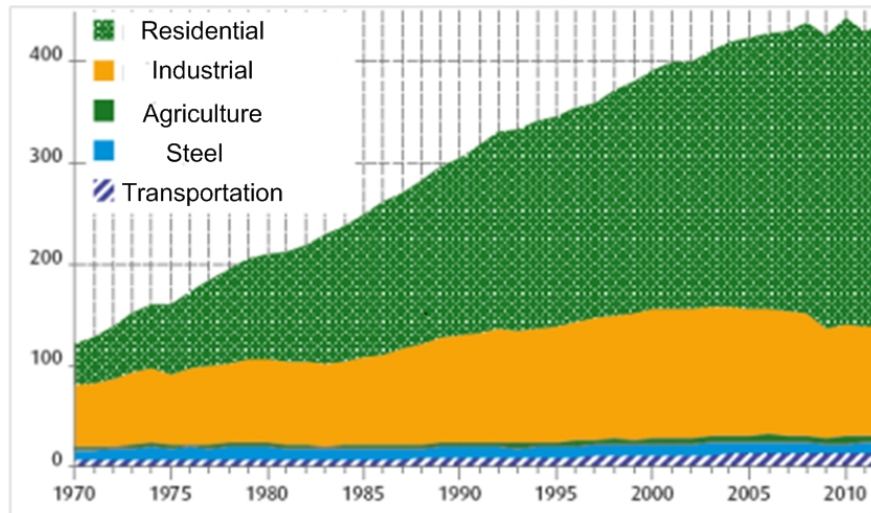

Figure 1.2: Global energy consumption in France from 1970 to 2010 [83]

order to better reduce the global energy consumption, Figure 1.2 helps us to better understand how the global energy is consumed [83]. We could see from this figure, the energy is shared by residential, transportation, industrial, steel and agriculture sectors. Since 1973 in France, the global energy consumption is increasing with a rhythm at 3 % every year. The residential electricity has become the principal energy consumption section since 1980. The residential tertiary service consumption in France has been multiplied five times which means an increase of more than 4% each year [83].

While we try to zoom in the energy consumption in the residential sector, which means the home environment, we could see from left side of Figure 1.3 the power consumption is mainly composed by the heating, hot water and other specific devices [17].

The energy consumption of the specific devices is composed by the lighting, washing and the multimedia usages shown in right side of Figure 1.3. It is important to note that the multimedia devices are the specific devices which consume a great part of energy at home [14]. There are two main reasons for the energy consumption of the multimedia devices is increasing: there are more and more energy is consumed on the audio video devices for more and more entertainment usages. And the personal computer is no more one computer, the peripherals like

home gateway, printer and so on spread rapidly in our home.

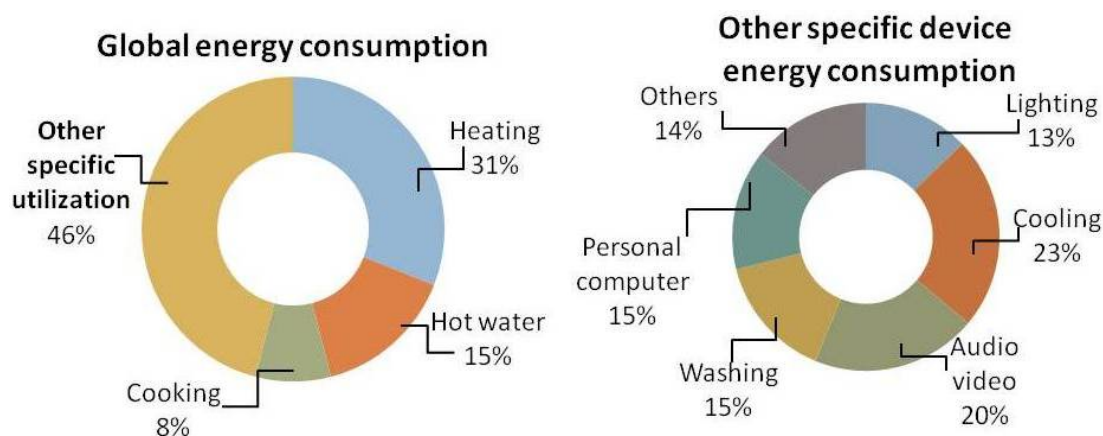

Figure 1.3: Left side: French residential energy consumption Right side: French other specific device energy consumption [14], [17]

Not only the consumption of energy is increasing, but the price of electricity is constantly rising. According to the Vaasa ETT report [15], in 2012 European residential electricity prices increase 2% faster than inflation. Residential energy prices endure a continuous upward trend since the beginning of 2010. The energy consumption is not negligible at all for families [24]. Even for several families, this dispense is becoming harder and harder to pay at the end of each month. Thus, it is quite important to reduce energy consumption in the home network and home devices for the environmental and economic reasons.

In this section, we firstly analyzed the climate change by the ICT sector, then we discuss in details the ICT energy consumption by zooming into the most rapidly increasing part: home environment. The problems that we study in the home environment will be presented in the next section.

1.2 Problems studied in this thesis

Digital Home is called “digital” thanks to the devices which may be connected by different communication technologies. The connected devices could be an home gateway, a Set-Top Box, a Personal Computer, a tablet, or home sensors, etc.. In this section, we will present the main problems that we studied in this thesis.

Network connectivity becomes ubiquitous. Being network-enabled is becoming an important feature for home devices. They need to provide various services, like on-line technology, multimedia sharing, video conference, etc., to home network users. Network connection technologies like WiFi, Ethernet, Power Line Communication are required for providing a comfort network for the service use. Although sometimes the connected devices are not in use, the WiFi, Ethernet or Power Line communication connections are maintained to keep an always active network to the user requirement. To be part of the network, devices such as a home gateway, or PLC plugs are always on all days in order to assure an always-on network which may not necessary. For example, if there is no device connects to the Power line communication plug, it is not necessary to keep this plug always on just for maintaining the network. We could sum up that the home network connections are not used in an energy efficient way.

As mentioned before, with the “Everywhere” network connection, devices work no more alone. They always work together to provide a collaborative service. The simplest collaborative service could be to download a file by laptop, this requires the home gateway provides the WiFi connection for the laptop and laptop launch the download. In this example, we have at least two devices work together for the collaborative download service. If we take a more complex UPnP audio video use case, the user controls the home devices with an UPnP Control Point (smart-phone, iPad or other tablet) and wants to watch a film on his UPnP Media Renderer (STB). This film is saved on his UPnP Media Server (PC). This is another collaborative service which shows us that it is interesting to find the relationship among the devices. It helps us to better control the right device at the right moment in a collaborative service. Moreover, the types of devices in the home network are various: for example, Personal Computer, Home GateWay, Set-Top Box and so on. In order to provide a collaborative service, all these different devices have different functionalities, characteristics which power control should be adapted to. In summary, the home network power control is no more a simple control on only one device, we should consider the home network collaborative services are provided by several devices.

In addition, devices are not turned on in an energy efficient way. Connected device, like laptop, can serve multiple services. In different services, different

Introduction

functional blocks are used in one laptop depend on the services. For example it may be used on the web surfing by WiFi or it may be used to share a file with another device by Bluetooth. Despite the request service, the connected devices are always turned on integrally. In this home network environment, numerous home devices are widely used and also integrally turned on to contribute to the different home network collaborative service. But these appliances are requested partially in different service requirements.

Another problem is the connected devices are not used in an energy efficient way. In most family, the Set-Top Box and television are becoming indispensable. The study from NRDC shows that two-third of the electricity consumed by Set-Top Box and TVs is consumed when they are idle [16]. While the devices are in idle state, it means that the devices are not needed by services. Although it is for sure that the energy consumed in the idle state is a real energy waste, users do not always turn off their devices. There is two reasons: First, not every user has the energy conscience. And also users do not turn off their devices, because they need to wait during the booting time while they need to enjoy the service immediately. Thus, devices consume unnecessary energy while they are not used.

User plays an important role in the home network environment, because the home network services are used by user and the quality of user experience directly impacts if the user will continue to use this service. It is important to provide a more energy efficient home network environment for users without impacting the user experience by studying their behaviors. Concretely, User behavior is the way how the user uses their devices, at what time, in what occasion etc. This is an important information for the device energy control. Thus, the energy control should use this information to become more adaptive and transparent for the user without changing their quotidian behavior. For most of the users, they will choose to use power management only in case that their experience will not be impacted by the implemented energy control management.

In this section, we details the problems that we studied on the network, service, device and user levels. Based on the problems we present in this section, the next main contribution section will be a brief response to the problems.

1.3 Main contributions

This thesis contributes to the control of device energy consumption in a home network. We propose a novel set of power control mechanisms for the current and future home network connections, devices and services in order to respond the home network energy consumption problems.

In order to be reactive for the home network user and energy efficient at the same time, we proposed an Overlay Energy Control Network (OECN) [98] which is formed by the overlay energy control nodes connected to home network device. In this contribution, two solutions, ZigBee Mandatory energy saving Solution (ZMS) and ZigBee Optional energy saving Solution (ZOS) are proposed by considering the different characteristics of different devices. Moreover, devices are turned off instead of staying in idle state after each utilization.

A testbed for HOme Power Efficiency system (HOPE) is implemented to demonstrate the technical solution for energy [93]. The HOPE solution uses an overlay control network which switches existing devices on or off according to their usage. This solution aims to be adaptive for the home network services which requires the collaboration of several devices.

Since the user plays an important role in the home network environment, we studied user's way of use of their equipment which occurs frequently. This information helps the power management to anticipate the user service request, make decision in advance to turn on the devices, this reduces the waiting delay for user. Meanwhile, we did an analysis on the service request which are collaborative service. We noticed that not the integral devices are required in the collaborative services. We control the devices based on the analysis of the collaborative services. Our control requires different functional blocks in different devices [96]. This model helps users to achieve more efficient energy consumption management [92]. We also registered a patent on this model which take into account the energy consumption and user experience [99].

For sure that when we turn off an electric element, the energy consumption will be decreased. However, this energy gain is often paid by the waiting delay for the user. Based on the former contribution, this collaborative overlay power management that offers several possible tradeoffs between the power consumption

and the waiting delay in the home network. Achieving the minimum waiting delay or the maximum energy efficiency would depend on the user exigencies [97].

Since network connections are always maintained although they are not used. For the purpose of network connection saving, we also proposed a patent to alternate the traffic between a traditional network interface and a low power consumption network interface [94]. When the traffic requires high debit, we use the traditional high power network interface, otherwise we maintain the low power network interface to be reactive for all connected devices.

In this section, we present the main contributions in this thesis. These contributions give the propositions to the energy consumption problems on the device, service, network level for the aim of providing a comfortable and energy efficient home network environment for the users.

1.4 Thesis outline

The thesis is divided into 8 chapters. Let's have a quick view of the content of this work:

Chapter 1 gives the introduction of our thesis. This chapter will give a presentation on the background and motivations of our thesis and the studied problems and main contributions in this context.

Chapter 2 presents evolution toward green home network environment. In this chapter, besides the typical home network connection, we will emphasis on the low power technologies and protocols.

Chapter 3 presents the existing power managements in the home network on the device level and network level.

Chapter 4 describes our work on the control network. We proposed an Overlay Energy Control Network which is formed by at least one overlay energy control node connected to each (controlled) home network device. Based on this overlay energy control network, we introduce two algorithms (ZMS and ZOS) and evaluate them by simulation results. This study provides a control method of controlling equipment by a low power network.

We implement in the Chapter 5 this low power control network solution in a testbed : HOme Power Efficiency System for a Green Network. In this demon-

stration, our solution reduces power consumption in a real home network with frequently used scenarios. This study enables us to demonstrate the overlay control solution is energy efficient and convenient for home network services which involves several devices.

We describes in Chapter 6 the models of our collaborative overlay power management system in which devices can be partially turned on depending on the services. And devices can also be turned on at the moment they are required by users.

Using the models defined formerly (see Chapter 6), in Chapter 7, we present our algorithm which learns the user behaviors in order to reduce energy consumption of a collaborative service.

Based on the former proposition in Chapter 6, we proposed a algorithm which provides different trade-offs between delay and energy gain for different user requirements in Chapter 8. This proposed solution could satisfy the user who is concerned about the energy and the user who is more concerned about their home network user experience.

The conclusion chapter, Chapter 9, synthesizes the contribution of the thesis. The perspective of our work will be detailed in this Chapter in short and long term.

The three patents that we mentioned in section 1.3 for the energy saving purpose are detailed in the annexes. Since the patent requests cover France region, these technical reports are edited in French.

Introduction

Chapter 2

Evolution toward green home network environment

Contents

| | | |
|------------|--|-----------|
| 2.1 | Introduction | 12 |
| 2.2 | Understand the home network environment | 12 |
| 2.3 | Wired and wireless network technologies | 14 |
| 2.3.1 | Power Line Communication | 14 |
| 2.3.2 | IEEE 1905.1 | 15 |
| 2.4 | Low power technologies | 17 |
| 2.4.1 | Bluetooth Low Energy | 17 |
| 2.4.2 | ZigBee and IEEE 802.15.4 | 18 |
| 2.4.3 | 6LoWPAN | 20 |
| 2.5 | UPnP protocol | 21 |
| 2.5.1 | UPnP Audio Video | 23 |
| 2.5.2 | UPnP Low Power | 25 |
| 2.5.3 | UPnP Energy Management | 25 |
| 2.6 | Conclusion | 26 |

2.1 Introduction

Do you remember? Since when do we have facilities like the following? We check the TV program on the tablet while we are in the coach. We push a video that we find with our smart phone on the TV to share it with friends. Even we download files from distant storages. In our home environment, the number of network-enabled devices around us is growing every day. And the possibility to interconnect each device is increasing simultaneously. Besides traditional connection technologies (like WiFi or Ethernet), low power network connection technologies emerge in the home network.

In this section, we present firstly the needs of networks, and how the networks are composed, especially local area networks. Then, we present the Power Line Communication technology which is rapidly progressing in the home data communication. The IEEE 1905, a convergent digital home network for heterogeneous technology. Thirdly, we will focus on three low power connections technologies: Bluetooth Low Energy, ZigBee and 6LoWPAN. We finish this section with the presentation of UPnP technology and 3 different UPnP services.

2.2 Understand the home network environment

Before diving into the home network communication technology and protocols, we will take an overview of the home network environment [78].

A simplest notion of a network is two or more devices interconnect with each other to transmit information [25]. For sure, the digital networks are more complex and multi-layered than this simple definition. It could be divided mainly in two types: Local Area Network (LAN) and Wide Area Network (WAN). Local Area Networks are small networks that covers the connected devices of a family, an office or a building. Wide Area Networks are networks that which much bigger and covers a larger geographic area like a city or a region. Internet is a kind of Wide Area Network [86].

Home network devices are interconnected with each other to former the Local Area Networks, and then some of these devices could interconnect with Wide Area Networks for example the Internet. Devices are connected to networks which are

heterogeneous and provide different services in different networks [34].

There are two main mechanic ways for the home network devices to connect to the networks:

- **Wired network:** this kind of networks requires cables for connecting and exchanging information. Ethernet cables are widely deployed in the buildings and houses. Besides the Ethernet cables, there are also power line cables [54], coaxial cables are firstly installed in the buildings for the electricity and television usages, and are now possible to use for the communication usage. We will detail the non legacy wired technologies and protocols like power line communication in the Section 2.3.
- **Wireless network:** this kind of networks uses the radio frequency to exchange the messages [3]. Besides WiFi, the most representative example, there are also different wireless networks exist in the home network. Like Bluetooth Low Energy, IEEE 802.15.4 low power technologies that we will talk in the Section 2.4.

Thanks to these different connections, the network enabled devices are connected with each other. These devices can be generally divided into two categories:

- **Network infrastructure devices:** the network infrastructure devices refer to the devices which enable the connectivity. These devices assure the inter-connectivity among the other edge devices. Besides the traditional network infrastructure devices which assure one type connection [64], like switch, router, WiFi extender. Now there are also some network infrastructures can assure simultaneously several connections [2]. For example, home plug provides WiFi and PLC connections in one network infrastructure device.
- **Edge devices:** an edge device primarily enables users to communicate with the networks. It is often a service provider in the home network environment or it could be a part a service provider by cooperating with other devices. In the last decade, there has been a proliferation of connected edge device in the home environment. The number of connected devices has led to a

sharp increase in energy consumption in the homes [18]. A home network is a complex environment which contains several different types edge devices: Set-Top Box (STB), Home Gateway (HGW), PC, laptop and so on [100].

Since edge devices are connected to each other with the help of the network infrastructure, they are not only controlled by users, they are also controlled or requested by other edge devices. It is thus important to study the protocols which cooperate these edge devices in Section 2.5.

2.3 Wired and wireless network technologies

In this section, we will give a brief presentation on the Power Line Communication and IEEE 1905, because these technologies are more and more expansively deployed besides the traditional connection Ethernet that we all know.

2.3.1 Power Line Communication

Power Line Communication (PLC) provides data transmission on the same conductors as the ones use for home electricity transport. It attracts more and more attention in recent years because of its connectivity advantage and transmission capacity. However, PLC has been in use for many decades. It was used firstly for utility control purposes at very low data rates.

Nowadays, Power Line Communication progresses in the high speed communication domain. Moreover, this attractive high speed communication does not require installing new infrastructure. These advantages, inherent to the use of power line, extend to homes, offices, vehicular systems, air planes and even spacecrafts.

In our home, the Power Line Communication is becoming a part of the home network like “Ethernet” [21] [58] [67]. It is convenient to use it as a multimedia distribution network (audio or video sharing) for its high data rates. Its bit rate is continuously increasing. On 2000, Home plug 1.1 had a 14 Mbps raw rate and 8 Mbps after coding rate. Later in 2006 the data rate of the HomePlug Audio Video [5] is up to 200 Mbps and 150 Mbps after coding. Consequently, the power consumption of the home plug cannot be ignored [2]. Take the example of Aztech

Homplug AV, its power consumption could be 6.5 watt [7]. As we know, the home plug should work at least in pair. It means at least 13 watts is consumed by PLC communication plugs.

It is thus important to turn off these kind of network infrastructure devices while they are not in use. However, there are several reasons that users don't wish turn them off.

- Waiting time: if the home plugs are turned off, the time from one home plug is turned on to the moment it is operational, is measured one or several minutes. People couldn't stand this long waiting time while they want their services immediately.
- Installation: it is difficult to plug off or turn off one home plug for their locations. For example, sometimes PLC plug is plugged behind a huge furniture.

In summary, the power line communication provides the facilities for our quotidian network, but the power consumption of this technology is not negligent. It is therefore necessary to find a solution to reduce the useless power consumption without changing user comfort.

2.3.2 IEEE 1905.1

IEEE association "Institute of Electrical and Electronics Engineers," has published a standard called IEEE 1905.1 in April 2013. The IEEE 1905.1 [1] offers a convergence layer, called inter-MAC layer, also called convergence layer or adaptation layer. It allows devices which may have not the same physique layer to communicate with each other above the MAC layer. IEEE 1905.1 unifies various network technologies which could be found within the same residential network through a common network enabler. The network technologies include three types of wired technologies: Ethernet IEEE 802.3, data transmission over electrical current IEEE 1901 (eg HomePlug Alliance HD-PLC [53]) or a coaxial Multimedia over CoAx (MoCA) [61] cable and one type of wireless technology: WiFi IEEE 802.11.

Evolution toward green home network environment

Figure 2.1 shows the IEEE 1905 in the OSI model. On the data link layer and physical layer, IEEE 1905 has Ethernet, WiFi, PLC and MoCA four different technologies. By running an abstraction layer, IEEE 1905.1 hides the diversity of MAC technologies.

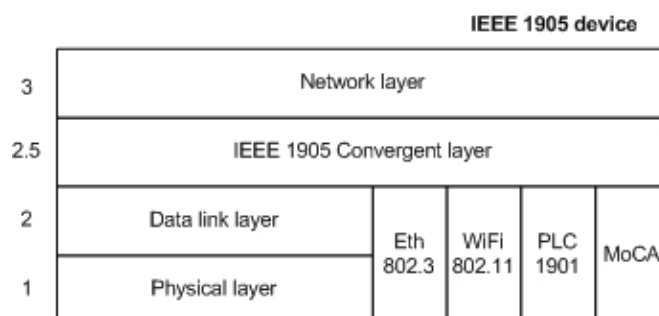

Figure 2.1: OSI model including 1905.1 [1]

After presenting the OSI model of the IEEE 1905.1, its advantages become obviously:

- Without an extra installation, a common setup procedure could add different devices into the network; establish a secure link; manage the link status and so on.
- The data packets could be transmitted from one network interface to any different network interface, regardless the protocols above the MAC layer.
- By using multiple interfaces, it provides a maximum aggregated throughput for the users.
- A unified link management could distribute the video streams over different paths to limit congestion and maintain reliability.
- In the case of one path between two interfaces is interrupted, the traffic could be transferred to another network path. This feature guarantees a robust home network environment.

Being attracted by numerous benefits of IEEE 1905.1, the brand nVoy [66] started to certify the IEEE 1905 products for commercial use. The objective is to build a union of different vendors who provides seamless IEEE 1905 products.

In this section, we detailed Power Line Communications and IEEE 1905 technology, we could see these technology provide more connection possibilities in the home network environment. At the same time, more energy is consumed on the connection technologies for these facilities. It is thus important to find solutions which permit to take advantage of the technologies by consuming the only the necessary power consumption.

2.4 Low power technologies

In this section, we will present several low power technologies: Bluetooth Low Energy, ZigBee and IEEE 802.15.4. And then we will present the 6LoWPAN technology which is based on Internet technology.

2.4.1 Bluetooth Low Energy

Since the last decade, Bluetooth is becoming more and more familiar for everyone. We can find a Bluetooth connection in our smart phone, tablet device, stream audio player in our car, even in our home entertainment system. Bluetooth is an emerging short range wireless network developed by Bluetooth Special Interest Group (SIG) [9]. Bluetooth uses 791 Mhz wide channels on the 2.4 Ghz Industrial, Scientific, Medical (ISM) radio band [38] [57] with a pseudo-random frequency hopping sequence.

Different from the traditional Bluetooth, Bluetooth Low Energy (BLE) [31] has been designed as a low power solution for monitoring and controlling usages. Traditional Bluetooth is connection oriented. When devices are connected, a link between these two devices is maintained even if there is no data transmission. There are three reasons that Bluetooth Low Energy consumes less energy[56]:

1. The duty cycle is longer, it means that the BLE goes to sleep for longer periods of time and it is waked up less frequently.
2. Second, it is able to send smaller data packets in short bursts to save on power comparing with the traditional Bluetooth.

3. It doesn't maintain links with devices when it's not communicating. The device goes to sleep and ends the link once the exchange is complete. A link is rapidly reestablished upon the next communication exchange.

With the new generation Bluetooth Low Energy technology, it is therefore interesting to use the low power technology for the low data transmission. We contribute two patents ideas [95],[23] which based on the Bluetooth Low Energy technology that we find in author's publications list at the end of this thesis.

2.4.2 ZigBee and IEEE 802.15.4

ZigBee is a specification which aims to create a wireless Personal Area Network (PAN) for the sensing and control purposes [6]. It is based on the IEEE 802.15.4 which provides a Physical layer and a Media Access Control layer for low-cost, low speed, and low-power wireless personal area networks.

2.4.2.1 ZigBee equipment

There are 3 roles in the ZigBee network: coordinator, router and end device. A coordinator is the center of the network. It provides coordination and other services (for instance association security) to the network. One PAN could have only one coordinator. A router could send a message to any device in the PAN. When the coordinator leaves the PAN, a router can be configured to replace it and coordinate the PAN. End devices are always at the end of the network. They can receive a message for them, and send back the required responses. Unlike routers, end devices could not pass messages which are not for them.

There are two types of ZigBee equipment: Full Function Device (FFD) and Reduced Function Device (RFD) [13]. The FFD can be a coordinator or a router. They could talk to any other device in the ZigBee network. In this kind of device, the complete protocol is implemented. The RFD is also called end device. It can only be the leaf in the ZigBee network. They cannot be a PAN coordinator.

2.4.2.2 ZigBee network

It exists 3 possible topologies in the ZigBee network (Figure 2.2) [20]: star topology, peer to peer topology and the tree cluster topology. In the star topology, coordinator is the center of the network; all messages should be exchanged with the coordinator. In the peer to peer topology, all FFD could connect to any other FFD. In the cluster tree topology, all leafs connect to an FFD; FFDs connect to the PAN coordinator.

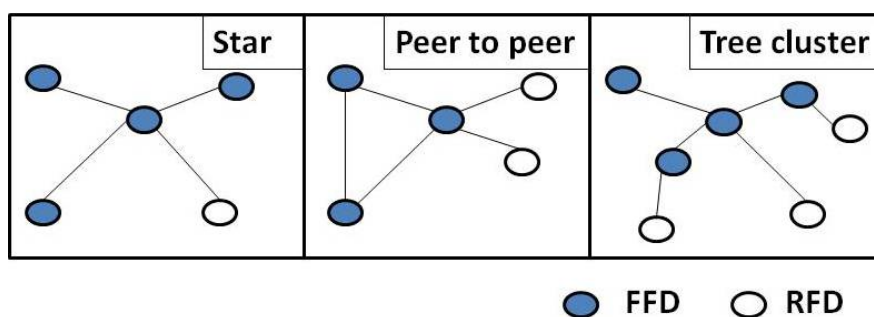

Figure 2.2: Three ZigBee topologies

ZigBee has an IEEE 64 bits extended address provided by the manufacture. In the PAN, each ZigBee has another 16 bits address which is unique within the PAN. There are four different frames in the IEEE 802.15.4: Beacon frame is used to organize the network. Command frame is used for association, disassociation, data and beacon requests, conflict notification. Data frame carried user data. Acknowledgment frames are sent when the data transmission is successful. ZigBee was provided over 816 MHz, 915 MHz or 2.4 GHz frequency spectrum.

In the literature, studies are progressing to improve the IEEE 802.15.4 and ZigBee protocols on the different aspects like bandwidths, coding, access [55], [51], [76], [80], [74].

Thanks to the low energy consumption and vary topology choices of ZigBee network, this technology is more and more used for the control, monitoring purposes in the home environment.

2.4.3 6LoWPAN

6LoWPAN is an acronym of IPv6 over Low power Wireless Personal Area Networks [81]. The 6LoWPAN protocol was, at the beginning, an adaptation layer allowing sending and receiving IPv6 packets over IEEE 802.15.4. Later, the IETF 6LoWPAN Working Group started recognized that other low power technologies are important for the Internet of Things (IoT). There is a new draft published in June 2014 for the transmission of 6LoWPAN packets over Bluetooth Low Energy [65]. And the drafts on 6LoWPAN over PLC and low power WiFi has been published [71], [87] in 2014.

Now 6LoWPAN has a broad range of applications in the facility, building, home automation, medical, and industry domains. The rapid development of 6LoWPAN applications is associated to its numerous benefits [52]:

- IP-based network could be easy connect with any other IP networks which are widely deployed in our daily life.
- Tools for managing and diagnosing IP-based networks already exist. The 6LoWPAN technology can easily reuse these tools.
- 6LoWPAN is based on a set of low power link technologies such as IEEE 802.15.4, Bluetooth Low Energy.
- 6LoWPAN has good scalability of crossing network infrastructure with mobility.
- It supports unicast, multicast and broadcast communications.

Figure 2.3 shows the 6LoWPAN protocol stack [63]. On the network layer, 6LoWPAN supports only IPv6 with a small adaptation layer which is called the LoWPAN. This layer has been defined to optimize IPv6 over IEEE 802.15.4 and similar low power link layers in [62].

Currently, researches on 6LoWPAN are actively progressing. In the work [42] of Jonathan Hui, they work on the IPv6 header compression format for datagrams in 6LoWPAN networks. Raza Shahid proposed in their work [75] a End-to-End (E2E) secure communication between IP enabled sensor networks

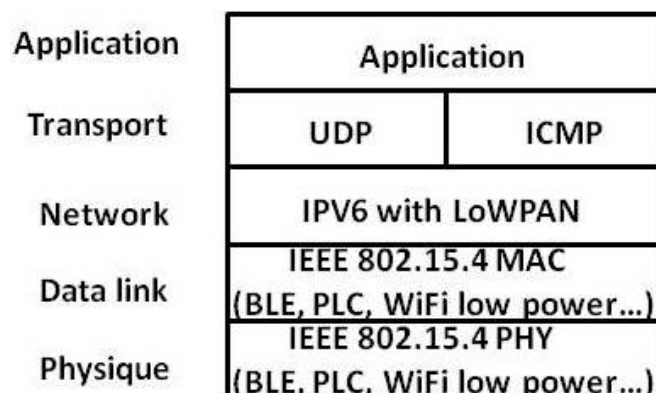

Figure 2.3: 6LoWPAN Protocol stack [63]

and the traditional Internet. This compressed lightweight 6LoWPAN extension for IPsec supports both IPsec’s Authentication Header (AH) and Encapsulation Security Payload (ESP).

The 6LoWPAN provides an interoperability that the applications don’t need to know the constraints of the physical links that carry their packets. This IP based advantage makes the 6LoWPAN very attractive.

In this section, we details three different wireless low power technologies, Bluetooth Low Energy, ZigBee and 6LoWPAN. It is interesting to observe that these technologies can establish and maintain communications by consuming much less energy than the legacy communication like WiFi, Ethernet or Power Line Communication.

2.5 UPnP protocol

The Universal Plug and Play (UPnP) technology, defined by UPnP forum since June 1999 [26], is composed by a set of protocols which permit network user equipment, like HGW, personal computer, network storage, STB, mobile devices, to collaborate together [59]. The UPnP protocol allows the discovery of each device in the network, and provides services like audio video sharing, digital data communication, digital entertainment, device power status reporting and device power management. UPnP uses common internet technologies like, IP, HTTP,

Evolution toward green home network environment

XML, SSDP and SOAP protocols, to provide services between the control point and devices. Device could be any entity in the network, like media servers, media renderers, printers, etc. Services are the functionalities for devices. A service could be an action which sends or receives arguments and returns values. Control point executes control of devices that provide services by invoking actions with certain argument values. The control point could be integrated with devices, it can also be a separate network entity.

| Control | Eventing | Presentation |
|-------------|----------|--------------|
| Description | | |
| Discovery | | |
| Addressing | | |

Figure 2.4: UPnP operation phases [59]

There 6 operation phases for the interaction between devices or between devices and control point [72]:

- Addressing: when the device first arrives in the network, it could get an IP address by this phase. And the device needs to check periodically the existence of a DHCP server .
- Discovery: Once a device gets an IP address, the control point becomes aware of the existence of the device. In this step, device also needs to send a SSDP : alive advertisements periodically to announce its existence to the control point.
- Description: After discovering the device, the control point could learn the details about the device and its services by this phase.
- Control: While there is a request of service, control point invokes the service action in the control step.

- Eventing: When the device changes its state, it could notify the control point by an eventing message.
- Presentation: In some case, device could present Web pages to the control point allowing for status and control interactions.

Figure 2.4 shows the six operation phases, which happen successively addressing, discovery, then description. The control, eventing and presentation phases may happen after the three first phases.

Based on this UPnP architecture, Dong-Sung Kim proposed a home network system using UPnP middleware and an embedded interface device [49]. This work was to design and implement a UPnP-based home network system with extended UPnP functions for networked home applications. The results of this work are useful and provide guidelines since 2002 for the design of home network systems using UPnP middleware and embedded interface modules for networked devices.

2.5.1 UPnP Audio Video

UPnP Audio Video (UPnP AV) is proposed for general interaction and service template between UPnP control point and UPnP AV device [77]. Various user scenarios can be realized by the UPnP AV architecture: User could watch a film which is saved in his Network Access Storage (NAS) with the help of his Set-Top Box. User could also listen to the PC saved music on a stereo system. User could also choose on his tablet a video to push to his Set-Top Box to enjoy with his friends.

These scenarios can be summarized by different features like content function, rendering control function and remote control function on the media server, media renderer and control point. In order to accomplish these features shown in Figure 2.5, the UPnP AV architecture defines different services [48]. Content directory service could browse and search content items which include the meta-data (title, author, resolution, format and etc.). The rendering content feature provides the control of the rendering characteristic, for example, volume, brightness. The connection manager lists the supported transfer protocols, data formats and existing streams. The AV transport service could control the play, pause or seek

commands during the media rendering. It is optional for the media server or renderer.

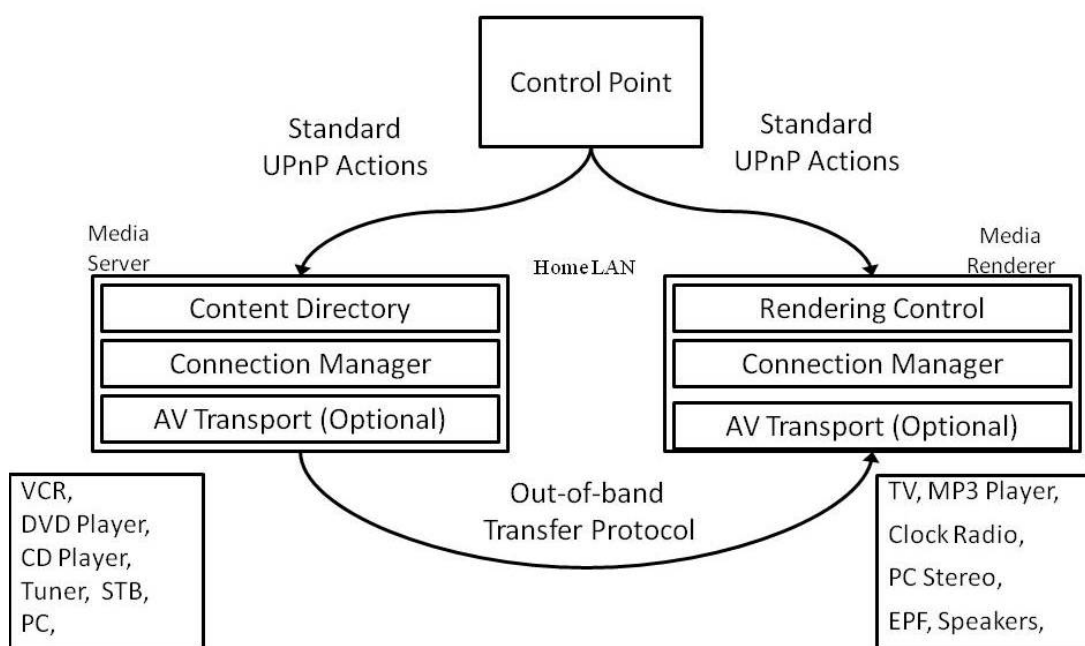

Figure 2.5: UPnP Audio Video architecture[48]

This UPnP architecture has been supervised by Digital Living Network Alliance (DLNA). The DLNA forum is supported by many companies in the consumer electronics, multimedia, entertainment, and mobile industries [89]. The objective of this forum is assuring the interoperability of all certified networked user equipment (for example personal computer, mobile device, printer and so on) regardless their brands.

Taking an example of the UPnP AV use case, the user uses his UPnP Control Point (tablet) to search for a film which is saved on the UPnP Media Server (PC) in order to watch it on the UPnP Media Renderer (STB). In order to search the film, the user firstly needs the connection between PC and his tablet to be guaranteed by the HGW. Then, when the user has found the film saved on the PC, the STB should be turned on in order to play the film. The STB provides its display interface block, video stream decoder block, authentication block and the

connection block, and the HGW assures the connection block during the entire service. This typical UPnP AV use case requires different connected devices to participate at different points in the service.

Thanks to the UPnP Audio Video services, there are more and more enhanced collaborative services in the home network environment for the user entertainment needs.

2.5.2 UPnP Low Power

UPnP low power is proposed in 2007 in the purpose of implementing different power saving modes to conserve energy of UPnP devices [27]. The proposed UPnP low power architecture defines two services in the home network: low power device service and power management proxy service with three UPnP Low Power elements, which are UPnP Low Power aware control point, UPnP Low Power device and UPnP basic power management proxy.

With the help of the UPnP Low Power architecture, the UPnP Low Power Device could announce its power states, its entry and its exit information to the network. The UPnP Low Power proxy provides the possibility of discovering the Low Power Device while it is in a low power mode and storing the methods of waking the Low Power device. The UPnP aware control point could monitor the power state of the Low Power devices, their entry and their exit messages. It could also provoke a wake-up or a go-to-sleep action of the Low Power devices.

In the UPnP Low Power service, device is considered as monolithic that will be put in different power states. Devices are managed integrally in this UPnP service. Thus, we present UPnP Energy Management, which is another UPnP service which controls device power consumption in a different vision.

2.5.3 UPnP Energy Management

UPnP Energy Management service is proposed in August 2013 in the purpose of providing energy management functionality to UPnP devices and their services [28]. Different from UPnP Low Power Management, the UPnP Energy Management does not consider the device as a monolithic element. The multiple

functionalities of one device could be managed by getting information on the device internal resources.

The UPnP Energy Management defines a main method to get network interface information: description, Media Access Control (MAC) address, interface type, network interface mode, IP address and wake on patterns and so on. The network interface could be: Ethernet, WiFi, HPNA over coax, home plug, MoCA, 1905 and others. The wake on pattern defines the pattern to wake on (and to go to sleep) this interface. In most cases, an network interface could be set in the operation mode in which it is shut down but able to wake on when a packet arrives at the interface [79] [29]. The most commonly wake up packet is called magic packet. The packet is generally composed by 6 bytes, i.e. 12 hex F: “FFFFFFFFFFFFFF”. Through the control points, the device internal resources could be controlled by UPnP Energy Management.

The UPnP energy management is interesting that it controls devices in a refined vision. It provides the possibilities to control different network interfaces separately in this service. We also use this refined control vision in our contributions.

2.6 Conclusion

In this section, we present firstly an overview of the home network environment, then we details the PLC and IEEE 1905 wired and wireless connection technologies. The low power technologies, Bluetooth Low Energy, ZigBee and 6LoWPAN, are discussed to provide the energy efficiency connection possibilities. At the end of this section, we presented the UPnP protocols and services like UPnP Audio Video, UPnP Low Power and UPnP Energy Management by the interconnection of devices. The home environment with the different technologies provide a more convenient network environment for users. This facilities require more energy consumption and also provide us several possibilities to reduce the energy consumption.

Chapter 3

Existing power management solutions

Contents

| | | |
|------------|---|-----------|
| 3.1 | Introduction | 28 |
| 3.2 | Device level power management | 28 |
| 3.2.1 | Advanced configuration and power interfaces | 28 |
| 3.2.2 | Dynamic Power management | 29 |
| 3.2.3 | Device element energy reduction | 30 |
| 3.3 | The network level proposed solutions | 32 |
| 3.3.1 | Home Automation Energy Management | 32 |
| 3.3.2 | Network connection power control | 33 |
| 3.3.3 | Home connected devices power consumption management | 34 |
| 3.4 | Conclusion | 35 |

3.1 Introduction

This chapter provides the reader with some required background to understand our contributions. It shows some limitations of current solutions that our work tried to solve. In Section 3.2 we present several power managements on the device level. Then in Section 3.3 we analyze the main power management techniques on network level.

3.2 Device level power management

3.2.1 Advanced configuration and power interfaces

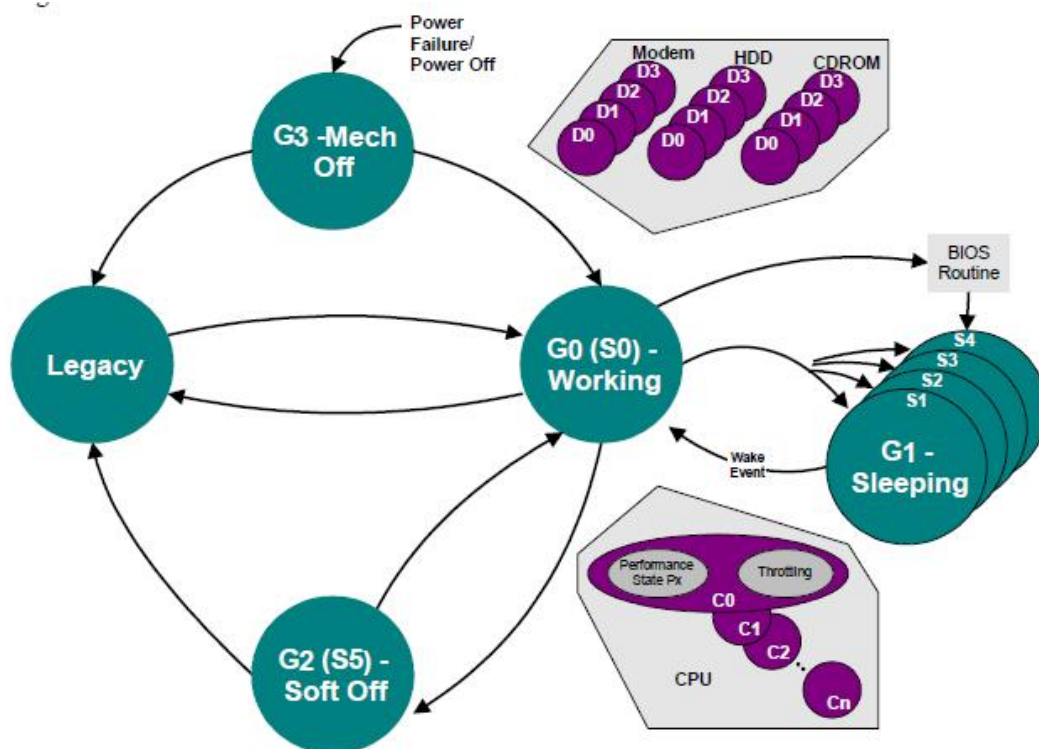

Figure 3.1: Power states defined by the ACPI for a personal computer [44]

An Advanced Configuration and Power Interface (ACPI) has been defined [44] by Hewlett-Packard, Intel, Microsoft, Phoenix and Toshiba to control device, like

a personal computer, and the whole system within the operating system. ACPI is an interface specification which defines both hardware elements and software elements for power management purpose.

Figure 3.1 shows the power states defined by the ACPI for a personal computer. In general, when a PC is required, it is in working mode. Individual elements like Modem, HDD, CD-ROM can be in low power mode (Dx) or processor can be in low power mode (Cx) if they are not in use. If the PC is idle or the user chooses to put device into sleeping mode, PC can go into one of several sleeping modes. If the user chooses to turn off the PC system, it goes to soft off mode. The legacy state is used less often. A computer supporting legacy BIOS boots in legacy state and transitions to the working state after the ACPI loads. If this ACPI function is not supported, the computer goes to working state directly. Mechanic off mode signifies the user unplugs the computer from the electrical supply.

Several functions are proposed in the ACPI specification: system is controlled to alternate between different modes as presented formerly. The individual subsystem may have also several power modes. Battery management policy includes a smart battery subsystem or a control method battery interface for the battery control. Power reduction is achieved with the help of these features.

As explained formerly in section 2.5, some control traffic is sent periodically, like UPnP discovery messages, which avoid the device to go to sleep mode which may be configured by the ACPI.

3.2.2 Dynamic Power management

The power dissipated by a CMOS circuit satisfies the following relation in formulas (3.1) [90]:

$$P \propto CV^2f \quad (3.1)$$

Where C is capacitance, V is voltage and f is frequency. Various techniques are proposed to achieve dynamic power reduction [8]. As the formulas illustrates, decreasing the voltage or the frequency or both parameters could reduce the power consumption of the system. Thus the dynamic power consumption could be managed by dynamic voltage scaling and frequency scaling power management.

Existing power management solutions

Dynamic voltage scaling [69] [68] is to increase or decrease the voltage of a component. While the voltage is increased, it is called overvolting. It is often used to increase the performance. On the contrary, the voltage scaling to decrease voltage is known as undervolting. By using the method of undervolting, the system could achieve the power reduction.

Dynamic clock frequency scaling [35] is a technique that the clock frequency reduction can be determines on the fly by the software. It is used to reduce the power consumption, heat output and the noise level of computer.

Meanwhile, there are impacts which should not be ignored on the performance.

- Latency generated while the frequency and voltage are decreased.
- CPU may not operate correctly while the voltage and the frequency are changing.
- A phase lock loop (PLL) is a control system that generates an output signal whose phase is related to the phase of an input signal [41]. If the CPU changes its clock frequency, the PLL should also be reprogrammed to provide the correct clock frequency for the external peripherals. Sometime, this is not designed to operate at different frequencies.

The dynamic voltage and frequency power management could reduce the power consumption of the devices elements. This requires the manufactures implement these methods by changing the device circuits.

3.2.3 Device element energy reduction

As explained in former section, techniques have been proposed to reduce energy consumption at the device level. Using dynamic power management, devices can be switched to a lower power mode when the service demand is reduced. In addition, algorithms have been proposed minimizing the energy consumption of device components.

Gupta et al. proposed a method that reduces the power supply when there is less traffic over Ethernet links [37]. In this paper, they design and evaluate a dynamic ethernet link shutdown (DELS) algorithm that uses buffer occupancy, the

behavior of previous packet arrival times and a configurable maximum bounded delay to make sleeping decisions. This work permits to achieve energy savings with little noticeable impact on packet loss or delay on the Ethernet links.

Gunaratne et al. propose another algorithm for the Ethernet link [36]. In their work, they design and evaluate a new adaptive link rate policy which uses output buffer thresholds and fine-grain utilization monitoring to determine when to switch link data rate. This work could be applied on the busy and smooth traffic.

There are other proposals aiming to control the memory in order to be more power efficient.

Puttaswamy et al. proposed a system level solution for the memory energy saving [73]. They propose frequency and voltage scaling of the off-chip buses and the memory chip and use a known micro-architectural enhancement called a store buffer to reduce the resulting impact on execution time.

Fan et al. propose an energy optimization techniques for the DRAMs control [19]. They develop an analytic model that approximates the idle time of DRAM chips. This model designed to determinate when the benefit of transitioning to a low power state is greater than the penalty for transitioning back to the active state.

However, it is not sufficient to save energy only at the level of each individual device. The power status of each home device is independent of the others. For example, when all family devices are not operational or not in use, it can be concluded that the home gateway no longer needs to provide a local network, and its Ethernet and WiFi components can be turned off. The activity or power status of one appliance is not independent information; this information can be used to manage other appliances. Consequently, our solution provides a collaborative system to control the power status of home connected devices at the network level and the power states of functional blocks in these collaborative devices at the device level.

3.3 The network level proposed solutions

In this section, we give an overview of existing systems on the network level. We clarify the systems into three categories: home automation power control, network connection power control and home connected devices power control.

3.3.1 Home Automation Energy Management

Dae-Man Han et al. proposed a Smart Home Energy Management System (SHEMS) [39], [40] based on an IEEE 802.15.4 and ZigBee. The proposed smart home energy management system divides and assigns various home network tasks to relative components. It controls various consumer home devices like heating, light, with the support of active sensor networks having both sensor and actuator components.

Hwang Il-Kyu et al. describe the design and development of a remote control for a smart home based on the Zigbee protocol [43]. In their application, they control electric devices in the home network using ZigBee protocol and infrared remote controller technology. A user can control all kinds of electric appliances connected in home network system by infrared remote controller. Infrared remote controller sends specific ZigBee command to control the electric devices. While the devices receive the ZigBee, they could be turned on or off the device directly by a ZigBee adapter on the power supply line. Devices could also be turned on or off if it could be controlled by an infrared remote controller by using the ZigBee to infrared remote converter.

Gill Khusvinder et al. proposed a ZigBee based home automation system is implemented for the monitoring and control of household devices [30]. Based on a locally and remotely ZigBee or WiFi control system, they implemented a virtual home on the Home GateWay for security and safety control. Moreover, authors demonstrate their proposition by developing and evaluating a testbed of four devices, a light switch, radiator valve, safety sensor and ZigBee remote control in the home automation system.

Although these studies domain is more about home automation than home network, it is interesting to see that sensors can be easily implemented into the residential environment. However, each home automation device often provides

one service alone, the home automation control is to control each device separately.

3.3.2 Network connection power control

Olivier Bouchet et al. [10], [50] proposed network-level system for reducing power consumption is based on a technology-independent layer, called an inter-MAC, from the Omega project [46], [85]. This inter-MAC convergence layer is positioned above the different MAC layer of the different technologies. The inter-MAC layer is composed of three functional planes (Figure 3.2): the control plane, the data plane and the management plane. The data plane is responsible for frame forwarding. The control plane is responsible for short-term decisions related to the establishment and release of paths and the processing of upper layer requests. It is divided into several engines: QoS, Monitoring, Inter-MAC Adapter and Green Path Selection. The green path selection protocol takes into account the following three metrics: available bandwidth, energy consumption, and radio frequency.

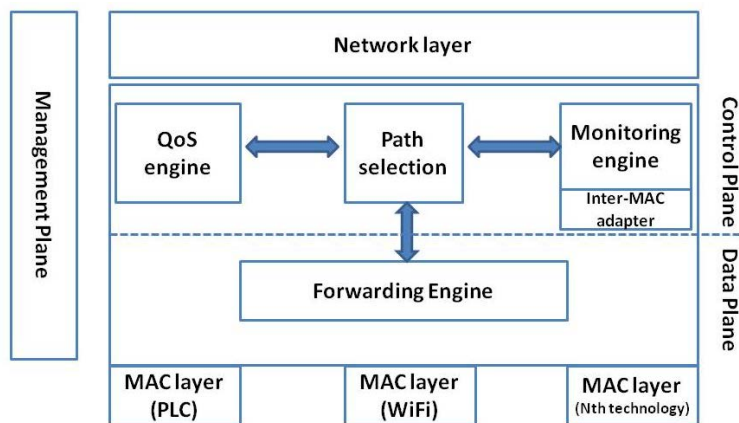

Figure 3.2: Network-level inter-MAC architecture

This solution provide the possibilities to choose the greenest path among the multiple paths. But, this requires all connections stay in power on state although some paths may not be used.

Vincenzo Suraci et al. proposed in their work [84] an integration of Wireless Sensor Network (WSN) with home gigabit access based on the Omega project

Existing power management solutions

[46]. They proposed that a Wireless Sensor Network and an Omega network can be applied for a mutual advantage. The WSN can rely on the gigabit network facilities when it is powered up. The gigabit network can be activated and deactivated dynamically relying on an always on and energy efficient wireless sensor network.

A new routing metric was proposed by Najet Boughanmi and Yeqiong Song [12], [11] to satisfy both energy and delay constraint in wireless sensor network. The advantage of this routing metrics is maximizing the sensor network lifetime while taking into account the delay requirement of real-time communications. In this routing metrics, packets could be classify into normal level and urgent level. The urgent level packets will be sent by passing the nodes with a critical energy level and normal level packets will not allowed to be sent by these critical energy level nodes.

These works progress the power consumption saving in the network field. However, they only focus on reducing the power consumption of network connections. Using network connections to reduce power consumption of other home network devices is not enough investigated in these studies.

3.3.3 Home connected devices power consumption management

Spyridon Tompros et al. proposed a generic network architecture [88] that allows generic implementation of energy saving applications for the home environment. Their proposition requires a Energy Monitoring Device (EMD) installed between the home gateway and the domotic appliances to monitor and control the devices. In their proposition, each device is considered and controlled as a integral entity. As explained earlier in the ACPI part (see section 3.2), the device may not be used integrally.

Youn-Kwae Jeong et al. proposed a network level solution that controls home network devices by reconfiguring the Power Control Element (PCE). Their proposed solution [47] supplies power only to the devices and the functional elements that are related to requested services. In their approach, all functional elements are turned on at the beginning of the service, despite the fact that early functional

modules are not needed at that time.

The UPnP AV use case [4] is a good example to illustrate why there is a time lapse between requested functional blocks in one service: the user controls the home devices with an UPnP Control Point (through his laptop, smartphone, or tablet) and wants to watch a film on his UPnP Media Renderer (STB). This film is saved on his UPnP Media Server (NAS). For this service, the content directory functional block on the UPnP Media Server is needed at the beginning of the service. The decoder functional block on the UPnP Media Renderer is required later by the service.

Therefore, our solution provides collaborative management according to the service request on each functional block in order to control the right functional block at the right moment.

3.4 Conclusion

In this Chapter 3, we illustrated the main technologies on the power consumption management. On the device level, ACPI provides different power states for the system and the individual elements in the system. The dynamic voltage power management and dynamic clock frequency power management could achieve the reduction of power consumption by decreasing the voltage and the clock frequency. The second part of Chapter 3 presents the main power management and their limitations on the network level. We analyze three categories power management on the network level: home automation, network connections and connected devices.

Existing power management solutions

Chapter 4

An Overlay Network for energy control

Contents

| | | |
|------------|--|-----------|
| 4.1 | Introduction | 38 |
| 4.2 | The proposed Overlay Energy Control Network . . . | 39 |
| 4.2.1 | Overlay Energy Control Network system | 39 |
| 4.2.2 | Proposed solutions based on Overlay Energy Control Network system | 42 |
| 4.3 | Simulation and analysis of results | 44 |
| 4.3.1 | Simulation methodology | 44 |
| 4.3.2 | Simulation of one device analysis of results | 53 |
| 4.3.3 | Analysis of results | 58 |
| 4.4 | Conclusion | 62 |

4.1 Introduction

In this chapter, our work is to reduce energy consumption in the home network environment by studying one main cause of the high energy consumption of the home network devices. The reason is that there is an increasing number of these home network devices with soaring power consumption in our homes. These devices are in idle state for hours when they are not in operation. They can not go to an ultra-low power consumption state when they are not in operation. The challenge of this problem is that these home network devices have a long switching time from idle state to sleeping state. Moreover, explicit user commands are required to switch the device from idle state to soft-off state.

Therefore, we propose an Overlay Energy Control Network (OECN) which can switch devices from idle state to sleeping state much more quickly and from idle state to soft-off state automatically in this chapter. The OECN is formed by overlay energy control node connected to each home network device. So that the OECN can be adaptive to our home network devices, the OECN is developed in two ways:

- All overlay energy control nodes in the home network are ZigBee nodes. This is a ZigBee Mandatory OECN Solution (ZMS).
- One or more devices become the overlay energy control nodes where there are no ZigBee modules on that device. This is a ZigBee Optional OECN Solution (ZOS).

The rest of the chapters are organized as follows. In section 4.2, we present the Overlay Energy Control Network. In section 4.3, we describe the model of different day types and application of three solutions. And we also provides the simulation results in this section. At the end of this chapter, we draw the conclusion and give some future perspective in the section 4.4.

4.2 The proposed Overlay Energy Control Network

As presented in the Section 2.2, in a home network, there are many kinds of devices such as a Home GateWay (HGW), Set-Top Box (STB), Power Line Communication (PLC) plugs, Personal Computer (PC), laptop, and so on. In order to reduce the overall energy consumption of the integral home network devices, a low power consumption control layer over this home network is proposed: this is an Overlay Energy Control Network. In this section, we present firstly the global architecture and the protocol stack of the OECN system, two solutions based on this system will be proposed.

4.2.1 Overlay Energy Control Network system

4.2.1.1 Global architecture

The Overlay Energy Control Network (OECN) is formed by an overlay energy control node connected to each home network device. The OECN power management coordinates the power states of all the home network devices. The overlay energy control nodes can exchange energy control messages. The devices can be turned on or turned off, or they can return to their power states when they receive the OECN messages.

We chose to implement the OECN power management in the Home GateWay because we assumed that this device is always present and in active state in the home network to support VOIP phone calls. By exchanging OECN messages, the devices centralize their information on the OECN management node. The OECN management collects the power information and controls the network devices (shown in Figure 4.1). The network topology dependence, network traffic and power state information of the devices is required by the OECN manager node. The information of network topology dependence shows the network infrastructure for each connected device. The network traffic information indicate the traffic load on each connection. The power state information is the actual power states of each devices, and the possible future power states for each device. Meanwhile, the OECN manager node controls the integral home network based

An Overlay Network for energy control

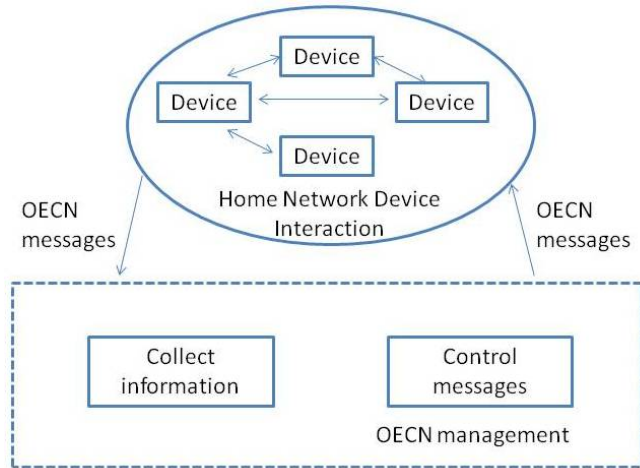

Figure 4.1: OECN Management

on the information from each device.

This always-on overlay architecture consumes little energy since it is partly constructed on the ultra-low power consumption ZigBee modules. Each ZigBee module consumes about 18 to 120 milliwatt hours per day, and it can turn on/turn off one device through the USB port. ZigBee is used to satisfy the need for a standard-based wireless network that has low power consumption, low data rates and robust security. The other part of the overlay architecture is based on the Ethernet. Our system could wake the devices up by implementing the method of Wake-On-Lan, turn the devices off and request the power state of the devices by the UPnP Low Power protocol. UPnP low power protocol is defined to satisfy the demand of reporting and tracking the power states of the UPnP nodes. If possible, the UPnP low power protocol could also request the device to enter the sleeping state.

Technically, there are two ways to implement the OECN control mechanism. The first one method is using ZigBee module. When one device receives the power turn-off message from ZigBee, it will be shut down by this command. If the device receives a wake up message from ZigBee which is plugged in the USB port, the device will be turned on. The USB interface consumes almost no power, but it only maintains the capability to receive a wake-on-usb signal

and then device could be woken up by wake-on-usb signal. Since home network devices are generally equipped with a USB port, we assume that we can apply our solution to those USB-equipped devices. The second method is using UPnP low power protocol. When one device does not equip a ZigBee module, it will be controlled by the UPnP Low Power protocol messages. If the device receives a wake up message from Ethernet interface, device will be turned on. When one device receives a go to sleep UPnP low power message by the Ethernet interface, the device will switch to sleep state by this message.

The difference of these two methods is, by using ZigBee module, device could be turned off, it is in the soft off mode. Without the ZigBee module, device could be go to sleeping mode quickly after receiving a command, but this is not the most energy efficient mode comparing to the soft off mode.

The devices can be turned on; turned off or they can switch to their power states according to the received the OECN messages. As explained formerly, the OECN can be implemented in two ways. This depends on the type of energy control node and the way overlay energy control messages are exchanged: if all OECN nodes are ZigBee nodes in the home network, this is a ZigBee Mandatory OECN Solution; if one or more OECN nodes are devices that do not have Zigbee modules, this is a ZigBee Optional OECN Solution. The reasons that we propose two methods are following: firstly, the communication between ZigBee modules could not be established for the long distance or the obstacles in the house like wall door between ZigBee modules. Secondly, the wake-on-USB may not be supported by the device, or the device may even do not have USB port. Thirdly, the expense of the ZigBee should be profitable comparing the energy gain of non-ZigBee method.

4.2.1.2 Protocol stack

In the overlay energy control network, any two user devices can communicate through ZigBee network or through the LAN (like Ethernet or WiFi). User device which is capable to support a ZigBee module should have following functions:

- It could power the ZigBee module by the USB interface.
- It could exchange the messages with the ZigBee USB interface

An Overlay Network for energy control

- It could be powered on/off while the device receives the message from the ZigBee module.

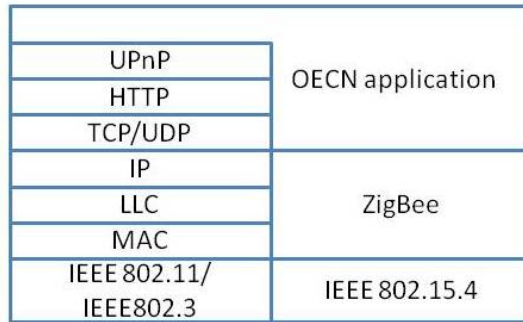

Figure 4.2: OECN Protocol Stack

As explained in the former section, between two user devices without ZigBee modules, the communication is realized by the UPnP low power messages over the HTTP protocol. Figure 4.2. shows the protocol stack of the proposed OECN. On the left side is the protocol stack used in the device which does not implement ZigBee .From the physical layer to application layer, device uses IEEE 802.11 and IEEE 802.3, the communication on the WiFi et Ethernet, TCP/UDP, HTTP and UPnP. On the left side shows is the protocol stack used in the device which plugs ZigBee module. The communication protocol is IEEE 802.15.4 and ZigBee. The OECN application could pass the OECN message to the device, and package the device information to send to the OECN power management.

4.2.2 Proposed solutions based on Overlay Energy Control Network system

4.2.2.1 ZigBee Mandatory energy-saving Solution

When all the energy control nodes are ZigBee modules, this is called a ZigBee Mandatory energy-saving Solution, as shown in Figure 4.3. There are several advantages to having ZigBee modules as control nodes. A device can be turned off and can also be started up by the ZigBee module connected to it. Therefore, this

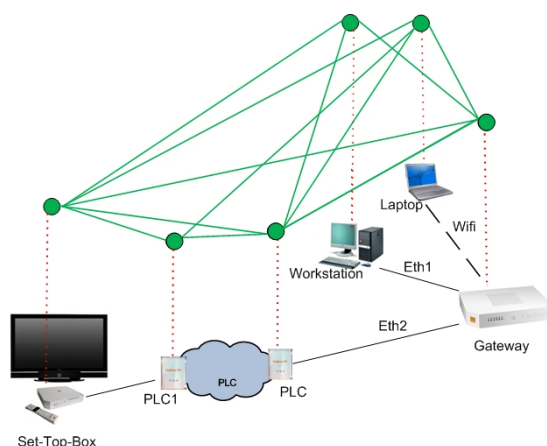

Figure 4.3: ZigBee Mandatory energy-saving Solution

device can go into an ultra-low power consumption state (soft-off state). Although there are some significant advantages to using ZigBee modules as overlay energy control nodes, it is not possible to use this solution everywhere. As it might not be possible to connect a ZigBee module to the device. For example, the ZigBee transmission diameter is limited. Thus, we propose another alternative solution, namely the ZigBee Optional energy-saving Solution.

4.2.2.2 ZigBee Optional energy-saving Solution

Compared to the ZMS, the ZigBee Optional energy-saving Solution (ZOS) does not need each device to be fitted with a ZigBee module. When there is no ZigBee module on a device, the device itself becomes the energy control node and the energy control messages are sent via the data home network.

In Figure 4.4, the OECN is formed by ZigBee OECN nodes, one PLC plug and the STB. The reasons why the devices (PLC plug and STB) become overlay energy control nodes are because:

- The set-top box is not equipped with a ZigBee module.
- The distance between the two PLC plugs is too great for the ZigBee transmission diameter.

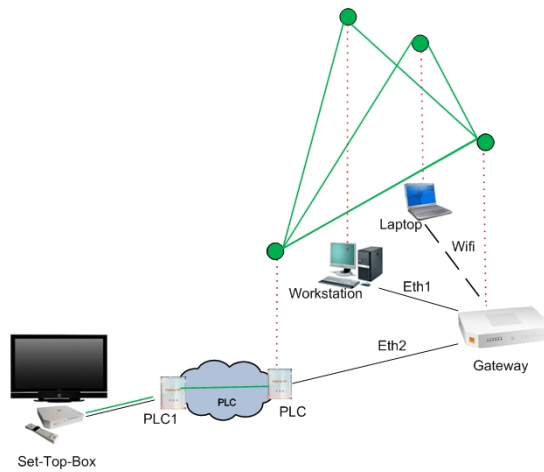

Figure 4.4: ZigBee Optional energy-saving Solution

On these non-ZigBee devices, the overlay energy control messages are sent through the data home network instead of a ZigBee network. Non-ZigBee devices can immediately go into a low power state (sleeping state) when there is no executing application. However, we cannot switch the device to a soft-off state since the OECN cannot turn on a soft-off device without the help of ZigBee module. Although not all devices can be switched to an ultra-low power consumption state (soft-off state), we can still save energy using the ZOS by only leaving active those elements required for being waked up. These elements could be Ethernet network interfaces or WiFi network interface (see Section 2.5.3).

4.3 Simulation and analysis of results

4.3.1 Simulation methodology

In order to demonstrate the efficiency of the two OECN solutions (ZMS and ZOS), we compare the performance of these two proposed solutions with a traditional energy-saving solution called a self-controlled solution.

- Self-controlled energy saving solution: the device controls its own power state. This means that the device goes into the low power consumption

state (sleeping state) by a user-defined condition (a one hour timer, for example).

- ZigBee Mandatory energy saving solution: the OECN manager controls all home network devices with a ZigBee module connected to each device. All overlay energy control messages will be transmitted by the ZigBee modules.
- ZigBee Optional energy saving solution: the OECN manager controls devices in a hybrid way. The overlay energy control messages will be sent by the ZigBee overlay network or the data home network.

In this section, we firstly build our device modelling which is in context of four different day types. Then we are going to apply three solutions on one or several devices.

4.3.1.1 Device Power State Modelling

We defined power states according to the Advanced Configuration and Power Interface (ACPI) standard in section 3.2:

- Working State: the device is on and applications are executed.
- Away State or Idle State: this is a subset of the working state. The device is on but idle, and no applications are executed. We distinguish this state from the working state because this state consumes a lot of energy that is not required by the user.
- Sleeping State: the device is sleeping.
- Soft-off State: the device is turned off, but the power supply is still plugged in to the power source.
- Mechanical-off State: The power supply to the device has been completely removed.

Initially, the device needs a long waiting time, typically half an hour to one hour, to switch from away/idle state to sleeping state. Moreover, users need to regulate the device manually to switch from away/idle state to soft-off state.

We can gain energy if the device stays in sleeping state or soft-off state instead of away/idle state. The Overlay Energy Control Network (OECN) which can switch devices from away/idle state to sleeping state much more quickly and from away/idle state to soft-off mode automatically.

4.3.1.2 Device Utilization Modelling

We first generated the device modelling, and on top of that we applied the energy efficient solutions. Each device in the home network may be used at random time. Thus, the device modelling is expected to characterise its stochastic behaviour. Here, we use a Markov process to describe each device. From the user's perspective, a home network device is either in operation (active) or not in operation (inactive). Figure 4.5 shows that the probability of one active device becoming inactive is v and the probability from inactive to active is r .

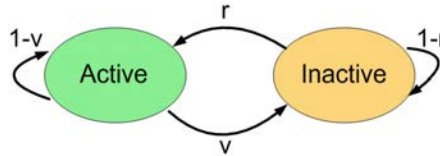

Figure 4.5: Device model from the user's perspective

As the utilization rate of one device may vary during the day, the device will be represented by different r and v values over the 24 hour period. The device active utilization ratio is defined as equation 4.1:

$$R_{active} = \frac{r}{r + v} \quad (4.1)$$

This device active utilization ratio gives the normalised probability of being in active state. When the device is active, this corresponds to “working state”. When the device is inactive, it can be in “away state”, “sleeping state” or “soft-off state”. The last two power states are low and ultra-low power consumption states. The different power states of an inactive device depend on the power-saving solution that we applied to this device.

We take a power consumption measurement of 4 devices : a STB, a PC, a

Table 4.1: Home network devices power consumption

| Device /Watt-hour | Working | Away | Sleeping | Soft-off |
|-------------------|---------|-------|----------|----------|
| STB | 21 | 19.2 | 13.5 | 2.5 |
| PC | 205 | 123.5 | 4.9 | 3.2 |
| laptop | 79 | 54 | 5 | 2.5 |
| PLC | 6 | 3 | 2.6 | 0.15 |

laptop and one PLC plug in one pair in different power states. These values are used to give an approximate power consumption of each type of home connected device in different states, as shown in Table 4.1: Using the PC as an example, we can see that it consumes 205 Watt-hours when it is in “working state”. This is the average power consumption when a user uses the PC to download or play multimedia files. The PC consumes 123.5 Watt-hours (away state) and 3.2 Watt-hours (soft-off state). The difference in power consumption in these two states is significant. It proves that changing the power state when the device is inactive can effectively save energy.

4.3.1.3 Four day types

In order to make the device modelling realistic and adaptive to the family home network devices, the probabilities r and v are categorised into four different day types. We need to define a set of r and v values for one device in one day type. This is an example of four day types for a family of four. As a telecom operator, we have chosen these four day types in order to simulate the user behaviors that how they use the devices. We also assumed that the home network devices are those shown in Figure 4.1.

- Day type 1 (Working day): Parents go to work and children go to school. We take the laptop as an example. The laptop has a high utilization ratio between 8am and 9am because one family member needs to check his/her email. In the evening from 8pm to 12pm, one family member wants to surf the internet. Thus, the laptop has also a significant utilization ratio. Each home network device has its own utilization ratio at each time.

An Overlay Network for energy control

- Day type 2 (Wednesday): On this day type, the children stay at home and parents are at work. On this day type, the set-top box has a relatively high utilization ratio during the daytime. The laptop and PC are used at various times throughout the whole day.
- Day type 3 (Weekend): All family members are at home. The laptop, PC and set-top box are needed at different times over the weekend.
- Day type 4 (Holiday day): The whole family is on holiday. Apart from the PC that is equipped with a home security camera, which is on, the other devices in the home network are turned off completely.

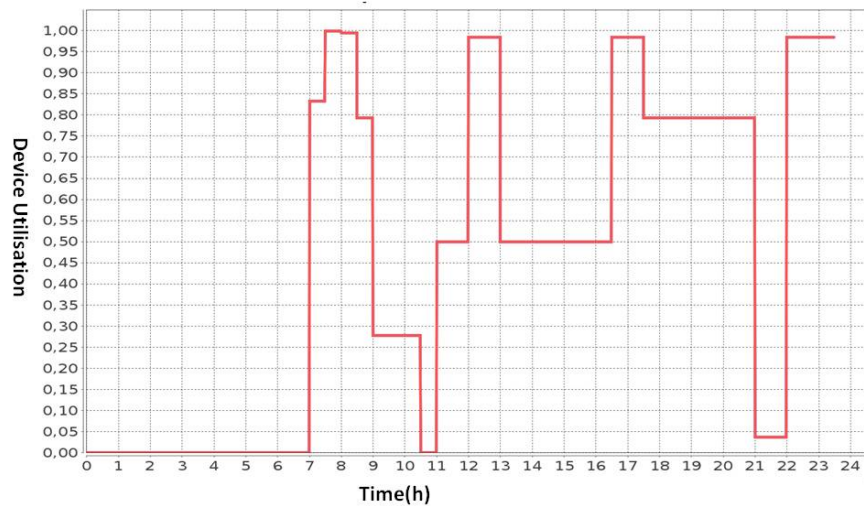

Figure 4.6: Set-top Box utilization ratio on working day

We use the set-top box on day type 1 as an example. As shown in Figure 4.6, all family members are at work or at school. The set-top box and television are turned on to watch the news when they wake up. That is why we have high device utilization at 7am. When the family members leave to go to school or work, the device utilization goes down. At 12 noon, we have peak device utilization, since

Table 4.2: An overlay network for energy control notation summary

| Notation | Definition |
|--|---|
| $w; s; a$ and o | working, sleeping, away and soft-off |
| $T_{sw}; T_{ws}; T_{aw}; T_{wa};$ $T_{as}; T_{wo}$ and T_{ow} | The transition time between two states. |
| $T_s; T_o; T_w$ and $T_a;$ | The time spent in one state. |
| $P_s; P_o; P_w$ and $P_a;$ | The power consumption in one state. |
| $P_{sw}; P_{ws}; P_{aw}; P_{wa};$ $P_{as}; P_{wo}$ and P_{ow} | The power consumption of each transition. |

the children return home to have lunch and watch television at the same time. In the evening, we also have high device utilization of the set-top box when every family member is at home. The device utilization of each device is relatively stable for each day type. Therefore, we can fix a set of device utilization values for each day type and for each device.

4.3.1.4 Application of the three solutions

As mentioned earlier, device utilization could be represented by a Markov process. Comparing this Markov process with the device power states, active corresponds to “working state”, while inactive corresponds to “away state”, “sleeping state” or “soft-off state”. The selected state depends on which energy efficient solution we apply.

Each energy efficient solution can therefore be defined by a finite-state machine. In the finite-state machine representation, we use the four power states which are cited in Section 1. From one power state to another, there is always a power and performance cost. A low power state has low power consumption and a long transition time. Conversely, a high power state has high power consumption and a short transition latency.

In our modelling, the abbreviations are defined in Table 4.2. The notations w, s, a and o represent the working, sleeping, away and soft-off power states. The T is the notation of time. When the notation T combines with one power state notation, it means the time spends in this state. When the notation T combines with two power state notations, it means the transition time spends between

An Overlay Network for energy control

these two power states. The P is the notation of the power consumption. When the notation P combines with one power state notation, it means the power consumption spends in this station. When the notation P combines with two power state notations, it means the transition power consumption between two power states.

Based on the device utilization model, we can apply the three solutions to the device. Figure 4.7 shows the application of the self-controlled energy-saving solution. If a device is not in operation, the device will go into “away mode”. Then, after the timer has timed out (For instance, $T_a =$ one hour), the device will go into sleeping state. After staying in sleeping state for T_s , the device will be woken up by user when he needs the device.

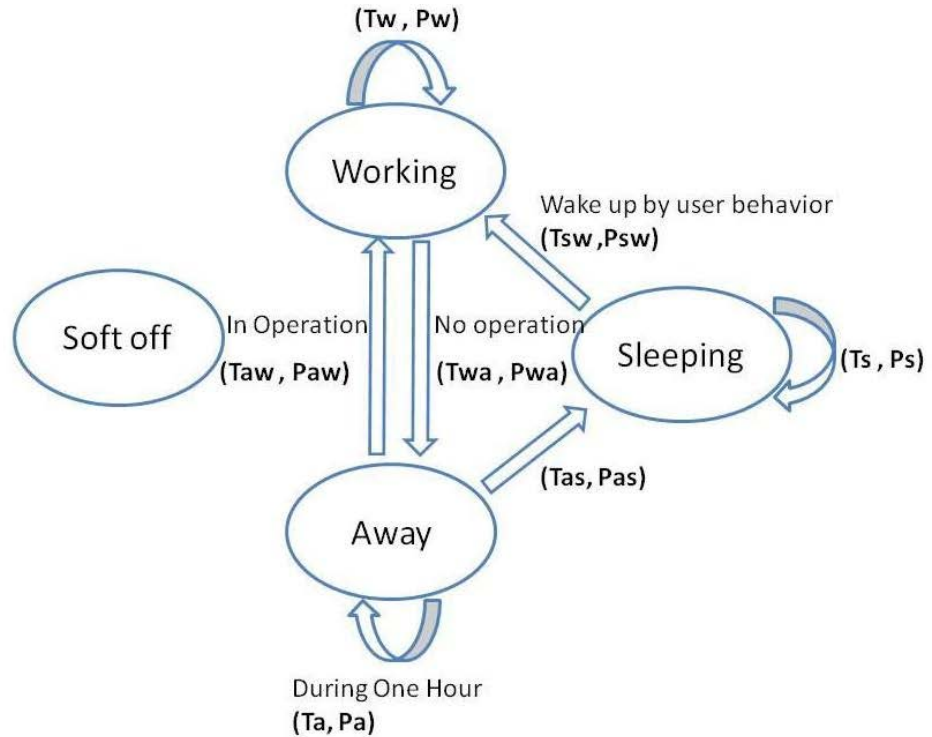

Figure 4.7: Self-controlled Energy Saving Solution

So we can define the total energy for the self-controlled solution as equation 4.2. The energy consumption the total energy consumption spent in the working

state, away state and sleeping state.

$$E_{self-controlled} = T_w \times P_w + T_a \times P_a + T_s \times P_s + T_{sw} \times P_{sw} + T_{aw} \times P_{aw} + T_{wa} \times P_{wa} + T_{as} \times P_{as} \quad (4.2)$$

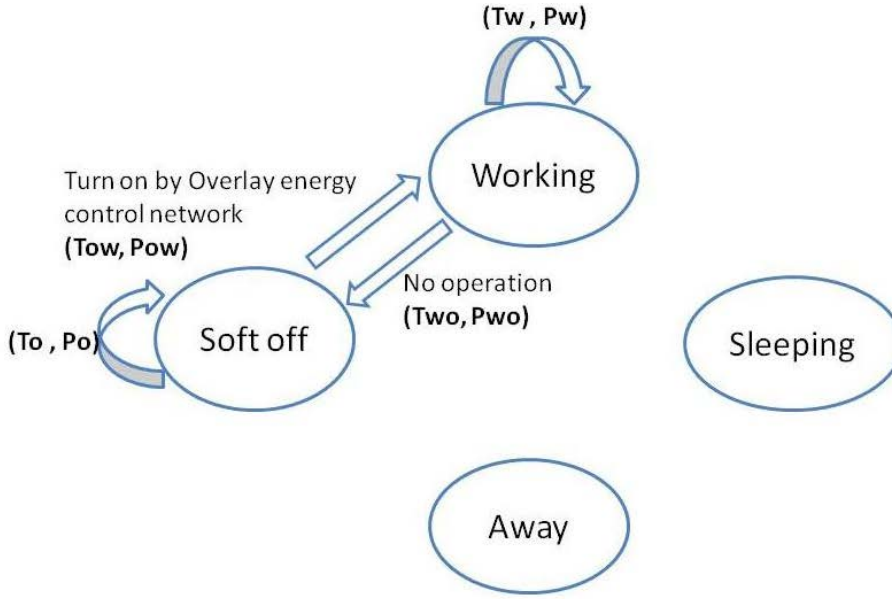

Figure 4.8: ZigBee Mandatory Energy Saving Solution

Figure 4.8 shows that in the ZMS, if the device is not in operation, the device will be put into soft-off state immediately after utilization. In this case, the device does not need to go into “away state”. The device transits from “soft-off” state directly to “away state”. In this way, device doesn’t need to consume energy in “away state” when it is not in use.

$$E_{zms} = T_w \times P_w + T_o \times P_o + T_{ow} \times P_{ow} + T_{wo} \times P_{wo} \quad (4.3)$$

Figure 4.9 Here, T_s in ZOS is equal to $T_a + T_s$ in the self-controlled solution. Since the transition power consumption is lower than the power consumption in each state, we ignore the power consumption on each transition 4.4.

Figure 4.9 Here, T_s in ZOS is equal to $T_a + T_s$ in the self-controlled solution. Since the transition power consumption is lower than the power consumption in

An Overlay Network for energy control

each state, we ignore the power consumption on each transition 4.4.

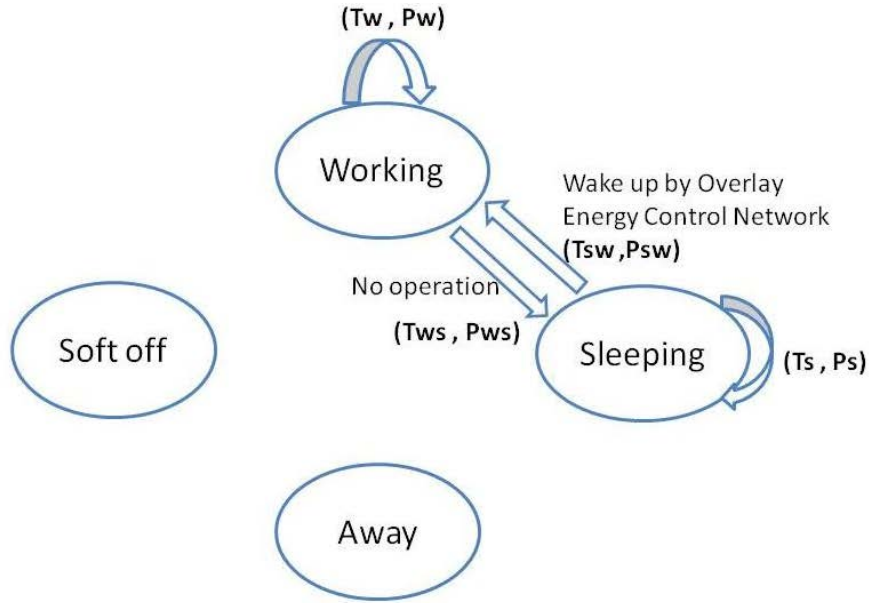

Figure 4.9: ZigBee Optional Energy Saving Solution

$$E_{ZOS} = T_w \times P_w + T_s \times P_s + T_{ws} \times P_{ws} + T_{ws} \times P_{ws} \quad (4.4)$$

In these three solutions, the energy consumed during the working state is the same. The greatest difference between the self-controlled solution and the OECN solutions is that the device does not need to remain in away state for the time defined by the timer. With the OECN solutions, we assume that the manager knows when a device will not be useful (could be switched off). For instance, the home network manager knows when the video broadcast is ending or when the internet connection is closed. Thus, devices could go to low power consumption states immediately if they are not in operation. Since P_a is always bigger than P_s or P_o , energy is saved by putting devices into sleeping state and soft-off state instead of away state.

4.3.2 Simulation of one device analysis of results

As presented above, we simulated the device utilization to evaluate these energy-saving solutions: self-controlled energy-saving solution, ZMS and ZOS. To simulate the three solutions applied to one device, we used the following parameters:

Power consumption of each device in different power states: $P_s; P_o; P_w$ and P_a , as presented in Table 1.

Device utilization probabilities over 24 hours: A defined timer T_a for the self-controlled solution. In our simulations, we used a one hour timer.

Number of simulation runs: 1,000. We compared the results obtained by 10,000 runs and 1,000 runs. The difference in results for laptop consumption on a day type 1 was lower than 1%. We can therefore assume that 1,000 times is sufficient to obtain good accuracy.

4.3.2.1 Simulation of one laptop on a “Weekend” day type

This is an example of one simulation based on one device in the home network. We firstly simulated laptop utilization on the weekend. Since all family members are at home on the weekend, they play video games and surf the internet nearly all day.

The laptop utilization ratio is defined by the red line in Figure 4.10(a). This values are simulation input. The blue line is the real generated laptop utilization by simulations. At 9.30am, there is a high probability that one family member at home is on the laptop until 11:30am. After lunch, it is also quite probable that one family member turns on the laptop. We can see an utilization peak at 8.30pm, since the father checks his personal email after dinner. We simulated the device usage 1,000 times based on the given probabilities. After each simulation of the device usage, we applied the three different energy-saving solutions to the device utilization. Figure 4.10(b) shows how the three power-saving solutions worked on this device for 1,000 simulation runs. The three colored lines plot average power consumption.

The red line is the power consumption of the device using the self-controlled energy solution. After operation, the device goes into away state for one hour, and then goes into sleeping state.

An Overlay Network for energy control

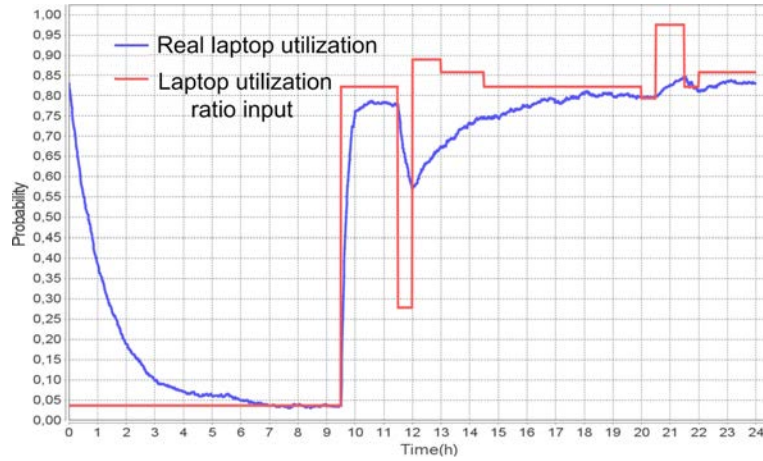

(a) Device utilization ratio on Weekend

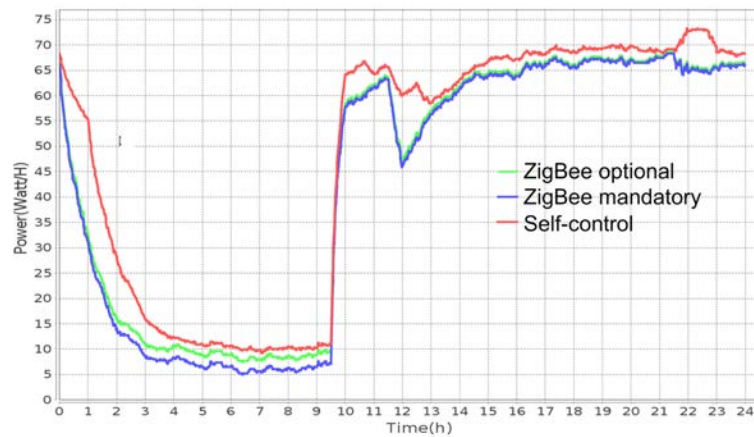

(b) Device power consumption on Weekend

Figure 4.10: 3 energy saving solutions apply on Laptop during Weekend

The blue line represents the power consumption of the device using the ZMS. The device goes into soft-off state immediately after operation.

The green line represents the power consumption of the device using the ZOS. This line sometimes overlaps with the ZMS line, because the power consumption in sleeping state and soft-off state are approximate. The device goes into sleeping state immediately after operation.

From Figure 4.10(b) we can clearly see that the power consumption in the sleeping state and soft-off state is less than in the idle state, for instance, from 11.30am to 12.30. Thus, the energy gain comes from the times when device

utilization changes from active to inactive.

4.3.2.2 Simulation for one laptop on a “Wednesday” day type

Energy is mostly gained when a device switches from active to inactive. In the first simulation example, there were fewer power state transitions. In this example, we simulated the same device on another day type where the power state transitions are more frequent.

On the Wednesday day type, the laptop is used at different times during the day. The stay time in active or inactive is more random and irregular than on the weekend day type. This is shown in Figure 4.11(a), where we have simulated laptop power consumption for a weekend day type. The red line is laptop utilization simulation input during Wednesday. The blue line is the real generated laptop utilization by simulations.

The power consumption obviously decreases when the laptop utilization ratio decreases in Figure 4.11(b). From 9.30am to 10.30am, there is an energy gain between the self-controlled solution and the OECN solutions. This is because the device is quickly turned off (ZMS) or switched to sleeping state (ZOS), instead of staying in away state (self-controlled solution). At 10.30am, the self-controlled solution consumes almost the same energy as the ZOS since the device is in sleeping state in these two solutions. The ZMS can gain more energy than the other two solutions because the device is in soft-off state which consumes less than in sleeping state. Our OECN solutions gain energy when there is a transition from active to inactive and while the device is in inactive state. There is a greater number of state transitions of power; more energy is gained.

4.3.2.3 Simulation parameters

Based on the home network shown in Figure 4.1, we will simulate the home network devices for one year (365 days).

In order to evaluate energy efficient solutions in a home network environment, simulations are carried out for different day types. In one year, we will have 191 type 1 days, 96 type 2 days, 48 type 3 days and 30 type 4 days. All these different days make up one year (365 days). This choice is representative on the basis of

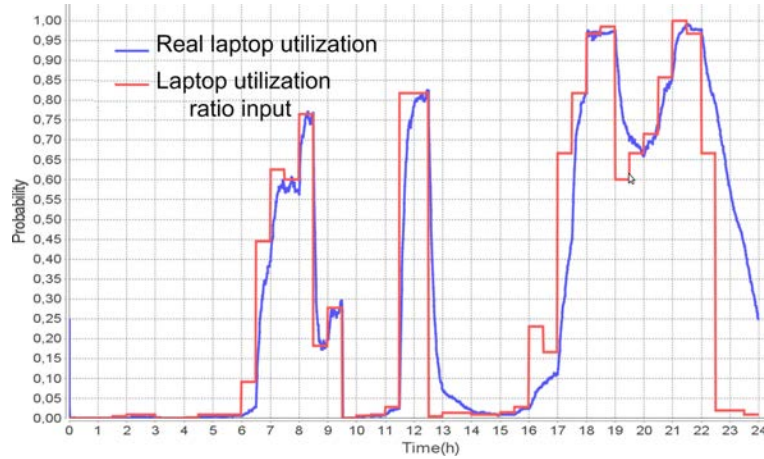

(a) Device power consumption on Wednesday

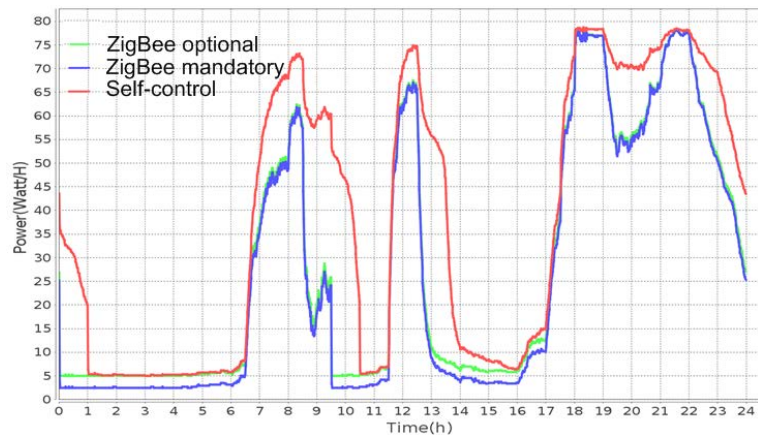

(b) Device power consumption on Wednesday

Figure 4.11: 3 energy saving solutions apply on Laptop during Wednesday

our own knowledge of our customers and how they use the devices.

The three energy-saving solutions are analysed in 3 metrics:

- Annual energy consumption: Energy consumption is the energy used in the whole home network in one year. The power consumption of the devices is presented in Table 1 (above). We take the energy consumption of the ZigBee modules into account for the OECN solutions.
- Daily delay: Daily delay is the cumulative waiting time every day. The waiting time is calculated from the moment that the device is requested to the moment that the device is in operation. It is the total duration of all

transitions from inactive to active. For these energy-saving solutions, the delay for one day is calculated as formula 4.5, 4.6, 4.7:

$$D_{self-controlled} = a \times T_{aw} + b \times T_{sw} \quad (4.5)$$

$$D_{ZMS} = (a + b) \times T_{ow} \quad (4.6)$$

$$D_{ZOS} = (a + b) \times T_{sw} \quad (4.7)$$

The $a+b$ is the number of times that the device changes state from inactive to active in one day. “a” is the number of times that the device changes state and does not stay in the inactive state for more than one hour. “b” is the number of times that the device changes state and stays in the inactive state for more than one hour. The transition time is shown in Table 4.3. The home network delay is the sum of the delays for each home network device.

Table 4.3: Device transition time (inactive to active)

| Device / Delay (second) | T_{aw} | T_{sw} | T_{ow} |
|-------------------------|----------|----------|----------|
| Gateway | 0,01 | 1 | 40 |
| STB | 0,01 | 7 | 80 |
| PLC | 0,01 | 1 | 3 |
| Workstation | 0,01 | 4 | 30 |
| Laptop | 0,01 | 2 | 25 |

- Cost: The total monetary cost of the three solutions. We calculate the cost of electricity based on the European electricity tariff (for the year 2012) in Table 4.4. This tariff is cheaper during the night than during the daytime. For the self-controlled energy solution, we calculated the cost of electricity. For the ZMS, we calculated the cost of the electricity and the ZigBee modules. For the ZOS, we calculated the electricity cost of the

An Overlay Network for energy control

electricity and the ZigBee module if the device has one. Otherwise, we just calculated the electricity cost of the device.

Table 4.4: Expense on electricity and ZigBee module

| | | |
|--------------------------------|------------------|--------------------|
| Electricity (euro /Kwatt-hour) | Day Rate: 0,1312 | Night Rate: 0,0895 |
| ZigBee Module (euro/ unite) | 6,05 | |

4.3.3 Analysis of results

The results of the three energy-saving solutions simulated on one home network is analyzed in three dimensions: energy consumption, delay and cost.

4.3.3.1 Energy consumption

From Figure 4.13 we can see the energy consumption of one home network with different energy solutions applied. Compared with the self-controlled solution, we can gain 21.79% energy with the ZMS and 16.96% energy consumption with the ZOS in one year (Figure 4.12). By applying the ZMS, the devices are in the soft off power state which consumes the least energy when they are not in operation. Without the help of the ZigBee modules in the ZOS system, the device could immediately goes to the sleeping power state after the operations and we note the sleeping power state is also a low energy cost state comparing with the idle power state. Among these four day types, an OECN solution is less effective at the weekend. We gain 10.58% with the ZMS and 7.28% with the ZOS. For day type 3, however, OECN solutions are quite effective for energy saving: 28% (ZMS) and 21% (ZOS). On day type 3, the devices change their power states more often than on day type 2. This is why OECN solutions are more effective on one day type than on another. As we explained in the section 4.3.2.2, the more frequently the device changes its state from active to inactive, the more energy is saved. That is why on day type 3 we might have a large energy gain by using OECN solutions. Meanwhile, delay performance increases when the energy gain increases.

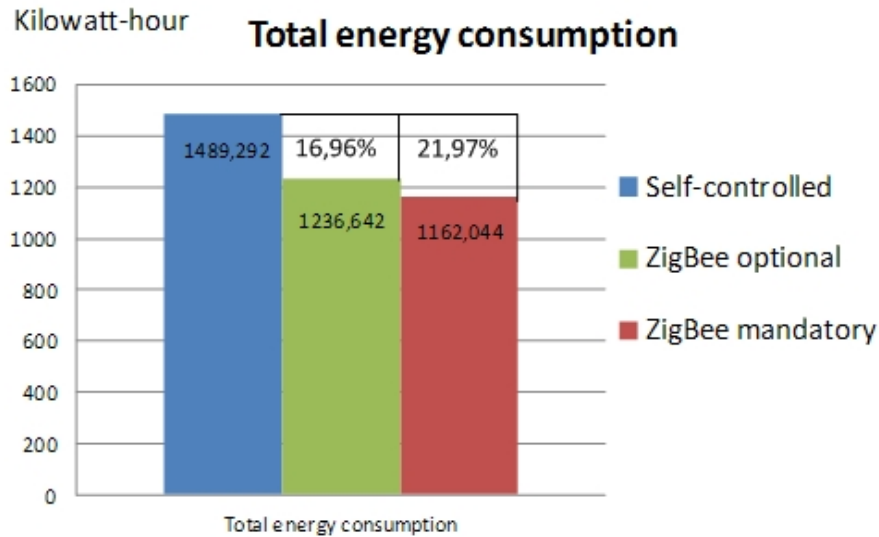

Figure 4.12: Home network total energy consumption result

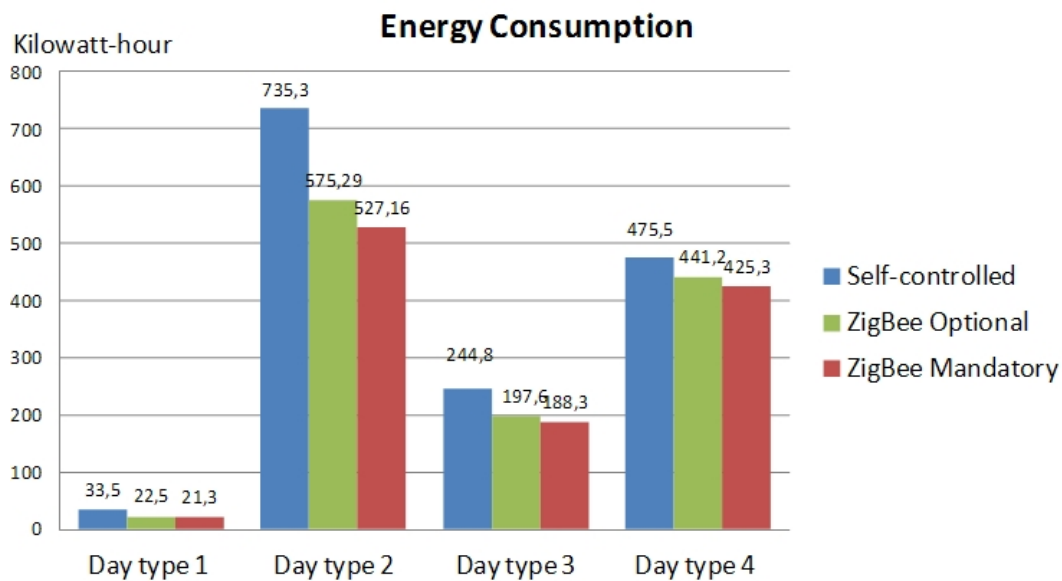

Figure 4.13: Home network energy consumption result

4.3.3.2 Home network delay

The OECN solutions are effective for energy saving. However, the energy gain is not free, and the OECN solutions pay by the delay to have the energy gain. As explained in the simulation setup, the daily delay is the sum of the delays for

An Overlay Network for energy control

each home network device. This cumulative delay per day of the home network is 7.63 minutes when using the ZigBee Mandatory Solution. This delay may be acceptable for some users who want to have a high energy gain. For other users, the ZOS could be an opportune trade-off, where the daily home network delay is only 0.77 minutes. Note that by applying ZMS, devices are capable to enter the lowest power state which needs longer time to return back to the working power state. That is why ZMS has a higher delay comparing to the other two solutions. ZOS and self-controlled solutions have similar delay for the different day types. However, using the self-controlled solution the user needs to turn on/turn off the user device manually which is not favourable for the quality of the user's experience. From this point of view, the additional delay of ZOS and ZMS is favourably compensated by the automatic OECN management.

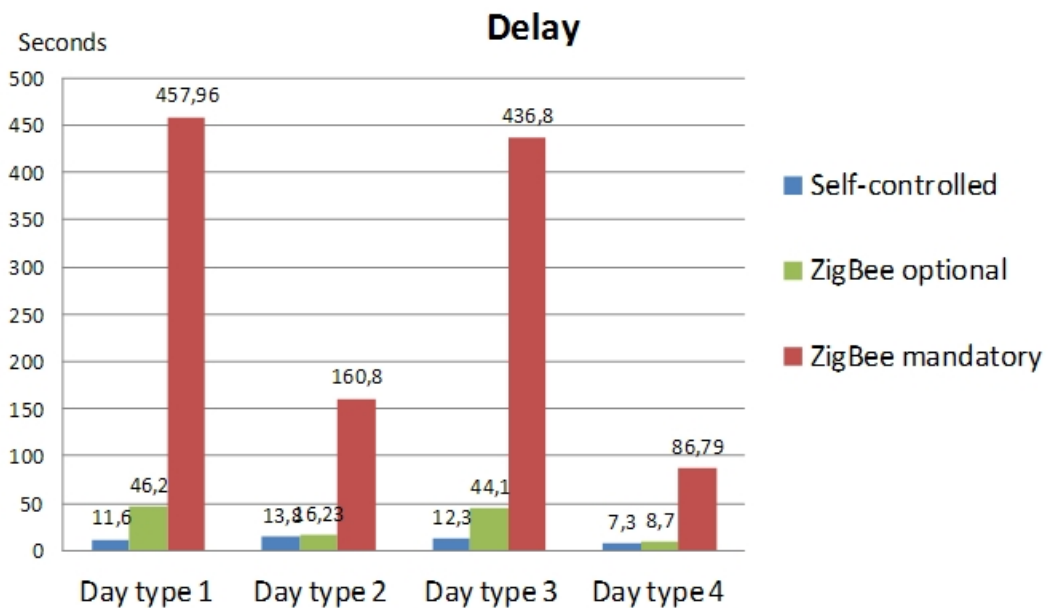

Figure 4.14: Home network delay result

The greater the amount of energy gained, the more delay there is. As shown in Figure 4.14 for day type 2, the daily delay of all home network devices is 1.447 minutes (ZMS) and 0.146 minutes (ZOS). For day type 3, the OECN solutions are effective for energy saving but we also have an additional delay with the OECN solutions. Every time energy is gained from transitions, the OECN solutions put

devices in a low or ultra-low power consumption state, which requires a longer time to wake up.

4.3.3.3 Home network electricity cost

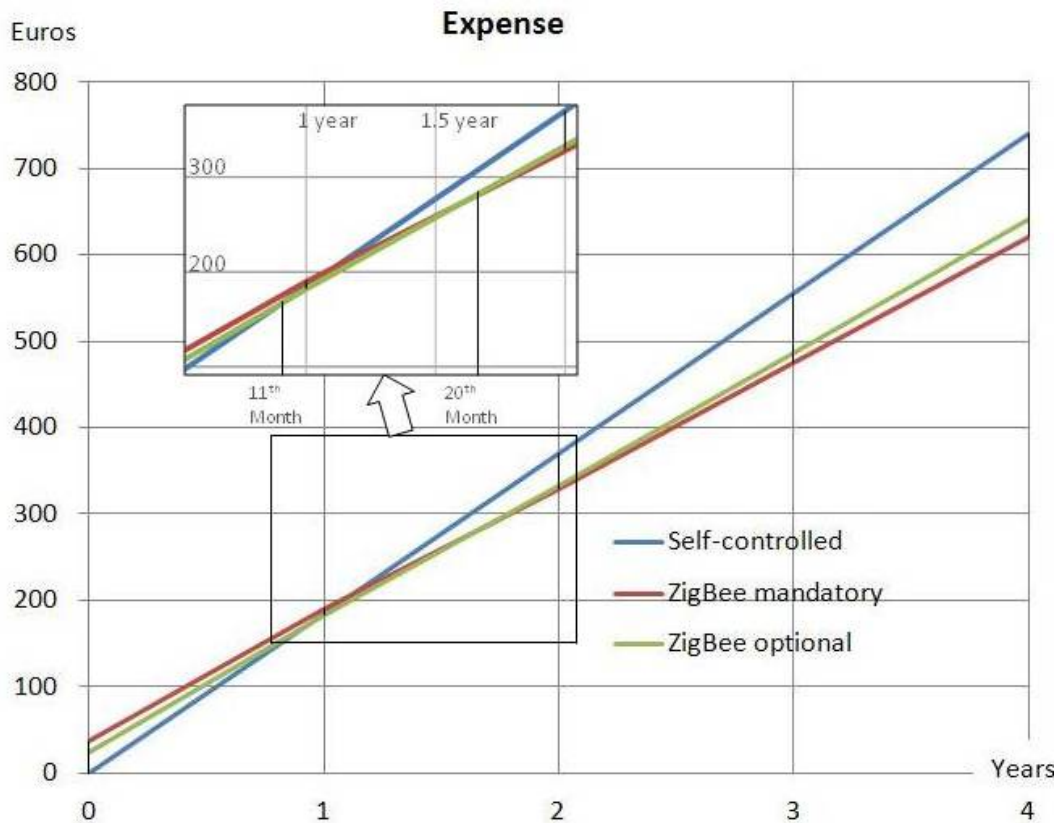

Figure 4.15: Home network cost result

Reducing electricity bills can be a powerful motivation for home network users. At first, extra money must be spent on ZigBee modules. In Figure 4.15, this family uses six ZigBee modules for ZMS and four ZigBee modules for ZOS. However, after one year, the total cost for the OECN solutions are less than the cost for the self-controlled solution. Comparing the two OECN solutions, the ZMS with six ZigBee modules consumes less energy than the ZOS after 1.5 years in our use case. For users who want to have a short term benefit in one year, they should choose the ZOS solution which is the most profitable solution from the 11th month to

the 20th month. Users who want to have a long term profit should choose the ZMS solution which is the most profitable energy saving solution after the 20th month.

4.4 Conclusion

In this chapter, we have proposed energy-saving solutions based on an Overlay Energy Control Network. This proposition aims to reduce the energy consumption of the home network devices, and thus reduce the environmental impacts caused by the carbon footprint from electricity generation. The proposed Overlay Energy Control Network provides two efficient energy-saving solutions for home network devices. Compared to the two OECN solutions, the device self-controlled energy solution is the solution that saves the least energy. The ZMS, which is based on a complete OECN, is more efficient in terms of energy saving, but it has a relatively high delay compared to the two other solutions. The ZOS, which is based on a partial OECN, is a good trade off between the energy gain and delay. The ZOS has at the same time energy efficiency and low delay. Our ZMS is proven to be an effective energy-saving solution. In addition, the ZOS is proven to be a good trade-off of energy saving and delay. This trade-off depends first and foremost on the selection of non-ZigBee devices and on the time each device takes to change state.

The future challenge will lie in combining ZMS and ZOS solutions for a certain amount of time, depending on our knowledge of usage or user behaviour. In the second phase, we plan to achieve better energy gain with minimum delay to assure better quality of user experience.

Chapter 5

A testbed for H0me Power Efficiency System for a Green Network

Contents

| | | |
|------------|---|-----------|
| 5.1 | Introduction | 63 |
| 5.2 | The testbed of H0me Power Efficiency system . . . | 64 |
| 5.2.1 | The architecture of H0me Power Efficiency System . . | 64 |
| 5.2.2 | The procedure of H0me Power Efficiency system . . . | 67 |
| 5.3 | Implementation of the H0me Power Efficiency System | 70 |
| 5.3.1 | The software of H0me Power Efficiency system | 70 |
| 5.3.2 | Use cases shown in the home network | 72 |
| 5.4 | Conclusion | 75 |

5.1 Introduction

In previous chapter, we presented an overlay power control network, the simulation results show us it is energy efficient to have a such home power control system. Therefore, in this chapter, we implemented a testbed of the H0me Power

Efficiency system. In this system, we have not only deployed a low power overlay control network for the devices which are adaptive to plug in ZigBee modules. We also introduce the technology UPnP Low Power (see Section 2.5.2) for the device which couldn't have a plugged ZigBee module. These two controlling choices in our testbed provide different technologies for different devices needs in the home system.

The integral system is a typical home network environment which provides varying services like browsing on the Internet, video sharing and etc. In order to cope with the problem that the devices are not used in an energy efficient way, our testbed will turn on the devices for the purpose of establishing and providing the service. At the end of the services, the power management will check the possibility to turn off the devices in order to avoid the unnecessary energy consumption.

The rest of the chapters are organized as follows: Section 5.2 presents the architecture of the system and the composition of software modules. Section 5.3 details the implementation of the H0me Power Energy system and discusses the performance of the demonstration in a typical 4 members family. At the end of the chapter, we synthesize a conclusion and gives future perspectives in Section 5.4.

5.2 The testbed of H0me Power Efficiency system

5.2.1 The architecture of H0me Power Efficiency System

In the last decade, there has been a proliferation of connected devices in the home environment. The number of connected devices has led to a sharp increase in energy consumption. As presented in the Section 2.2, a home network is a complex environment which can contain several different types of devices: Set-Top Box (STB), Home GateWay (HGW), Network Attached Storage (NAS), laptop, Power Line Communication (PLC) plugs and so on; which are interconnected with different kinds of connections: Wi-Fi, Ethernet and power line communication.

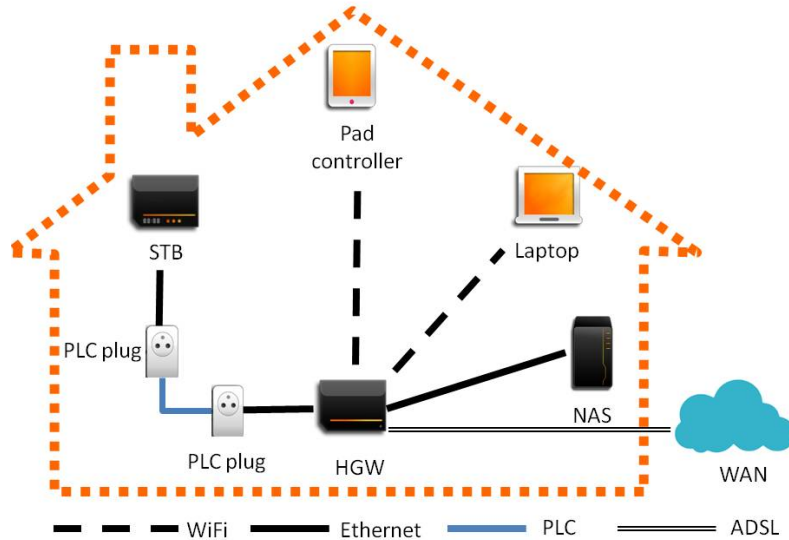

Figure 5.1: Home network environment

Based on this typical home network environment shown in the Figure 5.1, the HHome Power Efficiency System is designed to be energy efficient and adaptive for each device in this system.

In our testbed, shown in Figure 5.2, we have the HGW as the coordinator of the home network. Because it is the entry to the WAN for the LAN. And HGW is also the portal of the LAN for the others in WAN which want to communication with one device in the local area network. Therefore, it is obviously that information or services requests will be collected by the HGW, and the HGW will take charge of the service requests to control the devices. On the HGW, we implement a ZigBee coordinator and UPnP Low Power at the same time for the control purpose. The STB could provide services like IPTV, TV program replay. Since the STB is far from the HGW, the connection between HGW and the STB is assured by a pair of PLC plugs. In order to collect the power status and services requests of the STB and PLC plugs, they are equipped with ZigBee modules. The ZigBee modules are capable to send the information, services requests to the HGW and receive the control message from the HGW.

The laptop has multiple functions like check mails, view a film, store the files

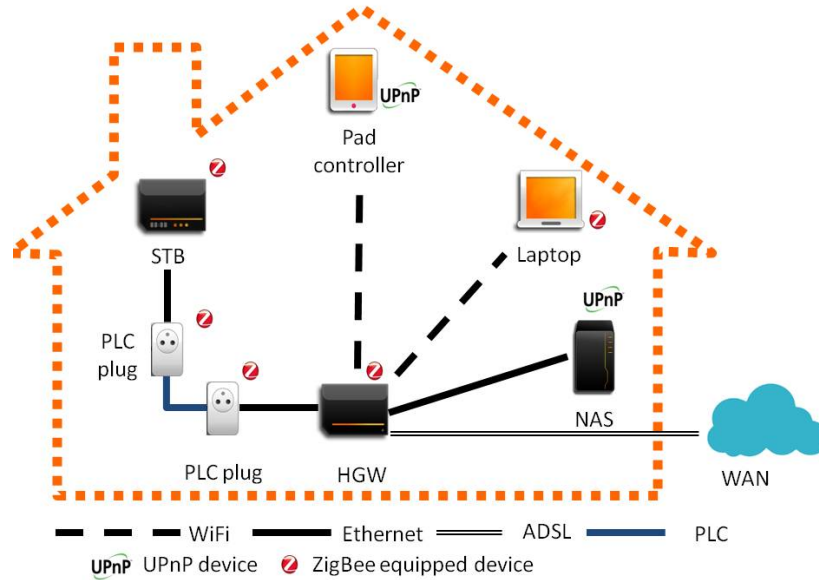

Figure 5.2: Architecture of HOMe Power Efficiency System

and etc. It often has both Ethernet and WiFi interfaces which provides the wired and wireless connections but continue to consume all the time while the Ethernet interface or WiFi interface is on. In some cases, although Ethernet interface or WiFi interface is on, user doesn't need to transfer data. Thus, we implement a ZigBee module to send service requests and receive control messages from the HGW. With the help of the ZigBee module, the connections could be off while there is no communication needs.

The NAS is often used to store the photos, audio video files in the home network. We choose to control the NAS by a low power UPNP interface. Since the main connection of a NAS is always Ethernet interface, it is possible to wake the NAS up by the UPNP low power wake up pattern like Wake On LAN. As presented in the Section 2.5.3, the interfaces could be set in the operation mode in which it is shut down but able to wake on when a magic packet arrives at the interface.

The tablet is a nomad device which provides a comfortable flexibility for the users. Users could browse on the Internet, view a video or check their mails everywhere at home under the WiFi coverage. Since the tablets are always designed

to be portable and easy to move with, we choose to implement application that user could monitor and control the integral home network system.

These devices collaborate in the home network to provide multiple services. For example, IPTV, audio video sharing, download files, and so on. After presenting characteristics of devices and the way of collecting data from these different devices and controlling these different devices, we will detail how the system manage these devices to provide an energy efficient home network environment.

5.2.2 The procedure of HOMe Power Efficiency system

In the previous section, we have discussed the architecture of the HOMe Power Energy system which is composed by different devices with different characteristics. In this section, we emphasize on the procedure of the system and we illustrate how the system works by exchanging messages.

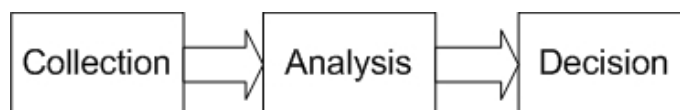

Figure 5.3: The procedure of the HOMe Power Efficiency System

Generally, the HOMe Power Energy (HOPE) system works in three steps to manage the network environment as shown in Figure 5.3. The first step is the collection of the information from the devices. The information includes the power status of the devices, the services request from the devices and also the device dependencies. Device dependencies is the dependency of all cooperating devices for one collaborative service. Thus, after receiving a service request, in the second step, the HOPE check the power status of each corresponding network infrastructures for requested devices. We implemented a network topology module for HOPE to verify which network infrastructure provide network connection to each device. Then HOPE system sends the power management decisions to the devices in the third step by using different low power technologies.

To be more concrete, Figure 5.4 shows the procedure how the HOPE system works. The system starts by launching a daemon process which checks regularly whether there is a service request. Once HOPE system detects a service

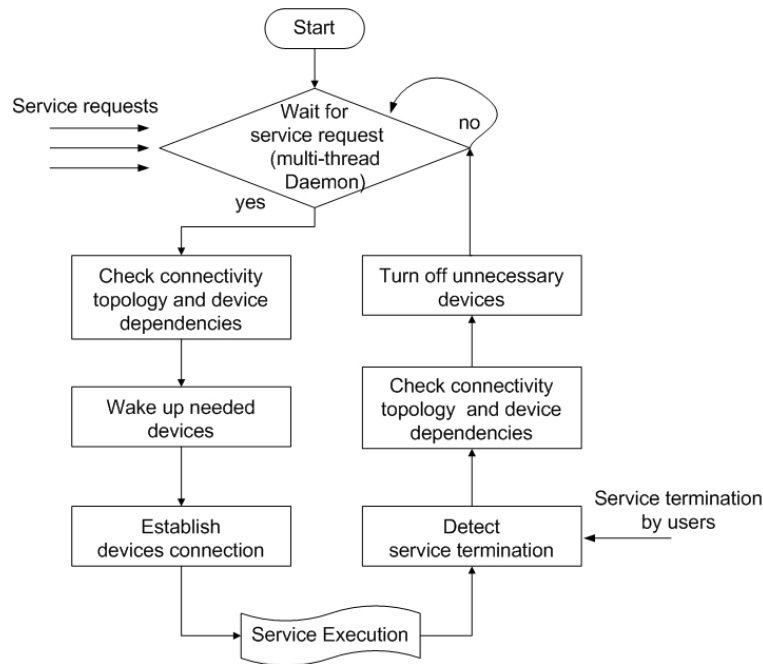

Figure 5.4: The algorithm of the HOme Power Efficiency system

request arrived from ZigBee or other communication interfaces, it firstly check the connectivity for the service. This means to check the high data rate transmission network connection(Ethernet, WiFi or PLC) established among all requested devices. Then HOPE system will check the device network connectivity dependency for the this requested service. It means to turn on all needed devices for this collaborative service. The control messages which turn on the connection interfaces and the devices may be sent by ZigBee or UPnP low power protocols. After all needed devices are turned on and the connection among these devices is established, and user could start to enjoy the service.

At the end of service, user could turn off one of the collaborative devices to announce the end of the service to HOPE system. The system then checks if it maintains the connectivity and devices for other services. In the case that the connectivity or devices are no longer needed by other executing services, a control message is sent to turn off unnecessary devices or interfaces in order to reduce unnecessary energy wastage.

In order to better understand the system, an example of the IPTV service

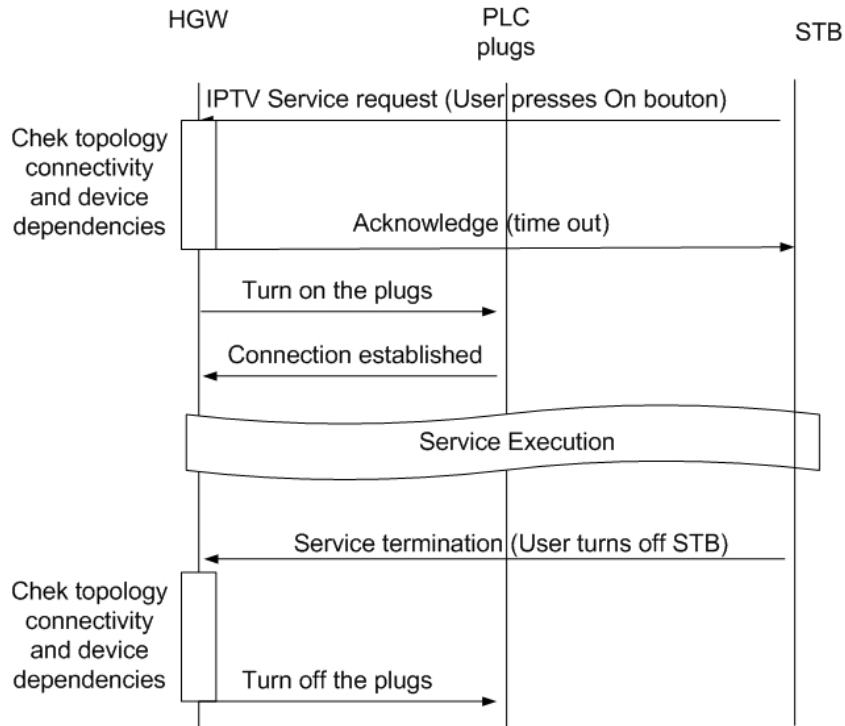

Figure 5.5: The exchanged messages of the IPTV service

is shown in Figure 5.5. In this example, we assume that all devices are used in an energy efficient way and they are all turned off after last service. At the beginning, user turns on his STB by using remote control to choose the IPTV service, the IPTV request is sent by the ZigBee module to HOPE system which is located in the HGW. Then the HGW checks that in order to establish the connection from STB to HGW, it should turn on the network infrastructure: a pair of PLC plugs. After the connection is established from STB to HGW and PLC plugs are turned on, user could watch the IPTV programs.

After watching the IPTV program, user decides to turn off the STB to go to sleep. This action provokes a service termination message to HOPE system. The HOPE system checks if the PLC plugs are needed by other devices. In this home network topology, only the STB is connected to the PLC plugs. Thus, while the STB is turned off, there is no need to maintain the PLC connection between STB and HGW. HOPE system sends a control message to turn off the pair of PLC plugs.

In this section, we have described the architecture of the HOMe Power Efficiency System and also the procedure of the HOPE management. In the next section, we will present the implementation of the system.

5.3 Implementation of the HOMe Power Efficiency System

5.3.1 The software of HOMe Power Efficiency system

Since the devices have different characteristics, we implement different software components in each device, as illustrated in Figure 5.6.

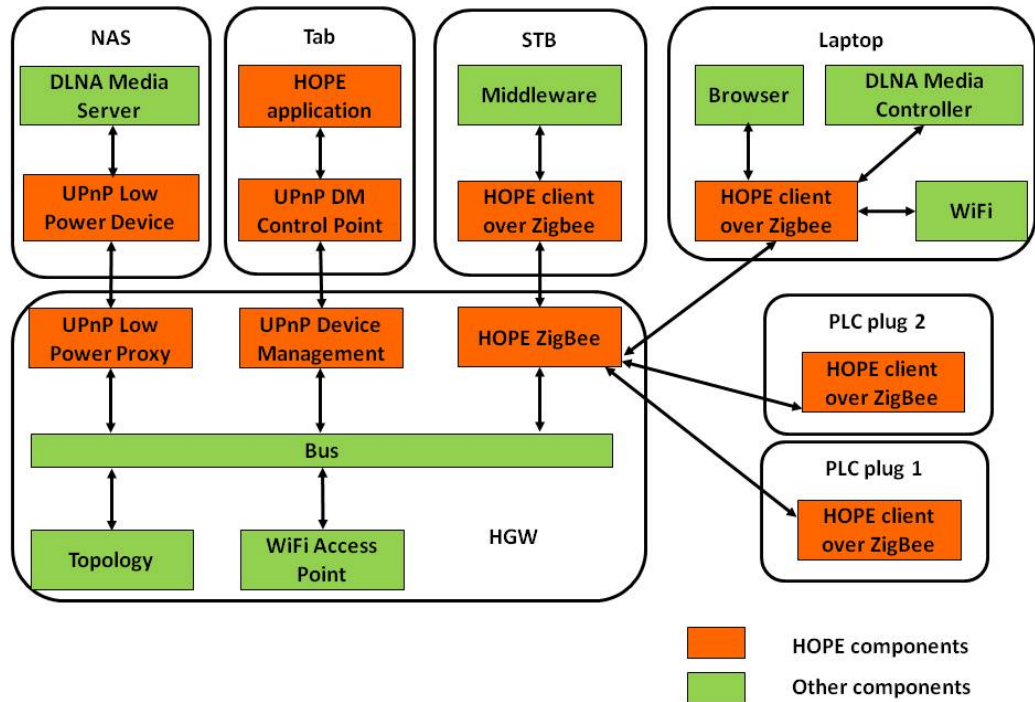

Figure 5.6: The software components of HOMe Power Efficiency System

In the HGW, we implemented 3 modules which don't exist originally in the HGW: UPnP low power proxy module, UPnP Device Management and the Zig-

Bee coordinator. The UPnP low power proxy helps the HOPE to control UPnP low power devices. HOPE ZigBee coordinator could communicate with ZigBee enabled devices. In order to control the devices, the UPnP device management store the whole data model of the devices, this information could be retrieved by using the UPnP device management control point (tablet). Based on the information obtained from UPnP lower power proxy, UPnP Device Management and also the ZigBee coordinator, HGW can control the power status of each device. If there is no service executed, the WiFi component of the HGW is turned off which reduces the unnecessary energy consumption. Once there is a service request from UPnP Low Power proxy or UPnP device management or ZigBee coordinator, the connections are established for the service.

In the PLC plugs, we implement a HOPE client over ZigBee. As explained in the Section 2.4.2, this ZigBee is an end device which exchange messages directly with the ZigBee coordinator via ZigBee network and the PLC plugs via the General-Purpose Input/Output (GPIO) interface. While the ZigBee client receives a control message, it could send turn on or turn off messages directly to PLC plugs.

There is also a ZigBee client implemented on the laptop, which interacts with the DLNA controller and the web browser to intercept the service request from the laptop. If there is a service request detected, ZigBee end device sends this service request to HGW which activates the WiFi component on the laptop and the WiFi component on the HGW.

On the STB, the HOPE client is also implemented to communicate with the middleware of the STB. While there is a service request, middleware sends the information to HGW by ZigBee network. On the contrary, when the HGW desires to control the STB, it could also send the control message by ZigBee network.

The NAS could be turned on or turned off by UPnP Low Power technology. As presented in the Section 2.4.2, the NAS could be put into sleep mode or turned off by the UPnP Low Power, and waked up by Wake On Lan.

On the tablet, we implemented a UPnP device management which could retrieve the information of all devices from the HGW to show on the HOPE android application on the tablet. Thanks to the HOPE application and UPnP device management, user can monitor the device power status and send the control

A testbed for H0me Power Efficiency System for a Green Network

message from the application.

With all different software modules implemented in different devices, the testbed is shown in Figure 5.7. This photo is taken from the laboratory, on the left side, we can see the STB connected to HGW by a pair of PLC plugs. In the middle, we can find the HGW. Laptop and tablet are connected to HGW by WiFi. On the right side, the NAS is connected to the HGW by Ethernet.



Figure 5.7: The testbed of the H0me Power Energy system

5.3.2 Use cases shown in the home network

We have played the following use cases on the implemented testbed to demonstrate the energy efficiency and service facilities.

In all these use cases, the home network devices can communicate with the HGW via WiFi using the UPnP DM protocol. The UPnP Device Management protocol publishes a data model that aggregates device information from the

A testbed for H0me Power Efficiency System for a Green Network

HGW coordinator. It allows the user to monitor the following informations for each device:

- Name
- Power status (active, active but disconnected from the network, standby, off)
- Power consumption
- Wake-up time
- IP address
- MAC address
- Connection type (Ethernet or WiFi)
- Actions available (standby, wake up, turn off)

We present two use cases that we played on our testbed:

1. Browsing on the Internet from laptop. This use case starts by opening a web browser from the laptop. The WiFi components on the HGW and laptop were both off since there was no data exchanged by the WiFi. The laptop detects that user needs the WiFi for the web browsing, it sends a service request by ZigBee client to the HGW. HGW coordinator receives the request and checks the topology module to determine which is the last connection mode for laptop: WiFi, Ethernet or PLC. Topology module indicates that laptop's last connection mode is WiFi so the HGW coordinator active the WiFi component on the HGW. The coordinator then sends to the laptop the information of waiting delay. This information indicates the delay that laptop needs to wait before the WiFi network is established. Meanwhile, the laptop also activates its WiFi interface. In addition, the laptop's browser waits until the WiFi connection is established.
2. Establishing and termination of the service IPTV.

A testbed for HHome Power Efficiency System for a Green Network

This use case is the example that we explained in Section 5.2.2, the user presses the “POWER” button on the STB remote control to start his STB. The action of turning on the STB is intercepted by the middleware, then send to HGW through the ZigBee. The HOPE system firstly changes the power status of the STB from off to on, then it turns on the PLC plugs immediately to provide the network connection for the STB. After the wake up time, user could watch the IPTV on his STB.

At the end of the service, user puts his STB into sleep mode by pressing the “POWER” button on the remote control. The action is intercepted and transmit to the HGW. HOPE coordinator receives this information and check the topology module to determine which network infrastructures are between TV decoder and Livebox. The topology module indicates that the PLC plugs provide the connection and they are not used by other devices, the coordinator decides to turn them off by sending them a ZigBee control message.

In these use cases, all devices in the LAN have implemented the economic mode. This “economic” mode allows the user to put the device into the sleep mode or turn off all of his devices while they are not in operation. By activating this mode at the service end, the user triggers the extinction of PLC plugs and turn off laptop, STB and the NAS. The power consumption of the devices are noted in TABLE 5.1. We take an example where HGW is turn on all day long, and other devices are turned on during service times with one or more startups times. In order to measure the energy efficiency performance, we compare this utilization configuration with home network devices which are turned on all day long.

If these home networked devices stay in power on mode one day, they will consume 1772 Watt. We compute the energy consumption of the home networked devices under the control of the HOPE system in this example configuration. All devices consume 554 watt when they are used in an energy efficient way. The energy percentage gain could be $(1772 - 554)/1772 = 68.73\%$. The energy gain is the total energy gain of several devices in this home network.

Table 5.1: Power consumption (Watt hour), Service Time: ST (hours) and Number of startups parameters of our testbed devices

| Device | Working | Away | Sleeping | Soft-off | ST | Startups Nb |
|--------|---------|------|----------|----------|----|-------------|
| HGW | 7.7 | 6.8 | NA | NA | 24 | 0 |
| STB | 20.3 | 20 | 18.8 | 0.4 | 6 | 6 |
| NAS | 30 | 26 | 3.5 | 2 | 3 | 4 |
| Laptop | 21.5 | 12.5 | 7.9 | 0.6 | 3 | 3 |
| PLC | 9.3 | 8.6 | NA | 0.4 | 6 | 6 |

5.4 Conclusion

In this chapter, we presented the testbed of H0me Power Energy system. Due to the problem that devices are not used in an energy efficient way, the HOPE system is proposed to reduce the unnecessary energy consumption. In the real home network use cases, we not only demonstrate the energy efficiency but also the ease of use of our solution. The implemented testbed shows that HOPE system could drastically reduce the consumption of home networks. Users can benefit from enriched home multimedia services and efficiently manage their power consumption. More over, user could view and control the the power consumption of his network from a control tablet.

In this testbed, the power control is no more a simple control on one device, we need to coordinate several devices to work together for a collaborative service. Since we observe collaborative services is provided by several devices, the next chapters will study the reduction of power consumption by only using necessary device functional blocks in order to further reduce the total power consumption of the home network.

A testbed for H0me Power Efficiency System for a Green Network

Chapter 6

Collaborative power management

Contents

| | | |
|------------|---|-----------|
| 6.1 | Introduction | 77 |
| 6.2 | Architecture of the collaborative power management | 78 |
| 6.2.1 | Power management | 78 |
| 6.2.2 | Home network connected devices | 80 |
| 6.2.3 | Low energy communication overlay network | 81 |
| 6.3 | Energy and delay models | 81 |
| 6.4 | Conclusion | 83 |

6.1 Introduction

In previous chapters, we presented a low power overlay energy control network which is more energy efficient than traditional home network and we also presented the testbed of the implementation of an overlay energy control system. In this chapter, we will present our collaborative power management, the device control via the low power control network and the modeling of the home network environment. Later in chapter 7 and chapter 8, we will apply an auto-learning algorithm and power-delay trade-off algorithm on this collaborative power management. Our main contributions in this chapter are the modeling of the collaborative power management and modeling of devices which are refined to the

functional blocks. In this chapter, we also give the notations for the energy and delay calculation models. This chapter is organized as followings: we present the power management in the section 6.2. The device notation and energy delay models are detailed in the section 6.3. At the end of this chapter, we conclude our modeling in the section 6.4.

6.2 Architecture of the collaborative power management

In this section, we detail the collaborative overlay control system, as shown in Figure 6.1, which is composed of the power management system, the collaborative home network connected devices, and the low energy overlay control network.

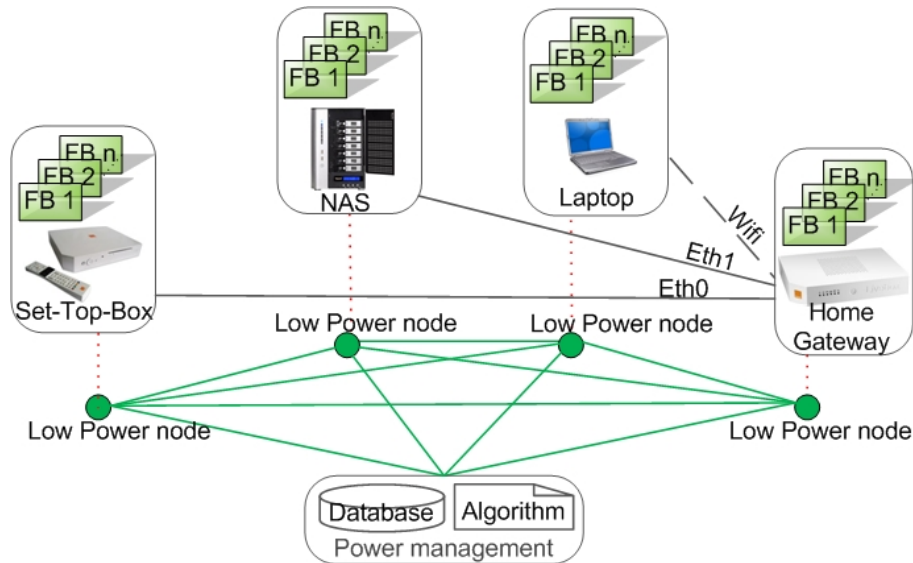

Figure 6.1: Collaborative home network service management

6.2.1 Power management

Power management comprises a database and a decision algorithm entity. The database is used to store records of user habits when they use services. For example, one family often turns on the TV at 8 o'clock to watch the news by

using the IPTV service. When one service is requested for the first time, the database gathers the information relating to the user request services in order to learn the habits of this family and the information relating to the family user reaction. After the first service launch, the power management improves the information that how users use this service in each service execution. According to the information collected by the system, the power management controls the device with fine granularity. The granularity of the control is said to be “fine” because the control can turn on/off the functional blocks that are necessary for the collaborative service at the point at which they are requested. We assume each home network collaborative service involves one or more devices that cooperate together to meet the service demand of the family. In reality, the collaborative service requests different functional blocks in these devices to work together for satisfying the service demand. Thus our power management helps the user to use the service by collaborating the necessary functional blocks in one or more devices.

A typical collaborative UPnP audio video service pattern within four devices is shown in Figure 6.2. The whole video sharing service is represented by the blue points in this Figure. The user uses their UPnP Control Point (laptop) to search for a film, which is stored on the UPnP Media Server (NAS) in order to watch it on the UPnP Media Renderer (STB). Each service occurrence requires different Functional Blocks (FB) in different devices. The user firstly needs the connection between their laptop and their NAS to be guaranteed by the HGW. Then, when the user has found the film saved on the NAS, the STB should be turned on in order to play the film. The content directory (FB1), connection manager (FB2), transfer server (FB3) functional blocks in NAS and the video stream decoder (FB1), display interface (FB2), authentication (FB3) and transfer client (FB4) functional blocks in STB are requested. The HGW provides the connection block during the entire service.

This typical UPnP AV use case requires different connected devices to participate at different points in the service. When the user decides to start the service, according to the information saved about this service, the power management sends control messages to each device as they are required. The requested information can be pre-loaded by the user in the power management, or by a process

Collaborative power management

of auto-learning in the power management. With the collaborative system, only the required components are turned on, and the components which are no longer needed when the service is terminated are turned off.

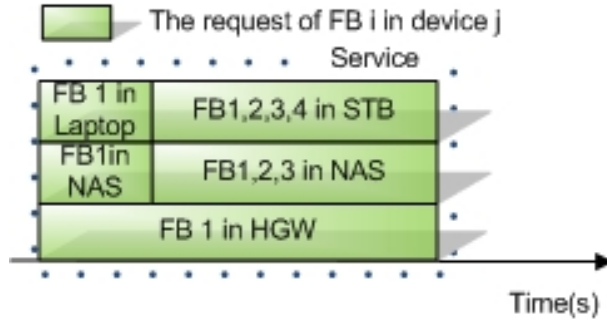

Figure 6.2: A service pattern example

6.2.2 Home network connected devices

In our proposal, we not only assume that collaborative services involve several devices, but also that each device is composed by one or more functional blocks. It is necessary to detail how one functional block pattern works in one device during one service as shown in Figure 6.3. If the power management decided to turn on the functional block before the request of the service, as shown in Figure 6.3(a), FB has three phases: starting, idling and operating. The starting phase defines the necessary starting time that begins when the functional block is turned on (t_{dec_on}) and lasts until the functional block is available ($t_{available}$). Then FB may be in the idle phase during a period of no activity until it is requested by a service. Once this FB is requested ($t_{request}$), it could execute the operation immediately since it is already operational. On the contrary, as shown in Figure 6.3(b), the request of this functional block may happen before this FB is available. FB will begin the service execution immediately (t_{dec_on}) upon becoming available ($t_{available}$) without having an idling phrase. In this case, the starting phase becomes a waiting delay before executing the service operation.

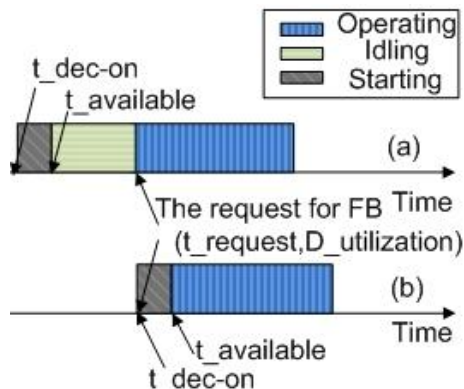

Figure 6.3: Functional block is turned on (a) in advance (b) by the service request

6.2.3 Low energy communication overlay network

We assume the use of a low energy communication overlay network: On each home network device, we propose an overlay low energy node by considering the characteristics of the device. These low power nodes form a low power overlay control network. The control message can be sent via ZigBee, Bluetooth Low Energy (BLE) or an UPnP Low Power (UPnP LP) network, depending on the capacity of the device. For example, it is possible that a new generation tablet will be equipped with BLE instead of having to add a ZigBee dongle to this tablet. The power consumption of a ZigBee module or BLE chipset is about a few milliwatts, which is much less than that of an Ethernet or WiFi network card, which consumes about 1.5 Watts. In our system, we assume that the overlay power control messages will be sent by a ZigBee or BLE module in order to ensure a low-power and always-on network. We assume that the multimedia data from services launched by users are exchanged over traditional home network (e.g. through Ethernet or Wifi network cards), enabling high bit rate exchange.

6.3 Energy and delay models

The notation of the parameters is described in the Table 6.1. The energy consumption of one service occurrence can be calculated using the following formula (6.1): where the $D_{on_{i,j}^k}$ is the on duration of the functional block in formula (6.2),

Collaborative power management

Table 6.1: Collaboration power management notation summary

| Notation | Definition |
|------------------------|---|
| Nb_dev | The number of devices in the home network |
| Nb_FB | Number of available functional blocks in one device |
| $FB_{i,j}$ | j^{th} functional block in i^{th} device. |
| Nb_ser | Number of service occurrences. |
| $service_k$ | k^{th} service instance |
| $P_FB_{i,j}$ | Power consumption of the j^{th} functional block in i^{th} device. |
| $t_request_{i,j}^k$ | The moment that one service request j^{th} functional block in i^{th} device in k^{th} service instance. |
| $t_available_{i,j}^k$ | The moment that j^{th} functional block in i^{th} device in k^{th} service instance is available |
| $t_dec - oni, j^k$ | The moment that power management decides to turn on j^{th} functional block in i^{th} device in k^{th} service instance |

which is composed of the starting phase, the operating phase of $FB_{i,j}$ in $service_k$ and the idling phase. The starting phase is the necessary period to launch a FB of one device. The utilization phase depends on the service requirement. The idling phase may be null when the service request $t_request_{i,j}^k$ is earlier than the FB being available at $t_available_{i,j}^k$.

$$E_k = \sum_{i=1}^{Nb_dev} \sum_{j=1}^{Nb_FB} P_FB_{i,j} \times D_on_{i,j}^k \quad (6.1)$$

$$D_on_{i,j}^k = D_starting_{i,j}^k + D_idling_{i,j}^k + D_operating_{i,j}^k \quad (6.2)$$

The $Delay_k$ is the total waiting time for the $service_k$, described in formula 6.3. There are two cases: if the FB is available before the arrival of the service request, there is no waiting time for the user. Thus, the delay is null in this case. Otherwise, if the service request arrives before the FB is available, the waiting time is the period from the $t_request_{i,j}^k$, to the $t_available_{i,j}^k$. The delay is the

difference between these two moments.

$$\begin{aligned}
 Delay_k = & \\
 & \sum_{i=1}^{Nb_dev} \sum_{j=1}^{Nb_FB} \begin{cases} 0, & (t_request_{i,j}^k < t_available_{i,j}^k) \\ D_starting_{i,j}^k, & else \end{cases} \quad (6.3)
 \end{aligned}$$

After having described our service patterns, functional block patterns, and energy and delay calculations, we will apply our propositions and other power management systems to the models in the next chapters.

6.4 Conclusion

In this section, we present the collaborative power management by illustrating the power management, home network connected devices and the low energy communication overlay network. In this section, we also describe our energy and delay models that we use in the Chapter 7 and Chapter 8. Based on the collaborative power management, we firstly propose a refined overlay power management algorithm and an auto-learning algorithm and we analyze the simulation results in Chapter 7. Afterwards, we propose another power-delay tradeoff algorithm and we analyze the simulation of this algorithm in the Chapter 8.

Collaborative power management

Chapter 7

Collaborative power management with refined overlay algorithms

Contents

| | | |
|------------|--|------------|
| 7.1 | Introduction | 86 |
| 7.2 | Refined Overlay Power Management & Refined Overlay Auto-Learning Power management | 87 |
| 7.3 | Power Management Modeling | 88 |
| 7.3.1 | User control power management | 88 |
| 7.3.2 | PCE power management | 89 |
| 7.3.3 | ROPM & ROAL power management | 90 |
| 7.4 | Setup of Simulations and Analysis of Results | 92 |
| 7.4.1 | Setup of simulations | 92 |
| 7.4.2 | Analysis of results | 93 |
| 7.5 | Conclusion | 102 |

7.1 Introduction

In the previous chapter, we present the collaborative power management and the models of the device and the collaborative service. In this chapter, we focus on the power management algorithm which analyze and learn the collaborative services and take into account the users quotidian behaviors. As mentioned in the Chapter 1, the problems we will study in this chapter are:

- The connected device provides multiple functions. As we have mentioned before, connected device, like laptop, can serve multiple services. In different services, different functional blocks are used in one laptop depends the services. For example it may be used on the web surfing by WiFi or it may be used to share a file with another device by Bluetooth. Different functional blocks are requested in one device while it executes different services.
- User plays an important role in the home network environment. For the user, it is important to provide a more energy efficient home network environment for users and having a minimum impact on the user experience. User behavior is the way how the user uses their devices, at what time, in what occasion etc. This is an important information for the device energy control. Thus, with this information, the energy control should use this information to become more adaptive and transparent for the user without changing their quotidian behavior.

This chapter is organized as follows: In Section 7.2, we present the refined overlay power management and the auto-learning power management. In Section 7.3, we describe the service and functional block patterns by considering the delay and energy models. In Section 7.4, we describe the models of power management. At the end, we draw the conclusion and the future perspective in Section 7.5.

7.2 Refined Overlay Power Management & Refined Overlay Auto-Learning Power management

Our first proposition is the Refined Overlay Power Management (ROPM). Based on collaborative power control management, this proposal takes into consideration the fact that the power management system already has pre loaded information about the different services. The service information could be loaded manually by users in advance. This information indicates the average request time of each functional block in one service. The request time of a device functional block is the time between the beginning of the service until the time when the functional block is requested.

However the registered request time of each functional block is an average value of user behavior for this service, and it cannot be exactly the same as actual user behavior. Indeed, the ROPM algorithm may turn on the functional blocks early or late. If the ROPM turns the functional blocks on early, the functional blocks will stay on until actually needed. Otherwise, if the control decision is too late compared to the actual need, the functional blocks will be turned on immediately after the ROPM detects the request by using technologies like *tsocks*. *Tsocks* is a library which transparently enables interception of outgoing messages on Linux like operating system. If the ROPM detects that the functional blocks are required, it will turn the functional blocks on immediately and ignore the control decision which will be too late.

Our second proposed solution is the Refined Overlay Auto-Learning power management (ROAL). It is not always possible to assume that the power management has an existing and perfect knowledge of user behaviors or device and service usages. Thus, it is difficult to predict the time when a functional block should be turned on.

Therefore, we propose the Refined Overlay Auto-Learning power management (ROAL), which is able to learn when to turn on the functional blocks in each collaborative service. When a service is launched for the first time, the ROAL turns on all the functional blocks which are necessary for the first service instance. Dur-

ing service execution, the ROAL gathers the information of when the functional blocks are actually requested, compares this gathered value to the saved information relating to former executions of this service, and calculates the average request time for each functional block.

7.3 Power Management Modeling

In this section, we firstly describe our two proposals and two usual solutions as comparisons.

7.3.1 User control power management

We assume that without the help of technology, users control all their home network devices manually and individually for energy saving: they turn the device on when they need it and they turn the device off at the end of the utilization. There are three main inconveniences:

1. The user needs to wait for the functional block starting time (which includes component lighting time, booting time, etc.)
2. When the device is turned on, all included $FB(1 \text{ to } Nb_FB)$ are turned on integrally.
3. Devices are controlled manually by users each time when they need to be turned on and turned off.

Formula (7.1) defines the decision of turning on the $FB_{i,j}$ in $service_k$ made by the user control power management.

$$User\ control : t_{dec_on_{i,j}^k} = t_{request_{i,j}^k} \quad (7.1)$$

The service is requested at the same moment that the user decides to turn the device on. Since $FB_{i,j}$ is always available after the service request, the duration $D_{on_{i,j}^k}$ of the $FB_{i,j}$ is composed of $D_{starting}$ and $D_{utilization}$. At the end of the service, the user will turn off the device manually. As we just explained, the

main inconveniences is that it is not automatic and could be tedious for users. Secondly, the device is turned on integrally despite all functional blocks are not required. Thirdly, users may not think ahead and therefore have to wait for the starting time of each FB before using them. Our proposition does not have these three major drawbacks.

7.3.2 PCE power management

The PCE [47] power management will not turn on all the functional blocks of a device, but all blocks that are required are turned on at the beginning of the service. Formula (7.2) defines the PCE decision to turn on all necessary $FB_{i,j}$ at the beginning of the service.

$$PCE : t_{dec.on}_{i,j}^k = t_{request}_{i=1,j}^k \quad (7.2)$$

We take the same example that we explained in the Section 6.2.1. Figure 7.1 shows that FB 1, 2, 3, 4 in STB and FB 1, 2, 3 are requested later in the UPnP video sharing service. In spite of the different request times, the PCE turns these later requested functional blocks at the beginning of the service. So these functional blocks in STB and NAS stay in a no-activity state until they are actually requested. The only delay of the PCE power management is the starting time when first requested devices are turned on. The main drawback in the PCE solution is that we can't achieve the maximum energy gain.

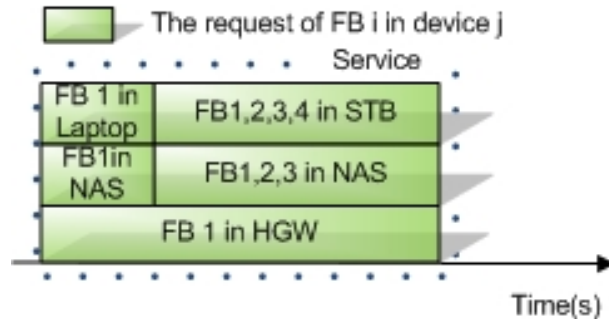

Figure 7.1: A service pattern example

7.3.3 ROPM & ROAL power management

Based on the collaborative power management, we describe our two propositions, namely ROPM and ROAL. We assume that ROPM has knowledge of the average request time of each functional block in the collaborative service. On the contrary, ROAL learns the request time of each functional block j of device i . that are required in the service execution. In formula (7.3), we describe the learning of the request time of each functional block. We calculate the average request time each time when the functional block is requested during the Nb_ser service instances.

$$t_request_learned_{i,j} = \frac{\sum_{k=1}^{Nb_ser} t_request_{i,j}^{k-1}}{Nb_ser} \quad (7.3)$$

Formula (7.4) describes decisions of the ROPM in the case that power management doesn't detect a functional block request. At the beginning of the service, the firstly used functional blocks are turned on upon the service beginning moment. If the refined power management does not detect a request of $FB_{i,j}$, it will turn on $FB_{i,j}$ based on the knowledge of average request time $t_request_preload$ and the device starting duration.

$$ROPM : t_dec_on_{i,j}^k = t_service_arrival + t_request_preload_{i,j} - D_starting \quad (7.4)$$

In the case that power management detects a functional block request, ROPM turns on the requested functional blocks immediately despite the decision is too late.

Similarly to the ROPM, the first used functional blocks are turned on upon the service beginning moment. Lately, ROPM decides to turned on the lately request functional blocks. Formula (7.5) describes decisions of the ROAL in the case that power management doesn't detect a functional block request.

$$ROAL : t_dec_on_{i,j}^k = t_service_arrival + t_request_learned_{i,j} - D_starting \quad (7.5)$$

In the case that power management detects a functional block request, ROAL turns on the requested functional blocks immediately.

There are always two cases when the ROPM or ROAL control the devices.

1. First case: power management decision is in advance comparing with the service request. The perfect condition is that ROPM and ROAL decisions are just in advance for the device starting time. The time when the functional block is available for a service is the moment when the functional block is requested. In this case, we minimize useless energy consumption and users do not need to wait for its service. The functional blocks are ready before they are requested. More the functional block is turned on in advance, more it consumes energy during the idling phrase. However, they are available immediately while users want their service.
2. Second case: it is also possible that the ROPM or ROAL decisions are too late comparing with the request of functional block. In this case, all requested functional blocks are turned on immediately after the detection of the request of functional block. In this case, the user needs to wait the availability of functional blocks. Obviously, waiting is not convenient for users.

The ROPM is applicable only in the condition that user or manufacture has information of user habits to upload in advance. This is not always possible in the user daily life. Each family or even each user has their own habits. It is hard for manufacture to predict.

Thus, ROAL is more realist for the home power management. At the beginning, the power management has no knowledge of the user habits. More the services are executed by the user, more ROAL gets the information about user habits.

Therefore, in the following sections we firstly present the setup of simulations, then we analyze firstly the service learning capacity of the ROAL. Secondly, we analyze energy efficiency and waiting delay of ROPM and ROAL by tuning different parameters in the simulation.

7.4 Setup of Simulations and Analysis of Results

7.4.1 Setup of simulations

In order to accurately measure power consumption and the waiting delay of each power management solutions, we implemented a typical home network, which was capable of executing a collaborative service in omnet++. The simulation is set up with one repeated service which needs two devices which collaborate together. We have selected this scenraion because its the simplest possible scenario. We assume that the results provided by the simualtion of this scenario will give good insights of the pros and cons of each solution. We assume that a mix of several services will give less radical results, will be more difficult to analyze and are longer to obtain. The service pattern is described in Section 6.2.1. The parameter values are given in Table 7.1. We recall the differences of our ROPM and ROAL propositions with User control and PCE power managements:

User control power management: We take a user who is mindful of energy conservation. This user turns on each device when its service is needed, and turns off each device when the service is no longer required.

PCE: The service is started with all necessary power control elements on at the beginning of the service. They will be turned off when the service finishes.

ROPM: Based on the pre-loaded knowledge of user habits, the functional blocks of each device in the service will be turned on immediately before the FB is needed.

ROAL: The required functional blocks are turned on when the service is requested for the first time. The ROAL learns the value of request time of each functional block during the service execution. After obtaining this information, the functional blocks will be controlled as in the ROPM.

We assume that the duration of the service inter arrival follows an exponential distribution, the mean value of which is $D_{average_service_inter_arrival}$ as shown in formula (7.6).

$$D_{service_inter_arrival} \sim exp\left(\frac{1}{D_{average_service_inter_arrival}}\right) \quad (7.6)$$

Table 7.1: Refined overlay algorithms simulation setup

| Notation | Value |
|--|-----------------|
| Number of devices | = 2 |
| Number of FBs in one device | = 10 |
| Mean value of duration utilization | = 1,000 seconds |
| Starting duration | = 100 seconds |
| Power consumption of one FB | = 10 watt |
| Average service inter arrival time | = 5,000 seconds |
| Simulation repetitions for each experiment | = 10 runs |
| Simulation limit time | = 100 hours |

In formula (7.7), the real value of each request time follows an exponential distribution, the standard deviation of which is $\frac{1}{\lambda_0(i,j,k)}$ and the mean value of which is $t_average_request_time$. The standard deviation $\frac{1}{\lambda_0(i,j)}$ describes the variation of user behavior which may turn on the FB_i, j more or less early or late around the time of the $\frac{1}{\lambda_0(i,j)}$ in the k^{th} service, with a standard deviation $\frac{1}{\lambda_0}$.

$$t_request_time_{i,j}^k = t - \frac{1}{\lambda_0(i,j,k)} + t_average_request_time_{i,j}^k \quad (7.7)$$

$$t \sim exp(\lambda_0(i,j,k)) \quad (7.8)$$

The duration of the utilization of each functional block also follows an exponential distribution, the mean value of which is $D_average_utilization_{i,j}^k$, as described in formula (7.9).

$$D_utilization_{i,j}^k \sim exp\left(\frac{1}{D_average_utilization_{i,j}^k}\right) \quad (7.9)$$

7.4.2 Analysis of results

In this section, we analyze the three sets of simulation results: The first study shows that the power management ROAL is able to learn an approximate accurate request time, when the simulation lasts for a long time. The second study shows

the energy efficiency and delay impact of each power management system, when increasing the average of the request time and variation of user habits. The third study shows the energy efficiency and delay impact when decreasing the variation of user habits with a fixed average request time.

7.4.2.1 Learning time for ROAL

The present study was designed to demonstrate that the ROAL can learn an accurate request time for each requested functional block, when the simulation duration is long enough. The simulation time limit varies from 10 hours to 500 hours, with steps of 10 hours. We carried out 10 runs for each different simulation time limit.

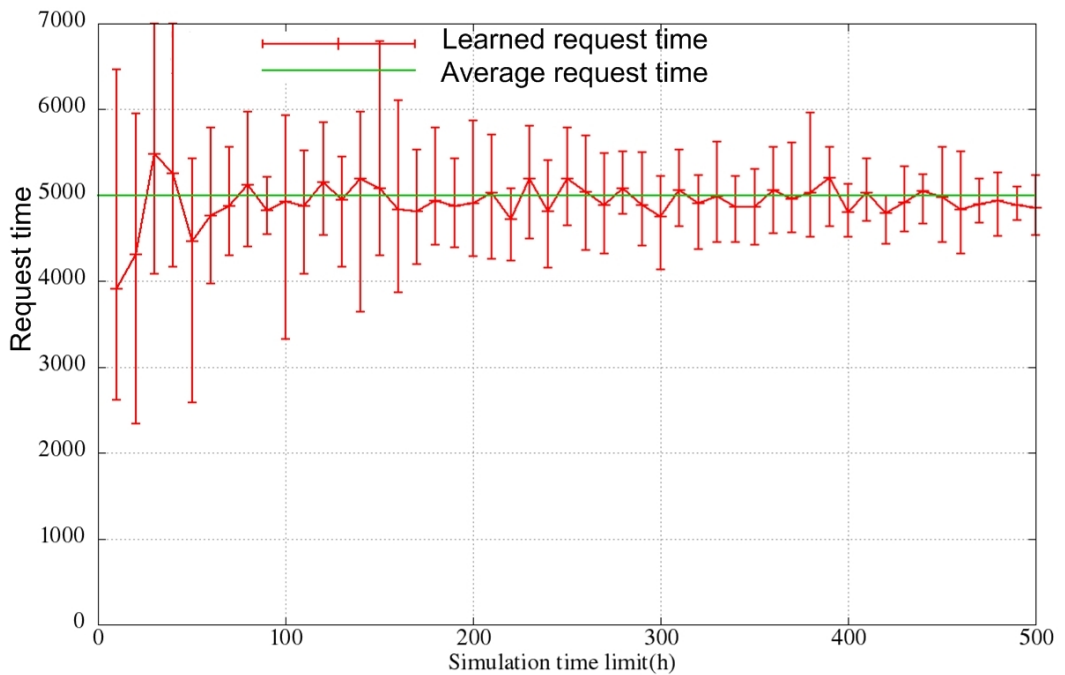

Figure 7.2: ROAL progress the user habits knowledge by increasing the simulation time

In Figure 7.2, each point on the line red is the value of $t_{request_learned}$ that the ROAL learned at the end of each simulation. When the simulation lasts for only 10 hours, the $t_{request_learned}$ is far from the average request time and the result of each run varies considerably, from 2300 seconds to 7000

seconds. However, when the simulation duration increases to about 200 hours, the ROAL obtains an accurate value of the $t_{request_learned}$. The result of the study indicates that if the ROAL has a sufficient learning period duration (200 hours, less than one week), it can learn an accurate value of request time of user habits. Since this value will impact the decisions $t_{dec-on}_{i,j}^k$, when the simulation limit time is increased, the power consumption and waiting delay of the ROAL power management will be impacted as shown in Figure 7.3 and Figure 7.4.

Figure 7.3 and Figure 7.4 show the average energy consumption and the average delay per service when the simulation duration is varied. In Figure 7.3, when the simulation lasts for just 10 hours, the ROAL has an energy consumption value between the PCE and the ROPM. Without an accurate request time, the ROAL turned the device on in advance. Therefore, the ROAL has a higher energy consumption when the simulation lasts for a short duration. When the simulations last for more than 200 hours, the average energy consumption is almost the same as the ROPM.

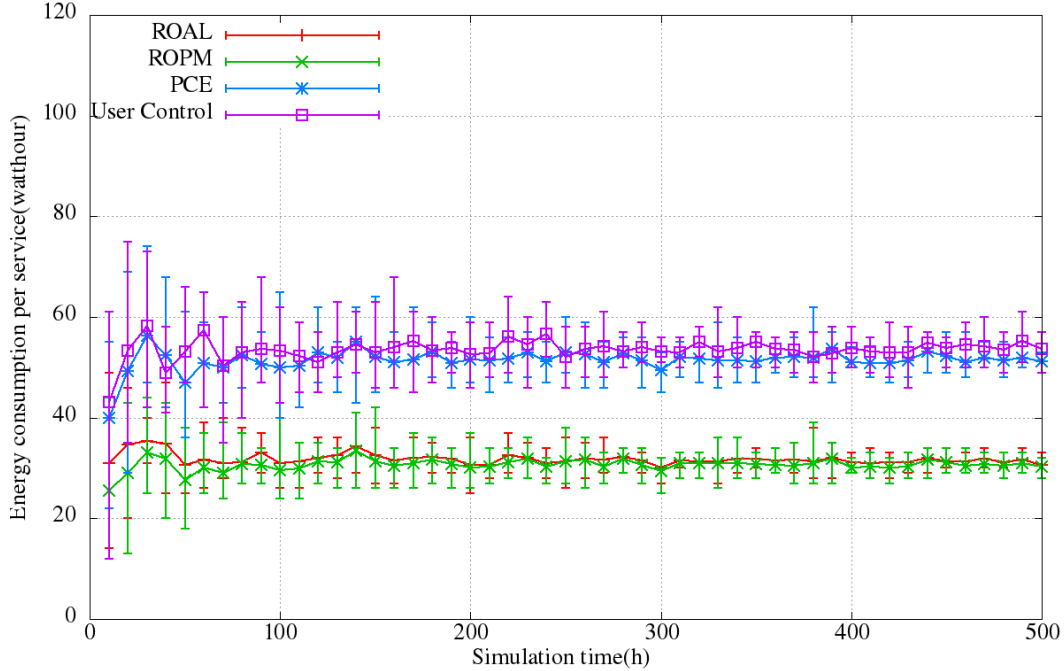

Figure 7.3: Energy consumption per service by increasing simulation duration

In Figure 7.4, when the simulation lasts for only 10 hours, the ROAL has

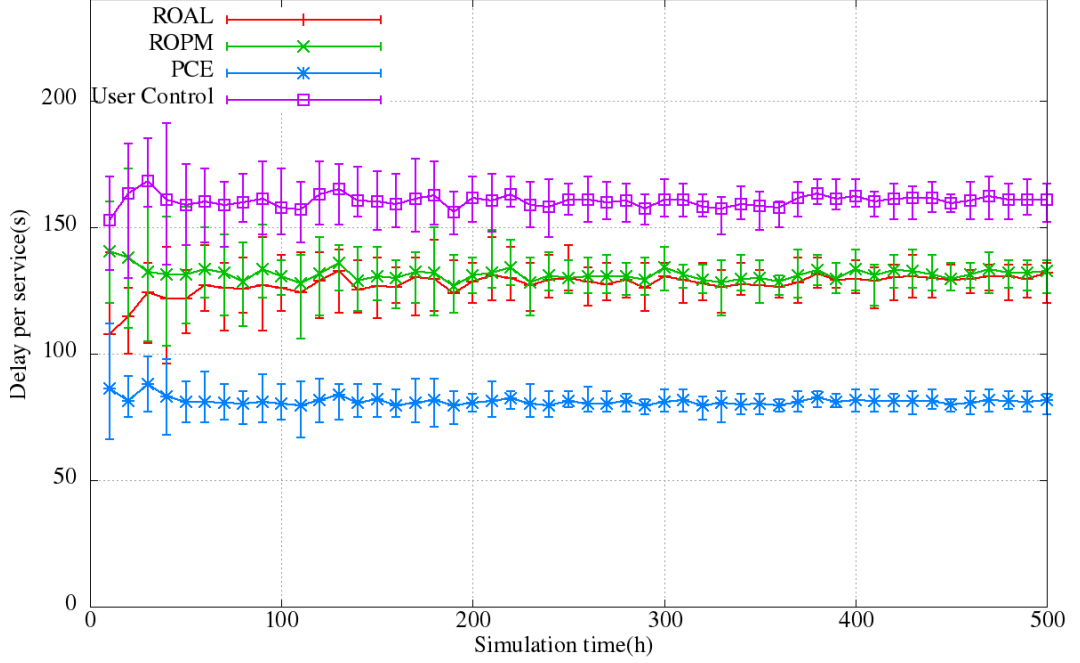

Figure 7.4: Delay per service by increasing simulation duration

a waiting delay value between the PCE and the ROPM. Because the ROAL does not have enough time to learn the accurate request time, $t_{request_learned}$ is lower than the user habit. In cases where the functional blocks, which are required later are frequently turned on in advance, there is no delay if they are already available before the service request arrives. Therefore, the delay of the ROAL approaches that of the PCE when the simulation lasts for only 10 hours. When the simulation lasts for more than 200 hours, the delay will become closer to the delay of the ROPM.

From this study, we can conclude that when the simulation lasts long enough, the ROAL may obtain approximate request time comparing the information which is pre-saved in the ROPM, and the ROAL has the same energy saving performance and waiting delay as the ROPM once the information relating to the average request time has been obtained.

7.4.2.2 Energy consumption and waiting delay by varying request time

In this scenario, the request time is varied from 0 to 5000 seconds, in steps of 100 seconds and with a standard deviation $\frac{1}{\lambda_0} = t_{average_request_time}_{i,j}^k$. As explained in Section 7.4, the $t_{request_time}_{i,j}^k$ follows an exponential process as in formula (7.7). When standard deviation $\frac{1}{\lambda_0} = t_{average_request_time}_{i,j}^k$, the formula can be simplified as in formula 7.10. This means that the generated user habits have a mean value of $t_{average_request_time}_{i,j}^k$, but the difference between the generated request time and the average value will increase with the increase of the standard deviation. The simulation time limit is set at 40 hours. This is a simulation time limit for which the ROAL has not learned an accurate request time according to the Section 7.4.2.1. Thus, we still have a difference between the ROPM and ROAL decisions.

$$t_{request_time}_{i,j}^k \sim exp\left(\frac{1}{t_{average_request_time}_{i,j}^k}\right) \quad (7.10)$$

In Figure 7.5, we can see that the energy consumption of the user control power management is almost stable because the devices are turned on integrally when the service requirements arrive and the devices are turned off integrally when the services are terminated. Therefore, the energy consumption of the user control power management corresponds to the service utilization. The energy consumption of the PCE power management increases continuously, since the PCE turns on all participating functional blocks from the beginning of the service. The more the request time increases, the more energy the functional blocks consume in the no-activity period. So, with the PCE, the total energy consumption in one service increases as the request time increases. The ROPM consumes less energy compared to the PCE because, once one service begins, those functional blocks that are not necessary, will not be launched at the beginning of the service. They are launched at the time that is pre-saved in the power management. Since the average request time $t_{average_request_time}$ is fixed, it is possible that one $FB_{i,j}$ is turned on earlier. The ROAL consumes less energy compared to the PCE and slightly more energy compared to the ROPM.

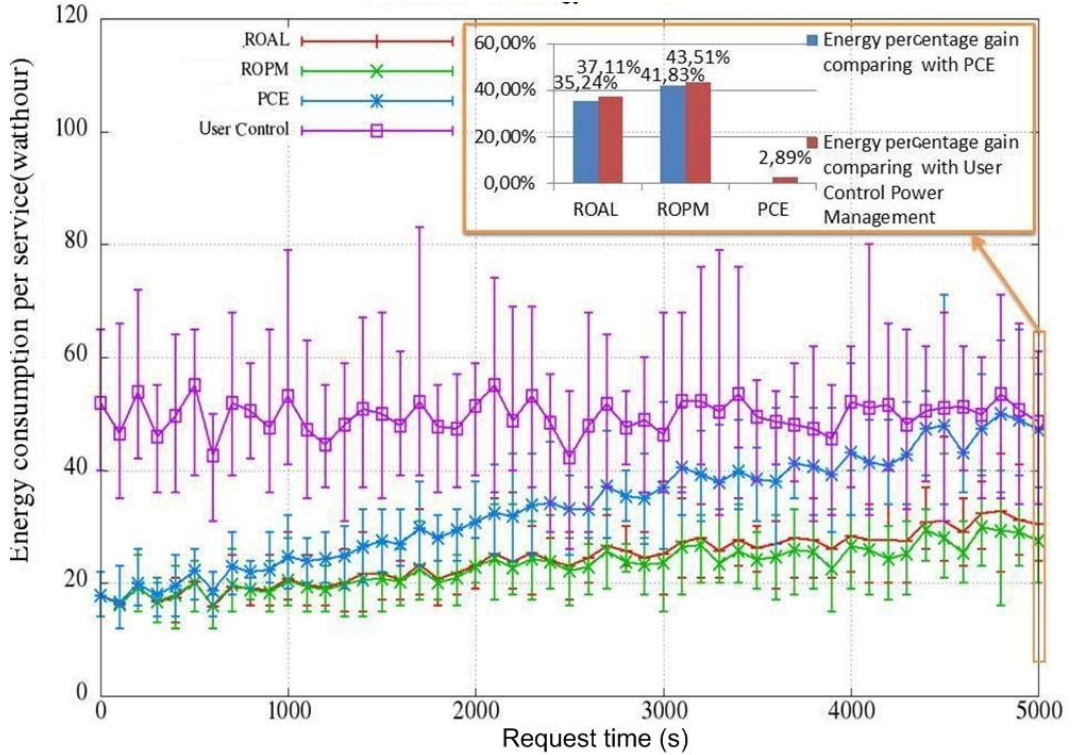

Figure 7.5: Energy consumption while changing request time

Unlike the ROPM, the ROAL does not have the knowledge of the time when the functional blocks are requested by the service. The ROAL power management begins like the PCE and turns on all functional blocks. The longer time the ROAL carries out the service, the more accurately it can learn the mean value of the $t_{average_request_time}$. Here, during a 40-hour simulation time, the ROAL learns to turn on the required functional blocks later, at a time that is closer to the real request time but which is still not perfectly accurate.

In this scenario, the ROPM and the ROAL have a 35.24% and 41.85% energy gain respectively, compared to the PCE power management. The ROPM and the ROAL can reach 37.11% and 43.51% energy gain respectively, compared to the user control power management.

Figure 7.6 shows the average waiting delay for each service. The user control power management turns on the devices when the service request arrives. Thus, there is always a waiting delay at the starting time before the device becomes

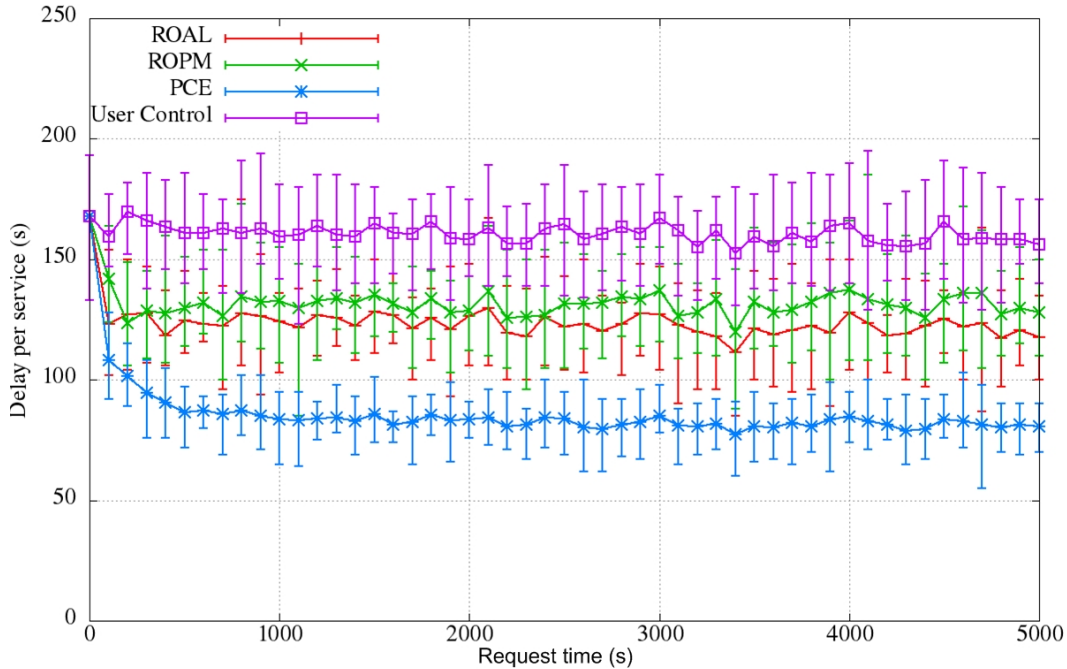

Figure 7.6: Delay while changing request time

available. The PCE has the smallest waiting delay because all of the functional blocks are turned on at the beginning of the service. The waiting delay of the PCE comes from the functional blocks that are used first. Although some of the functional blocks are needed later, they are already turned on.

Therefore, the PCE has the smallest delay and it is impossible to have a smaller delay, unless the functional blocks are never turned off. The PCE could be seen has an ideal form of management from the point of view of the delay, but it is the least advantageous from the power saving point of view (Cf. Figure 7.5). The ROPM has a greater waiting delay than the PCE. At the beginning of the service, there is always a waiting delay for the functional blocks that are used first. However, the functional blocks that are used later are turned on according to the predicted usual user behavior. If the functional blocks are turned on early, there is no generated delay. In contrast, it is also possible that the decision to turn on is later than the functional block requirements. When the ROPM detects the requirements of functional blocks, it turns the functional blocks on immediately. In this late decision case, the ROPM generates an extra delay

compared to the PCE. The ROAL has a smaller waiting delay than the ROPM because the ROAL has an inaccurate learned request time which is earlier than real user habit. There is a greater likelihood that the ROAL will turn $FB(i, j)$ on earlier than the average service request. If $FB(i, j)$ is available before the request, there is no waiting delay for the user.

The result of this study indicates that the ROPM is the most energy efficient system and has a smaller delay than the user control power management, but a greater delay than the ROAL and the PCE. The ROAL is second in terms of energy efficiency but has a smaller delay compared to the ROPM.

7.4.2.3 Energy consumption and waiting delay by varying standard deviation

In this Section we set the $t_average_request_time$ at 5000 seconds and decrease the standard deviation $\frac{1}{\lambda_0(i,j,k)}$ of the requirements of functional blocks which follows an exponential distribution as in formula (7.11). As explained before, the standard deviation of the request time represents the variation of user behavior. For example, the user may turn on his TV at 8pm as an average time. However, he could also turn on his TV 10 minutes later or 5 minutes earlier. The standard deviation describes this variation of user average behavior.

$$t_request_time_{i,j}^k = t - \frac{1}{\lambda_0(i,j,k)} + 5000 \quad (7.11)$$

$$t \sim exp(\lambda_0(i,j,k)) \quad (7.12)$$

When the standard deviation $\frac{1}{\lambda_0(i,j,k)}$ is decreased, it means that the user habits for turning on the functional blocks needed later gets increasingly closer to $t_average_request_time = 5000seconds$. The standard deviation of the request time decreases from 500 to 0 seconds with steps of 10 seconds.

In Figure 7.7, the energy consumption of the four power management systems are stable. The power consumption of the user control power management depends on the utilization of the device where the average value is fixed. Thus, the power consumption of the user control power management will remain stable. The

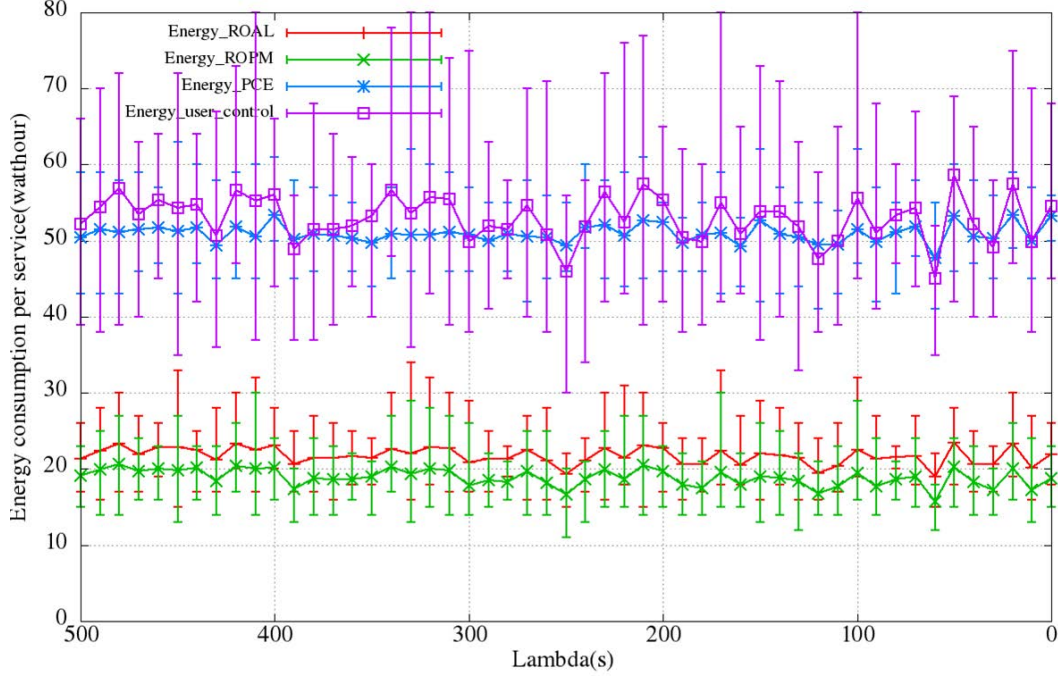

Figure 7.7: Energy consumption when standard deviation is changed

PCE power consumption stays stable because the power-on duration of $FB_{i,j}$ which corresponds to utilization and request time is stable. The decision of the ROMM power management takes into account the value of $t_{request_time}$ and the ROAL takes into account the value of $t_{request_time_learned}$. These two values will not change when the standard deviation is varied. Consequently, functional blocks are turned on based on fixed values in the ROMM and ROAL and the energy consumption stays stable as the last point $t_{average_request_time} = 5000$ in Figure 7.5.

Regarding the delay shown in Figure 7.8, we can see that the delay of the user control and PCE power management systems stay stable. The ROMM and ROAL delay decreases when the standard deviation is decreased. Since the standard deviation decreases, this means that the user behavior is approaching the pre-loaded request time or learned request time. The prediction of our power management's decision could be more accurate. Thus, the power management systems have a smaller delay impact.

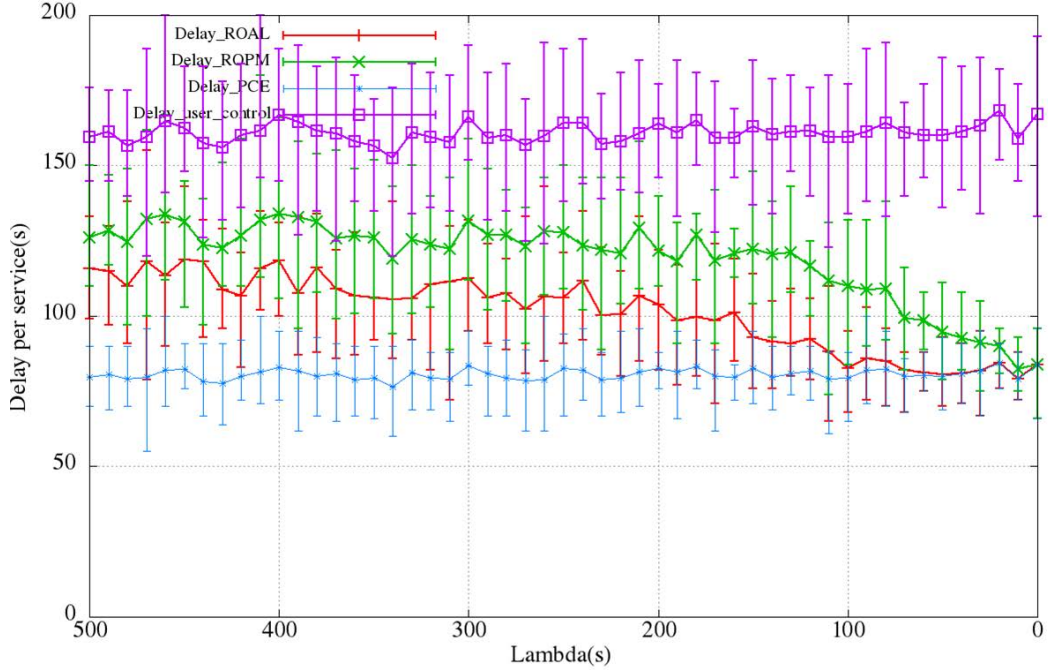

Figure 7.8: Delay when standard deviation is changed

7.5 Conclusion

In this chapter, we propose two power management systems based on refined overlay power management: ROPM and ROAL. Our two propositions are based on the service analysis by controlling functional blocks. The ROPM is energy efficient with the help of the pre-loaded user behavior information. The ROAL is able to obtain approximate user behavior information following a learning period and it has a facility for the implementation in the home network. The simulation results has shown that ROAL provides a same level of energy efficiency comparing with ROPM (see Section 7.4.2.2). The ROPM and ROAL can reach 37.11% and 43.51% energy gain respectively. Therefore, after analyzing the impact of the standard deviation on the delay, the next chapter will explore the auto-learning of the standard deviation of the user behavior probability distribution in order to retrieve the trade-off between waiting delay and energy efficiency.

Chapter 8

Collaborative power management with delay-power tradeoffs

Contents

| | | |
|------------|---|------------|
| 8.1 | Introduction | 103 |
| 8.2 | Proposed collaborative overlay power management power-delay tradeoff algorithm | 104 |
| 8.3 | Setup of simulations and analysis of results | 106 |
| 8.3.1 | Simulation setup | 106 |
| 8.3.2 | Simulation Results | 108 |
| 8.4 | Conclusion | 112 |

8.1 Introduction

As explained and measured in the former chapter, it is interesting to explore the collaborative power manage by proposing different delay-power tradeoffs. Therefore, in this chapter, we propose a collaborative overlay power management system in which appliances can be partially turned on depending on the request of the services. Moreover, by learning a user’s behavior, the collaborative overlay power management could trend to minimize power consumption or trend to

minimize the waiting delay. Regarding research on the different power consumption and waiting delay tradeoffs, our proposition allows to satisfy different user requirements on power consumption and waiting delay.

The rest of the chapter is organized as follows: Section 8.2 presents our collaborative overlay power management with power-delay tradeoffs algorithm. Section 8.3 analyzes the results of the simulation. Section 8.4 draws conclusions from our findings.

8.2 Proposed collaborative overlay power management power-delay tradeoff algorithm

Based on the collaborative overlay power management (COPM) presented in the chapter 6, we propose a power-delay tradeoff (PDT) algorithm. The proposed COPM Power-Delay Tradeoff (COPM-PDT) algorithm is illustrated in Figure 8.1: There are two parts in this algorithm.

The first part is the service learning part. As already explained in the chapter 7, we recall the process of the service learning. The COPM-PDT is launched by a daemon process which checks if one service is launched. If yes, the COPM-PDT will check if the service description has already been saved in the database. If this is a new occurring service, the power management will learn the functional blocks that were used by this new service and the service request time for each functional block $t_request_learned_{i,j}$. The formulas (8.1) calculates how the COPM-PDT learns the $t_request_learned_{i,j}$.

$$t_request_learned_{i,j} = \frac{\sum_{k=1}^{Nb_ser} t_request_{i,j}^{k-1}}{Nb_ser} \quad (8.1)$$

The second part of the algorithm is the power management control based on the service knowledge. If the service has already been learned by the power management, there will be two cases.

- In the first case when COPM-PDT detects a request for one FB, the FB will be turned on immediately. User needs to wait that the required FBs are ready.

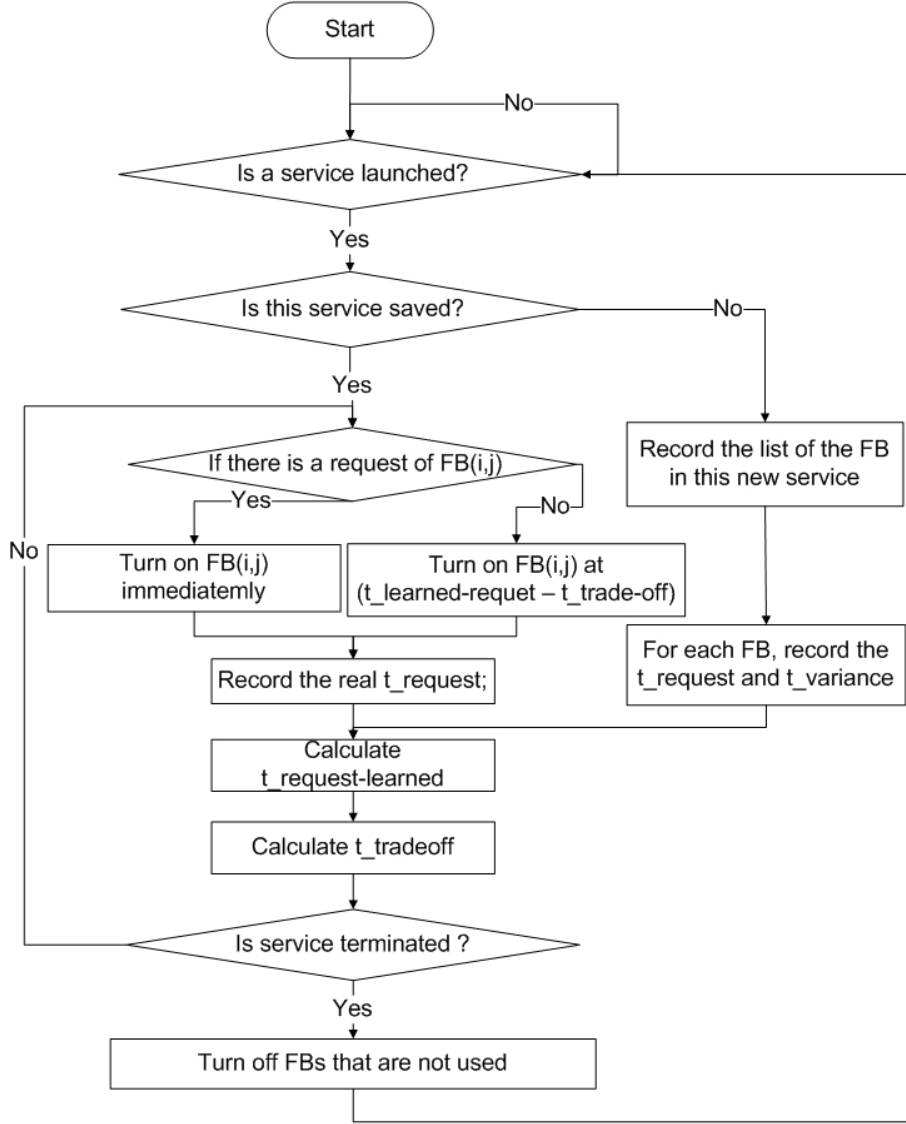

Figure 8.1: Algorithm of COPM-PDT

- In the second case when COPM-PDT does not detect an request for an FB, it controls the FB based on the learned user behavior. It means that each FB will be turned on $t_{dec.on}$, in the formula (8.2):

$$t_{dec.on}^k = t_{request\ learned}_{i,j} - t_{tradeoff} \quad (8.2)$$

The decision is based on the mean value of all recorded learned requests. Based on the learned mean value, COPM-PDT turns on the FB in advance of $t_tradeoff$ in order to minimize the waiting delay. The $t_tradeoff$ will be configured by the user satisfaction requirement α and the variance of the request ($t_request_variance$) as shown in formula (8.3). The variance of the request depends on how is user behavior. For example, one user each day turns on his STB at around 8 pm; sometimes it could be earlier or later depending on the user's behavior. For the user who is more concerned about power consumption and willing to wait, the user satisfaction requirement coefficient α will be small. And the $t_tradeoff$ will be relatively small. On the contrary, the $t_tradeoff$ will be relatively greater if the user wishes to start the service immediately. This value will be investigated in the simulation.

$$t_tradeoff_{i,j} = t_request_variance_{i,j}^k \times \alpha \quad (8.3)$$

In both two cases, after receiving the FB requests, COPM-PDT will update his database in order to calculate the new mean value of the request ($t_request_learned_{i,j}$) and the tradeoff value ($t_tradeoff$). And this new calculated $t_request_learned_{i,j}$ and $t_tradeoff$ will help the power management system control the devices for the next time when the service will be called. At the end of the service, COPM-PDT will turn off the FBs that are not needed by this or other services.

8.3 Setup of simulations and analysis of results

In this section, we will firstly present the setup of our simulation and the scenarios, and then we will analyze the simulation results in different scenarios.

8.3.1 Simulation setup

In order to accurately measure power consumption and the waiting delay of each power management, we implemented a typical home network, which was capable of executing a collaborative service in omnet++. In this typical home network,

Table 8.1: Delay-power tradeoffs algorithm simulation setup

| Notation | Value |
|--|-----------------|
| Number of device | = 5 |
| Number of FBs in one device | = 10 |
| Mean value of duration utilization | = 1,000 seconds |
| Starting duration | = 100 seconds |
| Power consumption of one FB | = 10 watt |
| Simulation repetitions for each experiment | = 10 runs |
| Simulation limit time | = 100 hours |

we had 5 devices that cooperate to provide services in the home network. The service inter arrival time follows an exponential distribution whose mean value is 5,000 seconds. Each arriving service requires different components in the device to achieve the complete service. The use of each component also follows an exponential distribution whose mean value is 1,000 seconds. It is also possible that there is a time lapse between the beginning of the service and the request of each FB. This time lapse follows a normal distribution. The parameters are described in TABLE 8.1.

Firstly, for the purpose of measuring the power efficiency and the waiting delay of our version of power management, we will tune the mean value of the request of the functional block. In this case, during the simulation limit time, our power management could have 3 scenarios:

$\alpha=0.99$, 99% of services are executed with a minimum waiting delay.

$\alpha=0.75$, 75% of services are executed with a minimum waiting delay.

$\alpha=0.50$, 50% of services are executed with a minimum waiting delay.

Secondly, in order to analyze the solutions, by tuning the tradeoff percentage, we will investigate the different power-delay tradeoff. We compare our COPM-PDT proposition versus User control power management and PCE power management:

User control power management: We assume a user who is mindful of energy conservation. This user turns on each device integrally when its service is needed, and turns off each device when the service is no longer required. This version of power management could be seen as an ideal behavior for the point of view of

delay and the worst behavior on the user which have to trigger every events.

PCE: The service is started with all necessary power control elements on at the beginning of the service. They will be turned off when the user finishes using the services [47].

8.3.2 Simulation Results

8.3.2.1 The request of the functional block

In this study, we first examined the changes on the request of functional blocks in 3 different tradeoff scenarios. To study the relationship between the $t_{request}$ and the power consumption and waiting delay. The distribution law of the request time of FB ($t_{request_{i,j}^k}$) follows a normal distribution whose standard deviation is 100 seconds. We varied the mean value of the distribution of the requested functional block from 0 seconds to 1,000 seconds.

From Figure 8.2 we can see that the energy consumption of the user control power management is almost stable because the devices are turned on integrally when the service requests arrive and the devices are turned off integrally when the services are terminated. Therefore, the energy consumption of the user control power management corresponds to the service utilization duration. In this experience, the utilization duration does not change, thus, the energy consumption of the user control remains stable. The energy consumption of the PCE power management increases continuously, since the PCE turns on all participating functional blocks from the beginning of the service. The increasing of the $t_{request}$ signifies that the requests of functional blocks are arriving increasingly later. The functional blocks will to consume more energy in the no-activity period. So, with the PCE, the total energy consumption in one service increases as the $t_{request}$ increases. The $COPM - PDT_{99}$, $COPM - PDT_{75}$, $COPM - PDT_{50}$ are configured to assure respectively 99%, 75%, 50% functional blocks should be ready while the request of the functional block is arriving. Therefore, the functional blocks in the $COPM - PDT_{99}$ are turned on much earlier than the $COPM - PDT_{75}$ and $COPM - PDT_{50}$. Thus, the energy consumption of $COPM - PDT_{99}$ is higher than $COPM - PDT_{75}$ and $COPM - PDT_{50}$.

Figure 8.3 shows the average waiting delay for each service. The user control

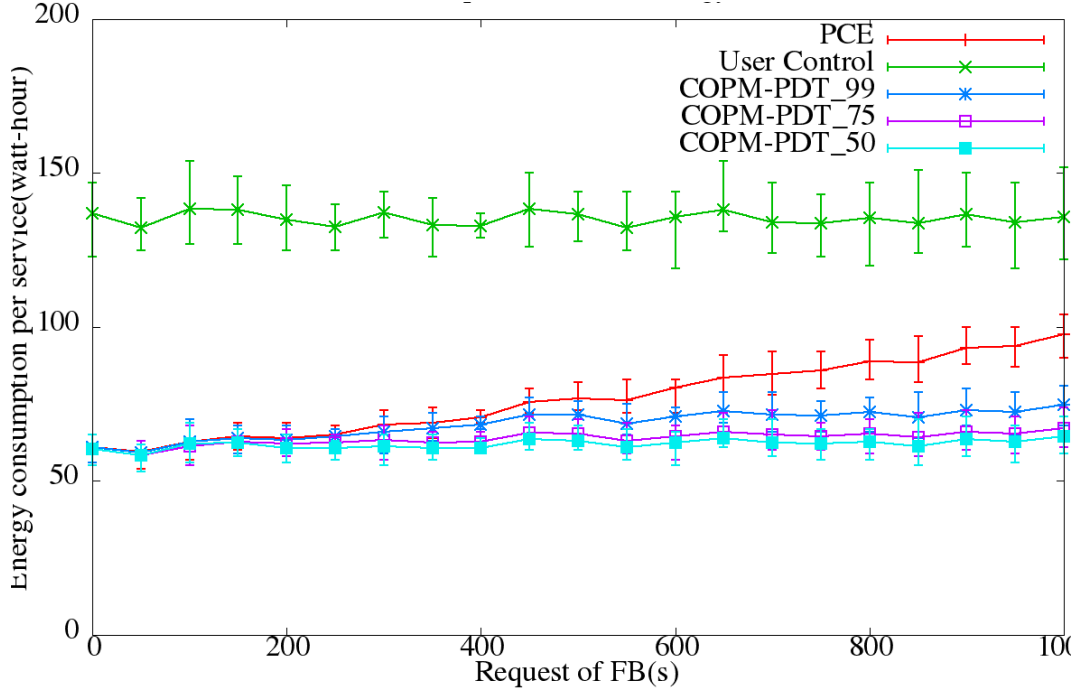

Figure 8.2: Energy while varying the request of Functional Block(FB)

power management turns on the devices when the service request arrives. Thus, there is always a waiting delay in the starting time before the device becomes available. The PCE has the smallest waiting delay because all of the functional blocks are turned on at the beginning of the service. The waiting delay of the PCE comes from the functional blocks that are used first. Although some of the functional blocks are needed later, they are already turned on. As explained before, the FBs controlled by $COPM - PDT_{99}$ are turned on much earlier than the $COPM - PDT_{75}$ and $COPM - PDT_{50}$ in order to minimize the waiting delay. Therefore the $COPM - PDT_{99}$ has almost the minimum waiting delay that we could achieve. $COPM - PDT_{75}$ has a higher delay since the functional blocks are often turned later than the $COPM - PDT_{99}$. $COPM - PDT_{50}$ has the shortest delay.

After seeing the trends of energy consumption and delay by varying the request of the functional block, we will zoom at the moment that the mean value of the request is 1,000 seconds in Figure 8.4 and TABLE 8.2. We can see that our proposition $COPM - PDT_{99}$ is the most energy efficient and a minimum delay:

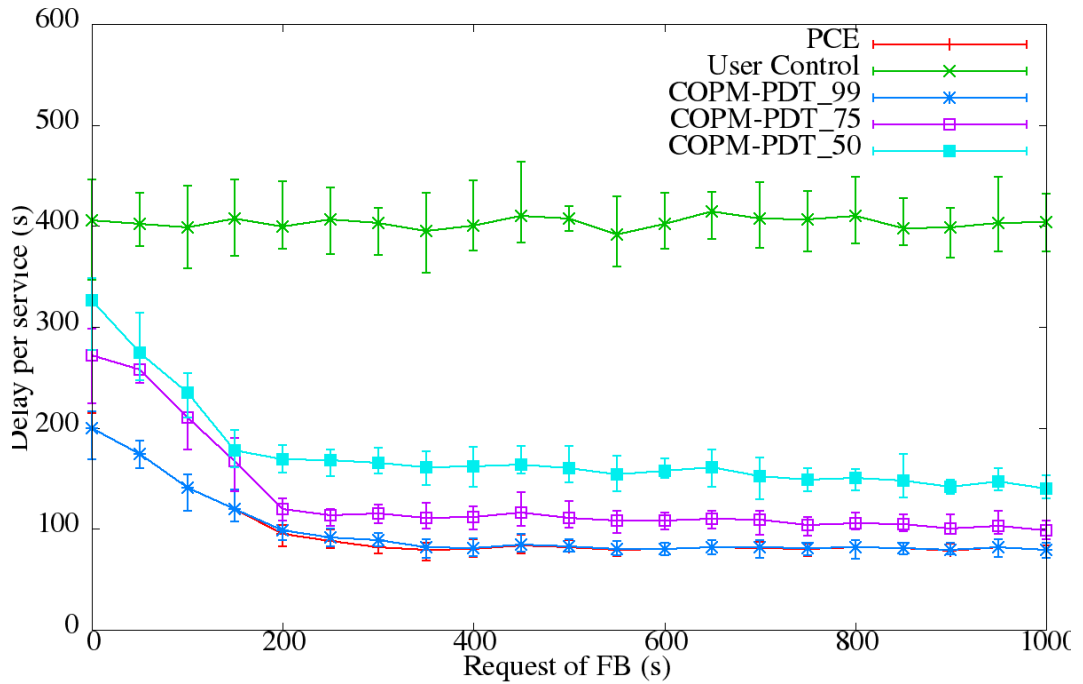

Figure 8.3: Delay while varying the request of Functional Block(FB)

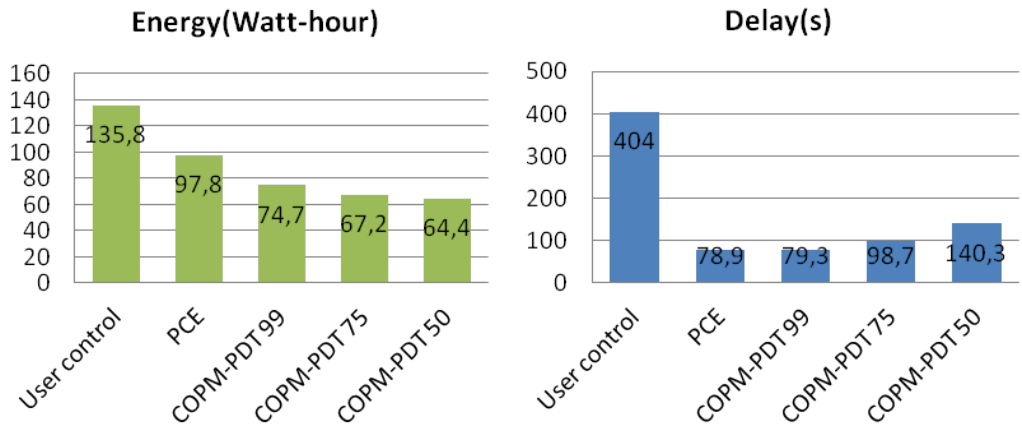

Figure 8.4: Energy consumption and delay while the request at 1000 seconds

*COPM – PDT*₉₉ consumes 74.7 watt-hours, compared with PCE we could have a 23.62% energy gain. In the same scenario, *COPM – PDT*₉₉ cause only 0.5% increased delay compared with PCE. For the users who prefer to have more energy gain at 31.29 % and may accept 20.06% delay more than PCE, they could

Table 8.2: Delay-power tradeoffs algorithm simulation energy and waiting delay results

| α | 99 | 75 | 50 |
|------------------------|--------|--------|--------|
| Increased Delay vs PCE | 0.5% | 20.06% | 43.75% |
| Energy gain vs PCE | 23.62% | 31.29% | 34.15% |

choose $COPM - PDT_{75}$. For those who want to obtain the maximum energy gain without considering the delay, the energy gain could be more than 34.15%.

8.3.2.2 The tradeoff coefficient

In this study, we will investigate the tradeoff percentage parameter from 0.01 to 0.99. We fixed the mean value of the distribution of the requested functional block at 1,000 seconds with a standard deviation fixed at 100 seconds.

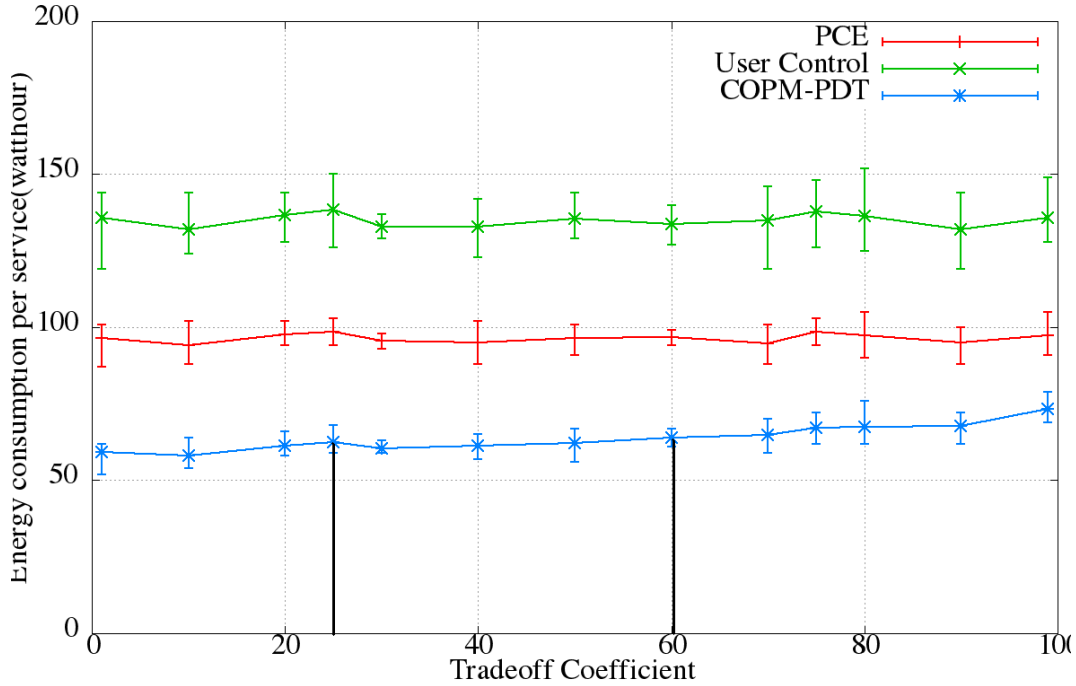

Figure 8.5: Energy consumption while varying the request of tradeoff coefficient

Figure 8.5 shows how energy consumption changes while we tune the tradeoff coefficient. Figure 8.6 shows how waiting delay changes in the same condition.

Collaborative power management with delay-power tradeoffs

These two figures can be divided into 3 regions. In the first part, while the coefficient is smaller than 0.25, the COPM-PDT trends to maximize the power consumption with a relatively high delay (Between 210 seconds to 400 seconds per service). The home network user may find this difficult to accept. The second region of tradeoff coefficient is between 0.25 and 0.6. The energy efficiency is almost the same as in the first region. Moreover the delay decreases almost by half compared with the first region. The tradeoff coefficient in the last region is from 0.6 to 0.99. Although the COPM-PDT is a little bit less energy efficient than the second region, the algorithm reaches almost the minimum waiting delay that we could achieve in one service. Based on this experience, the COPM-PDT provides 3 regions of choices for different user requirements in energy efficiency or waiting delay or a tradeoff between these two factors.

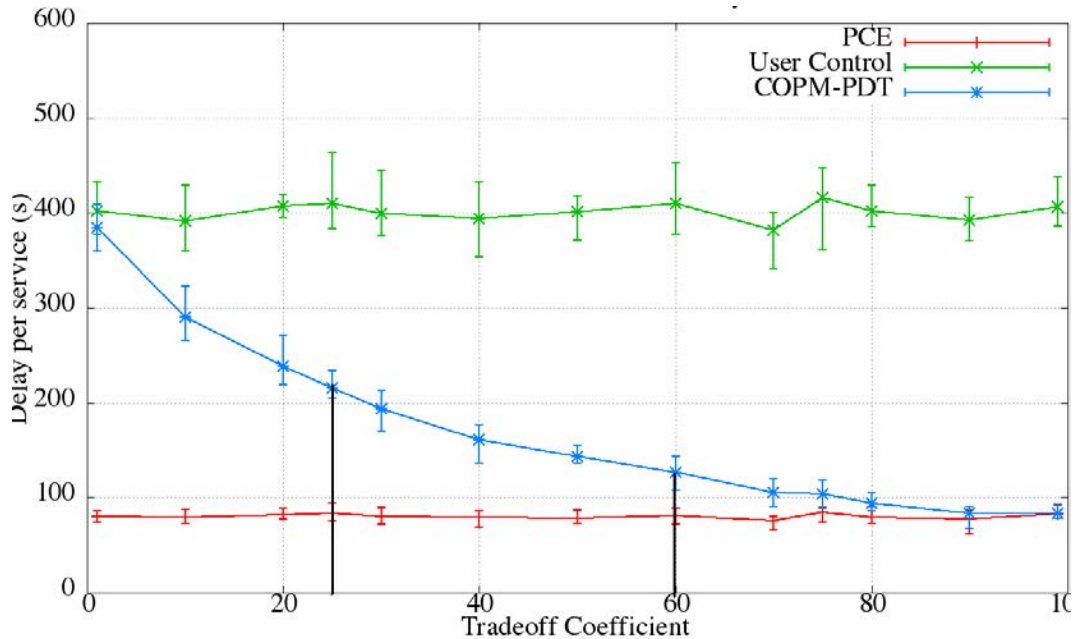

Figure 8.6: Delay while varying the request of tradeoff coefficient

8.4 Conclusion

In this chapter, we developed a collaborative overlay power management that offers several possible tradeoffs between the power consumption and the waiting

delay in the home network. Based on the learned knowledge of the user's behavior, our COPM-PDT proposal is capable to control collaborative devices by turning on the only requested functional blocks. Our proposed COPM-PDT algorithm exploits the tradeoff of power consumption and waiting delay. The results show that our proposition could be energy efficient and provide a low waiting delay for different user requirements. The results also show that COPM-PDT could achieve the minimum waiting delay or the maximum energy efficiency which would depend on the user exigencies.

Chapter 9

Conclusions and Future Perspective

Contents

| | |
|--|------------|
| 9.1 Conclusion | 115 |
| 9.1.1 The challenges of the complex home network environment | 116 |
| 9.1.2 Our responses to the challenges | 116 |
| 9.2 Perspective | 118 |

9.1 Conclusion

In the present thesis, we have studied the energy consumption control problem in a home network. The solutions of this problem rely on the good usage of important elements in the home network: home network connections, devices and power control algorithms. Our work gives a set of mechanisms for responding to the home network energy consumption problems.

9.1.1 The challenges of the complex home network environment

At the beginning of this thesis (see Section 1.2 and Section 2), our work has illustrated the variety of a home network environment which contains many connections, types of devices, protocols. Our study shows main problems. Firstly, connections are not used in an energy efficient way. There are more and more connections in the home network, and they consume permanently the energy while the networks are maintained although connections are not used. Secondly, devices are not used in an energy efficient way. Devices work together to provide a collaborative service. In each collaborative service, not all devices, or all functional blocks in the devices, are used all the time. However, they are turned on integrally when they are requested. Moreover, these devices stay in unnecessary power consumption idle state after the service execution.

Therefore, the challenges of our problems are to provide solutions to resolve these problems simultaneously. The first challenge is that home network should be reactive for the energy control purpose and connections should not consume high power consumption. How to control the collaborative service in an energy efficient way without impacting user experience? This is our second challenge.

In order to solve these main problems in the home network while considering all challenges, we proposed a low power overlay network over the traditional home network. This would be beneficial for the request of an always-on network. We also analyzed that the collaborative services could be energy efficient by controlling on the right functional blocks in the right device at the right moment for the requested service. Taking the user habits into consideration helps us to provide more user adaptive and energy efficient algorithms. Our work contributes to this evolution toward greener home network environments.

9.1.2 Our responses to the challenges

Our work has introduced low power overlay control network which controls an increasing number of home network devices with soaring power consumption in our homes (see Section 4). In most cases, devices and traditional high energy consumption networks are in idle states for hours. This part of energy is wasted

Conclusions and Future Perspective

almost uselessly, because devices and connections are maintained only in order to be able to react rapidly to service requests. Thus, we proposed an always-on low power network over the traditional high energy consumption network. The proposed Overlay Energy Control Network (OECN) can switch devices from idle state to sleeping state much more quickly and from idle state to soft-off state automatically. In this work, we noticed that our proposition ZMS, which is based on a complete OECN, is more efficient in terms of energy saving, but it has a relatively high delay compared to the two other solutions. The ZOS, which is based on a partial OECN, is a good trade off between the energy gain and delay. Since the simulation shows a great energy gain by our solutions, we were encouraged to demonstrate our overlay control network by a testbed in a real home environment.

This conception is implemented in our testbed for HOme Power Efficiency System (HOPE) in a real home network environment (see Section 5). HOPE system turns on the devices for the purpose of establishing and providing the service with the help of an overlay low power network. At the end of the services, the power management checks the possibility to turn off the devices in order to avoid unnecessary energy consumption. Our testbed is energy efficient and it provides high ease of use when users want to enjoy their collaborative services. The implemented testbed shows that HOPE system could drastically reduce the consumption of home networks. Users can benefit from enriched home multimedia services and efficiently manage their power consumption. By implementing the testbed on real use cases, we realized that more and more services request several different devices to collaborate together. We also realized that different functional blocks collaborate in the devices to provide services. We decided to investigate the collaborative power management.

Our OECN and HOPE solutions proposed and validated the concept of low power overlay control network. The OECN is validated by various scenarios in a simulator. HOPE solution is validated by several frequently requested collaborative use cases in a real home network environment.

Generally, our power energy saving mechanisms and the techniques applied in our collaborative power management are opportunistic:

- Data collection: the collection of the information could be the real time

Conclusions and Future Perspective

device status information or device static information (see Section 5.2.2). This information could also be achieved by a service learning process (see Section 7.3.3)

- **Analysis:** based on the collected information, the energy efficiency analysis is done on different levels. Our power management analyzed firstly the relationship between the collaborative services and devices involved in the services (see Section 6.2.1). Then the analysis focus on the functional block level in the devices. It shows that it is energy efficient to turn on the only requested functional blocks for the service (see Section 6.2.2). At the same time, the energy efficiency analysis should take into account the user quotidian habits. This helps to provide a solution which has high energy efficiency and good adaptability to users.
- **Control:** control algorithms are proposed for the energy saving and user comfort purpose. Our first control algorithm, which learns the user habits, shows that the energy saving performance is good (see Section 7). However, we pay this energy gain by a waiting delay. Afterwards, we proposed another control algorithm which provides power consumption and waiting delay tradeoffs. Our proposition allows for satisfying different user requirements on power consumption and waiting delay (see Section 8).

Our collaborative power management use the concept of the low power overlay control network to collect information. Based on the collected information, collaborative power management learns user habit on how they use their services which are provided by their devices. Meanwhile, collaborative power management also analyzes how the functional blocks in the devices collaborate together to provide user requested services. Thanks to this approach, our solutions achieve at same time a very good energy efficiency and a low waiting delay for user request.

9.2 Perspective

This thesis gives responses in a specific energy saving field, in a specific home network environment and was applied to a particular set of technologies. The

Conclusions and Future Perspective

extension to other areas and transposition of the concepts to other technologies could be obviously beneficial for related research. In this section, we present the possible perspectives of each part of our work in short term and long term.

In the short term, we could firstly progress the collaborative services analysis on the functional blocks. This could be an investigation with multi services which may need the same functional blocks in same devices. In this investigation, it is interesting to study the resource allocation while there are several service requests at the same time.

Secondly, it would be interesting to analyze more profoundly the trade-offs between energy consumption and other metric which could be bandwidth, packet size and transmission latency. With this variation our work could be extended in various research direction, for example, wireless communication direction.

Thirdly, the user habits learning procedure could be more intelligent and adaptive. We could work on our learning algorithm which could rapidly change when users change their habits.

In the long term, an overlay control network could be more heterogeneous. In our work, we used mainly the ZigBee and UPnP technologies. Thanks to the proliferation of sensors and ubiquitous low power wireless network, more and more devices are connected to the network. The control network messages could be transported by different networks like Bluetooth Low Energy, 6LoWPAN or other new low power wireless network. This could be beneficial to use the already installed low power network infrastructure for the power control. In this direction, this requires an homogeneous interface of different technologies. This is also the long term vision of the Internet of Things standardizations.

Information could be collected from different devices by different connections. Exploring the data collected by this heterogeneous overlay network could be useful not only for the energy saving purpose or also for the home automation, health care, social networking and so on.

Conclusions and Future Perspective

Patent1261565: Economiser l'énergie du réseau domestique tout en maintenant la QoE de l'utilisateur

A. Technique antérieure connue et problématique

Du fait de l'apparition de plus en plus d'équipements dans les réseaux domestiques, la consommation énergétique du réseau domestique devient une part importante de la consommation globale.

Les utilisateurs ne prennent pas toujours l'initiative d'éteindre les équipements à chaque fois après leur utilisation. Il existe des solutions pour contourner ce problème, comme par exemple:

1. Ajouter à chaque équipement une minuterie, activée lors des périodes de non-utilisation de l'équipement. Une fois le compte à rebours arrivé à échéance, l'équipement s'éteint de lui-même. L'utilisateur allume les équipements manuellement en fonction de ses besoins.
 - L'avantage de cette solution est que l'équipement reste actif (disponible rapidement pour l'utilisateur) pendant le décompte de temps.
 - Les inconvénients de cette solution sont que les équipements restent dans un état de haute consommation énergétique pendant le temps du décompte, et une fois le décompte terminé, l'allumage d'un équipement

n'est pas transparent pour les utilisateurs.

2. L'équipement est éteint tout de suite chaque fois après son utilisation par un coordinateur énergétique du réseau domestique. Les équipements sont allumés par le coordinateur ou par utilisateur.
 - L'avantage de cette solution est que les équipements restent dans un état bas de consommation si on ne les utilise pas.
 - L'inconvénient est que cette solution ajoute des temps d'attente avant chaque utilisation des équipements. Ceci représente une gêne notoire pour les utilisateurs qui sont forcés d'attendre des temps pouvant aller de quelques secondes à quelques minutes avant de pouvoir commencer à utiliser leurs équipements.

C'est dans le but de pallier à ces défauts que nous proposons une solution dont le principal rôle est de réduire la consommation d'énergie tout en gardant une meilleure Qualité d'Expérience Utilisateur(QoE).

B. Solution proposée

La solution est d'utiliser un Power Management (PM) intelligent pour économiser la consommation d'énergie en gérant le temps d'attente dans un réseau domestique.

Dans un réseau, on peut trouver des équipements tels que des ordinateurs, ordinateurs portables, tablettes tactiles, Set-Top-Box, etc (cf. Figure 1). Les équipements peuvent coopérer pour délivrer un ou plusieurs services, comme par exemple la STB collabore avec des prises Courant Porteur en Ligne (CPL) afin de fournir le service IPTV. D'autre part, certains équipements peuvent être amenés à fournir un service sans besoin de collaborer avec les autres, comme par exemple un ordinateur portable fournissant le service Web. Même si les utilisations des équipements sont complexes, il est possible de déterminer les habitudes des utilisateurs et d'adapter le réseau domestique à leurs besoins. Par exemple, certaines familles regarderont tout le temps l'IPTV à partir de 20h. Fort de cette observation, notre solution a pour but de réduire la consommation énergétique en

tenant compte des habitudes des utilisateurs, et ainsi être en mesure de pouvoir leur offrir une meilleure QoE.

Le PM proposé peut se situer dans la passerelle (Home GateWay) de la maison ou dans d'autres équipements de la maison. Dans cette entité PM, il y a trois principaux composants :

1. Collection : Ce composant collecte les états énergétiques des équipements, et les demandes d'allumage et d'extinction des équipements. En utilisant ces informations, la collection fournit les habitudes des utilisateurs de cette famille à la Database.
2. Database : Les données concernant les habitudes de l'utilisateur. Ces données proviennent de deux sources :
 - Les habitudes des utilisateurs que nous avons prédéterminées à l'aide d'études comportementales.
 - Les habitudes particulières à la famille déterminées par apprentissage tout au long de la vie du réseau et des utilisations des équipements dans le réseau domestique.
3. Contrôle : Avec les informations temps réel des équipements et les habitudes dans le Database, le Coordinateur envoie des commandes pour contrôler les états énergétiques des équipements de la maison de manière intelligente.

Deux cas d'utilisation permettent d'illustrer comment le PM gère les états énergétiques des équipements de la maison en tenant compte de la QoE:

Cas d'utilisation 1 : Il y a une vidéo de transfert de la STB vers PC1 de 18h30 jusqu'à 18h32.

Dans ce cas, le PC1 demande au PM d'allumer la STB et les prises CPL nécessaires pour transférer une vidéo de la STB. A la fin de la transmission, le PM éteint la STB ainsi que les prises CPL, mais pas le PC1. En effet, selon les habitudes enregistrées dans la Database, souvent après un transfert vidéo, on enchaîne une lecture vidéo. C'est la raison pour laquelle il est intéressant de laisser PC1 allumer pendant une durée ajustable en fonction des habitudes des utilisateurs. En même temps, nous allons collecter les réactions dans ce cas d'utilisation de cette famille pour améliorer notre solution.

Appendix A

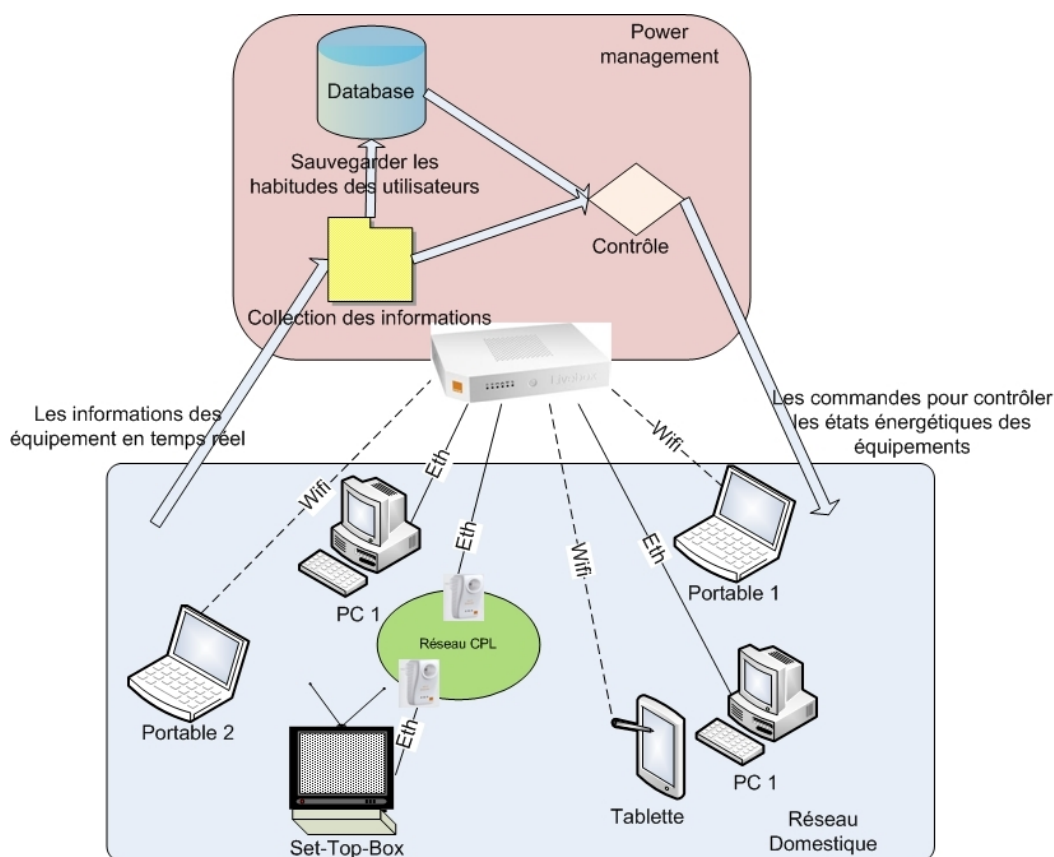

Figure 1: Architecture d'un réseau domestique avec son power management

Ici, nous montrons la consommation de PC1. Dans la solution énergétique normale, le power management éteint le PC tout de suite après un service de transfert de vidéo. Mais un peu de temps après, l'utilisateur demande une lecture de vidéo suite au transfert de cette vidéo. Le PC 1 est donc rallumé avec un temps de démarrage assez long. En revanche, avec notre solution nous avons appris que souvent après un transfert vidéo il y a une lecture de fichier sur l'équipement de réception. Notre power management va donc laisser allumer pendant une durée choisit en adéquation avec les habitudes collectées de la famille après un service de transfert. De ce fait, il n'y a pas de temps d'attente avant le service de lecture pour la solution proposée.

Cas d'utilisation 2 : PC1 lit une vidéo enregistrée dans la STB de 19h30 jusqu'à 19h58, La famille regarde l'IPTV à 20h.

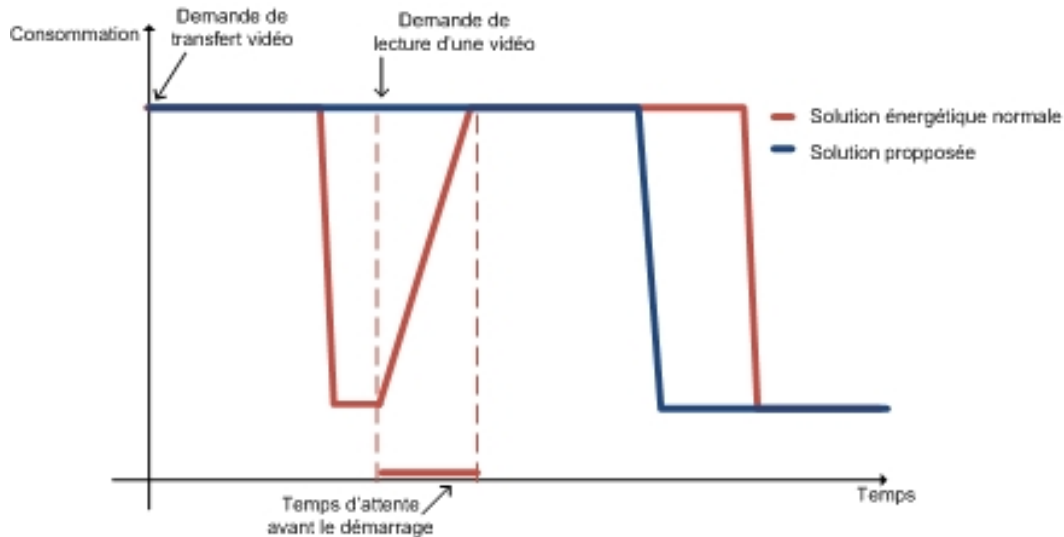

Figure 2: Comparaison des consommations avec ou sans la solution proposée

Dans ce cas d'utilisation, les équipements sont allumés comme dans le cas d'utilisation 1. Mais à la fin de la lecture, nous n'allons éteindre que le PC 1, car selon l'habitude de la famille, la STB sera allumé dans les 2 minutes qui suivent pour regarder l'IPTV.

Avec la solution proposée, nous allons pouvoir économiser l'énergie dans le réseau domestique tout en prenant en compte la QoE des utilisateurs avec une efficacité transparente.

Des solutions énergétiques existantes économisent des énergies en sacrifiant la QoE. Ceci est souvent inacceptable pour les fabricant des équipements, fournisseur du réseau et des utilisateurs. C'est pourquoi les solutions d'économie d'énergie ne sont pas fréquemment déployées.

En utilisant notre solution proposée, l'économie d'énergie est réalisée en maintenant la qualité des expériences des utilisateurs. C'est donc une solution mieux adaptée pour un réseau domestique.

C. Application de l'invention

Cette invention appliquée à un réseau domestique permettra d'économiser notablement la consommation globale d'électricité et d'adapter la gestion à l'expérience

Appendix A

de l'utilisateur. Nous pouvons très bien implémenter cette solution dans tout type d'équipement de la maison : passerelle, set-top box, Pcs, NAS, CPL etc.

Patent1352881: Système de gestion intelligente de la consommation à haut niveau de granularité en analysant des services collaboratifs

A. Technique antérieure connue et problématique

Récemment, le réseau domestique s'est fortement déployé. Il y a de plus en plus d'équipements, ce qui occasionne une augmentation de la consommation d'énergie dans la maison.

Il existe de nombreuses techniques de gestion de l'énergie, allant du niveau du chipset au niveau du système d'exploitation. L'idée essentielle étant de réduire la consommation d'énergie des équipements pendant les temps de veille ou de faible sollicitation (e.g. faible débit de données), elle peut être mise en place par des techniques diverses : Mise en veille après une période d'inactivité, gérer la puissance dynamique (DPM), réguler le débit des liaisons de données, etc. Ces techniques permettent de mettre en place des stratégies de gestion de l'énergie à l'échelle des chipsets ou des composants fonctionnels d'un même système. Mais, ces solutions ne prennent pas en considération la consommation globale des périphériques en réseau pour la mise en place de services en collaboration.

B. Solution proposée

Il y a de nombreux types de périphériques en réseau dans une maison. Typiquement, un réseau domestique peut contenir : une passerelle domestique, un serveur domestique, des appareils de domotique, une STB (Set-Top Box), un PC, une imprimante, des appareils multimédia, des appareils mobiles (e.g. smartphones) . Ces appareils ont des fonctions multiples et sont eux même composés de nombreux éléments fonctionnels indépendants pour collaborant pour fournir différents services. Ces services sont fournis en collaboration avec de nombreux appareils dans la maison.

Illustré dans la figure 1, notre solution proposée contient deux parties:

Partie 1 : La gestion d'énergie à haut niveau de granularité est montrée dans la Figure 3, où F signifie fonction ; C_{ij} signifie composant j dans le device i ; S signifie service collaborative ; D signifie device :

- La solution utilise un Power Management(PM) intelligent pour réduire la consommation d'énergie en tenant compte des services collaboratifs.
- Un service collaboratif (S_1 ou S_2) pourrait impliquer un ou plusieurs équipements. Chaque équipement a plusieurs fonctions qui sont réalisées par un ou plusieurs composants. Un service collaboratif peut donc être décomposé entre plusieurs composants qui réalisent des fonctions dans des équipements.
- La solution proposée va gérer les équipements en fonction des services auxquels ils participent. Le power management ne laisse allumés que les composants qui sont nécessaires à la mise en place des services demandés.

Partie 2 : L'intelligence d'apprentissage

- Le power management est également capable apprentissage (Figure 4 et Figure 5), afin de gérer les composants nécessaires dans des services collaboratifs (Figure 3).
- Il y a trois aspects à apprendre : l'heure du démarrage du service ; les correspondances Services collaboratives avec Devices; Device avec Fonctions; Fonctions avec Composants et l'enchaînement d'un service à l'autre service.

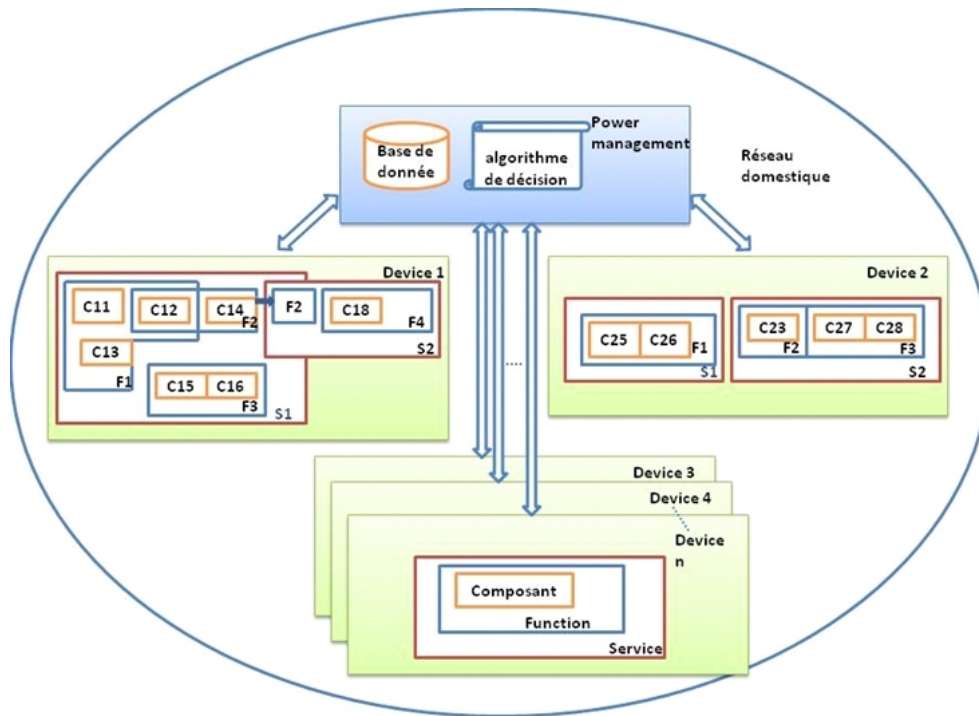

Figure 3: Architecture d'un réseau domestique avec son power management

Cas d'utilisation 1. IPTV:

Une STB demande un service IPTV. Power management gère 2 équipements: la passerelle et la STB pour fournir un service IPTV. Sur la STB, le power management a besoin de fonctions spécifiques comme: la connexion réseau, le codage vidéo, le déchiffrement des flux, et l'envoi du flux sur un dispositif d'affichage. Les composants comme le chipset de codage de flux, de déchiffrement des flux, et l'interface HDMI sont donc nécessaires. De même, sur la passerelle réseau, des fonctions spécifiques sont nécessaires, et notamment la connexion réseau est réalisée en activant des composants : carte réseau, interface Ethernet. Le power management ne va laisser allumés que les fonctions et composants indispensables pour le service à mettre en place.

Cas d'utilisation 2. Partage des contenus multimédia + lecture des fichiers multimédia:

Un serveur multimédia partage du contenu multimédia avec tous les équipements de la maison grâce à la technologie DLNA. Plus spécifiquement, chez un utilis-

Appendix B

Learning process

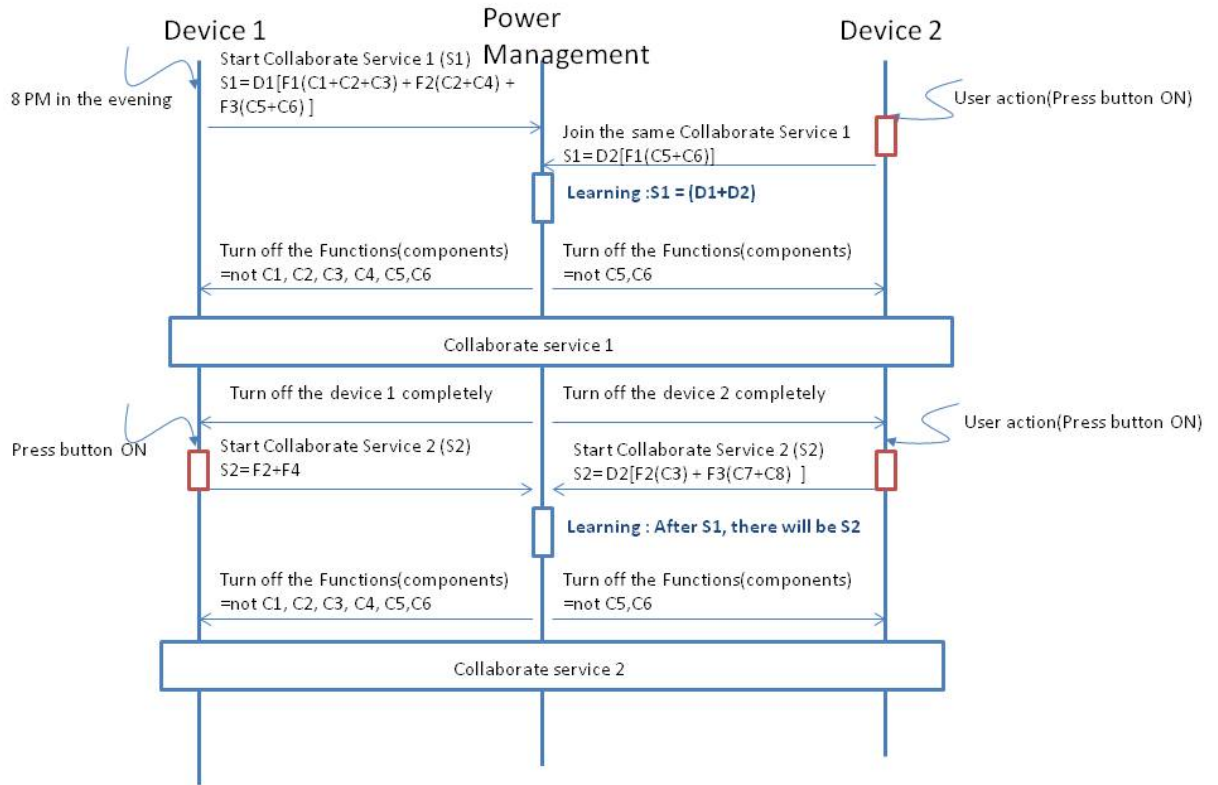

Figure 4: Apprentissage (Processus d'apprentissage)

teur, la STB parcourt les contenus du serveur multimédia plus souvent que les autres équipements dans la maison. Le power management est aussi capable d'apprendre des habitudes de l'utilisateur. Par exemple : il préfère regarder des films sur sa télé avec l'aide de sa STB. Grâce à cet apprentissage, le power management est également capable d'anticiper des enchainements de service collaboratifs en allumant des composants qui seront nécessaires à court-terme dans la mise en place d'un service collaboratif.

Exploring process

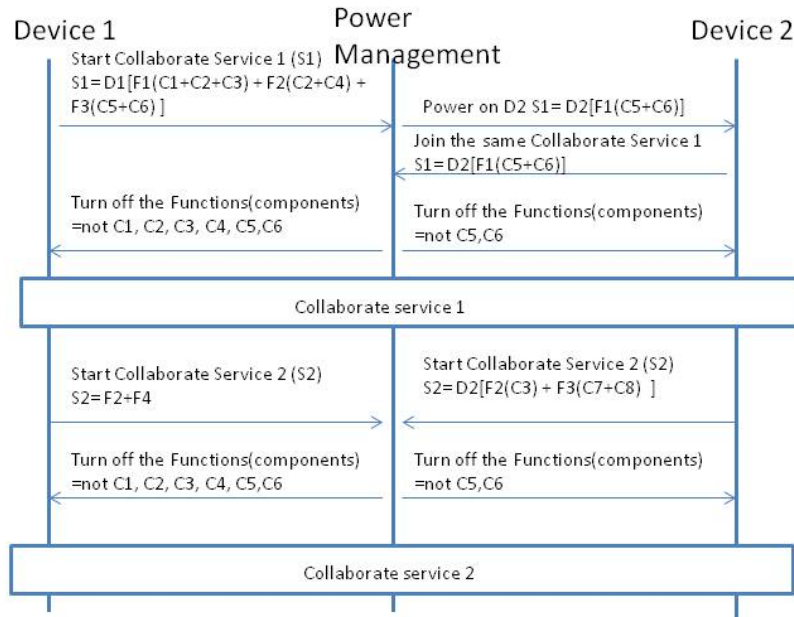

Figure 5: Apprentissage (Processus d'exploration)

C. Application de l'invention

Cette invention peut être appliquée dans les équipements qui ont des capacités de calcul dans le réseau domestique. Notamment dans la Livebox ou la STB.

L'invention proposée pourrait s'intégrer aux spécifications émises par DLNA. En effet, DLNA normalise déjà des Devices (DMS : Digital Media Server, DMR : Digital Media Printer, DMP : Digital media Printer) qui sont mis en relation par des DMC (Digital Media Controller). DLNA normalise aussi des services : ContentDirectory (qui permet de parcourir le contenu d'un DMS) AVTransport (qui permet de transporter le contenu AV d'un DMS ou d'un DMR), RenderingControl (pour contrôler le rendu d'un DMR), ScheduledRecording (pour programmer un

Appendix B

enregistrement). Chaque service est découpé en action : Browse, Play, CreateJob, ...

Actuellement, DLNA n'intègre pas la notion de composants, mais c'est quelque chose que DLNA commence à faire à travers la task force DLNA Low Power qui va permettra de récupérer le statut de la carte WiFi ou de la carte Ethernet. L'invention proposée ici vise à améliorer DLNA Low Power en permettant de désactiver et d'activer des composants supplémentaires comme le disque dur, le composant graphique HD, le composant graphique SD, le composant audio.

Patent 1359446: Mécanisme de gestion intelligente et transparente des connexions réseau IPv4/IPv6 par l'intermédiaire d'un réseau en overlay 6loWPAN

A. Technique antérieure connue et problématique

L'invention proposée ici, vise, à insérer un procédé permettant la gestion intelligente et transparente des interfaces réseau des équipements DLNA (Digital Living Network Alliance) du réseau domestique.

L'alliance DLNA, créée en 2003, utilise le protocole UPnP afin de mettre en relation des terminaux dans le réseau domestique comme : - un Media Server qui partage du contenu multimédia (ex : un PC ou une Livebox) - un Media Renderer qui affiche le contenu multimédia (ex : une console de jeu ou une télévision connectée) Pour mettre en relation ces équipements, l'utilisateur utilise un Control Point qui découvre les équipements et les met en relation. Par exemple, le Control Point présente le contenu du Media Server à l'utilisateur et lui permet de le jouer sur le Media Renderer. Il est à noter que dans la plupart des cas, le Control Point est localisé dans le même équipement que le device Media Renderer.

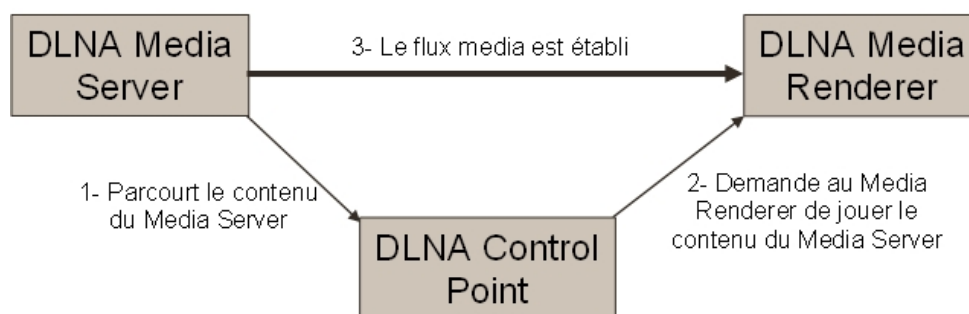

Figure 6: Relation entre équipements DLNA avec un Media Server

L'invention proposée ici, vise à résoudre le problème suivant. A l'heure actuelle, DLNA fonctionne sur le réseau IPv4 et des travaux sont en cours pour IPv6, l'utilisation de DLNA nécessite donc de maintenir en permanence en activité des liens IPv4 et IPv6 qui consomment beaucoup d'énergie afin de transmettre les messages d'annonce et de découverte en multicast UPnP. Or, les liens IPv4 et IPv6 peuvent consommer beaucoup d'énergie, par exemple, une paire de boîtiers CPLs (Courant Porteur en Ligne) consomme entre 7 et 10W. Un lien WiFi consomme entre 2 et 3W.

Dans le même temps, les équipements DLNA du réseau local sont, ou seront, tous connectés à un réseau de contrôle en overlay basse consommation du type ZigBee, Bluetooth 4.0, DECT ULE (Ultra Low Energy). Ces réseaux qui consomment peu (250 mW pour un chipset ZigBee) sont ou seront tous compatibles IPv6 et UPnP grâce à 6LoWPAN et COAP (l'équivalent du HTTP mais en moins verbeux) [60].

Des travaux ont débutés chez DLNA et une architecture DLNA Low Power est en cours de spécification (la v1 devrait être finalisée cette année). Cette architecture permettra au Control Point de découvrir les interfaces réseau des Media Server et des Media Renderer. Elle permettra aussi de découvrir leur statut de réserver l'équipement pour un temps donné. Cependant, la v1 ne permettra pas de mettre en veille ces interfaces. De plus, DLNA se focalise sur le réseau IPv4 / IPv6 traditionnel et ne prend pas encore compte l'émergence des réseaux overlay qui vont devenir de plus en plus présents sur les capteurs mais aussi sur les PCs, les smartphones et les tablettes notamment par l'intermédiaire du Bluetooth

4.0. Nous nous proposons donc dans cette invention d'étendre DLNA Low Power afin de prendre en compte l'émergence de ses réseaux 6loWPAN.

Le procédé proposé ici est innovant et intéressant industriellement car:

- il ne nécessite pas de modification des Control Points actuellement déployés
- il ne nécessite pas une modification importante des devices DLNA (Media Servers, Media Renderers, ...) et n'impose pas l'utilisation d'un réseau de capteur particulier. Ainsi le mécanisme peut fonctionner sur ZigBee, Bluetooth 4.0 ou DECT ULE.
- il est de plus compatible avec la norme DLNA Low Power actuelle et normalisable dans un avenir proche (dans une éventuelle version 2 du standard).
- il s'intègre parfaitement à la démarche de réduction des couts énergétiques et pourrait donc être utilisé pour tous les équipements DLNA Orange (Liveboxes, décodeurs TV numériques, NAS ...) afin de leur permettre de désactiver les interfaces dont ils n'ont pas besoin sans impact sur l'expérience client.

B. Solution proposée

La solution proposée ici consiste à mettre en oeuvre un dispositif intelligent qui désactivera le réseau IPv4/IPv6 « traditionnel » et fera passer les messages UPnP / DLNA (comme le multicast) sur le réseau 6loWPAN (Figure 7). Le dispositif réactivera le réseau « principal » uniquement lorsqu'il aura détecté que l'utilisateur souhaite être mis en relation avec l'équipement ou lorsqu'il détectera que la bande passante n'est plus suffisante.

Pour cela, il y a un composant intelligent sur la gateway par exemple qui implémente un DLNA Low Power v2 (la v1 permet uniquement de connaître le statut des interfaces) afin de désactiver l'interface IPv4 / IPv6 de l'équipement et d'activer l'interface 6loWPAN quand il n'y a plus beaucoup de trafic.

A ce moment, l'équipement va envoyer ses annonces UPnP / DLNA sur l'interface ZigBee/Bluetooth ou DECT ULE par l'intermédiaire de 6loWPAN

Appendix C

et COAP. De son côté, la gateway va récupérer ses messages et les envoyer sur le réseau IPv4 / IPv6.

Ensuite, quand la gateway détecte qu'il y a vraiment du trafic (par exemple, réponse au M-SEARCH ou volume de données supérieure à 75% de la bande passante du tuyau), elle réactive l'interface principale de l'équipement en utilisant DLNA Low Power v2 et désactive l'interface 6loWPAN.

Le cas d'usage suivant peut illustrer ce procédé innovant:

Utilisateur utilise une application sur son iPhone en liaison Wifi (application ControlPoint DLNA, par exemple PlugPlayer) pour découvrir le contenu multimédia présent sur son réseau local et le jouer sur ses différents lecteurs de contenu (ayant le rôle de Media Renderer). Utilisateur part de chez lui, la gateway détecte qu'il y a peu de trafic avec le PC et le décodeur TV numérique Orange, en conséquence, la gateway décide de désactiver la carte WiFi (pour le PC) et la carte Ethernet (pour la STB) en utilisant DLNA Low Power. De plus, la gateway décide d'activer l'interface Bluetooth Low Energy / 6loWPAN de ces deux équipements afin de maintenir une connexion basse consommation avec ces équipements.

Utilisateur rentre chez lui et démarre son application, il voit cependant parfaitement son PC dans son application. Lorsque utilisateur sélectionne son PC pour parcourir le contenu qu'il contient, la gateway réactive la carte WiFi du PC afin que utilisateur puisse visualiser le contenu du Media Server de son PC. Puis, lorsque utilisateur souhaite choisir le lecteur multimédia, il voit aussi parfaitement son décodeur TV numérique. Lorsqu'il le sélectionne, la gateway remet en route la carte Ethernet de son décodeur TV numérique afin que le décodeur puisse jouer le contenu. A la fin de sa lecture, la gateway désactive la carte Ethernet du décodeur et la carte WiFi du PC.

Il est à noter que la mise en veille des cartes du PC et du décodeur par cette invention peut permettre de mettre en veille, par un effet domino, les plugs CPLs qui sont sur le chemin ou la carte WiFi ou Ethernet de la gateway (si celle-ci détecte qu'il n'y a plus d'équipements connectés). Cette optimisation permettrait de gagner encore en économie d'énergie et pourrait faire l'objet d'une extension de cette demande d'invention.

Une autre optimisation serait la mise en place d'un mécanisme de proxy tel

que décrit par la demande de brevet 12 61492. Ce proxy répondrait à la place de l'équipement le temps de la remise en route de l'interface « principale ».

C. Application de l'invention

Le domaine d'application concerne le multimédia, le partage de contenu dans l'environnement domestique, tous les secteurs concernés par DLNA.

Enfin, la solution résout un problème concret du standard DLNA et notamment de l'architecture DLNA Low Power et pourrait donc être incluse dans les évolutions à court terme de ce standard.

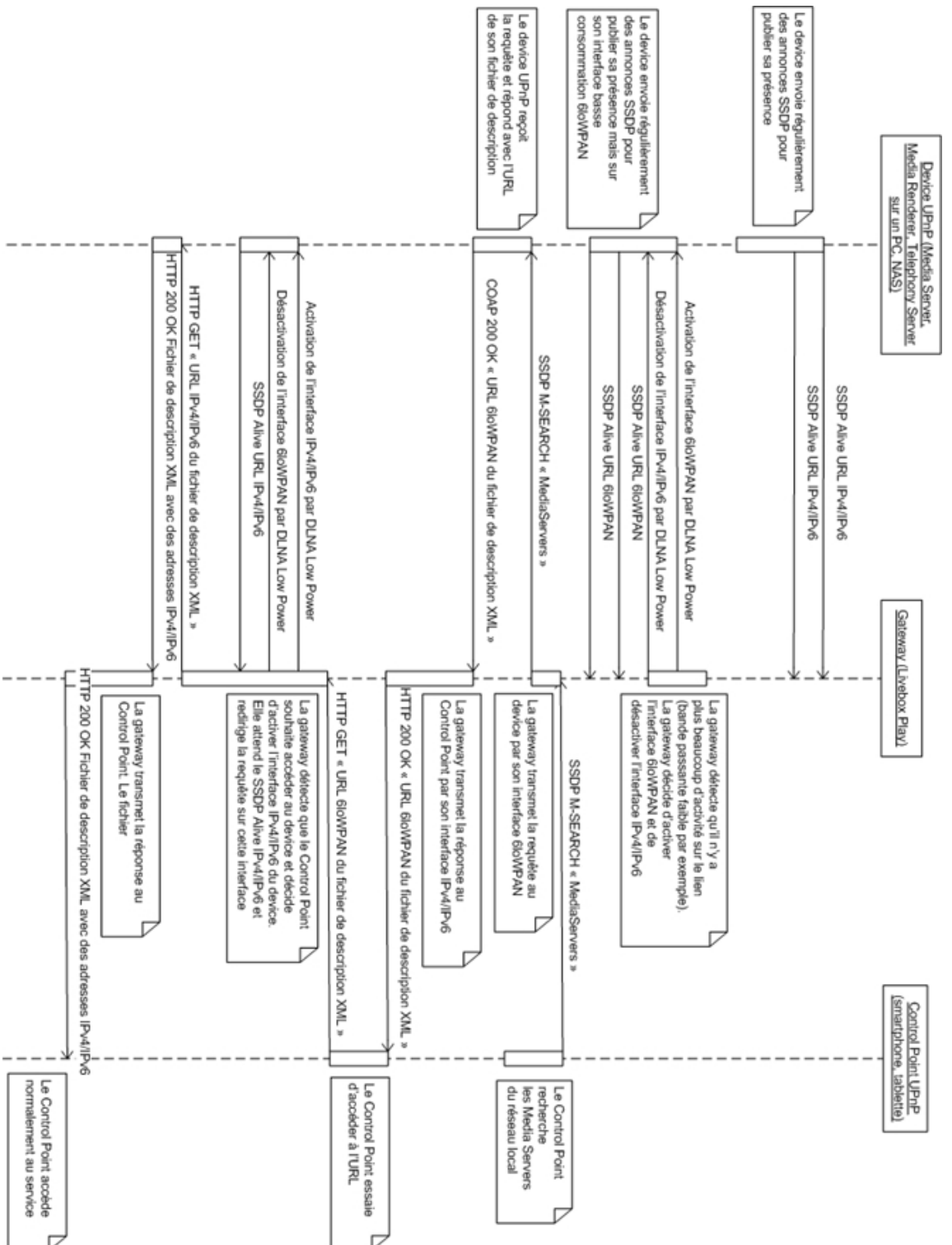

Figure 7: Diagramme de séquence de gestion de la mise en veille transparenter

Personal Publications

Articles

1. Yan, H, Fontaine, F, Bouchet, O, Vuichard, J, Javaudin, J, Lebouc, M, Hamon, M, Cousin, B, and Gueguen, C. “HOPE: HOme Power Efficiency System for a Green Network” IEEE INFOCOM’2013 Demo/Poster Session, Turin, Italy.
2. Yan, H, Cousin, B, Gueguen, C and Vuichard, J. “Refined Overlay Power Management in the Home Environment” IEEE GREENCOM ’2014, Taipei, Taiwan
3. Yan, H, Gueguen, C, Cousin, B, and Vuichard, J. “Collaborative Overlay Power Management based on the Delay-Power Trade-offs” IEEE FGCT ’2014, London, UK
Best paper award in IEEE FGCT

Patents

1. Yan, H, Mardon, G, and Gueguen, C (Dec 2012). “Economiser l’énergie du réseau domestique tout en maintenant la QoE de l’utilisateur” Patent 1261565 - France.
2. Yan, H, Fontaine, F, and Vuichard, J (Avr 2013) “Procédé de contrôle de la consommation énergétique d’équipements d’un réseau de communication local” Patent 1352881 - France.
3. Yan, H, Fontaine, F, (Oct 2013) “Mécanisme de gestion intelligente et transparente des connexions réseau IPv4/IPv6 par

Personal publications

- l'intermédiaire d'un réseau en overlay 6loWPAN", Patent 1359446 - France.
4. Fontaine, F, Yan, H, (Dec 2013) "Technique de communication dans un réseau local", Patent 1362832 - France.
 5. Fontaine, F, Yan, H, (Feb 2014) "Mécanisme de lissage de la consommation électrique des équipements UPnP", Patent 1452655-France.
 6. Yan, H, Fontaine, F, (Feb 2014) "An adaptive proxy for compliance of the equipments to IEEE 1905" Patent 1454940 -France
 7. Yan, H, Fontaine, F, (Sep 2014) "A repetition proxy for long distance communication between Bluetooth devices" Patent 1459280 - France
 8. Fontaine, F, Yan, H,(Sep 2014) "Detection mechanism of Bluetooth Low Energy devices (BLE) on the IP network using UPnP" Patent 1459283 - France

Book chapter

1. Yan, H, Vuichard, J, Cousin, B, Gueguen, C, and Mardon, G "Green Home Network based on an Overlay Energy Control Network" in the book "Green Networking and Communications" (Published by CRC Press, USA, oct 2013).

Poster

1. Yan, H, "Smart devices collaboration for a greener home network" Presented at "Journée des doctorants" Orange Labs, France, Sep 2014

Technical reports

1. *Econhome FUI 10: Deliverable 5.2: L'architecture du démonstrateur «HOMe Power Efficiency»*
2. *Econhome FUI 10: Deliverable 6.3: Présentation des démonstrateurs « Sélection de chemin Green » et « HOMe Power Efficiency»*
3. *Econhome FUI 10: Deliverable 6.4: Validation technique des démonstrateurs « Sélection de chemin Green » et « HOMe Power Efficiency»*

Personal publications

Bibliography

- [1] IEEE STD 1905.1. Ieee standard for a convergent digital home network for heterogeneous technologies. 2013. [15](#), [16](#)
- [2] KAYWAN H AFKHAMIE, SRINIVAS KATAR, LARRY YONGE, AND RICHARD NEWMAN. An overview of the upcoming homeplug av standard. In Power Line Communications and Its Applications, 2005 International Symposium on, pages 400–404. IEEE, 2005. [13](#), [14](#)
- [3] IAN F AKYILDIZ, XUDONG WANG, AND WEILIN WANG. Wireless mesh networks: a survey. Computer networks, 47[4]:445–487, 2005. [13](#)
- [4] DIGITAL LIVING NETWORK ALLIANCE. Use case scenarios white paper, June, 2004. [35](#)
- [5] HOMEPLUG ALLIANCE. Homeplug av specification, version 1.1, 2007. [14](#)
- [6] ZIGBEE ALLIANCE. Zigbee specifications, 2008. [18](#)
- [7] AZTECH. Aztech homeplugs power consumption. 2012. [15](#)
- [8] LUCA BENINI, ALESSANDRO BOGLIOLO, AND GIOVANNI DE MICHELI. A survey of design techniques for system-level dynamic power management. Very Large Scale Integration (VLSI) Systems, IEEE Transactions on, 8[3]:299–316, 2000. [29](#)
- [9] SIG BLUETOOTH. Bluetooth special interest group. Simple Pairing Whitepaper (Revision V10r00), 2006. [17](#)

BIBLIOGRAPHY

- [10] OLIVIER BOUCHET, ABDESSELEM KORTEBI, AND MATHIEU BOUCHER. Inter-mac green path selection for heterogeneous networks. In *Globecom Workshops (GC Wkshps)*, 2012 IEEE, pages 487–491. IEEE, 2012. [33](#)
- [11] NAJET BOUGHANMI AND YE-QIONG SONG. Improvement of zigbee routing protocol including energy and delay constraints. In *Junior Researcher Workshop on Real-Time Computing-JRWRTC’07 in conjunction with the 15th International Conference on Real-Time and Network Systems-RTNS 2007*, pages 19–22, 2007. [34](#)
- [12] NAJET BOUGHANMI AND YEQIONG SONG. A new routing metric for satisfying both energy and delay constraints in wireless sensor networks. *Journal of Signal Processing Systems*, 51[2]:137–143, 2008. [34](#)
- [13] WILLIAM C CRAIG. Zigbee: Wireless control that simply works. Program Manager Wireless Communications ZMD America, Inc, 2004. [18](#)
- [14] A DE ALMEIDA, P FONSECA, R BANDEIRINHA, T FERNANDES, R ARAÚJO, N URBANO, M DUPRET, JP ZIMMERMANN, B SCHLOMANN, E GRUBER, ET AL. Remodece: Residential monitoring to decrease energy use and carbon emissions in europe. Final report, page 96, 2008. [3](#), [4](#)
- [15] CHRISTOPHE DROMACQUE AND ANNA BOGACKA. European residential energy price report, 2013. [4](#)
- [16] INTERNATIONAL ENERGY AGENCY. More data, less energy. Technical report, 2014. [viii](#), [6](#)
- [17] STATISTICS EXPLAINED EUROSTAT. Consumption of energy. Technical report, 2012. [3](#), [4](#)
- [18] DAVE EVANS. The internet of things: how the next evolution of the internet is changing everything. CISCO white paper, 1, 2011. [14](#)
- [19] XIAOBO FAN, CARLA ELLIS, AND ALVIN LEBECK. Memory controller policies for dram power management. In *Proceedings of the 2001 inter-*

- national symposium on Low power electronics and design, pages 129–134. ACM, 2001. 31
- [20] SHAHIN FARAHANI. ZigBee Wireless Networks and Transceivers. Newnes, Newton, MA, USA, 2008. 19
- [21] HENDRIK C FERREIRA, HENRICUS M GROVÉ, OLAF HOOIJEN, AND AJ HAN VINCK. Power line communication. Wiley Online Library, 2001. 14
- [22] CHRISTOPHER B FIELD, VICENTE R BARROS, K MACH, AND M MASTRANDREA. Climate change 2014: impacts, adaptation, and vulnerability. Working Group II Contribution to the IPCC 5th Assessment Report—Technical Summary, pages 1–76, 2014. 2
- [23] FABRICE FONTAINE AND HAN YAN. Patent 1459283: Detection mechanism of bluetooth low energy devices (ble) on the ip network using upnp, 2014. 18
- [24] THE AMERICAN COALITION FOR CLEAN COAL ELECTRICITY (ACCCE). Energy cost impacts on american families, 2001-2012. Technical report, 2012. 4
- [25] A BEHROUZ FOROUZAN. Data Communications & Networking (sie). Tata McGraw-Hill Education, 2006. 12
- [26] UPNP FORUM. <http://www.upnp.org/>, 1999. 21
- [27] UPNP FORUM. Upnp low power architecture 1.0. 2007. 25
- [28] UPNP FORUM. Upnp energy management architecture 1.0. 2013. 25
- [29] KAZUO FUJII AND NAOTAKA KATOH. Wireless wake-on-lan power management, September 7 2010. US Patent 7,792,066. 26
- [30] KHUSVINDER GILL, SHUANG-HUA YANG, FANG YAO, AND XIN LU. A zigbee-based home automation system. Consumer Electronics, IEEE Transactions on, 55[2]:422–430, 2009. 32

BIBLIOGRAPHY

- [31] CARLES GOMEZ, JOAQUIM OLLER, AND JOSEP PARADELLS. Overview and evaluation of bluetooth low energy: An emerging low-power wireless technology. *Sensors*, 12[9]:11734–11753, 2012. [17](#)
- [32] GREENTOUCH. Greentouch green meter announcement, 2013. [1](#)
- [33] MARTIN GRIFFITHS. Ict and co2 emissions. 2008. [1](#)
- [34] REBECCA E GRINTER, W KEITH EDWARDS, MARK W NEWMAN, AND NICOLAS DUCHENEAUT. The work to make a home network work. In *ECSCW 2005*, pages 469–488. Springer, 2005. [13](#)
- [35] DIRK GRUNWALD, CHARLES B MORREY III, PHILIP LEVIS, MICHAEL NEUFELD, AND KEITH I FARKAS. Policies for dynamic clock scheduling. In *Proceedings of the 4th conference on Symposium on Operating System Design & Implementation-Volume 4*, pages 6–6. USENIX Association, 2000. [30](#)
- [36] CHAMARA GUNARATNE AND KEN CHRISTENSEN. Ethernet adaptive link rate: System design and performance evaluation. In *Local Computer Networks, Proceedings 2006 31st IEEE Conference on*, pages 28–35. IEEE, 2006. [31](#)
- [37] MARUTI GUPTA AND SURESH SINGH. Dynamic ethernet link shutdown for energy conservation on ethernet links. In *Communications, 2007. ICC'07. IEEE International Conference on*, pages 6156–6161. IEEE, 2007. [30](#)
- [38] JAAP HAARTSEN. Bluetooth-the universal radio interface for ad hoc, wireless connectivity. *Ericsson review*, 3[1]:110–117, 1998. [17](#)
- [39] DAE-MAN HAN AND JAE-HYUN LIM. Design and implementation of smart home energy management systems based on zigbee. *Consumer Electronics, IEEE Transactions on*, 56[3]:1417–1425, 2010. [32](#)
- [40] DAE-MAN HAN AND JAE-HYUN LIM. Smart home energy management system using ieee 802.15. 4 and zigbee. *Consumer Electronics, IEEE Transactions on*, 56[3]:1403–1410, 2010. [32](#)

- [41] GUAN-CHYUN HSIEH AND JAMES C HUNG. Phase-locked loop techniques. a survey. *Industrial Electronics, IEEE Transactions on*, 43[6]:609–615, 1996. [30](#)
- [42] JONATHAN HUI, PASCAL THUBERT, ET AL. Compression format for ipv6 datagrams in 6lowpan networks. *draft-ietf-6lowpan-hc-13* (work in progress), 2010. [20](#)
- [43] IL-KYU HWANG, DAE-SUNG LEE, AND JIN-WOOK BAEK. Home network configuring scheme for all electric appliances using zigbee-based integrated remote controller. *Consumer Electronics, IEEE Transactions on*, 55[3]:1300–1307, 2009. [32](#)
- [44] PHOENIX INTEL, MICROSOFT AND TOSHIBA. Advanced configuration and power interface specification. [28](#)
- [45] IPCC. *Climate change 2013: The physical science basis*, 2013. [2](#)
- [46] J-P JAVAUDIN, MARTIAL BELLEC, DIMITRIS VAROUTAS, AND VIN-CENZO SURACI. Omega ict project: Towards convergent gigabit home networks. In *Personal, Indoor and Mobile Radio Communications, 2008. PIMRC 2008. IEEE 19th International Symposium on*, pages 1–5. IEEE, 2008. [33](#), [34](#)
- [47] YOUN-KWAE JEONG, INTARK HAN, AND KWANG-ROH PARK. A network level power management for home network devices. *Consumer Electronics, IEEE Transactions on*, 54[2]:487–493, 2008. [34](#), [89](#), [108](#)
- [48] DONG-OH KANG, KYUCHANG KANG, SUNGGI CHOI, AND JEUNWOO LEE. Upnp av architectural multimedia system with a home gateway powered by the osgi platform. *Consumer Electronics, IEEE Transactions on*, 51[1]:87–93, 2005. [23](#), [24](#)
- [49] DONG-SUNG KIM, JAE-MIN LEE, WOOK HYUN KWON, AND IN KWAN YUH. Design and implementation of home network systems using upnp middleware for networked appliances. *IEEE Transactions on Consumer Electronics*, 48[4]:963–972, 2002. [23](#)

BIBLIOGRAPHY

- [50] ABDESSELEM KORTEBI AND OLIVIER BOUCHET. Performance evaluation of inter-mac green path selection protocol. In Ad Hoc Networking Workshop (MED-HOC-NET), 2013 12th Annual Mediterranean, pages 42–48. IEEE, 2013. [33](#)
- [51] ANIS KOUBAA, MÁRIO ALVES, BILEL NEFZI, AND YE-QIONG SONG. Improving the ieee 802.15. 4 slotted csma/ca mac for time-critical events in wireless sensor networks. 2006. [19](#)
- [52] NANDAKISHORE KUSHALNAGAR, GABRIEL MONTENEGRO, C SCHUMACHER, ET AL. Ipv6 over low-power wireless personal area networks (6lowpans): overview, assumptions, problem statement, and goals. RFC4919, August, 10, 2007. [20](#)
- [53] HANIPH A LATCHMAN, SRINIVAS KATAR, LARRY YONGE, AND SHERMAN GAVETTE. Homeplug AV and IEEE 1901: A Handbook for PLC Designers and Users. John Wiley & Sons, 2013. [15](#)
- [54] YU-JU LIN, H.A. LATCHMAN, MINKYU LEE, AND S. KATAR. A power line communication network infrastructure for the smart home. Wireless Communications, IEEE, 9[6]:104–111, Dec 2002. [13](#)
- [55] STÉPHANE LOHIER, ABDERREZAK RACHEDI, ISMAIL SALHI, AND ERWAN LIVOLANT. Multichannel access for bandwidth improvement in ieee 802.15. 4 wireless sensor networks. In Wireless Days (WD), 2011 IFIP, pages 1–6. IEEE, 2011. [19](#)
- [56] E. MACKENSEN, M. LAI, AND T.M. WENDT. Bluetooth low energy (ble) based wireless sensors. In Sensors, 2012 IEEE, pages 1–4, Oct 2012. [17](#)
- [57] PATRICIA MCDERMOTT-WELLS. What is bluetooth? Potentials, IEEE, 23[5]:33–35, 2004. [17](#)
- [58] H MENG, S CHEN, YL GUAN, CL LAW, PL SO, E GUNAWAN, AND TT LIE. Modeling of transfer characteristics for the broadband power line communication channel. Power Delivery, IEEE Transactions on, 19[3]:1057–1064, 2004. [14](#)

- [59] BRENT A MILLER, TOBY NIXON, CHARLIE TAI, AND MARK D WOOD. Home networking with universal plug and play. *Communications Magazine, IEEE*, 39[12]:104–109, 2001. [21](#), [22](#)
- [60] JIN MITSUGI, SHIGERU YONEMURA, HISAKAZU HADA, AND TATSUYA INABA. Bridging upnp and zigbee with coap: protocol and its performance evaluation. In *Proceedings of the workshop on Internet of Things and Service Platforms*, page 1. ACM, 2011. [134](#)
- [61] ANTON MONK, RONALD LEE, AND YOAV HEBRON. The multimedia over coax alliance. 2013. [15](#)
- [62] G MONTENEGRO, N KUSHALNAGAR, J HUI, AND D CULLER. Rfc 4944. Transmission of IPv6 packets over IEEE, 802[4]. [20](#)
- [63] GEOFF MULLIGAN. The 6lowpan architecture. In *Proceedings of the 4th workshop on Embedded networked sensors*, pages 78–82. ACM, 2007. [20](#), [21](#)
- [64] PETER NEWMAN, GREG MINSHALL, TOM LYON, AND LARRY HUSTON. Ip switching and gigabit routers. *IEEE Communications magazine*, 35[1]:64–69, 1997. [13](#)
- [65] J NIEMINEN, B PATIL, T SAVOLAINEN, M ISOMAKI, Z SHELBY, AND C GOMEZ. Transmission of ipv6 packets over bluetooth low energy. draftietf-6lowpan-btle-11 (work-in-progress), 2012. [20](#)
- [66] NVOY. nvoyn certification to usher hybrid home networking into the mainstream, 2013. [16](#)
- [67] NIOVI PAVLIDOU, AJ HAN VINCK, JAVAD YAZDANI, AND BAHRAM HONARY. Power line communications: state of the art and future trends. *IEEE Communications Magazine*, 41[4]:34–40, 2003. [14](#)
- [68] TREVOR PERING, TOM BURD, AND ROBERT BRODERSEN. The simulation and evaluation of dynamic voltage scaling algorithms. In *Proceedings of the 1998 international symposium on Low power electronics and design*, pages 76–81. ACM, 1998. [30](#)

BIBLIOGRAPHY

- [69] PADMANABHAN PILLAI AND KANG G SHIN. Real-time dynamic voltage scaling for low-power embedded operating systems. In *ACM SIGOPS Operating Systems Review*, 35, pages 89–102. ACM, 2001. [30](#)
- [70] GLOBAL ACTION PLAN. Green ict handbook a guide to green ict, 2009. [1](#)
- [71] DANIEL POPA AND JONATHAN HUI. 6lople: Transmission of ipv6 packets over ieee 1901.2 narrowband powerline communication networks. IETF, 2014. [20](#)
- [72] ALAN PRESSER, LEE FARRELL, DEVON KEMP, AND W LUPTON. Upnp device architecture 1.1. In *UPnP Forum*, 2008. [22](#)
- [73] KIRAN PUTTASWAMY, KYU-WON CHOI, JUN CHEOL PARK, VINCENT J MOONEY III, ABHIJIT CHATTERJEE, AND PEETER ELLERVEE. System level power-performance trade-offs in embedded systems using voltage and frequency scaling of off-chip buses and memory. In *Proceedings of the 15th international symposium on System Synthesis*, pages 225–230. ACM, 2002. [31](#)
- [74] IYAPPAN RAMACHANDRAN, ARINDAM K DAS, AND SUMIT ROY. Analysis of the contention access period of ieee 802.15. 4 mac. *ACM Transactions on Sensor Networks (TOSN)*, 3[1]:4, 2007. [19](#)
- [75] SHAHID RAZA, SIMON DUQUENNOY, TONY CHUNG, THIEMO VOIGT, UTZ ROEDIG, ET AL. Securing communication in 6lowpan with compressed ipsec. In *Distributed Computing in Sensor Systems and Workshops (DCOSS), 2011 International Conference on*, pages 1–8. IEEE, 2011. [20](#)
- [76] MUBASHIR HUSAIN REHMANI, THIERRY ALVES, STEPHANE LOHIER, ABDERREZAK RACHEDI, AND BENOIT POUSSOT. Towards intelligent antenna selection in ieee 802.15. 4 wireless sensor networks. In *Proceedings of the thirteenth ACM international symposium on Mobile Ad Hoc Networking and Computing*, pages 245–246. ACM, 2012. [19](#)
- [77] JOHN RITCHIE AND THOMAS KUEHNEL. Upnp av architecture: 0.83. For Universal Plug and Play Version, 1:1999–2002, 2002. [23](#)

- [78] BILL ROSE. Home networks: a standards perspective. *IEEE Communications Magazine*, 2011. 12
- [79] CHANG-HYUN RYU. Method and apparatus for controlling power of computer system using wake up lan (local area network) signal, July 8 2003. US Patent 6,591,368. 26
- [80] ISMAIL SALHI, YACINE GHAMRI-DOUDANE, STÉPHANE LOHIER, AND ERWAN LIVOLANT. Cozi: Basic coding for better bandwidth utilization in zigbee sensor networks. In *Global Telecommunications Conference (GLOBECOM 2010)*, 2010 IEEE, pages 1–6. IEEE, 2010. 19
- [81] ZACH SHELBY AND CARSTEN BORMANN. *6LoWPAN: The wireless embedded Internet*, 43. John Wiley & Sons, 2011. 20
- [82] ROYAL SOCIETY AND US NATIONAL ACADEMY OF SCIENCES. *Climate change evidence & causes*, 2013. 2
- [83] SOES. *Le bilan énergétique de la france pour 2010*. Technical report, 2010. 3
- [84] VINCENZO SURACI, ALESSIO CIMMINO, ROBERTO COLELLA, GUIDO ODDI, AND MARCO CASTRUCCI. Convergence in home gigabit networks: implementation of the inter-mac layer as a pluggable kernel module. In *Personal Indoor and Mobile Radio Communications (PIMRC)*, 2010 IEEE 21st International Symposium on, pages 2569–2574. IEEE, 2010. 33
- [85] VINCENZO SURACI AND ANDI PALO. Green networking: Integration of wireless sensor network with home gigabit access. In *Future Network & Mobile Summit (FutureNetw)*, 2011, pages 1–10. IEEE, 2011. 33
- [86] KEVIN THOMPSON, GREGORY J MILLER, AND RICK WILDER. Wide-area internet traffic patterns and characteristics. *Network*, IEEE, 11[6]:10–23, 1997. 12
- [87] PASCAL THUBERT. Requirements for an update to 6lowpan. *IETF*, 2014. 20

BIBLIOGRAPHY

- [88] SPYRIDON TOMPROS, NIKOLAOS MOURATIDIS, MAURICE DRAAIJER, ANDREAS FOGLAR, AND HALID HRASNICA. Enabling applicability of energy saving applications on the appliances of the home environment. *Network, IEEE*, 23[6]:8–16, 2009. [34](#)
- [89] NARAYANAN VENKITARAMAN. Wide-area media sharing with upnp/dlna. In *Consumer Communications and Networking Conference, 2008. CCNC 2008. 5th IEEE*, pages 294–298. IEEE, 2008. [24](#)
- [90] NEIL WESTE AND DAVID HARRIS. *Cmos vlsi design. A Circuits and Systems perspective*, Pearson Addison Wesley, 2005. [29](#)
- [91] T. WIEDMANN AND J. MINX. A Definition of 'Carbon Footprint', Chapter 1, pp. 1-11. Nova Science Publishers, Hauppauge NY, USA, 2008. [1](#)
- [92] HAN YAN, BERNARD COUSIN, CÉDRIC GUEGUEN, AND JEAN-PAUL VUICHARD. Refined overlay power management in the home environment. In *IEEE GREENCOM*, 2014. [7](#)
- [93] HAN YAN, FONTAINE FABRICE, OLIVIER BOUCHET, JEAN-PAUL VUICHARD, JEAN-PHILIPPE JAVAUDIN, BERNARD COUSIN, AND CÉDRIC GUEGUEN. Hope: Home power efficiency system for a green network. In *IEEE Infocom*, 2013. [7](#)
- [94] HAN YAN AND FABRICE FONTAINE. Patent 1359466: Mécanisme de gestion intelligente et transparente des connexions réseau ipv4/ipv6 par l'intermédiaire d'un réseau en overlay 6lowpan, 2013. [8](#)
- [95] HAN YAN AND FABRICE FONTAINE. Patent 1454940: An adaptive proxy for compliance of the equipments to ieee 1905 network, 2014. [18](#)
- [96] HAN YAN, FABRICE FONTAINE, AND JEAN-PAUL VUICHARD. Patent 1352881: Procédé de contrôle de la consommation énergétique d'équipements d'un réseau de communication local, 2013. [7](#)
- [97] HAN YAN, CÉDRIC GUEGUEN, BERNARD COUSIN, AND JEAN-PAUL VUICHARD. Collaborative overlay power management based on the delay-

BIBLIOGRAPHY

- power tradeoffs. In *IEEE Future Generation Communication technology*, 2014. 8
- [98] HAN YAN, CÉDRIC GUEGUEN, BERNARD COUSIN, JEAN PAUL VUICHARD, AND GIL MARDON. *Green Home Network based on an Overlay Energy Control Network*. CRC Press, USA, 2013. 7
- [99] HAN YAN, GIL MARDON, AND CÉDRIC GUEGUEN. Patent 1261565: Economiser l'énergie du réseau domestique tout en maintenant la qoe de l'utilisateur, 2012. 7
- [100] YAN ZHANG, RONG YU, SHENGLI XIE, WENQING YAO, YANG XIAO, AND MOHSEN GUIZANI. Home m2m networks: architectures, standards, and qos improvement. *Communications Magazine, IEEE*, 49[4]:44–52, 2011. 14