



HAL
open science

Energy saving solutions for integrated optical-wireless access networks

Glenda Gonzalez

► **To cite this version:**

Glenda Gonzalez. Energy saving solutions for integrated optical-wireless access networks. Networking and Internet Architecture [cs.NI]. Institut National des Télécommunications, 2015. English. NNT : 2015TELE0017 . tel-01239836

HAL Id: tel-01239836

<https://theses.hal.science/tel-01239836v1>

Submitted on 8 Dec 2015

HAL is a multi-disciplinary open access archive for the deposit and dissemination of scientific research documents, whether they are published or not. The documents may come from teaching and research institutions in France or abroad, or from public or private research centers.

L'archive ouverte pluridisciplinaire **HAL**, est destinée au dépôt et à la diffusion de documents scientifiques de niveau recherche, publiés ou non, émanant des établissements d'enseignement et de recherche français ou étrangers, des laboratoires publics ou privés.



THESE DE DOCTORAT CONJOINT TELECOM SUDPARIS et LUNIVERSITE PIERRE ET
MARIE CURIE

Spécialité:
Informatique et Réseaux

Ecole doctorale: Informatique, Télécommunications et Electronique de Paris

Présentée par
Glenda Zafir GONZALEZ DIAZ

Pour obtenir le grade de
DOCTEUR DE TELECOM SUDPARIS

Energy Saving Solutions for Integrated Optical-Wireless Access Networks

Soutenue le 09/07/2015
devant le jury composé de :
Directeur de thèse
Prof. Tülin ATMACA, Telecom SudParis

Rapporteurs
Prof. Philippe GRAVEY, Enseignant-chercheur Telecom Bretagne
Prof. Nihal PEKERGIN, Université Paris-Est Créteil

Examineurs
Prof. Tülin ATMACA, Telecom SudParis
Prof. Guy PUJOLLE, Université Pierre et Marie Curie
Prof. Catherine LEPERS, Telecom SudParis
M. Dominique CHIARONI Chercheur Senior Alcatel-Lucent France

These n° 2015TELE0017

Abstract

A big growth in the number of subscribers requiring broadband access is forecasted. The requirements of bandwidth due to the increasing traffic volume passing through each sector (core, metro, access) in a telecommunication network are varying. Each segment of the network is connected to another by a component who is in charge of the traffic shift from one part of the network to another (e.g. from metro to access). With the growing amount of traffic at this connection point, it is important to propose mechanisms to solve the traffic shift problem in efficient way.

Additionally, the traffic volume at the access level of the network becomes a challenge for the service providers. With the new and elevated transmission rates, and the connection requirements of the final users; it is expected that the optical access networks will constitute the largest energy consumers among the wired optical networks for the next ten years. In these networks, Optical Network Units (ONUs) consume over 65% of the total power consumption in Passive Optical Networks (PONs). In wireless networks, the global mobile data traffic has increased from 0.2exabytes/month in 2010 to 2.5exabytes/month in 2014. With this growth over 4 years it is expected that global mobile traffic will increase by a factor of 10 between 2014 and 2020. As consequence, over 60% of the total energy consumption in the service providers have been consumed by mobile Base Stations (BSs). These problems and the increasing impact of networks on the environment have made become the energy efficiency in telecommunication networks an important theme for researches. This dissertation hence focuses on the proposition of novel solutions for deal with the problems due to the growing of traffic in different segments of the network.

Firstly, we have studied the traffic shift between interconnected networks by using the synchronization as technique to solve this problem. The proposed solution consists in a packet creation mechanism named Common-Upgrade Timer Mechanism (CUTM) located at the Hub node which interconnects both networks. Finally, we have evaluated the performance of synchronous interconnected multi-ring networks in terms of access delay, jitter and packet filling ratio. Several simulations were ran with this purpose.

Secondly, we also explore the possibility of provisioning different services over the integration of optical-wireless technologies, which has been considered as a promising candidate for the deployment of high-speed and access networks. The energy efficiency problem in the optical-wireless integration has been taken into account. An architecture of design for the Optical Network Unit (ONU) is presented. The proposed architectural model integrates optical and wireless functionalities. Then, as the resource allocation is a key to save energy in the new network architectures, effective bandwidth management solutions have been proposed. Specifically two novel Dynamic Bandwidth Allocation (DBA) algorithms: Green Integrated Bandwidth Allocation (GIBA) and his enhanced version named Enhanced Green Integrated Bandwidth Allocation (eGIBA) have been presented. The DBA algorithms are performed via

a common medium access control protocol working in both domains as well: i) the optical resource allocation among ONUs in the optical domain, ii) and the optical/radio resource allocation among connected service subscribers in the optical/wireless domain. The algorithms have required an appropriate cooperation and integration of resource allocations so as to coordinate the communication between optical and wireless domains. GIBA and eGIBA allow active/sleep mode to transmitters and receivers at ONU. The approaches consider the End-To-End (E2E) packet delay, network throughput and some QoS constraints. We have conducted extensive simulations to demonstrate the effectiveness and advantages of the proposed solutions. A performance analysis by queuing models M/D/1 with vacation and gated was presented.

We have also proposed an energy efficiency algorithm for wireless receiver at hybrid ONUS. A protocol of communication between ONU-BSs was required for the use of the proposed algorithm. Mode active/save was considered for wireless receivers. Consequently, packet transmissions were synchronized between the ONUs and their associated BSs. The adaptive link rate was used to allow this process. The performance evaluation in terms of energy saving was evaluated by simulations. Also, a performance analysis by queuing models M/D/1 with vacation and gated was presented.

Finally, we have analyzed the heterogeneous traffic at hybrid ONU, then we have proposed a framework for a scheduling algorithm considering the characteristics of different traffic sources. We have evaluated performance by using static rules of service; however, the aim of this idea is to update the service rules in dynamic way.

Résumé

L'explosion de demande de bande passante est une conséquence de l'augmentation du volume de trafic. Les exigences des utilisateurs en termes de bande passante pour le transport du trafic dans chaque secteur (core, metro, accès) du réseau de télécommunication sont variables. Chaque segment du réseau est relié à un autre par un composant qui est en charge de transférer le trafic d'une partie du réseau à l'autre (par exemple réseau métro au réseau d'accès). Avec le transport du trafic accru au point de connexion, il est important de proposer des mécanismes pour transférer le trafic entre les réseaux interconnectés de manière efficace.

D'autre part, le volume de trafic au niveau du réseau d'accès est un défi pour les fournisseurs de services. Avec les débits très élevés de transmission (Gbit/s, Tbit/s), ainsi que les exigences de connexion des usagers finales; il est prévu que les réseaux d'accès optiques constituent les plus grands consommateurs d'énergie dans les réseaux optiques pour les dix prochaines années. Dans ces réseaux, les unités de réseau optique (ONUs) consomment plus de 65% de la consommation totale d'énergie dans les réseaux optiques passifs (PONs). Dans les réseaux sans fil, le trafic de données mobile mondial a augmenté de $0.2 \text{ exaoctets/mois}$ en 2010 à $2,5 \text{ exaoctets/mois}$ en 2014. Avec cette croissance durant 4 ans, il est prévu que le trafic mobile mondial va augmenter par un facteur de 10 entre 2014 et 2020. En conséquence, plus de 60% de la consommation totale d'énergie dans les fournisseurs de services ont été consommés par les stations de base mobiles (BSs). Les problèmes évoqués ci-dessus et l'impact croissant des réseaux sur l'environnement ont fait devenir l'efficacité énergétique dans les réseaux de télécommunications un thème important pour les recherches dans les réseaux de télécommunications. Cette thèse se concentre donc sur les propositions de nouvelles solutions aux problèmes liées à l'augmentation du volume de trafic dans différents segments des réseaux.

Tout d'abord, nous avons étudié différents schémas de transfert du trafic entre les réseaux interconnectés en utilisant la synchronisation comme la technique pour résoudre ce problème. Une alternative proposée est basée sur un mécanisme de création de paquets nommé Common-Upgrade Timer Mechanism (CUTM) situé au niveau du noeud Hub qui relie les deux réseaux. Plusieurs simulations ont été exécutées (en utilisant NS-2) afin d'obtenir les critères de performance en termes d'accès délai, la gigue et le taux de remplissage de paquets.

Deuxièmement, nous avons exploré aussi la possibilité d'offrir différents services dans les réseaux intégrés optiques-mobiles. Cette intégration au niveau de l'accès a été considérée comme une alternative pour le déploiement des réseaux d'accès à très haut débit. Dans ces réseaux intégrés, le problème de l'efficacité énergétique dans l'intégration optique-mobile a été considéré. Nous avons présenté une nouvelle architecture pour la conception de l'unité de réseau optique (ONU). Le modèle architectural proposé intègre des fonctionnalités optiques et mobiles. Puis, comme l'allocation de ressources a impact sur l'économie de l'énergie, des solutions efficaces pour la gestion de bande passante ont été proposées. Plus précisément deux nouveaux

algorithmes d'allocation de bande passante: Green Integrated Bandwidth Allocation(GIBA) et sa version améliorée nommée Enhanced Green Integrated Bandwidth Allocation (eGIBA) ont été présentés. Les deux algorithmes utilisent un protocole de contrôle d'accès commun dans les deux domaines: i) dans l'allocation des ressources optiques parmi les ONU dans le domaine optique, ii) et l'allocation des ressources optique/radio parmi les abonnés de services connectés à l'ONU dans les deux domaines optique/mobile. Les algorithmes ont exigé une coopération et une intégration appropriée dans l'allocation de ressources afin de coordonner la communication entre les domaines optiques et sans fil. GIBA et eGIBA permettent d'utiliser le mode "actif/sommeil" aux émetteurs et aux récepteurs situés dans l'ONU. Nous avons effectué des simulations pour démontrer l'efficacité et les avantages des solutions proposées. Une analyse des performances en utilisant les modèles M/D/1 avec "vacation" et "gated" a été présenté.

Nous avons également proposé un algorithme qui fournit l'efficacité énergétique pour les récepteurs sans fil dans les ONU hybride. Un protocole de communication entre ONU et BSs a été nécessaire pour l'utilisation de l'algorithme proposé. Le mode "actif/sommeil" n'a été considéré que pour les récepteurs sans fil. Les transmissions de paquets ont été synchronisées entre les ONU et leurs BSs associés. Le débit de transmission adaptative a été utilisé pour permettre ce processus. L'évaluation de la performance en termes d'économie d'énergie a été évaluée par des simulations. Aussi, une analyse des performances en utilisant modèles de files d'attente M/D/1 avec "vacation" et "gated" a été présenté.

Nous avons analysé le trafic hétérogène dans l'ONU hybride, nous avons proposé un cadre pour un algorithme d'ordonnancement en tenant compte les caractéristiques des différentes sources de trafic. Nous avons évalué les performances en utilisant quelques règles statiques de service. Toutefois, le but de cette idée est de mettre à jour les règles de service de façon dynamique. Il reste à faire l'implémentation de la proposition que nous avons fait.

Contents

1	Introduction	1
1.1	Why to save energy?	2
1.2	Problem Formulation	2
1.3	Dissertation Outline	3
2	Optical Networks, Wireless Networks and Next Generation of Optical-Wireless Access Networks	5
2.1	Optical Networks	6
2.2	Optical Metropolitan Area Networks (OMAN)	6
2.2.1	Switching Technique Evolution	6
2.2.2	Well-known OMAN Architectures	8
2.3	Optical Access Networks	10
2.3.1	Classification of Optical Access Networks	11
2.3.2	Passive Optical Networks (PONs)	13
2.3.3	PON Standards	16
2.4	Wireless Access Networks	20
2.4.1	First Generation (1G)	20
2.4.2	Second Generation (2G)	21
2.4.3	Third Generation (3G)	21
2.4.4	Fourth Generation (4G)	22
2.4.5	Fifth Generation (5G)	23
2.5	Optical-Wireless Access Networks	23
2.5.1	Independent Architecture	23
2.5.2	Hybrid Architecture	24
2.5.3	Unified connection oriented	25
2.5.4	Microwave-over-fiber	25
2.6	Energy Efficiency in Optical Access Networks	25
2.7	Energy Efficiency in Wireless Access Networks	27
2.8	Energy Efficiency in Integrated Optical-Wireless Access Networks	28
2.9	Concluding Remarks	30
3	Performance Evaluation of Interconnected Metro Rings	31
3.1	E2E Network Architecture	31
3.1.1	Studied Architecture	33
3.2	Packet Creation Mechanisms	36
3.2.1	Opportunist Mechanism (OM)	36
3.2.2	Common-Used Timer Mechanism (CUTM)	37

3.3	Simulation Parameters	39
3.4	Simulation Results	40
3.5	Concluding Remarks	44
4	Energy Saving in Integrated Optical-Wireless Access Networks	47
4.1	Integrated Optical-Wireless Access Network: Studied Architecture	47
4.2	MAC and Green Integrated Bandwidth Allocation (GIBA) in Integrated Optical-Wireless Access Network	50
4.3	Green Integrated Bandwidth Allocation (GIBA)	51
4.3.1	Extra-ONU Subalgorithm	52
4.3.2	Intra-ONU Subalgorithm	53
4.3.3	Proposed Energy Saving Model	55
4.3.4	GIBA Performance Evaluation	56
4.4	Enhanced Green Integrated Bandwidth Allocation (eGIBA)	61
4.5	Analysis of performance with queuing models	62
4.5.1	Queuing Delay Analysis	62
4.5.2	Estimation of Energy Consumed	64
4.5.3	Simulation Scenario and Numerical Results	65
4.6	Concluding Remarks	68
5	Efficiency Algorithm for Wireless Receivers (EAW)	69
5.1	System Model	69
5.2	Algorithm	74
5.3	Performance Analysis	76
5.3.1	Numerical Formulation	76
5.3.2	Asymptotic Approximation	77
5.3.3	Analysis by queuing models	78
5.4	Numerical Results	79
5.5	Concluding Remarks	83
6	Scheduling Mechanism for Optical-Wireless Networks	84
6.1	Proposed Architecture	84
6.2	Scheduling Algorithm	87
6.3	Dynamic Scheduling Algorithm	87
6.4	Simulation Results	89
6.5	Concluding Remarks	90
7	Conclusions	91
7.1	General Conclusions	91
7.2	Future Work	92

List of Figures

2.1	Optical packet switch	7
2.2	Reference OBS Switching	7
2.3	Burst transmission	8
2.4	RPR architecture	9
2.5	Point-to-Point system	12
2.6	Active Star system	12
2.7	Passive Tree system	13
2.8	TDMA System	14
2.9	SCMA System	14
2.10	WDMA System	15
2.11	EPON architecture	16
2.12	MPCP operation	17
2.13	DBA with computation time	19
2.14	Independent and Hybrid Architecture	24
3.1	Access, Core and Backbone Metro Networks [ECO 08]	32
3.2	E2E Metro Network Architecture	33
3.3	Multi-Ring Network Simulation	34
3.4	Architecture of hub	35
3.5	The synchronization shift between metro rings	36
3.6	Times associated to the Packet Creation Process	37
3.7	First procedure of CUTM	38
3.8	Last procedure of CUTM	38
3.9	Waiting time of electronic packets elapsed at Hub node applying OM	41
3.10	Waiting time of electronic packets elapsed at Hub node applying CUTM	41
3.11	Filling ratio obtained with OM and CUTM	42
3.12	Util/Effective Rates obtained with OM and CUTM	42
3.13	Util/Effective Rates obtained with OM and CUTM	43
3.14	Packet jitter at each node for Scenario 1	43
3.15	Packet jitter at each node for Scenario 2	44
3.16	Packet jitter at each node for Scenario 3	44
3.17	OM: Waiting time of electronic packets in Hub node in function of δt	45
3.18	CUTM: Waiting time of electronic packets in Hub node in function of δt	45
4.1	Proposed Architecture	48
4.2	Proposed ONU Model	49
4.3	QoS Mapping	50
4.4	Buffer Systems	51

4.5	Principle of GIBA	55
4.6	Mean Access Delay for CoS_1 going to OLT	56
4.7	Mean Access Delay for CoS_2 going to OLT	57
4.8	E2E Delay for CoS_1 going/coming to/from OLT	57
4.9	E2E Delay for CoS_1 going/coming to/from OLT	58
4.10	Mean Access Delay for CoS_1 wireless traffic	58
4.11	Mean Access Delay for CoS_2 wireless traffic	59
4.12	Mean Access Delay for CoS_1 Ethernet traffic	59
4.13	Mean Access Delay for CoS_2 Ethernet traffic	60
4.14	Energy Consumed by ONU	60
4.15	Principle of eGIBA	62
4.16	OLT traffic: Queuing Delay under different arrival rates	66
4.17	Ethernet traffic: Access Delay under different arrival rates	67
4.18	Wireless traffic: Queuing Delay under different arrival rates	67
4.19	Simulation and numerical results for Energy consumption	68
5.1	Access Network Architecture.	70
5.2	Pattern traffic considered.	70
5.3	Communication Process between ONU and BSs.	71
5.4	State Machine for Receivers.	72
5.5	State Machine for BSs.	73
5.6	RP obtained each cycle.	79
5.7	SP obtained each cycle.	80
5.8	Energy consumption ($Th = 0.7s$).	81
5.9	Improvement Factor ($Th = 0.7s$).	81
5.10	Mean Access Delay	82
5.11	Impact of Th on the receiver performance ($\lambda_1 = 0.01 \cdot C$ and $\lambda_{10} = 0.1 \cdot C$)	82
5.12	Mean Access Delay obtained by using M/D/1 with vacation model	83
6.1	Buffers System at ONU	85
6.2	Exterior buffer system	86
6.3	Local buffer system	86
6.4	Latency of CoS_1 , CoS_2 and CoS_3 for wireless connections	90

List of Tables

3.1	Classes of Service	39
3.3	QoS Requirements	40
3.2	Simulation Scenarios	40

Abbreviations

AMC	Adaptive Modulation and Coding
AMR	Adaptive Multi-Rate
ATM	Asynchronous Transfer Mode
BSs	Base Stations
CDM	Code Division Multiplexing
CES	Circuit Emulation Service
CO	Central Office
CSA	Credit service Allocation
DBA	Dynamic Bandwidth Allocation
DBDQ	Distributed Queue Dual Bus
EDGE	Enhanced Data rates for GSM Evolution
ESA	Elastic service Allocation
EPON	Ethernet Passive Optical Network
eNB	evolved nodeB
E2E	End-to-End
FDMA	Frequency Division Multiple Access
FEC	Forward Error Correction
FSA	Fixed service Allocation
FTTB	Fiber-to-the-Building
FTTC	Fiber-to-the-Curb
FTTH	Fiber-to-the-Home
FTTX	Fiber-to-the-Premise
FTTX	Fiber-to-the-X
GEM	GPON Encapsulation Method
GPON	Gigabit-PON
GPRS	General Packet Radio Service
GSM	Global System for Mobile Communication
HARQ	Hybrid Automatic Request
HDSPA	High-Speed Downlink Packet Access
HSPA	High Speed Packet Access
HSUPA	High-Speed Uplink Packet Access
IPACT	Interleaved Polling with Adaptive Cycle Time
ISP	Internet Service Provider
LSA	Limited service Allocation
LTE	Long Term Evolution

MPCP	MultiPoint-Control Protocol
MAC	Medium Access Control
MIMO	Multiple-Input Multiple-Output
MTW	Maximum Transmission Window
NG-PON	Next Generation PON
OCDMA	Optical Code Division Multiple Access
ODN	Optical Distribution Network
OLT	Optical Line Terminal
ONT	Optical Network Terminal
ONU	Optical Network Unit
ONUs	Optical Network Units
OFDM	Orthogonal Frequency Division Multiplexing
PDU	Protocol Data Unit
PON	Passive Optical Network
PONs	Passive Optical Networks
PtP	Point-to-Point
PtM	Point-to-Multipoint
RTT	Round-Trip Time
SCMA	Subcarrier Multiple Access
SIM	Subscriber Identity Module
TDM	Time Division Multiplexing
TDMA	Time Division Multiple Access
UMTS	Universal Mobile Telecommunications System
UTRAN	UMTS Terrestrial Radio Access Network
WCDMA	Wideband Code-Division Multiple Access
WDMA	Wavelength Division Multiple Access
WDM-PON	Wavelength Division Multiplexing PON
WiMAX	Worldwide Interoperability for Microwave Access

Chapter 1

Introduction

A network architecture consists of three main segments: backbone/core network, metro/regional network and access network. The metro network represents the sector connecting the core network with the access network. Access network is the last segment of the connection and it links the service provider's Central Office (CO) to end users. The traffic transported through these networks varies in each segment of the optical networking structure and it is growing day by day. This imposes to the new network architectures the implementation of mechanisms to face the new challenges associated to the big amount of traffic. Consequently, the transport plane has differently evolved in each part of the network (core, metro, access). The Passive Optical Networks (PONs) have attracted much attention of researchers because they are an excellent alternative for low cost broadband services. The huge capacity of optical technology seems to be a good solution for transmission of big traffic amount.

No only wired subscribers have contributed to the increasing traffic in the access level. The wireless clients services, applications (data and video) of new mobile devices to access the network (tablets, smartphones, laptops, etc.), the deployment of new generation of mobile networks and the number of mobile Internet subscribers have led to the growth of traffic volume. According to surveys, global mobile penetration rate will reach 100% after 2020 [[1]]. Moreover, as the internet of things becomes a reality, there will be massive growth in the number of connected devices which is expected to be around 50 billion devices by 2020. Simultaneously, the introduction of data hungry devices such as smartphones and tablets and associated applications are expected to lead to a thousand-fold traffic increase in 2020 in comparison with 2010 result in a monthly data traffic of 200 *exabytes* world-wide [[2],[3], [4]].

The integration of optical and wireless networks is a good alternative to improve this problem due to their complementary features of wide bandwidth and user mobility, respectively. It makes possible to reduce additional costs of the investment for purchasing equipment which is responsible for physical expansion of networks. However, it is expected that the power consumption increase due to the expansion of the network connectivity and to the augmentation of the data rate network. Modern communication networks have augmented the power consumption from approximately 0.4% of the global electricity consumption to 1% [[9]]. The energy consumption of current networks is 10000 times more than the absolute minimum requirement. The access segment consumes the 80% of the total power consumed by wired networks. In other side, the wireless access networks consume 0.5% of the global energy. Thus, the energy-saving technologies result a desirable objective in new integrated architecture systems.

In this sense, the Ethernet Passive Optical Network (EPON) standard has no management

protocols to reduce energy consumption. However, different techniques have been presented in the literature. These techniques utilize Sleep/Active mode for Optical Network Units (ONUs) while the Optical Line Terminal (OLT) is receiving data from other ONUs [[48], [49], [7],[8]]. To save energy in wireless networks, different algorithms to turn on/off some Base Stations (BSs) under traffic variation have been presented. Another proposed techniques are fast sleep modes solutions for BS components and resource allocation schemes including radio link design and radio resource management techniques. Also, the design of new wireless access networks consider the number and location of the radio access sites in order to satisfy certain coverage and capacity requirements with minimum deployment cost.

As result of the mentioned above, different protocols and intelligent mechanisms are required to handle the Sleep period of the ONUs to achieve maximum energy savings without compromising the requirements of users. On the other hand, Wireless networks must use efficiently the spectrum assigned and be highly reliable having an appropriate access speed to handle different traffic classes with different degrees.

In the scope of this dissertation, we aim to provide a study of the traffic passing from one sector of the network to another sector in interconnected networks belonging to different parts of the architecture. We will focus on the Metro Access Networks interconnected by Metro Core network in transparently way via a Hub node. Additionally, although several studies to save energy in wired and wireless access networks have been presented, the researches have been focused on separated way and the integration of both technologies have been neglected. This offers a wide domain to investigate, hence we also study the energy problem in integrated optical-wireless access networks.

1.1 Why to save energy?

In [[10]], the energy consumption of EPON devices was estimated at $270MW$, resulting in $2.37TWh$ annually. Out of the total value of $270MW$, $240MW$ are consumed by ONUs (approximately 88.7%). The ONUs could be considered the higher consummator of energy, then, decreasing the level of power consumed by ONU can substantially reduce the energy consumed by EPON. In other side, the energy cost of one wireless network constitutes almost 50% of OPEX [[11], [12]]. This is the cost associated to the electricity and the operation of off-(electrical)grid Base BSs. One of the biggest challenges for mobile operators is to provide 1000 – *fold* capacity to 50 billions devices. Consequently, as integrated optical-wireless access networks become a solution for big capacity in bandwidth demands and requirements of subscribers to access the information from anywhere and anytime, to anyone and anything, in a sustainable way; it is imperative to propose energy saving techniques in order to resolve in a efficiently way this problem.

1.2 Problem Formulation

Optical technology is an excellent solution for low cost broadband services. Additionally, it is easy to build and maintain due to the passive devices on the transmission line signal. It offers a big bandwidth capacity which made it becomes the preferred solution in modern telecommunication networks. In this kind of networks, usually, the high speed backbone sector can be connected with the high speed access sector by implementing metropolitan ring networks. We study the performance of interconnected Multi-Ring Networks (MRN) in which synchronous

Metropolitan Access (MA) Rings are interconnected by a synchronous Metropolitan Core (MC) Ring via a Hub Node who is in charge of the synchronization between them. In this architecture, the problem is how to synchronize the shift between metro rings in order to form core-based optical packets while ensuring the traffic routed efficiently through Hub node. To solve this problem, we propose a new mechanism called Common-Used Timer Mechanism (CUTM) inspired from CoS-Upgrade Mechanism (CUM) to create well filled optical packets in the hub.

In Passive Optical Networks, ONUs are the biggest consumers of energy. In wireless access networks the level of power consumed by BSs is considerably high. Consequently, the new hybrid ONU-BS for integrated Optical-Wireless access Networks is expected to consume energy considerably. We study the performance of integrated optical-wireless access networks by implementing energy-saving techniques. We deal with the tradeoff between energy consumption and network performance. Here, the big challenge is to decide between higher performance or lower energy consumption, and how much performance degradation is allowed for a certain energy saving. We propose a new architecture for the ONU of EPON, an effective QoS mapping mechanism of the different services supported by the integrated network, a DBA algorithm, and efficiently algorithms to use transmitters and receivers to reduce the power consumption. In order to support the QoS transmissions of network traffic originating from the heterogeneous networks (i.e., Optical and Wireless) within the autonomous access area, we propose a queuing scheme for handling the different classes of traffic at the ONU. Heterogeneous traffic is considered for all the proposed solutions.

1.3 Dissertation Outline

This dissertation is composed of seven chapters, which are organized as follows. Chapter 2 provides an introduction to modern telecommunication networks, to the optical access networks, their infrastructure and their evolution. A description and classification of metropolitan area networks is presented. Also, some architectures of metropolitan area networks are summarized. PONs are widely examined and different access techniques and standards are summarized. The evolution of wireless networks is given and the Optical-Wireless access networks' architectures are described. The advantages of the integrated access networks are listed.

Chapter 3 investigates performance analysis of multi-ring networks connected by a hub node in a transparent way. The problem of shift synchronization in the interconnected networks is treated. The performance of hub node is evaluated in terms of access delay and jitter. The study also includes the comparison between possible approaches for packet creation, to solve the major problem.

A very important topic is studied in Chapter 4. The first part proposes a model for hybrid ONU in integrated optical- wireless access networks. The second part presents: an algorithm of scheduling, a discipline of service, a mechanism of access control and a bandwidth allocation algorithm to save energy. An analysis of performance by queuing model to estimate mean access delay and the energy consumed by the hybrid ONU is summarized.

Chapter 5 focuses on the resource allocation in integrated optical-wireless access networks. Here, an algorithm for energy saving in wireless receivers by adapting transmission rate of channels is proposed. As in integrated access networks the traffic at ONU is homogeneous, to serv the different traffic kind regardless to QoS constraints is required.

Chapter 6 describes a scheduling for integrated optical-wireless access networks. This scheduling assures transmission of packets regardless QoS constraints. We introduce the static version of service discipline. We are working on the dynamic scheduling mechanism.

Chapter 7 concludes the dissertation with a summary of the main topics covered in this thesis, followed by some perspectives about future works.

Chapter 2

Optical Networks, Wireless Networks and Next Generation of Optical-Wireless Access Networks

Traditionally, networks are classified based on the physical properties of the channel; it means, fixed-line (wired-communications) and wireless (radio communications). According to this, today's core networks and metropolitan area networks (metro networks for simplicity) are almost entirely based on optical fiber systems. Moreover, the penetration of optical fiber communications in the access segment is progressing at a huge rate. Thus, the deployment of optical technologies in the access networks, through fixed/wireless convergence, could further reduce the role of wireless technology in transporting bandwidth over a reasonably long distance. The use of the fiber-optic transmission system has increased the bandwidth capacity of the single-fiber systems. Due to the growing of bandwidth requirements, the reduction of cost motivates the adoption of fiber-optic networks. As a result, dominant systems in the optical networking world such as Synchronous Optical Network (SONET)/Synchronous Digital Hierarchy (SDH) and the Internet Protocol (IP) become key elements on future networks. The physical network topology that best supports traffic demand generally varies with the segments (core, metro, access) of the optical networking structure. Metropolitan ring networks are usually used to connect the high speed backbone networks with the high speed access networks. There are different architectures of metro and access networks. A service implemented to respect QoS constraints could be provided by Point-to-Point fiber connection. However, this solution can be highly expensive. PONs seem as a promising technology to reduce costs associated to the architecture and the operation, for today and future architectures. Usually, PONs implement a tree topology sharing an access medium between subscribers. Different access methods are used to share the common medium. Time Division and Wavelength Division are very deployed in today PON solutions. In this chapter, the optical technologies are introduced. A description and classification of MAN is presented. Also, some very well known MAN architectures are summarized. Concepts and classification of Optical Access networks are presented. PONs are widely examined and different access techniques and standards are summarized. The evolution of wireless networks is given and basic concepts of Optical-Wireless access networks are presented.

2.1 Optical Networks

The first interest of optical technology is that it provides huge capacity for the networks. In addition, optical fibers offer a much more reliable medium of transmission than copper cables. Optical technology becomes a practical choice for the high speed network due to its huge capacity, reliable transmission path, and flexibility. An optical network means a communication network in which data is transmitted over fiber optic lines as pulses of light. It is developed in order to transmit data signals at high bit rates over a long distance. The optical communication benefits from numerous advantages of the optical fiber over the copper wire. As we know, the fiber optic is very flexible, lightweight and hair-thin medium leading to a very low propagation loss while the transmission bandwidth is extremely large, enabling a high-speed, broad-bandwidth and long-distance transmission.

2.2 Optical Metropolitan Area Networks (OMAN)

Metropolitan Area Networks (MAN) are based on the SONET/SDH optical network ring architecture. They provide a common solid infrastructure over which various services could be delivered. Namely, an inter-office (IOF) ring interconnects CO locations at higher bit rates, e.g., OC-48/STM-16 (2.5 Gbps). Among the different topologies possible for a MAN as ring, mesh, bus, etc., the ring topology is widely used. For instance, there are many standards for MAN having the ring topology such as Fiber Distributed Data Interface (FDDI) [17] token ring, Distributed Queue Dual Bus (DBDQ). This is due to the fact that the ring topology facilitates the switching decision as well as routing algorithms. Indeed, to address data to a destination, a ring node transmits data on the existing direction in which the node can receive it. On the other hand, if a problem occurs such as link cut or node failure, data may be redirected to the other direction of the ring during only a negligible time thanks to simple routing algorithms.

2.2.1 Switching Technique Evolution

As mentioned above, MAN is constructed over SONET/SDH based on the circuit switching technology. SONET/SDH standards were originally designed for Time Division Multiplexing (TDM) but current TDM equipments have trouble operating at high speed. The most important limitation of SONET/SDH is the lack of flexibility and scalability to deal with new services such as distributed applications and center data storage. One of other important disadvantages of the circuit switching is the long-term established connection. This means that a SONET/SDH connection is usually established and dimensioned for some months or years, and then traffic transported into this connection must be unchanged. If such connection type is terminated or MAN opens a new connection, SONET/SDH needs a very long time to reserve a new circuit. Therefore, the circuit switching may not be able to accommodate the bursty nature of Internet traffic in an effective manner [[18]]. As optical switching technology improves, the emergence of a photonic packet-switched network in which packets are switched and routed independently through the network entirely in the optical domain without conversion back to electronics at each node is predictable. Such optical packet-switched (OPS) network allows a greater degree of statistical multiplexing on optical fiber links and is better suited for handling bursty traffic than the optical circuit-switched network.

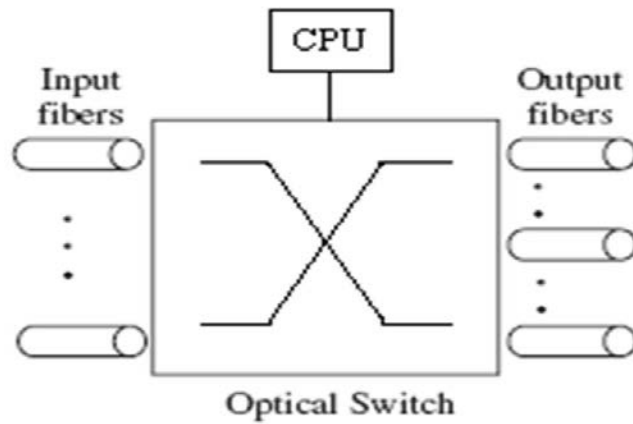

Figure 2.1: Optical packet switch

Nevertheless, the statistical multiplexing property introduces packet contentions at the output node entry. Contention occurs whenever two or more packets try to leave the photonic switch at the same output port on the same wavelength. In an optical packet switch, since the electronic memory is not used, thus a contention problem may be resolved by one of following methods: deflection routing, feedback, spectral resolution or temporal resolution.

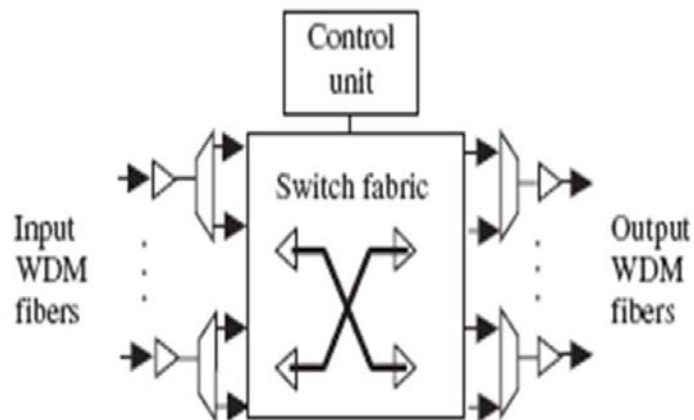

Figure 2.2: Reference OBS Switching

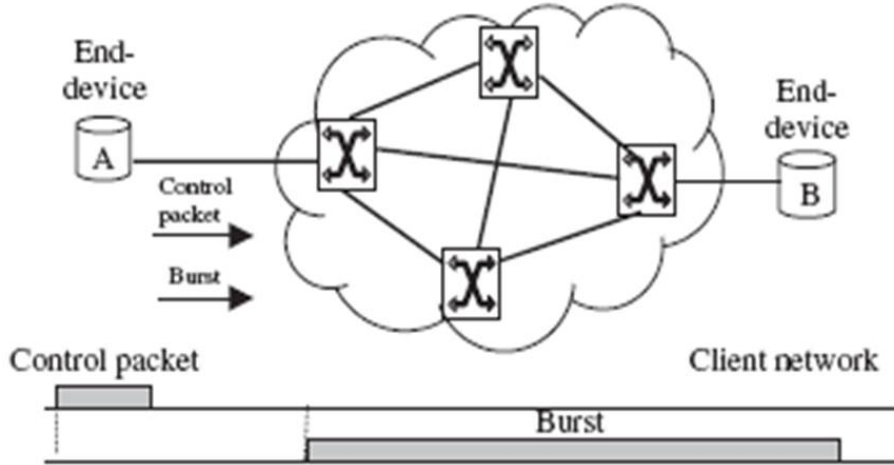

Figure 2.3: Burst transmission

Another challenge in the OPS is the synchronization. In a synchronous OPS network, time is slotted, and the switch fabric at each individual node can only be reconfigured at the beginning of a slot. All packets in a synchronous network have the same size, and the duration of slot is equal to the sum of the packet size and the optical header length. The synchronization of packets at switch input ports is often desired in order to minimize the contention. An Optical Burst Switching (OBS) is designed to achieve a balance between the optical circuit switching and the OPS. In an OBS scheme, the user data is collected at the edge of the network, sorted by destination address and transmitted across the network in variable size bursts. Prior to the transmission of each data burst, a control packet is sent into the network in order to establish a memory-less connection all along the way to the destination. The offset time (Fig. 2.3) allows the control packet to be processed and the switch to be set up before the burst arrives at the intermediate node; thus, no electronic or optical buffering is necessary at intermediate nodes while the control packet is being processed.

By reserving resources only for a specified period of time rather than reserving resources for an indefinite period of time, resources can be allocated in a more efficient manner and a higher degree of statistical multiplexing. Thus, the OBS is able to overcome some of limitations of the static bandwidth allocation incurred by the optical circuit switching. Furthermore, since data is transmitted in large bursts, the OBS reduces the technical requirement of fast optical switch.

2.2.2 Well-known OMAN Architectures

Resilient Packet Ring (RPR) standing for packet Add/Drop Multiplexer (ADM) solution has attracted much focus in the recent years. RPR (Fig. 2.4) defines a modified Ethernet

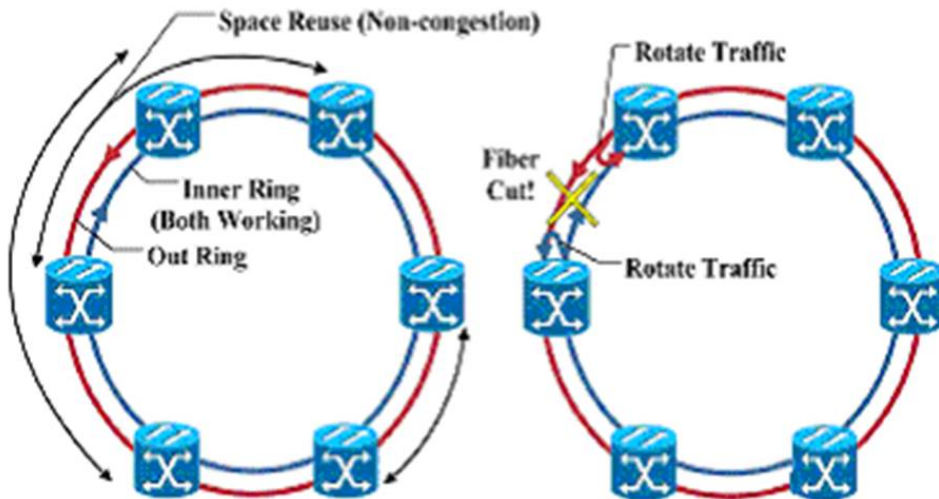

Figure 2.4: RPR architecture

Medium Access Control (MAC) protocol running over dual "ringlets" comprising multiple "Packet ADM" nodes. Each ring node contains electronic-buffers in a transit line, and forward transparently transit packets. RPR uses various methods to increase bandwidth re-use across a ring i.e. bandwidth multiplication [[19]]. As a result, the total ring throughput of a spatial reuse packet ring can be significantly higher than the capacity of a single link. So both ringlets can simultaneously carry working traffic and only need to activate the protection capacity during failure events. Additionally RPR is cost-effective for the packet transport. Packet ADM nodes are deployed to deliver a large converged service e.g. data (Internet LAN extension storage extension) voice-over-IP video-conferencing virtual leased line.

Another famous architecture for metro network is Dual Bus Optical Ring Network (DBORN) [[20]], which functions in the asynchronous mode. Logically, this network consists of two unidirectional buses: upstream and downstream. In the upstream bus, access nodes share a common transmission medium for carrying their traffic to a centralized node (called Hub node) while the downstream bus carries traffic from Hub node to all access nodes. For the cost-effective solution, each ring node possesses passive components, leading to the fact that they cannot drop any transit packets in upstream line. Another different point of DBORN with regard to RPR is the replacement of inline-buffers by Fiber Delay Line (FDL). Thanks to FDL, instead of containing transit packets in the electronic buffer, DBORN's access node does not require O/E/O conversion as compared to RPR, in the upstream transit line. DBORN employs optical unslotted: Carrier Sense Multiple Access with Collision Avoidance (CSMA/CA), protocol for detecting voids between two consecutive optical transit packets, which are usually occurred in the asynchronous mode. Since all transit packets pass across the FDL, CSMA/CA protocol can measure the size of voids and notify the node of inserting a local packet in the detected void.

A well-known optical architecture, SONET/SDH ring network, can be also applied for OMAN architecture. SONET/SDH ring networks provide multiplexing efficiency, reliability and timely transport of client signals but they require a high infrastructure cost and complex protocol for client signals. The most common implementation today is Generic Framing Procedure (GFP) over a SONET/SDH physical layer to supports all existing protocols at client layers. GFP protocol approved by the International Telecommunication Union (ITU-T) provides a framing format capable of supporting a diverse array of higher-layer protocols over any transport network. GFP supports two protocol mapping modes: frame mode and transparent mode. These two mapping modes are able to map all existing and emerging protocols. The frame mode is capable of adapting packet, or Protocol Data Unit (PDU), oriented protocols while the transparent mode is defined for adapting time-sensitive protocols that require very low transmission latency. The high cost of deploying high-speed data services over SONET/SDH network has retarded many service operators to update their existing network.

A MAN architecture named Optical Packet Switching Ring (OPSR), which is based on an all-optical infrastructure that offers equivalent features with lower cost while maximizing processing time as compared to other well-known architectures such as RPR or DBORN. The key element of such network is Packet Optical Add/Drop Multiplexer (POADM) so-called POADM ring network. POADM is necessary to deal with the Wavelength Division Multiplexing (WDM) dimension in the optical domain while significantly reducing packet processing time as compared to the opto-electronic model RPR. POADM module allows the node to exploit the optical transparency in the transit line. Basically, POADM nodes are connected by a bidirectional ring (2 fibers), allowing the implementation of security and resilience policies (as mentioned above). The operation on each direction is unidirectional. Thanks to active components, each node can receive, transmit or delete packets in the transit line of the node. POADM ring network functions in the synchronous mode with fixed-size packets. This solution avoids the bandwidth fragmentation problem since the ring path is divided into slots of equal durations. Voids on the ring will be multiple of the slot duration. The network link consists of several wavelengths: one for synchronization and control procedures, others for data transmission. Each out-line control packet, circulating on the control wavelength, provides information about the corresponding data carried on the same time interval on data channels. The control packet allows the node to detect whether corresponding data slots are occupied by an optical payload which is sent from an upstream node or not. The logical structure of nodes mainly consists of accordable optical transmitters and burst mode receivers. POADM architecture benefit the rely on shared optical wavelengths, which contributes to reduce the number of transponders required in the network. In this architecture, transmitters and receivers are out of the transit line, making it easier for the node to be upgraded, while limiting the service interruption and reducing the protection cost.

2.3 Optical Access Networks

Access networks interconnect each CO to end users, such as residential Internet users, corporations and institutions. The demand for applications is growing and higher bandwidth connections are required in the new access networks. The predominant traffic, specially with real-time applications, presents many challenges. Because the huge transmission capacity of optical technology, optical access networks became a good solution for the bottleneck problem

at the access level. According to the end-point or based on the infrastructure, a classification of optical access networks is proposed below.

2.3.1 Classification of Optical Access Networks

A. Classification by End-Point

Optical access networks is also named Fiber-To-The-X (FTTX) solutions, where X is referred to the end-point of the fiber line. The end point is not related to the structure of the optical access solution. We listed the possible end points next:

- Fiber-To-The-Home (FTTH) is referred to the Home as end-point.
- Fiber-To-The-Building (FTTB) has as end-point the business locations or buildings, here the subscribers are connected with LAN inside the building.
- Fiber-To-The-Curb (FTTC), in this architecture the end-point of fiber line is deployed in a cabinet for one or a number of streets, and subscriber connections using DSL or Cable Modem solutions.
- Fiber-To-The-Premises (FTTP) is a technology to provide Internet access by running fiber optic cable directly from an Internet Service Provider (ISP) to a user's home or business. It is considered one of the most future types of Internet technology, since there are no foreseeable devices that could use more bandwidth than can be sent via fiber optic cables. The disadvantage of this architecture is the difficulty and cost of its installation.

B. Classification by Infrastructure

Two alternative solutions exist to introduce optical fiber in the access loop: Point-to-Point (PtP) and Point-to-Multipoint (PtM) systems. Between the PtM architectures we can find: Active Star architecture and Passive Tree architecture. Other technologies like ring and bus can be used. However, ring is mostly common in metropolitan networks and bus is common in local area networks. A general classification is summarized below.

1. PtP. Each subscriber unit is connected to the CO with a separate fiber line. It requires separated fiber lines and end point for each fiber-line inside the CO. This solution increases the costs, and some stock problems can be faced due to the amount of ending points in the CO (Fig. 2.5).

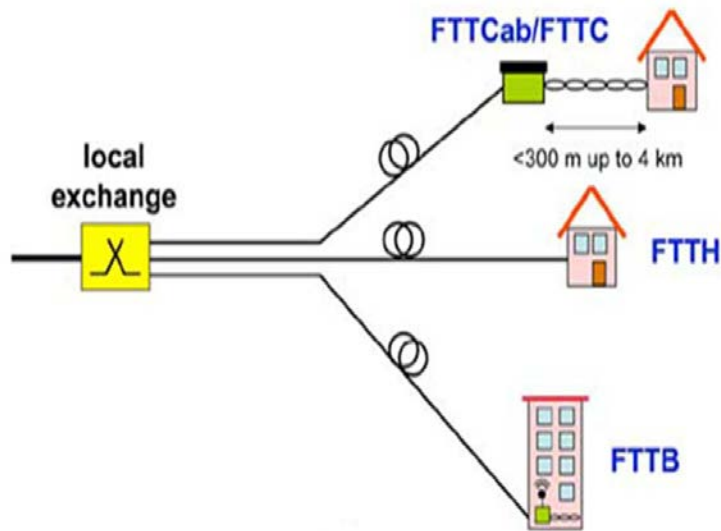

Figure 2.5: Point-to-Point system

2. Active Star Architecture. Here the network is connected to the CO by using a single fiber line. An active node is used to connect the CO and end points. Consequently, the number of fiber lines is decreased, the stock problem is minimized and the cost associated to the system is reduced (Fig. see Fig. 2.6). The inconvenient of this architecture is the electricity required for the active node to operate. The solution is less flexible compared to PtP, due to the sharing of the single fiber connecting the active node and the CO. Hence, the bandwidth capacity is reduced and it is smaller than PtP capacity. Because the cost associated to his implementation, this kind of architecture is more convenient than PtP.

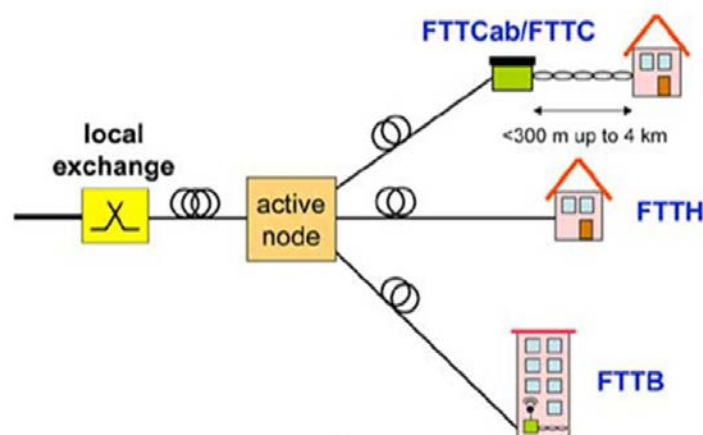

Figure 2.6: Active Star system

3. Passive Tree Architecture. In this solution (Fig. 2.7), the active node of the Active Star architecture is replaced by an optical splitter/combiner. By using this optical component

any active element is on the delivery line. This architecture is known as PON. The disadvantage of this architecture compared to the active star architecture is the number of users that can be connected. However, due to the cost for his implementation, PON becomes very popular in fix access networks. A description of this technology is presented in the next part of this section.

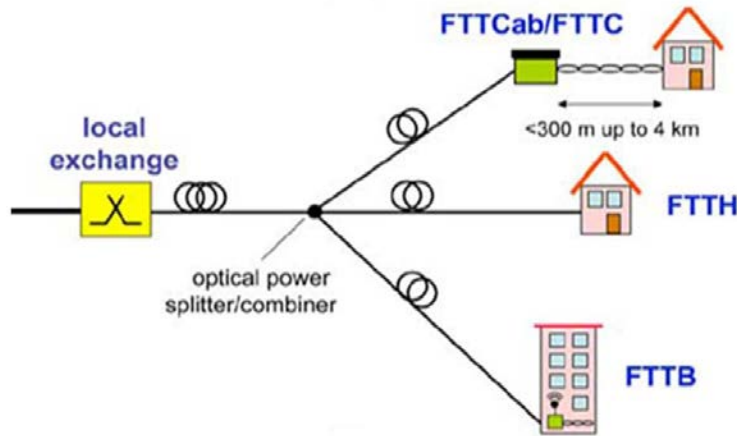

Figure 2.7: Passive Tree system

2.3.2 Passive Optical Networks (PONs)

A PON is formed by an Optical Line Terminal (OLT), located at the CO, and a set of Optical Network Units (ONUs) located at/in the neighbourhood of subscribers' premises. Between these active elements an Optical Distribution Network (ODN) is deployed, employing optical fibres and passive components (splitters/combiners and couplers). In the downstream direction (from OLT to ONUs), Ethernet frames are broadcast by OLT to all ONUs and are selectively received by each Optical Network Unit (ONU). In the upstream direction (from ONUs to OLT), since all ONUs share the same transmission medium, the system must employ a medium access technique to arbitrate access to the shared medium. The goal is to avoid data collision of different ONUs transmitting simultaneously and efficiently sharing the upstream transmission bandwidth among ONUs. The multiple access techniques used in PON are summarized below.

- a) Time Division Multiple Access (TDMA). Packets are transmitted in the upstream channel by granting a transmission window (or timeslot) to each ONU. Since ONUs are sharing the bandwidth, when the number of ONUs increase, the bandwidth of each ONU decreases. The upstream packets from the ONUs are time-interleaved, which requires synchronization of the packet transmission instants at the ONUs. This synchronization is achieved by means of grants sent from the local exchange, which informs the ONU when to send packets (Fig. 2.8). The correct timing uses the distance from each ONU to the local exchange. In the OLT at the local exchange, a burst mode receiver is required which can synchronize quickly to packets coming from different ONUs, and

which also can handle the different amplitude levels of packets due to differences in the path loss experienced. As the ONUs are sharing the transmission medium, the average of transmission capacity per ONU decreases when the number of ONUs grows.

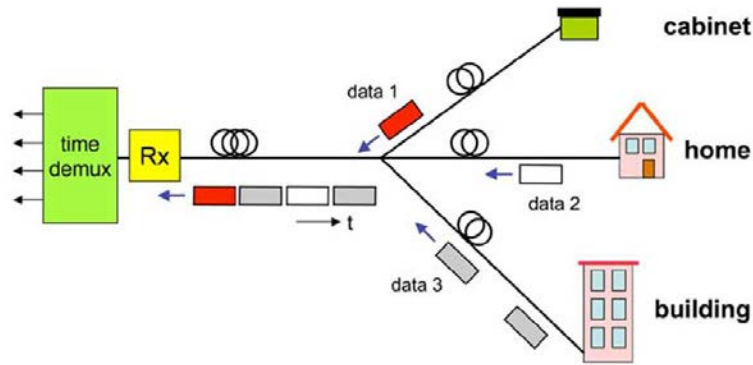

Figure 2.8: TDMA System

- b) Subcarrier Multiple Access (SCMA). The ONUs modulate their packet streams on different electrical carrier frequencies, which subsequently modulate the light intensity of their laser diodes. The packets are putted into independent frequency bands, which allow communication from an ONU to the OLT in the local exchange. These bands are demultiplexed again at the local exchange (Fig. 2.9). Each channels may carry a signal in a different format. No time synchronization of the channels is required.

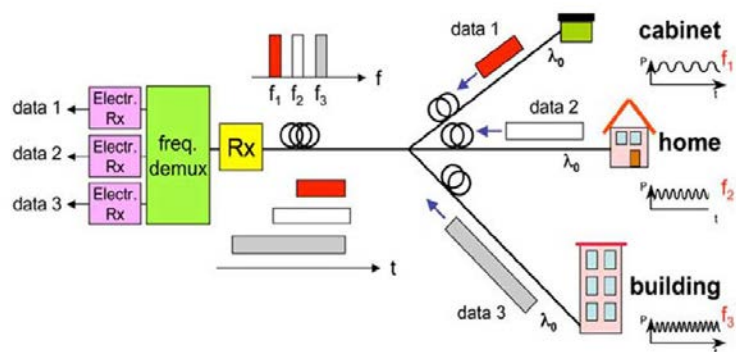

Figure 2.9: SCMA System

- c) Wavelength Division Multiple Access (WDMA). Also known as Wavelength Division Multiplexing (WDM-PON), each ONU uses a different wavelength channel to transmit packets to the OLT. The wavelength channels can be routed from the OLT to the appropriate ONU and backward by a wavelength demultiplexing/multiplexing device located at the splitter (Fig. 2.10). Wavelengths allow independent communication and they may carry different signal formats; also no time synchronization between the channels is required. The same wavelength channel may be used for upstream communication as well as for downstream simultaneously. In the upstream, every ONU needs a specific laser diode. This last, increases costs and complicates maintenance and stock inventory issues. Alternatively, the concept of colorless ONU concepts may be implemented to increase benefits in terms of scale economy, and thus lower costs.

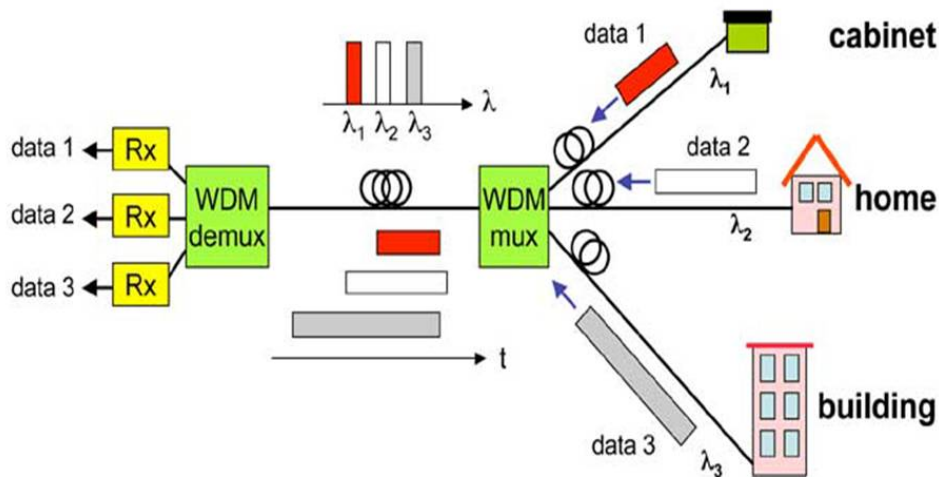

Figure 2.10: WDMA System

- d) Optical Code Division Multiple Access (OCDMA). In OCDMA, each ONU may use a different optical code to differentiate itself from the others. Two techniques exist time-sliced code words and spectrum-sliced code words. In a time-sliced OCDMA system, each ONU uses an on/off modulated sequence of optical pulses, with the data to be transmitted. The sequence duration must be at least a data bit duration, and a very high-speed sequence is needed to transmit moderate-speed data. The reach of the system is limited due to the increased dispersion impact and the decreasing power budget at high line rates. In the OLT at the local exchange, the data coming from the different ONUs is demultiplexed. The received signals are correlated with the known signature sequences. As the signature codes may be not perfectly orthogonal, some crosstalk may occur. In a spectrum-sliced OCDMA system, each ONU uses a combination of spectral slices with modulated intensity in the data to be transmitted. In the OLT, an optical

filter can be used to distinguish the data from that ONU. If the spectral slide codes are not perfectly orthogonal, some crosstalk will occur.

2.3.3 PON Standards

Different standards have been proposed in order to improve the performance of PON technologies. They are briefly described below.

A) Ethernet Passive Optical Network (EPON)

Each ONU processes the traffic destined to him, through the address contained in the header of the Protocol Data Unit (PDU). Upstream traffic (from all ONUs to OLT) uses an access method under control of the OLT located at the CO. This access method assigns time slots to each ONU for synchronized transmission of its data bursts. This process is named bandwidth allocation. The bandwidth allocation may be static or dynamically variable, for support of voice, data and video applications. In static allocation, OLT assigns a fixed-size transmission window based on ONU demand. On the other hand, in dynamic allocation, OLT allocates to each ONU a transmission window of variable length, based on each ONU demand. A description of the different approaches is presented below.

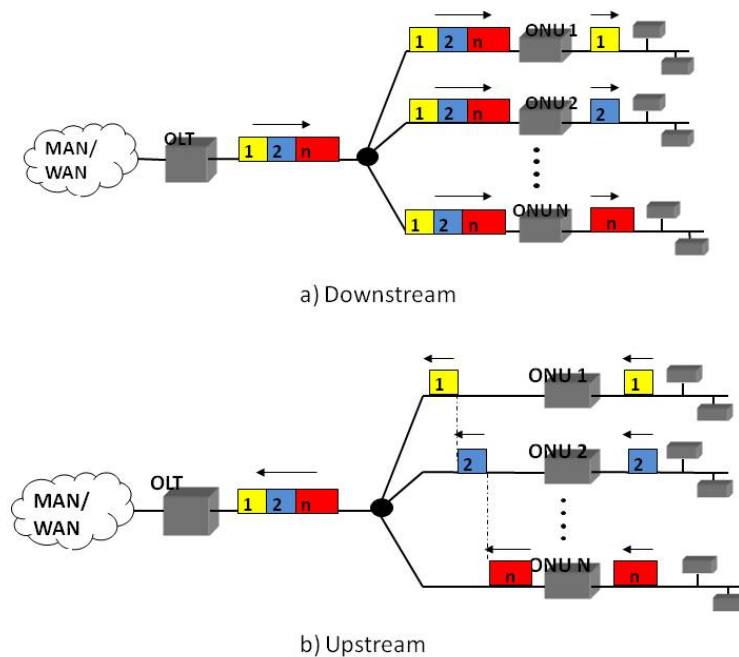

Figure 2.11: EPON architecture

- a) Statistical approach. A very known algorithm is the Interleaved Polling with Adaptive Cycle Time (IPACT). In IPACT, OLT polls ONUs individually and issues the granted transmission window to them in a round-robin cycle [[21]]. A polling message is scheduled in an interleaved way that reduces the bandwidth overhead and thus increases

the bandwidth utilisation rate of the upstream channel. On the other hand, the transmission cycle length is not static because it adapts to various cycle-based bandwidth requirements. By using a Maximum Transmission Window (MTW), ONUs with high traffic volumes are prevented from monopolizing the upstream bandwidth.

A communication process between OLT and ONUs has been defined. This process is named Multi-Point-Control-Protocol (MPCP). MPCP is not concerned with any particular bandwidth allocation. It is used to facilitate the implementation of various dynamic allocation algorithms and to assign dynamically the upstream bandwidth to each ONU in EPON. MPCP has two operation modes: normal mode and auto-discovery mode [[22]].

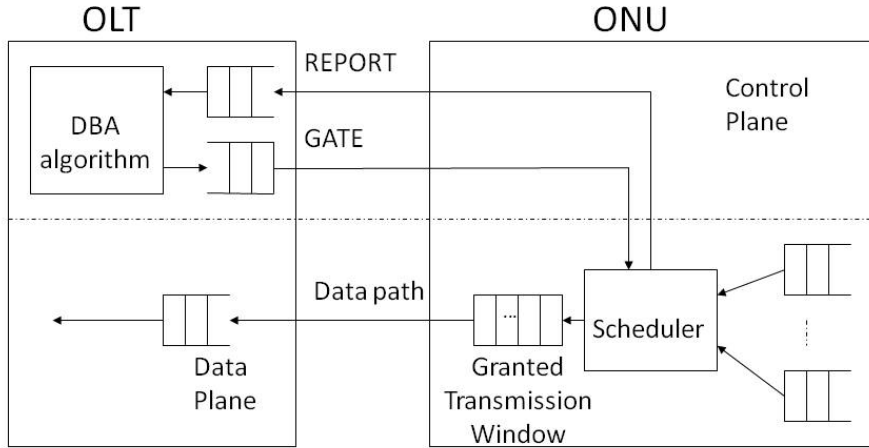

Figure 2.12: MPCP operation

- In the normal mode, MPCP relies on two Ethernet control messages: GATE and REPORT. Each ONU has priority queues that hold Ethernet frames ready for upstream transmission to OLT. The REPORT message is used by ONUs to report queue lengths. Upon receiving a REPORT message, OLT uses this information to execute the Dynamic Bandwidth Allocation (DBA) algorithm. The DBA algorithm computes the transmission start time and the granted transmission window for ONUs. After executing DBA algorithm, OLT transmits GATE messages to issue transmission grants to ONUs. ONU can update its local clock using the timestamp contained in each received transmission grant. Hence, each ONU is able to acquire and maintain the global synchronization. The transmission start time is expressed as an absolute timestamp according to this global synchronization. At the granted transmission start time, ONU will start its upstream transmission. The transmission may include multiple Ethernet frames depending on the transmission

window size and the local buffer occupancy of ONU. No frame fragmentation is allowed during the transmission. If the next frame cannot be transmitted in the current transmission window, it will be deferred to the next transmission window.

- In the auto-discovery mode, the protocol relies on three control messages, REGISTER, REGISTER_REQUEST, and REGISTER_ACK, which are used to discover and register a newly connected ONU, and to collect related information about that ONU, such as the Round-Trip Time (RTT) and the Medium Access Control (MAC) address.

Different static algorithms can be implemented, a categorization is summarized next:

- Fixed Service Allocation (FSA): the cycle length is always constant and transmission window has the same size for all ONUs.
- Limited Service Allocation (LSA): This scheme grants transmission window limited by a maximum transmission window size. In this case, the cycle length varies according to ONUs demands.
- Credit service Allocation (CSA): OLT grants the demanded window plus either a constant credit or a credit. This credit is proportional to the windows demanded by ONUs.
- Elastic service Allocation (ESA): it is based on assigning at most one maximum transmission window to each ONU in a round.

- b) DBA with computation time. The details of DBA algorithm with QoS support are presented in [[23]]. In this approach, upon receiving the REPORT message from an ONU, OLT does not answer immediately to this ONU. It must wait until REPORT messages from all ONUs are successfully received. Then, OLT collects the information in these messages as parameters for the DBA module to generate a table of granted transmission windows. It means, OLT requires a waiting time for the algorithm before retransmitting GATE messages. The data transmission is thus interrupted between two consecutive transmission cycles. As shown in Fig. 2.13, this mechanism results in some idle time that the upstream channel of the access network is not utilized. The idle time is estimated by supposing that all ONUs have the same round-trip time (RTT) to OLT as follows: $T_{idle} = RTT + \text{Computation Time}$.

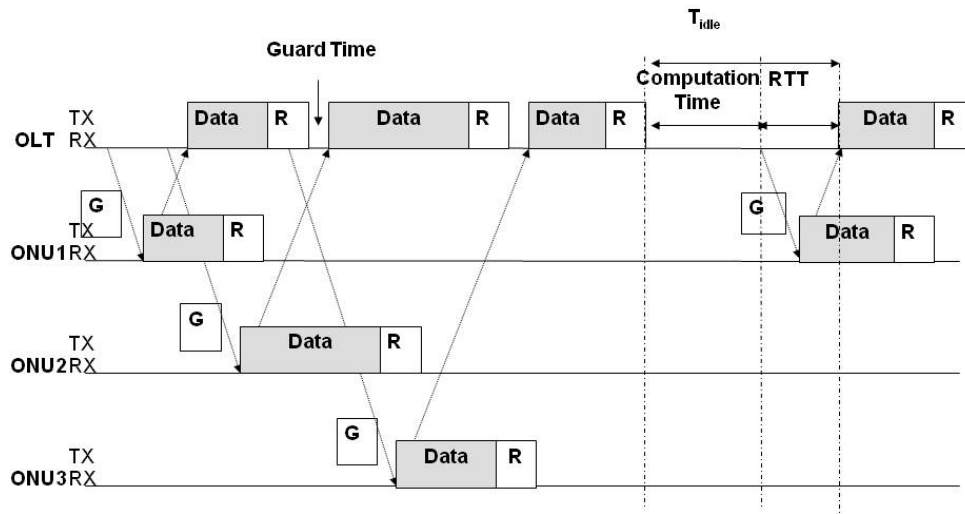

Figure 2.13: DBA with computation time

B) 10Gb-PON

Applications as IPTV, HDTV, 3DTV and online video gaming requires bandwidth per user no provided by EPON with capacity of $1Gb/s$. $10Gb$ -PON offers so much more bandwidth to FTTH and FTTB users. It can also fulfill the link capacity of $1Gb/s$ for access points of new wireless networks. In these networks, $10Gb/s$ is used in the downstream, and $1Gb/s$ and $10Gb/s$ are allowed in the upstream. They use VoIP for voice traffic and Circuit Emulation Service (CES) for other TDMA client signals. The MAC is based on the EPON protocol. It includes some enhancement Forward Error Correction (FEC) for error management. $10Gb$ -PON may overcome system bottlenecks by adjusting DBA algorithms implemented in EPON.

C) Gigabit-PON

In order to extend the capacity of PONs the ITU has set standards for the Gigabit-PON (GPON) in the $G.984.x$ series. In GPON Transmission (G.984.3) a framing format of $125\text{-}\mu s$ length is used, this frame can host a lot of different traffic formats. This GPON Encapsulation Method (GEM) may host Ethernet packets, and/or native Asynchronous Transfer Mode (ATM) packets, and/or native Time Division Multiplexing (TDM). In this way, a GPON system may operate in an Ethernet-packet-only mode, or in an ATM-only mode, or in a mixed mode. Ethernet frames may be fragmented among a number of GEM cells, which is not possible in the native IEEE 802.3 technology. Hence, GPON using GEM can obtain a high efficiency for transport of IP data payload, by utilizing up to 95% of the available bandwidth in the transmission channel. GPON also supports quality of service, as it enables service level agreement (SLA) negotiations between the OLT and the ONU through the ONU management and configuration interface set in G.984.4.

Next Generation of PON

Different ways of GPON evolution, known as Next Generation PON (NG-PON) have as goal to increase the bandwidth and reach of GPON, reusing the most of the passive optical network installed from the central to subscribers or ODN. Between the NG-PON we can find NG-PON1 and Wavelength Division Multiple PON (WDM-PON or NG-PON2). NG-PON1 is based on GPON ODN, whereas NG-PON2 require certain changes. There is great interest in the industry in both technologies.

XG-PON1 is the natural continuation in the evolution of PON technologies and although standards are ready. Interoperability is lower because of its lower time debug standard. In terms of energy consumption, this is considerably higher and the bandwidth requirements in short and medium term can be covered with GPON. However, GPON and XG-PON may coexist, due to a gradual migration process defined by ITU.

In the longer term WDM-PON will be deployed. In NG-PON2, new modulation formats such as Orthogonal Frequency Division Multiplexing (OFDM) or Code Division Multiplexing (CDM) have been investigated. The technologies required for WDM-PON are available today. Therefore, it is necessary to advance the standardization and achieve cost reduction of the optical components to be considered suitable for mass deployments. WDM-PON is actually much simpler than other PON technologies, because although physically keep the same architecture PtP TDM-PON, a virtual level each ONU has a dedicated wavelength. Thus, we can see each wavelength logically as a PtP channel, which can carry dedicated and symmetrical speeds for each user, ranging from $100Mbps$ to $10Gbps$. For transmission over a single fiber without interference wavelengths different bands are used in uplink and downlink. The WDM-PON, upward and downward wavelength may be unique to the subscriber or business customer on a FTTH Optical Network Terminal (ONT), but can also be shared by several subscribers FTTB/C. The use of WDM-PON access network offers great benefits over TDM-PON techniques. The improvements are related to management, operation and maintenance of the network easiest; security due to separation of traffic between subscribers.

2.4 Wireless Access Networks

Wireless Access Networks have evolved from the first generation (1G) until the fifth generation (5G), improving the transfer speed and including new technologies to provide service for new packet formats, applications and requirements of users. Technologies for each generation are described below.

2.4.1 First Generation (1G)

In 1980 the mobile cellular era had started, and since then mobile communications have significantly changed. 1G systems used analog transmission for speech services. First communications system offered handover and roaming capabilities but the cellular networks were unable to interoperate between countries. They were also significantly slower, and signals reach was not longer enough. In addition, analogue signals are more sensitive to interference problems. These were some disadvantages of 1G mobile networks. Traffic is multiplexed onto an Frequency Division Multiple Access (FDMA) system.

2.4.2 Second Generation (2G)

The second generation (2G) of mobile technologies started with the Global System for Mobile Communication (GSM). GSM is a digital technology that utilizes the microwave with signal transmission divided by time. GSM is capable of delivering voice and low speed data. The development of GSM results in General Packet Radio Service (GPRS), after, to improve speed a new technology was developed, the Enhanced Data rates for GSM Evolution (EDGE). In general, EDGE proposed speed three times greater than GPRS. 2.5GGPRS is a cellular wireless technology developed in between its predecessor, 2G, and its successor, 3G. The term "two and a half" (2.5 in informal language) is used to describe 2G systems that have implemented a packet switched domain in addition to the circuit switched domain. GPRS could provide data rates from 56 kbit/s up to 115 kbit/s . It can be used for services such as Wireless Application Protocol (WAP) access, Multimedia Messaging Service (MMS), and for Internet communication services such as email and World Wide Web access. GPRS data transfer is typically charged per megabyte of traffic transferred, while data communication via traditional circuit switching is billed per minute of connection time, independent of whether the user actually is utilizing the capacity or is in an idle state. 2.5G networks may support services such as WAP, MMS, SMS, mobile games, and search and directory.

2.75-Enhanced Data rates for GSM Evolution(EDGE) is a digital mobile phone technology which acts as a bolt-on enhancement to 2G and 2.5G GPRS networks. This technology works in GSM networks. EDGE technology is an extended version of GSM. It allows the clear and fast transmission of data and information. It is radio technology and is a part of 3G technologies. EDGE technology is preferred over GSM due to its flexibility to carry packet switch data and circuit switch data. EDGE transfers data in fewer seconds if we compare it with GPRS Technology. It does not need to install any additional hardware and software in order to make use of him. There are no additional charges for exploiting this technology. If a person is an ex GPRS Technology user he can utilize this technology without paying any additional charge

2.4.3 Third Generation (3G)

3G refers to the third generation of mobile telephony (that is, cellular) technology. The 3G as the name suggests, follows two earlier generations. 3G technologies enable network operators to offer users a wider range of more advanced services while achieving greater network capacity through improved spectral efficiency. Services include wide area wireless voice telephony, video calls, and broadband wireless data, all in a mobile environment. Additional features also include High Speed Packet Access (HSPA) data transmission capabilities able to deliver speeds up to 14.4 Mbit/s on the downlink and 5.8 Mbit/s on the uplink. 3G technologies make use of TDMA and CDMA and allow added services like mobile television, GPS (global positioning system) and video conferencing. The basic feature of 3G Technology is fast data transfer rates. 3G technology is much flexible, because it is able to support the 5 major radio technologies. These radio technologies operate under CDMA, TDMA and FDMA. For third generation (3G) some proposed technologies are:

- Universal Mobile Telecommunications System (UMTS), commonly referred named Wideband Code-Division Multiple Access (WCDMA) uses Wideband Adaptive Multi-Rate (AMR) for the codification of sound (voice codec), so the sound quality is obtained to be better than the previous generation. UMTS was developed and maintained by the

Third Generation Partnership Project (3GPP). It specifies a complete network system, which includes the radio access network (UMTS Terrestrial Radio Access Network, or UTRAN), the core network (Mobile Application Part) and the authentication of users via Subscriber Identity Module (SIM) cards. 3.5G High-Speed Downlink Packet Access (HSDPA) is a mobile telephony protocol, also called 3.5G, which provides a smooth evolutionary path for UMTS-based 3G networks allowing for higher data transfer speeds. HSDPA is a packet-based data service in WCDMA downlink. HSDPA implementations include Adaptive Modulation and Coding (AMC), Multiple-Input Multiple-Output (MIMO), Hybrid Automatic Request (HARQ), fast cell search, and advanced receiver design. 3.75G High-Speed Uplink Packet Access (HSUPA) refers to the technologies beyond the well defined 3G wireless/mobile technologies. HSUPA is a UMTS/WCDMA uplink evolution technology. The HSUPA mobile telecommunications technology is directly related to HSDPA and the two are complimentary to one another. HSUPA will enhance advanced person-to-person data applications with higher and symmetric data rates, like mobile e-mail and real-time person-to-person gaming. Traditional useful applications along with many consumer applications will benefit from enhanced uplink speed.

- Worldwide Interoperability for Microwave Access (WiMAX, based on the IEEE 802.16e) is essentially a PtM broadband wireless-access service that can be used efficiently for single-hop communication. WiMAX BSs can be placed indoor (installed by customer) or outdoor (installed by network operator) to manage the wireless network.
- Long Term Evolution (LTE) is the latest RAN technology standardized by the 3GPP. It consists of a new enhanced BS, called evolved nodeB (eNB) per 3GPP standards. Different releases have been defined in the past few years, each adding new features while preserving backwards compatibility. The first two releases (Release 8/9) are known as LTE [[24]].
- Release 10 is also known as LTE-Advanced (LTE-A) [[24]] which supports even higher bit rates. Note that LTE and LTE-A is the same technology and LTE-A is thus backwards compatible with LTE. LTE-A allows to adaptively change modulation (for translating the digital signal to an analogue signal that can be transmitted wireless), coding rate (for detection of the errors occurred due to wireless transmission), and bandwidth to enhance the channel quality.

2.4.4 Fourth Generation (4G)

It is a successor to 3G and 2G standards. The nomenclature of the generations generally refers to a change in the fundamental nature of the service, non-backwards compatible transmission technology and new frequency bands. 4G refers to all-IP packet-switched networks, mobile ultra-broadband (gigabit speed) access and multi-carrier transmission. The expectation for the 4G technology is basically the high quality audio/video streaming over end to end Internet Protocol.

2.4.5 Fifth Generation (5G)

5G is a name used in some research papers and projects to denote the next major phase of mobile telecommunications standards beyond the upcoming 4G standards. 5G technology has changed the means to use cell phones within very high bandwidth. User never experienced ever before such a high value technology. Nowadays mobile users have much awareness of the cell phone (mobile) technology. The 5G technologies include all type of advanced features which makes 5G technology most powerful and in huge demand in near future. The gigantic array of innovative technology being built into new cell phones is stunning. 5G technology has extraordinary data capabilities and has ability to tie together unrestricted call volumes and infinite data broadcast within latest mobile operating system. 5G technology has a bright future because it can handle best technologies and offer priceless handset to their customers. Maybe in coming days 5G technology takes over the world market. 5G Technologies have an extraordinary capability to support software and consultancy. The Router and switch technology used in 5G network provide high connectivity. The 5G technology distributes internet access to nodes within the building and can be deployed with union of wired or wireless network connections. The current trend of 5G technology has a glowing future.

2.5 Optical-Wireless Access Networks

New generation of access networks must provide access to the information anywhere, anytime, from/to anyone, from/to anything. To achieve this goal, optical and wireless access networks can be integrated in a complementary way. Indeed, there are some places where optical fiber cannot go, but where it is used, it provides a huge amount of available bandwidth. On the other hand, wireless access networks, potentially can go to many places, but their transmission channels are susceptible to a variety of impairments. Consequently, to satisfy new users requirements and the continuously increasing bandwidth demand, future access networks can use these technologies in an integrated way. Some architectures for integrated optical-wireless access networks have been proposed in [[48]], they are described below.

2.5.1 Independent Architecture

In this architecture (Fig. 2.14), the integration of optical and wireless is based on independent architectures. Each technology operates independently by considering a BS as an user served by one ONU. As long as the two devices support a common standard interface (e.g., Ethernet), they can be interconnected. In addition, each ONU can have interfaces to home users for wired access. Thus, the system can offer integrated services. With a common standardized interface (e.g., Ethernet), the direct benefit of the independent architecture is that the ONU and BS can be connected without any special requirements being met. However, because the PON and wireless systems operate independently, the ONU cannot see the details of how the BS schedules packets for its associated subscribed stations, while the BS cannot see the details of how the ONU schedules and sends upstream data to a PON OLT. Thus, the architecture may not take full advantage of the integration, particularly in optimal bandwidth allocation of the whole system. Moreover, two independent devices, an ONU and a BS, are required at the boundary of the two systems, which is likely to be more costly than using an integrated box as discussed later. Some works have been focused on this kind of architecture [[48],[49]].

2.5.2 Hybrid Architecture

A hybrid architecture is an enhanced integration, in which one ONU and a BS are integrated in a single system box (ONU-BS, Fig. 2.14). Such, an arrangement enables full integration of these two devices in both hardware and software. In hardware, there can be a number of CPUs (three in the example); for better integration, these CPUs can be further integrated into a single CPU. First CPU is responsible for data communications within the PON section and runs the PON protocols. Last CPU is responsible for data communications within the wireless section and runs the wireless protocols. Between them, a central CPU, coordinates the behavior of the other two CPUs. CPUs report their section states, and bandwidth allocation and request details to the central CPU; the latter makes decisions, and then instructs the other CPUs to request bandwidth from the upstream and allocate bandwidth to each SS in the downstream. The functional modules corresponding for upstream data communication, packet scheduler, priority queues, and packet classifier, wireless packet reconstructor and wireless upstream scheduler, ONU-BS central controller. One of the major benefits of this hybrid architecture is that the cost of equipment can be reduced as only a single device box is required. Moreover, because the integrated ONU-BS possesses full information on bandwidth request, allocation, and packet scheduling, optimal mechanisms can be adopted for bandwidth requests in the upstream direction of the PON network, and bandwidth allocation and packet scheduling in the downstream direction of the wireless network. Thus, compared to the previous independent architecture, this hybrid architecture is expected to improve the overall system performance in terms of throughput and service QoS. [[48]]

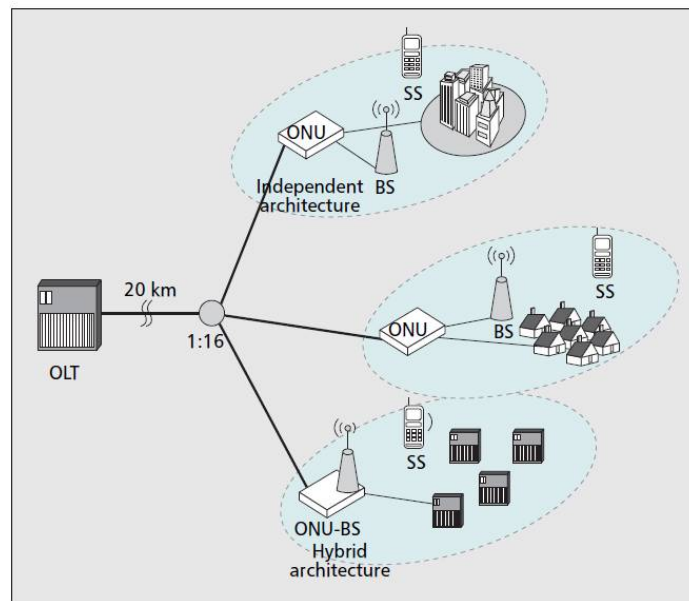

Figure 2.14: Independent and Hybrid Architecture

2.5.3 Unified connection oriented

When the wireless technology is a connection-oriented transmission technique, each service flow is assigned with a unique Connection ID and bandwidth requests and QoS support are connection-oriented. Based on connection-oriented bandwidth requests, an aggregate bandwidth is allocated to each SS, and this bandwidth is then allocated to each service connection associated with the SS. In contrast, PON technology does not support this type of connection. Rather, bandwidth requests are queue-oriented; an aggregate bandwidth is allocated to each ONU. Although the overall operational principles of the two types of networks are quite similar, particularly in the aspect of bandwidth request and allocation. In [[7],[8]], some keys about this architecture are presented.

2.5.4 Microwave-over-fiber

Each remote node is made up of an ONU, responsible for data communications of the PON, and a dumb antenna, responsible for relaying a radio signal from and to its associated microcell. PON signal is located at baseband and occupies frequencies up to $1.25GHz$. The radio signal is modulated on a wireless carrier frequency. These two signals are then multiplexed and modulated onto a common optical frequency (wavelength) and transmitted to an upstream central node. The authors describe concepts associated to this architecture in [[48]].

2.6 Energy Efficiency in Optical Access Networks

The design of new architectures for access networks must consider some important aspects as conservation and CO2 footprint reduction. Performances and service availability of battery-powered operations should be improved and the costs related to power consumption reduced. ONUs are big consumers of energy due to their activities. Consequently, different solutions have been proposed in order to reduce the power required by an ONU to operate. These solutions usually based on the idea that the ONUs are rarely used at their full potential and thus a lot of functionalities can be unpowered when inactive. According to a study about power saving in PONs conducted by ITU-T [[27]], those techniques allow to reduce the size and cost of backup batteries, and the average power consumption at all times. Furthermore these objectives should be reached sacrificing neither quality nor availability of service and some basic services like POTS (plain old telephone service) should always be available.

It is important to mention that these power saving techniques can require modifications of the hardware at the OLT and/or at the ONU, implying higher complexity and costs. These costs must be kept low for feasibility.

The most popular and discussed solutions to improve the power consumption on the ONU side can be classified into: ONU power shedding, ONU dozing, ONU deep sleep and ONU fast sleep techniques. This section presents each of these techniques.

a) Fast sleep mode

This technique uses a power save state for ONU. An ONU goes through a sequence of sleep cycles, each composed by a sleep and an active period. During sleep periods the ONU behaves just as if it was in deep sleep mode, it is completely powered off and some timing and activity

detection functions remain active. During active periods, instead, the ONU is normally active. The transitions between these two different periods are synchronized among all ONUs and they are controlled by the OLT. An ONU enters the sleep period after receiving the related message from the OLT and it wakes up when its timer (assigned by the OLT) expires and generates a wake-up signal. After the ONU has woken up it enters a synchronization state before recovering completely to normal operation. While ONU sleeps, the OLT buffers the downstream traffic addressed to it, which is delivered as soon as the ONU wakes up.

b) Deep sleep mode

In deep sleep technique, the transceivers and most functionalities of the ONU remain completely off for the entire duration of the power save state. Only, some basic functions (like activity detection and some local timing) remain optionally active. This allows to reach maximal power saving. Implementing this technique, an ONU can wake up when it is switched on by the customer or the local timer ends. The OLT must be informed of the ONUs transition to the save state, in order to avoid unnecessary alarming. While the ONU is deeply sleeping, the OLT can decide whether to keep on transmitting or discard downstream traffic. It can also allocate upstream traffic for the sleeping ONU but it should not expect any answer. OLT should allocate regular upstream grants to the sleeping ONU and this last can wake up and recover in a reasonable time. This technique is especially useful in particular situations as the switch of terminal equipment off or loss of services generated by the use of the technique considered tolerated.

c) Dozing sleep mode

The ONU transmitter can be powered off for certain periods of time while the ONU receiver must remain on all the time. ONU ignores its upstream allocations as long as it has no traffic to send but it keeps the downstream link fully operational allowing continuous delivering of traffic to the customer premises equipment. ONU can be waken up by a specific OLT request or by a local stimulus as traffic generation due to an internal process. In the meantime the OLT must send upstream grants to the dozing ONUs, without expecting any answer, so that they can recover immediately when they have traffic to send.

d) Shedding sleep mode

This technique considers that some ONUs functionalities may be inactive for a certain period of time and thus can receive a reduced amount of power or be switched off. The optical link is kept fully operational, it means ONU transceiver is always active. Traditional power shedding mode is applied only in case of main power supply failure. According to this solution, each interface kind of the ONU is associated to a particular shedding class. Each class is characterized by a static time parameter indicating the interval separating the moment when the relative interface support must be switched off from the moment of main power failure. An extended power shedding technique has also been proposed in order to apply it to more situations than just power failure. This solution allows the customer to inform the operator about specific time periods during which certain services are not used. In this way the operator has the opportunity to turn off those interfaces at the users ONU that are not required. This solution can be desirable for both the operator and the customer: while the operator does not require to decide when the ONU interfaces must be powered down, the customers can control

their own consumptions. In any case, the OLT is responsible for controlling and managing the power saving service. The ONU removes and restores the power when it is prescribed by the OLT. One advantage of power shedding is that it is a well understood and experimented technique because it is already largely applied in cellular phones, laptop PCs and monitors industries. Furthermore, according to an ITU-T study, power shedding can save over 70% of active power for a typical North-American ONU while the size of the backup battery can be reduced by more than 50%.

2.7 Energy Efficiency in Wireless Access Networks

Different energy saving solutions have been proposed for wireless access networks, they can be classified into 4 groups: i) hardware design to reduce the BS power consumption, ii) network management strategies regardless to the capacity offered and the actual demand, iii) radio resource management solutions to answer the question: when and how to transmit?, and iv) intelligent network architectures to cope with the traffic growth in a more energy efficient manner. A description of these techniques is presented below.

- a) **Hardware.** The energy consumption of BSs constitutes around 60% of the total energy consumption in wireless access network [[31],[28]]. In this regard, there is a huge potential for energy saving related to the power amplifiers as these are the main energy consumer of a BS [[29]]. Fast sleep modes solutions for BS components enable adapting to traffic load levels have been proposed and they offer promising approaches to minimize energy consumption [[29],[30], [31]].
- b) **Resource Allocation.** It is referred to the use of energy-aware resource allocation schemes, including radio link design and radio resource management techniques. The main objective of these approaches is to identify how a BS should make a decision on when and how to transmit data to multiple users within its cell considering the channel conditions of its users and the load conditions of the neighboring cells. Power control, Multiple-Input-Multiple-Output (MIMO), advanced retransmission schemes, coordinated Multi-Point (CoMP), interference mitigation, scheduling, etc. were proposed mainly to achieve higher peak data rates and lower latencies [[29],[30]]. To minimize the energy consumption, a good alternative is to establish the optimum balance between the demand and resources allocated [[32][34]]. 20% of the BSs carry 80% percent of the traffic even during the busy hour [[35]], so load conditions allows to propose energy efficiency oriented solutions. For high traffic load, different solutions have been proposed, specially applying MIMO techniques, to reduce energy consumption [[29], [36]].
- c) **Network Level.** The design of green wireless access networks must deal with the trade-off between the expected traffic requirements and the energy consumption per BS. It is required to define metrics [[37],[38],[39]] to evaluate optimized solutions and quantify the energy efficiency of a system. Also, the characterization of the total energy consumption by a specific network for specific operation and to formulate models indeed to predict the total power consumption in wireless access networks.
- d) **Network deployment.** Generally, it is referred to the objective design which means to determine the number and location of the radio access sites in order to satisfy certain coverage and capacity requirements with minimum deployment cost [[40]]. The aim

is maximizing energy efficiency rather than minimizing deployment cost. Currently networks are designed to guarantee a QoS level during peak rates. Nevertheless, traffic loads notably vary both spatially and temporally. 80% percent of the BSs carry only 20% percent of the total traffic, and only 10% of the BSs are highly loaded [[35]]. Therefore, the main fraction of energy is wasted due to this significant traffic variation and almost the load-independent nature of BS power consumption. Some solutions are: to reduce the number of active nodes in the network (i.e., by shutting down BSs when the traffic load is low), adaptive sectorization solutions by operating BSs in omnidirectional mode instead of tri-sectorized mode during low traffic situations, adaptive BS activation solutions based on the cell structures, bandwidth adaptation approaches can proposed based on the idea that using less frequency resources not only reduces the transmit power but also limits the number of reference symbols.

2.8 Energy Efficiency in Integrated Optical-Wireless Access Networks

Energy consumption in access networks is increasing. Networks consume 10,000 times more energy than the absolute minimum required. Today, Internet consumes approximately 0.4% of the total electricity consumption and is expected it increases to reach 1%. Recent studies show that PON consumes the least power among all the broadband access technologies [[41]]. It is expected that its energy consumption increases due to his evolution for supporting new data rates, for increasing reach abilities and split ratios, and for the use of active devices in wide areas. Some techniques have been proposed to reduce the energy consumption, among those, to put the ONU into sleep mode has been the most promising technique. Many mechanisms manipulate the sleep period of the ONU to achieve energy saving [[42]]. Energy saving in Ethernet networks has been recently addressed [[43]] and is currently under standardization [[44],[45]]. Similarly, energy efficiency in EPON via sleep mode is also being standardized and hence this subject is still in its earlier development stages [[46], [44]]. Most previous studies manipulate Dynamic Bandwidth Allocation (DBA) schemes such that an ONU can be put into sleep while the Optical Line Terminal (OLT) is receiving data from other ONUs [[47], [48], [49], [7]]. Protocols and intelligent mechanisms are required to handle the sleep period of the ONU to achieve maximum energy savings without compromising the requirements of users.

In wireless technologies, energy efficiency has long been studied. WiMAX has an energy saving mechanism already standardized [[50]]. However, for LTE technology is not the same case. Few years ago, BSs were considered as the most energy-greedy components of cellular networks, and it was established that they are under-utilized [[51], [52], [53], [54]]. Since then, several propositions to save energy have been pursued. These approaches reduce the carbon footprint of BSs by using the renewable energy sources, improving hardware components [[56]], and propose the sleep modes for BSs. The latter is considered an efficient solution to save significant amount of energy during low traffic periods [[57],[58],[59], [60], [61], [62]].

Generally, the energy problem in access networks has been studied in separated way for optical and wireless networks. Generally, solutions are proposed for wired or wireless networks without considering the integration as an all. In this work, we consider a real integration of the two types of networks, so the approaches proposed consider at the same time both traf-fics and network features. Some architectures have been proposed in the literature, Wireless

Optical Broadband Access Network (WOBAN) and Hybrid Optical Wireless Access Network (HOWAN). WOBAN is this cross-domain network architecture where end users receive broadband services through a wireless mesh front-end which is connected to the optical backhaul via gateway nodes. HOWAN is a very recently architecture where the optical backhaul and the wireless front-end are implemented by using wavelength division multiplexing/TDM PON, and WiFi wireless access technique respectively.

Next generation of integrated optical-wireless access networks is currently experiencing a remarkable proliferation. As it constitutes a good alternative solution for high-performance access networking, it has to be efficient and effective enough to compete with another low cost access architectures such as xDSL, standalone PONs, and 4G wireless technologies. Even though the literature looks abundant many challenges and opportunities towards wireless-optical integration following the aspects raised in [[63]], [[64]], [65], [66], [67]].

One of the topics to be studied is the impact of propagation delay. The works to develop hybrid DBA schemes assumes a fixed, predefined cycle for designing polling mechanisms in both optical and wireless domains, e.g., the fixed cycle MPCP. However, this assumption degrades the applicability of the DBA scheme. Hence, more efficient, dynamic, and flexible DBA schemes are required to address the future bandwidth starving services and applications.

QoS is a key in hybrid wireless-optical access networks. It governs the quality of the offered services. Most of the works found in the literature propose either a strict policy. To support adequate QoS services, it is required a monitor, control, and govern of call connections in the whole network applying an effective policy. The policy has to take into account fairness issues, SLAs, IP connections, throughput and delay guarantees, and individual contracts. [141] provide fairness provisioning; however it is limited to the mesh wireless domain. More efforts are needed to ensure fairness in FiWi access implementations. Moreover, extensive simulation and analytical frameworks are needed to identify the reliability and the effectiveness of an integrated access control under varied traffic conditions. Consequently, an integrated AC mechanism that applies to both optical and wireless, has not been seen in the literature, would be an interesting topic to investigate into.

The aim of the networks is to support and satisfy users requirements, preferences and constraints. To handle excessive traffic demand, providers deploy new network elements and hardware components, leading, thus, to increased amounts of energy required for their constituent operation. Access network constitutes a major energy consumer. It is estimated that access networks are responsible for the 70% of the overall telecommunication networks energy consumption [142]. Despite the fact that PONs, holding the core part of the modern hybrid wireless optical networks, are deemed as light energy consumers, effective energy efficient protocols and schemes are needed to reduce the consumption in hybrid wireless-optical networks. Even though several efforts push for green FiWi networks in the routing level [[70],[71],[72],[73],[74] , [75],[76],[77],[78],[79]], so far, the development of energy efficient access FiWi networks remains unexplored, regardless of the fact that the ITU pays high attention to development of high-performance energy efficient DBA schemes for new generation PONs. For instance, the study of how the sleep mode technique could be effectively applied to the hybrid ONUs could be a challenge for future work. Prediction and estimation techniques could be beneficial in the direction of tackling high propagation delays. As mentioned earlier, the usage of polling schemes, such as the MPCP, entails interconnection via control messages, as the GATE and REPORT.

The prediction methods found in the literature are limited to apply short-term bandwidth estimation, i.e., for the next cycle or frame. Long-term prediction techniques are required for

estimating volatile variable-bit-rate traffic employing high levels of cognition such as fuzzy logic, neural networks, and genetic programming. As an example, the development of a long-term predictor based on statistical data originated by real traffic patterns would be an interesting research topic. Most of the proposed DBA schemes for hybrid wireless optical networking consider only traffic generated by the wireless domain. However, this design could lead to serious deficiencies, if local traffic is, also, considered. Hence, an integrated DBA scheme is necessitated to support both traffic requests. To this end, it is interesting to study the structure of the polling scheme incorporated in the PON side, e.g., MPCP, when traffic requests arrive from both optical and wireless domains.

Finally, optimization could pave the way of developing commercial hybrid network components. Optimized DBA schemes may lead to high rates of utilization, which in return may allow maximum exploitation of the available resources offering a financially affordable ratio between spent money and revenue. Optimized techniques may be applied into several areas. For example, the order of treating bandwidth requests may be further studied so as to provide optimal schedules. Another example lies in the defined downlink-to-uplink ration regarding the used wireless platform. Various works indicate that adequately adjusting this ratio may lead to optimal or near optimal resource allocation [[80]], [[81]]. As a last note, various scheduling techniques could be studied and implemented to address the diverse scheduling needs coming from combining different technologies and architectures.

2.9 Concluding Remarks

In this chapter we have presented the basic definitions associated to the optical networks (core, metro, access). Some very well-known architectures have been summarized to give the main advantages of each one. It seems opportune to study an interconnected multi-ring-network architecture in which metropolitan access rings are interconnected by a metropolitan core ring via a Hub Node who is in charge of the synchronization between them. The major problem in this architecture is the shift of traffic from one ring of the network to another ring. The first part of this dissertation is dedicated to study this topic in the next chapter.

We have also introduced the evolution of wireless networks. The increasing number of subscribers, applications and consequently, bandwidth demand have originated many challenges in the new service provisioning. Novel technologies provide multi-service and the high flexibility with cost-effectiveness, are required in the metropolitan area and new (integrated) access networks. Given the continuous evolution of end-user demands, it is important to consider new architectures for integrated optical-wireless access networks. Many researchers are studying the energy efficiency problem on wired/wireless networks in separated way. A part of researches is focused on optical access networks and another is focused on wireless networks. However, the integrated optical-wireless architectures have been neglected. At the end of this chapter, promising architectures for integrated optical-wireless networks have been introduced. Since this type of network is still at its experimental stage, hence there is a wide domain to investigate. Between the most important points are: i) the integrated optical-wireless access network architecture with reduced cost of implementation and operational, ii) ONU architectures, QoS mapping mechanism of the different services supported by the integrated network, iii) the performance of ONU in terms of energy and QoS. The second part of this dissertation proposes some solutions to the listed problems.

Chapter 3

Performance Evaluation of Interconnected Metro Rings

Optical technology have attracted much attention of researchers because it is an excellent solution for low cost broadband services. The next generation of Metropolitan Area Network (MAN) requires flexible, scalable and manageable architectures to provide different type of services to their customers at the access or backbone networks. With passive devices on the transmission line signal, it is easy to build and maintain the network. So optical technologies become the first choice for metropolitan area network. Usually, the high speed backbone networks can be connected with the high speed access networks by implementing metropolitan ring networks. In this chapter, we study the performance of interconnected multi-ring network in which synchronous metropolitan access (rings) are interconnected by a synchronous metropolitan core (ring) via a Hub Node who is in charge of the synchronization between them. In this architecture, the problem is how to synchronize the shift between metro rings in order to form core-based optical packets while ensuring the traffic routed efficiently through Hub node. To solve this problem, we propose a new mechanism called Common-Used Timer Mechanism (CUTM) inspired from CoS-Upgrade Mechanism (CUM) to create well filled optical packets in the hub.

3.1 E2E Network Architecture

Metro core interconnects metro access networks, the interconnection between metro core and metro access can be done transparently through single access node (Hub node). Metro networks are generally considered SONET/SDH rings which carry the huge amount of bursty data traffic. The metro core and regional networks are normally both 2-fiber rings. A fiber failure in a metro access ring does not affect the traffic in the core and other access rings. The network thus becomes more reliability.

Dual Bus Optical Ring Network (DBORN) has been proposed as one of the first passive architecture for the metropolitan networks. More recently, a new transparent optical network providing packet-level granularity architecture have been proposed and studied. This architecture named ECOFRAME, its important characteristic is that it can be used as metro access and/or metro core network.

In [[13]], one architecture to integrate in a transparent way metro-access and metro-core ring networks is introduced. In [[14]], the design and develop of new devices to intercon-

nect metro access and metro core ring networks is presented. However, the synchronization problem between the networks has been neglected and a research opportunity exists in this sense. Mechanisms to create optical packets that improve the performance of multi-ring networks have been proposed in the literature. In this chapter, we present a new mechanism to create optical packets well filled and we compare the results obtained with the well known opportunistic mechanism in terms of waiting time, end to end delay, filling ratio, and jitter.

In this example [ECO 08], we consider 2 million subscribers. They are connected to the metro core (primary ring with 10 core stations) through access networks and metro networks. Each core station is connected with a secondary ring composing of 4 access stations (access nodes). So we have a total of 40 stations which are accessible. Each access station connects with 25 DSCUs which manages approximately 2000 subscribers across 60 PONs. We suppose that the amount of traffic from each network PON is approximately equal to 32Mbits/s, which requires a metro access with a capacity exceeding 200Gbit/s (40 wavelengths of 10Gbit/s responsible for 50%). Note that optical frames are transmitted from ONUs to OLT and from OLTs to DSCU under PtP connections.

The technology for an E2E architecture can be: ADSL towards PON in the access network and SONET/SDH/WDM towards all-optical packet switching/DWDM in the metro network. Besides, upstream traffic flux from OLTs to the metro access is statistically multiplexed through a Distant Subscriber Connection Unit (DSCU). A DSCU can be connected with several OLTs while an access node of the metro access can be connected with several DSCUs. As a result, a metro access (about 10 ring nodes) can support some thousands of PONs.

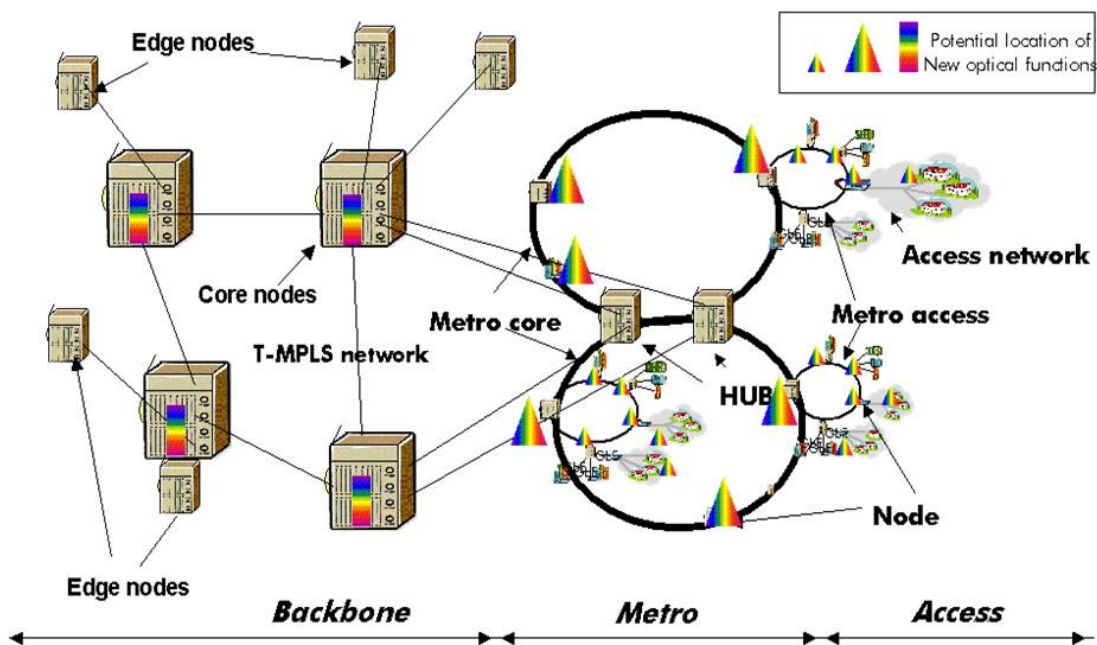

Figure 3.1: Access, Core and Backbone Metro Networks [ECO 08]

3.1.1 Studied Architecture

In this section, we present an architecture composed of two segments: metro access and metro core. For the access network synchronous DBORN architecture is considered and for core network ECOFRAME architecture. An example of an E2E network is shown as in Fig. 3.2. The interconnection is made via a hub node. We distinguish two traffic flows: 1) the traffic flowing from the access network to the core network through the hub, and 2) the traffic flow circulating in the core network. In an access node of metro access, the electronic packets are encapsulated in optical packets and transported through the hub. In the hub O/E/O converter is used to build new optical packets fill well coming from different nodes and going to same destination. These packets are stored in the queue in the hub. Hub architecture is presented in Fig. 3.4. It is composed of two parts: electronic part and optical part. In the electronic part, the packets are converted and stored in the buffer before processing. In optical part, it is used FDL.

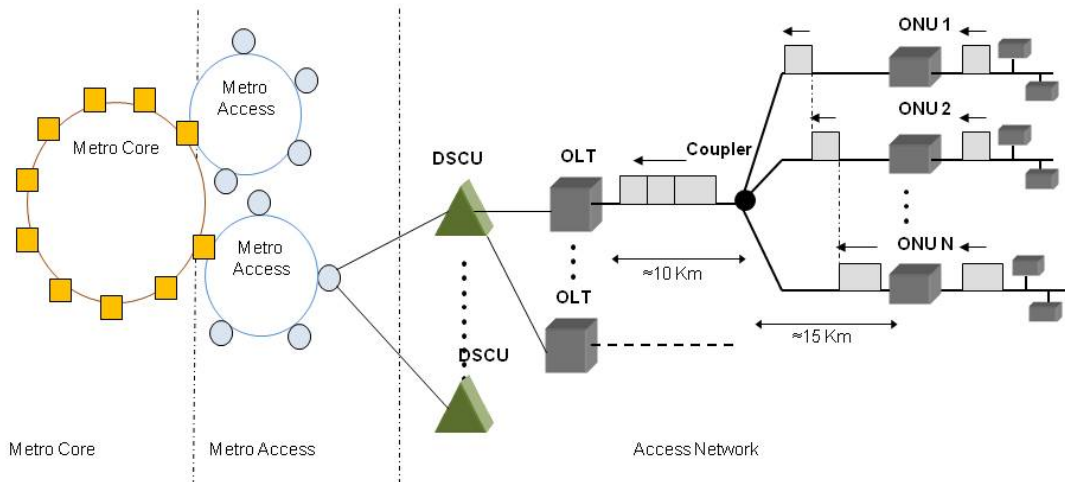

Figure 3.2: E2E Metro Network Architecture

For the sake of simplify, we use 2 metro rings in which one ring-based metro access connected to one ring-based metro core through a Hub node as shown in Fig. 3.3. Regarding the upstream path of the metro access, all access nodes send its local traffic to a destination node residing on the metro core network. The traffic is firstly transported to Hub node before being routed to the core metro network. Inside the Hub, since electronic packets coming from different sources have the same destination (the destination node is the node which stands behind Hub node in the metro core), they may be aggregated into a core-based optical packet in order to be transmitted in the core network.

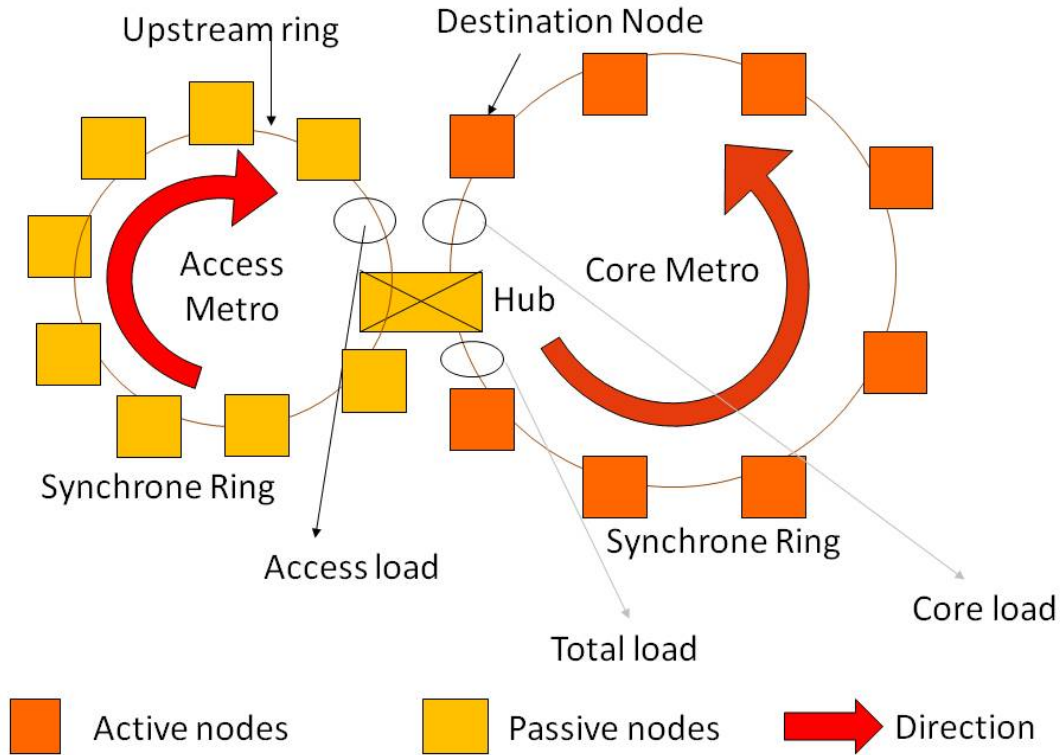

Figure 3.3: Multi-Ring Network Simulation

The traffic in the core network consists of two followings:

- A symmetric traffic: node i send its local traffic to node $(i + 2)$ (Hub node is not taken into account).
- Single traffic: from Hub node (the traffic is emitted from access nodes) to the destination node.

One of the roles of Hub is to create new optical packets well filled. From an access node residing in the metro access, electronic packets are firstly encapsulated into optical packets and then transported to the Hub. Depending on the access control mechanism used in Hub node, the optical packets may be directly put on optical buffers (to be ready for being routed to the core network) or be separated again into electronic packets which will be then contained in electronic buffers. The second leads to the creation of new optical packets, they can be created by using three mechanisms: 1) mutual combination (electronic packets coming from different access nodes can be combined together), 2) local combination (combined with local electronic packets of the hub) and 3) total combination (two combinations mentioned), totally according to class of service. This behaviour is very similar to GPFO mechanism [ENA 08] (which is developed in order to increase the filling ratio of the optical packets by entering electronic packets in intermediary nodes), so-called GPFO behaviour. In order to limit the complexity of the simulation, we consider only GPFO behaviour supported by mutual combination while resuming that Hub node does not function as a POP.

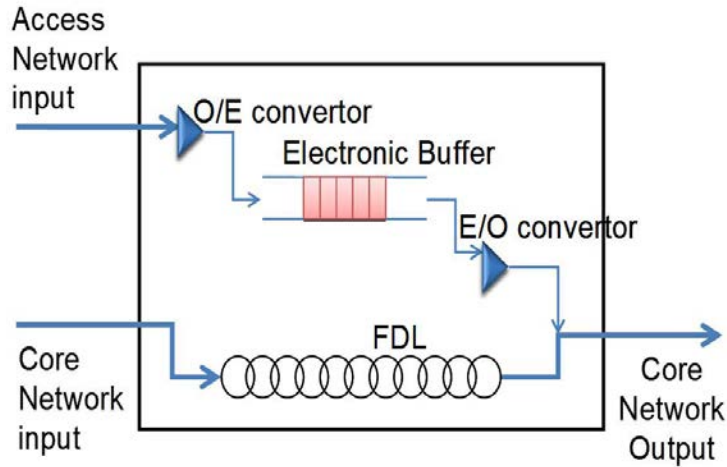

Figure 3.4: Architecture of hub

There are two key challenges to simulate a Hub node. The first one is the synchronization between interconnected rings (Fig. 3.5). Transmitting transparently optical packets through Hub node needs to consider this synchronization shift (called δt). The other challenge to simulate Hub node is the optical packet size supported by different rings. This is referred as granularity problem. In the second one, optical packets must be disassembled and re-aggregated but in different sizes before being switched. For simplicity, we suppose that two simulated rings support the same optical packet size. In general, a control packet will be dropped when corresponding data packets are received in Hub node. Inside Hub node, an optical control packet needs to be created and when a new optical data packet is created. Obviously, these created packets must accord characteristics of the core network. The insertion of data packets must satisfy the discipline of the traffic priority at Hub node the traffic in the core network has the priority higher than that in Hub node.

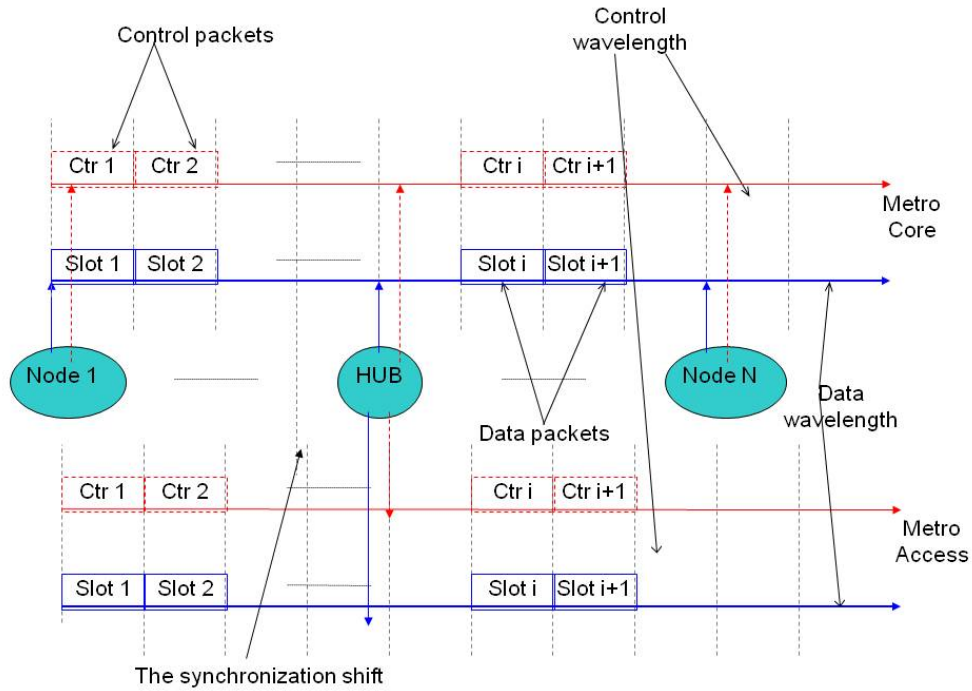

Figure 3.5: The synchronization shift between metro rings

3.2 Packet Creation Mechanisms

In this section, we describe two packet creation mechanisms that will be implemented in Hub node. As mentioned, Hub node connects two metropolitan rings. Therefore, the amount of traffic, which passes through Hub node for both directions: upstream and downstream paths, is normally very high. In order to be able to switch such high amount of traffic, Hub node should implement advanced mechanisms that take into account the optical packet creation process, the conversion O/E/O and the synchronization shift. Note that we should not apply directly existing mechanisms such as QoS-Upgrade, DCUM, etc. because of their complexity which may lead to the situation where Hub node is loaded. For this reason, we propose to apply two mechanisms: Opportunist Mechanism (OM) and Common-Used Timer Mechanism (CUTM).

3.2.1 Opportunist Mechanism (OM)

The creation of the optical fixed-size packet is only triggered when Hub node detects a free slot in the core network. Hub node firstly creates an optical packet from electronic packets of different CoS and then transmits the optical packet on the detected free slot. The creation of optical packets follows the next idea: high-priority electronic packets are firstly taken; otherwise low-priority electronic packets are taken.

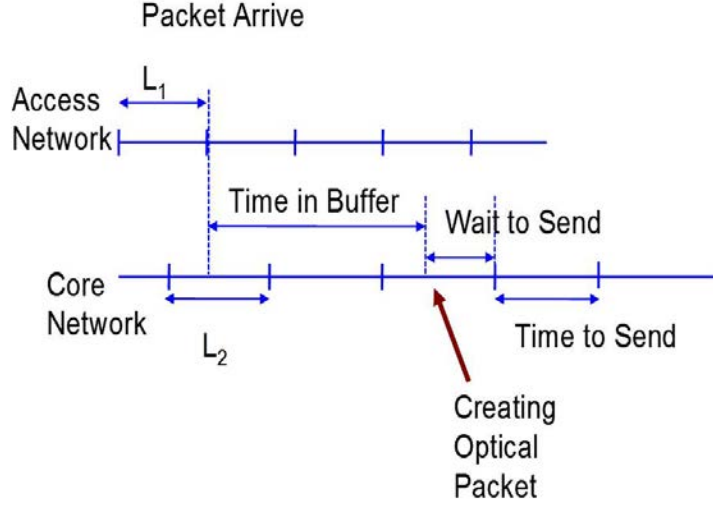

Figure 3.6: Times associated to the Packet Creation Process

3.2.2 Common-Used Timer Mechanism (CUTM)

In well-known timer-based mechanisms (CUM, Simple Aggregation), several timers are used. Each timer is attached to an aggregation buffer. Therefore, the number of timers increases as the number of optical CoS increases. This may cause the processing problem and they are not suitable methods which should be implemented inside Hub node. The main idea of CUTM (Common-Used Timer Mechanism) aims at minimizing the number of used timers. A good solution is to use only one timer for all CoS. In this context, all aggregation buffers are attached by a common timer.

At the Hub node, core network packets have higher priority than traffic of access network; therefore, the E/O converter is performed if there is no packet in the optical FDL (Fig. ??). Each ring is already synchronized but each one has different size of slot time and optical packet. Therefore, it is required to synchronize data inputs and outputs at the Hub. Let be δt the shift parameter to synchronize the output traffic. Lets denote L_1 and L_2 as the timeslot for metro core and metro access, respectively. The relation between the associated times to the packet creation process are specified in Fig. 3.6.

The procedures of CUTM are described in Fig. 3.7 and Fig. 3.8. Each time when the first electronic packet of any CoS arrives to any aggregation buffers, the mechanism is activated: It firstly examines the flag F (to the state ON if the flag is OFF) to verify the timer. In the case where the flag is already turned on, the procedure must check the sum of the size of all electronic packets in all aggregation buffers before enabling the Optical Packet Creation. If this sum is superior to α_{max} , the Optical Packet Creation hence will be triggered. On the other hand, the Optical Packet Creation is automatically triggered when the timer expires. At this moment, the Flag will be re-turned to OFF. The creation of optical packets is similar to Opportunist Mechanism: high-priority electronic packets are firstly taken; otherwise low-priority electronic packets are taken.

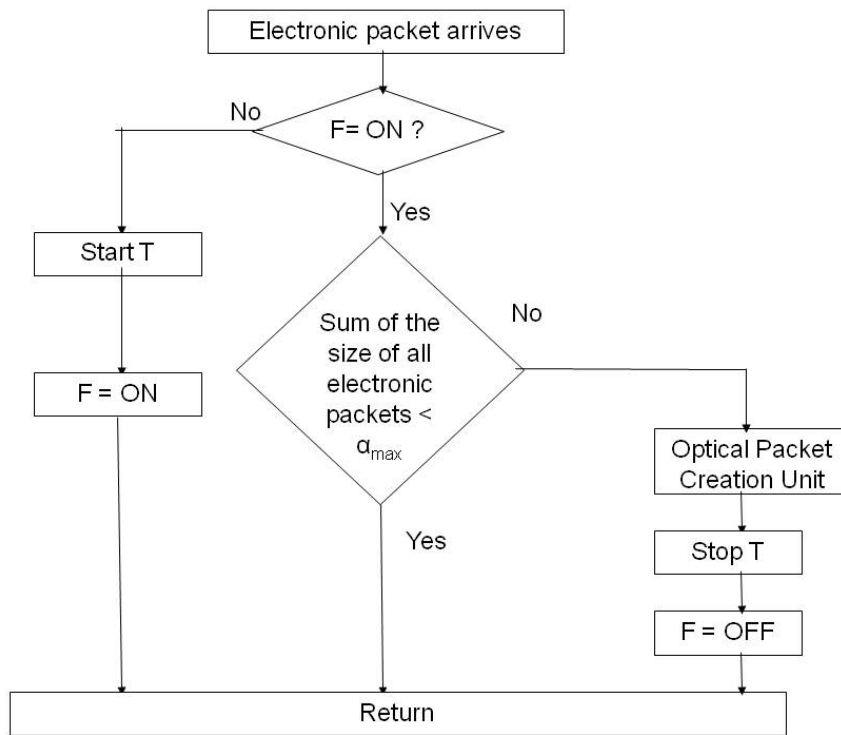

Figure 3.7: First procedure of CUTM

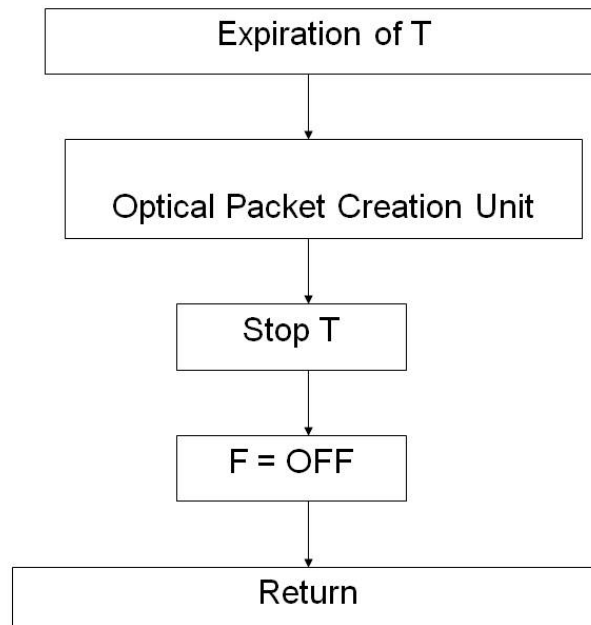

Figure 3.8: Last procedure of CUTM

3.3 Simulation Parameters

All the access nodes in the first ring will send the data to the last node. In the second ring network, there are 2 types of traffic flow: one coming from the access network and one is the local traffic (core network). In each link connecting 2 core nodes, there are 8 traffic flow from access network and 2 local traffics from other core nodes. The traffic in second network is symmetric. We consider 8 classes of service for electronic packets and 4 CoS for optical packets with different traffic sources models and packet sizes. Generally, many performance requirements must be met in order to transport specified data from the access network to the core network.

In reality, the capacity of the metro core is higher than the metro access. So, we set the capacity of the access network lower to the capacity of core network. The multi-class approach is used for both network types. We assume 8 CoS for client packets in the electronic domain. The premium traffic is generated from CBR sources with the packet size of 810 bytes. The non-premium traffic is modelled by an aggregation of IPP sources with different burstiness levels. Generated packets are of variable lengths according to the Internet packet length statistic for each non premium CoS (ID from 3 to 8). The optical buffer size is equal to 200Kbytes for the premium traffic class, 500Kbytes for silver and bronze traffic classes, 1000Kbytes for the BE traffic class. All the parameter for packet generation are shown in Table 3.1.

Table 3.1: Classes of Service

	% CoS	Electronic Packet Size (Octet)	Source	Optical buffer size
$CoS_1 - CoS_2$ Premium	10.4%	810	CBR	1600 KOctets
$CoS_3 - CoS_4$ Silver	13.2%	50, 500, 1500	MMPP	4000 KOctets
$CoS_5 - CoS_6$ Bronze	13.2%	50, 500, 1500	MMPP	4000 KOctets
$CoS_7 - CoS_8$ Best Effort	13.2%	50, 500, 1500	MMPP	8000 KOctets

Scenarios of simulation considered in this study are presented in Table 3.2. The QoS requirements were specified according to the MEF recommendations (Table 3.3).

Table 3.3: QoS Requirements

Class of service	Characteristic of service	Loss rate	Delay	Jitter
Premium	Telephone or real-time video application	< 0.001%	< 5ms	< 1ms
Bronze	Applications require guaranteed bandwidth	< 0.1%	< 15ms	N/S
Standard	Best effort services	< 0.5%	< 30ms	N/S

Table 3.2: Simulation Scenarios

	Bit rate	Optical Packet Size (Octet)	Load	Node traffic
Metro Access	10 Gb/s	10 μ s 12500 octets	35% - 3.5 Gb	437.5 Mb/s
Metro Core	10 Gb/s	10 μ s - 12500 octets	50% - 5 Gb	2.5 Gb/s
Metro Access	10 Gb/s	10 μ s 12500 octets	60% - 6 Gb	750 Mb/s
Metro Core	40 Gb/s	5 μ s - 12500 octets	70% - 28 Gb	14 Gb/s
Metro Access	10 Gb/s	10 μ s 12500 octets	60% - 6 Gb	750 Mb/s
Metro Core	10 Gb/s	10 μ s - 12500 octets	70% - 28 Gb	14 Gb/s

3.4 Simulation Results

Now, we may focus on Hub node performance by implementing OM and CUTM. We study the interaction of L1 and L2 in function of the bandwidth and packet size in each network. CUTM uses a timer equal to 100 μ s. The shift parameter δt is fixed to 1 μ s. In order to have significant results, we load the metro access network up to different configurations. We could see that there is no packet loss not only at source nodes but also in Hub node. For this reason, only the waiting time is presented.

Fig. 3.9 and 3.10 show the average waiting time of packets in the electronic buffers for each CoS and different scenarios. By applying OM is smaller than by applying CUTM. This is due to the fact that with OM Hub node immediately sends optical packets if it finds a free slot in the core network. By contrast, CUTM uses a timer to fill optical packets well and thus increases the waiting time of electronic packets. Based on these results we can say that CUTM is independent of the correlation between L_1 and L_2 ; but depends on the capacity of the Metro Core. The performance of hub using OM does not depend on the capacity of metro core; but it is sensitive to the correlation of L_1 and L_2 .

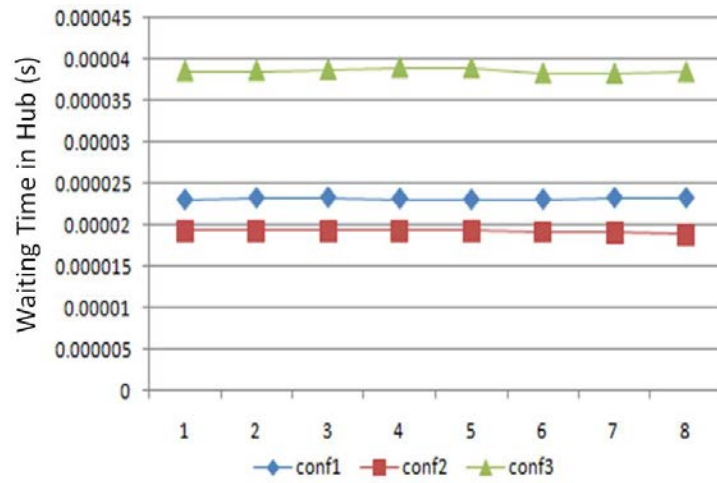

Figure 3.9: Waiting time of electronic packets elapsed at Hub node applying OM

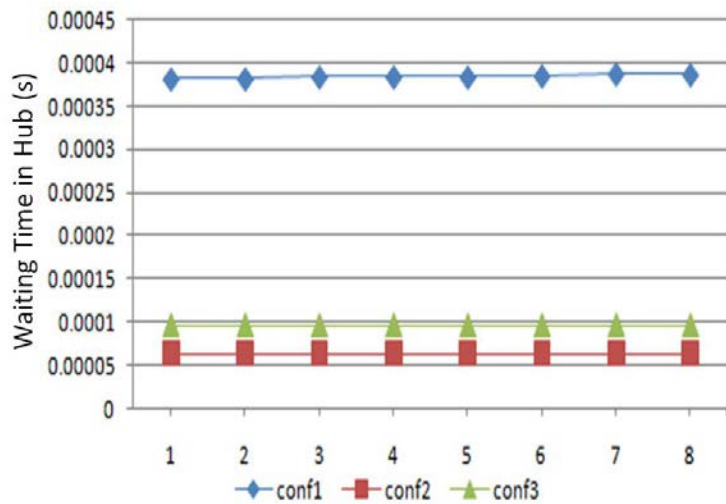

Figure 3.10: Waiting time of electronic packets elapsed at Hub node applying CUTM

Let's look at the average filling ratio of optical packets in Hub node (Fig. 3.11). We observe that the filling ratio obtained by using CUTM is higher than the obtained with OM. A common timer used in CUTM may retard electronic packets while maximizing the filling ratio. With small additional amount of the optical header, CUTM offers effective rate smaller than OM.

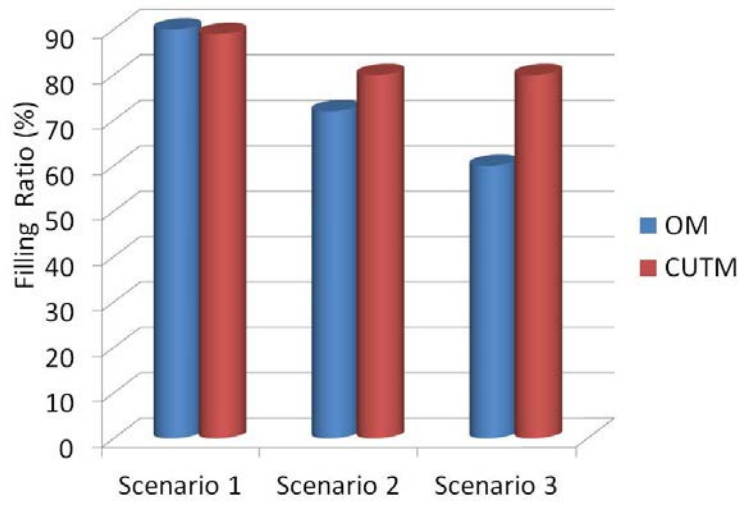

Figure 3.11: Filling ratio obtained with OM and CUTM

As we can see in Fig. 3.12 OM uses the network resources less effectively than CUTM. Again, this is due to the timer used by CUTM.

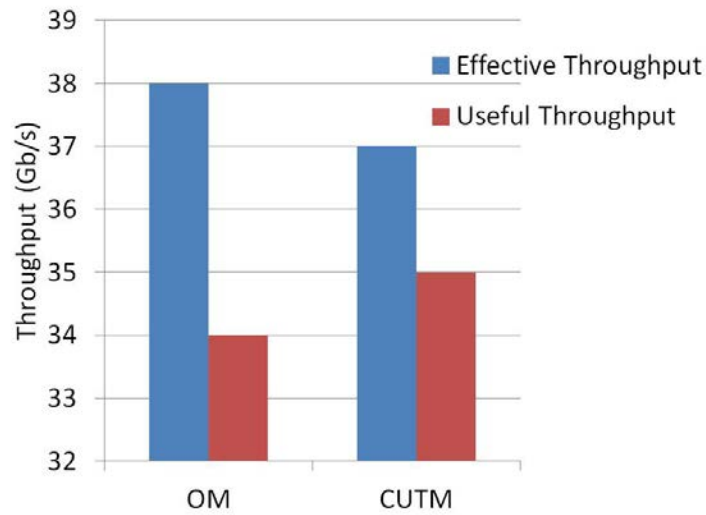

Figure 3.12: Util/Effective Rates obtained with OM and CUTM

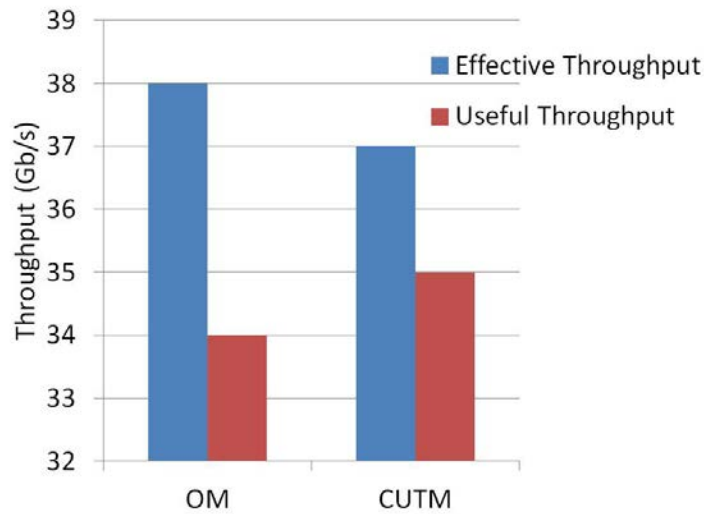

Figure 3.13: Util/Effective Rates obtained with OM and CUTM

Regarding the electronic packet jitter shown in Fig. 3.14, Fig. 3.15 and Fig. 3.16 we see that both mechanisms provide nearly identical average for all source nodes. Additionally, the electronic packet jitter obtained for different CoS seems to be the same. This is due to the fact that electronic packets, which are encapsulated in an optical packet, will be received in the same time when the optical packet finishes its travel at the destination node. In general, there from ten to hundred electronic packets will be encapsulated inside an optical container; this leads to low inter-arrival time measured at the destination node. Obtained packet jitters respect QoS constraints specified by MEF. Even for strictly delay-sensitive voice traffic. The results show that the jitter at the last node ensure the jitter condition for data flow specified, for both mechanisms.

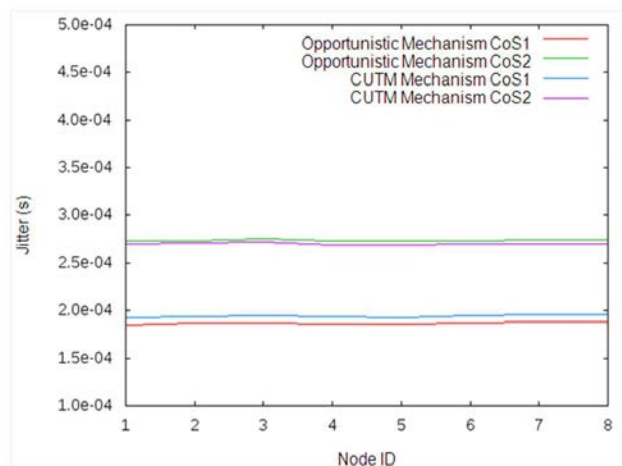

Figure 3.14: Packet jitter at each node for Scenario 1

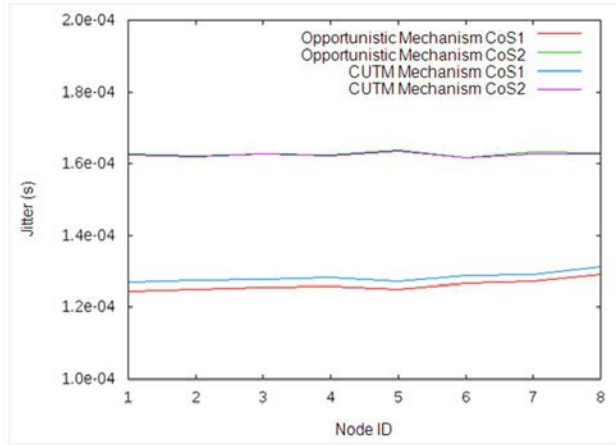

Figure 3.15: Packet jitter at each node for Scenario 2

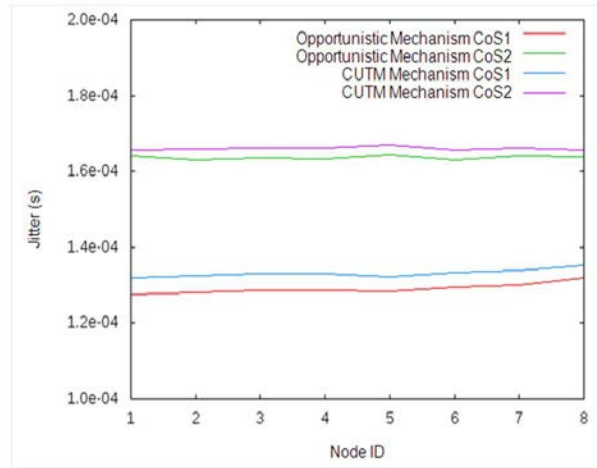

Figure 3.16: Packet jitter at each node for Scenario 3

Fig. 3.17 and 3.18 show the impact of the synchronisation shift over the performance of Hub node. The figure presents the average time of electronic packets passing across Hub node in function of δt . Only electronic packets, which come from a source node, are viewed. As an interesting result, the obtained waiting time is nearly the same. It seems that the waiting time does not depend on the δt . In other words, the synchronisation shift does not significantly impact the waiting time of electronic packets passing across Hub node. An explanation for this phenomenon is described as follows. Small δt does not affect the electronic packets. However, as the δt becomes larger, the waiting time increases at the beginning of the simulation but it decreases due to the stability of the simulation. Therefore, the average waiting time of all electronic packets is not representatively changed.

3.5 Concluding Remarks

Traffic transported through the networks is growing day by day, this imposes to the new architectures of networks the implementation of mechanisms to face the new challenges associated

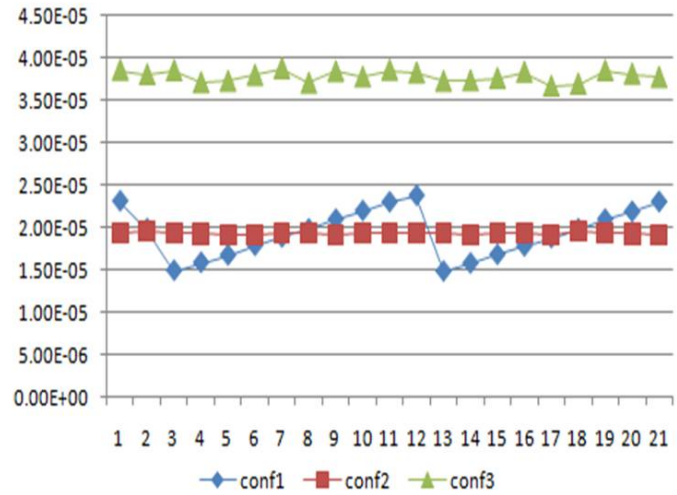

Figure 3.17: OM: Waiting time of electronic packets in Hub node in function of δt

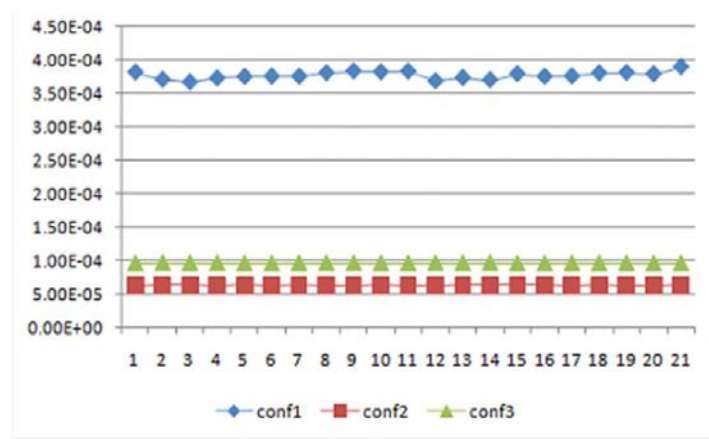

Figure 3.18: CUTM: Waiting time of electronic packets in Hub node in function of δt

to the big amount of traffic. Additionally, the traffic demand varies with the segments (Core, Metro, Access) of the optical networking structure. Consequently, the transport plane has evolved differently in each sector of the network. Metro Networks have usually ring architectures, they can be interconnected in transparently way by a Hub node. In interconnected rings, the pass of traffic from one network to other requires synchronization mechanisms which allow this process. A solution consists in packet creation mechanisms at the Hub node interconnecting both networks. In this chapter, we have evaluated the performance of interconnected multi-ring networks. The network consists of two metro rings in which a synchronous metro access (DBORN) connected to a synchronous metro core (ECOFRAME). The capacity of the Metro Core is larger than the Metro Access. By implementing two approaches: OM and CUTM, we have seen that the performance of Hub node is guaranteed (in terms of access delay and jitter) regardless of the synchronization shift. Additionally, the E2E performance does not depend on the source nodes. Performance comparison of OM and CUTM has been presented. CUTM offers a solution to solve the problem of synchronization and provides good network utilization. It is independent of the correlation between transmission time of a packet in the Metro Access and the transmission time of a packet in Metro Core, but depends on the Metro Core capacity. Performance of OM does not depend on Metro Core capacity but it is sensitive to the correlation of transmission time of a packet in the Metro Access and the transmission time of a packet in Metro Core. There is not a real impact of δt on the Hub performance, variation in waiting time at Hub is very small. We wish to study the impact δt on the performance with other traffic models.

In this order of ideas and without waste generality, due to the increasing amount of traffic and bandwidth required by users, the costs associated to the networks (construction and operation) and the energy consumed by them represents a large percentage of the total energy spent around the world. Integrated optical-mobile networks seems a good option to be used in access networks at the access level. These new architectures of networks must be designed and employ techniques to efficiently save energy. The next chapter deals with this problem.

Chapter 4

Energy Saving in Integrated Optical-Wireless Access Networks

ONUs and BSs are considered the biggest consumers of energy in PONs and wireless networks. Additionally, it is expected that in new hybrid ONUs with optical and wireless functionalities, the level of energy consumed will be considerably high.

The synchronization of traffic transmission/reception may be used to reduce the energy consumed by ONU. With this the transceivers can be turned off when they are not transmitting or receiving traffic. In this chapter, we propose a novel ONU for integrated optical-wireless networks. The design of the ONU considers the reduction of implementation costs (number of components) and operational costs (specially associated to the energy consumption). We describe a DBA algorithm to effectively and fairly allocate bandwidth with the goal of saving energy in the ONU. The proposed algorithm allows active/sleep mode to transmitters/receivers at ONU. We will focus: on upstream transmission (from ONUs to OLT), on downstream transmission (from OLT to ONUs), and on local traffic transmission (from ONUs to end users). To allow this, modifications in the OLT architecture are proposed, a MAC and DBA are required, and a scheduling algorithm and service discipline must be considered. Then, we simulate the integrated access network, in which the approaches that we will propose will be applied. We will show the improve of network performance in terms of packet access delay and energy as compared with existing algorithms.

4.1 Integrated Optical-Wireless Access Network: Studied Architecture

The proposed integrated access architecture is shown in Fig. 4.1, as we can see the OLT connects the integrated access network to an IP core or backbone network. The ONUs are composed by functional entities of Wireless Base Station (BS) and of EPON ONU into a single unit. These ONUs are connected to the OLT through passive splitter. They have Ethernet ports for wired connections and radios for wireless connections. In this work, as mentioned above, the hybrid ONU-BS is named ONU as in classical EPON. We consider two types of subscribers, Ethernet Service Subscribers (eSS) and Wireless Service Subscribers (wSS). The eSS are the original EPON subscribers, while the wSS are the original considered wireless technology subscribers. Traffic between the OLT and the ONU corresponds to data frames which are encapsulated in Ethernet PDUs; within the ONU, data frames are encapsulated

either as Ethernet or, according to the wireless technology used, in his corresponding PDUs (e.g. WiMAX, LTE). The packets are in Ethernet format over the wired interface, while over the air interface in the corresponding wireless PDUs.

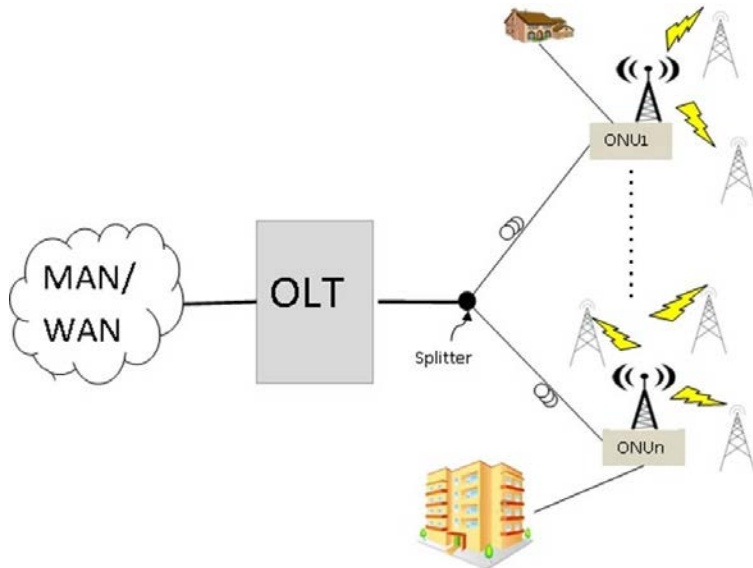

Figure 4.1: Proposed Architecture

The main functional entities of the converged ONU are shown in Fig. 4.2. The multiple classes of traffic coming into the unity are received first by the Traffic Identifier and Service Classifier module, which checks the incoming frames, and based on their origin and destination, determines whether they require encapsulation. If traffic must be encapsulated, it is sent to the Encapsulated Module; once traffic is formatted, it goes to the QoS Mapping Module, which, after applying QoS policy, buffers the packet into the mapped CoS queues. After, according to his destination, every packet will be buffered in one of the destination queues (OLT, wSS or eSS). Every destination, has different buffers to store packets according to the CoS which they belong. The Resource management module has information about the ONU state and executes the local DBA algorithm. The packet scheduling algorithm is executed by the Scheduling module, after receiving the eSS and wSS buffers statuses and bandwidth request details reported by the queue it sends the information to the Resource Management module; the latter utilizes this received information to make decisions, and to optimally allocate downstream resources to each buffer for transmission from ONU to end users.

The ONU has three receivers and two transmitters. Generally in the literature, the integrated ONU (considering WiMAX) into a single module either in terms of software and hardware functionalities is named ONU-BS. In case of an ONU and a cellular LTE’s BS (eNB) the unit is named ONU-eNB. In this work, we will refer to the unit as ONU wherever the case of study. The global traffic can be divided into three categories. CoS_1 for real-time traffic is high priority; it requires a low loss rate, and strictly limited E2E delay and jitter. The non-real-time guarantee traffic is named CoS_2 , with medium priority can have a loss rate; it requires a limited E2E delay and jitter. The Best Effort traffic is named CoS_3 , with lower priority it is no guarantee traffic. We believe that these traffic categories are enough to cover all types of traffic in the proposed architecture.

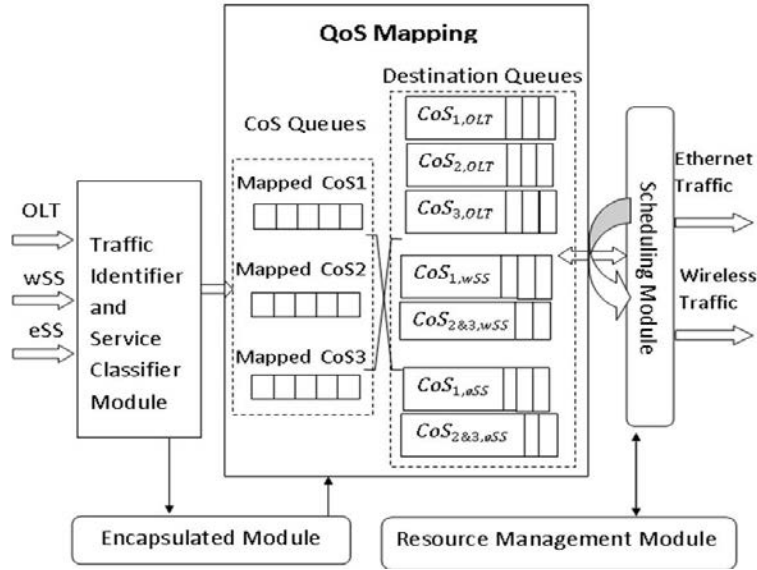

Figure 4.2: Proposed ONU Model

Traffic received by ONU is classified into Ethernet traffic and wireless traffic. We define some rules for the mapping of the services provided by the two standards and the services class offered by every part served by the ONU. For Ethernet traffic, applications supported with differentiated services are typically aggregated into three main CoS: Best Effort (BE) data traffic, Assured Forwarding (AF) traffic and Expedited Forwarding (EF) traffic. For wireless technologies the traffic differentiation is made based in their standards. The 802.16 documents specify five classes for the WiMAX standard services: Unsolicited Grant Service (UGS); Extended real-time Polling Service (ertPS), Real-time Polling Service (rtPS), Non-real-time Polling Service (nrtPS) and Best Effort (BE). The 3GPP/3GPP2 has defined nine traffic classes for LTE mainly according to their resource type, priority, delay, and packet error loss rate. All the assumptions and solutions in terms of QoS for LTE will be the considered for LTE-A.

We propose two steps for the QoS mapping and scheduling (Fig. 4.3) to configure admitted traffic considered:

- Stage I: traffic arriving will be mapped by using the mapping policy proposed in Figure. Admitted traffic is buffered in one of the three CoS queues. In such priority queue system, the priority level order is described as: $CoS_1 > CoS_2 > \dots CoS_n$, with 1 as the highest priority class and n the lowest priority.
- Stage II: Once traffic is classified by CoS, packets are stored in the buffer (corresponding to that CoS) according to destination. CoS_3 traffic in wSS and eSS queues is mixed with CoS_2 in the same buffer, respecting the priority order between them ($CoS_2 > CoS_3$).

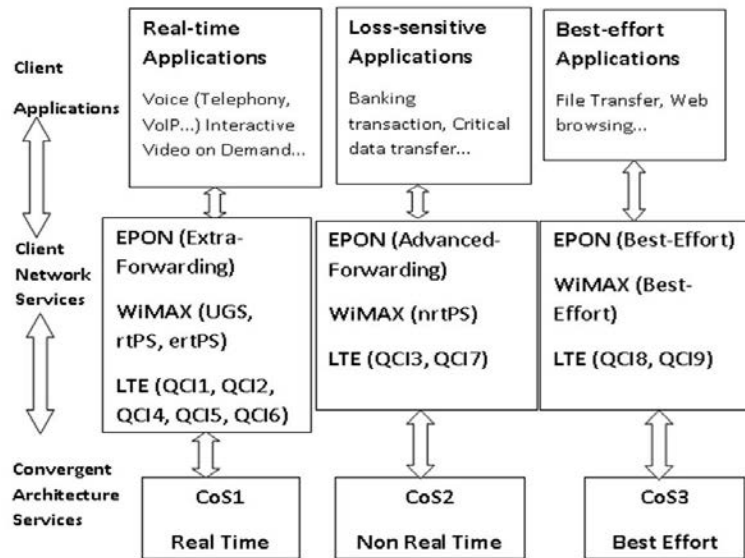

Figure 4.3: QoS Mapping

4.2 MAC and Green Integrated Bandwidth Allocation (GIBA) in Integrated Optical-Wireless Access Network

The OLT and the ONUs have different buffer systems which are described below.

- a) The OLT has a buffer system equipped with a buffer per ONU (q_{ONU_i}) (Fig. 4.4) for downstream traffic. Downstream traffic is the traffic coming from OLT to ONUs. Each buffer has been identified with the name of one ONU to establish correspondence between them, hence q_{ONU_i} buffers traffic going to ONU_i . The insertion of packets in buffers requires that OLT classifies the packets according to destination.
- b) Each ONU has a buffer system named OLT buffers with one queue per CoS. Generally, this traffic is called “exterior traffic”.
- c) Additionally, each ONU has one buffers system for traffic going to end users. This traffic is named “local traffic”. The buffer system for local traffic has two subspaces of queues, one is for local wireless traffic and the other for the Ethernet local traffic.

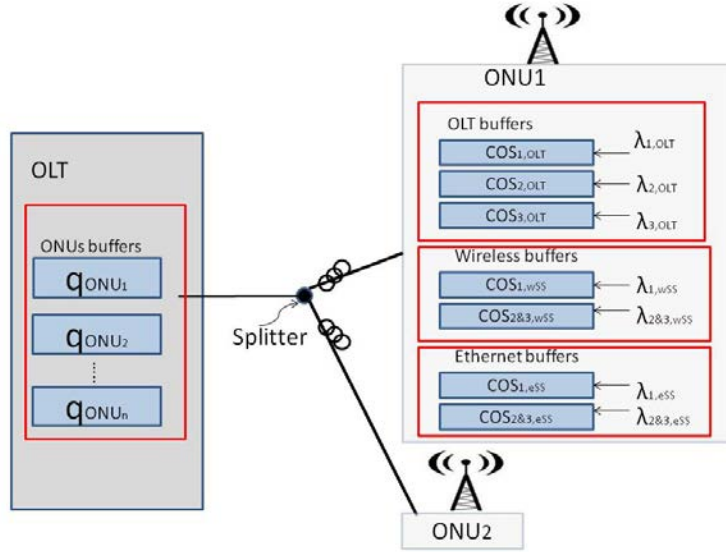

Figure 4.4: Buffer Systems

Transmission of packets in the different buffer systems share different resources of the network. We can differentiate the next resources sharing:

- In the upstream direction (transmission from ONUs to OLT), since all ONUs share the same transmission medium, the system must employ a MAC mechanism to arbitrate access to the shared medium. MAC prevents data of different ONUs transmitting simultaneously from the collision and efficiently shares the upstream transmission bandwidth among ONUs. This is achieved by granting a transmission window to each ONU and OLT issues the timeslot to them in a round robin cycle.
- According to the buffer system proposed for OLT, in the downstream direction (transmission from OLT to ONU) the buffers at OLT share the same transmission medium. Analogous to the precedent item; a MAC is employed to arbitrate the access of each q_{ONU_i} to the shared medium. OLT assigns a transmission window to each queue at OLT to also be served in a round robin discipline. Transmission in the downstream direction must respect the length of service cycle in the upstream direction.
- For local transmission (from ONU to end-users), buffers share the Ethernet transmitter (same used by upstream traffic) so it is required to define a MAC to the transmitter. Here, the service cycle of local buffers is limited by the length of service cycle in the upstream direction.

4.3 Green Integrated Bandwidth Allocation (GIBA)

We will describe now a novel approach for bandwidth allocation named Green Integrated Bandwidth Allocation (GIBA). As the OLT is the central controller of the network, it decides the upstream and downstream transmission windows for all ONUs and buffers at OLT. As in classically EPON, GIBA uses MPCP as communication process between OLT and ONUs. The communication process uses control messages gate and report. The report message contains the information about queue lengths at ONUs. The OLT must wait until all the report

messages are received before running GIBA. Once a scheduling decision is made, MPCP's gate control message is used to inform the ONUs. Each gate message contains the information required by ONUs to synchronize packet transmission, packet reception a cycle duration.

Each ONU has two interval of activities, during one service cycle. The transmission time of exterior traffic leads to the considered Highly Active Period (HAP). Transmission of local traffic is made during the named Lowly Active Period (LAP). The proposed GIBA requires the complete knowledge of traffic demand of each ONU for the next service cycle. The OLT must wait until all the report messages defined in the MPCP are received before running the DBA. Once the allocation of windows is done, a gate message is transmitted to all ONUs with the information required for synchronization. After reception of gate message each ONU will synchronize transmission and reception, but also ONU must assign bandwidth allocation to local traffic.

Consequently, GIBA uses two sub-algorithms to allocate bandwidth: extra-ONU bandwidth allocation and intra-ONU bandwidth allocation. The extra-ONU bandwidth allocation is referred to the execution of DBA at OLT. The intra-ONU bandwidth allocation is referred to the execution of DBA at ONU for local traffic. The algorithm can be summarized in next steps:

1. OLT executes the extra-ONU bandwidth allocation algorithm for UP/DOWN traffic. First, it allocates transmission window to all ONUs for the next service cycle. Then, it allocates transmission window to the buffers at OLT. Gate message is used to inform ONUs the lengths of: next transmission windows (in both directions UP/DOWN) and cycle.
2. By using the information received in gate message, each ONU executes the intra-ONU bandwidth allocation algorithm. Each ONU assigns a transmission window to each buffer storing traffic going to final users.

The service rules of traffic at ONU are listed next:

- ONU serves local wireless traffic, the service can be interrupted if it is time to serv upstream (exterior) traffic. This is due to the impossibility of ONU for deciding the use of link in the upstream direction. If the service is not interrupted, ONU will serv local traffic according to the windows assigned by him.
- ONU serves upstream/downstream traffic traffic during transmission windows allocated by OLT.
- ONU serves local Ethernet traffic during transmission window assigned by him.

These rules are applied to all ONUs except the first one. As the first ONU will use the upstream at the begin of cycle, in this case ONU serves upstream traffic and then local wireless traffic to finish with local Ethernet traffic according to transmission windows assigned by extra-ONU and intra-ONU algorithms.

4.3.1 Extra-ONU Subalgorithm

Let be $R_{up,i}(k)$ the demanded window of i^{th} ONU to transmit up traffic in cycle k . Let's denote $T_{up,i}(k)$ the transmission window allocated to i^{th} ONU in cycle k . Let be T_{max} the

maximum transmission window possible for ONU in one cycle.

$$T_{up,i}(k) = \begin{cases} R_{up,i}(k) & \text{if } R_{up,i}(k) < T_{max} \\ T_{max} & \text{if } R_{up,i}(k) \geq T_{max} \end{cases} \quad (4.1)$$

Let be $R_{down,i}(k)$ the demanded window of q_{ONU_i} during the cycle k . Let's denote $TM_{down,i}(k)$ and $T_{down,i}(k)$ the minimum transmission window for q_{ONU_i} and granted transmission window allocated to q_{ONU_i} in cycle k , respectively. The $TM_{down,i}(k)$ is obtained by using:

$$TM_{down,i}(k) = \begin{cases} R_{down,i}(k) & \text{if } R_{down,i}(k) < T_{up,i}(k) \\ T_{up,i}(k) & \text{if } R_{down,i}(k) \geq T_{up,i}(k) \end{cases} \quad (4.2)$$

The difference between $T_{up,i}(k)$ and $TM_{down,i}(k)$ defines the unused bandwidth by one ONU during one cycle. With the objective of allocate resources in better way. We will obtain the unused bandwidths for each ONU i and in case that the buffer $q_{ONU_{i+1}}$ requires more bandwidth a complementary window could be assigned to the last. The idea is then, to improve network performance in terms of E2E delay. So, let be $\Delta T_i(k)$ the unused bandwidth of ONU i in cycle k , it can be obtained as follow:

$$\Delta T_i(k) = \begin{cases} 0 & \text{if } T_{up,i}(k) \leq TM_{down,i}(k) \\ T_{up,i}(k) - TM_{down,i}(k) & \text{if } T_{up,i}(k) > TM_{down,i}(k) \end{cases} \quad (4.3)$$

Now, Let's define $\Delta Cr_i(k)$ as the required complementary bandwidth for $(i + 1)^{th}$ ONU in cycle k , with $1 < i < (n - 1)$. The $\Delta Cr_i(k)$ can be assigned by using the formula:

$$\Delta Cr_{i+1}(k) = R_{down,i+1}(k) - TM_{down,i+1}(k) \quad (4.4)$$

Let's denote ΔC_{i+1} the complementary bandwidth allocated to the $(i + 1)^{th}$ ONU, ΔC_{i+1} is obtained as:

$$\Delta C_{i+1}(k) = \begin{cases} \Delta Cr_{i+1}(k) & \text{if } \Delta Cr_{i+1}(k) \leq \Delta T_i(k) \\ \Delta T_i(k) & \text{if } \Delta Cr_{i+1}(k) > \Delta T_i(k) \end{cases} \quad (4.5)$$

The allocated $T_{down,i}(k)$ can be computed with the formula: $T_{down,i}(k) = TM_{down,i}(k) + \Delta C_i(k)$. Figure shows the algorithm principle. All the information about the transmission windows and length of next cycle are sent to the ONUs in the report message.

4.3.2 Intra-ONU Subalgorithm

Let be $R_{wSS,i}(k)$ the demanded window of i^{th} ONU to transmit local wireless traffic in cycle k . Let's denote $T_{wSS,i}(k)$ as the transmission window allocated to local wireless traffic of i^{th} ONU in cycle k . Let's denote $TM_{wSS,i}(k)$ the maximum transmission window allocated to local wireless traffic of i^{th} ONU in cycle k . This last one can be obtained as follow:

$$TM_{wSS,i}(k) = \gamma - (T_{REPORT} + T_{up,i}(k) + OH) \quad (4.6)$$

Then, $T_{wSS,i}(k)$ is assigned by using the formula:

$$T_{wSS,i}(k) = \begin{cases} R_{wSS,i}(k) & \text{if } R_{wSS,i}(k) < TM_{wSS,i}(k) \\ TM_{wSS,i}(k) & \text{if } R_{wSS,i}(k) \geq TM_{wSS,i}(k) \end{cases} \quad (4.7)$$

Let be $R_{eSS,i}(k)$ the demanded window of i^{th} ONU to transmit local wireless traffic in cycle k . Let's denote $T_{eSS,i}(k)$ the transmission window allocated to local wireless traffic of i^{th} ONU in cycle k . Let's denote $TM_{eSS,i}(k)$ the maximum transmission window allocated to local wireless traffic of i^{th} ONU in cycle k . This last one can be obtained as follow:

$$TM_{eSS,i}(k) = \gamma - (T_{REPORT} + T_{up,i}(k) + T_{wSS,i}(k) + OH) \quad (4.8)$$

Then, $T_{eSS,i}(k)$ is assigned by using the formula:

$$T_{eSS,i}(k) = \begin{cases} R_{eSS,i}(k) & \text{if } R_{eSS,i}(k) < TM_{eSS,i}(k) \\ TM_{eSS,i}(k) & \text{if } R_{eSS,i}(k) \geq TM_{eSS,i}(k) \end{cases} \quad (4.9)$$

The service discipline of local traffic is exhaustive in each subspace of buffers. As we can see, the cycle length γ obtained by OLT in order to serv exterior traffic allows us to obtain the service cycle of down traffic and local traffic in ONU.

After synchronize traffic transmission, the periods of activities per service cycle γ are defined for all the transmitters and receivers in each cycle. Hence, for each ONU, the receivers or transmitters no used in any instant of time t , his timing and traffic detection functions will be turn off with the goal of reducing energy consumption. The processing time of a gate message plus the guard interval between two contiguous downstream queues serves as a fixed reservation interval. Let be R_W , R_{Eth} and R_{OLT} the receivers of: wireless traffic coming from end users, Ethernet traffic coming from end users and traffic coming from OLT, respectively; and without waste generality, let be T_W the transmitter of wireless packets and T_E the transmitter of Ethernet packets. The saving mode for the transmitters and receivers are listed next:

- R_W and R_{Eth} will be always in active mode to allow the arrival of packets coming from the wireless/Ethernet end users served by the current ONU. No Sleep mode is applied for them.
- R_{OLT} will be in active mode during the reception of report message and $T_{down,i}(k)$ of the i^{th} ONU. The rest of period it will be in sleep mode.
- T_W will be in active mode during transmission of local wireless packets to end users. The rest of period it will be in sleep mode.
- T_E will be in active mode during transmission of local Ethernet packets to end users and transmission of extern traffic to OLT. The rest of period it will be in sleep mode.

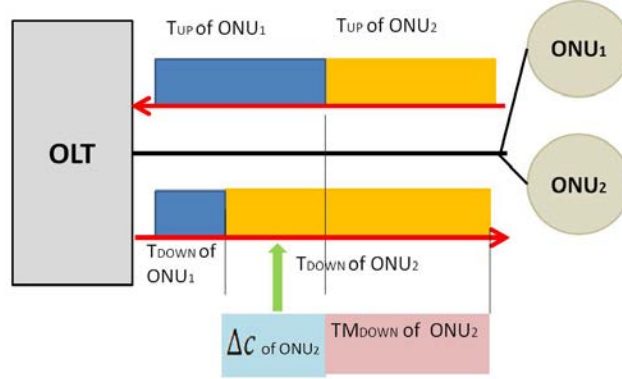

Figure 4.5: Principle of GIBA

4.3.3 Proposed Energy Saving Model

Let E_{ACCESS} , E_{OLT} and E_{ONU_i} denote the energy consumed by the access network, the OLT and the i^{th} ONU, respectively. Hence, the total energy consumed by the network can be formulated as follows:

$$E_{ACCESS} = E_{OLT} + \sum_{i=1}^n E_{ONU_i} \quad (4.10)$$

where n is the number of ONUs in the network. The BSs served by one ONU are not considered in this model because our study is concentrated on ONU, no saving techniques are applied in BSs served by this last. We assume that the OLT will be in active mode in any instant of time and it is not considered turned off (or his components) for saving energy. Lets denote $E_{ONU_i(k)}$ the energy consumed by the i^{th} ONU during the cycle k . The total energy consumed by one ONU in cycle k is given by:

$$E_{ONU_i(k)} = E_{OH}(k) + E_{ROLT}(k) + E_{RW}(k) + E_{RE}(k) + E_{TE}(k) + E_{TW}(k) + E_{BF}(k) \quad (4.11)$$

where $E_{OH}(k)$ denotes the energy consumed by ONU during the total overhead time (OH). The OH is the total time required to switch components at the ONU from off state to the active mode during one cycle k , it includes the free running clock drifts, the ONU clock recovery time, and the synchronization to the network after recovering the OLT clock. $E_{ROLT}(k)$, $E_{RW}(k)$, $E_{RE}(k)$, $E_{TE}(k)$, $E_{TW}(k)$ and $E_{BF}(k)$ are the energy consumed by the: Ethernet receptor for traffic coming from OLT, wireless receptors for traffic coming from end users, Ethernet receptors for traffic coming from end users, Ethernet transmitter, wireless transmitter, and ONU components in on state all time, respectively. Finally, we can obtain $E_{OH}(k)$ as $E_{OH} = T_{OH} * P_{total}$. where T_{OH} is the total overhead time, as we said before, and P_{total} is the total power spend by one ONU with all its transceivers and rest of components in active state. Let be $E_{tr}(k)$ the energy consumed by one transmitter/receiver. Let's denote P_{tr} and $AP(k)$ as the power consumed by the transceiver and the active period during one cycle k , respectively. $E_{tr}(k)$ can be obtained as $E_{tr}(k) = P_{tr} * AP(k)$.

4.3.4 GIBA Performance Evaluation

To study the the network performance by applying GIBA we use OPNET simulator. We consider an integrated access network consisting of 8 ONUs connected to one OLT through a passive coupler. We assume that the distance between the coupler and the OLT is about $10Km$ and between each ONU and the coupler (equal for all ONU) is about $15Km$. In our study we consider rate of upstream link from an ONU to the OLT as $1Gbps$ and the maximum cycle of time is set at $1ms$ (maximum window of $15Kbytes$ in the LSA scheme per ONU). The guard time separating two consecutive transmission windows is set to $5\mu s$. The Computation Time used in DBA is set to $10\mu s$.

Each ONU support 3 classes of traffic according to the mapping service described in previous section. Wireless traffic corresponds to: 60% is CoS_1 , 25% is CoS_2 , and 15% is CoS_3 . Ethernet traffic corresponds to: 15% is CoS_1 , 60% is CoS_2 , and 25% is CoS_3 . CoS_1 packets size is $70bytes$ and the source is CBR. CoS_2 packets size is $70bytes$ and the source is Pareto Process with shape parameter fixed at 1.4. CoS_3 packets sizes are $50bytes$, $500bytes$ and $1500bytes$; and the source is Pareto Process with shape parameter fixed at 1.4. We analyze and compare obtained results with the IPACT algorithm. Simulations for IPACT use three buffers, one for each CoS. We consider a full connected traffic matrix where each ONU can send traffic to all the ONUs in the network (including itself). Let's be P_{ROLT} , P_{REth} , P_{RW} , P_{TW} , P_{TEth} , and P_{BF} the power consumed by R_{OLT} , R_{Eth} , R_W , T_W , and T_{Eth} and the components in active state all the time; respectively. In the comparison we take as: $P_{ROLT} = P_{REth} = 1.03W$, $P_{RW} = 2.34W$, $P_{TW} = 4.602W$, $P_{TEth} = 2.06W$, and $P_{BF} = 0.75W$. The considered simulation time was $5s$. An ONU with all its components in active state consumes $P_{ONU_{Act}} = 11.812W$. The peak rates for each mobile technology considered are: WiMAX: up Rate = $30Mb/s$, down Rate = $75Mb/s$. LTE: up Rate = $75Mb/s$, down Rate = $300Mb/s$. LTE-A: up Rate = $100Mb/s$, down Rate = $1GB/s$.

Fig. 4.6 and Fig. 4.7 show the mean access delay obtained for each wireless technology considered. The results obtained by applying GIBA are compared with the obtained with the use of IPACT. For CoS_1 IPACT has a lower Mean Access Delay than GIBA. However, for CoS_2 GIBA has better performance.

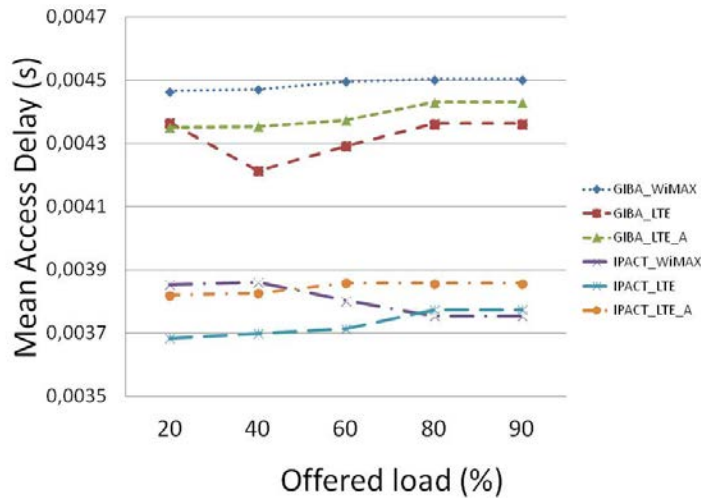

Figure 4.6: Mean Access Delay for CoS_1 going to OLT

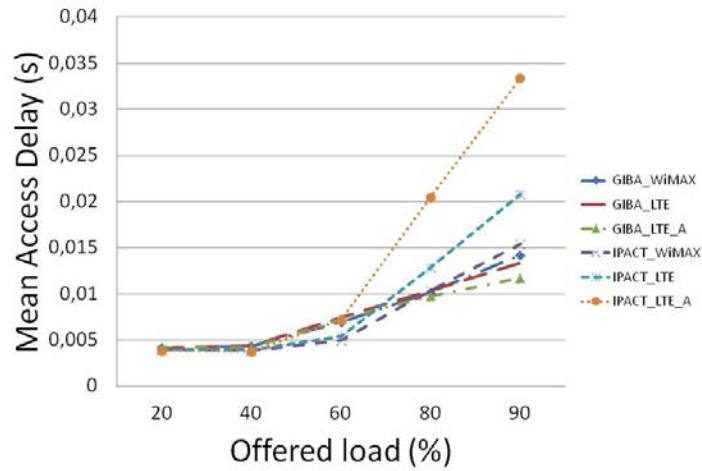

Figure 4.7: Mean Access Delay for CoS_2 going to OLT

Figures 4.8 and 4.9 show the transmission delay of the CoS_1 and CoS_2 from one ONU to another ONU, including the mean access delay at the source ONU. Here, IPACT has better performance than GIBA. For CoS_1 , the mean access delay decreases as the network load value between 20% and 60% increases, after the transmission delay stay around a specific value for all the technologies. The mean access delay increases as the network load value increases for CoS_2 . CoS_2 has better performance with GIBA for LTE and LTE-A.

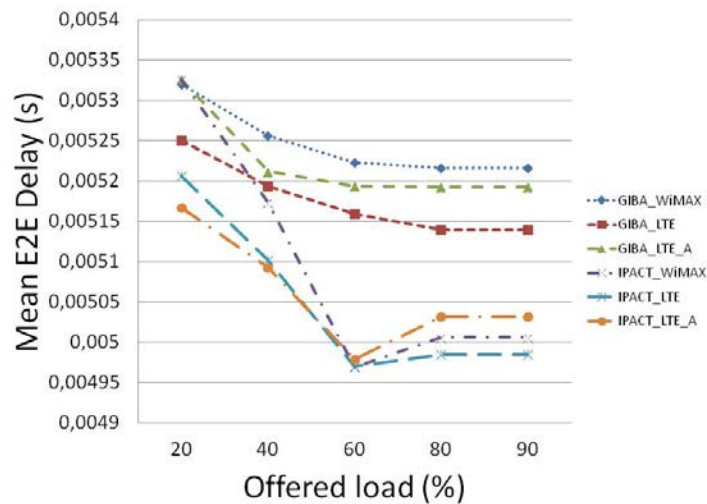

Figure 4.8: E2E Delay for CoS_1 going/coming to/from OLT

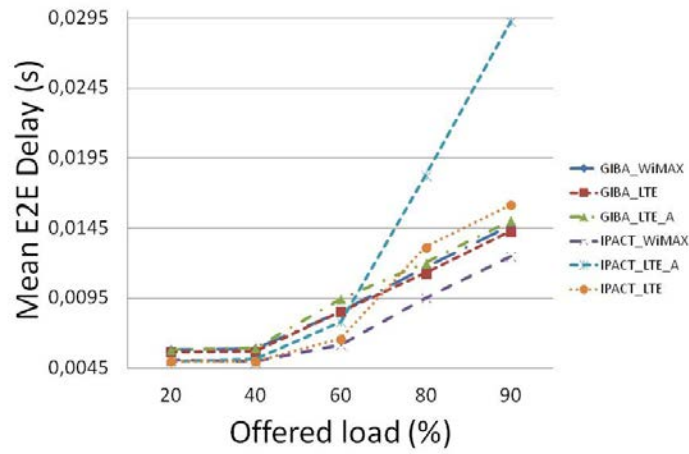

Figure 4.9: E2E Delay for CoS_1 going/coming to/from OLT

Fig. 4.10 shows the Mean Access Delay for GIBA in the three cases is lower than IPACT for CoS_1 , this is due to the fact that packets wait less time at OLT, and it means they arrive to the ONU faster. However, this time depends on the occupation of OLT and wireless buffers at ONU. For CoS_2 (Fig. 4.11) it is the opposed, with GIBA packets wait less time at OLT, but more at wSS buffers.

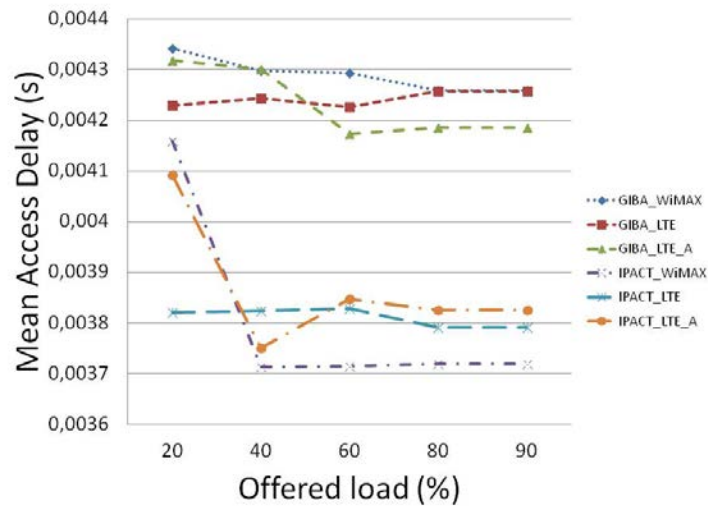

Figure 4.10: Mean Access Delay for CoS_1 wireless traffic

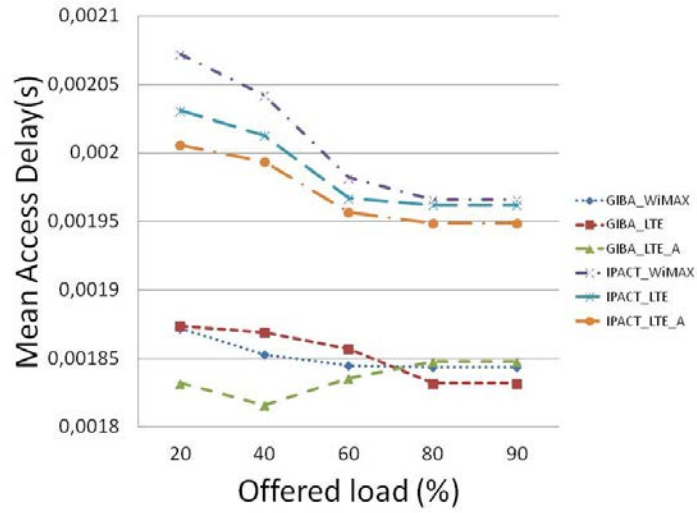

Figure 4.11: Mean Access Delay for CoS_2 wireless traffic

Figures 4.12 and 4.13 shows the Mean Access Delay for CoS_1 and CoS_2 with the implementation of GIBA is lower than IPACT. The analysis is equivalent to wSS buffers.

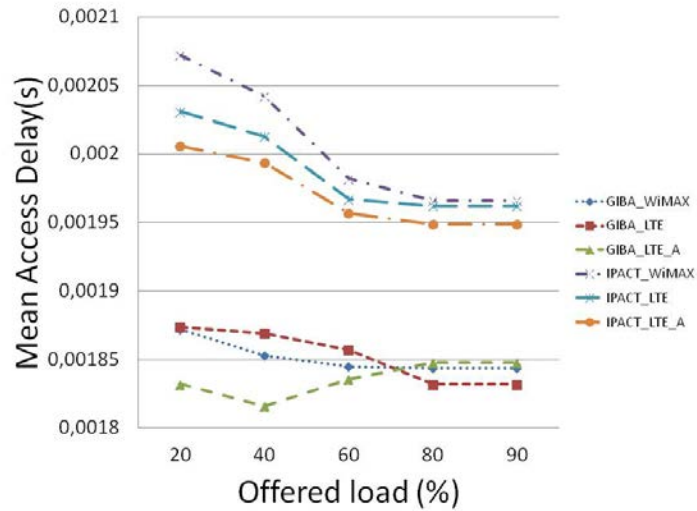

Figure 4.12: Mean Access Delay for CoS_1 Ethernet traffic

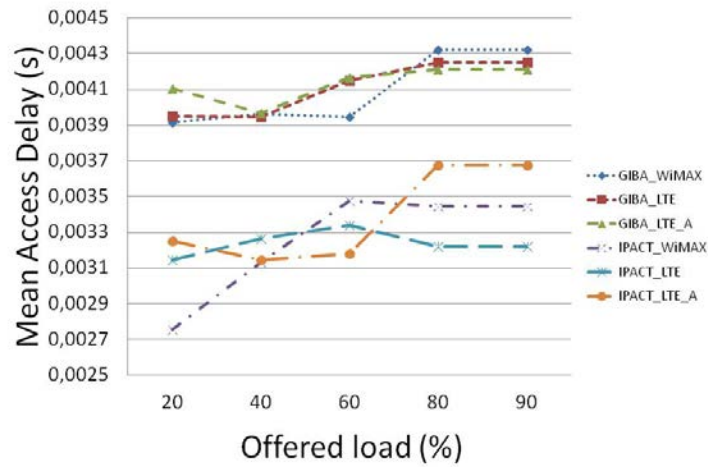

Figure 4.13: Mean Access Delay for CoS_2 Ethernet traffic

The results of Fig. 4.14 show the energy consumed by ONU with the implementation of GIBA. These results are compared with the obtained by IPACT-WiMAX (which is similar to IPACT-LTE and IPACT/LTE-A). With a charge maximal of ONU equivalent to $800Mb/s$ GIBA saves, in the worst of cases (WiMAX technology) almost 35% of energy; and in the best of cases (LTE-Advanced) almost 60%. With a charge maximal of ONU equivalent to $250Mb/s$ GIBA saves, in the worst of cases (WiMAX technology) almost 76% of energy; and in the best of cases (LTE-A) almost 83%.

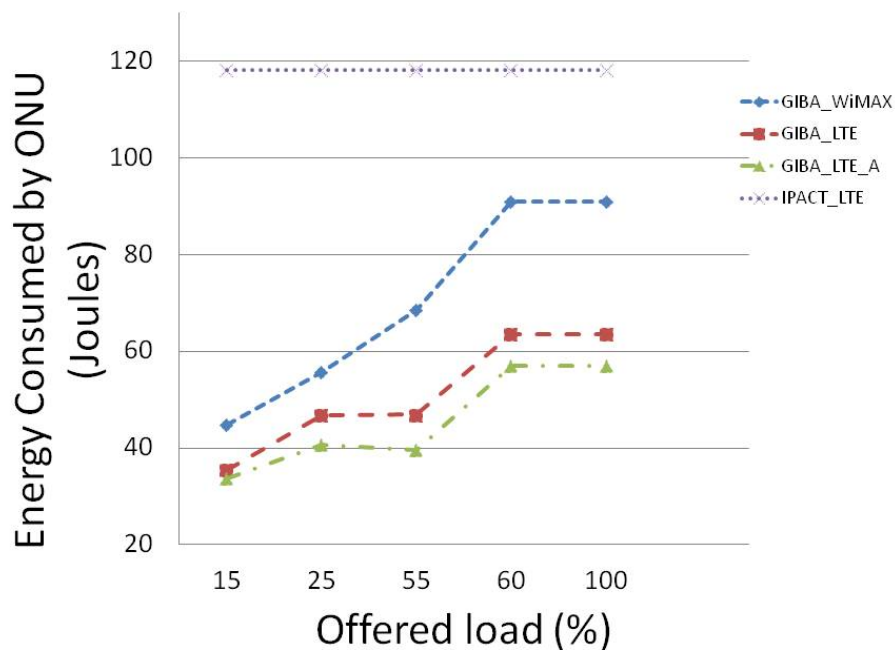

Figure 4.14: Energy Consumed by ONU

4.4 Enhanced Green Integrated Bandwidth Allocation (eGIBA)

GIBA is an alternative to the problem of energy in integrated optical-wireless access networks. However the allocation of windows in the downstream direction (from OLT to ONUs) is not fairly. If one ONU does not have traffic to transmit in the upstream, the queue buffering his downstream traffic will not has a window for transmission in the downstream. Additionally, the first ONU in the access level will never get complementary window because no precedent ONU can offer it unused bandwidth. Also, the unused bandwidth in the downstream could no be used by ONUs requiring more bandwidth due to the fact that is not the precedent ONU who is offering this extra window. For all the mentioned, in this section we propose an Enhanced Green Integrated Bandwidth Allocation (eGIBA). The aim of eGIBA is to allocate efficiently the bandwidth in the downstream. We expect improve the network performance by reducing the waiting time of packets at OLT and consequently the E2E delay.

The length of k^{th} cycle γ determines the allocation of windows in downstream transmission. The sum of all the downstream windows allocated to buffers at OLT must respect the length of current cycle. The algorithm operates based on the idea of sliding window. Here the begin of transmission in the downstream direction is not synchronized with that one in the upstream direction. The begin of transmission for packets in i^{th} buffer at OLT is placed in the ending of transmission for $(i - 1)^{th}$ buffer. Let be $\Delta_i(k)$ the unused bandwidth for q_{ONU_i} , it can be obtained as:

$$\Delta_i(k) = \begin{cases} 0 & \text{if } T_{up,i}(k) \leq TM_{down,i}(k) \\ T_{up,i}(k) - T_{down,i}(k) & \text{if } T_{up,i}(k) > TM_{down,i}(k) \end{cases} \quad (4.12)$$

Let's denote $\Delta E(k)$ the total bandwidth unused in the down direction during one cycle k . We can obtain it by using the next formula:

$$\Delta E(k) = \sum_{i=1}^n \Delta_i(k) \quad (4.13)$$

The complementary value $\Delta c_i(k)$ assigned to each q_{ONU_i} with $T_{up,i}(k) < R_{down,i}(k)$ is given by:

$$\Delta c_i(k) = \frac{R_{down,i}(k) - T_{up,i}(k)}{\sum_{i=1}^n R_{down,i}(k) - T_{up,i}(k)} \cdot \Delta E, \quad (4.14)$$

The assigned $T_{down,i}(k)$ can be obtained by using the next expression $T_{down,i}(k) = TM_{down,i}(k) + \Delta c_i(k)$. The next condition must be respected every service cycle k :

$$\sum_{i=1}^n T_{down,i}(k) \leq \gamma \quad (4.15)$$

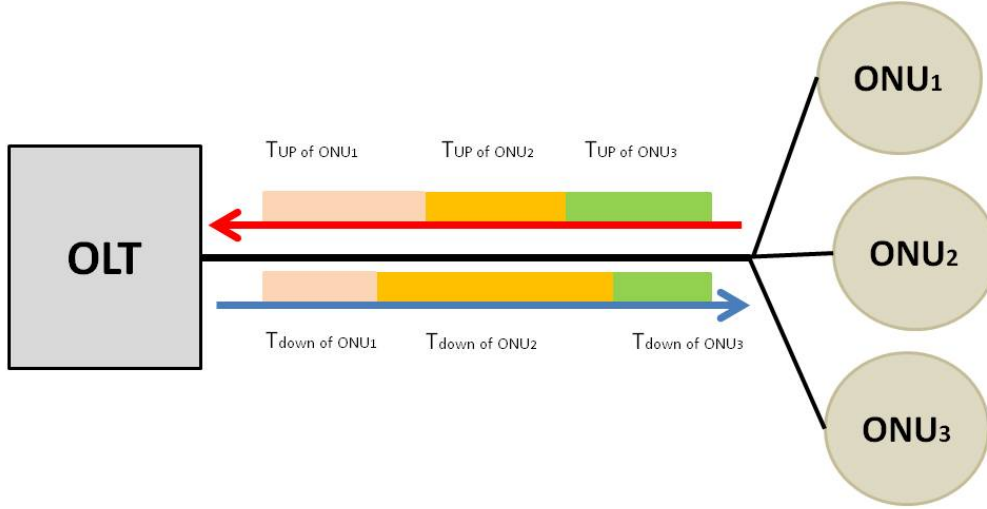

Figure 4.15: Principle of eGIBA

4.5 Analysis of performance with queuing models

In this section an analysis of network performance with queuing models is presented. The idea is to estimate the mean access delay of packets in each buffer subsystem, and the energy consumed by one ONU.

4.5.1 Queuing Delay Analysis

We provide a queuing delay analysis for packets in different buffer sets. However, these are approximations due to the difficulty in exact analysis based on the maximum transmission window between ONUs and OLT each cycle. Packets in each group of queues will experience different queuing delay according to the queue which belong. For simplicity, all packets are assumed to have same length.

Exterior Traffic

We analyse the queuing delay of packets buffered in $q_{OLT,i}$ at ONU until transmission to the OLT is possible. Let be C the upstream transmission speed of the PON (in bit/s). The n ONUs are located to a distance d in km from the OLT. The offered traffic load of ONU_i is ρ_i . The i^{th} ONU receives traffic from its users following a Poisson process with rate λ_i packets/s. Also, each packet requires a fixed amount of service time X . Let's denote L as the packet length, X can be obtained as $X = L/C$.

The load offered by all ONUs in the upstream is given by $\rho_{up} = \sum_{i=1}^n \rho_i$. Cycle length is measured as the service time of all ONUs in the network. We consider fixed cycle length,

assuming constant length for transmission window TW . The queuing delay is the time that a packet spends in buffer until the precedent arrival packets stored (in the same buffer) are transmitted. To obtain the queuing delay for packets in $q_{OLT,i}$, the Ethernet transmitter which is in charge of this traffic transmission was modeled as an independent $M/D/1$ queue with λ_i as the mean arrival rate to all OLT queues. The average queuing delay is given by:

$$E[W] = \frac{\rho_i}{2 \cdot (1 - \rho_i)} \cdot X \quad (4.16)$$

The analysis uses the idea of [5], the residual time is given by:

$$E[R] = \frac{\lambda \bar{x}^2}{2} + \frac{\bar{v}^2(1 - \rho_i)}{2\bar{v}} \quad (4.17)$$

$$E[R] = \frac{\lambda \bar{x}^2}{2} + \frac{v(1 - \rho_i)}{2} \quad (4.18)$$

The expected queuing delay for a packet is expressed as follows:

$$E[W] = \frac{\frac{\lambda \bar{x}^2}{2} + \frac{v(1 - \rho_i)}{2} + v}{(1 - \rho_i)} \quad (4.19)$$

then

$$E[W] = \frac{\lambda \bar{x}^2}{2(1 - \rho_i)} + \frac{v}{2} \quad (4.20)$$

As one ONU waits a cycle to use the upstream in PON. The Ethernet transmitter for this type of traffic has a vacation time v equal to one cycle. By analysing the queuing delay for this traffic, based on gated model we can obtain the same results. Finally we can get the queuing delay as:

$$E[W] = \frac{\lambda \bar{x}^2}{2(1 - \rho_i)} + \frac{\gamma}{2} \quad (4.21)$$

Downstream Traffic

Queuing delay of packets in ONUs buffers (at OLT), can be obtained based on $M/D/1$ with vacation model and gated service discipline. The analysis is similar to the presented for exterior traffic and we will not detailed. The offered traffic load of $q_{OLT,i}$ is ρ_i . The i^{th} buffer receives traffic following a Poisson process with rate λ_i packets/s. Also, each packet requires a fixed amount of service time X_d . Again, let's denote L as the packet length, X_d can be obtained as $X_d = L/C_d$, where C_d is the transmission capacity in the downstream.

The load offered by all buffers in the downstream is given by $\rho_{down} = \sum_{i=1}^n \rho_i$. Assuming constant length for transmission window TW_d . The queuing delay is the time that a packet spends in buffer until the precedent arrival packets stored (in the same buffer) are transmitted. To obtain the queuing delay for packets in $q_{OLT,i}$, the Ethernet transmitter which is in charge of this traffic transmission at OLT was modeled as an independent $M/D/1$ queue with λ_i as the mean arrival rate to all OLT queues. Due to the fact that the MAC in the downstream is similar to that on in the upstream. From the analysis presented for exterior traffic we can get the that

$$E[W] = \frac{\lambda(x_d)^2}{2(1 - \rho_i)} + \frac{\gamma}{2} \quad (4.22)$$

Local Wireless/Ethernet Traffic

Now, we want to obtain queuing delay for packets stored in wireless and Ethernet buffers at ONU. Let be $C_{down,q}$ in *bits/s* the transmission speed in the downstream direction of queue q . When $t \rightarrow \infty$, the buffer offers a traffic load each cycle $\rho_q = \lambda_q \cdot x_q$. With λ_q and x_q the arrival rate to the queue q and the service time of packets in queue q , respectively. Lets denote L as the packet length, x_q can be obtained as $x_q = L/C_{down,q}$.

We assume, occupation rate $\rho_q < 1$. Let be $T_{p,q}$ the length of transmission period for queue q . We can obtain the $E[W]$ in q by modelling as a $M/D/1$ queue with vacation, where λ_q is the mean arrival rate. The queue length γ was considered fix in previous section. Finally The average queuing delay in the buffer is given by:

$$E[W] = \frac{\rho_q}{2 \cdot (1 - \rho_q)} \cdot x_q + \frac{\gamma}{2} \quad (4.23)$$

By applying gated service discipline we get:

$$E[W] = \frac{\lambda_q(x_q)^2}{2(1 - \rho_q)} + \frac{\gamma}{2} \quad (4.24)$$

As we can see, expressions are similar and vacation time is in function of cycle length γ . This is due to the implementation of eGIBA.

4.5.2 Estimation of Energy Consumed

We estimate the energy consumption of one ONU implementing eGIBA. In general, transceivers will have one activity and one saving period during one cycle k .

One transceiver can work in two modes: active and saving. Considering that transceiver is always in the active state, whenever there are packets to transmit and the system behaves as if there are no saving periods present. Therefore, the performances achievable for the model is equal to that of the $M/G/1$ queue where an active period is the time interval during which the server continues to serve packets, and a saving period is the time interval when the system is empty. Let be $AP(k)$ and $SP(k)$ the activity and saving period during cycle k , respectively. Average activity period $E[AP]$ helps us to evaluate the delay performance of GIBA. Average saving period $E[SP]$ allows us to obtain the improvement in terms of energy efficiency. The $AP(k)$ and $SP(k)$ for each transmitter/receiver can be different. However, the analysis to estimate their values and the energy consumed by any transmitter/receiver is the same.

The performances of the $M/G/1$ queue essentially serve as a performance bounds. First, we propose to model each transmitter/receiver as a single server queue with server vacations where the single servers are the transmitters/receivers at ONU. We define the service time of a packet as the total amount of time needed to transmit a packet. The service time of a packet is x and the length of a $SP(k)$ is assumed to have general distributions $v(x)$, means \bar{v} , and $2nd$ moment \bar{v}^2 . The minimum AP is equal to the percentage of time required to serve the packets which is given by the utilization of the transceiver ρ during one service cycle. If we consider in the steady state the cycle length γ invariable, we get:

$$E[AP] = \rho \cdot \gamma = \lambda \cdot \bar{x} \cdot \gamma \quad (4.25)$$

The expression to get the percentage of time without activity during one cycle is given by:

$$E[SP] = (1 - \rho) \cdot \gamma \quad (4.26)$$

Considering that transceiver will keep transmitting/receiving packets until the buffers become empty (which is not possible because the maximum transmission windows allowed to share the media). That is, the transceiver will turn into the saving state only when all the packets have been transmitted. At the end of each $SP(k)$, if there are packets buffered, the packets will be transmitted exhaustively in the current $AP(k)$. The service time of a packet is determinist. In this way, the transmitter/receiver can be modeled with a $M/D/1$ queue with vacations offering exhaustive service discipline, and the $AP(k)$ of this exhaustive vacation model is not related to the $SP[k]$ at all. Therefore, the amount of time in active state is equal to the amount of time required to serve all packets given by times. The utilization factor per transceiver is $\rho = \lambda \cdot \bar{x}$. We also assume that a steady state always exists. That is $\rho < 1$. Furthermore, as $t \rightarrow \infty$, the fraction of time spent in $AP(k)$ is ρ , and thus the fraction of time occupied with vacations is $(1 - \rho)$. Hence, assuming time averages can be replaced by ensemble averages:

$$\lim_{t \rightarrow \infty} (1 - \rho)t \rightarrow \bar{v} \quad (4.27)$$

From the above description $E[SP] = \bar{v}$ in the steady state.

In a gated system, $E[SP]$ is the total vacation time v appearing in one service cycle γ . It is given by times γ the probability of the system being in saving state $(1 - \rho)$. So, $E[SP] = (1 - \rho) \cdot \gamma$, and consequently $E[AP] = \rho \cdot \gamma$.

Lets denote $E_{ONU_i(k)}$ the energy consumed by the i^{th} ONU during the cycle k . The total energy consumed by one ONU in any cycle is given by:

$$E_{ONU}(k) = E_{OH}(k) + E_{ROLT}(k) + E_{RW}(k) + E_{REth}(k) + E_{TEth}(k) + E_{TW}(k) + E_{BF}(k) \quad (4.28)$$

where $E_{OH}(k)$ denotes the energy consumed by ONU during the total overhead time (OH). $E_{ROLT}(k)$, $E_{RW}(k)$, $E_{REth}(k)$, $E_{TEth}(k)$, $E_{TW}(k)$ and $E_{BF}(k)$ are the energy consumed by the: Ethernet receptor used for traffic coming from OLT, wireless receptors used for traffic coming from final users, Ethernet receptors used for traffic coming from final users, Ethernet transmitter, wireless transmitter, and ONU components in on state all time, respectively. Finally we can obtain E_{OH} as $E_{OH} = T_{OH} * P_{total}$. where T_{OH} is the overhead time, as we said in previous section, and P_{total} is the total power spend by one ONU with all its transceivers and rest of components in active state. The energy consumed by one transmitter/receiver is calculated as $E_{tr}(k) = P_{tr} * AP(k)$, with P_{tr} as the power consumed by one transmitter/receiver. We can say that in steady state the energy consumed by one ONU is:

$$\lim_{t \rightarrow \infty} E_{ONU} = \sum_{i=1}^m \rho_i \cdot P_i \cdot t + E_{OH} + E_{BF} \quad (4.29)$$

where ρ_i and P_i are the utilisation factor and the power consumed by the i^{th} transceiver, respectively. m is the total number of transceivers in ONU.

4.5.3 Simulation Scenario and Numerical Results

In this section, we present some numerical results of our study. We consider an integrated access network consisting of 16 ONUs connected to one OLT through a passive coupler. We assume that the distance between the coupler and the OLT is about $10Km$ and between each ONU and the coupler (equal for all ONU) is about $15Km$. In our study, we consider rate

of upstream link from one ONU to the OLT as $1Gbps$ and the cycle length γ is set at $2ms$ (maximum window of $15Kbytes$ in the LSA scheme per ONU). The guard time separating two consecutive transmission windows is set to $5\mu s$. Only one packet length of $500bits$ was considered. The ReP has a duration of $50ms$. The Computation Time of GIBA is set to $10\mu s$. We consider a full connected traffic matrix where each ONU can send traffic to all the ONUs in the network. In the comparison we take as: $P_{REth} = 1.03W$, $P_{RW} = 2.34W$, $P_{TEth} = 2.06W$, $P_{TW} = 4.602W$ and $P_{BF} = 0.75W$. One ONU with all its components in active state consumes $P_{OH} = 11.812W$. The peak rates for each mobile technology considered are up rate $75Mb/s$ and down rate $300Mb/s$.

Fig. 4.16 shows the queuing delay of packets transmitted from ONU to OLT, under varying arrival rate. As expected, when we increase the arrival rate, the delay increases. With a bigger arrival rate of packets, the number of packets in queues are increasing, as we consider fix length of cycle, we can evidence the impact of increasing the expected number of packets in queue.

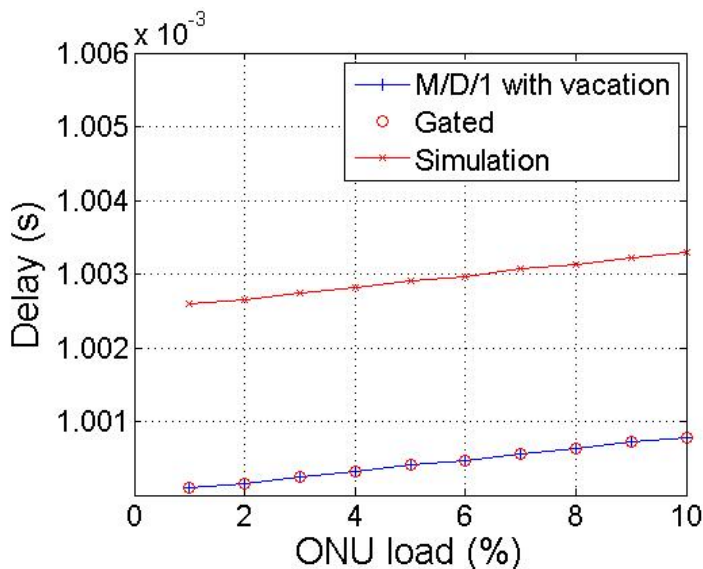

Figure 4.16: OLT traffic: Queuing Delay under different arrival rates

In Fig. 4.17 we can see the queuing delay of packets transmitted from ONU to Ethernet subscribers, under varying arrival rate. The queuing delay of these packets is bigger than queuing delay of packets in OLT buffers because the OLT traffic is priority. With the same transmission speed in the upstream and downstream direction, from ONU to OLT and from ONU to final users, the queuing delay for local traffic is still respecting QoS constraints compared to normally used parameters at the access PON.

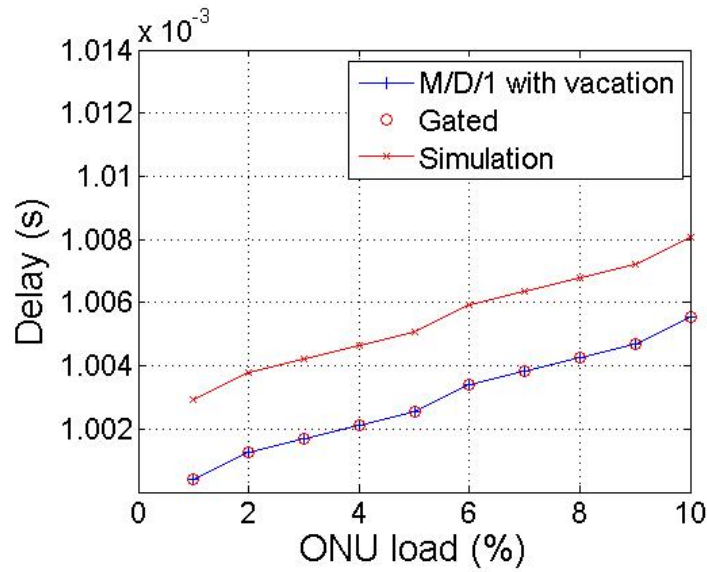

Figure 4.17: Ethernet traffic: Access Delay under different arrival rates

Fig. 4.18 shows the queuing delay of packets transmitted from ONU to Wireless subscribers, under varying arrival rate. When we compare the results with the obtained for local Ethernet traffic, these are similar. The wireless traffic is priority than Ethernet, however, the transmission rate of wireless traffic in the downstream is smaller than Ethernet transmission rate.

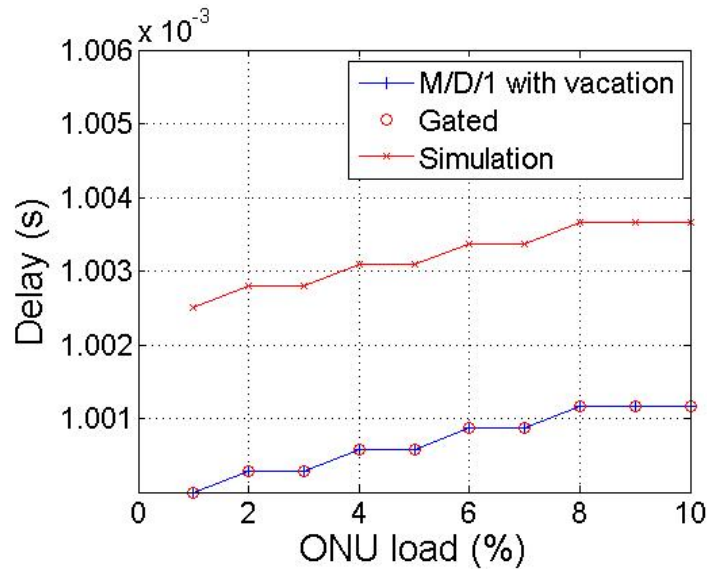

Figure 4.18: Wireless traffic: Queuing Delay under different arrival rates

Fig. 4.19 shows the energy consumed by ONU with the implementation of eGIBA. The energy consumption is increasing when the arrival rate of packets is also increasing. These results are compared with the obtained by the $M/D/1$ with vacation model. As we can see, the proposed solution allows us to study the performance of network in terms of energy consumption.

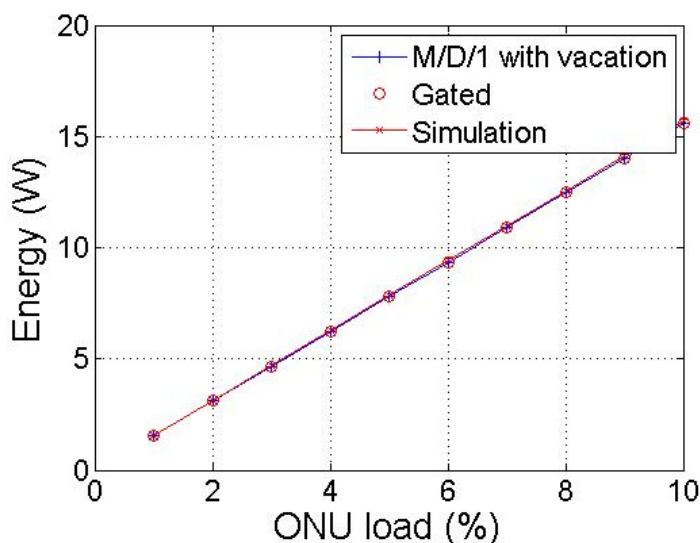

Figure 4.19: Simulation and numerical results for Energy consumption

4.6 Concluding Remarks

In this chapter, we have proposed a novel ONU for integrated optical-wireless access networks. We have presented two DBA algorithm as energy saving techniques. The first algorithm GIBA is improved to effectively and fairly allocate bandwidth, then we propose eGIBA. The proposed algorithms allows active/sleep mode to transmitters/receivers at ONU. To allow this, modifications in the buffer system at OLT were proposed, a MAC, a scheduling algorithm and service discipline for both approaches were specified. Simulation results highlight the advantages of GIBA and eGIBA. IPACT and any other version of interleaved polling schemes may have better network resource utilization, but they cannot enable to get the goal of this work in terms of energy.

GIBA and eGIBA do not consider active/sleep mode for the wireless/Ethernet receivers assigned to wSS and eSS respectively. This represents a very interesting topic in this kind of networks. This is due to the fact that in integrated optical-wireless access networks the novel architectures of hybrid ONUs face the challenging of reducing the power consumed. In order to propose an alternative efficiently algorithm for wireless receivers at ONU, we will present a novel algorithm in next chapter.

Chapter 5

Efficiency Algorithm for Wireless Receivers (EAW)

The new generations of integrated access networks face a big challenge because the wireless systems evidence an elevated consumption of energy. Different studies affirm that BSs are one of the network components with higher energy consumption [82], [83]. Consequently, some works have been focused on designing methods for power consumption reduction in BSs. For saving energy, in [84] the authors propose a vacation model based on queuing theory to model the system as a $M/D/1$ queue with server vacation. Exhaustive and gated disciplines are also considered. In [85], the authors consider a wireless network consisting of one access point and a wireless node, they seek scheduling algorithms that conserve battery power at the wireless node. In [86], a scheme is presented to store information in mobile relay nodes to be relayed to another nodes or BSs at a later instance of time based on channel conditions. The authors present in [87], a mathematical model to determine the energy dissipation of a node as a function of its sleep period and its distance to the destination for convergecast data patterns.

In [88], an algorithm of bandwidth allocation and scheduling on convergent access networks was presented. In that work, the packet transmission was synchronised. Some rules to turn on/off transmitters at ONU were implemented to reduce the energy consumption. However, the receivers at ONU were not considered to save energy. Our proposal is focused on switch active/saving algorithm for receivers in convergent access nodes.

5.1 System Model

In Fig. 5.1, the optical-wireless access network structure is presented. The Optical Line Terminal (OLT) is located at the central office and directly connected to the core network. Each access node, named ONU as in classical Passive Optical Network (PON), is connected to the OLT through one splitter. The ONUs are hybrid equipments, they provide wireless connectivity to one group of BSs and wired connectivity to fixed customers. One ONU serves a number n of BSs. In this example, each ONU is covering 6 cells. A tri-sector antenna is considered in the ONU. The traffic pattern considered (Fig. 5.2) was presented in [89]. It is based on real measurements observed on a normal weekday. When the traffic load is low, one sector of the tri-sector antenna is dedicated to the data traffic reception and the other two to the rest of traffic. Once the BSs receive data from final customers, they store the packet in one local buffer until the receiver (at ONU) is in active state. Packets at BS are inserted into

a first-in first-out (FIFO) queue.

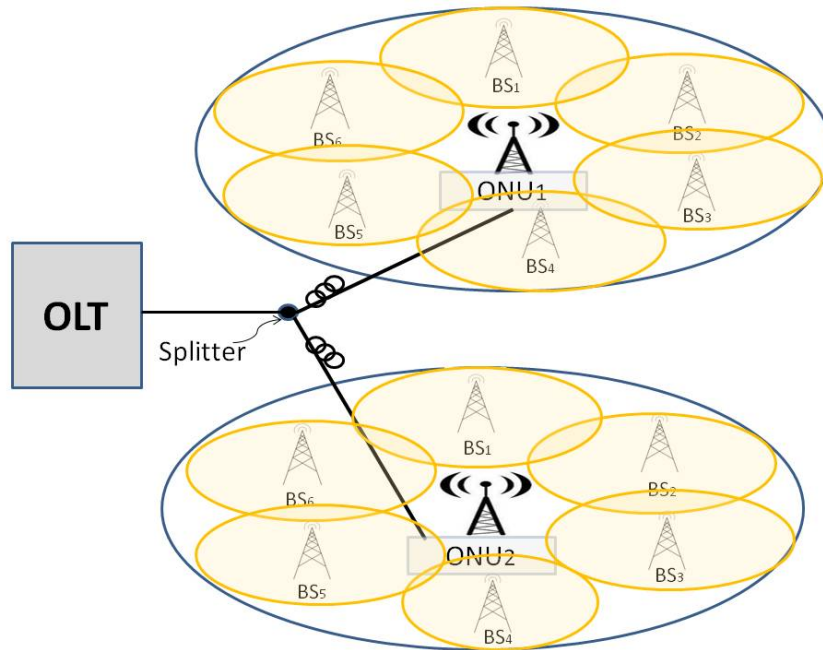

Figure 5.1: Access Network Architecture.

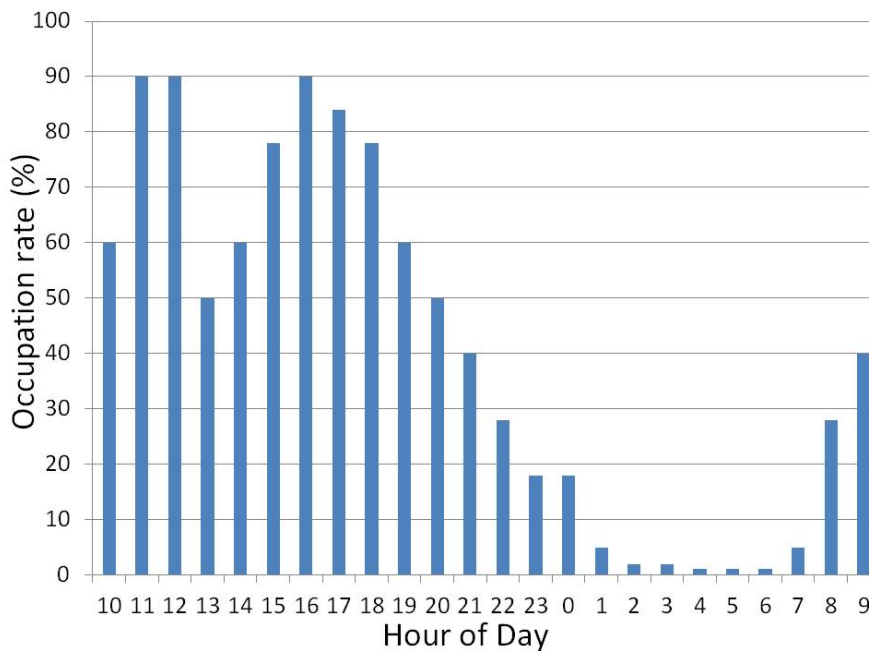

Figure 5.2: Pattern traffic considered.

Each BS is equipped with one buffer to store the data traffic going to the ONU until transmission is possible. Transmission of upstream data (from BSs to ONU) will be synchronized; this allows to wireless receivers turning into normal and energy saving states periodically. The communication between ONU and BSs (Fig. 5.3) uses two messages: REQUEST and

GRANT. REQUEST message is used to inform to ONU the queue length of BSs. The GRANT message is used to inform to BSs the length of Reception Period (RP) and Saving Period (SP). This process is done between one ONU and all the BSs served (by the current ONU), at the same time.

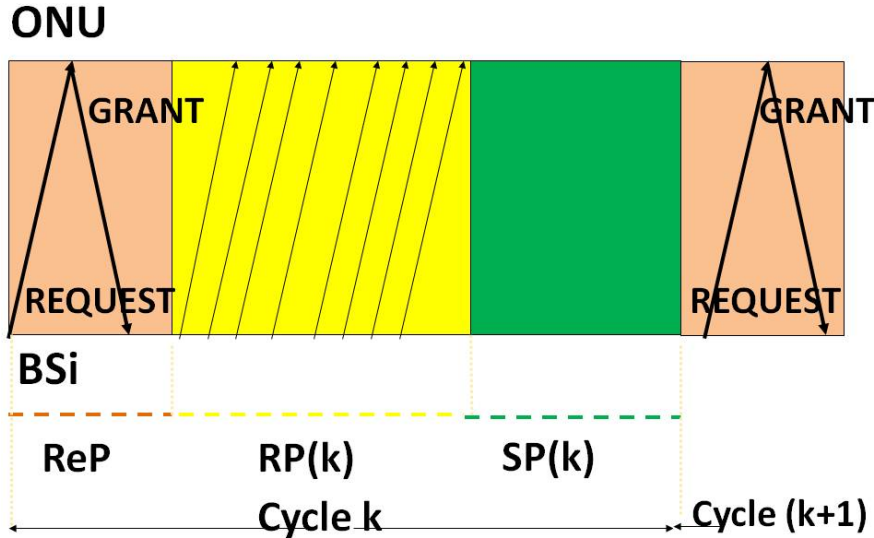

Figure 5.3: Communication Process between ONU and BSs.

Receivers work in two modes: Normal and Energy Saving. During the Normal mode it can be in Reservation state or in Reception state. Let's denote ReP the time spent in Reservation State, and let be $RP(k)$ and $SP(k)$ the time spent in Reception state and Saving state, respectively, during the cycle k . In ReP all the BSs send a REQUEST message to the ONU, the transmission window requested by each BS is based on its queue length. ONU allocates one sub-channel and transmission rate to each BS. After, it determines the next $RP(k)$ and $SP(k)$. Then, ONU sends GRANT messages to the BSs. GRANT message contains this information. ReP is constant during all the service cycles. All the BSs start data transmission after the ReP . When the $RP(k)$ ends, the wireless receiver turns into Saving state (according to $SP(k)$). During the $SP(k)$, there is no data packet reception by the wireless receiver, and the packets in the BSs are stored in one buffer to be sent in the forthcoming cycle. Some assumptions are considered for the proposed model: *i*) Packets to be transmitted in the cycle k , are known at the beginning of its ReP . *ii*) At the end of the ReP , ONU and all the BSs will have an idea of the packets number to be transmitted in the $RP(k)$ to start.

This communication and data reception/transmission process between the BSs and the ONU is represented as a finite state machine (Fig. 5.4 and Fig. 5.5) and summarized below. As we said, receivers work in two modes: Normal and Energy Saving. During the Normal mode it can be in Reservation State or in Reception State. Receiver stays in Reception State time period equal to $RP(k)$; once this time is out, the receiver will be turned into Saving state during $SP(k)$ length ($SP(k) > 0$), otherwise it goes directly to Reservation state. When receiver is in Energy Saving state, once the $SP(k)$ is out, it goes to the Reservation state to

restart the communication process and it defines the begins of a new service cycle. During Reservation state, receiver receives the REQUEST message of all the BSs. After, ONU calculates the $RP(k)$ and $SP(k)$ for the current cycle. These values are registered by ONU and then a GRANT message is transmitted to all the BSs. Once the ReP is out, the receiver goes to the Reception state ($RP(k) > 0$) or goes to the Energy Saving state ($RP(k) = 0$ and $SP > 0$)).

BSs work also in two modes: Transmission and No Transmission. During the Transmission mode they can be in Transmission or in Reservation state. BS stays in Transmission state a time period equal to $RP(k)$; once this time is out, if the receiver goes to Saving mode ($SP(k) > 0$), then BS goes to No Transmission state; otherwise, it goes directly to Reservation state. When BS is in No Transmission state, once the $SP(k)$ is out, it goes to the Reservation state. During Reservation state, BS calculates the queue length of its buffer, it sends a REQUEST message to the ONU, and it receives a GRANT from ONU. Once the ReP is out, the BS goes to Transmission state ($RP(k) > 0$) or to No Transmission state ($RP(k) = 0$ and $SP(k) > 0$).

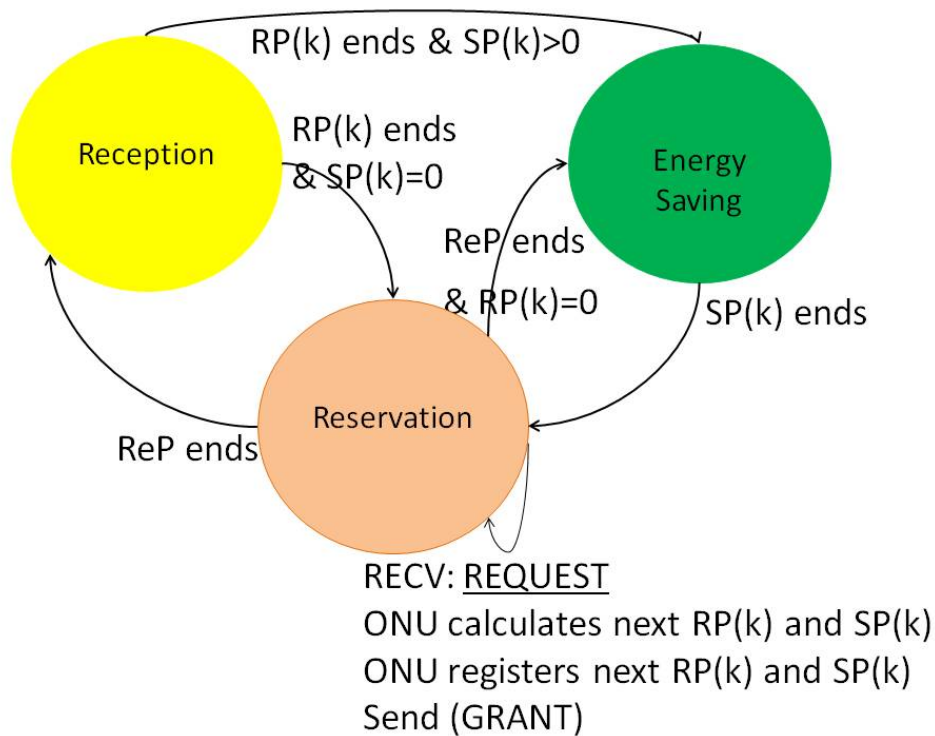

Figure 5.4: State Machine for Receivers.

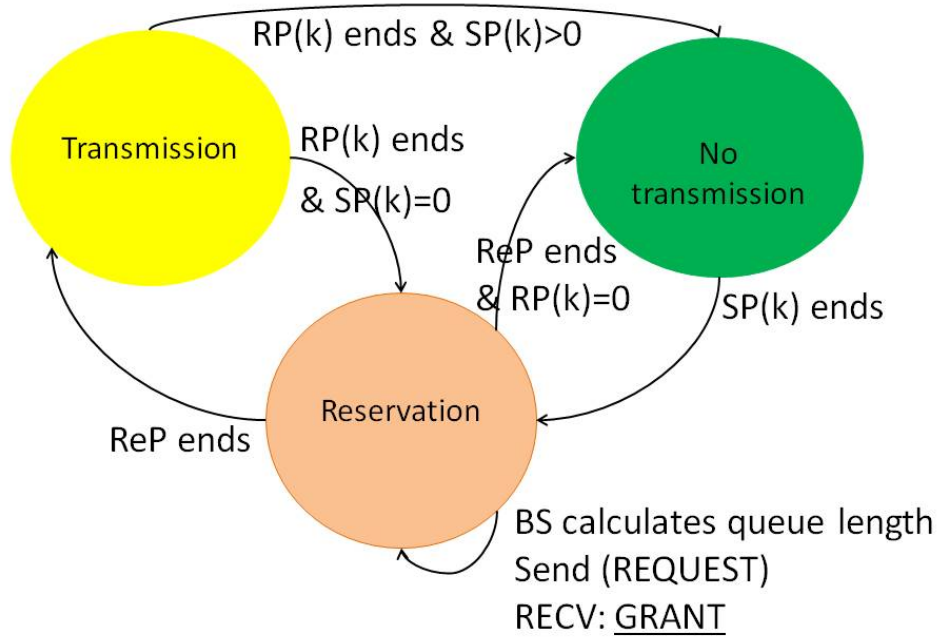

Figure 5.5: State Machine for BSs.

The algorithm uses link adaptation to change transmission parameters over a link. Specifically, data transmission rate is adapted every cycle, based on traffic arrival to BSs. ONU is in charge of obtain the link rate value during the *ReP*. Let be C the total channel capacity for uploading traffic from all BSs to ONU. Lets denote n as the maximum number of channels that can be served simultaneously, we must consider the following equation:

$$C = \sum_{i=1}^n r_i(k) \quad (5.1)$$

where $r_i(k)$ is the transmission rate of channel i allocated to BS_i for the next $RP(k)$. The algorithm to allocate the link rate to each channel follows the next steps:

- Step 1: Each BS calculates its queue length at *ReP* begins.
- Step 2: Every BS sends to the ONU the information obtained in step 1 by using the REQUEST message.
- Step 3: The synchronization of data reception between BSs and ONU, is reduced to minimize the difference between the individual transmission periods of all BSs. Let be $R_i(k)$ the amount traffic in the local buffer at BS_i , to be transmitted during the period k . Let be $TP_i(k)$ the transmission period required for BS_i to transmit its amount traffic $R_i(k)$, during the cycle k . Let denote $r_i(k)$ the rate of data transmission of BS_i in cycle k , we can obtain:

$$TP_i(k) = \begin{cases} \frac{R_i(k)}{r_i(k)} & \text{if } R_i(k) > 0 \\ 0 & \text{if } R_i(k) = 0 \end{cases} \quad (5.2)$$

It is important to remark that $r_i(k)$ and $R_i(k)$ can be variable. Consequently, $TP_i(k)$ can be also variable from one cycle to another. The synchronization problem can be solved as:

$$\forall_i \text{ Minimize } |TP_i(k) - TP_j(k)| \quad (5.3)$$

with $i, j = 1, 2, 3, \dots, n$ and $i \neq j$. In this step, ONU determines the link rate of each channel by using the next equation

$$r_i(k) = \begin{cases} \frac{R_i(k) \cdot C}{\sum_{l=1}^n R_l(k)} & \text{if } \sum_{l=1}^n R_l > 0 \\ 0 & \text{if } \sum_{l=1}^n R_l = 0 \end{cases} \quad (5.4)$$

Determining Saving Period

For any BS, $TP_i(k)$ is obtained by using the equation (5.8). The cycle length is obtained regardless the constraints of delay considered to provide QoS. Let be Th the time of life of one packet buffered in one BS, assuming l packets in the current BS at the beginning of the ReP , the last packet in the queue (p_l) will experiment the maximum access delay. From the precedent subsection, we can summarize that $RP(k) = TP_i(k), \forall 1 \leq i \leq n$. Consequently, the maximum length of $SP(k)$ is conditioned to:

$$ReP + RP(k-1) + SP(k-1) + ReP + TT_{l-1} \leq Th \quad (5.5)$$

where TT_{l-1} is the transmission time of $(l-1)$ packets buffered in the current BS. We can obtain an approximated length of $SP(k)$ by using the next expressions:

$$SP(k) = Th - (2ReP + RP(k-1) + SP(k-1) + TT_{l-1}) \quad (5.6)$$

if $Th > 2ReP + RP(k-1) + SP(k-1) + TT_{l-1}$, else $SP(k) = 0$.

5.2 Algorithm

Each BS has one buffer to store the data traffic going to the ONU until transmission is possible. Transmission from BSs to ONU will be synchronized; this allows to wireless receivers turning into normal and energy saving states periodically. The communication between ONU and BSs (Fig. 5.3) uses two messages: REQUEST and GRANT. REQUEST message is used to inform to ONU the queue length of BSs. The GRANT message is used to inform to BSs the length of Reception Period (RP) and Saving Period (SP). This process is done between one ONU and all the BSs served (by the current ONU), at the same time.

Wireless Receivers work in two modes: Normal and Energy Saving. During the Normal mode it can be in Reservation state or in Reception state. Lets denote ReP the time spent in Reservation State, and let be $RP(k)$ and $SP(k)$ the time spent in Reception state and Saving state during the cycle k , respectively. In ReP all the BSs send a REQUEST message to the ONU, the transmission window requested by each BS is based on its queue length. ONU allocates one sub-channel and transmission rate to each BS. After, it determines the next $RP(k)$ and $SP(k)$. Then, ONU sends GRANT messages to the BSs. GRANT message contains this information. ReP is constant during all the service cycles. All the BSs start

data transmission after the *ReP*. When the *RP(k)* ends, the wireless receiver turns into Saving state (according to *SP(k)*). During the *SP(k)*, there is no data packet reception by the wireless receiver, and the packets in the BSs are stored in one buffer to be sent in the forthcoming cycle. Some assumptions are considered for the proposed model: *i*) Packets to be transmitted in the cycle *k*, are known at the beginning of its *ReP*. *ii*) At the end of the *ReP*, ONU and all the BSs will have an idea of the packets number to be transmitted in the *RP(k)* to start.

EAW uses link adaptation to change transmission parameters over a link. Specifically, data transmission rate is adapted every cycle, based on traffic arrival to BSs. ONU is in charge of obtain the link rate value during the *ReP*. Let be *C* the total channel capacity for uploading traffic from all BSs to ONU. Lets denote *n* as the maximum number of channels that can be served simultaneously, we must consider the following equation:

$$C = \sum_{i=1}^n r_i(k) \quad (5.7)$$

where $r_i(k)$ is the transmission rate of channel *i* allocated to BS_i for the next *RP(k)*. The algorithm to allocate the link rate to each channel follows the next steps:

- Step 1: Each BS calculates its queue length at *ReP* begins.
- Step 2: Every BS sends to the ONU the information obtained in step 1 by using the REQUEST message.
- Step 3: The synchronization of data reception between BSs and ONU, is reduced to minimize the difference between the individual transmission periods of all BSs. Let be $R_i(k)$ the amount traffic in the local buffer at BS_i , to be transmitted during the period *k*. Let be $TP_i(k)$ the transmission period required for BS_i to transmit its amount traffic $R_i(k)$, during the cycle *k*. Let denote $r_i(k)$ the rate of data transmission of BS_i in cycle *k*, we can obtain:

$$TP_i(k) = \begin{cases} \frac{R_i(k)}{r_i(k)} & \text{if } R_i(k) > 0 \\ 0 & \text{if } R_i(k) = 0 \end{cases} \quad (5.8)$$

It is important to remark that $r_i(k)$ and $R_i(k)$ can be variable. Consequently, $TP_i(k)$ can be also variable from one cycle to another. The synchronization problem can be solved as:

$$\forall_i \text{ Minimize } |TP_i(k) - TP_j(k)| \quad (5.9)$$

with $i, j = 1, 2, 3, \dots, n$ and $i \neq j$. In this step, ONU determines the link rate of each channel by using the next equation

$$r_i(k) = \begin{cases} \frac{R_i(k) \cdot C}{\sum_{l=1}^n R_l(k)} & \text{if } \sum_{l=1}^n R_l > 0 \\ 0 & \text{if } \sum_{l=1}^n R_l = 0 \end{cases} \quad (5.10)$$

For any BS, $TP_i(k)$ is obtained by using the equation (5.8). The cycle length is obtained regardless the constraints of delay considered to provide QoS. Let be *Th* the time of life of one packet buffered in one BS, assuming *l* packets in the current BS at the beginning of the

ReP , the last packet in the queue (p_l) will experiment the maximum queuing delay. From the precedent subsection, we can summarize that $RP(k) = TP_i(k), \forall 1 \leq i \leq n$. Consequently, the maximum length of $SP(k)$ is conditioned to:

$$ReP + RP(k-1) + SP(k-1) + ReP + TT_{l-1} \leq Th \quad (5.11)$$

where TT_{l-1} is the transmission time of $(l-1)$ packets buffered in the current BS. We can obtain an approximated length of $SP(k)$ by using the next expressions:

$$SP(k) = Th - (2ReP + RP(k-1) + SP(k-1) + TT_{l-1}) \quad (5.12)$$

if $Th > 2ReP + RP(k-1) + SP(k-1) + TT_{l-1}$, else $SP(k) = 0$.

5.3 Performance Analysis

5.3.1 Numerical Formulation

In this section, we derive Numerical Formulation (NF) of the system. This formulation is done in terms of energy efficiency. Particularly, we focus on the percentage of energy efficiency improvement ω , compared between with and without applying our proposed algorithm. Let be $E_{ONU}(k)$ the energy consumed by one ONU during cycle k , we can obtain $E_{ONU}(k)$ by using:

$$E_{ONU}(k) = E_{WR}(k) + E_{ER}(k) + E_{WT}(k) + E_{ET}(k) + E_{BF}(k) \quad (5.13)$$

where $E_{WR}(k)$, $E_{ER}(k)$, $E_{WT}(k)$, $E_{ET}(k)$, and $E_{BF}(k)$ are the energy consumed by the set of wireless receivers, the set of Ethernet receivers, the set of wireless transmitters, the set of Ethernet transmitters and the energy consumed by the rest of components in the ONU, respectively, during the cycle k . $E_{WR}(k)$ is given by the sum of the energy consumed by all the wireless receivers at ONU. Let be M the number of wireless receivers at ONU, we can express $E_{WR}(k) = \sum_{w=1}^M E_w(k)$. In this sense, let be $E_{ReP}(k)$, $E_{RP}(k)$ and $E_{SP}(k)$ the energy consumed by one wireless receiver during the ReP , $RP(k)$ and $SP(k)$, respectively is given by:

$$E_w(k) = E_{ReP}(k) + E_{RP}(k) + E_{SP}(k) \quad (5.14)$$

$E_{RP}(k)$ is obtained by the energy consumed for the reception of REQUEST messages of all BSs, and the energy that the wireless receivers spend in sensing state (receiver is in active mode without receiving data transmission). Denote P_{rec} , P_{sen} and P_s as the power consumption of the receiver in receiving, sensing and energy saving mode, respectively. We can rewrite the equation (5.14) for one wireless receiver as:

$$E_w(k) = \sum_{i=1}^n (REQ * P_{rec} + C_T * P_{sen}) + E[RP] * P_{rec} + E[SP] * P_s \quad (5.15)$$

REQ is assumed constant value, it is the time period from ReP begin until REQUEST message reception. C_T is the time period from REQUEST reception until RP begin. During C_T the ONU executes the algorithm to obtain $RP(k)$ and $SP(k)$. $E[RP]$ and $E[SP]$ are the expected values of $RP(k)$ and $SP(k)$, respectively, and these expected values will be obtained

regardless to QoS constraints. Let us define $E_0(k)$ the energy consumption during the same length of time, assuming same number of packets in the BS buffers. If the energy saving algorithm is not applied, the energy consumed by one wireless receiver becomes as follow:

$$E_0(k) = \sum_{i=1}^n (REQ * P_{rec} + C_T * P_{sen}) + E[RP] * P_{rec} + E[SP] * P_{sen} \quad (5.16)$$

Let be T_{pkt} the average transmission time of one packet, with $RP = TT_{(l-1)} + T_{pkt}$. To derive $E[RP]$ and $E[SP]$, by using the equation (5.12) and taking expected value in both sides, we get the expression:

$$E[SP] = \frac{Th - (2E[RP] + 2ReP - T_{pkt})}{2} \quad (5.17)$$

Now, denote $\tilde{\lambda}$ as the packet arrival rate (in Mb) averaged (bits per unit of time) for the current ONU. Note that $\tilde{\lambda}$ may be time varying and its long-term average is denoted as λ . Once the receiver is in normal state, the BSs start uploading all the buffered packets. During the reception of data packets, there may also packets arriving at the BSs. These packets, as we said before, will be buffered and then be served in the next service cycle. Therefore we have the following relationship:

$$C \cdot RP(k) = \tilde{\lambda} \cdot (ReP + SP(k-1) + RP(k-1)) \quad (5.18)$$

Since $\tilde{\lambda}$ is unknown to the ONU, its long-term average λ is used as an estimate, where we assume that λ is a known parameter. In this sense, the estimated uploading period RP satisfies:

$$C \cdot E[RP] = \lambda \cdot (ReP + E[RP] + E[SP]) \quad (5.19)$$

After taking expectation in both sides, and by using the equation (5.30), we obtain the expected value of RP as:

$$E[RP] = \frac{\lambda \cdot (Th + T_{pkt})}{2 \cdot C} \quad (5.20)$$

With this result and by using the equation (5.30) we can obtain the energy consumed by the wireless receiver.

5.3.2 Asymptotic Approximation

We propose an Asymptotic Approximation (AA) for the RP and the SP . Without considering the ReP , and with $\tilde{\lambda}$ as the packet arrival rate (in Mb) averaged (number of packets per unit of time). Again, note that $\tilde{\lambda}$ may be time varying and its long-term average is denoted as λ . We propose a linear system of two equations with two variables. In solving the system of equations we try to find values for $E[RP]$ and $E[SP]$. Let be C a constant value denoting the transmission capacity of the channel (in number of packets). Lets denote Th the time of life of one packet buffered in one BS. The equation system to solve is:

$$\begin{aligned} C \cdot RP &= \lambda \cdot (RP + SP) \\ 2 \cdot RP + 2 \cdot SP &= Th \end{aligned}$$

Taking expectation in both sides of two equations and finding one solution for the equation system we get:

$$\begin{aligned} E[RP] &= \frac{\lambda \cdot Th}{2 \cdot C} \\ E[SP] &= \frac{(C - \lambda) \cdot Th}{2 \cdot C} \end{aligned}$$

Let be ω the energy efficiency factor considered in this study, it can be described as:

$$\omega = \frac{E_0 - E_w}{E_0} . \quad (5.21)$$

5.3.3 Analysis by queuing models

Now we want to analyze the reception of packets by the wireless receiver implementing EAW. This algorithm was described in the precedent section. The packet reception will be possible in some periods of time. Each incoming packet ξ may arrive to any ONU i and it will be subject to a queuing delay $W(\xi)$. The queuing delay of ξ arriving at i_{th} ONU is given by:

$$W(\xi) = R(\xi) + N(\xi)\bar{X}(\xi) + Re(\xi) \quad (5.22)$$

where $X(\xi)$ is the mean service time of packet ξ . $R(\xi)$ is the residual time of ξ and $Re(\xi)$ is the Re defined in the communication process between ONU and BSs. The queuing delay is equal to:

$$E[W] = E[R] + \frac{E[N]}{\bar{X}} + E[Re] \quad (5.23)$$

Hence in order to get the value of $E[W]$, we need to find $E[R]$ and $\frac{E[N]}{\bar{X}}$. ReP is constant, during this time the BSs served by the ONU will let know their queue lengths and will receive one message from the current ONU with the information about the link rate transmission, length of windows for transmission and saving periods. Using Little's theorem, the expected number of arriving packets while ξ is waiting, can be expressed by $\lambda E[W]$. As a result:

$$\frac{E[N]}{\bar{X}} = \rho \times E[W] \quad (5.24)$$

Hence, the expected queuing delay is then computed as follows:

$$E[W] = \frac{E[R] + E[Re]}{1 - \rho} \quad (5.25)$$

The residual time is given by:

$$E[R] = \frac{\lambda \bar{x}^2}{2} + \frac{\bar{v}^2(1 - \rho)}{2\bar{v}} \quad (5.26)$$

$$E[R] = \frac{\lambda \bar{x}^2}{2} + \frac{v(1 - \rho)}{2} \quad (5.27)$$

The expected queuing delay for a packet is expressed as follows:

$$E[W] = \frac{\frac{\lambda \bar{x}^2}{2} + \frac{v(1 - \rho)}{2} + Re}{(1 - \rho)} \quad (5.28)$$

then

$$E[W] = \frac{\lambda \bar{x}^2}{2(1-\rho)} + \frac{v}{2} + \frac{Re}{2} \quad (5.29)$$

The vacation time v is obtained by $E[SP]$, to get $E[SP]$ and $E[RP]$ we can use the expressions presented in previous sections:

$$E[SP] = \frac{Th - (2E[RP] + 2ReP - x)}{2} \quad (5.30)$$

$$E[RP] = \frac{\lambda \cdot (Th + x)}{2 \cdot C} \quad (5.31)$$

5.4 Numerical Results

In this section, we present simulation and numerical results. We develop a MatLab program to simulate the system where one ONU is serving 6 BSs. Only one packet length of 800bits was considered. The ReP has a duration of 50ms, the P_{rec} has a value of 787mW, the P_{sen} of 503mW and P_s of 44mW. The size of one REQUEST packet used is 20bits. The results were obtained with the 95% confidence intervals.

We present in Fig. 5.6 the average $RP(k)$ in each cycle. RP is the $E[RP]$ obtained by NF and AP, and the $RP(K)$ by Simulation. The value of $Th = 1s$ and $\lambda = 5\%$ of C (in number of packets). As we can appreciate, the NF and the AP results represent a lower bound for simulation results. The relative error between the simulation results and the NF is 0.018. The relative error between the simulation results and the AP is also 0.018.

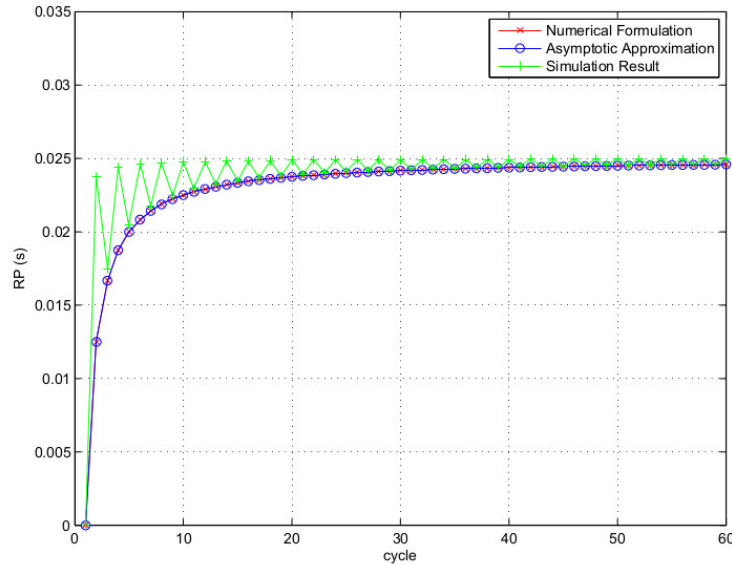

Figure 5.6: RP obtained each cycle.

Fig. 5.7 shows the average $SP(k)$ obtained in each cycle. SP is the $E[SP]$ obtained by NF and AP, and the $SP(K)$ obtained by Simulation. In the stationary state, NF is a lower bound for simulation results, and AA an upper bound for simulation results. In this case, the relative error between the simulation result and the NF is 0.0012, and between the AA

and the simulation result is 0.11. The results obtained with the NF are most precise than the results obtained with the AA. This is due to the fact that the AA does not consider all the parameters of the system. Specifically, the ReP and the T_{pkt} were not considered in our proposition.

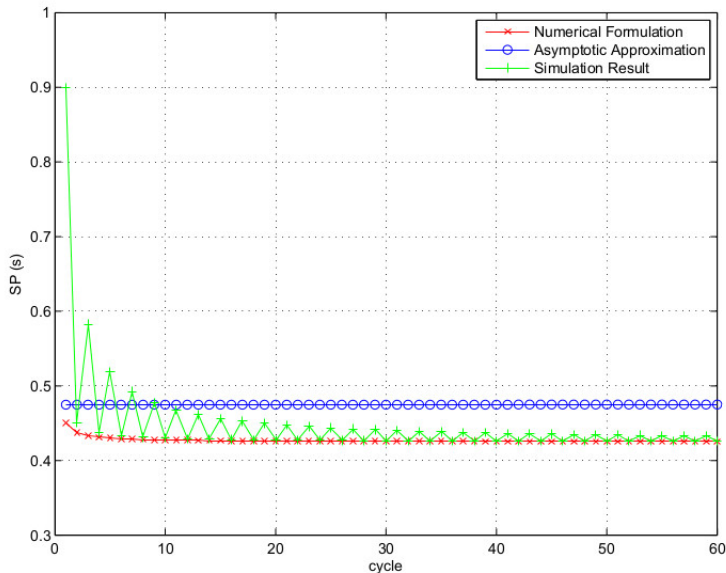

Figure 5.7: SP obtained each cycle.

The energy consumed by the receiver applying our algorithm is presented in Fig. 5.8. We can see the results obtained by NF, AA and simulation. All the results are very similar. As expected, the energy saving reduce when the arrival rate increase because the $RP(k)$ is also increasing. The Th value used is 0.7s. In Fig. 5.9 we can observe the factor of energy efficiency improved ω , during low load traffic period. The Th value is 0.7s. As we expected, the improvement is very representative approximative to 87% for very low traffic load, and when the traffic load is increasing ω is reducing.

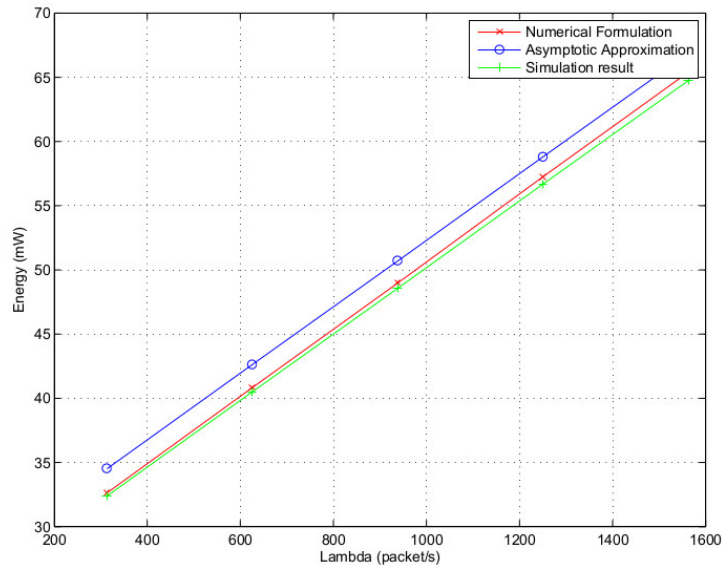

Figure 5.8: Energy consumption ($Th = 0.7s$).

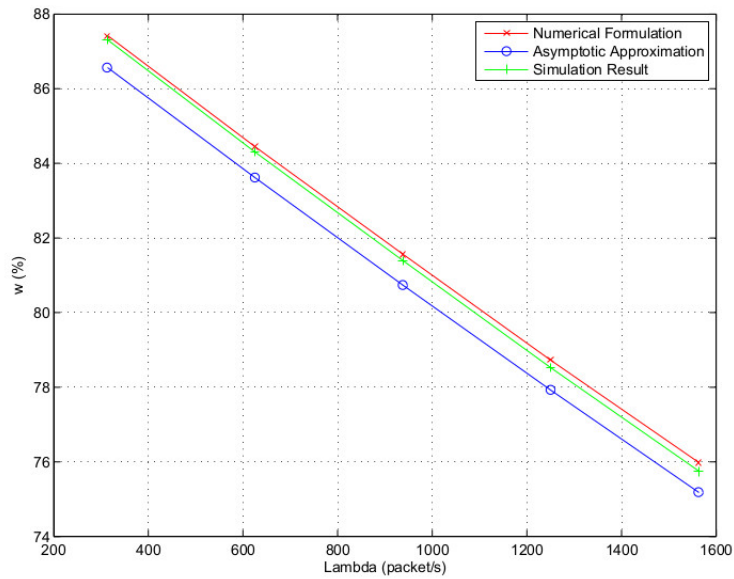

Figure 5.9: Improvement Factor ($Th = 0.7s$).

Fig. 5.10 shows the mean access delay of packets at BSs, under varying arrival rate. Only NF and simulation results are showed. When we increase the arrival rate, both results increase. The average of relative error is 0.015, which indicates the good performance of our NF.

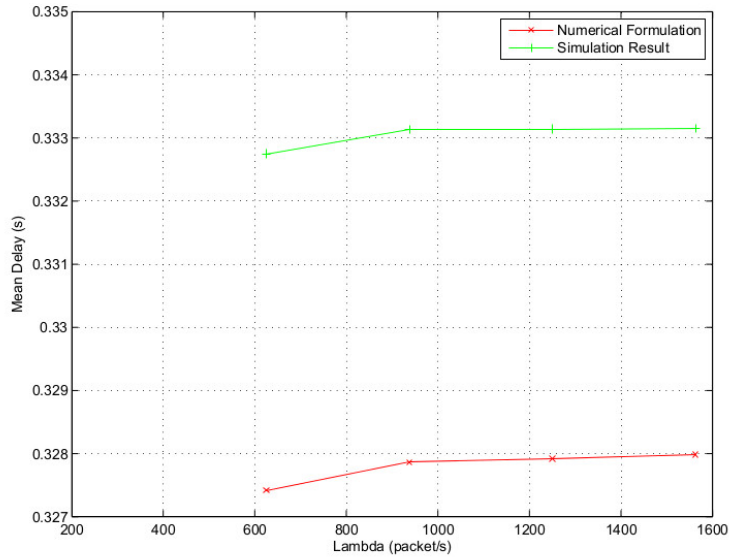

Figure 5.10: Mean Access Delay

To study the impact of Th on the performance of receiver (Fig. 5.12), we ran some simulations for different values of Th . We could observe that in the period of low traffic load, the Th parameter does not impact significantly the performance of the receiver. We present the results for $Th = 0.3s$, $Th = 1.0s$, $\lambda = 0.01 \cdot C$ (packets/s) (1% of the total capacity C defined already) and $\lambda = 0.1 \cdot C$ (packets/s) (10% of the total capacity C defined already).

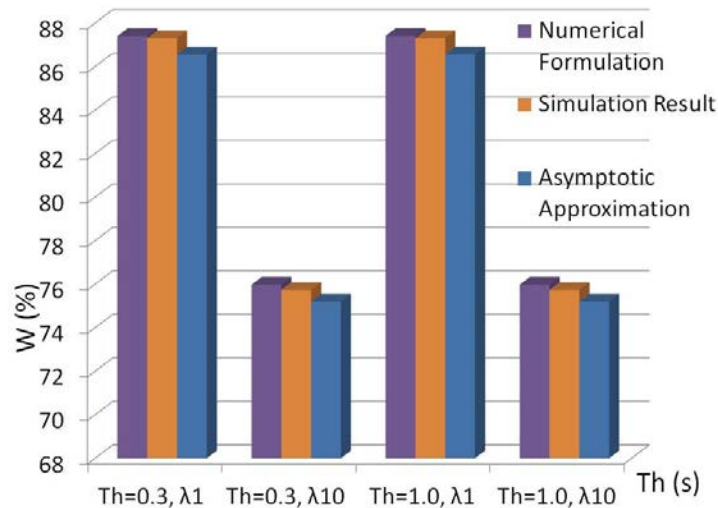

Figure 5.11: Impact of Th on the receiver performance ($\lambda_1 = 0.01 \cdot C$ and $\lambda_{10} = 0.1 \cdot C$)

Fig. 5.12 shows the mean access delay of packets at BSs, under varying arrival rate. Only M/D/1 with vacation model and simulation results are showed. For packet arrival with very low rate, when we increase the arrival rate, both results increase. After, the results stay almost invariable. The average of relative error is 0.005.

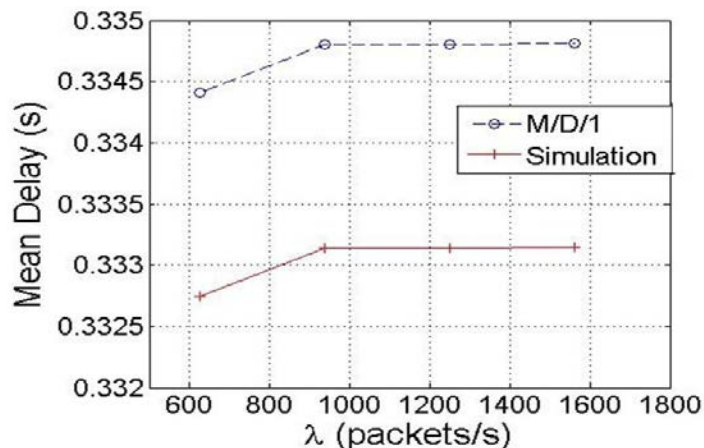

Figure 5.12: Mean Access Delay obtained by using M/D/1 with vacation model

5.5 Concluding Remarks

Integrated optical-wireless access networks constitute a wide domain for researches. In the literature, several works have been proposed to deal with the trade-off between energy and QoS. However, these propositions consider optical and wireless networks in separated way, the convergence of these technologies have been neglected. In this chapter, we have proposed an energy efficiency algorithm for wireless receiver at hybrid ONUS. A protocol of communication between ONU-BSs was required for the use of the proposed algorithm. Mode active/save is considered for wireless receivers. Consequently, packet transmissions are synchronized between the ONUs and their associated BSs. The adaptive link rate is used to allow this process. The performance of the proposed algorithm in terms of energy saving is evaluated by using MatLab. The results show that our algorithm can achieve significant energy level while keeping the access delay according to QoS constraints. Performance analysis of wireless receivers by queuing models M/D/1 with vacation and gated was presented. Numerical results were compared to the obtained by simulations. The results show the improvements on the performance of wireless receivers in terms of energy, under QoS constraints.

As we can remark, in integrated access network the traffic at ONU is heterogenous. Wireless and Optical traffic with different characteristics and requirements in terms of QoS are the source of traffic for the ONU. In the precedent chapter, a very simple scheduling algorithm for traffic at ONU was proposed. However, another service discipline different to priority scheduling algorithm may improve the network performance for local traffic. Also the priority considered for traffic at ONU can be established in better way. To study this problem, in the next chapter we present an algorithm of scheduling for hybrid ONUs in integrated access networks.

Chapter 6

Scheduling Mechanism for Optical-Wireless Networks

Some scheduling algorithms for integrated optical-wireless access networks have been proposed. However, the different approaches consider only the heterogeneous traffic at ONU transmitted from ONUs to OLT. The local traffic, transmitted from ONU (Ethernet and/or wireless) to end users does not have been considered. In this chapter, we propose a framework for a scheduling algorithm to be used in hybrid ONUs. The service rules take into account both traffics: exterior and local. The aim of this proposition is to define a framework for dynamically vary the rules in a Weighted Round Robin discipline

6.1 Proposed Architecture

Scheduling of different traffic class becomes now an inevitable role in supporting QoS of integrated optical-wireless access networks. The QoS management is performed in each ONU by maintaining several separate priority queues. Packets are classified and placed into their appropriate queues according to the CoS which they belong. We propose a scheme for handling the different classes of Ethernet and wireless traffic received at the ONU. We differentiate two traffic kind at ONU: exterior and local. Exterior traffic is referred to the traffic going to the OLT. Local traffic is that one transmitted from ONU to end users. As result, each ONU contains two buffering spaces and each buffering space contains one kind of traffic. Also, each ONU is assumed to have a QoS mapping mechanism to map the different packets into the considered CoS. In chapter 4, we have presented a QoS mapping taht will be used in this study. Hence, three different CoS were considered for Ethernet traffic: EF, AF, and BE; and the CoS established in the standards fo wireless technologies were also classified into three classes.

Each ONU is equipped with two subsystem of buffers, one for exterior traffic and the other for local traffic. In each subsystem there is two subspaces of queues. The system of buffers considered in the ONU is shown in Fig 6.1. As we can see the subspace of buffers for exterior traffic are differentiated by packet source. In opposite, the subspace of buffers for local traffic are differentiated according to destination. This is due to the fact that in terms of E2E delay wireless packets coming/going from/to wireless sources could be more sensitive to the E2E (and his propagation in the network).

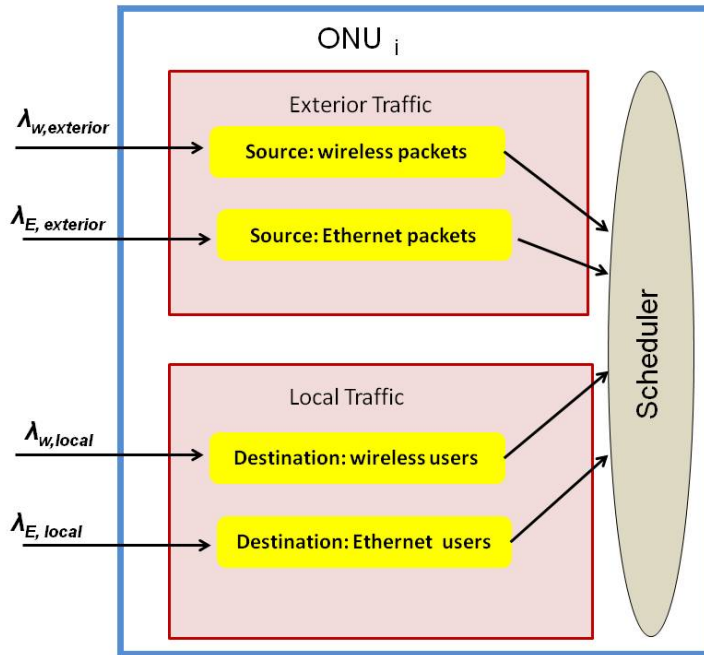

Figure 6.1: Buffers System at ONU

The traffic at ONU is described below. The description corresponds to a general case, one ONU applying another QoS mapping different to the considered in this study.

- a) Exterior traffic. The sources of this traffic are packets arriving to the ONU that must be transmitted to the OLT. Each node encloses M electronic buffers in order to accommodate a number of M Classes of Service (CoS) for exterior traffic. These buffers have unlimited capacity. Fig. 6.2 shows the queuing system inside an ONU. We suppose that wireless packets $CoS_{w,q}$ arrive to ONU following the Poisson process with a rate $\lambda_{w,q}$ and Ethernet packets $CoS_{E,q}$ arrive to ONU following the Poisson process with a rate $\lambda_{E,q}$, with $1 \leq q \leq M$.

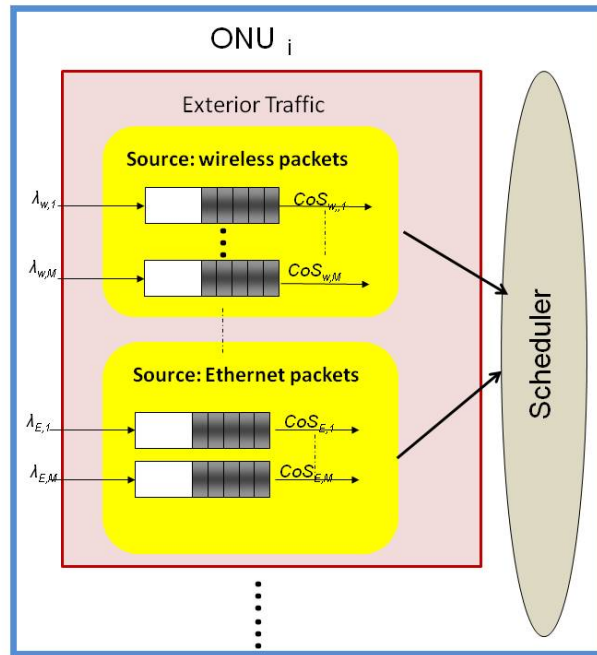

Figure 6.2: Exterior buffer system

- b) Local traffic. The sources of this traffic are packets arriving to the ONU that must be transmitted to the end users. Each node encloses 6 buffers in order to accommodate 6 priorities Q for local traffic. These buffers have unlimited capacity. Fig. 6.3 shows the queuing system inside an ONU. We suppose that packets arrive to each buffer following the Poisson process with a rate $\lambda_{source,destination}$.

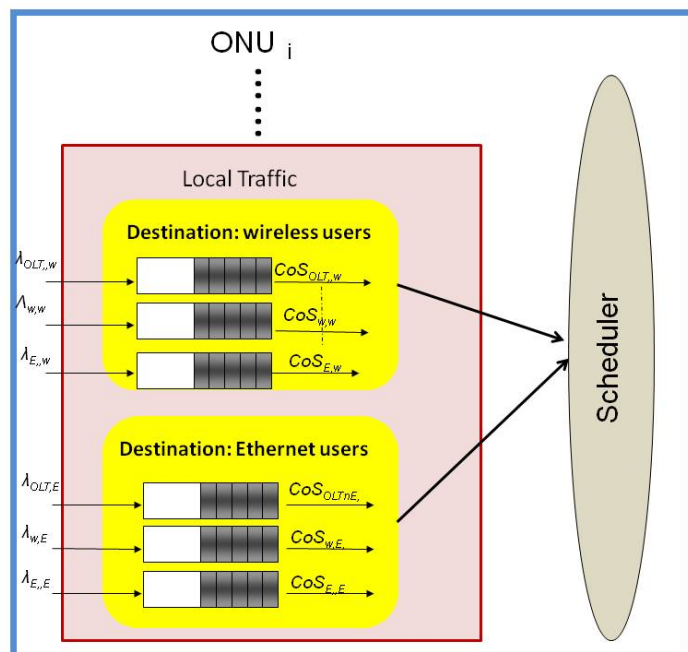

Figure 6.3: Local buffer system

6.2 Scheduling Algorithm

The proposed algorithm must consider in integrated way the two traffic kind at ONU (exterior and local). The algorithm can be summarized below:

1. The wireless buffers system is served until buffers for exterior traffic must be served or there is no more packets in wireless queues.
2. Then, the exterior traffic is served during the window allocated by OLT (according to the DBA presented in chapter 4).
3. Once the service of exterior traffic ends, the local Ethernet traffic is served until the end of cycle service or there is no more packets in Ethernet buffers.

Priority queuing is considered an useful and simple method for supporting multi-service. Priority scheduling mechanism transmit packets from the head of a given queue only if all higher priority queues are empty. If a higher priority packet arrives during waiting period of lower priority packet, it will be scheduled ahead of all the reported lower priority packets for the transmission time. This situation will penalize performance of lower priority traffic resulting in increasing the access delay and degrading QoS. Generally, QoS provisioning mechanisms for EPON use a Strict Priority (SP) scheduling strategy. In such strategy, a lower priority queue is scheduled for transmission if, and only if, all of the queues with a higher priority are empty. However, SP-based QoS provisioning mechanisms are intended specifically for homogeneous access network environments (i.e., Ethernet traffic only). As a result, they cannot satisfy both the QoS requirements of the Ethernet and wireless traffic carried in the integrated studied network. In this study, we introduce a scheduling algorithm with a service discipline for each buffer system at ONU, the appropriate modifications of the weighted round-robin (WRR) service can provide tight fairness properties and efficient delay guarantees. The aim is to allow a weight assignation in dynamic way while the actual traffic patterns for the different priorities are expected to vary over time, making it difficult to select a single optimal set of weights. The bandwidth allocation performed at each ONU is based on contemporary queue status information rather than the outdated information available at the OLT during inter-ONU scheduling. Thus, adaptability in each ONU, of each traffic queue's weights, to change traffic service conditions allows a more efficient bandwidth allocation. We propose a queue-based scheduling scheme and we refer to ONU buffer situation to decide the priority ratio of each buffer.

6.3 Dynamic Scheduling Algorithm

The appropriate modifications of the weighted round-robin (WRR) service can be done based on the effectiveness of the weights used. A module must be in charge of execute the algorithm. This module could be in ONU to handle information about the queue states updater than the case with the module placed at OLT. We propose a model for the system in charge of Scheduling in the ONU architecture, which is composed by three components such as: a system of rules, a system of credit allocation, and a discovery system.

- a) System of rules (SR). It stores the rules of service discipline. The rules are conditions if (condition) then decision. The structure of one rule considers only the buffers of its subspace and it is presented as:

- If ($CoS_{w,1} < V_1$ and/or $CoS_{w,2} < V_2$ and/or $CoS_{w,M} < V_M$ and/or $CoS_{E,1} < E_1$ and/or $CoS_{E,2} < E_2$ and/or $CoS_{E,M} < E_M$ then $W_1 = D_1$ and $W_2 = D_2$... and $W_M = D_M$ and $E_1 = D_{M+1}$ and $W_2 = D_{M+2}$... and $W_M = D_{2M}$. Where $CoS_{a,b}$ is the buffer length with source of traffic a and CoS_b , V_i is the maximum percentage of buffer filled, W_i the variable with the weight for i^{th} wireless buffer, E_i the variable with the weight for i^{th} Ethernet buffer and D_i the value assigned after validation of rules in each case.
- If ($CoS_{OLT,w} < R_1$ and/or $CoS_{w,w} < R_2$ and/or $CoS_{E,w} < R_3$ and/or $CoS_{OLT,E} < R_4$ and/or $CoS_{w,E} < R_5$ and/or $CoS_{E,E} < R_6$ then $P_1 = D_1$ and/or $P_2 = D_2$ and $P_3 = D_3$ and/or $P_4 = D_4$ and/or $P_5 = D_5$... and/or $P_6 = D_6$. Where $CoS_{a,b}$ is the buffer length with source of traffic a and CoS_b , R_i is the maximum percentage of buffer filled, P_i the variable with the weight for i^{th} wireless buffer, and D_i the value assigned after validation of rules in each case.

b) Credit Allocation System (SAC). It is in charge of the rule's performance evaluation. Based on the mean access delay of each traffic kind. It is responsible for assigning credit values to the rules. Let be $AD_{QoS,i}$ the mean access delay for packets in queue QoS of i^{th} class of service, and let's denote AD_i as the considered constraint of delay for i^{th} CoS. Let be QW_i the relation between measured access delay and maximum access delay for packets buffered in the same buffer. QW_i is calculated using the following equation:

$$QW_i = \frac{\bar{AD}_{QoS,i}}{AD_i} \quad (6.1)$$

where n The credit of one rule C can be obtained as:

$$C = \sum_{i=1}^{n_{buffers}} QW_i \quad (6.2)$$

where $n_{buffers}$ is the number of buffers in the subsystem of buffers exterior or local.

c) Discovery System (SD). It creates new and possibly more effective rules and replace the less effective. It could to define new buffer size in the condition part of the rule or weights for the WRR discipline. To define the possible size of filled buffer. It verifies the QW_i for one subsystem of rules and based on this rate it can determine which buffers could be reduce the number of packets served and which could increment. When the QW_i is near 0 this buffers could be have less weight in the next service. When the $QW_i = 1$ the weight for priorities buffers shouldn't be modified. When the $QW_i > 1$ for priorities queues the number of packets for the other queues should be reduced. The proportion to augmenter or decrease each buffer size should consider a general value for loss rate tolerated by all the classes of service defined by the service provider. Let be ΔP the proportion of packets to increase for buffers, and let's denote L the length of packets assuming that all packets have the same length. ΔP can be obtained as follow:

$$\Delta P = \sum_{i=1}^{n_{buffers}} 100 * L * \frac{(QW_i - 1)}{1 - QW_i} \quad (6.3)$$

To evolve and dynamically update the rules of service, the system should consider:

- According to the performance of ONU by using the rules, a credit will be assigned to the rules.
- Create new rules when the ONU does not have good performance in terms of access delay. The new rules will replace the existing rules.

6.4 Simulation Results

To evaluate the performance of the proposed scheduling scheme within an integrated Optical-Wireless system, a simulation model was developed comprising an access network with 16 ONUs and a single OLT. The available bandwidth for upstream transmissions was set to $1Gb/s$, while the guard time between ONU transmissions was specified as $5\mu s$. The RTT between an ONU and the OLT was randomly generated in accordance with a uniform distribution $U[100\mu s, 200\mu s]$, corresponding to a physical distance of $15 - 30km$. Ethernet traffic arriving at an ONU from end users are stored in one Ethernet buffer, while wireless packets awaiting transmission at the ONU are stored in a single buffer. The buffer sizes of Ethernet and wireless buffering space maintained at each ONU are identical and the amount of capacity of these transmission buffers was assumed to be $10Mbytes$. The OLT granted ONUs no more than the maximum window size $WMAX$, which was set to $15kbytes$. The effectiveness of the proposed scheduling was assessed by simulation using MatLab. The maximum latency requirement for CoS_2 connections was $300ms$ and each connection had its own minimum reserved traffic rate requirement and maximum sustained traffic rate which varied according to the rate of the transmitted video. The BE service does not have any QoS requirements. The simulations were focused on exterior traffic. The rules consider only the buffer length of the priority CoS in the subsystem of buffer. The rules used in this example are presented below:

1. Exterior Traffic. The service rules for this traffic kind are listed below:

- If the buffer $CoS_{w,1}$ is filled less than 30% then the priority ratio is configured to 4:2:1 for CoS1, CoS2, and CoS3. Once all the packets in the three queues is transmitted (in the best of cases), the service of EF, AF, and BE stars in exhaustive discipline.
- If the buffer CoS1 is filled between 30% and 70% then the priority ratio is configured to 4:1:0 for CoS1, CoS2 and CoS3 respectively. After, CoS3 queue is served exhaustive and finally the service of Ethernet queues stars in exhaustive discipline.
- If the buffer CoS1 is filled more than 70% then the priority ratio is configured to 1:0:0 for CoS1, CoS2 and CoS3 respectively. After, CoS3 queue is served exhaustive and finally the service of Ethernet queues stars in exhaustive discipline.

Fig. 6.4 shows the latency for each CoS (wireless connections), as we can see the latency of CoS_2 flows was almost constant, but it slightly increased when the traffic load in ONU approximated of $1Gbps$. Besides that, the delay values of CoS_3 connections are below the bound of $300ms$ when the total load is $1Gb/s$. The performance of BE connections suffered high latencies. It is important to note that our algorithm was able to provide delay values below the required bound even when the offered load was greater than $1Gb/s$.

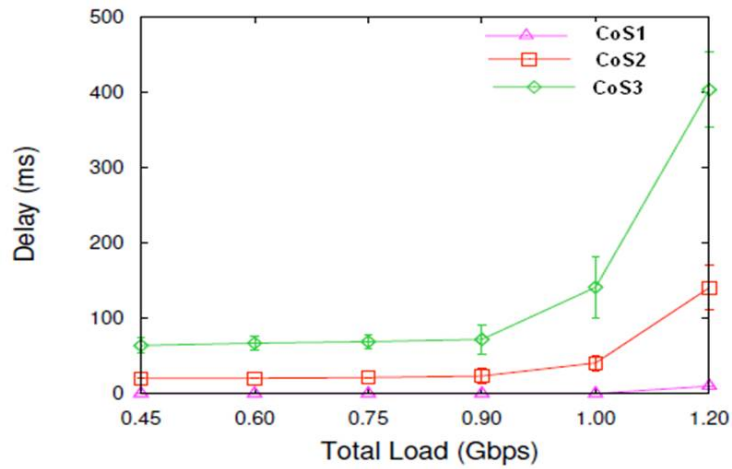

Figure 6.4: Latency of CoS1, CoS2 and CoS3 for wireless connections

6.5 Concluding Remarks

In this chapter we have presented a framework for an algorithm of scheduling in hybrid ONUs. The performance study through simulations of the algorithm should be done in order to demonstrate his effectiveness. We think that the proposition could provide an alternative to the problem of heterogeneous traffic in integrated access networks.

Chapter 7

Conclusions

7.1 General Conclusions

Optical technologies are used to deal with the explosion in data traffic. Devices more reliable at higher speeds have appeared in order to offer bandwidth according to users demand. New generation of optical networks must be designed and implemented taking in count the different traffic volume in each sector of the networking. The integration of optical and wireless networks constitutes a good alternative to solve the problems due to the end users requirements in terms of bandwidth and connectivity. However, the integration of optical and wireless networks at the access sector carries different research challenges such as, integrated resource allocation, QoS mapping and packet creation mechanisms, e.g. Additionally, the new architectures of access networks must include as an objective in their design and implementation: techniques, protocols and/or algorithms in order to save energy in an efficient manner. The last is due to the fact that the efficiency of energy represents one of the biggest challenges in the operation of modern telecommunication networks. It has been well investigated in wireless networks and in optical networks (access and backbone). However, the convergent networks does not have been considered as an all. In this thesis, after presenting a summarized description of concepts and definitions used in our study, we have addressed some of these challenges and we have proposed some solutions.

We started this dissertation in chapter 2 with a global view of the optical networks, wireless networks and the integrated optical-wireless access networks. We have presented, the basic definitions associated to the optical networks (core, metro, access) and some very well-known architectures have been summarized to list the main advantages of each one. We have also introduced in this chapter the evolution of wireless networks. Some existing architectures to integrate optical networks and wireless networks at the access segment have been described. We have given some techniques to save energy in optical networks and in wireless networks in independent way. Finally we have presented the challenges to face by new integrated optical-wireless access networks.

In chapter 3 we have studied interconnected rings networks. The problem of the pass of traffic from one network to another was analysed. The synchronization in the traffic shift was proposed. As a solution for the synchronization, a packet creation mechanisms at the Hub node interconnecting both networks was proposed. In this chapter, we have evaluated the performance of interconnected multi-ring networks. The network consists of two metro rings in which a synchronous metro access (DBORN) is connected to a synchronous metro core (ECOFAME). By implementing two approaches: the known OM and the proposed in this

work CUTM, we have seen that the performance of Hub node is guaranteed (in terms of access delay and jitter) regardless of the synchronization shift. Additionally, the E2E performance does not depend on the source nodes. Performance comparison of OM and CUTM has been presented. CUTM offers a solution to solve the problem of synchronization and provides good network utilization. In terms of energy efficiency, CUTM has presented better performance than OM because the filling ratio rate. By creating less number of packets than OM, it is expected that the energy spend by applying CUTM be lower than that one of the OM application.

In the scope of the dissertation, in chapter 4 we have proposed a model for a novel ONU in integrated optical-wireless access networks. The resource allocation to save energy is an alternative for the new solutions. A DBA algorithm was proposed. GIBA was implemented and performance of the network was evaluated. However, because of the disadvantage of GIBA, a new version to improve the resource allocation in effectively and fairly way was proposed (eGIBA). GIBA and eGIBA allow active/sleep mode to transmitters/receivers at ONU. To allow this, modifications in the buffer system at OLT were proposed, a MAC in the upstream and downstream direction and for local traffic at ONU, a scheduling algorithm and service discipline for both approaches were specified. Simulation results highlight the advantages of GIBA and eGIBA. The results were compared with results obtained by the very well-known IPACT. IPACT and any other version of interleaved polling schemes may have better network resource utilization, but they cannot enable to get the goal of this work in terms of energy.

To allow the mode active/save used in the chapter for some transceivers at ONU, we have proposed in chapter 5 an energy efficiency algorithm for wireless receiver at hybrid ONUs, which has not been considered in chapter 4. A protocol of communication between ONU-BSs was required for the use of the proposed algorithm. Consequently, packet transmissions were synchronized between the ONUs and their associated BSs. The adaptive link rate was used to allow this process. The performance of the proposed algorithm in terms of energy saving was evaluated by using MatLab. The results show that our algorithm can provide significant energy level while keeping the access delay according to QoS constraints. Performance analysis of wireless receivers by queuing models M/D/1 with vacation and gated was presented. Numerical results were compared to the obtained by simulations. The results show the improvements on the performance of wireless receivers in terms of energy, under QoS constraints.

In integrated wireless-access networks the traffic in ONUs is heterogenous. Wireless and optical traffic with different characteristics and requirements in terms of QoS are the source of traffic for the ONUs. A service discipline different to priority scheduling algorithm was considered to offer fairly to the traffic at ONU. To study this problem in chapter 6 we have presented a framework and an algorithm of scheduling based on WRR discipline.

7.2 Future Work

The study in chapter 3 has evaluated the performance for Hub node interconnecting metro access networks and metro core networks. As for a complete simulation of the end-to-end metro network, we plan to define some metrics to evaluate energy efficiency in the Hub node implementing CUTM and another mechanism of packet creation. In this way, we could establish the relationship between the filling ratio rate of packet creation mechanisms and the

energy saved.

In chapter 4, we have specifically proposed an architecture for hybrid ONU, it is particularly interesting to study the dimensioning of buffers to reduce the energy consumption and operational cost of this unity. This study could be extended to OLT regardless to the proposition of using one buffer per ONU at OLT. Also, to propose packet creation mechanisms for the heterogeneous traffic at ONU could improve the performance of the network in terms of energy and QoS. GIBA and eGIBA are polling mechanisms in both optical and wireless domains with dynamic length of cycle, which is one of the big challenges in integrated optical-wireless access networks. However, more efficient, dynamic, and flexible DBA schemes are required to address the future bandwidth starving services and applications.

The algorithm presented in chapter 5 is related to the wireless receivers at ONU. However, putting a the receiver (partially or completely) into the saving mode not only depends on the traffic availability, but also on the channel conditions at the wireless BS and the mobile users. This study should be extended in that way. Additionally, the use of active/saving mode for Ethernet receivers at ONU is an interesting theme of research. The big challenge should be determine the saving period by reducing loss rate.

The analysis of access delay for different traffics at ONU will be done by using queuing models and considering different sizes of packets for the considered CoS. As for reducing energy consumption the techniques are based on the synchronization which lead to the system to impose some retards in the packets transmission; one of the topics to be studied is the impact of propagation delay.

Most of the works found in the literature propose either a strict policy to support adequate QoS services. In chapter, 6 a framework for scheduling algorithm was presented. The policy takes into account fairness issues, throughput and delay guarantees. However, more efforts are needed to study deeply the fairness in his implementation. Extensive simulation and analytical framework are needed to identify the reliability and the effectiveness of this approach under varied traffic conditions.

Bibliography

- [1] Cisco Visual Networking Index: Global Mobile Data Traffic Forecast Update, 2014-2019, Cisco White Paper, Feb. 2015.
- [2] China Mobile Limited Annual Report 2014, China Mobile Limited Annual Report, 2015.
- [3] C. I, Green Evolution of Mobile Communications (CMCC Perspective), GreenTouch Members Meeting, Nov. 2012.
- [4] G. Auer et al., How Much Energy Is Needed To Run A Wireless Network? *IEEE Wireless Commun.*, no. 5, vol. 18, pp. 40-49, Oct. 2011.
- [5] J. Zhang and N. Ansari, Towards energy-efficient 1G-EPON and 10GEPON with sleep-aware MAC control and scheduling, *IEEE Communications Magazine*, vol. 49, no. 2, Feb. 2011.
- [6] Y. Yan, S.-W. Wong, L. Valcarenghi, S.-H. Yen, D. R. Campelo, S. Yamashita, L. Kazovsky, and L. Dittmann, Energy Management Mechanism for Ethernet Passive Optical Networks (EPONs), *Proceedings of IEEE International Conference on Communications (ICC10)*, Cape Town, South Africa, May 2010.
- [7] A. R. Dhaini, P.-H. Ho, and G. Shen, Toward Green Next-Generation Passive Optical Networks, *IEEE Communications Magazine*, Vol. 49, Issue 11, pp 94-101, Nov. 2011.
- [8] A. R. Dhaini, P.-H. Ho, and G. Shen, Energy Efficiency in Ethernet Passive Optical Networks: For How Long Can ONU Sleep? *University of Waterloo, Tech. Rep.*, Mar. 2011.
- [9] QoS-aware energy-efficient mechanism for sleeping mode ONUs in enhanced EPON, AliAkbar Nikoukar, I-Shyan Hwang, Andrew Tanny Liem, Chien-Jung Wang
- [10] Susumu Nishihara, Marek Hajduczenia, Hiroaki Mukai, Hesham Elbakoury, Ryan Hirth, Mitsunobu Kimura. Power-Saving Methods with Guaranteed Service Interoperability in Ethernet Passive Optical Networks *IEEE Communications Magazine (Impact Factor: 4.46)*. 09/2012; 50(9):110-117. DOI: 10.1109/MCOM.2012.6295720
- [11] 3GPP TSG-RAN WG1, Enhanced network energy efficiency, Valencia, Spain, January 2010.
- [12] D. Zeller, M. Olsson, O. Blume, A. Fehske, D. Ferling, W. Tomaselli, and I. Gdor, Sustainable Wireless Broadband Access to the Future Internet - The EARTH Project, in *The Future Internet*. Springer, 2013, vol. 7858, pp. 249271.

- [13] T. Atmaca and T. D. Nguyen, Interconnection of optical metro ring networks: End-to-End performance, Invited paper, IFIP WCC/NoF 2010 conference, Brisbane, Australia, September 2010.
- [14] T. Orphanoudakis, H. Leligou, E. Kosmatos, and A. Stavdas, Future Internet Infrastructure Based on The Transparent Integration of Access And Core Optical Transport Network. In: IEEE/OSA Optical Communications and Networking, July 2009.
- [15] Thaere EIDO, Tuan Dung NGUYEN, Tlin Atmaca, P. Gravey, A. Gravey, M. Morvan, J. Roberts, S. Oueslati, T. Ronald, D. Barth, D. Chiaroni, Dfinition du Plan de Transport (MAC, Protocoles), Livrable D2.1. French ANR Project / ECOFRAME (Elments de convergence pour les futurs rseaux daces et mtropolitains haut dbit), Conventions n 2006 TCOM 002 -01 -08. Project Report, January 2008.
- [16] Thaere EIDO, Dung Tuan NGUYEN, Tlin ATMACA, Packet Filling Optimization in Multiservice Slotted Optical Packet Switching MAN Networks, paper accepted for the Advanced International Conference on Telecommunications, AICT08, Athens June 2008.
- [17] FDDI Token Ring Media Access Control, American National Standard, ANSI X3.139-1987, November 5, 1986.
- [18] Springer, Optical Burst Switched Networks, 2005.
- [19] IEEE 802.17 Resilient Packet Ring Tutorial Fredrik Davik, Mete Yilmaz, Stein Gjessing, Necdet Uzun.
- [20] N. Le Sauze, E. Dotaro, L. Ciavaglia, DBORN (Dual Bus Optical Ring Network), An Optical Metropolitan Ethernet Solution, Research Report Alcatel, 2004.
- [21] Krammer, G., Mukherjee, B., and Pesavento, G.: IPACT: a dynamic protocol for an Ethernet PON (EPON), IEEE Commun. Mag., 2002, 40, (2), pp. 7480.
- [22] Michael P. McGarry, Martin Maier, and Martin Reisslein, Ethernet PONs: A Survey of Dynamic Bandwidth Allocation (DBA) Algorithms, IEEE Communications Magazine, Vol. 42, No. 8, pages S8-S15, August 2004.
- [23] Chadi M. Assi, Yinghua Ye, Sudhir Dixit, and Mohamed A.Ali, "Dynamic Bandwidth Allocation for Quality-of-Service Over Ethernet PONs", IEEE Journal on Selected Areas in Communications, Vol. 21, No. 9, Nov. 2003, pp. 1467-1476.
- [24] 3GPP, 3rd Generation Partnership Project: Technical Specification Group Radio Access Network: Evolved Universal Terrestrial Radio Access (E-UTRA): User equipment (UE) Radio Transmission and Reception (TS 36.101 v8.17.0 Release 8, v9.1.0 Release 9, v10.1.0 Release 10), 2008-2011
- [25] J. Zhang and N. Ansari, Towards energy-efficient 1G-EPON and 10GEPON with sleep-aware MAC control and scheduling, IEEE Communications Magazine, vol. 49, no. 2, Feb. 2011.

- [26] Y. Yan, S.-W. Wong, L. Valcarenghi, S.-H. Yen, D. R. Campelo, S. Yamashita, L. Kazovsky, and L. Dittmann, Energy Management Mechanism for Ethernet Passive Optical Networks (EPONs), Proceedings of IEEE International Conference on Communications (ICC10), Cape Town, South Africa, May 2010.
- [27] ITU-T Recommendation G.Sup45, GPON power conservation, 2009
- [28] X. Wang, A. Vasilakos, M. Chen, Y. Liu, and T. Kwon, A survey of green mobile networks: Opportunities and challenges, ACM/Springer Mobile Networks and Applications (MONET), vol. 17, no. 1, pp. 420, Feb. 2012.
- [29] C. Han, T. Harrold, S. Armour, I. Krikidis, S. Videv, P. Grant, H. Haas, J. Thompson, I. Ku, C. Wang, T. Le, M. Nakhai, J. Zhang, and L. Hanzo, "Green radio: radio techniques to enable energy-efficient wireless networks, IEEE Communications Magazine, vol. 49, no. 6, pp. 4654, June 2011.
- [30] D. Feng, C. Jiang, G. Lim, J. Cimini, L.J., G. Feng, and G. Li, A survey of energy-efficient wireless communications, IEEE Communications Surveys Tutorials, vol. 15, no. 1, pp. 167178, 2013.
- [31] Z. Hasan, H. Boostanimehr, and V. Bhargava, Green cellular networks: A survey, some research issues and challenges, IEEE Communications Surveys Tutorials, vol. 13, no. 4, pp. 524 540, quarter 2011.
- [32] C. Li and M. Neely, Energy-optimal scheduling with dynamic channel acquisition in wireless downlinks, IEEE Transactions on Mobile Computing, vol. 9, no. 4, pp. 527 539, April 2010.
- [33] G. Miao, N. Himayat, G. Li, and A. Swami, Cross-layer optimization for energy-efficient wireless communications: a survey, Wireless Communications and Mobile Computing, vol. 9, no. 4, pp. 529542, 2009.
- [34] W. Stark, H. Wang, A. Worthen, S. Lafortune, and D. Teneketzis, Lowenergy wireless communication network design, IEEE Transactions on Wireless Communications, vol. 9, no. 4, pp. 6072, Aug. 2002.
- [35] O. Blume, H. Eckhardt, S. Klein, E. Kuehn, and W. M. Wajda, Energy savings in mobile networks based on adaptation to traffic statistics, Bell Labs Technical Journal, vol. 15, no. 2, pp. 7794, 2010.
- [36] E. Calvanese Strinati and L. Hraut, Holistic approach for future energy efficient cellular networks, Springer-Verlag Elektrotechnik und Informationstechnik, vol. 127, no. 11, pp. 314320, 2010.
- [37] A. D. Gandhi and M. E. Newbury, Evaluation of the energy efficiency metrics for wireless networks, Bell Labs Technical Journal, vol. 16, no. 1, pp. 207215, June 2011.
- [38] T. Chen, H. Kim, and Y. Yang, Energy efficiency metrics for green wireless communications, in Proc. of IEEE Wireless Communications and Signal Processing (WCSP), Suzhou, China, Oct. 2010.

- [39] Energy Aware Radio and neTwork technologies consortium, EARTH Deliverable D2.4, Most suitable efficiency metrics and utility functions, Dec. 2011. [Online]. Available: <https://bscw.ict-earth.eu/pub/bscw.cgi/d70454/EARTHWP2D2.4.pdf>
- [40] K. Johansson, Cost Effective Deployment Strategies for Heterogeneous Wireless Networks, Ph.D. dissertation, KTH Information and Communication Technology, Stockholm, Sweden, Nov. 2007.
- [41] A. Dhaini, Design and Analysis of Green Mission-Critical Fiber-Wireless Broadband Access Networks Thesis of PhD, Electrical and Computer Engineering Waterloo, Ontario, Canada, 2011.
- [42] J. Baliga, R. Ayre, K. Hinton, W. V. Sorin, and R. S. Tucker, Energy Consumption in Optical IP Networks” IEEE/OSA Journal of Lightwave Technology, vol. 27, no. 13, pp. 2391-2403, July 2009.
- [43] ITU-T, GPON power conservation. [Online]. Available: <http://www.catr.cn/radar/itut/201007/P020100707531463472537.pdf>
- [44] J. Mandin, EPON power saving via sleep mode. [Online]. Available: http://www.ieee802.org/3/av/public/2008-09/3av_0809_mandin_4.pdf
- [45] M. Gupta and S. Singh, Using Low-power Modes for Energy Conservation in Ethernet LANs, in Proceedings of IEEE INFOCOM07, Anchorage, Alaska, USA, May 2007.
- [46] IEEE 802.3az Energy Efficient Ethernet Task Force. [Online]. Available: <http://www.ieee802.org/3/az/index.html>
- [47] S. Wong, L. Valcarenghi, S. Yen, D. R. Campelo, S. Yamashita, and L. Kazovsky, Sleep Mode for Energy Saving PONs: Advantages and Drawbacks, in Proceedings of IEEE GLOBECOM09, Hawaii, USA, Dec. 2009.
- [48] J. Zhang and N. Ansari, Towards energy-efficient 1G-EPON and 10GEPON with sleep-aware MAC control and scheduling, IEEE Communications Magazine, vol. 49, no. 2, Feb. 2011.
- [49] Y. Yan, S.-W. Wong, L. Valcarenghi, S.-H. Yen, D. R. Campelo, S. Yamashita, L. Kazovsky, and L. Dittmann, Energy Management Mechanism for Ethernet Passive Optical Networks (EPONs), Proceedings of IEEE International Conference on Communications (ICC10), Cape Town, South Africa, May 2010.
- [50] IEEE Standard for Local and Metropolitan Area Networks Part 16: Air Interface for Fixed Broadband Wireless Access Systems,” Online, 2004.
- [51] J.T. Louhi, Energy efficiency of modern cellular base stations, INTELEC 2007, Rome, Italy, September-October 2007.
- [52] H. O. Scheck, J. Louhi, Energy Efficiency of Cellular Networks, W-GREEN 2008, Lapland, Finland, September 2008.
- [53] Global Action Plan, An inefficient truth, <http://www.globalactionplan.org.uk/>, Global Action Plan Rep., 2007.

- [54] M. Hodes, Energy and power conversion: A telecommunication hardware vendors perspective, <http://www.peig.ie/pdfs/ALCATE1.PPT>, Power Electronics Industry Group, 2007.
- [55] Bi-annual Report November 2010, Green Power for Mobile, GSMA.
- [56] H. Claussen, L. T. W Ho, and F. Pivit, Effects of joint macrocell and residential picocell deployment on the network energy efficiency, IEEE 19th International Symposium on Personal, Indoor and Mobile Radio Communications (PIMRC), 2008, Cannes, France, September 2008.
- [57] Z. Niu, Y. Wu, J. Gong, Z. Yang, Cell zooming for cost-efficient green cellular networks, IEEE Communication Magazine, Vol. 48, n. 11, pp.74-79, November 2010.
- [58] L. Chiaraviglio, D. Ciullo, M. Meo, M. Ajmone Marsan, Energy-Aware UMTS Access Networks, W-GREEN 2008, Lapland, Finland, September 2008.
- [59] M. Ajmone Marsan, L. Chiaraviglio, D. Ciullo, M. Meo, Optimal Energy Savings in Cellular Access Networks, GreenComm09 - 1st International Workshop on Green Communications, Dresden, Germany, June 2009.
- [60] M. Ajmone Marsan, L. Chiaraviglio, D. Ciullo, M. Meo, Energy-Efficient Management of UMTS Access Networks, ITC 21 - 21st International Teletraffic Congress, Paris, France, September 2009.
- [61] E. Oh, B. Krishnamachari, X. Liu, Z. Niu, Toward dynamic energy efficient operation of cellular network infrastructure, IEEE Communication magazine, Vol. 49, n. 6, pp. 56-61, June 2011.
- [62] K. Son, H. Kim, Y. Yi and B. Krishnamachari, Base Station Operation and User Association Mechanisms for Energy-Delay Tradeoffs in Green Cellular Networks, IEEE Journal on Selected Area in Communications: Special Issue on Energy-Efficient Wireless Communications, 2011.
- [63] M. Maier, N. Ghazisaidi, and M. Reisslein, The audacity of Fiber-Wireless (FiWi) networks (Invited Paper), in Proc. ICST ACCESSNETS, Las Vegas, NV, USA, Oct. 2008, pp. 110.
- [64] T. Tsagklas and F. N. Pavlidou, A survey on radio-and-fiber FiWi network architectures, J. Sel. Areas Telecommun., pp. 1824, Mar. 2011, Cyber Journals, March Edition, 2011.
- [65] S. Aissa and M. Maier, Towards seamless Fiber-Wireless (FiWi) access networks: Convergence and challenges, in Proc. ICTON MW Conf., Dec. 68, 2007, pp. 16.
- [66] M. Maier and N. Ghazisaidi, QoS provisioning techniques for future Fiber-Wireless (FiWi) access networks, Future Internet, vol. 2, no. 2, pp. 126155, Jun. 2010.
- [67] N. Ghazisaidi, C. Lange, A. Gladisch, and M. Maier, Concepts, potentials and limitations of fiber-copper and Fiber-Wireless (FiWi) networks, presented at the Access Networks and In-house Communications, Karlsruhe, Germany, 2010, Paper AWC3.

- [68] J. Coimbra, G. Schtz, and N. Correia, A game-based algorithm for fair bandwidth allocation in Fibre-Wireless access networks, *Opt. Switching Netw.*, vol. 10, no. 2, pp. 149162, Apr. 2013.
- [69] C. Lange and A. Gladisch, On the energy consumption of FTTH access networks, presented at the Optical Fiber Communication Conference, San Diego, CA, USA, Mar. 2009, Paper JThA79.
- [70] X. Liu, N. Ghazisaidi, L. Ivanescu, R. Kang, and M. Maier, On the tradeoff between energy saving and QoS support for video delivery in IEEE-Based FiWi networks using real-world traffic traces, *J. Lightw. Technol.*, vol. 29, no. 18, pp. 26702676, Sep. 2011.
- [71] J. Coimbra, G. Schtz, and N. Correia, Energy efficient routing algorithm for fiber-wireless access networks: A network formation game approach, *Comput. Netw.*, vol. 60, no. 26, pp. 201216, Feb. 2014.
- [72] H. Chowdhury, I. Ashraf, and M. Katz, Energy-efficient connectivity in hybrid radio-optical wireless systems, in *Proc. 10th ISWCS*, Aug. 2730, 2013, pp. 15.
- [73] K. Togashi et al., On the effect of cooperation between power saving mechanisms in WLANs and PONs, in *Proc. IEEE ICC*, Jun. 913, 2013, pp. 62256229.
- [74] Z. Md Fadlullah et al., Smart FiWi networks: Challenges and solutions for QoS and green communications, *IEEE Intell. Syst.*, vol. 28, no. 2, pp. 8691, Mar./Apr. 2013.
- [75] X. Gong, W. Hou, L. Guo, and L. Zhang, Dynamic energy-saving algorithm in green hybrid wireless-optical broadband access network, *Optik*, vol. 124, no. 14, pp. 18741881, Jul. 2013.
- [76] K. Togashi et al., Cross layer analysis on ONU energy consumption in smart FiWi networks, *IEEE Wireless Commun. Lett.*, vol. 2, no. 6, pp. 695698, Dec. 2013.
- [77] Y. Liu, L. Guo, and J. Yang, Energy-efficient topology reconfiguration in green Fiber-Wireless (FiWi) access network, in *Proc. WOCC*, May 1618, 2013, pp. 555559.
- [78] L. G. Kazovsky et al., How to design an energy efficient fiber-wireless network, in *Proc. OFC/NFOEC*, Mar. 1721, 2013, pp. 13.
- [79] B. Kantarci, N. Naas, and H. T. Mouftah, Energy-efficient DBA and QoS in FiWi networks constrained to metro-access convergence, in *Proc. 14th ICTON*, Jul. 25, 2012, pp. 14.
- [80] A. Sarigiannidis, P. Nicopolitidis, G. Papadimitriou, P. Sarigiannidis, and M. Louta, Using learning automata for adaptively adjusting the downlink-to-uplink ratio in IEEE 802.16e wireless networks, in *Proc. IEEE ISCC*, Jun. 28Jul. 1, 2011, pp. 353358.
- [81] P. G. Sarigiannidis, G. I. Papadimitriou, P. Nicopolitidis, M. S. Obaidat, and A. S. Pomportsis, A novel adaptive mapping scheme for IEEE 802.16 mobile downlink framing, in *Proc. IEEE GLOBECOM*, Dec. 610, 2010, pp. 15.

- [82] Zhou, S., Gong, J., Yang, Z., Niu, Z., Yang, P.: Green Mobile Access Network with Dynamic Base Station Energy Saving. In: The Annual International Conference on Mobile Computing and Networking (ACM Mobicom 2009), Beijing (2009)
- [83] Oh, E., Krishnamachari, B.: Energy Savings through Dynamic Base Station Switching in Cellular Wireless Access Networks. In: IEEE Global Telecommunications Conference (GLOBECOM'2010), pp. 1–5 (2010)
- [84] Laun, K., M., Yue, O.: Modeling Synchronous Wakeup Patterns in Wireless Sensor Networks: Server Vacation Model Analysis. In: IEEE 16th International Symposium of Personal, Indoor and Mobile Radio Communications, (2005)
- [85] Pasca, S., Srividya, V., Premkumar, K.: Energy Efficient Sleep/Wake Scheduling of Stations in Wireless Networks. In: IEEE International Conference on Communication and Signal Processing (ICCSP'2013), pp. 382–386 (2013)
- [86] Kolios, P., Friderikos, V., Papadaki, K.: Mechanical Relaying in Cellular Networks with Soft-QoS Guarantees. In: IEEE Global Telecommunications Conference (GLOBECOM'2011), pp. 1–6 (2011)
- [87] Zhang, Y., Feng, Ch., Demirkol, I., Heinzelman, W. B.: Energy-Efficient Duty Cycle Assignment for Receiver-Based Convergecast in Wireless Sensor Networks. In : IEEE Global Telecommunications Conference (GLOBECOM'2010), p.p. 1–5 (2010)
- [88] Gonzalez, G., Atmaca, T.: An Integrated Bandwidth Allocation for Energy Saving in Fixed-Mobile Networks. In: IEEE International Workshop on Computer Aided Modelling and Design of Communication Links and Networks (CAMAD'2013), (2013)
- [89] 3GPP TR 36.922 V10.1.0: 3rd Generation partnership project: Technical specification group radio access network; Evolved Universal Terrestrial Radio Access (E-UTRA); Potential solutions for energy saving for EUTRAN; Release 10, Technical Report, (2011)