



HAL
open science

Robust cyclic scheduling applied to container management of medium sized seaport

Hongchang Zhang

► **To cite this version:**

Hongchang Zhang. Robust cyclic scheduling applied to container management of medium sized seaport. Automatic. Ecole Centrale de Lille, 2014. English. NNT : 2014ECLI0018 . tel-01266195

HAL Id: tel-01266195

<https://theses.hal.science/tel-01266195>

Submitted on 2 Feb 2016

HAL is a multi-disciplinary open access archive for the deposit and dissemination of scientific research documents, whether they are published or not. The documents may come from teaching and research institutions in France or abroad, or from public or private research centers.

L'archive ouverte pluridisciplinaire **HAL**, est destinée au dépôt et à la diffusion de documents scientifiques de niveau recherche, publiés ou non, émanant des établissements d'enseignement et de recherche français ou étrangers, des laboratoires publics ou privés.

N° d'ordre : 255

ECOLE CENTRALE DE LILLE

THESE

présentée en vue d'obtenir le grade de

DOCTEUR

en

Spécialité: Automatique Génie Informatique, Traitement du Signal et Images

Par

Hongchang ZHANG

DOCTORAT DELIVRE PAR L'ECOLE CENTRALE DE LILLE

Titre de la thèse

Ordonnancement cyclique robuste appliqué à la gestion des conteneurs dans les ports maritimes de taille moyenne

Robust cyclic scheduling applied to container management of medium sized seaport

Soutenue le 10 decembre 2014 devant le jury d'examen:

Président	Pr. Gilles GONCALVES	Universié d'Artois
Rapporteur	Pr. Isabel DEMONGODIN	Université Aix-Marseille
Rapporteur	Pr. Dimitri LEFEBVRE	Université du Havre
Membre	MCF, Patrice BONHOMME	INSA, Centre Val de Loire
Directeur de thèse	MCF, HDR Khaled MESGHOUNI	Ecole Centrale de Lille
Co-directeur de thèse	DR Simon COLLART-DUTILLEUL	IFSTTAR, Lille

Thèse préparée dans le Laboratoire d'Automatique, Génie Informatique et Signal
L.A.G.I.S., CNRS UMR 8219 – Ecole Centrale de Lille
Ecole Doctorale Sciences pour l'ingénieur ED 072
PRES Université Lille Nord-de-France

À ma fille

à ma femme

à toute ma famille

à mes professeurs

et à mes chère(s) ami(e)s

感谢，我的女儿

妻子

家人

导师

和朋友！

Acknowledgements

This work would not have been done by the help and supports of the kind people around me. I would like to take the opportunity to express the gratitude to thank all my friends and colleagues that have given me supports and encouragement during my thesis work.

First of all, I would like to express my deepest sense of gratitude to my supervisors, Mr. Khaled MESGHOUNI and Prof. Simon COLLART-DUTILLEUL, who offered their systematic guidance, meaningful advices, continuous patience and encouragement throughout the course of this thesis.

I acknowledge my very sincere gratitude to the jury members of my PHD committee. Thanks Prof. Isabel DEMONGODIN and Prof. Dimitri LEFEBVRE, who have reviewed carefully my thesis. And I also express my very heartfelt thanks to Prof. Gilles GONCALVES and Mr. Patrice BONHOMME, for their helpful advices and sharing of researching experience.

I would like to thank the members in the research team “Optimisation des Systèmes Logistiques (OSL)”. With their help, I have learnt a lot in the relative research domains and directions.

This research is also partially supported by the project PERFECT of the ANR. We sincerely thank the kindly assistance.

I am also thankful to all my colleagues in my office, Baisi LIU, Rahama LAHYANI, Lijuan ZHANG, Ben Li. Thanks to them, I have an agreeable and peaceful research environment. My thanks also go to Vanessa Fleury, Christine Yvoz and Brigitte Foncez, they help me a lot in the administrative work. I also want to thank Jacques and Patrick for their technician support in so many times.

My sincere appreciations also go to my friends, Daji, Zhanjun, Yu, Chen, Lijie, Youwei, Qi, Jing, Wan, Yihan, Bing, ..., for their friendship and a lot of help, which bring so much convenience and happiness to my three years life in Lille. And I also thank to all my French friends, they make me know a lot about the excellent French culture and the interesting history. I love France, and I love the kind and generous people in this country.

Finally, I take this opportunity to express the profound gratitude from the deep bottom of my heart to my beloved daughter Huanyan, my wife Yan, my parents, my brother, and all my families for their love and continuous emotional support that makes me be able to overcome the difficulties in the research life. In this three years,

their encouragement and support make me clam and peaceful when I miss so much the life with them in China.

Table of Contents

Acknowledgements	i
Table of Contents.....	iii
List of Tables	ix
List of Figure	xi
Abbreviations	xiii
General Introduction.....	1
Motivation.....	1
<i>About InTraDE.....</i>	<i>1</i>
<i>Our work boundary.....</i>	<i>2</i>
<i>The reason to use cyclic scheduling for robust control</i>	<i>3</i>
The methods and tools used in this thesis	4
Contributions	5
Outline of the thesis	6
Chapter 1 Literature Review	9
1.1 Seaport container terminal and non-cyclic container transit.....	10
<i>1.1.1 About container terminals.....</i>	<i>11</i>
1.1.1.1 Present situation and trends.....	11
1.1.1.2 Equipment and workflow	13
<i>1.1.2 Non-cyclic vehicles scheduling in container terminals</i>	<i>15</i>
1.2 Cyclic job-shop problem (CJSP) by using Petri Net	17
<i>1.2.1 Petri nets for handling time problem</i>	<i>18</i>
<i>1.2.2 P-time strongly connected event graph (PTSCEG)</i>	<i>20</i>
1.3 Cyclic job-shop problem (CJSP) based on MIP.....	22
<i>1.3.1 The main structure of MIP model</i>	<i>25</i>
1.3.1.1 The structure of MIP model for minimizing the cycle time.....	26

1.3.1.2	The structure of MIP model for minimizing the WIP	26
1.3.2	<i>Cutting techniques for MIP models</i>	27
1.4	Robust control of cyclic scheduling	28
1.4.1	<i>Strategy analysis of robust control</i>	29
1.4.2	<i>Robust scheduling techniques</i>	29
1.4.2.1	Non-cyclic robust scheduling	29
1.4.2.2	Cyclic robust scheduling	30
1.5	Conclusion	34
Chapter 2 P-time Strongly Connected Event Graph		
(PTSCEG) Modeling Techniques.....35		
2.1	PTSCEG definition and a job-shop example	36
2.1.1	<i>Definitions about PTSCEG</i>	36
2.1.2	<i>PTSCEG job-shop model</i>	37
2.2	The container transit procedures in seaport	39
2.3	Problem definition of the container transit procedures	41
2.4	PTSCEG model techniques for container transit procesures	44
2.4.1	<i>Routes modelling</i>	45
2.4.2	<i>Place capacity modelling</i>	45
2.4.3	<i>Shared crane operation space modelling</i>	46
2.4.4	<i>Intersections modelling</i>	47
2.4.5	<i>Ratio-driven task modelling</i>	49
2.4.5.1	The Hillion-like modelling technique	49
2.4.5.2	The OHL-like modelling technique	51
2.4.6	<i>The complete container transit PTSCEG model</i>	52
2.5	Cutting techniques	55
2.5.1	<i>The bound of the cycle time</i>	55
2.5.2	<i>The bound of tokens with demanded cycle time</i>	56
2.6	Conclusion	57

Chapter 3 Mixed Integer Programming (MIP) modeling techniques for cyclic scheduling.....59

- 3.1 The constraint family explanation..... 60**
 - 3.1.1 Constraints on all the places..... 61*
 - 3.1.2 Constraints on places in the process circuits 64*
 - 3.1.3 Constraints on places in the space status circuits 65*
 - 3.1.3.1 Constraint families in the non-shared space status circuits..... 66
 - 3.1.3.2 Constraint families in the shared space status circuits 67
- 3.2 The complete MIP models..... 69**
 - 3.2.1 The MIP model for minimizing the cycle time 70*
 - 3.2.1.1 Lower bound of cycle time..... 71
 - 3.2.1.2 The constraint number analysis..... 72
 - 3.2.2 The MIP model for minimizing the token number 72*
 - 3.2.2.1 Lower bound of token number 73
 - 3.2.2.2 The constraint number analysis..... 73
- 3.3 Case study of the seaport container transit 74**
- 3.1 Analysis of computing time 79**
- 3.2 The comparison with other similar models 80**
- 3.3 Conclusion 82**

Chapter 4 Robust Control for the 1-cyclic Scheduling.....83

- 4.1 The algorithms based on the control of transitions 84**
 - 4.1.1 Basic notation 84*
 - 4.1.2 Approach 1: Rejection of the disturbance on propagation path..... 88*
 - 4.1.2.1 Algorithm 88
 - 4.1.2.2 Description of the algorithm 89
 - 4.1.2.3 Analysis of the algorithm 90
 - 4.1.2.4 Illustrative example 90

4.1.3	<i>Approach 2: Rejection of the disturbance and generation of the parallel disturbance</i>	94
4.1.3.1	Algorithm	98
4.1.3.2	Description of the algorithm	99
4.1.3.3	Analysis of the algorithm	100
4.1.3.4	Illustrative example	100
4.1.4	<i>Comparison between Approach 1 and Approach 2</i>	103
4.2	The algorithm based on direct control of tokens' sojourn time .	105
4.2.1	<i>Basic notation</i>	106
4.2.1.1	The transmissible margin of the parallel similar temporal shift group	109
4.2.1.2	The compensable margin of the disturbance rejection group	112
4.2.2	<i>Approach 3: Generation of the parallel similar disturbance as soon as the disturbed is observed</i>	118
4.2.2.1	Algorithm	119
4.2.2.2	Description of the algorithm	121
4.2.2.3	Analysis of the algorithm	121
4.2.2.4	Illustrative example	123
4.2.3	<i>Comparisons with Approach 1 and Approach 2</i>	126
4.3	Conclusion	129
Chapter 5	Conclusions and Perspectives	131
	Conclusions	131
	Perspectives	133
	Appendices	135
	Glossary	137
	Résumé étendu en Français	141
	Introduction	141
	Chapitre 1 Etat de l'art	143

Chapitre 2 Graphe d'évènement P-temporels fortement connexes (PTSCEG): Techniques de modélisation	144
Chapitre 3 Programmation mixte en nombres entiers (MIP): Techniques de modélisation.....	145
Chapitre 4 Commande robuste pour l'ordonnancement 1-cyclique.....	146
Chapitre 5 Conclusions & Perspectives	147
Bibliography	151

List of Tables

Table 2.1. Production lines sequences	37
Table 2.2. The time windows for each place	38
Table 3.1. Time windows of places in process circuits	74
Table 3.2. Computing time of MIP model	79
Table 4.1. Local active robustness associated to mono-synchronized paths	91
Table 4.2. The similar disturbance on parallel concentrated paths	101
Table 4.3: The robustness margins of 3 approaches	128

List of Figure

Figure 1.1: Overview of port logistics. (Roh et al., 2007).....	10
Figure 1.2: Layout of the Container Terminal YANGSHAN, Shanghai, China. http://www.dianping.com/photos/7635647	12
Figure 1.3: Different types of handling equipment. (Grunow et al., 2006)	13
Figure 1.4: Flow of transports in a seaport container terminal. (Steenken et al., 2004).....	14
Figure 1.5: Transportation and handling chain of a container.(Steenken et al., 2004).....	15
Figure 2.1: Example of job-shop described by PTSCEG.	38
Figure 2.2: Overview of container transit in a seaport container terminal.	40
Figure 2.3: The sketch structure of the container transit.	42
Figure 2.4: The route between C1 and S1.....	45
Figure 2.5: Place capacity modeling by PTSCEG.....	46
Figure 2.6: The shared crane space S1 with two routes modeled by PTSCEG..	47
Figure 2.7: The intersection X1 modeled by PTSCEG.....	48
Figure 2.8: A Hillion-like method to model ratio-driven task.....	50
Figure 2.9: An OHL-like method to model the ratio-driven task.	51
Figure 2.10: The complete PTSCEG model of the import container transit procedures.	53
Figure 3.1: A PTSCEG with time windows.....	62
Figure 3.2: The Gantt chart for 1-cyclic schedule in G_2	63
Figure 3.3: The arriving time of tokens in the places.	64
Figure 3.4: Boolean variable β_{ij} determines the tokens number.....	65
Figure 3.5: 1-cyclic schedule of the token in non-shared space status circuits. .	66
Figure 3.6: 1-cyclic schedule in the shared space status circuit of S1.....	67
Figure 3.7: The shared space status circuit of C5	67
Figure 3.8: 1-cyclic schedule of the token in the shared space circuit of C5.	68

Figure 3.9: The optimization strategy of MIP models. 75

Figure 3.10: The stay time of AIVs in the QCs operation space. 77

Figure 3.11: The stay time of AIVs in the AYCs operation space. 77

Figure 3.12: The stay time of AIVs in the paths and the intersections. 78

Figure 4.1: Case of local active robustness on a synchronized transition. 85

Figure 4.2: Case of local active robust margin of mono-synchronized path. 87

Figure 4.3: PTSCEG model of two routes with one shared AYC. 91

Figure 4.4: One PTSCEG including concentrated paths. 95

Figure 4.5: Parallel concentrated path and disturbance propagation path. 97

Figure 4.6: Generation of similar disturbance on parallel concentrated paths. 101

Figure 4.7: The signal points on the AIV running routes. 104

Figure 4.8: The coupling of the tokens presented by Gantt graph. 106

Figure 4.9: The cutting of the tokens at coupling point. 107

Figure 4.10: The classification of the tokens. 108

Figure 4.11: The transmissible margin and compensable margin for token groups.
..... 123

Figure 4.12: 1-cyclic schedule of example in Figure 3.1. 127

Figure 5.1: The structure and procedures of robust cyclic methodology. 131

Abbreviations

AGV - Automated guided vehicle

AIV – Automated Intelligent Vehicle

ALV - Automated lifting vehicle

AYC – Automated Yard Crane

CP - Constraint Programming

InTraDE - Intelligent Transportation in Dynamic Environment

MIP - Mixed Integer Programming

MTS - Multi-trailer systems

NWE - North west Europe

PTSCEG - P-time strongly connected event graph

QC - Quay Crane

RMG - Rail-mounted gantry

RTG - Rubber-tired gantry

VRP - Vehicle routing problem

VRPST - Vehicle routing and scheduling problem with time window constraints

WIP - Work-in-progress

General Introduction

This work mainly contributes to apply the robust cyclic scheduling methodology on container transit systems using automated intelligent vehicle (AIV) in a medium sized seaport. Our work is based on a real industrial project, the InTraDE ‘Intelligent Transportation in Dynamic Environment’. We aim to offer some references to researchers and decision makers who want to implant the robust control and management in container transit activities, or even to other industrial domains.

Motivation

About InTraDE

The InTraDE project contributes to improve internal traffic management and optimization of space by developing a clean, safe, intelligent transportation system for a few ports within North West Europe (NWE).

The world seaborne trade has been developing considerably in the last decade, mainly due to globalization and continued development of emerging countries. This world growth has an influence on the development of ports and maritime terminals. But within NWE, few ports are able to keep pace with this growth. Increased international trade, with the stagnation of spaces available in these ports, leads to critical situations in terms of management of space and time. There is an urgent need to review the entire organization of these ports. The InTraDE aims to :

- improve the productivity of small and medium sized regional ports in NWE so they can be more competitive.
- contribute to the effort of national and European governments to divert some traffic from road to sea by improving the efficiency of short sea shipping.
- improve operational safety and reduce environmental impact on the region.

The research directions of InTraDE are defined as follows:

- To study traffic flow within confined spaces of container terminals and develop an insight into the factors influencing the overall productivity of such

Introduction

facilities, and to investigate existing traffic control methods and develop new methods where necessary to improve efficiency whilst ensuring safety.

- To identify automatic navigation methods and develop new algorithms for robust supervision, and to investigate practical issues in implementing automatic navigation system in container terminals.
- To develop an automatic traffic time-domain simulator for autonomous and human driven-vehicles within the terminals and to carry out a design case study of terminal layout using the simulator.
- To design, test and validate intelligent transport vehicle prototypes with dynamic environments inside confined spaces or combined urban-confined spaces.

Our work boundary

Our research involved specifically, in this project InTraDE, the management and conduct of Automated Intelligent Vehicles (AIVs) and time management for container transit procedures in a medium sized port, such as the seaport of *Le Havre* in France. The objective of our work is to develop and implement a robust cyclic scheduling methodology for supervision and conduct of container transit systems in confined spaces in the seaport. It is well known that, in the container terminals, the disturbance of time delay (on the cranes or the vehicles), time advance and equipment breakdown do exist, and can't be predicted or prevented. Our research strategy is to eliminate the disturbance by an active robust control technique with a cyclic dispatching of AIVs. If the disturbance is located in the robustness margin, by the active robust control, the disturbance can be eliminated by the system itself to avoid the possible conflicts of AIVs in the confined space without changing the initial cyclic schedule. If the disturbance is out of the robustness margin, the rescheduling should be made. The robust cyclic scheduling method can reduce the rescheduling cost and make the transit system more resilient and ensure more safety in the container transit field.

It is assumed the AIVs can locate their own position with some signal points set on the field. The AIVs and the cranes can keep a real time communication with a remote control center which can get the exact position of each AIV and can give a control signal to any AIVs or cranes if a disturbance is observed. By using the location sensor and the computer on the vehicle, the AIV can avoid the collisions automatical-

Introduction

ly between each other or with the other equipment or container stacks. And the AIV can control their speed and waiting time to respect the scheduled staying time in a resource, such as the crane operation space or one route. The information communication system for the control of transit activities are shown in the following figure.

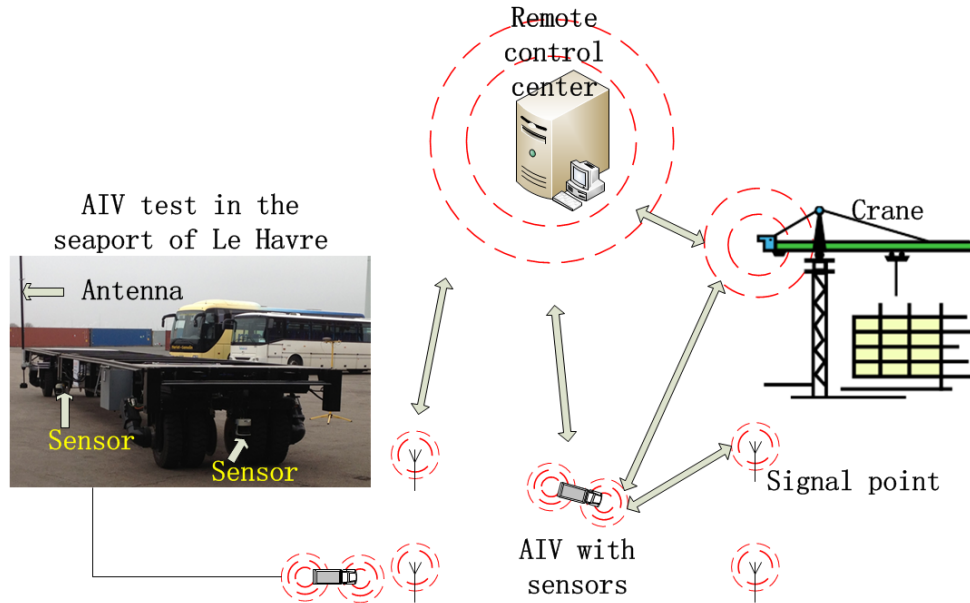

Figure 1: The information communication system in container terminals.

The reason to use cyclic scheduling for robust control

The cyclic scheduling is an attractive theme both in industrial and academic internationally. Its definition is that some set of activities can be repeated for an infinite number of times. Such types of scheduling problems arise in various application areas, such as compiler design, manufacturing, digital signal processing, railway scheduling, timetabling, etc. Compared to non-cyclic scheduling, cyclic scheduling has two main advantages. Firstly, the entire production plan can be predicted with only information of a partial schedule in just a repetitive period. Secondly, it is easier to apply a **control strategy** on the regular repetitive activities, compare with the stochastic activities. Considering **the regular activities** of the operations in the cyclic schedule, it is indeed less complex to set up a robustness algorithm for the cyclic scheduling than the non-cyclic scheduling. It is admitted that the cyclic scheduling does not guarantee a better productivity than the non-cyclic scheduling in an idealized environment without disturbances. But, the cyclic scheduling can adapt well with the robustness algo-

Introduction

rithms studied in this thesis. Since the unpredictable disturbances are inevitable, the cyclic scheduling might be a better choice from the global view point for the overall productivity. The others scheduling methods may waste much time on dealing with the disturbances.

The methods and tools used in this thesis

In this thesis, we use four main methods or tools to build our robust control cyclic scheduling methodology.

- The first mathematical tool is the P-time strongly connected event graph (PTSCEG). The PTSCEG is a special kind of strongly connected event graph with time windows dedicated to each place. As discussed in above section, the confined space and time management should be studied in our work. The places in PTSCEG can be used to model the operation space and the routes, the time window can be used to model the staying time of AIVs between the signal points or in the equipment operation space. And the transition of PTSCEG can be used to model the signal points which can help control the running of AIVs. In addition, the PTSCEG can be used as a structure base of the first and the second robustness algorithms presented in Chapter 4 .
- The second mathematical tool is the Mixed Integer Programming (MIP). The PTSCEG gives us an abstract model of the resources in the container transit field with time windows. The MIP is used to compute the cyclic schedule of the container transit system. In this schedule, the expected sojourn time of AIVs in each resource can be given, while respecting the demanded or optimal productivity. The achieved sojourn time should be located in the time windows. The PTSCEG is also a structure base for MIP in this thesis.
- The cyclic schedule achieved by MIP can be presented as the Gantt graph. Using Gantt graph, the schedule of AIVs and other equipment can be clearly shown. And the Gantt graph is a structure base for the third robustness algorithm in Chapter 4 .
- The robustness algorithms are used to compute the robustness margin on the nodes of the system. All the three algorithms introduced in Chapter 4 have a

Introduction

computing time in polynomial complexity. The size of the studied example in this thesis is a medium sized seaport as the port of *Le Havre*, which implies the computing time of algorithms can be acceptable for the real industrial activities.

Contributions

From the literature review in Chapter 1, it is found that there are many researches on cyclic scheduling problems, the job-shop robust control problems or the vehicles scheduling problems, but our work is the first to combine the cyclic scheduling and robust control for container transportation by AIVs in the seaport.

Firstly, we want to demonstrate that the PTSCEG can be applied to model the container transit process with a cyclic scheduling mode. The details of the modelling techniques are well presented to model the main production elements, such as the routes for translating the containers, the shared cranes of different routes, the intersections on the routes, the ratio-driven task, etc. It is admitted that the PTSCEG has been applied for modelling job-shop problems in many research, but our research aims at extending the application of PTSCEG to a special section of the supply-chain: container transportation in the seaports. The main assumption is that, if the cyclic scheduling is robust, it is able to face the system variations.

Secondly, we propose two new MIP mathematical models suitable to the cyclic scheduling of container transit system which can be modelled as PTSCEG. In our models, the constraint families are more concise, but strong enough. The new models do not just consider the operation constraints with time windows on the equipment resources or the route resources, but also consider the capacity of the resources (usually the space capacity). The new MIP models are more similar to a real industrial production system than the research results presented in the literature review, and the new ones have a good performance in computing time. With the MIP models, we can find the optimal cyclic schedule of AIVs for a medium sized seaport in short time. Thus, the traffic flow within the confined spaces and the overall productivity is optimized. Actually, the preliminary propositions built on a literature review have to be validated with regard to the computing time.

Thirdly, with some modification of robust control methods shown in the literature review, we apply two robust control algorithms on the cyclic scheduling of AIVs,

Introduction

using PTSCEG model as a structure base. To our knowledge, this is the first application of robust control cyclic scheduling on vehicles in seaport terminal. Moreover, the complexity of the computing time of these algorithms is polynomial.

Fourthly, we propose a new robust control algorithm based on the cyclic schedule obtained from the MIP model. Using Gantt graph, the structure of this algorithm is different from the two modified algorithms mentioned in the above paragraph. In a container terminal, the modified algorithms give control on the signal points to change the arriving time of the AIV within time windows in resources, but the new algorithm can directly give the control on vehicles. And the new one can better present the influence of disturbance to each AIV in the system, which maybe more interesting to the manager of container transit task.

Outline of the thesis

The content of the thesis is composed of five chapters, which is basically organized in a logical order as follows.

Chapter 1 is the first phase of work which includes an extensive literature review to acquire necessary knowledge based on the state of the art of the various tools considered. Firstly, we introduce the general container terminal structure and some non-cyclic vehicles dispatching methods in seaports. Then, we survey the state of the art of cyclic scheduling for job-shop problems by using Petri Net. Thirdly, the state of the art of Mixed Integer Programming (MIP) for job-shop cyclic scheduling is presented. Finally, we focus on the research results which combine the robust control and cyclic scheduling.

Chapter 2 concentrates on modelling the system by the P-time strongly connected event graph (PTSCEG). Firstly, some basic knowledge of P-time Petri Net is introduced by using a job-shop example. Then some more complex technique are presented for modelling the shared resource in the system, the capacity of resource, the ratio-driven products, etc. With explanations of the modelling techniques step by step, a complete PTSCEG model is given, which describes the container transportation task in a medium sized container terminal. Finally, the bounds of cycle time and token numbers for a PTSCEG are discussed, which can be used as cutting techniques for MIP model in Chapter 3.

Introduction

Chapter 3 focuses on the MIP mathematical modelling of the system which can be modelled as the PTSCEG. The modelling technique is explained step by step using a simple example. This MIP method is applied on the container transit model PTSCEG model presented in Chapter 2 . The MIP model here is used to give a cyclic schedule and compute the expected sojourn time of tokens within the time windows. The objective is to minimize the cycle time of the system and to minimize the number of AIVs. A comparison between our method and the previous methods is made, which shows our MIP models can better model the container transit procedures and have a good performance in computational time.

Chapter 4 highlights the combination of robust control and cyclic scheduling. Three algorithms are introduced. The first and the second are based on the structural control of transitions in a PTSCEG, which can give a robustness margin on the observable and controllable nodes of the system. If the disturbance is located in the robustness margin, the system can recover to initial cyclic mode by changing the firing time of the transitions without rebuilding the structure of the system. The third algorithm plays the same role in giving the robustness margin, which is based on the analysis of the cyclic schedule shown by Gantt graph. This algorithm gives the direct robust control on the sojourn time of each token in the places. The comparison among these three algorithms is made on the computing time complexity and the range of the robustness margin.

Chapter 5 concludes the contributions and the originalities of this thesis. Some interesting perspectives for further work are also proposed.

Introduction

Chapter 1 Literature Review

There are few literatures concerning about the robust cyclic scheduling methodology for the container transportation by automated intelligent vehicles (AIV) in the seaport. Hence, the literature review of this thesis has to be based on a widespread article study and a sophisticated collection of necessary methods or tools from a lot of related documents of different research domains, such as the seaport organization and container transit procedures, the Petri Nets which might be used to model the container transit procedure, the confined space and time domains, the mixed integer programming method which can be used to optimize the AIV flow to realize a maximal productivity, and the robust algorithms which can give a robust supervision and management on the automated stevedoring and container transit system.

In many literatures, the mathematical tools used in this thesis are often applied on the cyclic job-shop problems. Some kinds of these job-shop problems are very similar to the container transit procedures in the container terminal. The products can be seen as the containers, the transfers can be seen as the AIVs, the shared machines of different products can be seen as the shared cranes or intersections, etc. These similarities imply the possible transferability of the application of the mentioned methods from job-shop problem to our automated container transit system. Basing on the study of these methods, we finally extend their utilities to the sub section of the maritime supply chain: the container transportation in container terminals.

This chapter is organized as the follows.

Firstly, the general structure of container terminals and some non-cyclic container transit methods are introduced. Then, the state of the art of Petri Net for modelling job-shop cyclic scheduling is surveyed. Thirdly, the Mixed Integer Programming (MIP) for cyclic job-shop scheduling is presented. Finally, we focus on the research results combining the robust control and the cyclic scheduling.

1.1 Seaport container terminal and non-cyclic container transit

Firstly, the basic introduction of container terminals and the non-cyclic container transit scheduling are presented. The study of the container terminals includes the survey on the composition, function and complexity of the container terminals. This research makes the PTSCEG model or MIP model more consist with the reality, and can make us better understand the necessity to apply robust control in the container transit procedures. The study of the non-cyclic scheduling can give us some ideas about which are the most important criteria usually used to evaluate the container transit performance. These criteria can be used in the optimization of our cyclic container transit schedules. However, there are few cyclic container transit literatures can be referred.

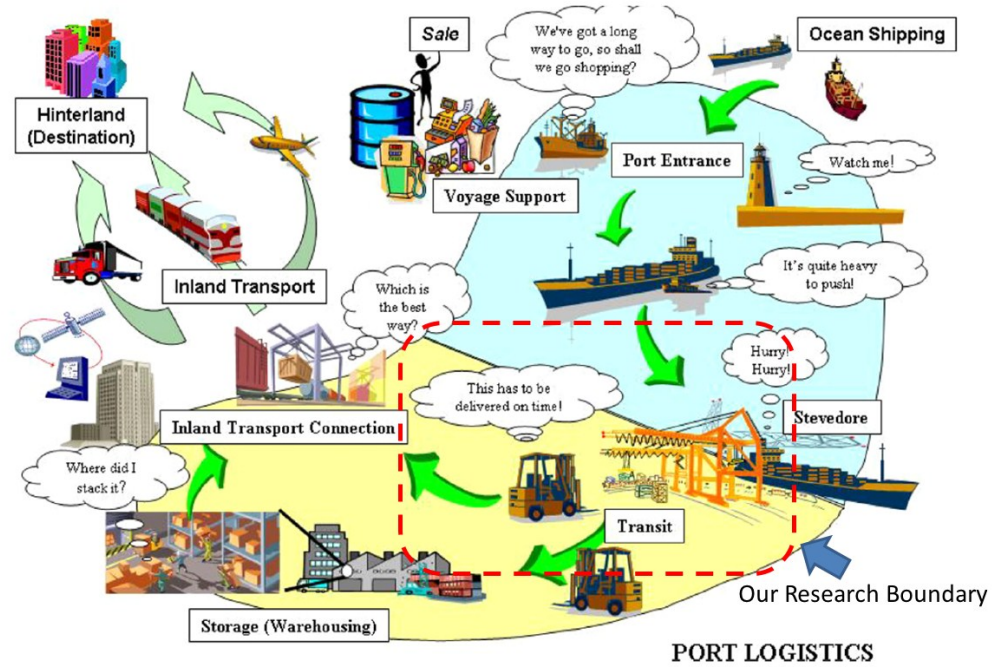

Figure 1.1: Overview of port logistics. (Roh et al., 2007)

Literature Review

1.1.1 About container terminals

1.1.1.1 Present situation and trends

In the last ten years, the ocean shipping has developed enormously. With increasing logistics demands of international commercial activities, a more efficient and more robust ocean transportation system is sought for reducing the supply-chain cost and for assuring the safety and the stability of the system (Zaghdoud et al., 2012).

In the maritime transportation, the use of containers for intercontinental maritime transport has dramatically increased. A further continuous increase is expected in the upcoming years. With an improved hull design, the modern cargo ships guarantee lower transportation cost and lower CO₂ emission than before, but they also give new challenges to seaport container terminals which should be more efficient, clean and robust. In 2013, the biggest container ship in the world *Maersk Mc-Kinney Møller* was launched. It can take 18,270 TEU (twenty-foot equivalent unit containers). With a large number of containers for the stevedoring request, it is possible to find some cyclic process in the container unloading/uploading or transit work among the cranes and the container stacks. The cyclic scheduling may be one choice of the scheduling methods to be applied in this kind of industrial procedures.

At the same time, the seaport competition is becoming ever more complex. The maritime terminal is no longer seen just as a simple place for cargo handling, but a functional element in a dynamic logistics chain, through which commodities, people, and information flow (Van de Voorde and Winkelmanns, 2002). Figure 1.1 illustrates a typical port logistics process in port: from ocean shipping to inland destination for import cargo. In this thesis, only the stevedoring and the transit of containers by AIVs in container terminals are studied, as shown in the red rimmed boundary in Figure 1.1. It is admitted that the seaport is a complex system including the berthing of the vessel, the stevedoring (unloading or uploading) of containers, the transit of containers, the stacking of containers, the cargo trucking, cargo warehouses, ship repairing, port information services, ship suppliers, the use of bunkering service before starting another voyage etc. (Roh et al., 2007). In the various handling, transportation and storage activities, the managers have only incomplete knowledge about future events, such as the changing arrival time of vessels, the location of containers in the vessel or in the yard, and even the weather condition. These information changes often, which needs a quick reactive scheduling. Moreover, the disturbances of the time delay or advance due to the cranes or the vehicles occur inevitably from time to time. The robust con-

Literature Review

trol of the container terminal system is urgently sought to eliminate the disturbances, especially in the medium sized seaports with only the confined operation space.

Over the recent years, there is also an ongoing trend in the development of seaport container terminal configurations to use automated container handling and transportation technology, particularly, in countries with high human resource cost. The manually driven cranes are going to be replaced by automated ones, and the automated guided vehicles (AGVs) are used instead of manually driven carts. Figure 1.2 illustrates the layout of one of the most highly automated seaport container terminal in China. This YANGSHAN port in Shanghai has a container handling capacity of 15 million TEU per year. These biggest modern seaports have very big operation filed. But, for the medium sized ports within NWE, it is not practical to expand the terminal filed scale in short time, considering the huge investment and the possible influence to the nature environment. Factually, for increasing handling capacities of the medium sized container terminals, the significant gains in productivity should be achieved through advanced terminal layouts, more efficient IT-support and improved logistics control software systems, as well as automated transportation and handling equipment. That's the motivation why the InTraDE project is proposed, especially why the AIV is designed.



Figure 1.2: Layout of the Container Terminal YANGSHAN, Shanghai, China.
<http://www.dianping.com/photos/7635647>

1.1.1.2 Equipment and workflow

The seaport container terminals not just greatly differ in size, but also in the type of transportation and handling equipment used. Regarding quay cranes (QC), single or dual-trolley cranes can be found. The latter employs an intermediate platform for buffering the loaded and unloaded container. It is supposed that, in our work, the quay crane can only take one container at a time. The most common types of yard cranes are rail-mounted gantry (RMG) cranes, rubber-tired gantry (RTG) cranes, straddle carriers, reach stackers and chassis-based transporters. Of these types of cranes only RMG cranes are suited for fully automated container handling which will be used as the automated yard cranes (AYC) in this thesis. Figure 1.3 exhibits the working principle of the different types of handling equipment and their comparative performance figures with respect to the number of TEUs, which can be stored per hectare. Different types of vehicles can be used both for the ship-to-yard transportation and the interface between the yard and the hinterland. The most common types are multi-trailer systems (MTS) with manned trucks, automated guided vehicles (AGVs), and automated lifting vehicles (ALVs). The latter ones, in contrast to AGVs, are capable of lifting a container by themselves (Yang et al., 2004). In the InTraDE project, the definition of Automated Intelligent Vehicle (AIV) is proposed. The characteristics of the AIV are inspired from those of AGV (Zaghdoud et al., 2012), but the AIV can move autonomously and intelligently not just by the command of control center. The AIV is not still applied in the real container transportation task. But some tests for AIVs in the real container terminals have been done.

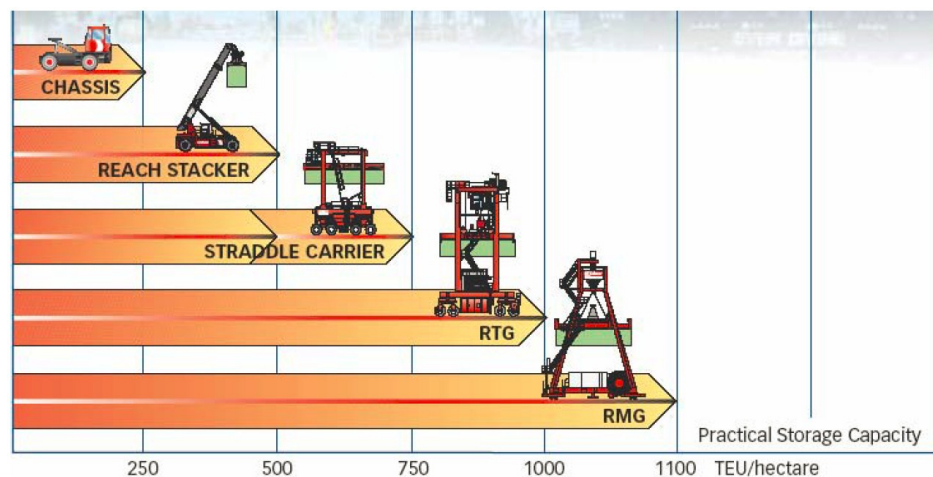

Figure 1.3: Different types of handling equipment. (Grunow et al., 2006)

Literature Review

Although the container terminals considerably differ in size, function and geometrical layout, they principally consist of the same sub-systems, as shown in Figure 1.4. The ship operation or berthing area is equipped with quay cranes for the loading and unloading of vessels. Import as well as export containers are reserved for reefer containers, which need electrical supply for cooling, or to store hazardous goods. Separate areas are used for empty containers. Some terminals employ sheds for stuffing and stripping containers or for additional logistics services. The truck and train operation area links the terminal to outside transportation systems (Steenken et al., 2004).

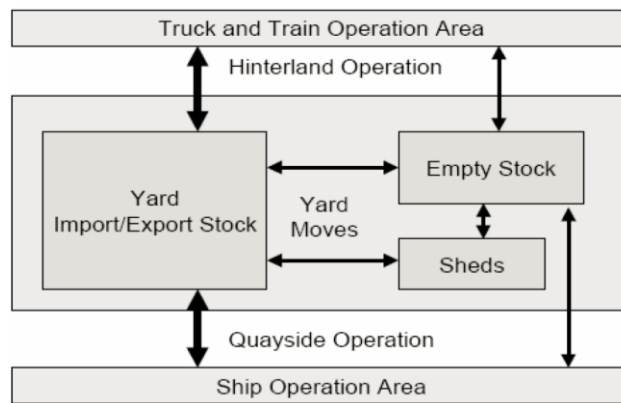

Figure 1.4: Flow of transports in a seaport container terminal. (Steenken et al., 2004)

The Figure 1.5 shows chain of operations for export (or import) containers. After arrival at the terminal by truck or train, the container is identified and registered with its major data (e.g. content, destination, outbound vessel, shipping line), picked up by internal transportation equipment and distributed to one of the storage blocks in the yard. The respective storage location is given by row, bay, and tier within the block in and is assigned in real time upon arrival of the container in the terminal. To store a container at the yard block, specific cranes or lifting vehicles are used. Finally, after arrival of the designated vessel, the container is unload from the yard block and transported to the berth where quay cranes load the container onto the vessel at a pre-defined stacking position. The operations necessary to handle an import container are performed in the reverse order (Jeon et al., 2011).

Totally speaking, it is a very complex task to schedule the huge number of concurrent operations with all the transportation and handling equipment involved. In view of the ever changing terminal conditions and the limited predictability of future events and their timing, this control task has to be solved in real time (Grunow et al.,

Literature Review

2006), and should be robust. In our work, with limited number of cranes and container stacks, the MIP can give a cyclic schedule in a short time for the container transit procedures. And the robustness algorithms can give the robustness margin on the nodes of the system in polynomial time. The robust cyclic scheduling can be used as a reactive scheduling for a medium size port to eliminate the unpredictable disturbance belonging to the robustness margin. If the disturbance is out of the robustness margin, it is also possible to reschedule a new cyclic schedule quickly. The efficiency of this robust cyclic management methodology is shown in this thesis.

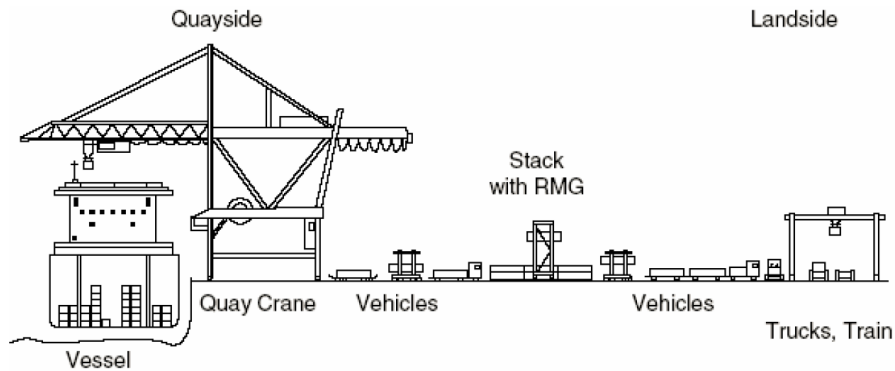

Figure 1.5: Transportation and handling chain of a container.(Steenken et al., 2004)

1.1.2 Non-cyclic vehicles scheduling in container terminals

The objective functions of non-cyclic scheduling, with or without time windows, are to minimize the travel distance, to minimize the energy cost, to minimize the total working time of vehicles (including the running time and the waiting time), to minimize the delay penalty etc. These criteria can help us to build the objective functions of the cyclic vehicle scheduling. The description of the non-cyclic container transit problem also gives us some reference to model the cyclic container procedures.

There are many articles about non-cyclic vehicles scheduling, which are almost based on heuristic or intelligent algorithms for giving a real time control. This subject is a special case of vehicle routing and scheduling problem with time window constraints (VRPST). Problems with time windows are from a computational complexity perspective quite difficult. Since the vehicle routing problem (VRP) is NP-hard. Therefore, the development of meta-heuristics algorithms for this problem is of primary interest. In (Solomon, 1987), the literature gives an overview of the heuristics algorithms for VRPST. In (Desrochers et al., 1992), the authors present a pulling al-

Literature Review

gorithm with 2-cycle elimination to solve the NP-hard problems with time windows. In (Gendreau et al., 1994), a Tabu search heuristic is discussed without time windows.

In (Bae and Kim, 2000), the authors consider selected issues related to minimize the travelling distance of single-load carriers. In (Qiu et al., 2002), they develop an overview of the scheduling and routing algorithm for AGVs. Another noticeable work is the paper by (Kim and Bae, 2004), they find an efficient look-ahead heuristic for minimizing the travel and waiting time of single-load AGVs, and the numerical result give a better performance than the conventional rules. (Grunow et al., 2005) gives a mixed integer linear programming for the AGV dispatching problem, they mainly investigate in the fast dispatching methods suitable for real time application. A network flow formulation for the dispatching problem of the automated guided vehicles is proposed by (Cheng et al., 2005), which includes minimizing the waiting time of the AGVs at the berth side and reducing the possibility that the AGVs will be clustered near there, and this formulation can be efficiently solved to obtain deployment strategies for large network sizes. (Nishimura et al., 2005) proposes a dynamic routing strategy for solving the yard trailers routing problem. They consider the travel distance and the overall cost. The simulation result shows the dynamic strategy is superior to a static routing strategy. But this method is not very applicable in a real-time dispatching strategy because of excessive computational requirements. In (Briskorn et al., 2006), they focus on the assignment of AIVs dispatching problems in real time control. Both the greedy priority rule and an exact algorithm are used in the real time control simulation. It is must to be mentioned that in (Ombuki et al., 2006) and (Zidi et al., 2012), they discuss the multi-objective VRP, which is more useful to the real work plan. More over a hybrid genetic and heuristic algorithm for AIV and quay cranes to minimize the overall make-span has been presented in (Homayouni et al., 2009). (Rashidi and Tsang, 2011) extends the standard network simplex algorithm (NSA) by giving a new algorithm NSA+. But NSA+ has certain limits in size. Beyond the limits, a greedy search is applied when the time available is short. (Jeon et al., 2011) suggests a routing method for AGV in port terminal that uses the Q-learning technique. It was shown that the travel time can be reduced by 17.3% by using the learning-based routes instead of the shortest-distance routes strategy. In (Zaghdoud et al., 2012), they mainly study the minimum total distance traversed by all AIVs of the system on considering a maximum equivalence in time taken by each AIV.

For our work, the first objective is to minimize the travel and waiting time of the overall AIVs group with a penalty of delayed delivery time. The second is to minimize the number of used AIVs. Then, the rest AIVs can be seen as the redundancy transport resource for the unpredictable breakdown of used AIVs. In other words, the first step is to find the solutions respecting the optimal productivity of container transit system. Then, we choose the solution with the least transport resources to realize this optimal productivity, which also reduces the energy cost and improve the clean production in the seaport.

1.2 Cyclic job-shop problem (CJSP) by using Petri Net

There are some similarities between the container transit procedures and job-shop problem. The product in job-shop can be seen as the container, the transfer may be seen as the AIVs, and the machines can be seen as the cranes in seaport, etc. Since few cyclic container transit literatures can be found, it is meaningful and useful to study the state of art of the cyclic job-shop problem.

The cyclic scheduling is defined as a set of activities that can be repeated for infinite number of times (Draper et al., 1999). More precisely, if $X(n)$ is the starting time (or ending time) of one activity, and n means the repeat numbers, then there is a constant C (called the cycle time which is the inverse of the periodic output rate) and one integer K such that

$$x(n+k) = x(n) + k * C \text{ for } n \in \mathbb{N}, k \in \mathbb{N}^+, C \geq 0 \quad (1.1)$$

In this kind of job-shop problem, a finite set of jobs is processed on a finite set of machines, and the machines repeat the operations by a period marked $k * C$ as shown in (1.1). Each job is characterized by a fixed order of operations, each of which is to be processed on a specific machine for a specified duration. Each machine can process at most one job at a time and once a job initiates processing on a given machine, it must complete processing uninterrupted. Factually, there is also a fixed visiting order for the containers to the different operation spaces of equipment. In the operation space, the AIV should stay for a demanded duration. And one crane can handle just one container unloading or uploading work at any moment.

It is supposed that only the 1-cyclic scheduling is studied in our work with $k=1$ in (1.1). Because the 1-cyclic schedule has the most regular activity for which

Literature Review

the robust control can be applied the most easily. Moreover, in (Korbaa et al., 1997c, Calvez et al., 1998, Bourdeaud'huy et al., 2011), they discussed the optimization of duration of transient state of cyclic scheduling. But only the steady state of cyclic scheduling is mainly discussed in this thesis, considering the transient state is just a very short period for cyclic scheduling.

There are two main research directions for cyclic job-shop scheduling. One is based on the time or timed Petri Nets models with heuristic algorithms, especially on the Petri Net event graph. And the other is mainly based on the Mixed Integer Programming (MIP) or Constraint Programming (CP). In this section, the state of the art of the first research direction is presented, and the reasons why the PTSCEG is chosen as the graphical modeling tool are explained step by step.

1.2.1 Petri nets for handling time problem

The concept of Petri net was first given in (Petri, 1962). Petri nets are a graphical and mathematical modeling tool applicable to many systems. As a graphical tool, Petri nets can be used as a virtual-communication aid similar to flow charts, block diagrams, and networks. In addition, tokens are used in these nets to simulate the dynamic and concurrent activities of systems. As a mathematical tool, it is possible to set up state equations, algebraic equations, and other mathematical models governing the behavior of systems (Murata, 1989). For our work, Petri nets are used to model the container transit procedures. The Petri nets can be a structure base to set up the constraints of MIP model to optimize the productivity and be a graphical tool to build the robustness algorithms.

After years of development, some extension tools were proposed basing on the low level petri-net models, including two kinds of the petri net for handling time problem, such as timed Petri nets and time Petri nets. In the container terminal, the time domain of the operations should be considered in the transportation flow. So, these two kinds Petri nets are more favorable for us than the other kinds of Petri nets.

In (Ramchandani, 1974), the T-timed Petri nets are derived from Petri nets by associating a firing finite duration with each transition of the net. The firing rule of T-timed Petri nets is first to account for the time it takes to fire a transition and second to express that a transition must fire as soon as it is enabled. These nets and related models have been used mainly for performance evaluation in (Ramamoorthy and Ho, 1980, Zuberek, 1998, Zuberek and Kubiak, 1999, Zuberek, 2001). Furthermore, the

Literature Review

timed petri net has two subclasses: P-timed petri nets and T-timed petri nets. The P-timed Petri nets were proposed in (Sifakis, 1980b). For each place of the P-timed Petri net, a delay representing the sojourn time of a token in this place is associated. In fact, these two kinds of modeling methods are equivalent to each other (Sifakis, 1980a). However, with a deterministic delay, the timed Petri nets can't describe well the changeable operation duration in the time domain or time window of each operation space in seaports.

In (Merlin, 1974, Merlin and Farber, 1976), a T-time Petri net was proposed. It is more general than timed Petri nets: a timed Petri net can be modeled by using a time Petri net, but the converse is not true. Time petri nets have been proved very convenient for expressing most of the temporal constraints while some of these constraints were difficult to express only in terms of firing durations. Merlin defined time Petri nets as Petri nets with labels: two values of time, two real numbers, a and b , with $a \leq b$, are associated with each transition. Assuming that any transition t_i is being continuously enabled after it has been enabled,

- a ($0 \leq a$), is the minimal time, starting from the time at which transition t_i is enabled, until this transition can fire, and
- b ($0 \leq b \leq \infty$), denotes the maximum time during which transition t_i can be enabled without being fired. Times a and b , for transition t_i , are relative to the moment at which transition t_i is enabled.

Assuming that the transition t_i , has been enabled at time θ , then t_i , even if it is continuously enabled, cannot fire before time $\theta + a$ and must fire before or at time $\theta + b$, unless it is disabled before its firing by the firing of another transition. Using these nets, Merlin discussed some recoverability problems in computer systems and in communication protocols. The time Petri nets is an enumerative analysis technique which allows one to simultaneously model the behavior and analyze the properties of timed systems (Berthomieu and Diaz, 1991).

However, by the semantic definition of T-time Petri nets, at the synchronized transition, the assigned time window means the operations from the input places have the same time interval. Conversely, the operation durations in different places are not equal and should be expressed as different time windows, considering the various kinds of equipment operation space. Thus, with a time window assigned on each place, the P-time Petri nets are a better choice for us to describe the activities of the container transit with time constraints.

Literature Review

In (Khansa et al., 1996b), the definition of a P-time Petri nets is given by a pair $\langle R|I \rangle$, where

- R is a marked Petri Net (David and Alla, 1994).
- $I: P \rightarrow (\mathcal{Q}^+ \cup \{0\}) \times (\mathcal{Q}^+ \cup \{+\infty\})$

$$p_i \rightarrow I_i = [a_i, b_i] \text{ with } 0 \leq a_i \leq b_i$$

I_i defines the interval of the staying time of a mark in the place p_i belonging to the set of places P. A mark in the place p_i is taken into account in transition validation when it has stayed in p_i for duration of at least a_i and at most b_i . After the duration b_i the token is dead. A token death state indicates that a potential time violation has occurred. The reader interested in the semantic analysis may consult (Boyer and Roux, 2008). The death of tokens generally occurs in places with a shared output synchronized transition of P-time Petri nets (Declerck and Didi Alaoui, 2004). It leads inevitably to the need for having formal methods ensuring the system control, e.g. the cyclic scheduling. It can be noticed that, in P-time Petri nets, the contribution of each token present in the net must be taken into account for preventing the token from dying whether it participates to the enabling a transition or not (BONHOMME, 2010). But, the possible death of the token can be used to define the penalty of delayed delivery time in the container transit. And, we use the MIP to ensure the system control.

1.2.2 P-time strongly connected event graph (PTSCEG)

As introduced in the above section, the P-time Petri nets can better model the time window of the operation space in container terminals. But, if a cyclic schedule is sought for the management of AIVs or cranes, a P-time Petri net would rather be strongly connected and be an event graph. The cycle time of P-time strongly connected event graph for 1-cyclic behavior can be determined (Declerck et al., 2007). The bound of the cycle time and the bound of number of tokens can also be defined, which can obviously reduce the computing time of MIP cyclic scheduling. The event graph has no conflicts. A Petri net is an event graph if and only if every place has exactly one input and one output transition. An event graph is the dual of a state graph in which if and only if every transition has exactly one input and one output place. In an event graph there may be synchronizations (i.e. a transition with at least two input places), but there is no conflict. As there is no conflict in event graph, the control complexity of the operation of the equipment (AIVs or cranes) is reduced theoretical-

Literature Review

ly. In a state graph, there may be conflict, but there is no synchronization (David and Alla, 2008).

An event graph is said to be strongly connected if there is a directed path connecting any pair of places in the graph without repeating any node (place or transition) in the net (Jain and Vemuri, 1998).

A P-time Petri net is a PTSCEG, if and only if each place has only one input and output transition, and any two places can be connected by a directed path without repeating any node of the P-time Petri net. More details about PTSCEG can be consulted in (Khansa et al., 1996a, Khansa et al., 1996b).

Factually, there are more articles concerning about the cyclic schedule of job-shop problem using T-timed strongly connected event graph. These T-timed works inspire us a lot of useful ideas on the P-time modeling techniques. In (Hillion and Proth, 1989), the Timed event graphs are used for modeling and analyzing job-shop systems. The modeling allows for evaluating the steady-state performance of the system under a deterministic and cyclic production process. Given any fixed processing times, the productivity of the system can be determined from the initial state. It is shown in particular that, given any desired product mix, it is possible to start the system with enough work-in-progress (WIP) so that some machines will be fully utilized in steady-state. These machines are called bottleneck machines, since they limit the throughput of the system. In that case, the system works at maximal rate and the productivity is optimum. The minimal number of WIP allowing an optimal functioning of the system is further specified as an integer linear programming problem. An efficient heuristic algorithm is finally developed to obtain a near-optimal solution.

Based on the work of (Hillion and Proth, 1989), the authors proposed some new modelling techniques and new heuristic algorithms (Ohl et al., 1994, Ohl et al., 1995, Korbaa et al., 1997b, Korbaa et al., 1997a, Korbaa et al., 2002). The problem of these heuristics is that they are based on different assumptions, or use different optimizing criteria, or have a very long resolution time (Ben Amar et al., 2007). Indeed, the Hillion's method doesn't guarantee the computation of a feasible schedule. In Ohl's algorithm, an operation only starts and ends during the same cycle. The algorithm of Korbaa required a certain time for the resolution to obtain a nearly optimal solution. In the heuristic algorithms, they tried three strategies for placing the operations, such as

- As soon as possible in the process slack time interval,

- As early as possible in the machine slack time interval,
- As late as possible in the machine slack time interval.

For the modelling techniques, in (Ohl et al., 1995), the authors presented a new systematic approach of modelling ratio-driven flexible manufacturing systems with T-timed Petri nets. They focused on the impact of universal or dedicated transport resources and the way the operation sequences are modelled as closed loops. Their method can give a tight lower bound than the method in (Hillion and Proth, 1989) which may induce unnecessary constraints on the WIP.

However, the graphical modelling tool used in our work is PTSCEG, which can be transformed from the timed event graphs. The container transportation procedures are well presented by the PTSCEG in Chapter 2. It is admitted that, the PTSCEG modelling techniques used in our work are basically based on a transformation or modification of the T-timed Petri nets modelling techniques in the articles mentioned above.

1.3 Cyclic job-shop problem (CJSP) based on MIP

In section 1.2 , we survey the state of the art of Petri nets for cyclic job-shop scheduling problem and container transit problem. The P-time Petri nets have many advantages to model the cyclic container transportation scheduling: it captures the precedence relations; conflicts could be avoided theoretically and time windows can be modeled easily and properly; it has a well-developed mathematical and practical foundation. Since the cyclic scheduling problem is NP-hard, heuristic algorithms are used in the works in 1.2.2. By using these heuristic algorithms, it is not always easy to get the expected sojourn time of tokens respecting the optimal cycle time or the optimal token number. The computing time might be too long which is not acceptable in the real industrial management.

But, there is another easier method to get the cyclic scheduling: applying MIP on CPLEX. This kind of method is directly based on the description of the precedence relations, conflicts and time windows etc. by mathematical constraints. In a medium sized port, if the number of the constraints is not very big and the bounds of the objective functions can be properly defined, it is possible to find the expected operation duration in a short time. If the computing time of MIP for cyclic schedule is short enough, this cyclic scheduling can handle the unpredictable changes in the dynamic

Literature Review

seaport activities. The work in Chapter 3 demonstrates that the MIP method is capable to face to the unpredictable events in the dynamic and complex seaport environment.

In (Roundy, 1992), the author considered the problem of finding cyclic schedules for a job in which all jobs are identical. It is assumed that a single product is produced on a number of machines. Each part is manufactured by performing a given set of operations in a pre-determined sequence. Each operation can be performed on exactly one machine. The goal was to minimize the cycle time and the work in progress (WIP) with a multi objective approach. However, it is a little trivial that just one kind of product is considered in the schedule.

In (Hanan and Munier, 1993), they defined an linear constraint between each pair of cyclic operations with determined time interval. The constraints explain the precedence relation between operations. In (Hanan, 1994), the author tried to give a general mixed linear programming for the cyclic scheduling problem with disjunctive resource constraints, using branch and bound enumeration procedure and two heuristics solving the problem.

And there are also many works presenting the mathematical constraints, the readers may consult in (Lee and Posner, 1997, Draper et al., 1999, Lee, 2000, Cavory et al., 2005, Brucker and Kampmeyer, 2008a, Brucker and Kampmeyer, 2008b, Fattahi et al., 2009, Frohlich and Steneberg, 2009, Brucker et al., 2012, Jalilvand-Nejad and Fattahi, 2013). Especially, in (Brucker and Kampmeyer, 2008b), they authors tried to give a general mathematical model for cyclic job-shop problem. Their proposed framework covers different versions of cyclic scheduling such as cyclic job shop, robotic cell, the single hoist scheduling and tool transportation between the machines. They showed that these problems can be formulated as a mixed integer linear programming model. But it is really hard to present all the cyclic scheduling problems by a general MIP model. Each kind problem has its special properties and constraints. And the models used in (Brucker and Kampmeyer, 2008b) always have some assumptions for simplifying the complexity of constraints. If we consider more real manufacturing factors such as the changeable durations of operations or the confined space for the transportation tools (e.g. the hoists), or we apply the cyclic scheduling in some special domains such as health-care (van Oostrum et al., 2008, Mannino et al., 2012, Holte and Mannino, 2013), there is no evidence that we can really give a general MIP model for all the cyclic scheduling problems.

Literature Review

So, the more meaningful research direction might be not trying to find a general MIP model for all the cyclic scheduling problems, but to find a MIP model with proper and suitable constraints for a special section cyclic problems with the similar functioning activities. The cyclic container transit problem by AIVs in seaport is very similar to the cyclic job-shop problems in (Seo and Lee, 2002, Bourdeaud'Huy and Korbaa, 2006, Ben Amar et al., 2010a, Ben Amar et al., 2010b, Ben Amar et al., 2011). Their graphical tools are timed event graphs. In (Seo and Lee, 2002), based on the steady-state analysis of cyclic schedule, the authors developed a MIP model for finding a processing sequence of the operations at each machine and the overtaking degrees, if necessary, that minimize the cycle time. Compared to (Seo and Lee, 2002), the MIP model designed in (Bourdeaud'Huy and Korbaa, 2006) is for optimizing the WIP. Especially, in (Ben Amar et al., 2010a, Ben Amar et al., 2010b), they consider the assembly and disassembly tasks for minimizing the cycle time or minimizing the WIP. In their job-shop models, the pallets allocated to products are used to fix the products as a support, and the pallets are transported by cranes or band transfers. The pallets can only be removed from the products after completely finishing the job. The number of pallets for one job is equal to the number of WIP. But they did not take the transportation time between machines into account, and they use the determined operation duration without changeable margins. In reality, it is impossible to ignore the transporting time, nor to assume that the duration is perfectly undisturbed.

Compared to our container transit model, the pallets can be seen as AIVs, the products can be seen as the containers, the machine workstations are the cranes operations space. If we can build similarly the constraints of the staying time of AIVs in each space and the constraints of the shared space, and if we add the constraints about the transporting time and the time windows, then the container transit process can be solved by MIP technique. For our work, to minimize the cycle time of PTSCEG stands for to realize the optimal overall productivity, and to minimize the WIP is to utilize the minimal number of AIVs to finish the transit task. Thus, the rest AIVs can be the redundancy transport resource for the breakdown of used vehicles.

However, the works in (Seo and Lee, 2002, Bourdeaud'Huy and Korbaa, 2006, Ben Amar et al., 2010a, Ben Amar et al., 2010b, Ben Amar et al., 2011) give us a design base for our MIP model in Chapter 3. The main structure of their models and the relative cutting techniques are presented in the following sections, 1.3.1 and 1.3.2.

Literature Review

1.3.1 The main structure of MIP model

The work in (Bourdeaud'Huy and Korbaa, 2006) is partially based on the work in (Seo and Lee, 2002). And the works in (Ben Amar et al., 2010a, Ben Amar et al., 2010b, Ben Amar et al., 2011) have the similar MIP structure to the MIP model in (Bourdeaud'Huy and Korbaa, 2006). There are two objective functions. One is to minimize the cycle time, another one is to minimize the WIP. Firstly, let us consider some notions.

- p_j : jobs or products, j is the index of jobs, $j \in \mathbb{N}^+$
- m_l : machines, l is the index of machines, $l \in \mathbb{N}^+$
- o_{jkl} : the k th operation of p_j processed on m_l , $k \in \mathbb{N}^*$
- t_{jkl} : start date of operation o_{jkl} , $t_{jkl} \geq 0$
- d_{jkl} : the duration of operation o_{jkl} , $d_{jkl} \geq 0$
- WIP_{jm} : the m th WIP for p_j , $m \in \mathbb{N}^+$
- W_j : total number of pallets for p_j , $W_j \in \mathbb{N}^+$
- W_{limit} : limit number of pallets for system, $W_{limit} \in \mathbb{N}^+$
- C : variable stands for cycle time of system, $C > 0$
- C_{max} : the optimal cycle time for cyclic scheduling of a production system, it is also the low bound of system's cycle time, $C_{max} > 0$
- J : $J = \max \{j\}$, the quantity of jobs
- K_j : number of operations for p_j
- L : $L = \max \{l\}$, the quantity of Machines
- α_{jk} a Boolean variable

1.3.1.1 The structure of MIP model for minimizing the cycle time

In this kind of model, the number of pallets is limited, and the cycle time is a rational variable. The objective function is to minimize the cycle time C .

- For all the operations, the starting time of an operation o_{jkl} should be located in the interval $[0, C)$. But the ending time of an operation can be bigger than C , which implies that one operation may cross the cycle time. We don't restrict the operation should be completely located in $[0, C)$. So, the generality of the cyclic scheduling is respected.
- For each pair of operations with precedence relation of the same kind of product p_j , one operation o_{jkl} should start after the ending time of its ancestor operation. If not, one more pallet should be added in the system, and $\alpha_{jk} = 1$.
- For each pair of operations executed on the same machine m_l , it should be to avoid the overlapping of two operations, considering one machine can execute one operation at most at a time.
- The number of the pallets should be less than the limited number W_{limit} .
- Lower bound of cycle time is used, seen in section 1.3.2.

1.3.1.2 The structure of MIP model for minimizing the WIP

In this kind of model, the cycle time C is fixed, respecting the demanded product rate. The objective function is to minimize the WIP

- In this kind of model, the number of pallets is limited, and the cycle time is a rational number. Notice that: in 1.3.1.1, the cycle time is a rational variable. The ending time of an operation can be bigger than C .
- For each pair of operations with precedence relation of the same kind of product p_j , one operation starts after the ending time of its ancestor operation. If not, one more pallet should be added in the system, and $\alpha_{jk} = 1$.
- For each pair of operations executed on the same machine m_l , it should be to avoid the overlapping of two operations, considering one machine can execute one operation at most at a time.

Literature Review

- Lower bound of WIP is used, seen in section 1.3.2.

1.3.2 Cutting techniques for MIP models

The optimal cycle time C_{max} for the production system is defined by the following expression (the definitions of the variables can be referred to section 1.3.1)

$$C_{max} = \max \left\{ \sum_{m_l} d_{jkl} \right\} \quad (1.2)$$

The expression $\sum_{m_l} d_{jkl}$ describes the sum of durations of the operations associated to the machine m_l . Let us denote by bottleneck machine the machine which has the greatest sum. Thus, the optimal cycle time is the sum of durations of the operations associated to the bottleneck machine. It is possible to obtain an optimal total production time by saturating the bottleneck machine of the considered production system (Bourdeaud'Huy and Korbaa, 2006).

The lower bound for cycle time:

$$C \geq C_{max} \quad (1.3)$$

The upper bound for cycle time:

$$C \leq \sum_1^J \sum_1^{K_j} d_{jkl} \quad (1.4)$$

The upper bound stands for the job-shop process only one job at a moment, only when this job is finished, the new job can be processed. Obviously, this is a stupid scheduling with low production efficiency.

The lower bound for WIP:

$$\sum_1^J \sum_1^{K_j} \alpha_{jk} \geq \sum_1^J \left\lceil \frac{\sum_1^{K_j} d_{jkl}}{C_{max}} \right\rceil \quad (1.5)$$

$\lceil \cdot \rceil$ stands for the ceiling operator. The above bound means if the sum of operations for one part is superior than C_{max} , more pallets should be used to guarantee the system run in C_{max} cycle time.

The upper bound for WIP:

$$\sum_{j=1}^J \sum_{k=1}^{K_j} \alpha_{jk} \leq \sum_{j=1}^J K_j \quad (1.6)$$

(1.6) implies that, in one cycle time, one pallet is used as transport resources for only one operation. This is an obvious waste of transport resources.

The use of cutting techniques can reduce the research space in MIP model. In (Ben Amar et al., 2007), the authors made experiments to prove that the cutting techniques can improve the practical performances of MIP solvers of CPLEX.

The cutting techniques presented above are used to compute the bound of the cycle time and number of tokens for timed Petri nets. So, some small modifications on these bound formulas should be done for better adapting to the PTSCEG, as shown in the section 2.5 of Chapter 2 . With these bounds, the MIP can give cyclic schedule in short time. Normally, the information about the container transport task can be known at least a few hours before the arrival of vessels, so it is possible to use the MIP as a scheduling tool to give cyclic schedule to the transit system. If the computing time is short enough (e.g. a few seconds), compared with the running time of AIVs on routes or the operation duration of cranes (normally a few minutes), the computing time of MIP can be neglected. Thus, the MIP can be used as a reactive scheduling method in real time if the disturbance is out of some robustness margin. If the disturbance is located in robustness margin, the robust control method is proposed in the following section, for avoiding unnecessary rescheduling.

1.4 Robust control of cyclic scheduling

In view of the ever changing terminal conditions and the limited predictability of future events and their timing, the robust supervision and management is sought to reduce or eliminate the influence of the disturbance on the system. Factually, there is a strong linkage among robustness, resilience and adaptability. But robustness emphasis the ability of system to continue functioning in the presence of internal and external challenges without fundamental changes to the initial setting of system.

In lots of articles, there are two main research directions of robust control. One is the strategy analysis based on the data statistics of the real manufacturing systems,

and the other one is the technique analysis based on the performance evaluation of applying techniques on mathematical models. In the last decades, the robust control is well studied in a lot of articles (Snyder, 2003, Herroelen and Leus, 2005, Möhring and Zaroliagis, 2009, Emmons and Vairaktarakis, 2012), but the study on the robust control of cyclic scheduling appears only in some of the papers. Considering the similarities between some job-shop problems and the container transit system, a few articles about the robust control techniques applied on manufacturing system are studied.

1.4.1 Strategy analysis of robust control

In (Jim and Kai, 2012), an on-line survey collected responses from 525 shippers, carriers, terminal operators, port authorities, third parties, freight forwarders and others operating in the port environment. This survey results show that the catastrophic failures in seaport are rare although the ports are always not resilient enough to handle large disruptions affecting loss of infrastructure and superstructure. It also suggests that the ports seem to be handling delays from small disruptions without significant impact on end customers. The survey result shows the importance of robust control in seaport for rejecting the delay disturbance in operations to decrease or eliminate the consequent impact on end customers. More study results about robust control strategies, especially in seaport transportation domain, are presented in (Haezendonck, 2001, Arndt and Müller-Christ, 2006, Sheffi, 2008, Berle, 2012, Trepte and Jr, 2014, Zhang et al., 2013a, Zhang et al., 2013b).

1.4.2 Robust scheduling techniques

1.4.2.1 Non-cyclic robust scheduling

In (JORGE LEON et al., 1994, Wang et al., 2009, Al-Hinai and ElMekkawy, 2011, Xiong et al., 2013), the authors study the machine breakdown problems using meta-heuristics. They mainly want to optimize two criteria. The first one is to minimize the make span without machine breakdown. The second one is to minimize the time gap between the schedule with machine breakdown and the schedule without machine breakdown. The object of their work is to find a robust scheduling which extends the initial make span the least.

A relative work of Machine Breakdown problem is the Perfect Maintenance problem which is studied in (Chung et al., 2009). This paper propose a modified genetic algorithm approach to deal with the distributed production models with mainte-

Literature Review

nance consideration, aiming to minimize the make span of the jobs. This paper also tests the influence of the relationship between the maintenance repairing time and the machine age to the performance of scheduling of maintenance during distributed scheduling.

In (Jensen, 2003), a robustness measure is defined and its properties are investigated. Through experiments, it is shown that using a genetic algorithm it is possible to find robust and flexible schedules with a low make span. These schedules are demonstrated to perform significantly better in rescheduling after a breakdown than ordinary schedules.

Notice that: the schedules discussed in these works are not cyclic. But these works can give us some ideas to understand better the meaning of robustness. Some concepts relative to robustness can be also applied into cyclic scheduling, such as the machine breakdown, the maintenance etc.

1.4.2.2 Cyclic robust scheduling

The robust cyclic scheduling of health-care problems are discussed in (Mannino et al., 2012, Holte and Mannino, 2013). The authors model both the uncertainty of patients' numbers and the cyclic schedule of the medical resource allocation as adjustable robust scheduling problems. They used MIP technique and developed a row and row generation algorithm and show it corresponds to the implementor/adversary algorithm for robust optimization introduced by (Bienstock, 2007) for portfolio selection. They applied their model to compute master surgery schedules for a real-life instance from a large hospital in Oslo. The robust cyclic scheduling is also studied in (Hendriks et al., 2010). They considered a planning problem of a terminal operator who has to construct a cyclic nominal timetable, according to which a set of cyclically arriving vessels is discharged. The time window is used to restrict the stochastic arrivals of vessels in port. And the MIP is used to construct a robust window-based cyclic berth plan.

However, the above non-cyclic robust scheduling methods or cyclic robust scheduling methods are based on a comparison between the optimal result and a good expect of make span for a mean of the stochastic disturbances. Their techniques can't give the exact solution about how to reject individually a given disturbance in system. Their methods need the rescheduling when a disturbance is observed. Considering the ever changing container conditions, using their techniques, the rescheduling is con-

Literature Review

stantly needed, which increase the management cost. And it is not assured that a proper reschedule can be found quickly every time.

In the following paragraphs, a robust control technique used in this thesis is presented. This robust control technique can evaluate the robust margin on nodes of systems. If the disturbance observed on a node is located in the robustness margin, it is possible to give a solution to eliminate the disturbance without changing the initial schedule of system. These robustness algorithms have a computing time in polynomial complexity. The following works use PTSCEG as a graphical analysis base. More details about PTSCEG nets can be seen in 1.2.2.

Definition 1.1 (Collart-Dutilleul and Craye, 2003): Robustness is defined as the ability of the system to remain valid with respect to the specifications when facing some expected or unexpected variations. Robustness characterizes the global capacity to deal with disturbances.

Definition 1.2 (Collart-Dutilleul et al., 2007): Passive robustness is when the required specifications are met without any need for a change in the control settings, even in the presence of variations.

Definition 1.3 (Collart-Dutilleul et al., 2013): Temporal control is the modification of the transition firing instants using a controlled P-time Petri net.

Definition 1.4 (Collart-Dutilleul et al., 2013): Active robustness is robustness ensured by the temporal control of the process transitions.

In (Jerbi et al., 2004, Collart-Dutilleul et al., 2007, Mhalla et al., 2013a), the authors studied the passive robustness control. The passive robustness control has the basic idea: only the sojourn time of tokens in the places standing for the free status of machines can be changed to reject the disturbance. For example, if there is a delay disturbance observed on the operation of one machine, then the machines responsible for the successive operations should shorten the free status time to reduce the delay. On the synchronized transition, the tokens of other paths synchronized with this delayed token maybe dead if the waiting time is too long to exceed the upper bound of time windows. The extreme waiting time of these tokens gives a lower bound of the robustness margin on the node where the disturbance is observed. The method to reject the advance disturbance is just an inverse process. But the authors ignore the possible disturbance propagating on the other paths. In (Collart-Dutilleul et al., 2013), the authors considered the disturbance that propagates along a path parallel to the disturbance propagation, which makes the passive robustness algorithm more complete.

Literature Review

The passive robustness algorithm applies passive robustness formulas on all the sequences of the mono-synchronised sub-path of a given PTSCEG. The algorithm is based on a function F , which is called recursively using a part of the net that is more and more restricted. When the robustness of a mono-synchronised sub-path is computed, it is removed from the net to be treated in the next use of function F . As the number of mono-synchronised sub-paths is finite, the convergence of the considered algorithm is proved, because the function stops when the sub-net is empty: $\varphi^* = \emptyset$. And the complexity of the computing time of the passive robustness algorithm is smaller than $O(n^4)$. The readers interested in the proof of the convergence of the algorithm and the computing complexity analysis may consult (Jerbi et al., 2009, Collart-Dutilleul et al., 2013).

However, it is a little trivial that only the free status duration of machines can change to deal with the disturbances. If the operation time on the machines can adjust, a larger robustness margin on nodes may be achieved. Both the time of the machine free status and the time of the operations can be changed to reject the disturbance; this is the basic idea of active robustness control.

The first approach of active robustness control is proposed in (Mhalla et al., 2008). This strategy consists of generating by the control, on the parallel paths, a temporal shift similar to the disturbance in order to avoid the death of tokens on the levels of synchronizations transitions. For example, two product processing paths have a shared synchronized transition, and there is one machine on each path. If the disturbance is a delay (an advance) observed on an operation executed on a machine, then, as a delay (respectively an advance), the similar temporal shift will be given by changing the operation time of the other machine on the parallel path. Thus, we give an active control on the parallel path to enlarge the passive robustness margin.

The second approach of active robustness control is proposed in (Collart-Dutilleul et al., 2007, Collart-Dutilleul et al., 2013). This strategy consists in rejecting the disturbance as soon as it is observed: if the disturbance is a delay (an advance), we generate advances (respectively delays) on the controlled transition firing time on the propagation path of the disturbance, in order to avoid violation of the schedule constraints. For example, there is a delay observed on an operation of a product on a machine. Before this delay propagates to its first synchronized transition, all the machines responsible for this product should shorten the operation time and the free status time as much as possible to avoid the token death on the synchronized transition.

Literature Review

The third approach combines the two above strategies (Mhalla et al., 2013b). This third strategy allows:

- To reject the disturbance by control as soon as it is observed on the path in which the disturbance is observed,
- To generate by the control, on the parallel paths, a temporal shift similar to the disturbance in order to avoid the death of marks on the levels of synchronization transitions.

The first and the second approach of active robustness control can give a larger robustness margin on node than the passive robustness margin. It is hard to make a comparison between the first and the second. Their performances depend mainly on which model we choose. But the third approach surely has better performance than the other two approaches, by combining the advantages of the first and the second. The computing time complexity of the active robustness algorithm is less than $O(n^6)$ (Collart-Dutilleul et al., 2013). The readers interested in more details about the three approaches of active robust control, such as the complete algorithms, the theoretical semantic analysis, or the examples, can consult (Mhalla et al., 2008, Collart-Dutilleul et al., 2013, Mhalla et al., 2013b).

As we mentioned a lot of times, the container transit procedures have the similar functioning properties with job-shop problems studied in (Collart-Dutilleul et al., 2007, Mhalla et al., 2008, Collart-Dutilleul et al., 2013, Mhalla et al., 2013a, Mhalla et al., 2013b). So, if the time delay or advance of AIVs or cranes is located in the robustness margin, it is possible to eliminate the disturbance by changing their operation durations temporarily without rescheduling the system's activities. The computing time of the robustness algorithms is in polynomial complexity. So, it is possible to achieve the robustness margin on nodes of the transit system in short time, if the container transit task is in a medium sized seaport. Thus, the robust cyclic control can be seen as a real time scheduling if the disturbance is in robustness margin.

In our automated and intelligent transit system, the related equipment has a real time communication with each other. The signal points can be seen as the transitions. If the transit procedures are modelled as PTSCEG, it is reasonable to suppose that each transition is observable and controllable, which is not guaranteed in the job-shop example studied by Collart-Dutilleul and Mhalla. Some modifications are proposed to make the algorithms more suitable to the control of AIVs, as shown in Chapter 4 .

1.5 Conclusion

In this chapter, we present an extensive literature review on the necessary knowledge based on the survey of the state of the art of the various tools or techniques. There are few articles directly focusing on the robust control of the seaport container transit. So the literature review has to be an interdisciplinary document survey. Some robust control or cyclic scheduling techniques applied on job-shop problem are studied. And the portability of these techniques to container transit procedures is discussed from time to time during the whole literature research.

Without changing the infrastructure of ports in NWE, the significant improvement of the productivity should be achieved through the advanced terminal layouts, a more efficient IT-support, as well as the automated intelligent transportation and handling equipment, such as the AIVs. The robust supervision and management is urgently needed for the ever changing terminal conditions and the limited predictability of future events with time window constraints in the confined space.

From the survey on the state of art of robust control and cyclic scheduling on job-shop problems, we consider the possibility to apply the cyclic scheduling for the stevedoring of a big number of containers. The robust control can be applied on a cyclic schedule more easily than on the non-cyclic schedule. Reasonably, it is easier to give control on a regular activity than on a stochastic activity. As a graphical tool to model the cyclic container transit procedures, the PTSCEG describes better the time windows and the confined space than the other kinds of Petri nets. The PTSCEG can give the bounds of cycle time and token number and can be an analysis structure of the robustness algorithms. It is reasonable to have a suppositional methodology structure as that *“Before the arrival of the vessels, the MIP can be used to give a cyclic schedule of the container transit task while respecting the optimal overall productivity. At the same time, the robustness algorithms can be used to compute the robustness margin on the nodes of system for the cyclic schedule. In view of the disturbance belonging to the robustness margin, without rescheduling for the container transportation, the robustness algorithm can be used to reduce or eliminate the disturbance in real time. If the disturbance is out of the margin, the MIP can be applied to give a new schedule in short time.”*

For the container transit procedures in a medium sized seaport, the applicability of the robust cyclic control methodology is demonstrated in the following chapters.

Chapter 2 P-time Strongly Connected Event

Graph (PTSCEG) Modeling Techniques

As discussed in the literature review, the time domain of the AIV's staying in the confined operation space or on the routes has to be considered in our work. As a P-time Petri net, the PTSCEG is chosen to model the time windows of vehicle staying time. Moreover, as a strongly connected event graph, the PTSCEG can easily offer the bound of the cycle time (the reciprocal of productivity) and token number (the AIV or crane number). These bounds can reduce the cyclic scheduling computing time. And there is no conflict in an event graph, so there is no conflict of route choosing for AIVs. And there are some mature robustness algorithms based on the structural computing of PTSCEG. Thus, after a sophisticated comparison among different kinds of time or timed Petri nets, the PTSCEG is chosen as the graphical tool to model the container transit procedures.

In this chapter, the seaport container transit procedure is modeled by PTSCEG technique step by step. The content is presented in the following order.

Firstly, a job-shop example is used to explain the definition of PTSCEG. Then, the container import and export procedures are introduced and a sketch map of the considered example is used give a problem description. Thirdly, the PTSCEG is used to model the shared crane operation places, the routes, the intersections of the routes, the ratio-driven transit task. Fourthly, a complete container transit PTSCEG is achieved step by step with the presented modeling techniques. Finally, the cutting techniques of the PTSCEG are discussed.

2.1 PTSCEG definition and a job-shop example

P-time Petri nets are convenient tools for modeling manufacturing system whose operations are not precisely given, but are included between a minimum and maximum value (Khansa et al., 1996a), such as the case for electroplating lines, chemical industry and food processing. In our work, a special kind of P-time Petri nets so called PTSCEG is used to model the container transit procedures with time constraints and resource constrains, which can avoid the unnecessary explosion of the state classes for cyclic scheduling. In this section, firstly, the basic definitions about PTSCEG are given once again as the follows. Then, a job-shop example is used to explain the basic modeling techniques of PTSCEG.

2.1.1 Definitions about PTSCEG

Definition 2.1(Khansa et al., 1996a): The formal definition of a P-time Petri net is given by a pair $\langle R|I \rangle$, where

- R is a marked Petri Net (David and Alla, 1994).
- $I : P \rightarrow (Q^+ \cup \{0\}) \times (Q^+ \cup \{+\infty\})$

$$p_i \rightarrow I_i = [a_i, b_i] \text{ with } 0 \leq a_i \leq b_i$$

I_i defines the interval of the staying time of a mark in the place p_i belonging to the set of places P. A mark in the place p_i is taken into account in transition validation when it has stayed in p_i for duration of at least a_i and at most b_i . After the duration b_i the token will be dead. The semantic specificity of P-time Petri nets is studied by (Boyer and Roux, 2008).

Definition 2.2 (Long and Descotes-Genon, 1993): An Event Graph is a particular Petri net in which each place has exactly one input transition and one output transition.

Definition 2.3: An Event Graph is a Strongly Connected Event Graph (SCEG) if and only if it exists an oriented path connecting each node to another.

Definition 2.4: A P-time Strongly Connected Event Graph (PTSCEG) is a kind of P-time Petri net which is also a SCEG.

In (Collart-Dutilleul et al., 2007), the PTSCEG is used to model a multi-product job-shop without assembling tasks. The job-shop problems are usually studied in the

PTSCEG Modeling Techniques

articles about cyclic control or scheduling rather than the container transit problem. The job-shop problems are better known and more easily to be understood by us. In the following section, we use a Hillion-like model to explain the definitions of PTSCEG. Based on the comprehension of PTSCEG job-shop model, and the similar points between the job-shop problems and the container transit problem, the PTSCEG container transit model is given step by step in sections 2.2 , 2.3 and 2.4 .

2.1.2 PTSCEG job-shop model

In this job-shop example, the pallets allocated to products are used to fix the products on the band transfer, and the pallets will only be removed from the products after completely finishing the job. So in this paper, the number of pallets for one job is equal to the number of work-in-progress (WIP) for this job. On band transfers, the quantity of pallets is limited by the limited transfer length and the space interval of pallets. The transferring time of pallets from one machining center to another is bounded by time windows. The processing machines are seen as machine resources. Each machine can process at most one job at a time, and once a job initiates processing on a given machine it must complete processing uninterrupted. The processing time on the machines is also a bounded time window. And the quantity of pallets and machines are limited.

Table 2.1. Production lines sequences

Product	Visiting sequences
Job1	T3-M1-T1-M2-T2-M3-T3
Job2	T5-M2-T4-M1-T5

The example consists of three machines M1, M2, M3, and five transfers T1, T2, T3, T4, T5. Transfers are used to translate the pallets among machining centers. The job-shop produces two types of products: Job1 and Job2, for which two production lines are designed as shown in Table 2.1. The pallets fixed to Job1 and Job2 are allocated or removed at T3 and T5 respectively. Once one machine finishes processing in a machining center, it must reset for a while for the consecutive operation of another machining job. As shown in Figure 2.1, R1, R2, R3, R4 and R5 stand for the free machines in the reset status.

PTSCEG Modeling Techniques

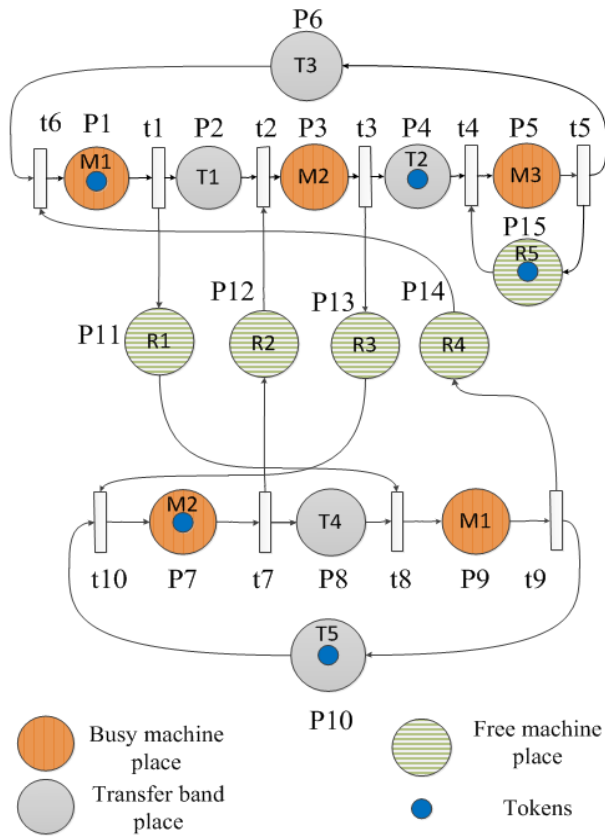

Figure 2.1: Example of job-shop described by PTSCEG.

Table 2.2. The time windows for each place

P_i	a_i	b_i
P1 (M1)	15	20
P2 (T1)	3	7
P3 (M2)	2	20
P4 (T2)	2	7
P5 (M3)	15	20
P6 (T3)	6	$+\infty$
P7 (M2)	5	12
P8 (T4)	10	20
P9 (M1)	2	20
P10 (T5)	31	$+\infty$
P11 (R1)	2	$+\infty$
P12 (R2)	2	$+\infty$
P13 (R3)	8	$+\infty$
P14 (R4)	8	$+\infty$
P15 (R5)	8	$+\infty$

The example is factually presented by a P-time strongly connected event graph (PTSCEG). In this kind of strongly connected graph, each place has just one input arc and one output arc. And it is always possible to connect any pair of two nodes by a directed path without repeating any node. And each place has also a time window with lower bound a_i and upper bound b_i . Here, the time windows stand for the bounded processing time, the bounded translating time or the bounded reset time. The time window of each place is given in Table 2.2.

Definition 2.5: Elementary circuit of PTSCEG is the path which can connect all the nodes of this path as a cycle without repeating any nodes of this path.

In this PTSCEG, There are 5 elementary circuits:

$$G_1 = (M1, t1, T1, t2, M2, t3, T2, t4, M3, t5, T3, t6),$$

$$G_2 = (M2, t7, T4, t8, M1, t9, T5, t10), \quad G_3 = (M1, t1, R1, t8, M1, t9, R4, t6),$$

$$G_4 = (M2, t3, R3, t10, M2, t7, R2, t2), \quad G_5 = (M3, t5, R5, t4).$$

G_1 and G_2 stand for the machining lines, in which the tokens stand for the pallets; G_3 , G_4 and G_5 stand for the busy-free-busy status changing circuits of machines M1, M2 and M3 respectively, in which the tokens stand for the machines. M1 and M2 are shared by Job1 and Job2. M3 is only responsible for machining Job1.

Factually, if we compare the job-shop problem and the container transit problem, the pallets in this job-shop problem can be seen as the AIVs in seaport, the band transfer of job-shop problem can be seen as the routes, the machines can be seen as the cranes or the intersections which are also the shared resources for AIVs, and the machining process circuit can be seen as a route circuit for a cyclic container transit. There are a lot of similar points between these two problems. Based on the comprehension of PTSCEG job-shop problem, the PTSCEG modeling techniques for container transit procedures are presented as follows.

2.2 The container transit procedures in seaport

The container terminal is a complex system including the berthing of the vessel, the stevedoring (unloading or uploading) of containers, the transit of containers, the stacking of containers, and the use of bunkering service before starting another voy-

age etc.(Roh et al., 2007). Any production factor may influence the staying time of ships in port. In this paper, we focus on three important factors: stevedoring of containers, transit, and container stacking. Generally, these tasks are performed by some specific handling equipment. We assume that three types of equipment are used for container import or export as shown in Figure 2.2, such as Quay Cranes (QCs), Automated Intelligent Vehicles (AIVs), and Automated Yard Cranes (AYCs).

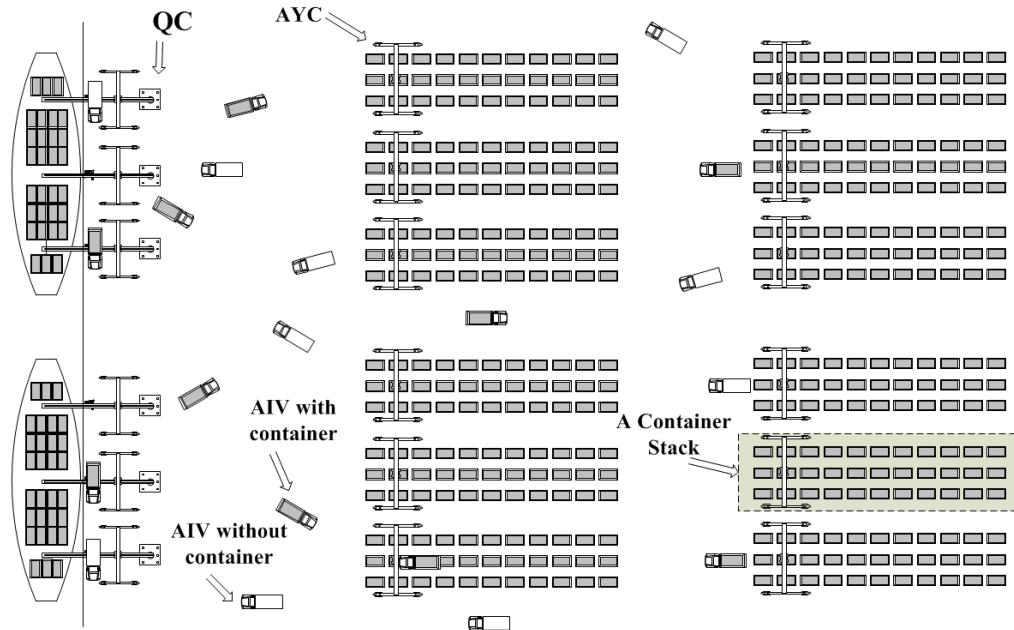

Figure 2.2: Overview of container transit in a seaport container terminal.

Normally, the container transit procedures can be classified as import operation and export operation.

- Import operation: when a ship arrives at a quay in a container terminal, the import containers are lifted by QCs and moved to an AIV. The AIV is used for transporting the container from the QCs operation space to the container stacks. Near the container stacks, an AYC picks up the container from the AIV and stacks it to the storage place. Figure 2.2 illustrates two ships full of import containers berthing by the quays.
- Export operations: When one empty AIV arrives at the container stacks, an AYC picks one export containers from the stacks and put it on the AIV. This export container is carried by the AIV to the appropriate QC which will lift the container to the ship.

As shown in Figure 2.2, two ships full of import containers berth by the quay for unloading work. For each ship, several QCs are assigned to unload containers, and a few AIVs are assigned to take the containers from QCs to AYCs. Some container stacks on the yard are used for storing the containers momentarily. For each stack, one AYC is assigned to take the container from the AIVs and to put the container on the stacks. In the beginning, only the import containers are removed from ships to stacks, but when there is enough empty space on the ships, the export containers can be taken to the ships at the same time to shorten the anchor time of ships in seaport. In this thesis, only the import container transportation is modeled. The export of containers is just a converse process if compared with the import activity.

This paper deals with a robust 1-cyclic scheduling problem respecting the demanded cycle time with operation time constraints and shared resource capacity constraints. The example presented in this paper includes the main important factors of a real container transit process, for instance, the limited number of vehicles, the limited space for unloading or uploading work, the confined space of intersections on crossing paths, and the bounded processing time of equipment. We study the bounded processing time and the limited capacity of four kinds of resources: QC operation space, AYC operation space, paths and confined intersections space on routes. The AIVs are assigned to transport the containers from the known original point to the known destination, using the known paths. The capacity for the working space of QCs and AYC is 1, which means that one crane can put just one container on one AIV at any moment. The capacity of intersections is 1 or 2 which will be more precisely explained in section 2.4.4. The capacity of routes is big enough for the AIVs, considering the limit number of vehicles and the sufficient space between QCs and AYC.

2.3 Problem definition of the container transit procedures

The models studied in this paper are based on the container transit operations shown in Figure 2.2: Overview of container transit in a seaport container terminal. There are two ships by the quays, 6 QCs are assigned to unloading the containers, 3 QCs for each ship respectively. Moreover, the containers' location place in ships or in stacks can be known in advance. A sketch structure of the model is given in Figure 2.3. There are 6 QCs operation spaces C1, C2, C3, C4, C5 and C6, and 6 AYC operation spaces such as S1, S2, S3, S4, S5 and S6. In each of the above 12 places, only one AIV is permitted to stay in at a time, considering the confined space and the safe-

PTSCEG Modeling Techniques

ty reasons. The AIVs can choose the shortest route between two signal points, maintain their trajectory and avoid collisions by a sensor location system, and also guarantee an information communication with the remote control center. The AIVs choose the straight segment between two points as the transit route, so the paths of the task can be fixed with the known original point of the container and the known destination point. As shown in Figure 2.3, 10 routes are given such as C1-S1, C2-S1, C2-S3, C3-S2, C3-S4, C4-S5, C5-S4, C5-S5, C5-S6 and C6-S6. We suppose that the routes guarantee a bi-direction pass for AIVs, which implies it is wide enough for two AIV's side by side running in converse direction. S1, C2, C3, S4, C5, S5 and S6 are shared crane operation space for more than two routes at the same time. X1 is an intersection of C2-S3 and C3-S2, X2 is an intersection of C4-S5 and C5-S4. We suppose that the intersection points cut the paths into two segments with a known ratio. For reducing the possibility of collision, if one AIV is on the intersection point, it will not restrict the passage of one AIV which uses the same route (bi-direction pass), but it will restrict the passage of the AIV which uses another route. Although AIVs are intelligent, we are not sure they can deal well with the complex location problem in a cross point with really confined space.

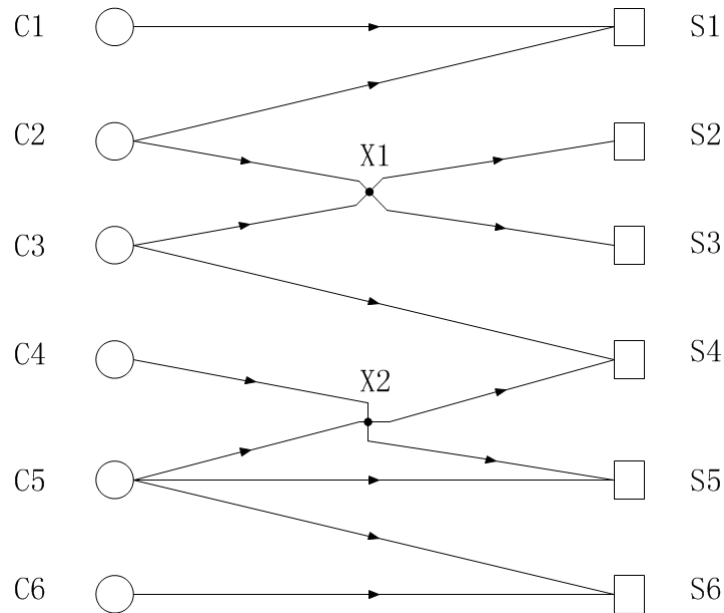

Figure 2.3: The sketch structure of the container transit.

In this container terminal, the AIVs visit the different places repetitively. The problems are how to assign the limited number of AIVs to different routes and how to design the AIVs timetable to realize a maximum output rate (minimal make-span),

and when the 1-cyclic schedule is found, how to apply a proper robust control to deal with the unpredictable disturbance in the system, such as the delay of AIVs and cranes. Anyway, an efficient and robust scheduling technique is sought in our work.

In the PTSCEG, two kinds of elementary circuits are studied. One is the process circuit, and the other is the space status circuit.

Definition 2.6: Process circuit is a kind of elementary circuit which represents the operation cycle of containers' transit process between QCs and AYC's.

Definition 2.7: Space status circuit is a kind of elementary circuit which represents the status changing cycle of an operation space.

Definition 2.8: Shared space status circuit is a kind of elementary circuit which represents the status changing cycle of a shared operation space.

Before the presentation of more content, let us consider some notions.

- G : the PTSCEG model
- G_i : i th elementary circuit represents the process circuit or the space status circuit, $i \in \mathbb{N}^+$
- p_{ij} : j th place of G_i , the places stand for the operation space of QCs, AYC's, the intersections, the paths, and the free status of a shared space $j \in \mathbb{N}^+$
- t_{ij} : j th transition of G_i
- ${}^{\circ}p_{ij} (p_{ij}^{\circ})$: the input (output) transition of p_{ij}
- V_{il} : the l th token of G_i , $l \in \mathbb{N}^+$
- s_{ij} : entering date of one token in p_{ij} , $s_{ij} \geq 0$
- q_{ij} : the sojourn time of one token in p_{ij} , $q_{ij} \geq 0$
- q_{ij}^e : the expected sojourn time of tokens to realize the demanded cycle time of system, $q_{ij}^e \geq 0$
- a_{ij} : the lower bound of q_{ij} , $a_{ij} \geq 0$
- b_{ij} : the upper bound of q_{ij} , $b_{ij} \geq 0$

PTSCEG Modeling Techniques

- W : total number of tokens in G , $W \in \mathbb{N}^+$
- W_i : the number of tokens in G_i , $W_i \in \mathbb{N}^+$
- W^{limit} : the limit number of tokens in G , $W^{\text{limit}} \in \mathbb{N}^+$
- W_i^{limit} : the limit number of tokens in G_i , $W_i^{\text{limit}} \in \mathbb{N}^+$
- C : variable stands for cycle time of G , $C > 0$
- C_i : variable stands for cycle time of circuit G_i , $C_i > 0$
- C^{min} : the minimal cycle time of G , $C^{\text{min}} > 0$
- C^{max} : the maximal cycle time of G , $C^{\text{max}} > 0$
- I : $I = \max \{i\}$, the number of G_i
- J_i : number of places in G_i
- β_{ij} : Boolean variable
- γ_{ij}^{ij} : Boolean variable

2.4 PTSCEG model techniques for container transit procesures

Based on the sketch structure of the container transit process, the PTSCEG is used to model the containers transit process with time window in the shared cranes' operation space, the routes and the intersections.

In this model, first the 10 routes are modeled. Then, the routes are connected by the shared space such as the shared crane space or intersections. Let us denote the process circuits C1-S1, C2-S1, C2-S3, C3-S2, C3-S4, C4-S5, C5-S4, C5-S5, C5-S6 and C6-S6 as $G_1, G_2, G_3, G_4, G_5, G_6, G_7, G_8, G_9$ and G_{10} , respectively. The QC operation space is the first place of G_i and its output transition is the first transition of G_i . This is a P-time Petri Net, so the time window for each place should also be given. For each place, let us denote $[a_{ij}, d_{ij}^e, b_{ij}]$, the lower bound of the time window, the expected sojourn time of tokens, and the upper bound of the time window, respec-

tively. The time window of all the free status places is given as $[0, q_{ij}^e, +\infty]$. Thus, one crane operation space can receive an AIV immediately as soon as it is free, but, the shared crane should sometimes stay in free status for a while to realize the global minimal cycle time of the system.

2.4.1 Routes modelling

Firstly, let us take $G_1(C1-S1)$ as an example to model one process circuit of a route. In Figure 2.4, C1 is the place where the import container is unloaded by QC, and then the container is taken from C1 to a stacking place S1. P12 stands for the route C1->S1. After finishing the stacking operation in S1, the AIV is empty, and it goes back to C1 by passing P14 which stands for the path S1->C1. Factually, P12 and P14 is the same route with converse direction (bi-direction pass).

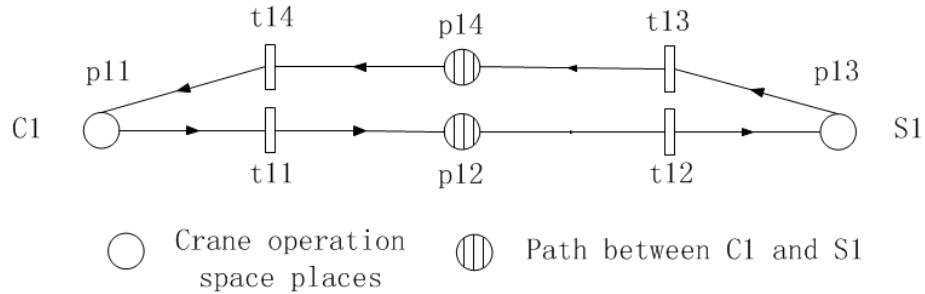

Figure 2.4: The route between C1 and S1.

2.4.2 Place capacity modelling

In reality, there are always constraints on the space capacity. For example, no crane operation space can receive unlimited AIVs. Factually, in our medium-sized seaport model, each crane operation space permit only one AIV's parking. More AIV's parking in one crane operation space easily causes the insecurity factors for the equipment, such as the collision of AIVs. Usually, we add a closed loop on the operation place and put the tokens with an expected capacity number to control the capacity of the places. As shown in Figure 2.5, the place p11 stands for the QC operation space C1, and the place p13 stands for an AYC operation space S1. In each of these two places, at most one AIV is permitted to stay in. We add a space status circuit (p11, t11, cf11, t14) on the C1 operation place, and we put one token in this close loop.

Then, there is at most one token in p11 by the control of the synchronized transition t14. For the place S1, we can add the space status circuit (p13, t13, sf11, t12) to control the number of tokens in S1.

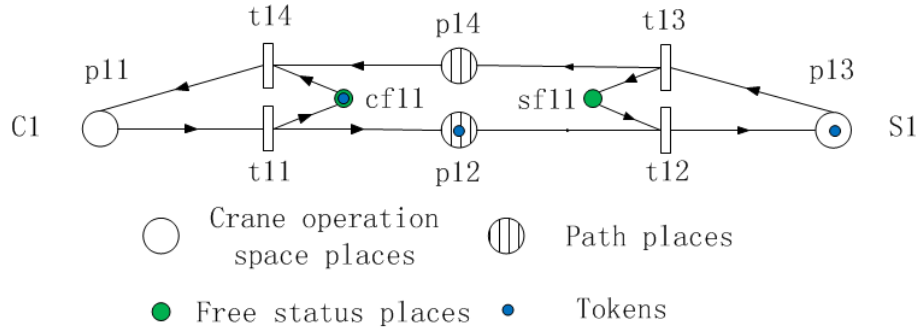

Figure 2.5: Place capacity modeling by PTSCEG.

The place cf11 is a free status place of p11, which means the operation space of C1 is empty and can be used immediately if necessary. And sf11 plays the same role for place p13. For the places p12 and p14, since the space of the route is big enough for the available AIVs, so, we don't need to add the close loops or the space status circuits to control the capacity.

More generally, for a system which can be expressed as a PTSCEG, if the capacity of one place should be limited, it is possible to add a close loop with the free status place of this place, and put the tokens with the demanded capacity number in the close loop, to control the token number.

2.4.3 Shared crane operation space modelling

Let us take S1 as an example to show how to model a shared crane space. As shown in Figure 2.6, the shared space status circuit of S1 is constituted by two free status places sf11 and sf12, and two busy status places, p13 and p23. The tokens in process circuits $G_1(C1-S1)$ and $G_2(C2-S1)$ represent the AIVs, and the token in the shared space circuit represent the capacity to receive AIV in the confined shared space. There is only one token in the S1 status circuit, which means only one AIV is permitted to unload containers in S1 at any moment. Hence, we don't need to add the capacity control circuits for p13 and p23.

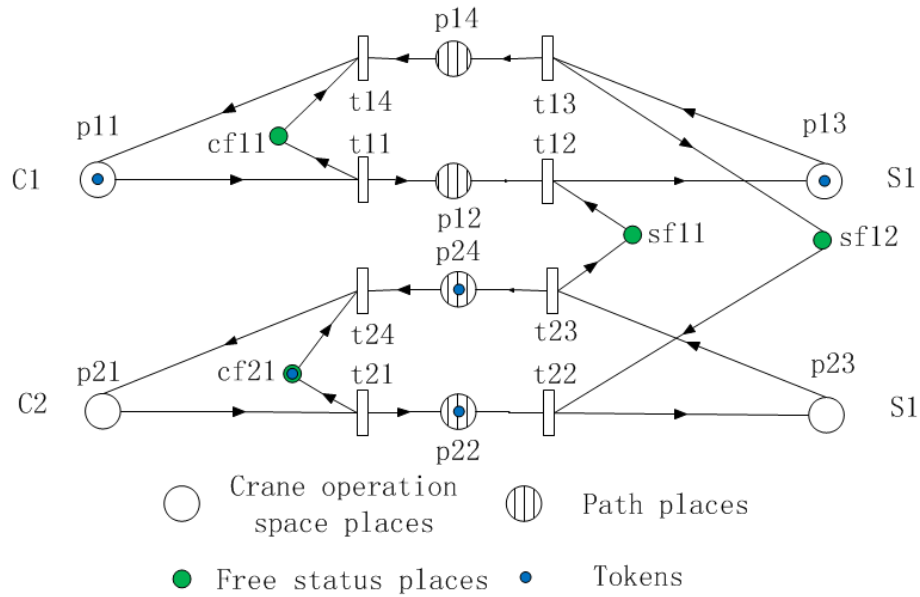

Figure 2.6: The shared crane space S1 with two routes modeled by PTSCEG.

The close loop of shared space status (p13, t13, sf12, t22, p23, t23, sf11, t12) connects the two process circuits G_1 and G_2 . The capacity of operation space S1 is controlled by the number of tokens in the shared space status circuit and the synchronized transitions t12 and t22. Only one token can appear in either p13 or p23 or the free status, and it is impossible to observe the token appear p13 and p23 at the same time. Thus, the shared space status models well the operation status of the shared cranes of different container transit paths.

More generally, for any shared space of a system which can be expressed as a PTSCEG, it is possible to add a shared space status circuit and put the limited capacity number of tokens in this circuit to model the shared space with demanded capacity.

2.4.4 Intersections modelling

The intersections are more complex to be modelled. As shown in Figure 2.7, in an intersection point X1 of two routes G_3 (C2-S3) and G_4 (C3-S2), the AIVs on the same path will not restrict the passage for each other, but the existence of one AIV will forbid the passage of AIVs on other crossing routes.

PTSCEG Modeling Techniques

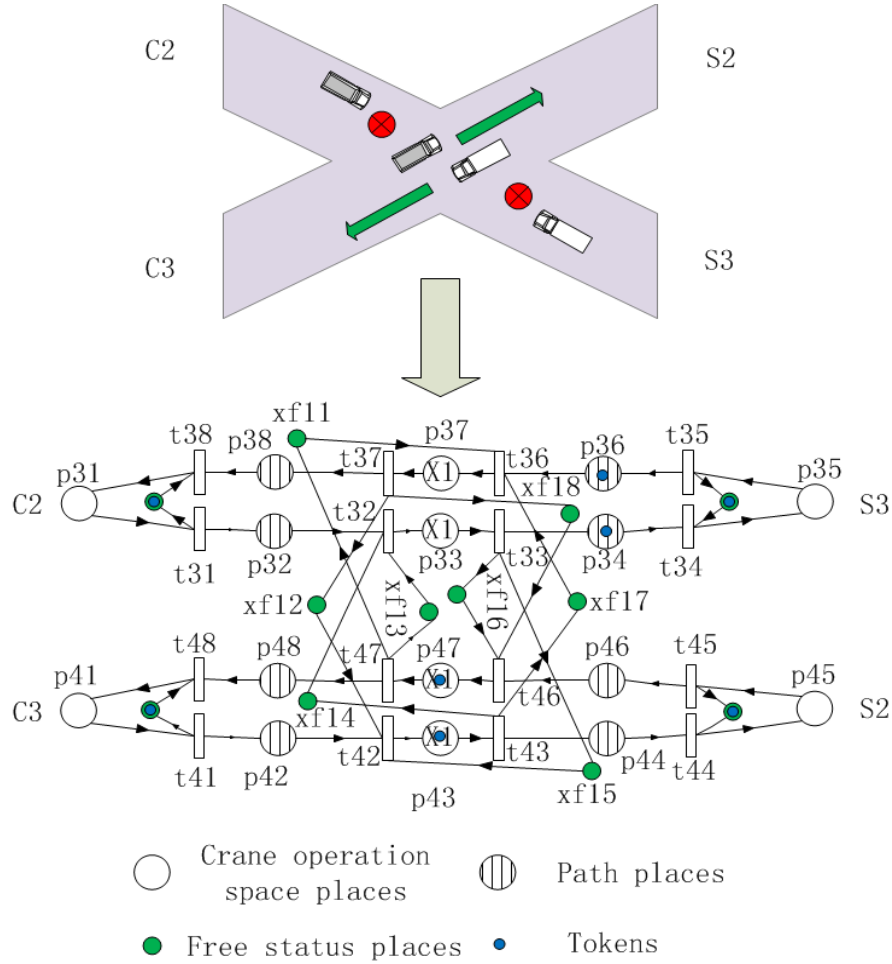

Figure 2.7: The intersection X1 modeled by PTSCEG.

X1 is a shared intersection space of G_3 and G_4 . The shared space status circuit can be used to control the number of tokens in X1. P33 and p37 stand for the X1 space on the route C2-S3 with converse direction. P43 and p47 stand for the X1 space on the route C3-S2 with converse direction. As we have assumed, in the intersections, the AIVs only forbid the passage of AIVs of other routes. So, p33 is a shared space place for p43 or p47, and p37 is a shared space place for p43 or p47. There are 4 shared space status circuits in Figure 2.7, such as

- (p33, t33, xf15, t42, p43, t43, xf14, t32)
- (p33, t33, xf16, t46, p47, t47, xf13, t32)
- (p37, t37, xf12, t42, p43, t43, xf17, t36)
- (p37, t37, xf18, t46, p47, t47, xf11, t36)

xf11, xf12, xf13, xf14, xf15, xf16, xf17 and xf18 are 8 free status places for X1.

Let us put one token in each of the 4 shared space status circuits. If there are tokens in p33 or p37 (p43 or p47), no token can enter into p43 or p47 (p33 or p37). By this control, the AIVs are much safer while passing the intersections. The AIVs are intelligent to avoid the collisions between each other on the routes with the same or converse direction, but it is still difficult for AIVs to deal with the location problem while facing AIVs from more than 3 directions (in the intersection point) in the same time. However, the intersection is a highly dynamic and complex environment for AIVs. So, the control on the intersections is necessary for reducing the collision probability of AIVs.

Moreover, the intersection control technique presented here may be extended to the intelligent traffic light control system. The cars on the route can be seen as AIVs, and the passage rule of cars on a crossroads is very similar to the restriction relation of AIVs in the intersection point.

2.4.5 *Ratio-driven task modelling*

For a real transportation task, the number of the containers transited on each route is not obliged to be equal. There is always a known transportation ratio for the different routes.

We suppose that:

- the transit ratio of containers on route i is given by r_i with, $\sum r_i = 1$,
- there exists a set of positive integers f_i with no common divisor greater than 1 and such that $r_i = f_i / \sum f_i$.

There are two modelling techniques to model the ratio-driven task, Hillion-like method and Ohl-like method.

2.4.5.1 **The Hillion-like modelling technique**

In (Hillion and Proth, 1989), a method to model the ratio-driven job shop system is presented. Their work is based on T-timed event graphs. The main idea of (Hillion and Proth, 1989) is to make the f_i same process circuits in parallel, and to connect the all the process circuits with shared machines.

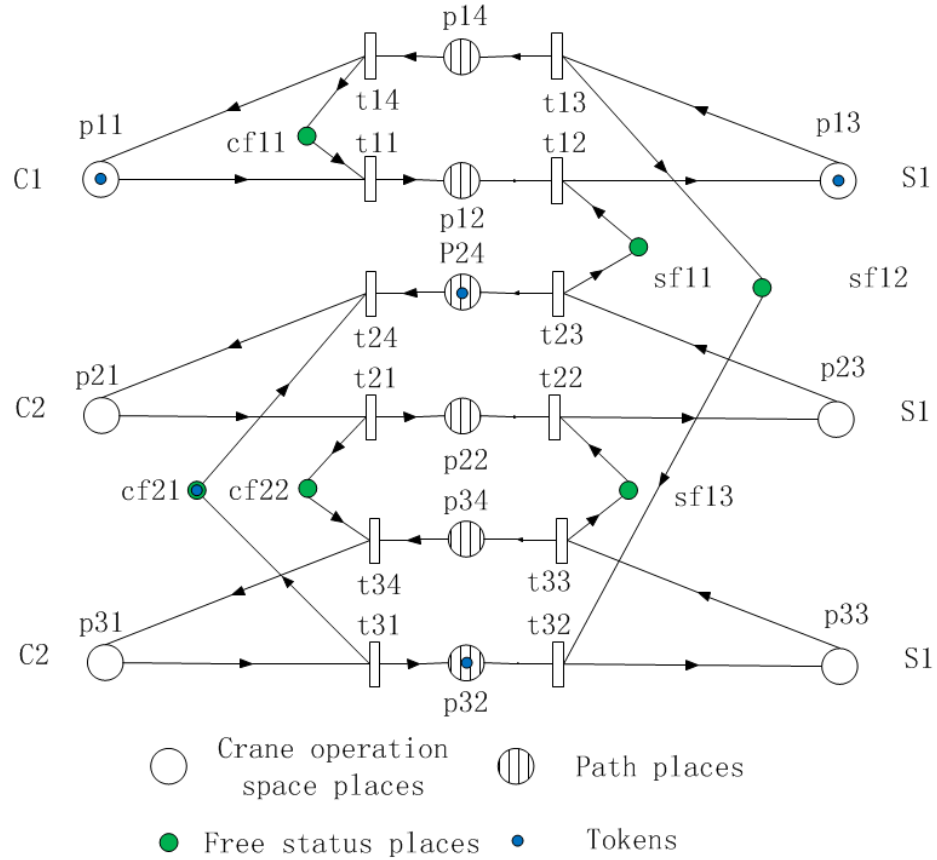

Figure 2.8: A Hillion-like method to model ratio-driven task

In this paper, our work is based on P-time event graphs. However, the idea is the same. Figure 2.8 shows an example using Hillion-like method to model ratio-driven cyclic task. We suppose the container transit task ratio on routes C1-S1 and C2-S1 is 1:2.

We give one process circuit standing for route C1-S1,

$$G_1: (p_{11}, t_{11}, p_{12}, t_{12}, p_{13}, t_{13}, p_{14}, t_{14}),$$

and two process circuits standing for route C2-S1,

$$G_2: (p_{21}, t_{21}, p_{22}, t_{22}, p_{23}, t_{23}, p_{24}, t_{24}),$$

$$G_3: (p_{31}, t_{31}, p_{32}, t_{31}, p_{33}, t_{33}, p_{34}, t_{34}).$$

PTSCEG Modeling Techniques

The three process circuits G_1 , G_2 and G_3 are connected by the shared space status circuits: (p13, t13, sf12, t32, p33, t33, sf13, t22, p23, t23, sf11, t12) and (p21, t21, cf22, t34, p31, t31, cf21, t24).

G_3 is just a repeat of G_2 , and all the process circuits are connected into parallel type. By this kind of modeling, per cycle time, one container can be transited on route C1-S1, and two containers can be transited on route C2-S1.

2.4.5.2 The OHL-like modelling technique

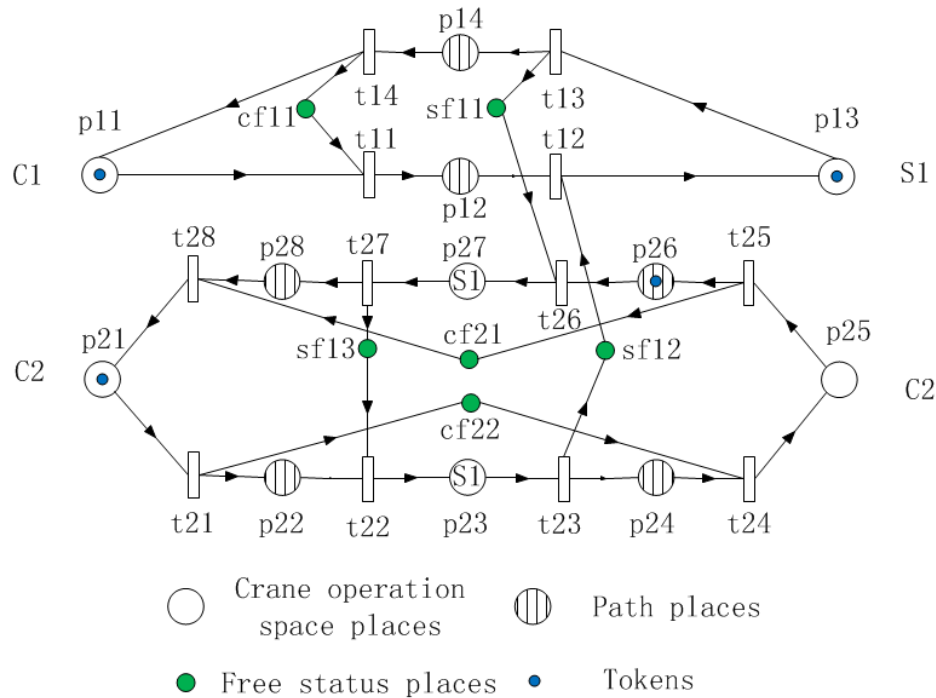

Figure 2.9: An OHL-like method to model the ratio-driven task.

In (Ohl et al., 1995), the authors gave a new modelling technique for the ratio-driven job-shop problems. Their work is also based on T-timed event graphs. The main idea in (Ohl et al., 1995) is to make the f_i same process circuits in series, and to connect the all the process circuits with shared machines.

We apply this idea on the PTSCEG model, as shown in Figure 2.9.

The route C1-S1 is expressed by one process circuit,

G_1 : (p11,t11, p12, t12, p13, t13, p14, t14).

PTSCEG Modeling Techniques

And the route C2-S1 is expressed by one process circuit repeating twice the container transit procedures in series,

G_2 : (p21, t21, p22, t22, p23, t23, p24, t24, p25, t25, p26, t26, p27, t27, p28, t28).

The two process circuits G_1 and G_2 are connected by the shared space status circuits (p13, t13, sf11, t26, p27, t27, sf13, t22, p23, t23, sf12, t12). By this kind of modeling, we can also realize transporting one container d on route C1-S1 and two containers on route C2-S1 per cycle time. If the cycle time is fixed, the lower bound of token number using OHL-like method is better than the Hillion-like method. The comparison of these two methods will be discussed in section 2.5 of Chapter 2

2.4.6 The complete container transit PTSCEG model

In the above sections, the PTSCEG is used to model the routes, the crane operation spaces, the intersections, the shared operation spaces and the ratio-driven task. Thus, a complete container transit procedure in the sketch map (Figure 2.3) can be expressed by a PTSCEG. Figure 2.10 shows the container transit procedures on 10 routes which are connected by the shared operation spaces.

We suppose that the container transit ratio on each route i is $r_i = 0.1$, $f_i = 1$, for $i=1\dots 10$. In other words, the number of containers transited on each route is equal. The hypothesis for the equal ratio does not lose the generality. Factually, our robust cyclic scheduling techniques are based on a theoretical semantic analysis of PTSCEG. The ratio-driven modelling technique in section 2.4.5 is used for give suitable PTSCEG model for ratio-driven task. Whatever the ratio is, as long as the ratio-driven task can be modelled as PTSCEG, we can apply the robust cyclic scheduling on it.

In the complete PTSCEG container transit model,

G_1 (C1-S1) and G_2 (C2-S1) are connected by the shared space status circuit of the AYC operation space S1,

G_2 (C2-S1) and G_3 (C2-S3) are connected by the shared space status circuit of the QC operation space C2,

G_3 (C2-S3) and G_4 (C3-S2) are connected by the shared space status circuits of the intersection space X1,

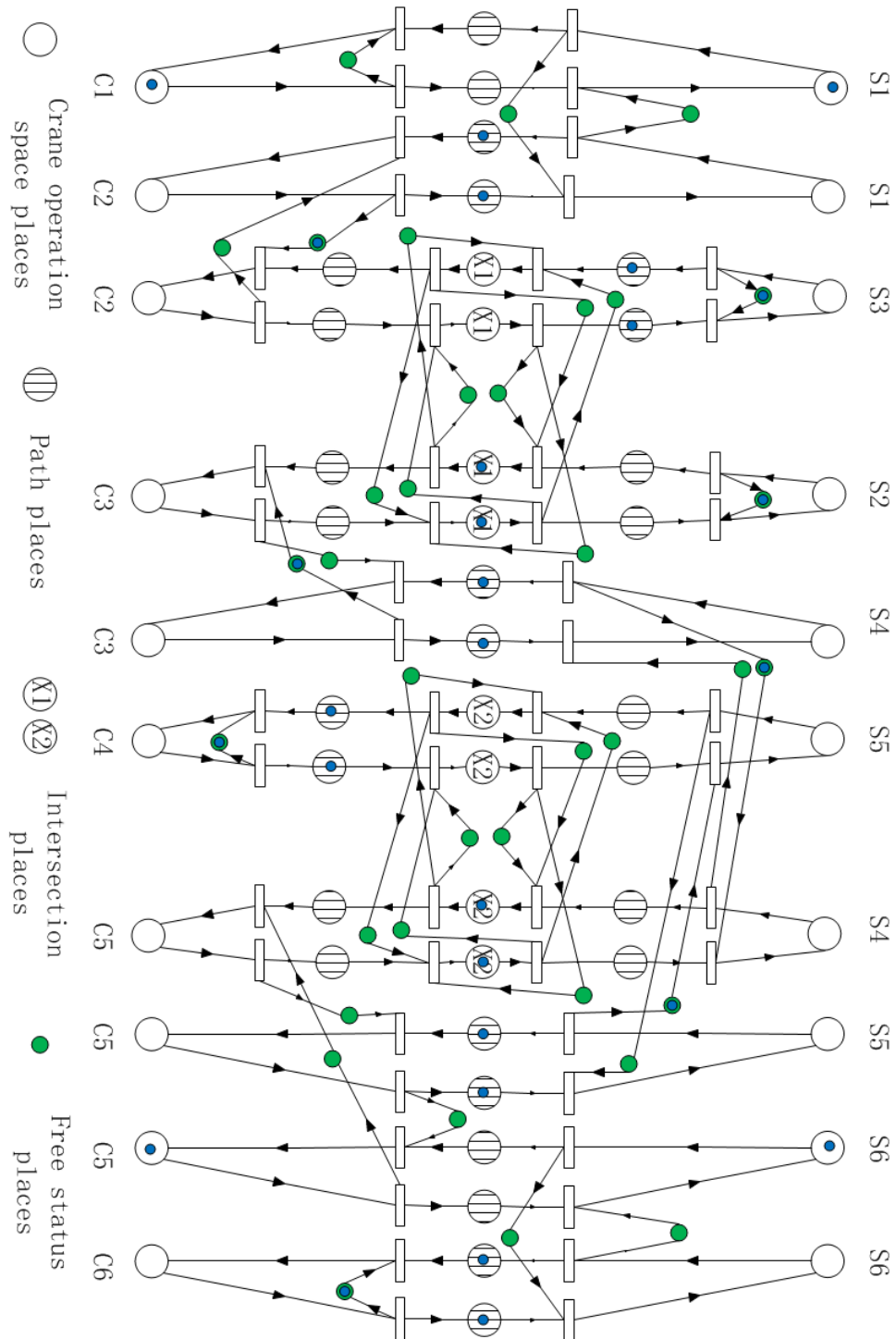

Figure 2.10: The complete PTSCEG model of the import container transit procedures.

PTSCEG Modeling Techniques

G_4 (C3-S2) and G_5 (C3-S4) are connected by the shared space status circuit of the QC operation space C3,

G_5 (C3-S4) and G_7 (C5-S4) are connected by the shared space status circuit of the AYC operation space S4,

G_6 (C4-S5) and G_7 (C5-S4) are connected by the shared space status circuits of the intersection space X2,

G_6 (C4-S5) and G_8 (C5-S5) are connected by the shared space status circuit of the AYC operation space S5,

G_7 (C5-S4), G_8 (C5-S5) and G_9 (C5-S6) are connected by the shared space status circuit of the QC operation space C5,

G_9 (C5-S6) and G_{10} (C6-S6) are connected by the shared space status circuit of the AYC operation space S6.

From the modelling steps, it is noticed that the PTSCEG has some advantages, such as,

- it captures the precedence relations of the operations,
- it avoid the conflicts of the use of the shared resources,
- it avoid the confusion of the AIVs to choose the routes,
- the time windows can be modelled easily,
- the space capacity can be modelled easily.

Moreover, the PTSCEG has a well-developed mathematical and practical foundation, and the lower or upper bound of the cycle time or the number of the tokens in process circuits can be given by the special properties of PTSCEG.

These advantages will be very useful in the work for the MIP modelling and the robust control technique. The section 2.5 will present the cutting techniques by using the special properties of PTSCEG. And these cutting techniques will be used in Chapter 3 for reducing the research space of MIP mathematical model.

2.5 Cutting techniques

As discussed in the section 1.3.2, the cutting techniques used in (Hillion and Proth, 1989, Bourdeaud'Huy and Korbaa, 2006, Ben Amar et al., 2007, Ben Amar et al., 2010b, Ben Amar et al., 2010a, Ben Amar et al., 2011) are shown, including the lower bound of the cycle time, the upper bound of the cycle time, the lower bound of the WIP number and the upper bound of the WIP number. In their works, the considered examples are the job-shop problems based on T-timed event graph. Thus, the operation time is a fixed duration rather than a changeable time window. And only the operation time on machines is taken into account, the transporting time of products among machines is ignored. But in this thesis, we use the PTSCEG which is a kind of strongly connected event graph with time windows. With PTSCEG, the operation time can be changeable in a time window, and the transporting time can be considered into the modeling. Based on the cutting techniques of T-timed event graph, we introduce some cutting techniques of PTSCEG as the follows.

2.5.1 The bound of the cycle time

In (Khansa et al., 1996b, Khansa et al., 1996a), the authors discussed the interval of the possible cycle time of a PTSCEG. It is known that a PTSCEG can be decomposed into several elementary circuits (see **Definition 2.5**). And each place of the elementary circuit has a time window $[a_{ij}, b_{ij}]$ to bound the sojourn time of tokens in it.

Thus, the cycle time of an elementary circuit G_i is $C_i = \frac{\sum_1^{J_i} q_{ij}}{W_i}$, which is located in the interval $[\frac{\sum_1^{J_i} a_{ij}}{W_i}, \frac{\sum_1^{J_i} b_{ij}}{W_i}]$.

The lower bound of cycle time of G is

$$C^{\min} = \max \left\{ \frac{\sum_1^{J_i} a_{ij}}{W_i} \right\} \quad (2.1)$$

$$\text{s.t. } \cap_i \left[\frac{\sum_1^{J_i} a_{ij}}{W_i}, \frac{\sum_1^{J_i} b_{ij}}{W_i} \right] \neq \emptyset$$

The upper bound of cycle time of G is

$$C^{\max} = \min \left\{ \frac{\sum_1^{J_i} b_{ij}}{W_i} \right\}. \quad (2.2)$$

$$\text{s.t. } \cap_i \left[\frac{\sum_1^{J_i} a_{ij}}{W_i}, \frac{\sum_1^{J_i} b_{ij}}{W_i} \right] \neq \emptyset$$

The lower bound of cycle time is usually used, which stands for the optimal productivity of the manufacturing activities. But the upper bound also makes sense in the real industrial activity. For example, a regular maintenance is given on a production line. We can insert the maintenance by degrading the performance of system with cycle time at least less than the upper bound. If the insert of the maintenance makes the cycle time bigger than the upper bound, then we should stop the system completely. The upper bound of cycle time gives us the worst performance of the system with the most degraded productivity without totally being suspended. However, sometimes, a degraded performance is better than completely stopping the system.

2.5.2 *The bound of tokens with demanded cycle time*

The number of tokens in process circuits has its physical meaning for job-shop problems or container transit procedures. For the job-shop problems in (Hillion and Proth, 1989, Ohl et al., 1995), the number of tokens in the process circuits stands for the number of the pallets for supporting the products. In our work, the number of tokens in the process circuits stands for the number of AIVs. It is always expected to realize the demanded cycle time with the least transport resources. Especially, in the container transit activities, the transport resource AIVs are very expensive. It is really interesting to use less AIVs to do the container stevedoring respecting the demanded delivery time. However, the upper bound of AIVs is not interesting for us, so it is not discussed in this work.

The main idea of (Hillion and Proth, 1989) is to make the same product process circuits in a parallel style, and the idea of (Ohl et al., 1995) is to make the same product process circuits in a series style. The lower bound of token number in (Ohl et al., 1995) is better than the lower bound in (Hillion and Proth, 1989). But all their works are based on T-timed event graph and the operation time can't be changed. We apply their ideas in PTSCEG with some necessary modifications.

For a demanded cycle time C_{demand} , the minimal number of tokens in circuits using Hillion-like method is,

$$B_1 = \sum_{\forall i} \left[\frac{\sum q_{ij}}{C_{\text{demand}}} \right] \cdot f_i \quad (2.3)$$

and the minimal number of tokens in circuits using OHL-like method is,

$$B_2 = \sum_{\forall i} \left[\frac{\sum q_{ij}}{C_{\text{demand}}} \cdot f_i \right] \quad (2.4)$$

Obviously we have $B_2 \leq B_1$. It is important to recognize that B_1 and B_2 are two bounds based on exactly the same assumptions about the transport system. The definition of q_{ij} and f_i can be found in the pages 37 and 43.

The cutting techniques in (2.1), (2.2), (2.3) and (2.4) will be used in Chapter 3 for reducing the researching space or reducing the computing time of Mixed Integer Programming (MIP) models.

2.6 Conclusion

In this chapter, for the container transit procedures, it is demonstrated that the PTSCEG can well model the time windows, the routes, the shared crane operation space, the intersections, and the ratio-driven task. Compared to the job-shop problems which appear in many articles (Collart-Dutilleul et al., 2007, Mhalla et al., 2008, Jerbi et al., 2009, Collart-Dutilleul et al., 2013, Mhalla et al., 2013a, Mhalla et al., 2013b), the PTSCEG is firstly used to model container transit in this thesis. As each place in PTSCEG has just one input arc and one output arc, there is no conflict. So, for the AIV staying in a confined space or on the route, there is no choice confusion for entering the next space, which implies the control complexity of the AIV group is reduced by the inherent property of event graph.

Moreover, the bound of cycle time and token number can be given for a PTSCEG model, which can be used as cutting techniques in the Chapter 3. The cycle time is the inverse of productivity, and the token number in the process circuits stands

PTSCEG Modeling Techniques

for the AIV number. In Chapter 3 , two objective functions will be given for the MIP model. One is to minimize the cycle time to realize the maximal productivity, and the other is to minimize the token number to reduce the AIV group control complexity and energy cost.

The PTSCEG container transit model given in this chapter is also a graphical base for the MIP mathematical model and the robust control algorithms. This complete model is often mentioned in the following chapters.

Chapter 3 Mixed Integer Programming (MIP)

modeling techniques for cyclic scheduling

In Chapter 2, the container transit PTSCEG modeling technique is presented. In a PTSCEG model, two kinds of elementary circuits exist, process circuit and space status circuit. The close loop (the elementary circuit) guarantees an inherent advantage to describe the cyclic scheduling. As the cyclic scheduling is NP-hard, the heuristic methods are used in many researches. But the heuristic methods may lead a long computing time and non-optimal solutions. Here, we introduce a simpler but efficient method to model and compute the 1-cyclic schedule. Based on the structure of the PTSCEG model, the MIP is used to describe the activities of tokens in one cycle time. Then, the constraints are programmed directly in CPLEX for cyclic scheduling. This method avoids the heavy workload of heuristic programming. For scheduling the container task in a medium sized container terminal, this method may be more acceptable for the technicians and manager of seaport. The transient period of cyclic scheduling is neglected considering the very short time compared with the steady state of cyclic schedule.

This chapter concentrates on the MIP modeling techniques for 1-cyclic scheduling of container transit procedures in a medium sized seaport. Since the operations executed on the machines of 1-cyclic scheduling repeat once per cycle time, so it needs just to study the constraints for the operations in one cycle time without losing the generality. Firstly, the constraint families for different kinds of places are presented. Then, the complete MIP models for minimizing the cycle time and the token number are given. Thirdly, based on the given time windows for each place in the complete PTSCEG model, the expected sojourn time within time windows for the cyclic schedule is achieved by MIP models with cutting techniques. The efficiency of the cutting techniques is also discussed in this chapter.

3.1 The constraint family explanation

In the Chapter 2 , the container transit process is modeled by PTSCEG. This kind of model can clearly present the precedence relations of operations in the container transit process, and can easily model the time windows. Based on the PTSCEG model, in this chapter, the MIP mathematical model is used to calculate the expected sojourn time in time windows. For 1-cyclic scheduling, the activities are repetitive in one cycle time C . So it just needs to study the processing activities in one cycle time instead of considering the activities in the whole production period. However, the computing time of a schedule in one cycle time C is much smaller than a schedule for the whole production period. Thus, the expected sojourn time can be computed in a short time. Three kinds of constraint families are presented here: general constrains for all the places; constraints of places in the process circuits; constraints of places in the shared space status circuits.

The notions used in this chapter is exactly the same as given in the section 2.3 .

- G : the PTSCEG model
- G_i : i th elementary circuit represents the process circuit or the space status circuit, $i \in \mathbb{N}^+$
- p_{ij} : j th place of G_i , the places stand for the operation space of QCs, AYCs, the intersections, the paths, and the free status of a shared space $j \in \mathbb{N}^+$
- t_{ij} : j th transition of G_i
- ${}^{\circ}p_{ij}({}^{\circ}p_{ij}^{\circ})$: the input (output) transition of p_{ij}
- V_{il} : the l th token for G_i , $l \in \mathbb{N}^+$
- s_{ij} : entering date of one token in p_{ij} , $s_{ij} \geq 0$
- q_{ij} : the sojourn time of one token in p_{ij} , $q_{ij} \geq 0$
- q_{ij}^e : the expected sojourn time of tokens to realize the demanded cycle time of system, $q_{ij}^e \geq 0$

- a_{ij} : the lower bound of q_{ij} , $a_{ij} \geq 0$
- b_{ij} : the upper bound of q_{ij} , $b_{ij} \geq 0$
- W : total number of tokens in G , $W \in \mathbb{N}^+$
- W_i : the number of tokens in G_i , $W_i \in \mathbb{N}^+$
- W^{limit} : the limit number of tokens in G , $W^{\text{limit}} \in \mathbb{N}^+$
- W_i^{limit} : the limit number of tokens in G_i , $W_i^{\text{limit}} \in \mathbb{N}^+$
- C : variable stands for cycle time of G , $C > 0$
- C_i : variable stands for cycle time of circuit G_i , $C_i > 0$
- C^{min} : the minimal cycle time of G , $C^{\text{min}} > 0$
- C^{max} : the maximal cycle time of G , $C^{\text{max}} > 0$
- I : $I = \max \{i\}$, the number of G_i
- J_i : number of places of G_i
- β_{ij} : Boolean variable
- $\gamma_{ij}^{i,j}$: Boolean variable

3.1.1 Constraints on all the places

Since the model is a PTSCEG, a time window $[a_{ij}, b_{ij}]$ should be assigned on every place p_{ij} . The a_{ij} is the lower bound of the sojourn time of tokens, and b_{ij} is the upper bound. In an elementary circuit G_i of G , p_{ij} is the j th place, and q_{ij} is the sojourn time of tokens in p_{ij} . The q_{ij} in the place p_{ij} is taken into account in transition validation when it has stayed in p_{ij} for duration of at least a_{ij} and at most b_{ij} . After the duration b_{ij} the token will be dead. The constraint family (3.1) describes the semantic definition of PTSCEG.

MIP Modeling Techniques

$$a_{ij} \leq q_{ij} \leq b_{ij} \tag{3.1}$$

Let us take the activities of tokens in elementary circuit G_2 as an example. $C2$ is its first place. $G_2 : (p21, t21, p22, t22, p23, t23, p24, t24)$, it is presented in Figure 3.1, and the time windows are also given. For each place, let us denote $[a_{ij}, b_{ij}]$ the lower bound of the time window, and the upper bound of the time window, respectively.

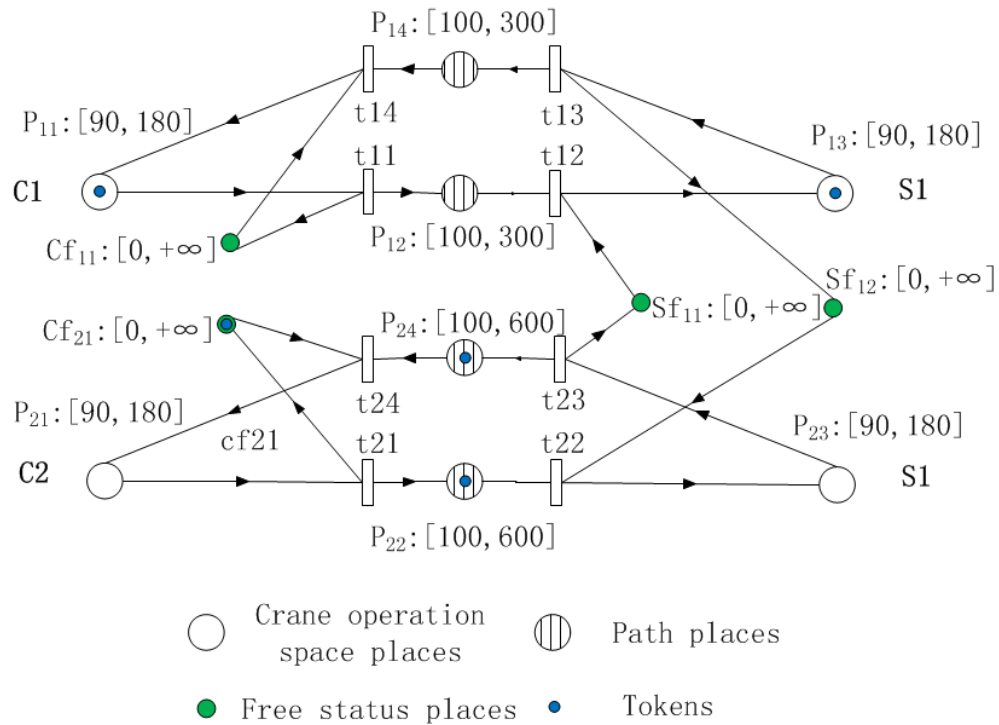

Figure 3.1: A PTSCEG with time windows

As shown in Figure 3.1, two tokens ($t21$ and $t22$) are put into G_2 . It is possible to give a 1-cyclic schedule for the activities of tokens in G_2 by the Gantt chart as shown in Figure 3.2.

In Figure 3.2, the cycle time of G_2 is 270, and all the sojourn time of the two tokens in all the places are located in the relative time windows. For example, the sojourn time of token $V21$ in $P24$ is 145, and it is located in the time window $[100, 300]$.

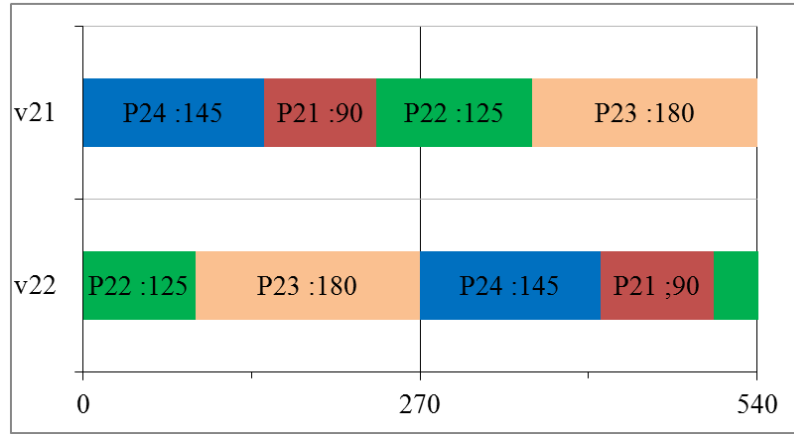

Figure 3.2: The Gantt chart for 1-cyclic schedule in G_2 .

In (1.1), the cyclic scheduling is defined as $x(n+k) = x(n) + k \cdot C$ for $n \in \mathbb{N}, k \in \mathbb{N}^+, C \geq 0$, $x(n)$ is the starting time (or ending time) of one activity, and n means the repeat numbers. In our work, we suppose $k=1$. The cyclic scheduling we study is so called 1-cyclic scheduling. Thus, all the activities of the tokens in the place will repeat one time per cycle time C . So it just needs to study the processing activities in one cycle time instead of considering the activities in the whole production make-span. Thus, the constraint family (3.2) can be given as follows,

$$0 \leq s_{ij} < C \quad (3.2)$$

To explain constraint family (3.2), let us also take the activities of tokens in elementary circuit G_2 as an example. This constraint family means that the arriving time of one token in a place is located in $[0, C)$. As shown in Figure 3.3, the cycle time of G_2 is 270. So, the entering time for each place is located in $[0, 270)$.

$$s_{21} = 145 ,$$

$$s_{22} = 235 ,$$

$$s_{23} = 90 ,$$

$$s_{24} = 0 .$$

The constraint families (3.1) and (3.2) should be respected in any place of a PTSCEG, no matter this place is in process circuit or the space status circuits. But

there are still some different special constraints which should be respected individually by the places in different kinds of circuits.

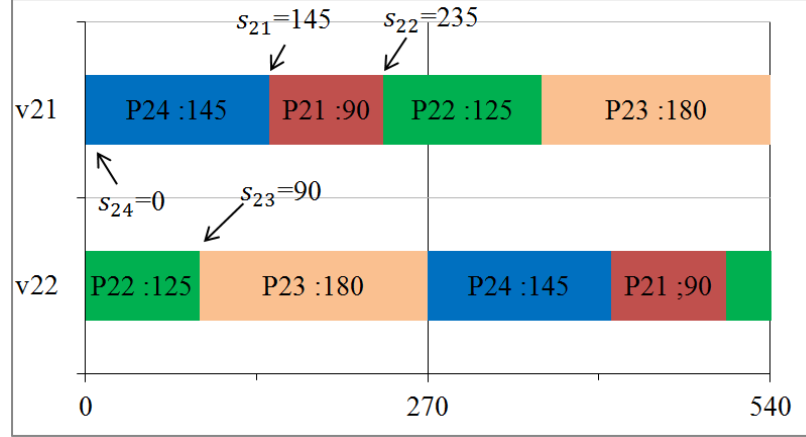

Figure 3.3: The arriving time of tokens in the places.

3.1.2 Constraints on places in the process circuits

$$s_{ij} + q_{ij} - s_{i(j\%J_i+1)} = \beta_{ij} * C \quad (3.3)$$

$$\sum_{i=1}^I \sum_{j=1}^{J_i} \beta_{ij} = W \leq W^{\text{limit}} \quad (3.4)$$

In our example, there are two kinds of elementary circuits: process circuits and space status circuits. Here, we use the activities of tokens in G_2 to explain the constraints of 1-cyclic scheduling for tokens in the process circuits. Two constraint families are given, (3.3) and (3.4). Here, % means the modulus operator, which can connect all the places in the process circuit as a cycle (Bourdeaud'Huy and Korbaa, 2006), while β_{ij} is a Boolean variable.

Constraint family (3.3) gives the precedence constraint of token's sojourn time in two consecutive places. The complementation % in (3.3) connects the two successive places, including the last place and the first place. For example, the following place of p_{24} is p_{21} which can be presented as $p_{2(4\%4+1)}$. And β_{ij} stands for the number of crossed cycles of q_{ij} .

Let us take the activities in p_{23} and p_{24} as an example to explain constraint family (3.3), as shown in Figure 3.4.

$$s_{23} + q_{23} - s_{2(3\%4+1)} = \beta_{23} * C \Leftrightarrow s_{23} + q_{23} - s_{24} = \beta_{23} * C \Rightarrow 90 + 180 - 0 = 1 * 270$$

When the sojourn time in a place crosses one cycle time, it needs to add a token in the circuit to reduce the cycle time. So the sum of β_{ij} is the total number of tokens in the process circuit, as shown in (3.4). For example, in Figure 3.4, there are 2 tokens, v_{21} and v_{22} , and the sum of β_{2j} is $0+0+1+1=2$. However, the total number of tokens should be less than the limited number of tokens. In other words, the number of used AIVs in system should be less than the number of all the AIVs.

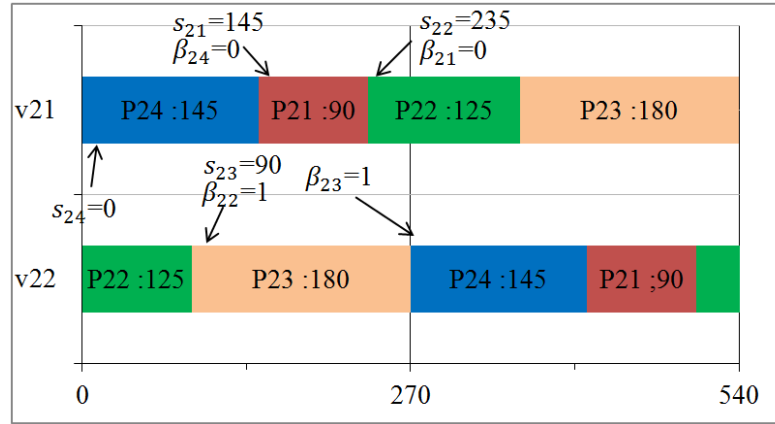

Figure 3.4: Boolean variable β_{ij} determines the tokens number.

3.1.3 Constraints on places in the space status circuits

In the above section 3.1.2, we have discussed the constraint families about the sojourn time and the arriving time of tokens in the process circuits in just one cycle time C . In this section, the constraint families about the activities of tokens in the space status circuits are studied.

In a PTSCEG model as shown in Figure 3.1, there are two kinds of space status circuits, one kind is the non-shared space status circuit, and the other kind is the shared space status circuit. In Figure 3.1, $(p_{11}, t_{11}, cf_{11}, t_{14})$ and $(p_{21}, t_{21}, cf_{21}, t_{24})$ are two non-shared space status circuit, and $(p_{13}, t_{13}, sf_{12}, t_{22}, p_{23}, t_{23}, sf_{11}, t_{12})$ is a shared space status circuit for process circuits G_1 and G_2 .

Normally, the non-shared space status circuit only control the capacity of the space place, but the shared space status circuit can also control the use assignment of the shared space. The constraint families of the different space status circuits are also different.

3.1.3.1 Constraint families in the non-shared space status circuits

In the non-shared space status circuits, the space is just used by one path, so there is no conflict for using the space. The constraints for the tokens in this kind of circuits are just the same as the constraints (3.3) and (3.4) in the process circuits. For example, after the unloading or uploading work, the crane should stay in the free status, after a while, it does the unloading/uploading again in a busy status. The two statuses are connected as a cycle just as expressed in (3.3). For the non-shared space place (non-shared QCs or non-shared AYC) in the complete seaport PTSCEG model as shown in Figure 2.10, the capacity is 1, so the number of the token is given as 1. The constraint family (3.4) can be changed as follows,

$$\sum_1^{J_i} \beta_{ij} = 1 \quad (3.5)$$

For example, in (p21, t21, cf21, t24), it is possible to give a 1-cyclic schedule by the Gantt chart as shown in Figure 3.5,

for constraint family (3.3), $s_{p21} + q_{p21} - s_{cf21} = \beta_{p21} * C \Rightarrow 145 + 90 - 235 = 0 * 270$,

$$s_{cf21} + q_{cf21} - s_{p21} = \beta_{cf21} * C \Rightarrow 235 + 180 - 145 = 1 * 270$$

,

for constraint family (3.5), $\beta_{cf21} + \beta_{p21} = 1 \Rightarrow 1 + 0 = 1$.

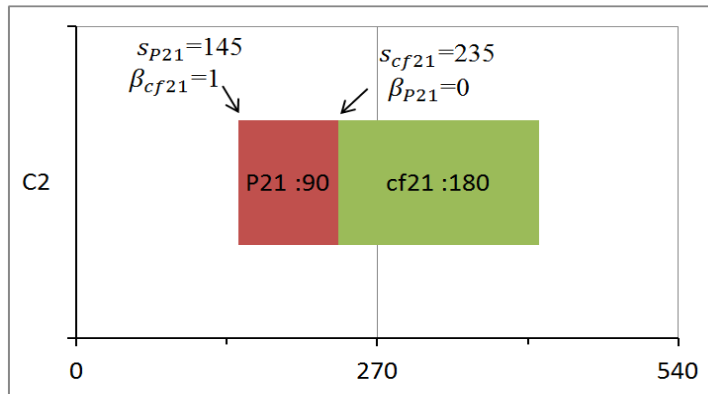

Figure 3.5: 1-cyclic schedule of the token in non-shared space status circuits.

3.1.3.2 Constraint families in the shared space status circuits

It should be noticed that, if a space place is just shared by two process circuits, then, the constraint families (3.3) and (3.5) are still suitable to determine the activities of the token in the shared space status circuit. Let us take the shared space circuit of S1 (p13, t13, sf12, t22, p23, t23, sf11, t12) as an example. As shown in Figure 3.6, (p13, sf12, p23, sf11) or (p23, sf11, p13, sf12) are the same cycle, and the constraint families (3.3) and (3.5) can be well applied to determine the 1-cyclic schedule of the token in this circuit.

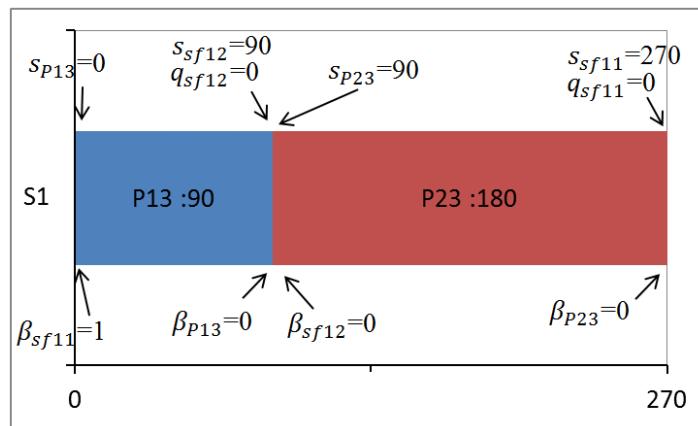

Figure 3.6: 1-cyclic schedule in the shared space status circuit of S1.

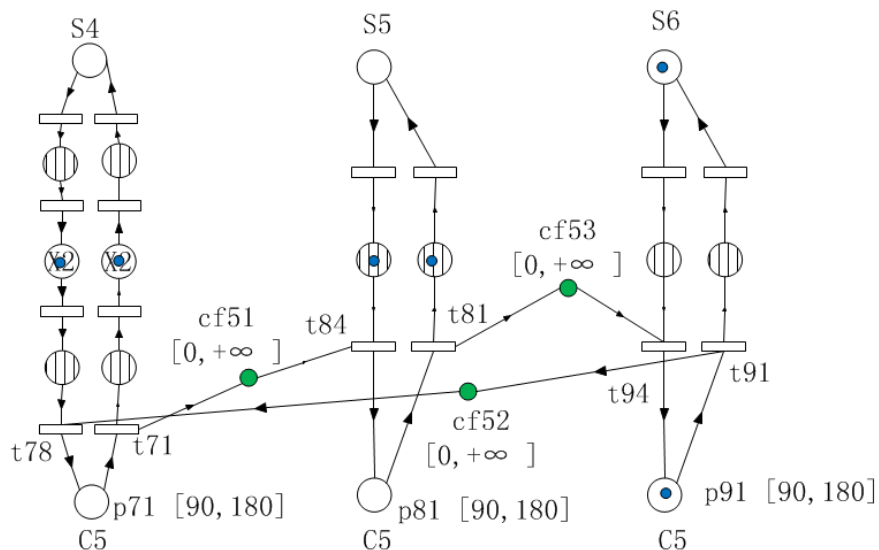

Figure 3.7: The shared space status circuit of C5

But if the space place is shared by more than two process circuits, the constraint families (3.3) and (3.5) lose the generality. Let us take the shared space C5 as an example, as shown in Figure 3.7. It is a part of the complete PTSCEG model in Figure 2.10. The space C5 is shared by three process circuits, $G_7(C5 \Leftrightarrow S4)$, $G_8(C5 \Leftrightarrow S5)$ and $G_9(C5 \Leftrightarrow S6)$. The cycle (p71, p81, p91) as shown in the figure is different with the cycle (p71, p91, p81). However, the cycle (p71, p81, p91) and the (p71, p91, p81) are both two possible solutions to optimize the 1-cyclic schedule. It is not reasonable to use only one possible space status cycle to optimize the cycle time. The order to use the space C5 for different process circuits should be a degree of freedom. The constraint families (3.3) and (3.5) can only be applied to a given cycle, but they are not suitable for a cycle in which the order of the places is not fixed.

$$s_{ij} + q_{ij} + a_{ij}^f - s_{i'j'} \leq \gamma_{ij}^{i'j'} * C \quad (3.6)$$

$$s_{i'j'} + q_{i'j'} + a_{i'j'}^f - s_{ij} \leq (1 - \gamma_{ij}^{i'j'}) * C \quad (3.7)$$

Constraint families (3.6) and (3.7) present the no overlap relation of the operations in places p_{ij} and $p_{i'j'}$ which stand for the same shared space busy status. The shared space can only be used by at most one process circuit at any moment. $\gamma_{ij}^{i'j'}$ is a Boolean variable. a_{ij}^f is the lower bound of the free status after the operation in p_{ij} . It is should be noticed that the time window of the free status of cranes is $[0, +\infty]$ as shown in Figure 3.7. So the sojourn time of token in P71 and P81, P81 and p91, P91 and P71 can be connected directly, if the sojourn time in free status place equals 0.

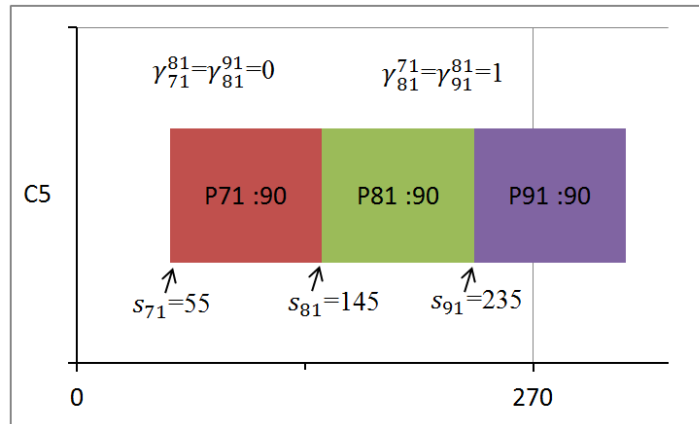

Figure 3.8: 1-cyclic schedule of the token in the shared space circuit of C5.

In Figure 3.8, a possible 1-cyclic schedule of the token in the shared space status circuit of C5 is given. Let us take P71 and P81 as an example.

$$\gamma_{71}^{81} = 0, \gamma_{81}^{71} = 1, a_{71}^f = 0, a_{81}^f = 0$$

$$s_{71} + q_{71} + a_{71}^f - s_{81} = 55 + 90 + 0 - 145 = 0 \leq 0 * C$$

$$s_{81} + q_{81} + a_{81}^f - s_{71} = 145 + 90 + 0 - 55 = 180 \leq (1 - 0) * C$$

Some constraint families similar with (3.6) and (3.7) have been discussed in (Seo and Lee, 2002) and (Bourdeaud'Huy and Korbaa, 2006). But in their works, the problems are modeled as timed Petri nets and the sojourn time of tokens q_{ij} can't be changed. In our work, the sojourn time q_{ij} is changeable in a time window $[a_{ij}, b_{ij}]$, which is more flexible than the work in (Seo and Lee, 2002) and (Bourdeaud'Huy and Korbaa, 2006). Their work is not adaptable for our container transit procedures with time windows and changeable operation durations.

3.2 The complete MIP models

In the above section 3.1, the necessary constraints for 1-cyclic schedule have been given. The objective functions are also important for a complete MIP model. In the seaport container transit procedure, the number of the AIVs is limited, the capacity of resources (crane operation space and intersections of crossing routes) is limited, and the processing time is bounded (the time window). With these limitations, for a transit procedure manager, the minimal cycle time (the reciprocal of maximal productivity) is a very important criterion to evaluate the performance of system. One single container transit can be finished in each process circuit (the routes) per cycle time. The smaller the cycle time is, the sooner the transit job can be finished, hence the better we can guarantee the delivery time of containers for their following destinations. So the first objective function is to minimize the cycle time.

Obj 1: Minimize (C).

But sometimes, the admissible solution is not unique, that means it exists more than one 1-cyclic schedule for AIVs to finish the job with the optimal cycle time. At this situation, for the manager of the container transit, it is more interesting to finish the job with less AIVs. The less AIVs we use, the less complex to control the AIVs

group it is. The free AIVs can be also seen as the reserve force to replace the used AIVs with unpredictable breakdown. Moreover, considering the objectives of In-TraDE project, it improves the clean production because we use as few AIV as we can to finish the task with less energy cost whilst respecting the optimal cycle time. So the second objective function is to minimize the used AIVs while respecting the optimal cycle time.

Obj 2: Minimize ($\sum W_i$), with G_i is a process circuit.

Based on the two objective functions, it is possible to give two kinds of MIP models. One is the MIP model which aims to minimize the cycle time with the limited transport resources. The other one is the MIP model which aims to minimize the AIVs number, when there are more than one admissible solution with the overall optimal cycle time.

3.2.1 The MIP model for minimizing the cycle time

Minimize : C s.t.

$$\forall i \in [1, I], \forall j \in [1, J_i],$$

$$a_{ij} \leq q_{ij} \leq b_{ij} \tag{3.8}$$

$$0 \leq s_{ij} < C \tag{3.9}$$

G_i is a process circuit or a non-shared space status circuit,

$$s_{ij} + q_{ij} - s_{i(j \% J_i + 1)} = \beta_{ij} * C \tag{3.10}$$

G_i are the process circuits,

$$\sum_{i=1}^I \sum_{j=1}^{J_i} \beta_{ij} = W \leq W^{\text{limit}} \quad (3.11)$$

.....

G_i is a non-shared space status circuit,

$$\sum_{j=1}^{J_i} \beta_{ij} = 1 \quad (3.12)$$

.....

G_i is a shared space status circuit,

$$s_{ij} + q_{ij} - s_{i'j'} \leq \gamma_{ij}^{i'j'} * C \quad (3.13)$$

$$s_{i'j'} + q_{i'j'} - s_{ij} \leq (1 - \gamma_{ij}^{i'j'}) * C \quad (3.14)$$

.....

In the above MIP model, we suppose the lower bound of the free status of shared space is zero. So the a_{ij}^f is neglected in (3.13) and (3.14).

And for the process circuits and the non-shared space status circuits, they use the same constraint family (3.10) to determine the arriving time and sojourn time of tokens. But they use the different constraint families to determine the token numbers in these circuits. For the process circuits, (3.11) implies that the number of the used AIVs on all the routes should be less than the number of all the AIVs. The number of AIVs on the single route is not very interesting for the manager of container transit. For each non-shared crane operation space circuit, the capacity to receive AIV should be 1 just as expressed in (3.12).

3.2.1.1 Lower bound of cycle time

The lower bound of the cycle time can directly referred to (2.1) as,

$$C \geq C^{\min} = \max \left\{ \frac{\sum_{i=1}^{J_i} a_{ij}}{W_i} \right\} \quad (3.15)$$

The upper bound of the cycle time can directly referred to (2.2) as,

$$C \leq C^{\max} = \min \left\{ \frac{\sum_1^{J_i} b_{ij}}{W_i} \right\} \quad (3.16)$$

3.2.1.2 The constraint number analysis

From (3.8) to (3.14), we have 7 constraint families.

Let us denote n the number of places in process circuits, h the number of the non-shared status circuits, and m the number of shared spaces, and l_m the number of process circuits which share the m^{th} space.

In total, the previous model contains:

- $2(n+h)+1$ integer variables,
- $n + 2h + \sum_1^m \frac{l_m(l_m-1)}{2}$ Boolean variables,
- $3(n+2h) + 3 + \sum_1^m l_m(l_m-1)$ constraints.

3.2.2 The MIP model for minimizing the token number

If the optimal cycle time is found with more than one solution, the second objective function should be considered to minimize the number of used AIVs.

$$\text{Minimize: } \sum_1^I \sum_1^{J_i} \beta_{ij}, \text{ with } G_i \text{ is a process circuit, s.t.}$$

$$\forall i \in [1, I], \forall j \in [1, J_i],$$

$$a_{ij} \leq q_{ij} \leq b_{ij} \quad (3.17)$$

$$0 \leq s_{ij} < C^{\min} \quad (3.18)$$

G_i is a process circuit or a non-shared space status circuit,

$$s_{ij} + q_{ij} - s_{i(j \% J_i + 1)} = \beta_{ij} * C^{\min} \quad (3.19)$$

.....

G_i is a non-shared space status circuit,

$$\sum_1^{J_i} \beta_{ij} = 1 \quad (3.20)$$

.....

G_i is a shared space status circuit,

$$s_{ij} + q_{ij} - s_{i'j'} \leq \gamma_{ij}^{i'j'} * C^{\min} \quad (3.21)$$

$$s_{i'j'} + q_{i'j'} - s_{ij} \leq (1 - \gamma_{ij}^{i'j'}) * C^{\min} \quad (3.22)$$

.....

In this model, the cycle time is not a variable, but a constant integer. C^{\min} is the optimal cycle time obtained by MIP model in section 3.2.1. And the object is to minimize the token number in the process circuits which stands for the AIV number.

3.2.2.1 Lower bound of token number

The lower bound of the number of token can directly referred to (2.4), as

$$\sum_1^I \sum_1^{J_i} \beta_{ij} \geq \sum_{\forall i} \left[\frac{\sum a_{ij}}{C^{\min}} \cdot f_i \right], \text{ with } G_i \text{ is a process circuit} \quad (3.23)$$

If we consider the example in Figure 2.10, f_i equals 1 for all the process circuits. Each path has the same task ratio $r_i = 0.1$. On each route, the transit rate of containers per cycle time is the same.

3.2.2.2 The constraint number analysis

Form (3.17) to (3.22), we have 6 constraint families.

MIP Modeling Techniques

Let us denote n the number of places in process circuits, h the number of the non-shared status circuits, and m the number of shared spaces, and l_m the number of process circuits which share the m^{th} space.

In total, the previous model contains:

- $2(n + h)$ integer variables,
- $n + 2h + \sum_1^m \frac{l_m(l_m - 1)}{2}$ Boolean variables,
- $3(n + 2h) + 1 + \sum_1^m l_m(l_m - 1)$ constraints.

3.3 Case study of the seaport container transit

Table 3.1. Time windows of places in process circuits

Circuits without intersections	Time windows							
$G_1(C1 \leftrightarrow S1)$	$p_{11}[90,180]$	$p_{12}[90,300]$	$p_{13}[90,180]$					$p_{14}[100,300]$
$G_2(C2 \leftrightarrow S1)$	$p_{21}[90,180]$	$p_{22}[90,600]$	$p_{23}[90,180]$					$p_{24}[100,600]$
$G_5(C3 \leftrightarrow S4)$	$p_{51}[90,180]$	$p_{52}[90,400]$	$p_{53}[90,180]$					$p_{54}[100,400]$
$G_8(C5 \leftrightarrow S5)$	$p_{81}[90,180]$	$p_{82}[90,600]$	$p_{83}[90,180]$					$p_{84}[100,600]$
$G_9(C5 \leftrightarrow S6)$	$p_{91}[90,180]$	$p_{92}[90,500]$	$p_{93}[90,180]$					$p_{94}[100,500]$
$G_{10}(C6 \leftrightarrow S6)$	$p_{101}[90,180]$	$p_{102}[90,600]$	$p_{103}[90,180]$					$p_{104}[100,600]$
Circuits with intersections	Time windows							
$G_3(C2 \leftrightarrow S3)$	p_{31} [90,180]	p_{32} [50,300]	p_{33} [5,10]	p_{34} [50,300]	p_{35} [90,180]	p_{36} [50,300]	p_{37} [5,10]	p_{38} [50,300]
$G_4(C3 \leftrightarrow S2)$	p_{41} [90,180]	p_{42} [50,280]	p_{43} [5,10]	p_{44} [50,280]	p_{45} [90,180]	p_{46} [50,280]	p_{47} [5,10]	p_{48} [50,280]
$G_6(C4 \leftrightarrow S5)$	p_{61} [90,180]	p_{62} [50,300]	p_{63} [5,10]	p_{64} [50,300]	p_{65} [90,180]	p_{66} [50,300]	p_{67} [5,10]	p_{68} [50,300]
$G_7(C5 \leftrightarrow S4)$	p_{71} [90,180]	p_{72} [50,270]	p_{73} [5,10]	p_{74} [50,270]	p_{75} [90,180]	p_{76} [50,270]	p_{77} [5,10]	p_{78} [50,270]

Let us apply the MIP models on the example shown in Figure 2.10. In a modern container terminal, it takes about 2 minutes for cranes to finish loading or unloading work. So the time window for QCs and AYC's can be set as [90,180] with the unit in seconds. The distance between QCs and AYC's is supposed to be about 500 meters, and the velocity of AIV is 5m/s. The time window for the AIV's to go along the routes

MIP Modeling Techniques

without intersections is $[100, b_{ij}]$. The AIV runs on the path with velocity 5m/s. When it arrives at the end of the segment of one path, it should stay at the end until the shared space is free. And a staying time on one path over more than b_{ij} seconds is not acceptable, and seen as a schedule failure. The value of b_{ij} depends on the emergency of the delivery time of containers. For the paths with intersections, the time window for each path segment is $[50, \frac{b_{ij}}{2}]$, as the intersections are set in the middle of route. And the time window of intersections is $[5,10]$. The time windows of places in process circuits are shown in Table 3.1. The time window for the free status of operation space place is $[0, +\infty]$, which means the cranes or intersections can be used immediately if they are in free status, or they can stay in free status if no AIV is arriving.

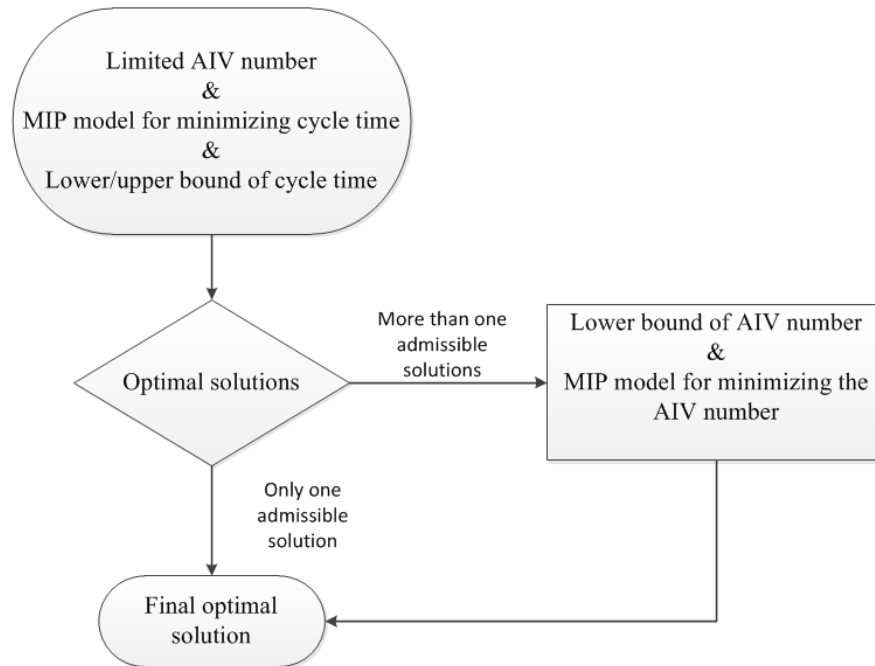

Figure 3.9: The optimization strategy of MIP models.

As shown in Figure 3.9, the strategy to optimize the 1-cyclic schedule is to minimize the cycle time with the limited AIV number. Then, if more than one admissible solution is found, the solution with the least AIV number should be chosen from all the admissible solutions. In our model, each ship has 3000 containers, and 22 AIVs are available to do the unloading work. Our aim is firstly to try to realize an optimal

MIP Modeling Techniques

cycle time, and then we want to use the least number of AIVs (less than 22 AIVs maybe) to realize the optimal cycle time.

Moreover, it is expected that some operation space can be fully used without waiting for the AIVs, which can be referred to the definition of bottleneck machine in the section 1.3.2. In other words, some cranes are saturated without free status, then, the overall maximal productivity is realized. The cyclic time of the system is controlled by the most busy crane status circuits. By the structure analysis of the model in Figure 2.10, the crane C5 can be saturated, and the status circuit of C5 is shared by three process circuits, which gives the lower bound of optimal cycle time which is $90 \times 3 = 270$ seconds.

In this case, for the MIP model minimizing cycle time with limited AIV number, we have: 123 integer variables, 83 Boolean variables, and 215 constraints; for the MIP model minimizing AIV number with optimal cycle time, we have: 122 integer variables, 83 Boolean variables, and 213 constraints. The CPLEX 12.5 is used to make the simulation on a computer with Intel (R) Core (TM) i3-2310M at 2.10 GHz and 4 Go RAM, under Window 7 (64 bit).

In Figure 3.10, Figure 3.11 and Figure 3.12, the 1-cyclic schedules for the AIVs with the optimal cycle time $C=270$ are found, staying in the QCs operation space, in the AYC's operation space and on the routes respectively.

The 20 used AIVs is less than the total 22 AIVs. It is sure that 20 is the minimal number of AIVs to realize optimal cycle time. For example, if just 19 AIVs are used in the schedule, it means one of the 10 routes can use just one AIV. The cycle time on this route is at least $90+100+90+100=380 > 270$ seconds, which is a paradox of the optimal cycle time.

It should be noticed that the computing time of these schedules is about only **2 seconds**. We also apply the MIP models on the job-shop problem discussed in the section 2.1.2. The computing time is only about **0.1 second**.

MIP Modeling Techniques

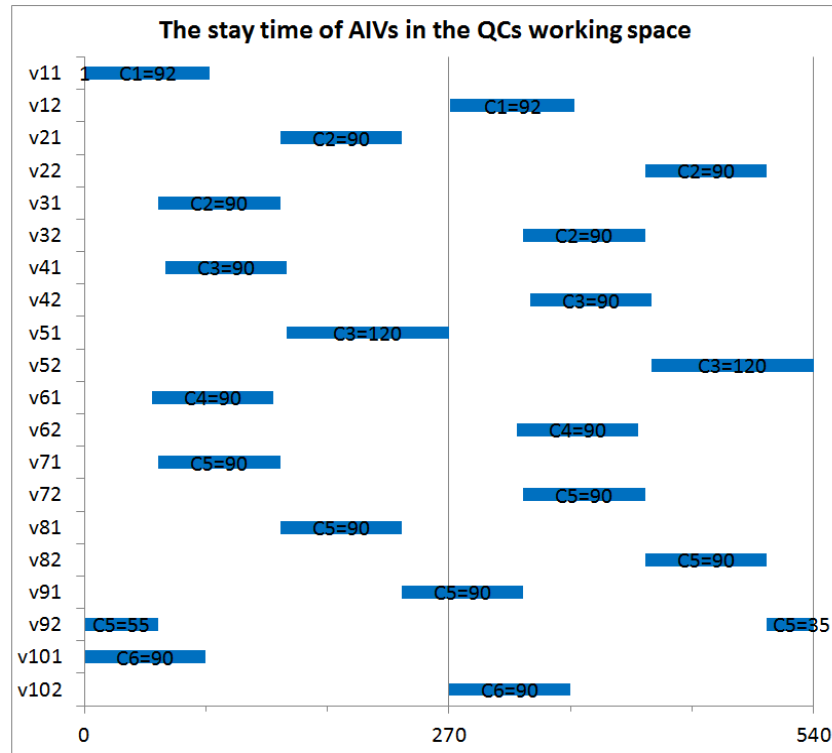

Figure 3.10: The stay time of AIVs in the QCs operation space.

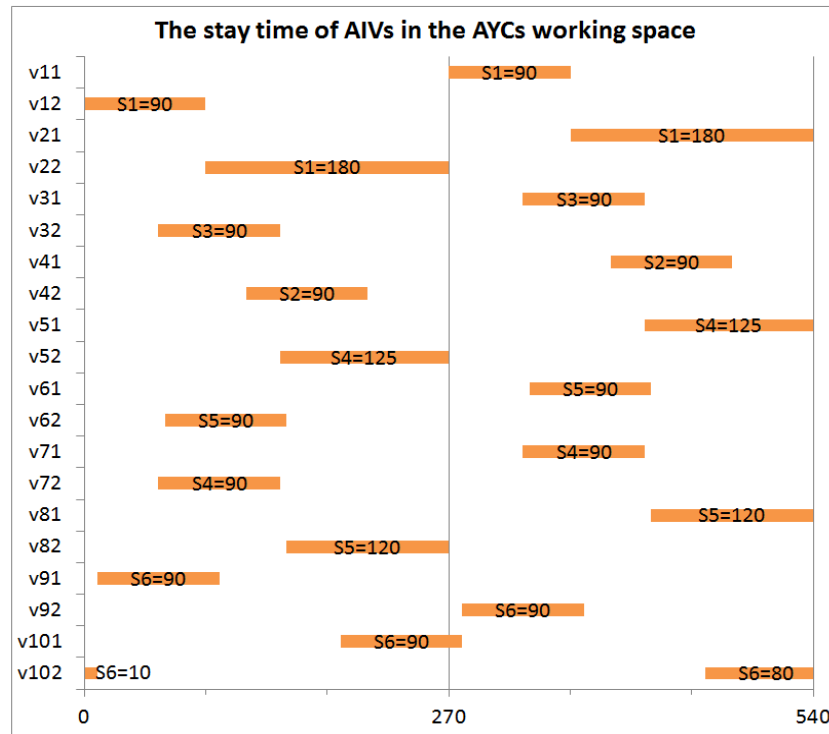

Figure 3.11: The stay time of AIVs in the AYC's operation space.

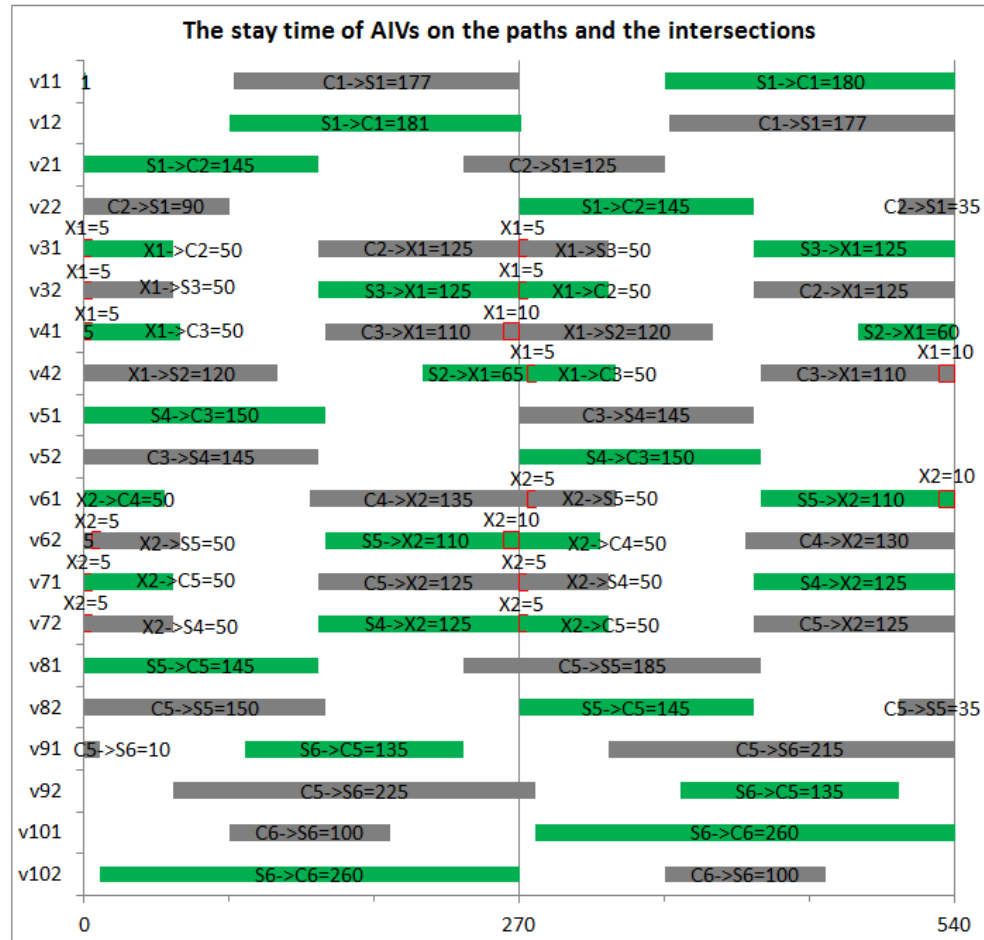

Figure 3.12: The stay time of AIVs in the paths and the intersections.

Normally, all the location places of containers on ships and their stacking place on the yard stacks can be known at least a few hours before the arrival of the vessels. So, it is practical to apply this technique to give a 1-cyclic schedule for the container transit task in advance. It is admitted that the transit routes should not be fixed in the whole unloading period. During the entire transit task, some routes can be eliminated if no more containers are transported to some stacks. If we consider the huge number of containers on a ship, in one or two hours, the routes are fixed, so the 1-cyclic schedule can be applied. Even if the routes are changed during the whole process, just a few seconds are required to give a new cyclic scheduling. However, if we schedule the whole process of unloading, it is possible to give a 1-cyclic schedule class in a short time. The 1-cyclic schedule class is constituted by several 1-cyclic schedules applied to different period of the unloading work with the change of routes.

MIP Modeling Techniques

The very short computational time of the 1-cyclic schedule implies another advantage of the MIP model: if the disturbance in the system is outside of the system's robustness margin, it is possible to reschedule a cyclic work plan in just a few seconds. The running duration of AIVs on routes and operation duration of cranes are in minute time unit. So, the computing time of 1-cyclic scheduling can be neglected. Reasonably, the 1-cyclic scheduling can be used as a reactive scheduling to reschedule in real time. The robustness margin means the range of disturbances which can be rejected by a system's control without changing the actual schedule. More details about active robustness margin are presented in the next chapter.

Table 3.2. Computing time of MIP model

Examples (20 tests for each example)		Route number	AIV number	Average computing time (s)		
				With lower and upper bounds	Without upper bound	Without lower bound
E1	Small or medium sized	3	7	0.072	0.106	0.225
E2		5	15	0.608	0.697	>600
E3		6	17	1.002	1.304	>600
E4		7	19	1.463	1.476	>600
E5		8	20	1.514	28.860	>600
E6		9	21	1.982	>600	>600
E7		10	22	2.001	>600	>600
E8	Large sized	11	23	5.530	>600	>600
E9		12	25	78.870	>600	>600
E10		13	27	>600	>600	>600
E11		14	29	>600	>600	>600
E12		15	31	>600	>600	>600

3.1 Analysis of computing time

Factually, the MIP models are also for different size of container transit task as shown in Table 3.2.

If the container transit task studied is in a container terminal no bigger than a medium size, the above table shows that the 1-cyclic schedule can be quickly found in a few seconds with the lower and upper bounds of the cycle time. For a computing time more than 600 seconds of MIP model without bounds, it is impossible to use the

relative schedule in real time as reactive scheduling, considering the operation duration and AIV running time in also in a few minutes.

Generally, there are three reasons for the efficiency of MIP method for 1-cyclic scheduling:

- The considered example is at most a medium sized seaport, which limit the number of constraints.
- We just need to consider the operations in one cycle time for 1-cyclic scheduling, which reduces obviously the number of constraints compared to non-cyclic scheduling. In the non-cyclic scheduling, we should study the constraints of operations in the whole make-span.
- The lower and upper bound of objective function can be precisely defined for the MIP models because of the inherent property of PTSCEG, which reduces obviously the searching space of the admissible solutions.

3.2 The comparison with other similar models

The models in (Seo and Lee, 2002, Bourdeaud'Huy and Korbaa, 2006, Ben Amar et al., 2010b, Ben Amar et al., 2010a, Ben Amar et al., 2011) are very similar to the seaport container transit model. However, they use examples less complex than the container transit model as shown in Figure 2.10. In their example, the pallets allocated to products are used to transport the job between machines, and the pallets will only be removed from the products after completely finishing the job. The pallets in their papers can be seen as the AIVs, the machines can be seen as the cranes, and the containers can be seen as the products. We improved their work with simplified MIP model structure and shorter computing time in (Zhang et al., 2014). The benchmark is shown in the **Appendices**. But the MIP models in these papers are based on T-timed Petri nets. The operation time of products on the machines is a fixed rational number. The products can stay on the machine until the next needed machine is ready, which implies the product can stay on one machine forever if the next machine is always busy. By the T-timed Petri nets, the time windows of operations can't be appropriately assigned to the relative machine places. And the transportation time of products among the machines are neglected in these works. For the container transit model in this paper, it is not acceptable to let one AIV stay in one place for ever without limited upper time bound. The time windows of operation places and the transportation

MIP Modeling Techniques

duration should be both considered in our MIP models. We add the time window constraints and the transport resource constraints in work of (Zhang et al., 2014), then, the MIP models adaptable to the container transit task are achieved in this chapter.

In (Brucker and Kampmeyer, 2008b), the authors try to give a general MIP model for cyclic job shop with transportation robots. Actually, their model is just for job shop problem of identical jobs and identical machines with only one transport robot. And the applied example is also very simple, with just 3 jobs and 3 machines. In (Brucker et al., 2012), they give a modified MIP model for solving the cyclic job shop problem with transportation. In this modified model, the number of the transport tool is still only one. And they apply this model on an example with 10 jobs and 10 machines. But in our seaport model, it is not reasonable to use only one AIV for the container transportation task. Factually, we have an AIV group. So the models in (Brucker and Kampmeyer, 2008b, Brucker et al., 2012) can't be applied to our seaport model. Unfortunately, the models in (van Oostrum et al., 2008, Mannino et al., 2012, Holte and Mannino, 2013) can't be applied to our seaport model too. They mainly study the health-care problem.

Totally speaking, among the papers about cyclic scheduling in recent years, only the works in (Seo and Lee, 2002, Bourdeaud'Huy and Korbaa, 2006, Ben Amar et al., 2010b, Ben Amar et al., 2010a, Ben Amar et al., 2011, Zhang et al., 2014) are similar to MIP models presented in this chapter. But these MIP models can't be applied to our seaport container transit procedures, because they don't consider the time window constraint of the machines and neglect the transport tools in their MIP models.

So it is impossible to make a benchmark of computing time with other cyclic scheduling methods. But our MIP models still have some special features compared to others,

- Our model includes the time window constraints: the models are based on the semantic property of PTSCEG, and the time windows are assigned to the crane operation space, the path and the intersections;
- Our model considers the transport tool: the AIVs are responsible to transport the containers (not just one transport tool);
- Our model has a good performance to solve the medium sized seaport container transit problem: the computing time is only about 2 seconds.

3.3 Conclusion

This chapter demonstrates that the MIP using CPLEX can be well applied to compute the 1-cyclic schedule of container transit task in a medium sized seaport in a short time. This method can be easily implanted in the real management of AIVs on considering the good compatibility of CPLEX.

The information about the location of container in the vessels and in the yard stacks can be known at least a few hours before the berthing of the vessels by the quays. The MIP modeling technique needs just a few seconds to give a cyclic schedule. So, the MIP modeling technique can be used as a predictable scheduling method to schedule the cyclic container transit a few hours before the stevedoring. When the stevedoring begins, the staying time of AIV on the routes or in the operation space is about a few minutes. So, the computing time of rescheduling by MIP can be neglected if a delay/advance disturbance is observed. The MIP modeling technique can also be seen as a reactive scheduling to reschedule the cyclic schedule in real time if necessary.

The transient period of two cyclic scheduling is very short compared with the steady state of cyclic scheduling. So, in our work, only the steady state is studied, and the readers interested in the transient issues may consult (Bourdeaud'huy et al., 2011, Calvez et al., 1998).

Chapter 4 Robust Control for the 1-cyclic Scheduling

Using the MIP scheduling methods, it is possible to find a 1-cyclic scheduling in short time. Thus, the expected sojourn time of AIVs in each place can be given properly to realize the overall optimal productivity. Accordingly, the robustness algorithms can be applied on the PTSCEG, which is based on the operation of sojourn time and time windows. The algorithms have a computing time in polynomial complexity, which makes it possible to compute the robustness margin on nodes of system in short time as the 1-cyclic schedule is given. When the stevedoring begins, if one disturbance is observed, we compare it with the robustness margin. If it is located in the robustness margin, we can reduce or eliminate the disturbance by the robustness algorithms. Moreover, for giving a better evaluation of the disturbance on all the AIVs in system, a new robustness algorithm is proposed. This algorithm has a structure base in Gantt graph, and its computing time is also polynomial.

This chapter introduces three kinds of robust control algorithms for the 1-cyclic scheduling of container transit task. The first kind and the second are directly based on the structural control of the firing time of transitions in PTSCEG models. The third is based on the control of the operation time of tokens in the Gantt graphs.

This chapter is basically organized as follows. Firstly, the two algorithms based on the structure analysis of PTSCEG are introduced. Then we compare the two algorithms in their computing complexity and the robustness margins. Thirdly, we introduce a new algorithm based on the analysis of operations in Gantt graph. The details about the compensable or transmissible margin of this new algorithm are well defined by formulas. Finally, we compare the advantages and disadvantages of these three algorithms.

4.1 The algorithms based on the control of transitions

The above chapter proposes a 1-cyclic scheduling technique for container transit process in a medium sized seaport. The achieved 1-cyclic schedule can just be applied in an idealized work environment without any disturbance in the system, but the unpredictable disturbances do exist in the real container terminal activities, such as the delay or advance of AIVs or cranes. In this section, we propose algorithms to compute the robust margin of each transition in PTSCEG to avoid the unnecessary alarm due to disturbance which may cause the rescheduling of system. The system can recover to initial normal status if the disturbance belongs to the robustness margin. As presented in the **Introduction** section, all the AIVs and cranes can keep a real time communication with a remote control center. This control center can get the exact position of each AIV by the signal points and can give a control signal to any AIVs or cranes. The signal points can be seen as the transitions in PTSCEG. Thus, for the PTSCEG model, it is reasonably supposed that each transition is observable and controllable. In other words, it is possible to observe and control the sojourn time of each token in any place by the output transition of this place.

4.1.1 Basic notation

Definition 4.1 (Collart-Dutilleul and Craye, 2003): Robustness is defined as the ability of the system to remain valid with respect to the specifications when facing some expected or unexpected variations. Robustness characterizes the global capacity to deal with disturbances.

Definition 4.2 (Jerbi et al., 2004): A mono-synchronized sub-path L_p is a path containing one and only one synchronization, which is its last node.

Definition 4.3 (Jerbi et al., 2004): An elementary mono-synchronized sub-path is a mono-synchronized sub-path beginning with a place p such that ${}^o p$ is a synchronization transition.

Definition 4.4 (Collart-Dutilleul et al., 2013): Temporal control is the modification of the transition firing instants using a controlled P-time Petri net.

Definition 4.5 (Collart-Dutilleul et al., 2013): Active robustness is robustness ensured by the temporal control of the process transitions.

Definition 4.6: It is said that a transition t has a local active robustness on $[\Delta t_{\min}, \Delta t_{\max}]$ if the occurrence of a disturbance $\Delta t \in [\Delta t_{\min}, \Delta t_{\max}]$ observed on t does not involve a token death at t .

The local active robustness margin of t can be calculated using the following formulas:

$$\Delta t_{\min} = \max_{p_{ij}^o=t} (a_{ij} - q_{ij}^e) \quad (4.1)$$

$$\Delta t_{\max} = \min_{p_{ij}^e=t} (b_{ij} - q_{ij}^e) \quad (4.2)$$

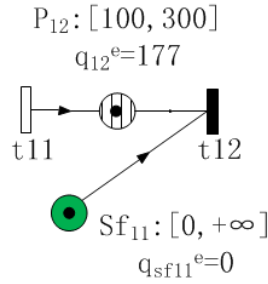

Figure 4.1: Case of local active robustness on a synchronized transition.

Example: Let us assume that a disturbance is observed on the synchronized transition t_{12} , as shown in Figure 4.1. Indeed,

$$\Delta t_{12\min} = \max(100 - 177, 0 - 0) = 0$$

$$\Delta t_{12\max} = \min(300 - 177, +\infty) = 123$$

Consequently, there is no token death on transition t_{12} if a disturbance $\Delta t \in [0, 123]$ is observed on t_{12} . For example, if a disturbance $\Delta t = 123$ is observed on t_{12} , it implies,

$$q_{12} = q_{12}^e + \Delta t = 177 + 123 = 300 = b_{12}, \text{ and } q_{sf11} = q_{sf11}^e + \Delta t = 0 + 123 = 123 \leq b_{sf11}.$$

Thus, no token dies as the sojourn time is still located in the time windows. But, if $\Delta t = 124$, then $q_{12} = 301 > b_{12}$, the token in p_{12} dies.

Definition 4.7: $\text{IN}(\text{Lp})$ is the first node of Lp , and $\text{OUT}(\text{Lp})$ is the last node of Lp .

Definition 4.8: It is said that a path Lp has a local active robustness on $[\delta_{\min}, \delta_{\max}]$ if the occurrence of a disturbance $\delta \in [\delta_{\min}, \delta_{\max}]$ observed on ${}^{\circ}\text{IN}(\text{Lp})$ does not involve a token death at the synchronization transitions of Lp .

To compute the local active robustness interval of Lp , the concepts of compensable and transmissible margins are introduced.

- Case of delay observed on ${}^{\circ}\text{IN}(\text{Lp})$

Let us denote by Δr_{c_k} and Δr_{t_k} , respectively, the compensable margin and the transmissible margin on the mono-synchronized sub-path Lp_k . The local active robustness delay margin Δr_{Lp_k} can be calculated using the following formulas:

$$\Delta r_{\text{Lp}_k} = \delta_{\max} = \Delta r_{c_k} + \Delta r_{t_k} \quad (4.3)$$

$$\Delta r_{c_k} = \sum_{p_{ij} \in \text{Lp}_k} (q_{ij}^e - a_{ij}) \quad (4.4)$$

$$\Delta r_{t_k} = \min_{p_{ij} = \text{OUT}(\text{Lp}_k), p_{ij} \notin \text{Lp}_k} (b_{ij} - q_{ij}^e) \quad (4.5)$$

- Case of advance observed on ${}^{\circ}\text{IN}(\text{Lp})$

Let us denote by Δa_{c_k} and Δa_{t_k} , respectively, the compensable margin and the transmissible margin on the mono-synchronized sub-path Lp_k .

The local active robustness delay margin Δa_{Lp_k} can be calculated using the following formulas:

Robust Control Algorithms

$$\Delta a_{Lp_k} = \delta_{\min} = \Delta a_{c_k} + \Delta a_{t_k} \quad (4.6)$$

$$\Delta a_{c_k} = \sum_{p_{ij} \in Lp_k} (q_{ij}^e - b_{ij}) \quad (4.7)$$

$$\Delta a_{t_k} = \max_{p_{ij} = \text{OUT}(Lp_k), p_{ij} \notin Lp_k} (a_{ij} - q_{ij}^e) \quad (4.8)$$

Example: Let us assume that a disturbance is observed on transition t_{11} , as shown in Figure 4.2. The local active robustness margin of path $Lp = (p_{12}, t_{12})$ can be calculated as follows:

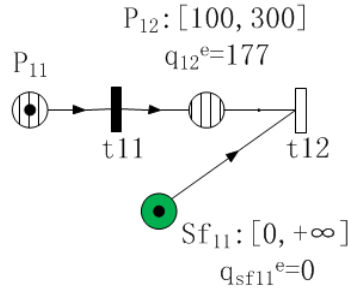

Figure 4.2: Case of local active robust margin of mono-synchronized path.

$$\Delta r_{c_k} = 177 - 100 = 77$$

$$\Delta r_{t_k} = +\infty - 0 = +\infty$$

$$\Delta r_{Lp_k} = \delta_{\max} = \Delta r_{c_k} + \Delta r_{t_k} = +\infty$$

$$\Delta a_{c_k} = 177 - 300 = -123$$

$$\Delta a_{t_k} = 0 - 0 = 0$$

$$\Delta a_{Lp_k} = \delta_{\min} = \Delta a_{c_k} + \Delta a_{t_k} = -123$$

Consequently, there is no token death on t_{12} with a disturbance $\delta \in [-123, +\infty]$ observed on the transition t_{11} . For example, a disturbance $\delta = -123$ is observed on t_{11} , which means one token arrives in the place p_{12} with 123 time units earlier. While

$q_{12} = 177 + 123 = 300$, another token will arrive in the place sf_{11} . The transition t_{12} is fired. But, if the disturbance $\delta = -124$ is observed on t_{11} , when $q_{12} = 300$, there is still no available token in sf_{11} . Then, the token in p_{12} is dead.

4.1.2 Approach 1: Rejection of the disturbance on propagation path

This strategy consists in reducing the disturbance as soon as it is observed: if the disturbance is a delay (respectively an advance), we generate advances (respectively delays) on the controlled transition firings on the propagation paths of the disturbance, in order to avoid the violation of the schedule constraints (Collart-Dutilleul et al., 2007).

In order to avoid the failure of the actual 1-cyclic schedule, a recursive algorithm allowing computing a margin of the time disturbance allowed on $\text{IN}(Lp)$ is presented. The following robustness margin algorithm is for dealing with delay disturbances. However, the algorithm for computing an advance robustness margin has a very similar algorithm structure. It is not presented in this paper.

4.1.2.1 Algorithm

Let us denote,

C_{ms} the set of mono-synchronised sub-paths,

C_{se} the set of elementary mono-synchronised sub-paths,

n the transition node where the disturbance is observed,

Δn_{max} the local active robustness of the node n ,

F the recursive function in algorithm,

Δr_t^i the value of Δr_t when F was used the i th time.

$$\varphi = \{Lp_k / (n^o = \text{IN}(Lp_k) \wedge (Lp_k \in C_{ms}) \wedge (Lp_k \in G))\},$$

$$\text{Margin} \leftarrow \min \left\{ \Delta n_{\max}, \min_k \left[\Delta r_{c_k} + F \left(G \setminus Lp_k, \text{OUT} (Lp_k)^o, \Delta r_{t_k} \right) \right] \right\},$$

$$F(G^*, p^*, \Delta r_{t_k})$$

{

$$\Delta r_t^i \leftarrow \Delta r_{t_k}$$

$$\varphi^* = \{ Lp_k / (p^* \in Lp_k) \wedge (Lp_k \in C_{se}) \wedge (Lp_k \in G^*) \}$$

If $(\varphi^* = \emptyset \text{ or } \Delta r_t^i = 0)$ then $(F \leftarrow \Delta r_t^i)$

Else

{

$$F \leftarrow \min \left\{ \Delta r_t^i, \min_k \left[\Delta r_{c_k} + F \left(G^* \setminus Lp_k, \text{OUT} (Lp_k)^o, \Delta r_{t_k} \right) \right] \right\}$$

}

}

4.1.2.2 Description of the algorithm

The algorithm behaves in such a way:

- Select the node where we want to calculate the active robustness margin,
- Build the set of mono-synchronised sub-paths φ defined as follows:

$$\varphi = \{ Lp_k / (n^o = \text{IN}(Lp_k) \wedge (Lp_k \in C_{ms}) \wedge (Lp_k \in G)) \}$$
- Calculate the active robustness margin associated to the set of sub-paths φ ,
- Remove the elementary mono-synchronized sub-path for the construction of the whole φ^* defined as follows:

$$\varphi^* = \{ Lp_k / (p^* \in Lp_k) \wedge (Lp_k \in C_{se}) \wedge (Lp_k \in G^*) \}$$

- Compute for each mono-synchronized sub-path of φ^* , the active robustness margin F defined as follows:

$$F \leftarrow \min \left\{ \Delta r_t^i, \min_k \left[\Delta r_{c_k} + F \left(G^* \setminus Lp_k, \text{OUT}(Lp_k)^o, \Delta r_{t_k} \right) \right] \right\}$$

- Stop the algorithm if the following condition is satisfied:

$$\text{If } (\varphi^* = \emptyset \text{ or } \Delta r_t^i = 0) \text{ then } (F \leftarrow \Delta r_t^i)$$

4.1.2.3 Analysis of the algorithm

The above algorithm applies the active robustness formula on all the sequences of the mono-synchronised sub-path. The algorithm is based on function F , which is called recursively using a part of the net that is more and more restricted. When the robustness of a mono-synchronised sub-path is computed, it is removed from the net to be treated in the next use of function F . As the number of mono-synchronised sub-paths is finite, the convergence of the considered algorithm is proved, because the function stops when the sub-net is empty: $\varphi^* = \emptyset$.

The polynomial computation time of this algorithm can be proved as follows (Collart-Dutilleul et al., 2013).

- The computation of the extreme firing instants for a given mono-synchronised sub-path is less complex than the same computation on the whole Petri net structure, which can be performed using an $O(n^3)$ time computing algorithm, where n corresponds to the number of transitions of the graph (Khansa, 1997).
- The number of mono-synchronised sub-paths is smaller than the number of transitions. Consequently, the complexity of the computing time of all the margins is smaller than $O(n^4)$.

The algorithm in our work has a modified structure compared with the algorithm in (Collart-Dutilleul et al., 2013). In our algorithm, each transition is controllable and observable, which presents a better modeling for the control on the AIVs.

4.1.2.4 Illustrative example

Figure 4.3 shows a part of the complete container transit model in Figure 2.10. The illustrative example here is composed of two routes, G_1 (C1-S1) and G_2 (C2-S1),

Robust Control Algorithms

with one shared AYC operating place S1. Figure 4.3 is very similar to the Figure 3.1. Here we use two route places with time window $[50,150]$ to replace the one route place with $[100,300]$. This change does not influence the achieved 1-cyclic schedule in the section 3.3, and this change contributes for a better comparison of the performance among different algorithms in the rest content of this chapter. To calculate the robustness margin on t_{22} , the compensable margins and the transmissible margins associated to some mono-synchronized sub-paths are summarized in Table 4.1.

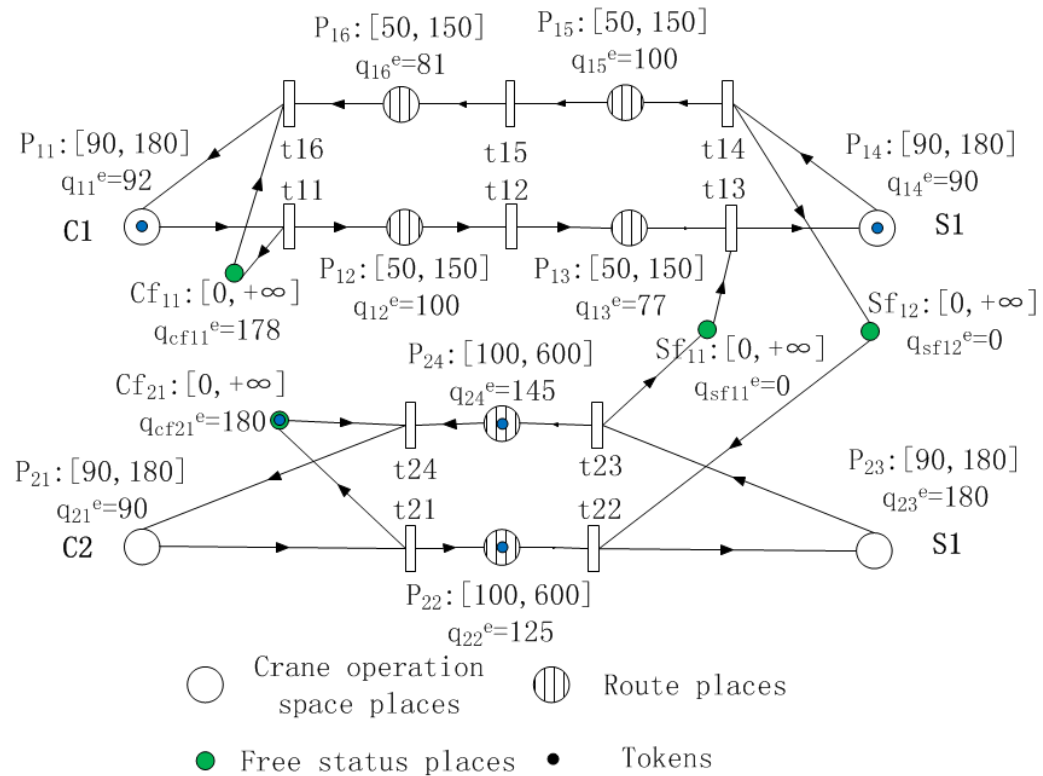

Figure 4.3: PTSCEG model of two routes with one shared AYC.

Table 4.1. Local active robustness associated to mono-synchronized paths

Path Lp_k	Δr_{c_k}	Δr_{t_k}
$Lp_1 = (p_{23}, t_{23}, p_{24}, t_{24})$	135	$+\infty$
$Lp_2 = (p_{23}, t_{23}, sf_{11}, t_{13})$	90	73

Robust Control Algorithms

$Lp_3 = (p_{21}, t_{21}, cf_{21}, t_{24})$	180	455
$Lp_4 = (p_{21}, t_{21}, p_{22}, t_{22})$	25	$+\infty$
$Lp_5 = (p_{14}, t_{14}, p_{15}, t_{15}, p_{16}, t_{16})$	81	$+\infty$
$Lp_6 = (p_{14}, t_{14}, sf_{12}, t_{22})$	0	475
$Lp_7 = (p_{11}, t_{11}, cf_{11}, t_{16})$	180	69
$Lp_8 = (p_{11}, t_{11}, p_{12}, t_{12}, p_{13}, t_{13})$	79	$+\infty$

Case study

$$\varphi = \{Lp_k / (t_{22}^o = IN(Lp_k) \wedge (Lp_k \in C_{ms}) \wedge (Lp_k \in G))\}$$

$$\varphi = \{Lp_1, Lp_2\}$$

$$\text{Margin} \leftarrow \min \left\{ (600 - 125), \min \left\{ \begin{array}{l} [135 + F(G \setminus Lp_1, p_{21}, +\infty)] \\ [90 + F(G \setminus Lp_2, p_{14}, 73)] \end{array} \right\} \right\}$$

Step 1: Computation of $F(G \setminus Lp_1, p_{21}, +\infty)$

$$\varphi^* = \{Lp_3, Lp_4\}$$

$$F \leftarrow \min \left\{ \begin{array}{l} \min[+\infty, 180 + F(G \setminus Lp_1 \setminus Lp_3, p_{21}, 455)] \\ \min[+\infty, 25 + F(G \setminus Lp_1 \setminus Lp_4, p_{23}, +\infty)] \end{array} \right\}$$

Step 1.1: Computation of $F(G \setminus Lp_1 \setminus Lp_3, p_{21}, 455)$

$$\varphi^* = \emptyset \text{ then } F \leftarrow 455$$

Step 1.2: Computation of $F(G \setminus Lp_1 \setminus Lp_4, p_{23}, +\infty)$

$$\varphi^* = \emptyset \text{ then } F \leftarrow +\infty$$

Step 2: Computation of $F(G \setminus Lp_2, p_{14}, 73)$

$$\varphi^* = \{Lp_5, Lp_6\}$$

Robust Control Algorithms

$$F \leftarrow \min \begin{cases} \min[73, 81 + F(G \setminus Lp_2 \setminus Lp_5, p_{11}, +\infty)] \\ \min[73, 0 + F(G \setminus Lp_2 \setminus Lp_6, p_{23}, 475)] \end{cases}$$

Step 2.1: Computation of $F(G \setminus Lp_2 \setminus Lp_5, p_{11}, +\infty)$

$$\varphi^* = \{Lp_7, Lp_8\}$$

$$F \leftarrow \min \begin{cases} \min[+\infty, 180 + F(G \setminus Lp_2 \setminus Lp_5 \setminus Lp_7, p_{11}, 69)] \\ \min[+\infty, 79 + F(G \setminus Lp_2 \setminus Lp_5 \setminus Lp_8, p_{14}, +\infty)] \end{cases}$$

Step 2.1.1: Computation of $F(G \setminus Lp_2 \setminus Lp_5 \setminus Lp_7, p_{11}, 69)$

$$\varphi^* = \emptyset \text{ then } F \leftarrow 69$$

Step 2.1.2: Computation of $F(G \setminus Lp_2 \setminus Lp_5 \setminus Lp_8, p_{14}, +\infty)$

$$\varphi^* = \emptyset \text{ then } F \leftarrow +\infty$$

Step 2.2: Computation of $F(G \setminus Lp_2 \setminus Lp_6, p_{23}, 475)$

$$\varphi^* = \emptyset \text{ then } F \leftarrow 475$$

Algorithm stops

Margin $\leftarrow 163$

The active robustness margin on t_{22} is 163, which means if any delay disturbance is less than 163 unit time, we rather give no false alarm, and the system can recover to the initial normal mode, if an active robust control is given.

Let $\delta=163$ be a delay disturbance observed on t_{22} in Figure 4.3. On the path Lp_1 , the disturbance can be first partially reduced by t_{23} to $73=163-(180-90)$. Then, the residue of disturbance 73 is decreased by t_{24} to $28=73-(145-100)$. As the transmissible margin of cf_{21} is $+\infty$, the residue 28 can be totally transmitted to p_{21} . In other words, the token in cf_{21} is also delayed actively with 28 time units. On the path Lp_3 , the residue 28 is completely eliminated in cf_{21} , as the compensable margin is 180. On the path Lp_4 , the residue is reduced to $3=28-25$. This residue 3 is transmitted to p_{23} ,

and is decreased completely to 0 in p_{23} . On the path Lp_2 , the compensable margin is 90. So, the disturbance is rejected to 73. This residue can be totally transmitted to p_{14} , as the transmissible margin of Lp_2 is 73. In other words, the token in p_{13} is also delayed with 73 time units. On the path Lp_5 , the residue 73 is completely reduced to 0 by a compensable margin 81. On the path Lp_6 , the residue 73 is transmitted to p_{23} by t_{22} . Finally, the residue of disturbance 73 is completely reduced to 0 in p_{23} .

4.1.3 Approach 2: Rejection of the disturbance and generation of the parallel disturbance

The generation of the parallel disturbance consists of adding by the control, on the parallel paths, a temporal shift similar to the disturbance in order to avoid the death of tokens at the levels of synchronization transitions (Mhalla et al., 2008, Mhalla et al., 2013b). Therefore, constraints violations are avoided. If the disturbance is a delay (or an advance), then the temporal shift will be a delay (respectively an advance) obtained by changing the firing instants of controlled transitions belonging to the parallel paths.

Factually, the approach 2 combines two strategies, the rejection of the disturbance on the propagation paths and the generation of the similar disturbance on the parallel paths. The approach 2 allows:

- To reject by control the disturbance as soon as it is observed,
- To generate by the control, on the parallel paths, a temporal shift similar to the disturbance in order to avoid the death of tokens on the synchronization transitions.

The strategy of rejection of disturbance is introduced in the section 4.1.2. In the following content, the parallel similar disturbance strategy is presented.

t_o : the transition where the disturbance is observed firstly.

t_s : the synchronized transition of the disturbance propagation path and its parallel paths.

Robust Control Algorithms

δ_c : the active control generated on the parallel paths to change the firing time of transitions.

$E(t_o, t_s)$: the set of directed paths connecting t_o to t_s .

Definition 4.9: A concentrated path L_{pc} is a path beginning with a place and ending with a transition, and each transition on this path has only one output arc.

As shown in Figure 4.4, the paths $(p22, t22, p23, t23)$ and $(p23, t23, p24, t24)$ are concentrated paths. But, the path $(p24, t24, p21, t21)$ is not a concentrated one, as its ending transition has two output arcs.

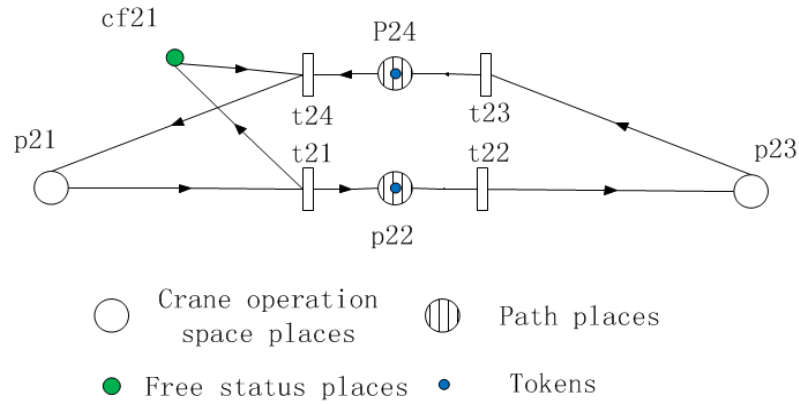

Figure 4.4: One PTSCEG including concentrated paths.

The value of δ_c can be computed as follows:

- Considering an advance observed on t_o

$$\delta_c = \max_{\substack{\text{OUT}(L_{pc})^{oo}=t_s \\ L_{pc} \in E(t_o, t_s)}} \left\{ \min \left[\sum_{p_{ij} \in L_{pc}} (a_{ij} - q_{ij}^e) \right] \right\} \quad (4.9)$$

$$\text{s.t.} \begin{cases} \sum_{p_{ij} \in \text{Lpc} \cup \text{OUT}(\text{Lpc})^o} q_{ij}^e < \sum_{p_{ij} \in \text{Lp}_k} q_{ij}^e \\ \text{OUT}(\text{Lp}_k) = \text{OUT}(\text{Lpc})^{oo} = t_s \\ \text{Lp}_k \in E(t_o, t_s) \end{cases}$$

- Considering a delay observed on t_o

$$\delta_c = \min_{\substack{\text{OUT}(\text{Lpc})^{oo} = t_s \\ \text{Lpc} \notin E(t_o, t_s)}} \left\{ \max \left[\sum_{p_{ij} \in \text{Lpc}} (b_{ij} - q_{ij}^e) \right] \right\} \quad (4.10)$$

$$\text{s.t.} \begin{cases} \sum_{p_{ij} \in \text{Lpc} \cup \text{OUT}(\text{Lpc})^o} q_{ij}^e < \sum_{p_{ij} \in \text{Lp}_k} q_{ij}^e \\ \text{OUT}(\text{Lp}_k) = \text{OUT}(\text{Lpc})^{oo} = t_s \\ \text{Lp}_k \in E(t_o, t_s) \end{cases}$$

In (4.9) and (4.10), Lp_k is the disturbance propagation path. The path Lpc is a part of the parallel path, because of $\text{OUT}(\text{Lp}_k) = \text{OUT}(\text{Lpc})^{oo} = t_s$. As shown in Figure 4.5, a disturbance is observed on t_{22} , and it propagates on one of the disturbance path ($p_{23}, t_{23}, sf_{11}, t_{13}$). The disturbance arrives in synchronized transition t_{13} . The path (p_{12}, t_{12}) is a parallel concentrated path.

Robust Control Algorithms

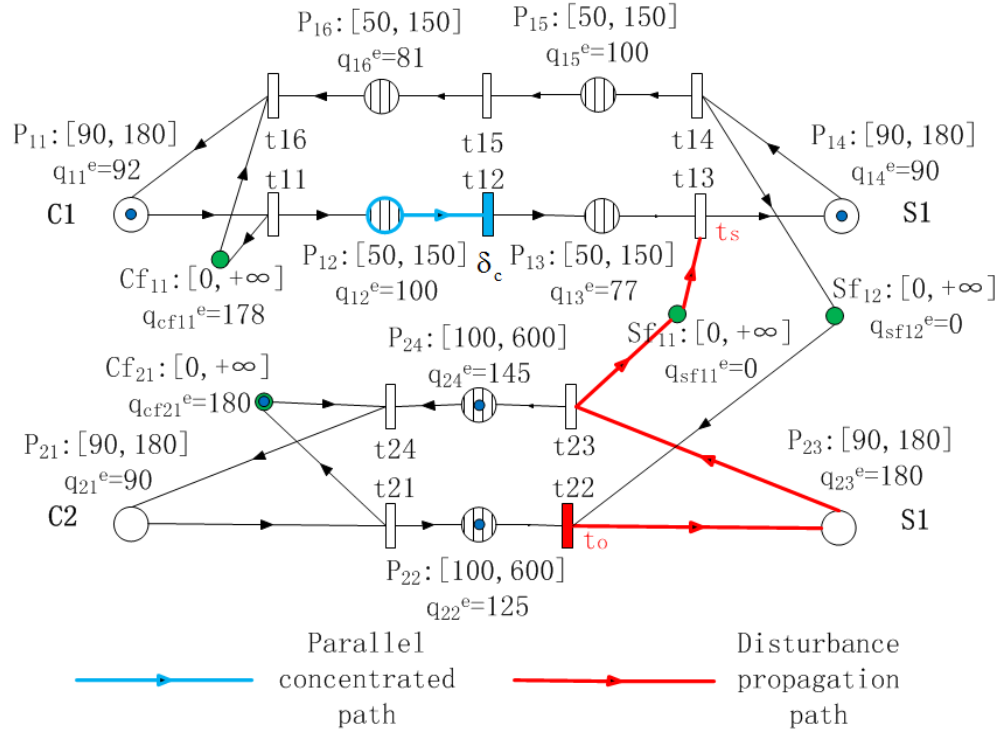

Figure 4.5: Parallel concentrated path and disturbance propagation path.

The constraint $\sum_{p_{ij} \in L_{pc} \cup \text{OUT}(L_{pc})^o} q_{ij}^c < \sum_{p_{ij} \in L_{p_k}} q_{ij}^c$ guarantees the control is given after the

disturbance observation time point. For example, $(q_{i_2}^c + q_{i_3}^c = 177)$ is inferior than the $(q_{23}^c + q_{sf11}^c = 180)$. So, when the disturbance is observed on t_{22} , the token which will meet t_{22} on t_{13} has not pass by the transition t_{12} . So the generating parallel similar disturbance by active control is possible. Factually, when the disturbance is observed, the token which will meet t_{22} on t_{13} still stays in p_{11} . But, $(p_{11}, t_{11}, p_{12}, t_{12})$ is not a concentrated path. If we generate the similar disturbance on t_{11} , this active control will also generate extra disturbance to the system by path (cf_{11}, t_{16}) , which is not expected to be seen in our strategy. The extra disturbance needs also the verification of the robust margin on its propagation paths, which increases drastically the complexity of computing time.

Compared with the definition of the similar parallel disturbance δ_c in (Mhalla et al., 2008, Mhalla et al., 2013b), the notion of δ_c in this report is more sophisticated and better defined. Under the premise of not generating extra disturbance, we give a

maximal similar parallel temporal shift. The readers interested in the notion of δ_c of Mhalla's may consult the work in (Mhalla et al., 2008, Mhalla et al., 2013b).

4.1.3.1 Algorithm

This is also a recursive algorithm allowing the rejection of the disturbance as soon as it is observed, while considering an active generation of disturbance on the parallel concentrated paths. This algorithm can give a better robustness margin, because the active generation of the parallel disturbance actually increases the transmissible range of the residue of the observed disturbance. However, the algorithm for computing an advance robustness margin has very similar computing structure, which is not discussed in this paper.

Let us denote,

C_{ms} the set of mono-synchronised sub-paths,

C_{se} the set of elementary mono-synchronised sub-paths,

n the transition node where the disturbance is observed,

Δn_{max} the local active robustness of the node n ,

F the recursive function in algorithm,

Δr_t^i the value of Δr_{t_k} when F was used the i th time

δ_c delays generated on the controlled transition firings on the concentrated parallel paths

$$\varphi = \{Lp_k / (n^o = IN(Lp_k) \wedge (Lp_k \in C_{ms}) \wedge (Lp_k \in G))\} ,$$

$$\text{Margin} \leftarrow \min\{\Delta n_{max}, \min_k \left[\Delta r_{c_k} + F(G \setminus Lp_k, OUT(Lp_k)^o, \Delta r_{t_k} + \delta_c) \right]\} ,$$

$$F(G^*, p^*, \Delta r_{t_k})$$

{

$$\Delta r_t^i \leftarrow \Delta r_{t_k}$$

$$\varphi^* = \{Lp_k / (p^* \in Lp_k) \wedge (Lp_k \in C_{se}) \wedge (Lp_k \in G^*)\}$$

If $(\varphi^* = \emptyset \text{ or } \Delta r_t^i = 0)$ then $(F \leftarrow \Delta r_t^i)$

Else

{

$$F \leftarrow \min \left\{ \Delta r_t^i, \min_k \left[\Delta r_{c_k} + F(G^* \setminus Lp_k, \text{OUT}(Lp_k)^o, \Delta r_{t_k} + \delta_c) \right] \right\}$$

}

}

4.1.3.2 Description of the algorithm

The algorithm behaves in such a way:

- Select the node where we want to calculate the active robustness margin,
 - Build the set of mono-synchronised sub-paths φ defined as follows:
- $$\varphi = \{Lp_k / (n^o = \text{IN}(Lp_k) \wedge (Lp_k \in C_{ms}) \wedge (Lp_k \in G))\}$$
- Calculate the active robustness margin associated to the set of sub-paths φ ,
 - Remove the elementary mono-synchronized sub-path for the construction of the whole φ^* defined as follows:

$$\varphi^* = \{Lp_k / (p^* \in Lp_k) \wedge (Lp_k \in C_{se}) \wedge (Lp_k \in G^*)\}$$

- Compute for each mono-synchronized sub-path of φ^* , the active robustness margin F defined as follows:

$$F \leftarrow \min \left\{ \Delta r_t^i, \min_k \left[\Delta r_{c_k} + F(G^* \setminus Lp_k, \text{OUT}(Lp_k)^o, \Delta r_{t_k} + \delta_c) \right] \right\}$$

It should be noticed that in approach 1, the maximal transmissible margin of the disturbance is determined by Δr_{t_k} , but in this approach, the margin is factually increased to $\Delta r_{t_k} + \delta_c$ by giving an active control on the transitions of the parallel concentrated paths.

- Stop the algorithm if the following condition is satisfied:

If $(\varphi^* = \emptyset \text{ or } \Delta r_t^i = 0)$ then $(F \leftarrow \Delta r_t^i)$

4.1.3.3 Analysis of the algorithm

Concerning the algorithm's convergence, the behaviour of the second approach is so similar to the first that a new convergence proof is not useful. The proof of the formula, which is recursively applied by the algorithm, can be found in (Jerbi et al., 2009).

The complexity of the computing time is smaller than $O(n^6)$, and n is the number of transitions. The readers interested in a theoretical analysis of the complexity of the algorithm's computing time may consult (Collart-Dutilleul et al., 2013). The algorithm in our work has a modified structure compared with the algorithm in (Collart-Dutilleul et al., 2013). In our algorithm, each transition is controllable and observable, which presents a better modeling for the control on the AIVs. The computing time of algorithm 2 is also acceptable. Although the complexity of algorithm 2 $O(n^6)$ is larger than the first one $O(n^4)$, the algorithm 2 indeed increases the robustness margin for a real industrial topology as shown in the section 4.1.3.4.

4.1.3.4 Illustrative example

To calculate the robustness margin on t_{22} in Figure 4.6, the compensable margin and the transmissible margin associated to some mono-synchronized sub-paths are summarized in Table 4.1. The active similar disturbance control δ_c is generated on the parallel concentrated paths, which are shown in Table 4.2.

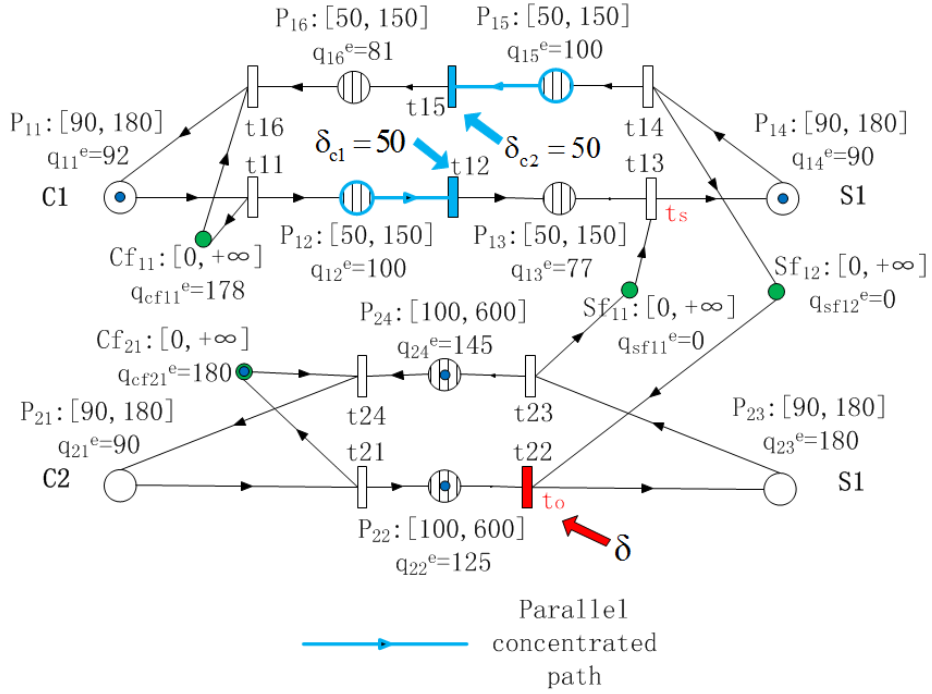

Figure 4.6: Generation of similar disturbance on parallel concentrated paths.

Table 4.2. The similar disturbance on parallel concentrated paths

Lpc	δ_c
$Lpc_1 = (p_{12}, t_{12})$	50
$Lpc_2 = (p_{15}, t_{15})$	50

Case study

$$\varphi = \{Lp_k / (t_{22}^o = IN(Lp_k) \wedge (Lp_k \in C_{ms}) \wedge (Lp_k \in G))\}$$

$$\varphi = \{Lp_1, Lp_2\}$$

$$\text{Margin} \leftarrow \min \left\{ (600 - 125), \min \left\{ \begin{array}{l} [135 + F(G \setminus Lp_1, p_{21}, +\infty)] \\ [90 + F(G \setminus Lp_2, p_{14}, 73 + 50)] \end{array} \right\} \right\}$$

Robust Control Algorithms

Step 1: Computation of $F(G \setminus Lp_1, p_{21}, +\infty)$

$$\varphi^* = \{Lp_3, Lp_4\}$$

$$F \leftarrow \min \begin{cases} \min[+\infty, 180 + F(G \setminus Lp_1 \setminus Lp_3, p_{21}, 455)] \\ \min[+\infty, 25 + F(G \setminus Lp_1 \setminus Lp_4, p_{23}, +\infty)] \end{cases}$$

Step 1.1: Computation of $F(G \setminus Lp_1 \setminus Lp_3, p_{21}, 455)$

$$\varphi^* = \emptyset \text{ then } F \leftarrow 455$$

Step 1.2: Computation of $F(G \setminus Lp_1 \setminus Lp_4, p_{23}, +\infty)$

$$\varphi^* = \emptyset \text{ then } F \leftarrow +\infty$$

Step 2: Computation of $F(G \setminus Lp_2, p_{14}, 123)$

$$\varphi^* = \{Lp_5, Lp_6\}$$

$$F \leftarrow \min \begin{cases} \min[123, 81 + F(G \setminus Lp_2 \setminus Lp_5, p_{11}, +\infty)] \\ \min[123, 0 + F(G \setminus Lp_2 \setminus Lp_6, p_{23}, 475)] \end{cases}$$

Step 2.1: Computation of $F(G \setminus Lp_2 \setminus Lp_5, p_{11}, +\infty)$

$$\varphi^* = \{Lp_7, Lp_8\}$$

$$F \leftarrow \min \begin{cases} \min[+\infty, 180 + F(G \setminus Lp_2 \setminus Lp_5 \setminus Lp_7, p_{11}, 69 + 50)] \\ \min[+\infty, 79 + F(G \setminus Lp_2 \setminus Lp_5 \setminus Lp_8, p_{14}, +\infty)] \end{cases}$$

Step 2.1.1: Computation of $F(G \setminus Lp_2 \setminus Lp_5 \setminus Lp_7, p_{11}, 119)$

$$\varphi^* = \emptyset \text{ then } F \leftarrow 119$$

Step 2.1.2: Computation of $F(G \setminus Lp_2 \setminus Lp_5 \setminus Lp_8, p_{14}, +\infty)$

$$\varphi^* = \emptyset \text{ then } F \leftarrow +\infty$$

Step 2.2: Computation of $F(G \setminus Lp_2 \setminus Lp_6, p_{23}, 475)$

$$\varphi^* = \emptyset \text{ then } F \leftarrow 475$$

Algorithm stops

Margin \leftarrow 213

The active robustness margin on t_{22} is 213. If any delay disturbance is less than 213 unit time, a false alarm can be avoided, and the system could recover to the initial normal mode. Using an active robust control generating parallel similar temporal shift, the robustness margin obtained by the second approach is better than the first approach.

Let $\delta=213$ be a delay disturbance observed on t_{22} in Figure 4.6. On the path Lp_1 , the disturbance can be first partially reduced by t_{23} to $123=213-(180-90)$. Then, the residue of disturbance 123 is reduced by t_{24} to $78=123-(145-100)$. As the transmissible margin of cf_{21} is $+\infty$, the residue 78 can be totally transmitted to p_{21} . In other words, the token in cf_{21} is also actively delayed with 78 time units. On the path Lp_3 , the residue 78 is completely decreased to 0 in cf_{21} , as the compensable margin is 180. On the path Lp_4 , the residue is rejected to $53=78-25$. This residue 53 is transmitted to p_{23} , and is reduced completely to 0 in p_{23} . On the path Lp_2 , the compensable margin is 90. So, the disturbance is reduced to 123. This residue can be totally transmitted to p_{14} , as the transmissible margin of Lp_2 is 73 and the parallel similar disturbance is 50. Factually, the token in p_{13} is also delayed with 123 time units compared to normal firing date of t_{13} . On the path Lp_5 , the residue 123 is rejected to 42 by a compensable margin 81. And, the residue 42 will be decreased completely to 0 on Lp_7 and Lp_8 , as the compensable margin is 180 and 79 respectively. On the path Lp_6 , the residue 123 is transmitted to p_{23} by t_{22} . Finally, the residue of disturbance 123 will be surely completely eliminated to 0, because the residue 123 will be reduced to $33=123-(213-123)$ on t_{22} , if we apply again the approach 2. Finally, the residue 33 is completely eliminated to 0 in p_{23} .

4.1.4 Comparison between Approach 1 and Approach 2

As discussed in sections 4.1.2.3 and 4.1.3.3, the complexity of computing time for approach 1 is $O(n^4)$, and the complexity of computing time of approach 2 is $O(n^6)$. So, concerning the complexity of computing time, approach 1 is better than

Robust Control Algorithms

approach 2. A higher order of the complexity in computing time of approach 2 is generated by the active parallel similar control given on the parallel concentrated paths.

But, concerning the robustness margin on the nodes, the approach 2 is better than approach 1, $\text{Margin}_1 \geq \text{Margin}_2$. By the generation of parallel similar temporal shift, the parallel concentrated paths can transmit more delay robustness because of $\Delta r_{t_k} + \delta_c \geq \delta_c$. In the example shown in Figure 4.6, for a disturbance observed on t_{22} , the robustness margin 213 of approach 2 is better than the robustness margin 163 of approach 1. But in an extreme condition as shown in Figure 3.1, there is no concentrated path in the example, $\delta_c = 0$. In this condition, the value of the robustness margin on node is computed by applying approach 1, with $\text{Margin}_1 = \text{Margin}_2 = 213$.

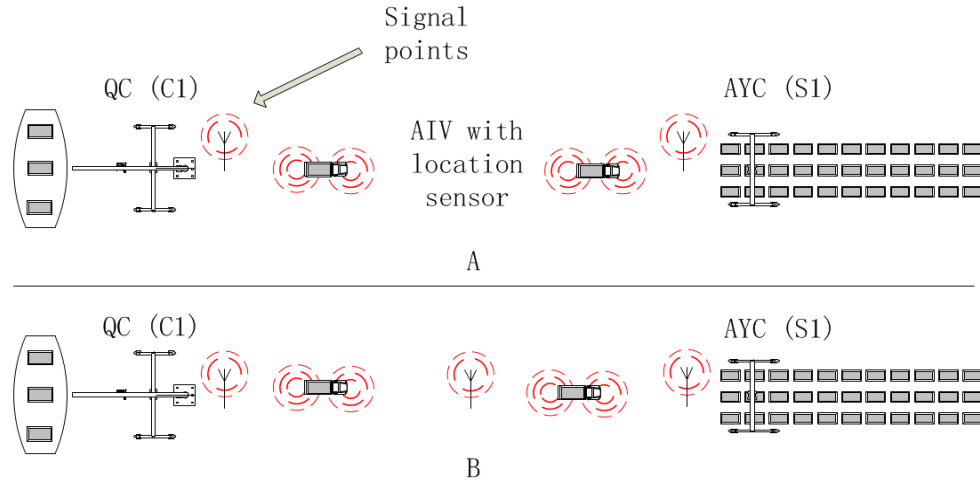

Figure 4.7: The signal points on the AIV running routes.

The analysis of results implies that approach 2 has a better performance if there are more controllable transitions on the parallel paths. For example, in Figure 3.1, there are two transitions between $p_{11}(C1)$ and $p_{13}(S1)$, and, in Figure 4.6, there are three transitions between $p_{11}(C1)$ and $p_{14}(S1)$. Factually, if the places between C1 and S1 stand for routes of the AIVs from the QCs to the AYCs, then the transitions can be seen as the signal points which help the AIV to locate their positions. It is reasonable that more signal points on the route can increase the location accuracy of the AIVs. And from a physical view, the signals of the signal points maybe blocked by the moving cranes, the container stacks or the other AIVs. So more signal points on the routes can indeed guarantee a better functioning of the AIVs, and increase the safety in the transit procedures. It is admitted that, the number of the signal points should be given

basing on the test and analysis result on the container transit filed by the engineers and the automated vehicle specialists. Because too many signal points will increase the investment of infrastructure, and will also raise the unnecessary controls on the AIVs which is strongly related to the management cost.

Figure 4.7.A shows the physical structure of path (t11,p12, t12) of the example shown in Figure 3.1. And Figure 4.7.B shows the physical structure of the path (t11, p12, t12, p12, t13) of the example shown in Figure 4.6. The plan B can give a better control on the AIVs with more signal points on the routes.

So, the transit procedure manager should make a choice to balance the complexity of computing time, the robustness margin of the system, the infrastructure investment and the control accuracy. The approach 1 has less complexity in computing time ($O(n^4)$), but less robustness margin and worse control for the AIVs. The approach 2 has more complexity in computing time ($O(n^6)$), but larger robustness margin (as least not less than the approach 1) and better control for the AIVs. If considering the resilience or the robustness of the system and the safety require for the system, the approach 2 is might be an even better choice.

4.2 The algorithm based on direct control of tokens' sojourn time

The section 4.1 presents the approach 1 and approach 2 which are two algorithms to compute the acceptable robustness margin on one node of PTSCEG. The rejection process of the advance (or delay) disturbance is based on the control of the transitions (the structure of the PTSCEG) with a delay (respectively an advance) firing time on the propagation path. The two algorithms guarantee that the rejection is given as soon as the disturbance is observed. And the approach 2 gives an active parallel similar temporal shift as large as possible, but not as soon as the disturbance is observed because of the constraints about the concentrated paths.

The algorithm presented in this section is based on the direct control of token's sojourn time in a 1-cyclic schedule Gantt graph. This algorithm guarantees the similar parallel disturbance control is actively given as soon as the disturbance is observed. This algorithm has also a computing time in polynomial complexity.

4.2.1 Basic notation

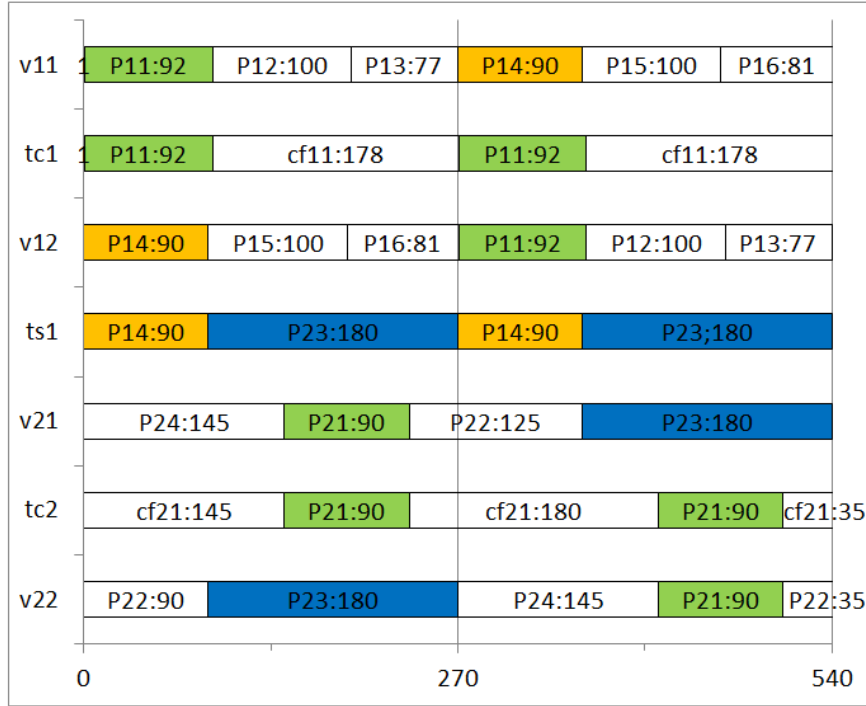

Figure 4.8: The coupling of the tokens presented by Gantt graph.

Definition 4.10: The coupling of tokens is a phenomenon that the tokens from different elementary circuits enter into one shared place and fuse as one single token in this shared place.

Let us take the 1-cyclic schedule of tokens in Figure 4.3 as an example. It is possible to give a 1-cyclic schedule for the tokens as shown in Figure 4.8. This schedule is shown in Gantt graph. v_{11} and v_{12} are two tokens in $G_1(C1 \Leftrightarrow S1)$; v_{21} and v_{22} are two tokens in $G_2(C2 \Leftrightarrow S1)$; t_{c1} is one token in the C1 operation space status circuit; t_{c2} is one token in the C2 operation status circuit; t_{s1} is one token in the S1 operation space circuit. The coupling of the tokens occurs in the shared places. The t_{s1} and v_{22} are coupled in p_{23} , the v_{21} and t_{c2} are coupled in p_{21} , and the t_{s1} and v_{21} are coupled in p_{23} etc. For the coupled tokens in the shared places, they fuse into one token. But when this token exits the shared place, it decomposes again to the initial tokens before entering the shared place. From a physical view, an empty AIV v_{21} enter

Robust Control Algorithms

into p_{21} to take the container, and one free QC (t_{c2}) is ready to lift the container from the vessel and put it on the AIV. The AIV and the crane do the unloading work in p_{21} . When the unloading is finished, AIV exits the operation place as a full AIV, and the crane becomes a free crane again.

Definition 4.11: The coupling point C_o is the time point when the coupling of tokens occurs.

For example, $C_o = 145$ is the coupling point of v_{21} and t_{c2} in p_{21} .

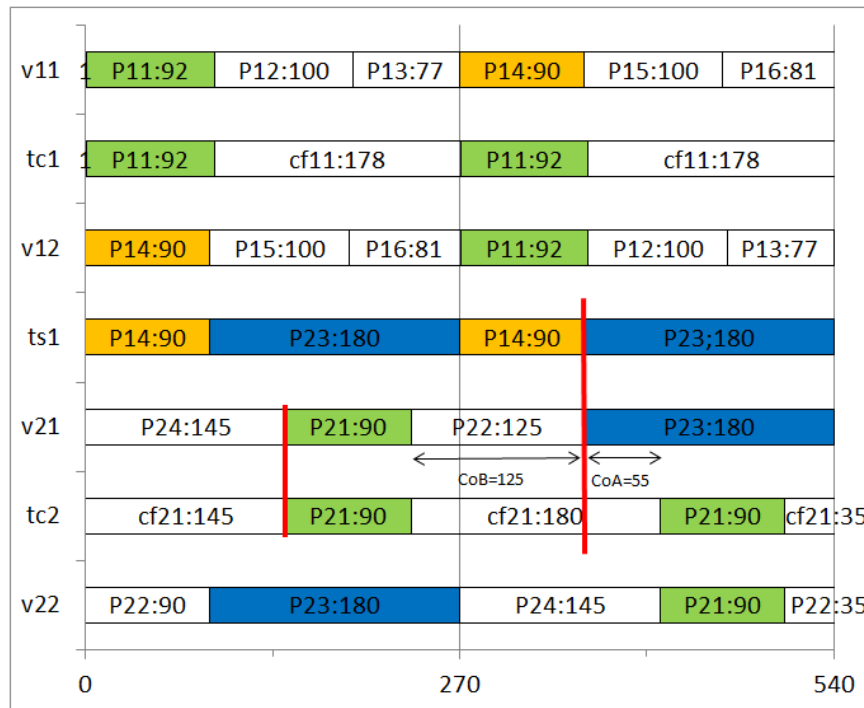

Figure 4.9: The cutting of the tokens at coupling point.

Definition 4.12: The cutting of token's sojourn time on coupling point is to divide the sojourn time of tokens which is not coupled at the coupling point but has been coupled with the present coupling token before the coupling point.

As shown in Figure 4.9, the token v_{21} is coupled with t_{c2} at the coupling point 145. Then, the token v_{21} is coupled with t_{s1} at another coupling point 360. The cou-

pling point 360 cuts the cf_{21} into two parts, since t_{c2} has coupled with v_{21} . Let us denote the part before (or after) the coupling point as C_oB (C_oA respectively). One part of cf_{21} has a duration $C_oB=125$, and the other part has a duration $C_oA=55$.

Definition 4.13: The disturbance rejection group is a set that only includes all the disturbed tokens and the tokens coupled by the disturbed tokens.

Definition 4.14: The parallel similar temporal shift group is a set that includes only the non-disturbed coupled tokens.

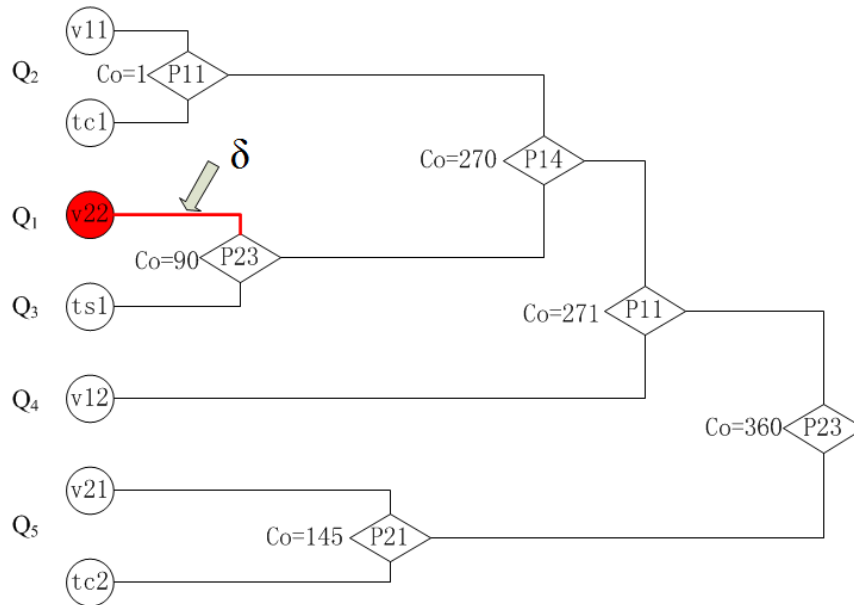

Figure 4.10: The classification of the tokens.

The Figure 4.10 shows the coupling progress of the tokens in 1-cyclic schedule of Figure 4.8. If the disturbance δ is observed on the sojourn time of v_{22} in the place p_{22} , just as the disturbance is observed on t_{22} in Figure 4.3, the t_{s1} will be coupled with v_{22} in the place p_{23} , then, the token set $Q_1 \cup Q_3$ is a disturbance rejection token group. From the coupling point, the tokens in $Q_1 \cup Q_3$ will be given a delay (advance) control to reject the observed disturbance which is an advance (delay respectively). The token v_{11} and t_{c1} are coupled in p_{11} . Normally, the two tokens finish the staying in p_{11} at $t=93$. So, when the disturbance is observed at $t=90$, it is still possible to give an active control on the token in p_{11} , with a parallel similar temporal shift. They

are in a parallel similar temporal shift group Q_2 . The tokens in Q_2 will be given a similar delay (or advance) control if the δ is a delay (an advance respectively). During the coupling progress, the token groups integrate step by step. $Q_1 \cup Q_3$ and Q_2 combine as Q^* which is a disturbance rejection token group in p_{14} . Because after the coupling point on p_{14} , all the tokens in Q^* should contribute to reduce the delay (advance) disturbance with advance (delay) control. Progressively, in p_{11} , Q^* and Q_4 combine to a new disturbance rejection token group $Q^* = Q^* + Q_4$. And in p_{23} , with $C_o = 360$, a disturbance token group including all the tokens is formed, with $Q^* = Q^* + Q_5$. During the coupling procedures, the disturbance rejection group absorbs more and more tokens, and the parallel similar temporal shift groups disappear gradually.

Definition 4.15: The pure coupling point C_{op} is a coupling point that the coupled tokens use the same control strategy (disturbance rejection or parallel similar temporal shift generation) before this coupling point.

Definition 4.16: The mixed coupling point C_{oM} is a coupling point that the coupled tokens use the different control strategies before this coupling point.

As shown in Figure 4.10, $C_o = 1$ and $C_o = 145$ are the pure coupling points, and $C_o = 90$, $C_o = 270$, $C_o = 271$ and $C_o = 360$ are the mixed coupling points where the tokens from different kinds of tokens groups are coupled.

4.2.1.1 The transmissible margin of the parallel similar temporal shift group

Let us denote

C_o^\diamond the time point where the disturbance is initially observed, all the active control should be given after this point,

C_{oM}^n the nth mixed coupling point, $n \in \mathbb{N}^+$

$\Delta\tau_Q$ the transmissible margin of the parallel similar temporal shift group between the C_o^\diamond and a mixed coupling point C_{oM}^n ,

C_{op}^k , the kth pure coupling point between C_o^\diamond and C_{oM}^n , $k \in \mathbb{N}^+$, $\aleph = \max(k)$,

p_{C_o} the operation of tokens cut by the coupling point C_o ,

C_oB the cutting part of p_{C_o} before C_o ,

C_oA the cutting part of p_{C_o} after C_o

Q_r the disturbance rejection token group,

Q_p The parallel similar temporal shift token group

In the **parallel similar temporal shift group**, it is possible to control the sojourn time of each token in each place to generate the similar disturbance as the disturbance observed in Q_r . The transmissible margin of the tokens in this group between the C_o^\diamond and a mixed coupling point C_{oM}^n can be computed using the following formulas

- **Case of a delay disturbance in Q_r**

For the transmissible margin from C_o^\diamond to C_{oM}^n

If $\exists C_{oP}^k$,

$$\Delta r_{IQ} = \min_{C_o^\diamond \rightarrow C_{oP}^1} \left[\sum_{v_{ij} \in Q_p} (b_{ij} - q_{ij}^e) \right] \quad (4.11)$$

$$\Delta r_{IQ} = \min_{C_{oP}^k \rightarrow C_{oP}^{k+1}} \left[\sum_{v_{ij} \in Q_p} (b_{ij} - q_{ij}^e) + (b_{ij} - q_{ij}^e - Rt_{ij}^k) \right] \quad (4.12)$$

s.t.

$$Rt_{ij}^k = \begin{cases} \max[0, \Delta r_{IQ} - \sum_{C_o^\diamond \rightarrow C_{oP}^1} (b_{ij} - q_{ij}^e)], k = 1 \\ \max[0, \Delta r_{IQ} - (b_{ij} - q_{ij}^e - Rt_{ij}^{k-1}) - \sum_{P_{ij} \neq P_{C_{oP}^{k-1}} \cup P_{C_{oP}^k}} (b_{ij} - q_{ij}^e)], k \geq 2 \end{cases}$$

$$\Delta r_{IQ} = \min_{C_{oP}^N \rightarrow C_{oM}^n} \left[\sum_{v_{ij} \in Q_p} (b_{ij} - q_{ij}^e) + (b_{ij} - q_{ij}^e - Rt_{ij}^N) \right] \quad (4.13)$$

As a consequence,

Robust Control Algorithms

$$\Delta r_{iQ} = \Delta r_{iQ} + \sum_k \Delta r_{iQ} + \Delta r_{iQ} \quad (4.14)$$

$\begin{matrix} C_o^\diamond \rightarrow C_{oM}^n & C_o^\diamond \rightarrow C_{oP}^l & C_{oP}^k \rightarrow C_{oP}^{k+1} & C_{oP}^N \rightarrow C_{oM}^n \end{matrix}$

.....

If $\{C_{oP}^k\} = \emptyset$

$$\Delta r_{iQ} = \min_{v_{ij} \in Q_p} \left[\sum (b_{ij} - q_{ij}^e) \right] \quad (4.15)$$

• **Case of an advance disturbance in Q_r**

For the transmissible margin from C_o^\diamond to C_{oM}^n

If $\exists C_{oP}^k$,

$$\Delta r_{iQ} = \max_{C_o^\diamond \rightarrow C_{oP}^l} \left\{ \sum_{P_{ij} \neq P_{C_o^\diamond} \cup P_{C_{oP}^l}} [a_{ij} - q_{ij}^e] + \max_{P_{ij} = P_{C_o^\diamond}} [-C_o^\diamond A, (a_{ij} - q_{ij}^e)] + \max_{P_{ij} = P_{C_{oP}^l}} [-C_{oP}^l B, (a_{ij} - q_{ij}^e)] \right\} \quad (4.16)$$

$$\Delta r_{iQ} = \max_{C_{oP}^k \rightarrow C_{oP}^{k+1}} \left\{ \sum_{P_{ij} \neq P_{C_{oP}^k} \cup P_{C_{oP}^{k+1}}} [a_{ij} - q_{ij}^e] + \max_{P_{ij} = P_{C_{oP}^k}} [-C_{oP}^k A, (a_{ij} - q_{ij}^e) - Rt_{ij}^k] + \max_{P_{ij} = P_{C_{oP}^{k+1}}} [-C_{oP}^{k+1} B, (a_{ij} - q_{ij}^e)] \right\} \quad (4.17)$$

s.t.

$$Rt_{ij}^k = \begin{cases} \min[0, \Delta r_{iQ} - \sum_{P_{ij} \neq P_{C_o^\diamond} \cup P_{C_{oP}^l}} (a_{ij} - q_{ij}^e) - \max_{P_{ij} = P_{C_o^\diamond}} (-C_o^\diamond A, a_{ij} - q_{ij}^e)], k = 1 \\ \min[0, \Delta r_{iQ} - \sum_{P_{ij} \neq P_{C_{oP}^{k-1}} \cup P_{C_{oP}^k}} (a_{ij} - q_{ij}^e) - \max_{P_{ij} = P_{C_{oP}^{k-1}}} (-C_{oP}^{k-1} A, a_{ij} - q_{ij}^e - Rt_{ij}^{k-1})], k \geq 2 \end{cases}$$

$$\Delta r_{tQ} = \max_{C_{oP}^N \rightarrow C_{oM}^n} \left\{ \sum_{\substack{v_{ij} \in Q_p \\ P_{ij} \neq P_{C_{oP}^N} \cup P_{C_{oM}^n}}} [a_{ij} - q_{ij}^e] + \max_{P_{ij} = P_{C_{oP}^N}} [-C_{oP}^N A, (a_{ij} - q_{ij}^e) - Rt_{ij}^N] + \max_{P_{ij} = P_{C_{oM}^n}} [-C_{oM}^n B, (a_{ij} - q_{ij}^e)] \right\} \quad (4.18)$$

As a consequence,

$$\Delta r_{tQ} = \Delta r_{tQ} + \sum_k \Delta r_{tQ} + \Delta r_{tQ} \quad (4.19)$$

$C_{oP}^0 \rightarrow C_{oM}^n$ $C_{oP}^0 \rightarrow C_{oP}^1$ $C_{oP}^k \rightarrow C_{oP}^{k+1}$ $C_{oP}^N \rightarrow C_{oM}^n$

.....

If $\{C_{oP}^k\} = \emptyset$

$$\Delta r_{tQ} = \max_{C_{oP}^0 \rightarrow C_{oM}^n} \left\{ \sum_{\substack{v_{ij} \in Q_p \\ P_{ij} \neq P_{C_{oP}^0} \cup P_{C_{oM}^n}}} [a_{ij} - q_{ij}^e] + \max_{P_{ij} = P_{C_{oP}^0}} [-C_{oP}^0 A, (a_{ij} - q_{ij}^e)] + \max_{P_{ij} = P_{C_{oM}^n}} [-C_{oM}^n B, (a_{ij} - q_{ij}^e)] \right\} \quad (4.20)$$

4.2.1.2 The compensable margin of the disturbance rejection group

In the **disturbance rejection token group**, it is possible to control the sojourn time of each token in each place to reduce the disturbance. The compensable margin of the tokens in this group between two successive mixed coupling points can be computed using the following formulas:

Let us denote

Δr_{cQ} the compensable margin the rejection disturbance token group between C_{oP}^0 and C_{oM}^1 , or between C_{oM}^n and C_{oM}^{n+1} ,

C_{oP}^k , the kth pure coupling point between C_{oM}^n and C_{oM}^{n+1} , $k \in \mathbb{N}^+$, $\aleph = \max(k)$,

- Case for a delay disturbance observed on a token

For the compensable margin from C_{oP}^0 to C_{oM}^1

If $\exists C_{oP}^k$,

Robust Control Algorithms

$$\Delta r_{cQ} = \min_{C_{op}^0 \rightarrow C_{op}^1} \left\{ \sum_{v_{ij} \in Q_r} [q_{ij}^e - a_{ij}] + \min_{P_{ij} \neq P_{C_{op}^1}} [C_{op}^1 B, (q_{ij}^e - a_{ij})] \right\} \quad (4.21)$$

$$\Delta r_{cQ} = \min_{C_{op}^k \rightarrow C_{op}^{k+1}} \left\{ \sum_{v_{ij} \in Q_r} [q_{ij}^e - a_{ij}] + \min_{P_{ij} \neq P_{C_{op}^k} \cup P_{C_{op}^{k+1}}} [C_{op}^{k+1} B, (q_{ij}^e - a_{ij})] + \min_{P_{ij} = P_{C_{op}^k}} [C_{op}^k A, q_{ij}^e - a_{ij} - Rc_{ij}^k] \right\} \quad (4.22)$$

s.t.

$$\left\{ \begin{array}{l} Rc_{ij}^1 = \max[0, \Delta r_{cQ} - \sum_{C_{op}^0 \rightarrow C_{op}^1} \sum_{P_{ij} \neq P_{C_{op}^1}} (q_{ij}^e - a_{ij})], k = 1 \\ Rc_{ij}^k = \max \left\{ 0, \Delta r_{cQ} - \sum_{C_{op}^{k-1} \rightarrow C_{op}^k} [q_{ij}^e - a_{ij}] - \min_{P_{ij} \neq P_{C_{op}^{k-1}} \cup P_{C_{op}^k}} [C_{op}^{k-1} A, q_{ij}^e - a_{ij} - Rc_{ij}^{k-1}] \right\}, k \geq 2 \end{array} \right.$$

$$\Delta r_{cQ} = \min_{C_{op}^N \rightarrow C_{om}^1} \left\{ \sum_{v_{ij} \in Q} [q_{ij}^e - a_{ij}] + \min_{P_{ij} \neq P_{C_{op}^N} \cup P_{C_{om}^1}} [C_{om}^1 B, (q_{ij}^e - a_{ij})] + \min_{P_{ij} = P_{C_{op}^N}} [C_{op}^N A, q_{ij}^e - a_{ij} - Rc_{ij}^N] \right\} \quad (4.23)$$

As a consequence,

$$\Delta r_{cQ} = \Delta r_{cQ} + \sum_{C_{op}^0 \rightarrow C_{om}^1} \sum_{C_{op}^0 \rightarrow C_{op}^1} \Delta r_{cQ} + \sum_{C_{op}^k \rightarrow C_{op}^{k+1}} \Delta r_{cQ} + \sum_{C_{op}^N \rightarrow C_{om}^1} \Delta r_{cQ} \quad (4.24)$$

If $\{C_{op}^k\} = \emptyset$,

$$\Delta r_{cQ} = \min_{C_{op}^0 \rightarrow C_{om}^1} \left\{ \sum_{v_{ij} \in Q_r} [q_{ij}^e - a_{ij}] + \min_{P_{ij} \neq P_{C_{om}^1}} [C_{om}^1 B, (q_{ij}^e - a_{ij})] \right\} \quad (4.25)$$

Robust Control Algorithms

For the compensable margin from C_{oM}^n to C_{oM}^{n+1}

If $\exists C_{oP}^k$ between C_{oM}^n and C_{oM}^{n+1} ,

$$\Delta r_{cQ} = \min_{v_{il}} \left\{ \begin{array}{l} \sum_{\substack{p_{ij} \neq p_{C_{oM}^n} \\ \cup p_{C_{oP}^k}}} [q_{ij}^e - a_{ij}] + \min_{\substack{v_{il} \in Q_p \text{ before } C_{oM}^n \\ p_{ij} = p_{C_{oP}^k}}} [C_{oP}^k B, (q_{ij}^e - a_{ij})] + \min_{p_{ij} = p_{C_{oM}^n}} [C_{oM}^n A, q_{ij}^e - a_{ij} + R_{ij}^t] \\ \sum_{\substack{p_{ij} \neq p_{C_{oM}^n} \\ \cup p_{C_{oP}^k}}} [q_{ij}^e - a_{ij}] + \min_{\substack{v_{il} \in Q_r \text{ before } C_{oM}^n \\ p_{ij} = p_{C_{oP}^k}}} [C_{oP}^k B, (q_{ij}^e - a_{ij})] + \min_{p_{ij} = p_{C_{oM}^n}} [C_{oM}^n A, q_{ij}^e - a_{ij} - R_{ij}^c] \end{array} \right\} \quad (4.26)$$

s. t.

$$R_{ij}^t = \left\{ \begin{array}{l} \max[0, \Delta r_{cQ} - (b_{ij} - q_{ij}^e - R_{ij}^t) - \sum_{\substack{p_{ij} = p_{C_{oP}^k} \\ \cup p_{C_{oM}^n}}} (b_{ij} - q_{ij}^e)] \\ \text{or} \\ \max[0, \Delta r_{cQ} - \sum_{p_{ij} \neq p_{C_{oM}^n}} (b_{ij} - q_{ij}^e)] \end{array} \right.$$

$$R_{ij}^c = \left\{ \begin{array}{l} \max[0, \Delta r_{cQ} - \min_{\substack{p_{ij} = p_{C_{oP}^k} \\ \cup p_{C_{oM}^n}}} (C_{oP}^k A, q_{ij}^e - a_{ij} - R_{ij}^c) - \sum_{p_{ij} \neq p_{C_{oM}^n}} (q_{ij}^e - a_{ij})] \\ \text{or} \\ \max[0, \Delta r_{cQ} - \sum_{p_{ij} \neq p_{C_{oM}^n}} (q_{ij}^e - a_{ij})] \end{array} \right.$$

$$\Delta r_{cQ} = \min_{v_{il}} \left\{ \sum_{\substack{p_{ij} \neq p_{C_{oP}^k} \\ \cup p_{C_{oP}^{k+1}}} [q_{ij}^e - a_{ij}] + \min_{p_{ij} = p_{C_{oP}^{k+1}}} [C_{oP}^{k+1} B, (q_{ij}^e - a_{ij})] + \min_{p_{ij} = p_{C_{oP}^k}} [C_{oP}^k A, q_{ij}^e - a_{ij} - R_{ij}^k] \right\} \quad (4.27)$$

s. t.

$$\begin{cases}
 \text{Rc}_{ij}^1 = \begin{cases} \max[0, \Delta r_{cQ} - \min(C_{oM}^n A, q_{ij}^e - a_{ij} + R_{ij}^t) - \sum_{P_{ij} \neq P_{C_{oM}^n} \cup P_{C_{oP}^1}} (q_{ij}^e - a_{ij})] \\ \text{or} \\ \max[0, \Delta r_{cQ} - \min(C_{oM}^n A, q_{ij}^e - a_{ij} - R_{ij}^c) - \sum_{P_{ij} \neq P_{C_{oM}^n} \cup P_{C_{oP}^1}} (q_{ij}^e - a_{ij})] \end{cases}, k = 1 \\
 \text{Rc}_{ij}^k = \max[0, \Delta r_{cQ} - \min(C_{oP}^{k-1} A, q_{ij}^e - a_{ij} - \text{Rc}_{ij}^{k-1}) - \sum_{P_{ij} \neq P_{C_{oP}^{k-1}} \cup P_{C_{oP}^k}} (q_{ij}^e - a_{ij})], k \geq 2
 \end{cases}$$

$$\Delta r_{cQ} = \min_{C_{oP}^N \rightarrow C_{oM}^{n+1}} \left\{ \sum_{P_{ij} \neq P_{C_{oP}^N} \cup P_{C_{oM}^{n+1}}} [q_{ij}^e - a_{ij}] + \min_{P_{ij} = P_{C_{oM}^{n+1}}} [C_{oM}^{n+1} B, (q_{ij}^e - a_{ij})] + \min_{P_{ij} = P_{C_{oP}^N}} [C_{oP}^N A, q_{ij}^e - a_{ij} - \text{Rc}_{ij}^N] \right\} \quad (4.28)$$

As a consequence,

$$\Delta r_{cQ} = \Delta r_{cQ} + \sum_k \Delta r_{cQ} + \Delta r_{cQ} \quad (4.29)$$

.....

If $\{C_{oP}^k\} = \emptyset$,

$$\Delta r_{cQ} = \min_{C_{oM}^n \rightarrow C_{oM}^{n+1}} \left\{ \begin{aligned} & \sum_{P_{ij} \neq P_{C_{oM}^n} \cup P_{C_{oM}^{n+1}}} [q_{ij}^e - a_{ij}] + \min_{P_{ij} = P_{C_{oM}^{n+1}}} [C_{oM}^{n+1} B, (q_{ij}^e - a_{ij})] + \min_{P_{ij} = P_{C_{oM}^n}} [C_{oM}^n A, q_{ij}^e - a_{ij} + R_{ij}^t] \\ & \sum_{P_{ij} \neq P_{C_{oM}^n} \cup P_{C_{oM}^{n+1}}} [q_{ij}^e - a_{ij}] + \min_{P_{ij} = P_{C_{oM}^{n+1}}} [C_{oM}^{n+1} B, (q_{ij}^e - a_{ij})] + \min_{P_{ij} = P_{C_{oM}^n}} [C_{oM}^n A, q_{ij}^e - a_{ij} - R_{ij}^c] \end{aligned} \right\} \quad (4.30)$$

-
- Case for an advance disturbance observed on a token
-

For the compensable margin from C_{oM}^\diamond to C_{oM}^1

If $\exists C_{oP}^k$,

$$\Delta r_{cQ} = \max_{C_o^\circ \rightarrow C_{oP}^1} \left[\sum_{v_{ij} \in Q_r} (q_{ij}^e - b_{ij}) \right] \quad (4.31)$$

$$\Delta r_{cQ} = \max_{C_{oP}^k \rightarrow C_{oP}^{k+1}} \left[\sum_{v_{ij} \in Q_r} (q_{ij}^e - b_{ij}) + (q_{ij}^e - b_{ij} - Rc_{ij}^k) \right] \quad (4.32)$$

s.t.

$$Rt_{ij}^k = \begin{cases} \min[0, \Delta r_{tQ} - \sum_{C_o^\circ \rightarrow C_{oP}^1} \sum_{P_{ij} \neq P_{C_{oP}^k}} (q_{ij}^e - b_{ij})], k = 1 \\ \min[0, \Delta r_{tQ} - (q_{ij}^e - b_{ij} - Rc_{ij}^{k-1}) - \sum_{C_{oP}^{k-1} \rightarrow C_{oP}^k} \sum_{P_{ij} \neq P_{C_{oP}^{k-1}} \cup P_{C_{oP}^k}} (q_{ij}^e - b_{ij})], k \geq 2 \end{cases}$$

$$\Delta r_{cQ} = \max_{C_{oP}^N \rightarrow C_{oM}^1} \left[\sum_{v_{ij} \in Q_r} (q_{ij}^e - b_{ij}) + (q_{ij}^e - b_{ij} - Rt_{ij}^N) \right] \quad (4.33)$$

As a consequence,

$$\Delta r_{cQ} = \Delta r_{cQ} + \sum_{C_o^\circ \rightarrow C_{oM}^1} \Delta r_{cQ} + \Delta r_{cQ} \quad (4.34)$$

.....
If $\{C_{oP}^k\} = \emptyset$

$$\Delta r_{cQ} = \max_{C_o^\circ \rightarrow C_{oM}^1} \left[\sum_{v_{ij} \in Q_r} (q_{ij}^e - b_{ij}) \right] \quad (4.35)$$

For the compensable margin from C_{oM}^n to C_{oM}^{n+1}

If $\exists C_{oP}^k$ between C_{oM}^n and C_{oM}^{n+1} ,

$$\Delta r_{cQ} = \max_{C_{oM}^n \rightarrow C_{oP}^l} \left\{ \begin{array}{l} \sum_{\substack{v_{il} \in Q_p \text{ before } C_{oM}^n \\ p_{ij} \neq p_{C_{oM}^n} \\ p_{ij} = p_{C_{oM}^n}}} [q_{ij}^e - b_{ij}] + [(q_{ij}^e - b_{ij} + R_{ij}^t)] \\ \sum_{\substack{v_{il} \in Q_r \text{ before } C_{oM}^n \\ p_{ij} \neq p_{C_{oM}^n} \\ p_{ij} = p_{C_{oM}^n}}} [q_{ij}^e - b_{ij}] + (q_{ij}^e - b_{ij} - R_{ij}^c) \end{array} \right\} \quad (4.36)$$

s.t.

$$R_{ij}^t = \left\{ \begin{array}{l} \min[0, \Delta r_{tQ} - (q_{ij}^e - b_{ij} - R_{ij}^t) - \sum_{\substack{p_{ij} = p_{C_{oP}^n} \\ p_{ij} \neq p_{C_{oP}^n} \cup p_{C_{oM}^n}}} (q_{ij}^e - b_{ij})] \\ \text{or} \\ \min[0, \Delta r_{tQ} - \sum_{\substack{C_{oP}^n \rightarrow C_{oM}^n \\ p_{ij} \neq p_{C_{oM}^n}}} (q_{ij}^e - b_{ij})] \end{array} \right.$$

$$R_{ij}^c = \left\{ \begin{array}{l} \min[0, \Delta r_{cQ} - (q_{ij}^e - b_{ij} - R_{ij}^c) - \sum_{\substack{p_{ij} = p_{C_{oP}^n} \\ p_{ij} \neq p_{C_{oP}^n} \cup p_{C_{oM}^l}}} (q_{ij}^e - b_{ij})] \\ \text{or} \\ \min[0, \Delta r_{cQ} - \sum_{\substack{C_{oP}^n \rightarrow C_{oM}^n \\ p_{ij} \neq p_{C_{oP}^n}}} (q_{ij}^e - b_{ij})] \end{array} \right.$$

$$\Delta r_{cQ} = \max_{C_{oP}^k \rightarrow C_{oP}^{k+1}} \left[\sum_{\substack{v_{il} \\ p_{ij} \neq p_{C_{oP}^k} \\ p_{ij} = p_{C_{oP}^k}}} (q_{ij}^e - b_{ij}) + (q_{ij}^e - b_{ij} - R_{ij}^k) \right] \quad (4.37)$$

s.t.

$$\left\{ \begin{array}{l} R_{ij}^1 = \left\{ \begin{array}{l} \min[0, \Delta r_{cQ} - (q_{ij}^e - b_{ij} + R_{ij}^1) - \sum_{\substack{p_{ij} = p_{C_{oM}^n} \\ p_{ij} \neq p_{C_{oM}^n} \cup p_{C_{oP}^l}}} (q_{ij}^e - b_{ij})] \\ \text{or} \\ \min[0, \Delta r_{cQ} - (q_{ij}^e - b_{ij} - R_{ij}^c) - \sum_{\substack{p_{ij} = p_{C_{oM}^n} \\ p_{ij} \neq p_{C_{oM}^n} \cup p_{C_{oP}^l}}} (q_{ij}^e - b_{ij})] \end{array} \right. , k = 1 \\ R_{ij}^k = \min[0, \Delta r_{cQ} - (q_{ij}^e - b_{ij} - R_{ij}^{k-1}) - \sum_{\substack{p_{ij} = p_{C_{oP}^{k-1}} \\ p_{ij} \neq p_{C_{oP}^{k-1}} \cup p_{C_{oP}^k}}} (q_{ij}^e - b_{ij})], k \geq 2 \end{array} \right.$$

$$\Delta r_{cQ} = \max_{C_{oP}^N \rightarrow C_{oM}^{n+1}} [\sum_{v_{ij}} (q_{ij}^e - b_{ij}) + (q_{ij}^e - b_{ij} - R_{ij}^N)] \quad (4.38)$$

As a consequence,

$$\Delta r_{cQ} = \Delta r_{cQ} + \sum_k \Delta r_{cQ} + \Delta r_{cQ} \quad (4.39)$$

If $\{C_{oP}^k\} = \emptyset$,

$$\Delta r_{cQ} = \max_{C_{oM}^n \rightarrow C_{oM}^{n+1}} [\sum_{v_{ij}} \left(\sum_{\substack{P_{ij} \neq P_{C_{oM}^n} \\ v_{ij} \in Q_p \text{ before } C_{oM}^n}} [q_{ij}^e - b_{ij}] + [(q_{ij}^e - b_{ij} + R_{ij}^t)] \right) + \left(\sum_{\substack{P_{ij} \neq P_{C_{oM}^n} \\ v_{ij} \in Q_r \text{ before } C_{oM}^n}} [q_{ij}^e - b_{ij}] + (q_{ij}^e - b_{ij} - R_{ij}^c) \right) \right] \quad (4.40)$$

4.2.2 Approach 3: Generation of the parallel similar disturbance as soon as the disturbed is observed

This approach generates a similar temporal shift in the parallel token group as soon as the disturbance is observed in order to avoid the death of tokens on the coupling points. Therefore, constraints violations are avoided. If the disturbance is a delay (an advance), then the temporal shift will be a delay (respectively an advance) obtained by changing the sojourn time of tokens belonging to the parallel similar temporal shift group. The approach 2 can't guarantee the similar temporal shift is given as soon as the disturbance is observed, but the approach 3 can.

Surely, for the tokens in the disturbance rejection group, the rejection control is also given as soon as the disturbance is observed.

Factually, the approach 3 applies two strategies, the rejection of the disturbance in the disturbance rejection group and the generation of the similar temporal shift in the parallel similar temporal shift group. The approach 3 allows:

- To reduce the disturbance by compensable control on the tokens in disturbance rejection group as soon as the disturbance is observed,
- To generate the parallel similar temporal shift on the tokens in the parallel similar temporal shift group as soon as the disturbance is observed.

The computation of the compensable control margin and the parallel similar temporal shift margin can be referred to the formulas in the sections 4.2.1.1 and 4.2.1.2.

4.2.2.1 Algorithm

This is also a recursive algorithm allowing the active rejection of the disturbance as soon as it is observed, while considering an active generation of the parallel similar temporal shift as soon as the disturbance is observed. The number of tokens in the disturbance rejection group increases during the computation progress, conversely, the number of the parallel similar temporal shift groups decreases.

Let us denote

Q_A the set including all the tokens,

Q_r the disturbance rejection group,

C_o^\diamond the time point where the disturbance is initially observed, all the active control should be given after this point,

C_{oM}^n the n th mixed coupling point, $n \in \mathbb{N}^+$,

Q_p^n the parallel similar temporal shift group having a C_{oM}^n with Q_r ,

Δt_0 the local robust margin of the sojourn time of the initially disturbed token in the place p_{ij} , for a delay (an advance) disturbance $\Delta t_0 = b_{ij} - q_{ij}^c$ ($\Delta t_0 = a_{ij} - q_{ij}^c$ respectively),

Δr_{tQ} the transmissible margin of the parallel similar temporal shift group between the C_o^\diamond and a mixed coupling point C_{oM}^n ,

Δr_{cQ} the compensable margin the rejection disturbance token group between C_o^\diamond and C_{oM}^1 , or between C_{oM}^n and C_{oM}^{n+1} .

Robust Control Algorithms

The following algorithm is for the computing a delay disturbance margin. However, the structure of the algorithm for an advance robustness margin is almost the same, which is not discussed in this thesis.

Initialize

Q_r is the set including only the tokens disturbed initially at C_o^\diamond ,

and $n=1$

.....

Margin $\leftarrow \min[\Delta t_0, \Delta r_{cQ} + F(Q_r, C_{oM}^n, \Delta r_{tQ_p^n})]$
 $C_o^\diamond \rightarrow C_{oM}^1$

$F(Q_r, C_{oM}^n, \Delta r_{tQ_p^n})$

{

$Q_r = Q_r \cup Q_p^n,$

$n=n+1,$

If ($Q_r = Q_A$ or $\Delta r_{tQ_p^{n-1}} = 0$) then $F \leftarrow \Delta r_{tQ_p^{n-1}},$

Else

{

$F \leftarrow \min[\Delta r_{tQ_p^{n-1}}, \Delta r_{cQ} + F(Q_r, C_{oM}^n, \Delta r_{tQ_p^n})]$
 $C_{oM}^{n-1} \rightarrow C_{oM}^n$

}

}

4.2.2.2 Description of the algorithm

The algorithm behaves in such a way:

- Select the place where we want to calculate the robustness margin of the sojourn time of the token in this place,
- Build the sets of the initial disturbance rejection group Q_r and the parallel similar temporal shift group Q_p^n ,
- Calculate the compensable robustness margin of the initial disturbance rejection group Δr_{cQ_r} , and the transmissible robustness margin of $\Delta r_{tQ_p^n}$,

- Add the set Q_p^n to the set Q_r , defined as:

$$Q_r = Q_r \cup Q_p^n$$

- Compute the robustness margin with a recursive function:

$$n=n+1$$

$$F \leftarrow \min[\Delta r_{tQ_p^{n-1}}, \Delta r_{cQ} + F(Q_r, C_{oM}^n, \Delta r_{tQ_p^n})]$$

$C_{oM}^{n-1} \rightarrow C_{oM}^n$

- Stop the algorithm if the following condition is satisfied:

$$\text{If } (Q_r = Q_A \text{ or } \Delta r_{tQ_p^{n-1}} = 0) \text{ then } F \leftarrow \Delta r_{tQ_p^{n-1}}.$$

4.2.2.3 Analysis of the algorithm

The above algorithm applies the robustness formulas on all the tokens. The algorithm is based on function F , which is called recursively using a part of the tokens until all the tokens are used by F or one transmissible margin is 0.

The convergence of the algorithm can be proved as follows.

- Since the space status circuit has just one token, this token can couple all the tokens in the process circuits which share the space status circuit in a finite

Robust Control Algorithms

number of cycle time $W_i \cdot C$. W_i is the number of tokens in process circuit G_i . Since all the space status circuits have just one token, the tokens in the process circuits can couple every other token in a finite number of cycle time $\max(W_i) \cdot C$. So, all the tokens can be coupled in a finite number of cycle time $\max(W_i) \cdot C$.

- Since all the tokens are coupled in $\max(W_i) \cdot C$, then, there are a finite number of the coupling points C_o (including the pure coupling points and the mixed coupling points) in this finite number of cycle time. So, the number of the mixed coupling points is also finite in this finite number of cycle time.
- So, F uses a limited number of mixed coupling points C_{oM} recursively until all the tokens are used ($Q_r = Q_A$) or $\Delta r_{t_{Q_p^{n-1}}} = 0$. And the algorithm stops if $Q_r = Q_A$ or $\Delta r_{t_{Q_p^{n-1}}} = 0$. Then, the convergence of the considered algorithm is proved.

The polynomial computation time of this algorithm can be proved as follows.

- Let us denote the number of all the places in PTSCEG as N_p . Considering the repetition of 1-cyclic schedule, these N_p places appear in a cycle time in the Gantt graph. Then, in $\max(W_i) \cdot C$, there are at most $N_p \cdot \max(W_i)$ places. So, there are at most $N_p \cdot \max(W_i)$ coupling points which are the beginning point of the shared places.
- For each coupling point, it should compare among the robustness margins of at most $\sum W_i$ tokens (all the tokens). For each token, on considering at most $N_p \cdot \max(W_i)$ cutting operations on the sojourn time of tokens, there are at most $2N_p \cdot \max(W_i)$ operations (divided by the cutting or not) which are used to compute the transmissible margin or the compensable margin. In total, for computing all the robustness margin of the all disturbance rejection groups or the parallel similar temporal shift groups, the number of the com-

puting operation is $N_p \cdot \max(W_i) \cdot \sum W_i \cdot 2N_p \cdot \max(W_i)$. The complexity of the computing time is $O(n^5)$.

- There are at most $\sum W_i$ mixed coupling points which should be less than the number of all the tokens. Given all the transmissible margin of all the parallel similar temporal shift groups and all the compensable margin of all the disturbance rejection groups, the number of the calculation steps of F to compute the robustness margin of a token in a place is less than $\sum W_i$. So the global complexity of computing time for the algorithm of approach 3 is at most $O(n^7)$.

The above analysis uses some rough approximations which aim to show that the computing time is reasonable. For approach 1 and approach 2, the complexity of computing time of algorithms depend on the number of the transitions, but the algorithm of approach 3 depends on the number of the places in PTSCEG and the number of all the tokens.

4.2.2.4 Illustrative example

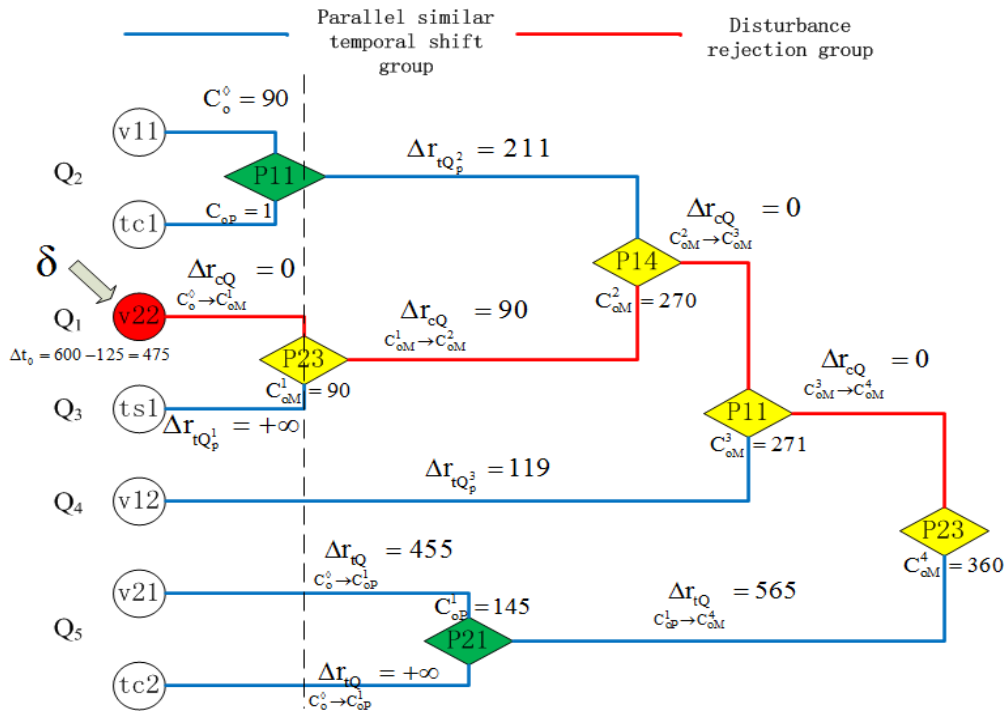

Figure 4.11: The transmissible margin and compensable margin for token groups.

To calculate the robustness margin on t_{22} of PTSCEG in Figure 4.3, it can also be seen as to calculate the robustness margin of the sojourn time of the token v_{22} in the place p_{22} in Figure 4.8.

The Figure 4.11 shows the classification of the tokens, the transmissible margins of the parallel similar temporal shift groups and the compensable margins of the disturbance rejection groups. We apply the algorithm of approach 3 to compute the robustness margin of the token v_{22} which has a delay disturbance observed in the place p_{22} .

Case study

Initialize

$$Q_r = Q_1$$

$n=1$

.....

$$\text{Margin} \leftarrow \min[475, 0 + F(Q_r, C_{oM}^1, \Delta r_{tQ_p^1})]$$

Step 1: Computation of $F(Q_r, C_{oM}^1, \Delta r_{tQ_p^1})$

$$Q_r = Q_r \cup Q_3$$

$n=1+1$

$$F \leftarrow \min[\Delta r_{tQ_p^1}, \Delta r_{cQ} \xrightarrow{C_{oM}^1 \rightarrow C_{oM}^2} + F(Q_r, C_{oM}^2, \Delta r_{tQ_p^2})] = \min[+\infty, 90 + F(Q_r, C_{oM}^2, \Delta r_{tQ_p^2})]$$

Step 1.1: Computation of $F(Q_r, C_{oM}^2, \Delta r_{tQ_p^2})$

$$Q_r = Q_r \cup Q_2$$

$n=2+1$

Robust Control Algorithms

$$F \leftarrow \min[\Delta r_{tQ_p^2}, \Delta r_{cQ} + F(Q_r, C_{oM}^3, \Delta r_{tQ_p^3})] = \min[211, 0 + F(Q_r, C_{oM}^3, \Delta r_{tQ_p^3})]$$

Step 1.1.1: Computation of $F(Q_r, C_{oM}^3, \Delta r_{tQ_p^3})$

$$Q_r = Q_r \cup Q_4$$

$$n=3+1$$

$$F \leftarrow \min[\Delta r_{tQ_p^3}, \Delta r_{cQ} + F(Q_r, C_{oM}^4, \Delta r_{tQ_p^4})]$$

$$= \min[119, 0 + F(Q_r, C_{oM}^4, \Delta r_{tQ_p^4})]$$

Step 1.1.1.1: Computation of $F(Q_r, C_{oM}^4, \Delta r_{tQ_p^4})$

$$Q_r = Q_r \cup Q_4$$

$$n=4+1$$

$$Q_r = Q_A$$

$$F \leftarrow (455 + 565) = 1020$$

Algorithm stops

Margin $\leftarrow 209$

The active robustness margin of sojourn time of v_{22} in p_{22} is 209. If any delay disturbance is less than 209, a false alarm can be avoided. The system can recover to the initial 1-cyclic schedule without death of the tokens at the level of coupling points, if giving an active robust control.

Let $\delta = 209$ be a delay disturbance observed on v_{22} in p_{22} in Figure 4.11. Factually, between p_{14} and p_{23} in S1 space status circuit, there is a free status place sf_{12} with a $+\infty$ transmissible margin. So, the delay can be transmitted to the place p_{23} by C_{oM}^1 . Then, from the first mixed coupling point to the second, the disturbance is reduced to 119 with $\Delta r_{cQ} = 90$. The transmissible margin of token group Q_2 is $C_{oM}^1 \rightarrow C_{oM}^2$.

211>119. So, the residue of the disturbance 119 can be transmitted to p_{14} by C_{oM}^2 . There is no disturbance rejection between the second and third mixed coupling points, because the compensable margin is 0. The transmissible margin of Q_4 is 119. The residue 119 can be transmitted to p_{11} by C_{oM}^3 . There is also no rejection of disturbance between C_{oM}^3 and C_{oM}^4 because of $\Delta r_{C_{oM}^3 \rightarrow C_{oM}^4} = 0$. But the residue 119 can be

transmitted to p_{23} passing C_{oM}^4 , because the transmissible margin of Q_5 is $\Delta r_{C_{oM}^4} = \min(455, +\infty) + 565 = 1020$. After the mixed coupling point C_{oM}^4 , all the to-

kens in the system can run in the initial 1-cyclic schedule without any token death. All the tokens are still delayed with the same disturbance 119. In other words, the 1-cyclic schedule is delayed for 119 unit time overall. The residue 119 can always be neglected considering the infinite repetition of 1-cyclic schedule. However, the residue may be rejected to 0 if the compensable margin between the pure coupling points for all the tokens in Q_A is computed. In a cycle time, the total compensable margin is

$$\sum_k \Delta r_{C_{op}^k \rightarrow C_{op}^{k+1}} \geq 0 . \text{ In a finite number of cycles, the residue is reduced to 0, if}$$

$$\sum_k \Delta r_{C_{op}^k \rightarrow C_{op}^{k+1}} > 0 .$$

4.2.3 Comparisons with Approach 1 and Approach 2

Concerning the robustness margin, let us take the robustness margin of token v_{22} in p_{22} as samples to make the comparisons,

- Let us denote example in Figure 4.3 as E1 which has concentrated paths in the process circuits. The result of the illustrative example in section 4.2.2.4 shows the robust margin of approach 3(Margin 3=209) is better than approach 1(Margin 1=163), but worse than approach 2(Margin 2=213).
- Let us denote example in Figure 3.1 as E2 which has no concentrated paths in the process circuits. For this example, the 1-cyclic schedule can be given in Figure 4.12. Applying the three approaches on E2, Margin 3=209 and Margin 1=Margin 2=213, the approach 3 is worse than the other two approaches.

Robust Control Algorithms

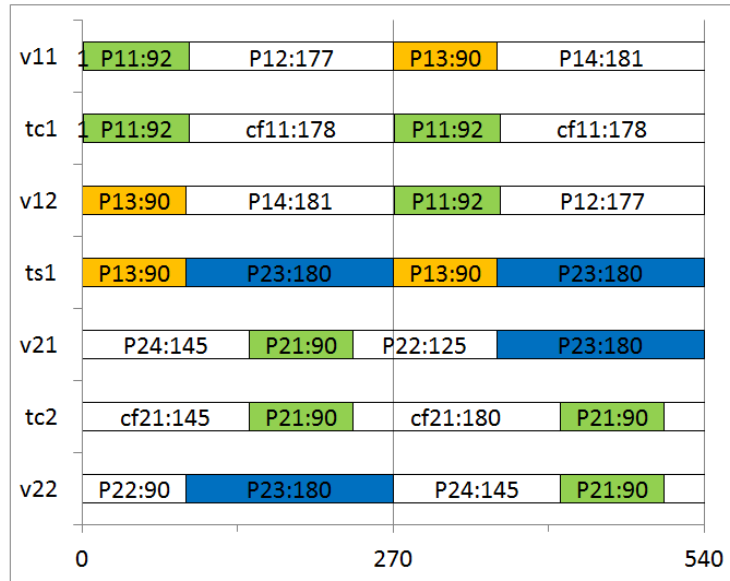

Let us suppose, on the back route of empty AIVs from S1 o C1, a regular maintenance is inserted. It is reasonable to increase the upper bound of the time windows of the route places on considering the extra maintenance time. We modify the upper bound of time windows as 300 for p_{15} and p_{16} in E1, and the upper bound of time window as 600 for p_{14} in E2.

- Let us denote the E1 with modified time window as E3. Applying the three approaches on E3 to compute robustness margin of token v_{22} in p_{22} , Margin 3=301, Margin 1=163 and Margin 2=213, the approach 3 is better than the other two approaches.
- Let us denote the E2 with modified time window as E4. Applying the three approaches on E4 to compute robustness margin of token v_{22} in p_{22} , Margin 3=301, Margin 1= Margin 2=213, the approach 3 is better than the other two approaches.

The comparison result can be summarized in the Table 4.3. In total, the approach 2 is better than approach 1 as discussed in details in the section 4.1.4. Anyway, the approach 3 is hard to be evaluated. Its performance depends on the setting of the bounds of the time windows. Comparing to approach 1 and approach 2, the approach 3 has one obvious advantage that it can give the parallel similar temporal shift as soon

Robust Control Algorithms

as the disturbance is observed. This advantage increases the transmissible margins. The other two approaches can't guarantee the parallel similar control is given just after the appearance of the disturbance. However, the approach 3 has also a disadvantage. During the coupling progress, the tokens are tied up to a unique set gradually. The liberty to change the sojourn time of the tokens is somehow restricted, which causes the decrease of transmissible margin or compensable margin sometimes. Thus, the advantage increasing the robust margin and the disadvantage decreasing the robust margin make the performance of approach 3 strongly depend on the setting of example's time windows.

Table 4.3: The robustness margins of 3 approaches

Examples	Margin 1	Margin 2	Margin 3
E1	163	213	209
E2	213	213	209
E3	163	213	301
E4	213	213	301

Concerning the complexity of computing time, the approach 1 is about $O(n^4)$, approach 2 is less than $O(n^6)$ and approach 3 is less than $O(n^7)$. It should be noticed that, for approach 1 and approach 2, n stands for the number of transitions, but for approach 3, n stands for the number of tokens and places. All of these 3 approaches can give a robustness margin on a node in PTSCEG in polynomial time. If the system is not very complex, the computing time should be acceptable from real industrial application viewpoint, such as the medium-sized seaport container transit procedures studied in our work. As shown in Figure 2.10, the number of transitions, the number of places and the number of tokens are accountable, so the three algorithms are reasonably applicable.

Concerning the complexity of control on all the tokens to deal with the disturbance, the approach 1 and the approach 2 focus on the control the firing time of the transitions. By these two approaches, it is possible to evaluate the influence of the disturbance for all the tokens in system by the semantic definition of PTSCEG, but it

is not obviously shown in the relative algorithms. However, the approach 3 has a Gantt graph structure base, and all the tokens are taken into account to compute the robustness margin. Comparing the approach 1 and approach 2, the approach 3 makes it easier to evaluate of the disturbance's influence on the whole system. On the management level in real industrial processes such as the control on the AIVs, it is interesting to know directly the influence of disturbance for each AIV or cranes. From the viewpoint of container transit manager, the approach 3 may be more attractive than the other two approaches

4.3 Conclusion

In this chapter, we present three approaches to compute the robustness margin on a node of container transit system. Concretely, approach 1 and approach 2 are based on modifying the algorithms in (Collart-Dutilleul et al., 2013, Mhalla et al., 2013b). These two modified algorithms are more suitable to the container transportation procedures. In addition, the modified algorithm includes a new sophisticated definition of active control on concentrated parallel path which avoids the extra disturbances caused by the active parallel control (see in **Definition 4.9**). The algorithm 3 is totally a new contribution. Theoretically, these methods can be applied to any manufacturing systems modeled by PTSCEG which are not very complex. If the disturbance of AIVs or cranes is located in the robustness margin, it is can be reduced by active control on changing the firing time of transitions (the passing time of signal points) or changing the sojourn time of tokens (the staying time of AIVs). And the container transit procedure can recover to its initial 1-cyclic schedule mode without rescheduling.

Three robustness margin algorithms are convergent and have polynomial computing time. For a system not very complex, such as the container transit procedures in a medium sized seaport, the number of the nodes, the number of the tokens and the number of the places are not so large. So, the computing time for the robustness margin on the nodes of system is acceptable. Before the arrival of the vessels, it is possible to give a cyclic schedule with known robustness margin of each node on the designed routing plan. So, the robust cyclic scheduling can be seen as a predictable scheduling. When the container transit task begins, the cyclic schedule is used. If a disturbance is located in the robustness margin, we reduce it by robustness algorithms. If not, we may reschedule the task by MIP in just a few seconds. Thus, the robust cy-

Robust Control Algorithms

cluc scheduling can be also seen as a reactive scheduling dealing with the disturbance in real time.

However, the three algorithms have their own properties individually. The complexity of computing time for approach 1, approach 2 and approach 3 are $O(n^4)$, $O(n^6)$ and $O(n^7)$ respectively. The approach 2 is better than approach 1 at the level of robustness margin because of a parallel similar temporal control on the parallel concentrated paths. For the container transit procedure, if more signal points are set on the route to help locate the position of AIVs, the approach 2 has better performance than approach 1. More signal source points imply more accuracy to locate the position of AIVs, which improve the safety management of the system. The approach 3 can give the parallel similar temporal control when the disturbance is observed, which increase the transmissible margins. But the approach 3 loses liberties of changing the sojourn time of the tokens during the coupling progress, which decreases the transmissible margins or the compensable margins. The robustness margin of approach 3 is not determined to be better than the other two approaches. The robustness margin of approach 3 depends on the setting of time windows of system. But the approach 3 can directly give an evaluation of the influence of the disturbance for all the tokens (the AIVs in the container transit example) in system, which maybe more interesting to the manager of real industrial processes.

Chapter 5 Conclusions and Perspectives

Conclusions

In this thesis, we present a robust control 1-cyclic scheduling methodology for the container transit procedures in a medium sized seaport. This methodology is proved to be applicable, practical and efficient in the robust supervision and management of automated intelligent transport system in the small and medium sized container terminals.

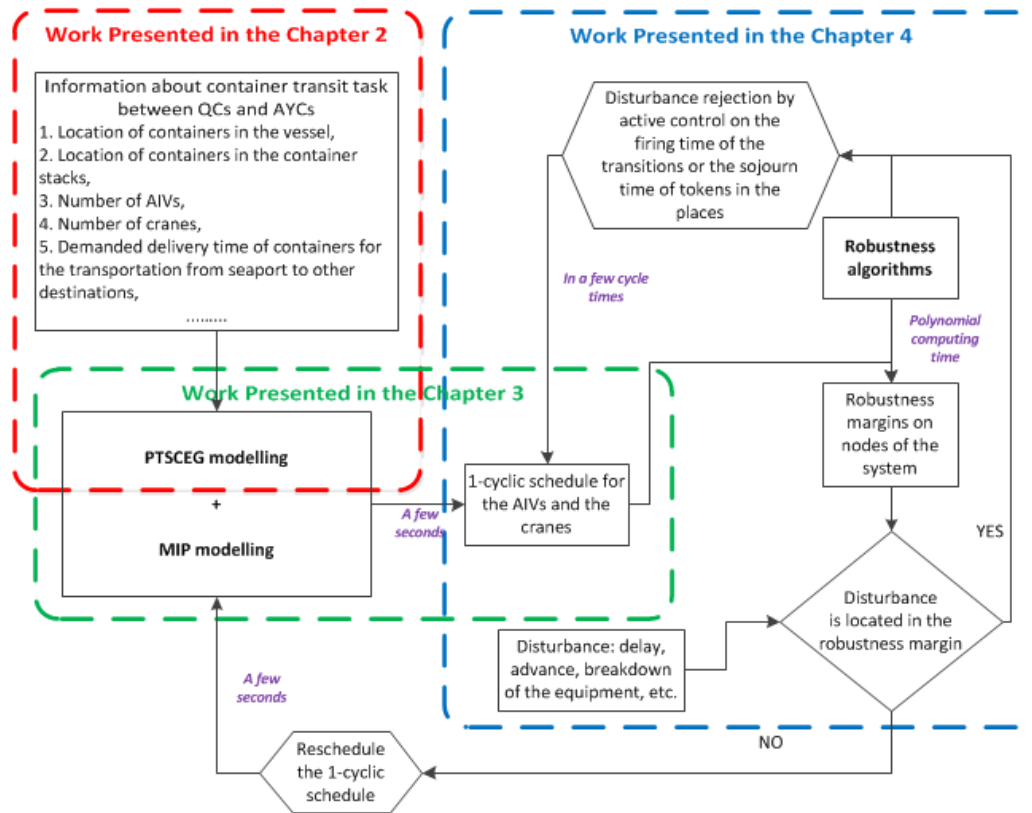

Figure 5.1: The structure and procedures of robust cyclic methodology.

With the known information about the container transit task, the **PTSCEG modelling** and the **MIP modelling** can give the cyclic schedule in short time before the

Conclusions and Perspectives

arrival of vessels. At the same time, the robustness margins of this cyclic schedule can be quickly computed by using **the robustness algorithms**. When the stevedoring begins, the containers are transported by the AIVs with the given cyclic schedule. If a delay or an advance disturbance is observed in the transit procedure, we compare this observed disturbance with the given robustness margin. If the disturbance is located in robustness margin, we use the robustness algorithms to reduce or eliminate the disturbance in a few cycle times. If the disturbance is out of the robustness margin, we use the MIP modelling technique to compute a new cyclic schedule in short time. Thus, our robust cyclic scheduling methodology is not just a predictable scheduling, but can be also seen as a reactive scheduling in real time. Our work content and the procedures of robust cyclic scheduling methodology are shown in Figure 5.1.

Our work makes some contributions both for academic research and for the real industrial application.

From the academic view, first, the container transit procedure in a medium sized seaport is modelled by PTSCEG which is always used in the job-shop problem modelling before our work. Second, 1-cyclic scheduling problem with time windows and transport resource (AIV) in a medium sized seaport is solved by MIP technique in a short time. Before our work, the MIP is usually seen in the cyclic job-shop scheduling problem. In these job-shop problems, the transport resources are always neglected. The third, the robust algorithms used for manufacturing problems in (Collart-Dutilleul et al., 2007, Mhalla et al., 2013b) are modified to be better suitable for the robust control on AIVs in container transit procedures. The fourth, a new algorithm having a structure base in Gantt graph is proposed. Using the new algorithm, it is much easier to evaluate the influence of the disturbance for each token in system. Totally speaking, we do offer some references to the researcher who wants to extend the utilities of PTSCEG, MIP modelling and robust cyclic scheduling in different industrial area. Moreover, we give new ideas about how to study the robust control of tokens in schedule presented by Gantt graph.

From the real industrial view, considering the background of our work, the In-TraDE project, first we optimize the traffic flow within the confined spaces of small and medium sized ports with overall optimal cycle time (the reciprocal of productivity). Second, we use as few AIVs as we can finish the container transit task, which improves the clean production in container terminal with less energy cost. The third,

Conclusions and Perspectives

we develop new algorithms for robust supervision of automatic intelligent transportation system to reduce or eliminate the disturbances. The fourth, we propose a new and complete methodology which can improve the efficiency whilst ensuring safety. We are not sure the cyclic scheduling is strictly better than the other scheduling methods in an idealized environment without disturbance, but the robust cyclic scheduling may lead a better performance of the overall productivity on taking the unpredictable and inevitable perturbations into account for a complex seaport environment.

Perspectives

In the future, we propose the following interesting directions raised by this thesis:

- In the section 2.4.4, we present the intersection modelling using PTSCEG. Factually, the intersections of the AIVs' routes can be seen as the crossroads in cities or towns. It is possible to extend this intersection modelling to study the control of the traffic lights of crossroads. And the transport network can be seen as the intersections plus the routes among intersections. It is possible to use the PTSCEG modelling techniques to model and to study the intelligent control of the traffic in smart cities or districts.
- The 1-cyclic scheduling method presented in Chapter 3 can be applied to more examples to verify its efficiency for systems are more complex.
- In Chapter 3 and Chapter 4 , comparing to the almost infinite repetitions of 1-cyclic schedule in steady state, we neglect the transient period of two 1-cyclic schedules which is presented in (Calvez et al., 1998, Bourdeaud'huy et al., 2011). But, it is still interesting to study the robust control algorithm which can also be applied in the transient period of cyclic schedules.
- The algorithm of approach 3 can insert the parallel similar temporal shift as soon as the disturbance is observed, which can increase the transmissible margins. But the coupling of tokens limits the changing of tokens' sojourn time, which decreases the compensable margins and transmissible margins. It is interesting to make a modification of algorithm 3 to weaken the influence of the coupling operation while the modified one can still insert the parallel active control as soon as the disturbance is observed. It is possible to

Conclusions and Perspectives

have a modified algorithm 3 which is absolutely better than algorithm 2 on the level of robustness margin.

- The robust control approach 3 is a recursive convergent strategy with computing operation on the coupling points of shared places in the Gantt graph, which is not like the approach 1 and approach 2 based on the PTSCEG. The approach 3 can be applied on a cyclic schedule, but non-cyclic schedule too. The structure base of approach 3 is Gantt graph. For the non-cyclic schedule presented by Gantt graph, it also has the shared places with coupling points if shared machines or other shared resources are used in this schedule. If it is possible to make the products of non-cyclic schedule coupled in a finite time. Then, it is possible to extend the algorithm of approach 3 to non-cyclic schedule robust control.
- The robustness algorithms have just been applied on manufacturing system in (Collart-Dutilleul et al., 2007, Collart-Dutilleul et al., 2013, Mhalla et al., 2013a, Mhalla et al., 2013b) and on the container transit system in this thesis. Considering the polynomial complexity for computing time, it is possible to apply the algorithms in the robust control of intelligent traffic management in smart cities, the supply chains, the aircraft scheduling in airports etc. which always face the time disturbance from inner or outer environment maybe causing a violation in the confined shared spaces.
- There are still a lot of works for realizing the real automated intelligent transportation in container terminals, such as the protocol conformance of intelligent devices, the coordination and conflict of man-driven vehicles and AIVs in the operations space, the implementation of our methodology into the real control system of AIVs, etc.

Appendices

The new model (call it NMW) for work in progress (WIP) minimization in (Zhang et al., 2014) has only 4 constraint families, on considering 7 families in model (Bourdeaud'Huy and Korbaa, 2006) (call this model MBK); The models (call it NMC) for cycle time minimization in this paper (Zhang et al., 2014) has only 5 constraint families, on considering 8 constraint families in model in (Ben Amar et al., 2011) (call this model MAR). The models in the paper (Zhang et al., 2014) shorten obviously the computing time as shown in Table 1 and Table 2.

Table 1. Computing time for WIP minimization

Model	Processing time t (s)										\bar{t}
NMW	0.07	0.12	0.06	0.09	0.10	0.04	0.10	0.07	0.07	0.07	0.079
MBK	0.15	0.20	0.21	0.24	0.17	0.15	0.15	0.17	0.15	0.24	0.183

Table 2. Computing time for cycle time minimization

Model	Processing time t (s)										\bar{t}
NMC	0.07	0.12	0.10	0.12	0.12	0.12	0.10	0.09	0.12	0.10	0.106
MAR	0.14	0.15	0.14	0.17	0.15	0.12	0.12	0.17	0.20	0.17	0.153

The gain for computing time can be calculated by the following formulation (Ben Amar et al., 2007).

$$Gain = 100 * \left(\frac{Computing\ time\ using\ original\ model}{Computing\ time\ using\ new\ model} - 1 \right)$$

Gain for Table 1:

$$Gain = 100 * \left(\frac{0.183}{0.079} - 1 \right) = 131.65$$

Gain for Table 2:

$$Gain = 100 * \left(\frac{0.153}{0.106} - 1 \right) = 44.34$$

The 1-cyclic schedules for WIP minimization found by NMW and MBK are shown in the following figures.

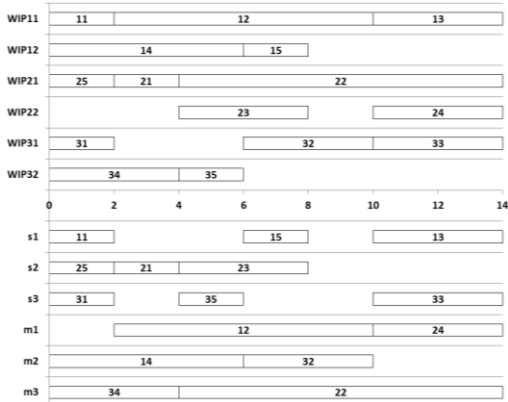

Fig.1.a. Schedule achieved by NMW

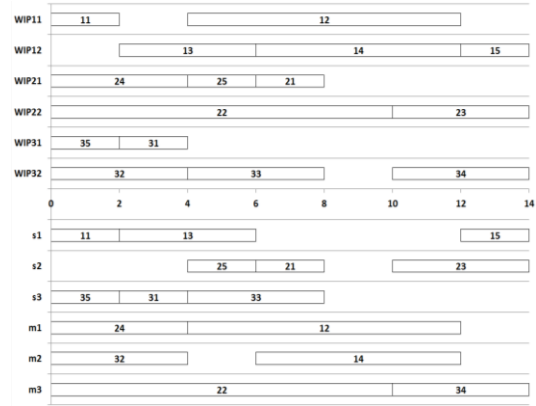

Fig.1.b. Schedule achieved by MBK

The 1-cyclic schedules for minimizing cycle time found by NMC and MAR are shown in the following figures.

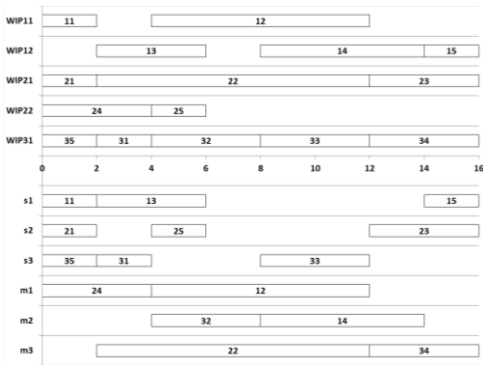

Fig.2.a. Schedule achieved by NMC

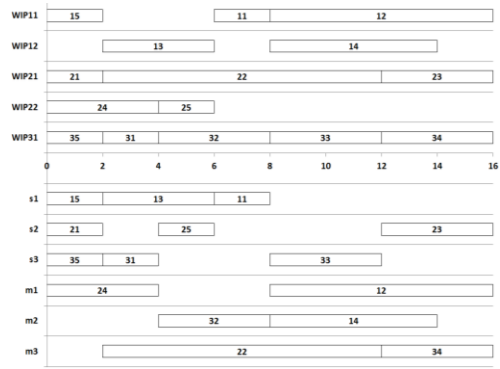

Fig.2.b. Schedule achieved by MAR

The readers interested in the description of the problem and the details about the MIP constraints may consult in (Zhang et al., 2014).

Glossary

- G : the PTSCEG model
- G_i : i th elementary circuit represents the process circuit or the space status circuit, $i \in \mathbb{N}^+$
- p_{ij} : j th place of G_i , the places stand for the operation space of QCs, AYCs, the intersections, the paths, and the free status of a shared space $j \in \mathbb{N}^+$
- t_{ij} : j th transition of G_i
- ${}^{\circ}p_{ij} (p_{ij}^{\circ})$: the input (output) transition of p_{ij}
- V_{il} : the l th token for G_i , $l \in \mathbb{N}^+$
- s_{ij} : entering date of one token in p_{ij} , $s_{ij} \geq 0$
- q_{ij} : the sojourn time of one token in p_{ij} , $q_{ij} \geq 0$
- q_{ij}^e : the expected sojourn time of tokens to realize the demanded cycle time of system, $q_{ij}^e \geq 0$
- a_{ij} : the lower bound of q_{ij} , $a_{ij} \geq 0$
- b_{ij} : the upper bound of q_{ij} , $b_{ij} \geq 0$
- W : total number of tokens in G , $W \in \mathbb{N}^+$
- W_i : the number of tokens in G_i , $W_i \in \mathbb{N}^+$
- W^{limit} : the limit number of tokens in G , $W^{\text{limit}} \in \mathbb{N}^+$
- W_i^{limit} : the limit number of tokens in G_i , $W_i^{\text{limit}} \in \mathbb{N}^+$
- C : variable stands for cycle time of G , $C > 0$
- C_i : variable stands for cycle time of circuit G_i , $C_i > 0$

-
- C^{\min} : the minimal cycle time of G , $C^{\min} > 0$
 - C^{\max} : the maximal cycle time of G , $C^{\max} > 0$
 - I : $I = \max \{i\}$, the number of G_i
 - J_i : number of places for G_i
 - β_{ij} : Boolean variable
 - $\gamma_{ij}^{i,j}$: Boolean variable
 - C_{ms} the set of mono-synchronised sub-paths,
 - C_{se} the set of elementary mono-synchronised sub-paths,
 - n the transition node where the disturbance is observed,
 - Δn_{\max} the local active robustness of the node n ,
 - F the recursive function in algorithm,
 - Δr_t^i the value of Δr_{t_k} when F was used the i th time.
 - δ_c delays generated on the controlled transition firings on the concentrated parallel path
 - C_o^\diamond the time point where the disturbance is initially observed, all the active control should be given after this point,
 - C_{oM}^n the n th mixed coupling point, $n \in \mathbb{N}^+$
 - Δr_{tQ} the transmissible margin of the parallel similar temporal shift group between the C_o^\diamond and a mixed coupling point C_{oM}^n ,
 - Δr_{cQ} the compensable margin the rejection disturbance token group between C_o^\diamond and C_{oM}^1 , or between C_{oM}^n and C_{oM}^{n+1} ,

-
- C_{op}^k the k th pure coupling point between C_o^\diamond and C_{oM}^n , $k \in \mathbb{N}^+$,
 $\aleph = \max(k)$,
 - p_{C_o} the operation of tokens cut by the coupling point C_o ,
 - C_oB the cutting part of p_{C_o} before C_o ,
 - C_oA the cutting part of p_{C_o} after C_o
 - Q_r the disturbance rejection token group,
 - Q_p The parallel similar disturbance token group



Résumé étendu en Français

Introduction

La contribution principale dans ce travail de thèse concerne la méthodologie de planification cyclique robuste appliquée aux systèmes de transport de conteneurs à l'aide de véhicule intelligent automatisée (AIV) dans les ports de taille moyenne. Nous avons effectué ce travail dans le cadre du projet Européen nommé 'InTraDE' (Intelligent Transportation for Dynamic Environment, 2009-2013)

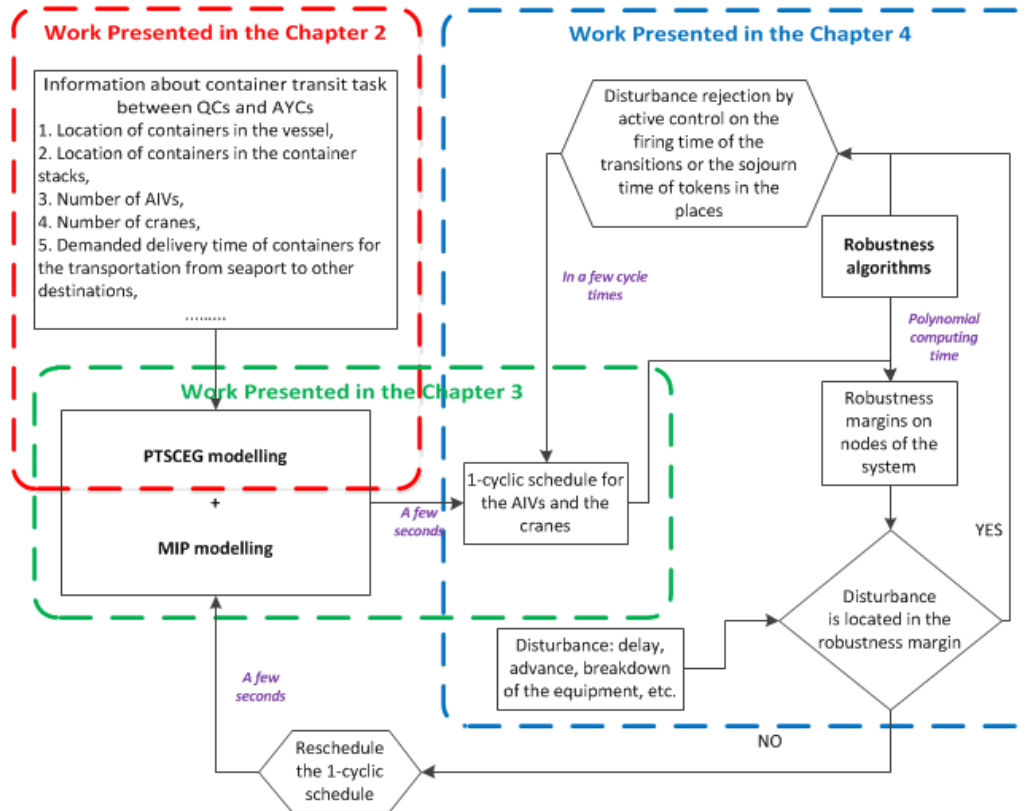

Figure 1 : Structure et méthodologie cyclique robuste.

La méthode de planification cyclique robuste que nous utilisons fonctionne de la manière suivante : l'emplacement des conteneurs sur les bateaux et sur les piles de triage peut être connu à l'avance, au moins quelques heures avant l'arrivée des navires à quai dans un port de taille moyenne. Comme le montre la figure 1. Sachant

que les informations concernant les tâches de transit de conteneurs sont connues, les graphes d'évènement P-temporels fortement connexes (**PTSCEG**) et la programmation mixte en nombres entiers (**MIP**) sont utilisées afin de trouver un ordonnancement cyclique 'optimale' dans un temps relativement court et ceci avant l'arrivée des navires à quai. Dans le même temps, **l'algorithme de robustesse** sera utilisé pour calculer rapidement les marges de robustesse pour cet ordonnancement cyclique. Lorsque la manutention commence, les conteneurs sont transportés par les AIV conformément à l'ordonnancement cyclique proposé. Si une perturbation (retard ou avance) est observée dans la procédure de transit, nous comparons cette perturbation observée avec la marge de robustesse calculée précédemment. Dans le cas où elle est située dans la marge de robustesse, elle pourra être réduite ou éliminée en quelques cycles grâce à l'algorithme de robustesse. Par contre, si elle est en dehors de la marge de robustesse, nous utilisons dans ce cas, la MIP pour trouver un nouvel ordonnancement cyclique en un temps relativement court. Ainsi, la méthodologie d'ordonnancement cyclique robuste que nous proposons est non seulement un ordonnancement prédictive mais également une méthodologie d'ordonnancement réactive en temps réel.

Cette thèse est composée de cinq chapitres organisés de la manière suivante:

Dans le chapitre 1, nous exposons un état de l'art et une étude bibliographique mettant l'accent sur trois aspects

- La pertinence de l'application d'une supervision et un management robuste pour le transport automatisé et intelligent dans les ports de taille moyenne,
- Les possibilités ainsi que les avantages à l'application d'un ordonnancement cyclique pour le contrôle robuste,
- Les raisons des différents choix de méthodes ou outils mathématiques comme PTSCEG, MIP et algorithmes de robustesse.

Le chapitre 2 se focalise sur la modélisation du système en utilisant les graphes d'évènement P-temporels fortement connexes (PTSCEG).

Dans le chapitre 3 nous traitons en se basons sur la description donnée par PTSCEG, une modélisation mathématique nommée MIP du système qui permet de calculer les temps de séjours des tâches dans les fenêtres de temps. L'utilisation du

CEPEX, permet de trouver un ordonnancement 1-cyclique ‘optimal’ en un temps réduit.

Le chapitre 4 détaille la combinaison de commande robuste et ordonnancement cyclique. Trois algorithmes sont proposés. Tous ces algorithmes ont un temps de calcul polynomial.

Le chapitre 5 conclut les contributions et les originalités de cette thèse. Des perspectives intéressantes pour la poursuite des travaux sont également proposées.

Chapitre 1 Etat de l’art

Partant du fait que la gestion des conteneurs dans les ports maritimes de taille moyenne est en constante évolution, en effet, la variation des conditions des terminaux, la visibilité réduite sur des événements futurs ne permet pas de proposer une planification précise des tâches à accomplir. Une surveillance accrue des systèmes de transport intelligent automatisée utilisée dans ces espaces de fonctionnement confinés est demandée afin d’éliminer toute perturbation. Les opérations de chargement/déchargement ou de transit peuvent être considérées comme des opérations répétitives, de ce fait, un ordonnancement cyclique sera utilisé pour proposer une planification de ce type de problème. En plus, il sera plus aisé d’appliquer une commande robuste sur un ordonnancement cyclique que sur son équivalent non-cyclique ainsi que de contrôler une activité régulière que stochastique.

Malheureusement, peu de littérature traite le sujet de l’ordonnancement cyclique robuste pour le transport des conteneurs par des véhicules intelligents automatisés (AIV) dans les ports maritimes. Néanmoins, la revue de littérature et l’état de l’art que nous avons effectué dans le cadre de cette thèse, se base sur une étude large et généralisée des outils et méthodes utilisés dans divers domaines de recherches plus ou moins proche du problème que nous traitons. Cependant, nous nous sommes plus intéressés aux articles et travaux concernant l’ordonnancement cyclique et le contrôle robuste des problèmes d’ordonnancement d’atelier du type job-shop. Certains de Ces problèmes sont similaires aux procédures et opérations effectuées dans les terminaux à conteneurs. En effet, il est tout à fait convenable de considérer les produits comme des conteneurs, les transferts comme des AIVs, les machines comme des grues ou des

intersections, etc. Cette similitude implique la possible transférabilité des méthodes et outils mathématique appliqués à l'ordonnement d'atelier à notre problème de transit automatisé des conteneurs. Ces outils mathématiques incluent PTSCEG, MIP et les Algorithmes de Robustesse.

Chapitre 2 Graphe d'évènement P-temporels fortement connexes

(PTSCEG): Techniques de modélisation

Dans notre travail nous devons considérer le domaine temporel des opérations, En effet, les AIVs ont un temps de séjour à passer dans les espaces confinés de fonctionnement et sur des temps de parcours pour relier les différents points. L'utilisation des PTSCEG, basé sur les réseaux de Petri P-temporels s'avère nécessaire pour modéliser les fenêtres de temps des périodes de séjour des AIVs. Les PTSCEG avec leur qualité de graphe d'évènements fortement connexe ont la possibilité de définir les bornes (limites) du temps de cycle (C'est-à-dire l'inverse de la productivité) et le nombre de jetons (c'est-à-dire pour nous, le nombre d'AIV ou de grue). Les bornes ainsi définie, peuvent réduire le temps de calcul de l'ordonnement de cyclique. Il est à noter également qu'il existe des algorithmes de calcul de robustesse matures basés sur le calcul structurel des PTSCEG

Dans ce chapitre et s'agissant des procédures de transit des conteneurs, il a été démontré que les PTSCEG peuvent ainsi modéliser les fenêtres de temps, les routes, les intersections, l'espace partagé de fonctionnement des grues et le ratio de transit des conteneurs sur les routes. Comparativement aux problèmes du job-shop qui apparait dans de nombreux (Collart-Dutilleul et al., 2007, Mhalla et al., 2008, Jerbi et al., 2009, Collart-Dutilleul et al., 2013, Mhalla et al., 2013a, Mhalla et al., 2013b), dans cette thèse, le PTSCGE est principalement utilisé pour modéliser le transit (déplacement) des conteneurs. Le modèle que nous proposons représente une base graphique pour la modélisation mathématique MIP et les algorithmes de calcul de robustesse.

Chapitre 3 Programmation mixte en nombres entiers (MIP):

Techniques de modélisation

Dans le chapitre 2, nous avons utilisé la modélisation PTSCEG pour modéliser les problèmes de transport de conteneurs. Dans un modèle de procédé effectué à l'aide d'un PTSCEG, deux types de circuits élémentaires existent, circuit de processus (de traitement) et circuit de statut de l'espace. Partant du fait que l'ordonnancement cyclique est NP-hard, de nombreux chercheurs s'orientent vers l'utilisation des heuristiques pour la résolution de ce type de problème. Mais ces techniques et méthodes ne conduisent pas à une solution optimale et peuvent consommer beaucoup de temps. Nous présentons dans ce travail, une méthode simple mais efficace pour modéliser et résoudre l'ordonnancement 1-cyclique. En se basant sur la structure du modèle PTSCEG, le MIP est utilisé pour décrire les activités des jetons de différents types de circuits élémentaires en un temps de cycle. Ensuite, pour l'établissement de l'ordonnancement cyclique et réduire la charge de travail pour la programmation, les contraintes sont programmées directement dans CPLEX.

Ce chapitre montre que la méthode MIP utilisant CPLEX peut être bien appliquée pour calculer (trouver) dans un laps de temps relativement court un ordonnancement 1-cyclique pour les opérations de transit des conteneurs dans un port maritime de taille moyenne. Cette méthode (technique) peut facilement être implémentée dans la gestion réelle des AIVs compte tenu de la bonne compatibilité du CPLEX.

Les informations concernant les positions des conteneurs sur les bateaux et sur les piles de triage peuvent être connu à l'avance, au moins quelques heures avant l'arrivée des navires à quai. La technique de modélisation MIP a besoin de très peu de temps, juste quelques secondes pour proposer un ordonnancement cyclique. Ainsi, elle pourra être utilisée comme une méthode d'ordonnancement prédictive pour ordonnancer le transit cyclique des conteneurs et cela plusieurs heures avant la manutention. Lorsque les opérations de chargements ou de déchargement débutent, les AIVs ne restent généralement que quelques minutes sur les routes ou sur les espaces des opérations. Ainsi, le temps de calcul pour un réordonnancement par MIP est négligeable si une perturbation retard/avance est observée. La méthode MIP peut

également être qualifiée d'ordonnancement réactif, en effet, elle permet de proposer un réordonnancement cyclique en temps réel si le besoin se fait sentir.

Chapitre 4 Commande robuste pour l'ordonnancement 1-cyclique

L'utilisation du MIP permet l'obtention d'un ordonnancement 1-cyclique en un temps réduit. Ainsi, le temps de séjour des AIVs dans chaque place pour être donné correctement permettant d'obtenir une productivité globale optimale. En conséquence, les algorithmes de robustesse peuvent être utilisés sur le PTSCEG ou les diagrammes de Gantt, qui se basent sur les temps de séjour et les fenêtres de temps des opérations.

Ce chapitre présente trois types d'algorithmes de contrôle robuste pour l'ordonnancement 1-cyclique des tâches de transit des conteneurs. Les deux premiers types sont directement basés sur le contrôle structural des temps de franchissement des transitions dans le modèle PTSCEG. Alors que le troisième type est basé sur le contrôle de la durée de vie des jetons dans les diagrammes de Gantt

Les trois algorithmes de calcul des marges de robustesse sont convergents et ont un temps de calcul polynomial. La gestion des transits des conteneurs dans un port maritime de taille moyenne, est un système peu complexe comme, en effet, le nombre de nœuds, le nombre de jetons ainsi que le nombre de place ne sont très important. Ainsi, le temps de calcul des marges de robustesse dans les nœuds du système est acceptable. Avant l'arrivée des navires à quai, il est possible de calculer les marges de robustesse pour chaque nœud du dit ordonnancement 1-cyclique. Lorsque les tâches de transit (de transport) des conteneurs débutent, l'ordonnancement cyclique est utilisé. Si une perturbation apparaît, et si elle est localisée dans la marge de robustesse, son effet sera réduit par l'algorithme de robustesse. Sion, nous pouvons réordonnancer les tâches par MIP en quelques secondes. Ainsi l'ordonnancement cyclique robuste peut être également considéré comme un ordonnancement réactif face aux perturbations qui occurrent en temps réel.

Chapitre 5 Conclusions & Perspectives

Dans cette thèse, nous présentons une méthode d'ordonnancement 1-cyclique robuste pour les opérations de transit des conteneurs dans les ports maritimes de taille moyenne. Cette méthodologie s'avère être applicable, efficace et pratique dans la gestion et la supervision robuste des systèmes de transport automatisés intelligents dans les terminaux à conteneurs de petite et moyenne taille.

Notre travail apporte plusieurs contributions tant à la fois dans le domaine de la recherche académique que dans le domaine des applications industrielles réelles.

Du point de vue académique, nous offrons plusieurs références pour les chercheurs qui veulent approfondir l'utilisation des méthodes de modélisation PTSCEG et MIP et les ordonnancements cycliques robustes dans les différents secteurs industriels, et notamment dans le transport des conteneurs dans les ports maritime de taille moyenne. Egalement, nous enrichissant ses connaissances en donnant quelques nouvelles idées sur les façons d'étudier le contrôle robuste des jetons dans l'ordonnancement présenté par le diagramme de Gantt.

Du point de vue des applications industrielles réelles, et vue que notre travail s'inscrivait dans le cadre du projet InTraDE, en premier lieu nous optimisons la fluidité de la circulation dans les espaces confinés pour les ports de petite et moyenne taille et cela en un temps d'exécution relativement court. En deuxième lieu, nous utilisons un nombre réduit d'AIV pour effectuer les différentes tâches de transport des conteneurs, ce qui permet de réduire le bilan énergétique dans ces terminaux à conteneurs. En troisième lieu, nous développons de nouveaux algorithmes pour la supervision robuste des systèmes de transport intelligent pour réduire ou éliminer les perturbations. En quatrième lieu, nous fournissons une méthodologie nouvelle et complète qui améliorera l'efficacité tout en assurant la sécurité. Nous nous pouvons nous avancés sur le fait que, l'ordonnancement cyclique est meilleur que les autres méthodes d'ordonnancement dans un environnement idéalisé sans perturbations, mais nous pouvons dire que l'ordonnancement cyclique robuste peut donner une meilleure performance de la productivité globale avec une prise en compte correcte des perturbations imprévisibles et inévitables qui surviennent dans cet enivrement portuaire complexe.

Pour nos travaux futurs nous proposons les orientations et directions suivantes :

- Dans la section 2.4.4, nous avons utilisé le PTSCEG pour modéliser l'intersection. Dans les faits, on pourrait considérer les intersections des routes des AIVs comme des intersections existantes dans les villes. Il est possible d'étendre cette modélisation d'intersections pour étudier le contrôle des feux de signalisation dans les carrefours. Nous pouvons également considérer les réseaux de transport comme un ensemble d'intersections entrecoupé par des portions de route. Il est ainsi possible d'utiliser la technique de modélisation PTSCEH pour modéliser et étudier le contrôle intelligent du trafic dans les villes et cités intelligentes.
- La méthode d'ordonnancement 1-cyclique présentée dans le chapitre 3 peut être appliquée à d'autres exemples en vérifiant son efficacité pour des systèmes plus complexes.
- Dans les chapitres 3 et 4, en comparant les répétitions presque à l'infinie de l'ordonnancement 1-cyclique dans les cas étudiés, nous négligeons les périodes transitoires de deux ordonnancement 1-cyclique qui est présenté dans (Calvez et al., 1998, Bourdeaud'huy et al., 2011). Mais il est aussi intéressant d'étudier l'algorithme de contrôle robuste qui peut être également appliqué à la période transitoire de l'ordonnancement cyclique.
- L'algorithme de l'approche 3 peut utiliser un décalage temporel parallèle similaire dès que la perturbation est observée ce qui augmente les marges transmissibles. Mais le couplage des jetons limite le changement du temps de séjour des jetons ce qui conduit à la réduction des marges compensables et transmissibles. Il donc est intéressant d'apporter des modifications à cet algorithme pour affaiblir l'influence des opérations de couplage au moment où il est encore possible d'insérer le contrôle actif dès que la perturbation est observée. Il est possible d'avoir un algorithme 3 modifié nettement meilleur que l'algorithme 2 au niveau de la marge de robustesse.
- Dans l'approche 3, le contrôle robuste est défini comme une stratégie récursive convergente avec des opérations de calcul sur les points de couplage des places partagées dans le diagramme de Gantt, ce qui n'est pas le cas dans les approches 1 et 2 qui sont basées sur le modèle PTSCEG.

L'approche 3, peut être appliquée uniquement à un ordonnancement non-cyclique. Elle est basée sur un diagramme de Gantt, si pour l'ordonnancement non cyclique nous utilisons des machines ou des ressources partagées pour cet ordonnancement, et si on peut réaliser des produits par un ordonnancement non cyclique en un temps infini. Il sera alors possible d'étendre l'algorithme de l'approche 3 au contrôle robuste de l'ordonnancement non cyclique.

- Les algorithmes de robustesses présentés dans (Collart-Dutilleul et al., 2007, Collart-Dutilleul et al., 2013, Mhalla et al., 2013a, Mhalla et al., 2013b) déjà appliqués aux problèmes de production manufacturière, ont été utilisés dans notre thèse aux problème de transit des conteneurs. Compte tenu de la complexité polynomiale des temps de calcul, il est possible d'utiliser les algorithmes de contrôle robuste de la gestion du trafic intelligent dans les chaînes logistique, la planification des vols dans les aéroports, dans les villes dites 'intelligentes', etc. qui font souvent face à des perturbations tant internes que externes et qui causes des problèmes importants dans ces espaces confinés et partages.

Il reste encore beaucoup de travaux à effectuer, concernant des aspects pratiques induisant des problématiques scientifiques d'intérêt, avant la réalisation réelle d'un transport intelligent automatisé dans les terminaux de conteneurs



Bibliography

AL-HINAI, N. & ELMEKKAWY, T. 2011. Robust and stable flexible job shop scheduling with random machine breakdowns using a hybrid genetic algorithm. *International Journal of Production Economics*, 132, 279-291.

ARNDT, L. & MILLER-CHRIST, G. 2006. Robustness in the Context of Autonomous Cooperating Logistic Processes: A Sustainability Perspective. *Operations Research Proceedings 2005*. Springer.

BAE, J. W. & KIM, K. H. 2000. A pooled dispatching strategy for automated guided vehicles in port container terminals. *Management Science and Financial Engineering*, 6, 47-67.

BEN AMAR, M., BOURDEAUD'HUY, T. & KORBAA, O. 2007. CYCLIC SCHEDULING MIP IMPLEMENTATION: CUTTING TECHNIQUES. *International Conference on Production Research ICPR'07*. Valparaiso, Chili.

BEN AMAR, M. A., CAMUS, H. & KORBAA, O. Formalization of cyclic scheduling problems with assembly tasks and work-in-process minimization. Proceedings of the Fourth international conference on Verification and Evaluation of Computer and Communication Systems, 2010a. British Computer Society, 46-54.

BEN AMAR, M. A., CAMUS, H. & KORBAA, O. 2010b. A mathematical model for cyclic scheduling with assembly tasks and Work-In-Process minimization. *Frontiers of Assembly and Manufacturing*. Springer.

BEN AMAR, M. A., CAMUS, H. & KORBAA, O. A mathematical model for cyclic scheduling with limited work-in-process and cycle time minimization. Proceedings of the Fifth international conference on Verification and Evaluation of Computer and Communication Systems, 2011. British Computer Society, 55-62.

BERLE, Ø. 2012. *Risk and resilience in global maritime supply chains*. University of Science and Technology.

BERTHOMIEU, B. & DIAZ, M. 1991. Modeling and verification of time dependent systems using time Petri nets. *IEEE transactions on software engineering*, 17, 259-273.

BIENSTOCK, D. 2007. Histogram models for robust portfolio optimization.

BONHOMME, P. 2010. Vers une nouvelle méthode de synthèse de commande pour les réseaux de Petri p-temporels. *Journal européen des systèmes automatisés*, 44, 161-180.

BOURDEAUD'HUY, T., BELKAHLA, O., YIM, P., KORBAA, O. & GHEDIRA, K. 2011. Transient inter-production scheduling based on Petri nets and constraint programming. *International Journal of Production Research*, 49, 6591-6608.

BOURDEAUD'HUY, T. & KORBAA, O. A mathematical model for cyclic scheduling with work-in-progress minimization. *Information Control Problems in Manufacturing*, 2006. 63-68.

BOYER, M. & ROUX, O. H. 2008. On the compared expressiveness of arc, place and transition time Petri nets. *Fundamenta Informaticae*, 88, 225-249.

BRISKORN, D., DREXL, A. & HARTMANN, S. 2006. Inventory-based dispatching of automated guided vehicles on container terminals. *OR Spectrum*, 28, 611-630.

BRUCKER, P., BURKE, E. K. & GROENEMEYER, S. 2012. A mixed integer programming model for the cyclic job-shop problem with transportation. *Discrete Applied Mathematics*, 160, 1924-1935.

BRUCKER, P. & KAMPMeyer, T. 2008a. Cyclic job shop scheduling problems with blocking. *Annals of Operations Research*, 159, 161-181.

BRUCKER, P. & KAMPMeyer, T. 2008b. A general model for cyclic machine scheduling problems. *Discrete Applied Mathematics*, 156, 2561-2572.

CALVEZ, S., AYGALINC, P. & BONHOMME, P. 1998. Transient functioning mode of manufacturing systems with operation time constraints. *The International Journal of Advanced Manufacturing Technology*, 14, 694-703.

CAVORY, G., DUPAS, R. & GONCALVES, G. 2005. A genetic approach to solving the problem of cyclic job shop scheduling with linear constraints. *European Journal of Operational Research*, 161, 73-85.

CHENG, Y.-L., SEN, H.-C., NATARAJAN, K., TEO, C.-P. & TAN, K.-C. 2005. Dispatching automated guided vehicles in a container terminal. *Supply Chain Optimization*. Springer.

CHUNG, S. H., CHAN, F. T. & CHAN, H. K. 2009. A modified genetic algorithm approach for scheduling of perfect maintenance in distributed production scheduling. *Engineering Applications of Artificial Intelligence*, 22, 1005-1014.

COLLART-DUTILLEUL, S. & CRAYE, E. Performance and tolerance evaluation. SAFEPROCESS'03, IFAC Symp. on Fault Detection, Supervision and Safety for Technical Processes, 2003.

COLLART-DUTILLEUL, S., JERBI, N., CRAYE, E. & BENREJEB, M. Robust dynamic control of multi-product job-shops. Management and Control of Production and Logistics, 2007. 265-270.

COLLART-DUTILLEUL, S., MHALLA, A., CRAYE, E. & BENREJEB, M. 2013. Active robustness of a milk manufacturing workshop with time constraints. *International Journal of Production Research*, 51, 9-25.

DAVID, R. & ALLA, H. 1994. Petri nets for modeling of dynamic systems: A survey. *Automatica*, 30, 175-202.

DAVID, R. & ALLA, H. 2008. Discrete, continuous, and hybrid Petri nets. *IEEE Control Systems*, 28, 81-84.

DECLERCK, P. & DIDI ALAOU, M. K. Modelling and analysis of P-time event graphs in the (min, max,+) algebra. Systems, Man and Cybernetics, 2004 IEEE International Conference on, 2004. IEEE, 1807-1812.

DECLERCK, P., GUEZZI, A. & BOIMOND, J.-L. Cycle time of p-time event graphs. ICINCO-ICSO, 2007. Citeseer, 489-496.

DESROCHERS, M., DESROSIERS, J. & SOLOMON, M. 1992. A new optimization algorithm for the vehicle routing problem with time windows. *Operations research*, 40, 342-354.

DRAPER, D., JONSSON, A. K., CLEMENTS, D. P. & JOSLIN, D. Cyclic scheduling. IJCAI, 1999. Citeseer, 1016-1021.

EMMONS, H. & VAIRAKTARAKIS, G. 2012. *Flow shop scheduling: theoretical results, algorithms, and applications*, Springer.

FATTAHI, P., JOLAI, F. & ARKAT, J. 2009. Flexible job shop scheduling with overlapping in operations. *Applied Mathematical Modelling*, 33, 3076-3087.

FROHLICH, R. & STENEBERG, S. C. Optimal cyclic multiple hoist scheduling for processes with loops and parallel resources. Systems, Man and Cybernetics, 2009. SMC 2009. IEEE International Conference on, 2009. IEEE, 287-292.

GENDREAU, M., HERTZ, A. & LAPORTE, G. 1994. A tabu search heuristic for the vehicle routing problem. *Management science*, 40, 1276-1290.

GRUNOW, M., G N THER, H.-O. & LEHMANN, M. 2005. *Dispatching multi-load AGVs in highly automated seaport container terminals*, Springer.

GRUNOW, M., G N THER, H.-O. & LEHMANN, M. 2006. Strategies for dispatching AGVs at automated seaport container terminals. *OR spectrum*, 28, 587-610.

HAEZENDONCK, E. 2001. *Essays on strategy analysis for seaports*, Garant.

HANEN, C. 1994. Study of a NP-hard cyclic scheduling problem: The recurrent job-shop. *European journal of operational research*, 72, 82-101.

HANEN, C. & MUNIER, A. 1993. *Cyclic scheduling on parallel processors: an overview*, Citeseer.

HENDRIKS, M., LAUMANN, M., LEFEBER, E. & UDDING, J. T. 2010. Robust cyclic berth planning of container vessels. *OR spectrum*, 32, 501-517.

HERROELEN, W. & LEUS, R. 2005. Project scheduling under uncertainty: Survey and research potentials. *European journal of operational research*, 165, 289-306.

HILLION, H. P. & PROTH, J.-M. 1989. Performance evaluation of job-shop systems using timed event-graphs. *Automatic Control, IEEE Transactions on*, 34, 3-9.

HOLTE, M. & MANNINO, C. 2013. The implementor/adversary algorithm for the cyclic and robust scheduling problem in health-care. *European Journal of Operational Research*, 226, 551-559.

HOMAYOUNI, S., TANG, S., ISMAIL, N., ARIFFIN, M. & SAMIN, R. A hybrid genetic-heuristic algorithm for scheduling of automated guided vehicles and quay cranes in automated container terminals. *Computers & Industrial Engineering*, 2009. CIE 2009. International Conference on, 2009. IEEE, 96-101.

JAIN, L. C. & VEMURI, V. R. 1998. *Industrial applications of neural networks*, CRC press.

JALILVAND-NEJAD, A. & FATTAHI, P. 2013. A mathematical model and genetic algorithm to cyclic flexible job shop scheduling problem. *Journal of Intelligent Manufacturing*, 1-14.

JENSEN, M. T. 2003. Generating robust and flexible job shop schedules using genetic algorithms. *Evolutionary Computation, IEEE Transactions on*, 7, 275-288.

JEON, S. M., KIM, K. H. & KOPFER, H. 2011. Routing automated guided vehicles in container terminals through the Q-learning technique. *Logistics Research*, 3, 19-27.

JERBI, N., COLLART-DUTILLEUL, S., CRAYE, E. & BENREJEB, M. Robust control of multi-product job-shops in repetitive functioning mode. *Systems, Man and Cybernetics*, 2004 IEEE International Conference on, 2004. IEEE, 4917-4922.

JERBI, N., COLLART-DUTILLEUL, S., CRAYE, E. & BENREJEB, M. 2009. Commande robuste des ateliers manufacturiers à contraintes de temps. *Journal européen des systèmes automatisés*, 43, 7-33.

JIM, R. & KAI, T. 2012. The MIT CTL Port Resilience Survey Report.

JORGE LEON, V., DAVID WU, S. & STORER, R. H. 1994. Robustness measures and robust scheduling for job shops. *IIE transactions*, 26, 32-43.

KHANSA, W. 1997. *Réseaux de Petri p-Temporels Contribution à l'Etude des Systèmes à Événements Discrets*.

KHANSA, W., AYGALINC, P. & DENAT, J.-P. Structural analysis of p-time Petri nets. CESA'96 IMACS Multiconference: computational engineering in systems applications, 1996a. 127-136.

KHANSA, W., DENAT, J.-P. & COLLART-DUTILLEUL, S. P-Time Petri Nets for manufacturing systems. International Workshop on Discrete Event Systems, WODES, 1996b. 94-102.

KIM, K. H. & BAE, J. W. 2004. A look-ahead dispatching method for automated guided vehicles in automated port container terminals. *Transportation science*, 38, 224-234.

KORBAA, O., CAMUS, H. & GENTINA, J.-C. FMS Cyclic Scheduling with Overlapping production cycles. Proceedings of 18th International Conference on Application and Theory of Petri Nets, Toulouse, France, 1997a.

KORBAA, O., CAMUS, H. & GENTINA, J.-C. Heuristic for the resolution of the general FMS cyclic scheduling problem. *Systems, Man, and Cybernetics*, 1997. Computational Cybernetics and Simulation., 1997 IEEE International Conference on, 1997b. IEEE, 2903-2908.

KORBAA, O., CAMUS, H. & GENTINA, J.-C. Transient state study for cyclic schedules: bounds and optimization. Assembly and Task Planning, 1997. ISATP 97., 1997 IEEE International Symposium on, 1997c. IEEE, 188-193.

KORBAA, O., CAMUS, H. & GENTINA, J.-C. 2002. A new cyclic scheduling algorithm for flexible manufacturing systems. *International Journal of Flexible Manufacturing Systems*, 14, 173-187.

LEE, T.-E. 2000. Stable earliest starting schedules for cyclic job shops: a linear system approach. *International Journal of Flexible Manufacturing Systems*, 12, 59-80.

LEE, T.-E. & POSNER, M. E. 1997. Performance measures and schedules in periodic job shops. *Operations Research*, 45, 72-91.

LONG, J. & DESCOTES-GENON, B. Flow optimization method for control synthesis of flexible manufacturing systems modeled by controlled timed Petri nets. Robotics and Automation, 1993. Proceedings., 1993 IEEE International Conference on, 1993. IEEE, 598-603.

M HRING, R. K. A. R. H. & ZAROLIAGIS, C. D. 2009. Robust and Online Large-Scale Optimization.

MANNINO, C., NILSSEN, E. J. & NORDLANDER, T. E. 2012. A pattern based, robust approach to cyclic master surgery scheduling. *Journal of Scheduling*, 15, 553-563.

MERLIN, P. M. 1974. A study of the recoverability of computing systems.

MERLIN, P. M. & FARBER, D. J. 1976. Recoverability of communication protocols--implications of a theoretical study. *Communications, IEEE Transactions on*, 24, 1036-1043.

MHALLA, A., COLLART-DUTILLEUL, S., BENREJEB, M. & CRAYE, E. 2013a. Computation of Passive Robustness Bound for Assembly/Disassembly Processes. *International Journal of Automation and Control Engineering*, 2.

MHALLA, A., JERBI, N., COLLART-DUTILLEUL, S., CRAYE, E. & BENREJEB, M. Robustness Computing of Multi product job shops with time constraint. 9th International Conference of Sciences and Techniques of Automatic and Computer Engineering (STA'08), Sousse, 2008.

MHALLA, A., JERBI, N., COLLART DUTILLEUL, S., CRAYE, E. & BENREJEB, M. 2013b. Robust control strategies facing disturbances in manufacturing workshops with time constraints. *Computers & Industrial Engineering*, 65, 268-276.

MURATA, T. 1989. Petri nets: Properties, analysis and applications. *Proceedings of the IEEE*, 77, 541-580.

NISHIMURA, E., IMAI, A. & PAPADIMITRIOU, S. 2005. Yard trailer routing at a maritime container terminal. *Transportation Research Part E: Logistics and Transportation Review*, 41, 53-76.

OHL, H., CAMUS, H., CASTELAIN, E. & GENTINA, J.-C. A heuristic algorithm for the computation of cyclic schedules and the necessary WIP to obtain optimal cycle time. *Computer Integrated Manufacturing and Automation Technology*, 1994., Proceedings of the Fourth International Conference on, 1994. IEEE, 339-344.

OHL, H., CAMUS, H., CASTELAIN, E. & GENTINA, J.-C. Petri net modeling of ratio-driven flexible manufacturing systems and implications on the WIP for cyclic schedules. *Systems, Man and Cybernetics*, 1995. Intelligent Systems for the 21st Century., IEEE International Conference on, 1995. IEEE, 3081-3086.

OMBUKI, B., ROSS, B. J. & HANSHAR, F. 2006. Multi-objective genetic algorithms for vehicle routing problem with time windows. *Applied Intelligence*, 24, 17-30.

PETRI, C. A. 1962. Kommunikation mit automaten.

QIU, L., HSU, W.-J., HUANG, S.-Y. & WANG, H. 2002. Scheduling and routing algorithms for AGVs: a survey. *International Journal of Production Research*, 40, 745-760.

RAMAMOORTHY, C. & HO, G. S. 1980. Performance evaluation of asynchronous concurrent systems using Petri nets. *Software Engineering, IEEE Transactions on*, 440-449.

RAMCHANDANI, C. 1974. Analysis of asynchronous concurrent systems by timed Petri nets.

RASHIDI, H. & TSANG, E. P. 2011. A complete and an incomplete algorithm for automated guided vehicle scheduling in container terminals. *Computers & Mathematics with Applications*, 61, 630-641.

ROH, H.-S., S LALWANI, C. & NAIM, M. M. 2007. Modelling a port logistics process using the structured analysis and design technique. *International Journal of Logistics Research and Applications*, 10, 283-302.

ROUNDY, R. 1992. Cyclic schedules for job shops with identical jobs. *Mathematics of Operations Research*, 17, 842-865.

SEO, J.-W. & LEE, T.-E. 2002. Steady-state analysis and scheduling of cyclic job shops with overtaking. *International Journal of Flexible Manufacturing Systems*, 14, 291-318.

SHEFFI, Y. 2008. Resilience: What it is and how to achieve it. Retrieved October, 1, 2013.

SIFAKIS, J. 1980a. Performance evaluation of systems using nets. *Net Theory and Applications*. Springer.

SIFAKIS, J. 1980b. Use of Petri nets for performance evaluation. *Acta Cybern.*, 4, 185-202.

SNYDER, L. V. 2003. *Supply chain robustness and reliability: Models and algorithms*. Northwestern University.

SOLOMON, M. M. 1987. Algorithms for the vehicle routing and scheduling problems with time window constraints. *Operations research*, 35, 254-265.

STEENKEN, D., VO, S. & STAHLBOCK, R. 2004. Container terminal operation and operations research-a classification and literature review. *OR spectrum*, 26, 3-49.

TREPTE, K. & JR, J. B. R. 2014. An initial exploration of port capacity bottlenecks in the USA port system and the implications on resilience. *International Journal of Shipping and Transport Logistics*, 6, 339-355.

VAN DE VOORDE, E. & WINKELMANS, W. 2002. A general introduction to port competition and management. *Huybrechts ea (eds.) Port Competitiveness, Ed. de Boeck, Antwerp*.

VAN OOSTRUM, J. M., VAN HOUDENHOVEN, M., HURINK, J. L., HANS, E. W., WULLINK, G. & KAZEMIER, G. 2008. A master surgical scheduling approach for cyclic scheduling in operating room departments. *OR spectrum*, 30, 355-374.

WANG, B., YANG, X.-F. & LI, Q.-Y. 2009. Genetic Simulated-Annealing Algorithm for Robust Job Shop Scheduling. *Fuzzy Information and Engineering Volume 2*. Springer.

XIONG, J., XING, L.-N. & CHEN, Y.-W. 2013. Robust scheduling for multi-objective flexible job-shop problems with random machine breakdowns. *International Journal of Production Economics*, 141, 112-126.

YANG, C., CHOI, Y. & HA, T. 2004. Simulation-based performance evaluation of transport vehicles at automated container terminals. *OR Spectrum*, 26, 149-170.

ZAGHDOUD, R., MESGHOUNI, K., COLLART-DUTILLEUL, S., ZIDI, K. & GHEDIRA, K. Optimization Problem of Assignment Containers to AIVs in a Container Terminal. *Control in Transportation Systems*, 2012. 274-279.

ZHANG, H., COLLART-DUTILLEUL, S. & MESGHOUNI, K. Parameters Optimization of Resources in a Container Terminal. *Large Scale Complex Systems Theory and Applications*, 2013a. 395-400.

ZHANG, H., COLLART-DUTILLEUL, S. & MESGHOUNI, K. 2013b. Seaport Productivity Research basing on P-time Petri Net. *IFAC MCPL 2013*. Fortaleza, Brazil.

ZHANG, H., COLLART-DUTILLEUL, S. & MESGHOUNI, K. 2014. Cyclic Scheduling Steady-State Analysis and Improved Mathematical Models. *IFAC World Congress 2014*. Cape Town, South Africa.

ZIDI, I., ZIDI, K., MESGHOUNI, K. & GHEDIRA, K. 2012. A contribution to the modelling and the resolution of a multi-objective dial a ride problem. *International Journal of Engineering Management and Economics*, 3, 95-116.

ZUBEREK, W. Timed Petri nets and performance evaluation of systems. IEEE INTERNATIONAL CONFERENCE ON SYSTEMS MAN AND CYBERNETICS, 1998. INSTITUTE OF ELECTRICAL ENGINEERS INC (IEEE), 278-283.

ZUBEREK, W. & KUBIAK, W. 1999. Timed Petri nets in modeling and analysis of simple schedules for manufacturing cells. *Computers & Mathematics with Applications*, 37, 191-206.

ZUBEREK, W. M. 2001. Timed Petri nets in modeling and analysis of cluster tools. *Robotics and Automation, IEEE Transactions on*, 17, 562-575.

Titre: Ordonnancement cyclique robuste appliqué à la gestion des conteneurs dans les ports maritimes de taille moyenne

Cette thèse présente une méthodologie d'ordonnancement cyclique robuste appliquée à la gestion des conteneurs dans les ports maritimes de taille moyenne. Ces derniers sont sujet constamment à des variations des conditions des terminaux, la visibilité réduite sur des événements futurs ne permet pas de proposer une planification précise des tâches à accomplir. L'ordonnancement cyclique robuste peut jouer un rôle primordial. Il permettra non seulement de proposer un ordonnancement prédictif pour le transport des conteneurs, mais aussi, il proposera également une planification robuste permettant d'éliminer les perturbations éventuelles en temps réel. Dans ce travail nous utilisons les Véhicules Intelligents Automatisés (AIV) pour transporter les conteneurs et nous modélisons les procédures de transit de ces derniers par des graphes d'événements P-temporels fortement connexes (PTSCEG). Avant l'arrivée d'un porte conteneur au port, un plan (planning) de transport des conteneurs est proposé en un temps court par la programmation mixte en nombres entiers (MIP). Des algorithmes polynomiaux de calcul de robustesse permettent de calculer sur les différents nœuds du système les marges de robustesse. Une fois le navire à quai, l'ordonnancement cyclique robuste est appliqué. Lorsqu'une perturbation est observée (localisée) dans le système, une comparaison avec la marge de robustesse connue est effectuée. Si cette perturbation est incluse dans la marge de robustesse, l'algorithme robuste est utilisé pour éliminer ces perturbations en quelques cycles. Dans le cas où la perturbation est trop importante, la méthode MIP est utilisée pour calculer un nouvel ordonnancement cyclique en un temps réduit.

Mots clés: gestion des conteneurs dans les ports maritimes, les véhicules intelligents automatisés, graphe d'événements P-temporel fortement connexe, programmation mixte en nombres entiers, Algorithme robuste, Ordonnancement cyclique robuste

Title: Robust cyclic scheduling applied to container management of medium sized seaport

This PhD thesis is dedicated to propose a robust cyclic scheduling methodology applied to container management of medium sized seaport which faces ever changing terminal conditions and the limited predictability of future events and their timing. The robust cyclic scheduling can be seen not just a predictable scheduling to compute a container transportation schedule, but also a reactive scheduling to eliminate the disturbances in real time. In this work, the automated intelligent vehicles (AIV) are used to transport the containers, and the P-time strongly connected event graph (PTSCEG) is used as a graphical tool to model the container transit procedures. Before the arrival of the container vessel, a cyclic container transit schedule can be given by the mixed integer programming (MIP) method in short time. The robustness margins on the nodes of the system can be computed by robustness algorithms in polynomial computing time. After the stevedoring begins, this robust cyclic schedule is used. When a disturbance is observed in system, it should be compared with the known robustness margin. If the disturbance belongs to the robustness margin, the robustness algorithm is used to eliminate the disturbance in a few cycle times. If not, the MIP method is used to compute a new cyclic schedule in short time.

Key words: Seaport Container Transportation, Automated Intelligent Vehicles, P-time strongly connected event graph, Mixed Integer Programming, Robustness Algorithm, Robust Cyclic Scheduling.