



**HAL**  
open science

# Estimation of driver awareness of pedestrian for an augmented reality advanced driving assistance system

Minh Tien Phan

► **To cite this version:**

Minh Tien Phan. Estimation of driver awareness of pedestrian for an augmented reality advanced driving assistance system. Other. Université de Technologie de Compiègne, 2016. English. NNT : 2016COMP2280 . tel-01508528

**HAL Id: tel-01508528**

**<https://theses.hal.science/tel-01508528>**

Submitted on 14 Apr 2017

**HAL** is a multi-disciplinary open access archive for the deposit and dissemination of scientific research documents, whether they are published or not. The documents may come from teaching and research institutions in France or abroad, or from public or private research centers.

L'archive ouverte pluridisciplinaire **HAL**, est destinée au dépôt et à la diffusion de documents scientifiques de niveau recherche, publiés ou non, émanant des établissements d'enseignement et de recherche français ou étrangers, des laboratoires publics ou privés.

Par **Minh Tien PHAN**

*Estimation of driver awareness of pedestrian for an augmented reality advanced driving assistance system*

Thèse présentée  
pour l'obtention du grade  
de Docteur de l'UTC



Soutenue le 27 juin 2016

**Spécialité** : Technologies de l'Information et des Systèmes : Unité  
de recherche Heudyasic [UMR-7253]

D2280



UNIVERSITY OF TECHNOLOGY OF COMPIÈGNE

Heudiasyc Laboratory, UMR CNRS 7253

## THESIS

presented by **PHAN MINH TIEN**

Defended on 06/27/2016

Submitted in partial fulfillment of the requirements for the degree of

**Doctor**

# **ESTIMATION OF DRIVER AWARENESS OF PEDESTRIAN FOR AN AUGMENTED REALITY ADVANCED DRIVING ASSISTANCE SYSTEM**

Thesis Committee:

Reviewers:	Frédéric Vanderhaegen	Professeur des Universités (PU) Lab.LAMIH - UVHC Valenciennes
	Guillaume Moreau	Professeur des Universités (PU) Lab.CRENAU- Ecole Centrale Nantes
Examiners:	Daniel Mestre	CNRS Research Director Lab.CRVM - Aix & Marseille Université
	Véronique Cherfaoui	Maître de Conférences (MCF), HDR Lab.Heudiasyc - UTC Compiègne.
Supervisors:	Vincent Frémont	Maître de Conférences (MCF), HDR Lab.Heudiasyc-UTC Compiègne.
	Indira Thouvenin	Enseignant Chercheur, HDR Lab.Heudiasyc-UTC Compiègne.
Guest	Mohamed Sallak	Maître de Conférences (MCF) , HDR Lab.Heudiasyc-UTC Compiègne







UNIVERSITÉ DE TECHNOLOGIE DE COMPIÈGNE

Laboratoire Heudiasyc, UMR CNRS 7253

## THÈSE

présenté par

**PHAN MINH TIEN**

Date de la soutenance : 27/06/2016

Soumis à la réalisation partielle des exigences pour le degré de

**Doctorat**

# ESTIMATION DE L'INATTENTION DU CONDUCTEUR VIS-À-VIS D'UN PIÉTON POUR UN SYSTÈME D'AIDE À LA CONDUITE AVANCÉ UTILISANT LA RÉALITÉ AUGMENTÉE

Thesis Committed:

Rapporteurs:	Frédéric Vanderhaegen	Professeur des Universités Lab.LAMIH - UVHC Valenciennes
	Guillaume Moreau	Professeur des Universités Lab.CRENAU - Ecole Centrale Nantes
Examineurs:	Daniel Mestre	Directeur de Recherche CNRS Lab.CRVM - Aix & Marseille Université
	Véronique Cherfaoui	Maître de Conférences, HDR Lab.Heudiasyc - UTC Compiègne.
Directeurs de thèse :	Vincent Frémont	Maître de Conférences, HDR Lab Heudiasyc-UTC Compiègne.
	Indira Thouvenin	Enseignant Chercheur, HDR Lab.Heudiasyc-UTC Compiègne.
Invité	Mohamed Sallak	Maître de Conférences, HDR Lab.Heudiasyc-UTC Compiègne



# Abstract

Augmented reality (AR) can potentially change the driver's user experience in significant ways. In contrast of the AR applications on smart phones or tablets, the Head-Up-Displays (HUD) technology based on a part or all wind-shield project information directly into the field of vision, so the driver does not have to look down at the instrument which maybe cause to the time-critical event misses. Until now, the HUD designers try to show not only basic information such as speed and navigation commands but also the aids and the annotations that help the driver to see potential dangers. However, *what should be displayed* and *when it has to be displayed* are still always the questions in critical driving context.

In another context, the pedestrian safety becomes a serious society problem when half of traffic accidents around the world are among pedestrians and cyclists. Several advanced Pedestrian Collision Warning Systems (PCWS) have been proposed to detect pedestrians using the on-board sensors and to inform the driver of their presences. However, most of these systems do not adapt to the driver's state and can become extremely distracting and annoying when they detect pedestrian.

For those reasons, this thesis focuses on proposing a new concept for the PCWS using AR (so called the AR-PCW system). Firstly, for the «*When*» question, the display decision has to take into account the driver's states and the critical situations. Therefore, we investigate the modelisation of the driver's awareness of a pedestrian (DAP) and the driver's unawareness of a pedestrian (DUP). In order to do that, an experimental approach is proposed to observe and to collect the driving data that present the DAP and the DUP. Then, the feature-based algorithms, the data-driven models based on the discriminative models (e.g. Support Vector Machine) or the generative models (e.g. Hidden Markov Model) are proposed to

recognize the DAP and the DUP. Secondly, for the «*What*» question, our proposition is inspired by the state-of-the-art on the AR in the driving context. The dynamic bounding-box surrounding the pedestrian and the static danger panel are used as the visual aids.

Finally, in this thesis, we study experimentally the benefits and the costs of the proposed AR-PCW system and the effects of the aids on the driver. A fixed-based driving simulator is used. A limited display zone on screen is proposed to simulate the HUD. Twenty five healthy middle-aged licensed drivers in ambiguous driving scenarios are explored. Indeed, the heading-car following is used as the main driving task whereas twenty three pedestrians appear in the circuit at different moment and with different behaviors. The car-follow task performance and the awareness of pedestrian are then accessed through the driver actions. The objective results as well as the subjective results show that the visual aids can enhance the driver's awareness of a pedestrian which is defined with three levels: *perception, vigilance and anticipation*.

This work has been funded by a Ministry scholarship and was carried out in the framework of the FUI18 SERA project, and the Labex MS2T which is funded by the French Government, through the program "Investments for the future" managed by the National Agency for Research (Reference ANR-11-IDEX-0004-02).

**Key words:** Pedestrian Collision Warning System, Situation Awareness, Driver Behavior Modeling, Machine Learning, Augmented Reality, Driving Simulator.

# Résumé

La réalité augmentée (Augmented Reality ou AR) peut potentiellement changer significativement l'expérience utilisateur. Au contraire les applications sur Smartphone ou tablette, les technologies d'affichage tête haute (Head Up Display ou HUD) aujourd'hui sont capables de projeter localement sur une zone du pare-brise ou globalement sur tout le pare-brise. Le conducteur peut alors percevoir l'information directement dans son champ de vision. Ce ne sont pas que les informations basiques comme vitesse ou navigation, le système peut aussi afficher des aides, des indicateurs qui guident l'attention du conducteur vers les dangers possibles. Il existe alors un challenge scientifique qui est de concevoir des visualisations d'interactions qui s'adaptent en fonction de l'observation de la scène mais aussi en fonction de l'observation du conducteur.

Dans le contexte des systèmes d'alerte de collision avec les piétons (Pedestrian Collision Warning System ou PCWS), l'efficacité de la détection du piéton a atteint un niveau élevé grâce à la technologie de vision. Pourtant, les systèmes d'alerte ne s'adaptent pas au conducteur et à la situation, ils deviennent alors une source de distraction et sont souvent négligés par le conducteur.

Pour ces raisons, ce travail de thèse consiste à proposer un nouveau concept de PCWS avec l'AR (nommé the AR-PCW system). Premièrement, nous nous concentrons sur l'étude de la conscience de la situation (Situation Awareness ou SA) du conducteur lorsqu'il y a un piéton présent devant le véhicule. Nous proposons une approche expérimentale pour collecter les données qui représentent l'attention du conducteur vis-à-vis du piéton (Driver Awareness of Pedestrian ou DAP) et l'inattention du conducteur vis-à-vis de celui-ci (Driver Unawareness of Pedestrian ou DUP). Ensuite, les algorithmes basées sur les caractéristiques, les

modèles d'apprentissage basés sur les modèles discriminants (ex, Support Vector Machine ou SVM) ou génératifs (Hidden Markov Model ou HMM) sont proposés pour estimer le DUP et le DAP. La décision de notre AR-PCW system est effectivement basée sur ce modèle. Deuxièmement, nous proposons les aides ARs pour améliorer le DAP après une étude de l'état de l'art sur les ARs dans le contexte de la conduite automobile. La boîte englobante autour du piéton et le panneau d'alerte de danger sont utilisés.

Finalement, nous étudions expérimentalement notre système AR-PCW en analysant les effets des aides AR sur le conducteur. Un simulateur de conduite est utilisé et la simulation d'une zone HUD dans la scène virtuelle sont proposés. Vingt-cinq conducteurs de 2 ans de permis de conduite ont participé à l'expérimentation. Les situations ambiguës sont créées dans le scénario de conduite afin de analyser le DAP. Le conducteur doit suivre un véhicule et les piétons apparaissent à différents moments. L'effet des aides AR sur le conducteur est analysé à travers ses performances à réaliser la tâche de poursuite et ses réactions qui engendrent le DAP. Les résultats objectifs et subjectifs montrent que les aides AR sont capables d'améliorer le DAP défini en trois niveaux : *perception, vigilance et anticipation*.

Ce travail de thèse a été financé sur une bourse ministère et a été réalisé dans le cadre des projets FUI18 SERA et Labex MS2T qui sont financé par le Gouvernement Français, à travers le programme « Investissement pour l'avenir » géré par le ANR (Référence ANR-11-IDEX-0004-02).

**Mots clés** : Système d'Alerte d'Anticollision avec Piétons, Conscience de la Situation, Modélisation des Comportements du Conducteur, Apprentissage Automatique, Réalité Augmentée, Simulateur de Conduite.

# Remerciements

Je tiens tout d'abord à remercier mes directeurs de thèse, Indira Thouvenin, et Vincent Frémont, qui a encadré ces travaux et m'a soutenu et conseillé durant ces quatre années.

Je remercie également Daniel Mestre, Directeur de recherche, Centre national de la recherche scientifique (CNRS) affilié à l'Institut des Sciences du Mouvement à l'Université Aix-Marseille); Frédéric Vanderhaegen, professeur à l'université de Valenciennes; Guillaume Moreau, Professeur à l'Ecole Centrale Nantes, pour avoir accepté de faire partie de mon jury de thèse.

Je remercie aussi Véronique Cherfaoui et Mohamed Sallak, Maîtres de conférences (HDR) à l'Université de Technologie de Compiègne, qui m'ont accepté de faire partie de mon jury de thèse et m'ont donné de précieux conseils sur mes travaux. J'adresse aussi mes remerciements aux membres de l'équipe ICI et de l'équipe DI du laboratoire Heudiasyc pour m'avoir accueilli au sein de leurs équipes.

J'aimerais remercier également toutes les personnes ayant participé à mes travaux : Zhenguo Cui, qui a participé aux développements du système et à la réalisation de l'expérimentation; les étudiants doctorants et les membres du personnel de l'UTC qui ont accepté de tester notre système; Je remercie aussi mes amis et collègues de la salle GI233 (Florian Jeanne, Marcio Fuckner, Xuan Truong Vu, Rémy Frénoy) pour leur bonne humeur et leur soutien. Enfin, je remercie ma famille pour son soutien et ses encouragements.





# Contents

<b>Abstract</b>	<b>iii</b>
<b>Résumé</b>	<b>v</b>
<b>Contents</b>	<b>ix</b>
<b>List of Figures</b>	<b>xiii</b>
<b>List of Tables</b>	<b>xix</b>
<b>Notations and Symbols</b>	<b>xxi</b>
<b>Acronyms</b>	<b>xxiii</b>
<b>1 Introduction</b>	<b>1</b>
1.1 Thesis Context . . . . .	1
1.1.1 Advanced Driver Assistance Systems . . . . .	1
1.1.2 Augmented Reality Driving . . . . .	3
1.1.3 Pedestrian Collision Warning Systems . . . . .	6
1.2 Thesis Presentation . . . . .	10
1.2.1 Objectives and Contributions . . . . .	10
1.2.2 Thesis Outline . . . . .	13
<b>2 Driver Awareness of Pedestrian Modeling</b>	<b>17</b>
2.1 Driver Awareness of Pedestrian Definitions . . . . .	18
2.1.1 Pedestrian Accident Origins . . . . .	18

2.1.2	Human Factors in Road Crashes . . . . .	21
2.1.3	Definitions of Driver Awareness of Pedestrian . . . . .	26
2.2	Surrogate Measures and Conceptual Model . . . . .	28
2.2.1	Potential Measures . . . . .	28
2.2.2	Conceptual Model . . . . .	32
2.3	Mathematical Models for Awareness and Unawareness Classification	33
2.3.1	Classifier Requirements . . . . .	34
2.3.2	First Proposition: Feature-based Algorithms . . . . .	34
2.3.3	Second Proposition: Discriminative Models . . . . .	37
2.3.4	Third Proposition: Hidden Markov Models . . . . .	42
2.4	Conclusion . . . . .	48
<b>3</b>	<b>Settings and Benchmark for Driver Awareness and Unawareness Classification</b>	<b>49</b>
3.1	Construction of a Driver Awareness of Pedestrian Dataset . . . . .	50
3.1.1	Related Work on Driver Behaviors Manipulation . . . . .	50
3.1.2	Manipulating the DAP and the DUP . . . . .	51
3.2	Dedicated Techniques for Setting Up the Classifiers . . . . .	55
3.2.1	Grid-Search Technique . . . . .	55
3.2.2	Generalization Test . . . . .	56
3.2.3	Receiver Operation Characteristic Curves . . . . .	57
3.3	Classifier Parameters Determination . . . . .	59
3.3.1	Feature-based Algorithms . . . . .	60
3.3.2	Discriminative Models . . . . .	62
3.3.3	Generative Models . . . . .	65
3.4	Classifiers Comparison Results . . . . .	70
3.4.1	$p\%$ Basic Generalization Test . . . . .	71
3.4.2	$k - Fold$ Cross-Validation . . . . .	72
3.5	Conclusion . . . . .	74
<b>4</b>	<b>Augmented Reality for Pedestrian Collision Warning Systems</b>	<b>75</b>
4.1	Head Up Displays and Augmented Reality . . . . .	76
4.1.1	Head Up Displays . . . . .	76

4.1.2	Driving Assistance Metaphors . . . . .	80
4.2	Proposed Metaphors . . . . .	85
4.2.1	A Conformal Dynamic Metaphor . . . . .	85
4.2.2	Decision Models and System Configurations . . . . .	88
4.3	Research Platform . . . . .	91
4.3.1	Driving Simulator Platform . . . . .	91
4.3.2	SCANeR Studio Environment . . . . .	91
4.3.3	Scenario Conception with SCANeR Studio . . . . .	93
4.4	Platform Developments . . . . .	94
4.4.1	Head-Up-Display simulation . . . . .	96
4.4.2	Visual Cues Implementation . . . . .	97
4.4.3	DAP/DUP Classification Simulink Model . . . . .	98
4.4.4	Decision Module Implementation . . . . .	99
4.5	Conclusion . . . . .	103
<b>5</b>	<b>Enhancing Driver Awareness of Pedestrian with Augmented Reality Cues</b>	<b>105</b>
5.1	Assessment of Driver Awareness of Pedestrian . . . . .	106
5.1.1	Previous Similar Experiments . . . . .	106
5.1.2	Proposed Method . . . . .	109
5.1.3	Experimental Procedure with the Driving Simulator . . . . .	113
5.2	Results . . . . .	117
5.2.1	Outcomes associated to Perception Level . . . . .	118
5.2.2	Outcomes associated to Vigilance Level . . . . .	120
5.2.3	Outcomes associated to Anticipation Level . . . . .	124
5.2.4	Others Outcomes . . . . .	125
5.3	Discussions . . . . .	130
5.3.1	Assessment of Driver Awareness of Pedestrian . . . . .	131
5.3.2	Costs and Benefits of the Visual Aids . . . . .	135
5.3.3	Design of Advanced Pedestrian Collision Warning Systems . . . . .	136
5.4	Conclusion . . . . .	137

<b>6</b>	<b>Conclusions and perspectives</b>	<b>139</b>
6.1	Thesis Summary . . . . .	139
6.2	Thesis Outcomes and Contributions . . . . .	144
6.3	Limitations and Perspectives . . . . .	147
6.3.1	Limitations . . . . .	147
6.3.2	Extension to the current work . . . . .	150
6.3.3	Long term developments . . . . .	151
<b>A</b>	<b>Appendix</b>	<b>153</b>
A.1	Algorithms . . . . .	153
A.1.1	Decomposition Method for Dual Problems (Eq. 2.3.7) . . . . .	153
A.1.2	RVM - Laplace's Approximation . . . . .	156
A.1.3	HMM -Forward Algorithm . . . . .	158
A.1.4	HMM - Expectation Maximization Algorithm . . . . .	159
A.1.5	ANOVA and Tukey's HSD . . . . .	161
A.2	Scenario Screen-shot Samples . . . . .	163
A.3	Code Structure . . . . .	165
A.4	Questionnaire . . . . .	169
	<b>References</b>	<b>171</b>

# List of Figures

1.1.1	Past and potential future evolutions towards automated cooperative driving [Bengler 14]. The blue box is added to indicate a novel category of ADAS. The sensors are dedicated for monitoring the driver and the driver-adaptive ADAS. . . . .	4
1.1.2	Road Traffic deaths by type of road users [DaSilva 03a] . . . . .	8
1.1.3	Mobileye and its interface that warns the driver in case of pre-crash [Mobileye 15]. . . . .	9
1.1.4	Time line of pedestrian protection measures and the reaction time for a given distance decreases with vehicle speed [Gandhi 07]. . .	9
1.1.5	Vehicle and infrastructure-based pedestrian detection. Data flow diagram showing distillation of information from raw signals up to appropriate action [Gandhi 07]. . . . .	11
2.1.1	Accident Tree, adopted from [Richard 06]. Human error is necessary but not a sufficient condition for accident occurrence . . . . .	18
2.1.2	Pre-crash scenarios . . . . .	21
2.1.3	Model of SA in Dynamic Making Process [Endsley 95a]. . . . .	23
2.1.4	Three levels of driver subjective risk estimation in a specific situation . . . . .	27
2.1.5	Case 1 and 2, the driver is supposed to be aware of pedestrian. If the driver is unaware of pedestrian (case 3), a warning is activated. .	28
2.2.1	The Conceptual Model for estimating the Driver Awareness of Pedestrian. . . . .	33
2.3.1	HMM-based decision process Architecture. . . . .	47

3.1.1	Driving simulator used for manipulating the driver's awareness of a pedestrian. . . . .	53
3.1.2	Awareness Data Sample. . . . .	54
3.1.3	Unawareness Data Sample. . . . .	55
3.2.1	ROC curve . . . . .	58
3.3.1	Three ROC curves with three values of the sliding time-windows $Tw$ . The <i>TTC</i> -based algorithm gives the best performances with $Tw = 1.5s$ . . . . .	61
3.3.2	Three ROC curves with three values of the sliding time-windows $Tw$ . The <i>RDP</i> -based algorithm gives the best performances with $Tw = 1.5s$ . . . . .	62
3.3.3	The best parameter combinations of SVM-based classifier ranked in increasing order for $Tw = 1s$ . The first rank gives the best combination of the SVM classifier for $Tw = 1s$ . . . . .	63
3.3.4	The best parameter combinations of SVM-based classifier ranked in increasing order for $Tw = 1.5s$ . The method reaches 79% of <i>TPR</i> at 5% of <i>FPR</i> with $\gamma = 2^{-3}$ , $C = 2^7$ . . . . .	64
3.3.5	The best parameters of SVM-based classifier ranked in increasing order for $Tw = 2s$ . . . . .	64
3.3.6	The best parameters of RVM-based classifier ranked in increasing order for $Tw = 1s$ . . . . .	65
3.3.7	The best parameters of RVM-based classifier ranked in increasing order for $Tw = 1.5s$ . The method reaches up to 82% of <i>TPR</i> at 5% of <i>FPR</i> with $\gamma = 2^{-7}$ . . . . .	66
3.3.8	The best parameters of RVM-based classifier ranked in increasing order for $Tw = 2s$ . . . . .	66
3.3.9	A Discret Hidden Markov Model with 3 hidden states and 243 observation states. . . . .	69
3.3.10	ROC Curves for the DHMM classifier with three values of $Tw$ . The $Tw=1.5s$ gives the best performances. A shorter $Tw$ may not capture enough significant information whereas a longer $Tw$ can over-fit the data and capture the redundant information. . . . .	70

3.3.11	15 combination of MGHMM-based classifier parameters, The model with $N = 10, M = 2$ and $Tw = 1.5s$ gives the best performance with more than 84% of TPR while maintaining the FPR under 5%. . . . .	71
3.4.1	ROC curves of six classifiers in the $p\%$ generalization test. In that case, 20% of the dataset is used for training and 80% of the dataset is used for testing. . . . .	72
3.4.2	Results from the $k - Fold$ Cross-validation of the classifiers, the MGHMM model showed the best performances with less dependency to the quantity of training data sequences. . . . .	73
4.1.1	The main components of a HUD[ <a href="#">Continental 15</a> ]. . . . .	77
4.1.2	The combiner HUDs . . . . .	79
4.1.3	Integrated windshield HUD concepts [ <a href="#">Rover 15</a> ][ <a href="#">Continental 15</a> ]. . . . .	79
4.1.4	Three-dimensional windshield display [ <a href="#">Takaki 11</a> ]. . . . .	80
4.1.5	Definition of «metaphor». . . . .	81
4.1.6	Point of interest discovering metaphors and Navigation Metaphors. . . . .	83
4.1.7	Driving Safety Metaphors. . . . .	86
4.2.1	The proposed visual cues for Pedestrian Collision Warning Systems. . . . .	88
4.3.1	Driving simulator platform piloted by SCANeR Studio environment. . . . .	92
4.3.2	SCANeR communication protocol [ <a href="#">Oktal 15</a> ]. . . . .	94
4.3.3	Creating a story with SCANeR Studio: The Pedestrian will cross the road at the crossing mark when the vehicle TOYOTA is on the position TRIGGER [ <a href="#">Oktal 15</a> ]. . . . .	95
4.3.4	The understandable scripting in SCANeR Studio [ <a href="#">Oktal 15</a> ]. . . . .	95
4.4.1	Simulated HUD in simulation conditions. . . . .	96
4.4.2	Visual plug-in Architecture in SCANeR SCANeR SDK. By building a visual plug-in, we can access to the Graphical Context and the Simulation Context of the Visual API. The pedestrian position on screen can be then determined. . . . .	98
4.4.3	The Simulink API of SCANeR Studio. . . . .	100

4.4.4 Matlab Simulink Model of the DUP/DAP Classification and the Simulink interface of SCANeR. (1) input block and the  $Tw$  buffer for concatenating the input signals. (2) S-function of DAP/DUP classifier. (3) Output block for the DAP likelihood value. . . . . 101

4.4.5 The communication between the modules of an Augmented Reality Pedestrian Collision Warning (AR-PCW) system implemented for a simulator. . . . . 102

4.4.6 Display of the bounding box when the pedestrian is detected far from the car. . . . . 103

4.4.7 Display of the bounding box and the warning panel when the driver is unaware of the pedestrian at the critical moment. . . . . 104

5.1.1 The scenario of the critical situations. . . . . 113

5.1.2 3D View of the Scenario (Step 1): When both vehicles are in the critical situation (From about 140mm tofrom the pedestrian), the lead vehicle begins to accelerate. . . . . 114

5.1.3 3D View of the Scenario (Step 2): The lead vehicle accelerates and can passes by the pedestrian shortly. . . . . 115

5.1.4 3D View of the Scenario (Step 3): When the distance between the test vehicle and the pedestrian is 30m. The pedestrian can be randomly activated to cross the road. . . . . 115

5.1.5 Step 3 in the driver’s view At 30m to the pedestrian, the pedestrian crosses the road suddenly. . . . . 116

5.2.1 Mean of VRT in each pedestrian situation. The result showed that, with the AR configuration (in green color); the driver noticed earlier the pedestrian. . . . . 119

5.2.2 Mean of VRT in all pedestrian situations and with all participants. The drivers notice the pedestrian sooner with AR configuration, which is indicated by the TTC in AR configuration which is the greatest. However, the variance of TTC in each configuration is important because of the variance between the participants or between the pedestrian situations. . . . . 119



5.2.3 Mean of VRD in each pedestrian situations. With the AR configuration (Green box), the driver pressed the button whenever the bounding box was displayed. So, it helps the driver to notice very soon and far from the pedestrian. . . . . 120

5.2.4 Mean of VRD in three configurations. This is the distance to the pedestrian when the pedestrian is noticed by the driver with the 3 aids configurations. We get the same conclusion as with the Visual Reaction Time (VRT). . . . . 121

5.2.5 Head Vehicle Distance for 23 pedestrian situations. In all pedestrian situations, the distance between two vehicles are greater with the AR configurations (Green Column). The driver seems to pay less attention on the head vehicle when the aids are on the pedestrian. The AR aids can direct the driver attention from the lead vehicle to the pedestrian. . . . . 122

5.2.6 Mean of Head Vehicle Distance (HVD). The result confirms that the driver is more vigilant on the pedestrian with AR configuration and loose distance to the lead vehicle . . . . . 123

5.2.7 Mean of Accelerator pedal position for the three aids configurations for each pedestrian situation. Without the AR (noAR configuration - blue column), the driver pressed more the accelerator pedal. The AR has effect on the driver's acceleration behaviors, the cues force the driver to slow down. . . . . 123

5.2.8 Mean of Accelerator Pedal Position for the three aids configurations. 124

5.2.9 Number of times, the urgent brakings were detected in each pedestrian situations . . . . . 125

5.2.10 The Sum of number of times, the urgent brakings were found in three configurations . . . . . 126

5.2.11 Number of times the DUP was detected from 100m for 23 pedestrian situations in the three configurations. It is found that the DUP is more detected with noAR configuration in every pedestrian situations. . . . . 127

5.2.12 Total number times, the DUP is detected in 100m comparison in the three configurations. There is a significant number of DUP detected in noAR configuration whereas there is no significant difference between AR and iAR configurations. . . . . 127

5.2.13 Number of time the DUP was detected in 2s in each of 23 pedestrian situations, driven in three configurations. It showed a significant high number of DUP were detected with the noAR driving (blue bar). . . . . 128

5.2.14 Total number of times the DUP was detected in 2s comparison for the three configurations. A significant number of DUP are found in driving with noAR. . . . . 128

6.3.1 Intelligent car platform for human behaviors and augmented reality researches. . . . . 152

A.1 Illustration curve of F-test distribution with k=3 groups and N=18 observations (6 observations per groups) at apha equal to 0.05 162

A.1 no HUD , no AR cue . . . . . 163

A.2 In front of a Pedestrian and no cue is displayed . . . . . 164

A.3 Pedestrian is augmented by a bounding box . . . . . 164

A.4 HUD Pedestrian is augmented by a bounding box, and the warning panel is displayed in the critical moment . . . . . 165

A.1 Code Structure . . . . . 165

A.2 Visual Aids and Simulation Implementation . . . . . 166

A.3 Data Collection . . . . . 166

A.4 Data Extraction/Annotation . . . . . 167

A.5 Mathematical Model Implementation . . . . . 168

A.6 Code structure of final experiment and result analysis . . . . . 168

A.1 Questionnaire (part 1) . . . . . 169

A.2 Questionnaire (part 2) . . . . . 170

# List of Tables

2.1	Statistic of pedestrian pre-crash scenarios. The results were obtained after four years (1994-1998) of analysis of pedestrian crashes in United States. The percentages refer to the frequency of each scenario relative to the size of all pedestrian crashes [DaSilva 03b].	20
2.2	Driver-Related Critical Reasons [Singh 15]. . . . .	22
3.1	True Positive Rate at 5% False Positive Rate for each method in the $k - fold$ cross-validation. . . . .	73
4.1	Response time population distribution. . . . .	89
4.2	Three configurations of the AR-PCW system. . . . .	90
5.1	Some significant questions asked in the questionnaire . . . . .	129



# Notations and Symbols

$\mathbb{R}, \mathbb{C}$	Sets of real and complex numbers respectively
$\mathbb{R}^n, \mathbb{C}^n$	Sets of n-dimensional real and complex linear space.
$\mathcal{F}$	High dimensional feature space
$f(\cdot)$	Scalar Function
$sgn(f(\cdot))$	Sign evaluation of the function $f$
$\lambda = \{\Pi, \mathbf{A}, \mathbf{B}\}$	Model $\lambda$ presented by three parameters : Sets of probabilities $\Pi$ , Matrix of probabilities $\mathbf{A}$ and $\mathbf{B}$
$\mathcal{N}(v, \boldsymbol{\mu}, \Sigma)$	Gaussian distribution of variable $v$ , mean vector $\boldsymbol{\mu}$ , and variance matrix $\Sigma$ .
$v$	scalar value
$\mathbf{O}$	multi-dimensional vector
$\mathbf{V}$	Matrix
$\mathbf{O}^T, \mathbf{V}^T$	Transpose of a vector or matrix
$P$	Symbol of the probability
$Tw$	Time Windows
$\tau_{th}$	A scalar threshold
$argmax_{\lambda} (f)$	A set of $\lambda$ for which the function $f$ attains its largest value
$g$	gravitational acceleration constant
$e^{(\cdot)}, exp(\cdot)$	Exponential function
$\nabla f(\cdot)$	gradient of function $f$



# Acronyms

ACC	Adaptive Cruise Control
ABS	Anti-lock Braking System
ABS	Anti-lock Braking System
APP	Accelerator Pedal Position
AR	Augmented Reality
AR-ADAS	Augmented Reality Advanced Driver Assistance Systems
AR-PCW	Augmented Reality Pedestrian Collision Warning
DAP	Driver Awareness of Pedestrian
DHMM	Discrete Hidden Markov Model
DUP	Driver Unawareness of Pedestrian
ECG	Electrocardiogram
EM	Expectation-Maximization algorithm
ESP	Electronic Stability Program
FA	False Alarm
FCAS	Forward Collision Avoidance Systems
FPR	False Positive Rate
GNSS	Global Navigation Satellite System
HDD	Head-Down Display
HMI	Human Machine Interaction
HMM	Hidden Markov Model
HUD	Head-Up Display
HVD	Head Vehicle Distance
LKAS	Lane Keeping Assistance Systems
MGHMM	Multivariate Gaussian Hidden Markov Model

MR	Miss Rate
NHTSA	National Highway Traffic Safety Administration
PPS	Pedestrian Protection Systemns
PCWS	Pedestrian Collision Warning Systems
RDP	Required Deceleration Parameter
ROC	Receiver Operation Characteristic
RVM	Relevance Vector Machine
SA	Situation Awareness
SDK	Software Development Kit
SVM	Support Vector Machine
SAGAT	Situation Awareness Global Accessment Technique
TPR	True Positive Rate
TTC	Time To Collision
Tukey's HDS	Tukey's Honest Significant Difference (test)
UFOV	Useful Field Of View
VRT	Visual Reaction Time
VRD	Visual Reaction Distance
WHO	World Heath Organization



# Chapter 1

## Introduction

### 1.1 Thesis Context

#### 1.1.1 Advanced Driver Assistance Systems

Every year, automobile manufacturers spend millions of dollars in funding development of cutting edge technologies to keep drivers safe and accident free while operating their vehicles. These technologies are known in the industry as the Advanced Driver Assistance Systems (ADAS). The objective of ADAS is to support drivers by either providing warning to reduce risk exposure, or automating some of the control tasks to relieve a driver from manual control of a vehicle.

Some of these technologies have been around for a long time, and they have already proven to result in an improved driving and better overall road safety. For example, the introduction of additional dynamic driving control, such as Anti-lock Braking System (ABS) or the Electronic Stability Program (ESP) have marked the milestones in ADAS development. Studies have shown that these systems are the second most efficient safety system for passengers, outmatched only by the seat-belt [Aga 03, Sferco 01]. Starting in November 2014, the ESP is even be a legal requirement in each new car in the European Union [Figaro 14]. A little further, the Speed Limiter or the Cruise Control are well known today and are widely implemented as additional options in new cars. They offers several benefits to drivers. They liberate some driver's workload in controlling the speed or in

reducing the driver fatigue by allowing him to rest their feet while long drives.

The second generation of driver assistance functions based on exteroceptive sensors focus on providing information and warnings to the driver. Exteroceptive sensors acquire information from outside the vehicle, including ultrasonic, radar, lidar or video sensors and to some extent Global Navigation Satellite System (GNSS)<sup>1</sup> receivers. These GNSS sensors provide information about the road ahead and the vehicle's position in the world. The others sensors aim to provide the presences as well as the driving status of other traffic participants. If the use of GNSS has become prevalent in present-day vehicles, the other sensors and theirs applications for ADAS are still under development and research. Parking assistance systems entered the market in the mid-1990s, e.g. [Yasui 02, Wada 03]. In these systems, ultrasonic sensors are used to detect obstacles in the surrounding environment. The electronic steering control is capable of entirely relieving the driver of vehicle control during the parking maneuver. Another popular ADAS is the Adaptive Cruise Control [Jurgen 06, Bengler 14] which sets another milestone in ADAS history. Through the implementation of electronic brake, drive control, and the very expensive radar technology, the current systems have the ability to work at full speed range and within traffic jam [Nix 09].

Forward Collision Avoidance Systems (FCAS) included the Pedestrian Collision Warning Systems (PCWS) or Lane Keeping Assistance Systems marked the third milestones in ADAS. They used inexpensive sensors such as low-range lidars, cameras or radars, and have been marketed under the names «City Safety» [Distner 09], «City Stop» [Focus 15] or «Mobileye» [Dagan 04]. By means of escalating warning levels, the driver is made aware of an impending collision. If there is no reaction from the driver, the vehicle actively brakes to mitigate accident severity once a collision is no longer avoidable [Maurer 12]. Technically, in order to have a high certainty decision, these systems are equipped an interconnected sensors with complex data fusion strategies [Stiller 11]. Today, radar and camera technologies currently dominate the ADAS sector for their complementary capacities.

The picture of ADAS evolution from a technology point of view can be seen in Fig. 1.1.1. The latest class of ADAS selects and controls trajectories beyond

---

<sup>1</sup>GNSS summarizes GPS, Galileo, and GLONASS for satellite-based localization.

the current request of the driver. The ultimate ADAS of the future should be capable of automated driving in all conceivable situations at a safety level significantly superior to that of a human driver. However, it must be acknowledged that automated driving in all conceivable traffic situations requires considerably more cognitive capabilities than available at the current state-of-the-art [Bengler 14]. Furthermore, clear definitions for liability, licensing, and registration of automated cars are yet to be devised. Therefore, as an interim stage, it remains a lot of research projects focus on so-called «semi-automation» or «driving delegation». These works focus on the cooperation between users and vehicle with objectives to enhance the comfort and the safety for driver.

In the area of ADAS, there are two conception approaches. There are approaches favoring the vehicle takes control whenever the driver is unable to, and automatically stops the vehicle or pilots it to a safe position [Ardelt 10]. In other approaches, the system alerts or guides the driver in a dangerous situation. The human-machine cooperation are mainly underlined in these second approaches [Flemisch 08, Biester 05, Doerzaph 10] and human factors play an important role in such systems that share tasks and responsibility between the human driver and the semi-automated vehicle. Therefore, the Driver Monitoring becomes the purposes in ADAS researches (see Fig. 1.1.1). The driver monitoring consists of observing the driver all along his driving and provide the indications about his states or his behaviors. The researchers are investigating the driver drowsiness detection, the driver inattention, distraction estimation, or other abnormal states of the driver that lead to an impaired driving. Some of them are already commercialized [Yeo 01].

### **1.1.2 Augmented Reality Driving**

In Advanced Driver Assistance Systems (ADAS), a close coupling between machine and driver can be achieved with active interfaces. The driver can be informed by ADAS of critical situations via several different modalities. Haptic interfaces include any sort of interfaces that will use force feedback or touch sensitivity. For example, Lane Keeping Assistance Systems (LKA) can include resistance or shaking of the steering wheel or resistance in the brake and accelerator pedals

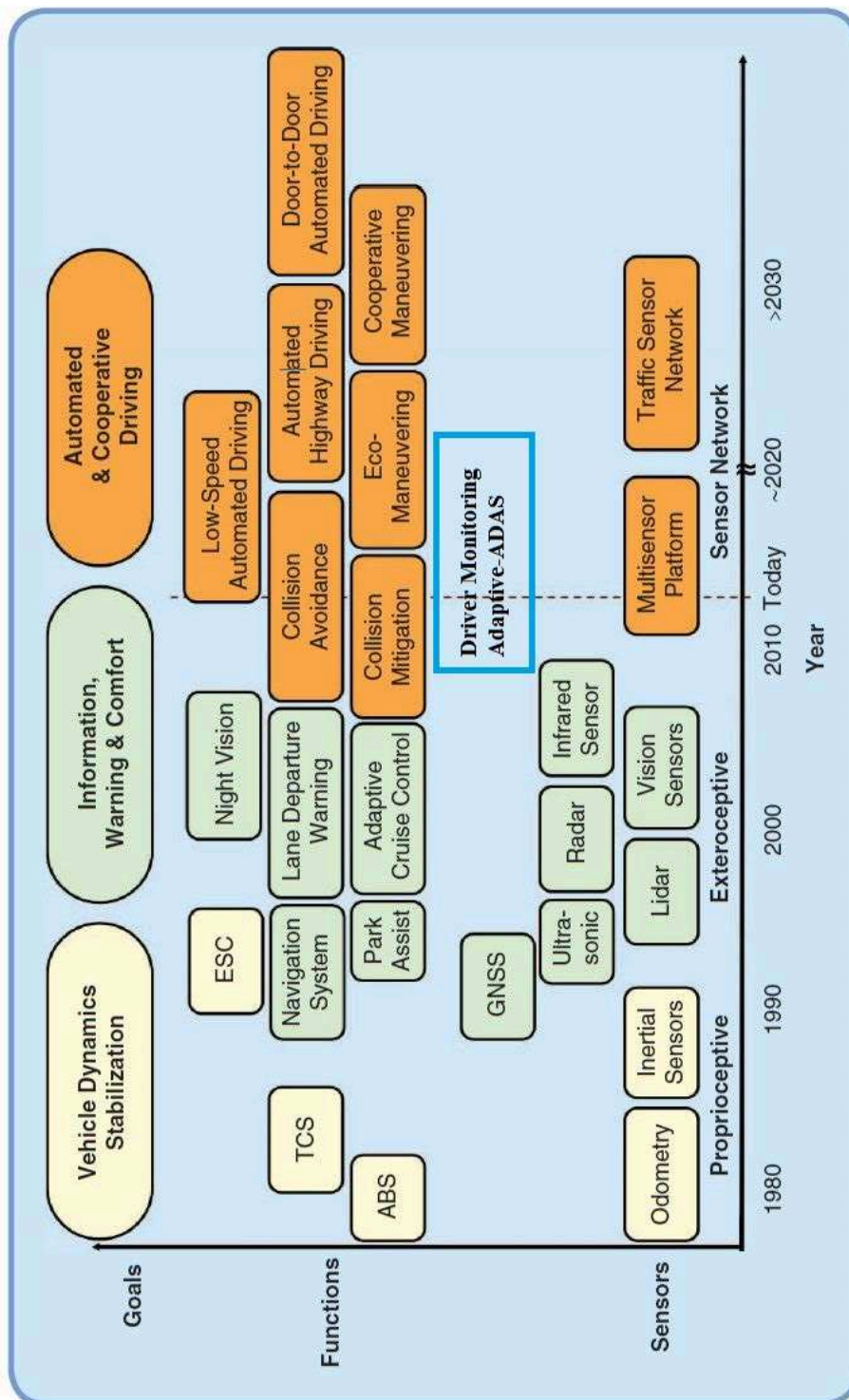

**Figure 1.1.1:** Past and potential future evolutions towards automated cooperative driving [Bengler 14]. The blue box is added to indicate a novel category of ADAS. The sensors are dedicated for monitoring the driver and the driver-adaptive ADAS.

[Katzourakis 11]. These have the advantage of being intuitive, quickly in informing the driver even if he is distracted. However, it supposes that the driver is usually in contact with the interface [Doshi 09b]. Audio interfaces are widely used in automobiles. Voiced commands are often given by navigation systems. Beeps and sounds are used to indicate the driver is not wearing seat belt or to help the driver in parking manoeuvres. However, the beeps and sound are only helpful if drivers know what sound means or if the sound occurs in conjunction with a visual cue [Doshi 09b]. Visual interfaces abound in the vehicular environment. Examples include the dashboard of the vehicle, showing the speedometer, tachometer, and side-screen monitors for navigation systems. Visual cues have the advantage of being able to quickly convey a wealth of information to the driver.

For the ADAS with high risk level like Forward Collision Avoidance Systems (FCA) or Pedestrian Collision Warning Systems (PCWS), the varying systems offer differing feedback to the drivers when crashes are imminent. A review of the systems can be found in [Shaout 11]. For example, Audi's Pre-Sense Plus System has four phases of operation: 1) provide visual and audible warnings and roll windows up, 2) apply light braking to gain driver attention, 3) apply high degree of automatic braking, 4) decelerates vehicle and applies full braking power. Ford's Collision Warning with Brake Support queues visual and audible alarms as well as recharges the brakes to increase the driver's braking performance. Honda's Collision Braking Mitigation System has three phases: 1) audible and visual warnings, 2) pretension the seat belt for the driver, 3) increased seat belt tensioning and automatic braking. Mercedes offers their Pre-Safe system which applies 40% partial braking and also alerts the driver of the incident. Toyota's Pre-Collision System offers similar features with seat belt pretensioning and partial brake application. Volkswagen's Front Assist also offers automatic braking as well as seat belt pretensioning. An appropriate interface with a suitable feedback is another challenge for the actual ADAS.

Recently, several car manufacturers have a lot of development and commercialization plans about Head-Up Display (HUD). This technology creates a new way for interactions between the driver and the vehicle. The HUDs can offer drivers various information related to safety and convenience such as velocity, driving di-

rection, warning messages, etc. [Charissis 10, Park 12, Doshi 09a]. Until now, the HUD systems mounted in a modern vehicle does not overlap information but displays a simple graphical information between the real world and a virtual driving information, which makes them significantly helpful. The HUD reduces the number and duration of the driver's sight deviations from the road, by projecting the required information directly into the driver's line of vision. This allows drivers to receive information without lowering their gaze, thus avoiding attention gaps that result from them taking their eyes off the road to look down at the information on a Head Down Display [Dingus 89, Green 99]. In this way, the driver can easily keep his driving under control [Kiefer 91, Kaptein 94], and can quickly respond to information relating to the road environment from the in-vehicle communication system [Lino 88, Okabayashi 89].

The Augmented Reality (AR) provides an attractive approach to augment the street scenery with conformal navigational aids [Narzt 04]. By highlighting important objects or regions using visual aids, AR starts a new approach for ADAS that we call AR-ADAS. Indeed, instead of alerting or warning the driver, the AR-ADAS provide the visual aids that are seen as part of the real scene. It helps enhancing the visibility of some important elements in the road scene such as obstacles or pedestrian, etc. It also helps the driver to do the right actions to avoid the potential dangers by giving the visual aids.

### 1.1.3 Pedestrian Collision Warning Systems

The Pedestrian Collision Warning Systems (PCWS) are particular types of ADAS that we want to study first and to combine with the Augmented Reality. The aim of PCWS is to detect the presence of both stationary and moving people in a specific area of interest around the moving host vehicle in order to warn the driver, perform braking actions or even warn pedestrians.

Indeed, pedestrians are the most vulnerable road users, whilst also being the most difficult to observe both in day and in night conditions. A World Health Organization report [WHO 13] describes that half of world's road traffic death occur among pedestrians, cyclists, motorcyclists (see Fig. 1.1.2). In high-income countries, pedestrian fatalities are relatively lower but still represent large socie-

tal and economic costs to the nations. In developing countries such as India or China, the problem is much worse. There are a large number of two wheelers, three wheelers, bicyclists, and pedestrians sharing the same road space with cars, buses, and trucks [Mohan 02, Mock 04]. Therefore, the pedestrian safety is one of the major motivator of both the scientific community and the automobile industry. In USA, the Pedestrian and Bicycle Safety Research Program [FHA 15] aims at enhancing the safety and mobility of pedestrian and bicyclists. The PATH project [PathProject 15] conducts research on pedestrian protection, driver behavior modeling and intersection collision prevention. Project PreVENT [PREVENT 15] of the European Union deals with the development of safety technologies which helps drivers prevent or mitigate the effects of an accident using sensor-based analysis of surrounding as well as the state of the driver. In particular, the sub-project COMPOSE focuses on detection of pedestrians, cyclists using data fusion from sensors and protection using autonomous or semi-autonomous braking. In the ADAS industry, Mobileye [Fleet 14] is a well know system for its Forward Collision Avoidance Systems. It also helps to detect pedestrians with a mono-camera and alert the driver in case of possible accidents across the small interface posed on the dashboard (see Fig. 1.1.3).

One can notice that pedestrian safety can be improved at several stages, as shown in Fig. 1.1.4. Long-term measures include design enhancements in infrastructure as well as vehicles to reduce the fatalities. These enhancements can be complemented by systems that detect the pedestrians and prevent accidents by warning the driver or triggering autonomous braking. In the cases where an accident cannot be prevented, collision mitigation devices that are incorporated into vehicle design enhancement can be deployed to reduce the impact of the collision on the pedestrian. In this work, we are interested in the PCWS involving pedestrian detection and driver warning system.

In [Gandhi 07], the authors explain a general PCWS with different levels from its raw signal data acquisition to actions that the PCWS feedback to drivers (see Fig. 1.1.5). The higher level in the pyramid uses the output information from the lower level combining with the models from the left side (indicated by rectangles). As one climbs up the pyramid, the useful information is distilled in successive



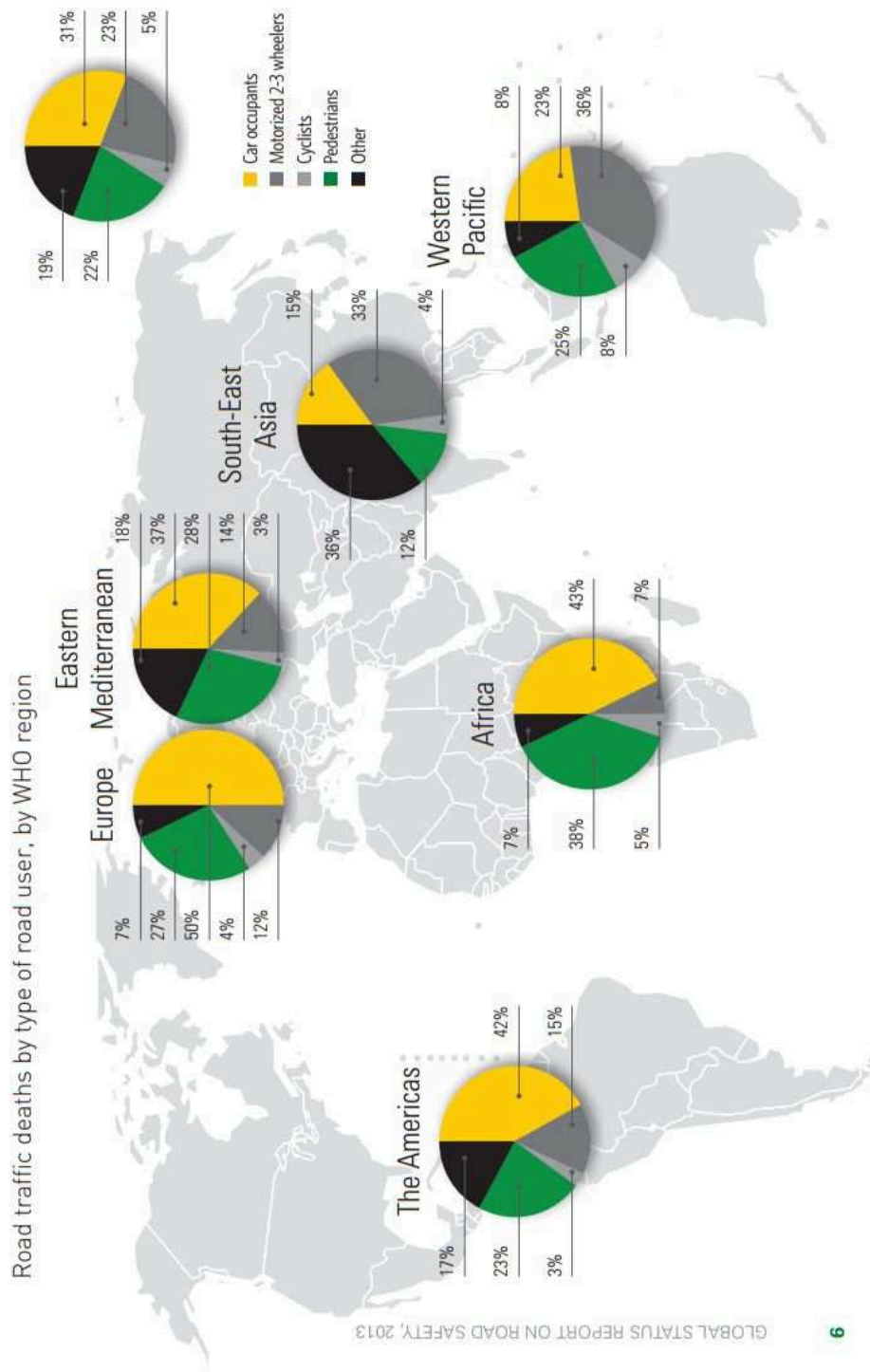
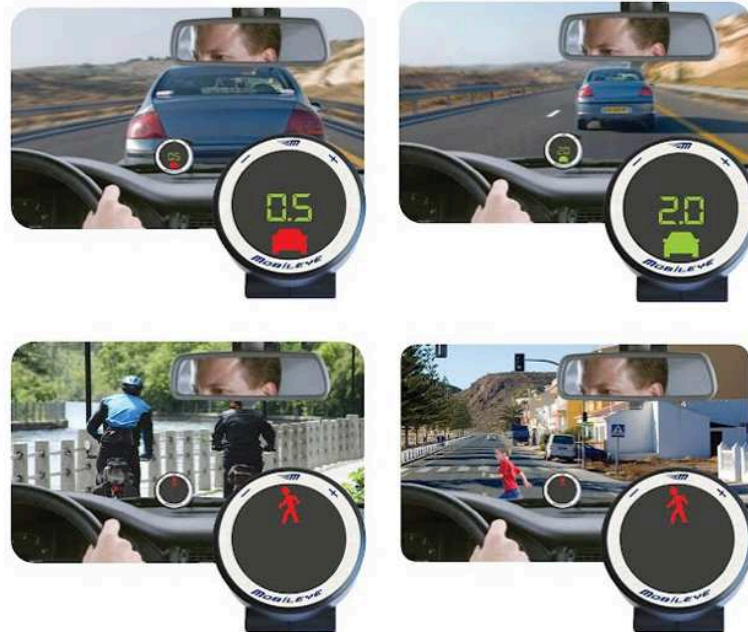
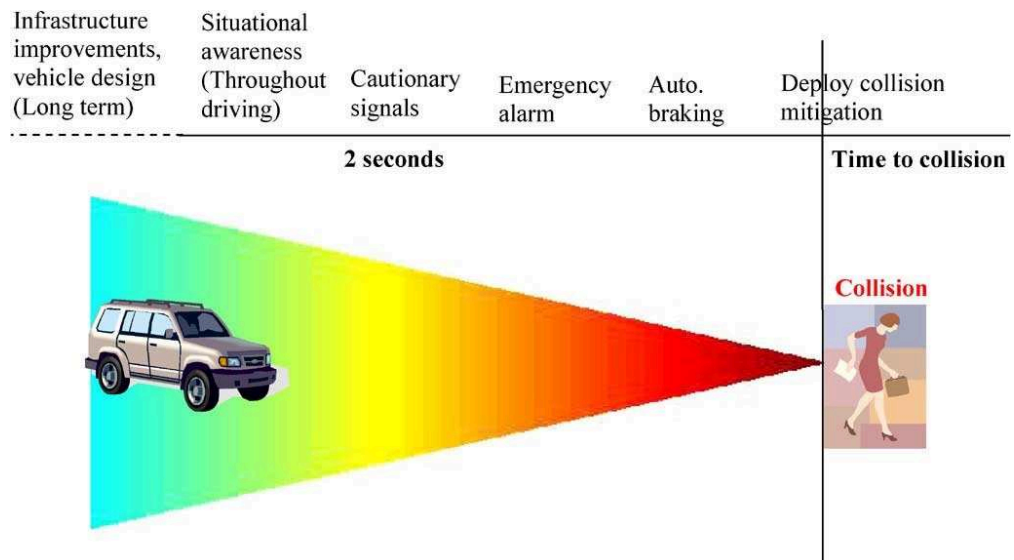

Figure 1.1.2: Road Traffic deaths by type of road users [DaSilva 03a]





**Figure 1.1.3:** *Mobileye and its interface that warns the driver in case of pre-crash [Mobileye 15].*



**Figure 1.1.4:** *Time line of pedestrian protection measures and the reaction time for a given distance decreases with vehicle speed [Gandhi 07].*

stages, until finally, one takes action based on a yes/no decision.

However, the line between these stages is often blurred. In Fig. 1.1.5, the levels 1,2,3,4 consist of the detection, tracking of pedestrian. Some approaches can combine detection and recognition, classification into one. The main issue of these stages is the high detection rate at the allowing false alarms. The fifth and sixth higher levels aims to give the decisions. We can imagine that system can give the probability of collision between the vehicle and pedestrians. The challenge of this stage is to take into account the pedestrian's behaviors, the driver's behaviors but also the interaction between these two. For example, a driver who is not in sleepiness state, but underestimates that the pedestrian crosses, the collision can happen because of driver's errors. Therefore, it is important to consider the driver, the pedestrian and the vehicle at a same stage before giving the collision probabilities (see Fig. 1.1.5, blue dotted rectangle).

For the highest level, the action is given in the function of the decision probability. In the case of high probability of collision, the driver is given an appropriate warning that enables corrective action. If the collision is imminent, the automatic safety systems could also be triggered to decelerate the vehicle in order to reduce the impact of the collision. Our work concerns mostly this stage. The visual aids are displayed to highlight the presence of the pedestrian and to warn the driver about the possible collision. Indeed, the reliability of these visual aids and its effects on the driver are these main challenges of this stage.

## 1.2 Thesis Presentation

### 1.2.1 Objectives and Contributions

This thesis is part of the research program running at Heudiasyc Laboratory on the Intelligent Vehicles. The program conducts a multidisciplinary research that includes perception systems, driver monitoring or advanced human machine interaction such as using augmented reality, etc. One of the projects is named FUI18 SERA (*Sécurité et Réalité Augmentée*) in which we develop an intelligent vehicle prototype. The vehicle is equipped a perception system with cameras, a driver monitoring system using stereo-vision and a combiner head up display plugged on

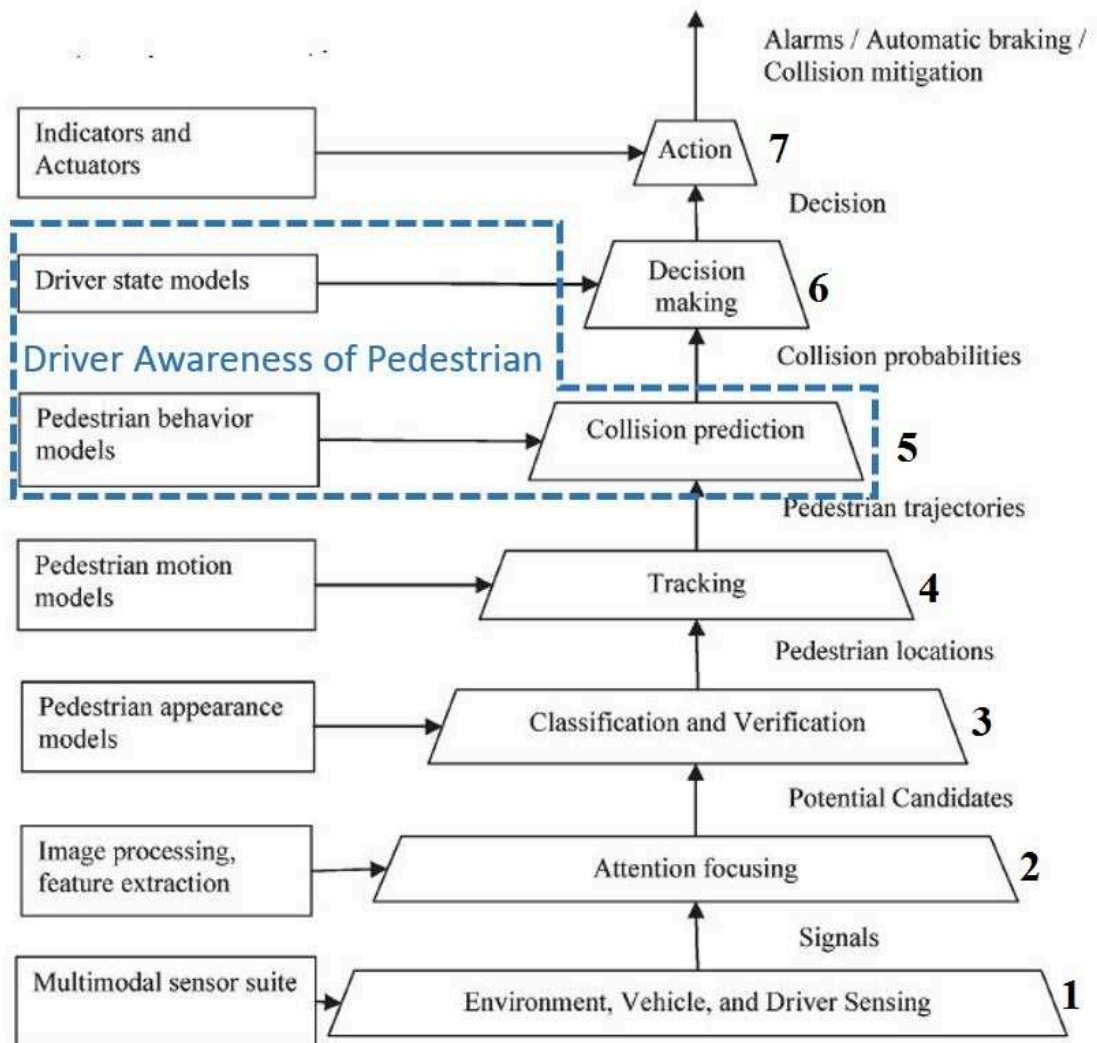

**Figure 1.1.5:** *Vehicle and infrastructure-based pedestrian detection. Data flow diagram showing distillation of information from raw signals up to appropriate action [Gandhi 07].*

the windshield. This system is able to extract the relevant information of situations and is expected to display the visual assistance to help the driver in ambiguous situations. This project aims to merge the augmented reality technologies with the ADAS area and towards an augmented reality driving conception in future.

As justified before, the Pedestrian Collision Warning System (PCWS) is a specific ADAS that we want to address first. Moreover, in order to reducing the distraction, the system is required to be capable to adapt the driver's behaviors. Therefore, there are two main objectives in this study: The first objective is to model the driver's awareness of a pedestrian whereas the second one is to design a augmented reality metaphor for enhancing the driver's awareness in order to avoid the potential collisions. We call this system as the Augmented Reality Pedestrian Collision Warning (AR-PCW) system.

For the first objective, the thesis is expected to provide a general framework for analyzing the driver's behaviors in situations with pedestrians. Therefore, it can be divided into some sub-objectives: first of all, there is the requirement of an experimental protocol that allows us to observe, to collect and to label the surrogate measures in situation with pedestrians. In this protocol, the scenarios are supposed to be able to provoke the driver to be Aware of Pedestrian (DAP) or to be Unaware of Pedestrian (DUP). Then, based on these annotated driving data, another sub-objective is to propose a mathematical model that can estimate whenever the driver is aware or unaware of the pedestrian. At this stage, an analysis on the classification performance of the models with the constructed database is also required.

For the second objective, the thesis is expected to propose a visual assistance system that can enhance the driver's awareness. This assistance is expected to adapt to the driver's behaviors by taking into account the model of DAP/DUP achieved for the first objective. Moreover, the study has to demonstrate that the proposed visual assistance system is suitable for an implementation with augmented reality technologies on cars. Another sub-objective in consequence is to carry out an experiment in order to analyze the effects of the visual metaphors on the driver and to validate the proposed AR-PCW system.

By achieving all these objectives, this thesis will provide a complete framework to

study a new concept of a driver-adaptive augmented reality driving assistance. The research conducted during this thesis is highly multidisciplinary and contributes to the knowledge in different fields.

On the field of cognitive psychology, the study highlights the importance to consider the driver's cognitive states and behaviors in the specific situations. This study shows the differences in the driver's behaviors whenever he is aware or unaware of a hazard on road ( such as a pedestrian in this case). In road safety field, this work emphasizes the importance of a new design of a Pedestrian Collision Warning System which reduces the distraction by taking into account the driver's behaviors and which allows to drive in keeping eye on road with the augmented reality cues. In the driver modeling field, we identify the surrogate measures of driving behaviors that represent the driver's awareness of a pedestrian and demonstrate the ability of different mathematical models to estimate these behaviors. These models can be generalized and applied to others ADAS research problems. In Human-Machine-Interaction field, this study contributes a framework to experiment and validate an ADAS interface by assessing the driver's situation awareness on road while using the interface. It proposes the reasonable protocols for observing the driving behaviors in scenarios with pedestrians and for analyzing the impacts of the visual aids on the driver. At this early stage, this work is designed and implemented for a driving simulator experiment, however, it shows promising results to extend the research on a real car platform.

## **1.2.2 Thesis Outline**

### **Chapter 2: Driver Awareness of Pedestrian Modeling**

This chapter covers the background of the first objective. In the first section, the road accident origins and the pedestrian pre-crash scenarios are presented. Then, some important notions and definitions such as driver's behavior, driver's attention, distraction and driver's situation awareness from literature are provided in order to understand the different cognitive states of the driver in situation with pedestrians. Based on this understanding, two definitions of the Driver Awareness of Pedestrian (DAP) are then proposed. In the second section, we represent our conceptual model for estimating whenever the driver is aware or unaware of a pe-

destrian. We explain why we choose the driving measures such as acceleration, braking or the time-to-collision for our models. In the third section, three approaches with two mathematical models for each approach are proposed to classify the DUP and the DAP. The first approach is to use the threshold-based algorithms such as the Time-To-Collision-based algorithm. The second approach is to use the discriminant models such as the Support Vector Machine (SVM) and the third one is to use the generative models such as the Hidden Markov Model (HMM). We also discuss on their advantages and disadvantages for our conceptual system. Thus, the criteria for choosing the most suitable approach for our problem are also mentioned in this chapter.

### **Chapter 3: Settings and Benchmark for Driver Awareness and Unawareness Classification**

This chapter details how we choose the best values for the parameters of the classifiers in the proposed approaches. We present in this chapter how we design the experiments to observe the driver's behaviors in situations with pedestrians. This experiments protocol allows us to manipulate the driver to be aware or unaware of a pedestrian and to collect the driving data in this time period.

We also present the dedicated techniques for the algorithm parametrization. This includes the Grid-Search technique and the Receiver Operation Characteristic curves. Then, two evaluation techniques, the  $p\%$  generalization test and the  $k - fold$  cross-validation are proposed to compare the performance between the classifiers. Finally, we justify our choice of the Multivariate Gaussian Hidden Markov Models (MGHMM) for the implementation as the classifier or a further estimator of our driver's awareness of a pedestrian (DAP) model. From now, we have a statistical mathematical model that can classify whenever the driver is aware or unaware of the pedestrian. The output of this classification will be taken into account in our proposition of a Pedestrian Collision Warning System.

### **Chapter 4: Augmented Reality for Pedestrian Collision Warning Systems**

The chapter 4 begins by providing a state-of-the-art augmented reality technology in the driving context. This review shows the interests and the needs to provide a

novel visualization for driving safety. In the design of an augmented reality pedestrian collision warning system, we highlight the necessity of taking into account the driver's awareness of the pedestrian. Then, a visual metaphor is proposed for enhancing the driver awareness whenever he is unaware of that pedestrian and a potential collision can happen. The proposed system is so called AR-PCW system (Augmented Reality Pedestrian Collision Warning System). This chapter presents also the implementation of this system on the driving simulator. Two configurations of the AR-PCW system are proposed: one consists of displaying the visual aids permanently during the situation with pedestrians (so-called AR) and the other is based on the driver's awareness of a pedestrian that we called iAR (intelligent Augmented Reality).

## **Chapter 5: Enhancing Driver's Awareness of Pedestrian using Augmented Reality Cues**

In this chapter, we focus on the experiment to analyze the costs and the benefits of the proposed AR-PCW system. In order to do that, our goal is to assess the driver's awareness of a pedestrian (DAP) during his drivings using the AR-PCW system. In the first section, we present the general method and the experiment protocol that allow to assess explicitly the DAP. Then, we highlight the outcome variables that are associated to three levels of the DAP (*perception, vigilance* and *anticipation* levels). In the second section, we present the experiment procedure using a simulator platform. The DAP are compared between the drivings with the AR, iAR configurations and the ones without assistance (called noAR). The experimental results are then exposed using the analysis of variance.

Finally, this chapter provides a global discussion on every aspects of this experiment. We talk about the advantages and the disadvantages of using a simulator. We discuss on the insufficiency of our DAP model. We discuss also on the protocol to assess the DAP. Finally, we highlight the important requirements in the developement of an augmented reality application.

## **Chapter 6: Conclusions and Perspectives**

Chapter 6 concludes the thesis with a summary of the work presented in previous chapters. We continue to discuss on the issues and the insights that have been identified in the course of this work along with paths for future research.

Parts of the work presented in this thesis have been published in the following international conferences articles:

Phan, M. T., Frémont, V., Thouvenin, I., Sallak, M., & Cherfaoui, V. (2015, June). Estimation of driver awareness of pedestrian based on Hidden Markov Model. In *Intelligent Vehicles Symposium (IV), 2015 IEEE* (pp. 970-975). IEEE.

Phan, M. T., Frémont, V., Thouvenin, I., Sallak, M., & Cherfaoui, V. (2014, October). Recognizing driver awareness of pedestrian. In *Intelligent Transportation Systems (ITSC), 2014 IEEE 17th International Conference on* (pp. 1027-1032). IEEE.

Phan, M. T., Thouvenin, I., Frémont, V., & Cherfaoui, V. (2014, January). Estimating driver unawareness of pedestrian based on visual behaviors and driving behaviors. In *International Joint Conference on Computer Vision, Imaging and Computer Graphics Theory and Applications (VISIGRAPP)*.



## Chapter 2

# Driver Awareness of Pedestrian Modeling

This chapter presents one of the main contributions of this thesis, the modeling of the Driver Awareness of Pedestrian (DAP). First of all, we provide in Section 2.1, an understanding of accident origins in the situation with pedestrian, the human factors in road crashes and towards the definitions of the DAP.

Section 2.2 consists of the observation and the measurement of the Driver Awareness of Pedestrian. Based on a survey on the related works, the surrogate measures that can interpret the Driver Awareness of Pedestrian are proposed. The conceptual model for estimating the DAP and the DUP is also presented in this section.

Section 2.3 highlights the previous mathematical algorithms that are employed to estimate, detect or predict the driver's impaired behaviors. At this stage, we consider the classification problem instead of the estimation problem. Indeed, we propose six models for classifying whenever the driver is aware or unaware of a pedestrian. They are divided into three approaches: The threshold-based algorithms, the discriminative models such as the Support Vector Machine or Relevance Vector Machine, and the generative approaches with the Hidden Markov Models

This chapter is completed by a conclusion (Section 2.4) in which we justify our prior choice of the Gaussian Mixture Hidden Markov Models for classifying the

DUP and the DAP.

## 2.1 Driver Awareness of Pedestrian Definitions

### 2.1.1 Pedestrian Accident Origins

Traffic scenarios leading to an accident are often very complex and are a combination of several factors. From a system-ergonomic point of view, an accident (top-event) can arise if a traffic conflict and an inappropriate treatment of the conflict occur ([Richard 06] see Fig. 2.1.1). The traffic-conflict can be defined as a traffic situation in which traffic participants challenge a risk of causing a collision if they do not change their direction or speed. Thus, only an unresolved conflict leads to an accident. Therefore, an analysis of near accidents is as relevant to understanding causes of accidents as accident analysis itself. By analyzing human behavior, we can observe errors which can lead to accidents if other factors would have been present.

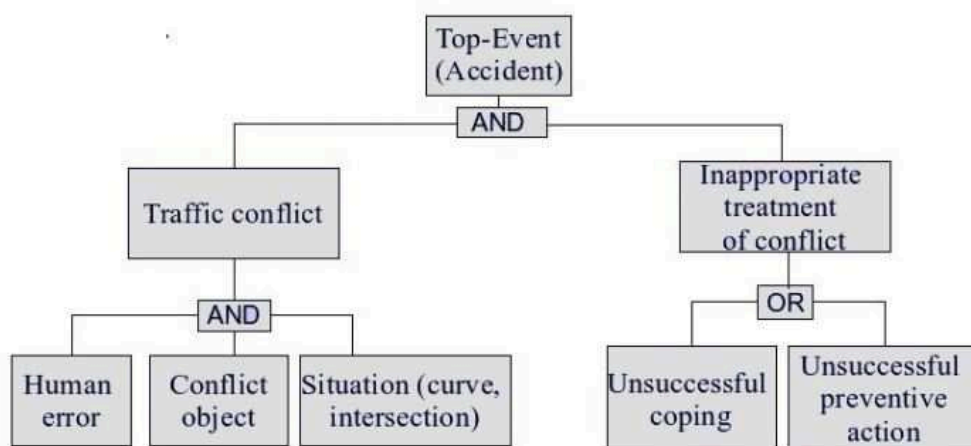

**Figure 2.1.1:** *Accident Tree, adopted from [Richard 06]. Human error is necessary but not a sufficient condition for accident occurrence .*

In an accident, the cause factors can be classified by into two classes depending on the situation where the information is objectively missing or not objectively missing [Plavšić 10].

- **Information «objectively missing»**

- view occlusion (other vehicles, vegetation, infrastructure, curve...)
- visibility conditions (darkness, rain, snow, fog, lights from other vehicles...)
- others (missing traffic sign...)

- **Information «not objectively missing»**

- deficient usage of information: -
  - \* information overlooked (inside, outside distraction, look-but-not-see, wrong focus, overload...)
  - \* information forgotten (processing deficits ( $7\pm 2$  chunks), low concentration...)
  - \* conscious violation (exceeding speed, not keeping distance, not respecting traffic signs, right of way...)
- wrong usage of information:
  - \* wrong evaluation (of distance, speed, intention of other traffic participants...)
  - \* wrong action or goal (giving gas instead of braking...)
  - \* wrong action (too strong steering...)
  - \* operation mistake (confusing gas and brake pedal...).

In the scenario where there is a pedestrian appearing in front of the car, the accident can happen for different critical reasons. The driver does not notice the pedestrian because of view occlusion, pedestrian visibility, missing of traffic sign. These causes can be avoided by enhancing the infrastructures. On the other hand, when the information about the pedestrian is not objectively missing, the wrong evaluation, or underestimate that the pedestrian can cross the road are the main causes for a collision. Under the concept of risk, Fuller et al. defined that as a subjective risk when the driver's own estimate of the probability of collision

[Fuller 05]. In this thesis, we are interested in particularly this subjective risk and have the objective to detect this potential danger based on the driver's behaviors.

On the study of the pre-crash scenarios from USA-National Highway Traffic Safety Administration [DaSilva 03b], there are ten major scenarios that happened accident to the pedestrian (Tab. 2.1). This statistical study shows that, the majority of all pedestrian crashes happened away from junction, a junction being the area formed by the connection of two roadways. The study also showed that, in about 76% of pedestrian crash, the vehicle was going straight with the speed between 40km/h and 60km/h. The data analysis indicated that 25% of fatalities occurred in pre-crash scenarios where the pedestrian is walking along, playing, or working on the roadway. Moreover, the analysis of crash contributing factors in those ten specific scenarios revealed that a very high percentage of accidents were involved by alcohol and by drivers inattention. An example of pre-crash scenario is, a pedestrian is waiting on the road side-walk and has intention to cross the road when a car is coming. Then, he estimates the distance and the arrival time of the car and crosses the road. Whereas, the car driver is doing a second task (telephone, talking, etc) or thinking on another things or even he has seen the pedestrian but underestimate the possibility that the pedestrian can cross the road. Then, the accident happens (see Fig. 2.1.2).

Vehicle is	Pedestrian is	at Roadway	Percentage
going straight	crossing	non-junction	25.9%
going straight	crossing	intersection	18.5%
going straight	darling on to	non-junction	16%
turning left	crossing	intersection	8.6%
turning right	crossing	intersection	6.2%
going straight	walking along	non-junction	3.7%
going straight	darling on to	intersection	2.5%
backing up	N/A	N/A	2.5%
going straight	on sidewalk	non-junction	1.2%
going straight	playing/working	non-junction	1.2

**Table 2.1:** *Statistic of pedestrian pre-crash scenarios. The results were obtained after four years (1994-1998) of analysis of pedestrian crashes in United States. The percentages refer to the frequency of each scenario relative to the size of all pedestrian crashes [DaSilva 03b].*

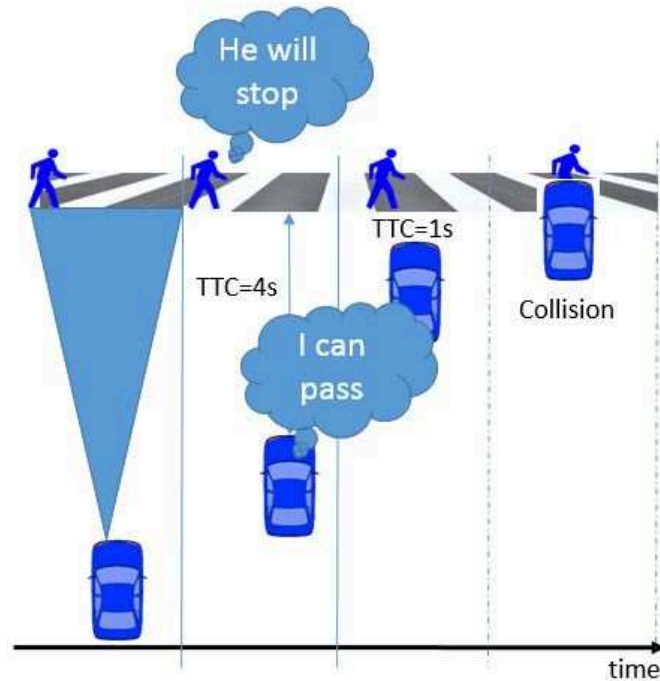

Figure 2.1.2: Pre-crash scenarios

### 2.1.2 Human Factors in Road Crashes

Human error is the main factor lead to accidents. The USA National Motor Vehicle Crash Causation Survey [Singh 15] found in the study in 2015 that human errors accounting for over 94 of accident. The 6% others are about vehicles, environment or others critical reasons. According to this survey, the driver-related critical reasons are broadly classified into recognition errors, decision errors, performance errors, and non-performance errors. The statistics in Table 2.2 show that the recognition error, which included driver's inattention, internal and external distractions, and inadequate surveillance, was the most (41%) frequently assigned critical reason. Decision error such as driving too fast for conditions, too fast for the curve, false assumption of others actions, illegal maneuver and misjudgment of gap or others speed accounted for about 33 percent ( $\pm 3.7\%$ ) of the crashes. In about 11 percent ( $\pm 2.7\%$ ) of the crashes, the critical reason was performance error such as overcompensation, poor directional control, etc. Sleep was the most com-

mon critical reason among non-performance errors that accounted for 7 percent ( $\pm 1.0\%$ ) of the crashes. Other driver errors were recorded as critical reasons for about 8 percent ( $\pm 1.9\%$ ) of the drivers.

Critical Reason	Number of Crashes	Percentage
Recognition Error	845,000	41% $\pm 2.2\%$
Decision Error	684,000	33% $\pm 3.7\%$
Performance Error	210,000	11% $\pm 2.7\%$
Non-Performance Error (sleep, etc.)	145,000	7% $\pm 1.0\%$
Other	162,000	8% $\pm 1.9\%$
Total	2,046,000	100%

**Table 2.2:** *Driver-Related Critical Reasons [Singh 15].*

The difference between driver’s performance and driver’s behaviors is central for understanding the driver’s errors in a critical situation that lead to crashes. Since normal driving is a self-paced task, the driver performance is related to what the driver can do while the driver behavior is what a driver does do [Evans 04]. The critical reasons which are mentioned above signify what the driver has already done and means the driver’s behaviors. On the other hand, the driver’s performance depends on the driver’s knowledge, skills, perceptual and cognitive abilities which are related to the driver concept of the situation awareness while driver behavior is what the driver chooses to do with these attributes.

The driver’s awareness of pedestrians can be related to both driver’s performance and driver’s behaviors. Therefore, in order to understand the driver’s awareness of pedestrians, we need to clarify the factors in the driver’s behaviors and the driver’s performance that could lead to an error or a potential accident: Situation Awareness, Attention, Distraction and Vigilance.

### **Situation Awareness**

Situation Awareness (SA) is a term derived originally from the aviation field and it aims to describe and integrate all different cognitive aspects necessary for the correct performance of some task [Plavšić 10]). Endsley [Endsley 95a] defined the situation awareness as «the perception of the elements in the environment within a

volume of time and space, the comprehension of their meaning and the projection of their status in the near future» (see Fig. 2.1.3).

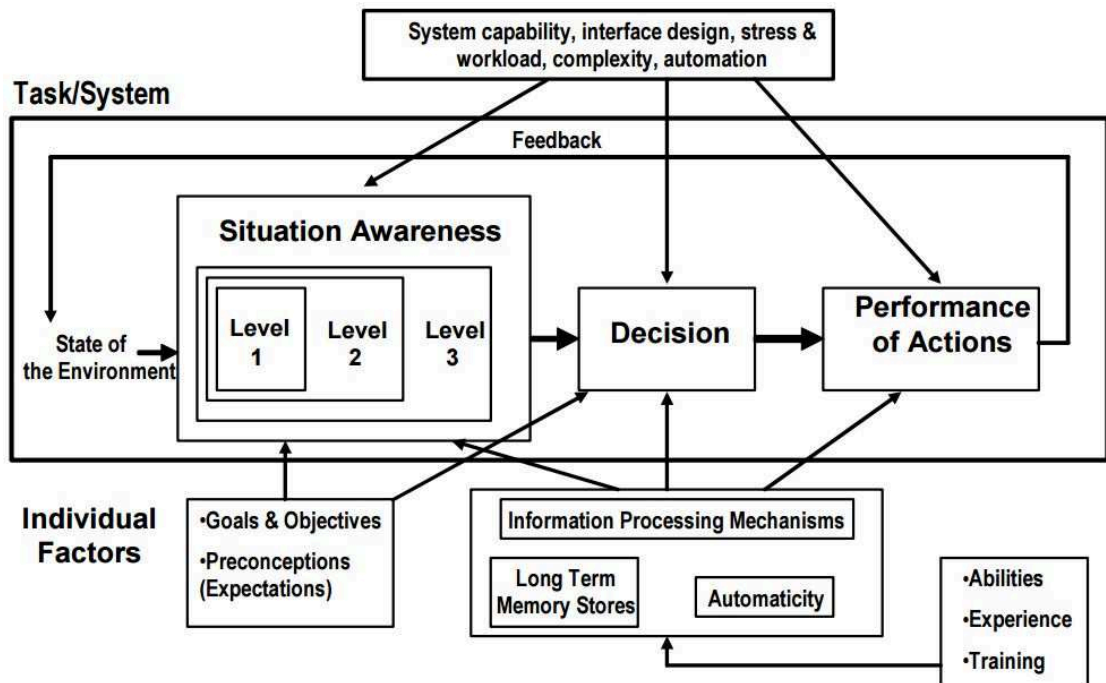

**Figure 2.1.3:** Model of SA in Dynamic Making Process [Endsley 95a].

Ma and Kaber [Ma 05] summarized underlying factors in driver SA, including navigation knowledge, environment and interaction knowledge, spatial orientation knowledge and vehicle status knowledge. They suggested an integration of these forms of knowledge in a model of driver information processing to achieve accurate SA. However, there have been few empirical studies of how drivers may form these types of knowledge for SA and what task, environment or system features, such as in-vehicle automation, play a role.

In [Ward 00, Matthews 01], the authors related levels of Situation Awareness defined by Endsley, including perception (Level 1 of SA), comprehension (Level 2 of SA) and projection (Level 3 of SA) (see Fig. 2.1.3) to specific driving tasks. They defined the situation awareness in three levels, operational, tactical and strategic levels. For example, in operational driving tasks, drivers are engaged in actions upon vehicle actuators in order to maintain stable control. They said operational driving tasks, including steering and braking responses, primarily require Level 1

of SA. In [Matthews 01], the authors said: ‘Level 2 SA may (also) be involved, if driving processes generate error messages’. For example, a driver may understand the rate of vehicle deceleration to be insufficient (Level 2 SA) for a particular perceived stopping distance (Level 1 SA). In tactical driving tasks, Matthews et al. observed that there is a high requirement for Levels 1 and 2 SA to, for example, facilitate safe manoeuvres of a vehicle in traffic by judging and comparing lane positions. Level 3 SA is also relevant to such interactive driving situations where there is a high requirement for near-term projection of changes in the driving course and traffic patterns. In strategic driving tasks, when navigation plans are being formulated, there is also a high requirement for Level 3 SA.

In [Smith 95], the authors use a more operational definition of situation awareness that can be directly seen in the operator’s behavior: they define it as «adaptive, externally directed consciousness». Certain factors or dimensions in environment restrict a operator’s behavioral opportunities. An operator who correctly interprets these factors is able to behave correctly in a certain environment and can therefore be defined as situationally aware. This definition seems very suitable to directly measure a driver’s awareness of a pedestrian by observing his/her behavior in the reaction in the situation with a pedestrian.

On these point of view, a pedestrian appears in front of the car is considered as a particular situation in road. The driver’s driving formation, experience or routine can be seen in his driver situation awareness. The driver’s perception level (level 1 of SA) is presented by the moment the driver perceives the pedestrian, the comprehension (level 2 of SA) can be measured on his estimation of the possibility the pedestrian can cross the road, and the projection (level 3 of SA) consists of the good decision (slow down, accelerate, stop, etc) that the driver has chosen regarding to pedestrian within the actual driving task.

### **Inattention or Distraction**

The second notion we want to consider is Attention. Attention has been defined as the “concentration of the mind upon an object; maximal integration of the higher mental processes” [Engström 13]. In the scientific literature, Attention as defined in [Matlin 02], “is a concentration of mental activity” and is divided



into two interrelated categories: 1) Divided Attention, which involves attending to simultaneous tasks or basically paying equal attention to several tasks. As mentioned in [Matlin 02], the human perceptual system can only handle some divided tasks or simultaneous tasks which require equal attention, but incidentally fails when the tasks become highly demanding. 2) Selective Attention, this type of attention involves situations where people are confronted with two or more simultaneous tasks and they have to attend to one of the tasks while ignoring the other. As in [Matlin 02], “selective attention studies often shows that, people notice little about irrelevant tasks”.

In other hand, the inattention is defined as the “failure to pay attention or take notice” [Brown 02]. In [Victor 08], the author defined driver inattention as “improper selection of information, either a lack of selection or the selection of irrelevant information”. For [Treat 80], driver inattention occurs “whenever a driver is delayed in the recognition of information needed to safely accomplish the driving task, because of having chosen to direct his attention elsewhere for some non-compelling reason”. Senders defines driver ‘inattention’ as “an ex post factor identification of something that was not being looked at and was immediately followed by a reportable accident that might have been avoided if the ‘something’ had been looked at” [Hancock 09]. As one can see, these meanings are diverse.

In a recent crash study, driver inattention was defined as occurring “when the driver’s mind has wandered from the driving task for some non-compelling reason” such as when the driver is “focusing on internal thoughts (i.e., daydreaming, problem solving, worrying about family problems, etc.) and not focusing attention on the driving task” [Craft 09]. Talbot and Fagerlind [Talbot 13], in a pan-European study of 1005 crashes, defined driver inattention as “low vigilance due to loss of focus”

### **Vigilance**

The vigilance is therefore defined, in particular, as the ability to sustain attention to a task for a period of time [Davies 82] [Parasuraman 98]. The research on vigilance is often specifically related to a vigilance decrement, the decline in attention-requiring performance over an extended period of time [Mackworth 64].

Animal behavior scientists and psychiatric clinicians use the term vigilance similarly but more specifically referring to attention to potential threats or dangers, with hypo-vigilance being one of the symptoms of post-traumatic stress disorder [Association 94]. This usage of vigilance is probably closest to the common lay usage and to the English dictionary primary definitions of vigilance, e.g. ‘state of being alertly watchful, especially to avoid danger’ [Webster 05].

In another definition, vigilance describes “a state of readiness to detect and respond to certain specified small changes occurring at random time intervals in the environment” [Mackworth 64]. The requirements of the driving task performed on long distance drives very much resembles this definition, because the ability to detect small changes in the environment is a crucial factor in safe driving. Accordingly, states of reduced vigilance, e.g., due to long and monotonous drives, are a main cause of traffic accidents [Thiffault 03]. The development of driving assistance systems and active safety systems targeting low-vigilance conditions requires a comprehensive understanding and characterization of this cognitive state. For future applications, a reliable, real time estimation of vigilance state and, more specifically, of the driver’s reactivity, is desirable.

### 2.1.3 Definitions of Driver Awareness of Pedestrian

In this study, we analyze the scenario which creates the most crash to pedestrians. We observe the driver’s reactions in this scenarios and detect the driver impaired behavior. We define this as the **Driver Unawareness of Pedestrian**. This includes the fact that the pedestrian is not perceived or perceived too late to react. But most of time, it describes the fact that the driver underestimates the risk of the situation. The **Driver Awareness of Pedestrian** is in contrast, consists of the driver who has a high level of situation awareness, is attention and vigilance vis-a-vis the pedestrian in front of the vehicle. Regarding two concepts : driver behavior and driver performance [Fuller 05], we give two definitions of the Driver Awareness of Pedestrian.

**Definition 1** (based on Driver Behavior Concept): Awareness of Pedestrian and Unawareness of Pedestrian are the driver's behaviors in situations with a pedestrian being in front of the vehicle. The Driver Unawareness of Pedestrian includes the fact that the pedestrian is not perceived or is perceived too late to react or the fact that the driver underestimates the risk of the situation. On the other hand, the Driver Awareness of Pedestrian includes the fact that the driver perceives the pedestrian and be able to react to the situation whenever the pedestrian cross suddenly the road.

**Definition 2** (based on Driver Performance Concept): Driver Awareness of Pedestrian and Driver Unawareness of Pedestrian are the performance of the driver in situation with a pedestrian being in front of the vehicle. This performance is defined with three levels. The Perception level, the Vigilance level and the Anticipation level. The Perception level consists of the moment the driver figures out there is a pedestrian on road. The Vigilance level is the ability of the driver to sustain attention to the pedestrian and his estimations of the possibility that pedestrian can cross the road. And the Anticipation level consists of right actions that driver chooses to do in that situation such as stopping, passing by, slowing down or speeding up, etc. (see Fig 2.1.4).

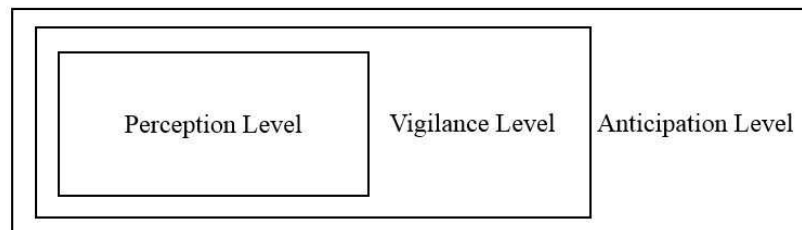

**Figure 2.1.4:** *Three levels of driver subjective risk estimation in a specific situation .*

In the point of view of what happen in a scenario and neglecting the chance factor, if a driver who notices the pedestrian, then, carefully analyzes the situation, chooses to stop or pass by the pedestrian safely, he is considered to be aware of that pedestrian (Case 1 and 2 in Fig 2.1.5). If not, he is considered as be unaware of that pedestrian (Case 3 in Fig. 2.1.5).

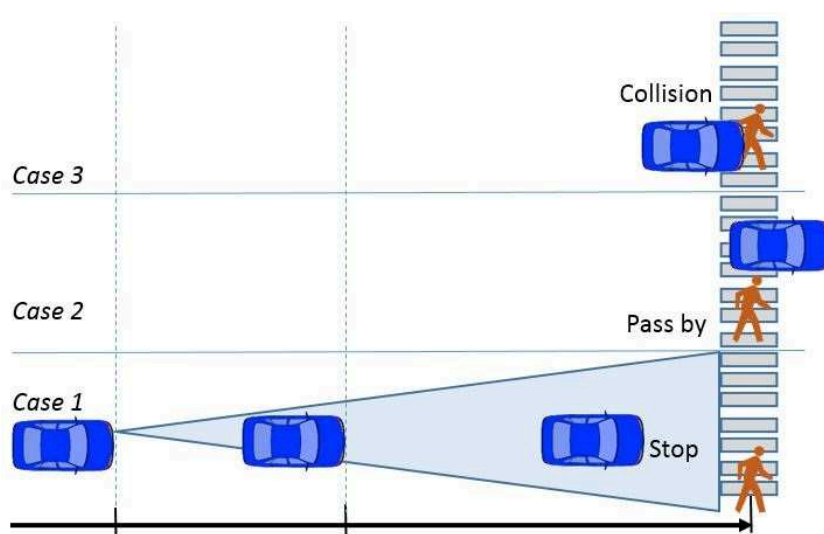

**Figure 2.1.5:** *Case 1 and 2, the driver is supposed to be aware of pedestrian. If the driver is unaware of pedestrian (case 3), a warning is activated. .*

## 2.2 Surrogate Measures and Conceptual Model

In this section, we are interested in the observations and the surrogate measures of our models. First of all, we review some potential observations in the driver's behaviors study literature, then, we present our choice of surrogate measures that will be used as input of the model.

### 2.2.1 Potential Measures

#### Physiological Signal Observation

The physiological signals such as heart rate, respiration or Electroencephalography (EEG) are considered to be the most reliable signals to analyze the driver's behaviors and to detect inattentiveness. Heart rate is easily determined through Electrocardiogram (ECG) signal. The mental stress while driving for example, increases blood pressure, heart rate and activate the sympathetic nervous system. There are significance impacts in the heart rate when a driver is in a state of cognitive inattention (thinking while driving for example) [Akin 08]. Moreover, the EEG signal has various frequency bands which can signify different states of the

driver. For example, there is evidence that the increase of the alpha band (8-13Hz) corresponds to relaxation. Increase of the delta band ( $0.5 - 4Hz$ ) and the theta band ( $4 - 8Hz$ ) correspond to sleep activity and drowsiness which signify a potential failure of attention and behaviors [Östlund 04, Santana Diaz 02]. In another experiment, twelve types of energy parameters computed from three bands alpha, beta, and delta were chosen as the evaluation index of driver fatigue [Li 12].

The skin temperature was measured while performing arithmetic tasks while driving [Itoh 09]. Another work also found that there was a raise in the skin temperature of the participants while they were distracted [Wesley 10]

However, these techniques are obtrusive, since it is necessary to attach some electrodes on the drivers, causing annoyance to them. Consequently, it is difficult to be implemented in the real-life applications.

### **Visual Behaviors Observation**

The driver's behaviors could be somehow observed from the changes in their facial features like eyes, head and face. This measurements have the advantage of being unobtrusive, since they could be collected with remote eye-head trackers. Moreover, they are quite reliable. In this context, several measurements have been proposed. Measurements related to head movement such as nodding frequency and those related to the eye region such as eyelid distance changes, eye close duration, blinking frequency, and the recently developed parameter PERCLOS (percentage of time in a minute that the eye is 80% closed) were widely used in research [Lin 12]. After extracting these features, Bergasa and Mohamad-Hoseyn Sigari [Bergasa 08, Sigari 13] built a fuzzy model or finite state machine to estimate the inattentive, distracted or fatigue state of driver. Another cue is the size of the pupils. The pupil is the part of the iris that allows light to enter the retina. Besides light, the pupil dilates when mental or cognitive effort is given. It was observed that the pupil was dilated and the diameter of average pupil size increased by 15 when the driver was cognitively distracted [Akin 08, Benedetto 11a]. Gaze behaviors are another cues that can be used as a metric to find if the concentration of the driver was on driving or not. It was noticed that, when the driver was cognitively distracted, glancing at instruments and mirrors decreased significantly

[Harbluk 02]. A simple method to detect the driver's attention was proposed by Fletcher and Zelinsky [Fletcher 09]. They used driver's gaze vector and road scene event correlation to estimate if the driver has seen the event or not. Due to the "looking but not seeing" problem, this work was not able to reliably determine if a certain road event (pedestrian for example) is perceived by the driver. However it could identify if the driver has not perceived a road event. Deeper in this context, Doshi and Trivedi [Doshi 12] provided a result on the observation of the dynamic of overt visual attentions shifts. They found that there are various interactions between head and eye movements that are useful in detecting the driver distractions, as well as the driver intent. Indeed, their results validated the differences existing between goal-oriented and stimulus-oriented gaze shift. Moreover, this feature could be observed in dynamics of eye and head movements. They also investigated the problem of detecting the intent of the driver in changing lane which was considered to be a goal-oriented attention shift. This result showed that the driver attentiveness or awareness of something should be observed through the dynamic of many parameters.

### **Driving Behaviors Observation**

Another method on the driver's inattention research is to detect it indirectly through driving actions such as vehicle speed, steering wheel movement, lateral position, and break or acceleration pedal states [Imamura 08, Ueno 94]. The projects conducted by HASTE (Human Machine and the Safety of Traffic in Europe ) demonstrated that the steering measures were significantly affected by the visual task, when a subject had to perform the visual task, the steering effort was higher than in the baseline condition [Östlund 04]. The IVDRs (In-vehicle Data Recorder) offer valuable information on a driver's behavior through the analysis of automobile-operating information. Jensen and Wagner [Jensen 11] also proposed a combination of three analysis methods to evaluate the driver's performance: data threshold violations, phase plane analysis with limits and a recurrence plot with outlier limits

These methods were based on the measurements of vehicle speed, engine speed, vehicle latitude and longitude coordinates, and lateral accelerations. Although

these techniques are not obtrusive, they are subject to several limitations such as vehicle type, driver experience, geometric characteristics, state of road, etc. [Bergasa 08].

### **The measurements in the study of the Drivers Awareness of pedestrian**

To the best of our knowledge, there are no studies that are directly related to the estimation of the driver unawareness of pedestrian or other traffic events. The most closely related works are those of Fukagawa and Yamada [Fukagawa 13] who proposed a hypothesis that is likely linked to our work.

Their study was based on the driver's operational data such as pressure on the accelerator pedal, pressure on the brake pedal (called acceleration reaction), steering angle and vehicle behavior data such as vehicle speed to estimate the driver's awareness of pedestrian. Their hypothesis was that whenever a pedestrian appears on the road, if the driver noticed it, he had to do the acceleration reaction somehow. They used the driving action data collected by Research Institute of Human Engineering for Quality of Life [Akamatsu 03]. From that, they proposed to calculate the probability of acceleration reaction being observed at a distance given that response to driver's aware of the pedestrian. This probability was assumed to be a log-normal distribution. They also proposed to calculate the probability of acceleration reaction being observed at a distance given that not in response to driver's aware of the pedestrian and this probability was considered to be a uniform distribution. Hence, using Bayes theorem, they calculated the probability that one acceleration reaction was caused in response to driver's awareness of pedestrian. However, there is a couple of weaknesses in this study. Firstly, in the data collected in real and actual road condition, it was supposed that whenever a pedestrian appeared on road, the driver had to notice them, this is hard to verify. Secondly, the driver could totally accelerate if he had been aware of the pedestrians and identify that they were not in danger. On the other hand, this probability model is not reliable because of the use of a specific distribution law. Finally, this study can not determine if the driver has not noticed the pedestrian or has been unaware of them.

Based on the different measurements presented above, the researcher can pro-

posed the mathematical models in order to estimate, predict the impaired driving and the driver abnormal states. In the next part, we will present our conceptual model that aims to estimate whenever the driver is aware of unaware of a pedestrian. In this conception, the model will take the driving signal measurements as its inputs and uses the mathematical models to compute the probability that the driver is aware of pedestrian.

### 2.2.2 Conceptual Model

For the measurement, we chose to use four driving signals: The vehicle speed denoted  $v$  in km/h; The acceleration pedal position denoted  $a$  which were normalized and takes value in  $[0; 1]$ . This value is equal to 0 means that the driver releases completely the accelerator pedal and on the contrary, when the drive pressed completely the accelerator pedal, this value is equal to 1; The braking force, denoted  $b$  which takes value in  $[0; 400]$ (Newton Unit - N) and the steering wheel angle, denoted  $s$  which takes value in  $[-\pi, \pi]$  radian rad. There was also one derivative signal which was the Time-to-Collision ( $TTC$ ) in second s, The  $TTC$  presented the relationship between the distance to the pedestrian and the speed of the vehicle. Finally, at each instant  $t$ , the observed data is:

$$\mathbf{O}(t) = [a(t), b(t), s(t), v(t), TTC(t)]^T \quad (2.2.1)$$

For simplifying the writing of the formulation, we write  $\mathbf{O}$  at instant  $j$  as follows:

$$\mathbf{O}_j = [a_j, b_j, s_j, v_j, TTC_j]^T \quad (2.2.2)$$

Than, let consider a temporal data sequence of  $\mathbf{O}(t)$  as an input of the model, we have the input of the models is:

$$\mathbf{V}_i = [\mathbf{O}_i, \mathbf{O}_{i+1}, \dots, \mathbf{O}_{i+h*Tw}]^T \quad (2.2.3)$$

where  $Tw$  is the sequence size in term of time and  $h * Tw$  is the sequence size in term of data point in which  $h$  is sensors frequency calculated in  $(1/Hz)$

The Figure.2.2.1 shows the structure of the model of estimation of the driver's awareness of pedestrian. In the next section, we will explore the mathematical



algorithms that can be used for estimation.

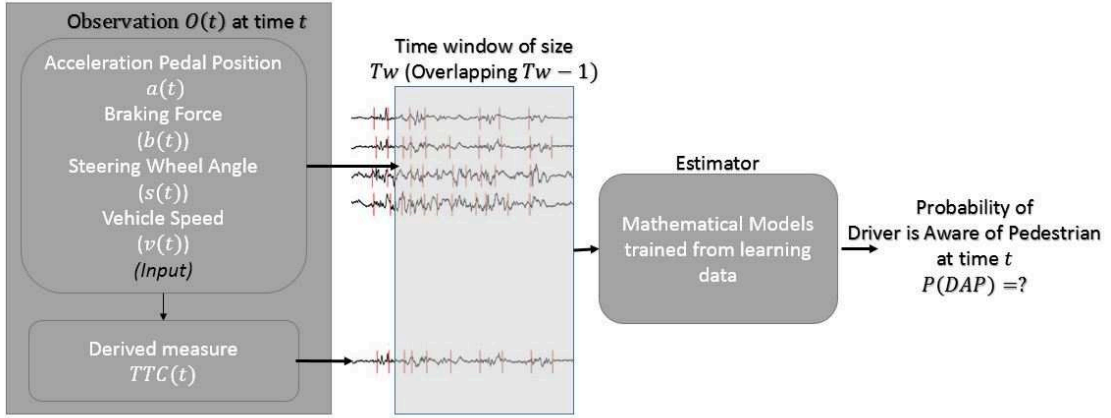

**Figure 2.2.1:** *The Conceptual Model for estimating the Driver Awareness of Pedestrian.*

## 2.3 Mathematical Models for Awareness and Unawareness Classification

As presented in the above conceptual model, our objective is to estimate the probability that the driver is aware of the pedestrian at every instant when the pedestrian appears in front of the car. In the first stage, in order to better analyse the performance of the algorithms, the problem of estimation of the driver's awareness of a pedestrian (*DAP*) and estimation of the driver's unawareness of a pedestrian (*DUP*) are formulated as a standard classification problem [Aoude 12]:

Given a training data set  $\{(\mathbf{V}_i, y_i) | i = 1, 2, \dots, m\}$ , where  $\mathbf{V}_i \in \mathbb{R}^d$  is the  $d$ -dimensional features of driving data and is associated with a target  $y_i \in \{DAP, DUP\}$ . Without loss of generality, we can replace the set  $\{DAP, DUP\}$  by  $\{0, 1\}$  or  $\{-1, 1\}$ . The goal is to fit a decision function  $g(\mathbf{V})$  that approximates the relation inherited between the data set points and it can be used later on to infer the output  $y_*$  for a new input data  $\mathbf{V}_*$ .

### 2.3.1 Classifier Requirements

Before choosing and implementing the classifiers, some a priori criteria are defined for the algorithms. They have to:

- allow an implementation in real-time: In term of complexity, the model has to allow the development of a real-time device implemented in the car.
- be adaptable to detecting in real-time what means that the DAP or the DUP has to be detected at each instant of time.
- have been successfully applied, even in different domains other than road safety research to insure the reliability of the model.
- be able to cope with inter-individual differences. Because the driver's performance and behaviors are somehow dependent on the driver's driving style, we would like to have a model that no need to be trained for each driver.
- have the feasibility of the model in term of time: it requires a reasonable time to be implemented (regarding to the thesis deadline).
- be data quantity independent. Indeed, as the driver's behaviors in the critical situation are difficult to be observed and measured. A model which is not much dependent to data quantity is expected.

We proposed to study six different classifiers which can be divided into three propositions: the threshold-based algorithms, the discriminative models and the generative models. A detailed discussion about their characteristics as well as the training step are given in the next parts.

### 2.3.2 First Proposition: Feature-based Algorithms

#### The Time-To-Collision

One of the most intuitive approaches to detect the driver unawareness is to use the time-to-collision (*TTC*). This type of temporal property is usually used for road traffic safety analysis [Kiefer 05]. Indeed, the *TTC* is defined as: «*The time*

required for two vehicles to collide if they continue at their present speed and on the same path» [Hayward 72]. It is simply calculated as:

$$TTC = \frac{r}{|v - v_{ped}|}. \quad (2.3.1)$$

Where  $v$  and  $v_{ped}$  are respectively the vehicle speed and the pedestrian speed,  $r$  is the distance between the vehicle and the pedestrian. For this classification algorithm, the  $TTC$  value is computed when the vehicle's deceleration crosses a predefined threshold  $d_{th}$  that indicates a reaction of the driver when he is aware of the pedestrian. Then the driver is classified as DUP if  $TTC < TTC_{th}$  where  $TTC_{th}$  is the predefined threshold. The  $TTC_{th}$  is chosen as the time given for the driver to stop safely in front of the pedestrian. This static parameter can be adjusted to change how conservative the algorithm is in its classifications.

We adapt this idea and create a  $TTC$ -based classification based on the training data. With each sequence in the training data set  $\{(\mathbf{V}_i, y_i), i = 1, 2, ..m\}$ , the decision value is calculated for each input sequence  $\mathbf{V}_i$ (2.1). If there is an instant  $j$  when the vehicle's deceleration crosses  $d_{th}$ , the decision function  $g(\mathbf{V}_i)$  takes the  $TTC_j$  value at this moment. In the event that the vehicle never crosses this threshold,  $g(\mathbf{V}_i)$  takes the smallest value of the  $TTC$  in this sequence. The Algo. 2.1 shows how to calculate the decision function  $g(\mathbf{V})$  from a sequence observation  $\mathbf{V}$ .

---

**Algorithm 2.1**  $TTC$ -based algorithm

---

- Input: Training data set  $\{(\mathbf{V}_i, y_i), i = 1, 2, ..m\}$ .
- Output: The detection threshold  $TTC_{th}$

1. **For**  $i := 1$  **To**  $m$

• **With** each  $\mathbf{V}_i$  **do** :

a) Calculating the deceleration of the vehicle at each instant  $j$ :

$$d_j = \frac{v^{(j+1)} - v^{(j)}}{h} \text{ (m/s}^2\text{)}, h \text{ is the time step size, } h = \frac{1}{20}\text{s}$$

b) **If**  $\exists j$  that  $d_j < d_{th}$  **then**  $g(\mathbf{V}_i) = TTC_j$ , **Else**  $g(\mathbf{V}_i)$  takes the smallest value of  $TTC$  in the sequence  $\mathbf{V}_i$

---

In the classification step, with a new  $\mathbf{V}_*$  sequence, we calculate  $g(\mathbf{V}_*)$ . If  $g(\mathbf{V}_*)$  is greater than the  $TTC_{th}$  threshold that was chosen in ROC curves test, the driver behavior is classified into the DAP class, otherwise, it is classified into the DUP class if not.

### The Required Deceleration Parameter

The second simple technique is to use the Required Deceleration Parameter ( $RDP$ ). In [Neale 06][Aoude 12], the  $RDP$  has been used to classify the driver as compliant or violant when he enters into a road intersection. The idea is to provide the deceleration needed for the vehicle to stop safely knowing its distance to an obstacle and its current speed. It is defined as:

$$RDP = \frac{v^2}{2rg} \quad (2.3.2)$$

where  $g$  is the gravitational acceleration constant.

For a given  $RDP_{th}$  threshold, the driver is classified as DAP whenever the  $RDP$  is greater than  $RDP_{th}$ .

Since the pedestrian speed is neglected in the formula of the  $TTC$  (Eq. 2.3.1), the  $RDP$  represents the acceleration reaction of the driver at the specific critical time. The Eq. 2.3.2 can be rewritten as follows:

$$RDP = \frac{v^2}{2rg} = \frac{v}{2TTCg} \quad (2.3.3)$$

Given a training data set  $\{(\mathbf{V}_i, y_i), i = 1, 2, ..m\}$ , the  $RDP_j$  value is calculated at every instant  $j$  in the sequence  $\mathbf{V}_i$ . Then, the decision function  $g(\mathbf{V}_i)$  takes the greatest value of those  $RDP_j$  values. Indeed, the greatest value of  $RDP_j$  will be the most significant to compare between a DUP sequence and a DAP sequence. The  $RDP_{th}$  threshold is then specified in evaluation step using the ROC curve.

The algorithm for calculating the decision function  $g$  in the RDP method is presented in Algo. 2.2.

---

**Algorithm 2.2** RDP-based algorithm

---

- Input: Training data set  $\{(\mathbf{V}_i, y_i), i = 1, 2, ..m\}$ .
  - Output: The detection threshold  $RDP_{th}$
1. **For**  $i:= 1$  **To**  $m$ 
    - **With** each  $\mathbf{V}_i$  **do** :
      - a) Calculating the  $RDP$  at each instant  $j$ :
 
$$RDP_j = \frac{v(j)}{2TTC_j * g}$$
      - b)  $g(\mathbf{V}_i) = \max_{j \in [1..length(\mathbf{V}_i)]}(RDP_j)$
- 

### 2.3.3 Second Proposition: Discriminative Models

#### The Support Vector Machine

In the discriminative approaches, the Support Vector Machine (SVM) is a well known statistical learning theory which was developed by Cortes and Vapnik [Cortes 95]. It is typically applied to many areas such as such as pattern recognition, regression, equalization, classification and is adopted in applications such as remote sensing [Mountrakis 11], text classification [Tong 02], face detection [Osuna 97], image classification [Chapelle 99], human dynamic gait recognition [Begg 05], and so on.

Concerning the adaptation to recognize the driver behaviors, the SVM is also widely used in different variants. In [Aoude 12], the SVM was used and followed by a Bayesian filter to determine the probability that the driver is compliant or violant before entering an intersection. The performance raised to 84% of true detection validated on the realistic driving data. In [Qian 10], the authors used sequentially two SVMs to identify the driver based on their driving actions. In [Kim 07, Chang 11], the driver lane-change intention was estimated using SVM. In [Liang 07], the driver cognitive distraction was detected using the SVM, the input data was the eye movement data and driving measures.

We applied straightforwardly the C-SVM version of SVM [Chang 11] to classify whether the driver is aware or unaware of pedestrian. The input data is the feature

$\mathbf{V}$  of driving actions as described in Eq. 2.2.3.

The basic idea of the SVM is to map the observed data  $\mathbf{V}$  (Eq. 2.2.3) which is a feature of  $\mathbb{R}^d$  low-dimension, into a high-dimensional feature space  $\mathcal{F}$  via a nonlinear mapping  $\phi$ , and to do linear classification in this space. The decision function is written as follow:

$$g(\mathbf{V}) = \mathbf{w} \cdot \phi(\mathbf{V}) + b \quad (2.3.4)$$

with  $\phi : \mathbb{R}^d \rightarrow \mathcal{F}$ ,  $\mathbf{w} \in \mathcal{F}$ , and  $b$  is a bias threshold,

Then the output class is given by evaluating the sign of the decision function:

$$y = \text{Sgn}(g(\mathbf{V})) = \text{Sgn}(\mathbf{w}\phi(\mathbf{V}) + b) \quad (2.3.5)$$

Given a training data set  $\{(\mathbf{V}_i, y_i), i = 1, 2, \dots, m\}$ , with  $y_i \in \{-1; 1\}$ . Training the C-SVM consists of solving the following primal optimization problem:

$$\min_{\mathbf{w}, b, \xi} \frac{1}{2} \mathbf{w}^T \mathbf{w} + C \sum_{i=1}^m \xi_i \quad (2.3.6)$$

subject to  $y_i(\mathbf{w}^T \phi(\mathbf{V}_i) + b) \geq 1 - \xi_i$ ,

$$\xi_i \geq 0, i = 1, 2, \dots, m$$

Where  $C > 0$  is the regularization parameter. Moreover, due to the possible high dimensionality of the vector variable  $\mathbf{w}$ , Eq. 2.3.6 is usually solved by the following dual problem:

$$\min_{\mathbf{w}, b, \xi} \frac{1}{2} \boldsymbol{\alpha}^T \mathbf{Q} \boldsymbol{\alpha} - \mathbf{e}^T \boldsymbol{\alpha} \quad (2.3.7)$$

subject to  $\mathbf{y}^T \boldsymbol{\alpha} = 0$ ,

$$0 \leq \alpha_i \leq C, i = 1, \dots, m$$

where  $\mathbf{e} = [1, \dots, 1]^T$  is the vector of all ones,  $\mathbf{Q}$  is an  $m$  by  $m$  positive predefine matrix,  $\mathbf{Q}_{ij} \equiv y_i y_j K(\mathbf{V}_i, \mathbf{V}_j)$ , and  $K(\mathbf{V}_i, \mathbf{V}_j) \equiv \boldsymbol{\phi}(\mathbf{V}_i)^T \boldsymbol{\phi}(\mathbf{V}_j)$  is the kernel function.

The algorithm is used to solved this dual problem is presented in **Appendix. A.1.1.** Once the dual problem (Eq. 2.3.7) is solved, using the primal-dual relationship, the optimal  $\mathbf{w}$  satisfies:

$$\mathbf{w} = \sum_{i=1}^m y_i \alpha_i \boldsymbol{\phi}(\mathbf{V}_i) \quad (2.3.8)$$

and the decision function for new data input  $\mathbf{V}_*$  is:

$$g(\mathbf{V}_*) = \mathbf{w} \boldsymbol{\phi}(\mathbf{V}_*) + b = \sum_{i=1}^m y_i \alpha_i K(\mathbf{V}_i, \mathbf{V}_*) + b \quad (2.3.9)$$

Then the output class  $y_*$  is:

$$y_* = \text{Sgn}(g(\mathbf{V}_*)) = \text{Sgn}(\mathbf{w}^T \boldsymbol{\phi}(\mathbf{V}_*) + b) = \text{Sgn}\left(\sum_{i=1}^m y_i \alpha_i K(\mathbf{V}_i, \mathbf{V}_*) + b\right) \quad (2.3.10)$$

We store  $y_i$ ,  $\alpha_i$ ,  $\forall i$ , label names, support vectors and other information such as kernel parameters in the model for the DAP/DUP classification.

In this thesis, we firstly used the Radial Basis Function (RBF) for all discriminative model. The RBF kernel is efficient in complex non-separable classification problems due to its ability for nonlinear input mapping.

$$K(\mathbf{V}_i, \mathbf{V}_j) = \exp(-\gamma \|\mathbf{V}_i - \mathbf{V}_j\|^2) \quad (2.3.11)$$

Therefore, in order to get a good classifier, it is important to run the SVM classifier on the training data set with different values of the regularization  $C$  (in Eq. 2.3.6) and the  $\gamma$  parameter in the kernel (Eq. 2.3.11).

### The Relevance Vector Machine

The SVM model has also some limitations. It outputs a hard decision rather than the posterior probabilities. Ideally, we would like to estimate the conditional distribution  $P(t|x)$  in order to capture the uncertainty in our decision model. Moreover, this class membership is necessary to adapt to varying class priors and asymmetric misclassification costs.

SVMs make unnecessarily liberal use of basis functions since the number of support vectors required typically grows linearly with the size of the training set. Some form of post-processing is often required to reduce computational complexity. Moreover, it is necessary to estimate the error/margin trade-off parameter  $C$  (in Eq. 2.3.6). This generally entails a cross-validation procedure, which is wasteful both of data and computation [Tipping 01].

Therefore, another method that follows the same functional form with the SVM, namely the Relevance Vector Machine can be used to avoid this limitation based on Bayesian techniques[Tipping 01]. The RVM classifier outputs a class membership likelihood that represents the probability that the test data is belong to a given class.

The RVM has been applied in [Doshi 12] to detect the lane changes intention of the driver based on the eye/head movement. In [Yogameena 10], the authors used the multi-RVM in a one-vs-all scheme to classify different classes of human behaviors such as run, jump, walk,etc. They have been also compared to the SVM and have showed a better performance.

The RVM is firstly considered for the regression problem. Given the same input-target data set  $\{\mathbf{V}_i, t_i\}, i = 1, 2, \dots, m$  but now  $t_i$  takes the scalar value instead of being  $\{0, 1\}$ .

Now, we adopt the function notation  $g(\mathbf{V})$  of the SVM (Eq. 2.3.4) as follow:

$$t_i = g(\mathbf{V}_i) + \epsilon = \mathbf{w} \cdot \boldsymbol{\phi}(\mathbf{V}_i) + \epsilon_i \quad (2.3.12)$$



Where  $\epsilon$  is additive noise. This noise is assumed to be mean-zero Gaussian with variance  $\sigma^2$ .

Let us consider the conditional distribution  $P(t_i|\mathbf{V})$ . Thus, we can write  $P(t_i|\mathbf{V}_i) = \mathcal{N}(t_i|g(\mathbf{V}_i), \sigma^2)$  where the notation specifies a Gaussian distribution over  $t_i$  with the mean  $g(\mathbf{V}_i)$  and the variance is  $\sigma^2$ . As in SVM, we consider the same kernel function  $K(\mathbf{V}_i, \mathbf{V}_j) \equiv \phi(\mathbf{V}_i)^T \phi(\mathbf{V}_j) = \exp(-\gamma \|\mathbf{V}_i - \mathbf{V}_j\|^2)$ . Due to the assumption of independence of the  $t_i$ , the likelihood  $P(\mathbf{t}|\mathbf{V})$  of the complete data set can be written as:

$$P(\mathbf{t}|\mathbf{w}, \sigma^2) = (2\pi\sigma^2)^{-m/2} \exp\{-\gamma \|\mathbf{t} - \Phi\mathbf{w}\|\} \quad (2.3.13)$$

where  $\mathbf{t} = [t_1, t_2, \dots, t_m]^T$ ,  $\mathbf{w} = [w_1, w_2, \dots, w_m]^T$ , and  $\Phi$  is the  $m \times m$  design matrix

$$\Phi = [\mathbf{K}(\mathbf{V}_1), \mathbf{K}(\mathbf{V}_2), \dots, \mathbf{K}(\mathbf{V}_m)]^T \quad (2.3.14)$$

where  $\mathbf{K}(\mathbf{V}_i) = [1, K(\mathbf{V}_i, \mathbf{V}_1), \dots, K(\mathbf{V}_i, \mathbf{V}_m)]^T$ .

We would expect maximum-likelihood estimation of  $\mathbf{w}$  and  $\sigma^2$  of Eq. 2.3.13. This procedure requires certain step of imposing additional constraints on the parameters and approximation over  $\mathbf{w}$ . The detail of the approximation and estimation the  $\mathbf{w}$  and  $\sigma^2$  from the labeled data set can be found in the work of Tipping [Tipping 01]

In the inference step, having defined the prior, Bayesian inference proceeds by computing, from Bayes' rule, the posterior over all unknowns given the data:

$$P(\mathbf{w}, \sigma^2|\mathbf{t}) = \frac{P(\mathbf{t}|\mathbf{w}, \sigma^2)P(\mathbf{w}, \sigma^2)}{P(\mathbf{t})} \quad (2.3.15)$$

With a new data  $\mathbf{V}_*$ , predictions are made for the corresponding target  $t_*$ , in term of the predictive distribution:

$$P(t_*|\mathbf{t}) = \int P(t_*|\mathbf{w}, \sigma^2)P(\mathbf{w}, \sigma^2|\mathbf{t})d\mathbf{w}d\sigma^2$$

To those familiar, or even not-so-familiar, with Bayesian methods, it may come as no surprise to learn that we cannot perform these computations in full analyti-

cally, and must seek an effective approximation A.1.2. Further detail of the RVM can be found in [Tipping 01].

Back to our problem with is a two-class classification between the *DAP* and the *DUP*, it is desired to predict the posterior probability of membership of one of the classes given the input  $\mathbf{V}_i$ . The formulation of the classification follow statistical convention and generalize the linear model by applying the logistic sigmoid link function  $\sigma\{g(\mathbf{V}_i)\} = 1/(1 + e^{-g(\mathbf{V}_i)})$  and adopting the Bernoulli distribution for  $P(y_i|\mathbf{V}_i)$ , we write the likelihood as:

$$P(\mathbf{y}|\mathbf{w}) = \prod_{i=1}^m \sigma\{g(\mathbf{V}_i)\}^{y_i} [1 - \sigma\{g(\mathbf{V}_i)\}]^{1-y_i} \quad (2.3.16)$$

where, following the probabilistic specification, the target  $y_i \in \{0, 1\}$ .

A approximation procedure, which is based on Laplace’s method is then proposed to map the classification problem to a regression one. And it follows the same technique to estimate the  $\mathbf{w}$  (See Appendix A.1.2).

In practical, the kernel  $K$  is the only parameter needed to be chosen in the RVM model. So, we employ once again the Radial Basis Function (RbF) as the kernel function. Therefore the only parameter needs to be set up for the model, is the  $\gamma$ .

### 2.3.4 Third Proposition: Hidden Markov Models

A Hidden Markov Model (HMM) can be considered as a dynamic Bayesian Network with two concurrent stochastic processes, a Markov process and a general stochastic process [Rabiner 89]. That is, in a HMM, the states in the Markov process are not directly measurable, but the output, dependent on the states, are observable. While second process is “what we can see of the world” (ex via the sensors), the first one can be considered as “why the world is like that” ( the driver wants to slow down, to turn etc). For example, in the field of voice recognition the invisible process are phonemes, and the visible process is the vocal signal [Rabiner 89]. Two of these hypotheses are: There is an invisible process which evolves state by state; and the study of the visible signal could provide information on this process. Their first presentation in 1989 by Rabiner [Rabiner 89] brought the

development of effective algorithms both for the inference and for the learning. Their uses in various studies shows that HMMs are well adapted to the problems with multidimensional nature where the time aspect is fundamental.

Speech recognition is the main domain that have successfully used the HMMs [Juang 91], followed by the technique for signature recognition [Yang 95], and gesture recognition [Starner 95].

In the driving context, the HMMs have been used with different schemes. In [Liu 97], in order to predict the driver intentions (right turn, left turn and stop), a series of HMMs have been used to model each type of intention. The observable outputs are the driving actions on the 2 seconds right before the intention is taken. The results of the intention recognitions in a simulator experiment showed up to 87% of accuracy.

Pentland and Liu modeled more diversified situations (stop at the next intersection, turn left at the next intersection, turn right at the next intersection, change lane, over-take car, go straight) in a simulator [Pentland 99]. They assumed that the human driving strategy on the vehicle is different according to the states of the driving activity. For example, they divided the lane change into six successive stages: (1) center the car on the initial lane, (2) look if the opposite lane is free, (3) initiate the change of direction, (4) change of lane, (5) end of the change, and (6) center the car in the new lane. With each stage, a Kalman Filter is associated, and each sequence is modeled by a HMM whose input parameters are the adequacy output from each filter.

In [Liu 97], a single HMM has been used to identify the vehicles in conflict with other vehicles in a limited intersection road with appropriate measurements of the ego-vehicle and surrounding vehicle dynamics. In [Aoude 12], the Gaussian Hidden Markov Model is used to classify the driver as violator or compliant at intersection from the driving signals collected in naturalistic driving. In this framework, the observation are the continuous signals and the emission distribution is modeled by a Gaussian distribution. In results, the HMM could reach up to 80% of good recognition between driver compliant or violator.

Therefore, in a prior choice, we consider that the Hidden Markov Models as the most suitable approach to model the driver's awareness of pedestrian. The

cognitive states of the driver in his vigilance process, his inattentive states or his situation awareness levels are unobservable. The Driver Awareness of a Pedestrian is also a cognitive process which could be considered as a sequential states which is time related. However, the states are not be able to measure directly. At each instant, this process is situated at a different state. Although these states are impossible to observe directly, we can observe and measure their consequences at each instant of time which are the actions on steering wheel or pedals. Moreover, the formalism of the HMMs is suitable for taking into account the transitions between phases and for its structural possibility to model temporal dilatation

In order to explore different characteristics of the HMMs, we have implemented two versions, the discrete hidden Markov model (DHMM) and the Multi-Variate Gaussian Hidden Markov Models (MGHMM) which is a continuous version of HMM. The two version of HMMs is expected to covers all the flexibility of the HMMs.

### The Discrete Hidden Markov Model

Different probability parameters give the relation among the states, and between the states and the visible output. A HMM can be characterized by:

- A set of  $N$  distinct states  $S = \{S_1, S_2, \dots, S_N\}$  of system.
- The initial state distribution  $\Pi = \{\pi_1, \pi_2, \dots, \pi_N\}$  where  $\pi_i = P(s_t = S_i)$ ,  $1 \leq i \leq N$ . Where  $s_t$  is the state of system at time  $t$ .
- The state transitions probability distribution  $\mathbf{A} = [a_{ij}]$  where  $a_{ij} = P(s_t = S_j | s_{t-1} = S_i)$ ,  $1 \leq i, j, \leq N$ .

Each state can produce one of  $M$  distinct observation symbols from the code book  $\{C_1, C_2, \dots, C_M\}$ . Where  $C_i$  is a predetermined symbol.

That is why we call the Discrete Hidden Markov Model (DHMM).

- The emission probability:  $\mathbf{B} = [b_j(m)]$  where  $b_j(m) = P(o_t = O_m | s_t = S_j)$ ,  $1 \leq m \leq M, 1 \leq j \leq N$ . Where  $v_t$  is the discrete observation at time  $t$ .

Therefore, the DHMM can be written as follows  $\lambda = \{\mathbf{A}, \mathbf{B}, \Pi\}$ .

In order to apply the DHMM, we need firstly to determinate the observation code book  $\{C_1, C_2, \dots, C_M\}$  from the continuous observation signal  $\mathbf{O}_j$  (see Eq 2.2.2). Then, we need to determine the best values of the parameters:  $N, M$  and the probability matrix  $\mathbf{A}, \mathbf{B}, \Pi$ .

### The Multivariate Gaussian Hidden Markov Model (MGHMM)

In [Phan 14a], we have proposed to a discrete HMM to classify the DUP and the DAP. However, the discretization of the driving signal can lead to a degradation of its signification. Thus, we proposed to use the observation as a continuous signal and to model the distribution of emission by a Gaussian mixture distribution. The Gaussian distribution is the most common and easily analyzed continuous distribution. Using the driving actions, we propose to build two Gaussian-mixture-HMMs for two distinct behaviors: Driver Awareness of Pedestrian (DAP) and Driver Unawareness of Pedestrian (DUP).

The MGHMM has the same components of the DHMM, except the emission distribution is defined as follows:

- At a time  $t$  each state can produce one  $d$ -dimension vector of observation  $\mathbf{O}$  which is composed of the continuous driving signals. This emission probability distribution is assumed to be a mixture of multivariate Gaussian:  $\mathbf{B} = \{b_j(\mathbf{O}) = \frac{1}{M} \sum_{m=1}^M \mathcal{N}(\mathbf{O}, \mu_{jm}, \Sigma_{jm})\}$  where  $M$  is number of component of mixture and each component  $\mathcal{N}$  is a  $d$ -variate Gaussian distribution parametrized by a mean vector  $\mu_{jm}$  and a covariance matrix  $\Sigma_{jm}$ .

Therefore, the MGHMM can be also written in a more compact form as  $\lambda = \{\Pi, \mathbf{A}, \mathbf{B}\}$ . The MGHMM design also consists of the determination of the best combination of the parameters:  $N, M, \mathbf{A}, \Pi, \mu_{jm}, \Sigma_{jm}$ ,

Even with DHMM or MGHMM, there are three problems of interest that must be solved for the model to be useful in real-world applications, the evaluation problem, the decoding problem and the learning problem [Rabiner 89]:

Problem 1 (Evaluation Problem):

Given the observation sequence  $\mathbf{V} = \mathbf{O}_1 \mathbf{O}_2 \dots \mathbf{O}_{h*Tw}$ , and a model  $\lambda = \{\Pi, \mathbf{A}, \mathbf{B}\}$ , how do we efficiently compute  $P(\mathbf{V}|\lambda)$ , the probability of the observation sequence, given the model?

Problem 2 (Decoding Problem):

Given the observation sequence  $\mathbf{V} = \mathbf{O}_1\mathbf{O}_2\dots\mathbf{O}_{h*Tw}$ , and a model  $\lambda = \{\Pi, \mathbf{A}, \mathbf{B}\}$ , how do we choose a corresponding state sequence  $\mathbf{S} = S_1S_2\dots S_T$  which is optimal in some meaningful sense (i.e., best 'explain' the observations).

Problem 3 (Learning Problem):

How do we adjust the model parameter  $\lambda = \{\Pi, \mathbf{A}, \mathbf{B}\}$  to maximize  $P(\mathbf{V}|\lambda)$ .

### The DAP and the DUP classification model.

The training technique and the decision process is the same for both DHMM and MGHMM. In fact, the DAP and DUP are modeled separately. In this study, we are interested in the evaluation problem and the learning problem.

Let us consider two HMM models  $\lambda_{DAP}$  and  $\lambda_{DUP}$  which represent the DAP and the DUP respectively.

$$\lambda_{DAP} = \{\mathbf{A}_{DAP}, \mathbf{B}_{DAP}, \Pi_{DAP}\} \quad (2.3.17)$$

$$\lambda_{DUP} = \{\mathbf{A}_{DUP}, \mathbf{B}_{DUP}, \Pi_{DUP}\} \quad (2.3.18)$$

Firstly, we apply the learning problem which allows us to optimally adapt the model parameters to the observed training data. Suppose we have two sequences of observations from training data: one is from the DAP ( $\mathbf{V}_{DAP}$ ) and the other is from the DUP ( $\mathbf{V}_{DUP}$ ). These sequences can be considered emissions produced by the two HMM modeling behaviors:  $\lambda_{DAP}$  and  $\lambda_{DUP}$ .

Using the expectation-maximization (EM) algorithm (see Appendix A.1.4), two models  $\lambda_{DAP}$  and  $\lambda_{DUP}$  are learned from  $\mathbf{V}_{DAP}$  and  $\mathbf{V}_{DUP}$  respectively. Indeed, the EM algorithm adjusts the parameters of the given models by maximizing the conditional probabilities of the sequences of observations.

The final models are computed by solving the following problems:

$$\lambda_{DAP}^* = \underset{\lambda}{argmax} P(\mathbf{V}_{DAP}|\lambda_{DAP}) \quad (2.3.19)$$

$$\lambda_{DUP}^* = \underset{\lambda}{argmax} P(\mathbf{V}_{DUP}|\lambda_{DUP}) \quad (2.3.20)$$

Secondly, given a new sequence of observations  $\mathbf{V}_*$ , the forward algorithm (See Appendix. A.1.3) is used for  $\lambda_{DAP}$  and  $\lambda_{DUP}$  to calculate the posterior probabilities  $P(\mathbf{V}_*|\lambda_{DAP})$  and  $P(\mathbf{V}_*|\lambda_{DUP})$ . These probabilities presents how well the models match the given  $\mathbf{V}_*$  (evaluation problem ). Moreover, since nothing is known beforehand, the prior over the model is assumed to be uniform  $P(\lambda_{DAP}) = P(\lambda_{DUP}) = 0.5$ .

Finally, for this classifier, the likelihood ratio  $\frac{P(\mathbf{V}_*,\lambda_{DUP})}{P(\mathbf{V}_*,\lambda_{DAP})}$  is calculated to determine whether the driver is likely to be aware or unaware of pedestrian. The threshold  $\tau_{th}$  is selected to adjust the performance of the DAP/DUP classification. It is usually computed by using the *log*-probabilities which introduces the exponential ( $e$ ) term in the formula:

$$\frac{P(\mathbf{V}_*, \lambda_{DUP})}{P(\mathbf{V}_*, \lambda_{DAP})} = \frac{P(\mathbf{V}_*|\lambda_{DUP})P(\lambda_{DUP})}{P(\mathbf{V}_*|\lambda_{DAP})P(\lambda_{DAP})} = \frac{P(\mathbf{V}_*|\lambda_{DUP})}{P(\mathbf{V}_*|\lambda_{DAP})} > e^{\tau_{th}} \quad (2.3.21)$$

If the likelihood ratio is greater than  $e^{\tau_{th}}$ , the sequence of observations  $\mathbf{V}_*$  is classified as DUP and as DAP if not. Again, the classification occurs on the observations in a  $T_w$  sliding time window. The Fig. 2.3.1 summarizes this HMM-based architecture. From here, we can see that the decision function  $g(\mathbf{V})$  is presented by the likelihood ratio.

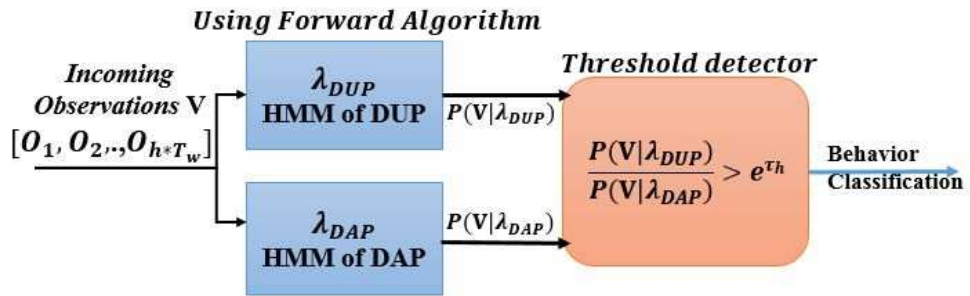

Figure 2.3.1: HMM-based decision process Architecture.

## **2.4 Conclusion**

This chapter underscores the gap in the literature in term of cognitive psychology and driver's unawareness of pedestrian detections. It provides a reasonable definition of the driver's awareness of pedestrian and proves the choice of measurement of driving actions as an evidence. Moreover, a wide range of mathematical models that can be applied are also represented. The choice of Hidden Markov Model-based methods is justified in prior by its advantage of implementation, inter-individual and reliability in road safety domain.

Due to the difficulty of creating a pedestrian scenario in real conditions, it is necessary to use firstly in a control environment. A real road experiments is therefore not possible at this stage. Therefore, in chapter 3, we will present how we use a driving simulator to manipulate the Driver Awareness of Pedestrian. Furthermore, together with this chapter, the chapter 3 concerns the implementations of the mathematical methods. We will present a framework to observe and model the driver's behaviors in a particular situation.



## Chapter 3

# Settings and Benchmark for Driver Awareness and Unawareness Classification

This chapter presents the implementation and the setting of the hyper-parameters of the classifiers presented in Chapter 2. A training dataset and specific parametrization techniques are employed. Section 3.1 provides the way of creating a dataset of the driver's awareness or unawareness of a pedestrian (the DAP and the DUP). Section 3.2 highlights the popular tools that are used to select the best values for the parameters. These tools are the  $p\%$  generalization test, the  $k - fold$  cross-validation, and the grid-search technique associated to the Receiver Operation Characteristics Curves. Then, in Section 3.3, based on some prior knowledge from the data and the generalization test, we present the best values for the parameters in each classifier. In Section 3.4, a performance comparison between the classifiers through the generalization tests are highlighted and discussed. The chapter ends with a conclusion (see Section 3.5) on the model which is chosen for a real-time classifier implementation.

## 3.1 Construction of a Driver Awareness of Pedestrian Dataset

### 3.1.1 Related Work on Driver Behaviors Manipulation

In order to model the driver's behaviors or the driver's abnormal states, some researchers have created the situations and the scenarios that generate those behaviors. The experiments can be conducted with a real car but most of them are done on a driving simulator because it is easier to create the impaired driving behaviors.

The driver's drowsiness and sleepiness are the simplest phenomena to be created and to be observed. The participants try to sleep when the scientists measure the surrogate data [Yu 07]. In [Akin 08], two experts with extended experience on interpreting the drowsiness data evaluate and rate the recordings used for this study. Each of them inspects the recordings, and then agrees on which record sequences clearly indicate awake, drowsy or sleepy states of the subject. In [Li 08], the participants are asked to drive on the same road with the same scenario. The monotonous scenario makes the subject to feel drowsy easily and even to fall asleep. In order to guarantee the monotony, the experiment is carried on an illuminated and sound proof room for at least one hour and a half.

To manipulate the cognitive inattention, Harbluk et al. propose to perform mental arithmetic questions like single digit addition (considered as an easy task), double digit addition (difficult task) through a mobile phone. The participants have to respond to the tasks through the mobile phone in hands free mode [Harbluk 07]. The participants are also asked to drive on a road with heavy traffic for eight kilometers (8000 m) while the three tasks previously described, are performed. The level of inattention of the participant are calculated through an eye tracker as well as by the way in which the brakes are applied. Wesley et al. manipulate cognitive distraction by asking the driver to answer a call while driving and he is also asked to answer two prerecorded question sets [Wesley 10]. One is a combination of basic, logical and simple mathematics and the other set comprised of ambiguous questions. If the driver answers wrong then the questions are asked

again in order to keep distracting the driver

To manipulate visual distraction, the drivers are asked to visually see a touch screen placed in front of them and they are asked to press the moving circle on the screen. The driver's inattention is monitored by tracking the lane changes and the eye movements [Benedetto 11b]. In another experiment, the visual distraction is monitored by asking the drivers to respond to a text message on their mobile phone.

Most of the researchers have manipulated cognitive distraction and visual distraction on the driver separately. To find the combined effect of both, Liang et al. asked the participants to listen audio clips similar to those in the cognitive task and to select the orientation in the touch screen using the interface similar to the visual task. Blink frequency and various vehicle oriented measures like steering error, lane position, braking impact are monitored to identify the drivers cognitive and visual distraction states [Liang 07].

### 3.1.2 Manipulating the DAP and the DUP

#### **An experiment with the driving simulator**

Let consider a situation where a pedestrian appears at a certain distance in front of the vehicle. The pedestrian can be in different states (walking, standing, running) at different traffic positions (on lane, crossing mark, side walk). As stated above, the pedestrian is vulnerable and he can cross the road at any moment. Then the situation becomes dangerous for him. The aim of the experiment is to manipulate the driver to be aware of unaware of a pedestrian and to collect the driving data during these behaviors happen.

In order to do that, a driving simulator has been used (see Fig. 3.1.1). Ten active drivers (7 men and 3 women) were invited to participate to the study during ten days. They had to drive with the simulator as they do with the real car on the routes and the scenarios that we have predefined. The driving was randomly fulfilled in different moments of the day. The mean age of the participants was 24 years (range from 20 to 28).

In order to limit the complexity of the situations, all scenarios did not contain other vehicle and only one pedestrian appeared in each scene. The ego-vehicle

and road parameters such as vehicle weight, size, or others features were fixed to simulate real-world conditions. The road track has been chosen to be a one-lane main road passing through a village. The maximum speed of the vehicle was limited to 27.8m/s to discourage excessive speed. Twenty pedestrians were put on straight road and they were in different appearances and did different activities. A pedestrian can be a man or a woman, wearing red, yellow or green clothes. They can be in different states such as walking on the side-walk or on the lane, running on the sidewalk, tending to cross the road at the crossing mark, or even not at a crossing mark, etc. The scenarios are made more diversified in order to neglect the influence of the pedestrian differences on the driver's awareness.

Two driving conditions in which the driver is conducted to be aware or unaware of a pedestrian, have been proposed. We call them the DAP and the DUP manipulations. In the DAP manipulation, before each driving, we encouraged the driver to avoid as possible as he could, the collision with the pedestrian. A message of TTC value and the distance to the next pedestrian were displayed in the bottom-center of the screen through the driving time. Moreover, the driver was asked to press on a button on the steering wheel (on right hand) to indicate he had noticed a pedestrian. In this manipulation, if the driver did not make collision to pedestrian, he was considered to be DAP. On the other hand, in the DUP manipulation, there is no message, no button-pressing task, and the pedestrians are set to be invisible. The driver was asked to drive normally. If the driver makes a collision with an invisible pedestrian, he was considered to be DUP. In order to annotate the DAP and the DUP data, we propose two assumptions:

- 1. The driver is considered to be aware of the pedestrian if the driver has pressed on the button to indicate his perception of the pedestrian and passes by the pedestrian without any accident.*
- 2. If the driver is unaware of a pedestrian, he drives and does the same maneuvers on the vehicle like there is no pedestrian on the road.*

## **Data collections**

Here, we aim to collect both the visual behaviors and the driving actions of the driver. We guess that the correlation between where the driver looks and how the

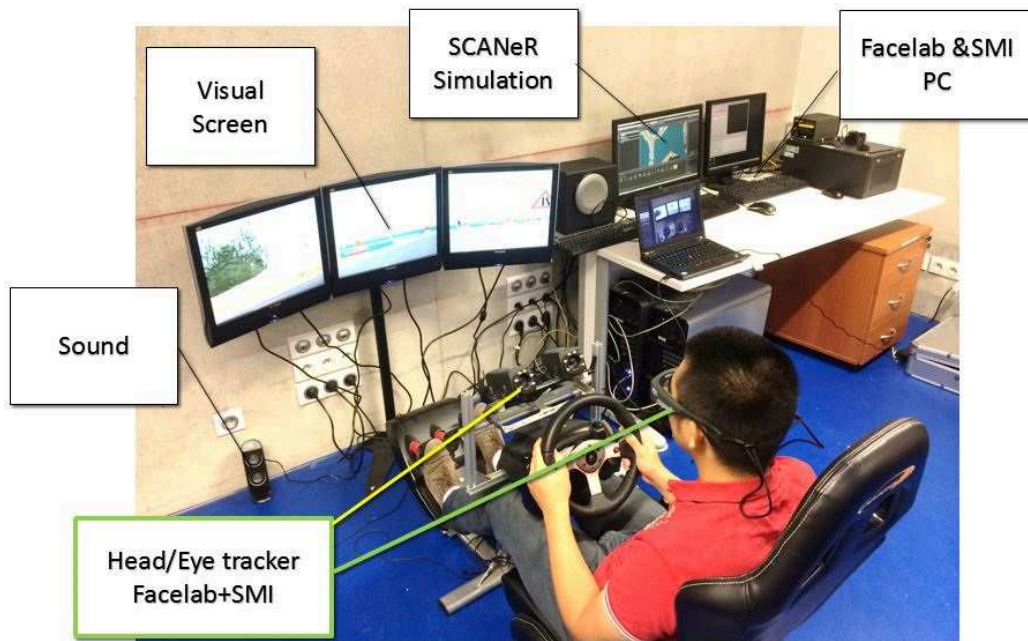

**Figure 3.1.1:** *Driving simulator used for manipulating the driver's awareness of a pedestrian.*

driver reacts could help to infer if the driver is aware or unaware of a pedestrian. However, due to the fact that there is only one pedestrian in our scenario, we suppose that, whenever a pedestrian appears in front of the car, the driver will notice the pedestrian. Therefore, the objective is, by using the driving actions, to classify whereas the driver is unaware or aware of that pedestrian.

Moreover, we suppose that the acceleration and the steering behaviors are the most important actions that need to be considered. This is because they reflect the fact that the driver is vigilant or not. On the other hand, the time-to-collision between the vehicle and the pedestrian is also taken into account, this variable represents the danger level of the situation. We think that the relationship between the driver's acceleration behavior and the situation danger level can interpret the fact that the driver is aware of the pedestrian.

Thus, the driving actions data are automatically and synchronously logged into a hard-disk at  $20Hz$  without any filtering or smoothing processing. Based on the second hypothesis, we extracted the driving data that are supposed to capture the driver's awareness of a pedestrian. Indeed, during each driving time in the DAP

manipulation, from the instant when the driver pressed the button to the instant that the vehicle passes by the pedestrian or stops in front of the pedestrian, we extracted all these driving data.

Because of the varying vehicle speed, this time period is from 3s to 6s length (from 60 to 120 value points). The same time period is used to extract data in the DUP manipulation. Moreover, only the driving that makes collision with invisible pedestrian is taken into account for the DUP estimation.

In the DAP manipulation, some reactions of the driver such as decelerating then braking in front of the pedestrian or turning the steering wheel, appear to avoid the pedestrian and passing by him. For example, in the Fig. 3.1.2, the driver releases accelerator pedal at 5s of  $TTC$  and at 2s of  $TTC$ , then he begins braking. On the other hand, the DUP manipulation showed that none of these reactions occurs in the same time periods (see Fig. 3.1.3).

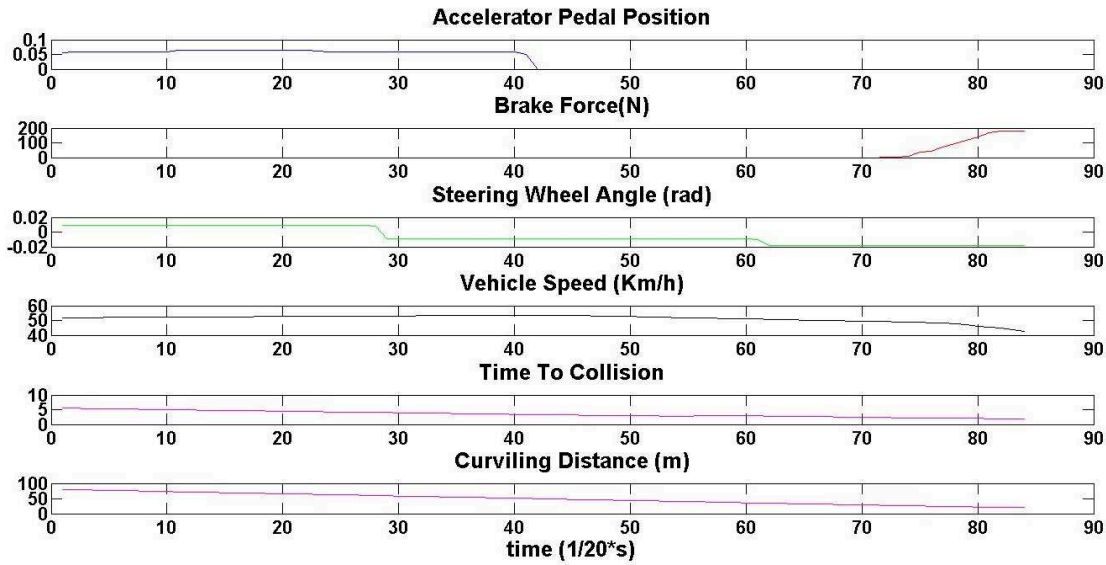

**Figure 3.1.2:** Awareness Data Sample.

With the second assumption, we used an overlapping-sliding-windows of size  $Tw$  on the data to segment the data into sequences. Each sequence corresponds to a data matrix that has  $Tw * 20$  lines and 5 columns. This segment is used as a feature vector to train or to detect the DAP and the DUP. The  $Tw$  parameter has to be carefully chosen in order to capture the characteristics of the DAP or

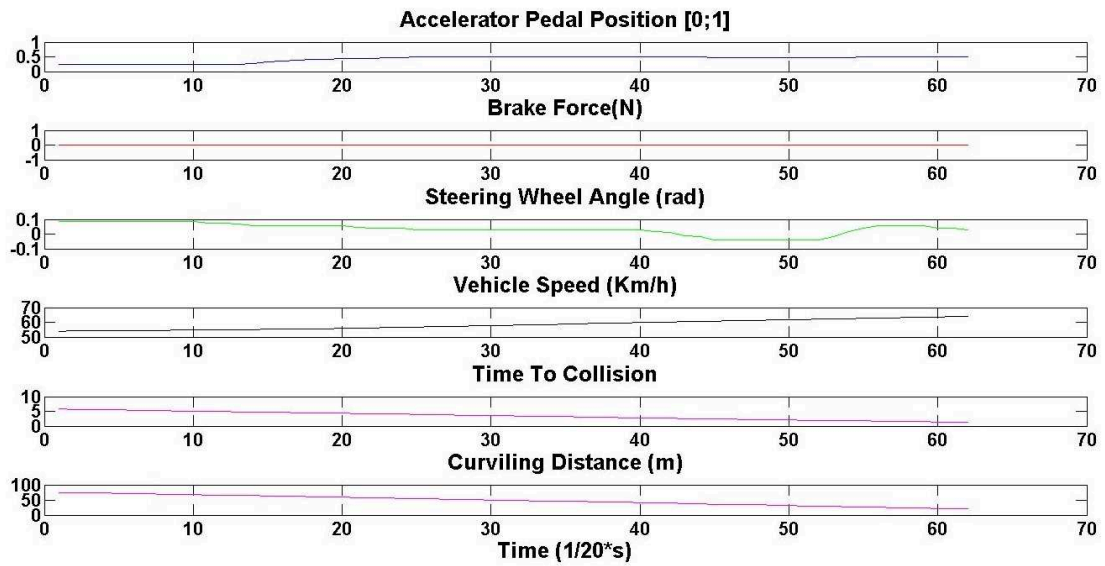

Figure 3.1.3: *Unawareness Data Sample.*

the DUP behaviors. Indeed, too long  $Tw$  may contain too much noise and can lead to over-fitting over the models whereas too short  $Tw$  cannot capture sufficient relevant features from the observation.

## 3.2 Dedicated Techniques for Setting Up the Classifiers

Setting up the classifier consists of selecting the best values of the parameters in the algorithm. It is also known as «Hyper-parameter optimization» problem. Since we consider statistical models, this process has to be done for each new dataset. The goal is to optimize the classification performance on an independent dataset. In this preliminary optimization, the grid-search technique and the generalization test associated with the receiver operator characteristics (ROC) curves are proposed.

### 3.2.1 Grid-Search Technique

The traditional way of performing hyper-parameter optimization is a gridsearch, or a parameter sweep, which is an exhaustive search through a manually specified

subset of the hyper-parameter space of a learning algorithm. A grid search algorithm must be guided by some performance metric that can be typically measured by the  $p\%$  generalization test or the cross-validation that will be presented below.

The grid-search is straightforward and, there exist several advanced methods that can save computational time by, for example, approximating the cross-validation rate or performing a random search technique as in [Bergstra 12]. However, there are two motivations why we prefer to use a simple grid-search approach. One is that, psychologically, we may not feel safe to use methods that avoid doing an exhaustive parameter search by approximations or heuristics. The other reason is that the computational time required to find good parameters by grid-search is not much more than by advanced methods since there are not a lot of parameters need to be considered in our proposed classifiers (see Section 2.3.3). Furthermore, the grid-search can be easily executed in parallel when each parameter in the combination is independent. Since doing a complete grid-search may still be time-consuming, we propose to use a loose grid (large scale value) to find out the best region.

Then, it is possible to conduct a finer grid search on that region in order to get better results.

### 3.2.2 Generalization Test

As explained before, in any predictive learning task, such as classification, the model parameters should be selected to obtain a high level of performance of the learning machine. The grid-search helps to select the best models hyperparameter from data based on a parametric estimation. The basic fact is that an assumption of an underlying dependency with a simple known parametric form is an ensuing need, then limiting its applicability in practice. Recent approaches allow a wide class of models with varying complexity. The learning task then consists of selecting the model with optimal complexity and of estimating the model parameters from the training data.

Using the data selected from the experiment described in Chapter 2, the classifiers are trained and tested on the same data set. The training and testing are performed using two different techniques: 1) the  $p\%$  basic generalization test and



2) the  $k - fold$  cross validation [Duda 12]. Both techniques aim at evaluating the generalization property of the tested classifiers.

The first one is a straightforward test of generalization. It consists of taking randomly  $p$  data subset for training all parameter combinations of each classifier. Then, we performed the parametrized classifier on the  $(100 - p)$  remaining data subset. This technique demonstrates the generalization property of the classifiers. This property is essential for any warning method to perform successfully when it is deployed on driver assistance systems, particularly given the number of vehicles encountered in everyday driving [Aoude 12].

The second technique is the standard  $k - fold$  cross validation that is also used for testing the generalization property of the classifiers [Aoude 12, Duda 12]. This involves randomly dividing the data set into  $k$  disjoint and equally sized parts. The classifiers are trained  $k - 1$  times while leaving out, each time, a different set for validation. The mean of the  $k$  trials gives the performance of the classifier in term of its ability to classify any new input data. The advantage of the  $k - fold$  cross validation is that, by cycling through  $k$  parts, all available training data can be used while retaining the ability to test on a disjoint set of test data.

The best parameter combination of each classifier is chosen after using the first  $p\%$  basic generalization test. Then, these classifiers with chosen parameters are then tested using the  $k - fold$  cross validation technique in order to compare their classification performances.

### 3.2.3 Receiver Operation Characteristic Curves

The Receiver Operating Characteristics (ROC) curve has been introduced by the signal processing community in order to evaluate the capability of an human operator to distinguish informative radar signal from noise [Metz 78]. From a research point of view, it is often used to evaluate the performances of object detectors [Paisitkriangkrai 13].

The ROC curve is a two-dimensional measure of classification performance (see Fig. 3.2.1). It can be understood as a plot of the probability of classifying correctly the positive examples (or True Positive Rate or TPR) against the rate of incorrectly classifying true negative examples (False Positive Rate or FPR). In this sense, one

can interpret this curve as a comparison of the classifier across the entire range of class distributions and error costs.

Usually, a decision rule is performed by selecting a decision threshold which separates the positive and negative classes. Thus, when dealing with minimum error classifiers, most of the time this threshold is set in order to approximate the Bayes error rate [Rakotomamonjy 04]. However, class distributions or error costs that the optimal threshold associated to the Bayes risk varies within a large range of values, and for each possible value of this threshold a pair of true-positive and false positive performance rate is thus obtained. Hence, ROC curves can be completely determined by varying this threshold value. Thus, one of the most interesting point of ROC curve is that if error costs or class distributions are unknown, the classifier performances can still be characterized and optimized. Fig. 3.2.1 depicts an example of the ROC curve of a given classifier. The diagonal line corresponds to the ROC curve of a classifier that predicts the class at random. The more the performance improves the further the curve is near to the upper left corner of the plot.

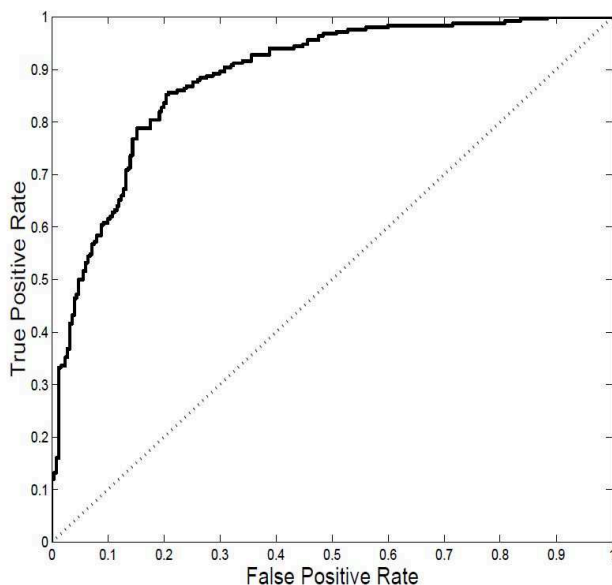

**Figure 3.2.1:** *ROC curve .*

To determine the classifier's parameters and to evaluate the results of the generation tests, a ROC curve is used to display the true positive and false positive

rates of each set of parameters. The curves were generated by varying a parameter of interest (or set of parameters), which is referred as the  $\beta$  parameter in the Signal Detection Theory terminology [McNicol 05]. Each point on the ROC curve then corresponds to a different value of the  $\beta$  parameter (or hyperparameter). The  $\beta$  in each classifier is subsequently detailed in its respective section. The optimal parameter of  $\beta$  is determined by the choice of the False Positive Rate (FPR) and the True Positive Rate (TPR). The values indicate the accuracy that is required in each application. For example, in accordance with automotive industry, the maximum FPR is chosen to be 5% [Aoude 12, Doerzaph 10].

### 3.3 Classifier Parameters Determination

As already said in Chapter 2, the problem of estimation of the driver's awareness of a pedestrian (DAP) is considered as a classification problem. In this section, we apply the ROC curves and the  $p\%$  generalization test to determine the optimal values for the hyperparameter in each algorithm. This hyperparameter is considered as the  $\beta$  parameter in ROC curves describes above. The decision function  $g(\mathbf{V})$  are then used as the score of the the ROC curves.

The training and parameters selection are performed on the data collected from the DAP and the DUP manipulation. For the data representing the driver's awareness of a pedestrian, 2000 sequences collected from the DAP manipulation are used. On other hand, 1000 sequences collected from DUP manipulation are used. In the first test, we set  $p\%$  to be 20% in order to have sufficient data for training. Therefore, 400 sequences representing the DAP (DAP sequence) and 200 sequences representing the DUP sequences (DUP sequence) are used for the training phase, whereas the testing phase consists of 1600 DAP sequences and 800 DUP sequences.

Moreover, the choice of FPR on the ROC curve to determine the  $\beta$  parameters, is based on the automotive application industry recommendations. Indeed, warning algorithms must take into consideration driver tolerance levels, i.e., they should try to ensure that the rate of false alarms is below a certain "annoyance" level that is acceptable for most drivers. The maximum false positive rate should be chosen to be under 5% [Doerzaph 07]. Therefore, the developed algorithms are designed

and tuned under the constraint of keeping false positive rates below 5 while trying to maximize true positive rates.

### 3.3.1 Feature-based Algorithms

#### The Time-To-Collision (*TTC*)

The first parameter for the *TTC*-based algorithm is the deceleration reaction threshold that indicates the awareness of pedestrian. This value is chosen at  $-0.075g$  in this study (where  $g = 9.81\text{m/s}^2$  is the gravity acceleration constant). Indeed, the vehicle deceleration is less than  $-0.075g$  represents a brake activation [Doerzaph 07]. Thus, the signification of this algorithm is detected when the driver brakes in the situation with a pedestrian. If the driver brakes before a critical Time-To-Collision, he is considered as awareness of that pedestrian. The second one is the  $TTC_{th}$  parameter. The third parameter is the windows time  $Tw$ . Constrained by development time, three values of 1s, 1.5s and 2s are tested for this parameter. Therefore, we drew the ROC curves for three values of  $Tw$  (see Fig. 3.3.1). By selecting the FPR at 5%. We can get the best TPR and consequently the  $TTC_{th}$  associated.

Fig. 3.3.1 shows that the *TTC*-based classifier works best with a  $Tw$  of 1.5s. The  $TTC_{th}$  is set at 1.6s. This means that, the driver is considered to be DAP if he decelerates by braking before 1.6s of *TTC* and considered to be DUP if not.

Regarding the result on the Fig. 3.3.1, we can see that the result of the *TTC*-based approach is really poor. Indeed, reminding the model training step, we've trained the *TTC* classifier with a dataset in which the data are the overlapping sequence segmented from a long sequence that was annotated as DUP or DAP. That means that every *TTC* value can be found in DAP or DUP segmented sequences. Moreover, in the DUP sequence, the driver has never done a braking. The *TTC* value in the DUP sequence is always the last value of the *TTC* in that sequence.

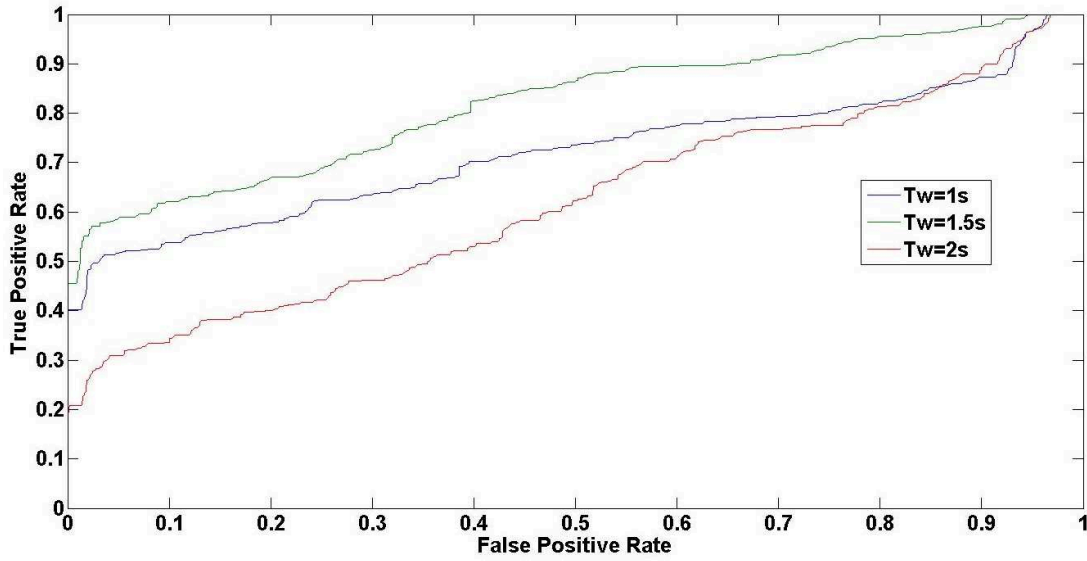

**Figure 3.3.1:** Three ROC curves with three values of the sliding time-windows  $T_w$ . The TTC-based algorithm gives the best performances with  $T_w = 1.5s$ .

### The Required Deceleration Parameter ( $RDP$ )

In the  $RDP$ -based method, the only parameter is  $RDP_{th}$ . These  $RDP$  values are ranged from  $0.05g$  to  $7g$  (where  $g = 9.81m/s^2$  is the gravity acceleration constant).

Fig. 3.3.2 shows that the  $RDP$  – based classifier performed the best with a  $T_w$  of 1.5s with a  $FPR$  smaller than 5%. The  $TPR$  reaches 60% , and the  $RPD$  threshold is then taken at  $0.6667g$ . With 20% of  $FPR$ , the  $TPR$  can reach up to 70%.

Compared to the  $TTC$ -based algorithm, the  $RDP$ -based algorithm obtains a better result. The  $RDP$  indication represents the relationship between the vehicle speed and the critical  $TTC$ . This relationship may better describe the characteristic vigilance of a driver is situation with a pedestrian appearing in the neighborhood of the car.

Indeed, with the threshold based methods, we can see that the data is more discriminative with a  $T_w$  of 1.5s.

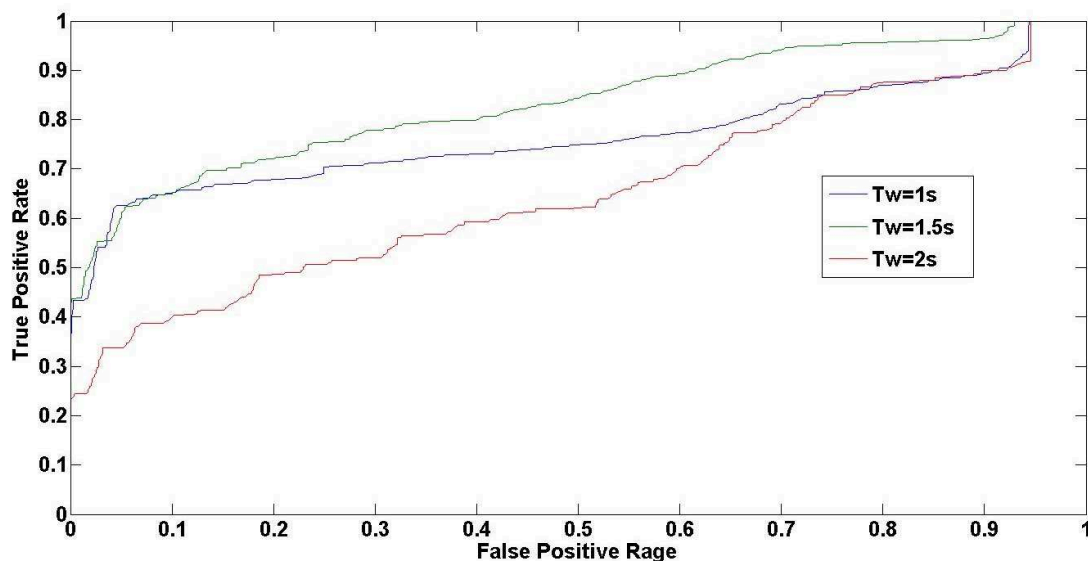

**Figure 3.3.2:** Three ROC curves with three values of the sliding time-windows  $Tw$ . The RDP-based algorithm gives the best performances with  $Tw = 1.5s$ .

### 3.3.2 Discriminative Models

#### Support Vector Machine (SVM)

We run a SVM classifier with several values of  $C$  and  $\gamma$  to determine which parameters combination might be the best for a performing model. That is, the one that could better express the causal relation among variables that govern the quality within the driving platform. This is accessed through the evaluation of the performance accuracy. By using the  $p$  generalization test, we divide the data into a training dataset and into a validation dataset for model evaluation.

As mentioned in chapter 2 exist three parameters of the SVM model that need to be optimized: the  $C$ ,  $Tw$  and  $\gamma$  parameters. We employed the grid-search technique to identify the best parameters. While  $Tw$  takes values in 1s, 1.5s or 2s, the  $C$  value was exponentially taken in  $[2^{-3}, 2^{-1}, \dots, 2^9, 2^{11}]$  and  $\gamma$  varied in  $[2^{-11}, 2^{-9}, \dots, 2^1, 2^3]$ . In the software implementation, the LIBSVM toolkit has been used [Chang 11]. The optimization problems expressed in Eq. 2.3.7 is solved by an iterative manner where the stopping tolerance is set to  $10^{-3}$  (See detail in Appendix 1).

As a consequence from the choice of  $C$  and  $\gamma$ , a larger  $C$  corresponds to a smaller number of support vectors as well as a larger number of training iterations. Larger  $\gamma$  corresponds to a poorer balanced classification, which means that the defective classifier model gives the lower accuracy on one side of the classification destination but higher accuracy on the other side, as well as the larger  $C$  does so [Qian 10].

All combinations of these parameters have been introduced into the  $p\% = 20\%$  basic generalization test. Fig. 3.3.3, 3.3.4 and 3.3.5 show the ten combinations of the parameters that produced the highest rates of true positives while maintaining a FPR below 5% for three values 1s, 1.5s and 2s of  $Tw$ . Finally, the best results of this test are obtained with the following combination of parameters:  $Tw = 1.5$ ,  $C = 2^7$ , and  $\gamma = 2^{-3}$  (see Fig. 3.3.4). These values can be changed to reflect a bias toward one driving behavior if the system is given a prior knowledge of the target driving history.

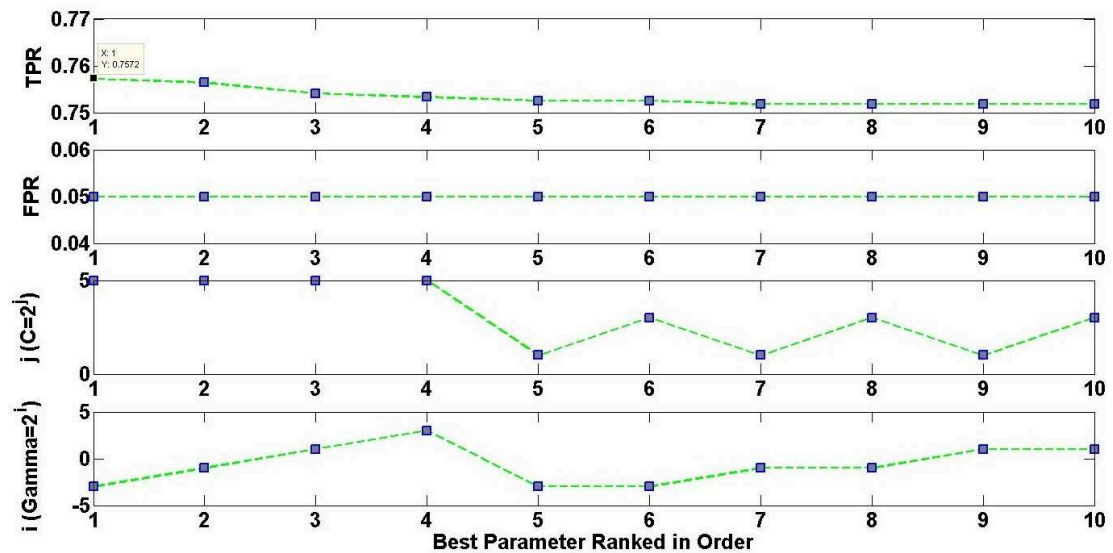

**Figure 3.3.3:** The best parameter combinations of SVM-based classifier ranked in increasing order for  $Tw = 1s$ . The first rank gives the best combination of the SVM classifier for  $Tw = 1s$ .

### Relevance Vector Machine (RVM)

Applied to the problem of DUP/DAP classification, a Radial Basis Function Kernel ( $K(x, y) = \exp(-\gamma \|x - y\|^2)$ ) has been used? Therefore the parameters needed to

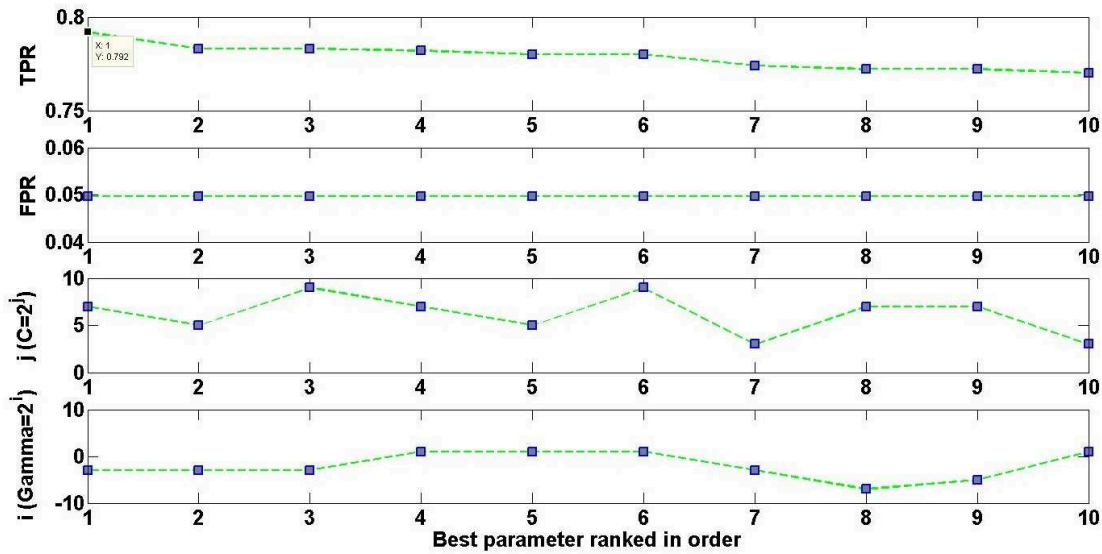

Figure 3.3.4: The best parameter combinations of SVM-based classifier ranked in increasing order for  $T_w = 1.5s$ . The method reaches 79% of TPR at 5% of FPR with  $\gamma = 2^{-3}$ ,  $C = 2^7$ .

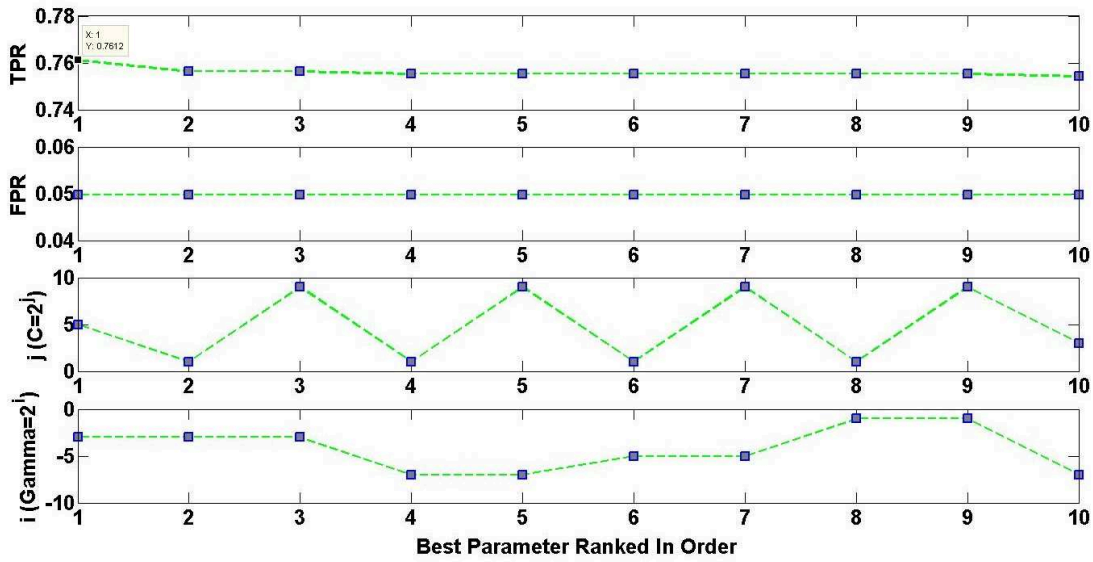

Figure 3.3.5: The best parameters of SVM-based classifier ranked in increasing order for  $T_w = 2s$ .



be defined are: The length of the window detection  $Tw$  and the  $\gamma$  value of the kernel. The decision function  $g(\mathbf{V})$  is taken from 0 to 1 because the RVM classifier outputs the class membership (Likelihood) [Tipping 01]. .

Fig. 3.3.6, 3.3.7, and 3.3.8 show the ten combinations that produced the highest rates of true positives while maintaining a false positive rate below 5 for one basic generalization test with each specific window time. The best result of this test is obtained using the combination of following parameters:  $Tw = 1.5$ , and  $\gamma = 2^{-7}$ . Like in the SVM case, these values could be changed to reflect a bias toward one driving behavior if the system is given a prior knowledge of the target driving history.

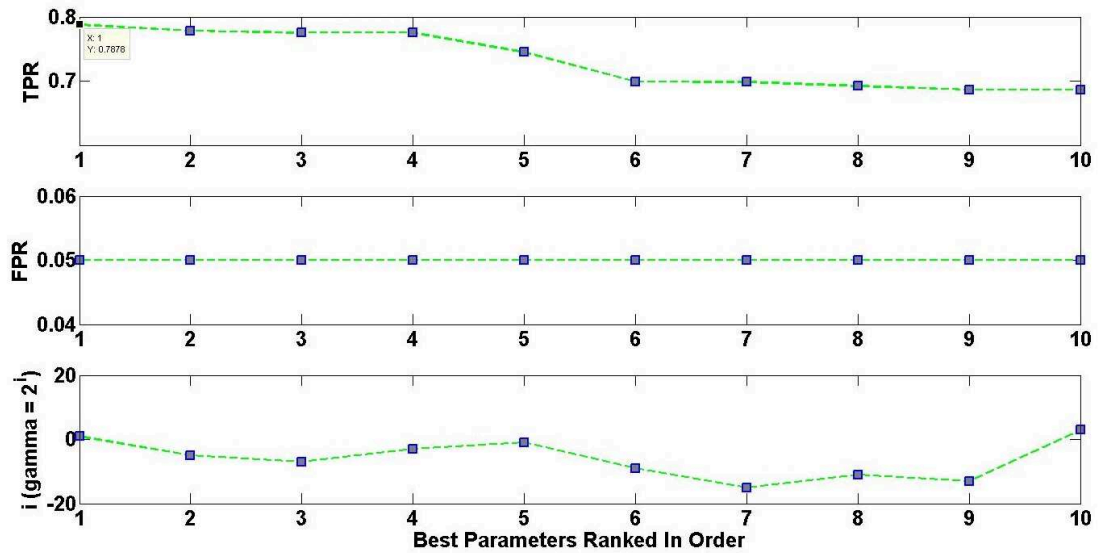

Figure 3.3.6: The best parameters of RVM-based classifier ranked in increasing order for  $Tw = 1s$ .

### 3.3.3 Generative Models

#### Discrete-Hidden Markov Model (DHMM)

The first implementation of our Hidden Markov Model-based algorithm has been presented in [Phan 14b]. We have based on the situation awareness theory [Endsley 95a] to represent the Driver Awareness of Pedestrian (DAP) and the Driver

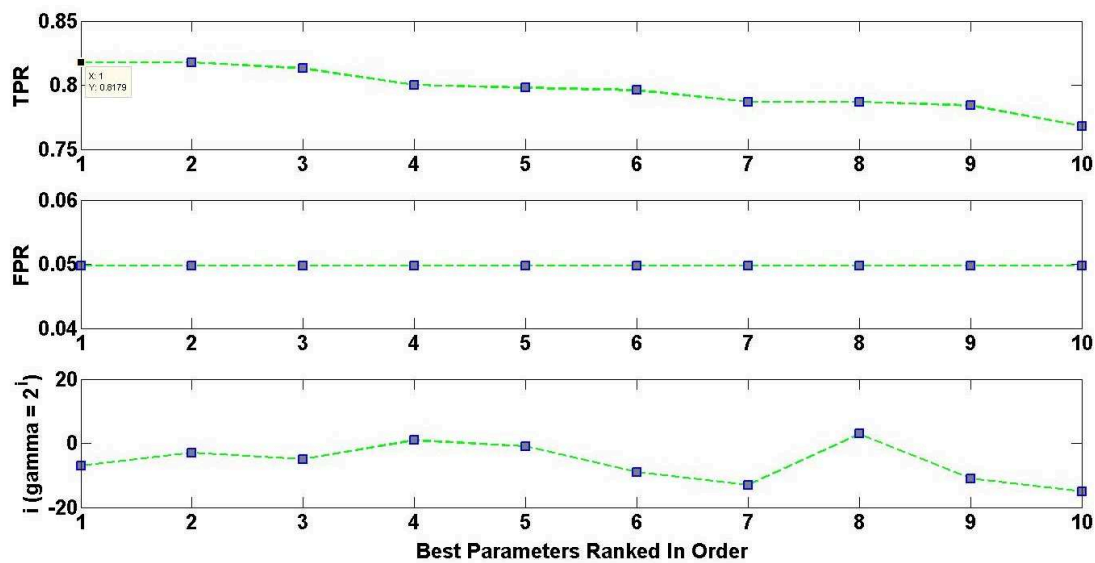

Figure 3.3.7: The best parameters of RVM-based classifier ranked in increasing order for  $T_w = 1.5s$ . The method reaches up to 82% of TPR at 5% of FPR with  $\gamma = 2^{-7}$ .

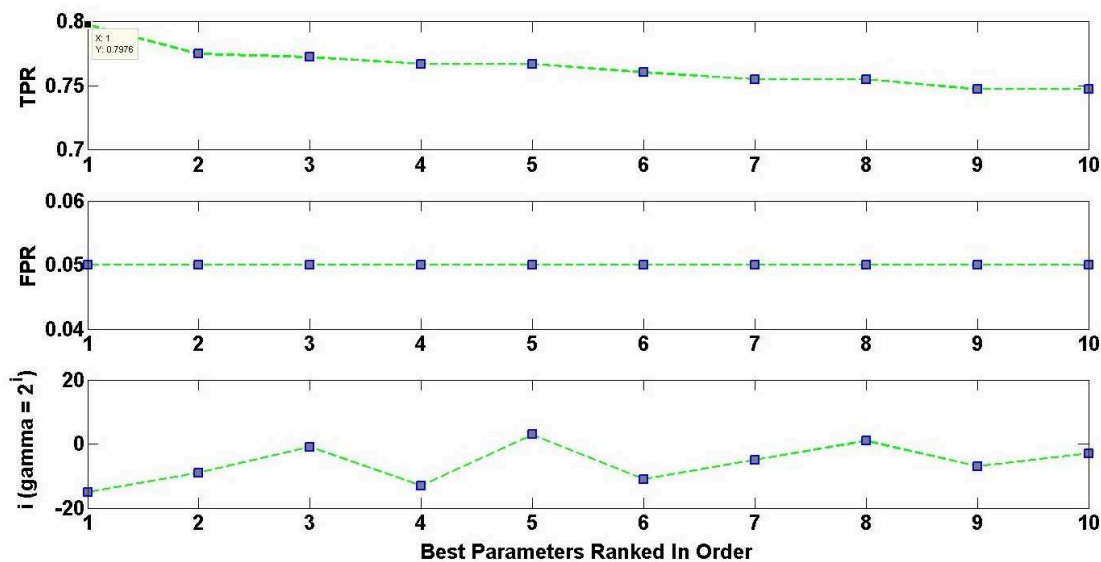

Figure 3.3.8: The best parameters of RVM-based classifier ranked in increasing order for  $T_w = 2s$ .

Unawareness of Pedestrian (DUP). Indeed, the situation awareness from [Endsley 95a], consists of three levels: *Perception*, *Comprehension* and *Projection*. We used these levels as three hidden states in the Markov model of the DAP.

In the situation where a pedestrian appears on the road in front of the vehicle, the driver's behaviors regarding the pedestrian could be seen as a sequence of state through *Perception (S1) – Comprehension (S2) – Projection (S3)*. These states are not directly observable but can be characterized by a set of driving actions which is called an observation vector  $\mathbf{V}$  (see Fig. 3.3.9). It could be assumed that the driver will adopt different sequences of action with different levels in each action when he is aware or unaware of a pedestrian.

We choosed to consider three temporal signals of driving actions: Accelerator Pedal Position  $a(t)$ , Braking Force  $b(t)$  and Steering Wheel Angle  $s(t)$ . Moreover, as seen in the RDP method, the relationship between the vehicle speed  $v(t)$  and the time to collision  $TTC(t)$  gives a significant indication on inferring the driver behaviors. Therefore, we added these two signals on the input temporal signals of driving actions. Moreover, the signals are discretized and shaped into a discrete symbol representing an observation at each time instant  $t$ . The discretization procedure is presented in the Algo. 3.1.

In Algo. 3.1, each dimension of the observation vector  $\mathbf{O}_d$  gets the value in  $\{ '0'; '1'; '2' \}$ . This observation vector is then converted into a single symbol by concatenating the symbols of each dimension. Therefore, the observation set is  $\{ '00000', \dots, '22222' \}$ . In the implementation, we consider the symbols as a 3-based number and we convert it into a 10-based number (see last line of the Algo. 3.1). Finally, the observation at time  $t$  is  $V(t)$ , a symbol in the codebook of  $\{ '1'; '2'; \dots; '243' \}$ .

Let  $\{S_i\}_{i \in \{1,2,3\}}$  be a discrete, homogeneous, Markov chain representing the  $N = 3$  states of the DAP or the DUP. Therefore we get a HMM with 3 hidden states and 242 observation states (see Fig. 3.3.9).

Three values of  $Tw$  ( $1s$ ,  $1.5s$  and  $2s$ ) is tested whereas the FPR is chosen at 5%. The ROC curve (see Fig. 3.3.10) showed that with the time window  $Tw = 1.5s$  the classifier gives the best result. However, the choice of the number of states or the number of observations will limit the performance of the HMM. Therefore in the

**Algorithm 3.1** Discretization of the temporal signals and observation symbol construction

At each instant  $t$ , the received observation vector is noted as:

$$\mathbf{O}(t) = [a(t), b(t), s(t), v(t), TTC(t)]^T$$

The discrete Accelerator pedal position  $a_d(t)$  is set as:

- '0' *Light* if  $a(t)$  is in  $[0, 0.1]$
- '1' *Medium* if  $a(t)$  is in  $]0.1, 0.5[$
- '2' *Deep* if  $a(t)$  is in  $[0.5, 1]$

The discrete Braking Force  $b_d(t)$  is set as:

- '0' *No Braking* if  $b(t)$  is equal to 0
- '1' *Light Braking* if  $b(t)$  is in  $]0, 100[$
- '2' *Deep Braking* if  $b(t)$  is in  $[100, 400]$

The discrete Steering Wheel Angle  $s_d(t)$  is set as:

- '0' *Turn Left* if  $s(t)$  is lower than 0
- '1' *Keeping ahead* if  $s(t)$  is equal to 0
- '2' *Turn Right* if  $s(t)$  is higher than 0

The discrete *TTC*  $TTC_d(t)$  is set as:

- '0' *Critical* if  $TTC(t)$  is lower than 2
- '1' *Normal* if  $TTC(t)$  is equal in  $[2, 4]$
- '2' *Not Critical* if  $TTC(t)$  is higher than 4

The discrete *Speed*  $v_d(t)$  is set as:

- '0' *Slow* if  $v(t)$  is lower than 30
- '1' *Normal* if  $v(t)$  is in  $[30, 70]$
- '2' *High* if  $v(t)$  is higher than 70

The discrete observation vector  $\mathbf{O}_d = [a_d(t), b_d(t), s_d(t), v_d(t), TTC_d(t)]^T$

Converting the multi-observation symbols into one-observation symbol:

$$V(t) = a_d(t).3^4 + b_d(t).3^3 + s_d(t).3^2 + v_d(t).3^1 + TTC_d(t).3^0 + 1$$

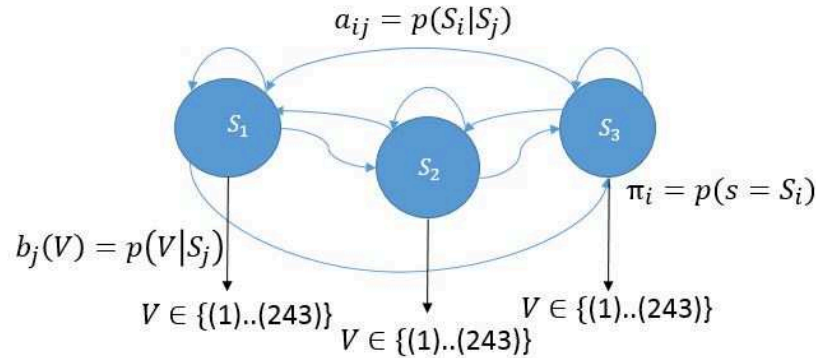

**Figure 3.3.9:** A Discret Hidden Markov Model with 3 hidden states and 243 observation states.

continuous version of the HMM (the MGHMM), we chose the classification with a variant number of states and the emission probability modeled by a multivariate Gaussian.

### Multivariate Gaussian Hidden Markov Model (MGHMM)

Like for the others classifiers parameters settings, the FPR is also chosen at 5. Whereas the DHMM method has already the number of hidden states and the number of observation states, in the MGHMM, we expect to find experimentally the right number of the hidden states. Thus, there are four key parameters for the MGHMM-based method: 1) the number of hidden states  $N$ ; 2) the number of Gaussian component  $M$  for the emission mixture-distribution  $B$ ; 3) the detection sliding window size  $Tw$ ; and 4) the decision threshold  $\tau_{th}$ . The number of states determines how many different modes the HMMs can capture, and as a result, the range of behaviors that can be classified accurately. Different numbers of component  $M$  are also tested in order to find out the model that best represents the probability distribution of the observations emission. However, increasing the number of states or the number of component also increases the complexity of the model and the risk of over fitting the training data.

We choose to consider from 8 to 13 hidden states, and from 1 to 3 Gaussian components of mixture distribution. In term of the size of the detection windows,

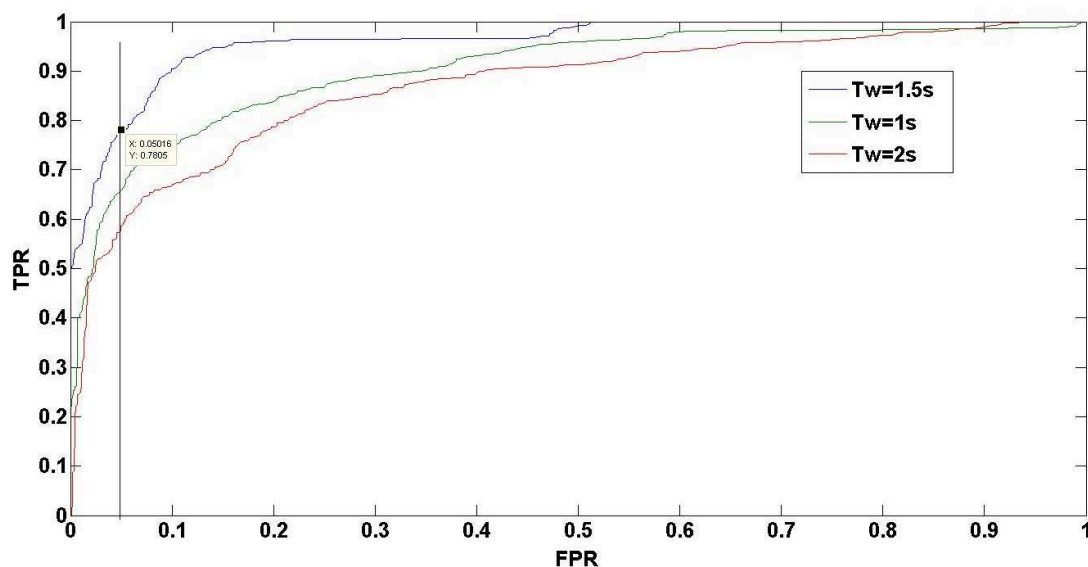
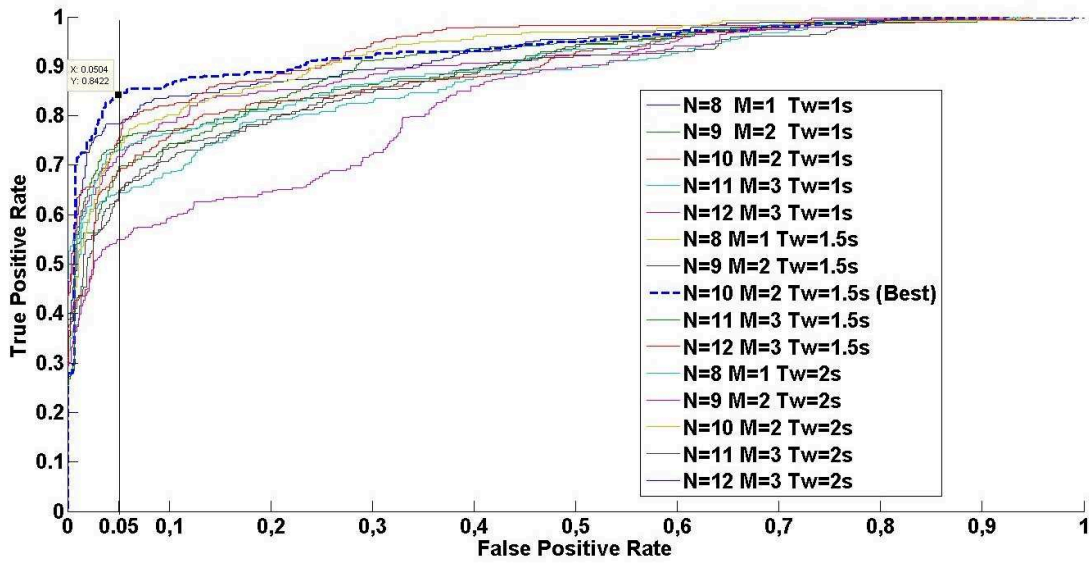

**Figure 3.3.10:** ROC Curves for the DHMM classifier with three values of  $T_w$ . The  $T_w=1.5s$  gives the best performances. A shorter  $T_w$  may not capture enough significant information whereas a longer  $T_w$  can over-fit the data and capture the redundant information.

three values of  $T_w$  of 1s, 1.5s and 2s (consist of 20, 30 and 40 observation data points) are tested. All combinations of these parameters were tested in order to find out the best model parameters that gives the best performance. The decision threshold  $\tau_h$  can be found when it maximizes the TPR at a given FPR. Fig. 3.3.11 showed the result of the best combinations that produced the highest TPR while maintaining a FPR is below 5% for the generalization test. Finally, the parameters are chosen as:  $N = 10$ ,  $M=2$ ,  $T_w = 1.5s$ , and  $\tau_{th} = 214$ . This combination gives the best performance of the classification at 84,2% of TPR.

### 3.4 Classifiers Comparison Results

All the methods have been developed under Matlab. The discriminative methods have been implemented with Pattern Recognition Toolkit [Tipping 01]. The HMM-based method is implemented by using PMTK toolkit [Murphy 10]. Although the HMM method seems a complex technique comparing to the other methods, most of the computational complexity appears during the training phase. For online



**Figure 3.3.11:** 15 combination of MGHMM-based classifier parameters, The model with  $N = 10, M = 2$  and  $Tw = 1.5s$  gives the best performance with more than 84% of TPR while maintaining the FPR under 5%.

classification of a new sequence of observations, the computation time is small. One testing run-time takes an average of 2ms per sequence on a laptop core i5 2.4Ghz. Here, we just compare the performance of these methods in an offline manner.

### 3.4.1 $p\%$ Basic Generalization Test

The ROC curves for the six methods (see Fig. 3.4.1) show that the HMM-based method outperformed the others methods. At 5% of FPR, the MGHMM reaches up to 82% of TPR whereas the DHMM reaches 66%. The discriminative methods got a good result too with 80% for the RVM and 74% with the SVM. The threshold-based methods got much poorer performances. As we expected, the HMM-based classifier performed better because it is a richer model that couples observations into states that can better characterize driver's behavior. Moreover, it confirms our hypothesis on the time dependencies of the driver's behavior evolution when he is aware of a pedestrian. The RVM performs better than the SVM because it is more flexible in term of choosing the  $\beta$  threshold which is the likelihood of

belonging to a class.

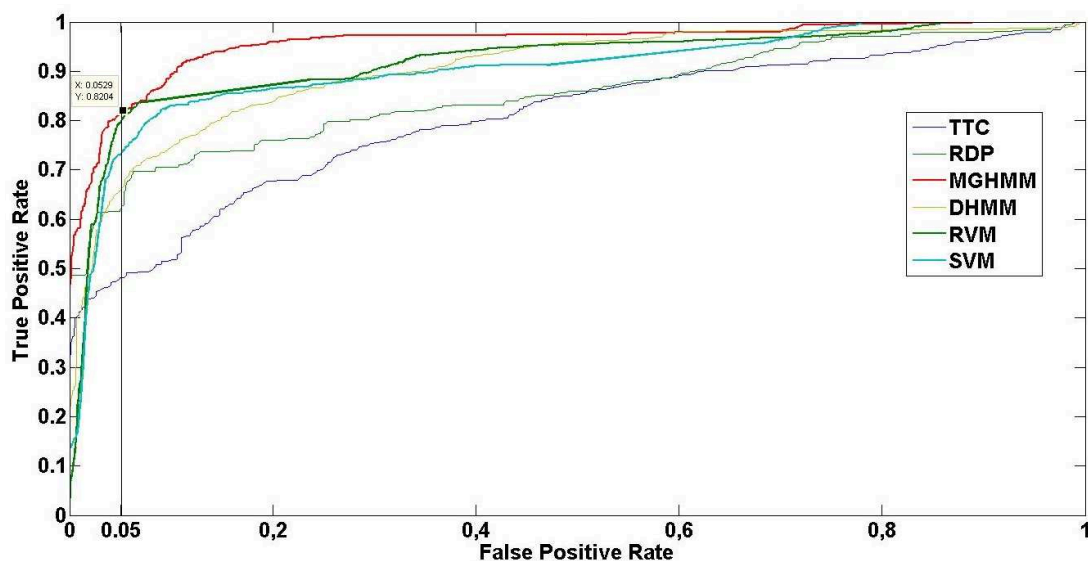

**Figure 3.4.1:** ROC curves of six classifiers in the  $p\%$  generalization test. In that case, 20% of the dataset is used for training and 80% of the dataset is used for testing.

### 3.4.2 $k - Fold$ Cross-Validation

The second validation uses the standard  $k - fold$  cross-validation technique for generalization testing. It involves to randomly divide the training set into  $k$  disjoint and equally sized sets. All the classification algorithms are trained  $k$  times while leaving out, each time, a different set for validation. The advantage of this  $k - fold$  cross-validation is that, by cycling through the  $k$  parts, all the data training data can be used while retaining the ability to test on a disjoint set of testing data. Moreover, increasing  $k$  means less number of training sequences. This validation estimates the performances of the classifiers in term of its ability to classify any given new input sequence. In this validation, there are 2500 sequences presenting the DAP and 1500 sequences presenting DUP are used in the  $k - fold$  cross-validation with  $k = 4$ . The table of TPR for 5% of FPR on the six methods is then given in Table 3.1. The MGHMM-based method gives good performances with 78.2% of TPR at 5% of FPR . This test confirms the consistency of this method while



classifying a new sequence of observations.

The HMMs are found to be less data-dependent (see Fig. 3.4.2). In real conditions, it is hard to make the experiment and collect a lot of data representing clearly the DAP and/or the DUP. Therefore, the model that requires less data is more suitable. Thus, we chose MGHMM as the model for the classification of the DAP and the DUP in the rest of the manuscript.

Method	k=4	k=5	k=10	k=20
TTC-based	42.9%	41%	39.3%	37.5%
RDP-based	56.5%	55.3%	51.2%	50.7%
SVM-based	72.0%	69.5%	65.6%	64%
RVM-based	74.2%	72.1%	66.1%	60.2%
DHMM-based	73%	72.2%	66.5%	63.1%
MGHMM-based	78.2%	77.4%	76.0%	75.8%

**Table 3.1:** *True Positive Rate at 5% False Positive Rate for each method in the  $k$ -fold cross-validation.*

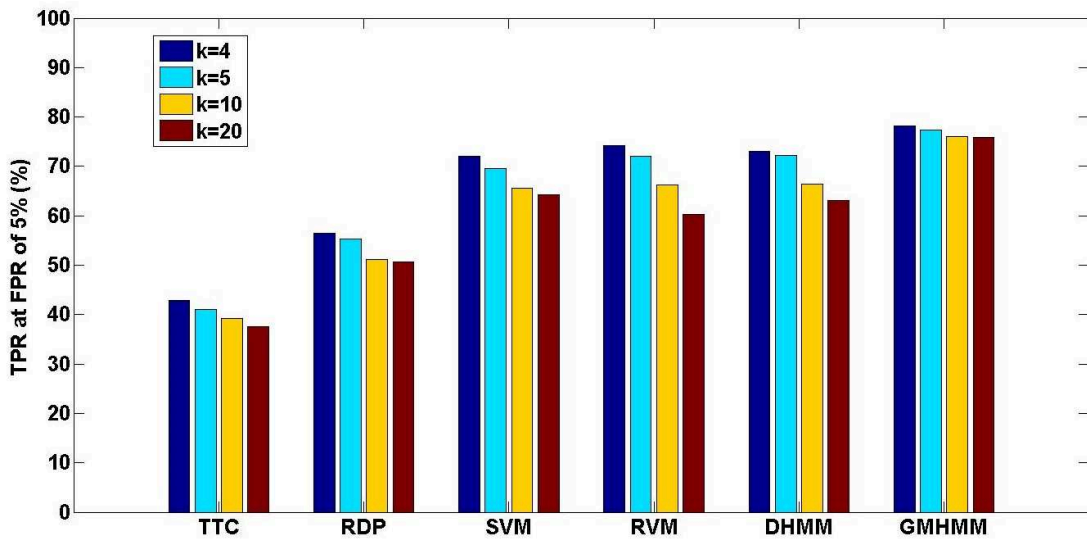

**Figure 3.4.2:** *Results from the  $k$ -Fold Cross-validation of the classifiers, the MGHMM model showed the best performances with less dependency to the quantity of training data sequences.*

## 3.5 Conclusion

In this chapter, the selection process between several classification algorithms has been carried out by using the  $p\%$  generalization test and the Receiver Operation Characteristic curves. The  $k$ -fold cross validations have been also performed for different number of folds. In the training step, it is also important to note that, the sliding time-windows with the length of  $Tw = 1.5s$  is found to be the good choice to capture significantly the driver's awareness of a pedestrian through the driver's actions on the pedals and the steering wheel.

The preliminary results have showed the best performance of the MGHMM method and justified our choice of implementation this classifier in the Pedestrian Warning Collision System. Indeed, the MGHMM method satisfies our criterions demanded for the application. In term of complexity, the MGHMM allows the development of a real-time application. The training step can consume much more time and data but the classification or detection step can be executed very quickly by a simple calculation of the likelihood. The MGHMM is also approved to be successfully used in various applications in human-behavior recognition (see Section 2.3.4). . Moreover, as the MGHMM can output the probability that a input sequence belongs to the DAP or to the DUP classes, it can help us to take into account the decision uncertainty in the future work. In this evaluation, the MGHMM is not tested for its capability to cope with inter-individual differences, but it showed a good consistency of the result when we decrease the number of learning samples. We think that the MGHMM presenting the driver's awareness of a pedestrian would be implemented for each driver in order to avoid the the differences between individuals.

Finally, the MGHMM is a generative method, which is less dependent on the data quantity. For example, the DUP data is hard to get, but with only the DAP data, we can already build a MGHMM model to estimate the probability that the driver is aware of a pedestrian.

## Chapter 4

# Augmented Reality for Pedestrian Collision Warning Systems

Augmented reality (AR) in automobiles can potentially alter the driver's user experience in significant ways. With the emergence of new technologies like head-up displays (HUDs) that are AR capable, designers can now provide visual aids and annotations that alter what the driver focuses on, and how they accomplish their driving task. In contrast to AR applications on smart phones or tablets, the windshield offers a direct and larger field-of-view of the actual environment. While it can potentially alleviate cognitive load and create more enjoyment in the driving task, it can also introduce new risks. In this chapter, we propose a survey on some existing HUDs and AR concepts and its visualization metaphors for car driving applications (Section 4.1). Then we detail our visual metaphor, as a proof of concept, which is expected to enhance the driver's awareness of a pedestrian (Section 4.2). In Section 4.3, we present our research platform which is a driving simulator based on the software developed by SCANeR Studio. The implementation details of the proposed AR-PCW system on the simulator are presented in Section 4.4. Finally, a conclusion of this chapter is provided in Section 4.5.

## 4.1 Head Up Displays and Augmented Reality

### 4.1.1 Head Up Displays

A head-up display (HUD) is any transparent display that presents data without requiring users to look away from their usual viewpoints. The origin of the name stems from a pilot being able to view information with the head positioned «up» and looking forward, instead of angled down looking at lower instruments. A HUD has also the advantage that the pilot's eyes do not need to refocus to view outside after looking at the optically nearer instruments. Although they were initially developed for military aviation, HUDs are now used in commercial aircraft, automobiles and other, mostly for professional applications.

A typical HUD contains three primary components: a projector unit, a combiner, and a video generation computer [Previc 04]. The Fig. 4.1.1 shows the HUD concept of Continental manufacturer.

**The projection unit** in a typical HUD is an optical collimator setup: a convex lens or concave mirror with a Cathodic Ray Tube [Yoshiharu 69], light emitting diode, or liquid crystal display at its focus. This setup (a design that has been around since the invention of the reflector sight in 1900's) produces an image where the light is collimated, i.e. the focal point is perceived to be at infinity.

**The combiner** is typically an angled flat piece of glass (a beam splitter) located directly in front of the viewer which can be the windshield, that redirects the projected image from projector in such a way as to see the field of view and the projected infinity image at the same time. Combiners may have special coatings that reflect the monochromatic light projected onto it from the projector unit while allowing all other wavelengths of light to pass through. In some optical layouts, combiners may also have a curved surface to refocus the image from the projector.

**The Picture Generation Unit**, which provides the interface between the HUD (i.e. the projection unit) and the systems/data to be displayed and generates the imagery and symbology to be displayed by the projection unit .

There are several factors that interplay in the design of a HUD [Spitzer 14]:

**Field of View (FOV)**, indicates the angle(s), vertically as well as horizontally, subtended at the viewer's eye, that the combiner displays symbology in relation

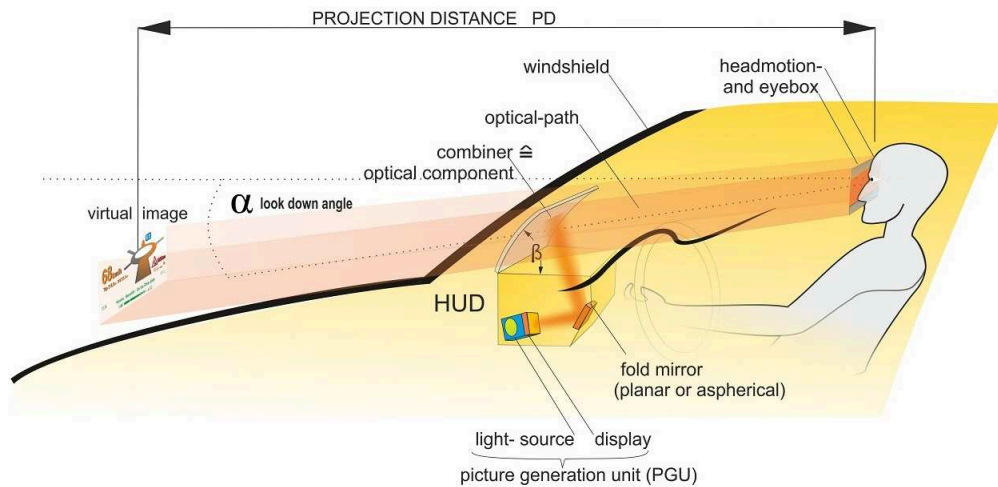

**Figure 4.1.1:** *The main components of a HUD*[Continental 15].

to the outside view. A narrow FOV means that the view (of a runway, for example) through the combiner might include little additional information beyond the perimeters of the runway environment; whereas a wide FOV would allow a broaden view. Because the human eyes are separated, each eye receives a different image. The HUD image is viewable by one or both eyes, depending on technical and budget limitations in the design process. Modern expectations are that both eyes view the same image, in other words a «binocular Field of View».

**Collimation** – The projected image is collimated so the light rays are parallel. Because the light rays are parallel, the human pupils focus on infinity to get a clear image. Collimated images on the HUD combiner are perceived as existing at or near optical infinity. This means that the viewer's eyes do not need to refocus to view the outside world and the image displayed by the HUD. This feature is critical for effective HUDs: not having to refocus between HUD-displayed symbolic information and the overlaid outside world objects is one of the main advantages of collimated HUDs. It gives HUDs special consideration in safety-critical and time-critical maneuvers. For example, in the final stages of landing, the few seconds a pilot re-focus inside the cockpit, and then back outside, are very critical. Another example, on the driving, one second eye off road at 100 km/h of speed means the driver has lost 30 meters in front of him. Collimation is therefore a primary distinguishing feature of high-performance HUDs and differentiates them

from consumer-quality systems that, for example, simply reflect uncollimated information off a car's windshield (causing drivers to refocus and shift attention from the road ahead).

**Eye-box** – The optical collimator produces a cylinder of parallel light so the display can only be viewed while the viewer's eyes are somewhere within that cylinder, a three-dimensional area called the head motion box or eye-box. Modern HUD eye-boxes are usually about 12 lateral by 7 vertical by 15 longitudinal centimeters. This allows the viewer some freedom of head movement but movement too far up/down left/right will cause the display to vanish off the edge of the collimator and movement too far back will cause it to crop off around the edge (vignette). The viewer is able to view the entire display as long as one of the eyes is inside the eye-box.

**Luminance/contrast** – Displays have adjustments in luminance and contrast to account for ambient lighting, which can vary widely (e.g., from the glare of bright clouds to moonless night approaches to minimally lit fields).

**Scaling** – The displayed image (flight path, pitch and yaw scaling, etc.), are scaled to present to the viewer a picture that overlays the outside world in an exact 1:1 relationship. For example, objects (such as a runway threshold) that are 3 degrees below the horizon as viewed from the cockpit must appear at the -3 degree index on the HUD display.

**Compatibility** – HUD components are designed to be compatible with other avionics, displays, etc.

Nowadays, all automobile manufacturers are able to equip a HUD on their car. It can be in form of a combiner system like in Fig. 4.1.1 which is a product of Continental [Continental 15] or in Fig. 4.1.2, the product of BMW [BMW 15] and Pioneer [Pioneer 15]. Some HUD are a limited zone directly integrated on the windshield (see Fig. 4.1.3).

However, it is difficult to apply the HUDs in safety systems. Indeed, when the virtual information cannot be projected at different distance ranges, it does not overlap on the real object. Due to the parallax problem, the driver is not able to focus on the HUD and on the road at the same time [Wood 06, Doshi 09b]. This may create a distraction to the driver. In order to solve this problem, a super



(a) BMW Head Up Screen [BMW 15].



(b) Combiner Pioneer HUD [Pioneer 15].

Figure 4.1.2: The combiner HUDs .

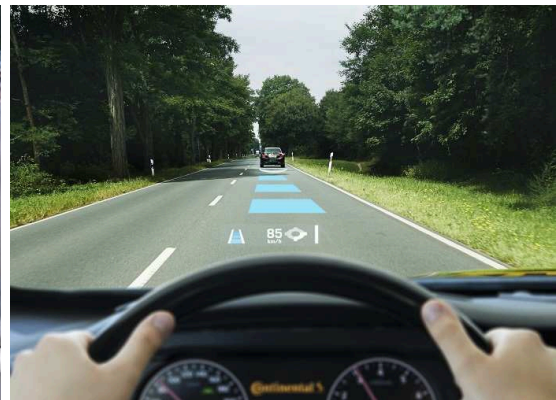
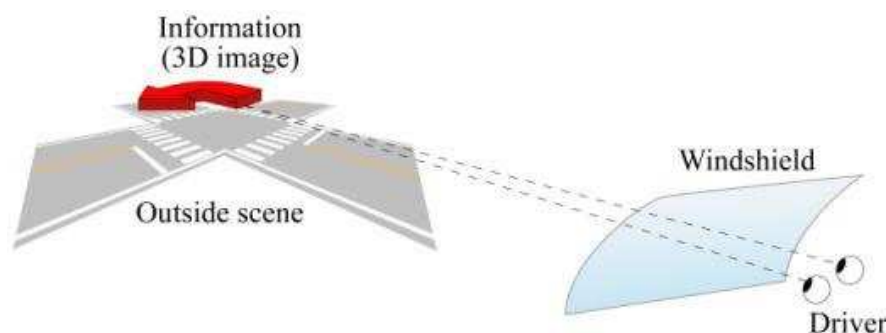

Figure 4.1.3: Integrated windshield HUD concepts [Rover 15][Continental 15].

multi-view windshield display has been developed using three-dimensional display technology [Takaki 11, Nakamura 04]. The system employs two parallax images to the left and the right eye and enables the presentation of driving information in the vicinity of objects in the front scene. Typically, this system allows to implement such an Augmented Reality (AR) concept on cars which refers to the perfection in combining real and artificial stimuli [Azuma 97].

When three-dimensional display technology is applied to the windshield display, the information, that is strongly related to an object in the front scene could be displayed in the vicinity of the object, as shown in Fig. 4.1.4. Drivers are, therefore, not required to change their gaze direction or the accommodation of their eyes to see the information while driving. The gaze movements and the re-accommodation time are minimized. The 3D images can be displayed from just in front of the vehicle to more than 100m ahead of the vehicle in the depth direction of the front driving scene.



**Figure 4.1.4:** *Three-dimensional windshield display [Takaki 11].*

### 4.1.2 Driving Assistance Metaphors

Beside the research on the HUD technologies, the content to display on a HUD, and the pertinence of displayed objects is also a challenge for driving assistance systems. This content is often composed of annotations, a visualization paradigm and a metaphor giving contextualized or collocated information to the driver.

The term metaphor is well know as to give an idea of some unknown thing or concept, by illustrating it with something else which is known and which originally



has nothing to do with it (see Fig. 4.1.5 ) [Szabó 95]. In science of user interface, the term «visualization metaphor» is defined by Averbukh et al. [Averbukh 07] as «a map that establishes the correspondence between concepts and objects of the application domain under modeling and a system of some similarities and analogies». This map generates a set of views and a set of methods for communication with visual objects. The role of metaphors is to illustrate the unknown, not easily imaginable things. When people encounter something new which they want to learn, then they try to fit it into their knowledge structure, using their already acquired knowledge about other things. If the program can be related to an object of everyday life, then the user will easily be familiar with it. The most widely used such metaphor is the desktop. A significant part of office systems is based on it. The program, as it appears on the screen, is identified with the top of an office desk, on which documents and tools can be placed. Documents can usually be seen in individual, partially overlapping «windows», as if they were partially on top of each other. Documents can be arranged into «folders», they can be modified, appended to each other, destroyed etc.

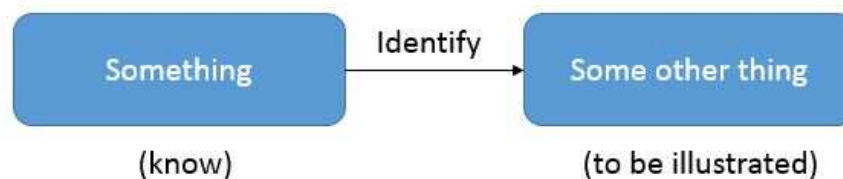

**Figure 4.1.5:** *Definition of «metaphor».*

In the driving context, different metaphors have been proposed for driver assistance. According to their utilities, these metaphors can be classified into the following categories: navigation , points of interest discovery metaphors, and driving safety.

### **Metaphors for Navigation and for Discovering Points of Interest**

The navigation assistance helps the driver to choose a direction while the planning assistance allows the user to reach its destination without prior knowledge on the

road topology or on the followed path. Narzt et al. [Narzt 04] describe two metaphors types in the field of car assistance systems. The metaphor of the augmented road (see Fig. 4.1.6a) provides the user a highlighted way to follow when looking directly at the road. For example, it allows to notice that a back exit has been missed or to find the right exit on a roundabout without having to check. This metaphor is for planning assistance even if the information presented to the user is a middle term one (useful until the next intersection). Another metaphor presents a virtual car to follow as it accelerates, brakes or activates turn signal. In this case, the information is a short term one (about one second) (see Fig. 4.1.6b).

The metaphor of unrolled map [Kim 09] is an improvement of the metaphor of the augmented road. The aim is to give the user a global knowledge of the environment. A map is unrolled as the vehicle is moving. The part on the ground indicates the path to be taken immediately. The other part in the sky shows the structure of the surrounding road network. A curved area allows a continuous transition between the two modes of representation (see Fig. 4.1.6c). It provides a knowledge of the road network in the medium term, using the technique of LOD (Level Of Detail). The results of tests in simulation (i.e. virtual reality) show a reduction in navigation errors in older peoples and problems caused by divided attention. This metaphor has been developed on the new full wind-shield HUD of General Motors in order to validate these results in real situations. An AR navigation conception (see Fig. 4.1.6d) is also being developed by the Pioneer company [Techcrunch 11].

A variant of the annotation metaphor (see Fig. 4.1.6e and Fig. 4.1.6f) is the metaphors to discover points of interest. This is used to provide the user additional knowledge without distraction. Narzt et al. [Narzt 04] offers the annotation metaphor with contextual information. The authors suggest to take into account the vehicle's state in order to provide information suitable to the driver's needs such as: location of a gas station and the fuel price when running low on fuel (see Fig. 4.1.6e). They use a haptic touch pad to present the points of interest. The user can touch the points of interest to select them. He has both visual feedback via augmented reality, and haptic feedback through the pavement. He can finally click on a point of interest (always via the keypad), and get more information.



(a) *Metaphor of Augmented Road [Narzt 04].*



(b) *Virtual Car Metaphor [Narzt 04].*

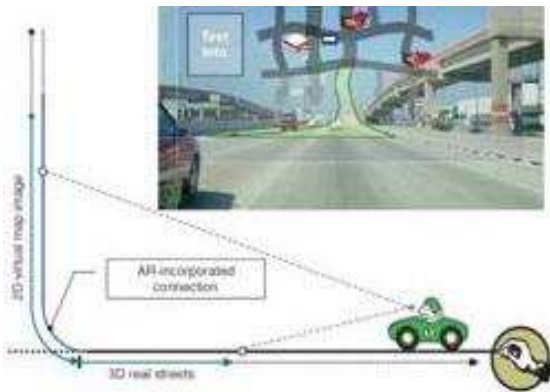

(c) *Road network metaphors [Kim 09].*



(d) *Metaphors from Pioneer Society [Techcrunch 11].*



(e) *Point of Interest Metaphor [Narzt 04].*



(f) *Point of Interest Metaphors with possibility of feedback [Narzt 04].*

**Figure 4.1.6:** *Point of interest discovering metaphors and Navigation Metaphors.*

## Metaphors for Driving Safety

The driving safety assistance is all resources used to provide the user with information needed to drive as safely as possible. The aim is to complement the ability to detect hazards, overcome the unawareness, enhance the vigilance. The metaphor of a highlighter [Narzt 04, Eyraud 15] shown in Fig. 4.1.7c and Fig. 4.1.7d allows to highlight some of the details existing in the driver's field of view in order to attract his attention. It is possible to highlight other vehicles, pedestrians and lanes. We can notice that the highlighting of the road is similar to the augmented road metaphor. However, the context and the goals are not the same. Indeed, in the first case, the aim is to guide the driver along a route. In the second case, the aim is to help the user to locate the path when the lane is not clear or when the visibility is poor. The metaphor of the radar [Tonnis 06] looks like a top view of the vehicle in two dimensions. Imminent hazards are marked with an arrow indicating their direction. The user can see the dangers that are on front of the vehicle (see Fig. 4.1.7a ). This metaphor is exocentric (i.e. external to), also the user must perform mental transformations to bring the information in the egocentric reference. The exocentric metaphors are not suitable for driving assistance [Tonnis 06]. The metaphor of the vane [Tonnis 06] is presented as a three dimensional arrow pointing to imminent danger (see Fig. 4.1.7b ). The arrow is attached to a virtual pole in front of the car, and helps preventing cognitive changes (otherwise some subjects perform a mental translation of the arrow to the location of their head). Unlike the metaphor of the radar, the metaphor of the wind vane keeps an egocentric view while providing the driver with information on items that are not in his visual field. The advantage of staying in egocentric visualizations is that it frees the driver to perform mental transformations before processing information.

In [Charissis 10], the authors proposed a safety metaphors with three symbols: These are the lane symbol, the lead vehicles symbol, and the traffic congestion symbol (see Fig. 4.1.7f). The lane symbol offers an easily identifiable "virtual pathway" which provides a point of reference for the vehicle's position on the road and helps avoid accidental lane departures. Further, the lane symbol also acts as a warning for the existence of obstacles in near vicinity of the vehicle (like an overtaking car or a lane barrier). The latter functionality is achieved by the color

coding of the lane symbol; a green color on a lane strip indicates the absence of an obstacle at that side of the vehicle, whilst red coloring denotes some obstruction being present. The lead vehicle symbol is superimposed on the first row of leading vehicles and acts as a collision avoidance mechanism by notifying the driver of the position of other vehicles of interest. The symbol itself is also color-coded and varies in size so as to denote distance and level of risk. The traffic congestion symbol alerts the driver to the presence of other groups of vehicles, moving slowly or being stationary at some point along the route and in the near vicinity. The presence of this prompt hints to the driver to reduce speed in anticipation of a slower traffic flow. In [Rusch 13a], the author proposed to use the bounding box (see Fig. 4.1.7e) as a conformal aid to highlight the hazards and directing the driver attention to the hazard.

## 4.2 Proposed Metaphors

### 4.2.1 A Conformal Dynamic Metaphor

Based on the survey above, we propose a metaphor for directing the driver's visual attention and for enhancing the driver's awareness of pedestrian. According to the intelligence of the decision and the relation with object to be augmented, a visual metaphor can be also classified as static or dynamic, conformal or non-conformal.

A static metaphor means that we will constantly display the cues, regardless of the situation. This may be useful if that information needs to be considered constantly or if the driver has to be constantly aware of that information, for example the speed or the engine temperature.

A Dynamic metaphor monitors the state of the environment and the vehicle, and their change accordingly, and potentially alerting the driver if there is an impending event to be aware of. Navigation systems are certainly dynamic, as well as dashboard warning lights for "engine check" and others driving safety metaphors. The dynamic metaphors infer the intent or the focus of the driver and determine whether displaying information is useful or distracting. As previously mentioned, the today-PCWS become quickly distracting and annoying. They alert the driver every time a pedestrian is detected even when the driver is already aware



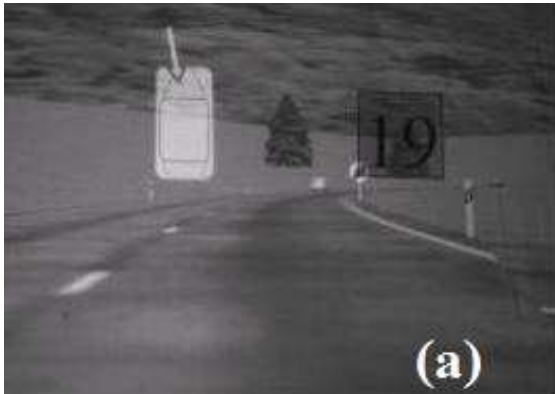

(a) Radar Metaphors [Tonnis 06].

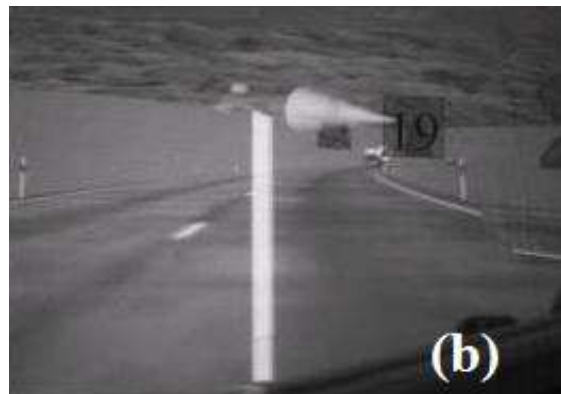

(b) Arrow Metaphors [Tonnis 06].



(c) Lane Mark Metaphor [Eyraud 15].



(d) Lane and Obstacle Highlight Metaphor [Narzt 04].

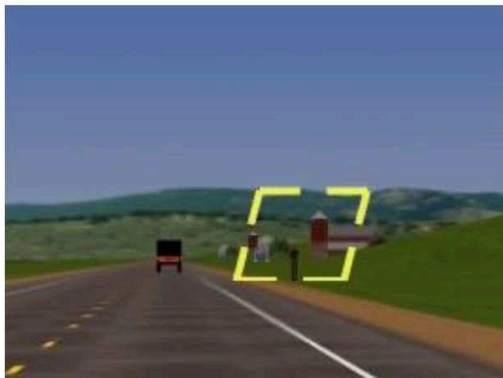

(e) Bounding Box Symbol [Rusch 13a].



(f) Metaphors proposed by Vassilis Charissis [Charissis 10].

**Figure 4.1.7:** Driving Safety Metaphors.

of that pedestrian. Thus, in this study, a dynamic metaphor is proposed to display the cue according to the driver’s awareness and the criticality of the situation.

On the other hand, the position of the cue and the collocation with the element on the scene are another property of the metaphors. This is also known as the conformity of the metaphor. Non-conformal metaphors are collimated at a predefined depth (usually 2.5m to 4m) on the road in front of the driver. They are used typically to display the speed or other vehicle information, etc. However, they also provide information about the traffic environment, such as cars and pedestrian [Caird 01]. The advantage of the non-conformal display is that the driver knows exactly where the cue is displayed and gets used to it with the virtual information. However, it can create occlusion with the traffic elements such as precedent cars or obstacles. In contrast, a conformal metaphor is represented by the virtual imagery that is overlaid on the elements in the traffic environment. The image is optically superimposed on the objects it augments. In some driving scenarios such as night driving or hazard apparitions, the conformal display has a performance advantage over non-conformal display [Gish 95, Ward 94].

In order to benefit the advantages of each type of metaphors in the context with pedestrians, we propose a dynamic metaphor with two cues. First, we propose a non-conformal cue which is the “Pedestrian Attention” panel. The panel is displayed at the bottom left of the HUD. Second, we propose a conformal cue which is the bounding box at the pedestrian position (see Fig. 4.2.1). The bounding box has been used in [Rusch 13b] for directing the driver attention to hazardous events. The authors found that the static bounding box was actually related to longer reaction times than using no cues. In [Schall Jr 13], the authors explored the use of bounding boxes for elderly drivers and found that they improved detection of hazardous object under low visibility, while not interfering with the detection of non-hazardous objects. In [Charissis 07], different rectangles in different colors were used to highlight the lead vehicles, to act as a rear collision warning system and to enhance the situation awareness of the driver. Moreover, the yellow color is chosen to convey a warning rather than an immediate threat [Chapanis 94, Gelasca 05]. Otherwise, in case the system detects that the situation is critical, a yellow pedestrian warning panel will be displayed at the left corner of the HUD.

This aid is expected to remind that the pedestrian is vulnerable and can cross the road at any moment. It will warn the driver from the potential accident to the pedestrian.

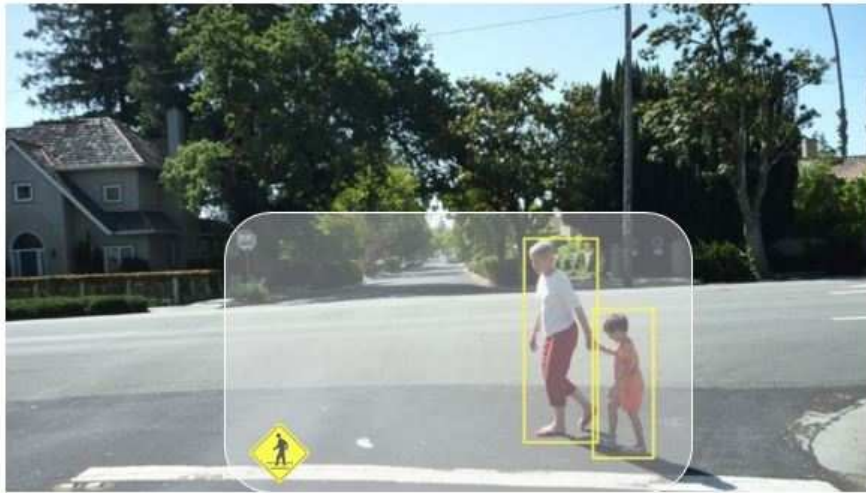

**Figure 4.2.1:** *The proposed visual cues for Pedestrian Collision Warning Systems.*

## 4.2.2 Decision Models and System Configurations

The decision modeling consists of defining the rules to execute the visual cues (the bounding box and the warning panel). Indeed, the warning panel is displayed only when the situation is detected as a danger or a critical moment. At first stage, we consider the Time-To-Collision to determine the danger of the situation. Therefore, we define the critical-Time-To-Collision ( $TTC_{critical}$ ) and the critical-Distance ( $d_{critical}$ ).  $TTC_{critical}$  represents the amount of time the driver is given to react after being warned that he is in potential collision with a pedestrian whereas. The  $d_{critical}$  plays the role of a safety net. In most case, the  $TTC_{critical}$  happens first, but for some cases where the vehicle approaches the pedestrian with a low speed, the  $TTC_{critical}$  is met when the vehicle is too close to the pedestrian. the  $d_{critical}$  is calculated as follows:

$$d_{critical} = v_{veh} * TTC_{critical} \quad (4.2.1)$$



For example, when the vehicle speed ( $v_{veh}$ ) is about 30km/h( 8.3m/s) and the  $TTC_{critical}$  is found at 2s, thus, the distance is equal to 16.6m. It is already too close to the pedestrian. The  $d_{critical}$  should be taken into account first. The critical moment (CM) is then defined in function of the critical distance ( $d_{critical}$ ) to the pedestrian and the  $TTC_{critical}$  between the vehicle and the pedestrian. As in [Aoude 12, McLaughlin 08], we base the choice of  $TTC_{critical}$  on the cumulative human response time distribution. This distribution answers the following question: Given a specific driver response time, what is the percentage of population that is able to react to a potential collision.

To summarize, the larger the response time, the bigger the percentage of population to react on time to the warning. But a larger response time is expected to lead to a worse performance of the warning because it can become annoying to the driver. The Tab. 4.1 gives this distribution. They are 1.0, 1.6, and 2.0s, corresponding to 45%, 80%, and 90% of the population, respectively.

$TTC_{critical}(s)$	$d_{critical}(m)$	Population percentage
1.0	8.3	45%
1.6	13.3	80%
2.0	16.6	90%

**Table 4.1:** *Response time population distribution.*

In order to better analyze the benefits of a dynamic metaphor, we proposed two decision modules which present also the main differences between two configurations of the proposed AR-PCW system. The first one is a basic configuration (named Augmented Reality or AR) in which, the visual cues are displayed whenever the pedestrian is detected, the second one is an intelligent configuration (named intelligent Augmented Reality or iAR), in which, the visual cues are displayed in function of the critical moments (see Tab. 4.2). In the AR configuration, the bounding box is displayed whenever a pedestrian is detected in front of the car and the warning panel is displayed when the driver is in a critical moment (i.e., 2s of TTC). In the iAR configuration, the rules are the same than with AR configuration. However, the decision takes into account the driver's awareness and the critical moments at this time. The aids are displayed only when the driver is detected to be unaware of that pedestrian.

Configuration	Bounding Box Activation	Bounding Box Deactivation
noAR	No	No
AR	Pedestrian Detected	No Pedestrian
iAR	DUP detected	DAP detected
	Panel Activation	Panel Deactivation
noAR	No	No
AR	CM	No CM or no Pedestrian
iAR	DUP Detected at CM	DAP detected or no CM

**Table 4.2:** Three configurations of the AR-PCW system.

It is important to note that, the reliability plays an important role in the automation systems. Trust of in-vehicle technology is linked to warning system reliability and sensitivity settings [Lee 04]. High False Alarm (FA) rates associated with high sensitivity, can reduce driver trust in the alerting system and annoy the driver. It can lead to failure of benefit from the warnings and overall increase in driver errors [Ben-Yaacov 02, Bliss 03, Dingus 97, Maltz 04]. A reliability of 70 may be a critical crossover point for performance; no automation may be better than automation that is less than 70% reliable [Dixon 07].

In our proposed system, the AR configuration will display the cues with 100% of reliability because the perfection of the pedestrian detection in the virtual environment. Whereas, in the iAR configuration, the reliability of the display decision is strongly related to the reliability of the DAP/DUP classification. Indeed, The DAP/DUP classification has been validated in Chapter 3 and has proven to be at a level of 74% of reliability. Therefore, it is difficult to analyze separately the benefits of the cues in the iAR configuration.

However, we decide to implement both configurations on a driving simulator and set up an experiment in order to observe the effect of the whole system under those configurations. In the following sections, we present the study platform and the implementation of the AR-PCW system on a driving simulator.

## 4.3 Research Platform

### 4.3.1 Driving Simulator Platform

In the chapter 2, we have talked about a driving simulator which has been used to manipulate the driver's awareness and unawareness. This system is reused in this final experiment. However, the 3-screens visual screen (see Fig. 4.3.1a) is replaced by a projector (See. Fig. 4.3.1b). The driving simulator consists of a software that generates the 3D environment and the models of the different elements in it. The user interface of the driving simulator contains a driver seat, a steering wheel, three real pedals and a clutch kit. The interface is designed to be as comfortable as possible in order to facilitate various conditions of the experiments. The driver can adjust the seat to be comfortable as he wants and the simulated vehicle can be chosen between the manual and the automatic gearbox. The interface of the simulator is configured as shown in Fig. 4.3.1b. The projector screen is placed at 1.5m in front of the driver. The screen width is 1.6m. The screen covers mostly 90degree the field of view. The 3D images, sound and interaction between the driver and the simulator interface are piloted by the SCANeR Studio software. Three computers of  $2.7GHz$  are dedicated to run the system. One is used to run the scenario module, one is used to execute the 3D visual module whereas one other is used to run the user additional modules such as the driver monitoring sensors or the model of driver's awareness of pedestrian that we have developed (see Fig. 4.3.1a).

### 4.3.2 SCANeR Studio Environment

SCANeR Studio is a driving simulation software tool developed by Oktal [Oktal 15]. This software is extendable and flexible in order to allow us to add more plug-ins that fit our needs of research. SCANeR Studio proposes 5 main modes:

- «Vehicle mode»: Create any mathematical model of vehicle (car, truck, tank...). Analyze their behaviors, see the reaction and the component (shock, brakes, lights, wheels...).
- «Terrain mode»: Create a road network including logical information (as

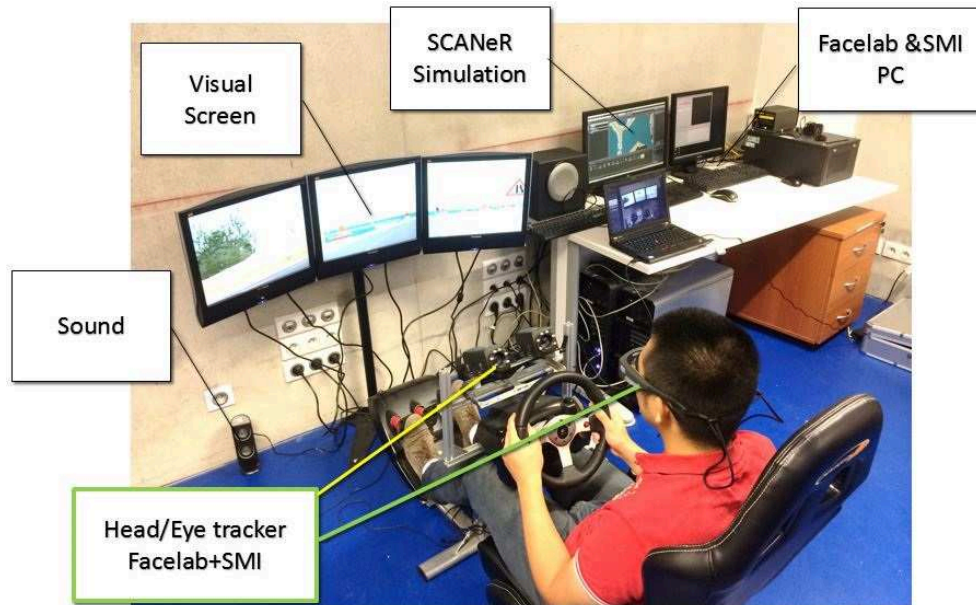

(a) The driving simulator with three-screen system.



(b) The visual module with a projector screen.

**Figure 4.3.1:** Driving simulator platform piloted by SCANeR Studio environment.

signs, traffic light, speed limit...) and including a 3D graphical environment.

- «Scenario mode»: Create exercise based on vehicles and terrain in order to improve: a driver, a road infrastructure, commands of a cockpit... .Tune situation and manage autonomous vehicles around the driver, create dangerous situation, ask him to respect instructions, get some mathematical measurements, etc.

- «Simulation mode»: Launch exercise and manage all the simulator (SCANeR's modules). The simulator is composed of hardware for sound, visualization, motion, etc. SCANeR's modules are process that manage the hardware or other software.

- «Analysis mode»: See the results of the exercise by analyzing: graphs results, 3D animation, data sheet, etc. There are two main kind of users that work on SCANeR Studio: The experiment instructor uses the simulation mode in order to launch exercises or uses other mode to prepare or debrief exercises. The experimental subject drives the vehicle (which means: Uses the cockpit through the acquisition module), taking in account: the visual environment (which means: Seeing the dynamic scene through visual modules), the sound environment (which means: Hearing noise through the sound module), the movements (which means: Feeling the reaction of the motion platform), etc.

SCANeR studio applications are 32-bit and 64-bit applications. They use a common communication protocol. An Ethernet Network is used to transfer messages between applications. Fig. 4.3.2 illustrates SCANeR studio's distributed architecture concept.

### 4.3.3 Scenario Conception with SCANeR Studio

The Fig. 4.3.3 shows the scenario mode interface of SCANeR Studio and shows an example of what we can create in SCANeR Studio. In this example, we want to see the reaction of the driver when he sees a pedestrian who has intention to cross the road. Firstly, we add the elements for the scenario: the vehicle (Toyota), the pedestrian (a casual woman) and a Trigger (Toyota detector) which allows to detect when the vehicle is at that position. Moreover, for the pedestrian's behaviors, the studio allows us to manipulate the movement, the trajectory and the pedestrian's behaviors such as running, walking, crossing, etc. We can also set the speed of

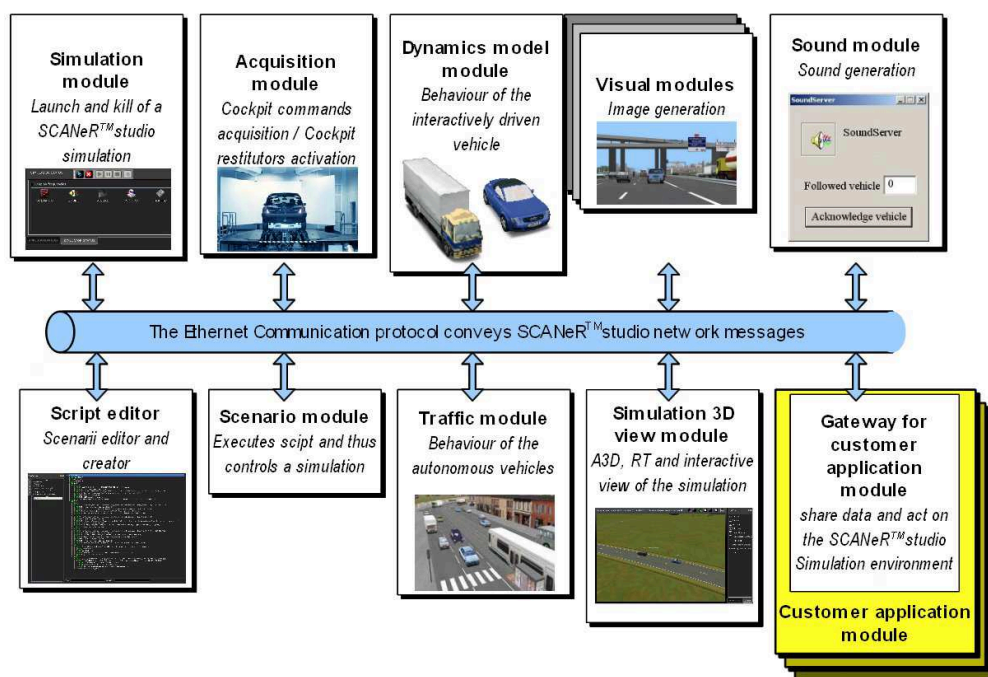
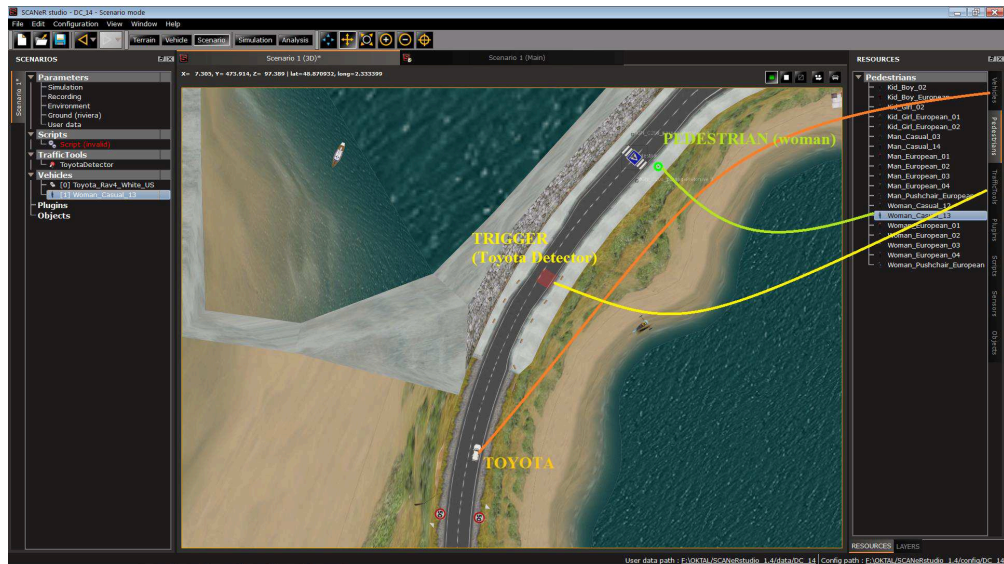

Figure 4.3.2: SCANeR communication protocol [Oktal 15].

the movement of the pedestrians. Secondly, we create a script that manipulates the pedestrian to cross the road when the vehicle is at the trigger position. The scripting in SCANeR studio is easily understandable (see Fig. 4.3.4).

## 4.4 Platform Developments

In this section, we present our system implementation on a driving simulator. First of all, we simulate a HUD with a transparent zone on the screen. Then, we implement the bounding box and the warning panel using the visual API and scripting module of SCANeR. We build the DAP and DUP classification with Matlab Simulink and do the co-simulation with SCANeR Studio. The system decision model is finally implemented using the SCANeR Scripting.



**Figure 4.3.3:** *Creating a story with SCANer Studio: The Pedestrian will cross the road at the crossing mark when the vehicle TOYOTA is on the position TRIGGER [Oktal 15].*

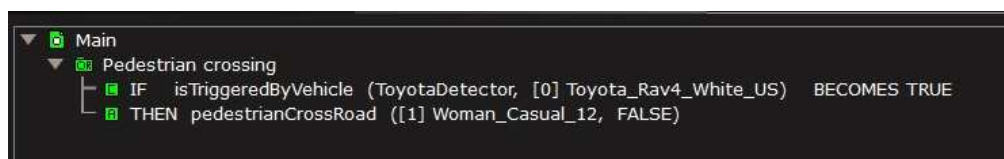

**Figure 4.3.4:** *The understandable scripting in SCANer Studio [Oktal 15].*



### 4.4.1 Head-Up-Display simulation

A real HUD, through the SERA project (mentioned in Section 1.2) is expected in this thesis. However, due to technical difficulties and manufacturing delays, we did not use a real HUD. Therefore, we propose to simulate a HUD on the screen of the simulator. In [Charissis 10, Charissis 07], the HUD is supposed to be the whole wind-shield. Thus, the visual cues can be displayed everywhere on the screen. However, it is possible that a small zone of the windshield in front of the driver will be dedicated to the AR zone according to our knowledge of industrial wind-shield manufacturing. Therefore, we propose a transparency zone (higher opacity) rendered as a rectangle to simulate a combined HUD. This zone covers the center part of the driver's field of view. This transparency zone and the visual cues are supposed to create an impression of a HUD to the driver (see Fig. 4.4.1). Moreover, the aid symbols are only displayed in this HUD zone. For example, if a bounding box is displayed on a 3D virtual pedestrian, the HUD will be able to display it according to the position of the pedestrian in the scene and its projection on the transparency zone of the windshield. This means that the active AR zone is limited to the transparency zone.



**Figure 4.4.1:** *Simulated HUD in simulation conditions.*



### 4.4.2 Visual Cues Implementation

SCANeR studio facilitates the implementation of the cues by providing the script to display 2D images on defined screen positions. Therefore, in order to display the pedestrian bounding box, we have to determine the 2D position of the pedestrian on the screen. Moreover, a visual Plug-in API is provided in the studio, the API offers the ability to access, modify or increase the 3D representation of simulation.

The API is based on C++ and allows developers to gain access to SCANeR visual module and simulation data (Vehicle properties, terrain, weather, etc). Fig. 4.4.2 shows the architecture of the plug-in. Plug-ins are collections of dynamic libraries composed of two parts: An «interface» part that allows visual plug-in management to dynamically load each plug-in and an «implementation» part composed of a set of call-back functions that will be called during each step of the rendering process. The functions «*config()*, *load()* or *unload()*» are used to create and initiate the new plug-in. Then, at each SCANeR's time step, the «*update()*, *preDraw()* and *postDraw()*» functions are called at each frame in the application process. Within these functions, it is able to access to the visual API.

To access the simulation information, the visual plug-ins make use of the visual API which are two main classes (see Fig. 4.4.2). The «Simulation Context» provides simulation data such as vehicle properties, weather conditions, database properties and many other tools can be accessed through the Simulation Context class.

By accessing on the Graphical Context of the Visual Module, then, we can have the information about the virtual camera .Moreover, the necessary matrix for the projection from 3D scene to 2D screen can obtained by using the OpenSceneGraph (OSG) library [Burns 04] Thus, can calculate the pedestrian 2D position on the displayed screen. This is the position where we superimpose the bounding box used in the metaphor. The Scripting module of SCANeR allows us to easily display a 2D image of the bounding box at the defined screen position (see Algo. 4.1 ).

In detail, from the Graphical Context and using OpenSceneGraph, we can get the *camViewMatrix* and *camProjMatrix* which are the view matrix and the projection matrix of the virtual camera. Thus, suppose that *3DPos* is the 3D position of the pedestrian on the virtual scene, and *2DPos* is the 2D position

of the pedestrian on the screen that we need to determine, the formulation is as follows:

$$2DPos = 3DPos * camViewMatrix * camProjMatrix \quad (4.4.1)$$

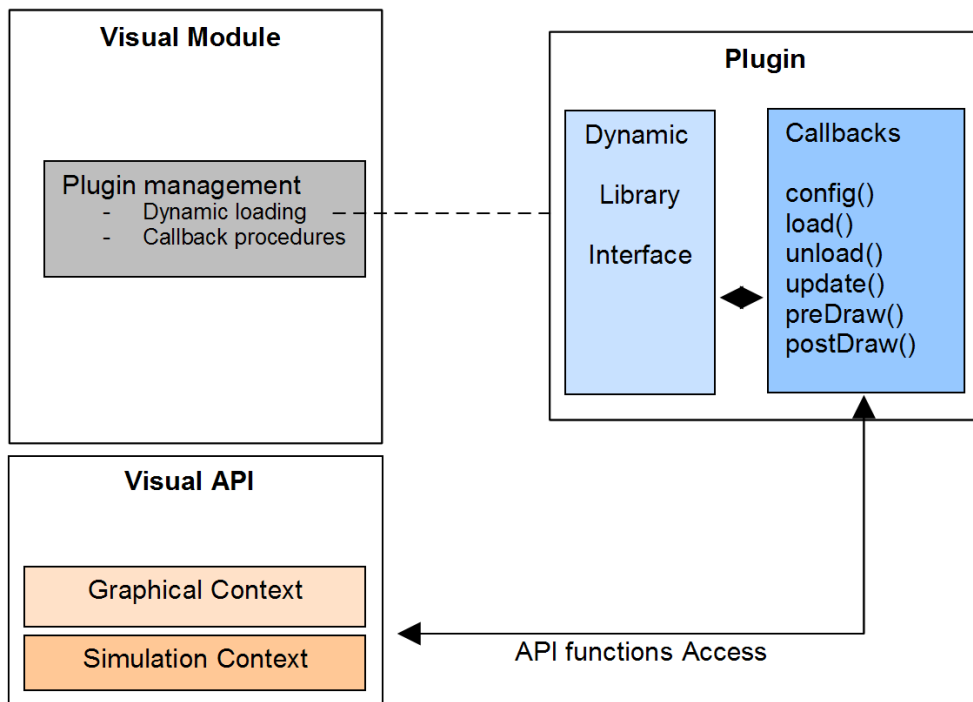

**Figure 4.4.2:** *Visual plug-in Architecture in SCANeR SCANeR SDK. By building a visual plug-in, we can access to the Graphical Context and the Simulation Context of the Visual API. The pedestrian position on screen can be then determined.*

### 4.4.3 DAP/DUP Classification Simulink Model

The classifier of the DAP and the DUP have been presented in Chapter 2 and Chapter 3. They have been implemented into a S-Function of Matlab Simulink because SCANeR provides a Simulink library that enables to access to the SCANeR communication protocol. We can have access to all the simulation data and we can act on simulator components from a Simulink model. During the design phase, we are able to do co-simulation. It is possible to start in parallel the SCA-

NeR simulation and the Matlab simulation, both of them communicating together. The Simulink model can then be compiled to an executable module to be used in a production environment on a computer where Matlab is not installed.

The Controller block (see Fig. 4.4.3a) allows to configure the parameters of the communication between Simulink model and SCANeR. We have to configure the name of this block as the same name of the process that we create in SCANeR Studio. This helps SCANeR to recognize the Simulink model. Moreover, there are some parameters that need to be configured to indicate the properties of this process on SCANeR such as execution frequency, option on synchronization, etc. The Input blocks (see Fig. 4.4.3b) allow using simulation data in the Simulink model. These blocks have output ports but do not have input ports. Their default name is made up with the category and the message name followed by “Input”. Each output port represents a field of the message. When a message is received, all fields are updated at the same time step. The Output block (see Fig. 4.4.3c) allow sending Simulink model outputs to other SCANeR modules. These blocks have input ports but don’t have output ports. Their default name is made up with the category and the message name followed by “Output”. Each input port represents a field of the message. A message is always sent with all of its fields.

Fig. 4.4.4 shows the Simulink model of the DAP/DUP classifier with all the communication interfaces of SCANeR Studio. We add a buffer concatenate the driving input signals from the input block (the orange ones). This forms a  $5 \times 30$  matrix of driving data that are taken by the acquisition module. It represents the  $Tw$  sliding time windows mentioned in DAP/DUP classifier model (see Sec. 2.2.2 of Chapter 2).

#### 4.4.4 Decision Module Implementation

Fig. 4.4.5 presents the concept of the AR-PCW system in which the decision module is dedicated to determine the activation and deactivation of the visual cues in the intelligent Augmented Reality (iAR) configuration. In the AR configuration, we get the same structure but without the DAP/DUP classification.

The decision module (see Tab. 4.2) is implemented as a script on SCANeR Studio. In the scripts, we use the following variables to form the decision of

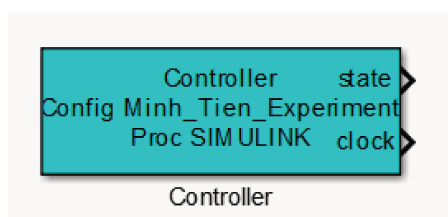

(a) Controller Block which allows SCANeR Studio to recognize the Simulink model via its process name and configurations.

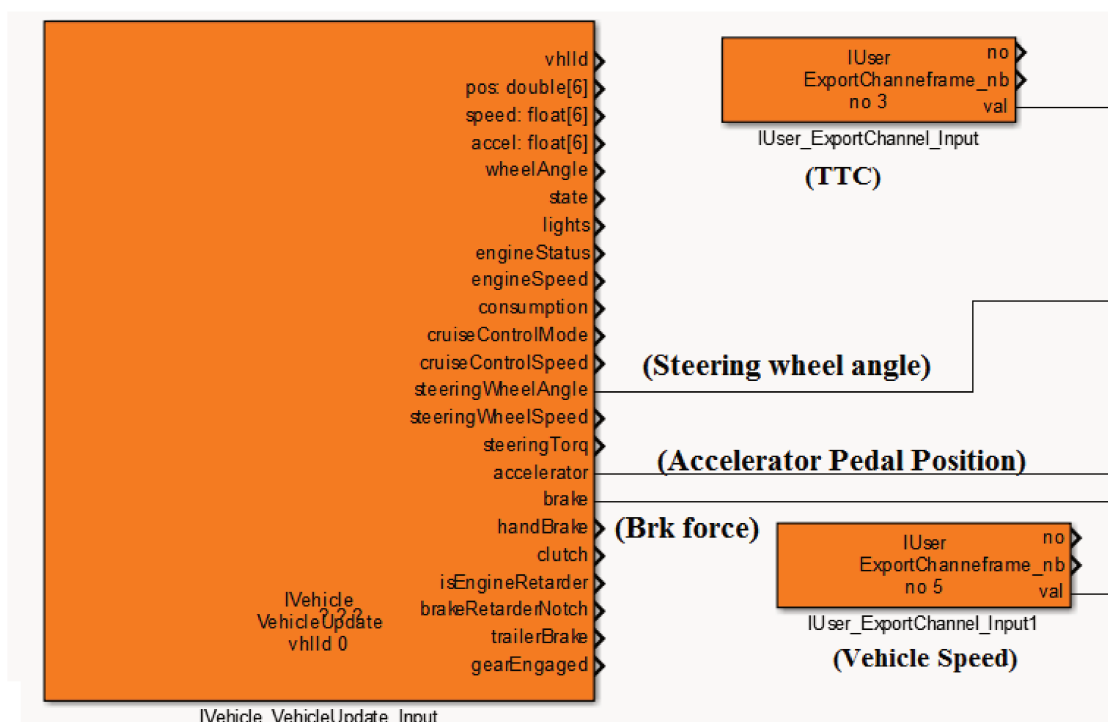

(b) The input Block which allow to access into the SCANeR acquisition module and to get the observations such as driver actions or vehicle information.

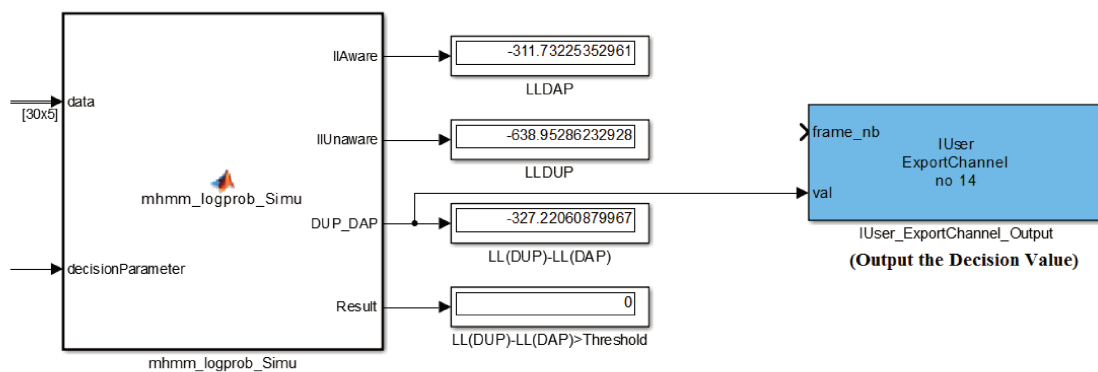

(c) The DAP/DUP Classifier which is developed using the S-Function. The blue block is the output Block which allows to send the calculated data from Simulink to SCANeR 100Studio.

Figure 4.4.3: The Simulink API of SCANeR Studio.

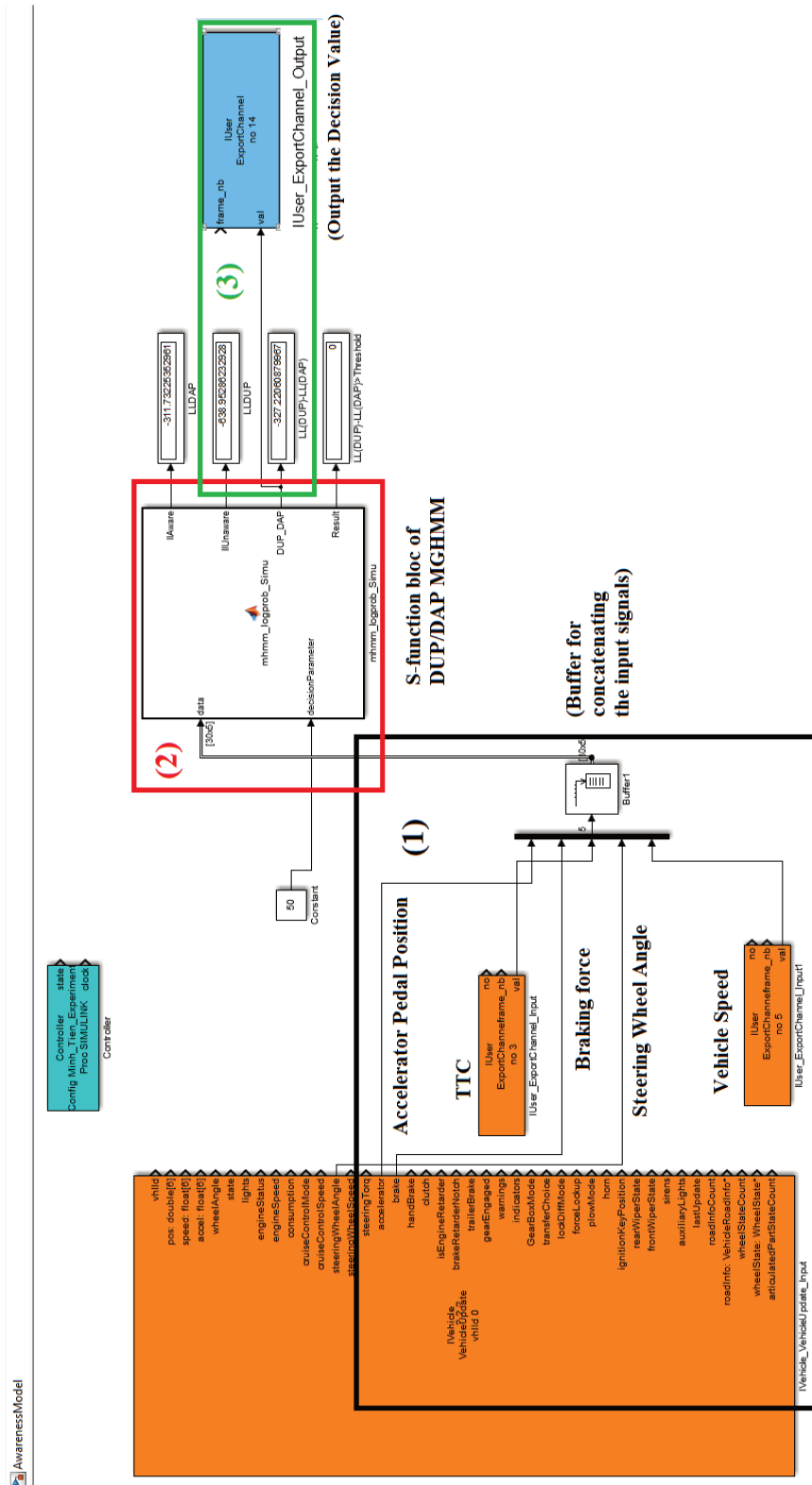

**Figure 4.4.4:** *Matlab Simulink Model of the DUP/DAP Classification and the Simulink interface of SCANer. (1) input block and the Tw buffer for concatenating the input signals. (2) S-function of DAP/DUP classifier. (3) Output block for the DAP likelihood value.*

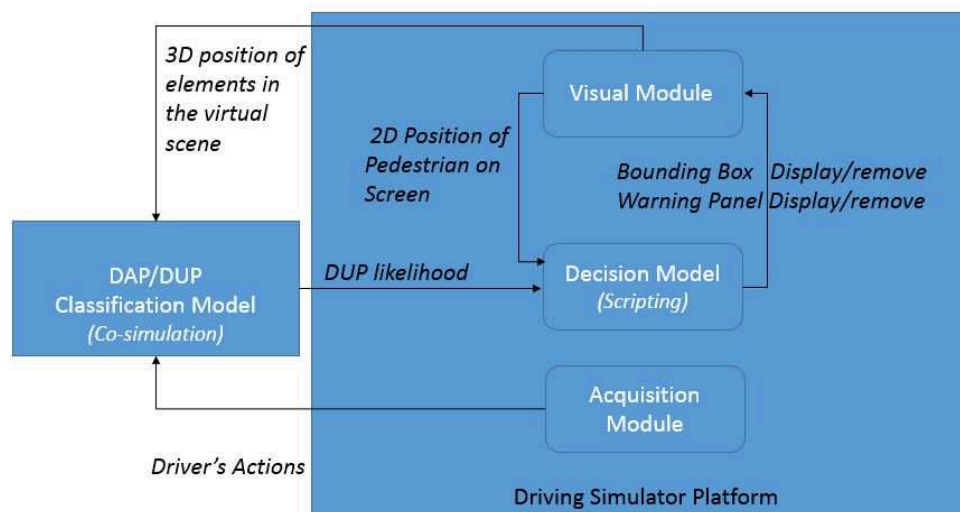

**Figure 4.4.5:** The communication between the modules of an Augmented Reality Pedestrian Collision Warning (AR-PCW) system implemented for a simulator.

displaying and removing the cues: The variable  $DUPdecision$  is the output of the DAP/DUP classifier which indicates whenever the driver is aware of unaware of the nearest pedestrian. The  $POSdecision$  variable indicates whenever the pedestrian is found to be within the HUD zone. The  $CMdecision$  variable indicates the critical moment.  $POSdecision$  is equal to 1 when the pedestrian is found to be within the HUD zone.  $CMdecision$  is equal to 1 when the  $TTC_{critical}$  or the  $d_{critical}$  are detected (see Tab. 4.1).  $DUPdecision$  is greater than 0 if the driver is detected to be unaware of the pedestrian.

The scripting of the proposed iAR configuration can be summarized in the Algo. 4.1.

---

**Algorithm 4.1** Algorithm for displaying the cues in the iAR configuration.

---

**If** [ $POSdecision = 1$ ] **And** [ $DUPdecision > 0$ ] **Then** [Display the Bounding box at 2DPos]  
**Else** [Remove the Bounding box at 2DPos]  
**If** [ $POSdecision = 1$ ] **And** [ $DUPdecision > 0$ ] **And** [ $CMdecision = 1$ ] **Then** [Display the Warning Panel]  
**Else** [Remove the Warning Panel]

---

Fig. 4.4.6 and Fig. 4.4.7 show how the visual cues are displayed in the 3D

virtual environment. When the critical moment is not detected, there is only a bounding box whereas two cues are displayed when the driver is supposed to be unaware of the pedestrian and the situation is detected as critical.



**Figure 4.4.6:** *Display of the bounding box when the pedestrian is detected far from the car.*

## 4.5 Conclusion

We have presented a review on the related work on Augmented Reality applied to driving context. We categorize metaphors in three types: the navigation metaphors, the discovering point of interest metaphors and the driving safety metaphors. The different modalities and characteristics of the metaphors have been discussed. A visual metaphor is then proposed, as a proof of concept, for the AR-PCW system for enhancing the driver's awareness of pedestrians. In this concept, we use two types of visual cues: One is a conformal cue, the bounding box, and the other is a non-conformal cue, the warning panel.

Two configurations of the AR-PCW system have also been proposed. In the AR configuration, the bounding box is displayed whenever a pedestrian is detected in front of the car and the warning panel is displayed when the critical moment (CM) is detected. In the iAR configuration, the decision has the same rules as the AR configuration in term of the critical moment. Moreover, the iAR also takes



**Figure 4.4.7:** *Display of the bounding box and the warning panel when the driver is unaware of the pedestrian at the critical moment.*

into account the decision of the DAP/DUP classification. In order to analyze if the AR-PCW system can have benefits or impacts on the driver, an experimental study is necessary. Therefore, we toward an experiment using a simulator that will be presented in Chapter 5.



## Chapter 5

# Enhancing Driver Awareness of Pedestrian with Augmented Reality Cues

This chapter presents the final experiment proposed to study the costs and the benefits of the augmented reality pedestrian anticollision warning (AR-PCW) system proposed in Chapter 4. In particular, we plan to analyze if the visual cues can enhance the driver's awareness of a pedestrian (DAP). Three levels of the DAP are evaluated when the driver is driving with the visual cues. Three configurations of the system noAR, AR and iAR (see Tab. 4.2) are compared in term of the driver's awareness of a pedestrian.

Three levels of the driver's awareness of a pedestrian (DAP): *perception* level, *vigilance* level, and *anticipation* level are assessed through the measurable outcomes during the driving in pedestrian situations. Indeed, we search to answer these questions: Are the aids able to enhance the driver's perception time to the pedestrian? Are the aids able to make the driver to be more vigilance in situation with a pedestrian? Can the aids change the driver decision in an ambiguous situation? Do the aids distract the driver in his decision making? How reliable is the system decision module proposed in chapter 4? and what happen if the system is not accurate? We expect that the system in its AR and iAR configurations can have a positive influence on the driver when the aids increase the perception of a

pedestrian appearing in front of the car.

In Section 5.1, and based on a short survey of the related works assessing the driver situation awareness, we propose to evaluate our method objectively on the driver's awareness of a pedestrian (DAP). Then, we present the experimental procedure, the apparatus and the subject population. Due to the limit of the implementation of a real Head Up Display (HUD), the experiment is carried out with a simulated HUD zone on the virtual scene.

In Section 5.2, we analyze the outcomes associated to each level of the driver's awareness of a pedestrian by using the variance analysis. From that, we can see the costs et benefits of the sytem. In Section 5.3, we provide a discussion on the results and on different aspects of the study followed by an intermediate conclusion in Section 5.4.

## 5.1 Assessment of Driver Awareness of Pedestrian

This section consists of proposing a novel method to study the effect of the visual metaphors on the driver's awareness of pedestrian. We do firstly a review on the related work that aimed to assess the driver's situation awareness. Based on this study, we define the observable outcomes that are associated to each level of the driver's awareness of pedestrian (*perception*, *vigilance* and *anticipation* levels). Then, we design an experiment protocol that allows to measure implicitly these outcomes and to determine the costs and the benefits of the AR-PCW system in term of enhancing the driver's awareness of pedestrians.

### 5.1.1 Previous Similar Experiments

A Technique called SAGAT (Situation Awareness Global Assessment Technique) is a global tool developed to access Situation Awareness of the cockpit pilots. Endsley [Endsley 95b] lays out the criteria for SA measurement which has subsequently become one of the standard instruments. Here, participants are intermittently queried, in the middle of a dynamic simulation, about the values of various state parameters in the process under supervision. This query is issued when the display is blanked, so that the operator must rely on working memory to answer the

questions. In the first two experiments, the author examines the extent of loss of SA revealed by SAGAT by probing at different time points across several minutes following each blank [Gugerty 98]. In the second experiment, the author addresses the critical issue of the extent to which such queries disrupt the process being measured (or disrupt it differentially across different conditions). Importantly, the author's conclusion, echoed by Pew [Pew 00], is that such interference is minimal. It is noteworthy that other approaches to SA measurement have been advocated. As one example, the Situation Present Assessment Measure, or SPAM [Durso 07] assesses the speed of accessing information from a non-blanked display. It provides a more sensitive, continuously distributed (time) measure that requires less memory decay as the SAGAT technique. In the driving context, the SAGAT technique has also been used to assess the driver's situation awareness at the intersections. In [Plavšić 10], the authors have created four critical scenarios at the intersections and provided a questionnaire to evaluate their focus of attention before accident. This technique contains both strengths and weakness [Alexander 05]. It is easy to use when we can build a set of queries about the situation to assess the driver SA in that specific situation. However, this technique is intrusive because the driver has to stop driving to answer the questions. The participants may need to recall specific information on the driving environment from their earlier performance. Therefore, the measure may be biased by subject recall ability.

As another approach, the loss of SA can be inferred from changes in performance on tasks for which good SA is essential. For example, the freeway driver who pulls into another lane in front of an overtaking car can be inferred to have poor SA. This would be an example of an implicit SA measure. In this approach, one need to identify operators, tasks, environments and system factors that may mediate the role of the various levels of SA. As an example, in [Ma 07], the authors investigated the effects of adaptive cruise control (ACC) and mobile phone use on driver SA and performance in a lead-car following task primarily involving operational behaviors. Their results revealed that SA improved with the use of ACC and decreased with use of the mobile phone under normal driving conditions. They also found significant positive correlations between SA and aspects of driving performance. They observed that all levels of SA defined by Endsley [Endsley 95a]

(*perception, comprehension and projection*) appear to have an impact on operational driving behaviors in the following tasks and, consequently, performances. In general, the use of ACC and mobile phones may be mediating factors in linkages of SA to specific driving behaviors and performance.

In [N. Schomig 13], the authors have used the second task in order to study the performance of the driver and to assess the Situation Awareness. At predetermined points of the route, the choice to perform an additional task was proposed to the driver. The possibility of accepting and rejecting the second task was then given either just before a critical situation or in a non-critical situation. This offer was signaled by a question mark projected in the front scenery comparable to a head up display. After the question mark appeared, the driver had to decide within some seconds whether the situation was suitable for the secondary task or not. If he accepted the task, he had to press the button attached at the steering wheel. The driver was then instructed to perform the secondary task in accordance with the demands of the current driving situation. The secondary task consisted of a visual task in which numbers displayed on a screen placed low in the middle console and the driver had to read aloud. Each number was presented for 500ms and then the next number appeared. If there was an error, the secondary task ended. The number of acceptance for secondary task in critical and non-critical situation are then compared. The result showed that the driver rejected more secondary tasks in critical compared to non-critical situations. Furthermore, drivers needed a longer time for that decision and the task execution was shorter. The adaptation of secondary task interaction was also assessed by analyzing the eye movement behaviors. The main idea of this technique is to create the contradiction between critical situation and non-critical situation and offer for the secondary task. The driver's situation awareness is scored in function of the driver does not accept the secondary task in critical situations. This technique seems more natural to assess the driver's SA. However, the use of distraction is inappropriate in driving. The accident happened because of the distraction and not the driver's low SA. Moreover, our goal is to evaluate the visual cues which are provided to the driver during the driving time. This requires a focus of the driver on the cues, using a visual distraction task that is not suitable for our goal.

In term of the benefits and costs of the visual cues, in [Rusch 13b], the authors have analyzed the effect of the AR cues on the driver's attention. They have proposed a protocol in which the driver was asked to follow a lead vehicle and to keep a good distance with that vehicle. Then, the driver is asked to press a button whenever they see a hazard such as a panel or a pedestrian. The driver attention was assessed on the moment that the driver pressed the button. Moreover, the performance of the following task is also an criterion for evaluating the costs of the visual cues. In [Schall Jr 13], the authors have also used this technique to study if the AR cues can helps the elder peoples in detection of hazards on road. Their results were promising for improving older driver safety by increasing hazard detection without interfering with driving task performance. However, directing the driver's attention to a hazard does not mean the driver will be aware of the danger could happen to that hazard such as a pedestrian.

The previous work showed that it is more suitable to measure implicitly the driver'SA in order to determine the costs and the benefits of the visual metaphors in the driving context. Moreover, it showed that performing the following task in avoiding accident to pedestrian is a difficult task that needs a high situation awareness. Based on this idea, we propose an experiment to assess the driver's awareness of pedestrian and to identify the effects of proposed the visual metaphor of the chapter 4.

### 5.1.2 Proposed Method

#### Recall of Driver's Awareness of Pedestrian (or DAP) Definition

In chapter 3, we have defined the driver's awareness of a pedestrian with three levels: the *perception* level, the *vigilance* level and the *anticipation* level.

In the situation where a pedestrian appears in front of the car, we define the driver's awareness of pedestrian as the perception of that pedestrian with respect to time (*perception* level, level 1 of DAP), the attention that the driver has to pay to that pedestrian (*vigilance* level, level 2 of DAP) and the driver's reactions in case the pedestrian crosses suddenly the road (*anticipation* level, level 3 of DAP).

In the *perception* level, the DAP can be assessed at the moment when the driver notice the presence of that pedestrian. This moment can be measured in the

value of the time to collision (*TTC*) between the vehicle and the pedestrian. The driver get high level of perception if he notices the pedestrian with a large *TTC*. This variable is used to evaluate the attention of the driver to the hazard as in [Rusch 13b].

In the *vigilance* level, it is supposed that the driver has noticed the pedestrian, the driver's reactions on the acceleration pedal or the brake pedal are the indications to evaluate the level of driver's vigilance. We suppose that the pedestrian can cross the road at any moment. Therefore, the more the driver accelerates, the less attention he pays to the pedestrian.

In the *anticipation* level, if the driver does a urgent braking or an accident happens to the pedestrian, the driver is considered to be at a low level of anticipation in situations with pedestrians.

### **The Experimental Protocol**

In order to assess the DAP, we will create the ambiguous situations where the driver has to decide to choose good driving actions to avoid accidents with pedestrians. A lead vehicle following task is proposed to the driver as a primary driving task. Indeed, the participant has to keep a constant distance with a lead vehicle. At certain predetermined road points, there are the pedestrians appear and have intention to cross the road in front of the road. This lead vehicle following task makes the experience more representative of typical driving situations and engages drivers so that the pedestrian would be more difficult to perceive or could be neglected by the driver.

In the experiment, the lead vehicle accelerates randomly when it enters into the situation with the pedestrian and it will pass by the pedestrian before the participant's vehicle. At this point, we suppose that the participant will also accelerate to catch up the lead vehicle. Furthermore, the pedestrians are on the side walk and they are able to cross the road at any moment. The participant has to choose the right decisions between keeping distance with the lead vehicle and lifting up the pedestrian crossing. The driver's performance in the lead vehicle following task and his reactions to avoid the accidents with the pedestrians are then measured in order to evaluate his situation awareness.

Moreover, our objective is to analyze the costs and the benefits of the proposed system by assessing the driver's awareness of a pedestrian. Therefore, the participant has to drive three times: one time with no visual assistance (noAR configuration) and two times in which the driver is provided the AR and iAR configurations.

### Dependent, Independent Variables and Hypotheses

«An independent variable, sometimes called an experimental or predictor variable, is a variable that is being manipulated in an experiment in order to observe the effect on a dependent variable, sometimes called an outcome variable.» [Statistics 13]

In this experiment, independent variable includes participants, pedestrian situations and the head vehicle's behaviors. We hypothesize that the system with its AR and iAR configurations (dependent variables) would help to enhance the DAP in its three levels. Each level is then evaluated through the following outcome measures (dependent variables):

- Outcomes associated with the *perception* level: The Visual Reaction Time (VRT) and the Visual Reaction Distance (VRD) are considered. The Visual Reaction Time is the moment (calculated in TTC) when the driver notices the pedestrian and presses the button. Visual Reaction Distance is the same of Visual Reaction Time but it is calculated in the distance between the vehicle and the pedestrian. We expect that the AR and iAR configuration of the system will enhance the visibility of the pedestrian and the driver will notice the pedestrian sooner with AR aids.
- Outcomes associated with the *vigilance* level: The Head Vehicle Distance and the Accelerator Pedal Position (APP) are analyzed. We expect that the driver will be more vigilant with the aids. This means the Accelerator Pedal Position is smaller with the AR configurations and the Head Vehicle Distance is shortest with noAR.
- Outcomes associated with the *anticipation* level: The number of time the driver brakes urgently (so called Urgent Braking ) is calculated. We hypot-

hesize that the driver does more Urgent Braking with the noAR configuration compared to the drivings with the AR configurations.

### Validation Method

In the validation step, we will consider the mean of each outcome over the participants and over the pedestrian situations. The differences between three configurations (noAR, AR and iAR) will be exposed using the one-way Analysis of Variance (ANOVA ) tools. Follow up the Tukey's honest significant different (Tukey's HSD) test will be used to specify the configuration has the most different outcomes compared to the others. This ANOVA test enables us to see how effective the differences between the driving with and without visual aids in term of the driver's awareness of a pedestrian. The formulation of ANOVA and the Tukey's HSD post-hoc test can be found in Appendix. A.1.5

In our experiment, we have  $k = 3$  groups of data (noAR, AR and iAR),  $N_{subject}$  participants and  $N_{ped}$  pedestrians in each driving time. Therefore, for each group, we can collect  $N = N_{subject} * N_{ped}$  observations for each outcome defined above. The result of ANOVA calculates the ratio of the within-group variation to between-group variation ( $F$ ) as follows:

$$F(k - 1, N - k) = \frac{SSR/(k - 1)}{SSE/(N - k)} \quad (5.1.1)$$

Where  $k - 1$  and  $N - k$  are called as the degree of freedom associated with source. Then,  $N - k$  is the within-groups degrees of freedom ,  $k - 1$  is the between-groups degrees of freedom , and  $N - 1$  is the total degrees of freedom ( $N - 1 = (N - k) + (k - 1)$ ).  $SSR$  is the sum of squares due to between-group effect and  $SSE$  is sum of squared within-group effect

This result is usually associated with a  $p$ -value which is the probability that computed test-statistic  $F$  can take a smaller value than the  $F - critical$  value which is derived from the cumulative distribution function of the Fisher-distribution. In consequence, the difference between groups is confirmed when  $F > F - critical$  and  $p$ -value is small (in this study,  $p < 0.05$  is chosen as the criterion).



### 5.1.3 Experimental Procedure with the Driving Simulator

#### Apparatus

The driving simulator SCANeR (see Fig. 4.3.1) is used for this experiment. In Chapter 4, we have implemented the simulation of the Head Up Display zone on the screen. We have proposed a pedestrian collision warning systems using the metaphor with the bounding box and the warning panel. Two configurations AR and iAR of the system have been implemented using the scripting module and the co-simulation between SCANeR Studio and the DAP/DUP classification Matlab Simulink model.

#### Scenarios

Twenty-three pedestrians are randomly placed and regularly distributed on the test circuit so that creates twenty three critical situations. The Fig. 5.1.1 shows typically what happens for each critical situation.

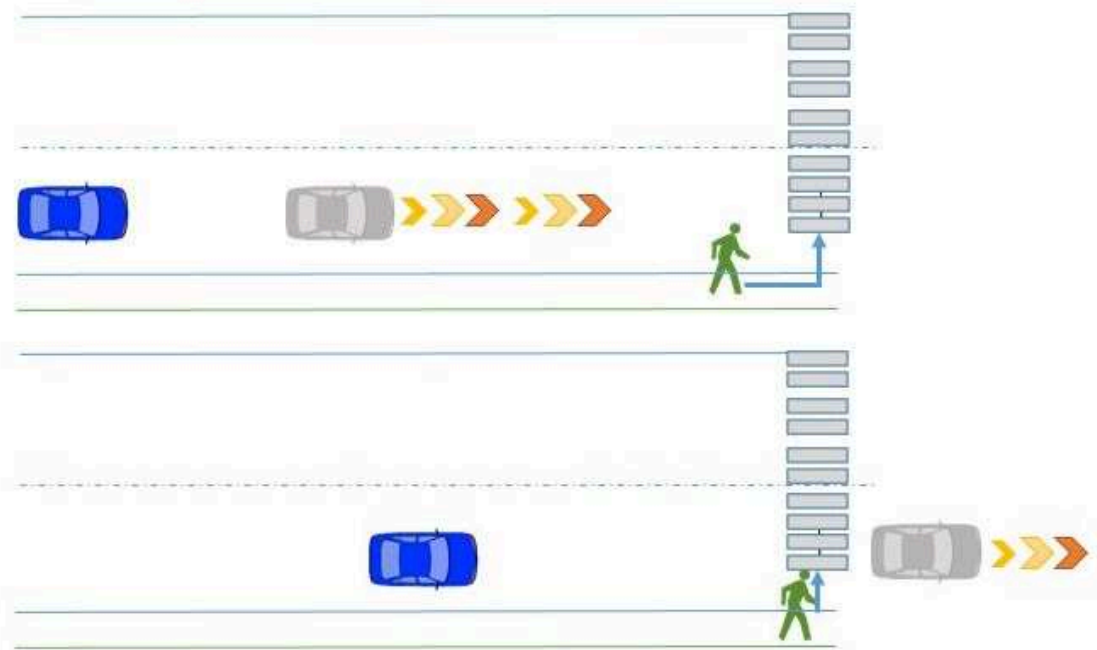

**Figure 5.1.1:** *The scenario of the critical situations.*

For each situation, there is only one pedestrian appearing with a different appearance (man or woman, adult or kid, diversified clothes colors) and with different manners (walk on side walk, run on side walk or stand at the side walk). The critical situation begins at 140m from the pedestrian and finishes when both vehicles pass by the pedestrian (see Fig. 5.1.2). When the test vehicle enters into the critical situation, the lead vehicle will accelerate with an acceleration of 4, 6, 8 or 10 km/h and it will pass by the pedestrian shortly (see Fig. 5.1.3). The acceleration value is chosen randomly in order to limit the repetition effect. Then, when the distance between the test vehicle and the pedestrian reaches 30m, the pedestrian can be randomly activated to cross the road (see Fig. 5.1.4). The Fig. 5.1.5 shows the scene in the driver's view angle at this moment. When both vehicles passed the pedestrian, the lead vehicle will decelerate until the distance of two vehicle reaches 50m. This is to begin a new situation with the next pedestrian. Before the driving test, the participant is warmed that the pedestrians are vulnerable and they can cross the road at any moment even if there is no crossing mark.

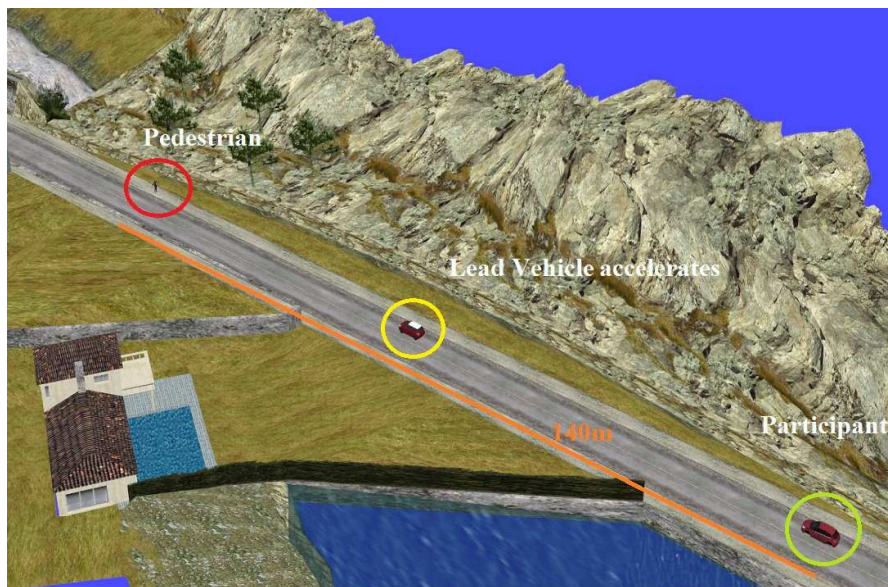

**Figure 5.1.2:** 3D View of the Scenario (Step 1): When both vehicles are in the critical situation (From about 140mm tofrom the pedestrian), the lead vehicle begins to accelerate.



**Figure 5.1.3:** *3D View of the Scenario (Step 2): The lead vehicle accelerates and can pass by the pedestrian shortly.*



**Figure 5.1.4:** *3D View of the Scenario (Step 3): When the distance between the test vehicle and the pedestrian is 30m. The pedestrian can be randomly activated to cross the road.*





**Figure 5.1.5:** *Step 3 in the driver's view At 30m to the pedestrian, the pedestrian crosses the road suddenly.*

### **Experimental Procedure**

The experimental procedure consists of a platform familiarization phase and a testing phase. The testing phase contains three driving sequences.

Before entering to the experiment, the participant receives an explanation of the purpose of the study and provided consent. Prior to the drive, the participant is allowed to adjust the seat, steering wheel, and mirrors for comfort. Then, the participant is instructed how to control the simulator. The vehicle is simulated with a automatic gear box in order to simplify the maneuver for the participant. We indicate the buttons to start and stop the platform, the vehicle pedals and the button on which the driver has to press whenever he notices a pedestrian.

Then, the participant passes into two practical sessions. On the first one, the participant drives freely to get familiar with the platform. In this driving sequence, he is instructed to adjust the speed, to accelerate to 100 km/h or to stop in front of a crossing mark. The participant is also asked to estimate his vehicle speed. The session ends when the participant gives a good answer about his actual speed without looking at the dashboard which is displayed at the upper left corner of the screen. On the second practical session, the participant is trained to perform the task of following a lead vehicle. During this session, the instructor recommends and trains the driver to keep a distance about 50 m to the lead vehicle. When the participant feels familiar to the task, he can start the formal tests. There is no pedestrian in this session. The practice sessions aim to train the participant

in the driving task without using the dashboard which may influence the effect of the visual cues.

The testing phase contains three driving sequences. Each driving takes from 15 to 20 minutes and all the three tests are passed on the same route. However, the traffic elements such as the lead vehicle's behaviors and the pedestrian's appearances are randomly changed. Note that the positions of the pedestrians in three driving test are the same, only their appearances are changed.

In each of three driving tests, the participant drives with one of three configurations (the noAR, the AR, and the iAR) at each time. The configuration is randomly chosen by the instructor for each driving. By changing the order of the configuration for the participants, we can eliminate the learning and the repetition effect in the overall data collected with all participants.

### **Participants**

The sample involved 27 subjects. Two of them did not finish the test due to the driver sickness of the simulator. All upcoming data refer to the 25 subjects who did finish the drive. All the participant had at least three years licensed driving and was familiar with the simulator. Moreover, these participants have no disease about eye or physic. They are ranged from 21 to 35 years old. 21 subjects are male and 4 subjects are female. Due to the fact that subjects were not paid for participating, the sample involved mainly students from Université de Technologie de Compiègne.

## **5.2 Results**

In this section, we want to determine indeed if the AR and iAR can enhance the driver's awareness of pedestrian in the three levels, *perception*, *vigilance* or *anticipation*. Three driving time with or without assistance configurations (no-AR, AR, iAR) are considered as three groups of observation. 25 participants had to drive in three configurations, and in each driving time, 23 pedestrian scenarios were given. However, for each variable, we deleted the aberrant data when the driver forgot to press the button or in some scenarios the driver lost the lead

vehicle.

Each outcome is considered in two times. In the first time, we compare the outcome between three driving times overall the participants at each pedestrian situation. Indeed, at this stage, we suppose that the same positions of the pedestrians on road in three driving times can give impact on the driver. In the second time, we compare the mean value of the outcomes between three driving times over all situations and over all participants. Then, The ANOVA and Tukey's HSD tests will confirm on the hypotheses given above.

## 5.2.1 Outcomes associated to Perception Level

### Visual Reaction Times (VRT)

This outcome is measured by the moment (calculated in Time To Collision) that the driver presses the button when he notice a pedestrian in front of the vehicle. Fourteen participants followed the recommendations and pressed the button when they noticed the pedestrian. The others just forgot the instructions and we could not get the VRT data from these participants. Therefore, we had finally 14 participants for this result.

The VRT corresponds to the perception level of the DAP. The Fig 5.2.1 exposed the result of VRT for 23 pedestrian situations whereas the Fig. 5.2.2 showed the mean values of VRT of three configurations for all pedestrian scenarios. The ANOVA results confirmed there was a statistically significant difference between the noAR, AR and iAR configurations ( $F(2, 963) = 18.74, p < 0.05$ ). The Tukey's HSD test also revealed that, in the noAR configuration, the driver noticed significantly lately the pedestrian when the vehicle is around 3s of *TTC* to the pedestrian. Moreover there is no significant different between the AR configuration and the iAR configuration, the driver noticed the pedestrian around for 4.5s of *TTC* with AR configuration and for 4.2s of *TTC* with the iAR configuration.

Regarding the Fig. 5.2.1, the VRT values are found different between the pedestrian situations. This is perhaps due to the difference between the road situations, pedestrian's behaviors or the latency in button presses. However, in every situations, the driver noticed the pedestrian soonest with AR configuration, followed by the iAR and with noAR.

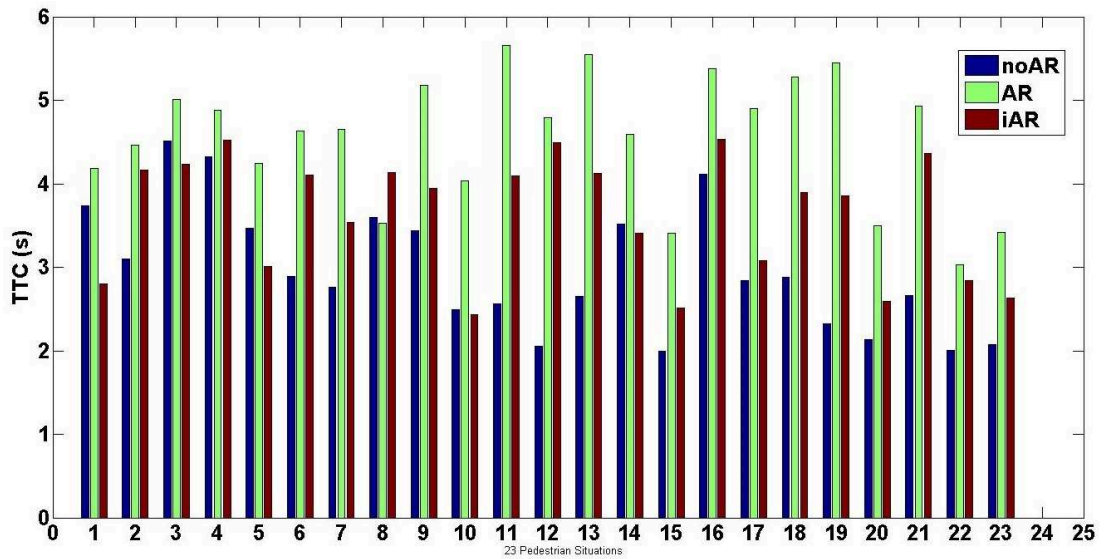

**Figure 5.2.1:** Mean of VRT in each pedestrian situation. The result showed that, with the AR configuration (in green color); the driver noticed earlier the pedestrian.

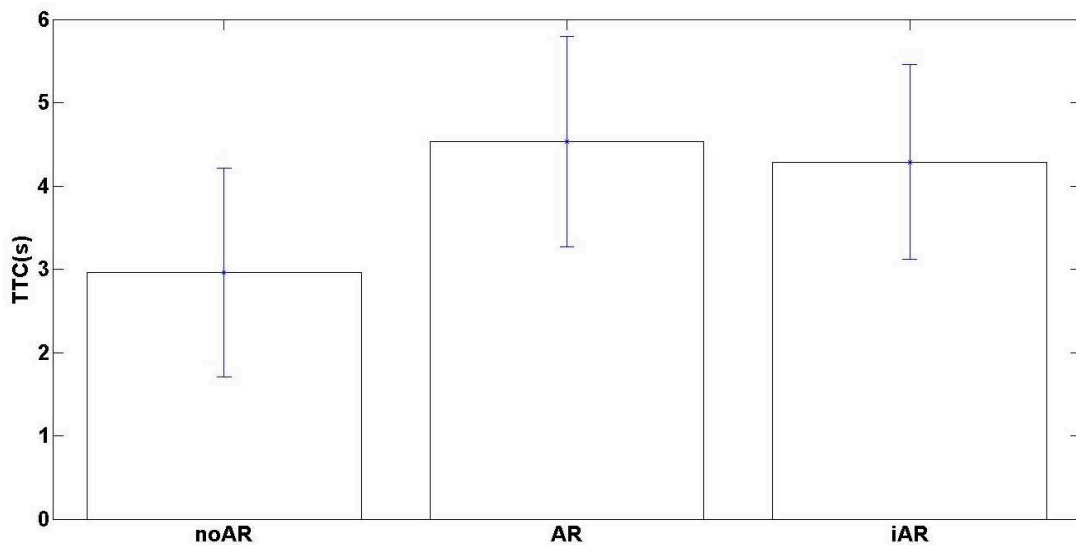

**Figure 5.2.2:** Mean of VRT in all pedestrian situations and with all participants. The drivers notice the pedestrian sooner with AR configuration, which is indicated by the TTC in AR configuration which is the greatest. However, the variance of TTC in each configuration is important because of the variance between the participants or between the pedestrian situations.

### Visual Reaction Distances (VRD)

We also consider the distance to the pedestrian when the reactions are detected, namely the Visual Reaction Distance (VRD). In each of the 23 pedestrian scenarios, we could see that the driver noticed lately (smaller value of VRD) the pedestrians (see Fig. 5.2.3). The ANOVA confirmed there was a significantly difference of VRD between the noAR, AR and iAR configurations ( $F(2, 963) = 12.38, p < 0.05$ ). The results of Tukey's HSD test confirmed that the AR and iAR configurations can help the driver to locate and to notice the pedestrian earlier comparing to the noAR configuration. The driver pressed the button at about 81m of distance to pedestrian with the AR configuration, at 78m with the iAR configuration whereas he noticed the pedestrian at 64m with the noAR configuration (see Fig 5.2.4).

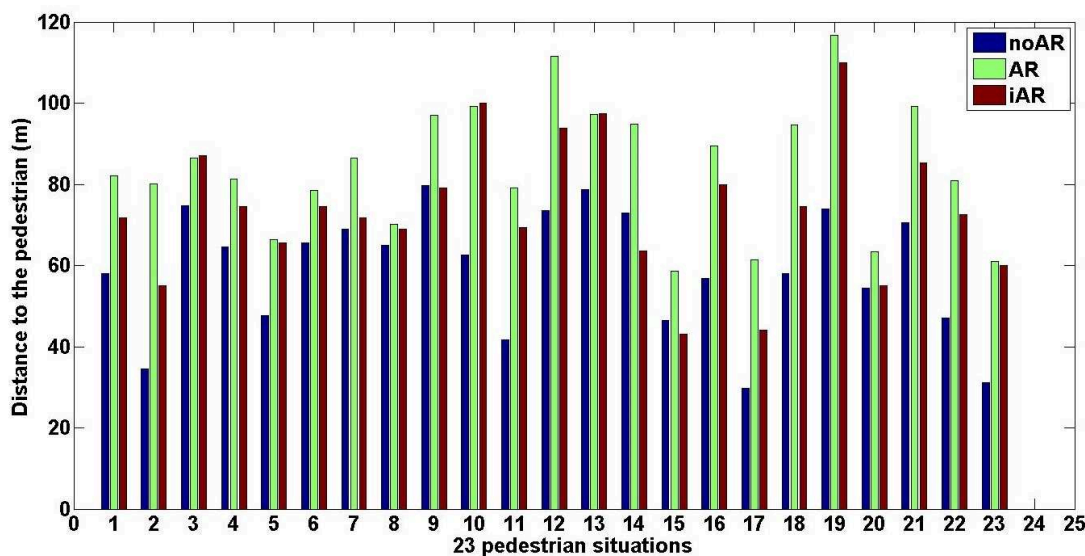
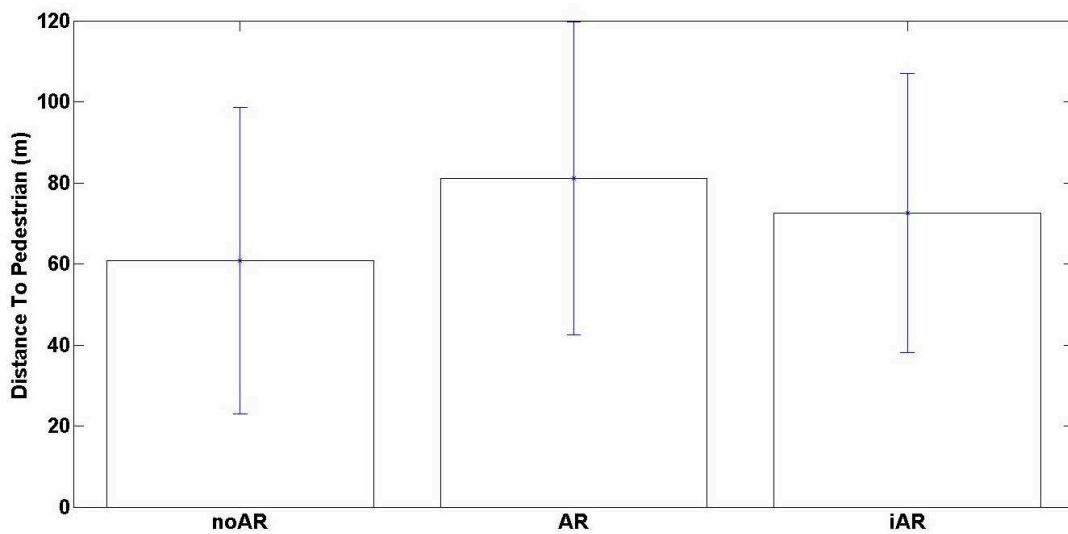

**Figure 5.2.3:** Mean of VRD in each pedestrian situations. With the AR configuration (Green box), the driver pressed the button whenever the bounding box was displayed. So, it helps the driver to notice very soon and far from the pedestrian.

### 5.2.2 Outcomes associated to Vigilance Level

The driver's vigilance can be seen from his decision to catch the lead vehicle or to decelerate in front of the pedestrian. Therefore, his vigilance level in this situation





**Figure 5.2.4:** *Mean of VRD in three configurations. This is the distance to the pedestrian when the pedestrian is noticed by the driver with the 3 aids configurations. We get the same conclusion as with the Visual Reaction Time (VRT).*

can be observed through two variables. First, the Head Vehicle Distance which is calculated by taking the mean of distance between two vehicles during the situation with pedestrian. However, depending on the start positions of both vehicle in pedestrian situations, the variance of distance was very important. Therefore, we considered a second variable which is the Accelerator Pedal Position. It signifies the acceleration behavior of the driver in pedestrian situations.

### Head Vehicle Distance (HVD)

Graphically, head vehicle following task was performed better with no-AR, we observed that the driver kept a shortest distance to the head vehicle ) because they are more concentrate into task when there is noAR aids (see Fig. 5.2.5). The ANOVA results revealed a significant difference of HVD between three configurations ( $F(2, 1722) = 4.87, p < 0.05$ ). The Tukey's HSD test confirmed that, with the AR configuration, the driver was less performing in keeping distance with the lead vehicle ( 118m). Thus, he was more vigilant to pedestrians (See Fig. 5.2.6). The test also revealed significantly that the iAR also make the driver to be more

vigilant to pedestrians and be less performing on following task (97m) compared to the noAR configuration (86m).

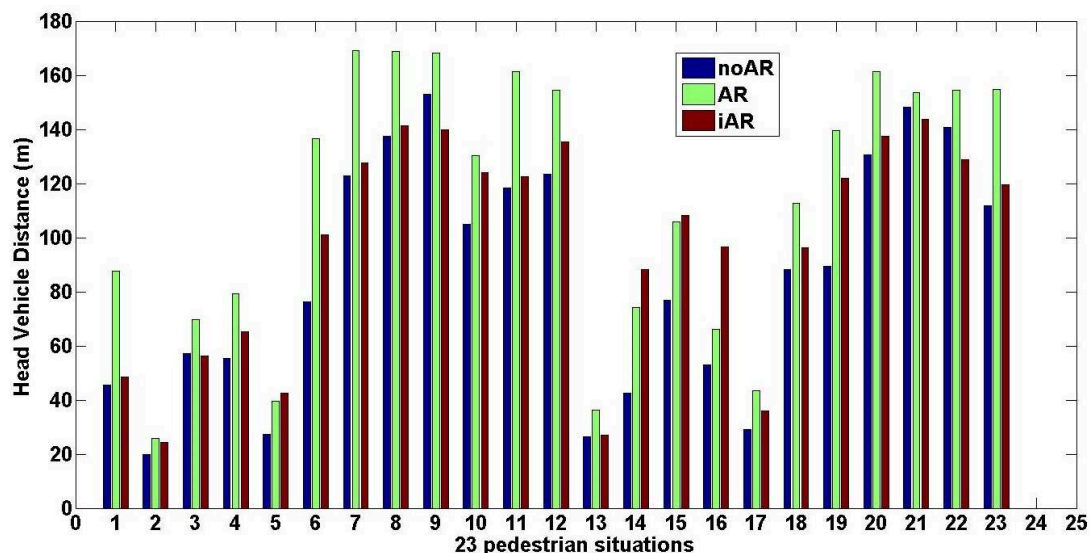

**Figure 5.2.5:** *Head Vehicle Distance for 23 pedestrian situations. In all pedestrian situations, the distance between two vehicles are greater with the AR configurations (Green Column). The driver seems to pay less attention on the head vehicle when the aids are on the pedestrian. The AR aids can direct the driver attention from the lead vehicle to the pedestrian.*

### Accelerator Pedal Position (APP)

In every pedestrian situation, the drivers were found to accelerate more aggressively when there was the noAR configuration is given (see Fig. 5.2.7). The ANOVA confirmed the difference of APP between three configurations ( $F(2, 1722) = 9.11, p < 0.05$ ). The Tukey's HSD test revealed that the driver pressed more deeply the accelerator pedal with noAR (mean equal to 0.46) (see Fig. 5.2.8). A significant different of APP between AR and iAR configurations was also revealed.

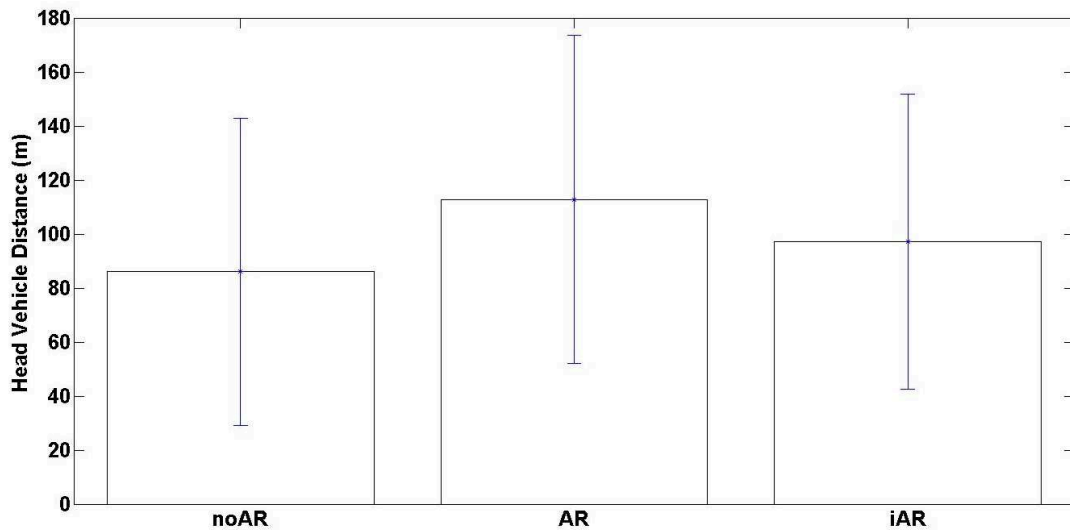

**Figure 5.2.6:** Mean of Head Vehicle Distance (HVD). The result confirms that the driver is more vigilant on the pedestrian with AR configuration and loose distance to the lead vehicle

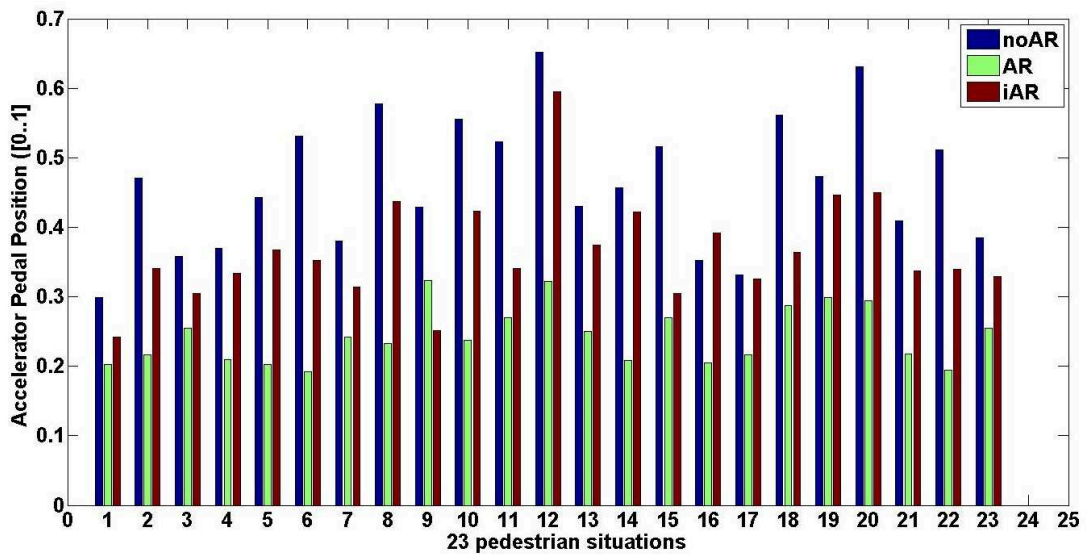

**Figure 5.2.7:** Mean of Accelerator pedal position for the three aids configurations for each pedestrian situation. Without the AR (noAR configuration - blue column), the driver pressed more the accelerator pedal. The AR has effect on the driver's acceleration behaviors, the cues force the driver to slow down.

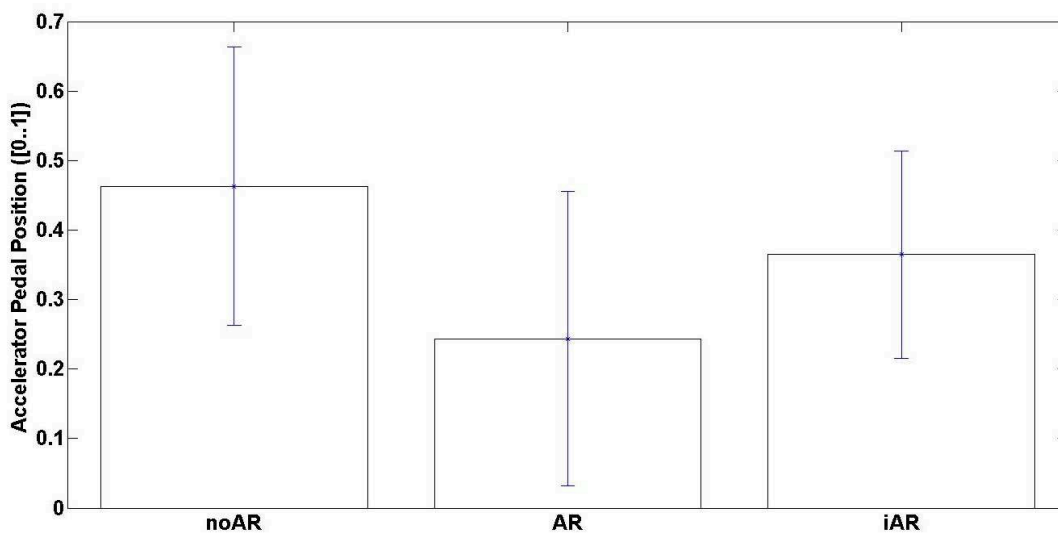

Figure 5.2.8: Mean of Accelerator Pedal Position for the three aids configurations.

### 5.2.3 Outcomes associated to Anticipation Level

#### Urgent Braking

A braking is considered to be urgent whenever the force applied on the pedal is detected to be over 200N at a *TTC* smaller than 2s.

In the total of all the driving test, 72 hard braking were detected with the noAR configuration, this number was found for 11 times with AR configuration and 26 times with iAR configuration (see Fig. 5.2.10). The AR configuration is found having more influence on the driver's awareness. In case of the iAR configuration, the cues were displayed and were removed in function of the DAP/DUP classification which was not perfectly accuracy (see Chapter 3). Therefore, the missed detection of DUP could lead to the non display of cues and could consequently lead to the urgent brakings when the driver was unaware of the pedestrian. Moreover, whenever the cues were removed because of the DAP were detected, the driver thought that the danger were disappeared and he was less aware of the pedestrian. In consequence, when the pedestrian crossed the road, the driver had to brake urgently to avoid the accident.

The Fig. 5.2.9 showed the number of urgent brakings detected in each pedestrian situation. With noAR configuration, there was always the driver who braked

urgently in front of the pedestrians. On the contrary, with the AR configuration and iAR configuration, we found less the urgent brakings. Indeed, the AR aids forced the driver to be attentive to pedestrian, more vigilant and finally it was found that the driver had a better anticipation in critical situations.

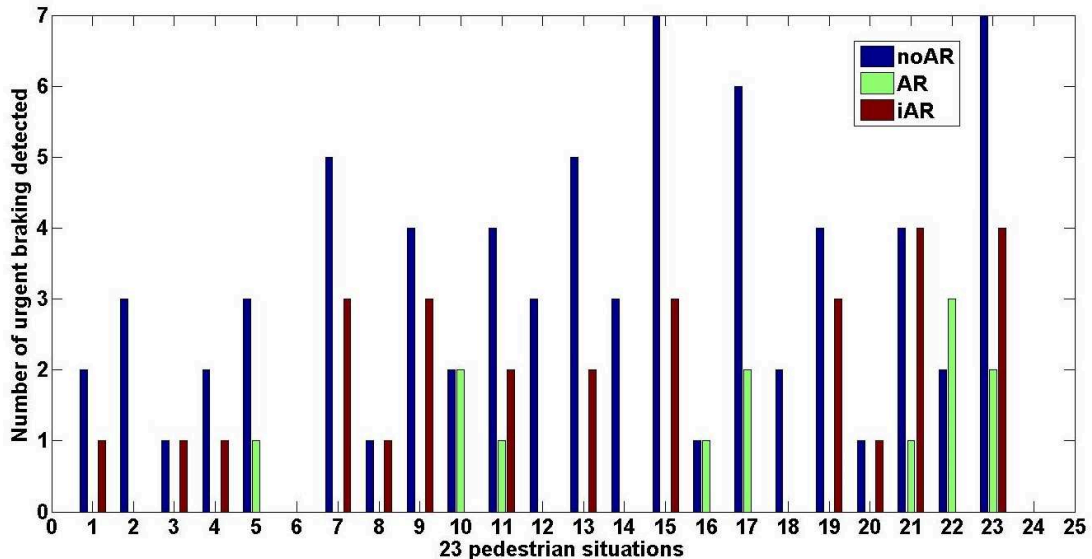

Figure 5.2.9: Number of times, the urgent brakings were detected in each pedestrian situations

## 5.2.4 Others Outcomes

### Number of DUP detected.

We aimed evaluating the performances of the DAP/DUP estimation in this experiment. The number of time the driver was detected as unawareness of pedestrian (DUP), is exposed. We suppose to study this value for two moments when the driver is in situation with the pedestrian. In one hand, we study number of time the driver is detected as the DUP from 100m to the pedestrian (case 1). On the other hand, we study this number from the moment that the  $TTC$  is equal to 2s (case 2) which is considered to be a critical moment in the situation with a pedestrian.

The Fig. 5.2.11 showed the number of the DUP that were detected when the

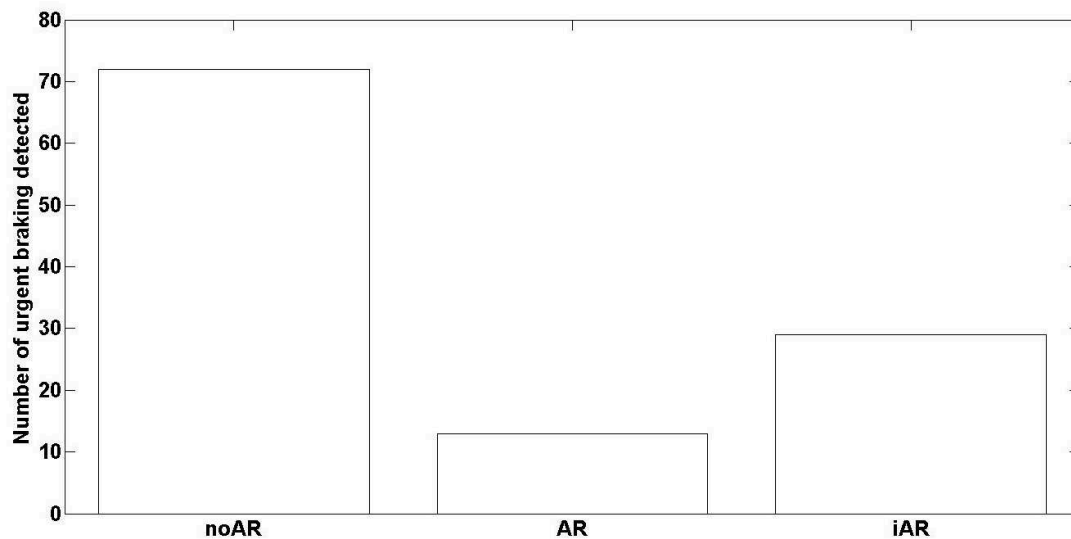

**Figure 5.2.10:** *The Sum of number of times, the urgent brakings were found in three configurations*

driver is from 100 m to pedestrians. The DUP was more detected with noAR configuration. The result was found more significant in the case 2. In the critical situation where the *TTC* was equal to 2s, the DUP was much more detected with the noAR configuration compared to the AR and iAR configuration (see Fig. 5.2.13).

In both case, the ANOVA results revealed that the number of detected DUP was significantly different between the three configurations ( $(F(2, 1724) = 9.58, p < 0.05)$  in the case 1 and  $(F(2, 1724) = 18.55, p < 0.05)$  in the case 2). The Fig. 5.2.12 and the Fig. 5.2.14 showed the total number of time the DUP was detected. In both case, this number in noAR configuration is greater than in the AR and iAR configurations. Moreover, the result showed that there was not significant difference in number of DUP detected between AR and iAR configurations. The both configurations had the same accuracy in term of enhancing the driver's awareness. However, we can see that the DUP was always detected in both AR and iAR configuration. This is due to the fact that the DAP/DUP classification is not efficient or the visual cues are not useful, or both reasons.

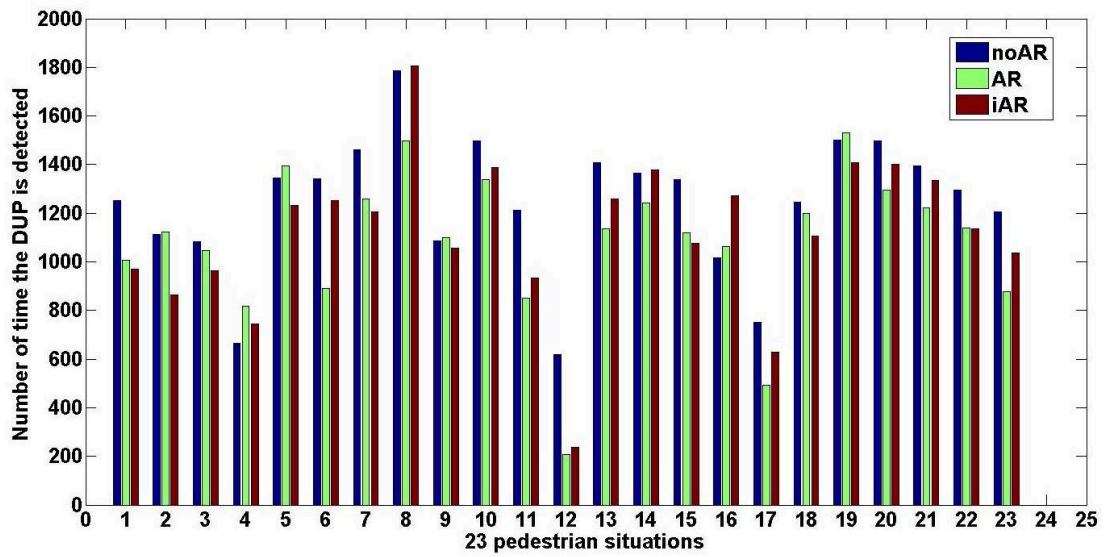

Figure 5.2.11: Number of times the DUP was detected from 100m for 23 pedestrian situations in the three configurations. It is found that the DUP is more detected with noAR configuration in every pedestrian situations.

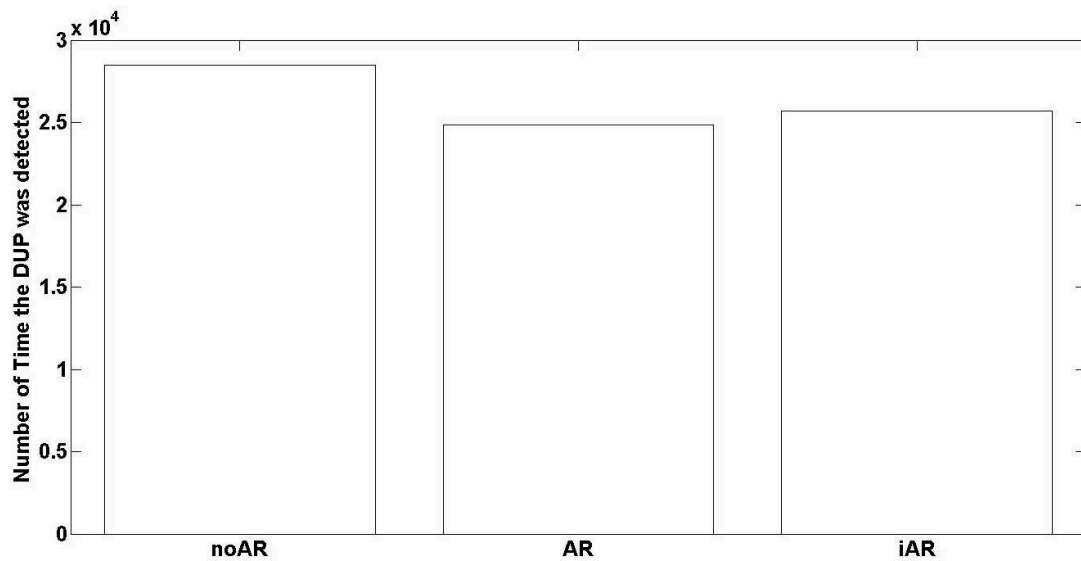

Figure 5.2.12: Total number times, the DUP is detected in 100m comparison in the three configurations. There is a significant number of DUP detected in noAR configuration whereas there is no significant difference between AR and iAR configurations.

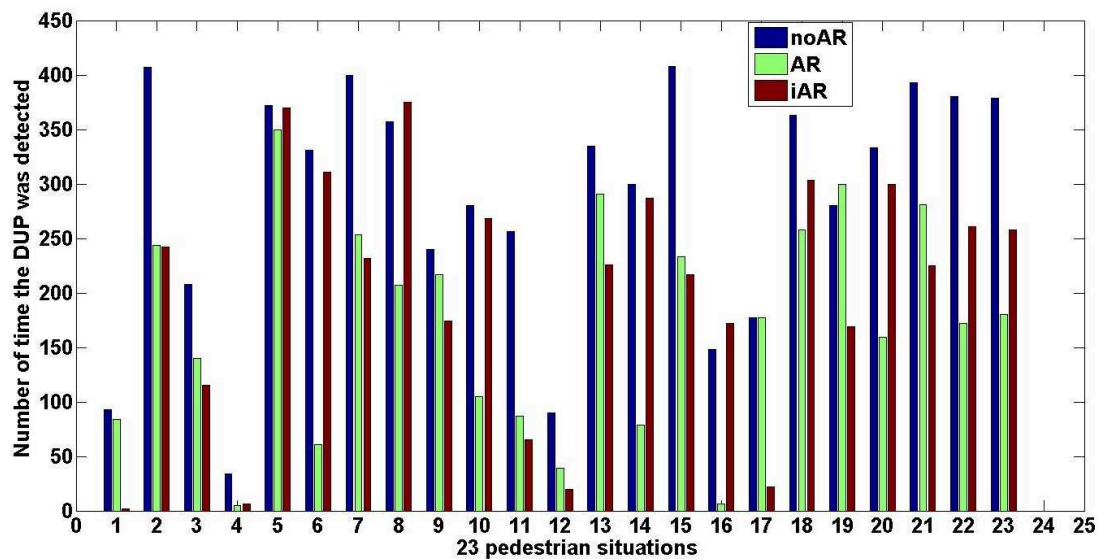

Figure 5.2.13: Number of time the DUP was detected in 2s in each of 23 pedestrian situations, driven in three configurations. It showed a significant high number of DUP were detected with the noAR driving (blue bar).

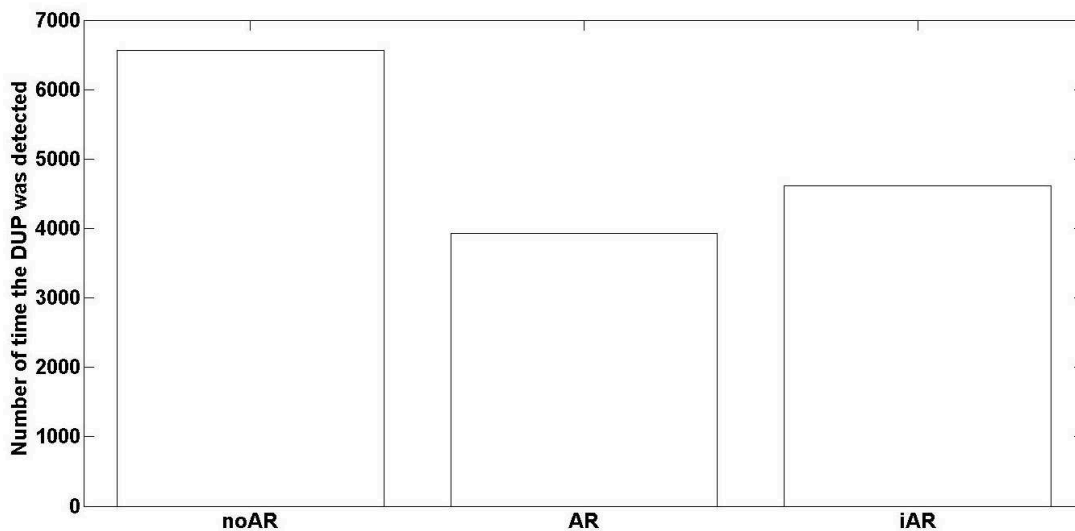

Figure 5.2.14: Total number of times the DUP was detected in 2s comparison for the three configurations. A significant number of DUP are found in driving with noAR.



## Subjective results analysis

The Tab. 5.1 gave some ideas about the questionnaire (see Appendix. A.4). The questionnaire was given after each driving with iAR configuration is passed. The results confirmed mostly the advantage of the iAR configuration. Firstly all the participants feed-backed that they had driven like in the real life (the *question Q06*). This demonstrated that the drivers have felt comfortable with the simulator. For the scenario difficulty, the lead vehicle following task was considered as quite difficult (*question Q07*), 20/25 participants have answered «*difficult*», and have commented that the difficulty was because the lead vehicle reacts too spontaneous. Moreover, 19/25 drivers answered that they had not tried to catch the lead vehicle (*question Q05*) and they had been aware of the pedestrians (*answered as «normal» or «completely»*).

For the questions concerning the iAR configuration, all the participant answered that they would be please to use a HUD in their cars and most of them (19/25) highlighted the efficient of the iAR configuration (*question Q12*). On the other hand, 17/25 of participants preferred the bounding box than the pedestrian panel (*question Q11*). They argued that the bounding box helped them to identify where the pedestrian is, whereas the pedestrian panel did not and somehow forced them to brake and make them distracted.

	Questions	Result
Q06	Do you perform the driving like in real conditions? (Yes/No)	25/25 Yes
Q07	The driving task is difficult? (easy/normal/difficult/)	20/25 difficult
Q05	Are you try to catch the lead vehicle? (Yes/No)	19/25 No
Q09	Are you aware of the pedestrians? (completly/normal/not at all)	4/25 not at all
Q10	Would you like to use this combiner HUD ? (Yes/No)	25/25 Yes
Q11	Which cue do you prefer?(BoundingBox/Warning Panel)	17/25 Box
Q12	Is the iAR efficient? (Efficient/Not Efficient/Distracting).	19/25 Efficient

**Table 5.1:** *Some significant questions asked in the questionnaire*

## 5.3 Discussions

Inattention either caused by the car driver or by the pedestrian, is one reason for dangerous situations between cars and pedestrians. All kind of accident scenario contain one main challenge to be solved, which is how to make the driver aware of the pedestrian or make the pedestrian aware of the approaching car. There are also significant problems in ADAS design. such as getting the right position of the pedestrian, of the car, filtering the useless information, communicating the appropriate information, etc. However, these problems could be ameliorated with the high accuracy sensors available today, such as the on-board camera, infrared light camera, radar or laser based sensors. These sensors could be mounted as well on road side infrastructure [Trivedi 07].

In this study, we suppose that the pedestrian can make errors at any moment. This leads to dangerous situations for himself and for the car drivers. Therefore, the Pedestrian Collision Warning System (or PCWS) used in the intelligent vehicles has to understand and to take into account the driver's behaviors, in order to improve the driver's awareness without distraction and annoyance. Estimating the driver awareness or unawareness of a pedestrian and enhancing the driver's awareness with the augmented reality cues are the main challenges of this work.

In the first part of the study, we begin with an experiment to observe the behaviors of the drivers whenever a pedestrian is appearing in front of the vehicle. The driver awareness of pedestrian is then defined in term of behavior as well as in term of performance. We found that the driver actions are different whenever he is aware of a pedestrian. Moreover, the driver does not react when he is unaware of the pedestrian. These assumptions allow us to collect the data from the experiments with the driving simulator. The data is then used to train the model of driver awareness of pedestrian (DAP) which is based on the Hidden Markov Model formalism.

In the second part, an Advanced Driving Assistance System using the visual cues, has been implemented. This concept takes into account the decision of the DAP model and provide the augmented reality cues on the pedestrians. That are expected to helps the driver sooner identify the pedestrian and be aware of the

pedestrian. In the function of the critical time to collision and the DAP decision, the bounding box surrounding the pedestrian and a danger panel are displayed simultaneously. Then, we carried out an experiment with 25 participants on a driving simulator in order to: analyze the DAP model, its decision process, and to evaluate the effects of the visual cues on the driver in term of his/her performance of the following task and his/her awareness of a pedestrian.

In the situation with pedestrian, we find that the driver can archive a higher *perception* level with the AR cues. Indeed, the bounding box can enhance the visibility of the pedestrian, the driver notices the bounding box before noticing the pedestrian. The driver are also more vigilant with the AR cues (*vigilance* level). The aids somehow put the driver is a sensation that something could happen such as the pedestrian crossing. It makes the driver slowing down in situations. The result shows that the driver presses less the accelerator pedal when the aids are displayed. In the *anticipation* level, the urgent braking is the indication to evaluate the driver's awareness. The preliminary results indicate the driver brakes urgently more often while driving without the aids.

In the following sections, we will continue to discuss on every aspects of the study. Firstly, we discuss on the experiment and its protocol for assessing the driver's situation awareness. Then, we express the possible effects of the visual aids on the driver's awareness. At last, we highlight some remarks on the process of designing the head-up display and the visual metaphor in the augmented reality applications.

### **5.3.1 Assessment of Driver Awareness of Pedestrian**

In our study, in spite of the limit of using a simulated HUD on the simulator, using a simulator has a lot of advantage and becomes indispensable. The first advantage of the simulator was its controllability and its possibility of encountering dangerous driving conditions without being physically at risk. It allows us to create the critical situations which are difficult to create in real conditions. We were able to manipulate the pedestrians to cross with random behaviors. We could claim the driver to follow a lead vehicle or to press the button when he noticed a pedestrian, and so on. The second advantage of the simulator was the ease of data

collection. Indeed, a driving simulator could measure the driving actions accurately and efficiently. With a real vehicle, it was far more cumbersome to obtain complete, synchronized, and accurate measurement data. It is a fundamental challenge to get an accurate recording of where a real vehicle actually is in the world. For example, in an instrumented vehicle, it was hard to determine the distance between the vehicles, while in the simulator this information was readily available. Therefore, it helped us to conclude on our problem without the influence of the reliability of sensors. The third advantage of simulators was its opportunity for feedback and instructions. We could simulate, test and evaluate the novel interface with a simulated HUD and the visual - interaction metaphors.

In order to measure the driver's situation awareness or the driver's behaviors in the complex systems, the researchers proposed different techniques. The situation awareness is mostly assessed using the SAGAT technique (Situation Awareness Global Assessment Technique [Endsley 95b]). It is also known as the freeze probe technique. Typically, a task is randomly frozen, all displays and screens are blanked and a set of SA queries regarding the current situation at the time of the freeze is administered. Participants are required to answer each query based upon their knowledge and understanding of the situation at the point of the freeze. The participant's responses were compared to the state of the system at the point of the freeze and an overall SA score is calculated at the end of the trial. This technique requires a complete and well-thought questionnaire in order to assess subjectively the driver. Each level of SA is related to some questions with different difficulties. However, this technique is intrusive and hard to build a set of queries to assess the driver SA in a specific situation. Moreover, another limitation of posing SA queries at the close of trials is that participants may need to recall specific information on the driving environment from their earlier performance. Therefore, the measure may be biased by subject recall ability.

In [N. Schomig 13], the authors assessed three SA levels of the driver through his interactions with a secondary task. The driver is asked to answer certain questions while he is driving. Moreover, he has possibility to accept or deny second task. The critical and non-critical situations are given. Whenever the driver accepts to execute the second task, his performance on driving task and on second task

are then measured. The result on the driver's acceptance, performance related to situations are supposed to be the indication for interfering the driver SA. However, the use of distraction is inappropriate in driving. The accident happened because of the distraction and not the driver's low SA. Moreover, we aimed also to observe the effects of the AR configurations on the driver's performance. Therefore, the distraction is not suitable. In [Rusch 13a], the authors proposed a protocol in which the driver is asked to follow a lead vehicle whereas there are the hazard appears on road such as pedestrians or traffic signs. They evaluated the AR aid (the bounding box on the secondary object) and found that the aid could help to direct the visual attention of the driver. However, the use of distraction is inappropriate in driving. The accident happened because of the distraction and not the driver's low SA. Moreover, we aimed also to observe the effects of the AR configurations on the driver's performance. Therefore, the distraction is not suitable here.

In order to avoid these limits, we have proposed a novel protocol to assess the driver's SA and the driver's performance. In the protocol, we ask for the driver to do a main driving task which is to follow a lead vehicle. Moreover, the driver is asked to press a button attached on the steering wheel to indicate that he has seen a pedestrian. We created the driving circuit in which there were 23 pedestrians along the course. But there was always one pedestrian in front of the car at each moment. When the participant's vehicle enters into the study zone (140m to the pedestrian), the lead vehicle begins to accelerate. Indeed, the participant did not know before this behavior of the lead vehicle. At this moment, the participant had a mental conflict between catching up the lead vehicle and being aware of pedestrian crossing.

Three levels of the driver's awareness (Perception, Vigilance and Anticipation) could be objectively assessed through the different outcome variables that represent the interaction between the driver and environment elements (lead vehicle and pedestrians). The Perception level can be assessed by the moment when the driver notices the pedestrian. This moment is computed in terms of time to collision. The vigilance level is evaluated via the pedal accelerator position and the distance to the lead vehicle. The Anticipation level can be assessed through the urgent braking

that the driver have done in front of the pedestrian. This protocol helps to measure objectively the driver's situation awareness without any distraction. The driver can drive normally during the test and is not interrupted for the questionnaire.

However, during the experiment, we have noticed that the driver's reactions varied a lot between the situations. In the results presented above, such as Visual Time Reaction, Accelerator Pedal Position, etc, the variance are really important. Indeed, the driver's awareness changed a lot in each pedestrian situation and a long the experiment. For the first pedestrians on road, the drivers didn't care too much and they were less vigilant, after two or three times that pedestrians crossed the road, the driver paid more attention and was more careful of that. Our technique of assessment of the driver's situation awareness necessities a wide range of situation in order to eliminate the repetition effect on the results. On the other side, the complexity of situations has to be the same because it also influences the results. Moreover, as human can learn and learn fast, the driver's situation awareness is naturally improved during the experiment.

Moreover, in contrast to the SAGAT technique, we could not measure by questionnaire the driver situation awareness. In the perception level, we could assess the moment he noticed the pedestrian and not how long or how much he focus on the pedestrian. If the SAGAT technique is used, we can asked the driver about the pedestrian appearance for example. In the Vigilance level, the driver's awareness of pedestrian were assessed by the driver acceleration behavior, the distance to the lead vehicle. However, like we mentioned above, it may be due to the driving style of the driver and the ability of the each driver. In the last level (Anticipation level), the number of urgent brakings was analyzed. However, an urgent braking can be due to a driving style, a good reflection driver do more urgent braking but there is no accident at all.

In fact, the main limit of our experiment was the scenarios, the low complexity of the scenarios produced a ceiling effect, in as much as the pedestrians were easily perceived and the alerts were superfluous for the driver. In a study of driver distraction [Lee 01] they found impairment (increased VRT) depended on scene complexity. With consistency with the work in [Yeh 01], aid salience played a role in the ability of a participant to detect targets. The aid helped to ensure that

drivers perceived targets. However, target visibility played a role in the ability of a participant to perceive targets. Some pedestrians were visible before the aid appeared. In some cases participants responded to them even before the aid appeared.

One more thing, the head poses and the eye movements are considered to be the interesting and discriminative information for analyzing the driver situation awareness and driver attention [Doshi 11, Rusch 13a]. However, because of the technical problem with the simulator, we could not calibrate the eye/head tracking sensor with the simulator.

Another limit was on the population analysis, there was only one group of population is considered. All of them are students, the participants characteristics such as their useful field of view, their style of driving were not considered.

### 5.3.2 Costs and Benefits of the Visual Aids

Pedestrians were considered as the low-salience target [Merlo 99, Yeh 99] which are less visible than car and difficult to be detected. In our result, the AR aids were found to help driver in the perception level, the driver perceived much sooner the pedestrian. We found the same conclusion with Schall et al. [Schall Jr 13] that the aids could help the driver to perceive earlier the hazard. We found the same result with Rusch et al. [Rusch 13a] who found that the visual aids could potentially direct the driver attention to the hazard.

Moreover, we found that the AR aids influenced the driver's vigilance. They did not focus only on the head vehicle following task and were more aware of the pedestrians. The drivers did not brake urgently with the AR aids and were less aggressive driving in term of speed in the situation with pedestrian.

Since driving is a visual and motor control process, it is possible that the visual search demands associated with retrieving information from the aids display also degraded the driving task performance. In [Dzindolet 02], the author highlighted that the automation human aids can cause comparable levels of distraction on driver navigation. However, It is also important to remark the different between conformal aids and non conformal aids. Indeed, the aids in their study is not conformal which can distract more than the conformal aids. The non conformal

aids (such as the warning panel) involve enclosed non-changing opaque rhombus shapes. These non-conformal aids therefore make the driver complicated to discriminate information about the targets (pedestrians) in which the aids highlighted. In contrast, the conformal aids (such as bounding box around the pedestrian) were found that it did not produce any negative masking effects. After the experiment, we found that the conformal aids can enhance the driver's awareness without distracting them.

### 5.3.3 Design of Advanced Pedestrian Collision Warning Systems

HUDs and Augmented Reality can open a new experience in the driving task. The HUD is specially useful in the low visibility conditions [Charissis 07]. The visual cues can direct the driver attention into the hazards such as pedestrians or road signs [Schall Jr 13, Rusch 13b]. In this study, the visual aids are found to be able to enhance the driver's situation awareness. Indeed, with the augmented information, the driver notices sooner the pedestrian, and the cues force the driver to slow down the vehicle and to be more attentive and vigilant into the pedestrian. Moreover, if the driver is always unaware of the pedestrian, the panel warning can push the driver to brake if the situation becomes critical.

In this study, we have not studied different properties of the HUD and Visual Aids. For example, the different field of view and depth field of the HUD can have effect onto the viewer. The different colors, different form, size of the visual cues can also have influence on the driver's behaviors. The design of the HUD and the augmented reality application have to consider these characteristics in order to provide an appropriate cues.

The activation and deactivation of the aids can be considered as the driver-vehicle-pedestrian interaction model. In this decision, we take into account the driver's awareness of a pedestrian and the *TTC* into the decision. There are a limit that need to be considered. The decision did not take into account the pedestrian's behavior which may be crucial for the decision. It will be not necessary to display the cues if the pedestrian has not intention to cross the road. The model should take into account the pedestrian's behaviors in order to provide a finer decision.



Comparing to the related work, we provide another aspect in designing a new ADAS that is the driver's situation awareness while using the system. Basically, these previous works considered subjectively the driver and his inattentive states such as sleepiness, drowsiness or distracted by hand phone which are helpful but not sufficient for the pedestrian accident purposes. The driver could be in normal state but if he underestimates the danger level of the situation, the accident can also happen. Therefore, our study is dedicated on analyzing the driver and his interaction with a particular situation as with pedestrian. Other critical situations have been also considered such as before entering a intersection or in the complex danger scenarios [Plavšić 10, Aoude 12].

## 5.4 Conclusion

The situation where a pedestrian appears in front of the vehicle contains a high risk of accident. The driver's awareness of a pedestrian (DAP) is operationally defined in three levels (*perception*, *vigilance* and *anticipation* levels) that can directly be seen in driver's behaviors. In this chapter, we propose an experiment in which the driver is asked to follow a lead vehicle and to be aware of pedestrians. The ambiguous situations require the driver to choose the appropriate actions. From that, the outcomes associated to each level of DAP can be measured.

An experiment has been carried out on the driving simulator. The effects of the visual assistance on the driver were analyzed by evaluating his awareness of a pedestrian. The driving with AR and iAR configuration have been compared with the drivings without any aid (noAR). The outcomes associated to each level of the driver's awareness of pedestrian were exposed. It was found evidence that the AR aids help to enhance the driver's awareness of a pedestrian in the perception level because the pedestrian visibility is clearly enhanced with the visual aids. Moreover, it was also found that the drivers were more vigilant to the fact that the pedestrian could cross the road suddenly. Therefore, it involved that the drivers did less the urgent braking. In general, the experimental results showed positive effects of the AR aids. However, we found that the experiments contained also some limits. Indeed, the iAR configuration could not be validated with this

experiment. We also noticed that there was a correlation between the number of urgent brakings and the number of DUP detected. Indeed, the more the driver was detected as unawareness, the more urgent brakings during his driving were found. This could somehow show that the DAP/DUP classification is accurate. On the questionnaire, the participants gave a positive feedback about the iAR aids. However, this requires another experiment in order to validate explicitly the DAP/DUP classification.

Different aspects of the study were also discussed in this chapter. Some limitations of the protocol, the experiment scenarios and procedure were highlighted. We will continue to discuss on these limits and give some perspectives of the study in the next chapter.

## Chapter 6

# Conclusions and perspectives

This chapter brings together the work presented in all the previous chapters. It highlights the research contributions and issues in light of the original aims of this thesis.

The Section 6.1 summarizes the work described in the previous chapters. Then the Section 6.2 gives an evaluation on this research followed by the contributions highlights of this work within multiple research fields. In the last section 6.3, we continue to discuss on the results with their limitations and perspectives. We propose some promising future works on driver behavior study, statistical modeling and on the driver assistance application using augmented reality.

### 6.1 Thesis Summary

#### Chapter 1: Introduction

In Chapter 1, the issues of the actual Advanced Driver Assistance Systems (ADAS) and the promising future of Augmented Reality (AR) in driving context were introduced. A state of the art of ADAS showed that researches on «semi-automation» systems are still important and a lot of challenges for the researcher remains. Moreover, it is important to consider simultaneously the driver and the scenario context. Indeed, the driver monitoring in ADAS consists of taking into account the driver states, of estimating the impaired behaviors and of predicting the possible errors from the driver. Moreover, the driver's behavior and his errors are very

various in different scenarios, so the ADAS have to focus on driver behavior estimation in each particular scenarios.

In this thesis, the Pedestrian Collision Warning Systems were chosen as the particular application of this research. The issues and challenges of the Pedestrian Collision Warning Systems are presented. Actually, the today-PCWS become quickly distracting and annoying when they detect pedestrians. Therefore, the first challenge of the proposed system is to take into account if the driver is aware or unaware of a pedestrian in order to provide an appropriate feedback. The second challenge is to innovate the driver-system interaction using the visual aids through the Head-Up-Display Systems. This augmented reality system is expected to enhance the safety for traffic users .

With this in mind, the central aim of this thesis was to propose a system that is able to enhance the driver's awareness of pedestrian. Thus, we proposed an exploration of the driver's behaviors in situations where a pedestrian appears in front of the car. This helped to design models that are able to detect whenever the driver is aware or unaware of a pedestrian. Then, we provided an Augmented Reality Pedestrian Collision Warning (AR-PCW) system based on this model and used the visual aids to enhance the driver's awareness. The system was then evaluated using the driving simulator.

## **Chapter 2: Driver Awareness of Pedestrian Modeling**

In this chapter, the driver's awareness of a pedestrian (DAP) was defined based on two points of view. From the performance point of view, the DAP was defined in three levels: *perception* level, *vigilance* level and *anticipation* level.

From the behavior point of view, the DAP was defined as a normal behavior that does not produce a collision to pedestrian. On the contrary, the Driver Unawareness of Pedestrian (DUP) was considered as an impaired behaviors that generate collision to pedestrian. With this understanding, when the driver is unaware of a pedestrian, he is supposed to drive as if there is no pedestrian on the road or as if he has not noticed the pedestrian.

A wide range of methods that can detect the driver's impaired behaviors were also reviewed. The literature showed that the driving and the visual actions were

the most suitable solutions for interfering the driver's awareness of unawareness of pedestrian. However, with the technical difficulty, the first implementation of the study used only the driving actions. The scenarios of the experiment were designed to be more evident for the driver to notice the pedestrian. Therefore, the visual reaction in this case can be neglected.

After defining and characterizing the driver's awareness of a pedestrian in the first step, we proposed a study on the mathematical methodology that uses current statistical knowledge to classify the driver's behaviors. The use of these mathematical models draw upon the signification of the collected data representing the driver's behaviors in situation with a pedestrian.

The chapter presented different classification models that could be used in this research. One of the most intuitive classification algorithms were to use the time-to-collision (TTC) threshold or the required deceleration parameter (RDP). We described also two discriminative models that have widely been used in driver behaviors classification: the Support Vector Machine (SVM) and the Relevance Vector Machine (RVM). Finally, the proposed generative models with Gaussian-Multivariate Hidden Markov Models were presented and supposed to be the best models for its ability to capture the temporal characteristics of the DAP.

### **Chapter 3: Settings and Benchmark for Driver Awareness and Unawareness Estimation**

The chapter outlined the implementation of the approaches described in the chapter 2. The problem of estimating whether the driver is aware or unaware of a pedestrian has been transformed in a classification problem. We argued that evaluating the algorithm's classification performance is crucial for choosing an accurate estimator.

This chapter presented firstly a manipulation of the driver's behaviors using the driving simulator. We presented the methodology to create two behaviors: driver's aware of a pedestrian and driver's unawareness of a pedestrian. The driving data were then collected and annotated during the manipulation experiments.

Secondly, the chapter presented the training step and the performance comparison between the classifiers. Basing on the collected data set, the Grid-Search

technique and the Receiver Operating Characteristics (ROC) were used to train and to test the classifiers. In the training phase, the grid-search technique has been used to set up the parameters of the algorithms. Different parameters values were used, and for each combination of the values of the parameters, the classifiers were trained with 20% of the dataset, and then 80% of the dataset were used to test and to draw the ROC curves. The best parameters combination for each algorithm was chosen from the greatest True Positive Rate whereas the False Positive Rate was chosen at 5%.

Once the best parameter combination was chosen for each classifier, the  $k$  – *fold* cross-validation was performed. In the preliminary results, the Multivariate Gaussian Hidden Markov Model (MGHMM) based classifier were found to have the best performances with more than 78% of true classification in the 4 – *fold* test. It confirmed our hypothesis that the temporal characteristic is relevant to assess the driver’s awareness of pedestrian and was chosen to be implemented in our proposed AR-PCW system.

#### **Chapter 4: Augmented Reality for Pedestrian Anti-collision Warning Systems**

This chapter associated with the Chapter 5 marked the second contribution of this thesis. It was devoted to describe the whole pedestrian collision warning system that uses the augmented reality (AR-PCW). Firstly, a survey on the visual, interactive metaphors in the driving context were provided. The previous driving assistance metaphors were categorized according to their purposes: the metaphors for navigating, the metaphors for discovering a point of interest and the metaphors for driving safety. Regarding the existing applications, there is no existing system that helps enhancing the driver’s awareness of pedestrians. Therefore, we proposed a dynamic metaphor for helping the driver to avoid the collision with pedestrian by using two types of symbols. The bounding box was used as a conformal symbol to enhance the visibility of the pedestrian and to highlight the importance to be aware of the pedestrian. The warning panel was used as a non-conformal symbol and it forced the driver to react (to decelerate) if a near-collision is detected.

These metaphors were strongly coupled with the decision model that indicates

the moment to activate or deactivate the symbols. Two configurations of the proposed AR-PCW were considered: augmented reality (AR) configuration and intelligent augmented reality (iAR) configuration. The iAR is more complex than the AR configuration because it takes into account not only the time-to-collision critical moment but also the driver's awareness of pedestrian which is based on the DAP/DUP classifications model in chapter 3.

### **Chapter 5 Enhancing Driver Awareness of Pedestrian using Augmented Reality Cues**

In this chapter, an experiment on the driving simulator was proposed to evaluate the AR-PCW system by assessing the driver's awareness of pedestrians. We compared the DAP between three configuration of the system (AR, iAR and noAR-without cues). In order to do that, we did firstly a review on the related work that aimed to measure the driver's situation awareness. Then, we proposed a method to assess implicitly three levels of the DAP. In this protocol, the driver had to perform a primary task (to follow a lead vehicle), and meanwhile, he had to be vigilant to pedestrians crossing the road. Three levels of DAP were then assessed through his interaction with pedestrians and his following task performance.

In the second section, we presented the experimental results obtained from 25 participants. The outcomes associated to each level of the driver's awareness of a pedestrian were figured out. The Visual Reaction Time (VRT) representing the *perception* level, the accelerator pedal position (APP) representing the *vigilance* level and the Urgent Braking (UB) number presenting the *anticipation* level were the main outcomes that were exposed. In the AR and iAR configurations, the bounding box was found to be able to enhance the visibility of the pedestrian. Indeed, the VRT was found much smaller in the noAR configuration. In the *vigilance* level, the results confirmed our hypothesis that the drivers were more vigilant while using the AR and iAR configurations and they pressed more deeply the accelerator pedal with the noAR configuration. For the *anticipation* level, the number of Urgent Braking was found to appear more often with noAR configuration.

The chapter 5 provided also a deep discussion on this experiment. Firstly, it highlighted the limits of the experiment, its protocol and the measurement

limitation. The driver's eye and gaze features were not collected. The protocol did not allow to assess subjectively the driver's situation awareness like the SAGAT technique of Endsley [Endsley 95b]. The iAR has not been evaluated because the driver's behavior is sensitive to the accuracy of the display decision. Moreover, the classification of driver's awareness is not fully accurate. The protocol did not take into account the useful field of view of the driver which is one important characteristic.

However, the experiments highlighted some positive points in this thesis. The protocol showed interesting behaviors for assessing objectively the driver's situation awareness through his driving reactions. Moreover, the study showed that the AR cues can enhance the driver's awareness of pedestrian but the accuracy of the display decision is also crucial. In a subjective analysis, the users showed their favor for the conformal cue which is the bounding box. They commented that the bounding box helped them to notice sooner the pedestrian and forced them to be more vigilant to it.

## 6.2 Thesis Outcomes and Contributions

### Original Aims

The original aims were to identify a set of contributing factors to pedestrian crashes, to estimate the driver's unawareness of pedestrian in real-time and to provide a suitable AR-PCW.

More precisely this thesis proposes to answer to the following research questions:

- what is the driver's awareness of a hazard such as pedestrian?
- how can the driver's awareness or unawareness of pedestrian be modeled statistically?
- how can we enhance the performance of the pedestrian collision warning systems by taking into account the driver's behaviors?
- how can augmented reality be associated to the ADAS such as the pedestrian protection systems?



- what are the effects of augmented reality on the driver's behaviors and driving conditions?

### **Proposed Approach**

The approach to answer the first questions above was to use a driving simulator to manipulate the driver's awareness of a pedestrian. We supposed that if the driver is unaware of a pedestrian, he drives as if there is no pedestrian on road. From that, we could collect and annotate the driving data. Then, based on this collected driving data, the driver's awareness of a pedestrian estimation was proposed. At the first stage, a wide range of mathematical models were used for classifying the DAP and the DUP. The output of this classifier was then directly injected in the warning decision. This helped to answer to the second and the third questions above.

On the other side, a survey on the visual metaphors in the driving context was required. Based on a deep analysis of the advantages and disadvantages of each work, we proposed the visual metaphor that can be used in a pedestrian collision warning system. As explained, the visual metaphors could enhance the visibility of pedestrian and enhance the driver's ability to avoid collisions. Both of conformal and non-conformal cues were supposed to be suitable for our metaphor. Indeed, when the conformal cues (the bounding box) could enhance the obstacle's visibility, it would help the driver to be more vigilant with the hazard. Otherwise, the non conformal cues (the warning panel) could force the driver to react immediately.

An AR-PCW system was then proposed using the visual metaphor and the DAP/DUP classification. Then, an experiment on the driving simulator was carried out to answer to the last questions above. Before a real-car implementation, the driving simulator could help us to control the situations, to easily measure the driver's reaction and to implement the visual metaphors.

### **Thesis outcomes**

Two definitions of driver's awareness of a pedestrian (DAP) have been proposed in order to better understand the phenomenon in both sides: driver's performances and driver's behaviors. On the one hand, considering the DAP as a driver's beha-

behavior allowed us to model the DAP based on the driving reactions in situation when a pedestrian. On the other hand, considering the DAP as a driver's performance allowed us to evaluate explicitly the DAP during the driving with the AR-PCW systems.

Our research provided a range of models for classifying whereas the driver is aware or unaware of a pedestrian (DAP or DUP). The study found that the Hidden Markov Model based algorithms, especially the MGHMM is the most performing because it can capture the temporal characteristic of the driver's behaviors. Moreover, 1.5s is found to be the optimal time windows to capture this behavior. This model is also suitable for a real-time implementation. The parameterization is flexible and can be optimized for each driver.

This thesis proposed also a new protocol for assessing the driver's situation awareness, particularly the driver's awareness of pedestrian. An experiment was carried out on the driving simulator and the statistical results on 25 participants showed that the AR aids could enhance the driver's awareness of pedestrians.

### **Thesis contributions**

By achieving all thesis's primary objectives, this work provides a solid framework to study a new concept of the ADAS that is associated with the Augmented Reality. The system can be adaptive to the user and to a specific context. The research conducted during this thesis is highly multidisciplinary and contributes to the knowledge in the following different fields.

In the field of cognitive psychology, the study highlights the importance to consider the driver cognitive states and behaviors in the specific situations. This study shows the differences in the behaviors of the driver when he is aware or unaware of a road element such as a pedestrian. In the road safety field, this work analyzes the specific scenarios of risk and helps to design a Pedestrian Collision Warning System which reduces the distraction by taking into account the driver's behaviors and uses the augmented reality cues (the AR-PCW system). In the driver modeling field, we identify the surrogate measures of driving actions that represent the driver's awareness of the pedestrian and demonstrate the ability of different mathematical models in estimating the driver behaviors. In Human-Machine In-

teraction field, this study builds a framework to experiment and to validate the interaction metaphors between ADAS interfaces and users. It proposes the reasonable protocol for observing the driver's behaviors in scenarios with pedestrians and for analyzing the impacts of the visual aids on the driver. The driver's behaviors estimation and the performance of real-time learning-based driver assistance systems are the main challenges of future ADAS. Therefore, the contributions of this thesis could be extended to different real-time applications in ADAS.

## **6.3 Limitations and Perspectives**

### **6.3.1 Limitations**

This study tackles the problem of accidents that happen to pedestrian because of the driver's unawareness. The main challenges to be solved are how to model the driver's awareness of a pedestrian for an augmented reality pedestrian collision warning system. Beside the promising results, this research features some limitations that should be highlighted.

#### **a) Driving simulator**

All of this study was carried out on a driving simulator. It has nevertheless allowed the control of (i) many of parameters influencing the driver's behavior when driving and hence highlighting the features of driver's awareness of pedestrian and (ii) the safety of this experiment. However, it has always a limited physical, perceptual and behavioral fidelity. It is hard to give the driver the same sensations of driving a real car. During the experiment, we have noted that some drivers do not really engage in the driving task as in the real life. They tempted to finish the experiment as soon as possible or some searched for the pedestrian to discover what would happen. These behaviors are not really realistic because we do not seek a pedestrian when we're driving. The toy impression of the simulator such as steering wheel or pedals may evoke unrealistic driving behaviors and therefore produce invalid research outcomes. It is known as the simulator infidelity. Participants may become demotivated by a limited-fidelity simulator and prefer

a real vehicle instead (or a more costly high-fidelity simulator for that matter). According to K  ppler [K  ppler 93], while safety is often cited as an advantage of driving simulation, sometimes this same feature is interpreted as a disadvantage. For example, K  ppler pointed out that real danger and the real consequences of actions do not occur in a driving simulator, giving rise to a false sense of safety, responsibility, or competence since the DAP and DUP models have been created from driving simulator data. This provides useful information on how to model the problem at stake and what measures to use, but it does not have the reliability of an on-road experiment. The use of a driving simulator not only represents an artificial environment but it contains the scope of different road and traffic conditions that can be presented.

### **b) Driver behavior manipulation approach**

In the manipulations of the Driver Awareness of Pedestrian (DAP) and the Driver Unawareness of Pedestrian (DUP), the influence of the displayed messages of *TTC* and the distance to the next pedestrian should be analyzed. It could be considered as a second task when the driver has to perceive and to decide to take into account this message. He can neglect the message, or perceives it lately. There is a high probability that the driver is aware of the message and not of the pedestrian. More details of this kind of study can be found in [N. Schomig 13]. Two proposed assumptions are also the complicated problems that are out of scope of this research. During the period from the driver's perception of the pedestrian to the moment of passing by the pedestrian, the driver has been considered to be aware of that pedestrian. However, the chance factor has to be considered. There is a possibility that the driver is unaware of the pedestrian but the accident luckily does not happen.

### **c) Surrogate measures**

The driving actions and the visual behaviors are considered as surrogate measures for this model. The visual behaviors are usually measured with an eye tracker. However, the eye-tracker could not be implemented on the simulator due to the limit of the simulator. Indeed, various work have proved that the relationship

between head and eye shift could interfere the visual attention behaviors of the driver [Doshi 12]. Moreover, a prior data analysis and an approach for dimension reduction (Fourier Transform, Principal Component Analysis, etc) would be recommended to highlight the correlation between the measures and to decrease the computational cost of the learning or the detection steps.

#### **d) Classification problem**

Another limitation on the modeling is the consideration of the problematic as a classification problem. Indeed, with the collected data, we could only annotate the data in DAP or DUP classes. It is better to consider the problem as a regression in order to have a fine output of the decision.

In this validation, the goal was to determine which algorithm can classify accurately the DAP and the DUP. This implies that the performance in terms of identification of the different states of DAP could not be seen. At last, the algorithms need to be discussed around the dynamics behind the change of DAP and DUP. The question on the relation between the surrogate measures and the algorithms is required to be answered.

#### **e) Visual cue ergonomics**

In this metaphor, we proposed to use the bounding box and the warning panel as the visual cues for aiding the driver. However, the ergonomic of the cues were not considered because of the limits of the simulator SDK. Colors, sizes or the smoothness of the display technique need to be taken into account in the design of the assistance system.

#### **f) The experiment**

Next, for the second part of the final experiment, the protocol could not allow to measure subjectively the driver's situation awareness. The questionnaire was also a limit of the study, it could not be used to conclude that the driver is more aware of pedestrians with or without AR cues. This study did not provide a conclusion on the accuracy of the iAR followed by the estimation of the driver's awareness of pedestrian. A relatively small number of participants have participated in this

experiment. Therefore, more participants would be needed to test the reliability of the system for an in-vehicle implementation. The participant characteristics such as personal useful field of view were not considered. While the likely impact of such bias is unclear, it still represents a potential limitation.

Most of the participant feedbacked that the iAR aids were accurate and were displayed at the right moments. However, there was no objective indication that could confirm that the iAR cues were accurate and that they did not constitute a distraction to the driver.

### **6.3.2 Extension to the current work**

#### **a) Taking into account the driver's visual reactions**

An implementation of the eye-tracker will be crucial for the next experiment. The correlation between the driver's gaze direction to pedestrian and his reactions would be analyzed.

Another model of the DAP and the DUP can be established and compared to the proposed model. We think that the visual behaviors are significant for estimating whereas the driver is aware of unaware of a road hazard. In term of mathematical model, some presented limitations could be solved with further analysis.

#### **b) Analyzing the statistical data and reducing the input dimensionality of the model**

A statistical analysis on the surrogate measures would be needed. A deep study on determining which surrogate measures could be redundant or which combinations would be essential. After that, an application of the feature extraction techniques such as Fourier Transformation, or Principle Component Analysis would be necessary for reducing the complexity of the model.

#### **c) Determining the danger level of situations**

For the DAP model, a fine grid-search would be necessary for setting up the parameters of the MGHMM model. Moreover, in order to provide visual cues to the driver in difficult situations, it could be interesting to determine the danger levels

of that situation. This model of situation danger level would take into account the DAP estimation model and a model of the pedestrian's crossing intention. A hierarchical state machine or fuzzy models could be firstly employed to determinate the danger level of the situation and to provide an appropriate warning associated to each danger level.

#### **d) Proposing a novel experiment**

At this stage, further experiments with the simulator would be still needed. The next protocol would have to allow us to measure both subjectively and objectively the driver's awareness of pedestrian. For example, after each time the driver passes by a pedestrian, the driving test could be buzzed and the driver could answer the questions concerning the passed scene. For example, we can ask the driver about the appearance of the pedestrian in order to evaluate his situation awareness.

The last steps that require attention in the research of an add-on vehicle device are the ergonomics of such a device and the question of acceptance by drivers. When an appropriate interface is provided, the ergonomic study would be needed to ensure that such visual metaphors do not distract the driver and increase crash risks.

### **6.3.3 Long term developments**

#### **a) Towards a computational model of the driver's Situation Awareness (SA)**

Up until now, the thesis focuses on the pedestrian accidents where the driver's situation unawareness (SA) is the main cause. Moreover, by considering each typical scenario, we can measure implicitly the driver's SA and design the computational models of driver's SA.

The thesis would be generalized from driver's awareness of a pedestrian to the driver's awareness of critical situations such as entering an intersection or approaching a pedestrian crossing walk, etc. In this direction, we need to identify the characteristics of situations that have impacts on the driver's SA. For example, the monotony of the road from home to offices can decrease the driver's SA whereas the dissonance of the hazard events on road can enhance the driver's SA [Vander-

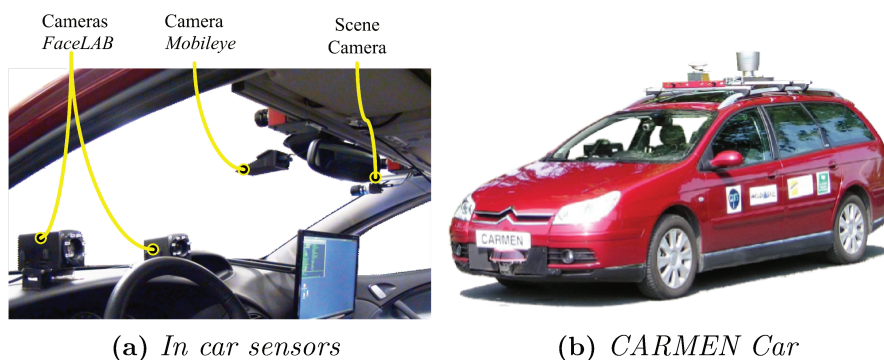

**Figure 6.3.1:** *Intelligent car platform for human behaviors and augmented reality researches.*

haegen 14]. A study on the models for detecting the monotony or the dissonance are highly recommended. Indeed, the concept of the driver's SA has to be strongly defined in the context of the situations.

### **b) Towards an experiment on the real car platform**

Developments and implementation of the multi-sensors systems on the real car will be mandatory. Our intelligent vehicle platform is actually being developed through the project FUI18 SERA in which different industrial partners are interested in (see Fig. 6.3.1). The driver monitoring system would be completed by the coupling between the eye/head tracker and the in-vehicle sensors such as pedals or steering wheel sensors. Moreover, different sensors such as lidars or cameras will be used for the environment perception system. Therefore, a data fusion process for all these sensors would be another interesting research topic.

Moreover, with the combiner HUD provided by the industrial partner, the question is to understand how to display the conformal cues on the objects to augment them. Then, an important research topic is to design an experimental protocol allowing an evaluation of the driver's situation awareness. The typical scenarios which contain the characteristics such as the monotony or the dissonance would be considered. Both the objective and subjective measurements followed by an appropriate annotation mechanism would be necessary. Finally, in order to validate such an AR-ADAS by assessing the driver's SA, it would be important getting a large number of participants and a great amount of driving time.



# Appendix A

## Appendix

### A.1 Algorithms

#### A.1.1 Decomposition Method for Dual Problems (Eq. 2.3.7)

##### *Algorithm*

We consider the following general form of SVM in Section 2.3.3.

$$\begin{aligned} \min_{\alpha} (f(\alpha) &= \frac{1}{2} \alpha^T \mathbf{Q} \alpha - \mathbf{e}^T \alpha) && \text{(A.1.1)} \\ \text{Subject to } & \mathbf{y}^T \alpha = 0 \\ & 0 \leq \alpha_i \leq C, t = 1, \dots, l \end{aligned}$$

where  $\mathbf{e} = [1, \dots, 1]^T$  is the vector of all ones,  $\mathbf{Q}$  is an  $m$  by  $m$  positive predefine matrix,  $Q_{ij} \equiv y_i y_j K(\mathbf{V}_i, \mathbf{V}_j)$ , and  $K_{ij} \equiv K(\mathbf{V}_i, \mathbf{V}_j) \equiv \phi(\mathbf{V}_i)^T \phi(\mathbf{V}_j)$  is the kernel function.

In our work, we used the Libsvm that considers a Sequential Minimal Optimization (SMO) method to solve this problem.

##### ***Stopping Criteria and Working Set Selection***

The Karush-Kuhn-Tucker (KKT) optimality condition of problem (Eq. A.1.1) implies that a feasible  $\alpha$  is a stationary point of Eq. A.1.1 if and only if there exists a number  $b$  and two non-negative vectors  $\lambda$  and  $\xi$  such that

---

**Algorithm A.1** (An SMO-type decomposition method.[Fan 05])

---

1. Find  $\alpha^1$  as the initial feasible solution. Set  $k = 1$
2. If  $\alpha^k$  is a stationary point (Stop Criteria) of problem Eq. A.1.1, stop. Otherwise, find a *two-element* working set  $B = \{i, j\}$  by (Working Set Selection or WSS-A.2). define  $N = \{1, 2, \dots, l \setminus B\}$ . Let  $\alpha_B^k$  and  $\alpha_N^k$  be sub-vectors of  $\alpha^k$  corresponding to  $B$  and  $N$ , respectively.

3. if  $a_{ij} \equiv K_{ii} + K_{jj} - 2K_{ij} > 0$ ,  
Solve the following sub-problem with the variable  $\alpha_B = [\alpha_i \alpha_j]^T$ ,

$$\min_{\alpha_i \alpha_j} \frac{1}{2} [\alpha_i \alpha_j] \begin{bmatrix} Q_{ii} & Q_{ij} \\ Q_{ii} & Q_{jj} \end{bmatrix} \begin{bmatrix} \alpha_i \\ \alpha_j \end{bmatrix} + (Q_{BN} \alpha_N^k)^T \begin{bmatrix} \alpha_i \\ \alpha_j \end{bmatrix} \quad (\text{A.1.2})$$

$$\text{Subject to } 0 \leq \alpha_i, \alpha_j \leq C, \\ y_i \alpha_i + y_j \alpha_j = 0$$

else

Let  $\tau$  be a small positive constant and solve

$$\min_{\alpha_i \alpha_j} \frac{1}{2} [\alpha_i \alpha_j] \begin{bmatrix} Q_{ii} & Q_{ij} \\ Q_{ii} & Q_{jj} \end{bmatrix} \begin{bmatrix} \alpha_i \\ \alpha_j \end{bmatrix} + (Q_{BN} \alpha_N^k)^T \begin{bmatrix} \alpha_i \\ \alpha_j \end{bmatrix} + \frac{\tau - a_{ij}}{4} ((\alpha_i - \alpha_i^k)^2 + (\alpha_j - \alpha_j^k)^2) \quad (\text{A.1.3})$$

$$\text{Subject to } 0 \leq \alpha_i, \alpha_j \leq C, \\ y_i \alpha_i + y_j \alpha_j = 0$$

4. Set  $\alpha_B^{k+1}$  to be the optimal solution of sub-problem (Eq.A.1.2 and Eq.A.1.3 ), and  $\alpha_N^{k+1} \equiv \alpha_N^k$ .

Set  $k \leftarrow k + 1$  and go to step 2.

---

$$\nabla f(\boldsymbol{\alpha}) + b\mathbf{y} = \boldsymbol{\lambda} - \boldsymbol{\xi}, \quad (\text{A.1.4})$$

$$\lambda_i \alpha_i = 0, \xi_i(C - \alpha_i) = 0, \lambda_i \geq 0, \xi_i \geq 0, i = 1, \dots, l \quad (\text{A.1.5})$$

where  $\nabla f(\boldsymbol{\alpha}) \equiv \mathbf{Q}\boldsymbol{\alpha}$  is the gradient of  $f(\boldsymbol{\alpha})$ . Note that if  $\mathbf{Q}$  is Positive Semi Definite, from the primal-dual relationship,  $\boldsymbol{\lambda}, b$  and  $\mathbf{w}$  generated by Eq. 2.3.8 form an optimal solution of the primal problem. The condition Eq. A.1.5 can be written as

$$\nabla_i f(\boldsymbol{\alpha}) + b\mathbf{y}_i \begin{cases} \geq 0 \text{ if } \alpha_i \leq C \\ \leq 0 \text{ if } \alpha_i > 0 \end{cases} \quad (\text{A.1.6})$$

Since  $y_i = \pm 1$ , condition Eq.A.1.6 is equivalent to that there exists  $b$  such that

$$m(\boldsymbol{\alpha}) \leq b \leq M(\boldsymbol{\alpha}) \quad (\text{A.1.7})$$

where

$$m(\boldsymbol{\alpha}) \equiv \max_{i \in I_{up}(\boldsymbol{\alpha})} -y_i \nabla_i f(\boldsymbol{\alpha}) \quad \text{and} \quad M(\boldsymbol{\alpha}) \equiv \min_{i \in I_{low}(\boldsymbol{\alpha})} -y_i \nabla_i f(\boldsymbol{\alpha}) \quad (\text{A.1.8})$$

and

$$I_{up}(\boldsymbol{\alpha}) \equiv \{t | \alpha_t < C, y_t = 1 \text{ or } \alpha_t > 0, y_t = -1\} \quad (\text{A.1.9})$$

$$I_{low}(\boldsymbol{\alpha}) \equiv \{t | \alpha_t < C, y_t = -1 \text{ or } \alpha_t > 0, y_t = 1\} \quad (\text{A.1.10})$$

That is, a feasible  $\boldsymbol{\alpha}$  is a stationary point of problem Eq.A.1.1 if and only if

$$m(\boldsymbol{\alpha}) \leq M(\boldsymbol{\alpha}) \quad (\text{A.1.11})$$

From Eq.A.1.11, a suitable stopping condition is

$$m(\boldsymbol{\alpha}^k) - M(\boldsymbol{\alpha}^k) \leq \epsilon, \quad (\text{A.1.12})$$

where  $\epsilon$  is the tolerance.

For the selection of the working set  $B$ , we use the following procedure from the work of Fan et al. [Fan 05]:

---

**Algorithm A.2 WSS 1**

---

1. For all  $t, s$ , define

$$a_{ts} \equiv K_{tt} + K_{ss} - 2K_{ts}, \quad b_{ts} \equiv -y_t \nabla_t f(\alpha^k) + y_s \nabla_s f(\alpha^k) > 0, \quad (\text{A.1.13})$$

and

$$\bar{a}_{ts} \equiv \begin{cases} a_{ts} & \text{if } a_{ts} > 0 \\ \tau & \text{otherwise.} \end{cases} \quad (\text{A.1.14})$$

Select

$$i \in \underset{t}{\operatorname{argmax}} \{-y_t \nabla_t f(\alpha^k) | t \in I_{up}(\alpha^k)\}, \quad (\text{A.1.15})$$

and

$$j \in \underset{t}{\operatorname{argmax}} \left\{ -\frac{b_{it}^2}{\bar{a}_{it}} | t \in I_{low}(\alpha^k), -y_t \nabla_t f(\alpha^k) < -y_i \nabla_i f(\alpha^k) \right\}, \quad (\text{A.1.16})$$

Return  $B = \{i, j\}$

The procedure selects a pair  $\{i, j\}$ , approximately minimizing the function value; see the term  $-b_{it}^2/\bar{a}_{it}$  in Eq.A.1.16.

---

### A.1.2 RVM - Laplace's Approximation

Let us consider the binary classification as our problem statement, where  $y_i \in \{0, 1\}$ , we adapt simply the target conditional distribution (likelihood function) and link the function to take into account the change in the target quantities.

As the consequence, we must introduce an additional approximation step in the algorithm. For two-class classification, it is desired to predict the posterior probability of membership of one of the classes given the input  $\mathbf{V}$ . We follow statistical convention and generalize the linear model by applying the logistic sigmoid link

function  $\sigma(g) = 1 / (1 + e^{-g})$  to  $g(\mathbf{V})$  and, adopting the Bernoulli distribution for  $P(y|\mathbf{V})$ , we write the likelihood as:

$$P(y|\mathbf{w}) = \prod_{i=1}^m \sigma\{g(\mathbf{V}_i)\}^{y_i} [1 - \sigma\{g(\mathbf{V}_i)\}]^{1-y_i} \quad (\text{A.1.17})$$

where, following from the probabilistic specification, the targets  $y_i \in \{0, 1\}$ . The noise  $\epsilon$  variance is ignored here.

An approximation procedure, as used by Mackay [MacKay 92] is used to calculate the weight  $\mathbf{w}$ , which is based on Laplace's method :

1. For the current, fixed, values of  $\boldsymbol{\alpha}$ , the «most probable» weights  $\mathbf{w}_{MP}$  are found, giving the location of the mode of posterior distribution.

Since  $p(\mathbf{w}|\mathbf{y}, \boldsymbol{\alpha}) \propto p(\mathbf{y}|\mathbf{w})p(\mathbf{w}|\boldsymbol{\alpha})$ , this is equivalent to finding the maximum, over  $\mathbf{w}$ , of

$$\log(p(\mathbf{y}|\mathbf{w})p(\mathbf{w}|\boldsymbol{\alpha})) \stackrel{!}{=} m \sum [y_i \log(g(\mathbf{V}_i)) + (1 - y_i) \log(1 - g(\mathbf{V}_i))] - \frac{1}{2} \mathbf{w}^T \mathbf{A} \mathbf{w} \quad (\text{A.1.18})$$

where  $\mathbf{A} = \text{diag}(\alpha_0, \alpha_1, \dots, \alpha_m)$ . By adapting the efficient «iteratively-reweight least-squares» algorithm, This procedure determines  $\mathbf{w}_{MP}$ .

2. Laplace's method is simply a quadratic approximation to the log-posterior around its mode. The quantity (Eq.A.1.18) is differentiated twice to give:

$$\nabla_{\mathbf{w}} \nabla_{\mathbf{w}} \log P(\mathbf{w}|\mathbf{y}, \boldsymbol{\alpha})|_{\mathbf{w}_{MP}} = -(\boldsymbol{\Phi}^T \mathbf{B} \boldsymbol{\Phi} + \mathbf{A}), \quad (\text{A.1.19})$$

where  $\mathbf{B} = \text{diag}(\beta_1, \beta_2, \dots, \beta_m)$  is a diagonal matrix with  $\beta_i = \sigma\{g(\mathbf{V}_i)\} [1 - \sigma\{g(\mathbf{V}_i)\}]$

This is then negated and inverted to give the covariance  $\Sigma$  for a Gaussian approximation to the posterior over weights centered at  $\mathbf{w}_{MP}$ .

3. Using the statistics  $\Sigma$  and  $\mathbf{w}_{MP}$  (in place of  $\mu$ ) of the Gaussian approximation, the hyper-parameters are updated in identical fashion to the regression case.

After having the hyper-parameters, with a new data  $\mathbf{V}_*$ , the prediction that the data is belong to which class is made by using Gaussian distribution:

$$P(y = 1|\mathbf{V}_*) = \mathcal{N}(y = 1|g(\mathbf{V}_*), \sigma^2) \quad (\text{A.1.20})$$

### A.1.3 HMM -Forward Algorithm

The evaluation problem consists of determining the probability of the observation sequence, given the model. Indeed, given a sequence of observation  $\mathbf{V} = [\mathbf{O}_1, \mathbf{O}_2, \dots, \mathbf{O}_T]$  and the model  $\lambda = \{\mathbf{A}, \mathbf{B}, \Pi\}$  how do we efficiently compute  $P(\mathbf{V}|\lambda)$ . This problem give us the idea how to classified a observation sequence into two classes DAP and DUP. The forward algorithm is an efficient method for computing this probability [Rabiner 89] and is defined as follows.

Let  $\alpha_i(t)$  be given by :

$$\alpha_i(t) = P(\mathbf{O}_1, \mathbf{O}_2, \dots, \mathbf{O}_t, s_t = s_i|\lambda) \quad (\text{A.1.21})$$

Which is the probability by observing the partial sequence  $[\mathbf{O}_1, \mathbf{O}_2, \dots, \mathbf{O}_t]$  and having the current state  $s_t$  at time  $t$  equal to  $s_i$  given the model  $\lambda$ . Then the forward algorithm is initialized using the initial state distribution  $\pi$ , i.e.,

$$\alpha_i(t = 1) = \pi_i b_i(\mathbf{O}_1), i \quad 1 \leq i \leq N \quad (\text{A.1.22})$$

The probability of each subsequent partial sequence of observations for  $t = 1, \dots, T - 1$  is given by:

$$\alpha_j(t + 1) = \left[ \sum_{i=1}^N \alpha_i(t) a_{ij} \right] b_j(\mathbf{O}_{t+1}), \quad 1 \leq t \leq T - 1 \text{ and } 1 \leq j \leq N \quad (\text{A.1.23})$$

Upon determination at  $t = T$ , the algorithm returns the desired probability

$$P(\mathbf{V}|\lambda) = \sum_{i=1}^N \alpha_i(T). \quad (\text{A.1.24})$$

### A.1.4 HMM - Expectation Maximization Algorithm

The second problem is the learning problem. It is all about how do we adjust the model parameter  $\lambda = \{\mathbf{A}, \mathbf{B}, \mathbf{\Pi}\}$  to maximize  $P(\mathbf{V}|\lambda)$ . A standard technique for doing so, i.e., the Expectation-Maximization (EM) algorithm, is subsequently summarized. The complete algorithm is detailed in [Bilmes 98].

Given a set of  $K$  observation sequences (training data)  $\mathbf{V}_1, \mathbf{V}_2, \dots, \mathbf{V}_K$ , the EM algorithm computes the maximum-likelihood estimates of the HMM parameters, i.e.,

$$\lambda^*(\mathbf{A}, \mathbf{B}, \mathbf{\Pi}) = \underset{\lambda}{\operatorname{argmax}} P(\mathbf{V}_1, \mathbf{V}_2, \dots, \mathbf{V}_K | \lambda(\mathbf{A}, \mathbf{B}, \mathbf{\Pi})). \quad (\text{A.1.25})$$

To do so, it uses the forward algorithm, as defined earlier, as well as the backward algorithm [Rabiner 89], which is defined similar to the forward algorithm. Let

$$\beta_i(t) = P(\mathbf{O}_{t+1}, \mathbf{O}_{k+2}, \dots, \mathbf{O}_T | s_t = s_i, \lambda) \quad (\text{A.1.26})$$

be the probability of observing the rest of the partial sequence of observations at time  $t$  for  $t \leq T$ . Then the backward algorithm follows as

$$\beta_i(t = T) = 1 \quad (\text{A.1.27})$$

$$\beta_j(t) = \sum_{i=1}^N a_{ij} b_j(\mathbf{O}_{t+1}) \beta_i(t+1) \quad 1 \leq t \leq T-1 \text{ and } 1 \leq j \leq N \quad (\text{A.1.28})$$

Using the terms  $\alpha_i(t)$  from the forward algorithm and  $\beta_i(t)$  from the backward algorithm, the probability of being in state  $s_i$  at time  $t$  given the observation  $\mathbf{V}$  is given by

$$\gamma_i(t) = P(s_t = s_i | \mathbf{V}, \lambda) = \frac{\alpha_i(t) \beta_i(t)}{\sum_{i=1}^N \alpha_i(t) \beta_i(t)} \quad (\text{A.1.29})$$

Then, the probability of being in state  $s_i$ , at time  $t$  and state  $s_j$  at time  $t+1$  is given by

$$\xi_{ij}(t) = P(s_t = s_i, s_{t+1} = s_j | \mathbf{V}, \lambda) = \frac{\alpha_i(t) a_{ij} b_j(\mathbf{O}_{t+1}) \beta_j(t+1)}{\sum_{i=1}^N \sum_{j=1}^N \alpha_i(t) a_{ij} b_j(\mathbf{O}_{t+1}) \beta_j(t+1)} \quad (\text{A.1.30})$$

From these terms, the parameters of an update HMM  $\lambda^*$  are computed with the following update equations:

$$\pi^*_{*i} = \gamma(t=1) \quad (\text{A.1.31})$$

$$a_{ij} = \frac{\sum_{t=1}^{T-1} \xi_{ij}(t)}{\sum_{t=1}^{T-1} \gamma_i(t)} \quad (\text{A.1.32})$$

For the DHMM, the emission distribution  $b_j^*(m)$  is updated as follows:

$$b_j^*(m) = \frac{\sum_{t=1}^T \gamma_j(t)}{\sum_{t=1}^T \gamma_j(t)} \quad (\text{A.1.33})$$

For the GMHMM, the emission distribution  $b_j(m)$  is presented by the mean vector  $\boldsymbol{\mu}^*_{jm}$  and a covariance matrix  $\boldsymbol{\Sigma}^*_{jm}$ . These parameters are computed as follows:

$$\boldsymbol{\mu}^*_{jm} = \frac{\sum_{t=1}^T \gamma_{jm}(t) \cdot \mathbf{O}_t}{\sum_{t=1}^T \gamma_{jm}(t)} \quad (\text{A.1.34})$$

$$\boldsymbol{\Sigma}^*_{jm} = \frac{\sum_{t=1}^T \gamma_{jm}(t) \cdot (\mathbf{O}_t - \boldsymbol{\mu}_{jm})(\mathbf{O}_t - \boldsymbol{\mu}_{jm})^T}{\sum_{t=1}^T \gamma_{jm}(t)} \quad (\text{A.1.35})$$

where prime denotes vector transpose and where  $\gamma_{jm}(t)$  generalizes to  $\gamma_j(t)$  in case of a simple mixture, or a discrete density like in DHMM. It is probability of being in state  $j$  at time  $t$  with the  $m^{\text{th}}$  mixture component accounting for  $\mathbf{O}_t$ , i.e.,

$$\gamma_{jm}(t) = \left[ \frac{\alpha_j(t) \beta_j(t)}{\sum_{j=1}^N \alpha_j(t) \beta_j(t)} \right] \left[ \frac{\mathcal{N}(\mathbf{O}_t, \boldsymbol{\mu}_{jm}, \boldsymbol{\Sigma}_{jm})}{\sum_{m=1}^M \mathcal{N}(\mathbf{O}_t, \boldsymbol{\mu}_{jm}, \boldsymbol{\Sigma}_{jm})} \right] \quad (\text{A.1.36})$$

These maximum-likelihood estimates reflect the relative frequencies of the state transitions and emissions in the training data. Repeating this procedure with  $\lambda$  replaced by  $\lambda^*$  is guaranteed to converge to a local maximum [Bilmes 98], i.e.,



as the number of iterations increases,  $P(\mathbf{V}_1, \mathbf{V}_2, \dots, \mathbf{V}_K | \lambda^*) - P(\mathbf{V}_1, \mathbf{V}_2, \dots, \mathbf{V}_K | \lambda)$  converge to 0. The resulting  $\lambda$  is the maximum likelihood model. Since the EM algorithm is only guaranteed to converge to a local maximum, several sets of random initializations can be necessary to reduce the effects of local maximum on the final model parameters.

### A.1.5 ANOVA and Tukey's HSD

#### ANOVA

We used the one-way ANOVA to compare the means between groups of observation by partitioning the total variation in the data into two components:

Variation of group means from the overall mean, i.e.,  $\bar{y}_j - \bar{y}$  (variation between groups), where  $\bar{y}_j$  is the sample mean of group  $j$  and  $\bar{y}$  is the overall sample mean.

Variation of observations in each group from their mean estimates,  $y_{ij} - \bar{y}_j$  (variation within group).

In other words, ANOVA partitions the total sum of squares (SST) into sum of squares due to between-groups effects (SSR) and sum of squared errors (SSE).

$$\underbrace{\sum_i \sum_j (y_{ij} - \bar{y})^2}_{SST} = \underbrace{\sum_j n_j (\bar{y}_j - \bar{y})^2}_{SSR} + \underbrace{\sum_i \sum_j (y_{ij} - \bar{y}_j)^2}_{SSE} \quad (\text{A.1.37})$$

where  $n_j$  is the sample size of the  $j^{\text{th}}$  group,  $j = 1, 2, 3$ .

Then ANOVA compares the variation between groups to the variation within groups. If the ratio of within-group variation to between-group variation is significantly high, then we can conclude that the group means are significantly different from each other. You can measure this using a test statistic that has an F-distribution with  $(k - 1, N - k)$  degrees of freedom:

$$F = \frac{SSR / (k - 1)}{SSE / (N - k)} = \frac{MSR}{MSE} \sim F_{k-1, N-k} \quad (\text{A.1.38})$$

where  $MSR$  is the mean squared treatment,  $MSE$  is the mean squared error,  $k$  is the number of groups, and  $N$  is the total number of observations.

In the next step, this  $F$  ratio is used to compared with the critical value of the

*F* – test. If the *p* – value for the *F*-test is smaller than the significance level, then the test rejects the null hypothesis that all group means are equal and concludes that at least one of the group means is different from the others. The most common significance levels are 0.05 and 0.01. In Fig. A.1, an example with the *F*-ratio is equal to 9.27, it is greater than *F* – test critical value (3.682 at *p* – value=0.05), we can conclude that there is a significant different between the groups.

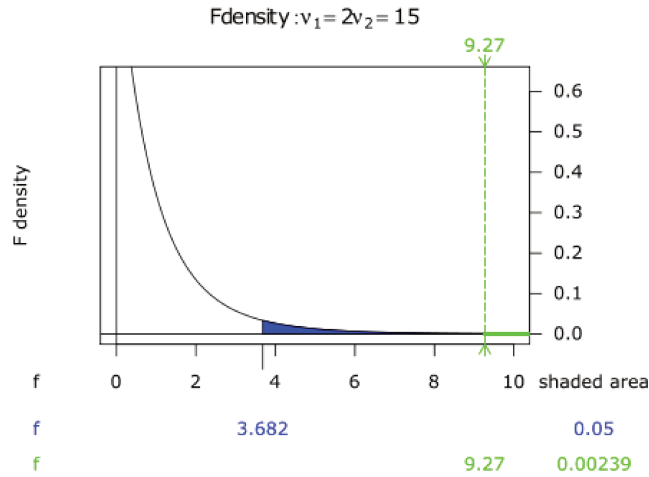

**Figure A.1:** Illustration curve of *F*-test distribution with  $k=3$  groups and  $N= 18$  observations (6 observations per groups) at  $\alpha$  equal to 0.05

### Tukey’s HSD test

The Tukey’s Honest Signification Difference (HSD) test is based on studentized range distribution. Reject the null hypothesis between two group  $\alpha_i, \alpha_j$  if

$$|t| = \frac{|\bar{y}_i - \bar{y}_j|}{\sqrt{MSE(\frac{1}{n_i} + \frac{1}{n_j})}} > \frac{1}{\sqrt{2}} q_{\alpha, k, N-k} \quad (\text{A.1.39})$$

Where  $q_{\alpha, k, N-k}$  is the upper  $100 * (1-\alpha)$  th percentile of the studentized range distribution with parameter  $k$  and  $N-k$  degrees of freedom.  $k$  is the number of groups (treatments or marginal means) and  $N$  is the total number of observations.

Tukey’s honestly significant difference procedure is optimal for balanced one-way ANOVA and similar procedures with equal sample sizes. It has been proven to be conservative for one-way ANOVA with different sample sizes. According

to the unproven Tukey-Kramer conjecture, it is also accurate for problems where the quantities being compared are correlated, as in analysis of covariance with unbalanced covariate values.

## A.2 Scenario Screen-shot Samples



**Figure A.1:** *no HUD , no AR cue*



**Figure A.2:** *In front of a Pedestrian and no cue is displayed*

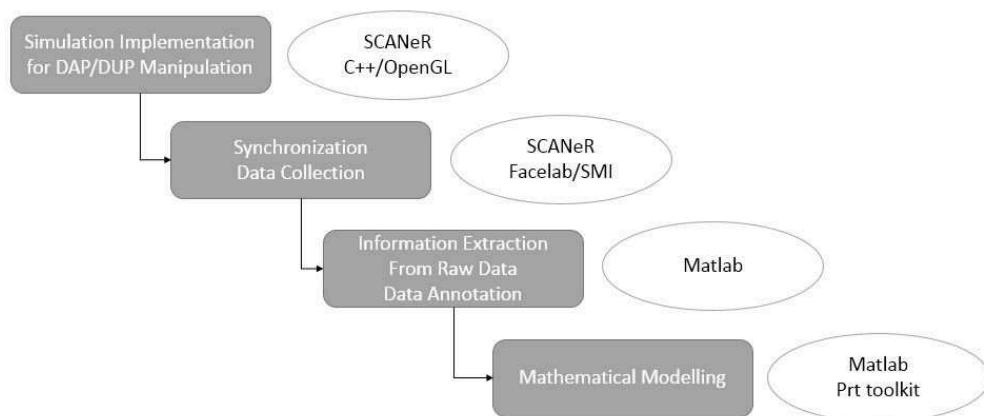

**Figure A.3:** *Pedestrian is augmented by a bounding box*

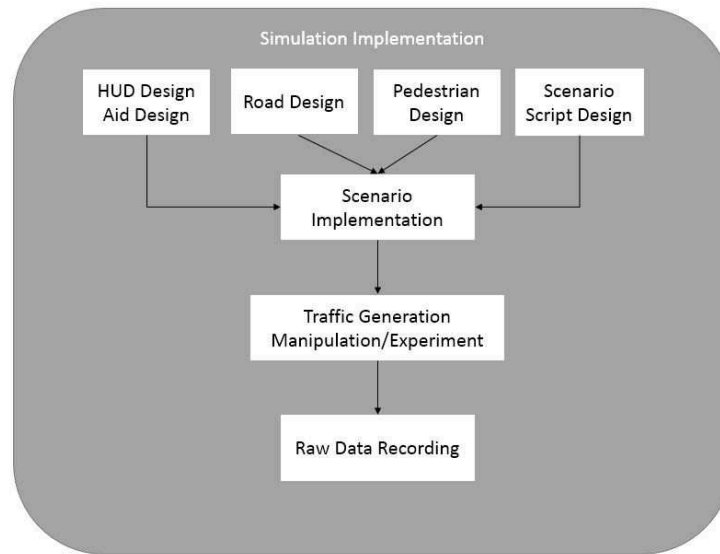

**Figure A.4:** *HUD Pedestrian is augmented by a bounding box, and the warning panel is displayed in the critical moment*

## A.3 Code Structure



**Figure A.1:** *Code Structure*



**Figure A.2:** *Visual Aids and Simulation Implementation*

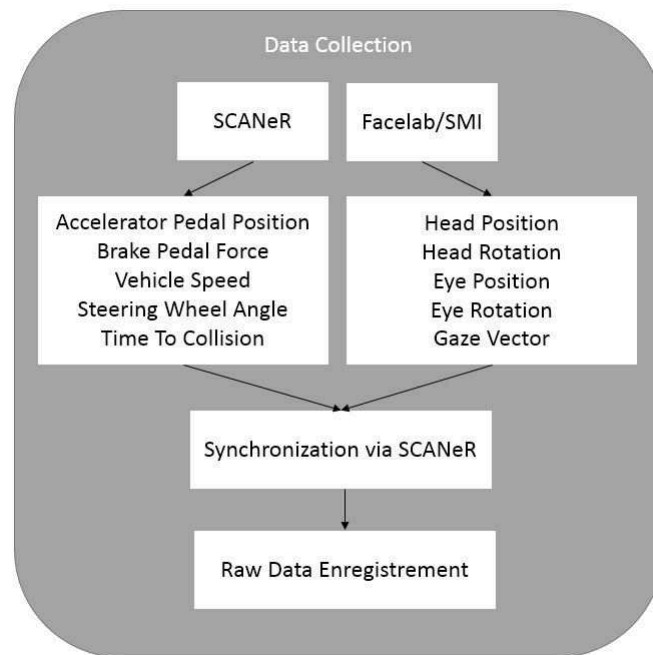

**Figure A.3:** *Data Collection*

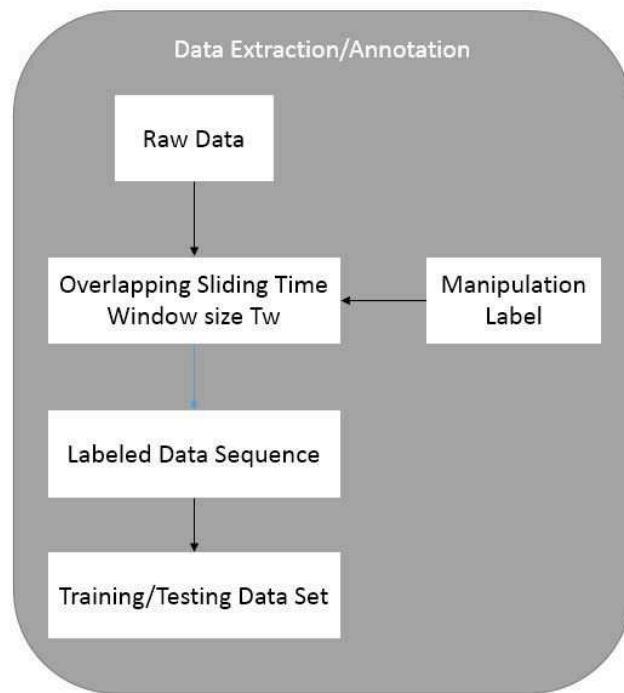

**Figure A.4:** *Data Extraction/Annotation*

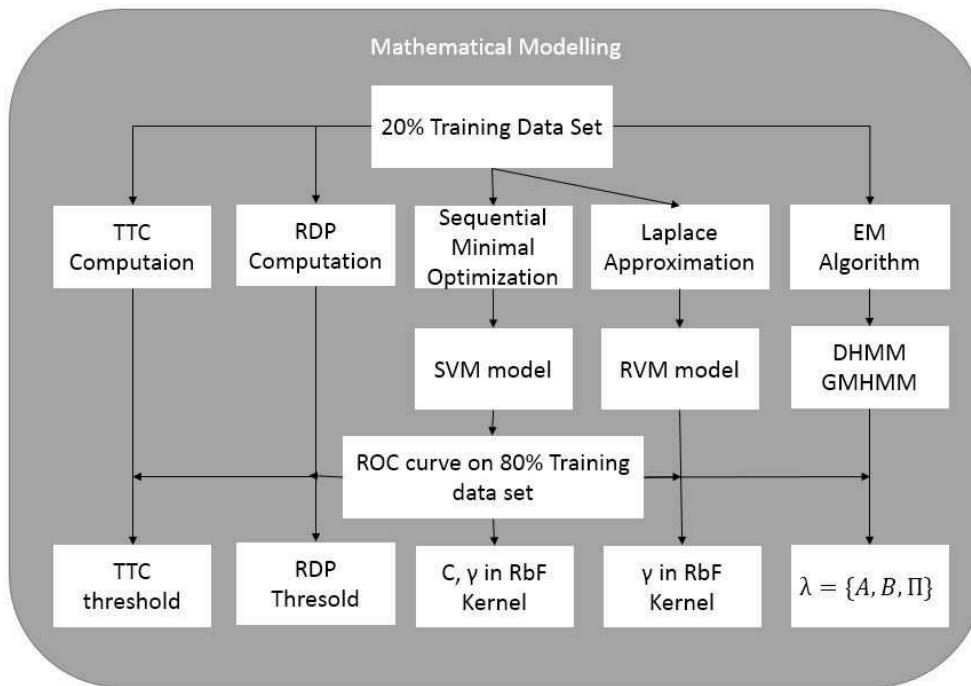

Figure A.5: *Mathematical Model Implementation*

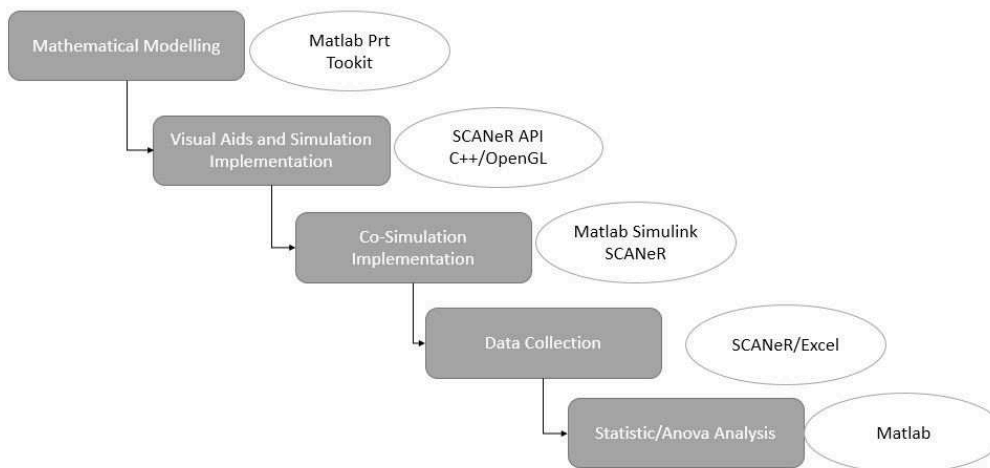

Figure A.6: *Code structure of final experiment and result analysis*



## A.4 Questionnaire

**Nom**

**Prénom**

**Âge**

**Sexe:**  
Homme/Femme

**Permis de conduire**

- Voiture
- Moto
- Bateau
- Avion
- Autres

**Avez-vous déjà eu des expériences avec les simulateurs?**  
Oui/Non

**Avez-vous déjà eu des expériences avec la réalité virtuelle?**

**Considérez-vous l'outil informatique comme familier?**  
Très familier / Moyennement familier / Pas du tout familier

**À quelle fréquence jouez-vous aux jeux vidéo ?**  
Tous les jours / Plusieurs fois par semaine / Plusieurs fois par mois / Pas du tout

Figure A.1: Questionnaire (part 1)

**1. Pensez-vous avoir du mal à conduire avec le volant?**  
Jamais/Parfois/Plusieurs fois/Tout le temps

**2. Pensez-vous avoir freiné inutilement ?**  
Jamais/Parfois/Plusieurs fois/Tout le temps

**3. Pensez-vous avoir poussé l'accélérateur à l'extrême ?**  
Jamais/Parfois/Plusieurs fois/Tout le temps

**5. J'ai essayé de poursuivre le véhicule devant le plus possible ?**  
Oui/ Non  
 Oui  
 Non

**6. Ma conduite était dangereuse?**  
Complètement/Assez/Normal/Peu/Pas du tout

**7. D'après vous, la tâche de conduite proposée est:**  
Très facile/Facile/Normal/Difficile/Très difficile

**8. Étiez-vous stressé ?**  
Complètement/Assez/Normal/Peu/Pas du tout

**9. Êtes-vous attentif vis-à-vis du piéton?**  
Complètement/Normal/Pas du tout

**9bis. Êtes-vous sûr?**  
1 2 3 4 5  
Non, pas du tout      Oui, 100%

**10. Voulez-vous utiliser cette interface HUD en réel?**  
 Yes  
 No

**11. Quelle métaphore d'affichage préférez-vous ?**  
 Panneau d'attention  
 Boite englobante

**12. Que pensez vous de l'affichage adaptatif des métaphores?**  
 Efficace  
 Moyenne  
 Pas efficace  
 Dérangeant

Figure A.2: Questionnaire (part 2)

# References

- [Aga 03] Masami Aga & Akio Okada. *Analysis of vehicle stability control (VSC)'s effectiveness from accident data*. In Proceedings of the 18 th ESV Conference, paper, numéro 541, 2003.
- [Akamatsu 03] Motoyuki Akamatsu, Yasuo Sakaguchi & Masayuki Okuwa. *Modeling of Driving Behavior When Approaching an Intersection Based on Measured Behavioral Data on An Actual Road*. Proceedings of the Human Factors and Ergonomics Society Annual Meeting, vol. 47, no. 16, pages 1895–1899, 2003.
- [Akin 08] Mehmet Akin, MuhammedB. Kurt, Necmettin Sezgin & Muhittin Bayram. *Estimating vigilance level by using EEG and EMG signals*. Neural Computing and Applications, vol. 17, no. 3, pages 227–236, 2008.
- [Alexander 05] Amy L Alexander, Christopher D Wickens & Thomas J Hardy. *Synthetic vision systems: The effects of guidance symbology, display size, and field of view*. Human Factors: The Journal of the Human Factors and Ergonomics Society, vol. 47, no. 4, pages 693–707, 2005.
- [Aoude 12] G.S. Aoude, V.R. Desaraju, L.H. Stephens & J.P. How. *Driver Behavior Classification at Intersections and Validation on Large Naturalistic Data Set*. Intelligent Transportation

- Systems, IEEE Transactions on, vol. 13, no. 2, pages 724–736, June 2012.
- [Ardelt 10] Michael Ardelt, Peter Waldmann, Nico Kaempchen & Florian Himm. *Strategic decision-making process in advanced driver assistance systems*. In Advances in Automotive Control, pages 566–571, 2010.
- [Association 94] American Psychiatric Association, American Psychiatric Association *et al.* *Diagnostic and statistical manual of mental disorders (DSM)*. Washington, DC: American psychiatric association, pages 143–7, 1994.
- [Averbukh 07] Vladimir Averbukh, Mikhail Bakhterev, Aleksandr Baydalin, Damir Ismagilov & Polina Trushenkova. *Interface and Visualization Metaphors*. In JulieA. Jacko, editeur, Human-Computer Interaction. Interaction Platforms and Techniques, volume 4551 of *Lecture Notes in Computer Science*, pages 13–22. Springer Berlin Heidelberg, 2007.
- [Azuma 97] Ronald T Azuma *et al.* *A survey of augmented reality*. Presence, vol. 6, no. 4, pages 355–385, 1997.
- [Begg 05] Rezaul K Begg, Marimuthu Palaniswami & Brendan Owen. *Support vector machines for automated gait classification*. Biomedical Engineering, IEEE Transactions on, vol. 52, no. 5, pages 828–838, 2005.
- [Ben-Yaacov 02] Avner Ben-Yaacov, Masha Maltz & David Shinar. *Effects of an in-vehicle collision avoidance warning system on short- and long-term driving performance*. Human Factors: The Journal of the Human Factors and Ergonomics Society, vol. 44, no. 2, pages 335–342, 2002.
- [Benedetto 11a] Simone Benedetto, Marco Pedrotti, Luca Minin, Thierry Baccino, Alessandra Re & Roberto Montanari. *Driver wor-*

- 
- kload and eye blink duration*. Transportation Research Part F: Traffic Psychology and Behaviour, vol. 14, no. 3, pages 199 – 208, 2011.
- [Benedetto 11b] Simone Benedetto, Marco Pedrotti, Luca Minin, Thierry Baccino, Alessandra Re & Roberto Montanari. *Driver workload and eye blink duration*. Transportation research part F: traffic psychology and behaviour, vol. 14, no. 3, pages 199–208, 2011.
- [Bengler 14] Klaus Bengler, Klaus Dietmayer, Berthold Färber, Markus Maurer, Christoph Stiller & Hermann Winner. *Three Decades of Driver Assistance Systems*. 2014.
- [Bergasa 08] LuisM. Bergasa, MiguelA. Nuevo, Rafael Barea & Elena Lopez. *Visual Monitoring of Driver Inattention*. In Danil Prokhorov, editeur, Computational Intelligence in Automotive Applications, volume 132 of *Studies in Computational Intelligence*, pages 19–37. Springer Berlin Heidelberg, 2008.
- [Bergstra 12] James Bergstra & Yoshua Bengio. *Random search for hyperparameter optimization*. The Journal of Machine Learning Research, vol. 13, no. 1, pages 281–305, 2012.
- [Biester 05] Lars Biester & R Bosch. *The concept of cooperative automation in cars: Results from the experiment “overtaking on highways”*. In Proc. Int. Driving Symp. Human Factors in Driver Assessment, Training, and Vehicle Design, USA, pages 342–348, 2005.
- [Bilmes 98] Jeff A Bilmes *et al.* *A gentle tutorial of the EM algorithm and its application to parameter estimation for Gaussian mixture and hidden Markov models*. International Computer Science Institute, vol. 4, no. 510, page 126, 1998.

- [Bliss 03] James P Bliss & Sarah A Acton. *Alarm mistrust in automobiles: how collision alarm reliability affects driving*. Applied ergonomics, vol. 34, no. 6, pages 499–509, 2003.
- [BMW 15] BMW. *BMW Head-Up Display*, 2015.
- [Brown 02] Lesley Brown. *Shorter oxford english dictionary. vol. 2: Nz: on historical principles*. Oxford University Press, 2002.
- [Burns 04] Don Burns & Robert Osfield. *Open scene graph a: Introduction, b: Examples and applications*. 2004.
- [Caird 01] J Caird, W Horrey & C Edwards. *Effects of conformal and nonconformal vision enhancement systems on older-driver performance*. Transportation Research Record: Journal of the Transportation Research Board, no. 1759, pages 38–45, 2001.
- [Chang 11] Chih-Chung Chang & Chih-Jen Lin. *LIBSVM: A library for support vector machines*. ACM Transactions on Intelligent Systems and Technology (TIST), vol. 2, no. 3, page 27, 2011.
- [Chapanis 94] Alphonse Chapanis. *Hazards associated with three signal words and four colours on warning signs*. Ergonomics, vol. 37, no. 2, pages 265–275, 1994.
- [Chapelle 99] Olivier Chapelle, Patrick Haffner & Vladimir N Vapnik. *Support vector machines for histogram-based image classification*. Neural Networks, IEEE Transactions on, vol. 10, no. 5, pages 1055–1064, 1999.
- [Charissis 07] V. Charissis & M. Naef. *Evaluation of Prototype Automotive Head-Up Display Interface: Testing Driver’s Focusing Ability through a VR Simulation*. In Intelligent Vehicles Symposium, 2007 IEEE, pages 560–565, June 2007.

- 
- [Charissis 10] Vassilis Charissis & Stylianos Papanastasiou. *Human-machine collaboration through vehicle head up display interface*. *Cognition, Technology & Work*, vol. 12, no. 1, pages 41–50, 2010.
- [Continental 15] Continental. *Combiner Head Up Display*, 2015.
- [Cortes 95] Corinna Cortes & Vladimir Vapnik. *Support-vector networks*. *Machine learning*, vol. 20, no. 3, pages 273–297, 1995.
- [Craft 09] Ralph H Craft & Brian Preslopsky. *Driver distraction and inattention in the USA large truck and national motor vehicle crash causation studies*. 2009.
- [Dagan 04] Erez Dagan, Ofer Mano, Gideon P Stein & Amnon Shashua. *Forward collision warning with a single camera*. In *Intelligent Vehicles Symposium, 2004 IEEE*, pages 37–42. IEEE, 2004.
- [DaSilva 03a] MP DaSilva, JD Smith & WG Najm. *Analysis of pedestrian crashes*. Rapport technique, 2003.
- [DaSilva 03b] MP DaSilva, JD Smith & WG Najm. *Analysis of pedestrian crashes*. Rapport technique, 2003.
- [Davies 82] David Roy Davies & Raja Parasuraman. *The psychology of vigilance*. Academic Pr, 1982.
- [Dingus 89] Thomas A Dingus, Melissa C Hulse, Jonathan F Antin & Walter W Wierwille. *Attentional demand requirements of an automobile moving-map navigation system*. *Transportation Research Part A: General*, vol. 23, no. 4, pages 301–315, 1989.
- [Dingus 97] Thomas A Dingus, Daniel V McGehee, Natarajan Manakkal, Steven K Jahns, Cher Carney & Jonathan M Hankey. *Human factors field evaluation of automotive headway maintenance/collision warning devices*. *Human Factors*:

- The Journal of the Human Factors and Ergonomics Society, vol. 39, no. 2, pages 216–229, 1997.
- [Distner 09] Martin Distner, Mattias Bengtsson, Thomas Broberg & Lotta Jakobsson. *City safety—a system addressing rear-end collisions at low speeds*. In Proc. 21st International Technical Conference on the Enhanced Safety of Vehicles, numéro 09-0371, 2009.
- [Dixon 07] Stephen R Dixon, Christopher D Wickens & Jason S McCarley. *On the independence of compliance and reliance: Are automation false alarms worse than misses?* Human Factors: The Journal of the Human Factors and Ergonomics Society, vol. 49, no. 4, pages 564–572, 2007.
- [Doerzaph 07] Zachary R Doerzaph. *Development of a threat assessment algorithm for intersection collision avoidance systems*. PhD thesis, Virginia Polytechnic Institute and State University, 2007.
- [Doerzaph 10] Zachary R Doerzaph, Vicki Neale & Raymond Kiefer. *Cooperative intersection collision avoidance for violations: threat assessment algorithm development and evaluation method*. In Transportation Research Board 89th Annual Meeting, numéro 10-2748, 2010.
- [Doshi 09a] A Doshi, Shinko Yuanhsien Cheng & M.M. Trivedi. *A Novel Active Heads-Up Display for Driver Assistance*. Systems, Man, and Cybernetics, Part B: Cybernetics, IEEE Transactions on, vol. 39, no. 1, pages 85–93, Feb 2009.
- [Doshi 09b] Anup Doshi, Shinko Yuanhsien Cheng & Mohan Manubhai Trivedi. *A novel active heads-up display for driver assistance*. Systems, Man, and Cybernetics, Part B: Cybernetics, IEEE Transactions on, vol. 39, no. 1, pages 85–93, 2009.



- 
- [Doshi 11] A. Doshi, B.T. Morris & M.M. Trivedi. *On-road prediction of driver's intent with multimodal sensory cues*. Pervasive Computing, IEEE, vol. 10, no. 3, pages 22–34, 2011.
- [Doshi 12] Anup Doshi & Mohan M. Trivedi. *Head and eye gaze dynamics during visual attention shifts in complex environments*. Journal of Vision, vol. 12, no. 2, 2012.
- [Duda 12] Richard O Duda, Peter E Hart & David G Stork. Pattern classification. John Wiley & Sons, 2012.
- [Durso 07] Francis T Durso, Katherine A Rawson & Sara Girotto. *Comprehension and situation awareness*. Handbook of applied cognition, vol. 2, pages 163–193, 2007.
- [Dzindolet 02] Mary T Dzindolet, Linda G Pierce, Hall P Beck & Lloyd A Dawe. *The perceived utility of human and automated aids in a visual detection task*. Human Factors: The Journal of the Human Factors and Ergonomics Society, vol. 44, no. 1, pages 79–94, 2002.
- [Endsley 95a] M. R. Endsley. *Toward a Theory of Situation Awareness in Dynamic Systems*. Human Factors: The Journal of the Human Factors and Ergonomics Society, vol. 37, no. 1, pages 32–64, 1995.
- [Endsley 95b] Mica R Endsley. *Measurement of situation awareness in dynamic systems*. Human Factors: The Journal of the Human Factors and Ergonomics Society, vol. 37, no. 1, pages 65–84, 1995.
- [Engström 13] J Engström, CA Monk, RJ Hanowski, WJ Horrey, JD Lee, DV McGehee, M Regan, A Stevens, E Traube, M Tuukkanen *et al.* *A conceptual framework and taxonomy for understanding and categorizing driver inattention*. Brussels, Belgium: European Commission, 2013.

- [Evans 04] Leonard Evans. Traffic safety. 2004.
- [Eyraud 15] Robin Eyraud, Elisabetta Zibetti & Thierry Baccino. *Allocation of visual attention while driving with simulated augmented reality*. Transportation Research Part F: Traffic Psychology and Behaviour, vol. 32, no. 0, pages 46 – 55, 2015.
- [Fan 05] Rong-En Fan, Pai-Hsuen Chen & Chih-Jen Lin. *Working set selection using second order information for training support vector machines*. The Journal of Machine Learning Research, vol. 6, pages 1889–1918, 2005.
- [FHA 15] Federal Highway Administration. *FHA. Pedestrian and Bicyclist Safety*. [<http://www.fhwa.dot.gov/research/topics/safety/pedbike/>], 2015.
- [Figaro 14] Le Figaro. *ESP obligatoire, jamais plus de travers*, 10 2014.
- [Fleet 14] Protecting Your Fleet & Improving Your Bottom Line. *Collision Avoidance System*. 2014.
- [Flemisch 08] Frank Flemisch, Johann Kelsch, Christian Löper, Anna Schieben, Julian Schindler & Matthias Heesen. *Cooperative control and active interfaces for vehicle assistance and automation*. In FISITA World automotive congress, 2008.
- [Fletcher 09] Luke Fletcher & Alexander Zelinsky. *Driver Inattention Detection based on Eye Gaze-Road Event Correlation*. Int. J. Rob. Res., vol. 28, no. 6, pages 774–801, #jun# 2009.
- [Focus 15] Ford Focus. *Active City Stop*. [Online], 2015.
- [Fukagawa 13] Y. Fukagawa & K. Yamada. *Estimating driver awareness of pedestrians from driving behavior based on a probabilistic model*. In Intelligent Vehicles Symposium (IV), 2013 IEEE, pages 1155–1160, June 2013.

- [Fuller 05] Ray Fuller. *Towards a general theory of driver behaviour*. Accident Analysis & Prevention, vol. 37, no. 3, pages 461–472, 2005.
- [Gandhi 07] Tarak Gandhi & Mohan Manubhai Trivedi. *Pedestrian protection systems: Issues, survey, and challenges*. Intelligent Transportation Systems, IEEE Transactions on, vol. 8, no. 3, pages 413–430, 2007.
- [Gelasca 05] Elisa Drelie Gelasca, Danko Tomasic & Touradj Ebrahimi. *Which colors best catch your eyes: a subjective study of color saliency*. In First International Workshop on Video Processing and Quality Metrics for Consumer Electronics. Citeseer, 2005.
- [Gish 95] Kenneth W Gish & Loren Staplin. *Human factors aspects of using head up displays in automobiles: A review of the literature*. 1995.
- [Green 99] Paul Green. *The 15-second rule for driver information systems*. In Proceedings of the ITS America Ninth Annual Meeting, 1999.
- [Gugerty 98] Leo Gugerty. *Evidence from a partial report task for forgetting in dynamic spatial memory*. Human Factors: The Journal of the Human Factors and Ergonomics Society, vol. 40, no. 3, pages 498–508, 1998.
- [Hancock 09] Peter A Hancock, Mustapha Mouloua & John W Senders. *On the philosophical foundations of the distracted driver and driving distraction*. 2009.
- [Harbluk 02] Joanne L Harbluk, Y Ian Noy & Moshe Eizenman. *The impact of cognitive distraction on driver visual behaviour and vehicle control*. Rapport technique, 2002.

- [Harbluk 07] Joanne L Harbluk, Y Ian Noy, Patricia L Trbovich & Moshe Eizenman. *An on-road assessment of cognitive distraction: Impacts on drivers' visual behavior and braking performance*. Accident Analysis & Prevention, vol. 39, no. 2, pages 372–379, 2007.
- [Hayward 72] J.C. Hayward, Pennsylvania Transportation, Traffic Safety Center & National Research Council (U.S.). Highway Research Board. Meeting. Near miss determination through use of a scale of danger. Numéro 7115 in Report (Pennsylvania Transportation and Traffic Safety Center). Pennsylvania Transportation and Traffic Safety Center, The Pennsylvania State University, 1972.
- [Imamura 08] T. Imamura, H. Yamashita, R. bin Othman, Zhong Zhang & T. Miyake. *Driving behavior classification river sensing based on vehicle steering wheel operations*. In SICE Annual Conference, 2008, pages 2714–2718, 2008.
- [Itoh 09] Makoto Itoh. *Individual differences in effects of secondary cognitive activity during driving on temperature at the nose tip*. In Mechatronics and Automation, 2009. ICMA 2009. International Conference on, pages 7–11. IEEE, 2009.
- [Jensen 11] M Jensen, J Wagner & K Alexander. *Analysis of in-vehicle driver behaviour data for improved safety*. International journal of vehicle safety, vol. 5, no. 3, pages 197–212, 2011.
- [Juang 91] B. H. Juang & L. R. Rabiner. *Hidden Markov Models for Speech Recognition*. Technometrics, vol. 33, no. 3, pages 251–272, 1991.
- [Jurgen 06] Ronald K Jurgen. *Adaptive cruise control*. Training, vol. 2012, pages 11–19, 2006.

- [Käppler 93] WD Käppler. *Views on the role of simulation in driver training*. In Proc 12th European Annual Conference on Human Decision Making and Manual Control, pages 5–12, 1993.
- [Kaptein 94] NA Kaptein. *Benefits of in-car head-up displays*. 1994.
- [Katzourakis 11] Diomidis Katzourakis, David Abbink, Riender Happee, Edward Holweg *et al.* *Steering force feedback for human-machine-interface automotive experiments*. Instrumentation and Measurement, IEEE Transactions on, vol. 60, no. 1, pages 32–43, 2011.
- [Kiefer 91] Raymond J Kiefer. *Effect of a head-up versus head-down digital speedometer on visual sampling behavior and speed control performance during daytime automobile driving*. Rapport technique, SAE Technical Paper, 1991.
- [Kiefer 05] Raymond J Kiefer, Jeremy Salinger & John J Ference. *STATUS OF NHTSAs REAR-END CRASH PREVENTION RESEARCH PROGRAM*. 2005.
- [Kim 07] Sunghoon Kim, Jeongho Park, Seong-Ik Cho, Soonyoung Park & Kyoungho Choi. *Lane detection using support vector machines*. In Proceedings of the Eleventh IASTED International Conference on Internet and Multimedia Systems and Applications, IMSA '07, pages 91–95, Anaheim, CA, USA, 2007. ACTA Press.
- [Kim 09] SeungJun Kim & Anind K Dey. *Simulated augmented reality windshield display as a cognitive mapping aid for elder driver navigation*. In Proceedings of the SIGCHI Conference on Human Factors in Computing Systems, pages 133–142. ACM, 2009.
- [Lee 01] John D Lee, Brent Caven, Steven Haake & Timothy L Brown. *Speech-based interaction with in-vehicle computers*:

- The effect of speech-based e-mail on drivers' attention to the roadway.* Human Factors: The Journal of the Human Factors and Ergonomics Society, vol. 43, no. 4, pages 631–640, 2001.
- [Lee 04] John D Lee & Katrina A See. *Trust in automation: Designing for appropriate reliance.* Human Factors: The Journal of the Human Factors and Ergonomics Society, vol. 46, no. 1, pages 50–80, 2004.
- [Li 08] Mu Li, Jia-Wei Fu & Bao-Liang Lu. *Estimating vigilance in driving simulation using probabilistic PCA.* In Engineering in Medicine and Biology Society, 2008. EMBS 2008. 30th Annual International Conference of the IEEE, pages 5000–5003. IEEE, 2008.
- [Li 12] Xuanpeng Li, E. Seignez, P. Loonis & A. Lambert. *Vision-based estimation of driving inattention fused via Dempster-Shafer theory.* In Cyber Technology in Automation, Control, and Intelligent Systems (CYBER), 2012 IEEE International Conference on, pages 393–398, 2012.
- [Liang 07] Yulan Liang, Michelle L Reyes & John D Lee. *Real-time detection of driver cognitive distraction using support vector machines.* Intelligent Transportation Systems, IEEE Transactions on, vol. 8, no. 2, pages 340–350, 2007.
- [Lin 12] Sheng Tong Lin, Ying Ying Tan, Pei Ying Chua, Lian Kheng Tey & Chie Hui Ang. *PERCLOS Threshold for Drowsiness Detection during Real Driving.* Journal of Vision, vol. 12, no. 9, page 546, 2012.
- [Lino 88] Tadashi Lino, Tatsumi Otsuka & Yoshiyuki Suzuki. *Development of heads-up display for a motor vehicle.* Rapport technique, SAE Technical Paper, 1988.

- [Liu 97] A. Liu & A. Pentland. *Towards real-time recognition of driver intentions*. In Intelligent Transportation System, 1997. ITSC '97., IEEE Conference on, pages 236–241, Nov 1997.
- [Ma 05] Ruiqi Ma & David B Kaber. *Situation awareness and workload in driving while using adaptive cruise control and a cell phone*. International Journal of Industrial Ergonomics, vol. 35, no. 10, pages 939–953, 2005.
- [Ma 07] R Ma & David B Kaber. *Situation awareness and driving performance in a simulated navigation task*. Ergonomics, vol. 50, no. 8, pages 1351–1364, 2007.
- [MacKay 92] David JC MacKay. *The evidence framework applied to classification networks*. Neural computation, vol. 4, no. 5, pages 720–736, 1992.
- [Mackworth 64] Jane F Mackworth. *Performance decrement in vigilance, threshold, and high-speed perceptual motor tasks*. Canadian Journal of Psychology/Revue canadienne de psychologie, vol. 18, no. 3, page 209, 1964.
- [Maltz 04] Masha Maltz & David Shinar. *Imperfect in-vehicle collision avoidance warning systems can aid drivers*. Human Factors: The Journal of the Human Factors and Ergonomics Society, vol. 46, no. 2, pages 357–366, 2004.
- [Matlin 02] M Matlin. *Cognition (5th)*. USA: Thomson Learning, 2002.
- [Matthews 01] Michael Matthews, David Bryant, Robert Webb & Joanne Harbluk. *Model for situation awareness and driving: Application to analysis and research for intelligent transportation systems*. Transportation Research Record: Journal of the Transportation Research Board, no. 1779, pages 26–32, 2001.

- [Maurer 12] Markus Maurer. *Forward collision warning and avoidance*. In Handbook of Intelligent Vehicles, pages 657–687. Springer, 2012.
- [McLaughlin 08] Shane B McLaughlin, Jonathan M Hankey & Thomas A Dingus. *A method for evaluating collision avoidance systems using naturalistic driving data*. Accident Analysis & Prevention, vol. 40, no. 1, pages 8–16, 2008.
- [McNicol 05] Don McNicol. A primer of signal detection theory. Psychology Press, 2005.
- [Merlo 99] James Louis Merlo. *Effect of Reliability on Cue Effectiveness and Display Signaling*. Rapport technique, DTIC Document, 1999.
- [Metz 78] Charles E Metz. *Basic principles of ROC analysis*. In Seminars in nuclear medicine, volume 8, pages 283–298. Elsevier, 1978.
- [Mobileye 15] Mobileye. *Mobileye Pedestrian Collision Warning (PCW)*. Online, 2015.
- [Mock 04] Charles Mock, Robert Quansah, Rajam Krishnan, Carlos Arreola-Risa & Frederick Rivara. *Strengthening the prevention and care of injuries worldwide*. The Lancet, vol. 363, no. 9427, pages 2172–2179, 2004.
- [Mohan 02] DINESH Mohan. *Work trips and safety of bicyclists*. Indian Journal of Transport Management, vol. 26, no. 2, pages 225–233, 2002.
- [Mountrakis 11] Giorgos Mountrakis, Jungho Im & Caesar Ogole. *Support vector machines in remote sensing: A review*. ISPRS Journal of Photogrammetry and Remote Sensing, vol. 66, no. 3, pages 247–259, 2011.



- [Murphy 10] K. Murphy. *Hidden Markov Model (HMM) toolbox for Matlab*. Available: <http://www.ai.mit.edu/~murphyk/Software/HMM/hmm.html>, 2010.
- [N. Schomig 13] B. Metz N. Schomig. *Three levels of situation awareness in driving with secondary tasks*. *Safety Science*, vol. 56, no. 0, pages 44 – 51, 2013. *Situation Awareness and Safety*.
- [Nakamura 04] K Nakamura, J Inada, M Kakizaki, T Fujikawa, S Kasiwada, H Ando & N Kawahara. *Windshield Display for Intelligent transport system*. In *Proceedings of the 11th World Congress on Intelligent Transportation Systems*, Nagoya, Japan, 2004.
- [Narzt 04] Wolfgang Narzt, Gustav Pomberger, Alois Ferscha, Horst Kolb & Christopher Lindinger. *A New Visualization Concept for Navigation Systems*. In Christian Stary & Constantine Stephanidis, editors, *User-Centered Interaction Paradigms for Universal Access in the Information Society*, volume 3196 of *Lecture Notes in Computer Science*, pages 440–451. Springer Berlin Heidelberg, 2004.
- [Neale 06] Vicki Lewis Neale & Catherine C McGhee. *Intersection decision support: evaluation of a violation Warning system to mitigate straight crossing path collisions*. Rapport technique, Virginia Transportation Research Council, 2006.
- [Nix 09] Axel Nix & James Kemp. *Full speed range adaptive cruise control system*, April 7 2009. US Patent App. 12/419,495.
- [Okabayashi 89] Shigeru Okabayashi, Masao Sakata, Jun'ichi Fukano, Shigetoshi Daidoji, Chikara Hashimoto & Tomonari Ishikawa. *Development of practical heads-up display for production vehicle application*. Rapport technique, SAE Technical Paper, 1989.

- [Oktal 15] Oktal. *Driving simulation engine SCAneR*. <http://www.scannersimulation.com>, 2015.
- [Östlund 04] J Östlund, L Nilsson, O Carsten, N Merat, H Jamson, S Jamson, S Mouta, J Carvalhais, J Santos, V Anttila *et al.* *HMI and safety-related driver performance*. 2004.
- [Osuna 97] Edgar Osuna, Robert Freund & Federico Girosi. *Training support vector machines: an application to face detection*. In *Computer Vision and Pattern Recognition, 1997. Proceedings., 1997 IEEE Computer Society Conference on*, pages 130–136. IEEE, 1997.
- [Paisitkriangkrai 13] S. Paisitkriangkrai, Chunhua Shen & A. van den Hengel. *Efficient Pedestrian Detection by Directly Optimizing the Partial Area under the ROC Curve*. In *Computer Vision (ICCV), 2013 IEEE International Conference on*, pages 1057–1064, Dec 2013.
- [Parasuraman 98] Raja Parasuraman, Joel S Warm & Judi E See. *Brain systems of vigilance*. 1998.
- [Park 12] Hye Sun Park & Kyong-Ho Kim. *Driver-view based augmented-reality HUD system: concept and background*. In *19th ITS World Congress*, 2012.
- [PathProject 15] PathProject. *Partners for Advanced Transportation Technology*. <http://www.path.berkeley.edu/>, 2015.
- [Pentland 99] Alex Pentland & Andrew Liu. *Modeling and prediction of human behavior*. *Neural computation*, vol. 11, no. 1, pages 229–242, 1999.
- [Pew 00] Richard W Pew. *The state of situation awareness measurement: Heading toward the next century*. *Situation awareness analysis and measurement*, pages 33–50, 2000.

- [Phan 14a] Minh Tien Phan, Vincent Fremont, Indira Thouvenin, Mohamed Sallak & Veronique Cherfaoui. *Recognizing Driver Awareness of Pedestrian*. In Intelligent Transportation Systems (ITSC), 2014 IEEE 17th International Conference on, pages 1027–1032, Oct 2014.
- [Phan 14b] Minh Tien Phan, Vincent Frémont, Indira Thouvenin, Mohamed Sallak & Véronique Cherfaoui. *Recognizing Driver Awareness of Pedestrian*. In Intelligent Transportation Systems (ITSC), 2014 IEEE 17th International Conference on, pages 1027–1032. IEEE, 2014.
- [Pioneer 15] Pioneer. *Pioneer Navgate HUD*, 2015.
- [Plavšić 10] Marina Plavšić, Gudrun Klinker & Heiner Bubb. *Situation awareness assessment in critical driving situations at intersections by task and human error analysis*. Human Factors and Ergonomics in Manufacturing & Service Industries, vol. 20, no. 3, pages 177–191, 2010.
- [PREVENT 15] PREVENT. *Preventive and Active Safety Application*. Online, 2015.
- [Previc 04] Fred H Previc. *Spatial disorientation in aviation*, volume 203. Aiaa, 2004.
- [Qian 10] Huihuan Qian, Yongsheng Ou, Xinyu Wu, Xiaoning Meng & Yangsheng Xu. *Support Vector Machine for Behavior-Based Driver Identification System*. Journal of Robotics, vol. 2010, 2010.
- [Rabiner 89] L. Rabiner. *A tutorial on hidden Markov models and selected applications in speech recognition*. Proceedings of the IEEE, vol. 77, no. 2, pages 257–286, Feb 1989.

- [Rakotomamonjy 04] Alain Rakotomamonjy. *Support vector machines and area under ROC curve*. PSI-INSA de Rouen: Technical Report, 2004.
- [Richard 06] Christian M Richard, John L Campbell & James L Brown. *Task analysis of intersection driving scenarios: Information processing bottlenecks*. Rapport technique, 2006.
- [Rover 15] Land Rover. *Jaguar Land Rover's HUD system*, 2015.
- [Rusch 13a] Michelle L. Rusch, Mark C. Schall Jr., Patrick Gavin, John D. Lee, Jeffrey D. Dawson, Shaun Vecera & Matthew Rizzo. *Directing driver attention with augmented reality cues*. Transportation Research Part F: Traffic Psychology and Behaviour, vol. 16, no. 0, pages 127 – 137, 2013.
- [Rusch 13b] Michelle L. Rusch, Mark C. Schall Jr., Patrick Gavin, John D. Lee, Jeffrey D. Dawson, Shaun Vecera & Matthew Rizzo. *Directing driver attention with augmented reality cues*. Transportation Research Part F: Traffic Psychology and Behaviour, vol. 16, no. 0, pages 127 – 137, 2013.
- [Santana Diaz 02] A. Santana Diaz, B. Jammes, D. Esteve & M. Gonzalez Mendoza. *Driver hypovigilance diagnosis using wavelets and statistical analysis*. In Intelligent Transportation Systems, 2002. Proceedings. The IEEE 5th International Conference on, pages 162–167, 2002.
- [Schall Jr 13] Mark C Schall Jr, Michelle L Rusch, John D Lee, Jeffrey D Dawson, Geb Thomas, Nazan Aksan & Matthew Rizzo. *Augmented reality cues and elderly driver hazard perception*. Human Factors: The Journal of the Human Factors and Ergonomics Society, vol. 55, no. 3, pages 643–658, 2013.
- [Sferco 01] Raimondo Sferco, Yves Page, Jean-Yves Le Coz & P Fay. *Potential effectiveness of electronic stability programs (ESP)–*

- 
- What European field studies tell us.* In Proceeding of 17 th ESV Conference. Amsterdam, The Netherlands, 2001.
- [Shaout 11] Adnan Shaout, Dominic Colella & S Awad. *Advanced driver assistance systems-past, present and future.* In Computer Engineering Conference (ICENCO), 2011 Seventh International, pages 72–82. IEEE, 2011.
- [Sigari 13] Mohamad-Hoseyn Sigari, Mahmood Fathy & Mohsen Soryani. *A driver face monitoring system for fatigue and distraction detection.* International journal of vehicular technology, vol. 2013, 2013.
- [Singh 15] Santokh Singh. *Critical Reasons for Crashes Investigated in the National Motor Vehicle Crash Causation Survey.* Rapport technique, 2015.
- [Smith 95] Kip Smith & Peter A Hancock. *Situation awareness is adaptive, externally directed consciousness.* Human Factors: The Journal of the Human Factors and Ergonomics Society, vol. 37, no. 1, pages 137–148, 1995.
- [Spitzer 14] Cary Spitzer, Uma Ferrell & Thomas Ferrell. *Digital avionics handbook.* CRC Press, 2014.
- [Starner 95] T. Starner, A.P. Pentland, Massachusetts Institute of Technology. Media Laboratory. Vision, Modeling Group & Massachusetts Institute of Technology. Perceptual Computing Section. Visual recognition of american sign language using hidden markov models. M.I.T. Media Lab Vision and Modeling Group technical report. Perceptual Computing Section, Media Laboratory, Massachusetts Institute of Technology, 1995.
- [Statistics 13] Laerd Statistics. *One-way ANOVA in SPSS.* Retrieved December, vol. 21, page 2013, 2013.

- [Stiller 11] Christoph Stiller, Fernando Puente Leòn & Marco Kruse. *Information fusion for automotive applications—An overview*. *Information fusion*, vol. 12, no. 4, pages 244–252, 2011.
- [Szabó 95] Katalin Szabó. *Metaphors and the user interface*. U RI: <http://www.katalinszabo.com/metaphor.htm> (visited on 03/05/2015), 1995.
- [Takaki 11] Yasuhiro Takaki, Yohei Urano, Shinji Kashiwada, Hiroshi Ando & Koji Nakamura. *Super multi-view windshield display for long-distance image information presentation*. *Optics express*, vol. 19, no. 2, pages 704–716, 2011.
- [Talbot 13] Rachel Talbot, Helen Fagerlind & Andrew Morris. *Exploring inattention and distraction in the SafetyNet Accident Causation Database*. *Accident Analysis & Prevention*, vol. 60, pages 445–455, 2013.
- [Techcrunch 11] Techcrunch. *Pioneer Shows Augmented Reality-Powered Car Navigation System*, May 2011.
- [Thiffault 03] Pierre Thiffault & Jacques Bergeron. *Monotony of road environment and driver fatigue: a simulator study*. *Accident Analysis & Prevention*, vol. 35, no. 3, pages 381–391, 2003.
- [Tipping 01] Michael E Tipping. *Sparse Bayesian learning and the relevance vector machine*. *The journal of machine learning research*, vol. 1, pages 211–244, 2001.
- [Tong 02] Simon Tong & Daphne Koller. *Support vector machine active learning with applications to text classification*. *The Journal of Machine Learning Research*, vol. 2, pages 45–66, 2002.
- [Tonnis 06] Marcus Tonnis & Gudrun Klinker. *Effective control of a car driver’s attention for visual and acoustic guidance towards the direction of imminent dangers*. In *Proceedings of the*

- 
- 5th IEEE and ACM International Symposium on Mixed and Augmented Reality, pages 13–22. IEEE Computer Society, 2006.
- [Treat 80] John R Treat. *A study of precrash factors involved in traffic accidents*. HSRI Research Review, 1980.
- [Trivedi 07] M.M. Trivedi, T. Gandhi & J. McCall. *Looking-In and Looking-Out of a Vehicle: Computer-Vision-Based Enhanced Vehicle Safety*. Intelligent Transportation Systems, IEEE Transactions on, vol. 8, no. 1, pages 108–120, March 2007.
- [Ueno 94] H. Ueno, M. Kaneda & M. Tsukino. *Development of drowsiness detection system*. In Vehicle Navigation and Information Systems Conference, 1994. Proceedings., 1994, pages 15–20, 1994.
- [Vanderhaegen 14] Frédéric Vanderhaegen. *Dissonance Engineering: A New Challenge to Analyse Risky Knowledge When using a System*. International Journal of Computers Communications & Control, vol. 9, no. 6, pages 776–785, 2014.
- [Victor 08] Trent W Victor, Johan Engström & Joanne L Harbluk. *10 Distraction Assessment Methods Based on Visual Behavior and Event Detection*. Driver distraction: theory, effects, and mitigation, page 135, 2008.
- [Wada 03] Massaki Wada, Kang Sup Yoon & Hideki Hashimoto. *Development of advanced parking assistance system*. Industrial Electronics, IEEE Transactions on, vol. 50, no. 1, pages 4–17, 2003.
- [Ward 94] Nicholas J Ward & Andrew Parkes. *Head-up displays and their automotive application: An overview of human factors issues affecting safety*. Accident Analysis & Prevention, vol. 26, no. 6, pages 703–717, 1994.

- [Ward 00] Nicholas J Ward. *Automation of task processes: An example of intelligent transportation systems*. Human Factors and Ergonomics in Manufacturing & Service Industries, vol. 10, no. 4, pages 395–408, 2000.
- [Webster 05] Merriam Webster. *Online dictionary*, 2005.
- [Wesley 10] Avinash Wesley, Dvijesh Shastri & Ioannis Pavlidis. *A novel method to monitor driver’s distractions*. In CHI’10 Extended Abstracts on Human Factors in Computing Systems, pages 4273–4278. ACM, 2010.
- [WHO 13] WHO. *World Health Organization, 2013. Global Status Report on Road Safety Supporting a decade of action*. 2013.
- [Wood 06] Robert B Wood & Peter J Howells. *Head-up displays*. CRC Prss LLC, URL: [http://www.davi.ws/avionics/TheAvionicsHandbook\\_Cap\\_4.pdf](http://www.davi.ws/avionics/TheAvionicsHandbook_Cap_4.pdf) [cited 14 July 2014], 2006.
- [Yang 95] L. Yang, B.K. Widjaja & R. Prasad. *Application of hidden Markov models for signature verification*. Pattern Recognition, vol. 28, no. 2, pages 161 – 170, 1995.
- [Yasui 02] Nobuhiko Yasui & Atsushi Iisaka. *Parking assistance system*, November 19 2002. US Patent 6,483,429.
- [Yeh 99] Michelle Yeh, Christopher D Wickens & F Jacob Seagull. *Target cuing in visual search: the effects of conformality and display location on the allocation of visual attention*. Human Factors: The Journal of the Human Factors and Ergonomics Society, vol. 41, no. 4, pages 524–542, 1999.
- [Yeh 01] Michelle Yeh & Christopher D Wickens. *Display signaling in augmented reality: Effects of cue reliability and image realism on attention allocation and trust calibration*. Human



- Factors: The Journal of the Human Factors and Ergonomics Society, vol. 43, no. 3, pages 355–365, 2001.
- [Yeo 01] Jung-hack Yeo. *Driver's drowsiness detection method of drowsy driving warning system*, June 5 2001. US Patent 6,243,015.
- [Yogameena 10] B Yogameena, S Veera Lakshmi, M Archana & S Raju Abhaikumar. *Human behavior classification using multi-class relevance vector machine*. Journal of Computer Science, vol. 6, no. 9, pages 1021–6, 2010.
- [Yoshiharu 69] Katagiri Yoshiharu, Miyaoka Senri, Ohgoshi Akio & Yoshida Susumu. *Cathode ray tube*, June 3 1969. US Patent 3,448,316.
- [Yu 07] Hong Yu, Li-Chen Shi & Bao-Liang Lu. *Vigilance estimation based on EEG signals*. In Proceedings of IEEE/ICME International Conference on Complex Medical Engineering, 2007.