



**HAL**  
open science

## Shift spaces on groups : computability and dynamics

Sebastián Andrés Barbieri Lemp

► **To cite this version:**

Sebastián Andrés Barbieri Lemp. Shift spaces on groups : computability and dynamics. Computation and Language [cs.CL]. Université de Lyon, 2017. English. NNT : 2017LYSEN021 . tel-01563302

**HAL Id: tel-01563302**

**<https://theses.hal.science/tel-01563302v1>**

Submitted on 17 Jul 2017

**HAL** is a multi-disciplinary open access archive for the deposit and dissemination of scientific research documents, whether they are published or not. The documents may come from teaching and research institutions in France or abroad, or from public or private research centers.

L'archive ouverte pluridisciplinaire **HAL**, est destinée au dépôt et à la diffusion de documents scientifiques de niveau recherche, publiés ou non, émanant des établissements d'enseignement et de recherche français ou étrangers, des laboratoires publics ou privés.



Numéro National de Thèse : 2017LYSEN021

## Thèse de Doctorat de l'Université de Lyon

opérée par,

### **l'École Normale Supérieure de Lyon**

École doctorale InfoMaths N° 512

École doctorale en Informatique et Mathématiques de Lyon

Spécialité de doctorat : Informatique

Soutenue publiquement le 28 juin 2017 par,

**Sebastián Andrés BARBIERI LEMP**

---

# Shift spaces on groups: computability and dynamics

Calculabilité et dynamique des sous-décalages sur des  
groupes

---

Devant le jury composé de :

<b>Berthé, Valérie</b>	Directrice de Recherche, Université Paris Diderot - Paris 7	rapporteuse
<b>Marcus, Brian</b>	Professeur, University of British Columbia	rapporteur
<b>Petite, Samuel</b>	Maître de Conférences, Université de Picardie Jules Verne	rapporteur
<b>Aubrun, Nathalie</b>	Chargée de Recherche, ENS de Lyon	co-encadrante
<b>De Cornulier, Yves</b>	Chargé de Recherche, Université Paris-Sud	membre
<b>Ghys, Étienne</b>	Directeur de Recherche, ENS de Lyon	membre
<b>Jeandel, Emmanuel</b>	Professeur des Universités, Université de Lorraine	membre
<b>Thomassé, Stéphan</b>	Professeur des Universités, ENS de Lyon	directeur

## Résumé

Les sous-décalages sont des ensembles de coloriages d'un groupe définis en excluant certains motifs, et munis d'une action de décalage. Ces objets apparaissent naturellement comme discrétisations de systèmes dynamiques : à partir d'une partition de l'espace, on associe à chaque point de ce dernier la suite des partitions visitées sous l'action du système.

Plusieurs résultats récents ont mis en évidence la riche interaction entre la dynamique des sous-décalages et leur propriétés algorithmiques. Un exemple remarquable est la classification des entropies des sous-décalages multidimensionnels de type fini comme l'ensemble des nombres récursivement énumérables à droite. Cette thèse s'intéresse aux sous-décalages avec une approche double : d'un côté on s'intéresse à leurs propriétés dynamiques et de l'autre on les étudie comme des modèles de calcul.

Cette thèse contient plusieurs résultats : une condition combinatoire suffisante prouvant qu'un sous-décalage dans un groupe dénombrable est non-vide, un théorème de simulation qui réalise une action effective d'un groupe de type fini comme un facteur d'une sous-action d'un sous-décalage de type fini, une caractérisation de l'effectivité à l'aide de machines de Turing généralisées et l'indécidabilité du problème de torsion pour deux groupes, qui sont invariants de systèmes dynamiques.

Comme corollaires de nos résultats, nous obtenons d'abord une preuve courte de l'existence de sous-décalages fortement apériodiques sur tout groupe dénombrable. Puis, dans le cas d'un produit semi-direct de la grille bidimensionnelle avec un groupe de type fini avec problème du mot décidable, nous montrons que le sous-décalage obtenu est de type fini.

## Abstract

Shift spaces are sets of colorings of a group which avoid a set of forbidden patterns and are endowed with a shift action. These spaces appear naturally as discrete versions of dynamical systems: they are obtained by partitioning the phase space and mapping each element into the sequence of partitions visited by its orbit.

Several breakthroughs in this domain have pointed out the intricate relationship between dynamics of shift spaces and their computability properties. One remarkable example is the classification of the entropies of multidimensional subshifts of finite type as the set of right recursively enumerable numbers. This work explores shift spaces with a dual approach: on the one hand we are interested in their dynamical properties and on the other hand we study these objects as computational models.

Four salient results have been obtained as a result of this approach: (1) a combinatorial condition ensuring non-emptiness of subshifts on arbitrary countable groups; (2) a simulation theorem which realizes effective actions of finitely generated groups as factors of a subaction of a subshift of finite type; (3) a characterization of effectiveness with oracles using generalized Turing machines and (4) the undecidability of the torsion problem for two group invariants of shift spaces.

As byproducts of these results we obtain a simple proof of the existence of strongly aperiodic subshifts in countable groups. Furthermore, we realize them as subshifts of finite type in the case of a semidirect product of a  $d$ -dimensional integer lattice with a finitely generated group with decidable word problem whenever  $d > 1$ .

# Sommaire

Résumé	2
Abstract	3
Introduction en français	v
Introduction in english	xiv
<b>1 Shift spaces</b>	<b>1</b>
1.1 Subshifts in groups . . . . .	2
1.1.1 Symbolic morphisms . . . . .	4
1.1.2 Dynamical properties . . . . .	6
1.2 Classes of subshifts . . . . .	9
1.2.1 Subshifts of finite type . . . . .	9
1.2.2 Sofic subshifts . . . . .	14
1.2.3 Effectively closed subshifts . . . . .	16
<b>2 Free actions and densities in subshifts</b>	<b>24</b>
2.1 Non-empty strongly aperiodic subshifts . . . . .	25
2.1.1 Lovász local lemma . . . . .	27
2.1.2 A non-empty strongly aperiodic subshift over $\{0,1\}$ in any countable group. . . . .	28
2.1.3 A graph-oriented construction and some computational properties	29
2.2 Realization of densities . . . . .	33
<b>3 A simulation theorem for actions of finitely generated groups</b>	<b>43</b>
3.1 Introduction: simulation theorems . . . . .	43
3.2 Substitutions and Toeplitz configurations . . . . .	47
3.2.1 Substitutions . . . . .	47
3.2.2 Toeplitz configurations . . . . .	49
3.3 The simulation theorem . . . . .	50
3.3.1 A set of $\mathbb{Z}^2$ -substitutions which are permuted by actions of $\text{Aut}(\mathbb{Z}^2)$ . . . . .	51
3.3.2 Encoding configurations in Toeplitz sequences. . . . .	54
3.3.3 Proof of Theorem 3.7 . . . . .	57
3.4 Consequences and remarks . . . . .	62

3.4.1	The simulation theorem for expansive effective dynamical systems	63
3.4.2	Existence of strongly aperiodic SFT in a class of groups obtained by semidirect products	65
3.4.3	A generalization and comments on the size of the extension	67
<b>4</b>	<b>A new notion of effectiveness for subshifts in groups</b>	<b>68</b>
4.1	The One-or-less subshift	69
4.2	$G$ -effectiveness and $G$ -machines	70
4.2.1	Application: a simulation theorem with oracles	78
4.3	Separating sofic and effective subshifts	84
<b>5</b>	<b>Computability in group invariants of shift spaces</b>	<b>89</b>
5.1	Two group invariants of shift spaces	91
5.2	Computability properties	94
5.2.1	Computability in the topological full group	97
5.2.2	Computability in the automorphism group	105
	<b>Conclusions et perspectives en français</b>	<b>112</b>
	<b>Conclusions and perspectives</b>	<b>115</b>
<b>A</b>	<b>Computability</b>	<b>117</b>
A.1	Languages and Turing machines	117
A.2	Computable functions, sets and numbers	120
A.2.1	Oracles and reductions	121
<b>B</b>	<b>Group Theory</b>	<b>123</b>
B.1	Basic definitions	123
B.1.1	Group homomorphisms	124
B.1.2	Free groups and presentations	125
B.1.3	Cayley graph and generator metrics	126
B.1.4	Recursive presentations and the word problem	126
B.2	Classes of groups	129
B.2.1	Abelian groups	129
B.2.2	Amenable groups	129
B.2.3	Residually finite groups	131
<b>C</b>	<b>Dynamical Systems</b>	<b>132</b>
C.1	Dynamical systems and topological morphisms	132
C.2	Expansive, equicontinuous and distal systems	133
C.3	Entropy	135
	<b>Bibliography</b>	<b>137</b>

# List of Figures

1	Une partition de $X$ en deux sous-ensembles, et le codage associé de l'orbite de $x \in X$ . . . . .	vi
2	Une configuration d'un $\mathbb{Z}^2$ -sous-décalage défini par motifs interdits. . . . .	vii
3	Le graphe de dépendance des chapitres. . . . .	xii
4	Diagrammes indiquant proportionnellement les connaissances requises pour chacun des chapitres. . . . .	xiii
5	A partition of $X$ into two parts and a coding of the orbit of $x \in X$ . . . . .	xv
6	A configuration of a $\mathbb{Z}^2$ -subshift defined by forbidden patterns. . . . .	xvi
7	The dependence graph of the chapters . . . . .	xx
8	Pie charts indicating the percentage of knowledge required in each subject for every chapter . . . . .	xxi
1.1	A configuration $x \in \{\blacksquare, \square\}^{\mathbb{Z}^2/20\mathbb{Z}^2}$ and its image by $\sigma^{(10,18)}$ . . . . .	2
1.2	The majority rule sliding block code acting on a $\mathbb{Z}^2$ configuration. . . . .	4
1.3	From left to right: An aperiodic, periodic, strongly periodic and uniform configuration in $\{\square, \blacksquare\}^{\mathbb{Z}^2}$ . . . . .	6
1.4	A configuration in the Ledrappier subshift. . . . .	10
1.5	If the set $C$ is interpreted as a finite set of colors, a Wang tile defined by a tuple $(t_N, t_W, t_S, t_E)$ of colors and can be represented as shown. . . . .	12
1.6	A tiling $\tau$ and a partial valid tiling of the plane. . . . .	12
1.7	The transformation of a forbidden pattern into a Wang tile. . . . .	13
1.8	SFT extension for $X_{\leq 1}$ in the case of a free group. . . . .	15
1.9	Configuration in the mirror shift and technique showing non-soficity. . . . .	19
2.1	The set of Robinson tiles up to rotation and reflection. . . . .	25
2.2	A macrotile appearing in the Robinson tiling. . . . .	26
2.3	Two colorings of $C_5$ . The left is not square-free and the right one is. . . . .	30
2.4	In green, an example of 2-covering and 2-separating set in $PSL(2, \mathbb{Z}) \cong \mathbb{Z}/2\mathbb{Z} * \mathbb{Z}/3\mathbb{Z}$ . Green vertices are at distance at least 3 from each other, and every vertex is at distance at most 2 from a green vertex. . . . .	35
2.5	A covering forest of $G$ . In the left section of the image the edge structure is emphasized by writing the parent functions explicitly. In the right section we remark the cluster structure for $g \in A_2$ . . . . .	37
2.6	A path from an element $h$ of $\mathcal{C}_n(g)$ to $g$ which inductively proves the inclusion $\mathcal{C}_n(g) \subset B_S(g, \frac{1}{2}(5^n - 1))$ . . . . .	38

3.1	A substitution rule $r$ generating a side of Koch’s snowflake [Koc06]. . . . .	47
3.2	First four iterations of the Sierpiński triangle substitution. . . . .	48
3.3	The patterns of order 3 and 4 of $\mathfrak{s}_v$ for $v = (1, 1)$ . . . . .	52
3.4	The diagram for the proof of Theorem 3.15. . . . .	64
4.1	A fixed head transition of an $F_2$ -machine. . . . .	73
4.2	A moving head transition of a $\mathbb{Z}^2$ -machine. . . . .	73
4.3	Construction of the machine $\mathcal{M}$ as a multiple head $G$ -machine. . . . .	76
4.4	Example of a configuration of $Y_2$ for the group $\mathbb{Z}^2$ with the canonical generators. The symbols 0, 1 and 2 are represented by the colors $\blacksquare$ , $\square$ and $\blacksquare$ respectively. . . . .	79
4.5	A typical configuration in $U \subseteq (\{\bullet, \star, \oplus, \triangleright\} \cup S) \times \{0, 1, 2\}^{G \times \mathbb{Z}}$ . Symbols on the left side of the picture correspond to the first coordinate of the configuration, and the part in $\{0, 1, 2\}^{G \times \mathbb{Z}}$ is on the right. On the example, the bottom $\oplus$ is the $n$ -th appearance after $\star$ . . . . .	81
4.6	A sofic subshift which doubles its period. . . . .	84
5.1	Basic coding of the construction. The outer ring of 1s (blue) codes the boundary of the cell and the state. The middle ring of 0s separates the zones. The inner ring (green) codes the information. . . . .	101
5.2	An example of macrotile $\mathcal{M}(t)$ of side $M = 6$ . The red arrows represent the function $\mathbf{left}(t) = (1, 0)$ while the blue arrows represent $\mathbf{right}(t) = (0, 1)$ . The bottom left black square represents $b_{5,1} = 1$ . . . . .	103
5.3	A finite word in $\mathcal{A}^*$ is divided into zones by the third tape. The dashed lines separate each zone and the colours indicate which tape is being pointed at by the arrow next to the state. . . . .	109
5.4	Every zone is wrapped around as a conveyor belt, where $\phi(T)$ acts as if it were $T$ seeing a periodic word. . . . .	110
A.1	A Turing machine transition where $\delta(\blacksquare, q) = (\square, r, +1)$ . . . . .	118
A.2	A representation of the transition function of a machine deciding $L$ . . . . .	119
C.1	The application of Arnold’s cat transformation on “The Hermitage Court Outrunner Cat” by Eldar Zakirov . . . . .	132



# Introduction

Dans sa définition classique, un système dynamique consiste en un couple  $(X, T)$ , où  $X$  est un ensemble et  $T : \mathbb{R}^+ \times X \rightarrow X$  est une fonction décrivant l'évolution des éléments de  $X$  au cours du temps. Ces objets mathématiques sont intéressants non seulement en tant que tels, mais aussi parce qu'ils permettent de décrire des phénomènes physiques, comme par exemple le comportement du système solaire, l'évolution d'un écosystème au cours du temps, les variations de concentration d'une molécule donnée dans un mélange chimique soumis à la chaleur, ou encore la trajectoire d'une particule chargée dans un champ magnétique.

D'un point de vue strictement mathématique, il n'y a aucune justification théorique à limiter l'étude des systèmes dynamiques à ceux définis avec un temps continu : un système peut tout aussi bien être analysé à pas de temps discrets. De plus, si l'évolution du système est réversible, alors son action peut être modélisée par un groupe abstrait agissant sur l'ensemble  $X$ . Cette modification est tout à fait naturelle si l'on s'intéresse à l'action conjointe de plusieurs homéomorphismes  $T_1, \dots, T_n$ , qui en plus d'agir sur le même espace  $X$  satisfont un ensemble de relations  $R$ . Ces actions et leurs relations peuvent s'exprimer par l'action d'un groupe  $T : G \curvearrowright X$  où  $G \cong \langle T_1, \dots, T_n \mid R \rangle$  et  $T(T_{i_1} \cdots T_{i_k}, x) = T_{i_1} \circ \cdots \circ T_{i_k}(x)$ . Par exemple, si la seule relation  $T_1 \circ T_2 = T_2 \circ T_1$  existe, alors l'action conjointe de  $T_1$  et  $T_2$  peut être étudiée comme une  $\mathbb{Z}^2$ -action sur  $X$ . Ceci justifie pleinement l'étude du cas général, pour un système dynamique, d'un groupe dénombrable arbitraire agissant sur l'espace.

Ces systèmes peuvent se révéler difficiles à étudier, et tout un panel d'outils a été développé afin d'améliorer leur compréhension. Une approche particulièrement intéressante considère une partition finie de l'ensemble  $X$ , et code chaque élément de l'ensemble  $X$  par la suite des partitions visitées par son orbite. On retrouve cette idée originellement dans les travaux d'Hadamard [Had98], qui étudie les géodésiques de surface de courbure négative. Cette idée sera fréquemment réutilisée par la suite, mais la première étude véritablement dédiée à cette technique se trouve dans le travail fondateur de Morse et Hedlund [HM38]. Leur article «Symbolic dynamics» présente la première description systématique de ce qui était jusqu'alors une technique utilisée de manière sporadique pour étudier les propriétés de récurrence dans les systèmes dynamiques.

Avant d'introduire la dynamique symbolique dans le cas général, définissons plus précisément ce qui est entendu par codification d'un système dynamique par une partition. Prenons le cas particulier où  $T$  est une  $\mathbb{Z}$ -action par homéomorphismes d'un espace topologique compact  $X$  et  $\mathcal{P} = \{P_1, \dots, P_n\}$  est une partition d'ouverts-fermés de  $X$ . Considérons la fonction  $\varphi : X \rightarrow \{1, \dots, n\}^{\mathbb{Z}}$  définie par

$$\varphi(x)(n) = i \iff T^n(x) \in P_i.$$

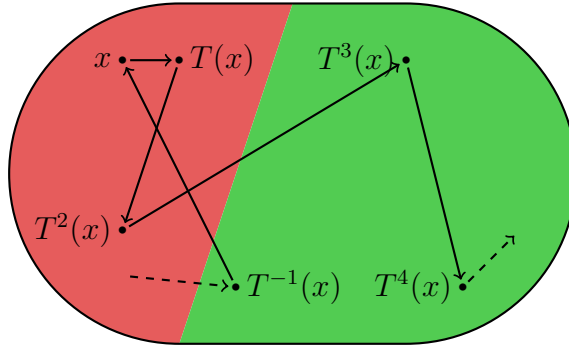

$$\varphi(x) = \cdots \begin{array}{cccccc} \color{green}\blacksquare & \color{red}\blacksquare & \color{red}\blacksquare & \color{red}\blacksquare & \color{green}\blacksquare & \color{green}\blacksquare \\ -1 & 0 & 1 & 2 & 3 & 4 \end{array} \cdots \in \{\color{red}\blacksquare, \color{green}\blacksquare\}^{\mathbb{Z}}$$

Figure 1: Une partition de  $X$  en deux sous-ensembles, et le codage associé de l'orbite de  $x \in X$

Cette fonction  $\varphi$  associe à chaque élément  $x$  de  $X$  la suite d'étiquettes qui décrit les éléments de la partition visités par  $x$  sous l'action de l'homéomorphisme  $T$ , comme illustré sur la Figure 5. Considérons à présent l'ensemble de toutes les suites obtenues comme un codage

$$\varphi(X) = \{y \in \{1, \dots, n\}^{\mathbb{Z}} \mid \exists x \in X, y = \varphi(x)\}.$$

Cet ensemble  $\varphi(X)$  présente deux propriétés intéressantes. D'abord,  $\varphi(X)$  est fermé pour la topologie produit. Ensuite, si on munit  $\{1, \dots, n\}^{\mathbb{Z}}$  de la fonction  $\sigma$  qui décale une suite vers la gauche, on obtient que  $\sigma(\varphi(x)) = \varphi(T(x))$  et donc que  $\varphi(X)$  est invariant par l'action du décalage. Cela fait de  $(\varphi(X), \sigma)$  lui-même un système dynamique.

Selon la partition choisie, le système codé  $(\varphi(X), \sigma)$  présentera plus ou moins d'intérêt par rapport au système initial  $(X, T)$ . Si la partition triviale à un seul élément est utilisée, alors le système codé ne contiendra qu'une seule configuration, ce qui est inintéressant. Il est néanmoins possible de montrer qu'une grande classe de systèmes dynamiques, ceux pour lesquels  $X$  est un espace topologique de dimension zéro et où l'action  $T$  est expansive, peut être codée de façon à préserver toutes les propriétés dynamiques du système initial.

Etudier les systèmes dynamiques à travers leurs codages confère un double bénéfice. D'une part, un homéomorphisme  $T$  potentiellement compliqué est remplacé par un simple décalage sur un ensemble de suites, et donc la complexité de  $T$  se retrouve encodée dans la topologie du codage. D'autre part, si le système codé peut se représenter de façon finie, il devient possible de l'étudier sous l'angle de la calculabilité.

La dynamique symbolique étudie les systèmes dynamiques à travers leurs codages. Ces objets sont appelés espaces de décalages ou encore sous-décalages. D'un point de vue moderne, on peut comprendre les sous-décalages comme des ensembles de coloriage d'un groupe  $G$  par un alphabet fini  $\mathcal{A}$  qui soient à la fois fermés et invariants

par décalage. Il est intéressant de noter que tout sous-décalage peut aussi se décrire d'un point de vue combinatoire, comme l'ensemble des coloriage de  $G$  qui évitent un ensemble de coloriages finis.

Plus précisément, un motif est un coloriage d'une partie finie d'un groupe. Par exemple, si on considère le groupe additif  $(\mathbb{Z}^2, +)$  et l'alphabet  $\mathcal{A} = \{\blacksquare, \blacksquare, \blacksquare\}$ , deux exemples de motifs avec supports respectifs  $F_1 = \{(0, 0), (1, 0)\}$  et  $F_2 = \{(0, 0), (0, 1)\}$  sont  $\blacksquare\blacksquare$  et  $\blacksquare$ . A partir d'un ensemble de motifs, on peut définir un sous-décalage comme l'ensemble des coloriages dans lesquels aucun décalage de ces motifs n'apparaît. Par exemple, un coloriage appartenant au sous-décalage défini par les deux motifs ci-dessus est présenté sur la Figure 6. A partir de maintenant, nous utiliserons le terme «configurations» pour parler de coloriages.

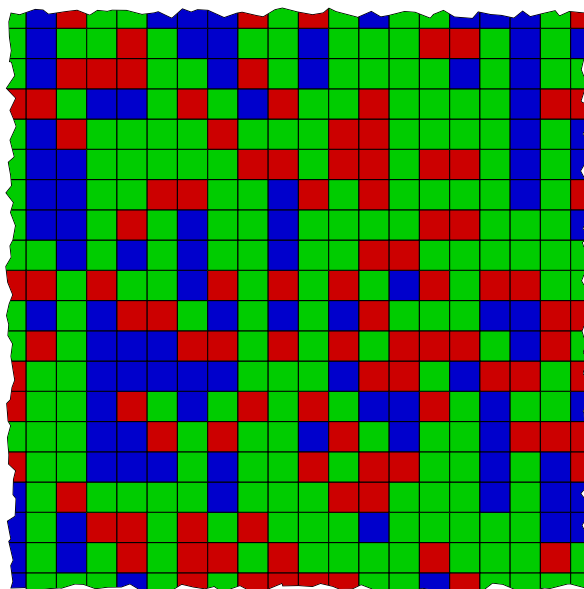

Figure 2: Une configuration d'un  $\mathbb{Z}^2$ -sous-décalage défini par motifs interdits.

Cette description des sous-décalages à l'aide de motifs interdits donne lieu à trois classes de sous-décalages, que l'on peut classer par complexité croissante de l'ensemble des motifs interdits qui les définissent. La première classe est la classe des sous-décalages de type fini (SFT), ceux que l'on peut définir par une liste finie de motifs interdits (l'exemple précédent en fait donc partie). La deuxième classe est celle des sous-décalages sofiques, qui s'obtiennent comme facteurs de SFT par une fonction qui ne dépend que d'un voisinage fini. Enfin on définit la classe des sous-décalages effectivement fermés, qui sont les sous-décalages que l'on peut définir à l'aide d'un ensemble récursivement énumérable de motifs interdits.

Les sous-décalages ont été particulièrement étudiés dans le cas de  $\mathbb{Z}$ -actions, et la majorité des principaux résultats connus à ce jour concernant ces objets se trouve dans [LM95]. En particulier, les SFT et sous-décalages sofiques possèdent une caractérisation à l'aide de graphes étiquetés, et leurs entropies sont exactement les multiples rationnels positifs de logarithmes de nombres de Perron [Lin84]. De plus, les sous-décalages de type fini contiennent toujours des configurations périodiques, et de

nombreux invariants dynamiques peuvent être calculés de façon effective à l’aide de leur description finie. Cependant, même si ces objets sont bien compris, des questions ouvertes subsistent, comme celle de savoir si on peut décider de manière algorithmique si deux sous-décalages sont topologiquement conjugués, autrement dit s’ils sont indistingables du point de vue de la dynamique topologique [Boy08].

Plus récemment, les  $\mathbb{Z}^d$ -sous-décalages pour  $d \geq 2$  ont reçu une attention particulière de la part de la communauté [BS08, BS09, PS14, KM13]. De nombreuses propriétés satisfaites par les sous-décalages de type fini de dimension 1 ne le sont pas en dimension supérieure. Par exemple, il existe des SFT de dimension 2 qui ne contiennent aucune configuration périodique [Ber66, Rob71, Kar96] ou même seulement des configurations non-récurrentes [Han74, Mye74]. De façon similaire, un SFT de dimension 1 avec une entropie suffisamment grande se factorise sur l’ensemble de toutes les configurations, alors qu’on sait montrer que ce n’est pas nécessairement le cas en dimension supérieure [BPS10]. Du point de vue de la calculabilité, le problème de décider si un sous-décalage défini par un ensemble fini de motifs interdits est non vide devient indécidable [Ber66]. Une explication possible à ce résultat surprenant est que les SFT et sous-décalages sofiques de dimension supérieure sont très proches des sous-décalages effectivement fermés de dimension moindre.

Un résultat d’Hochman [Hoc09] montre que tout système dynamique sur un ensemble de Cantor peut, s’il est effectivement fermé, se réaliser comme la sous-action d’un SFT de dimension 3. Ce résultat a été amélioré de manière significative dans le cas particulier des sous-décalages, pour lesquels on sait montrer que tout sous-décalage effectivement fermé sur  $\mathbb{Z}$  peut être obtenu comme la sous-action projective d’un SFT sur  $\mathbb{Z}^2$ . En d’autres termes, cela signifie que des sous-décalages unidimensionnel complexes peuvent apparaître comme les projections horizontales d’un sous-décalage de dimension 2 très simple. Une conséquence fondamentale de ces résultats est le travail novateur de Hochman et Meyerovitch [HM10], qui montre que l’ensemble des nombres que l’on peut obtenir comme entropie topologique de SFT de dimension 2 est exactement l’ensemble des nombres récursivement énumérables à droite. Ce résultat illustre parfaitement les liens forts entre systèmes dynamiques multidimensionnels et notions de calculabilité.

Ces dernières années, les sous-décalages définis sur des groupes quelconques ont gagné en intérêt, comme l’attestent les récents travaux [Pia06, Pia08, Kri07b, FT15, CP15, LP16]. Dans ce contexte général, des phénomènes encore plus compliqués peuvent surgir. Par exemple, si le groupe  $G$  n’est pas résiduellement fini, il n’est plus vrai que l’ensemble des configurations périodiques est dense dans l’ensemble de toutes les configurations [CSC09]. De plus, si  $G$  devient plus complexe d’un point de vue calculabilité, il peut devenir impossible de détecter de manière algorithmique si un codage de motif est cohérent [ABS17]. Il est donc intéressant de s’interroger sur les propriétés de groupe responsables de ces comportements. Par exemple, on peut montrer que pour des groupes récursivement présentés, des sous-décalages de type fini ne contenant aucune configuration périodique peuvent exister, à condition que le groupe ait un problème du mot décidable [Jea15]. Des questions de calculabilité sur des sous-décalages définis sur un groupe de type fini ont été étudiés à de multiples reprises ces dernières années [BS13, Coh17, ST15, Jea15].

L'objectif de cette thèse est de comprendre en profondeur la nature des interactions entre propriétés dynamiques et propriétés de calculabilité des sous-décalages sur des groupes. En particulier, nous nous attaquons aux problèmes suivants : réaliser certaines structures dans des groupes, comme des sous-décalages ne contenant aucune configuration périodique, ou bien des sous-décalages avec densités uniformes ; le problème de simuler une action effectivement fermée sur un ensemble de Cantor par une action plus simple sur un groupe plus grand ; définir un bon modèle de calcul sur des groupes avec problème du mot indécidable ; comprendre les propriétés de calculabilité de certains invariants classiques de sous-décalages, comme le groupe d'automorphismes ou encore le groupe plein topologique, et en particulier la décidabilité des problèmes du mot et de torsion.

### Principales contributions

Un résultat dû à Miller [Mil12] donne une condition combinatoire sur un ensemble de mots interdits qui suffit à assurer que le  $\mathbb{Z}$ -sous-décalage qu'il définit est non vide. Notre premier résultat généralise la condition de Miller au cas d'un groupe dénombrable arbitraire : nous donnons ainsi une condition combinatoire sur un ensemble de motifs interdits qui, si elle est vérifiée, garantit la non vacuité du sous-décalage qu'il définit. Cette condition est obtenue en appliquant une technique fréquemment utilisée en théorie des graphes : la version asymétrique du lemme local de Lovász. Nous appliquons cette condition à une suite bien choisie de motifs pour obtenir une preuve non constructive de l'existence d'un sous-décalage non vide fortement aperiodique sur un alphabet à deux symboles, et ce pour un groupe dénombrable arbitraire. Nous donnons ainsi une preuve plus courte du résultat principal de [GJS09]. De plus, en appliquant à nouveau le lemme local de Lovász, nous parvenons à montrer une version effectivement fermée, c'est-à-dire un sous-décalage dont les motifs interdits peuvent être donnés à l'aide d'une machine de Turing, de ce résultat dans le cas d'un groupe de type fini avec problème du mot décidable. Nous nous intéressons également à la question de l'existence pour les groupes de type fini d'un sous-décalage ayant la propriété de densité uniforme pour un certain choix de partie génératrice. Cette fois-ci, le lemme local de Lovász ne s'applique pas, mais nous contournons le problème et répondons à cette question par l'affirmative dans le cas des groupes de croissance sous-exponentielle. Nous utilisons pour cela une construction combinatoire basée sur des ensemble de Delone.

Nous démontrons ensuite un analogue dynamique du théorème de Highman [Hig61] pour les groupes récursivement présentés, à savoir que toute action effectivement fermée d'un groupe de type fini  $G$  sur un ensemble de Cantor peut être réalisée comme le facteur d'une sous-action d'un sous-décalage de type fini défini sur un groupe de la forme  $\mathbb{Z}^2 \rtimes G$ . Pour se faire, nous utilisons des techniques provenant des substitutions multidimensionnelles et des suites de Toeplitz. Parmi ces techniques, on peut notamment citer le fameux théorème de Mozes [Moz89] établissant qu'un sous-décalage défini par une substitution multidimensionnelle est le facteur d'un SFT, ainsi que le théorème de simulation dû à Aubrun et Sablik [AS13], et qui montre que tout  $\mathbb{Z}$ -sous-décalage effectivement fermé peut être réalisé comme la sous-action projective d'un facteur d'un  $\mathbb{Z}^2$ -SFT.

Nous appelons ce dernier résultat «théorème de simulation», car il permet de simuler des systèmes dynamiques compliqués comme des sous-actions de systèmes plus simples. Nous utilisons par la suite ce théorème comme une boîte noire, qui permet de produire des SFT avec des caractéristiques particulières. En particulier, nous appliquons ce théorème au sous-décalage fortement apériodique effectivement fermé, dont nous avons montré l'existence précédemment, et obtenons ainsi une preuve de l'existence de sous-décalages de type fini fortement apériodiques pour tout groupe de la forme  $\mathbb{Z}^2 \rtimes G$ , à la seule condition que le groupe  $G$  soit de type fini et ait un problème du mot décidable. En particulier, notre résultat donne une nouvelle preuve de l'existence de SFT fortement apériodique non vide sur le groupe d'Heisenberg discret.

Le problème du mot cherche à répondre à la question algorithmique suivante : existe-t-il un algorithme qui décide si un mot sur une présentation récursive est égale à l'identité du groupe ? Dans cette partie, nous changeons radicalement de point de vue pour adopter celui des modèles de calcul, et nous intéressons à une nouvelle classe de sous-décalages : celle des sous-décalages  $G$ -effectivement fermés. Ces derniers sont définis par un ensemble de motifs interdits que l'on peut énumérer à l'aide d'une machine de Turing modifiée, dont on a augmenté la puissance de calcul en lui adjoignant le problème du mot du groupe  $G$  comme oracle. Nous montrons plusieurs propriétés remarquables de cette classe, qui font de la  $G$ -effectivité un candidat crédible pour définir une notion d'effectivité sur les groupes de type fini. Nous montrons de plus que ces sous-décalages sont caractérisés par une classe naturelle de machines de Turing généralisées, qui au lieu de calculer sur un ruban bi-infini utilisent le graphe de Cayley du groupe comme ruban, et dont la tête de lecture se déplace selon un ensemble fini de générateurs. Nous montrons aussi que cette classe est strictement séparée de celle des sous-décalages sofiques dans trois cas : les groupes moyennables, les groupes avec une infinité de bouts et les groupes récursivement présentés avec problème du mot indécidable.

Nous nous interrogeons aussi sur la possibilité d'un théorème de simulation pour des sous-décalages  $G$ -effectivement fermés. Cette classe de sous-décalages n'est pas stable par sous-dynamique projective, néanmoins nous montrons l'existence d'un sous-décalage  $G \times \mathbb{Z}$ -effectif universel, au sens où le produit de celui-ci avec un sous-décalage de type fini peut simuler n'importe quel sous-décalage  $G$ -effectivement fermé, pourvu que ce dernier contienne un  $G$ -SFT comme sous-système. Pour le montrer, nous utilisons pleinement la caractérisation des sous-décalages  $G$ -effectivement fermés à l'aide de machines de Turing généralisées, ainsi qu'une construction combinatoire utilisant des ensembles de Delone.

Enfin nous nous intéressons à deux groupes qui, à isomorphisme près, sont des invariants de systèmes dynamiques par conjugaison topologique : le groupe d'automorphismes et le groupe plein topologique. Le premier, le groupe d'automorphismes, est l'ensemble de tous les homéomorphismes de l'espace qui commutent avec l'action. Il a été particulièrement étudié dans le cas du décalage plein sur  $\mathbb{Z}^d$  ; dans ce cas particulier, il est plus souvent exprimé et étudié comme le groupe des automates cellulaires réversibles. Le deuxième, le groupe plein topologique, est formé de tous les homéomorphismes de l'espace pour lesquels l'action sur une configuration  $x$  peut s'écrire sous la forme

$\phi(x) = T^{s(x)}(x)$ , où  $s : X \rightarrow G$  est une fonction continue. Nous étudions ces deux groupes à travers le prisme de la théorie de la calculabilité : nous donnons d'abord des conditions suffisantes pour qu'ils soient récursivement présentés, et dans ce cadre nous nous intéressons à deux langages formels, le problème du mot et le problème de torsion.

Concernant le problème du mot, nous donnons des conditions suffisantes pour qu'il soit décidable dans ces deux groupes. Le problème de torsion s'interroge sur l'existence d'un algorithme qui décide si un mot sur une présentation récursive représente un élément de torsion, c'est-à-dire un élément  $g \in G$  tel que  $g^n = 1_G$  pour un certain  $n \geq 1$ . Pour le problème de torsion, les conditions suffisantes que nous exhibons sont différentes pour les deux groupes. Nous montrons d'abord que le groupe d'automorphismes d'un  $\mathbb{Z}$ -décalage plein contient une sous-groupe de type fini avec problème de torsion indécidable, alors que le problème de torsion du groupe topologique de n'importe quel  $\mathbb{Z}$ -sous-décalage sofique est décidable. Les deux groupes ont par contre des propriétés similaires en dimension supérieure. Par exemple ils ont tous deux problème de torsion indécidable pour un  $\mathbb{Z}^d$ -décalage plein dès que  $d \geq 2$ .

## Organisation du manuscrit

Afin d'étudier les riches interactions entre théorie de la calculabilité et dynamique, nous avons largement pioché des concepts et techniques au sein de quatre domaines : théorie de la calculabilité, systèmes dynamiques, combinatoire et théorie des groupes.

Le présent manuscrit est organisé en cinq chapitres, eux-mêmes suivis de trois annexes. Ces dernières doivent être vues comme des lexiques enrichis sur la théorie de la calculabilité, la théorie des groupes et la dynamique topologique, dans lesquels le lecteur pourra trouver les définitions de concepts classiques de chacun de ces domaines. Il n'est pas attendu une lecture linéaire de ces annexes, mais plutôt que le lecteur s'y réfère tout au long des chapitres pour y trouver des références qui lui manqueraient.

Le premier chapitre présente les sous-décalages, définit de façon précise les notions de dynamique symbolique sur des groupes et en montre les résultats fondamentaux. La plupart du contenu de ce chapitre se retrouve donc ailleurs dans la littérature, ou bien fait partie du folklore du domaine. La seule contribution nouvelle es trouve dans la dernière sous-partie, consacrée aux sous-décalages effectivement fermés sur des groupes de type fini. Ces derniers résultats sont tirés d'un article en collaboration avec Nathalie Aubrun et Mathieu Sablik [ABS17].

Les quatre chapitres suivants présentent les résultats obtenus durant cette thèse. Ils sont organisés comme suit.

Le Chapitre 2 se compose de deux parties. Dans la première, nous présentons un lemme combinatoire pour montrer la non vacuité de sous-décalages, ainsi que les preuves de l'existence d'un sous-décalage fortement apériodique pour un groupe dénombrable, et de l'existence d'un sous-décalage fortement apériodique effectif pour un groupe de type fini avec problème de mot décidable. Dans la seconde partie, nous présentons une construction combinatoire d'un sous-décalage qui réalise des densités uniformes pour un groupe de croissance sous-exponentielle. Les résultats présentés

dans ce chapitre sont identiques à ceux obtenus en collaboration avec Nathalie Aubrun et Stéphan Thomassé [ABT15].

Le Chapitre 3 est entièrement consacré à notre théorème de simulation. Il débute par une introduction présentant à la fois les résultats de Highman et de Hochman, ainsi que les ingrédients de la preuve utilisant les substitutions multidimensionnelles et les sous-décalages Toeplitz. Nous énonçons ensuite le théorème principal, en présentons les détails de la preuve et mentionnons enfin quelques unes de ses conséquences. Ces résultats proviennent principalement du travail de l’auteur avec Mathieu Sablik [BS17].

Le Chapitre 4 concerne l’étude de notre modèle étendu de  $G$ -effectivité pour des sous-décalages sur des groupes de type fini. Nous commençons par illustrer les limites de cette notion sur un exemple: le sous-décalage *One-or-less*  $X_{\leq 1}$ . Cet exemple motive notre nouveau modèle, que nous présentons. Puis nous donnons une caractérisation de notre modèle par des  $G$ -machines en termes de calculabilité, et présentons dans ce cadre notre théorème de simulation. Nous terminons le chapitre par une discussion sur la séparation de deux classes de sous-décalages, les sous-décalages sofiques et les sous-décalages effectifs, sur trois classes de groupes. Ces résultats proviennent aussi de l’article [ABS17].

Enfin dans le Chapitre 5 nous nous intéressons aux aspects de calculabilité, à la fois dans le groupe d’automorphismes et le groupe plein topologique. Nous commençons par introduire ces concepts, et donnons la définition de trois langages formels s’appuyant sur ces concepts. Nous portons une attention particulière à définir ces trois langages dans le cas où les groupes ne sont pas de type fini. Enfin, nous étudions ces langages pour chacun des deux groupes, en commençant par le groupe plein topologique et en terminant par le groupe d’automorphismes. Les résultats présentés ici sont une adaptation par l’auteur de travaux en commun avec Jarkko Kari et Ville Salo [BKS16].

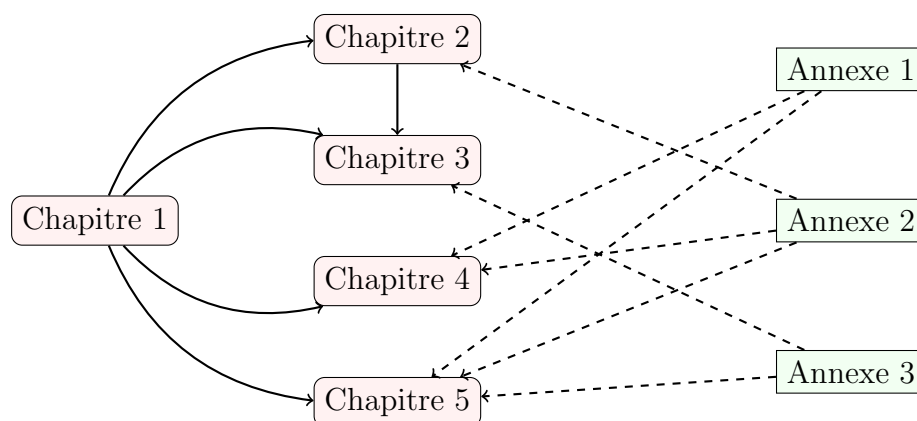

Figure 3: Le graphe de dépendance des chapitres.

Certains chapitres peuvent être lus indépendamment des autres. Dans la Figure 7, nous montrons comment ils dépendent les uns des autres, et quelles annexes les concernent. Les flèches en pointillés partant d’une annexe indiquent que cette annexe contient des définitions ou concepts classiques utilisés dans le chapitre pointé par la



flèche. Les flèches pleines partant d'un chapitre indiquent que des résultats de ce chapitre sont nécessaires à la compréhension du chapitre pointé par la flèche.

Afin de donner au lecteur une idée du contenu de chaque chapitre, nous représentons chacun d'eux par un diagramme montrant dans quelles proportions il appartient à différents domaines. Il ne s'agit bien évidemment pas d'une mesure objective, mais plutôt d'un aperçu du contenu de chacun selon l'auteur. Ces diagrammes sont présentés dans la Figure 8.

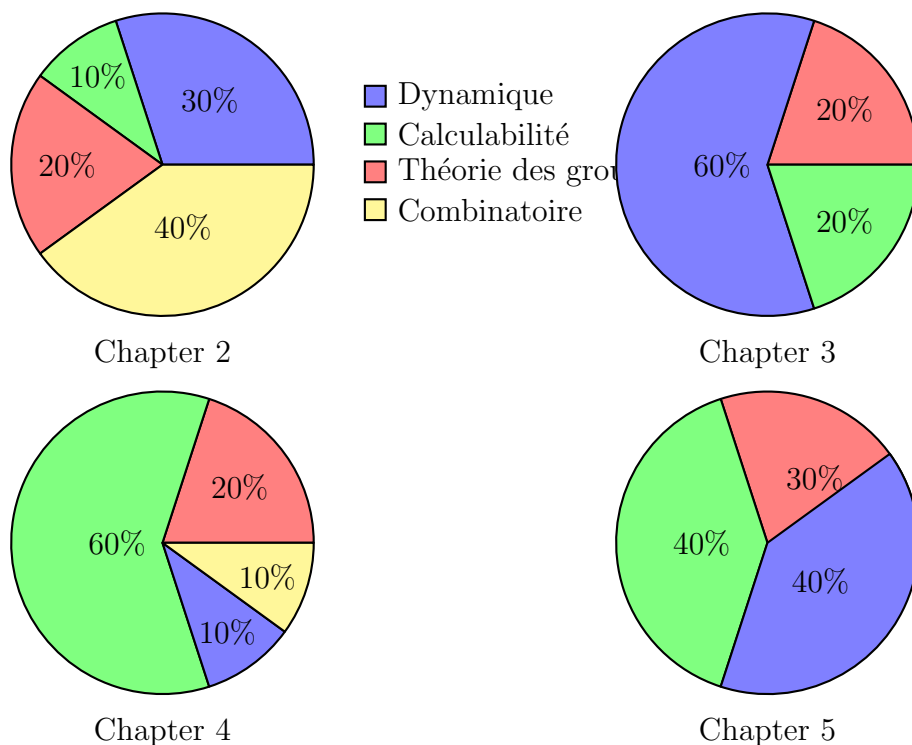

Figure 4: Diagrammes indiquant proportionnellement les connaissances requises pour chacun des chapitres.

### Conventions

- L'ensemble des nombres naturels  $\mathbb{N}$  contient 0.
- Sauf mention contraire, une action de groupe est une action à droite. Un graphe de Cayley est un graphe de Cayley à droite.
- On suppose qu'un ensemble générateur d'un groupe contient l'identité et est stable par inverse.
- Par défaut les groupes sont notés multiplicativement, sauf dans le cas d'un groupe abélien ou on préférera la notation additive.

# Introduction

From a classical perspective, dynamical systems consist of a pair  $(X, T)$  where  $X$  is a set and  $T : \mathbb{R}^+ \times X \rightarrow X$  is a function which describes the evolution of elements of  $X$  in time. Not only are they interesting as mathematical objects, but also paramount in the modeling of physical phenomena: the behavior of the solar system, the evolution of an ecosystem in time, changes in the concentration of a molecule on a chemical substance subject to heat, the trajectory of a charged particle in a magnetic field, etc.

From a mathematical point of view, there is no theoretical imperative restricting the study of dynamical systems exclusively to continuous time: a system can also be analyzed in discrete time jumps. What is more, if the evolution of the system is reversible in time, then the action can be modeled by an abstract group acting over  $X$ . This modification is quite natural if one is interested in the joint action of several homeomorphisms  $T_1, \dots, T_n$  of the same space  $X$ , which furthermore satisfy a set of relations  $R$ . These actions and their relations can be expressed by the joint group action  $T : G \curvearrowright X$  where  $G \cong \langle T_1, \dots, T_n \mid R \rangle$  and  $T(T_{i_1} \cdots T_{i_k}, x) = T_{i_1} \circ \cdots \circ T_{i_k}(x)$ . For instance, if the relation  $T_1 \circ T_2 = T_2 \circ T_1$  holds, then the joint action of  $T_1$  and  $T_2$  can be studied as a  $\mathbb{Z}^2$ -action over  $X$ . It is therefore natural to study the general case of an arbitrary countable group acting over the space.

These systems can be quite difficult to study and several tools have been developed in order to better understand them. A particularly interesting approach is to partition the set  $X$  into finitely many parts and subsequently code each element of the set as the sequence of partitions visited by its orbit. This idea can be traced back to the work of Hadamard [Had98], who used it to study geodesics on surfaces of negative curvature. Although the technique was used by many over the years following the development of Hadamard, the first study specifically dedicated to this technique was described in the founding article by Morse and Hedlund [HM38]. Their “Symbolic dynamics” constituted the first systematic description of what had been, until that point, a technique sporadically used to study recurrence properties in dynamical systems.

Before introducing symbolic dynamics in the general case, we define more precisely what we mean by a codification of a dynamical system by a partition. We consider the special case where  $T$  is a  $\mathbb{Z}$ -action by homeomorphisms of a compact topological space  $X$  and  $\mathcal{P} = \{P_1, \dots, P_n\}$  is a clopen partition of  $X$ . Consider the function  $\varphi : X \rightarrow \{1, \dots, n\}^{\mathbb{Z}}$  which is defined by:

$$\varphi(x)(n) = i \iff T^n(x) \in P_i.$$

The function  $\varphi$  associates each element  $x$  of  $X$  to a sequence of labels describing which set of the partition is visited by the orbit of  $x$  under the homeomorphism  $T$  as

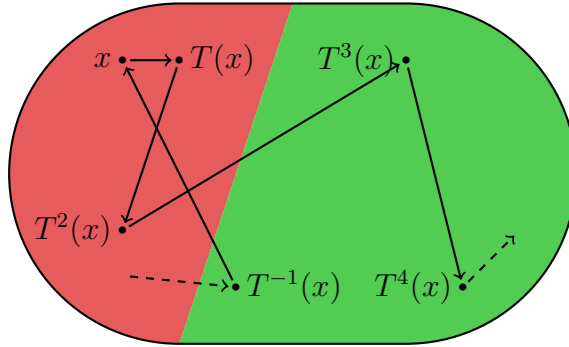

$$\varphi(x) = \cdots \begin{array}{cccccc} \color{green}\blacksquare & \color{red}\blacksquare & \color{red}\blacksquare & \color{red}\blacksquare & \color{green}\blacksquare & \color{green}\blacksquare \\ -1 & 0 & 1 & 2 & 3 & 4 \end{array} \cdots \in \{\color{red}\blacksquare, \color{green}\blacksquare\}^{\mathbb{Z}}$$

Figure 5: A partition of  $X$  into two parts and a coding of the orbit of  $x \in X$

shown in Figure 5. Now, consider the set of all the sequences obtained by a coding

$$\varphi(X) = \{y \in \{1, \dots, n\}^{\mathbb{Z}} \mid \exists x \in X, y = \varphi(x)\}$$

There are two interesting properties of  $\varphi(X)$ : first,  $\varphi(X)$  is closed for the product topology; second, if we endow  $\{1, \dots, n\}^{\mathbb{Z}}$  with the function  $\sigma$  which shifts a sequence to the left, we obtain that  $\sigma(\varphi(x)) = \varphi(T(x))$  and thus  $\varphi(X)$  is invariant under the shift action. This makes  $(\varphi(X), \sigma)$  a dynamical system on itself.

The interest of the coded system  $(\varphi(X), \sigma)$  with respect to the original dynamical system  $(X, T)$  depends on the partition. If the trivial partition with only one element is chosen, then the coded system contains only one configuration, which is not of much interest. Nevertheless, it can be shown that a large class of dynamical systems, namely, those where  $X$  is a zero-dimensional topological space and the action  $T$  is expansive, can be coded in a way that their dynamics are completely preserved.

Studying dynamical systems through their codings presents two remarkable advantages. On the one hand, a potentially complicated homeomorphism  $T$  is replaced by a simple shift over a set of sequences and hence the complexity is instead encoded in the topology. On the other hand, if the coded system can be represented in a finite manner, it becomes amenable to be analyzed with computability tools.

Symbolic dynamics is the discipline which studies the dynamical systems obtained through codings. These objects are called shifts spaces or subshifts. From a modern viewpoint, we can understand subshifts as sets of closed and shift invariant colorings of a group  $G$  by a finite alphabet  $\mathcal{A}$ . What is interesting is that each subshift can also be described in a combinatorial way as the set of colorings of  $G$  which avoids a set of finite colorings.

More specifically, a pattern is a coloring of a finite subset of a group. For instance, if we consider the additive group  $(\mathbb{Z}^2, +)$  and the alphabet  $\mathcal{A} = \{\color{red}\blacksquare, \color{green}\blacksquare, \color{blue}\blacksquare\}$ , two examples of patterns with supports  $F_1 = \{(0, 0), (1, 0)\}$  and  $F_2 = \{(0, 0), (0, 1)\}$  are respectively  $\color{red}\blacksquare \color{blue}\blacksquare$  and  $\color{green}\blacksquare \color{blue}\blacksquare$ . From a set of patterns, one can define a subshift as the set

of all colorings such that no translation of these patterns appears. For instance, one such coloring belonging to the subshift defined by the two patterns above is shown on Figure 6. From now on we shall refer to colorings in a subshift as “configurations”.

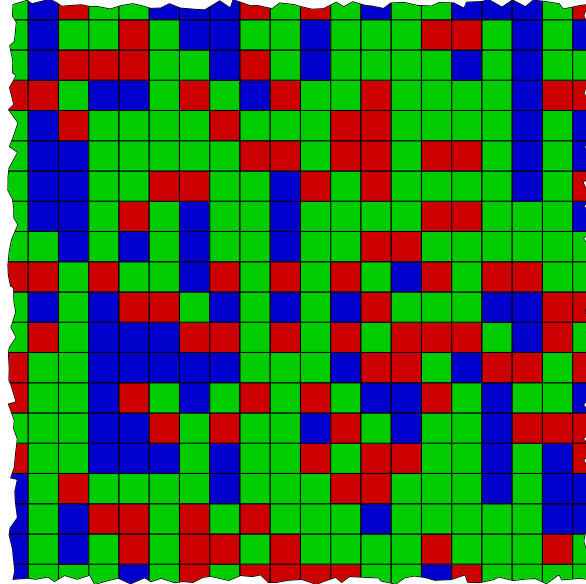

Figure 6: A configuration of a  $\mathbb{Z}^2$ -subshift defined by forbidden patterns.

The previous description of shift spaces through forbidden patterns gives rise to three classes of subshifts that can be described by them in increasing levels of complexity: the first is the class of subshifts of finite type (SFT), which are those that can be defined by a finite list of forbidden patterns as the previous example. The second is the class of sofic subshifts, which can be obtained as factors of SFTs through a function which depends only on a finite neighborhood. Finally, there is the class of effectively closed subshifts, which can be defined by a recursively enumerable set of forbidden patterns.

Shift spaces have been thoroughly studied in the case of  $\mathbb{Z}$ -actions, most of the core results of that theory can be found in [LM95]. In particular, SFTs and sofic subshifts are characterized by labeled graphs and their entropies correspond to nonnegative rational multiples of logarithms of Perron numbers [Lin84]. What is more, they always contain periodic configurations and several dynamical invariants can be computed effectively from their finite descriptions. Even if they are well understood, there are still open questions, such as whether it can be algorithmically decided if two subshifts are topologically conjugate, that is, if they are indistinguishable from the point of view of topological dynamics [Boy08].

More recently,  $\mathbb{Z}^d$ -subshifts for  $d \geq 2$  have begun to gain interest in the community [BS08, BS09, PS14, KM13]. Several properties which are satisfied by one-dimensional subshifts of finite type no longer hold in higher dimensions. For instance, there exist two-dimensional SFTs which contain no periodic configurations [Ber66, Rob71, Kar96] or which only contain non-recursive configurations [Han74, Mye74]. Also, a one-dimensional SFT with sufficiently large entropy always factorizes onto the

set of all configurations, while it has been shown that this is not always the case in higher dimensions [BPS10]. From a computability point of view, the problem of deciding if a subshift defined by a finite set of forbidden patterns is non-empty becomes undecidable [Ber66]. One explanation for these phenomena happening is the fact that multidimensional SFTs and sofic subshifts are very close to lower dimensional effectively closed subshifts.

A result by Hochman [Hoc09] showed that every effectively closed dynamical system over a Cantor set can be realized as a factor of a subaction of a  $\mathbb{Z}^3$ -SFT. This result was subsequently improved in the case of shift spaces where it was shown that every effectively closed  $\mathbb{Z}$ -subshift can be obtained as a projective subaction of a  $\mathbb{Z}^2$ -SFT. In simple words, this means that complicated one-dimensional shift spaces can appear as the horizontal projections of a very simple two-dimensional subshift. A fundamental consequence which can be obtained from these results is the groundbreaking theorem of Hochman and Meyerovitch [HM10], where the set of numbers which can be achieved as topological entropies of two dimensional subshifts of finite type is characterized as the set of numbers which are right recursively enumerable. This clearly exemplifies the intricate relation between multidimensional dynamical systems and computability concepts.

In the recent years, subshifts defined on arbitrary groups have also gained attention, see for instance [Pia06, Pia08, Kri07b, FT15, CP15, LP16]. In this general case, even more complicated phenomena can happen. For instance, if the group  $G$  is not residually finite, it is no longer true that the set of periodic configurations form a dense set with respect to the set of all configurations [CSC09]. Moreover, if  $G$  becomes computationally harder, it might not even be possible to algorithmically recognize if a codification of a pattern is consistent [ABS17]. Nevertheless, it remains interesting to analyze which specific group properties are responsible for these behaviors. For instance, it can be shown that for recursively presented groups, subshifts of finite type with no periodic configurations can only exist if the word problem of the group is decidable [Jea15]. In fact, these last few years many articles have investigated computational aspects of subshifts on finitely generated groups [BS13, Coh17, ST15, Jea15].

The objective of this thesis to deepen the understanding of the interplay between dynamic and computability properties of shift spaces in groups. In particular, we tackle the following problems: realizing structures in groups, such as subshifts with no periodic configurations and subshifts with uniform density; the problem whether an effectively closed action over a Cantor set can be simulated as part of a simpler action on a larger group; the question of what is a good model of computation on groups where the word problem becomes undecidable; and the computability properties of famous group invariants of shift spaces, such as the automorphism group and the topological full group. In particular, we study the decidability of their word and torsion problems.

## Main contributions

A result by Miller [Mil12] gives a combinatorial condition over sets of forbidden words which is enough to ensure that the  $\mathbb{Z}$ -subshift defined by them is non-empty.

Our first result is a generalization of Miller’s condition to the case of arbitrary countable groups. Namely, we derive a combinatorial condition on sets of forbidden patterns, which if satisfied, gives a guarantee of the non-emptiness of the subshift defined by them. This is obtained by the application of a technique frequently used in graph theory: the asymmetrical version of Lovász local lemma. We apply this condition to a specific sequence of patterns to give a non-constructive proof of the existence of strongly aperiodic non-empty subshifts over a two symbol alphabet in arbitrary countable groups, thus giving a short proof of the main result of [GJS09]. Furthermore, using again Lovász local lemma, we are able to obtain an effectively closed version –that is, one whose forbidden patterns can be described by Turing machines– of this result in the case of finitely generated groups with decidable word problem. We also delve into the question of whether a subshift having uniform density with respect to a fixed set of generators exists in every finitely generated group. Although the technique with Lovász local lemma cannot be applied in this case, we manage to give a positive answer in the case of groups of sub-exponential growth, where an explicit combinatorial construction based on Delone sets is presented.

Following this, we prove a dynamical analogue of Highman’s theorem [Hig61] for recursively presented groups, namely, that every effectively closed action of a finitely generated group  $G$  over a Cantor set can be realized as a factor of a subaction of a subshift of finite type defined on a group of the form  $\mathbb{Z}^2 \rtimes G$ . In order to show this, we use techniques sprouting from multidimensional substitutions and Toeplitz sequences, notably the theorem by Mozes [Moz89] showing that any subshift generated by a multidimensional substitution is a factor of an SFT, and the simulation theorem by Aubrun and Sablik [AS13] showing that every effectively closed  $\mathbb{Z}$ -subshift can be realized as a projective subaction of a factor of a  $\mathbb{Z}^2$ -SFT.

We call this previous result a “simulation theorem” as it allows to simulate complicated dynamical systems as subactions of simple ones. We subsequently use our simulation theorem as a black box to produce SFTs with peculiar characteristics. Notably, we apply this theorem to the effectively closed strongly aperiodic subshift obtained before to obtain a proof of the existence of strongly aperiodic subshifts of finite type for any group of the form  $\mathbb{Z}^2 \rtimes G$ , subject only to the condition that  $G$  is finitely generated and has decidable word problem. In particular, this gives a new proof that the discrete Heisenberg group admits non-empty strongly aperiodic SFTs.

The word problem concerns the following algorithmic question: can an algorithm be given which decides whether a word on a recursive presentation is equal to the identity of the group? The next object studied here takes a sharp turn towards the model of computation viewpoint. Here, a class of subshifts which we call  $G$ -effectively closed is studied. These objects are defined by a set of forbidden patterns which can be enumerated by a Turing machine with the extra power of an oracle to the word problem of the group  $G$ . We show that this class has several remarkable properties which make it a good candidate for a notion of effectiveness in finitely generated groups. Furthermore, we show that these subshifts can be characterized by a natural class of generalized Turing machines, which instead of performing computation on a bi-infinite tape, use the Cayley graph of a group and move according to a finite set of generators. We furthermore show that this class is strictly separated from that of

sofic subshifts in three cases: amenable groups, groups with infinitely many ends and recursively presented groups with undecidable word problem.

We also study the possibility of a simulation theorem for  $G$ -effectively closed subshifts. Although we show that this class is not stable by projective subdynamics, we prove that there exists an universal  $G \times Z$ -effective subshift, such that a product of itself with a subshift of finite type can simulate any  $G$ -effectively closed subshift as long as it contains a  $G$ -SFT as a subsystem. In order to show this we strongly use the characterization of  $G$ -effectively closed subshifts by generalized Turing machines and a combinatorial construction using Delone sets.

Finally we study two groups, which up to isomorphism, are invariants of dynamical systems under topological conjugacy: the automorphism group and the topological full group. The first consists of all homeomorphisms of the space which commute with the action. This group is largely studied in the case of a full  $\mathbb{Z}^d$ -shift, where it is more commonly known as the group of reversible cellular automata. The second one is formed by all homeomorphisms of the space for which the action on a configuration  $x$  has the form  $\phi(x) = T^{s(x)}(x)$  for a continuous function  $s : X \rightarrow G$ . We tackle these groups from a computability perspective: first we give sufficient conditions for them to be recursively presented, and when in that case, we focus our study on two formal languages: the word problem and the torsion problem.

With respect to the word problem we give sufficient conditions for it to be decidable in these two groups. On the other hand, the torsion problem concerns the existence of an algorithm which decides if a word on a recursive presentation represents a torsion element, that is, a  $g \in G$  such that  $g^n = 1_G$  for some  $n \geq 1$ . Here the answer is different for both groups. On the one hand, we show that the automorphism group of any full  $\mathbb{Z}$ -shift contains a finitely generated subgroup with undecidable torsion problem, while the torsion problem of the topological full group of any sofic  $\mathbb{Z}$ -subshift is decidable. Nonetheless, we also show that for  $\mathbb{Z}^d$  with  $d \geq 2$  both the topological full group and automorphism groups of a full  $\mathbb{Z}^d$ -shift have undecidable torsion problem.

## Organization of the manuscript

In order to study this rich interplay between computability and dynamics a large variety of methods were drawn from four areas: computability, dynamical systems, combinatorics and group theory.

The manuscript is organized into five chapters along with three appendixes. The three appendixes are meant as extended glossaries on computability theory, group theory and topological dynamics where the basic definitions can be found. These appendixes are not meant to be read linearly, but mostly to consult references which are either used sporadically or are common knowledge of the theory.

The first chapter concerns shift spaces and is intended as a place to carefully define the basic notions and prove the fundamental results of symbolic dynamics on groups. Most of the contents of it are either found in the literature or are folklore proofs. The only part which is novel is the last subsection dedicated to effectively closed subshifts in finitely generated groups. The latter results come from an article of the author in collaboration with Nathalie Aubrun and Mathieu Sablik [ABS17].

The following four chapters present the results obtained during this thesis. They are organized thematically as follows:

In Chapter 2 is divided into two parts. In the first one, we present the combinatorial lemma to prove non-emptiness of subshifts, followed by the proofs of the existence of strongly aperiodic subshifts in both the countable case and the effective version for finitely generated groups with decidable word problem. In the second part we present a combinatorial construction of a subshift which realizes uniform densities in any group with sub-exponential growth. The result presented are the same as those obtained in collaboration with Nathalie Aubrun and Stéphan Thomassé [ABT15].

Chapter 3 is dedicated to present our simulation theorem. It begins with an introduction presenting both Highman’s and Hochman’s results and the facts about multidimensional substitutions and Toeplitz subshifts needed for the proof of the theorem. Following this, we state the main theorem and present its proof in detail. Finally, some consequences of the theorem are presented. The results here are principally from the work of the author with Mathieu Sablik [BS17].

Chapter 4 concerns the study of our extended model of  $G$ -effectiveness for subshifts in finitely generated groups. We begin by exhibiting the limitations of effectively closed subshifts by means of an example: the One-or-less subshift  $X_{\leq 1}$ , thus motivating and introducing our new model. We proceed to characterize our model by  $G$ -machines in computability terms, and then we present our simulation theorem in this context. We finish the chapter by discussing the separation of sofic and effective subshifts in three classes of groups. These results also come from [ABS17].

Finally, in Chapter 5 we tackle the computability aspects of both the automorphism group and the topological full group. We begin by introducing them, and three formal languages that can be defined upon them. We take special care to address these languages in the case where the groups are not finitely generated. Finally, we study these languages in both cases, presenting first the case of the topological full group and finishing with the automorphism group. These result are an adaptation of the author of a joint work with Jarkko Kari and Ville Salo [BKS16].

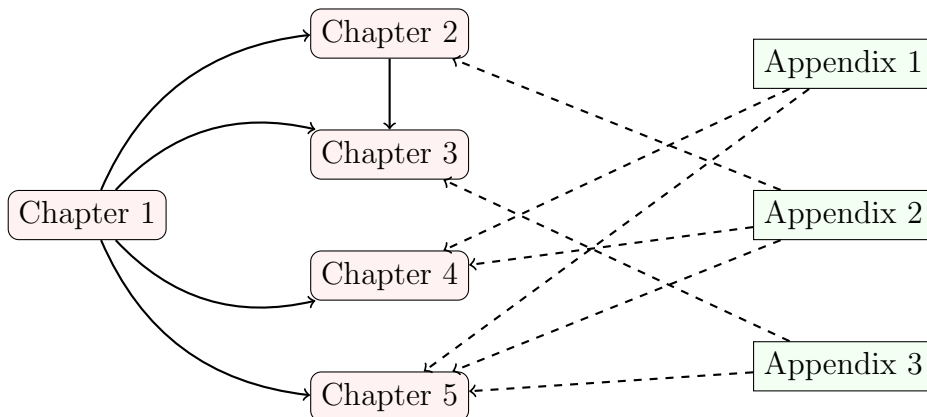

Figure 7: The dependence graph of the chapters

Some of the chapters can be read independently from the others. In Figure 7 we show how they depend on each other, and which annexes concern them. The



dashed arrows from the annexes indicate that they give support to the chapter by providing definitions of well known concepts, while the straight arrows indicate that some results from the starting node are required to understand the pointed node.

In order to give an idea to the reader of what are the contents of each chapter, we can represent each one of them as a pie chart showing what percentage of the chapter belongs to each domain. It does not represent any objective measure but only the subjective view of the author. This is shown on Figure 8

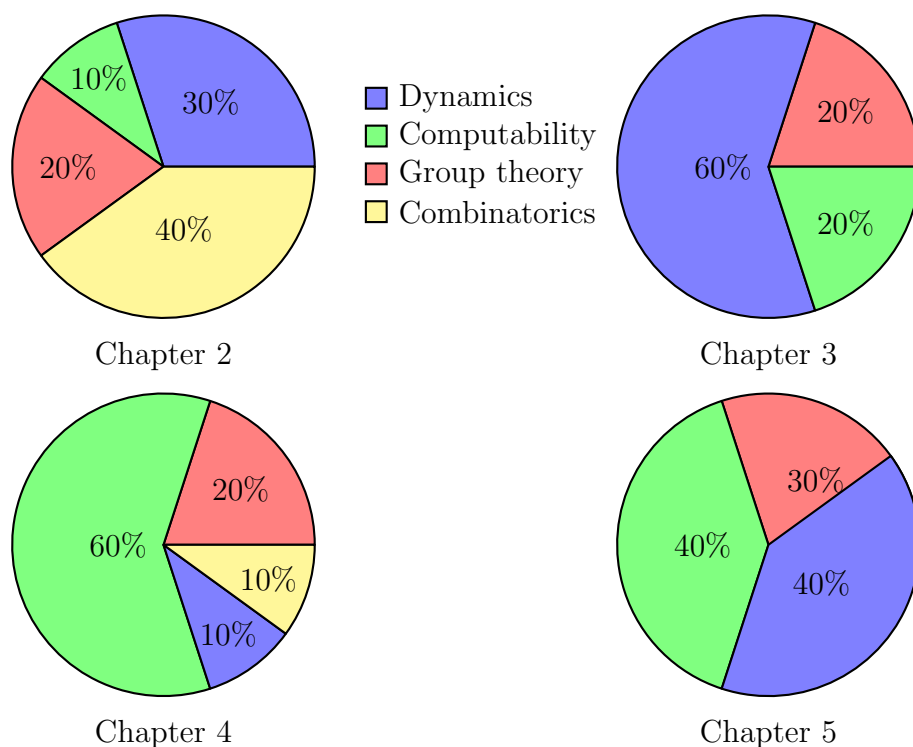

Figure 8: Pie charts indicating the percentage of knowledge required in each subject for every chapter

### Conventions

- The set of natural numbers  $\mathbb{N}$  starts from 0.
- Every group action is a left group action unless stated otherwise. Every Cayley graph is a right Cayley graph.
- Whenever considering a finite set of generators of a group, we assume it is closed by inverses and that it contains the identity.
- Groups are written multiplicatively by default, unless it is an abelian group in which case the additive notation is used.

# Chapter 1

## Shift spaces

Symbolic dynamics is the discipline which studies a specific type of dynamical system called a subshift or shift space. From a modern viewpoint, shift spaces can be understood as sets of colorings of a group  $G$  by a finite alphabet  $\mathcal{A}$  equipped with the shift action, which associates to each coloring its translate by an element of the group. The sets of colorings which form subshifts can be either defined as subsets of the product space  $\mathcal{A}^G$  that are both closed for the product topology and invariant under the shift action, or equivalently, as a set of colorings of a group  $G$  by some finite alphabet  $\mathcal{A}$  that respect local constraints given by forbidden patterns.

Shift spaces have been thoroughly studied in the case of  $\mathbb{Z}$ -actions, most of the core results of that theory can be found on [LM95]. More recently,  $\mathbb{Z}^d$ -subshifts for  $d \geq 2$  have begun to gain interest in the community [Hoc09, PS14, BPS10, Pav12, KM13] and since the work of Hochman and Meyerovitch [HM10], where the set of numbers which can be achieved as topological entropies of two dimensional subshifts of finite type is completely classified, the interest on the subject has substantially increased. In the recent years, subshifts defined on arbitrary groups have gained attention, see for instance [Pia06, Pia08, Kri07b, FT15, CP15, LP16]. Very recent results also tackle computational aspects of subshifts on finitely generated groups [BS13, Coh17, ST15, Jea15].

The purpose of this chapter is to give a formal introduction to shift spaces defined on groups and fix the notations for the subsequent chapters. The hope of the author is that this introductory chapter will serve future researchers interested in the subject as a place where basic definitions and folklore proofs for the general setting of subshifts over groups can be found. In this perspective, the objects introduced here will be copiously accompanied by examples from the literature.

The structure of this chapter is the following: We begin by introducing subshifts over groups from both a topological and a combinatorial point of view, and the different symbolic morphisms between them. Following that, we present a few dynamical notions for these objects which will be used in the next chapters. We end this chapter by introducing three important classes of subshifts: Subshifts of finite type, sofic subshifts and effectively closed subshifts.

## 1.1 Subshifts in groups

Let  $\mathcal{A}$  be a non-empty finite set and  $G$  a group. The set  $\mathcal{A}^G := \{x : G \rightarrow \mathcal{A}\}$  consists of all functions from  $G$  to  $\mathcal{A}$ . We can think of  $\mathcal{A}^G$  as the set of colorings of the group  $G$  by elements of  $\mathcal{A}$ . We refer to the set  $\mathcal{A}$  as an *alphabet* and its elements  $a \in \mathcal{A}$  are called *symbols*. We also use the word *configuration* to denote an element  $x \in \mathcal{A}^G$  and use the notation  $x_g$  instead of  $x(g)$  to refer to the symbol at position  $g \in G$ .

The set  $\mathcal{A}^G$  is endowed with the left group action  $\sigma : G \times \mathcal{A}^G \rightarrow \mathcal{A}^G$  given by

$$\sigma(g, x)_h := x_{g^{-1}h}.$$

We refer to  $\sigma$  as the *shift action*. We also use the notation  $\sigma^g(x)$  to denote  $\sigma(g, x)$ .

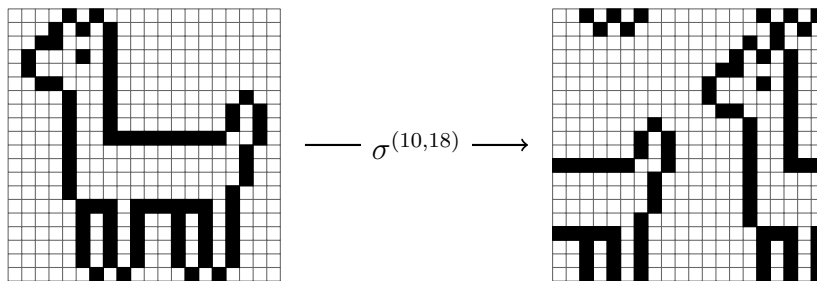

Figure 1.1: A configuration  $x \in \{\blacksquare, \square\}^{\mathbb{Z}^2/20\mathbb{Z}^2}$  and its image by  $\sigma^{(10,18)}$ .

**Definition 1.1.** The dynamical system  $(\mathcal{A}^G, \sigma)$  is called the full  $G$ -shift.

*Remark.* There are four possibilities when defining  $\sigma$  as a group action: one could either define  $\sigma^g(x)_h$  as  $x_{g^{-1}h}$ ,  $x_{gh}$ ,  $x_{hg^{-1}}$  or  $x_{hg}$ . The first and the fourth define left group actions, while the second and the third are right group actions. From a theoretical point of view, the choice is arbitrary, though ours is based on the fact that we prefer right Cayley graphs (see Definition B.14), as extending words to the right is more common. A left action by left multiplication behaves correctly as a translation with respect to this graph. The only downside is that  $\sigma$  does not correspond to the left shift in  $\mathbb{Z}$  but to the right shift.

We endow the set  $\mathcal{A}^G$  with the product of the discrete topology on  $\mathcal{A}$ . By Tychonoff's theorem,  $\mathcal{A}^G$  is a compact space and a clopen subbase is given by the *cylinders*  $[a]_g := \{x \in \mathcal{A}^G \mid x_g = a\}$ . In the case where  $G$  is a countable group  $\mathcal{A}^G$  becomes a metric space and the product topology is generated by the metric  $\tilde{d} : \mathcal{A}^G \times \mathcal{A}^G \rightarrow \mathbb{R}$  defined by  $\tilde{d}(x, y) = 2^{-\inf\{n \in \mathbb{N} \mid x_{g_n} \neq y_{g_n}\}}$  where  $(g_n)_{n \in \mathbb{N}}$  is an enumeration of  $G$ . If  $G$  is finitely generated this metric can be replaced by  $d : \mathcal{A}^G \times \mathcal{A}^G \rightarrow \mathbb{R}$  where  $d(x, y) = 2^{-\inf\{|g|_S \mid g \in G, x_g \neq y_g\}}$  and  $|g|_S$  is a word metric associated to a finite set  $S$  of generators of  $G$ .

We say that a finite subset  $F \subset G$  is a *support*. Given two supports  $F, S$  we denote by  $FS$  the set  $FS := \{fs \mid f \in F, s \in S\}$  and by  $F^k = \{f_1, \dots, f_k \mid \forall 1 \leq i \leq k, f_i \in F\}$ . A *pattern* with support  $F$  is an element  $p \in \mathcal{A}^F$  and we write  $\text{supp}(p) = F$  to say that the support of  $p$  is  $F$ . We also denote the cylinder generated by  $p$  in

position  $g$  as  $[p]_g := \bigcap_{h \in F} [p_h]_{gh}$ , and  $[p] := [p]_{1_G}$ . We say that a pattern  $p$  *appears* in a configuration  $x \in \mathcal{A}^G$  and write  $p \sqsubset x$  if there exists  $g \in G$  such that  $x \in [p]_g$ . We say that a pattern  $q$  is a *subpattern* of  $p$  and write  $q \sqsubset p$  if there exists  $g \in G$  such that  $[p] \subset [q]_g$ .

**Definition 1.2.** A *subshift* is a subset  $X \subset \mathcal{A}^G$  which is closed and shift-invariant, that is,  $\forall g \in G, \sigma^g(X) \subset X$ .

*Remark.* In all formality, given the fact that we are dealing with dynamical systems, we should be writing  $(X, \sigma)$  to denote a subshift. Nevertheless we prefer to omit the action to ease the notation. We also speak of  $G$ -subshift to make the group explicit when dealing with subshifts over different groups. This notation is of special use in Chapter 3.

Equivalently, we can define a subshift as the set of all configurations in  $\mathcal{A}^G$  which avoid a set of forbidden patterns.

**Proposition 1.1.** *Let  $X \subset \mathcal{A}^G$ . The following are equivalent:*

- (1)  $X$  is a subshift.
- (2) There exists a set  $\mathcal{F}$  of patterns such that

$$X = \mathcal{A}^G \setminus \bigcup_{p \in \mathcal{F}, g \in G} [p]_g.$$

- (3) There exists a set  $\mathcal{F}$  of patterns such that  $X = \{x \in \mathcal{A}^G \mid p \sqsubset x \implies p \notin \mathcal{F}\}$ .

*Proof.* It is straightforward to show that (2) and (3) are equivalent and that any set of the form (2) is closed and shift-invariant. Let  $X$  be a subshift. As the cylinders form a subbase, we can write

$$X = \mathcal{A}^G \setminus \bigcup_{i \in I} \left( \bigcap_{j \in J_i} [a_j]_{g_j} \right) = \mathcal{A}^G \setminus \bigcup_{i \in I} [p_i]$$

where  $p_i = \bigcap_{j \in J_i} [a_j]_{g_j}$  is a cylinder. Therefore  $X$  is the complement of an union of cylinders. As  $X$  is shift-invariant we have  $\sigma^g(X) = X$  for every  $g \in G$ , hence we obtain:

$$X = \mathcal{A}^G \setminus \bigcup_{i \in I, g \in G} [p_i]_g.$$

which proves (2) by setting  $\mathcal{F} := \bigcup_{i \in I} \{p_i\}$ . □

**Definition 1.3.** The *language*  $L(X)$  of a subshift  $X \subset \mathcal{A}^G$  is the set of patterns  $p$  that appear in a configuration of  $X$ , that is,  $[p] \cap X \neq \emptyset$ . In particular  $L(\mathcal{A}^G)$  is the set of all patterns.

For any finite support  $F \subset G$  we also define the language restricted to the support  $F$  as  $L_F(X) := L(X) \cap \mathcal{A}^F$ .

*Remark.* In the case where  $G = \mathbb{Z}$  we can identify connected patterns with words in  $\mathcal{A}^*$ . This justifies the usage of the word language to speak about the set of patterns appearing in a subshift.

### 1.1.1 Symbolic morphisms

Let  $X \subset \mathcal{A}^G$  and  $Y \subset \mathcal{B}^G$  be subshifts. A map  $\phi : X \rightarrow Y$  is said to be *shift commuting* (in the literature, for example in [CSC09], this property is also called *G-equivariant*) if for every  $g \in G$  then  $\phi \circ \sigma^g = \sigma^g \circ \phi$ .

**Definition 1.4.** A continuous shift-commuting map  $\phi : X \rightarrow Y$  between two subshifts is called a *morphism*.

A surjective morphism is called a *factor map* and we write the existence of a factor map from  $X$  to  $Y$  by  $X \twoheadrightarrow Y$ . If there is a factor map from  $X$  to  $Y$  we say that  $Y$  is a *factor* of  $X$  and that  $X$  is an *extension* of  $Y$ . A bijective morphism is called a *conjugacy* and the fact that two subshifts are conjugate is written  $X \cong Y$ .

This definition of morphism is just a special case of Definition C.3 from the dynamical systems appendix. What is particular about the case of symbolic systems is that morphisms can be characterized combinatorially. Let  $\mathcal{A}, \mathcal{B}$  be alphabets and  $F \subset G$  be a support and consider a local map  $\Phi : \mathcal{A}^F \rightarrow \mathcal{B}$  which sends patterns in  $\mathcal{A}^F$  to symbols in  $\mathcal{B}$ . We can define a map  $\phi : \mathcal{A}^G \rightarrow \mathcal{B}^G$  given by  $\phi(x)_g = \Phi(\sigma^{g^{-1}}(x)|_F)$ . Any function  $\phi$  defined in such a way is called a *sliding-block code*.

*Example 1.1.* Let  $X = \{\square, \blacksquare\}^{\mathbb{Z}^2}$  be the full  $\mathbb{Z}^2$ -shift on two symbols. The majority rule map  $\phi$  is the sliding-block code defined by  $\Phi : \{\square, \blacksquare\}^{\{-1,0,1\}^2} \rightarrow \{\square, \blacksquare\}$  where  $\Phi(p)$  is defined as the symbol which appears the most in  $p$ . In Figure 1.2 the majority rule is applied to a configuration. The left red rectangle indicates the support of  $\Phi$  and the right one its image.

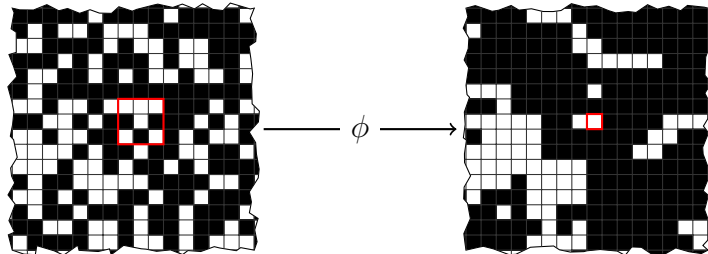

Figure 1.2: The majority rule sliding block code acting on a  $\mathbb{Z}^2$  configuration.

**Theorem 1.2** (Curtis-Lyndon-Hedlund [Hed69]). *Let  $X \subset \mathcal{A}^G, Y \subset \mathcal{B}^G$  be subshifts and  $\phi : X \rightarrow Y$  be a map. Then  $\phi$  is a morphism if and only if  $\phi$  is a sliding block code.*

*Proof.* Let  $\phi$  be a sliding block code. By definition there exists a local map  $\Phi : \mathcal{A}^F \rightarrow \mathcal{B}$  such that for every  $g \in G$  we have  $\phi(x)_g = \Phi(\sigma^{g^{-1}}(x)|_F)$ . Then

$$(\sigma^h \circ \phi(x))_g = \phi(x)_{h^{-1}g} = \Phi(\sigma^{g^{-1}h}(x)|_F) = \Phi(\sigma^{g^{-1}}(\sigma^h(x))|_F) = (\phi \circ \sigma^h(x))_g.$$

Therefore  $\phi$  is shift-commuting. Let  $p \in L(\mathcal{B}^G)$  be a pattern. By definition it can be written as a finite intersection of cylinders  $[b]_g$  for  $b \in \mathcal{B}$ . As  $\phi^{-1}([b]_g) = \{x \in \mathcal{A}^G \mid$

$\sigma^{g^{-1}}(x)|_F \in \Phi^{-1}(b)$  is open, we conclude that  $\phi^{-1}([p])$  is open. As the cylinders form a basis of the topology we conclude that the preimage of any open set is open and therefore  $\phi$  is continuous.

Conversely,  $\pi_{1_G} : \mathcal{B}^G \rightarrow \mathcal{B}$  defined by  $\pi_{1_G}(y) := y_{1_G}$  is continuous in the product topology. Therefore  $\pi_{1_G} \circ \phi$  is also continuous. Consider the sets  $U_{x,R} = \{x' \in X \mid x'|_R = x|_R, \pi_{1_G} \circ \phi(x) = \pi_{1_G} \circ \phi(x')\}$  where  $R \subset G$  is a support and  $x \in X$ . Obviously  $x \in U_{x,R}$  and therefore these sets form an open cover of  $\mathcal{A}^G$ . By compactness we can extract a finite subcover  $U_{x_i, R_i}$  and define  $F := \bigcup_{i \in I} R_i$ . Given two configurations  $x, x' \in X$  which coincide in  $F$  we have by definition that  $\pi_{1_G} \circ \phi(x) = \pi_{1_G} \circ \phi(x')$ , therefore there is a well defined function  $\Phi : L_F(X) \rightarrow \mathcal{B}$  such that for any  $x \in X$  then  $\Phi(x|_F) = \phi(x)_{1_G}$ . Extend  $\Phi$  to  $\mathcal{A}^F$  arbitrarily. As  $\phi$  is shift invariant we get that

$$\phi(x)_g = (\sigma^{g^{-1}} \circ \phi(x))_{1_G} = (\phi \circ \sigma^{g^{-1}}(x))_{1_G} = \Phi(\sigma^{g^{-1}}(x)|_F)$$

which concludes the proof.  $\square$

*Remark.* The original proof appeared in a paper of Hedlund [Hed69] where he credited Curtis and Lyndon as co-discoverers, it was originally presented only for  $G = \mathbb{Z}$  but their proof already contained the essentials. The version presented in this thesis is an adaptation of the proof in [CSC09].

This is a good time to introduce a useful construction called the Higher-block subshift, which enables the possibility to reduce the existence of factor maps to an equivalent version where the local function has trivial support. Formally: A sliding-block code  $\phi$  is said to be a *1-block code* if it is defined by a function  $\Phi : \mathcal{A}^F \rightarrow \mathcal{B}$  where  $F = \{1_G\}$ . That is,  $\Phi$  is just a relabeling of the alphabet.

**Definition 1.5.** Let  $X \subset \mathcal{A}^G$  be a subshift and let  $F \subset G$  be a support containing  $1_G$ . We define the higher-block subshift  $X^{[F]} \subset (\mathcal{A}^F)^G$  as the set

$$X^{[F]} := \{y \in (\mathcal{A}^F)^G \mid ((y_g)_{1_G})_{g \in G} \in X \text{ and } \forall h \in F, (y_g)_h = (y_{gh})_{1_G}\}.$$

**Proposition 1.3.** *Let  $X \subset \mathcal{A}^G$  be a subshift. Then  $X \cong X^{[F]}$ .*

*Proof.* Let  $\phi : X^{[F]} \rightarrow X$  be the 1-block code defined by the local function  $\Phi : \mathcal{A}^F \rightarrow \mathcal{A}$  such that  $\Phi((a_f)_{f \in F}) = a_{1_G}$ . The condition  $((y_g)_{1_G})_{g \in G} \in X$  implies that  $\phi(X^{[F]}) \subset X$ . Surjectivity comes from the fact that for any  $x \in X$  the configuration  $(\sigma^{g^{-1}}(x)|_F)_{g \in G}$  belongs to  $X^{[F]}$  and is sent to  $x$ . Finally, given  $y, y' \in X^{[F]}$  such that  $\phi(y) = \phi(y')$  we obtain that  $\forall g \in G$  and  $f \in F$  then

$$(y_g)_f = (y_{gf})_{1_G} = \phi(y)_{gf} = \phi(y')_{gf} = (y'_{gf})_{1_G} = (y'_g)_f.$$

Therefore  $y = y'$  and  $\phi$  is injective.  $\square$

For every sliding block code  $\phi : X \rightarrow Y$  with local function  $\Phi : \mathcal{A}^F \rightarrow \mathcal{B}$  we can consider a conjugacy  $\psi : X^{[F]} \rightarrow X$  and a 1-block code  $\hat{\phi} : X^{[F]} \rightarrow Y$  defined by  $\hat{\phi} = \phi \circ \psi$ . This means that for every extension of a subshift  $Y$  we can ask for a conjugate version  $\hat{X} := X^{[F]}$  of  $X$  which extends  $Y$  by a 1-block code. This is particularly useful when doing proofs as it simplifies computations.

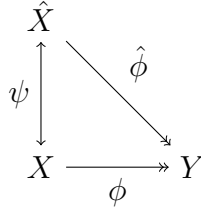

We denote the monoid of all endomorphisms  $\phi : X \rightarrow X$  as  $\text{End}(X)$  and the group of automorphisms by  $\text{Aut}(X)$ . In the case where  $X$  is the full  $G$ -shift we say  $\phi \in \text{End}(\mathcal{A}^G)$  is a *cellular automaton*. A cellular automaton is said to be *reversible* if there exists another cellular automaton  $\tau$  such that  $\phi \circ \tau = \tau \circ \phi = \text{id}$ . The previous theorem characterizes reversible cellular automata as automorphisms of the full  $G$ -shift. These objects play an important part in Chapter 5.

### 1.1.2 Dynamical properties

In this subsection we introduce a few dynamical properties of subshifts. The notion of conjugacy between two dynamical systems amounts to saying that from a dynamical point of view, they are indistinguishable. In this setting, when stating that a property is dynamical, it is meant that it is an invariant of conjugacy, that is to say, if two subshifts are conjugate and one satisfies the property then the other also does. Some of these are particular cases of those presented in Appendix C, but their extended usage in the following chapters justifies their introduction here.

Given a configuration  $x \in \mathcal{A}^G$  we denote its orbit by  $\text{Orb}_\sigma(x) = \{\sigma^g(x) \mid g \in G\}$  and its stabilizer by  $\text{Stab}_\sigma(x) = \{g \in G \mid \sigma^g(x) = x\}$ .

**Definition 1.6.** A configuration  $x \in X$  is:

- *Aperiodic* if  $\sigma^g(x) = x \implies g = 1_G$ .
- *Periodic* if there exists  $g \in G \setminus \{1_G\}$  such that  $\sigma^g(x) = x$ .
- *Strongly periodic* if  $|\text{Orb}_\sigma(x)| < \infty$ .
- *Uniform* if there is  $a \in \mathcal{A}$  such that  $\forall g \in G, x_g = a$ .

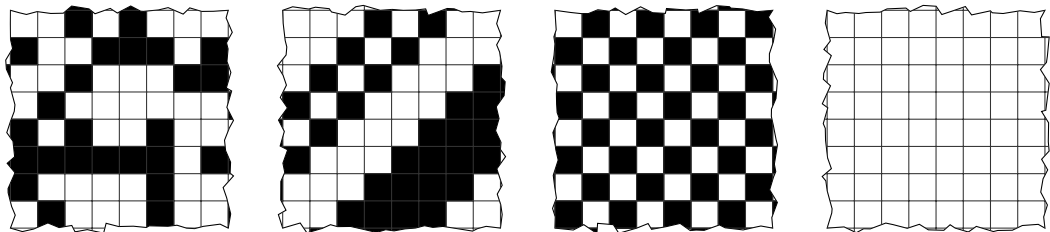

Figure 1.3: From left to right: An aperiodic, periodic, strongly periodic and uniform configuration in  $\{\square, \blacksquare\}^{\mathbb{Z}^2}$ .

*Example 1.2.* In Figure 1.3 we show four examples of configurations. In the leftmost one, there is no apparent period so this could be part of an aperiodic configuration. In the second one there is a period in direction  $v = (1, 1)$ . In the third one, the configuration is a bi-infinite checkerboard and  $|\text{Orb}_\sigma(x)| = 2$ . The last configuration is uniform.

**Definition 1.7.** A subshift  $X \subset \mathcal{A}^G$  is:

- *Weakly aperiodic* if  $X$  contains no strongly periodic configurations.
- *Strongly aperiodic* if the shift action is free, that is,  $X$  contains no periodic configurations:  $\forall x \in X, \text{Stab}_\sigma(x) = \{1_G\}$ .

The notion of strong aperiodicity implies that of weak aperiodicity. They are the same in the case where every non-trivial subgroup of  $G$  has finite index in  $G$ . For instance, if  $G = \mathbb{Z}$  both notions coincide.

*Example 1.3.* Let  $R_\alpha : \mathbb{Z} \curvearrowright \mathbb{R}/\mathbb{Z}$  be the rotation of of angle  $\alpha \in \mathbb{R}$  where  $R_\alpha^n(x) := x + n\alpha \pmod{1}$ . We can consider the set  $X_\alpha$  of all bi-infinite sequences  $\varphi(x) \in \{0, 1\}^{\mathbb{Z}}$  such that there exists  $x \in \mathbb{R}/\mathbb{Z}$  such that  $\varphi(x)_n = 1 \iff R^n(x) \in [0, \alpha)$ .

If  $\alpha \in \mathbb{R} \setminus \mathbb{Q}$  then  $X_\alpha$  is called a *Sturmian subshift* and  $\alpha$  is called its *slope*. It is a classical example of a strongly aperiodic subshift.

In Chapter 2 we introduce a technique which allows us to construct strongly aperiodic subshifts in arbitrary countable groups. This construction is once again used in Chapter 3 to get a much sharper result for subshifts of finite type.

**Definition 1.8.** A subshift  $X \subset \mathcal{A}^G$  is said to be:

- *Irreducible* if  $\sigma$  acts transitively on  $X$ , that is, if for every pair of patterns  $p, q \in L(X)$  there exists  $x \in X$  such that  $p \sqsubset x$  and  $q \sqsubset x$ .
- *Minimal* if for every closed and shift invariant  $Y \subset X$  either  $Y = \emptyset$  or  $Y = X$ .

In the case of a countable group, the language  $L(X)$  of any subshift is countable, therefore in the case of an irreducible subshift  $X$  one could enumerate its patterns  $p_1, p_2, \dots$  and construct a sequence  $(x_n)_{n \in \mathbb{N}}$  such that  $\forall i \leq n \ p_i \sqsubset x_n$ . By definition, any accumulation point of  $(x_n)_{n \in \mathbb{N}}$  satisfies that  $\overline{\text{Orb}_\sigma(x)} = X$ . This gives an equivalent definition of irreducible subshifts as those which admit a configuration  $x \in X$  satisfying  $\overline{\text{Orb}_\sigma(x)} = X$ .

For minimal subshifts, the previous property is in fact held by every configuration.

**Proposition 1.4.** *Let  $X \subset \mathcal{A}^G$  be a subshift. Then  $X$  is minimal if and only if  $\forall x \in X \ \overline{\text{Orb}_\sigma(x)} = X$ .*

*Proof.* Let  $x \in X$ . Then  $Y = \overline{\text{Orb}_\sigma(x)}$  is a closed and shift invariant subset of  $X$ . If  $X$  is minimal then either  $Y = \emptyset$  or  $Y = X$ , as  $x \in Y$  we have  $Y = X$ . Conversely, let  $Y \subset X$  be closed and shift-invariant and suppose  $Y \neq \emptyset$ . Then  $\exists x \in X \cap Y$  and thus  $X = \overline{\text{Orb}_\sigma(x)} \subset Y$ , therefore  $Y = X$ .  $\square$



A notion which is not directly used in the following chapters but that nonetheless appears in several examples is the topological entropy. It is a conjugacy invariant which gives a measure of how complex a dynamical system is. We begin by giving a definition in the case of a  $\mathbb{Z}$ -subshift.

**Definition 1.9.** Let  $X \subset \mathcal{A}^{\mathbb{Z}}$  be a subshift. Its topological entropy is given by:

$$h_{\text{top}}(X) := \lim_{N \rightarrow \infty} \frac{1}{N} \log(|L_{\{0, \dots, N-1\}}(X)|).$$

The limit in the above definition always converges because the function  $f(n) = |L_{\{0, \dots, n-1\}}(X)|$  is subadditive. Moreover, using Fekete's subadditive lemma it can be shown that  $h_{\text{top}}(X) = \inf_{N \geq 1} \frac{1}{N} \log(|L_{\{0, \dots, N-1\}}(X)|)$ .

*Example 1.4.* Let  $\mathcal{A}^{\mathbb{Z}}$  be the full shift. As there are no restrictions  $|L_{\{0, \dots, N-1\}}(X)| = |\mathcal{A}|^N$  and thus

$$h_{\text{top}}(\mathcal{A}^{\mathbb{Z}}) = \log(|\mathcal{A}|).$$

*Example 1.5.* The set of configurations:

$$X_{\text{Fib}} := \{x \in \{0, 1\}^{\mathbb{Z}} \mid x_n = 1 \implies x_{n+1} = 0\}$$

is called the Golden-mean shift or the Fibonacci shift. It is the set of all bi-infinite sequences where two 1s never appear next to each other. Let  $L_N := |L_{\{0, \dots, N-1\}}(X)|$ , in order to count  $L_N$  one can separate them in those ending in a 0 (there are exactly  $L_{N-1}$ ) and those ending in a 1 (must be preceded by a 0 and thus there are  $L_{N-2}$ ). We obtain that  $L_N$  satisfies the Fibonacci recurrence  $L_N = L_{N-1} + L_{N-2}$  starting from  $L_1 = 2$ ,  $L_2 = 3$ . Therefore we have that  $|L_{\{0, \dots, N-1\}}(X)| = \frac{(\frac{1+\sqrt{5}}{2})^{N+2} - (\frac{1-\sqrt{5}}{2})^{N+2}}{\sqrt{5}}$  and thus  $h_{\text{top}}(X_{\text{Fib}}) = \log(\frac{1+\sqrt{5}}{2})$ .

In the case of a general group the notion of entropy is more subtle. Two properties of the topological entropy of  $\mathbb{Z}$ -actions that would be desirable in the general case are that the full shift  $\mathcal{A}^{\mathbb{Z}}$  has entropy  $h_{\text{top}}(\mathcal{A}^{\mathbb{Z}}) = \log(|\mathcal{A}|)$  and that factor maps reduce the entropy. Ornstein and Weiss [OW87] produced a seemingly bizarre example of a factor map between the full shift on two symbols and the full shift on four symbols in the free group  $F_2$ . This example shows that a general entropy theory must forcefully abandon one of these properties. Nevertheless, in the case of amenable groups the standard theory generalizes nicely.

**Definition 1.10.** Let  $G$  be a countable amenable group and  $X \subset \mathcal{A}^G$  a subshift. The topological entropy of  $X$  is given by:

$$h_{\text{top}}(X) := \lim_{n \rightarrow \infty} \frac{1}{|F_n|} \log(|L_{F_n}(X)|)$$

where  $(F_n)_{n \in \mathbb{N}}$  is any Følner sequence (see Definition B.22).

As in the case of a  $\mathbb{Z}$ -subshift, the limit always exist and does not depend on the Følner sequence. Here this fact follows from the Ornstein-Weiss lemma [OW87]

which is a generalization of Fekete’s lemma to amenable groups. In this case, one can also show that the entropy is equal to the infimum. In fact Downarowicz et al [DFR15] showed that it can be obtained as the infimum over all finite supports:  $h_{\text{top}}(X) = \inf_{F \subset G, |F| < \infty} \frac{1}{|F|} \log(|L_F(X)|)$ .

In the case of a non-amenable group there is no general entropy theory. However, it is noteworthy to say that there is a far-reaching generalization in the case of sofic groups developed by Bowen [Bow10] and generalized to the topological setting by Kerr and Li [KL11]. In this case the entropy depends on a sofic approximation of the group.

## 1.2 Classes of subshifts

In this section three important classes of subshifts are introduced. It is straightforward to show that if a group  $G$  is countably infinite, then the set of all subshifts over a fixed finite alphabet is uncountable, even if we quotient by conjugacy (see Exercise 4.3.7 from [LM95]). It is therefore interesting to explore what is the class of subshifts we can get when we restrict to a countable set where every element can be defined by a finite amount of information. This brings us to three classes that are widely studied in the literature: subshifts of finite type, sofic subshifts and effectively closed subshifts.

### 1.2.1 Subshifts of finite type

The class of subshifts of finite type (SFT) consists of all subshifts which can be defined by a finite set of forbidden patterns. In this sense it is one of the simplest classes that can be defined. In the case where  $G = \mathbb{Z}$  these objects are well understood and can be characterized as the set of bi-infinite walks in a subgraph of a De Bruijn graph, see for instance [LM95]. In this case, almost all properties are well understood with a remarkable exception being the conjugacy problem [Boy08] which asks whether it can be algorithmically decidable if two SFTs are dynamically conjugate.

In the case where  $G = \mathbb{Z}^d$  with  $d \geq 2$ , it turns out that subshifts of finite type become much more complicated. While in  $\mathbb{Z}$  every SFT contains periodic configurations there are  $\mathbb{Z}^2$ -SFTs which are strongly aperiodic [Rob71, Kar96]. Also, given a set of forbidden words it is decidable whether a  $\mathbb{Z}$ -subshift defined by that set is empty –it amount to finding a cycle in a graph– while in  $\mathbb{Z}^2$  that same problem is undecidable [Ber66, Rob71]. Said otherwise, there is no general algorithm deciding if a finite set of forbidden patterns yields a non-empty subshift.

Even though we claim that the class of SFTs is very simple, in the literature there are classes that are even more restrictive. For instance, if we endow the finite alphabet  $\mathcal{A}$  with a finite group structure and ask  $X \subset \mathcal{A}^G$  to be also a group with pointwise composition we obtain the class of *group shifts*. In the case where  $G = \mathbb{Z}^d$  it can be proven that they form a subclass of SFTs [KS88]. Another subclass of SFTs which has been lately studied is the one of *Hom-shifts* [CM16] where subshifts are defined as the set of graph homomorphisms from the Cayley graph of  $\mathbb{Z}^d$  to some finite

undirected graph. Analogously, they can be defined as the class of nearest neighbor subshifts which are invariant under automorphisms of the Cayley graph of  $\mathbb{Z}^d$ .

In this section we introduce subshifts of finite type in the setting of general groups, show some examples, and prove a few results which will be useful in the following chapters.

**Definition 1.11.** A subshift  $X \subset \mathcal{A}^G$  is of *finite type* (SFT) if there exist a finite set  $\mathcal{F} \subset L(\mathcal{A}^G)$  of forbidden patterns such that  $X = X_{\mathcal{F}}$ .

*Example 1.6.* Let  $X_{\text{Fib}}$  be the Golden-mean shift from Example 1.5.  $X_{\text{Fib}}$  is a subshift of finite type as  $X = X_{\mathcal{F}}$  for  $\mathcal{F} = \{11\}$ .

*Example 1.7.* Let  $G = \mathbb{Z}^2$  and  $\mathcal{A} = \mathbb{Z}/2\mathbb{Z}$ . The set of configurations

$$X_{\text{Led}} := \{x \in (\mathbb{Z}/2\mathbb{Z})^{\mathbb{Z}^2} \mid \forall (i, j) \in \mathbb{Z}^2, x_{(i,j)} + x_{(i+1,j)} + x_{(i,j+1)} = 0\}$$

is called the Ledrappier shift [Led87] or the three dot system. It is an SFT and an example of a configuration can be seen in Figure 1.4.

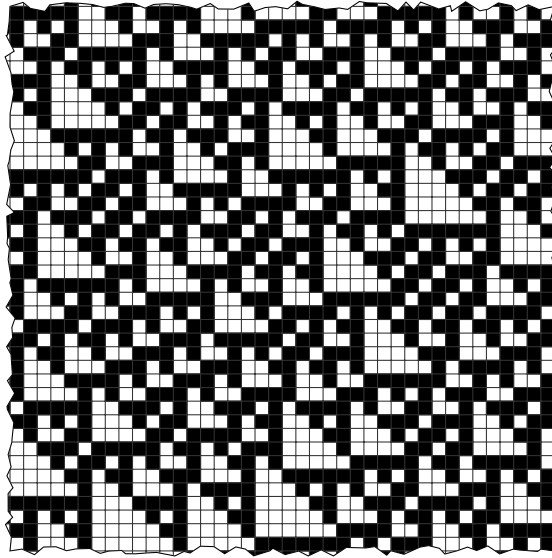

Figure 1.4: A configuration in the Ledrappier subshift.

The first important property of subshifts of finite type is that they form a conjugacy class.

**Proposition 1.5.** Let  $X \subset \mathcal{A}^G$  and  $Y \subset \mathcal{B}^G$  be subshifts. If  $X \cong Y$  and  $X$  is an SFT then  $Y$  is also an SFT.

*Proof.* Let  $\phi : Y \rightarrow X$  be a conjugacy,  $\psi : X \rightarrow Y$  its inverse and  $\mathcal{F}_X$  a finite set of forbidden patterns defining  $X$ . Without loss of generality, we can choose a support  $F \subset G$  such that  $\Phi : \mathcal{B}^F \rightarrow \mathcal{A}$  is the local map defining  $\phi$ ,  $\Psi : \mathcal{A}^F \rightarrow \mathcal{B}$  is the local map defining  $\psi$  and  $1_G \in F$ . For a pattern  $p \in \mathcal{A}^R$  define  $\Phi^{-1}(p) \subset \mathcal{B}^{RF}$  as the set

of patterns  $q$  of support  $RF$  such that  $\forall r \in R$  and  $\forall f \in F$ ,  $\Phi(\{q_{rf}\}_{f \in F}) = p_r$ . We claim that  $Y$  is defined by the finite set of forbidden patterns

$$\mathcal{F}_Y := \bigcup_{p \in \mathcal{F}} \Phi^{-1}(p) \cup \left( \mathcal{B}^{F^2} \setminus L_{F^2}(Y) \right).$$

First, let  $y \in Y$  and suppose there is  $q \in \mathcal{F}_Y$  such that  $q \sqsubset y$ . As  $y \in Y$  we have  $q \notin \mathcal{B}^{F^2} \setminus L_{F^2}(Y)$  and thus  $q$  must be of the form  $\Phi^{-1}(p)$  for some  $p \in \mathcal{F}_X$ . Let  $g \in G$  such that  $y \in [q]_g$ , by definition we obtain that for each  $r \in \text{supp}(p)$ ,

$$\phi(y)_{gr} = \Phi(\sigma^{(gr)^{-1}}(y)|_F) = \Phi(\{q_{rf}\}_{f \in F}) = p_r.$$

Therefore  $p \sqsubset \phi(x)$ . As  $p \in \mathcal{F}_X$  and  $\phi(x) \in X$  this gives a contradiction and hence for each  $q \sqsubset y$  we have  $q \notin \mathcal{F}_Y$ .

Conversely, let  $y \in \mathcal{B}^G$  such that each  $q \sqsubset y$  does not belong to  $\mathcal{F}_Y$ . By definition of  $\mathcal{F}_Y$ , we have that  $\phi(y)$  does not contain patterns in  $\mathcal{F}_X$  and thus  $\phi(y) \in X$  and thus  $\psi \circ \phi(y) \in Y$ . A priori, it might happen that  $\psi \circ \phi(y) \neq y$ . Nevertheless,

$$\begin{aligned} \psi(\phi(y))_g &= \Psi(\sigma^{g^{-1}}(\phi(y))|_F) \\ &= \Psi(\phi(\sigma^{g^{-1}}(y))|_F) \\ &= \Psi(\Phi(\{\sigma^{f^{-1}g^{-1}}(y)|_F\}_{f \in F})) \\ &= \Psi \circ \Phi(\sigma^{g^{-1}}(y)|_{F^2}). \end{aligned}$$

As  $\psi \circ \sigma$  acts as the identity in  $Y$ , then forcefully it acts as the identity in each pattern appearing in some configuration in  $Y$ , more precisely, in any pattern in  $L_{F^2}(Y)$ . By definition of  $\mathcal{F}_Y$ , we have that  $\sigma^{g^{-1}}(y)|_{F^2} \in L_{F^2}(Y)$  and therefore  $\Psi(\Phi(\sigma^{g^{-1}}(y)|_{F^2})) = y_g$  from where we conclude that  $y \in Y$ .  $\square$

**Definition 1.12.** Let  $S$  be a finite subset of a group  $G$ . A subshift  $X \subset \mathcal{A}^G$  is said to be *nearest neighbor with respect to  $S$*  if there exists a set  $\mathcal{F} \subset L(\mathcal{A}^G)$  such that  $X = X_{\mathcal{F}}$  and every pattern  $p \in \mathcal{F}$  satisfies  $\text{supp}(p) = \{1_G, s\}$  for some  $s \in S$ . Such a set of forbidden patterns is also said to be *nearest neighbor*.

Nearest neighbor subshifts can be interpreted as colorings of the Cayley graph  $\Gamma(G, S)$  such that for each edge  $\{g, gs\}$  the choices of color are restricted according to the nearest neighbor set of forbidden patterns.

*Example 1.8.* The set  $X = \{x \in \mathcal{A}^G \mid \forall g \in G, \forall s \in S, x_g \neq x_{gs}\}$  of graph colorings by  $\mathcal{A}$  of the Cayley graph  $\Gamma(G, S)$  is a nearest neighbor subshift.

*Example 1.9.* A *Wang tile* is a 4-tuple  $t = (t_N, t_W, t_S, t_E) \in C^4$  where  $C$  is a finite set. It represents a unit square whose edges are colored according to the tuple interpreting the letters  $N, S, W, E$  as North, South, West and East respectively. See Figure 1.5.

A set  $\tau \subset C^4$  of Wang tiles is called a *tileset*. We say  $x : \mathbb{Z}^2 \rightarrow \tau$  is a valid tiling of the plane by  $\tau$  if and only if for every  $(i, j) \in \mathbb{Z}^2$ :

$$x(i, j)_N = x(i, j + 1)_S \text{ and } x(i, j)_E = x(i + 1, j)_W.$$



Figure 1.5: If the set  $C$  is interpreted as a finite set of colors, a Wang tile defined by a tuple  $(t_N, t_W, t_S, t_E)$  of colors and can be represented as shown.

Said otherwise, a valid tiling is an assignment of tiles from  $\tau$  to every position of  $\mathbb{Z}^2$  such that adjacent Wang tiles share the same color over adjacent edges, see Figure 1.6. The set of all valid tilings by a tileset is a nearest neighbor  $\mathbb{Z}^2$ -subshift for  $S = \{(1, 0), (-1, 0), (0, 1), (0, -1)\}$ .

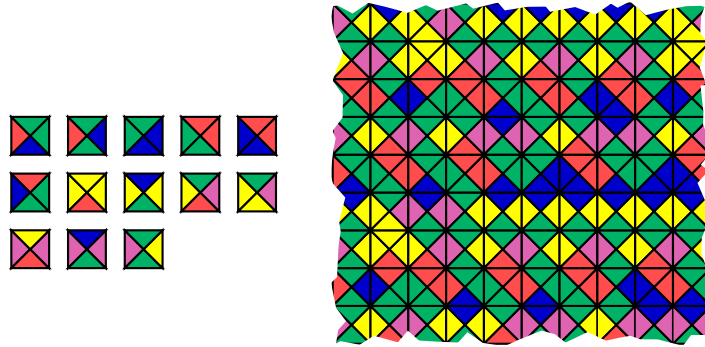

Figure 1.6: A tileset  $\tau$  and a partial valid tiling of the plane.

Every nearest neighbor subshift is of finite type, indeed, any set  $\mathcal{F}$  satisfying the constraints satisfies  $|\mathcal{F}| \leq |\mathcal{A}|^{2|S|}$ . The converse is false. For instance, the sequence of  $\mathbb{Z}$ -subshifts  $\{X_n\}_{n \in \mathbb{N}}$  where  $X_n \subset \{0, 1\}^{\mathbb{Z}}$  is defined by  $\mathcal{F}_n = \{1^n\}$  is a countable set of subshifts of finite type which satisfy that  $1^{n-1} \in L(X_n) \setminus \bigcup_{m < n} L(X_m)$ . Therefore an infinite number of them are forcefully not nearest neighbor. Nevertheless, every subshift of finite type is conjugate to a nearest neighbor subshift.

Before showing that result in generality, we illustrate informally in Figure 1.7 how this conjugacy works in the case we would like to turn a  $\mathbb{Z}^2$  subshift into an equivalent set of Wang tiles. As the set of forbidden patterns is finite, there exists a big enough  $n \in \mathbb{N}$  such that the support of every forbidden pattern is contained in  $[0, n]^2$ . Then one can construct the set of colorings of  $[0, n]^2$  which do not contain forbidden patterns and turn each one of them into Wang tiles which through their adjacency colors force two contiguous patterns to overlap. This technique gives a one to one correspondence between the set of valid tilings of the Wang tiles and the configurations in the original subshift which can be shown to be a conjugacy.

**Proposition 1.6.** *Every subshift of finite type is conjugate to a nearest neighbor subshift.*

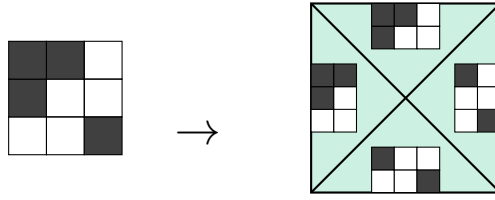

Figure 1.7: The transformation of a forbidden pattern into a Wang tile.

*Proof.* Let  $\mathcal{F}$  be a finite set of forbidden patterns defining  $X_{\mathcal{F}} \subset \mathcal{A}^G$  and let  $F := \{1_G\} \cup \bigcup_{p \in \mathcal{F}} \text{supp}(p)$  which is finite because  $G$  is finitely generated. By Proposition 1.3 we have that  $X \cong X^{[F]}$ . The subshift  $X^{[F]}$  is easily shown to be a nearest neighbor subshift with respect to  $F$ . Indeed, the condition “ $\forall h \in F, (y_g)_h = (y_{gh})_{1_G}$ ” can be coded by the patterns  $p$  with support  $\{1_G, h\}$  such that  $(p_{1_G})_h \neq (p_h)_{1_G}$  and the condition “ $((y_g)_{1_G})_{g \in G} \in X$ ” is achieved forbidding all  $\tilde{p} \in \mathcal{A}^F$  such that  $\tilde{p}|_{\text{supp}(p)} = p$  for some  $p \in \mathcal{F}$ .  $\square$

In the case where  $G$  is a finitely generated group, this result can be made stronger in the following sense:

**Proposition 1.7.** *If  $G$  is finitely generated by the set  $S$  then every subshift of finite type is conjugate to a nearest neighbor subshift with respect to  $S$ .*

*Proof.* Let  $\mathcal{F}$  be a finite set of forbidden patterns defining  $X_{\mathcal{F}} \subset \mathcal{A}^G$  and consider  $N := \max_{h \in \text{supp}(p), p \in \mathcal{F}} |h|_S$  and  $F := B_S(1_G, N)$  be the ball of size  $N$  in the Cayley graph  $\Gamma(G, S)$ . Again we have that  $X \cong X^{[F]}$ . We claim  $X^{[F]}$  is a nearest neighbor subshift with respect to  $S$ .

Similarly to the previous proof, the condition “ $((y_g)_{1_G})_{g \in G} \in X$ ” is achieved forbidding all  $\tilde{p} \in \mathcal{A}^F$  such that  $\tilde{p}|_{\text{supp}(p)} = p$  for some  $p \in \mathcal{F}$ . The condition “ $\forall h \in F, (y_g)_h = (y_{gh})_{1_G}$ ” is this time coded by all patterns with support  $p$  with support  $\{1_G, s\}$  such that there exists  $g \in B_S(1_G, N) \cap B_S(s, N)$  such that  $(p_{1_G})_g \neq (p_s)_{s^{-1}g}$ . Indeed, if  $h \in F$  then we can write  $h =_G s_1, \dots, s_n \in S^n$  for some  $n \leq N$  and we have that  $(y_{1_G})_h = (y_{s_1})_{s_1^{-1}h}$ ,  $(y_{s_1})_{s_1^{-1}h} = (y_{s_1 s_2})_{s_2^{-1} s_1^{-1} h}$ , etc. Iterating this we obtain:

$$(y_{1_G})_h = (y_{s_1, \dots, s_n})_{s_n^{-1}, \dots, s_1^{-1} h} = (y_h)_{1_G}.$$

$\square$

Another interesting property of subshifts of finite type is that in the case of a countable group action they are a dense subset for the Hausdorff topology on the set of all subshifts over a fixed alphabet. Formally, we say a sequence of subshifts  $(X_n)_{n \in \mathbb{N}}$  converges to  $X \subset \mathcal{A}^G$  if for every finite support  $F \subset G$  then  $L_F(X_n) \rightarrow L_F(X)$ .

**Proposition 1.8.** *Let  $G$  be a countable group and  $\mathcal{A}$  an alphabet. Then the set of all SFTs with alphabet  $\mathcal{A}$  is dense in the set of all subshifts with alphabet  $\mathcal{A}$ . Furthermore, every subshift can be obtained as an intersection of SFTs.*

*Proof.* As  $G$  is countable, we can enumerate all supports of  $F$  in a sequence  $(F_n)_{n \in \mathbb{N}}$ . Let  $X \subset \mathcal{A}^G$  be a subshift and consider  $\mathcal{F}_n := \bigcap_{m \leq n} \mathcal{A}^{F_m} \setminus L_{F_m}(X)$  and  $X_n := X_{\mathcal{F}_n}$ . By definition each  $X_n$  is an SFT and  $(X_n)_{n \in \mathbb{N}} \rightarrow X$  and as the sequence is nested we get  $\bigcap_{n \in \mathbb{N}} X_n = X$ .  $\square$

## 1.2.2 Sofic subshifts

A disadvantage of SFTs is that their image under a factor map is not necessarily an SFT. It is natural to consider the smallest class of subshifts which contains all subshifts of finite type and is closed under factors. The resulting class is the one of sofic subshifts. The term was coined by Weiss [Wei73] and comes from Hebrew meaning “finite”. The same term is used to refer to the class of sofic groups [Wei00] which contains both amenable and residually finite groups.

As with subshifts of finite type, the properties of sofic subshifts are rather well understood in the case  $G = \mathbb{Z}$ , but several open questions still remain in the multi-dimensional case. For instance, it is known that topological entropy decreases under factor maps. In the case of  $\mathbb{Z}$ -subshifts every sofic subshift admits an SFT extension with the same entropy. The question of whether every  $\mathbb{Z}^2$  sofic subshift admits an equal entropy SFT extension is still open although it is known that SFT extensions with arbitrarily close entropy can always be found [Des06].

**Definition 1.13.** A subshift  $Y$  is *sofic* if it is a factor of an SFT. That is, if there exists an SFT  $X$  and a factor map  $\phi : X \rightarrow Y$ .

Sofic subshifts are faithful to the philosophy of being defined with a finite amount of information. Indeed, they just add the codification of the local function  $\Phi$  which defines the factor. Furthermore, they can always be regarded as relabellings of some SFT by choosing a conjugate higher block extension as in Proposition 1.3.

*Example 1.10.* The subshift  $X_{\leq 1} := \{x \in \{0, 1\}^G \mid 1 \in \{x_g, x_h\} \implies g = h\}$  containing at most one appearance of 1 is a sofic subshift if  $G = \mathbb{Z}$ . Indeed, one can consider the alphabet  $\mathcal{A} = \{\leftarrow, \heartsuit, \rightarrow\}$  with the set of forbidden words  $\mathcal{F} = \{\heartsuit \leftarrow, \heartsuit \heartsuit, \rightarrow \heartsuit, \rightarrow \leftarrow\}$ . This generates a subshift where all configurations are either uniform arrow configurations or of the form  $\dots \leftarrow \leftarrow \heartsuit \rightarrow \rightarrow \dots$ . The 1-block code  $\phi : X_{\mathcal{F}} \rightarrow X_{\leq 1}$  that sends  $\heartsuit$  to 1 and  $\{\leftarrow, \rightarrow\}$  to 0 factors onto  $X_{\leq 1}$ .

If  $G$  is now the free group of rank 2 then again  $X_{\leq 1}$  is a sofic  $F_2$ -subshift by an analogous construction which is shown in Figure 1.8. In Chapter 4 it will be shown that there are groups where  $X_{\leq 1}$  is not sofic.

**Proposition 1.9.** *The property of being a sofic subshift is invariant under conjugacy*

*Proof.* Let  $Z \cong Y$  and  $Y$  be a sofic subshift. By definition, there exists an SFT  $X$  and a factor map  $\phi : X \rightarrow Y$ . Let  $\psi : Y \rightarrow Z$  be a conjugacy and consider  $\psi \circ \phi : X \rightarrow Z$ . By definition  $\psi \circ \phi$  is a factor map, therefore  $Z$  is a sofic subshift.  $\square$

*Example 1.11.* Let  $G$  be a finitely generated group and  $S$  a set of generators of  $G$  such that  $S^{-1} \subset S$ . The *even shift*  $S_{\text{even}} \subset \{0, 1\}^G$  is the set of all configurations

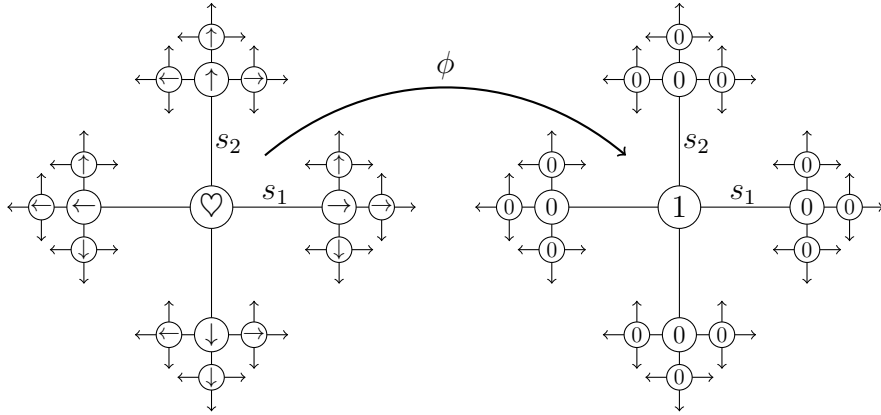

Figure 1.8: SFT extension for  $X_{\leq 1}$  in the case of a free group.

$x$  such that any maximal finite connected component of  $x^{-1}(1) \subset G$  in the Cayley graph  $\Gamma(G, S)$  has even size. Said otherwise, each finite connected component of ones has even size.

$S_{\text{even}}$  can be shown to always be sofic, the proof below is folklore to the best of the author's knowledge, though the statement that it is an easy exercise appears in a short note by Hochman describing a related open problem: whether the analogously defined odd shift  $S_{\text{odd}}$  is sofic for  $G = \mathbb{Z}^d$  and the canonical set of generators. This problem still remains open for  $d \geq 3$ .

**Proposition 1.10.** *If  $G$  is infinite,  $S_{\text{even}}$  is sofic and not an SFT.*

*Proof.* Suppose  $S_{\text{even}}$  is an SFT, let  $\mathcal{F}$  be a finite set of forbidden patterns such that  $X_{\mathcal{F}} = S_{\text{even}}$  and let  $F = \bigcup_{p \in \mathcal{F}} \text{supp}(p)$ . Let  $N = \max_{f \in F} |f|_S$  and consider  $\hat{g} \in G$  such that  $M := |\hat{g}|_S > 2N$  and  $M$  is even. As  $G$  is infinite this element exists. Now consider a geodesic  $\mathcal{G} := \{1_G = g_0, g_1, \dots, g_M = \hat{g}\}$  from  $1_G$  to  $\hat{g}$ . The indicator function  $1_{\mathcal{G}}$  of  $\mathcal{G}$  is not in  $S_{\text{even}}$  because  $\mathcal{G} = (1_{\mathcal{G}})^{-1}(1)$  is connected in  $\Gamma(G, S)$  and has odd size. Nevertheless  $1_{\mathcal{G}} \in X_{\mathcal{F}}$ . Indeed, as  $M > 2N$  then for every  $g \in G$  and  $F' \subset F$  we have that either  $\hat{g} \notin gF'$  or  $1_G \notin gF'$ . As  $1_{\mathcal{G}}$  can be repaired by either turning the symbol at  $1_G$  or  $\hat{g}$  to 0 we conclude that  $\sigma^{g^{-1}}(1_{\mathcal{G}})|_{F'} \in L(S_{\text{even}}) \notin \mathcal{F}$  and thus  $1_{\mathcal{G}} \in X_{\mathcal{F}}$ , a contradiction.

To see that  $S_{\text{even}}$  is sofic we construct an SFT extension  $X_{\mathcal{F}}$  and a 1-block code  $\phi : X_{\mathcal{F}} \rightarrow S_{\text{even}}$ . Consider the finite set of functions  $(\varphi_i)_{i \in I}$  with  $\varphi_i : S \rightarrow \{0, 1\}$  such that  $|\varphi_i^{-1}(1)|$  is either 0 or an odd number. Now consider the alphabet  $\mathcal{A} = \{\varphi_i, i \in I\}$  and the subshift  $X_{\mathcal{F}} \subseteq \mathcal{A}^G$  given by  $\mathcal{F} = \bigcup_{s \in S} \mathcal{F}_s$  where  $\mathcal{F}_s := \{p \in \mathcal{A}^{\{1_G, s\}} \mid p_{1_G}(s) \neq p_s(s^{-1})\}$ . The intuition behind this is that each element of  $\mathcal{A}$  represents either a 0, or a vertex of a graph with odd degree which must match correctly in every direction. Finally, consider the 1-block code  $\phi$  given by the local function that maps  $\varphi \equiv 0$  to 0 and any other  $\varphi \in \mathcal{A}$  to 1.

Let  $x \in X_{\mathcal{F}}$  and suppose there is a finite maximal component  $\mathcal{C} \subset \phi(x)^{-1}(1)$ . Then for each  $g \in \mathcal{C}$  we have that  $x_g$  is not the  $\varphi \equiv 0$  function. By definition of  $\mathcal{F}$  and the handshaking lemma we have that  $\sum_{g \in \mathcal{C}, s \in S} x_g(s)$  is even, but for each  $g$



we have  $\sum_{s \in S} x_g(s)$  is odd, therefore we conclude that  $|\mathcal{C}|$  must be even and thus  $\phi(x) \in S_{\text{even}}$ .

Conversely, let  $y \in S_{\text{even}}$ . By compactness of  $\{0, 1\}^G$  it is sufficient to construct for each support  $F$  a configuration  $x \in X_{\mathcal{F}}$  such that  $\phi(x)|_F = y|_F$ . Let  $\hat{y}$  be a configuration such that  $\hat{y}|_F = y|_F$ ,  $\hat{y}^{-1}(1) \subset FS$  and  $\hat{y} \in S_{\text{even}}$ . Such a configuration can be obtained by deleting 1s in  $FS \setminus F$ . For each connected component  $\mathcal{C} \subset \hat{y}^{-1}(1)$  take a covering tree in  $\Gamma(G, S)$ . If every node in the covering tree has odd degree interpret them as elements of  $\mathcal{A}$  and we are done, if not, take a vertex in the covering tree that has even degree and remove it. As the number of vertices in the tree is even, there must exist an odd number of subtrees that have odd degree. By reconnecting this vertex to every such odd component (we use a symbol from  $\mathcal{A}$ ), we obtain a forest of subtrees where each has an even number of vertices and the total number of vertices with even degree has been reduced by one. Iterating this procedure yields a forest where every node has odd degree and thus a covering of the component that can be realized by elements of  $\mathcal{A}$ . This produces  $x \in X_{\mathcal{F}}$  such that  $\phi(x) = \hat{y}$  and thus  $\phi(x)|_F = y|_F$ . Therefore  $\phi$  is surjective.  $\square$

Sofic subshifts are of special importance in  $\mathbb{Z}^2$  as they form a class big enough to contain several subshifts of dynamical importance [Moz89, AS13]. In Chapter 3 this fact will be made precise and used as the main tool for Theorem 3.7.

### 1.2.3 Effectively closed subshifts

Recently, the use of computability theory has become essential in the study of subshifts of finite type. For example, in  $\mathbb{Z}^d$  for  $d \geq 2$  the possible entropies of SFTs are characterized as the set of right recursively enumerable numbers [HM10]. This type of results comes from the possibility to encode Turing machines inside  $\mathbb{Z}^d$ -SFTs. The study of such results led to the introduction of the class of effectively closed  $\mathbb{Z}^d$ -subshifts, defined by a recursively enumerable set of forbidden patterns. This class was introduced by Hochman [Hoc09] who showed that they admit an almost trivial isometric extension which is a subaction of a  $\mathbb{Z}^{d+2}$ -SFT. The construction was improved with two different techniques [AS13, DRS10] to get a realization in sofic  $\mathbb{Z}^{d+1}$ -subshifts as projective subdynamics. Thus with an increase of one of the dimension, effectively closed  $\mathbb{Z}^d$ -subshifts are very close to sofic subshifts. Hochman's result suggests that if we play with the structure on which subshifts are defined, some strong links between sofic and effectively closed subshifts may emerge. This problematic is the core of Chapter 3.

When considering subshifts defined on the group  $\mathbb{Z}$ , patterns with connected supports can be identified as words over a finite alphabet. In that context a subshift  $X \subset \mathcal{A}^{\mathbb{Z}}$  is *effectively closed* if there is a recursively enumerable set of forbidden words that defines it. The objective of this last part of the introductory chapter is to generalize this definition to the class of finitely generated groups. On  $\mathbb{Z}^d$ , a finite pattern is no longer a word, but can be easily coded as a word – via any recursive bijection between  $\mathbb{Z}^d$  and  $\mathbb{Z}$ . Then effective  $\mathbb{Z}^d$ -subshifts correspond to subshifts which

can be defined by a set of forbidden patterns that admits a recognizable set of codings. In groups with undecidable word problem this recursive bijection does not exist.

One way to tackle that problem is to use the set of word representations on a finitely generated group to define effectively closed subshifts through the formalism of pattern codings. Even though this gives a clean and practical definition, it will be seen that the class of subshifts it defines starts losing properties when the word problem of the group is not decidable. In Chapter 4 a broader class of subshifts which avoids this problem is studied.

In the remainder of this section, all groups are finitely generated. We show that this class can be defined either by recursively enumerable or decidable sets of pattern codings, that it contains all subshifts of finite type and that it is stable under finite intersections. We also show that under the assumption that the underlying group is recursively presented this class can be defined using a maximal sets of pattern codings, it is stable under factors, finite unions and projective subdynamics. Therefore showing that in this case the class of effectively closed subshifts contains all sofic subshifts and is invariant under conjugacy.

**Definition 1.14.** Let  $G$  be a finitely generated group and  $\mathcal{A}$  an alphabet. A *pattern coding*  $c$  is a finite set of tuples  $c = (w_i, a_i)_{i \in I}$  where  $w_i \in S^*$  is a word in the generators of  $G$  and  $a_i \in \mathcal{A}$  is a symbol.

For a pattern coding  $c$  we define its associated cylinder  $[c] := \bigcap_{(w,a) \in c} [a]_w$ . We say that a pattern coding is *consistent* if  $[c] \neq \emptyset$ . Equivalently,  $c$  is consistent if for every pair of tuples such that  $w_i =_G w_j$  then  $a_i = a_j$ . For a consistent pattern coding  $c$  we define the pattern  $\mathfrak{p}(c) \in \mathcal{A}^F$  where  $F = \bigcup_{i \in I} w_i$  and  $\mathfrak{p}(c)_{w_i} = a_i$ .

*Example 1.12.* Let  $BS(1, 2) \cong \langle a, b \mid ab = ba^2 \rangle$  be a Baumslag-Solitar group and  $\mathcal{A} = \{0, 1\}$ . Then the pattern coding

$$\begin{array}{ccc} (\epsilon, 0) & (b, 1) & (a, 1) \\ (ab, 0) & (ba^2, 0) & (ba, 1) \end{array}$$

is consistent, since all the words above on  $S = \{a, b, a^{-1}, b^{-1}\}$  represent different elements in  $G$  except for  $ab$  and  $ba^2$  that are assigned the same symbol. The pattern it defines is:

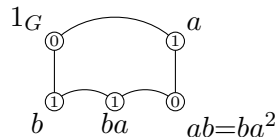

But the pattern coding

$$\begin{array}{ccc} (\epsilon, 0) & (a^2, 1) & (bab^{-1}a, 1) \\ (a, 1) & (ba, 1) & (abab^{-1}, 0) \end{array}$$

is inconsistent since words  $abab^{-1}$  and  $bab^{-1}a$  represent the same element in  $G$  but are assigned different symbols.

**Definition 1.15.** A set of pattern codings  $\mathcal{C}$  is said to be *recursively enumerable* if there is a Turing machine which takes as input a pattern coding  $c$  and accepts it if and only if  $c \in \mathcal{C}$ . It is said to be *decidable* if both  $\mathcal{C}$  and its complement are recursively enumerable.

**Definition 1.16.** A subshift  $X \subset \mathcal{A}^G$  is *effectively closed* if there is a recursively enumerable set of pattern codings  $\mathcal{C}$  such that:

$$X = X_{\mathcal{C}} := \mathcal{A}^G \setminus \bigcup_{g \in G, c \in \mathcal{C}} [c]_g.$$

Note that implicitly we define effectively closed subshifts for finitely generated groups without specifying the set of generators. The specific choice of the set of generators  $S$  is irrelevant as one can easily translate one in terms of the other. Notice that inconsistent pattern codings do not contribute to the union, and that consistent ones satisfy  $[c]_g = [\mathbf{p}(c)]_g$ . Therefore, the subshift defined by a set of pattern codings  $\mathcal{C}$  only depends on the set of consistent ones, in the sense that if  $\mathbf{p}(\mathcal{C}) := \{\mathbf{p}(c) \mid c \in \mathcal{C}\}$  is the set of patterns defined by the consistent pattern codings of  $\mathcal{C}$  then  $X_{\mathcal{C}} = X_{\mathbf{p}(\mathcal{C})}$ .

*Example 1.13.* Consider the alphabet  $\mathcal{A} = \{\square, \blacksquare, \color{red}\square\}$  and the set of configurations  $X_{\text{mirror}}$  such that the following forbidden patterns do not appear.

$$\mathcal{F} := \left\{ \begin{array}{c} \square \\ \color{red}\square \end{array}, \begin{array}{c} \blacksquare \\ \color{red}\square \end{array}, \begin{array}{c} \color{red}\square \\ \square \end{array}, \begin{array}{c} \color{red}\square \\ \blacksquare \end{array} \right\} \cup \bigcup_{w \in \mathcal{A}^*} \left\{ \begin{array}{c} \color{red}\square w \color{red}\square \\ \blacksquare w \color{red}\square w^R \square, \square w \color{red}\square w^R \blacksquare \end{array} \right\},$$

where  $w^R$  denotes the reverse of the word  $w$ .

This subshift is called the *Mirror shift*. It consists of all configurations such that if a red symbol appears, then the whole vertical line is red (this line is called the mirror) and no other position has red symbols. If a mirror appears, then both sides of the mirror must be reflexions of each other, see Figure 1.9 for an example of a configuration.  $X_{\text{mirror}}$  is easily seen to be effectively closed, while it can be proven that it is not sofic. Indeed, if  $S$  is the canonical set of generators of  $\mathbb{Z}^2$ , then  $|B_{n+1} \setminus B_n|/|B_n|$  tends to 0 as  $n$  goes to infinity. From this it is possible to deduce that in a suitable SFT extension of the mirror shift, there are two different patterns sharing the same boundary which yield different patterns in the mirror subshift. As shown in Figure 1.9, switching a pattern for the other produces a point outside the subshift yielding a contradiction. In Chapter 4 we generalize this same technique to arbitrary amenable groups in Theorem 4.14.

We could also define the class of effectively closed subshifts by the existence of a decidable set of pattern codings rather than a recursively enumerable one. This justifies the usage of the word “effectively”. The following proposition is commonly known to hold true in  $G = \mathbb{Z}^d$ . Here we present a general version which works in every finitely generated group.

**Proposition 1.11.** *Let  $X \subset \mathcal{A}^G$  be an effectively closed subshift. Then there exists a decidable set of pattern codings  $\mathcal{C}$  such that  $X = X_{\mathcal{C}}$ .*

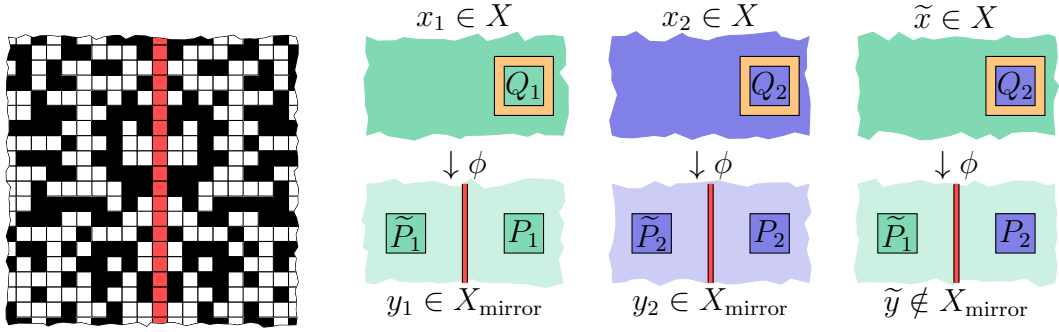

Figure 1.9: Configuration in the mirror shift and technique showing non-soficity.

*Proof.* Let  $\mathcal{C}'$  a recursively enumerable set of pattern codings such that  $X = X_{\mathcal{C}'}$ . If  $\mathcal{C}'$  is finite the result is trivial. Otherwise there exists a recursive enumeration  $\mathcal{C}' = \{c_0, c_1, \dots\}$ . For a pattern coding  $c$  we define its length as  $|c| = \max_{(w,a) \in c} |w|$ . For  $n \in \mathbb{N}$  let  $L_n = \max_{k \leq n} |c_k|$  and define  $\mathcal{C}_n$  as the finite set of all pattern codings  $c$  which satisfy the following properties:

- Every  $w \in S^*$  with  $|w| \leq L_n$  appears in exactly one pair in  $c$ .
- $(w, a) \in c$  implies that  $|w| \leq L_n$ .
- If  $(w, a) \in c_n$  then  $(w, a) \in c$ .

That is,  $\mathcal{C}_n$  is the set of all pattern codings which are completions of  $c_n$  up to every word of length at most  $L_n$  in every possible way. Consider  $\mathcal{C} = \bigcup_{n \in \mathbb{N}} \mathcal{C}_n$ . Clearly it satisfies that  $X = X_{\mathcal{C}}$ . We claim it is decidable.

Consider the algorithm which does the following on input  $c$ : It initializes  $n$  to 0. Then it enters into the following loop: First it produces the pattern coding  $c_n$ . If  $L_n > |c|$  it rejects the input. Otherwise it calculates the set  $\mathcal{C}_n$ . If  $c \in \mathcal{C}_n$  then it accepts, otherwise it increases the value of  $n$  by 1.

As  $L_n$  is increasing and cannot stay in the same value indefinitely this algorithm eventually ends for every input.  $\square$

In what follows we will show which are the liberties one can take when choosing a defining set of pattern codings and the structural properties of this class.

**Proposition 1.12.** *Let  $G$  be a finitely generated group and  $\mathcal{A}$  be an alphabet with at least two symbols. The following are equivalent:*

1.  $G$  is recursively presented.
2.  $\text{WP}(G)$  is recursively enumerable.
3. The set of inconsistent pattern codings is recursively enumerable.

*Proof.* The equivalence between the two first statements is evident. Let  $G$  have recursively enumerable word problem. As  $u =_G v \Leftrightarrow uv^{-1} =_G 1_G$  the set of inconsistent pattern codings is recursively enumerable. Indeed, for  $n \in \mathbb{N}$ , a Turing machine on input  $c$  can simulate iteratively for  $n$  steps the machine recognizing  $\text{WP}(G)$  applied to  $uv^{-1}$  for every pair  $(u, a), (v, b) \in c$  with  $a \neq b \in \mathcal{A}$  and accept if this procedure accepts for some  $n$ . Conversely, given  $w \in S^*$ , it suffices to give as input to the machine recognizing the inconsistency of the pattern codings  $c = \{(\epsilon, a), (w, b)\}$  with  $a \neq b \in \mathcal{A}$  in order to recognize if  $w =_G 1_G$ .  $\square$

**Lemma 1.13.** *Let  $X \subset \mathcal{A}^G$  be an effectively closed subshift. If  $G$  is recursively presented then it is possible to choose  $\mathcal{C}$  to be a recursively enumerable and maximal – for inclusion – set of pattern codings such that  $X = X_{\mathcal{C}}$ .*

This lemma is fundamental for the rest of the section and parts of Chapter 3 and 4. In what remains of this chapter, every time the statement of a result requires as hypothesis that a group  $G$  is recursively presented, it is because its proof uses the existence of a recursively enumerable and maximal set of pattern codings for some effectively closed  $G$ -subshift.

*Proof.* A pattern coding  $c$  belongs to the maximal set  $\mathcal{C}$  defining  $X$  if and only if  $X \cap [c] = \emptyset$ . Let  $c \in \mathcal{C}$  and  $\mathcal{C}'$  a recursively enumerable set such that  $X = X_{\mathcal{C}'}$ . Then:

$$[c] = \bigcap_{(w,a) \in c} [a]_w \subset \bigcup_{c' \in \mathcal{C}', g \in G} \bigcap_{(w',a') \in c'} [a']_{gw'}$$

By compactness we may extract a finite open cover indexed by  $c'_i, g_i$  such that:

$$[c] \subset \bigcup_{i \leq n} [c'_i]_{g_i} \tag{1}$$

Note that each of these  $g_i$  can be represented as a finite word in  $S^*$ . Now let  $T$  be the Turing machine which does iteratively for  $n \in \mathbb{N}$  the following:

- Runs  $n$  steps the machine  $T_1$  recognizing  $\text{WP}(G)$  for every word in  $S^*$  of length smaller than  $n$ .
- Runs  $n$  steps the machine  $T_2$  recognizing  $\mathcal{C}'$  for every pattern coding defined on a subset of words of  $S^*$  of length smaller than  $n$ .
- Let  $\sim_n$  be the equivalence relation for words in  $S^*$  of length smaller than  $n$  such that  $u \sim_n v$  if  $uv^{-1}$  has been already accepted by  $T_1$ . Let  $\mathcal{C}_n$  be the pattern codings already accepted by  $T_2$ . If every word in  $c$  has length smaller than  $n$  check if the following relation is true under  $\sim_n$ :

$$\bigcap_{(w,a) \in c} [a]_w \subset \bigcup_{c' \in \mathcal{C}_n, |u| \leq n} \bigcap_{(w',a') \in c'} [a']_{uw'}$$

If it is true, accept, otherwise increase  $n$  by 1 and continue.

Let  $m$  be the max of all  $|w|$  such that  $(w, a) \in c$ , and  $|w'|$  such that  $(w', a') \in c'_i$  and all  $|g_i|$ . By definition, there exists an  $N \in \mathbb{N}$  such that every  $c'_i$  for  $i \leq n$  is accepted and every word representing  $1_G$  of length smaller than  $2m$  is accepted. This means that at stage  $N$  relation (1) is satisfied and  $T$  accepts  $c$ . If  $c$  is not in the maximal set, the machine  $T$  never accepts.  $\square$

*Remark.* Lemma 1.13 is no longer true if  $G$  is not recursively presented. Indeed, the maximal set of pattern codings defining the full shift is given by the set of all inconsistent pattern codings, which is recursively enumerable if and only if  $G$  is recursively presented by Proposition 1.12.

**Proposition 1.14.** *The class of SFTs is contained in the class of effectively closed subshifts.*

*Proof.* Let  $X$  be an SFT. Then  $X = X_{\mathcal{F}}$  for a finite set  $\mathcal{F}$ . For each  $p \in \mathcal{F}$  consider a pattern coding  $c_p$  such that  $\mathfrak{p}(c_p) = p$  and let  $\mathcal{C} = \{c_p \mid p \in \mathcal{F}\}$ . Clearly  $X = X_{\mathcal{C}}$  and as  $\mathcal{C}$  is finite it is recursively enumerable.  $\square$

**Proposition 1.15.** *The class of effectively closed subshifts is closed by finite intersections.*

*Proof.* Let  $X = X_{\mathcal{C}_X}$  and  $Y = Y_{\mathcal{C}_Y}$  be effectively closed subshifts. Without loss of generality suppose  $X, Y \subset \mathcal{A}^G$  (same alphabet) and note that:

$$\begin{aligned} X \cap Y &= \left( \mathcal{A}^G \setminus \bigcup_{g \in G, c \in \mathcal{C}_X} [c]_g \right) \cap \left( \mathcal{A}^G \setminus \bigcup_{h \in G, c' \in \mathcal{C}_Y} [c']_g \right) \\ &= \mathcal{A}^G \setminus \bigcup_{g \in G, c \in \mathcal{C}_X \cup \mathcal{C}_Y} [c]_g \\ &= X_{\mathcal{C}_X \cup \mathcal{C}_Y} \end{aligned}$$

Therefore, it suffices on input  $c$  to launch the Turing machines recognizing  $\mathcal{C}_X$  and  $\mathcal{C}_Y$  in parallel and accept if either of them accepts.  $\square$

The previous result obviously does not extend to countable intersections. By Proposition 1.8 every subshift is obtainable as an intersection of SFTs. If Proposition 1.15 were true for countable unions we would conclude that all subshifts are effectively closed. But there is an uncountable number of subshifts on a fixed alphabet, and effectively closed subshifts clearly constitute a countable set, so there must be one that is not effectively closed.

**Proposition 1.16.** *For a recursively presented group the class of effectively closed subshifts is closed by finite unions.*

*Proof.* Let  $X = X_{\mathcal{C}_X}$  and  $Y = Y_{\mathcal{C}_Y}$  be effectively closed subshifts. As  $G$  is recursively presented we can suppose  $\mathcal{C}_X$  and  $\mathcal{C}_Y$  are maximal as in Lemma 1.13. As in the previous proof we can show:

$$X \cup Y = \mathcal{A}^G \setminus \left( \left( \bigcup_{g \in G, c \in \mathcal{C}_X} \bigcap_{(w,a) \in c} [a]_{gw} \right) \cap \left( \bigcup_{g \in G, c \in \mathcal{C}_Y} \bigcap_{(w,a) \in c} [a]_{gw} \right) \right)$$

Thus, as these sets are maximal we have  $X \cup Y = X_{\mathcal{C}_X \cap \mathcal{C}_Y}$ . It suffices therefore to launch both Turing machines and accept if both accept.  $\square$

**Proposition 1.17.** *For recursively presented groups the class of effectively closed subshifts is closed under factors.*

*Proof.* Let  $X \subset \mathcal{A}^G$  be an effectively closed subshift. As  $G$  is recursively presented, the recursively enumerable set of pattern codings  $\mathcal{C}_X$  can be chosen to be maximal by Lemma 1.13. Consider a factor code  $\phi : X \rightarrow Y$  defined by a local function  $\Phi : \mathcal{A}^F \rightarrow \mathcal{B}$  with  $F = \{f_1, \dots, f_{|F|}\}$  where  $f_1, \dots, f_{|F|}$  are words of  $S^*$ .

As  $\phi$  is surjective, for each  $b \in \mathcal{B}$  then  $|\Phi^{-1}(b)| > 0$ . Therefore we can associate to a pair  $(w, b)$  a non-empty finite set of pattern codings

$$\mathcal{C}_{w,b} = \{(wf_i, p_{f_i})_{i=1, \dots, |F|} \mid p \in \Phi^{-1}(b)\}.$$

That is,  $\mathcal{C}_{w,b}$  is a finite set of pattern codings over  $\mathcal{A}$  representing every possible preimage of  $b$ . For a pattern coding  $c = (w_i, b_i)_{i \leq n}$  where  $b_i \in \mathcal{B}$  we define:

$$\mathcal{C}_c = \left\{ \bigcup_{(w,b) \in c} \tilde{c}_{w,b} \mid \tilde{c}_{w,b} \in \mathcal{C}_{w,b} \right\}.$$

That is,  $\mathcal{C}_c$  is the finite set of pattern codings formed by choosing one possible preimage for each letter. This set has the property that if  $\Phi$  is applied pointwise then  $\Phi(\mathbf{p}(\mathcal{C}_c)) = \{\mathbf{p}(c)\}$ . Let  $T$  be the Turing machine which on input  $c$  runs the machine recognizing  $\mathcal{C}_X$  on every pattern coding in  $\mathcal{C}_c$ . If it accepts for every input, then  $T$  accepts  $c$ . Let  $\mathcal{C}_Y$  be the set of pattern codings accepted by  $T$ . We claim  $Y = Y_{\mathcal{C}_Y}$ .

Let  $y \in Y_{\mathcal{C}_Y}$  a sequence of finite supports such that  $F_n \nearrow G$ . For each pattern coding  $c$  such that  $\mathbf{p}(c) = y|_{F_n}$ , there is a pattern coding  $c_n \in \mathcal{C}_c$  which does not belong to  $\mathcal{C}_X$ . As  $\mathcal{C}_X$  is maximal we have that  $[\mathbf{p}(c_n)] \cap X \neq \emptyset$ . Extracting a configuration  $x_n$  from  $[\mathbf{p}(c_n)] \cap X$  we obtain a sequence  $(x_n)_{n \in \mathbb{N}}$ . By compactness there is a converging subsequence with limit  $\tilde{x} \in X$ . By continuity of  $\phi$  we have that  $y = \phi(\tilde{x}) \in Y$ . Conversely if  $y \in Y$  there exists  $x \in X$  such that  $\phi(x) = y$ . Therefore for every finite  $F' \subset G$  and pattern coding  $c$  with  $\mathbf{p}(c) = y|_{F'}$  there exists a pattern coding  $\tilde{c} \in \mathcal{C}_c$  such that  $\mathbf{p}(\tilde{c}) = x|_{F'}$ . Therefore,  $c \in \mathcal{C}_y$  and thus  $y \in Y_{\mathcal{C}_Y}$ .  $\square$

**Corollary 1.18.** *For a recursively presented group the following are true:*

- *The class of effectively closed subshifts is invariant under conjugacy.*
- *The class of effectively closed subshifts contains all sofic subshifts.*

We do not know if the previous results extend to the general case where  $G$  is not recursively presented. The main obstruction is that without that hypothesis there is no control on the representations of the finite set  $F$  which defines the local rule of the factor. As an example, consider a 1-block code  $\phi$ . In order to detect forbidden patterns by using the recursively enumerable set defining  $X$  we would need to touch all possible representations of  $F = \{1_G\}$ , which is exactly the word problem of the group  $\text{WP}(G)$ .

**Definition 1.17.** Let  $H \leq G$  be a subgroup of  $G$ . Given a subshift  $X \subset \mathcal{A}^G$  the  $H$ -projective subdynamics of  $X$  is the subshift  $\pi_H(X) \subset \mathcal{A}^H$  defined as:

$$\pi_H(X) = \{x \in \mathcal{A}^H \mid \exists y \in X, \forall h \in H, x_h = y_h\}$$

**Proposition 1.19.** *Let  $G$  be a recursively presented group and  $H \leq G$  a finitely generated subgroup of  $G$ . If  $X \subset \mathcal{A}^G$  is effectively closed, then its  $H$ -projective subdynamics  $\pi_H(X)$  is effectively closed.*

*Proof.* As  $H$  is finitely generated, there exists a finite set  $S' \subset H$  such that  $\langle S' \rangle = H$ . As  $G$  is finitely generated by  $S$  there exists a function  $\gamma : S' \rightarrow S^*$  such that  $s' =_G \gamma(s')$  (that is, every element of  $S'$  can be written as a word in  $S^*$ ). Extend the function  $\gamma$  to act by concatenation over words in  $S'^*$ .

As  $G$  is recursively presented, by Lemma 1.13 the set of pattern codings  $\mathcal{C}_G$  defining  $X$  can be chosen to be maximal. Let  $c = (w_i, a_i)_{i \in I}$  a pattern coding where  $w_i \in S'^*$  and consider  $\gamma(c) = (\gamma(w_i), a_i)_{i \in I}$ . Let  $T$  be the Turing machine which on input  $c$  runs the algorithm recognizing  $\mathcal{C}_G$  on input  $\gamma(c)$  and accepts if and only if this machine accepts. Clearly  $\mathcal{C}_H = \{c \mid T \text{ accepts } c\}$  is recursively enumerable. Also, as  $\mathcal{C}_G$  is a maximal set of pattern codings then  $c \in \mathcal{C}_H \iff [\mathbf{p}(\gamma(c))] \cap X = \emptyset$ . Therefore  $\pi_H(X) = X_{\mathcal{C}_H}$ .  $\square$

Proposition 1.19 put together with Corollary 1.18 imply that in recursively presented groups the projective subdynamics of SFTs and sofic subshifts are always effectively closed. In the case of  $\mathbb{Z}^2$  there is a converse to that statement in the following form:

**Theorem 1.20** (Aubrun-Sablik [AS13], Durand-Romashchenko-Shen [DRS10]). *For any effectively closed  $\mathbb{Z}$ -subshift  $X$  there exists a sofic  $\mathbb{Z}^2$ -subshift  $Y$  such that  $\pi_{\mathbb{Z}}(Y) = X$ .*

The concept of projective subdynamics takes a central role in Chapter 3 where we prove an extended version of this theorem for finitely generated groups.



## Chapter 2

# Free actions and densities in subshifts

This chapter presents the results obtained in collaboration with Nathalie Aubrun and Stéphan Thomassé which can be found in [ABT15]. We consider two general aspects of realizability which concern subshifts in groups: The first one asks if it is possible to construct a strongly aperiodic subshift, that is, one such that the shift action is free. The second aspect is inspired by Sturmian words, by the fact that the factors of length  $n$  carry a density of 1's which converges to the slope of the irrational rotation which generates the word [PF02, BR10]. Here, given a finitely generated group and its word metric given by a set of generators, we ask if it is possible to construct a subshift  $X \subset \{0, 1\}^G$  such that for every configuration  $x \in X$  and every sequence  $(g_n)_{n \in \mathbb{N}}$  of group elements, the density of 1's over the balls  $B_S(g_n, n)$  always converges to a fixed density  $\alpha \in [0, 1]$ . We call this property *uniform density*.

The existence of a countable group which does not admit a non-empty strongly aperiodic subshift over the alphabet  $\{0, 1\}$  was asked in [GU09] and subsequently answered negatively in [GJS09]. Nevertheless, their proof uses descriptive set theory and is not elementary. In this chapter, the asymmetric version of Lovász local lemma [AS08] is combined with the compactness of the set of configurations to get a nice tool to prove non-emptiness of subshifts defined by forbidden patterns. This technique, inspired in the results of Alon et al [AGHR02], is in some sense the analogue of the probabilistic method in graph theory, and provides very short proofs of the existence of configurations in subshifts. We use it to prove again in a succinct way the existence of a strongly aperiodic subshift on any countable group. We also extend the previous result by showing that in finitely generated groups with decidable word problem it is possible to construct non-empty strongly aperiodic subshifts which are effectively closed. More specifically we show:

**Theorem 2.4** (Aubrun, B, Thomassé). *Every countable group  $G$  has a non-empty, strongly aperiodic subshift on the alphabet  $\{0, 1\}$ .*

**Theorem 2.6** (Aubrun, B, Thomassé). *Every finitely generated group with decidable word problem has a non-empty effectively closed strongly aperiodic subshift.*

It is noteworthy to remark that up to this date two articles [Ele17, Ber17] have appeared in arXiv that build up from the techniques that we present in this chapter. Specifically speaking, Elek [Ele17] gives a measured version of Theorem 2.6 for finitely generated sofic groups and Bernshteyn [Ber17] uses a measured version of the Lovász local lemma to show that Theorem 2.6 holds even if we start from an arbitrary shift-invariant open set.

The second part of this chapter deals with densities in groups. In  $\mathbb{Z}$ , for any  $\alpha \in [0, 1]$  there exists a subshift  $X$  over the alphabet  $\{0, 1\}$  such for any connected support  $F$ , any pattern  $p \in L_F(X)$  satisfies that  $|\{f \in F \mid p_f = 1\}|/|F|$  takes at most two values:  $\lfloor \alpha|F| \rfloor$  and  $\lceil \alpha|F| \rceil$ . This condition is called being *balanced*. This property is realized by the subshift generated by the Sturmian sequence coded by the rotation  $R_\alpha \curvearrowright \mathbb{R}/\mathbb{Z}$  of angle  $\alpha$ . In general groups a configuration such that the amount of 1's over any finite connected support of size  $n$  has at most two values is not possible as the group's geometry is too wild. Instead, we propose the uniform density property of a subshift as a generalization of the aforementioned property of Sturmian subshifts. In this direction, we are able to prove a more technical result which implies the existence of non-empty subshifts with uniform density in every group of subexponential growth. Formally, we show the following result.

**Theorem 2.10** (Aubrun, B, Thomassé). *Let  $G$  be an infinite and finitely generated amenable group and  $\alpha \in [0, 1]$ . Then there exists a non-empty subshift  $X_\alpha \subset \{0, 1\}^G$  with  $\lim_{n \rightarrow \infty} \text{dens}(1, F_n, x) = \alpha$  for any  $x \in X_\alpha$  and any Følner sequence  $(F_n)_{n \in \mathbb{N}}$ .*

That is, by replacing the sequence of intervals of  $\mathbb{Z}$  for a general Følner sequence we produce a subshift where the densities of 1's converge to a fixed value  $\alpha$ . We show that the subshifts given by our construction are weakly aperiodic if  $\alpha \notin \mathbb{Q}$ .

## 2.1 Non-empty strongly aperiodic subshifts

Recall from Definition 1.7 that a subshift  $X \subset \mathcal{A}^G$  is called strongly aperiodic if every configuration  $x \in X$  is aperiodic. It is well known that every  $\mathbb{Z}$ -subshift of finite type contains a periodic configuration [LM95]. However, it was proven by Berger [Ber66] that there are  $\mathbb{Z}^2$ -SFTs which are strongly aperiodic. This result has been proven several times with different techniques [Rob71, Kar96, JR15] giving a variety of ingenious constructions.

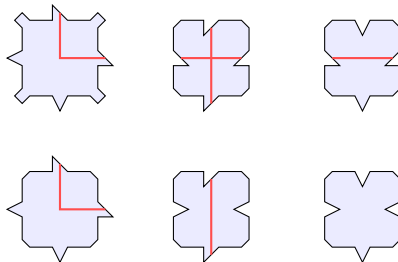

Figure 2.1: The set of Robinson tiles up to rotation and reflection.

For instance, the construction of Robinson uses an alphabet which can be interpreted as the finite set of figures obtained through rotations and reflections of the *tiles* shown in Figure 2.1 along with the rules that two tiles can be put next to each other if and only if they match geometrically. Of course, these tiles can be translated into a finite alphabet and a finite set of forbidden patterns defining a subshift of finite type. The structure from the Robinson tiles forces a sequence of arbitrarily big hierarchical structures called *macrotiles* to appear in every configuration, one of these is shown in Figure 2.2. The proof of aperiodicity of this object is based on the fact that any non-trivial shift will not leave invariant a big enough macrotile.

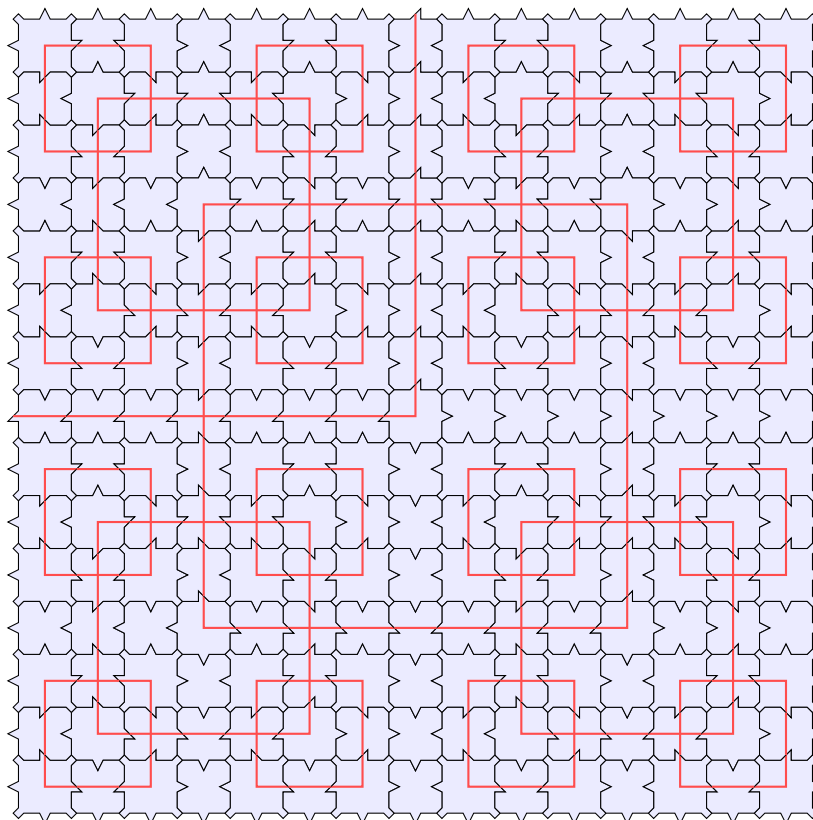

Figure 2.2: A macrotile appearing in the Robinson tiling.

The problem of characterizing the groups which admit strongly aperiodic SFTs remains an open problem up to this day. We further study what is known in this domain in Chapter 3. However, a much simpler question is whether a strongly aperiodic effectively closed  $G$ -subshift exists, or even if there are any non-empty strongly aperiodic subshifts at all. The objective of this section is to develop the tools to give a full answer to the last question and a complete classification in the case of recursively presented group for the former.

We begin by introducing an important combinatorial tool: the asymmetric version of the Lovász local lemma. We then extract from this lemma a suitable version that can be used to prove the existence of configurations in subshifts. Finally, we proceed to the construction of the strongly aperiodic subshifts in these two cases.

### 2.1.1 Lovász local lemma

**Lemma 2.1** (Asymmetric Lovász local lemma). *Let  $\mathcal{A} := \{A_1, A_2, \dots, A_n\}$  be a finite collection of measurable sets in a probability space  $(X, \mu, \mathcal{B})$ . For  $A \in \mathcal{A}$ , let  $\Gamma(A)$  be the smallest subset of  $\mathcal{A}$  such that  $A$  is independent of the collection  $\mathcal{A} \setminus (\{A\} \cup \Gamma(A))$ . Suppose there exists a function  $x : \mathcal{A} \rightarrow (0, 1)$  such that:*

$$\forall A \in \mathcal{A} : \mu(A) \leq x(A) \prod_{B \in \Gamma(A)} (1 - x(B))$$

then the probability of avoiding all events in  $\mathcal{A}$  is positive. Specifically

$$\mu \left( X \setminus \bigcup_{i=1}^n A_i \right) \geq \prod_{A \in \mathcal{A}} (1 - x(A)) > 0.$$

A proof for Lemma 2.1 can be found in [AS08]. The sets  $A_1, A_2, \dots, A_n$  can be seen as bad events that we want to avoid. In the context of the present application where  $\mathcal{A}$  is a finite alphabet and  $G$  a countable group, we will choose the probability space to be  $X = \mathcal{A}^G$  with  $\mu$  any Bernoulli probability measure on  $\mathcal{A}^G$ . Suppose  $X$  is a subshift defined by a set of forbidden patterns  $\mathcal{F} = \bigcup_{n \geq 1} \mathcal{F}_n$  where  $\mathcal{F}_n \subset \mathcal{A}^{S_n}$  is a finite set of patterns with support  $S_n$ . We will consider the bad events  $A_{n,g} = \bigcup_{p \in \mathcal{F}_n} [p]_g = \{x \in \mathcal{A}^G : x|_{gS_n} \in \mathcal{F}_n\}$ , that is to say one of the forbidden patterns  $p \in \mathcal{F}_n$  appears in position  $g$ . Subshifts might be defined by an infinite amount of forbidden patterns while the lemma only holds for a finite collection of bad events. Nevertheless the compactness of  $\mathcal{A}^G$  allows us to use the lemma anyway, as explained in what follows.

**Lemma 2.2** (Aubrun, B, Thomassé). *Let  $G$  a countable group and  $X \subset \mathcal{A}^G$  a subshift defined by the set of forbidden patterns  $\mathcal{F} = \bigcup_{n \geq 1} \mathcal{F}_n$ , where  $\mathcal{F}_n \subset \mathcal{A}^{S_n}$ . Let  $\mu$  be a Bernoulli probability measure on  $\mathcal{A}^G$ . Suppose that there exists a function  $x : \mathbb{N} \times G \rightarrow (0, 1)$  such that:*

$$\forall n \in \mathbb{N}, g \in G, \mu(A_{n,g}) \leq x(n, g) \prod_{\substack{gS_n \cap hS_k \neq \emptyfty \\ (k,h) \neq (n,g)}} (1 - x(k, h)), \quad (*)$$

where  $A_{n,g} = \{x \in \mathcal{A}^G : x|_{gS_n} \in \mathcal{F}_n\}$ . Then the subshift  $X$  is non-empty.

*Proof.* Consider an enumeration  $\{g_k\}_{k \in \mathbb{N}}$  of  $G$ . For every  $n \in \mathbb{N}$ , we apply Lemma 2.1 to construct a configuration  $x_n \in \mathcal{A}^G$  that satisfies the following property: for every forbidden pattern  $p \in \mathcal{F}_k$  such that  $k \leq n$  and every  $g \in \{g_k\}_{k \leq n}$  such that  $gS_k \subseteq \{g_k\}_{k \leq n}$ , we have  $x_n \notin [p]_g$  – in other terms, the configuration  $x_n$  avoids all the forbidden patterns in  $\bigcup_{k \leq n} \mathcal{F}_k$  on the finite set  $\{g_1, \dots, g_n\} \subset G$ . Indeed, in order to show the existence of  $x_n$  we only need that for every  $k \leq n$  and  $g \in G$  such that  $gS_k \subseteq \{g_k\}_{k \leq n}$ ,

$$\mu(A_{k,g}) \leq x(k, g) \prod_{\substack{gS_k \cap hS_{k'} \neq \emptyset \\ hS_{k'} \subseteq \{g_0, \dots, g_n\} \\ (k',h) \neq (k,g), k \leq n}} (1 - x(k', h))$$

which is a relaxation of condition (\*) by the fact that  $0 \leq x(k', h) \leq 1$ . The local lemma holds since the set  $\{g_0, \dots, g_n\}$  is finite and we only consider a finite number of forbidden patterns, consequently we only consider a finite number of bad events  $A_{k,g}$ .

As  $G$  is countable, compactness is also sequential and we can extract from  $(x_n)_{n \in \mathbb{N}}$  a subsequence  $(x_{\phi(n)})_{n \in \mathbb{N}}$  converging to some  $x \in \mathcal{A}^G$ . Then  $x$  does not contain any forbidden pattern  $p \in \mathcal{F}$ . Suppose it were the case, that is to say, there exists some  $g \in G$  and  $p \in \mathcal{F}_m$  such that  $x \in [p]_g$ . Since there exists also  $n, l$  such that  $g = g_l$  and  $gS_m \subset \{g_0, \dots, g_n\}$ , by definition of the metric there exists some  $N \geq \max\{m, n, l\}$  sufficiently big which such that  $\phi(N)$  appears in the subsequence  $(\phi(n))_{n \in \mathbb{N}}$ . Then  $x_N$  contains the forbidden pattern  $p$  somewhere in  $(x_N)|_{\{g_1, \dots, g_N\}}$ . This contradicts the construction of the sequence  $(x_n)_{n \in \mathbb{N}}$ , thus  $x \in X_{\mathcal{F}}$ .  $\square$

### 2.1.2 A non-empty strongly aperiodic subshift over $\{0, 1\}$ in any countable group.

Consider a configuration  $x \in \{0, 1\}^G$ . We say that  $x$  has *the distinct neighborhood property* – in [GJS09] they call  $x$  a 2-coloring – if for every  $h \in G \setminus \{1_G\}$  there exists a finite subset  $T \subset G$  such that:

$$\forall g \in G : \sigma^{(gh)^{-1}}(x)|_T \neq \sigma^{g^{-1}}(x)|_T.$$

**Proposition 2.3.** *If a configuration  $x \in \{0, 1\}^G$  has the distinct neighborhood property, then the  $G$ -subshift  $X := \text{Orb}_{\sigma}(x)$  is strongly aperiodic.*

*Proof.* Let  $y \in X$ . By definition there exists a sequence  $(g_i)_{i \in \mathbb{N}}$  such that  $\sigma^{g_i}(x)$  converges to  $y$  in the product topology. Suppose there is  $h \neq 1_G$  such that  $\sigma^h(y) = y$ , then by continuity of the shift action under the product topology we have that  $\sigma^{hg_i}(x) \rightarrow \sigma^h(y) = y$ . Since  $x$  has the distinct neighborhood property, there exists a finite subset  $T$  of  $G$  – associated to  $h^{-1}$  – such that  $\forall g \in G : \sigma^{hg^{-1}}(x)|_T \neq \sigma^{g^{-1}}(x)|_T$ . By definition of convergence, there exists  $n \in \mathbb{N}$  such that  $T \subset \{g_0, g_1, \dots, g_n\}$  and  $m \in \mathbb{N}$  satisfying:

$$\sigma^{hg_m}(x)|_{\{g_0, g_1, \dots, g_n\}} = y|_{\{g_0, g_1, \dots, g_n\}} = \sigma^{g_m}(x)|_{\{g_0, g_1, \dots, g_n\}}$$

Therefore  $\sigma^{hg_m}(x)|_T = \sigma^{g_m}(x)|_T$ , a contradiction.  $\square$

**Theorem 2.4** (Aubrun, B, Thomassé). *Every countable group  $G$  has a non-empty, strongly aperiodic subshift on the alphabet  $\{0, 1\}$ .*

*Proof.* The case where  $G$  is finite is trivial, as the  $G$ -SFT given by

$$X := \{x \in \{0, 1\}^G \mid |x^{-1}(1)| = 1\}$$

is strongly aperiodic. Indeed, let  $x \in X$  and  $g \in G$  be the only element such that  $x_g = 1$ . Let  $h \in \text{stab}_{\sigma}(x)$  then  $\sigma^h(x) = x$  which implies that  $x_{h^{-1}g} = x_g = 1$  and thus  $h = 1_G$ . For the rest of the proof we suppose that  $G$  is countably infinite.

Let  $(s_i)_{i \in \mathbb{N}}$  be an enumeration of  $G$  such that  $s_0 = 1_G$ . Choose  $(T_i)_{i \in \mathbb{N}}$  a sequence of finite subsets of  $G$  such that for every  $i \in \mathbb{N}$ ,  $T_i \cap s_i T_i = \emptyset$  and  $|T_i| = C \cdot i$ , where  $C$  is a constant to be defined later. These sets always exist as  $G$  is infinite.

Consider the uniform Bernoulli probability  $\mu$  in  $\{0, 1\}^G$  and the collection of sets  $\mathcal{A} := \{A_{n,g}\}_{n \geq 1, g \in G}$  given by  $A_{n,g} = \{x \in \{0, 1\}^G \mid \sigma^{g^{-1}}(x)|_{T_n} = \sigma^{(gs_n)^{-1}}x|_{T_n}\}$ . Note that each set is a union of cylinders and that the existence of a configuration  $\tilde{x}$  in the intersection of the complement of these sets allows us to conclude the theorem by producing a configuration with the distinct neighborhood property. Our strategy is to apply Lemma 2.2 to ensure its existence.

As the intersection  $s_n T_n \cap T_n$  is empty we have that  $\mu(A_{n,g}) = 2^{-|T_n|} = 2^{-Cn}$ . Consider one set  $A_{n,g}$ . The number of sets  $A_{m,g'}$  for a fixed  $m \in \mathbb{N}$  which are not independent from  $A_{n,g}$  is at most  $4C^2 nm$  – observe that  $A_{n,g}$  is independent from  $A_{m,g'}$  if and only if  $(gT_n \cup gs_n T_n)$  does not intersect  $(g'T_m \cup g's_m T_m)$ . We also define  $x(A_{n,g}) := 2^{-\frac{Cn}{2}}$ . Therefore, in order to conclude we must prove that:

$$2^{-Cn} \leq 2^{-\frac{Cn}{2}} \prod_{m=1}^{\infty} (1 - 2^{-\frac{Cm}{2}})^{4C^2 nm}.$$

Using the fact that  $1 - x \geq 2^{-2x}$  if  $x \leq 1/2$  we obtain the following bound:

$$\begin{aligned} 2^{-\frac{Cn}{2}} \prod_{m=1}^{\infty} (1 - 2^{-\frac{Cm}{2}})^{4C^2 nm} &\geq 2^{-\frac{Cn}{2}} \prod_{m=1}^{\infty} 2^{-8C^2 nm 2^{-\frac{Cm}{2}}} \\ &= 2^{-\frac{Cn}{2}} 2^{-8C^2 \sum_{m=1}^{\infty} nm 2^{-\frac{Cm}{2}}} \end{aligned}$$

Therefore, it suffices to prove that:

$$\begin{aligned} 2^{-\frac{Cn}{2}} &\leq 2^{-8C^2 \sum_{m=1}^{\infty} nm 2^{-\frac{Cm}{2}}} \\ \iff 1 &\geq 16C \sum_{m=1}^{\infty} m 2^{-\frac{Cm}{2}} \\ \iff 1 &\geq 16C \frac{2^{\frac{C}{2}}}{(2^{\frac{C}{2}} - 1)^2} \end{aligned}$$

The previous inequality holds true for  $C \geq 17$ . Therefore choosing  $C = 17$  completes the proof by application of Lemma 2.2.  $\square$

### 2.1.3 A graph-oriented construction and some computational properties

In this subsection we present another construction of a non-empty strongly aperiodic subshift. This construction is not as general as the previous one, as it only holds for finitely generated groups, and the size of the alphabet is rather large. Nevertheless,

it can be defined by a natural property which allows us to use it in computability constructions with ease.

Let  $\Gamma = (V, E)$  be a simple graph, consider a finite alphabet  $\mathcal{A}$  and a coloring  $x \in \mathcal{A}^V$  of the vertices of  $\Gamma$ . We say  $x$  contains a *vertex-square path* if there exists an odd length path  $p = v_1 \dots v_{2n}$  such that  $x_{v_i} = x_{v_{i+n}}$  for every  $1 \leq i \leq n$ . If the coloring  $x$  does not contain any vertex-square path then we say it is a *square-free vertex coloring*.

*Example 2.1.* Consider the cycle on five vertices  $C_5$ . Any coloring of its vertices with three colors forces the appearance of a vertex-square path.



Figure 2.3: Two colorings of  $C_5$ . The left is not square-free and the right one is.

Next we show a proposition which is a slight modification of a proof which can be found in [AGHR02].

**Proposition 2.5.** *Let  $G$  be a group which is generated by the finite set  $S$ . Then there exists a square-free vertex coloring of the undirected right Cayley graph  $\Gamma(G, S)$  with  $2^{19}|S|^2$  colors.*

*Proof.* Consider a finite alphabet  $\mathcal{A}$  and let  $X = \mathcal{A}^{\Gamma(G, S)}$  be the set of all vertex colorings of the Cayley graph  $\Gamma(G, S)$ . We define  $\mu$  as the uniform Bernoulli probability, that is, for  $a \in \mathcal{A}$  and  $g \in G$  then

$$\mu(\{x \in X \mid x_g = a\}) = \frac{1}{|\mathcal{A}|}.$$

Consider  $\mathcal{P}$  as the set of all odd length paths in  $\Gamma(G, S)$ . For  $p \in \mathcal{P}$  let  $A_p$  be the set of colorings of  $\Gamma(G, S)$  such that  $p$  is a square under that coloring and note that if  $p$  is of length  $2n - 1$  then  $\mu(A_p) = |\mathcal{A}|^{-n}$  if there exists a path of said length. Consider  $\mathcal{A}_n = \{A_p \mid p \text{ has length } 2n - 1\}$  and  $\mathcal{A} = \{A_p \mid p \in \mathcal{P}\} = \bigcup_{n \geq 1} \mathcal{A}_n$ . In order to apply Lemma 2.2, we define  $x(A_p) := (8|S|^2)^{-n}$  for  $A_p \in \mathcal{A}_n$ . The lemma holds if for every  $A \in \mathcal{A}$  then  $\mu(A) \leq x(A) \prod_{B \in \Gamma(A)} (1 - x(B))$ . Replacing both sides yields the necessary condition:

$$\forall n \geq 1, |\mathcal{A}|^{-n} \leq (8|S|^2)^{-n} \prod_{j \geq 1} (1 - (8|S|^2)^{-j})^{|\Gamma(A_p) \cap A_j|}.$$

$|\Gamma(A_p) \cap A_j|$  corresponds to the amount of paths of length  $2j - 1$  which share a vertex with  $p$ . If  $p$  has length  $2n - 1$  this can be bounded by  $4nj(2|S|^2)^{2j}$ . Indeed, there are at most  $(2|S|^2)^{2j}$  paths of length  $2j - 1$  starting from a vertex  $v$ . Each of

these paths can intersect a given vertex of  $p$  in  $2j$  positions and there are  $2n$  vertices in  $p$ . Hence, we need to show:

$$\forall n \geq 1, |\mathcal{A}|^{-n} \leq (8|S|^2)^{-n} \prod_{j \geq 1} (1 - (8|S|^2)^{-j})^{4nj(2|S|)^{2j}}.$$

Using the inequality  $1 - x \geq 2^{-2x}$  if  $x \leq 1/2$ , the requirement to apply the lemma can be restrained further so that the following is required to conclude:

$$\begin{aligned} \forall n \geq 1, |\mathcal{A}|^{-n} &\leq (8|S|^2)^{-n} \prod_{j \geq 1} 2^{-8nj(8|S|^2)^{-j}(4|S|^2)^j} \\ &= (8|S|^2)^{-n} \prod_{j \geq 1} 2^{-8nj2^{-j}} \end{aligned}$$

or equivalently:

$$\begin{aligned} |\mathcal{A}| &\geq (8|S|^2) 2^{8 \sum_{j \geq 1} j 2^{-j}} \\ &\geq 2^{19} |S|^2. \end{aligned}$$

The latter inequality is satisfied by hypothesis, therefore, there exists a coloring of the graph such that no path of odd length is a square under that coloring.  $\square$

**Theorem 2.6** (Aubrun, B, Thomassé). *Every finitely generated group  $G$  has a non-empty strongly aperiodic subshift  $X$ . Furthermore, if  $G$  has a decidable word problem, then  $X$  can be chosen to be effectively closed.*

*Proof.* Let  $S$  be a set of generators of  $G$  and  $\mathcal{A}$  an alphabet such that  $|\mathcal{A}| \geq 2^{19}|S|^2$ . Consider the set of forbidden patterns  $\mathcal{F}$  defined as follows: Take  $\mathcal{P}$  the set of all finite paths of odd length of  $\Gamma(G, S)$ . For every  $p \in \mathcal{P}$  we define the set of patterns  $\Pi_p$  as those with support  $p$  and such that they are vertex-square paths. Let  $\mathcal{F} = \bigcup_{p \in \mathcal{P}} \Pi_p$  and let  $X = X_{\mathcal{F}}$  be the subshift defined by this set of forbidden patterns. By Proposition 2.5 this subshift is non-empty. Furthermore, if  $\text{WP}(G)$  is decidable then pattern codings of vertex-square paths can be recognized with a Turing machine and consequently  $X$  is effectively closed. We claim it is strongly aperiodic.

Let  $x \in X$  and  $g \in \text{stab}_{\sigma}(x)$ . We are going to show that if  $g \neq 1_G$  then  $x$  contains a vertex-square path. Consider an expression of  $g$  as an element of  $S^*$  such it can be factorized as  $g =_G u w v$  with  $u =_G v^{-1}$ . This can always be done by choosing  $u = v = \varepsilon$  and  $w$  a product of generators producing  $g$ . Amongst all those possible representations choose one such that  $|w|$  is minimal. Clearly  $|w| = 0$  implies that  $g = 1_G$ , so we suppose  $|w| > 0$ . Let  $w = w_1 \dots w_n$  and consider the odd length walk  $\pi = v_0 v_1 \dots v_{2n-1}$  defined by:

$$v_i := \begin{cases} 1_G & \text{if } i = 0 \\ w_1 \dots w_i & \text{if } i \in \{1, \dots, n\} \\ w w_1 \dots w_{i-n} & \text{if } i \in \{n+1, \dots, 2n-1\} \end{cases}$$



We claim that  $\pi$  is a path. Indeed, by definition  $w$  can not be reduced and thus there are no repeated vertices in  $v_0v_1 \dots v_n$  nor in  $v_{n+1} \dots v_{2n-1}$ . Therefore if there is a repeated vertex then it appears once in both parts. Suppose that it happens, thus we can consider two factorizations  $w = ab$  and  $w = cd$  such that  $a =_G abc$ . We obtain that  $b = c^{-1}$ . Obviously  $|c| = |b|$ , if not,  $w$  can be written as  $abcc^{-1} =_G ac^{-1}$  or  $b^{-1}bcd =_G b^{-1}d$  which contradicts the minimality of  $|w|$ . Without loss of generality, we can replace  $c$  by the word obtained by reversing the order and inversing the letters of  $b$ . Moreover,  $|c| > 0$  and thus  $|b| > 0$  which means that  $w$  is written as follows:

$$w = a_1 \dots a_k b_1 \dots b_l = b_l^{-1} \dots b_1^{-1} d_1 \dots d_k$$

Therefore we can factorize  $b_l^{-1}$  and  $b_l$  from both sides obtaining a smaller word  $w'$  in the representation of  $g$ . This contradiction show that indeed  $\pi$  is a path. To conclude, we have that  $g =_G u w u^{-1}$  and since  $g \in \text{stab}_\sigma(x)$  which is normal in  $G$ , so does  $h$  the group element represented by the word  $w$  and therefore  $h^{-1} \in \text{stab}_\sigma(x)$ . This means that  $x_{v_j} = x_{hv_j} = x_{v_{j+n}}$  for all  $j \in \{0, \dots, n-1\}$ , yielding a square-vertex path. Therefore  $|w| = 0$  and thus  $g = uv = 1_G$ .  $\square$

*Remark.* In the previous proof we argued that if the word problem of  $G$  is decidable then the subshift constructed is effectively closed. It is important to notice that it does not suffice that  $\text{WP}(G)$  is recursively enumerable. Indeed, a recursively enumerable word problem allows the construction of upper approximations to the balls  $B_S(1_G, n)$  of the Cayley graph but at any given iteration it provides no guarantee of the convergence. That is, one might detect a square path only to find out later on that the middle vertex was the same as the starting one in the group. One might wonder if it is possible to do better and make the previous construction work in recursively presented groups. In what remains of this section it will be shown that it is not possible.

Theorem 2.6 provides a non-empty strongly aperiodic subshift which is effectively closed if  $\text{WP}(G)$  is decidable. Recently Jeandel [Jea15] has shown that for recursively presented groups, if the group admits a non-empty effectively closed strongly aperiodic subshift then its word problem is decidable. Moreover, he has shown that the same conclusion stands when we allow every configuration to have a finite –instead of trivial– stabilizer. Our result actually shows the converse, that is, that every recursively presented group with decidable word problem admits a non-empty strongly aperiodic effectively closed subshift. In the remainder of this section we prove this equivalence.

**Lemma 2.7.** *Let  $G$  be a finitely generated group,  $S \subset G$  a finite set of generators and  $X \subset \mathcal{A}^G$  a non-empty strongly aperiodic subshift. There exists a function  $f : \mathbb{N} \rightarrow \mathbb{N}$  such that for every  $x \in X$ , if  $g \in B_S(1_G, n) \setminus \{1_G\}$  then  $x|_{B_S(1_G, f(n))} \neq \sigma^g(x)|_{B_S(1_G, f(n))}$ .*

*Proof.* Suppose  $f$  does not exist, thus there exists  $n \in \mathbb{N}$  and a sequence  $(x_j, g_j)_{j \in \mathbb{N}} \subset X \times B_S(1_G, n) \setminus \{1_G\}$  such that  $x_j|_{B_S(1_G, j)} = \sigma^{g_j}(x_j)|_{B_S(1_G, j)}$ . As  $B_S(1_G, n)$  is finite there exists  $\bar{g} \neq 1_G$  which appears infinitely often in  $(g_j)_{j \in \mathbb{N}}$ . Consider the subsequence  $(x_k)_{k \in \mathbb{N}, g_k = \bar{g}}$  and from there extract a converging subsequence  $(x_{k_\alpha}) \rightarrow \bar{x} \in X$ . We

claim that  $\bar{g} \in \text{stab}_\sigma(\bar{x})$ . By definition of convergence, for every  $m \in \mathbb{N}$  there exists  $N_\alpha \geq m$  such that  $\bar{x}|_{B_S(1_G, m+n)} = (x_{N_\alpha})|_{B_S(1_G, m+n)}$  and thus

$$\bar{x}|_{B_S(1_G, m)} = x_{N_\alpha}|_{B_S(1_G, m)} = \sigma^{\bar{g}}(x_{N_\alpha})|_{B_S(1_G, m)} = \sigma^{\bar{g}}(\bar{x})|_{B_S(1_G, m)}$$

So for every  $m \in \mathbb{N}$  we have  $\bar{x}|_{B_S(1_G, m)} = \sigma^{\bar{g}}(\bar{x})|_{B_S(1_G, m)}$  and therefore  $\forall g \in G : \bar{x}_g = \bar{x}_{\bar{g}^{-1}g}$ . This is a contradiction as  $X$  is strongly aperiodic.  $\square$

**Theorem 2.8** (Aubrun, B, Thomassé). *Let  $G$  be a recursively presented and finitely generated group. There exists a non-empty strongly aperiodic effectively closed subshift  $X \subset \mathcal{A}^G$  if and only if  $\text{WP}(G)$  is decidable.*

*Proof.* Theorem 2.6 yields the desired construction. Conversely, suppose there is a non-empty effectively closed subshift  $X$  which is strongly aperiodic. As  $G$  is recursively presented then  $\text{WP}(G)$  is recursively enumerable and Theorem 1.13 ensures the existence of a Turing machine  $T$  which accepts a maximal set of pattern codings  $\mathcal{C}$  such that  $X = X_{\mathcal{C}}$ .

Let  $w \in S^*$ . We present an algorithm which accepts if and only if  $w \neq_G 1_G$ . Consider the ball of size  $n$  in the free monoid over the alphabet  $S^*$ , that is  $\Lambda_n = \{u \in S^* \mid |u| \leq n\}$  and consider the set  $\Lambda_n \cup w\Lambda_n$ . For each one of these sets we construct the set  $\mathcal{C}_n$  of all pattern codings  $c$  such that for  $u \in \Lambda_n$  then  $(u, a) \in c$  if and only if  $(wu, a) \in c$ . That is, we force the ball of size  $n$  around the empty word  $\epsilon$  and  $w$  to be the same. Consider the algorithm which iteratively runs  $T$  on every pattern coding of  $\mathcal{C}_1, \mathcal{C}_2, \dots, \mathcal{C}_j$  up to  $j$  steps and then does  $j \leftarrow j + 1$  and which accepts  $w$  if and only if every pattern coding in a particular  $\mathcal{C}_i$  is accepted by  $T$ . If  $w =_G 1_G$  the algorithm can never accept as it would mean no patterns are constructible around  $1_G$  and thus  $X = \emptyset$ . Conversely, if  $w \neq_G 1_G$  then using the function  $f$  given by Lemma 2.7 we get that for every  $x \in X$  if  $w \neq_G 1_G$  then  $x|_{B_S(1_G, f(|w|))} \neq \sigma^{w^{-1}}(x)|_{B_S(1_G, f(|w|))}$  thus every pattern in  $\mathcal{C}_{f(|w|)}$  is either inconsistent or represents a forbidden pattern, and therefore  $T$  must accept every pattern of  $\mathcal{C}_{f(|w|)}$ .  $\square$

One may ask if it is possible to construct non-empty strongly aperiodic subshifts which satisfy stronger constraints, such as being of finite type, sofic or effectively closed. The previous result shows that our construction is in this sense optimal for recursively presented groups with undecidable word problem.

**Corollary 2.9.** *Let  $G$  is a finitely generated and recursively presented group with undecidable word problem and  $X \subset \mathcal{A}^G$  be a subshift. If  $X$  is an SFT, sofic or effectively closed then  $X$  contains a periodic configuration.*

In Chapter 3 an extended version of Theorem 2.8 which concerns arbitrary effective group actions over a Cantor set will be shown.

## 2.2 Realization of densities

In this section we construct over any infinite and finitely generated group a non-empty subshift over  $\{0, 1\}$  with the property that the density of 1's over any Følner sequence

converges to a fixed  $\alpha \in [0, 1]$ . From this result we derive the existence of uniform density subshifts for infinite groups of subexponential growth for any finite set of generators. Furthermore, we show that said subshifts are always weakly aperiodic.

**Definition 2.1.** Let  $F \subset G$  be a finite subset of a group and  $x \in \{0, 1\}^G$  be a configuration. We define the *density of 1's in  $F$  and  $x$*  as:

$$\text{dens}(1, x|_F) = \text{dens}(1, F, x) = \frac{|\{f \in F \mid x_f = 1\}|}{|F|}.$$

Similarly if  $p \in \mathcal{A}^F$  is a pattern, we denote by  $\text{dens}(1, p)$  the ratio  $\frac{|\{f \in F \mid p_f = 1\}|}{|F|}$ .

**Definition 2.2.** Let  $G$  be a finitely generated group and  $S$  a finite set of generators. We say a  $G$ -subshift over  $\{0, 1\}$  has uniform density  $\alpha \in [0, 1]$  if for every configuration  $x \in X$  and for every sequence  $(g_n)_{n \in \mathbb{N}}$  of elements in  $G$ , one has  $\text{dens}(1, B_S(g_n, n), x) \rightarrow \alpha$ .

In a way similar to the previous definition, we could say a configuration  $x \in \{0, 1\}^G$  has density  $\alpha \in [0, 1]$  for some sequence of subsets  $(T_n)_{n \in \mathbb{N}}$  if for each sequence of elements  $(g_n)_{n \in \mathbb{N}}$  we have that  $\text{dens}(1, g_n T_n, x) \rightarrow \alpha$ . Nevertheless, contrary to the preceding section, Lovász local lemma cannot directly be applied to prove the existence of such configurations. If we define the forbidden sets to be  $A_{n,g} = \{x \in \{0, 1\}^G \mid |\text{dens}(1, g T_n, x) - \alpha| > \delta_n \alpha\}$  for some sequence of error terms  $\delta_n \rightarrow 0$  we obtain that the measure of this set can be bounded above using the Chernoff bounds by  $2 \exp(-\delta_n^2 \alpha |T_n|/3)$ . For any function which bounds these values by above, after some elimination of exponents, we obtain that the left hand side of the inequality required by the local lemma depends on  $\delta_n$  while the right hand side is constant. Therefore we tackle this problem with a different approach.

Nevertheless, if the condition that the group is amenable (see Definition B.21) is added, not only it is possible to obtain a result like the one defined in the previous paragraph, moreover, the density over every Følner sequence can be asked to converge to the same fixed  $\alpha$ .

**Theorem 2.10** (Aubrun, B, Thomassé). *Let  $G$  be an infinite and finitely generated amenable group and  $\alpha \in [0, 1]$ . Then there exists a non-empty subshift  $X_\alpha \subset \{0, 1\}^G$  with  $\lim_{n \rightarrow \infty} \text{dens}(1, F_n, x) = \alpha$  for any  $x \in X_\alpha$  and any Følner sequence  $(F_n)_{n \in \mathbb{N}}$ .*

Before showing this theorem, we must introduce Delone sets. This notion will also be used in the proof of Theorem 4.11 in Chapter 4.

**Definition 2.3.** Let  $(X, d)$  be a metric space and  $D \subset X$ .

- The *packing radius* of  $D$  is  $r_D = \frac{1}{2} \inf \{d(x, y) \mid x, y \in D, x \neq y\}$ .
- The *covering radius* of  $D$  is given by  $c_D = \sup \{d(x, D) \mid x \in X\}$ .

A set with non-zero packing radius and finite covering radius is said to be *Delone*.

In words, the packing radius is an upper bound to the size of the balls that can be put simultaneously in every point in  $D$  such that they do not touch each other. The covering radius is a lower bound to the size of the balls which cover the space completely if put over the points of  $D$ . We say  $D \subset X$  is  $s$ -covering if  $s \geq c_D$  and that  $D$  is  $s$ -separating if  $s < 2r_D$ .

*Remark.* A Delone subset of a non-empty set must be non-empty.

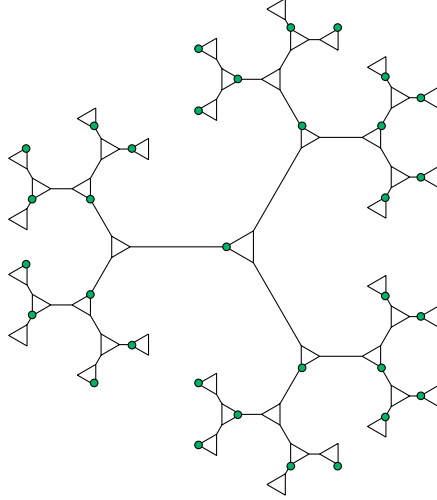

Figure 2.4: In green, an example of 2-covering and 2-separating set in  $PSL(2, \mathbb{Z}) \cong \mathbb{Z}/2\mathbb{Z} * \mathbb{Z}/3\mathbb{Z}$ . Green vertices are at distance at least 3 from each other, and every vertex is at distance at most 2 from a green vertex.

**Lemma 2.11.** *Let  $(X, d)$  be a metric space and  $r \in \mathbb{N}$ . There exists a set  $D_r$  which is  $r$ -separating and  $r$ -covering.*

*Proof.* Suppose we have an  $r$ -separating set  $D$  which is not  $r$ -covering. Then the set  $K := \{x \in X \mid d(D, x) > r\}$  is not empty and  $D$  can be extended by an element of  $K$ . Thus any maximal for inclusion  $r$ -separating set is also  $r$ -covering.

We only need to show that maximal  $r$ -separating sets exist. Let  $(\mathcal{S}, \subset)$  be the set of  $r$ -separating subsets of  $X$  ordered by inclusion. Clearly  $\emptyset \in \mathcal{S}$  and given a chain  $\{A_i\}_{i \in I} \subset \mathcal{S}$  we have that  $A = \bigcup_{i \in I} A_i$  is an upper-bound. Indeed, if  $x, y \in A$  then  $x \in A_i$  and  $y \in A_j$  for some  $i, j \in I$ . As  $\{A_i\}_{i \in I}$  is a chain, then either  $A_i \subset A_j$  or  $A_j \subset A_i$ . As any of these two sets is  $r$ -separating we get that  $d(x, y) > r$  and hence  $A \in \mathcal{S}$ . By Zorn's lemma there exists a maximal  $r$ -separating set.  $\square$

Now we are ready to begin the proof of Theorem 2.10.

*Proof.* For supports  $F, K$  let  $Int(F, K) := \{g \in F \mid \forall k \in K, gk \in F\}$  be the interior of  $F$  with respect to  $K$  and  $\partial_K F := F \setminus Int(F, K)$  the boundary of  $F$  with respect to  $K$  (for more details, see Definition B.23)

If  $\alpha \in \{0, 1\}$  or  $G$  is not amenable the result is trivial. Let  $\alpha \in (0, 1)$ , and define  $K_n := B_S(1_G, 5^n)$  and consider the subshift  $X_\alpha$  given by the set of forbidden patterns

$\mathcal{F}$  such that for  $p \in \{0, 1\}^F$  (where  $F \subset G$ ,  $|F| < \infty$ ) belongs to  $\mathcal{F}$  if and only if the following condition is not satisfied:

$$2n|\partial_{K_n} F| < |F| \implies |\text{dens}(1, p) - \alpha| \leq \frac{1}{n}$$

In other words, we forbid a pattern  $p$  with support  $F$  if the ratio  $\frac{|\partial_{K_n} F|}{|F|}$  is sufficiently small and the density of ones in  $p$  is further than  $\frac{1}{n}$  from  $\alpha$ .

Consider a Følner sequence  $(F_n)_{n \in \mathbb{N}}$  and let  $m \in \mathbb{N}$  and  $x \in X_\alpha$ . As  $\lim_{n \rightarrow \infty} \frac{|\partial_{K_m} F_n|}{|F_n|} = 0$  there exists  $N \in \mathbb{N}$  such that

$$\forall n \geq N \quad \frac{|\partial_{K_m} F_n|}{|F_n|} < \frac{1}{2m}$$

Therefore, for every  $n \geq N$  we get that  $|\text{dens}(1, x|_{F_n}) - \alpha| \leq \frac{1}{m}$ . As  $m$  can be made arbitrarily big we obtain that  $\lim_{n \rightarrow \infty} \text{dens}(1, F_n, x) = \alpha$ .

We only need to show that  $X_\alpha \neq \emptyset$ . Our strategy will be to inductively construct an infinite covering forest of  $G$ , and then put a Sturmian word along an enumeration of the leaves of each of its trees. The configuration  $x \in \{0, 1\}^G$  obtained by this process will belong to  $X_\alpha$ . The following objects – that are formally described below – will be used to formalize this idea: a sequence  $(A_n)_{n \in \mathbb{N}} \subset 2^G$  of subsets of  $G$ , a sequence  $(\mathbf{p}_n)_{n \in \mathbb{N}} : G \rightarrow A_n$  of functions and a sequence  $(\Gamma_n)_{n \in \mathbb{N}}$  of graphs on vertex sets  $(A_n)_{n \in \mathbb{N}}$  respectively. They are defined by the following recurrences, with base cases  $A_0 = G$ ,  $\mathbf{p}_0 = id$  and  $\Gamma_0 = \Gamma(G, S)$  where  $S$  is a finite set of generators of  $G$ :

1. The set  $A_{n+1}$  is chosen as a 2-separating and 2-covering subset of  $A_n$  for the distance induced by  $\Gamma_n$ . In particular, the sets  $(A_n)_{n \in \mathbb{N}}$  are nested.
2. Suppose  $\mathbf{p}_n : G \rightarrow A_n$  is already defined, we first define  $\mathbf{p}_{n+1}$  on  $A_n$  and then extend it to  $G$ . Consider an element  $g \in A_n$ . Since  $A_{n+1}$  2-covers  $A_n$  in  $\Gamma_n$ , there are only three possible cases.
  - $g \in A_{n+1}$ : in this case we set  $\mathbf{p}_{n+1}(g) = g$ .
  - $d_{\Gamma_n}(g, A_{n+1}) = 1$ : there exists a unique  $h \in A_{n+1}$  that satisfies  $d_{\Gamma_n}(g, h) = 1$  – uniqueness comes from the fact that  $A_{n+1}$  is 2-separating – and we set  $\mathbf{p}_{n+1}(g) = h$ .
  - $d_{\Gamma_n}(g, A_{n+1}) = 2$ : we arbitrarily choose one  $h \in A_{n+1}$  that realizes  $d_{\Gamma_n}(g, h) = 2$  and set  $\mathbf{p}_{n+1}(g) = h$ .

For  $g' \in G \setminus A_n$  we finally extend this function by  $\mathbf{p}_{n+1} := \mathbf{p}_{n+1} \circ \mathbf{p}_n$ .

3. For  $g \in A_n$  define the  $n$ -cluster of  $g$  by  $\mathcal{C}_n(g) := \{h \in G \mid \mathbf{p}_n(h) = g\}$ . The element  $g \in A_n$  is called the *center* of the cluster  $\mathcal{C}_n(g)$ . The graph  $\Gamma_{n+1}$  has vertex set  $A_{n+1}$ , and there is an edge in  $\Gamma_{n+1}$  between two elements  $g, h \in A_{n+1}$  if and only if there exist  $g' \in \mathcal{C}_n(g)$  and  $h' \in \mathcal{C}_n(h)$  that are neighbors in  $\Gamma(G, S)$ .

The *covering forest* defined by the sequence  $(A_n, \mathbf{p}_n, \Gamma_n)_{n \in \mathbb{N}}$  is  $(V, E)$ , where the set of vertices  $V$  is the multiset  $\bigsqcup_{n \in \mathbb{N}} A_n$ , and the edges are given by the parent functions:  $(g, h) \in E$  if and only if  $g \in A_n$ ,  $h \in A_{n+1}$  and  $\mathbf{p}_n(g) = h$ . In particular the successive applications of  $\mathbf{p}_1, \dots, \mathbf{p}_n$  to an element  $g \in G = A_0$  gives the path from the leaf labeled by  $g$  to its height  $n$  parent. The cluster  $\mathcal{C}_n(g)$  corresponds to the set of labels of descendants of the node labeled by  $g$  that appears at height  $n$  in the covering forest. The cluster  $\mathcal{C}_{n+1}(g)$  is obtained as the union of the cluster  $\mathcal{C}_n(g)$ , all clusters  $\mathcal{C}_n(h)$  for  $h \in A_n$  such that  $d_{\Gamma_n}(g, h) = 1$  and clusters  $\mathcal{C}_n(h')$  for  $h' \in A_n$  such that  $d_{\Gamma_n}(g, h') = 2$  for which the parent function  $\mathbf{p}_{n+1}(h')$  has been chosen to be  $g$  (see Figure 2.5). Remark that every cluster  $\mathcal{C}_n(g)$  is connected in  $\Gamma$  as it is the finite union of adjacent connected sets in  $\Gamma$ .

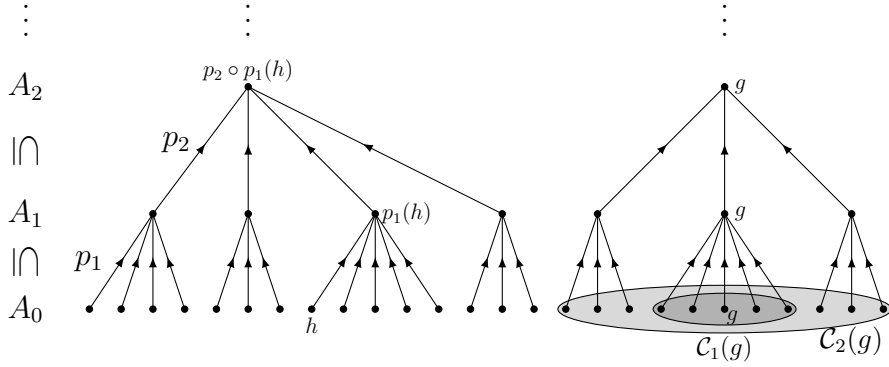

Figure 2.5: A covering forest of  $G$ . In the left section of the image the edge structure is emphasized by writing the parent functions explicitly. In the right section we remark the cluster structure for  $g \in A_2$ .

Note that definition 3 above is equivalent to what follows: for  $g, h \in A_{n+1}$  then the edge  $(g, h)$  is in  $E(\Gamma_{n+1})$  if and only if there exists a path  $g_1 = g, g_2, \dots, g_m = h$  from  $g$  to  $h$  in  $\Gamma(G, S)$  such that for every  $i \in \{1, \dots, m\}$  we have  $\mathbf{p}_{n+1}(g_i) \in \{g, h\}$ .

**Claim 1.** *Let  $g \in A_n$ , then  $B_S(g, n) \subset \mathcal{C}_n(g) \subset B_S(g, \frac{1}{2}(5^n - 1))$ .*

*Proof.* We prove the claim by induction. It stands true for  $n = 0$ .

- Consider  $\mathcal{C}_n(g)$ . By induction hypothesis,  $B_S(g, n-1) \subset \mathcal{C}_{n-1}(g) \subset \mathcal{C}_n(g)$ . Let  $h \in B_S(g, n) \setminus B_S(g, n-1)$ . Either  $h \in \mathcal{C}_{n-1}(g)$  and we are done, or  $h \in \mathcal{C}_{n-1}(g')$  for some  $g' \in A_{n-1}$ . Then necessarily  $d_{\Gamma_{n-1}}(g, g') = 1$ , since  $hs \in B_S(g, n-1) \subset \mathcal{C}_{n-1}(g)$  for some  $s \in S$ . Finally as  $A_n$  is a 2-separating subset of the vertices of  $\Gamma_{n-1}$  we get that  $\mathcal{C}_{n-1}(g') \subset \mathcal{C}_n(g)$  thus  $h \in \mathcal{C}_n(g)$ . We conclude that  $B_S(g, n) \subset \mathcal{C}_n(g)$ . Note that the same argument proves that  $\mathcal{C}_n(g') \cdot (S) \subset \mathcal{C}_{n+1}(g')$  for every  $n \in \mathbb{N}$  and  $g' \in A_{n+1}$ .
- Suppose inductively that for every  $g \in A_{n-1}$  the inclusion  $\mathcal{C}_{n-1}(g) \subset B_S(g, \frac{1}{2}(5^{n-1} - 1))$  holds. Fix one  $g \in A_n$  and consider an element  $h$  in the cluster  $\mathcal{C}_n(g)$ . We show that  $d_G(h, g) \leq \frac{1}{2}(5^n - 1)$  by constructing a path of length at most  $\frac{1}{2}(5^n - 1)$  from  $h$  to  $g$ . By definition of the cluster  $\mathcal{C}_n(g)$ , we know that the

element  $h' \in A_{n-1}$  such that  $h \in \mathcal{C}_{n-1}(h')$  satisfies  $d_{\Gamma_{n-1}}(g, h') \leq 2$ . In the sequel we will only consider the case where this distance is exactly 2 as it is the worst case. Thus we assume that there exists a path  $h' \rightarrow h'' \rightarrow g$  of length 2 between this  $h'$  and  $g$  in  $\Gamma_{n-1}$ . By definition of the graph  $\Gamma_{n-1}$ , this implies the existence of  $k' \in \mathcal{C}_{n-1}(h')$  and  $k'' \in \mathcal{C}_{n-1}(h'')$  that are neighbors in  $\Gamma(G, S)$  and  $\ell'' \in \mathcal{C}_{n-1}(h'')$  and  $\ell \in \mathcal{C}_{n-1}(g)$  that are neighbors in  $\Gamma(G, S)$ . Putting everything together, we can build the following path in  $\Gamma(G, S)$  (see Figure 2.6):

$$h \rightarrow \cdots \rightarrow h' \rightarrow \cdots \rightarrow k' \rightarrow k'' \rightarrow \cdots \rightarrow h'' \rightarrow \cdots \rightarrow \ell'' \rightarrow \ell \rightarrow \cdots \rightarrow g.$$

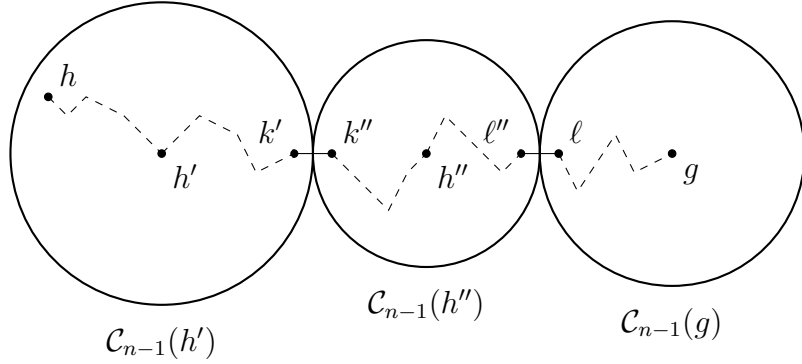

Figure 2.6: A path from an element  $h$  of  $\mathcal{C}_n(g)$  to  $g$  which inductively proves the inclusion  $\mathcal{C}_n(g) \subset B_S(g, \frac{1}{2}(5^n - 1))$ .

Since they all link an element of a cluster of level  $n - 1$  to the center of this cluster, the induction hypothesis implies that we can choose the five subpaths  $h \rightarrow \cdots \rightarrow h'$ ,  $h' \rightarrow \cdots \rightarrow k'$ ,  $k'' \rightarrow \cdots \rightarrow h''$ ,  $h'' \rightarrow \cdots \rightarrow \ell''$  and  $\ell \rightarrow \cdots \rightarrow g$  of length at most  $\frac{1}{2}(5^{n-1} - 1)$ . Thus the total length of the path is at most  $5 \cdot \frac{1}{2}(5^{n-1} - 1) + 2 \leq \frac{1}{2}(5^n - 1)$ . Therefore  $\mathcal{C}_n(g) \subset B_S(g, \frac{1}{2}(5^n - 1))$ .

□

Let  $x \in \{0, 1\}^G$  be a configuration such that for every  $n \in \mathbb{N}$  and  $g \in A_n$

$$\lfloor \alpha |\mathcal{C}_n(g)| \rfloor \leq |\{h \in \mathcal{C}_n(g) \mid x_h = 1\}| \leq \lfloor \alpha |\mathcal{C}_n(g)| \rfloor + 1. \quad (2.1)$$

**Claim 2.** *There exists a configuration  $x$  that satisfies condition (2.1).*

*Proof.* Consider the covering forest given by some sequence  $(A_n, \mathbf{p}_n, \Gamma_n)_{n \in \mathbb{N}}$  as specified above. For every component  $C$  of this forest, take  $\phi_C$  a convex enumeration of its leaves: if  $g$  and  $g'$  are two leaves of  $C$  with the same parent of height  $n$  for some  $n \in \mathbb{N}$  – i.e.  $\mathbf{p}_n(g) = \mathbf{p}_n(g')$  – then the preimage  $h$  of every integer between  $\phi_C(g)$  and  $\phi_C(g')$  satisfies that  $\mathbf{p}_n(h) = \mathbf{p}_n(g)$ . Such an enumeration always exists.

Let  $(w_k)_{k \in \mathbb{N}}$  be a Sturmian word of slope  $\alpha$ . We can build a configuration  $x$  by putting the Sturmian sequence  $(w_k)_{k \in \mathbb{N}}$  along the convex enumeration chosen for every component of the forest. Since Sturmian words are balanced, we deduce that the configuration  $x$  satisfies condition (2.1). □

**Claim 3.** *If a configuration  $x \in \{0, 1\}^G$  satisfies condition (2.1), then  $x$  belongs to  $X_\alpha$ .*

*Proof.* Let  $x$  be such a configuration and take some  $n \in \mathbb{N}$ . Let  $F$  be a set such that  $2n|\partial_{K_n} F| < |F|$  – remember that  $K_n$  is  $B_S(1_G, 5^n)$  – and consider the pattern  $p := x|_F$ . Let  $V := \text{Int}(F, B_S(1_G, \frac{1}{2}(5^n - 1))) \cap A_n$  and  $R = F \setminus \bigcup_{v \in V} \mathcal{C}_n(v)$ . As  $\bigcup_{v \in V} \mathcal{C}_n(v) \subset \bigcup_{v \in V} vB_S(1_G, \frac{1}{2}(5^n - 1)) \subset F$  we get that:

$$\frac{1}{|F|} \sum_{v \in V} (\lfloor \alpha |\mathcal{C}_n(v)| \rfloor) \leq \text{dens}(1, p) \leq \frac{1}{|F|} \sum_{v \in V} (\lfloor \alpha |\mathcal{C}_n(v)| \rfloor + 1) + \frac{|R|}{|F|}.$$

Before working on those inequalities we remark two facts:

1.  $R \subset \partial_{K_n} F$ . Therefore  $\frac{|R|}{|F|} < \frac{1}{2n}$ .
2.  $|V| \leq \frac{|F|}{|B_S(1_G, n)|}$ .

Indeed, let  $r \in \text{Int}(F, K_n)$ . That is, for all  $g \in K_n$  then  $rg \in F$ . As  $d(r, \mathfrak{p}_n(r)) \leq \frac{1}{2}(5^n - 1)$  then  $\mathfrak{p}_n(r) \in \text{Int}(F, B_S(1_G, 5^n - \frac{1}{2}(5^n - 1))) \subset \text{Int}(F, B_S(1_G, \frac{1}{2}(5^n - 1)))$  therefore  $\mathfrak{p}_n(r) \in V$ . That means that  $r \notin R$ , therefore  $R \subset F \setminus \text{Int}(F, K_n) = \partial_{K_n} F$ . The second remark is a consequence of Claim 1

From the left side we get:

$$\begin{aligned} \text{dens}(1, p) &\geq \frac{1}{|F|} \sum_{v \in V} (\lfloor \alpha |\mathcal{C}_n(v)| \rfloor) \\ &\geq \frac{\alpha}{|F|} \sum_{v \in V} |\mathcal{C}_n(v)| - \frac{|V|}{|F|} \\ &\geq \alpha \frac{|\bigcup_{v \in V} \mathcal{C}_n(v)|}{|F|} - \frac{|F|}{|F||B_S(1_G, n)|} \\ &\geq \alpha \frac{|F \setminus R|}{|F|} - \frac{1}{|B_S(1_G, n)|} \\ &\geq \alpha(1 - \frac{1}{2n}) - \frac{1}{2n} \\ &\geq \alpha - \frac{1}{n} \end{aligned}$$

While from the right side:

$$\begin{aligned} \text{dens}(1, p) &\leq \frac{1}{|F|} \sum_{v \in V} (\lfloor \alpha |\mathcal{C}_n(v)| \rfloor + 1) + \frac{|R|}{|F|} \\ &\leq \frac{\alpha}{|F|} \sum_{v \in V} (|\mathcal{C}_n(v)|) + \frac{|V|}{|F|} + \frac{1}{2n} \\ &\leq \alpha \frac{|\bigcup_{v \in V} \mathcal{C}_n(v)|}{|F|} + \frac{|F|}{|F||B_S(1_G, n)|} + \frac{1}{2n} \\ &\leq \alpha + \frac{1}{n} \end{aligned}$$

□



Putting together Claims 2, 1 and 3, we obtain that  $X_\alpha \neq \emptyset$  which completes the proof of Theorem 2.10.  $\square$

*Remark.* In the case where  $\alpha$  is a computable number and  $G$  has decidable word problem the subshift  $X_\alpha$  given in the previous proof is effectively closed.

By noting that in the case of a group of subexponential growth, the sequence of balls always forms a Følner sequence, we obtain the following result.

**Corollary 2.12.** *Let  $G$  be a group of subexponential growth, for every set of generators  $S$  and  $\alpha \in [0, 1]$  there exists a non-empty  $G$ -subshift with uniform density.*

**Definition 2.4.** Let  $G$  be a group and  $S$  a finite set of generators. The rate of convergence of a subshift  $X$  with uniform density  $\alpha$  is the function

$$\theta_X(n) := \inf\{k \in \mathbb{N} \mid \sup_{g \in G, x \in X} |\text{dens}(1, B(g, k), x) - \alpha| \leq \frac{1}{n}\}.$$

As the construction given in Theorem 2.10 is explicit, we can give bounds for the rate of convergence of  $X_\alpha$ . Indeed, let  $\gamma$  denote the growth of a group  $G$ , that is,  $\gamma(k) = |B(1_G, k)|$  for a fixed set of generators  $S$ . Let  $x \in X$ ,  $g \in G$  and  $B_k := B(g, k)$ . By definition of  $X_\alpha$ , if  $2n|\partial_{B(1_G, 5^n)} B_k| < |B_k|$  then  $|\text{dens}(1, B_k, x) - \alpha| < \frac{1}{n}$  for each  $x \in X$  and  $g \in G$ .

As  $\partial_{B(1_G, 5^n)} B_k = B_k \setminus B_{k-2 \cdot 5^n}$  if  $k \geq 2 \cdot 5^n$ , we obtain that:

$$\theta_{X_\alpha}(n) = \inf\{k \geq 2 \cdot 5^n \mid 2n(\gamma(k) - \gamma(k - 2 \cdot 5^n)) < \gamma(k)\}.$$

Therefore a lower bound is always  $\theta_{X_\alpha}(n) \geq 2 \cdot 5^n$ . The upper bound depends on the growth rate of the group. For instance, if  $G$  has polynomial growth then  $\theta_{X_\alpha}(n) = O(n \cdot 5^n)$ . Indeed, if  $\gamma(k) = k^d$  for some  $d \geq 1$  we can write:

$$\begin{aligned} 2n(k^d - (k - 2 \cdot 5^n)^d) < k^d &\iff 1 - \left(1 - \frac{2 \cdot 5^n}{k}\right)^d < \frac{1}{2n} \\ &\iff \left(1 - \frac{2 \cdot 5^n}{k}\right)^d > 1 - \frac{1}{2n} \end{aligned}$$

By Bernoulli's inequality,  $\left(1 - \frac{2 \cdot 5^n}{k}\right)^d \geq 1 - \frac{2d \cdot 5^n}{k}$ . Hence it suffices to choose  $k > 4nd \cdot 5^n$ . This shows that  $\theta_{X_\alpha}(n) = O(n \cdot 5^n)$ . In the case of a group of subexponential growth, an upper bound can be computed with an analogous reasoning given the exact rate of growth  $2^{k^\beta}$  for some  $\beta \in (0, 1)$ .

As  $X_\alpha$  has the uniform density property, it is reasonable to think it might share other properties with Sturmian sequences. It is a natural question to wonder if it satisfies a form of aperiodicity. This is indeed the case.

**Proposition 2.13.** *Let  $\alpha \in [0, 1] \setminus \mathbb{Q}$ . Then  $X_\alpha$  is weakly aperiodic.*

*Proof.* Suppose there exist a configuration  $x \in X_\alpha$  and an integer  $n \in \mathbb{N}$  such that  $|Orb_\sigma(x)| = n$ . Let  $D := \{g_i\}_{1 \leq i \leq n} \subset G$  such that each  $\sigma^{g_i}(x)$  represents a different element of  $Orb_\sigma(x)$ , with  $g_1 = 1_G$ . Consider also  $\alpha' = dens(1, x|_D) \in \mathbb{Q}$  and  $N = \max_{1 \leq i \leq n} d(1_G, g_i)$ .

Let  $m \in \mathbb{N}$  such that  $\frac{2}{m} < |\alpha - \alpha'|$  and  $5^m > \frac{N}{2}$ . Recall that  $K_m := B_S(1_G, 5^m)$  and consider a finite subset  $F \subset G$  such that  $2m|\partial_{K_m}F| < |F|$  – by amenability of  $G$  such a subset always exists. As  $x \in X_\alpha$  we get that  $|dens(1, x|_F) - \alpha| < \frac{1}{m}$ . Let  $V = Int(F, B_S(1_G, N)) \cap stab_\sigma(x)$  and  $R = F \setminus VD$ . Note that by definition of  $N$ ,  $VD = \bigcup_{v \in V} vD \subset F$  and that as each  $v \in stab_\sigma(x)$  then  $dens(1, x|_{vD}) = dens(1, x|_D) = \alpha'$ . We obtain:

$$dens(1, x|_D) \frac{|VD|}{|F|} \leq dens(1, x|_F) \leq dens(1, x|_D) \frac{|VD|}{|F|} + \frac{|R|}{|F|}$$

Let  $g \in Int(F, K_m)$ . Since the configuration  $x$  is supposed to have finite orbit  $\{x, \sigma^{g^2}(x), \dots, \sigma^{g^n}(x)\}$ , there exists  $l \in \{1, \dots, n\}$  such that  $\sigma^{g^{-1}}(x) = \sigma^{g^l}(x)$ . Therefore  $g_l^{-1}g \in stab_\sigma(x)$  which is a subgroup, thus  $gg_l \in stab_\sigma(x)$ . As  $d(g, gg_l) \leq N$  and  $gg_l \in V$  then we conclude that  $Int(F, K_m) \subset VD$  (because we have chosen  $g_1 = 1_G$ ) and therefore  $R \subset \partial_{K_m}F$ .

Similarly to the previous proof, we bound each side using this relation, obtaining:

$$\begin{aligned} \alpha' \frac{|VD|}{|F|} &\leq dens(1, x|_F) \leq \alpha' \frac{|VD|}{|F|} + \frac{|R|}{|F|} \\ \alpha' \frac{|F \setminus R|}{|F|} &\leq dens(1, x|_F) \leq \alpha' + \frac{|\partial_{K_m}F|}{|F|} \\ \alpha'(1 - \frac{1}{2m}) &\leq dens(1, x|_F) \leq \alpha' + \frac{1}{2m} \\ \alpha' - \frac{1}{2m} &\leq dens(1, x|_F) \leq \alpha' + \frac{1}{2m} \end{aligned}$$

Therefore  $|dens(1, x|_F) - \alpha'| < \frac{1}{m}$  and  $|dens(1, x|_F) - \alpha| < \frac{1}{m}$  which implies that  $|\alpha - \alpha'| < \frac{2}{m}$  contradicting the definition of  $m$ .  $\square$

In the case of  $\mathbb{Z}^2$ , the subshift  $X_\alpha$  defined in the proof of Theorem 2.10 is not strongly aperiodic, since it contains the following configurations with non-trivial stabilizer: take a bi-infinite Sturmian word and repeat it vertically so that a configuration  $x \in \{0, 1\}^{\mathbb{Z}^2}$  is defined. Then  $x \in X_\alpha$  since no forbidden pattern defining  $X_\alpha$  appears in  $x$ . Thus Proposition 2.13 is in some sense the best we can do for this particular construction.

The statement of Theorem 2.10 itself requires amenability for the group  $G$  in order to be meaningful, since we want the density to converge to  $\alpha$  for every Følner sequence. Therefore, it doesn't say anything about non-amenable groups. For free groups, we can build configurations (and therefore, subshifts) with uniform density by constructing a regular covering tree and putting a Sturmian sequence on every level of this tree. Nevertheless, we still don't know if this kind of construction is always possible. To our knowledge the following question remains open:

*Question.* Let  $G$  be an infinite group generated by a finite set  $S$  and  $\alpha \in [0, 1]$ . Does there exist a subshift  $Y_\alpha \subset \{0, 1\}^G$  with uniform density  $\alpha$  ?

# Chapter 3

## A simulation theorem for actions of finitely generated groups

A famous result of Hochman [Hoc09] states that every  $\mathbb{Z}^d$  action over a Cantor set which can be defined by Turing machines in a specific way can be realized as a factor of a subaction of a  $\mathbb{Z}^{d+2}$ -subshift of finite type. This means that the action can be somehow “simulated” by a new system which is defined only by a finite number of constrains.

This chapter is dedicated to present the results of the author in collaboration with Mathieu Sablik [BS17] which consist of a generalization of Hochman’s theorem in two simultaneous directions: The group  $\mathbb{Z}^d$  is replaced by an arbitrary finitely generated group  $H$  and we take the subaction from an arbitrary semidirect product  $\mathbb{Z}^2 \rtimes H$ . As a corollary of that result, we obtain that every group of the form  $\mathbb{Z}^2 \rtimes H$  admits a non-empty strongly aperiodic subshift of finite type whenever the word problem of  $H$  is decidable.

### 3.1 Introduction: simulation theorems

Consider a mathematical object which admits a definition through an infinite set of constrains. A natural question to ask is whether the same object can in some sense be described with a finite amount of information. For instance, the decimal expansion of an arbitrary real number  $\alpha$  is, a priori, defined by the infinite sequence of its values. However, if  $\alpha \in \mathbb{Q}$  the same object can be described by a pair of integers, if  $\alpha$  is algebraic it admits a description with a polynomial in  $\mathbb{Q}[x]$  and if  $\alpha$  is computable then it can be described by a Turing machine  $T$ .

In loose words, a simulation theorem is a mathematical result which explains how to embed an object which is defined by infinitely many constrains but described with a finite amount of information into an object which is of the same type as the previous one but is defined by finitely many constrains. In this sense, we can say that the first object is simulated by the second object.

This previous description is, of course, not precise, and a simulation theorem is better illustrated by example through a well known result proved by Highman in

1961.

**Theorem 3.1** (Highman [Hig61]). *Every recursively presented group  $H$  can be embedded as a subgroup of some finitely presented group  $G$ .*

This kind of results often yield powerful corollaries, the main reason being the fact that producing examples of objects which have some desired property and are defined by a finite number of constraints is much harder than finding an object with the property and an arbitrary number of restrictions. A well-known example is the result by Novikov and Boone:

**Theorem 3.2** (Novikov [Nov55], Boone [Boo58]). *There exist finitely presented groups with undecidable word problem.*

Their proofs were constructive and quite intricate. With Highman's theorem a proof can be given quite easily. The following proof was taken from [MKS04].

*Proof.* By Highman's theorem, it suffices to exhibit a recursively presented group with undecidable word problem as the finitely presented group it embeds into will automatically have undecidable word problem. Let  $K \subset \mathbb{N}$  be a recursively enumerable but undecidable subset of natural numbers, say for instance, an enumeration of all Turing machines that halt on empty input and

$$G = \langle a, b, c, d \mid b^{-n}ab^n = c^{-n}dc^n, n \in K \rangle.$$

By definition,  $G$  is a recursively presented group and it is possible to show that  $b^{-n}ab^n c^{-n}d^{-1}c^n = 1_G$  if and only if  $n \in K$ . Suppose  $\text{WP}(G)$  is decidable, then given  $n \in \mathbb{N}$  one could use the algorithm for  $\text{WP}(G)$  on the word  $b^{-n}ab^n c^{-n}d^{-1}c^n$  to decide if  $n \in K$  and thus  $K$  would be decidable yielding a contradiction.  $\square$

In order to study simulation theorems for dynamical systems we need to introduce two relevant notions: effectively closed dynamical systems and subactions.

Consider the space  $X$  to be a Cantor set equipped with the product topology and a finitely generated group  $G$  acting over  $X$ . Without loss of generality, we consider  $X$  to be a closed subset of  $\{0, 1\}^{\mathbb{N}}$ .

**Definition 3.1.** Let  $S$  be a finite set of generators for  $G$ . An *effectively closed  $G$ -dynamical system* is a dynamical system  $(X, f)$  where:

1.  $X \subset \{0, 1\}^{\mathbb{N}}$  is a closed effective subset:  $X = \{0, 1\}^{\mathbb{N}} \setminus \bigcup_{i \in I} [w_i]$  where  $\{w_i\}_{i \in I} \subset \{0, 1\}^*$  is a recursively enumerable language. That means that  $X$  is the complement of a union of cylinders which can be enumerated by a Turing machine.
2.  $f$  is an effectively closed action: there exists a Turing machine which on entry  $s \in S$  and  $w \in \{0, 1\}^*$  enumerates a sequence of words  $(w_j)_{j \in J}$  such that  $f_s^{-1}([w]) = \{0, 1\}^{\mathbb{N}} \setminus \bigcup_{j \in J} [w_j]$ .

The idea behind the definition is the following: There is a Turing machine  $T$  which given a word  $g \in S^*$  representing an element of  $G$  and  $n$  coordinates of  $x \in X \subset \{0, 1\}^{\mathbb{N}}$  returns an approximation of the preimage of  $x$  by  $f_g$ .

*Remark.* Any  $G$ -action over a Cantor set can be seen as a shift space over an infinite alphabet: Indeed,  $(X, f)$  can be seen as  $Y \subset (\{0, 1\}^{\mathbb{N}})^G$  equipped with the shift action where  $y \in Y$  if and only if for every  $g \in G$ ,  $y_g = f_g(y_{1_G})$ . In this setting, effectively closed dynamical systems correspond to effectively closed subshifts in this infinite alphabet.

**Definition 3.2.** Let  $(X, f)$  be a dynamical system where  $f : G \times X \rightarrow X$  is a left group action. For  $H \leq G$  we define the  $H$ -subaction of  $(X, f)$  as the system  $(X, f^H)$  where  $f^H : H \times X \rightarrow X$  is the restriction of  $f$  to  $H$ .

*Remark.* In the case of a subshift  $(X, \sigma)$  we should be careful to distinguish subactions from projective subdynamics, see Definition 1.17. In the case of projective subdynamics the shift space  $X$  is also reduced and the resulting object is also a subshift. In the case of subactions, there is no guarantee that  $(X, \sigma^H)$  is expansive, and therefore it might not be conjugate to a subshift.

*Example 3.1.* Let  $\{0, 1\}^{\mathbb{Z}^2}$  be the full  $\mathbb{Z}^2$ -shift and consider its horizontal  $(\mathbb{Z}, 0)$ -subaction. If we take the sequence of configurations  $(x^n)_{n \in \mathbb{N}}$  such that  $(x^n)_v = 1 \iff v = (0, n)$  we have that:

$$\sup_{h \in (\mathbb{Z}, 0)} d(\sigma^h(x^n), \sigma^h(x^m)) = d(x^n, x^m) = 2^{-\min(n, m)}.$$

Therefore there can not be an expansivity constant  $C > 0$  for the subaction.

The study of subactions has been extremely fruitful to obtain properties of  $\mathbb{Z}^d$  actions, see for instance the study of expansive subdynamics of  $\mathbb{Z}^d$  actions [BL97, ELMW01]. It is thus appealing to ask the following question: What systems can be obtained as subactions of a class of dynamical systems?

For the class of  $\mathbb{Z}^d$ -SFTs it is known that the subactions are effectively closed dynamical systems, but there is still no characterization of the exact class of dynamical systems that can arise. Nevertheless, there is the following simulation theorem by Hochman:

**Theorem 3.3** (Hochman [Hoc09]). *Every effectively closed  $\mathbb{Z}^d$ -dynamical system  $(X, f)$  admits an almost trivial isometric extension (ATIE) which can be realized as the subaction of a  $\mathbb{Z}^{d+2}$ -SFT.*

An extension  $(Z, f_Z) \twoheadrightarrow (X, f_X)$  is an ATIE if we can interpolate a factor

$$(Z, f_Z) \twoheadrightarrow (X, f_Y) \times (W, f_W) \twoheadrightarrow (X, f_X)$$

such that  $(W, f_W)$  is an isometric action of a totally disconnected space,  $\phi_1 : (X, f_Y) \times (W, f_W) \twoheadrightarrow (X, f_Y)$  is the projection of the first coordinate and  $\phi_2 : (Z, f_Z) \twoheadrightarrow (X, f_Y) \times (W, f_W)$  is almost everywhere 1-1, that is, it satisfies that the set of points with unique preimage has measure 1 under any invariant Borel probability measure. The idea behind the notion of ATIE is of an extension which is in a certain sense “small”. It consists basically on adding a simple system  $(W, f_W)$  (for example an odometer) as a product and then considering a measure equivalent action as the

extension. Many properties such as the topological entropy (at least for  $\mathbb{Z}^d$ -actions) are preserved by taking ATIEs [Hoc09].

Hochman's result has subsequently been improved for the expansive case by Theorem 1.20 showing that every effectively closed subshift can be obtained as the projective subdynamics of a sofic  $\mathbb{Z}^2$ -subshift. These kind of results yield powerful techniques to prove properties about the original systems. An example is the characterization of the set of entropies of  $\mathbb{Z}^2$ -SFTs [HM10] as the set of right recursively enumerable numbers.

The goal of this chapter is to prove the following extension of Hochman's theorem:

**Theorem 3.7** (B, Sablik). *For every effectively closed  $H$ -dynamical system  $(X, f)$  there exists a  $(\mathbb{Z}^2 \rtimes H)$ -SFT whose  $H$ -subaction is an extension of  $(X, f)$ .*

In the case when  $H$  is a recursively presented group, it will be shown that Theorem 3.7 can be presented in a purely symbolic dynamics fashion for expansive actions, namely we show:

**Theorem 3.16** (B, Sablik). *Let  $X$  be an effectively closed  $H$ -subshift. Then there exists a sofic  $(\mathbb{Z}^2 \rtimes H)$ -subshift  $Y$  such that its  $H$ -projective subdynamics  $\pi_H(Y)$  is  $X$ .*

It is known that every  $\mathbb{Z}$ -SFT contains a periodic configuration [LM95]. However, it was shown by Berger [Ber66] that there are  $\mathbb{Z}^2$ -SFTs which are strongly aperiodic, that is, such that the shift acts freely on the set of configurations. This result has been proven several times with different techniques [Rob71, Kar96, JR15] giving a variety of constructions. However, it remains an open question which is the class of groups which admit strongly aperiodic SFTs. Amongst the class of groups that do admit strongly aperiodic SFTs are:  $\mathbb{Z}^d$  for  $d > 1$ , hyperbolic surface groups [CGS15], Osin and Ivanov monster groups [Jea15], and the direct product  $G \times \mathbb{Z}$  for a particular class of groups  $G$  which includes Thompson's  $T$  group and  $\mathrm{PSL}(2, \mathbb{Z})$  [Jea15]. It is also known that no group with two or more ends can contain strongly aperiodic SFTs [Coh17] and that recursively presented groups which admit strongly aperiodic SFTs must have decidable word problem [Jea15].

As an application of Theorem 3.7 we present a new class of groups which admit strongly aperiodic SFTs, that is:

**Theorem 3.17** (B, Sablik). *Every semidirect product  $\mathbb{Z}^2 \rtimes H$  where  $H$  is finitely generated and has decidable word problem admits a non-empty strongly aperiodic SFT.*

Amongst this new class of groups which admit strongly aperiodic SFTs, we remark the discrete Heisenberg group which admits a presentation  $\mathcal{H} \cong \mathbb{Z}^2 \rtimes \mathbb{Z}$ . A construction by Ugarcovici, Sahin and Schraudner showing that  $\mathcal{H}$  admits strongly aperiodic SFTs was already presented in a workshop [Sah14] in 2014. The results that are presented in this chapter provide a new proof of this result along with a positive answer to their question asking if similar constructions can be realized in the powers of the Heisenberg group, the Flip group and the Sol group.

## 3.2 Substitutions and Toeplitz configurations

In this short section two important concepts are introduced: multidimensional substitutions and Toeplitz configurations. These two notions will be important ingredients for the proof of Theorem 3.7. Also, throughout this chapter the following notation is used: if  $x \in \mathcal{A}^G$  is a configuration such that for all  $g \in F \subset G$  then  $x_g = a \in \mathcal{A}$  we just write  $x|_F \equiv a$ .

### 3.2.1 Substitutions

Here we present a very brief overview of multidimensional substitutions where the essentials needed to understand the proof of Theorem 3.7 are presented. For a broader view on the topic the reader is referred to [PF02].

**Definition 3.3.** A *substitution* is a function  $\mathbf{s} : \mathcal{A} \rightarrow L(\mathcal{A}^{\mathbb{Z}^d})$  which takes an element  $a$  of a finite alphabet  $\mathcal{A}$  and associates it to a pattern  $\mathbf{s}(a)$ .

These objects can be regarded as the discrete counterpart of geometrical substitutions such as the one in Figure 3.1. We will only review the two-dimensional case  $d = 2$  and all substitutions studied in this chapter will be of the form  $\mathbf{s} : \mathcal{A} \rightarrow \mathcal{A}^{R(n)}$  where  $R(n) = \{(v_1, v_2) \in \mathbb{Z}^2 \mid 0 \leq v_i < n\}$ . That is,  $\mathbf{s}$  sends each symbol to a square array of symbols. This simplification is quite useful, as defining the concatenation of substitutions is extremely simple compared to the general case [JK12].



Figure 3.1: A substitution rule  $r$  generating a side of Koch's snowflake [Koc06].

The function  $\mathbf{s} : \mathcal{A} \rightarrow \mathcal{A}^{R(n)}$  can be extended recursively by concatenation to  $\mathbf{s}^m : \mathcal{A} \rightarrow \mathcal{A}^{R(n^m)}$  where  $\mathbf{s}^0 = \text{id}$ ,  $\mathbf{s}^1 = \mathbf{s}$  and for  $m \geq 2$ :

$$\mathbf{s}^m(a)_v := \mathbf{s}(\mathbf{s}^{m-1}(a)_{\lfloor v/n \rfloor})_{v - \lfloor v/n \rfloor}.$$

*Example 3.2.* Consider  $\mathcal{A} = \{\square, \blacksquare\}$ . The substitution  $\mathbf{s}$  such that:

$$\square \rightarrow \begin{array}{|c|c|} \hline \square & \square \\ \hline \square & \square \\ \hline \end{array} \quad \text{and} \quad \blacksquare \rightarrow \begin{array}{|c|c|} \hline \square & \blacksquare \\ \hline \blacksquare & \blacksquare \\ \hline \end{array}$$

is called the Sierpiński triangle substitution and is extended by concatenation as shown in Figure 3.2.

**Definition 3.4.** Let  $\mathbf{s} : \mathcal{A} \rightarrow \mathcal{A}^{R(n)}$  be a substitution. The *subshift generated by  $\mathbf{s}$*  is the set of configurations  $X_{\mathbf{s}} \subset \mathcal{A}^{\mathbb{Z}^2}$  defined by:

$$X_{\mathbf{s}} := \{x \in \mathcal{A}^{\mathbb{Z}^2} \mid p \sqsubset x \implies \exists m \in \mathbb{N}, a \in \mathcal{A} \text{ such that } p \sqsubset \mathbf{s}^m(a)\}.$$



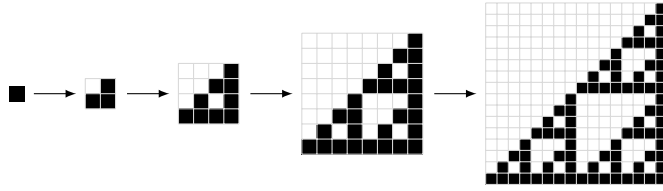

Figure 3.2: First four iterations of the Sierpiński triangle substitution.

In words, the subshift generated by a substitution is the set of configurations such that every pattern appearing in them also appears in an iteration of the substitution rule. In what follows we relate two combinatorial properties of substitutions with the subshifts they generate.

**Definition 3.5.** A substitution  $\mathfrak{s} : \mathcal{A} \rightarrow \mathcal{A}^{R(n)}$  is said to be *primitive* if for each  $a \in \mathcal{A}$  there exists  $m \in \mathbb{N}$  such that for every  $b \in \mathcal{A}$  there exists  $v \in R(n^m)$  such that  $\mathfrak{s}^m(a)_v = b$ .

**Proposition 3.4.** *If  $\mathfrak{s}$  is primitive, then  $X_{\mathfrak{s}}$  is minimal.*

*Proof.* Let  $x \in X_{\mathfrak{s}}$ . By Proposition 1.4 it suffices to show that  $\overline{\text{Orb}_{\sigma}(x)} = X_{\mathfrak{s}}$ . Let  $y \in X_{\mathfrak{s}}$ , we have that  $y \in \overline{\text{Orb}_{\sigma}(x)}$  if and only if for every finite support  $F$  then  $y|_F \sqsubset x$ . By definition of  $X_{\mathfrak{s}}$  it suffices to show that for every  $k \in \mathbb{N}$  and  $a \in \mathcal{A}$  then  $\mathfrak{s}^k(a) \sqsubset x$ . Let  $N := \max_{b \in \mathcal{A}} \min\{m \in \mathbb{N} \mid \mathfrak{s}^m(b) \text{ contains every } a \in \mathcal{A}\}$ . As  $\mathfrak{s}$  is primitive, we have that  $N < \infty$ . Then we have that for every  $k \in \mathbb{N}$  and  $a, b \in \mathcal{A}$  the relation  $\mathfrak{s}^k(a) \sqsubset \mathfrak{s}^{k+N}(b)$  holds. By definition of  $X_{\mathfrak{s}}$  we have that  $x|_{R(n^{k+N+1})}$  is contained in  $\mathfrak{s}^M(c)$  for some  $c \in \mathcal{A}$ . In particular  $x|_{R(n^{k+N+1})}$  must contain some pattern of the form  $\mathfrak{s}^{k+N}(b)$  and therefore  $\mathfrak{s}^k(a) \sqsubset x$ .  $\square$

**Definition 3.6.** A substitution  $\mathfrak{s} : \mathcal{A} \rightarrow \mathcal{A}^{R(n)}$  is said to have *unique derivation* if for every  $z \in X_{\mathfrak{s}}$  there exists a unique  $y \in X_{\mathfrak{s}}$  and  $v \in R(n)$  such that

$$\forall u \in \mathbb{Z}^2, \sigma^v(z)_u = \mathfrak{s}(y_{\lfloor u/n \rfloor})_{u - \lfloor u/n \rfloor}.$$

It is simple to show using a compactness argument that every configuration  $z \in X_{\mathfrak{s}}$  can be subdivided in blocks  $R(n)$  –that is the meaning of  $v \in R(n)$  in the previous definition– and de-substituted to obtain  $y \in X_{\mathfrak{s}}$ . The condition of unique derivation implies that the subdivision and de-substitution processes are unique for every configuration. In the proof of Theorem 3.7 a substitution with unique derivation is used as a tool. Here we show examples of how this property can fail.

*Example 3.3.* Consider  $\mathcal{A} = \{\square, \blacksquare\}$  and  $\mathfrak{s}_1$  such that:

$$\square \rightarrow \begin{array}{|c|c|} \hline \square & \square \\ \hline \blacksquare & \blacksquare \\ \hline \end{array} \quad \text{and} \quad \blacksquare \rightarrow \begin{array}{|c|c|} \hline \blacksquare & \blacksquare \\ \hline \blacksquare & \square \\ \hline \end{array}.$$

This primitive substitution generates a subshift  $X_{\mathfrak{s}_1}$  composed of a single periodic orbit of size 4. Any configuration in that orbit can be uniquely subdivided into squares  $R(2)$  but has multiple choices for de-substitution.

Now consider again  $\mathcal{A} = \{\square, \blacksquare\}$  and  $\mathfrak{s}_2$  such that:

$$\square \rightarrow \begin{array}{|c|c|} \hline \square & \square \\ \hline \square & \square \\ \hline \end{array} \quad \text{and} \quad \blacksquare \rightarrow \begin{array}{|c|c|} \hline \blacksquare & \blacksquare \\ \hline \blacksquare & \blacksquare \\ \hline \end{array}.$$

This substitution generates a subshift  $X_{\mathfrak{s}_2}$  composed of two uniform configurations. Each configuration has a unique choice for de-substitution but multiple choices for subdivision into squares  $R(2)$ .

The importance of the property of unique derivation is that it gives dynamical information about the subshift generated by a substitution. This is illustrated by a result by Mozes from 1989.

**Theorem 3.5** (Mozes [Moz89]). *Let  $s$  be a  $\mathbb{Z}^2$ -substitution. Then  $X_s$  is a sofic  $\mathbb{Z}^2$ -subshift. Moreover, if  $s$  has unique derivation then  $X_s$  admits an almost 1-1 SFT extension.*

This theorem has since been extended to  $\mathbb{Z}^d$  for  $d \geq 2$  as a special case of geometrical  $\mathbb{R}^d$  substitutions by Goodman-Strauss [GS98]. The theorem has also been extended in a different direction by Aubrun and Sablik [SA14] who showed that in the case of effective  $\mathcal{S}$ -adic subshifts, that is, subshifts which are produced by an effective sequence of  $\mathbb{Z}^d$  substitutions, the resulting system is also sofic.

The importance of Theorem 3.5 is that it allows to extract SFT extensions of systems generated by substitutions without having to define them explicitly. This will be used as part of Proposition 3.8 in Section 3.3.

### 3.2.2 Toeplitz configurations

Toeplitz sequences were initially introduced for one-sided dynamical systems by Jacobs and Keane in [JK69]. In their setting they consist of sequences  $\{0, 1\}^{\mathbb{N}}$  constructed by the following method: Initially begin with a sequence filled with blank symbols  $\sqcup$ . Then, replace iteratively the positions of the sequence which are still marked by  $\sqcup$  by a periodic sequence of symbols 0, 1 and  $\sqcup$ .

Nowadays Toeplitz configurations can be defined on arbitrary groups. We begin with a structural definition rather than a constructive one. In this setting, Toeplitz configurations correspond to those where each symbol repeats periodically across the group in every direction.

**Definition 3.7.** A configuration  $x \in \mathcal{A}^G$  is said to be *Toeplitz* if for every  $g \in G$  there is a finite index subgroup  $H \leq G$  such that  $x|_{Hg} \equiv x_g$ .

An obvious example of Toeplitz configurations are strongly periodic configurations such as a uniform configuration consisting of a single symbol. Even if Definition 3.7 is valid in any group, it is not always of interest, for instance, in an infinite simple group such as a Tarski Monster [Ol'81] uniform configurations are indeed the only example. Indeed, if  $x$  is Toeplitz, there is  $H \leq G$  such that  $x|_H = x|_{1_G}$  and  $[G : H] < \infty$ . One can then extract from  $H$  a normal subgroup  $N \trianglelefteq G$  such that  $[G : N] < \infty$ , forcing by simplicity that  $H = G$ .

The interest of these configurations lies in the subshifts they generate.

**Definition 3.8.** A subshift  $X$  is *Toeplitz* if there exists a Toeplitz configuration  $x$  such that  $X = \overline{\text{Orb}_\sigma(x)}$ .

These objects are interesting for many reasons. A natural class where these objects are interesting is the one of residually finite groups. In this case the intersection of the normal subgroups of finite index is trivial, and nested sequences of such groups can be used to construct interesting examples. For instance, if the group is also amenable, it can be shown that any real number can be realized as the topological entropy of a minimal Toeplitz subshift [Kri07b, LP16].

The fact that Toeplitz subshifts are minimal always holds, here we present a brief proof.

**Proposition 3.6.** *Let  $x \in \mathcal{A}^G$  a Toeplitz configuration. Then  $\overline{\text{Orb}_\sigma(x)}$  is minimal.*

*Proof.* Let  $y \in \overline{\text{Orb}_\sigma(x)}$ . It suffices to show that  $x \in \overline{\text{Orb}_\sigma(y)}$ . To show that, it suffices to prove that for every pattern  $p \sqsubset x$  then  $p \sqsubset y$ . Indeed, let  $p = x|_F$ . For each  $f \in F$  let  $H_f \leq G$  be the finite index subgroup such that  $x|_{H_f f} \equiv x_f$ . As finite intersections of groups of finite index are again subgroups of finite index, we have that  $H_p := \bigcap_{f \in F} H_f$  satisfies  $[G : H_p] < \infty$  and  $\forall h \in H_p$  we have  $x_{hf} = p_f$ .

Let  $(g_n)_{n \in \mathbb{N}}$  such that  $\sigma^{g_n}(x) \rightarrow y$ . Then for each  $f \in F$  we have  $\sigma^{g_n}(x)|_{g_n H_p f} \equiv x_f$ . As  $H_p$  has finite index, the sequence  $(g_n H_p)_{n \in \mathbb{N}}$  has finitely many cosets and therefore a  $\bar{g}H_p$  appears infinitely often. We conclude that for every  $f \in F$  then  $y|_{\bar{g}H_p f} \equiv p_f$ . In particular  $\sigma^{\bar{g}^{-1}}(y)|_F = p$  and thus  $p \sqsubset y$ .  $\square$

In Section 3.3 an effective dynamical system will be coded into an effectively closed Toeplitz  $\mathbb{Z}^d$ -subshift.

### 3.3 The simulation theorem

The purpose of this section is to prove the following result:

**Theorem 3.7** (B, Sablik). *Let  $H$  be finitely generated group and  $G = \mathbb{Z}^2 \rtimes H$ . For every effectively closed  $H$ -dynamical system  $(X, f)$  there exists a  $G$ -SFT whose  $H$ -subaction is an extension of  $(X, f)$ .*

We begin by introducing some useful constructions. The general scheme of the proof is the following: First, we construct for each non-zero vector  $v \in (\mathbb{Z}/3\mathbb{Z})^2$  a substitution  $\mathbf{s}_v$ . Each configuration on the subshift generated by  $\mathbf{s}_v$  encodes countably many copies of  $\mathbb{Z}^2$  as lattices. These lattices are situated in a way such that any automorphism  $\varphi \in \text{Aut}(\mathbb{Z}^2)$  acting over the space of configurations by permuting the coordinates has as an image the subshift generated by  $\mathbf{s}_{\tilde{\varphi}(v)}$ , where  $\tilde{\varphi} \in \text{Aut}((\mathbb{Z}/3\mathbb{Z})^2)$  is the automorphism of  $(\mathbb{Z}/3\mathbb{Z})^2$  obtained by reducing each entry of the matrix representation of  $\varphi$  modulo 3. The purpose of the lattices is to encode a finite amount of information, namely, each lattice will be later on paired to a specific coordinate of a configuration in  $\{0, 1\}^{\mathbb{N}}$  and will transmit this information when moving in  $G$  by elements of  $H$ .

The second ingredient of this proof is a joint encoding of the elements of  $X$  and the  $H$ -dynamical system  $f$  in an effective Toeplitz  $\mathbb{Z}$ -subshift. We do so in a way that the horizontal and vertical projections of the  $n$ -th order lattice of the previous construction always match with the  $n$ -th coordinate of  $x \in X \subset \{0,1\}^{\mathbb{N}}$ . For technical reasons of matching all the possible projections, we parametrize these Toeplitz subshifts with a natural number  $q \in \{1,2\}$ .

Afterwards, we extend the Toeplitz subshift to a  $\mathbb{Z}^2$ -subshift by repeating rows (or columns). Using a known simulation theorem we obtain that this object is a sofic  $\mathbb{Z}^2$ -subshift from which we extract an SFT extension. We then proceed to couple this structure with the substitution subshifts described above in such a way that the symbols encoded by the Toeplitz layers match with the lattices of the substitution.

Finally, we extend this construction to a  $G$ -SFT by adding local rules that ensure that if the  $(\mathbb{Z}^2, 0)$ -coset of a configuration  $y$  in said subshift codes  $x \in X$  then for any  $h \in H$  the  $(\mathbb{Z}^2, 0)$ -coset of  $\sigma^h(y)$  codes  $f_h(x)$ . This set of rules is described as a finite amount of forbidden patterns.

Finally, we define the factor code, and show that it satisfies the required properties.

### 3.3.1 A set of $\mathbb{Z}^2$ -substitutions which are permuted by actions of $\text{Aut}(\mathbb{Z}^2)$ .

Let  $p \geq 3$  be an integer. We define a substitution over a two symbol alphabet which generates a sofic  $\mathbb{Z}^2$ -subshift encoding translations of  $p^{m+1}\mathbb{Z}^2$  for  $m \in \mathbb{N}$ . In the proof of the simulation theorem we will only use the case where  $p = 3$ , but we prefer to proceed here with more generality.

To make notations shorter, we write  $\vec{0} = (0,0) \in \mathbb{Z}^2$  throughout the whole proof. Let  $v \in (\mathbb{Z}/p\mathbb{Z})^2 \setminus \{\vec{0}\}$  and  $\mathcal{A} = \{\square, \blacksquare\}$ . The  $\mathbb{Z}^2$ -substitution  $\mathbf{s}_v : \mathcal{A} \rightarrow \mathcal{A}^{R(p)}$  is defined by:

$$(\mathbf{s}_v(\square))_u = \begin{cases} \blacksquare & \text{if } u = v \\ \square & \text{otherwise.} \end{cases} \quad (\mathbf{s}_v(\blacksquare))_u = \begin{cases} \blacksquare & \text{if } u \in \{\vec{0}, v\} \\ \square & \text{otherwise.} \end{cases}$$

As an example, if  $p = 3$  and  $v = (1,1)$  we get the following:

$$\mathbf{s}_v(\square) = \begin{array}{|c|c|c|} \hline \square & \square & \square \\ \hline \square & \blacksquare & \square \\ \hline \square & \square & \square \\ \hline \end{array} \quad \mathbf{s}_v(\blacksquare) = \begin{array}{|c|c|c|} \hline \square & \square & \square \\ \hline \square & \blacksquare & \square \\ \hline \blacksquare & \square & \square \\ \hline \end{array}$$

In this example the patterns  $\mathbf{s}_v^3(\blacksquare)$  and  $\mathbf{s}_v^4(\blacksquare)$  can be seen in Figure 3.3.

To a substitution  $\mathbf{s}_v$  we associate the subshift  $\text{Sub}_v := X_{\mathbf{s}_v}$  defined as the set of  $\mathbb{Z}^2$ -configurations such that every subpattern appears in some iteration of the substitution  $\mathbf{s}_v$ .

$$\text{Sub}_v = \{x \in \{\square, \blacksquare\}^{\mathbb{Z}^2} \mid \forall P \sqsubset x, \exists n \in \mathbb{N} : P \sqsubset \mathbf{s}_v^n(\blacksquare)\}$$

**Proposition 3.8.** *The following statements hold:*

- (1)  $\text{Sub}_v$  is a minimal subshift.

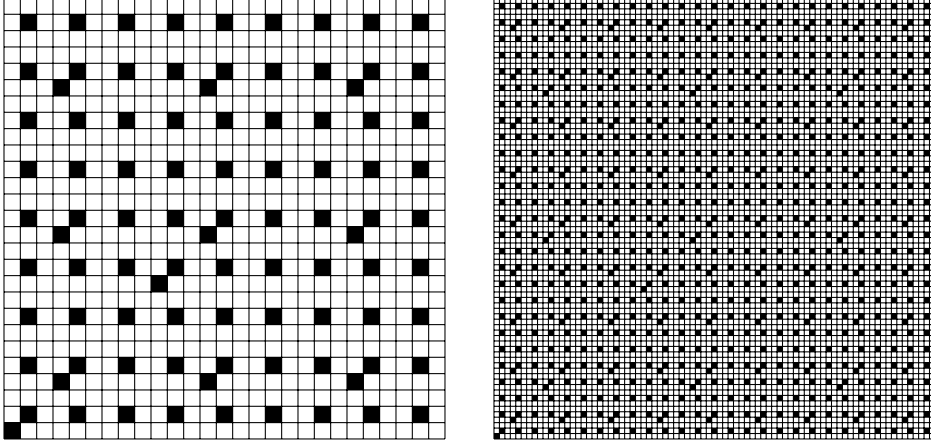

Figure 3.3: The patterns of order 3 and 4 of  $\mathbf{s}_v$  for  $v = (1, 1)$ .

- (2)  $\mathbf{s}_v$  has unique derivation.
- (3)  $\mathbf{Sub}_v$  is a  $\mathbb{Z}^2$ -sofic subshift which admits an almost 1-1 SFT extension
- (4) The Toeplitz configuration  $\tau \in \{\square, \blacksquare\}^{\mathbb{Z}^2}$  defined by:

$$\tau_u = \begin{cases} \blacksquare & \text{if } \exists n \in \mathbb{N}, u \in p^n v + p^{n+1} \mathbb{Z}^2 \\ \square & \text{otherwise} \end{cases}$$

belongs to  $\mathbf{Sub}_v$ . In particular  $\overline{\text{Orb}(\tau)} = \mathbf{Sub}_v$  is a Toeplitz subshift.

*Proof.* The substitution  $\mathbf{s}_v$  is primitive and any subshift generated by a primitive substitution is minimal by Proposition 3.4, therefore (1) holds.

For the unique derivation, let  $z, y \in \mathbf{Sub}_v$  such that for any  $u \in R(p)$   $z_{p(x,y)+u} = \mathbf{s}_v(y_{(x,y)u})$ . As  $(\mathbf{s}_v(\square))_v = (\mathbf{s}_v(\blacksquare))_v = \blacksquare$  we infer that  $\forall w \in v + p\mathbb{Z}^2$  then  $z_w = \blacksquare$ . If there existed another way to subdivide  $z$  there would have to be a disjoint  $p\mathbb{Z}^2$ -lattice of  $\blacksquare$ . As each vector  $u \in (\mathbb{Z}/p\mathbb{Z})^2 \setminus \{\vec{0}, v\}$  satisfies  $(\mathbf{s}_v(\square))_u = (\mathbf{s}_v(\blacksquare))_u = \square$  the only possibility is that  $\forall w \in \vec{0} + p\mathbb{Z}^2$  then  $z_w = \blacksquare$ , but as  $(\mathbf{s}_v(\square))_{\vec{0}} = \square$  this would imply that  $y = \blacksquare^{\mathbb{Z}^2}$  which is clearly not an element of  $\mathbf{Sub}_v$ . Hence (2) holds.

By Theorem 3.5  $\mathbf{Sub}_v$  is a  $\mathbb{Z}^2$ -sofic subshift. Furthermore, as  $\mathbf{s}_v$  has unique derivation, the SFT extension can be chosen to be almost 1-1. This settles (3).

To show (4) it suffices to prove that all of the finite windows of the form  $\tau|_{[0, p^n - 1]^2}$  appear in some iteration of  $\mathbf{s}_v$ . Indeed, as  $\tau$  is Toeplitz, every pattern appearing in  $\tau$  must also appear in the  $\mathbb{N}^2$  portion of the plane. The claim follows directly as it can be verified inductively that  $\tau|_{[0, p^n - 1]^2} = \mathbf{s}_v^n(\square)$  and  $\mathbf{s}_v^n(\square) \sqsubset \mathbf{s}_v^{n+1}(\blacksquare)$ . Also, as  $\mathbf{Sub}_v$  is minimal it follows that  $\overline{\text{Orb}(\tau)} = \mathbf{Sub}_v$  proving (4).  $\square$

Proposition 3.8 gives an useful way to describe elements from  $\mathbf{Sub}_v$ . Namely, for each  $z \in \mathbf{Sub}_v$  there is a sequence of  $\mathbb{Z}^2$  vectors  $\{u_k\}_{k \in \mathbb{N}}$  such that  $\sigma^{u_k}(\tau) \rightarrow z$ . Let  $K_n \in \mathbb{N}$  be such that  $\forall k \geq K_n$  then  $\sigma^{u_k}(\tau)|_{[0, p^n - 1]^2} = z|_{[0, p^n - 1]^2}$  and define  $\bar{u}_n := u_{K_n}$

mod  $(p^{n+1}, p^{n+1})$ . We have that for  $m \in \mathbb{N}$   $\sigma^{u_k}(\tau)|_{p^m v + u_k + p^{m+1}\mathbb{Z}^2}$  is composed uniquely of black squares. In the case where  $m \leq n$  and  $k \geq K_n$  we have

$$p^m v + u_k + p^{m+1}\mathbb{Z}^2 = \bar{u}_n + p^m v + p^{m+1}\mathbb{Z}^2.$$

Therefore, we can conclude that for every  $m \leq n$  if we define  $B_m(z) := \bar{u}_n + p^m v + p^{m+1}\mathbb{Z}^2$  then  $z|_{B_m(z)}$  is composed uniquely of black squares. Moreover, each  $\bar{u}_n$  is unique as any other possibility would shift the position of the  $p^{m+1}\mathbb{Z}^2$ -lattice of black squares which is already fixed.

Let  $\{\bar{u}_n\}_{n \in \mathbb{N}}$  be the sequence of vectors associated to  $z \in \mathbf{Sub}_v$ . Then for every  $m \leq n$  we have  $\bar{u}_m = \bar{u}_n \pmod{(p^{m+1}, p^{m+1})}$ . Conversely, for each sequence  $\{\bar{u}_n\}_{n \in \mathbb{N}}$  which satisfies this restriction we can construct a configuration  $\bar{z} \in \mathbf{Sub}_v$  as an accumulation point of  $\sigma^{\bar{u}_n}(\tau)$  which therefore has the property that  $B_n(\bar{z}) = \bar{u}_n + p^n v + p^{n+1}\mathbb{Z}^2$  for all  $n \in \mathbb{N}$ .

**Proposition 3.9.** *Let  $\varphi \in \text{Aut}(\mathbb{Z}^2)$  be represented as  $A_\varphi \in \text{GL}(2, \mathbb{Z})$  and let  $A_{\tilde{\varphi}} \in \mathcal{M}(\mathbb{Z}/p\mathbb{Z}, 2)$  be the matrix obtained by reducing the entries of  $A_\varphi$  modulo  $p$ .  $A_{\tilde{\varphi}}$  defines an automorphism  $\tilde{\varphi} \in \text{Aut}((\mathbb{Z}/p\mathbb{Z})^2)$  by left multiplication. We have that:*

$$\varphi(B_m(z)) = \varphi(\bar{u}_n) + p^m \tilde{\varphi}(v) + p^{m+1}\mathbb{Z}^2.$$

In particular  $\forall z \in \mathbf{Sub}_v$ , then  $z \circ \varphi \in \mathbf{Sub}_{\tilde{\varphi}(v)}$  and  $B_m(z \circ \varphi) = \varphi(B_m(z))$ .

*Proof.* Let  $z \in \mathbf{Sub}_v$  and  $B_m(z)$  as defined above, then, given any  $n \geq m$ :

$$\begin{aligned} \varphi(B_m(z)) &= \varphi(\bar{u}_n + p^m v + p^{m+1}\mathbb{Z}^2) \\ &= \varphi(\bar{u}_n) + p^m A_\varphi v + p^{m+1}\mathbb{Z}^2 \\ &= \varphi(\bar{u}_n) + p^m (A_{\tilde{\varphi}} + p(\frac{A_\varphi - A_{\tilde{\varphi}}}{p}))v + p^{m+1}\mathbb{Z}^2 \\ &= \varphi(\bar{u}_n) + p^m A_{\tilde{\varphi}} v + p^{m+1}((\frac{A_\varphi - A_{\tilde{\varphi}}}{p})v + \mathbb{Z}^2) \\ &= \varphi(\bar{u}_n) + p^m \tilde{\varphi}(v) + p^{m+1}\mathbb{Z}^2 \end{aligned}$$

This means that for fixed  $n \in \mathbb{N}$  all lattices of size  $m \leq n$  are sent to lattices appearing in configurations of  $\mathbf{Sub}_{\tilde{\varphi}(v)}$ . Indeed, as  $\bar{u}_m = \bar{u}_n \pmod{(p^{m+1}, p^{m+1})}$  we have  $\varphi(\bar{u}_m) = \varphi(\bar{u}_n) \pmod{(p^{m+1}, p^{m+1})}$  and therefore the sequence  $\{\varphi(\bar{u}_n)\}_{n \in \mathbb{N}}$  defines a configuration in  $\mathbf{Sub}_{\tilde{\varphi}(v)}$ . Following a compactness argument one concludes that  $z \circ \varphi \in \mathbf{Sub}_{\tilde{\varphi}(v)}$  and  $B_m(z \circ \varphi) = \varphi(B_m(z))$ .  $\square$

The importance of Proposition 3.9 is that it states that any automorphism of  $\mathbb{Z}^2$  correctly maps the lattices  $B_m(z)$  to those of another substitution. We shall use these lattices to encode elements of  $\{0, 1\}^{\mathbb{N}}$  belonging to our  $H$ -dynamical system  $(X, f)$ . In order to do this, we need to define a subshift which matches these lattices to actual values from  $X$  and that also codes the action of  $f$ .

### 3.3.2 Encoding configurations in Toeplitz sequences.

Consider  $p \geq 3, q \in \{1, \dots, p-1\}$  and the encoding  $\Psi_q : \{0, 1\}^{\mathbb{N}} \rightarrow \{0, 1, \$\}^{\mathbb{Z}}$  given by:

$$\Psi_q(x)_j = \begin{cases} x_n & \text{if } j = qp^n \pmod{p^{n+1}} \\ \$ & \text{in the contrary case.} \end{cases}$$

The idea behind this encoding is to match for each  $m \in \mathbb{N}$  the horizontal and vertical projections of the lattice  $B_m(z)$  for some  $z \in \mathbf{Sub}_v$  to the symbol  $x_m$ . We need to do this for every possible choice of  $q$  as the projections of the lattices might differ depending on the substitution. For instance, the horizontal projection associated to  $v = (1, 1)$  is different from the one for  $v = (2, 2)$ . We begin this section by studying the structure of the encoding  $\Psi_q$ .

First notice that  $\Psi_q(x)|_{q+p\mathbb{Z}} \equiv x_0$  and  $\forall q' \in \{1, \dots, p-1\} \setminus \{q\}$  we have that  $\Psi_q(x)_{q'+p\mathbb{Z}} \equiv \$$ . Indeed, as  $q' + pk \not\equiv 0 \pmod{p}$  thus  $q' + pk \not\equiv p^i \pmod{p^{i+1}}$ . Also, if  $i \geq 1$  and  $\Psi_q(x)_j = x_i$  then  $\Psi_q(x)_{j+q} = x_0$  as  $j = p^i \pmod{p^{i+1}} \implies j = 0 \pmod{p}$ . This means that every  $x_0$  is a special coordinate in a string of  $p-1$  symbols where every other symbol is  $\$$  and every  $x_i$  with  $i \geq 1$  is necessarily followed by such string. The important property we derive from these computations is that the lattice of  $x_0$  can be recognized locally. Indeed, each  $x_0$  is preceded by  $q-1$  symbols  $\$$  and followed by  $p-q-1$  symbols  $\$$ . If  $p \geq 3$  and  $q-1 \neq p-q-1$  this is enough to locally recognize the position of the lattice in a string of  $p$  symbols as  $x_0$  is the only lattice satisfying that property. If  $q-1 = p-q-1$  the previous property is now true for any symbol but the decoding can be done in any string of  $2p$  symbols because if  $\Psi_q(x)_j = x_m$  for some  $m > 0$  then  $\Psi_q(x)_{j+p} = \Psi_q(x)_{j-p} = \$$  and any false positive can be detected in a finite window.

For  $x = (x_i)_{i \in \mathbb{N}} \in \{0, 1\}^{\mathbb{N}}$  let  $\sigma(x) \in \{0, 1\}^{\mathbb{N}}$  be defined by  $\sigma(x)_i = x_{i+1}$  (we shall use the same notation as in the case of the group shift action, though in this case it's a one-sided  $\mathbb{N}$ -action). We define also for  $k \in \mathbb{Z}/p\mathbb{Z}$  the transformation  $\Omega_k : \{0, 1, \$\}^{\mathbb{Z}} \rightarrow \{0, 1, \$\}^{\mathbb{Z}}$  by  $(\Omega_k(y))_j = y_{j+p+k}$ . It is straightforward from the definition of  $\Psi_q$  that  $\Omega_0$  transforms the coding of  $x \in \{0, 1\}^{\mathbb{N}}$  into that of its shifted version, that is  $\Omega_0(\Psi_q(x)) = \Psi_q(\sigma(x))$ . Also, one can directly check that  $\Omega_k = \Omega_0 \circ \sigma^{-k}$  and  $\Omega_0 \circ \sigma^{p\ell} = \sigma^\ell \circ \Omega_0$ .

**Proposition 3.10.** *Let  $x \in \{0, 1\}^{\mathbb{N}}$  and  $y \in \overline{\text{Orb}_\sigma(\Psi_q(x))}$ . There exists a unique  $k_0 \in \mathbb{Z}/p\mathbb{Z}$  such that:*

$$\Omega_{k_0}(y) \in \overline{\text{Orb}_\sigma(\Psi_q(\sigma(x)))}.$$

*Proof.* The application  $\Omega_k$  is clearly continuous in the product topology as fixing  $y$  in the interval  $\mathbb{Z} \cap [-lp, lp-1]$  for  $l \geq 1$  necessarily fixes  $\Omega_k(y)$  in the interval  $\mathbb{Z} \cap [-l, l-1]$ .

Let  $y \in \overline{\text{Orb}_\sigma(\Psi_q(x))}$ . As  $\Psi_q(x)|_{q+p\mathbb{Z}} \equiv x_0$  we can deduce by compactness that there exists  $k \in \mathbb{Z}/p\mathbb{Z}$  such that  $y|_{k+p\mathbb{Z}} \equiv x_0$ . Define  $k_0 := k - q \pmod{p}$ . Then for each  $n \in \mathbb{Z}$  we have  $y_{pn+k_0+1}, \dots, y_{k_0+p-1} = \$^{q-1}x_0\$^{p-q-1}$  as words. This necessarily implies that any other choice of  $k_0$  would make  $\Omega_{k_0}(y)$  be a constant configuration

which clearly does not belong to  $\overline{\text{Orb}_\sigma(\Psi_q(\sigma(x)))}$  therefore making the previous choice the only possible one. Consider a sequence  $(\sigma^{n_i}(\Psi_q(x)))_{i \in \mathbb{N}} \rightarrow y$ . Without loss of generality we can ask that  $n_i \in p\mathbb{Z} + k_0$ , if not it suffices to eliminate a finite number of terms. For any  $n_i$  of the form  $p\ell + k_0$  we get that

$$\begin{aligned} \Omega_{k_0}(\sigma^{p\ell+k_0}(\Psi_q(x))) &= \Omega_0 \circ \sigma^{-k_0} \circ \sigma^{k_0} \circ \sigma^{p\ell}(\Psi_q(x)) \\ &= \Omega_0 \circ \sigma^{p\ell}(\Psi_q(x)) \\ &= \sigma^\ell \circ \Omega_0(\Psi_q(x)) \\ &= \sigma^\ell(\Psi_q(\sigma(x))) \in \text{Orb}(\Psi_q(\sigma(x))) \end{aligned}$$

As  $\Omega_k$  is continuous, we obtain that  $\Omega_{k_0}(y) \in \overline{\text{Orb}_\sigma(\Psi_q(\sigma(x)))}$ .  $\square$

*Example 3.4.* For  $p = 3$ ,  $q = 1$  and  $x = x_0x_1x_2\dots$  we obtain that:

$$\begin{aligned} \Psi_q(x)|_{\{0,\dots,30\}} &= \$x_0\$x_1x_0\$\$x_0\$x_2x_0\$x_1x_0\$\$x_0\$\$x_0\$x_1x_0\$\$x_0\$x_3x_0\$x_1 \\ \Omega_0(\Psi_q(x))|_{\{0,\dots,10\}} &= \$x_1\$x_2x_1\$\$x_1\$x_3x_1 = \Psi_q(\sigma(x))|_{\{0,\dots,10\}} \\ \Omega_0^2(\Psi_q(x))|_{\{0,\dots,3\}} &= \$x_2\$x_3 = \Psi_q(\sigma^2(x))|_{\{0,\dots,3\}} \end{aligned}$$

Proposition 3.10 shows explicitly that  $x \in \{0, 1\}^{\mathbb{N}}$  can be decoded not only from  $\Psi_q(x)$  but from any element of the closure of the orbit of  $\Psi_q(x)$  under the shift action. Indeed, given  $y^0 \in \overline{\text{Orb}_\sigma(\Psi_q(x))}$  we find the unique value  $k_0 \in \mathbb{Z}/p\mathbb{Z}$  as above and deduce that  $x_0 = (y^0)_{k_0+q}$ . Next one takes  $y^1 := \Omega_{k_0}(y^0)$  and finds a new value  $k_1$  as before and so  $x_1 = (y^1)_{k_1+q}$ . Iterating this procedure one gets a sequence  $y^i$  such that  $y^i := \Omega_{k_i}(y^{i-1}) \in \overline{\text{Orb}_\sigma(\Psi_q(\sigma^i(x)))}$  and  $x_i = (y^i)_{k_i+q}$ .

**Proposition 3.11.** *Let  $x, x' \in \{0, 1\}^{\mathbb{N}}$ .  $\overline{\text{Orb}_\sigma(\Psi_q(x))} \cap \overline{\text{Orb}_\sigma(\Psi_q(x'))} \neq \emptyset$  if and only if  $x = x'$ .*

*Proof.* Let  $y \in \overline{\text{Orb}_\sigma(\Psi_q(x))} \cap \overline{\text{Orb}_\sigma(\Psi_q(x'))}$ . Using Proposition 3.10 we can find a unique  $k_0 \in \mathbb{Z}/p\mathbb{Z}$  such that  $\Omega_{k_0}(y) \in \overline{\text{Orb}_\sigma(\Psi_q(\sigma(x)))}$  and thus  $x_0 = y_{k_0+q}$ . The same proposition gives  $k'_0 \in \mathbb{Z}/p\mathbb{Z}$  such that  $\Omega_{k'_0}(y) \in \overline{\text{Orb}_\sigma(\Psi_q(\sigma(x'))}$  and so  $x'_0 = y_{k'_0+q}$ . Nevertheless in the proof of Proposition 3.10 we see that any other choice of  $k_0$  would give a constant configuration and therefore  $k_0 = k'_0$ . This implies that  $x_0 = x'_0$  and  $\Omega_{k_0}(y) \in \overline{\text{Orb}_\sigma(\Psi_q(\sigma(x)))} \cap \overline{\text{Orb}_\sigma(\Psi_q(\sigma(x'))}$ . Iterating this argument we obtain that for every  $n \in \mathbb{N}$  then  $x_n = x'_n$  holds and thus  $x = x'$ . The other direction is trivial as  $\Psi_q(x) \in \overline{\text{Orb}_\sigma(\Psi_q(\sigma(x)))} \neq \emptyset$ .  $\square$

Before continuing, we study the structure of the subshift  $\overline{\text{Orb}_\sigma(\Psi_q(x))}$ . Every element here encodes the structure of  $x$  by repeating its  $n$ -th coordinate in gaps of size  $p^{n+1}$ . Therefore, every non  $\$$  element appears periodically with at most one exception – a position obtained by compactness – which we denote by  $x_\infty$ . This point may take any value if both 0 and 1 appear infinitely often in  $x$  but is restricted if  $x$  is eventually constant. This point has its analogue in the configurations  $z \in \text{Sub}_p$ . All



of the  $\blacksquare$  symbols appear in square lattices with the exception of at most one. We call this degenerated lattice  $B_\infty(z)$  and make the remark that  $B_\infty(z)$  might be empty.

Let  $(X, f)$  be an  $H$ -dynamical system and  $p \geq 3$ . We use the encoding  $\Psi_q$  defined above to construct a  $\mathbb{Z}$ -subshift  $\text{Top}(X, f)$  which encodes the configurations of  $X$  and the action of  $f$  around a unit ball in  $H$ . Formally, let  $S \subset H$  be a finite set such that  $1_H \in S$  and  $\langle S \rangle = H$ . We define by  $\Psi(x)$  as the configuration in  $(\{0, 1, \$\}^{\{1, \dots, p-1\} \times S})^{\mathbb{Z}}$  such that  $(\Psi(x)_n)_{(q,s)} = \Psi_q(f_s(x))_n$ .

$\text{Top}(X, f) \subset (\{0, 1, \$\}^{\{1, \dots, p-1\} \times S})^{\mathbb{Z}}$  is the  $\mathbb{Z}$ -subshift given by:

$$\text{Top}(X, f) := \bigcup_{x \in X} \left( \overline{\text{Orb}_\sigma(\Psi(x))} \right)$$

Elements of  $\text{Top}(X, f)$  can be thought of as  $(p-1)|S|$ -tuples of configurations in  $\{0, 1, \$\}^{\mathbb{Z}}$  where the tuple associated to the pair  $(q, s)$  belongs to  $\overline{\text{Orb}_\sigma(\Psi_q(f_s(x)))}$ . Here the shift action is taken diagonally, that is, each configuration is shifted simultaneously. The idea behind this construction is to let each  $q$ -row code an element  $x \in X$  and its image  $f_s(x)$  for each  $s \in S$ . Given  $y \in \text{Top}(X, f)$  we denote the projection to the  $(q, s)$ -th layer by  $\text{Layer}_{q,s}(y) \in \{0, 1, \$\}^{\mathbb{Z}}$ . We need to do this for every possible  $q$  just for technical reasons, as we'll need to match every possible lattice in the substitution defined above.

**Proposition 3.12.** *If  $(X, f)$  is an effectively closed  $H$ -dynamical system then  $\text{Top}(X, f)$  is an effectively closed  $\mathbb{Z}$ -subshift.*

*Proof.*  $\text{Top}(X, f)$  is clearly shift invariant. To see that it is closed consider a sequence of configurations  $\{y_n\}_{n \in \mathbb{N}} \subset \overline{\text{Top}(X, f)}$  converging to  $y$ . By Proposition 3.11 each  $y_n$  belongs to a unique orbit  $\overline{\text{Orb}_\sigma(\Psi(x^n))}$  for  $x^n \in X$  as they are pairwise disjoint. It is also straightforward to see that  $y \in \overline{\text{Orb}_\sigma(\Psi(x))}$  for some  $x \in \{0, 1, \$\}^{\mathbb{N}}$ . It suffices to show that  $x \in X$ . As  $\Omega_k$  is continuous we get that  $\Omega_k(\text{Layer}_{q,s}(y_n)) \rightarrow \Omega_k(\text{Layer}_{q,s}(y))$ . Clearly the sequence of  $k_0$  given by Proposition 3.10 associated to  $y_n$  must stabilize and hence there is  $N \in \mathbb{N}$  such that for every  $n \geq N$  then  $y_n$  belongs to an orbit  $\overline{\text{Orb}_\sigma(\Psi(x^n))}$  where  $(x^n)_0 = x_0 = (\text{Layer}_{q,1_H}(y))_{k_0+q}$ . Iterating this argument we get that for each  $m \in \mathbb{N}$  there exists  $N_m$  such that for every  $n \geq N_m$  then  $(x^n)_i = x_i$  for each  $i \leq m$ . We conclude that  $x^n$  converges to  $x$ . As  $X$  is closed we obtain that  $y \in \text{Top}(X, f)$ .

A set of forbidden patterns defining  $\text{Top}(X, f)$  can be given explicitly. We consider for  $n \in \mathbb{N}$  all words of length  $p^{n+1}$  over the alphabet  $\{ \$, 0, 1 \}^{|S|(p-1)}$  which do not appear in any configuration of  $\text{Top}(X, f)$ . As this is an increasing sequence of forbidden patterns it is enough to define  $\text{Top}(X, f)$ .

This set of forbidden words is recursively enumerable. The following algorithm accepts a set of forbidden patterns defining  $\text{Top}(X, f)$ . Let the input be a word of length  $p^n$  for  $n \in \mathbb{N}$ . The structure of  $\text{Top}(X, f)$  makes it possible to recognize algorithmically all gaps in every layer (formally the algorithm checks that each substring of  $p$  contiguous symbols is a cyclic permutation of  $a\$^{q-1}b\$^{p-q-1}$  for some  $a \in \{0, 1, \$\}$  and  $b \in \{0, 1\}$ ). Then if this stage is passed, it computes  $k_0$  from Proposition 3.10 for each layer, checks that  $b$  is the same symbol throughout the word. Finally it checks

that  $k_0$  is the same in every layer (thus the layers are aligned). Then it applies  $\Omega_{k_0}$  to this string obtaining a word of length  $p^{n-1}$ . The algorithm is repeated until reaching a word of length 0. If at any stage a check fails, the word is accepted as forbidden.

The previous stage recognizes all words that haven't got the correct structure. After that stage ends, we can use the same algorithm and the function  $\Omega_k$  to decode  $n$  coordinates  $x_0 x_1 \dots x_{n-1}$  for each pair  $(q, s)$  and check for every  $s$  that the word is the same independently of  $q$ . If this stage is passed we end up with  $|S|$  words which depend only on  $s$  and we denote them by  $(w_s)_{s \in S}$ . Here we run two recognition algorithms in parallel. One searches for a cylinder  $[w_s] \not\subset X$  and the other searches if  $[w_{1_H}] \not\subset f_s^{-1}([w_s])$ . If any of these two searches succeed at a certain step then the algorithm returns that the pattern is forbidden. These two last algorithms do exist as  $(X, f)$  is an effectively closed  $H$ -dynamical system.  $\square$

The subshift  $\text{Top}(X, f)$  is the ingredient of the proof which allows us to simulate points  $x \in X$  and their images under the generators of  $H$  in a sofic  $\mathbb{Z}^2$ -subshift which contains this information. The next step is to put one of these configurations in each  $\mathbb{Z}^2$ -coset of  $\mathbb{Z}^2 \rtimes_{\varphi} H$  and force by local rules that the shift action by  $(0, h)$  yields the  $\mathbb{Z}^2$ -coset where the point  $f_h(x)$  is codified. The obvious obstruction to this idea is the fact that the action under  $(0, h)$  in a semidirect product disturbs the adjacency relations in a coset if the automorphism  $\varphi_h$  is not trivial. The way to go around this obstruction is to use the lattices given by the layer  $\text{Sub}_v$  which are invariant under automorphisms. We specify how these two elements go together in the next subsection.

### 3.3.3 Proof of Theorem 3.7

Denote  $\varphi : H \rightarrow \text{Aut}(\mathbb{Z}^2)$  a group homomorphism such that  $G = \mathbb{Z}^2 \rtimes_{\varphi} H$  is given by:

$$(n_1, h_1) \cdot (n_2, h_2) = (n_1 + \varphi_{h_1}(n_2), h_1 h_2)$$

Let  $S$  be a finite set of generators of  $H$  where  $1_H \in S$ ,  $|S| = d$  and let's fix the parameter  $p = 3$  which is used to construct  $\text{Top}(X, f)$  (which contains thus  $2d$  layers) and the substitutions  $\text{Sub}_v$  for  $v \in (\mathbb{Z}/3\mathbb{Z})^2 \setminus \{\vec{0}\}$ . Consider the following two  $\mathbb{Z}^2$ -subshifts.

$$\text{Top}(X, f)^H \subseteq (\{0, 1, \$\}^{2d})^{\mathbb{Z}^2}$$

$$\text{Top}(X, f)^V \subseteq (\{0, 1, \$\}^{2d})^{\mathbb{Z}^2}$$

Where  $x \in \text{Top}(X, f)^H$  is the subshift whose projection to  $(\mathbb{Z}, 0)$  belongs to  $\text{Top}(X, f)$  and any vertical strip is constant. Analogously  $x \in \text{Top}(X, f)^V$  is the subshift whose projection to  $(0, \mathbb{Z})$  belongs to  $\text{Top}(X, f)$  and any horizontal strip is constant. Formally:  $x \in \text{Top}(X, f)^H$  if  $\forall i, j \in \mathbb{Z}$  then  $x_{i,j} = x_{i,j+1}$  and  $(x_{(i,0)})_{i \in \mathbb{Z}} \in \text{Top}(X, f)$ . An analogous definition can be given for  $\text{Top}(X, f)^V$ . Proposition 3.12 says that  $\text{Top}(X, f)$  is an effective  $\mathbb{Z}$ -subshift and therefore  $\text{Top}(X, f)^H$  and  $\text{Top}(X, f)^V$  are sofic  $\mathbb{Z}^2$ -subshifts by the simulation theorem proven in [AS13, DRS10]. Next we are

going to put these subshifts together with the substitution layers to create a rich structure in each  $\mathbb{Z}^2$ -coset.

Consider the product subshift  $\text{Top}(X, f)^H \times \text{Top}(X, f)^V \times \bigotimes_{v \in (\mathbb{Z}/3\mathbb{Z})^2 \setminus \{\vec{0}\}} \text{Sub}_v$ . Given a configuration  $y$  in that product we denote by  $\text{Layer}^H(y)$  and  $\text{Layer}^V(y)$  the projections to the horizontal and vertical layer respectively. If we want to precise the tuple we will use the notation  $\text{Layer}_{q,s}^H(y)$  and  $\text{Layer}_{q,s}^V(y)$  respectively. Also, for  $v \in (\mathbb{Z}/3\mathbb{Z})^2 \setminus \{\vec{0}\}$ , we denote by  $\text{Sub}_v(y)$  the projection to the corresponding substitutive layer. We define  $\Pi(X, f) \subset \text{Top}(X, f)^H \times \text{Top}(X, f)^V \times \bigotimes_{v \in (\mathbb{Z}/3\mathbb{Z})^2 \setminus \{\vec{0}\}} \text{Sub}_v$  as the set of configurations  $y$  which satisfy the following rules:

1.  $\forall u \in \mathbb{Z}^2$  and  $(a, b) \in (\mathbb{Z}/3\mathbb{Z})^2 \setminus \{\vec{0}\}$  the following is satisfied. If  $a \neq 0$  then  $(\text{Sub}_{(a,b)}(y))_u = \blacksquare$  if and only if  $(\text{Layer}_{a,1_H}^H(y))_u \in \{0, 1\}$ . Analogously, if  $b \neq 0$  then then  $(\text{Sub}_{(a,b)}(y))_u = \blacksquare$  if and only if  $(\text{Layer}_{b,1_H}^V(y))_u \in \{0, 1\}$ .
2. If  $(\text{Sub}_{(1,1)}(y))_u = \blacksquare$  then  $\forall s \in S$   $(\text{Layer}_{1,s}^H(y))_u = (\text{Layer}_{1,s}^V(y))_u$ .

The  $\mathbb{Z}^2$ -subshift  $\Pi(X, f)$  is sofic. Indeed, all the component are sofic subshifts and the added rules are local (we just forbid symbols in the product alphabet). Recall that we denote by  $B_m(z)$  the  $m$ -th lattice of black squares in a configuration  $z$  in a substitutive layer.

**Claim 4.** *Let  $y \in \Pi(X, f)$ ,  $(a, b) \in (\mathbb{Z}/3\mathbb{Z})^2 \setminus \{\vec{0}\}$  and  $z = \text{Sub}_{(a,b)}(y)$ . Suppose that  $\text{Layer}^H(y)$  is given by  $x \in X$ . Then:*

- If  $a \neq 0$  then  $\forall m \in \mathbb{N}, \forall s \in S$ :  $\text{Layer}_{a,s}^H(y)|_{B_m(z)} \equiv f_s(x)_m$
- If  $b \neq 0$  then  $\forall m \in \mathbb{N}, \forall s \in S$ :  $\text{Layer}_{b,s}^V(y)|_{B_m(z)} \equiv f_s(x)_m$
- The configurations in the layers  $\text{Top}(X, f)^H$  and  $\text{Top}(X, f)^V$  are defined by the same  $x \in X$ .

*Proof.* Let  $a \neq 0$ . It suffices to show this property for  $s = 1_H$  as the definition of  $\text{Top}(X, f)$  forces the configurations to be aligned. The lattice  $B_0(z)$  has the form  $\bar{u}_0 + (a, b) + 3\mathbb{Z}^2$ , therefore its projection in the horizontal coordinate is of the form  $k_0 + 3\mathbb{Z}$ . Using the structure of  $\Psi_a(x)$  there are three possibilities for 3-lattices: One contains uniformly the symbol  $x_0$ , another contains only the symbol  $\$$  and the third one contains  $\Psi_a(\sigma(x))$  by proposition 3.10. The first rule of  $\Pi(X, f)$  rules out the second and third possibility because there would be  $\$$ 's matched with  $\blacksquare$ . Therefore  $\text{Layer}_{a,1_H}^H|_{B_0(z)} \equiv x_0$ . Inductively, let  $B_m(z) = \bar{u}_m + (a, b)3^m + 3^{m+1}\mathbb{Z}^2$  and suppose  $\forall m' < m$   $\text{Layer}_{a,1_H}^H|_{B_{m'}(z)} \equiv x_{m'}$ . Note that for  $m'$  the projection to the horizontal layer is of the form  $k_{m'} + 3^{m'+1}\mathbb{Z}$ . Using iteratively the previous argument and applying the function  $\Omega_{k_{m'}}$  defined in 3.10 we end up with three possibilities for  $3^m$ -lattices (that is, the value of  $k_{m'}$ ), and again the first rule of  $\Pi(X, f)$  rules out two of them, yielding  $\text{Layer}_{a,1_H}^H|_{B_m(z)} \equiv x_m$ .

Suppose the configuration in  $\text{Top}(X, f)^V$  is given by  $x' \in X$ . For  $b$  the proof is analogous and we get that  $b \neq 0$  implies that  $\forall m \in \mathbb{N}, \forall s \in S$ :  $\text{Layer}_{b,s}^V|_{B_m(z)} \equiv f_s(x')_m$ .

Now set  $(a, b) = (1, 1)$ . The second rule of  $\Pi(X, f)$  implies that  $\forall s \in S, m \in \mathbb{N}$  then  $(\mathbf{Layer}_{1,s}^H(y))|_{B_m(z)} = (\mathbf{Layer}_{1,s}^V(y))|_{B_m(z)}$ . Using the previous two properties we conclude that  $\forall s \in S, m \in \mathbb{N}$  we have  $f_s(x)_m = f_s(x')_m$ . Using  $s = 1_H$  yields  $x = x'$  hence proving the second and third statement.  $\square$

From Claim 4 we obtain that each configuration  $y \in \Pi(X, f)$  contains the information of a single  $x \in X$ . We can thus define properly the decoding function  $\Upsilon : \Pi(X, f) \rightarrow X$  such that  $\Upsilon(y) = x$  if and only if  $\forall m \in \mathbb{N} : \mathbf{Layer}_{1,1_H}^H(y)|_{B_m(\text{Sub}_{(1,1)}(y))} \equiv x_m$ .

Consider the set of forbidden patterns  $\mathcal{F}$  defining  $\Pi(X, f)$ . Each of these patterns has a finite support  $F \subset \mathbb{Z}^2$ . We extend those patterns to patterns in  $G = \mathbb{Z}^2 \rtimes_{\varphi} H$  by associating  $d \in F \rightarrow (d, 1_H) \in G$ . Therefore every pattern  $P \in \mathcal{F}$  with support  $F \subset \mathbb{Z}^2$  is embedded into a pattern  $\tilde{p}$  with support  $F \times \{1_H\} \subset G$ . We consider the set  $\tilde{\mathcal{F}} = \{\tilde{p} \mid p \in \mathcal{F}\}$  and we define  $\mathbf{Final}(X, f)$  as the subshift over the same alphabet as  $\Pi(X, f)$  defined by the set of forbidden patterns  $\tilde{\mathcal{F}} \cup \mathcal{G}$  where  $\mathcal{G}$  is defined as follows:

For each  $s \in S$  consider  $\varphi_{s^{-1}}$  the automorphism associated to  $s^{-1}$  and  $(a, b) = \tilde{\varphi}_{s^{-1}}(1, 1)$ . We put in  $\mathcal{G}$  all the patterns  $P$  with support  $\{(\vec{0}, 1_H), (\vec{0}, s^{-1})\}$  which satisfy that  $\mathbf{Sub}_{(a,b)}(P_{(\vec{0}, 1_H)}) = \blacksquare$  but either:

- $\mathbf{Sub}_{(1,1)}(P_{(\vec{0}, s^{-1})}) \neq \blacksquare$  or
- $\mathbf{Sub}_{(1,1)}(P_{(\vec{0}, s^{-1})}) = \blacksquare$  and
  - If  $a \neq 0$  then  $\mathbf{Layer}_{a,s}^H(P_{(\vec{0}, 1_H)}) \neq \mathbf{Layer}_{1,1_H}^H(P_{(\vec{0}, s^{-1})})$  or
  - If  $b \neq 0$  then  $\mathbf{Layer}_{b,s}^V(P_{(\vec{0}, 1_H)}) \neq \mathbf{Layer}_{1,1_H}^V(P_{(\vec{0}, s^{-1})})$ .

In simpler words: we force that every  $\blacksquare$  in layer  $\mathbf{Sub}_{(a,b)}$  of the  $(\mathbb{Z}^2, 1_H)$ -coset must be matched with a  $\blacksquare$  in  $\mathbf{Sub}_{(1,1)}$  in the  $(\mathbb{Z}^2, s^{-1})$ -coset and that if  $a \neq 0$  then the symbol in  $(\vec{0}, 1_H)$  in  $\mathbf{Layer}_{a,s}^H$  is the same as the symbol in  $(\vec{0}, s^{-1})$  in  $\mathbf{Layer}_{1,1_H}^H$ . If  $b \neq 0$  we impose that the symbol in  $(\vec{0}, 1_H)$  in  $\mathbf{Layer}_{b,s}^V$  is the same as the symbol in  $(\vec{0}, s^{-1})$  in  $\mathbf{Layer}_{1,1_H}^V$ .

Before continuing let's translate  $\tilde{\mathcal{F}} \cup \mathcal{G}$  into properties of  $\mathbf{Final}(X, f)$ . In order to do that properly, for  $y \in \mathbf{Final}(X, f)$  we denote by  $\pi(y)$  the  $\mathbb{Z}^2$ -configuration such that  $\forall u \in \mathbb{Z}^2 \pi(y)_u = y_{(u, 1_H)}$ .

**Claim 5.**  *$\mathbf{Final}(X, f)$  satisfies the following properties:*

- $\mathbf{Final}(X, f)$  is a sofic  $G$ -subshift.
- Let  $y \in \mathbf{Final}(X, f)$ . Then  $\pi(y) \in \Pi(X, f)$ .
- If  $\Upsilon(\pi(y)) = x$  then  $\forall h \in H, \Upsilon(\pi(\sigma^{(\vec{0}, h)}(y))) = f_h(x)$ .

*Proof.* As  $\Pi(X, f)$  is sofic, it admits an SFT extension  $\phi : \widehat{\Pi}(X, f) \twoheadrightarrow \Pi(X, f)$ . By embedding as above a finite list of forbidden patterns defining  $\widehat{\Pi}(X, f)$  into  $G$

we obtain a  $G$ -SFT extension of  $X_{\tilde{f}}$ . Adding to this list of forbidden patterns the pullback of the finite list of forbidden patterns  $\mathcal{G}$  under the local code  $\Phi$  defining  $\phi$  we obtain an SFT extension  $\widehat{\mathbf{Final}}(X, f)$  of  $\mathbf{Final}(X, f)$ .

The second property comes directly from the definition of  $\mathbf{Final}(X, f)$  as it contains an embedding of every forbidden pattern defining  $\Pi(X, f)$ . Note that it may happen that  $y|_{(\mathbb{Z}^2, h)}$  seen as a  $\mathbb{Z}^2$ -configuration does not belong to  $\Pi(X, f)$  for some  $h \in H$ , but  $\pi(\sigma^{\vec{0}, h}(y))$  always does.

Let's prove the third property: We claim that it suffices to prove the property for  $s \in S$ . Indeed, given  $h \in H$ , as  $H = \langle S \rangle$  there exists a minimal length word representing  $h$ . If  $h = 1_H$  the result is immediate. If not, then  $h = sh'$  for some  $h' \in H$  having a shorter word representation. Suppose this third property holds for all words of strictly smaller length and define  $y' = \sigma^{\vec{0}, h'}(y)$ . We have that  $\Upsilon(\pi(y')) = f_{h'}(x) = x'$ , so:

$$\Upsilon(\pi(\sigma^{\vec{0}, h}(y))) = \Upsilon(\pi(\sigma^{\vec{0}, s}(y'))) = f_s(x') = f_s(f_{h'}(x)) = f_h(x).$$

It suffices therefore to prove the property for  $s \in S$ . Let's denote  $y' = \sigma^{\vec{0}, s}(y)$  and let  $\Upsilon(\pi(y)) = x$  and  $\Upsilon(\pi(y')) = x'$ . We want to prove that  $x' = f_s(x)$ . Let  $\tilde{\varphi}_{s^{-1}}(1, 1) = (a, b)$  and suppose that  $a \neq 0$  (if  $a = 0$  then  $b \neq 0$  and the argument is analogous). Let  $m \in \mathbb{N}$ , using Claim 4 we obtain

$$\begin{aligned} \mathbf{Layer}_{1, 1_H}^H(y')|_{(B_m(\mathbf{Sub}_{(1,1)}(y')), 1_H)} &\equiv x'_m \\ \mathbf{Layer}_{a, s}^H(y)|_{(B_m(\mathbf{Sub}_{(a,b)}(y)), 1_H)} &\equiv f_s(x)_m. \end{aligned}$$

Using the forbidden patterns  $\mathcal{G}$  results in

$$\begin{aligned} \mathbf{Sub}_{(1,1)}(y)|_{(B_m(\mathbf{Sub}_{(a,b)}(y)), s^{-1})} &\equiv \blacksquare \\ \mathbf{Layer}_{1, 1_H}^H(y)|_{(B_m(\mathbf{Sub}_{(a,b)}(y)), s^{-1})} &\equiv f_s(x)_m. \end{aligned}$$

Finally, developing the action on  $y'$  yields

$$\begin{aligned} y'|_{(B_m(\mathbf{Sub}_{(1,1)}(y')), 1_H)} &= \sigma^{\vec{0}, s}(y)|_{(B_m(\mathbf{Sub}_{(1,1)}(y')), 1_H)} \\ &= y|_{(\vec{0}, s^{-1})(B_m(\mathbf{Sub}_{(1,1)}(y')), 1_H)} \\ &= y|_{(\varphi_{s^{-1}}(B_m(\mathbf{Sub}_{(1,1)}(y))), s^{-1})}. \end{aligned}$$

Using Proposition 3.9 we obtain that:

$$\varphi_{s^{-1}}(B_m(\mathbf{Sub}_{(1,1)}(y'))) = B_m(\mathbf{Sub}_{(1,1)}(y')) \circ \varphi_{s^{-1}} \text{ and } \mathbf{Sub}_{(1,1)}(y') \circ \varphi_{s^{-1}} \in \mathbf{Sub}_{(a,b)}.$$

As we also have  $\forall m \in \mathbb{N}$  that:

$$\mathbf{Sub}_{(1,1)}(y')|_{(B_m(\mathbf{Sub}_{(1,1)}(y')), 1_H)} \equiv \blacksquare \text{ and } \mathbf{Sub}_{(1,1)}(y)|_{(B_m(\mathbf{Sub}_{(a,b)}(y)), s^{-1})} \equiv \blacksquare$$

we conclude that  $\varphi_{s^{-1}}(B_m(\mathbf{Sub}_{(1,1)}(y'))) = B_m(\mathbf{Sub}_{(a,b)}(y))$ . Therefore,

$$\mathbf{Layer}_{1, 1_H}^H(y')|_{(B_m(\mathbf{Sub}_{(1,1)}(y')), 1_H)} = \mathbf{Layer}_{1, 1_H}^H(y)|_{(B_m(\mathbf{Sub}_{(a,b)}(y)), s^{-1})}.$$

Which yields  $x'_m = f_s(x)_m$ . As  $m \in \mathbb{N}$  is arbitrary  $x' = f_s(x)$ .  $\square$

Finally we are ready to finish the proof. Consider again the SFT extension  $\widehat{\mathbf{Final}}(X, f)$  of  $\mathbf{Final}(X, f)$ , the factor map  $\phi : \widehat{\mathbf{Final}}(X, f) \twoheadrightarrow \mathbf{Final}(X, f)$  and the subaction  $(\widehat{\mathbf{Final}}(X, f), \sigma^H)$ .

**Proposition 3.13.**  $\Upsilon \circ \pi \circ \phi$  is a factor map from  $(\widehat{\mathbf{Final}}(X, f), \sigma^H)$  to  $(X, f)$ .

*Proof.* As  $\phi : \widehat{\mathbf{Final}}(X, f) \twoheadrightarrow \mathbf{Final}(X, f)$  it suffices to show that  $\Upsilon \circ \pi$  is a factor map from  $(\mathbf{Final}(X, f), \sigma^H)$  to  $(X, f)$ . Let  $y \in \mathbf{Final}(X, f)$ . Following Claim 5 we have  $\pi(y) \in \Pi(X, f)$  and thus  $\Upsilon(\pi(y)) \in X$ . Moreover, setting  $\Upsilon(\pi(y)) = x$  yields  $\forall h \in H$  that  $\Upsilon(\sigma^{(\vec{0}, h)}(y)) = f_h(x)$ . This implies

$$\forall h \in H : (\Upsilon \circ \pi) \circ \sigma^{(\vec{0}, h)} = f_h \circ (\Upsilon \circ \pi).$$

Also, both  $\Upsilon$  and  $\pi$  are clearly continuous, therefore, it only remains to show that  $\Upsilon \circ \pi$  is surjective. Let  $x \in X$ , we construct a configuration  $\hat{y} \in \mathbf{Final}(X, f)$  such that  $\Upsilon(\pi(\hat{y})) = x$ .

In order to do this, we begin by constructing a sequence of configurations  $(y^h)_{h \in H}$  which belong to  $\Pi(X, f)$ . For  $(a, b) \in (\mathbb{Z}/3\mathbb{Z})^2 \setminus \{\vec{0}\}$  let  $z_{(a,b)} \in \mathbf{Sub}_{(a,b)}$  be the Toeplitz configuration defined in Proposition 3.8 part (4). The configuration  $z_{(a,b)}$  satisfies  $B_m(z_{(a,b)}) = (a, b)3^m + 3^{m+1}\mathbb{Z}^2$  for  $m \in \mathbb{N}$  and  $B_\infty(z_{(a,b)}) = \emptyset$ . We define  $y^h \in \Pi(X, f)$  by specifying the configuration in each layer. For a substitutive layer we have  $\mathbf{Sub}_{(a,b)}(y^h) = z_{(a,b)}$  and for the Toeplitz layers we have that  $\forall u = (u_1, u_2) \in \mathbb{Z}^2$ ,  $s \in S$ ,  $a, b \in \{1, 2\}$  then  $\mathbf{Layer}_{a,s}^H(y^h)_u = \Psi_a(f_s(f_h(x)))_{u_1}$  and  $\mathbf{Layer}_{b,s}^V(y^h)_u = \Psi_b(f_s(f_h(x)))_{u_2}$ . It can easily be verified that for each  $h \in H$  the configuration  $y^h \in \Pi(X, f)$ .

Finally, we define  $\hat{y}$  as follows:

$$\hat{y}_{(u,h)} = (y^{h^{-1}})_{\varphi_{h^{-1}}(u)}.$$

As  $\varphi_{1_H}u = u$  then  $\pi(\hat{y}) = y^{1_H}$  and thus  $\Upsilon(\pi(\hat{y})) = f_{1_H}(x) = x$ . It suffices to show that  $\hat{y} \in \mathbf{Final}(X, f)$ . This comes down to showing that no patterns in  $\mathcal{F}$  or  $\mathcal{G}$  appear in  $\hat{y}$ . Suppose a pattern  $P \in \mathcal{F}$  appears at position  $g = (u, h)$ , that is  $\hat{y} \in [P]_g \iff \sigma^{g^{-1}}(\hat{y}) \in [P]_{1_G}$ . As  $P$  has a support contained in  $(\mathbb{Z}^2, 1_H)$  then  $\pi(\sigma^{g^{-1}}(\hat{y})) \notin \Pi(X, f)$ . Nonetheless:

$$\begin{aligned} \sigma^{g^{-1}}(\hat{y})_{(u', 1_H)} &= \hat{y}_{(u,h)(u', 1_H)} \\ &= \hat{y}_{(u+\varphi_h(u'), h)} \\ &= (y^{h^{-1}})_{u'+\varphi_{h^{-1}}(u)} \\ &= (\sigma^{-\varphi_{h^{-1}}(u)}(y^{h^{-1}}))_{u'}. \end{aligned}$$

Therefore  $\pi(\sigma^{g^{-1}}(\hat{y})) = \sigma^{-\varphi_{h^{-1}}(u)}(y^{h^{-1}}) \in \Pi(X, f)$  which is a contradiction. Hence  $\hat{y}$  does not contain any pattern from  $\mathcal{F}$ . It remains to show it contains no patterns in  $\mathcal{G}$ . Recall that patterns  $P \in \mathcal{G}$  have support  $\{(\vec{0}, 1_H), (\vec{0}, s^{-1})\}$  for  $s \in S$ . Let

$g = (u, h)$  such that  $\sigma^{g^{-1}}(\hat{y}) \in [P]_{1_G}$ . Then  $\sigma^{g^{-1}}(\hat{y})_{(\vec{0}, 1_H)} = (\sigma^{-\varphi_{h^{-1}}(u)}(y^{h^{-1}}))_{\vec{0}}$  and

$$\begin{aligned}\sigma^{g^{-1}}(\hat{y})_{(\vec{0}, s^{-1})} &= \hat{y}_{(u, h)}_{(\vec{0}, s^{-1})} \\ &= \hat{y}_{(u, hs^{-1})} \\ &= (y^{sh^{-1}})_{\varphi_{(sh^{-1})}u} \\ &= (\sigma^{-(\varphi_{(sh^{-1})}u)}(y^{sh^{-1}}))_{\vec{0}}.\end{aligned}$$

Let  $m \in \mathbb{N}$  and denote  $(a, b) = \tilde{\varphi}_{s^{-1}}(1, 1)$ . By definition  $B_m(\text{Sub}_{(a,b)}(y^{h^{-1}})) = (a, b)3^m + 3^{m+1}\mathbb{Z}^2$  therefore,

$$B_m(\text{Sub}_{(a,b)}(\sigma^{-\varphi_{h^{-1}}(u)}(y^{h^{-1}}))) = (a, b)3^m - \varphi_{h^{-1}}(u) + 3^{m+1}\mathbb{Z}^2$$

In the other hand,

$$B_m(\text{Sub}_{(1,1)}(\sigma^{-\varphi_{(sh^{-1})}u}(y^{sh^{-1}}))) = (1, 1)3^m - \varphi_{(sh^{-1})}u + 3^{m+1}\mathbb{Z}^2.$$

So, if  $\text{Sub}_{(a,b)}(\sigma^{g^{-1}}(\hat{y}))_{(\vec{0}, 1_H)} = \blacksquare$  then  $\vec{0} \in (a, b)3^m - \varphi_{h^{-1}}(u) + 3^{m+1}\mathbb{Z}^2$  for some  $m \in \mathbb{N}$ . Applying  $\varphi_s$  at both sides we obtain:

$$\begin{aligned}\varphi_s(\vec{0}) = \vec{0} &\in \varphi_s(a, b)3^m - \varphi_{(sh^{-1})}u + 3^{m+1}\mathbb{Z}^2 \\ &= \tilde{\varphi}_s(a, b)3^m - \varphi_{(sh^{-1})}u + 3^{m+1}\mathbb{Z}^2 \\ &= (1, 1)3^m - \varphi_{(sh^{-1})}u + 3^{m+1}\mathbb{Z}^2 \\ &= B_m(\text{Sub}_{(1,1)}(\sigma^{-\varphi_{(sh^{-1})}u}(y^{sh^{-1}}))).\end{aligned}$$

Implying that  $\text{Sub}_{(1,1)}(\sigma^{g^{-1}}(\hat{y}))_{(\vec{0}, s^{-1})} = \blacksquare$ . Moreover, if either  $a$  or  $b$  is non-zero (here we treat only the  $a \neq 0$  case as the  $b \neq 0$  case is analogous), then, using the previous computation we get:

$$\text{Layer}_{a,s}^H(\sigma^{g^{-1}}(\hat{y}))_{(\vec{0}, 1_H)} = f_s(f_{h^{-1}}(x))_m$$

$$\text{Layer}_{1,1_H}^H(\sigma^{g^{-1}}(\hat{y}))_{(\vec{0}, s^{-1})} = f_{sh^{-1}}(x)_m.$$

So no patterns from  $\mathcal{G}$  appear, yielding  $\hat{y} \in \text{Final}(X, f)$ .  $\square$

Proposition 3.13 concludes the proof of Theorem 3.7.

## 3.4 Consequences and remarks

In this last section some consequences of the simulation theorem are studied. The first one is in the case of expansive actions. Here we show that we can replace the subaction by the projective subdynamics and obtain the same result. The second consequence is an application of Theorem 3.7 to produce non-empty strongly aperiodic subshifts of finite type in a class of groups where this was previously unknown. We also extend

a Theorem of Jeandel [Jea15] to the existence of effectively closed strongly aperiodic dynamical systems in general.

We close this section by remarking that the technique used to prove Theorem 3.7 is valid in an even larger class (namely, simulation in  $\mathbb{Z}^d \rtimes G$ ) and with a discussion on the size of the extension. Indeed, in Hochman's article [Hoc09] the subaction is shown to be an almost trivial isometric extension. We dedicate the last part of this section to informally discuss the size of the factor in our construction and how a similar result could be obtained.

### 3.4.1 The simulation theorem for expansive effective dynamical systems

We begin by showing the following proposition which extends Proposition 3.14 to symbolic factors of dynamical systems.

**Proposition 3.14.** *For every finitely generated group, any  $G$ -subshift which is the factor of an effectively closed  $G$ -dynamical system is itself effectively closed.*

*Proof.* Let  $G$  be generated by the finite symmetric set  $S \subset G$ ,  $(X, f)$  an effectively closed  $G$ -dynamical system over a Cantor set,  $(Y, \sigma)$  a  $G$ -subshift and  $\phi : (X, f) \rightarrow (Y, \sigma)$  a factor.

Recall that  $X \subset \{0, 1\}^{\mathbb{N}}$  and  $Y \subset \mathcal{A}^G$  for some finite  $\mathcal{A}$ . As both  $X$  and  $Y$  are compact,  $\phi$  is uniformly continuous. Therefore for each  $a \in \mathcal{A}$  then  $\phi^{-1}([a]) = W_a$  where  $W_a$  is a clopen set depending on a finite number of coordinates. For any pattern coding  $c$  and  $v \in S^*$ :

$$\phi^{-1} \left( \bigcap_{(w,a) \in c} [a]_{vw} \right) = \bigcap_{(w,a) \in c} \phi^{-1}(\sigma^{vw}([a])) = \bigcap_{(w,a) \in c} f_{vw}(\phi^{-1}([a]))$$

Therefore,

$$Y \cap \bigcap_{(w,a) \in c} [a]_{vw} = \emptyset \implies X \cap \bigcap_{(w,a) \in c} f_{vw}(W_a) = \emptyset.$$

As  $(X, f)$  is effectively closed, there is a Turing machine which can approximate the set  $\bigcap_{(w,a) \in c} f_{vw}(W_a)$  as each  $W_a$  is just a finite union of a finite intersection of cylinders and  $vw \in S^*$ . Also, for each partial approximation we can enumerate the cylinders which approximate the complement of  $X$  to recognize if the intersection is empty, namely, to check if  $f_{vw}(W_a)$  is contained in the complement. Using these tools we can construct a Turing machine recognizing a maximal set of forbidden pattern codings defining  $Y$ .  $\square$

**Theorem 3.15** (B, Sablik). *Let  $H$  be a finitely generated group and  $(X, f)$  an effectively closed expansive  $H$ -dynamical system over a Cantor set. Then there exists a  $(\mathbb{Z}^2 \rtimes H)$ -sofic subshift  $Y$  such that its  $H$ -projective subdynamics  $\pi_H(Y)$  is conjugated to  $(X, f)$ .*



*Proof.* Consider first  $(X, f)$  an effectively closed expansive  $H$ -dynamical system over a Cantor set. By Theorem 3.7 there exists an  $(\mathbb{Z}^2 \rtimes H)$ -SFT  $\hat{X}$  such that its  $H$ -subaction  $(\hat{X}, \sigma^H)$  is an extension of  $(X, f)$ . Denote the factor map by  $\phi : (\hat{X}, \sigma^H) \rightarrow (X, f)$ . Let  $C > 0$  be the expansivity constant of  $(X, f)$ . As  $X$  is a Cantor set one can choose a clopen partition  $\mathcal{P} = \{P_1, \dots, P_n\}$  such that every  $P_i \in \mathcal{P}$  satisfies  $\text{diam}(P_i) < C$ . Given  $x \neq y \in X$  the expansivity implies the existence of  $h \in H$  such that  $d(f_h(x), f_h(y)) \geq C$ . Therefore the refinement  $f_h(\mathcal{P}) \vee \mathcal{P}$  separates  $x$  and  $y$ . This means that  $\mathcal{P}$  is a generating partition.

Let  $X_i = \phi^{-1}(P_i)$  and the continuous shift-commuting map  $\hat{\phi} : \hat{X} \rightarrow \{1, \dots, n\}^{\mathbb{Z}^2 \rtimes H}$  where  $\hat{\phi}(\hat{x})_{(u,h)} = i \iff \sigma^{(u,h)}(\hat{x}) \in X_i$ . By definition  $Y := \hat{\phi}(\hat{X})$  is a sofic  $(\mathbb{Z}^2 \rtimes H)$ -subshift. We claim its projective subdynamics  $(\pi_H(Y), \sigma)$  are conjugate to  $(X, f)$ . To see this define  $\tilde{\phi} : X \rightarrow \{1, \dots, n\}^H$  such that  $\tilde{\phi}(x)_h = i \iff x \in f_h(P_i)$ . Obviously  $\tilde{\phi}$  is continuous and as  $\mathcal{P}$  is generating, we have that  $\tilde{\phi}$  is injective. It is also clear by definition that  $\tilde{\phi}(X) = \pi_H(Y)$  and that  $\tilde{\phi} \circ f_h = \sigma^h \circ \tilde{\phi}$ . Therefore  $(X, f)$  is conjugate to  $(\pi_H(Y), \sigma)$ .  $\square$

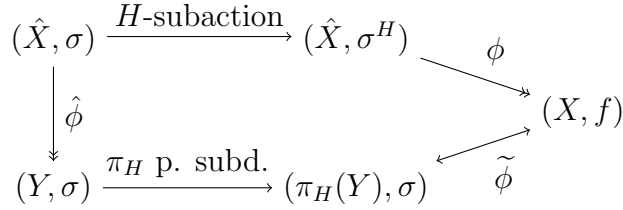

Figure 3.4: The diagram for the proof of Theorem 3.15.

**Theorem 3.16** (B, Sablik). *Let  $H$  be a finitely generated and recursively presented group. For every effectively closed  $H$ -subshift  $Z$  there exists a sofic  $(\mathbb{Z}^2 \rtimes H)$ -subshift  $Y$  such that its  $H$ -projective subdynamics  $\pi_H(Y)$  is  $Z$ .*

*Proof.* Let  $S \subset H$  is a finite set such that  $\langle S \rangle = H$ . Consider a recursive bijection  $\varphi : \mathbb{N} \rightarrow S^*$  where  $S^*$  is the set of all words on  $S$ . As  $H$  is recursively presented, then its word problem  $\text{WP}(H) = \{w \in S^* \mid w = 1_H\}$  is recursively enumerable and there is a Turing machine  $T$  which accepts a pair  $(n, n') \in \mathbb{N}^2$  if and only if  $\varphi(n) = \varphi(n')$  as elements of  $H$ .

For simplicity, we suppose  $Z \subset \{0, 1\}^G$ . Consider the map  $\rho : Z \rightarrow \{0, 1\}^{\mathbb{N}}$  where  $\rho(z)_n = z_{\varphi(n)}$  where  $\varphi(n) \in S^*$  is identified as an element of  $H$ . Consider the set  $\Omega = \rho(Z)$  and the  $H$ -action  $f : H \times \Omega \rightarrow \Omega$  defined as  $f_h(\rho(z)) = \rho(\sigma^h(z))$ . Clearly  $\rho$  is a conjugacy between  $(Z, \sigma)$  and  $(\Omega, f)$ . We claim that  $(\Omega, f)$  is an effectively closed  $H$ -dynamical system.

Indeed, let  $w \in \{0, 1\}^{\mathbb{N}}$ . A Turing machine which accepts  $w$  if and only if  $[w] \in \{0, 1\}^{\mathbb{N}} \setminus \Omega$  is given by the following scheme: for each pair  $(n, n')$  in the support of  $w$  run  $T$  in parallel. if  $T$  accepts for a pair such that  $w_n \neq w_{n'}$  then accept  $w$  (this means that  $w$  did not codify a configuration in  $\mathcal{A}^{\mathbb{Z}}$  as two words codifying different group elements have different symbols). Also, in parallel, use the algorithm recognizing a

maximal set of forbidden patterns for  $Z$  over the pattern coding  $c_w = (\varphi(n), w_n)_{n \leq |w|}$ . This eliminates all  $w$  which codify configurations containing forbidden patterns in  $Z$ . For  $f_s^{-1}[w]$  just note that the application  $n \rightarrow \varphi(s^{-1}\varphi^{-1}(n))$  is recursive, thus  $f_s^{-1}[w]$  can be calculated.

It suffices to apply Theorem 3.15 to  $(\Omega, f)$  to obtain a sofic  $(\mathbb{Z}^2 \rtimes H)$ -subshift  $Y$  such that  $(\pi_H(Y), \sigma)$  is conjugate to  $(Z, \sigma)$ . One can then extend this conjugacy to act over  $Y$  in such a way to obtain a factor  $\hat{Y}$  of  $Y$  such that  $\pi_H(\hat{Y}) = Z$ .  $\square$

In the case of a bigger alphabet  $\mathcal{A}$ , we can code each  $a \in \mathcal{A}$  as a word in  $\{0, 1\}^k$  and redefine  $\rho$  such that for  $z \in Z$  then  $\rho(z)_n = (z_{\varphi(\lfloor n/k \rfloor)})_{n \bmod k}$ . This construction also defines a conjugated system  $(\Omega, f)$  which is effectively closed.

We can describe this symbolic factor map in a simple way. Consider first the case where the alphabet is  $\{0, 1\}$ . An explicit way to describe it is to force the recursive bijection  $\varphi$  described above to satisfy  $\varphi(0)$  to be the empty word coding  $1_H$  and notice that in the sofic subshift  $\mathbf{Final}(\Omega, f')$  the symbol  $z_{1_H}$  is therefore coded in the lattice containing  $x_0$  in each  $\mathbb{Z}^2$ -coset. It suffices to use a big enough factor to recognize the first lattice in a Toeplitz layer and project to the value  $x_0$  everywhere. In the case of a finite alphabet which is coded as words in  $\{0, 1\}^k$  it suffices to recognize the first  $k$  lattices and project the symbol they code.

### 3.4.2 Existence of strongly aperiodic SFT in a class of groups obtained by semidirect products

Next we show how these previous theorems can be applied to produce strongly aperiodic subshifts of finite type. Recall that a  $G$ -subshift  $(X, \sigma)$  is *strongly aperiodic* if the shift action is free, that is, for every  $x \in X$ ,  $\sigma^g(x) = x$  implies that  $g = 1_G$ .

**Theorem 3.17** (B, Sablik). *Let  $H$  be a finitely generated group and  $(X, f)$  a non-empty effectively closed  $H$ -dynamical system which is free. Then  $G \cong \mathbb{Z}^2 \rtimes H$  admits a non-empty strongly aperiodic SFT.*

*Proof.* We begin by recalling the following general property of factor maps. Suppose there is a factor  $\phi : (X, f) \rightarrow (Y, f')$ , and let  $x \in X$  such that  $f_g(x) = x$ . Then  $f'_g(\phi(x)) = \phi(f_g(x)) = \phi(x) \in Y$ . This means that if  $f'$  is a free action then  $f$  is also a free action.

By Theorem 3.7 we can construct the  $(\mathbb{Z}^2 \rtimes H)$ -SFT  $\widehat{\mathbf{Final}}(X, f)$  such that  $(\widehat{\mathbf{Final}}(X, f), \sigma^H)$  is an extension of  $(X, f)$  via the factor  $\phi_1 = \Upsilon \circ \pi \circ \phi$ . We also consider the factor  $\phi_2 = \mathbf{Sub}_{(1,1)} \circ \phi$  which sends  $\widehat{\mathbf{Final}}(X, f)$  first to  $\mathbf{Final}(X, f)$  and then to its  $\mathbf{Sub}_{(1,1)}$  layer.

Let  $y \in \widehat{\mathbf{Final}}(X, f)$  and  $(z, h) \in \mathbb{Z}^2 \rtimes H$  such that  $\sigma^{(z,h)}(y) = y$ . This implies that  $\phi_2(y) = \sigma^{(z,h)}(\phi_2(y)) = \sigma^{(z,1_H)}(\sigma^{(0,h)}(\phi_2(y)))$ . As we have seen in the proof of Theorem 3.7, the action  $\sigma^{(0,h)}$  leaves the lattices  $(B_m)_{m \in \mathbb{N}}$  of  $\mathbf{Sub}_{(1,1)}$  invariant in the  $(\mathbb{Z}^2, 1_H)$ -coset. Let  $M > \|z\|^2$ . Then  $\sigma^{(z,0)}$  does not leave invariant the lattice  $B_M$ . This implies that  $z = \vec{0}$ . Therefore,  $\sigma^{(\vec{0},h)}(y) = y$ . Applying  $\phi_1$  we obtain that  $f_h(y) = y$ , and thus  $h = 1_H$ . Therefore  $(z, h) = (\vec{0}, 1_H)$  and  $\widehat{\mathbf{Final}}(X, f)$  is strongly aperiodic. It is non-empty as  $X \neq \emptyset$ .  $\square$

In the case where  $H$  has decidable word problem, the coding of Theorem 3.16 can be applied to the subshift from Theorem 2.6 to obtain a free non-empty effectively closed  $H$ -dynamical system  $(\Omega, f')$ . Applying Theorem 3.17 to  $H$  and  $(\Omega, f')$  allows us to state the following corollary.

**Corollary 3.18.** *Let  $H$  be a finitely generated group with decidable word problem, then  $\mathbb{Z}^2 \rtimes H$  admits a non-empty strongly aperiodic SFT.*

We remark that this corollary is an alternative proof to a construction done by Ugarcovici, Sahin and Schraudner [Sah14] showing that the discrete Heisenberg group  $\mathcal{H}$  admits non-empty strongly aperiodic SFTs. This falls directly from our theorem as  $\mathcal{H} \cong \mathbb{Z}^2 \rtimes_{\varphi} \mathbb{Z}$  for  $\varphi(1) = \begin{pmatrix} 1 & 1 \\ 0 & 1 \end{pmatrix}$ . In their proof they use a similar trick using as a base the Robinson tiling [Rob71]. They use the lattices of crosses in this object to match the different  $(\mathbb{Z}^2, 0)$ -cosets correctly to force a trivial action in the  $\mathbb{Z}$  direction and use a counter machine to create aperiodicity in the other direction. In our construction the Robinson tiling got replaced by the substitutive subshifts  $\mathbf{Sub}_{(a,b)}$  which are able to match correctly the cosets of any possible automorphism and the counter machine by the simulation of the free  $H$ -dynamical system. Although our construction is more general, theirs has the advantage that the size of the alphabet is certainly smaller and easier to compute.

We also bring to attention the fact that that Corollary 3.18 answers some open questions in their talk. The same property holds for the Flip, Sol groups and the powers of the Heisenberg group, since they can be represented as  $\mathbb{Z}^2 \rtimes_{\varphi} \mathbb{Z}$  for  $\varphi$  given by the matrices  $\begin{pmatrix} 0 & 1 \\ 1 & 0 \end{pmatrix}$ ,  $\begin{pmatrix} 1 & 1 \\ 1 & 0 \end{pmatrix}$  and  $\begin{pmatrix} 1 & n \\ 0 & 1 \end{pmatrix}$  respectively. The only case in their list which is not solved is a two-dimensional Baumslag Solitar group which we do not know how to express as a semidirect product.

Theorem 2.8 says that for recursively presented groups  $G$ , the existence of a non-empty strongly aperiodic effectively closed subshift  $X \subset \mathcal{A}^G$  implies that the word problem of  $G$  is decidable. We can extend this to the case of arbitrary dynamical systems. This gives a deep relation between computability and dynamical properties.

**Corollary 3.19.** *Let  $H$  be a recursively presented and finitely generated group. There exists a free effectively closed  $H$ -dynamical system if and only if the word problem of  $H$  is decidable.*

*Proof.* If the word problem of  $H$  is decidable, we can use the effectively closed subshift constructed in Theorem 2.6 as an example. Conversely, Jeandel's result implies that if a recursively presented group admits a non-empty effectively closed and strongly aperiodic subshift then it's word problem is decidable. Using Theorem 3.17 we can construct a strongly aperiodic subshift from any free effectively closed  $H$ -dynamical system. Therefore the word problem of  $H$  is decidable.  $\square$

### 3.4.3 A generalization and comments on the size of the extension

In this last portion we want to make explicit that the technique used in the proof of Theorem 3.7 can be easily be generalized to the following context

**Theorem 3.20** (B, Sablik). *Let  $H$  be finitely generated group,  $d \geq 2$  and  $G = \mathbb{Z}^d \rtimes H$ . For every  $H$ -effectively closed dynamical system  $(X, f)$  there exists a  $G$ -SFT whose  $H$ -subaction is an extension of  $(X, f)$ .*

Indeed, instead of considering vectors in  $(\mathbb{Z}/3\mathbb{Z})^2 \setminus \{\vec{0}\}$  we use  $v \in (\mathbb{Z}/3\mathbb{Z})^d \setminus \{\vec{0}\}$  and  $d$ -dimensional substitutions  $\mathbf{s}_v$  defined analogously. The subshifts generated by these substitutions carry  $\mathbb{Z}^d$ -lattices and the configurations  $z \in \mathbf{Sub}_v$  can be described in the same way as before by lattices  $B_m(z)$ . The Toeplitz construction  $\mathbf{Top}(X, f)$  remains the same but instead of just constructing  $\mathbf{Top}(X, f)^H$  and  $\mathbf{Top}(X, f)^V$  we construct  $\mathbf{Top}(X, f)^{e_i}$  for every canonical vector  $\{e_i\}_{i \leq d}$  where the  $\langle e_i \rangle$ -projective subdynamics yields  $\mathbf{Top}(X, f)$  and the configurations are extended periodically everywhere else. The rest of the construction translates directly to this setting.

We also want to remark the following: Hochman's theorem (Theorem 3.3) gives further information about the extension in dynamical terms. It is an almost trivial isometric extension (ATIE). In our construction the only obstruction towards obtaining an ATIE is the use of the simulation theorem of effectively closed  $\mathbb{Z}$ -subshifts as projective subactions of sofic  $\mathbb{Z}^2$ -subshifts. This theorem in its current state does not yield an almost everywhere 1-1 extension. The rest of the proof can be adapted to obtain an ATIE, for instance, the substitutive layers can be coupled in a single substitution to avoid the degree of freedom when either  $a$  or  $b$  are zero. Furthermore, the substitutive layers and the Toeplitz structure can be factorized in the isometric action as they are invariant under the  $H$ -subaction. Therefore, the maps  $\Upsilon \circ \pi$  do not pose obstructions to obtaining an ATIE. All that remains to study is the factor  $\phi : \widehat{\mathbf{Final}}(X, f) \rightarrow \mathbf{Final}(X, f)$ . Here the substitutive layers do not present a problem as they come from a primitive substitution with unique derivation and thus Mozes's theorem [Moz89] gives the almost 1-1 SFT extension. The only thing that might pose difficulties is the aforementioned almost 1-1 SFT extension for  $\mathbf{Top}(X, f)^H$  and  $\mathbf{Top}(X, f)^V$  that could be obtained by refining that simulation theorem.

# Chapter 4

## A new notion of effectiveness for subshifts in groups

The objective of this chapter is to study a suitable way of extending the notion of effectively closed subshift to the context of finitely generated groups in such a way that the word problem of the group stops being a hindrance. The results which are exhibited in this chapter correspond to those published in [ABS17] and were obtained in collaboration with Nathalie Aubrun and Mathieu Sablik.

We begin by introducing the One-or-less-subshift  $X_{\leq 1}$  which consists in all configurations containing at most one appearance of a non-zero symbol, and use it to exemplify the problems that might arise in effectively closed subshifts. This subshift has the property of being effectively closed in recursively presented groups if and only if the word problem is decidable. This example, besides illustrating the limitations of the notion of effectively closed subshifts, answers an open question posed by Dahmani and Yaman concerning the work [DY08].

In order to escape the limitations of effectively closed subshifts, we introduce  $G$ -effectively closed subshifts as objects which are defined by a Turing machine with access to an oracle of the word problem of the group. Although we show that these objects are a good theoretical frame in many aspects, they do not behave well with respect to projective subdynamics. In order to justify the usage of the oracle we introduce an abstract model of Turing machine which instead of a bi-infinite tape uses a group. These objects are quite similar to Turing machines except that they move using a finite set of generators of  $G$  and work over patterns instead of words. This object allows us to define  $G$ -recursively enumerable and  $G$ -decidable sets of patterns and gives a way to explicitly construct Turing machines with oracles. In Theorems 4.7 and 4.8 we make this relationship explicit with the aim of concluding in Corollary 4.9 that these  $G$ -machines give an alternative definition of  $G$ -effectively closed subshifts.

Following the previous construction we give an application of  $G$ -machines. In Theorem 4.11 we show that for every infinite and finitely generated group  $G$  there exists a universal  $G \times \mathbb{Z}$ -effective subshift  $U$  such that the product of  $U$  with a  $G \times \mathbb{Z}$ -full shift can be restricted by a finite amount of forbidden patterns and a factor code to obtain any  $G$ -effectively closed subshift which satisfies a technical property as a

projective subdynamics.

We end this chapter by studying the following question: Is there a group  $G$  where the class of effectively closed subshifts coincides with the class of sofic subshifts? This question is motivated by the novel work in [AS16] where they show that this property holds for structures resembling subshifts defined in shears of the Baumslag-Solitar group  $BS(1, 2)$  under the assumption of a technical property. While their result is certainly quite specific, it raises the previous question in a natural way. A negative answer is given to that question for three classes of groups, namely:

- recursively presented groups with undecidable word problem – Theorem 4.12,
- infinite amenable groups – Theorem 4.14,
- groups which have two or more ends – Theorem 4.15.

## 4.1 The One-or-less subshift

In Subsection 1.2.3 several results about effectively closed subshifts have been shown to depend on the group  $G$  being recursively presented. Here we argue that even in that case the class is not large enough to contain an extremely simple subshift.

**Definition 4.1.** the subshift  $X_{\leq 1} \subset \{0, 1\}^G$  whose configurations contain at most one appearance of the letter 1 is called the *One-or-less subshift*.

$$X_{\leq 1} = \{x \in \{0, 1\}^G \mid 1 \in \{x_g, x_h\} \implies g = h\}$$

As we shall see later, this subshift is related to the word problem of a group. In the literature, it is sometimes called the “sunny side up” subshift. We begin by showing some properties of  $X_{\leq 1}$ .

**Proposition 4.1.** *If  $G$  is infinite, then  $X_{\leq 1}$  is not an SFT.*

*Proof.* Suppose  $X_{\leq 1} = X_{\mathcal{F}}$  for a finite  $\mathcal{F}$  and let  $F = \bigcup_{p \in \mathcal{F}} \text{supp}(p)$ ,  $U = \bigcup_{h \in F^{-1}} hF$  and note that  $|U| < \infty$ . As  $G$  is infinite, there exists  $g \in G \setminus U$ . Consider the configuration  $x \in \{0, 1\}^G$  which takes the value 1 in  $\{1_G, g\}$  and 0 elsewhere. Clearly  $x \notin [p]_h$  for every  $h \in G$  and  $p \in \mathcal{F}$  otherwise  $\{1_G, g\} \subset hF$  implying that  $hF \subset U$  and thus  $g \in U$ . Therefore  $x \in X_{\mathcal{F}}$  but  $x \notin X_{\leq 1}$ .  $\square$

This subshift has already been studied in [DY08]. We refer to their article for the following statement. There, the authors showed that some properties of the action of a relatively hyperbolic group on its boundary are related to  $X_{\leq 1}$  being sofic. They said a group  $G$  has the *special symbol property* if  $X_{\leq 1} \subset \{0, 1\}^G$  is a sofic subshift. They furthermore proved some stability properties for that property among which are:

1. if  $G$  has the special symbol property then  $G$  is finitely generated.

2. If  $G$  splits in a short exact sequence  $1 \rightarrow N \rightarrow G \rightarrow H \rightarrow 1$  and both  $N$  and  $H$  satisfy the special symbol property, then  $G$  also does.
3. If  $[G : H] < \infty$  then  $G$  has the special symbol property if and only if  $H$  does.
4. The special symbol property is true for:
  - Finitely generated free groups.
  - Finitely generated abelian groups.
  - Hyperbolic groups.
  - Poly-hyperbolic groups.

Besides the restriction of  $G$  being finitely generated the authors did not present any example of a group without the special symbol property. In this section we introduce a computability obstruction for this property which at the same time shows one of the limitations of the classical approach to effectiveness.

**Proposition 4.2.** *Let  $G$  be a recursively presented group. Then  $X_{\leq 1}$  is effectively closed if and only if  $\text{WP}(G)$  is decidable.*

*Proof.* If  $\text{WP}(G)$  is decidable then  $X_{\leq 1}$  is effectively closed. Indeed, an algorithm recognizing a maximal set of pattern codings  $\mathcal{C}$  such that  $X_{\leq 1} = X_{\mathcal{C}}$  is the following: On input  $c$  it considers every pair  $(w_1, 1), (w_2, 1)$  in  $c$  and accepts if and only if  $w_1 w_2^{-1} \neq_G 1_G$  for a pair. Conversely, as  $G$  is recursively presented, the word problem is already recursively enumerable. It suffices to show it is co-recursively enumerable.

By Lemma 1.13 there exists a maximal set of forbidden pattern codings  $\mathcal{C}$  with  $X_{\leq 1} = X_{\mathcal{C}}$ . Given  $w \in S^*$ , consider the pattern coding  $c_w = \{(\epsilon, 1), (w, 1)\}$ . Note that  $w \neq_G 1_G \iff c_w \in \mathcal{C}$ . The algorithm which on input  $w \in S^*$  runs the algorithm recognizing  $\mathcal{C}$  on input  $c_w$  and accepts if and only if this one accepts recognizes  $S^* \setminus \text{WP}(G)$ . Hence  $\text{WP}(G)$  is co-recursively enumerable.  $\square$

Using Proposition 1.17 we obtain the following corollary which gives explicit examples of groups without the special symbol property.

**Corollary 4.3.** *If  $G$  is recursively presented and  $\text{WP}(G)$  is undecidable, then  $X_{\leq 1}$  is not sofic.*

## 4.2 $G$ -effectiveness and $G$ -machines

In order to escape the limitations of Lemma 1.13 and Proposition 1.17 and include subshifts such as  $X_{\leq 1}$ , we introduce the class of  $G$ -effectively closed subshifts. We begin by giving a formal definition through oracle Turing machines and then we proceed to show that they correspond to the subshifts defined by a more concrete version of Turing machine.

An oracle Turing machine is a Turing machine with an additional element, called the oracle, that can be queried in a single step of computation. The oracle is an

arbitrary language and the query consists on asking if a word belongs to that language. A rigorous definition of oracle Turing machines is given in [AB09, Sip06].

Let  $\mathcal{O}$  be a language. A set of pattern codings  $\mathcal{C}$  is said to be *recursively enumerable with oracle  $\mathcal{O}$*  if there exists a Turing machine with oracle  $\mathcal{O}$  which accepts input  $c$  if and only if  $c \in \mathcal{C}$ .

**Definition 4.2.** A subshift  $X \subset \mathcal{A}^G$  is  *$G$ -effectively closed* if there is a set of pattern codings  $\mathcal{C}$  such that  $X = X_{\mathcal{C}}$ , and  $\mathcal{C}$  is recursively enumerable with oracle  $\text{WP}(G)$ .

The following properties either fall directly from the definition or are obtained from adding the word problem  $\text{WP}(G)$  as oracle to the results from Subsection 1.2.3. Let  $G$  be a finitely generated group, then:

1. If  $X$  a  $G$ -effectively closed subshift then a maximal set of pattern codings  $\mathcal{C}$  such that  $X = X_{\mathcal{C}}$  is recursively enumerable with oracle  $\text{WP}(G)$ .
2. The class of  $G$ -effectively closed subshifts is closed under finite intersections and unions.
3. The class of  $G$ -effectively closed subshifts is closed under factors.
4. Being  $G$ -effectively closed is a conjugacy invariant.
5. The class of  $G$ -effectively closed subshifts contains all sofic subshifts.
6. The class of  $G$ -effectively closed subshifts contains all effectively closed subshifts.
7. If  $\text{WP}(G)$  is decidable, then every  $G$ -effectively closed subshift is effectively closed.
8.  $X_{\leq 1}$  is a  $G$ -effectively closed subshift.

The only property which does not hold is the stability under taking projective subdynamics. Clearly if  $X \subset \mathcal{A}^G$  is  $G$ -effectively closed then for any finitely generated  $H \leq G$  we would have that the  $H$ -projective subdynamics  $\pi_H(X)$  can be defined by a set of pattern codings which is recursively enumerable with oracle  $\text{WP}(G)$ . Nevertheless, it may not be possible to recognize such set with Turing machines using oracle  $\text{WP}(H)$ .

**Proposition 4.4.** *Let  $G$  be a group which is not recursively presented. There exists a  $(G \times \mathbb{Z})$ -effectively closed subshift  $X \subset \mathcal{A}^{G \times \mathbb{Z}}$  such that its  $\mathbb{Z}$ -projective subdynamics is not  $\mathbb{Z}$ -effectively closed.*

*Proof.* Let  $\mathcal{A} = S \cup \{\star\}$ . For  $w \in S^*$ , let  $p_w$  defined over the support  $\{1_G\} \times \{0, \dots, |w| + 1\}$  such that  $(p_w)_{(1_G, 0)} = (p_w)_{(1_G, |w|+1)} = \star$  and for  $j \in \{1, \dots, |w|\}$  then  $(p_w)_{(1_G, j)} = w_j$ . Let  $X := X_{\mathcal{F}} \subset \mathcal{A}^{G \times \mathbb{Z}}$  be defined by the set of forbidden patterns  $\mathcal{F} = \{p_w \mid w \in \text{WP}(G)\}$ . Clearly  $X$  is  $(G \times \mathbb{Z})$ -effectively closed. Every  $\mathbb{Z}$ -coset of a configuration  $x \in X$  contains a bi-infinite sequence  $y \in \mathcal{A}^{\mathbb{Z}}$  such that either  $y$



contains at most one symbol  $\star$  or every word appearing between two appearances of  $\star$  represents  $1_G$  in  $G$ .

We claim that  $\pi_{\mathbb{Z}}(X)$  is not effectively closed. If it were, there would exist a maximal set of forbidden pattern codings which is recursively enumerable and defines  $\pi_{\mathbb{Z}}(X)$ . Therefore given  $w \in S^*$  a machine could run the algorithm for the word  $\star w \star$  and it would be accepted if and only if  $w =_G 1_G$ . This would imply that  $G$  is recursively presented.  $\square$

Classical Turing machines keep their information in a bi-infinite tape, and are only able to work on inputs which are codified in the form of words. While in  $\mathbb{Z}$  this is a natural model to study subshifts, it becomes cumbersome in general groups as we are forced to introduce pattern codings. Moreover, as we saw in Section 1.2.3, there is a number of constraints to what can be done with Turing machines when  $\text{WP}(G)$  is undecidable, and a general setting forces the use of oracles.

In this section we introduce an alternative model of computation which we call a  $G$ -machine. In this model, the tape is replaced by a finitely generated group  $G$ . These machines receive patterns  $p \in L(\mathcal{A}^G)$  as input instead of words and move by using the set  $S$  of generators. Similar machines using Cayley graphs as a tape have already been mentioned in [GM07] and studied in more detail in [dC11], but these machines take their input as a word in an auxiliary tape and only use the graph as a working tape. Another work considering subshifts defined by one or more Turing machine heads walking on the group has also been done in [ST15].

We begin by defining  $G$ -machines and the classes of languages they define. Then we present some robustness results similar to the ones satisfied by classical Turing machines. As the main result of this section, we characterize the class of  $G$ -effectively closed subshifts as those whose set of forbidden patterns is  $G$ -recursively enumerable, hence giving a characterization of this class without the use of oracles.

**Definition 4.3.** A  $G$ -machine is a 6-tuple  $(Q, \Sigma, \sqcup, q_0, Q_F, \delta)$  where  $Q$  is a finite set of states,  $\Sigma$  is a finite alphabet,  $\sqcup \in \Sigma$  is the blank symbol,  $q_0 \in Q$  is the initial state,  $Q_F \subset Q$  is the set of accepting states and  $\delta : \Sigma \times Q \rightarrow \Sigma \times Q \times S$  is the transition function.

As in the case of Turing machines, we can define the action of a Turing machine in two different ways. We call these the *fixed head* and *moving head* models.

In the fixed head model, a  $G$ -machine  $T$  acts on the set  $\Sigma^G \times Q$  as follows: let  $(x, q) \in \Sigma^G \times Q$  and  $\delta(x_{1_G}, q) = (a, q', s)$ . Then  $T(x, q) = (\sigma^{s^{-1}}(\tilde{x}), q')$  where  $\tilde{x}|_{1_G} = a$  and  $\tilde{x}|_{G \setminus \{1_G\}} = x|_{G \setminus \{1_G\}}$ . Figure 4.1 illustrates this action when  $G$  is a free group. Here the head of the Turing machine is assumed to stay at a fixed position and the tape moves instead.

In the moving tape model, a  $G$ -machine  $T$  acts on the set  $\Sigma^G \times G \times Q$  as follows: let  $(x, g, q) \in \Sigma^G \times G \times Q$  and  $\delta(x_{1_G}, q) = (a, q', s)$ . Then  $T(x, g, q) = (\tilde{x}, gs, q')$  where  $\tilde{x}|_{1_G} = a$  and  $\tilde{x}|_{G \setminus \{1_G\}} = x|_{G \setminus \{1_G\}}$ . Figure 4.2 illustrates this action when  $G$  is  $\mathbb{Z}^2$ . Here the tape remains fixed and the second coordinate keeps track of the position of the head.

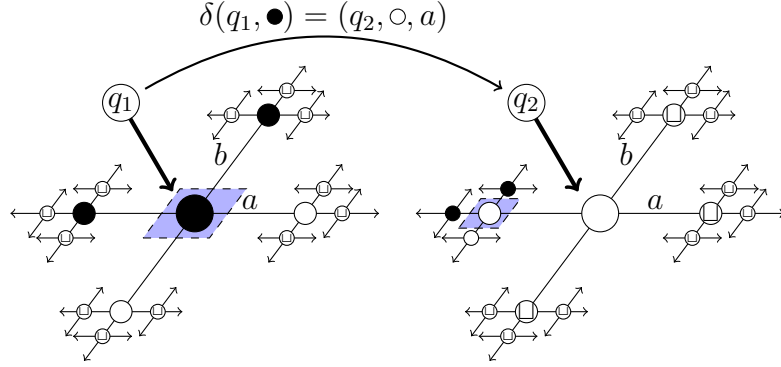

Figure 4.1: A fixed head transition of an  $F_2$ -machine.

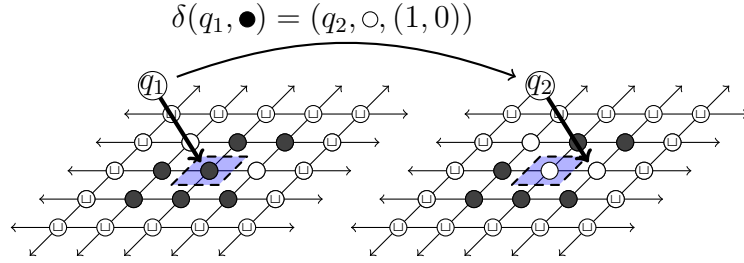

Figure 4.2: A moving head transition of a  $\mathbb{Z}^2$ -machine.

Let  $F \subset G$  be a finite set and  $p \in \Sigma^F$ . Let  $x^p \in \Sigma^G$  be the configuration such that  $(x^p)|_F = p$  and  $(x^p)|_{G \setminus F} \equiv \sqcup$ . We say that  $T$  *accepts*  $p$  if there is  $n \in \mathbb{N}$  such that  $T^n(x^p, q_0) \in \Sigma^G \times Q_F$  in the fixed head model or equivalently  $T^n(x^p, 1_G, q_0) \in \Sigma^G \times G \times Q_F$  in the moving head model.  $L \subset L(\Sigma^G)$  is  $G$ -*recursively enumerable* if there exists a  $G$ -machine  $T$  which accepts  $p \in L(\Sigma^G)$  if and only if  $p \in L$ . If both  $L$  and  $L(\Sigma^G) \setminus L$  are  $G$ -recursively enumerable we say  $L$  is  $G$ -*decidable*.

So far we have defined these machines using a fixed set of generators  $S$ . In the next proposition we show that the languages defined by such machines do not depend of this arbitrary choice.

**Proposition 4.5.** *Let  $S, S'$  be finite subsets of  $G$  such that  $\langle S \rangle = \langle S' \rangle = G$ . Let  $L \subset L(\mathcal{A}^G)$  be recursively enumerable using  $S'$  as the movement set. Then  $L$  is recursively enumerable using  $S$ .*

*Proof.* Let  $T_{S'}$  be a  $G$ -machine using  $S'$  as the movement set recognizing  $L$ . As  $\langle S \rangle = G$  each  $s' \in S'$  can be written as  $s' = s_1 \dots s_{n(s')}$  where every  $s_i \in S$ . Consider  $T_S$  a copy of  $T_{S'}$  where for each state  $q \in Q$  we add a copy  $q_{s', s_i}$  for  $s' \in S'$  and  $i \in \{1, \dots, n(s')\}$ , and every instruction  $\delta(a, q) = (b, r, s')$  in  $T_{S'}$  is replaced with the instructions:

- $\delta(a, q) = (b, r_{s', s_1}, s_1)$

- $\forall a \in \Sigma$  and  $1 \leq i < n(s)$ ,  $\delta(a, r_{s',s_i}) = (a, r_{s',s_{i+1}}, s_{i+1})$
- $\forall a \in \Sigma$ ,  $\delta(a, r_{s',s_{n(s')}}) = (a, r, 1_G)$ .

The modified machine  $T_S$  moves with the set of generators  $S$  and accepts the same patterns as  $T_{S'}$ .  $\square$

The class of  $G$ -machines shares also the robustness of Turing machines with respect to slight changes in its definition. For example, we can allow multiple tapes with multiple independent writing heads. We shall briefly and informally define this model as it will be used as a tool in a proof later on.

A *multiple head  $G$ -machine* is the same as a  $G$ -machine, except that the machine uses  $G^n$  as a tape and the transition function is  $\delta : \Sigma^n \times Q \rightarrow \Sigma^n \times Q \times S^n$ , where  $n$  is the number of heads of the machine. The action of this machines is defined analogously as before in either the moving head or moving tape model. It *accepts* a pattern  $p \in L(\mathcal{A}^G)$  if starting from the initial configuration  $((x^p, \sqcup^G, \dots, \sqcup^G), q_0)$  the machine reaches in a finite number of steps an accepting state in  $Q_F$ .

In these machines each head works on its own tape, but can “read” the content of other tapes. By codifying independent movements of a tape accordingly, it is able to read not only what each head is looking at a certain step but what is written in an arbitrary finite portion of the other tapes.

**Proposition 4.6.** *Let  $L \subset L(\Sigma^G)$ . There exists a multiple head  $G$ -machine which accepts exactly patterns  $p \in L$  if and only if  $L$  is  $G$ -recursively enumerable.*

This extended model is useful to prove the second of the following two results which links oracle machines to  $G$ -machines. The first result is relatively straightforward, as  $G$ -machines can be simulated by a machine with oracle  $\text{WP}(G)$  by creating arbitrarily big balls of the Cayley graph. The second result is more interesting as it says that oracle machines can be simulated by  $G$ -machines.

**Theorem 4.7** (Aubrun, B, Sablik). *Let  $L \subset L(\Sigma^G)$  be  $G$ -recursively enumerable. Then there exists a recursively enumerable with oracle  $\text{WP}(G)$  set of pattern codings  $\mathcal{C}$  such that  $L = \mathfrak{p}(\mathcal{C})$ .*

*Proof.* Suppose  $T_G$  is the  $G$ -machine recognizing  $L$ . With an oracle of  $\text{WP}(G)$ , a machine can construct balls  $B_n$  of  $\Gamma(G, S)$  for arbitrary  $n$ . A codification of  $B_n$  allows a classical Turing machine to simulate at least  $n$  applications of  $T_G$  in the moving head model as the head starts in the origin and moves at most one generator per iteration. Let  $T$  be the Turing machine with oracle  $\text{WP}(G)$  which does the following on input  $c$ .

- Let  $N = 2 \max_{(w,a) \in c} |w|$ . Solve the word problem for all  $w \in S^*$  of length at most  $N$ . If  $c$  is inconsistent accept.
- Let  $k = N$  and iterate the following procedure: Solve the word problem for  $w \in S^*$  of length at most  $k$  and simulate  $T_G$  over  $\mathfrak{p}(c)$  for  $k$  steps. If this procedure accepts then accept, otherwise increase  $k$  by 1.

Clearly,  $T$  accepts  $c$  if and only if either  $c$  is inconsistent or  $\mathfrak{p}(c) \in L$ .  $\square$

**Definition 4.4.** A language  $L \subset L(\Sigma^G)$  is said to be *closed by extensions* if for each  $p_1 \in \Sigma^{F_1}$ ,  $p_2 \in \Sigma^{F_2}$  such that  $F_1 \subset F_2$  and  $p_2|_{F_1} = p_1$  then  $p_1 \in L \implies p_2 \in L$ .

**Theorem 4.8** (Aubrun, B, Sablik). *Let  $G$  be an infinite group and  $\mathcal{C}$  a recursively enumerable with oracle  $\mathfrak{WP}(G)$  set of pattern codings. If  $\mathfrak{p}(\mathcal{C})$  is closed by extensions, then  $\mathfrak{p}(\mathcal{C})$  is  $G$ -recursively enumerable.*

*Proof.* Without loss of generality we can suppose  $\mathcal{C}$  is a maximal set of pattern codings which gives  $\mathfrak{p}(\mathcal{C})$ . Moreover we can also assume that  $T$  is a one-sided Turing machine with a reading tape and a working tape.

The construction is a multiple head  $G$ -machine  $\mathcal{M}$  which consists of the following six layers (see Figure 4.3):

1. A storage layer  $\mathcal{M}_{\text{STORE}}$  where the input  $p \in L(\Sigma^G)$  is stored.
2. A machine  $\mathcal{M}_{\text{PATH}}$  which constructs an arbitrarily long one-sided non-intersecting path starting from  $1_G$ .
3. A machine  $\mathcal{M}_{\text{VISIT}}$  which is able to visit iteratively all the elements of  $B_n$  for  $n \in \mathbb{N}$  starting with  $n$  initially assigned to 1.
4. A Machine  $\mathcal{M}_{\text{ORACLE}}$  which solves  $\mathfrak{WP}(G)$ .
5. An auxiliary layer  $\mathcal{M}_{\text{AUX}}$  which serves as a nexus between the first layer and the sixth.
6. A simulation layer  $\mathcal{M}_{\text{SIM}}$  which simulates  $T$  in the one-sided path created by  $\mathcal{M}_{\text{PATH}}$ .

We will first describe  $\mathcal{M}_{\text{PATH}}$  and  $\mathcal{M}_{\text{VISIT}}$  which are the most complicated components. Then we will describe the general workings of the machine.

We begin by describing  $\mathcal{M}_{\text{PATH}}$  in detail. Let the set of generators be  $S = \{g_1, \dots, g_k\}$  and consider the  $G$ -machine  $\mathcal{M}_{\text{PATH}} := (Q, \Sigma, \sqcup, q_0, Q_F, \delta)$  where  $Q := \{I, B\} \cup (S \times \{\leftarrow, \rightarrow\})$ ,  $\Sigma = (\{\sqcup, \triangleright\} \cup S) \times \{\sqcup, \otimes\} \times (\{\sqcup\} \cup S)$ ,  $q_0 = I$ ,  $Q_F = \emptyset$  (we force the machine to loop), and  $\delta$  is given by the following rules where  $*_i$  stands for an arbitrary fixed symbol.

$$\begin{aligned} \delta((\sqcup, \sqcup, \sqcup), I) &= ((\triangleright, \otimes, g_1), g_1^{\leftarrow}, g_1). \\ \delta((\sqcup, \sqcup, \sqcup), g_i^{\leftarrow}) &= ((g_i, \otimes, \sqcup), g_1^{\rightarrow}, 1_G). \\ \delta((*_1, \otimes, *_2), g_i^{\rightarrow}) &= ((*_1, \otimes, g_i), g_i^{\leftarrow}, g_i). \\ \delta((*_1, \otimes, *_2), g_i^{\leftarrow}) &= ((*_1, \otimes, *_2), B, g_i^{-1}). \\ \delta((g_j, \otimes, g_i), B) &= \begin{cases} ((g_j, \otimes, g_i), g_{i+1}^{\rightarrow}, 1_G), & \text{if } i < k \\ ((\sqcup, \sqcup, \sqcup), B, g_j^{-1}), & \text{if } i = k. \end{cases} \end{aligned}$$

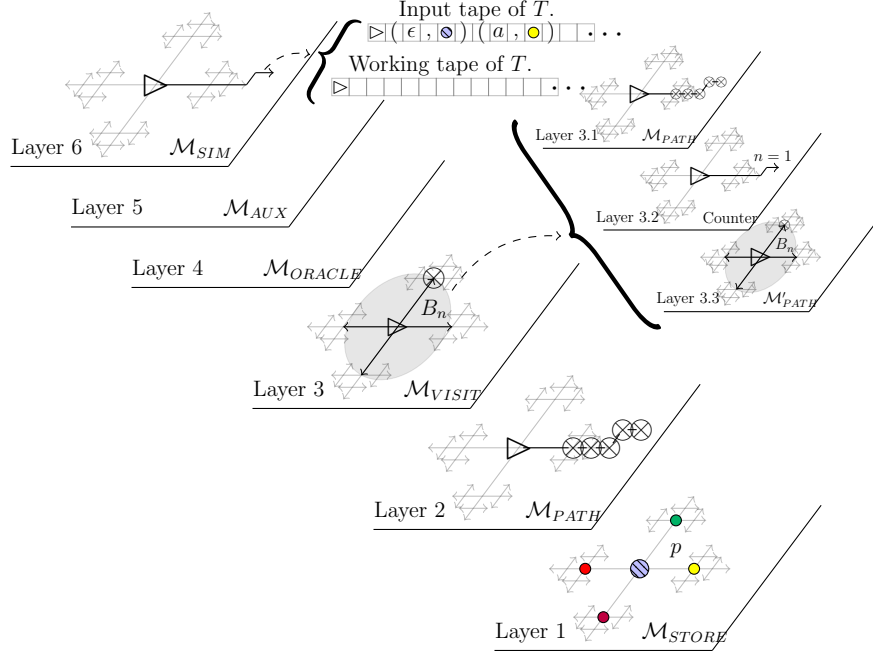

Figure 4.3: Construction of the machine  $\mathcal{M}$  as a multiple head  $G$ -machine.

$$\delta((\triangleright, \otimes, g_i), B) = ((\triangleright, \otimes, g_i), g_{i+1}^{\rightarrow}, 1_G), \text{ if } i < k$$

The rules from  $\delta$  codify a backtracking in  $G$  which marks a one-sided non-intersecting infinite path in  $G$ . The states  $I$  and  $B$  stand for initialization and backtracking respectively. The elements from  $\Sigma$  are triples  $(a_1, a_2, a_3)$  which indicate the following information: my left and right neighbors are  $a_1$  and  $a_3$  respectively and I belong to the path if  $a_2 = \otimes$ . The first rule initializes the infinite path by using the symbol  $\triangleright$  to indicate that there is no element to the left, marks the identity of the group as part of the path by using  $\otimes$  and sets the next element in the direction  $g_1$ . The second and third rules mark the left and right neighbors respectively and move to the next position. Rule 4 deals with the case of reaching a position already marked and going back. Rule 5 and 6 search the next available direction which potentially admits an infinite path and backtrack if every position has already been searched. Rule 6 lacks a case where  $i = 2k$  on purpose because such a state is never reached as the group is infinite.

Next we describe  $\mathcal{M}_{\text{VISIT}}$  that visits all elements of every ball  $B_n$  in  $G$  iteratively. It suffices to construct it as a multiple head  $G$ -machine with three layers as follows. The first layer runs a copy of  $\mathcal{M}_{\text{PATH}}$ . The second layer makes use of the path defined by  $\mathcal{M}_{\text{PATH}}$  to simulate a counter which has value  $n \in \mathbb{N}$  – any one-sided Turing machine can be simulated in the path by identifying the instructions  $L, R$  with the first and third coordinates of  $\Sigma$ . The third layer runs another copy of  $\mathcal{M}_{\text{PATH}}$ , which is allowed only to run over words of length  $n$ . This is achieved by using the counter in second layer to measure the length of the path visited by the third layer and restrict it to be less than  $n$ . Each time the whole ball  $B_n$  is visited (that is,  $((\triangleright, \otimes, g_k), B)$

is reached in the third layer) then the counter in the second layer increments  $n$  by 1 and the third layer starts anew.

If at a given time the first layer, which constructs the one-sided path, backtracks until reaching a cell used by the counter in the second layer, then the second and third layers are erased and restart. As the group is infinite, then by choosing an adequate number of computation steps, the path generated by  $\mathcal{M}_{\text{PATH}}$  in the first layer is arbitrarily long. Thus the head of the third tape is able to visit every element of  $B_n$  for arbitrarily big  $n$ .

Finally, we describe the overall functioning of  $\mathcal{M}$ :

- The input  $p \in L(\Sigma^G)$  is stored in  $\mathcal{M}_{\text{STORE}}$  whose head mimics that of  $\mathcal{M}_{\text{VISIT}}$  without changing anything.
- The machines  $\mathcal{M}_{\text{PATH}}$  and  $\mathcal{M}_{\text{VISIT}}$  run independently.
- $\mathcal{M}_{\text{SIM}}$  uses the path given by  $\mathcal{M}_{\text{PATH}}$  to simulate two one-sided Turing machine tapes: an input tape where input will be stored, and a working tape which simulates  $T$  over that input.
- If at any moment the working tape of  $\mathcal{M}_{\text{SIM}}$  makes a call to the oracle  $\text{WP}(G)$ , then  $\mathcal{M}_{\text{ORACLE}}$  is made to mark the origin, follow the path  $w \in S^*$  and accept the call if the last symbol is marked. Then it erases everything and goes back to the origin.
- Whenever  $\mathcal{M}_{\text{VISIT}}$  arrives at a position where the first layer is not marked by  $\sqcup$ , the head at  $\mathcal{M}_{\text{AUX}}$  follows the path  $w$  marked from  $1_G$  by the first layer of  $\mathcal{M}_{\text{VISIT}}$  and writes  $(w, a)$  in the input tape of  $\mathcal{M}_{\text{SIM}}$ . Then  $\mathcal{M}_{\text{AUX}}$  marks position  $w$  as already visited and returns to  $1_G$ .
- If at a given time  $\mathcal{M}_{\text{AUX}}$  extends the pattern coding written in the reading tape of the fifth layer, then the working tape of  $\mathcal{M}_{\text{SIM}}$  erases everything and begins anew.
- If at any moment the end of the simulated path created by  $\mathcal{M}_{\text{PATH}}$  backtracks into a cell used by the written portion of  $\mathcal{M}_{\text{SIM}}$ , then the content of all tapes except  $\mathcal{M}_{\text{PATH}}$  and  $\mathcal{M}_{\text{STORE}}$  is erased and they start anew.
- $\mathcal{M}$  accepts if and only if the working tape of  $\mathcal{M}_{\text{SIM}}$  does.

As  $\mathcal{M}_{\text{PATH}}$  is able to construct arbitrarily long one-sided and non-intersecting paths, there is a finite number of computation steps such that  $\mathcal{M}_{\text{VISIT}}$  will visit all of the support of  $p$ . Thus the fourth layer will write a consistent pattern coding  $c$  such that  $p = \mathbf{p}(c)$  which is accepted by the working tape of  $\mathcal{M}_{\text{SIM}}$  if and only if  $p \in \mathbf{p}(\mathcal{C})$  (as  $\mathcal{C}$  is maximal). By considering a path which has length at least two times the running time of all the other algorithms, this eventually happens. Conversely, if  $p \notin \mathbf{p}(\mathcal{C})$ , as  $\mathbf{p}(\mathcal{C})$  is closed by extensions, the acceptance of any partial coding  $c'$  would mean that  $p \in \mathbf{p}(\mathcal{C})$ , therefore, the machine never accepts.  $\square$

**Corollary 4.9.** *A subshift  $X \subset \mathcal{A}^G$  is  $G$ -effectively closed if and only if there exists a  $G$ -recursively enumerable set  $\mathcal{F} \subset L(\mathcal{A}^G)$  such that  $X = X_{\mathcal{F}}$ .*

*Proof.* As  $X$  is  $G$ -effectively closed, the set of forbidden pattern codings  $\mathcal{C}$  can be chosen to be maximal. This in turn gives a maximal set of forbidden patterns  $\mathfrak{p}(\mathcal{C})$  which is closed by extensions. Theorems 4.7 and 4.8 imply the result.  $\square$

For a language  $L \subset \mathcal{A}^*$  we define the Turing jump  $L'$  as the halting problem for Turing machines with oracle  $L$ .

Let  $\text{HALT}_G = \{\langle T \rangle \mid T \text{ is a } G\text{-machine which accepts the empty input}\}$ .

**Corollary 4.10.** *Let  $G$  be an infinite group.  $\text{HALT}_G$  is  $\text{WP}(G)'$ -hard, that is, it is at least as hard as the halting problem for Turing machines with oracle  $\text{WP}(G)$ .*

*Proof.* Let  $T$  be a Turing machine with oracle  $\text{WP}(G)$ . Consider the construction from Theorem 4.8 without the Visit and Auxiliary tapes. Thus, there is only the tape which searches the infinite path, the oracle layer, and the layer which simulates  $T$  (now only on empty input). It is clear that this machine accepts the empty input (and all inputs) if and only if  $T$  accepts the empty input.  $\square$

Corollary 4.9 implies that  $G$ -effectively closed subshifts can be defined either by oracle machines or by  $G$ -machines. This nice characterization allows us to simulate Turing machines in groups which may not even have torsion-free elements. In what remains of this section we present an application of these machines to construct a simulation theorem.

### 4.2.1 Application: a simulation theorem with oracles

Here we explore an analogue of Theorem 3.7 for  $G$ -effectively closed subshifts. As Propositions 1.19 and 4.4 show, an analogue can not hold for arbitrary  $G$ -effectively closed subshifts when  $G$  is recursively presented as the projective subdynamics of a sofic subshift would necessarily be effectively closed. Nevertheless, using  $G$ -machines, we can obtain a similar result if we allow the addition of a particular subshift as an universal oracle to our construction. Formally we show:

**Theorem 4.11** (Aubrun, B, Sablik). *For every finitely generated group  $G$ , there exists a  $G \times \mathbb{Z}$ -effectively closed subshift  $U \subset \tilde{\mathcal{B}}^{G \times \mathbb{Z}}$  such that for every  $G$ -effectively closed subshift  $X \subset \mathcal{A}^G$  which contains a uniform configuration ( $\exists \bar{a} \in \mathcal{A}$  such that  $\bar{a}^G \in X$ ), there exists an alphabet  $\mathcal{B}$ , a finite set of forbidden patterns  $\mathcal{F}$  on alphabet  $\tilde{\mathcal{B}} \times \mathcal{B}$  and a 1-block code  $\phi$  such that:*

$$\pi_G \left( \phi \left( (U \times \mathcal{B}^{G \times \mathbb{Z}}) \setminus \bigcup_{p \in \mathcal{F}, h \in G \times \mathbb{Z}} [p]_h \right) \right) = X.$$

In order to define  $U$  we need to use the notion of Delone set which was introduced in Definition 2.3. We first define  $Y_n \subset \{0, 1, 2\}^G$  as the subshift defined by the following set of forbidden patterns  $\mathcal{F}_n$ :

- All  $p \in \{0, 2\}^{B_S(1_G, 4n)}$ .
- $p \in \{0, 1, 2\}^{B_S(1_G, n)}$  such that  $p_{1_G} = 1$  and there exists  $g \in B_S(1_G, n) \setminus \{1_G\}$  with  $p_g \neq 2$ .
- $p \in \{1, 2\}^F$  where  $F$  is a connected component of  $\Gamma(G, S)$  and there exist  $g_1, g_2 \in F, g_1 \neq g_2$  such that  $p_{g_1} = p_{g_2} = 1$ .

That is,  $Y_n$  is the set of configurations  $y$  where, if we denote by  $D_y$  the set of positions marked in  $y$  by a 1, then  $D_y$  forms a Delone set with  $r_{D_y} \geq n$  and  $c_{D_y} \leq 4n$ . Also, each 1 is surrounded by a ball of size at least  $n$  marked by 2's and there is no path of 2's connecting two adjacent 1s. See Figure 4.4 for an example in  $\mathbb{Z}^2$ .

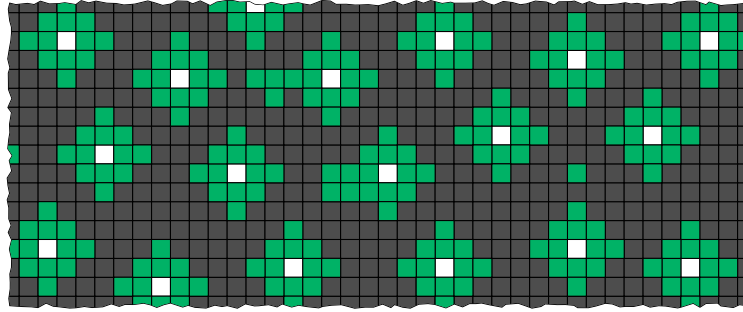

Figure 4.4: Example of a configuration of  $Y_2$  for the group  $\mathbb{Z}^2$  with the canonical generators. The symbols 0, 1 and 2 are represented by the colors  $\blacksquare$ ,  $\square$  and  $\blacksquare$  respectively.

**Claim.**  $\forall n \geq 1$ ,  $Y_n$  is a non-empty,  $G$ -effectively closed subshift.

*Proof.* The set  $\mathcal{F}_n$  can easily be recognized by a Turing machine with oracle  $\text{WP}(G)$ , so  $Y_n$  is  $G$ -effectively closed. For the non-empty part, Lemma 2.11 implies that a Delone set  $D$  satisfying  $r_D \geq 2n$  and  $c_D \leq 4n$  always exists. Now, define  $y \in \{0, 1, 2\}^G$  as:

$$y_g = \begin{cases} 1 & \text{if } g \in D \\ 2 & \text{if } 0 < d(g, D) \leq n \\ 0 & \text{else} \end{cases}$$

As  $c_D \geq 2n$  and  $n \geq 1$  it follows that there is no path consisting of 2's between a pair of 1's. It follows that  $y \in Y_n$ .  $\square$

Consider a  $G$ -machine  $T$  with alphabet  $\Sigma$  and set of states  $Q$  whose head never leaves a bounded support  $F$ . Using a pigeonhole argument, it can be shown that if it accepts, it must do so before  $|Q| \cdot |F| \cdot |\Sigma|^{|F|}$  steps. Consider the function  $\text{time} : \mathbb{N} \rightarrow \mathbb{N}$  given by  $\text{time}(n) = n^{n^2+n+1}$ . It is clearly a computable function which satisfies the following property: for any  $G$ -machine  $T$ , there exists  $N \in \mathbb{N}$  such that for every  $n \geq N$ , if  $T$  accepts a pattern  $p$  without leaving the support  $B_S(1_G, n)$  then it does so before  $\text{time}(n)$  steps. Indeed, we can always bound  $B_S(1_G, n) \leq |S|^n$  and thus an



upper bound for the maximum number of steps without leaving the support  $B_S(1_G, n)$  is given by  $|Q| \cdot |S|^n \cdot |\Sigma|^{|S|^n}$ . Choosing  $N \geq \max\{|Q|, |S|, |\Sigma|\}$  we get that  $\forall n \geq N$  the number of steps is bounded by  $n^{n^2+n+1}$ .

We are going to construct a  $\mathbb{Z}$ -subshift  $X_{\mathbf{time}}$  which encodes the function  $\mathbf{time}$  and instructions for a Turing machine in a convenient way. Consider the alphabet  $\mathcal{A}_X = \{\bullet, \star, \oplus, \triangleright\} \cup S$ . Let  $\tilde{x} \in \mathcal{A}_X^{\mathbb{N}}$  be the infinite concatenation of  $\{w_n\}_{n \in \mathbb{N}}$ , where  $w_0 = \star$  and for  $n \geq 1$  the word  $w_n$  is defined as follows. Let  $u_1, \dots, u_{k(n)}$  be the lexicographic enumeration of all words in  $S^*$  of length at most  $4n$ . Then,

$$v_{j,n} = u_j \triangleright \bullet^{\mathbf{time}(n)} u_j^{-1}, \text{ and } w_n = \oplus v_{0,n} v_{1,n}, \dots, v_{k(n),n}$$

*Example 4.1.* Let  $S = \{a, a^{-1}\}$  and suppose just for this example that the words are enumerated up to length  $n$  instead of  $4n$ , and that  $\mathbf{time}(1) = 2$  and  $\mathbf{time}(2) = 3$ . Then the first symbols of  $\tilde{x}$  would be:

$$\begin{aligned} \tilde{x} = & \star \oplus \triangleright \bullet \bullet a \triangleright \bullet \bullet a^{-1} a^{-1} \triangleright \bullet \bullet a \oplus \triangleright \bullet \bullet \bullet a \triangleright \bullet \bullet \bullet a^{-1} a^{-1} \triangleright \bullet \bullet \bullet a \\ & aa \triangleright \bullet \bullet \bullet a^{-1} a^{-1} aa^{-1} \triangleright \bullet \bullet \bullet aa^{-1} a^{-1} a \triangleright \bullet \bullet \bullet a^{-1} aa^{-1} a^{-1} \triangleright \bullet \bullet \bullet aa \dots \end{aligned}$$

With the infinite word  $\tilde{x}$  in hand, we define  $X_{\mathbf{time}} \subset \mathcal{A}_X^{\mathbb{Z}}$  as the subshift such that if  $x \in X$  and  $x_n = \star$ , then for all  $m \geq 0$  we have  $x_{n+m} = \tilde{x}_m$ . Clearly the forbidden patterns of  $X_{\mathbf{time}}$  can be recognized by a Turing machine.

Let  $\tilde{X}_{\mathbf{time}} \subset \mathcal{A}_X^{G \times \mathbb{Z}}$  be the periodic extension of  $X_{\mathbf{time}}$ . That is, for all  $\tilde{t} \in \tilde{X}_{\mathbf{time}}$  and  $g \in G$  we have  $\tilde{t}_{(g,k)} = \tilde{t}_{(1_G,k)}$  and the configuration  $x \in \mathcal{A}_X^{\mathbb{Z}}$  defined by  $x_k = \tilde{t}_{(1_G,k)}$  belongs to  $X_{\mathbf{time}}$ .

Finally, we define  $U \subset \tilde{X}_{\mathbf{time}} \times \{0, 1, 2\}^{G \times \mathbb{Z}}$  by a set of forbidden patterns. In order to describe this set, we denote by  $\pi_1$  and  $\pi_2$  the projections to the first and second coordinate respectively.

- Let  $(k_n)_{n \geq 1}$  be the sequence of positions in  $\tilde{x}$  such that  $\tilde{x}_{k_n} = \oplus$ . Recall that  $\mathcal{F}_n$  denotes the set of forbidden patterns defining  $Y_n$ . We forbid all patterns  $p$  with support  $F \ni (1_G, 0)$  such that  $\pi_1(p)_{(1_G,0)} = \star$  and for which there is  $n \in \mathbb{N}$  such that the restriction of  $\pi_2(p)$  to  $F_n = \{(g, k_n) \mid (g, k_n) \in F\}$  contains a pattern in  $\mathcal{F}_n$ .
- We forbid all patterns  $p$  with support  $F = \{(1_G, 0), (1_G, 1)\}$  such that  $\pi_1(p)_{(1_G,1)} \in \{\triangleright, \bullet\}$  and  $\pi_2(p)_{(1_G,1)} \neq \pi_2(p)_{(1_G,0)}$ .
- For  $s \in S$ , we forbid all patterns with support  $F_s = \{(1_G, 0), (s, 1)\}$  such that  $\pi_1(p)_{(s,1)} = s$  and  $\pi_2(p)_{(s,1)} \neq \pi_2(p)_{(1_G,0)}$ .

In other words, these patterns use the information on the first coordinate to force a structure on the second one as follows: The  $n$ -th coordinate marked with  $\oplus$  after a  $\star$  must carry a configuration  $y \in Y_n$  in the second coordinate. The symbols  $\triangleright$  and  $\bullet$  in the layer  $(G, m)$  just copy the configuration in the layer  $(G, m - 1)$ . The symbols from  $S$  shift the whole configuration by  $s \in S$ . See Figure 4.5.

**Claim.**  $U$  is a non-empty,  $G \times \mathbb{Z}$ -effectively closed subshift.

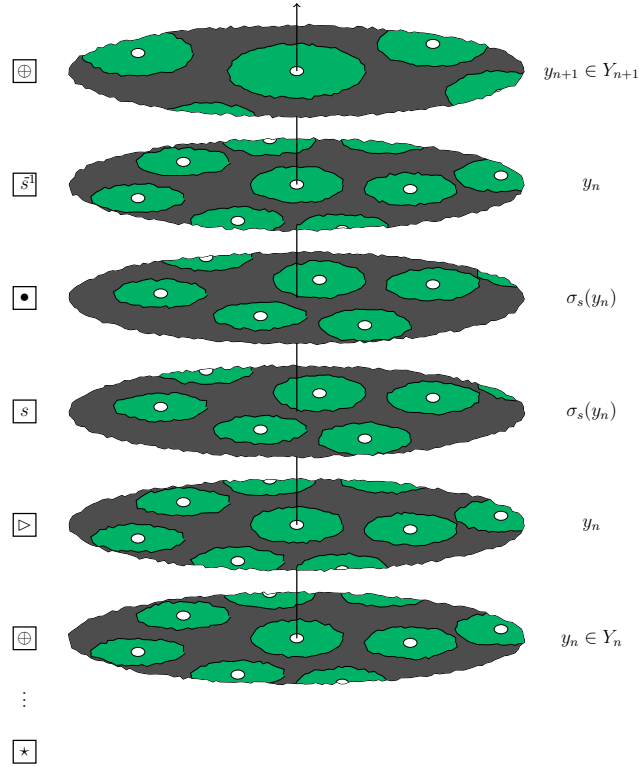

Figure 4.5: A typical configuration in  $U \subseteq (\{\bullet, \star, \oplus, \triangleright\} \cup S) \times \{0, 1, 2\}^{G \times \mathbb{Z}}$ . Symbols on the left side of the picture correspond to the first coordinate of the configuration, and the part in  $\{0, 1, 2\}^{G \times \mathbb{Z}}$  is on the right. On the example, the bottom  $\oplus$  is the  $n$ -th appearance after  $\star$ .

*Proof.* The first set of forbidden patterns is recursively enumerable with oracle  $\text{WP}(G)$  as  $(k_n)$  is computable and  $Y_n$  is  $G$ -effectively closed (the Turing machine accepting patterns of  $Y_n$  can be constructed universally for all  $(Y_n)_{n \in \mathbb{N}}$  such that it receives  $n \in \mathbb{N}$ ,  $p \in \{0, 1, 2\}^G$  as an input and accepts if  $[p] \cap Y_n = \emptyset$ ). The rest of the forbidden patterns is a finite set, therefore  $U$  is a  $G \times \mathbb{Z}$ -effectively closed subshift. It is non-empty as each  $Y_n$  is non-empty.  $\square$

Now that the description of  $U$  is done, we are ready to show Theorem 4.11.

*Proof.* Let  $\mathcal{A}$  be the alphabet of  $X$  and  $T$  be the  $G$ -machine which on input  $p \in L(\mathcal{A}^G)$  accepts if and only if  $[p] \cap X = \emptyset$ . Using  $\mathcal{M}_{\text{visit}}$  from Theorem 4.8 we can construct from  $T$  a machine  $\tilde{T}$  working on an infinite configuration whose description is as follows.

The machine  $\tilde{T}$  contains two tapes: a reading tape which is never modified and initially filled with symbols from  $\mathcal{A}$ , and a working tape. The machine  $\tilde{T}$  iterates infinitely for  $n = 1, 2, \dots$  as follows: for  $n \in \mathbb{N}$ , the machine iterates in order  $k = 1, 2, \dots, n$  the following procedure:

- Copy the pattern appearing in the reading tape in the support  $B_S(1_G, k)$  around the head to the working tape.

- Run  $T$  over this pattern  $n$  steps. If  $T$  accepts at some point, then  $\tilde{T}$  accepts.
- Erase everything in the working tape and go back to the starting position.

Let  $\Sigma \ni \sqcup$  be the alphabet of the working tape of  $\tilde{T}$  and let its set of states be  $Q = \{1, \dots, k\}$ , where 1 is the initial state and  $k$  the only accepting state. We model this machine as a subshift on  $G \times \mathbb{Z}$ . We define the alphabet  $\mathcal{B} = \mathcal{A} \times \Sigma \times \{0, \dots, k\}$ . Here  $\mathcal{A}$  is the alphabet of  $X$ ,  $\Sigma$  is the alphabet of the working tape and  $\{0, \dots, k\}$  codes the state of the head of a  $G$ -machine, 0 coding the absence of a head. In order to describe the finite set of forbidden patterns we introduce some notation. Recall that  $U$  is defined over the alphabet  $\{\bullet, \star, \oplus, \triangleright\} \times \{0, 1, 2\}$ . Therefore the set of forbidden patterns  $\mathcal{F}$  is defined over the alphabet  $\mathcal{A}_{\text{Final}}$  where:

$$\mathcal{A}_{\text{Final}} = \{\bullet, \star, \oplus, \triangleright\} \times \{0, 1, 2\} \times \mathcal{A} \times \Sigma \times \{0, \dots, k\}.$$

We denote the projection to each of these five coordinates by  $\pi_1, \dots, \pi_5$  respectively. The forbidden patterns in  $\mathcal{F}$  belong to four categories: *configuration patterns*, *starting patterns*, *ending patterns* and *transitions patterns*.

The *configuration patterns* force that every  $\mathbb{Z}$ -coset sees the same symbol in the third coordinate. Said otherwise, the third coordinate is invariant under the action of  $\mathbb{Z}$ . To obtain this we forbid all  $p$  with support  $\{(1_G, 0), (1_G, 1)\}$  such that  $\pi_3(p_{(1_G, 0)}) \neq \pi_3(p_{(1_G, 1)})$ .

The *starting patterns* are defined by forbidding symbols in  $\mathcal{A}_{\text{Final}}$  in a way such that every time the symbol  $\triangleright$  appears in a  $G$ -coset, then the working tape symbols are empty (that is, marked by  $\sqcup$ ) and all positions marked by 1 carry a head with the initial state. Formally, we force that all  $a \in \mathcal{A}_{\text{Final}}$  such that  $\pi_1(a) = \triangleright$  must also satisfy  $\pi_4(a) = \sqcup$ . Furthermore, if  $\pi_2(a) = 1$  then  $\pi_5(a) = 1$  and if  $\pi_2(a) \in \{0, 2\}$  then  $\pi_5(a) = 0$ .

The *ending patterns* are described by forbidding the appearance of any symbol containing the accepting state  $k$ . Formally, every symbol  $a \in \mathcal{A}_{\text{Final}}$  such that  $\pi_5(a) = k$  is forbidden.

The *transition patterns* describe the evolution of  $\tilde{T}$  after a symbol  $\triangleright$ . Each time the symbol  $\bullet$  appears it marks that the  $G$ -machines must execute one step with respect to the previous  $G$ -coset. Basically, if the head is inside a zone given by a 1 or a 2 these patterns execute a step of  $\tilde{T}$ . If the head reaches the border then it does nothing. The formal description is given by the forbidden patterns in  $A_1 \cup A_2 \cup A_3 \cup A_4$  defined as follows:

- Consider the support  $F = \{(1_G, 0), (1_G, 1)\}$ . We define  $A_1$  as the set of  $p \in \mathcal{A}^F$  such that  $\pi_1(p_{(1_G, 1)}) = \bullet$ ,  $\pi_2(p_{(1_G, 1)}) \neq 0$ ,  $\pi_4 \times \pi_5(p_{(1_G, 0)}) = (a, 0)$  and  $\pi_4 \times \pi_5(p_{(1_G, 1)}) = (b, \cdot)$  with  $b \neq a$ .
- Consider the set of all transitions  $\delta(a, q) = (b, r, s)$  of the  $G$ -machine  $\tilde{T}$ .
  - Let  $F = \{(1_G, 0), (1_G, 1)\}$ , we define  $A_2$  as the set of  $p \in \mathcal{A}^F$  such that  $\pi_1(p_{(1_G, 1)}) = \bullet$ ,  $\pi_2(p_{(1_G, 1)}) \neq 0$ ,  $\pi_4 \times \pi_5(p_{(1_G, 0)}) = (a, q)$  and  $\pi_4 \times \pi_5(p_{(1_G, 1)}) = (c, \cdot)$  with  $c \neq b$ .

– Let  $F_s = \{(1_G, 0), (s, 1)\}$ , we define  $A_3$  as the set of  $p \in \mathcal{A}^{F_s}$  such that  $\pi_1(p_{(1_G, s)}) = \bullet$ ,  $\pi_2(p_{(1_G, s)}) \neq 0$ ,  $\pi_4 \times \pi_5(p_{(1_G, 0)}) = (a, q)$  and  $\pi_4 \times \pi_5(p_{(s, 1)}) = (\cdot, t)$  with  $t \neq r$ .

- Consider the support  $F = \{(1_G, 0), (1_G, 1)\}$ . We define  $A_4$  as the set of  $p \in \mathcal{A}^F$  such that  $\pi_1 \times \pi_2(p_{(1_G, 1)}) = (\bullet, 0)$  and  $\pi_4 \times \pi_5(p_{(1_G, 0)}) \neq \pi_4 \times \pi_5(p_{(1_G, 1)})$ .

Finally, we describe the 1-block code  $\phi$ . Let  $\bar{a} \in \mathcal{A}$  be a symbol such that  $\bar{a}^G \in X$ . We define a local function  $\Phi : \mathcal{A}_{\text{Final}} \rightarrow \mathcal{A}$  by:

$$\Phi(a) = \begin{cases} \pi_3(a) & \text{if } \pi_1(a) = \star \\ \bar{a} & \text{otherwise} \end{cases}$$

and we set  $\phi(x)_{(g, k)} = \Phi(x_{(g, k)})$ .

Let  $x \in \mathcal{A}^G$  be the  $G$ -projective subdynamics of  $\phi(z)$ , where  $z \in U \times \mathcal{B}^{G \times \mathbb{Z}}$  and avoids all forbidden patterns in  $\mathcal{F}$ . By definition of  $U$ , as  $\tilde{X}_{\text{time}}$  is a periodic extension, each  $G$ -coset of  $z$  is either completely marked by  $\star$  or does not contain a  $\star$  at all. If this last case happens, then  $x = \bar{a}^G \in X$ . Otherwise  $\pi_1(z)_{(g, 0)} = \star$  and thus by definition of  $U$  we have  $\pi_1(z)_{(g, k)} = \tilde{x}_k$ . Suppose  $x \notin X$ , then there exists a ball  $B_n$  and  $p \in \mathcal{A}^{B_n}$  such that  $[p] \cap X = \emptyset$ . This implies that  $T$  accepts the input  $p$  in a finite number of steps  $n_T$ . By definition,  $\tilde{T}$  also accepts all configurations in  $[p]$  in a number of steps bounded by a function of  $n_T$ . Let  $B_m$  be a ball such that  $\tilde{T}$  never leaves  $B_m$  when working on  $[p]$  (one could take for instance  $m$  as the bound on the number of steps). Let  $N \geq \max\{|Q|, |S|, |\Sigma|, m\}$ . Then we know that  $\tilde{T}$  starting on position  $1_G$  would accept an input in  $[p]$  in less than  $\text{time}(N)$  steps. Consider  $k_N$  the position of the  $N$ -th appearance of  $\otimes$  in  $\tilde{x}$ . By definition we know that in the  $G$ -coset in  $k_N$ , the second coordinate contains a configuration  $y \in \{0, 1, 2\}^G$  such that  $y \in Y_N$ . Therefore, there exists  $g \in B_S(1_G, 4N)$  such that  $y_g = 1$ . As each word of length smaller or equal to  $4N$  appears, then a codification of  $g^{-1}$  eventually does. Using the rules of  $U$ , this means that after this word the next coset is marked by  $\triangleright$ , and the configuration in the second coordinate is  $y' = \sigma^{g^{-1}(y)}$  thus  $y'_{1_{G^-}} = 1$ . By definition of  $\tilde{x}$ , the next  $\text{time}(N)$  cosets are marked by  $\bullet$  thus simulating  $\tilde{T}$  for that number of steps as long as the head does not see a 0 in the second coordinate. As there is a ball of size at least  $N$  around the identity marked by a symbol 2, then  $\tilde{T}$  is run for  $\text{time}(N)$  steps, thus reaching the accepting state  $k$  which is forbidden. This contradicts that  $x \notin X$ .

Conversely, each  $x \in X$  can be obtained by constructing a configuration  $z$  such that  $\pi_3(z)_{(g, k)} = x_g$  and  $\pi_1(z)_{(g, 0)} = \star$ . By definition of  $\tilde{T}$  and similar arguments as above, this configuration can be completed for all  $g \in G$  and  $k \geq 0$  without producing forbidden patterns. For  $k \leq 0$  we can just fill the coordinate  $(g, k)$  with the symbol  $(\bullet, 0, x_g, \sqcup, 0)$  without creating forbidden patterns.  $\square$

We remark that the condition that  $X$  must contain a uniform configuration can easily be replaced by weaker statements. For example, it suffices to contain a periodic configuration or more generally, a  $G$ -SFT  $Y$  such that  $Y \subset X$ . In the proof above it

would suffice to add a  $\mathbb{Z}$ -periodic extension of  $Y$  as an extra coordinate and change the definition of the 1-block code  $\phi$  such that it projects to this coordinate instead of  $\bar{a}$ .

Another interesting aspect of this construction is that even if the subshift  $U$  is  $G \times \mathbb{Z}$ -effectively closed in general, it can sometimes be forced to be a sofic subshift. For example, if  $G = \mathbb{Z}^d$  then  $X_{\text{time}}$  is an effectively closed  $\mathbb{Z}$ -subshift and thus its periodic extension is a sofic  $\mathbb{Z}^{d+1}$ -subshift by [AS13, DRS10]. Also, we remark that in the second coordinate of  $U$ , it suffices to contain a non-empty subsystem of  $Y_n$  in each  $G$ -coset. For  $\mathbb{Z}^d$  it is not hard to produce sofic subshifts with those properties. For example, the subshift shown in Figure 4.6 in which each horizontal strip contains a periodic configuration which doubles its period when advancing vertically can be easily shown to be sofic and adapted by adding extra symbols to produce a suitable subsystem of the second layer of  $U$ .

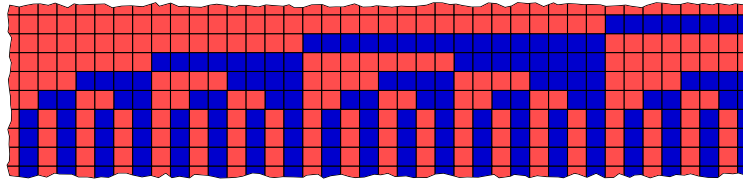

Figure 4.6: A sofic subshift which doubles its period.

### 4.3 Separating sofic and effective subshifts

In the work of Aubrun and Sablik [AS16], it is shown that for subshifts in the hyperbolic plane that satisfy a technical condition, the property of being sofic is equal to the property of being effectively closed. By hyperbolic plane it is meant the monoid  $M = \langle a, a^{-1}, b \mid ab = ba^2, aa^{-1} = 1_M \rangle$  which looks like a shear of the Baumslag-Solitar group  $BS(1, 2)$  (here all the definitions given above for groups naturally extend to monoids). The reason behind this fact is that the doubling structure of this monoid allows to transmit the information on a row  $b^n \langle a \rangle$  to all rows  $b^m \langle a \rangle$  where  $m \geq n$ , and thus a Turing machine calculation can be implemented as an extra SFT extension. This shows that any subshift defined by a recursively enumerated set of pattern codings is in fact a sofic subshift in that context.

This result raises the following questions:

- If we consider the group  $BS(1, 2)$ , is it true that every effectively closed subshift is sofic?
- Is there any group  $G$  such that every  $G$ -effectively closed subshift is sofic?
- Is there any group such that the class of effectively closed subshifts and sofic subshifts coincide?

In this section we give a negative answer to the first question, and give partial negative answers to the second and third questions. More precisely, we show that the equality between the class of  $G$ -effectively closed subshifts and sofic subshifts cannot happen in three cases: recursively presented groups with undecidable word problem, amenable groups and groups with two or more ends.

**Theorem 4.12** (Aubrun, B, Sablik). *For every recursively presented group  $G$  with undecidable word problem there exists a  $G$ -effectively closed subshift which is not sofic*

*Proof.* The subshift  $X_{\leq 1}$  is  $G$ -effectively closed but not sofic for recursively presented  $G$  as stated in Corollary 4.3.  $\square$

Clearly, this does not say anything about the existence of effectively closed subshifts which are not sofic when the word problem is undecidable. In fact, it is not even known whether  $X_{\leq 1}$  is sofic for all groups with decidable word problem.

For the case of amenable groups, we take inspiration in the mirror shift from Example 1.13. This subshift is effectively closed but not sofic. In what follows we generalize the technique which is used to prove its non-soficity to amenable groups.

For a finitely generated group we say a sequence of elements  $(g_n)_{n \in \mathbb{N}}$  is recursive if there is a Turing machine which on input  $n$  produces a word  $w \in S^*$  such that  $w =_G g_n$ . If the Turing machine uses oracle  $\mathcal{O}$  then the sequence is said to be recursive with oracle  $\mathcal{O}$ .

**Lemma 4.13.** *Let  $B_n := B_S(1_G, n)$ . For every infinite group  $G$  there exists a pair of recursive sequences  $(g_n)_{n \in \mathbb{N}}$ ,  $(h_n)_{n \in \mathbb{N}}$  with oracle  $\text{WP}(G)$  such that the family of sets*

$$\mathcal{S} = \{\{1_G\}\} \cup \{g_n B_n\}_{n \in \mathbb{N}} \cup \{h_n B_n\}_{n \in \mathbb{N}}$$

*is pairwise disjoint.*

*Proof.* Fix a total order on  $S$  and extend it to a lexicographic order in  $S^*$ . Let  $T_g, T_h$  be the Turing machines with oracle  $\text{WP}(G)$  that do the following on input  $n \in \mathbb{N}$ .

- Let  $N = 1 + 2 \sum_{k=1}^n (2k+1) = 1 + 2n(n+2)$ . Solve the word problem for every  $w \in S^*$  such that  $|w| \leq 2N$ . This allows to construct  $B_N$  of the Cayley graph  $\Gamma(G, S)$ .
- Assign the value 0 to every  $g \in B_N \setminus \{1_G\}$ , and 1 to  $1_G$ . Assign initially the value  $g_0, \dots, g_n, h_0, \dots, h_n$  to  $\epsilon$ . And initiate a variable  $k$  with its value set initially to 0.
- While  $k \leq n$  do the following: Iterate over all  $w \in S^*$  lexicographically. If for  $w$  all of the values of  $wB_k$  have the value 0 then:
  - Turn all of the values in  $wB_k$  to 1.
  - if  $g_k = \epsilon$  set  $g_k = w$ .
  - otherwise, set  $h_k = w$  and assign  $k \leftarrow k + 1$ .

- For the machine  $T_g$  return  $g_n$ , for  $T_h$  return  $h_n$ .

As  $G$  is infinite and finitely generated there exist elements of arbitrary length. Therefore the bound  $N$  suffices to construct all these disjoint balls: Indeed, it is the sum of the diameters of the considered sets. Moreover, as the lexicographic order is fixed beforehand this algorithm will always produce the same values, therefore it gives a recursive enumeration of the desired sets.  $\square$

**Theorem 4.14** (Aubrun, B, Sablik). *Let  $G$  be an infinite amenable group. Then there exists a  $G$ -effectively closed subshift which is not sofic.*

*Proof.* Let  $(g_n)_{n \in \mathbb{N}}, (h_n)_{n \in \mathbb{N}}$  be recursive sequences with oracle  $\text{WP}(G)$  as in Lemma 4.13, and consider the subshift  $Y \subset \{0, 1, 2\}^G$  defined as  $Y = Y_1 \cap Y_2$  where:

$$Y_1 = \{y \in \{0, 1, 2\}^G \mid 2 \in \{y_g, y_h\} \implies g = h\}$$

$$Y_2 = \{y \in \{0, 1, 2\}^G \mid y_g = 2 \implies \forall n \in \mathbb{N}, \sigma^{g_n^{-1}g^{-1}}(y)|_{B_n} = \sigma^{h_n^{-1}g^{-1}}(y)|_{B_n}\}$$

It is clear these two sets are closed and shift-invariant, thus  $Y$  is a subshift. Moreover, they are both  $G$ -effectively closed subshifts:  $Y_1$  is defined by all pattern codings which contain a pair  $(w_1, 2), (w_2, 2)$  such that  $w_1 \neq_G w_2$  and  $Y_2$  by all pattern codings which contain a triple  $(w_1, 2), (w_2, a), (w_3, b)$  with  $a \neq b$  for which there exists  $n \in \mathbb{N}$  and  $h \in B_n$  such that  $w_2 =_G w_1 g_n h$  and  $w_3 =_G w_1 h_n h$ . As the sequences are recursive with  $\text{WP}(G)$  as oracle this is an effectively enumerable set with oracle  $\text{WP}(G)$ . As the class of  $G$ -effectively closed subshifts is closed under intersections we obtain that  $Y$  is  $G$ -effectively closed.

We are going to show that  $Y$  is not sofic. As  $G$  is amenable (see [CSC09]), for each  $\varepsilon > 0$  and finite  $K \subset G$  there exists a non-empty finite set  $F \subset G$  such that:

$$\forall k \in K, \frac{|F \setminus Fk|}{|F|} < \varepsilon$$

Suppose  $Y$  is sofic, then there exists an SFT  $X \subset \mathcal{B}^G$  and a factor code  $\phi : X \rightarrow Y$ . Without loss of generality one can suppose that  $\phi$  is a 1-block code, that is, it is defined by a local rule  $\Phi : \mathcal{B} \rightarrow \mathcal{A}$ . Indeed, if this was not the case, and  $\tilde{\Phi} : \mathcal{B}^F \rightarrow \mathcal{A}$  for  $F \neq \{1_G\}$  we can find a conjugated version of  $X$  over the alphabet  $\tilde{\mathcal{B}} := \mathcal{B}^F$  which is given by the conjugacy  $\tilde{\phi} : X \rightarrow \tilde{X}$  such that  $\tilde{\phi}(x)_g = \sigma^{g^{-1}}(x)|_F$ . As being SFT is a conjugacy invariant we can choose without loss of generality  $\tilde{X}$  as the extension.

Let  $K$  be the union of the supports of  $p \in \mathcal{F}$  where  $X = X_{\mathcal{F}}$  and  $|\mathcal{F}| < \infty$ ,  $\varepsilon = \frac{\log(2)}{|K| \log(|\mathcal{B}|)}$  and for simplicity denote  $\partial_K F = F \setminus \bigcap_{k \in K} Fk$ . We obtain that there is  $F$  such that:

$$\frac{|\partial_K F|}{|F|} \leq \sum_{k \in K} \frac{|F \setminus Fk|}{|F|} < |K| \frac{\log(2)}{|K| \log(|\mathcal{B}|)} = \frac{\log(2)}{\log(|\mathcal{B}|)}$$

Note that the previous property is invariant by translation, that is, if  $F$  satisfies this property, then  $gF$  also does for each  $g \in G$ . By choosing a large enough  $n \in \mathbb{N}$  such that  $F \subset B_n$ , then  $g_n F \subset g_n B_n$ .

Putting everything together, we can find a set  $F$  such that  $|\mathcal{B}|^{|\partial F|} < 2^{|F|}$  and there exists  $n \in \mathbb{N}$  such that  $1_G \notin g_n F$ ,  $g_n F \subset g_n B_n$  and  $g_n F \cap h_n B_n = \emptyset$ .

Consider the set of patterns:

$$\mathcal{P} = \{p : \{1_G\} \cup g_n F \rightarrow \{0, 1, 2\} \mid p_{1_G} = 2, \forall h \in g_n F : p_h \in \{0, 1\}\}$$

Clearly  $|\mathcal{P}| = 2^{|F|}$ . As  $g_n F \subset g_n B_n$  then for each  $p \in \mathcal{P}$ ,  $[p]_{1_G} \cap Y \neq \emptyset$ . Let  $y^p \in [p]_{1_G} \cap Y$  and  $x^p \in X$  such that  $\phi(x^p) = y^p$ . As  $|\mathcal{B}|^{|\partial F|} < 2^{|F|}$  by pigeonhole principle there are  $x^{p_1} \neq x^{p_2}$  such that  $x^{p_1}|_{g_n \partial F} = x^{p_2}|_{g_n \partial F}$ .

By definition of  $K$  we obtain that  $\tilde{x} \in X$  where  $\tilde{x}$  is the configuration defined as  $\tilde{x}|_F = x^{p_1}|_F$  and  $\tilde{x}|_{G \setminus F} = x^{p_2}|_{G \setminus F}$ . As  $\phi$  is a 1-block code we get that  $\phi(\tilde{x})|_F = y^{p_1}|_F$  and  $\phi(\tilde{x})|_{G \setminus F} = y^{p_2}|_{G \setminus F}$ . Consider  $\bar{g} \in B_n$  such that  $(y^{p_1})_{g_n \bar{g}} \neq (y^{p_2})_{g_n \bar{g}}$ . Then:

$$\begin{aligned} \phi(\tilde{x})_{h_n \bar{g}} &= (y^{p_2})_{h_n \bar{g}} = (y^{p_2})_{g_n \bar{g}} \\ \phi(\tilde{x})_{g_n \bar{g}} &= (y^{p_1})_{g_n \bar{g}} \end{aligned}$$

Therefore  $\phi(\tilde{x})_{h_n \bar{g}} \neq \phi(\tilde{x})_{g_n \bar{g}}$  but  $\phi(\tilde{x})_{1_G} = 2$  which means that  $\phi(\tilde{x}) \notin Y$ .  $\square$

In particular, this theorem gives a negative answer in the case of  $BS(1, 2)$  which is solvable and thus amenable.

**Definition 4.5.** The *number of ends*  $e(G)$  of the group  $G$  is the limit as  $n$  tends to infinity of the number of infinite connected components of  $\Gamma(G, S) \setminus B_n$ .

The number of ends is a quasi-isomorphism invariant and thus it does not depend on the choice of  $S$ . It is also known that for a finitely generated group  $G$  then  $e(G) \in \{0, 1, 2, \infty\}$ . Stallings theorem about ends of groups [Sta68] gives a constructive characterization of the groups satisfying  $e(G) \geq 2$ . In particular we have  $e(G) = 2$  if and only if  $G$  is infinite and virtually cyclic.

**Theorem 4.15** (Aubrun, B, Sablik). *Let  $G$  be a finitely generated group where  $e(G) \geq 2$ . Then there are  $G$ -effectively closed subshifts which are not sofic.*

*Proof.* Let  $N \in \mathbb{N}$  such that  $\Gamma(G, S) \setminus B_N$  contains at least two different infinite connected components  $C_1$  and  $C_2$ .

Let  $(g_i)_{i \in \mathbb{N}} \subset C_1$  and  $(h_i)_{i \in \mathbb{N}} \subset C_2$  be sequences with no repeated elements. Let  $Y \subset \{0, 1, 2\}^G$  defined as  $Y = Y_1 \cap Y_2$  where:

$$Y_1 = \{y \in \{0, 1, 2\}^G \mid 2 \in \{y_g, y_h\} \implies g = h\}$$

$$Y_2 = \{y \in \{0, 1, 2\}^G \mid y_g = 2 \implies \forall n \in \mathbb{N}, y_{gg_n} = y_{gh_n}\}$$

Analogously to the proof of Theorem 4.14, if the sequences are recursive with oracle  $\text{WP}(G)$  then  $Y$  is effectively closed. We claim such sequences exist.

Fix a total order on  $S$  and extend it to a lexicographic order in  $S^*$ . Let  $N$  as above and let  $w_0 \in S^*$  such that  $w_0 =_G g_0 \in C_1$ . Consider the Turing machines  $T_g$  with oracle  $\text{WP}(G)$  that on input  $n \in \mathbb{N}$ :

- If  $n = 0$  returns  $w_0$ .



- Let  $M = N + n + |w_0|$ . Solve the word problem for every  $w \in S^*$  such that  $|w| \leq 2M$ . This allows to construct  $B_M$  of  $\Gamma(G, S)$ .
- Let  $H_{g_0}$  be the connected component of  $B_M \setminus B_N$  which contains  $g_0$ .
- Assign the value 0 to every element of  $H_{g_0} \setminus \{w_0\}$ . and 1 to  $w_0$ . Assign  $g_1, \dots, g_n$  to  $\epsilon$ . And initiate a variable  $k$  with its value set initially to 1.
- While  $k \leq n$  do the following: Iterate over all  $w \in S^*$  lexicographically. If  $w_0w$  has the value 0 and belongs to  $H_{g_0}$  then:
  - Turn the value  $w_0w$  to 1.
  - Assign  $g_k = w_0w$  and increase  $k$  by 1.
- Return  $g_n$ .

As the component  $C_1$  is infinite, the value of  $M$  suffices to find  $n$  different elements. It is clear this machine yields a sequence of distinct elements in component  $C_1$ . The machine  $T_h$  for the sequence in the component  $C_2$  is analogous.

Suppose  $Y$  is sofic. As in Theorem 4.14 we can consider an SFT extension  $X \subset \mathcal{B}^G$  given by a 1-block code  $\phi : X \rightarrow Y$ . Let also  $M \in \mathbb{N}$  be a bound such that the union of all the supports of one finite set of forbidden patterns defining  $X$  is contained in  $B_M$ . Let  $L = N + M$ .

As  $G$  is finitely generated  $|B_L| < \infty$ . Consider thus the finite set  $\mathcal{P} = \{p \in \mathcal{B}^{B_L} \mid \phi([p]_{1_G}) \cap [2]_{1_G} \neq \emptyset\}$ . Clearly  $|\mathcal{P}| \leq |\mathcal{B}|^{|B_L|} < \infty$ . Consider  $w \in \{0, 1\}^{\mathbb{N}}$  and fix  $y^w \in \bigcap_{n \in \mathbb{N}} [w_n]_{g_n} \cap [2]_{1_G}$ . Clearly  $y^w \in Y$ . As there is an infinite number of such  $y^w$  there exist  $w_1 \neq w_2$  and  $x^{w_1}, x^{w_2} \in X$  such that  $\phi(x^{w_1}) = y^{w_1}$  and  $\phi(x^{w_2}) = y^{w_2}$  and  $x^{w_1}|_{B_L} = x^{w_2}|_{B_L}$ .

By definition of  $L$  we have that  $\tilde{x} \in X$  where:

$$\tilde{x}_g = \begin{cases} (x^{w_1})_g, & \text{if } g \in C_1 \\ (x^{w_2})_g, & \text{if } g \in G \setminus C_1 \end{cases}$$

Thus  $\tilde{y} = \phi(\tilde{x})$  satisfies that  $\tilde{y}_{1_g} = 2$ ,  $\tilde{y}|_{C_1} = (y^{w_1})|_{C_1}$  and  $\tilde{y}|_{C_2} = (y^{w_2})|_{C_2}$ . Let  $n \in \mathbb{N}$  such that  $(w_1)_n \neq (w_2)_n$ . Then:  $\tilde{y}_{g_n} = (y^{w_1})_{g_n}$  and  $\tilde{y}_{h_n} = (y^{w_2})_{h_n} = (y^{w_2})_{g_n}$ . Therefore  $\tilde{y} \notin Y_2$  which implies that  $\tilde{y} \notin Y$ .  $\square$

## Chapter 5

# Computability in group invariants of shift spaces

Given two dynamical systems, a natural question is whether they are conjugate or not. In particular, if the systems can somehow be coded with a finite amount of information the question can be asked from a computability point of view. For instance, one could ask if there is an algorithm that receives as input two lists of forbidden words and decides if the two  $\mathbb{Z}$ -subshifts of finite type defined by those lists are conjugate. To date this question still remains an open problem [Boy08]. In the case of  $\mathbb{Z}^d$ -subshifts of finite type the same problem is known to be undecidable. This follows from the fact that it is undecidable whether a finite set of forbidden patterns defined an empty subshift [Ber66]. Moreover, recent studies have given even more precise bounds on the hardness of conjugacy [JV15].

A simpler task is to find tools to determine whether two systems are not conjugate; conjugacy invariants are quite practical in this respect, namely, if a particular invariant is not the same in both systems then that invariant certifies the fact that they cannot be conjugate. For example, the golden mean shift from Example 1.5 cannot be conjugate to a full  $\mathbb{Z}$ -shift because their entropies are different.

The objective of this chapter is to study from a computability perspective two groups which up to isomorphism are invariants of dynamical systems: the automorphism group and the topological full group. These objects have been extensively studied in the literature in the case of  $\mathbb{Z}$ -actions. Just to give a few examples, for the automorphism group see [Hed69, BLR88, KR90, Hoc10, Sal15, DDMP16, CFKP16] and for the topological full group [GPS99, GM14, EM13, Mat15, JM12].

The automorphism group  $\text{Aut}(X, T)$  of a dynamical system  $(X, T)$  is the set of all the homeomorphisms from the space  $X$  to itself which commute with the group action  $T$ . In the case of the shift space  $(\mathcal{A}^G, \sigma)$ , its automorphism group  $\text{Aut}(\mathcal{A}^G)$  consists of all reversible cellular automata, that is to say, all those which admit a cellular automaton inverse. Apart from the theoretical interest in understanding the structure of these groups, they have also been proposed for practical applications. For instance, Kari [Kar90] proposed to use automata in  $\text{Aut}(\mathcal{A}^{\mathbb{Z}^2})$  in public key cryptography.

The full group  $[T]$  of a dynamical system  $(X, T)$  where  $T : G \curvearrowright X$ , was originally defined by Dye [Dye59, Dye63] as an invariant of orbit equivalence for measurable

dynamical systems, More recently, it has also been shown to be a complete invariant of orbit equivalence in the topological setting [Med11]. The full group consists of all homeomorphisms  $\phi$  of the space such that for each  $x \in X$  then  $\phi(x) = T^g(x)$  for some  $g \in G$ . In the case where the space  $X$  is a Cantor set, a more interesting (and smaller) object is a subgroup of  $[T]$  denoted by  $[[T]]$  and called the topological full group. Here, not only  $\phi(x) = T^g(x)$  but  $\phi(x) = T^{s(x)}(x)$  for a continuous function  $s : X \rightarrow G$ . In the case of a full shift this object can also be interpreted as a group of abstract Turing machines which are globally reversible and do not change the tape [BKS16].

The problematics tackled in this chapter concern the computational properties of these group invariants, for instance: is it possible to give algorithmic descriptions of these groups? If so, does a Turing machine which decides if a sequence of descriptions of elements in the groups represents the identity exists? Can it be decided if a given description represents a torsion element?

The results presented in this chapter all come from joint work with Jarkko Kari and Ville Salo. In [BKS16] we study an abstract group of reversible Turing machines which contains in a rather natural way the topological full group and has a close relationship with the automorphism group of a full shift. All of the computability results presented here come from the study of this group. Here I show these results without explicitly introducing the group of Turing machines, focusing instead on the computability aspects in detail.

We can summarize the main results presented in this chapter in Table 5.1. Here WP, TP and FP stand for the word problem, torsion problem and finiteness problem which will be introduced further on and D,U stand respectively for decidable and undecidable. The rows marked by “Group” must be read as follows: in the case of decidability, that there is a recursive presentation of the group where the respective problem is decidable; in the case of undecidability, that for every recursive presentation of the group the problem is undecidable. On the other hand, the rows marked as “F.g subgroups  $H$ ” must be read as either: every finitely generated subgroup  $H$  has decidable problem or there exists a finitely generated subgroup with undecidable problem. We bring to the attention of the reader the fact that while these problems are not dimension sensitive for the automorphism group, they are fundamentally different in the case of the topological full group.

Problem \ Group		$X = \mathcal{A}^{\mathbb{Z}}$		$X = \mathcal{A}^{\mathbb{Z}^d}, d > 1$	
		$[[\sigma]]_X$	$\text{Aut}(X)$	$[[\sigma]]_X$	$\text{Aut}(X)$
Group	WP( $G$ )	D	D	D	D
	TP( $G$ )	D	U	U	U
	FP( $G$ )	D	U	U	U
F.g subgroups $H$	WP( $H$ )	D	D	D	D
	TP( $H$ )	D	U	U	U
	FP( $H$ )	D	U	U	U

Table 5.1: D stands for decidable, U for undecidable.

## 5.1 Two group invariants of shift spaces

In this section two known invariants of shift spaces are presented: the automorphism group and the topological full group. Although we give a general definition of these objects for dynamical systems, our focus will be on the symbolic case and on  $G = \mathbb{Z}^d$ . We begin by defining these objects, showing a few simple properties and giving a little bit of history of what is known about them.

**Definition 5.1.** Let  $(X, T)$  be a dynamical system where  $T : G \curvearrowright X$ . The *automorphism group* of  $(X, T)$  is defined as

$$\text{Aut}(X, T) = \{\phi \in \text{Homeo}(X) \mid \forall g \in G, [T^g, \phi] = \text{id}\}$$

with composition as the group operation. In the case of a subshift  $(X, \sigma)$  we relax the notation and just write  $\text{Aut}(X)$  to denote the set of shift-commuting homeomorphisms of  $X$ .

This group has been extensively studied in the case of a full  $\mathbb{Z}$ -shift and more generally, in the case of a mixing  $\mathbb{Z}$ -SFT where it happens that these groups are known to be very large. To be precise, Kim and Roush [KR90] showed the automorphism group of any full  $\mathbb{Z}$ -shift  $\text{Aut}(\mathcal{A}^{\mathbb{Z}})$  embeds into the automorphism group of any non-trivial mixing  $\mathbb{Z}$ -SFT. Furthermore, Boyle, Lind and Rudolph [BLR88] showed that for any mixing  $\mathbb{Z}$ -SFT its automorphism group contains an isomorphic copy of: the direct sum of every countable collection of finite groups, any free group on a countable number of generators and the countable direct sum of  $\mathbb{Z}$ . In particular, the result of Kim and Roush implies that  $\text{Aut}(\{0, 1\}^{\mathbb{Z}}) \hookrightarrow \text{Aut}(\mathcal{A}^{\mathbb{Z}})$  and  $\text{Aut}(\mathcal{A}^{\mathbb{Z}}) \hookrightarrow \text{Aut}(\{0, 1\}^{\mathbb{Z}})$  for any alphabet  $\mathcal{A}$  with at least two symbols, nevertheless it is still unknown whether  $\text{Aut}(\{0, 1\}^{\mathbb{Z}}) \cong \text{Aut}(\{0, 1, 2\}^{\mathbb{Z}})$  [BLR88].

**Definition 5.2.** Let  $(X, T)$  be a dynamical system where  $T : G \curvearrowright X$  and denote by  $C(X, G)$  the set of continuous functions from  $X$  to  $G$  where  $G$  is equipped with the discrete topology. The *topological full group* of  $(X, T)$  is defined as

$$[[T]] = \{\phi \in \text{Homeo}(X) \mid \exists s \in C(X, G), \phi(x) = T^{s(x)}(x)\}$$

with composition as the group operation. The continuous function  $s : X \rightarrow G$  is called the *cocycle*. In the case of a subshift the full group is denoted by  $[[\sigma]]$ .

*Remark.* This object is usually studied in the literature in the case of minimal actions over the Cantor set, which justifies the notation  $[[T]]$  without reference to the space. In order to avoid confusion, when more than one subshift is involved or the context is not clear enough, we denote the topological full group of  $(X, \sigma)$  by  $[[\sigma]]_X$ .

This notion is studied as a natural subgroup of a less restrictive notion called the *full group* introduced by Dye [Dye59] where the continuity assumption on the cocycle  $s$  is dropped. It was originally meant as an algebraic invariant of orbit equivalence for dynamical systems. In the literature, the topological full group is often studied in the case of a minimal action over a Cantor set. Just to name a few remarkable

results in this context: A Theorem by Giordano, Putnam and Skau [GPS99] shows that two topological full groups of minimal actions  $T, S$  are isomorphic if and only if the actions are flip conjugated, that is, there is  $\alpha \in \text{Homeo}(X)$  such that  $T = \alpha S \alpha^{-1}$  or  $T = \alpha S^{-1} \alpha^{-1}$ . Matui [Mat06] showed that the commutator subgroup of  $[[T]]$  is simple and finitely generated and Juschenko and Monod [JM12] showed that  $[[T]]$  is amenable, thus giving natural examples of infinite, finitely generated, amenable and simple groups

In our case, we focus on the topological full groups of non-minimal systems, specifically, we will be mostly speaking about  $[[\sigma]]$  for a full  $\mathbb{Z}^d$ -shift  $(\mathcal{A}^{\mathbb{Z}^d}, \sigma)$ . We begin by showing a few properties of these groups.

**Proposition 5.1.** *Let  $(X, T)$  and  $(Y, S)$  be conjugate  $G$ -dynamical systems. Then  $\text{Aut}(X, T) \cong \text{Aut}(Y, S)$  and  $[[T]] \cong [[S]]$ .*

*Proof.* Let  $\phi : X \rightarrow Y$  be a conjugacy. Define  $\eta : \text{Homeo}(X) \rightarrow \text{Homeo}(Y)$  by  $\eta(\varphi) = \phi \circ \varphi \circ \phi^{-1}$ . Clearly  $\eta$  is a homomorphism as:

$$\eta(\varphi_1 \circ \varphi_2) = \phi \circ (\varphi_1 \circ \varphi_2) \circ \phi^{-1} = (\phi \circ \varphi_1 \circ \phi^{-1}) \circ (\phi \circ \varphi_2 \circ \phi^{-1}) = \eta(\varphi_1) \circ \eta(\varphi_2).$$

Moreover, it is an isomorphism. Let  $\varphi_1, \varphi_2$  such that  $\eta(\varphi_1) = \eta(\varphi_2)$ . Then  $\forall x \in X$  we have:

$$\varphi_1(x) = \phi^{-1}(\eta(\varphi_1)(\phi(x))) = \phi^{-1}(\eta(\varphi_2)(\phi(x))) = \varphi_2(x).$$

Thus  $\varphi_1 = \varphi_2$  and  $\eta$  is injective. To show its onto it suffices to take  $\tilde{\varphi} \in \text{Homeo}(Y)$  and note that  $\varphi := \phi^{-1} \circ \tilde{\varphi} \circ \phi \in \text{Homeo}(X)$  and  $\eta(\varphi) = \tilde{\varphi}$ .

Let  $\varphi \in \text{Aut}(X, T)$  and let  $g \in G$ . We have:

$$S^g \circ \phi \circ \varphi \circ \phi^{-1} = \phi \circ T^g \circ \varphi \circ \phi^{-1} = \phi \circ \varphi \circ T^g \circ \phi^{-1} = \phi \circ \varphi \circ \phi^{-1} \circ S^g$$

and therefore for each  $g \in G$ ,  $[S^g, \eta(\varphi)] = \text{id}$  and thus  $\eta(\varphi) \in \text{Aut}(Y, S)$ . This shows that  $\text{Aut}(X, T) \cong \text{Aut}(Y, S)$ .

If  $\varphi \in [[T]]$ , by definition we have that there is a cocycle  $s \in C(X, G)$  such that  $\varphi(x) = T^{s(x)}(x)$ . Note that  $s' := s \circ \phi^{-1} \in C(Y, G)$  and let  $y = \phi(x)$ . Then:

$$\eta(\varphi)(y) = \phi \circ \varphi \circ \phi^{-1}(y) = \phi(T^{s(x)}(x)) = S^{s \circ \phi^{-1}(y)}(\phi(x)) = S^{s'(y)}(y).$$

Therefore  $\eta(\varphi) \in [[S]]$  and has cocycle  $s'$ . This shows that  $[[T]] \cong [[S]]$ . □

The topological full group admits an explicit characterization in the case where the space  $X$  is a Cantor set. It boils down to the fact that the cocycle has a bounded image and only depends on a finite clopen partition. In the case of a shift space it can be written as follows:

**Proposition 5.2.** *Let  $X \subset \mathcal{A}^G$  a subshift and  $\phi \in \text{Homeo}(X)$ . Then  $\phi \in [[\sigma]]$  if and only if  $\exists p_1, \dots, p_n \in L(X)$  and  $g_1, \dots, g_n \in G$  such that  $X = \bigcup_{i=1}^n [p_i]$ ,  $\forall i \neq j$ ,  $[p_i] \cap [p_j] = \emptyset$  and  $\phi(x) = \sigma^{g_i}(x) \iff x \in [p_i]$ .*

*Proof.* The “if” direction is straightforward as  $s : X \rightarrow G$  defined by  $s(x) = g_i \iff x \in [p_i]$  is continuous and  $\phi(x) = \sigma^{s(x)}(x)$ . Conversely, if  $\phi \in [[\sigma]]$  then there exists a cocycle  $s : X \rightarrow G$ . Write  $X = \bigcup_{g \in G} s^{-1}(g)$ . The sets  $s^{-1}(g)$  are pairwise disjoint and as  $\{g\}$  is open in the discrete topology of  $G$ , then  $s^{-1}(g)$  is open in the product topology of  $\mathcal{A}^G \cap X$ . This means that  $\{s^{-1}(g) \mid g \in G\}$  is an open partition of  $X$ . Furthermore, write each  $s^{-1}(g)$  as a union of cylinders defined by patterns:  $s^{-1}(g) = \bigcup_{i \in I_g} [p_{i,g}]$ .

As  $X$  is compact there is a finite subcover  $X = [p_{i_1, g_1}] \cup [p_{i_2, g_2}] \cdots \cup [p_{i_m, g_m}]$ . By definition if  $g_j \neq g_k$  then  $[p_{i_j, g_j}] \cap [p_{i_k, g_k}] = \emptyset$ . We can refine this partition to obtain  $p_1, \dots, p_n$  which form a disjoint partition of  $X$  and by definition  $s$  is constant on each  $[p_i]$ . Setting  $g_i$  as the value of  $s$  over  $[p_i]$  we obtain the result.  $\square$

**Proposition 5.3.** *Let  $G$  be a countable group and  $X \subset \mathcal{A}^G$  a subshift. Then the cardinality of both  $\text{Aut}(X)$  and  $[[\sigma]]$  is at most countably infinite.*

*Proof.* By Theorem 1.2 every shift commuting homeomorphism is a sliding-block code. It suffices to show that there are at most countably many. Indeed, As  $G$  is countable the set of supports  $F \subset G$  is countable and every sliding block code is defined by a support  $F$  and a function from  $\mathcal{A}^F \rightarrow \mathcal{A}$ . As the countable union of finite sets is countable, we get that  $\text{Aut}(X)$  is at most countable.

In the case of the topological full group, Proposition 5.2 implies that every element is defined by a finite set of patterns and group elements. This is once again at most countable if  $G$  is countable.  $\square$

Homeomorphisms in the topological full group do not necessarily commute with the action, therefore they may not belong to the automorphism group. In fact, the topological full group could be larger than the automorphism group.

*Example 5.1.* Let  $(X_{\text{Led}}, \sigma)$  be the Ledrappier subshift from Example 1.7. It can be shown that the only automorphisms over  $X_{\text{Led}}$  are the shifts:  $\text{Aut}(X_{\text{Led}}) \cong \mathbb{Z}^2$  (see for instance [Sch95] or [BRY16]). It is also easy to show that the projective  $(\mathbb{Z}, 0)$ -subdynamics of  $X_{\text{Led}}$  is  $\pi_{(\mathbb{Z}, 0)}(X_{\text{Led}}) = \{0, 1\}^{\mathbb{Z}}$ . As elements of the topological full group need not be shift-commuting, the topological full group  $[[X]]_{\mathcal{A}^{\mathbb{Z}}}$  of a full  $\mathbb{Z}$ -shift over  $\{0, 1\}$  embeds into  $[[\sigma]]_{X_{\text{Led}}}$ . In particular, as every countable free group embeds into the topological full group of a full  $\mathbb{Z}$ -shift [BKS16] we get that for  $(X_{\text{Led}}, \sigma)$  then  $F_2 \hookrightarrow [[\sigma]]_{X_{\text{Led}}} \not\rightarrow \text{Aut}(X_{\text{Led}}) \cong \mathbb{Z}^2$ .

Although the previous example shows that the topological full group of a shift space might be larger than its automorphism group, there is a canonical embedding from the topological full group into the automorphism group of the shift space times a full  $G$ -shift over a two symbol alphabet.

**Proposition 5.4.** *Let  $X \subset \mathcal{A}^G$  be a subshift and  $[[\sigma]]$  its topological full group. Then,*

$$[[\sigma]] \hookrightarrow \text{Aut}(X \times \{0, 1\}^G).$$

*Proof.* We claim that any pair  $(\phi, x) \in [[\sigma]] \times X$  induces a permutation  $\pi_{\phi, x} \in \text{Sym}(G)$ . Namely, let  $s : X \rightarrow G$  be the cocycle of  $\phi$ , then:

$$\pi_{\phi, x}(g) := s(\sigma^g(x))g.$$

Let's first show that  $\pi_{\phi,x}$  is injective. If  $\pi_{\phi,x}(g) = \pi_{\phi,x}(h)$  then  $\phi(\sigma^g(x)) = \sigma^{s(\sigma^g(x))g}(x) = \sigma^{s(\sigma^h(x))h}(x) = \phi(\sigma^h(x))$ . As  $\phi$  is a homeomorphism, we obtain that  $\sigma^g(x) = \sigma^h(x)$ , implying that  $s(\sigma^g(x)) = s(\sigma^h(x))$  and therefore  $g = h$ . Hence  $\pi_{\phi,x}$  is injective.

If  $s_1, s_2$  are the cocycles of  $\phi_1$  and  $\phi_2$  respectively then the cocycle of  $\phi_1 \circ \phi_2$  is  $s_3(x) := s_2(\sigma^{s_1(x)}(x))s_1(x)$ . A simple calculation yields:

$$\pi_{\phi_1,x} \circ \pi_{\phi_2,x}(g) = \pi_{\phi_1,x}(s_1(\sigma^g(x))g) = s_2(\sigma^{s_1(\sigma^g(x))g}(x))s_1(\sigma^g(x))g = s_3(\sigma^g(x))g$$

Therefore  $\pi_{\phi_1 \circ \phi_2,x} = \pi_{\phi_1,x} \circ \pi_{\phi_2,x}$  and thus  $\pi_{\phi,x} \circ \pi_{\phi^{-1},x} = \pi_{\text{id},x} = \text{id}$ . This means that every  $h \in G$  it suffices to take  $g := \pi_{\phi^{-1},x}(h)$  and we have  $\pi_{\phi,x}(g) = h$  showing that  $\pi_{\phi,x}$  is surjective.

Let  $\varphi : [[\sigma]] \rightarrow \text{Aut}(X \times \{0, 1\}^G)$  defined by  $\varphi(\phi)(x, y) = (x, \tilde{y})$  where:

$$\tilde{y}_g = 1 \iff g = \pi_{\phi,x}(h) \text{ and } y_h = 1.$$

That is,  $\varphi(\phi)$  does not modify  $x$  but permutes the positions marked by 1 in the second coordinate by  $\pi_{\phi,x}$ . By Proposition 5.2 the cocycle  $s$  only depends on a finite support (the union of the support of all the  $p_i$ ) and thus  $\varphi(\phi)$  is continuous. It is also straightforward to check that  $\varphi(\phi)$  commutes with  $\sigma^g$  for every  $g \in G$ . Therefore  $\varphi(\phi) \in \text{Aut}(X \times \{0, 1\}^G)$ .

We claim  $\varphi$  is a monomorphism. It is clearly a morphism as the permutation induced by  $\phi_1 \circ \phi_2$  is just  $\pi_{\phi_1,x} \circ \pi_{\phi_2,x}$ . Now, if  $\phi_1 \neq \phi_2$  there is  $x \in X$  where they act differently. If we consider the configuration  $(x, y)$  where  $y_{1_G} = 1$  and 0 elsewhere, then  $\phi_1(x, y) \neq \phi_2(x, y)$ . Therefore  $\varphi$  is injective.  $\square$

In particular, as every full  $\mathbb{Z}$ -shift with at least two symbols embeds into each mixing  $\mathbb{Z}$ -SFT [KR90], we obtain the following Corollary.

**Corollary 5.5.** *Let  $[[\sigma]]$  be the topological full group of the full  $\mathbb{Z}$ -shift on two symbols. Then  $[[\sigma]]$  embeds into any mixing  $\mathbb{Z}$ -SFT.*

## 5.2 Computability properties

We focus our study on three formal languages that can be defined on groups: the word problem, the torsion problem and the finiteness problem. The first consists of the set of words written on a set of generators which represent the identity of the group. The second language consists of all words for which a power of the element they represent is equal to the identity. The last one consists of all finite sequences of words such that the elements they represent generate a finite group.

**Definition 5.3.** Let  $G$  be a finitely generated group and  $S \subset G$  a finite generating set. We define:

- The *word problem* of  $G$  as the language

$$\text{WP}(G) := \{w \in S^* \mid w =_G 1_G\}.$$

- The *torsion problem* of  $G$  as the language

$$\text{TP}(G) := \{w \in S^* \mid \exists n \in \mathbb{N}, w^n =_G 1_G\}.$$

- The *finiteness problem* of  $G$  as the language

$$\text{FP}(G) := \{w_1, \dots, w_k \in S^* \mid |\langle w_1, \dots, w_k \rangle_G| < \infty\}.$$

*Remark.* The notations  $\text{WP}(G)$ ,  $\text{TP}(G)$  and  $\text{FP}(G)$  do not make reference to a set of generators. The reason behind this is that we are only interested in their computability properties. Formally speaking, given the languages  $\text{WP}(G, S_1)$  and  $\text{WP}(G, S_2)$  of the word problem of  $G$  with respect to fixed set of generators  $S_1$  and  $S_2$ , there exists a computable reduction  $\varphi : \text{WP}(G, S_1) \rightarrow \text{WP}(G, S_2)$  which is given by replacing each appearance of  $s \in S_1$  by a fixed word in  $S_2^*$  representing  $s$ . For more details, see Proposition B.5. The same holds for  $\text{TP}(G)$  and  $\text{FP}(G)$ .

If  $\text{WP}(G)$  is recursively enumerable, then the same holds for  $\text{TP}(G)$  and  $\text{FP}(G)$ . However, neither  $\text{WP}(G)$  or  $\text{TP}(G)$  can be Turing-reduced to the other. In Theorem 5.11 we show an example of a finitely generated group with decidable word problem but undecidable torsion problem. The converse can also happen as shown in the following example.

*Example 5.2.* Let  $p$  be a prime number. An infinite group  $G$  is called a  $p$ -Tarski monster if every non-trivial subgroup has order  $p$ . Ol'shanskii [Ol'81] showed that for each prime  $p \geq 10^{75}$  there are uncountably many non-isomorphic  $p$ -Tarski monsters and that they are finitely generated. By definition, each element of a Tarski monster satisfies  $g^p = 1_G$ . In consequence the torsion problem of all of these groups is decidable. On the other hand, as the set of Turing machines is countable, there must exist a Tarski monster with undecidable word problem.

However, in the case of the torsion and finiteness problem the situation is better. Here we have that  $\text{TP}(G)$  can be Turing-reduced to  $\text{FP}(G)$ . Indeed, given  $w \in S^*$  one can run the algorithm deciding  $\text{FP}(G)$  over the list consisting solely on the word  $w$  and accept if and only if it does. By definition this algorithm accepts only in the case where  $|\langle w \rangle_G| < \infty$  and thus where there is a power of  $w$  which is the identity.

In order to study these languages in automorphism groups and topological full groups, we need to extend their definition to countable groups which are not finitely generated. This is no longer independent of the presentation.

**Definition 5.4.** The *word problem* of a recursive group presentation  $\langle S \mid R \rangle$  is defined as the language

$$\text{WP}(S \mid R) = \{w \in S^* \mid w =_{\langle S \mid R \rangle} 1_{\langle S \mid R \rangle}\}$$

The torsion and finiteness problem are defined analogously.

In contrast to the case of finitely generated groups, there can be two recursive presentations of the same group with word problems which are not Turing equivalent.



*Example 5.3.* Let  $K \subset \mathbb{N}$  be a recursively enumerable but undecidable subset of natural numbers and

$$\begin{aligned} G &\cong \langle \{a_n\}_{n \in \mathbb{N}} \mid \{[a_n, a_m]\}_{n, m \in \mathbb{N}} \cup \{(a_k)^2\}_{k \in K} \rangle \\ &\cong \langle \{b_n\}_{n \in \mathbb{N}} \mid \{[b_n, b_m]\}_{n, m \in \mathbb{N}} \cup \{(b_\ell)^2\}_{\ell \text{ is even}} \rangle. \end{aligned}$$

Both presentations give the same group  $G$ . Indeed, given two bijections  $\varphi_0 : \mathbb{N} \rightarrow K$  and  $\varphi_1 : \mathbb{N} \rightarrow \mathbb{N} \setminus K$  we can define the isomorphism such that  $\varphi(b_{2i}) = a_{\varphi_0(i)}$  and  $\varphi(b_{2i+1}) = a_{\varphi_1(i)}$ .

The first presentation has undecidable word and torsion problem: otherwise one could decide whether  $k \in K$  by using the algorithm solving the word or torsion problem over  $a_k^2$ . However, the second presentation has decidable word and torsion problem.

**Definition 5.5.** We say a countable group  $G$  has decidable *word problem* (respectively *torsion problem* and *finiteness problem*) if there exists a recursive presentation of  $G$  with decidable word problem (respectively torsion problem and finiteness problem).

It is straightforward to see that if  $G$  has decidable word problem, then each finitely generated subgroup of  $G$  also does. The following example shows that the converse does not hold: a recursively presented group with undecidable word problem can be such that every finitely generated subgroup of it has decidable word problem. This justifies the need for Definition 5.5.

*Example 5.4.* Let  $K \subset \mathbb{N}$  be a recursively enumerable but undecidable subset of natural numbers,  $\{p_k\}_{k \in \mathbb{N}}$ ,  $\{q_k\}_{k \in \mathbb{N}}$  two disjoint recursive enumerations of prime numbers (for instance, the primes which are respectively 1 and 3 mod 4) and a group  $G$  defined by the following recursive presentation:

$$G = \langle \{a_n\}_{n \in \mathbb{N}} \mid \{[a_n, a_m], (a_n)^{p_n q_n}\}_{n, m \in \mathbb{N}} \cup \{(a_k)^{p_k}\}_{k \in K} \rangle.$$

$G$  is abelian as the relations  $\{[a_n, a_m]\}_{n, m \in \mathbb{N}}$  hold. As a consequence, every finitely generated subgroup of  $G$  is equal up to isomorphism to one of the form  $\mathbb{Z}^d \times \prod_{i \leq \ell} \mathbb{Z}/p_i^{k_i} \mathbb{Z}$  (in fact, in this case  $d = 0$ ) and has therefore decidable word, torsion and finiteness problem. On the other hand, suppose  $G$  admits a recursive presentation  $\langle S \mid R \rangle$  with decidable word problem and let  $k \in \mathbb{N}$ . It is not hard to see that there exists a group element  $g \in G \setminus \{1_G\}$  such that  $g^{q_k} = 1_G$  if and only if  $k \notin K$ . Therefore, an algorithm accepting if and only if  $k \notin K$  is given by the one which enumerates all words in  $S^*$ , runs  $\text{WP}(G)$  over  $w$  and  $w^{q_k}$  and accepts if and only if the algorithm for  $\text{WP}(G)$  rejects  $w$  and accepts  $w^{q_k}$  for some  $w \in S^*$ . This shows that  $K$  is co-recursively enumerable, thus contradicting the fact that  $K$  is undecidable.

*Remark.* An arbitrary countable group requires a uniform Turing machine to decide its word problem. In the previous example, we see that even though such a machine might not exist, it might be the case that every finitely generated group admits such a machine. This is one of the main motivations for Theorem 5.11 and Theorem 5.19.

In what follows we study these three problems in the case where the group is either the topological full group or the automorphism group of a subshift. Even though many of the results presented here are in the case of arbitrary subshifts in groups, the main focus is on the case of a full  $\mathbb{Z}^d$ -shift.

### 5.2.1 Computability in the topological full group

We begin by showing that the word problem of the topological full group is decidable as long as the language of the shift space is decidable and the group has decidable word problem.

**Proposition 5.6.** *Let  $G$  be a finitely generated group with decidable word problem and  $X \subset \mathcal{A}^G$  a subshift. If  $X$  is effectively closed then  $[[\sigma]]_X$  is recursively presented. Furthermore, if the set of pattern codings:*

$$\{c \text{ pattern coding} \mid [c] \cap X = \emptyset\}$$

*is decidable, then  $[[\sigma]]_X$  has decidable word problem.*

*Proof.* By Proposition 5.2 we know that every element of  $[[\sigma]]_{\mathcal{A}^G}$  –more precisely its cocycle– can be represented by a finite list of patterns and group elements. Let  $\phi_1, \phi_2$  be elements of a topological full group where the cocycle of  $\phi_1$  is determined by a partition  $\{[p_1], \dots, [p_n]\}$  of  $X$  and group elements  $g_1, \dots, g_n$  and that of  $\phi_2$  by  $\{[q_1], \dots, [q_m]\}$  and  $h_1, \dots, h_m$  respectively. Then the cocycle of  $\phi_1 \circ \phi_2$  is given by the refinement  $\{[q_1], \dots, [q_m]\} \vee \{\sigma^{g_1}([p_1]), \dots, \sigma^{g_n}([p_n])\}$  where the new partition  $[q_i] \cap \sigma^{g_j}([p_j])$  is now associated to  $h_i g_j$ .

The previous computation shows the following: if in the description of a cocycle we replace patterns and group elements by pattern codings and words over a finite set of generators respectively, the composition of cocycles can be computed.

Let  $S$  be a finite generating set of  $G$  and  $\mathcal{C}$  the set of all pattern codings. Each finite subset of  $F \subset \mathcal{C} \times S^*$  represents a cocycle  $s_F$ . Let  $A$  be the set of finite subsets  $F$  of  $\mathcal{C} \times S^*$  such that:

- All pattern codings appearing in  $F$  are consistent;
- The set of pattern codings appearing in  $F$  forms a partition of  $\mathcal{A}^G$ ;
- $\phi$  defined by  $\phi(x) = \sigma^{s_F(x)}(x)$  is a homeomorphism.

We claim that  $A$  is a decidable set. Indeed, given an input  $F$  the first and second conditions can be easily checked due to  $\text{WP}(G)$  being decidable. For the third one, let  $F = \{(c_1, w_1), \dots, (c_n, w_n)\}$  and suppose that it has already been checked that  $\{[c_1], \dots, [c_n]\}$  is a partition of  $\mathcal{A}^G$ . It suffices to check if  $\{[w_1 \cdot c_1], \dots, [w_n \cdot c_n]\}$  is a partition where given  $c = (u_i, a_i)_{i \in I}$  the pattern coding  $w \cdot c$  is defined by  $w \cdot c = (wu_i, a_i)_{i \in I}$ . This can also be checked using the algorithm to decide  $\text{WP}(G)$ . Now, if  $\{[w_1 \cdot c_1], \dots, [w_n \cdot c_n]\}$  is a partition, it suffices to define  $F' = \{(w_1 \cdot c_1, w_1^{-1}), \dots, (w_n \cdot$

$c_n, w_n^{-1})\}$  which gives a cocycle for an inverse; if it is not a partition, then the function defined by the cocycle  $s_F$  is not surjective and thus not a homeomorphism.

We are going to build a recursive group presentation for  $[[\sigma]]_X$  using  $A$  as the set of generators. By definition,  $A$  is a recursive set and every element in it is in  $[[\sigma]]_{\mathcal{A}G}$ . Let  $R = R_1 \cup R_2 \subset A^*$  be the set of relations defined as:

$$R_1 = \{F \in A \mid \exists(c, w) \in F \text{ such that } [c] \cap X = \emptyset \text{ and } w \neq_G 1_G\}$$

$$R_2 = \{F_1 F_2 F_3^{-1} \in A^3 \mid s_{F_1} \circ s_{F_2} = s_{F_3}\}$$

As  $X$  is effectively closed, by Lemma 1.13 we obtain that the set  $R_1$  is recursively enumerable. Also, by the arguments explained above,  $R_2$  is decidable and thus  $\langle A \mid R \rangle$  is a recursive presentation. We claim that  $[[\sigma]]_X \cong \langle A \mid R \rangle$ . Indeed, the set  $R_1$  identifies with the identity all homeomorphisms which have non-trivial movement outside of  $X$ , therefore leaving only elements of  $[[\sigma]]_X$  in  $A$ . The second rule correctly simulates the composition. This shows that  $[[\sigma]]_X$  is recursively presented.

Finally, suppose that the set of pattern codings  $c$  such that  $[c] \cap X = \emptyset$  is decidable. We show that  $\langle A \mid R \rangle$  has decidable word problem: Let  $w = F_1 F_2 \dots F_n \in A^*$ . Composing the rules as explained above, we obtain  $F_w \in A$  such that  $F_1 F_2 \dots F_n =_{\langle A \mid R \rangle} F_w$ . It suffices to run the following procedure on  $F_w$ : if there exists a pair  $(c, w) \in F_w$  with  $w \neq 1_G$  and  $[c] \cap X \neq \emptyset$ , return  $w \neq_{\langle A \mid R \rangle} \text{id}$ . Otherwise return  $w =_{\langle A \mid R \rangle} \text{id}$ . This can be implemented by putting together the algorithm to decide  $\text{WP}(G)$  and that which decides if  $[c] \cap X = \emptyset$ .  $\square$

**Corollary 5.7.** *Let  $G$  be a finitely generated group with decidable word problem. Then the topological full group  $[[\sigma]]$  of the full  $G$ -shift is a recursively presented group with decidable word problem.*

The previous result is not surprising as elements of the topological full group are defined by local information. One way of visualizing them is to put a Turing machine head in the identity of the group, look at the configuration around a finite radius, and decide the movement of the head according to the pattern which is seen.

In what follows we focus on the torsion problem of the topological full group. In this case the problem happens to be dimension sensitive. We show that for sofic  $\mathbb{Z}$ -subshifts both the finiteness and torsion problems are decidable, while the full  $\mathbb{Z}^2$ -shift over a two symbol alphabet already contains a finitely generated subgroup with undecidable torsion problem.

**Theorem 5.8** (B, Kari, Salo). *Let  $(X, \sigma)$  be a sofic  $\mathbb{Z}$ -subshift. The finiteness problem of  $[[\sigma]]_X$  is decidable.*

*Proof.* By Proposition 5.6 we have that  $\text{WP}([[\sigma]]_X)$  is decidable. As a consequence,  $\text{FP}([[\sigma]]_X)$  is recursively enumerable. Hence, it suffices to show that it is co-recursively enumerable.

Let  $\phi_1, \dots, \phi_n \in [[\sigma]]_X$  and  $T = \{\phi_1, \dots, \phi_n\} \cup \{\phi_1^{-1}, \dots, \phi_n^{-1}\}$ . From the description of each of these elements of  $T$ , one can easily extract  $N \in \mathbb{N}$  such that both the support of the patterns  $p_1, \dots, p_n$  defining it and the image of its cocycle are contained in  $\{-N, \dots, N\}$ .

To any sofic  $\mathbb{Z}$ -subshift one can associate an object called the syntactic monoid, for a formal definition see [LM95]. It consists of a finite monoid  $\mathcal{M}$  with an absorbing element  $0$  and a computable function  $\mathbf{m} : \mathcal{A}^* \rightarrow \mathcal{M}$  such that for every  $u, v \in \mathcal{A}^*$  then  $\mathbf{m}(u)\mathbf{m}(v) = \mathbf{m}(uv)$  and  $\mathbf{m}(w) = 0$  if and only if  $w \notin L(X)$ . This object gives an abstract representation of the set of right extensions of a word  $u \in \mathcal{A}^*$ , that is, the set of  $x^+ \in \mathcal{A}^{\mathbb{N}}$  such that each subword of  $ux^+$  is in  $L(X)$ .

Also, define  $\mathbf{d} : \mathcal{A}^* \rightarrow \mathcal{D}$  where  $\mathcal{D}$  is the set of functions from  $\{-N, \dots, N\}$  to  $2^{\{-N, \dots, N\}}$  where  $\mathbf{d}(u)$  is defined as follows:  $m \in (\mathbf{d}(u))(n)$  if and only if for every left and right extension  $x^-, x^+$  such that  $x^- \cdot ux^+ \in X$  there exist  $t_1, \dots, t_k \in T$  such that  $(t_k \circ \dots \circ t_1) \circ \sigma^n(x^- \cdot ux^+) = \sigma^m(x^- \cdot ux^+)$ . In simpler words, if one starts at position  $n$  with respect to the start of  $u$ , there is a sequence of elements of  $T$  which end up at position  $m$  with respect to the end of  $u$ .

We can define a product  $*$  in  $\mathcal{D}$  as follows, let  $f_1, f_2$  be two functions in that space and define  $m \in (f_2 * f_1)(n)$  if and only if there exists  $k \in \{-N, \dots, N\}$  such that  $m \in f_2(k)$  and  $k \in f_1(n)$ . It follows directly from the definition that  $\mathbf{d}(u) * \mathbf{d}(v) = \mathbf{d}(uv)$ . Moreover, using a labeled graph representation of  $X$  and the fact that the movement of each  $t \in T$  is bounded by  $N$  we obtain that  $\mathbf{d}$  is computable.

Consider  $\varphi(u) : \mathcal{A}^* \rightarrow \mathcal{M} \times \mathcal{D}$  defined by  $\varphi(u) := (\mathbf{m}(u), \mathbf{d}(u))$ . By definition,  $\varphi$  is a semigroup morphism. We claim there exists  $M > 0$  such that for each word  $w \in L(X)$  of length at least  $M$ , then there exists a subword  $uv \sqsubset w$  where both  $u, v$  are non-empty and  $\varphi(u) = \varphi(v) = \varphi(uv)$ . To prove this claim, let  $w$  be a word of length  $\ell$ , and consider the set  $A = \{(i, j) \mid 0 \leq i < j \leq \ell\}$  and the coloring  $c(i, j) = \varphi(w|_{\{i, \dots, j-1\}})$ . By Ramsey's theorem, there exists a large enough  $M$  (depending only on  $|\mathcal{M} \times \mathcal{D}|$ ) such that there is a monochromatic triple  $(i, j), (j, k), (i, k)$ . Defining  $u = w|_{\{i, \dots, j-1\}}$  and  $v = w|_{\{j, \dots, k-1\}}$  yields the result.

Finally, given such a pair  $u, v$ , it follows that for  $k \geq 1$

$$\varphi(u) = \varphi(uv) = \varphi(u)\varphi(v) = \varphi(u)\varphi(u) = \dots = \varphi(u^k).$$

Now, consider again  $\langle T \rangle$ . If this group is infinite, then there exists arbitrarily big words  $w \in L(X)$  and  $n$  such that  $\mathbf{d}(w)(n) \neq \emptyset$ . By the previous argument, if  $w$  is long enough, then there is  $u \sqsubset w$  such that  $\varphi(u) = \varphi(u^k)$  for all  $k \in \mathbb{N}$ .  $\mathbf{d}(u)(n) \neq \emptyset$ , otherwise it would "block"  $w$  and force  $\mathbf{d}(w)(n) = \emptyset$ . Also  $\mathbf{m}(u) \neq 0$  as  $u \in L(X)$ . Therefore there are arbitrarily big words  $u^k \in L(X)$  such that  $\mathbf{d}(u^k)(n) \neq \emptyset$ , meaning that there is a sequence of  $t_i \in T$  which shifts to the right on  $u^k$ . As the cocycle of each homeomorphism is bounded by  $N$ , there are arbitrarily long words in  $\langle T \rangle$  which act differently to any smaller length word. Hence  $\langle T \rangle$  is infinite. As  $\mathbf{d}$  is computable, this ends the proof.  $\square$

**Corollary 5.9.** *Let  $(X, \sigma)$  be a sofic  $\mathbb{Z}$ -subshift. The torsion problem of  $[[\sigma]]_X$  is decidable.*

Before tackling the problem in the multidimensional case, we recall the snake tiling problem introduced in [Kar03]. It is the computational problem which has as input a set of Wang tiles (see Example 1.9) with a direction arrow drawn on them and asks whether there is a partial tiling of the plane  $x : \mathbb{Z}^2 \rightarrow \tau \cup \{\epsilon\}$  – that is, some positions

can be left without tiles (they are assigned  $\epsilon$ ) – such that if among two adjacent tiles the arrow of one points to the other then they share the same color on the adjacent edge. Furthermore we ask that at least one bi-infinite path appears while following the arrows drawn on the tiles.

For the next proof we are going to use a slightly modified version of the snake tiling problem.

**Definition 5.6.** Let  $D = \{(1, 0), (-1, 0), (0, 1), (0, -1)\}$ ,  $\tau$  be a set of Wang tiles and  $\mathbf{left} : \tau \rightarrow D$ ,  $\mathbf{right} : \tau \rightarrow D$  functions. We define the *snake tiling problem* as the set  $\mathbf{STP} = \{\tau, \mathbf{left}, \mathbf{right} \mid \text{there is a snake}\}$  where the property “there is a snake” is defined as: there exists a partial tiling  $x : \mathbb{Z}^2 \rightarrow \tau \cup \{\epsilon\}$  and a function  $p : \mathbb{Z} \rightarrow \mathbb{Z}^2$  such that  $x(p(n)) \in \tau$ ,  $p(n+1) - p(n) = \mathbf{right}(x(p(n)))$  and  $p(n) - p(n+1) = \mathbf{left}(x(p(n+1)))$  for all  $n \in \mathbb{Z}$ . Furthermore, all the Wang tiles  $\tau$  appearing on  $x$  must match their non- $\epsilon$  neighbors along the arrows.

**Theorem 5.10** (Kari [Kar03]). *STP is undecidable.*

We are ready to prove the main result of this section.

**Theorem 5.11** (B, Kari, Salo). *Let  $(\mathcal{A}^{\mathbb{Z}^d}, \sigma)$  where  $|\mathcal{A}| \geq 2$ . There is a finitely generated subgroup of  $[[\sigma]]$  whose torsion problem is undecidable if and only if  $d \geq 2$ .*

*Proof.* If  $d = 1$ , Theorem 5.8 implies the decidability of the torsion problem. If  $d \geq 2$ , then  $[[\sigma]]_{\mathcal{A}^{\mathbb{Z}^2}} \hookrightarrow [[\sigma]]_{\mathcal{A}^{\mathbb{Z}^d}}$ . Therefore it suffices to work on  $d = 2$ .

Consider an instance  $(\tau, \mathbf{left}, \mathbf{right})$  of  $\mathbf{STP}$ , fix an alphabet  $\Sigma$  such that  $|\Sigma| > |\tau|$  and associate the first  $|\tau|$  symbols in  $\Sigma$  to the tiles in  $\tau$  and the rest to the empty tile. We construct a homeomorphism  $T$  of  $\Sigma^{\mathbb{Z}^2} \times \{L, R\}$  which gives a non-torsion element if and only if  $(\tau, \mathbf{left}, \mathbf{right})$  admits a snake. Afterwards we will show that the behavior of this object can be simulated by elements of the topological full group.

We will call  $L$  and  $R$  *direction bits* standing for right and left. The homeomorphism  $T$  acts as follows:

- Let  $t$  be the tile at  $(0, 0)$ . If  $t = \epsilon$ , do nothing.
- Otherwise:
  - If the direction bit is  $L$ : check the tile in the direction  $\mathbf{left}(t)$ . If it matches correctly with  $t$ , shift to that position, otherwise switch the state to  $R$ .
  - If the direction bit is  $R$ : check the tile in the direction  $\mathbf{right}(t)$ . If it matches correctly with  $t$ , shift to that position, otherwise switch the state to  $L$ .

Clearly  $T$  is a homeomorphism and its inverse is given by the one which does the same but switches the roles of  $R$  and  $L$ . If  $(\tau, \mathbf{left}, \mathbf{right})$  admits a snake, it suffices to consider the configuration in  $\Sigma^{\mathbb{Z}^2}$  that contains an infinite snake passing through the origin. Clearly  $T$  shifts the configuration to infinity in that configuration without repeating positions or changing the state, thus showing that  $T$  is a non-torsion element

(if the configuration containing the snake is periodic, it suffices to modify it outside a big enough ball to get that arbitrary big powers of  $T$  do not leave the modified configuration invariant). Conversely, if  $(T, \text{left}, \text{right})$  does not admit a snake, then there is a uniform bound on how far  $T$  can shift from its starting position before encountering an error or entering a cycle and henceforth  $T$  has finite order. Indeed, if such a bound did not exist, one could extract an infinite snake by compactness.

We construct a finite set of elements of  $[[\sigma]]$  which simulates an instance of **STP** and the behavior of  $T$ . For this we are going to use a specific  $7 \times 7$  square coding which is shown on Figure 5.1. This coding is composed of three zones. The *outer zone* consists of a ring of 1s of side length 7 which serves to code unambiguously the boundary of the structure. The four bottom left 1s of this zone are used to code the states. The *middle zone* consists of a ring of 0s of side length 5 which serves to separate the three zones so no ambiguity is possible. Finally there is the *inner zone* consisting of a  $3 \times 3$  square containing a configuration in  $\{0, 1\}^9$ . Four of these bits  $l_1, l_2, r_1, r_2$  serve to code two directions in  $D = \{(1, 0), (-1, 0), (0, 1), (0, -1)\}$ . The purpose of the rest of the bits are going to be specified later on.

1	1	1	1	1	1	1
1	0	0	0	0	0	1
1	0	$b_1$	$b_2$	$b_3$	0	1
1	0	$r_1$	$r_2$	$b_4$	0	1
1	0	$l_1$	$l_2$	$b_5$	0	1
1	0	0	0	0	0	1
1	1	1	1	1	1	1

Figure 5.1: Basic coding of the construction. The outer ring of 1s (blue) codes the boundary of the cell and the state. The middle ring of 0s separates the zones. The inner ring (green) codes the information.

For this construction we are going to use a two bit string  $s \in \{0, 1\}^2$  as the set of states (which is to be coded by the position amongst the four fixed places in the outer ring of 1s). The first bit is the *direction bit*, that is, it takes the role of  $L$  and  $R$  for the first construction. The second bit is the *auxiliary bit*, whose role will become clear later on.

Let  $C$  be the set of all patterns of shape as in Figure 5.1 centered in one of four fixed positions in the ring of 1s, that is, such that the support is of the form  $([-i, 7-i] \times [0, 7]) \cap \mathbb{Z}^2$  for some  $i \in \{0, 1, 2, 3\}$ . We consider the following finite set of elements of  $[[\sigma]]$  as our generating set  $S$ .

1.  $\{T_{\vec{v}}\}_{\vec{v} \in D}$  that shifts in the direction  $\vec{v} \in D$  independently of the configuration.
2.  $T_{\text{walk}}$  that shifts along the direction codified by  $l_1, l_2$  or  $r_1, r_2$  depending on the direction bit.
3.  $\{g_c\}_{c \in C}$  that flips the direction bit if the current pattern is  $c \in C$ ,
4.  $\{h_c\}_{c \in C}$  that flips the auxiliary bit if the current pattern is  $c \in C$ ,

5.  $\{g_{+,c}\}_{c \in C}$  that adds the auxiliary bit to the direction bit if the current pattern is  $c \in C$ , and
6.  $\{h_{+,c}\}_{c \in C}$  that adds the direction bit to the auxiliary bit if the current pattern is  $c \in C$ ,

$T_{\text{walk}}$  is the only element which needs to be carefully defined. It acts similarly to  $T$  defined in the beginning. Formally it does the following:

- If the pattern around the identity does not correspond to a  $c \in C$ , do nothing.
- Otherwise:
  - If the direction bit is 0 check the pattern centered in  $7\text{left}(t)$  from the actual position. If it is a valid  $c' \in C$  in the same state and its two right bits code  $-\text{left}(t)$  then shift by  $7\text{left}(t)$ . Otherwise flip the direction bit to 1.
  - If the direction bit is 1. Check the pattern centered in  $7\text{right}(t)$  from the actual position. If it is a valid  $c' \in C$  in the same state and its two left bits code  $-\text{right}(t)$  then shift by  $7\text{right}(t)$ . Otherwise flip the direction bit to 0.

$T_{\vec{v}}$  is just the shift by  $\vec{v} \in D$  and thus belongs in  $[[\sigma]]$ .  $T_{\text{walk}}$  is also a homeomorphism in  $[[\sigma]]$  as an inverse can be obtained by switching the role of the direction bits. The rest of the homeomorphisms are clearly involutions in  $[[\sigma]]$ . As  $\langle D \rangle = \mathbb{Z}^2$  we have that for every vector  $\vec{u} \in \mathbb{Z}^2$  then  $T_{\vec{u}} \in \langle S \rangle$ .

Let  $p^*$  be a pattern consisting of the concatenation of patterns from  $c$  which are well aligned along the columns and lines of 1s. More formally, for a finite  $F \subset \mathbb{Z}^2$ ,  $p^*$  is a pattern with support  $7F + (([-i, 7-i] \times [0, 7]) \cap \mathbb{Z}^2)$  for some  $i \in \{0, 1, 2, 3\}$  and such that for every  $\vec{v} \in F$  then  $\sigma_{-7\vec{v}}(p^*)|_{([-i, 7-i] \times [0, 7]) \cap \mathbb{Z}^2} \in C$ . We define  $g_{p^*}$  and  $h_{p^*}$  as the elements of the topological full group which flip the direction bit and the auxiliary bit respectively if they read  $p^*$ . We claim  $g_{p^*}, h_{p^*} \in \langle S \rangle$ . If  $p^*$  is defined by some singleton  $F = \{\vec{v}\}$  it suffices to note that  $g_{p^*} = T_{-7\vec{v}} \circ g_c \circ T_{7\vec{v}}$  and  $h_{p^*} = T_{-7\vec{v}} \circ h_c \circ T_{7\vec{v}}$  for the appropriate  $c \in C$ . Inductively, we can choose  $\vec{v} \in F$  and separate  $p^*$  as the disjoint union of the pattern  $p_{F \setminus \{\vec{v}\}}^*$  defined by  $F \setminus \{\vec{v}\}$ , and the pattern  $p_{\vec{v}}^*$  defined by  $\vec{v}$  and thus write:

$$g_{p^*} = (T_{-7\vec{v}} \circ g_{+,c} \circ T_{7\vec{v}} \circ h_{p_{F \setminus \{\vec{v}\}}^*})^2, \text{ and } h_{p^*} = (T_{-7\vec{v}} \circ h_{+,c} \circ T_{7\vec{v}} \circ g_{p_{F \setminus \{\vec{v}\}}^*})^2.$$

Consider an instance  $(\tau, \text{left}, \text{right})$  of the snake tiling problem. The information associated to each tile  $t \in \tau$  consists of a 4-tuple of colors  $(c_1, c_2, c_3, c_4)$  and the directions  $\text{left}(t)$  and  $\text{right}(t)$ . Suppose the tiles of  $\tau$  are defined using  $N$  colors. Let  $M \in \mathbb{N}$  such that  $M^2 > \log_2(N)$ . We define for each  $t \in \tau$  a macrotile  $\mathcal{M}(t)$  as a fixed square array of patterns of shape as in Figure 5.1 of side length  $M$  (see Figure 5.2). We fix an enumeration of these patterns from the bottom left to the upper right as  $\{c_j\}_{1 \leq j \leq M^2}$  and denote the bit  $b_i$  of  $c_j$  as  $b_{i,j}$ . We demand  $\mathcal{M}(t)$  to satisfy the following properties:

- For  $i \in \{1, 2, 3, 4\}$  the sequence of bits  $\{b_{i,j}\}_{1 \leq j \leq M^2}$  codifies the color  $c_i$ .
- $b_{5,1} = 1$  and for all  $j > 1$  the bit  $b_{5,j} = 0$ .
- The bits  $l_1, l_2$  and  $r_1, r_2$  of  $c_1$  code  $\mathbf{left}(t)$  and  $\mathbf{right}(t)$  respectively.
- If  $\mathbf{left}(t) = (1, 0)$  then for all  $2 \leq j \leq M$  we have that  $l_1, l_2$  and  $r_1, r_2$  of  $c_j$  code  $(1, 0)$  and  $(-1, 0)$  respectively.
- If  $\mathbf{right}(t) = (1, 0)$  then for all  $2 \leq j \leq M$  we have that  $l_1, l_2$  and  $r_1, r_2$  of  $c_j$  code  $(-1, 0)$  and  $(1, 0)$  respectively.
- If  $\mathbf{left}(t) = (0, 1)$  then for all  $1 \leq j \leq M - 1$  we have that  $l_1, l_2$  and  $r_1, r_2$  of  $c_{1+jM}$  code  $(0, 1)$  and  $(0, -1)$  respectively.
- If  $\mathbf{right}(t) = (0, 1)$  then for all  $1 \leq j \leq M - 1$  we have that  $l_1, l_2$  and  $r_1, r_2$  of  $c_{1+jM}$  code  $(0, -1)$  and  $(0, 1)$  respectively.

As  $M^2 > \log_2(N)$  it is possible to satisfy the first requirement. The rest are possible to satisfy as  $\mathbf{left}(t) \neq \mathbf{right}(t)$ . An example of such a macrotile is represented in Figure 5.2.

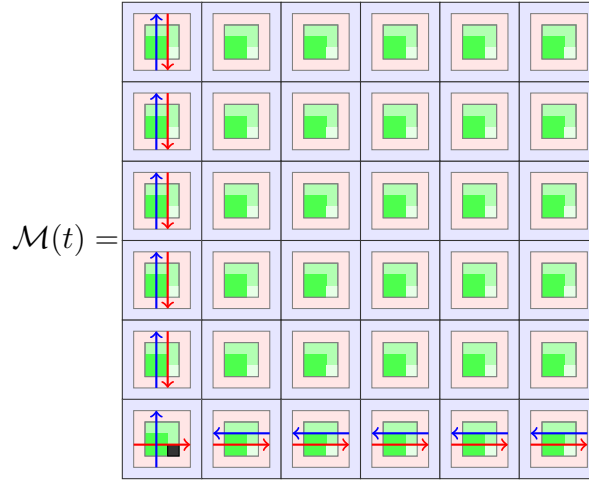

Figure 5.2: An example of macrotile  $\mathcal{M}(t)$  of side  $M = 6$ . The red arrows represent the function  $\mathbf{left}(t) = (1, 0)$  while the blue arrows represent  $\mathbf{right}(t) = (0, 1)$ . The bottom left black square represents  $b_{5,1} = 1$ .

Associate all arrays of  $M \times M$  codings which do not represent some  $t \in T$  to the  $\epsilon$  tile. Also, let  $\mathcal{M}$  be the set of all patterns given as an array of  $3 \times 3$  macrotiles which represent a valid local pattern of the snake problem and such that the middle tile is not an  $\epsilon$  tile and are centered in the bottom left position of the middle macrotile.

Consider the element  $T^* \in \langle S \rangle$  given by:

$$T^* = (T_{\text{walk}})^M \circ \prod_{p^* \in \mathcal{M}} g_{p^*} \circ \prod_{c \in C} g_c$$



We claim that  $T^*$  is a torsion element if and only if  $(\tau, \text{left}, \text{right})$  does not admit a snake.

If  $(\tau, \text{left}, \text{right})$  admits a snake, it suffices to take a configuration with a snake, replace each tile and  $\epsilon$  in it by a corresponding macrotile and apply  $T^*$  in the configuration where the origin is at the lower left corner of a macrotile belonging to the snake. The homeomorphism  $T^*$  will first detect some pattern  $c \in C$ , so exactly one  $g_c$  will flip the direction bit once. Then it will detect a valid pattern  $p^*$  of the snake problem and thus  $g_{p^*}$  will flip again the direction bit amounting to no action at all. Finally,  $(T_{\text{walk}})^M$  will just walk towards the lower left corner of the next macrotile. As the initial configuration coded a snake, repeating this procedure will make  $T^*$  act as  $T$  and shift to infinity, therefore  $T^*$  is not a torsion element.

For the converse, we need to analyze with more care the behavior of  $T^*$ . First of all, if in the initial configuration the initial position is not over a pattern  $c \in C$ , then  $T^*$  by definition acts trivially. Otherwise, suppose it belongs to  $\bigcup_{c \in C} [c]$ . The application of  $\prod_{p^* \in \mathcal{M}} g_{p^*} \circ \prod_{c \in C} g_c$  can only change the state, and thus it stays there. Also, by definition of  $T_{\text{walk}}$ , the origin will always see an element of  $C$  after applying  $(T_{\text{walk}})^M$ . This means that after applying  $T^*$  the configuration always remains in  $\bigcup_{c \in C} [c]$ .

There are two possible behaviors of  $T^*$  starting from a pattern in  $C$ . If the configuration is not in  $\bigcup_{p^* \in \mathcal{M}} [p^*]$  then the direction bit is flipped by  $g_c$ , the second part does nothing, and  $T_{\text{walk}}$  is applied  $M$  times. Otherwise the direction bit is flipped two times, amounting to no flip at all and  $T_{\text{walk}}$  is applied  $M$  times.

These two behaviors translate into the following: If the configuration is in  $\bigcup_{p^* \in \mathcal{M}} [p^*]$  then  $T^*$  can either move into another valid array (and correctly simulate the working of  $T$  defined at first in the proof), or it can fall outside a valid array of macrotiles. If it does this, then another application of  $T^*$  undoes the last  $M$  steps of  $T_{\text{walk}}$  and changes the direction bit. Therefore the configuration continues to live inside a valid array of  $\mathcal{M}$  and simulate  $T$ . In this case we can use the uniform bound on the length of the snake to find a bound  $N$  such that  $(T^*)^N$  acts trivially over all these configurations. The only case remaining is when initially the configuration is not in  $\bigcup_{p^* \in \mathcal{M}} [p^*]$  and after one application of  $T^*$  it stays that way. In this case, we just have that  $(T^*)^2$  acts trivially over these configurations. Thus showing that  $(T^*)^{2N} = id$  and hence  $T^*$  is a torsion element of  $\langle S \rangle$ .

Therefore, if the torsion problem of this subgroup is decidable, given an instance of STP one could construct a homeomorphism  $T^*$  associated to the instance and use the algorithm to decide if there is a snake. This contradicts the undecidability of STP.  $\square$

Using Proposition 5.4 we obtain the following.

**Corollary 5.12.** *Let  $\mathcal{A}$  be an alphabet with at least 4 symbols and  $d \geq 2$ . Then  $\text{Aut}(\mathcal{A}^{\mathbb{Z}^d})$  contains a finitely generated group with undecidable torsion problem.*

*Remark.* The finitely generated group from Theorem 5.11 gives a nice example of a group with decidable word problem but undecidable torsion problem.

## 5.2.2 Computability in the automorphism group

As in the case of the topological full group, we begin with the study of the word problem. By Theorem 1.2 each endomorphism of a shift space can be represented through a sliding block code. This implies that the basic operations between automata can be computed.

**Proposition 5.13.** *Let  $G$  be a finitely generated group with decidable word problem,  $S$  a finite set of generators and  $\phi_1, \phi_2 \in \text{End}(\mathcal{A}^G)$ . Suppose  $\phi_1$  and  $\phi_2$  are consistently represented as sliding-block codes through a function from a finite set of pattern codings (written using  $S$ ) to  $\mathcal{A}$ . The following properties hold:*

- *There is an algorithm which computes a sliding-block code representation for  $\phi_2 \circ \phi_1$ .*
- *if  $\phi_1 \in \text{Aut}(\mathcal{A}^G)$ , there is an algorithm which computes a sliding-block code representation for  $\phi_1^{-1}$ .*

*Proof.* Let  $N_1$  and  $N_2$  be respectively the maximum length of a word appearing in a pattern coding of  $\phi_1$  and  $\phi_2$  respectively. Use the algorithm of  $\text{WP}(G)$  to solve the word problem for every word  $w \in S^*$  such that  $|w| \leq 2(N_1 + N_2)$ . This gives a representation of the ball  $B := B_S(G, N_1 + N_2)$  of the Cayley graph  $\Gamma(G, S)$ . Using this representation an algorithm can compute every pattern  $p \in \mathcal{A}^B$ , apply  $\phi_1$  and obtain completely the restriction of its image in  $B_S(G, N_2)$ . Now apply  $\phi_2$  to get the image at  $1_G$ ,  $\phi_2 \circ \phi_1(p) \in \mathcal{A}$ . For each pattern  $p \in \mathcal{A}^B$  find a pattern coding representing it and assign it to  $\phi_2 \circ \phi_1(p)$ . This gives a representation for  $\phi_2 \circ \phi_1$ .

For the second property, iteratively use  $\text{WP}(G)$  to compute  $B_S(G, N)$  for each  $N \in \mathbb{N}$ , enumerate all of the endomorphisms defined by sliding-block codes over this support and compute the composition. If one of these compositions is equal to the projection to the identity, return the representation of the endomorphism. As  $\phi_1 \in \text{Aut}(\mathcal{A}^G)$  the procedure must eventually stop.  $\square$

An article by Boyle, Lind and Rudolph [BLR88] shows that  $\text{Aut}(\mathcal{A}^{\mathbb{Z}})$  contains no finitely generated subgroup with undecidable word problem. They attribute this result to Kitchens. The fact that the same result holds true for any finitely generated group with decidable word problem follows directly from Proposition 5.13.

**Proposition 5.14.** *Let  $G$  be a finitely generated group with decidable word problem and  $H$  be a finitely generated subgroup of  $\text{Aut}(\mathcal{A}^G)$ . Then the word problem of  $H$  is decidable.*

*Proof.* Let  $S = \phi_1, \dots, \phi_n$  be a set of generators of  $H$ . A sliding-block code description of the  $\phi_i$  is a finite amount of information and can be hard coded in an algorithm. Given a word in  $S^*$ , Proposition 5.13 implies that a rule for the automorphism given by that word can be computed, and thus the equality to the identity map can be tested.  $\square$

The previous result extends to a subshift  $X$  whenever its language is decidable in a similar fashion as the topological full group: that is, if the set of pattern codings  $c$  such that  $[c] \cap X = \emptyset$  is decidable, then the same result holds. However, this is not the case if that set is only recursively enumerable: There exist  $\mathbb{Z}^2$ -SFTs whose automorphism group contains a finitely generated group with undecidable word problem. This is a yet unpublished result which has been communicated to the author by Guillon, Jeandel and Vanier and also by Kari.

As shown in Example 5.4 it might happen that every finitely generated subgroup has decidable word problem but the whole group admits no recursive presentation with decidable word problem. In the case where  $G = \mathbb{Z}$  it was first shown by Amoroso and Patt [AP72] that the computability problem of testing whether a cellular automaton given by its sliding block code representation is reversible is decidable. Therefore a recursive presentation for  $\text{Aut}(\mathcal{A}^{\mathbb{Z}})$  with decidable word problem can be constructed using the set of reversible sliding block codes. On the other hand, Kari [Kar90] showed that the same problem in  $G = \mathbb{Z}^2$  becomes undecidable. However, this does not mean that the word problem is undecidable. In fact,  $\text{WP}(\mathcal{A}^G)$  is still decidable as long as  $G$  has decidable word problem. The following construction is based on an idea communicated by Kari and Salo.

**Proposition 5.15.** *For any finitely generated group  $G$  with decidable word problem  $\text{WP}(\text{Aut}(\mathcal{A}^G))$  is decidable.*

*Proof.* By Proposition 5.13 the set  $B$  of sliding-block code representations which are automorphisms is recursively enumerable, therefore there exists a computable enumeration  $f : \mathbb{N} \rightarrow B$ . Consider the representation  $\langle S \mid R \rangle$  where  $S = \mathbb{N}$  and  $w \in R$  if and only if the following algorithm accepts: for each  $w_i$  appearing in  $w$  compute  $f(w_i)$ , then compute a representation  $b = f(w_1)f(w_2) \dots f(w_{|w|})$  and accept if and only if  $b = \text{id}$ . It is clear that  $\text{Aut}(\mathcal{A}^G) = \langle S \mid R \rangle$  and  $R = \text{WP}(\text{Aut}(\mathcal{A}^G))$ . Moreover, an algorithm for determining whether  $w \notin R$  can be done by doing the same and checking whether  $b \neq \text{id}$ . This shows that  $\text{WP}(\langle S \mid R \rangle)$  is decidable.  $\square$

Recall that a Turing machine acts on the set  $\Sigma^{\mathbb{Z}} \times Q \times \mathbb{Z}$  as explained in Appendix A. For the rest of this chapter, we refer to those Turing machines as “classical” in order to distinguish them from the objects treated in [BKS16]. We say a classical Turing machine  $T$  is *reversible* if there exists another classical Turing machine  $T'$  such that  $T \circ T'$  acts trivially on  $\Sigma^{\mathbb{Z}} \times Q \times \mathbb{Z}$ . We end this section by presenting (most of) the proof that there exists a finitely generated subgroup of  $\text{Aut}(\{0,1\}^{\mathbb{Z}})$  with undecidable torsion problem. The proof of this result depends on the following four steps:

- The computability problem of whether a classical reversible Turing machine is a torsion element or not (ie:  $T^n = \text{id}$  for some  $n \in \mathbb{N}$ ) is undecidable. This is a result due to Kari and Ollinger [KO08].
- The behavior of reversible classical Turing machines can be represented into a group EL.

- EL is finitely generated and has undecidable torsion problem.
- There is a function which “transfers” the torsion problem of EL into that of  $\text{Aut}(\{0, 1\}^{\mathbb{Z}})$ .

The first step is already done in [KO08]. Here we will explain informally how to do the second and third step without giving all the details, and give the full development of the fourth step. We begin by defining EL.

**Definition 5.7.** EL is the subgroup of homeomorphisms of  $\{0, 1\}^{\mathbb{Z}}$  generated by the following set:

- The shifts  $(\sigma^n)_{n \in \mathbb{Z}}$ .
- Local permutations  $T_\pi$  where  $\pi \in \text{Sym}(\{0, 1\}^F)$  for some finite  $F \subset \mathbb{Z}$  and given  $x \in \{0, 1\}^{\mathbb{Z}}$  the action of  $T_\pi$  is defined as:

$$T_\pi(x)_n := \begin{cases} x_n & \text{if } n \notin F \\ \pi(x|_F)_n & \text{if } n \in F. \end{cases}$$

- Controlled position swaps  $T_{u,v,w}$  for words  $u, v, w \in \{0, 1\}^*$  which act as involutions by switching

$$\begin{aligned} T_{u,v,w}(x^- u.vwx^+) &= (x^- uv.wx^+) \\ T_{u,v,w}(x^- uv.wx^+) &= (x^- u.vwx^+) \end{aligned}$$

for each  $x^-, x^+$  and act as the identity elsewhere.

*Remark.* In [BKS16], EL is defined as the group of elementary Turing machines, it consists of all reversible Turing machines which can be constructed by composing machines which do not move the head, and machines which do not change the tape. In here we reduce EL to a simpler object which is sufficient to prove Theorem 5.19.

*Remark.* Note that not each choice of  $u, v, w$  will give a homeomorphism, in particular  $u = v = w$  do not. We only take the position swaps which are homeomorphisms. In fact, they are elements of  $[[\sigma]]$ .

Firstly, in [BKS16] it is shown that each reversible classical Turing machine  $T$  acting on  $\Sigma^{\mathbb{Z}} \times Q \times \mathbb{Z}$  can be written as  $T = T_1 \circ T_0$  where  $T_0 \in \text{Sym}(\Sigma \times Q)$  performs a state-symbol permutation around the origin and  $T_1$  shifts the head by a vector in  $\{-1, 0, 1\}$  only depending on the current state. The first step of the proof is to show that these machines can be encoded as elements of EL. Let  $T$  be a classical reversible Turing machine acting over  $\Sigma^{\mathbb{Z}} \times Q \times \mathbb{Z}$ . The proof of this fact is done by choosing  $m$  such that  $2^m > |\Sigma|(|Q \cup \{\sqcup\}|)$  and encoding each pair  $(a, q) \in \Sigma \times (Q \cup \{\sqcup\})$  as a different word  $[a, q] \in \{0, 1\}^m$ . It can be shown that each reversible classical Turing machine can be coded effectively into EL and that the coded elements of EL mimic the behavior of  $T$ . Therefore, if the torsion problem of EL were decidable, it could be used to decide the torsion problem of a reversible classical Turing machine, contradicting the result of [KO08]. This shows that the torsion problem of EL is undecidable.

The next step is showing that EL is finitely generated. The full proof of this fact is technical and spans several pages, here we only give the main ideas.

The shifts are already generated by  $\sigma^1$  and  $\sigma^{-1}$ . Next, if we add the local permutations which swap the symbols at  $F = \{0, 1\}$  we can compose them with the shifts to get all permutations which swap two arbitrary positions. Next we add  $\text{Sym}(\{0, 1\}^R)$  for a fixed set  $R$  of size 4. We can show that every element of  $\text{Sym}(\{0, 1\}^F)$  for arbitrary  $F$  can be decomposed in swaps and elements of  $\text{Sym}(\{0, 1\}^R)$  (details can be found in the arXiv version of [BKS16]). This shows that the group generated by the local permutations and the shifts is finitely generated. Finally, in order to add all position swaps, we reduce through conjugacy by elements of the previous group any controlled position swap to  $T_{\epsilon, 1, 0^m}$  for some  $m \in \mathbb{N}$ . Through further decomposition, these  $T_{\epsilon, 1, 0^m}$  can be built from basic blocks  $T_{\epsilon, 1, 0^k}$  where  $k \leq 2$ . These arguments yield the following result:

**Theorem 5.16** (B, Kari, Salo). *EL is finitely generated and  $\text{TP}(\text{EL})$  is undecidable.*

In the following, the free monoid generated by the elements of a group  $G$  is written  $G^*$ . We can interpret words of  $G^*$  as elements of  $G$  in the obvious way.

**Definition 5.8.** Let  $G$  and  $H$  be groups and  $\mathcal{P}$  be a group property. We say a function  $\phi : G \rightarrow H$  is  $\mathcal{P}$ -preserving if the following holds: For every finite set  $F \subset G^*$  the group  $\langle w \mid w \in F \rangle \leq G$  has property  $\mathcal{P}$  if and only if the group  $\langle \phi(w_1)\phi(w_2) \cdots \phi(w_{|w|}) \mid w \in F \rangle$  has property  $\mathcal{P}$

We remark that  $\mathcal{P}$ -preserving functions  $\phi$  need not be morphisms as we do not ask that  $\phi(w_1w_2) = \phi(w_1)\phi(w_2)$ . We only demand that property  $\mathcal{P}$  is preserved when applying  $\phi$  to the symbols appearing in the words in  $F$ .

In what follows we are going to use the property  $\mathcal{P}$  of being finite. We use this property to extend a computability invariant such as the torsion problem of a group onto another group even if no embedding from the first group to the second exists. This kind of extension obviously demands that the function  $\phi$  is in some way computable. We will say a function  $\phi : G \rightarrow H$  is *computable* if both  $G$  and  $H$  have decidable word problem for some fixed presentation and there is a Turing machine which turns a presentation of  $g \in G$  into a presentation of  $\phi(g) \in H$ .

**Lemma 5.17.** *Let  $G$  be a finitely generated group with undecidable torsion problem and generating set  $S$ . Suppose there exists a computable finiteness-preserving function  $\phi : G \rightarrow H$ , then the subgroup  $H' = \langle \{\phi(s)\}_{s \in S} \rangle \leq H$  has undecidable torsion problem.*

*Proof.* Suppose the group  $H'$  generated by the  $\phi(s)$  has decidable torsion problem and let  $w \in S^*$ . As  $\phi$  is finiteness-preserving we have that  $\langle w \rangle$  is finite if and only if  $\langle \phi(w_1)\phi(w_2) \cdots \phi(w_{|w|}) \rangle$  is finite. This means  $w$  has finite order in  $G$  if and only if  $\phi(w_1)\phi(w_2) \cdots \phi(w_{|w|})$  has finite order in  $H'$ . As  $\phi$  is computable the word  $\phi(w_1)\phi(w_2) \cdots \phi(w_{|w|})$  can be computed from  $w$  and the algorithm to decide the torsion problem in  $H'$  could be thus used to decide the torsion problem in  $G$ .  $\square$

The previous lemma indicates that in order to prove the theorem, we now simply need to provide a finiteness-preserving map from EL into  $\text{Aut}(\{0, 1\}^{\mathbb{Z}})$ . For this, first

note that any  $T \in \text{EL}$  can also be interpreted as a homeomorphism of  $\{0, 1\} \times \mathbb{Z}$ . Indeed, interpret the second coordinate as a head indicating a new origin. Then the shifts can act by shifting the head by the inverse, and both the local permutations and the controlled position swaps can act around the head.

The following construction uses the previous interpretation and is based on a conveyor belt construction where the action of  $T \in \text{EL}$  is delocalized by making multiple heads appear in a configuration and applying the action of  $T$  independently around each head. In order to do this without creating conflicts, the tape is separated into zones which contain at most one head and the action of  $T$  is applied by running over the zone cyclically, as in a conveyor belt. We specify this in the Lemma 5.18.

**Lemma 5.18.** *Let  $\mathcal{A} = \{0, 1\}^2 \times \{\leftarrow, \rightarrow, \uparrow, \downarrow\}$ . There is a computable finiteness-preserving map  $\phi : \text{EL} \rightarrow \text{Aut}(\mathcal{A}^{\mathbb{Z}})$ .*

*Proof.* The alphabet  $\mathcal{A}$  consists of triples and thus  $\mathcal{A}^{\mathbb{Z}}$  can be thought of as consisting of three tapes. Each of the first two tapes carries a configuration in  $\{0, 1\}^{\mathbb{Z}}$  while the third tape has symbols in  $\{\leftarrow, \rightarrow, \uparrow, \downarrow\}$ . A head is represented by a symbol in  $\{\uparrow, \downarrow\}$ . If this value is  $\uparrow$ , the head is on the first (‘topmost’) tape and if it is  $\downarrow$ , on the second (‘bottom’) tape.  $\leftarrow$  means the head is to the left of the current cell on the current zone (if the current zone contains a head), while  $\rightarrow$  means the head is to the right.

A configuration in  $\mathcal{A}^{\mathbb{Z}}$  is split into zones by the contents of the third tape. Namely, every finite portion of the third tape can be split uniquely into pieces of the forms  $\rightarrow^* a \leftarrow^*$  and  $\rightarrow^* \leftarrow^*$  where  $a \in \{\uparrow, \downarrow\}$ . We call these pieces *zones*, see Figure 5.3. To define the finiteness-preserving map  $\phi : \text{EL} \rightarrow \text{Aut}(\mathcal{A}^{\mathbb{Z}})$  it is enough to do so in every piece of this form.

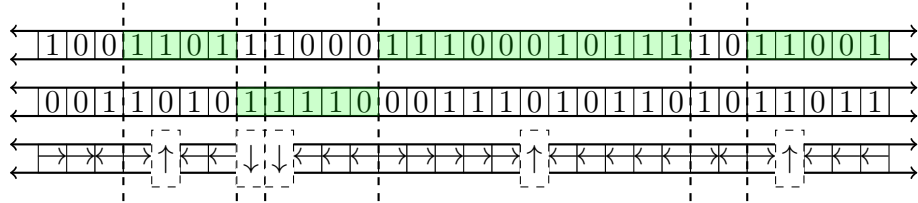

Figure 5.3: A finite word in  $\mathcal{A}^*$  is divided into zones by the third tape. The dashed lines separate each zone and the colours indicate which tape is being pointed at by the arrow next to the state.

Let  $T \in \text{EL}$  interpreted as an action over  $\{0, 1\}^{\mathbb{Z}} \times \mathbb{Z}$  and note  $T(x, 0) = (T_1(x), T_2(x))$ . To each  $T$  one can associate a radius  $r$  defined as  $\max_{x \in \{0, 1\}^{\mathbb{Z}}} d(T(x, 0))$  where

$$d(T(x, 0)) = \max\left\{\min_{M \in \mathbb{N}}\{x|_{\mathbb{Z} \setminus \{-M, \dots, M\}} = T_1(x)|_{\mathbb{Z} \setminus \{-M, \dots, M\}}, |T_2(x)|\}\right\}.$$

In words, it is the maximum taken over all configurations of the movement of the head and the distance of a local permutation from the origin. As the action of each element of  $\text{EL}$  only depends on finitely many coordinates, the radius can be computed.

Let  $T \in \text{EL}$  have radius  $r$ . We define  $\phi(T) \in \text{Aut}(\mathcal{A}^{\mathbb{Z}})$  by its action over each zone as follows: If the zone has no head or the zone is of size less than  $2r + 1$ , do nothing.

Otherwise let  $u_0, \dots, u_{m-1}$  and  $v_0, \dots, v_{m-1}$  be the words in the first and second tape respectively,  $a \in \{\uparrow, \downarrow\}$  be the head and  $\ell \in \{0, \dots, m-1\}$  the position of the head in the third tape. Using this information we can construct the configuration  $z \in \{0, 1\}^{\mathbb{Z}}$  given by:

$$z_i = \begin{cases} u_j & \text{if } j = (i \bmod 2m) \in \{0, \dots, m-1\} \\ v_{2m-j-1} & \text{if } j = (i \bmod 2m) \in \{m, \dots, 2m-1\} \end{cases}$$

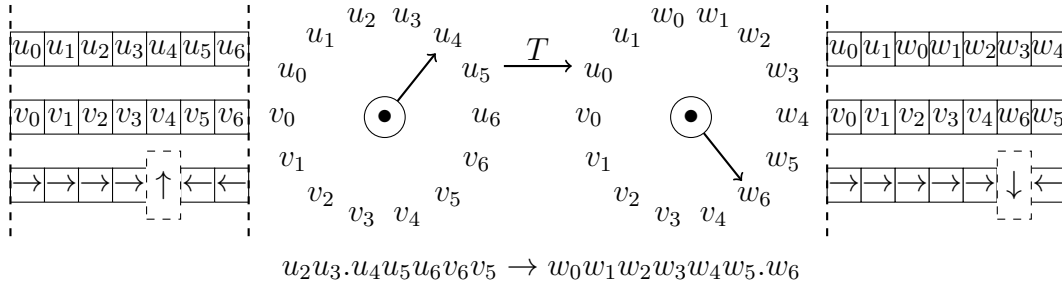

Figure 5.4: Every zone is wrapped around as a conveyor belt, where  $\phi(T)$  acts as if it were  $T$  seeing a periodic word.

Apply  $T$  to  $z$ , where the position of the head is on  $\ell$  if  $a = \uparrow$  and on  $2m - \ell - 1$  otherwise. Recode the result again updating the left and right arrows so that the zone does not change its shape as shown in Figure 5.4.

Clearly  $\phi(T) \in \text{Aut}(\mathcal{A}^{\mathbb{Z}})$ . In fact, for each bounded zone,  $\phi(T)$  induces a permutation of all possible heads and tape contents while on unbounded zones it acts as  $T$  on an infinite configuration. Also,  $\phi$  is clearly a computable map. It suffices to show that  $\phi$  preserves the property of being finite.

Consider  $F \subset \text{EL}^*$ , and  $H = \langle \phi(w_1)\phi(w_2)\cdots\phi(w_{|w|}) \mid w \in F \rangle$  generated in  $\text{Aut}(\mathcal{A}^{\mathbb{Z}})$ . If  $\langle F \rangle$  is infinite, just note that the action of  $\phi(T)$  over any configuration such that the third tape is a single unbounded zone with a head, (that is  $\cdots \leftarrow \leftarrow \leftarrow \uparrow \rightarrow \rightarrow \rightarrow \cdots$ ) replicates exactly the behavior of  $T$  on the first tape. Therefore each element of  $\langle F \rangle$  will act differently over at least one configuration of this form, implying that  $H$  is infinite. Conversely, if  $\langle F \rangle$  is finite then every word in  $F^*$  represents a torsion element. The action over any tape which is unbounded or larger than the maximum movement from the origin attained by an element of  $\langle F \rangle$  obviously acts as the original machine. Therefore the only possible problem could arise in zones whose length is bounded by a fixed length  $h$ . But the number of different changes on these zones is bounded as each action is a permutation over a finite set. Therefore  $H$  is finite and a rough bound is  $|H| \leq |\langle F \rangle| \cdot (\prod_{m \leq h} (m2^{2m+1})!)$   $\square$   $\square$

From Lemma 5.17 and Lemma 5.18 we obtain that for some alphabet  $\mathcal{A}$  with 16 symbols there is a finitely generated subgroup  $G \leq \text{Aut}(\mathcal{A}^{\mathbb{Z}})$  such that the torsion problem of  $G$  is undecidable. As  $\text{Aut}(\mathcal{A}^{\mathbb{Z}})$  embeds into  $\text{Aut}(\{0, 1\}^{\mathbb{Z}})$  we get:

**Theorem 5.19** (B, Kari, Salo). *There is a finitely generated subgroup  $G \leq \text{Aut}(\{0, 1\}^{\mathbb{Z}})$  with undecidable torsion problem.*

Combined with the results of Salo [Sal15], we obtain the following corollary.

**Corollary 5.20.** *Let  $X$  be a sofic  $\mathbb{Z}$ -subshift with positive entropy. Then there is a finitely generated subgroup of  $\text{Aut}(X)$  with undecidable torsion problem.*

What is more, using the basic fact that  $\text{Aut}(\mathcal{A}^{\mathbb{Z}}) \hookrightarrow \text{Aut}(\mathcal{A}^{\mathbb{Z}^d})$  for every  $d \geq 1$ , we obtain a stronger version of Corollary 5.12

**Corollary 5.21.** *For any alphabet  $\mathcal{A}$  with at least two symbols,  $\text{Aut}(\mathcal{A}^{\mathbb{Z}^d})$  contains a finitely generated subgroup with undecidable torsion problem.*



## Conclusions et perspectives

L'objectif principal de cette thèse est la recherche de liens entre les propriétés dynamiques et celles de calcul des sous-décalages sur des groupes. Nous présentons de nombreux résultats originaux qui éclairent cette problématique sous un jour nouveau. Dans ce qui suit, nous présentons les principales contributions obtenues dans chaque chapitre. Nous discutons ensuite de généralisations possibles à un contexte plus large, et de leur applicabilité à d'autres problèmes.

Dans le Chapitre 2 on montre le Lemme 2.2 qui donne une condition suffisante pour qu'un jeu de motifs interdits  $\mathcal{F} = \{p_1, p_2, \dots\}$  définisse un sous-décalage non vide. Ce résultat est utilisé pour donner une preuve rapide du Théorème 2.4 ainsi que du Théorème 2.6. On pourrait naturellement utiliser ce lemme pour s'intéresser à d'autres propriétés des sous-décalages. En particulier, Ronnie Pavlov a suggéré qu'il pourrait être une bonne idée d'utiliser le Lemme 2.2 pour étudier les ensembles de motifs inévitables. Avec cette technique, on obtient une borne inférieure sur la taille minimale d'un tel jeu. Une autre application souhaitable serait d'utiliser le lemme pour obtenir des sous-décalages vérifiant des conditions de mélange. En particulier, l'existence de  $\mathbb{Z}^2$ -sous-décalages *corner-gluing* fortement apériodiques est un problème ouvert. Cette technique donnerait une preuve non constructive du résultat.

Dans la deuxième partie du Chapitre 2 on construit dans le Théorème 2.10 un sous-décalage qui contient une densité uniforme pour un  $\alpha \in [0, 1]$  fixé pour chaque groupe de croissance sous-exponentielle. On se demande si cette propriété peut être étendue à des groupes arbitraires avec croissance exponentielle. En particulier, il est possible de donner une construction explicite pour les groupes libres, mais le cas général reste inconnu.

Le Chapitre 3 est consacré à un Théorème de simulation (Théorème 3.7). Il constitue une extension du Théorème d'Hochman 3.3 au cas des groupes de type fini. La question qui reste non résolue est de savoir si le Théorème 1.20 qui simule un sous-décalage effectivement fermé dans un  $\mathbb{Z}^2$  sous-décalage sofique peut être généralisé de la même manière. Cela semble peu évident pour deux raisons : d'abord, les constructions par Aubrun et Sablik et celle de Durand, Romaschenko et Shen sont basées sur une structure substitutive. Cette approche semble difficile à implémenter en général dans un groupe finement présenté. Cependant il semble possible de résoudre cela grâce à un théorème de Seward [Sew14] qui implique que chaque groupe infini admet un jeu de générateurs pour lequel le graphe de Cayley peut être disjoint par des chemins bi-infinis. Jeandel a suggéré que ce résultat pourrait donner une manière d'étendre le Théorème 3.7 pour produire  $(H_1 \times H_2) \rtimes G$  pour des groupes infinis arbitraires  $H_1$  and  $H_2$ .

Dans le Chapitre 4 nous avons proposé une nouvelle notion d'effectivité qui se caractérise à l'aide d'oracles. Bien que cette notion présente de nombreux avantages,

notamment celui d'être caractérisé par des  $G$ -machines, elle échoue en revanche à satisfaire la propriété de stabilité par sous-dynamique projective. Cette situation ne se produit que dans un cas clairement identifié : si le sous-groupe sur lequel on projette a un problème du mot plus faible que le groupe original. En effet, dans ce cas la  $G$ -classe peut être utilisée par une machine de Turing pour effectuer un calcul et ainsi avoir accès au problème du mot de  $G$  comme oracle. Il n'est donc pas déraisonnable d'espérer un théorème de simulation pour les sous-décalages  $G$ -effectivement fermés, avec des hypothèses plus faibles que celles du Théorème 4.11. A ce jour nous ignorons encore si un tel résultat existe, mais comme expliqué précédemment il semble tout à fait plausible.

L'objectif du Chapitre 5 était d'analyser les problèmes du mot, de torsion et de finitude pour deux groupes invariants de systèmes dynamiques. Les résultats obtenus y sont présentés comme des résultats sur ces deux groupes, groupe d'automorphismes et groupe plein topologique. Il est important de noter que ces deux groupes proviennent de l'étude du groupe abstrait des machines de Turing, qui contient de manière assez naturelle le groupe plein topologique et est très étroitement lié au groupe d'automorphismes du décalage plein. Dans ce modèle plus général, de nombreuses questions restent ouvertes. Par exemple, on sait que  $\text{Aut}(\{0, 1\}^{\mathbb{Z}})$  se plonge dans  $\text{Aut}(\{0, 1, 2\}^{\mathbb{Z}})$ , mais on ignore si le modèle équivalent des machines de Turing réversibles sur un alphabet à deux symboles se plonge dans celui sur un alphabet à trois symboles, ou encore l'inverse. Il n'existe pas non plus de bonne caractérisation du sous-groupes des commutateurs de ces objets. Toutes ces questions sont prometteuses, au sens où elles permettent de construire des exemples de groupes avec des propriétés spécifiques comme dans [JM12].

Nous montrons dans les Théorèmes 5.8 et Théorèmes 5.11 que le problème de torsion du groupe plein topologique d'un  $\mathbb{Z}^d$ -décalage plein dépend de la dimension. Une généralisation directe de la preuve de ces résultats d'indécidabilité aux groupes quelconques reposerait sur deux choses : d'abord que le *snake tiling problem* pour ces groupes soit aussi indécidable, et ensuite que le groupe possède des sous-groupes d'indice fini suffisamment grands pour permettre d'y coder des tuiles. La deuxième condition pourrait raisonnablement être affaiblie de sorte qu'on ait seulement besoin d'un ensemble couvrant et non d'un sous-groupe. Nous n'avons cependant pas de preuve de ce résultat dans un cadre général.

Le Théorème 5.19 montre l'existence d'un groupe de type fini avec problème de torsion décidable dans  $\text{Aut}(\{0, 1\}^{\mathbb{Z}})$ . Ce résultat peut s'étendre au cas de groupes contenant un élément sans torsion, en y plongeant  $\text{Aut}(\{0, 1\}^{\mathbb{Z}})$ . Mais on ne peut pas le généraliser directement aux groupes périodiques. Il semble cependant raisonnable de montrer que ce résultat reste vrai pour les groupes qui ne sont pas localement finis, en utilisant à la fois des géodésiques et des marqueurs [BLR88].

D'un autre point de vue, il semble intéressant d'étudier comment se comporte le problème de torsion de groupes d'automorphismes lorsque l'on se limite au cas de sous-décalages plus simples. Par exemple, les travaux de Cyr, Kra [KC16] et Donoso, Durand, Maass et Petite [DDMP16] donnent des exemples de sous-décalages de faible complexité pour lesquels on sait caractériser le groupe d'automorphismes et montrer qu'il a problème de torsion décidable. Ceci motive l'auteur à s'intéresser au cas de

sous-décalages algébriques d'entropie nulle, car ceux-ci ont à la fois faible complexité et peuvent avoir des groupes d'automorphismes très différents. Par exemple, le sous-décalage de Ledrappier  $(X_{\text{Led}}, \sigma)$  de l'Exemple 1.7 vérifie que  $\text{Aut}(X_{\text{Led}}) \cong \mathbb{Z}^2$ , alors que le groupe d'automorphismes du sous-décalage  $X \subset (\mathbb{Z}/2\mathbb{Z})^{\mathbb{Z}^2}$  formé des configurations  $x$  qui vérifient que pour tout  $(i, j) \in \mathbb{Z}^2$   $x_{(i,j)} + x_{(i+1,j)} + x_{(i,j+1)} + x_{(i+1,j+1)} = 0 \pmod{2}$  contient une large classe d'homéomorphismes, les automates cellulaires *color-blind* [ST13].

## Conclusions and perspectives

The main goal of this thesis was the search for links between dynamical and computational properties of shift spaces in groups. We have presented numerous new results which shed new light on this problematic. In what follows we recall the main contributions obtained in each chapter. We then discuss whether these results can be generalized to a broader context and if they can be applied to other problems.

In Chapter 2 we showed Lemma 2.2 which gives a sufficient condition for a set of forbidden patterns  $\mathcal{F} = \{p_1, p_2, \dots\}$  to define a non-empty subshift. This result was used to give short proofs of Theorem 2.4 and Theorem 2.6. It would only seem natural to use our technical Lemma to investigate other properties of subshifts. In particular, Ronnie Pavlov suggested the author that it would be a good idea to use Lemma 2.2 to study sets of unavoidable patterns, that is, sets of patterns defined over a fixed support whose removal forces a subshift to be empty. With this technique in hand, it is possible to give lower bounds on the minimum size of such set. Another highly desirable application is to use the lemma to obtain subshifts with mixing conditions. In particular, it is open whether a corner-gluing strongly aperiodic  $\mathbb{Z}^2$ -subshift exists. It might be possible to use this technique to give a non-constructive proof.

In the second part of Chapter 2 we constructed in Theorem 2.10 a subshift containing uniform density for a fixed  $\alpha \in [0, 1]$  for each group of sub-exponential growth. We ask ourselves whether this property can be extended to arbitrary groups with exponential growth. In particular, it is possible to give an explicit construction for free groups, but the general case remains unknown to us.

Chapter 3 was dedicated to our simulation theorem which was presented in Theorem 3.7. This constitutes an extension of Hochman's Theorem 3.3 to the case of finitely generated groups. The obvious question which remains unanswered is whether Theorem 1.20 which simulates an effectively closed subshift inside a sofic  $\mathbb{Z}^2$ -subshift can be generalized analogously. This seems complicated for two reasons: first, both the construction by Aubrun and Sablik and that of Durand, Romashchenko and Shen are based on a substitutive structure. In the first case this is explicitly a subshift generated by a  $\mathbb{Z}^2$ -substitution while in the second a self-similar tiling of the plane. This approach seems hard to implement in general finitely generated groups, for instance, in co-Hopfian groups where no subgroup is isomorphic to the whole group. However, it might be possible to work this out thanks to a Theorem by Seward [Sew14] which implies that every infinite group admits a set of generators for which the Cayley graph can be covered by disjoint bi-infinite paths. It was suggested by Jeandel that this result also might give a way of extending Theorem 3.7 to products  $(H_1 \times H_2) \rtimes G$  for arbitrary infinite groups  $H_1$  and  $H_2$ .

In Chapter 4 we proposed a new notion of effectiveness which can be characterized by oracles. Although this notion has many advantages such as the characterization

by  $G$ -machines, it fails to be stable under projective subdynamics. Nevertheless this only happens if the subgroup taken under the projective subdynamics has a weaker word problem than the original one. In this case, the  $G$ -coset can be used by a Turing machine performing computation to gain access to an oracle to the word problem of  $G$ . It is therefore not unreasonable to expect some sort of simulation theorem for  $G$ -effectively closed subshifts with less conditions than Theorem 4.11. We still do not know if such a result is possible, but it certainly seems plausible.

The focus of Chapter 5 was to analyze the word, torsion and finiteness problems for two group invariants of dynamical systems. Although we presented the results in a stand-alone manner, they come from the study of an abstract group of reversible Turing machines which contains in a rather natural way the topological full group and has a tight relationship with the automorphism group of a full shift. In this generalized model there are still several questions which remain open. For instance, it is known that  $\text{Aut}(\{0, 1\}^{\mathbb{Z}})$  embeds into  $\text{Aut}(\{0, 1, 2\}^{\mathbb{Z}})$ . However, we do not know if the equivalent model of reversible Turing machines for two symbol alphabets embeds into the three symbol alphabet one or vice-versa. We also do not have a nice characterization of the commutator subgroups of those objects. All of these questions show promise in the sense that they allow the construction of examples of groups with peculiar properties as in [JM12].

We showed in Theorem 5.8 and Theorem 5.11 that the torsion problem of the topological full group of a full  $\mathbb{Z}^d$ -shift is dependent on the dimension. A direct generalization of the proof of the undecidability result to arbitrary groups would depend upon two facts: (1) that the snake tiling problem for said groups is undecidable and (2), that the group admits finite index subgroups large enough to allow the coding of tiles. It seems reasonable that the second condition can be weakened in such a way that a only a covering set is needed instead of a subgroup. However, we have yet no proof in this general setting.

Theorem 5.19 shows the existence of a finitely generated group with undecidable torsion problem in  $\text{Aut}(\{0, 1\}^{\mathbb{Z}})$ . This can be extended to other groups containing a torsion-free element by embedding  $\text{Aut}(\{0, 1\}^{\mathbb{Z}})$ . However, the same does not directly hold for periodic groups. It seems however quite reasonable to extend this to groups which are not locally finite through the combined use of geodesics and markers [BLR88].

From another point of view, it seems interesting to study what happens with the torsion problem of automorphism groups as soon as we restrict the subshift to be simpler. For instance, studies by Cyr, Kra [KC16] and Donoso, Durand, Maass and Petite [DDMP16] show examples of subshifts of low complexity for which the automorphism groups can be characterized and have decidable torsion problem. It seems quite appealing to the author to study the case of algebraic subshifts of zero-entropy, as they have low complexity while at the same time great variations in their automorphism groups: For instance, the Ledrappier subshift  $(X_{\text{Led}}, \sigma)$  from Example 1.7 satisfies  $\text{Aut}(X_{\text{Led}}) \cong \mathbb{Z}^2$  while the automorphism group of the subshift  $X \subset (\mathbb{Z}/2\mathbb{Z})^{\mathbb{Z}^2}$  consisting on the configurations  $x$  which satisfy for each  $(i, j) \in \mathbb{Z}^2$   $x_{(i,j)} + x_{(i+1,j)} + x_{(i,j+1)} + x_{(i+1,j+1)} = 0 \pmod 2$  contains a large class of homeomorphisms, namely, all color-blind cellular automata [ST13].

# Appendix A

## Computability

Turing machines are mathematical objects introduced by Alan Turing [Tur36] that model the idea of computation. That is, these machines model what can be done by following a finite set of rules, having neither time nor memory limitations. It is generally accepted that Turing machines capture this notion correctly. One strong argument towards this is the Church-Turing thesis, where three competing notions for computability were shown to be equivalent: Turing machines,  $\lambda$ -calculus and the theory of recursive functions.

This appendix deals with computability notions with the aim to define the concepts used in the main manuscript. The reader might note that some definitions are simpler from the ones used in a textbook introduction to computability. For instance, the Turing machines defined here are using only one alphabet instead of different working and input alphabets and they contain no rejecting state. Although the objects are certainly different, the classes of languages defined by them are the same. The references for this appendix are [Sip06, AB09, RJ87].

### A.1 Languages and Turing machines

**Definition A.1.** Let  $\Sigma$  be a set.

- A *word* is an element  $w \in \Sigma^n$  for some  $n \in \mathbb{N}$ . We denote the empty word by  $\epsilon$ .
- The set of all words is denoted by  $\Sigma^* := \bigcup_{n \in \mathbb{N}} \Sigma^n$ .
- A *language* is a subset  $L \subset \Sigma^*$ .

*Remark.* Note that the previous definition does not ask for  $\Sigma$  to be finite. In what follows, we will consider mostly finite sets, in this case we call  $\Sigma$  an *alphabet*.

**Definition A.2.** A *Turing machine* is a 6-tuple  $(Q, \Sigma, \sqcup, q_0, Q_F, \delta)$  where  $Q$  is a finite set of states,  $\Sigma$  is an alphabet,  $\sqcup \in \Sigma$  is the blank symbol,  $q_0 \in Q$  is the initial state,  $Q_F \subset Q$  is the set of accepting states and  $\delta : \Sigma \times Q \rightarrow \Sigma \times Q \times \{-1, 0, +1\}$  is the transition function.

We want to think of  $\mathbb{Z}$  as a bi-infinite tape filled with symbols from  $\Sigma$ , accompanied by a head which carries a state and points to a position of  $\mathbb{Z}$ . This whole idea can be represented by an element of  $\Sigma^{\mathbb{Z}} \times Q \times \mathbb{Z}$ . In this sense, a Turing machine  $T$  acts on  $\Sigma^{\mathbb{Z}} \times Q \times \mathbb{Z}$  as follows: let  $(x, q, n) \in \Sigma^{\mathbb{Z}} \times Q \times \mathbb{Z}$  and  $\delta(x_n, q) = (a, r, d)$ . Then  $T(x, q, n) = (\tilde{x}, r, n + d)$  where  $\tilde{x}_n = a$  and  $\tilde{x}|_{\mathbb{Z} \setminus \{n\}} = x|_{\mathbb{Z} \setminus \{0\}}$ . See Figure A.1.

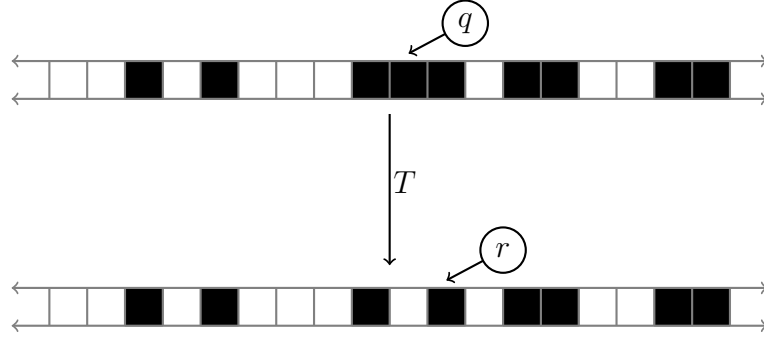

Figure A.1: A Turing machine transition where  $\delta(\blacksquare, q) = (\square, r, +1)$ .

A word  $w \in (\Sigma \setminus \{\sqcup\})^*$  is called in this context an *input*. We say  $T$  *halts* on input  $w$  if there exists  $n \in \mathbb{N}$  such that  $T^n(x^w, q_0, 0) \in \Sigma^{\mathbb{Z}} \times Q_F \times \mathbb{Z}$  where  $x^w$  is the configuration such that:

$$(x^w)_m = \begin{cases} w_m & \text{if } m \in \{0, \dots, |w| - 1\} \\ \sqcup & \text{otherwise.} \end{cases}$$

Said in simpler words,  $T$  halts on  $w$  if it reaches a state in  $Q_F$  in a finite number of steps starting from the configuration that has  $w$  at the origin and blank symbols everywhere else.

*Remark.* It is possible to partition  $Q_F$  into accepting states  $Q_A$  and rejecting states  $Q_R$ . In this case we say  $T$  *accepts*  $w$  if it halts on input  $w$  on a state in  $Q_A$  and that  $T$  *rejects*  $w$  if it halts on input  $w$  on a state in  $Q_R$ .

**Definition A.3.** A Language  $L \subset (\Sigma \setminus \{\sqcup\})^*$  is,

- *recursively enumerable* if there exists a Turing machine  $T$  which halts on  $w$  if and only if  $w \in L$ .
- *co-recursively enumerable* if  $(\Sigma \setminus \{\sqcup\})^* \setminus L$  is recursively enumerable.
- *decidable* if  $L$  is both recursively enumerable and co-recursively enumerable.
- *undecidable* if  $L$  is not decidable.

In the case of a decidable language, there are two Turing machines  $T_1$  and  $T_2$  which if run on parallel halt in every possible input. It is often better to think about this as a single Turing machine  $T$  which halts in every input, with the halting states  $Q_F$  partitioned into accepting and rejecting states and such that  $w \in L$  if and only if  $T$  accepts  $L$ . These two notions are equivalent.

These classes of languages are often called differently depending on the context. Decidable languages are also called effective or recursive. Recursively enumerable languages are also called effectively enumerable, recognizable, or semi-decidable.

*Remark.* The reason behind the name recursively enumerable is that if there is a machine which halts on input  $w$  if and only if  $w \in L$ , then there is another machine which writes on the tape in some order all of the words in  $L$ . In order to do this, a machine can store a counter coding a number  $n \in \mathbb{N}$  and iteratively write all words of length smaller than  $n$  and run  $T$  for  $n$  steps. At each time that  $T$  halts on a word, it writes it in the right part of the tape if it has not already been written.

*Example A.1.* The language  $L = \{a^n b^n \mid n \in \mathbb{N}\}$  is decidable. A Turing machine which accepts it is shown in Figure A.2. Here the states are represented as nodes, and an arrow  $u \rightarrow v, d$  from  $q$  to  $r$  means that  $\delta(u, q) = (v, r, d)$ . The accepting state is  $q_a$  and any transition not shown in the picture means that the machine goes to  $q_r$  and rejects.

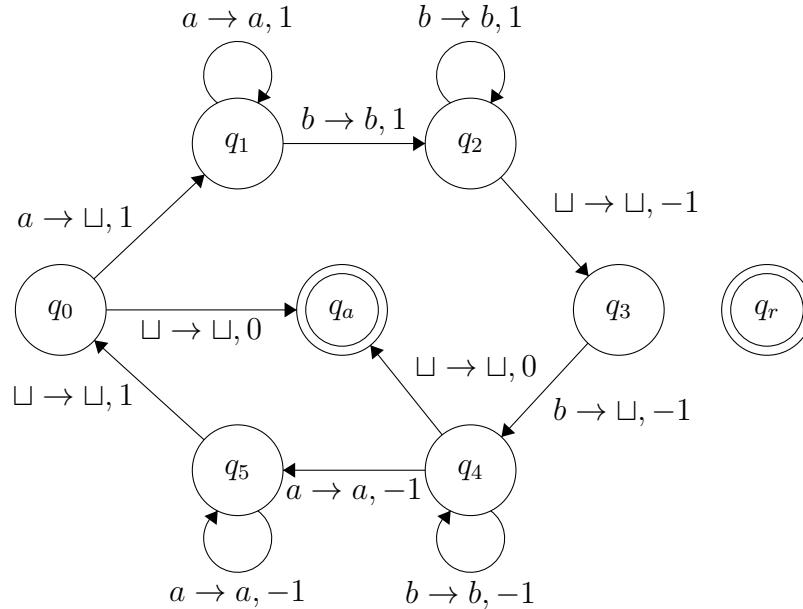

Figure A.2: A representation of the transition function of a machine deciding  $L$ .

Each Turing machine is defined by a finite amount of information. One can therefore encode the description of a Turing machine as a word in a suitable language. Without further details, let's denote by  $\langle \cdot \rangle$  a fixed coding. In what follows  $\langle T, w \rangle$  is a coding of a pair  $T, w$  where  $T$  is a Turing machine and  $w \in \Sigma^*$ .

*Example A.2* (For a proof see [Sip06]). The language

$$\text{HALT} := \{\langle T, w \rangle \mid T \text{ halts on input } w\}$$

is recursively enumerable.

This means that there exists a Turing machine  $T_U$  which given a coding of another machine  $\langle T \rangle$  and a word  $w$  halts if and only if  $T$  halts on  $w$ . This means that  $T_U$  is



able to simulate the behavior of  $T$  on input  $w$ . Such a machine can be constructed explicitly, and is called a *universal Turing machine*

**Theorem A.1** (Turing [Tur36]). *HALT is undecidable.*

*Proof.* Suppose HALT was decidable, then there exists a Turing machine  $H$  which halts on every input  $\langle T, w \rangle$  and accepts if and only if  $T$  accepts  $w$ . One can therefore construct a machine  $N$  which on entry  $\langle T \rangle$  accepts if  $H$  rejects  $\langle T, \langle T \rangle \rangle$  and rejects if  $H$  accepts  $\langle T, \langle T \rangle \rangle$ .

Consider  $N$  on input  $\langle N \rangle$ . If  $N$  accepts, then by definition  $H$  rejects  $\langle N, \langle N \rangle \rangle$  which means that  $N$  rejects the input  $\langle N \rangle$ . On the other hand, if  $N$  rejects  $\langle N \rangle$  then by definition  $H$  accepts  $\langle N, \langle N \rangle \rangle$  which then implies that  $N$  accepts  $\langle N \rangle$ . This yields a contradiction.  $\square$

## A.2 Computable functions, sets and numbers

**Definition A.4.** A function  $f : \Sigma^* \rightarrow \Sigma^*$  is called *total computable* if there exists a Turing machine which on input  $w \in \Sigma^*$  halts containing  $f(w)$  in the tape.

*Remark.* In the literature this concept can also be found under the name total recursive function.

The notion of computable function is also used to refer to partial functions, that is, functions which are only defined in a subset of  $\Sigma^*$ . In this case the machine only halts in that specific subset. The prefix “total” is added in order to differentiate these two concepts.

We also want to have computable functions between objects which are not languages. In this case, as with Turing machines, we need to codify these objects as words in order to work with them. This codification is done independently for each object.

*Example A.3.* We can code  $n \in \mathbb{N}$  in binary as a string  $\langle n \rangle_2 \in \{0, 1\}^*$ . We say a function  $f : \mathbb{N} \rightarrow \mathbb{N}$  is total computable, if  $f' : \{0, 1\}^* \rightarrow \{0, 1\}^*$  is total computable where  $f'(\langle n \rangle_2) := \langle f(n) \rangle_2$ .

**Proposition A.2.** *A language  $L$  is decidable, if and only if there exists a total computable function  $f : \Sigma^* \rightarrow \{0, 1\}$  such that  $f(w) = 1 \iff w \in L$ .*

The following proposition justifies the usage of the name “enumerable” for recursively enumerable languages.

**Proposition A.3.** *A language  $L$  is recursively enumerable, if and only if there exists a total computable onto function  $f : \mathbb{N} \rightarrow L$ .*

**Definition A.5.** Consider again the a coding of  $\mathbb{N}$  as binary strings. A set  $S \subset \mathbb{N}$  is called *recursively enumerable* if there exists a total computable function  $f : \mathbb{N} \rightarrow S$ . Furthermore, it is called *recursive* if there exists a total recursive function  $f : \mathbb{N} \rightarrow \{0, 1\}$  such that  $S = f^{-1}(1)$ .

*Example A.4.* Suppose we want to code objects which are of the form  $(w_i, a_i)_{i \leq n}$  where  $w_i \in \Sigma^*$  and  $a \in \Sigma'$ . That is, finite sets of tuples containing a word  $w_i \in \Sigma^*$  and an symbol  $a$  from another alphabet  $\Sigma'$ . One way to code  $(w_i, a_i)_{i \leq n}$  is to use a word  $u \in (\Sigma \cup \Sigma' \cup \{(\cdot), \#, |\})^*$  such that:

$$(w_i, a_i)_{i \leq n} \text{ is coded as } (w_1|a_1)\#(w_2|a_2)\# \dots \#(w_n|a_n).$$

We say that a set  $\mathcal{C}$  of these objects is recursively enumerable, if there exists a total computable function  $f : \mathbb{N} \rightarrow (\Sigma \cup \Sigma' \cup \{(\cdot), \#, |\})^*$  such that the set of codings of  $\mathcal{C}$  is the image of  $f$ . We say that  $\mathcal{C}$  is computable, if and only if there exists a total computable function  $g : (\Sigma \cup \Sigma' \cup \{(\cdot), \#, |\})^* \rightarrow \{0, 1\}$  such that  $g(\langle c \rangle) = 1 \iff c \in \mathcal{C}$ .

In the context where  $\Sigma$  is a finite set of generators of a group and  $\Sigma'$  a finite alphabet, these objects are called *pattern codings*.

*Remark.* Note that in this last example the set of words in  $(\Sigma \cup \Sigma' \cup \{(\cdot), \#, |\})^*$  which are not valid codings is non-empty. As long as the language of all non-valid codings is decidable, it does not pose a problem.

We finish this section by defining computable numbers. These objects appear naturally in dynamical systems, for instance in the classification of the entropies of  $\mathbb{Z}^2$ -SFTs [HM10].

**Definition A.6.** Let  $\alpha \in \mathbb{R}$  be a real number. We say that

- $\alpha$  is *upper semicomputable* or *right recursively enumerable* if there exists a computable function  $f : \mathbb{N} \rightarrow \mathbb{Q}$  such that  $\alpha = \inf_{n \in \mathbb{N}} f(n)$ ;
- $\alpha$  is *lower semicomputable* or *left recursively enumerable* if there exists a computable function  $f : \mathbb{N} \rightarrow \mathbb{Q}$  such that  $\alpha = \sup_{n \in \mathbb{N}} f(n)$ ;
- $\alpha$  is *computable* if there exists a computable function  $f : \mathbb{N} \rightarrow \mathbb{Q}$  such that  $|f(n) - \alpha| < \frac{1}{n}$ .

## A.2.1 Oracles and reductions

A reduction between two languages is a way to compare them in terms of their complexity. Here we present two notions of reductions: Turing reduction and many-one reduction. In order to introduce the first notion we need to speak about oracle machines. The following definition is not completely formal, for a complete definition see [AB09].

**Definition A.7.** Let  $\mathcal{O}$  be a language. A *Turing machine with oracle  $\mathcal{O}$*  is a Turing machine with a special state  $q_{\text{oracle}} \in Q$  and an extra tape. The computation of this machine is as usual except that when it enters the state  $q_{\text{oracle}}$  having on the second tape a word  $w$ , the transition function depends on whether  $w \in \mathcal{O}$ .

In other words, a Turing machine with oracle  $\mathcal{O}$ , is a Turing machine which has complete knowledge of a language  $\mathcal{O}$  and can use it as a black box in its routine.

**Definition A.8.** Let  $L, L'$  be languages. We say  $L$  is Turing reducible to  $L'$  and write  $L \leq_T L'$  if there exists a Turing machine with oracle  $L'$  which decides  $L$ . If both  $L \leq_T L'$  and  $L' \leq_T L$  we write  $L \equiv_T L'$  and say they are Turing equivalent.

*Example A.5.* Let  $L$  be a recursively enumerable language, then  $L \leq_T \text{HALT}$ . Indeed, let  $T$  be the Turing machine which halts if and only if  $w \in L$ . A Turing machine with oracle  $\text{HALT}$  deciding  $L$  is given by a machine which on input  $w$  constructs a coding  $\langle T \rangle$  and writes  $\langle T, w \rangle$  in the second tape and then goes to the state  $q_{\text{oracle}}$ . The machine halts if and only if the oracle says that  $\langle T, w \rangle \in \text{HALT}$ .

Turing reduction is not able to distinguish between a language and its complement due to the fact that it is only defined by decidability. Its use is to give a formal way of expressing the phrase: “if  $X$  is decidable then  $Y$  is decidable”. In particular, for every language  $L \equiv_T \Sigma^* \setminus L$ . A finer notion of reduction is the following:

**Definition A.9.** Let  $L, L'$  be languages. We say  $L$  is many-one reducible to  $L'$  and write  $L \leq_m L'$  if and only if there exists a total computable function  $f$  such that

$$w \in A \iff f(w) \in B.$$

Furthermore, if  $L \leq_m L'$  and  $L' \leq_m L$  we write  $L \equiv_m L'$  and say they are many-one equivalent.

For all of the purposes of this manuscript, we can think of many-one equivalent languages as computably equivalent languages. In particular, all of the properties such as being decidable, recursively enumerable and co-recursively enumerable are preserved by many-one equivalence.

# Appendix B

## Group Theory

In this appendix we review some basics of group theory. The objective is to define and precise the notation of the concepts that appear in the manuscript. In particular, we take special care of concepts which are not easily found in the literature, as group presentations and their computability properties. It is important to declare that this chapter is by no means intended as a proper introduction to the subject and many proofs are omitted. For a better introduction of the fundamentals of group theory we refer the reader to [Hun80, Lan02]. For more on classes of groups to [CSC09].

### B.1 Basic definitions

**Definition B.1.** A *group* is a pair  $(G, *)$  where  $G$  is a set and  $* : G \times G \rightarrow G$  is an operation which verifies:

1.  $\forall x, y, z \in G, (x * y) * z = x * (y * z)$ .
2.  $\exists 1_G \in G$  such that  $\forall x \in G, 1_G * x = x * 1_G = x$ .
3.  $\forall x \in G, \exists x^{-1} \in G$  such that  $x * x^{-1} = x^{-1} * x = 1_G$ .

*Remark.* In order to simplify the notation, the operation symbol is often omitted: instead of writing  $x * y$  we just write  $xy$ . Also, when the group operation is clear, we refer to the group  $(G, *)$  just by the set  $G$ . For instance, we refer to  $\mathbb{Z}$  as the group of integers while formally we mean  $(\mathbb{Z}, +)$ .

**Definition B.2.** Let  $H \subset G$ . We say  $H$  is a *subgroup* if the following conditions hold:

1.  $\forall h_1, h_2 \in H, h_1 h_2 \in H$ .
2.  $1_G \in H$ .
3.  $\forall h \in H, h^{-1} \in H$ .

We denote  $H$  is a subgroup of  $G$  by  $H \leq G$ . Furthermore if for each  $g \in G$  and  $h \in H$  we have  $ghg^{-1} \in H$ , we say that  $H$  is a *normal subgroup* and write  $H \triangleleft G$ .

**Definition B.3.** A subgroup  $H \leq G$  induces an equivalence relation  $\sim_H$  defined by  $g_1 \sim_H g_2$  if and only if there exists  $h \in H$  such that  $g_1 h = g_2$ . We denote the set of *left cosets* by  $G/H := G/\sim_H$  and define the *index* of  $H$  as  $[G : H] := |G/H|$ .

*Remark.* Let  $H \triangleleft G$  and  $gH \in G/H$ . As  $ghg^{-1} \in H$  for each  $g \in H$ , we have that  $gH = Hg$ . We can endow  $G/H$  with the operation defined by  $(g_1H)(g_2H) := (g_1g_2)H$ . This operation is well defined because:

$$(g_1H)(g_2H) = g_1(Hg_2)H = g_1(g_2H)H = g_1g_2HH = g_1g_2H.$$

**Definition B.4.** If  $H$  is a normal subgroup of  $G$ , then the group  $G/H$  endowed with the operation defined by  $(g_1H)(g_2H) := (g_1g_2)H$  is called a *quotient group*.

**Definition B.5.** Let  $F \subset G$  we denote by  $\langle F \rangle$  the smallest subgroup of  $G$  which contains  $F$ .

Recall that given a set  $S$ , a word is an element  $w \in S^* = \bigcup_{n \in \mathbb{N}} S^n$ . For words  $u, v \in G^*$  we write  $u =_G v$  if after applying the group operation on each pair of contiguous symbols the same element of  $G$  is obtained. The following proposition can easily be verified:

**Proposition B.1.**  $\langle F \rangle = \{g \in G \mid \exists u \in (F \cup F^{-1})^* \text{ such that } u =_G g\}$ .

**Definition B.6.** We say a group  $G$  is *finitely generated* if there exists a finite subset  $S \subset G$  such that  $G = \langle S \rangle$ . Such a set  $S$  is called a set of *generators* for  $G$ . The rank of  $G$  is defined as the smallest cardinality of a set of generators for  $G$ .

### B.1.1 Group homomorphisms

**Definition B.7.** Let  $G, H$  be groups. A function  $\varphi : G \rightarrow H$  is an *homomorphism* if

$$\forall x, y \in G, \varphi(xy) = \varphi(x)\varphi(y).$$

**Definition B.8.** Let  $G, H$  be groups and  $\varphi : G \rightarrow H$  a homomorphism.

- If  $\varphi$  is injective it is a *monomorphism*.
- If  $\varphi$  is surjective it is an *epimorphism*.
- If  $\varphi$  is bijective it is an *isomorphism*.
- If  $H = G$  then  $\varphi$  is called an *endomorphism*.
- If  $\varphi$  is an isomorphism and an endomorphism it is an *automorphism*.

*Remark.* We say that  $G$  and  $H$  are *isomorphic* if there is an isomorphism from  $G$  to  $H$ . It means that they are the same group up to notation. We denote that  $G$  and  $H$  are isomorphic by  $G \cong H$ .

*Remark.* Note that whenever  $S$  is a set of generators for  $G$ , in order to define a morphism from  $G$  it suffices to define it for  $S$ .

*Example B.1.* Let  $(\mathbb{Z}, +)$  be the group of integers with addition and for  $\alpha \in \mathbb{R}$  consider  $(C_\alpha, \cdot)$  the multiplicative group of complex numbers which can be written as  $e^{ni\pi\alpha}$  for some  $n \in \mathbb{Z}$ . Then  $(\mathbb{Z}, +) \cong (C_\alpha, \cdot)$  if and only if  $\alpha \notin \mathbb{Q}$ .

**Theorem B.2** (First isomorphism theorem). *Let  $G, H$  be groups and  $\varphi : G \rightarrow H$  a homomorphism.*

1.  $\text{Ker}(\varphi) := \{g \in G \mid \varphi(g) = 1_H\}$  is a normal subgroup of  $G$ .
2.  $\varphi(G)$  is a subgroup of  $H$ .
3.  $\varphi(G) \cong G/\text{Ker}(\varphi)$ .

## B.1.2 Free groups and presentations

**Definition B.9.** Let  $S$  be a set and consider a copy  $S^{-1} = \{s^{-1} \mid s \in S\}$ . We say a word in  $(S \cup S^{-1})^*$  is *reduced* if it does not contain  $ss^{-1}$  or  $s^{-1}s$  as subwords. Every word in  $(S \cup S^{-1})^*$  can be reduced to a unique minimal word by successively eliminating every apparition of  $ss^{-1}$  or  $s^{-1}s$ .

**Definition B.10.** The *free group* over  $S$  is defined as the set  $F_S$  of all reduced words in  $(S \cup S^{-1})^*$  endowed with word concatenation followed by reduction as the operation.

*Example B.2.* Let  $S, S'$  be sets of the same cardinality. Then  $F_S \cong F_{S'}$ . This means that for each cardinality there is only one free group up to isomorphism. For an integer  $n \geq 1$  we denote by  $F_n$  the free group of rank  $n$  defined by the set  $S = \{1, \dots, n\}$ .

A combinatorial way to look at groups is using presentations. These are canonical descriptions of groups given by a set and a language.

**Definition B.11.** A *group presentation* is a pair  $(S, R)$  where  $S$  is a set and  $R \subset (S \cup S^{-1})^*$  is a set of words.

**Definition B.12.** Let  $(S, R)$  be a presentation, the group defined by  $(S, R)$  is

$$\langle S \mid R \rangle := F_S/N_R.$$

Here  $F_S$  is the free group over  $S$  and  $N_R$  is the conjugate closure of  $R$ , that is,  $N_R = \langle \{grg^{-1} \mid g \in F_S \text{ and } r \in R\} \rangle$ .

In other words,  $\langle S \mid R \rangle$  is the largest quotient of the free group over  $S$  such that every word in  $R$  is identified to the empty word. Elements of  $S$  are called *generators* and words of  $R$  are called *relators*.

**Definition B.13.** We say  $(S, R)$  is a presentation for  $G$  if

$$G \cong \langle S \mid R \rangle.$$

*Example B.3.*

$$\begin{aligned} F_S &\cong \langle S \mid \emptyset \rangle. \\ \mathbb{Z}^2 &\cong \langle a, b \mid aba^{-1}b^{-1} \rangle. \\ \mathbb{Z}/n\mathbb{Z} &\cong \langle a \mid a^n \rangle. \end{aligned}$$

*Remark.* Each element of a finitely generated group can be seen as a word in  $(S \cup S^{-1})^*$ . From now on, we will convene that a set of generators contains its inverses to avoid writing  $S \cup S^{-1}$ . This convention does not hold when speaking about the rank of the group.

### B.1.3 Cayley graph and generator metrics

**Definition B.14.** Given  $S \subset G$  the right *Cayley graph* of  $G$  with respect to  $S$  is the directed graph  $\Gamma(G, S)$  whose vertex set is  $G$  and its set of arcs is given by  $E = \{(g, gs) \mid g \in G, s \in S\}$ .

For  $g \in G$  we denote by  $|g|_S$  the length of the shortest path from  $1_G$  to  $g$  in  $\Gamma(G, S)$ . This induces a distance  $d_S(g, h) := |g^{-1}h|_S$  which makes  $(G, d_S)$  a metric space. We denote the closed ball centered in  $g \in G$  of radius  $r$  by  $B_S(g, r) = \{h \in G \mid d_S(g, h) \leq r\}$ .

*Example B.4.* Consider the group  $(\mathbb{Z}^2, +)$  and let  $S = \{(0, 1), (1, 0), (0, -1), (-1, 0)\}$  be the canonical set of generators. Then  $\Gamma(\mathbb{Z}^2, S)$  is the bi-infinite grid and  $d_S(v_1, v_2) = |v_1 - v_2|_{\ell_1}$  is the taxicab norm.

**Proposition B.3.** *Let  $S_1, S_2$  be two finite sets of generators for a finitely generated group  $G$ . Then the metrics  $d_{S_1}$  and  $d_{S_2}$  are equivalent. In particular, the topology defined by  $d_{S_1}$  and  $d_{S_2}$  is the same.*

In particular, if for a group  $G$  and two set of generators  $S_1, S_2$  we define  $\gamma_{S_i} : \mathbb{N} \rightarrow \mathbb{N}$  by  $\gamma_{S_i}(n) = |B_S(1_G, n)|$ , we have that they are the same up to a constant. Let  $[\gamma_{S_i}]$  be the equivalence class of  $S_i$  if we quotient all functions  $f : \mathbb{N} \rightarrow \mathbb{N}$  by equivalence up to a constant. Clearly  $[\gamma_{S_1}] = [\gamma_{S_2}]$ .

**Definition B.15.** Let  $G$  be a finitely generated group. We define its growth as  $[\gamma_S]$  for some finite set of generators  $S$  of  $G$ .

*Example B.5.* If  $G = \mathbb{Z}^d$  then its growth is  $[n^d + 1]$  and thus polynomial, if  $G = F_d$  the free group on  $d$  elements, then its growth is  $[(2d - 1)^n]$  and hence exponential. It is a non-trivial fact that there exist groups whose growth is sub-exponential but not polynomial, an example is the Grigorchuk group [Gri85].

### B.1.4 Recursive presentations and the word problem

**Definition B.16.** We say a group  $G$  is *recursively presented* if there exists a presentation  $(S, R)$  such that  $G \cong \langle S \mid R \rangle$ ,  $S$  is a recursive set and  $R \subset S^*$  is a recursively enumerable language. If there exists a presentation for  $G$  for which both  $S$  and  $R$  are finite we say  $G$  is *finitely presented*.

*Example B.6.* The additive group of rational numbers is a recursively presented group.

$$(\mathbb{Q}, +) \cong \langle \{a_n\}_{n \in \mathbb{N}} \mid (a_n)^n a_{n-1}^{-1} \rangle$$

Indeed, note that  $\varphi(a_n) := \frac{1}{n!}$  defines an isomorphism.

*Remark.* As the previous example shows, a recursively presented group is not necessarily finitely generated.

**Proposition B.4.** *Let  $G$  be a group. The following are equivalent:*

- (i)  $G$  is recursively presented.
- (ii)  $G$  admits a presentation  $\langle S, R \rangle$  with  $S$  recursive and  $R$  decidable.
- (iii)  $G$  admits a presentation  $\langle S, R \rangle$  with both  $S$  and  $R$  recursively enumerable.
- (iv)  $G$  admits a presentation  $\langle S, R \rangle$  where  $S$  is co-recursively enumerable and  $R$  is recursively enumerable.

*Proof.* Clearly we have (i)  $\implies$  (iii), (i)  $\implies$  (iv) and (ii)  $\implies$  (i).

(i)  $\implies$  (ii) Let  $\langle S \mid R \rangle \cong G$  with  $S$  recursive and  $R$  recursively enumerable and let  $\# \notin S$ . By definition, there exists a Turing machine  $T$  which accepts on input  $w$  if and only if  $w \in R$ . For  $w \in R$  we can define  $n_w$  as the number of steps that  $T$  takes to accept it. Consider:

$$S' := S \cup \{\#\}$$

$$R' := \{\#\} \cup \{w\#^{n_w} \mid w \in R\}$$

Clearly  $G \cong \langle S' \mid R' \rangle$  as  $\# \in R'$ .  $S'$  is still recursive, and now  $R'$  becomes decidable: In order to decide if  $u \in R'$  it suffices to check if  $u = \#$  (accept in that case), check if it is of the form  $w\#^k$  (reject otherwise) and simulate  $T$  on input  $w$  for  $k$  steps and accept if and only if  $T$  halts and accepts exactly on  $t$  steps.

(iii)  $\implies$  (i) Let  $\langle S \mid R \rangle \cong G$  with  $S$  and  $R$  recursively enumerable. Identify  $S$  as a subset of  $\mathbb{N}$ . As  $S$  is recursively enumerable, there exists a computable enumeration  $f : \mathbb{N} \rightarrow S$ . Let  $D := \{(n, m) \in \mathbb{N} \times \mathbb{N} \mid f(n) = m\}$  and define:

$$S' = \mathbb{N} \times \mathbb{N}$$

$$R' = \{(n, m) \notin D\} \cup \{u = u_1, \dots, u_n \in D^* \mid u_i = (n_i, m_i), m_1, m_2, \dots, m_n \in R\}$$

The set  $D$  is decidable: it suffices on entry  $(n, m)$  to run the enumeration algorithm for  $S$  until it outputs  $n$  values and check whether  $f(n) = m$ . As all pairs  $(n, m) \notin D$  are associated to the identity, the only remaining ones are  $(n, m)$  for  $f(n) = m$  which can be identified to  $S$ . The second part of  $R'$  is also recursively enumerable: given  $u \in S'^*$  it suffices to run the algorithm for  $D$  over every symbol of  $u$ , and if it accepts on every entry, run the algorithm for  $R$  on the word formed by projecting  $u$  to the second coordinate. From these arguments it is straightforward to conclude that  $G \cong \langle S' \mid R' \rangle$ .



(iv)  $\implies$  (i) Let  $\langle S|R \rangle \cong G$  with  $S$  co-recursively enumerable and  $R$  recursively enumerable. Identify  $S$  as a subset of  $\mathbb{N}$  and define:

$$S' = \mathbb{N}$$

$$R' = \{\mathbb{N} \setminus S\} \cup R$$

The presentation  $\langle S' | R' \rangle$  is now recursive. Furthermore, as every  $s \notin S$  got identified to the identity, it defined a group isomorphic to  $G$ .  $\square$

A recursive presentation gives a way to store the structure of a group using a finite amount of information, namely, the Turing machines which code  $S$  and  $R$ . Nevertheless, this does not always allows us to understand the local structure of the group. An useful concept in that respect is the word problem.

**Definition B.17.** The *word problem* of a group  $G$  with respect to a finite set  $S$  is the language  $\text{WP}(G, S) = \{w \in S^* \mid w =_G 1_G\}$ .

From an informal point of view, a finitely generated group has decidable word problem if and only if for a finite set of generators  $S$  there is an algorithm that given  $n \in \mathbb{N}$  can construct a representation of  $B_S(1_G, n)$  in  $\Gamma(G, S)$ . If the word problem is only recursively enumerable, then there exists an algorithm that given  $n, m \in \mathbb{N}$  can construct upwards approximations  $B_m$  of  $B_S(1_G, n)$  such that  $B_m \searrow B_S(1_G, n)$  when  $m \rightarrow \infty$ , but gives no computable bound on the  $m$  for which the sequence stabilizes.

**Proposition B.5.** Let  $S_1, S_2$  be two finite sets of generators for  $G$ . Then  $\text{WP}(G, S_1)$  is many-one equivalent to  $\text{WP}(G, S_2)$ .

*Proof.* As  $\langle S_2 \rangle = G$  we have that each  $s \in S_1$  can be written as  $u(s) \in S_2^*$  such that  $s =_G u(s)$ . As  $S_1$  is finite, the function which sends a word  $s_0 \cdots s_k \in S_1^*$  to  $u(s_0) \cdots u(s_k) \in S_2^*$  is total computable and  $s_0 \cdots s_k = 1_G \iff u(s_0) \cdots u(s_k) = 1_G$ .  $\square$

In view of Proposition B.5 we can in terms of computability unambiguously speak about the word problem of a finitely generated group  $G$  and denote it as  $\text{WP}(G)$ .

**Proposition B.6.** A finitely generated group  $G$  is recursively presented if and only if  $\text{WP}(G)$  is recursively enumerable.

*Proof.* If  $\text{WP}(G, S)$  is recursively enumerable one can choose  $(S, \text{WP}(G, S))$  as a presentation for  $G$ . Conversely, as  $G$  is recursively presented then  $G \cong F_S/N_R$  for some recursively enumerable  $R \subset S^*$ . Given  $u \in F_S$  we have  $u =_G 1_G$  if and only if  $u \in N_R$ , therefore it suffices to be able to recognize this set. An algorithm which does this is the following: Iteratively for each  $n \in \mathbb{N}$  run for  $n$  steps the algorithm recognizing  $R$  on all words on  $S^*$  of length at most  $n$ . Let  $A_n$  be the list of accepted words so far. Build  $B_n = \{w\ell w^{-1} \mid |w| < n, \ell \in B_n\}$  and  $C_n = \{u \in B_n^* \mid |u| \leq n\}$ . The set  $C_n$  approximates the conjugate closure of  $R$ . It is easy to see that every possible word in  $N_R$  appears in  $C_n$  for large enough  $n$ .  $\square$

In the case where the group  $G$  is not finitely generated we need to be more specific about what do we mean by its word problem.

**Definition B.18.** The *word problem* of a recursive group presentation  $\langle S \mid R \rangle$  is defined as the language

$$\text{WP}(S \mid R) = \{w \in S^* \mid w =_{\langle S \mid R \rangle} 1_{\langle S \mid R \rangle}\}$$

Contrary to the case of presentations where  $S$  is finite, here it might happen that two recursive presentations are not many one equivalent. See Example 5.3. We say  $G$  has decidable word problem if and only if there exists a recursive presentation  $G \cong \langle S \mid R \rangle$  such that  $\text{WP}(S \mid R)$  is decidable.

## B.2 Classes of groups

### B.2.1 Abelian groups

**Definition B.19.** Let  $g, h$  be elements of a group. The *commutator* of  $g$  and  $h$  is defined as

$$[g, h] := ghg^{-1}h^{-1}.$$

**Definition B.20.** A group  $G$  is called *abelian* if for every  $g, h$  we have  $[g, h] = 1_G$ .

*Remark.* Given the fact that  $gh = hg$  for every pair of elements, we drop the multiplicative notation for an additive one and write  $g + h$  instead of  $gh$ .

The following theorem classifies completely all finitely generated abelian groups. See [Hun80] for a proof.

**Theorem B.7** (Fundamental theorem of finitely generated abelian groups). *Let  $G$  be a finitely generated abelian group, then there exists  $d, m \geq 0$  and prime powers  $q_1, \dots, q_m$  such that*

$$G \cong \mathbb{Z}^d \oplus \mathbb{Z}/q_1\mathbb{Z} \oplus \dots \oplus \mathbb{Z}/q_t\mathbb{Z}$$

### B.2.2 Amenable groups

Let  $G$  be a group. A measure  $\mu : 2^G \rightarrow [0, \infty)$  is called *left-invariant* if  $\forall A \subset G$ ,  $\mu(A) = \mu(gA)$  for each  $g \in G$ .

**Definition B.21.** A group  $G$  is called *amenable* if there exists a left-invariant finitely additive probability measure  $\mu : 2^G \rightarrow [0, 1]$ .

*Example B.7.* Any finite group  $G$  is amenable. A measure given is by

$$\mu(A) = \frac{|A \cap G|}{|G|}.$$

*Example B.8.* Let  $\mathbb{Z}$  be the group of integers and define  $\nu_n$  as the measure given by  $\nu_n(A) = \frac{|A \cap \{-n, \dots, n\}|}{2n+1}$ . Each  $\nu_n$  is a probability measure, thus the sequence  $(\nu_n)_{n \in \mathbb{N}}$  can be seen as a sequence of operators of norm 1 in  $(\ell^\infty(G))^*$ . By the Banach-Alaoglu theorem, the unit ball of  $(\ell^\infty(G))^*$  is sequentially compact in the weak-\* topology and thus one can extract a converging subsequence  $\nu_{n_i} \rightarrow^* \mu$ . Clearly  $\mu$  is a probability measure. Furthermore, given  $m \in \mathbb{Z}$  we have  $|\nu_n(m+A) - \nu_n(A)| \leq \frac{m}{2n+1}$  which converges to 0 as  $n$  goes to infinity. Hence  $\mu(m+A) = \mu(A)$ . This shows that  $\mathbb{Z}$  is amenable.

*Example B.9.* The free group  $F_2$  of rank 2 is not amenable. Let  $F_2$  be presented by  $\langle a, b \mid \emptyset \rangle$  and suppose a left-invariant probability measure  $\mu : 2^{F_2} \rightarrow [0, 1]$  exists. Let  $A \subset F_2$  be the set of elements beginning with  $a^k$  for  $k \neq 0$  in reduced form. Clearly  $F_2 = A \cup aA$ , therefore  $1 = \mu(F_2) = \mu(A \cup aA) \leq \mu(A) + \mu(aA) = 2\mu(A)$  and thus  $\mu(A) \geq 1/2$ .

On the other hand,  $A, bA$  and  $b^2A$  are pairwise disjoint, therefore  $3\mu(A) \leq \mu(A) + \mu(bA) + \mu(b^2A) \leq 1$ . Therefore  $\mu(A) \leq 1/3$ , yielding a contradiction.

The class of amenable groups contains all finite, abelian, nilpotent and solvable groups. It also satisfies several stability properties.

**Proposition B.8** (See [CSC09]). *The class of amenable satisfies the following stability properties:*

- *If  $G$  is amenable and  $H \leq G$ , then  $H$  is amenable.*
- *If  $G$  is amenable and  $H \triangleleft G$ , then  $G/H$  is amenable.*
- *If  $H \triangleleft G$  and both  $H$  and  $G/H$  are amenable then  $G$  is amenable.*
- *If  $H, G$  are amenable, then  $G \times H$  is amenable.*
- *A direct limit of amenable groups is amenable.*

The amenability of a group has many equivalent definitions – many of which can be found in Chapter 4 of [CSC09]. From a combinatorial point of view the most interesting one is the Følner condition.

**Definition B.22.** Let  $G$  be a group and  $(A, \leq)$  a directed set. A net  $(F_\alpha)_{\alpha \in A}$  is called a *Følner net*, if each  $F_\alpha$  is a non-empty finite subset of  $G$  such that  $\forall g \in G$ :

$$\lim_{\alpha} \frac{|gF_\alpha \Delta F_\alpha|}{|F_\alpha|} = 0.$$

**Theorem B.9** (Følner condition. For a proof see [CSC09]). *A group is amenable if and only if it admits a Følner net.*

*Remark.* In the case of a countable group, the net can be replaced by a sequence.

*Example B.10.* Let  $G = \mathbb{Z}^d$  and let  $F_n := \{0 \dots, n-1\}^d$ . For every vector  $v \in \mathbb{Z}^d$  we have  $|(v + F_n) \Delta F_n| = O(n^{d-1})$  while  $|F_n| = n^d$ , therefore:

$$\lim_{n \rightarrow \infty} \frac{|(v + F_n) \Delta F_n|}{|F_n|} = 0$$

This shows that  $\mathbb{Z}^d$  is amenable, note that the method is much simpler than that of Example B.9. In fact, the technique used in that first example is the core of the proof that the Følner condition implies amenability.

**Definition B.23.** Let  $F, K$  be finite subsets of a group  $G$ .

- $\text{Int}(F, K) := \{g \in F \mid \forall k \in K, gk \in F\}$  is the *interior* of  $F$  with respect to  $K$
- $\partial_K F := F \setminus \text{Int}(F, K)$  is the *boundary* of  $F$  with respect to  $K$

**Theorem B.10** (See [CSC09]). *A countable group  $G$  is amenable if and only if there exists a sequence of non-empty subsets  $(F_n)_{n \in \mathbb{N}}$  of  $G$  such that for every finite subset  $K \subset G$ :*

$$\lim_{n \rightarrow \infty} \frac{|\partial_K F_n|}{|F_n|} = 0.$$

That is to say, for any finite set  $K$  the boundaries of the sets  $F_n$  with respect to  $K$  grow slower than themselves.

### B.2.3 Residually finite groups

**Definition B.24.** A group  $G$  is called *residually finite* if for each  $g \in G \setminus \{1_G\}$  there exists a finite group  $F$  and a morphism  $\varphi : G \rightarrow F$  such that  $\varphi(g) \neq 1_F$ .

**Proposition B.11.** *A group  $G$  is residually finite if and only if the intersection of all normal subgroups of  $G$  of finite index is trivial.*

*Proof.* Let  $G$  be residually finite and take  $g \in G \setminus \{1_G\}$ . By definition there exists a finite group  $F$  and a morphism  $\varphi$  such that  $g \notin \text{Ker}(\varphi)$ .  $\text{Ker}(\varphi)$  is always a normal subgroup, and as  $F$  is finite we have that  $[G : \text{Ker}(\varphi)] < \infty$ . Therefore  $g$  does not belong to the intersection of all normal subgroups of finite index. Conversely, let  $g \in G \setminus \{1_G\}$  and consider  $N \triangleleft G$  such that  $g \notin N$ . It suffices to define  $\varphi : G \rightarrow G/N$  by  $\varphi(h) = hN$ . As  $N$  is a normal subgroup of finite index,  $G/N$  is a finite group and  $\varphi(g) = gN \neq 1_{G/N}$ .  $\square$

Examples of residually finite groups include: free groups, finite groups, finitely generated nilpotent groups and finitely generated linear groups.

# Appendix C

## Dynamical Systems

From a classical perspective, dynamical systems are objects consisting of a pair  $(X, T)$  where  $X$  is a set and  $T : X \rightarrow X$  is a function which describes the evolution of elements of  $X$ . In the context of this appendix, we place ourselves in the case where  $T$  is a group action  $G \curvearrowright X$  by homeomorphisms. We will review some basic concepts from topological dynamical systems. As with the other appendixes, it is just meant as a place to consult definitions and does not intend to be a proper introduction to the subject. For that we recommend the following references [PY98, Kit98, Pet83].

### C.1 Dynamical systems and topological morphisms

**Definition C.1.** We say  $(X, T)$  is a  $G$ -dynamical system if  $X$  is a topological space and  $T : G \times X \rightarrow X$  is a group action by homeomorphisms.

*Example C.1.* Consider the Arnold's cat transformation  $T : \mathbb{R}^2/\mathbb{Z}^2 \rightarrow \mathbb{R}^2/\mathbb{Z}^2$  given by  $T(x, y) = (2x + y, x + y) \pmod 1$ .



Figure C.1: The application of Arnold's cat transformation on "The Hermitage Court Outrunner Cat" by Eldar Zakirov

This gives an example of a  $\mathbb{Z}$ -action by homeomorphisms over the space  $X = \mathbb{R}^2/\mathbb{Z}^2$ .

*Example C.2.* The *odometer* is the  $\mathbb{Z}$ -dynamical system where  $X = \{0, 1\}^{\mathbb{N}}$  and  $T(x)$  is defined as follows: if  $x = 1111\dots$  then  $T(x) = 0000\dots$ . Otherwise let  $k(x)$  be the index of the first 0 in  $x$ . Then:

$$T(x)_n = \begin{cases} 1 & \text{if } n = k(x) \\ 0 & \text{if } n < k(x) \\ x_n & \text{if } n > k(x) \end{cases}$$

It is called an odometer because the action is addition in base 2.

Another example of dynamical system are subshifts. The objects which are the object of study of this manuscript.

**Definition C.2.**  $(X, \sigma)$  is a  $G$ -subshift if there exists a finite set  $\mathcal{A}$  such that  $X$  is a closed subset of  $\mathcal{A}^G$  and  $\sigma : G \times X \rightarrow X$  is defined by

$$\sigma^g(x)_h = x_{g^{-1}h}.$$

**Definition C.3.** Let  $(X, T)$  and  $(Y, S)$  be dynamical systems. A continuous map  $\phi : X \rightarrow Y$  which commutes with the group actions, that is

$$\forall g \in G, \phi \circ T^g = S^g \circ \phi$$

is called a *topological morphism*.

A surjective topological morphism  $\phi : X \rightarrow Y$  is a *topological factor* and we say that  $(Y, S)$  is a *topological factor* of  $(X, T)$  and that  $(X, T)$  is a *topological extension* of  $(Y, S)$ . When  $\phi$  is a bijection and its inverse is continuous we say it is a *topological conjugacy* and that  $(X, T)$  is *topologically conjugated* to  $(Y, S)$ .

**Definition C.4.** A  $G$ -dynamical system  $(X, T)$  is called:

- *Irreducible*, if for every pair of open sets  $U, V$  there exists  $g \in G$  and such that  $U \cap T^g(V) \neq \emptyset$ .
- *Topologically mixing*, if there exists a finite  $F \subset G$  such that for every pair of open sets  $U, V$  and ever  $g \in G \setminus F$  we have  $U \cap T^g(V) \neq \emptyset$ .
- *Minimal*, if for every non-empty  $Y \subset X$  such that for every  $g \in G, T^g(Y) \subset Y$ , then  $Y = X$ .

## C.2 Expansive, equicontinuous and distal systems

For the remainder of this section,  $(X, d)$  is a compact metric space.

**Definition C.5.** A  $G$ -dynamical system  $(X, T)$  is *expansive* if there exists a constant  $C > 0$  such that for every  $x, y \in X$  such that  $x \neq y$ , then

$$\exists g \in G, d(T^g(x), T^g(y)) > C$$

$C$  is called the *expansivity constant* of the system  $(X, T)$ .

*Example C.3.* If  $G$  is countable, any subshift is expansive. Indeed, the space  $\mathcal{A}^G$  is metrizable with  $\tilde{d}(x, y) = 2^{-\inf\{n \in \mathbb{N} \mid x_{g_n} \neq y_{g_n}\}}$  where  $(g_n)_{n \in \mathbb{N}}$  is an enumeration of  $G$ . An expansivity constant in this case is just  $C = \frac{1}{2}$ .

In other words, an expansive system is one which separates points. No matter how close they are, there exists an instant  $g \in G$  where they will be at distance at least  $C$ . The opposite notion is that of an equicontinuous system, where points which are close remain so along their orbits.

**Definition C.6.** A  $G$ -dynamical system  $(X, T)$  is called *equicontinuous* if the family  $\{T^g\}_{g \in G}$  is equicontinuous. That is,

$$\forall \epsilon > 0, \exists \delta > 0, \forall x, y \in X, d(x, y) < \delta \implies \forall g \in G, d(T^g(x), T^g(y)) < \epsilon.$$

*Example C.4.* The odometer with the metric  $d(x, y) = \inf\{n \in \mathbb{N} \mid x_n \neq y_n\}$  is equicontinuous. Indeed, if two configuration coincide in the first  $n$  symbols, they will continue to do so along their orbits.

The last notion we introduce here is that of a distal system. These are the systems where points cannot get arbitrarily close to each other.

**Definition C.7.** A  $G$ -dynamical system  $(X, T)$  is *distal* if for every  $x, y \in X$  such that  $x \neq y$ , then

$$\inf_{g \in G} d(T^g(x), T^g(y)) > 0$$

A pair  $(x, y)$  satisfying that property is called a *distal pair*.

*Example C.5.* Consider the  $\mathbb{Z}$ -subshift consisting of two points:  $x = \dots 0101.0101 \dots$  and  $y = \dots 1010.1010 \dots$ . Clearly  $d(\sigma^n(x), \sigma^n(y)) = d(x, y) > 0$ . Therefore it is a distal system.

**Definition C.8.** Let  $X$  be a topological space and  $\mathcal{U} = \{U_i\}_{i \in I}, \mathcal{V} = \{V_j\}_{j \in J}$  two open covers of  $X$ . We denote by  $\mathcal{U} \vee \mathcal{V}$  the refinement of  $\mathcal{U}$  and  $\mathcal{V}$  defined by:

$$\mathcal{U} \vee \mathcal{V} := \{U_i \cap V_j\}_{(i,j) \in I \times J}$$

**Definition C.9.** Let  $X$  be a topological space,  $G$  a group,  $\mathcal{P} = \{P_i\}_{i \in I}$  a partition by open sets of  $X$  and for  $g \in G$  define  $T^g(\mathcal{P}) := \{T^g(P_i)\}_{i \in I}$ . We say that  $\mathcal{P}$  is a *generating partition* if for each  $x, y \in X$  there exists  $g \in G$  such that  $x$  and  $y$  belong to different sets of  $T^g(\mathcal{P})$ .

The following result was originally shown by Hedlund for the case of  $\mathbb{Z}$ -actions.

**Theorem C.1** (Hedlund [Hed69]). *A  $G$ -dynamical system is topologically conjugate to a subshift if and only if it is zero-dimensional and expansive.*

*Proof.* Any subshift (and thus any system topologically conjugate to it) is zero-dimensional and expansive. Conversely, let  $C > 0$  be the expansivity constant of  $(X, T)$  and consider a finite open partition  $\mathcal{P} = \{P_1, \dots, P_n\}$  such that every

$P_i \in \mathcal{P}$  satisfies  $\text{diam}(P_i) < C$ . This partition always exists due to  $X$  being zero-dimensional. Given  $x \neq y \in X$ , the expansivity implies the existence of  $h \in H$  such that  $d(T^h(x), T^h(y)) \geq C$ . Therefore the refinement  $\mathcal{P} \vee T^h(\mathcal{P})$  separates  $x$  and  $y$ . This means that  $\mathcal{P}$  is a generating partition.

Let  $\phi : (X, T) \rightarrow (\{1, \dots, n\}^G, \sigma)$  be such that  $\phi(x)_g = i \iff x \in T^g(P_i)$ .  $\phi$  is clearly continuous and as  $\mathcal{P}$  is a generating, we have that  $\phi$  is injective. Furthermore,  $\phi$  intertwines the actions:

$$\begin{aligned} \phi(T^h(x))_g = i &\iff T^h(x) \in T^g(P_i) \\ &\iff x \in T^{h^{-1}g}(P_i) \\ &\iff \phi(x)_{h^{-1}g} = i \\ &\iff \sigma^h(\phi(x))_g = i. \end{aligned}$$

Therefore  $\phi$  is an injective topological morphism. This implies that  $(X, T)$  is topologically conjugate to  $(\phi(X), \sigma)$ .  $\square$

### C.3 Entropy

For a proof of the following result, see [Kri07a].

**Lemma C.2** (Ornstein-Weiss lemma [OW87]). *Let  $G$  be a countable amenable group,  $\text{Fin}(G)$  the set of finite subsets of  $G$  and  $f : \text{Fin}(G) \rightarrow \mathbb{R}$  a function satisfying the following conditions:*

1.  $\forall A, B \in \text{Fin}(G), f(A \cup B) \leq f(A) + f(B)$ .
2.  $\forall A \in \text{Fin}(G), \forall g \in G, f(gA) = f(A)$ .

*Then there exists  $\alpha \in \mathbb{R}$  such that for any Følner sequence  $(F_n)_{n \in \mathbb{N}}$*

$$\lim_{n \rightarrow \infty} \frac{h(F_n)}{|F_n|} = \alpha.$$

Let  $(X, T)$  be a dynamical system where  $X$  is compact and  $T$  is an action of a countable amenable group. Given an open cover  $\mathcal{U} := \{U_i\}_{i \in I}$  of  $X$ , we denote by  $N(\mathcal{U})$  the smallest size of an open subcover of  $\mathcal{U}$ . As  $X$  is compact this is well defined. Also denote by  $T^g(\mathcal{U}) := \{T^g(U_i)\}_{i \in I}$ . Given a finite subset  $F \subset G$  we define:

$$\mathcal{U}_F := \bigvee_{g \in F} T^g(\mathcal{U}).$$

By Lemma C.2, if  $(F_n)_{n \in \mathbb{N}}$  is a Følner sequence, then the limit

$$h(\mathcal{U}, X, G) := \lim_{n \rightarrow \infty} \frac{\log(N(\mathcal{U}_{F_n}))}{|F_n|}$$

is well defined and does not depend on  $(F_n)_{n \in \mathbb{N}}$ . With the definition of  $h(\mathcal{U}, X, G)$  in hand we can define the topological entropy.



**Definition C.10.** Let  $(X, T)$  be a dynamical system where  $X$  is compact and  $T$  is an action of an amenable group. The *topological entropy* of  $(X, T)$  is

$$h_{top}(X, T) := \sup_{\mathcal{U} \text{ open cover of } X} h(\mathcal{U}, X, G)$$

It can be shown that the sup is attained by any generating partition. In particular, as the partition at the identity is a generating partition for a subshift, it gives a basis for Definition 1.10.

# Index

- $G$ -machine, 72
  - accepts, 73
  - fixed head model, 72
  - moving head model, 72
  - multiple head, 74
  - multiple head accepts, 74
- $s$ -covering, 35
- $s$ -separating, 35
- almost trivial isometric extension, 45
- alphabet, 2, 117
- automorphism group, 91
- balanced sequence, 25
- Cayley graph, 126
- cellular automaton, 6
  - reversible, 6
- cluster, 36
  - center, 36
- cocycle, 91
- computable function, 120
- configuration, 2
  - aperiodic, 6
  - periodic, 6
  - strongly periodic, 6
  - Toeplitz, 49
  - uniform, 6
- conjugacy, 4
- covering forest, 37
- covering radius, 34
- cylinder, 2
- Delone set, 34
- distal pair, 134
- dynamical system
  - distal, 134
  - equicontinuous, 134
  - expansive, 133
  - factor, 133
  - irreducible, 133
  - minimal, 133
  - topological extension, 133
  - topologically conjugated, 133
  - topologically mixing, 133
- effectively closed
  - $G$ -dynamical system, 44
- even shift, 14
- expansivity constant, 133
- Følner net, 130
- factor map, 4
- finiteness problem, 95
  - countable group, 96
- full group, 91
- generating partition, 134
- group, 123
  - abelian, 129
  - amenable, 129
  - automorphism, 124
  - boundary of a set, 131
  - commutator, 129
  - endomorphism, 124
  - epimorphism, 124
  - finitely generated, 124
  - finitely presented, 126
  - free, 125
  - generators, 124
  - homomorphism, 124
  - index of a subgroup, 124
  - interior with respect to a set, 131
  - isomorphic, 124
  - isomorphism, 124
  - left cosets, 124
  - monomorphism, 124

- normal subgroup, 123
- quotient, 124
- recursively presented, 126
- residually finite, 131
- subgroup, 123
- group presentation, 125
  - generators, 125
  - relators, 125
- group shift, 9
- Hom-shift, 9
- input, 118
- language, 117
  - $G$ -decidable, 73
  - $G$ -recursively enumerable, 73
  - closed by extensions, 75
  - co-recursively enumerable, 118
  - decidable, 118
  - recursively enumerable, 118
  - recursively enumerable with oracle  $\mathcal{O}$ , 71
  - undecidable, 118
- measure
  - left-invariant, 129
- Mirror shift, 18
- number
  - computable, 121
  - left recursively enumerable, 121
  - lower semicomputable, 121
  - right recursively enumerable, 121
  - upper semicomputable, 121
- odometer, 133
- One-or-less subshift, 69
- packing radius, 34
- pattern, 2
  - appears in a configuration, 3
  - set of nearest neighbor, 11
  - subpattern, 3
  - support, 2
- pattern coding, 17, 121
  - consistent, 17
- decidable, 18
  - recursively enumerable, 18
- projective subdynamics, 23
- recursive set, 120
- recursively enumerable set, 120
- Robinson tiling
  - macrotile, 26
  - tiles, 26
- shift action, 2
- shift commuting, 4
- sliding-block code, 4
  - 1-block code, 5
- snake tiling problem, 100
- special symbol property, 69
- square-free vertex coloring, 30
- Sturmian subshift, 7
  - slope, 7
- subaction, 45
- subshift, 3
  - $G$ -effectively closed, 71
  - generated by a substitution, 47
  - effectively closed, 16, 18
  - extension, 4
  - factor, 4
  - irreducible, 7
  - language of a subshift, 3
  - minimal, 7
  - morphism, 4
  - nearest neighbor, 11
  - of finite type, 10
  - sofic, 14
  - strongly aperiodic, 7, 25
  - Toeplitz, 50
  - weakly aperiodic, 7
- substitution, 47
  - primitive, 48
  - unique derivation, 48
- symbol, 2
- the distinct neighborhood property, 28
- tileset, 11
- topological conjugacy, 133
- topological entropy, 136
- topological factor, 133

- topological full group, 91
- topological morphism, 133
- torsion problem, 95
  - countable group, 96
- Turing machine, 117
  - accepts, 118
  - halts, 118
  - oracle, 121
  - rejects, 118
  - reversible, 106
  - universal, 120
- vertex-square path, 30
- Wang tile, 11
- word, 117
  - reduced, 125
- word problem, 94, 128
  - countable group, 96
  - recursive presentation, 95, 129

# Personal bibliography

- [ABS17] Nathalie Aubrun, Sebastián Barbieri, and Mathieu Sablik. A notion of effectiveness for subshifts on finitely generated groups. *Theoretical Computer Science*, 661:35 – 55, 2017.
- [ABT15] Nathalie Aubrun, Sebastián Barbieri, and Stéphan Thomassé. Realization of aperiodic subshifts and uniform densities in groups. arXiv:1507.03369, 2015.
- [BKS16] Sebastián Barbieri, Jarkko Kari, and Ville Salo. The group of reversible turing machines. In *Cellular Automata and Discrete Complex Systems, Proceedings*, pages 49–62, 2016.
- [BS17] Sebastián Barbieri and Mathieu Sablik. A generalization of the simulation theorem for semidirect products. *to appear in Ergodic Theory and Dynamical Systems*, 2017.

# Bibliography

- [AB09] Sanjeev Arora and Boaz Barak. *Computational Complexity: A Modern Approach*. Cambridge University Press, 2009.
- [AGHR02] Noga Alon, Jaroslaw Grytczuk, Mariusz Haluszczak, and Oliver Rior-dan. Nonrepetitive colorings of graphs. *Random Structures & Algorithms*, 21(3-4):336–346, 2002.
- [AP72] Serafino Amoroso and Yale N. Patt. Decision procedures for surjectivity and injectivity of parallel maps for tessellation structures. *Journal of Computer and System Sciences*, 6(5):448–464, 1972.
- [AS08] Noga Alon and Joel H. Spencer. *The probabilistic method*. Wiley, 2008.
- [AS13] Nathalie Aubrun and Mathieu Sablik. Simulation of effective subshifts by two-dimensional subshifts of finite type. *Acta Applicandae Mathematicae*, 126:35–63, 2013.
- [AS16] Nathalie Aubrun and Mathieu Sablik. Row-constrained effective sets of colourings in the 2-fold horocyclic tessellations of  $\mathbb{H}^2$  are sofic. arXiv:1602.04061, 2016.
- [Ber66] Robert Berger. *The Undecidability of the Domino Problem*. American Mathematical Society, 1966.
- [Ber17] Anton Bernshteyn. Free subshifts with invariant measures from the lovász local lemma. arXiv:1702.02792, 2017.
- [BKS16] Sebastián Barbieri, Jarkko Kari, and Ville Salo. The group of reversible turing machines. In *Cellular Automata and Discrete Complex Systems, Proceedings*, pages 49–62, 2016.
- [BL97] Mike Boyle and Douglas A. Lind. Expansive subdynamics. *Transactions of the American Mathematical Society*, 349(1):55–102, 1997.
- [BLR88] Mike Boyle, Douglas A. Lind, and Daniel Rudolph. The automorphism group of a shift of finite type. *Transactions of the American Mathematical Society*, 306(1):71–114, 1988.

- [Boo58] William W. Boone. The word problem. *Proceedings of the National Academy of Science USA*, 44:1061–1065, 1958.
- [Bow10] Lewis Bowen. Measure conjugacy invariants for actions of countable sofic groups. *Journal of the American Mathematical Society*, 23(1):217–245, 2010.
- [Boy08] Mike Boyle. Open problems in symbolic dynamics. *Contemporary mathematics*, 469:69–118, 2008.
- [BPS10] Mike Boyle, Ronnie Pavlov, and Michael Schraudner. Multidimensional sofic shifts without separation and their factors. *Transactions of the American Mathematical Society*, 362(9):4617–4653, 2010.
- [BR10] Valérie Berthé and Michel Rigo. *Combinatorics, Automata and Number Theory*. Encyclopedia of Mathematics and its Applications. Cambridge University Press, 2010.
- [BRY16] Michael Baake, John Roberts, and Reem Yassawi. Reversing and extended symmetries of shift spaces. arXiv:1611.05756, 2016.
- [BS08] Mike Boyle and Michael Schraudner.  $\mathbb{Z}^d$  group shifts and bernoulli factors. *Ergodic Theory and Dynamical Systems*, 28(02):367–387, 2008.
- [BS09] Mike Boyle and Michael Schraudner. Shifts of finite type without equal entropy full shift factors. *Journal of Difference Equations and Applications*, 15(1):47–52, 2009.
- [BS13] Alexis Ballier and Maya Stein. The domino problem on groups of polynomial growth. arXiv:1311.4222, 2013.
- [CFKP16] Van Cyr, John Franks, Bryna Kra, and Samuel Petite. Distortion and the automorphism group of a shift. arXiv:1611.05913, 2016.
- [CGS15] David B. Cohen and Chaim Goodman-Strauss. Strongly aperiodic subshifts on surface groups. arXiv:1510.06439, 2015.
- [CM16] Nishant Chandgotia and Brian Marcus. Mixing properties for hom-shifts and the distance between walks on associated graphs. arXiv:1607.08357, 2016.
- [Coh17] David B. Cohen. The large scale geometry of strongly aperiodic subshifts of finite type. *Advances in Mathematics*, 308:599–626, 2017.
- [CP15] David Carroll and Andrew Penland. Periodic points on shifts of finite type and commensurability invariants of groups. *New York Journal of Mathematics*, 21:811–822, 2015.
- [CSC09] Tullio Ceccherini-Silberstein and Michel Coornaert. *Cellular Automata and Groups*. Springer, 2009.

- [dC11] Aubrey da Cunha. Turing machines on cayley graphs. In LevD. Beklemishev and Ruy de Queiroz, editors, *Logic, Language, Information and Computation*, volume 6642 of *Lecture Notes in Computer Science*, pages 84–94. Springer Berlin Heidelberg, 2011.
- [DDMP16] Sebastián Donoso, Fabien Durand, Alejandro Maass, and Samuel Petite. On automorphism groups of low complexity subshifts. *Ergodic Theory and Dynamical Systems*, 36(1):64–95, 002 2016.
- [Des06] Angela Desai. Subsystem entropy for  $\mathbb{Z}^d$  sofic shifts. *Indagationes Mathematicae*, 17(3):353–359, 2006.
- [DFR15] Tomasz Downarowicz, Bartosz Frej, and Pierre-Paul Romagnoli. Shearer’s inequality and infimum rule for shannon entropy and topological entropy. arXiv:1502.07459, 2015.
- [DRS10] Bruno Durand, Andrei Romashchenko, and Alexander Shen. Effective closed subshifts in 1d can be implemented in 2d. In *Fields of Logic and Computation*, pages 208–226. Springer Nature, 2010.
- [DY08] François Dahmani and Asli Yaman. Symbolic dynamics and relatively hyperbolic groups. *Groups, Geometry, and Dynamics*, 2(2):165–184, 2008.
- [Dye59] H. A. Dye. On groups of measure preserving transformations. i. *American Journal of Mathematics*, 81(1):119–159, 1959.
- [Dye63] H. A. Dye. On groups of measure preserving transformations. ii. *American Journal of Mathematics*, 85(4):551–576, 1963.
- [Ele17] Gábor Elek. On uniformly recurrent subgroups of finitely generated groups. arXiv:1702.01631, 2017.
- [ELMW01] Manfred Einsiedler, Douglas A. Lind, Richard Miles, and Thomas Ward. Expansive subdynamics for algebraic  $\mathbb{Z}^d$ -actions. *Ergodic theory and dynamical systems*, 21(06):1695–1729, 2001.
- [EM13] Gábor Elek and Nicolas Monod. On the topological full group of a minimal cantor  $\mathbb{Z}^2$ -system. *Proceedings of the American Mathematical Society*, 141(10):3549–3552, 2013.
- [FT15] Joshua Frisch and Omer Tamuz. Symbolic dynamics on amenable groups: the entropy of generic shifts. arXiv:1503.06251, 2015.
- [GJS09] Su Gao, Steve Jackson, and Brandon Seward. A coloring property for countable groups. *Mathematical Proceedings of the Cambridge Philosophical Society*, 147:579–592, 11 2009.
- [GM07] Anahí Gajardo and Jacques Mazoyer. One head machines from a symbolic approach. *Theoretical Computer Science*, 370(1-3):34–47, 2007.



- [GM14] Rostislav Grigorchuk and Konstantin Medynets. On algebraic properties of topological full groups. *Sbornik: Mathematics*, 205(6):843, 2014.
- [GPS99] Thierry Giordano, Ian F. Putnam, and Christian F. Skau. Full groups of cantor minimal systems. *Israel Journal of Mathematics*, 111(1):285–320, 1999.
- [Gri85] Rostislav Grigorchuk. Degrees of growth of finitely generated groups, and the theory of invariant means. *Mathematics of the USSR-Izvestiya*, 25(2):259–300, 1985.
- [GS98] Chaim Goodman-Strauss. Matching rules and substitution tilings. *Annals of Mathematics*, 147(1):181–223, 1998.
- [GU09] Eli Glasner and Vladimir V. Uspenskij. Effective minimal subflows of bernoulli flows. *Proceedings of the American Mathematical Society*, 137(9):3147–3154, 2009.
- [Had98] Jacques Hadamard. Les surfaces à courbures opposées et leurs lignes géodésiques. *Journal de Mathématiques Pures et Appliquées*, 4:27–74, 1898.
- [Han74] William Hanf. Nonrecursive tilings of the plane. i. *The Journal of Symbolic Logic*, 39(2):283–285, 1974.
- [Hed69] Gustav A. Hedlund. Endomorphisms and automorphisms of the shift dynamical system. *Mathematical systems theory*, 3(4):320–375, 1969.
- [Hig61] Graham Higman. Subgroups of finitely presented groups. *Proceedings of the Royal Society of London. Series A, Mathematical and Physical Sciences*, 262(1311):455–475, 1961.
- [HM38] Gustav A. Hedlund and Marston Morse. Symbolic dynamics. *American Journal of Mathematics*, 60(4):815–866, 1938.
- [HM10] Mike Hochman and Tom Meyerovitch. A characterization of the entropies of multidimensional shifts of finite type. *Annals of Mathematics*, 171(3):2011–2038, 2010.
- [Hoc09] Mike Hochman. On the dynamics and recursive properties of multidimensional symbolic systems. *Inventiones Mathematicae*, 176(1):131–167, 2009.
- [Hoc10] Mike Hochman. On the automorphism groups of multidimensional shifts of finite type. *Ergodic Theory and Dynamical Systems*, 30(03):809–840, 2010.
- [Hun80] Thomas W. Hungerford. *Algebra*. Springer New York, 1980.

- [Jea15] Emmanuel Jeandel. Aperiodic subshifts of finite type on groups. arXiv:1501.06831, 2015.
- [JK69] Konrad Jacobs and Michael Keane. 0-1-sequences of toeplitz type. *Zeitschrift für Wahrscheinlichkeitstheorie und Verwandte Gebiete*, 13(2):123–131, 1969.
- [JK12] Timo Jolivet and Jarkko Kari. Consistency of multidimensional combinatorial substitutions. *Theoretical Computer Science*, 454:178–188, 2012.
- [JM12] Kate Juschenko and Nicolas Monod. Cantor systems, piecewise translations and simple amenable groups. arXiv:1204.2132, 2012.
- [JR15] Emmanuel Jeandel and Michael Rao. An aperiodic set of 11 wang tiles. arXiv:1506.06492, 2015.
- [JV15] Emmanuel Jeandel and Pascal Vanier. Hardness of conjugacy, embedding and factorization of multidimensional subshifts. *Journal of Computer and System Sciences*, 81(8):1648–1664, 2015.
- [Kar90] Jarkko Kari. Reversibility of 2d cellular automata is undecidable. *Physica D: Nonlinear Phenomena*, 45(1):379–385, 1990.
- [Kar96] Jarkko Kari. A small aperiodic set of wang tiles. *Discrete Mathematics*, 160:259–264, 1996.
- [Kar03] Jarkko Kari. Infinite snake tiling problems. In *Developments in Language Theory*, pages 67–77. Springer Nature, 2003.
- [KC16] Bryna Kra and Van Cyr. The automorphism group of a minimal shift of stretched exponential growth. *Journal of Modern Dynamics*, 10(02):483–495, 2016.
- [Kit98] Bruce Kitchens. *Symbolic Dynamics*. Springer New York, 1998.
- [KL11] David Kerr and Hanfeng Li. Entropy and the variational principle for actions of sofic groups. *Inventiones mathematicae*, 186(3):501–558, 2011.
- [KM13] Steve Kass and Kathleen Madden. A sufficient condition for non-soficness of higher-dimensional subshifts. *Proc. Amer. Math. Soc.*, 141:3803–3816, 2013.
- [KO08] Jarkko Kari and Nicolas Ollinger. *Periodicity and Immortality in Reversible Computing*, pages 419–430. Springer Berlin Heidelberg, Berlin, Heidelberg, 2008.
- [Koc06] Helge von Koch. Une méthode géométrique élémentaire pour l’étude de certaines questions de la théorie des courbes plane. *Acta Math*, 30:145–174, 1906.

- [KR90] Ki Hang Kim and Fred W. Roush. On the automorphism groups of subshifts. *Pure Mathematics and Applications*, 1(4):203–230, 1990.
- [Kri07a] Fabrice Krieger. *Le lemme d’Ornstein-Weiss d’après Gromov*, pages 99–112. Mathematical Sciences Research Institute Publications. Cambridge University Press, 2007.
- [Kri07b] Fabrice Krieger. Sous-décalages de toeplitz sur les groupes moyennables résiduellement finis. *Journal of the London Mathematical Society*, 75(2):447, 2007.
- [KS88] Bruce Kitchens and Klaus Schmidt. *Periodic points, decidability and Markov subgroups*, pages 440–454. Springer Berlin Heidelberg, Berlin, Heidelberg, 1988.
- [Lan02] Serge Lang. *Algebra*. Graduate Texts in Mathematics. Springer New York, 2002.
- [Led87] François Ledrappier. Un champ markovien peut être d’entropie nulle et mélangeant. *Acad. Sci. Paris*, 287:561–562, 1987.
- [Lin84] Douglas A. Lind. The entropies of topological markov shifts and a related class of algebraic integers. *Ergodic Theory and Dynamical Systems*, 4(2):283–300, 1984.
- [LM95] Douglas A. Lind and Brian Marcus. *An Introduction to Symbolic Dynamics and Coding*. Cambridge University Press, 1995.
- [LP16] Martha Lacka and Marta Pietrzyk. Quasi-uniform convergence in dynamical systems generated by an amenable group action. arXiv:1610.09675, 2016.
- [Mat06] Hiroki Matui. Some remarks on topological full groups of Cantor minimal systems. *International Journal of Mathematics*, 17(02):231–251, 2006.
- [Mat15] Hiroki Matui. Topological full groups of one-sided shifts of finite type. *Journal für die reine und angewandte Mathematik*, 2015(705):35–84, 2015.
- [Med11] Konstantin Medynets. Reconstruction of orbits of cantor systems from full groups. *Bulletin of the London Mathematical Society*, 43(6):1104–1110, 2011.
- [Mil12] Joseph S. Miller. Two notes on subshifts. *Proceedings of the American Mathematical Society*, 140(5):1617–1622, 2012.
- [MKS04] Wilhelm Magnus, Abraham Karrass, and Donald Solitar. *Combinatorial Group Theory: Presentations of Groups in Terms of Generators and Relations*. Dover Books on Mathematics Series. Dover Publications, 2004.

- [Moz89] Shahar Mozes. Tilings, substitution systems and dynamical systems generated by them. *Journal d'Analyse Mathématique*, 53(1):139–186, 1989.
- [Mye74] Dale Myers. Nonrecursive tilings of the plane. ii. *The Journal of Symbolic Logic*, 39(2):286–294, 1974.
- [Nov55] Pyotr Novikov. On the algorithmic unsolvability of the word problem in group theory. *Proceedings of the Steklov Institute of Mathematics*, 44:143 pp. (Russian), 1955.
- [Ol'81] Alexander Yu Ol'shanskii. An infinite group with subgroups of prime orders. *Mathematics of the USSR-Izvestiya*, 16(2):279, 1981.
- [OW87] Donald S. Ornstein and Benjamin Weiss. Entropy and isomorphism theorems for actions of amenable groups. *Journal d'Analyse Mathématique*, 48(1):1–141, 1987.
- [Pav12] Ronnie Pavlov. A class of nonsofic multidimensional shift spaces. *Proceedings of the American Mathematical Society*, 141(3):987–996, 2012.
- [Pet83] Karl E. Petersen. *Ergodic theory*. Cambridge University Press, 1983.
- [PF02] N. Pytheas Fogg. *Substitutions in Dynamics, Arithmetics and Combinatorics*, volume 1794 of *Lecture Notes in Mathematics*. Springer, 2002.
- [Pia06] Steven T. Piantadosi. Symbolic dynamics on free groups. Master's thesis, University of North Carolina, Chapel Hill, 2006.
- [Pia08] Steven T. Piantadosi. Symbolic dynamics on free groups. *Discrete and Continuous Dynamical Systems*, 20(3):725–738, 2008.
- [PS14] Ronnie Pavlov and Michael Schraudner. Classification of sofic projective subdynamics of multidimensional shifts of finite type. *Transactions of the American Mathematical Society*, 367(5):3371–3421, 2014.
- [PY98] Mark Pollicott and Michiko Yuri. *Dynamical Systems and Ergodic Theory*. London Mathematical Society Student Texts. Cambridge University Press, 1998.
- [RJ87] Hartley Rogers Jr. *Theory of Recursive Functions and Effective Computability*. MIT Press, Cambridge, MA, USA, 1987.
- [Rob71] Raphael M. Robinson. Undecidability and nonperiodicity for tilings of the plane. *Inventiones Mathematicae*, 12:177–209, 1971.
- [SA14] Mathieu Sablik and Nathalie Aubrun. Multidimensional effective S-adic subshift are sofic. *Uniform Distribution Theory*, 9(2):7–29, 2014.
- [Sah14] Ayse Sahin. A strongly aperiodic heisenberg shift of finite type. Talk in Workshop on Symbolic Dynamics on finitely presented Groups, 2014.

- [Sal15] Ville Salo. A note on subgroups of automorphism groups of full shifts. arXiv:1507.00820, 2015.
- [Sch95] Klaus Schmidt. *Dynamical Systems of Algebraic Origin*. Springer Nature, 1995.
- [Sew14] Brandon Seward. Burnside’s problem, spanning trees and tilings. *Geometry & Topology*, 18(1):179–210, 2014.
- [Sip06] Michael Sipser. *Introduction to the Theory of Computation*. Thomson Course Technology, 2006.
- [ST13] Ville Salo and Ilkka Törmä. Color blind cellular automata. In *Cellular Automata and Discrete Complex Systems*, pages 139–154. Springer Nature, 2013.
- [ST15] Ville Salo and Ilkka Törmä. Group-walking automata. *Cellular Automata and Discrete Complex Systems: 21st IFIP WG 1.5 International Workshop, AUTOMATA 2015, Turku, Finland, June 8-10, 2015. Proceedings*, pages 224–237, 2015.
- [Sta68] John R. Stallings. On torsion-free groups with infinitely many ends. *Annals of Mathematics*, 88(2):312–334, 1968.
- [Tur36] Alan M. Turing. On computable numbers, with an application to the Entscheidungsproblem. *Proceedings of the London Mathematical Society. Second Series*, 42:230–265, 1936.
- [Wei73] Benjamin Weiss. Subshifts of finite type and sofic systems. *Monatshefte für Mathematik*, 77:462–474, 1973.
- [Wei00] Benjamin Weiss. Sofic groups and dynamical systems. *Sankhyā, Ser. A*, 62(3):350–359, 2000.