



HAL
open science

Resource Allocation Frameworks for Multi-carrier-based Cognitive Radio Networks with full and Statistical CSI

Juwendo Denis

► **To cite this version:**

Juwendo Denis. Resource Allocation Frameworks for Multi-carrier-based Cognitive Radio Networks with full and Statistical CSI. Networking and Internet Architecture [cs.NI]. Conservatoire national des arts et metiers - CNAM, 2016. English. NNT : 2016CNAM1069 . tel-01597704

HAL Id: tel-01597704

<https://theses.hal.science/tel-01597704v1>

Submitted on 28 Sep 2017

HAL is a multi-disciplinary open access archive for the deposit and dissemination of scientific research documents, whether they are published or not. The documents may come from teaching and research institutions in France or abroad, or from public or private research centers.

L'archive ouverte pluridisciplinaire **HAL**, est destinée au dépôt et à la diffusion de documents scientifiques de niveau recherche, publiés ou non, émanant des établissements d'enseignement et de recherche français ou étrangers, des laboratoires publics ou privés.

**CONSERVATOIRE NATIONAL
DES ARTS ET MÉTIERS**

le cnam

École doctorale d'Informatique, Télécommunications et Électronique (EDITE)

Centre d'Études et de Recherche en Informatique et Communications (CEDRIC)

THÈSE DE DOCTORAT

présentée par : **Juwendo DENIS**

soutenue le : **26 Juin 2016**

pour obtenir le grade de : **Docteur du Conservatoire National des Arts et Métiers**

Spécialité : **Radiocommunications**

Resource Allocation Frameworks for Multi-carrier-based Cognitive Radio Networks with Full and Statistical CSI

THÈSE dirigée par

M. LE RUYET Didier

Professeur des Universités, CNAM

RAPPORTEURS

M. JORSWIECK Eduard

*Professeur des Universités, Université Technique de
Dresde*

M. LASAULCE Samson

Directeur de Recherche, CNRS

PRÉSIDENT

M. CIBLAT Philippe

Professeur des Universités, Télécom ParisTech

EXAMINATEURS

Mme. PISCHELLA Mylène

Maître de conférences, CNAM

M. BADER Carlos Faouzi

Professeur Adjoint, Centrale Supélec

To my mother Lumaine M. Denis

Acknowledgements

My Phd thesis would not have been completed without the support of a lot of people.

Foremost, I am grateful to Professor Didier Le Ruyet, director of my Phd thesis, for providing me with such a great opportunity and also his supervision of my research work. I am also grateful to co-advisor, Dr. Mylène Pischella, for helpful and interesting discussions. Their guidance helped me in all the time of research and writing of this thesis.

I would like to express my sincere gratitude to Dr. Rostom Zakaria and Dr. Yahia Medjahdi for extensive and thoughtful discussions. Your constructive criticisms helped me a lot to improve the quality of my research. It was a great pleasure for me to discuss with you and thank you again for proofreading some of my research works.

I would also like to thank my fellow labmates: Rémi Chauvat, Dr. Wosen Kassa, Dr. Marwa Chami, Dr. Salma Hamda, Dr. Krishna Bulusy, Ali Kabalan, Yannick Paugam, for the stimulating discussions, and for all the fun we have had in the last three years.

Thank you to all of my friends who have been also very supportive. Special thank you to Midgard Elidor, Pierre Charles Denis, Hsiao Family and Mari Kamada who have always encouraged me pursuing my dreams.

Last but not the least, I would like to thank my family: my mother Lumaine M. Denis, my father Ovide Denis and my siblings for their unconditional love and for supporting me spiritually throughout my life.

Above all, I owe it all to Almighty God, my Lord and savior for granting me the wisdom, health and strength to undertake this research task and enabling me to its completion.

Résumé

La prolifération des technologies sans fil ont entraîné une demande accrue en termes de ressource spectrale. Face à l'accroissement du nombre d'utilisateurs désirant accéder au réseau, il existera un risque élevé de congestion au niveau de l'accès au spectre radio. Pour pallier à ce problème, il devient essentiel de recourir à un partage dynamique du spectre. L'avènement de la technologie de radio cognitive répond de manière adéquate aux besoins actuels. En effet, cette technologie permet à des utilisateurs secondaires d'accéder à des bandes de fréquence affectées à des utilisateurs primaires. Néanmoins, l'interférence générée par les utilisateurs secondaires peut avoir un impact négatif sur la performance du système primaire surtout dans un système où il n'existe pas de coopération active entre les utilisateurs primaires et secondaires en présence de modulations à porteuses multiples. En conséquence, allouer les ressource radio et contrôler la puissance émise de manière judicieuse sont importants pour combattre l'effet négatif inhérent aux transmissions asynchrones. Dans cette thèse, nous nous intéressons à l'étude de certaines problématiques d'allocation de ressources pour un réseau désynchronisé de radio cognitive qui utilise des modulations à porteuses multiples. Dans un premier temps, nous supposons que la connaissance des informations de canal est disponible à l'émission. Nous étudions des techniques permettant d'optimiser l'allocation de ressources afin de minimiser la somme des puissances émises au niveau des utilisateurs secondaires. Nous nous intéressons aussi à la conception d'algorithmes permettant d'optimiser l'efficacité énergétique des utilisateurs secondaires. La seconde partie de la thèse concerne l'optimisation de la fonction d'utilité des utilisateurs secondaires en tenant compte des contraintes de probabilité de coupure des utilisateurs primaires et secondaires. Les différents algorithmes proposés ont été examinés par simulation afin d'illustrer les résultats théoriques obtenus. Les résultats de simulations démontrent que les méthodes proposées permettent de trouver des solutions qui sont très proches de l'optimale.

Mots-clés– Radio cognitive, optimisation convexe, modulations à porteuses multiples, allocation de ressources, probabilité de coupure, efficacité énergétique, OFDM, FBMC.

Abstract

The ubiquity and proliferation of wireless technology and services considerably lead to a sharp increase in the number of individuals requiring access to wireless networks in recent decades. The growing number of mobile subscribers results into a dramatic increasing request for more radio spectrum. Consequently, underutilized yet scarce radio spectrum becomes overwhelmingly crowded. Therefore, the advent of new radio resource management paradigm capable of switching from static licensed spectrum management to dynamic spectrum access is of great importance. Cognitive radio (CR) emerged as a promising technology capable of enhancing the radio spectrum by permitting unlicensed users known as secondary users to coexist with primary users. Meanwhile, multi-carrier modulations that can efficiently overcome the detrimental effect of multipath fading in a wireless channel are very appealing for the physical layer of cognitive radio networks. However, the lack of cooperation between primary and secondary users may lead to asynchronous transmission and consequently result into inter-carrier interferences. Judicious resource allocation frameworks need to be designed in order to maintain the coexistence between primary and secondary users. Guaranteeing secondary users' quality of service (QoS), while ensuring that interferences generated to the primary users are tolerable, poses significant challenges for the design of wireless cognitive radio networks. This dissertation focuses on resource, i.e. subcarrier and power, allocation for multi-carrier-based downlink cognitive radio networks under perfect or statistical channel state information (CSI) with secondary users interact either cooperatively or competitively. Firstly, the problem of margin adaptive and energy-efficiency optimization are investigated considering perfect CSI at the secondary users' side. Secondly, assuming statistical CSI available at the secondary users, we address the problem of utility maximization under primary and secondary outage constraints. We provide some near-optimal resource allocation schemes to tackle the aforementioned problems. The findings and proposed frameworks

can eventually be used for performance assessment and design of practical cognitive radio networks.

Index terms— Cognitive radio, convex optimisation, multicarrier modulations, resource allocation, outage probability, green communication, energy efficiency, OFDM, FBMC.

Résumé de la thèse en français

Chapitre 1: Introduction

Durant les deux dernières décennies, l'ubiquité et la prolifération des technologies sans fil ont entraîné une forte augmentation de demande de la ressource spectrale. Face à la croissance incessante du nombre d'utilisateurs désirant accéder au réseau, il existera un risque assez élevé de congestion au niveau de l'accès au spectre radio. Pour pallier à ce problème, il devient essentiel de recourir à un partage dynamique du spectre au détriment du mode de gestion statique de la bande de fréquence. L'avènement de la radio cognitive répond pertinemment aux besoins actuels car elle permet à des utilisateurs dits secondaires d'accéder à des bandes de fréquence qui restent affectées à des utilisateurs dits primaires.

Au regard de certaines caractéristiques inhérentes aux modulations à porteuses multiples, celles-ci sont très appropriées à la couche physique des réseaux de radio cognitive. Cependant, le manque de coopération active entre les utilisateurs primaires et secondaires est susceptible d'entraîner une communication désynchronisée entre les systèmes primaires et secondaires. En conséquence, une allocation judicieuse en termes de ressource radio et de contrôle de puissances devient impérative pour combattre l'effet négatif propre aux transmissions asynchrones qui devient aussi un défi de taille pour la conception et la mise en œuvre des réseaux de radio cognitive. Dans cette thèse, nous nous intéressons à l'étude de certaines problématiques d'allocation de ressources pour un réseau désynchronisé de radio cognitive qui utilise des modulations à porteuses multiples.

Dans un premier temps, nous supposons que la connaissance des informations de canal est disponible à l'émission. Nous étudions des techniques permettant d'optimiser l'allocation

de ressources afin de minimiser la somme des puissances émises au niveau des utilisateurs secondaires. Nous nous intéressons aussi à la conception d'algorithmes permettant d'optimiser l'efficacité énergétique des utilisateurs secondaires. La seconde partie de la thèse concerne l'optimisation de la fonction d'utilité des utilisateurs secondaires en tenant compte des contraintes de probabilité de coupure des utilisateurs primaires et secondaires. Cette probabilité de coupure découle de l'hypothèse de la connaissance de la distribution du canal au niveau des stations de base secondaires. Les différents algorithmes proposés ont été examinés par simulation afin d'illustrer les résultats théoriques obtenus. Les résultats de simulations démontrent que les méthodes proposées permettent de trouver des solutions qui sont très proches de l'optimale.

Chapitre 2: Préliminaires

De nos jours, il existe une forte demande en terme d'accès au spectre de fréquence. Ceci résulte de la prolifération des technologies sans fil d'une part et de l'accroissement vertigineux du nombre d'utilisateurs qui désirent accéder au réseau d'autre part. En conséquence, certaines parties du spectre fréquentiel risquent d'être encombrées par la présence d'utilisateurs. En parallèle, il convient de noter que certaines bandes de fréquence sont utilisées de manière sporadique. Celles-ci pourraient être éventuellement mises à la disposition de potentiels utilisateurs si la gestion des bandes de fréquence était assurée de manière dynamique en général. Il s'avère donc important de se recourir aux technologies de radio cognitive pour parvenir à une utilisation plus efficace du spectre.

L'objectif principal de la radio cognitive est d'exploiter au maximum l'utilisation du spectre en permettant à des utilisateurs primaires de partager leurs bandes de fréquence avec des utilisateurs secondaires. L'idée de la radio cognitive a été officiellement présentée par Joseph Mitola [1]. Par ailleurs, le principe de la radio cognitive qui est basé sur l'accès dynamique du spectre, DSA (dynamic spectrum access) a été repris dans la norme IEEE 802.22 [2]. Cependant, cette coexistence entre utilisateurs primaires et utilisateurs secondaires n'est possible que si l'interférence générée par les utilisateurs secondaires n'a pas d'impact négatif sur la qualité de service (QoS) des utilisateurs primaires. Il est donc impératif de contraindre la valeur maximale d'interférence des utilisateurs secondaires à ne pas dépasser une valeur seuil. Cette approche est connue sous le nom de température d'interférence.

Les modulations à porteuses multiples sont très utilisées dans les réseaux cellulaires émergents tels que le WiMAX et le 3GPP LTE. En effet, ces modulations sont des techniques de multiplexage fréquentiel permettant de transformer un canal sélectif en fréquence en un ensemble de canaux parallèles et plats [3]. Dans la norme IEEE 802.22, il est connu que la couche physique (PHY) des réseaux de radio cognitive est basée sur l'orthogonal frequency division multiple access (OFDMA) pour la voie montante et descendante. Les modulations à porteuses multiples ont été proposées comme candidat potentiel à la couche physique des réseaux de radio cognitive [4–8].

Dans cette thèse, on s'intéressera à deux types de modulations qui sont: l'OFDM (orthogonal frequency division multiplexing) et le FBMC (Filter based bank multi-carrier modulation).

- Parmi les différents types de modulations à porteuses multiples, l'OFDM est probablement celle qui jouit de la plus grande notoriété. Le principe de fonctionnement de l'OFDM dont le synoptique est présenté dans la Figure 1 a été développé dans

la littérature [9]. Pour pouvoir contrecarrer l'effet de la sélectivité fréquentielle et temporelle du canal, la bande de fréquence d'un système OFDM est divisée en de multiples sous-porteuses qui sont orthogonales les unes par rapport aux autres. Par ailleurs, chaque symbole OFDM est précédé d'un intervalle de garde afin de minimiser le risque d'interférence inter-symbole.

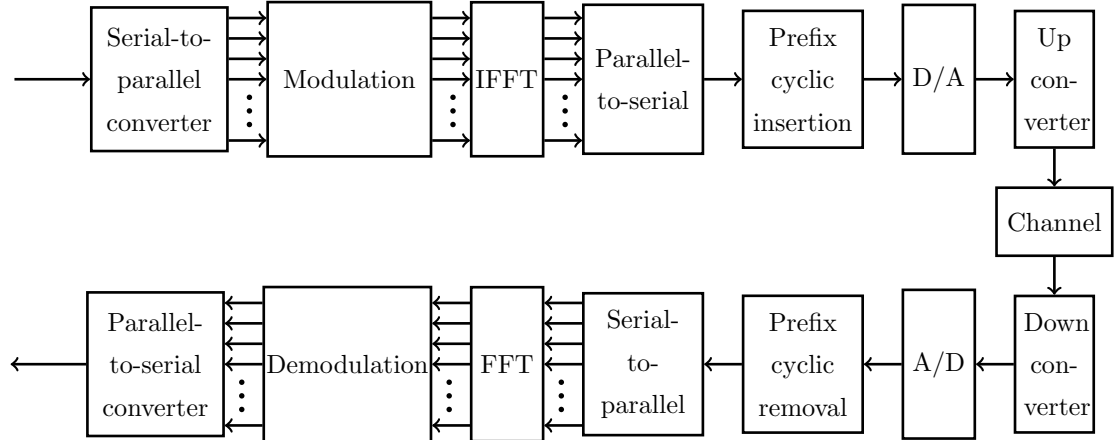


FIGURE 1: Synoptique d'un système OFDM

Malgré les multiples avantages d'un système OFDM, il présente en parallèle de nombreux inconvénients [7, 10]. Par exemple, Les signaux OFDM sont très sensibles aux interférences inter-porteuses causées par les décalages en temps et en fréquence. Cette situation conduira à une baisse de performance dans le cas d'un système asynchrone. Par ailleurs, le spectre d'un signal OFDM a une très mauvaise localisation en fréquence comme le montre la Figure suivante.

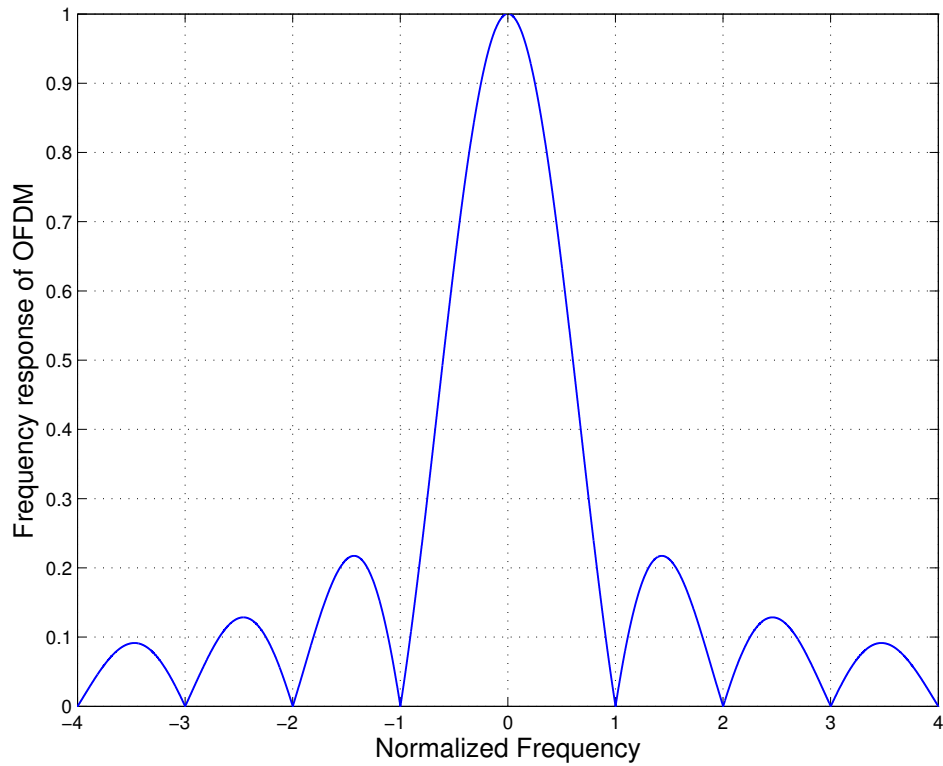


FIGURE 2: Réponse fréquentielle de l'OFDM

- Les inconvénients que présentent les systèmes OFDM ont poussé les chercheurs à fouiller afin de proposer d'autres formes d'ondes plus performantes que l'OFDM. Le FBMC présente des caractéristiques intéressantes qui l'élèvent au rang des concurrents directs de l'OFDM comme candidat potentiel pour la couche physique de la 5G [6, 11]. Le synoptique d'un système FBMC est présenté dans la Figure 3.

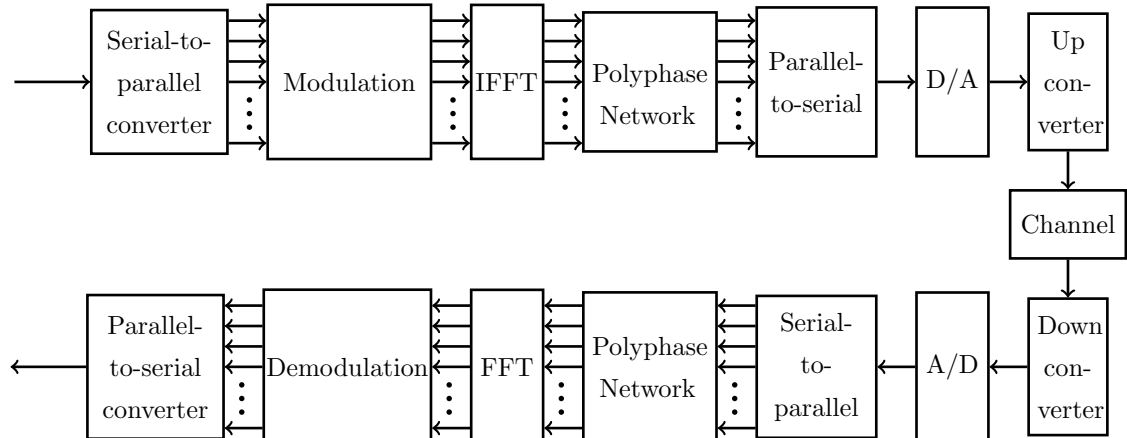


FIGURE 3: Synoptique d'un système FBMC

Le principe du FBMC se rapproche de celui de l'OFDM. La différence entre les deux systèmes réside dans le fait qu'il n'y a pas d'intervalle de garde dans un système FBMC. Aussi, il faut noter l'utilisation d'un filtre prototype dans un système FBMC. Les signaux FBMC s'étalent sur un nombre limité de sous-porteuses entraînant une meilleure localisation en fréquence comme démontrée dans la figure suivante.

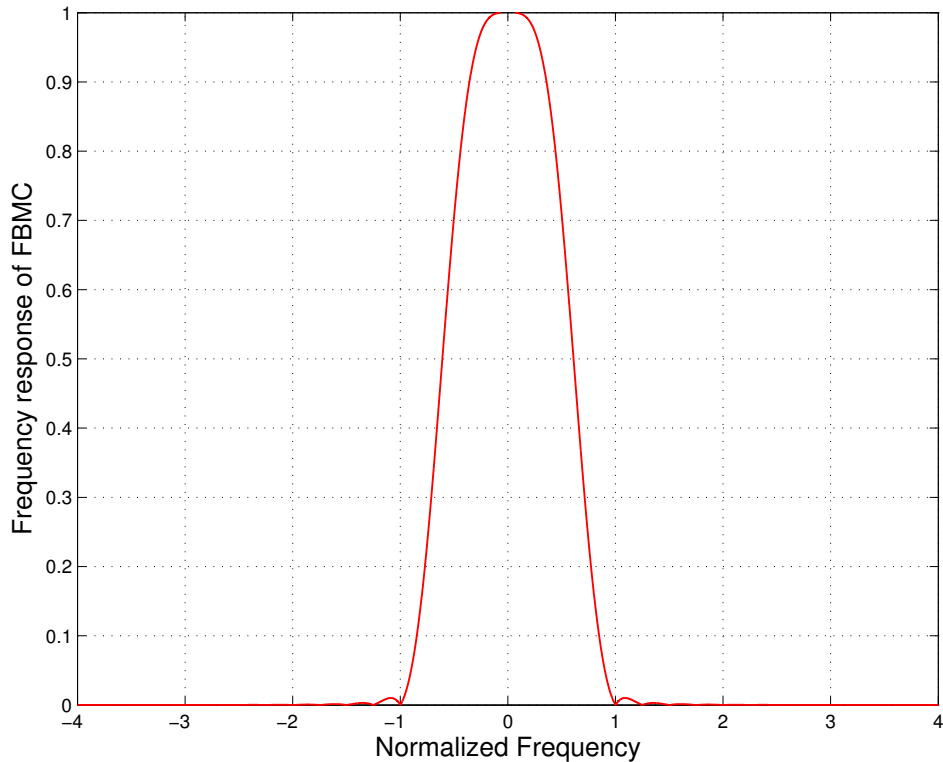


FIGURE 4: Réponse fréquentielle du FBMC

Dans un système de radio cognitive, il est beaucoup plus judicieux de supposer que les systèmes primaires et secondaires ne n'interagissent pas. De cette hypothèse découlera la présence d'interférence inter-porteuses engendrée par la transmission asynchrone inhérente aux deux systèmes. Une analyse rigoureuse de l'impact des interférences asynchrones a été présentée dans la littérature [12, 13]. Les auteurs de ces travaux ont présenté un tableau de gain d'interférence que nous reportons dans la Table 1 et dont nous nous servons dans la suite de la thèse.

TABLE 1: Gains d'interférence

Subcarrier	OFDM	FBMC
l-8	1.12×10^{-3}	0
l-7	1.84×10^{-3}	0
l-6	2.5×10^{-3}	0
l-5	3.59×10^{-3}	0
l-4	5.6×10^{-3}	0
l-3	9.95×10^{-3}	0
l-2	2.23×10^{-2}	0
l-1	8.94×10^{-2}	8.81×10^{-2}
l	7.05×10^{-1}	8.23×10^{-1}
l+1	8.94×10^{-2}	8.81×10^{-2}
l+2	2.23×10^{-2}	0
l+3	9.95×10^{-3}	0
l+4	5.6×10^{-3}	0
l+5	3.59×10^{-3}	0
l+6	2.5×10^{-3}	0
l+7	1.84×10^{-3}	0
l+8	1.12×10^{-3}	0

Chapter 3: Nouvelle méthode d'allocation de puissance distribuée pour un réseau de radio cognitive.

La croissance rapide de la charge de trafic des réseaux émergents pose un sérieux problème lié à l'augmentation insoutenable de la consommation d'énergie. Il y a donc nécessité d'une anticipation pour contrecarrer ce problème de consommation d'énergie qui ne doit pas être traité à la légère. Par ailleurs, la puissance émise par les stations de base dans les sous-porteuses compte pour beaucoup dans la consommation totale du réseau. Il faut donc se recourir à une gestion judicieuse de la puissance disponible en la distribuant de manière très efficace dans les sous-porteuses non seulement pour réduire les interférences mais aussi pour assurer une utilisation efficace de l'énergie.

Dans ce chapitre, nous considérons le problème de minimisation de la puissance émise par les stations de base secondaires sous contraintes de débit minimal par utilisateur secondaire et de température d'interférence imposée par les utilisateurs primaires. Nous supposons que la connaissance des informations de canal est disponible au niveau des stations de base secondaires. Il est important de noter que dans ce scénario, nous avons considéré un seul récepteur par cellule secondaire. Nous avons reformulé le problème en usant de l'approche de théorie des jeux. Il a été démontré que l'existence de l'équilibre de Nash est assurée si la stratégie de chaque joueur (station de base secondaire) suivait la méthode itérative de waterfilling (IWF) modifié.

Nous avons proposé une condition suffisante d'unicité de l'équilibre de Nash du jeu correspondant. Cependant, cette condition n'est vérifiée que si l'interférence reçue par les utilisateurs est très faible. Par ailleurs, nous avons proposé un critère de convergence distribué pour les méthodes itératives couramment utilisées pour résoudre les systèmes d'équations comme la méthode de Gauss-Seidel ou de Jacobi. En usant de ce critère de convergence, nous proposons un algorithme qui converge toujours vers un point fixe et unique. Nos analyses théoriques ont été illustrées par des simulations présentées dans les figures ci-dessous.

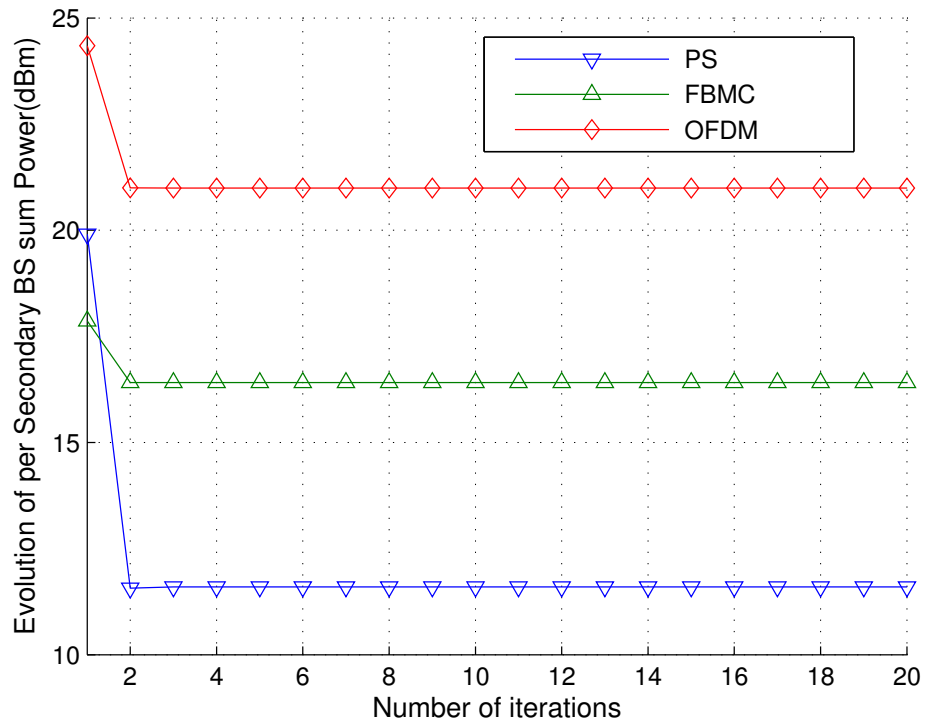


FIGURE 5: Valeur moyenne de puissance émise

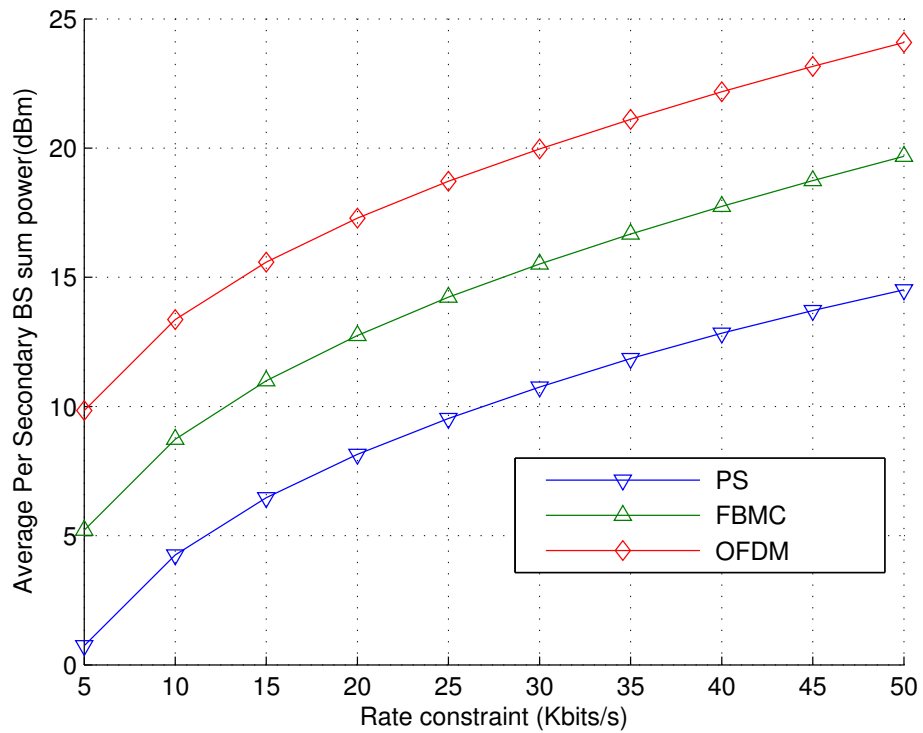


FIGURE 6: Valeur moyenne de puissance émise

Nous avons observé qu'il existe une différence non-négligeable entre la performance du système avec FBMC et celle du système avec OFDM. Ceci est dû à l'étalement de l'interférence inter-porteuses qui est plus important dans le cas de OFDM que du FBMC.

Chapter 4: Allocation de ressources basée sur l'efficacité énergétique

Dans ce chapitre, nous adressons la problématique d'efficacité énergétique pour un réseau de radio cognitive. L'efficacité énergétique se définit comme étant l'efficacité avec laquelle les systèmes liés aux technologies de l'information et de la communication (TIC) utilisent l'énergie pour la transmission de données. L'accroissement incessant des services multimédias couplé avec la croissance vertigineuse de l'utilisation des systèmes de communication sans fil provoqueront indéniablement une augmentation importante d'émission de gaz à effet de serre. En conséquence, les réseaux futur de communication (5G) feront face à un défi énorme en terme de besoin énergétique. Il est donc important d'adresser le problème d'allocation de ressources en tenant compte d'un tel besoin.

Le scénario considéré dans ce chapitre est plus général que celui étudié dans le chapitre précédent. Par ailleurs, nous supposons que la connaissance des informations de canal est disponible à l'émission. Nous étudions le problème d'efficacité énergétique exprimée en bit par Joule dans deux contextes différents.

- Premièrement, nous considérons un système de radio cognitive où les stations de base secondaires sont autorisées à coopérer afin de mieux faciliter la gestion des interférences. Un tel scénario nécessite en revanche la présence permanente d'un contrôleur global capable d'effectuer de manière centralisée l'allocation de ressources en terme de sous-porteuses et de puissance. Le principal objectif du contrôleur est d'allouer les ressources disponibles afin de maximiser la fonction d'efficacité énergétique globale définie comme

$$EE = \frac{\text{Débit total du système}}{\text{Puissance totale émise}}$$

Ce problème d'optimisation appartient à la classe des problèmes dits NP-difficile¹. On propose de le résoudre en ayant recours à la méthode d'optimisation alternée. Il convient tout d'abord de résoudre le problème d'allocation de sous-porteuses en supposant connue l'allocation de puissance. Il est important de noter qu'une station de base peut allouer une sous-porteuse à l'utilisateur qui a le plus grand ratio signal utile sur interférence plus bruit, SINR (signal-to-interference-plus-noise ratio), dans la sous-porteuse. Une fois les sous-porteuses allouées, le contrôleur peut ensuite s'occuper de la distribution de la puissance dans les sous-porteuses. Cette procédure est répétée jusqu'à convergence de la méthode alternée.

Le problème de contrôle de puissance présente cependant certaines difficultés vu que ce n'est pas un problème convexe. La méthode proposée pour le résoudre

¹Un problème appartient à la classe des problèmes NP-difficile s'il s'y réduit en temps polynomial.

consiste tout d'abord à approximer de manière conservative la fonction coût en utilisant le théorème de Taylor. Étant un problème quasi-concave, on peut se recourir à la technique de Dinkelbach pour résoudre le problème approximé. Nous proposons un algorithme (centralisé) d'approximation convexe successive, SCADA (joint successive convex approximation Dinkelbach algorithm) afin d'obtenir un point stationnaire du problème de control de puissance. Il est important de noter que dans certains cas le point stationnaire correspond à la solution optimale (globale) du problème.

L'exécution d'un algorithme centralisé peut cependant se révéler très gourmande en terme de mémoire surtout pour les problèmes dont la dimension est très élevée. En guise de palliatif, nous proposons une version distribuée de l'algorithme SCADA (distributed SCADA) pour résoudre le problème d'allocation de puissance. L'algorithme proposé s'appuie sur la notion de decomposition du problème dual et peut être exécuté en parallele par chaque station de base secondaire.

- Deuxièmement, nous nous intéresserons à un réseau de radio cognitive où les stations de base secondaires opèrent de manière indépendante les unes des autres. L'allocation de ressource tenant compte de l'efficacité énergétique peut alors s'effectuer de manière distribuée au niveau des stations de base secondaire. Afin de mieux mettre en exergue le caractère compétitif de l'environnement dans lequel évoluent les stations de base secondaire, le problème d'optimisation d'efficacité énergétique est reformulé selon un contexte de théorie des jeux. On propose un algorithme basé sur la méthode de Dinkelbach où chaque émetteur peut allouer de manière alternée sous-porteuses et puissance. Nous démontrons que l'existence d'un équilibre de Nash, NE (Nash Equilibrium), est assurée dans le cadre du jeu. Nous proposons aussi une condition suffisante qui assure l'unicité de l'équilibre de Nash.

Nos résultats théoriques ont été illustrés par des simulations présentées dans les figures ci-dessous.

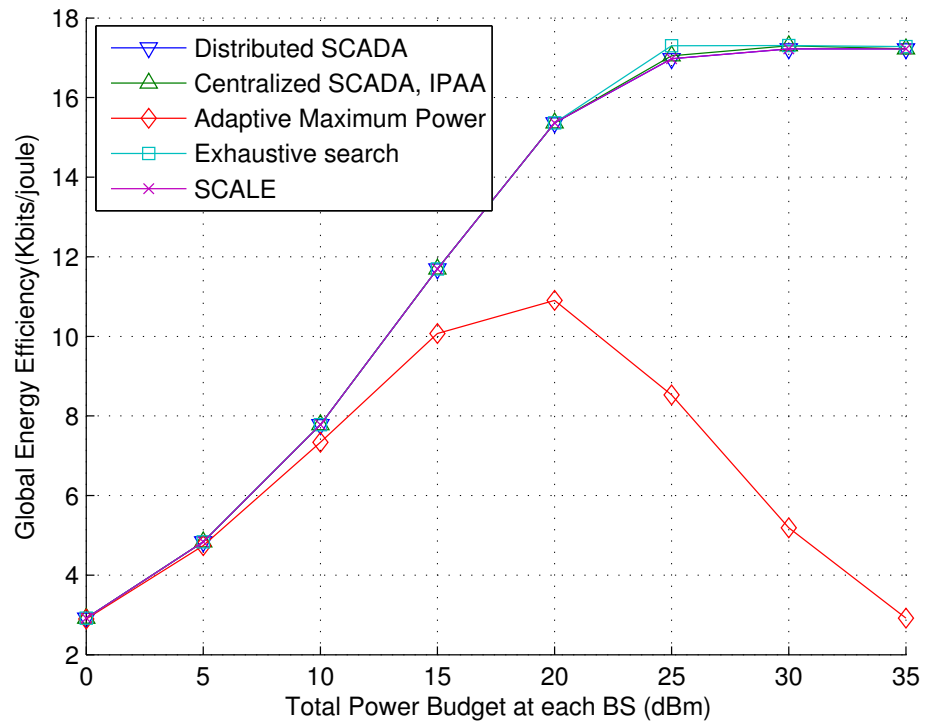


FIGURE 7: Comparaison avec la méthode optimale de la recherche exhaustive pour le cas mono-porteuse

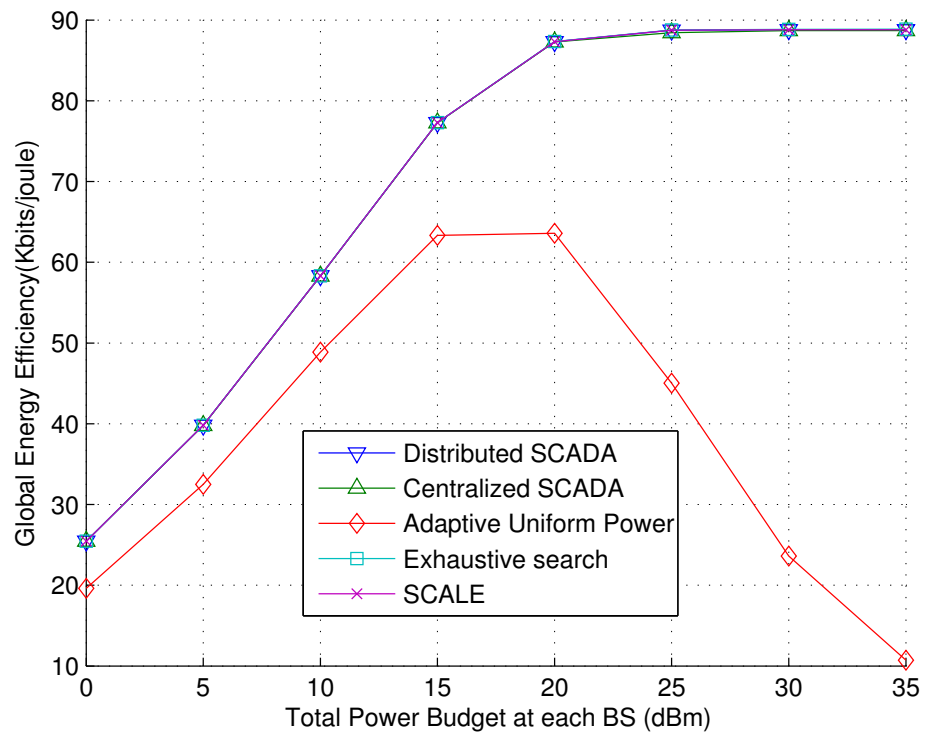


FIGURE 8: Comparaison avec la méthode optimale de la recherche exhaustive pour le cas de 3 sous-porteuses

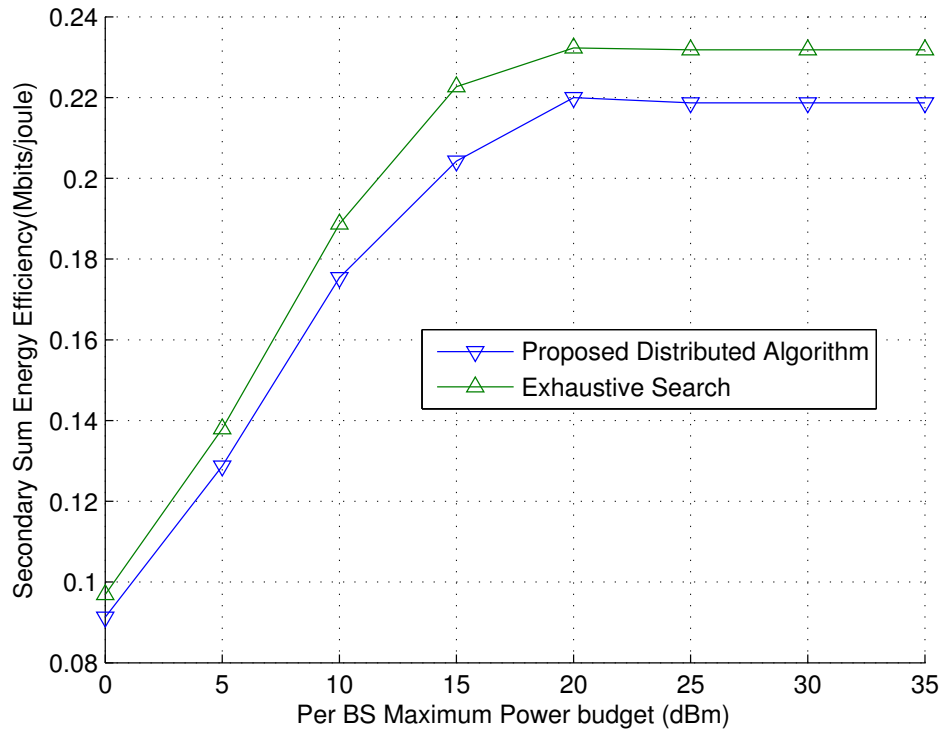


FIGURE 9: Comparaison avec la méthode optimale de la recherche exhaustive pour le cas mono-porteuse

Chapter 5: Allocation de ressources avec connaissance statistique du canal

Dans les chapitres précédents, les ressources sont allouées partant de l'hypothèse que la connaissance exacte des informations du canal est disponible au niveau des stations de base. La remontée des informations sur l'état du canal requiert cependant un coût. Elle est très longue et peut facilement devenir désuète. Pour contourner ce problème, il serait en revanche préférable de supposer la connaissance de la distribution du canal à l'émission. L'avantage d'une telle hypothèse réside dans le fait que la connaissance statistique du canal peut être obtenue sans engorger le réseau de signalisation. Aussi, il est intéressant de noter que la distribution du canal est beaucoup moins variable avec le temps. Cependant, avec la connaissance statistique du canal, la transmission est sujet aux coupures. Dans un tel contexte, il est donc intéressant d'étudier la performance d'un réseau de radio cognitive pour pouvoir évaluer l'impact d'une telle hypothèse.

Dans ce chapitre, nous nous intéressons à l'optimisation de la fonction d'utilité des utilisateurs secondaires sous contraintes de probabilité de coupure des utilisateurs primaires et secondaires. Nous considérons un réseau de radio cognitive contenant un émetteur et un récepteur primaire, et aussi un émetteur secondaire desservant plusieurs utilisateurs

secondaires. Nous considérons le cas où les stations de base primaire et secondaire sont synchronisées. Nous nous intéresserons aussi au cas où elles sont asynchrones.

Dans les deux cas, le problème d'optimisation est un problème appartenant à la classe NP-difficile. Pour contourner la difficulté inhérente à l'obtention d'une solution optimale du problème d'allocation conjointe de sous-porteuses et de puissance, nous proposons de le résoudre au moyen d'un algorithme sous-optimal. La méthode proposée consiste à résoudre l'allocation de sous-porteuses suivie de l'allocation de puissance. Les sous-porteuses sont allouées selon une approche se basant sur la probabilité de coupure. Afin de résoudre le problème de contrôle de puissance, nous proposons dans un premier temps une borne supérieure à l'expression des probabilités de coupure. Nous proposons un algorithme basé sur la méthode d'optimisation alternée afin de trouver une solution proche de l'optimal du problème de contrôle de puissance. L'algorithme proposé résout de manière itérative un ensemble de problèmes de faisabilité (feasibility problem) en se recourant à la méthode de dichotomie.

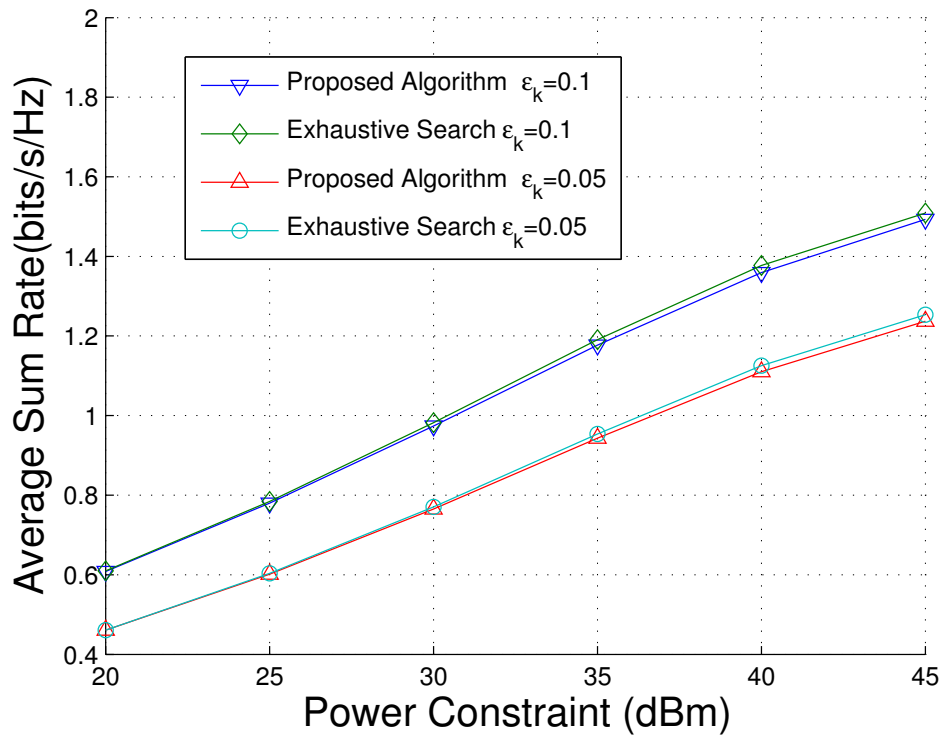


FIGURE 10: Comparaison avec la méthode optimale de la recherche exhaustive

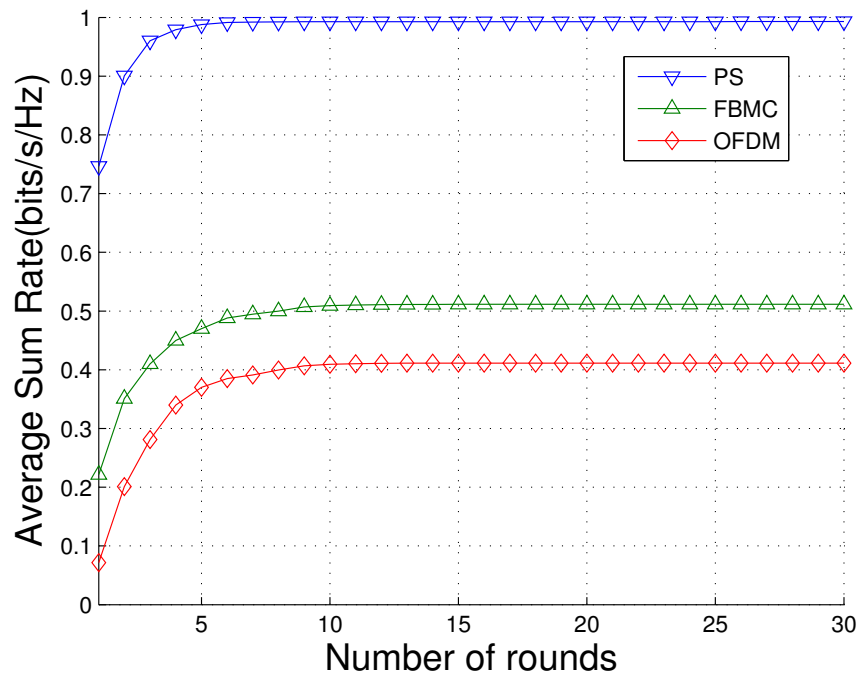


FIGURE 11: Convergence de l'algorithme proposé

Chapter 6: Conclusion

Les enjeux en terme d'allocation de ressources pour les réseaux 5G sont multiples. Dans cette thèse, nous avons proposé et évalué la performance de plusieurs algorithmes d'allocation de ressources pour un système de radio cognitive dans deux contextes différents:

- **Connaissance de l'état instantané du canal disponible à l'émission**

Face à la problématique de consommation d'énergie très présente dans les réseaux émergents, nous avons adressé le problème de minimisation de puissance émise et aussi le problème d'efficacité énergétique. Nous avons proposé des algorithmes distribués pour résoudre le problème de minimisation de puissance émise. Quant au problème d'efficacité énergétique, une approche centralisée a été adoptée dans le cas où les stations de base secondaires sont autorisées à coopérer, et une méthode distribuée a été proposée pour résoudre le problème reformulé dans un contexte de théorie des jeux quand les stations de base opéraient de manière indépendante. Les résultats de simulation ont démontré que les approches proposées peuvent des fois obtenir la solution optimale du problème étudié.

- **Connaissance statistique du canal à l'émetteur**

L'hypothèse de la connaissance statistique du canal présente certains avantages que nous avons voulu exploiter. Cependant, les coupures de transmission qui peuvent en résulter doivent être prise en compte dans le problème d'allocation de ressources. Nous avons ainsi étudié le problème d'optimisation de la fonction d'utilité des utilisateurs secondaires sous contraintes de probabilité de coupure des utilisateurs primaires et secondaires. Pour contourner la difficulté inhérente à l'obtention d'une solution optimale du problème d'allocation conjointe de sous-porteuses et de puissance, nous proposons de le résoudre au moyen d'un algorithme sous-optimal. La méthode proposée a été validée par les résultats de simulation.

Contents

Acknowledgements	ii
Résumé	iv
Abstract	vi
Contents	xxv
List of Figures	xxviii
List of Tables	xxx
Abbreviations	xxxix
Symbols	xxxiv
1 Introduction	1
1.1 Motivation	1
1.2 Outline of the dissertation and research contributions	3
1.3 Related publications	6
1.3.1 Conference publications	6
1.3.2 Journal publications	7
2 Technical Background	8
2.1 Introduction	8
2.2 Overview of Cognitive Radio (CR) Networks	9
2.2.1 Dynamic Spectrum Access	10
2.2.2 Standards for Cognitive Radio	12
2.2.3 Interference temperature	13
2.3 Physical layer multi-carrier (MC) modulations	14
2.3.1 Orthogonal frequency division multiplexing (OFDM)	15
2.3.2 Filter based bank multi-carrier modulation (FBMC)	17
2.3.3 Asynchronous interference for multi-carrier CR networks	20
2.3.4 Resource allocation in multi-carrier networks	22

2.4	Configuration of cognitive radio networks	28
2.5	Review of convex optimization theory	30
2.5.1	Convex sets	30
2.5.2	Convex function	32
2.5.3	Convex problem	34
2.5.4	Duality	35
2.5.5	Karush-Kuhn-Tucker (KKT) optimality conditions	36
2.6	Dual decomposition Method	37
2.7	Methods for non-convex problems	39
2.7.1	Successive convex approximation (SCA)	39
2.7.2	Alternating optimization method	41
2.8	Fractional optimization	42
3	Efficient Distributed Power Allocation for Cognitive Radio Networks	46
3.1	Introduction	46
3.1.1	Literature review	47
3.1.2	Contribution	48
3.1.3	Organization of this chapter	48
3.2	System model and problem formulation	49
3.2.1	System model	49
3.2.2	Problem Formulation	51
3.3	Convergence Criterion	52
3.3.1	Modified Water-filling-based Algorithm	52
3.3.2	Uniqueness of Nash equilibrium	54
3.4	New Distributed Scheme	54
3.5	Numerical results	58
3.6	Conclusion	61
4	Energy-Efficiency Based Resource Allocation Framework for Cognitive Radio Networks	63
4.1	Introduction	64
4.1.1	State-of-the-Art	64
4.1.2	Contribution	66
4.1.3	Organization of the chapter	67
4.2	System Model	67
4.2.1	Cooperative secondary BSs	68
4.2.2	Non-cooperative secondary BSs	68
4.2.3	Temperature-Interference Constraints	69
4.3	Cooperative Transmission Strategy	70
4.3.1	Subcarrier allocation	71
4.3.2	Power Allocation	71
4.4	Joint successive convex approximation and Dinkelbach procedure	73
4.4.1	Convergence Analysis	75
4.4.2	Alternating Optimization	77
4.5	Cooperative Distributed Approach	77
4.5.1	Implementation issues and overhead signaling exchange for Algorithm 9	81

4.6	Non-Cooperative Transmission Strategy	83
4.6.1	Existence of Nash Equilibrium and Description of our proposed Algorithm	85
4.6.2	Uniqueness of the Nash Equilibrium	87
4.7	Numerical results	87
4.8	Conclusion	96
Appendices		98
4.A	Proof of Proposition 4.1	98
4.B	Proof of Proposition 4.3	100
4.C	Proof of Proposition 4.4	101
5	Resource Allocation for Cognitive Radio Networks with Statistical CSI	104
5.1	Introduction	105
5.1.1	Literature Review	105
5.1.2	Contribution	106
5.1.3	The organization of this chapter	107
5.2	System Model	107
5.2.1	Synchronous cognitive radio	108
5.2.2	Asynchronous cognitive radio	109
5.3	Synchronous problem statement	109
5.3.1	Subcarrier Allocation Scheme	110
5.3.2	Power Control Scheme	111
5.4	Special Cases	115
5.4.1	Single carrier scenario	116
5.4.2	Single mobile terminal multi-carrier scenario	117
5.5	General Solution	120
5.6	Asynchronous Networks	124
5.7	Numerical results	127
5.8	Conclusion	132
Appendices		134
5.A	Proof of Lemma 5.1	134
5.B	Proof of Lemma 5.2	134
5.C	Proof of Lemma 5.3	135
5.D	Proof of Lemma 5.4	136
5.E	Proof of Proposition 5.2	137
5.F	Proof of Lemma 5.5	139
6	Conclusion and Future Research Direction	140
6.1	Summary of this dissertation	140
6.2	Perspectives for future work	142

List of Figures

1	Synoptique d'un système OFDM	xi
2	Réponse fréquentielle de l'OFDM	xii
3	Synoptique d'un système FBMC	xii
4	Réponse fréquentielle du FBMC	xiii
5	Valeur moyenne de puissance émise	xvi
6	Valeur moyenne de puissance émise	xvi
7	Comparaison avec la méthode optimale de la recherche exhaustive pour le cas mono-porteuse	xx
8	Comparaison avec la méthode optimale de la recherche exhaustive pour le cas de 3 sous-porteuses	xx
9	Comparaison avec la méthode optimale de la recherche exhaustive pour le cas mono-porteuse	xxi
10	Comparaison avec la méthode optimale de la recherche exhaustive	xxii
11	Convergence de l'algorithme proposé	xxiii
2.1	Block diagram of an OFDM system	16
2.2	Frequency response of OFDM	17
2.3	Block diagram of an FBMC system	18
2.4	Frequency response of FBMC using PHYDYAS prototype filter	19
2.5	Frequency responses of both OFDM and FBMC with PHYDYAS proto- type filter	21
2.6	A cognitive radio network	29
2.7	Convex set	31
2.8	A non-convex set	31
2.9	Convex function	32
2.10	Decomposition of a problem into several subproblems	37
2.11	Geometric representation of SCA	40
3.1	Average sum secondary power versus rate constraint	59
3.2	Average sum secondary power versus rate constraint	60
3.3	Convergence behaviour of the SINR.	61
4.1	Performance comparison with the optimal exhaustive search for $L = 1$	89
4.2	Performance comparison with the optimal exhaustive search for $L = 3$	90
4.3	Convergence behavior of the proposed Algorithm 8 for $L = 16$	91

4.4	Convergence curve versus rounds of Algorithm 8 for different feasible initial point for $L = 16$.	92
4.5	Average global energy-efficiency versus P_{\max} for $L = 16$	93
4.6	Comparison with optimal centralized exhaustive search $L=1$	94
4.7	Average sum energy-efficiency versus P_{\max} for $L = 16$	94
4.8	Convergence behavior of the distributed scheme for solving NPAG for $L = 16$	95
4.9	Convergence curve versus number of iterations for different initial power allocation schemes for $L = 16$	96
5.1	Comparison between exact probability and the proposed bound for $L = 8$.	113
5.1	Performance of our proposed Algorithm 13 in terms of sum rate versus secondary outage requirements	129
5.3	Performance comparison of the proposed Algorithm 13 with uniform power allocation and perfect CSI case for $L = 16$.	130
5.4	Performance of proposed sequential Algorithm 13 for $L = 16$.	131
5.5	Performance of proposed sequential Algorithm 14 for $L = 16$.	132
5.6	Performance of proposed sequential Algorithm 14 for different values of P_{\max} .	133

List of Tables

1	Gains d'interférence	xiv
2.1	Interference weights vector	22
4.1	Simulation Parameters	88

Abbreviations

5G	5th Generation
AWGN	Additive White Gaussian Noise
BS	Base Station
CDI	Channel Distribution Information
CR	Cognitive Radio
CSI	Channel State Information
DSA	Dynamic Spectrum Access
EE	Energy- Efficiency
FBMC	Filter-Bank Multi-Carrier
FFT	Fast Fourier Transform
IDFT	Inverse Discrete Fourier Transform
IEEE	Institute of Electrical and Electronic Engineers
IFFT	Inverse Fast Fourier Transform
ISI	Inter-Symbol-Interference
KKT	Karush-Kuhn-Tucker
LTE	Long Term Evolution
MC	Multicarrier Modulation
MIMO	Multi-Input Multi-Output
MISO	Multi-Input Single-Output
MT	Mobile Terminal
NE	Nash Equilibrium
OFDM	Orthogonal Frequency Division Multiplexing

OFDMA	O rthogonal F requency D ivision M ultiple A ccess
OQAM	O ffset Q uadrature A mplitude M odulation
OSA	O pportunistic S pectrum A ccess
PHYDYAS	P HYSical Layer for D Ynamic Spectrum A ccess S Cognitive Radio
PU	P rimary U ser
QAM	Q uadrature A mplitude M odulation
QoS	Q uality of S ervice
SINR	S ignal-to- I nterference-plus- N oise R atio
SISO	S ingle- I nput S ingle- O utput
SU	S econdary U ser

Symbols

Notations

The notations used in this dissertation are summarized as follows:

$(\cdot)^\top$	Transpose operator
$\text{diag}(\cdot)$	Diagonal matrix
$\ln(\cdot)$	Natural logarithm
$\log_2(\cdot)$	Logarithm to base 2
$\Pr(\cdot)$	Probability function
$\mathbb{E}(\cdot)$	Expectation operator
$ \cdot $	Absolute value
\mathbb{R}	The set of real values
\mathbb{R}_+	The set of positive real values
$\mathcal{L}(\cdot)$	The Lagrangian associated with an optimization problem
∇f	The gradient of function f
$\nabla^2 f$	The Hessian of function f
$ \Omega $	The cardinality of the set Ω
$[x]^+$	The maximum between 0 and x
$(\cdot)^*$	The optimal value of
\succeq	Positive definite

Thesis specific notations

This a non-exhaustive list of most relevant notations used throughout this dissertation.

General notations:

\mathcal{K}	The number of secondary users
L	The number of subcarriers
B	The total available bandwidth
\mathcal{Q}	The number of primary users
P_k^l	Power of the k th secondary base station on the l th subcarrier
\mathbf{P}_k	Power allocation vector of the k th secondary base station
\mathbf{P}_{-k}	Power allocation vector of all except the k th secondary base station
\mathbf{P}	Power allocation of the entire secondary network
p_q^l	Power of the q th primary base station on the l th subcarrier
N_0	Noise power on each subcarrier
P_{\max}	Total power budget at each base station
\mathcal{P}_k	Feasible set of the transmission strategy of the k th secondary base station

Notations specific to chapter 3:

$G_{k,k}^l$	channel gain between secondary base station k and its served mobile terminal on subcarrier l
$G_{k,j}^l$	Channel gain between base station of secondary user k and mobile terminal of secondary user j on subcarrier l
$H_{k,q}^l$	Channel gain between base station of secondary user k and receiver of the primary user q within the l th subcarrier
$I_q^{k,\max}$	Maximum interferences allowed by the q th primary user
$\mathcal{I}_{q,k}^l$	Set of subcarrier of q th primary base station that suffers from interferences generated by the l th subcarrier of the k -th secondary base station
$\widehat{\mathcal{R}}_k$	Rate constraint of the secondary user k .
U_k	The pay-off function of the k th secondary base station
γ_k^l	The signal-to-noise-ratio of secondary user k on subcarrier l
$\mathbf{\Gamma}_k$	The signal-to-noise-ration vector for secondary user k

Notations specific to chapter 4:

$\theta_{k,u}^l$	Subcarrier allocation indicator for secondary base station k
Θ_k	Feasible subcarrier allocation matrix for secondary base station k
$u(k, l)$	Secondary mobile terminal that was assigned the l -th subcarrier by its serving base station k
\mathcal{U}_k	Number of secondary mobile terminals served by the k th secondary base station
$G_{j,u(k,l)}^l$	Channel gain from the j th secondary base station to user u served by the k th secondary base station on the l th subcarrier
$H_{q,u(k,l)}^l$	Channel gain from the q th primary base station to user u served by the k th secondary base station on the l th subcarrier
I_q^{\max}	The global interference prescribed requirement for the q th primary mobile terminal
$I_q^{k,\max}$	The maximum interferences allowed by the q th primary user
\mathbf{P}^l	Power allocation vector of the entire secondary network on the l th subcarrier
$\Gamma_{k,u(k,l)}^l$	Signal-to-noise-ratio measured by user u on subcarrier l
$P_{c,k}$	Circuit power at the k th secondary base station
ξ	Drain efficiency
U_k	Utility function of secondary base station k

Notations specific to chapter 5:

Θ	Feasible subcarrier allocation matrix for the secondary base station
Ω_k	Set of subcarriers assigned to the k th secondary mobile terminal
$h_{i,j}^l$	Channel link from base station i to mobile terminal j on the l th subcarrier
R_p	Transmission data rate of the primary base station
P_s^l	Power allocation of the secondary base station on subcarrier l
\mathbf{P}_s	Power allocation vector of the secondary base station
R_k	Transmit data rate of the k secondary mobile terminal
\mathcal{U}	Utility function of the secondary system
ϵ_k	Outage requirement for the k th secondary mobile terminal

Chapter 1

Introduction

Motivation

In recent decades, ubiquity and rapid proliferation of wireless technology lead to a sharp increasing in the number of individual requiring access to wireless networks. The growing number of mobile subscribers coupled with the explosion of high quality wireless applications result into a dramatic increasing request for more radio spectrum. Underutilized yet scarce radio spectrum becomes overwhelmingly crowded. It is becoming urgent to alternate from fixed frequency resource assignment, i.e., static licensed spectrum management, to dynamic spectrum access (DSA). Cognitive radio (CR) emerged as a promising technology capable of enhancing the radio spectrum.

Due to its dynamic and opportunistic spectrum access capability, CR technology can efficiently tackle the problem of spectrum underutilization and spectrum scarcity. The philosophy of cognitive radio technology is to permit unlicensed users known as secondary users (SUs) to transmit within the licensed spectrum owned by primary users (PUs) [14]. The coexistence idea between primary users and secondary users promoting by cognitive radio can be done using two different paradigms [15]. Firstly, primary and secondary users may coexist in an overlay

fashion. This coexistence strategy requires that the secondary users have prior knowledge about the primary users transmit signal information. More concretely, secondary users are granted permission to opportunistically access and communicate only over licensed radio spectrum that left vacant or unused by the primary users. Secondly, the coexistence between PUs and SUs can be done through an underlay strategy. This transmission strategy permit to the secondary users to simultaneously with the primary users operate on the radio spectrum provided that their radiated interferences remain under certain threshold in order not to degrade the quality of service (QoS) of the primary users transmission to an unacceptable level.

Long Term Evolution (LTE)-Advanced as well as WiMAX resort to multi-carrier (MC) modulation techniques such as orthogonal frequency-division multiplexing (OFDM) to overcome the detrimental effect of multipath fading inherent to any wireless network channel. Filter bank multi-carrier (FBMC) emerges as good alternative to OFDM for 5G wireless networks applications [16]. It is known that multi-carrier modulations are very appealing to dynamic spectrum access in cognitive radio networks [8]. Besides, FBMC is being promoting as a good candidate for the physical layer for the dynamic spectrum access in cognitive radio networks [17]. Multi-carrier modulations can combat the effect of inter-symbol interference (ISI) for perfectly synchronized networks. However, for asynchronous networks, the orthogonality incurred in resorting to multi-carrier modulations may be destroyed to some extent. Consequently, asynchronism will result in inter-carrier interference.

For more practical scenario of cognitive radio networks, there is no interaction between primary and secondary users. The lack of cooperation between the primary users and the secondary users may lead to asynchronous transmission between the primary and secondary system. Inter-carrier interferences coupled with inter-secondary interferences may hamper reliable communication if judicious resource allocation is not properly done for multi-carrier-based cognitive radio networks. Therefore, it is of utmost importance for the secondary users to resort to an efficient resource management strategy to achieve higher performance while ensuring the non-degradation of the primary users QoS. In this dissertation, we focus on

optimizing the limited resource, i.e., radio spectrum and total transmit power, to ensure reliable transmission for the secondary users from a downlink point of view.

For wireless networks, the design of proper resource optimization is relevant not only to the chosen performance metric or figure of merit, it is highly depend of the availability, i.e., the nature of the knowledge of the channel state information (CSI). In this thesis dissertation, we design resource allocation for multi-carrier-based asynchronous cognitive radio networks under the assumption of perfect and statistical knowledge of channel state information.

In the first part of this dissertation, we focus our attention on asynchronous downlink cognitive radio networks with perfect channel state information at the secondary transmitters or base stations side. This is an idealization of currently existing practical communication networks. We design algorithms relevant to resource management in order to optimize the secondary users spectral-efficiency, transmit power and energy-efficiency.

The ideal assumption of perfect CSI may be impractical for cognitive radio setting partly because of the lack of cooperation between primary and secondary users. Also, perfect CSI may induce some feedback overhead from the point of view of the secondary users. In the second part of this dissertation, we investigate resource allocation for multi-carrier-based downlink cognitive networks assuming statistical channel state information. However, with statistical CSI, the communication within the network is prone to outage which occurs whenever the transmission rate is higher than the instantaneous capacity that the channel can support. Therefore, resource allocation is done by taking into consideration the metric of outage.

Outline of the dissertation and research contributions

This dissertation is organized as follows:

Chapter 2: Technical background

The technical background used throughout this dissertation is presented in Chapter 2. More specifically, a summary of main technical concepts such that cognitive radio together with dynamic spectrum access (DSA) is provided. In addition to that, we briefly introduce some standards that govern the development and deployment of cognitive radio and the principle of physical layer (PHY) multi-carrier (MC) modulations is also described. In the second part of Chapter 2, a brief description of optimization theory concepts is given. Moreover, some advanced techniques such as successive convex approximation (SCA) and alternating optimization method to solve non-convex optimization problems are also introduced.

Chapter 3: Efficient distributed power allocation for cognitive radio networks

In Chapter 3, we address the problem of secondary users power minimization. It turns out that the optimal power allocation strategy for each secondary base station is given by the modified Water-filling. To assure robustness of the given solution, we provide a sufficient convergence condition to a Nash-equilibrium (NE) point for the modified Water-filling algorithm. In addition to that, we propose a new and efficient distributed algorithm that always converges to a unique Nash equilibrium of the non-cooperative power allocation-based game.

Chapter 4: Energy-efficiency based resource allocation framework for cognitive radio networks

In Chapter 4, we study the problem of energy-efficiency (EE) maximization under secondary total power and primary interference constraints by making two assumptions

- We start by assuming that the secondary base stations (BSs) are interacting with each other. We consider a centralized approach to solve the energy-efficiency optimization problem for the cognitive radio network. An

alternating-based approach is proposed to solve the joint power-subcarrier allocation problem. Subcarriers are allocated using a heuristic method for a given feasible power allocation. Then, a conservative approximation the non-convex power control problem is given. In order to efficiently obtain a solution to the non-convex power control problem, we design a joint *Successive Convex Approximation-Dinkelbach Algorithm (SCADA)* that converges to a stationary point of the original non-convex power control problem. On top of that, a dual decomposition-based decentralized algorithm with lower overhead complexity is also proposed.

- Secondly, we assume no cooperation among the secondary base stations. The problem of energy-efficiency maximization is recast invoking the concept of game theory and a fully distributed algorithm of low complexity is provided and is shown to converge to a Nash-equilibrium (NE) point. Moreover, we identify a sufficient condition that guarantees uniqueness of the achieved Nash equilibrium.

Chapter 5: Resource allocation for cognitive radio networks with statistical CSI

In Chapter 5, we address the problem of utility optimization under primary and secondary users' outage transmission constraints. We consider both synchronous and asynchronous cognitive radio networks. We design a resource allocation framework that guarantees data outage requirement for both primary and secondary systems. More concretely, we circumvent the prohibitively high computational complexity incurred addressing the joint subcarrier-power allocation problem by solving two separable independent problems. A bisection search method is invoked to find solution to the subcarrier allocation problem. Then, we design a tractable approximation to tackle the nonexistence closed form expression for the primary and secondary outage probabilities that renders the power control optimization problem intractable. A polynomial time solvable algorithm to find near-optimal

solutions to the reformulated tractable power control problem based on alternating optimization method is proposed. The proposed approach sequentially solves a feasibility problem using bisection method.

Chapter 6: Conclusion and future research direction

Finally, we conclude the dissertation in Chapter 6 by briefly summarize our main contribution. Moreover, we highlight some potential research direction that can be further explored.

Related publications

The contain of this dissertation is mainly based on the following publications.

Conference publications

- **Juwendo Denis, Mylène Pischella and Didier Le Ruyet**, *Efficient Power Allocation Approach for Asynchronous Cognitive Radio Networks with FBMC/OFDM*, To appear at 11th EAI International Conference on Cognitive Radio Oriented Wireless Networks (CROWNCOM 2016).
- **Juwendo Denis, Mylène Pischella and Didier Le Ruyet**, *Optimal Energy-efficient Power Allocation For Asynchronous Cognitive Radio Networks using FBMC/OFDM*, In proc. at IEEE Wireless Communications and Networking Conference (WCNC 2016), April 2016.
- **Juwendo Denis, Mylène Pischella and Didier Le Ruyet**, *Resource Allocation for Asynchronous Cognitive Radio Networks with FBMC/OFDM under Statistical CSI*, In proc. at the 41st IEEE International Conference on Acoustics, Speech and Signal Processing (ICASSP 2016), March 2016.
- **Juwendo Denis, Mylène Pischella and Didier Le Ruyet**, *A Conservative Approach to Sum Rate Maximization in Asynchronous Ad Hoc Networks using Multi-Carrier Modulation Schemes*, International Symposium on Wireless Communications (ISWCS 2014), pp. 323-227 August 2014.

Journal publications

- **Juwendo Denis, Mylène Pischella and Didier Le Ruyet**, *Resource Allocation under Outage Constraint in Multi-carrier based Cognitive Radio Networks*, Submitted at IEEE Transaction on Wireless Communications, Dec. 2015.
- **Juwendo Denis, Mylène Pischella and Didier Le Ruyet**, *Energy-Efficiency Based Resource Allocation Framework for Cognitive Radio Networks with OFDM/FBMC*, Submitted at IEEE Transaction on Vehicular Technology, Jul. 2015.
- **Juwendo Denis, Mylène Pischella and Didier Le Ruyet**, *A Generalized Convergence Criterion to Achieve Maximum Fairness Among Users in Downlink Asynchronous Networks using OFDM/FBMC*, IEEE, Communications Letters, Vol. 18 No. 11 pp. 2003-2006, Nov. 2014.

Chapter 2

Technical Background

Introduction

In this chapter, we provide a brief summary of main technical concepts to be used throughout this dissertation. Recall that the main focus of this dissertation is resource allocation for multi-carrier-based cognitive radio networks. We start this chapter by firstly presenting an overview of cognitive radio networks. More concretely, the advent of cognitive radio together with the dynamic spectrum access (DSA) are described. In addition to that, key standards that govern the development and deployment of cognitive radio are presented.

Secondly, we elucidate the principle of physical layer (PHY) multi-carrier (MC) modulations. We briefly describe the main multi-carrier modulations that are used in this dissertation. More importantly, a summary encompassing pros and cons of orthogonal frequency division multiplexing (OFDM) and filter based bank multi-carrier modulations (FBMC) is provided.

Lastly, a brief description of some major optimization theory concepts is given. Bear in mind that the resource allocation problem is to be formulated as an optimization problem. Consequently, it is of utmost importance to introduce basic

concepts such as convex set and convex function which are mandatory when defining a convex optimization problem. The concept of duality which permits to find optimal solution of standard convex optimization problem using Karush-Kuhn-Tucker (KKT) optimality conditions is also presenting.

In this chapter, the idea of dual decomposition method and some advanced methods such as successive convex approximation (SCA) and alternating optimization method destined to solve non-convex optimization problems are also described. At last, we introduce the problem of fractional optimization and some approaches destined to tackle such problem.

Overview of Cognitive Radio (CR) Networks

The ubiquity and rapid proliferation of wireless technology lead to a sharp increasing in the number of individual requiring access to wireless networks. The exponentially growing number of mobile subscribers coupled with the explosion of high quality wireless applications is challenged by the scarcity of the radio spectrum mainly due to static spectrum management paradigm. In order to increase government revenue, regulatory authorities, such as the Federal Communications Commission (FCC) in the United States, tend to provide spectrum to highest bidder. Despite this growing trend, the regulatory authorities fortunately do dedicate a certain amount of spectrum for users that aims to operate at low power. Transmission over such unlicensed spectrum is governed by the Institute of Electrical and Electronics Engineers (IEEE) standards such as IEEE 802.15.4 and IEEE 802.11.

In recent years, regulatory organizations have demonstrated that owned radio spectra are often underutilized [18, 19]. Finding a way to circumvent or to prevent the waste of such scarce resource remained an appealing issue. On top of that, users demand for more bandwidth keep increasing. These two bottlenecks have paved the way for a new spectrum management paradigm. Cognitive radio (CR) equipped with both opportunistic spectrum access (OSA) and dynamic spectrum

access (DSA) capabilities emerged as a promising technology capable of enhancing the radio spectrum.

Cognitive radio which can be interpreted as the intersection between personal technology and computational intelligence was defined by Mitola as [1]

Definition 2.1 (Cognitive Radio [1]). *Cognitive radio identifies the point at which wireless personal digital assistants together with appropriate networks having adequate knowledge about radio spectrum and related computer-to-computer communications to:*

- *identify user potential communications needs in terms of use context and to*
- *provide radio spectrum together with wireless services that are mostly adequate to those needs.*

In other words, resorting to cognitive radio technology appears as an efficient yet appropriate solution to radio spectrum scarcity and severe spectrum underutilization. The main objective of such technology is to conveniently enhance spectral efficiency by overlaying a secondary system on an existing primary system. The overlaying procedure does not however require any change in the structure of the current licensed system. Consequently, cognitive radio devices should be equipped with adequate technology to be able firstly to efficiently sense surrounding radio environment. Secondly, cognitive radio should be incorporated with the capability of making judicious decision to opportunistically access the spectrum or not based on the assessment result of the activities on the surrounding primary system.

Dynamic Spectrum Access

The dynamic spectrum access (DSA) can simply be referred as a non-static spectrum management strategy. The DSA paradigm is usually characterized based on the three following models [20]: dynamic exclusive use model, open sharing model and hierarchical access model.

- In the first model, the basic philosophy of spectrum regulation policy where radio spectrum bands are licensed to wireless services for exclusive use is

maintained while introducing some flexibilities in order to improve spectrum efficiency. For instance, the spectrum licensee is entitled to lease or share the assigned radio spectrum for business profit. However, the sharing or leasing procedures are not mandated by official regulation policies. Another flexibility is related to dynamic spectrum allocation exploiting both space and time traffic statistic of different services. More specifically, at a given time in a given location, radio spectrum is assigned to wireless services for private use.

- Regarding the open sharing model, it advocates the shared access to non-exclusive use. This model is sometimes referred as spectrum common [21]. For such sharing model, the right to utilize the spectrum is shared among several users provided a well-established protocol that clearly addresses the mechanism of the spectrum management. The management mechanism anticipates radio spectrum access procedure during period of congestion, determines policies to mandate users and forecasts solutions to eventual conflicts that may arise among users.
- The third model endorses a hierarchical structure to regulate the spectrum access mechanism between the primary and secondary users. Compared to the two aforementioned spectrum sharing models, the hierarchical structure is probably the most appealing yet adequate sharing model for current spectrum management regulations. The philosophy behind this model consists of granting permission to secondary users (SUs) to access the spectrum owned by the primary users (PUs) while limiting the interferences received by the primary users. The protocol that permits secondary users to access the radio spectrum is established on the basis of the two following access paradigms: spectrum overlay and spectrum underlay paradigm.
 - For spectrum overlay access known also as spectrum pooling [22], the secondary users can only access vacant, i.e. unoccupied radio spectrum. More concretely, the radio spectrum overlay strategy consists of granting permission to secondary users to instantaneously detect availability and to eventually use radio spectrum owned by primary users in a non-intrusive fashion. The concept of time and space is very important

for overlay access strategy. Moreover, appropriate sensing capability is required at the secondary users end for overlay access paradigm.

- Different from overlay access strategy, the underlay access paradigm which is the access mechanism that we consider throughout this dissertation, does not rely on neither detection nor exploitation of spectrum white space. The secondary users can simultaneously with the primary users communicate over the radio spectrum band as long as they operate below the noise floor of the primary users by judiciously controlling their transmit power. More explicitly, for underlay access framework, careful control of secondary users transmit power need to be done in order not to degrade the quality of service (QoS) of primary users. As long as the degradation of the QoS of the primary users is tolerable secondary users may have clearance to transmit over the radio spectrum. Consequently, developing efficient algorithms pertaining to power management is crucial for the operation of spectrum overlay frameworks.

Standards for Cognitive Radio

Cognitive radio technology in wireless communication has drawn increasing attention at both industry and academia, recently. A great deal of research works have been devoted towards the improvement and deployment of cognitive radio [23][24]. In addition to that, civil and military bodies have also exhibited huge interest for highly intelligent radio technology. We are gradually moving towards real implementation of cognitive radio networks. Consequently, well-established standardization procedures are of utmost importance.

An exhaustive survey of standards pertaining to the development of cognitive radio technology was done in [25]. These techniques are considered for wireless services in unlicensed very high frequency (VHF) and ultra high frequency (UHF) television bands mainly because frequencies in VHF and UHF spectrum bands are very appealing from a network deployment point-of-view. More importantly, at these frequencies, signals incur lower attenuation which imply broader base station

coverage. Two major standardization efforts that are in advanced stage and that support dynamic spectrum access are discussed below.

- The IEEE P1900 standard [26] addresses techniques and methods related to dynamic spectrum access for 3G/4G, WiFi and WiMax networks that require interference management and coordination of wireless technology. It also includes protocols for information sharing and network management. From a network point of view, It provides vertical and horizontal network reconfiguration management methods for inter-interoperability for wireless networks without fixed infrastructure.
- The IEEE 802.22 standard [2] was developed to define an air interface such as physical layer and media access layer (MAC) standard based on cognitive radio techniques. This standard establishes the operating mechanisms regulations for the use of unlicensed wireless operation in the analog television band. More specifically, the IEEE 802.22 standard is being developed for wireless regional area networks (WRANs) in order to provide wide broadband Internet connectivity. The licensed radio spectra range targeted by this standard varies from 54 to 862 MHz. This range of spectrum is usually assigned for television services since most of television channels in these frequency spectra are largely unused especially in rural regions.

Interference temperature

It is worth noting that while secondary users can access the radio spectrum, the primary users remain the owner of the spectrum. Therefore, coexistence of secondary users with the primary users requires real-time wide-band monitoring of the licensed spectrum. Whenever coexistence is permitted using an underlay framework, interference temperature limit prescribed by primary users should not be violated, otherwise degradation of the primary users QoS will no longer be tolerable. The proper way to impose an interference constraint to the secondary users is very complicated. This should be done by judiciously finding a trade off between restrictive constraints, i.e. constraints that can marginalize the gain of

opportunistic spectrum access, and loose constraints, i.e. constraints that may impact the compatibility with legacy systems.

Some traditional approaches advocate to limit the transmit power of the secondary users. More concretely, these frameworks propose of restricting the transmit power of the secondary users below a prescribed noise floor. This however can sometimes be problematic due to the emergence of new unpredictable yet random source of interference. In order to respond to this issue while enforcing interference limit received by primary users, the spectrum policy task has proposed the interference temperature [27] as a new metric on interference assessment.

In general, the interference temperature is implicitly or explicitly captures by the maximum interference power level perceived by any active primary user. This mechanism consists of specifying the noise floor of primary users. The metric interference temperature becomes inherent to spectrum opportunistic access and implicitly indicates how to determine the transmission power of secondary users. This interference temperature should be imposed according to the aggregated transmission activities of the secondary users. It can be done using either a network-centric or user-centric point of view. However, for secondary users operating in a network-centric transmission strategy, each secondary user should be aware of the node level constraint in order to make proper power management decision. Moving from network-centric to user-centric interference constraint usually requires to take into consideration geolocation and therefore the signal attenuation due to fading and shadowing.

Physical layer multi-carrier (MC) modulations

Generally speaking, inter-symbol interference (ISI) is inherent to transmission over wide-band channel. In fact, ISI occurs when residue of previous symbols overlap with the current symbol. The effect of inter-symbol interference is a direct consequence of delay spread. One possible way to combat the detrimental effect of inter-symbol interference is to resort to multi-carrier modulations [28, 29]. The

basic principle of multi-carrier modulation consists of converting the frequency-selective channel into a set of non-interfering yet orthogonal channels where each channel experiences narrowband flat fading [3].

One advantage of multi-carrier systems is the capability of spreading out the total signal interval in order to reduce sensitiveness to delay spread. In addition to that, multi-carrier modulations can also attenuate the burst caused by Rayleigh fading by simply spreading out a fade over several adjacent symbols [30]. Standards such as IEEE 802.11a are equipped with multi-carrier systems for the physical layer of wireless local area network (WLAN) modem [31]. In IEEE 802.22, the physical layer for cognitive radio network is based on orthogonal frequency division multiple access (OFDMA) for both uplink and downlink access. On top of that, multi-carrier modulation has been promoted as a good candidate for the physical layer of cognitive radio networks [4–8]. In [5], Farhang-Boroujeny et al. reviewed different types of multi-carrier modulations proposed for cognitive radio networks. The two main multi-carrier modulations invoked throughout this dissertation are discussed below.

Orthogonal frequency division multiplexing (OFDM)

The orthogonal frequency division multiplexing (OFDM) is probably the most widely-used multi-carrier modulation scheme. OFDM has been advocated as a good candidate for the physical layer of cognitive radio networks [5, 8]. The philosophy behind OFDM was summarized in [9] and is graphically portrayed in Figure 2.1. Basically, the principle of OFDM consists of transmitting a single data stream over a finite number of subcarriers in order to increase the robustness against the frequency selective fading or narrowband interference. More concretely, the total bandwidth of the signal is divided into a finite number yet non-overlapping frequency subcarriers. The spacing between the subcarriers is chosen so that they are orthogonal to each other. The bandwidth of each subcarrier is small compared with the coherence bandwidth of the channel. To mitigate the effect of inter-symbol interference, a cyclic prefix of at least same length that the channel impulse response is appended at the beginning of each transmit symbol.

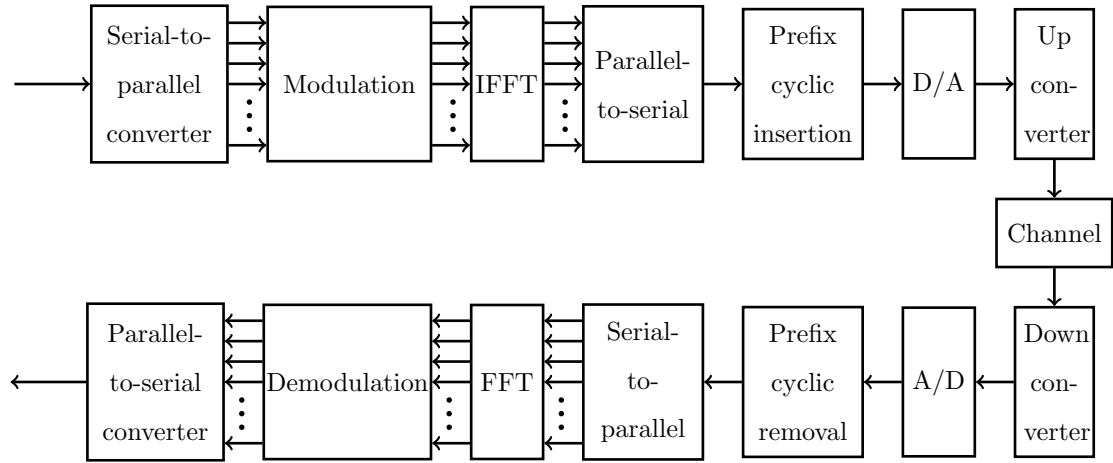


FIGURE 2.1: Block diagram of an OFDM system

The OFDM continuous-time baseband transmit signal can be written as

$$s(t) = \sum_{m=0}^{N-1} \sum_{n=-\infty}^{+\infty} x_{m,n} f_T(t - n(T + \Delta)) e^{j\frac{2\pi}{T}m(t-n(T+\Delta))} \quad (2.1)$$

where

- m denotes the subcarrier index.
- $x_{m,n}$ is the transmit complex-valued symbol
- T is the OFDM symbol duration.
- $f(t)$ is a rectangular pulse shape.
- Δ is the duration of the cyclic prefix.

Despite a great deal of advantages, OFDM suffers some major drawbacks [7, 10] and particularly for the application of cognitive radio networks. In general, OFDM exhibits the following shortcomings:

- Underutilization of time and additional power overhead due to the insertion of cyclic prefix [3].
- OFDM signals are very sensitive to timing and frequency offset which may cause loss of performance in case of asynchronous networks [32].

- Significant side-lobes of the frequency response of the rectangular pulse shape as depicted in Figure 2.2. This is a major reason for spectral efficiency decrease in asynchronous transmission.

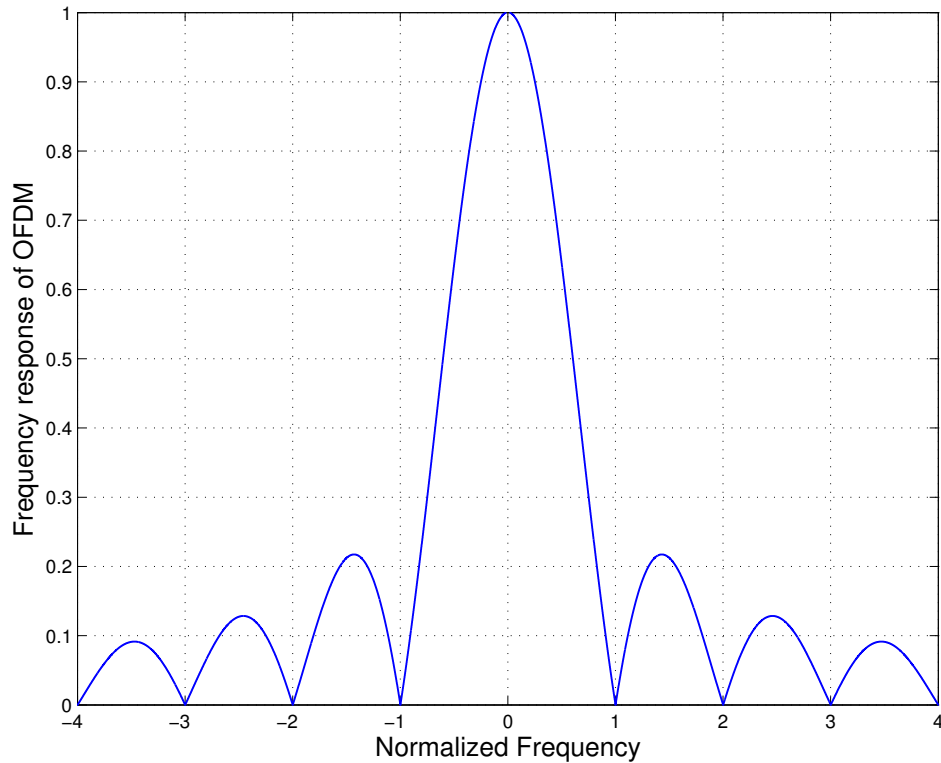


FIGURE 2.2: Frequency response of OFDM

Filter based bank multi-carrier modulation (FBMC)

The drawbacks incurred using OFDM have fostered the search for some alternative multi-carrier modulations capable of overcoming the aforementioned disadvantages. Filter bank multi-carrier modulations (FBMC) has been promoted as an appealing multi-carrier schemes [6, 11]. The principle of FBMC is very similar to the previously described OFDM. The block diagram of FBMC is depicted in Figure 2.3. However, there are two main differences between OFDM and FBMC which we state below:

- OFDM modulated signals required the appendage of a cyclic prefix at the beginning of each symbol whereas the need of such cyclic prefix is dismissed for FBMC modulated signals.
- Also for FBMC symbols, the signal on each subcarrier is filtered by band-limited filter known as prototype filter [33]. Prototype filters are usually low-pass filters well localized in time and frequency [34]. An exhaustive list of different types of filters can be found in [35].

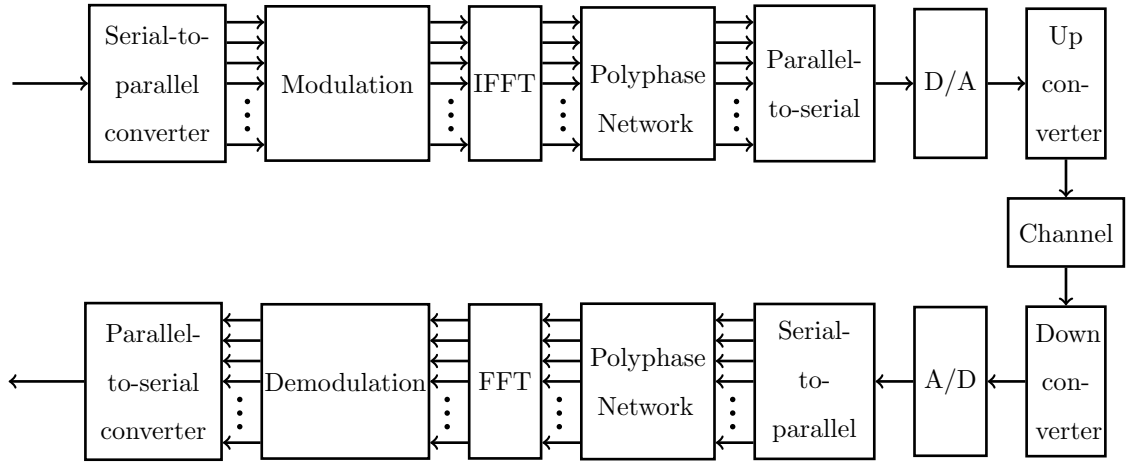


FIGURE 2.3: Block diagram of an FBMC system

The main idea of FBMC system is to transmit data symbol modulated using offset quadrature amplitude modulation (OQAM) instead of using the conventional QAM [36]. The continuous-time baseband transmit signal for FBMC system is given by

$$s(t) = \sum_{m=0}^{N-1} \sum_{n=-\infty}^{+\infty} x_{m,n} f_T(t - nT/2) e^{j\frac{2\pi}{T}mt} e^{j(\frac{\pi}{2}(m+n) - \pi mn)} \quad (2.2)$$

where $x_{m,n}$ is the transmit real-valued symbol. The main advantages of filter bank multi-carrier modulations are highlighted below.

- The fact of discarding the cyclic prefix or any guard interval in time domain for an FBMC modulated symbols contributes to increase the spectral efficiency [5].

- The signal on each subcarrier for FBMC modulated symbols is well confined within the subcarrier, i.e the signal power does not span over adjacent subcarriers. More specifically, filter bank multi-carrier modulations can overcome the spectral leakage problems of OFDM. Therefore, FBMC is highly appropriate for asynchronous multiple access and reduces inter-carrier interferences.
- The filtering capability of FBMC systems makes them very adequate for filling radio spectrum holes in cognitive radio networks [37].
- Thanks to its spectral confinements as shown in Figure 2.4, FBMC based systems can reduce guard band at the frequency boundaries which will lead to an increasing in the spectral efficiency.

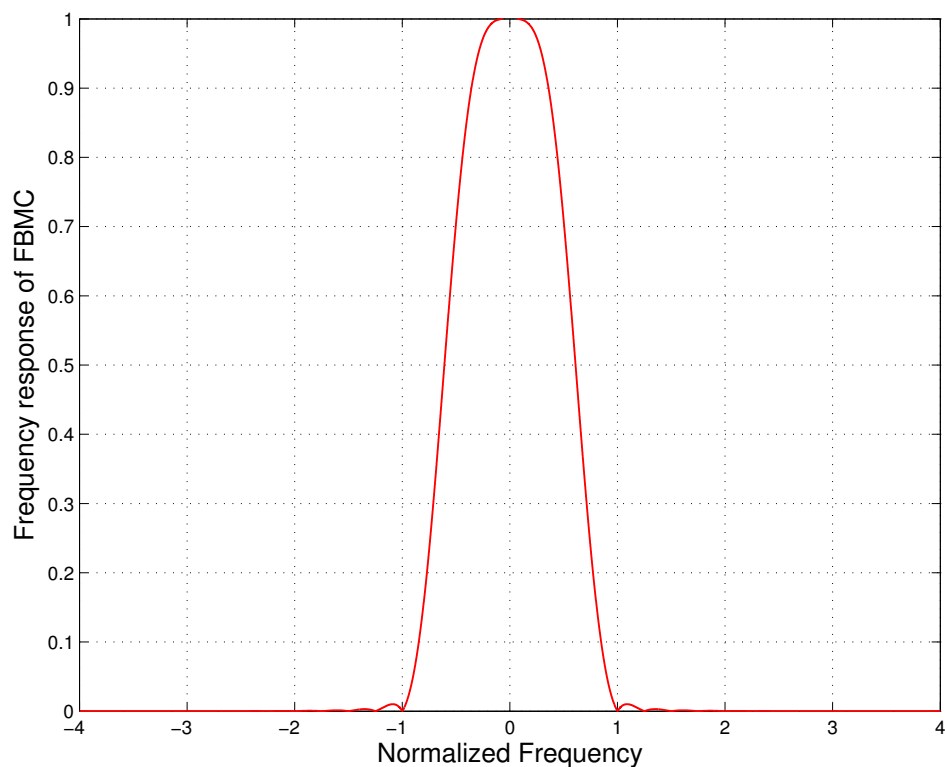


FIGURE 2.4: Frequency response of FBMC using PHYDYAS prototype filter

Asynchronous interference for multi-carrier CR networks

For more practical scenario of cognitive radio networks, it is more judicious to assume that the primary and the secondary system are not interacting with each other. Under such assumption, primary and secondary system will not be synchronized. The asynchronous transmission will result in inter-carrier interferences since the timing offset between both systems are different and is subject to change at any time.

The rigorous analysis of asynchronous interference model was done in [12, 13] where the authors provided analysis about the impact of inter-carrier interference on the performance of any asynchronous network in general. More specifically, by modeling the timing offset as a uniform random variable, Medjahdi et al. quantified the number of subcarriers affected by interference generated from a given subcarrier in [12]. Moreover, the authors in [12] demonstrated that up to 17 subcarriers are affected when OFDM is utilized and 3 subcarriers suffer from this interference in the case of FBMC implemented with PHYDYAS filter [17]. An insight on how interferences are spanned over adjacent subcarrier in asynchronous networks can be depicted in Figure 2.5 given below.

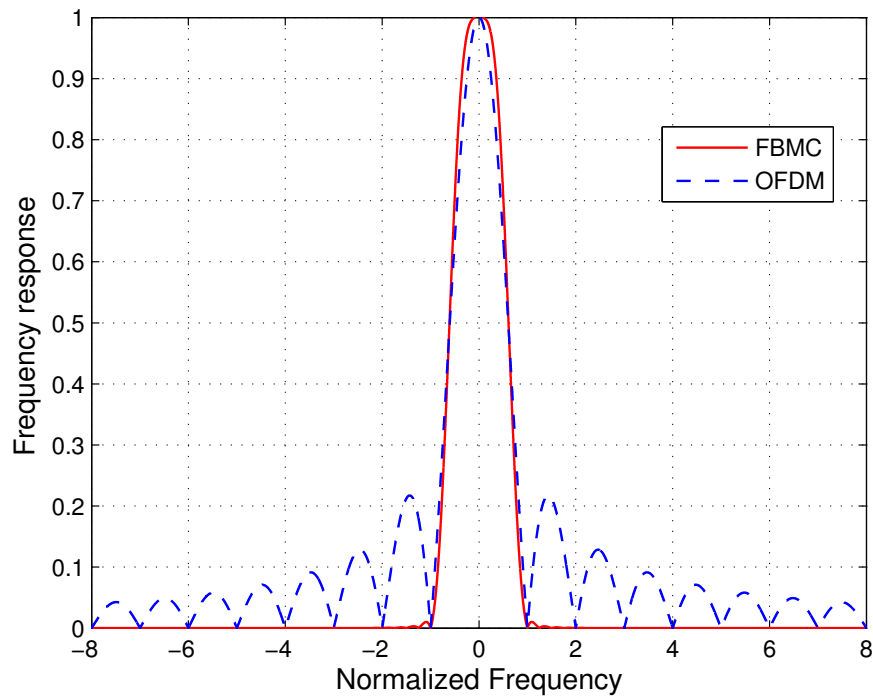


FIGURE 2.5: Frequency responses of both OFDM and FBMC with PHYDYAS prototype filter

Throughout this dissertation, to better capture the asynchronism between primary and secondary system, and also by assuming that the timing offset between both system is modeled as a uniform random variable, we invoke the interference weight vector derived in [12], which we summarize in Table 2.1. Unless otherwise indicated, the interference weight vector will be denoted $V = [V_0, \dots, V_S]$ where $S = 1$ in the case of FBMC and $S = 8$ in the case of OFDM.

The interference weight vector is denoted $V = [V_0, \dots, V_S]$ where $S = 1$ in the case of FBMC and $S = 8$ in the case of OFDM.

TABLE 2.1: Interference weights vector

Subcarrier	OFDM	FBMC
l-8	1.12×10^{-3}	0
l-7	1.84×10^{-3}	0
l-6	2.5×10^{-3}	0
l-5	3.59×10^{-3}	0
l-4	5.6×10^{-3}	0
l-3	9.95×10^{-3}	0
l-2	2.23×10^{-2}	0
l-1	8.94×10^{-2}	8.81×10^{-2}
l	7.05×10^{-1}	8.23×10^{-1}
l+1	8.94×10^{-2}	8.81×10^{-2}
l+2	2.23×10^{-2}	0
l+3	9.95×10^{-3}	0
l+4	5.6×10^{-3}	0
l+5	3.59×10^{-3}	0
l+6	2.5×10^{-3}	0
l+7	1.84×10^{-3}	0
l+8	1.12×10^{-3}	0

Resource allocation in multi-carrier networks

Generally speaking, proper resource management constitutes a basic yet fundamental task in designing a wireless communication network. In fact, judicious subcarrier and power assessments may be required in order to achieve higher system's performance. To improve the performance of the system, it is important to resort to resource management in order to mitigate the effect of multi-user interferences which is a main cause of performance degradation. In addition to that, resource management may provide an efficient utilization of some scarce resources such as radio spectrum and power. Moreover, judicious power assignment will directly lead to longer lifetime battery.

Resource management can be done using a centralized or decentralized perspective. Centralized resource allocation is a very effective since it can mitigate the effect of inter-cell interferences. However, a centralized implementation may require huge signaling exchange among the users. On the contrary, a distributed approach can achieve a trade of between signaling overhead and system performance. Discussions about centralized and decentralized approaches for interference channel can be found in [38–40] and references therein.

Consider a OFDM channel model with L independent subcarriers. Assume that there are \mathcal{K} transceiver pairs. Let $x_k^l \in \mathcal{C}$ where \mathcal{C} is the complex space, be the transmitted signal of the k th transmitter on the l th subcarrier. Denote P_k^l its corresponding power. Let $h_{k,j}^l \in \mathcal{C}$ denote the channel between the k th transmitter and the j th receiver on subcarrier l . Let $w_k^l \sim \mathcal{CN}(0, N_0)$ be the complex Gaussian noise with variance N_0 . Under these considerations, the signal $y_k^l \in \mathcal{C}$ that k th receiver measures on subcarrier l can be expressed as

$$y_k^l = h_{k,k}^l x_k^l + \sum_{j \neq k} h_{j,k}^l x_j^l + w_k^l \quad (2.3)$$

The corresponding signal to interference plus noise (SINR) ratio is given by

$$\text{SINR}_k^l = \frac{P_k^l |h_{k,k}^l|^2}{N_0 + \sum_{j \neq k} P_j^l |h_{j,k}^l|^2} \quad (2.4)$$

In the case of asynchronous FBMC/OFDM networks, (2.4) can be written as

$$\text{SINR}_k^l = \frac{P_k^l |h_{k,k}^l|^2}{N_0 + \sum_{j \neq k} P_j^l V_{|l-l'|} |h_{j,k}^{l'}|^2} \quad (2.5)$$

where V is given in Table 2.1.

And the downlink channel capacity is formulated as [41]

$$C_k^l = \log_2 (1 + \text{SINR}_k^l) \quad (2.6)$$

In general, a wireless communication system should guarantee users QoS as well as fairness through efficient resource allocation. Mathematically speaking, the

resource allocation problem can be formulated as the problem of optimizing a certain system level utility function subject to resource budget constraints.

First, define the utility function as [42]

$$\mathcal{U}_\beta(R_1, R_2, \dots, R_{\mathcal{K}}) = \begin{cases} \sum_{k=1}^{\mathcal{K}} \frac{\alpha_k R_k^{1-\beta}}{(1-\beta)}, \beta \geq 0, \beta \neq 1 \\ \sum_{k=1}^{\mathcal{K}} \alpha_k \ln R_k, \beta = 1 \end{cases}$$

where for user $k = 1, \dots, \mathcal{K}$, R_k denotes the transmission rate. In addition, the coefficient $\alpha_k \in [0, 1]$ with $\sum_{k=1}^{\mathcal{K}} \alpha_k = 1$, captures the user priority. The fairness parameter β enhances the trade off between user fairness and resource utilization. The system utility function corresponds to

1. The weighted sum rate, i.e. $\mathcal{U}_\beta(R_1, R_2, \dots, R_{\mathcal{K}}) = \sum_{k=1}^{\mathcal{K}} \alpha_k R_k$, if $\beta = 0$.
2. The weighted geometric mean rate, i.e. $\mathcal{U}_\beta(R_1, R_2, \dots, R_{\mathcal{K}}) = \sum_{k=1}^{\mathcal{K}} \alpha_k \ln R_k$ obtained by letting $\beta = 1$.
3. The weighted harmonic mean rate, i.e. $\mathcal{U}_\beta(R_1, R_2, \dots, R_{\mathcal{K}}) = \left(\sum_{k=1}^{\mathcal{K}} \alpha_k R_k^{-1} \right)^{-1}$, if $\beta = 2$.
4. The minimum rate, i.e. $\mathcal{U}_\beta(R_1, R_2, \dots, R_{\mathcal{K}}) = \min_{1 \leq k \leq \mathcal{K}} R_k$, obtained by setting $\beta = \infty$.

Next, we provide a non-exhaustive list of different types of allocation problems for multi-carrier-based wireless networks encountered in the literature. We sort the problems into two groups based on the knowledge of the channel state information (CSI).

Perfect knowledge of CSI

1. Utility maximization problem

The utility optimization problem consists of finding the optimal power allocation $\{P_k^*\}$ to maximize the utility function subject to total power budget

[43–46]. The problem can be written as

$$\begin{aligned}
& \underset{\{P_k^l\}_{k,l}}{\text{maximize}} \mathcal{U}_\beta(R_1, R_2, \dots, R_\mathcal{K}) \\
& \text{subject to } R_k = \sum_{l=1}^L \log_2(1 + \text{SINR}_k^l), \forall k \\
& \sum_{l=1}^L P_k^l \leq P_{\max}, \forall k \\
& P_k^l \geq 0, \forall k \forall l
\end{aligned} \tag{2.7}$$

where P_{\max} is the total power budget available at each transmitter. To find the optimal solution to problem 2.7, a centralized approach based on dual decomposition was proposed in [43, 47, 48]. Priced-based distributed optimal solution was addressed in [49]. In [50] the author present a distributed approach based on game theory. They provided a condition for global convergence of their proposed solution.

2. Minimize sum power problem

There exists a paradigm that is considering as the dual of the design of resource allocation algorithm. This resource allocation paradigm consists of guaranteeing the QoS to all the users while minimizing the total power consumption [51–54]. This formulation is very important in application such as voice communication. Define \tilde{R}_k the target rate for the k th user. The min-power problem known as margin adaptive optimization [51, 54] can be formulated as

$$\begin{aligned}
& \underset{\{P_k^l\}_{k,l}}{\text{minimize}} \sum_{k=1}^{\mathcal{K}} \sum_{l=1}^L P_k^l \\
& \text{subject to } \tilde{R}_k \leq \sum_{l=1}^L \log_2(1 + \text{SINR}_k^l), \forall k \\
& P_k^l \geq 0, \forall k \forall l
\end{aligned} \tag{2.8}$$

Iterative approach solving problem (2.8) was proposed in [55]. By reformulating the problem as geometric programming problem, optimal solution to problem (2.8) was provided in [56]. Optimal solution based on iterative

Water-filling algorithm for broadcast channel where decoding order was taking into consideration was given in [57].

3. Energy-efficiency problem

There exist several definitions for energy-efficiency function. The most commonly used is the ratio between the system total achievable sum rate to the system total power consumption. It is known as global energy-efficiency (GEE) [58]

$$\mathbf{GEE} = \frac{\sum_{k=1}^{\mathcal{K}} \sum_{l=1}^L \log_2 (1 + \text{SINR}_k^l)}{\sum_{k=1}^{\mathcal{K}} (P_{c,k} + \sum_{l=1}^L \xi P_k^l)} \quad (2.9)$$

The total power consumption at the denominator is characterized as the sum of two terms, accounting for the power dissipated in the circuit and the amplifier, respectively [59, 60]. More specifically, $P_{c,k}$ corresponds to the power dissipated in the circuit blocks whereas ξ , is the reciprocal of drain efficiency of the power amplifier. The energy-efficiency maximization problem is given by

$$\begin{aligned} & \underset{\{P_k^l\}_{k,l}}{\text{maximize}} \quad \frac{\sum_{k=1}^{\mathcal{K}} \sum_{l=1}^L \log_2 (1 + \text{SINR}_k^l)}{\sum_{k=1}^{\mathcal{K}} (P_{c,k} + \sum_{l=1}^L \xi P_k^l)} \\ & \text{subject to} \quad \sum_{l=1}^L P_k^l \leq P_{\max}, \forall k \\ & \quad \quad \quad P_k^l \geq 0, \forall k \forall l \end{aligned} \quad (2.10)$$

A centralized approach to find solution to problem (2.10) was provided in [61]. A price-based distributed approach to solve the single carrier counterpart of problem (2.10) was given in [62].

Statistical knowledge of CSI

Perfect CSI requires some overhead information. In fact, CSI can be acquired by uplink estimation in the time division duplex (TDD) setting where there is a reciprocity between the uplink and downlink channels. In the frequency division duplex (FDD) mode, the receiver needs to estimate the channel and feeds this information back to the transmitter. This may result into huge overhead communication. In contrast to the CSI, channel distribution information (CDI) may

remain unchanged over a relatively long period of time and thus considerably reducing the amount of feedback information. With CDI at the transmitter, the system may experience outage. A user is in outage when the transmitted rate is greater than the achievable channel rate. Now, we extend the aforementioned problems to their statistical CSI counterpart.

1. Utility maximization problem

Given an outage requirement $\epsilon_k \in (0, 1), \forall k$ for all users, the outage constrained maximization problem can be formulated as

$$\begin{aligned}
 & \underset{R_k, \forall k, \{P_k^l\}_{k,l}}{\text{maximize}} \quad \mathcal{U}_\beta(R_1, R_2, \dots, R_\mathcal{K}) \\
 & \text{subject to} \quad \Pr \left\{ R_k > \sum_{l=1}^L \log_2 (1 + \text{SINR}_k^l) \right\} \leq \epsilon_k, \forall k \\
 & \quad \sum_{l=1}^L P_k^l \leq P_{\max}, \forall k \\
 & \quad R_k \geq 0, \forall k \\
 & \quad P_k^l \geq 0, \forall k, \forall l
 \end{aligned} \tag{2.11}$$

Due to the non-existence mathematical closed-form of the outage probability, problem (2.11) is still a challenging problem. Efficient approaches destined to find the optimal power allocation to problem (2.11) are yet to be found. The single carrier multiple-input single output (MISO) case was investigated in [63].

2. Minimize sum power problem

Given $\tilde{R}_k > 0, \forall k$ the rate requirement for the k th user, the rate-outage constrained problem can be formulated as

$$\begin{aligned}
 & \underset{\{P_k^l\}_{k,l}}{\text{minimize}} \quad \sum_{k=1}^{\mathcal{K}} \sum_{l=1}^L P_k^l \\
 & \text{subject to} \quad \Pr \left\{ \tilde{R}_k > \sum_{l=1}^L \log_2 (1 + \text{SINR}_k^l) \right\} \leq \epsilon_k, \forall k \\
 & \quad P_k^l \geq 0, \forall k \forall l
 \end{aligned} \tag{2.12}$$

Similarly to problem (2.11), the optimization problem (2.12) is very challenging and approaches permitting to compute the optimal solution are so far unknown. The single carrier MISO counterpart was investigated in [64].

Configuration of cognitive radio networks

In this manuscript, we consider an underlay cognitive radio network that is deployed in a network-centric point of view serving both primary and secondary users. The considered cognitive radio network inherits basic structure of current cellular network, i.e., it consists of base stations (BSs), mobile terminals (MTs) and a backbone network as depicted in Figure 2.6. In this network, mobile terminal can access a base station using one-hop strategy. In addition to that, mobile terminals located under the transmission range of the same base station, i.e within the same cell, should communicate via the BS. Within a particular cell, communication is done in a way such that there is no intra-cell interference. The base stations in the network can execute one or multiple communication protocols based on the demands received from the serving mobile terminals. Communications between different cells either within the primary or the secondary system are routed through the backbone network.

Recall that cognitive radio grants permission to secondary users to access private radio spectrum owned by the primary users. Therefore, the architecture of a cognitive radio network should have two main parts: a secondary system network and primary system network that are using a common radio spectrum band. In this dissertation, we assume in general that the primary system network consists of several primary cells having each one primary base station serving one primary mobile terminal. Furthermore, we assume that within the primary system there is no inter-cell interferences. In other word, the received interference measured at primary users comes from the activities of the secondary users.

The secondary system network refers to a network composed of several secondary cells. Each secondary cell consists of one secondary base station that serves several secondary mobile terminals. Secondary base stations are not only creating

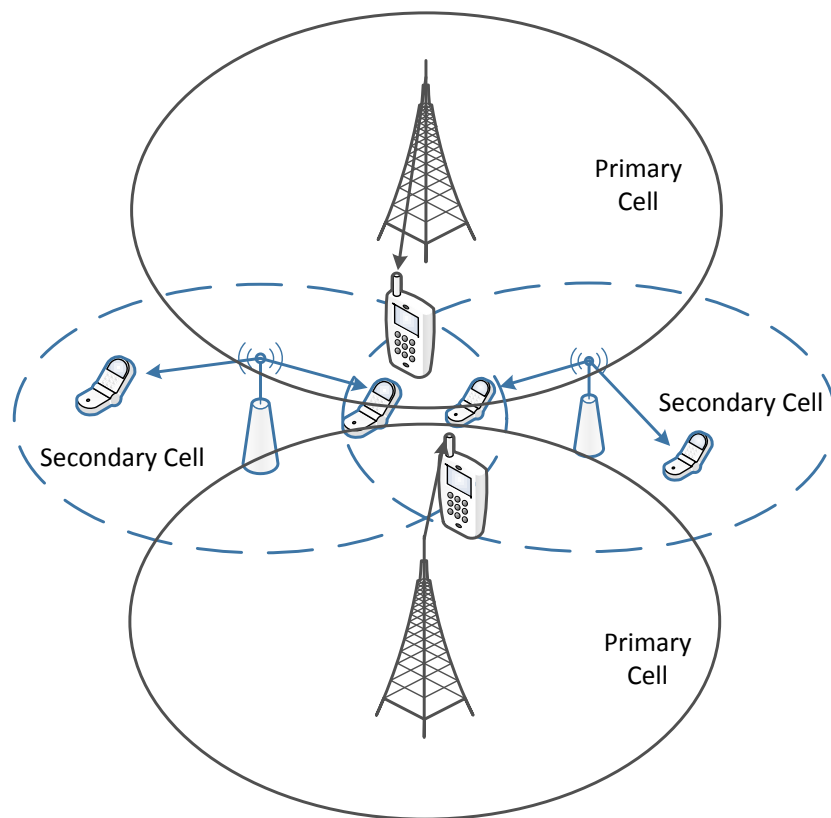


FIGURE 2.6: A cognitive radio network

interferences to the primary users, they also generate interferences to each other. It is therefore more judicious to assume the existence of central network entity responsible of coordinating the spectrum usage. The central entity is named spectrum broker [65, 66]. It can play the role of band manager. Its responsibility consists of gathering operation information from each secondary base station (for each cell) and sometimes assigns the radio spectrum band to achieve efficient and fair spectrum sharing among the secondary users.

Review of convex optimization theory

In this dissertation, we study the problem of resource allocation for cognitive radio networks. In general, resource allocation problem can be formulated as an optimization problem with an objective function and several constraints. In subsequent sections, we introduce some important concepts used to characterize an optimization problem. Throughout this dissertation, we thrive to formulate the resource allocation problem as a standard convex optimization problem ¹. In fact, the main advantage of standard convex optimization problem is that any local optimum is also global.

During the last three decades, optimization theory has been a very well-investigated topic area in both practical and theoretical aspects. In this section, we provide a summary of some basic concepts mostly taken from [67, 68]. In subsequent subsections, we may use for simplicity \mathbf{x} to denote a vector in \mathbb{R}^n with components $\mathbf{x} = (x_1, \dots, x_n)^\top$ without explicitly mentioning that $\mathbf{x} \in \mathbb{R}^n$.

Convex sets

A set \mathcal{C} is said to be a convex set if for any two points $\mathbf{x}_1, \mathbf{x}_2 \in \mathcal{C}$, their convex combination lies in \mathcal{C} . This means, for any $\theta_1, \theta_2 \in \mathbb{R}_+$ such that $\theta_1 + \theta_2 = 1$, we have

$$\theta_1 \mathbf{x}_1 + \theta_2 \mathbf{x}_2 \in \mathcal{C}$$

Simply speaking, a set is a convex set if every point in the set can be seen by every other point in the set, along an unobstructed straight line between them. Figure 2.7 illustrates a simple convex set whereas Figure 2.8 depicts a non-convex set.

¹The term ‘‘standard convex optimization’’ will be rigorously defined later in this chapter

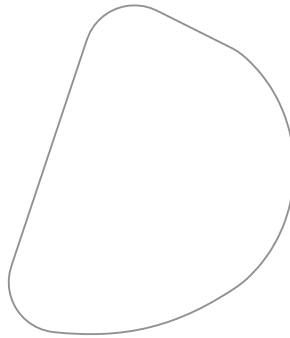


FIGURE 2.7: Convex set

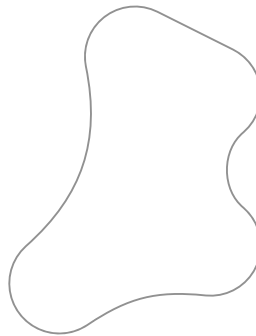


FIGURE 2.8: A non-convex set

The following examples are important examples of convex set that will be encountered throughout this dissertation.

- Any line is affine hence is a convex set.
- Any subspace is affine and therefore is a convex set.
- A hyperplane defined as the set of points with a constant inner product to a given vector is an affine set, i.e.,

$$\{\mathbf{x} \mid a^\top \mathbf{x} = b\}$$

with $\mathbf{x} \in \mathbb{R}^n$, $a \in \mathbb{R}^n$, $a \neq 0$ and $b \in \mathbb{R}$.

- A halfspace defined as

$$\{\mathbf{x} \mid a^\top \mathbf{x} \leq b\}$$

is a convex set.

- A polyhedron defined as the solution set of a finite number of linear equalities and inequalities

$$\mathcal{P} \triangleq \{\mathbf{x} \mid a_j^\top \mathbf{x} \leq b_j, j = 1, \dots, m, c_j^\top \mathbf{x} = d_j, j = 1, \dots, p\}$$

Since a polyhedron is the intersection of a finite number of hyperplanes and halfspaces, it is hence a convex set.

Convex function

A function $f : \mathbb{R}^n \rightarrow \mathbb{R}$ is said to be a convex function if it meets the following conditions:

- The domain of f , $\mathbf{dom} f$, is a convex set.
- For all $\mathbf{x}_1, \mathbf{x}_2 \in \mathbf{dom} f$, for all θ with $0 \leq \theta \leq 1$, we have as illustrated in Figure 2.9

$$f(\theta \mathbf{x}_1 + (1 - \theta)\mathbf{x}_2) \leq \theta f(\mathbf{x}_1) + (1 - \theta)f(\mathbf{x}_2)$$

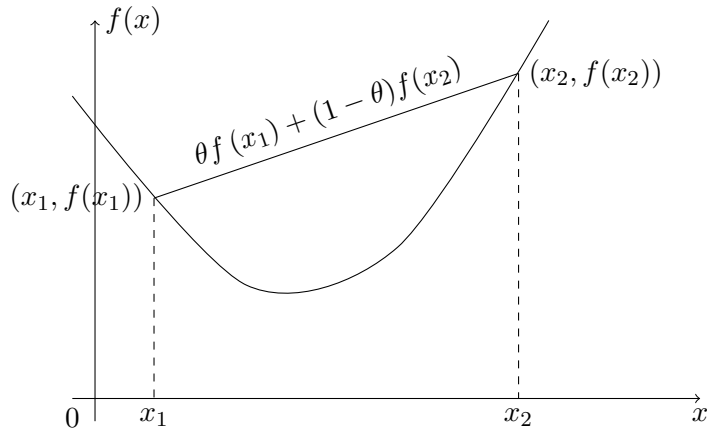


FIGURE 2.9: Convex function

Remark 2.1. A function f is said to be a concave function if $-f$ is a convex function. More concretely, f is a concave function if

- $\mathbf{dom} f$ is a convex set.

- For all $\mathbf{x}_1, \mathbf{x}_2 \in \mathbf{dom} f$, for all θ with $0 \leq \theta \leq 1$

$$f(\theta\mathbf{x}_1 + (1 - \theta)\mathbf{x}_2) \geq \theta f(\mathbf{x}_1) + (1 - \theta)f(\mathbf{x}_2)$$

In order to verify the convexity of a function f , we may resort to the aforementioned definition. Besides, we may also use the following two properties to verify whether a function f is convex or not.

Property 1. First-order condition

Assume that the gradient of f , ∇f , does exist at every point of $\mathbf{dom} f$. We say that the function f is convex if and only if $\mathbf{dom} f$ is a convex set and

$$f(\mathbf{y}) \geq f(\mathbf{x}) + \nabla f(\mathbf{x})^\top (\mathbf{y} - \mathbf{x}), \quad \forall \mathbf{y}, \mathbf{x} \in \mathbf{dom} f \quad (2.13)$$

Property 2. Second-order condition

Suppose that a function f is twice differentiable, i.e., the *Hessian* of f exists at every point of $\mathbf{dom} f$. Then, f is a convex function if and only if $\mathbf{dom} f$ is a convex set and its Hessian is positive semidefinite, that is

$$\nabla^2 f(\mathbf{x}) \succeq 0, \quad \forall \mathbf{x} \in \mathbf{dom} f \quad (2.14)$$

Remark 2.2. *Throughout this dissertation, we use some operations that preserve either convexity or concavity of functions. The two mostly used operations are*

1. Nonnegative weighted sum

Let f_1, \dots, f_m be m convex functions and w_1, \dots, w_m be m nonnegative weights then the combination of the convex functions with the weights, i.e., $\sum_{i=1}^m w_i f_i$, is a convex function.

2. Composition with affine mapping

Assume $f: \mathbb{R}^n \rightarrow \mathbb{R}$ is a convex (concave) function, then for any $A \in \mathbb{R}^{n \times m}$ and any $b \in \mathbb{R}^n$, the function $g: \mathbb{R}^m \rightarrow \mathbb{R}$ defined as $g(\mathbf{x}) = f(A\mathbf{x} + b)$ with $\mathbf{dom} g = \{\mathbf{x} \mid A\mathbf{x} + b \in \mathbf{dom} f\}$ is also a convex (concave) function.

Next, we define quasiconvex function.

Definition 2.2 (Quasiconvex function). *A function $f : \mathbb{R}^n \rightarrow \mathbb{R}$ is said to be a quasiconvex function if its sublevel set which is defined as*

$$S_\alpha = \{\mathbf{x} \in \mathbf{dom} f \mid f(\mathbf{x}) \leq \alpha\}$$

is a convex set for all $\alpha \in \mathbb{R}$. On the other hand, f is a quasiconcave function if $-f$ is quasiconvex. More concretely, f is a quasiconcave function if its superlevel defined as

$$S_\alpha = \{\mathbf{x} \in \mathbf{dom} f \mid f(\mathbf{x}) \geq \alpha\}$$

is convex for every α .

Convex problem

In general, an optimization problem can be structured as follows

$$\begin{aligned} \min f_0(\mathbf{x}) \\ \text{s.t. } f_i(\mathbf{x}) \leq 0, \quad i = 1, \dots, m \\ h_i(\mathbf{x}) \leq 0, \quad i = 1, \dots, p \end{aligned} \tag{2.15}$$

where “min” stands for “minimize” whereas “s.t” denotes “subject to”. The function $f_0 : \mathbb{R}^n \rightarrow \mathbb{R}$ is the objective function. The functions $f_i : \mathbb{R}^n \rightarrow \mathbb{R}$, $i = 1, \dots, m$ are inequality constraint functions while $h_i : \mathbb{R}^n \rightarrow \mathbb{R}$, $i = 1, \dots, p$ are equality constraint functions

The domain of the optimization problem (2.15) is defined as

$$\mathcal{D} = \left\{ \bigcap_{i=0}^m \mathbf{dom} f_i \right\} \cap \left\{ \bigcap_{i=1}^p \mathbf{dom} h_i \right\} \tag{2.16}$$

and its feasible or constraint set is defined as

$$\mathcal{C} = \{\mathbf{x} \mid f_i(\mathbf{x}) \leq 0, \quad i = 1, \dots, m, \quad h_i(\mathbf{x}) \leq 0, \quad i = 1, \dots, p\} \tag{2.17}$$

The optimal value f^* of the optimization problem (2.15) is defined as

$$f^* = \inf_{\mathbf{x} \in \mathcal{C}} f_0(\mathbf{x}) \quad (2.18)$$

where ‘‘inf’’ refers to infimum. A point \mathbf{x}^* is optimal if $\mathbf{x}^* \in \mathcal{C}$ and $f_0(\mathbf{x}^*) = f^*$. If the objective function of an optimization problem is zero, its optimal value is either zero or infinity. This is usually referred as feasibility problem and is written as

$$\begin{aligned} \text{find } \mathbf{x} \\ \text{s.t. } \mathbf{x} \in \mathcal{C} \end{aligned} \quad (2.19)$$

Definition 2.3 (Convex optimization problem). *The optimization problem (2.15) is a standard convex optimization problem if the functions f_1, \dots, f_m are convex functions and h_1, \dots, h_p are affine functions.*

We state two important facts about convex problem²

Fact 2.1. *For a convex problem, any locally optimal solution is globally optimal.*

Fact 2.2. *Suppose that the objective function f_0 is a differentiable function and that the associated optimization problem is convex. Therefore a point $\mathbf{x} \in \mathcal{C}$ is optimal if and only if*

$$\nabla f(\mathbf{x})^\top (\mathbf{y} - \mathbf{x}) \geq 0, \quad \forall \mathbf{y} \in \mathcal{C} \quad (2.20)$$

Duality

The Lagrangian $\mathcal{L} : \mathbb{R}^n \times \mathbb{R}^m \times \mathbb{R}^p \rightarrow \mathbb{R}$ associated with problem (2.15) is formulated as

$$\mathcal{L}(\mathbf{x}, \boldsymbol{\lambda}, \boldsymbol{\nu}) = f_0(\mathbf{x}) + \sum_{i=1}^m \lambda_i f_i(\mathbf{x}) + \sum_{i=1}^p \nu_i h_i(\mathbf{x}) \quad (2.21)$$

where $\boldsymbol{\lambda} = (\lambda_1, \dots, \lambda_m)^\top$ and $\boldsymbol{\nu} = (\nu_1, \dots, \nu_p)^\top$ are called the dual variables or Lagrange multipliers, associated with the m inequality constraints and p equality constraints of problem (2.15), respectively.

² Throughout the rest of this dissertation, the terms convex problem and standard convex optimization problem are used interchangeably.

The associated dual function is defined as

$$g(\boldsymbol{\lambda}, \boldsymbol{\nu}) = \inf_{\mathbf{x} \in \mathcal{D}} \mathcal{L}(\mathbf{x}, \boldsymbol{\lambda}, \boldsymbol{\nu}) \quad (2.22)$$

with

$$\mathbf{dom} \, g = \{(\boldsymbol{\lambda}, \boldsymbol{\nu}) \mid g(\boldsymbol{\lambda}, \boldsymbol{\nu}) > -\infty\}$$

The dual problem of the primal problem (2.15) is formulated as

$$\begin{aligned} \max_{(\boldsymbol{\lambda}, \boldsymbol{\nu}) \in \mathbf{dom} \, g} \quad & g(\boldsymbol{\lambda}, \boldsymbol{\nu}) \\ \text{s.t.} \quad & \boldsymbol{\lambda} \succeq 0 \end{aligned} \quad (2.23)$$

Let d^* defined as

$$d^* = \sup\{g(\boldsymbol{\lambda}, \boldsymbol{\nu}) \mid \boldsymbol{\lambda} \succeq 0, \boldsymbol{\nu} \in \mathbb{R}^p\}$$

be the optimal value of the dual problem (2.23). Therefore, the result $d^* \leq f^*$ and $d^* = f^*$ is known as weak duality and strong duality, respectively. Strong duality usually holds for convex problem.

Karush-Kuhn-Tucker (KKT) optimality conditions

We assume that the functions $f_i, i = 1, \dots, m$ and $h_i, i = 1, \dots, p$ are differentiable at each point on their respective domain. Moreover, suppose that the primal problem (2.15) is convex. The KKT conditions listed below are sufficient for the primal optimal points \mathbf{x}^* and dual optimal $(\boldsymbol{\lambda}^*, \boldsymbol{\nu}^*)$.

$$\begin{aligned} \nabla f_0(\mathbf{x}^*) + \sum_{i=1}^m \lambda_i^* \nabla f_i(\mathbf{x}^*) + \sum_{i=1}^p \nu_i^* \nabla h_i(\mathbf{x}^*) &= 0 \\ f_i(\mathbf{x}^*) &\leq 0, \quad i = 1, \dots, m \\ h_i(\mathbf{x}^*) &= 0, \quad i = 1, \dots, p \\ \lambda_i^* &\geq 0, \quad i = 1, \dots, m \\ \lambda_i^* \nabla f_i(\mathbf{x}^*) &= 0, \quad i = 1, \dots, m \end{aligned} \quad (2.24)$$

To summarize, for a convex function with differentiable objective and constraint functions, any points that satisfy the KKT conditions are primal and dual optimal

and moreover it holds true that $d^* = f^*$. If in addition to that, the constraint functions satisfy the Slater's condition [67], then the KKT conditions are necessary and sufficient conditions for optimality.

Dual decomposition Method

For resource allocation, it may be very profitable to resort to distributed implementation especially for large scale networks where centralized implementation may be very difficult to achieve. The decomposition theory can be very helpful in the sense that it leads to a semi-distributed solution. The philosophy behind the decomposition method is the decompose a large scale problem into distributively solvable small scale subproblems. The subproblems are then coordinated by a higher level master problem [68, 69] as indicated in Figure 2.10.

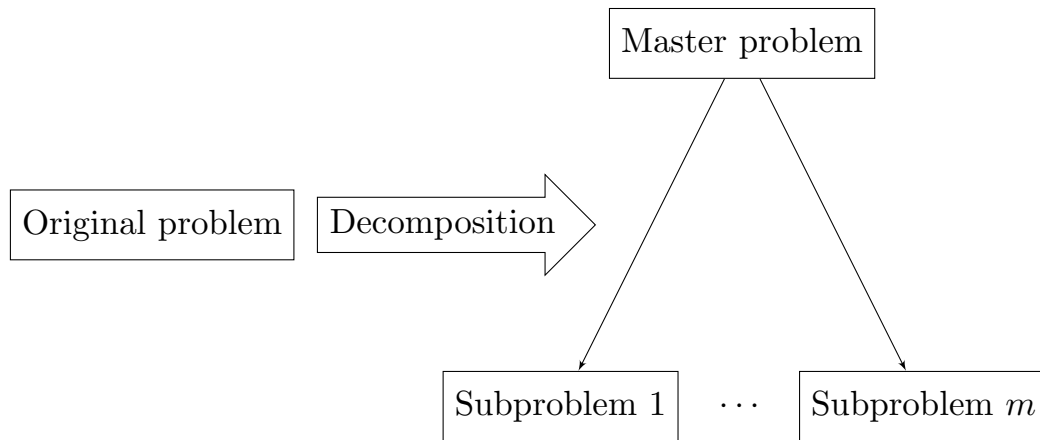


FIGURE 2.10: Decomposition of a problem into several subproblems

In this section, we give a brief summary of the decomposition technique based on dual decomposition method [70, 71].

Consider the following convex optimization problem

$$\begin{aligned}
 \min_{\mathbf{x}_1, \dots, \mathbf{x}_m} \quad & \sum_{i=1}^m f_i(\mathbf{x}_i) \\
 \text{s.t.} \quad & \sum_{i=1}^m h_i(\mathbf{x}_i) \leq c
 \end{aligned} \tag{2.25}$$

The constraint of the optimization problem (2.25) is a coupled constraint. Clearly, in the absence of the constraint $\sum_{i=1}^m h_i(\mathbf{x}_i) \leq c$ then problem (2.25) would be decoupled. The Lagrangian associated to problem (2.25) is written as

$$\mathcal{L}(\mathbf{x}, \lambda) = \sum_{i=1}^m f_i(\mathbf{x}_i) + \lambda \left(\sum_{i=1}^m h_i(\mathbf{x}_i) - c \right) \quad (2.26)$$

where λ is the dual variable associated to the inequality constraint. For a given λ , the dual decomposition results of solving at the lower level for each i the following subproblem.

$$\mathbf{x}_i^* = \arg \min f_i(\mathbf{x}_i) + \lambda h_i(\mathbf{x}_i), \quad i = 1, \dots, m \quad (2.27)$$

Let $g_i(\lambda, \mathbf{x}_i^*) \triangleq f_i(\mathbf{x}_i^*) + \lambda h_i(\mathbf{x}_i^*)$. At the higher level, the master dual problem is given

$$\begin{aligned} \max_{\lambda} g(\lambda) &= \sum_{i=1}^m g_i(\lambda, \mathbf{x}_i^*) - \lambda c \\ \text{s.t. } \lambda &\geq 0 \end{aligned} \quad (2.28)$$

Since the solution for problem (2.27) is unique, it can be inferred that $g(\lambda)$ is a differentiable function and therefore can be solved using subgradient method [70, 71]. The subgradient approach to solve problem (2.28) is given by

$$\lambda^{(t)} = \left(\lambda^{(t-1)} + \alpha \left(\sum_{i=1}^m h_i(\mathbf{x}_i) - c \right) \right)^+ \quad (2.29)$$

where $(x)^+ \triangleq \max(0, x)$, $\alpha > 0$ is a relatively small step-size while t corresponds to the iteration index. The dual variable $\lambda^{(t)}$ is guaranteed to converge to the dual optimal λ [70, 71], i.e.,

$$\lambda^* = \lim_{t \rightarrow \infty} \lambda^{(t)} \quad (2.30)$$

Moreover, since the duality gap for problem (2.25) is zero and the solution for problem (2.27) is unique, it can infer that the primal variable $\mathbf{x}_i^*(\lambda^{(t)})$ will converge to the primal optimal variables \mathbf{x}_i^* .

Methods for non-convex problems

In Chapter 4 and Chapter 5, we will see that sometimes the formulated resource allocation problem is not a convex problem. Therefore, the search for polynomial time solvable algorithms to efficiently find solutions to such problems is of great importance. The successive convex approximation (SCA) and alternating optimization approaches are powerful optimization tools capable of obtaining stationary points of a non-convex optimization problem. We provide a brief description of such approaches below.

Successive convex approximation (SCA)

Consider the following non-convex optimization problem

$$\begin{aligned} \min_{\mathbf{x}} \quad & f_0(\mathbf{x}) \\ \text{s.t.} \quad & f_i(\mathbf{x}) \geq 0, \quad i = 1, \dots, m \end{aligned} \tag{2.31}$$

One possible approach to efficiently solve problem (2.31) is to resort to the successive convex approximation method. This method was greatly investigated in the literature [72–75]. The philosophy behind the SCA approach is to solve a sequence of locally tight convex approximation problems of the original problem (2.31). The approximate problems should however satisfy some conditions to ensure that the solution at convergence meets the KKT conditions for the optimization problem (2.31). The graphical explanation of the SCA method is given in Figure 2.11.

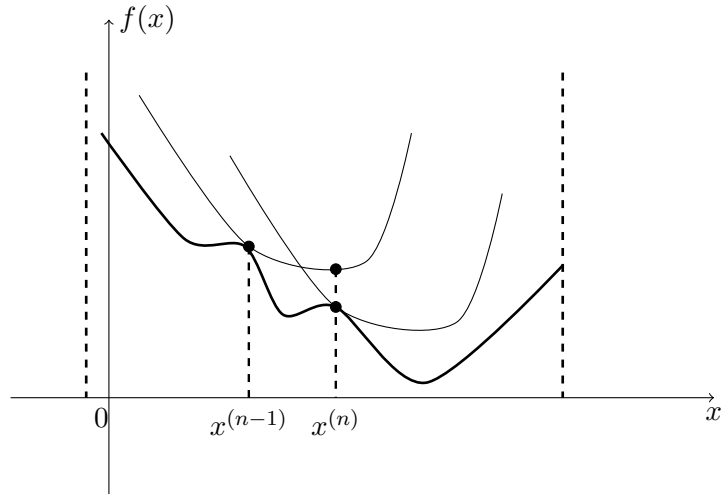


FIGURE 2.11: Geometric representation of SCA

More importantly, at each iteration n , the following convex problem is solved.

$$\begin{aligned} \hat{\mathbf{x}} &= \arg \min_{\mathbf{x}} \bar{f}_0(\mathbf{x}, \bar{\mathbf{x}}^{(n-1)}) \\ &\text{s.t. } \bar{f}_i(\mathbf{x}) \geq 0, \quad i = 1, \dots, m \end{aligned} \quad (2.32)$$

The optimal solution $\hat{\mathbf{x}}$ for problem (2.32) can be found by invoking the KKT conditions (2.24). The SCA Algorithm to efficiently solve problem is summarize as

Algorithm 1 Successive convex approximation method for solving problem (2.31)

1. Find a feasible $\bar{\mathbf{x}}^{(0)}$ to (2.31), and let $n = 0$;
 2. Repeat
 - (a) Set $n \leftarrow n + 1$;
 - (b) Find $\hat{\mathbf{x}}^{(n)}$ solving problem (2.32) ;
 - (c) Set $\bar{\mathbf{x}}^{(n)} \leftarrow \hat{\mathbf{x}}$;
 3. Stop when convergence criterion is reached.
-

The sequence $\{\hat{\mathbf{x}}^{(n)}\}_{n=1}^{\infty}$ generated by the SCA Algorithm is guaranteed to converge to a stationary point of problem (2.31) as long as the following conditions are met [73, Proposition 2, Theorem 2(b)]

1. Problem (2.32) has a unique solution.
2. $f_i(\mathbf{x})$ is a differentiable function of \mathbf{x} .
3. $\bar{f}_i(\mathbf{x}, \mathbf{y})$ is a continuous in (\mathbf{x}, \mathbf{y})
4. Function value consistency : $\bar{f}_i(\mathbf{x}, \mathbf{x}) = f_i(\mathbf{x}), \forall \mathbf{x}$.
5. Gradient consistency: $\nabla \bar{f}_i(\cdot, \mathbf{x})|_{\mathbf{x}=\mathbf{y}} = \nabla f_i(\mathbf{x})|_{\mathbf{x}=\mathbf{y}}, \forall \mathbf{x}$.
6. Upper-bound: $\bar{f}_i(\mathbf{x}, \mathbf{y}) \geq f_i(\mathbf{x}), \forall \mathbf{x} \forall \mathbf{y}$.

Alternating optimization method

In this subsection, we introduce the concept of alternating optimization approach [68] that allows to distributively solve a given optimization problem. To better explain the idea of alternating optimization, let consider the following optimization problem

$$\begin{aligned} \min_{\mathbf{x}_1, \dots, \mathbf{x}_m} f(\mathbf{x}_1, \mathbf{x}_2, \dots, \mathbf{x}_m) \\ \text{s.t. } h_i(\mathbf{x}_i) \leq c_i, i = 1, \dots, m \end{aligned} \quad (2.33)$$

For a fixed value of $(\bar{\mathbf{x}}_1, \dots, \bar{\mathbf{x}}_{i-1}, \bar{\mathbf{x}}_{i+1}, \dots, \bar{\mathbf{x}}_m)$, consider the problem

$$\begin{aligned} \hat{\mathbf{x}}_i = \arg \min_{\mathbf{x}_i} f(\bar{\mathbf{x}}_1, \dots, \bar{\mathbf{x}}_{i-1}, \mathbf{x}_i, \bar{\mathbf{x}}_{i+1}, \dots, \bar{\mathbf{x}}_m) \\ \text{s.t. } h_i(\mathbf{x}_i) \leq c_i \end{aligned} \quad (2.34)$$

If the solution of the optimization problem (2.34) is unique, the alternating optimization approach summarized in Algorithm 2 may be therefore invoked to solve problem (2.33).

Algorithm 2 Alternating optimization method for solving problem (2.33)

1. Find a feasible $\bar{\mathbf{x}}_i^{(0)}$, $i = 1, \dots, m$ to problem (2.31), and let $n = 0$;
 2. Repeat
 - (a) Set $n \leftarrow n + 1$;
 - (b) For $i = 1, \dots, m$, do
 - Find $\hat{\mathbf{x}}_i^{(n)}$ by solving

$$\begin{aligned} \min_{\mathbf{x}_i} \quad & f(\bar{\mathbf{x}}_1^n, \dots, \bar{\mathbf{x}}_{i-1}^{(n)}, \mathbf{x}_i, \bar{\mathbf{x}}_{i+1}^{(n-1)}, \dots, \bar{\mathbf{x}}_m^{(n-1)}) \\ \text{s.t.} \quad & h_i(\mathbf{x}_i) \leq c_i \end{aligned}$$
 - Set $\bar{\mathbf{x}}_i^{(n)} \leftarrow \hat{\mathbf{x}}_i^{(n)}$;
 3. Stop when convergence criterion is reached.
-

The convergence of Algorithm 2 is established through the following theorem.

Theorem 2.1. [68, Proposition 2.7.1] *The sequence $\{\hat{\mathbf{x}}_1^{(n)}, \dots, \hat{\mathbf{x}}_m^{(n)}\}_{n=1}^{\infty}$ generated by Algorithm 2 converges to a stationary point of problem (2.33) if the following two criteria are met:*

- (i) *The function $f(\mathbf{x}_1, \mathbf{x}_2, \dots, \mathbf{x}_m)$ is continuously differentiable in $(\mathbf{x}_1, \mathbf{x}_2, \dots, \mathbf{x}_m)$.*
- (ii) *The solution of problem (2.34) is unique.*

Fractional optimization

In this section, we present a review of fractional programming. Consider the following optimization problem

$$\begin{aligned} \max_{\mathbf{x}} \quad & \frac{f(\mathbf{x})}{g(\mathbf{x})} \\ \text{s.t.} \quad & \mathbf{x} \in \mathcal{C} \end{aligned} \tag{2.35}$$

where \mathcal{C} is a convex set, $f(\mathbf{x})$ and $g(\mathbf{x})$ are respectively concave and convex function of \mathbf{x} . Let π^* denote the maximum of the objective function. In other words,

$$\pi^* \triangleq \frac{f(\mathbf{x}^*)}{g(\mathbf{x}^*)} = \max_{\mathbf{x} \in \mathcal{C}} \frac{f(\mathbf{x})}{g(\mathbf{x})} \quad (2.36)$$

The following lemma provides sufficient and necessary optimality conditions.

Lemma 2.1. *The optimal solution \mathbf{x}^* for problem (2.35) is achieved if and only if*

$$\max_{\mathbf{x} \in \mathcal{C}} (f(\mathbf{x}) - \pi^*g(\mathbf{x})) = 0 \quad (2.37)$$

Proof: We begin the proof by demonstrating the sufficient condition. Suppose $\widehat{\mathbf{x}}^*$ be the optimal solution for problem (2.37). Then for any $\mathbf{x} \in \mathcal{C}$, we have

$$f(\mathbf{x}) - \pi^*g(\mathbf{x}) \leq f(\widehat{\mathbf{x}}^*) - \pi^*g(\widehat{\mathbf{x}}^*) = 0$$

from this equation, we have

$$\begin{aligned} f(\mathbf{x}) - \pi^*g(\mathbf{x}) \leq 0 &\rightarrow \frac{f(\mathbf{x})}{g(\mathbf{x})} \leq \pi^* \\ f(\widehat{\mathbf{x}}^*) - \pi^*g(\widehat{\mathbf{x}}^*) = 0 &\rightarrow \pi^* = \frac{f(\widehat{\mathbf{x}}^*)}{g(\widehat{\mathbf{x}}^*)} \end{aligned} \quad (2.38)$$

which leads to

$$\frac{f(\mathbf{x})}{g(\mathbf{x})} \leq \frac{f(\widehat{\mathbf{x}}^*)}{g(\widehat{\mathbf{x}}^*)}$$

so $\widehat{\mathbf{x}}^*$ is optimal for problem (2.37). Now, suppose that \mathbf{x}^* is the optimal solution for problem (2.37). Then, for any $\mathbf{x} \in \mathcal{C}$, we have

$$\frac{f(\mathbf{x})}{g(\mathbf{x})} \leq \frac{f(\mathbf{x}^*)}{g(\mathbf{x}^*)} = \pi^*$$

which leads to

$$\begin{aligned} f(\mathbf{x}) - \pi^*g(\mathbf{x}) &\leq 0 \\ f(\mathbf{x}^*) - \pi^*g(\mathbf{x}^*) &= 0 \end{aligned} \quad (2.39)$$

Hence, from (2.39), it can be said that the maximum value of (2.37) is 0 and therefore can be achieved by \mathbf{x}^* . ■

From Lemma 2.1, it can be inferred that if π^* is known beforehand, then we can tackle the optimization problem (2.35) by solving problem (2.37).

Lemma 2.2. [76] *Assuming that $f(\mathbf{x})$, $g(\mathbf{x})$ are continuous functions of \mathbf{x} and \mathcal{C} is a nonempty compact set, the function $F(\pi)$ defined in (2.40) is a strictly decreasing function of π .*

$$F(\pi) \triangleq \max_{\mathbf{x} \in \mathcal{C}} (f(\mathbf{x}) - \pi g(\mathbf{x})) \quad (2.40)$$

Proof: Consider $\hat{\pi}$, $\tilde{\pi}$ such that $\hat{\pi} > \tilde{\pi}$ and the corresponding $\hat{\mathbf{x}}$, $\tilde{\mathbf{x}}$ such that

$$\hat{\mathbf{x}} = \arg \max_{\mathbf{x} \in \mathcal{C}} (f(\mathbf{x}) - \hat{\pi}g(\mathbf{x}))$$

$$\tilde{\mathbf{x}} = \arg \max_{\mathbf{x} \in \mathcal{C}} (f(\mathbf{x}) - \tilde{\pi}g(\mathbf{x}))$$

We have,

$$\begin{aligned} F(\hat{\pi}) &= \max_{\mathbf{x} \in \mathcal{C}} (f(\mathbf{x}) - \hat{\pi}g(\mathbf{x})) = f(\hat{\mathbf{x}}) - \hat{\pi}g(\hat{\mathbf{x}}) \\ &< f(\hat{\mathbf{x}}) - \tilde{\pi}g(\hat{\mathbf{x}}) \leq f(\tilde{\mathbf{x}}) - \tilde{\pi}g(\tilde{\mathbf{x}}) \\ &= F(\tilde{\pi}) \end{aligned}$$

This concludes the proof of Lemma 2.2 ■

Corollary 2.1. [77] *Let π^* denote the maximum of the objective function for problem 2.35, and let $F(\pi)$ be defined as in (2.40). We have the following statements.*

$$F(\pi) > 0 \iff \pi < \pi^*$$

$$F(\pi) < 0 \iff \pi > \pi^*$$

Therefore, we can solve problem 2.35 by finding the root of the function $F(\pi)$ such that the optimality condition given in (2.37) is satisfied. Different approaches destined to solve $F(\pi) = 0$ was summarized in [78]. In this work, we resort to the Dinkelbach' procedure [76] given in Algorithm 3.

Algorithm 3 Dinkelbach's procedure [76]

- 1: **Input** A solution accuracy $\tilde{\epsilon} > 0$, $\pi^{(0)} = 0$ and let $n = 0$.
 - 2: **repeat**
 - 3: Use $\pi = \pi^{(n)}$ to find $\mathbf{x}^{(n)*}$ in (2.40);
 - 4: $n = n + 1$;
 - 5: Update $\pi^{(n)} = \frac{f(\mathbf{x}^{(n-1)*})}{g(\mathbf{x}^{(n-1)*})}$
 - 6: **until** $F(\pi^{(n)}) < \tilde{\epsilon}$
 - 7: **Output** \mathbf{x} .
-

The Dinkelbach' algorithm is mainly based on Newton method. Recall that at the n th iteration, the Newton update is given by

$$\pi^{(n)} = \pi^{(n-1)} - \frac{F(\pi^{(n-1)})}{F'(\pi^{(n-1)})} = \pi^{(n-1)} - \frac{f(\mathbf{x}^*) - \pi^{(n-1)}g(\mathbf{x}^*)}{-g(\mathbf{x}^*)} = \frac{f(\mathbf{x}^*)}{g(\mathbf{x}^*)}$$

Moreover, the Dinkelbach' algorithm converges to the optimal solution of problem 2.35 [79] and has a superlinear convergence rate.

Chapter 3

Efficient Distributed Power Allocation for Cognitive Radio Networks

In this chapter, we address the problem of power minimization under rate constraint for a multi-carrier-based underlay cognitive radio network. The problem is formulated as a non-cooperative power allocation game (NCPAG) in order to provide distributed solutions. A sufficient condition that guarantees convergence of the modified water-filling algorithm to a unique Nash-equilibrium (NE) is given. Moreover, we provide a per-subcarrier convergence criterion and propose a new distributed algorithm that always converges to a unique Nash equilibrium of the non-cooperative power allocation game. Simulation analyses are then provided to demonstrate the efficiency of our proposed distributed algorithms.

Introduction

New paradigms such as cognitive radio that can enable efficient spectrum utilization emerge to anticipate shortages of radio spectrum in wireless networks that face increasing number of demand from users. To better enhance the efficiency

of spectrum sharing in wireless networks, judicious resource allocation is of great importance especially from the point of view of the secondary users.

Literature review

For asynchronous multi-carrier-based CR networks, judicious resource allocation is required to mitigate the effect of inter-carrier interference. The problem of resource allocation for asynchronous underlay CR networks employing FBMC and OFDM was greatly studied over the past decade [80–87]. These findings can be categorized whether they addressed the resource allocation from an uplink point of view [81, 83, 85–87] or using a downlink perspective [80, 82, 84].

In [80], the authors addressed the downlink resource allocation for a multi-carrier-based cognitive radio network consisting of a single primary user and a single secondary user. In [82], Shaat et al. proposed a modified Water-filling solution to the problem of downlink rate maximization multi-cell CR network.

Zhang et. al investigated the joint subcarrier-power allocation in order to maximize the uplink sum rate problem in [85, 86]. The authors proposed a multiple access channel (MAC) technique to sub-optimally solve the problem. They transform the problem into a concave optimization and motivated by game theory approach they propose a distributed approach based on iterative Water-filling algorithm.

In [87], the authors addressed the problem of uplink rate maximization considering total power constraint and outage probability of primary systems. A sequential-based approach was proposed to tackle the point subcarrier-power allocation problem. They reformulate the subcarrier allocation so that the problem becomes a bipartite graph and invoke the Hungarian algorithm to find optimal solution to the problem. The gradient projection method was utilized to compute the power allocation.

Contribution

In this chapter, we investigate the problem of sum power minimization subject to rate constraint for downlink asynchronous underlay cognitive radio networks with FBMC and OFDM. To the best of our knowledge, no other research group has addressed this issue.

- Motivated by the concept of strategic non-cooperative game [88, 89], we recast the problem as a non-cooperative power allocation game (NCPAG) where each secondary base station is considered as a player that competes against the other secondary base stations by choosing the strategy that maximizes its own utility function.
- We derive a sufficient condition for the global convergence, i.e convergence to a unique Nash equilibrium point of the NCPAG for the modified Water-filling algorithm.
- We provide a per-subcarrier convergence criterion for iterative method. Using the distributed criterion, we propose a robust new distributed algorithm that achieves global convergence solution to the non-cooperative power allocation game.

Organization of this chapter

In this chapter, we start by introducing the system model in Section 3.2. The considered problem is also described in Section 3.2. In Section 3.3, we introduce a criterion that guarantees convergence of the Water-filling approach to a unique Nash equilibrium point. We describe our new decentralized approach that utilizes the proposed distributed convergence criterion in Section 3.4. Numerical results highlighting some important features of our proposed schemes are given in Section 3.5. Finally, we conclude this chapter in Section 3.6.

System model and problem formulation

System model

In this chapter, we consider a cognitive radio network that consists of \mathcal{Q} active primary users and \mathcal{K} active secondary users. Each active primary and SU is formed by a single transmitter-receiver pair. Throughout this dissertation, we make the following assumption.

1. We consider a downlink transmission.
2. The total spectrum is divided into L subcarriers. Each subcarrier has a bandwidth B .
3. All mobile terminals (MT) and base stations are equipped each with a single antenna.
4. The primary BSs are located far enough from the primary mobile terminals that are not located in the same cell. So, they do not interfere with these primary mobile terminals.
5. Primary base stations have a fixed transmission power scheme regardless of the transmission strategy used by the secondary users.

In this chapter, we assume that there is no interaction between the secondary users in the secondary system. Due to the distributed nature of cognitive radio network, all secondary MTs use single user detection i.e., interference caused by other SUs and the PUs are treated as noise. We assume that channel gains which include path loss and shadowing change sufficiently slowly to be considered unchanged during each scheduling interval. Perfect knowledge of channel state information (CSI) is available at each BS. The CSI between secondary BS and primary MT can be periodically measured by a band manager [90]. Also, the MTs can estimate the CSI and feed it back to their respective serving BS.

In this dissertation, we denote

- P_k^l : the power that the k th secondary BS allocates on the l th subcarrier.
- $\mathbf{P}_k \triangleq (P_k^1, \dots, P_k^L)^\top$: the power allocation vector of the k th secondary BS
- $\mathbf{P}_{-k} \triangleq \{\mathbf{P}_j\}_{j \in \{1, \dots, k-1, k+1, \dots, \mathcal{K}\}}$: the set of transmit power of all secondary BSs except the k th secondary BS.
- $\mathbf{P} = (\mathbf{P}_1, \dots, \mathbf{P}_\mathcal{K})^\top$: all secondary BSs power vector.
- $G_{k,k}^l$: the channel gain between secondary BS k and its served MT on subcarrier l .
- $G_{k,j}^l$: the channel gain between BS of secondary user k and MT of secondary user j on subcarrier l .
- $H_{k,q}^l$: the channel gain between BS of SU k and receiver of the PU q within the l th subcarrier.
- p_q^l : the power allocation of the q th primary base station on subcarrier l .

The achievable data rate of the secondary MT k is given by

$$\mathcal{R}_k(\mathbf{P}_k, \mathbf{P}_{-k}) = \sum_{l=1}^L B \log_2 \left(1 + \frac{P_k^l G_{k,k}^l}{\bar{N}_k^l + I_k^l} \right) \quad (3.1)$$

where

$$I_k^l = \sum_{j \neq k} \sum_{l'=1}^L P_j^{l'} V_{|l-l'|} G_{j,k}^{l'}, \quad \text{and} \quad \bar{N}_k^l = N_0 + \sum_{q=1}^{\mathcal{Q}} \sum_{l'=1}^L p_q^{l'} V_{|l-l'|} H_{q,k}^{l'}$$

N_0 denotes the thermal noise on any subcarrier l and $H_{q,k}^l$, the channel gain between the q th primary BS and the mobile terminal of SU k on the l th subcarrier. V is the interference weight defined in Table 2.1.

For underlay CR networks, secondary users can communicate at the same time with the PUs on the same frequency band provided that the degradation induced on the QoS of the primary users is tolerable. This is captured by preventing the interference caused by SUs activity to the k th PU from exceeding a predefined threshold. We consider a user-centric (individual) interference constraint. The

individual interference constraint is imposed at each SU to limit interferences radiated to each primary MT. This constraint is suitable for distributed configuration where SUs are not permitted to exchange any signaling [91]. It can be written as

$$\sum_{l=1}^L P_k^l \sum_{\nu \in \mathcal{I}_{q,k}^l} H_{k,q}^{\nu'} V_{|l-\nu|} \leq I_q^{k,\max}, \forall q, \forall k \quad (3.2)$$

where $I_q^{k,\max}$ is the maximum interferences allowed by the q th PU and $\mathcal{I}_{q,k}^l$ represents the set of subcarrier of q th primary BS that suffers from interferences generated by the l th subcarrier of the k -th secondary BS.

Problem Formulation

In this chapter, we formulate the transmission strategy of the secondary users as a non-cooperative power allocation game (NCPAG). Let \mathcal{P}_k be the feasible set of the transmission strategy of secondary BS k .

$$\mathcal{P}_k(\mathbf{P}_{-k}) \triangleq \left\{ \mathbf{P}_k : \begin{cases} \sum_{l=1}^L P_k^l \sum_{\nu \in \mathcal{I}_{q,k}^l} H_{k,q}^{\nu'} V_{|l-\nu|} \leq I_q^{k,\max}, \forall q \\ \mathcal{R}_k(\mathbf{P}_k, \mathbf{P}_{-k}) \geq \widehat{\mathcal{R}}_k \\ P_k^l \geq 0, \forall l \end{cases} \right\} \quad (3.3)$$

where $\widehat{\mathcal{R}}_k$ is the rate constraint of the SU k . The non-cooperative game is formulated as

$$\mathcal{G} = \{\mathcal{K}, \{\mathcal{P}_k\}, \{U_k\}\}$$

where $\mathcal{K} = \{1, 2, \dots, \mathcal{K}\}$ is the index set of the secondary BSs, \mathcal{P}_k the strategy space for the k th secondary BS defined in (3.3) and U_k denotes the pay-off function of the k th player and is defined as

$$U_k(\mathbf{P}_k) = -\mathbf{1}^\top \mathbf{P}_k = -\sum_{l=1}^L P_k^l$$

where $\mathbf{1}$ is vector of entry 1. The non-cooperative game is executed in a sequential fashion at the secondary BSs. More specifically, the game is formulated as

$$\text{NCPAG : } \max_{\mathbf{P}_k \in \mathcal{P}_k(\mathbf{P}_{-k})} U_k(\mathbf{P}_k), \quad \forall k \in \mathcal{K} \quad (3.4)$$

It is worthwhile noting that although each player selfishly optimizes his pay-off function, any change in his power allocation does influence the power allocation of all other players whenever the system is not in an equilibrium state.

Definition 3.1. *A strategy profile \mathbf{P}^* is said to be a pure-strategy Nash equilibrium (NE) if it meets the following requirement.*

$$U_k(\mathbf{P}_k^*) \geq U_k(\mathbf{P}_k), \quad \forall k, \quad \forall \mathbf{P}_k \in \mathcal{P}_k(\mathbf{P}_{-k})$$

A Nash equilibrium is reached for the NCPAG game if any player cannot achieve lower sum power by unilaterally changing its own strategy.

Convergence Criterion

Given the power allocation of all other payers \mathbf{P}_{-k} , the optimal solution strategy solving problem (3.4) can be computed using the KKT condition and is given by the modified water-filling (MWF), i.e.,

$$P_k^l = \text{MWF}_k(\mathbf{P}_{-k}^l) = \left[\frac{\nu_k \frac{B}{\ln 2}}{1 + \sum_{q=1}^Q \mu_q^k \left(\sum_{l' \in \mathcal{I}_{q,k}^l} H_{k,q}^{l'} V_{|l-l'|} \right)} - \frac{\bar{N}_k^l + I_k^l}{G_{k,k}^l} \right]^+ \quad (3.5)$$

where $[x]^+ \triangleq \max(x, 0)$ and $\nu_k, \{\mu_q^k\}$ are the Lagrangian multipliers associated to the rate constraint and primary interference constraints, respectively. The existence of a NE for the proposed game is given in the following Lemma.

Lemma 3.1. [92] *A feasible strategy \mathbf{P}^* is a NE of the NCPAG if and only if it satisfies*

$$\mathbf{P}_k^* = \text{MWF}_k(\mathbf{P}_{-k}^*)$$

Modified Water-filling-based Algorithm

The secondary system solution can be written compactly as

$$\mathbf{P} = \xi(\boldsymbol{\nu}, \boldsymbol{\mu}) - \mathbf{G}^{-1} \bar{\mathbf{N}} - \mathbf{G}^{-1} \bar{\mathbf{G}} \mathbf{P} \quad (3.6)$$

where $\boldsymbol{\nu} = (\nu_1, \dots, \nu_{\mathcal{K}})^\top$, $\boldsymbol{\mu} = (\boldsymbol{\mu}_1, \dots, \boldsymbol{\mu}_{\mathcal{K}})^\top$ with $\boldsymbol{\mu}_k = (\mu_1^k, \dots, \mu_Q^k)^\top$. And

$$\begin{aligned} \xi(\boldsymbol{\nu}, \boldsymbol{\mu}) &\triangleq (\xi(\nu_1, \boldsymbol{\mu}_1), \dots, \xi(\nu_{\mathcal{K}}, \boldsymbol{\mu}_{\mathcal{K}}))^\top \\ \xi(\nu_s, \boldsymbol{\mu}) &\triangleq \left(\frac{\nu_k \frac{B}{\ln 2}}{1 + \sum_{q=1}^{\mathcal{Q}} \mu_q^k \left(\sum_{l' \in \mathcal{I}_{q,k}^l} H_{k,q}^{l'} V_{|l-l'|} \right)}, \dots, \right. \\ &\quad \left. \frac{\nu_k \frac{B}{\ln 2}}{1 + \sum_{q=1}^{\mathcal{Q}} \mu_q^k \left(\sum_{l' \in \mathcal{I}_{q,k}^l} H_{k,q}^{l'} V_{|l-l'|} \right)} \right)^\top \end{aligned} \quad (3.7)$$

Moreover, the direct channel gain, \mathbf{G} and the noise plus multi-user interference $\bar{\mathbf{N}}$, of the whole secondary system are defined respectively by,

$$\begin{aligned} \mathbf{G} &= \text{diag} (G_{1,1}^1, \dots, G_{1,1}^L, \dots, G_{\mathcal{K},\mathcal{K}}^1, \dots, G_{\mathcal{K},\mathcal{K}}^L), \\ \bar{\mathbf{N}} &= (\bar{N}_1^1, \dots, \bar{N}_1^L, \dots, \bar{N}_{\mathcal{K}}^1, \dots, \bar{N}_{\mathcal{K}}^L)^\top \end{aligned} \quad (3.8)$$

And $\bar{\mathbf{G}}$ is defined in (3.9). More specifically, $\mathbf{0}_k$ denotes a $L \times L$ zero entry matrix and $\bar{\mathbf{G}}$ is the interference matrix of the entire secondary system.

$$\bar{\mathbf{G}} \triangleq \begin{pmatrix} \mathbf{0}_1 & \bar{\mathbf{G}}_{12} & \dots & \bar{\mathbf{G}}_{1\mathcal{K}} \\ \bar{\mathbf{G}}_{21} & \mathbf{0}_2 & \dots & \bar{\mathbf{G}}_{2\mathcal{K}} \\ \vdots & \vdots & \ddots & \vdots \\ \bar{\mathbf{G}}_{\mathcal{K}1} & \bar{\mathbf{G}}_{\mathcal{K}2} & \dots & \mathbf{0}_{\mathcal{K}} \end{pmatrix}, \quad (3.9)$$

$$\bar{\mathbf{G}}_{j,k} = \begin{pmatrix} G_{j,k}^1 V_0 & G_{j,k}^2 V_1 & \dots & G_{j,k}^L V_{|L-1|} \\ G_{j,k}^1 V_1 & G_{j,k}^2 V_0 & \dots & G_{j,k}^L V_{|L-2|} \\ \vdots & \vdots & \ddots & \vdots \\ G_{j,k}^1 V_{|L-1|} & G_{j,k}^2 V_{|L-2|} & \dots & G_{j,k}^L V_0 \end{pmatrix}$$

At the n th iteration, the modified Water-filling function can be expressed as

$$\mathbf{P}^{(n)} = \text{MWF}(\mathbf{P}^{(n-1)}) = \xi(\boldsymbol{\nu}, \boldsymbol{\mu}) - \mathbf{G}^{-1} \bar{\mathbf{N}} - \mathbf{G}^{-1} \bar{\mathbf{G}} \mathbf{P}^{(n-1)} \quad (3.10)$$

The proposed approach is summarized as follow.

Algorithm 4 Iterative modified Water-filling algorithm for solving (3.4)

- 1: **Input** A solution accuracy $\epsilon > 0$ and a feasible \mathbf{P}^0 .
 - 2: Set $n = 0$;
 - 3: **repeat**
 - 4: $n = n + 1$;
 - 5: Find \mathbf{P}^n by using (3.10);
 - 6: For each secondary BS k , update $\nu_k, \boldsymbol{\mu}_k$ by using bisection method.
 - 7: **until** Nash equilibrium is reached
 - 8: **Output** \mathbf{P}^n .
-

Uniqueness of Nash equilibrium

Now, we provide a sufficient criterion for convergence of the proposed Algorithm 4 to a unique NE point of the game \mathcal{G} . This is done in the following theorem.

Theorem 3.1. *The sequence $\{\mathbf{P}^{(n)}\}_{n=1}^{\infty}$ generated by the proposed Algorithm 13 converges to a unique NE regardless of the initial power allocation value if*

$$\sum_{j=1, j \neq k}^{\kappa} \frac{\sum_{l'=1}^L V_{|l-l'|} G_{j,k}^{l'}}{G_{k,k}^l} \leq \frac{1}{2}, \quad \forall k, l \quad (3.11)$$

Proof: The proof of Theorem 3.1 follows directly from [93, Theorem 5]. ■

From the sufficient condition provided in Theorem 3.1, we know that the proposed game NCPAG converges to a unique Nash equilibrium point if interferences are sufficiently small. In other words, if all interferers are far apart then the NCPAG may converge to a unique Nash equilibrium.

New Distributed Scheme

From Theorem 3.1, we notice that our proposed Algorithm 4 converges to a unique NE point only if the sufficient convergence condition is met. In this section, we propose a distributed algorithm that always converges to a unique NE point of

\mathcal{G} . This is done by providing a new distributed convergence criterion that can be embedded into problem (3.4).

From the signal-to-interference-plus-noise ratio (SINR), γ_k^l for secondary user k on subcarrier l , the power P_k^l that secondary base station k allocates on subcarrier l is given as

$$P_k^l = \gamma_k^l \left(\frac{\bar{N}_k^l}{G_{k,k}^l} + \frac{\sum_{j \neq k}^{\mathcal{K}} \sum_{l'=1}^L P_j^{l'} V_{|l-l'|} G_{j,k}^{l'}}{G_{k,k}^l} \right) \quad (3.12)$$

which can be compactly written as

$$\mathbf{P} = \mathbf{G}^{-1} \mathbf{\Gamma} \bar{\mathbf{G}} \mathbf{P} + \mathbf{G}^{-1} \mathbf{\Gamma} \bar{\mathbf{N}} \quad (3.13)$$

where $\mathbf{\Gamma} = \text{diag}(\gamma_1^1, \dots, \gamma_1^L, \dots, \gamma_{\mathcal{K}}^1, \dots, \gamma_{\mathcal{K}}^L)$. For a fixed SINR $\mathbf{\Gamma}$, at the n th iteration, the power allocation function ϕ is expressed as

$$\mathbf{P}^{(n)} = \phi(\mathbf{P}^{(n-1)}, \mathbf{\Gamma}) = \mathbf{G}^{-1} \mathbf{\Gamma} \bar{\mathbf{G}} \mathbf{P}^{(n-1)} + \mathbf{G}^{-1} \mathbf{\Gamma} \bar{\mathbf{N}} \quad (3.14)$$

Theorem 3.2. *The power allocation scheme (3.14) converges to a unique fixed point for any arbitrary starting point if*

$$\frac{\gamma_k^l \left(\sum_{j \neq k}^{\mathcal{K}} \sum_{l'=1}^L V_{|l-l'|} G_{j,k}^{l'} \right)}{G_{k,k}^l} < 1, \quad \forall k, l \quad (3.15)$$

Proof: Given an arbitrary initial power $\mathbf{P}^{(0)}$, we have

$$\begin{aligned} \|\mathbf{P}^{(n+1)} - \mathbf{P}^{(n)}\| &= \|\mathbf{G}^{-1} \mathbf{\Gamma} \bar{\mathbf{G}} (\mathbf{P}^{(n)} - \mathbf{P}^{(n-1)})\| \\ &\leq \|\mathbf{G}^{-1} \mathbf{\Gamma} \bar{\mathbf{G}}\| \|\mathbf{P}^{(n)} - \mathbf{P}^{(n-1)}\| \\ &\leq \|\mathbf{G}^{-1} \mathbf{\Gamma} \bar{\mathbf{G}}\|_{\infty} \|\mathbf{P}^{(n)} - \mathbf{P}^{(n-1)}\| \\ &\leq \zeta \|\mathbf{P}^{(n)} - \mathbf{P}^{(n-1)}\| \\ &\leq \zeta^{n+1} \|\mathbf{P}^{(1)} - \mathbf{P}^{(0)}\| \end{aligned} \quad (3.16)$$

where $\zeta = \max_{\substack{1 \leq k \leq \mathcal{K} \\ 1 \leq l \leq L}} \frac{\gamma_k^l \left(\sum_{j \neq k}^{\mathcal{K}} \sum_{l'=1}^L V_{|l-l'|} G_{j,k}^{l'} \right)}{G_{k,k}^l}$. It follows that for $\forall n, M \geq 0$,

$$\begin{aligned} \|\mathbf{P}^{(n+M)} - \mathbf{P}^{(n)}\| &= \sum_{m=1}^M \|\mathbf{P}^{(n+m)} - \mathbf{P}^{(n+m-1)}\| \\ &= \zeta^n \sum_{m=1}^M \zeta^m \|\mathbf{P}^{(1)} - \mathbf{P}^{(0)}\| \\ &\stackrel{(b)}{\leq} \frac{\zeta^n}{1 - \zeta} \|\mathbf{P}^{(1)} - \mathbf{P}^{(0)}\| \end{aligned}$$

(b) is verified if $\frac{\gamma_k^l \left(\sum_{j \neq k}^{\mathcal{K}} \sum_{l'=1}^L V_{|l-l'|} G_{j,k}^{l'} \right)}{G_{k,k}^l} < 1, \forall l, \forall k$. Hence, we obtain a Cauchy sequence which is a convergent sequence.

Moreover, it is straightforward to demonstrate that $\phi(\cdot)$ is a contraction function. Therefore, the power allocation scheme converges to a unique fixed point [94] $\mathbf{P}^* = (\mathbf{I} - \mathbf{G}^{-1}\mathbf{\Gamma}\mathbf{G})^{-1} \mathbf{G}^{-1}\mathbf{\Gamma}\mathbf{N}$. ■

Remark 3.1. First, the criterion in theorem 3.2 is a convergence condition per subcarrier. Secondly, we notice that when $l = 1$, our proposed sufficient condition (3.15) coincides with the convergence criterion given in [92] for the water-filling. Thirdly, this convergence criterion is a generalization of the criterion proposed in [95].

To be able to use (3.12) as a solution to the NCPAG, the value of $\gamma_k^l, \forall k, l$ is required. From (3.12), we see there exists a one-to-one mapping from P_k^l to $\gamma_k^l, \forall k, l$. This one-to-one mapping is defined by $P_k^l = \gamma_k^l \hat{I}_k^l$ where

$$\hat{I}_k^l \triangleq \frac{\left(\bar{N}_k^l + \sum_{j \neq k}^{\mathcal{K}} \sum_{l'=1}^L P_j^{l'} V_{|l-l'|} G_{j,k}^{l'} \right)}{G_{k,k}^l}$$

Define the following variable

$$C_k^l \triangleq \frac{G_{k,k}^l}{\sum_{j \neq k}^{\mathcal{K}} \sum_{l'=1}^L V_{|l-l'|} G_{j,k}^{l'}}$$

Let $\mathbf{\Gamma}_k = (\gamma_k^1, \dots, \gamma_k^L)^\top$ be the SINR vector for secondary user k . At the n th round, $\mathbf{\Gamma}_k^{(n)}$ can be found by solving the following convex optimization problem

$$\begin{aligned}
\min_{\mathbf{\Gamma}_k \geq 0} \quad & \sum_{l=1}^L \gamma_k^l \widehat{I}_k^{l,(n-1)} \\
\text{s.t.} \quad & \widehat{\mathcal{R}}_k \leq \sum_{l=1}^L B \log_2 (1 + \gamma_k^l) \\
& \sum_{l=1}^L \gamma_k^l \widehat{I}_k^{l,(n-1)} \sum_{l' \in \mathcal{I}_{q,k}^l} H_{k,q}^{l'} V_{|l-l'|} \leq I_q^{k,\max}, \forall q, \\
& \gamma_k^l \leq C_k^l - \delta_1, \forall l
\end{aligned} \tag{3.19}$$

The optimal solution of problem (3.19) is given by

$$\gamma_k^{l*} = \left[\frac{\nu_k \frac{B}{\ln 2}}{\widehat{I}_k^{l,(n-1)} \left(1 + \left(\sum_{q=1}^Q \mu_q^k \left(\sum_{l' \in \mathcal{I}_{q,k}^l} H_{k,q}^{l'} V_{|l-l'|} \right) \right) \right)} - 1 \right]_0^{C_k^l - \delta_1} \tag{3.20}$$

In fact, it is important to notice that without the second constraint, problem (3.19) is equivalent to problem (3.4). The criterion in (3.15) is embedded into the optimization problem (3.19) as a constraint in order to assure the convergence of the algorithm to a fixed point. Notice that an infinitesimal positive constant δ_1 is deducted from the convergence criterion to relax the constraint. The game \mathcal{G} given in (3.4) is solved by alternately solving problem (3.19) and substituting each $\gamma_k^l, \forall k, l$ in (3.12). The proposed new algorithm is summarized as

Algorithm 5 New distributed algorithm to solve (3.4)

- 1: **Input** A solution accuracy $\epsilon > 0$ and a feasible \mathbf{P}^0 .
 - 2: Set $n = 0$;
 - 3: **repeat**
 - 4: $n = n + 1$;
 - 5: Obtain $\mathbf{\Gamma}_k^{(n)}, \forall k$ by solving problem (3.19);
 - 6: Calculate $P_k^{l,(n)}, \forall k, l$ by using (3.12).
 - 7: **until** Convergence is reached
 - 8: **Output** \mathbf{P}^n .
-

From the structure of the proposed Algorithm 5, we see that it always converges to a unique and fixed NE point of the game \mathcal{G} , the solution is given by

$$\mathbf{P}^* = (\mathbf{I} - \mathbf{G}^{-1}\mathbf{T}\overline{\mathbf{G}})^{-1} \mathbf{G}^{-1}\mathbf{T}\overline{\mathbf{N}}$$

To implement our proposed distributed Algorithms 13 and 5, the secondary MTs need to measure the noise-plus-interference on each subcarrier at each iteration. This value is then feeding back to the respective secondary BS. This operation is repeated until convergence or stopping criterion of both algorithms is reached. Clearly, in terms of signalling overhead, our proposed algorithms by using local information only need little signalling overhead.

Numerical results

We present the performance of our proposed Algorithm 4 and Algorithm 5 via numerical results. All results are conducted using Monte Carlo simulation by averaging over 300 channel realizations.

In this chapter, we consider the following parameters,

- An underlay cognitive radio network that consists of 2 primary transceiver pairs and 5 secondary transceiver pairs.
- The primary BSs are located at a distance of 1.2km from each other.
- The secondary base stations are randomly located at a distance varying from 0.1 km to 0.5 km away from the primary base stations.
- Each mobile terminal is uniformly located within a 0.5 km radius circle from its serving base station.
- There are $L = 32$ subcarriers.
- Unless otherwise stated, $\widehat{\mathcal{R}}_s = 30$ Kbits/s $\delta_1 = 10^{-5}$ and $\epsilon = 10^{-4}$.

The following simulation parameters are utilized throughout this dissertation

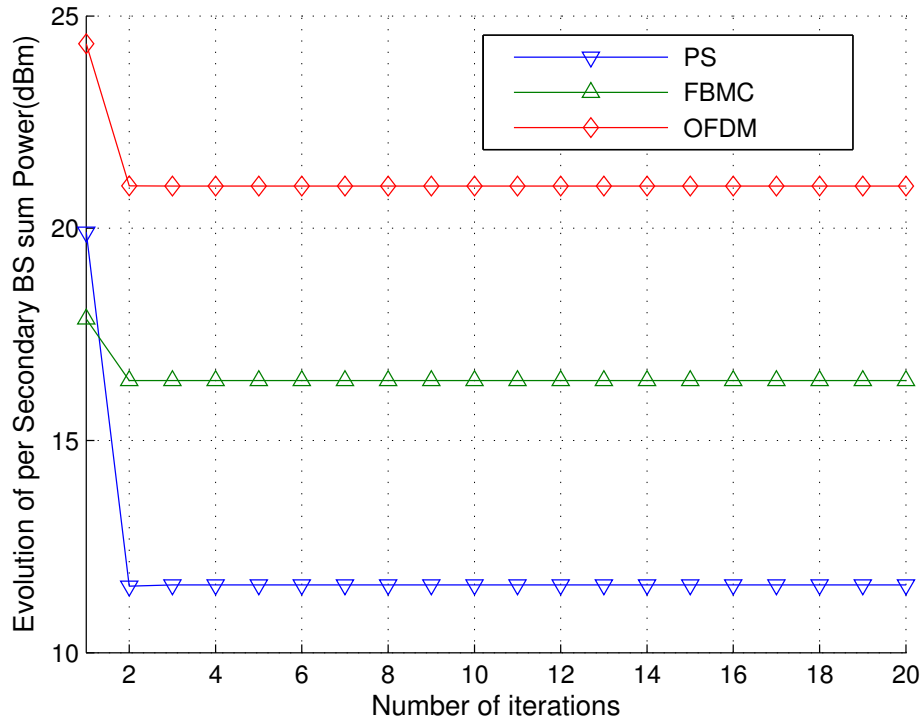


FIGURE 3.1: Average sum secondary power versus rate constraint

- The bandwidth of each subcarrier $B = 15\text{KHz}$.
- The path loss model for the channel is $L_{\text{dB}}(d) = 128.1 + 37.6 \times \log_{10}(d)$, where d is the distance between a BS and a MT.
- The shadowing's standard deviation is 6 dB.
- The noise power with a subcarrier $N_0 = -174 \text{ dBm/Hz}$.
- Each primary base station q has a uniform power transmission $p_q^l = \frac{P_{\max}}{L}, \forall l$ with $P_{\max} = 33 \text{ dBm}$.
- The interference threshold $I_q^{l,\max}$ is computed by assuming only 10% of the PU q interference-free achievable rate degradation is permitted on subcarrier $l, \forall l$.

To evaluate the proposed Algorithms 4 and 5, we also compare with the perfect synchronization case denoted as PS. In this case, the interference weight is $V^{\text{PS}} = \{1\}$. Both algorithms are initialized by assuming uniform power on each subcarrier mainly P_{\max}/L .

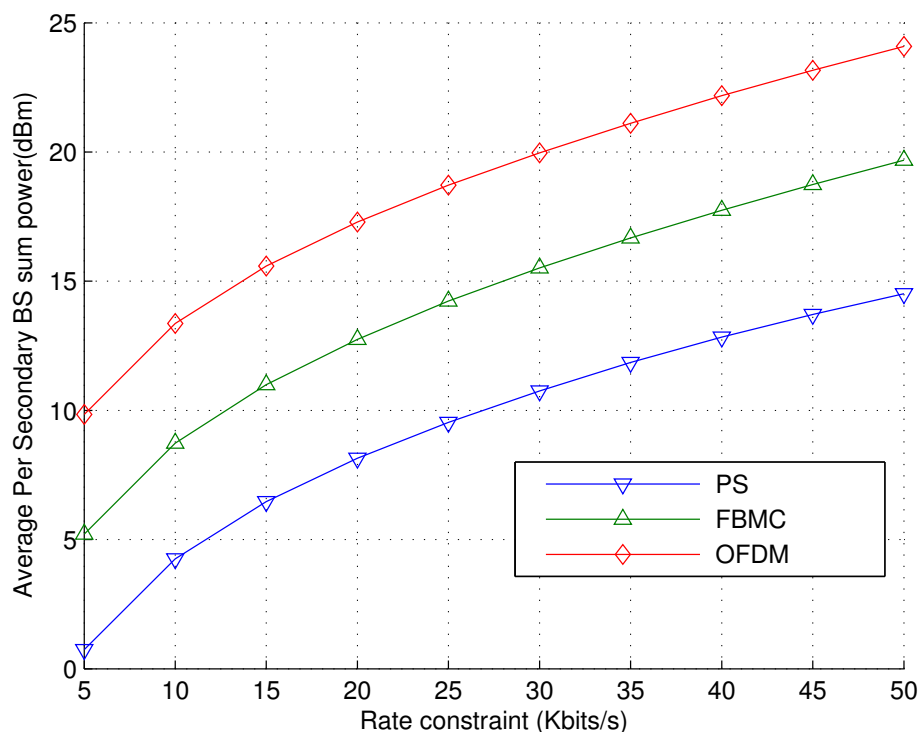


FIGURE 3.2: Average sum secondary power versus rate constraint

Figure 3.1 and Figure 3.2 portray the convergence properties and the performance of our proposed Algorithm 4 for different multi-carrier modulation scheme. Figure 3.1 depicts the evolution of the per secondary BS sum power. From Figure 3.1, it can be clearly inferred that the proposed Algorithm 4 converges irrespective of the modulation method. It is important to observe the gap between the performance of PS and the one achieved by OFDM and FBMC. This is the consequence of inter-carrier interference induced by asynchronism and lack of cooperation.

Figure 3.2 depicts the performance of our proposed Algorithm 4 in terms of average sum power versus per BS power rate constraint. We can see that the sum power achieved by the proposed Algorithm 4 tends to increase as the rate constraint increases. From Figure 3.2, we also observe a gain varying from 21.98% to 22.70% between the sum power with FBMC compared with the sum power achieved with OFDM.

In section 3.4, we provided rigorous theoretical analysis of the convergence of the power control using the distributed convergence criterion. Executing Algorithm 5 requires to alternate between the search of SINR values and the iterative method

for the power control. Intuitively, one could guess that the SINR vector function should eventually converge. However, the theoretical analysis of the convergence of the SINR is challenging. Now, we look into the convergence of the SINR vector by mean of simulation. Indeed, Figure 3.3 depicts the performance of our proposed Algorithm 5. It shows the convergence behaviour of the SINR vector. From Figure 3.3, we clearly observe that the sequence of the SINR vector converges regardless of the multi-carrier modulation scheme.

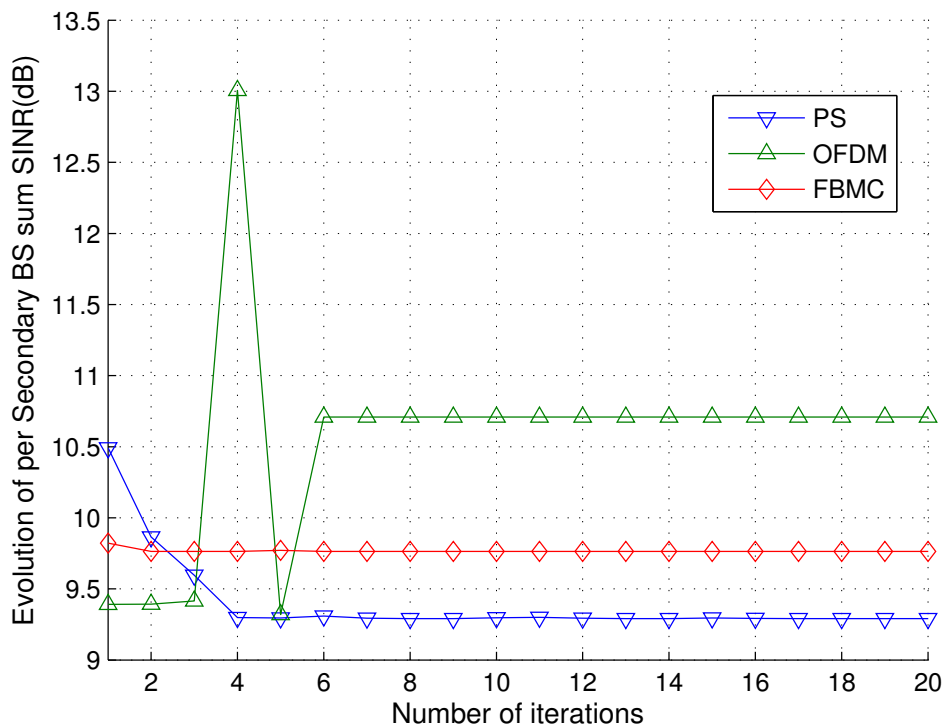


FIGURE 3.3: Convergence behaviour of the SINR.

Conclusion

In this chapter, we proposed two distributed algorithms to solve the problem of secondary sum power minimization for an underlay downlink asynchronous cognitive radio network with OFDM/FBMC. The problem was reformulated as a non-cooperative power control game. We provide a sufficient convergence criterion to a Nash equilibrium point of the NCPAG. Moreover, we provide a new algorithm that solves alternately the power vector and the SINR vector. The new algorithm

always converges to a unique fixed Nash equilibrium point. Furthermore, we have through numerical results validated the efficiency of the proposed schemes.

Chapter 4

Energy-Efficiency Based Resource Allocation Framework for Cognitive Radio Networks

In this chapter, we investigate the problem of secondary users' energy-efficiency (EE) maximization problem under secondary total power and primary interference constraints. Firstly, by assuming cooperation among the secondary base stations, a centralized approach is considered to solve the energy efficiency optimization problem for the cognitive radio network. We propose an alternating-based approach to solve the joint power-subcarrier allocation problem. More precisely, in the first place, subcarriers are allocated using a heuristic method for a given feasible power allocation. Then, we conservatively approximate the non-convex power control problem and propose a joint *Successive Convex Approximation-Dinkelbach Algorithm (SCADA)* to efficiently obtain a solution to the non-convex power control problem. The proposed algorithm is shown to converge to a solution that coincides with the stationary point of the original non-convex power control subproblem. Moreover, we propose a dual decomposition-based decentralized version of the centralized SCADA. Secondly, under the assumption of no cooperation among the secondary BSs, we propose a fully distributed power control algorithm

using the perspective of game theory. The proposed algorithm is shown to converge to a Nash-equilibrium (NE) point. Moreover, we propose a sufficient condition that guarantees uniqueness of the achieved NE. Extensive simulation analyses are further provided to highlight the advantages and demonstrate the efficiency of our proposed schemes.

Introduction

In recent decades, ubiquity and rapid proliferation of wireless technology and services have raised concerns over the fast increase in green house emission and energy consumption at battery-powered devices. There is a growing trend to focus on energy-efficient transmission in wireless networks in general and future generation (5G) cellular networks [61, 96, 97] in particular. There exists a wide variety of definitions for energy-efficiency. In this dissertation, we invoke the most widely used definition, i.e. the ratio between the achievable transmission rate and the total power consumption which is generally measured in bits/Joule [98, 99]. The problem of resource allocation for energy-efficiency optimization has been extensively studied under various scenarios. More importantly, the EE optimization was investigated in frequency-selective interference channel [99], point-to-point multiple-input multiple output (MIMO) channel [100, 101], parallel additive white Gaussian noise (AWGN) channel [102], multiple-input single output (MISO) relay channel [103] multiple access channel (MAC) [104].

Meanwhile, due to its agility and adaptation capability, cognitive radio opens up new control perspective for energy-efficient pervasive wireless communications [105]. Investigate energy-efficient-based resource allocation for cognitive radio networks is therefore of great importance.

State-of-the-Art

The energy-efficiency (EE) optimization problem for cognitive radio network consists in optimizing the SUs energy-efficiency function subject to PUs interference

and SUs total power constraints. Sometimes user minimum rate requirements constraint may be incorporated in the constraints set. Whenever this happens, we refer to the problem as minimum data rate constraint EE optimization problem. Recently, the energy-efficient resource optimization for downlink MC-based CR networks has drawn a lot of attention [106–113]. These works can be classified into three categories according to the configuration of their system model. The first class encompasses works that consider a single primary and a single secondary transceiver configuration [106–109]. More precisely, the authors in [106] proposed a water-filling factor aided search approach to solve the minimum data rate constraint EE optimization problem while in [107], Yang et al. invoked an iterative algorithm to optimally solve the EE maximization problem. The research works [108, 109] investigated the EE optimization problem by taking into account sensing access strategy.

The second category includes researches that investigate networks with one primary transceiver and either one or several secondary cells. Regardless of the number of secondary cells, SUs employ access point (AP) strategy such that no two secondary transmitters interfere with each other [110, 111]. The authors in [111] provided a low complexity solution by invoking the Charnes-Cooper Transformation to solve the minimum data rate constraint EE optimization problem. In [110], Cong et al. use the branch and bound approach to find optimal solutions to the EE optimization problem.

The last group consists of works on CR networks that have multiple primary and multiple secondary cells [112, 113]. Similarly to previously cited works [110, 111], there are no inter-secondary-cells interferences. In [112], Wang et al. employ a time sharing approach to obtain a near optimal solution to the EE optimization problem that takes into consideration the traffic demand of SUs. A bisection-based algorithm is provided to find the optimal solution in an iterative fashion for the EE optimization problem in [113].

Contribution

In all the aforementioned works, there were no inter-secondary-cells interferences and primary and secondary systems were assumed to be perfectly synchronized. We know that for more practical scenarios, lack of cooperation between PU and SU may lead to asynchronous transmission between PUs and SUs. This motivates us to address the downlink energy-efficiency optimization problem for a cognitive radio network with multiple primary base stations and multiple secondary BSs where PUs and SUs are not synchronized. Moreover, we take into consideration an interference-limited secondary system i.e., the secondary BSs are interfering with each other. The downlink energy-efficiency optimization problem is addressed for the following two cases: a) SUs are cooperating b) SUs are not cooperating. The main contributions of this chapter can be summarized as follow.

- We formulate the problem of EE optimization for cooperative secondary users using a centralized perspective. We propose an alternating-based approach to solve the joint subcarrier-power allocation problem. Firstly, a heuristic scheme is used to solve the subcarrier allocation problem for a feasible power allocation vector. Secondly, for a given subcarrier allocation scheme, we conservatively approximate the non-convex power allocation optimization problem by using first-order Taylor approximation. This procedure is repeated until convergence of the alternating-based optimization method.
- In addition to that, we propose a centralized power allocation algorithm termed as joint *Successive Convex Approximation-Dinkelback Algorithm (SCADA)* to obtain a near-optimal solution to the non-convex power control EE optimization problem. We analytically demonstrate that the proposed centralized power allocation algorithm is guaranteed to yield a solution that is a stationary point of the original non-convex power control problem.
- More over, in order to alleviate communication overhead incurred by implementing the centralized SCADA, we propose a dual decomposition based distributed algorithm to efficiently find a solution to the non-convex power control problem.

- For the non-cooperative secondary users' case, we recast the problem of energy-efficiency optimization invoking the concept of game theory. We propose a fully decentralized algorithm to solve the non-cooperative power allocation game (NPAG). Moreover, we provide rigorous convergence analysis to a Nash-equilibrium (NE) of the proposed distributed scheme.
- Furthermore, we identify a sufficient condition for the uniqueness of the Nash-equilibrium to which converges our proposed distributed algorithm.

Organization of the chapter

The remainder of this chapter is structured as follows. In Section 4.2, the system model is presented. The cooperative transmission resource allocation problem formulation is given in Section 4.3 together with the conservative approximation for solving the power control problem of the downlink energy-efficiency problem. In Section 4.4, we introduce the proposed centralized SCADA algorithm and investigate the corresponding theoretical convergence analysis. We introduce the dual decomposition-based distributed version of the proposed SCADA in Section 4.5. The non-cooperative energy-efficiency problem formulation is solved in Section 4.6. In Section 4.7, we provide simulation results showing the efficiency of our proposed methods. And finally, we provide a short conclusion to this chapter in Section 4.8.

System Model

In this chapter, we assume that each secondary BSs serves \mathcal{U}_k mobile terminals. It is assumed that each MT is connected to only one BS and each base station serves at most one MT at a given time on each subcarrier. Let $\theta_{k,u}^l$ be the subcarrier allocation indicator. If secondary BS k assigns subcarrier l to user u , the value of $\theta_{k,u}^l$ is 1 otherwise it is zero. Therefore, a feasible subcarrier allocation matrix $\Theta_k = \{\theta_{k,u}^l\}_{u,l=1}^{\mathcal{U}_k,L}$ for any secondary BS k should belong to the set

$$\Theta_k \triangleq \left\{ \Theta_k : \left\{ \sum_{u=1}^{\mathcal{U}_k} \theta_{k,u}^l \leq 1, \theta_{k,u}^l \in \{0, 1\}, \forall l \right\} \right\} \quad (4.1)$$

As in the previous chapter, the network consists of \mathcal{Q} active primary cells. In each primary cell, there is a base station-mobile terminal pair.

Cooperative secondary BSs

In the first part of this chapter, it is assumed that the secondary BSs are coordinated so that they are perfectly synchronized. The signal-to-interference-plus-noise (SINR) measured by user $u \in \mathcal{U}_k$ on the l -th subcarrier can be expressed as

$$\Gamma_{k,u(k,l)}^l = \frac{P_k^l G_{k,u(k,l)}^l}{N_0 + \sum_{j \neq k} P_j^l G_{j,u(k,l)}^l + \sum_{q=1}^{\mathcal{Q}} \sum_{l'=1}^L p_q^{l'} V_{|l-l'|} H_{q,u(k,l)}^{l'}} \quad (4.2)$$

where

- $u(k, l)$ denotes the secondary mobile terminal $u \in \mathcal{U}_k$ that was assigned the l -th subcarrier by its serving base station k .
- $G_{j,u(k,l)}^l$ is the channel gain from the j th secondary BS to user $u \in \mathcal{U}_k$ on the l th subcarrier.
- $H_{q,u(k,l)}^l$ is the channel gain between primary base station q and user $u \in \mathcal{U}_k$.
- V is the interference weight defined in Table 2.1.

This configuration leads to a secondary network-centric energy-efficiency [61], known as global energy-efficiency (GEE) [58] defined as

$$\mathbf{GEE} = \frac{\sum_{k=1}^{\mathcal{K}} \sum_{l=1}^L B \log_2 \left(1 + \Gamma_{k,u(k,l)}^l \right)}{\sum_{k=1}^{\mathcal{K}} \left(P_{c,k} + \sum_{l=1}^L \xi P_k^l \right)} \quad (4.3)$$

Recall from Section 2.3.4 that $P_{c,k}$ corresponds to the power dissipated in the circuit blocks whereas ξ , is the reciprocal of drain efficiency of the power amplifier.

Non-cooperative secondary BSs

In the second part of this chapter, it is assumed that the secondary base stations are operating independently without any interaction with one another. As a result,

secondary BSs are not synchronized and the secondary system is prone to incur asynchronous transmission. To model this effect, the SINR stated in (4.2) can be rewritten as:

$$\Gamma_{k,u(k,l)}^l = \frac{P_k^l G_{k,u(k,l)}^l}{N_0 + I_{k,u(k,l)}^l}$$

where $I_{k,u(k,l)}^l$ corresponds to the interference that user $u \in \mathcal{U}_k$ measures on sub-carrier l and is expressed as

$$I_{k,u(k,l)}^l = \sum_{j \neq k} \sum_{l'=1}^L P_j^{l'} V_{|l-l'|} G_{j,u(k,l)}^{l'} + \sum_{q=1}^{\mathcal{K}} \sum_{l'=1}^L p_q^{l'} V_{|l-l'|} H_{q,u(k,l)}^{l'} \quad (4.4)$$

Contrarily to (4.3), for asynchronous secondary cell transmission, it is more judicious to consider user-centric energy-efficiency function [61] which is defined as [114]

$$\mathbf{EE}_k = \frac{\sum_{l=1}^L B \log_2 \left(1 + \Gamma_{k,u(k,l)}^l \right)}{P_{c,k} + \sum_{l=1}^L \xi P_k^l} \quad (4.5)$$

Temperature-Interference Constraints

Based on the two previous assumptions, two kind of interferences constraints are considered.

- The global interference constraint which can be used in a centralized scheme prevents the aggregate interference generated by all SUs to each active primary receiver from exceeding a predefined threshold. It can be expressed as [14, 115]

$$\sum_{k=1}^{\mathcal{K}} \sum_{l=1}^L P_k^l \sum_{l' \in \mathcal{I}_{q,k}^l} H_{k,q}^{l'} V_{|l-l'|} \leq I_q^{\max}, \forall q \quad (4.6)$$

where I_q^{\max} is the global interference prescribed requirement for the q th primary mobile terminal.

- The individual interference constraint is imposed at each SU to limit interferences radiated to each primary MT. This constraint is suitable for distributed configuration where SUs are not permitted to exchange any signaling [91]. It

can be written as

$$\sum_{l=1}^L P_k^l \sum_{l' \in \mathcal{I}_{q,k}^l} H_{k,q}^{l'} V_{|l-l'|} \leq I_q^{k,\max}, \forall q, \forall k \quad (4.7)$$

where $I_q^{k,\max}$ is the maximum interferences allowed by the q th PU.

Cooperative Transmission Strategy

In this section, we introduce analytical frameworks to find solution to the problem of energy-efficiency maximization for the case of coordinating secondary BSs. We adopt a centralized design where a central controller is required to gather all network parameters (e.g., CSI of all links) and to compute the solution in a centralized fashion.

Before formally stating the problem formulation, let us define the following set

$$\mathcal{X} \triangleq \left\{ \mathbf{P} : \begin{cases} \sum_{k=1}^{\mathcal{K}} \sum_{l=1}^L P_k^l \sum_{l' \in \mathcal{I}_{q,k}^l} H_{k,q}^{l'} V_{|l-l'|} \leq I_q^{\max}, \forall q \\ \sum_{l=1}^L P_k^l \leq P_{\max}, \forall k \\ P_k^l \geq 0, \forall k, \forall l \end{cases} \right\} \quad (4.8)$$

The set \mathcal{X} encompasses the total power constraint for all secondary BSs as well as the global interference constraints for the PUs. It is straightforward to prove that the set \mathcal{X} is a convex set.

The joint power-subcarrier optimization problem can be written as

$$\begin{aligned} \max_{\Theta_k, \forall k, \mathbf{P}} & \frac{\sum_{k=1}^{\mathcal{K}} \sum_{l=1}^L \sum_{u=1}^{\mathcal{U}_k} B \theta_{k,u}^l \log_2 \left(1 + \Gamma_{k,u(k,l)}^l \right)}{\sum_{k=1}^{\mathcal{K}} \left(P_{c,k} + \sum_{l=1}^L \xi P_k^l \right)} \\ \text{s.t. } & \Theta_k \in \Theta_k, \forall k \text{ and } \mathbf{P} \in \mathcal{X} \end{aligned} \quad (4.9)$$

Problem (5.3) is a mixed integer problem and therefore of high computational complexity in the optimal solution. To circumvent the burden of the prohibitively high computational complexity inherent to the optimal solution of the joint power-subcarrier allocation problem and motivated by the alternating optimization method

introduced in Subsection 2.7.2, we propose to solve problem (5.3) in an alternate fashion. More specifically, given $\tilde{\mathbf{P}}$, a feasible power allocation for problem (5.3), we solve the subcarrier allocation problem. Once the subcarrier allocation solution is known, we solve the power allocation problem. And this procedure is repeated until convergence.

Subcarrier allocation

Given $\tilde{\mathbf{P}}$, a feasible power allocation, we focus on the subcarrier allocation problem. With a fixed power allocation, the objective function of the optimization becomes the secondary sum achievable rate. The subcarrier allocation is separable across the secondary BSs and across the subcarriers and is solved using the following heuristic approach,

$$u(k, l) = \arg \max_{u=1, \dots, \mathcal{U}_k} \frac{\tilde{P}_k^l G_{k,u}^l}{N_0 + \sum_{j \neq k} \tilde{P}_k^l G_{j,u}^l + \sum_{q=1}^Q \sum_{l'=1}^L p_q^{l'} V_{|l-l'|} H_{q,u}^{l'}} \quad (4.10)$$

Once the subcarrier allocation procedure is completed, the power allocation problem can be investigated.

Power Allocation

Given the subcarrier allocation, the global energy-efficiency power control problem can be expressed as

$$\max_{\mathbf{P} \in \mathcal{X}} \mathbf{EE}(\mathbf{P}) \triangleq \frac{\sum_{k=1}^{\mathcal{K}} \sum_{l=1}^L B \log_2 \left(1 + \Gamma_{k,u(k,l)}^l \right)}{\sum_{k=1}^{\mathcal{K}} \left(P_{c,k} + \sum_{l=1}^L \xi P_k^l \right)} \quad (4.11)$$

The optimal solution for problem (4.11) can be found by exhaustive search method. The exhaustive search consists of making a grid by discretizing the power into N levels on each subcarrier. The value of the energy-efficiency is computed for each feasible point of the grid. The complexity of the exhaustive search approach is $\mathcal{O}(N^{\mathcal{K} \times L})$. This complexity increases exponentially with $\mathcal{K} \times L$. For a simple search where $\mathcal{K} = 2, L = 3$ and $N = 20$, this method requires $\mathcal{O}(20^6)$ iterations.

For more practical scenario, i.e., large scale networks, the exhaustive search approach will be computationally prohibitive. The need for polynomial time solvable algorithm to problem (4.11) is very important.

Problem (4.11) is a non-convex optimization problem because the objective function is not a convex function. It is therefore very challenging to directly solve it. Consequently, we resort to some approximations to efficiently solve problem (4.11). Notice that the numerator of the objective function can be written as the difference of two concave functions, i.e.,

$$\log_2 (1 + \Gamma_{k,u(k,l)}^l) = g_k^l(\mathbf{P}^l) - f_k^l(\mathbf{P}^l)$$

with

$$\begin{aligned} f_k^l(\mathbf{P}^l) &\triangleq \log_2 \left(\sum_{j \neq k}^{\mathcal{K}} P_j^l G_{j,u(k,l)}^l + \bar{N}_k^l \right), \quad g_k^l(\mathbf{P}^l) \triangleq \log_2 \left(\sum_{j=1}^{\mathcal{K}} P_j^l G_{j,u(k,l)}^l + \bar{N}_k^l \right) \\ \bar{N}_k^l &\triangleq N_0 + \sum_{q=1}^{\mathcal{K}} \sum_{l'=1}^L P_q^{l'} V_{|l-l'|} H_{q,u(k,l)}^{l'} \end{aligned} \quad (4.12)$$

Motivated by the approach developed in [72, 73, 75], we deal with the non-convexity by conservatively approximating the objective function. This is done by invoking the first order approximation. More specifically, given $\bar{\mathbf{P}}$, a feasible point for the optimization problem (4.11), $f_k^l(\mathbf{P}^l)$ is approximated by its first order Taylor expansion which is given by

$$\begin{aligned} f_k^l(\mathbf{P}^l) &\approx \log_2 \left(\sum_{j \neq k}^{\mathcal{K}} \bar{P}_j^l G_{j,u(k,l)}^l + \bar{N}_k^l \right) + \sum_{j \neq k}^{\mathcal{K}} \left(\frac{G_{j,u(k,l)}^l}{\ln 2 \left(\sum_{j \neq k}^{\mathcal{K}} \bar{P}_j^l G_{j,u(k,l)}^l + \bar{N}_k^l \right)} (P_j^l - \bar{P}_j^l) \right) \\ &\triangleq \bar{f}_k^l(\mathbf{P}^l, \bar{\mathbf{P}}^l) \end{aligned} \quad (4.13)$$

By using (4.13), we can conservatively approximate problem (4.11) as

$$\max_{\mathbf{P} \in \mathcal{X}} \overline{\mathbf{EE}}(\mathbf{P}, \bar{\mathbf{P}}) = \frac{\sum_{k=1}^{\mathcal{K}} \sum_{l=1}^L B \left(g_k^l(\mathbf{P}^l) - \bar{f}_k^l(\mathbf{P}^l, \bar{\mathbf{P}}^l) \right)}{\sum_{k=1}^{\mathcal{K}} \left(P_{c,k} + \sum_{l=1}^L \xi P_k^l \right)} \quad (4.14)$$

Lemma 4.1. *The objective function $\overline{\mathbf{EE}}(\mathbf{P}, \bar{\mathbf{P}})$ is a quasi-concave function.*

Proof: Consider the super-level set defined as

$$S_\alpha = \{\mathbf{P} \in \mathcal{X} \mid \overline{\mathbf{E}\mathbf{E}}(\mathbf{P}, \overline{\mathbf{P}}) \geq \alpha, \forall \alpha \in \mathbb{R}\}.$$

We know that $\overline{\mathbf{E}\mathbf{E}}(\mathbf{P}, \overline{\mathbf{P}})$ is a quasi-concave function if S_α is a convex set. Suppose $\alpha = 0$, we have $\overline{\mathbf{E}\mathbf{E}}(\mathbf{P}, \overline{\mathbf{P}}) \geq 0$ which implies that

$$S_0 = \left\{ \mathbf{P} \mid - \sum_{k=1}^{\mathcal{K}} \sum_{l=1}^L B \left(g_k^l(\mathbf{P}^l) - \bar{f}_k^l(\mathbf{P}^l, \overline{\mathbf{P}}^l) \right) \leq 0 \right\}$$

It is straightforward to see that S_0 is a halfspace which is a convex set based on the structure of the function $g_k(\cdot)$ and $f_k(\cdot)$. For $\alpha \neq 0$, we have

$$S_\alpha = \left\{ \mathbf{P} \mid \alpha \sum_{k=1}^{\mathcal{K}} \left(P_{c,k} + \sum_{l=1}^L \xi P_k^l \right) - \sum_{k=1}^{\mathcal{K}} \sum_{l=1}^L B_T \left(g_k^l(\mathbf{P}^l) - \bar{f}_k^l(\mathbf{P}^l, \overline{\mathbf{P}}^l) \right) \leq 0 \right\}$$

which is also halfspace hence a convex set. Therefore, S_α is a convex set $\forall \alpha \in \mathbb{R}$. Hence, $\overline{\mathbf{E}\mathbf{E}}(\mathbf{P}, \overline{\mathbf{P}})$ is a quasi-concave function of \mathbf{P} . \blacksquare

Joint successive convex approximation and Dinkelbach procedure

In this section, we propose a joint Successive Convex Approximation along with Dinkelbach's procedure Algorithm (*SCADA*) to solve (4.14). In fact, problem (4.14) was obtained by approximating the optimization problem (4.11) at a given feasible point $\overline{\mathbf{P}}$. We can circumvent the hurdle of solving the non-convex optimization problem (4.11) by solving a sequence of approximated problem as indicated in (4.14). At each iteration, the conservative approximation can be further improved if we successively approximate problem (4.11) based on the optimal solution obtained by solving the optimization problem (4.14) in the previous iteration. This is basically the idea of successive convex approximation introduced in Subsection 2.7.1. Starting from a feasible point $\overline{\mathbf{P}}^{(0)}$, let $\widehat{\mathbf{P}}^{(n-1)}$ be the optimal solution obtained in the $(n-1)$ th iteration, the function $f_k^l(\mathbf{P}^l)$ can be approximated at the n th iteration using $\overline{\mathbf{P}}^{(n-1)} = \widehat{\mathbf{P}}^{(n-1)}$. More specifically, at the n th iteration, we

solve the following optimization problem

$$\hat{\mathbf{P}}^{(n)} = \arg \max_{\mathbf{P} \in \mathcal{X}} \overline{\mathbf{E}\mathbf{E}}(\mathbf{P}, \overline{\mathbf{P}}^{(n-1)}) \quad (4.15)$$

To find a solution to problem (4.15), we use a parametric optimization approach which can be solved by the Dinkelbach's procedure [76] which was introduced in Section 2.8. Note several approaches such as parametric and non-parametric optimization to solve fractional optimization were summarized in [116].

Based on Section 2.8, to find the solution to problem (4.15), we solve the following convex optimization problem

$$\max_{\mathbf{P} \in \mathcal{X}} \phi(\mathbf{P}, \overline{\mathbf{P}}^{(n-1)}) \triangleq \sum_{k=1}^{\mathcal{K}} \sum_{l=1}^L B \left(g_k^l(\mathbf{P}^{l,(n-1)}) - \bar{f}_k^l(\mathbf{P}^l, \overline{\mathbf{P}}^{l,(n-1)}) \right) - \pi \sum_{k=1}^{\mathcal{K}} \left(P_{c,k} + \sum_{l=1}^L \xi P_k^l \right) \quad (4.16)$$

Problem (4.16) is a parametric optimization problem with parameter π . It can be efficiently solved iteratively by using Algorithm 6.

Algorithm 6 Dinkelbach's procedure for solving (4.15) [76]

- 1: **Input** A solution accuracy $\tilde{\epsilon} > 0$ and $\pi = 0$.
 - 2: **repeat**
 - 3: Compute \mathbf{P} by solving problem (4.16);
 - 4: Update $\pi = \frac{\sum_{k=1}^{\mathcal{K}} \sum_{l=1}^L B \left(g_k^l(\mathbf{P}^l) - \bar{f}_k^l(\mathbf{P}^l, \overline{\mathbf{P}}^{l,(n-1)}) \right)}{\sum_{k=1}^{\mathcal{K}} (P_{c,k} + \sum_{l=1}^L \xi P_k^l)}$;
 - 5: **until** $\phi(\mathbf{P}, \overline{\mathbf{P}}^{(n-1)}) \leq \tilde{\epsilon}$
 - 6: **Output** The solution \mathbf{P} .
-

Consequently, the proposed centralized method to solve (4.11) is summarized in Algorithm 7.

Algorithm 7 SCADA algorithm for solving problem (4.11)

- 1: **Input** A solution accuracy $\epsilon > 0$ and a feasible point $\bar{\mathbf{P}}[0]$ for problem (4.11).
 - 2: Set $n = 0$;
 - 3: **repeat**
 - 4: $n = n + 1$;
 - 5: Compute $\hat{\mathbf{P}}^{(n)}$ by using Algorithm 6 to solve $\hat{\mathbf{P}}^{(n)} = \arg \max_{\mathbf{P} \in \mathcal{X}} \phi(\mathbf{P}, \bar{\mathbf{P}}^{(n-1)})$;
 - 6: Update $\bar{\mathbf{P}}^{(n)} = \hat{\mathbf{P}}^{(n)}$;
 - 7: **until** stopping criterion
 - 8: **Output** the approximated solution $\hat{\mathbf{P}}^{(n)}$.
-

To find the solution for problem (4.11), the proposed centralized SCADA requires a total complexity of $\kappa_\pi \cdot \mathcal{O}((LK)^3)$ per iteration, where κ_π is the total number of iterations required by the Dinkelbach's procedure (i.e., Algorithm 6) to converge.

Convergence Analysis

Theorem 4.1. *The sequence $\left\{ \overline{\mathbf{EE}} \left(\hat{\mathbf{P}}^{(n)}, \bar{\mathbf{P}}^{(n)} \right) \right\}_{n=1}^{\infty}$ generated by the proposed Algorithm 7 converges.*

Proof: From step 6 of Algorithm 7, we see that the solution $\hat{\mathbf{P}}^{(n)}$ obtained at the n -th iteration is used as the iterated value for problem (4.15) at the $(n + 1)$ -th iteration which implies that

$$\overline{\mathbf{EE}} \left(\hat{\mathbf{P}}^{(n+1)}, \bar{\mathbf{P}}^{(n)} \right) = \overline{\mathbf{EE}} \left(\hat{\mathbf{P}}^{(n+1)}, \hat{\mathbf{P}}^{(n)} \right) \geq \overline{\mathbf{EE}} \left(\hat{\mathbf{P}}^{(n)}, \hat{\mathbf{P}}^{(n)} \right) = \mathbf{EE} \left(\hat{\mathbf{P}}^{(n)} \right)$$

and

$$\begin{aligned} \mathbf{EE} \left(\hat{\mathbf{P}}^{(n)} \right) &= \frac{\sum_{k=1}^{\mathcal{K}} \sum_{l=1}^L B \left(g_k^l \left(\hat{\mathbf{P}}^{l,(n)} \right) - f_k^l \left(\hat{\mathbf{P}}^{l,(n)} \right) \right)}{\sum_{k=1}^{\mathcal{K}} \left(P_{c,k} + \sum_{l=1}^L \xi \hat{P}_k^{l,(n)} \right)} \\ &\stackrel{(a)}{\geq} \frac{\sum_{k=1}^{\mathcal{K}} \sum_{l=1}^L B_T \left(g_k^l \left(\hat{\mathbf{P}}^{l,(n)} \right) - \bar{f}_k^l \left(\hat{\mathbf{P}}^{l,(n)}, \bar{\mathbf{P}}^{l,(n-1)} \right) \right)}{\sum_{k=1}^{\mathcal{K}} \left(P_{c,k} + \sum_{l=1}^L \xi \hat{P}_k^{l,(n)} \right)} \\ &= \overline{\mathbf{EE}} \left(\hat{\mathbf{P}}^{(n)}, \bar{\mathbf{P}}^{(n-1)} \right) \end{aligned} \quad (4.17)$$

where (a) follows from the concavity of $f_k^l(\widehat{\mathbf{P}}^{l,(n)})$. Due to secondary BSs power constraint and primary interference constraint, the objective function $\overline{\mathbf{E}\mathbf{E}}(\widehat{\mathbf{P}}^{(n)}, \overline{\mathbf{P}}^{(n-1)})$ is bounded above. Consequently, we can say that the sequence of objective function generated by the proposed Algorithm 7 converges. ■

Theorem 4.2. *Any limit point of the optimization problem (4.15) generated by Algorithm 7 is a stationary point of problem (4.11).*

Proof: To prove Theorem 4.2, we only need to demonstrate that the proposed Algorithm 7 is a special case of the successive upper-bound minimization (SUM) algorithm [73]. Note that,

- $\overline{\mathbf{E}\mathbf{E}}(\mathbf{P}, \overline{\mathbf{P}})$ is a continuous function of both \mathbf{P} and $\overline{\mathbf{P}}$.
- In addition to that, $\overline{\mathbf{E}\mathbf{E}}(\mathbf{P}, \overline{\mathbf{P}})$ is a locally tight lower bound for $\mathbf{E}\mathbf{E}(\mathbf{P})$, i.e.,

$$\begin{aligned} \overline{\mathbf{E}\mathbf{E}}(\overline{\mathbf{P}}, \overline{\mathbf{P}}) &= \frac{\sum_{k=1}^{\mathcal{K}} \sum_{l=1}^L B \left(g_k^l(\overline{\mathbf{P}}^l) - \overline{f}_k^l(\overline{\mathbf{P}}^l, \overline{\mathbf{P}}^l) \right)}{\sum_{k=1}^{\mathcal{K}} \left(P_{c,k} + \sum_{l=1}^L \xi P_k^l \right)} \\ &= \frac{\sum_{k=1}^{\mathcal{K}} \sum_{l=1}^L B \left(g_k^l(\overline{\mathbf{P}}^l) - f_k^l(\overline{\mathbf{P}}^l) \right)}{\sum_{k=1}^{\mathcal{K}} \left(P_{c,k} + \sum_{l=1}^L \xi P_k^l \right)} \\ &= \mathbf{E}\mathbf{E}(\overline{\mathbf{P}}) \end{aligned}$$

and

$$\begin{aligned} \overline{\mathbf{E}\mathbf{E}}(\mathbf{P}, \overline{\mathbf{P}}) &= \frac{\sum_{k=1}^{\mathcal{K}} \sum_{l=1}^L B \left(g_k^l(\mathbf{P}^l) - \overline{f}_k^l(\mathbf{P}^l, \overline{\mathbf{P}}^l) \right)}{\sum_{k=1}^{\mathcal{K}} \left(P_{c,k} + \sum_{l=1}^L \xi P_k^l \right)} \\ &\leq \frac{\sum_{k=1}^{\mathcal{K}} \sum_{l=1}^L B \left(g_k^l(\mathbf{P}^l) - f_k^l(\mathbf{P}^l) \right)}{\sum_{k=1}^{\mathcal{K}} \left(P_{c,k} + \sum_{l=1}^L \xi P_k^l \right)} \\ &= \mathbf{E}\mathbf{E}(\mathbf{P}) \end{aligned}$$

- Also it is straightforward to verify that $\frac{\partial \overline{\mathbf{E}\mathbf{E}}(\mathbf{P}, \overline{\mathbf{P}})}{\partial \mathbf{P}} \Big|_{\mathbf{P} \rightarrow \overline{\mathbf{P}}} = \frac{\partial \mathbf{E}\mathbf{E}(\mathbf{P})}{\partial \mathbf{P}} \Big|_{\mathbf{P} \rightarrow \overline{\mathbf{P}}}$

Therefore, the proposed Algorithm 7 is essentially the SUM approach [73]. And according to [73, Theorem1], any limit point generated by Algorithm 7 is a stationary point of problem (4.11). Theorem 4.2 is thus proved. ■

Alternating Optimization

As previously mentioned, we solve the joint subcarrier-point allocation problem (5.3) by resorting to the alternating-based optimization method introduced in Subsection 2.7.2. We summarize the alternating-based approach in Algorithm 8. It is worthwhile mentioning that Algorithm 8 is guaranteed to converge by [58, Proposition 2].

Algorithm 8 Alternating-based method for solving problem (5.3)

1. Initialize $\tilde{\mathbf{P}}$, and find $\Theta_k, \forall k$ using (4.10);
 2. Repeat
 - (a) Compute $\hat{\mathbf{P}}$ by running Algorithm 7;
 - (b) Set $\tilde{\mathbf{P}} = \hat{\mathbf{P}}$;
 - (c) Find $\Theta_k, \forall k$ using (4.10);
 3. Stop when convergence is reached.
-

Cooperative Distributed Approach

The implementation of Algorithm 8 requires the central algorithm 7 to find the power allocation (step 2-a). Executing the proposed centralized Algorithm 7, as most of centralized algorithms, can be computationally demanding especially in the case of large scale networks. In this section, in order to alleviate the communication overhead and signaling exchanges required by any centralized implementation, we propose a semi-distributed version of Algorithm 7 based on dual decomposition to find the power allocation.

For the implementation of a distributed algorithm, a separable objective function is needed. Finding some mechanisms to parallelize the objective function of problem (4.11) is crucial for the development of a decentralized method. Some approaches were investigated in the literature [73, 117]. Following the same philosophy of decomposition presented in [73, 117], we approximate the difference of concave

functions in the objective function of problem (4.11) by using the first order Taylor expansion. More concretely, given feasible point $\bar{\mathbf{P}}$, $g_k^l(\mathbf{P}^l)$ can be approximated as

$$\begin{aligned} & g_k^l(\mathbf{P}^l) \\ & \approx \log_2 \left(\sum_{j=1}^{\mathcal{K}} \bar{P}_j^l G_{j,u(k,l)}^l + \bar{N}_k^l \right) + \sum_{j \neq k}^{\mathcal{K}} \left(\frac{G_{j,u(k,l)}^l}{\ln 2 \left(\sum_{i=1}^{\mathcal{K}} \bar{P}_i^l G_{i,u(k,l)}^l + \bar{N}_k^l \right)} \left(P_j^l - \bar{P}_j^l \right) \right) \\ & = \bar{g}_k^l(\mathbf{P}^l, \bar{\mathbf{P}}^l) \end{aligned} \quad (4.18)$$

By combining (4.13) and (4.18), it results that

$$\begin{aligned} & \sum_{k=1}^{\mathcal{K}} \sum_{l=1}^L \left(\bar{g}_k^l(\mathbf{P}^l, \bar{\mathbf{P}}^l) - \bar{f}_k^l(\mathbf{P}^l, \bar{\mathbf{P}}^l) \right) \triangleq \sum_{k=1}^{\mathcal{K}} \sum_{l=1}^L \psi_k^l(P_k^l, \bar{\mathbf{P}}^l) \\ & \triangleq \sum_{k=1}^{\mathcal{K}} \sum_{l=1}^L \left(\log_2 \left(1 + \frac{P_k^l G_{k,u(k,l)}^l}{\sum_{j \neq k}^{\mathcal{K}} \bar{P}_j^l G_{j,u(k,l)}^l + \bar{N}_k^l} \right) - \frac{1}{\ln 2} \sum_{j \neq k}^{\mathcal{K}} \varrho_{k,j}^l(\bar{\mathbf{P}}^l) \left(P_k^l - \bar{P}_k^l \right) \right) \end{aligned} \quad (4.19)$$

where

$$\varrho_{k,j}^l(\bar{\mathbf{P}}^l) \triangleq \frac{G_{k,u(j,l)}^l}{\sum_{i \neq j}^{\mathcal{K}} \bar{P}_i^l G_{i,u(j,l)}^l + \bar{N}_j^l} - \frac{G_{k,u(j,l)}^l}{\sum_{i=1}^{\mathcal{K}} \bar{P}_i^l G_{i,u(j,l)}^l + \bar{N}_j^l}$$

In fact, $\varrho_{k,j}^l(\bar{\mathbf{P}}^l)$ can be interpreted as the interference price [118, 119] that limits the transmit power of secondary BS k on subcarrier l . Consequently, the proposed distributed scheme can also be understood as a pricing-based approach. Using (4.19), the objective function of problem (4.11) can be restrictively approximated as

$$\frac{\sum_{k=1}^{\mathcal{K}} \sum_{l=1}^L B \left(g_k^l(\mathbf{P}^l) - f_k^l(\mathbf{P}^l) \right)}{\sum_{k=1}^{\mathcal{K}} \left(P_{c,k} + \sum_{l=1}^L \xi P_k^l \right)} \approx \frac{\sum_{k=1}^{\mathcal{K}} \left(B \sum_{l=1}^L \psi_k^l(P_k^l, \bar{\mathbf{P}}^l) - \frac{\tau_k}{2} \|\mathbf{P}_k - \bar{\mathbf{P}}_k\|^2 \right)}{\sum_{k=1}^{\mathcal{K}} \left(P_{c,k} + \sum_{l=1}^L \xi P_k^l \right)} \triangleq \widetilde{\mathbf{EE}}(\mathbf{P}, \bar{\mathbf{P}}) \quad (4.20)$$

where $\mathbf{P}_k \triangleq (P_k^1, \dots, P_k^L)^\top$ corresponds to the transmit power vector of the k th secondary BS whereas τ_k is a proximal-like regularization parameter which plays an important role in the convergence of the iterative approach destined to solve problem (4.11) [69]. The function given in (4.20) is the global (network-centric) energy-efficiency function. To provide a distributed approach, we need to write a

BS-centric (in contrast to network-centric) objective function. To do so, we conservatively approximate problem (4.11) using similar argument as in the previous section. More specifically, at the n th iteration, we solve the following optimization problem

$$\begin{aligned} \widehat{\mathbf{P}}^{(n)} = & \arg \max_{\mathbf{P} \in \overline{\mathcal{X}}} \widetilde{\mathbf{E}\mathbf{E}} \left(\mathbf{P}, \overline{\mathbf{P}}^{(n)} \right) \\ \text{s.t.} & \sum_{k=1}^{\mathcal{K}} \sum_{l=1}^L P_k^l \sum_{\nu \in \mathcal{I}_{q,k}^l} H_{k,q}^{\nu} V_{|l-\nu|} \leq I_q^{\max}, \forall q \end{aligned} \quad (4.21)$$

where

$$\overline{\mathcal{X}} \triangleq \left\{ \mathbf{P} \left\{ \begin{array}{l} \sum_{l=1}^L P_k^l \leq P_{\max}, \forall k \\ P_k^l \geq 0, \forall k, \forall l \end{array} \right. \right\} \quad (4.22)$$

One can prove by using the argument provided in Lemma 4.1 that problem (4.21) is a quasi-concave optimization problem. Problem (4.21) can therefore be solved by resorting to the Dinkelbach's procedure. This is done by solving the convex optimization problem (4.23) given by.

$$\begin{aligned} \max_{\mathbf{P} \in \overline{\mathcal{X}}} & \sum_{k=1}^{\mathcal{K}} \left(\sum_{l=1}^L \psi_k^l(P_k^l, \overline{\mathbf{P}}^{l,(n-1)}) - \frac{\tau_k}{2} \|\mathbf{P}_k - \overline{\mathbf{P}}_k^{(n-1)}\|^2 - \pi \sum_{l=1}^L (\xi P_k^l + P_c) \right) \\ \text{s.t.} & \sum_{k=1}^{\mathcal{K}} \sum_{l=1}^L P_k^l \sum_{\nu \in \mathcal{I}_{q,k}^l} H_{k,q}^{\nu} V_{|l-\nu|} \leq I_q^{\max}, \forall q \end{aligned} \quad (4.23)$$

Although the objective function of the convex optimization problem (4.23) is a separable function, the problem cannot be solved in parallel at the secondary BSs due to the couple primary interference constraint. We need to further investigate the dual problem. The Lagrangian function associated with problem (4.23) is given by

$$\begin{aligned} \widehat{\mathcal{L}}(\mathbf{P}, \boldsymbol{\lambda}, \overline{\mathbf{P}}^{(n-1)}) = & \sum_{q=1}^{\mathcal{Q}} \lambda_q \left(\sum_{k=1}^{\mathcal{K}} \sum_{l=1}^L P_k^l \sum_{\nu \in \mathcal{I}_{q,k}^l} H_{k,q}^{\nu} V_{|l-\nu|} - I_q^{\max} \right) \\ & - \sum_{k=1}^{\mathcal{K}} \left(\sum_{l=1}^L \psi_k^l(P_k^l, \overline{\mathbf{P}}^{l,(n-1)}) - \frac{\tau_k}{2} \|\mathbf{P}_k - \overline{\mathbf{P}}_k^{(n-1)}\|^2 - \pi \sum_{l=1}^L (\xi P_k^l + P_c) \right) \end{aligned} \quad (4.24)$$

with $\mathbf{P} \in \overline{\mathcal{X}}$, and $\boldsymbol{\lambda} = (\lambda_1, \dots, \lambda_{\mathcal{Q}})^{\top}$ is the dual variable vector associated with the primary interference constraint.

Motivated by the dual decomposition approach given in Section 2.6, we divide the optimization problem (4.23) into two levels of optimization problem. At the lower level, the optimization problem is solved in parallel at the secondary BSs. Consequently, each BS needs to solve the local convex optimization problem (4.25) given by

$$\begin{aligned} \max_{P_k^l, \forall l} \sum_{l=1}^L \psi_k^l(P_k^l, \bar{\mathbf{P}}^{l, (n-1)}) - \frac{\tau_k}{2} \|\mathbf{P}_k - \bar{\mathbf{P}}_k^{(n-1)}\|^2 - \pi \sum_{l=1}^L (\xi P_k^l + P_c) - \sum_{q=1}^Q \lambda_q \sum_{l=1}^L P_k^l \sum_{l' \in \mathcal{I}_{q,k}^l} H_{k,q}^{l'} V_{|l-l'|} \\ \text{s.t. } P_k^l \geq 0, \forall l, \quad \sum_{l=1}^L P_k^l \leq P_{\max} \end{aligned} \quad (4.25)$$

At the higher level, the master problem is given as

$$\min_{\boldsymbol{\lambda} \geq 0} \max_{\mathbf{P}} \widehat{\mathcal{L}}(\mathbf{P}, \boldsymbol{\lambda}, \bar{\mathbf{P}}^{(n-1)}) \quad (4.26)$$

The value of $\boldsymbol{\lambda}$ can be determined at the higher level by using the sub-gradient method [70, 71]. More specifically, at the m th iteration, $\lambda^{(m)}$ is given by

$$\lambda_q^{(m)} = \left(\lambda^{(m-1)} + \beta_q \left(\sum_{k=1}^{\mathcal{K}} \sum_{l=1}^L P_k^l G_{k,p}^l \sum_{l' \in \mathcal{I}_k^l} V_{|l-l'|} - I_{\text{tot}} \right) \right)^+, \forall q \quad (4.27)$$

where $\beta_q > 0$ is small positive step size and $(\cdot)^+$ denotes the projection onto the nonnegative orthant. Since problem (4.23) is a convex problem, the dual variable vector $\boldsymbol{\lambda}^{(m)}$ generated by the subgradient approach is guaranteed to converge to the dual optimal $\boldsymbol{\lambda}^*$ as $m \rightarrow \infty$ [70, 120]. Next proposition summarizes the optimal solution for problem (4.25).

Proposition 4.1. *At the lower level, the optimal power that secondary BS k allocates on subcarrier l is given by*

$$P_k^l = \left(\max \left(\frac{-b_k^l + \sqrt{(b_k^l)^2 - 4\tau_k \zeta_k^l \left(\alpha_k^l - \frac{\zeta_k^l}{\ln 2} - \tau_k \bar{P}_k^l [n-1] \right)}}{2\tau_k \zeta_k^l}, \right. \right. \\ \left. \left. \frac{-b_k^l - \sqrt{(b_k^l)^2 - 4\tau_k \zeta_k^l \left(\alpha_k^l - \frac{\zeta_k^l}{\ln 2} - \tau_k \bar{P}_k^l [n-1] \right)}}{2\tau_k \zeta_k^l} \right) \right)^+ \quad (4.28)$$

where the variables α_k^l, ζ_k^l are defined in (4.37) and b_k^l in (4.38).

Proof: See Appendix 4.A. ■

Our proposed dual decomposition-based decentralized joint successive convex approximation with Dinkelbach's procedure to solve problem (4.11) is summarized in Algorithm 9.

Algorithm 9 Dual Decomposition-based Distributed SCADA for solving (4.11)

- 1: Initialization: $\bar{\mathbf{P}}^{(0)}, n = 1$;
 - 2: **repeat**
 - 3: Set $\pi = 0$;
 - 4: **repeat**
 - 5: Initialization $\boldsymbol{\lambda}^{(0)}, m = 1$;
 - 6: **repeat**
 - 7: Find \mathbf{P}_k in parallel at each secondary BS using (4.28);
 - 8: Compute $\lambda_q, \forall q$ according to the sub-gradient update (5.21b);
 - 9: **until** $|\lambda_q^{(m)} - \lambda_q^{(m-1)}| < \epsilon_2, \forall q$
 - 10: Update π as follows

$$\pi \leftarrow \widetilde{\mathbf{EE}}(\mathbf{P}, \bar{\mathbf{P}}^{(n-1)})$$
 - 11: **until** Convergence of the Dinkelbach's procedure;
 - 12: Update $\bar{\mathbf{P}}^{(n)} = \bar{\mathbf{P}}^{(n-1)} + \gamma[n](\mathbf{P} - \bar{\mathbf{P}}^{(n-1)})$;
 - 13: **until** stopping criterion
 - 14: **Output** the approximated solution $\hat{\mathbf{P}}$.
-

Let κ_λ be the number of iterations it takes for the sub-gradient approach to converge. The dual decomposition-based distributed SCADA requires a total complexity of $\kappa_\pi LK \cdot \mathcal{O}(\kappa_\lambda Q)$ per iteration.

Implementation issues and overhead signaling exchange for Algorithm 9

To implement the proposed Algorithm 9, each secondary BS should know the interferences generated by other secondary BSs, their direct channel gains and

the interference prices. Measuring the interferences and direct channel gains can be locally done within each secondary cell. The interference prices should be exchanged between the secondary BSs. In fact, the prices should be broadcasted by each secondary BS to the other running secondary BSs at the beginning of each iteration.

At each round at the lower level, each secondary BS k need to broadcast $\{\varrho_{j,k}^l(\bar{\mathbf{P}}^l)\}_{l=1}^L$ to the $\mathcal{K} - 1$ other secondary BSs. Each $\varrho_{j,k}^l(\bar{\mathbf{P}}^l)$ contains the interferences plus the noise (IN) measured on the l th subcarrier, the useful signal and the cross-channel gain. As for the cross-channel gain, it can be acquired at the j th secondary BS using uplink-downlink duality. The overhead complexity at the lower level is therefore $2L(\mathcal{K} - 1)\mathcal{K}$ real values exchanged in a point-to-point fashion. The update π and $\boldsymbol{\lambda}$ is done at the higher level where one of the secondary BSs gathers all power allocation values and all achievable rate. We may therefore consider a CR network where all secondary BSs are connected by dedicated backhaul links Hence, from lower to higher level, $(\mathcal{K} - 1)(L + 3)$ real values are exchanging through backhaul links such as optical fibers. We assume that the successive convex approximation converges within κ iterations. Consequently, the total communication overhead of the proposed Algorithm 9 is $\kappa\kappa_\pi\kappa_\lambda(\mathcal{K} - 1)(2L\mathcal{K} + L + 3)$ real scalars.

It is worthwhile to note that for practical implementation, the feedback overhead may be considerably reduced while executing the algorithm. Firstly, the secondary BSs may exchange the interferences price only when it changes significantly. Notice that due to the quasi-static assumption on the channel gains, there will be no need to exchange the interference prices at each iteration. Secondly, strong interferences are usually generated by nearby cells. Consequently, signaling exchanges may be done only with cells located in the same vicinity. Hence, this gives to the distributed algorithm an important practical (implementation) advantage over centralized in terms of scalability.

Non-Cooperative Transmission Strategy

The proposed Algorithm 7 in Section 4.4 requires a central node that has full knowledge of CSI and interferences at each MT. In Section 4.5, a cooperative semi-distributed approach that needs some signaling exchanges among the secondary BS was proposed. In this section, we proposed a totally distributed scheme that does not require the intervention of a central controller or signaling exchange. We investigate the scenario where the secondary BSs are not interacting with one another so that resource allocation can be done based only on local information. More precisely, the interferences radiated by other secondary BSs are treated as noise at each secondary MT. The basis ideology behind our proposed distributed approach is the inherent competitive nature of non-cooperative CR networks. In fact, each secondary BS aims to selfishly maximize his own utility function with no a priori knowledge of other secondary BSs strategies. The system is designed to reach a Nash equilibrium (NE) which is a very well-known concept within the framework of game theory [121].

The utility function for each player ¹ (secondary base station) is defined as follow

$$U_k(\mathbf{P}_k, \mathbf{P}_{-k}) = \mathbf{E}\mathbf{E}_k = \frac{\sum_{l=1}^L B \log_2 \left(1 + \frac{P_k^l G_{k,u(k,l)}^l}{N_0 + I_{k,u(k,l)}^l} \right)}{P_{c,k} + \sum_{l=1}^L \xi P_k^l} \quad (4.29)$$

where $\mathbf{P}_{-k} \triangleq \mathbf{P}/\mathbf{P}_k$ is the set of all secondary BS power allocation except the k th one. For the operation of the non-cooperative CR network, the following two constraints are considered.

- The individual interference constraint defined in (4.7).
- Total power constraint i.e., $\sum_{l=1}^L P_k^l \leq P_{\max}, \forall k$.

¹In the sequel, the term *player* and the term *secondary base station* is used interchangeably.

The admission strategy \mathcal{P}_k for player k is obtained by combining the two aforementioned constraints, i.e.,

$$\mathcal{P}_k \triangleq \left\{ \mathbf{P}_k : \left\{ \begin{array}{l} \sum_{l=1}^L P_k^l \sum_{l' \in \mathcal{I}_{q,k}^l} H_{k,q}^{l'} V_{|l-l'|} \leq I_q^{k,\max}, \forall q \\ P_k^l \geq 0, \forall l, \quad \sum_{l=1}^L P_k^l \leq P_{\max} \end{array} \right. \right\} \quad (4.30)$$

and denote by $\mathcal{P} = \mathcal{P}_1 \times \mathcal{P}_2 \times \cdots \times \mathcal{P}_{\mathcal{K}}$, the set of feasible power for all secondary BSs. Similarly to previous sections, the joint subcarrier-power resource allocation problem is solved by using the alternating optimization method [68]. Given a feasible power allocation $\tilde{\mathbf{P}}_k \in \mathcal{P}_k$, each secondary BS k assigns the subcarriers using the following heuristic scheme

$$u(k, l) = \arg \max_{u=1, \dots, \mathcal{U}_k} \frac{\tilde{P}_k^l G_{k,u}^l}{N_0 + I_{k,u}^l} \quad (4.31)$$

where $I_{k,u}^l$ is given in (4.4). Once the subcarrier allocation is known, the power allocation is solved as the solution of non-cooperative power allocation game (NPAG) which is defined as

$$\mathcal{G} = \{\mathcal{K}, \{\mathcal{P}_k\}, \{U_k\}\}$$

where $\mathcal{K} = \{1, 2, \dots, \mathcal{K}\}$ is the index set of the secondary BSs, \mathcal{P}_k the strategy space for the k th secondary BS defined in (4.30) and U_k denotes the payoff function of the k th player formulated in (4.29).

The non-cooperative game is executed in a sequential fashion at the secondary BSs. More specifically, the game is formulated as

$$\text{NPAG} : \quad \max_{\mathbf{P}_k \in \mathcal{P}_k} U_k(\mathbf{P}_k, \mathbf{P}_{-k}), \quad \forall k \in \mathcal{K} \quad (4.32)$$

It is worthwhile noting that although each player selfishly optimizes his payoff function, any change in his power allocation does influence the power allocation of all other players whenever the system is not in an equilibrium state. Therefore, it is important to characterize the equilibrium of the proposed NPAG game. This is done in the following subsection.

Existence of Nash Equilibrium and Description of our proposed Algorithm

Definition 4.1. A strategy profile \mathbf{P}^* is said to be a pure-strategy Nash equilibrium (NE) if it meets the following requirement.

$$U_k(\mathbf{P}_k^*, \mathbf{P}_{-k}^*) \geq U_k(\mathbf{P}_k, \mathbf{P}_{-k}^*), \quad \forall k, \quad \forall \mathbf{P}_k \in \mathcal{P}_k$$

From Definition 4.2, it can be inferred that a pure-strategy Nash equilibrium is an action profile with the important property that no single player can obtain a higher utility function value by deviating unilaterally from this profile. Now, we proceed to demonstrate that a pure-strategy NE is attainable under the proposed game (4.32).

Proposition 4.2. The NPAG game will reach a pure-strategy Nash equilibrium.

Proof: In [121], the authors provide a sufficient condition for the existence of a NE in a game. We summarize the sufficient condition as in the following claim

Fact 4.1. There exists a pure-strategy NE in the NPAG game if

- The strategy set $\mathcal{P}_k, \forall k$ is a closed and bounded convex set.
- The utility function $U_k(\mathbf{P}_k, \mathbf{P}_{-k})$ is continuous in $(\mathbf{P}_k, \mathbf{P}_{-k})$ and quasi-concave in \mathbf{P}_k .

Clearly, the strategy set \mathcal{P}_k meets the first condition as it is defined as the secondary power and primary interference constraint. The utility function $U_k(\mathbf{P}_k, \mathbf{P}_{-k})$ which is a continuous function of $(\mathbf{P}_k, \mathbf{P}_{-k})$ is written as a fractional function. Moreover, the function $U_k(\mathbf{P}_k, \mathbf{P}_{-k})$ can be proved to be a quasi-concave function of \mathbf{P}_k by using similar argument as in Lemma 4.1. This concludes our proof. ■

Proposition 4.3. The best response of each player can be found using the Dinkelbach's procedure summarized in Algorithm 10 and is given by

$$P_k^l = \left[\frac{\frac{1}{\ln 2}}{\pi + \eta_k + \sum_{q=1}^{\mathcal{Q}} \nu_q^k \sum_{l' \in \mathcal{I}_{q,k}^l} H_{k,q}^{l'} V_{|l-l'|}} - \frac{N_0 + I_{k,u(k,l)}^l}{G_{k,u(k,l)}^l} \right]^+ \quad (4.33)$$

$$\triangleq \Phi_k^l(\mathbf{P}_{-k})$$

where η_k and ν_k^q are Lagrangian multiplier associated with the total power and individual interference constraints, respectively.

Proof: See Appendix 4.B. ■

Algorithm 10 Dinkelbach's procedure to find the best response for each secondary BS

- 1: **Input** A solution accuracy $\tilde{\epsilon} > 0$ and $\pi = 0$.
 - 2: **repeat**
 - 3: Compute $P_k^l, \forall l$ by using (4.33);
 - 4: Update $\pi = U_k(\mathbf{P}_k, \mathbf{P}_{-k})$
 - 5: **until** $\sum_{l=1}^L \left(B \log_2 \left(1 + \frac{P_k^l G_{k,u}^l(k,l)}{N_0 + I_{k,u}^l(k,l)} \right) - \pi \xi P_k^l \right) - \pi P_{c,k} \leq \tilde{\epsilon}$
 - 6: **Output** \mathbf{P}_k .
-

Let $\Phi_k(\mathbf{P}_{-k}) \triangleq (\Phi_k^1(\mathbf{P}_{-k}), \dots, \Phi_k^L(\mathbf{P}_{-k}))^\top$ be the best response function for player k while $\Phi(\mathbf{P}) \triangleq (\Phi_1(\mathbf{P}_{-1}), \dots, \Phi_K(\mathbf{P}_{-K}))^\top$ denote the best response function of the entire secondary system. We elaborate the distributed power allocation algorithm for solving NPAG by providing a detailed step-by-step description as follows:

Step 1 - Initialization: Each secondary BS finds a feasible power allocation.

Step 2 - Interference measurement: Each secondary MT measures its received SINR on all assigned subcarriers based on best response power allocation vector of other secondary BSs at the previous iteration.

Step 3 - Interference feedback: The secondary MTs feed back the interferences measured in **Step 2** to their serving BS.

Step 4 - Best response calculation: Each secondary BS performs power allocation by using Algorithm 10.

Step 5 - Iteration: Repeat **Step 2** to **Step 4** until NPAG reaches an equilibrium.

Based on Proposition 4.2, we know there exists at least one NE for the NPAG game. It follows that the optimal strategy at any NE point must meet $\mathbf{P}^* = \Phi(\mathbf{P}^*)$. In other words, every limit point of the sequence generated by the proposed distributed power allocation algorithm is an equilibrium power profile strategy. It is

worthwhile to note that although several NE points may exist for the NPAG, once the power allocation converges to one NE, no player has the incentive to move to a different equilibrium point. Another important observation about the proposed algorithm is that it is a fully decentralized algorithm since only local information is needed at each secondary BS to compute his best response.

Uniqueness of the Nash Equilibrium

So far, we have seen that the proposed distributed algorithm is guaranteed to converge to a NE. However, multiple Nash equilibriums may exist. It is therefore important to investigate some conditions for the uniqueness of the NE, i.e., sufficient conditions that guarantee $\Phi(\mathbf{P})$ to be a contraction mapping. This is done via the following Proposition.

Proposition 4.4. *The proposed distributed power allocation Algorithm converges to a unique NE of NPAG game for any set of feasible initial power allocation if for each player k*

$$\sum_{j=1, j \neq k}^{\mathcal{K}} \sum_{l=1}^L \sum_{l' \in \mathcal{I}_{k,j}^l} \left(G_{j,u(k,l')}^{l'} V_{|l-l'|} \right)^2 \sup_{\boldsymbol{\vartheta}_k \in \Omega_k} \sum_{l=1}^L \sum_{\bar{l}=1}^L \frac{1_{\{\vartheta_k^l > \varsigma_k(\pi, \eta_k, \{\nu_q^k\}_{q=1}^{\mathcal{Q}})\}}}{\left(G_{k,u(k,l)}^l \right)^2} \times \quad (4.34)$$

$$\left((\vartheta_k^{\bar{l}})^2 \frac{\partial (1/\varsigma_k(\pi, \eta_k, \{\nu_q^k\}_{q=1}^{\mathcal{Q}}))}{\partial \vartheta_k^{\bar{l}}} + 1_{\{l=\bar{l}\}} \right)^2 < 1$$

where $\Omega_k = \prod_{l=1}^L \left(0, \frac{G_{k,u(k,l)}^l}{N_0} \right]$ and $\boldsymbol{\vartheta}_k = (\vartheta_k^1, \dots, \vartheta_k^L)^\top$ whereas ϑ_k^l and $\varsigma_k(\pi, \eta_k, \{\nu_q^k\}_{q=1}^{\mathcal{Q}})$ are defined in (4.44).

Proof: See Appendix 4.C. ■

Numerical results

In this section, we evaluate the performance of our proposed algorithms by carrying out numerical experiments that are conducted using Monte Carlo simulations. In

TABLE 4.1: Simulation Parameters

Parameters	Value
Primary BS maximum transmit power	33dBm
Secondary BS maximum transmit power	33dBm
Subcarrier bandwidth	15 KHz
Standard deviation of shadowing	9 dB
Noise power spectral density	-174 dBm/Hz
Solutions accuracy $\epsilon, \epsilon_1, \epsilon_2$	10^{-4}
Solutions accuracy $\tilde{\epsilon}, \bar{\epsilon}, \hat{\epsilon}$	10^{-4}
Drain efficiency ξ [122]	3.8
Circuit power $P_{c,k}, \forall k$	0.5 W
$\tau_k, \forall k$	10^{-9}

fact, all of our results are obtained by averaging over 300 channel realizations. We consider a CR network consisting of three primary BSs and four secondary BSs. Each primary BS serves one MT and the secondary BSs serve 5 MTs each. The distance between any secondary BS to the primary BSs is randomly chosen between 0.1 and 0.5 km. Each MT is randomly located within a circle of radius 0.5 km centered at its serving BS. The model parameters for our scenario is summarized in Table 4.1.

First, our proposed Algorithms 7 and 9 are compared with the optimal exhaustive search. We consider the cases where $L = 1$ and $L = 3$. When $L = 1$, we consider $\mathcal{K} = 4$ and $\mathcal{Q} = 3$. For $L = 1$, Algorithm 7 coincides with iterative power allocation algorithm (IPAA) given in [123], a special case of Algorithm 7. We also compare with the solution obtained in [61] that is a special case of [58] which we term as SCALE. The heuristic adaptive maximum power is also given. We use the term adaptive maximum power to emphasize that we adaptively reduce the maximum power by 2 % whenever the primary interference constraint is not met. From Figure 4.1, we see that our proposed Algorithms 7 and 9 achieve the GEE optimal solution for $P_{\max} \leq 20$ dBm. For higher values of P_{\max} , there is a marginal gap (less than 1.5 %) between the optimal solution and the proposed approaches. Notice that there is negligible gap (less than 0.5%) between all centralized schemes (proposed centralized SCADA, IPAA, SCALE) and our proposed distributed SCADA for $P_{\max} > 20$ dBm.

Figure 4.2 portrays performance comparison with the exhaustive search for $L = 3$.

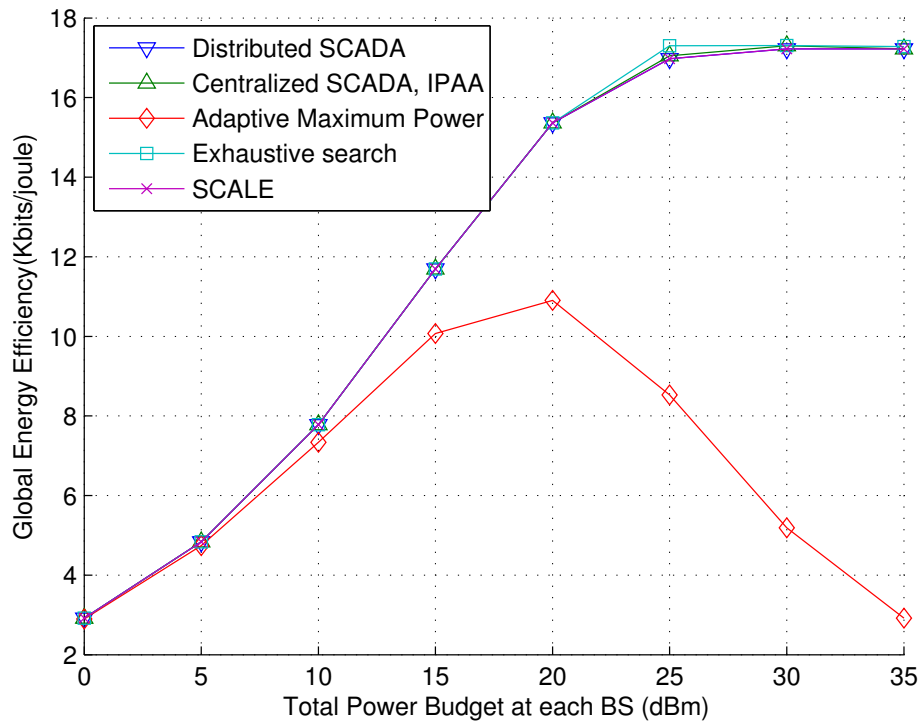


FIGURE 4.1: Performance comparison with the optimal exhaustive search for $L = 1$.

We consider $\mathcal{K} = 2$ and $\mathcal{Q} = 2$ due to the high computational complexity incurred by implementing the exhaustive search approach. From Figure 4.2, it can be inferred that our proposed centralized and decentralized SCADA achieve near optimal solution. Both Figure 4.2 and Figure 4.1 indicate that the dual decomposition-based distributed SCADA algorithm 9 is as efficient as the centralized proposed Algorithm 7 and the centralized SCALE algorithm. Therefore, we can conclude that for very large scale cognitive radio networks, it is more judicious to use the proposed dual decomposition-based distributed SCADA algorithm 9 instead of its centralized counterpart or other centralized approaches.

In the following example, Algorithm 8 is initialized by assuming an adaptive uniform power allocation on each subcarrier for each secondary cell. For the adaptive power allocation scheme, we start with $P_k^l = \frac{P_{\max}}{L}$, $\forall k, \forall l$, and reduce by 2% whenever the PUs interference constraints are not met. This procedure is repeated until a feasible uniform power allocation is found.

Example 4.1.

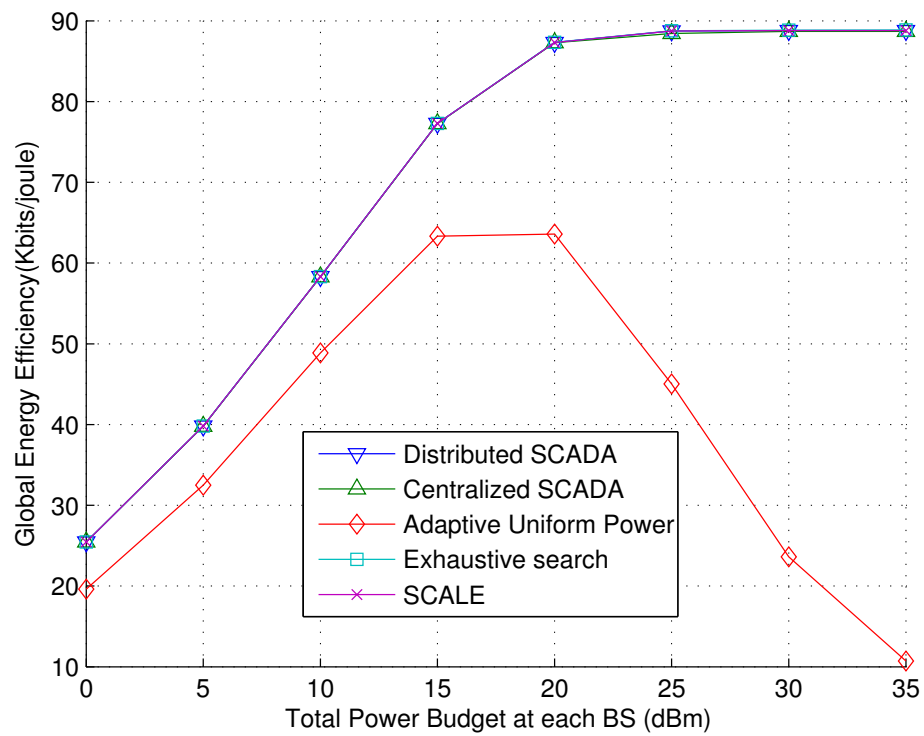


FIGURE 4.2: Performance comparison with the optimal exhaustive search for $L = 3$.

In our simulations, we compare also with the perfect synchronization case denoted as PS. Figure 4.3 investigates the convergence properties of the proposed Algorithm 8 under different multi-carrier modulation techniques.

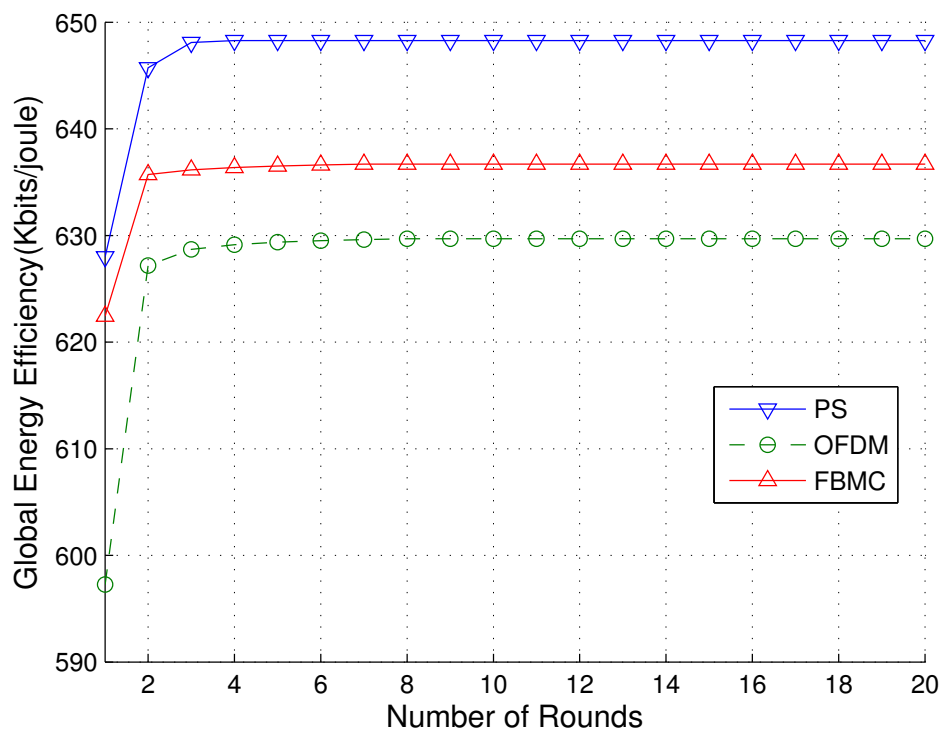


FIGURE 4.3: Convergence behavior of the proposed Algorithm 8 for $L = 16$.

Figure 4.3 demonstrates that the proposed algorithm converges regardless of the modulation scheme utilized. Moreover, we can see that the attainable energy efficiency value is different for each multi-carrier modulation. In fact, there is a gap of 2% between the achievable EE value with PS and the corresponding EE value attained by using FBMC confirming the detrimental effect of inter-carrier interferences. In addition, Figure 4.3 indicates that this gap of almost 2% between the global EE value achieved with FBMC compared to corresponding EE value obtained using OFDM.

The convergence robustness of the proposed Algorithm Algorithm 8 is evaluated in Figure 4.4.

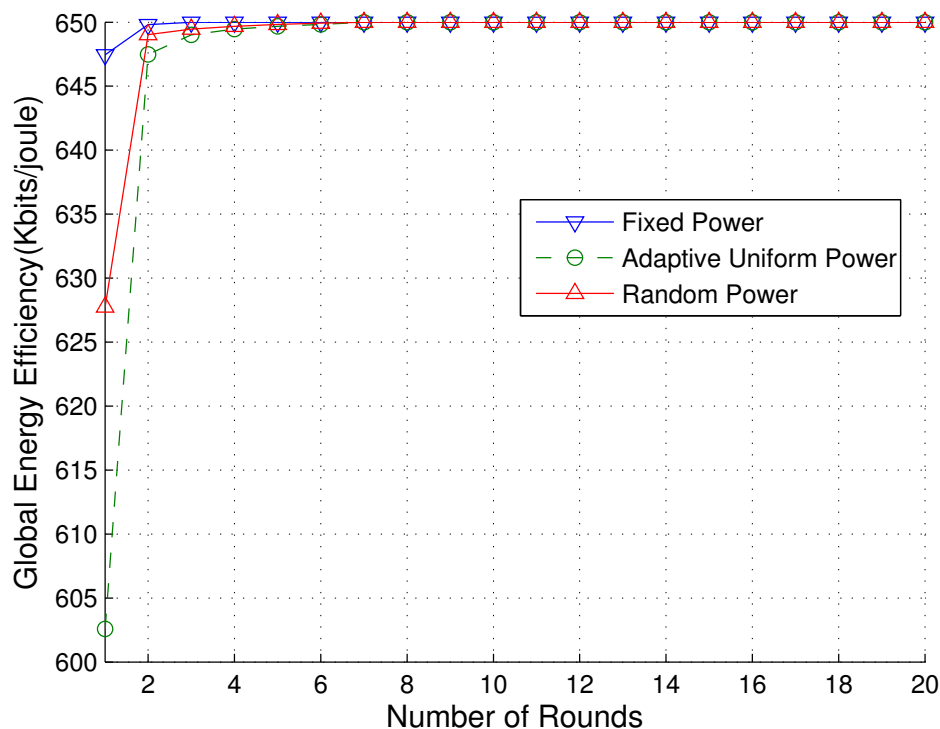


FIGURE 4.4: Convergence curve versus rounds of Algorithm 8 for different feasible initial point for $L = 16$.

We consider the following three feasible allocation power : the adaptive uniform power allocation scheme described previously, random initialization scheme and a fixed uniform power allocation $P_k^l = -70$ dBm, $\forall k, l$. It can be observed from Figure 4.4 that the algorithm converges to the same value of energy-efficiency implying that it is robust to feasible initial power allocation.

The comparison of our proposed centralized algorithm 8 and the SCALE in terms of achievable total energy efficiency versus total power constraint only for the case of FBMC is given in Figure 4.5. We also compare with the heuristic adaptive uniform power allocation. From Figure 4.5, we can observe that our proposed centralized considerably outperforms the adaptive uniform power allocation scheme.

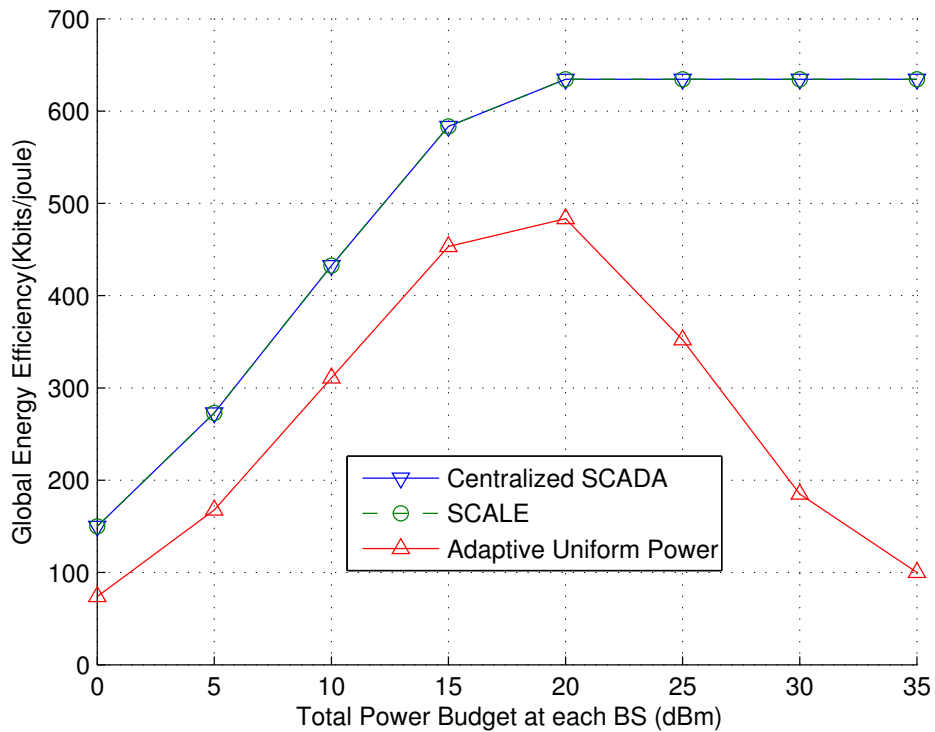


FIGURE 4.5: Average global energy-efficiency versus P_{\max} for $L = 16$

Example 4.2.

In this example, we present the performance evaluation of the alternating-based distributed scheme destined to solve the non-cooperative power allocation game (NPAG). We start by presenting the performance comparison of our proposed distributed Algorithm with the optimal centralized exhaustive search for $L = 1$ in Figure 4.6. We consider $\mathcal{K} = 4$ and $\mathcal{Q} = 3$. There is a performance gap varying from 6% to 9.5% between the exhaustive search approach and our fully distributed algorithm.

Figure 4.7 depicts the performance comparison between our alternating-based proposed distributed algorithm, the alternating-based decentralized dual decomposition SCADA and the distributed adaptive pricing [124]. From Figure 4.7, we observe a performance gain of 0.3% to 1.4% between the decentralized SCADA and the distributed pricing scheme. There is also a performance gain of 0.8% to 2.3% between the proposed decentralized dual-decomposition based Algorithm and the proposed fully distributed Algorithm.

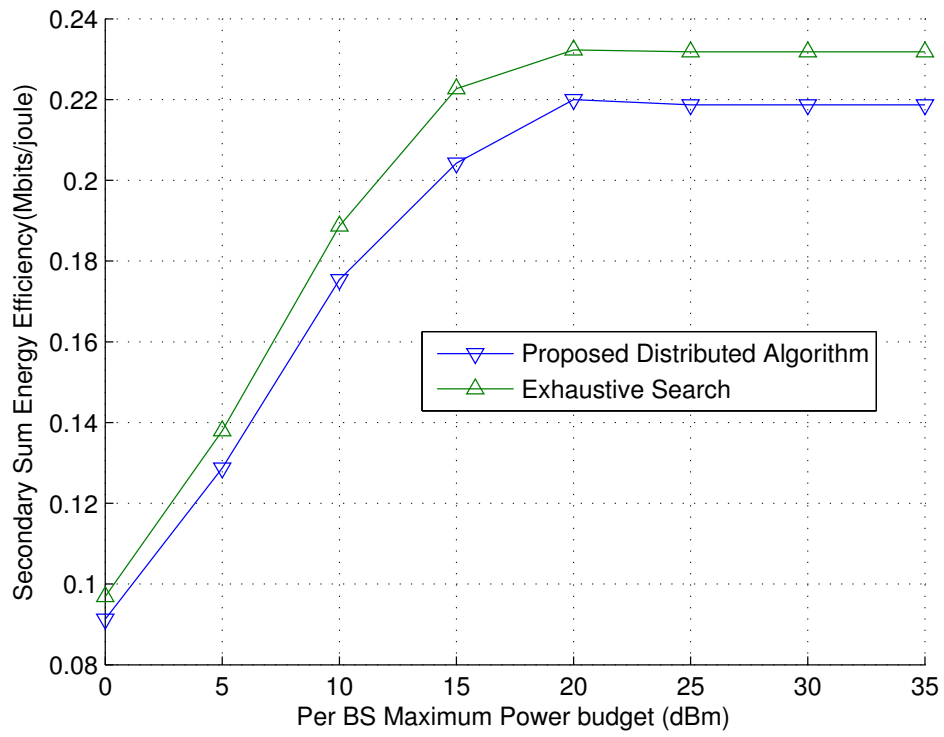
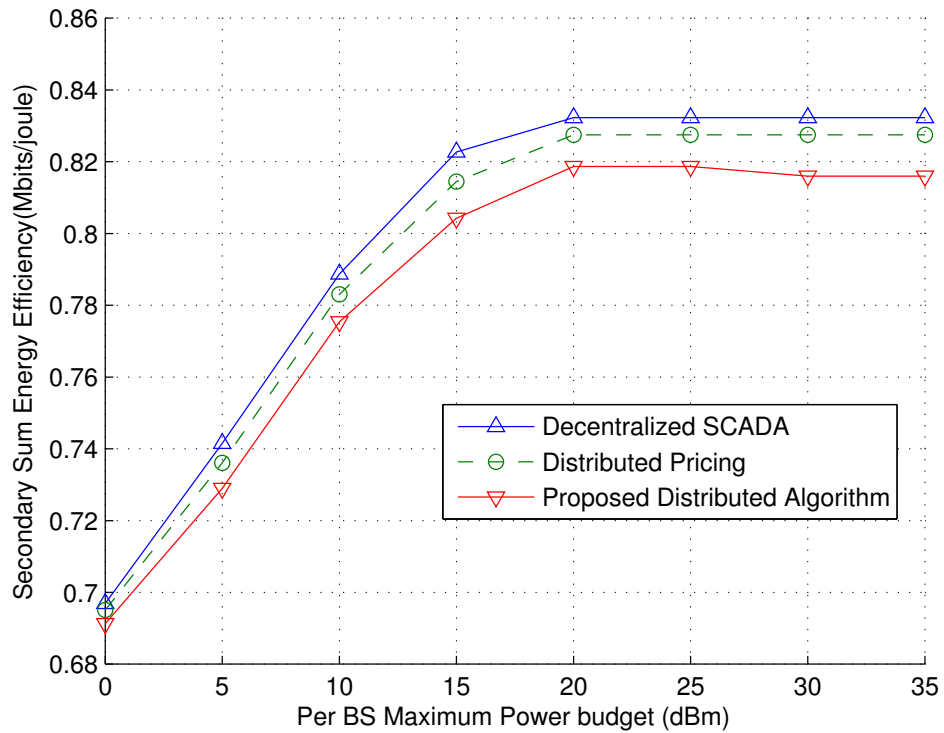
FIGURE 4.6: Comparison with optimal centralized exhaustive search $L=1$ FIGURE 4.7: Average sum energy-efficiency versus P_{\max} for $L = 16$

Figure 4.8 investigates the convergence properties of the proposed alternating-based non-cooperative distributed algorithm. Figure 4.8 shows that the proposed algorithm converges for the following multi-carrier modulation: PS , FBMC and OFDM. Higher energy-efficiency value is achieved with the perfect synchronization case. In fact, there is a gap of 33% between the performance of the attainable EE value using PS and the corresponding EE value achieved using FBMC and 21.3% between FBMC and OFDM .

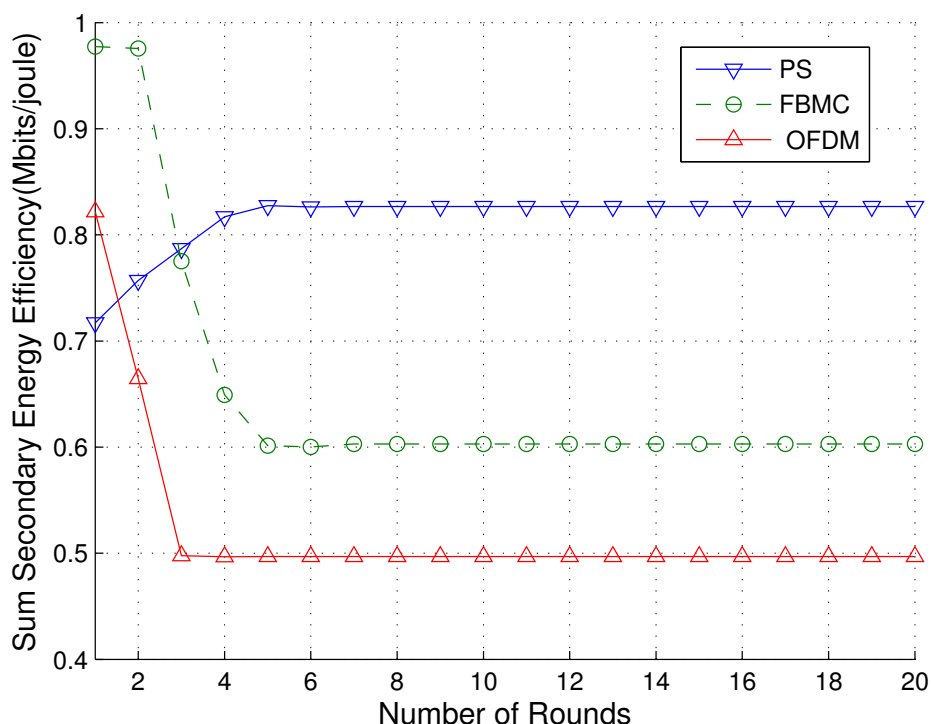


FIGURE 4.8: Convergence behavior of the distributed scheme for solving NPAG for $L = 16$

The convergence behavior, i.e., the evolution of the sum secondary achievable energy efficiency at each iteration, of our proposed non-cooperative distributed power allocation algorithm for different feasible initial powers is depicted in Figure 4.9. We consider the adaptive uniform power allocation scheme described previously, a feasible random initialization scheme and a fixed uniform power allocation $P_k^l = -70$ dBm, $\forall k, l$. It can be observed from Figure 4.9 that the algorithm converges to the same value of energy-efficiency regardless of the initial

power allocation method. This indicates that our proposed alternating-based non-cooperative distributed algorithm to solve the NPAG is robust to feasible initial power allocation.

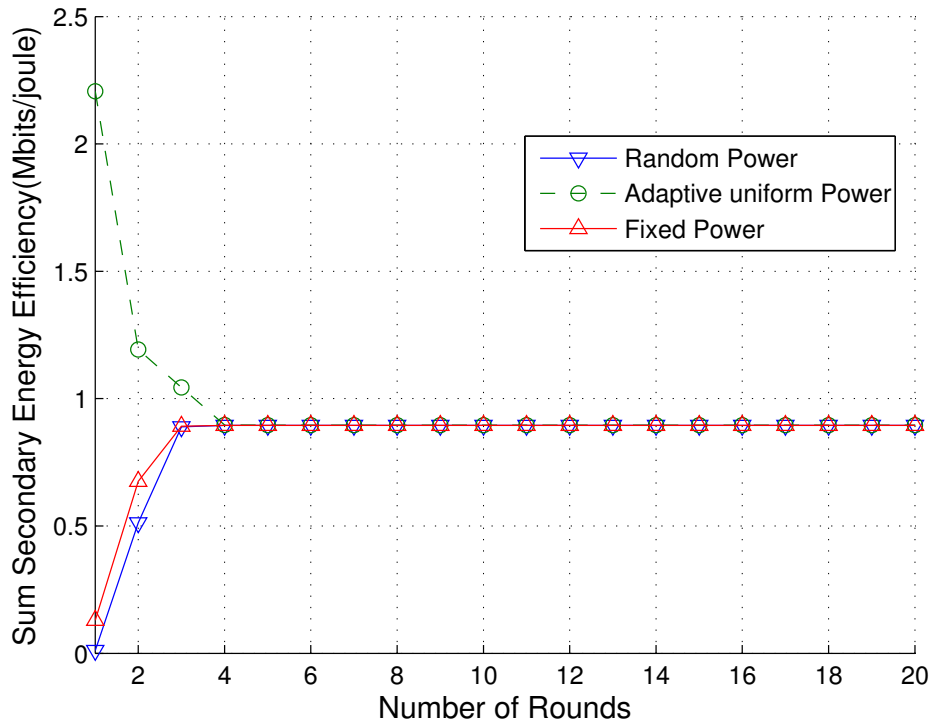


FIGURE 4.9: Convergence curve versus number of iterations for different initial power allocation schemes for $L = 16$

Conclusion

In this chapter, we investigated the problem of resource allocation for a multi-carrier-based cognitive radio network. We proposed an alternating-based optimization framework to tackle the joint subcarrier-power allocation for the energy-efficiency optimization problem. Moreover, we presented two efficient approximations for solving the non-convex power control problem for the case of cooperative secondary users. We presented a centralized SCADA algorithm which follows from a conservative first-order approximation techniques. The proposed SCADA algorithm yields solutions that coincide with stationary points of the original non-convex power control. Furthermore, we provided a dual decomposition-based decentralized version of SCADA which was shown via simulation analyses to be as

efficient as its centralized counterpart. For the non-cooperative secondary BSs, we proposed a totally distributed scheme based on game theory. The proposed non-cooperative decentralized framework was proved to reach a NE point. Sufficient condition that guarantees convergence a unique NE was also given. Our numerical results have demonstrated the efficiency of our proposed algorithms. The simulation analysis further established that, the network achieves higher energy-efficiency value when the multi-carrier modulation technique utilized is FBMC instead of OFDM.

Appendix

Proof of Proposition 4.1

To begin with the proof, let us write the Lagrangian associated with problem (4.25).

$$\begin{aligned} \mathcal{L}(\mathbf{P}_k, \mu_k, \bar{\mathbf{P}}^{(n-1)}) = & \mu_k \left(\sum_{l=1}^L P_k^l - P_{\max} \right) - \left(\sum_{l=1}^L \psi_k^l(P_k^l, \bar{\mathbf{P}}^{l,(n-1)}) - \frac{\tau_k}{2} \|\mathbf{P}_k - \bar{\mathbf{P}}_k^{(n-1)}\|^2 \right. \\ & \left. - \pi \sum_{l=1}^L (\xi P_k^l + P_c) - \sum_{q=1}^Q \lambda_q \sum_{l=1}^L P_k^l \sum_{l' \in \mathcal{I}_{q,k}^l} H_{k,q}^{l'} V_{|l-l'|} \right) \end{aligned}$$

Since problem (4.25) is a standard convex optimization problem. The optimal solution for problem (4.25) is found by using the Karush-Kuhn-Tucker (KKT) conditions [67] which are given by

$$\begin{aligned} \mu_k^* & \geq 0, \\ \mu_k^* \left(\sum_{l=1}^L P_k^{l*} - P_{\max} \right) & = 0 \\ \nabla_{\mathbf{P}_k} \mathcal{L}(\mathbf{P}_k^*, \mu_k^*, \bar{\mathbf{P}}^{(n-1)}) & = 0 \end{aligned} \tag{4.35}$$

In the KKT conditions, the condition $\nabla_{\mathbf{P}_k} \mathcal{L}(\mathbf{P}_k, \mu_k, \bar{\mathbf{P}}^{(n-1)}) = 0$ is equivalent to

$$\begin{aligned} \alpha_k^l - \frac{1}{\ln 2} \frac{\zeta_k^l}{1 + \bar{P}_k^l \zeta_k^l} + \tau_k (P_k^l - \bar{P}_k^{l,(n-1)}) &= 0 \\ \tau_k \zeta_k^l (P_k^l)^2 + \left(\alpha_k^l \zeta_k^l + \tau_k - \tau_k \zeta_k^l \bar{P}_k^{l,(n-1)} \right) P_k^l + \left(\alpha_k^l - \frac{\zeta_k^l}{\ln 2} - \tau_k \bar{P}_k^{l,(n-1)} \right) &= 0 \end{aligned} \quad (4.36)$$

where

$$\begin{aligned} \alpha_k^l &= \sum_{q=1}^Q \lambda_q \sum_{l' \in \mathcal{I}_{q,k}^l} H_{k,q}^{l'} V_{|l-l'|} + \mu_k + \xi \pi + \frac{1}{\ln 2} \sum_{j \neq k} \rho_{k,j}^l \left(\bar{\mathbf{P}}^{l,(n-1)} \right) \\ \zeta_k^l &= \frac{G_{k,u(k,l)}^l}{\sum_{j \neq k}^K \bar{P}_j^{l,(n-1)} G_{j,u(k,l)}^l + \bar{N}_k^l} \end{aligned} \quad (4.37)$$

The second equation in (4.36) is a quadratic equation. Therefore, the optimal solution can be obtained by resorting to the determinant method and is given by

$$P_k^l = \left(\max \left(\frac{-b_k^l + \sqrt{(b_k^l)^2 - 4\tau_k \zeta_k^l \left(\alpha_k^l - \frac{\zeta_k^l}{\ln 2} - \tau_k \bar{P}_k^l [n-1] \right)}}{2\tau_k \zeta_k^l}, \frac{-b_k^l - \sqrt{(b_k^l)^2 - 4\tau_k \zeta_k^l \left(\alpha_k^l - \frac{\zeta_k^l}{\ln 2} - \tau_k \bar{P}_k^l [n-1] \right)}}{2\tau_k \zeta_k^l} \right) \right)^+$$

with

$$b_k^l = \left(\alpha_k^l \zeta_k^l + \tau_k - \tau_k \zeta_k^l \bar{P}_k^l [n-1] \right) \quad (4.38)$$

Since the convex optimization problem (4.25) satisfies the Slater's condition, we know that the KKT conditions are necessary and sufficient condition for optimality. This concludes our proof. \blacksquare

Proof of Proposition 4.3

Since the utility function $U_k(\mathbf{P}_k, \mathbf{P}_{-k})$ is a fractional quasi-concave function, the best response can be found by solving the following convex optimization problem

$$\max_{\mathbf{P}_k \in \mathcal{P}_k} \sum_{l=1}^L \left(B \log_2 \left(1 + \frac{P_k^l G_{k,u(k,l)}^l}{N_0 + I_{k,u(k,l)}^l} \right) - \pi \xi P_k^l \right) - P_{c,k} \pi \quad (4.39)$$

The Lagrangian function associated to problem (4.39) can be written as

$$\begin{aligned} \mathcal{L}(\mathbf{P}_k, \{\nu_q^k\}_{q=1}^{\mathcal{Q}}, \eta_k) &= \eta_k \left(\sum_{l=1}^L P_k^l - P_{\max} \right) + \sum_{q=1}^{\mathcal{Q}} \nu_q^k \left(\sum_{l=1}^L P_k^l \sum_{\nu' \in \mathcal{I}_{q,k}^l} H_{k,q}^{\nu'} V_{|l-\nu'|} - I_q^{k,\max} \right) \\ &\quad - \sum_{l=1}^L \left(B \log_2 \left(1 + \frac{P_k^l G_{k,u(k,l)}^l}{N_0 + I_{k,u(k,l)}^l} \right) - \pi \xi P_k^l \right) + \pi P_c \end{aligned}$$

The corresponding KKT conditions are given by

$$\begin{aligned} \eta_k^* &\geq 0 \\ \nu_q^{k*} &\geq 0 \\ \eta_k^* \left(\sum_{l=1}^L P_k^{l*} - P_{\max} \right) &= 0 \\ \nu_q^{k*} \left(\sum_{l=1}^L P_k^{l*} \sum_{\nu' \in \mathcal{I}_{q,k}^l} H_{k,q}^{\nu'} V_{|l-\nu'|} - I_q^{k,\max} \right) &= 0 \\ \eta_k + \sum_{q=1}^{\mathcal{Q}} \nu_q^k \sum_{\nu' \in \mathcal{I}_{q,k}^l} H_{k,q}^{\nu'} V_{|l-\nu'|} + \xi \pi - \frac{\ln 2 \frac{G_{k,u(k,l)}^l}{N_0 + I_{k,u(k,l)}^l}}{1 + \frac{P_k^l G_{k,u(k,l)}^l}{N_0 + I_{k,u(k,l)}^l}} &= 0 \end{aligned} \quad (4.40)$$

By using the last equation of the KKT conditions, it is straightforward to show that

$$P_k^l = \left[\frac{\frac{1}{\ln 2}}{\pi + \eta_k + \sum_{q=1}^{\mathcal{Q}} \nu_q^k \sum_{\nu' \in \mathcal{I}_{q,k}^l} H_{k,q}^{\nu'} V_{|l-\nu'|}} - \frac{N_0 + I_{k,u(k,l)}^l}{G_{k,u(k,l)}^l} \right]^+$$

This concludes the proof. ■

Proof of Proposition 4.4

According to [99, Theorem 4], the NPAG converges to a unique NE, i.e., $\Phi(\mathbf{P})$ is a contraction mapping if

$$\left\| \frac{\partial \mathbf{I}_k}{\partial \mathbf{P}_{-k}} \right\| \sup_{\mathbf{I}_k \in (\mathbb{R}^+)^L} \left\| \frac{\partial \Phi_k(\mathbf{P}_{-k})}{\partial \mathbf{I}_k} \right\| < 1 \quad (4.41)$$

where $\mathbf{I}_k \triangleq (I_{k,u(k,1)}^1, \dots, I_{k,u(k,L)}^L)^\top$ whereas $\sup_{\mathbf{I}_k}$ denotes the supremum on all feasible \mathbf{I}_k . By extending [99, equation (19)] to asynchronous CR networks, we have

$$\left\| \frac{\partial \mathbf{I}_k}{\partial \mathbf{P}_{-k}} \right\| = \sqrt{\sum_{j=1, j \neq k}^{\mathcal{K}} \sum_{l=1}^L \sum_{l' \in \mathcal{I}_{k,j}^l} (G_{j,k(u,l')}^{l'} V_{|l-l'|})^2} \quad (4.42)$$

To compute $\left\| \frac{\partial \Phi_k(\mathbf{P}_{-k})}{\partial \mathbf{I}_k} \right\|$, we need $\frac{\partial \Phi_k(\mathbf{P}_{-k})}{\partial \mathbf{I}_k}$ which is explicitly given by

$$\frac{\partial \Phi_k(\mathbf{P}_{-k})}{\partial \mathbf{I}_k} = \begin{pmatrix} \frac{\partial \Phi_k^1(\mathbf{P}_{-k})}{\partial I_{k,u(k,1)}^1} & \dots & \frac{\partial \Phi_k^L(\mathbf{P}_{-k})}{\partial I_{k,u(k,1)}^1} \\ \vdots & \ddots & \vdots \\ \frac{\partial \Phi_k^1(\mathbf{P}_{-k})}{\partial I_{k,u(k,L)}^L} & \dots & \frac{\partial \Phi_k^L(\mathbf{P}_{-k})}{\partial I_{k,u(k,L)}^L} \end{pmatrix}$$

Note that best response for player k , $P_k^l = \Phi_k^l(\mathbf{P}_{-k})$, on subcarrier l can be rewritten as

$$P_k^l = \begin{cases} \frac{1}{\varsigma_k(\pi, \eta_k, \{\nu_q^k\}_{q=1}^{\mathcal{Q}})} - \frac{1}{\vartheta_k^l}, & \text{if } \vartheta_k^l > \varsigma_k(\pi, \eta_k, \{\nu_q^k\}_{q=1}^{\mathcal{Q}}) \\ 0, & \text{otherwise} \end{cases} \quad (4.43)$$

where,

$$\vartheta_k^l \triangleq \frac{G_{k,u(k,l)}^l}{N_0 + I_{k,u(k,l)}^l} \quad (4.44)$$

$$\varsigma_k(\pi, \eta_k, \{\nu_q^k\}_{q=1}^{\mathcal{Q}}) \triangleq \ln 2 \left(\pi + \eta_k + \sum_{q=1}^{\mathcal{Q}} \nu_q^k \sum_{l' \in \mathcal{I}_{q,k}^l} H_{k,q}^{l'} V_{|l-l'|} \right)$$

Hence,

$$\begin{aligned} \frac{\partial P_k^l}{\partial I_{k,u(k,l)}^l} &= -1_{\{\vartheta_k^l > \varsigma_k(\pi, \eta_k, \{\nu_q^k\}_{q=1}^Q)\}} \\ &\times \left(\frac{(\vartheta_k^l)^2}{G_{k,u(k,l)}^l} \frac{\partial (1/\varsigma_k(\pi, \eta_k, \{\nu_q^k\}_{q=1}^Q))}{\partial \vartheta_k^l} + \frac{1}{G_{k,u(k,l)}^l} \right) \end{aligned} \quad (4.45)$$

where $1_{\{\cdot\}}$ denotes the indicator function. For $\bar{l} \neq l$, we have

$$\begin{aligned} \frac{\partial P_k^l}{\partial I_{k,u(k,\bar{l})}^{\bar{l}}} &= -1_{\{\vartheta_k^l > \varsigma_k(\pi, \eta_k, \{\nu_q^k\}_{q=1}^Q)\}} \\ &\times \left(\frac{(\vartheta_k^{\bar{l}})^2}{G_{k,u(k,\bar{l})}^{\bar{l}}} \frac{\partial (1/\varsigma_k(\pi, \eta_k, \{\nu_q^k\}_{q=1}^Q))}{\partial \vartheta_k^{\bar{l}}} \right) \end{aligned} \quad (4.46)$$

Hence,

$$\begin{aligned} \frac{\partial P_k^l}{\partial I_{k,u(k,\bar{l})}^{\bar{l}}} &= -\frac{1_{\{\vartheta_k^l > \varsigma_k(\pi, \eta_k, \{\nu_q^k\}_{q=1}^Q)\}}}{G_{k,u(k,l)}^l} \\ &\times \left((\vartheta_k^{\bar{l}})^2 \frac{\partial (1/\varsigma_k(\pi, \eta_k, \{\nu_q^k\}_{q=1}^Q))}{\partial \vartheta_k^{\bar{l}}} + 1_{\{l=\bar{l}\}} \right) \end{aligned} \quad (4.47)$$

Consequently,

$$\begin{aligned} \left\| \frac{\partial \Phi_k(\mathbf{P}_{-k})}{\partial \mathbf{I}_k} \right\| &= \sqrt{\sum_{l=1}^L \sum_{\bar{l}=1}^L \left(\frac{\partial P_k^l}{\partial I_{k,u(k,\bar{l})}^{\bar{l}}} \right)^2} \\ &= \left(\sum_{l=1}^L \sum_{\bar{l}=1}^L \frac{1_{\{\vartheta_k^l > \varsigma_k(\pi, \eta_k, \{\nu_q^k\}_{q=1}^Q)\}}}{(G_{k,u(k,l)}^l)^2} \times \right. \\ &\quad \left. \left((\vartheta_k^{\bar{l}})^2 \frac{\partial (1/\varsigma_k(\pi, \eta_k, \{\nu_q^k\}_{q=1}^Q))}{\partial \vartheta_k^{\bar{l}}} + 1_{\{l=\bar{l}\}} \right)^2 \right)^{\frac{1}{2}} \end{aligned} \quad (4.48)$$

Let $\boldsymbol{\vartheta}_k = (\vartheta_k^1, \dots, \vartheta_k^L)^\top$. Since there exist a one-to-one and onto mapping between ϑ_k^l and $I_{k,u(k,l)}^l, \forall k, \forall l$, then

$$\sup_{\mathbf{I}_k \in (\mathbb{R}^+)^L} \left\| \frac{\partial \Phi_k(\mathbf{P}_{-k})}{\partial \mathbf{I}_k} \right\| = \sup_{\boldsymbol{\vartheta}_k \in \Omega_k} \left\| \frac{\partial \Phi_k(\mathbf{P}_{-k})}{\partial \mathbf{I}_k} \right\| \quad (4.49)$$

with

$$\Omega_k = \prod_{l=1}^L \left(0, \frac{G_{k,u(k,l)}^l}{N_0} \right]$$

The proof is completed by combining (4.49) with (4.48) and (4.42). ■

Chapter 5

Resource Allocation for Cognitive Radio Networks with Statistical CSI

In the first part of this dissertation, we studied resource allocation for a cognitive radio networks assuming perfect knowledge of channel state information (CSI). For more practical scenario, the system may incur huge overhead communication with perfect CSI assumption. In the second part of this dissertation, we address resource allocation for a multi-carrier based cognitive radio network under the assumption that only the downlink channel distribution information (CDI) of both primary and secondary systems is known a priori to the secondary base station. More specifically, we investigate the problem of secondary utility maximization under primary and secondary user outage constraints and total power constraint. To circumvent the inherent high computational complexity investigating the challenging non-convex joint power-subcarrier allocation problem, we propose to solve the problem in two stages. Firstly, the subcarrier allocation is solved by means of bisection search method. Secondly, we formulate a conservatively tractable constraints to the non-convex power control problem and propose a polynomial-time solvable algorithm based on alternating optimization method to efficiently obtain near-optimal solutions to the reformulated problem. Extensive simulation results

are further provided to corroborate the validity of the theoretical findings and demonstrate the efficiency of our proposed algorithms.

Introduction

Literature Review

The topic of resource allocation within OFDM-based CR networks has been considerably investigated in the past decades. A great deal of efforts have been devoted towards developing judicious resource allocation [125–128] leading to higher spectral efficiency. More specifically, the authors in [126] proposed a joint subcarrier and power allocation algorithm for cooperative multiuser OFDM cognitive radio. In [127], Almalfouh et al., investigated both the downlink and uplink resource allocation problem for OFDMA-based CR networks while in [128], the authors studied the secondary achievable rate maximization problem under primary rate loss constraint.

Moreover, judicious resource allocation to mitigate the influence of inter-carrier interferences in asynchronous multi-carrier based CR was greatly investigated in the literature [80, 82, 85]. In [80], the authors studied the downlink capacity maximization under total power and primary interference constraints while investigating the joint downlink subcarrier-power allocation in [82]. In [85], Zhang et al., studied the uplink rate maximization under total power constraint.

In all aforementioned works, it was assumed that perfect primary system channel state information (CSI) is known to the SU base stations (BSs). For more practical scenarios, the lack of cooperation between the PU and the SU system makes it improbable for SU users to have perfect knowledge of the PU system CSI. Resource allocation for OFDMA-based CR under primary channel uncertainty was investigated in [129–132]. The authors in [129] studied the uplink weighted sum rate optimization problem under PU chance constraint which implicitly captures the PU system channel uncertainty inherent to the PU interference. A similar problem was investigated in [130] where the authors expressed the PU interference uncertainty using an ellipsoidal uncertainty region.

Few works have considered channel distribution information (CDI) of the primary system. In [131, 132] Gong et al., investigated the problem of single carrier ergodic rate maximization under primary user outage constraint by assuming primary system statistical CSI. However, the ergodic capacity which consists of the long-term achievable rate averaging over the time-varying channels is less viable for real-time application such as voice communication systems because it requires a coding procedure over infinitely many channel realizations. The delay incurred for the ergodic capacity cannot however be tolerated by real time application.

The prior research papers [129–132] have assumed perfect knowledge of instantaneous secondary CSI be known to the secondary BS. Consequently, secondary mobile terminals (MTs) need to feed back the estimated CSI to the secondary BS. This procedure requires a considerably huge amount of overhead and therefore makes it less viable for more practical scenarios. On the contrary, a secondary user CDI is likely to remain unchanged over a long period of time so that a lesser amount of information needs to be fed back from the secondary MTs to the secondary BS. However, the MT may incur outage transmission under limited delay constraints and due to channel fading. Outage happens whenever the achievable rate is less than the transmission rate.

Contribution

In this work, we investigate the downlink secondary utility optimization problem under primary and secondary users' outage transmission constraints for both synchronous and asynchronous cognitive radio networks. The key contributions of this paper are as follows:

- We design an OFDM/FBMC based resource allocation paradigm that guarantees data outage requirement for both primary and secondary systems within a cognitive radio network. To the best of our knowledge, there is no existing work that attempts to address the problem of OFDMA/FBMC-based cognitive radio resource allocation under both primary and secondary statistical CSI assumptions.

- We circumvent the prohibitively high computational complexity incurred addressing the joint subcarrier-power allocation problem by solving two separable independent problems. More specifically, we propose a bisection search method to the subcarrier allocation problem. We construct a tractable approximation to tackle the nonexistence closed form expression for the primary and secondary outage probabilities that renders the power control optimization problem intractable.
- We design a polynomial time solvable algorithm to find near-optimal solutions to the reformulated tractable power control problem. More specifically, motivated by the alternating optimization method [68], we propose an approach that sequentially solves a feasibility problem using bisection method.

The organization of this chapter

The remainder of this chapter is structured as follows. In Section 5.2, the system model is presented. The synchronous problem formulation is given in Section 5.3 together with the proposed subcarrier allocation scheme. A conservative tractable approximation for the downlink utility problem is also described in 5.3. Special cases for the downlink power control problem are introduced in Section 5.4. In Section 5.5, the proposed alternating-based algorithm is investigated. The asynchronous problem formulation is solved in Section 5.6. In section 5.7, we provide simulation results showing the efficiency of our proposed methods. And finally, we conclude the paper in Section 5.8.

System Model

In this chapter, we consider a simple spectrum sharing network with one primary and one secondary cell. The primary cell consists of one base station and one mobile terminal. In the secondary cell, the secondary base station serves \mathcal{K}^1 .

Let θ_k^l be the subcarrier allocation indicator. Therefore, a feasible subcarrier allocation matrix $\Theta = \{\theta_k^l\}_{k,l=1}^{\mathcal{K},L}$ for the secondary base station should belong to

¹The notation in this chapter is different from the notations used in previous chapters

the set

$$\Theta \triangleq \left\{ \Theta_k : \left\{ \sum_{k=1}^{\mathcal{K}} \theta_k^l \leq 1, \theta_k^l \in \{0, 1\}, \forall l \right\} \right\} \quad (5.1)$$

We denote Ω_k with $\sum_{k=1}^{\mathcal{K}} |\Omega_k| = L$, $\cap_{k=1}^{\mathcal{K}} \Omega_k = \emptyset$, the set of subcarrier allocated to the k th secondary mobile terminal.

We suppose that the primary links statistical information is available at the secondary BS. This information can be made available to the secondary system via a band controller [90]. We further assume that the secondary BS can acquire only the statistical distribution of the channel link to its serving MTs. We consider a frequency selective slow fading channel model and assume single user detection at each MT. Under this setting, we consider two types of transmission within the cognitive radio network.

Synchronous cognitive radio

We begin by introducing the setting where primary and secondary system are perfectly synchronized. However, given only the knowledge of CDI, the data transmission would suffer from outage. For any transmission rate $R_p > 0$, the outage probability of the PU channel is written as

$$\Pr \left\{ \sum_{l=1}^L \log_2 \left(1 + \frac{P_p^l |h_{p,p}^l|^2}{N_0 + P_s^l |h_{s,p}^l|^2} \right) < R_p \right\} \quad (5.2)$$

where P_s^l is the power that the secondary BS adaptively allocates to the l th subcarrier and N_0 corresponds to the noise power on each subcarrier. $h_{i,j}^l$ denotes the channel from BS i to mobile terminal j on subcarrier l . It is assumed that $h_{i,j}^l \sim \mathcal{CN}(0, g_{i,j}^l)$, where $g_{i,j}^l > 0$ represents the l th subcarrier channel variance and is known to the secondary BS.

Within the secondary system, the instantaneous signal to interference plus noise ratio SINR of user $k \in \{1, \dots, \mathcal{K}\}$ which was assigned the l th subcarrier is given by

$$\Gamma_{s,k}^l = \frac{P_s^l |h_{s,k}^l|^2}{N_0 + P_p^l |h_{p,k}^l|^2}$$

Similarly to the primary system, the secondary system is prone to outage. For any transmission rate $R_k > 0$, the outage event $\sum_{l \in \Omega_k} \log_2 (1 + \Gamma_{s,k}^l) < R_k$ occurs with a nonzero probability.

Asynchronous cognitive radio

The asynchronous counterpart of (5.2) is written as

$$\epsilon_p = \Pr \left\{ \sum_{l=1}^L \log_2 \left(1 + \frac{P_p^l |h_{p,p}^l|^2}{N_0 + \sum_{l'=1}^L P_s^{l'} V_{|l-l'|} |h_{s,p}^{l'}|^2} \right) < R_p \right\}$$

and the secondary outage event is expressed as

$$\sum_{l \in \Omega_k} \log_2 \left(1 + \frac{P_s^l |h_{s,k}^l|^2}{N_0 + \sum_{l'=1}^L P_p^{l'} V_{|l-l'|} |h_{p,k}^{l'}|^2} \right) < R_k$$

where V is the interference weight defined Table 2.1. Before we proceed to explicitly state the problem formulation, let us define the following variables

$$\mathbf{P}_s = (P_s^1, \dots, P_s^L)^\top, \quad \mathbf{R} = (R_1, \dots, R_{\mathcal{K}})^\top,$$

where \mathbf{P}_s denotes the power vector allocation of the secondary BS. \mathbf{R} represents the secondary transmit rate vector.

Synchronous problem statement

Given an outage probability threshold $\epsilon_k \in (0, 1)$ for all secondary mobile terminal k , $\epsilon_p \in (0, 1)$ for the primary system and a power constraint P_{\max} , our purpose is to optimize the secondary BS resource allocation such that the predefined secondary system utility function $\mathcal{U}(R_1, \dots, R_{\mathcal{K}})$ is maximized while satisfying the probability of outage of both primary and secondary system. The synchronous

downlink outage constrained utility maximization problem is expressed as

$$\begin{aligned}
& \max_{\substack{\mathbf{P}_s \geq 0, \mathbf{R} \geq 0 \\ \Theta_k \in \Theta, \forall k}} \mathcal{U}(R_1, \dots, R_{\mathcal{K}}) \\
& \text{s.t. } \Pr \left\{ \sum_{l=1}^L \theta_k^l \log_2 (1 + \Gamma_{s,k}^l) < R_k \right\} \leq \epsilon_k, \quad k = 1, \dots, \mathcal{K} \\
& \Pr \left\{ \sum_{l=1}^L \log_2 \left(1 + \frac{P_p^l |h_{p,p}^l|^2}{N_0 + P_s^l |h_{s,p}^l|^2} \right) < R_p \right\} \leq \epsilon_p \\
& \sum_{l=1}^L P_s^l \leq P_{\max}
\end{aligned} \tag{5.3}$$

Recall that the utility function was defined in Subsection 2.3.4

$$\mathcal{U}_{\hat{\beta}}(R_1, R_2, \dots, R_{\mathcal{K}}) = \begin{cases} \sum_{k=1}^{\mathcal{K}} \frac{\hat{\alpha}_k R_k^{1-\hat{\beta}}}{(1-\hat{\beta})}, \hat{\beta} \geq 0, \hat{\beta} \neq 1 \\ \sum_{k=1}^{\mathcal{K}} \hat{\alpha}_k \ln R_k, \hat{\beta} = 1 \end{cases}$$

There are two interesting points to make here. Firstly, for any value of $\hat{\beta}$, it can easily verify that the utility function $\mathcal{U}_{\hat{\beta}}(R_1, R_2, \dots, R_{\mathcal{K}})$ is jointly concave in $R_k, \forall k$. Secondly, the utility function is an additively separable function.

Problem (5.3) is a combinatorial problem and therefore computationally intractable optimization problem. In order to circumvent the computational complexity burden, we adopt a sub-optimal strategy that consists of solving problem (5.3) in two stages. In the first stage, the subcarrier allocation problem is investigated followed by the power control problem in the second stage.

Subcarrier Allocation Scheme

In this subsection, we address the subcarrier allocation problem. Given a uniform power allocation $P_s^l = \frac{P_{\max}}{L}, \forall l$ and a transmitted target rate r_l for each subcarrier

l , the per-subcarrier outage probability is written as

$$\begin{aligned} \Pr \left\{ \log_2 \left(1 + \frac{P_s^l |h_{s,k}^l|^2}{N_0 + P_p^l |h_{p,k}^l|^2} \right) < r_l \right\} &= \Pr \left\{ \log_2 \left(1 + \frac{\frac{P_{\max}}{L} |h_{s,k}^l|^2}{N_0 + \frac{P_{\max}}{L} |h_{p,k}^l|^2} \right) < r_l \right\} \\ &= 1 - e^{-\frac{N_0(2^{r_l}-1)}{g_{s,k}^l \frac{P_{\max}}{L}}} \left(\frac{g_{s,k}^l \frac{P_{\max}}{L}}{g_{s,k}^l \frac{P_{\max}}{L} + g_{p,k}^l \frac{P_{\max}}{L} (2^{r_l}-1)} \right) \end{aligned} \quad (5.4)$$

The secondary BS allocates the l th subcarrier to the mobile terminal that maximizes the rate r_l subject to the outage probability given in (5.4).

$$\begin{aligned} \arg \max_{k=1, \dots, \mathcal{K}} r_l \\ \text{s.t. } r_l \geq 0 \\ 1 - e^{-\frac{N_0(2^{r_l}-1)}{g_{s,k}^l \frac{P_{\max}}{L}}} \left(\frac{g_{s,k}^l \frac{P_{\max}}{L}}{g_{s,k}^l \frac{P_{\max}}{L} + g_{p,k}^l \frac{P_{\max}}{L} (2^{r_l}-1)} \right) \leq \bar{\epsilon} \end{aligned} \quad (5.5)$$

The solution to problem (5.5) can be found by using bisection method [67] solving

$$\frac{N_0(2^{r_l}-1)}{g_{s,k}^l \frac{P_{\max}}{L}} + \log \left(1 + \frac{g_{p,k}^l \frac{P_{\max}}{L} (2^{r_l}-1)}{g_{s,k}^l \frac{P_{\max}}{L}} \right) + \log(1 - \bar{\epsilon}) = 0 \quad (5.6)$$

Once the subcarrier allocation is known, it remains fixed and the power control allocation can be studied.

Power Control Scheme

Provided that subcarrier allocation is known, problem (5.3) becomes

$$\begin{aligned} \max_{\mathbf{P}_s \geq 0, \mathbf{R} \geq 0} \mathcal{U}(R_1, \dots, R_{\mathcal{K}}) \\ \text{s.t. } \Pr \left\{ \sum_{l \in \Omega_k} \log_2 (1 + \Gamma_{s,k}^l) < R_k \right\} \leq \epsilon_k, \quad k = 1, \dots, \mathcal{K} \\ \Pr \left\{ \sum_{l=1}^L \log_2 \left(1 + \frac{P_p^l |h_{p,p}^l|^2}{N_0 + P_s^l |h_{s,p}^l|^2} \right) < R_p \right\} \leq \epsilon_p \\ \sum_{l=1}^L P_s^l \leq P_{\max} \end{aligned} \quad (5.7)$$

To the best of our knowledge, there is no closed-form expression for the primary and secondary outage probability expression in the outage constraints. Problem

(5.7) is intractable and difficult to handle directly. The optimal transmission strategy for the OFDMA-based outage constrained problem is unknown thus far, perhaps because of this reason. Consequently, solving problem (5.7) requires some careful and tractable approximations. The outage probabilities are tractably approximated in the following lemma.

Lemma 5.1. *The primary and secondary outage transmission probability can be upper bounded respectively by*

$$\Pr \left\{ \sum_{l=1}^L \log_2 \left(1 + \frac{P_p^l |h_{p,p}^l|^2}{N_0 + P_s^l |h_{s,p}^l|^2} \right) < R_p \right\} \leq 1 - \prod_{l=1}^L \left(e^{-\frac{N_0 \bar{\alpha}}{g_{p,p}^l P_p^l}} \left(\frac{g_{p,p}^l P_p^l}{g_{p,p}^l P_p^l + g_{s,p}^l P_s^l \bar{\alpha}} \right) \right)$$

where $\bar{\alpha} = 2^{R_p/L} - 1$, and $\forall k = 1, \dots, \mathcal{K}$,

$$\Pr \left\{ \sum_{l \in \Omega_k} \log_2 (1 + \Gamma_{s,k}^l) < R_k \right\} \leq 1 - \prod_{l \in \Omega_k} \left(e^{-\frac{N_0 (2^{R_k/|\Omega_k|} - 1)}{g_{s,k}^l P_s^l}} \frac{g_{s,k}^l P_s^l}{g_{s,k}^l P_s^l + g_{p,k}^l P_p^l (2^{R_k/|\Omega_k|} - 1)} \right)$$

Proof: See Appendix 5.A. ■

We now investigate the accuracy of the proposed approximation by comparing the proposed bound with the exact empirical outage probability, using Monte-Carlo simulations. In fact, the empirical probability is obtained by generating 5000 channel realizations for 5000 Monte-Carlo trials. Simulations are done for $L = 8$ and under the assumption of equal power allocation on each subcarrier.

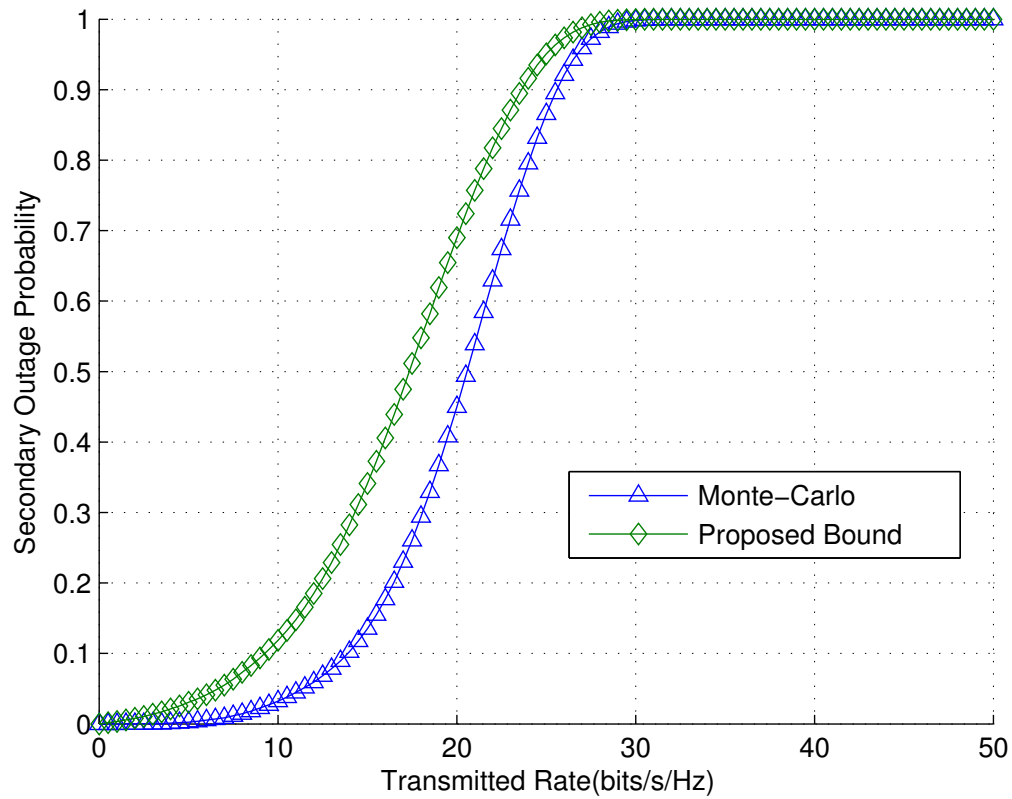


FIGURE 5.1: Comparison between exact probability and the proposed bound for $L = 8$.

From Figure 5.1, it can be observed that the bounds are tight at low and high transmit rate and may be loose at intermediate spectral efficiency value. From these observations, it can be inferred that for applications that need low spectral efficiency, the proposed bound is very suitable since it behaves almost similarly as the exact outage probability.

Using Lemma 5.1, the optimization problem (5.7) can be approximated as

$$\begin{aligned}
& \max_{\mathbf{P}_s \geq 0, \mathbf{R} \geq 0} \mathcal{U}(R_1, \dots, R_K) \\
& \text{s.t. } 1 - \prod_{l \in \Omega_k} \left(e^{-\frac{N_0(2^{R_k/|\Omega_k|}-1)}{g_{s,k}^l P_s^l}} \left(\frac{g_{s,k}^l P_s^l}{g_{s,k}^l P_s^l + g_{p,k}^l P_p^l (2^{R_k/|\Omega_k|}-1)} \right) \right) \leq \epsilon_k, \forall k \\
& 1 - \prod_{l=1}^L \left(e^{-\frac{N_0 \bar{\alpha}}{g_{p,p}^l P_p^l}} \left(\frac{g_{p,p}^l P_p^l}{g_{p,p}^l P_p^l + g_{s,p}^l P_s^l \bar{\alpha}} \right) \right) \leq \epsilon_0 \\
& \sum_{l=1}^L P_s^l \leq P_{\max}
\end{aligned} \tag{5.8}$$

Notice that the optimization problem (5.8) is a conservative approximation of problem (5.7). More specifically, any feasible point of problem (5.8) is also feasible for the optimization problem (5.7). Since problem (5.7) cannot be solved because of the non-existence closed-form expression for the outages, the ultimate goal of our paper is to solve the tractable approximation given in (5.8).

One possible approach to find an optimal solution to problem (5.8) is to use exhaustive search method. For each subcarrier, the total power constraint is discretized into N levels constituting a power grid and the primary outage constraint is verified for each possible point. The optimal achievable rate for each secondary user is therefore calculated by using bisection method to solve each secondary outage constraint. The complexity of the exhaustive search method is $N^L \cdot \lceil \log_2(\check{R} \cdot \delta^{-1}) \rceil$, where \check{R} is an upper bound to the secondary rate and $\delta > 0$ is an accuracy to the bisection method. The complexity of this approach increases exponentially with L which makes it more viable only for small L . For a simple search where $L = 3$ and $N = 20$, this method requires $20^3 \cdot \lceil \log_2(\check{R} \cdot \delta^{-1}) \rceil$ iterations. For more practical scenario, i.e., networks with large number of subcarriers, the exhaustive search approach will be computationally prohibitive. The need for polynomial time solvable efficient algorithm to problem (5.8) is of great importance.

The optimization problem (5.8) is equivalent to ²

$$\begin{aligned}
& \max_{\mathbf{P}_s \geq 0, \mathbf{R} \geq 0} \mathcal{U}(R_1, \dots, R_{\mathcal{K}}) \\
& \text{s.t.} \quad \sum_{l \in \Omega_k} \frac{N_0(2^{R_k/|\Omega_k|} - 1)}{g_{s,k}^l P_s^l} + \sum_{l \in \Omega_k} \log \left(1 + \frac{g_{p,k}^l P_p^l (2^{R_k/|\Omega_k|} - 1)}{g_{s,k}^l P_s^l} \right) \leq \rho_k, \quad \forall k \\
& \quad \sum_{l=1}^L \frac{N_0 \bar{\alpha}}{g_{p,p}^l P_p^l} + \sum_{l=1}^L \log \left(1 + \frac{g_{s,p}^l P_s^l \bar{\alpha}}{g_{p,p}^l P_p^l} \right) \leq \bar{\rho}_p \\
& \quad \sum_{l=1}^L P_s^l \leq P_{\max}
\end{aligned} \tag{5.9}$$

where $\bar{\rho}_p = -\log(1 - \epsilon_p)$ and $\rho_k = -\log(1 - \epsilon_k)$. Now, we proceed to take a closer look at its structure to gain some insights into the optimal solution. Consequently, we state the following lemma.

Lemma 5.2. *Suppose that the utility function $\mathcal{U}(R_1, \dots, R_{\mathcal{K}})$ is strictly increasing with respect to R_k , for $k = 1 \dots, \mathcal{K}$, all secondary user outage constraints in the optimization problem (5.9) will be active when optimality is reached.*

Proof: See Appendix 5.B. ■

Lemma 5.2 will play an important role in the subsequent sections. For instance, if the power allocation is known then the transmit rate can be calculated by means of bisection method. Before we proceed to solve problem (5.9), let us investigate some special cases.

Special Cases

In this section, we turn our attention to problem (5.9) in the case where a single secondary MT is served by the secondary BS. More specifically, we investigate problem (5.9) with one secondary MT for single carrier and multi-carrier scenario, respectively.

²In this work, the equivalence between both problems means that a global solution to problem (5.9) can be found by a global solution to (5.8) and vice versa.

Single carrier scenario

When the primary and secondary systems are sharing only one subcarrier, problem (5.9) is recast as

$$\begin{aligned}
 & \max_{P_s \geq 0, R_1 \geq 0} R_1 \\
 & \text{s.t. } f(R_1, P_s) = \frac{N_0(2^{R_1} - 1)}{g_{s,1}P_s} + \log \left(1 + \frac{g_{p,1}P_p(2^{R_1} - 1)}{g_{s,1}P_s} \right) - \rho_1 \leq 0 \\
 & \quad \frac{N_0\bar{\alpha}}{g_{p,p}P_p} + \log \left(1 + \frac{g_{s,p}P_s\bar{\alpha}}{g_{p,p}P_p} \right) \leq \bar{\rho}_p \\
 & \quad P_s \leq P_{\max}
 \end{aligned} \tag{5.10}$$

The function $f(R_1, P_s)$ is an increasing function of R_1 and we know, based on Lemma 5.2, $f(R_1^*, P_s^*) = 0$ where R_1^*, P_s^* are the optimal solution of problem (5.10). The solution to the optimization problem (5.10) can be therefore computed using the following proposition.

Proposition 5.1. *The optimal power control solution of problem (5.10) is given by*

$$P_s^* = \left(\min \left\{ \frac{g_{p,p}P_p}{g_{s,p}\bar{\alpha}} \left(e^{\bar{\rho}_p - \frac{N_0\bar{\alpha}}{g_{p,p}P_p}} - 1 \right), P_{\max} \right\} \right)^+ \tag{5.11}$$

R_1^* is found by using bisection search to solve $f(R_1^*, P_s^*) = 0$.

The optimal power allocation is restricted either by the power constraint or the secondary outage constraint. The bisection method to find R_1^* is summarized in Algorithm 11

Remark 5.1. *Observe that for the single carrier case, the optimal solution set for the original problem (5.3) coincides with the the optimal solution set for the conservative approximation (5.8).*

Algorithm 11 Bisection method for solving problem (5.10)

1. Initialize $R_{\text{low}} = 0$ and $R_{\text{up}} = \log_2 \left(1 + \rho_1 \frac{g_{s,1} P_{\text{max}}}{N_0} \right)$;
2. Repeat
 - (a) Compute $\bar{R} = (R_{\text{low}} + R_{\text{up}})/2$;
 - (b) Find $f(\bar{R})$;
 - (c) if $f(\bar{R}) \leq 0$ set $R_{\text{low}} = \bar{R}$, otherwise set $R_{\text{up}} = \bar{R}$;
3. Stop when $|R_{\text{low}} - R_{\text{up}}| \leq \delta_1$.

Where $\delta_1 > 0$ is a given solution accuracy

In fact, it requires $\lceil \log_2(R_{\text{up}} \cdot \delta_1^{-1}) \rceil$ iterations for the bisection method to converge to δ_1 -optimality solution.

Single mobile terminal multi-carrier scenario

Now, we proceed to solve the optimization problem (5.8) when the secondary BS is serving a single user within L subcarriers. The corresponding optimization problem is written as

$$\begin{aligned}
 & \max_{\mathbf{P}_s \geq 0, R_1 \geq 0} R_1 \\
 & \text{s.t.} \quad \sum_{l=1}^L \frac{N_0(2^{R_1/L} - 1)}{g_{s,1}^l P_s^l} + \sum_{l=1}^L \log \left(1 + \frac{g_{p,1}^l P_p^l (2^{R_1/L} - 1)}{g_{s,1}^l P_s^l} \right) \leq \rho_1 \\
 & \quad \sum_{l=1}^L \frac{N_0 \bar{\alpha}}{g_{p,p}^l P_p^l} + \sum_{l=1}^L \log \left(1 + \frac{g_{s,p}^l P_s^l \bar{\alpha}}{g_{p,p}^l P_p^l} \right) \leq \bar{\rho}_p \\
 & \quad \sum_{l=1}^L P_s^l \leq P_{\text{max}}
 \end{aligned} \tag{5.12}$$

To get some insights into the optimal solution of the non-convex optimization problem (5.12), we focus on the corresponding feasibility problem. Given a transmit

rate value $\bar{R}_1 \geq 0$, the feasibility problem is written as follows

$$\begin{aligned}
& \max_{\mathbf{P}_s \geq 0} 0 \\
& \text{s.t.} \quad \sum_{l=1}^L \frac{N_0(2^{\bar{R}_1/L} - 1)}{g_{s,1}^l P_s^l} + \sum_{l=1}^L \log \left(1 + \frac{g_{p,1}^l P_p^l (2^{\bar{R}_1/L} - 1)}{g_{s,1}^l P_s^l} \right) \leq \rho_1 \\
& \quad \sum_{l=1}^L \frac{N_0 \bar{\alpha}}{g_{p,p}^l P_p^l} + \sum_{l=1}^L \log \left(1 + \frac{g_{s,p}^l P_s^l \bar{\alpha}}{g_{p,p}^l P_p^l} \right) \leq \bar{\rho}_p \\
& \quad \sum_{l=1}^L P_s^l \leq P_{\max}
\end{aligned} \tag{5.13}$$

The optimization problem given in (5.12) and the corresponding feasibility problem (5.13) are closely related. This relevance is stated in the following lemma.

Lemma 5.3. *For the feasibility optimization problem stated in (5.13) to be feasible, it is necessary and sufficient that $\bar{R}_1 \leq R_1^*$, where R_1^* is the optimal solution for problem (5.12).*

Proof: See Appendix 5.C ■

Lemma 5.3 can be utilized as the basis idea that permits us to construct an algorithm to solve problem (5.12) using bisection method, by sequentially solving a convex feasibility problem as pointed out in [67, Section 4.2.5]. The feasibility problem (5.13) is however non-convex. Let $y_s^l = \log(P_s^l)$, $\forall l$ and let $\tilde{\gamma}_1 \triangleq (2^{R_1/L} - 1)$, problem (5.13) is equivalent to

$$\begin{aligned}
& \min_{y_s^l \in \mathbb{R}, \forall l, x \in \mathbb{R}} x \\
& \text{s.t.} \quad \sum_{l=1}^L \frac{N_0 \tilde{\gamma}_1}{g_{s,1}^l e^{y_s^l}} + \sum_{l=1}^L \log \left(1 + \frac{g_{p,1}^l P_p^l \tilde{\gamma}_1}{g_{s,1}^l e^{y_s^l}} \right) - \rho_1 \leq x \\
& \quad \sum_{l=1}^L \frac{N_0 \bar{\alpha}}{g_{p,p}^l P_p^l} + \sum_{l=1}^L \log \left(1 + \frac{g_{s,p}^l e^{y_s^l} \bar{\alpha}}{g_{p,p}^l P_p^l} \right) \leq \bar{\rho}_p \\
& \quad \sum_{l=1}^L e^{y_s^l} \leq P_{\max}
\end{aligned} \tag{5.14}$$

Lemma 5.4. *Problem (5.14) is a convex optimization problem.*

Proof: See Appendix 5.D. ■

Proposition 5.2. *The optimal objective function value of problem (5.14) is given by*

$$x^* = \sum_{l=1}^L \frac{N_0 \tilde{\gamma}_1}{g_{s,1}^l e^{y_s^{l*}}} + \sum_{l=1}^L \log \left(1 + \frac{g_{p,1}^l P_p^l \tilde{\gamma}_1}{g_{s,1}^l e^{y_s^{l*}}} \right) - \rho_1 \quad (5.15)$$

where $y_s^{l*}, \forall l$ are optimal power allocation solution for problem (5.14) which can be computed by solving

$$\frac{\lambda \frac{g_{s,p}^l e^{y_s^l \bar{\alpha}}}{g_{p,p}^l P_p^l}}{1 + \frac{g_{s,p}^l e^{y_s^l \bar{\alpha}}}{g_{p,p}^l P_p^l}} + \mu e^{y_s^l} - \left(\frac{N_0 \tilde{\gamma}_1 e^{-y_s^l}}{g_{s,1}^l} + \frac{\frac{g_{p,1}^l P_p^l \tilde{\gamma}_1 e^{-y_s^l}}{g_{s,1}^l}}{1 + \frac{g_{p,1}^l P_p^l \tilde{\gamma}_1 e^{-y_s^l}}{g_{s,1}^l}} \right) = 0 \quad (5.16)$$

using the bisection method. In (5.16), λ, μ are Lagrangian multipliers corresponding to the convex optimization problem (5.14).

Proof: See Appendix 5.E. ■

The nonnegative dual variables λ, μ can be obtained by using subgradient method. More importantly, at the n th and n' th iteration,

$$\begin{aligned} \lambda^{(n)} &= \left[\lambda^{(n-1)} + \beta_2 \left(\sum_{l=1}^L \frac{N_0 \bar{\alpha}}{g_{p,p}^l P_p^l} + \sum_{l=1}^L \log \left(1 + \frac{g_{s,p}^l e^{y_s^l \bar{\alpha}}}{g_{p,p}^l P_p^l} \right) - \bar{\rho}_p \right) \right]^+ \\ \mu^{(n')} &= \left[\mu^{(n'-1)} + \beta_1 \left(\sum_{l=1}^L e^{y_s^l} - P_{\max} \right) \right]^+ \end{aligned} \quad (5.17)$$

The proposed algorithm to solve problem (5.12) is summarized as follow.

Algorithm 12 Bisection method for solving problem (5.12)

1. Initialization \underline{R} and $\check{R} = L \cdot \max_{l=1, \dots, L} \log_2 \left(1 + \frac{\rho_1 g_{s,1}^l P_{\max}}{LN_0} \right)$;
2. Repeat
 - (a) Compute $\tilde{R}_1 = (\underline{R} + \check{R})/2$;
 - (b) Repeat
 - i. Initialization : $\lambda^{(0)}$, $n = 1$;
 - ii. Repeat
 - A. Initialization : $\mu^{(0)}$, $n' = 1$;
 - B. Repeat
 - Find $y_s^l, \forall l$ by bisection search;
 - Update $\mu^{(n')}$ using the subgradient update given in (5.17);
 - C. Stop when $|\mu^{(n')} - \mu^{(n'-1)}| \leq \epsilon_1$;
 - D. Update $\lambda^{(n)}$ by using (5.17);
 - iii. Stop when $|\lambda^{(n)} - \lambda^{(n-1)}| \leq \epsilon_2$;
 - (c) Calculate x using (5.15);
 - (d) If problem (5.14) is feasible, i.e., if $x \leq 0$ set $\underline{R} = \tilde{R}_1$, otherwise set $\check{R} = \tilde{R}_1$;
3. Stop when $\check{R} - \underline{R} < \delta_3$;

Where $\epsilon_1 > 0$, $\epsilon_2 > 0$, $\delta_3 > 0$ are solutions accuracy and β_1, β_2 small step size.

Since problem (5.14) is a convex problem, the dual variables $\mu^{(n')}$, $\lambda^{(n)}$ generated by the subgradient approach are guaranteed to converge to the dual optimal μ^* , λ^* respectively as $n', n \rightarrow \infty$ [70, 120]. The worst case complexity of algorithm 12 is $L\kappa_\mu\kappa_\lambda \cdot \lceil \log_2(\check{R}\delta_3^{-1}) \rceil \cdot \mathcal{O}(\log_2(\delta_2^{-1}))$. More specifically, κ_μ and κ_λ denote the number of iterations needed for μ and λ respectively to converge. $\mathcal{O}(\log_2(\delta_2^{-1}))$ is the complexity to find each value of y_s^l .

General Solution

In the section, we turn our attention to problem (5.9). It is straightforward to see that secondary outage constraints in problem (5.9) are decoupled. Moreover,

the objective function is a separable function. We can therefore use the idea of alternating optimization method introduced in Subsection 2.7.2 to solve problem (5.9). The idea is to solve problem (5.9) from one secondary user to another, i.e., in a round-robin fashion. More specifically, starting with feasible rate $\widehat{R}_1, \dots, \widehat{R}_K$ to problem (5.9). At the n th round, the following problem is solved for user k

$$\begin{aligned}
\widehat{R}_k^{(n)} = \arg \max_{\mathbf{P}_s \geq 0, \widehat{R}_k \geq 0} & \mathcal{U} \left(\widehat{R}_1^{(n)}, \dots, \widehat{R}_{k-1}^{(n)}, R_k, \widehat{R}_{k+1}^{(n-1)}, \dots, \widehat{R}_K^{(n-1)} \right) \\
\text{s.t.} & \sum_{l \in \Omega_k} \frac{N_0(2^{R_k/|\Omega_k|} - 1)}{g_{s,k}^l P_s^l} + \sum_{l \in \Omega_k} \log \left(1 + \frac{g_{p,k}^l P_p^l (2^{R_k/|\Omega_k|} - 1)}{g_{s,k}^l P_s^l} \right) \leq \rho_k \\
& \sum_{l \in \Omega_j} \frac{N_0(2^{\widehat{R}_j^{(n-1)\{j>k\}}/|\Omega_j|} - 1)}{g_{s,j}^l P_s^l} + \sum_{l \in \Omega_j} \log \left(1 + \frac{g_{p,j}^l P_p^l (2^{\widehat{R}_j^{(n-1)\{j>k\}}/|\Omega_j|} - 1)}{g_{s,j}^l P_s^l} \right) \leq \rho_j, \forall j \neq k \\
& \sum_{l=1}^L \frac{N_0 \bar{\alpha}}{g_{p,p}^l P_p^l} + \sum_{l=1}^L \log \left(1 + \frac{g_{s,p}^l P_s^l \bar{\alpha}}{g_{p,p}^l P_p^l} \right) \leq \bar{\rho}_p \\
& \sum_{l=1}^L P_s^l \leq P_{\max}
\end{aligned} \tag{5.18}$$

where $1_{\{j>k\}}$ is the indicator function. There is one interesting point to make here. When the problem is solved for the k th secondary user, the third constraint indicates that the secondary BS needs to optimize the k th user rate R_k while assuring that the outage requirement of all other secondary user is not violated. Problem (5.18) can be solved using the same approach developed in Section 5.4.2. Given a rate \bar{R}_k , let $y_s^l = \log(P_s^l)$, $\forall l$ and let $\tilde{\gamma}_k \triangleq (2^{\bar{R}_k/|\Omega_k|} - 1)$, the corresponding feasibility problem is formulated as

$$\begin{aligned}
\min_{y_s^l \in \mathbb{R}, \forall l, x \in \mathbb{R}} & x \\
\text{s.t.} & \sum_{l \in \Omega_k} \frac{N_0 \tilde{\gamma}_k}{g_{s,k}^l e^{y_s^l}} + \sum_{l \in \Omega_k} \log \left(1 + \frac{g_{p,k}^l P_p^l \tilde{\gamma}_k}{g_{s,k}^l e^{y_s^l}} \right) - \rho_k \leq x \\
& \sum_{l \in \Omega_j} \frac{N_0 \tilde{\gamma}_j}{g_{s,j}^l e^{y_s^l}} + \sum_{l \in \Omega_j} \log \left(1 + \frac{g_{p,j}^l P_p^l \tilde{\gamma}_j}{g_{s,j}^l e^{y_s^l}} \right) \leq \rho_j, \forall j \neq k \\
& \sum_{l=1}^L \frac{N_0 \bar{\alpha}}{g_{p,p}^l P_p^l} + \sum_{l=1}^L \log \left(1 + \frac{g_{s,p}^l e^{y_s^l} \bar{\alpha}}{g_{p,p}^l P_p^l} \right) \leq \bar{\rho}_p \\
& \sum_{l=1}^L e^{y_s^l} \leq P_{\max}
\end{aligned} \tag{5.19}$$

It can be proved that problem (5.19) is a convex optimization problem. Therefore, the optimal solution for problem (5.19) can be obtained using the KKT conditions. To do so, let us first write the Lagrangian associated with the problem (5.19).

$$\begin{aligned} \mathcal{L}(\mathbf{y}, \boldsymbol{\xi}_{-k}, x, \lambda, \mu, \nu) = & x + \nu \left(\sum_{l \in \Omega_k} \frac{N_0 \tilde{\gamma}_k}{g_{s,k}^l e^{y_s^l}} + \sum_{l \in \Omega_k} \log \left(1 + \frac{g_{p,k}^l P_p^l \tilde{\gamma}_k}{g_{s,k}^l e^{y_s^l}} \right) - \rho_k - x \right) \\ & + \sum_{j \neq k} \xi_j \left(\sum_{l \in \Omega_j} \frac{N_0 \tilde{\gamma}_j}{g_{s,j}^l e^{y_s^l}} + \sum_{l \in \Omega_j} \log \left(1 + \frac{g_{p,j}^l P_p^l \tilde{\gamma}_j}{g_{s,j}^l e^{y_s^l}} \right) - \rho_j \right) \\ & + \lambda \left(\sum_{l=1}^L \frac{N_0 \bar{\alpha}}{g_{p,p}^l P_p^l} + \sum_{l=1}^L \log \left(1 + \frac{g_{s,p}^l e^{y_s^l} \bar{\alpha}}{g_{p,p}^l P_p^l} \right) - \bar{\rho}_p \right) \\ & + \mu \left(\sum_{l=1}^L e^{y_s^l} - P_{\max} \right) \end{aligned}$$

where $\mathbf{y} = (y_s^1, \dots, y_s^L)^\top$, $\boldsymbol{\xi}_{-k} = (\xi_1, \dots, \xi_{k-1}, \xi_{k+1}, \dots, \xi_K)^\top$. The KKT conditions are given by

$$\boldsymbol{\xi}_{-k} \geq 0, \lambda^* \geq 0, \mu^* \geq 0, \nu^* \geq 0 \quad (5.20a)$$

$$\nu^* \left(\sum_{l \in \Omega_k} \frac{N_0 \tilde{\gamma}_k}{g_{s,k}^l e^{y_s^{l*}}} + \sum_{l \in \Omega_k} \log \left(1 + \frac{g_{p,k}^l P_p^l \tilde{\gamma}_k}{g_{s,k}^l e^{y_s^{l*}}} \right) - \rho_k - x^* \right) = 0 \quad (5.20b)$$

$$\frac{\partial \mathcal{L}(\mathbf{y}, x, \lambda, \mu, \nu)}{\partial x} = 1 - \nu^* = 0 \rightarrow \nu^* = 1 \quad (5.20c)$$

$$\frac{\partial \mathcal{L}(\mathbf{y}, x, \lambda, \mu, \nu)}{\partial y_s^l} = \frac{\lambda \frac{g_{s,p}^l e^{y_s^l} \bar{\alpha}}{g_{p,p}^l P_p^l}}{1 + \frac{g_{s,p}^l e^{y_s^l} \bar{\alpha}}{g_{p,p}^l P_p^l}} + \mu e^{y_s^l} - \nu \left(\frac{N_0 \tilde{\gamma}_k e^{-y_s^l}}{g_{s,k}^l} + \frac{\frac{g_{p,k}^l P_p^l \tilde{\gamma}_k e^{-y_s^l}}{g_{s,k}^l}}{1 + \frac{g_{p,k}^l P_p^l \tilde{\gamma}_k e^{-y_s^l}}{g_{s,k}^l}} \right) = 0, \forall l \in \Omega_k \quad (5.20d)$$

$$\frac{\partial \mathcal{L}(\mathbf{y}, x, \lambda, \mu, \nu)}{\partial y_s^l} = \frac{\lambda \frac{g_{s,p}^l e^{y_s^l} \bar{\alpha}}{g_{p,p}^l P_p^l}}{1 + \frac{g_{s,p}^l e^{y_s^l} \bar{\alpha}}{g_{p,p}^l P_p^l}} + \mu e^{y_s^l} - \xi_j \left(\frac{N_0 \tilde{\gamma}_j e^{-y_s^l}}{g_{s,j}^l} + \frac{\frac{g_{p,j}^l P_p^l \tilde{\gamma}_j e^{-y_s^l}}{g_{s,j}^l}}{1 + \frac{g_{p,j}^l P_p^l \tilde{\gamma}_j e^{-y_s^l}}{g_{s,j}^l}} \right) = 0, \forall l \in \Omega_{j \neq k} \quad (5.20e)$$

the optimal value of ν^* is $\nu^* = 1$ by (5.20c). By plugging ν^* in (5.20b), we find,

$$x^* = \sum_{l \in \Omega_k} \frac{N_0 \tilde{\gamma}_k}{g_{s,k}^l e^{y_s^{l*}}} + \sum_{l \in \Omega_k} \log \left(1 + \frac{g_{p,k}^l P_p^l \tilde{\gamma}_k}{g_{s,k}^l e^{y_s^{l*}}} \right) - \rho_k$$

Moreover, it is straightforward to prove that the function $\frac{\partial \mathcal{L}(\mathbf{y}, x, \lambda, \mu, \nu)}{\partial y_s^l}$ in (5.20d) and (5.20e) is an increasing function of y_s^l . Therefore, we can use bisection method to find $y_s^l, \forall l$ by solving $\frac{\partial \mathcal{L}(\mathbf{y}, x, \lambda, \mu, \nu)}{\partial y_s^l} = 0, \forall l$. As before, the dual variables are updated using subgradient method. More specifically, at the n th iteration, $\mu^{(n)}, \lambda^{(n)}$ and $\xi_{-k}^{(n)}$ are given respectively by

$$\mu^{(n)} = \left[\mu^{(n-1)} + \beta_1 \left(\sum_{l=1}^L e^{y_s^l} - P_{\max} \right) \right]^+ \quad (5.21a)$$

$$\lambda^{(n)} = \left[\lambda^{(n-1)} + \beta_2 \left(\sum_{l=1}^L \frac{N_0 \bar{\alpha}}{g_{p,p}^l P_p^l} + \sum_{l=1}^L \log \left(1 + \frac{g_{s,p}^l e^{y_s^l} \bar{\alpha}}{g_{p,p}^l P_p^l} \right) - \bar{\rho}_p \right) \right]^+ \quad (5.21b)$$

$$\xi_j^{(n)} = \left[\xi_j^{(n-1)} + \beta_3 \left(\sum_{l \in \Omega_j} \frac{N_0 \tilde{\gamma}_j}{g_{s,j}^l e^{y_s^l}} + \sum_{l \in \Omega_j} \log \left(1 + \frac{g_{p,j}^l P_p^l \tilde{\gamma}_j}{g_{s,j}^l e^{y_s^l}} \right) - \rho_j \right) \right]^+, \quad \forall j \neq k \quad (5.21c)$$

where $\beta_1 > 0, \beta_2 > 0, \beta_3 > 0$ are small positive step size. The dual variables are guaranteed to converge because problem (5.19) is a convex problem [70, 120].

The proposed alternating-based approach to efficiently solve problem (5.18) is summarize in Algorithm 13.

Algorithm 13 Alternating-based algorithm for solving (5.9)

1. Initialization: $\widehat{\mathbf{R}}^{(0)}, n = 1$, repeat;
2. For $k = 1$ to \mathcal{K}
 - (a) Initialization: \underline{R} and \check{R} , repeat;
 - $\tilde{R}_1 = (\underline{R} + \check{R})/2$;
 - Find x and $(\{y_s^{l*}\}_{l=1}^L)$ by solving problem (5.19);
 - Update $\underline{R} = \tilde{R}_1$ if problem (5.19) is feasible, i.e., $x \leq 0$. Set otherwise $\check{R} = \tilde{R}_1$;
 - (b) Stop when $\check{R} - \underline{R} < \delta_3$;
 - (c) Update $\widehat{R}_k^{(n)} = \check{R}$;
3. Until convergence of the alternating method.

Where $\delta_3 > 0$ is solution accuracy.

Let κ denote the number of iterations it takes for the alternating approach to converge. The overall complexity order of the proposed alternating-based Algorithm

13 is $\mathcal{K}L\kappa\kappa_\mu\kappa_\lambda\kappa_\xi \cdot \lceil \log_2(\check{R}\delta_3^{-1}) \rceil \cdot \mathcal{O}(\log_2(\delta_2^{-1}))$. In fact, to solve (5.19), it requires $\kappa_\nu, \kappa_\lambda, \kappa_\xi$ number of rounds for the subgradient method to converge to $\mu^*, \lambda^*, \xi_{-k}^*$ respectively. In addition, $\lceil \log_2(\check{R}\delta_3^{-1}) \rceil$ is the complexity of the bisection method to compute each R_k while $\mathcal{O}(\log_2(\delta_2^{-1}))$ is the complexity order to find each y_s^l . The convergence of Algorithm 13 is ensured by observing that the objective function is nondecreasing at each iteration and is implicitly upper bounded by the outage constraints and the total power constraint. Moreover, it converges to a stationary point of problem (5.9). This is stated in the following theorem.

Theorem 5.1. *Suppose that the utility function $\mathcal{U}(R_1, \dots, R_{\mathcal{K}})$ is strictly increasing and differentiable with respect to R_k for any $k = 1, \dots, \mathcal{K}$, the sequence $\{\mathcal{U}(R_1^{(n)}, \dots, R_{\mathcal{K}}^{(n)})\}_{n=1}^\infty$ generated by Algorithm 13 converges. Moreover, any limit point of the sequence $\{\hat{\mathbf{R}}^{(n)}, \mathbf{P}_s^{(n)}\}$ is a stationary point of problem (5.9).*

Proof: The proof of Theorem 5.1 follows directly from [68]. ■

Asynchronous Networks

In this section, the secondary system downlink utility maximization problem for a network that experiences asynchronous transmission between primary and secondary system is presented. We are able to show that the downlink utility optimization problem can be solved using our proposed alternating-based algorithm although the outage expression structure in the case of asynchronous transmission is different from its synchronous counterpart.

In this section, we mainly focus on the power control problem for the downlink asynchronous utility optimization. Subcarrier can be assigned in a similar manner as (5.6) by incorporating in equation (5.4) the interference weight vector. The asynchronous subcarrier allocation solution can be computed by solving the following optimization problem using bisection search method.

$$\begin{aligned} & \arg \max_{k=1, \dots, \mathcal{K}} r_l \\ & \text{s.t. } r_l \geq 0 \\ & \text{s.t. } 1 - e^{-\frac{N_0(2^{\bar{r}_l} - 1)}{g_{s,k}^l \frac{P_{\max}}{L}}} \prod_{l' \in \mathcal{L}_l} \left(\frac{g_{s,k}^l}{g_{s,k}^l + g_{p,k}^{l'} V_{|l-l'|} (2^{\bar{r}_l} - 1)} \right) \leq \bar{\epsilon} \end{aligned} \quad (5.22)$$

where \mathcal{L}_l represents the set of subcarrier that interferes with the l th subcarrier.

The power control of the outage constrained utility maximization problem becomes even more difficult to handle in the presence of inter-carrier interferences. As previously done, we provide a tractable approximation to the primary and secondary system outage probability expression. This is done via the following lemma.

Lemma 5.5. *The asynchronous outage probability of the primary and secondary can be upper bounded by*

$$\begin{aligned}
& \Pr \left\{ \sum_{l=1}^L \log_2 \left(1 + \frac{P_p^l |h_{p,p}^l|^2}{N_0 + \sum_{l' \in \mathcal{L}_l} P_s^{l'} |h_{s,p}^{l'}|^2 V_{|l-l'|}} \right) < R_p \right\} \\
& \leq 1 - \left(\prod_{l=1}^L e^{-\frac{N_0 \bar{\alpha}}{g_{p,p}^l P_p^l}} \right) \left(\prod_{l'=1}^L \left(\frac{1}{1 + \bar{\alpha} \sum_{l \in I_{p,l'}} \frac{g_{s,p}^{l'} P_s^{l'} V_{|l-l'|}}{g_{p,p}^l P_p^l}} \right) \right) \\
& \Pr \left\{ \sum_{l \in \Omega_k} \log_2 \left(1 + \frac{P_s^l |h_{s,k}^l|^2}{N_0 + \sum_{l' \in \mathcal{L}_l} P_p^{l'} |h_{p,k}^{l'}|^2 V_{|l-l'|}} \right) < R_k \right\} \\
& \leq 1 - \left(\prod_{l \in \Omega_k} e^{-\frac{N_0 (2^{R_k/|\Omega_k|} - 1)}{g_{s,k}^l P_s^l}} \right) \left(\prod_{l'=1}^L \left(\frac{1}{1 + \sum_{l \in I_{k,l'}} \frac{g_{p,k}^{l'} P_p^{l'} V_{|l-l'|} (2^{R_k/|\Omega_k|} - 1)}{g_{s,k}^l P_s^l}} \right) \right) \quad (5.23)
\end{aligned}$$

where $I_{j,i}$ denotes the set of subcarriers allocated to j that suffers interferences generated by the i th subcarrier.

Proof: See Appendix 5.F. ■

The asynchronous downlink optimization problem can be conservatively approximated as

$$\begin{aligned}
& \max_{\mathbf{P}_S \geq 0, \mathbf{R} \geq 0} \mathcal{U} (R_1, \dots, R_K) \\
& \text{s.t. } 1 - \prod_{l \in \Omega_k} e^{-\frac{N_0 (2^{R_k/|\Omega_k|} - 1)}{g_{s,k}^l P_s^l}} \prod_{l'=1}^L \left(\frac{1}{1 + \sum_{l \in I_{k,l'}} \frac{g_{p,k}^{l'} P_p^{l'} V_{|l-l'|} (2^{R_k/|\Omega_k|} - 1)}{g_{s,k}^l P_s^l}} \right) \leq \epsilon_k, \forall k \\
& 1 - \prod_{l=1}^L e^{-\frac{N_0 \bar{\alpha}}{g_{p,p}^l P_p^l}} \prod_{l'=1}^L \left(\frac{1}{1 + \bar{\alpha} \sum_{l \in I_{p,l'}} \frac{g_{s,p}^{l'} P_s^{l'} V_{|l-l'|}}{g_{p,p}^l P_p^l}} \right) \leq \epsilon_p \\
& \sum_{l=1}^L P_s^l \leq P_{\max} \quad (5.24)
\end{aligned}$$

Problem (5.24) is solved using the idea of alternating optimization method. More importantly, at the n -th round, the following optimization problem is solved for the k -th secondary user.

$$\begin{aligned}
\widehat{R}_k^{(n)} &= \arg \max_{\mathbf{P}_s \geq 0, R_k \geq 0} \mathcal{U} \left(\widehat{R}_1^{(n)}, \dots, \widehat{R}_{k-1}^{(n)}, R_k, \widehat{R}_{k+1}^{(n-1)}, \dots, \widehat{R}_K^{(n-1)} \right) \\
\text{s.t. } & \sum_{l \in \Omega_k} \frac{N_0(2^{R_k/|\Omega_k|} - 1)}{g_{s,k}^l P_s^l} + \sum_{l'=1}^L \log \left(1 + \sum_{l \in I_{k,l'}} \frac{g_{p,k}^{l'} P_p^{l'} V_{|l-l'|} (2^{R_k/|\Omega_k|} - 1)}{g_{s,k}^l P_s^l} \right) \leq \rho_k \\
& \sum_{l \in \Omega_j} \frac{N_0(2^{\widehat{R}_j^{(n-1)\{j>k\}}/|\Omega_j|} - 1)}{g_{s,j}^l P_s^l} + \sum_{l'=1}^L \log \left(1 + \sum_{l \in I_{j,l'}} \frac{g_{p,j}^{l'} P_p^{l'} V_{|l-l'|} (2^{\widehat{R}_j^{(n-1)\{j>k\}}/|\Omega_j|} - 1)}{g_{s,j}^l P_s^l} \right) \leq \rho_j, \forall j \neq k \\
& \sum_{l'=1}^L \frac{N_0 \bar{\alpha}}{g_{p,p}^{l'} P_p^{l'}} + \sum_{l=1}^L \log \left(1 + \sum_{l' \in I_{p,l}} \frac{\bar{\alpha} g_{s,p}^l P_s^l V_{|l-l'|}}{g_{p,p}^{l'} P_p^{l'}} \right) \leq \bar{\rho}_p \\
& \sum_{l=1}^L P_s^l \leq P_{\max}
\end{aligned} \tag{5.25}$$

Problem (5.25) can be solved by means of bisection approach over the rate by solving a feasibility problem at each iteration. The feasibility problem is written as

$$\begin{aligned}
& \min_{\mathbf{y} \in \mathbb{R}, x \in \mathbb{R}} x \\
\text{s.t. } & \sum_{l \in \Omega_k} \frac{N_0 \tilde{\gamma}_k}{g_{s,k}^l e^{y_s^l}} + \sum_{l'=1}^L \log \left(1 + \sum_{l \in I_{k,l'}} \frac{g_{p,k}^{l'} P_p^{l'} V_{|l-l'|} \tilde{\gamma}_j}{g_{s,k}^l e^{y_s^l}} \right) \leq \rho_k \\
& \sum_{l \in \Omega_j} \frac{N_0 \tilde{\gamma}_j}{g_{s,j}^l e^{y_s^l}} + \sum_{l'=1}^L \log \left(1 + \sum_{l \in I_{j,l'}} \frac{g_{p,j}^{l'} P_p^{l'} V_{|l-l'|} \tilde{\gamma}_j}{g_{s,j}^l e^{y_s^l}} \right) \leq \rho_j, \forall j \neq k \\
& \sum_{l'=1}^L \frac{N_0 \bar{\alpha}}{g_{p,p}^{l'} P_p^{l'}} + \sum_{l=1}^L \log \left(1 + \sum_{l' \in I_{p,l}} \frac{\bar{\alpha} g_{s,p}^l e^{y_s^l} V_{|l-l'|}}{g_{p,p}^{l'} P_p^{l'}} \right) \leq \bar{\rho}_p \\
& \sum_{l=1}^L e^{y_s^l} \leq P_{\max}
\end{aligned} \tag{5.26}$$

Problem (5.26) is a convex optimization problem and can be efficiently solved by utilizing interior-point method based solvers such as CVX [133]. The alternating-based algorithm to find solutions to problem (5.24) is summarized in Algorithm 14.

Algorithm 14 Alternating-based algorithm for solving (5.24)

1. Initialization: $\widehat{\mathbf{R}}^{(0)}$, $n = 1$, repeat;
2. For $k = 1$ to \mathcal{K}
 - (a) Initialization: \underline{R} and \check{R} , repeat;
 - $\tilde{R}_1 = (\underline{R} + \check{R})/2$;
 - Find x and $(\{y_s^{l*}\}_{l=1}^L)$ by solving problem (5.26);
 - Update $\underline{R} = \tilde{R}_1$ if problem (5.26) is feasible, i.e., $x \leq 0$. Set otherwise $\check{R} = \tilde{R}_1$;
 - (b) Stop when $\check{R} - \underline{R} < \delta_3$;
 - (c) Update $\widehat{R}_k^{(n)} = \check{R}$;
3. Until convergence of the alternating method.

Where $\delta_3 > 0$ is solution accuracy.

The complexity of the interior-point method for solving problem (5.26) is $\mathcal{O}((L+1)\log(\epsilon_4^{-1}))$ [67], where ϵ_4 is a solution accuracy. Therefore, the worst-case complexity order of the proposed Algorithm 14 is $\mathcal{K}L\kappa \cdot \lceil \log_2(\check{R}\delta_3^{-1}) \rceil \cdot \mathcal{O}((L+1)\log(\epsilon_4^{-1}))$ where κ is the number of rounds it requires for the alternating method to converge while $\lceil \log_2(\check{R}\delta_3^{-1}) \rceil$ is the complexity of the bisection search to find each value of R_k . Similarly to the synchronous counterpart, the proposed alternating-based Algorithm 14 is guaranteed to converge.

Numerical results

In this section, we provide extensive simulation examples to illustrate the performance and the convergence properties of our proposed Algorithm 13 and Algorithm 14. All of our simulations were conducted using Monte Carlo simulations.

Our scenario consists of one base station and 4 mobile terminals within the secondary system. The distance between both BSs is randomly chosen between 0.1 and 0.5 km. Each MT is randomly located within a circle of radius 0.5 km centered at its serving BS. The secondary transmitted target rate per subcarrier is $\bar{r}_l = 15$ kBit/s while the primary system transmitted target rate is $R_p = L \times 15$ kBit/s.

The PU power is $P_p^l = \frac{P_{\max}}{L}$, $\forall l$ and its maximum tolerable outage probability requirement is fixed to $\epsilon_p = 0.1$. The stopping condition for Algorithm 13 and 14 is either

$$\left| \mathcal{U}(\widehat{R}_1[n], \dots, \widehat{R}_K[n]) - \mathcal{U}(\widehat{R}_1[n-1], \dots, \widehat{R}_K[n-1]) \right| < 10^{-3} \left| \mathcal{U}(\widehat{R}_1[n-1], \dots, \widehat{R}_K[n-1]) \right|$$

or $n = 50$ iterations.

Example 5.1. :

We start by examining the performance of our proposed alternating-based Algorithm 13 by comparing it with the exhaustive search. We want to assure that our proposed algorithm is viable and check its ability to reach the global optimal points. The performance comparison between our proposed Algorithm 13 and the exhaustive search method is given in terms of average sum rate versus secondary outage requirements for a fixed P_{\max} . The comparison is also done in terms of average sum rate versus P_{\max} for two different secondary outage requirements $\epsilon_k = (0.05, 0.1)$. The comparison is given in Figure 5.1 and Figure ??.

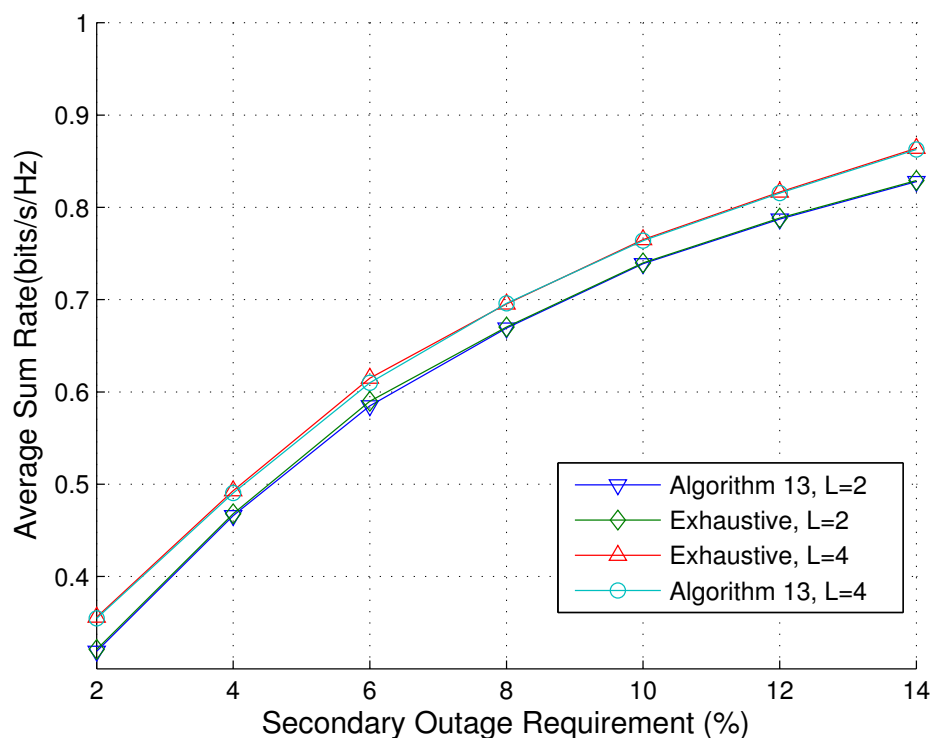


FIGURE 5.1: Performance of our proposed Algorithm 13 in terms of sum rate versus secondary outage requirements

These figures demonstrate that our proposed Algorithm 13 achieves almost the same average sum rate as the exhaustive search approach with a relatively small gap. In fact, the gain between the performance of the exhaustive search method and our proposed Algorithm 13 is less than 2.3%. This clearly indicates that the proposed approach achieves near optimal solution for the power control outage constrained utility optimization problem (5.8).

Example 5.2. :

To further demonstrate the performance efficiency of our proposed Algorithm 13, we evaluate the performance for the case of $L = 16$. Under such assumption, the exhaustive search approach is too complex to be implemented. We therefore compare with the heuristic adaptive power allocation scheme since, to the best of our knowledge, there is no existing methods for comparison. In Figure 5.3, we also provide simulations results for the perfect CSI studied in [128].

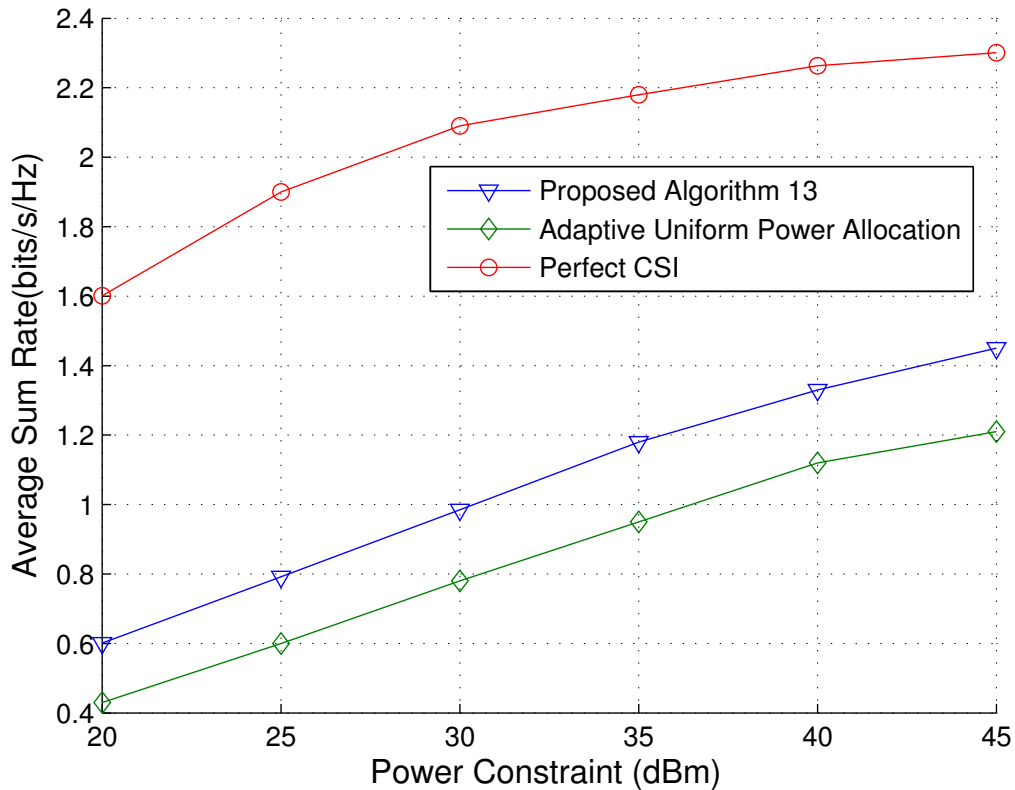


FIGURE 5.3: Performance comparison of the proposed Algorithm 13 with uniform power allocation and perfect CSI case for $L = 16$.

As expected, there is a significant gap between the performance of the network with perfect CSI and statistical CSI. From Figure 5.3, we see that our proposed Algorithm 13 outperforms the heuristic uniform power allocation scheme.

Figure 5.4 demonstrates the simulation results for the weighted harmonic mean rate versus power constraint P_{\max} . The user priority is chosen to be $(\hat{\alpha}_1, \hat{\alpha}_2, \hat{\alpha}_3, \hat{\alpha}_4) = (\frac{1}{2}, \frac{1}{8}, \frac{1}{8}, \frac{1}{4})$. It can be observed that the proposed algorithm yields higher harmonic mean rate comparing to the adaptive power allocation method. We observe also that Figure 5.1 displays a slow growth for P_{\max} higher than 40 dBm. One explanation for this phenomena is that the user fairness plays a crucial role in the performance of the harmonic mean rate and therefore prevents it to grow at high power constraint.

Example 5.3.

In this example, we examine the performance of our proposed Algorithm 14. As a benchmark for our simulation results, we consider the performance of Algorithm

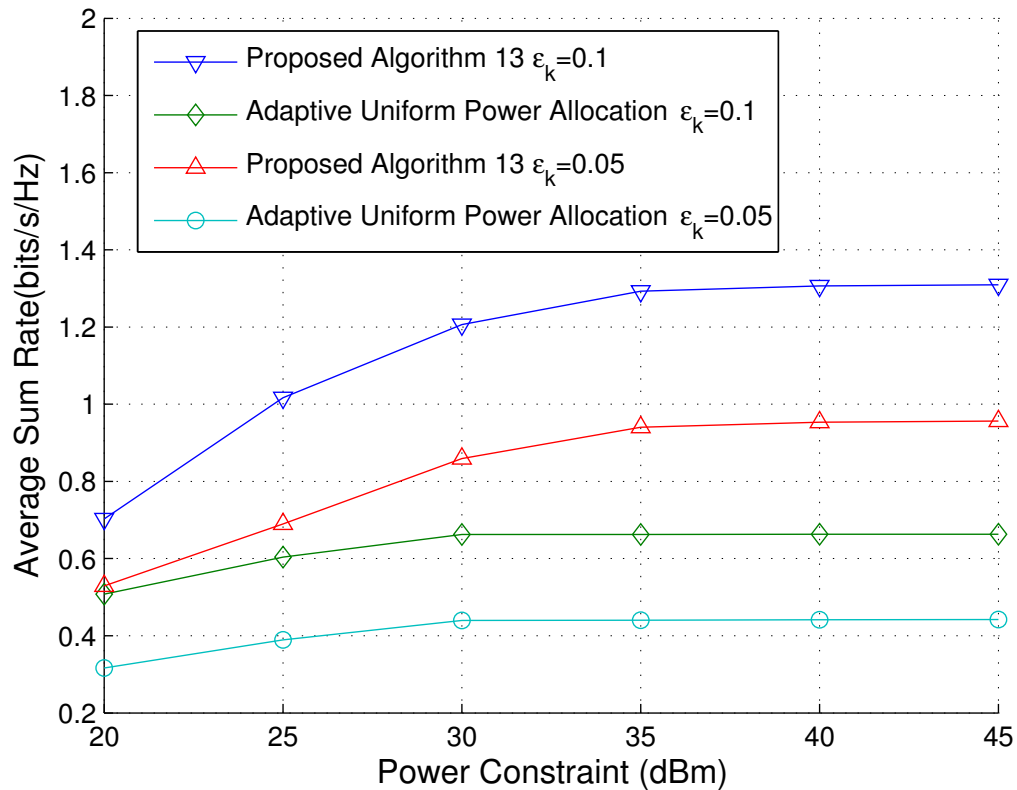


FIGURE 5.4: Performance of proposed sequential Algorithm 13 for $L = 16$.

13, i.e., the perfect synchronization case. We evaluate the effectiveness of our proposed sequential Algorithm 14 for both OFDM and FBMC. It can also be observed that, there exists a gain of 109% to 147% between the sum rate achieved by Algorithm 13 and sum rate achieved by Algorithm 14, confirming the degradation of the quality of service of the secondary users in the case where the network incurs asynchronous transmission. This is due to the loss of orthogonality between subcarriers and, as demonstrated in [12], to interferences that spread over adjacent subcarriers.

Figure 5.5 depicts the sum rate versus total power constraint P_{\max} achieved by the proposed sequential Algorithm 14. From Figure 5.5, we can observe that there is a gain of 21% to 29% between the sum rate achieved using FBMC and the sum rate achieved by utilizing OFDM.

Figure 5.6 demonstrates the simulation results in terms of weighted geometric mean rate versus secondary outage requirement, with user priority, i.e., $(\hat{\alpha}_1, \hat{\alpha}_2, \hat{\alpha}_3, \hat{\alpha}_4) =$

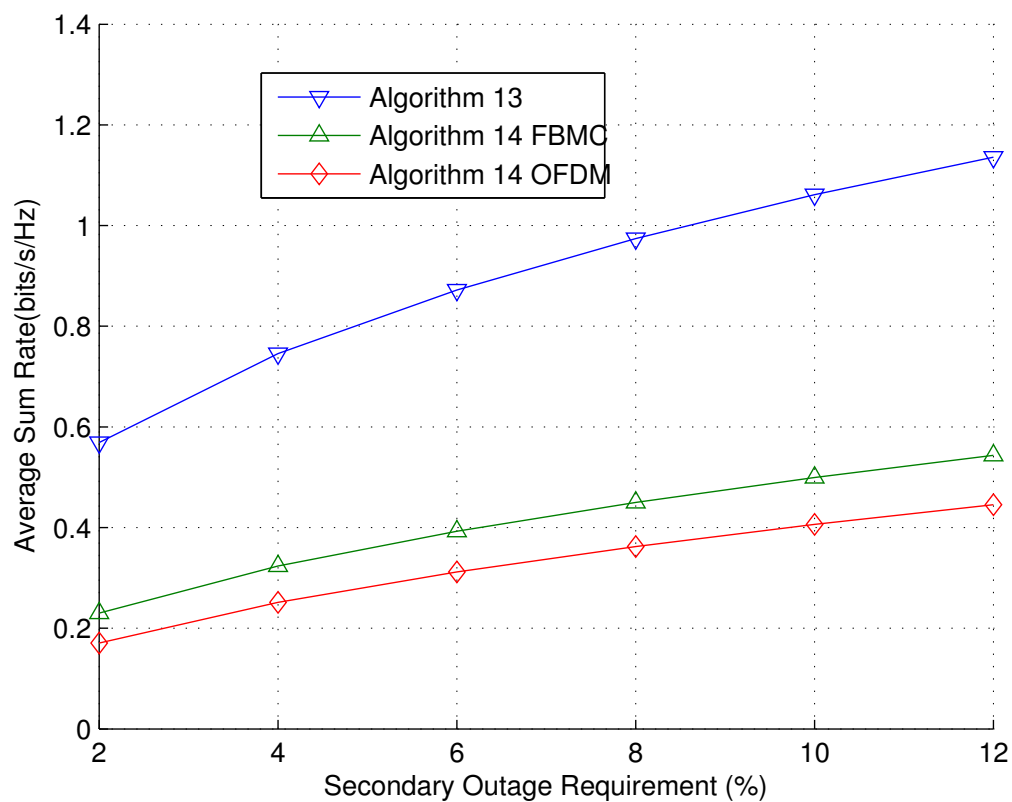


FIGURE 5.5: Performance of proposed sequential Algorithm 14 for $L = 16$.

$(\frac{1}{4}, \frac{1}{4}, \frac{1}{4}, \frac{1}{4})$. As in the case of sum rate, the weighted geometric mean rate achieved by the proposed algorithm is higher when FBMC is used than OFDM and there is a gain of 12% to 16% between both performances. Figure 5.5 and Figure 5.6 corroborate the claim that for asynchronous networks FBMC is better suited than OFDM.

Conclusion

In this chapter, we discussed a multi-carrier based outage constrained utility maximization problem for synchronous and asynchronous cognitive radio networks. We proposed a new subcarrier allocation that takes into consideration the statistical CSI assumption. Moreover, we proposed a conservative tractable approximation to the non-convex outage constraints. We proposed a polynomial time solvable sequential algorithm based on the idea of alternating optimization. Our simulation

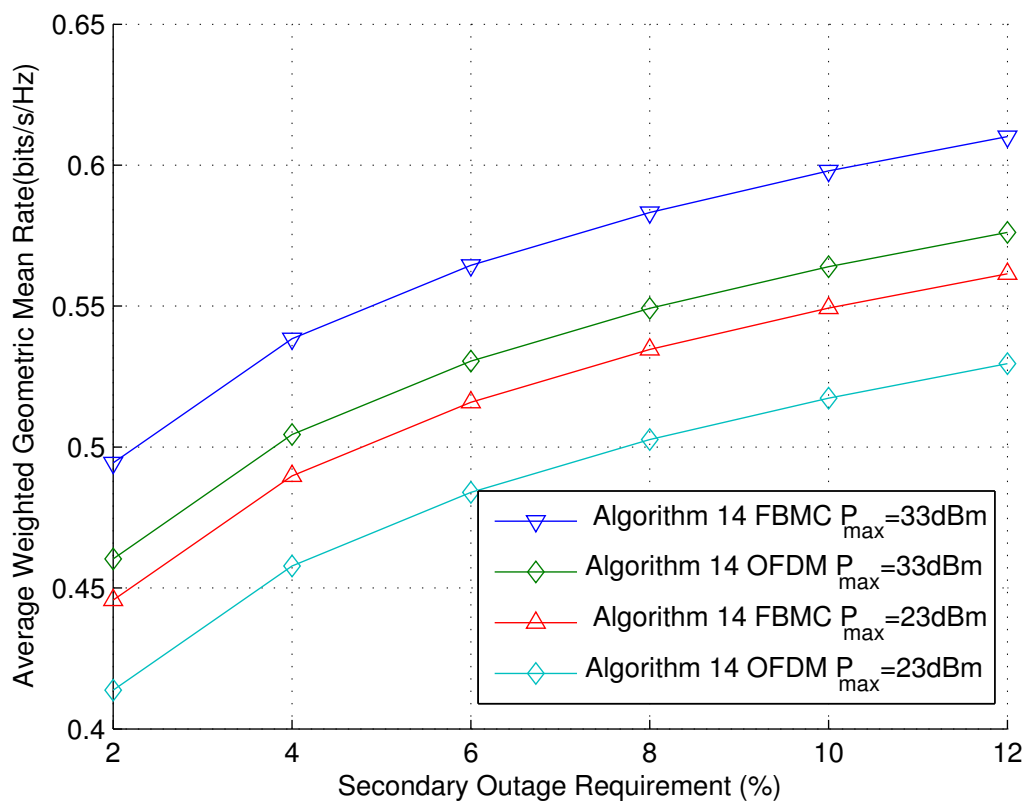


FIGURE 5.6: Performance of proposed sequential Algorithm 14 for different values of P_{\max} .

results indicated that our proposed alternating-based algorithm can yield near-optimal solutions for $L = 2$ and $L = 4$ and significantly outperforms the heuristic adaptive uniform power allocation. The simulation analysis further demonstrated that, in the case of asynchronous network, the network achieves higher utility function when the multi-carrier modulation technique utilized is FBMC instead of OFDM.

Appendix

Proof of Lemma 5.1

To begin with the proof, we rewrite the PU outage probability

$$\begin{aligned}
\Pr \left\{ \sum_{l=1}^L \log_2 \left(1 + \frac{P_p^l |h_{p,p}^l|^2}{N_0 + P_s^l |h_{s,p}^l|^2} \right) < R_p \right\} &= \Pr \left\{ \sum_{l=1}^L \log_2 (1 + \bar{z}_p^l) < R_p \right\} \\
&\leq 1 - \Pr \left\{ \bigcap_{l=1}^L \{ \bar{z}_p^l \geq 2^{R_p/L} - 1 \} \right\} \\
&= 1 - \prod_{l=1}^L \Pr \{ \bar{z}_p^l \geq 2^{R_p/L} - 1 \} \\
&= 1 - \prod_{l=1}^L \left(e^{-\frac{N_0 \bar{\alpha}}{g_{p,p}^l P_p^l}} \left(\frac{g_{p,p}^l P_p^l}{g_{p,p}^l P_p^l + g_{s,p}^l P_s^l \bar{\alpha}} \right) \right)
\end{aligned} \tag{5.27}$$

where $\bar{z}_p^l = \frac{P_p^l |h_{p,p}^l|^2}{N_0 + P_s^l |h_{s,p}^l|^2}$. By using a similar argument, an upper bound to the secondary outage probability can also be computed. This concludes the proof. ■

Proof of Lemma 5.2

Let $\mathbf{R}^*, \mathbf{P}_s^*$ be the optimal solution for problem (5.9) and assume that at least one of the secondary user outage constraint is not active. Without loss of generality, we

assume that the outage constraint of the first secondary user is not active. Hence,

$$f(R_1^*, \{P_s^{l*}\}_{l \in \Omega_1}) = \sum_{l \in \Omega_1} \frac{N_0(2^{R_1^*/|\Omega_1|} - 1)}{g_{s,1}^l P_s^{l*}} + \sum_{l \in \Omega_1} \log \left(1 + \frac{g_{p,1}^l P_p^l (2^{R_1^*/|\Omega_1|} - 1)}{g_{s,1}^l P_s^{l*}} \right) - \rho_1 \leq 0$$

Now, we proceed to demonstrate that the function $f(R_1^*, \{P_s^{l*}\}_{l \in \Omega_1})$ is an increasing function of R_1^* . To do so, let us investigate the first derivative of $f(R_1^*, \{P_s^{l*}\}_{l \in \Omega_1})$ with respect to R_1^* .

$$\frac{\partial f(R_1^*, \{P_s^{l*}\}_{l \in \Omega_1})}{\partial R_1^*} = \frac{\ln 2}{|\Omega_1|} \sum_{l \in \Omega_1} \left(\frac{N_0 2^{R_1^*/|\Omega_1|}}{g_{s,1}^l P_s^{l*}} + \frac{\frac{g_{p,1}^l P_p^l 2^{R_1^*/|\Omega_1|}}{g_{s,1}^l P_s^{l*}}}{1 + \frac{g_{p,1}^l P_p^l (2^{R_1^*/|\Omega_1|} - 1)}{g_{s,1}^l P_s^{l*}}} \right) > 0$$

The derivative $\frac{\partial f(R_1^*, \{P_s^{l*}\}_{l \in \Omega_1})}{\partial R_1^*}$ is greater than zero, we therefore say that $f(R_1^*, \{P_s^{l*}\}_{l \in \Omega_1})$ is an increasing function of R_1^* . Thus, we can find a new set of optimal solution denoted by $\{\widehat{R}_1^*, \dots, R_{\mathcal{K}}^*, \mathbf{P}_s^*\}$ satisfying all constraints of the optimization problem (5.9) such that $f(\widehat{R}_1^*, \{P_s^{l*}\}_{l \in \Omega_1}) = 0$. Since $f(x, \{P_s^{l*}\}_{l \in \Omega_1})$ is an increasing function of x , it yields $\widehat{R}_1^* > R_1^*$ which implies that $\mathcal{U}(\widehat{R}_1^*, \dots, R_{\mathcal{K}}^*) > \mathcal{U}(R_1^*, \dots, R_{\mathcal{K}}^*)$. This leads to a contradiction. \blacksquare

Proof of Lemma 5.3

First of all, we proceed to prove the necessary condition. To do so, denote by \mathcal{F} and $\overline{\mathcal{F}}$ the feasible set for problem (5.12) and (5.13), respectively. Let $\{R_1^*, \mathbf{P}_s^*\} \in \mathcal{F}$ be the optimal solution set for problem (5.12). Consider

$$f(x, \mathbf{P}_s) = \sum_{l=1}^L \frac{N_0(2^{x/L} - 1)}{g_{s,1}^l P_s^l} + \sum_{l=1}^L \log \left(1 + \frac{g_{p,1}^l P_p^l (2^{x/L} - 1)}{g_{s,1}^l P_s^l} \right) - \rho_1$$

Based on Lemma 5.2, we know that $f(R_1^*, \mathbf{P}_s^*) = 0$. Moreover, we know that $f(x, \mathbf{P}_s)$ is an increasing function of x . Since $\overline{R}_1 \leq R_1^*$, we must have $f(\overline{R}_1, \mathbf{P}_s^*) \leq 0$ which implies that $\{\overline{R}_1, \mathbf{P}_s^*\} \in \overline{\mathcal{F}}$. Therefore, problem (5.13) is feasible.

Now, we proceed to prove the sufficient condition. Suppose that problem (5.13) is feasible. There exists $\{\overline{R}_1, \overline{\mathbf{P}}_s\} \in \overline{\mathcal{F}}$ such that $f(\overline{R}_1, \overline{\mathbf{P}}_s) \leq 0$. Based on the structure of $f(x, \cdot)$, we can use bisection method to find \widehat{R}_1 , the solution of

$f(\widehat{R}_1, \overline{\mathbf{P}}_s) = 0$. Hence, $\overline{R}_1 \leq \widehat{R}_1$ and $\{\widehat{R}_1, \overline{\mathbf{P}}_s\} \in \mathcal{F}$. Therefore, we must have $\overline{R}_1 \leq \widehat{R}_1 \leq R_1^*$. Obviously, we will have $\overline{\mathbf{P}}_s = \mathbf{P}_s^*$ whenever $\overline{R}_1 = R_1^*$ ■

Proof of Lemma 5.4

It is straightforward to prove the convexity of the last constraint being the sum of convex functions. Consider

$$f(y_s^1, \dots, y_s^L) = \sum_{l=1}^L \frac{N_0 \bar{\alpha}}{g_{p,p}^l P_p^l} + \sum_{l=1}^L \log \left(1 + \frac{g_{s,p}^l e^{y_s^l} \bar{\alpha}}{g_{p,p}^l P_p^l} \right) - \bar{\rho}_p$$

which we rewrite as

$$f(y_s^1, \dots, y_s^L) = \sum_{l=1}^L \log \left(1 + a^l e^{y_s^l} \right) + b$$

where $a^l = \frac{g_{s,p}^l \bar{\alpha}}{g_{p,p}^l P_p^l} \geq 0$ and $b = \sum_{l=1}^L \frac{N_0 \bar{\alpha}}{g_{p,p}^l P_p^l} - \bar{\rho}_p$. The Hessian of $f(\cdot)$ is given by

$$\nabla^2 f(y_s^1, \dots, y_s^L) = \text{diag} \left(\frac{a^1 e^{y_s^1}}{(1 + a^1 e^{y_s^1})^2}, \dots, \frac{a^L e^{y_s^L}}{(1 + a^L e^{y_s^L})^2} \right)$$

Let $\mathbf{v} = (v_1, \dots, v_L)^\top$, we have

$$\mathbf{v}^\top \nabla^2 f(y_s^1, \dots, y_s^L) \mathbf{v} = \sum_{l=1}^L \frac{a^l e^{y_s^l}}{(1 + a^l e^{y_s^l})^2} (v_l)^2 \geq 0$$

Hence, the Hessian of $f(\cdot)$ is positive definite, i.e., $\nabla^2 f(y_s^1, \dots, y_s^L) \succeq 0$. Therefore, the primary outage constraint is a convex constraint. Similarly, let

$$f(\{y_s^l\}_{l \in \Omega_k}, z_k) = \sum_{l \in \Omega_k} \frac{N_0 e^{z_k - y_s^l}}{g_{s,k}^l} + \sum_{l \in \Omega_k} \log \left(1 + \frac{g_{p,k}^l P_p^l e^{z_k - y_s^l}}{g_{s,k}^l} \right) - \rho_k$$

which can be rewritten as

$$f(\{y_s^l\}_{l \in \Omega_k}, z_k) = \sum_{l \in \Omega_k} \bar{a}^l e^{z_k - y_s^l} + \sum_{l \in \Omega_k} \log \left(1 + b^l e^{z_k - y_s^l} \right) - \rho_k$$

where $\bar{a}^l = \frac{N_0}{g_{s,k}^l} \geq 0$ and $\bar{b}^l = \frac{g_{p,k}^l P_p^l}{g_{s,k}^l} \geq 0$. We have,

$$\bar{\mathbf{v}}^\top \nabla^2 f(\{y_s^l\}_{l \in \Omega_k}, z_k) \bar{\mathbf{v}} = \sum_{l \in \Omega_k} \left(\bar{a}^l e^{z_k - y_s^l} + \frac{\bar{b}^l e^{z_k - y_s^l}}{(1 + \bar{b}^l e^{z_k - y_s^l})^2} \right) (\bar{v}_l - \bar{v}_{|\Omega_k|+1})^2 \geq 0$$

where $\bar{\mathbf{v}} = (\bar{v}_1, \dots, \bar{v}_{|\Omega_k|+1})^\top$. Therefore, $\nabla^2 f(\{y_s^l\}_{l \in \Omega_k}, z_k) \succeq 0$ and we conclude that the secondary users outage constraint is a convex constraint. ■

Proof of Proposition 5.2

Based on Lemma 5.4, we know that problem (5.14) is a convex optimization problem. Therefore, the optimal solutions can be obtained by means of the Karush-Kuhn-Tucker (KKT) [67] conditions. The Lagrangian associated with the problem (5.14) is formulated as

$$\begin{aligned} \mathcal{L}(\mathbf{y}, x, \lambda, \mu, \nu) = & x + \nu \left(\sum_{l=1}^L \frac{N_0 \tilde{\gamma}_1}{g_{s,1}^l e^{y_s^l}} + \sum_{l=1}^L \log \left(1 + \frac{g_{p,1}^l P_p^l \tilde{\gamma}_1}{g_{s,1}^l e^{y_s^l}} \right) - \rho_1 - x \right) \\ & \lambda \left(\sum_{l=1}^L \frac{N_0 \bar{\alpha}}{g_{p,p}^l P_p^l} + \sum_{l=1}^L \log \left(1 + \frac{g_{s,p}^l e^{y_s^l} \bar{\alpha}}{g_{p,p}^l P_p^l} \right) - \bar{\rho}_p \right) \\ & + \mu \left(\sum_{l=1}^L e^{y_s^l} - P_{\max} \right) \end{aligned}$$

The KKT conditions are given by

$$\lambda^* \geq 0, \mu^* \geq 0, \nu^* \geq 0 \quad (5.28a)$$

$$\nu^* \left(\sum_{l=1}^L \frac{N_0 \tilde{\gamma}_1}{g_{s,1}^l e^{y_s^{l*}}} + \sum_{l=1}^L \log \left(1 + \frac{g_{p,1}^l P_p^l \tilde{\gamma}_1}{g_{s,1}^l e^{y_s^{l*}}} \right) - \rho_1 - x^* \right) = 0 \quad (5.28b)$$

$$\lambda^* \left(\sum_{l=1}^L \frac{N_0 \bar{\alpha}}{g_{p,p}^l P_p^l} + \sum_{l=1}^L \log \left(1 + \frac{g_{s,p}^l e^{y_s^{l*}} \bar{\alpha}}{g_{p,p}^l P_p^l} \right) - \bar{\rho}_p \right) = 0 \quad (5.28c)$$

$$\mu^* \left(\sum_{l=1}^L e^{y_s^{l*}} - P_{\max} \right) = 0 \quad (5.28d)$$

$$\frac{\partial \mathcal{L}(\mathbf{y}, x, \lambda, \mu, \nu)}{\partial x} = 1 - \nu^* = 0 \rightarrow \nu^* = 1 \quad (5.28e)$$

$$\frac{\partial \mathcal{L}(\mathbf{y}, x, \lambda, \mu, \nu)}{\partial y_s^l} = \frac{\lambda \frac{g_{s,p}^l e^{y_s^l} \bar{\alpha}}{g_{p,p}^l P_p^l}}{1 + \frac{g_{s,p}^l e^{y_s^l} \bar{\alpha}}{g_{p,p}^l P_p^l}} + \mu e^{y_s^l} - \left(\frac{N_0 \tilde{\gamma}_1 e^{-y_s^l}}{g_{s,1}^l} + \frac{\frac{g_{p,1}^l P_p^l \tilde{\gamma}_1 e^{-y_s^l}}{g_{s,1}^l}}{1 + \frac{g_{p,1}^l P_p^l \tilde{\gamma}_1 e^{-y_s^l}}{g_{s,1}^l}} \right) = 0 \quad (5.28f)$$

The optimal value of $\nu^* = 1$ by (5.28e). By substituting the value of ν^* in (5.28b),

$$x^* = \sum_{l=1}^L \frac{N_0 \tilde{\gamma}_1}{g_{s,1}^l e^{y_s^{l*}}} + \sum_{l=1}^L \log \left(1 + \frac{g_{p,1}^l P_p^l \tilde{\gamma}_1}{g_{s,1}^l e^{y_s^{l*}}} \right) - \rho_1$$

In (5.28f), let $\frac{\partial \mathcal{L}(\mathbf{y}, x, \lambda, \mu, \nu)}{\partial y_s^l} \triangleq \widehat{\mathcal{G}}(y_s^l, \lambda, \mu)$. The derivative of $\widehat{\mathcal{G}}(y_s^l, \lambda, \mu)$ with respect to y_s^l is given by

$$\frac{\lambda \frac{g_{s,p}^l e^{y_s^l} \bar{\alpha}}{g_{p,p}^l P_p^l}}{\left(1 + \frac{g_{s,p}^l e^{y_s^l} \bar{\alpha}}{g_{p,p}^l P_p^l} \right)^2} + \mu e^{y_s^l} + \left(\frac{N_0 \tilde{\gamma}_1 e^{-y_s^l}}{g_{s,1}^l} + \frac{\frac{g_{p,1}^l P_p^l \tilde{\gamma}_1 e^{-y_s^l}}{g_{s,1}^l}}{\left(1 + \frac{g_{p,1}^l P_p^l \tilde{\gamma}_1 e^{-y_s^l}}{g_{s,1}^l} \right)^2} \right) \geq 0 \quad (5.29)$$

Since the derivative of the function $\widehat{\mathcal{G}}(y_s^l, \lambda, \mu)$ w.r.t y_s^l is greater than zero, it can be inferred that $\widehat{\mathcal{G}}(y_s^l, \lambda, \mu)$ is an increasing function of y_s^l . Therefore, for a fixed λ and μ , bisection approach can be used to solved $\widehat{\mathcal{G}}(y_s^l, \lambda, \mu) = 0$. ■

Proof of Lemma 5.5

To begin with the proof, let us rewrite the primary outage probability

$$\begin{aligned}
& \Pr \left\{ \sum_{l=1}^L \log_2 \left(1 + \frac{P_p^l |h_{p,p}^l|^2}{N_0 + \sum_{l' \in \mathcal{L}_l} P_s^{l'} |h_{s,p}^{l'}|^2 V_{|l-l'|}} \right) < R_p \right\} \\
& \leq 1 - \Pr \left\{ \bigcap_{l=1}^L \left\{ \frac{x_p^l}{N_0 + \sum_{l' \in \mathcal{L}_l} x_s^{l'} V_{|l-l'|}} \geq 2^{R_p/L} - 1 \right\} \right\} \\
& = 1 - \Pr \left\{ \bigcap_{l=1}^L \left\{ \frac{x_p^l}{N_0 + \sum_{l' \in \mathcal{L}_l} x_s^{l'} V_{|l-l'|}} \geq \bar{\alpha} \right\} \right\} \tag{5.30}
\end{aligned}$$

where $x_p^l = P_p^l |h_{p,p}^l|^2$ and $x_s^{l'} = P_s^{l'} |h_{s,p}^{l'}|^2$. Here, x_p^l and $x_s^{l'}$ are exponential random variables and we denote their mean by $\frac{1}{\gamma_p^l}$ and $\frac{1}{\gamma_s^{l'}}$, respectively. Consider the following probability,

$$\begin{aligned}
& \Pr \left\{ \bigcap_{l=1}^L \left\{ \frac{x_p^l}{N_0 + \sum_{l' \in \mathcal{L}_l} x_s^{l'} V_{|l-l'|}} \geq \bar{\alpha} \right\} \right\} = \Pr \left\{ \bigcap_{l=1}^L \{\mathcal{O}_p^l\} \right\} \\
& = \mathbb{E}_{\{x_1^{l'}\}_{l' \in \mathcal{L}_L}} \left[\cdots \mathbb{E}_{\{x_1^{l'}\}_{l' \in \mathcal{L}_1}} \left[\mathbb{E}_{x_p^L} \left[1_{\mathcal{O}_p^L} \cdots \mathbb{E}_{x_p^1} \left[1_{\mathcal{O}_p^1} \mid \{x_1^{l'}\}_{l' \in \mathcal{L}_1} \right] \cdots \mid \{x_1^{l'}\}_{l' \in \mathcal{L}_L} \right] \right] \cdots \right] \\
& = \mathbb{E}_{\{x_1^{l'}\}_{l' \in \mathcal{L}_L}} \left[\cdots \mathbb{E}_{\{x_1^{l'}\}_{l' \in \mathcal{L}_1}} \left[e^{-\frac{(N_0 + \sum_{l' \in \mathcal{L}_L} x_1^{l'} V_{|l-l'|}) \bar{\alpha}}{\gamma_p^L}} \cdots e^{-\frac{(N_0 + \sum_{l' \in \mathcal{L}_1} x_1^{l'} V_{|l-l'|}) \bar{\alpha}}{\gamma_p^1}} \right] \cdots \right] \\
& = \mathbb{E}_{\{x_1^{l'}\}_{l' \in \mathcal{L}_L}} \left[\cdots \mathbb{E}_{\{x_1^{l'}\}_{l' \in \mathcal{L}_1}} \left[e^{-\frac{(\sum_{l' \in \mathcal{L}_L} x_1^{l'} V_{|l-l'|}) \bar{\alpha}}{\gamma_p^L}} \cdots e^{-\frac{(\sum_{l' \in \mathcal{L}_1} x_1^{l'} V_{|l-l'|}) \bar{\alpha}}{\gamma_p^1}} \right] \cdots \right] \prod_{l=1}^L \exp^{-\frac{N_0 \bar{\alpha}}{\gamma_p^l}} \\
& = \left(\prod_{l=1}^L \exp^{-\frac{N_0 \bar{\alpha}}{P_p^l g_{p,p}^l}} \right) \left(\prod_{l'=1}^L \left(\frac{1}{1 + \bar{\alpha} \sum_{l \in \mathcal{I}_{p,l'}} \frac{P_s^{l'} g_{s,p}^{l'} V_{|l-l'|}}{P_p^l g_{p,p}^l}} \right) \right) \tag{5.31}
\end{aligned}$$

where \mathcal{O}_p^l denotes the non-outage event within the l -th subcarrier. 1_A is the indicator function for event A and $\mathbb{E}[\cdot]$ denotes the statistical expectation. The upper bound to the primary outage probability can be found by combining (5.30) and (5.31). By a similar reasoning, the upper bound to the secondary user can also be calculated. \blacksquare

Chapter 6

Conclusion and Future Research Direction

Summary of this dissertation

In this dissertation, we studied the problem of resource allocation to assure reliable transmission for multi-carrier-based asynchronous downlink cognitive radio networks. The problem was investigated from the perspective of perfect and statistical knowledge of channel state information.

Firstly, we addressed the problem of secondary users power minimization under data rate requirement constraint and primary interference constraints in Chapter 3. We provided a sufficient condition that guarantees convergence to a Nash-equilibrium (NE) point for the modified water-filling algorithm. Moreover, we proposed a fully distributed convergence criterion, i.e a per-subcarrier convergence criterion. By utilizing such convergence criterion, we proposed a new and efficient distributed algorithm that always converges to a unique and fixed point.

Secondly, we considered the problem of energy-efficiency maximization under secondary total power and primary interference constraints in Chapter 4. The problem was investigated from both centralized and decentralized point of view. For

the centralized perspective, it was assumed cooperation between the secondary base stations. We proposed an alternating-based scheme to solve the joint power-subcarrier allocation problem. The subcarrier allocation was done using a heuristic approach. As for the power control, we conservatively approximated the non-convex problem and we designed a joint *Successive Convex Approximation-Dinkelbach Algorithm (SCADA)* to obtain a stationary point of the original non-convex power control problem. Numerical results showed that the proposed algorithm achieved near optimal solution at least for low-scale networks. In addition to that, in order to alleviate the overhead complexity incurred by implementing a centralized algorithm, we proposed a dual decomposition-based distributed algorithm. The simulation results demonstrated that the decentralized algorithm is as efficient as the centralized algorithm. That makes the dual-decomposition based algorithm more viable for large scale networks.

From a decentralized perspective, we assumed no cooperation among the secondary base stations. We reformulated the energy-efficiency problem as a game theory problem. We demonstrated the existence of a Nash-equilibrium point of the proposed game. On top of that, we identified a sufficient condition guaranteeing the uniqueness of the Nash equilibrium point. We observed from the simulation results that the proposed distributed scheme is robust with respect to initial power allocation. In addition to that, although there is a gap between the performance of the game theory-based distributed approach and the centralized schemes, the distributed scheme does need negligible information exchange since only local information is need within each secondary cell.

Lastly, we discussed a multi-carrier based outage constrained utility maximization problem for synchronous and asynchronous cognitive radio networks in Chapter 5. The outage comes from the fact that statistical channel state information was taken into consideration. To assign the subcarriers, we took into account the statistical CSI assumption. To solve the power control problem, we first proposed a conservative tractable approximation to the non-convex outage constraints. Using the outage approximation, we provided a conservative approximation of the power control problem. We provided optimal solution for some special cases. As for the general case, we designed a polynomial time solvable sequential algorithm based

on the idea of alternating optimization approach. From the numerical results, we saw that the proposed alternating-based algorithm converges to a near-optimal solutions especially in the case of low scale networks. Moreover, the simulations also indicated that the proposed scheme significantly outperforms the heuristic adaptive uniform power allocation.

Regardless the assumption made on the knowledge of channel state information, the numerical results always indicate two things. Firstly, there is significant performance loss between the perfect synchronization case compared to either FBMC or OFDM in case of asynchronous networks. This clearly indicates that inter-carrier interferences have a negative impact on the performance of the system. Secondly, for asynchronous networks, the performance of the algorithms is always better when we utilize FBMC that the performance achieved if OFDM is used.

Perspectives for future work

The topic of resource allocation in multi-carrier-based cognitive radio networks is a very broad topic. Some aspects have been considered in this dissertation. Some other interesting topics or aspects can potentially be addressed. We provide some suggestions either for extending the current work or some new yet potential future research directions.

- We have studied downlink multi-carrier based cognitive radio networks. It can interesting to look at the problem from an uplink point of view.
- In this dissertation, we considered both perfect and statistical channel state information, the work done in the dissertation can be extended to the case of imperfect channel state information.
- In chapter 5, we considered one primary and one secondary base station. For future work, a more general system model consisting of multiple primary and multiple secondary base station can be investigated.
- For fully distributed implementation, we have considered user-centric primary interference constraints. However, for more practical scenario, it is more

judicious to assume network-centric primary interference constraint which introduces a coupled constraint. The investigation into efficient approaches to deal with such constraint and to yield optimal solution can be considered as a good research direction.

- Throughout this manuscript, we considered nodes with only a single antenna. These approaches can be extended to multiple-input multiple-output (MIMO) cognitive radio networks. The direct extension in the case of OFDM may be done without any complication in terms of interference analysis especially for perfect synchronization case. However, in the case of asynchronous networks, the inter-carrier interferences have not been studied yet. Therefore, a first step should be to provide rigorous analysis for the inter-carrier interferences for MIMO FBMC network and eventually provide an interference weight vector. In a second step, the interference weight vector can be used in order to study resource allocation for MIMO cognitive radio networks with FBMC.

Bibliography

- [1] Joseph Mitola III. Cognitive radio: An integrated agent architecture for software defined radio. URL <http://www.diva-portal.org/smash/get/diva2:8730/FULLTEXT01.pdf>.
- [2] IEEE Std. 802.22 IEEE 802.22 Working Group on Wireless Regional Area Networks (WRANs), for a cognitive radio-based PHY /MAC /air-interface for use by license-exempt devices in spectrum that is allocated to the TV Broadcast Service. 2005. URL <http://grouper.ieee.org/groups/802/22/>.
- [3] David Tse and Pramod Viswanath. *Fundamentals of Wireless Communication*. Cambridge University Press, New York, NY, USA, 2005.
- [4] I. Budiarjo, H. Nikookar, and L.P. Ligthart. Cognitive radio modulation techniques. *Signal Processing Magazine, IEEE*, 25(6):24–34, November 2008.
- [5] B. Farhang-Boroujeny and R. Kempter. Multicarrier communication techniques for spectrum sensing and communication in cognitive radios. *Communications Magazine, IEEE*, 46(4):80–85, April 2008.
- [6] B. Farhang-Boroujeny. Filter bank spectrum sensing for cognitive radios. *Signal Processing, IEEE Transactions on*, 56(5):1801–1811, May 2008.

- [7] T. Weiss, J. Hillenbrand, A. Krohn, and F.K. Jondral. Mutual interference in OFDM-based spectrum pooling systems. In *Vehicular Technology Conference, 2004. VTC 2004-Spring. 2004 IEEE 59th*, volume 4, pages 1873–1877, May 2004.
- [8] T.A Weiss and F.K. Jondral. Spectrum pooling: an innovative strategy for the enhancement of spectrum efficiency. *IEEE, Communications Magazine*, 42(3):S8–14, Mar 2004.
- [9] A. Pandharipande. Principles of OFDM. *Potentials, IEEE*, 21(2):16–19, Apr 2002.
- [10] H. Mahmoud, T. Yucek, and H. Arslan. OFDM for cognitive radio: merits and challenges. *Wireless Communications, IEEE*, 16(2):6–15, April 2009.
- [11] Roland Kempter, Rong Rong Chen, and Lekun Lin. Filter bank multitone: A physical layer candidate for cognitive radios. In *2005 Software Defined Radio Technical Conference*, 2005.
- [12] Y. Medjahdi, M. Terre, D. Le Ruyet, D. Roviras, J.A. Nossek, and L. Baltar. Inter-cell interference analysis for OFDM/FBMC systems. In *IEEE 10th Workshop on Signal Processing Advances in Wireless Communications (SPAWC)*, pages 598–602, 2009.
- [13] Jacques Palicot Quentin Bodinier, Faouzi Bader. Modeling interference between ofdm/oqam and cp-ofdm: Limitations of the psd-based model. *CoRR*, abs/1603.08697, 2016. URL <http://http://arxiv.org/abs/1603.08697>.
- [14] Simon Haykin. Cognitive radio: brain-empowered wireless communications. *IEEE Journal on, Selected Areas in Communications*, 23(2):201–220, Feb 2005.
- [15] A. Goldsmith, S.A. Jafar, I. Maric, and S. Srinivasa. Breaking spectrum gridlock with cognitive radios: An information theoretic perspective. *Proceedings of the IEEE*, 97(5):894–914, May 2009.
- [16] G. Wunder, M. Kasparick, S. ten Brink, F. Schaich, T. Wild, I. Gaspar, E. Ohlmer, S. Krone, N. Michailow, A. Navarro, G. Fettweis, D. Ktenas,

- V. Berg, M. Dryjanski, S. Pietrzyk, and B. Eged. 5GNOW: Challenging the LTE design paradigms of orthogonality and synchronicity. In *Vehicular Technology Conference (VTC Spring), 2013 IEEE 77th*, pages 1–5, June 2013.
- [17] PHYDYAS. Physical layer for dynamic spectrum access and cognitive radio. URL <http://www.ict-phydyas.org/>.
- [18] FCC. *ET Docket No 02-155 Spectrum policy task force report. Federal Communications Commission (FCC)*. 2002.
- [19] FCC. *ET Docket No 03-222 Notice of proposed rule making and order. Federal Communications Commission (FCC)*. 2003.
- [20] Qing Zhao and B.M. Sadler. A survey of dynamic spectrum access. *Signal Processing Magazine, IEEE*, 24(3):79–89, May 2007.
- [21] W. Lehr and J. Crowcroft. Managing shared access to a spectrum commons. In *New Frontiers in Dynamic Spectrum Access Networks, 2005. DySPAN 2005. 2005 First IEEE International Symposium on*, pages 420–444, Nov 2005.
- [22] J. Mitola. Cognitive radio for flexible mobile multimedia communications. In *Mobile Multimedia Communications, 1999. (MoMuC '99) 1999 IEEE International Workshop on*, pages 3–10, 1999.
- [23] Huseyin Arslan. *Cognitive Radio, Software Defined Radio, and Adaptive Wireless Systems (Signals and Communication Technology)*. Springer-Verlag New York, Inc., Secaucus, NJ, USA, 2007. ISBN 1402055412.
- [24] Przemyslaw Pawelczak. Cognitive radio information centre. URL <http://grouper.ieee.org/groups/dyspan/crinfo/>.
- [25] A.N. Mody, M.J. Sherman, R. Martinez, R. Reddy, and T. Kiernan. Survey of IEEE standards supporting cognitive radio and dynamic spectrum access. In *Military Communications Conference, 2008. MILCOM 2008. IEEE*, pages 1–7, Nov 2008.

- [26] Standard Definitions, System Functionality Concepts for Dynamic Spectrum Access: Terminology Relating to Emerging Wireless Networks, and IEEE P1900.1/D4.00 Spectrum Management. March 2008.
- [27] Federal Communications Commission. Establishment of interference temperature metric to quantify and manage interference and to expand available unlicensed operation in certain fixed mobile and satellite frequency bands. *ET Docket 03-289, Notice of Inquiry and Proposed Rulemaking*, 2003.
- [28] L.J. Cimini. Analysis and simulation of a digital mobile channel using orthogonal frequency division multiplexing. *IEEE Transactions on, Communications*, 33(7):665–675, Jul 1985.
- [29] B. Le Floch, M. Alard, and C. Berrou. Coded orthogonal frequency division multiplex [TV broadcasting]. *Proceedings of the IEEE*, 83(6):982–996, Jun 1995.
- [30] L. Cimini. Analysis and simulation of a digital mobile channel using orthogonal frequency division multiplexing. *IEEE Transactions on Communications*, 33(7):665–675, Jul 1985.
- [31] IEEE draft supplement to standard [for] information technology-telecommunications and information exchange between systems-local and metropolitan area networks-specific requirements -part 11: Wireless LAN medium access control (MAC) and physical layer (PHY) specifications: Supplement to IEEE std 802.11-1999. *IEEE Std P802.11a/D7*, 1999.
- [32] T. Hidalgo Stitz. *Filter Bank Techniques for the Physical Layer in Wireless Communications*. Ph.D. thesis, Tampere University of Technology, 2010.
- [33] P. Siohan, C. Siclet, and N. Lacaille. Analysis and design of OFDM/OQAM systems based on filterbank theory. *Signal Processing, IEEE Transactions on*, 50(5):1170–1183, May 2002.
- [34] P. P. Vaidyanathan. *Multirate Systems and Filter Banks*. Prentice-Hall, 1993.

- [35] A. Sahin, I. Guvenc, and H. Arslan. A survey on multicarrier communications: Prototype filters, lattice structures, and implementation aspects. *Communications Surveys Tutorials, IEEE*, 16(3):1312–1338, Third 2014.
- [36] P. Siohan, C. Siclet, and N. Lacaille. Analysis and design of OFDM/OQAM systems based on filterbank theory. *IEEE Transactions on Signal Processing*, 50(5):1170–1183, May 2002.
- [37] B. Farhang-Boroujeny. OFDM versus filter bank multicarrier. *Signal Processing Magazine, IEEE*, 28(3):92–112, May 2011.
- [38] G. J. Foschini, K. Karakayali, and R. A. Valenzuela. Coordinating multiple antenna cellular networks to achieve enormous spectral efficiency. *IEE Proceedings - Communications*, 153(4):548–555, August 2006.
- [39] D. Gesbert, S. G. Kiani, A. Gjendemsjo, and G. E. Oien. Adaptation, coordination, and distributed resource allocation in interference-limited wireless networks. *Proceedings of the IEEE*, 95(12):2393–2409, Dec 2007.
- [40] M. Sawahashi, Y. Kishiyama, A. Morimoto, D. Nishikawa, and M. Tanno. Coordinated multipoint transmission/reception techniques for lte-advanced [coordinated and distributed mimo]. *IEEE Wireless Communications*, 17(3):26–34, June 2010.
- [41] Thomas M. Cover and Joy A. Thomas. *Elements of Information Theory*. Wiley-Interscience, New York, NY, USA, 1991.
- [42] Jeonghoon Mo and J. Walrand. Fair end-to-end window-based congestion control. *Networking, IEEE/ACM Transactions on*, 8(5):556–567, Oct 2000.
- [43] R. Cendrillon, M. Moonen, J. Verlinden, T. Bostoen, and W. Yu. Optimal multiuser spectrum management for digital subscriber lines. In *Communications, 2004 IEEE International Conference on*, volume 1, pages 1–5, 2004.
- [44] Zukang Shen, J.G. Andrews, and B.L. Evans. Optimal power allocation in multiuser OFDM systems. In *Global Telecommunications Conference, 2003. GLOBECOM '03. IEEE*, volume 1, pages 337–341 Vol.1, Dec 2003.

- [45] J. Papandriopoulos and J. S. Evans. Low-complexity distributed algorithms for spectrum balancing in multi-user DSL networks. In *Communications, 2006. ICC '06. IEEE International Conference on*, volume 7, pages 3270–3275, June 2006.
- [46] J. Papandriopoulos and J.S. Evans. SCALE: A low-complexity distributed protocol for spectrum balancing in multiuser dsl networks. *IEEE Transactions on, Information Theory*, 55(8):3711–3724, Aug 2009.
- [47] Wei Yu and R. Lui. Dual methods for nonconvex spectrum optimization of multicarrier systems. *IEEE Transactions on Communications*, 54(7):1310–1322, July 2006.
- [48] R. Cendrillon, Wei Yu, M. Moonen, J. Verlinden, and T. Bostoen. Optimal multiuser spectrum balancing for digital subscriber lines. *IEEE Transactions on Communications*, 54(5):922–933, May 2006.
- [49] M. Chiang, S. Zhang, and P. Hande. Distributed rate allocation for inelastic flows: optimization frameworks, optimality conditions, and optimal algorithms. In *Proceedings IEEE 24th Annual Joint Conference of the IEEE Computer and Communications Societies.*, volume 4, pages 2679–2690 vol. 4, March 2005.
- [50] G. Scutari, D. P. Palomar, and S. Barbarossa. Asynchronous iterative water-filling for gaussian frequency-selective interference channels. *IEEE Transactions on Information Theory*, 54(7):2868–2878, July 2008.
- [51] Cheong Yui Wong, R.S. Cheng, K.B. Lataief, and R.D. Murch. Multiuser OFDM with adaptive subcarrier, bit, and power allocation. *IEEE Journal on, Selected Areas in Communications.*, 17(10):1747–1758, 1999.
- [52] D. Kivanc, Guoqing Li, and Hui Liu. Computationally efficient bandwidth allocation and power control for OFDMA. *IEEE Transactions on Wireless Communications*, 2(6):1150–1158, Nov 2003.
- [53] Ho Seok Kim, J. S. Kwak, Jung Min Choi, and Jae Hong Lee. Efficient subcarrier and bit allocation algorithm for OFDMA system with adaptive

- modulation. In *Vehicular Technology Conference, 2004. VTC 2004-Spring. 2004 IEEE 59th*, volume 3, pages 1816–1820, May 2004.
- [54] Inhyoung Kim, In-Soon Park, and Y. H. Lee. Use of linear programming for dynamic subcarrier and bit allocation in multiuser OFDM. *IEEE Transactions on Vehicular Technology*, 55(4):1195–1207, July 2006.
- [55] Jisung Oh, Seung-Jean Kim, and J. M. Cioffi. Optimum power allocation and control for OFDM in multiple access channels. In *Vehicular Technology Conference, 2004. VTC2004-Fall. 2004 IEEE 60th*, volume 2, pages 774–778 Vol. 2, Sept 2004.
- [56] K. Seong, D. D. Yu, Y. Kim, and J. M. Cioffi. CTH03-5: Optimal Resource Allocation via Geometric Programming for OFDM Broadcast and Multiple Access Channels. In *IEEE Globecom 2006*, pages 1–5, Nov 2006.
- [57] D. D. Yu and J. M. Cioffi. SPC10-2: Iterative Water-filling for Optimal Resource Allocation in OFDM Multiple-Access and Broadcast Channels. In *IEEE Globecom 2006*, pages 1–5, Nov 2006.
- [58] L. Venturino, A. Zappone, C. Risi, and S. Buzzi. Energy-efficient scheduling and power allocation in downlink OFDMA networks with base station coordination. *IEEE Transactions on, Wireless Communications*, 14(1):1–14, Jan 2015.
- [59] Shuguang Cui, A.J. Goldsmith, and A. Bahai. Energy-constrained modulation optimization. *IEEE Transactions on, Wireless Communications*, 4(5): 2349–2360, Sept 2005.
- [60] O. Arnold, F. Richter, G. Fettweis, and O. Blume. Power consumption modeling of different base station types in heterogeneous cellular networks. In *Future Network and Mobile Summit, 2010*, pages 1–8, June 2010.
- [61] Alessio Zappone, Luca Sanguinetti, Giacomo Bacci, Eduard A. Jorswieck, and Mérouane Debbah. Energy-efficient power control: A look at 5G wireless technologies. *CoRR*, abs/1503.04609, 2015. URL <http://arxiv.org/abs/1503.04609>.

- [62] C. Pan, W. Xu, W. Zhang, J. Wang, H. Ren, and M. Chen. Weighted sum energy efficiency maximization in ad hoc networks. *IEEE Wireless Communications Letters*, 4(3):233–236, June 2015.
- [63] W. C. Li, T. H. Chang, C. Lin, and C. Y. Chi. Coordinated beamforming for multiuser mimo interference channel under rate outage constraints. *IEEE Transactions on Signal Processing*, 61(5):1087–1103, March 2013.
- [64] K. Y. Wang, A. M. C. So, T. H. Chang, W. K. Ma, and C. Y. Chi. Outage constrained robust transmit optimization for multiuser mimo downlinks: Tractable approximations by conic optimization. *IEEE Transactions on Signal Processing*, 62(21):5690–5705, Nov 2014.
- [65] C. Raman, R.D. Yates, and Narayan B. Mandayam. Scheduling variable rate links via a spectrum server. In *New Frontiers in Dynamic Spectrum Access Networks, 2005. DySPAN 2005. 2005 First IEEE International Symposium on*, pages 110–118, Nov 2005.
- [66] M.M. Buddhikot, P. Kolodzy, S. Miller, K. Ryan, and J. Evans. DIM-SUMnet: new directions in wireless networking using coordinated dynamic spectrum. In *World of Wireless Mobile and Multimedia Networks, 2005. WoWMoM 2005. Sixth IEEE International Symposium on a*, pages 78–85, June 2005.
- [67] Stephen Boyd and Lieven Vandenberghe. *Convex Optimization*. Cambridge, U.K., Cambridge Univ. Press, 2004.
- [68] Dimitri P. Bertsekas. *Nonlinear Programming*. Athena Scientific, Belmont, MA, 1999.
- [69] Dimitri P. Bertsekas and John N. Tsitsiklis. *Parallel and distributed computation: numerical methods*. Athena Scientific, 1997.
- [70] D.P. Palomar and Mung Chiang. A tutorial on decomposition methods for network utility maximization. *IEEE Journal on, Selected Areas in Communications*, 24(8):1439–1451, Aug 2006.

- [71] D.P. Palomar and Mung Chiang. Alternative distributed algorithms for network utility maximization: Framework and applications. *IEEE Transactions on, Automatic Control*, 52(12):2254–2269, Dec 2007.
- [72] Barry R. Marks and Gordon P. Wright. A general inner approximation algorithm for nonconvex mathematical programs. *Operations Research*, 26(4):681–683, 1978.
- [73] Meisam Razaviyayn, Mingyi Hong, and Zhi-Quan Luo. A unified convergence analysis of block successive minimization methods for nonsmooth optimization. *SIAM Journal on Optimization*, 23(2):1126–1153, 2013.
- [74] Mingyi Hong, Qiang Li, Ya-Feng Liu, and Zhi-Quan Luo. Decomposition by successive convex approximation: A unifying approach for linear transceiver design in heterogeneous network. 2013. URL <http://arxiv.org/abs/1210.1507>.
- [75] Amir Beck, Aharon Ben-Tal, and Luba Tetruashvili. A sequential parametric convex approximation method with applications to nonconvex truss topology design problems. *J. Global Optimization*, 47:29–51, 2010.
- [76] Werner Dinkelbach. On nonlinear fractional programming. *Management Science*, 13(7):492–498, 1967.
- [77] Siegfried Schaiblei and Toshihide Ibaraki. Fractional programming. *European J. Operational Research*, 12(4):325–338, 1983.
- [78] Toshihide Ibaraki. Parametric approaches to fractional programs. *Mathematical Programming*, 26(3):345–362, 1983.
- [79] Siegfried Schaiblei. Fractional programming. II, on Dinkelbach’s algorithm. *Management Science*, 22(8):868–873, 1976.
- [80] M. Shaat and F. Bader. Low complexity power loading scheme in cognitive radio networks: FBMC capability. In *IEEE 20th International Symposium on, Personal, Indoor and Mobile Radio Communications*, pages 2597–2602, Sept 2009.

- [81] Haijian Zhang, D. Le Ruyet, D. Roviras, and Hong Sun. Uplink capacity comparison of OFDM / FBMC based cognitive radio networks. In *IEEE International Conference on, Communications (ICC)*, pages 1–5, May 2010.
- [82] M. Shaat and F. Bader. A two-step resource allocation algorithm in multi-carrier based cognitive radio systems. In *IEEE, Wireless Communications and Networking Conference (WCNC)*, pages 1–6, April 2010.
- [83] M. Shaat and F. Bader. An uplink resource allocation algorithm for OFDM and FBMC based cognitive radio systems. In *2010 Proceedings of the Fifth International Conference on Cognitive Radio Oriented Wireless Networks and Communications*, pages 1–6, June 2010.
- [84] Musbah Shaat and Faouzi Bader. Computationally efficient power allocation algorithm in multicarrier-based cognitive radio networks: Ofdm and fbmc systems. *EURASIP J. Adv. Signal Process*, Jan 2010.
- [85] Haijian Zhang, D. Le Ruyet, D. Roviras, and Hong Sun. Noncooperative multicell resource allocation of FBMC-based cognitive radio systems. *vehicular Technology, IEEE Transactions on*, 61(2):799–811, Feb 2012.
- [86] H. Zhang, D. Le Ruyet, D. Roviras, and H. Sun. Resource allocation of noncooperative multi-cell for cognitive radio networks. In *2009 6th International Symposium on Wireless Communications Systems*, pages 101–105, Sept 2009.
- [87] H. Zhang, D. Le Ruyet, D. Roviras, and H. Sun. Capacity analysis of OFDM / FBMC based Cognitive Radio networks with estimated CSI. In *2010 Proceedings of the Fifth International Conference on Cognitive Radio Oriented Wireless Networks and Communications*, pages 1–5, June 2010.
- [88] M. J. Osborne and A. Rubinstein. *A course in Game Theory*. MIT Press, Cambridge, MA, 1994.
- [89] J.P. Aubin. *Mathematical Method for Game and Economic Theory*. Elsevier, Amsterdam, the Netherlands, 1980.

- [90] H.A. Suraweera, P.J. Smith, and M. Shafi. Capacity limits and performance analysis of cognitive radio with imperfect channel knowledge. *IEEE Transactions on, Vehicular Technology*, 59(4):1811–1822, May 2010.
- [91] Jong-Shi Pang and G. Scutari. Joint sensing and power allocation in non-convex cognitive radio games: Quasi-nash equilibria. *IEEE Transactions on, Signal Processing*, 61(9):2366–2382, May 2013.
- [92] J. S. Pang, G. Scutari, F. Facchinei, and C. Wang. Distributed power allocation with rate constraints in gaussian parallel interference channels. *IEEE Transactions on Information Theory*, 54(8):3471–3489, Aug 2008.
- [93] K. k. Leung, C. W. Sung, and K. W. Shum. Iterative waterfilling for parallel gaussian interference channels. In *Communications, 2006. ICC '06. IEEE International Conference on*, volume 12, pages 5491–5494, June 2006.
- [94] Carl D. Meyer. *Matrix Analysis and Applied Linear Algebra*. Society for Industrial and Applied Mathematics, 2000.
- [95] M. Pischella and J. C Belfiore. Distributed resource allocation for rate-constrained users in multi-cell OFDMA networks. *IEEE Communications Letters*, 12(4):250–252, 2008.
- [96] Zhisheng Niu. TANGO: traffic-aware network planning and green operation. *IEEE, Wireless Communications*, 18(5):25–29, October 2011.
- [97] J.G. Andrews, S. Buzzi, Wan Choi, S.V. Hanly, A. Lozano, A.C.K. Soong, and J.C. Zhang. What will 5G be? *IEEE Journal on, Selected Areas in Communications*, 32(6):1065–1082, June 2014.
- [98] S.M. Betz and H.V. Poor. Energy efficient communications in CDMA networks: A game theoretic analysis considering operating costs. *Signal Processing, IEEE Transactions on*, 56(10):5181–5190, Oct 2008.
- [99] Guowang Miao, N. Himayat, G.Y. Li, and S. Talwar. Distributed interference-aware energy-efficient power optimization. *IEEE Transactions on, Wireless Communications*, 10(4):1323–1333, April 2011.

-
- [100] Zhijiat Chong and E. Jorswieck. Energy-efficient power control for MIMO time-varying channels. In *Online Conference on Green Communications (GreenCom), 2011 IEEE*, pages 92–97, Sept 2011.
- [101] E.V. Belmega and S. Lasaulce. Energy-efficient precoding for multiple-antenna terminals. *Signal Processing, IEEE Transactions on*, 59(1):329–340, Jan 2011.
- [102] Christian Isheden and G.P. Fettweis. Energy-efficient multi-carrier link adaptation with sum rate-dependent circuit power. In *Global Telecommunications Conference (GLOBECOM 2010), 2010 IEEE*, pages 1–6, Dec 2010.
- [103] Wei-Chiang Li, Rui-Yu Chang, Kun-Yu Wang, and Chong-Yung Chi. Energy-efficient precoding matrix design for relay-aided multiuser downlink networks. In *Acoustics, Speech and Signal Processing (ICASSP), 2015 IEEE International Conference on*, pages 3098–3102, April 2015.
- [104] M. Le Treust and S. Lasaulce. A repeated game formulation of energy-efficient decentralized power control. *Wireless Communications, IEEE Transactions on*, 9(9):2860–2869, September 2010.
- [105] G. Gur and F. Alagoz. Green wireless communications via cognitive dimension: an overview. *IEEE, Network*, 25(2):50–56, March 2011.
- [106] Junling Mao, Gang Xie, Jinchun Gao, and Yuanan Liu. Energy efficiency optimization for OFDM-based cognitive radio systems: A water-filling factor aided search method. *IEEE Transactions on, Wireless Communications*, 12(5):2366–2375, May 2013.
- [107] Yan Wang, Wenjun Xu, Kewen Yang, and Jiaru Lin. Optimal energy-efficient power allocation for OFDM-based cognitive radio networks. *IEEE, Communications Letters*, 16(9):1420–1423, September 2012.
- [108] A. Alabbasi, Z. Rezki, and B. Shihada. Energy efficient resource allocation for cognitive radios: A generalized sensing analysis. *IEEE Transactions on, Wireless Communications*, 14(5):2455–2469, May 2015.

- [109] Yiyang Pei, Ying-Chang Liang, K.C. Teh, and Kwok Hung Li. Energy-efficient design of sequential channel sensing in cognitive radio networks: Optimal sensing strategy, power allocation, and sensing order. *IEEE Journal on, Selected Areas in Communications*, 29(8):1648–1659, September 2011.
- [110] Cong Xiong, Lu Lu, and G.Ye. Li. Energy-efficient spectrum access in cognitive radios. *IEEE Journal on, Selected Areas in Communications*, 32(3):550–562, March 2014.
- [111] K. Illanko, M. Naeem, A. Anpalagan, and D. Androutsos. Low complexity energy efficient power allocation for green cognitive radio with rate constraints. In *2012 IEEE, Global Communications Conference (GLOBECOM)*, pages 3377–3382, Dec 2012.
- [112] Shaowei Wang, Mengyao Ge, and Wentao Zhao. Energy-efficient resource allocation for OFDM-based cognitive radio networks. *IEEE Transactions on, Communications*, 61(8):3181–3191, August 2013.
- [113] Weijia Shi and Shaowei Wang. Energy-efficient resource allocation in cognitive radio systems. In *Wireless Communications and Networking Conference (WCNC), 2013 IEEE*, pages 4618–4623, April 2013.
- [114] Cong Xiong, G.Y. Li, Shunqing Zhang, Yan Chen, and Shugong Xu. Energy-efficient resource allocation in OFDMA networks. *IEEE Transactions on, Communications*, 60(12):3767–3778, December 2012.
- [115] J. S. Pang, G. Scutari, D. P. Palomar, and F. Facchinei. Design of cognitive radio systems under temperature-interference constraints: A variational inequality approach. *IEEE Transactions on Signal Processing*, 58(6):3251–3271, June 2010.
- [116] Christian Isheden, Zhijiat Chong, E. Jorswieck, and Gerhard Fettweis. Framework for link-level energy efficiency optimization with informed transmitter. *IEEE Transactions on, Wireless Communications*, 11(8):2946–2957, August 2012.

-
- [117] A. Alvarado, G. Scutari, and Jong-Shi Pang. A new decomposition method for multiuser DC-programming and its applications. *IEEE Transactions on, Signal Processing*, 62(11):2984–2998, June 2014.
- [118] D.A. Schmidt, Changxin Shi, R.A. Berry, M.L. Honig, and W. Utschick. Distributed resource allocation schemes. *IEEE, Signal Processing Magazine*, 26(5):53–63, September 2009.
- [119] Changxin Shi, R.A. Berry, and M.L. Honig. Monotonic convergence of distributed interference pricing in wireless networks. In *IEEE International Symposium on, Information Theory (ISIT)*, pages 1619–1623, June 2009.
- [120] Dimitri P. Bertsekas, Asuman E. Ozdaglar, and Angelia Nedić. *Convex analysis and optimization*. Athena Scientific, 2003.
- [121] D. Fugenberg and J. Tirole. *Game Theory*. MIT Press, Cambridge, MA, 1991.
- [122] G. Auer, V. Giannini, C. Desset, I. Godor, P. Skillermark, M. Olsson, M.A. Imran, D. Sabella, M.J. Gonzalez, O. Blume, and A. Fehske. How much energy is needed to run a wireless network? *IEEE, Wireless Communications*, 18(5):40–49, October 2011.
- [123] Yuzhou Li, Min Sheng, Chungang Yang, and Xijun Wang. Energy efficiency and spectral efficiency tradeoff in interference-limited wireless networks. *IEEE, Communications Letters*, 17(10):1924–1927, October 2013.
- [124] Cunhua Pan, Wei Xu, Wence Zhang, Jiangzhou Wang, Hong Ren, and Ming Chen. Weighted sum energy efficiency maximization in ad hoc networks. *Wireless Communications Letters, IEEE*, 4(3):233–236, June 2015.
- [125] Yonghong Zhang and C. Leung. Resource allocation in an OFDM-based cognitive radio system. *IEEE Transactions on, Communications*, 57(7):1928–1931, July 2009.
- [126] Chiuan-Hsu Chen, Chin-Liang Wang, and Chih-Tsung Chen. A resource allocation scheme for cooperative multiuser OFDM-based cognitive radio systems. *IEEE Transactions on, Communications*, 59(11):3204–3215, November 2011.

-
- [127] S.M. Almfouh and G.L. Stuber. Interference-aware radio resource allocation in OFDMA-based cognitive radio networks. *IEEE Transactions on, Vehicular Technology*, 60(4):1699–1713, May 2011.
- [128] Xin Kang, H.K. Garg, Ying-Chang Liang, and Rui Zhang. Optimal power allocation for OFDM-based cognitive radio with new primary transmission protection criteria. *IEEE Transactions on, Wireless Communications*, 9(6):2066–2075, June 2010.
- [129] Nasim Yahya Soltani, Seung-Jun Kim, and Georgios B. Giannakis. Chance-constrained optimization of OFDMA cognitive radio uplinks. *IEEE Transactions on, Wireless Communications*, 12(3):1098–1107, March 2013.
- [130] Seung-Jun Kim, N.Y. Soltani, and G.B. Giannakis. Resource allocation for OFDMA cognitive radios under channel uncertainty. *IEEE Transactions on, Wireless Communications*, 12(7):3578–3587, July 2013.
- [131] Xitao Gong, A. Ispas, and G. Ascheid. Outage-constrained power control in spectrum sharing systems with partial primary csi. In *Global Communications Conference (GLOBECOM), 2012 IEEE*, pages 3879–3885, Dec 2012.
- [132] Xitao Gong, A. Ispas, G. Dartmann, and G. Ascheid. Outage-constrained power allocation in spectrum sharing systems with partial csi. *IEEE Transactions on, Communications*, 62(2):452–466, February 2014.
- [133] M. Grant and S. Boyd. CVX: Matlab software for disciplined convex programming, version 2.0 (beta). December 2013. URL <http://cvxr.com/cvx/>.