



HAL
open science

LES MARIAGES TRANSNATIONAUX DES FAMILLES PAKISTANAISES IMMIGRÉES EN FRANCE

Abida Sabir Sharif

► **To cite this version:**

Abida Sabir Sharif. LES MARIAGES TRANSNATIONAUX DES FAMILLES PAKISTANAISES IMMIGRÉES EN FRANCE. Sociologie. Université Paris Saclay (COMUE), 2016. Français. NNT : 2016SACLV121 . tel-01650007

HAL Id: tel-01650007

<https://theses.hal.science/tel-01650007>

Submitted on 28 Nov 2017

HAL is a multi-disciplinary open access archive for the deposit and dissemination of scientific research documents, whether they are published or not. The documents may come from teaching and research institutions in France or abroad, or from public or private research centers.

L'archive ouverte pluridisciplinaire **HAL**, est destinée au dépôt et à la diffusion de documents scientifiques de niveau recherche, publiés ou non, émanant des établissements d'enseignement et de recherche français ou étrangers, des laboratoires publics ou privés.

NNT: 2016SACLV121

THESE DE DOCTORAT
DE L'UNIVERSITE PARIS-SACLAY,
préparée à l'Université Versailles Saint-Quentin en Yvelines

ÉCOLE DOCTORALE N°578
Sciences de l'homme et de la société

Spécialité de doctorat : Sociologie

Par

Mme Abida SHARIF

LES MARIAGES TRANSNATIONAUX DES FAMILLES
PAKISTANAISES IMMIGREES EN FRANCE

Thèse présentée et soutenue à Guyancourt, le 16 Décembre 2016

Composition du Jury :

M. **DRESSEN** Marnix, Professeur de sociologie à l'Université de Versailles
Saint-Quentin-en-Yvelines - Laboratoire PRINTEMPS, *Président du Jury*

Mme **HERTRICH** Véronique, Directrice de recherche à l'Institut national
d'études démographiques - INED, *Examinatrice*

Mme de **LOENZIEN** Myriam, Démographe / Chargée de recherche à IRD-
CEPED, *Rapporteuse*

M. **MILBURN** Philip, Professeur de sociologie à l'Université Rennes 2
Directeur de thèse

Mme **SAMUEL** Olivia, Maître de conférences de démographie à l'Université
de Versailles Saint-Quentin-en-Yvelines - Laboratoire PRINTEMPS,
Co-directrice de thèse

M. **ZAMAN** Muhammad, Professeur de sociologie à Quaid-i-Azam University,
Islamabad, Pakistan, *Rapporteur*



NNT: 2016SACLV121

**A DISSERTATION FOR L'UNIVERSITE PARIS-SACLAY,
Prepared at l'Université Versailles Saint-Quentin en Yvelines**

ÉCOLE DOCTORALE N°578
Sciences de l'Homme et de la Société ED SHS

TRANSNATIONAL MARRIAGES OF PAKISTANI IMMIGRANT FAMILIES IN FRANCE

in partial fulfilment of the requirements

for the degree of

Doctor of Philosophy

in the subject of

Sociology

by

Ms. Abida Sharif

December 16, 2016

ABSTRACT

Marrying back home' is one of the transnational practices demonstrated by Pakistani diaspora to maintain their links with their country of origin. This study is an attempt to understand the mechanism of transnational marriages and how transnational links are maintained, produced and reproduced by organizing marriages between families residing in France and Pakistan. Data were collected by employing qualitative research methods. As marriage is the collective affair of the family in Pakistan, it was considered essential to not only interview the spouses but their parents as well. Both corresponding families (the family of groom and the family of bride) in France and in Pakistan were interviewed to understand transnational marriage. The preferred pool of potential spouses is comprised of different layers of Punjabi kinship. Well maintained reciprocal relationships, cultural preferences to arrange marriages within kin, trust on acquaintances and to avoid the risk of anonymity, were considered key determinants to define the primary spouse selection criteria. These determinants are supplemented by the complimentary criteria, including education, age, morality, and behavioral traits. Once primary and complimentary criteria are met, both generations (parents and their children) negotiate the adequacy of potential spouse to reach to the final decision of marriage. Family's obligations, children's capital, the interplay of authority, resistance and the kin, family's marriage history, preserving the roots, and the transnational trust between the siblings determine the adequacy of a spouse as well as of the marriage. Though transnational Pakistani marriages follow the traditional patterns to celebrate marriage, nonetheless, migration has introduced some important alterations to different norms as practiced in Pakistan. In the similar vein, the family and household structure are undergoing transition due to their simultaneous presence between *here and there*. Transnational marriages maintain transnational links by inscribing the cultural values for family and marriage. However, the relationships across gender and generation are on the move by carrying the cultural influences from the host society.

Keywords: Transnationalism, migration, family and marriage, Kinship, adequate spouse, Pakistan, France

RESUME

'Marrying back home' (« se marier au pays ») est une pratique internationale que l'on trouve couramment au sein de la diaspora pakistanaise. Cette étude entreprend de saisir le mécanisme de ces mariages transnationaux et comment les liens transnationaux sont maintenus, produits et reproduits par l'organisation de mariages entre les familles résidant en France et au Pakistan. Les données ont été recueillies en utilisant des méthodes de recherche qualitative. Comme le mariage est un enjeu qui concerne l'ensemble de la famille au Pakistan, il est apparu essentiel d'interviewer les époux, mais aussi leurs parents. Les deux familles en lien (celle de l'époux et celle de la mariée) en France et au Pakistan ont été interrogées afin de mettre à jour les logiques du mariage transnational. Le choix privilégié des époux se fait à l'intérieur des différents niveaux de la parenté au Punjab. Les éléments déterminants pour définir les critères de sélection consistent principalement dans des relations réciproques bien afferries, un respect de la tradition du mariage au sein des liens de parenté et une confiance dans les personnes proches afin d'amenuiser le risque d'anonymat. D'autres critères viennent au second rang comme l'éducation, l'âge, la moralité et les traits comportementaux. Lorsque l'ensemble de ces critères sont réunis, les deux générations négocient alors la mise en correspondance des conjoints potentiels en vue de la décision finale du mariage. Les exigences d'une telle correspondance sont liées au respect des obligations familiales, à la valeur accordée aux enfants, au jeu entre autorité, résistance à celle-ci et parenté, à l'histoire maritale de la famille, à la préservation des racines et à la confiance transnationale au sein de la fratrie. Bien que les mariages transnationaux pakistanaise suivent les modèles traditionnels pour célébrer le mariage, l'émigration a toutefois introduit des modifications significatives vis-à-vis des règles en vigueur au Pakistan. Selon un processus semblable, la structure familiale et des ménages est en cours de transition en raison de la présence simultanée des deux familles dans chaque pays. Si les mariages transnationaux maintiennent les liens familiaux entre les deux pays en réaffirmant les valeurs culturelles liées au mariage, les modalités des relations entre hommes et femmes et entre générations évoluent néanmoins suivant les influences culturelles de la société d'accueil.

Mots-clés: transnationalisme, migration, famille et mariage, la parenté, conjoint approprié, Pakistan, France

TABLE OF CONTENTS

ABSTRACT	1
RESUME	2
ACKNOWLEDGEMENTS	9
INTRODUCTION	11
Important Research Questions	17
Objectives of the study	19
Outline of dissertation Chapters	19
CHAPTER 1. PAKISTANI DIASPORA AND MARRIAGE-MIGRATION	23
1.1. Pakistanis in France	23
1.1.1. Trajectories of Emigration and Immigration	24
1.1.2. Socio-cultural and economic profile	27
1.2. Understanding Transnational marriages: Perspective on marriage-migration	33
1.2.1. Methodological Nationalism	36
1.2.2. Transnationalism	38
Concluding Remarks	44
CHAPTER 2. MARRIAGE INSTITUTION IN PAKISTAN: THE PUNJABI CONTEXT	47
2.1. The Punjabi Kinship	48
2.1.1. Networks of relatedness	50
2.2. Family and household	59
2.2.1. Gender and power relationships	62
2.3. Nuptiality Pattern and Trend in Pakistan	66
2.3.1. Nuptiality Pattern in Punjab	73
2.4. Understanding adequate spouse: Perspectives on spouse selection	80
2.4.1 Social Exchange	80
2.4.2. Interplay of Structure and Agency	86
Concluding Remarks	89

CHAPTER 3. RESEARCH METHODOLOGY	93
3.1. Qualitative Research Design	94
3.1.1. Multi-sited ethnographic approach	96
3.1.2. Field	96
3.1.3. Tools for data collection	100
3.2. Strategy to enter into the field	104
3.3. Data collection and data preparing for interpretation	107
3.3.1. Transcription, partial transliteration and translation	108
3.3.2. Anonymization of the data	109
3.3.3. Preparing analytical schemas	109
3.4. Fieldwork experiences and problems	112
3.4.1. Sensitivity of the issue under study	113
3.4.2. Researcher's positionality and self-reflexivity	115
CHAPTER 4. KIN-ENDOGAMY: THE PRIMARY CRITERIA OF SPOUSE SELECTION	121
4.1. Close-kin marriages	127
4.1.1. Marriages between matrilineal cousins	129
4.1.2. Marriages between patrilineal cousins	135
4.2. Extended-kin Marriages	137
4.2.1. Marriages between agnates	137
4.2.2. Marriages between affines	143
4.3. Exogamy	149
4.3.1. Marriages within social network	150
4.3.2. Marriages outside the social network	155
Concluding remarks	162
CHAPTER 5. SPOUSE PREFERENCES: THE COMPLIMENTARY CRITERIA OF SPOUSE SELECTION	167
5.1. Education	169
5.1.1. Educational system in Pakistan	170
5.1.2. Educational situation of families	171
5.1.3. Education as strategic capital	173

5.2.	Age	178
5.2.1.	Age at marriage	178
5.2.2.	Gender age gap	182
5.2.3.	Elder wives and younger husbands	186
5.3.	Morality	189
5.4.	Responsibility of parental families in Pakistan	197
5.5.	Attitudes and Values: Tradition versus modernity	199
5.6.	Transnational marriage: An avenue of opportunities?	202
	Concluding Remarks	204
CHAPTER 6. SELECTING THE ADEQUATE SPOUSE: NEGOTIATIONS AND DECISIONS		207
6.1.	Matchmaking: Searching the marriage proposal	209
6.2.	Managing the strategies to select an adequate spouse	215
6.2.1.	Family's obligations and children's capital	219
6.2.2.	The interplay of authority, resistance and the kin	222
6.2.3.	Reflections from the past: Family's marriage's history	229
6.2.4.	Preserving the roots: Transnational trust between the siblings	235
	Concluding Remarks	240
CHAPTER 7. PROCESS OF TRANSNATIONAL MARRIAGE CEREMONY		245
7.1.	Rituals and customs	246
7.1.1.	Betrothal	249
7.1.2.	Pre-Wedding Ceremonies	253
7.1.3.	The wedding ceremonies	259
7.1.4.	Post-wedding ceremonies	269
7.2.	The transition process	273
7.2.1.	Departure and Dwelling	274
	Concluding Remarks	279
CHAPTER 8. DYNAMICS OF TRADITION AND TRANSITION IN FAMILY AND HOUSEHOLD		283
8.1.	The dynamics of relationships across gender and generation	284
8.1.1.	Parents and Children	287

8.1.2. Being a <i>bahu</i> (daughter-in-law)	297
8.1.3. Being <i>ghar damad</i> (a live-in son-in-law)	303
Concluding Remarks	309
CONCLUSION	313
REFERENCES	321
ANNEXURES	337

LIST OF TABLES AND FIGURES

<i>Table 1. SMAM by sex over time</i>	73
<i>Table 2. SMAM by Province and sex over time</i>	75
<i>Table 3. Details of interviews and respondent families in France and Pakistan</i>	111
<i>Table 4. Pool of spouse preferences within and outside the kin</i>	126
<i>Figure: 1. Proportions (%) of never-married population by sex and age</i>	68
<i>Figure 2. Trends in SMAM by Sex over 5 Decades in Pakistan</i>	69
<i>Figure 3. Proportion of Ever-married by sex, age & year</i>	70
<i>Figure 4. Distribution of Marital status by Age, Sex and Year</i>	72
<i>Figure 5. Proportion of ever married by age and province</i>	74
<i>Figure 6. Proportion of ever married female population of age 20-24 by educational attainment and divisions</i>	77
<i>Figure 7. Proportion of ever married female population of age 20-24 by type of residence and divisions</i>	79
<i>Figure 8: Genogram of Family LC4</i>	224

ACKNOWLEDGEMENTS

First of all, I wish to express my gratitude to **Almighty Allah** who bestowed me with the abilities to utilize my intellect for this scholarly adventure. A PhD research dissertation, being a laborious project, cannot be completed without the assistance, guidance and encouragement of several academic as well as non-academic comrades, and I have been fortunate to find many during this journey.

I would like to thank my thesis supervisor **Mr. Philip MILBURN** for his encouragement, guidance and help throughout the thesis. This project could not have been initiated without my co-director **Mrs. Olivia SAMUEL**'s personal interest in my Master's dissertation on spouse selection mechanism in Punjab, Pakistan and afterwards her immense motivation to proceed for doctoral research by incorporating migration into spouse selection to understand the transnational marriage behavior of Pakistani immigrant families residing in France. I feel that my words are less valuable to truly portray the contribution of my director and co-director towards my project who always stood right behind me to offer their help.

This doctorate project was materialized with the institutional support by **Laboratoire Professions Institutions Temporalités (PRINTEMPS)** at **Université de Versailles, Saint Quentin-en-Yvelines**, and financial support by **Institut Nationale d'Etudes Démographiques (INED)** for which I am highly thankful. INED not only supported me for living but also for my multi-sited fieldwork that required a handsome amount of money to collect data from different localities, both in France and in Pakistan. However, the greater contribution of this institute was on my academic socialization with the help of its learned and reputable scholars, notably in Research Unit 4 (Démographie, genre et sociétés) and Research Unit 8 (Migrations internationales et minorités) who invested their valuable time and energy to refine my work.

I am greatly indebted to my co-tutor at INED, **Mrs. Véronique HERTRICH**, for her constant support, both moral as well as academic. She encouraged me to equip myself in quantitative research methods by attending European Doctoral School of Demography. She enthusiastically guided me during every step of this project to

meet its logical ends, despite the fact that she is confronting health issues. To improve qualitative aspects of my expertise and to discuss the initial research plan of this dissertation, she invited other well-known researchers, including **Mr. Jacques VERON** (Director of Research at Ined), **Mr. Christophe Z GUILMOTO** (Director of Research at IRD), **Mrs. Isabelle ATTANE** (Director of Research at Ined), **Mrs. Sylvie LAMBART** (Associate Professor at Paris School of Economics), **Mrs. Sajeda AMIN** (Senior Associate Researcher in Population Council, United States), and **Mrs. Geraldine VIVIER** (Researcher in qualitative and quantitative survey at Ined); and I am highly indebted to them for their meaningful contribution to improve the quality of my work. This project would have been held in abeyance, had my director, co-director and co-tutor not persuaded me to muster up my courage after some shocking events in my life. I am much obliged for their emotional camaraderie.

I am highly obliged to **Mr. Roger Ballard** (Director of the Centre for Applied South Asian Studies, UK) who, despite his health problems, came to France to discuss the initial findings of my fieldwork. His critical suggestions helped me to understand the structure of kinship behind the transnational marriages. I equally intend to express my thankfulness to **Dr. Muhammad ZAMAN** who not only assisted me during my fieldwork in Pakistan but also provided valuable suggestions on the theoretical part of my work.

I also wish to express my gratitude to **Mrs. Saliha BELKADI**, language instructor and the association of Amicale Laïque, Saint Cyr L'école for providing me the opportunity to learn French language. I am also thankful to my respondent families who volunteered for this project and trusted my research ethics for the very sensitive and highly personalized information.

I want to acknowledge the emotional support by my family, including my parents and my in-laws. My special thanks to my husband **Imran SABIR** whose intellectual support in thesis write-up, emotional encouragement to complete it and cooperation in household chores helped me to produce this manuscript. I am highly indebted to my daughter **Wajiha** also who inspired me to complete my thesis (despite the fact that she had been frequently deprived of my time and attention due to my academic engagements) that I had left during the days of depression and grief.

INTRODUCTION

Large-scale immigration flows—a contemporary factor inherently variant in characteristics— has been changing the face of Western European societies by introducing the diversified cultural traits (Milewski & Hamel 2010). This multi-cultural context is created by the transnational interconnectivities; ties which immigrants maintain between their country of origin and country of settlement (Levitt 2009; Smith 2003; Faist 2000; Vertovec 1999). France is also confronting relatively new type of [migrants'] settlement with a more mobile character, a continuous circulation with a bi-presence “here” in the host country and “there” in the country of origin (Campani & Salimbeni 2004:4). According to migration scholars, migration divides kin (Schiller, Basch & Blanc 1992a). Where some immigrants may construct their family and kin in their host countries, others' sense of belongingness and connectedness with indigenous roots persists (Harriss & Shaw 2006). These connections are maintained via networks of relatedness over time and again through regular visits, exchange of socio-economic remittances, and most importantly by marrying back; called transnational marriages.

A dominant trend in Western Europe (UK, Denmark, Sweden, Norway and France) has been observed recently that the descendants of immigrants belonging to South-Asian-origin societies return to their parents' countries of origin to find spouses. 'Marrying back home' is one of the transnational practices demonstrated by Pakistani diaspora as well around the world (Rytter 2012; Moliner 2012; Nadim 2012; Iqbal 2009; Charsley 2007; Singla 2006), hereinafter called transnational marriage, the subject matter of current study. Transnational marriage is defined by Charsley as *an enduring relationship—that is taking place within pre-existing active transnational networks—marriage between people resident in different states* (2012:19).

Neither marrying for migration nor its conditions directions and actors are new. Charsley (2012) mentioned Japanese brides who migrated to the United States to

find their would-be Japanese husbands serving as military men. In the historical context of Europe-Indian sub-continent, as chronicled by Anne De Courcy (2013), galleons of English girls known as the *Fishing Fleets* were sent to India to find a husband out of British soldiers and other servicemen of East India Company during British Raj between the late 17th and mid-20th. In the similar vein, connections across borders, produced as a consequence of migration, are not new but as old as the human migration activity itself. Previously, it was not easy to maintain and preserve transnational links—whether economic, political, cultural and/or familial—as it has become recently more easy relatively after the advancement of modern technology particularly in communication and travel (Bauböck, & Faist 2010; Portes 2003; Castles 2002).

Transnationalism became an impugned issue among the scholars of migration by the end of 20th century, when national state policies began to treat immigrants intrusively. Sociological and anthropological literature on immigrants and their settlement in the host country views the issue from various angles. Initially migration scholarship viewed post-migratory connections in a polarized division; methodological nationalism (Basch et al. 1994; Glick Schiller et al. 1992) and transnationalism (Vertovec 1999). Diasporas were also discussed as the base and a precondition for developing transnational links (Vertovec & Cohen 1999). Prior to transnational connections, diaspora was created by the immigrants who shared common origin ethno-national identities. Diaspora, once dispersed but self-identified and evident in many host societies, is a central point of interest in studying the transnational networking and is more or less archetype to transnational communities (Quayson & Daswani 2013). Diaspora's imaginary gaze of belongingness and managing the boundary within host societies on one hand, and contemporary transnational links 'here' and 'there' on the other hand, both have challenged the concepts of nation-state bounded identities and urge to (de)construct and to (re)understand the ways in which immigrants situate their affiliations to the countries of origin and settlement. Transnational lives are less prone to homogenous nature of modern nation-state, as transnational migrants practice multifaceted lifestyles

containing more importantly languages, different but parallel cultural streams, and networks of relationships across state borders.

Levitt (2009) analyzed transnational connections as a venture; for emigrants it may be a route to capital accumulation and remittance on one hand, and a route to root for the immigrant community on the other hand. While Shaw (2001) questions the 'root' as just acquiring the mere cultural preservation in diaspora. Or there exist the affiliations for familial ties and notions of relatedness at the heart of maintaining transnational links (Ballard 2004), importantly through marrying back home (Charsley 2010). Williams (2010) views marriages as *both a consequence and an instigator* of transnational links.

Being relatively new research field, transnational marriages hold distinct attention due to wide variety of questions being analyzed by the academia at different levels; micro (individual agency and family), meso (the kinship structure) and macro (nation-state). Studies on transnational practices of Pakistani Diaspora in Europe highlight the expectations of kinship structure in maintaining transnational links (Iqbal 2006). It may establish the relationships between siblings residing in different countries by arranging the marriages of their children (Charsley 2013). Transnational marriages could be a cause to develop links in the origin country, and a consequence too followed by the already established transnational networks (Williams 2010). Other migration researches have shown that transnational consanguineous marriages are directly linked to the creation of social networks between the families and kin in emigrant and immigrant countries (Bryceson & Vuorela 2002; Shaw 2001; Werbner 1999). The nature of consanguineous marriages is legally perceived equal to force marriages (Liversage & Rytter 2015) because the children who have been brought up in western countries try to resist against their parents' suggested marriage proposals (Liversage 2012).

Despite above mentioned rich academic literature, doing well with various themes i.e. assimilation, integration, multiculturalism and state policies related to host

country's perspective, transnational marriage is still under-theorized (Williams 2010) and a fragmented research field in marriage-related-migration scholarship (Charsley 2013) when it comes to understand transnational marriages from below; the agency as well as from the above; both perspectives not only the country of host but the country of origin also. It is in this context that current study joins the debate on transnational marriages by taking the role of agency—the couple and their parents—into account.

Agency perspective informs an understanding of the individuality of human subjects but require subjective judgements about motivations, aspirations and intentions (Williams 2010:34).

The more agency narrative leans towards individual choice, the more it appears to depict an actor as sole responsible to make his/her marriage choices. *And in sociological terms there is a very significant difference between the concepts of 'individual' or 'free' choice and contextual or relational choice* (Smart & Shipman 2004:4). Individuals act and react with reference to the relative choices belonging to themselves as well as to others. Studying agency in current research means studying both the actors and as well the undercurrents behind their observable marriage behavior and their reactions to the complexities of the power structure of family, kinship, cultural norms and the migration.

Next to agency, I take the context of family—both the family of bride and family of bridegroom—into account due to their significant role in marriage as well as migration. Research on marriage institution in Pakistani culture, be in the country of origin or in the country of settlement, asserted a chronicled statement that marriage is an alliance between the two families rather the union of two individuals (Charsley 2013, Rytter 2013, Charsley & Shaw 2006, Ballard 1990, Donnan 1988, Das 1973, Wakil 1970, Eglar 1960). Sociological debates in these studies provide extensive explanations on how parents exercise authority on their children's marriage behavior and how do children having lesser power confront their parents at one hand, and on the other how parents and their children come to a consensus to finalize marriage decisions. However, rarely both corresponding families have been taken into

account to explain how the marriage decisions are negotiated between the two corresponding families of bride and bridegroom.

Marriage is considered a collective affair of family in Pakistani cultural context (Muhammad 2008; Qadeer 2006). It is the institution of the family of potential marriage migrants in country of origin that plays decisive role in making the marriage and migration decision and after the migration which later affects the process of his/her integration in the host country (Koc & Onan 2004). It is in this context that current research in addition to actor's agency, approaches simultaneously both families in emigrant as well as in immigrant country to understand the familial circumstances behind the decision of transnational marriages.

In addition to the couple and their parental families, I take the kinsmen into account to understand the observed endogamous nature of transnational marriages. Researches on Pakistani diaspora in Europe show that Pakistani immigrant families dominantly practice consanguineous marriages (Malik 2015, Muhammad 215, Rytter 2013; Charsley 2010). Few explored the nature of consanguineous marriages being organized between the first cousins (Shaw 2001). The complexities of the kinship structure in Pakistan—that guides marriage rules for its members who are preferable spouses and who are not—have been under intense focus of researches between 70s and early 90s however later underwent negligence with some exceptions (Iqbal 2006, Shaw 2001). Kinship appears to be undergoing a revival. Who is kin and what does it mean for the parents and children of immigrant families (Shaw 2001)? For Pakistani-origin immigrants, kinship relatedness being *one of the most important arena [is] an important aspect of the strategy for survival within the wider British social system*, according to Iqbal (2006). While studying kin ties among British Pakistani, she argues *that kinship involves not just rights, rules and obligations, but that it is also a realm of new possibilities, and this becomes apparent when we look at inter-generational conflicts and marital practices* (Iqbal 2006:2). It is worth mentioning that kinsmen left-behind become the locomotive to formulate various strategies either to help other family members to migrate, to develop transnational family networks, to permanently settle in the host country, and/or the

return migration. It is in this context that current research looks into the different layers of the kinship structure to understand who the preferred kin are to organize transnational marriages and why. And what if Pakistani immigrant families do not find eligible marriage proposals within kin back-home.

Last but not the least, current research looks into the norms and values that Pakistani immigrants practice while deciding as well as experiencing for transnational institution of marriage. Marriage is mandatory to form and to reproduce a family (Qadeer 2006) and is as an inevitable decision for Pakistani immigrant descendants (Rytter 2013) that may create tensions between the two generations. Abou-Zahab (2007) points out that French-born Pakistani descendants face problems of adaptation to parents' origin culture. And when it comes to understand the cultural values and norms of family and marriage of Pakistanis, it is important to note that Pakistan is not a society of homogenous group of people with uniform cultural practices of family and marriage. They differ in their matrimonial and family practices from each other (Donnan 1997). Due to their multi-ethnic belongingness first and the migration, Pakistani immigrants' marriage institution tend to vary not only from each other but also different from the matrimonial system of the South Asian diaspora (Ballard 1990) as well as of the host society. The notion of being 'Pakistani' is an umbrella term that cannot adequately reflect the ethnic diversity found in Pakistani immigrants (Shaw 2001) as well as their matrimonial system. Current research deals with Punjabi ethnic community of Pakistani diaspora in France. It would help us to understand how transnational marriages are organized with reference to different ethnic communities who seek their national belonging to two different nation-states while maintaining their and ethnic cultural values.

For immigrant parents, family and marriage institution of host country may not be as ideal as their indigenous one but for their children it could be, thus creating the intergenerational conflicts. Blood relationships and kinship for the immigrant parents is taken for granted as indispensable, whereas for their children it may be a matter of affinity choices (Schiller, Basch & Blanc, 1995). Indigenous cultural values of collectivity, unity and loyalty towards family, kin and marriage are differently

perceived by the nation-state as well. While working on the marriage behavior of Franco-Malagasy, Jennifer Cole (2014) observed an entangled relationship between marriage, kinship and French state. Transnational marriages is one of the most controversial and problematic issues in Europe (Wray 2011) including France (Kringelbach 2013) being perceived as a growing threat to French sovereignty. The interconnection between migrants' marriage and migration, predominantly in the case of French former colonies, are being studied given the fact that marriage is one of the channels to migrate France (Collet & Santelli 2015; Santelli, 2010; Munoz 1999). However, less available information on the marriage behavior of other statistically invisible migrant diasporas, like Pakistanis in South Asian diaspora in France (Moliner 2009) and lack of information about their transnational links with their left-behind family and kin, partly explains the gaps in our understanding of Pakistani migrants' marriage behavior. Few studies discuss the issues of Pakistanis settlement and integration in France (Abou-Zahab 2007; Hanif 2007; Krieger-Krynicky, 1993 & 1989), however very little is known about their marriage behavior. This study for the first time in France examines the phenomenon of transnational marriages in Pakistani immigrant families residing in France by taking into account the couple, their parents and their parents-in-law residing in France and Pakistan. The interplay of agency and structure helps us to understand the inner working of transnational marriages mechanism.

Important Research Questions

The main focus of this study is to understand how transnational marriages are organized between Pakistani immigrant families residing in France and their corresponding families residing in Pakistan. By taking into account the actors behind transnational marriages and their role in deciding marriages, this study is interested in how marriage decisions are taken by the spouses and their respective parental families? What factors and motivations are behind their marriage decisions?

It is also interesting to know how intergenerational matrimonial interests and motives of the couple and their families vary and/or coexist in transnational social spaces.

For the family living in Pakistan, it could be more meaningful to arrange marriages of their children with those who are living abroad, so that their children could get the chances of migration, and to become French national as well as they could avail relatively better living standard. Do family's interest may vary according to the sex of their children, particularly if their son could have better job chances and more earnings which ultimately could earn better living for the left behind-family members and/or their possible chances to go abroad for the purpose of family reunification?

In the similar vein, what are the points of similarities, differences and/or ambivalences between parents, their children and their kin on the discourse of choosing a life partner? How their marriage behavior is perceived by their significant others; the kinsmen in Pakistani cultural context. What is the role of their transnational kinsmen in formulating the marriage behavior of parents and their children? How do different cultural norms of the societies of origin and host shape and influence their ideologies of family and marriage? How does marriage behavior of Pakistani immigrant families configure or reconfigure the cultural ideologies and practices related to gender, generation, family and marriage in a transnational context? And last but not the least, how the transnational links are maintained, produced and reproduced by organizing marriages between Pakistani immigrant families residing in France and families residing in Pakistan.

A variety of interests, motives and choices of the involved actors not only vary at agency level depending on the individual's positions and experiences in his/her family and network of relatedness but also depend on the structural constraints i.e. politico-legal, economic, and social frameworks of the origin and host countries at wider level. Further, what strategies are adopted by the actors of transnational marriage when immigration policies and the interests of Nation-state collide with the individuals' and family's cross-border activities?

Objectives of the study

To respond to the questions posed above, the current study inquires about the systematic mechanism of organizing transnational marriages in Pakistani immigrant families in France. In this regard, the very first objective is to know the preferences of children and their parents for selecting spouse and/or daughter/son-in-law from back-home, and to investigate the differences and/or similarities of spouse selection criteria across gender and generation. Secondly, it focuses on the pool of spouses to explore the filtration process of required attributes in adequate spouses from the potential ones. Thirdly, it looks into the decision making process of how both generations, negotiate the adequacy of spouses before proceeding for final decision to marry, and to see if there are intervening factors to mold and/or influence their marriage decisions. Fourthly, it looks into the process of celebration of transnational marriage to understand if the traditional marriage ceremony has undergone transition and/or changes due to migration. Fifthly, it analyzes the family and household structures in order to understand how relationships across gender and generation are redefined by transnational marriage.

Outline of dissertation Chapters

Keeping in view the interlinked role of migration and marriage and its significance on the creation of transnational links across nation-state borders, chapter one (**Pakistani diaspora and marriage-migration**) is divided into two parts to introduce the issue and its related theoretical problems. Section one concentrates on elaborating the arrival and settlement of the first generation of Pakistani diaspora in France followed by family reunification. Subsequently their socio-cultural and economic profile are discussed. Part two encompasses the theoretical debate over understanding methodological nationalism and transnationalism to interpret the marriage behavior and pattern of migrant communities. Nation-state and

Since the focus of this study is the Punjabi ethnic community of Pakistan—which proportionally is the predominant ethnic group in France as well as the most

populous province with a high rate of overseas emigration as compare to other provinces of Pakistan. Serving as background to understand the indigenous marriage behavior of Pakistani immigrants in France, chapter two (**Marriage institution in Pakistan: The Punjabi context**) in its first two parts describes the attributes and traits of Punjabi kinship structure, and family and household patterns. Third part focus on contemporary power relationships across gender and generation and geographic areas. Third part looks into the marriage and nuptiality patterns. Fourth part covers the theoretical debate on understanding the mechanism of spouse selection through two different perspectives, social exchange and the interplay of structure and agency.

As this research contextualizes the marriage behavior of French-Pakistanis in transnational context, chapter three (**Research Methodology**) is divided into four parts. Part one explains the rational why and how multi-cited ethnographic approach was employed as qualitative research method to meet the objectives of this study. Part 2 provides the justification behind selecting the specific field and describes in detail of the strategies to enter into the field. Part 3 focuses on the detailed description of data collection into digital form, its conversion into transcriptions and then its translation. Finally, this part illustrates how researcher prepared the analytical schemes after anonymizing the data which was intended to be used as evidence and also as direct quotes to support the arguments developed during the course of this dissertation in the coming chapters. Last part of this chapter portrays a reflexive debate on the sensitivity of the issue under study first, and then the difficulties and field experiences of the researcher. This section instigates some serious concerns on the positionality of the researcher and her genuine approaches to cope with the problems that partly hindered the process of data collection and even threatened the repute of the researcher.

Chapter four (**Kin-Endogamy: The Primary Criteria of Spouse Selection**) initiated by discussion on spouse selection criteria, the very first objective of this research by highlighting the very important aspect of the issue: transnational marriages are predominantly endogamous. By looking into the different layers of the

Punjabi kinship, this chapter explores that different layers of Punjabi kinship are considered the potential pool of spouses. Part one and two encircles the debate on the factors conducive for marriages among close and extended kin. Part three illustrates the situations where Pakistani immigrant families practice exogamy preferably within the family's social network and outside the social network in stranger families; the least trusted and preferred pool of potential spouses.

As kin network was revealed as the primary criterion to search for an adequate spouse for a transnational marriage, Chapter five (**Spouse Preferences: The Complimentary Criteria of Spouse Selection**) depicts the second layer of those benchmarks set by transnational families to choose spouses for their children. Each of these—including education, age, morality, family responsibility, attitudes and values, and citizenship—is discussed in details in the six parts of this chapter.

Chapter six (**Selecting the Adequate Spouse: Negotiations and Decisions**) takes the discussion of defining spouse criteria to the next stage where the adequacy of the spouse as well as of the marriage decision are negotiated between generations. It is divided into two parts. First section itinerates the steps taken by the family and the children to seek marriage proposals, whereas the second part deals with the strategies of actors employed to negotiate and/or to influence the decision of finalizing marriage decision.

Once the adequate spouse is finalized, next step is to formally initiate and celebrate the process of celebrating transnational marriage; covered in detail in chapter seven (**Process of Transnational Marriage Ceremony**). This chapter is divided into two parts. First part discusses although most of the marriage ceremonies are celebrated as per traditionally defined rules and rituals by the Pakistani society, yet there are variations and alterations that are elucidated owing to different socio-cultural, religious and economic factors, the subject matter of part one. Part two focus on the transitional period between departure of the brides and her dwelling in their family-in-law's kin home before migrating to France.

Until now the discussion has been concentrated on the prerequisites and the process of a transnational marriage. Chapter eight (**Dynamics of Tradition and Transition in Family and Household**) sheds light on the transnational life after marriage and the interrelationship between the actors. This chapter instigates the discussion over two important aspects of migrant communities: gender and generation. Understanding the nature of relationships divided in these two broader classifications would clarify the indigenous perspective which has often been ignored by classical studies over the issue before envisaging any concluding propositions. This chapter is divided into three parts. Part one focuses on the relationship between parents and children and the changes parenting is adopting. Part two and three focus on the transnational experiences of daughter-in-law and son-in-law and their spouses.

Finally, this study offers a **Conclusion** that conjures up the subject of migration and marriage in resonance to the theoretical debate of transnational social spaces by expounding the significance of the families and networks of relatedness of the immigrants who have often been ignored and marginalized for their apparently invisible role in transnational marriage. It comes up with three important implications. First, nation-state borders and distances cannot be taken as an alibi to marginalize the definition of family. Second, transnational spouse choices are not haphazard or incoherent to the cultural rules of marriage. Third, transnationally created social spaces affect the nature and dynamics of relationships across gender and generation.

CHAPTER 1

PAKISTANI DIASPORA AND MARRIAGE-MIGRATION

1.1. Pakistanis in France

Pakistan is listed at 6th in the top-ten emigration countries with almost 7 million overseas Pakistanis (Ratha, Plaza & Dervisevic 2016). In year 2016, out of 295,298 emigrated Pakistanis, more than half of them were from the most populous province Punjab (Bureau of Emigration & Overseas Employment, 2016).

In 2010, approximately 2.2 million Pakistanis were living in Europe (Abbasi 2010), mainly in the Western Europe; 800,000 in United Kingdom, 78,000 in Germany and 60,000 in France (Pakistan's Ministry of Foreign Affairs, 2010). Estimations on how many Pakistanis are living in France vary. In year 2011 Bouillier (2011) estimates that around 70,000 Pakistanis are living in France. In 2014, non-official estimates by Pakistani Embassy in France claim that around 100,000 to 125,000 Pakistanis were present in France; and Île-de-France is hosting majority of them. Apart from estimations, the reliable statistical information from French census, mentioned by Moliner (2009) in her study on South Asian diaspora, reveals 16,300 Pakistanis living in France; amongst them 5300 hold French nationality by acquisition and rest of 11000 are categorized as foreigners. She (ibid) while exploring the ethnic affiliations of the Pakistanis in France, found that Pakistani Punjabis are the second largest group among South Asian diaspora, living in different cities of France i.e. Lyon, Strasbourg and Marseilles.

Apart from Moliner's, (ibid) there are few qualitative studies by Krieger-Krynicky, (1989 & 1993) and Abou-Zahab (2007) who dealt with settlement experiences as well the socio-economic profile of Pakistani diaspora in France. Another study deals with the integration of the second generation of Pakistani immigrants in France (Hanif 2007). I will seek help from the above mentioned data sources and studies to summarize the history of Pakistanis' migration towards France and the socioeconomic and demographic characteristics of Pakistanis diaspora in France is

the subject matter of the current chapter. I also rely on my personal observations as well as the discussions with official persons at the embassy of Pakistan in Paris, religious, cultural, and political focal persons, media representatives and social workers active in Pakistani diaspora during my fieldwork for the current study. First, I summarize historically and sequentially when and how Pakistanis, particularly belonging to Punjabi ethnicity being the focus of the current study, arrived in Europe, and then how France happened to become their destination country. In the parallel, I contextualized the political economy of Punjabis' migration and socio-economic push and pull factors in the origin as well as in the origin countries. Finally, I will focus on the socioeconomic and cultural characteristic of Pakistanis in France, so that the reader could understand how Pakistani individuals and families under study are dispersed on the map of France.

1.1.1. Trajectories of Emigration and Immigration

In the first place, I look into the migration trajectory of Pakistanis towards Europe.

Punjabis' migration from the Indian-subcontinent towards Europe dates back to 1849 when Punjab became the part of British Raj. Punjabis being classified as loyal and martial race were recruited for Bengal Army, and the rest of young population especially from *Mirpur*¹ strived for new economic opportunities, and started working as stokers on the ships sailing between Bombay and Britain (Ballard 1987). In the late 19th century, Punjab was suffering due to worsened socioeconomic and disastrous health conditions i.e. shortage of land, droughts, famine and epidemics (Meena 2015; Tandon 2013) as a consequence of colonial policies in the sub-continent. A great number of workers as indentured laborers were transported to East Africa and Caribbean, in addition to Europe, between 1850s and 1920s (Quayson 2013).

The *Mirpuri* stokers who initially came and stayed in Britain became stranded merchant seamen (Dahya 1974), as industrial jobs were difficult to find until WW II ended and British industry faced serious shortage of labor force. The laborers'

¹ The largest city of independent Kashmir, currently the part of Pakistan.

supply was not up to the demand and those who were available were not ready to be the part of less paid and overloaded burden of labor under harsh working conditions (Ballard 1987). It was then when *Mirpuri* migrants called their kinsmen to Britain (Khan 1977). It was relatively easy to enter, reside and get employment in Britain during those times, because Pakistan was the dominion within Commonwealth. A kin-based chain migration started (Anwar 1995), and during the 50s significant number of emigrants moved to European countries (Jan 2010). These kinsmen mostly belonged to the Barani (rain-fed) areas of Northern Punjab and were habituated to work outside and far from their residences. Further, the project of Mangla Dam construction in 1961 in *Mirpur* district displaced thousands of the inhabitants. Majority of them were offered work permits in Britain as compensation by the Government of Pakistan. These migrants continued to call their kinsmen and also the friends until the Commonwealth Immigrants Act (1962 & 1968) induced restrictions. In early 70s, Britain underwent the economic recession and working opportunities ceased, making the immigration relatively more difficult.

The restrictive policies on immigration in general and particularly on kin immigration and the decline of post-war economic boom in Britain redirected Pakistanis' conventional emigration patterns and nature of immigration. It is at this moment when emigrants from Pakistan started to settle in new destinations, including France (Abou-Zahab 2007). Those who could not succeed to move to Britain and/or found work in their transit countries in Scandinavia preferred to stay there. Thus, Norway and the Netherlands became their new destinations, followed by Germany and France.

Now I focus on Pakistanis' migration history and the nature of settlement in France.

During 60s, as told by one of my informant, the Pakistani migrants in France, under somewhat similar circumstances like their co-ethnics in Scandinavian countries, found relatively easy work i.e. in cuisine and agriculture sectors as compared to the heavy industry related work in Britain. Due to relatively comfortable working environment, they preferred to stay in France. During that time, the diplomatic relationships between the two states, France and Pakistan, turned to be stronger against the threats posed by the re-active policies of the cold war (Dar 2013). In

1957, the President of Pakistan visited France and then French Prime Minister George Pompidou reciprocated this gesture by visiting Pakistan in 1965. Later, both states also became allies on nuclear program. The cordial relationships between two countries attracted the Pakistanis to migrate to France. In 1970, Government of Pakistan under the leadership of Zulfikar Ali Bhutto made the process of passport delivery quick and easy. Resultantly, many Pakistanis departed towards Gulf, American and European States. Abou-Zahab (2007) while tracing the settlement of Pakistanis in France says that the first public appearance of few Pakistanis was observed in 1974 when they accompanied Tunisians and Mauritians in a hunger strike to support the rights of undocumented immigrants. The strike ended on their regularization that persuaded more Pakistani immigrants to come and to settle in France. I was frequently told by some of my respondents from religious and political associations of Pakistanis in France that during the strike days in 1974, Pakistani Prime Minister Zulfikar Ali Bhutto was on an official tour to France to attend funeral of George Pompidou. He met those Pakistani protestors in person to assure them their legal status in France. According to one of my respondents, the regularization was made possible only due to Bhutto's personal relations and efforts with French authorities.

When Pakistani immigrants started to settle in France during 1970s, France was introducing its regulatory policies on immigration to restrict the flow from its former colonies. Those policies were also devised in an effort to make it possible the return of migrants to their countries of origin. For this purpose, France held negotiations and agreements with immigrants' countries of origin at one hand. At the other hand, practicing Islam was allowed at workplaces, and schools were teaching immigrants the language of their origin country aiming to prepare them for return. The project, voluntary in nature, however remained unsuccessful (Campani & Salimbeni 2004). Subsequently, political asylum first in 1980s provided opportunities to many Pakistanis families to settle in France following the family reunification rule (Moliner 2012; Abou-Zahab 2007). 10 out of 16 families, I investigated came to France during 1980 to 1983. Another political asylum policy again in 1990s provided opportunity to Pakistani to come and settle in France (ibid) and to quit Pakistan due to political

and economic upheaval in the origin country. During these last two decades of the 20th century, Pakistan underwent some of the worst socio-political and economic upheavals i.e. political instability due to Zia-Bhutto conflict, the emergence of militant groups, confrontation at borders, the Gulf war and importantly the inflation. These factors persuaded many Pakistanis to migrate towards European countries thus exploring more new destinations; Greece, Italy and Spain.

Then after attacks on World Trade Centre on 9th September, Pakistan and Afghanistan were enormously affected by the aftermaths of war on terror, which urged many people to leave their war-afflicted regions and seek asylum in European countries, including France. Additionally, the Government of Pakistan with the help of United States in order to combat extremism, began to invest in higher education and financed a significant number of students seeking their doctoral studies in economically developed countries, and Pakistani students were sent to France as a result of a bi-lateral mutual agreement between the both countries. Do marriage and subsequent family reunification remain a route to migrate to France in case of the descendants of second generation of Pakistani immigrants, as we observed in case of the first generation? And if yes, then what circumstance presented in origin as well as host societies? It will be discussed in the subsequent chapters as per the information on the marriage choices of my investigated families.

1.1.2. Socio-cultural and economic profile

Based on historical and contemporary migratory flows in France, I now look into the composition of Pakistani diaspora in France. Pioneer migrants as well as their families who are long settled in France since 1960s are at the base of diaspora birth as well as important element of its existence in France. Majority of them are Punjabis belonging to the rural areas of Northern Punjab. There are other ethnic groups as well; Pakhtoon from the province of KPK with rural background and Sindhis belonging to both urban as well as rural areas. Very few are from Balochistan province. The majority of the pioneers with low level of education was non-skilled who came to France for the labor. Currently, many of them are well settled in business sector i.e. restaurant, laundry, construction, banquet halls, garments,

export and import of indigenous Pakistani crafts. Their educated children including daughters and sons are doing jobs in different sectors i.e. engineering, technology, medicine, law, human resource, automobile industry and media. Those sons who could not complete their education join their family business. The wives of pioneer migrants remained active soon after joining their husbands by doing different jobs mainly in the garment sector as they were skilled in stitching and knitting. Others who could not join the job market started to sew cloths for co-ethnic as well as other ethnic communities. Now many of these Pakistani women being aged are inactive in job sector but active in cultural and religious associations. The younger female generation who could not join formal job sector are doing home-based business in traditional Pakistani cloths, jewelry, Urdu language tuition, beauty salon and cuisine. The overall income of these families is sufficient to the extent that many of them are owners of their homes and also secure themselves financially in Pakistan by buying property and/or starting business there. Those families who are well established in business prefer to live in Hauts-de-Seine and Seine-et-Marne.

Another prominent feature of Pakistani diaspora are the students; the new addition since 2005. Higher Education Commission of Pakistan started to finance Pakistani young scholars for higher studies in France. HEC by far has sent around 1000 Pakistani students and researchers enrolled in different French universities doing PhDs and research (HEC, 2015). Few preferred to stay and called their families (wives and children), while most of them have either returned back to Pakistan or have intentions to return after completing their education and research. They prefer not to mix up and participate in Pakistani diaspora affairs, but the political. They are not frequently observed to participate in community's collective religious-cultural and social activities. They usually form their close groups of educational migrants. Their distance from the Diaspora affairs could be due to their compulsion to return back to their homeland for familial reasons and/or as they are bound to serve their country for a minimum period of five years after completing their higher education in France. These students organize regular small scale gatherings for religious and cultural festivals in isolation to that of mainstream Pakistani community's, where only they and their families participate.

Male labor migrants, who came from Greece, Spain, Portugal and Italy due to the recession and poor economic conditions are also part of the Pakistani diaspora. Depending on the nature of their contacts—relatives, friends, network of acquaintance etc. — with their co-ethnic in France, they are working in different sectors i.e. restaurants, construction and automobile. They are not necessarily uneducated and unskilled as compared to their forerunner co-ethnics. Due to worsen economic conditions in Pakistan, lack of job opportunities, inflation, and lesser earnings persuaded even the educated and skilled Pakistanis to emigrate to fulfil their economic responsibilities for their families, including parents and siblings.

Pakistanis in France are generally regarded as invisible community among other diasporas. A possible explanation could be their lesser number and their being non-francophone unlike migrants from Maghrebian². However, upon inquisition they usually contradict this perception, and claim their active participation in different socioeconomic, cultural and political activities. These participations are usually sex-segregated—the prominent feature of the public life of Pakistani community. There is a clear distinction in public and private life with reference to gender. Normally religious and cultural festivals are celebrated distinctly. In case, being celebrated in one hall, then separate sitting and eating arrangements for male and female are made. Mixing up of sitting and eating arrangements is regarded inappropriate. Individual male participants are not expected to join those gatherings which are family oriented. In public gatherings like the political ones, females are accompanied by their male family members, but they are very few. Except some in-door meetings of political parties and of literary councils, female participation in public gathering is considered highly inappropriate. There are number of cultural associations working on different agendas including female empowerment, promoting ethnic language and literature, bridging the gap by advocating integration into the host society etc. The meetings of these associations are organized in the public city halls provided by Mayer's office. However, religious gatherings are organized in privately hired spaces.

² There could be other cultural and social barriers that will be discussed in the following chapters.

Some associations work simultaneously for cultural as well as religious causes. These associations are very active and hold good reputation among Pakistani community due to the charity services they provide to Pakistanis to teach Urdu as well as Arabic languages, to learn Islamic as well as cultural values, and organizing national festivals of France as well as of Pakistan. The programs of these events are announced in both French as well as in Urdu. Expenditures to maintain and organize such religious-cultural events come from the philanthropic efforts of Pakistani community. Businessmen either of large or small scale and others participate regularly in charity programs. These centers are used as proxy to mosques where Eid prayers are offered in addition to the funeral prayers. Religious personalities from Pakistan come to these centers to deliver lectures on different occasions. Many religious sects are found in Pakistani community as we find the presence of different political parties belonging to Pakistan. Sometimes it becomes very complex to separate the cultural and political ideologies of some religious associations. One of the cultural religious association adheres to a well-known political party and simultaneously work for the religious, cultural and political motives. One of these association started working in mid 90s and have established many branches in different cities of France is considered very trustworthy by now. Advices and help on family and marriage issues i.e. children socialization, marriage and divorce, are sought from the advisory board as well from the transnational network of this association. One of the marriage proposal of my investigated family was advised by the same association.

The political engagements of Pakistanis in France tend to exhibit diverse behavior than that of cultural and religious associations particularly in terms of gender ideologies and integration into host society. Very often the political parties make women wings thus encouraging Pakistani immigrant women to come to the public surface. By organizing the ceremonies of national and cultural days of France as well as of Pakistan, the charity dinners and the joint meetings of the political bodies in different restaurants and halls, these parties challenge the ideologies of female participation in diasporic affairs. Then the political activities can be summarized in trans-local perspective; in the local city in which they reside in France and the

localities in Pakistan from where they originate and/or they have families involved in politics. Taking part in the local body elections show their socio-cultural as well as political and economic interest in the host society. They are well connected to the French politics as well, and play a significant role in the local city mayor elections. Their younger generation is more active and visible than their parents in local politics. If French language barrier could be an explanatory factor at one hand, at the other hand is younger generation's disinterest in the politics of Pakistan. Few of them accompany their parents to participate in the activities and campaigns for political parties based in Pakistan. The pioneer Pakistani migrant males are far more active in the politics of their country of origin. Almost all of the political parties of Pakistan—notably Pakistan Tehreek-e-Insaaf, Pakistan Muslim League with (N) and (Q) wings, Pakistan people's Party, Pakistan Awami Tehreek—have their well-structured and organized overseas wings for men and women. President, vice president, general secretary, party's spokespersons and media secretary all must have French nationality preferably and/or permanent residence in France. These bodies include male and female representatives from Pakistani diaspora.

Those who are active in the politics in France, are also active in Pakistan. Being dual nationals, they maintain transnational political links and networks. They participate as candidates in local elections in their constituencies in Pakistan. And to win the elections, they very often participate and/or initiate community development related projects; free medical dispensaries and causal medical health camps, schools, carpeted roads from their villages to access nearby cities etc. They also support political campaigns of their relatives and friends in Pakistan. When there are general elections in Pakistan, they visit their country to support their parties and lead the rallies. During their transnational political engagements, it is quite common that political rivalries in addition to their business rivalries divide them into different groups, thus effecting the overall intra-diaspora economic activities while producing new alliances not only in France but also in Pakistan.

The economic sector of Pakistani community is diversified having strong commercial traditions as well as an integrated entrepreneur system. The business of Garments—import as well as export—is owned and managed at large by many

pioneer Pakistani migrants. Their journey started in Sentier area as laborers hired by the then Jew businessmen and continued to sustain and expand, currently with Chinese also. If they have produced renowned trademarks and are the owner of costly garment boutiques at one hand, at the other they are vendors and daily wagers in the small scale garment business in open air markets. The female of first generation migrants joined their husbands in garments sector also, as revealed by many female respondents of first generation in my investigated families. The nature of their activity was dominantly home-based with few exceptions where they went to the near-by small home based factories to sew the cloths with the help of heavy industrial sewing machines.

There are other large-scale businesses that are based on purely ethnic demands and the employees and customers mostly belonging to Pakistan, like the banquet halls offering services to marriage as well as other cultural ceremonies, the Pakistani restaurants serving a variety of ethnic food, and the grocery stores selling vegetables, rice and other edible items imported from Pakistan. Then there are small scale businessmen like the boutiques selling and stitching traditional Pakistani costumes and cloths and the traditional barber and beauty salons. Some of Pakistanis introduced innovations to their business by joining other ethnic businessmen especially in celebrating the marriage ceremony. Such banquet halls serve both Pakistani and Maghrebian diaspora through a variety of food menu, décor and entertainment services.

For the last couple of decades, many Pakistanis are engaged in the construction business, especially in Île-de-France. Many of them are renowned constructors who have multiple work-contracts with multinational companies. Some of them own their companies thus producing job opportunities to many of their co-ethnic laborers in paint, electricity, plumbing and house décor. Many of daily wage laborers can be spotted around *Gare du Nord*, *Gare de l'Est*, and *Strasbourg-Saint-Denis* while waiting for labor opportunities. These areas are also the hub of South Asian commerce with dozens of small scale restaurants, grocery stores, sweets shops and halal butcher shops.

Generally, their professional and business relationships extended to their familial relationships, and they are more likely to dwell in their proximities to one another. Although they tend to have relationships within their diaspora, however, commercial relations do not necessarily turn into amicable and familial relations. Their children grow up together but are less likely to be considered as potential spouses for each other. Despite the fact that the first generation of male Pakistani migrants preferred to marry with the women from different national and ethnic backgrounds (Fisher 2006), they however considered this as the last option for their children. Inter-ethnic business are well appreciated but not the marriages (Charsley, Bolognani, Spencer, Ersanilli & Jayaweera 2016). They predominantly wish their children to choose spouses from Pakistan and endeavor to socialize their children right from their birth in such a way that they should comply with their desire to remain connected to their native country and its culture by marrying back home (Shaw 2001; Ballard 2004). This phenomenon can be better understood by contextualizing transnational marriage through different theoretical debates and empirical research on the issue, the subject matter of the next part.

1.2. Understanding Transnational marriages: Perspective on marriage-migration

Classical scholarship on international migration has been providing the explanations to how and why international migration perpetuates ((Thieme 2006). Migration has historically been viewed through different lenses of social theory that continue to explain the phenomena related to migration in relative time and space. One of the most common determinants of these theoretical explanations, especially after the World War II, has been the concept of nation-state. Modern nation-state, as one of the most powerful post-colonial entity, has been considered both as origin as well as the destination of the immigrants travelled principally for economic opportunities. Their flow has predominantly been from Global South towards the Global North. Host societies initially considered their arrivals as beneficial for the growth of their economy due to the availability of cheap labor. Later, the surplus of immigrants was considered as a threat to national economy (Schmidt 2011:55) and culture

(assimilation and integration) (Joppke & Morawska 2014; Brubaker 2001; Joppke 2007; Alba & Nee 1997), and then to the national security (Koopmans, Michalowski & Waibel 2012; Obama 2010; Johnson 2007; Chacón 2006; Adamson 2006), especially after the beginning of 21st century.

During recent years, civil unrests and economic restructuring have created highly asymmetrical life chances among developed and developing countries in such a way that migration is becoming the only viable way for survival for the people of many 3rd world countries (Monsutti, 2016; Boyle, Halfacree & Robinson 2014; Papastergiadis 2013). To restrict and control the influx of migrants, Western countries are continuously making and altering their policies that are affecting and in consequence being affected by the strategies of immigrants to enter into the 'lands of opportunities'. These contestations between migrants and the modern nation-state have been viewed through two major approaches: methodological nationalism and transnationalism.

Modern nation-state, while offering citizenship to non-native immigrants, anticipate their allegiance to the cultural and social values of the host society. Their loyalty and commitment to the host culture is judged through various indicators of integration. On the other hand, immigrants adopt various strategies to keep their connections with their native cultures. One of the strategies adopted by immigrants to perpetuate their links with their native societies is to marry back home. Such marriages are considered one of the impediments to the process of assimilation/integration, and state policies are in continuous evolution to discourage such strategies of immigrants.

Different theoretical approaches help us understand the issue of marriage migration from different angles keeping in view the interplay of the structure and agency; Nation-state as structural force, and immigrant as agency to play their role in transnationally defined social spaces. These approaches not only provide possible explanations to why immigrants prefer to marry in their countries of origin, but also highlight cross-border paradoxes of desirability that define, and/or sometimes determine the reservoir of choices for the stakeholders of marriage-migration.

Methodological nationalism enlightens us, on the one hand during the postwar years, how it influenced the epistemological domain of social sciences in conceiving and analyzing the nationalist thinking, and what is its relationship with marriage-migration, on the other hand. State as a sole sovereignty and the nation as a homogenous group practicing similar cultural values and the remittance remain in focus in the methodological nationalism's perspective. However, it is to clarify that migrants' experiences could be understood better by contextualizing them in transnationalism provided the *linkages* based on *simultaneity* of the flows of ideas and values (Mazzucato 2008), and until unless it does not fall prey to the fundamental assumptions of methodological nationalism; migrants' assimilation eventually and taking the nation-state's border as equal to the concept of society (Glick-Schiller 2010). Schiller views such studies, being disconnected from the social theory and closer to the global power structure; with the purpose to produce only the contradictory narratives that *either demonize the migrants or celebrate them* (2010:2). Being under theorized, some other approaches were introduced to transnationalism notably transnational social fields (Levitt & Glick-Schiller 2004; Levitt, 2001) and transnational social spaces (Pries 2001, 1999; Smith & Guarnizo 1998). Some of the core concepts; structure-agency, social networks, social capital, and embeddedness are borrowed from sociology that have also been employed in conceptualizing transnational migration (Lacroix 2014; Vertovec 2003).

To understand the ongoing debate on transnational migration and where does marriage-migration stand, it is worth relooking the literature how it views marriage migration. The following parts in a chronological order discuss the emergence of both of the perspectives mentioned above and the socio-economic circumstances under which these perspectives tend to explain the life-world of transnational migrants in their host and origin countries. Beyond the binary approaches I also focus on how the interplay of both (national and transnational) perspectives influence the contour of transnational social spaces where transnational actors while being embedded in their host societies are continuously devising the strategies to remain in contact with their origin societies.

1.2.1. Methodological Nationalism

To understand why transnational marriage is considered an obstacle to integration by modern nation-state, we need first to deconstruct the concept of integration; the demarcation of 'us and 'they' under the paradox of nations' cultural clash according to methodological nationalism. It is also necessary to reflect back on how the epistemological domain of social sciences has constructed our understanding on the birth of nation-state, and how the episteme has historically been created to serve the purposes of nation-state. How did postwar social scientists perceive and conceptualize international migration? Wimmer & Glick-Schiller (2002) describe three modes of methodological nationalism, which shape epistemological knowledge of social sciences.

- i. Ignorance: Social theory ignores how modern nation-state was born. *The social sciences were captured by the apparent naturalness and givenness of a world divided into societies along the lines of nation-states..... Methodological nationalism produced systematic blindness towards the paradox that modernization has led the creation of national communities amidst a modern society supposedly dominated by the principles of achievements (2002:304).*
- ii. Naturalization is taking national discourses, agendas, loyalties and histories for granted, without problematizing them or making them an object of an analysis in its own right. *Instead nationally bounded societies are taken to be the naturally given entities to study (ibid).*
- iii. Territorial Limitation: *The territorialization of social science imaginary and the reduction of the analytical focus to the boundaries of the nation-state (2002:307)* that is to say to analyze any social phenomenon according to the lines and boundaries of nation-state.

In constituting the social world, once the modern nation conceived as natural entity, the very next step was to codify the nationalist thinking. And to this, it was necessary to dissolve the-then prevalent different notions of peoplehood; *people as sovereign entity* [ruled by a kind of democracy], *people as citizen of state* [having equal rights],

people as a group of obligatory solidarity [towards their kin under the reciprocal system], and *people as an ethnic community* [sharing common cultural practice] (2002:308). The notions of different peoplehood were first fused into a nation and redefined under the flag of functional integration by the nation-state. Parallel to nation's territorial emergence, the emergence of the society came to surface. Sovereignty is not the people but the institution of politics, culture would be found in national identity, citizenship would be the national legal system and groups would be found in the social system (ibid). People belonging to 'other' nation-state are the 'others'. Similarly, it highlights the new epistemological posture adopted by researchers in the social sciences. As Wimmer and Glick-Schiller notice it: "We have been able to begin to analyse and discuss transnational migration and long distance nationalism because we have changed the lens through which we perceive and analyse the world, putting aside some of the preconceptions of methodological nationalism" (2002:322).

The debate about the limits of methodological nationalism has grown since the late 1990s, mainly among the Anglo-Saxon and German scholars (Amelina 2012; Schiller 2009; Chernilo 2008; Pries 2005; Wimmer & Schiller 2003; Wimmer & Glick Schiller 2002; Chernilo 2006;). The principle of reciprocal determination between state and society (Beck 2006) presupposed by methodological nationalism is reflected in the social science research in the premise of the coincidence of social boundaries, unscrupulously coincided with the state borders (Wimmer & Glick Schiller 2002). Social practices in different spheres of life as diverse as culture, language, work, education and marriage etc. are therefore defined and standardized in relation to the container as "their", for the people of other nation-states (Beck 2000). Methodological nationalism is thus based on the "territorialization of social science imaginary and the reduction of the analytical focus to the boundaries of the nation-state. The social sciences have become obsessed with describing processes within nation-state boundaries as contrasted with those outside, and have correspondingly lost sight of the connections between such nationally defined territories" (Wimmer & Glick Schiller 2002:307). However, the question of how to address the issue of multiple identities, multiple loyalties and transnational actions

& interactions becomes increasingly relevant and intriguing for the scholars of migration.

Transnational Researchers, through their work, question the ability of this epistemological approach to grasp the social change brought about by globalized social practices. They demonstrate that transmigrants, their ability to act remotely and to avail for themselves several national allegiances, undermine the principles of equivalence between sovereignty and citizenship, between the people on one side, and the nation and social solidarity within the national fields of the other group (Wimmer & Glick Schiller 2002). The territorial coincidence is no longer a necessary condition for the definition and expression of national belonging (Levitt & Glick Schiller 2003; Faist 2000). Transnationalism must therefore be understood as an integral part of the national process of redefinition, and thus marks an epistemological shift in sociological research (Beck & Lau 2005).

1.2.2. Transnationalism

Transnationalism, as a practice conceived in response to the critique on methodological nationalism, when produced as a consequence of transnational marriage, holds several promulgations that contest, trivialize and/or circumvent the regulations of the modern nation-state to keep the citizen loyal only to its intended interests. Transnationalism is often considered a direct threat to the framework provided by modern nation-state to define and interpret the nature of relationships and state policy as their supposed locomotive (Wimmer & Glick-Schiller 2002). Studying variegated cross-border activities of international migrants *reflect[s] various approaches and often-discrete conceptual repertoires* (Vertovec 2003:2). In doing so, varied terms, such as 'international', 'multinational' and 'transnational' were coined that are often used interchangeably. Portes (2001) distinguished these terms from general to specific contexts. For him, the activities between two-nation-states are categorized as international at macro-level; the multinational activities are the associational agendas and programs between different institutions situated in multiple countries at meso level. At the micro level are the transnational activities of the non-institutional actors, groups and networks across borders. It is within the

context of Porte's typology that the marriage-migration of Pakistani immigrants can be better understood as a transnational activity.

What is transnationalism? There are various definitions, that nevertheless revolve around the concepts of exchange relations and cross-border practices, so that transcend national boundaries as the main benchmark for the exercise of an activity or for the assertion of social identity. In the field of migration, the existence and maintenance of links across several places at once - or the feeling of "belonging to multiple spaces while geographically living in a single space" - has always been a feature of the experience of the migrants. Spending a transnational life contains different means in different contexts. It may mean temporary or permanent engagement with pluri-local sociocultural contexts, that would impact the exchanges and interactions of the immigrant in his/her country of living. These exchanges not only take the form of ideas, values and practices at micro-level (i.e. effecting the family and peer group) but also political and economic contributions at macro-level (i.e. effecting different social institutions, including educational, religious, economic and political). Transnationalism strengthens links between people, communities and societies across borders, altering the social, cultural, economic and political spheres of the origin and destination societies. By analyzing the scope, purpose and impact of their policies, policy makers are expected to look beyond national borders. Cross-border links that migration creates between societies require states to formulate and implement appropriate policy measures. There are two reasons for this: first, a migration policy that is part of a transnational context normally has implications that go beyond the national sphere to which it is applied. Second, the success or failure of such a policy depends, to varying degrees, of realities beyond the borders.

The forces of globalization and their impact on cross-border mobility lead increasingly to consider migration from a transnational perspective. Today, it is difficult to ignore cross-border connections of immigrations under nationalist policies. The accelerated development of communication networks, transport and information on the effect of globalization has strengthened the ties of migrants with multiple locations. Migration patterns have also changed: migration today is short term or long term, temporary or permanent, or consists of a series of routes with

multiple stages, and the return to places of origin. As part of the chain migration, migrants from a given city or region of a country predominantly move to a particular region or city in another country, often with the help of networks. Although not new, this phenomenon is a strong channel of transnationalism along with the transnational marriages. Under the effect of these mutations, it is common that migrants complete their education in a country, work and raise their children in another, and/or probably spend their retirement in a third country, provided numerous variations to their strategies are taken into consideration.

The transnational theory reveals that migrants, when living abroad, maintain links with their origin country (Levitt & Glick Schiller 2004). In this sense, the transnationalism is close to the network theory. It focuses primarily on how immigrants maintain their links with their home country while living abroad: not only attending the diaspora or having contact with people around them who are left behind, but also through visits they make to their country of origin. Migrants can adopt several strategies to continue their practice of transnationalism, including their participation in religious practices and other sociocultural activities related to their country of origin while being in the destination country, and also by send money to, paying visits to and exchanging gifts with their relatives living in their country of origin. The type of transnational activities and their intensity can vary. Nevertheless, the theory of international migration contributes to better understanding of the links that migrants maintain with their origin country. It also helps to understand how the identity of migrants is constructed over time, that combines traits of both their society of origin and the destination (Vertovec 2001). It also argues that the transnational identity of migrants influences their lives after returning home. Moreover, transnational theory does not consider the return as the end of the migration cycle. It highlights that multiple cycles of coming and going are quite possible (Levitt & Jaworsky 2007).

The debate of transnationalism surfaced in the academia almost a quarter century ago, primarily from Nina Glick Schiller, Szanton White and Linda Bash during early 1990s, when they published a series of manuscripts to highlight the paradoxical nature of nation-state, and transnationalism as an alternative framework to

understand migration from multiple contexts. These texts form a whole new paradigm that encourages researchers to consider transnationalism—presented as the product of global economic policies of 1980s—as an alternative to the concepts of assimilation or cultural pluralism, hitherto the most discussed in migration issues. During the end of 1990s, the transnationalism was further popularized by the writings of Portes (1996); Guarnizo & Smith (1998); Mahler (1998); Smith & Guarnizo (1998); Portes, Guarnizo & Landolt (1999); and, Vertovec (1999).

As constructed primarily by US anthropologists and sociologists, the notion of migration transnationalism refers to the emergence of a “social process in which migrants establish social fields that transcend cultural, political and geographical boundaries” (Bash, Glick Schiller, & Szanton Blanc 1994:7). Immigrants are considered transmigrants when they develop and maintain multiple relationships—family, economic, social, organizational, religious and political—straddling the borders. The migration patterns are characterized by maintaining social relationships, and transnational marriage is considered as one of the strategies to continue transnationalism (Beck-Gernsheim 2007). By recomposing daily multiple familial, professional and institutional connections with the country of origin, these migrants are actively involved in the process of circulation of material and symbolic culture. Their social networks interlace a dense mesh of a social field that goes beyond national borders of the host society, and their identities are equally defined in multi-national contexts. This way of simultaneously being in several worlds—here and there—sort requires a comprehensive framework for binary analysis that could explain the migrants’ condition of being mobile and sedentary in different national contexts.

Portes (1996) explains the functioning of transnational communities in connection to economic factors. According to him, cross-border communities emerge as a consequence of migration, who continue to perform their social and economic activities across two countries (the native and the destination). These transnational communities have advantage of information as well as of price differentials between both countries: with such an advantageous position, these transnational migrants exploit and profit from the capitalist system. Portes sees the trans-nationalization of

working as a potentially powerful phenomenon: it is an adaptation from the below to the globalization of capital which could in the long term, slow the growth of international inequalities or, in the short term, minimize regional disparities and inequalities in the countries of emigration.

In an edited volume, Guarnizo & Smith (1998) offered a comprehensive description of how transnationalism is linked to capitalism, media, world economy and identity construction of immigrants. This volume was one of the premier scholarly efforts to challenge the understanding of social positioning of migrants within the boundaries of nation-state, and highlighted the factors beyond national explanations and regulations that contribute in our understanding of several pluri-local realities. In the similar vein, Portes et al (1999) endeavored to clear some commonly conceived misunderstandings related to the concept of transnationalism and its adherent notions by reviewing different approaches to understand migration across geographies. They also offered conceptual guidelines to transform the concept of transnationalism into empirically verifiable object of research which could be employed in different social settings. However, their endeavor to offer a clear methodology of transnationalism was as fragile as their critique on the methodological nationalism, which was adequately covered by Glick-Shiller (2002).

Keeping in view the important technological advancements which ameliorated the modes of communication and travel with such a pace that was unimaginable a couple of decades ago, magnitude of transnational interconnectivities exacerbated the volume of scholarly activities around the concept. Thus, the intensity and simultaneity of regular transnational activities led not only to the emergence of new ways of being in the world but also to the transformation of social structures and the emergence of transnational habitus (Vertovec 2004). Indeed, the mobility of people, ideas, knowledge and objects, becomes one of the central features of the (post) reflexive modernity (Beck & Lau, 2005). The question is to understand the mechanisms through which mobility generates new dynamics and social structures across conventionally conceived borders as taken-for-granted contours of reality construction.

In the study of international migration, transnational approach helped to deconstruct the image of the supposedly rootless immigrant, who was assumed to break his/her connections with the original in order to assimilate into the host society. It stresses the acknowledgement of 'full-duplex' migrant with the ability to exchange between the host and origin societies simultaneously, and capable of developing a switching capacity between 'here and there', reflecting co-presence.

The concept of transnationalism has taken on very different meanings, depending on the intensity, the degree of institutionalization and the impact of transnational practices. According to Vancea (2009), we can distinguish between: (a) "Transnationalism from above", with reference to the activities taking place over national boundaries and are initiated by governments or business corporations; and, "transnationalism from below", to refer to the initiatives taken by migrants, including transnational marriage; (b) "narrow Transnationalism", regular activities requiring a permanent investment with a high degree of institutionalization; and "broad Transnationalism", concerning casual transnational links and practices; (c) "core Transnationalism" relating to predictable and modeled activities in a particular sphere of social life; and, "expanded Transnationalism" covering occasional transnational practices in several spheres of activities; (d) "linear Transnationalism" created by projects of return migrants; "Resource-based Transnationalism" related to the position of migrants in the labor market and its resources in terms of mobility; and, "reactive Transnationalism" which is a response to discrimination in the host countries.

Vertovec (1999) highlights six different dimensions of migrant transnationalism, which describes: (1) a social morphology—kind of "social formation that crosses borders" (Guarnizo 1997; Landolt 2001); (2) a type of consciousness based on dual or multiple identifications, which produce a plurality of communities, connections and solidarities; (3) a cultural mode of reproduction based on the syncretism, creolization and cultural hybridity, facilitated by the emergence of "new transnational social spaces" (Pries 2001); (4) of capital flows, whether produced within transnational corporations or transnational migrant communities, for the privileged way of money transfers (remittances); (5) modes of political commitment expressed

at the level of migrants or States which implement policies to capture the resources of their nationals; (6) reconstruction of a form of 'place' or locality because transnational practices are changing the relationship of individuals to space. These different forms of transnationalism give rise to 'transnational social spaces' built through transnational interaction and practices. They also allow the formation of new transnational habitus as an expression of glocalization (Nedelcu 2012).

Transnationalism is considered both the product as well as the contributing factor of cross-border marriages. Lievens (1999) asserts it as transnational endogamy when one of the spouses living in the host country imports his/her spouse from his/her country of origin. The flow of such endogamous migration is usually from low income countries to high income states. Citizenship of the migrant plays the key role to determine the pattern and nature of transnational spaces constructed across geographies (Vertovec 2004). Marrying back home does not merely entail the arrival of more people from economically deprived lands to satisfy their economic needs. It maintains and strengthens those links that migrants are predisposed with. Understanding such networks of relationships, according to Cameron (2006) is crucial to discern "cultural rejuvenation" and heritage preservation impulses of the migrants through transnational marriages.

Concluding Remarks

Although Pakistanis began to dwell in France since 1960s, precise information about their exact number is yet to be ensured. Scholars have generally ignored the Pakistani diaspora in France and its migration related behavior due to its less significant quantity and characteristically supposed resemblance with the diaspora in Great Britain. Peculiarly rising interest in migration behavior of diverse ethnic communities in different European countries in the last decade has motivated the researcher to understand the phenomenon of marriage migration among Pakistani diaspora in France which as an issue of social and demographic research has never been studied.

Scholars of transnationalism point out that the analysis of migrant populations has traditionally been influenced by the representations of migrant communities

dwelling, acting and interacting within national boundaries. According to these representations, the world corresponded to a space fragmented into separate territories framing people with distinctive sociocultural characteristics and ideologies. Migration was thought to be a linear process that would automatically divorce the migrant from his/her origin country. Contemporary migration theories, according to the theorists discussed above, treat the issue of migration and its stakeholders (migrants, modern nation-state and local populations) in a different way than these were treated under methodological nationalism, because they do not subscribe more to the idea of the final rupture. Most of the current academic debate consider migrants as transmigrants—rooted in the host countries, who maintain ties to their country of origin. Their connections (familial, economic, symbolic) transcend borders by means of advanced communication & travel, and then perpetuate by marrying back home. This is a reconfiguration of the social spaces. Migrants build a space which is no longer limited to a single territory, and, thanks to modern means of communication and transport, extends well beyond the borders of the host country. This dissertation will show, in the coming chapters, that the reconfiguration of the space of the origin country does not end within the walls of home or the borders of a country, and is expanded across geographies, as reflected by my respondents' propensities (As suggested by Yurdakul 2009:2, *Seeing through the migrants' eyes*) to own a bi-local space beyond the territorial and political boundaries.

CHAPTER 2

MARRIAGE INSTITUTION IN PAKISTAN: THE PUNJABI CONTEXT

This chapter serves as a background to present the holistic canvas of how family and marriage institution looks like in the origin country, Pakistan, particularly the Punjabi context. It first presents the traditional apparatus of Punjabi kinship system followed by a discussion over the power dynamics in family and household structure. Then it takes us to Pakistani marriage market to examine the nuptiality patterns being influenced by education and residential patterns. Lastly we go through the scholarly debates to frame the adequacy of spouse selection; a critical part of transnational marriage mechanism.

This chapter is divided into three parts. The purpose of the first part is two- folded; to capture the behavioral codes of conduct in kinship and family as well as attitudinal trends in the marriage market. First purpose is to examine the structure of Punjabi kinship and to describe what its fundamental assumptions for family, marriage and household arenas are, through sociological and anthropological lenses. It also examines the power structure of household and family by digging the nature of relationship across gender and generation. The purpose of second part is to provide explanation for nuptiality trends through demographic lenses. The role of sex, education and residential pattern play determinant role in actors' entry into marriage market. Third part focuses on the rules of the game to be followed to weight spouse adequacy and to deal with the puzzle who are considered marriage partners. Under the paradigm of social exchange theory, this part views if reciprocity works as the guiding principle for selecting an adequate spouse or not and if there is any link between reciprocity, kinship structure and marriage choices? The last sub-part shifts its focus from rules of the game to the practices of the game and examines how the actors tend to devise certain strategies to cope with rules under uncertain and risky situations. Actors' positioning with reference to their capital is of highly importance

in explaining spouse selection behavior behind the cultural reproduction of values, the divergence and/or emerging new accommodations.

2.1. The Punjabi Kinship

In traditional setup of Punjab, a variety of kinship systems and kin terminologies can be found to signify the social ladder of hierarchy in terms of individuals' identities and their belongingness to a particular group, and how do they interact each other when it comes to the question of marriage. The networks of relatedness in a Punjabi society may comprise; *Qaum*, *Qabila*, *Biraderi*, *Khandan* and *Rishtadar*. However, it is to be clear that these terms are not unanimously used in Punjabi culture even if some researchers have often been using these terms synonymously, due to the confusion they might confronted with varying ecological, geographical and cultural fallacies. Another key factor responsible for this vagueness is contemporary researchers' little or no interest to scrutinize the Muslim Punjabi kinship system in Pakistan since the pioneers have worked and defined these terms long ago³. This is why I am unable to find rich literature on the issue as I found on Punjabi Kinship in India. Although the basic assumptions of Punjabi kinship in India and Pakistan for familial relationships and power system across gender and generation are somewhat similar however there lies big difference between Muslim and non-Muslim Punjabi kinship system in providing socio-cultural guidelines related to marriage. One of the biggest difference between the Indian and Pakistani Punjabi kinship system are the marriage rule of incest taboo. In Indian Non-Muslim Punjabi kinship marriage is not preferred within the close kin as cousins are considered equal to sister and brother because they share common lineage. While contrarily, the Muslim Punjabi Kinship system advocates kin-endogamy strongly. Another difference is that Indian Non-Muslim Punjabi kinship seeks new alliances through marriage, while Muslim Punjabi kinship system prefer to maintains and strengthens the already existing kin-network. As traditional family system is undergoing transition where

³ Shortly I shall cite contemporary and classical studies done on marriage, and family as well as on some other issues in Punjab, Pakistan and have examined the kinship accordingly.

gender and generational relationships are on the move, the marriage is no exception. One of the major shifts in contemporary marriage behavior in Pakistani Punjab is that individuals are marrying out of the family meaning kinship is seeking new alliances through marriage. The networks of relatedness and determinants of identity too are on move, meaning kinship structure is too undergoing the transitional phase. This is why, a validate updated knowledge on Punjabi kinship system and notions of relatedness in Pakistan is the need of the day as this research gap is alarming and worth consideration for future research in the field of kinship, especially in view of technological advancements redefining kinship, and trends and notions of relatedness in Pakistan. The first and second part of this chapter is an endeavor to shed light, systematically from the past to present, on indigenous terminological usages to identify the networks of relatedness and to explain the nuptiality patterns so that we could know what is happening in the contemporary marriage market in Pakistan⁴. This will also help us to understand which types of customary terms, notions of connectedness and kinship systems are practiced in Punjab to symbolize networks of relatedness and the web of relationships.

In seeking guidelines, the family traditionally relies on kinship system in Punjab, which entails a variety of social attitudes and practices related to the institution of marriage. Marriage institution basically heterosexual, entails religious, legal and cultural rights and obligations of marital relationship. It provides two sets of social rules regarding spouse choices; endogamy being a prevalent preference and exogamy being less practiced. Kinship play a determinant role in filtering the adequate marriage partner from the pool of potential spouse. To know why do families rely on kinship, and why endogamy is widespread, we need to know the socio-economic value of kinship structure at one hand, and what kind of socio-economic security kin group provide to its members at the other. Another justification lies in the logic when families do not prefer to develop relationship through marriage

⁴ The content of these parts comes from my Masters' dissertations on 'Spouse selection in Punjab, Pakistan: A descriptive analysis across gender, generation and geographic area' (2010), and on 'Nuptiality Patterns and Trends in Pakistan: A Descriptive Analysis at Regional Level (2012).

with those families who stand at lower strata of the social ladder's hierarchy. Before knowing the system of family and marriage, it is worth looking into the basis of the system meaning who to marry or not and who are to be included or excluded from the conventional definition of family, relatives and networks.

2.1.1. Networks of relatedness

Initiating with the term **Qaum**, a system of socioeconomic stratification in which strata are closed and a person's membership is determined at birth. Ahmed provided *Qaum's* colloquial understandings in Punjabi culture:

What is a Qaum? The general meaning of the word Qaum is tribe, sect, people or nation. But obviously the villagers do not use the term in this sense. A man's Qaum is determined by birth: he is born into his father's Qaum even when the latter is married to a woman of a different Qaum. (Ahmad 1970:109)

His definition is based on what he examined in a Punjabi village *Jalpana* in West Punjab where the applicability of concepts of social stratifications — class, socioeconomic status and caste — are attached to *Qaum* and differentiation within different *Qaums* occurs on the basis of either occupation or ethnicity. *Qaum* is also a substituting term to caste but not exactly equal to the caste system as it prevails in India. *Qaum* in terms of social stratification was not created by a single practice, but rather it had been developed through continuous social stratification practices of Punjabi society over several thousands of years. In Indo-Pak subcontinent, Muslims and Hindus have been living and interacting together for centuries. There are plenty of examples which signify assimilation and acculturation processes between them, and *Qaum* is one of them. In India, castes are ranked along an axiom of purity and pollution, while in Pakistan the case is not exactly the same. As Stephen M. Lyon emphasizes:

I should stress, at this point, that I do not believe that caste.... has a great deal of relevance in the Pakistani context. This is not to say that caste is irrelevant or that there is not caste discrimination, simply that the coherent ideological system which Dumont argues as fundamental to India is not applicable [in Pakistani Punjab]. (Lyon 2002:126)

In Pakistani conventional set up, the term caste is used as a metaphor to *Qaum* (Ahmad 1970). In *Jalpana*, villagers are divided into two broad divisions on the basis of occupation; cultivators (*zamindar*) and peasants (*kammi*). *Zamindar* are ranked higher than *batai* (sharecroppers) socially. He defines the term *kammi* as:

The word kammi refers to those who serve. In the most general sense all those who serve the village as a whole, or assist the cultivator in his occupation, are called kammis. The general category of kammi, therefore, includes not only such groups as barbers, and cobblers, but also the pir [spiritual healer] and miana [religious teacher] (Ahmad 1970:107).

Non-cultivators are further subdivided hierarchically into agricultural artisans (carpenters, barbers, blacksmiths and potters) and nonagricultural artisans (cobblers and drummers). Nonetheless, contrary to his categorization of *Pir* and *Miana* as *kammi*, even in other parts of Punjab, *Pir* and *miana* are not seen merely as occupational groups but assumed as holy charismatic personalities who socially, politically, economically and culturally are highly respected and valued. He observed some exceptions that *Qaum's* identity may be restrict within one generation but it could be changed if one changes his profession. To elaborate it, he gave examples of a *Kookara Zamindars* who have become *Faqirs* (caretakers) of the village shrine, two barbers (*Kammi*) who became *Malik* and a *Kammi* carpenter who has become *Miana* of mosque. He, however, could not provide logical explanations behind his claim that how a person either from higher or lower social category could change his *Qaum*, and how he is respected and treated according to his new position? Here, he missed very important concepts of ascribed status and achieved status. A person may achieve new position but he cannot change his ascribed status in a traditional village setting. He still would be recognized as a member of *Zamindar*/barber *Qaums* although he prefers to become *Faqir*/*Malik*.

Traditional occupation gives the group its name as well as its general position in the social hierarchy. Distinctions based on occupation signify different *Qaums* as hierarchically high or low which remain significant social markers. For instance, landlords, businessman, merchants e.g., *Arain*, *Rajput*, *Mughal*, *Malik*, *Chaudhary*

and *Khan* are considered as high *Qaums* while *Mouchi* (cobbler), *Tarkhan* (woodworker), *Kumhar* (potter), *Naae* (Barber) and *Jolaha* (carpet or cloth makers) are marked as low *Qaums*. Some *Qaums* are also further categorized as lower based on their low value occupations, e.g. *Miraasi* (the entertainer) and *Machi* (water-fetcher).

Another worth considering fact is that in Punjab, *Qaum's* superiority or inferiority not only depends on occupations but also on geographic localities. As in *Bhalot*, predominantly a Gujar village, Gujar is considered a higher *Qaum*, whereas the situation is different in Kasur and Lahore, in East Central Punjab, as *Arain Qaum* is considered higher than *Gujar*.

When Punjabis contact someone based on Qaum affiliation they are not looking for an equal-- they are looking for either a subordinate or super-ordinate of the same Qaum. Qaum affiliation does not make men equal, it makes them approachable. So while Qaum organization itself is not hierarchical, it is one mechanism for establishing contact between strangers who then immediately assume hierarchical roles. (Lyon 2002:142)

Lyon (2002) conducted an ethnographic research on power and patronage in Bhalot village in Attock District, lies in northern Punjab. His findings reveal that terms *Qaum* and *Zaat* are too complicated terms to define separately because of commonly held beliefs that *Zaat* and *Qaum* are biologically founded categories. Skillfully discussing the term *Qaum* as it is practiced there, Lyon compared the versatile usage of terms *Qaum* and *Zaat* in different geographies by quoting the examples of Lahore, Attock and Taxila cities of Punjab because of closer proximity and influence of Pakhtoon culture on Punjabi.

This [Qaum] refers both to categories that might be viewed as 'ethnic' groups (i.e. corresponding to linguistic, religious and place of origin criterion, for example Gujar, Pathan, Baloch, German), as well as categories closer to Leach's notion of caste based on occupational specialization (i.e. barber, tailor, cobbler etc.). The term serves as a catch all for categories which may be tribe, caste, nationality or ethnicity. As such, Qaum is simultaneously highly useful, versatile and amazingly frustrating as a point of reference. (Lyon 2002:126).

In the absence of *classical* caste system like India, proxies are used for ethnic and linguistic groups also called *Qaum* like *Sindhi* or *Baloch*⁵; geographical conditions like *Muhajir*⁶, tribal affiliations like *Pakhtoon* or *Pathan*⁷, intra-linguistic variations like *Saraiki*⁸ and religious denominations and/or sects like *Sunnites* and *Shias*⁹.

As noted above, in Punjab, there are distinctive ethnic groups where identity matters and whose criteria of making identities differ greatly. Some kin-groups' identities are based on occupation and ethnicity, while others are recognized purely on the basis of descent systems, like in case of *Qabila*. It is characteristically closer to the concept of clan. *Qabila* is a group of kinsmen who recognize a common ancestor (known or unknown). *Qabila* affiliation is based on descent to metaphorically identify a person. *Qabila Bano-Hashim*, for example, symbolizes that their ancestor *Hashim* is common. *Yousaf Zai, Jamali, Afridi, and Sherwani* all are examples of different *Qabila* in Pakistan who do not share only common ancestor but a common place of their origin. Contrary to current residential and occupational patterns, *Qabila* members traditionally used to follow a single occupation and occupy same geographic territory. There may be different lineages in a *Qabila*, but these lineages consider themselves as descendants of a common ancestor. *Sayyad* in Punjab, for example, have unique descent line and not only share their common ancestor of religious personalities but also share a common religious sect too. They do not make affinal relationships outside *Sayyad*. In case of non-availability of suitable marriage

⁵ Individuals who speaks *Balochi* and live in Balochistan, one of the four provinces of Pakistan. This clarity is equally applicable to the term *Sindi*.

⁶ *Muhajir* literal meaning the migrant, those individuals who migrated from India to Pakistan after Indian sub-continent partition in 1947.

⁷ Those who belong to Pakhtoon tribe, spread along the borders of Pakistan and Afghanistan.

⁸ A dialect of Punjabi language

⁹ Two major sects of Islam

matches within *Sayyad*, it is preferred to remain unmarried instead of searching marriage proposals outside.

Biraderi like *Qaum* is another puzzle to contour network of relatedness. It is relatively more adjacent to kinship systems rather than the previous two. Honor plays crucial role in defining the activities and nature of interaction among *Biraderi* members in Punjab. Parallel to the notion of honor is Urdu word *Izzat*. *Biraderi* shares the concept of common prestige. In case when someone marries against the expectations of his/her *Biraderi*, there are many idiomatic phrases which reflect the sense of being disrespected and ashamed for example, *Naak Kat'na* (literal meaning cutting the nose, but symbolically it denotes to destroy one's honor); and, *Pag'ri uchalna* (literal meaning throwing the turban. The turban denotes symbolic meaning of respect thus the idiom means being disrespectful to the norms of family and/or kin-group). If Lyon (2002) understand *Izzat* a measure to rank people according to their actions, for Eglar (1986) it was a measure to judge the behavior of individuals. Thomas, Sabiha, & Peter also confirm that honor in *Biraderi* is shared and judged through the marriage behavior of the family. They quote Eglar:

Eglar has determined that the most important social group outside the immediate household is the patriline or Biraderi. Eglar stresses that marriage is a critical Biraderi function, that all members have an interest in the contract, since honor (Izzat) is ascribed to the whole group on the basis of how its individual members behave. (Thomas, Sabiha, & Peter, 1986:492)

Biraderi includes the relatives from both of parent's sides, according to Eglar. In the similar vein Korson also described the term *Biraderi* equal to clan and says:

A word of Persian origin meaning brotherhood or clan, but in contemporary Pakistan the term includes all those related by blood, however distant. (Korson 1969:153)

He further explained that blood relationships set homogenous community life in the same cultural region, and larger, expanded and integrated family groups are its basic social units. Alavi did his research on "kinship in West Punjab villages" in Sahiwal during 1968-69 and for the first time he defined *Biraderi* in the real sense in local context as it was being practiced by his respondents too.

The basic institution of the kinship system of Muslims of west Punjab is the Biraderi. For the moment we may translate the word Biraderi as brotherhood which emphasizes horizontal fraternal ties between contemporaries rather than convergence of vertical lines of descent which is also implied in the concept of Biraderi. Many social anthropologists would probably translate the term as patrilineage since male members of a Biraderi are all descendants of a common known male ancestor. (Alavi 1972:1-2)

He narrated that in Punjabi cultural system, a *Biraderi* is a “*compromise kin group*” which is conceived of as “*a collection of related households*”. According to him, *Biraderi* membership and inheritance both are transmitted along the male line. *Biraderi* members claim as being the same blood descent even if their mother come from outside *Biraderi*. Mother’s parents and her siblings constitute *Nanke* relatives. He confined the concept of *Biraderi*, from most general to most specific with a sliding semantic structure, as “*Biraderi of participation*” and “*Biraderi of recognition*”. *Biraderi of recognition* lies within the boundary of mutual knowledge of the actual links of common descent. *Biraderi of recognition*, or descent group in its most general meaning, includes *Biraderi* relations with all those who trace their common ancestor through paternal line. Without written records, *Biraderi* is determined by the limits of knowing and recognition. *Biraderi of participation* denotes those households within *Biraderi of recognition* who actually participate in a ritual of exchange of presents/gifts called *Vartan Bhaji* on certain occasions as birth, marriage and death. The *Vartan Bhaji*, system of gift exchange is the building block in his analysis of *Biraderi* relationships. Membership of *Biraderi of participation* is determined by the expression of the ritual *Vartan Bhaji*. He defined *Vartan Bhaji* as:

The word Vartan means “dealing” or “buying”; it is often used by itself, subject to context, to refer to the relationship Vartan Bhaji. The meaning of Bhaji is sweets. The presentations given in Vartan Bhaji are called neondra or nyota. (Alavi 1972:8)

For him, *Vartan Bhaji* must be continued because it not only defines membership of the *Biraderi of participation* but it also provides an unambiguous ritual procedure for termination of the relationship. Wakil (1970) also explains comprehensively while setting boundaries of *Biraderi* relation by the custom of *Bhaji*. While defining *Biraderi*, he cited the term *Biraderi* as *neither, a specifically located ecological or*

geographical group (Blunt 1931), a patrilineage (Eglar, 1960), nor only the blood relatives (Korson, 1969:153). Instead he defines *Biraderi* as:

The system of reference is called the Biraderi, a term of Persian origin and a derivative of the word Birader meaning brother. Biraderi literally means a brotherhood. It is a bilateral system and consists of consanguine (excluding ego's primary relatives) and affinal relatives among whom a "brotherly" sentiment or system of relationship is supposed to prevail. (Wakil 1970:700)

According to him, *Biraderi* system consists of a larger circle of relatives who share a common identity by a common name and by more confined circle that is determined by competitive gift giving called *Bhaji*. *Biraderi* is generally an endogamous group in which the most preferred mates for marriage are cross and parallel cousins. He further asserts that the boundaries of *Biraderi* are usually unclear and confused since they depend on memory, contact over geographical distances, degree of strictness of endogamy and most of all on complex gift exchange system. *Bhaji* refers to the commodities exchanged, which may vary from cash to material substances. In principle, all members of *Biraderi* are considered to have *Bhaji* relationship with each other but actually, *Bhaji* and its amount depends upon the nature and degree of relationship between donor and recipient. There are different categories of *Biraderi* relatives i.e., secondary, tertiary, quaternary, quinary, but *Bhaji* relationship is confined only to some of them.

On the basis of *Bhaji*, he also divides *Biraderi* into two categories; *general Biraderi* and *effective Biraderi*. Everybody within the larger circle belongs to *general Biraderi* and there is no restriction of *Bhaji* relationship. However, for each ego the *effective Biraderi* is that limited group within which ego has reciprocal *Bhaji* relationships. *Bhaji* encircles ego, his family of procreation and family of orientation. However, in a traditional setup of *Bhaji* circle, family of orientation plays more significant role on the occasions of birth, marriage and death. He sums up that the closer the kin ties are, the greater the *Bhaji* is.

No doubt, he appealingly distinguishes *Biraderi* types on the basis of *Bhaji* and nature of relationships, but he could not explain logically why family of orientation is

not the part of *Biraderi*. At one time, he considers *Bhaji* as the distinctive phenomenon for classifying *Biraderi* consisting of both consanguine and affinal relations but subsequently he claims that family of orientation is not the part of *Biraderi*.

Alvi while working on Punjabi Muslim kinship in Pakistan (2001 & 2007) describes *Bhaji* (gift exchange) relations, and categorizes male and female *Biraderi* relations on the basis of *Bhaji*. She also categorizes *Biraderi* as 'own' and 'others' based upon type and nature of gift exchange. In *Punjab*, the notion of caste is directly related to, though not replaceable by, the notion of the *Biraderi*. *Biraderi* opposing to caste is subject-dependent and gender-dependent. Its content always differs according to the context in which it is used. It may mean people of one lineage or of same occupation or may refer to the people of one caste living anywhere in the world. Women often assume *Biraderi* only those relatives with whom they entertain one particular kind of gift exchange. The *Biraderi*, as defined and explained by Alvi is a network of social relationships with the practice of gift exchange (material or non-material), generally referred to as *Bhaji*, differentiating the *apne* (own) from the *ghair* (others). She considers *Biraderi* as *people (irrespective of their caste) between them exchange of gifts exists*. Although she relates *Biraderi* to caste but did not apparently clarify which parameters could mark that both are related to each other. In addition, she locates individuals having same occupation as *Biraderi* if exchange of gifts between them is present. In contrast to above mentioned researchers, Shaw defines the term *Biraderi* more broadly.

Literally 'brotherhood', usually denotes relatives who know each other well, can demonstrate their relatedness and live in the same place. Sometimes, however, Biraderi describes everyone with whom there is an assumed kinship link, known or not. (Shaw 2001:322)

She might have taken *Biraderi* relatively unrestricted to blood relationship than the previous researchers. As she did not precise what does she mean by relatives and/or who exactly these relatives are? By adding a common place of living she does not, however, clarify what she means by 'live in the same place'. Is it a common residence (may be dwelling)? Or it is the particular geographic area, they are

sharing? If she means dwelling in same household, then *Biraderi* is equal to *Khandan*.

The closest circle of kinship is ***Khandan*** (family) and ***Rishtadari*** (relatives), as compared to previous three networks of relatedness, these are comparatively less complicated notions of connectedness. The term *Khandan* falls within the ties of blood relations. Usually interpretation of *Khandan* varies geographically from one ethnic group to another but mostly it is equally used for family. Das (1973) translated the term *Khandan* by the word family. However, she confessed that to define *Khandan* in terms of the accepted classification of kinship groups is extremely difficult. For her family and kinsmen are equal to *Khandan*. She sets three principal features of *Khandan*; members of *Khandan* assume common descent, a strong preference for kin-marriage and non-cumulative inheritance as one inherits property only from father's side. Within *Khandan*, another term *Shareeka* is frequently used. It is similar to parcenary but it exclusively includes agnatic relationships. As Lyon (2002) describes that ***Shareeka*** are those people who most likely lay competing claims to family resources.

Another term that is coincided with *Khandan* is *Rishtadar* (relative) to symbolize *Biraderi* relations. *Rishtadar* are *those within the Biraderi as well as affines from outside* (Eglar 1960:81-82). Thomas, Sabiha, & Peter (1986) distinctively define *Biraderi* and *Rishtadari* on the order of male ego. *Biraderi* relations are those which all descend from a common male ancestor. *Rishtadar* on the other hand, members of a separate patriline are related to male ego through his mother as affinal. According to Alavi:

Affines who are not member of the same Biraderi are known as Rishtadar and are distinguished from Biraderis with whom no marriage relationship exists, who are known as nokh or ghair (strangers). (Alavi 1972:7)

Shaw & Charsley interpret *Rishtadar* and *Rishta* as:

Relatives are rishte-dar, literally 'owners of connection', the -dar suffix indicating possession. A Rishta in this sense can extend to relationships other than those of marriage and to non-kin, such as

neighbors. This connotation of Rishta is also helpful for understanding what people seek in a marriage proposal or match. As has often been repeated, south Asian arranged marriages are not simply relationships between individuals, but between families. (Shaw & Charsley 2006:408)

They further explain that *rishta* for the purpose of marriage may strengthen the previous close kinship relations. Distinctions in relatives are made by Ballard (1990) also who differentiate relatives on the basis of marriage. Affines are ego's relatives with whom one develops relationship through marriage. Mother's side relatives are called affines. Similarly, the traditional term **Saak** is used to denote parental family of ego's mother. *Saak* (relatives) is generally coincided against *Shareeka*. If ego compete with *Shareeka* for inheritance, *Saak* often intervene to take the side of ego and try to solve the disputes. *Saak*'s also intervene when the marriage of their daughter faces problems like the tilted relationships between the daughter-in-law and family-in-law and so on.

To conclude, *Punjabi* kinship is a complex network of relatedness. At macro level, there is large amount of variability among different notions of belongingness that first places individuals and their families on the ladder of social stratification. Then it differentiates the ties of relationships by categorizing into different types and structures. Family being the building block of any kinship structure is equally important to look how family and household structure are guided by kinship at meso level, the subject matter of the next part. Then I will focus on what is the nature and kind of relationships, patterns of interaction and attitudes across gender and generation at micro level, or called agency.

2.2. Family and household

In Pakistan as an Islamic society, kinship and family are strongly influenced by Islamic traditions and Islamic norms of marriage and family formation (Donnan 1988). Though religious traditions are a point of reference in family affairs, but are not always in line with cultural values of family and marriage. As Carroll (1996) argues that the impact of Pakistani religious traditions is slightly different from other Muslim nations. Indigenous traditions have more impact on family and kinship than

Islamic traditions. If in religious teachings, nuclear household is preferred and wife is not obliged to live with her family-in-law, the Punjabi kinship advocates joint and extended households where a traditional daughter-in-law is expected to take care of the family members.

If family institution in Punjab is a unit of economic production, distribution and consumption (Das 1976). Family and *Biraderi* are building blocks of social organization and do not stand separately in Punjabi family life. Individual's social life is encircled by family and kin because they not only facilitate individual for the fulfillment of different tasks but also provide them protection and social identity in the stratified society. Individuals residing in the same house share common descent, common values and have a long-term commitment to each other. The cohesion and support are considered basic aspects for family's composition and well-functioning, although the intensity of intimacy and extent of visits to *rishta daar* are visibly less in city dwellers than the villagers. Within passage of time, family unit wherever it resides either in rural or urban areas, is loosening up and the structures are becoming more malleable. The new traits of family are being emerged. Now family members share some characteristics of dependency, welfare and solidarity (Qadeer 2006).

In villages the hold of *Biraderi* and *Rishta daar* is still dominant on individual lives; either they are parents or their children. Though youth resists, but their verbal resistance has not much importance for their parents, as for parents they are not yet enough experienced to give opinions or to understand the complexities of life. In urban area, parents though do not admit the hold of *Biraderi* in their daily life, but hence they trace their identity back to *Biraderi* and maintain connection with *Rishta daar* through arranging marriages and regular *Vartan Bhaji* exchanges. Yet it does not mean that all rural and urban parents think in the same direction. Education, exposure to media and life's experiences not only affect the younger generation but the elder too. They are redefining who their immediate and first family members are; their life partner and children either married or unmarried.

In general, family affairs are dealt in collectivity in Punjabi village; no matter members share a particular household or living separately in nuclear family or extended family type (Lyon, 2002). In case of geographic mobility, even from one village to another for the purpose of proximity to educational institutes, the term 'expanded' (instead of term 'extended') can give us better understanding that how rural individuals take care of their relatives or expanded families. The emergence of new systems in family types shows that collectivism and individualism co-exist. Due to the changing familial conditions and developmental cycle such as separate household, gender role, geographic mobility and parents' dependency over young children, the very common and traditional 'joint family', and 'extended family' types have transformed into 'nuclear family' and 'expanded family' types in both urban and rural areas. The trends of family in composition, functions, and values, have changed and they are not the same now as were in the past. Casual observation reveals that *strong and pervasive orientation to family and family values* (Donnan 1997:1) have changed *from generation to generation although the change may have been glacial and not very perceptible* (Qadeer 2006:189). Sociological evidence is strong that parents influence and mold their children's attitude towards certain direction (Smith, 1983; Smith & Self, 1980; Starrels 1992), so is in Pakistan where the relationships across gender and generation are diverging from tradition. The notion of intergenerational transmission of familial attitudes and orientations towards family-ism becomes problematic when younger generations may well part ways with their elders in beliefs, values, and behavior. Apart from diverging behavior, convergence may exist between both of them. Parents and children negotiate on familial issues, particularly of marriage. Parents and children who discuss marriage related issues, are considered modern because traditionally marriage is considered the arena of parents and children are expected to remain silent in terms of observing shame as marriage is right of passage to sexual life. Education, urban residency and media have added other meanings to marriage such as the compatibility of the spouses, a modern trait that is to be found only when both would-be spouses interact with each other. Once fiancés were not expected to interact, now engagements are followed by the interactions of the would-be spouses. Though marriage remains the

collective affair of the family, hence the compatibility factor has become the part and parcel of marriage decision being taken by the modern urban families.

“Crudely, they may be said to be modernizing, but it is a modernization within the grooves of invented traditions. They are certainly not adopting Western trends entirely, although some are being incorporated”. (Qadeer 2006:189)

Changing residential pattern with reference to children’s independency is another new addition to the traditional family and household structures. If at one hand, young generation considers familial support as a track towards their independency, older generation who themselves have sufficient resources or have exposure to modern culture tend to encourage their children to have separate residences and becoming self-dependent. Children are encouraged to pursue their career even if they have to live separately from parents in other cities than their home towns. The transnational marriage is an illustrating example in this regard when children particularly male migrate to other countries hoping to get higher education and to excel their careers.

2.2.1. Gender and power relationships

Like the other South Asian traditional societies, household as a subsistence unit in Punjab requires a clear cut authority attribution, and well defined status and role of its members. Whom decision making power is assigned and why? Punjabi family *has been and continues to be male-centered* (Qadeer 2006) and almost every description, since 1969 until today, defines it as a traditional set up of household under the supervision of a male guardian because Punjabi society is patriarchal, patrilocal, and patrilineal and so is the institution of family (Kakepoto, Brohi, & Jariko 2012; Qadeer 2006; Donnan 1997; Das 1973; Korson 1969). Authority is exercise in the sense that a person generally father is responsible for wellbeing and maintenance of family and plays a dominant role in decision making in any affair for the family irrespective of sex either his son and/or daughter, and irrespective of children’s age. Parents are considered wise as they are elder and have experienced the realities of life more than of the children.

Although male is the head of the family, but the issue of decision making is not always assigned to male in every sphere of life, as it is normally a constructed misnomer for a patriarchal society. It nonetheless depends upon the structure, composition and function of the family residing in different geographic areas. In the extended family in rural area, grandparents are assigned the power of decision making whereas in urban areas, nuclear family system assign decision making power to male, generally father and also to the female that is mother. Internal migration enables a female to be empowered through education and lesser influence from the kin notably. Farooq & Cheema (2005) found that migration from rural to urban areas in Pakistan bring modern values thus eroding gender-based discrimination. Other intervening factors include parents' dependency due to their lesser capacity to accelerate economic resources of the family, their older ages, woman's participation in labor force, residential proximity to networks of relatedness, inheritance, façade of religious teachings and most importantly amalgamation of religion and culture. It is fact that the predominant majority of households are headed by males in Punjab. Nonetheless, patriarchal authority is not always exercised dictatorially, but in other forms too i.e. matriarchal and egalitarian, especially when it comes to the decision making in matrimonial affairs. In Punjab, the emigration rate is higher than that of other provinces, as in 2016, more than half of the total of Pakistani emigrants came from the province of Punjab. International migration not only brings prosperity to the family, but chances to get higher education and dwelling in the cities. Such households are headed by female due to male's migration (Donnan 1997). It is astonishing that most of the literature on gender based power relations in Punjabi families does not reflect such variations of exercising power. Previous studies (Khan 2011; Roomi & Parrott 2008; Winkvist & Akhtar 2000; Mandelbaum 1993; Afshar 1989) reveal the subordination of Pakistani women to men and impositions of decisions by their male relatives. My observations are, to some extent, in concurrence with the typology of Oppong (1980) concerning female roles. She has classified female's roles as individual, domestic, parental, conjugal, kin, community, and occupational. In Punjab, women are generally expected to perform within these boundaries of roles and status along with cultural expectations of how women should behave ideally in particular settings ranging from

private to public sphere (Kakepoto, Brohi, & Jariko 2012). A dual system of categories as reflected in the literature—male is in public sphere and female in private domain—imposes the dichotomous classification of traditional segregations of male and female, which seems factually inaccurate. For example, women in Punjab play a significant role in the agriculture industry and work side by side along with their male counterparts. Similarly, almost all the higher education institutions in urban Punjab have the system of coeducation, and there were 65 females enrolled against every 100 males for higher education in 2003-04 (Batool, Sajid, & Shaheen 2013:19).

It is commonly reported that South Asian men retain family authority over their wives, even in households (Shah et al. 2006; Beishon, Modood, & Virdee 1998). However, many factors determine the locus of authority in the Punjabi household. Hierarchical ordering in the family includes the age factor too. If grandfather is living with the family, traditionally he is considered the main decision maker; after him the status of decision goes to the grandmother. As Parkes (1997) testifies that before the authority shifts to elder male child, parents' economic dependency and old age has already been paved the way. Similarly, if a female inherits more property from his parental family, she can significantly play her role in decision making and sometimes exercising authority not only on her children but also over her male counterpart as well. The role of female agency is far more active in marriages than that of male; from searching spouses to the final ceremony of marriage, much of the task of marriage is considered as woman's domain. Further, as the kin-marriages are preferred, a woman in the web of kin shares double relationships. She may not be only the daughter-in-law, but a niece. Ballard (2004) while analyzing female agency highlights the role of a male and a female in Punjabi kinship structure:

But whilst the positions of formal subordination to which Punjabi women are conventionally allocated cannot be gainsaid, to assume on this basis that the terms and conditions of every aspect of their existence is wholly determined by male hegemony, whose demands they are wholly incapable of resisting, is most misleading. On the contrary close ethnographic inspection of the quotidian processes of everyday life soon reveals that Punjabi women – just like members of all other excluded and subordinated groups – have

in fact developed an immense capacity for agency, even if they frequently have no alternative but to deploy what Scott (1985) has graphically described as 'the weapons of the weak' to achieve their goals. Ballard (2004:3)

He observed that Punjabi women though do not indulge in physical violence with their men, but they defend themselves by using the symbolic vigor Punjabi language thus defaming the male in the eyes of others. The double bond of kin relationships also secures a woman if she is mistreated by her husband. Her parents-in-law are not just the member of family-in-law; in fact, they share pre-marriage kin relationships. For Ballard, the existence of pre-marriage relationships is very crucial to determine a female's positioning in the Punjabi kinship system.

In shifting the boundaries of traditional gender roles, factors like social change in urban area in terms of woman's employment, co-education and exposure to western culture through media and internet have played significant role. Woman's participation in labor force gives her opportunity to challenge her husband's authority if he decides solely. A study conducted by Khan and Qureshi (2002) suggests that compared with housewives, a significantly larger proportion of working women reported having greater autonomy as measured either by involvement in or independent domestic decision making as well as in freedom of movement. Employment of women thus seems to be an enabling process that helps to break down the patriarchal system and promote egalitarian relationships within households. In traditional society, ideologies apportion men with greater social status and power than women. In contrast, modern ideologies allow a more egalitarian distribution of social status and power (Talbani & Hasanali 2000).

Woman's participation in education and employment sector is encouraging them to construct their own realities and to view their intimate relationship through these constructions. And the construction of reality of the women living with modern visions in Punjab can be manifest in their attitudes towards the adoption of nuclear family system in contrast to rural women. Though patriarchy in rural areas is more functional than urban, but its base is getting weaker because of social change which

is emerging not only in urban but rural areas as well; and most importantly, through females and young children's participation in the process of decision making.

The discussion above based on mostly qualitative studies encircles the traditional apparatus of Punjabi kinship and the socio-cultural transition it is undergoing through. We observed that attitudes towards joint and extended family systems have changed and individuals prefer to live in nuclear families. Rural to urban migration, education, female's employment are the most influencing factors that not only minimize gender based discrimination and but also enhance her power to challenge the traditional decision making authorities when it comes the question of spouse selection. Do education and residential patterns have any link to her entry into marriage market? The following part focus on the historical as well as contemporary nuptiality patterns to understand the marriage market in Pakistan, particularly in Punjab. First we see how the institution of marriage is regarded and what are the national and provincial trends to entry into marriage market by age and sex? The ratios of ever-married and divorce rates depicts the universality of marriage. The intervening factors, education and residency, depicts that marriage is being postponed and the gender-age gap between the couple is continuously reducing.

2.3. Nuptiality Pattern and Trend in Pakistan

Marriage is one of the most important institutions not only for the individual but also for the society. For individual, it is the transitionary time to adulthood, to be relatively independent, both socially and economically, to start family formation. For the society, it is the source of reuniting several families into reproduction, production and consumption units (Ikamari 2005). From cultural and religious perspectives, historically and cross-culturally changing phenomenon of how one marries and *who marries whom is of perennial interest* (Hollingshead 1950). In addition to who marries whom, the pattern and way how one marries is a question of great interest at individual and societal level. Thus, the proportion of married population is worth investigation not only because of the close temporal links between marriage and the fertility (especially in the religious societies where marriage is the only legitimate

way towards childbearing), but also because the age when men and women marry has consequences for the formation of family and for gender relations within society.

Pakistani society is in transition and at this point traditional and modern values for spouse selection coexist. Still marriage by entailing religious and cultural obligations is the only legal way to procreate family. Afzal also highlights the issue in following way:

The patterns of age at marriage are of special significance in a Muslim country like Pakistan where marriage is the only socially acceptable means of gratifying the mating instinct. Afzal (1974:27)

Marriage pattern is heterosexual and intra-sex marriages are not legitimate. There are no data available for cohabitation and out-of-wedlock births as to form non-marital sexual relation is considered adultery in Pakistan. To save and to maintain the sanctity of marriage contracts, divorce is also discouraged. The proportions of divorced persons out of ever-married population were less than 1% for female aged 45-49 in 2007¹⁰ and 0.4 % for the male population of same age group in 2003¹¹. These proportions have slightly increased from 1981 (0.5 % for female, 0.3% for male)¹². However, no profound changes are observed in the proportions of divorced, revealing the sanctity of the norm that how important it is to remain married.

The discussion until now clarifies the scenario that marriage in Pakistan is still universal and there is no sign of canceling it and replacing it with any other mating strategy. However, to see the nuptiality transition in Pakistan, we find that the postponement of marriage has been happening since 1951 (Sathar & Kianai 1998) as the proportions of never-married continue to increase in the earlier ages.

¹⁰ PDHS, 2007

¹¹ UN Demographic Survey 2003 in Pakistan

¹² National Census of Pakistan, 1981

Figure: 1. Proportions (%) of never-married population by sex and age

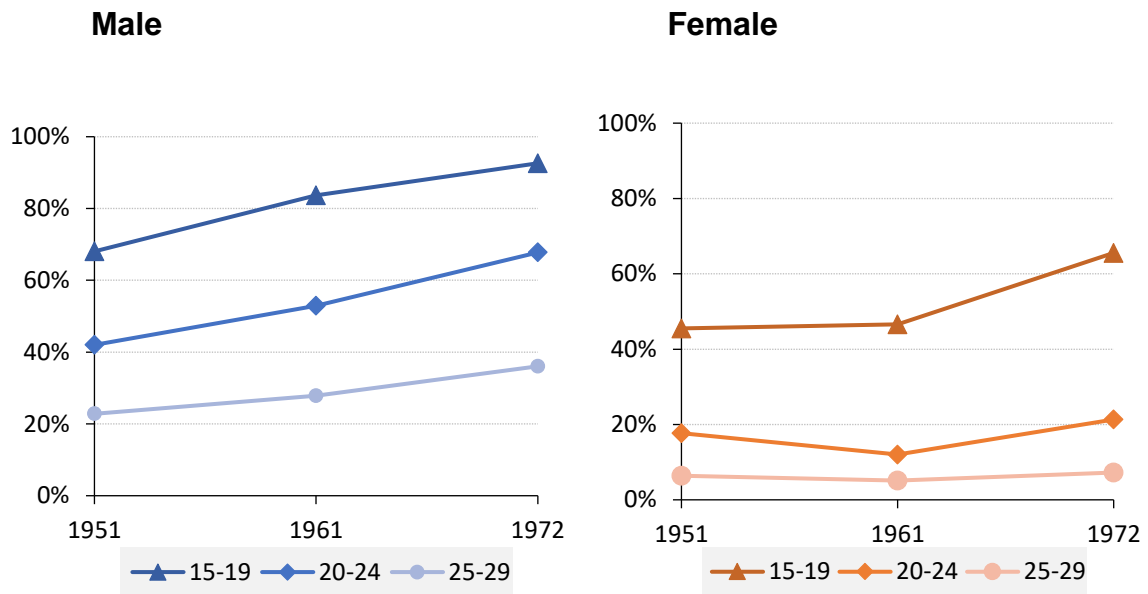

Source: Census 1951-1972 as quoted by Sathar & Kianai (1998)

Figure 1 confirm this increasing trend for the proportions of never-married by ages 15-19, 20-24 and 25-29 for both sexes. In two decades, the trend is continuously increasing for male across all age groups. For female, remarkable change can be observed by year 1972.

Similar to Never-married proportions, SMAM is another significant nuptiality indicator to confirm the trend if the entry into marriage market is being postponed or not in Pakistan. Sathar & Kianai (1998) noted that in the 1990s, according to Pakistan Demographic and Health Survey - PDHS (1990-91) females are experiencing greater change in average age at marriage than males.

From a historical perspective, Xenos & Gultiano (1992) conclude that SMAM across both sexes has been continuously increasing since 1920s, particularly for female.

Figure 2. Trends in SMAM by Sex over 5 Decades in Pakistan

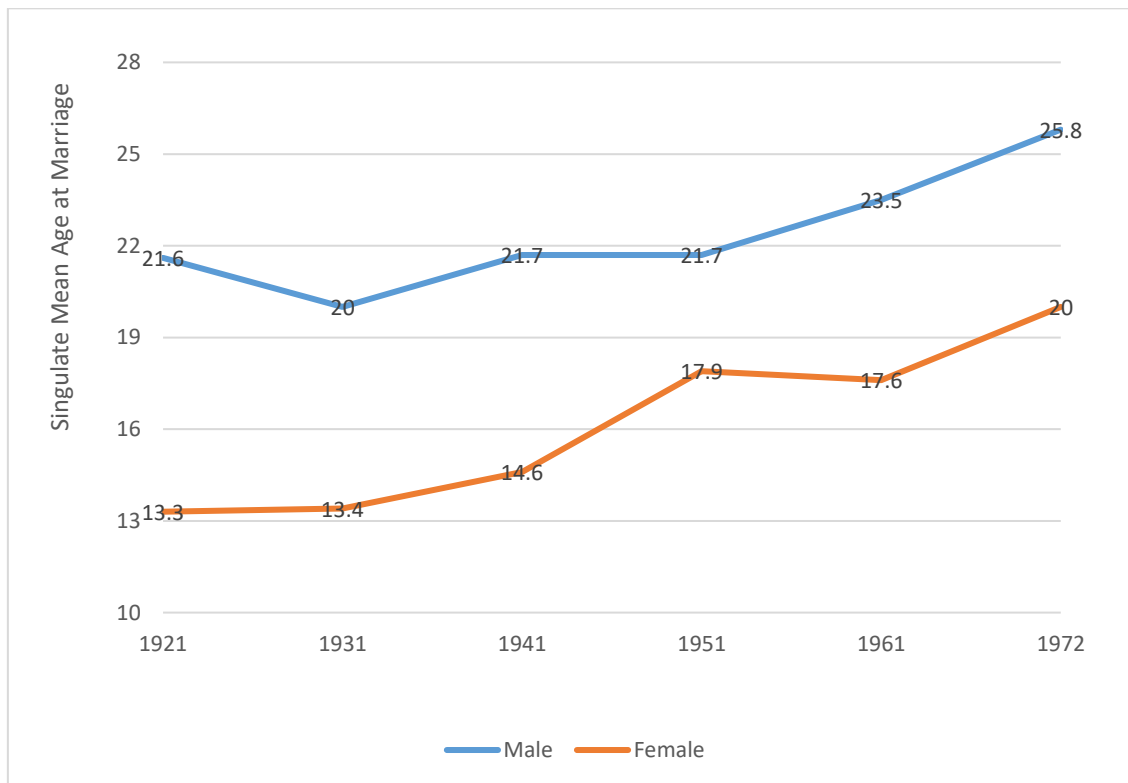

Source: Census 1921-1972 as quoted by Xenos & Gultiano (1992)

According to Figure 2, a steep rise of 3.3 years SMAM for female in 1951 could be the result of partial aftereffects of the massive migration due to the partition of Indian subcontinent into Pakistan and India. During the previous decade (1931-1941), SMAM for both sexes in India and Pakistan was identical. However, 4 years after the partition (in 1951), SMAM for female was enumerated 15.5 in India and 17.9 in Pakistan, and it continued to increase in Pakistan as compared to India for the coming decades as well. During 1950, Bangladesh (former East Pakistan) was having even lowest female SMAM (14.4) while Sri Lanka was having the highest female SMAM (20.9). Research by Xenos & Gultiano (1992) points out that from 1920s to 1970s, increase in male SMAM was significant within the South Asian regions (Pakistan: 21.7 to 25.8; India: 20.2 to 22.4; Sri Lanka: 24.4 to 27.7).

Marriages in early ages, particularly for female, and universality of marriage across both sexes from history until now have been two predominant nuptiality patterns in Pakistan. Though the proportions of early marriage have decreased in the recent past and Pakistan has been experiencing nuptiality transition more specifically since 1960s (Sathar and Kiani 1986), the universality of marriage is still true according to recent data. To observe variations, a baseline portrait of how nuptiality pattern looks like at national and provincial level in Pakistan is needed. Preceding general findings of population under study are intended to serve this purpose.

Figure 3. Proportion of Ever-married by sex, age & year

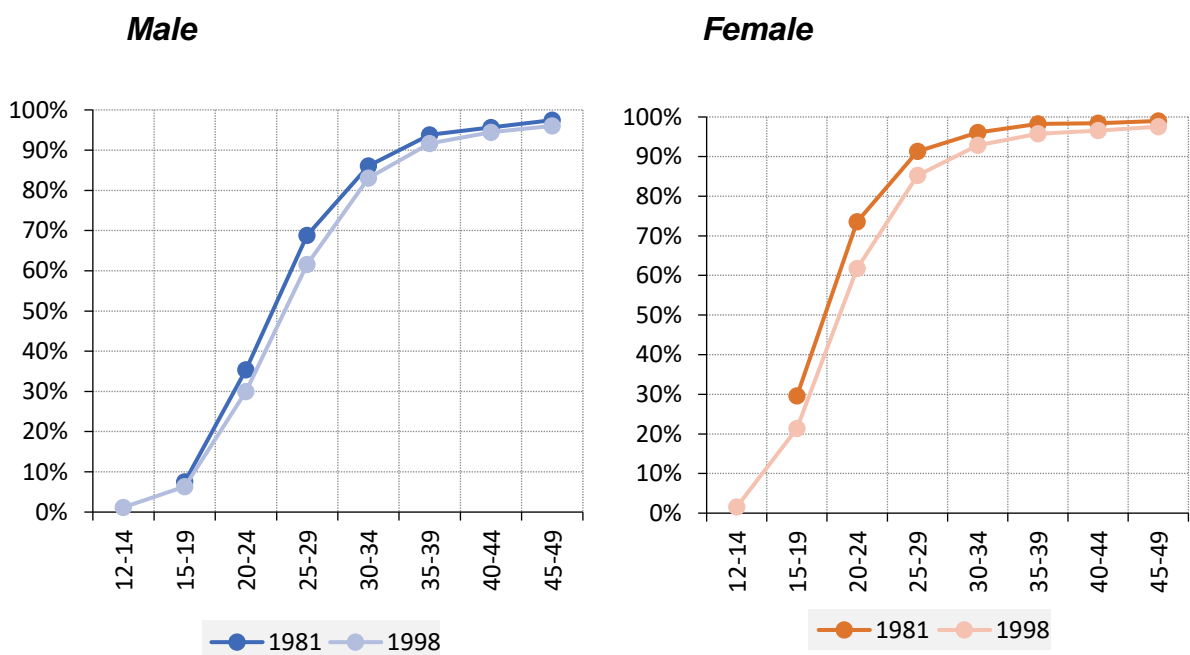

Source: IPUMS-International data

By taking into account the gap and lag between the two sexes, which is low but not insignificant, figure 3 reflects the general picture of ever-married proportions by sex, indicating that the norm of being married for both sexes has always been universal across time in Pakistan. More than 95% of population was married at least once by the age of 49 in both census years. Small yet significant differences between the ever-married male across time indicate the delay of marriage. For ever-married female the difference is quite high as compared to men. 9-10 percentage decrease

in proportions of early marriages by age 15-19 & 20-24 is remarkable as compared to male. However, trend for male in ever-married proportion by age 25-29 is significantly decreased (10%). It is important to note that in the census of 1981, the minimum available age group of married population was 15-19 years, whereas in 1998, it was 12-14 years. In 1981, the proportions of female married population in age groups 15-19, 20-24 and 25-29 were 29.3%, 72.5% and 89.6% respectively, whereas, in 1998 these figures were reduced to 20.9%, 60.8% and 83.7% respectively. On the other hand, married male population in 1981 for the same age groups was 7.4%, 34.7% and 67.8% respectively, which later turned out to be 6.1%, 29.4% and 60.7% respectively in 1998, also confirming the global trend that 'men marry later' as compared to women. Figure 3 also indicates the fact that 60% of Pakistani female population is married by the age of 20-24, whereas same percentage of male population is married by age 25-29.

The glimpses of all available marital statuses by each year and each sex are presented in Figure 4. Interestingly, the proportion of divorced population is less than one percent of total married population in both census years, reflecting the sanctity of marriage tradition among Pakistanis. Figure 4 also highlights the fact that widowhood is more prevalent among females as compared to males. The proportions of never-married particularly in female are remarkably different from what was happening in 1981. Various researches that were conducted at that time in Pakistan and in the neighboring countries confirm the transition in female age at marriage (See, for example, Sathar & Kiani 1998; Caldwell 1993; Xenos & Gultiano 1992; Caldwell et al 1982; and, Smith & Karim 1980).

Figure 4. Distribution of Marital status by Age, Sex and Year

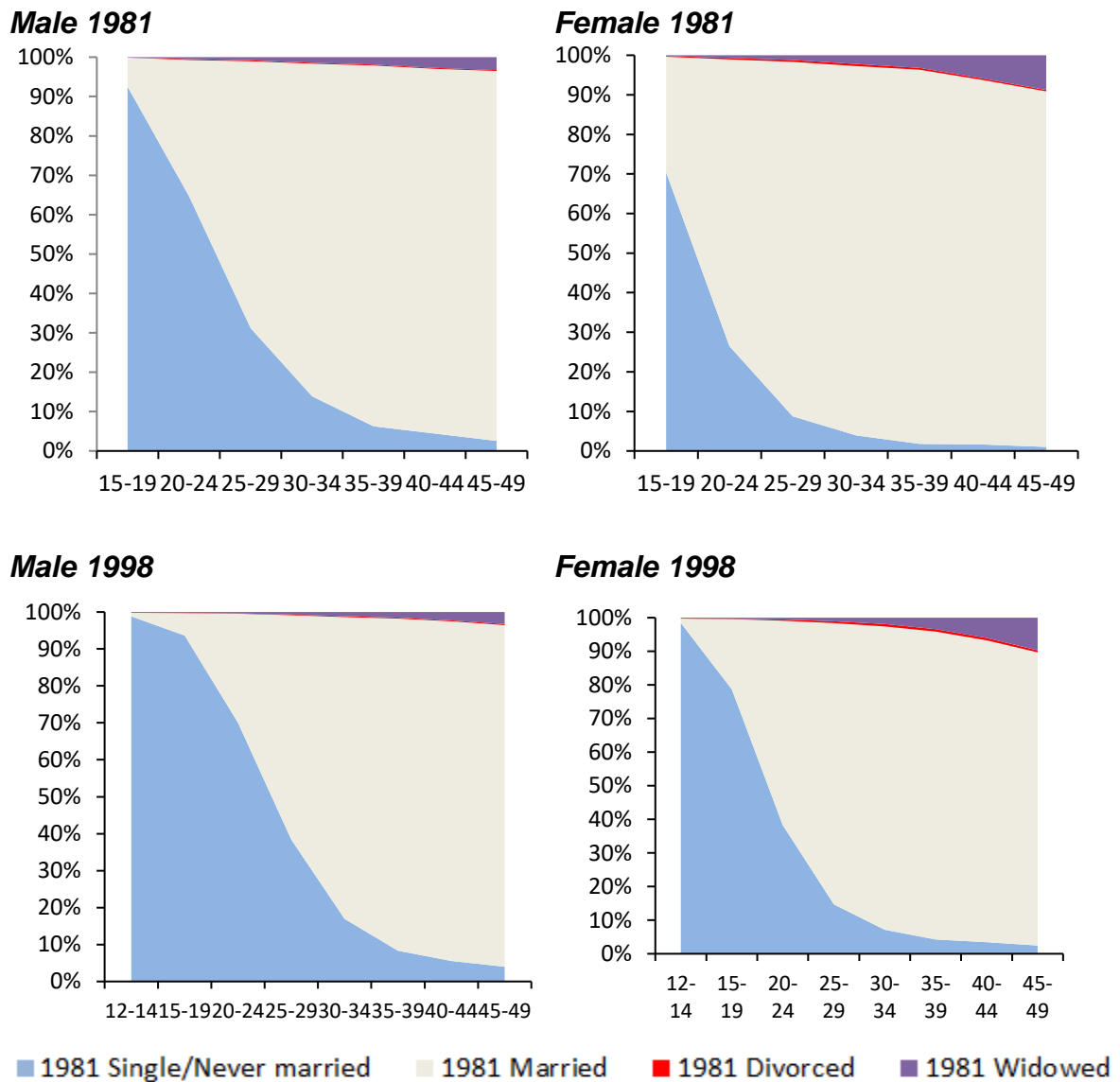

Source: IPUMS-International data.

Trends in increased proportions of ever-married in marital status at National level suggest delayed entry into marriage and increase in age at marriage, especially for females. However, to be precise about these trends, we have to delineate this change by calculating SMAM. Table 1 provides the SMAM by sex for both census years under study. Given that SMAM is an indirect measure, we can assume but very little about the change over time. A delay of almost one year can be observed

after 17 years of data enumeration, whereas reduction is particularly striking for females' SMAM (1.36 year delay).

Table 1. SMAM by sex over time

Year	Sex	SMAM
1981	Male	25.13
	Female	20.40
	Total	22.88
1998	Male	25.89
	Female	21.76
	Total	23.86

Source: IPUMS-International data.

Later, according to Pakistan Demographic Health Survey 2005-07, a rise in SMAM across sex was observed; significantly for male 29.9, and for female it was observed 23.2. SMAM for female in the next Pakistan DHS 2013-13 does not rise as observed 23.1.

2.3.1. Nuptiality Pattern in Punjab

As this study focuses on transnational Punjabi families for their marriage patterns, it is important to understand their nuptiality in general not only by contextualizing its trends in comparison to other provinces but also by highlighting regional variations within Punjab. Figure 5 portrays an interesting picture of ever married population by age in Punjab and other provinces of Pakistan in 1981 and 1998, respectively. Data in 1981 reflects notable similarity of the behavior of ever married population among provinces. In 1998, a variation can be observed across provinces for the ever married population, with Punjab and Baluchistan being at two opposite extremes for the population of age 15-30, and Sindh and NWFP behaving almost identically in the middle. While making any inferences, one should not forget that Baluchistan, being the largest province by geography, is dwelled by the smallest population of Pakistan (around 5%), thus having lowest population density, whereas Punjab inhabits the largest share of Pakistani population (more than 50%).

Figure 5. Proportion of ever married by age and province

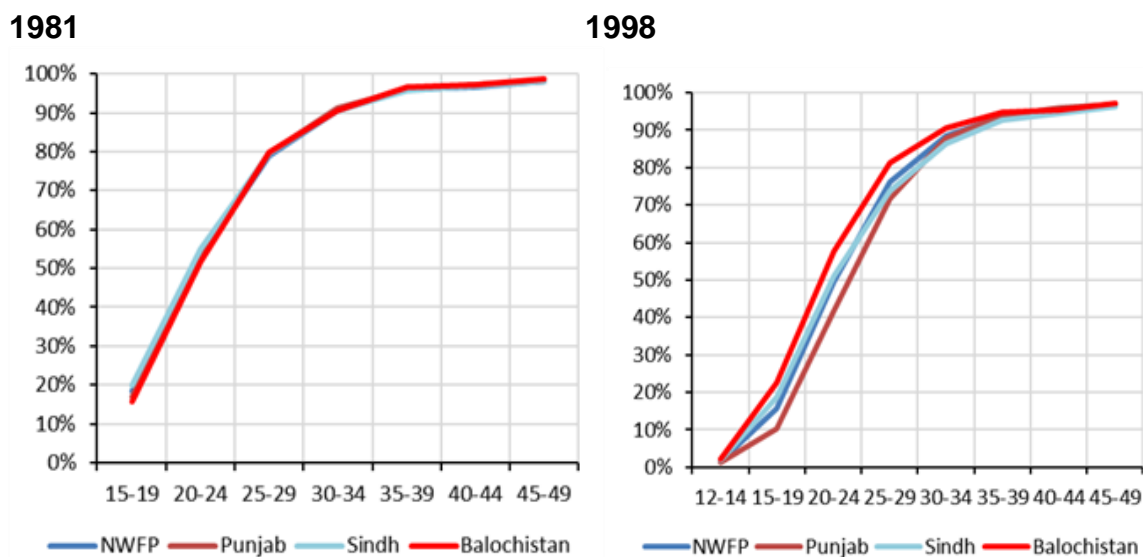

Source: IPUMS-International data.

Universality of marriage in Pakistan is clearly visible from the data. What, however, is needed to be established as a baseline for further analysis is to where these provinces stand at mean position and how precisely they vary from the national trend and then from one another. Table 2 projects the detailed picture of such variations of similarities across provinces by SMAM. SMAM differences among provinces were not as conspicuous in 1981 as they are in 1998, especially for female population. Astonishingly, Baluchistan reflects high decrease (almost one and half years) in the SMAM of male population, whereas Punjab has significant increase (more than one and half years) in the SMAM of its female population. As we can find identical behaviors of provinces in 1981 and little variations in 1998 with one another, it is important to explore nuptiality trends of Punjab at division¹³ level to discover how far or how close those micro units are from their central provincial trends and how nuptiality pattern vary within these macro units.

¹³ Division denotes the administrative division of Pakistan, larger as compared to district and smaller as compared to province. It is the second largest-scale geographic identifier available in the census samples of Pakistan at IPUMS-International.

Table 2. SMAM by Province and sex over time

Province	1981			1998		
	<i>Male</i>	<i>Female</i>	<i>Total</i>	<i>Male</i>	<i>Female</i>	<i>Total</i>
NWFP	25.4	20.2	22.9	25.7	20.9	23.3
Punjab	25.1	20.6	22.9	26.3	22.3	24.3
Sindh	25.0	20.0	22.7	25.3	21.2	23.3
Baluchistan	25.5	20.1	23.2	24.0	20.3	22.2
TOTAL	25.1	20.4	22.9	25.9	21.8	23.9

Source: IPUMS-International data.

The study of marriage prevalence, age at marriage, and SMAM at divisional level highlights some important nuptiality trends in Pakistan over time. Marriage patterns vary within and across provinces when divisions are taken into account; they have changed significantly across time and across divisions. The age at marriage of female population is increasing in nearly all regions of Pakistan. The difference between male and female age at marriage tends to decrease. Two main determinants for these trends are considered education and urbanization, which are explored at divisional levels in Punjab.

Concentrating to the factors which are being analyzed for the selective age-groups in the coming part; education and residential patterns, we observe that the divisions that are facing urbanization; ultimately attracting the larger population mobility to cities and growth of population even in the slum areas of cities have higher differences in the proportions of ever-married population. However, if the factor of education is juxtaposed with urbanization and residential pattern to analyze the correlation between all of them, research proved that the longest delay in age at marriage and postponement of marriage in earlier ages will occur in cities and town respectively (Hull 2002).

As explained previously, it is observed in Punjab that women generally enter into marriage earlier than men. In 1998, by age 15-19 almost 10 % and by age 45-49, more than 95% women are ever-married. Generally, at the provincial level (more than 60%) and partially at divisional level, age-group 20-24 was observed the most critical period for women's nuptiality behavior. Female SMAM observed at provincial level in Punjab (22) tends to vary greatly across its divisions. The increasing

proportions of never-married female indicate that generally marriage is being postponed, most particularly in age 20-24. On the other hand, the postponement of never-married male by age 15-19 is less significant at provincial level, however at divisional level this age group shows diverse behavior. Proportions of never-married male did increase but with less pace as compared to women. The increasing proportions of never-married male: by age 15-19 indicate that like women, generally marriage for male is also being postponed, most particularly in age 25-29. Average male SMAM in Punjab is observed to be 26 years in 1998, belonging to the age-group where most of the never-married male proportions fall. Research in Pakistan and in neighboring countries having similar socio-cultural background has proved that change in age at marriage is closely related to the educational attainment and residential pattern (Caldwell 2005; Ikamari 2005; Sheela & Audinarayana 2000; Sathar & Kiani 1998; Xenos & Gultiano 1992; Caldwell et al 1983; Smith & Karim 1980).

To understand the factors in further detail, nuptiality in each age group by sex is analyzed with four educational attainment levels and by rural, urban residence. Education may affect in various ways to the nuptiality pattern. Sathar and Kiani (1998) concluded that the prominent rise in singlehood proportions especially in female in Pakistan are associated with larger amount of time in childhood and adulthood responsibilities. Caldwell (1993) highlights that years spent in education are determinant years for the transitional phase most importantly in female nuptiality behavior. For higher education graphs of male and female, Caldwell et al. (1983) relates the level of educational attainment to the entry into marriage as well. Those who have higher educational level tend to go for employment, thus increasing the age at marriage. Figure 6 portrays two graphs; one with no formal education, and the other with graduation (14 years) and above education against the proportions of ever-married females respectively over time across divisions. These graphs confirm the scenario that education delays the marriage, whereas illiteracy reflects individuals' increased chances of getting married earlier than those who are enrolled in educational institutions. As we observe in the graph of educated females, different divisions in Punjab are behaving almost unanimously with insignificant variations. In

1998, only 18-23 percent of highly educated female population of age 20-24 in Punjab was ever married.

Figure 6. Proportion of ever married female population of age 20-24 by educational attainment and divisions.

No formal education

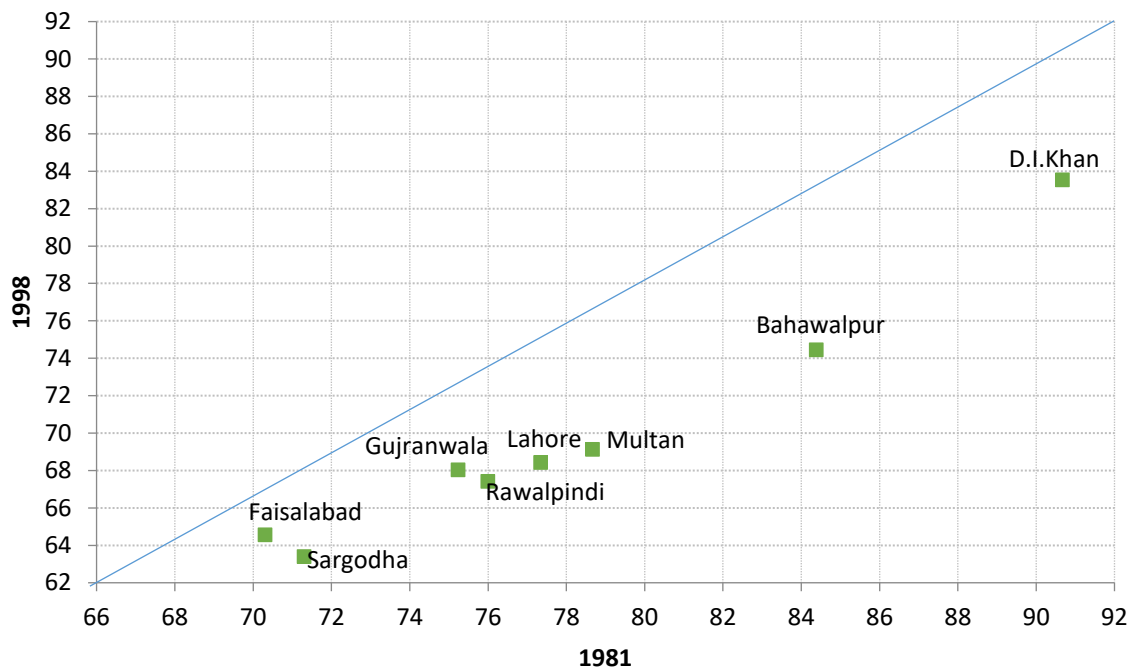

Graduation and above

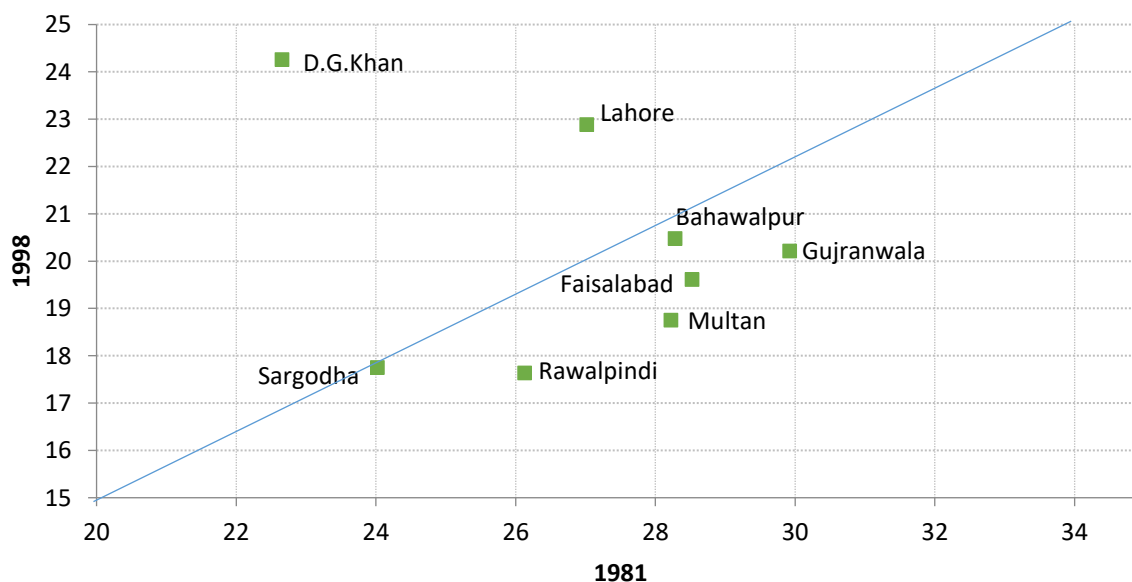

Source: IPUMS-International data.

One of the possible explanations for a strong association between delay in marriage and higher level of education could be that educational attainment not only provides 'more years of freedom' (Sathar and Kiani 1998) but also provides the chance to use it as resource to arrange for marriage expenses. The extravagant spending on matrimonial ceremonies is strongly prevailed in Pakistan for both spouses. It is a symbol of shame in the indigenous culture if family, particularly father or elder brother, fails to arrange expenses for their daughter/sister (Kotalova 1996). Thus educated men being head of the household are not only supposed to arrange the marriages of their male children but firstly try to arrange dowries and other expenses for the female. In the similar way, educated girls, when enter into labor market instead of marriage, try not only to maximize the resource pool of the household, but also save money for their dowries. Thus educated women in the employment sector have more control over resources, and try to attract ideal partners in the similar fashion as men do. But in doing so they enter very late into the marriage market as compared to those females who do not strive for education.

A related factor that causes change in nuptiality pattern is the residential pattern. However, comparative research by Dixon (1980) and Smith (1980) on rural-urban setting and marriage behavior show that it is the family system which is working inherently at the base of nuptiality behavior rather than the mere rural-urban territorial differences. The difference is much visible if the birth-origin: either rural or urban are included into the analysis. Individuals tend to behave according to the value system they keep at familial basis. In addition, the residential arrangements either joint family or nuclear family systems also affect nuptiality pattern, individuals living in village and in nuclear family system may marry later as compared to the family living jointly in the city. Apart from familial level interpretation, the transformation of agrarian village into industrial cities, the pace of urbanization, exposure to the modern value also shape nuptiality behavior of urban and rural population. By taking into account the only two residential patterns, urban and rural, Smith (1980) asserts that in Asian countries urban women marry later than women in rural areas. In Pakistan, the urbanization process has been at higher degree (Zaman & Ara 2000). In Figure 7, comparisons between the ever-married women

by residential area demonstrate that urban women are less likely to marry as compared to their counterparts in the rural areas at the same age.

Figure 7. Proportion of ever married female population of age 20-24 by type of residence and divisions.

Urban areas

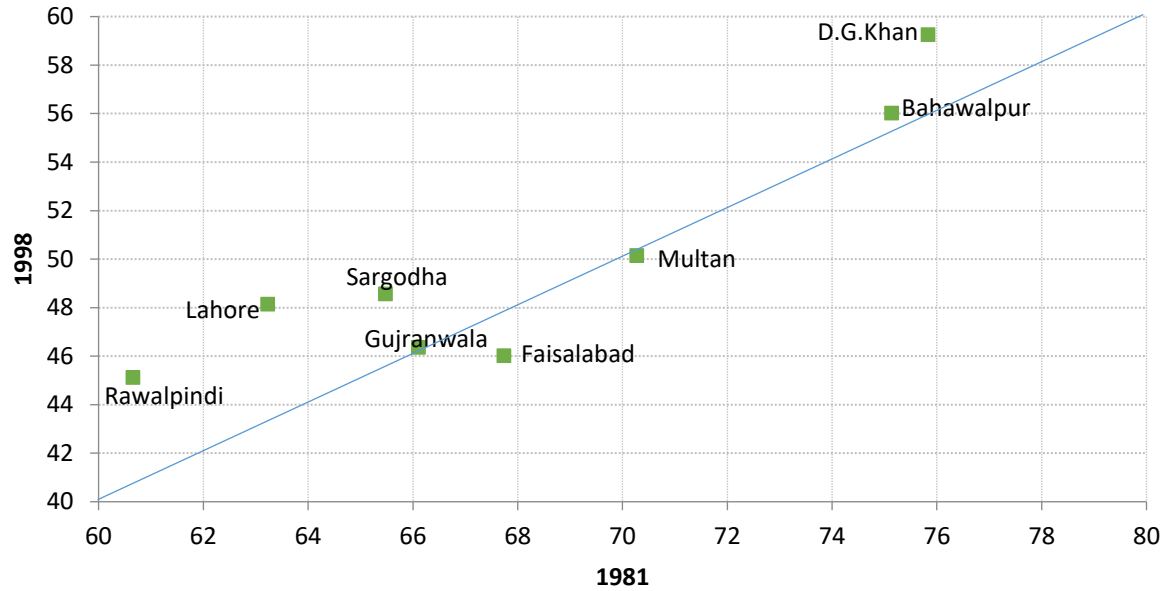

Rural areas

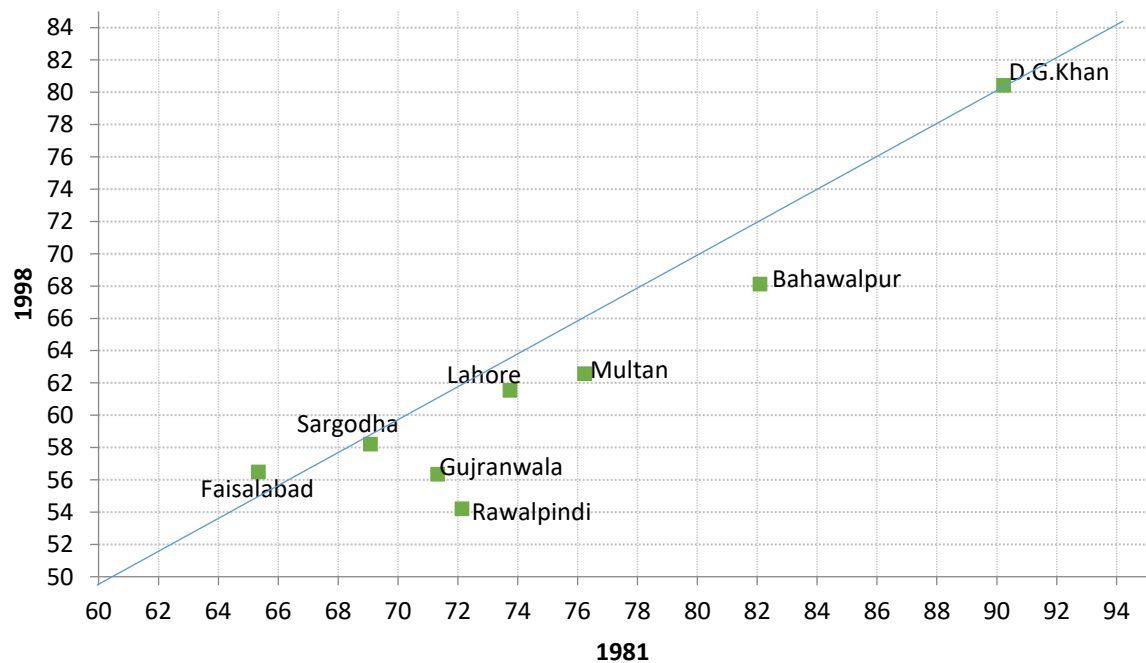

Source: IPUMS-International data.

These figures demonstrate how nuptiality patterns are developed in Pakistan in general and in Punjab in particular over time with reference to different influencing factors, including geographic locality of the actors and their levels of education. These general attributes of Punjabi community can be understood and explained through different perspectives on how and why certain spouses are selected and/or filtered, and what factors play key role in deciding about an adequate spouse out of the pool of multiple potential spouses.

2.4. Understanding adequate spouse: Perspectives on spouse selection

This part sheds light on some of the relevant concepts from theoretical assumptions to understand the criteria of spouse selection; a critical part of the mechanism of transnational marriage. This part is divided into two parts. Part one deals with the guiding principles of spouse selection criteria, or in other words, the rules of the game. This part mainly focuses on Sahlins' typology of reciprocity explaining why the nature of reciprocity determines the maintaining and/or ceasing any relationship between groups and networks. Afterwards, Strauss' theory on reciprocity and marriage alliance explains how reciprocity, governed by the kinship, makes the group functional and seeks new alliance and maintains existing networks through marriage. Part two of this part deals with the interplay between the structure and agency, highlighting the actor's practices and strategies, which he/she adopts for spouse selection, mainly by following Bourdieu's theory of power and practice.

2.4.1 Social Exchange

Social exchange encompasses the whole range of interactions that produce obligations on the part of the actors who are interdependent to one another to satisfy their needs. Social exchange theory has been developed on the work of Bronislaw Malinowski, Marcel Mauss, Marshall Sahlins, and Claude Lévi-Strauss. Reciprocity, being the focus of their scholarly work, determines the social exchange, nature of relationships and marriage alliance.

The gift and reciprocity were first discovered by Bronislaw Malinowski in 1922 in tribal societies of the Western Pacific (Malinowski 1922). In 1923, Marcel Mauss published *The Gift* (Mauss 1950). Malinowski (1959) identified the reciprocity among the savage societies and how they followed the customary practices to maintain reciprocity. This social activity was in-between the volunteer acts of the savage people and obligation of the reciprocity among those people. It shows that all human societies, except the Western, have an economy governed by the reciprocity of gifts (the popular obligations of giving, receiving and return). But the supremacy of Western society strongly suggests that the exchange is the most advanced form of human benefits. The most convenient solution for connecting exchange and reciprocity is to interpret reciprocity as an archaic exchange.

Similarly, Mauss (1950) found women as a commodity to reciprocate in African society. This was perceived as “gift” but in reality it was reciprocity between the two families to maintain soft and cordial relations. It was a kind of diplomacy to strengthen two tribes and develop relations that may be used in need. The idea that the gift is *the gift of self* that leads to the other idea that is addictive for others, because in reality, the donor, would be inalienable. One who would receive the symbolic value in exchange of material commodity, and the receiver would be obliged to return it to the donor or to remain obliged. Thus, reciprocity was the basic cement that promoted social exchange among actors as well as exchange of communities among African societies.

Reflection of reciprocity is not limited among the savage or African societies; it was almost a universal practice. The reciprocity has always been embedded in every society and community in the past as well as in the present. It was more visible among the transitional societies who are peculiar to follow certain traits of the reciprocity (as part of the manifested action) and developed society follow the patterns of reciprocity as a part of their latent function.

Economic reciprocity and social exchange is fundamental part of human interaction. Rather, it provides a space to interact and exchange their social relations. Sahlins (1972) found three types of economic reciprocity. He identified generalized,

balanced and negative reciprocity. For him, the generalized exchange has unspecified time frame and the actor never has immediate expectation of the reciprocity. They invest for uncertain period of time. For instance, if parents invest on their children, they may expect their children's support when they are in need. Mostly, this kind of reciprocity is altruistic and brings sense of belongings among the actors. In anyway, the investor has expectation that he/ she gets in return in the generalized reciprocity within the structure of mutual obligations.

For Sahlins (1972), balanced reciprocity is direct reciprocity in which an actor has to reciprocate immediately. This balanced reciprocity expects that other actor reciprocates equally. Commonly, the actor expects that the value of the reciprocity (gift) is higher or equal. If one does not reciprocate equally, he/ she terminates his/ her relation with the receiver. One aspect is really important in the balanced reciprocity and that is mutual "trust". It is not an obligation by law to reciprocate but only mutual trust among the two actors. Thus, balanced reciprocity, for Sahlins (1972), exists among two equal status people and they interact on the basis of equality.

Negative reciprocity is a kind of reciprocity in which an actor expects higher response from the second party. This is a kind of barter system among two unknown persons and/ or among non-kin. Negative reciprocity is based on a kind of self-interest and matter of defense. It has low or minimum trust and time among parties. For instance, if a person hit to another person, he/ she is expected that the second actor reciprocates with equal or more vigor. It is impersonal reciprocity and demands an immediate reaction from the second party. Examples of negative reciprocity are gambling, theft and robbery. Sahlins does not equate the negative reciprocity with deviancy. It is only in terms of economic exchange.

For example, if one person/ party gives a gift or share anything or support to the other party, the second party does not give equal or more response to the first person, the person feels 'exploited'. He terminates the relation or demands more response from the second person/ party. What is missing in Sahlins' negative reciprocity is the social, economic and moral conditions of any society. He did not

take into account the given social and structural conditions of the society. More specifically, he was unable to conceptualize that the reciprocity has also certain kind of adequacy and it can take place on the basis of certain moral obligations as well.

Reciprocity is integral part of human relations and it is the basic element of social exchange. It provides a strong social bond among actors. It becomes more important if an actor has intimate relation. It is supposed to create strong social bonding and bridging (Putnam 2000) among spouses. It links the actors into a network of mutual interests and they feel that they have support from their spouse, relatives and kinship network.

On the other hand, Levi-Strauss (1969) denies that the reciprocity of gifts is motivated by an emotional connection. Levi-Strauss criticizes Mauss for mystifying the native magicians who were used to justify their events that seem inexplicable whenever they were needed to substitute the reasoning. But he admits that the gift brings a new value to the relationships. In primitive societies, it would help to create the alliance. When a gift is relayed by the donor, we can say, to initiate the reciprocity of gifts, there is much more that is exchanged, in addition to the commodities alone.

The prominent work of Lévi-Strauss (1969) focuses on three issues related to exchange in his work on “elementary forms of kinship”: reciprocity, alliances and structural elements of social exchange. He reveals that societies were based on the basic glue of reciprocity. This is either direct, indirect, generalized or restricted exchange. People always reciprocate things, social relations and/or obligations. For Lévi-Strauss, this reciprocity prevails in the forms of cousin marriages which he identified in different parts of the world. These were any form of patrilineal, matrilineal, parallel and cross cousin marriages. The inner working of reciprocity was to strengthen the existing kin relationships as well as to seek new alliances. Marriages based on reciprocity were in the form of exogamy and/or hypergamy. Reciprocity was integral part of the consanguinity and in strengthening the mutual relations between the two parties. For Levi-Strauss, kinship was not just to provide

guidelines to a group's functioning like the reciprocity discussed above, but it meant marriage. Kinship determines the rules whom to marry or not.

Social exchange, in the form of reciprocity, also exists among cousins and it forms alliances among them. He was of the view that consanguinity is to strengthen kinship network. They become ally and stakeholders to each other. Once they select their spouses from their cousins, the actors have economic, social and cultural support. They feel united and they work for the benefit of their own kinship network. This kinship network provides the safety, stability, mutual dependency and interweaves them into a web of relationships, where every kin has certain obligations and benefits. They bring a sense of social safety and they feel that they are part of one's own kinship. This also brings sense of social superiority and people feel proud that they were descent and kin of a certain race and tribe. Whenever any kin have social, economic needs, the kinship network is invoked to help him/ her during crisis. Among traditional and primitive societies, the kinship is also responsible to get, secure and utilize the resources together. It is also responsible to protect from any possible threat to any actor from outside. This also promotes stability within one's tribe in order to maintain order, stability and welfare of the kinship members.

Kinship is also woven into social structure. It has rules and regulations which the kinship members follow. According to Lévi-Strauss (1969), the kinship structure is just like linguistic principals. Every language has grammatical rules and they vary from one language to another. However, they are basic elements of any language and without them there is hardly any communication possible. They provide sense and meanings of the words and sentences. Just like linguistic rules, kinship also has rules and they vary from one kinship system to the other system. Kinship provides bonding force to keep every member into an interwoven web of relationships. Kinship network actors perform their role within these kinship rules. The kinship rules stress mutual cooperation, teamwork, and assign tasks as per the strength of their members. These members have strong sense of reciprocity. If any one of them leaves the kinship, he/ she will have to face serious consequences, and they

become vulnerable to live without any support. Nonetheless, kinship is not only the source of reciprocity and social exchange, but it is also consumer of the reciprocity and social exchange. One can find patches of reciprocity in kinship exchange but it is not only limited to economic exchange, but economic activity is an integral part of the reciprocity.

The notion of reciprocity, by the classical exchange theorists, has been used to disparate descriptive or theoretical purposes, too often lacking rigor (Molm 2003). A major difference is however very clear at the outset. One stream of thought, primarily related to the sociological tradition, defines reciprocity as exchange of commodities with socially estimated values (almost) equivalent in a given qualitative or quantitative measurement system (as proposed by the proponents of rational exchange, like G. C. Homans and Peter Blau). The other stream, especially related to anthropology, defines reciprocity as a requirement to make a provision against another, the question of the value of benefits are not taken directly into consideration here. And reciprocity is often viewed as directly proportional to rationalized exchange to satisfy inflicted obligations of relationships.

The phenomenon of spouse selection with reference to transnational marriage can be analyzed with the lens of the reciprocity and social exchange. For instance, individuals who are interested for transnational marriages, they have developed some sort of preferences for ideal spouses. In searching the ideal spouses, the actors minimize the cost and maximize the rewards. If an ideal spouse is found within the kin, and if kin-relationships have already been promoted and secured by the reciprocity and close intimacy, the reward is worth for the individual and his/her family, as they are part of the very kin group they invested in. On the contrary, if the ideal spouse is within the kin but reciprocal ties are not maintained and/or the exchange is not balanced, the likelihood to reject such marriage proposal is higher. However, it is not to be assumed that transnational marriages are solely kin-oriented and/or kin-based reciprocity-oriented. The similar logic works in maintaining relationships with the social network. Apart from reciprocity, other spousal attributes are important too to be exchanged. If we assume physical attraction as per

evolutionary theory of mating is the pre-requisite, individuals may get married. Another way of thought as per economic explanation is that individuals always calculate what is in their best interest. According to the theory of economic mobility (Gottschalk & Spolaore 2002), if a person from origin /or developing country is getting married with a person belonging to developed world, he/ she would be looking for upward social mobility. Equally they have access to better economic opportunity and upward economic mobility. On the other hand, person having the citizenship rights of his/her host country might be looking for ethnic, linguistic, cultural and kinship based networking. Spouse selection choices are evaluated within the given social conditions. When immigrants go back to their origin country for marriage purposes, within their family as well as close networks, they have more say in socio-economic decisions. At one hand, they have more respect and chances to get best possible spouses from the marriage market and on the other they are able to maintaining their cultural roots. Individuals may marry to route in first, and may marry to roots in later case, in an exchange of their particular capitals. Both of the spouses evaluate the immigration policies of the developed world and what opportunities and possibilities they are traveling for and to settling there. If the immigration policies are open and friendly, the couple would proceed for marriage, otherwise restricted policies and long-awaited procedures to get spouse visa may invoke the potential spouse to calculate on the basis of rational choice. Either they have to find a way to tackle policy by devising some strategies and to proceed for marriage, or they prefer to step back in order to avoid the risks involved in.

2.4.2. Interplay of Structure and Agency

This part focuses on the interplay of structure and agency in delineating the process of transnational marriage. It reflects how agency (Pakistani immigrants) is constrained by several structural confinements (like bi-local culture, geographic boundaries, and state policies) that direct and/or redirect its strategies to marry. On the other hand, agency of migrants is not merely reflected as static cultural ciphers and coerced individuals who abide by the rules determined by the structure and have no ability to reflect back. Rather, migrants' potentiality to actively engage in the

process of transgressing those structural boundaries plays a significant role to push the structural actors to reconfigure structural perimeters. It is this contention that help transform the confines of national boundaries into transnational social spaces where agency plays its active part in producing and reproducing new and dynamic structures.

The potential spouses are socialized in different societies (fields) and they are equipped with different forms of characteristics and resources (capital). Their capitals are evaluated for exchange, where status-capital exchange holds central place in filtering an adequate spouse. A triangle of reciprocity, emotions and capital exchange makes the phenomenon of transnational marriage as a distinguished feature (habitus) of Pakistani diaspora.

Understanding the issue of transnational marriage through the conceptualization provided by Bourdieu would direct us towards the analysis of matrimonial strategies of French Pakistanis as unifying the marriage market across borders. This detailed analysis, both from structure and agency context, would help us explain the interplay of kinship networks (structure) and potential spouses (agency) in finalizing the decision to marry outside their country of residence. Although very localized in time and space, the process described by Bourdieu and concepts that emerge from his analysis offer particularly fertile ground for the study of the marriage market of French Pakistanis.

On the one hand, the study of matrimonial strategies of Pakistanis, which differ for Pakistanis living and France and in Pakistan, in Bourdieu's analysis would be placed at a central position while explaining the process of transnational marriage (Bourdieu 1972a). According to his framework, the transnational marriage can both be considered a manifestation and a cause of the transformation of the marriage market. This dynamic can generally be observed in Pakistani diaspora, especially in United Kingdom. On the other hand, changes in the family structure due to the existence of hybrid culture can also be understood through the framework provided by Bourdieu. Indeed, he is worth discussion for his eloquent and convincingly congruous concepts of habitus, field and capital (Bourdieu 1972b). It highlights how

the parents of spouses play a crucial role not only in socializing their children's habitus in such a way to preserve the cultural capital of their origin country but also in deciding their field of marriage to select an adequate spouse.

Finally, the notion of uniting the cross-border cultural traits associated with the marriage market allows a meaningful analysis of the growth of marriage migration, especially of low-income countries. The contestation of structure-agency discussed here, is much wider than that observed by Bourdieu, as part of the globalization process. Thus, the concepts proposed by Bourdieu are useful but also limited in their explanatory rigor, given the different contexts and temporality.

For example, a person from the Pakistani origin is socialized to respect, take care of their elders and act according to the advice and wishes of their parents from birth till his/ her mature age. He/ she is expected to get married among cousins. Preference is given to the cousin of both parents' lineage, where both parents have close kinship link. This is to maintain and accumulate social capital in the form of kinship. After getting married, these young spouses are expected to live together in joint family and contribute in the form of earnings (economic capital). They are supposed to help, assist and give respect to other relatives. If all cousins and relatives are united and they assist to each other and take place in the activity of mutual welfare, wellbeing, it is perceived as of high social values (symbolic capital). This collectivity provide alliance, social structure to act for mutual interests; and interact and give a chance to promote reciprocity and mutual exchange among kinship network (Lévi-Strauss 1969). Opponent party, if any exists, or rivals may avoid the conflict with above mentioned family. It produces and reproduces the social and economic linkages among the kinship network.

However, a person with the Pakistani origin living in France/ abroad may have mixed socialization. They would not only be trained in the Pakistani cultural and social context, but also they would be socialized and trained in the host society's (France) norms, values and culture. They are trained to be an individual, an active actor and get rid from the host society traditions. They would be trained to live in nuclear family and enjoy the life within the Western parameters. They are expected to be the loyal

of the Western nation state and state structure rather than being loyal to the kinship or family. Nevertheless, the French host society (field) may give chance to act and interact the actors with the host and native social values and norms of the both of the society. They generate a kind of new challenges and opportunities for the actors and the actors are supposed to deal with them in their own interests.

Consequently, these actors have dual socialization and an actor has serious challenges. If they maintain their native social values, it will be challenge to the host country's social values. However, if they follow the host social values and they look after the family and kinship social and economic needs, they lost their social, cultural and economic capitals. They have to live in confusion, vagueness and in illusions. Many of them try to produce and reproduce the Pakistani values as they are trained within the Pakistani values and norms at home.

Contrarily, some of them may deviate and they mix up the social values of the both countries. They adopt the social values of the host country and mix up with the Pakistani values and norms system for their own vested interests and to avoid the criticism from both sides. For instance, they may get married with a cousin, have family in the Pakistani cultural context. Meanwhile, some of them may have an additional girlfriend/ boyfriend from France and they would be following the social order of the French society. When they are at home with their family, they may follow Pakistani lifestyle. However, when they are with the French girlfriend, they avoid to follow Pakistani value system.

Concluding Remarks

Marriage and nuptiality patterns in Punjab, Pakistan revolve around a wide variety of kinship structures to ensure the universality of marriage as the legitimate and virtually the only source of meeting the sexual and fertility needs of individuals. Kinship structures range from the smallest unit of relatedness, such as family, and extends to the broader circles, such as *Biraderi*. These circles not only play their role in the identity construction of an individual being the member of kinship, but are also considered to be key actors in defining and choosing appropriate marriage

proposal in Punjab. Forming affinal relationship can only be contextualized by understanding the extent to which a network of relatedness plays its role in different stages of spouse selection. An individual views himself/herself as part of these networks for his/her self-categorization, and thereby his/her notions of choice and consent are congenially resonated to that of the larger structure. This however does not necessarily mean that individual, being the agency, is construed by the choice limit inflicted by these structures. It's an interplay of structure, socialization and autonomy that contributes to the decision making process in a typical Punjabi marriage.

Nuptiality pattern in Punjab reflects that marriage at earlier ages particularly for female and universality of marriage for both sexes are the predominant historical features. However, in the near past, nuptiality indicators, such as early age marriages are experiencing a transitional phase since 1960s and continue to decline, yet the universality of marriage is still prevalent as more than 95 percent of the population is ever-married by age 45-49. Less than one percent divorced persons out of ever-married population in Punjab indicates persistent sanctity of marriage tradition. Pakistan being predominantly religious in marital sphere shows no sign of replacing or abating marriage with any other mating strategy; cohabitation or non-martial unions. There is evidence that marriage patterns in the province of Punjab vary within and across regions; and have changed significantly over time. The Singulate Mean Age at Marriage tends to increase in most of the divisions of Punjab, especially for females. The difference in Gender Age-gap is decreasing continuously due the fact that more women are delaying their marriages; the proportions of singlehood have increased for both sexes while in some divisions exceptionally male continues to marry earlier, thus lessening the gender age-gap as a whole. A delay in marriage age is echoed by decreasing proportions of ever married populations between 1981 and 1998, especially for females of age group 20-24. increase in female SMAM over time reaffirms significant delay in female age at marriage as compared to her counterpart in Punjab. Determinant factors, education and urbanization, are affecting nuptiality across both sexes. Education and urbanization are two important factors positively associated with the

postponement of marriage. Education may influence the entry into marriage market in various ways as compared to rural-urban residential set-ups. Almost every division in Punjab is experiencing steady and consistent declining proportions of ever-married male and female by age 20-24. These figures can be contextualized within the theoretical frameworks on spouse selection.

The origin of the spouse selection criteria dates back to prehistoric societies when male's ability and capacity to provide shelter and food to his family and a female who could bear and rear the children were primary requisites. Sociological and anthropological studies provide us evolutionary, socio-economic and behavioral perspectives to understand 'who marries whom'. The scholarly work of Malinowski (1922), Mauss (1950), Sahlins (1972) and Lévi-Strauss (1969) as described in the theory of social exchange between family and family's networks explains if and/or why reciprocal relationships serve as building blocks to define spouse selection preferences. For Bourdieu, strategies of spouse selection are part and parcel of the game of marriage to reach to the best possible ends. This perspective analyzes the actor in terms of his/her capital, his/her positioning and the relationship between capital and power. In sum, this theoretical debate focuses the issues of adequacy of a spouse and inner working of transnational marriages.

CHAPTER 3

RESEARCH METHODOLOGY

This study is an attempt to understand why and how transnational marriage are organized and how links are maintained, produced and reproduced by marriage. Since the selection of appropriate research method is directly determined by the objectives of a study and the feasibility to approach the data, I describe, in this part, my strategy why I adopted the qualitative research design and what is the rationale for this choice. I emphasize particularly the methodological considerations while studying the phenomenon of Pakistani transnational marriage, an intimate affair of the couple that is to be concealed from outsiders, a private issue where a web of the relationships between the two families is intertwined, and a sensitive issue as migration is involved.

Analyzing how transnational marriages crystalize the (re)configuration to kinship structure is one of the aims of the study that is more of explorative and of descriptive in nature to paint the picture of spouse selection in a transnational setup where individual choices are (un)congenially resonated with that of the group's, i.e. the kin, to which he/she is an integral part. Additionally, gender roles and ideologies too influence their matrimonial choices. As a consequence of taking into account the highly complex nature of interpersonal relationships involved in this research (that is to say how do kindred count when it comes to the issues of connections, emotional bonding and care), a more flexible and thorough approach was required to understand these within their specific sociocultural context. This could only be achieved by first-hand contact with the involved real actors by knowing comprehensively about their personal narrations of their life-long experiences regarding their subjective decisions to marry and/or not to marry, not by inferences from what people do in artificial settings like experiments or from what they are offered to choose from a list of predetermined options regarding their matrimonial decisions.

3.1. Qualitative Research Design

The qualitative methods were preferred to imply so that social events and processes regarding the role of individuals and their families in marriage choices must be thoroughly explained by those who narrate them in terms of their relationships to the context in which they occur. The relatively more accurate and reliable information could only be collected by developing trust and by building rapport with the people under study prior to getting information about such a sensitive issue of marriage and spouse selection, especially in a community where people are not easily open to the strangers.

If one is to be able to explain human actions effectively one must gain an understanding of the cultural perspectives on which they are based. It is argued that sociologist must not assume that he/she already knows others' perspectives, even in his/her own society, because particular groups and individuals develop distinctive worldviews. This is especially true for the largely complex and transnational communities, and Pakistani diaspora in France is the one such. Being socially and culturally different from their host society, they develop distinctive ways of orienting to the world that may need to be understood if their matrimonial behavior is to be explained.

Another justification for employing qualitative research technique to study how transnational marriage crystallizes the transnational links is the conception of research process as inductive or discovery-based; rather than as being limited to the testing of explicit hypotheses. Social research, if conducted by approaching the issue under investigation with prefixed propositions and presuppositions, may not be able to reveal it as entrenched contextually and phenomenologically as one might observe that in the real life world. The focus of this research was narrowed and sharpened, as it proceeded qualitatively. In this way:

theoretical ideas that frame descriptions and explanations of what was observed were developed over the course of the research. Such ideas are regarded as a valuable outcome of, not a precondition for, research. (Hammersley 1990:9)

In sum, qualitative research method is employed for this research with the aim of understanding the lifelong experiences of Pakistani immigrant community in France who maintain their transnational links by marrying back. I have used a variety of modus operandi to collect the data: personal experiences, participant observation and in-depth interviews by employing case study method to explore the less understood behavior (Mitchell 1983) related to marriage institution of French-Pakistani families. Although Yin (1989) guides us how to adopt case study method as a research strategy to observe the phenomenon in its natural settings and context, yet there are no specific set of scientific guidelines how to do it (Meyer 2001). The decisions related to design a case study are left to researcher's table, which according to Meyer, is the strength as well as weakness of the method. *It is strength because it allows tailoring the design and data collection procedures to the research questions. On the other hand, this approach has resulted in many poor case studies, leaving it open to criticism* (ibid 2001: 329-330). Keeping in mind the limitations of case study method, the multiple sources I applied for data collection in addition to case study method not only enriched my data but also provided me with different angles to view the issue under study.

It is important to clarify that this study does not claim to be as value free as a science ought to be. Yet it endeavors to approach the issue from descriptive, but critical view, to interpret the responses of individuals under study in their time-space context by comparing and (de)constructing their narratives with that of their other family members who were actively involved in their matrimonial choices. My personal approach, being scholarly gaze that is casted upon the social world (Bourdieu & Wacquant 1992:69), to this study is also influenced by the specific version of knowledge which I have acquired, not only through my professional training but also through the very process of socialization in the very social context that I am putting here under investigation. It, thus, is highly unlikely to remain a value-free, detached and unblemished researcher in my professional role while using the 'scientific methods' of studying the community of people of my own belonging. On the other hand, my membership to the community under study has equally been advantageous from many standpoints. I could speak the languages they were

comfortable to talk into. I could understand the symbolic connotations and lexicons which they utilized while telling their stories, as the language expresses the cultural complexities through the use of metonymy. I could avoid the situation in which a stranger could have been a source or a medium of cultural shock for the community under study.

3.1.1. Multi-sited ethnographic approach

Where migration, at one side, provides an opportunity to economic benefits and permanent settlements in the host society, it, unequivocally, also instigates the fear of loss of connectedness to the origin. This brings both localities into a juxtaposition not only for the immigrants, but for the researcher as well who wishes to understand their contextual choices. In order to meet the objectives of the study, multi-sited ethnographic fieldwork approach was adopted to collect the data. The spirit of multi-sited research is to track the issue under investigation, and its relational phenomena across space (since these relationships are considerably tenacious but geographically dispersed). Research design for the present research takes into account a number of connections across spatial boundaries where occurrences in one space (France) are directly related to and be explained by their ontological manifestations in the other (Pakistan). When multi-sited method comes to be employed as one of the methods of social research, it encompasses multiple geographic localities as field through which the researcher proceeds by displacing himself/herself in two or more locations to gather the data. Marcus (1995) has discussed the use of this method in more details. His review of multi-site methods employed by different ethnographic studies provides a very useful strategy to systematically investigate the issue of transnational marriages of Pakistanis, which ultimately required the fieldwork to be conducted in multiple localities, both in France and in Pakistan.

3.1.2. Field

As marriage migration tends to be circulatory and transnational, my field is multi-sited. This is to say that transnational marriages must be understood by taking those

corresponding families into account who are connected through marriage but living in two different countries. Thus, beyond the classical 'one-way flow' analysis, current study is analyzing the marriage migration flow from both sides of the countries; from the emigrant (Pakistan) to immigrant (France) and from the immigrant to emigrant. I took several important considerations while defining my research field that is multi-sited capturing the both flows of emigration and immigration.

Most of the studies on migration focus only on the country of settlement i.e. the local socio-economic and political aspects to highlight the assimilation, integration of the immigrants, discriminations found in labor mobility, asylum, clandestine behavior and human trafficking. Some have even taken the issue from a normative and humanistic view point to criticize the immigration policies, but within the host country's perspective at macro level. Anthropologists, however, considered to explore the immigration at micro level when they did focus on the family, socialization, marriage and kinship relationships of immigrants. Yet, many of them too were limited to see the issue only from within the host country, instead of encompassing the whole scenario by seeking the prior migratory circumstances and post migratory connections maintained back in the country of origin. In this way, an important life event of a migrant has been ignored or omitted by the previous researches. My study is an endeavor to fill this gap by taking the two-way flow into account; from immigrant (France) to emigrant (Pakistan) and vice versa.

Marriage, in Pakistani cultural context, is an alliance between two families. Individuals of Pakistani diaspora, unlike the cultural context of their country of settlement, have to pass through their families to construct any affirmative matrimonial relationship. It is the family (parents, elder siblings) and the kin who introduce the would-be bride and bridegroom to each other, rather the opposite, as observed in their host society. Before developing the affinal relationships, various characteristics of families are sought out i.e. family's reputation and respect in the community/locality, integrity to the cultural values and belief system, social standing, the family size and the economic status. How does the belongingness to certain caste and ethnicity influence family's decision to opt for or refrain from organizing a

marriage? What is the role of kinship structure and its influence on family in organizing marriages within family (either paternal or maternal family), outside of the family and/or the caste? These are the issues and questions which can't be answered by merely inquiring the family members living in the host country and ignoring their counterparts in Pakistan, who play the critical role in constructing and perpetuating these transnational links, and this study is one of the very few efforts to encompass the views and scenarios of both sides.

My contestation to undertake both generations, the parents and their married children, for this study represents the significance of their respective roles in matrimonial decisions. Marriage decision is controlled by elders of the family; especially parents. Individual's (son/daughter and son/daughter-in-law) behavior, being agency i.e. consent, fears, expectations, motivations, confirmation, resiliency, buoyancy, participation in decision making processes like the marriage rituals and celebrations, should be contextualized within intergenerational relationships and family, if the marriage choices are to be accurately understood. Because, it is the community who considers that between motivations and responsibility—from care to obligation and to obey the tradition— lies the family value system equally supported and maintained by the traditional kinship structure.

The field research was undertaken in three phases in Île-de-France (France) and *Punjab* (Pakistan) in multiple localities. Since marriage is a family affair for the community under study, I not only opted to interview the couple living in France but at least one of their respective parents as well. It is important to note that my universe for this study comprises only of those Pakistani families who are living in Île-de-France with at least one of their child, either born or raised in France and he/she is married 'back home'.

In order to define my field, when I started to look for the statistics on the number of Pakistanis, their geographic distribution in France and how they arrived here, I was little disappointed to find out that the desired information was either not available, or it was considered confidential to be accessible. However, several informal conversations with my key informants and with few personnel at the Embassy of

Pakistan in Paris led me to assume that the majority of Pakistanis lives in Île-de-France. Since it was not practical, due to time and financial constraints, to travel, and was difficult as well to trace out the Pakistani diaspora throughout the country, I decided to focus my attention only to those families living in Île-de-France. During the first phase of my data collection, I interviewed the married couples and their parents living in Île-de-France. For the second phase, I had to travel to Pakistan to interview the corresponding parents of the spouses who came to France via family reunion after getting married with French national Pakistanis. In this way, my field was vastly scattered throughout the province of Punjab in Pakistan. When I was in Pakistan, I found few new families there who married at least one of their children in France. Thus, their corresponding families were interviewed during the third phase, again in Île-de-France.

Concerns about family's definitions, types and structure of household vary according to the normative structure of any given society. Post-modern anthropologists have shed light on how parents and children define family; to whom they include and to whom they exclude from their ideal family boundary? Does family exit beyond geographical boundaries and across epistemological fields? Knowing the *inherent logic* of connections and networks across borders the institution of family has gained attention of migration scholars due to its profound effects on bringing and bridging the cultures of different societies (Bryceson and Vuorela 2002). A family, in one cultural context, may mean only the couple and their unmarried children. In another, a family could be perceived as the couple and their married and unmarried children living within a household or beyond four walls. A family may also include both sets of parents and siblings of the couple and their children, regardless of their (children's) matrimonial status, and this family is called *Khaandaan* in Pakistani Punjab.

For this study a 'family' is taken as a unit of analysis which includes 'a set of two parents-in-law and their children who are in a relational alliance through the marriages'—the family in Pakistani diaspora living in France and the corresponding family living in Pakistan. A family living in Île-de-France with at least one parent and

at least one of their children raised in France and married in Pakistan was considered as the minimum requirement. Additionally, at least one of the parents-in-law in the corresponding family living in Pakistan was also included. In this way, a family including couple and at least one of their parents, was considered as unit of analysis for this study. In other words, minimum four respondents in a family (the couple, mother/father and mother/father-in-law) were interviewed. However, an ideal family to be interviewed for this study was considered which could have both parents and parents-in-law alive along with the married couple willing to be interviewed. My intention to take such a family was not only to maintain the gender balance in both generations but to see the role of each gender and generation in a marriage decision taken at family level as well. At the end of my data collection phase, I was able to conduct 73 interviews in 16 families in both, France and Pakistan. Despite my efforts to maintain gender balance, the sample comprises of 43 female and 28 male respondents.

3.1.3. Tools for data collection

I have employed in-depth interview technique to obtain information about the immigration, marriage, and settlement experiences of my respondents. Interviews, when used as technique to collect data, pave the way to construct a kind of relationship between the researcher and his/her respondents which helps his/her aim of observing/recording the issue under study in a natural setting—a social environment where his/her presence as a researcher becomes the least interference in naturally occurring behavior. It provided me with an opportunity to not only obtain their narrations of their lives and event histories but also to get into their ethno-methods through participant observations. It also let me win their trust and confidence to the extent that some of them became so amicable to me to reveal what they initially considered 'secret and personal' enough to conceal. Although, being a female researcher, I had a limited access to the male world of Pakistani community, yet they were able to trust the opposite gender, but of their own community, to talk about their personal lives being inquired via interview technique.

Thus, my analysis and interpretations in the study come from in-depth audio recorded interviews.

Data recording may be described along two dimensions: fidelity and structure. An open-ended interview, when properly recorded, has high fidelity and little structure, whereas a standardized paper-and-pencil test has both high fidelity and high structure. (Rudestam & Newton, 2007: 111)

I have interview manuscripts of some respondents who were not agree for audio recording. Notes from my fieldwork diary together with my field experiences and observation helped me to contextualize the narrations of my respondents along with their symbolic interactions.

The interview guide prepared to get information from parents settled in France consisted on four parts. First part inquired about the event of their marriage. I was interested to know how their own marriage took place and what their spouse preferences were before getting married. The way parents narrate their marriage decisions, either taken by their kin and parents or by themselves, gives insights to understand their own positions being active and/or passive actors. Parents were also asked to narrate how they feel about their marital life, so that I could make a link between their aspirations, regrets and decisions regarding their children's marriages and family set-ups. Then they were asked about the marriage event of their child(ren); parents' preferences for their son/daughter in-law and in-law family, decision making process, taking (or not) their child(ren)'s consent. Prior to this, a detailed narration of the marriage ceremonies, celebrations, gifts exchange and dowry was also inquired. Decision making power, meeting of children before marriage, the likely effects of media, education were the next core issues asked to the parents. Additionally, parents were requested to talk about the nature of their relationships with their son/daughter in-law. This part served the dual purpose of getting information as well as repo-building with the respondents.

The second part of the interview guide for parents in France was developed to ask the respondents to recount their experiences of the way they socialized their child(ren) and the nature of their relationships with them and between them during

deferent stages of their lives: from childhood to adulthood; from home to school; from siblings to their peer group. Information collected in this part was important not only to understand the intergenerational (grandparents, parents, and children) ties and nature of power relationships within the family, but also to contextualize the gender, ethnic and religious ideologies in their country of settlement.

In part three, parents were asked to narrate their personal migration related experiences: how and why they came to France, their settlement experiences, social adjustment, adaptation, integration and plans to return to Pakistan. Then they were inquired about their connections, linkages and strategies to maintain those linkages with their country of origin. It is in this part that their ontological transnational spatiality is inquired about. It explores the 'transnationalism from below' maintained through a very strong kinship structure which connects its practitioners beyond political demarcation: 'nation-state' borders. There were questions about the reciprocal relationships as well between the family in France and the family in Pakistan. I asked questions about their participation in socio-cultural and political life in France to explore the complex interplay of the origin culture, social adjustment and integration to understand their varied constructions of 'here'. My contestation to learn their migratory experiences stems from the previously established argument by a number of researchers, that as the migration motives vary, so does the propensity of the immigrants to return to their origin country or to settle down in the host country permanently. Thus, it was important to know about the migratory experiences of Pakistani diaspora in France and the motives behind their decisions to settle permanently.

Last part contained the questions about parents' demographic information like, age, education, occupation, caste/ethnicity, geographic origin and dwelling patterns. Interview Guide Schedule used for Parents in France is annexed at the end of this chapter as Annexure I.

Interview Guide schedule used for parents in Pakistan contains almost identical questions in four parts with an omission of the questions related to the migration

issue because they never migrated to France. Interview Guide Schedule used for Parents in Pakistan is provided at the end of this chapter as Annexure II.

The guide schedule used to take interviews from married couple (the 2nd generation in this study) also consisted on four parts. In the first part, I asked them, similar to their parents, to narrate their marriage related experiences ranging from the spouse selection process to their lives after marriage. It gives me their introspective view of their subjective feelings and their choices in organizing their own marriages with that of their parents and, thus, to understand at what point and under what circumstances the marriage decision becomes a collective affair. Son/daughter-in-law was additionally asked to describe his/her experiences and the nature of relationship with his/her family-in-law before and after arriving in France. They were also asked about their relationship with their spouse. This part also comprised of the questions on inter-gender relationships and spouse selection preferences. It covered the internal and external factors at agency-structure confrontation level. How the internal factors (language, education, poverty, habits, seeking personal betterment) and external (country-specific migration policies, spouse-visa issues, the risk to fall under the state-identified legal definition of certain marriages, dwelling) influence an individual's choices, and decisions to marry or not to marry with a person staying elsewhere.

In the second part, I questioned about their experiences at different life stages, their educational history and experiences in school life and entering into adolescence. How they were advised (or not) about their intermingling with the opposite sex, their dressing codes, their participation in household tasks. It was crucial to understand how they were able to improvise from a number of choices of cultural references of various kinds which they had accumulated through their socialization in French educational institutions, in Pakistani versions of religious and cultural institutions in France, from peers of diverse national and ethno-racial backgrounds, and most importantly from their parents and the kin when they visited their homeland time and again during vacations, and if they had stayed in Pakistan for longer but temporary periods during adolescent age.

The second part of the interview guide of children was identical to some extent to the third part of the interview guide of parents which thoroughly inquired about the intergenerational relationships. In the 3rd part, I was interested to know about their perceptions towards the importance of kinship relatedness, relatives and their preferences for their family make-up and set-up. Questions about their transnational connectivity and gifts exchange in priming the transnational links, and about care and responsibility were also asked. In the last part there were questions about their demographic, personal and family information. Interview Guide Schedule for Children is also annexed at the end of this chapter as Annexure III.

Besides in-depth interviews with my respondents, I did not ignore another emerging third party matchmaking mean in the Pakistani community; marriage bureaus. Marrying within Pakistani diaspora in France, elsewhere in Europe and back in the origin country when parents/children adopt multiple channels to search an appropriate spouse, marriage bureaus are consulted. Two case studies of marriage bureaus as modern match-making means were also conducted, one each in Paris and in *Lahore*. A list of key questions was prepared to inquire from the heads of marriage bureaus. Questions were asked about the families' preferences and criteria for choosing spouses for their children, desired family's social and economic background, spouses' self-consultancy and behavioral change in the clients regarding their criteria for searching competent spouses and in-law families.

3.2. Strategy to enter into the field

As my study tends to describe the very personal accounts of family and marriage histories, so the information collected as data are considered highly sensitive. It triggers a great concern of respondents while sharing the stories of intimate relationships to a stranger. Though I belong to the same origin country as to my respondents, it was nonetheless not an easy task to enter in an immigrant community which is known for its character of being discrete and close. Further, it was very difficult to convince my respondents for being part of this study. To cope with the problem of entering into the field and to maximize the heterogeneity of respondents' demographic profile, I adopted different routes. At the first stage, I

changed my previous residence and dwelled in a city in the department 93 in Île-de-France, known for ghettoization of Pakistani community in order to be a familiar face within the French Pakistani immigrant community. I also became member of different Pakistani-origin cultural and religious associations who play major role in the collective life of diaspora. I attended cultural get-togethers and regular religious congregations scheduled on monthly basis. After few months, my regular presence facilitated me to introduce myself. In the coming months, some Pakistani mothers and I were acquainted, bit friendly and used to say each other 'see you in the next gathering'. At times, I participated in some panel discussions and thus succeeded to become a familiar face for some, yet a complete stranger for many.

In these types of get-togethers, sex-segregation is very strongly practiced. Only women, mostly grandmothers, mothers and their young daughters/daughters-in-law are the participants. As per requirement of my research, it was inevitable to contact the male, being either father, father-in-law and/or husband, members of the community as well. I observed that in the local wings of Pakistani political parties here in France, there were women wings which facilitate mixed gender get-togethers. So, I joined different political parties as a member. To be familiar with younger generation particularly active at social networking sites, I became the member of different online social networking groups of Pakistani immigrants living in France. I observed that the issues under discussion on these groups varied, and at times focused parent-child perceptions of the practices of marriage. Mostly, I remained silent and observed these online threads. At times, I initiated threads myself on different marriage-migration related issues. Later, I contacted individual members via private messages to ask for their consent for being interviewed. Apart from these social networking websites, marriage bureau personnel and local representatives of Pakistani community (religious / cultural / political / academic) in France were also contacted to get help in finding the respondent families. I also attended wedding ceremonies in France and in Pakistan as participant observer.

Under such circumstances, the complexity of the issue under study was directly related to the time, essentially required to be recognized as an insider in order to

enter into the field. More time was needed to persuade the respondent families for interviews, and finally to convince them to provide the contacts of the corresponding families in Pakistan. The anticipated timeframe for data collection, thus, could not be observed. So, it took me almost seven months to collect data in France and to ensure the accordance of corresponding families in Pakistan. Now discuss how the time and space jointly could influence the collection as well as the quality of data on the issue of transnational marriage. As there were at least four interviews in each family, it was necessary to imply sufficient time intervals among interviews. Thus all interviews were decided to be conducted in different social settings with a considerable time interval between the four interviews in one family in order to maintain the reliability of data. Further, I considered the family's living system and structure of household as significant influencing factors to define the appropriate social setting for taking interviews. This is to say that in families where parents and their children living together, I preferred to take the interviews of each respondent of the family in different social setting. Most of the parent (s) were interviewed in their homes. Interviewing them at their homes if it was a relief from traveling for them at one hand, at the other hand it was very helpful for me to maintain a privacy between the both generations. In fact, it enriched my data in many ways; first when parents mostly mothers were interviewed in France during the day timings, their children and/or husbands usually were used to remain out of the home either due to job hours and/or to do other asks related to family affairs. Thus interview activity was less influenced and intervened by the presence of their family members. One of the issue that could influence the quality of data was Pakistani family's value system which assigns cultural authority to the elders over the younger generation. Had I intended to interview the children in their homes, it was quite possible that their parents would have been present in the same room. So, I preferred to take interviews from the children outside the home. The place of interview depending on the nature of their activities was decided either their offices and/or nearby restaurants, and the parks also. Interviewing both generations separately in different spaces let both of us (the interviewee and the interviewer) free from the intervention of the 'significant others'. Another issue was to avoid the synchronized narrations about their spouse choices, since both generations were aware of the fact that were

being interviewed on the matter. So, I adopted the strategy to set certain time interval between the two interviews in the very family. This is to say, if I had interviewed any of parent and or children in France, I did not go back to the family until a particular time gap spanning 2-3 weeks. I adopted the same strategies in Pakistan related to time and space, except the time interval that was bit shorter around 1-2 weeks. The time constraints were related to the Respondents availability also since some of them were available only on week-ends, so a considerable amount of time was required to schedule the interviews with respondents. Initially it was planned to complete the data collection in France within four months (until the end of March 2013). Thus, it took me more than a year to collect the data (December 2012-March 2014).

3.3. Data collection and data preparing for interpretation

Both corresponding families (the family of groom and the family of bride) were interviewed to understand the match-making decisions at each side. It was inevitable to not to ignore the bride and the groom to be part of my respondents. The data were collected in three phases: 1st phase in Île-de-France (December, 2012-July, 2013); 2nd phase in Pakistan (August-November, 2013); and, 3rd phase again in Île-de-France (February-March 2014).

During the 1st phase, interviews were conducted in thirteen families in different cities in Île-de-France. In 2nd phase, field work in Pakistan was pluri-local and was further divided into two stages; the first stage directly dealt with the corresponding families whose contacts were provided by the immigrant families in France. During the second stage, new respondent families were sought who have maintained affinal relationships by arranging the marriages of their children within their relatives living in France. In the province of Punjab, total eighteen sites, including villages and cities, were identified and later visited for data collection, between September and November 2013.

The data collection strategy was different than that employed in France. Field area localities in Pakistan were scattered and situated at longer distances from each

other. Thus, keeping in view the time constraint, I mapped the adjacent areas and requested my respondent to give me appointments within the same timeframe when I planned to meet other respondents in their surroundings. During these visits, I also visited their relatives in order to know how kin networking is being evolved and exercised at local and transnational levels. Since, being a female, it was not considered secure for me to travel alone, I had to get help from my male family members to be accompanied. Additionally, few key informants were sought for the purpose of reconnaissance of the field areas. Due to the security reasons, all of them were from my acquainted networks. Their help was a great support, and a necessary step not only in searching out for new respondent families but to reach to the already identified corresponding families as well. I identified new families often in the neighborhood villages/cities of my field area.

After returning to France, 3rd phase of fieldwork was carried out during February-March 2014. I conducted interviews with three corresponding families in France whose contacts I had obtained during my fieldwork in Pakistan. Thus, in March 2014, I completed my 3rd and last data collection phase.

3.3.1. Transcription, partial transliteration and translation

My respondents belong to multilingual backgrounds. There is not one language as a medium of communication. However, most of them preferred to talk in Urdu (national language of Pakistan) and Punjabi with regionally varied dialects, sometimes blended with the French and English vocabulary. I, being born and socialized in Punjab, Pakistan, and being well acquainted with both English and French as languages of instruction during my higher education, had no problem in understanding and communicating with my respondents. It was, nevertheless, a monumental task to transcribe and translate the audio recorded interviews. Each interview protracts almost 80 minutes on average. The complexity of field had already made me to spend more time in the field than anticipated initially. Transcribing and translating such a huge data required almost six more months to be done. In order to save sufficient time for data analysis, it was decided to hire a professional who could understand English, Urdu and various Punjabi dialects and

could transcribe all interviews in Urdu. Once the transcriptions were done, I verified the manuscripts of transcribed interviews by thorough readings while listening the original recordings at the same time, not only for the purpose of synchronization but also to translate French words and sentences into Urdu. It was not feasible to translate all interviews word by word in English. Thus, I translated only those parts which were required to be used either as direct quotations or as to contextualize my interpretations of the narrations.

3.3.2. Anonymization of the data

In marriage decision, there are several persons of a family who play their respective roles beyond 'the decision-making process of marriage'. Their roles involve sharing of certain tasks of engagement/marriage ceremonies and/or going to market for purchasing dowry and gifts, mostly young boys and women. Elders of the family pay particular attention to the reception/departure of marriage procession and marriage feasts. Thus there are many important characters in the marriage histories of respondents. All of the names of families, individuals and places were coded in order to preserve their privacy. The coding structure is universal for each individual in each family under each relationship category— either father/mother, father/mother-in-law, the couple (husband and wife), siblings of couple, siblings of mother/father and mother/father-in-law and grandparents (maternal and paternal). If the marriage proposal introducer was other than the family members, he/she was given a code synchronized with the same family's coding scheme. The alphabetic and numerical values in the code changed as the number of respondents in a family and their place of residence changes in each family case history. Initial letters of their city names were taken to create the code of family and number of respondents in each family unit.

3.3.3. Preparing analytical schemas

The profiles of each family were prepared to summarize the demographic as well as marital details of the respondents. Each family profile contains descriptive annotations for different variables classified into analytical themes (such as pool of

spouse choices, characteristics of the spouses, introducer of the marriage proposal, the rituals and customs involved in marriage ceremony, and transnational spatiality of the kin). Based on the family's genealogical map constructed with the help of notes taken during fieldwork, an additional summary of each family's marriage histories was prepared. This is to say that the details of marriages of parents and of the siblings of the ego respondents were gathered so that I could analyze the complexity of the nature of kin and/or non kin relationships essential to select any spouse as adequate one. This information helped me to draw their family genograms and synthetic tables which are presented here and in the following chapters.

The table 3 contains the details of number of families and number of interviewees in each family in France and in the corresponding family in Pakistan. It shows also who actually the respondents are in each family as being the main actors of the marriage decision.

Table 3, a comprehensive snapshot of details of number of interviews in each family, presents how many families participated in the research; how many interviews were taken in each family and who were the respondents in both corresponding families in France and Pakistan. The Ego respondents are the second generation of the French-Pakistani immigrant families, who are married 'back home'. Interviews were taken from them and their parents in France, living in the region of Île-de-France, particularly in Seine-Saint-Denis, Val-d'Oise, Val-de-Marne and Seine-et-Marne departments. Their spouse came from Pakistan and the corresponding families-in-law are living in Punjab, Pakistan mainly in villages nearby the cities Rawalpindi, Jhelum, Gujrat, Mandi Bahauddin, Lahore, and Bahawalpur.

Table 3. Details of interviews and respondent families in France and Pakistan

Details of interviews and respondent families in France and Pakistan						
Sr	Family Code	Interviews	Respondents			
			Respondents in France			Respondents in Pakistan
			Son/Daughter (ego)	Parents/Siblings	Son/Daughter-in-law	Parents/Family-in-law
1	Family VP5	5	Son	Both Parents	Daughter-in-law	Mother-in-law
2	Family LC4	4	Son	Mother	Daughter-in-law	Mother-in-law
3	Family VG4	4	Daughter	Father	Son-in-law	Father-in-law
4	Family OZ5	5	Daughter	Both Parents	Son-in-law	Father-in-law
5	Family AB4	4	Daughter	Father	Son-in-law	Brother-in-law
6	Family VB4	4	Daughter	Mother	Son-in-law	Mother-in-law
7	Family CO6	6	Son and Daughter	Father	Daughter- and Son-in-law	Mother-in-law
8	Family VI4	4	Son	Mother	Daughter-in-law	Mother-in-law
9	Family PI3	3	Daughter (not interviewed)	Mother	Son-in-law	Father-in-law
10	Family SD5	5	Son	Both Parents	Daughter-in-law	Mother-in-law
11	Family TR4	4	Son	Mother	Daughter-in-law	Mother-in-law
12	Family SC5	5	Son	Both Parents	Daughter-in-law	Mother-in-law
13	Family CB4	4	Daughter	Mother	Son-in-law	Mother-in-law
14	Family LG4	4	Daughter	Mother	Son-in-law	Mother-in-law
15	Family LP4	4	Daughter	Brother	Son-in-law	Mother-in-law
16	Family LM8	8	2 Daughters	Both Parents	2 Sons-in-law	2 Mothers-in-law

A total number of 16 French-Pakistani immigrant families and their corresponding families were interviewed to understand the mechanism of transnational marriage and system and structure of family and household. In 16 families, there are 18 transnational marriage cases including 2 cases based on exchange marriage. The distribution of respondents based on intergenerational relationships is as follows: in France, the total number of the younger generation (ego) is 36, including 7 sons, 11

daughters (1 of the daughter could not be interviewed, the details are given elsewhere in the thesis); and their spouses accordingly; 7 daughters-in-law and 11 sons-in-law. Total number of their parents is 21 including 1 guardian (8 fathers, 12 mothers and 1 brother). On the other hand, the total number of their parent-in-law is 17 including 1 guardian (3 fathers-in-law, 13 mothers-in-law and 1 brother-in-law). Respondents' distribution based on gender and geographic locality is as follows: There are 31 males and 42 females. Among them, 27 males and 29 females are living in France while 4 males and 13 are living in Pakistan. In sum a total of 73 interviews were conducted.

3.4. Fieldwork experiences and problems

'Being there' as a participant observer during the long term fieldwork not only equips us with first hand experiences of the daily lives of the individuals under observation (Cohen 2000), but also enables us to balance our subjectivities and objectivities on the issue under research (Clifford 1986). In doing so, we may get rich data and the triumph is at our side. Similarly, we may face a myriad of problems ranging from simple to the complex ones. I alike many other researchers also faced field work crises. Despite being successful in getting rich data, sometimes I failed as an observer and left with fieldwork tragedies. I remember the chaotic moments when alleged gossips about my research were disseminated by a key respondent, a leader of the political party in French-Pakistani community who offered me to join her party in exchange of the interview for this study, which I refused politely. Consequently, I was denied to attend certain marriage events celebrated among his social networks. It was my inability to foresee the problems if I engage someone from the political arena of Pakistani community. I was caught up by extreme confusion when fabricated stories were told by my informants about their marriage histories to reflect 'all is well' situation that manipulated my understandings; a family case that I never fully understood. In the following parts, I explain in detail the nature of problems that I confronted during my fieldwork, and why and how actually it happened.

3.4.1. Sensitivity of the issue under study

As described previously, issues concerning marriage and family are considered private domains and are strictly related to individuals' and family's honor and reputation at the same time. The access is, thus, provided only to the family members and close friends. Keeping in view the very sensitive nature of my research area, I had to adopt different strategies which were embedded in the very cultural context I was socialized with. I avoided to talk and ask about the matters related to profanity, as defined culturally, in a way which could have triggered their sense of embarrassment and shame. It, for example, is forbidden to talk about the sexual behavior with the opposite sex. I did not ask directly to my respondents on this issue, unless they were comfortable to talk about it. Similarly, there was a reluctance in parents' willingness to provide me the contacts of their corresponding families in Pakistan for the reason that I, being an outsider and knowing their own version of the nature of relationships, might create troubles by discussing the matrimonial issues of both sides. It took me a considerable time and efforts to win their trust to gain access to what respondents, in their relational context, have defined as *private*. I did not abandon my respondents after interviewing them formally and continued to converse with them on phone and in person time and again. I, sometimes, had to attend their family and religious celebrations and had to exchange gifts to reach to their levels of expectations where an amicable relation of trust could be warranted. It, nevertheless, finally resulted in gaining access to my required data.

Initially individual respondents (parents and children) belonging to twenty-nine different families were agreed to talk. However, four out of twenty-nine families, whom I initially interviewed did not allowed me to talk to the rest of their family members. Respondents belonging to eleven families refused to provide me contacts of their corresponding families in Pakistan. One mother denied me for further interviews in her family when she came to know that I have talked to the ex-wife of his son-in-law. Thus I had to abandon a total of sixteen out of twenty-nine identified families due to their refusals. One of the corresponding families in Pakistan which initially agreed for interview denied me later when I reached Pakistan. On the other

hand, in Pakistan, I identified six new families who have married their children in France. However, one out of these six corresponding families denied me when I came back in France without specifying any reason. Two of the identified families moved somewhere else in Europe and excused even not to be available at Skype due to their post-migratory schedule. One of them asked to wait until summer vacations 2014, if I can. Finally, out of thirty-five interviewed families, only sixteen families (confirming corresponding families too) were left to be part of this study.

Most of my respondent families, due to the very sensitive nature of the issue, wanted me to interview them collectively in the presence of one another. There is a cultural value of 'respect for parents and elders of the family' which could have influenced the individual's response, especially of their children. This scenario was often difficult to handle. I explained them how important it is for my study as a social research to talk in the presence of none while they are being interviewed. I convinced them that each individual's responses are kept secret and would then be codified to preserve their privacy. Additionally, I scheduled my appointments in such a way that I could interview different people at different places and in different times. If, for example, I interviewed the parents (of one the available parents) in their home, I requested their married children to give me an appointment for another venue, sometimes at a restaurant, at their place of work or at my home. In this way, I was able to deal with their perceived sense of harmonized and unanimous response on the issue, by avoiding to offend the value of *intergenerational respect*.

My respondents belong to a culture where codes of mutual respect are hierarchically defined. There are number of *ifs and buts* to express the sense of emotional attachment and feelings among spouses, parents, siblings of both genders. My inquiries, being an outsider, of their interpersonal relationships were not warmly welcomed. Their fears of *being exposed to a stranger* could have resulted in serious rupture of their family relationships. I had to face a strong sense of *all is well* feeling while talking to them initially. It was only when their fears were vanished, after a considerable time, they began to talk about *there is something wrong* as well. My post-fieldwork informal talks with those respondents who were in the process of

getting divorce revealed more about the nature of their conflicts than during formal interview sessions, as they were in a relationship with their *significant others* at that time.

3.4.2. Researcher's positionality and self-reflexivity

Present research has been unique in its methodological scope. As described previously, this study takes into account transnational spaces and complex intertwined networks of relationships to understand the cross-border contextualization of marriages. Unlike previous studies, it deals comprehensively with both families in the host country as well as in the country of origin. Such a complex nature of methodology made the data collection as one of the most arduous tasks during this research. Although it did not appear as laborious on paper as it proved to be in the field, starting from finding my respondents to convincing them to be part of this research.

I faced some methodological issues while employing multi-sited research method. As researchers (See, for example, Falzon 2016; Coleman & Von 2012; and, Amelina 2010) on multiple occasions reprimanded those using multi-sited research method to be prepared for unintended and unexpected situations, because such research is characteristically considered as having less available roadmaps to carry the research in systematic way. I faced several hindrances while conducting my fieldwork at both localities. One of the pertinent problems was the incoherence of my respondents' willingness to be interviewed. Many of my respondent families who were initially willing to be part of this study, were later reverted from their consent, mainly due to the sensitivity of the data required for this study. As described previously, the unit of analysis for this study is a family consisting at least of the parents and their married couples. There were many occasions when parents and their children in France were willing to be interviewed but their corresponding families in Pakistan refused to provide data. Similarly, after interviewing one of the spouses, I was denied access to the other family members, who were skeptical of the scope of my research especially when they were told that I will travel to Pakistan as well to inquire about their matrimonial issues from their in-law family. Due to such

cross-border apprehensions, the refusal rate was mounting that cost me a lot of anxiety and time, especially when I had already interviewed almost half of the family in France and their corresponding family in Pakistan refused to be part of this study, even after their initial commitment.

Multi-sited research requires the researcher to travel extensively across geographies to collect data. The task becomes laborious when there is time and resource constraint, and researcher has to convince his/her respondents to agree upon specific timeframe. As my respondents were geographically scattered, it was fatiguing to manage their availability schedules. Those families who were living in Ile-de-France were visited several times because not every family member was available at the given time. However, the real drudgery was to make sure the availability of respondents in Pakistan at a given time. Punjab, being the second largest geographic unit of Pakistan, is 205,344 square kilometers large, and my corresponding families were scattered all over Punjab. It was a monumental task to convince my respondents to make sure their availability at the time of appointments with them. Additionally, I had to manage the appointments in such a way that the respondents, who were living in adjacent cities or in proximity to one another, could meet me in one go. Sometimes I was successful in my strategy, but the other times I had to travel again as long as 300 to 400 kilometers to interview my respondents from corresponding families.

There is no harm in confessing that it is the researcher who gains the most out of a research project, especially when it is of academic nature, and I expressed my gratitude for them being volunteer to help me gain this benefit. This, however, is not the one and only consequence of the social research. The aim of my study is that it will help the Pakistani community as well to know about themselves, by narrating their perspectives in dialogue and by instigating their own versions of their lives' important events and issues. My intention to choose out of a number of choices to work on their lives was that they will sense being acknowledged academically and invigorated by a previously unattended curiosity being shown in their understandings and their own views of themselves.

In order to meet the objectives of this research, I had to seek those respondents from Île-de-France who were French Pakistanis and were married to a spouse from Pakistan. Being a fresh face in Pakistani community and not much aware of their demographic profiles, I started to look for the needle in the haystack. There is always a degree of concerns and fears when we interact with a stranger. When I first entered into the Pakistani community in France being a researcher, I had to deal with these, by maintaining my professional ethics and by keeping in view my respondents' cultural considerations. It was advantageous for me to be a Pakistani Muslim of the same ethnic background with which my respondents associate themselves. There were, nonetheless, inevitable inquisitions about myself when I asked them to talk about themselves. They did not take my position of cultural insider as taken for granted. We were *the others* for each other. There was a pile of questions about my identity and colossal skepticism about the purpose of *talk to them about them*. Who am I? Why am I doing what I am doing? Who is behind me? How do I manage my living being student? What I have to gain from my research project? Why am I inquiring about the Pakistanis only, especially about the migrated spouses? Am I an agent of French state? Why I, being a woman, am interested to know about men? It was a challenge for me to choose appropriate responses which could satisfy their queries and interpretations of my positionality before I could be given access to their personal lives.

It is very difficult for a researcher, being part of his/her own research, to completely detach himself/herself from the possible consequences of his/her role as participant of the ethnographic research. My participation in Pakistani community in France generated several identities for me, often controversial and in conflict with my key identity. As described previously, I had to be part of several social, political and religious groups in order to get access to and be a familiar face in Pakistani community. These groups were neither impartial, nor unanimously accepted in the community. Their contestations with each other were often reflected as personal grudges and as character assassinations of their respective members. It was in this context that my affiliation to one group was frequently taken as dissonance with the other. It is important to note that almost every group contacted me to persuade me

to give up my existing group membership and join theirs. Not because I was an enthusiastic actor with dynamic abilities to carry the group activities in efficient manner. But it was principally due to my status as PhD student. My personal identity as highly educated female was considered valuable for boosting the cumulative image of the group in Pakistani community. Such scenarios were truly hurting, not only my personal identity within the Pakistani community but at times it became a serious issue of my reputation. It was mainly because women-wings of political parties in France were not considered to be having good reputation in community, and so were considered the members. Intra party disputes were frequently turned into abusive and violent conflicts, and women often had to face the situations of online harassments. Their Facebook profiles were forged, and fake objectionable pictures were fraudulently created to scandalize them in order to gain some vested political interests. These situations became a real threat to my personal identity as well-respected student from Pakistan, and I was then being labelled as part of the ill-reputed political gangs. Thus, to exit from the field became harder than it was to enter into the field, by dissociating myself from all such groups at the end of the data collection phase.

My professional affiliation with INED was sometimes taken as an identity of a French state agent working against the economic, cultural and religious interests of Pakistani families who are facing difficulties in immigration policies. Social researchers often face such situations in the field, especially while working with the people having little or no fervency of *knowing about others*. Sometimes, I have been under their skeptical eye. They were persuaded to not to believe on any of my explanations and justifications and wanted to keep an attitude that *I should mind my own business*, instead of finding about whatever others do.

This, however, was not the predominant face of the community. There were many who could understand my fair motives and who felt honored to express their feelings, offered me a gratitude for being a good listener to their life histories, and showed their keen interest in my research project itself. I, keeping in view the sensitivity of the issue, thus, made a considerable effort to negotiate the research

ethics while not compromising the objectives of the research. After explaining the aims and objectives of my research and satisfying their inquiries about my own identity, I used to ask their formal consent to be part of my study. I promised them that their confidentiality would not be compromised at any cost. Their identity indicators, including their names and places of residence, would be coded to ensure anonymity. And most importantly, the finding of the study would not be used to harm their familial, cultural, religious and economic lives.

CHAPTER 4

KIN-ENDOGAMY: THE PRIMARY CRITERIA OF SPOUSE SELECTION

In chapter 2, we see that only marriage is socially, legally and religiously acceptable means to gratify mating desire and to procreate family in Pakistan. The norm of being married for both sexes is universal as more than 95% of population is married at least once by the age 49, according to the last census of Pakistan. To maintain its sanctity, marriage institution revolves around a variety of social attitudes and practices. Marriage is considered a long term relationship thus divorces is discouraged as the proportions of divorced persons out of ever-married were 1.7% for female and 1% for the male. Like other South Asian societies, Pakistan is undergoing nuptiality transition tied to education, employment, changing gender ideologies and structural patterns of family organization. It is in this context, that standard demographic studies of age at marriage, early/late entry into marriage market, and proportions of ever married/divorced population do not reveal the complexity of the marriage institution in Pakistan.

In the similar vein marriage, by involving migration with far-reaching socio-economic implications to family and kinship, is needed to be understood from the perspectives of both families living across border. How do Pakistani families living in France organize marriages of their children within families living in Pakistan? What is their criteria of spouse selection? How do they negotiate the adequacy of a particular spouse? What is the process of transnational marriages? To understand the internal dynamics of transnational marriage, chapter 2 and the subsequent chapters focus sequentially on the mechanism of transnational marriages starting from (i) searching a spouse within the pool of eligible spouses to (ii) filter them through preferential criteria until (iii) the negotiation between parents and their children on selecting an adequate spouse before (iv) the celebration of marriage event finally.

Current chapter examines the pattern of spouse choices of Pakistani immigrant parents and their children. Spouse choices are generally guided by the two sets of marriage rules; prevalent endogamy and infrequent exogamy. Punjabi marriage institution entails certain rules concerning whom to marry. Some are considered eligible spouses while others are not, and this is what is called in sociological terms 'the pool of eligible spouses'. The social dimension of the pool encircles first the endogamy within different layers of Punjabi kinship system and then the exogamy within and outside of the transnational social networks. It is argued that different layers of Punjabi kinship system help us better to understand the spouse choices of Pakistani immigrant families. In the previous discussion on theoretical perspectives over kinship—lineage descent and network alliance—marriage has been interpreted as a cultural preference. Yet, both perspectives differ parochially in interpreting what marriage serves to kinship system. According to lineage descent kinship perspective, preference for kin endogamy is a strategy to secure kin group cohesion and purity of blood. Whereas network-alliance perspective view kin exogamy is a way to maintain and create new alliances between families. In line with the theoretical debate, this chapter enlarges the discussion by examining the role of kinship layers in shaping the spouse choices? How trust and reciprocal ties as building blocks for marriage alliances influence spouse selection criteria?

Kin endogamy is largely practiced in Pakistan. A report by Pakistan National Institute for Population Studies (2008) figured that Pakistan has highest rates of consanguineous marriages in South Asia region. According to DHS Pakistan (2012-13), 65% marriages are kin-endogamous with a share of 56% marriages organized between first and second cousins. 28% amongst these are arranged between paternal first cousins; 20% are between maternal first cousins; 8% between second cousins; and 9% between other relatives. Marriages between non-relatives count only 35%. Do we observe preference for consanguineous marriages if the focus is shifted from national to transnational marriage behavior of Pakistanis? Initially, it has been argued that Pakistani immigrants' settlement in host countries will decrease

the chances to import a spouse from Pakistan, as there would be more potential spouses within the pool of co-ethnic diaspora (Shaw 1988). However, later years witnessed higher rates of transnational marriages mainly consanguineous among Pakistani immigrants¹⁴.

Though marriage preferences explained by the anthropological researches on Pakistani marriage institution evince two major trends; first kin endogamy is highly practiced, and second, these marriages are predominantly consanguineous in nature (Charsley 2013, Rytter 2013, Charsley & Shaw 2006, Ballard 1990, Donnan 1988, Das 1973, Wakil 1970, Eglar 1960). Yet sociological determinants of spouse preferences have been little explored except in few recent studies (Hanif, Alvi & Ali 2014; Nayab 2009; Zaib-un-Nisa et al. 2006; Hussain 1999). Why do Pakistanis show strong preference for kin-endogamy? Amongst kin, who are preferred and who are not? Why certain kin are preferred over others? Do the potential spouses in the pool belong to kin or to other social origins as well? Current chapter is an endeavor to assess and to compare the social positions and origins of the marriage partners while examining the pool of potential spouses preferred by parents and their children.

To understand why kin-endogamy is less explored, Shaw (2001) comes with two strong points. Firstly, she is convinced that it is not just the cultural preference among Pakistani immigrants as depicted in literature. She insists that the way a child is socialized, socioeconomic status of the family, the process of marriage decision making and migration must be taken into account to understand spouse selection mechanism within kin. Another problem she found in literature is the blanket term 'Pakistani culture' that often obscures the ethnic diversity and its inherent distinct marriage rules, which thereby do not receive considerable attention. This is equally true in case of Punjabi kinship. The inherent problem in literature in looking at kin-

¹⁴ According to 'Born in Bradford Survey', 71% spouses of British Pakistanis came from Pakistan (Shaw, 2001).

endogamous behavior is its over simplified categorization. The umbrella term 'kin-marriage' is used for all marriages organized within kin that eventually does not reflect the intrinsic variations in Punjabi kinship structure. It is within this context that current chapter examines the magnitude of the pool of eligible spouses firstly generated by different layers of Punjabi kinship; close kin, extended kin, the affines and the agnates. Spouses belonging to and outside the social network of the family are also part of the pool of eligible spouses, though least preferred.

Punjabi kinship system expects its members to marry within group. Those families who have children of marriageable age are expected to search spouses within the kin-pool. Individual's life, be it parent or the child, revolves around the family affiliations which entails a set of roles and duties. This is due to the very enduring nature of responsibilities and group solidarity that Schneider (1977) views the family and kinship as an integrated entity where marriages within kin are preferred not only to create, maintain but also to secure alliances between families. Careful attention is needed while interpreting that every potential spouse within the close-kin pool is readily available. To knit the new alliances between extended-kin, Punjabi marriage rules guide the families to choose prospective spouses from the extended-kin and to facilitate their integration in their family-in-law.

One of the classical understandings, this study reiterates, is the strong preference for kin endogamy; as 12 out of 16 marriages of my respondents are organized within kin. The prevalent preference for kin endogamy shows that the marriage behavior of Pakistani immigrant families in France is very similar to their co-ethnic diaspora residing in other European countries, as noted by different researches¹⁵.

¹⁵ See, for example, Ballard (1990), Bolognani (2008), Charsley (2013 & 2012), Charsley, Qureshi & Shaw (2008), and Shaw (2001) for UK; Nadim (2014) for Norway; Rytter (2013) for Denmark and Sweden; Casier at al (2013) for Belgium; and Zakar at al. (2012) for Germany.

Nonetheless it does not portray the complex picture of Punjabi kinship layers, as discussed previously. Kin endogamy does not entail a homogenous group, devoid of variations. It involves different sub-variations like matrilineal and patrilineal cousin spouses belonging to the close-kin layer and spouses belonging to extended-kin including agnatic and affinal relatives. In this way, my data includes a variety of cases which comprehensively represent the kinship structure; from proximity to distance in terms of closeness of blood relationships that bind them into kin-obligations and reciprocal relationships. Table 4 depicts the marriage preferences within and outside the kin.

We observe that out of 12 kin-marriages, 4 marriages are organized between the close kin while 8 between the extended-kin. Amongst 4 close-kin marriages, 3 marriages are organized between matrilineal cousins (2 marriages with mothers' sisters' daughters in Families VP5 and LC4; and 1 marriage with mother's brother's son in Family VG4); whereas 1 marriage is organized with patrilineal cousin (with father's brother's daughter in Family OZ5).

Analyzing the next layer, the extended-kin, we observe that it has a share of 8 marriages. Among these, 6 marriages are organized between the agnatic relatives. The agnatic relatives are the cousins of parents of spouses. 4 marriages are organized within the agnatic relatives from father's side whereas 2 marriages are organized between agnatic relatives belonging to mother's side. Marriages within affinal relatives are organized in two families; TR4 & SC5. Both families have already married their children in past and opted to organize more marriages between their children.

Table 4. Pool of spouse preferences within and outside the kin

Pool of spouse preferences within and outside the kin					
S r.	Family Code	Pool of Spouses		The Couple	
				Spouse in France	Spouse from Pakistan
1	Family VP5	Close-Kin	Matrilateral	Husband	Maternal aunt's daughter
2	Family LC4		Matrilateral	Husband	Maternal aunt's daughter
3	Family VG4		Matrilateral	Wife	Maternal uncle's son
4	Family OZ5		Patrilateral	Wife	Paternal uncle's son
5	Family AB4	Extended-Kin	Agnates	Wife	Father's cousin's son
6	Family VB4		Agnates	Wife	Father's cousin's son
7	Family CO6		Agnates	Husband	Father's cousin's daughter
8	Family VI4		Agnates	Husband	Father's cousin's daughter
9	Family PI3		Agnates	Wife	Father's cousin's son
10	Family SD5		Agnates	Husband	Mother's cousin's daughter
11	Family TR4		Affines	Husband	Brother's wife's sister
12	Family SC5		Affines	Husband	Maternal uncle's sister-in-law's daughter
13	Family CB4		Within Social Network	Wife	Father's friend's friend's son
14	Family LG4	Within Social Network	Wife	Father's friend's son	
15	Family LP4	Exogamy	Out of Social Network	Wife	husband belongs to strange family
16	Family LM8		Out of Social Network	Wife	husband belongs to strange family

Table 4 shows that all of the spouses were not selected from the close and extended relatives. The spouse pool comprised 4 cases of marriages that are organized outside the kin including family's social network. In case of Family CB4, the mother relied on her late husband's friends' network to find a spouse for her daughter. In

the similar vein, in Family LG4, the spouse of the daughter is the son of father's friend. In both cases, families preferred to seek a spouse within their acquaintances. They did not want to marry their children in anonymous families. In case of Family LG4, both families knew each other very well and have prior-marriage reciprocal relationships. In case of Family CB4, the mother of the bride and the father of the bridegroom were introduced to each other through a common family friend.

My data contains a couple of marriage cases that are organized outside the social network in stranger families. Families LP4 and LM8 organized the marriages of their daughters in families whom they did not know previously. In case of LM8, the marriage was organized through a marriage-broker lady. In case of Family LP4, the bride and bridegroom themselves intended to marry and asked their parents to initiate marriage proposal talks between two families.

After describing the dimension of spouse pool, the subsequent portions of this chapter analyze why the spouses within and outside the kin are selected and what were the factors behind that actors take into account? It is interesting to note that criteria to find adequate spouse are defined and refined by the actors who keep in mind the existing cultural expectations, one's social position and the past marriage experiences of the family.

4.1. Close-kin marriages

In order to explain why close-kin endogamy is prevalent, there are several socio-cultural and religious factors to be considered important. First of all is the factor of marriage taboos. In contrast to other co-ethnic Punjabi South Asian diaspora, especially Punjabi Sikh and Hindu, Punjabi Muslim marriage rules do not refrain its members from marrying within close-kin including both the patrilateral and matrilineal. Close-kin marriages are, rather, regarded as positive marriage strategies. Kin marriages, especially within close relatives, are not only a way to remain within the kinship network, but to strengthen the existing ties as well. Parents' siblings have the cultural privilege and the priority to ask marriage proposals first. Such marriage proposals are encouraged because the bonds of close blood

relationships already exist. And to define the nature of blood relationships, the participants of this study often correlate it to care and reciprocity as father in Family VG4 contextualizes it:

If we are related by blood but not related by care, we are not having true relationships. Blood relatedness demands you certain obligations and prior to all obligations is that you should take care of your siblings. Care in such a way that if they are poor, you help them. If they are in time of need, you stand side by side them. If they have to manage their problems by themselves and if they are helped by others instead you, what one has to do with blood relations? To give and to take is what makes us together otherwise we are apart.

If siblings do not follow the rule of reciprocity, the very kinship structure does not perceive them affirmative to the norms of strengthening or securing relationship bonds. Punjabi kinship does not focus only on 'being related by blood' obligation but being the part of the care circle and the reciprocal relationships too. The reciprocity for him may take any form; it may in terms of care and it may in terms of monetary exchange as well. Reciprocity in materialistic sense could be either equal or lesser in cost, as it depends on the economic conditions of a family. Punjabi kinship regulates the reciprocal relationships between the two families. When corresponding Punjabi families across borders share blood relationships and consistently maintain reciprocity through care, exchange of gifts, goodwill gestures, salutations and visits, there are strong chances to marry their children with each other's as we observe in case of Family LC4. The mother-in-law narrates it as follows:

If my sister has been taking care of my family, I too did not allow any fraction to disturb our relationship of care. I tried my best to take care of my sister and her family whenever they visited Pakistan. And when they were about to go back to France, I and my daughters loaded them with traditional items like sweets, eatable items and cloths. The two-way care relationship between two of us, led us to fix the marriages of our children.

Well-maintained reciprocal relationships play determinant role in organizing close-kin marriages across borders. In addition to well maintain kin-relationships through reciprocity and care, property inheritance and its maintenance is another factor

playing determinant role in practicing close-kin marriages like in Family OZ5 that I will discuss in detail in the part 4.1.2 entitled Marriages between patrilineal cousins.

Based on the previous anthropological accounts on Punjabi kinship structure and on the narrations of my respondents, close kin marriages are further divided into two categories; marriages that are organized between maternal cousins and the marriages that are organized between paternal cousins. In the following part I analyze the preferences to choose spouses from these layers.

4.1.1. Marriages between matrilineal cousins

3 out of 4 close-kin marriages are organized between first maternal cousins. 2 out of 3 marriages are organized with mother's sisters' daughters in Families VP4 and LC4. The other marriage is organized with mother's brother's son in Family VG4. Only 1 marriage was organized between the patrilineal cousins in OZ5. Contrary to the often observed spouse preferences as patriarchal culture prefers marriages between patrilineal cousins over the matrilineal ones, the investigated families in my data reveal more inclination towards matrilineal first cousins.

Close-kin marriage is the tradition in Family LC4. Since generations, spouses are chosen from the close-kin pool. The mother (younger) and mother-in-law (elder) are sisters. Keeping in mind that her elder sister's economic conditions are hand to mouth, she has been supporting her economically. The younger sister before her migration to France, assured her elder sister that she would not only continue to support her economically but would arrange the marriage her son with her niece (elder sister's daughter). She had been taking care of her elder sister until the marriage of her son with her niece. Later her son is equally persuaded that financial and emotional taking care of his elder aunt is his responsibility. According to him, he was only ten years old when he came to France. Though he never returned to Pakistan (until a week before his marriage), yet he frequently used to have telephonic conversations with his aunt. Since his childhood until he grew young, he was continuously told by his mother to who he is going to marry. His mother and his aunt have been informing him about what her fiancé was doing over the period,

particularly about her educational and household activities. For him marrying with his maternal aunt:

[It] was like something happening naturally to me. My aunt and her daughters have been part of our family. I never think about of any girlfriend in France, because I was a shy guy and because I knew that a day I would marry with my maternal cousin. After marriage, I feel I am the elder son of my aunt.

His narration depicts how both sisters have been maintaining their relationships by remaining in a system of sibling care and how they have been making the minds of their children for the marriage. If marrying with his maternal cousin is something natural to him, his wife's thoughts however are not alike him. She interpreted her marriage differently.

I was very happy. I know in marriages there are always some kind of disputes like in cases of my mother and my elder sister. But marrying within close relatives makes you feel comfortable. My father never worked hard, and my mother had to arrange. After disputing, my mother never left home because she knew she would not get any support from her half-brothers. Our aunts took care of us. My elder sister is married with my maternal cousin in Pakistan and if there is some dispute, my maternal aunt is already there to take care of the matter. The thought that my aunt would be my mother-in-law made me comfortable about my marriage. That's why I was happy.

Her mother is married in the extended agnates, whereas her sister is married with her maternal cousin. By compare her marriage case with that of her mother's and elder sister's, she found it advantageous to marry within close kin. Because she missed the effective intervention by and support of her maternal kin in case of disputes between her parents. On the other hand, her elder sister, being married to her maternal cousin, has the support of kinship whenever such situation arises. When I asked the mother in Family LC4, what led her to choose her niece as her daughter-in-law, she replied:

When I was pregnant for the first time, my elder sister gave birth to her second daughter. My sister was married to a poor man with no permanent source of income. She was worried. Then my eldest sister and I said to her not to worry about. If I would bear a son, I

would marry my son with your second daughter. My eldest sister said same for her elder daughter. Among all of us sisters, she is the only one having five daughters. My parents died long ago, and we do not have any real brother but half-brothers. We all sisters take care of her and arranged the marriages of our nieces with our sons.

In Punjabi kinship, married female expect help and support from her parents, mainly brothers in case of any dispute with her husband. That was not however true in case of Family LC4. Bearing only the girls under such poor economic conditions in combination with the cultural constraint of son preference, her sisters came forward to help her economically and to organize the marriages of her daughters. Their behavior is a way to manifest sisterhood solidarities in the Punjabi culture. To what extent such sisterhood solidarities may work, is revealed by the mother-in-law.

If it would have been only the decision of my sister, all of my daughters would have been married to all of her sons. But her sister-in-law (her husband's sister) was very jealous and was not happy, actually she wanted to marry her daughter there. My brother-in-law second his sister's opinion and did not want us to proceed for another marriage. God knows better what His planning is, my nephew rejected his paternal aunt's daughter's marriage proposal.

It is common in Punjabi culture that a potential spouse may receive several marriage proposals. The mother preferred to marry her younger son to her niece, but the father and his sister wanted him to marry with his paternal cousin. By organizing the marriage, the solidarities of sisterhood at one hand and the solidarities of sister-brotherhood on the hand are thought to be maintained. The other side of the picture is that close-kin marriages are not always organized due to the conflicts between siblings as we observe that father and his sister were against his marriage with his maternal cousin. In such circumstances, the tradition of close-kin marriage is repudiated, as the son did so. He neither married his maternal cousin nor the paternal. Interpretations of affection, responsibility and the sibling solidarities are crucial factors that produce close-kin marriages and conflicts between siblings may cause hurdles to practice close-kin marriages as well. Favoring marriages within

close-kin by both generations shows their conformity to the family tradition of close-kin marriages.

Close-kin marriages may not be the family's tradition as in case of Family VP5, but a preference and a strategy to secure the family from future risks. The mother (younger) and mother-in-law (elder) in Family VP5 are sisters and are married with their cousins belonging to extended relatives. The younger sister lives in France and has a son and three daughters. The elder sisters live in Pakistan and has two sons and one daughter. The younger sister confessed to her sister that she could not socialize her son accordingly in France, and she is worried about his marriage behavior. He was reluctant to get married with Pakistani girl. He is her only son and she hopes to spend her old age with him. She felt herself unsecure as she did not want him to be snatched away by some girlfriend. She requested her elder sister to accept her son's marriage proposal to save him as well as to save her sister's family. The elder sister was reluctant to accept, nonetheless, she was at last persuaded to help her due to her sister's beseeched behavior and the assurance that her sister will treat her daughter alike her real daughters. When I talked with the daughter of elder sister who was married with son of her younger aunt, she told that:

I never thought to marry in France. Actually I am the only daughter so my parents also never thought to marry me in a far country even in close relatives. But my aunt's continuous insistence and appealing for asking my marriage proposal made my mother's heart merciful. My mother did not directly talk to me but asked my maternal uncle's wife to convince me, because I am very attached to her. She said that you are the only daughter, so is your cousin. The marriage will be successful because your maternal aunt's assurance is there and she is asking marriage proposal very eagerly. I thought it would be good to marry.

We observe that the bride was convinced by her aunt's appealing behavior and assurance to treat her nicely. Marriage as a life-time decision is a prevailing believe in Pakistan and the assurance by elders that the marriage would be successful is the prime concern of the actors involved in marriage. There are three other important factors in Family VP5 to understand why maternal aunt intended to choose her niece as her daughter-in-law. At the first place are her concerns to secure her son, her

family and herself in old age by not allowing him to marry outside the family. Marrying outside the family is a very strong concern of the parents in investigated families in France. If their children marry elsewhere other than their own family or at least in Pakistani community, the differences of cultures widen the gap between the family-in-law and daughter-in-law. Often parents exemplify those cases when Pakistani boys married with Arab origin girls and they are facing cultural clash problems. To remain secured within the kinship structure, the mother succeeded to get support from her elder sister, brother and sister-in-law. She also asked support from paternal uncle of the bride. With the help of kin's intervention, another factor favoring kin-marriages, a member of the kinship structure remained its integral part through choosing a spouse within. To ensure her and her family's embeddedness within kin-group, close kin members convinced the bride and her father. Last but not least is the trust factor as explained by the mother:

I had trust on my elder sister that she would not disappoint me. I had trust that she would understand my problems, my feelings of insecurity. I felt that was I going to lose my son? Would it be possible to get my son back? Would there be any girl that could be his life-partner and enough wise to understand my feelings of agony? Only parents and brothers and sisters can share your pain.

There were marriage proposals for her son but she preferred to trust on her blood relatives. She relied on her siblings. Family VP5 reflects the interplay of trust and prerogative that the sisters and the kin group felt towards each other.

It is important to clarify that close kin marriages don't necessarily occur only between the two families who are not economically at par to each other like in case of family LC4 or have certain obligation to towards each other like in Family VP5. In circumstances where both families share equal socioeconomic status and where benefits of migrating to a develop country are also not involved as motivating factor, yet they preferred close kin marriage, like in case of family VG4 that I am going to discuss. Family VG4 can be categorized as an example of the transnational kin network who strictly follow the rule of close-kin marriages. VG4 belongs to a renowned caste and is an influential landlord family in their origin locality in Pakistan. Family's business is well settled in France too. The father in Family VG4 has

sponsored many of his relatives and village fellows in settling in France. This is due to his efforts, that a big chunk of his close relatives lives in France. A strong kin network is established locally and transnationally. The rules of Punjabi marriage system are strictly followed. Transnational marriages have introduced some vivid changes to the traditional Punjabi marriage rules like the French-born Pakistani bride does not depart to Pakistan after marriage, instead her husband joins her. However, In Family VG4, there is no aberration to this rule. French-born brides depart to Pakistan to live with their husbands and families-in-law. These brides visit their parents and siblings in France only at some particular times during the year i.e. to spend summer vacations, in case of maternity issues or in case of siblings' marriages. When the daughter completed her college, she was asked to stay at home to learn household chores that she would be expected to do after her marriage. She told me about the practice of close-kin marriage:

I had the idea since my childhood that I would be married with any of my cousins. That was what I saw in my family. All of my sisters, brothers and cousins are married within family. When my maternal uncle asked my proposal, my parents immediately accepted it.

She is married with her maternal cousin who is a physician by profession. Her family-in-law is highly educated and holds US citizenship, yet they prefer to live in Pakistan. She departed to Pakistan after her marriage and enjoys her stay there. She admires house servants' facility, shopping, the joint family's atmosphere and proximate residency of her extended family relatives, which she did not find in France.

In Punjabi kinship, joint family system includes parents, their married sons along their wives and children, and unmarried children. It is very common that grandparents are also living with any of their married son, mostly with the youngest son. It is also observed that grandparents are living with their married sons along their wives and children in a same house. The kitchens may or may not be shared. In such situations grandparents may decide to arrange the marriages of their grandchildren as it happened in case of Family OZ5 that I discuss in the following portion.

4.1.2. Marriages between patrilateral cousins

The father in Family OZ5 is living in France since early 70s. He has 2 daughters from his first marriage with French. After divorce, he along his daughters went back to Pakistan for familial support to bring the girls up. He joined his parents and unmarried sisters who were living with his elder brother and his family. During this time, the marriage decision of his elder girl was proposed by the grandfather. The girl was expected to marry with her paternal cousin (paternal uncle's son). The father got married for second time with his cousin belonging to extended relatives. After some years of marriage, he called his wife and daughters back to France. When the girl turned 20, her marriages was organized. Why did she get marry with her paternal cousin, when I asked, she said:

Because we were engaged since our childhood. When we went back to Pakistan, my mother-in-law took a lot of care of us. I was sad and was missing my mother. My younger sister was more attached to our paternal aunt and I was more attached to my mother-in-law. I stayed in Pakistan until the age of 13 and at that age, I knew whom I am going to get married.

The period that she spent in Pakistan with her paternal uncle and his wife played crucial role in creating affiliation with them. The way her aunt took care of her made her integration easy into the family. Under such circumstances as faced by the father and his daughters, creating and strengthening emotional ties with close relatives becomes easy if their close relatives in Pakistan say them a warm welcome and try to console them. The father alike his daughter used to remember those days that were very difficult for them. The support they get from close relatives laid the base for marriage. Were their other reasons too behind the decision of marriage? 'Of course there were' said the father:

He took care of my daughters when I came back to France. That was the time when my father decided that we should think about the better future of my daughter. Our father left mountainous land for us. We mountainous people love our land and do not like to sell and to divide it, instead we buy more. My brother took care of my property during all the period since I left Pakistan until the day I am in France. If my land remains safe under my elder brother's supervision, my daughter definitely would be safe if she becomes his daughter-in-law.

Fixing the marriage, according to him, brought both families closer than ever. Both families did not have to face any issue related to land inheritance. The land after all belongs to the children of the brothers. To keep the inheritance within family is a tradition in Family OZ5. The father-in-law in Pakistan is still taking care of family property. He has another interesting point of view why he married his son with his niece.

The daughters belong to us; they are our blood. That's why I encouraged my brother to struggle hard to get their guardianship after the divorce. His French wife had been living in Pakistan, but she could not adjust. She belonged to France, her roots were there, so she returned there. My brother and his daughters returned to us because they belong to us.

The narration of father-in-law depicts the avenue of belongingness. For him, the daughters share his blood. He traced their roots back in his family. Arranging the marriage with his son has been regarded by him as a route to root.

Since close kin marriages are widely and repeatedly practiced, it is a common tradition to arrange the marriages of a couple of sisters with another couple of brothers. As we observe in case of Family LC4, the mother and her youngest sister are married with a couple of brothers. Both of the sisters and brothers intend to continue the tradition of repeated kin marriages as they are planning to fix the marriages of their children with each other. In such cases close kin bonds become double as we also observe in case of Family VG4. A cousin could be the matrilineal as well as patrilineal cousin at the same time. The importance is given to the intertwined web of relationships as a whole, rather to its distinctive layers. Both families at each side often perceive it an ideal situation, because the bonds of sisterhood and brotherhood would refrain them from developing the feelings of rivalry and/or animosity in inheritance related matters. It is perceived advantageous to stay in the joint family household where emotional attachment of agnatic relationships supersedes the affinal ties. In the part following, I describe those marriage cases that are organized between the extended kin. The factors behind remain part of the discussion.

4.2. Extended-kin Marriages

It is observed that in traditional Punjabi kinship structure, the repeated practice of marriages within kin create an interwoven web of blood relationships, thus sometimes it becomes less important to distinguish who are the patrilineal and matrilineal instead relatives are regarded as *biraderi*, Urdu language term used for extended-kin. *Biraderi* includes the agnatic and the affinal relatives. Agnates are those relatives with whom ego share blood relationships through common patrilineal descent. Relatives from mother's side are also part of the *biraderi*. Affines are those relatives with whom ego is related through marriage relationships. As compare to close-kin marriages, extended-kin marriages are widely practiced in my investigated families. There are 8 marriages that are organized within extended-kin; 6 in agnates and 2 in affines.

4.2.1 Marriages between agnates

Marrying within caste, kin-group cohesiveness, purity of blood, obligations towards siblings, the issue of property inheritance have been described as major factors that led my investigated families to marry their children within close-kin. This part continues to explore further why they prefer to choose spouses from their extended-kin layers? The reciprocal relationships continue to play important role in choosing spouse from extended kin-layers as we observed in case of close-kin marriages. Nonetheless, the nature of reciprocity is different in both cases. In close-kin marriages, reciprocity means responsibility and it is more about to take care of their siblings both emotionally and financially. Whereas in extended-kin it is less attached with responsibility, and is expected the obligation of giving and taking on parallel basis, theoretically. It is understandable that immigrant families are at better economic position as compare to their relatives in Pakistan, yet the sense of getting back, even if not equal in amount and quantity exist. Continuous interaction between extended relatives, another factor, enhances the chances to choose spouse from within. Being in touch enable them to know more about each other family's living style, school of thought and children's activities. It builds trust and lessens the risks

of marriage failure. To explain these factors in detail, I start with the marriage histories of families of who chose spouses from agnatic kin-layer.

In previous parts, I have described in detail why helping to his relatives and village fellows to settle down in France was a necessary part of his obligations according to father in Family VG4. In the similar vein, father in Family AB4 has been doing for his relatives but since some years, he has modified his preferences of close-kin marriages. He arranged the marriage of his daughter with his cousin's son. Why did he include extended kin into the potential spouse pool? Being related to a family who prefer close-kin, how did he manage to abandon the practice? His response to my questions helps us to understand his action:

The poor state of my youngest son, who is not fit mentally, made us to think what doctors say. He is not the only child in our family who is like this. Here doctors say that I am married with my first cousin that is why my son is having this problem. It is very difficult to see your child in this state, so I decided not to arrange the marriages of my children with the children of my siblings. It is true that marriages between the children of brothers and sisters are appreciated in my family. But I convinced them that better not to marry, if all of us are going to have abnormal kids.

He is convinced his son is having some genetic disorders due to the practice of repeated close kin marriages. Though he abandoned the practice of first cousin marriages, yet he did not opt to marry his children outside the kin. Instead he remained conformist to the general rule of Punjabi marriage system and arranged the marriages of his children within extended-kin. The father (his cousin) of his son-in-law is not alive so, the eldest son is the guardian of family after his father's death. He too is of the mind like the father in Family AB4 that genetic disorders are to be avoided. For him, it is possible by marrying within extended-kin and also outside the kin. He explains:

My first marriage is with my paternal cousin. It has been more than 15 years to our marriage, that we did not have any kid. 8 years ago, I arranged the marriage of my younger brother in extended relatives, but he too has no kid. What would we do to our family's name and lineage was the question that I asked myself and had to face by my relatives also. So, 3 years ago, I remarried. My second wife is not from my kin and we have two kids now.

In case of childlessness, the kin-group itself expects and pressurizes its members too look for the possible solutions. Under such circumstances, second marriage is considered a possible solution even if it is outside the kin. He is of the view that his younger brother too should think about second marriage. When I talked the daughter in Family AB4 on the issue of second marriage of his husband, she said:

Alike my sister-in-law, I will feel bad if he marries. But at the same time the good thing is she has a son. Actually, my brother-in-law and his second wife decided that they would give their first child to her. She adopted it. We are rich and own much land. We have big bungalows in Pakistan and in France too, but all is in vain if we don't have kids. So, I myself proposed my husband to remarry. But he very strictly asked me not to talk over the issue. He thinks marrying in or out of the family is not the reason. It is God's will.

Comparing the narrations of the family AB4, we observe that there is conflict of opinions and actions over the issues of genetic disorder and marrying within kin. To have normal and healthy kids, the norm of close-kin marriage is altered by the norm of extended-kin marriage as the father did for her daughter. Choosing a spouse from outside the kin-pool was another solution to the child bearing issue. Individuals try to secure the norms of family's name, lineage and to have the heirs that eventually modify the boundaries of the pool of potential spouses.

Punjabi marriage rules make sure that its members should get married, even if they are not potential spouses in the marriage market. Exchange marriages within kin is one amongst those guidelines that was followed by Family CO6. The daughter in Family CO6 is the victim of autism thus is not regarded as a potential spouse in the marriage market. So her father arranged her marriage in exchange of her two brothers within extended kin. Alike Family CO6, exchange marriage within agnatic relatives was practiced by Family VI4, however under different circumstances. The daughter-in-law unveils the decision of her exchange marriage with the son of her father's cousin:

When I was teenager, my father-in-law asked my marriage proposal. Actually he is the elder of the family too, so nobody objected his decision. However, my father said him to wait until I get mature. But he did not consider my father's suggestion. I got

engaged. When it came the time of my marriage, my father-in-law proposed his daughter's marriage with my brother. This is how our exchange marriages were happened unexpectedly.

Unexpected though the exchange marriage proposal was, yet it was accepted as parents in both families had maintained their relationships well. According to the mother-in-law, they had very warm relations, but the exchange marriage converted the warm relationships into cold. Her daughter-in-law is living in France, however her daughter to go to Pakistan to join her spouse. Her son-in-law is also not ready to come to France to join his spouse. She hopes that a day her daughter will understand the importance of kin.

It is not unusual that children of Pakistani immigrants, unlike their parents, do not build strong emotional ties with their relatives back in Pakistan and do not consider Pakistan as home country. I did not have the chance to meet her daughter directly, but her mother-in-law's conversation with me signifies that she was not happy on her marriage decision.

She was like that, like arrogant person since her childhood. Whenever she visited us in Pakistan, she passed unpleasant comments on the ways a life is led normally here. Mud constructed houses, animals around the house, and relatives' frequent visits to each other. She did not used to accompany her parents instead stayed in the air conditioned the whole day long. That's why she could not have develop good friendship with her age fellow cousins. We thought that after marriage and having kid, she would be alright, but she is still same.

Sometimes marriages within agnates do not work as it is expected by the parents. It is not necessary if parents have good relationships with their cousins, their children will follow the same route. Living in a different atmosphere far from the relatives minimize the likelihood of emotional attachments with the relatives back in Pakistan, as it happened in case of the daughter in Family VI4. Since her childhood, as told by her mother-in-law, she did not feel herself comfortable with her relatives in Pakistan. That is why she did not join her husband who otherwise being an educated successful business man belongs to the potential spouses' pool.

Finding a good spouse from the kin-pool is however not easy, as mentioned by mother in Family PI3. She introduces herself as a left-behind wife of unsuccessful business man and a mother of 3 daughters and 2 sons. She comments in detail how difficult it is to select desired and to reject the unwanted marriage proposals from kin, especially if one follow the norm of kin-marriages. Her daughter is married with the son of her husband's cousin. There was another marriage proposal for her by the elder brother of her daughter's mother-in-law who asked the marriage proposal first. Parents and the daughter were not happy however they did not refuse directly, instead apologized that the girl is studying so they would not want to interrupt her education. Refusing directly to the kin's proposals may create conflicts within the kin-group members, and the elders in kin-group may boycott the family. If a family does not like the marriage proposal from the kin, they have to devise such accuses equal to—in mother's words—'*sap vi mar jaiye ty laathi vv na tootty*'. It is a Punjabi proverb literally means '*the snake must be killed but the stick shouldn't break*', which can be interpreted as '*get rid of the problem while keeping yourself safe*'.

The reason behind the refusal was that they were interested to marry her with the son of their cousin. Later, the father directly asked his cousin if he is agreed, they could proceed for marriage. The cousin was very happy and said yes immediately because there were cherished relationship with the two families. However, cousin's wife was not agreed because her elder brother had firstly asked the marriage proposal. She was afraid her brother would boycott her, and her fear was true. Parents in both families were boycotted by their respective parents, because they did not respect the norm that someone from the close kin-circle had asked the marriage proposal first. They had to convince their parents that it was not suitable for her, yet they did not marry her elsewhere but within the kin. One of the maternal aunts of the bride played crucial role in convincing the grandparents of the couple on the point that the bride and bridegroom are happy for their marriage. Eventually the marriage was celebrated however the elder brother of mother-in-law did not participate. His non participation in the marriage ceremony represents his dissenting opinion against the decision. Conflicts-laden marriage proposal between the kin may make the relationships between two families fragile. Often the kin group is involved

in actively to mend such fractures. In cases where relationship bonds are many folded, the temporarily boycott ends very soon as we observed in case of Family LC4. It may take some time to start the process of patch up as in case of Family PI3. It may result in permanent boycott that I observe only in case of divorce in Family VP5. The duration of boycott may take as long as several years and may get an end by another marriage proposal to be initiated between the two families. To illustrate it more laboratory, I present the case of Family SD5.

The son in Family SD5 was adopted by his paternal uncle and aunt who came to France in early 70s. He is married with the daughter of his mother's cousin. His marriage ceased the boycott between his extended kin belonging to paternal and maternal sides. Actually one of his mother's cousin (male) was married to one of his father's cousins (female), however the marriage ended in divorce. Since then, both of families were at distance. His real father in Pakistan found that one of his wife's cousin's daughter is up to their expectations as a daughter-in-law, however had fear that past marriage experience may hinder to proceed for another marriage proposal. He discussed the matter directly to another male cousin who is living in Canada and is the paternal uncle of the then-expected daughter-in-law. His daughter is also married with the brother of the then-expected daughter-in-law. Being an intermediary, he assured his brother and his wife (also his daughter's parents-in-law) about the fair intensions of Family SD5. Followed by discussions, the marriage proposal of son in Family SD5 was expected by the bride's parents. Past marriage experiences of the family influence on the likelihood of acceptance of future marriage proposal variously in my investigated families. The mother of bride expressed her doubts as:

If a divorce happens, it does not mean families are involved in. It could be the fault of the couple too. But a good family always try to avoid the divorce. The marriage proposal for my daughter was appealing however we doubted that what if they divorce our daughter as a revenge to the divorce of their daughter? My husband's brother however made us to understand to let our apprehensions go.

Their concerns were first wiped out by bride's paternal uncle and later by bride's successful adjustment in her family-in-law. The couple is living in France and their families back in Pakistan are clung together.

Another example to illustrate past marriage experience and its influence on the pool of spouses comes from Family LM8. The eldest daughter is married with her paternal cousin. However, her mother did not want to marry her remaining daughters in her family-in-law because she and her daughters did not like kin's traditional living styles. She arranged the marriages of two of her younger daughters outside the family which ended in divorces. Since then she prioritizes the kin-pool. Though she did not find the marriage proposals from the close-kin pool yet she knew some relatives belonging to extended families who could be prospectus pool of spouses. Her daughters' marriages turned the family's interest towards finding spouses within the kin. My investigated families' inclination towards kin marriages is further discussed in the following part where I describe the most outer layer of extended-kin relatives called affine.

4.2.2. Marriages between affines

Affines are considered trusted layer of kinship structure. Affines are those relatives with whom one construct and share the relationships through marriages. This layer is the direct product of marriage alliances between the two families. If past marriage alliance acquires the status of secured relationship, and the couples are well integrated into their families-in-law, affines families are regarded favorable pool of spouses for further marriages. With affines, marriage experiences count much more as compare to the agnates because only the success of past marriage alliance seeds the likelihood of future marriages. I have a couple of marriage cases where families repeated the marriages within their affines. In case of Family TR4, the son is married with the sister of his sister-in-law (his elder brother's wife) and in Family SC5, the son is married with the daughter of his maternal uncle's wife's cousin.

Family TR4 is living in France and is amongst the pioneer families migrating towards France during late 60s. There are 3 sons and 2 daughters. All of them are married

within the different layers of kinship and the social network of the family in France and in Pakistan. The eldest son is married with a girl belonging to the social network of the family in Pakistan. After some years to their marriage, the eldest son along his parental family went to Pakistan to attend a marriage ceremony held in his family-in-law. There his younger brother liked his wife's sister. Both families knew each other and did not object. Their *nikkah* (marriage contract) held and the celebration of the marriage event was postponed until the spouse visa is accredited. The couple is now living in France in joint family system. Why did the son want to marry with the sister of his sister-in-law? He comes with interesting explanations:

Because I was acquainted to my sister-in-law. She is different than us. She is genial and takes care of all of us nicely. When I saw her sister, I found her charming, well-mannered and gracious like her elder sister. So I thought I should try out.

The first factor that he finds interesting is the prior-marriage familial links with his wife. Then his sister-in-law's behavior, under his observation, lays the basis to proceed for another marriage alliance. He has other criteria—her charm, well mannered, gentle—as well which urged him to select the spouse within the affinal kin pool. There are other factors too told by his mother-in-law:

I have only daughters, 9 daughters. They don't have any brother. Elder sisters sought the marriage proposals for their younger sisters. This is how it happened. All of them are married and living abroad. When my daughter said that her brother-in-law wants to marry the younger one, I said you should decide you know better your family-in-law and his habits. She said, mama I am satisfied. I said if you are satisfied then I am satisfied.

Her elder daughter's satisfactory nature of relationships with her family-in-law was a positive factor for mother to accept the marriage proposal for her younger daughter. In the first place when she mentions that she does not have any son, she did not speak over it again until other moment of the discussion while mentioning being unable to give dowry to her daughters. Her husband was a clerk who did not leave any asset behind. If she had any son, she might had followed the custom of dowry. She admired the behavior of her daughter's parents-in-law who forbade her to give any dowry items. For her, marrying another daughter in such supportive

family was very appealing decision. Parents-in-law's denial for dowry is equal to support economically the mother of 9 daughters. In close-kin marriages we have observed that immigrant parents support economically their siblings in Pakistan. They offer money to arrange lavish marriage feasts, to buy dowry and to arrange the gifts. In marriages within affines, like in case of Family TR4, denying dowry is a kind of saving the expenditure for a widow mother who have many daughters to marry. Such marriage alliance if at one hand broadens the circle of kinship and makes the affines the part of spouse pool, produces the inevitable kin-group supporting attributes at the other hand. It also reduces the risk of failure of marriages as we observe that in Family TR4, previous marriage case has secured the status of successfulness and trustworthy. For mother, marrying her son with the sister of her daughter-in-law was an escaping from the risk of failure of marriage because:

I thought if the elder couple can live happily, then why not the younger couple? The plus point is that my younger son himself asked for. His wish showed her seriousness for marriage.

By the elder couple, the mother means her elder son and his wife, and by the younger couple she means younger son and his wife. She relates the successfulness of marriage with the behavior of her son too, who himself preferred to marry. The successful marriage of the elder siblings of bride and bridegroom works as a bench mark for families at both sides. Protection from failure of marriage is a major concern of the family members, however each perceived in different ways; if sibling's marriage's success is important for the mothers at both sides, for bridegroom it was the modest behavior of his sister-in-law. Does the bride also share similar thoughts or not? For her, it is more about being with her sister and not feeling alone in a strange country. She speaks in the following lines that how does she perceive her marriage alliance:

I felt good because the most important thing to me is that my elder sister is there. When she came here, we felt sad she is living in a faraway stranger country. We always talked that she does not have any sibling around her. But now it is not the case, we are together and pass good time. We don't feel alone.

Marrying with strangers living on a strange land have been an apprehensive issue for the bride and her family in the past. The marriage alliances in Family TR4 elaborate the kin making process step by step; first from being strangers to being the trustworthy affines in prior marriage case. In the latter marriage case, minimizing the effect of stranger land by marrying the siblings within the very family. The sisters do not feel alone themselves on a strange land as they together constitute a family there. Repeated marriage cases within affines are often observed in my investigated families. In the following, I present the case of Family SC5, another marriage within affines. However, the factors behind the marriage alliance are different than that of Family TR4. The grand mothers in both families belong to the same village situated in Punjab, Pakistan.

Family SC5 is living in France. The parents have 3 sons. The eldest son was married with his paternal cousin who was born and grown up in Holland. His wife did not want to stay in France because she could not pursue her career due to the language effect. She wanted him to shift in Holland. He denied as he was going to face same problem of language difference. The marriage ended in divorce. Two years later, the parents arranged his second marriage within affines. The marriage proposal was asked by the husband of paternal aunt of bridegroom. His paternal aunt is married with the cousin bride's mother. The bride, born and brought up in Pakistan, belongs to a very traditional family. She recounts her marriage proposal:

We are not strangers. We knew each other. My husband's maternal grandmother was friend of my maternal grandmother. They belonged to same village. My mother knows them. My uncle is married with my husband's paternal aunt. When they ask my marriage proposal, my father said 'no' because they were demanding my photo and my husband wanted to see me before marriage. My mother and the paternal aunt brought me to a restaurant where we took lunch with my husband and mother-in-law. He liked me. However, it was a sneak meeting, my father never knew about it. I think it was good to meet my husband. It was like wave of fresh breeze. He is nice man and I am happy.

In the first place, alike family TR4, affinal relationship was one factor to choose spouse within the kin pool. Nonetheless, she later comes with important explanation about the strict environment at her home. They were living in joint family system

where girls have lesser say. She was happy in getting married with a person who is living in France and is enough open minded that he wants to see and to talk his wife before marriage. She was informed about the dissolution of first marriage of her husband but she had no objection because firstly she knew what the cause was behind and secondly, being less educated, she was not going to do any job after marriage. Her mother also in addition presented another important explanation of how she was assured by her cousin that the family is of good conduct and open minded towards girls. She said that:

Marrying children within relatives is encouraged in our family. No strict compulsion is put to marry the children within kin by hook or by crook. I do not want her to marry in stone heart relatives like my family-in-law. We tried our best to hide the information that the bridegroom is divorcee. But as you know in joint family system, there are eavesdroppers and it is very easy to diffuse the news. We did not care about the issue of divorce and trusted on my cousin's words. My cousin told us that his family-in-law is of good conduct. He took the responsibility if something bad happens to our daughter.

The decision to marry her daughter is the output of what mother learnt from her own marriage experience. Her preference is to marry her daughter in relatives yet she is very precise about what qualities those relatives have to possess. She looks the quality of being kind heart in the potential family-in-law of her daughter. She does not want her daughters to get married in families who have rigid ideologies towards girls. Her queries are placated by her cousin's assurance. On the other hand, the family of bridegroom was not looking for kind heart people but a traditional family who has brought up their daughter according to the cultural norms. They were looking a marriage proposal only within relatives. The mother of the bridegroom feels that the first marriage of her son has taught them many lessons. For her:

Neither all the relatives are same nor their ways to socialize their children. My elder daughter-in-law is not well educated but is wise and understanding. The credit goes to her parents. Education is not socialization. I shall say that we were betrayed by our close relatives as it happened in the first marriage of my elder son. We were betrayed also by the strangers; my younger daughter-in-law has snatched my son. Perhaps we all are similar to a degree. Living here costs us. We cannot make the minds of our children.

Marrying her sons in and out of the relatives has been a mixed experience for her. In case of first marriage of her elder son, she thinks that those relatives including herself who live abroad cannot socialize their children well. After the divorce, she opted to search the spouses for her sons in Pakistan. For her elder son's second marriage, she feels satisfied as her daughter-in-law understands how to live and behave with parents-in-law. For her younger son, she has feelings of deprivation and seize. Due to disputes, the younger daughter-in-law and son do not live with them. Her younger daughter-in-law belongs to a strange family and the marriage proposal was introduced by a family's friend. She hopes to marry her last and youngest son in the family of her elder daughter-in-law. However, her husband is not agreed and wants to marry him with the daughter of his friend, a Pakistani family living in France. He says that:

If something happens against our expectations, does it mean that the marriage decision was wrong? There are multiple reasons, some are to be solved and some are out of control. Both of my sons and their wives confronted issues and tried to adjust with each other. I wanted to marry my youngest son with my friend's daughter. Of course, he too will face some problems initially like every couple. But within passage of time, the marriage traces her track naturally. I want to escape from the spouse visa regularities. It is long process and the couple starts suspecting each other's intensions before they live together.

He is not against marrying his children within the pool of kin-families belonging to Pakistan or to co-diaspora. He does not see any fault in the marriage decisions. For him, marriage initially undergoes some issues and it is quite natural. The couple finds harmony with passage of time. However, the factor that is out of control is the lengthy procedure to get spouse visa particularly in case of cousin marriages. He wanted to escape from the process because the duration from demanding spouse visa to its accreditation is long and it causes ruffles between the couple before they are together. This is why he readjusts the boundaries of spouse pool for his youngest son and includes his Pakistani friend's family into it.

A detailed discussion until now makes it evident that most of my investigated families prefer to arrange the marriages of their children within different layers of the kin.

Close blood ties, sibling solidarities, kin group cohesiveness, well-maintained reciprocal relationships, trust, care, the risk of marriage failure, genetic disorders, successful marriage alliances, constructing the transnational kin-network, escaping from spouse visa regulations and cultural norms of endogamy were some of the most prominent leading factors to define the contour of spouse pool belonging to close to extended relatives. As I described earlier that I have some cases of marriages outside the kin, what the factors are behind exogamy will be discussed in the following part.

4.3. Exogamy

Instead marrying all of their children within the relatives, some families prefer to arrange marriages outside their kin-group too. It is worth mentioning to clarify that kin-marriage cases of my investigated families (that I presented in each layer of kinship in the previous part) are the marriages of my ego respondents. I do not present the marriage histories of ego's siblings in detail. According to my observation regarding marriage histories of ego's siblings, I find variety of marriage choices. Apart from kin marriages, there are cases of marriages within acquainted circle and within the stranger families too. The pool of spouses includes the Pakistani diaspora in France, in other European countries and in the USA as well. The variety of such marriage behavior is seen in Families LM8, VP5, LC4, LG4, and TR4, who preferred endogamy as well as exogamy too. This part seeks answers why marriage histories of a family present the variety of spouse choices? Why the marriages of some of their children are organized out of the kin? This part presents those marriage cases in the data where families redefined the boundaries of spouse pool. They included family's friend and stranger families into the pool contour by practicing exogamy.

To describe the choices adequately I divided respondents' choices of exogamy into two parts; marriages within the social network and marriages outside the social network. The social network includes family's friend and the acquaintance circle. They knew each other directly or indirectly through family friends. There are two marriages arranged outside the social network. The spouses belonged to stranger

families. A marriage proposals was introduced by the marriage broker lady and the other one by the couple themselves.

4.3.1. Marriages within social network

Although 12 out of 16 spouses in my data are chosen from the kin-pool showing a strong inclination towards traditional pattern of spouse selection, it should not be assumed that change in their marriage behavior has not been taken place. The context and circumstances under which these families are living have not only effected the nature of pool of potential spouses but transformed the co-diasporic and back-home social network relationships into a distinctive kind of extra-familial kinship structure, particularly when it comes to the question 'where to find potential spouses for their children'? The social networks of the families in France and Pakistan become the subject of spouse scrutiny. To elaborate it in detail, I present a marriage case and the circumstances under which the spouses of the ego and of her siblings were chosen from the social network of the family in Pakistan and in France.

Family LG4 is living in France since 20 years. The father is the only son of his parents and came to France for the betterment of his parents, wife and children who were living under extreme poverty conditions. After the death of his parents, his family joined him and rarely went back to Pakistan because they don't think they have any blood relatives there. The mother has siblings living in Pakistan but she had boycotted them long ago when she did not find any support from them during poor days in Pakistan. Father's childhood friend in Pakistan remained in contact with them throughout the period. It is he who was made responsible to search the spouses for his daughters. He referred some of the marriage proposals to the family, but these were not up to expectations. Then the friend himself asked his son's marriage proposal for the eldest daughter. Parents went to Pakistan along their daughter to evaluate the potential spouse. The marriage proposal was accepted and after 6 months, their marriage was celebrated in Pakistan. It took them almost two years to get the spouse visa for their son-in-law. Later for their younger daughter, however, they did not seek any spouse from Pakistan but from their co-ethnic

diaspora within the families belonging to their social network. For their third daughter, they again sought a spouses from their social network of Pakistani families. They chose spouses for their daughters from their social network, it is needed to know what were the factors leading them to choose their spouses from their social network? In the similar vein, it is interest to know further why elder daughter's spouse belonged to family's social network in Pakistan and younger daughters' spouses belonged to family's social network in France?

As described earlier in the case history, that father did not has any sibling, so there were no paternal relatives in Pakistan but the maternal. However, mother's boycott excluded the maternal relatives from the pool of potential spouses. The elder daughter, my ego respondent, narrates as:

It is true we sisters have been missing our relatives, or say not the relatives, in fact the moments that we could have spent in Pakistan. During vacations, when our friends used to go to Pakistan and tell the stories of good time spending there, and back to France laden with gifts whilst we stayed in France. That period was tough. My mother is strict, never wanted to visit her sisters and brothers. My parents only started to look back when we turned to marriageable age. My marriage made little difference. I went there with my kids every year, but since their schooling, it is once every two to three years. The tough period starts for my children now. They have maternal relatives here; they have paternal relatives there. I asked my parents not to repeat the same thing again and again. Enough is enough. Better to marry younger sisters in France, so that the children could have their relatives at a place. I am elder so my opinion matters. I persuaded my parents to wed them here. My sisters also took my side.

Apparently it seems that non-availability of spouses within kin-pool led the family to search spouses outside. However, it is not as it seems. Both parents have their extended relatives in Pakistan. The mother has her siblings as well. They did not prefer to connect them to search for marriages proposals. In addition to boycott, they did not maintain their connection with them as having relatives 'there' was not important to them. Nonetheless, for their children it was not the case. They missed those links that their parents could not maintain. So they do not want, as evident from the daughter's narration, to happen it again. Having relatives 'here' and 'there'

is important for her but she thinks it is of little importance. Her eldest son is paralyzed and she is in permanent need to have familial support. Due to her son's illness, she could not continue her job. So for her, it is more convenient and convincing to have grandparents at a place. These factors pushed her to argue with her parents on her younger sisters' marriages. Her mother verifies her narration and says:

Children copy what others are doing. They see that other Pakistani families are marrying their children with each other. It aspires them. They want to have parents and families-in-law here. My daughters insisted us to think out of the box. For sure, we were not going to marry them in relatives. But we did not want them to marry anywhere. It is risky and I did not want to put it at stake. We looked those families with whom we have good relationships.

Regular interaction with the families in the social circle lessens the risks involved in arranging marriage. These risks firstly are related to the characteristics of the potential spouses and their families. Marrying their elder daughter with a friend's son was not risky for them because father knew his friend since his childhood. To know more about the family and the potential spouse, they went back to Pakistan and accepted the marriage proposal after the evaluation. The parents remained concerned for the risks while searching spouses for their daughters in their social network in France. The risks and uncertainties difficult to foresee like having the paralyzed kids and lacking the support from family-in-law can be managed if the pool of spouses is readjusted, according to the daughter. The mother said that her daughter's opinion was good. Her younger daughters have support from their family-in-law whenever they are in need of. Their kids enjoy the presence of their maternal and paternal relatives. One of her younger daughters is working as a midwife, and has her mother-in-law's support to take care of her kids. It is observed those families who have not blood relatives around them, they consider their friends' families as their extra-familial relatives. The mother felt her friends like her real sisters. She celebrates religious and cultural festivals with them and visits them on different occasions. Her daughters however did not feel comfortable with the fictive kinship relations instead cultivated their affinal kin network by persuading their parents to think out of the traditional box of spouse selection pool. The absence of blood relatives is observed in another family CB4, however the family did not try to cultivate

neither the local nor the transnational network of kinship, instead relied on their social network to arrange the marriage of their daughter.

The mother in Family CB4 is widow and living in France since almost 35 years. After her husband's death, she did not go back to Pakistan with her little kids because her parents were poor. She has 2 sons and 1 daughter. His husband laid the basis of a religious-cultural organization and actively worked hard for it. After his death, the advisory board of the organization decided to support his widow and children economically and socially. With some of the families of the advisory board, the mother of Family CB4 had good relationships that helped her to take care of her children. Her daughter had to quit her study after her college education because her elder brother did not permit her to study further. During the same period her mother started to search marriage proposals for her, and to do this, she sought help from the ex-president of the very religious-cultural organization. Soon she found a potential spouse for her daughter. She recounts why she wanted to marry her daughter with the very boy, and why she did not search a marriage proposal within her family:

I had proposals for her from family. My brother wanted her marriage proposal. My sister said me for exchange marriages. But I denied both because being a widow I cannot not afford the expenditures needed to bring my son-in-law from Pakistan like many Pakistani fathers bear the expenditures and arrange jobs for sons-in-law. I cannot do. I don't know how to fill the visa application. My daughter is not that smart. Her brother did not allow her to get education. She is not like other Pakistani girls who can bring their husbands from Pakistan. They work and show the government that they earn well. My daughter does not work. I looked for a son-in-law who could not only bear his family expenditures but who could move to France by his own resources, and to find such boy in my family was not possible.

For her daughter, she deliberately did not choose any spouse from the kin-pool. She is unable to support her son-in-law economically, legally and socially. She exemplifies other Pakistani fathers who manage to bring their sons-in-law. I observed in my respondent families that mostly father is responsible for his son-in-law's spouse visa procedure, residence and job. Until he learns French language

and finds a job, he usually works with his father-in-law who often is a businessman or a shopkeeper. He lives with his family-in-law. His wife too plays an important role by providing justification of sufficient financial resources to apply for spouse's visa. In Family CB4, the father is died, and the mother and daughter are unable to take such responsibility, as she compares her daughter and herself with other Pakistani families. Their relatives in Pakistan though are poor and may afford the visa process fees and traveling expenditures, nonetheless mother did not want to proceed because after migration of her son-in-law, she did not find it possible to arrange a residence and a job for him. She relied on her social network and found a son-in-law within it. She did not want to trust on strangers and to marry her daughter there because she afraid they would not understand her complicate situation. This is why she preferred to choose an independent son-in-law from her social network. When I talked with her son-in-law about his spouse choice, he is aware of his mother-in-law's situation. He narrates:

I belong to a Sayyad family and you must have heard that Sayyad do not marry out of family. But you see I am married out of family. How? In fact, the rule is strictly followed for girls, some exceptions are for boys and I enjoyed that exception. My parents wanted to marry me in the family like all of my brothers and sisters are married within Sayyad. The girl with whom my parents thought to marry me is the daughter of my maternal uncle. However, his wife wanted to marry her with nephew because she was more affiliated with them and they were rich than us. I said my parents to let me to go abroad and to venture my fortune. After few years' struggle, I got Portuguese residency papers. I came to France for a temporary work. A day, my father's friend lightly talked about his friend's family searching a spouse for their daughter. He said I can meet the family and can see the girl. And if I am agreed he may become a mediatory to bring both families at table.

Although he likes endogamy if the spouses are compatible as in case of his brothers' marriages. His sisters-in-law are cousins among themselves. However, he staunchly dislikes to follow blindly the practice of endogamy, particularly the way Sayyad are conformists. He compares the marriages of his brothers and his own with the marriages of his sisters. For him, his sisters' marriages within family were unjust and this is due to this injustice that his parents realized their fault after some

years of their daughters' marriages. He feels satisfied that the pool of potential spouses in his family is being modified. Some of his female cousins are married out of family. His own wife does not belong to his caste. In case of Family CB4, the bride belongs to a reputed caste nonetheless her caste is not considered as noble as of her husband's. Their belonging to different castes is superseded by their affiliation to a religious association that discourages the classifications fabricated by caste system. The marriages that take place within social network in the co-diaspora or in Pakistan, the issue of caste is often ignored and importance is given to the fame of the family.

Interestingly, the factor of caste did not create any hurdle in the two marriages cases within social networks. In case of Family LG4, the caste of the bridegroom is of lower stratum as compare to the bride's. Bridegroom's mother was skeptical about the acceptance of her son's marriage proposal due to her lower caste status. However, it did not make any problem. The family of bride did not consider it a hurdle to arrange the marriages of their daughters into other castes irrespective their hierarchal positioning.

If finding an independent son-in-law from the pool of family's social network was inevitable for mother in Family CB4, Family LG4 on the other hand, sought to cultivate the basis for their kin in their social networks in France and in Pakistan. The preference to search spouses from the family's social network was a strategy for both families to avoid the uncertainties that may increase whilst making marriages alliance with stranger families. Do Pakistani immigrants intend to arrange marriages in families who neither belong to their kin nor to their trusted social networks? If yes, why they do so and what are the motivations behind? The following part inquires the answers of these questions by presenting marriage cases of two of investigated families.

4.3.2. Marriages outside the social network

Family LP4 came to France during the late 70s. Both of the parents had died and survived by 1 son and 1 daughter. The siblings are married and at the time of their

marriages, their father was alive. The brother is married with his maternal cousin and is the guardian of the family after his father's death. His sister is married out of family and caste. Her marriage case is under observation.

She has been visiting her relatives in Pakistan since her childhood. After her mother's death, she did not go to Pakistan. She concentrated on her education and postponed her marriage until she sets her professional career. Her father supported her decisions related to job and marriage. On her spouse choice, she says:

I personally think that trips to Pakistan along children are made to realize them the importance of relatives and to learn the familial values. I did so. I respect my relatives, but marrying with someone amongst them is another story. I had some preferences and I was clear that I would marry with a Pakistani guy. When I met my husband, for a certain period of time, I evaluated him. Then I told my father about him.

When she met her husband, he was living in France with his elder brother and sister. He came from Pakistan to help his brother in his business. When she told her father about him, her father wanted to meet the guy and to know more about his family's fame and origin. Her father first met his siblings in France and then went to Pakistan to meet his parents and relatives. She said that her father was satisfied and accepted the marriage proposal. When I talked her husband, how did he come to inform his family about his spouse choice? He said that:

I was afraid that my parents would not accept it, because they had visited France to meet us. They went back earlier than planned because they did not like French environment. They did not like the way people dressed up here. I was afraid. I talked to my sister and brother. They met with my father-in-law and my wife. After their satisfaction, my elder brother said to my parents that the family is gentle. But the final decision is up to you. After meeting with my wife's father and uncle in Pakistan, my parents said yes.

According to the traditional marriage rules, the pool of spouses is pre-determined and it is not expected that children define its boundaries. In the similar vein, it is less common that children themselves take initiative to introduce their spouse choices to their parents. In case of Family LP4, we observe the changing trend. The couple themselves chose each other from a pool of stranger spouses. From being stranger

to become husband and wife, they first evaluated each other for certain period of time before informing their families. Later their families too verified about each other through family's friend and face to face discussions. The changing trend of spouse pool though is disturbing one for mother-in-law, but she finds it inevitable as her children have travelled to unknown lands.

In our times, it was nonexistent that parents discuss the marriage decision of their children in front of them. Children themselves wanted to avoid to talk and did not see their fiancés until marriage. They trusted on their parents' wishes and wisdom. Now children took the task. They know that we don't know. When the father of my daughter-in-law came to us, the gossip of our relatives and neighbors were about the nobility of his family. He himself proposed us his daughter's marriage. We bear the gossips of our relatives many times. The marriage was celebrated in France.

Relatives' gossips and exemplifying parents' involvement in spouse choice depict the cultural reaction against the spouse choice of her son. Marrying their children is considered the prime responsibility of the parents. From searching a spouse to marriage event celebrations, parents play vital role. In Family LP4, the son chooses her spouse against the cultural norms, the mother finds herself powerless as she felt her task is being taken away. She describes the cultural norm where the parents of girl do not propose their daughter's marriage proposal themselves, and if they do so, doubts over their nobility are raised. Her relatives did not consider the family-in-law of her son as a noble family alike them and passed such comments that she had to bear. Do the feelings of uneasiness prevail in family of bride or not as both families are strangers to each other? The brother of the bride is vocal about the geographic background of the family.

We belong to Lahore to a class that is urban and liberal. I asked my father not to proceed for my sister's marriage proposal because they are rural, backward people, very traditional. My appraisals about them went wrong. They did not problematize my sister's life.

Marrying one's children out of the family's social network is a serious concern of elders of the family because they have certain appraisals for strangers. If bridegrooms' mother is concerned about untraditional family of bride, bride's brother was worried about the traditional bridegroom's family. Despite their concerns, they

are agreed with the couple who chose a spouse from a pool, a pool for which their families have different point of views. Young generation is thought the channel of change into the family, and in case of Family LP4, it seems true. The young couple convinced their respective families to adjust the strangers into the pool of potential spouses. Nevertheless, it is not the case always. The parents also may take initiative to bring the changes into the marriage rules. To elaborate it, I present the case of Family LM8. Both generations the parents and their children adjusted the boundaries of their spouse selection criteria. The success and or failure of the marriages made them to readjust their spouse choices within the kin, the social network and the strangers as well.

Family LM8 lives in France since 1977. The couple has 5 daughters and 1 son. Except the youngest daughter, all of the siblings are married. The eldest daughter is married with her paternal cousin; the son of her elder paternal uncle. When her marriage proposal was proposed by her uncle, her mother and she herself were not happy. The reason behind unhappiness was mother's stilted relationships with her family in law because she had lived initial days of her marriage difficult and could not develop affiliation with them. The mother and her daughter got agreed conditionally if the guy comes to France after marriage. Her paternal aunt was not agreed because he is the only son of the family. Negotiations between the two families ended on what mother and her daughter has asked for. The marriage was celebrated in Pakistan and since then the couple is living in France.

For second daughter's marriage, the mother started to search proposal outside the family in Pakistan and contacted a marriage broker lady. She proposed some marriage proposals within stranger families, after evaluating the mother and daughter found one boy according to expectations. Couple' marriage was celebrated in Pakistan, and the husband came to France after a year. The couple could not develop good relationships and after two years of marriage they proceeded for divorce. Her divorce influenced the future decisions of her siblings' marriage profoundly. The mother and her children had neither interest in marrying within kin, nor they trusted any more on the families living in Pakistan. For them,

marrying within Pakistani community in France is worthier in terms of the circumstances under which the young generation grows up. Through a marriage broker lady based in France, they selected a spouse for their 3rd daughter within Pakistani diaspora in France. Both families preferred to celebrate the marriage in France instead going back to Pakistan. Coincidentally the marriage of 3rd daughter also ended in divorce within a year. Condemning and grousing against the ex-husbands and families-in-law of her daughters, the mother said:

In Pakistan, we found the covetous people. We went to the bad and could not understand their ill-natured intentions. The only motive they had was to migrate. We tolerated it because his migration was necessary for us too. But when we knew his extra marital affair, it was intolerable. My daughters said that it is due the strictness in Pakistan that the boys are infatuated towards girls. Then we thought to search a family here to escape from the greedy motive of migration and to select a boy who is not alike him. Our bad luck, we were deceived again on my younger daughter's marriage. Her mother-in-law, very authoritative, did not allow her to reside separately. Instead she could have enjoyed her initial days of her marriage, she was overburdened with the household chores while continuing her job as well. Living in France has no influence on them. They are narrow minded. She bore up what I bore up in my family-in-law. Thank God, my eldest daughter did not bear up though she is married with her cousin.

The mother compares the marriage cases of three of his daughters that were arranged within kin and stranger families. While comparing her eldest son-in-law better than other, she counts double relationships with him as his aunt and mother-in-law. She is of the view that bad and good people are everywhere hence relatives are more understanding than the stranger families. According to her it is not true that the stranger families are always to be avoided to construct marriage relationships. She presents her daughter-in-law case. Her son liked a girl of Pakistani family in France and insisted his parents to ask her marriage proposal. The mother went to evaluate the family and did not like their rural style of living. For her, they are ill-mannered who don't know how to deal with guests. At first she was disappointed but later she felt good when her son's family-in-law said them welcome according to their expectations. She said that she had socialized her daughter-in-

law according to her family's living style. Both families were stranger to each other, hence they respected each other. She remembers the family-in-law of her 4th daughter as being nice people who informed her that their son is engaged with his cousin in Pakistan. The boy her daughter likes is a labor migrant in France and was expected to get married with his cousin in Pakistan. When his parents knew the news, they talked with the parents in Family LM8 to not to proceed for marriage. The mother said that we were not happy too, however her daughter and the boy married without their parents' permission. When I asked her, as she has been modifying the pool of potential spouses for her daughters, what plans she and her divorced daughters have for future? She said:

Bad and good people are everywhere. My personal experiences urge me to search their spouses within the families whom I know, at least. When you confront with strangers, it is all about confrontation. Nobody comes to settle the issue between the two. Either you compromise or you break the link. When you confront with those whom you know or have relationships, someone comes to interfere or not, your former relationships interfere. Relationships urge you to stop and to take care of the other rather being egoistic. The sacrifice happens only between the close ones. My eldest son-in-law not only came to France but is very obedient guy. In every thick and thin, he stands with us. I pray, God forbidden, my daughters may not come across such families again.

The variation in her behavior to select spouses for her daughters from the pool of kin and outside it, is worth noting. Examples from her daughters' marriage can be used to illustrate the variation. One common expectation that she acquires from her society is making the marriage a successful contract. And to fulfil the expectation, she changes the pool of potential spouses for her daughters each time. She did not consider her family-in-law as an ideal pool to select the spouse for her eldest daughter. For her second daughter, she considers a family in Pakistan worthy to make marriage alliance. The divorce of her daughter shapes the contour of pool of spouse and she includes the Pakistani families living in France. When her third daughter gets divorce, it extensively influences her ideals about where to marry her daughters. Although at the start of her narration, she comments about finding good and bad marriage matches, yet at the end she is inclined towards arranging

marriages within the families whom she know and has pre-marriage relationships. Relationships save the families from disputation eventually making the marriage successful alliance between the two. Her 2nd eldest daughter is agreed with her mother that marriage between the individuals who know each other is more convincing but she is against the view to marry only within a particular set of families whom she and her parents know. For her it is more important to focus on her spouse's attributes than the importance given to being acquainting with his family.

Marriage as predetermined social expectation is the essential part of an individual's life. To fulfil it, my investigated Pakistani immigrant families also tend to arrange marriages within the stranger families. Fears related to the safety and security of the spouses and marriage, they inquire about the fame of family and potential spouses before initiating the procedure of asking marriage proposal. Their marriage experiences shape family's arbitrary expectations to what a potential spouse look like and how and where to find him/her. Their expectations differ from one another. For Family LM8, kin network appears as trusted pool of spouses after the failure of their daughters' marriages outside the social network. Next to kin, the pool of acquainted families within the social network appear on their criteria, although the daughter is more concerned about the spouse's qualities. Couple in Family LP4 also prefers spouse's attributes rather than the family's background. In Family LP4, bridegroom's mother and relatives are more concerned about the nobility of the family of bride, bride's father is concerned about the fame and social background of the bridegroom's family. After verifying about each other, what makes parents to proceed for marriage alliance is their children' disbelief on finding a spouse within particular pools predetermined by their families. Do parents and children perceive potential spouses differently and if yes, how do they negotiate spouse's characteristics? After describing the social origin of pool of potential spouses in the current chapter, what criteria parents and children have for the spouses is the subject matter of the next chapter. What kind of spouse's attributes are actually important for the children and parents in order to choose a spouse will be discussed in detail.

Concluding remarks

In sociological perspectives over kinship—lineage descent and network alliance, marriage has been interpreted as a cultural preference. Yet, these perspectives differ parochially in interpreting what marriage serves to kinship system. According to lineage descent kinship perspective, preference for kin endogamy is a strategy to secure kin group cohesion and purity of blood. Whereas network-alliance perspective view kin exogamy is a way to maintain and create new alliances between families. It is often argued that migration divides the kin yet the sense of belongingness persists particularly through transnational marriages. Transnational marriages not only maintain kinship connection but reduce the risk of weaken kinship ties. However, in addition to preserving kinship ties and the way inner working of transnational marriage is perceived at kinship structural level is not often exactly what it looks like below at the familial level and most important at agency level. To understand it accordingly, it is needed to look into the process of spouse selection process in a developmental approach that is to say; from searching a marriage proposal within a pool of spouses to filtering the potential one, and from negotiating the adequacy of the spouse to reaching to the final decision of marriage. Kin-endogamy is largely practiced by Pakistani immigrant families. However, the blanket term 'kin' does not accentuate the complete canvas of kinship structure. Whom do they belong and what is the importance of their social origins in the process of spouse selection? In order to understand the nature of kin-endogamy I examine different layers of Pakistani Punjabi kinship structure. I focus on cases of exogamy where marriages were arranged within and outside the social network to sketch the contour of the pool of potential spouses in transnational marriages.

The preferred pool of potential spouses is comprised of different layers of Punjabi kinship. The close kin layer includes matrilineal and patrilineal cousins. Sibling's caring attitude produces the reciprocal relationships between them. Well-maintained

reciprocal relationships are the building blocks to organize consanguineous marriages. Close blood relationships are considered trusted thus called for help to re-divert immigrants' children's marital choices. The issues of property inheritance and maintenance are significant determinants to choose spouses from the close-kin pool. Close-kin marriages create conflicts when a marriage proposal is asked by two siblings simultaneously or the marriage's successfulness does not appear as expected. Elders of the family intervene to bring the conflict to an end or to reduce the degree of tension. Unresolved conflicts, broken trusted relationships and non-availability of adequate spouses within close kin amplify the pool of spouses and include extended-kin into it.

The pool of extended kin is consisted of affinal and agnatic relatives. The cultural norm of endogamy plays vital role in selecting spouse from the pool of agnatic kin. Resourceful immigrant families prefer to construct transnational kin networks and encourage spouse selection from the group thus maintaining group cohesiveness. Repeated agnatic marriage cases interwoven the families into a strongly connected web of relationship thus promoting the ideas that potential spouses are group resources and are to be utilized within group. Choosing spouses from the agnatic kin also disenthralled them from the strict visa regulations on close-kin spouse. Avoiding the risks of genetic disorders and the successful marriage alliances are other determinants to choose spouses from the pool of affinal-kin.

Families' previous marriage enlarge the boundaries of pool of potential spouses. The nature of relationships of parents and children with their kin expand the contour of potential spouses. Those who have bitter experiences in case of kin-endogamy prefer to search spouses outside the family. Their inclination to arrange the marriages outside the kin makes a vivid difference between the families whom they know and the families whom they don't know. Families belonging to their social networks are considered more reliable to construct marriage alliances. The existence of pre-marriage relationships directly between the two families smoothen the way to exogamy. Sponsoring a son-in-law for his visa, residence and job are

directly related to family's socio-economic conditions thus redirecting spouse choices within the social network. Non-availability of kin and to construct such relationships with trusted friends of family is another important determinant to arrange marriages within social network. Spouses belonging to outside the social network are scrutinized with great evaluation due to the factors of anonymity and lack of trust. Families opt for such marriages links their spouse choices to different circumstances; spouses are introduced by the younger generation itself, parents were not satisfied with the nature of relationship with their near ones, and the conflicts within family over a marriage proposal. Making marriage alliances with stranger families is the least preferred pool of spouses. It is worth mentioning that caste consciousness does not work in case of exogamy. Once a family starts searching spouses outside the family, fame and nobility of family supersede caste consciousness.

No matter what particular pool of spouse is important for my family investigated families and no matter how much their choices differ from one another, one thing is common among all; the sanctity of marriage institute. Marriage is universal and is considered a life-time decision. To maintain its sanctity, spouse selection process is the basic element. Parents and their children are predetermined and keep exploring the pool of potential spouse inside and outside the kin until they find one according to their expectations. And if the expectations are not met, they redefine who to marry and redesign the basic framework of pool of potential spouses. The marriages of the individuals who are left outside the pool of potential spouses due to any genetic disorder or non-availability of the adequate spouses is prime responsibility of the family. In such cases families adopt less practiced yet functional strategy of exchange of siblings to marry their children between themselves.

Migration have introduced changes to the desired characteristics and contour of the pool of spouse. To lessen the migration effect, families devise certain strategies to influence their children's marriage choices. Telephonic conversations, regular visits to Pakistan, exchange of gifts, and spending some years in Pakistan while children

are adolescents are ways to direct their children towards a specific pool of potential spouses. When children are young, families' informal talks for the possibility future marriage alliance are considered helpful in realizing the children whom to select as their spouses.

CHAPTER 5

SPOUSE PREFERENCES: THE COMPLIMENTARY CRITERIA OF SPOUSE SELECTION

Once the primary criteria—the social origin of the eligible spouses—is negotiated, the marriage process proceeds towards its second step where potential spouses are filtered through complimentary preferential criteria. Current chapter examines the very criteria spanning from socio-economic to personality characteristics of the potential spouses. Spouses' characteristics such as age, education, behavioral traits i.e. morality, responsibility and attitude towards social values are sought in order to organize positive assortative marriage that secures stable and long lasting marriage alliances between the two families. It is argued that individuals evaluate their own social positions and capitals while actively aspiring to find ideal characteristics in their potential spouses. It is also observed that the phenomenon of marriage-migration has created fluctuation in the motivations and aspiration of the parents as well as of their children while filtering the potential spouses. Spouse selection preferences along with the inherent motive—marry to migrate—vary according to individual's own position, experiences and capital holding in his/her kin network on the one hand, and the politico-legal, economic, and social contexts of the origin and host countries on the other.

Immigrants' spouse choices have become the subject matter of political, legal and scientific discussions. Empirical studies dealing with Pakistani diaspora communities in different European countries show consistently an identical trend that many Pakistani immigrants prefer marrying a spouse who belong to their country of origin. Accordingly, different factors are sought behind the preferences of the actors involved in transnational marriages. In the previous chapter we have observed various factors to choose spouses from the different layers of the kinship structure. Care, sibling solidarities and well-maintained reciprocal relationships are some of the important determining factors to choose spouses from the pool of close-

kin. Cultural norms of kin-endogamy, group cohesiveness and transnational kin networks are described important factors to choose spouses from the pool of extended-kin. Nonetheless kin marriages are not the thorough depiction of the canvas of transnational marriages. Although kin-group intimacy and cohesiveness is guarded by transnational marriages in most of the cases of my investigated families, this, however, may not be the only motivation behind their spouse preference. Individuals also seek someone who could talk to them in their mother tongue, and having similar sociocultural practices and traditions as their own. In other words, a spouse is preferred who is perceived as culturally identical to their own, as it is anticipated that the perception of similarity of values and opinions would lead to mutual confirmation of each other's behavior and worldviews¹⁶. The excessive significance that is devoted to marrying 'within the kin-group' is therefore under constant negotiation; as transnational kinship structure does not function like a corporation in the marriage market through fixed and formal rules. Due to migration factors, families look outside the kin too. The contour of the pool of potential spouses encircles spouses from and outside the family's social network also. Factors largely responsible for spouse selection within social network are family's pre-marriage relationship, trust and non-availability of the potential spouses. Families past marriage experiences and nature of relationships with their kin play a vital role in selecting the spouses outside the social network despite the risk of being stranger. A careful evaluation of the potential family-in-law is carried out secretly through the trusted network of friends. In line with the structural factors and perspectives at familial and kinship level that define the primary criteria of spouse selection, this chapter examines the motives of the agency; the parents and their children in defining their complementary spouse selection criteria of an adequate spouse. What individual characteristics are required to define an individual as an adequate spouse? How adequate spouses are filtered?

¹⁶ For detailed discussion, see Kalmijn, M., (1998), 'Intermarriage and homogamy: causes, patterns, trends', *Annual Review of Sociology*, 24: 395–421.

Before describing the preferences of an adequate spouse, it is important to clarify that the narrations of my respondents to define adequacy of the spouses were heavily influenced by their post marital experiences. It may appear a departure from those ideals which they envisioned before marriage to their real experiences after marriages. However, their very experiences, no matter how bitter or how genial they are, helped them to define and redefine who an adequate couple (*Munasib jorr*) is. What they have looked for and what it appeared later.

Individuals not only evaluate their own social positions while actively seeking for but also aspire to find ideal characteristics in their potential spouses. In doing so, it is not to be assumed that the parents are only the ones who play active role in defining an ideal spouse in transnational marriages. In the previous chapter it has been discussed that parents do not blindly accept the rule of kin-marriage. They look spouses outside the family within and outside their social network. In doing so, they do not neglect their children's preferences. Special attention is paid first to carefully identification of the potential spouse in the pool of spouses, then, children's consensus is sought. The children may take initiative to identify their spouses and to present them to their parents. The selection criteria must meet certain ideals which parents and their children intend to seek in ideal spouses. In the following part, I describe the ideal characteristics that are most preferred by the parents and their children in defining spouse's adequacy.

5.1. Education

The correlation between education and marriage has been accepted widely. A large amount of sociological, anthropological and demographic literature indicates that education characterizes significantly marriage behavior and nuptiality pattern in various ways. Where education has strong effect on the timings of marriage (Ikamari 2005; Brüderl & Diekmann, 1997), Sathar and Kiani (1998) concluded that the prominent rise in singlehood proportions especially in female in Pakistan are associated with their education. Another study also asserts that years spent in education are determinant years for the transitional phase of female nuptiality behavior and most importantly their entry into at marriage (Caldwell, Reddy &

Caldwell, 1983). Given that higher level of education contribute in postponing the marriage, there are evidences that educational homophily is considered highly important attribute selecting a spouse (Lin & Lundquist, 2013). In this part, I describe education as a desired attribute of the spouse selection criteria of my investigated families in France and in Pakistan. How do the respondents situate the importance of education in spouse selection criteria while living in two different geographic places that are different to each other in terms of socio-cultural values, hence merge in transnational spaces? What does education mean and what costs parents bear in both countries' context? Before I proceed to the findings that education has been described as the most desired attribute in future spouses by both generations in both societies, I will elaborate what educational facilities were available to the immigrant parent respondent at the time of their migration to France and under this context what did it cost them to educate their children while living in France. On the other hand, how parents living in Pakistan bear educational expenditures of their children?

I argue that educational capital of parents and the context in which these immigrant parents have been grown up provide better understandings of the way they socialize their children. In doing so, I examine what was the educational capital of the parents and how did it influence their preference for education, as a crucial criterion to select spouses for their children.

5.1.1. Educational system in Pakistan

The formal educational system of Pakistan is three tiered which includes elementary (8 years duration), secondary (4 years duration) and Higher (4 years duration) levels. After completing the secondary and higher levels, certain diplomas and certificates of occupational trainings are granted respectively under the informal educational system. Though religious education system is practiced widely, but it has almost nothing to do with the job market. Further, unlike France, early education has not been freely available to the citizen of Pakistan until the introduction of 'right to free and compulsory education in Pakistan' at provincial levels in 2011. Until the start of 2014, the act is still waiting to be implemented at national level. Despite

recently introduced educational reforms in governmental schools, these schools are performing poorly and far behind from the privately owned educational institutes. Lack of infrastructural facilities and improper allocation of funding are other issues still to be dealt with. So, parents do not trust on governmental early educational system and run for private education that is very expensive in Pakistan. Parents bear solely all the costs of education of their children. The situation was even worse in past when during late 60s, Pakistani immigrants started to migrate in European countries other than UK. At that time, Pakistan's literacy rate was growing very poorly; it has improved from 0.5% per year (during 1960s and 1870s) to 26.2% (1980) to 43.9% (1998).

5.1.2. Educational situation of families

As discussed previously, mostly migrant families were from rural areas where there were no schools at that time. Only primary level schools were available to a set of villages. Majority of these schools were for boys only. Structural and cultural constraints along poverty further worsen the situation. Most of the parents in my data are either illiterate or less educated. In France, fathers with an elementary educational level are relatively more educated than the mothers who have just passed almost five years in formal education sector. In inter-gender comparison across both set of parents, though the fathers in Pakistan are more educated than the fathers living in France, yet we find intra gender educational disparities also. Mothers in both societies share similar educational capital, they were less educated than their counterparts. Parents' educational context along the migration effect, French free educational system, and the difficulties (i.e. language and lower level of education) they encounter while integrating in the formal job sector and French society, nonetheless have dually influenced parents' vision about 'being educated'. On one hand, they encouraged their children for education, and on the other hand, they admitted that their educational incapability could not harness the educational capacities of their children. They felt regret that their children could not get enough education according to their aspirations and the efforts on one hand, and on the other hand, they express feelings of contentment for their next generation's

education. They expressed that as their children are married with educated persons, and as their children know the French educational system and language also, so there are higher chances of successful educational achievements of their grandchildren. Family PI3 represents the scenario. The mother in Family PI3 is illiterate while her husband had completed his first 10 years of education. After 10 years of her marriage she migrated for France to join her husband. She recalled the difficulties she and her children had to bear while living in a village with their illiterate relatives. The couple was very determined to educate their children in France and to marry them only with the educated spouses. Initially, the mother was of the view to never go back to Pakistan to seek the spouses of her children within her illiterate relatives. However, when her daughter was around 15 years old, they came to know that some of their relative families are trying hard to educate their children. So the couple started to keep an eye over their relatives' children and to look for an educated son-in-law. They found the son of their cousin intelligent as he was doing diploma in computer. It was very convincing marriage match. So, she along her husband proposed the marriage proposal of their daughter to that family. At the time of marriage, their daughter was doing a job after quitting her studies while their son-in-law was appearing in graduation exams. Alike him, in my study, majority of the spouses mostly male were more educated than their counterparts. According to Mahé (1992), the spouses chosen by *Maghrebian* immigrants in France have higher educational attainment levels and an above average ability in speaking French language. They belong to the desired pool of preferred spouses. Thus these spouses were neither illiterate nor belonging to marginal and non-modern social strata. Though in my study, the parents in France organized the marriages of their children within their kinship structure in Pakistan, hence they accepted the most educated among the available marriage proposals for their children. However, the case is not same for parents living in Pakistan. In their spouse selection criteria, migration supersedes the educational capital of their children. In the following discussion I will focus on the question how education intersects gender and migration in spouse selection process.

5.1.3. Education as strategic capital

Families in France, when look for an adequate match within and outside of the kin, prefer to choose well educated spouses from Pakistan. Education being one of the most preferred and desired attributes is expressed consistently across each generation and gender. A general consensus is developed by families in my data that an educated person is more flexible, open minded, less traditional, and quick learner of values of new cultural environment. However, being educated does is perceived differently across generations and gender? My study shows that where education for boys is considered a necessary attribute to earn livelihood and to be integrated into job market successfully. For girls, education does not necessarily mean to do job and to be independent economically. Instead education is used as precautionary measured attribute only in case if their marriage is ruptured. Educated girls are perceived potential good mother who can socialize their children better as compare to uneducated mothers. As compare to their uneducated mother-s-in-law, as discussed previously, educated daughters-in-law are also considered helpful in helping the child in his/her studies. If any husband wishes for a working lady as a wife, he thinks the education of his wife is useless because the whole day long she keeps busy in household chores and taking care of the family, as it happened in Family VP5. However, his mother believes on the dominant trend that an educated daughter-in-law would be able not only to understand the gender relations in the host society, but also would be a good mother in the future. Similarly, the father in family TR4 links the good socialization of his grandchildren and marital adjustment to the education of his daughter-in-law:

MashaAllah (God willing), she, being educated, understands her husband's behavior and thus never had any serious issues with him, except few minor quarrels which is normal in every marital relation. She is very cautious to handle her children's schooling and socialization.

Another husband in family VG4 recalls his longing for an educated wife who may share common interests with him; taking interest in similar activates, like politics, tourism and soft music. Both of the above marriage cases are though result of strong close kin marriage preferences, yet one of them husband in Family VG4 managed

his longings of an educated life partner but after the marriage. His wife left her parental family back in France and joined her husband in Pakistan. A year later after their marriage, the couple came to France so that the wife could re-continue her studies. The husband told me:

I felt that my wife is happy with me, but she is developing an inferiority complex because I am a doctor and she did just matriculation. I argued with my parents and my younger maternal uncle [brother of her mother and father-in-law) that I would take her to France so that she could re-continue her studies. After her bachelor studies, she is preparing for Master now. Gradually, we learning that each one of us need to change ourselves and gradually we are finding one another more compatible and compassionate.

Above narrated case where the husband is doctor by profession while his wife is just housewife with a lower level of education presents how does a husband plan a strategy to realize his once ideal preferential criterion of an educated wife. He often discussed those particular issues that include in his wife's interest list. Previously both have huge differences in their leisure time activities that has been changed now. The wife joins her husband while watching cricket and husband joins his wife while watching a Bollywood drama.

As for potential husband and/or son-in-law, education, in parents' view, would give him an opportunity to not only get more chances in finding out a better job, but also to be better adjusted by quickly learning the language. Therefore, when parents search for an adequate spouse for their daughter among their close kin relatives, they prefer those who have done at least graduation and preferably master and/or have obtained a specialized professional degree. For example, there were other educated cousins available as potential spouses for the wife in Family VG4, but her parents selected the one who is doctor by profession. In Family PI3, the husband was selected as an adequate spouse because he was earning computer diploma while other cousins were not enough educated. In close kin cousin marriages where parents in France have been keeping an eye over the potential son/daughter-in-law they encouraged them to continue their studies. And where the informal accordance is given for marriage proposals, parents in France not only helped them financially

to continue their studies but guided them to choose certain subjects in order to better integrate in their future professional career in France. This trend however is observed more strongly in case of sons-in-law. The father in Family OZ5 is running a security agency in France. He afforded the economic expenditures of his nephew's (son-in-law) education, guided him to pursue his studies majorly in mathematics and computing. When after marriage, he came to France, he joined his father-in-law's security agency.

An educated person is also viewed as being more open and liberal in accepting the sociocultural values of the host society other than his own. Additionally, parents expect that an educated person would be more obedient, respectable to others. As the mother in family LM8 narrates how his son-in-law happened to be different from what she expected from him being educated:

We selected him as our daughter's match because he was educated. For sure he was not the person we expected. He was not an obedient and wise guy. He used to speak without thinking and often used to making contemptuous comments over my behavior and on our family's living style.

Her daughter while describing her preference of an educated husband narrates:

My ideal spouse was an educated person. Someone who could understand the way I am, who could understand the problems if appear in our relationship; all in just one word, he must be wise.

Due to the differences, the marriage however could not last long and couple has proceeded for divorce during the interviewing the family. When I talked to her husband about the differences on defining an educated adequate spouse, he responded:

An educated person is not a dumb guy. I did master in computer sciences and I was running a tuition academy successfully in Pakistan. It was third day of my arrival in France after marriage, when my mother-in-law came and asked me to join my father-in-law who is running his business of open market (marché). Later my parents-in-law and my wife asked me to continue working as a laborer in the family business. Actually they did not need an educated husband but a bakra.... [Billy Goat].

Though their higher educational levels when compare to their French born wives present a visible disparity, it could be viewed in two ways. Their education as their strategic resources bring them the chance to be selected for and to migrate. However, the resources and chance to be earned through migration supersede educational capital. Donnan (1994) in his study in Pakistan sees education as a strategic resource at individual and familial level. It is important to note that there exist gender disparities when it comes to the question of formulation of education as strategic resource and its usage in Pakistan. For boys it is related to their employment as parents in their old ages live with their sons and become depended to them for old age care and financial matters (Eriksen & Sørheim 2003). And as there exists gender-based professional segregation in Pakistan also, certain professions like engineering and information technology are perceived more suitable for boys and are to be acquired through more financial and time investments as compare to other professions like teaching that is perceived highly appropriate profession for women. So, parents invest more money on boy's education as compare to the girls'. Thus education of an individual become a strategic capital especially when the family institute bears the costs of expensive educational system in a Pakistan. For families living in France, daughter/son's-in-law's education also becomes a strategic resource in learning French language and to proceed for French naturalization. My study also finds another gender script in the educational capital differently for daughter-in-law and son-in-law. That is particularly related to the daughter's-in-law ability to take care of extra tasks of familial life that are to be managed outside of the four walls of her home in France. In Pakistan, joint family structure divides the familial tasks across gender; the boys are principally bread winners and are supposed to take care of the familial tasks outside the household. Whereas girls are supposed to take care of familial tasks within the household. When the very girl comes to France after marriage, she has to do what she has perhaps never done in Pakistan. She has to go regularly to do grocery, to accompany her children for school, to go to bank, and to visits governmental institutes for the purposes of registration of different events of familial life. This is why her education becomes important for her family-in-law in France. As described previously, an educated daughter-in-law is the potential good mother, her education

is also perceived helpful when she will have to take care of those household chores that are to be done out of the four walls of her home. After living their life in French society, the respondents have reformulated their preferential criteria for choosing an educated daughter-in-law. While on the other hand when the potential daughters-in-law are selected, they lose their motivations to continue education. Further, Coleman (1988) has stressed that educational achievements of the members are influenced by familial backgrounds. In Family VP5, when the daughter-in-law knew about the finalization of marriage proposal that she would be eventually married with her maternal cousin in France, she lost her motivation to get further education. She was encouraged by her mother-in-law to do beautician course. It is argued that husband manages the capital of his wife (Singly 1997), however in the cases mentioned above we see that families-in-law in France build and/or manage the capital of their sons/daughters-in-law in various ways that differ according to gender. For daughter-in-law they prefer education yet they try to restrict her further educational achievements as we have seen in case of Family SD5. It may be because of the mismatch of educational background of the couple as we found in case of Family LC4 where daughter-in-law was encouraged to get education until matriculation as her husband was still studying; it may be because of the nature of the job one is supposed to do after migrating to France as we see in the case of son-in-law of Family OZ5 where his father-in-law redirected his educational interests; it may be part of their cautionary strategies about daughter/son-in-law's independency, as we find in case of CB4, where we see that the mother favored strongly her son-in-law's educational background as a positive way towards his independency in France. In the start of this part, the literature argued for a link between education and the age at marriage. The next part continues to explain this link while focusing more on the age at marriage, gender age gap, the timings a marriage proposal is introduced. How these attributes are further expressed and what if losing motivation in education becomes equal to the costs that sons/daughters-in-law pay as being marriage migrant in the context of reception.

5.2. Age

Issues of age at marriage and gender age gap are worthy issues to be discussed in analyzing spouse choices. My study describes different marriage cases where respondents not only situate their ages at marriage but ages at the time of marriage proposal introductions and finalizations within the contexts of their strategic resources; education and migration. In the first part of the following discussion, I analyze age at marriage and provide respondents' actual as well as the idealized ages at marriage. In the subsequent part I focus on the age gap between a couple and how it is perceived across both generations. Then I narrate how families in Pakistan situate their children's education as their strategic resource and how families in France situate their status of holding French residency. In doing so how does the exchange of very strategic resources influence the migration of spouses?

5.2.1. Age at marriage

Given that the different levels of educational attainment determines either one's early age entry into and/or postponement of marriage until late age, the concepts of age at marriage and gender age gap has been dealt well sociologically and demographically. However according to Desai & Andrist (2010), demographic research has encountered some difficulties while analyzing the spouse selection decision that are the interest of corporate families under dominant kinship structure. They further say that adding gender scripts in sociological analysis of age at marriage and gender age gap though have not been easy yet it provided fruitful understandings. They provide Dyson and Moore's (1983) study as an example that analyzed kinship and gender in India, yet they treated gender as a unit of kinship structure, instead analyzing gender scripts in its own right. It is argued by the feminist perspectives that marriage is the key social institute that produce and reproduce gender scripts related to age at marriage. In the same vein, though demographic findings from its latest census (1998) have proved that Pakistan alike other neighboring societies has a societal standard of marrying until a specific age, certainly different for female (21 years) and male (25 years). According to the law, the age at marriage in Pakistan is 16 for girls and 18 for boys. (Child Marriage

Restraint Act 1929). Since February, 2015, the proposed amendments (18 age at marriage for both female and male) in Child Marriage Restraint Act has been approved by Punjab province. Compulsory education for children aged 5 to 16 years old is one of the steps taken to discourage early age marriages in Pakistan. This part analyzes firstly if individuals marry until the average age of societal standard or not. If they do or do not do so, what are the differences across gender and how do they deal with early/delaying marriage decisions while having a certain amount of symbolic and strategic capitals? The analysis will help us to understand how spouse selection choices produce and reproduce the gender scripts in age at marriage during the spouse selection procedure.

The age at marriage in first generation of my respondents has been in conformation of the then societal norms; most of the parents got married by the age group of 16-22 before and/or without migration. It is to be noted that early and late age groups are to be viewed accordingly for female and male. Migration and having the residency papers effected particularly the age at marriage of fathers, delaying the age at marriage until the maximum of age 28 (only in one case). In the younger generation case, none of the marriages have been organized before the international standard age at marriage; 18 years old. However intra-generation and intra-gender comparison shows that the French born sons got married earlier than those sons-in-law who came to France after marriage migration. On the other hand, French born daughters got married bit later as compare to those daughters-in-law who came from Pakistan after marriage. The marriage behavior observed in French born daughters and Pakistan-born daughters-in-law is somewhat alike that of Singly' (1997) observation concerning the type of different capitals women have and the cultural and social prices they pay while their early/delayed entering into marriage market. To find the major factors behind younger generation's entry into marriage and the link between them I now present some of the marriage cases. In this regard my first question is that do the timings when a marriage proposal was introduced have any link with the costs they bear; that is to say completing the education at one hand, and with age at marriage on the other hand? And if yes, what are the gender differences and how it effects their entry into marriage with reference to their

respective capitals; that is to say their educational achievements and the professional activities before marriage? In family SD5, the daughter-in-law was pursuing her graduation studies by age 19 when her marriage proposal was finalized. At that time, her family in law forbade her to study more, as she was not assumed to do any job after marriage. Though she has been very committed to continue her education and never thought to pursue any job career, yet she has to abandon her interest. By age 21 she got married and could never complete her studies afterwards. She is content over her age at marriage and the marriage decision according to the context in which she has been brought up, but she wished if her parents might have waited to say final yes to her marriage proposal so that she could have finished her studies. In this case we see that the timing of marriage proposal has affected her education. She thinks that she got married timely in an appropriate age, but if she had been allowed to complete her education, she might have been married somewhere else in Pakistan. Accepting a 'suitable' marriage proposal for oneself and one's daughter is a general concern of all families in my study. Parents as well as daughters do not want to lose the 'good' marriage proposal so that their daughter could stay happily in a long term relationship, even if she had to bear the cost of getting married at early age.

Sometimes education succeeded to play a positive role in delaying marriages as expressed by the daughter-in-law in Family SC5. Though she could not continue her education and got married by age 19, she insisted her parents to do not marry her younger sisters until they complete their education. In her own case, neither she or her parents nor her family-in-law were of the view to delay marriage because her husband was going to be married for the second time, while she was the eldest among her sisters. Alike her, in Family PI3 the mother is very committed to delay the marriages of her children until the completion of their education. It is interesting to note that a general ideal consensus is developed on not to delay marriages by age 25 and onwards for female and male so that they could not indulge them in extra marital relationships.

Until now we know what age at marriage means for daughters and daughters-in-law, the next part of my question focuses on the disparities that exist between the genders. As far as the sons and sons-in-laws are concerned, I found that sons-in-law as compare to daughters-in-law found themselves at more vulnerable positions when they compare their age at the time of marriage proposal finalization, educational achievements and professional and occupational integration in France. When I talked with the son-in-law in Family PI3, he just bursted and spoke against the wrong timings of marriage proposal asking. At that time, he was pursuing his studies while his father was in conversation with his father-in-law to finalize his marriage proposal. For him, at that age, it felt good, but he feels himself nowhere especially now as his marriage is about to break. Due to early age marriage proposal finalization, he had to switch her study interests which ultimately did not bring him any profit. Now he cannot go back to Pakistan as there is an academic absence gap of almost 4 years, so he cannot re-continue his studies neither in Pakistan nor in France. He thinks that parents must take of the timings of marriage proposal finalization. For majority of my male respondents age at marriage was not a serious concern at the time of marriages, yet it become the part of their post marriage reflections. The son in Family LC4 was very happy when by age 20, he got married. But now he says that it was really early age to marry. His parents did not leave him enough time to analyze what an early age marriage may cost him in terms of emotional attachments and an ideal look that a couple presents to their social networks. Age related reflections were also shared by son in Family VP5. He is not happy with age at marriage. He did not tell precisely at what age he got married, but preferred to get married around age 27-28. For his early age marriage, he accused his mother. His wife however later told me that during that period when their marriage proposal talks were being carried out, he was living with his girlfriend. So to restrain his sexual life within the institute of marriage, his mother rushed for marriage. *Thus a long gap between puberty and marriage is seen as a risky period by parents who seek to minimize this risk by arranging an early marriage* (Desai & Andrist, 2010:3). Above discussion revolves around the reflections of the female and male respondents over the question of age at marriage. The cultural and social experiences that they went through confirms Bozon & Héran (2006) explanations

that there exist not only different calendars for male's and female's age at marriage but the gender age gap differs according to their gender as well. The next part continues the discussion on gender age gap in the process of spouse selection process.

5.2.2. Gender age gap

In the last part 'age at marriage', views of brides/grooms' over their own ages at marriage were narrated. In this part we will see the age gap between the couple. In the first place I see if parents as well as their children were aware of the exact ages of the selected spouses or not? In the second place, if they found big age gap like the bride was very younger than her groom, in such cases what made them to proceed? In the similar vein if the brides were elder than their grooms, what made them to proceed?

In my data, in fourteen out of sixteen marriage cases the wives were younger to their husbands. In cases where wives were younger, 1 year is observed as the minimum age-gap while 10 years as the maximum. Upon inquiring about the ages at marriage of the potential spouse, and age gap between the spouses, majority of the younger generation exactly know the ages of their potential spouses (the number of years i.e. 21). Whereas parents often reported either estimated ages mostly in form of numbers of years where time spans more than a single digit i.e. 21 or 22 years old. And/or they reported wrong; especially the ages of their daughters and daughters-in-law. Age-related specifications show that age is part of parents' critical preferential criteria, especially in case of female. Female aging was linked to the child birth process; it is commonly reported that female should at least be 5 years younger to her husband. As she bears children, so she looks more aged. In response to my questions about the big age gaps and bride as being equal or elder to her husband, younger generation as well as the elder were ideally agreed that there is no harm in marrying brides/grooms elder to themselves, and very often they quoted the example from Islamic teachings that how Prophet Muhammad by age 25 married a 40 years old widow Khadija. Nonetheless the general trend of spouse

selection among my respondent Pakistani families is the preference for a bride younger than her husband.

Generally, if a marriage proposal acquires the 'adequate' status after the filtration process, age gap between the couple is ignored. To understand the gender scripts that produce justifications of refusal and acceptance of marriage proposals, Family VG4 appears as an important to highlight this noticeable behavior. The son-in-law in VG4 told that his family follow the tradition of marrying within close relatives, and age-gap is ignored generally.

Similarities in interests are our problems, we are today's generation and our parents and their siblings are yesterday's. They still do the ways their forefathers have been doing. I found every other couple mismatched in my family. Age gap is the most common among them. Girls should be married within family, so wait, wait, and wait. And finally let's marry them with the younger boys. In contrast a boy like me who has completed 27 years of his life in a continuous struggle wants to marry a mature mind girl. But what happens, you know? Let's marry him with a 20 years old girl who has never been ambitious for her career. Her life's only project is to take care of household.

This narration redirects our understanding towards the concept of 'purity of blood' through marriages. Some families belonging to particular lineages i.e. Sayed practice group endogamy strictly and so persistently that the ideal criteria of choosing a spouse becomes the blood belongingness. And in such cases, age gap becomes one of the common forms of mismatch as told by son-in-law Family VG5.

However, in my study like the one by Charsley (2013) among British Pakistani, there is evidence of refusal to a particular marriage proposal based on the criterion of mismatch in couple's age. And parents and their children have provided reasons and justification to their refusal as well. The refusals based on mismatch in age were found in Family LM8. The mother wanted to marry her daughters out of family due to the nature of relationships with her family-in-law. However, after an unsuccessful experience of marriage out of family, she started to search marriage proposal within the close network of family. One of her relative family proposed their son's marriage proposal to her. She did not accept because he was 2 years younger to her

daughter. She had fear that boys generally look younger even if they are older in age. She said that her daughter also refused due the mismatch in ages. Their fears are exactly similar to that of daughter-in-law in Family LC4, who takes care of herself very much because she is just one year older than her husband. Mismatch in ages in terms of physical aging is a strong reason to refuse the marriage proposals and are classified unsuitable. Mismatch in ages in terms of child bearing is another factor not to be ignored. Child-bearing is one of the prime purpose of marriage and child rearing is one of the ideal attributes of an ideal woman. In cases where the women are older, it is very often to refuse the marriage proposals. And in the same regard, as far as the male is concerned, similar logic of refusal is not applied in my respondent families. I did not find a single case where a suitable marriage proposal of a male has been refused due to his older age. To discuss this particular behavior, I present the marriage histories in Family AB4. The daughter in Family AB4 aged 35 recounts her husband's brother's marriage:

He remained childless by the age of around 50. Then the elders of our family advised him to marry so that he could have his heirs. His wife also my maternal cousin was not agreed but she has to follow the decision of the elders of the family. His second wife at the time of marriage was around 19 years old, she now has children now.

She further recounts that she herself has participated in searching a spouse for his husband's brother. And she found it normal as it is customary practice to marry a younger girl especially if the purpose of the marriage is to have child. Though the elders of her family did not speak about her husband's second marriage, she showed her concerns that if in the coming years, she does not bear any child what her husband would do? When I asked what she would do, she said that she would not be able to stop the marriage. Because it is her husband's right to have children. She then talks about the house she had bought in France as a security for herself, where she will not have to live with the potential co-wife of her husband. The refusal of marriage proposal shows that there exist gender inequalities when it comes to the question of older age of the wife especially. As far as the aged husbands are concerned, we have seen Family AB4 that the age gap between the couple has never been a concern. Same behavior we see in the case of Family CB4, yet the

age gap of the couple is favored by the mother and the daughter herself. The daughter in Family CB4 belongs to traditional family. Her father died since her childhood. All of the major decisions including her education, social life, friendships and marriage have been taken by her elder brother. However, when she got married to her husband who is almost 11 years older to her, he encouraged her to learn driving, so that she could remain less dependent to her husband for going outside the home, either for shopping or meeting her friends. For her:

The age-gap between us did not become an obstacle instead our marital relations are very good due to the age difference. He is mature and treats me as if I am a teen ager. He ignores my faults. I still do not know how to cook Lahori food. And you will laugh to hear that instead saying me to learn, he cooks himself.

Her narration in combination to the previously provided narrations of respondents, my data provide interesting insights in order to understand the behavior of rejection and acceptance of a marriage proposal based on age gap criteria. These insights have rarely been discussed previously. Thus I argue that the concept of age gap is highly diverse and depends on the suitability of a marriage proposal. Yet there exists difference across gender while filtering a marriage proposal as suitable or unsuitable. Generally, in case of male, there is an acceptance of large age gaps especially if his marriage proposal is found attractive. There is rejection as well especially when male is younger than the wife, even his marriage proposal is filtered to attraction. The major reason behind rejection is the fear that parents and their daughters have for female's early physical aging process in connection with the child bearing process. Marriage proposal where grooms are younger than their wives are considered unsuitable but under certain circumstances as in case of Families LC4 and CO6, are accepted. Leaving these cases side with some variation, this study shows a general trend as observed by (Bozon 1991) also that in the majority of the marriages cases of my respondent, the brides are younger than their husbands. This trend also confirms the general trend of Pakistani marriage market that brides younger than their grooms is the dominant behavior and is widely accepted across gender and generation with some variations as discussed in this part.

5.2.3. Elder wives and younger husbands

Now I proceed towards the cases where wives are found older than their husbands and will analyze what made them to proceed against the general trend of Pakistani marriage market, where wives are always idealized younger than husbands? Only two family cases are found where two wives were elder than their husbands. In cases where wives were older, an age gap spanning less than a year is observed as the minimum while almost 3 years as the maximum. The first case belongs to Family LC4. The mothers of the couple are sisters and they fixed the betrothment of the couple since their infancy. According to groom, the age gap is not a big so it would not make any big differences. On the other hand, the bride, however, was very concerned about the age gap and told that she takes care of herself. As she is elder and has given birth to three daughters, she regularly does physical exercises. The factor (as discussed previously in details in the part 'marriages between matrilineal cousins') that led to happen this marriage is principally the sisterhood solidarities between the mothers of bride and groom. Further the analysis of the interviews and the informal talks carried out in Family LC4, another factor is as the bride's parents are has five sisters and all of her parental family has been helped financially by her aunt (mother-in-law), there are strong bonds of emotional attachments.

The literature on spouse choices implies that where there are more similarities between the two individuals, there more chances of attraction. If we shift the focus from similarities to the differences among the potential couple in combination with their familial background, the tendency to marry with an elder wife is expected to be changed as we have seen in Family LC4. What if we combine the factor of siblings' marriages to understand a couple's marriage behavior? Do elder siblings' marriages (re)direct the marriages younger siblings or not? If yes, how? Does the criterion of age gap matter or not?

To understand the marriage behavior of the couple within this context, I exemplify Family CO6. A Family CO6 has only a daughter aged 30 years now. She is diagnosed autist and thus has little chance in Pakistani marriage market to be

selected as an appropriate spouse. Her parents however fixed her marriage with her cousin in exchange of two of her brothers. In exchange marriage system, generally the exchange is followed basically on the rule of equality and such exchange is based on the exchange of women, that is to say a sister is given in exchange of her brother. However, in Family CO6, the exchange is neither equal nor the sisters are given in exchange of their brothers. Instead the marriage proposals of two brothers are given in exchange of their single sister. In the first couple, the husband is younger than his wife with an age gap of almost three years. The second couple shares almost same ages with an age gap of one year. In the third couple, the wife is younger than her husband with an age gap of four. The elders of Family CO6 decided for the exchange marriages of the three couples. The husband in third couple's case is himself part of those elders who decided for exchange marriages. During his talks to me, he clearly said that as his father had been died since some years, he has been made responsible to take care of the duties his father had left to him, according to the ritual. In Punjab, when a father dies, next day the elders of the family perform a ritual to appoint his eldest son as a symbolic replacement to his deceased father. As he is the eldest male in family, so he is assumed to take care of the very responsibility that his father has been carrying. The duties he has to deal with includes the marriages of their sisters and brothers. He told that in exchange of his marriage, his two sisters were going to be married. So he by supporting the decision of his elders has fulfilled the duties he was supposed to perform. He did not prefer to talk over the ages of his sisters. However, his mother told that age gap matters where there are no prior marriage contacts. Her children and their spouses has grown up and played together in the same street of the villages during childhood, so they did not find it weary; neither the exchange marriage nor the age gaps. Over the ages at marriage and the age gap between her daughter and son-in-law, she told that:

If there are not much cases in our family where the husband is younger than of his wife, there are also not much cases of big age difference between the husband and the wife. Actually marrying the girls by age 25 is a common trend since generations in our family, however exchange marriage is the first case in our family that happened by chance.

Over the question if the exchange marriage was a part of strategy or not, when I talked with the father of sons' in Family CO6, he said that:

Without plans we cannot manage our familial issues. Initially I took the opinion of my wife over the exchange marriages of our children, she first refused, but later agreed. My daughter is not alike other girls in my village. She is not talkative but innocent and simple. Though we say she is Allah Lok [Literal meaning of Allah is god and lok stands for people. Such person is perceived peaceful and closer to god as compared to others who are busy in the worldly affairs] but when you will meet her, you will find how active she is in household chores; she cooks very well, she takes care of her elder brother and paternal aunt, she does not go outside the home for the sake of gossips with friends.

According to the marriage market in Pakistan, the standard behavior of a girl in terms of her sociability is related to the ways she deals with people around her. A shy and less talkative girl is perceived less adjustable in her family-in-law, especially in case of joint family system. Being expressive while remaining obedient is one of the filters a girl passes through. When I met her in Pakistan, she was accompanied by her paternal aunt and a female friend (almost 10 years younger to her). She was very reserved and instead of talking, she continued to pass a shy smile over my questions. From father's description we find at one hand that he admits inexplicitly that his daughter is not 'normal' according to the set standards of accepted behavior of a girl in Pakistan marriage market; however, he expresses that to run a household, she is capable of. In the similar vein, the brother who married in exchange of his sister, expressed his feelings for his sister. In contrast to his father, however, he was confident that:

So what if our sister lacks some qualities, we either are not ideal. We all have some sort of incapability, yet we have to deal with. Marrying with parents' accordance is blessing. I have no issues if their sister [his wife] is elder. So they too should not have any issue if my sister is not extra active. If we three cousins have married wherever we wished for, our selfish decisions would not have brought happiness to our sisters. Brothers are there to protect their sister not to bury them under the mountains of sorrow.

During my visit to their village and informal talks with their relatives, it was clear that exchange marriage is not the tradition of the family, and it happened to deal with the

problems (growing ages of a couple of sister as one side and the autistic sister at the other side). The paternal aunt describes the sons in both families as obedient and dutiful who cooperated with their parents to secure the honor of their families at one hand and to fulfill the duties of brothers on the other hand.

5.3. Morality

In the start of previous part, I discussed the criterion of age at marriage in relation to the question of sexuality while presenting the case of Family VP5. The concerns for female and male sexuality hold heavy places in spouse selection criteria. This part continues to describe where do the concerns over sexuality in spouse selection criteria stand? Do the concerns are showed differently across the gender and generation? Before I go to the details, it is worth mentioning that with some variations, there is a dichotomous division over the criteria of sexuality; pre- and post-marriage concerns. Pre marriage concerns regarding son/daughter-in-law's sexuality belong to parents' domain mainly. In the similar vein, their children also have pre marriage concerns over the sexuality of their potential spouses. However, children neither directly talk with their parents and parents-in-law nor they demand them about the sexuality of their potential spouses. On the other hand, this is not always true. In some cases, the potential husbands showed trust on the information provided by their parents at one hand, and took details secretly about the character of their potential wives from their social network on the other hand. As far as female are concerned, they rely whatever their parents have told them at one hand, and if they are in contact with their potential husbands, they ask them directly as we find in case of Family LP4. Some wives did not take information through their social network before marriage, nonetheless they are far active and more expressive in showing their concerns over their husbands' sexuality after the marriage as we find in cases of Families OZ5 and LG4. Husbands were however less expressive and wives were more expressive over the question of sexuality of their spouses. As the focus of this part to identify the spouse selection criteria before marriage, it must not be assumed that the concerns over sexuality and loyalty of the potential spouses belongs to pre-marriage ideals only. Keeping in mind that the couple had passed

some years of marital life in a society where fidelity and loyalty are differently defined than of their origin country's values, and where the sexual life is not only confined to the institute of marriage, the respondents mainly female talked more on post marriage criteria; the risks they face and strategies they adopted to keep an eye over their husbands. I will discuss the details shortly in the coming text. So keeping in mind these variations, I proceed to towards the case histories of my respondent families.

My respondents in both generation across the gender showed strong preference for spouses who possess sound character. Although virginity of a girl prior to her first marriage is expected to be preserved in the Muslim and Punjabi culture, my respondents mainly the parents did not express such preferences. This could be due to the lack of direct and open communication over the issue between parent-children as it is considered inappropriate and in descent to talk with parents even over his/her marriage. This could be due to the very norms of discouraging open communication over sexuality between and even within gender and generation which are observed in Punjabi culture. It is considered highly inappropriate if male and female talk over their sexuality openly or even secretly. Further, familial honor is maintained by not disclosing the anomalies in sexual behavior of their children. This is why that my male as well female respondents especially the elder generation were not expressive regarding the sexual behavior of their children, including daughter/son-in-law. Few mothers discreetly talked about other co-ethnic Pakistani's children's bad character without disclosing their identity, whereas fathers hesitated to talk over or to provide any detail. In doing so, they were not only preserving the cultural norms to avoid sexuality related talks but were maintaining their familial secrets also. Nonetheless, the younger generation discreetly hinted for and expressed explicitly about their reservations.

Keeping in view that ethnocentrism sneaks in easily, as my respondents belong to two different societies, the ways they expressed their concerns for the sexuality and soundness of the character of their potential spouses, were heavily influenced by their respective experiences of being raised and socialized with. Their concerns

were in favor and also against of the environments they are and have been living in before and after their marriages. I shall present first the marriage cases that shows how living and raised in France may affect the spouse selection criteria especially when it comes to the question of pre marriage sexual life of the spouse. Later I shall analyze similar question in Pakistani' context.

Born and raised in Pakistan, the son-in-law in family CB4 came to Spain before his marriage. Later he came to France. He recalls his living experiences in different EU countries and claims that getting indulge in bad activities is very easy here. So he had some fears in mind concerning his wife who is born and socialized in French society. He was very concerned for his wife's pre-marriage sexual behavior.

I wished to marry only a pious girl who had not been indulged in any kind of romantic relationships in the past....

The term 'pious' is used in various way yet it is uniquely referred to an ideal character. If interpreted religiously, it means a person who have believe on god and obeys him. If used to judge a person's behavior for his family in cultural context, it may mean a person who takes care of his parents and family. In his narration he talks about the sexual character of his wife. Even if his potential wife has no physical relation with someone, her romantic involvement is a serious concern for him. He used his close friend's network to know more about the character of his wife and the fame of his family-in-law in France. After the satisfactory information, he showed his consent to proceed with this marriage proposal. Another husband in my data, born in Pakistan but raised in France inquired about his potential wife. When his father (Family SD5) proposed him a marriage proposal belong to his matrilineal extended relatives, he said his father to wait little though his father has assured him. He himself inquired about the character of his potential wife through his male cousins in Pakistan. He too proceeded once he was satisfied. Similar fears and concerns over the sexuality of spouse were shared by the young couple in Family LP4. The husband born and raised in Pakistan came to France before his marriage. He met his wife in France and they kept meeting for three years in order to know more about each other and their compatibility. The wife is born and raised in France and had serious concerns about her husband's sexual character before marriage. She told

that both of them did not decided for their marriage at once, though they had liking feelings for each other.

Finding a boyfriend is easy, finding husband [is] very hard. Living in temporary relationships is easy, living in the long relationship [is] very hard. Enjoying non-serious relationship is easy, remaining serious in relation [is] hard. This is why I did not rush for marriage. I very clearly told him not to expect any dating relationship with me.

Her narration shows her behavioral confirmation to the traditional matrimonial system when she warned him and decided to know about his seriousness. As she has been brought up in a modest family in France, who considers education and job essential, she compared two systems of partner choice at the same time. The one she observed in her family, the other she has observed during her educational life. She however is not of the view to depend parents and family to find a groom. Instead she looked herself for. Her husband too was not facing any hurdle when he proposed his spouse choice to his family, though he belonged to a very traditional family. Alike his wife, he too was very conscious about his marriage and life partner's character.

We first met in a musical show. Here in France it is not strange. I liked her and she too liked me. She looked simple and dressed modestly. I liked her appearance. Later we started to meet, but not very often. It took us almost three years to finally decide for marriage. We both were serious with each other at the end.

The husband alike his wife too was concerned about her seriousness in relationship. As they met in a musical show, the first meeting place that the wife did not disclose, he took relatively more time in developing the trust, knowing their compatibilities and judging their commitments in the relationship. Once they were satisfied with their queries, both of them informed their families for approval. In these two families, one attribute of the sons-in-law is common that they were not marriage migrant as compare to their fellows in other families in my data. Both have spent some years prior to marriage in France and other European countries. In terms of easy entrance into sexual life, their fears for their spouses are almost similar to their fellow generation; the French-born children. However, the sons-in-law who came from Pakistan after the marriage were different in terms of not only the proper

experiences of European life but in term of illusionary exposure to Europe through media. Through Hollywood movies, the son-in-law in Family PI3, had developed an idea what does European life looks like.

I used to think that an adult lives freely here. He can have girlfriends very easily. She can have boyfriends easily. So it is hard to remain single and to wait for marriage. I was like under an immense fear and psychological pressure what if she likes someone else. I never ask my fiancée directly about her private life. However, when our marriage date was fixed, I asked her. I was very worried at that time if she minds my question and what if she discloses my question to elders. In this case, it might bring me a lot of shame in front of the elders. Luckily, she did not make it an issue and assured me that there is no one in her life.

When the elders of family are involved and if children take some steps on their own, it might create a problem, however, he felt himself lucky that he did not have to bear the cost of his courage. He told that all of his fears were proven wrong when he started to live with his wife after marriage migration. He is of the view that if someone is good and knows how to remain in limits, European life style cannot influence him. The risk of European life style was a common point of my respondents' discussion. The son in Family LC4 shared similar fears. Though he dislikes his early age marriage yet he appreciates very much his wife and likes her sound character too. He very often talked how careful his wife is in socializing their daughters. He proudly said that neither he nor his wife allowed their daughters to see cartoon channels as they are according to the rules they teach their daughters. Yet he wishes to remarry again, and if he would have a chance he will marry with a French-Pakistani girl who must possess sound character. Though the ways of inquiry differ, yet one thing is common that sometimes husbands born in France and in Pakistan try to get information about the character of their wives before giving consent for marriage.

Alike the male, young female respondents also showed their prior marriage concerns over the character of their husbands. However, there are differences in expressing the preferences across gender. Most of the narrations of husbands revolve around the pre-marital character of their wives, whereas female respondents simultaneously expressed their pre and post marital preferences. Husband's fidelity

and sexuality after marriage is one of the most discussed and desired characteristic. Female respondents often doubted their husbands who are more mobile in finding a job and who have moved from a close traditional to open modern society where there are more opportunities of interaction with female colleagues that could lead him towards friendship. Though young wives (born and raised and in France and those came from Pakistan) have doubts over their husbands, yet they differ in ways to verify their doubts and to resolve the issues. In Family LM8, the wife did not bother much about her husband's prior marriage character as she and her parents trusted her maternal uncle in Pakistan who was supposed to verify about him and his family's reputation. But after the marriage, she doubted and continued to check secretly the message history of her husband's mobile phone. A day she accidentally found that the email account of her husband is still logged in. She found some email conversations between her husband and his girlfriend which lead the couple's marriage dissolution. She firstly forgave him, however when she found that her husband did not listen her and deceived her, she filed a case for divorce against an infidel husband. She informed her parents and they supported her decision for divorce. She is now planning for second marriage and is determined to show no compromises over the character and fidelity of her husband. When I asked her husband what were the reasons behind the divorce, he first hesitated, then told that his wife doubted him.

When I was in Pakistan, I have some girlfriends, but you do not take it equal to having a girlfriend in Europe. As I have run a tuition institute, there were my students. One of the student got study visa for France and she contacted with me for some help. I helped her even when she came in France. This was the reason that my wife doubted me.

According to him as his wife was having useless doubts, and his student was in need of help, so he accompanied secretly his student to different governmental institutes to get her registered in France. While on the other hand, his wife and his family-in-law spied him secretly. When his wife knew that he has been often seen in the company of his girl student, she confiscated his passport and expelled him from the home. Later he got his passport back through Pakistani embassy in Paris and

had to proceed for divorce. I should mention that this couple is the only one in my respondent families, where I observe a very close behavioral compatibility based on their interviews. Their responses over their leisure time interests, taking care of household chores jointly, their future projects of buying an apartment, working hard in their respective professions and joint saving bank accounts were almost same. Whereas their responses over having a child, husband's fidelity and wife's carelessness for her family-in-law were in contrast. The issue of sexuality holds such a strong place in spouse selection criteria that it may lead towards divorce, as we have seen in Family LM8. It is reported commonly by sons-in-law in my respondent families that their wives being dominant in taking many decisions were also hastened in filing the divorce, whereas their parents instead interfering positively to save the marriage institute often back their daughter's decisions. Sometimes parents and siblings also direct the decisions. Almost similar doubts over son-in-law were emerged in Family PI3 also. The mother-in-law in Family PI3 told me that her son-in-law never knew that his mobile phone is hacked.

My daughter told me that she checked his (her husband's) mobile calling history and knew that he is used to call Pakistan and elsewhere whenever she is not with him. We discussed the matter with my elder son. So in order to know about what exactly the matter is and if he is secretly involved with someone else or not, my son secretly installed a software in my son-in-law's mobile that recorded in and outgoing calls. When we heard, there was nothing like there is any girl. But we found that he used to tell his father about our familial matters and asking help where to do job or not. He also often sends and save money without informing us.

The Mother-in-law admits that she is very dominant not only her children but on her son-in-law also. She provides justifications that it is due to her dominant behavior that her family is not indulged in bad behavioral activities. She recounted many stories in her surroundings without mentioning the family names that the how the children of some families have girl/boyfriends and brought shame to their parents in the eyes of whole Pakistani community. One of her mentioning families is also my respondent family. The Family VP5's has three daughters and a son. The eldest son is married with his maternal cousin in Pakistan. It took him almost five years to call his wife and his daughter in France due to long visa process. When she came, soon

she started to feel that her husband is not very much interested in her. Her mother-in-law interfered but in vain. After six years of marriage, the wife knew about her husband's girlfriend and a son from that girlfriend, she did not inform her parents back in Pakistan. Because her husband asked pardon. However later he continued his relationships with other girlfriends and even did not fulfil the duties of being father. Though her mother-in-law (maternal aunt) asked her to remain optimistic, she nonetheless proceeded for divorce. She is determined to re marry with a guy who must be conscious about the seriousness of marital relations and who could also behave properly like a father with her kids.

From the above mentioned family cases we see that though there are differences across gender and generation over the ways how to deal with the issue of pre and post marriage fidelity and sexuality. The concept of collective honor of the places heavy emphasis in the kinship structure in Pakistan. There are numerous cases reported each year in Pakistan where the girls who eloped from their homes were murdered by their male relatives, mostly fathers, brother and uncles. Though I did not have any such in my respondent families yet I have been told repeatedly a case that is often repeated in gossips in many families. A Pakistani girl was burnt alive after the sexual assault. The murderers were two friends French-born Pakistanis and they killed her upon knowing that she was dating and having sexual relations with both of them. The concept of honor may not only the issues of female sexuality but of the male as well as we have seen in my data. Additionally, the gendered geographies of power that are awarded to its citizens by both nation states; Pakistan and French have powerful influences over the way sexuality is dealt. In Family VP5, we have seen that upon knowing her husband's cohabitation and a baby boy, the daughter-in-law has been consoled many times by her mother and mother-in-law. Their consoling behavior is exactly what is expected by Pakistani marriage system. However, her father encouraged her to proceed for divorce is actually a decision that goes against the cultural values. According to the daughter-in-law her father second her divorce decision not because he is very educated but because he is very religious person and of the view that Islam discourages such marital relationships. Apart from the religious and cultural interpretations, she thinks that its due to the

social security system of France that gave her hope that even if she is divorced and jobless, system will take care of her and her children. As her father is retired officer, he could not be able to support her in the long run. So she found French system as more security than that of Pakistan. Otherwise if she had been in Pakistan, she might have been living with his unfaithful husband for the sake of her daughters' better future.

5.4. Responsibility of parental families in Pakistan

In the introduction chapter, I have mentioned that the purposes— a transnational marriage serves— may mean different at some points not only for both families in emigrant and immigrant countries but for their children also. Derived from previous research findings, I assume that one may find common interest upon the issue of continuity of familial value system. For family living in Pakistan, it could be more meaningful to arrange to marriages of their children with those who are living abroad, so that they could avail relatively better living standard after moving there; the chances of becoming French national, particularly their son would have better job and more earnings which ultimately would bring a lavish living standard for other family members living behind and their possible chances to go abroad for the purpose of family reunification. For Pakistani-French family, migration of son-in-law may reveal their interest in their daughter's physical proximity to them even after her marriage as she does not depart to her husband's or family-in-law home. On the contrary her husband leaves his parental home and country to join her. Thus parents and their daughter try to avoid from the cultural clashes if she moves to her parents' native country. Their daughter finds more convenient to reside far from her family-in-law. Parents choose a daughter-in-law being raised and brought up in a traditional society to preserve and transfer the very indigenous value system to their future grandchildren. For Pakistani-French parents, the culture of host country may not be ideal as their indigenous one but for their children it could be, thus creating the intergenerational conflicts. Blood relationships and kinship for the immigrant parents is taken for granted as indispensable, whereas for their children it may be a matter of affinity choices (Schiller, Basch & Blanc, 1995). How obligations towards their

respective families have been fulfilled and what is the nature of the obligations that the family lived behind expect from its members is the subject matter of this part. How such obligations become the part of the preferential criteria of parents and their children? Does being responsible of the family lived behind applied equally to male and female child?

Sometimes, husband's responsibilities towards his parental family in Pakistan become one of most disliked attribute of an adequate spouse. For example, wives in Family PI3 and Family LG4 mentioned negatively certain behavioral manifestations of their husbands like sending gifts and money back to Pakistan to their parents and siblings, frequent telephonic conversations spanning long duration, supporting and helping especially male members of his network of relatedness to migrate. The mother in Family PI3 told that she asked her son to spy the conversations of her son-in-law at skype when he talked with his father back in Pakistan. She had doubt that her son-in-law sends more money to Pakistan than sharing the common household expenditures. Whilst her son-in-law told me that he did never send money to Pakistan, but saved in his bank account. H said that his wife is giving all of her salary to her mother, so he is not going to hand over his own. The wife in Family LG4 told that when his husband tried for visit visa application to call his mother in France, she deliberately submitted incomplete file. As her husband could not speak French language, so nobody could ever know why the visa application was rejected. She dislikes if her family-in-law knows more about her living style in France. So, she denied to adjust her brother-in-law in her household after his arrived in France.

Other behavioral traits like, caring, loving, fidelity, non-violent/non-aggressive, and obedient are the part of their preferential criteria with a variation across gender and generation. As one of my female respondents of family SD5, who came to France after marriage, describes her spouse preferences as being loving, caring and respectful. Prior to her marriage she had knew about the behavioral traits of her husband who happen to be somewhat aggressive and short tempered, which she does not like. However, actors contextualize themselves as well while constructing

their spousal preferences. A French-Pakistani wife in family CB4 shared the similar preferences of a spouse as my other female respondents by taking into account her own self:

Like every girl of my age, I too wished to marry a handsome, charming, caring and loyal person who could give respect to my family as well. But I know that reality often does not correspond to our ideals and particularly when I used to view myself being dependent, less mobile, not much educated and lacking confidence while communication.

5.5. Attitudes and Values: Tradition versus modernity

Families living in France prefer to have a less traditional son-in-law, but, to the contrary, a more traditional daughter-in-law from Pakistan. A less traditional male, according to them, would be less impugning and opposing to certain cultural norms that her future spouse is expected to follow as part of French society, i.e. driving, shaking hand with opposite gender, formal dressing, and dining out etc. They also expect him to be less concerned about his family lived-behind in Pakistan and more concerned about his family here in France. For example, he should not be economically dependent on his in-laws, and rather should save his money for different future projects, like buying a house, offering his wife and children a luxurious life and if possible start his own business here in France, instead of sending money to support his parents and siblings in Pakistan. As described in detail the portrait of an adequate son-in-law by a mother living in France:

As a parent, I always searched for a nice guy for my daughter. A nice guy means he who has no bad habits like smoking, drinking and indulging with other girls. He should be hard working. Mr. K impressed me because of his hard working ability. He belongs to a family that was not economically much dependent on him....

On the other hand, they are of the view that a more traditional female from Pakistan is preferred because she would be more compromising over spousal disputes, take responsibility of household chores, play an active role in the socialization of her children, and more importantly would be more caring for her parents-in-law. A father

in family SC5 expressed his views about an adequate daughter-in-law in these words:

Everybody has his/her choice and I made clear to my boys that you can marry by your own choice but the girl should be Pakistani and must be well versed in religious teachings. Because I don't want my grandchildren to lead astray either because of spousal conflicts or because of (bad) socialization by their mother.

In Pakistan, the male children, along with their wives, are expected to be responsible for meeting the needs (both economic as well as socio-psychological) of their aging parents. Those male children who fail to keep their parents with them face negative social sanctions by their relatives and kin group. Although France, unlike Pakistan, have the facility of old-age homes (*maison de retraite*) which could have alleviated the sense of insecurity of parents during old age, in case their children refuse to accommodate with them. However, they revoke the cultural context of their origin country and expect their daughter-in-law to treat them well. Their expectations may range from staying with them in the same house and taking care of their food, health and clothing needs to visiting them often and helping them economically, in case their son and daughter-in-law don't reside with them in the same house.

It is interesting to note that in case of multiple male children, when parents in France are unable to dwell in the same house due to its small size, they prefer to keep their married children and their spouses with them unless they find their own apartment/house, which is also expected to be in their proximity—preferably in the same or neighboring town. If none of their children lives with them, they are expected to visit them often and to take care of their financial needs. In both cases, a traditional daughter-in-law, according to them, can better meet their expectations, especially when she already has kin relations with them.

A family with a divorced or separated child(ren) is more likely to face difficulties in finding spouses for the rest of their children. Spousal disputes often lead to separation and/or divorce, which creates bad reputation of the family. Parents in France are likely to avoid any such possibility by preferring a traditional daughter-in-law. They are of the view that they are living in a society where spousal disputes

frequently result in the breakdown of relationships, causing problems not only for both the husband and wife but also for their children and their parents as well. A traditional daughter-in-law, would be more compromising and thus would be more likely to save her marriage.

Socialization of grand-children is a very important issue for the parents in France. Being born in France, children are more likely to internalize the cultural values and ways of being of the host society. However, they think that the cultural values of their origin can also be transmitted if parents consciously guide their children about how things are done by introducing social sanctions to their children's actions. Similarly, they value their religious traditions which they desire to continue to their posterity. A traditional daughter-in-law is expected to be equipped with the knowledge of religious traditions and cultural norms. Parents think that she, being more available as compared to her husband, would play a key role in the socialization of their grand-children.

They don't expect from their daughter-in-law to be a working woman because they think that their son would play the role of breadwinner for the family. They, nevertheless, prefer that she should be well trained in the household chores, like cooking, cleaning, maintaining and decorating house etc.

Although they prefer a spouse for their children who may not necessarily belong to the urban geographic locality, however they make sure that he/she should not possess a villager mindset, to whom they label as *Paindu*. The word *Paindu*, may be translated as 'the villager', but it signifies some important behavioral traits, rather merely depicting someone's rural geographic origin. A *Paindu*, according to my respondents, is the one who does not have a sense of adequate dressing; lacks confidence and manners while communicating with others, especially with opposite sex; is not much sociable, and more importantly, does not respect the relationship hierarchy. Such person, being part of their family, would bring humiliation and disgrace to the family.

5.6. Transnational marriage: An avenue of opportunities?

Families living in France, being relatively at an advantageous position, can be selective among the children of their in figuring out who would be their future son and/or daughter-in-law. However, such a luxury is not available to the families living in Pakistan, as relatives of transnational families. Instead of narrating their preferences for their children's spouses, they told their motives, fears and concerns, and strategies to cope with these. Why should it be desirable for them if their son or daughter marries someone who is resident in a distant country? Is it simply because that the power of the family alliance is stronger than the opposing forces, like the geographical distance, that are created in the migration situation. Or, the picture is more complex than what it appears to be? It is indeed the whole complex of considerations, motives and ambitions which plays its role in their acceptance of a transnational spouse. This includes the influence of the kin-group as well. Interestingly, the difference between home and host country leads to the transnational marriage in such cases.

France, being first world country, features to possess several economic and promising future opportunities for the people living in third world countries like Pakistan, where poverty and deprivation strongly favor the idea of any possible route to emigration. Thanks to mass media, like movies, TV, newspapers and magazines, which plays an important role in reflecting a voluptuous image of the first world countries to stimulate the immigration impulse of the people for their better futures. In other words, while viewing such prosperous images of the Western countries, they ask themselves: why should I be poor, oppressed, hungry and hopeless, if there are people elsewhere who have plenty to eat, have a house and a car, and can go to the doctor while being ill? Why suffer here? Why not try to get there? Thus migration—a promising exit from the troubles and sufferings and a promising entry to a better life—becomes a dream for many people in the countries like Pakistan. And, transnational marriage is seen as an opportunity to migration to their dreamlands, like France.

After the First World War, labor was required in the first world countries, and so many people could come as labor migrants. It is only recently, when poverty and unemployment is on the rise in these countries, that the migrants are undesirable. However, there is still a legal way to enter into Europe: "Family reunification". Those who are legally the residents of France and have successfully completed the process of naturalization, can call in their close family members who live elsewhere. The more the migration becomes a desirable project for the people of poor countries like Pakistan, the more different migration routes turn out to be closed by the policy, and thus the more the transnational marriage becomes the desired goal to hope, and to dream of a better life. For example, in Pakistan: "Young men pin their hopes of social advancement on going to England by marrying a relative there" (Shaw 2004:279).

A transnational marriage, therefore, opens new avenues of upward mobility. Both, the parents and children, in the wake of migration and globalization, find any such proposal as an attractive opportunity, not only of socially appropriate family alliance by holding in the social fabric of origin society in the new transnational spaces, but also a way out of the local misery. Their preferences and ideal criteria may not necessarily find the proposed spouse as a desirable candidate for marriage, yet they accept the proposal as a package composed of hope, fear, risk, and trust.

Most of the families in Pakistan, when offered a proposal by the families in France, had several apprehensions about the future of their children. Although they hope that due to existing family links with the in-law family in France, their children would be treated well and would have better chances of being socially and/or economically adjusted in the new country. However, they still find themselves in a risk taking position, because they know little about the future spouses and their sociocultural and/or economic activities and repute in the society, which is almost inaccessible to them directly. They fear about his/her character and behavior, yet they trust the descriptions of their relatives who introduce such proposals to them.

Concluding Remarks

Marrying their children within the kin-pool is the primary spouse selection criteria of most of my investigated families, nonetheless, it is not the only filter to select adequate spouses. Some of them marry out of the kin-pool. Either they marry within family or outside, the primary criteria of my investigated families reflects a specific feature; their spouses belong to Pakistani pool. The primary criteria however remain incomplete without the complementary criteria. If required individualistic characteristics are not found in a potential spouse within kin, then it is not considered adequate. Families search the pool of potential spouses outside the kin. Complimentary criteria basically revolve around socio-economic and behavioral traits of the potential spouses. Most desired individualistic characteristics are education, age at marriage, gender-age gap, morality, responsibility of parental families, attitude towards tradition and modernity, and values of transnational families. Both generations actively participate in filtering who an adequate spouse is from the primary and complimentary spouse selection criteria. Once the adequate spouses are identified, parents and their children steps further to negotiate who amongst them is adequate spouse before proceeding to finalize the decision to marry.

Primary and complimentary criteria of spouse selection is formulated by several factors. However, these factors are not distributed symmetrically across gender, generation and territory. There are, first, the obligations of family loyalty and relatedness, which require the family in host country to reformulate the strategies in the face of increasing barriers to migration: whereas family in the country of origin may take marriage as a migration opportunity. Second, globally prevailing inequality between the first and the third world countries put the immigrant family to an advantageous position of higher status and prestige in their origin society, where they have more negotiating power in the local marriage market as compared to their kin relatives. Third, gender and intergenerational relations are on the move, not only in the host society, but also in immigrant families: men and women of the generations of parents and children, though differ in their spouse preferences, adopt

different strategies to affect as well as influence each other's decision making power in marriage market.

Spouse selection preferences are cautiously made, governed and evaluated through social norms. However, it does not mean that spouse preferences of Pakistani families in France reflect a static, homogenous set of criteria which could be exclusively linked to their native cultural habitus. Migrants of Pakistani origin in France are not simply the Pakistanis. They also form—in terms of experiences, expectations, needs, and even values—a community with various reflections of their host country. In cultural hybridism under transnational context, their life experiences are not simply a continuation of the traditions which they took from Pakistan and conserved as it was upon their arrival in France. They are being influenced and affected by the experiences of migration, and of the social, political, legal, and economic conditions in their host country. The intervening factors influence underlying configuration of spouse preferences across borders. This is to say that spouse selection preferences along with the inherent motive—marry to migrate—vary according to individual's own position, experiences and capital holding in his/her kin network on the one hand, and the politico-legal, economic, and social contexts of the origin and host countries on the other. From religion to secularism, from family institution to individual agency, and from being married to remaining unmarried, there is always a dual frame of reference—the tension between here and there—which equally affects their spouse preferences shaped by the hybrid cultural environment. Furthermore, if we shift the focus from cultural rules of marriage to the individuals' ideal preferences of a particular spouse, it brings deeper insights to understand how the criteria of choosing an adequate husband/wife and son/daughter-in-law is perceived by the individual agency. Several factors including intra-family dynamics, and particularly socioeconomic capitals of the potential spouses i.e. education, sociability, morality, behavioral traits and values that play their part in the construction of preferential criteria of actors involved in transnational marriages.

CHAPTER 6

SELECTING THE ADEQUATE SPOUSE: NEGOTIATIONS AND DECISIONS

One of the objectives of current research is to analyze the mechanism of spouse selection in French-Pakistani families. Firstly, we examined the question of who are the potential spouses and highlights the primary spouse selection criteria of parents and their children. We observe that the kin—being primary criteria—are preferred pool of spouses. The practice of kin-endogamy is followed by organizing the marriages of children within the different layers of kinship structure. However primary criteria remain incomplete without the complimentary criteria of spouse selection. A brief discussion on complementary criteria in chapter 5 demonstrates that potential spouses are filtered through different socio-cultural, economic and behavioral criteria. Cultural factors being the building blocks of primary criteria and the individual's particular capital being the building block of complimentary criteria jointly filter potential ones from the pool of spouses. Once the parents and their children have expressed their primary and complimentary criteria and filtered potential spouses from the pool, the negotiations on selecting an adequate spouse start between the two generations before finalizing the decision of marriage. Current chapter examine the very negotiations across gender and generation on the discourse of who an adequate spouse is?

'Marrying back home' is considered problematic under the paradox of cultural clash meaning 'us' and 'their'. Post industrialist west sees marriage must be based on intimacy and love between the two. To marry or not to marry is a highly personal decision and is related to one's own choice and individual's right. Whereas in Pakistani cultural set-up, interpersonal relationships are to be developed and found within the institute of marriage that defines certain obligations to be fulfilled mutually by each member of the family, be it parents or the children. Pervasive ideas—emerged from the anthropological and sociological simplified studies of marriage

choices—provided sweeping generalizations and divided the practices of marriage into dichotomous domains; the traditional and modern. It is in this context, that current chapter digs the strategies adopted by parents and their children in order to finalize an adequate spouse in transnational settings where modern and traditional values coexist. The chapter also analyzes the role kin plays at times when parents and their children do not find their respective spouse selections criteria compatible. This chapter also inquires further steps in line with the spouse selection mechanism; how marriage proposals are sought and asked? Who play the role of match maker? Do Pakistani immigrant families rely on traditional matchmaking means or do they trust on the modern marriage bureaus? The discussion is followed by how the question of spouse's adequacy is negotiated between parents and their children? How the consensus is built if conflict over spouse choices emerge between the both generations? What is the role of transnational kin in shaping spouse choices and what strategies are made to finalize marriage decision? By focusing on agency under the transnationalism from below perspective, this chapter adds deep insights to the existing literature on marriage choices of Pakistani immigrants. Pakistani transnational marriages are sometimes perceived equal to force marriages where parents are considered main decision makers while children have lesser authority over their marriage choices. Contrary to the monochrome of tradition and modernity where spouse choices are analyzed either the domain of parents or the children, this chapter highlights how the transnational marriage becomes the collective affair of the families across borders when not only the parents, their children and kin play decisive role but the migration factors also. In the similar vein, immigrants' spouse choices are viewed against the host society's cultural norm as a root cause of poor integration. This chapter argues that Pakistani immigrants' spouse choices are continuously being molded by their transnational presence in both societies. Thus instead labeling immigrant's choices as of insiders and outsiders under the paradoxes of tradition or the modernity, it is needed to understand how their choices are formulated and the decision to select an adequate spouse are negotiated.

6.1. Matchmaking: Searching the marriage proposal

Notwithstanding which mechanism to choose a spouse is more or less successful, preferred or prevalent, a variety of matchmaking practices can be found around the world (Schwartz & Scott 2000). These practices may range from individual's autonomous steps, where parents have little say or inert participation in the marriage decisions of their children (Buunk & Solano 2010) to parents' control on children spouse choices. Searching spouses through modern professionals such as marriage bureaus and matrimonial websites is gaining popularity in today's world. Since it does not necessarily involve directly the interested parties (Lu 2008), professional agents of these institutions themselves contact with different families and collect the information about the candidates interested to marry.

The ethnographic work on marriage behavior of Pakistani immigrants is rich yet thin especially when it comes to the practice of searching the marriage proposals. This practice is reducibly attached to the professional match makers and marriage bureaus. This study argues that it should not be assumed that kin-endogamy let Pakistani immigrant families off to search the marriage proposal assuming they have certain marriage proposals under their nose. I observe that generally three means of matchmaking that are prevailing in French-Pakistani families to search a marriage proposal; firstly, the parents and elders of the family, secondly the couple, and thirdly the marriage brokers including the traditional match makers and professional marriage bureaus. The most prevalent means to search a spouse is the family. According to my investigated families, most of the marriage proposals are actively sought by engaging the parents and elders of the family. Parents and elders of the family as being the informal match makers also devise certain strategies of matchmaking over a considerable period of time.

Shaw (2001) calls this means 'arranged matchmaking'. She sheds light on why and how do they do so by explaining that the notions of purity of blood, religion, culture, social intimacy and the close connection among relatives determine it. This is why arranged matchmaking means is wide spread in Pakistani immigrants, according to her. Another explanation behind its prevalence comes from the cultural privilege

given to elders of the family in match making process, according to my study. To understand, it is first needed to know who these elders are and what nature of relationship they share to the extent that they could influence marriage decisions of the family. In this regard, the term *rishta* helps us. *Rishta* is used in various contexts. *Rishta* is generally translated into existing blood relationship; it is used as *rishta poochna* meaning asking marriage proposal; *rishta dhoondhna* meaning searching the marriage proposal; and *rishta kerna* meaning accepting the marriage proposal to construct relationship bond through marriage. In the first case, the nature and bond of *rishta* (blood relationship) authorize certain relatives as being the match maker at one hand, and determine the acceptance and rejection of his/her proposed *rishta* (marriage proposal) on the other. For example, the opinions of paternal and maternal grandparents of the family for marriage proposals are sought and regarded positively. If they propose a marriage proposal, their suggestions are respected. Most of the marriages of parents belonging to my investigated families were proposed mainly by their grandparents and parents. Contrary to parents' own marriage proposal initiation experiences, when it came to the question of their children's marriages, the cultural privilege given to grandparents remains invisible. Now parents, their siblings and children remain active in the process of searching marriage proposals by employing different means of match making.

In addition to rely on blood relatives, as a prevalent means to search and introduce marriage proposals, the network of the family is also considered trusted one. Families CB4 and LG4, both relied on their network in this regard. Family's close friends help in finding the spouses for immigrant Pakistani families, especially when male member of the family is either absent or deceased. The father in Family CB4 was one of the founding members of overseas branch of a religious and political party of Pakistani origin in France. His party colleagues and friends remained in contact with his wife after his death and supported in several socialization and education related issues of her children. One of them also helped her to find spouse for her daughter. Similarly, family LG4's friend, based in Pakistan, played vital role in searching spouses for his friend's children. Efforts to search marriage proposals through family elders and network of the family show that parents were not the only

ones who sought the marriage proposals. If in Families SD5, VP5, PI3, LM8 and CO6, parents and children jointly sought marriage proposals; in Families SC5, VG4, and LC4, parents' siblings were active in searching marriage proposals too. While Families LG4 and CB4 trusted on their social networks, Family LM8 relied on the professional match makers in seeking marriage proposals. In Family LP4, the couple itself proposed their marriage to their families. Though spouse matchmaking means vary in my respondent families however the most trusted means remains family.

In line with Shaw's comment on arranged matchmaking (2001), the literature on Pakistani immigrants' marriage behavior define an arranged match making on the basis of two basic characteristics; the introducer of marriage proposal and the bonds of love between the potential spouses. The first characteristic revolves around the question who is the initiator of marriage proposal, parents or the couple? A marriage is considered arranged if parents initiate and introduce marriage proposal to their children and proceed for the finalization of the marriage even after seeking children consent. If children choose their spouses themselves, the matchmaking is called autonomous based on couple's choice. The second characteristic is the presence of the love bond between the potential spouses; if it is not developed before the marriage proposal is asked, the marriage is categorized arranged; otherwise it is autonomous based on love. However, such classification does not reflect the inner working of how marriage proposals are introduced and proposed. All of marriages proposals of my respondents have been asked formally by parents. Does it denote that the marriages were arranged? My interest here is not to dig out the existence or nonexistence of emotional attachments between the potential spouses. Instead my contestation is that asking the marriage proposal is a ritual according to the normative behavior of Punjabi marriage market and the prime duty of the parents, even if the couple has developed some sort of 'love bond', they have to consult their families in order to get married. To elaborate it, I present the case of Family LP4 where the matchmaking means is the couple itself. The couple first invested considerable time to know each other's behavioral traits before informing their parents about their marriage choices. According to the indigenous normative

expectations, the couple did not find it adequate to propose their marriage proposals directly to their potential spouses' families, instead they expect their parents to do so. The couple in Family LP4 did not approach their expected family-in-law directly, instead the bridegroom approached his elder sister and the bride approached her elder brother in order to convey their spouse choices to their respective parents. In the similar cultural context, the parents of the bride do not generally propose their daughter's marriage proposal to the groom family. In fact, it is the groom's family who is supposed to do so. The elder brother of the bridegroom in Family LP4 approached the father of bride to initiate the marriage talks. In close kin marriages, where the parents of the bride and groom are siblings, the informal talks about marriage proposals may initiated without any difference of being parent of the groom or bride. However, it is the groom family who always propose formally, according to the cultural norms as it happened in Families LC4 and VP5. A family's involvement is not to be taken as a classifying determinant of arranged match making means, instead family's involvement is to be seen as a part of spouse selection process according to the indigenous cultural norms of marriage.

Why, though, are normative definitions of marriage invariably silent on such matters? The answer, in my view, is plain to see. Because the social order is individualistically conceived – as has been the Euro-American norm ever since the Enlightenment – limitations on personal freedom are invariably viewed as a potential source of oppression. So it is that in such an individualistically conceived world the libertarian discourse of rights invariably views the prospect that those self-same individual right holders might have necessary obligations to others with great skepticism, even when those others are one's children, one's parents, or other close kinsfolk. (Ballard, 2006:4)

Without considering the collectivity of the institute of family and kinship and its importance in individual's life, these normative standards overlook marriage behavior of Pakistani immigrants. Parents, children and kin are a part of the group where marriage is a collective affair. Particularly in societies where cultural values of collectivity, unity and family loyalty are prevalent, it is against the indigenous context to set individuality as standard determinant factors to classify marriage proposals sought and introduced by the institute of family.

The third matchmaking means in my investigated families is to hire the marriage brokers. In villages the family hires the services of a *bichola* (literally means a go-between matchmaker) to search for spouses and/or to send marriage proposals to the families of interest. Families do not engage themselves in the searching process outside the kin in order to avoid the social embarrassment and keep the process completely concealed from their extended relatives. According to Kalsi (2004), *bichola* plays his active role as matchmaker even today in many rural parts of Pakistan and India and is considered a reliable means to arrange marriage alliance between the families. He is assigned to provide vital information about the would-be spouses and their families. Like many other immigrant Pakistani families, Family LM8 hires the services of a marriage broker ladies based in Pakistan and France.

Contrary to the old customs, the role of traditional male matchmaker is replaced by the modern professional marriage bureau personnel. Some of them have their proper offices and websites also. Though they fix their fees in local and international currencies, yet fee charges vary according to the economic status of the client families. The matchmaking profession is majorly headed by the female marriage broker ladies in France and in Pakistan, according to my observation. These are recently getting popular as matchmaking means in Pakistani community in France. They are more professional and their strategy to prepare family's marriage profile is interesting too. They prepare individual' and family' characteristics-based profiles and offer marriage proposals to the families who are in contact with them. Some of these marriage broker ladies live in France and some in Pakistan. They among themselves create a network and continuously keep in contact with one another to exchange information on marriage proposals transnationally. Those who are based in France pass on the marriage demands of French-Pakistani families to those marriage broker ladies who are based in Pakistan. During the interviews the marriage broker lady—a renowned *rishtay kerwany wali* (female marriage broker) in Pakistani community in France—told me that her younger sister works also as marriage broker lady in Pakistan. Both exchange information of their clients to match spouses across borders, and then introduce their respective clients to each other. If families of both sides are convinced by the exchange of information and pictures,

family residing in France then decides to visit Pakistan. If they are further interested after first face-to-face meeting, several visits across border by different family members are made to finalize the proposal. Mostly parents contact her to search for the marriage proposals. When the family of the potential spouse is not involved, she finds it very difficult to seek a match, thus she refuses those individuals who contact her for their marriages because families in Pakistan do not consider such marriage proposals reliable as elders of family are absent. Initially she adopted the strategy to publish her advertisements on her Facebook page made for matrimonial services. However, being disappointed by the response, she now advertises her marriage proposal offers in online Urdu newspapers. These newspapers are based in Pakistan but are sponsored by the French-Pakistani immigrant businessmen. She told me that mostly visitors of her Facebook page make fun of such adverts, however, her advertisement in newspapers are considered seriously and families contact her.

Recently print and electronic media-based advertisements, particularly matrimonial websites, are playing active role in searching and proposing partners in the marriage market. However, the use of such means is perceived dubious and less reliable. Families, who use newspaper advertisement services, hesitate to be seen, according to Charsley (2013). She, in Pakistani cultural context, explains profoundly that most of Pakistani marriages are contracted within the close kin circle thus creating less desirability for modern professional matchmaking means. Despite the presence of a number of matrimonial websites and Facebook pages, Pakistani immigrants in France are too skeptical to rely on matrimonial websites as a modern matchmaking source. It is surprising to note that none of my respondent families in France and in Pakistan have employed matrimonial websites to search the spouses. Even the younger generation did not report a single such incident due as such matchmaking means are not considered serious, and trustworthy because the risk of uncertainty and privacy breach is involved.

6.2. Managing the strategies to select an adequate spouse

The emphasis on the role of Pakistani parents in terms of assertion and authority on the spouse choices of their descendants and mismatch between the opinions and priorities of both generations has been the subject matter of many studies concluding that marriages are arranged by the parents (Mohammad 2015; Liversage & Rytter 2015; Dale & Ahmed 2011; Harris & Shaw 2006; Qadeer 2006; Charsley 2005; Zaidi & Shuraydi (2002)). Some others observed that children do not necessarily follow the parental choices and try to influence their marriage decisions often by resisting (Zaman 2014; Rytter 2012; Ballard 2011). Continuing the ongoing debate on the said issue, this part analyzes under what circumstances the French-Pakistani immigrants and their descendants apprehend the adequacy of a spouse to proceed for marriage. We have seen in previous chapters' discussion that parents and their children have expressed their primary and complimentary preferences for adequate spouse, it would not be idle to say that despite the variations both generations actively participate in determining spouse selection criteria. Before I proceed towards how parents and their children negotiate on the adequacy of a spouse, I review some of the literature focusing on the cultural interpretations of adequacy of spouse choices in Pakistani immigrants' origin and host societies.

Depicting marriage as a collective affair of family in Pakistani cultural context (Charsley 2013, Rytter 2013, Charsley & Shaw 2006, Qadeer 2006, Ballard 1990, Donnan 1988, Das 1973, Wakil 1970, Eglar 1960) comes with three interpretations. Firstly, marriage as the domain of elders of the families, where the couple's role is very minimum equal to do nothing with. Secondly, marriage is to serve majorly the alliance between the groups of families, so individual's choices are to be controlled and/or ignored. Thirdly placing the parents and children at opponent places often presents the differences between the younger and elder generations. Such paradigms view transnational marriages equal to force as the couple has little and/or no control over their rights pertaining to marriage choices (Liversage & Rytter 2015) in the host societies. Transnational marriages being contested arena in public, political and media opinion are also fervently considered as *a root cause of poor*

integration (Migration Watch 2005) under the integration paradox of 'insider' and 'outsider' (Ballard 2008). In Pakistan where interpersonal relationships are to be developed and found within the institution of marriage, marriage define certain obligations that are to be fulfilled mutually by each member. Whereas post industrialist West sees modern interpersonal intimate relationship as an independent entity from the marriage institution; meaning that if two individuals are living happily in a romantic relationship, then it is not necessary to marry. What is necessary is that marriage is a bond that must be based on intimacy and love between the two. To marry or not to marry is a highly personal decision and is related to one's own choice and individual right (Smart & Shipman 2004). Such pervasive ideas—emerged from the anthropological and sociological over simplified studies on kinship and marriage—provided sweeping generalizations and divided the practices of marriage into dichotomous domains; the traditional and modern (Casier, Heyse, Clycq, Zemni & Timmerman 2013). Kuper (2008) while analyzing the practice of cousin marriages criticized the oppositional approaches that labeled the practices of partner choice, marriage behavior and reciprocal kin relationships of the natives and of the foreigners as 'primitive' and 'civilized'. As a consequence, the western immigration policies see negatively the marriage migration from nonwestern primitive world towards the civilized west. He insisted that to understand the marriage behavior with respect to the collectivity of kinship, it is needed *first [to] abandon the opposition between the modern and the traditional, the West and the Rest* (2008:1). Ballard (2008) incites to be cautious to do not make negative judgments when approaching the arena of kinship and marriage of Pakistani immigrant families.

The dichotomous approaches however have been challenged by the growing trend of transnational practices within the institute of family and marriage. Last two decades have produced rich literature on transnational marriage and kinship practices based on extensive ethnographic work in combination with both perspectives and contexts; the country of origin and the country of host. A study by Casier et al. (2006) done in Pakistani immigrants deals with partner choices and deconstructs the boundaries of tradition and modernity. The study concludes that

individuals simultaneously try to balance their partner choices with that of the set models of tradition and modernity. They find themselves in a constant state of resistance. Another study has shown that adaptation to parents' origin cultural tradition of organizing marriage is one of challenges and most debatable issue between the immigrants and their children (Abou-Zahab 2007). A study done in Pakistani transnational families argues that when a researcher enters in the field with an idea as a model in mind and *those who do not fit with the model are seen as engaged in futile resistance*, then his/her observation marginalizes the differences found within the field. The immigrant families living in the western world are neither static with traditionalism nor opponent of the modernism, instead are facing challenges especially within the domain of marriage (Smart & Shipman 2004). Similarly, families in Pakistan do not essentially assume that marriage traditions are just to be followed blindly, as we observe in the first chapters of this part while focusing on the pool of potential spouses. The practices of kin-endogamy tradition are followed by choosing the spouses from the different layers of kinship structure, and from and outside the social networks too. In the similar vein, the cousins are not haphazardly filtered as potential spouses, instead cautiously chosen by parents and their children according to their particular criteria. Their criteria not only demonstrated the differences and similarities but also how experiences of migration and cultural hybridity influence the adequacy of spouse choices. Once the spouses are filtered, parents and children proceed to next step of negotiations for finalizing the adequate spouse.

Keeping in mind the above mentioned complexities of the divided contexts of tradition and modernity, I argue that marriage related traditional behavior of my respondent of Pakistani immigrant families is subject to change; and the ideologies of traditional spouses are being negotiated between the parents and their children in Pakistan and France. No matter if individuals belong to collective or traditional societies, they neither totally *free to marry whomever they pleased* nor their spouse choices *radically* confined by their parents, culture and society (Knox & Schacht, 2012:174). They quote Medora's (2007) findings that in collectivistic and familistic India, children perceive their parents as wiser and able to choose suitable spouses

for them. Different though, these explanations yet produce a common narration that spouse choices have rarely been left to chance. Spouse choices are cautiously weighed at individual and familial levels. Choices are internalized through socialization and are shaped and reshaped by legal, social and cultural context (Iqbal 2006, Shaw 2001). An individual's choice is always determined by his/her life-long experiences and available options. Similarly, the choice of marriage partner is equally determined by the contextual factors for an individual, be it of a modern society or of a traditional one. *And in sociological terms there is a very significant difference between the concepts of 'individual' or 'free' choice and contextual or relational choice* (Smart & Shipman 2004:4). Individuals act and react with reference to the contextual or relative factors influencing them as well as their significant others in expressing the adequacy of a spouse. In Pakistan, individual's life, be it parent or a child, revolves around the family affiliations, and marriage is mandatory to reproduce and to construct such relationships. Rytter writes:

Partner choices and marriage are, ideally, once-in-a-lifetime decisions. To second-generation Pakistanis it is therefore not so much a question of whether they are going to be married or not, but rather a question of when, where and to whom. In this respect, marriage constitutes an inevitable, irrevocable decision about one's life trajectory and future horizons. (2013:69)

This is due to the very interlinked questions when to get married and the future horizons in a strange land, that most of the French-Pakistani fathers who came to France were either married before their migration or got married shortly afterwards while visiting their families in Pakistan. Many of them expressed their marriage experiences in terms of where, when and to whom. Losing their son was a fear that made their parents to get them marry so that they could remain in touch with their families back in Pakistan. Marrying within kin was commonly practiced. Three of them in Families LC4, LM8, & VP5 had expressed their preferences for their cousins to whom they eventually got married. The parents in Families AB4, CB4, SD5, LP4, SC5, and OZ5 were though relatives but they never interacted with each other before marriage. Whereas parents in Families VB4, VG4, VI4, LG4, and TR4 had frequent interaction as they were living either in the same villages or in proximity. All

of the parents told that their parents had talked with them about marriage decisions. These talks if not equal to taking their consent in formal setting were not less than their accordance to marriage decisions taken by their parents and grandparents. The French-Pakistani parents themselves are a generation whose marriage decisions were managed by their parents and themselves. And who intervened in the spouse choices of their children too. It could be owing to parents' diversified marriage and migratory experiences that no one from the younger generation told me that their marriages are product of forceful decisions. It is worth mentioning that that parents' marriage experiences do not necessary formulate identical marriage choices of their children in the very family. In case of Family LC4, contrary to their own marriage decision the parents turned down their son's choice to marry with his maternal cousin. Instead they exercised coercion that resulted in their son's deviation. In the similar vein, parents in Family LM8 did not approved their daughter's spouse choice that resulted in boycott. Mother in Family PI3 who was the supporter of kin-endogamy and got married with her cousin, is now against the kin-marriages due to failure of her daughter's marriage with her cousin. On the other side, according to most of my younger respondents, their marriage decisions were neither free of parental control nor individualistic. The decision to finalize marriage proposals were carefully processed through intergenerational evaluations and negotiations. In the following paragraphs, I present some strategies that were employed to select adequate spouses. To do this, I choose some of family cases to describe what were the characteristics of the couple firstly, and how their adequacy was determined subsequently? Then discussion will be followed by how do both generations negotiate the decision to marry? And if the kin intervene, what is their role particularly being the mediator in cases of intergenerational estrangements on marital issues?

6.2.1. Family's obligations and children's capital

In Family CO6, the norm of exchange marriage was practiced. In exchange of a sister, two brothers were married with their cousins. Traditionally in exchange marriage system, daughters are exchanged to wed their sons. However, in case of

Family CO6, the norm was practiced reversely. To know why it happened, I first look into the characteristics of the couples involved in and then the adequacy of their couple hood. In the first couple's case, the bride being the victim of autism does not meet the standard criteria of adequate spouse. Neither she is educated nor her behavior is alike other cousins who are actively participating in nurturing their relationships with their spouses and families-in-law. Nonetheless, she is active in managing the household chores like cooking, cleansing, washing and ironing the clothes. The bridegroom is educated until matriculation level and has no health issues. He earns well and currently living in France. He is the eldest son of his parents. After his father's death he is responsible to organize the marriages of his sisters. His sisters have crossed the ideal age to get married, so to marry them in adequate families, he accepted the marriage proposal of his uncle's daughter; and in exchange, organized the marriages of his sisters with his uncle's sons (wife's brothers).

Apparently according to the marriage market rules, all of the couples did not share any similarity in their characteristics, yet they got married. In the case of second couple, the bride and bridegroom shares same age group; and in the case of third couple, the bride is elder than her bridegroom. Further, both brides are educated until primary and their bridegrooms are not uneducated. There is considerable difference in the economic well-being of both families. The family of autistic girl is landlord and living in France while her husband's family owns no land and lives in Pakistan. Can we call the couples adequate? How did the couples and their families determine the adequacy? Although their marriages were held within the kin-group alike most cases of my respondents, but Family CO6 differs interestingly in spouse's choice formulation when they confront the problem of non-availability of adequate spouses for an autistic daughter at one hand and for the aged daughters on the other hand. Religious and cultural norm of 'being married' makes the marriage universal in Pakistan. Another social obligation that male members of the family have to fulfil is not only to organize the marriages of their daughters and sisters, but to bear the economic expenditures of the marriage event too. To remain conformists to these norms, brothers at both sides formulated their spouses' choice that revolve around

their duty to organize the marriages of their sisters. If viewed from the patriarchal society's lenses, the adequacy that brothers determine for their spouses seems unfit and contrary to the norm that wives should be younger than their husbands; healthy spouses to bear the children, and similarity between their characteristics.

When I talked to the mother-in-law of the autistic girl in Pakistan, she was not a strong supporter of exchange marriages. For her, it is difficult to sustain relations based on exchange but if one has no other options available then exchange marriage should be organized within close relatives. In close relationships, almost everyone is familiar to one another. Being the kin and residing in the same village, both families know each other very well since long. The cousins studied in the same school and grown up playing together in the same household compounds. It facilitates them to keep their exchanged relationships sustained. The couples expressed contentment and happiness over the choices of their parents. None of the three brothers expressed their views over their personal spouse choices or disliking their spouses. They talked about the honor of the families and securing their dear ones as well as themselves from the embarrassing comments of the society. According to researches on exchange marriages in Pakistan (Jacoby & Mansuri 2010; Zaman 2008), exchange marriage brings sense of security for women because if one is mistreated by her husband, the other exchanged one bears the consequences too. In this way, husbands at both sides try to keep their relations smooth. Another determinant factor behind the adequacy is spouses' migration to France. Both of the daughters-in-law and the son-in-law in Family CO6 are now living in France. The father provided his son-in-law all the support he needed to settle in France; from getting the visa until helping him in starting his business. The father was trying to get her daughter's visa for France also.

The exchange marriages Family CO6 reflect the values of *rishta dari* obligation where we see how the parents tried to secure their children's marriages; the altruistic brotherhood responsibilities where brothers receive appreciation from their significant others; the evaluation of individuals' capital and its utilization within family

are the ways to secure family's honor in the society. Family CO6 highlights the diverse marriage behavior of Punjabi families.

Many times, family's socio-economic capital is utilized to enhance children's capital. When it is done, family tries to keep the resources within the kin, as we see in case of Family VG4. The bridegroom is a physician, whereas his French-Pakistan bride is under graduate. The father of the bridegroom is of the view to utilize the resources within family; either the resources are educated children and/or the economic standing of the family. On the other hand, the father of bridegroom has played a pivotal role in creating the transnational kin structure in France and Pakistan. He had helped many of his relatives and village fellows to migrate to France. Unlike the bridegrooms in Family CO6, the bridegroom in Family VG4 is not against the kin marriages, but against the mis matching of the couples. According to him, there are few couples who could manage the inadequacy. He himself managed to motivate his spouse and his parents if his wife could continue her high education. In Family CO6, the parents and children seem to share similar views on to whom one should get married whereas in Family VG4, there are differences between the two generations. The strategies, employed by the children in both families, to minimize the differences were not to reject the marriage proposal and to create intergenerational conflicts, but to try to adjust the criteria of adequacy of the spouses to remain in harmonious relationships.

The choices of parents and their children are not always congruent to each other's'. Sometimes, spouse choices create intra- and inter-generational conflicting scenarios simultaneously. Some kin intervene to solve the issue, while others are actually the perpetuators of the conflict between the parents and their children. To elaborate it further, I present the case of Family LC4 in the following lines.

6.2.2. The interplay of authority, resistance and the kin

The formulation and reformulation of spouse choices in Family LC4 deconstruct a popular perception that males, particularly the fathers, play major role in selecting and finalizing the potential spouses. Instead we will see how females, particularly

the mothers, devise strategies of match making and utilize kin ties to shape husbands' decisions for the marriages of their children. Family LC4 highlights how the marriage behavior of the family is influenced by their kin's intervention. Kin play positive as well as negative role in selecting and rejecting the marriage proposals at one hand, the nature of *rishta dari* initiate as well as resolves the conflict in Family LC4 at the other hand. We will also find how parents as well as the children face resistance from each other that ultimately reformulate family's criteria of spouse adequacy. I intend to discuss this family in detail as a representative case of spouse choices formulation over time from one generation to other. The details reflect what it means to be in the network of *rishta dar* for parents and their children and how *rishta dari* is secured through the strategic selection of certain spouses.

Family LC4 lives in France and has seven sons. Spouses have been preferably chosen from the layer of close kin however it is not the case now days in the family LC4. The genealogical table (see Figure 8) represents the history of marriages within close kin and outside the Pakistani diaspora. The marriage case I am going to present belongs to the eldest son who is married with his maternal cousin. The bridegroom born in Pakistan came to France by age 7. He works as auto mechanic after getting his diploma. His bride is educated until matriculation level and is active in household chores. What was the criteria of the couple and their families? Did they find adequate spouses accordingly? Over his spouse choices, the bridegroom says:

I got married when I was around 20. I did not have any specific criteria then. Although I was happy but we had some differences, our habits and language were not same. Because I got education in France, I grew here and she got everything in Pakistan. Her way of dressing did not appeal me. She did not like if I stay out late. But slowly, I knew her better. In fact, she is what I prefer now. She is very careful in up bringing our daughters, so I am. She is not found of outings and prefers to pass time with family.

The bridegroom compares the differences between his wife's and his characteristics before and after the marriage, then how did he got agreed to marry the girl? He admits that his marriage decision was not his own, but his will was directed through a strategic plan made by his mother and his maternal aunt (mother-in-law). He

mentions some other factors i.e. his migration, education and emotional bonds with his maternal aunt.

Figure 8: Genogram of Family LC4

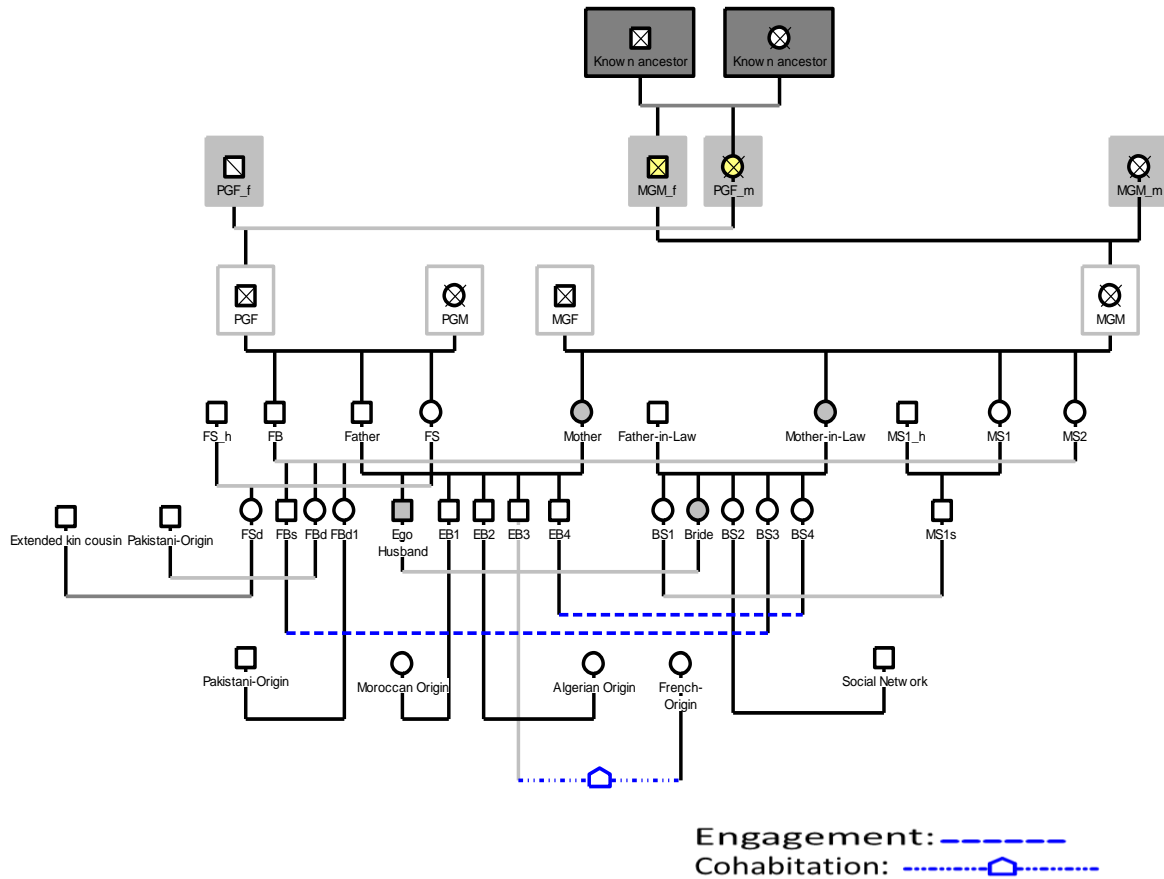

The intended plans of his marriage started to be discussed informally between the two sisters when he was not even born and his wife was about 6 months old. Since his teenage, his mother has been making him conscious about his fiancée; what she has been studying, how she looked like, and what were her habits. On the other side, his aunt was socializing her daughter the way she could adjust herself in France after the marriage. His aunt has been sending him gifts being the expected son-in-law. These kind of gestures developed his emotional attachments with his maternal aunt, a strong factor that, according to him, shaped his spouse choice. His aunt's economic condition was not good, so he alike his mother has been helping

her. He considers himself as her aunt's son and is responsible for the financial needs of her family. Another factor that influenced his marriage decision was his late entry into educational system due to the migration. He was elder among his class fellows that made him shy and less interactive, so he could not motivate himself to initiate friendship with any girl. Furthermore, he was eldest among his brothers, so he was advised to behave in such a way that his brothers could follow his footsteps. Owing to the mentioned factors, he got married to the girl whom he has been engaged since childhood. His marriage was going smooth until his younger brother wished to marry his younger sister-in-law. His marriage came to stake because his father was not agreed and asked him to pressurize her aunt to wed her daughter elsewhere. He stood against his father and favored his younger brothers' marriage choice. He being the eldest son at one side and the son-in-law at the other side played the role of mediator and negotiated with his parents and aunt. The father then involved his younger brother and brother's wife (also the younger sister of mother and mother-in-law in Family LC4) into the issue and tried to influence the other marriages going to held within the kin group in future.

According to cultural expectations ideally such spouse choices are appreciated where there are chances of repeated close kin marriages. Then, why did the father resist his younger son's marriage choice? With the help of his brother and brother's wife, did he succeed to convince his son not to get married there? What was father's criteria to choose a daughter-in-law? Now I explain what circumstances actually were behind the behavior of father and his son, which I knew my visit to the maternal aunt in Pakistan. In Punjabi families, it is common that the expected couples share the preexisting bonds of *rishta dari* with their families-in-law prior to their marriage. Though parents in Family LC4 are cousins and share similar lineage descent, where the rule of kin marriages prefers patrilateral marriages over the matrilateral ones, the mother preferred her niece at one hand and father preferred his own at the other hand that made family's spouse choices controversial.

The controversy began when the Family LC4 went to Pakistan to celebrate the marriage of eldest son. During the ceremony, the younger son liked his maternal

cousin (also the sister of bride) and wanted to marry her. His mother and maternal aunt were happy to hear, because long ago they have planned to marry their children with each other. Both sisters were married with a gap of one year; coincidentally the elder sister (mother-in-law) has 6 daughters whereas the younger (mother) has 6 sons. The younger sister assured her eldest sister not to worry about the marriages of her daughters as she has 6 sons. Both of them, made the minds of their elder children since the childhood that they would be the marrying with each other in future. The timings a marriage proposal is introduced to the children played determinant role as neither the bridegroom nor the bride ever thought about marrying elsewhere. Their spouse choices were further directed through their informal engagement since their childhood. After the successful marriage arrangement of the eldest one, both sisters were determined to marry the younger son with the younger niece, as the younger son expressed his interest too. What were maternal aunt's views on her nephew's spouse choice, she says that:

I alike my elder sister was very happy. Both of my daughters would be getting married eventually in the same family. And the family is none other than my sister. We were happy because my nephews were thinking the same as we two sisters. My nephews raised in France are saying themselves to their parents to marry us with their cousins. It was not easy to happen. My brother-in-law was not happy. He wanted to see his niece as his daughter-in-law.

Knowing one's child's wish to marry within kin was a pleasant surprise for maternal aunt because being raised in a different cultural environment may socialize the children contrary to the parents' origin society's values. The resistance that she faced from her brother-in-law was unexpected. In spite of the resistance, she and her sister encouraged younger son to confront his father over his spouse choice. The reason behind father's resistance was the marriage case of his eldest within the maternal relatives. He insisted that the priority should be given to the paternal relatives, in case of his second eldest son's marriage. Actually he preferred his niece (sister's daughter) as his future daughter-in-law. The father at one hand and the mother at other hand kept insisting for their respective marriage proposals due the prevalent expectations of sibling bonds in the Punjabi kinship structure. When both of them were unable to come to a common point, the father called his kin to interfere.

Father's younger brother is married with the sister of mother and mother-in-law in Family LC4. They together insisted the mother-in-law to arrange the marriage of her younger daughter either somewhere else or her younger sister is interested to ask her daughter's marriage proposal. So that the tussle between the parents and son could resolved, and the paternal and maternal relationships could be saved. The significance of relationships is internalized in children from very early age. Such learnings and respective kinship reciprocities work at the core of marriage decisions. The mother-in-law however denied to do so. *In context where kinship networks are as strongly patrilineal as they are patriarchal in character, it is all too easy to underestimate the scope for female agency where women appearing completely powerless and become little more than pawns in male power-players* (Ballard 2004:2). Shaw also describes Pakistani women's dominant role in mediating marriage negotiations and their strategies to *influence the thinking that precedes any formal arrangement* of marriage (1997:149). The mother-in-law was quite hopeful that her nephew in France would continue to assert his marriage choice over his father.

The negotiations remained unclear and the younger generation took the matter in their hand. The third son of the Family LC4 interfered in the matter and went to Pakistan to ask his maternal aunt for a secret paper marriage with her daughter whom his elder brother liked. He would take her to France, then he would divorce her so that his brother could marry her. His aunt however did not agree. She apprehended the marriage dissolution of her elder daughter:

My daughter and son-in-law asked me not to wait for the marriage proposal. At that moment I felt it is better not to proceed. It is unwise to settle the life of a daughter while disturbing the other. I said my nephew and my sister to step back. We all were sad. My daughter wept but later days brought her immense prosperity. Alas, my nephew never found that happiness.

Though she supported her daughter's and nephew's marriage choice, but she did not want to disturb her elder daughter's marriage. Being the maternal aunt, she felt sorry for her nephew, who boycotted his father and refused to marry with his paternal cousin. He and his younger brother married with Arab girls. Since then, the parents

in Family LC4 are living like they are apart. Both condemn each other over their sons' marriages outside. When I met the mother, she spoke a lot against those Pakistani parents, including her husband and herself, who failed to build consensus over the marriage choices of their children. She said that her and her husband's contrariness ultimately forced their children to resist and deviate. Their two sons not only rejected the marriage proposals suggested by parents but also determined to never get married within kin-group. The parents failed to convince their sons to get married even in the Pakistani community in France. She told that this is due to the intra-parental conflicts which led two of her sons to marry with Arab-origin girls.

Close inspection to the narrations of family LC4 reveals that choices formulation in Punjabi kinship system is complex especially when kin marriages are family norm from one generation to other. Existing bonds of close relationships expect them to secure the group ties instead fulfilling the individual choices. Parents and children resisting each other simultaneously were trying to save their siblinghood ties. Both generations first tried to convince each other, later adopted different strategies to influence each other's spouse choices. Ballard describes such strategies as the rules of game which are easily mistaken if one is not able to understand the symbolic power arenas in Punjabi households. For him, success in settling desired marriage proposals and relationships of reciprocity depends mainly on the skill to handle their *rivals* and *opponents* whilst living in the rule of kinship. Thus chances are fair to get succeeded if one is capable to deploy such tactics whilst adjusting carefully within kin. As, both sisters while securing their sisterhood solidarities could not anticipate the resistance from the other side, where similar solidarities of sister-brother hood derived from the very law of *rishta dari* were playing against them. Though some months later, both sisters succeeded to fix a marriage between their youngest children, nonetheless they were not able to materialize what they initially planned. Sons' resistance to their father's suggested marriage proposal represents that fathers are not always capable to control the spouse choices of their children, even if they involve the kin. The kin very often parents' siblings try to redirect children's spouse choices, in case of Family LC4 however it resulted other way round. Children are not necessarily the ones who accept whatever marriage proposals are

introduced by their parents and close relatives. Despite their parents' disapproval, children not only actively express their choices to marry but adopt strategies accordingly. Family LC4's children's spouse choices caused their parents to rethink about the future marriage choices of their unmarried children.

Kin marriages influence family's future marriages; it may yield more kin marriages or may seize it, depending on the nature of the marriage experiences and the quality of the marital life. Nonetheless, it is not necessary that identical marriage experiences may formulate identical choices in every family. The question how family's previous marriage experiences contour the adequacy of a spouse, will enlarge the discussion on spouse adequacy in the following paragraphs.

6.2.3. Reflections from the past: Family's marriage's history

Family LM8 is living in France since 1974. They have six children; five girls and one son. Except the youngest daughter, all of the children are married. Based on the marital experiences of the parents and their children, Family LM8 represents behavioral variety in selecting an adequate spouse.

Marrying within relatives is not obligatory, however the question of caste is a serious concern. Parents in Family LM8 are far relatives and their marriage decision was taken by their elders. Their marriage proposal was suggested by their grandfathers who were doing business in similar fields in a nearby market. Both families knew each other well. After 2 years of the marriage, the family shifted to France. During her stay in Pakistan, the mother did not have good relationships with her husband's brothers and their wives. Her family-in-law was big in size and all of them were living together in a same house. Based on her experiences with her family-in-law, she was against the marriage proposal of her eldest daughter, proposed by her husband's elder brother. What happened subsequently the marriage of her eldest daughter modified the spouse selection criteria for next daughter. Although both daughters' marriages ceremonies were celebrated in Pakistan, yet the marriage decisions were taken under different circumstances.

The eldest daughter got married with her paternal cousin. When her father introduced her marriage proposal, she accepted it half-heartedly. Her mother did not like it due to her bitter relationships with her husband's brother's family. However, she had to accept it because she had other daughters to marry them, and it was very difficult for her to search their appropriate spouses while living in France. The mother and daughter demanded that the bridegroom would live in France after the marriage. The mother of bridegroom was against the demand because she has only one son. She narrates:

I was not against the marriage proposal but the condition. When my husband told me what they are demanding, I said no because I have only one son. Because we have established business in Pakistan. My husband, his father and his father's father have been doing well. We did not need money or nationality. My husband did not take their demand seriously and made me satisfied that it would be temporary. But the reality is that it was not temporary. Now days, my son is trying to get my residence permit for France. Because my husband is died and after the marriages of my daughters, I am living alone in this big house. Nothing is according to my expectations. My dreams to see my grandchildren playing in my courtyard are shattered. We were businessmen, but my son is out crier. Our business, the pride and heritage of the family is ruined.

Living in the ancestors' home with grandchildren and taking care of family's business are the to-be-fulfilled dreams that parents generally expect from their married sons. A daughter-in-law living with their parents-in-law is considered adequate one. Spouse's adequacy is also related to taking care of family's heritage. The mother does not find his son's marriage as an adequate decision. Though she knows she would join her son in France, she feels sorry for family's heritage; the joint family system, living in the forefather's home, and family's business. She feels sorry for her married daughters too who would not be able to spend some days with their mother in the parental home after her migration to France. Her husband did not anticipate what the circumstances of his brother's family in France were, and that their son would not come back. On the scenarios, what her son says:

My father and father-in-law are brothers. Both of them expected me to solve their problems. My father's problem was to solve my uncle's problems. And my uncle's first problem was to marry his many

daughters. His other problem was to have a responsible son who could help him in running his business. His own son was not cooperative. I worked as a vendor in the open markets. My education left far behind in Pakistan. Now I am 'in' in the field. After 13 years of marriage, I am 'in' in the eyes my family-in-law. For them, I am a better son-in-law but for my mother I am not a better son.

He alike his mother understands the adequacy of marriage decision and considers himself not a good son at one hand, and at the other he expresses what the expectations of his father and uncle were and how he fulfilled those by marrying and migrating to France. By being 'in' he means being successful. Despite the fact that he is educated, he worked like a laborer and now days he is successful in his business. He knew that his wife and aunt were not happy over the marriage decision, yet he succeeded to be considered as a better son-in-law. It is interesting to know what circumstances drove his wife and mother-in-law to change their considerations for him; from being an unwanted marriage partner to an adequate spouse? The explanations come from the marriage experiences of the second elder daughter of Family LM8.

As we know that the mother was not willing to marry her daughters within kin-relatives, so she preferred to search spouses outside the kin. Through a marriage broker lady in Pakistan, she started to search adequate spouse for her second elder daughter. She along her daughter visited Pakistan three to four times to scrutinize the marriage proposals suggested by the marriage broker lady. In 2005, they found one marriage proposal according to their criteria. The bridegroom belongs to a prestigious caste, and is educated. He was willing to move to France after the marriage. His family was also agreed that the bride would not stay in Pakistan after the marriage. The marriage was celebrated in Pakistan in 2006 and the bridegroom joined his bride in France in the same year. After 6 years of marriage, the couple started having problems. Although the bride and her mother both were concerned about his behavioral traits, yet the nature of their concerns was different. The bride was more concerned about the loyal relationships between the couple while his mother was more concerned about his obedience and responsibilities. The mother compares the adequacy of her elder and younger sons-in-law in the following way:

He is an ill-mannered person who does not know how to behave with the elders. He belongs to a poor and greedy family. They want money, that's why they said ok to our demands. While my nephew belongs to us. We run business since generations. We are not greedy. He owns our problems. He never misbehaved with us. He is obedient.

Spousal traits notably the economic responsibilities of parents and siblings left behind in Pakistan play important role in selecting an adequate son-in-law. A boy lesser responsible for his parental family's economic needs is preferred. Her younger son-in-law is the eldest son and is supposed to send money to his parents in Pakistan that according to her detailed narrations is a sign of greed. However, her daughter does not share her mother's views on spouse adequacy. She admits that her husband earned more salary than her, and he never demanded her to help him in fulfilling the economic needs of his family back in Pakistan. The couple was saving money to purchase an apartment. She is more concerned about his character and fidelity that led the couple to divorce. Over the spouse adequacy, she says:

He was involved in another girl, that's why our marriage interrupted.... I uncovered their relationship accidentally. One day in the first year of our marriage, he left his laptop at home and forgot to sign out from Yahoo. I read their chat and e-mails. I quit the home, went to my parental home and told them about the issue. They asked his standpoint. He excused and promised to not to do it again. My parents insisted me for patch-up. I came back to my home and made him clear that whatever has done until this moment is past for me. You would not find my behavior as chiding and at the same time, I would expect loyalty.... But he deceived me throughout the six years of our marital life. It was a day of June 2012, when he was in hurry and forgot his mobile phone at home. I picked up and saw his Skype was online. I read his chat with his girlfriend mentioning that he would be at meeting place within half-an-hour. I did not talk to him, rather I went to my elder sister and revealed all about his swindled conduct. She asked my intensions for future. I said that I would not live with him anymore. She said say him to pick his luggage and leave the home within half-an-hour. I did so. I could not bear it; he was not a good partner. He alike most of Pakistani boys cannot handle the freedom here, like having girlfriends.

She compares her husband with other Pakistani males on the issue of having girlfriends. She tolerated his disloyal behavior once, however could not bear later.

Her marriage experience generated a conception in Family LM8 that sons-in-law coming from Pakistan are unable to handle the freedom in France, thus, are prone to the culture of having girlfriends. Disloyalty if found in spouse may start disputes eventually leading the couple to divorce. So to avoid divorce, the Family LM8 started to look spouses for their daughters in French-Pakistani community. They believed that French-Pakistani boys are not opportunity seekers because they are socialized in France. They formulated their spouse choices that instead marrying within relatives or back in Pakistan, it would be better to search spouses within Pakistani diaspora in France. So through a marriage broker lady, they married their forth daughter with a French-Pakistani boy. She had to live with her husband's parents and siblings in a joint family system, a disputed issue that was not discussed at the time of marriage proposal's finalization. Although they found the boy adequate one; being born and raised in France, he was earning handsome salary, yet he could not ask his parents to live separately. The couple could not settle the issue of residence and their marriage ended in divorce.

Until the interviews, the mother of Family LM8 was of the view to marry within kin and close friends of the family. Family LM8's marriage choices were reformulated after every marriage of the daughters. The mother and her daughters think that spouses are to be chosen within kin and the circle of family acquaintance with whom they have durable and trusted contacts. The reformulation is not only based on the bad marriage experiences within kin as of the mother but also the good and satisfactory marriage experiences within kin as in case of the eldest daughter. The eldest son in-law belongs to close *rishta dar* and shares double kin relationships that have been proved to be exemplary and an ideal choice after more than a decade of happy marital life of the couple.

It is not always true that choices and preferences, once determined, are to be followed. Individuals learn from their past marriage experiences and tend to modify their future spouse choices. Kin-endogamy may forge more kin-marriages thus a greater inclination towards kin-group and/or it may work contrarily. Family PI3 has been strongly following the norm of marrying within kin. The daughter is married with

her parents' cousin. She got divorce after three years of the marriage. After the divorce of her daughter, the mother in Family PI3 has changed her mind and strongly opposes choosing spouses within kin. It is interesting to note that those cases ended in divorce, the criteria of adequacy— prior and after the marriage—concentrate mainly on the behavioral traits. When the son-in-law in Family PI3 was chosen as an adequate spouse, the nature of his relationship bond, education and personality were the filtering characteristics. However, what led the couple to dispute and to get divorce is his naïve behavior, according to him:

I always see what was wrong in myself. In the initial days of our marriage, my wife insisted me to live separately from his parents and sisters and brother. But every other; my uncle, my aunt, my parents said no, you should save some money to purchase your apartment. Until live jointly. It was the very first clash between us. When I said for having a baby, she said that she is not yet prepared for. Gradually our relationship turned cold. I was naïve. I should have listened my wife.

An adequate spouse for him is the one who listens his/her partner and is cooperative. If he would have cooperative on the issue of child bearing and if he has arranged for a separate residence, his marriage could have survived. He blames himself and his family members for his divorce. In case of Families LM8 and PI3, marriage choices are determined, interfered and regulated by couple's close kin mainly their parents. The impact of their involvement in marriage decisions sometimes is strong, that children do not step forward against the will of their parents. The youngest son-in-law in Family LM8 and the son-in-law in Family PI3 both could not resist their parents' involvement in their married lives. For their wives and families-in-law, their inadequacy in behavioral traits was not acceptable. In quest of adequate spouses, Family LM8 after each marriage of their children reformulated their future spouse choices while the daughter in Family PI3 rejects marrying in Pakistan. The analysis of both families' cases reveal that spousal adequacy is traits sought before marriage are important in selecting an adequate spouse, yet the debate on the adequacy continues after the marriage. Some couples are able to manage the inadequacy like we find in case of Family VG4, when the son-in-law a physician by profession found that his wife's graduation is not enough.

He convinced his wife parents and parents-in-law for her higher education. It did not influence on his family's marriage norm within kin unlike Family PI3.

Family's marriage experiences influence children's as well as parents' perceptions for future marriages in the family. It is commonly perceived that spouse selection criteria determine the adequacy of potential spouse before marriage, and as soon as the potential spouses become the actual spouses, the quest for the ideal spousal characteristics is fulfilled. It is to be noted that adequacy of spouse indeed is a dynamic process which lasts even after the marriage and both spouses evaluate their real attributes against the ideal characteristics in a given cultural context. Similarly, parents with more than one child do not hold the fixed criteria for an adequate spouse. Their personal marriage experiences and the marriage experiences of their children determine their scales of adequacy for future spouses of their unmarried children.

6.2.4. Preserving the roots: Transnational trust between the siblings

Migration scholars. Migration scholars recognize that the children of immigrants when socialized in transnational fields manifest behavioral differences in maintaining links with the origin country and in acquiring the values of host countries when it comes to the question of whom to marry. The knowledge and practices they learn are useful for them in many ways. Unlike their parents, they are more active in negotiating the opportunities and meeting the challenges while connecting themselves to the institutions of both countries. By applying their knowledge in the institution of family and marriage, they may bring density in their ties by marrying back home as we have observed previously in cases of Families OZ5, CO6, VG4 and/or they may reject the values of their parents' origin country as we observed in case of younger daughter's marriage in Family LM8 and younger sons' marriage behavior in Family LC4. How do children simultaneously resist to the ideal spouse selection criteria of their parents and adopt host country's spouse selection values? To elaborate the scenario, I present the case of Family VP5 where there is a continuous tussle between the elder and younger generation over the issue of adequate spouses and whom to marry. The case of Family VP5 sheds light on how

the roots in the origin country are supposed to be maintained through marriage, and how and why family's kin cooperate with them in preserving their roots. This case study also underlines the active role mothers play in organizing the marriages of their children despite the fact that their children and husbands are not fully agreed on their criteria of spouse adequacy. To convince their children and husbands, close relatives are being approached by mothers. They collectively influence the marriage choices canvas of the family. Once marriage is organized, I focus on the bride and bridegroom that how and in what way the couple tried to construct their matrimonial relationships and how the nature of their relationship affects the existing ties between the two families?

Najia and Nasrin are two sisters. Najia is younger and is the mother of four children; one son and three daughters. She lives in France and arranged the marriage of her son with her sister's daughter. Her sister called Nasrin lives in Pakistan and she has three children; two sons and one daughter. Both had discussed informally to arrange the marriages of their children once they would be of marriageable ages. However, neither they fixed their engagement nor did they disclose the matter to anybody in their families.

After migrating to France, Najia has been visiting Pakistan regularly during the summer vacations each year. The children of both sisters developed good terms with each other. Both sisters hoped that amiable relationships between their kids would invigorate their longing to marry their children with each other. Without regard to what his mother and aunt were wishing, Najia's son called Omar did not show any interest in marrying with his maternal cousin called Ishrat. Ishrat also was not interested to marry with Omar. As she was the only daughter of her parents, her father also did not wanted to marry her far away. Ishrat and her father have some concerns over Omar's behavior. For Ishrat:

He was very careless. He was more interested in renting the lavish vehicles in Pakistan during his visit and the whole day he remained busy in racing. It was his routine on every visit to Pakistan. During most of the time, he used to stay out and to come home late at night. Whenever I asked my aunt, why he is so? She used to reply, 'we come here to enjoy the holidays because life in France is very busy'.

When my aunt asked my marriage proposal, I denied. My father also was not happy and supported my decision. He said that Omar's current habits predict that he would not be a responsible person after marriage. My father was right; marriage is all about being responsible.

Not being responsible in taking care of family members and in saving the economic resources is the characteristic that filtered Omar as an inadequate spouse. If his behavior was inadequate for Ishrat and her father, for his mother it was understandable as she justified it as temporary period of enjoyment in Pakistan.

When Omar turned 21, Najia talks to her son for the marriage. He denied because he was living in a union with a French girl and have a son too. Najia's husband asked her to let him free for some time and do not force. She insisted if she would wait more, they may lose their son. Her husband says:

In fact, we had lost our son already, and our daughters too. My wife is in panic, I can understand. But at the same time, I understand my children are brought up here. They do French things because they are French. They have their own standards to choose their spouses. We being parents oppose them but it is in vain to insist them. They do little care what Pakistani values are.

He understands if children are being raised and socialized in another cultural environment than his own, the children will manifest less attachment to their parents' origin country and more inclination towards the host country's values. He talks about his daughters and based on elder daughter's marriage experience, he asks his wife to wait for and do not insist their son. After some time, she again started to convince her son for marriage. I did not know what the actual circumstances were under which her son says yes to his cousin's marriage proposal until I met Nasrin in Pakistan. She said that:

My sister convinced her son saying he is her only hope to remain in contact with her Pakistani relatives. She said same to me. She did not tell me about his French wife and son in a clear manner but talked in a camouflaged way that French environment would not spare his son. I felt sympathy for her. After all she is my sister and children are the precious assets. What she would do if Omar marries a French girl. He would crack her mother's roots.

For both sisters, a French girl cannot be an adequate spouse. An adequate spouse does not cut the family's roots instead marriages work like a bridge between the relatives living across the borders. To remain in touch with kin and roots, marriage is a route and an adequate spouse is the key person to sustain the system. Trusty and sympathetic relationships between the two sisters work as the back bone of marriage decision. When Omar got agreed for the marriage, both sisters contacted their kin members to convince Ishrat and her father for the marriage. First they approach the maternal aunt of Ishrat who is very close to Ishrat. She convinces Ishrat about life in France as far better than Pakistan. She also highlights that all of her three sisters-in-law would be married and as Omar is the only son so she would not face the usual tussles in family-in-law tussles. Later Ishrat's mother joined the talk and reminded her that if her maternal aunt would be her mother-in-law, it would not less than a blessing. Her aunt Najia also ensured her Omar's responsible behavior in France. Eventually, Ishrat got agreed for marriage. Once she is agreed, both sisters contacted to the younger brother of Ishrat's father in order to intervene in the matter. His brother lives in Kuwait and has been helping Ishrat's family in meeting economic needs. He convinced his elder brother not to halt Ishrat's better future in France. Ishrat's father though said yes to the marriage proposal, but did not actively participate in the marriage event.

Soon after the marriage, Omar returned to France and did not show mature behavior towards his responsibilities. The relationship between both families turned cold, however they never boycotted each other. Both sisters tried to keep the couple in touch. It took almost seven years to Ishrat to get spouse visa because Omar did not do any job on regular basis. In the meanwhile, the couple became the parents of two baby girls. When Ishrat arrived in France, she found Omar's behavior unpredictable. Sometimes, he remained close to his family, and sometimes he used to absent from home for many days. She was worried and wanted to know why he did so. Her mother-in-law explained her that as he is sports car racer, so he passes his time with his friends. She remained doubtful because her husband is not passionate in their conjugal relationship. Few months later, she knows accidentally about his husband's extra marital relationships. She also found summon letter by

court over a child custody-conflict between his husband and his girlfriend. She asked her husband and parents-in-law for explanations. Her husband admitted and asked for pardon. Her parents-in-law also requested her to ignore the past of Omar whatever it was. She compromised for the sake of his daughters and ignored the matter hoping that he would take responsibility of the household expenditures and would not remain in touch with his girlfriend again. But nothing happened according to her expectations. A day after disputing her husband, she left the home with her two daughters. She has been living in social services home. Later she filed her case in court for divorce. Her paternal uncle living in Kuwait and sister-in-law (brother's wife living in Denmark) have been sending her money for daily expenditures in France. A year passed and the divorce case was in the court when she convinced by her mother and aunt and hoping he would be careful to take the responsibility of his wife and daughters reconciled with her husband and family-in-law. However, she was disappointed again by her husband's behavior. Tired due to her marriage crisis, she decided to go back to Pakistan to her parents. Now she along her two daughters is living with her parents in Pakistan. The divorce case in court is yet to be decided.

Her mother and aunt are trying for patch-up but Ishrat, her father and brothers are against it. They are supporting Ishrat's decision for divorce as Omar is neither an adequate father nor the adequate husband. They asked her to proceed for divorce and to do not make any compromise. The kin group also decided to take side of Ishrat on the issue of her daughters' custody case in court filed by Omar. Her family-in-law is facing complete boycott from relatives living in Pakistan, Kuwait and Europe. The kin group is also accusing Omar's parents for the improper socialization of their children who are continuously creating embarrassment for kin group and doubts for future marriages within kin across borders. . Alike Omar, the marriage of his sister is also on stake. The parents arranged the marriage of their elder daughter within agnates, but she could not adjust with her family-in-law in Pakistan. Najia analyzes her daughter's behavior in the following way:

She is not obliged to live in Pakistan permanently, yet they expect her to spend some holidays there. After marriage, she lived there for some days and insisted her husband to go to Denmark. He

denied, he completed his education and wants to stay in Pakistan with his family. She came back to us. She dislikes the old-fashioned constructed house of her family-in-law, the dirty roads and the quality of food. Her family-in-law is rich. They say her to live there and construct her house the way she wants. But she does not listen. Neither she demands divorce nor does she live with them. She is foolish and will regret a day.

The daughter does not find it interesting to live in Pakistan and insists her husband to come back to Europe. For her, husband's behavior is not acceptable that eventually shatters his adequacy. Her mother appreciates the behavior of her daughter's family-in-law and condemns her behavior by highlighting the risks in future. Generational tensions between the parents and children over the issue of adequate spouses urge parents and their kin in Family VP5 to reassess their children's ideological references for their marriage behavior. A generation that is raised with a variety of different and competing ideological values on marriage, tries to figure out how to live with home and host countries' values. The tension becomes acute when any of the parents and children reject each other's points of references in defining who an adequate spouse is. Omar's consents for marrying with his cousin tracks his engagements with his parents' origin values at one hand, and the presence of his French partner and a son points his connectedness with French values on the other hand. In the origin country, kin's cooperation especially his aunt's sympathy for his mother and the trust between the two sisters are utilized to preserve the roots. The kin group cautiously and continuously evaluate, make and govern spouse adequacies in transnational context.

Concluding Remarks

Transnational marriages among Pakistani immigrants hold attention of the academia under the paradox of clash of cultural values thus dividing the marriage practices of immigrants and of the native dichotomously. My study based on in-depth interviews with French-Pakistani parents and their children contributes to the discussion on how spouse selection criteria is formulated in transnational context where the cultural values of the both societies coexist. The transnational apparatus of Pakistani Punjabi kinship and immigrant families' post migration settlement

experiences are reexamined in order to understand the spouse selection mechanism. Though strongly inclined towards marrying within kin, the pool of kin spouses remains the primary criteria of French-Pakistani immigrant families. Kin marriages are considered as benchmarks of good relationships between the kin members across borders. Several cultural expectations are taken to account while organizing the marriages within kin. Kin endogamy as the primary criteria however remain incomplete without the complimentary criteria. Parents and their children described their preferences for socio-economic and behavioral traits of the potential spouses including education, age, morality and the values of transnational families. Both generations actively participate in determining who an adequate spouse is since the parents and their children have expressed their preferences for adequate spouse. Once the characteristics of potential spouses are identified, families start searching spouses for their children. Generally, three matchmaking means are adopted to look for adequate spouses. First of all are the most trusted ones; the parents and the elders of the family, who traditionally are assumed to search spouses for their children and then to initiate intergenerational discussions on the question of adequacy. They together with the kin group devise certain strategies to influence children's perception for adequate spouses. Early age formal and informal accordance for their marriages play decisive role in shaping the minds of their children. Secondly the children themselves are active in matching the matches and introducing their marriage proposals to their parents. It is needed to clear even if the children have chosen their spouses, they have to propose their marriage proposals through their parents. The third matchmaking means is to hire the marriage brokers including the traditional and the modern marriage bureaus. However, this means is least trusted and least practiced to search for potential spouses. Once potential spouses are filtered according to the primary and complimentary spouse criteria, intergenerational discussion on the adequacy of the very spouse and marriage decision begin.

Given the fact that most of the marriages are arranged by the parents and that children try to influence their marriage decision, this chapter identifies four strategies

adopted by French-Pakistani immigrants and their descendants to apprehend the adequacy of a spouse and of a marriage decision.

At the first stance are the familial obligations and responsibilities that are evaluated in the context of the socio-economic capitals of the individuals and families. Parents and their children prioritize obligations and responsibilities that they owe towards their family. They evaluate individual capital as well as of family's thus developing an accordance for spouse selection process. This strategy illustrates mainly that parents and children may formulate their choices without any conflict.

Secondly, if the spouse preferences of both generations are not in accordance, close relatives intervene as mediators and guide the parents and their children to adjust their spouse choices. It is observed that incompatible spouse preferences of parents and their children create intergenerational difference, very often leading to boycott. At that stage, close kin's interventions guide the parents and their children to reformulate their spouse choices. The interplay of resistance, authority and kin's interventions reflects how the web of kin relationships is secured at the time of selecting an adequate spouse.

Thirdly, the past marriage experiences of the family reformulate future marriage decisions, however it is not necessary that identical marriage experiences may produce identical behavioral reformulations in all families. Similarly, the marriage experiences of the parents and siblings in a family may led parents and their children to redefine who an adequate spouse is.

Spouse adequacy is verily related to maintain the links with the origin country. Spouses who do not belong to the origin country of the parents are not considered adequate by the parents. In the similar vein, their children being born and raised up in different yet competing ideological values in the transnational field try to figure out their ideologies of adequate spouses. Kin back in Pakistan play supportive role by accepting the marriage proposals offered by their immigrant siblings. The trust and sympathetic relationships between the siblings are the building blocks to preserve the roots.

Neither completely repudiating the dichotomous divisions of tradition and modernity nor agreeing to the simplified explanation of parental control over the spouse choices of their children, this paper argue that spouse choices of Pakistani immigrant families are developed in hybrid cultural environment. Primary spouse choices are resonated with their general pattern of marrying within kin at on hand. Complimentary spouse selection criteria clarify that the characteristics they look for in adequate spouse are not in contrast to the host society's cultural expectation.

CHAPTER 7

PROCESS OF TRANSNATIONAL MARRIAGE CEREMONY

Describing the process of transnational marriage is not less than a challenge due to the ethnic variety and the dynamics of marriage migration experienced by Pakistani diaspora. To narrate transnational marriage mechanism adequately, I started with basic descriptions of how spouses are selected within and outside of the family's networks. Then, the primary and complimentary preferential spouse criteria of parents and their children were explored. Subsequent discussion encircled the nature and familial circumstances under which the adequacy of potential spouses was negotiated to finalize the decision of marriage. A child's marriage may plan as early as he/she is born. Later, he/she participates actively in accepting, rejecting and redefining his/her marriage proposals. Once adequate spouses are finalized, the process of marriage proceeds towards the final stages of wedding celebrations, and post marriage transitional phase in transnational context that is the subject matter of current chapter.

Marriage is the major event that represents the customs and rituals more elaborately than the other life events of birth and death in Pakistani cultural set-up. Studying marriage customs is relevant to understand the social reproduction of cultural values within the institute of transnational family. It is with this intension that current chapter describes alliance between the two families and strengthening of the pre-existing relationships are further developed through the customs of reciprocity and gift exchange at the event of marriage. The chapter describes different pre- and post-marriage ceremonies held in Pakistan and France. How and in what ways, migration has inserted changes and modification to traditional rituals and customs? How do Pakistani immigrant families arrive to manage their dwelling in case when they do not own any house in their localities of origin, yet they have to stay to celebrate their marriage events, and to wait for re-unification? In this case, where do the brides depart and stay?

In the first place, I describe the ceremonies of engagement and wedding in detail. In line with previous chapters, current chapter enlarges the discussion over marriage process among Pakistani Punjabi immigrant families in France by shifting its focus on the subsequent stages; firstly, is the custom of asking the marriage proposals. The acceptance of marriage proposals proceeds towards the ceremony of engagement. Depending on the economic circumstance and the availability of family members at each side, the wedding date is fixed. Side by side, I focus on the socio-economic resources of the couple, their parents and their kin that are utilized in wedding ceremony. Alliance between the two families and strengthening the pre-existing relationships are further developed through the customs of gift exchange and reciprocity called *vartan bhaji* or *lain dain*.

At the second place, I focus particularly on migration that has introduced changes and modifications to the traditional Punjabi marriage process, resulting in multiplicity of certain wedding customs and the temporary adjustments in the dwelling traditions. In case of transnational marriage, it is worthwhile to understand how migration policies delay the supposedly immediate departure of a bride from her parents' home to that of her in-laws, and what strategies are adopted during transition period while waiting for the visa. Similarly, in case of French-born Pakistani bride, how migration, being an opportunity for the groom, can circumvent the tradition of *rukhsati* (departure) of bride, and instead allows the husband to join her in France. Additionally, I also look into the phenomenon of postponement of marriage consummation, which is also observed by other researchers in different transnational contexts for Pakistani diaspora (see, for example, Charsley 2013). The discussion over these changing and transitional processes of post-marriage phase will be carried out in the last part of this chapter.

7.1. Rituals and customs

Research on transnational marriage ceremonies and relevant religious rituals is a prominent feature of British studies on Pakistani diaspora (Shaw 2014; Charsley 2006; Mand 2006; Ballard 2004; Gardner & Grillo 2002; McLoughlin 1998; Werbner 1986). Studying marriage customs is also relevant to understand the social

reproduction of cultural values within the institution of transnational family. Døving (2009) in his research on Norwegian Pakistani families finds that rituals are surrounded by institutions and are ensured to be followed thus making the ritual as a protected form of action. Rituals can disappear, be altered and rebuilt. Mand (2006) also comments that marriage rituals represent the invention and reinvention. He alike Døving (2007) argues that migration reproduces and enhances the social capital through marriage rituals.

Marriage as rite of passage is one of the ritual (Terian 2004) that allows the children of Pakistani immigrants to transit from one status to another. Customs and rituals involved in Pakistani marriage ceremony not only convey the symbolic representation of the marriage festivity but the reproduction and the reinforcement of the newly assigned statuses and roles (Durrani & Khan 2014; Kalmijn 2004). The aim of this part is to see how wedding ceremonies mobilize the socio-cultural capital between the two families in transnational setting. First I narrate generally how the event of a transnational Pakistani Punjabi marriage is organized and celebrated in France and Pakistan. It presents a portrayal of typical wedding customs as wedding ceremonies in Pakistan are manifestation of family's honor, prestige and group cohesion (Zaman 2011). Side by side, I discuss the customs of gift exchanges at each event that is important not only in selecting an adequate spouse, as described previously but in reproducing the social capital within families and kin-networks.

As noted previously, marriage being a collective affair of family in Punjab, entails several cultural rules, customs, rituals, prohibitions and obligations that revolve not only around the spouses but their parents as well as their kin relations. Because of their insistent character, the rituals are a relatively stable platform to replenish the collective behavior: the morphology of the rituals illustrate the latitude of social actors in the expression of their collective identity and self-image. The ritual, in its most basic sense, is both a personal as well as a collective but repetitive action, which is performed according to a more or less immutable code of conduct. It is a gesture that is not justified either by the need of comfort or pleasure, nor to meet the basic requirements of life. According to Turner (1982), the ritual is a social

construction that allows individual to experience collective rationality of the reality. Its importance and composition therefore vary with the cultural and social organizational context in which it unfolds. The ritual does not exist alone; it makes sense in a set of shared actions which are symbolic in nature. This would be a form of expression of social ties, a way to reaffirm, in turn, the continuity of the rules constituting the fabric of social life and interrelationships of a network of relatedness. Individuals are socialized into the rituals to understand their respective roles (Erika 2006). Thus practicing rituals places the individual in a well-defined role, and determines his/her place in the larger structure by reassuring the choices he/she makes. The interplay of individual, his/her networks of relatedness and wedding ceremonies reflects diverse trends and traditions both in national and transnational contexts.

In case of single marriage event, a typical Pakistani Punjabi wedding ceremony is divided into pre and post wedding rituals and can continue up to four consecutive days; first is the *rasm-e-henna* day (applying henna), second day is the *Barat* day (marriage procession), *walima* (wedding meal presented by groom's parents) is third day and *maklawā* (groom's parents go to bride's parents to bring the couple back home) is the last and fourth day. In cases where the marriage events of two or more siblings are planned simultaneously, their wedding ceremonies span over several days. In transnational context, additional ceremonies of *henna* and *walima* are organized in France for those relative families and networks of friends who could not depart to Pakistan to participate in the marriage.

In the following part, I describe the process of transnational marriage ceremony that starts from the custom of engagement. After the engagement, there are customs practiced before the marriage (*din rakhna* means fixing the marriage date and *rasm-e-henna* means applying henna), on the wedding day (*salami* means presenting money to groom, *barat* means the marriage procession, *nikkah* means the marriage contract, *roti* means the wedding meal, *vari* means family-in-law presents gifts to bride, *doodh pilaai* means offering sweetened milk to groom, *dowry*, *rukhsati* means bride's departure to groom's home and *munh dikhai* means bride's meeting with the

member of his family-in-law) and after the wedding day (*walima* means wedding meal presented by groom's family and *maklawā* means bride and groom depart to bride's parents' home at the end of *walima* day). While celebrating these ceremonies, different actors (i.e. spouses, parents, grand-parents, uncles, aunts, cousins etc.) are supposed to play their respective roles which are also described in detail.

7.1.1. Betrothal

Betrothal can both be a formal ceremony or a verbal promise of Punjabi parents and/or guardians of both spouses with the intention to marry their children. It is the period between the proposal for marriage and the formal/legal/legitimate marriage contract, which can range right from the birth of the children to their marriage. Acceptance of marriage proposal is assured by both sides of parents before formally proceeding for betrothal ceremony. Once a marriage proposal is verbally accepted by the parents of both spouses, the groom's family (including parents, grand-parents, aunts and/or uncles) first visits the bride's home to perform rituals of *mangani* literally means betrothal or engagement. After their visit, the bride's parents do the same on an alternate day and present them some gifts as a part of the engagement ceremony. Both families organize lavish meals on their respective days of engagement and distribute sweets among their relatives and neighbors. Both families exchange clothes, shoes, ornaments and money particularly presented to the spouses and their parents, not only on the engagement day but also time to time. The exchange of gifts and money in both formal and verbal engagements symbolizes the certitude of the marriage proposal. While visiting the homes of each other during betrothal period, both spouses themselves are not allowed to accompany their parents. They are not supposed to enter in each other's home before the day of marriage.

Formal betrothal celebrations and their respective rituals often depend on the socioeconomic status of the families. The more the family is rich, the more likely it is to spend extravagantly on the engagement ceremony. Unlike traditional families, these families distribute the invitation cards and organize grand events by inviting

professional entertainers. They even hire event management companies to make the event more successful. On the other hand, traditional families tend to celebrate engagements within their closer relatives.

Transnational families also organize engagement ceremonies in the traditional manner but there are certain variations that are introduced due to different constraints. Celebrating formal or informal engagement ceremony depends on many factors; if it is practical for the family living in France to depart to Pakistan depending on their budget; if both families are agreed to organize an engagement ceremony; how and where to organize, and who among their relatives will participate in it; and, above all, what purpose engagement ceremony is going to serve if the decision to marry is imminent. Pakistani families living in France normally rely on their relatives in Pakistan to arrange, manage and organize formal engagement ceremonies. When spouses and their parents are unable to travel to Pakistan, they engage their grand-parents, uncles and/or aunts to exchange gifts on their behalf with the family of Pakistani spouse. However, the expenditures are paid by the families in France.

During the engagement period, the tradition of gift exchange is expected to be followed by parents at each side. The exchange of gifts at each side represents the cultural reproduction of reciprocity transnationally. Generally, clothes and money for their would-be children-in-law and sweets for their families are sent on major religious and cultural festivals. Due to migration effect, the nature of gifts exchange has been changed. The socio-cultural capital of each family is represented by the nature of the gifts that are exchanged. The parents-in-law in France prefer to send mobile phones, perfumes, watches, and cosmetics to their would-be children while parents-in-law in Pakistan send the traditional items including readymade and handmade traditional Pakistani dresses with matching shoes and jewelry, bangles, henna, and eatable dry food.

All of the interviewed Pakistani families in France followed the custom of betrothal, either formally or informally. While most of the transnational French Pakistani marriages were endogamous, parents with the intention to marry their children with

the children of their siblings did not consider to necessary to formally engage their children. Their verbal undertakings remained valid marriage proposals for their children. However, not all the interviewed parents avoided the custom of formal betrothal. Those who practiced the rituals of betrothal formally provided an interesting rationale embedded in their cultural context.

When children are grown up to their marriageable age, they are considered as potential spouses by the kin network and other people of acquaintances, who sooner or later contact the parents to ask for their proposals. It sometimes becomes hectic and/or embarrassing for the parents of an informally engaged child to refuse new proposals. When the marriage proposal of the son in family SD5 () was finalized, the son and his parents were in France. The father of the groom asked his elder brother to go to bride's home in Pakistan along the elders of close family for formal engagement. For groom's uncle (in Pakistan):

Though they say that engagement is just a custom and is not an obligation to be followed. But in my opinion, it is necessary because people should know about your marriage relationships. No matter either the engagement ceremony is extravagant or simple, or even it's the wastage of money, it should inform other people that our children are [formally] engaged, so that nobody could come to us to ask for their marriage proposals. It saves us from wasting the time and efforts.

He conveyed what other families in France and Pakistan were generally agreed on the purpose of engagement. Identical behavior was found in some other families (Families CB4, LP4 and VI4) who experienced similar circumstances. To rely on close family's members in Pakistan and to honor them to represent on behalf of the family living in France is a trend that is only found in transnational settings. Otherwise in local settings in Pakistan, parents themselves arrange the engagement ceremonies of their children. After identifying the potential marriage proposals and verifying about the repute of the family and characteristics of the spouse, one of the parents living in France departs to Pakistan to proceed for further steps of wedding.

Although rituals play very significant role in formal engagement for Punjabi families living in France, yet they rationally evaluate temporal and spatial constraints.

Generally, when parents go to Pakistan to visit their close relatives, looking for potential spouse for their children is one of the priority purposes of their visit. If they find an adequate proposal, they prefer to accept it on the spot without waiting for the presence of other family members. This saves them both time and money. In Family PI3 (), the parents were visiting their relatives in Pakistan when they found two marriage proposals for their daughter. The mother went back to France to talk to her daughter. She shared the information with her daughter and showed her their pictures. Her daughter preferred one amongst them. Then the father who prolonged his stay in Pakistan proceeded for the formal engagement ceremony. His (father's) mother and elder brother accompanied him for the rituals performed during engagement ceremony. Such situation was also observed in family LM8. The mother and daughter in family LM8 went to Pakistan to evaluate the available marriage proposals. Though not fully convinced, yet they were agreed on one amongst them, because they did not want to arrange another air trip to Pakistan. So the mother informed her husband back in France.

When I told the details, he said if the boy is adequate and up to our expectations, go for the engagement. I along my brother and brother-in-law managed everything. It was useless to call all of my daughters, sons and husband from France. Better to save the time and money. I visited the family, presented sweets and clothes and then they did the same. That's all, the engagement in one single trip!

Peculiar adjustments in case of transnational engagement ceremonies at one hand show how the kin networks serve their ties across borders, and on the other hand how they utilize human as well as economic resources of their networks to compensate for the situations in the absence of spouses' immediate family members. Parents when alive are normally supposed to be present at betrothal ceremony, do not have to come to Pakistan; instead their siblings in Pakistan substitute them to manage the engagement ceremony. Previously they were also active in helping the parents to search for adequate marriage proposals.

The custom of engagement entails certain obligations to the fiancés. Usually both of them are not expected to interact with each other until they are married (Zaman

2011). I observed that fiancés interact with each other and their parents also knew that their children are in touch. Only few parents did not want their children to interact. Like in Family PI3, the mother forbade her daughter to contact her fiancé (also her cousin). However, she did not know that her daughter was interacting with her fiancé. Likewise, in family SC5, the father in principle is against the interaction between the two fiancés, however he regrets that it is almost impossible to follow some of the traditions these days. When his son went to Pakistan to finalize his marriage decision, he made it conditional that without seeing and talking to his fiancée, he would not marry. In marriages between close cousins, the interaction between the fiancés was not a taboo, yet they used to talk less. The mother in family LC4 told that she never forbade her son to talk to her fiancé, as he himself was a shy guy, so he never initiated to interact.

The cases where formal engagement ceremony was not celebrated are only those families who shared close maternal and paternal blood relationships and where the marriage proposals have long been discussed informally when the children were infants or very younger in age; like in families VP5, LC4 and OZ5. In these cases, engagement period continued as long as 20 years until the wedding ceremony.

Betrothal, whether formal or informal, and its rituals play significant role in a transnational marriage by offering a period of transition from promise or intention to marry to the actual event of marriage. During the transitional period, parents at both sides prepare the minds of their children to accept their spouses and give their respective consents for marriage. In cases, where children were not engaged since childhood, they utilize the available timespan between betrothal and marriage to know their mutual compatibility.

7.1.2. Pre-Wedding Ceremonies

Due to the predominant prevalence of arranged marriages as a norm in Punjabi families along with the preference for kin-marriage and the continuity of relationships based on gift exchanges, the marriage ceremony itself becomes a mode of cultural reproduction. The cultural reproduction takes place at the family level when we

analyze family's marriage strategies (Bourdieu, 2002). It is important to understand how do transnational wedding ceremonies reproduce the cultural values? In response to this question, I seek guideline primarily from Faist's theory of transnational social spaces (2000). He provides three basic elements to describe transnational social spaces: the kinship groups who are united through the ties of reciprocity, the transnational circuit that support the system of reciprocal exchange, and the transnational community who shares the common identity. In the following paragraphs, we look into the transnational Pakistani wedding ceremony and find how resources of networks of relatedness in Pakistan and also in France are mobilized in order to organize the wedding ceremony through the system of *vartan bhaji* (reciprocity).

Historically and cross-culturally in sub-continent, the feature marriages share in common is that most of the marriages are arranged by and through families, even in cases where the couples themselves introduce their marriage proposals to their families. Families' and kin's involvement in wedding ceremonies is considered essential part of the marriage event. A wedding ceremony without the participation of the kin-group reveals that family's links and ties with their kin-group are weak thus excluding them from the appropriate part of the matrimonial circuit. A typical Punjabi wedding ceremony is divide into three parts; the pre-wedding, the wedding and post wedding.

Pre-wedding ceremonies in Pakistani Punjabi transnational marriages include *din rakhna* (the fixing of marriage date) and *rasm-e-henna* (applying henna).

Din rakhna is the custom when parents and close relatives of groom visit bride's parents to fix the marriage date. Bride's parents also invite their elder family members at this event and organize lunch and/or dinner. Traditionally lunar dates are followed in villages due to the fact that Pakistan is an agricultural country. The harvest seasons bring money to family, so are considered perfect moments of the year to celebrate wedding ceremonies. The expenditures required for wedding feasts, to buy dowry and gifts come from the harvest. From religious point of view, Friday is considered a blessed day for marriage. However transnational factors like

the differences in the educational calendars of France and Pakistan, working days and traveling from a country to another have introduced modifications to the traditions. Weekend is preferred as wedding day and summer vacations are considered practical. Fixation of date may span over 1-3 months, however I observed that the span varies between 1-2 months. This time period is usually fixed to facilitate both families and the couple to get ready for wedding event. Both families clean their houses and renew the paints of the houses. These domestic rituals are a sign of how important the festivity is, attached to wedding event.

For fixing the date, usually it is the mother who travel from France. She is also responsible to buy dowry and other items that are to be presented as gifts. In deciding for the wedding event like the menu, selecting and booking the event place, printing and distribution of marriage invitation cards, she is helped by her close male relatives from her family-in-law and parental family. Later on her daughter (French-born would-be bride) joins her. She herself shops for her marriage like the wedding day dress, the dresses to put on soon after the marriage, gold jewelry, shoes and other items related to fashion. She also shops for her husband. The role of Pakistani women in wedding ceremonies is much more active as compare to the men. They are the controller of the wedding rituals (Werbner 1986). The father and sons come to Pakistan only 1-2 weeks before the marriage date. Once they are in Pakistan, they took the responsibility of the activities to be done outside the home, particularly related to the wedding feast and the transportation. French-Pakistani groom also relies on her mother and/or sisters to shop for him. Most of his shopping items are purchased by them. Before joining them in Pakistan, he remains in touch with them via video chats. He also relies on his male cousins and friends to search and to book hotel for honeymoon tour. Does male do not find time to go to Pakistan or do they do not find any interest in pre-marriage tasks? The explanations come from the structural constraints and cultural perspective on gendered-based activities in marriage institute. The structural constraints, first of all the job and/or business working hours limit their mobility for long period of time. Female especially the mothers on the other hand do not confront such constraints as they are housewives. Fathers and sons also do not find it convenient to travel for the sake of tasks that

could be done by their male relatives in Pakistan. Having secured the transnational ties with their kin in Pakistan, it produces them the opportunity to focus on their job/business, that otherwise is not practical in Pakistan. Further the cultural codes to assign different tasks to male and female play determinant role in understanding why male do not depart to Pakistan as early as their counterparts. From searching spouses to shop for wedding event, women are majorly responsible in local Pakistani context. Also practiced in France, however there are some variations like the autonomy as well as the responsibility. Education as a preferential characteristic is sought in would-be daughter-in-law so that they could manage the household chores as well as the activities outside the home. For in door household tasks they are socialized accordingly since long, however the tasks outside the home are newer to them to which they do not encounter in Pakistan. They compare often themselves with their female relatives in Pakistan. They feel that they are more autonomous in their decisions related to household chores, shopping and grocery as males depart early in the morning and return often late in the evening. According to Muhammad (2015), transnational marriage makes the female agency to negotiate on the basis of more egalitarian gender dynamics. However, they also feel themselves more occupied ones who relatively have lesser help and cooperation that eventually make them more independent in taking certain decisions. Once both are habituated to their tasks, mothers find themselves more concerned to the matters related to family and home, while male find themselves more concerned to their job/business, though marriage remains the major interest of the two. The father of the bride in Family AB4 recounts how he and his wife managed the task of wedding shopping of their daughter:

They have the time, the interest and the stamina too. I mean, to go for wedding shopping and to go for hundred times; and to remain in the market for several hours; and to wander from one shop to another, I mean this is something I cannot afford. We men also have to go but not for trendy shopping. We go there where they don't go. Like to evaluate the wedding meal menu and the prices, and to look after marriage hall services, and to arrange the transportation. And this does not mean that my wife and I never accompanied each other on my daughter's wedding. For purchasing dowry items, we were together. We bought furniture together. We bought electronic

items together. Some items were already prepared, you know, mothers start purchasing and saving in advance, years before the marriage of the daughters.

Traditionally, mothers began to collect dowry items for their daughters right after their birth, assuming that when she will be old enough to get married, God knows we might not be financially in a position to purchase everything at once. The items that are usually purchased in advance as dowry are related to utensils, kitchen items, bedding and the gold jewelry for Pakistani-born brides as described by my respondents. Whereas for French-born brides, the dowry shopping is instantaneous; mostly after fixing the wedding date. The fixing of date and the timespan facilitates the parents as well as the couple to prepare for the wedding event.

While fixing the wedding date, bride's menstruation date is considered very important, as specified by my respondents. Interpreting this ritual represents the basic purposes of marriage; to legitimately start the sexual life and to procreate. The cultural ritual is naturalized in order to ensure that the couple may enjoy the initial phase of their sexual life without any inconvenience and the fertile days may be fruitful. Both the bride and groom are advised to eat modestly but the health food until the wedding day. Foods producing acidity, heat and fat are prohibited for the couple. Foods producing energy for body are encouraged to be included in their meals. To remain and/or become more attractive and beautiful, brides are continuously applied different types of body masks and massages. Couple especially the bride is prohibited from unnecessary visits outside the home. It is believed that couple going to wed is vulnerable to the evil spirits outside the home. So they are advised not to leave home but only in case of need. Unnecessary visits outside the home are prohibited. Staying at home and taking rest as much as possible is considered fruitful for healthy body and soul of the couple. During this transforming as well as transitional phases, a couple is prepared for new phase of their life that they were never habituated before.

Rasm-e-henna is another custom from a series of transitional phase from singlehood to married. The duration of its celebrations varies. Some families initiate

it seven days before the wedding day by applying *ubtan* to the bride. *Ubtan* is a thick paste made with a mixture of turmeric powder, herbs and oil to give shine and beauty to the skin and body. The practice is repeated daily along with some hours of dancing and singing in the evening. The bride is not expected to do household chores. This custom is to realize her and others in her family that she is a guest to her parental home from now onwards. Some families celebrate it three days before the wedding day.

Generally, this festival is celebrated within the four walls of the homes of bride and groom, and is reserved only for female belonging to relative and neighborhood families. In some cases, both families decide to visit each other's homes and to celebrate the event together. In this case, males of the family are also involved in dancing and singing but it happens outside the home. In urban and modern families, the custom of separating the male and female is not practiced usually. However, none of the respondents told me that they have celebrated this custom jointly. All celebrated it a day before the wedding day, in a modest way and without visiting each other. Some brides told me that they have celebrated *henna* ritual in France also with their friends belonging to different ethnicities.

The home of groom is decorated with lightening. Bride's home is not decorated alike groom as her departure is considered a moment of grief and happiness at the same time. Grief can be explained in terms of the separation of the daughter from her parental family and in terms of the risks she may encounter during the marital life. Though her spouse is filtered through a number of criteria as explained in previous chapters, yet the marriage is considered a subject of fate. Honor and shame is another reason behind it as described by Werbner (1986). The emphasis placed on female's sexual chastity before her marriage followed by a transition from a state of sexual innocence to the state of sexuality though approved religiously and culturally still remains the issue of shame for bride's family. On the other hand, happiness manifests the moments of satisfaction and relief as the parental family is succeeded to play their role according to the religious and cultural obligations to marry the child.

Decorated with plastic and colorful papers, the plastic plates are filled with henna and candles. Female and the children hold plates in their hands while signing traditional songs. Then they put it on ground in front of the bride who with half-covered face sits on a flowery decorated chair. First of all, elder female relatives come forward to start the ritual of henna. They, one by one, put a little bit henna on bride's hand, massage few drops of oil on her hair and give her a little piece of sweet to eat. Then they give some money to the poor ladies hired to do household chores during the wedding ceremony. Oiling her hair represents elders' affection, applying *henna* represents the colors of married life that bride is going to enjoy and to eat sweets represents the happiness. Then, seven female relatives who are married and have children come forward to continue all the customary gestures done by the elder female relatives previously. It is believed that the married and fertile women will pass same states to the would-be-bride. Finally, it is the turn of bride's unmarried cousins and friends to follow the customary gestures. At the end of the ceremony, the bride deliberately slap lightly to any of her unmarried female cousin and/or friend so that her marriage event may plan as early as possible. Alike bride, the *henna* ceremony is celebrated at groom's home too where he is encircled by his female relatives and experiences same customary gestures alike the bride. The way a henna ceremony proceeds and the involved gestures reflect the cultural belief of divine blessings upon the couple.

7.1.3. The wedding ceremonies

Wedding day is the symbolic representation of the span of social circle of both families. Close to extended affines and agnates, and the network of acquaintances including friends, neighbors and business colleagues are invited to share the joyous moment of marriage. The wedding ceremony of daughter-in-law in Family AB4 was one of the most lavish wedding ceremonies of Pakistani immigrant families whom I talked. Her parents-in-law were not alive so her elder brother-in-law as the guardian of the younger siblings is acting head of the household. When I talked with him about the customs of the wedding day, his narrations were heavily loaded about the nature and number of the guests he and the family of the bride had invited. For him:

People know you better by the number of the guests who join you on your happy moments. You might ask if the heads count. I say yes, it shows the nature of your relationships with your relatives and friends. It shows how active you have been in others' joyous and sorrowful events. If someone does not join you, it matters little. But if the significant number of your relatives and friends do not join you, it means there must be some problem in your embeddedness within your circle. On my brother's marriage, the father of the bride especially reminded me to invite relatives and friends as many as I want. We were around 1000 guests on barat day and more than 1500 on the walima day. And it might be interesting for you to know, that I did not count the number of poor people who enjoyed the wedding meal at both sides. This is one of the memorable days in our village.

The poor people in the village and/or community are preferred to hire to do marriage related tasks. Female are assigned different tasks inside the home like cooking, cleansing the home, washing cloths and utensils, and serving female guests. Their male partners are assigned the duties outside the home i.e. to deliver marriage invitation cards, to shop the grocery items in order to cook the wedding feast, and to serve male guests. Though very common few decades ago, still it is largely practiced that families in villages hire the *nai* (hair dressers) for the said tasks. A *nai* is a go-between matchmaker who does not receive fix fees by the family where the marriage is being celebrated. Apart from the family, the relatives and guests also give them money during the process of spouse search and marriage. The money offered to *nai* apparently is perceive as a kind of wage. However, it is a custom and has deep roots in the nature and construction of reciprocal relationship between the families. Throughout the marriage process, a *nai* is assigned multiple tasks and is rewarded accordingly by kin families who have exchanged gifts and money with each other. Marriage invitation cards (if not given personally to the invited families) are normally distributed by *nai* and he is sent to relatives who reside at near and far destinations. If one family pays the *nai* more money, it indicates enthusiasm in the relationship; and is memorized as deposit to be returned on the marriage ceremony of the very family. A reduction in the payment may lead to freeze the relationship in the future. Reciprocity in the case of *nai* analogizes the profound complexity of reciprocal relationship in the broader social networks. Marriage is not just about celebrating and enjoying the feasts, but an occasion where gift exchanges, in its

various forms, determine the nature of reciprocal relationships, either families want to continue or discontinue. Marriage ceremony is also an occasion where one can observe extensive manifestation of reciprocal relationships and emotional attachments between the corresponding families, relatives, friends and extended social networks as the male member of the Family AB4 highlighted. It is also an integral part of the mobilization of socioeconomic resources of the families. If family's socio-economic status is considered to be one of the factors in constructing marital relationships in traditional societies (Johnson 1998), the wedding ceremonies can increase and maintain families' social prestige, honor, and cohesion within their social network (Zaman 2011). It is argued that in agrarian societies, the amount of grains owned by a family is proxy to its socioeconomic status, thus selecting spouse from the families sharing identical social status were considered favorable (Segalen & Richard 1986). Handsome amounts of transactions in form of cash, gold jewelry, costly cloths and lavish wedding feasts are favored in Punjabi marriages.

Wedding ceremony is the symbolic representation of family's economic span too. To what extent a wedding ceremony can be lavish and festive depends on the economic conditions of the family. Some Pakistani immigrant families celebrated the wedding ceremony in such munificent ways that they don't hesitate to show me the pictures and films they made to memorize the event. The father and mother in Family CO6 both insisted me to watch the wedding ceremony film and the picture also, so that I could see how generously and happily they married their children. When I was watching the film and pictures of wedding ceremony, they were sitting next to me and were telling me about details of each ceremony. Upon inquiring about the guests, I came to know that the socio-economic spanning of Family CO6 is also based on the reciprocal relationships that they have maintained over the years. It was for the first time that the marriages of their two sons and a daughter were planned and all events were planned to happen in the same week. It was for the first time that family CO6 was going to get back the reciprocity, they have contributed in the marriage ceremonies of their relatives and network of acquaintances.

Reciprocity is the tradition where if family A gives some gifts and/or money to family B's wedding ceremony, in return family A will receive (from Family B) either equivalent or bit higher contribution. There are no absolute rules to pay back all the amount of reciprocity at once. In cases of other future marriage cases, one may postpone certain part of the reciprocity. However, it is expected to pay back at least equivalently. In transnational marriages, I observed that the exchange of gifts was never based on egalitarian principles and/or equivalent in cost, though reciprocity is an essential part of the wedding ceremonies. A common narration of parents (from France) over marriage expenditure was that they do not expect their relative families in Pakistan to spend extravagantly on wedding ceremonies. Instead they ask them to spend according to their capacity. There are some families who believed to make the ceremony less expensive and as simple as it could be, like in cases of Families CB4 and SC5. Some families preferred to help their relatives in order to manage the wedding expenditures, but only in case of close kin marriages like in family LC4; the mother decided to bear the wedding expenditures of the whole marriage event (her son got married with her niece). In case of Family OZ5, the father went to Pakistan a month before the marriage of his daughter with his nephew (the son of elder brother). He gave generous amount of money to his brother to arrange a lavish wedding feast and *walima* ceremony. However, this trend is not observed in other marriages within extended relatives and the marriages outside the family. Almost all wedding ceremonies were celebrated traditionally with some variations introduced due to migration.

Wedding ceremonies in Pakistani Punjabi transnational marriages include *salami* (giving money to groom by his family and kin), *barat* (the marriage procession), *nikkah* (marriage contract), *roti* (the wedding meal), *vari* (family-in-law presents gifts to bride), *doodh pilaai* (offering milk to drink), *dowry*, *salami* again (money given by his in-law family and their kin) *rukhsati* (bride's departure to groom's home) and *munh dikhai* (bride's meeting with the members of her family-in-law).

The day of wedding called *barat* day starts with some traditional customs. In the morning hours, the groom takes bath and is surrounded by his mother, sisters and

sisters-in-law (wives of elder brothers, if married) to perform some rituals. The eldest sister-in-law initiates to beautify him. Then his sisters come forward to continue the custom. In return they receive money from the groom. Later on, he goes outside the home and joins his male relatives and friends to receive *salami*. **Salami** (some amount of money as gift which is reciprocated by the relatives of the groom who already received or in future are expected to receive salami) is presented to groom. After this custom, the groom and all the guests depart for bride's home called *barat* (marriage procession).

On the other side, the rituals of wedding day are different than that of the groom. Bride does not receive any *salami*, instead her parents (mother inside the house and father outside the home) receive money and edible things (also based on reciprocity) from their relatives. The bride is accompanied by one or two of her relatives to go to the beauty parlor for make-up. Once she is ready, she is not expected to reveal herself to other guests until the groom arrives and she sits next to him.

As soon as the *barat* arrives at bride's home and/or in marriage hall, they are received with warm welcome wishes and enjoy great hospitality. The groom again receives *salami* from the bride's relatives. As marriages are arranged within kin, the guests belong to same kin and enjoy the wedding ceremony collectively. Then the **nikkah** (obligated marriage contract in accordance to religious regulations) is held. After *nikkah* ceremony, **roti** (the wedding meal) is served to the guests. However according to the tradition, *roti* (the wedding meal) is served separately to the male and female guests.

The meal conveys prestige of bride's family. If meal menu is not up to the expectations, and/or is not properly served, it may cause disgrace to bride's family. *Roti* has been very important part of the narration of the parents especially of fathers. The father in Family VB4 is running the business of marriage banquet hall in France and in Pakistan since years. He talked in detail what the wedding meal may mean in France and in Pakistan; how wedding meal is served and what changes the meal menu has gone through. He also told how he has served the *roti* to the guests on

his children's marriages. It does not matter either the wedding event is being celebrated in France or Pakistan, *roti* is symbolic manifestation of a family's socio-economic positioning. He celebrated the marriages of all of his children in Pakistan. For sons' marriages, he performed the ritual of *walima* twice; first in Pakistan and then in France. For daughters' marriages, he offered a lavish wedding meal to the guests in Pakistan. Though the basic cooking style of meal menu is Pakistani yet the menu of the meal differs in France than to Pakistan. For him:

What people expect is that I am running marriage hall business. So I don't have to face any problem in deciding about the meals of my children's weddings. They are right in their expectation but I would say only in case of Pakistan. Look, I have to be very careful about what people will say if I could not do as I should do. In France we are not the Pakistani participants only. We have relationships with others [different national and ethnic communities] too; there are Pakistanis who have married with Arabian, Maurrassian, Indian and French people; then we have friends in these communities. So I planned a quality meal menu to let others know how rich Pakistani cuisine is. I offer a mixed menu too to satisfy the taste bud of my guests. In Pakistan, I can escape from such problems. A variety of meal based on meat menu is appreciated above all.

While describing what wedding meal menu should be, the father has been very concerned. He realizes that his guests are not only his Pakistanis relatives but the 'others' also. The 'others' are his co-ethnics who are married with other than their co-ethnics. The 'others' also include their friends in the other diaspora communities. The father is the part of that 'others' circle. This circle is the circle of transnational families. Pakistani families have maintained their transnational ties through marriages with their kin back in Pakistan, and they have developed new kin ties with 'others' as well. Their inter-ethnic and inter-diaspora marriages in France extend their networks of relationships beyond their own diaspora to reciprocate their relationships. Those 'others' often play a significant role in their social lives in France as being their fictive kin networks. And to present them an appropriate wedding meal of their taste becomes equally important for transnational Pakistanis in France, as depicted by my respondents.

In Punjab, Pakistan the wedding meal may include a variety of food items made of mutton and beef, rice prepared with meat, desserts, fruits and vegetable salads, bread and soft drinks. Government of Pakistan has introduced law against the lavish wedding feasts to curb the extravagant spending that was considered as showoff of family's wealth¹⁷. It induces one-dish menu comprised of only tea or soft drinks not only as the wedding but the *walima* meal too. However, it is not strictly followed by the public since it is against the local traditions. Father in Family CO6 comments on the scenario as follows:

Do we take tea with biscuits in lunch or dinner? Then how it is true for the wedding meal? Marriage procession if comes from 2 to 3 hundred miles away, and then they have to go back on the same day, would the guests not feel hungry? Instead serving them with hospitality, you just wet their mouth with a cup of tea or soda and let them go hungry? Are these our values?

Parents remain very concerned about the wedding meal whether it is served in banquet hall or in the courtyard of the house. In villages, people do not prefer to go to banquet hall as they consider the food is of low quality, of limited choice, and costly. They think that guests can eat better in the self-arranged wedding feasts as compared to the banquet halls. Banquet halls are obliged to follow the law, and by avoiding the banquet halls, they may easily bypass the law of One-Dish menu.

After serving and enjoying the wedding meal, the bride joins the guests and is escorted to the decorated stage where the groom is already sitting. The groom and bride sit side by side for further rituals. The parents of bride present valuable and expensive gifts i.e. branded wrist watch, gold necklace, clothes and perfumes to the groom and his family. Sister(s) of the bride present(s) sweetened milk to the groom and receives some money. This custom is called ***doodh pilaai***.

The family of groom also brings particular gifts for the bride, called ***vari***. It is comprised of fancy and costly dresses, shoes, cosmetic items, gold jewelry and other useable items related to the customary fashion. The quantity of *vari* depends

¹⁷ <http://punjablaws.gov.pk/laws/461.html>

on the economic conditions of the family. The more a family is wealthy, the more is the cost and quantity of the *vari*. The eldest sister of the groom shows the *vari* to the female relatives of the bride. The quality and quantity of *vari* is critically evaluated by the relatives. If not according to the socioeconomic status of the family, it may cause dishonor to the family. Alike the *vari* presented by the groom's family, the custom of dowry is indispensable, and dowry items are displayed by the bride's family.

Dowry called *jahaiz* in Urdu and *daaj* in Punjabi as manifestation of bride's family honor, prestige and economic prosperity is given on the same day of *barat* and *rukhsati* (departure of the bride). Now days, dowry items are sent to family-in-law's home some days before the wedding day. It is considered convenient for both families to arrange and organize the furniture in groom's house before the bride comes to her family-in-law. Though in transnational marriages, a variety of behavior related to dowry is observed, yet the custom of dowry is followed in all marriage events. The families of brides in France and Pakistan with higher socioeconomic status spend a lot of money over dowry, despite the fact that the bride is not going to live in Pakistan for long. She sooner or later has to depart to France. Families OZ5, BZ5, VG4 and AB4 gave plenteous dowry to their daughters in Pakistan and again in France when the couple is reunited after getting visa. Some parents only purchased couple's bedroom furniture without buying any other home and kitchen electronic appliances in Pakistan. Once their daughter is migrated to France to join her husband, her parents again gave her dowry. In few cases, parents' economic status was not stable, so they did not offer any dowry until the couple is in France.

If French-born daughter is economically independent before her marriage, like in case of family LM8, she manages to furnish her apartment before her Pakistani husband joins her. According to my observation, to arrange a separate apartment is considered part of dowry in France. The issue of renting an apartment needs particular attention that creates tussle not only between the couple but between the families as well. To dig out the issue, I present the cases of Family LM8 and Family PI3 as explaining examples. When I talked with the couple in Family LM8, their

divorce petition was in the court. Renting an apartment was one among the several reasons that the husband counted. For him:

The qualities I appreciate in my wife became the reason of the divorce too. Actually my family-in-law especially my mother-in-law did not want us to live in separate apartment. When she saw that her daughter is spending handsome money on furnishing our apartment and buying the car, she started to insist us to stay at her home and to save the money instead. I am clear that this was just a tactic to keep her daughter's earnings within her family. Actually she was disappointed to see that instead saving money for her younger sisters' marriages, her daughter is focusing on buying an apartment and the car.

His wife however did not listen her mother and did not dwell in her parental home. Nonetheless, she shifted in a nearby city so that her mother may feel tranquil. Shifting in nearby city, according to her husband disturbed them because his mother-in-law used to insist them to take dinner frequently with family-in-law. Alike her, in case of family PI3, though the daughter was economically independent, eager to dwell with her husband in a separate apartment than that of parental, however she could not do that. Because her husband is the nephew of her father, so they preferred to live jointly until the couple saves some money to purchase their own apartment. The daughter was not satisfied and compromised to the wishes of her father and husband, that later created tussle between the couple and the family members resulting in divorce. Her husband narrated in the way as follows:

My wife was not happy that we live in her parental home. But I though it is not just my family-in-law home but the home of my uncle too. We both were earning good and we could afford renting an apartment. I admit that it was my fault basically. I must have shifted to a separate house. Then our fate that things went bad. My father-in-law remarried and my wife had to own the economic responsibility of her younger siblings. Afterwards, I insisted but she said she could not abandon her siblings like her father did.

The nature of pre-marriage close relationship ties between the son-in-law and father-in-law influenced the decision to rent an apartment. The custom of dowry giving is the prime responsibility of the parents, and if the bride is in job market, she shares the burden, as per my observation in France in Pakistan too. In Pakistan, the

bride saves her earnings and purchases dowry items mostly related to cloths and gold jewelry. The bride in France saves her earnings to rent a separate apartment and/or to buy a car after the marriage. The difference between the savings of brides' earnings in both societies are influenced by the nature of the needs that they are going to meet after the marriage.

It is needed to be clear that sharing the burden of dowry is not an obligation. According to the cultural norms in Pakistan, even if the economic situation of the family is poor, and the bride is in job sector, her parents are prime responsible to arrange for dowry. In Family CO6, the father of youngest daughter-in-law is a farmer. He practiced the custom of dowry despite the fact that his daughter would depart to France. In Pakistan, female's participation in formal job sector is very low (22.2% according to Pakistan Labor Force Surveys and ILO for year 2010-2011), so they do not share the burden of the dowry. In France, only one bride in Family CB4 did not share the burden of dowry because she was not allowed by her elder brother to complete her studies and then to start any job. Her mother gave her the basic items of dowry while celebrating marriage in Pakistan. Later, her husband in France managed to furnish the apartment. It is interesting to note that though couples do not stay in Pakistan, yet their bedrooms are reserved for them when they are back to Pakistan for visit purposes.

The wedding day comes to its final stage of departure of the bride called *rukhsati*. Bride's departure is a moment of grand emotions combining happiness, sadness and the fear. Happiness for the parents is in the sense that they have fulfilled their divine duty to wed their child. Sadness in the sense that they are not going to stay together. They also confront with the fear if their child's marriage is going to be successful or not. Marriage is to be secured, this is why much attention is paid during the process of spouse selection. After the careful procedure, the departure of the bride still makes the parents and family members to feel insecure until she feeds them back with good news about her adjustment in family-in-law. A daughter is considered equal to blessing from a religious point of view. So, at the end of wedding day when it is time to depart, she throws grains, often the rice, into the court-yard of

parental home. It is believed that performing this custom will produce blessings and prosperity to the bride's parents even if she departs. At departure time, bridal's family sends meal with bride so that her family-in-law does not have to arrange the dinner. The meal to be given is prepared in advance along the wedding meal.

When she arrives to her family-in-law's home, her mother-in-law perform certain customs. When bride enters, first of all, the mother-in-law pours out some oil at the entrance door. It is believed that the fortune, she is blessed with will be continued in her new home. Then the relatives of her family-in-law, and the persons from the neighborhood present her money called *munh dikhai*. Then, her youngest brother-in-law presents her some money and get some money in return too. He sits in her lap too. This custom signifies the cultural belief that she may bring prosperity to her family-in-law and may have a son. The marriage is consummated on the wedding night. Consummation of marriage leads towards the obligatory religious ritual *walima* on the following day of wedding.

7.1.4. Post-wedding ceremonies

Post-wedding ceremonies include *walima* (wedding meal presented by groom's family) and *maklawa* (bride and groom depart to bride's parents' home at the end of *walima* day). The second day of wedding event is called *walima* Day. In the morning, it is the custom that bride's parents send breakfast to her family-in-law's home. The quantity is sufficient to serve all of the guests there. After the breakfast, the bride may depart to a beauty salon or someone is hired to beautify the bride. On *barat* day, the bride wears the dress purchased by herself or by her parental family. The color of her dress is typically hot like the red, costly and heavily embroidered. On *walima* day, she wears the dress presented by her family-in-law. It is costly but less embroidered and soft in color as compare to *barat* day's dress. The custom of wearing dresses differently on both days reflects the new bonds of belongingness that the bride has gone through; from a daughter to a daughter-in-law.

Around mid-day the *walima* ceremony starts. *Walima* is a ritual considered obligatory to celebrate, if the couple has consummated the marriage. To this

ceremony, bride's parental family and relatives are invited. Alike the meal menu of wedding day served by bride's parents, the menu of *walima* also symbolizes the prestige of groom's family. The participants of *walima* are numerous because the groom's family invite more guests on *walima* than that of *barat*. The presentation of money and gift exchanges is the part of *walima*. In some cases, *walima* ceremony is delayed until Pakistani groom/bride joins his/her spouse in France.

Ideally *walima* ceremony is celebrated once. However, in transnational marriages of the French-born grooms, it is celebrated twice, first in Pakistan and then again in France. Only close family members depart to Pakistan to participate in the marriage. Those who could not depart joins *walima* ceremony in France. The frequent narrated reason behind multiplicity of the *walima* ritual is the relationship ties with co-ethnic and other ethnic communities in France. Alike Father in Family VB4, the son in Family SD5 is concerned about the 'others' in France and recalls his *walima* ceremony as:

As you know already I brought up here so do have my connections here. My friends, my father's friends, my mother's friends and our relative families, a long list to go. You know everybody cannot afford to go to Pakistan to attend the marriage ceremony. Some don't have money, some don't have time, [and] some don't find it secure. I too could not afford inviting [them]...You know hospitality problem. There are many other guests too in Pakistan. And you too want to enjoy marriage [ceremony]. So better to arrange another walima here. Your fellows who could not join, would enjoy it.

He adds the economic resources and the time as other reasons behind celebrating the *walima* in France. Most of the younger respondents alike him also counted their links and networks with other than Pakistani diaspora important. Younger generation repeatedly mentioned that as their grandparental families and cousins are not in France, so they are used to replace them since their childhood. Once they have found their fictive grandparents and cousins, they care about them. They find their friends equal to their cousins and family members. The *henna* ceremony organized by bride's family and *walima* ceremony organized by groom's family are for these fictive kin networks. Reciprocity is another motive to celebrate *walima* in France as mentioned by a mother in Family VI4. According to her:

So what if we have no blood relationships here. Here we do not live in isolation. With some Pakistani families we have maintained very close relationships. Some of them have organized the marriages of their children between themselves. We participated in their marriage and presented them gifts. We do so regularly. And when it was our turn [marriage], and they could not go to Pakistan, we organize walima here. That is an occasion of shared happiness and an occasion of lain dain [gift exchange].

It is said that transnational marriages produce chain migration especially migration of the close relatives, yet many families do not have close relatives in France as the mother mentioned. In case when they don't have real kinship, they develop close relationship ties with their co-ethnics, and relate themselves to each other through the fictive kinship. They consider them alike their kin. The fictive kin relationships if secured through trust and reciprocity may lead them to develop affinal kinship. The reciprocal relationships and the practice of organizing the marriages between the co-ethnic bind them like a family. So they don't feel themselves alone as the mother clarifies. They also satisfy their connections while organizing a *walima* ceremony. Compared to French-born grooms, in case of French-born brides, the *walima* is celebrated in Pakistan. As *walima* is given by the groom's family, so I never encountered any case where it was followed otherwise. Instead French-born daughter celebrates her *henna* ceremony two times; for the first time in France before departing to Pakistan and then in Pakistan according to the tradition. She invites her friends and her parents also invite their relatives and friends. The logic to celebrate *henna* is same as it is applied for *walima* ceremony.

Now I return back to the narratives of *walima* in traditional setting in Pakistan. At the end of the *walima*, bride and groom depart to bride's parents and stay there for a day or two. This custom is called ***maklawa***. In cases where the geographic distance is long and traveling may require considerable hours, the stay of the couple at the home of bride's parents may prolong. Alike engagement and fixing of the wedding day date, only important close members of the family are invited for *maklawa* custom. Alike other wedding customs, the exchange of gifts and money is part of this custom too.

After coming back to groom's home, the couple goes for honeymoon trip spanning a week generally. Some may prefer to stay at home. All of my respondent young couples went for honeymoon. The purpose of honeymoon as I was told is to understand each other by passing good quality time; that otherwise becomes difficult while living with the family. Some parents share the similar point of view and comments that children are young, they should enjoy the earlier days of their married life. While very few parents consider it wastage of money, modern-day artificial custom against the traditional settings where a couple gradually understand not only each other but to adjust in the family atmosphere.

Transnational couples undergo rapid post-marriage transitional stages. Traditionally in local Pakistani settings, a bride is not expected to start cooking and household chores in the earliest weeks of her married life. Though in transnational marriages, brides are not assigned the tasks of household chores and cooking, however they are expected to prepare traditional dessert. Instead cooking spicy and hot food, preference for sweet food is a sign of delightful beginning of married life. Family members enjoy the dessert and it is also distributed among their neighbors.

All of the wedding ceremonies of the interviewed French-Pakistanis were celebrated in Pakistan except one case in family LP4, who celebrated the marriage of their daughter in France. The reasons behind celebrating the wedding in France were multiple. Firstly, the groom was residing in France at the time of his marriage because he came to Spain as a laborer before moving to France. Secondly, his elder brother and sister (married on exchange basis with their French-Pakistani maternal cousins), were already residing in France. His parents asked his maternal aunt and uncle (also the parents-in-law of groom's siblings) as being the elders in France to take the responsibility of representing them on the marriage event. His brother and sister took the responsibility to manage the wedding event, so it was decided that the marriage ceremony would be organized in France. After the marriage, the couple and the relatives went back to Pakistan for the ritual of *Walima*. Though groom's parents had given their approval for his marriage, neither they nor their Pakistani relatives could participate in the marriage. So to celebrate the

marriage with relatives, it was decided to organize *walima* in Pakistan. The mother of the groom in Family LP4 narrates the scenario as follows:

Imagine how strange it will be for you if your son marries in France and you and your husband and all of your relatives remain in Pakistan? My husband was sick so we could not afford to travel to France. I asked my sister and my brother-in-law to arrange all. Aunt is equal to mother. But I, as mother, could not see how my son looks like in his wedding dress. I missed the Barat in France. So we asked them to come back for walima ceremony. We invited our brothers and sisters for salami. Then they invited all of us to take food together.

During spouse selection process, the preferential criteria at first stage filters the potential spouses and their families-in-law according to the expectations of the individual and his/her family. The capitals of spouses and their respective families play determinant role in finalizing any marriage proposal. This cautious selection makes basis for further relationships between the two families. The reciprocity involved in pre and post wedding ceremonies is actually a building bond between the two families. The idea behind manifestation of material resources involved in wedding ceremony is that it must maximizes the socio-economic prestige of both of the families. In line with the custom of reciprocity that plays central role in maintaining and developing the relationship ties, the wedding ceremony also mobilizes the economic and human resources of the kin to help the families to marry their children. Organizing marriages within their network of relatedness may bring ease that the newlywed couple will transit from one status to another in comfortable environment that lead them to adjust better.

7.2. The transition process

In the previous part, we see that the event of transnational marriage is celebrated according to the local wedding customs, with some variations that make it more lavish and festive with some additional customs introduced by the migration. After the wedding ceremony in traditional local settings, the bride is adjusted into her family-in-law and the couple starts their marital life gradually. As the migration is internal, so it has little impact on the wedding ceremony, also on the couple and their adjustment. However, in transnational context, the couple passes through

transitional phases due to the regulations on international marriage migration. In line with the objectives of this chapter, in this part I describe some variations that I observed in transnational marriages which I name as post wedding transitional process. Temporary adjustments, frequently described side by side, are the bride's departure to her family-in-law's home first and then her dwelling in Pakistan until she joins her husband. I describe the French Pakistani bride and Pakistani bride's cases side by side and intra gender differences during the transitional process. Studying these transitional phases will help us further to we observe what changes migration has introduced to the traditional Pakistani marriage institute. Is transnational kin network formulating new strategies to sustain and to reproduce marriage customs? How the perceived risks involved in marrying transnationally are reduced by delaying the consummation of marriage or not? How do Pakistani immigrant families arrive to manage their dwelling in case when they do not own any house in their localities of origin, yet they have to stay to celebrate marriages, and to wait for re-unification? In this case, where do the brides depart and stay?

7.2.1. Departure and Dwelling

The marriage contract called *nikkah* is the principal and essential religious obligation, without it the marriage is considered illegitimate. *Nikkah* is followed by the ritual of *rukhsati* (bride's departure) which involves consummation of marriage generally. In religious context, the consummation of marriage is an important determinant to address several conjugal issues related to menarche, age at marriage, obligatory *walima* ceremony, divorce and widowhood. Derived from religious guidelines the Pakistani marriage customs also interpret marriage consummation obligatory, however when to consummate is a matter of choice. In transnational marriages among British-Pakistani immigrant families, Charsley (2013) observed that *rukhsati* is delayed in order to escape from the risks that transnational marriage may create, particularly faced by women due to the convention of virilocality. I however did not find any case where the custom of *rukhsati* and consummation of marriage was delayed. It could be due to the factor that most of the marriages were arranged within the kin group either close or extended where the relationships between two families were already secured

through reciprocity and it achieved the status of trusted ones. Even if, the marriages were arranged outside the kin, the families belong to the network of acquaintance, where the issues of anonymity and mistrust were not involved. This could be also due to the sustained and vigorous kin links that are building blocks for the transnational relationships that Portes, Guarnizo, & Landolt (1999) previously identified. Later, Cameron (2006) also found empirical evidence to support Portes' argument that transnational marriages at one hand sustain the kin relationships across borders and increase the density of kin group in the country of settlement on the other.

The inner working of transnational marriage is of particular interest when it comes to describe the transitional process concerning the bride's departure and her dwelling in Pakistan; an issue remains unexplored. Though the trend of studies on Pakistani immigrants' inclination towards constructing the houses in home country is recent and examine the links between house construction, return migration and remittance (Hassan 2010; Bolognani 2007); the studies do not analyze the actual analysis of the spatial terms like space and place (Gielis 2009) often used in transnational marriages. This part tries to fill the gap by focusing on the place equal to 'home' and the role played by the agency; the Pakistani immigrants and their kin in celebrating the transnational marriages at one hand and how does a bride's temporary dwelling in the 'home' may contribute to manage the customary tradition of virilocality. Erdal (2012) while working on the trend of constructing houses among Norwegian-Pakistani immigrants summarizes that as spatiality is not often the main focus of the studies, the recent developments in this arena reflects three dimension; first is that distance matters in terms of constructing the relationships between the immigrants and their kin in the country of origin. If an immigrant constructs a houses, he/she is in need of their kin to look after their property. Secondly locality is very important in terms of their embeddedness in particular localities. Building a house thus is significant symbolically, practically and economically in both localities; in the countries of settlement and origin. Thirdly building houses in each locality reflects immigrants' multiple identities. Thus house building becomes a focal point in understanding the life projects of immigrants including the transnational marriages. In line with what constructing houses may produce to Pakistani immigrants, the

purpose of this part is to see if these houses are equal to home that may serve the purpose of dwelling during the post marriage transition process. If not, how French-Pakistanis manage it and what strategies are adopted?

First of all, it is needed to understand that those French-Pakistani families who have established business in France and Pakistan have higher inclination towards building the houses in Pakistan and occasional dwelling therein. After arranging a marriage of any of their elder son, the duration of parents' dwelling in Pakistan prolongs as the married son is assumed to be independent and enough wise to take care of the business and his unmarried siblings. The daughter-in-law is assumed to replace her mother-in-law in doing household chores. In such cases, the marriages of younger children are always celebrated in their proper homes in Pakistan. Having homes in both localities in France and Pakistan and a transnational dwelling is the scenario happened in cases of five families out of sixteen; AB4, CO6, SD4, OZ5, VB4 and VG4. It reflects especially how the construction of house and making it home retains central place in the spatial dimensions of transnational arenas. At the time of fieldwork for this study, the father in family VB4 was on business trip to France while the mother was in Pakistan. When I contacted him to talk about the marriage of his daughter, he invited me to come to Pakistan for detailed discussion. He was interested to show me his home in Pakistan and how he celebrated the marriage ceremony of his daughter there. When I was in Pakistan, he was again on business trip to France. Then I talked to the mother there. For her, she did not have to find the marriage proposal of their children in such a way as compare to their co-ethnic diaspora in France and she relates it to having a home in Pakistan. She also counts the difference in the wedding ceremonies.

When I went to France, my husband and I had strong desire to construct our own house in Pakistan and we did so. However, we did not make it happen to dwell here permanently because children were of school going age. My husband expanded his business in Pakistan with the help of his elder brother and we started to dwell in Pakistan. I along my children used to spend school holidays in Pakistan each year. This helped the children to remain in touch with their kin, to understand the culture and to remain in focus as potential spouses.

Her narration reflects that constructing houses in Pakistan has been a dream of Pakistani immigrants. The parents also thought to not to focus only on the materialistic gain of the house but to utilize it in reproducing the cultural norm of arranging the marriages within kin. They wanted to save their children from the risks of not being selected as ideal spouses or failure of their marriages. Alike Family VB4, there are other families too in my data set who own a house in Pakistan and find no problem during their stay in Pakistan for the purpose of visit and/or organizing the marriages of their children. However, there are other families too, who either do not own any house at all or owned houses in past but sold due to some financial issues.

If constructing home reflects that immigrant families remember their roots and maintain their connections with their homeland at one hand, property ensure security against the potential risks. In case of need, they may sell their houses. This leads towards the relative newer phenomenon of remittance flow back to the countries of settlement. Recent economic crisis/recession around the globe has effected the remittance flows. The findings of my data reveal that many immigrants sold their properties in Pakistan mainly the big houses in order to support their collapsing business and/or to meet the daily needs in case of joblessness in France. Under such circumstances, how do these families manage to organize the marriage ceremony and the issues of their stay in Pakistan, receiving their daughters-in-law and their dwelling until brides join their spouses?

The father and mother in Family VP5 invested money in buying property in Pakistan. They also constructed a house in Pakistan. When the children were younger, they alike other co-ethnic families used to spend holidays in Pakistan. However, in later years, due to loss in business they gradually sold their property as well as the house. When it came to go to Pakistan to celebrate the marriage of their elder son, they stayed in the home of groom's maternal uncle (also the maternal uncle of bride). As the relationship bond was very close, all of the involved families did not bother about the dwelling issues. The bride departed to the very home and stayed there until she

departed to France. For bride, that home was equal to that of her family-in-law's and husband's home. She narrates it in the following manner:

Since long it was clear that my family-in-law will stay in my maternal uncle's home to celebrate marriage. So obviously his home for me was equal to my family-in-law's home. Since my rukhsati to my departure to France, I dwell there for almost four years. Though my parental home was situated in the neighboring town, but I did not dwell there. And whenever my husband and others from my family-in-law were visiting me, they also stayed in the very home.

Comparing her statement to that of mother in Family VB4 over the issue of owning a house in Pakistan, we notice two contrasting dimensions pertaining to spouse selection and celebrating marriage. The mother in Family VB4 found that owing home in Pakistan had helped her in finding adequate spouses for her children and also in celebrating their marriages. While in case of Family VP when they do not own any, it did not create any problem in finding a daughter-in-law, in celebrating the marriage and the dwelling issues too as the narration of daughter-in-law conveys. The explanation behind the behavioral variations comes from the analysis of the close ties that the families and their kin share. Also, the transnational marriage is the relational event and a common interest of the kin group. The daughter-in-law relates the home of her maternal uncle to the home of her family-in-law in France, and this is what Faist (2000) calls the transnational social spaces. The relativity of the home enables the daughter-in-law to dwell there until her migration to France and also facilitates French-Pakistani family to stay there during temporary visits to Pakistan.

Upon searching the answer to the query that whether in case Pakistani immigrants do not own any house, do they rent houses for the purpose of celebrating marriages or not? I find not a single family having done this. Instead renting, they preferred to stay in the homes of their siblings. Renting a house may cause serious concerns of insecurity among the would-be in-law families. In Pakistan owing a house is a social capital and those families who own a house are preferred for affinal ties. Those families who do not own any house are considered less conscious about the possible economic risks in future. If Pakistani immigrant families have maintaining

ties with their relatives in Pakistan well, it not only helps them in rapport developing while searching spouses outside the kin but also capacitates them to stay and to organize the marriage ceremony in the homes of their relatives. The duration of their temporary stay could be as long as two month or as short as one week depending in different circumstances. In case of Pakistani daughter-in-law, the duration of temporary dwelling in Pakistan depends majorly on the visa process and the conditions to its accreditation. It could be as long as 4 years as in case of Family VP4 or as short as 3 months as in case of Family LC4.

Concluding Remarks

This chapter reviews in depth how transnational marriage ceremonies of Pakistani immigrants are held in France and in Pakistan. And how rituals and customs involved in transnational marriages mobilize, reproduce or enhance the social capital of the spouses, their families and kin. To serve the purposes of this chapter, I start narrating about how the rituals and customs are performed in transnational marriages, followed by the focus on the logics of practicing them. Then, I make comparisons between the local marriage ceremony in Pakistan and the transnational marriage ceremony in France and Pakistan. In doing so, I particularly highlight the convergence, divergence and modifications that transnational marriage yields to the traditional marriage institute.

Having provided a basic sketch of how ceremonies are organized across borders, several points are considerable. Firstly, Pakistanis living in France show identical marriage behavior with their co-ethnic diaspora in Europe; they select spouses from their origin country. Very often these spouses are chosen from the kin. Their transnational wedding ceremonies generally follow the typical portrayal of traditional Pakistani wedding ceremony that is divided into pre- and post-wedding ceremonies. Practicing the traditional customs and rituals signifies their deep roots of transnational connections with their homeland. They prefer to go back to Pakistan to celebrate the marriages because on one hand they have found spouses from there and on the other, they find it more convenient because their relatives can share the joyous moments of the marriage. Kin's participation in the wedding ceremony is

the crucial part of their reciprocal relationships that secure their cohesiveness within the kin group. Another interesting motive is to get the social approval of the marriage by the kin in case when a marriage is celebrated first in France, although this is rare. French-Pakistani families go back to Pakistan to celebrate it once again by offering a wedding to the relatives at both sides.

Secondly, the multiplicity of certain rituals and practices is observed in transnational wedding ceremony, like *henna* and *walima* are being celebrated twice; once in Pakistan and then in France. The meal offered at these events in France is a mixture of oriental and occidental tastes because the guests are other than Pakistani community too whom one has developed marital and reciprocal relationships. Transnational Pakistani families are a part of the other transnational diaspora families too. Where Pakistanis have maintained their kin networks back in Pakistan, there they have also developed their fictive kinship and social networks in France.

Thirdly, several modifications have been introduced to the rituals and customs especially the festivity attached to marriage, offering lavish wedding meals and new forms of reciprocal relationships. Those living in France have higher economic status thus spend relatively much on wedding ceremony as compare to their counterparts living in Pakistan. Marriages that are organized between the children of the siblings, family living in France often presents money to their siblings in Pakistan so that they can organize wedding event more lavish. If siblings are poor, the family in France takes all the economic responsibility of the wedding event. The emphasis that is put on the importance of wedding meals and festivity is to memorize the event of marriage, as marriage is considered one of the major important life events. Another wedding feature influenced by transnational marriages is the modified versions of reciprocity. In contrast to local traditions of gifts exchange, the nature of gifts depends where a family lives. Weighted neither in quantity nor in quality yet compulsory to sustain the transnational ties between kin, the reciprocity works as the backbone of the kin relationships. Wedding ceremony crystalizes the reciprocal relationships that are maintained in France with the co-ethnics and other than the co-ethnic communities. Through wedding reciprocities, French-Pakistanis do not

only maintain their kin cohesiveness in Pakistan but are also embedded in France in the local diaspora and other communities.

Fourthly, the basic building elements of the wedding ceremony are the reciprocity and exchange of gifts that are managed by the female agency. Wedding ceremony brings the female agency to the forefront that how far she is active and powerful in taking certain decisions regarding the spouse selection process and the management of the wedding event. A closer inspection of the customs and rituals of wedding ceremony reveals that female especially French Pakistani mothers and daughters are far more active than the fathers and sons in family in managing the event of wedding. Their migratory experiences and the confidence they acquire together with free time, economic resources and their positing in the kinship structure enable them to decide independently about certain parts of the wedding event.

Fifthly, transnational marriage ceremony mobilizes as well as generates socio-economic capital of the individuals and their families across borders. From the engagement period to the pre-wedding customs, the bride and groom are prepared under specific cultural codes of conduct so that the couple may behave well physically, psychologically and socially. The basic necessities of a household—from infrastructure to the useable items—are provided to the newlywed couple. Their families get back the resources what they have invest in the wedding events of their kin and reutilize for wedding customs specially for dowry, *vari* and wedding feasts. In addition to the exchange of gifts in the given social contexts, the responsibility of wedding expenditures becomes the prime duty of kin. Further, due to the conditions involved in international migration and visa accreditation, the economic and social resources of the kin are called in time of need and emergency. Instead renting the houses in Pakistan, different strategies are developed. Amongst one is to consider siblings' and close relatives' homes equal to family-in-law's home in France to celebrate the wedding. The Pakistani-brides stay there as long as they are awarded permission to join their French-Pakistani spouses in France.

CHAPTER 8

DYNAMICS OF TRADITION AND TRANSITION IN FAMILY AND HOUSEHOLD

In the previous discussion, we observed the significant and vital role of the institution of family in migration, selecting spouses and organizing marriages of Pakistani immigrant families. The family influenced marriage and migration orientations of parents and their descendants, differently. As far as the first generation of migrants is concerned, the cultural norms of joint and extended families permitted the married sons to migrate while held their wives and children in Pakistan for long as compare to other South Asian diaspora. While unmarried male migrants were called back by their parents to marry within family's relatives. After family reunifications in France, they remained in touch with their families in Pakistan thus starting kin-based chain migration and producing transnational links with families. Due to strict policies on kin immigration, different strategies to migrate were employed by the families across borders, and the marriages of the second generation is one amongst them. As far as second generation is concerned, we observe lesser direct influence of kinship on their family life in France, as compare to their parents. The marriage remains collective affair of family despite the fact that children have more say in their marriage decisions. 14 out of 18 spouses belonged to their relatives making kin a primary criteria of spouse selection. Family, kin and marriage are interlinked and remain inseparable for Pakistani immigrants in France.

Pakistani's family institution holds a momentousness place in sociological studies observed varyingly in terms of its value, functions and composition; from a unit of common group welfare and cohesiveness (Das 1976) to economic production, distribution and consumption (Donnan 1997); from a channel of transmission of cultural values revolving around kin and social identity to a channel for individuals' security, comfort and social capital (Qadeer 2006). Qadeer observed that family's compositions and relationships between family members are not the same as in

past. The change, though glacial and not very perceptible, loosening the boundaries of family. If family's composition is becoming more malleable and its functions are being reinterpreted and redefined in Pakistan due to education, urbanization, and modern values (2006:189) then what changes and modification migration has introduced to the institution of family of Pakistani immigrants in France? Given the fact that transnational marriages paved the way to form a family across borders as a bride/bridegroom's migration is necessary to join her/his spouse, in what ways transnational marriages have influenced the traditional structure and functions of Punjabi family and household, the subject matter of the current chapter. In the similar vein, does family inscribe the indigenous cultural values in terms of relationships between the actors—children and parents, children-in-law and parents-in-law, and husband and wife—who have been raised up differently in their respective societies. And if yes, what is the nature of their relationships across gender and generation? Is family institution of French-Pakistanis playing any role in the social reproduction of gender ideologies and generational relations and/or introducing new codes of conduct in transnational context.

8.1. The dynamics of relationships across gender and generation

Relationship in Pakistani family life are shaped by two basic rules; hierarchy and loyalty to the kin-group (Shaw 2004). Hierarchy delivers authority and varies across gender and generation while loyalty is expressed by respecting the values of family. It is argued that the codes of conduct in Pakistani family institution are largely devised by religion and culture. If for Donnan (1997) family affairs and family composition in Pakistan have been strongly influenced by Islamic traditions, for Carroll (1996) the religion could be a point of reference in family affairs, yet not always in line with the indigenous culture. She argues that indigenous cultural traditions have more impact on family and kinship than the Islamic ones (1996:91). Other argue that the indigenous traditions itself are influenced by different cultures and religions of the invaders who came to subcontinent (Keay 2011; Khalid & Gilani 2009), thus leaving an amalgamation of various religious and cultural values for family traditions in Pakistan. If religion and culture—being the most influential factors

to devise the codes of conduct for the institution of family—are a point of reference for Pakistani immigrant parents at one hand, at the other, *the second generation have increasingly become ‘experts of (Islamic) knowledge’, a resource which they use in intergenerational negotiations with their parents* (Rytter, 2010:612). The sources of their knowledge expertise according to my observation are not just the formal religious and educational institutions and/or the religious and cultural teachings given by their parents verbally, but also the informal interactions with their peers belonging to other Muslim ethnic communities in France. Thus the amalgamation of cultural and religious values for family affairs first generation acquired in Pakistani cultural set-up, is challenged by their second generation who brought up in multi-ethnic environment and learning multi-cultural values. This is why both generations speak differently about their habitus of authority and respect in relationships across gender and generation. In this regard my observation resembles to that of Rytter (2010). He observed intergenerational gap on exercising authority and observing respect in Pakistani immigrants’ family life in Denmark. He says parents and children go through the process of re-positioning as the first generation migrants are getting older and holding the status of grandparents while the second generation is entering into marriage market and are becoming parents. One’s re-positioning produces self-reflexivity often resulted in behavioral disagreements between generations. The ideals of good behavior are determined by the hierarchy found in Pakistani family system, said by Shaw (2000). While studying British-Pakistani families, she observed that hierarchy assigns clearly defined role to family members depending on their age, sex and status. Authority attached with age is culturally assigned to the elders while the younger generation is expected to obey elders and respect their opinions, points-of-view and values. Authority is attached to status as well. A father’s say is less important than of the grandfather. A wife’s say gains more importance when she acquires the status of mother. A mother-in-law’s day in family affairs is welcomed than that of her daughter-in-law. Hierarchy varies by sex also. Shaw (ibid) gives examples that how younger males show respect towards their elders by not smoking and cracking jokes in the presence of their elders. These elders could be father, uncle, father’s friend and elder brothers. Girl’s’ modesty is associated with having scarf on head in front of her

elders and practicing veil in the public sphere. Rytter (2010) also gives some examples of how the second generation of Pakistani migrants is expected to behave by not criticizing and not making fun of the cultural values of their elders. Why authority is exercised by elders and how younger generation respond to is revealed by one of my informants:

'Follow your elders' words, if not, at least stay silent' is a piece of advice that almost every one of us has heard about... I don't say that I obeyed my elders all the time. Naturally, it is not possible. But I did not say 'no' to them directly. Instead I used to say 'jee, acha' [Ok, good]. Now children confront directly... They are French, they argue. We are Pakistani, we remained silent to safe relationships and family.

Elder generation often cite the nature of their relationships with their elders. For him, elders exercise authority to safe relationships and the family. When his elders asked him to do something, his behavior was affirmative, at least verbally. The younger generation confront and argue, so their behavior is less affirmative to the notion of doing good relationships and family. The behavioral codes of conduct, varied across gender and generation, are a part of the cultural expression of doing 'good family'. Articulating intergenerational relationships to the single cultural container of nation-state, elder generation tends to be more Pakistani, while younger generation seeks their attachments with more than one ideologies at the same time; being Pakistani and French in addition to the member of Muslim Ummah as expressed by a male from the younger generation:

'Regardless of generational order, what is right is right' this is what I learnt in my school. This is what Islam preaches. For example, if I wanna go with my friends on long drive at late night, Islamic and French teachings have no problem. But Pakistani teachings have problem... I argue and sometimes I don't speak back. This is how I do in my Pakistani family.

His 'knowledge expertise' in Islam as said by Rytter (2010) and in both cultural traditions enables him to argue to challenge the generational order concerning the righteousness of one's action. For him righteousness does not change its meanings with the hierarchal positioning of both generations. If he avoids speaking-back, it does not mean whatever elders demand is right. Instead it is his expression of the

'respect' in maintaining intergenerational relationships. Both generations' cultural expressions of being obedient have varied across time and space. Intergenerational difference on the continuity of values and traditions are not striking but consistent as Nesbitt (1995) while working on cultural history and cultural choices of Punjabis in Britain says:

The meanings of culture are many.... [culture] is not a static phenomenon but consists of multiple processes, involving a temporal dimension of both continuity and change. This in turn entails selection, whether conscious or not, by ensuing generations from a changing array of options (1995:225).

There are definitional discordances between the both generations and gender on the options what traditions are to be followed, Pakistani, French and/or Islamic, to maintain relations in family, nonetheless, attitudinal inclination towards preserving the tradition of doing good Pakistani family is observed among young generations, notably among the males in second generation and spouses from Pakistan. When they become parents, they reflect their childhood experiences off and on, and play the role a navigator of intergenerational continuity of indigenous values and traditions. The females however do not reflect similar behavior. Contrarily to male, they have been more conformist during their childhood, nonetheless in late 20s, they keep distance from their parental families to make their own family.

There does not exist necessarily the disagreement between the two generations on family affairs, but accordance also on doing 'good family'. In the following part, I present in detail how relationships across generation and gender are experienced in transnational context where not only the ideals of hierarchy and good relationships vary in family system but undergo transitions and changes owing to migration that brings different patterns of socialization and education under one roof.

8.1.1. Parents and Children

Talbani & Hasanali (2000) found that due to the varied cultural role expectations found in origin and host societies, the transitional period from adolescence to adulthood is perceived difficult and stressful by the daughters of Canadian-Pakistani

immigrant parents. Rytter (2010) mentions Pakistani-Danish youngsters who are the subject matter of the community gossips because they criticize openly their parents' values as *silly, old fashioned or exotic*. The contestation between both generations, as explained by Beauchemin, Lagrange & Safi (2011), is due to their experiences of dual frame of references of 'between 'here' and 'there'. Abou-Zahab (2007) speaks about the descendants of French-Pakistani immigrants who face problems in adapting the cultural values of their parents' origin society. The comparison of differences between here and there becomes complex when conflict between two generation emerges on the perceptions and practices of ideologies of gender and hierarchy. Sathar et al. (2002) found in Pakistan that the role of youngster's agency in decision making varies according to their sex, age and the nature of the issue under discussion. There is a notable gap between parents and their children on how both perceive and practice authority to important decisions during children's adolescence; education, work and marriage.

When disagreement between children and parents come to surface, parents' ability to properly socialize their children is questioned (Rytter 2010). To explain how the process of intergenerational transmission of values is experienced by French-Pakistani immigrant parents and their children in France, it is of highly importance to describe the process of socialization, first. The nature of the relationships between parents and their children and also between the siblings were and are being shaped by the socialization strategies that parents and the Pakistani community in France adopt at one hand. And at the other hand, children's own experiences of the socio-cultural and political environment of here and there.

Pakistani immigrants' families came France during the late 70s and early 80s quite later than that of other family reunifications in South Asian diaspora. One of the many reasons behind delayed family reunification was their perception of host society's values in contestation to their own. At the time of arrival, most of their children were less than the age of 10 and some were still to born. Though socialization process begins as soon as a child starts to learn social behavior, nonetheless when children grew older and entered into their adolescent ages,

parents adopted different strategies to transmit their cultural values. Islamic education, language, hierarchy in family system, gender-based code of conduct and kin-relationships were the prominent indigenous values to be transmitted to the children. If some parents preferred to socialize their children while staying in France like in Families SD5, PI3, LG4, TR4, SC5, others find it difficult to transmit and decided to go back to Pakistan for some years so that children not only could learn but experience the values themselves like in cases of Families LM8, VI4 and OZ5. Some families left their daughters only with their grandparents for the socialization purposes like we find in case of Families AB4 and CO6. Within passage of time, it became difficult for families to spend such long period of time in Pakistan due to educational policies like the regular attendance of the children in school. Children also forgot French language. To deal the collective problem, it was Pakistani community in France felt the need to make socio-cultural platforms to teach cultural values to children. These institutions helped families and they started to spend only summer holidays in Pakistan for socialization purpose in addition to enjoy the holidays, like in case of VP5, LC4, and VI4. This trend now is being followed by many families, as reported by my key informants. I present some cases of the above mentioned families to discuss in what ways socialization strategies were up to the expectation or not, and if these strategies influenced the relationship between parents and children and if yes, in what ways the ideologies of gender and generation are negotiated between them?

When the Family LM8 came to France in 1977, the eldest daughter was a new-born then. In the next two consecutive years the family had two more daughters and then a son in 1982. Earlier in 1988, the mother decided to go back to Pakistan permanently. Proper socialization of the children was one amongst the other reasons behind the decision to go back. Here is mother's reminiscence on the matter:

My husband and I both worked for some years, but when our children grew, we felt that our absence was not a good action for our children. So, I decided to go back to Pakistan. My husband said he will not join us, but I insisted his presence is necessary.... We had some problems there like less support from my family-in-law

and difficulties in starting a business.... But time proved later my decision was perfect. Amtul (eldest daughter) turned 10, Aysha 9 and Hiba 8 and learning in this age continues for life time. Although Amtul was very shy and responsible since younger age, because I had to go for work and she had to take care of her younger siblings..... In Pakistan, they went to school and learnt sharm-o-haya [chastity] and not to mix up with boys. They learnt from other girls how to dress themselves properly. They learnt from cousins how to respecting their elders. Brief, they learnt who their parents are and who do they belong.... We came back to France in 1994. What Amtul and Aysha learnt there, they applied here on their younger siblings and taught them how to behave? It was the friendly relationships between the siblings that I never needed to guide them afterwards.

Socialization process of the children became successful due to many factors according to the mother. First of all is her decision to go back to Pakistan where her daughters learnt their roots of belongingness. She wanted to transmit the ideologies of power and hierarchy in family that her daughters learnt from their cousins, and the ideologies of gender that her daughters learnt during their education. Cultural environment, educational institutions and the kin-group were not available to her in France. The effectiveness of her decision to socialize daughters in Pakistan seems partially functional for her family if we look into the affairs of family LM8 in detail, particularly daughters' relationships with their siblings and parents and then the marriage decisions. Mother gives credit to her elder daughters who being the role models effectively trained their younger siblings and redirected their orientations towards the indigenous norms. Female agency be it the mother, daughters or the cousins played vital role in marinating family norms. According to Aysha, her mother holds a dominant position in her family as compare to her father:

My mother's opinion is most important in my life.... in our family. She has been around us always... yes, also my father but very little. I sought her advice on every matter. Recently I started a business, and I asked her views. She encouraged me to get divorce. I respect her and Amtul very much because both sacrificed a lot for us.

For mother, the norm of respect is a part and parcel of hierarchal positioning in family, which she transmitted to Aysha through socialization. However, for Aysha respect is linked to the altruistic behavior of her mother, who has been working for

the economic prosperity of the family and of the elder sister who has been taking care of her. The status a father in traditional Punjabi family holds is the head of the family, the bread-winner and the one holding most of the power in family hierarchy. However due to migration when mother is out of home for the economic prosperity of the family, the power structure undergoes changes, as we are observing in case of Family LM8. Contrary to her socialization strategy, mother's working inspired her daughter to redefine who holds central place in family's affairs. Her daughter is not seeking permission from any of her parents, a behavior that does not reflect the values she acquired in Pakistan. Instead she seeks advices and opinions of her mother not of her father. She played decisive role in her marriage. Along her mother, she visited Pakistan many times to filter adequate spouse for her. Her decision for divorce was encouraged by her mother.

I observed that mothers in my informant families hold noticeable weight in decision making than the fathers when it comes to socialize children and to decide for their marriages. Lesser influence from the kin due to migration in combination to working conditions of fathers are important factors to understand why it is so. As mentioned previously, most of the first generation migrants belong to the rain fed agricultural areas. Due to lesser production crops, they were habituated to do labor far from their homes. In their absence, wives and children remained under the supervision of elders in joint multigenerational and extended family systems. When migrants' families came to France, the effect of residential proximity minimized thus lessening the influence on gender hierarchies in Punjabi kinship system. And as the male migrants are less educated and unskilled workers, labor opportunities for them were unplanned and unpredictable. So as soon as they found any opportunity, they did not hesitate to grab it. Depending on the nature of labor, sometimes they used to travel to other departments and to live with other co-ethnic for many days. Mostly who found work around their residential area, used to remain absent from home the whole day long. Thus the mothers in addition to take care of children and household chores became responsible for the activities outside the four wall. Their involvement in children's curricular as well as extra-curricular activities increased despite the fact that their ability of speak and understand French language was insufficient. Within

passage of time, their say in children's social life and marriage decisions gained importance, also observed by Shakari (2013). Her study found that children seek permission from their mothers than fathers in Pakistani immigrant families in Denmark. She quotes Varghese & Rae's (2009) explanation that mother's more say is due to the cultural expectation from Indian mothers who are responsible to teach cultural values to children, so they exercise more power than the fathers. The role of the father became more of economic provider than head of the family and sole decision maker as we find in case of Family LM8. Although fathers' nature of economic activities has changed, from unplanned labor opportunities to well-established business and expertise in skilled labor job, still their absence from home is a common trend found in Pakistani immigrant families in France. However, the trend is bit different among the second generation male. Their childhood experiences shape their ideals of being good father. Asif, the eldest son in Family SD5 highlights the differences in the following way:

I was 13 or perhaps 14 years old enough mature to feel the upheaval in our family when we came to France. Ammi jee (mother) deeply suffered. She felt like prisoner because I went to school and father to the shop, and she with Hassan and Zahra (brother and sister). When we departed to school, father was still in bed. If we were in the home, he was in the shop. During week-ends, his routine was same. Gradually we habituated and did not miss his presence.... I could understand why he was such as. My routine is not like him. I do business. I can make myself busy 24 hours but I go back to home timely. I don't want my children to miss me.... My up-bringing is in France; I feel happy to cook food for my family at week-end. Week-end is for my children.

By reflecting back his father's work routine and comparing it with his own work routine, he talks about his longings to spend time with his father. Although before migrating to France, they were experiencing the absence of their father, but were living in joint family system with their grandparents and uncle and his family. However, the scenario was different after migration and they were not expecting their father's absence. Although he habituated within passage of time, yet it influenced deeply his ideals of fatherhood. Another important factor to influence his ideals of fatherhood was his learnings in Pakistan as he said he was enough mature

to feel the upheaval by age 13. Children's age 13 has been very crucial age for Pakistani immigrant parents to socialize their children, as we observed in Family LM8. Alike, Family LM8, the children in Families VI4 and OZ5 were brought back to Pakistan who spent 3-5 years there for the same purpose. It is worth mentioning that those children who were taken to Pakistan and those who migrated to France during their adolescence are more likely to practice indigenous values in their families and to redefine parenthood. However, this likelihood varies across and intra-gender depending on their age and status of single or married. During adolescence and before marriage, sons are more likely to defer parents' ideologies of hierarchy whereas daughters are less likely to confront. After marriage and during late 20s, sons tend to inscribe hierarchy in their families and to maintain good relationships with their parents whereas daughters are more likely to reject and confront such ideologies and keep distance from parents if they reinforce them to compromise in case the couple is in contestation¹⁸.

Between the two generations, there is little common ground on what parenthood is when it comes to parents' roles regarding authority, respect and providing care and resources to the family. If parents' narrations are more generic, reflections drew from their own proper experiences are part of children's narration. Indigenous culture is point of reference for parents to define what children's behavior be like while modern and individual culture are points of references for children's perception of ideal fatherhood and motherhood. Asif likes to cook for family, a traditional feminine attribute, and espouses his behavior with French culture. Spending week-end time with his children is more appreciable for him instead spending week-end at the shop as his father did. The ideals of parenthood have undergone changes due to the detraditionalization of gender roles experienced under transnational forces (Beck

¹⁸ The practices to inscribe, defer, and/or reject hierarchy in familial relationships is further influenced by children's spouses from Pakistan; the details I provide in the following sub-parts 8.1.1 discussing the experiences of daughters-in-law and of sons -in-law in 8.1.2.

and Beck-Gernsheim, 2002). In exploring 'are fathers changing' Williams (2008) quoting Lamb (1987) says fathering have many meanings but primarily four emerged in different epochs; *the moral teacher, breadwinner, sex-role model, and, most recently, the nurturing father* (2008:488). It is the role of a nurturing father that Asif defines in his own way of fathering being emotionally close to his children. In the similar vein, the ideal ways of good motherhood have changed as we find in case of Family LM8; what strategy Aysha's mother employed initially to transmit the ideologies of hierarchy is in contrast to her encouraging behavior for her daughter to proceed for divorce instead exercising parental authority to reinforce gendered relations in the institution of marriage. I observe similar tendency in changing mothering roles in Family PI3, when mother while contesting her husband's say urged her daughter to proceed for divorce. Mother's contestation to father is to be seen in terms of her empowered mothering in contestation to the patriarchal system (O'reilly 2010).

On the contrary, there are other mothers who are practicing traditional motherhood roles in accordance to their family traditions as we find in Families AB4 and CO6. Samia, the daughter in Family AB4 sent back to her grandparents in Pakistan, so that she could remain 'safe' from the risks found in French culture. She provides the details:

I lived only 1 year in France. When my residency papers were done, I was sent back to Pakistan. I wept a lot but nobody took care, not even my mother..... You see I am the only daughter of my parents. But they kept my brothers with them. They got education, freedom and businesses.... I got nothing. My wishes to live with them and to get education were not important. Their fear was important that I would get spoiled by France's culture. After 20 years I am back to France permanently because I am married.... all their fears have flown.

We observe the notions of mothering, and transmission of gendered codes of conduct related to honor and shame. Mothers are considered emotionally more close to their children due to child bearing, rearing and caring practices, but Samina was disappointed when she speaks in particular about her mother who neither take care of her education, nor her wishes to live with her. For her mothering is a female's

nurturing role to take care of her dependent children (Terry 2000). Rich (1995) perceive motherhood as an institution, which remains under male control and where gender intersect culture (Ritzer, 2007:939). Mothers are perceived to act for collective interest than that of individual and personal choices (Budig 2004). Their children are not solely raised up by them. Before migration, mothers lived in joint family system and were helped by others as observed by Collins (1991) that kin are involved in raising and socializing their children. After migration families AB4 and CO6 relied on their kin as well as on elder children.

Samia also feels agitation against her mother *for having accepted, too readily and passively, “whatever comes”* to her (Rich 1995:243). “Whatever” are the varied ideologies of gender found in a patriarchal society. Her parents kept their sons in France and sent her to Pakistan adhering to the varied ideology of gender that the chastity is to be maintained by controlling girls and segregating them from the public life. When Samia talks about her parents’ fear for her chastity before her marriage, it is the expression of cultural control on and preserving of female’s sexuality to fulfil the expected gendered roles before marriage. Being single and living in a hazardous environment may produce risks to defile honor of the family, however ‘marriage’ appears to make the significance of hazards zero for her parents’ fear that vanished afterwards her marriage. Does it happen in such manner in the Punjabi culture, when daughters leave parents’ home after marriage? Partially true but not in the exact manner as explained by Herchamn (1981). His extensive ethnographic work on Punjabi kinship and marriage clarifies that married daughter remain the concern of parental family. *Honor tends to be a male attribute, while shame belongs to women* (Pope 2011:26) and the *daughters of shame* (Sanghera 2009) damages the honor of their families in the eyes of others. In villages social sanctions ranging from limiting female mobility outside the home to honor killing— are practiced by the Punjabi patriarchal system through the system and the intervention of *Punchaiyat*¹⁹. The chastity of sons is not of that much importance as they are given ‘freedom’ to

¹⁹ Mathew defines Panchayat as ‘*self-governing village communities*’. For details please see George Mathew’s book ‘Status of Panchayati Raj in the States of India, 1994’.

get education in a society whose values are apparently risky and in contrast to their own.

Intergenerational ties and relationships between parents and their children can be summarized into two border dimensions; alliance and conflict (Bianchi, Hotz, McGarry, & Seltzer 2006). Cooperation involves solidarity, altruistic and caring behavior towards others' interests in doing maintaining good family relationships (Bengtson 2000). *Conflict perspectives on family behavior often align with "quid-pro-quo" models of exchange... all parties understand and accept the rules for exchange and all parties benefit from the exchange, self-interested behavior may occur under conditions of minimal conflict* (Bianchi, Hotz, McGarry, & Seltzer 2006:6). Maintaining relationship, in conflict dimension, need adequate exchange because younger generation does not necessarily follow the rules of the game (Zaman 2013). The conflict observed between generations and across gender manifest that family members hold varied interests in relationships and perceptions towards different statuses in terms of their varied experiences of here and there. To minimize the difference, elder generations contextualize their statuses and introduces the element of adequacy in their roles and actions whereas the younger generation challenging the notions of ideal fathering and mothering, reflect back on their parent-child relationships and re-define the ideals of parenting. Do conflict and cooperation shape relationships between families-in-law and children-in-law? In what ways the ideologies of adequate daughter/son-in-law influence the nature of relationships across generation and gender is the subject matter of next part.

Classical ideologies of ideal womanhood and her role before and after her marriage within the institution of family; of parents and of family-in-law, have undergone substantive changes particularly in cities, argues Weiss (1998) due to technological advancement, labor opportunities and the mass media. Her ethnographic study in the Walled City Lahore insists that *characterizing traditional society as patriarchal, patrilineal, and patrilocal tells us little about the actual relationships between men and women.... because beneath this public face lies a significant amount of social confusion, particularly regarding changing gender roles, expectations, and*

possibilities (1998: 126-127). The social confusion emerges when modern ideologies confront patriarchal ideologies and brings distorted change in the society called neopatriarchy (Sharabi 1992). Neopatriarchy help us to understand the experiences of transnational spouses due to their simultaneous transnational engagements in traditional and modern societies.

8.1.2. Being a *bahu* (daughter-in-law)

Be careful in fixing the marriage of daughter, but more careful in selecting a daughter-in-law. She is one who makes up future generations.... good habits.... (The mother-in-law in Family VB4)

Sons must remember who they marry. If they marry a Pakistani girl, they would find Pakistaniyat in their home. Pakistani food, Pakistani dressing, Pakistani Television.... If they marry others, they keep quarrelling on.... quarrel even on spending happy days of vacation. One says in Pakistan the other says in Morocco. Children belong to none. (The mother-in-law in Family LC4)

Searching five daughters-in-law was not easy job for me. Important is the couple should look compatible.... The families also should be compatible..... Two of my daughters-in-law are real sisters. (The mother-in-law in Family TR4)

Intergenerational spouse selection criteria, before marriage, reveal what kind of capitals are sought in would-be daughter-in-law in terms of age, education, behavioral traits and her orientation towards modern and traditional values. Above mentioned quotes explains in what ways the utilization of the capital of daughters-in-law is perceived by mothers-in-law and how it does influence the relationships between the mother-in-law and daughter-in-law.

In the previous discussion we have observed that mothers play a vital role in seeking, filtering and finalizing marriage proposals of their children. As they transmit the cultural value to their children, in the similar vein they handover the tradition of home-making to their sons and daughters-in-law. The politics of the household and family relationships are managed by the female agency (Ballard 2004) be it mother-

in-law or the daughter-in-law. Wasim (2014) argues that the relationships between South Asian mothers-in-law and daughters-in-law are studied less but represented overly in the popular culture of the media. Media often portrayed them *destined to not relate well to each* and the nature of their relationships is *potentially tumultuous*. Ballard (2004) argues that the conflicted nature of their relationship in fact crystalize intra-gender power hierarchies in the household. It is in in this context that I analyze what being a daughter-in-law means to both; the mothers-in-law and the daughters-in-law, who often mention each other while discussing their familial relationships.

For mother-in-law in Family VB4, to produce well-mannered generation, a well-mannered mother is pre-requisite. She looks into the institution of motherhood like mother-in-law in Family LC4 when she says '*Pakistniyat*', she means not only to persuade sons for similar cultural traits in their future wives but also to warn them about the difference if they find their wives from 'other' ethnic communities. In fact, her eldest daughter-in-law is her niece, two of her daughters-in-law are Moroccan and Tunisian, and another son wishes to marry French girl. Due to the diversity found in her sons' marriage behavior, she talks about the conflict between her sons, daughters-in-law and herself. She foresees the identity belongingness of her grandchildren neither to Pakistan nor to 'others' because there are ideological differences in upbringing the children. Ideologies of mothering that her daughters-in-law have acquired remain a critical concern for her. In Pakistani culture, motherhood is one of the elements of Pakistani womanhood as observed by O'reilly (2010). As far as the couple's similarity is concerned, the mother-in-law in Family TR4 finds it equally important to have similarities in both families' behavior. She and her other family members have good relationships with the family of her eldest daughter, this is why they decided to ask marriage proposal of the younger sister of their daughter-in-law.

The above mentioned narrations demonstrate that individual, familial and cultural characteristics are to be found in their daughters-in-law to develop good relationships. What are the views of the daughters-in-law about the nature of their relationships? Do they resist what mothers-in-law prefer?

Most of the daughters-in-law were in accordance to their points of view related to produce well-mannered generations, however there are conflicts on the upbringing ideologies, as we find in case of Ishrat, the daughter-in-law in Family VP5:

My aunt always talks about what she did for family and what I should do. She says those times were difficult, these days it is easy to find work. It's irritating. I did not study much but I did a course for time pass. I can open a beauty parlor but I will not. I am already bearing the consequences of my mother's work. She earned money but lost her children.

She alike the elder generation considers that children socialization is important and does not want to lose them. And to that, she is not going to do any work, a strategy to invest her time on her children. There are conflicts over on non-participation in any formal and/or informal job sector. In case a mother-in-law mentions her struggle during her initial period of migration and urges her daughter-in-law to do some work, she takes her behavior irritating. She alike all of the daughters-in-law in my study does not work in any formal job sector²⁰. Do the daughters-in-law being raised and socialized in Pakistan avoid to do jobs? The obvious reasons behind their non-participation in job sector is the language barrier at one hand and their irrelevant education at the other hand. Other justifications are first the secured and sufficient earning resources of their husbands. And then the lack of confidence they found in themselves. If not in the economic sector, then do they tend to become traditional mothers belonging to household chores and taking care of the children?

Staying home does not mean I am workless. My preference is my children, that's all.... their grandmother intervenes and I don't like.... I am a mother myself, I have the right how to educate and dress-up my children.... It's my duty not hers. I does not mean her intentions are wrong for us, I mean she has done what she wanted with her children. Now, let me to do and to have trust.... Believe me evil exists everywhere. Pakistan is not a safe place. I know what the young student girls are going through....

²⁰ Apart from them, I observed there are many ex-daughters-in-law who have independent income through occasional and informal home-based small labor opportunities like food, sewing and to teach Quran and Urdu and English languages.

The narration belongs to Rabia in Family SD5, who holds bachelor degree of baccalaureate with an advance research diploma in education. She was doing Masters when got married. Based on her experiences outside the home while studying in college and in an academy, for her, contrarily to her generation's strategy to raise children in Pakistan, for her risks are everywhere and Pakistani atmosphere is no exception to raise the children assuming it a 'safe place'. It is her prime interest in her children, that she neither considers herself inactive nor she want her mother-in-law to intervene in her children's affairs. Being educated urges Rabia to raise voice for her mothering instead allowing her children's grandmother to mother her children.

In addition to children's up-bringing and daughter-in-law non-participation in work, there are spheres where daughters-in-law finds their mothers-in-law's behavior 'nagging' and vice versa. If a mother-in-law finds it interesting to buy vegetables from the open air market, her daughter-in-law find it convenient to go to supermarkets. If a daughter-in-law finds it easy to finish the household chores on time, her mother-in-law prefer to stay in bed late. If a mothers-in-law have family friends in Pakistani community and want to take her daughter-in-law there, for her daughter-in-law, *it is most boring to listen old Pakistani aunties' self-praising stories and then the gossips about others' children* (Daughter-in-law in Family TR4). Apparently tiny these issues are, but reveal a great deal of the feminine activities of Pakistani immigrant mothers-in-law and their daughters-in-law; the division of labor based on gendered ideologies.

Besides the intra-gender contestation, there are other parts of their lives when both thank fully acknowledge each other presence. Daughters-in-law feel the presence of their mothers-in-law necessary. Many daughters-in-law thought about the period when they missed their families soon after their migration, and their mothers-in-law have been the encouragement sources for them. They never interfered if they have had long chats with their families in Pakistan. They speak about their different yet difficult pregnancies and baby delivering moments when their mothers-in-law were

next to them to help and their continuous support from taking care of their new born babies to accompany their school going children. Mothers-in-law also expressed their feelings in terms of Daughters-in-laws blessing. The celebration of the religious and cultural events would have been blandness without the company of their daughters-in-law, who adds color and flavor to the party. Daughters-in-law's presence was a relief in the moments of deep sorrow, when someone of their close relatives died. A mother-in-law in Family CB4 says:

What else could be relieving other than to see my grandchildren and their mother who make my house home? After the death of their father, my children were busy in school. I felt alone, because I did not work. Now my niece is there, we keep talking on. We know our family well, so the gup shup (chit chat) continues. You would laugh to hear my son's comment, 'what do you deduce from it'? I said, 'you would not understand'.

The mother-in-law feels content to see her daughter-in-law whose presence in her home makes the home complete and fades away her feelings of loneliness due to her husband's death and children's engagement in their studies. Her chit chat, her son's comment and her response are noticeable, particularly, due to the feelings of belongingness. They share pre-marriage relationship. Her daughter-in-law is her niece; the daughter of her sister.

Does pre-marriage relationship influence the nature and quality of the relationships between mother-in-law and daughter-in-law? I found a diversity in their behavior in this regard. Although many mothers-in-laws and their daughters-in-law talked about their conflicts as well as accordance on issues mentioned above, yet feelings of security and empowerment are developed within both particularly at times when they confront male agency. In Family VP5, the daughter-in-law felt her daughters and herself secure with her mother-in-law (her maternal aunt) when her husband used to remain absent from home several days. The daughter-in-law in Family LC4 felt herself empowered due to her mother-in-law's (her maternal aunt) courage when her father-in-law warns her mother to do not proceed for the marriage proposal of

her younger daughter with his younger son²¹. Pre-marriage relationships expect obligations as well thus producing the vulnerability too.

Fouzia in Family VI4 and Zara in Family CO6 are married with their paternal cousins on the basis of exchange, both find themselves at vulnerable place due to the nature of exchanged relationships. If Fouzia, finds her living experiences with her family-in-law complex and difficult due to her sister'-in-law behavior to not to join her husband in Pakistan²². Nonetheless her relationships with her husband are genial. Zara finds herself at a more vulnerable position than Fouzia. She finds the behavior of her husband 'cold' and 'reserved'. Because it has been passed 2 years to their marriage, and he did not yet apply for her spouse visa. The close blood relationship ties ensure them the safety of the marriage, simultaneously they feel themselves vulnerable.

Marriage preferences of my investigated families inclined towards kin make it clear that most of the daughters/sons-in-law have pre-marriage blood relationships with their families-in-law. After their marriage, they share double relationships; niece/nephew and *bahu/damad* (a live-in son-in-law). However, sharing pre-marriage relationship and being *bahu* and/or *ghar damad* mean different to different actors' marriage experiences. After analyzing the diversified experiences of female agency in terms of intra-gender conflicts as well as accordance, empowerment as well as the vulnerabilities, feelings of blessing as well as of thankfulness, irritating as well as cooperative behavior, now I turn towards the nature of experiences of *ghar damad*, an actor of transnational marriages who remained least studied but quite visible in the academia since 2005 when Charsley wrote about "*unhappy husbands*".

²¹ The detailed case histories of both families have been provided in previous chapters.

²² More details on the nature of the couple's relationship are discussed in next section 8.3.2.

8.1.3. Being *ghar damad* (a live-in son-in-law)

Ghar damad, *Ghar jmai*, *Ghar J'wai* are the various colloquial terms used for househusband and/or a live-in son-in-law. In Punjabi culture, the rule of the marriage is the departure of the bride to groom's home and to live with her family-in-law. In exceptional cases, when a family do not have sons, but only the daughters, they turn the rule aside and asks the son-in-law to join them. Usually it is practiced while marrying youngest daughter so that the parents could avoid to live alone and to hand over the economic and family care responsibilities to the husband of their youngest daughter. However, this practice is not welcomed by the patriarchal ideologies of power hierarchies.

'*What it means to be a man*' Malik (2015) differentiates masculinity and man; man is about his biological and reproductive characteristics while masculinity is a set of his role and behavioral characteristics constructed by the culture and society (2015:58). Neither the ideologies for masculinities are common nor do these ideologies put all the men into equal status. Different guidelines to construct ideologies of masculinities vary across cultures and depend upon his nature of position in a certain social setting. In Punjabi patriarchal kinship structure, different ideologies of masculinities exist and are primarily associated with his status and role. The nature and quality of status and role-performance produces unequal and inadequate masculinities. Power attached to certain status differs according to the position of the man in the hierarchical structure of Punjabi kinship. Further, the symbolic meanings of his role-performance determine the positioning of his masculinity in comparison to other men in the kinship structure. Elder male of the group holds more power and prestige than the younger members. A living grandfather in the family hierarchy positioned at the top holding the utmost power. Next to him, is the father holding less power on his immediate family and/or younger siblings. Intra-gender inequalities in masculinities are produced by the intergenerational hierarchy and power structure among Punjabi men. The symbolic meanings of his role-performance are embedded deeply in his honor (*izzat*) and shame (*ghairat*). Taking care of his honor and shame earns him masculine

adequacy otherwise inadequate masculine. His honor defined by cultural rules of family and marriage in Punjab is associated with the patriarchy. According to patriarchal code of conduct, adequate masculinity is when he receives wife and holds hegemonic positions of bread-winner and head of the household. He is the one himself independently set the codes of conduct for each member of family. It turns into adequate masculinity when he joins his wife and starts to live in the house of his father-in-law. There he does not hold unequal masculinity and inferior position not as compare to his wife, but to his father-in-law due to his generational order; the elder, as well as his role-performance; the provider:

The relationship of dependence and authority between the two men subverts the normative structure of kinship hierarchies that place wife givers as subordinate to wife takers and is the key to understand the figure of the uxorilocal son-in-law. (Chopra :42-43)

His hegemony converts into subjugation and independency into dependency. This is why the masculinity of a live-in son-in-law is regarded negatively and ironically in Punjabi culture. Punjabi proverb 'sohre ghar j'wai kutta' (a son-in-law lives in the house of his family-in-law like a cur) passes the opprobrious symbolic representation of his living in family-in-law's house. It is with this background that we can understand the experiences of a *ghar damad* of Pakistani immigrant families in France.

In transnational marriages, a Pakistani born daughter-in-law emigrate from Pakistan to join her husband; the son of Pakistani immigrant parents, and lives with her family-in-law in France. However, when it come to the marriage of the daughter of Pakistani immigrant parents, she does depart to Pakistan with the intention to live with her family-in-law. Instead her husband joins her in France and lives with his parents-in-law. His living in the house of his parents-in-law is a transitional and relatively short period of time spanning 3-5 years as I observed in families under study. Some of them left earlier like as soon as the couple's economic resources are sufficient to bear the household expenditures or there were conflict making the environment clumsy to maintain the relationship. On the other hand, some may stay longer due to their kin- obligation towards their families-in-law given the fact that they share pre-

marriage relationships with them, and/or due to particular circumstances in case there is no other elder in the family-in-law to take care of them. I present some of the cases that would help us to understand— beyond the dichotomous approaches of empowered and/or vulnerable sons-in-law, happy and or unhappy husbands— that how behavioral variety crystalize the nature of the relationships between live-in sons-in-law and their families-in-law in Pakistani immigrant families in France.

Jamal son-in-law in Family CB4 has been living with his family-in-law since three years after his marriage with Beena, the daughter of Family CB4. Before his marriage he has independent residence in France as he was doing a job in a Pakistani religious and cultural association. The couple went to Pakistan for wedding ceremony. There, his parents asked him to leave his residence and to live with his family-in-law due to two reasons; first was the particular circumstances of his family-in-law, his father-in-law has been died. The friend of both families (also the marriage proposal introducer and the colleague of his later father-in-law) requested his parents if he could live with his family-in-law to take care of the family affairs. Secondly he was planning to purchase his own apartment after marriage. He was reluctant to do so because Beena has two brothers, both of them could have taken care of the family affairs. However, encouraged by his mother-in-law, he could not say no to his parents. He talks about his fear and the nature of his relationships:

I have many brothers and a relationship of respect has always been observed in our family. Elder brother is kind and authoritative towards younger brother, and the younger respects his authority and it continues from the top elder brother to the bottom youngest brother. When my parents started to insist me to consider my mother-in-law's wish, I thought how I would behave with my brothers-in-law, and how they would respond me? I thought to apply the different method than that of my brothers, I would remain kind and friendly to them, because both of them are younger in ages. I knew it would work because I understand the psychology of those Pakistani young boys who used to attend the meetings of associations. And believe me it was successful. I have jovial relationship with the elder one, we both are friends. With the younger, the relationships are so so.... He does not talk much and is reserved not with me but with all his family.

The inter-gender relationship between the all men of the family are genial as told by Jamal. There was not any clash between them, except the one. It could be due to the less age difference factor that they have, it could be due to Jamal's strategy as he talked about, or it could be due to the Jamal's economic independence that did not disturb his relationships. He had been participating in the household expenditures. After living three years, he purchased his own apartment and shifted. The one conflicted matter was Beena's wish to learn driving. When he asked her to go for, his brother-in-law argued with him as he was against the decision. Jamal *firmly but in a polite manner* as he says *denied him because Beena belongs to me now. I am responsible*. Although he remained kind to them, while holding his masculine attribute being not submissive to the younger and reminding him the traditional rule who Beena belongs to after marriage.

The traditional kinship rules of belongingness are generally accepted by parental families that after the marriage, a daughter's main concern is her husband and her children. She is not expected to interfere in her parental family affairs particularly the issues related to her married brother's family. In case she is eldest, her say in her younger siblings' socialization, education and marriages is sought and regarded positively. In case of Tina, the daughter in Family PI3, she is the responsible of her younger siblings' economic needs, a task that she never talked about which later became one of the reasons behind the couple's separation. Her husband Ijaz, the son-in-law in Family PI3 talks about:

After living few months with my uncle, Tina asked me to live in another home. I insisted to save some money so that we could purchase our own instead to bear rent. Then circumstances changed.... After the 2nd marriage of my uncle, she said she could not leave her parental family behind and to make her own home. I kept insisting.... and one night, my aunt expelled me from her home. I had no home. I had no family.... I felt immense misery as my heart is going to stop. I wanted to fly back to my parents.

If we compare the Family CB4 and PI3, in both cases the fathers are no more part of the family. In Family CB4, he had died, and in Family PI3, the father is expelled from home due to his 2nd marriage in Pakistan. Beena and her mother in Family CB4

as compare to Tina and her mother are dependent on Jamal to be take care of, while Tine is an independent girl and her siblings rely on her. She and her mother exercise power; Tina neither agrees to have a kid nor do she depart with her husband. Her mother expelled her son-in-law as she had done the same with her husband. Ijaz was devastated because he had lost family and home both. Alike Ijaz is the case of khan, the son-in-law, in Family LM8 expelled from his home by his wife. He expressed almost similar feelings like Ijaz and talks about how he like other sons-in-law is treated by their families-in-law in France.

A son-in-law is treated like a bakra.... as we don't have feelings.... I lived with family-in-law because the home was only their.... when Aysha said me to get out, I was living in my own home.... I could have denied, but I said myself wait until her anger vanishes. But my elder sister-in-law and mother-in-law never allowed her to think for reconcile.

I had heard the term *bakra* [Billy goat] repeatedly during the interviews with the sons-in-laws as it has been distinctly stated. This term literally means a billy goat that is available for religious sacrificial ceremonies to God and is used for those male who migrate on the basis of marriage. Khan symbolized himself to *bakra* like a dumb guy who is available for any task, even to be sacrificed for the interests of family-in-law. Khan invested the money in furnishing the apartment and to buy a car, but he never gets anything back. Like *bakra* another term 'imported husband' is also used for sons-in-law for that one feels as being treated like a commodity, as told by son-in-law in Family VG4, whose family and many relatives are settled in European countries and in the United States. In his village, people call them imported husbands.

Residing in Family-in-law home makes the son-in-law's position weak and vulnerable. The families participated in my study have discussed the issue of son-in-law departure to France but deny their daughters' departure to Pakistan.

The mother-in-law in Family VI4 is skeptical about the socialization of her daughter. She took it taken for granted that her daughter-in-law would join her in Pakistan. Her son and daughter are married with their paternal cousins on the basis of exchange.

Her daughter Fouzia migrated to France to live with her husband and family-in-law. Whereas her daughter-in-law Mariyam is not agreed to come to Pakistan to live with her husband and family-in-law, because she does not like the joint family structure of her family-in-law living in a village.

When Mariyam comes, she passes her time in her room. She spends some time with us, but not with our relatives.... She is not wrong. She is doing what she learnt from her mother. That is why wisdom says before you select your daughter-in-law, have a look on her mother's ways of living life. The daughter is the mirror of her mother.

The mother herself did not reside in Pakistan, so her daughter is also not going to reside in Pakistan after marriage. Her son-in-law is also not agreed to go to France because he does not want to dependent on his family-in-law as told by mother in Family VI4. Rukhsana the daughter-in-law in family SC5 told that the issue of residency was behind the divorce of her husband's first marriage. However she did never think of to live separately because she herself belong to a join family system and for her it would be very difficult to live separately from her family-in-law, first. Then, the younger daughter-in-law of Family SC4 did not live with them. Soon after the marriage, she shifted in another apartment without taking the consent of the elders. So neither she nor her parents are perceived positively by her family-in-law and the social network of her family-in-law. This is why living with family, Rukhsana wants to avoid the negative remarks for herself and the disrespect for her parents.

For my respondent families in France, marriage serves as an institution to transmit indigenous value system as well as a route to roots for their descendent. However their interests vary by the sex of their children when their spouses join them. Parents-in-law may choose a daughter-in-law being raised and brought up in a traditional society to preserve and transfer the very indigenous value system to the family and to their future grandchildren. However as far as their daughter is concerned, migration of son-in-law may reveal their interest in their daughter's physical proximity to them as after her marriage as she does not depart to her husband's or family-in-law home. Instead contrary to the indigenous rule of

marriage, her husband leaves his home as well as country to join her. By doing so parents and their daughter try to avoid from the cultural clashes if she moves to her parents' native country, as narrated by the mother-in-law in Family VI4. ? Their daughter may find more convenient to reside far from her family-in-law, as contrary to the traditional marriage norms, her husband leaves his parental home and country to join her.

In case of close-kin marriages, however, I observed that conflict is of secondary importance than the kin-obligations. Sons-in-law do find themselves in confrontation, but the respect for blood relationships urged them to not to prioritize their differences but the belongingness and ties they share. The son-in-law in Family OZ5, Raheel is the nephew of his father-in-law. Before the marriage, his uncle's support economic as well encouragement helped him to continue her education. However, after the marriage, his relationship with his uncle turned unpleasant

I am taking care of one of his firm. He is very authoritative and treats me like I am his employee.... Or should I say he treats me like his son, as my father says 'he would have been doing same to me, because establishing business and securing reputation in France is not 'hala jee ka ghar' [a place of comfort].

Apparently it seems that both of the elders try to make him understand about the basics of business that is not easy to establish, however the behavior his father-in-law shows is not pleasant for him. Instead going against, he keeps listening and do not confront. In Family AB4, the son-in-law finds himself in confrontation to his father-in-law. He preferred to establish his own business. Although he owns his own home in France, yet is living in the home of his father-in-law, because his wife is the only daughter of her parents. And he also like to live there as the couple has no children. So living in joint family system in that home is interesting for him.

Concluding Remarks

How relationships are maintained and what is the nature of the relationship is across gender and generation were the main questions dealt in this chapter. To understand the different strands of the relationship between the family members of Pakistani

immigrant families, I look into different strategies as the building block of relationship. The most important amongst is the socialization.

To transmit the cultural ideologies of family, marriage, and power hierarchies with reference to generation and gender, parents socialized their children differently. Some preferred to go to Pakistan and others relied on the religious and cultural associations in Pakistani diaspora, in addition to the usage of modern day technologies to visit Pakistani for some period of time each year for the socialization purpose. Socialization earned them success or failure, it is difficult to respond plainly in yes or no.

The two component are widely used by the both generations to explain the nature of their relationships; authority and respect. The nature of relationship between the two generations is basically arbitrary depending on the nature of the issue and status and position of parents and their children under a certain context. If parents seem to struggle to retain the absolute power, their children challenge the notion of authority and respect. Both attach different meanings how to exercise authority and what does it mean to be respectful. Both uses different routes to come to the common goal of 'doing good family'. Family remains the major concern of both generations. When elder generation idealizing their own way of parenting try to intervene the parenting ways of the younger generation, the differences in ideologies towards mothering and fathering are noticeable. For younger generation, the care their fathers provided to them was more like to provide than nurturing them. For young males, earning money is important, so is spending time with family. They employ gender-based division of labor into their household, where wife's responsibility is to take care of the children, to cook food and to do the household chores. Due to migration, she does the extra tasks as compared to the other wives in Pakistan; tasks related to grocery and children's schooling. Their wives being raised in relatively more traditional families as of families-in-law, accept the division as compare to the daughters of Pakistani immigrant families. In doing so, less conflicts are observed between the couple but between the mother-in-law and daughter-in-law. The relationship between both is less about the issues of

dominance and subordination like found in intergenerational relationships. It is more about the nature of different experiences and the difficulties both faced and went through; initial days of migration, the settlement problems, the availability and non-availability of modern day facilities. Mothers-in-law tend to be role model for their grandchildren, daughters-in-law prefer to teach their own ways to children. Altruistic behavior of mothers-in-law is acknowledged, but they do not want to put themselves into difficulties until unless their husbands are fulfilling the needs of the family.

As far as the daughters of Pakistani immigrant families are concerned, they are self-dependent and expect their husbands to be independent. Initially they lived with their parental families. Residing with family-in-law is not easy for sons-in-law. Their masculinities remain in adequate because they depend on their family-in-law's economic resources. As soon as the couple and/or the son-in-law is self-dependent, they shifted into separate residence. There the possible revival of traditional ideologies of hierarchy create tussle between the couple in addition to husband's emotional and financial responsibilities and emotional belongingness to the left-behind family.

Transnational marriage broadens the contour of families. For daughters-in-law, those who are left behind remains the part of the parental families, however in case of sons-in-law, it does not happen in the same way. Their obligations towards their families back in Pakistan and their responsibilities towards their "immediate families put them relatively at a vulnerable place, especially when both families take each other as opponents. In case of sons-in-law belonging to stranger families, conflicts are less likely to resolve. In case of close-kin marriages, conflicts are more likely to be handled.

CONCLUSION

This study began with limited but specifically defined objectives to understand the phenomenon of transnational marriage in French-Pakistanis families. In order to understand the mechanism of transnational marriage, the study dealt with how migration affects their decision to marry; and more importantly, how transnational marriages are associated with maintaining and perpetuating connections with networks of relatedness in cross-border geographies. Using qualitative research methods, those parents and their married children from France as well as from Pakistan were interviewed who were involved in transnational French-Pakistani marriages. Despite all the difficulties and complexities posed by this research, researcher was finally able to collect data from sixteen families. Despite being settled in France they still prefer to marry their children back in Pakistan, which becomes an intriguing question to inquire, as was taken into account by this study.

Initial chapters of this dissertation comprehensively describe the process of arrival and settlement of Pakistani migrants of Punjabi ethnic community which is the focus of this study, as well as their detailed description of the significant cultural traits related to their marriage and identity construction. In addition to this, researcher has also contextualized their migration and marriage choices in the theoretical perspectives and transnationalism, marriage migration and social exchange. Consecutive chapters explore the criteria of defining an adequate spouse in transnational context for the Punjabi families settled in France, and the process of negotiating and finalizing the decision to marry an adequate spouse. Final two chapters portray how transnational marriages are celebrated in transnational localities and how post-marriage experiences of interrelationships produce specific dynamics of a household for an immigrant.

Migration is deeply embedded in the social fabric of modern Western Europe. Recent sociopolitical conditions in less developed countries have produced many push factors for their citizens to find relatively peaceful abode and viable economic

opportunities elsewhere than their native countries. This has increased the cause of concern among the natives of the developed countries, for the likely impact on their own sociocultural lives. Debates on migration, its potential threats and possible solutions to minimize those threats have continuously been carried out in both academic as well as power corridors, which often shaped and reshaped immigration policies. One of the important functions of these policies was to restrict the influx of immigrants by creating certain checks, as well as to homogenize those who were already present in the host countries through the strategies of integration and multiculturalism.

Despite the welfare approach of the host countries towards immigrants, these policies assumed many definitions of several cultural aspects of the immigrants from methodological nationalism. One of these assumptions that was largely practiced and even is being practiced to restrict chain migration is the definition of family, which not only excludes the non-dependent children but also the siblings and the parents of the non-dependent immigrants (Stalford, 2002). Such definitions inherently reduce the natural emotional bonding of immigrants to politically demarcated territorial spaces, where geographic cleavage is taken as precondition to the disconnection with the networks of relatedness and allegiance to nationally defined social ties. Immigrants are put into situations, more often than not, where their cross-border activities and their less engagement with the culture of the host country are viewed skeptically.

On the other hand, immigrants, being the product of their native societies, consider these host countries more for the pragmatic reasons and less for emotional bonding. Substantial economic opportunities and relatively peaceful living environment persuade them to settle permanently in these societies. Whereas, geographic distance from their networks of relatedness, the socialization of their children in an alien culture, and identity crisis that emerges out of their ideological conflicts with the host society keep them in a constant state of struggle to negotiate with the host society to transcend geographic loyalty in an effort to preserve their biographic history and its manufacturers. Their desire for omnipresence at both sites creates

transnational social space for them, which is often regarded negatively, both by their country of origin and their country of settlement. They formulate different techniques to preserve their transnational space by playing according to the rules and regulations determined by the host country. One of these techniques which has been strategically very crucial to maintain transnational links as well as to preserve their identities is to marry back home. Transnational marriage, especially after the turn of the century, has been an important source of legal migration for diaspora communities, like Pakistan, already settled in the developed countries.

Theoretically, transnational dynamic perspectives treat the migration from the actors' view and look beyond the vision of migration as perceived in terms of dichotomous spatiality and temporality, either here *or* there, and instead considers both here *and* there; between two worlds. The issue of assimilation and integration has shifted to the possible deployment of multiple identities and loyalties, including "deterritorialized" transnationalism. The individual and the density of its social networks are the preferred unit of analysis of studies, considering mainly the transnational perspective as a form of globalization from below, which originates in the practices of migrants themselves as being the principal actors (Tarrus 2002; Portes, Guarnizo & Landolt 1999; Smith & Guarnizo 1998; Portes 1997). Despite the abundance of theoretical reflections on the transnational aspects of the immigrants, lack of empirical research on transnational practices of Pakistani diaspora in non-UK national contexts reverberates the exigence to mobilize scholars working on migration. In the social sciences and humanities, the transnational perspective is now widely used to study many aspects of life of migrants. However, the early studies that had stressed the significance of studying cross-border lives, have relatively focused little on the family lives of the migrants, particularly in Southeast Asia. In particular, the impact of transnational marriages on family practices remains, to date, an under-researched area.

This study, being first systematic effort to understand the transnational behavior of Pakistani diaspora in France, comes up with three important implications:

First, borders and distances cannot be taken as an alibi to marginalize the definition of family. Early generations of Punjabi migrants from Pakistan came with the intention to return back after earning a substantial amount of money to support their families left-behind. Although most of them could not return, yet they continue to consider their left-behinds as members of their own family. They are ceaselessly engaged in maintaining links, especially with their siblings and the children of their siblings, with the intention to help them migrate through marriage. Two crucial dimensions appear in this regard. The first is the emotional and existential density that continues to be of their relationships with the left behinds, despite their geographic separation. The search for well-being of their children and improving their future are at the origin of their marriage-migration, and also the efforts to maintain ties and minimize distance. The solicitude of care remains fundamental in the experience of the actors, although it can only be exercised in close physical conditions and daily presence. It cannot be reduced to simple ideological scaffolding, as would the most radically constructionist positions claim. The second dimension concerns the weaving of transnational ties. In whatever way we intend to analyze the theories of transnationalism, it appears difficult to deny that on the micro level, dislocation of family units whose members live in different countries and especially the experience of remote emotional bonding is the sign of a significant increase in the frequency and density of relations and exchanges that cross borders. The many possibilities offered by communication technology, old and recent, act to facilitate the distant relationships between families separated by emigration.

In this research, one of the objectives was to understand how transnational marriages contribute to maintaining links with the families in Pakistan. Our findings indicate that they preserve their links not only to keep their networks of relatedness but also to transmit the sense of family and promote membership in the family group to their children, while preserving the elements of their origin culture. Transnational links reflect the great importance attached to the family and the desire of immigrants to convey to their children that value, most often associated with the immigrant parents. Moreover, for the child it is not just to know his family through the pursuit

of transnational contacts, but also to recognize the connections to the larger family that stays in the origin country. This means that through these contacts, the child discovers the place of the family of the immigrant parents with whom he has less chance to have direct contact due to geographical distance. Transnational linkages therefore allow the child to enroll in family history and share the biography, thus ensuring the continuity of the lineage. For the parents, one of the important functions of bringing up their children in transnational context is to preserve the links with their origins. It also allows them to circumvent the major influence on their membership of the social context in which their children grow up. The repeated contact with extended family gives children a better understanding of the culture of the immigrant parents. Grandparents, siblings and their children, in this regard, play an important symbolic role. In the eyes of immigrant parents, these extended family relationships personify an ideal transmission of cultural elements, which are considered an essential capital for the identity construction of their children. back and forth between the home country and the country of origin, in all their forms, can reduce the negative effects of the physical separation of family members on intergenerational relations and enable the transmission of certain aspects of the culture. Moreover, despite the geographical distance and although many couples develop relations with both families, some feel closer to the family of origin of the immigrant spouse and retain more contact with thereof. The close and frequent contact between members of a group of relatives across borders make the transnational marriage more probable for their children.

The French born Pakistani children, on the other hand, do not necessarily share the relational connectivity projects of their parents. Although their consent is considered important while making decisions about their marriages, yet they appear to disagree in some cases with their parents on the definitions of an adequate spouse, and consequently may refuse to maintain links with the networks of relatedness of their parents. However, such aberrations are considered inappropriate to the desired behavior and are treated with sanctions. This intergenerational gap reflects that the transnationalism is not produced symmetrically across generations.

Second, transnational spouse choices are not haphazard or incoherent to the cultural rules of marriage. Spouse choices are purposefully made based on several primary and complementary criteria. Historically, the debate of rational choice undermines the emotional ties by predominantly viewing it from economic perspective. To define the terms of the current debate and the positions of the various stakeholders, the issue of free choice was required to be analyzed from various angles as debated in previous chapters, such as the meaning and the significance given to the marriage not only by the spouses, but also by their parents and the kin network, and the relationship of individuals to the geographical and legal constraints that determine certain choices. Children of transnational families are socialized in dual cultural environments which are qualitatively different in their ideologies of marriage and spouse choices. Globalization and deterritorialization assume that individuals have more freedom of choice as compared to what they can exercise within national boundaries. If individuals are freer than before, according to the modern ideals of the marital relationship, defined from the standards of equality, freedom of choice, and also by the contractual relationships negotiated between independent actors outside the institutional frameworks, while being present in the ambient social discourse, reflects only part of the contemporary realities. Certainly the transformations of intimacy were accompanied by a decline in institutional regulations (religious, legal, social, etc.) of married life in modern societies. Yet there are structural inequalities, gender relations, social expectations, duties and responsibilities that limit the ability of “free choice” of individuals. When thought of in terms of freedom of choice, marital arrangements are instead perceived as free arrangements of power relations that exist between spouses. The choice thus poses *a priori* that the couples negotiate them and they come to agreements, based on which their everyday behavior should be understood. However, intimate relationships and their composition in Pakistani diaspora community are much more complex and also based on collective social norms that directly affect the choices of individuals and marital relations. Love, as an indispensable factor, that is supposed to direct the intimate relationship dynamics in French cultural setting, would not be the only qualifier to choose an adequate spouse in another cultural setting.

This study demonstrates that the persistence of kin-endogamy in transnational marriages is greatly embedded in the pre-marital socialization of the children of immigrants that help them steer their spouse choices. More broadly, migrant parents prepare their children for their future premises of spousal relationships by not only identifying for them their pool of choices but also by constantly directing them towards those choices. Despite the differences in migration patterns of these immigrants, a large majority of them prefers kin-endogamy. Their strategies for kin-endogamy are life-long projects which are more geared to the cultural values of their origin country that reinforce their belief that the spouses—coming from their home country, specifically those who belong to their kin-network—are better able to meet their domestic and familial expectations. Transnational links maintained since the infancy of their children contribute to convert those reciprocal relationships with their kin into the marital relationships of their children. Thereby, they are ultimately successful not only in maintaining and perpetuating their links with their families left-behind but also in preserving their origin culture in their host society by creating transnational social spaces.

Third, transnationally created social spaces affect the nature and dynamics of gender relationships, which are traditionally viewed from patriarchal perspective. Instead of merely analyzing gender relationships from the positions of dominance, this study focuses more on the contextual choices, circumstances and positions of both genders for spouse selection and on the division of labor within the transnational household. The study argues that positions of dominance in a transnational marriage are arbitrary and cannot be assumed as fixed entities for a particular gender.

In case of immigrant parents, female holds stronger position in certain spheres of life as compared to male. A mother, for example, being less engaged in economic activities, stayed closer to her children and exercised her will more as compared to the father who spent most of his time outside the home due to professional/business engagements. Consequently, she has more authority and say in spouse choices and matrimonial affairs of her children as compared to the father. Similarly, the

transnational endogamous choices of children are in strong juxtaposition to the conjugal model inherited from their parents: in most of the cases they considered that their parents were in best position to advise on who will be an “adequate spouse”. Regardless of their gender, they not only tend to comply with the role expectation regarding the alliance, but also confirm to the conjugal model based on their desired gendered division of labor: the wife manages the household and educational tasks of children and generally prefers not to be engaged in professional and/or economic activities; whereas husband takes the responsibility of economic activities for the whole family. The separation of spheres and tasks has wider implications for the respective positions of both genders in a typical transnational Pakistani family in France.

This, however, does not reflect as smoothly functional relationship in atypical cases where position of dominance of a gender is determined by his/her geographic origin. If the spouse, regardless of his/her gender, is French born Pakistani, he/she holds hegemonic position in the matrimonial relationship. Spouse who comes from Pakistan would consider his/her position more vulnerable in case of disputes and would tend to be more compromising, even in those situations where his/her position of dominance could have been protected by the culture of origin country. In this way, gendered inequalities are often determined by the positions of dominance and subordination based on the nationality of the spouse. According to Jamieson (1999), individuals are able to find a balance in their relationships often through sustained and creative efforts to reconcile their multiple identities. This is done because the energy used to sustain a relationship of intimacy despite inequality is often greater than that which seeks to reduce these inequalities.

REFERENCES

- Abbasi, N. M. (2010). The Pakistani community in Europe and its impact on democracy building in Pakistan. International Institute for Democracy and Electoral Assistance.
- Abou-Zahab, M. (2007). Migrants pakistanais en France. *Hommes & migrations*, (1268-1269), 96-103.
- Abrams, D., & Hogg, M. A. (1998). Prospects for research in group processes and intergroup relations. *Group Processes & Intergroup Relations*, 1(1), 7-20.
- Adamson, F. B. (2006). Crossing borders: international migration and national security. *International security*, 31(1), 165-199.
- Afshar, H. (1989). Gender roles and the 'moral economy of kin' among Pakistani women in West Yorkshire. *Journal of Ethnic and Migration Studies*, 15(2), 211-225.
- Afzal, M. (1974). Population of Pakistan. Islamabad: Pakistan Institute of Development Economics.
- Ahmad, S. (1970). Social stratification in a Punjabi village. *Contributions to Indian Sociology*, 105(4), 105-125.
- Alavi, H. A. (1972). Kinship in West Punjab villages. *Contribution to Indian Sociology*, 6(1), 1-27.
- Alba, R., & Nee, V. (1997). Rethinking assimilation theory for a new era of immigration. *International migration review*, 826-874.
- Alvi, A. (2001). The category of the person in rural Punjab. *Social Anthropology*, 9(01), 45-63.
- Alvi, A. (2007). India and the Muslim Punjab: a unified approach to South Asian kinship. *Journal of the Royal Anthropological Institute*, 13(3), 657-678.
- Amelina, A. (2010, January). Searching for an appropriate research strategy on transnational migration: the logic of multi-sited research and the advantage of the cultural interferences approach. In *Forum Qualitative Sozialforschung/Forum: Qualitative Social Research* (Vol. 11, No. 1).
- Amelina, A. (Ed.). (2012). *Beyond methodological nationalism: Research methodologies for cross-border studies* (Vol. 24). Routledge.
- Andersen, S. M., Reznik, I., & Chen, S. 1997. The self in relation to others: Cognitive and motivational underpinnings. In J. G. Snodgrass & R. L. Thompson (Eds.), *The self across psychology* (pp. 233-275). New York: New York Academy of Sciences.
- Anwar, M. (1995): "Social Networks of Pakistanis in the UK: A Re-evaluation" in Roger, A. and Vertovec, S. (1995): *The Urban Context. Ethnicity, Social Networks and Situational Analysis*, Oxford: Berg Publisher.
- Arendell, Terry (November 2000). "Conceiving and Investigating Motherhood: The Decade's Scholarship". *Journal of Marriage and Family*. 62 (4): 1192–1207.
- Arendt, Hannah. 1970. *On Violence*. New York: Harvest Books.
- Attané, I., & Barbieri, M. (2009). The Demography of East and Southeast Asia from the 1950s to the 2000s. *Population (English edition)*, 64(1), 9-146.

- Ballard, R. (1987) 'The political economy of migration: Pakistan, Britain, and the Middle East', in Eades, J. (ed.) *Migrants, Workers, and the Social Order*. London: Tavistock, 7–41.
- Ballard, R. (1990). Migration and kinship: the differential effect of marriage rules on the processes of Punjabi migration to Britain. *South Asians overseas: Migration and ethnicity*, 219-249.
- Ballard, R. (2004). Riste and Ristedari: the significance of marriage in the dynamics of transnational kinship networks. Retrieved from <http://archiv.ub.uni-heidelberg.de/savifadok/292/1/ristedari.pdf> on January 09, 2014.
- Ballard, R. (2008). Inside and outside: Contrasting perspectives on the dynamics of kinship and marriage in contemporary South Asian transnational networks. *The family in question: Immigrants and minorities in multicultural Europe*, 37-70.
- Ballard, R. (2011). Honour Killing? Or just plain homicide?. *Cultural expertise and litigation: Patterns, conflicts, narratives*, 123-148.
- Basch, L., Glick Schiller, N., & Szanton Blanc, C. (1994). *Nations unbound. Transnational Projects, Postcolonial Predicaments and Deterritorialized Nation States*. Lahorne, PA: Gordon and Breach.
- Batool, S. Q., Sajid, M. A., & Shaheen, I. (2013). Gender and Higher Education in Pakistan. *International Journal of Gender and Women's Studies*, 1(1), 15-28.
- Bauböck, R., & Faist, T. (2010). *Diaspora and transnationalism: Concepts, theories and methods* (p. 360). Amsterdam University Press.
- Beauchemin, C., Lagrange, H., & Safi, M. (2011). Transnationalism and immigrant assimilation in France: between here and there? In *Document de Travail* 172. Ined, France.
- Beck, U. (2000). The cosmopolitan perspective: sociology of the second age of modernity. *The British journal of sociology*, 51(1), 79-105.
- Beck, U. and E. Beck-Gernsheim (2002) *Individualization: Institutionalized Individualism and its Social and Political Consequences*. London: SAGE.
- Beck, U., & Lau, C. (2005). Second modernity as a research agenda: theoretical and empirical explorations in the 'meta-change' of modern society. *The British journal of sociology*, 56(4), 525-557.
- Beck-Gernsheim, E. (2002). *Reinventing the family: In search of new lifestyles*. Polity.
- Beck-Gernsheim, E. (2007). Transnational lives, transnational marriages: a review of the evidence from migrant communities in Europe. *Global Networks*, 7(3), 271-288.
- Beishon, S., Modood, T., & Virdee, S. (1998). *Ethnic minority families* (No. 857). Policy Studies Institute.
- Bengtson, Vern L. (2000). "Beyond the Nuclear Family: The Increasing Importance of Multigenerational Bonds." *Journal of Marriage and the Family*, 6, 1-16.
- Berthoud, R. (2000). *Family formation in multi-cultural Britain: three patterns of diversity*. Colchester: Institute for Social and Economic Research, University of Essex.
- Bianchi, S. M., Hotz, V. J., McGarry, K. M., & Seltzer, J. A. (2006). Intergenerational ties: Alternative theories, empirical findings and trends, and remaining challenges. *California Center for Population Research*.

- Bolognani, M. 2007. The myth of return: dismissal, survival or revival? A Bradford example of transnationalism as a political instrument. *Journal of Ethnic and Migration Studies* 33: 59–76.
- Botev, N. (1990). Nuptiality in the course of the demographic transition: the experience of the Balkan countries. *Population Studies*, 44(1), 107-126.
- Bouillier, V. (2011). French law courts and South Asian litigants. In L. Holden (éd.), *Cultural Expertise and Litigation: Patterns, Conflicts, Narratives*, 53-70.
- Bourdieu, P. (1972, July). Les stratégies matrimoniales dans le système de reproduction. In *Annales. Histoire, Sciences Sociales* (Vol. 27, No. 4/5, pp. 1105-1127). EHESS.
- Bourdieu, P. 1972. *Esquisse d'une théorie de la pratique*. Librairie Droz.
- Bourdieu, P., & Wacquant, L. J. (Eds.). (1992). *An invitation to reflexive sociology*. University of Chicago Press.
- Boyle, P., Halfacree, K. H., & Robinson, V. (2014). *Exploring contemporary migration*. Routledge.
- Bozon, M. (1991). Women and the age gap between spouses: an accepted domination? *Population and English Selection*, 113-148.
- Bozon, M., & Héran, F. (2006). *La formation du couple: textes essentiels pour la sociologie de la famille*. La découverte.
- Brewer, Marilyn B. (1991). "The Social Self: On Being the Same and Different at the Same Time." *Personality and Social Psychology Bulletin* 17:475-482.
- Brubaker, R. (2001). The return of assimilation? Changing perspectives on immigration and its sequels in France, Germany, and the United States. *Ethnic and racial studies*, 24(4), 531-548.
- Brüderl, J., & Diekmann, A. (1997). *Education and Marriage. A Comparative Study*. Retrieved August, 20, 2006.
- Bryant, J., & Oliver, M. B. (Eds.). (2009). *Media effects: Advances in theory and research*. Routledge.
- Bryceson, D. F., & Vuorela, U. (Eds.). (2002). *The transnational family: New European frontiers and global networks* (Vol. 25). Berg.
- Budig, M. (2004). Feminism and the family. *The Blackwell companion to the sociology of families*, 416-434.
- Budlender, D., Chobokoane, N., & Simelane, S. (2004). Marriage patterns in South Africa: methodological and substantive issues. *Southern African Journal of Demography*, 1-25.
- Bureau of Emigration & Overseas Employment, Government of Pakistan. Factsheet of Workers Registered for Overseas Employment. Retrieved on March 10, 2016 from <http://www.beoe.gov.pk/files/statistics/2016/province-2016.pdf>
- Buunk, A. P., & Solano, A. C. (2010). Conflicting preferences of parents and offspring over criteria for a mate: a study in Argentina. *Journal of Family Psychology*, 24(4), 391.
- Caldwell, J. (1993). The Asian Fertility Revolution: its implications for Transition Theory. In & I. R. Leete, *The Revolution in Asian Fertility*. Clarendon: Oxford.
- Caldwell, J. C., Reddy, P. H., & Caldwell, P. (1983). The causes of marriage change in South India. *Population studies*, 37(3), 343-361.
- Cameron, H. (2006, September). An examination of the demographic impact of 'transnational marriage' between citizens of the UK and the Indian

- subcontinent. In *conference on Political demography: ethnic, national and religious dimensions* (pp. 29-30).
- Campani, G., & Salimbeni, O. (2004). Marriage Migration in France, Country Study. *DAPHNE Programme- European Commission, Project: Marriage as Immigration Gate: the Situation of Female Marriage Migrants from Third Countries in the EU Member States (HeiRat I)*. Berlin Institute for Comparative Social Research.
- Carpenter, Sandra. 2000. "Effects of cultural tightness and collectivism on self-concept and causal attributions." *Cross-Cultural Research* 34:38.
- Carroll, L. (1996). Qur'an 2: 229:" A Charter Granted to the Wife"? *Judicial Khul'in Pakistan*. *Islamic Law and Society*, 3(1), 91-126.
- Casier, M., Heyse, P., Clycq, N., Zemni, S., & Timmerman, C. (2013). Breaking the in-group out-group: shifting boundaries in transnational partner choice processes of individuals of Moroccan, Tunisian, Algerian, Turkish, Punjabi Sikh, Pakistani and Albanian descent in Belgium. *The Sociological Review*, 61(3), 460-478.
- Castles, S. (2002). Migration and community formation under conditions of globalization. *International migration review*, 36(4), 1143-1168.
- Chacón, J. M. (2006). Unsecured borders: Immigration restrictions, crime control and national security. *Conn. L. Rev.*, 39, 1827.
- Charsley, K. (2005). Unhappy husbands: Masculinity and migration in transnational Pakistani marriages. *Journal of the Royal Anthropological Institute*, 11(1), 85-105.
- Charsley, K. (2007). Risk, trust, gender and transnational cousin marriage among British Pakistanis. *Ethnic and Racial Studies*, 30(6), 1117-1131.
- Charsley, K. (Ed.). (2012). *Transnational Marriage: New Perspectives from Europe and Beyond*. Routledge.
- Charsley, K. (2013). *Transnational Pakistani Connections: Marrying 'Back Home'*. Routledge.
- Charsley, K., Bolognani, M., Spencer, S., Ersanilli, E., Jayaweera, H. (2016) *Marriage Migration and Integration Report*, Bristol, UK: University of Bristol
- Charsley, K., & Shaw, A. (2006). South Asian transnational marriages in comparative perspective. *Global Networks*, 6(4), 331-344.
- Chernilo, D. (2006). Social theory's methodological nationalism myth and reality. *European journal of social theory*, 9(1), 5-22.
- Chernilo, D. (2008). *A social theory of the nation-state: The political forms of modernity beyond methodological nationalism*. Routledge.
- Cipolla, C. M. (1969). *Literacy and Development in the West*. London: Pelican.
- Clifford, J. (1986). Introduction: Partial truths. In *Writing culture: The poetics and politics of ethnography*, edited by J. Clifford and G. Marcus, 1–26. Berkeley: University of California Press.
- Coale, A. J. (1971). Age Patterns of Marriage. *Population Studies*, 193-214.
- Cohen, J. H. (2000). Problems in the field: Participant observation and the assumption of neutrality. *Field Methods*, 12(4), 316-333.
- Cole, J. (2014). Working misunderstandings: The tangled relationship between kinship, Franco-Malagasy binational marriages, and the French State. *Cultural Anthropology*, 29(3), 527-551.

- Coleman, J. S. (1988). Social capital in the creation of human capital. *American journal of sociology*, 95-120.
- Coleman, S., & Von Hellermann, P. (Eds.). (2012). *Multi-sited ethnography: problems and possibilities in the translocation of research methods*. Routledge.
- Collet, B., & Santelli, E. (2015). *Couples d'ici, parents d'ailleurs: parcours de descendants d'immigrés*. Presses universitaires de France.
- Dahya, B. (1974). 'Pakistani ethnicity in industrial cities in Britain', in *Urban Ethnicity*, ed. A. Cohen, pp. 77-118, London: Tavistock.
- Dale, A., & Ahmed, S. (2011). Marriage and employment patterns amongst UK-raised Indian, Pakistani, and Bangladeshi women. *Ethnic and Racial Studies*, 34(6), 902-924.
- Dar, H. (2013). France and Pakistan: Story of an Unwritten Alliance. *Pakistan Vision*, 14(2), 51A.
- Das, V. (1973). The structure of marriage preferences: An account from Pakistani fiction. *Man*, 8(1), 30-45.
- De Courcy, A. (2012). *The fishing fleet: husband-hunting in the Raj*. Hachette UK. Chicago
- Desai, S., & Andrist, L. (2010). Gender scripts and age at marriage in India. *Demography*, 47(3), 667-687.
- Donnan, H. (1988). *Marriage among Muslims: preference and choice in northern Pakistan*. Brill.
- Donnan, H. (1997). Family and household in Pakistan in Donnan, H., & Selier, F. (Eds.). *Family and gender in Pakistan: domestic organization in a Muslim society*. (pp. 1-24). New Dehli: Hindustan Publishing Corporation.
- Durrani, A., & Khan, R. N. A. (2014). Women roles in weddings: ethnography of wedding rituals among Rajput in Punjab, Pakistan. *Eurasian Journal of Anthropology*, 5(1), 32-45.
- Dyson, T., & Moore, M. (1983). On kinship structure, female autonomy, and demographic behavior in India. *Population and development review*, 35-60.
- Eglar, Z. (1960). *A Punjabi Village in Pakistan*. New York: Columbia University Press.
- Erdal, M. B. (2012) 'Who is the money for? Remittances within and beyond the household in Pakistan'. *Asian and Pacific Migration Journal*, 21(4), 437-457.
- Esteve, A., Lesthaeghe, R., & López-Gay, A. (2012). The Latin American Cohabitation Boom, 1970–2007. *Population and Development Review*, 38(1), 55-81.
- Faist, T. (2000). Transnationalization in international migration: implications for the study of citizenship and culture. *Ethnic and racial studies*, 23(2), 189-222.
- Faist, T. (2010). Diaspora and transnationalism: What kind of dance partners? In *Diaspora and transnationalism: Concepts, theories and methods*, edited by Bauböck, R., & Faist, T., 9-34. Amsterdam: The IMISCOE-Amsterdam University Press.
- Falzon, M. A. (Ed.). (2016). *Multi-sited ethnography: Theory, praxis and locality in contemporary research*. Routledge.
- Faris, Robert E.L. 1947. "Interaction of generations and family stability." *American Sociological Review* 12:159–164.

- Farooq, M., & Cheema, M. A. (2005). Likelihood Impact of Internal Migration on Family Institution in Punjab, Pakistan. *Journal of Agricultural and Social Sciences*, 1(2), 148-151.
- Ferdoos, Amber. 2005. Social Status of Rural and Urban Working Women in Pakistan – A Comparative Study. Universität Osnabrück.
- Fisher, M. H. (2006). *Counterflows to Colonialism: Indian Travellers and Settlers in Britain, 1600-1857*. Orient Blackswan.
- Friedman, J. (1997). Simplifying complexity: assimilating the global in a small paradise. *Siting culture: the shifting anthropological object*, 268-291.
- Gardner, K., & Grillo, R. (2002). Transnational households and ritual: an overview. *Global networks*, 2(3), 179-190.
- Giddens, A. (2007). *The constitution of society: Outline of the theory of structuration*. University of California Press.
- Gielis, R. (2009). A global sense of migrant places: towards a place perspective in the study of migrant transnationalism. *Global Networks*, 9(2), 271-287.
- Glick-Schiller, N. (2010). A global perspective on transnational migration: Theorising migration without methodological nationalism. In R. Bauböck & T. Faist (Eds.), *Diaspora and Transnationalism. Concepts, Theories and Methods* (pp. 109-129). Amsterdam: Amsterdam University Press.
- Gottschalk, P., & Spolaore, E. 2002. On the evaluation of economic mobility. *The Review of Economic Studies*, 69(1), 191-208.
- Guarnizo, L. E. (1997). The emergence of a transnational social formation and the mirage of return migration among Dominican transmigrants. *Identities Global Studies in Culture and Power*, 4(2), 281-322.
- Guarnizo, L. E., & Smith, M. P. (1998). The locations of transnationalism. *Transnationalism from below*, 6, 3-34.
- Habbakuk, H. J. (1955). Family Structure and Economic Change in 19th century Europe. *Journal of Economic History*, 15(1), 1-12.
- Hajnal, J. (1965). European marriage patterns in perspective. In D. Glass, & D. Eversley, *Population in History* (pp. 101-143). London: Edward Arnold.
- Hammel, E. A. (1990). A theory of culture for demography. *Population and Development Review*, 455-485.
- Hammersley, M. (1990). *Reading ethnographic research: A critical guide*. Longman.
- Hanif, R. (2007). Que disent les jeunes Pakistanais de l'intégration? *Hommes & Migrations* (1268-1269), 104-109.
- Harris, K. & Shaw, A. (2006). Family care and transnational kinship: British Pakistani experiences. In *Kinship Matters*, ed. Ebtehaj, F., Lindley, B, Richards, M. Hart Press: Cambridge.
- Harwood, J., & Roy, A. (2005). Social identity theory and mass communication research. In J. Harwood, & H. Giles (Eds.), *Inter group communication: Multiple perspectives* (pp. 189-212). New York: Peter Lang.
- Hollingshead, A. B. (1950). Cultural factors in the selection of marriage mates. *American Sociological Review*, 15(5), 619-627.
- Hondagneu-Sotelo, P., & Avila, E. (1997). "I'm Here, but I'm There" the Meanings of Latina Transnational Motherhood. *Gender & Society*, 11(5), 548-571.
- Hull, T. (2002). The marriage revolution in Indonesia. Paper deliv.

- Hussain, R. (1999). Community perceptions of reasons for preference for consanguineous marriages in Pakistan. *Journal of biosocial science*, 31(04), 449-461.
- Ikamari, L. D. (2005). The effect of education on the timing of marriage in Kenya. *Demographic Research*, 12(1), 1-28.
- Ip, G.W.M., & Bond, M. H. 1995. "Culture, values, and the spontaneous self-concept." *Asian Journal of Psychology*, 1, 29-35.
- Iqbal, N. (2006). *Transnational subjectivities: the practice of relatedness among British Pakistanis* (Doctoral dissertation, Durham University). Retrieved on September 13, 2014 from http://etheses.dur.ac.uk/2552/1/2552_563.pdf.
- Jacoby, H. G., & Mansuri, G. (2010). Watta Satta: Bride Exchange and Women's Welfare in Rural Pakistan. *The American Economic Review*, 1804-1825.
- Jamieson, L. (1999). Intimacy transformed? A critical look at the pure relationship'. *Sociology*, 33(3), 477-494.
- Jan, M. A. (2010). Pakistan's national emigration policy: a review. Policy Paper Series, 35.
- Johnson, K. R. (2007). Protecting National Security Through More Liberal Admission of Immigrants. *U. Chi. Legal F.*, 157.
- Johnson, M. (1998). *Lore: capturing traditional environmental knowledge*. Diane Publishing.
- Joppke, C. (2007). Beyond national models: Civic integration policies for immigrants in Western Europe. *West European Politics*, 30(1), 1-22.
- Joppke, C., & Morawska, E. (2014). Integrating immigrants in liberal nation-states: policies and practices. In *Toward assimilation and citizenship: Immigrants in liberal nation-states* (pp. 1-36). Palgrave Macmillan UK.
- Takepoto, H., Brohi, A. A., & Jariko, G. A. (2012). Impact of Social Change upon Family as Social Institution with Special Focus on Pakistan: A Sociological Analysis. *International Research Journal of Arts and Humanities*, 40(40), 103.
- Kalmijn, M. (2004). Marriage rituals as reinforcers of role transitions: An analysis of weddings in the Netherlands. *Journal of Marriage and Family*, 66(3), 582-594.
- Kalmijn, M., (1998), 'Intermarriage and homogamy: causes, patterns, trends', *Annual Review of Sociology*, 24: 395-421.
- Kashima, Y., Foddy, M., & Platow, M. (Eds.). (2002). *Self and identity: Personal, social, and symbolic*. Psychology Press.
- Keay, J. (2011). *India: A History. Revised and Updated*. Grove/Atlantic, Inc.
- Khalid, S., & Gilani, A. H. (2009). Distinctive cultural and geographical legacy of Bahawalpur. *Pakistaniaat: A Journal of Pakistan Studies*, 2(2), 1-17.
- Khan, S. (2011). *Zina, transnational feminism, and the moral regulation of Pakistani women*. UBC Press.
- Khan, V. S. (1977). The Pakistanis: Mirpuri Villagers at Home and in Bradford. In Watson, James L. (ed.). *Between two cultures*. Oxford: Basil Blackwell.
- King, S. (1998). English historical demography and the nuptiality conundrum: New perspectives. *Historical Social Research/Historische Sozialforschung*, 130-156.
- Knodel, J., & Maynes, M. J. (1976). Urban and rural marriage patterns in imperial Germany. *Journal of Family History*, 1(2), 129.

- Knox, D. & Schacht, C. (2012). *Choices in relationships: An introduction to marriage and the family*. Cengage Learning.
- Koc, I., & Onan, I. (2004). International Migrants' Remittances and Welfare Status of the Left-Behind Families in Turkey. *International Migration Review*, 38(1), 78-112.
- Koopmans, R., Michalowski, I., & Waibel, S. (2012). Citizenship Rights for Immigrants: National Political Processes and Cross-National Convergence in Western Europe, 1980–2008. *American Journal of Sociology*, 117(4), 1202-1245.
- Korson, J. H. (1969). Student attitudes toward mate selection in a Muslim society: Pakistan. *Journal of Marriage and the Family*, 31(1), 153-165.
- Kotolova, J. (1996). *Belonging to Others: Cultural Construction of Womenhood in a Village in Bangladesh*. Dhaka.: University Press Limited.
- Krieger-Krynicky, A. (1989). Immigrés pakistanais en France. Réfugiés afghans au Pakistan. *Hommes et Migrations*, 1121(1), 11-15.
- Krieger-Krynicky, A. (1993). Indiens, Pakistanais, Sri Lankais : 1ère partie : Le sous-continent indien. *Accueillir*, vol. 190, 1993/05-06. - p. 14-38.
- Kringelbach, H. N. (2013). 'Mixed marriage', citizenship and the policing of intimacy in contemporary France. *University of Oxford*.
- Kuper, A. (2008). Changing the subject—about cousin marriage, among other things. *Journal of the Royal Anthropological Institute*, 14(4), 717-735.
- Lacroix, T. (2014). Conceptualizing transnational engagements: a structure and agency perspective on (hometown) transnationalism. *International Migration Review*, 48(3), 643-679.
- Lalujee, Mansur, and Radoslava Angelova. 1995. "Person Description in India, Britain, and Bulgaria." *Journal of Cross-Cultural Psychology* 26:645-657.
- Lamb, M.E. (1987) 'Introduction: The Emergent American Father', in M.E. Lamb (ed.) *The Father Role: A Cross-cultural Perspective*, pp. 1–26. Hillsdale, NJ: Lawrence Erlbaum
- Landolt, P. (2001). Salvadoran economic transnationalism: Embedded strategies for household maintenance, immigrant incorporation, and entrepreneurial expansion. *Global Networks*, 1(3), 217-242.
- Lévi-Strauss, C. 1969. *The elementary structures of kinship (No. 340)*. Beacon Press.
- Levitt, P. (2001). Transnational migration: taking stock and future directions. *Global networks*, 1(3), 195-216.
- Levitt, P. (2009). Roots and routes: understanding the lives of the second generation transnationally. *Journal of Ethnic and Migration Studies*, 35(7), 1225-1242.
- Levitt, P., & Jaworsky, B. N. (2007). Transnational migration studies: Past developments and future trends. *Annual Review of Sociology*, 33, 129-156.
- Levitt, P., & Schiller, N. G. (2004). Conceptualizing Simultaneity: A Transnational Social Field Perspective on Society. *International migration review*, 38(3), 1002-1039.
- Lievens, J. (1999). Family-forming migration from Turkey and Morocco to Belgium: The demand for marriage partners from the countries of origin. *International migration review*, 717-744.

- Lin, K. H., & Lundquist, J. (2013). Mate Selection in Cyberspace: The Interpart of Race, Gender, and Education. *American Journal of Sociology*, 119(1), 183-215.
- Liversage, A. & Rytter, M. (2015). 'A cousin marriage equals a forced marriage: Transnational marriages between closely related spouses in Denmark'. In A. Shaw, & A. Raz (Eds.), *cousin marriage: between tradition, genetic risk and cultural change*. Copenhagen: Berghahn Books.
- Liversage, A. (2012). Gender, Conflict and Subordination within the Household: Turkish Migrant Marriage and Divorce in Denmark. *Journal of Ethnic and Migration Studies*, 38(7), 1119-1136.
- Lyon, S. M. (2002). Power and patronage in Pakistan (Doctoral dissertation, University of Kent).
- Mahé, A. (1996). Entre le religieux, le juridique et le politique: l'éthique. Réflexions sur la nature du rigorisme moral et sanctionné pas les assemblées villageoises de Grande Kabylie. *Anthropologie et sociétés*, 20(2), 85-110.
- Mahler, S. J. (1998). Theoretical and empirical contributions toward a research agenda for transnationalism. *Transnationalism from below*, 6, 64-100.
- Malik, A. A. (2015). Of Migration, Marriage, and Men: Rethinking the Masculinity of Transnational Husbands from Rural Pakistan. *Gender and Sexuality in Muslim Cultures*, 55.
- Malinowski, B. (1922). 2002. *Argonauts of the Western Pacific: An account of native enterprise and adventure in the archipelagoes of Melanesian New Guinea*. Routledge.
- Mand, K. (2006). Social capital and transnational South Asian families: Rituals, care and provision. London South Bank University.
- Mandelbaum, D. G. (1993). Women's seclusion and men's honor: Sex roles in North India, Bangladesh, and Pakistan. University of Arizona Press.
- Marcus, G. E. (1995). Ethnography in/of the world system: the emergence of multi-sited ethnography. *Annual review of anthropology*, 24(1), 95-117.
- Markus, Hazel R., and Shinobu Kitayama. 1991. "Culture and the self: Implications for cognition, emotion, and motivation." *Psychological Review* 98:224-253.
- Mathew, G. (1995). *Status of Panchayati Raj in the States of India, 1994*. concept publishing company.
- Matters, ed. Ebtehaj, F., Lindley, B, Richards, M. Hart Press: Cambridge.
- Mauss, M. (1950). 1990. *The gift: The form and reason for exchange in archaic societies*. Paris.
- Mazzucato, V. (2008). The double engagement: Transnationalism and integration. Ghanaian migrants' lives between Ghana and the Netherlands. *Journal of ethnic and migration studies*, 34(2), 199-216.
- McCracken, G. 2008. Transformations: Identity construction in Contemporary Culture. Bloomington: Indiana University Press.
- McLoughlin, S. (1998). The mosque-centre, community-mosque: multi-functions, funding and the reconstruction of Islam in Bradford. *Scottish Journal of Religious Studies*, 19, 211-228.
- Meena, H. K. (2015). Famine in Late 19th Century India: Natural or Man-Made. *Journal of Human and Social Science Research*; Vol, 6(01), 035-044.

- Meyer, C. B. (2001). A case in case study methodology. *Field methods*, 13(4), 329-352.
- Migration Watch, U. K. (2005). Transnational Marriage and the Formation of Ghettoes. *Briefing Paper*, Retrieved from <http://www.migrationwatchuk.org/Briefingpaper/document/128> on December 05, 2012.
- Milewski, N., & Hamel, C. (2010). Union Formation and Partner Choice in a Transnational Context: The Case of Descendants of Turkish Immigrants in France. *International Migration Review*, 44(3), 615-658.
- Miller, J G. 1984. "Culture and development of everyday social explanation." *Journal of personality and social psychology* 46:961-78.
- Mitchell, J. C. (1983). Case and situation analysis1. *The sociological review*, 31(2), 187-211.
- Moen, P., Erickson, M. A., & Dempster-McClain, D. (1997). Their mother's daughters? The intergenerational transmission of gender attitudes in a world of changing roles. *Journal of Marriage and the Family*, 281-293.
- Mohammad, R. (2015). Transnational shift: marriage, home and belonging for British-Pakistani Muslim women. *Social & Cultural Geography*, 16(6), 593-614.
- Moliner, C. (2009). Invisible et modèle? Première approche de l'immigration sud-asiatique en France. Rapport d'étude pour la Direction de l'accueil, de l'intégration et de la citoyenneté, ministère de l'Immigration, de l'Intégration, de l'Identité nationale et du Développement solidaire.
- Moliner, C. (2012). Indian migrants in France: Country report. CARIM-India RR 2012/11. Robert Schuman Centre for Advanced Studies, San Domenico di Fiesole (FI): European University Institute.
- Molm, L. D. 2003. Theoretical comparisons of forms of exchange. *Sociological Theory*, 21(1), 1-17.
- Monsutti, A. (2016). War and migration: social networks and economic strategies of the Hazaras of Afghanistan. Routledge.
- Munoz, M. C. (1999). Epouser au pays, vivre en France. *Revue européenne des migrations internationales*, 15(3), 101-123.
- Nadim, M. 'Doing family'in transnational marriages: Second generation women's attachment to work. Retrieved from http://cream.conference-services.net/resources/952/3365/pdf/MGDNF2013_0212.pdf on December 05, 2013.
- Naseem, J. (2016). Everyday Racism and Discrimination in France and Britain: A Comparative Study of the Educational and Professional Experiences of Second Generation Graduate Women. Unpublished Doctoral dissertation, University College London.
- Nayab, D. (2009). Who marries whom in Pakistan? Role of education in marriage timing and spouse selection. *Pakistan Institute of Development Economics*.
- Nedelcu, M. (2012). Migrants' new transnational habitus: rethinking migration through a cosmopolitan lens in the digital age. *Journal of Ethnic and Migration Studies*, 38(9), 1339-1356.
- Nesbitt, E. (1995). Panjabis in Britain: Cultural history and cultural choices. *South Asia Research*, 15(2), 221-240.

- Oppong, C. (1980). Synopsis of seven roles and status of women: an outline of a conceptual and methodological approach (No. 207213). International Labour Organization.
- O'reilly, A. (Ed.). (2010). *Encyclopedia of motherhood*. Sage Publications.
- Papastergiadis, N. (2013). *The turbulence of migration: globalization, deterritorialization and hybridity*. John Wiley & Sons.
- Parkes, P. 1997. Kalasha domestic society: practice, ceremony and domain. In H. Donnan, & F. Selier (ed.) *Family and Gender in Pakistan: domestic organization in a Muslim society*. New Delhi: Hindustan Publishing Corporation, pp. 25- 63.
- Pope, N. (2011). *Honor killings in the twenty-first century*. Springer.
- Popenoe, D. (1988). *Disturbing the nest: Family change and decline in modern societies*. Transaction Publishers.
- Portes, A. (1996). Transnational communities: Their emergence and significance in the contemporary world-system. *Contributions in Economics and Economic History*, 151-168.
- Portes, A. (2001). Introduction: the debates and significance of immigrant transnationalism. *Global networks*, 1(3), 181-194.
- Portes, A. (2003). Conclusion: Theoretical convergencies and empirical evidence in the study of immigrant transnationalism. *International migration review*, 37(3), 874-892.
- Portes, A., Guarnizo, L. E., & Landolt, P. (1999). The study of transnationalism: pitfalls and promise of an emergent research field. *Ethnic and racial studies*, 22(2), 217-237.
- Portes, A., Guarnizo, L. E., & Landolt, P. (1999). The study of transnationalism: pitfalls and promise of an emergent research field. *Ethnic and racial studies*, 22(2), 217-237.
- Pries, L. (2001). The approach of transnational social spaces: responding to new configurations of the social and the spatial. In L. Pries (Ed.), *New transnational social spaces: International migration and transnational companies in the early twenty-first century* (pp. 3–33). New York: Routledge.
- Pries, L. (2005). Configurations of geographic and societal spaces: a sociological proposal between 'methodological nationalism' and the 'spaces of flows'. *Global Networks*, 5(2), 167-190.
- Pries, L. (Ed.). (1999). *Migration and transnational social spaces*. Ashgate Pub Limited.
- Putnam, Robert D. 2000. *Bowling Alone: The Collapse and Revival of American Community*. New York: Simons and Schuster.
- Qadeer, M. (2006). *Pakistan*. Routledge.
- Quayson, A. (2013). Postcolonialism and the Diasporic Imaginary. In *A Companion to Diaspora and Transnationalism* Edited by Quayson, A. and Daswani, G. 139-160. West Sussex: Blackwell Publishing.
- Quayson, A., & Daswani, G. (Eds.). (2013). *A Companion to Diaspora and Transnationalism*. John Wiley & Sons.
- Rytter, M. (2012). Between preferences: marriage and mobility among Danish Pakistani youth. *Journal of the Royal Anthropological Institute*, 18(3), 572-590.

- Quien, A. (2007). Femmes indiennes au travail à Paris. *Hommes & migrations*, (1268-1269), 160-167.
- Qureshi, K., and S. Moores. 1999. "Identity remix: Tradition and translation in the lives of young Pakistani Scots." *European Journal of Cultural Studies* 2:311.
- Ratha, D., Plaza, S. & Dervisevic, E. (2016). *Migration and Remittances Factbook 2016*. World Bank Publications.
- Reid, Scott a., Howard Giles, and Jessica R. Abrams. 2004. "A Social Identity Model of Media Usage and Effects." *Zeitschrift für Medienpsychologie* 16:17-25.
- Rhee, E, J S Uleman, H K Lee, and R J Roman. 1995. "Spontaneous self-descriptions and ethnic identities in individualistic and collectivistic cultures." *Journal of personality and social psychology* 69:142-52.
- Ritzer, G. (Ed.). (2007). *The Blackwell encyclopedia of sociology* (Vol. 1479). Malden, MA: Blackwell Publishing.
- Roomi, M. A., & Parrott, G. (2008). Barriers to development and progression of women entrepreneurs in Pakistan. *Journal of Entrepreneurship*, 17(1), 59-72.
- Rudestam, K. E., & Newton, R. R. (2007). The method chapter: Describing your research plan. In *Surviving your dissertation: A comprehensive guide to content and process*, 87-117. Sage Publications.
- Rytter, M. (2010). A sunbeam of hope: negotiations of identity and belonging among Pakistanis in Denmark. *Journal of Ethnic and Migration Studies*, 36(4), 599-617.
- Rytter, M. (2012). Semi-legal family life: Pakistani couples in the borderlands of Denmark and Sweden. *Global Networks*, 12(1), 91-108.
- Rytter, M. (2013). *Family upheaval: generation, mobility and relatedness among Pakistani migrants in Denmark* (Vol. 21). Berghahn Books.
- Sahlins, M. D. 1972. *Social stratification in Polynesia* (Vol. 29). University of Washington Press.
- Sanghera, J. (2009). *Daughters of shame*. Hachette UK.
- Santelli, E. (2010). Entre ici et là-bas: les parcours d'entrepreneurs transnationaux. Investissement économique en Algérie des descendants de l'immigration algérienne de France. *Sociologie*, 1(3), 393-411.
- Sathar, Z. A., Kiani, M. F., & Soomro, G. Y. (1998). Some Consequences of Rising Age at Marriage in Pakistan [with Comments]. *The Pakistan Development Review*, 541-556.
- Sathar, Z. A., ul Haque, M., Faizunnissa, A., Sultana, M., Lloyd, C. B., Diers, J. A., & Grant, M. Adolescents and Youth in Pakistan, 2001-02.
- Schiller, N. G., Basch, L., & Blanc, C. S. (1992). Transnationalism: A new analytic framework for understanding migration. In *Towards a transnational perspective on migration: Race, class, ethnicity, and nationalism reconsidered*, ed. Schiller, N. G., Basch, L., & Blanc, C. S. New York Academy of Sciences: New York.
- Schiller, N. G., Basch, L., & Blanc, C. S. (1995). From Immigrant to Transmigrant: Theorizing Transnational Migration. *Anthropological quarterly*, 68(1).
- Schmidt, G. (2011). Migration and Marriage. *Nordic journal of migration research*, 1(2), 55-59.
- Schöpflin, G. (2001). The construction of identity. *Österreichischer Wissenschaftstag*, 1-10.

- Segalen, M., & Richard, P. (1986). Marrying kinsmen in Pays Bigouden Sud, Brittany. *Journal of Family History*, 11(2), 109-130.
- Selier, F. (1997). Expanded family and extended community: migrants in Karachi.
- Shah, M., Khan, R., Naushad, K., Jadoon, M. A., & Alam, I. (2006). Women being the most neglected agent in the South Asian societies. *Pak J Life Soc Sci*, 4, 81-85.
- Shakari, Y. (2013). *Family, Socialization and Migration in Norwegian-Pakistani Families* (Doctoral dissertation, University of Oslo).
- Sharabi, H. (1992). *Neopatriarchy: A theory of distorted change in Arab society*. Oxford University Press.
- Shaw, A. (1988). *A Pakistani community in Britain*. Oxford: Blackwell.
- Shaw, A. (2001). Kinship, Cultural Preference and Immigration: Consanguineous Marriage among British Pakistanis. *The Journal of the Royal Anthropological Institute*, 7(2), 315-334.
- Shaw, A. (2004). Immigrant families in the UK. *The Blackwell Companion to the Sociology of Families*. Malden ua: Blackwell, 270-285.
- Shaw, A. (2011). Risk and reproductive decisions: British Pakistani couples' responses to genetic counselling. *Social Science & Medicine*, 73(1), 111-120.
- Shaw, A., & Charsley, K. (2006). Rishtas: adding emotion to strategy in understanding British Pakistani transnational marriages. *Global Networks*, 6(4), 405-421.
- Sheela, J., & Audinarayana, N. (2000). Determinants of female age at first marriage in Tamil Nadu-An analysis of NFHS data. *Journal of Family Welfare*, 46(2), 25-32.
- Singla, R. (2006). Intimate Partnership Formation and Intergenerational Relationships among Ethnic Minority Youth in Denmark. *Outlines. Critical Practice Studies*, 8(2), 76-97.
- Singly, F. D. (1997). La mobilisation familiale pour le capital scolaire. *École, familles, le malentendu*. Paris: Textuel.
- Smart, C., & Shipman, B. (2004). Visions in monochrome: families, marriage and the individualization thesis. *The British journal of sociology*, 55(4), 491-509.
- Smith, M. D., & Self, G. D. (1980). The congruence between mothers' and daughters' sex-role attitudes: A research note. *Journal of Marriage and the Family*.
- Smith, M. P. (2003). Transnationalism and citizenship. In *Approaching Transnationalisms* (pp. 15-38). Springer US.
- Vertovec, S. (1999). Conceiving and researching transnationalism. *Ethnic and racial studies*, 22(2), 447-462.
- Smith, M. P., & Guarnizo, L. E. (Eds.). (1998). *Transnationalism from below* (Vol. 6). Transaction Publishers.
- Smith, P. C., & Karim, S. M. (1980). *Urbanisation, Education and Marriage Patterns: Four Cases from Asia*. East-West Population Centre.
- Smith, T. E. (1983). Parental influence: A review of the evidence of influence and a theoretical model of the parental influence process. *Research in sociology of education and socialization*, 4, 13-45.
- Stalford, H. (2002). Concepts of Family under EU Law—Lessons from the ECHR. *International Journal of Law, Policy and the Family*, 16(3), 410-434.

- Starrels, M. E. (1992). Attitude similarity between mothers and children regarding maternal employment. *Journal of Marriage and the Family*, 91-103.
- Stets, J. E., & Burke, P. J. (2000). Identity theory and social identity theory. *Social psychology quarterly*, 224-237.
- Stryker, S. (1980). *Symbolic interactionism: A social structural version*. Benjamin-Cummings Publishing Company.
- Tajfel, H. (1972), 'Experiments in a vacuum', in J. Israel and H. Tajfel (eds), *The Context of Social Psychology: A Critical Assessment*, Academic Press, London.
- Tajfel, H. and Turner, J.C. (1979). "An integrative theory of intergroup conflict", in W.G.Austin and S.Worchel (eds) *The Social Psychology of Intergroup Relations*, Monterey, Calif.: Brooks-Cole.
- Talbani, A., & Hasanali, P. (2000). Adolescent females between tradition and modernity: Gender role socialization in South Asian immigrant culture. *Journal of adolescence*, 23(5), 615-627.
- Talmon, Yonina. (1964). "Mate selection in collective settlements." *American Sociological Review* 29:491–508.
- Tandon (2013) on Epidemics in Colonial Punjab. [Tandon, S. (2010) Epidemics in Colonial Punjab. *Journal of Punjab Studies*. Vol 20 (1 & 2), 217-242.
- Terian, S. K. (2004). In Salamone, F. A. (Ed.) *Routledge Encyclopedia of Religious Rites, Rituals and Festivals*. Routledge.
- Thieme, S. (2006). *Social networks and migration: Far West Nepalese labour migrants in Delhi (Vol. 7)*. LIT Verlag Münster.
- Thomas, E. F., Sabiha, H. S., & Peter, C. S. (1986). Rural Punjabi social organization and marriage timing strategies in Pakistan. *Demography*, 23(4), 489-508.
- Triandis, Harry C. (1989). "The self and social behavior in differing cultural contexts." *Psychological Review* 96:506-520.
- Turner, V. W. (1982). *From ritual to theatre: The human seriousness of play*. Paj Publications.
- Vancea, M. (2009). *The political transnationalism of immigrant associations in Barcelona*. Universitat Pomeu Fabra.
- Varghese, Anita & Jenkins, Sharon Rae 2009, "Parental overprotection, cultural value conflict, and psychological adaptation among Asian Indian Women", *Signs: Sex roles*, vol. 61, no. 3.
- Véron, J., Horko, K., Kneipp, R., & Rogers, G. (2008). *The Demography of South Asia from the 1950s to the 2000s: A Summary of Changes and a Statistical Assessment*. *Population (English version)*, 63(1), 9-89.
- Vertovec, S. (1999). Conceiving and researching transnationalism. *Ethnic and racial studies*, 22(2), 447-462.
- Vertovec, S. (2001). Transnationalism and identity. *Journal of Ethnic and Migration studies*, 27(4), 573-582.
- Vertovec, S. (2003). Migration and other modes of transnationalism: towards conceptual cross-fertilization. *International migration review*, 37(3), 641-665.
- Vertovec, S. (2004). Migrant transnationalism and modes of transformation. *International migration review*, 970-1001.

- Vertovec, S., & Cohen, R. (1999). Migration, diasporas and transnationalism. *Cheltenham/Northampton*.
- Wakil, P. A. (1970). Explorations into the kin-networks of the Punjabi society: a preliminary statement. *Journal of Marriage and the Family*, 700-707.
- Wasim, F. (2014). *South Asian American Daughter-in-law/mother-in-law Relationships, Cultural Values Conflict, and Help-seeking for Domestic Violence* (Doctoral dissertation, Oklahoma State University).
- Watkins, D., S. Mortazavi, and I. Trofimova. (2000). "Independent and interdependent conceptions of self: An investigation of age, gender, and culture differences in importance and satisfaction ratings." *Cross-Cultural Research* 34:113.
- Weiss, A. M. (1998). The slow yet steady path to women's empowerment in Pakistan. *Islam, gender and social change*, 124-43.
- Weiss, Anita M. (2002). *Walls within Walls: Life Histories of Working Women in the Old City of Lahore*. New York: Oxford University Press.
- Werbner, P. (1986). The virgin and the clown ritual elaboration in Pakistani migrants' weddings. *Man*, 227-250.
- Werbner, P. (1999). Global pathways. Working class cosmopolitans and the creation of transnational ethnic worlds. *Social anthropology*, 7(1), 17-35.
- Williams, L. (2010). *Global marriage. Cross-border marriage migration in global context. England: Palgrave Macmillan*.
- Williams, S. (2008). What is fatherhood? Searching for the reflexive father. *Sociology*, 42(3), 487-502.
- Wimmer, A., & Glick Schiller, N. (2002). Methodological nationalism and beyond: nation–state building, migration and the social sciences. *Global networks*, 2(4), 301-334.
- Wimmer, A., & Schiller, N. G. (2003). Methodological nationalism, the social sciences, and the study of migration: An essay in historical epistemology. *International migration review*, 37(3), 576-610.
- Winkvist, A., & Akhtar, H. Z. (2000). God should give daughters to rich families only: attitudes towards childbearing among low-income women in Punjab, Pakistan. *Social Science & Medicine*, 51(1), 73-81.
- Wray, H. (2011). *Regulating marriage migration into the UK: A stranger in the home*. Ashgate Publishing, Ltd.
- Xenos, P., & Gultiano, S. A. (1992, September). Trends in Female and Male Age at Marriage and Celibacy in Asia. *Papers of the Program on Population*, p. 120.
- Yin, R. K. (1989). *Case study research: Design and methods*, revised edition. Applied Social Research Methods Series, 5.
- Yurdakul, G. (2009). *From guest workers into Muslims: the transformation of Turkish immigrant associations in Germany*. Cambridge Scholars Publishing: Newcastle.
- Zaidi, A. U., & Shuraydi, M. (2002). Perceptions of arranged marriages by young Pakistani Muslim women living in a Western society. *Journal of Comparative Family Studies*, Vol 33 (4), 495-514.
- Zaman, A., & Ara, I. (2000). Rising urbanization in Pakistan, some facts and suggestions. *The Journal NIPA*, 7, 31-46.

- Zaman, M. (2008). Socio-cultural security, emotions and exchange marriages in an agrarian community. *South Asia Research*, 28(3), 285-298.
- Zaman, M. (2011). Exchange marriages in South Punjab, Pakistan: a sociological analysis of kinship structure, agency, and symbolic culture. Peter Lang.
- Zaman, M. (2013). Exchange Marriages in a Community of Pakistan: Adequate Social Exchange. *The Family Journal*, 1066480713505058.
- Zaman, M. (2014). Exchange Marriages in a Community of Pakistan: Adequate Social Exchange. *The Family Journal: Counseling and Therapy for Couples and Families*. Vol 22(1) 69-77.

ANNEXURE I

SUMMARY PROFILE OF RESPONDENT PAKISTANI IMMIGRANT FAMILIES IN FRANCE

Serial No.	Family Code	Migration year	Details
1	VP5	1983	<p>Parents have 1 son and 3 daughters. The eldest son was married to a spouse from Pakistan. The daughter-in-law with two children is living with family-in-law.</p> <p>The eldest among daughters is married with her paternal cousin and living with her parents, she did not join her husband who lives and works in Denmark. 2nd daughter is engaged with her cousin belonging to extended kin living in Australia. The youngest daughter is unmarried and perusing her education.</p>
2	LC4	1977	<p>Parents have 7 sons. The eldest son is married; his marriage case is under study. He is living in a separate apartment with his wife and 3 daughters. The 2nd and 3rd sons of the family are married with Moroccan and Tunisian women and living in separate apartments. 4th son is unmarried but in a relationship with a French girl. 5th son is engaged with his maternal cousin. 6th & 7th sons are unmarried and pursuing their studies.</p>
3	VG4	1980	<p>Parents have 3 sons and 2 daughters. The eldest daughter is married and living with her husband</p>

			<p>in her parental home. Her marriage case is under study.</p> <p>The rest of the children are unmarried. Parents are determined to arrange their marriage within relatives (afterwards they finish their studies and/or settle their business).</p>
4	OZ5	1981	<p>Parents have 1 son and 3 daughters. The eldest daughter is married; her marriage case is under study. She is living along her husband in a separate apartment.</p> <p>Rest of the children are pursuing education</p>
5	AB4	1969	<p>Parents have 5 sons and 1 daughter. The daughter is married and living with her husband in her parental home. Her marriage case in under study.</p> <p>All of the sons are married within close kin and doing business. All of the daughters-in-law along children are living with family-in-law, jointly.</p>
6	VB4	1981	<p>Parents have 3 sons and 2 daughters. The youngest daughter is married with her cousin belong to extended relatives. She is living separately from her parents with her husband and 2 children. Her marriage case is under study.</p> <p>The eldest daughter is married with a paternal cousin and living separately from her parents with her husband and children. She is living along her husband with her parents. Two of the sons are married with two paternal cousins (both are sisters). The daughters-in-law along children are living with family-in-law. The youngest son is unmarried and doing business. His parents are</p>

			looking for his marriage proposal in relatives in Pakistan.
7	CO6	1970	<p>Parents have 4 sons and 1 daughter. The daughter is married on exchange basis and is living in Pakistan. The 2nd and 3rd are married with their cousins in exchange of their sister. Their marriages cases are under study.</p> <p>The first son is single and lives in Pakistan to take care of family's land. The 4th son is married with his cousin-belonging to extended relatives. All the daughters-in-law are living along children with their family-in-law.</p>
8	VI4	1981	<p>Parents have 2 sons and 2 daughters. The eldest son and daughter are married on exchange basis. The daughter-in-law along 1 child is living with her family-in-law. The daughter is also living with her parental family. Her husband is living in Pakistan. Their marriage cases are under study.</p> <p>Younger son and daughter have completed their studies. Parents are looking for daughter's marriage proposals in co-ethnic diaspora, while they tend to marry their son within relatives in Pakistan.</p>
9	PI3	1982	<p>Parents have 3 sons and 3 daughters. The eldest daughter is married; her marriage case is under study. She is living along her husband with her parents. Since some months, due to conflicts, her husband left his family-in-law home.</p> <p>The rest of the children are unmarried. 2 daughters and 1 son have complete their</p>

			education and mother is looking for their marriage proposals in co-ethnic diaspora. The 2 youngest sons are pursuing their education
10	SD5	1975	<p>Parents have 2 sons and 2 daughters. Only the eldest son is married, his marriage case is under study. He is living in a separate apartment near to his parents' apartment.</p> <p>The younger sister is about to complete her education and her parents are looking for her marriage proposal in Pakistan. the youngest brother is pursuing his education.</p>
11	TR4	1975	<p>Parents have 3 sons and 1 daughter. 1st and 2nd son is married within relatives. Their wives are sisters. Both daughters-in-law are living with family-in-law. The marriage case of 2nd son is under study.</p> <p>The daughter is married with a boy from co-ethnic diaspora. She is living with her family-in-law. The youngest son is doing job and his parents are looking for his marriage proposal within family's social network in Pakistan.</p>
12	SC5	1981	<p>Parents have 4 sons. The eldest son is married; his marriage case is under study. The daughter-in-law with 4 children is living with her family-in-law.</p> <p>2nd son is married with a girl belonging to family's network in Pakistan and living in a separate residence. 3rd son is unmarried but in relationship with a French girl. His parents are looking for his marriage proposal in co-ethnic diaspora. 4th son is unmarried and pursuing his education.</p>

13	CB4	1981	<p>Parents have 2 sons and 1 daughter. The daughter is married with a guy from family's social network. Her marriage case is under study.</p> <p>The elder son is married with his maternal cousin. The daughter-in-law with two children is living with the family. The younger son is unmarried but in relationship with a French girl. His mother is not looking any marriage proposal for him, instead waiting if he changes his mind.</p>
14	LG4	1981	<p>Parents have 1 son and 3 daughters. The eldest daughter is married with a guy from family's network. She is living separately from her parents with 3 children and husband. Her marriage case is under study.</p> <p>2nd is married with a guy from family's network. She lives separately from her parents. 3rd daughters are married with a guy from co-ethnic diaspora. She is also living separately from her parents. The youngest son is pursuing his studies.</p>
15	LP4	1982	<p>Parents have 1 son and 1 daughter. The daughter is married with a boy from out of her family's social network. She is living in a separate residence with her husband and 1 child. Her marriage case is under study.</p> <p>The eldest son is married with his paternal cousin.</p>
16	LM8	1974	<p>The family has 1 son and 5 daughters. The eldest daughter is married with her paternal cousin and is living separately from her parents along her 4 children, husband. The 2nd eldest daughter is married with a guy from outside the family's</p>

			<p>network. She is living with her parents. The marriage cases of both daughters are under study.</p> <p>3rd daughter is married with a Pakistani guy outside the family's network. Her family has boycotted her due to her marriage choices against parents 'will. 4th daughter is married with a co-ethnic boy and lives with her family-in-law. 5th daughter has completed his education and parents are looking her marriage proposal in co-ethnic diaspora. The son is married with a girl from his co-ethnic diaspora.</p>
--	--	--	---

ANNEXURE II

Interview Guide (Parents)

PART 1: MARRIAGE

- 1.1. Recall how did your marriages take place?
(Important points to know: Age at marriage, consent, marriage in relatives/caste/outside lineage, knowing & meeting the then-future spouse, engagement, rituals & celebrations, gift exchanges and dowry)
 - 1.2. Had you any preferences about your then-future spouse?
(Asking about the yearnings of marital life)
 - 1.3. Did (do) you tend to marry your children in the similar ways as it was in your case?
(To talk about marriages in communities other than Pakistani, if parents are open to talk; asking about love marriages and cohabitation)
 - 1.4. Please tell me how the marriage(s) of your son/daughter took place?
[To talk about the “Important points to know” as it was asked in the case of parents’ marriage (question: 1)]
- *** *In case if parent(s) directly indicate that son/daughter was not agreed to marry; ask if there were any pre-marriage discussions between parents and their children? If children later on agreed (or not); what strategies parents adopted to convince them?*
- 1.5. What were (are) your preferences for son/daughter-in-law?
 - 1.6. How do you find your relationship with your daughter/son-in-law?
Talking about the expectation, aspirations & fears about son/daughter-in-law (prior to marriage) and relationship nature (after marriage)

PART 2: Intergenerational Ties and Power Relationships in Family

- 2.1. Dwelling and composition of the family
Take the factual detailed information (about relationship, place of birth; France/elsewhere, if family members are dispersed in France/elsewhere ask about the reasons, age, sex, education, profession/job, marital status) of all family members [if the family is large and extended then make the genealogical tree of the family]

*** be careful to ask about 'the decision making' for son and daughter separately on the following 2, 3 & 4 questions)

- 2.2. Recalling the history of children's school life
Activates during educational life; outings/trips, get-togethers on week-ends, soirée spéciale, friendships, interruptions in the academic career
- 2.3. Experiences when children were (are) entering into adolescence?
Friendship and intermingling with opposite sex, travel to spend vacations with friends, leisure time activities, media exposure, dressing. To ask parental advices to son and daughter on the previously said activities; in case of disapproved by daughter/son; what (did) do you do [strategies to cope]? Who did (do) you talk to about children's disobeying behavior? (any intermediary(s))
- 2.4. Distribution of tasks among different family members
Shopping, payment and accompanying [grocery, household items, dress]; housework [cleaning, laundry, food preparation]; childcare.
- 2.5. Do you encourage discussions between all family members before taking final decisions regarding the issues discussed previously?

PART 3: Migration & Transnational Spatiality

- 3.1. Recall how did you migrate to France?
Reasons/events that led to migrate, age & marital status at the time of migration
- 3.2. How was your settlement experience in France?
Searching for job/business/labor, dwelling, language, networking, talking about the quartier and neighborhood, where respondent has been living until now.
- 3.3. At the beginning in France, what was your impression about France & about people's living styles?
- 3.4. How do you feel about living in France, now?
Social adjustment in French society/ethnic communities other than Pakistani; interests/participation in the activities/events organized by the local Mairie of your city / state and other communities.
- 3.5. Will (do) you plan to leave France and to go back to Pakistan permanently (In case "yes" ask about the reasons)
- 3.6. Being away from Pakistan, do you feel like lost?
Knowing about if the respondent has relatives here, member/founder of any overseas-based your ethnic community/association, interest/participation in the activities organized by these community/associations
- 3.7. Do you talk about Pakistan?

What do you talk about Pakistan? Who do you talk? What (did) do you tell to your children about Pakistan?

- 3.8. Is it important for you to maintain links with your origin country?
Maintain links via: visiting, phone calling, email, sending money, having property there, have founded/support any welfare / charity association /institute there, watching/reading Pakistani media, Speaking and teaching to children Pakistani national and/or local languages, political affiliations with Pakistani political parties,
- 3.9. Who did you leave behind in Pakistan?
Knowing about the nature & extent of responsibility, dependents and relationship with them, if helped someone from lived-behind to come to France.
- 3.10. Did (do) you visit Pakistan?
Asking about the purposes of visit and duration, gift exchanges
- 3.11. During the visit to Pakistan; do you talk about your daily life in France?
What do you tell them?
- 3.12. During the visit to Pakistan; do you talk also about France?
What do you talk about?

PART 4: Demographic Information

- 4.1. Family code
- 4.2. Sex
- 4.3. Age
- 4.4. Education
- 4.5. Profession/occupation/Business
- 4.6. Caste / Ethnicity
- 4.7. Geographic Origin in Pakistan
- 4.8. City of Residence in France
- 4.9. Current Residence Status (French citizenship/nationality)
- 4.10. Years in France
- 4.11. Personal Income
- 4.12. Family's total income

ANNEXURE III

Interview Guide (Children)

PART 1: MARRIAGE

- 1.1. Recall how did your marriages take place?
(Important points to know: Age at marriage, consent, marriage in relatives/caste/outside lineage, knowing & meeting the then-future spouse, engagement, rituals & celebrations, gift exchanges and dowry)
- 1.2. Do/did you have any preferences regarding an ideal life partner?
Preferences for your in-law family
- 1.3. How do you find your relationship with your spouse?
Talking about the expectation, aspirations & fears about the then-future spouse; relationship nature (after marriage); if intended to marry other way; love marriage; marriages in communities other than Pakistani, cohabitation

*** In case if children(s) directly talk that they were not agreed to marry; ask if there were any pre-marriage discussions between parents and them? If later on parents/children were convinced (or not); what strategies were employed?

***** For Daughter/son in-law**

- 1.4. How did you find your relationship with your in-law family after arriving in France?
Relationships (between husband/wife's sisters & brothers and you, between mother-in-law and you, between father-in-law and you)

PART 2: Intergenerational Ties and Power Relationships in Family

- 2.6. Dwelling and composition of the family
Take the detailed factual information (about relationship, place of birth; France/elsewhere, if family members are dispersed in France/elsewhere ask about the reasons, age, sex, education) of all family members
- *** be careful to ask about 'decision making' on the following 2, 3 & 4 questions)
- 2.7. Recalling the history of children's school life
Activities during educational life; outings/trips, get-togethers on week-ends, soirée spéciale, friendships, interruptions in the academic career.
- 2.8. Experiences when you were entering into adolescence?
Friendship and intermingling with opposite sex, travel to spend vacations with friends, leisure time activities, media exposure, dressing. To ask if there were parental advices on the previously said activities; what did you do [strategies

to cope]; parents (mother/father) were/was more prone to be authoritative or open-minded? who did you talk to about parents' authoritative behavior?

- 2.9. Distribution of tasks among different family members
Shopping, payment and accompanying [grocery, household items, dress]; housework [cleaning, laundry, food preparation]; childcare.
- 2.10. Did (do) discussions between all members (of family) are encouraged before taking the final decisions regarding the issues discussed previously?

PART 3: Migration & Transnational Spatiality

***Do not ask question 1, 2 & 3 if the son/daughter are born in France

- 3.13. Recall how did you migrate to France?
Reasons/events that led to migrate, age & marital status at the time of migration
- 3.14. How was your settlement experience in France?
Searching for job/business/labor, dwelling, language and networking, talking about the quartier and neighborhood, where respondent have been living until now.
- 3.15. At the beginning in France, what was your impression about France & about people's living styles?
- 3.16. How do you feel about living in France, now?
Social adjustment in French society/ethnic communities other than Pakistani; interests/participation in the activities/events organized by the local Mairie of your city / state and other communities.
- 3.17. Will (do) you plan to leave France and to go back to Pakistan permanently (In case "yes" ask about the reasons)
- 3.18. Being away from Pakistan, do you feel like lost?
Knowing about if the respondent has relatives here, member/founder of any overseas-based your ethnic community/association, interest/participation in the activities organized by these community/associations
- 3.19. Do you talk about Pakistan?
What do you talk about Pakistan? Who do you talk?
- 3.20. What (did) do your parents tell you about Pakistan?
- 3.21. Is it important for you to maintain links with your origin country?
Maintain links via: visiting, phone calling, email, sending money, having property there, have founded/support any welfare / charity association /institute there, watching/reading Pakistani media, Speaking and teaching to children Pakistani national and/or local languages, political affiliations with Pakistani political parties,
- 3.22. Who did you leave behind in Pakistan?

Knowing about the nature & extent of responsibility, dependents and relationship with them, if helped someone from lived-behind to come to France.

3.23. Did (do) you visit Pakistan?

Asking about the purposes of visit and duration, gift exchanges

3.24. During the visit to Pakistan; do you talk about your daily life in France?

What do you tell them?

PART 4: Demographic Information

4.13. Family code

4.14. Sex

4.15. Age

4.16. Education

4.17. Profession/occupation/Business

4.18. Caste / Ethnicity

4.19. Geographic Origin in Pakistan / France

4.20. City of Residence in France

4.21. Current Residence Status (French citizenship/nationality)

4.22. Years in France

4.23. Personal Income

4.24. Family's total income

ANNEXURE IV

RESUME DETAILLE

1. Introduction

« Se marier au pays » est une pratique transnationale courante parmi la diaspora pakistanaise (Rytter 2012; Moliner 2012; Nadim 2012; Iqbal 2009; Charsley 2007; Singla 2006), que nous nommerons ici mariage transnational : elle sera l'objet de cette étude. Ce type de mariage est défini par Charsley comme « un mariage de relation durable – c'est-à-dire inscrit dans des réseaux transnationaux actifs – entre personnes résidant dans des États différents » (2012:19). La France connaît une immigration liée au mariage induisant une circulation et une présence alternative régulière entre les pays d'accueil et d'origine. Ce processus implique que ces immigrants suscitent échanges et rapprochements entre les normes culturelles des deux nations. Ceci contribue à former des dissensions voire une opposition entre les générations, comme le souligne Abou-Zahab (2007) s'agissant des enfants d'immigrés pakistanais nés en France. Ces mariages transnationaux constituent un objet de controverse majeur car considérés comme une menace pour la souveraineté nationale (Cole 2014; Kringelbach 2013) dans une approche paradoxale en termes d'intégration entre nationaux et étrangers (Ballard 2008). La question de l'installation et de l'intégration des Pakistanais en France est peu abordée par la recherche (Abou-Zahab 2007; Hanif 2007; Krieger-Krynicky, 1993 & 1989), et on sait très peu de choses sur leur comportement vis-à-vis du mariage qu'ils ont acquis dans un processus de socialisation différent dans les deux pays. Notre travail étudie pour la première fois l'institution du mariage des immigrants pakistanais en France. Il importe de souligner ici que la société pakistanaise n'est pas culturellement uniforme notamment pour ce qui concerne les pratiques et traditions du mariage. Les différences ne sont pas uniquement parmi les Pakistanais

mais elles existent également avec le système matrimonial propre à la diaspora du Sud-Est asiatique. Dès lors, le terme générique de « Pakistanais » interdit de saisir la diversité ethnique propre aux immigrés issus de ce pays (Shaw, 2001). Aussi notre recherche est-elle centrée sur la diaspora originaire du Punjab installée en France.

Dans le contexte culturel de cette région du Pakistan, l'institution matrimoniale est une affaire qui concerne l'ensemble de la famille (Muhammad 2008; Qadeer 2006) et qui suppose de ce fait des critères déterminants de sélection du futur conjoint. De tels critères sont susceptibles d'induire des conflits ou des accords entre enfants et parents quant à savoir avec qui se marier ainsi que le lieu, la date et le contenu de la cérémonie. Dès lors, il s'avère pertinent d'examiner les intérêts et motivations des couples autant que des familles dans ce contexte transnational. Aussi, dans cette perspective, nous nous focaliserons sur la manière dont les époux sont sélectionnés et les mariages organisés entre familles pakistanaises installées en France et leurs homologues au pays. Prenant en compte les acteurs (le couple et leurs parents respectifs) et leur rôle en la matière, notre recherche analyse la manière dont la pertinence du choix du conjoint est négociée entre les deux générations. Quels sont les éléments d'équivalences, de différences, voire d'ambivalences, entre les parents, avec les enfants à marier, et le reste de la famille quant aux références pour le choix du conjoint ? Comment la décision du mariage est-elle prise respectivement par les parents et les enfants ?

Afin de répondre à ces questions, la recherche porte son regard sur le mécanisme systémique d'organisation du mariage transnational au sein des familles pakistanaises en France. Dans cette perspective, le premier objectif consiste à rendre compte de la manière dont l'espace social dans lequel les futurs conjoints possibles est délimité. La seconde démarche consiste à identifier les critères de sélection du conjoint propres aux parents et aux enfants. En troisième lieu, la recherche rend compte du processus de sélection effectif permettant de trouver les futurs conjoints éligibles recelant les caractéristiques adéquates. Elle examine le processus de prise de décision pour lequel les deux générations négocient la correspondance des conjoints avant de se décider effectivement le mariage, et quels facteurs entrent en ligne de compte en la matière. La quatrième étape

entreprind de saisir la cérémonie des mariages transnationaux et notamment de voir si elle est affectée par les effets de la migration. Le cinquième point consiste à analyser les évolutions des structures familiales et de celles de l'organisation du ménage, concernant notamment une éventuelle redéfinition des relations de genre et entre générations.

2. Méthodologie de la recherche

La recherche a débuté par une exploration de la littérature scientifique existante sur le choix du conjoint, les idéologies du genre, les structures de parenté et les expériences migratoires. Pour bien saisir le caractère fort complexe des relations interpersonnelles croisées entre genres et entre générations, une approche flexible et exhaustive s'avère nécessaire : des entretiens approfondis ont représenté la meilleure option dans cette perspective. Le mariage impliquant une migration matrimoniale entre les pays, il est indispensable de comprendre les circonstances et les motivations de ces mouvements. Pour saisir le processus matrimonial, il convient en outre de bien prendre en considération les familles en correspondance pour chaque union, compte tenu de leur différences d'environnement national et socio-culturel. Aussi une enquête de terrain multi-sites s'est avérée nécessaire pour aller au-delà de l'approche unilatérale dans le pays d'accueil qui prévaut dans la plupart des travaux sur les mariages transnationaux. Ma recherche vise à dépasser cette limite heuristique en mettant en perspective les deux sociétés. Il s'agit donc d'analyser les flux migratoires matrimoniaux dans leur double dimension et dans les deux sens du mouvement. Le terrain multi-sites est situé dans 16 villes d'Île-de-France et 19 villes et villages du Punjab pakistanais, tous les enquêtés appartenant à la culture punjabie. Le recueil de données a débuté en décembre 2012 et s'est achevé en mars 2014, il s'est déroulé en trois phases en France et au Pakistan. Dans le contexte culturel pakistanais, le mariage est une affaire collective au sein de la famille et il s'agit d'une alliance entre deux familles plutôt que deux individualités : dès lors, les deux époux et leurs familles respectives ont également été interrogés afin de bien comprendre le mécanisme des unions transnationales. Ainsi, au moins quatre entretiens approfondis ont été effectués dans chaque

famille : les deux époux et au moins un parent de chacune de leurs familles respectives. L'échantillon totalise 18 cas d'histoires de mariage.

Les entretiens ayant pour principe de faire un compte rendu très personnel des histoires de famille et des mariages, cela a suscité quelque inquiétude chez les enquêtés, lorsqu'ils évoquaient la nature de leur relation. Bien que je sois originaire du même pays, il était néanmoins malaisé de pénétrer une communauté immigrée connue pour son caractère discret et fermé. D'un côté, le fait que je sois moi-même pakistanaise, musulmane et punjabis, partageant les fondements culturels avec les enquêtés pouvait constituer un avantage. Il n'en restait pas moins, d'un autre côté, une interrogation quant au fait que je sois une chercheuse et une étrangère à leur communauté car je n'étais pas intégrée aux réseaux de relations sociales de celle-ci. Ils n'ont pas considéré comme allant de soi ma position de membres de leur culture : je gardais statut d'« étrangère ». Dès lors, les premières tentatives pour recueillir des données fut un échec. J'ai dû emprunter différentes voies pour traiter le problème consistant à acquérir leur confiance. Pour que ma présence devienne familière aux familles pakistanaises, je me suis installée dans le département de Seine-Saint-Denis où celles-ci sont nombreuses. Je me suis inscrite dans différentes associations culturelles, religieuses et politiques de Pakistanais d'origine, qui jouent un rôle majeur dans la vie collective de cette communauté. Une présence régulière s'étalant sur plusieurs mois m'a permis d'être facilement reconnue plus directement par les enquêtés éligibles. Certains d'entre eux ont été contactés par l'intermédiaire de conseillères matrimoniales, par la participation dans des groupes basés sur des sites de réseaux sociaux et à travers des réseaux personnels de quelques amis.

3. Les mécanismes du mariage transnational

Pour qu'un mariage soit socialement, légalement et religieusement acceptable, cela suppose de donner suite à une volonté de rencontrer et de développer une famille au Pakistan. Par ailleurs, pour conserver sa sacralité, l'institution du mariage s'appuie sur une série de pratiques et de comportements sociaux. Le mariage est considéré comme une relation durable et on dissuade dès lors de divorcer : la

proportion de personnes divorcées parmi les époux était en 1998 de 1,7 % pour les femmes et 1 % pour les hommes, selon le dernier recensement du Pakistan. De plus, le fait d'être marié constitue une norme universelle, 95 % de la population ayant été mariés au moins une fois à l'âge de 49 ans selon ce même recensement. À l'instar des pays voisins du Sud-Est asiatique, le Pakistan subit une transition en matière de nuptialité liée à l'éducation, à l'emploi, à l'urbanisation, à l'évolution des idéologies relatives au genre, et aux configurations structurelles de l'organisation familiale et du mariage suite au processus migratoire.

Le choix du conjoint est généralement défini par deux ensembles de règles maritales : la prééminence de l'endogamie et la rareté de l'exogamie. L'institution du mariage au Punjab induit certaines règles quant au choix du conjoint. Certaines personnes peuvent être considérées comme des conjoints éligibles et d'autres non et c'est ce que l'on appelle en termes sociologiques « le périmètre des conjoints éligibles ». Le premier ressort social de ce périmètre renvoie à l'endogamie à l'intérieur des différentes couches du système de parenté punjabi, et en second lieu, à l'exogamie au sein et à l'extérieur des réseaux sociaux transnationaux. Le schéma n°1 permet de mieux comprendre le périmètre des conjoints dans les familles pakistanaises immigrées enquêtées.

Schéma n°1. Périmètre des conjoints préférentiels au sein et à l'extérieur de la parenté

	Famille Code	Périmètre des conjoints	Le couple		
			Conjoint en France	Conjoint venant du Pakistan	
1	Famille VP5	Parenté proche	Matrilatéral	Epoux	Fille de la tante maternelle
2	Famille LC4		Matrilatéral	Epoux	Fille de la tante maternelle
3	Famille VG4		Matrilatéral	Epouse	Fils de l'oncle maternel
4	Famille OZ5		Agnatique	Epouse	Fils de l'oncle paternel
5	Famille AB4	Parenté élargie	Agnatique	Epouse	Fils du cousin du père
6	Famille VB4		Agnatique	Epouse	Fils du cousin paternel
7	Famille CO6		Agnatique	Epoux	Fille du cousin paternel
8	Famille VI4		Agnatique	Epoux	Fille du cousin paternel
9	Famille PI3		Agnatique	Epouse	Fils du cousin paternel
10	Famille SD5		Agnatique	Epoux	Fille du cousin maternel
11	Famille TR4		Apparenté	Epoux	Sœur de la femme du frère
12	Famille SC5		Apparenté	Epoux	Fille de la belle-sœur de l'oncle maternel
13	Famille CB4	Exogamie	Au sein du réseau social	Epouse	Fils de l'ami d'un ami du père
14	Famille LG4		Au sein du réseau social	Epouse	Fils d'un ami du père
15	Famille LP4		Hors relations sociales	Epouse	Epoux issu d'une famille sans lien
16	Famille LM8		Hors relations sociales	Epouse	Epoux issu d'une famille sans lien

3.1. L'endogamie de parentèle : critère premier du choix du conjoint

Le périmètre idéal de conjoints éligibles renvoie à différentes couches au sein de la parenté au Punjab. La parentèle proche inclut les cousins matrilatéraux et patrilatéraux. La bienveillance mutuelle au sein des fratries permet des relations réciproques en leur sein. De telles relations bien entretenues constituent les

fondements permettant d'organiser des mariages endogames. Des relations familiales proches inspirent confiance et les proches sont donc sollicités pour orienter les choix des enfants au sein des familles immigrées. En outre, les questions de la transmission et du maintien de la propriété dans la famille constituent un élément déterminant dans le choix du conjoint à l'intérieur d'un périmètre de la parentèle. Les mariages à l'intérieur d'une parentèle proche engendrent des conflits lorsqu'une proposition de mariage est formulée simultanément par deux membres d'une fratrie ou lorsque la proposition du mariage ne constitue pas une réussite comme prévu. Les plus anciens membres de la famille interviennent pour mettre fin au conflit ou du moins pour réduire le niveau de tension. Dès lors qu'un conflit n'est pas résolu, que la confiance relationnelle est rompue ou qu'il n'existe pas de conjoint éligible au sein de la parentèle rapprochée, le périmètre s'agrandit et inclut la parenté élargie.

Ainsi étendu à la parenté élargie, le périmètre couvre des relations agnatique (une généalogie est agnatique lorsqu'elle ne prend en compte que les hommes) ou des relations d'apparentés (les relations alliées par le mariage). Les familles immigrées ayant des ressources préfèrent élaborer des réseaux transnationaux de parenté et encouragent le choix du conjoint à l'intérieur de ce groupe dont elle vise à maintenir la cohésion de la sorte. La réitération de mariage de ce type construit un réseau interfamilial très solide et cela contribue à promouvoir l'idée que le choix du conjoint en son sein constitue une ressource et qu'on doit y avoir recours. Pour les enquêtés, le choix du conjoint dans un cercle élargi est également lié à l'évitement des risques biologiques liés à une proximité génétique. Les mariages successifs au sein des familles repoussent les limites du périmètre des conjoints éligibles. La nature des relations des parents et des enfants au sein de la parenté contribue à cette extension. Ceux qui ont une expérience malheureuse de mariage endogamique préfèrent chercher les conjoints à l'extérieur de la famille. La recherche de conjoints en dehors de la parenté pose un clivage très marqué entre les familles connues et celles qui ne le sont pas. Les familles appartenant au réseau social inspirent davantage confiance pour établir des alliances matrimoniales. L'existence de relations amicales entre les deux familles facilite le recours à l'exogamie.

Les conjoints choisis à l'extérieur du réseau des relations sociales font l'objet d'une évaluation très rigoureuse parce qu'ils ne sont pas connus de la famille et de l'absence de confiance qui en résulte. Les cas de conjoints choisis en dehors du cercle de connaissances sont liés à différentes circonstances spécifiques : les conjoints sont présentés par les enfants eux-mêmes, les parents ne sont pas satisfaits des relations qu'ils entretiennent avec leurs proches ou bien il existe des conflits passés au sujet de propositions de mariage. La perspective d'alliances avec une famille inconnue constitue la situation la moins appréciée. Il convient de noter ici que la référence à la caste n'intervient pas dans ces alliances exogames. En effet, quand une famille recherche des conjoints à l'extérieur de la parenté, la reconnaissance et la valeur sociales de la famille de conjoint potentielle précèdent toute préférence de caste.

Une fois les critères principaux de choix du conjoint sont satisfaits, le processus de mariage transnational franchit une seconde étape où les conjoints éligibles sont sélectionnés au moyen de critères de préférence complémentaires.

3.2. Les caractéristiques du conjoint : critères de sélection complémentaires

Ces critères renvoient principalement aux caractéristiques socio-économiques et aux comportements des prétendants. Les principales caractéristiques prises en considération sont le niveau d'études, l'âge et le différentiel d'âge entre conjoints, la moralité, la responsabilité parentale sur l'enfant mâle (qui est également attendue de la belle-fille après le mariage), le comportement relatif aux valeurs relevant de la tradition et de la modernité, et les valeurs associées à l'appartenance à des familles transnationales.

Tous ces critères ne sont toutefois pas partagés de même façon entre les deux sexes, entre les générations et selon le pays de résidence. En premier lieu, les obligations de loyauté familiale impliquent que la famille établie dans un pays étranger redéfinisse ses stratégies en fonction des entraves croissantes à l'immigration, alors que la famille restée au Pakistan est susceptible de considérer le mariage comme une opportunité de migration. En second lieu, les inégalités socio-économiques entre la France et le Pakistan mettent la famille émigrée en

position avantageuse, dotée d'un statut plus prestigieux vis-à-vis du pays d'origine, ayant ainsi un surcroît de pouvoir de négociation au sein du marché matrimonial local par rapport à d'autres membres de la famille. Troisièmement, les relations de genre et intergénérationnelles sont en pleine évolution, non seulement dans les pays d'accueil mais aussi parmi les familles immigrées : des hommes et les femmes appartenant aux générations des parents et des enfants, bien qu'ils diffèrent dans leurs préférences matrimoniales, adoptent des stratégies différentes pour influencer leur processus de décision matrimonial.

3.3. Choisir le bon conjoint : négociations et décisions

Il existe trois principaux moyens pour décider du conjoint le plus approprié. En premier lieu, le moyen qui inspire le plus de confiance : le choix est effectué par les parents et les anciens de la famille qui sont supposés, dans la tradition, chercher un conjoint pour leurs enfants et ensuite initier des discussions intergénérationnelles. Les accords formels et informels au sujet de leur mariage jouent un rôle décisif dans la formation de l'esprit des enfants en la matière. Deuxièmement, les enfants eux-mêmes contribuent fortement à établir des relations par leurs choix personnels et soumettre des propositions de mariage à leurs parents. Quand les enfants choisissent leur conjoint, ils doivent passer par l'approbation de leurs parents. Le troisième moyen de réunir des conjoints consiste à solliciter des conseillères matrimoniales, sur un mode traditionnel ou sur un mode moderne (Offrant la possibilité de rencontrer les deux conjoints seuls avant le mariage.). Cette dernière option est toutefois celle qui inspire le moins confiance et donc la moins pratiquée.

Notre recherche a identifié quatre stratégies différentes qu'utilisent les familles pakistanaises immigrées en France afin de négocier le mariage et le conjoint adéquats. En premier lieu les potentialités en termes d'exercice des obligations et des responsabilités familiales sont évaluées compte tenu des capitaux socio-économiques des individus et de leurs familles. Ce sont ces caractéristiques prioritaires que parents et enfants doivent garantir à leurs familles. Ils évaluent non seulement les attributs personnels de conjoint mais aussi ceux de la famille, pour développer ainsi un consensus sur le processus de sélection des conjoints. Cette

stratégie illustre principalement que les parents et les enfants peuvent formuler leurs choix rationnellement sans se livrer nécessairement à aucun conflit

En second lieu, si les deux générations sont en désaccord sur les préférences, des parents proches interviennent comme médiateurs et orientent parents et enfants pour rapprocher leurs choix. Nous avons observé que des préférences incompatibles entre parents et enfants contribuent à forger des fractures intergénérationnelles allant parfois jusqu'à la rupture. Dans ce cas, l'intervention des parents proches oriente parents et enfants vers une redéfinition dans leur choix du conjoint. Un exemple de désaccord est celui du cas où le fiancé présent n'est pas originaire du Pakistan. L'union n'est pas considérée comme acceptable par les parents qui estiment que le mariage doit maintenir des liens avec le pays d'origine. De la même manière, les enfants nés et élevés dans des valeurs culturelles et idéologiques différentes voire opposées entre celles qui prévalent en France et au Pakistan, font valoir leurs conceptions du conjoint idéal. La combinaison de résistance, d'exercice de l'autorité et d'intervention de la parentèle illustre la manière dont les relations de parenté sont réaffirmées durant les occasions de sélection des conjoints.

Troisième aspect, les expériences passées de mariage au sein de la famille contribuent à modifier des futures décisions. De la même manière, les expériences de mariage des parents et de leurs frères ou sœurs peuvent amener à redéfinir la figure de l'époux idéal dans la relation intergénérationnelle. Sans ignorer l'opposition entre tradition et modernité et sans reprendre à notre compte la thèse postule que, s'agissant des familles pakistanaises immigrées, ce choix se réalise dans un environnement culturel hybride. Les rationalités premières du choix du conjoint s'opèrent en priorité dans une configuration générale du mariage au sein de la parenté. Les critères complémentaires assurent que les caractéristiques recherchées pour le conjoint idéal ne sont pas en contradiction avec les attentes propres à la culture de la société d'accueil mais également de la culture d'origine. Une fois que les conjoints éligibles sont identifiés, les parents et leurs enfants entrent dans une étape de négociation quant au choix de l'époux idéal parmi ceux-ci, avant de finaliser la décision de demande en mariage.

3.4. La cérémonie de mariage transnational

Dans le cas d'une seule cérémonie, le mariage typique pakistanais punjabi se divise en deux rituels, avant et après la cérémonie de mariage et peut ensuite se poursuivre jusqu'à quatre jours consécutifs. Il y a d'abord le jour de *rasm-e-henna* (l'application du *henna*), puis un deuxième jour du *barat*, c'est-à-dire de la procession de mariage, la troisième journée est celle du *walima* (le repas de mariage offert aux parents du marié), le quatrième et dernier jour étant consacré au *maklawa*, durant lequel les parents du marié se rendent chez ceux de la mariée pour ramener le couple chez lui. Dans les cas où les mariages de plusieurs membres d'une fratrie sont organisés simultanément, les cérémonies de mariage s'étalent sur plusieurs jours.

L'organisation de mariages transnationaux présente plusieurs aspects majeurs. Tout d'abord, les cérémonies répondent aux caractéristiques typiques des mariages traditionnels pakistanais, découpés en cérémonies préalable et postérieure au mariage en lui-même. La mise en œuvre de ces coutumes et rituels traditionnels vient marquer l'enracinement de la relation avec le pays d'origine. Les familles préfèrent se rendre au Pakistan pour célébrer les mariages car, d'une part, le conjoint choisi (du Pakistan) y réside et d'autre part, cela permet à l'ensemble de la famille de profiter des joies de la cérémonie. En effet, la participation de la famille étendue constitue un élément central pour maintenir des relations réciproques et par conséquent la cohésion familiale.

Par ailleurs, la multiplication de certaines pratiques et de certains rituels est observable dans ce type de mariages transnationaux, comme lorsque les fêtes de mariage que sont le *henna* et le *walima* sont célébrées deux fois de suite, une fois au Pakistan puis une autre en France. Le repas offert lors des cérémonies en France mélange les goûts culinaires français et occidentaux car une partie des invités est issue de familles pakistanaises avec qui la famille a développé des relations de réciprocité matrimoniale.

Enfin, du fait du caractère transnational de ces unions, plusieurs modifications ont été introduites dans le rituel et dans les coutumes, notamment quant aux festivités, telles qu'offrir des repas très copieux et développer de nouvelles formes de relations réciproques. Les familles installées en France disposent d'un statut économique

plus enviable et dès lors dépensent davantage pour la cérémonie de mariage par rapport à leurs homologues restés au Pakistan. Quand les mariages sont organisés entre les enfants issus d'une même fratrie, la famille installée en France propose le plus souvent de l'argent aux frères ou sœurs restés au Pakistan afin qu'ils puissent organiser une cérémonie plus somptueuse. Dans le cas où la fratrie est très démunie économiquement, la famille émigrée endosse toutes les dépenses qu'impose la cérémonie.

Autre point, la famille de la future épouse prend en charge la fonction d'échange de présents. En effet, la cérémonie de mariage doit faire porter le projecteur sur la famille de l'épouse afin de montrer à quel point elle est active et a les capacités à prendre certaines décisions dans le processus de choix du conjoint et dans la réalisation de cette cérémonie. Une analyse fine des rituels et coutumes de telles cérémonies indique que les mères et les filles sont beaucoup plus actives que les pères et les fils dans ce processus de préparation des cérémonies du mariage.

4. Les effets de la tradition et de la transition sur la famille et le foyer

Plusieurs stratégies sont utilisées pour maintenir la forme traditionnelle des relations de genre et des relations intergénérationnelles, la socialisation en constituant la forme la plus importante. Il existe ainsi des différences entre les familles enquêtées dans l'éducation qu'elles donnent à leurs enfants, afin de transmettre les valeurs culturelles de la famille, du mariage et des rapports sociaux hiérarchiques. Certaines préfèrent envoyer leurs enfants au Pakistan. D'autres s'appuient sur les associations culturelles et religieuses de la diaspora pakistanaise, ou ont recours aux nouvelles technologies de la communication afin de se rendre au Pakistan pour une courte période annuelle, dans une visée éducative. La réussite d'une telle éducation est tout à fait incertaine et ne peut pas être mesurée. Néanmoins, les deux générations se réfèrent à deux éléments majeurs pour caractériser leurs relations mutuelles : l'autorité et le respect. La relation entre les deux générations dépend du statut et de la position des parents et de leurs enfants dans un certain contexte. Les parents semblent tout faire pour conserver leur pouvoir de décision provenant de l'idéologie culturelle d'origine alors que leurs enfants tendent à

remettre en question les principes d'autorité et de respect. Chaque partie semble attribuer des valeurs différentes quant à la manière d'exercer l'autorité et quant à ce que signifie le respect. Ils suivent des chemins différents pour atteindre l'objectif partagé de fonder une bonne famille. En effet, l'enjeu de famille reste la principale préoccupation pour les deux générations. Quand la génération des parents tente d'intervenir sur le mode d'éducation parentale, les différences de définition du rôle paternel ou maternel surgissent. La génération des enfants a souvent connu des pères dont le rôle a consisté à procurer des ressources économiques plutôt que s'occuper des enfants. Elles ont davantage à voir avec la différence des expériences et des difficultés rencontrées lors de la période de migration, d'installation et l'évolution des facilités modernes offertes par la société d'accueil. Les belles-mères en France tendent à vouloir exercer un rôle de modèle pour les petits-enfants tandis que leurs belles-filles venues du Pakistan ont une conception différente de l'éducation. La volonté de bien faire des belles-mères est acceptée, les belles-filles ne souhaitant pas se mettre en difficulté tant que leur mari subvient aux besoins de la famille.

Les jeunes hommes (quelle que soit leur origine) adoptent une division du travail genrée au sein de leur foyer, où la responsabilité féminine consiste à s'occuper des enfants, à préparer les repas et endosser les principales activités domestiques. Du fait de l'immigration, les épouses réalisent des tâches supplémentaires que constituent les courses et la scolarisation des enfants. Ces épouses ayant été élevées dans les familles plutôt traditionnelles au Pakistan, elles acceptent cette division du travail davantage que les filles des familles immigrées en France dans l'enfance. Dès lors, on observe moins de conflits au sein du couple et entre belles-mères et belles-filles venues en France pour se marier.

Les filles de familles installées en France sont quant à elles beaucoup plus autonomes et attendent une autonomie de la part de leur mari. Dès que le couple ou le gendre devient autonome, ils s'installent dans leur propre logement. Il peut alors surgir un retour des idéologies traditionnelles en termes de hiérarchie, qui suscite alors des tensions au sein du couple auxquelles viennent s'ajouter les responsabilités affectives et financières du mari vis-à-vis de sa famille restée au pays. Le mariage transnational élargit les contours de la famille. Les obligations et

les responsabilités des gendres vis-à-vis de la famille d'origine au Pakistan les mettent en position relativement vulnérable, en particulier lorsque les familles se trouvent en opposition. Dans le cas où le gendre appartient à une famille étrangère au périmètre d'éligibilité traditionnel, les conflits ont d'autant moins de chance d'être résolus, à l'inverse des cas où les mariages sont conclus au sein d'une proximité de parentèle, les conflits y étant plus faciles à résoudre.

Conclusion

L'analyse des processus de mariage transnational constitue un véritable défi du fait de la variété ethnique et celle des dynamiques du mariage que rencontre la diaspora pakistanaise. Afin de rendre compte au mieux des mécanismes en jeu en la matière, Je me suis concentrée que sur l'ethnicité punjapie et j'ai commencé par décrire les principes de base du choix du conjoint à l'intérieur et à l'extérieur des réseaux familiaux. Ensuite, les critères préférentiels primaires et complémentaires des parents et de leurs enfants dans la sélection du conjoint ont été envisagés. Ont été ensuite discutées les conditions de déroulement des négociations familiales dans l'identification des conjoints éligibles et la finalisation de la décision. Les phases postérieures au mariage ; par exemple, le choix de la résidence, et les dynamiques de la tradition et de la transition dans la famille, présentent des effets très importants, notamment sur les structures de la famille, des relations familiales et notamment quant aux liens entre genres et entre générations.

Malgré les difficultés et la complexité que cette recherche a présentées, nous sommes néanmoins parvenus à des conclusions importantes. Premièrement, les frontières et les distances ne sauraient être considérées comme un alibi pour marginaliser la définition de la famille la définition de la famille. Les premières générations de migrants punjabi sont arrivées du Pakistan avec l'intention de retourner au pays après avoir gagné suffisamment d'argent pour subvenir aux besoins de leur famille restée au pays. Bien que la plupart n'ait jamais pu y retourner, elles prennent néanmoins celle-ci toujours en considération. Elles maintiennent des liens notamment avec leur fratrie et leurs enfants, par le lien du mariage.

En second lieu, les choix du conjoint sont consciemment réalisés sur la base de plusieurs critères primaires et complémentaires. Notre étude démontre que la persistance d'une endogamie de parenté au sein des mariages transnationaux est fortement installée dans la socialisation primaire des enfants des familles migrantes qui les assistent dans le processus de choix du conjoint. Plus largement, les parents migrants préparent leurs enfants aux prémices de leurs relations matrimoniales, non seulement en identifiant le périmètre des choix possibles mais aussi en les orientant régulièrement vers de tels choix. Malgré des configurations migratoires différentes, une grande majorité des enquêtés a fait le choix de l'endogamie au sein de sa parenté. Leur stratégie en la matière, constitue des projets pour la vie entière qui sont plus ou moins enracinés dans les valeurs culturelles de leur pays d'origine. Elle renforce la croyance que les futurs conjoints – notamment issus du pays d'origine quand ils sont membres du réseau de parenté – sont mieux à même de correspondre à leurs attentes domestiques et familiales. Les liens transnationaux maintenus depuis l'enfance de leur progéniture contribuent à convertir ces relations réciproques avec leur parenté en vue d'alliances qui unissent les enfants qui ont grandi ici et là-bas. De la sorte, cela leur permet non seulement de maintenir et de perpétuer des liens avec leur famille restée au pays mais aussi de préserver leur culture d'origine dans la société d'accueil en créant des espaces sociaux transnationaux.

Troisièmement, ces espaces ainsi créés font évoluer la nature et la dynamique des relations de genre, considéré généralement dans une perspective patriarcale. Plutôt que d'analyser simplement des relations en termes de position dominante ou de subordination, cette recherche s'est davantage intéressée aux circonstances et au positionnement des hommes et des femmes concernant le choix du conjoint et la division du travail au sein des foyers transnationaux. Elle affirme que les positions dominantes dans le mariage transnational sont variables selon les générations et ne peuvent être considérées comme intangibles pour un acteur particulier impliqué dans cette situation de mariage. Dans le cas où le conjoint, nonobstant son genre, est un Pakistanais né en France, il ou elle détient une position hégémonique dans la relation maritale. Celui qui vient du Pakistan tend à considérer sa position comme plus vulnérable en cas de différend, ce qui le met en délicatesse quand bien même

sa position dominante pourrait être protégée par la culture d'origine. De la sorte, les inégalités de genre sont le plus souvent déterminées par la position de domination et de subordination liée au contexte de socialisation du conjoint, en France ou au Pakistan.