



HAL
open science

Challenging the "Demand Driven MRP" Promises : a Discrete Event Simulation Approach

Romain Miclo

► **To cite this version:**

Romain Miclo. Challenging the "Demand Driven MRP" Promises : a Discrete Event Simulation Approach. Modeling and Simulation. Ecole des Mines d'Albi-Carmaux, 2016. English. NNT : 2016EMAC0016 . tel-01673811

HAL Id: tel-01673811

<https://theses.hal.science/tel-01673811>

Submitted on 1 Jan 2018

HAL is a multi-disciplinary open access archive for the deposit and dissemination of scientific research documents, whether they are published or not. The documents may come from teaching and research institutions in France or abroad, or from public or private research centers.

L'archive ouverte pluridisciplinaire **HAL**, est destinée au dépôt et à la diffusion de documents scientifiques de niveau recherche, publiés ou non, émanant des établissements d'enseignement et de recherche français ou étrangers, des laboratoires publics ou privés.

Université Fédérale



Toulouse Midi-Pyrénées

THÈSE

En vue de l'obtention du

DOCTORAT DE L'UNIVERSITÉ DE TOULOUSE

Délivré par :

École Nationale Supérieure des Mines d'Albi-Carmaux

Présentée et soutenue par :

Romain MICLO

le mercredi 7 décembre 2016

Titre :

Challenging the "Demand Driven MRP" Promises:
a Discrete Event Simulation Approach

École doctorale et discipline ou spécialité :

EDSYS : Génie Industriel 4200046

Unité de recherche :

Centre Génie Industriel - École des Mines d'Albi-Carmaux

Directeur/trice(s) de Thèse :

Matthieu LAURAS

Jacques LAMOTHE

Jury :

Pierre BAPTISTE, Professeur, École Polytechnique de Montréal, Rapporteur

Steven MELNYK, Professeur, Michigan State University, Rapporteur

Patrick BURLAT, Professeur, École des Mines de Saint-Etienne, Président

Philippe BORNERT, PDG de AGILEA, Examineur

Carol PTAK, Ingénieur, Demand Driven Institute, Examinatrice

Franck FONTANILI, Maître assistant, École des Mines d'Albi-Carmaux, Co-encadrant

Matthieu LAURAS, Maître assistant HDR, École des Mines d'Albi-Carmaux, Directeur

Jacques LAMOTHE, Professeur, École des Mines d'Albi-Carmaux, Co-Directeur

REMERCIEMENTS

Un travail de thèse de 3 ans peut très certainement paraître fastidieux ou déroutant. Je ne pourrais pas dire que ça n'est jamais arrivé, mais dans mon cas ce que je retiens réellement de ces 3 années est un formidable enrichissement personnel et professionnel. Ce travail, je ne l'ai pas mené seul, c'est pourquoi j'aimerais remercier ici quelques personnes qui ont contribué à ce que je considère être une réussite.

Je veux tout d'abord remercier mon jury, et quel jury j'ai eu l'occasion d'avoir lors de cette thèse ! I thank Pierre Baptiste and Steven Melnyk for having reported the thesis and for giving me such relevant questions and ideas for further research that I would be honoured to also explore with you.

I also thank Carol Ptak for accepting to come for this PhD and for her accurate questions and advices to keep on researching on DDMRP.

Merci enfin à Patrick Burlat d'avoir accepté de présider ce jury de thèse ainsi que pour ses remarques avisées. Je te remercie également pour l'intérêt que tu as pu avoir sur mon travail tout au long de la thèse.

Si j'ai réussi à soutenir ce travail et avoir du plaisir lors de ces 3 années, c'est en grande partie grâce à la qualité de l'encadrement dont j'ai pu bénéficier.

Franck, je te remercie pour tout le temps et l'énergie que tu as dépensés lors de ces 3 années ainsi que pour la passion sur de nombreux sujets que tu as su me transmettre.

Jacques, ta créativité hors norme ainsi que ta rigueur scientifique sur de nombreux points m'ont été nécessaires : je te remercie pour tout cela¹.

Guillaume, merci pour m'avoir suivi depuis mon arrivée chez Agilea et pour le point d'honneur que tu mettais à être disponible à chacune de mes sollicitations (à n'importe quelle heure du jour, de la nuit ou du week-end).

Matthieu, je voudrais te remercier pour ton suivi lors de ces dernières années, mais pas seulement. C'est un réel plaisir de t'avoir eu en tant que directeur, avec ta capacité à arbitrer sur l'orientation et la manière d'atteindre les objectifs fixés qui m'impressionne encore maintenant, le tout en mettant en confiance les gens avec lesquels tu travailles. Et ça n'est qu'une partie des raisons qui me réjouissent de continuer à travailler avec toi.

Si j'ai pris autant de plaisir à faire cette thèse, c'est en grande partie grâce aux qualités humaines des personnes d'Agilea et du centre Génie Industriel à Albi.

D'abord, merci Philippe pour m'avoir suivi, pour ta bienveillance ainsi que pour la confiance que tu m'as accordée depuis mon arrivée chez Agilea et pour ta conviction profonde sur les intérêts de la recherche. Pour réussir il faut un esprit saint dans un corps saint, merci Agathe de m'avoir permis de limiter l'écart entre les 2 avec ces nombreuses séquences de squash. Je veux particulièrement remercier les jeunes d'Agilea (Agathe, Thomas, Clémence, Noémie et

¹ : Je te remercie également pour l'extrême rigueur que tu as pu avoir dans le suivi de ton thésard lors des conférences et essentiellement des repas où on a pu échanger sur de nombreux points ☺

également Kevin pour sa foi en la recherche) qui m'ont particulièrement soutenus et avec qui c'est une vraie joie de travailler ! Je remercie les associés et les plus anciens d'Agilea que je n'ai pas hésité à solliciter (Damien, Pascal, Bernard, Anthony, Vincent) et tous les autres de l'équipe (Liudmila, Agnès, Isabelle, Camille, Thomas, Sarah, Saga, Pauline).

Je veux également remercier pour leur soutien notre bureau de choc au laboratoire à Albi : Laura, Safae et Shadan. Merci Maceram pour m'avoir hébergé, aussi bien préparé le canard et aidé à me motiver pour faire cette thèse ! Un merci particulier à la cellule de développement et à toi Nico pour ta patience et ta bonne humeur : réussir à me faire coder n'était vraiment pas gagné d'avance. Un merci aussi particulier à Isabelle, la maman du centre, toujours là quand on en a besoin et qui est plus stressée que nous pour nos soucis de déplacements ou l'organisation de notre soutenance. Merci à toute l'équipe et plus particulièrement à ceux que j'ai pu plus côtoyer : Aurélie, Seb et Seb, Tiexin, Fred, Elise, Sina, Audrey, Andrès, Raph', Anne-Marie.

Ensuite, ce que j'ai pu apprendre et confirmer lors de cette thèse, c'est que pour réussir professionnellement il faut un « socle personnel » particulièrement solide. Je suis encore plus convaincu d'avoir la chance d'en avoir un.

Je remercie mes amis, et quels amis ! pour leur soutien : tout la bande se reconnaîtra, affectueusement surnommée "les animaux" pour leur côté primitif, inapprivoisable mais terriblement attachante et surtout toujours présente quand on en a besoin !

Je remercie ma famille, plus que présente et importante à mes yeux, et plus particulièrement mes parents et mon frère qui n'ont pas besoin que je leur dise à quel point ils comptent pour moi.

Les remerciements pourraient encore être nombreux¹ mais je tiens à remercier le meilleur pour la fin, enfin la meilleure en l'occurrence... Chantal, tu es là depuis de nombreuses années à mes côtés, tu sais à quel point je te remercie sur ce travail, ces nombreuses relectures d'articles, du manuscrit d'une thèse que tu dois presque connaître autant que moi... Mais je te remercie simplement d'être là tous les jours et je sais que le chemin que l'on va faire ensemble va encore durer et je suis pressé de le partager avec toi.

¹ : Je remercie par exemple la playlist Spotify « Concentration maximum » qui a été une alliée précieuse pendant les nombreux jours de rédaction.

CONTENTS

CHAPTER I. BACKGROUND, SCIENTIFIC AND INDUSTRIAL ISSUES.....	7
1. DEMAND-DRIVEN MATERIAL REQUIREMENTS PLANNING (DDMRP).....	9
2. MANUSCRIPT OVERVIEW	11
CHAPTER II. DEMAND-DRIVEN MATERIAL REQUIREMENTS PLANNING: PRESENTATION AND CRITICAL ANALYSIS.....	14
1. DEFINITION OF DEMAND DRIVEN MRP	16
1.1. <i>Introduction to the method</i>	16
1.1.1. DDMRP's inheritance.....	16
1.1.2. Frequent shortfalls	16
1.1.3. DDMRP principles	17
1.2. <i>Buffer profile & levels</i>	18
1.3. <i>Strategic Inventory Positioning</i>	22
1.4. <i>Positioning, sizing and an ROI analysis example</i>	25
1.5. <i>Dynamic Adjustment</i>	28
1.6. <i>Demand Driven Planning</i>	28
1.7. <i>Visible and Collaborative Execution</i>	30
2. DDMRP AMONG THE OTHER MATERIAL MANAGEMENT METHODS	34
2.1. <i>The different flow management types</i>	34
2.2. <i>Push system: Manufacturing Resources Planning (MRP II)</i>	35
2.2.1. Strategic Business Plan	35
2.2.2. Sales and Operations Planning and Resource Requirements Planning	35
2.2.3. Master Production Schedule and Rough-Cut Capacity Planning.....	36
2.2.4. Material Requirements Planning	36
2.2.5. Production Activity Control and Input / Output Control Order sequencing..	37
2.3. <i>Pull flow systems</i>	37
2.3.1. One piece flow.....	37
2.3.2. Specific Kanban system.....	37
2.3.3. Base-Stock system.....	38
2.3.4. Extended Kanban system	39
2.3.5. Generic Kanban system	40
2.3.6. Constant Work In Process.....	40
2.3.7. Other methods	41
2.4. <i>Other material management methods</i>	41
2.4.1. Hybrid push-pull systems.....	41
2.4.1.1. Horizontal Hybrid systems.....	41
2.4.1.2. Vertical Hybrid systems	42
2.4.1.3. Other hybrid systems	43
2.4.2. Bottleneck management methods.....	43
2.5. <i>And DDMRP?</i>	44
3. A QUALITATIVE COMPARISON OF MATERIAL MANAGEMENT METHODS.....	45
3.1. <i>Methods description according to the different horizons</i>	45

3.2. <i>The main differentiation criteria</i>	46
3.3. <i>DDMRP topics to challenge</i>	50
3.3.1. From a strategic point of view (P1).....	50
3.3.2. From a tactical point of view (P2 to P5).....	51
3.3.3. From an operational point of view (P6 to P8)	52
CHAPTER III. MRP II, DDMRP AND KANBAN ASSESSMENT WITH A DESIGN OF EXPERIMENTS	53
1. THE CASE STUDY	56
1.1. <i>Overall presentation</i>	56
1.2. <i>Realistic representation of the case study</i>	57
1.3. <i>Discrete Event Simulation choice</i>	57
1.4. <i>Detailed data and hypotheses</i>	58
2. MATERIAL MANAGEMENT METHODS APPLIED TO THE CASE STUDY	65
2.1. <i>The issues</i>	65
2.2. <i>MRP II</i>	67
2.3. <i>DDMRP</i>	68
2.3.1. Buffer positioning	68
2.3.2. Buffer positioning comparison with the experts.....	71
2.3.3. Buffer sizing	71
2.3.4. DDMRP management	72
2.4. <i>Kanban</i>	73
3. DESIGN OF EXPERIMENTS	76
3.1. <i>DOE objectives and hypothesis</i>	76
3.1.1. Objectives	76
3.1.2. Scenario hypothesis.....	77
3.2. <i>The DOE</i>	77
3.2.1. Initial scenario: the comparative basis scenario.....	77
3.2.1.1. Results.....	77
3.2.1.2. The comparison basis for the other scenarios	78
3.2.2. Process variability	79
3.2.3. Demand variability.....	80
3.2.4. Foreseeable seasonality demand	82
3.2.5. High demand variability with demand visibility	84
3.2.6. Scenario synthesis	86
3.3. <i>Inventory management</i>	87
3.3.1. Inventory distribution with a demand variability scenario.....	88
3.3.2. Inventory distribution with high demand variability and a demand visibility scenario	89
CHAPTER III CONCLUSION AND FUTURE WORK.....	91
<i>Conclusion</i>	91
<i>Future work</i>	93

CHAPTER IV. ADJUSTING DDMRP PARAMETERS.....	95
1. DDMRP SIZING IMPROVEMENT FOR THE KANBAN GAME	96
1.1. <i>Context</i>	96
1.2. <i>Scenario retained and initial sizing</i>	97
2. “GENERIC” METAHEURISTIC APPROACH	99
3. OPTIMISATION WITH BUSINESS RULES	104
3.1. <i>Business algorithm definition</i>	104
3.1.1. <i>Parameter and variable definitions</i>	104
3.1.2. <i>Algorithm definition</i>	105
3.2. <i>Business algorithm application</i>	109
3.3. <i>Better scenario results comparison for DDMRP parameters</i>	112
4. OPTIMISATION FROM A GOOD SOLUTION OBTAINED	115
4.1. <i>OTD maximisation objective function</i>	116
4.2. <i>OTD and WC weighting objective function</i>	119
4.3. <i>Goal programming objective function</i>	121
4.4. <i>WC and OTD global analysis</i>	124
CHAPTER IV CONCLUSION AND FUTURE WORK.....	126
<i>Conclusion</i>	126
<i>Future work</i>	127
CHAPTER V. INDUSTRIAL APPLICATION: A REAL CASE STUDY	128
1. CONTEXT	129
2. CASE STUDY MODELLING.....	130
2.1. <i>Environment modelling</i>	130
2.2. <i>Modelling hypothesis</i>	132
2.3. <i>Buffer sizing and dynamic adjustments</i>	133
2.3.1. <i>Buffer sizing</i>	133
2.3.2. <i>Dynamic adjustments</i>	134
2.4. <i>Planning modelling</i>	135
2.5. <i>Execution modelling</i>	135
3. SIMULATION ANALYSIS.....	136
3.1. <i>Initial situation</i>	136
3.2. <i>Daily to weekly NFE calculation</i>	138
3.3. <i>Minimum lot-size challenge</i>	138
3.4. <i>Demand variability impacts for DDMRP and MRP implementations</i>	140
3.5. <i>The limit of demand variability absorption with DDMRP</i>	142
4. DDMRP OPTIMISATION	144
4.1. <i>Objective function with stable demand</i>	144
4.2. <i>Objective function with demand variability</i>	145
CHAPTER V CONCLUSION AND FUTURE WORK	147
<i>Conclusion</i>	147
<i>Future work</i>	148

CHAPTER VI. CONCLUSION AND FUTURE WORK.....	149
1.1. <i>General conclusion</i>	149
1.2. <i>Future Work</i>	151
1.2.1. Regarding variability management	151
1.2.2. Regarding decision support	152
1.2.3. Regarding positioning buffers	152
1.2.4. Regarding Lead Time considerations.....	152
1.2.5. Regarding the economic dimension	153
RESUME DE THESE EN FRANÇAIS	154
1. CHAPITRE I. CONTEXTE, PROBLEMATIQUES SCIENTIFIQUES ET INDUSTRIELLES.....	155
2. CHAPITRE II. DEMAND DRIVEN MATERIAL REQUIREMENTS PLANNING : PRESENTATION ET ANALYSE CRITIQUE	157
3. CHAPITRE III. EVALUATION DE MRP II, DDMRP ET KANBAN AVEC LA REALISATION D'UN PLAN D'EXPERIENCES	159
4. CHAPITRE IV. AJUSTER LES PARAMETRES DE DDMRP	161
5. CHAPITRE V. APPLICATION INDUSTRIELLE : UN CAS D'ETUDE REEL	163
6. CONCLUSION GENERALE ET PERSPECTIVES DE RECHERCHE	164
REFERENCES	169
TABLE OF ILLUSTRATIONS.....	174
APPENDICES	178
<i>Appendix A: Kanban Game® Witness® model</i>	179
<i>Appendix B: Witness® Simulated Annealing explanations</i>	180
<i>Appendix C: JV Group Witness model</i>	182

Chapter I.

BACKGROUND, SCIENTIFIC AND INDUSTRIAL ISSUES

“He who seeks for methods without having a definite problem in mind seeks for the most part in vain.”

David Hilbert¹, 1902

After being long studied, the Supply Chain Management (SCM) concept is currently perceived as an organisation network that manages physical, information and financial flows. This network involves downstream and upstream relations with different processes and activities that provide a product or a service in order to satisfy the customer (Christopher, 1992a).

These material management tools and methods have been adapted to the market over the past several decades. In a perpetually changing industrial world, enterprises are coping with numerous challenges. However, the industrial environment is currently facing increasing variability. Furthermore, industrial environment systems are becoming more and more complex with ever-present financial constraints. SCM has not escaped this rule. Many scientific works have been developed on this theme and nowadays almost all companies are aware that their competitiveness comes through SCM. Unfortunately, a significant number of industrials do not know how to improve their Supply Chain by implementing current best practices.

The material management methods traditionally used by companies are now showing their limits. The market has (almost) completely changed since the 70's and 80's and there are now difficulties satisfying customers and managing costs in numerous industrial environments. MRP II (Manufacturing Resources Planning), which is the most widespread method, has only seen a few developments since the 70's. The circumstances that allowed for its good results have dramatically changed in the vast majority of business sectors. The “Lean Toolbox” has also allowed companies to improve their functioning but there are underlying limits. These limits concern the adaptation to unstable environments (with different variability sources) as well as the limits to being applied to the entirety of a Supply Chain.

This is why it is mandatory to reinvent appropriate practices and tools for coping with the new market rules: globalisation and increases in uncertainty, in variability and in industrial environment complexity.

Demand Driven Material Requirements Planning (DDMRP) is a promising recent method that is designed to tackle these current issues: DDMRP is a complete planning and execution method that promises to manage the Supply Chain from customer demand (Chapter I.1). DDMRP training is obtained through three certifications: Certified Demand Driven Planner (CDDP),

¹ : German mathematician (1862 – 1943)

Certified Demand Driven Leader (CDDL) and Certified Systemic Problem Solver (CSPS) conferred by the Demand Driven Institute (DDI). In fact, DDMRP is increasingly being implemented around the world in companies of different sizes and business sectors.

The main DDMRP promises are promoting flow by reducing variability and detecting demand variations. DDMRP reveals the weak links of other push or pull flow methods with references to MRP II and Lean Management. These methods have already revealed their advantages but they are currently showing their limits and DDMRP promises to deal with these limits: But what are these promises worth in reality? Furthermore, DDMRP has been the subject of very little research (Chapter II.1) even if other laboratories begin to be interested in the method such as the “Laboratoire Poly-DDMRP¹”. This is why it is scientifically interesting to focus this PhD work on DDMRP and to challenge its promises.

AGILEA, a consulting and training company in SCM, was created in 2009 in Toulouse to help its customers adapt to these new market rules with appropriate methods and tools. In addition to being experts in all SC segments and material management methods, AGILEA consultants are DDMRP stakeholders as well as DDMRP trainers (one of the world leaders) and DDMRP implementation project managers. AGILEA is strongly involved in this subject, as mentioned in the acknowledgements of the new DDMRP book (Ptak and Smith, 2016). Therefore, it is obvious that this research work is also interesting from an industrial point of view.

To summarise, DDMRP is a promising recent material management method in which AGILEA is a major stakeholder. All these promises, however, have not been scientifically identified and have only been tested with a few existing works of research: this is why this research focuses on “Challenging the Demand Driven MRP Promises”. The next section will explain how this research on DDMRP was led.

¹ Laboratoire Poly-DDMRP: <http://www.polymtl.ca/poly-ddmrp/>

1. Demand-Driven Material Requirements Planning (DDMRP)

DDMRP was created by Carol Ptak and Chad Smith at the beginning of the 21st century and was presented in the 3rd edition of Orlicky's Material Requirements Planning in 2011 (Ptak and Smith, 2011) and in the Demand Driven Material Requirements (DDMRP) book (Ptak and Smith, 2016).

In order to cope with current market issues, DDMRP uses well-known concepts taken from MRP (Material Requirements Planning)¹, DRP (Distribution Requirements Planning)², Lean³, 6 Sigma⁴, and TOC (Theory Of Constraints)⁵ along with specific innovations (Figure I-I).

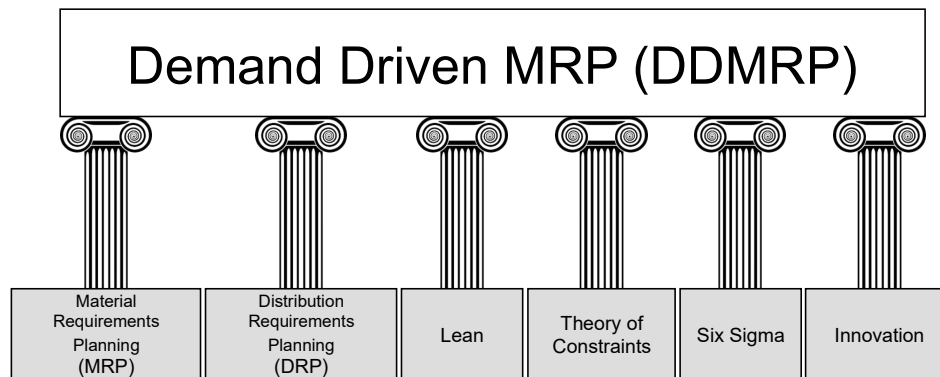

Figure I-I: The six DDMRP pillars

¹ : MRP: "A set of techniques that uses bill of material data, inventory data, and the master production schedule to calculate requirements for materials. It makes recommendations to release replenishment orders for material. [...] Time-phased MRP is accomplished by exploding the bill of material, adjusting for inventory quantities on hand and on order, and offsetting the net requirements by the appropriate lead times." ("APICS Dictionary 12th Edition," 2008) More details in Chapter II.2.2.

² : DRP: "The function of determining the need to replenish inventory at branch warehouses. A time-phased order point approach is used where the planned orders at the branch warehouse level are "exploded" via MRP logic to become gross requirements on the supplying source." ("APICS Dictionary 12th Edition," 2008)

³ : Lean: "A philosophy of production that emphasizes the minimization of the amount of all resources (including time) used in the various activities of the enterprise. It involves identifying and eliminating non-value-adding activities in design, production, supply chain management, and dealing with the customers. [...] It contains a set of principles and practices to reduce cost through the relentless removal of waste and through the simplification of all manufacturing and support processes." ("APICS Dictionary 12th Edition," 2008)

⁴ : 6 Sigma: "The six-sigma approach is a set of concepts and practices that key on reducing variability in processes and reducing deficiencies in the product. [...] Six sigma is a business process that permits organizations to improve bottom-line performance, creating and monitoring business activities to reduce waste and resource requirements while increasing customer satisfaction." ("APICS Dictionary 12th Edition," 2008)

⁵ : TOC: "A holistic management philosophy developed by Dr. Eliyahu M. Goldratt that is based on the principles that complex systems exhibit inherent simplicity. Even a very complex system made up of thousands of people and pieces of equipment can have at any given time only a very, very small number of variables – perhaps only one (known as a constraint) – that actually limits the ability to generate more of the system's goal." ("APICS Dictionary 12th Edition," 2008) Detailed in Chapter II.2.4.2.

DDMRP is divided into 3 steps and 5 components (Figure I-II). The first step, “position”, consists in determining where to position the decoupling points¹ in the Supply Chain (acting as a shock absorber). Then the flow is protected with buffers that are sized and dynamically adjusted according to the demand level. Finally, the flow is pulled firstly with demand driven planning which enables the supply orders to be generated. It is then possible to move to execution phase which is a daily visual and collaborative management step. The different steps will be further detailed in Chapter II.

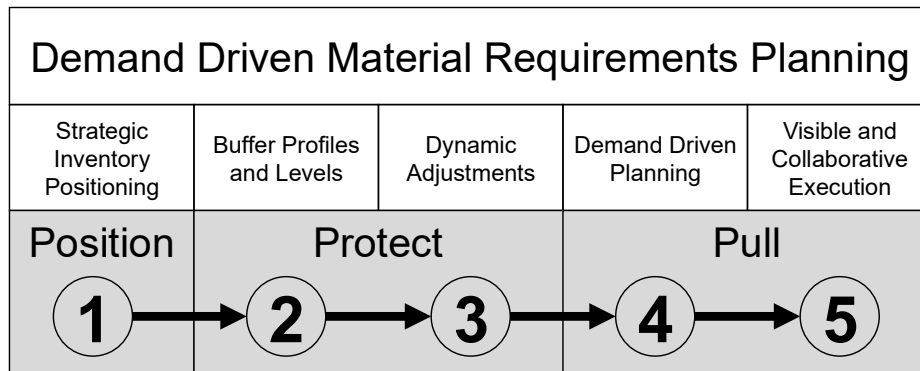

Figure I-II: the 3 steps and 5 components to implement DDMRP

¹ Decoupling points: “The locations in the product structure or distribution network where inventory is placed to create independence between processes or entities. Selection of decoupling points is a strategic decision that determines customer lead times and inventory investment.” (“APICS Dictionary 12th Edition,” 2008)

2. Manuscript overview

This research is therefore aimed at challenging DDMRP. The complete theory has already been developed; nevertheless, could there be some theoretical points to question? Before challenging DDMRP features, the method must be well described. This is why DDMRP main mechanisms will be described in the next chapter (Chapter II) following the implementation process defined in Figure I-II. In order to detail the method, it is interesting to position and compare DDMRP to usual other methods which are implemented in reality. In this second chapter, a literature review will present the main material management types and the main methods currently in use. The most well-known material management methods types deal with push or pull flow methods: on one hand, push flow methods follow forecasts to produce and reach a desired inventory level. On the other hand, pull flow methods are directly produced from the real customer demand (the customer for a machine can be the next machine) and begin to produce again (or not) based on real consumption. MRP II is the most representative and widespread method implemented in the world (even though it was developed several decades ago). Contrary to MRP II, Kanban is the most well-known pull flow method. Therefore, after detailing MRP II and Kanban in Chapter II, DDMRP will be qualitatively compared to these two “giants” according to several criteria. The objective is to have a list of qualitative DDMRP issues to challenge.

From this qualitative list of points, the most important ones from a scientific and an industrial point of view will be retained in order to compare them. This time, however, the analysis will be led according to a quantitative approach. Indeed, this is a current limit: there is no quantitative work comparing DDMRP and other material management methods. Therefore, Chapter III will focus on a design of experiments. This study will be realised with a theoretical but realistic case study (compared to AGILEA customers) with simulation. The tool (detailed in Chapter III) which is the most appropriate, and thus retained for this study, is Discrete Event Simulation (DES). This plan will challenge claims such as DDMRP’s resiliency to variability sources, a high-loaded system and other factors. The objective will be to compare the behaviours of MRP II, Kanban and DDMRP with their variability sources. In the current market, the goal is to reach a perfect (or nearly perfect) On Time Delivery (OTD) rate¹. However, given the economical background, companies are more and more attentive to financial issues: this is why the second criteria chosen to arbitrate between the systems will be the Working Capital² (WC). Therefore, the design of experiments must provide the best OTD rate for each scenario with a minimum Work In Process³ (WIP) amount translated into WC. The objective is to be able to identify in which case a material management method is better than another and for which reason(s). The design of experiments results will also lead to further research.

¹ OTD rate: a measurement of process and supply chain efficiency which measures the amount of finished goods or services delivered to customers on time and in full.

² Working Capital (or net working capital): “The current assets of a firm minus its current liabilities.” (“APICS Dictionary 12th Edition,” 2008)

³ Work In Process: “A good or goods in various stages of completion throughout the plant, including all material from raw material that has been released for initial processing up to completely processed material awaiting final inspection and acceptance as finished goods inventory. Many accounting systems also include the value of semifinished stock and components in this category.” (“APICS Dictionary 12th Edition,” 2008)

From these conclusions, one main issue in DDMRP implementation concerns DDMRP buffer sizing. In Chapter III, a dramatic sensitivity will be emphasised with the choice of DDMRP buffer parameters. Indeed, in this chapter buffers have been sized without accurate rules. This is a critical limit: there are risks of losing time and money in order to correctly size the buffers. Worse, it could lead to DDMRP project implementation failure with substantial financial losses and a loss of motivation for the stakeholders. Therefore, in Chapter IV, DDMRP settings will be challenged with an optimisation work to help in determining the best settings more rapidly, when DDMRP is implemented. This optimisation work will focus on the same case study in order to analyse the sensitivity degree of some DDMRP buffer parameters. From an intuitive initial buffer sizing, we will propose a business algorithm based on experience. In order to analyse its performance, this business algorithm will be compared to a “generic” metaheuristic approach in order to see which algorithm converges more rapidly. At this point, it will not be sure that the results cannot be improved. The last part of this chapter will try once again to improve results: from the rapid solution obtained with the business algorithm, the metaheuristic approach will be applied (with different objective functions).

The first four chapters deal with issues or case studies that are theoretical. This PhD work was realised in collaboration with an industrial company (called Conventions Industrielles de Formation par la Recherche, or CIFRE in France), a real DDMRP implementation would have been a welcome added value to the current research work. This is even more true as DDMRP is relatively recent with limited feedback from past experience. A real DDMRP implementation will be detailed in Chapter V: a DES study has just been implemented with an aeronautical supplier that produces mechanical parts. This on-going study focuses on a new product sold by a JV Group company: an airplane seat base reference. The goal is to assess DDMRP impacts on a limited workshop scale that combines machining and assembling activities. These impacts will be assessed from the current situation managed with MRP II and results on OTD and WC Key Performance Indicators (KPI) that the company intends to improve. In this real case, there are also variability sources (especially with demand). Therefore, it will be possible to assess the variability impacts with DDMRP or MRP II strategies. These project results are also important in order to consider a possible DDMRP implementation for the entire company.

The figure below (Figure I-III) summarises these different topics and illustrates the manuscript plan that will be followed. This work follows a scientific approach (Benyoucef, 2008) with the following main steps :

- Formalisation: characterise the industrial problem in order to formulate a scientific one (Chapter II).
- Resolution: develop original methods (for non referenced problems in literature) or use existing methods. In both cases, the scientific issues are deeply developed to bring an added-value to literature (Chapter III and Chapter IV).
- Application: illustrate and try the different proposition on a real case study or even several of them. The objective is to demonstrate the proposed contributions compared to existing solutions (Chapter V).

As we progress in the manuscript, the research work will become more specific. The DDMRP environment will be detailed from a generic point of view. From the issues and points to challenge, the work will be more and more specific. In addition, with DDMRP, several steps must be taken to implement the material method with the many choices and parameters that are in the method. Therefore, with more specific work, the number of parameters in the DDMRP environment that will be studied will decrease (the two axes in Figure I-III).

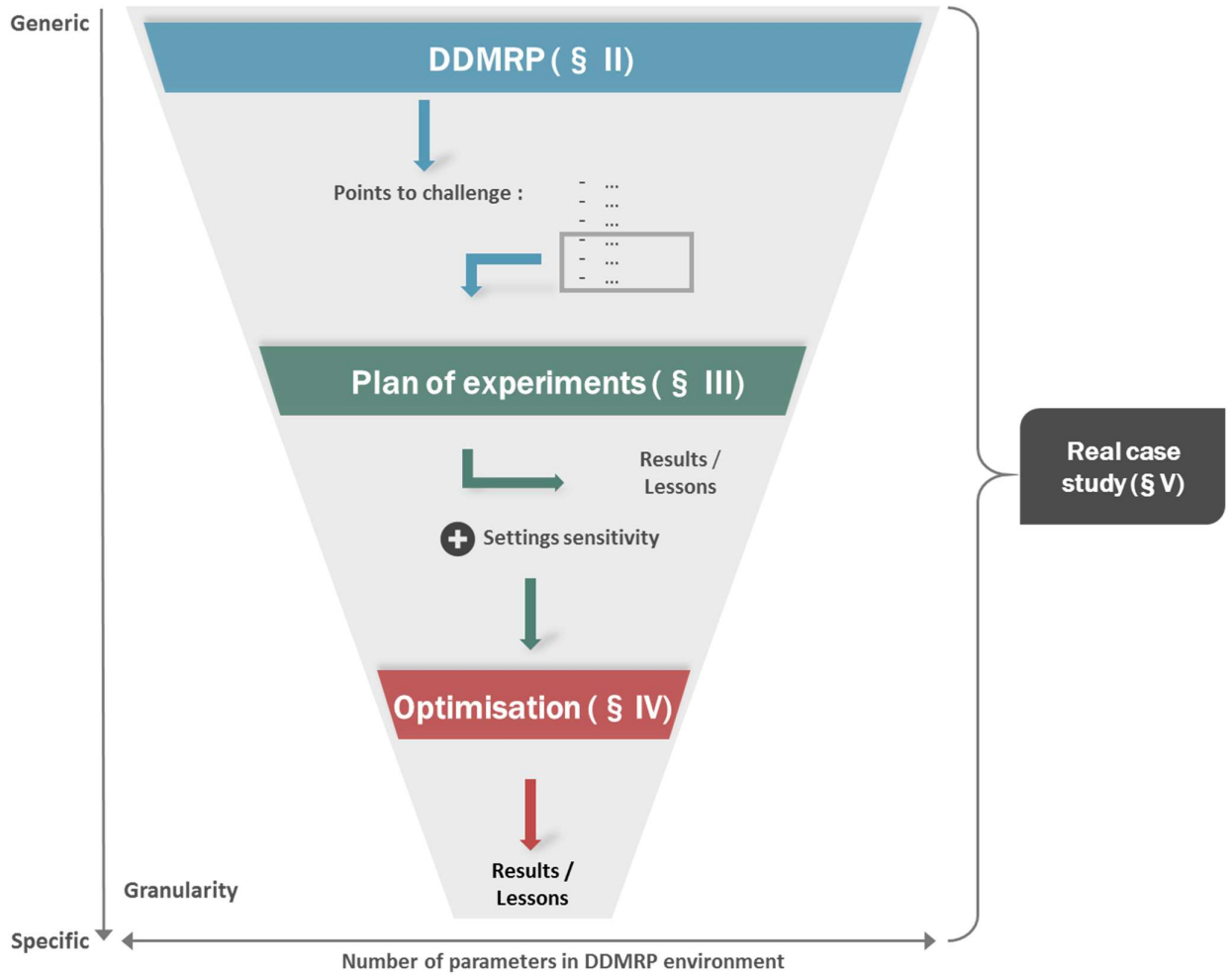

Figure I-III: Manuscript Big Picture

As briefly described in this chapter, DDMRP is a promising method: several of its points will be discussed throughout this manuscript. Indeed, this is one of the first works of research on this subject. This is why, in Chapter VI, there will be an important conclusion, and regarding future developments especially, research which should have priority.

Chapter II.

DEMAND-DRIVEN MATERIAL REQUIREMENTS PLANNING: PRESENTATION AND CRITICAL ANALYSIS

“Always design a thing by considering it in its next larger context – a chair in a room, a room in a house, a house in an environment, an environment in a city plan.”

Eliel Saarinen¹

“The world has changed, and further technology barriers have been removed. Companies will succeed not because they improve, refine, and speed up the enforcement of obsolete rules and logic but because they are able to fundamentally adapt their operating rules and systems to the new global circumstances.”(Ptak and Smith, 2011)

DDMRP is based on this statement. This new method is promising. This chapter, as illustrated in Figure II-I, focuses on an explanation of DDMRP and a critical analysis compared to other material management methods. The first section introduces the main concepts of DDMRP. From this introduction, some points will be identified in order to be challenged. Then these main points will be further developed and challenged in Chapter III and Chapter IV.

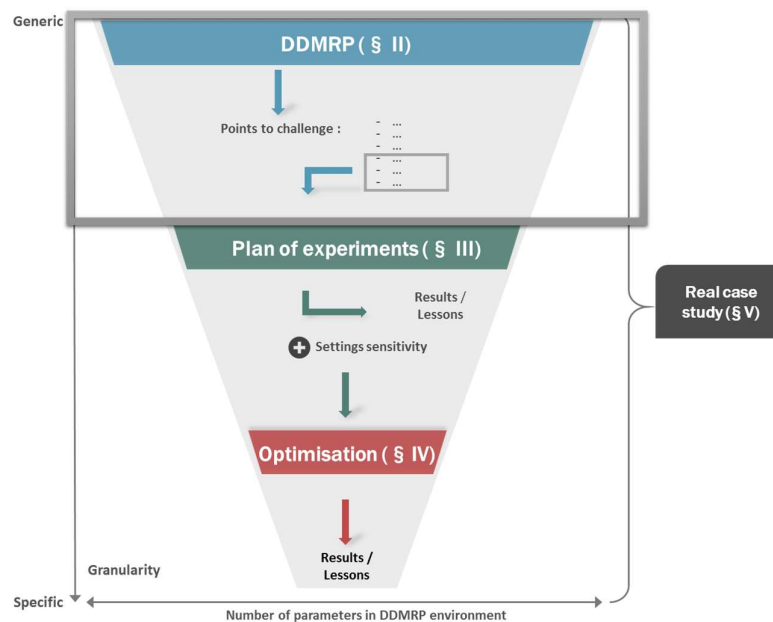

Figure II-I: Big Picture – DDMRP presentation and critical analysis

¹ : Finnish architect (1873 – 1950)

Although DDMRP is a recent method, it is interesting to compare it to the existing main material management methods: the second section describes these methods.

On one hand, MRP II is well-known as the push material management method of reference (and is the most widespread in the industrial world). On the other hand, Kanban is recognized as a major pull material management method with numerous implementations and research work in the literature. That is why a more in-depth comparison will be realised in the third section of this chapter.

From all these analyses and statements, a list of the main points to be challenged by themes and points that need further research work, will be given and prioritised.

1. Definition of Demand Driven MRP

1.1. Introduction to the method

Material management methods currently in use have unsatisfying results in numerous cases due to market and process variabilities. DDMRP is presented as a way to overcome these issues: so how does it work and why would it solve these issues?

In this section, the DDMRP presentation is mainly based on two books: “Orlicky's Material Requirements Planning, Third Edition” (Ptak and Smith, 2011) and the “Demand Driven Material Requirements Planning” (DDMRP) book (Ptak and Smith, 2016). All figures and tables in this first section are taken from these two books.

1.1.1. DDMRP's inheritance

An assessment of DDMRP is that there are good practices in MRP and in Lean. However, using both methods at the same time leads to conflicts (eg. MRP targets reordering before consumption, contrary to Lean). DDMRP is based on 5 well-known pillars: MRP, DRP, Lean, TOC, and Six Sigma to maintain the best practices. In order to obtain a complete method, DDMRP also includes several innovations. These 6 pillars are presented in Figure I-I.

“The key is to keep those [MRP good practices] attributes but eliminate MRP's critical shortcomings while integrating the pull-based replenishment tactics and visibility behind today's demand-driven concepts into one system in a dynamic and highly visible format. The solution is called demand-driven MRP (DDMRP).” (Ptak and Smith, 2011)

1.1.2. Frequent shortfalls

The first DDMRP principle highlights inventory distribution dispersion in companies. Indeed, there is often too much WIP of the wrong reference and too few of the references wanted by the customers. In DDMRP training, this is called “bi-modal inventory distribution” as shown in Figure II-II below (dark red with “too little” is a synonym of shortage and blue with “too much” is a synonym of a large inventory excess). What is more, the reference inventory level often goes through one extremity of the curve to the other, which is the result of lot sizes that are too big and a late effective launching of production orders. That is why one of the main DDMRP objectives is to dramatically improve inventory management.

From the point of view of the currently implemented methods, several issues are known. MRP and DRP have bi-modal inventory distribution with long lead times compared to what would be possible to realise. It is also complicated to implement continuous improvement because the main problems may not be easily found. Furthermore, there are gaps in the theory as regards inventory management with big lot sizes, safety stocks and stock objectives that are mixed up. Lean implementation supposes low variabilities and low diversity in each production facility, which is complicated in current market.

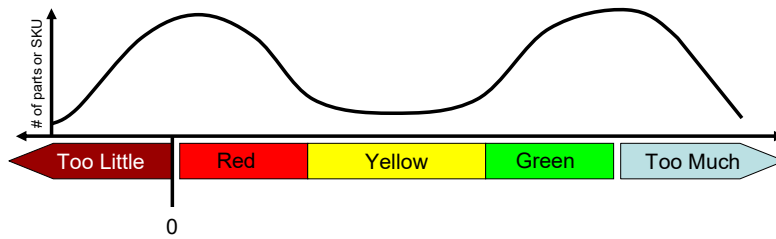

Figure II-II: A bi-modal inventory distribution curve (Ptak and Smith, 2016)

1.1.3. DDMRP principles

As illustrated below (Figure II-III), DDMRP achieves centred inventory distribution, which is a prerequisite to improving its service level and its WIP amount to reduce the WC.

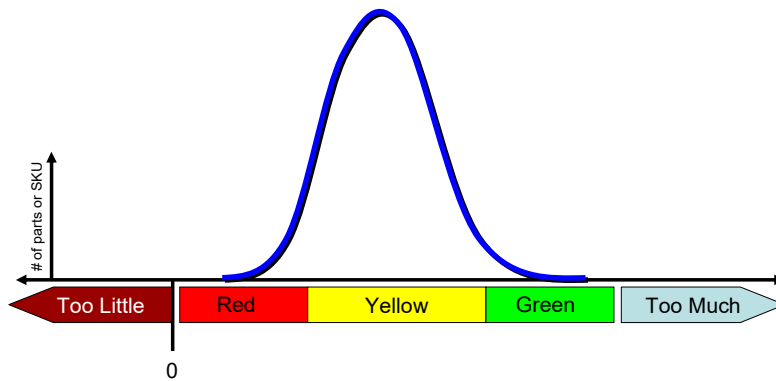

Figure II-III: Inventory distribution targeted with DDMRP (Ptak and Smith, 2016)

DDMRP uses routing and Bill Of Materials (BOMs) with buffers located in these BOMs: DDMRP buffers represent decoupling points in order to absorb the variability sources (they are strategically positioned). Then the flow is pulled between the different DDMRP buffers. Between the BOM references (without DDMRP buffers), MRP management is kept for generating orders. Furthermore, DDMRP uses two inventory vision types from this definition (Johnson and Montgomery, 1974): the on-hand inventory and an “extended” inventory position: the Net Flow Equation (Chapter II.1.6).

In order to reach the WIP and WC objectives, the DDMRP implementation process follows three steps: buffer positioning, protecting and pulling the flow. These three steps include the five components that are detailed below:

- Strategic Inventory Positioning: the goal is to know where to place the decoupling point. These points are decoupled with buffers as illustrated in Figure II-IV.
- Buffer Profiles and Levels: as the decoupling points are settled, the different DDMRP buffers can be sized to cope with variability and demand.

- **Dynamic Adjustments:** with variability such as seasonality, demand trend evolution, product ramp-up or ramp-down, the buffers must be dynamically adjusted.
- **Demand Driven Planning:** with the first three steps, the DDMRP environment is defined. It is now possible to plan the flow. Demand Driven Planning allows priorities to be determined and supply orders to be generated.
- **Visible Collaborative Execution:** the final component facilitates management of the daily routine with regular problems. This component manages flow with different types of alerts and prioritises orders to ensure customer delivery on time.

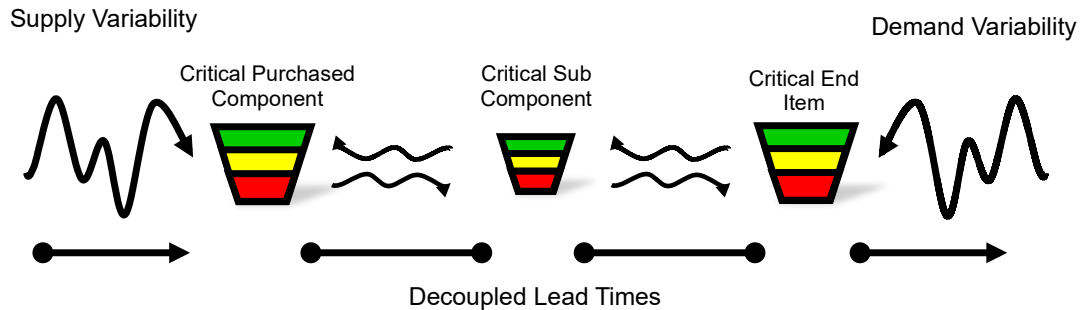

Figure II-IV: Illustration of decoupling point impacts (Ptak and Smith, 2016)

The DDMRP sequence implementation is detailed in Figure I-II.

For easier comprehension, the buffer profiles and levels step will be detailed before the Strategic Inventory Positioning step: the goal is to better understand the first DDMRP implementation step's impacts.

1.2. Buffer profile & levels

As buffers are placed in the process (Chapter II.1.3) they can be sized to reach the decoupling objectives. A DDMRP buffer is composed of three visual zones: green, yellow and red. These different zones are defined in Figure II-V:

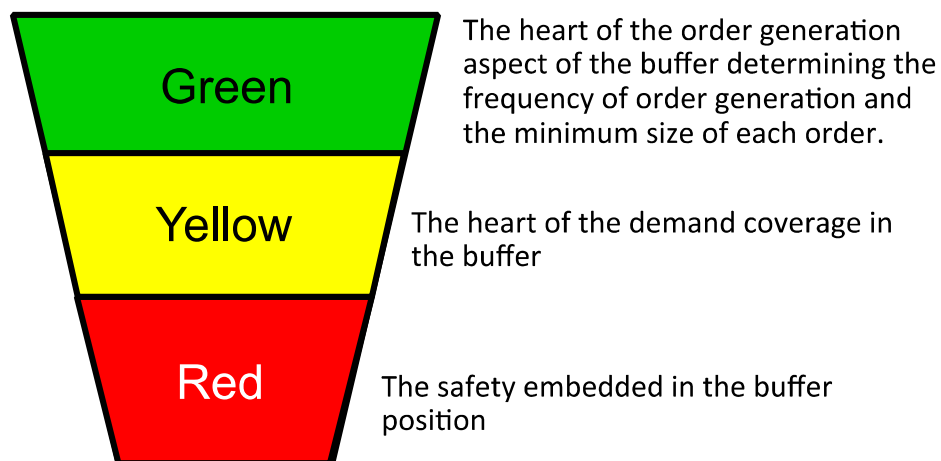

Figure II-V: Definition of DDMRP stock buffer zones (Ptak and Smith, 2016)

The next question is: how to size these three zones? Four individual part parameters are required as well as 3 buffer profile parameters in order to manage this step. The 4 individual part parameters are described below:

- Location: for distributed parts, this will have an impact on the buffer sizing
- Decoupling Lead Time: according to the part's lead time, the zone profiles will be differently sized. Indeed, depending on whether a part has a short or long lead time, its behaviour and management will be adapted.
- Minimum Order Quantity (MOQ): if there is a significant MOQ, the means of generating supply orders must also be adapted (this will impact the green zone, Figure II-V)
- Average Daily Usage (ADU): all the stock buffer zones will be proportional to daily consumption.

Then, the parts will be assigned to buffer profiles. These buffer profiles will be organised depending on 3 buffer profile parameters:

- Item Type: parts must firstly be grouped according to their type. They can be purchased, manufactured or distributed.
- Decoupling Lead Time Category: the lead time will be determined by categories such as short, medium and long lead time (these may be more detailed).
- Variability Category: the variability will also be determined by categories, such as low, medium and high variability (these may also be more detailed).

It is interesting to note that the last two parameters have no mathematical definition. They must be defined from experience (or individual common sense) with some rules.

From these 3 parameters, the buffer profiles can be classified as suggested in Table II-I. This table example is composed of 36 buffer types. In reality, some of them may not be adapted and the system may be managed by 10 to 20 buffer profiles. The first letter corresponds to Purchased, Manufactured, Distributed or Intermediate. The second letter corresponds to Short, Medium or Long Lead Time and the last letter is for Low, Medium or High Variability.

		Part Type					
		Purchased	Manufactured	Distributed	Intermediate		
Lead Time Category	Short	PSL	MSL	DSL	ISL	Low	Variability Category
		PSM	MSM	DSM	ISM	Medium	
		PSH	MSH	DSH	ISH	High	
	Medium	PML	MML	DML	IML	Low	
		PMM	MMM	DMM	IMM	Medium	
		PMH	MMH	DMH	IMH	High	
	Long	PLL	MLL	DLL	ILL	Low	
		PLM	MLM	DLM	ILM	Medium	
		PLH	MLH	DLH	ILH	High	

Table II-I: Buffer profile classification example (Ptak and Smith, 2016)

All the previously detailed features are summarised in Figure II-VI. The “X” means an “AND” operator (both themes are needed to obtain zone and buffer levels).

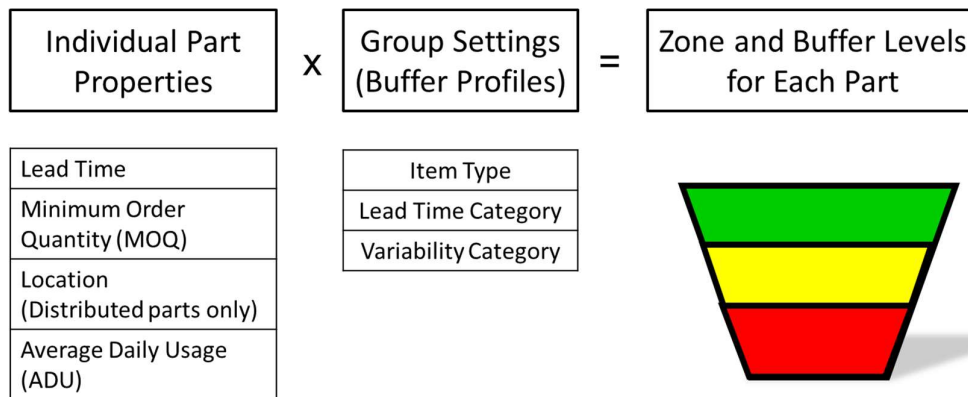

Figure II-VI: Parameters required to size DDMRP stock buffers (Ptak and Smith, 2016)

With all this data, stock buffers can be sized according to an Inventory position point of view. Firstly, the Yellow zone is “the heart of the demand coverage”. This zone is sized as:

$$\text{Yellow zone} = \text{ADU} \times \text{DLT}$$

Then, the Red zone is composed of a Red zone base and a Red zone safety. The first zone is based on a lead time issue whereas the safety zone is sized to absorb variability (demand and supply).

- (1) Red zone base = Yellow zone x Lead Time factor
- (2) Red zone safety = Red zone base x Variability Factor
- (3) Red zone = Red zone base + Red zone safety

These equations had not been justified until now. The red zone represents the “emergency shock absorber” such as the safety stock for MRP II and it would be interesting to justify this red zone sizing.

“Historically, it was believed that the higher the service level desired, the higher was the safety stock, and vice versa. The investment in this inventory category therefore can be controlled by manipulating the service-level value.” (Ptak and Smith, 2011)

The current hypothesis made in DDMRP deals with these lead time and variability factors: they must be adapted to the company context. However, DDMRP provides some categories for both lead time and variability factors (Figure II-VII):

1	Red Base	Lead Time Factor Range	The Red Zone Base is determined by the Lead Time Factor
	Long Lead Time	20-40% ADU x DLT	
	Medium Lead Time	41-60% ADU x DLT	
	Short Lead Time	61-100% ADU x DLT	
2	Red Safety	Variability Factor Range	Red Safety is determined by the Variability Factor multiplied against the calculated Red Base from above
	High Variability	61-100% of Red Base	
	Medium Variability	41-60% of Red Base	
	Low Variability	0-40% of Red Base	
3	Calculated Red Base + Red Safety = Total Red Zone		

Figure II-VII: DDMRP Lead-Time Factor and Variability Factor suggestions (Ptak and Smith, 2016)

Additionally, in order to have a more regular flow, items with a long lead time have a shorter percentage in order to produce these articles more often.

Finally, the green zone is “the heart of the order generation aspect of the buffer determining the frequency of order generation and the minimum size of each order”(Ptak and Smith, 2016). There are different ways to size the green zone:

- (1) Green zone = Yellow zone x Lead Time Factor
- (2) Green zone = MOQ
- (3) Green zone = ADU x imposed or desired order cycle in days

The Lead Time Factor for the green zone can be different from the red zone Lead Time Factor. The way to size this green zone is chosen by the company for the most convenient way to do it: in general, it is the maximum value of (1), (2) or (3).

As soon as the three zones have been sized, “Top Of” equations are calculated. A complete DDMRP buffer is detailed below in Figure II-VIII.

- (1) Top Of Red (TOR) = Red zone
- (2) Top Of Yellow (TOY) = TOR + Yellow Zone
- (3) Top Of Green (TOG) = TOY + Green Zone

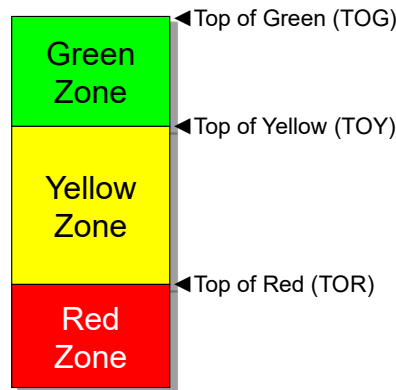

Figure II-VIII: DDMRP buffer zones and “top of” zones

Therefore, TOG is the sum of all the DDMRP stock buffer zones. All these themes will be illustrated with an example in Chapter II.1.4 after the explanation of Strategic Inventory Positioning.

1.3. Strategic Inventory Positioning

The first component for implementing DDMRP is strategic inventory positioning: it is at the heart of the method. The goal is to position the different DDMRP strategic buffers, contrary to other methods. As explained in DDMRP, “Now, the first question to be asked is “where” to put inventory rather than to answer the question of “how much” (Ptak and Smith, 2011).

These strategic buffers are decoupling points in order to manage variability sources and their main consequence: the Bullwhip Effect (Forrester, 1961; Lee et al., 1997). The decoupling point impacts are illustrated in Figure II-IV. In order to place decoupling points, some important criteria must be analysed: customer tolerance time¹, market potential lead time², sales order visibility horizon³, external variability⁴, inventory leverage and flexibility⁵ and critical operation protection⁶.

As regards variability, 4 main DDMRP variability sources are identified here (Figure II-IX):

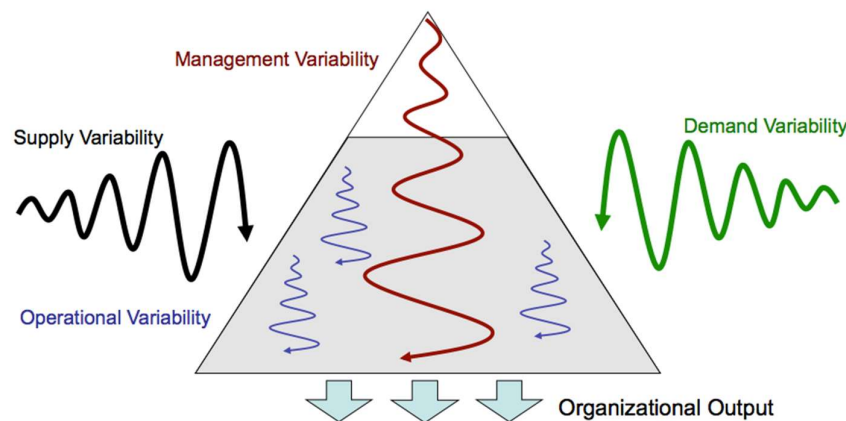

Figure II-IX: 4 main variability sources (Ptak and Smith, 2011)

¹ Customer tolerance time (or demand lead time): “The amount of time potential customers are willing to wait for the delivery of a good or a service.” (“APICS Dictionary 12th Edition,” 2008)

² Market potential lead time: “This lead time will allow an increase of price or the capture of additional business either through existing or new customer channels.” (Ptak and Smith, 2011)

³ Sales order visibility horizon: “The time frame in which we typically become aware of sales orders or actual dependent demand.” (Ptak and Smith, 2011)

⁴ External variability: “Demand variability: The potential for swings and spikes in demand that could overwhelm resources (capacity, stock, cash, etc.). Supply variability: The potential for and severity of disruptions in sources of supply and/or specific suppliers.” (Ptak and Smith, 2011)

⁵ Inventory leverage and flexibility: “The places in the integrated bill of material (BOM) structure (matrix bill of material) or the distribution network that enables a company with the most available options as well as the best lead time compression to meet the business needs.” (Ptak and Smith, 2011)

⁶ Critical operation protection: “These types of operations include areas that have limited capacity or where quality can be compromised by disruptions or where variability tends to be accumulated and/or amplified.” (Ptak and Smith, 2011)

- Supply variability: in terms of time and quantities
- Demand variability: in terms of time and quantities
- Operational variability: due to process management with potential breakdowns, operation time variations, and quality issues
- Management variability: in the strategy used to manage the system and the way it is explained to the different teams

A DDMRP contribution concerns a new Lead Time concept: Decoupling Lead Time (DLT), also known as Actively-Synchronized Lead Time (ASRLT) in previous DDMRP documents: “DLT is a pivotal building block for where to position inventory, the size of those inventory positions, and critical date-driven alerts and priorities.”(Ptak and Smith, 2011). It is indeed required to assess appropriate lead times in order to well apply a material management strategy. Lead times assessment is really sensitive and this issue has already created problems with MRP (Melnik and Piper, 1981).

DLT could be described as the longest unprotected lead time in a BOM. For a reference, the longest unprotected “path” in the BOM is the longest sum of manufacturing or production lead times from this reference to another buffer or the lowest BOM level (with component supply). The DLT time can be explained with an article BOM example named FPD for Final Product D (Ptak and Smith, 2016) below (

Figure II-X). The FPD end item is composed of several subassembly parts manufactured from 3 purchased components (401P, 410P and 412P) with respectively 10, 45 and 45 lead time days. The manufacturing lead times for each reference is the value in the circle (in days). A DDMRP buffer positioning scenario is also defined (Figure II-XI) for this BOM.

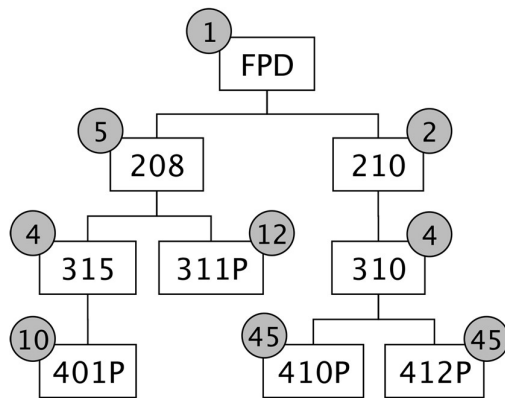

Figure II-X: FPD BOM example

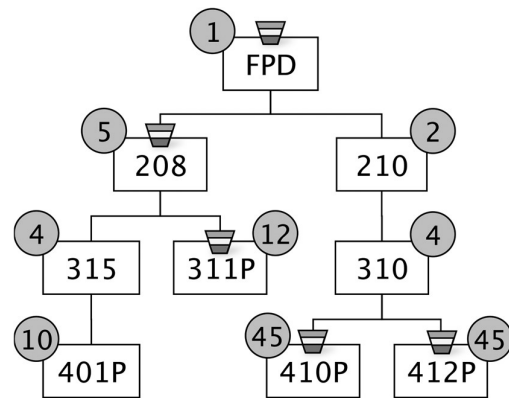

Figure II-XI: DDMRP buffer positioning example (Ptak and Smith, 2016)

In this buffer positioning scenario, FPD item DLT would be the longest between “1” (because 208 is buffered) and “7” (1 for FPD, 2 for 210 and 4 for 310), so FPD DLT is 7 (compared with 1 for MLT and 52 for CLT).

In addition, for 208 in the first scenario (Figure II-XII), its DLT is 19 days (5 + 4 + 10). Positioning a decoupling point in 401P saves 10 DLT days to reach 9 days of DLT (Figure II-XIII).

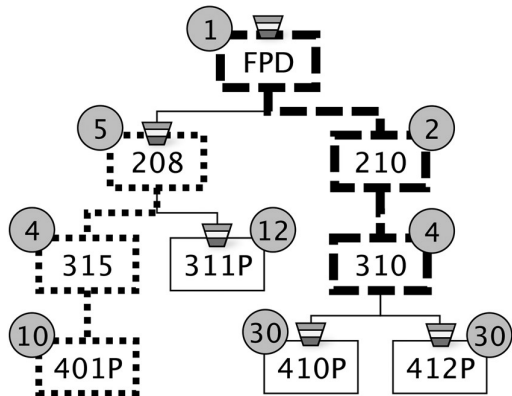

Figure II-XII: FPD DLT explanation (Ptak and Smith, 2016)

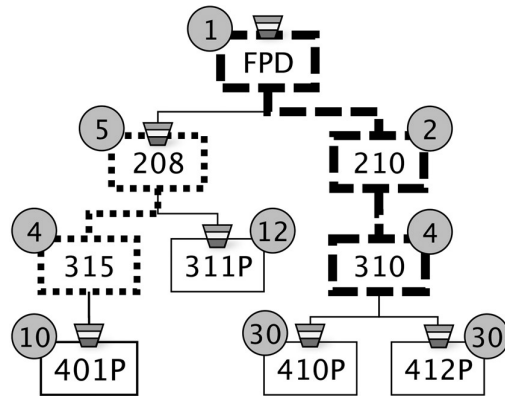

Figure II-XIII: Another 208 DLT scenario (Ptak and Smith, 2016)

This reasoning must be adapted to all BOMs in a company. Indeed, an item may not be interesting to buffer due to its cost; however, it might be worthwhile because this item could also be used in numerous other BOMs. There is already early research work on the buffer positioning analysis in a BOM (Jiang and Rim, 2016; Rim et al., 2014). This work focuses on a make-to-order environment and provides a “systematic solution procedure to determine the optimisation location of stocks” where the goal is to minimise total inventory. The non-linear problem is optimised with a genetic algorithm. The results are interesting with 10 to 50 references. However, this work needs further developments to be adapted to an entire company scale because for the moment it is too complex to have more than 50 references (calculated time) and it is only available in a Make To Order environment (MTO).

In DDMRP, “only” the strategic parts for the company must be buffered. An item can be strategic for several reasons: having a dramatic lead time compression, being a strategic product to sell, being mandatory to have a product available under contract, or having positive Return On Investment¹ (ROI) by buffering an item, for example. This can be compared to MRP where nothing is decoupled or to Kanban where everything is decoupled: with DDMRP, only buffers have decoupling points.

As regards this last point, an ROI analysis must be performed in order to validate the retained scenario: this requires the sizing of the buffers depending on their relative position. This is developed in the next section (Chapter II.1.4).

¹ Return On Investment: “A relative measure of financial performance which provides a means to compare various investments by calculating the profits returned over a specified time period. In TOC, ROI is calculated as throughput minus operating expense divided by investment.” (“APICS Dictionary 12th Edition,” 2008)

1.4. Positioning, sizing and an ROI analysis example

The first two DDMRP components have just been explained. Sizing for 2 parts is detailed in Table II-II. For these 2 parts, lead time factors (green and red) are 25% and the variability factor is 50%. For both items, the green zone is sized according to the lead time factor equation because it is higher than the MOQ and Order Cycle equation. As regards FPA, its TOG is 8,125 and 11,213 for FPC.

FPA		FPC	
Green Zone	1250	Green Zone	1725
	LT Factor: 1250 (5000 x .25)		LT Factor: 1725 (6900 x .25)
	Minimum Order Quantity: 250		Minimum Order Quantity: 250
	Order Cycle: 750 (3(DOC) x 250(ADU))		Order Cycle: 900 (3(DOC) x 300(ADU))
Yellow Zone	5000 (20(DLT) x 250(ADU))	Yellow Zone	6900 (23(DLT) x 300(ADU))
Red Zone	1875 (1250 + 625)	Red Zone	2588 (1725 + 863)
	Base: 1250 (5000 x .25)		Base: 1725 (6900 x .25)
	Safety: 625 (1250 x .5)		Safety: 863 (1725 x .5)

Table II-II: Two DDMRP stock buffer sizing examples (Ptak and Smith, 2016)

As regards buffer management, if the buffer is well configured, the on-hand inventory level must be in the yellow zone. As the yellow zone represents the in-process orders, the on-hand inventory level must be between TOR and TOR + green zone (Figure II-XIV). This is why the average on-hand inventory, if a stock buffer is positioned, is equivalent to:

$$\text{Average on-hand inventory} = \text{TOR} + \frac{1}{2} \times \text{Green zone}$$

However, with this reasoning, the WIP is not assessed (from a financial point of view): there is no gap for components but there may be significant gap for produced references (the WIP should be equivalent to the yellow zone).

Average on-hand inventory for FPA is $1,875 + 1250 \times \frac{1}{2}$, so 2,500 and 3,450 for FPC.

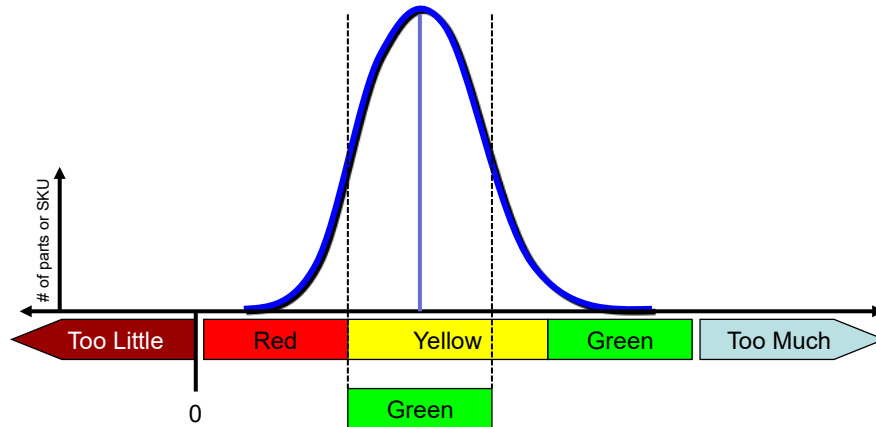

Figure II-XIV: DDMRP on-hand distribution target (Ptak and Smith, 2016)

As explained before, a buffer must help to reach the customer tolerance time, but positioning a stock buffer must also reduce costs (Working Capital) with a WIP reduction. The cost analysis can be illustrated with Figure II-XV and the three BOMs. In this case it could be interesting to analyse the 201 part buffering. For FPA, the DLT is 20 days before decoupling (1 + 5 + 4 + 10) and would be 7 days after (with FPA, 203 and 303 with 1 + 2 + 4). So by buffering 201 it would be a compression of 13 lead time days. The buffer profile consequences are illustrated in Figure II-XVI. The same reasoning should be followed in this part with the two other BOMs, because 201 is also on the DLT path.

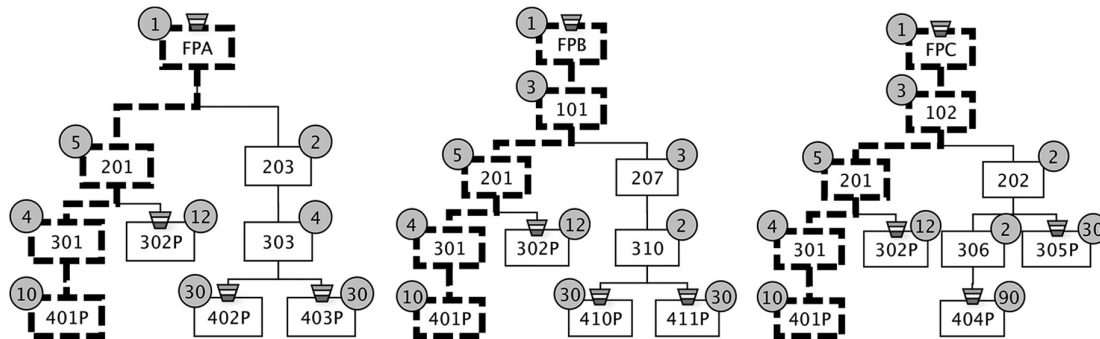

Figure II-XV: FPA, FPB and FPC BOM examples (Ptak and Smith, 2016)

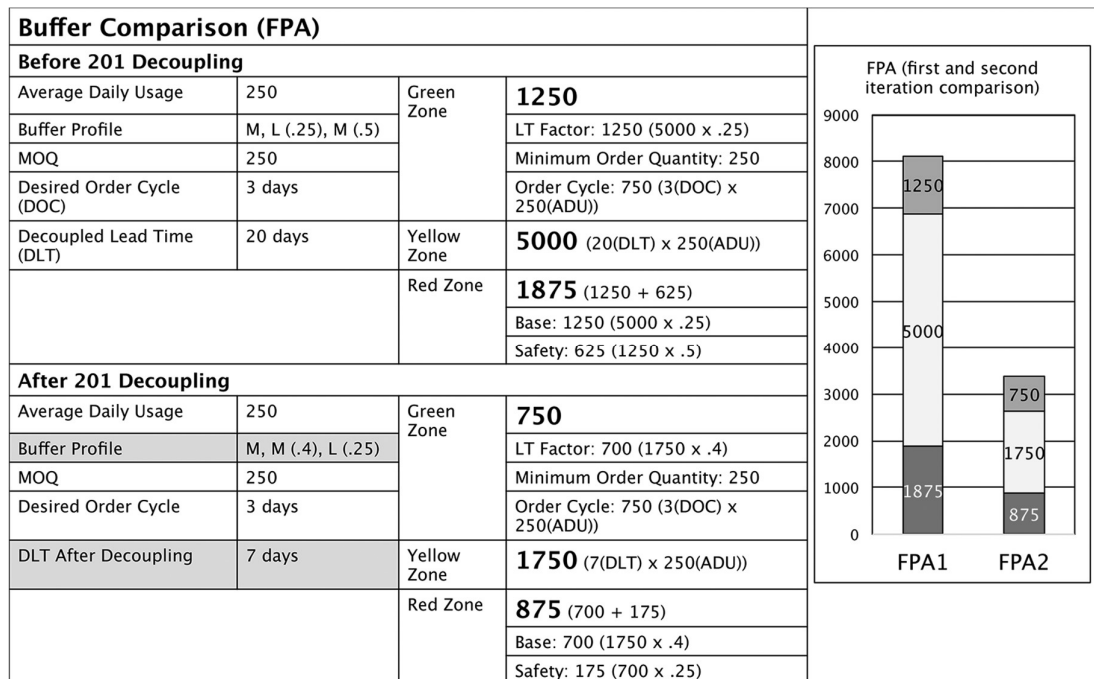

Figure II-XVI: Buffer comparison example with other DDMRP buffer positions (Ptak and Smith, 2016)

It is notable that with this lead time compression, the buffer profile applied to the reference changes, with lead time factors from 25% to 40% and a variability factor from 50% to 25%. This lead time compression can now be assessed from a financial point of view. Firstly, the material costs (and only these costs) must be known for this evaluation. A DDMRP hypothesis

is: “If those allocations [labour allocations] are considered, the picture becomes even more skewed in favour of the decoupling points placed lower in the product structures; those parts don’t get that “value added” that higher-level components get and consequently look “cheaper” to hold. However, there is no real difference from a true working capital perspective” (Ptak and Smith, 2016). With this reasoning, value added is therefore not implemented. But it can create significant financial assessment gaps for companies with consequent value added to their products.

The purchase costs of items are given in Figure II-XVII, so the FPA cost is \$460 in this example:

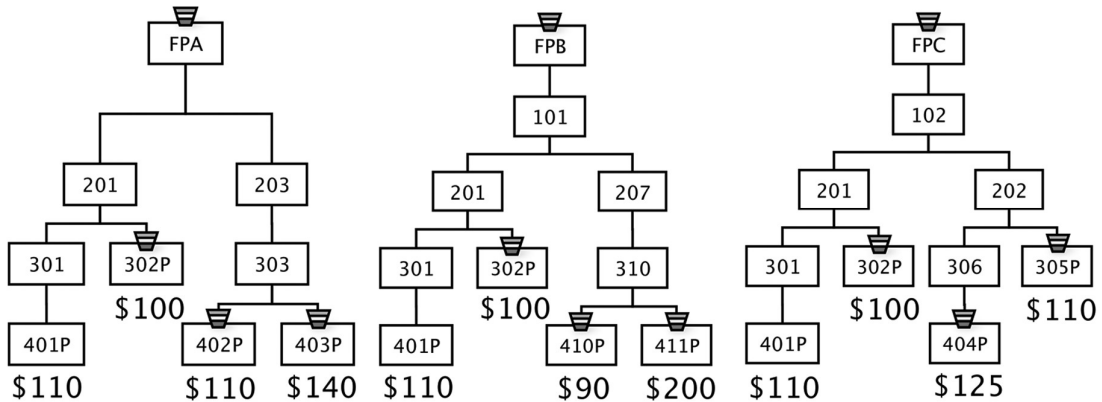

Figure II-XVII: Items purchase cost (Ptak and Smith, 2016)

The FPA lead time compression reduces from 2,500 to 1,250 the average on-hand target (Figure II-XVIII), which reduces inventory from \$1,150,000 to \$575,000.

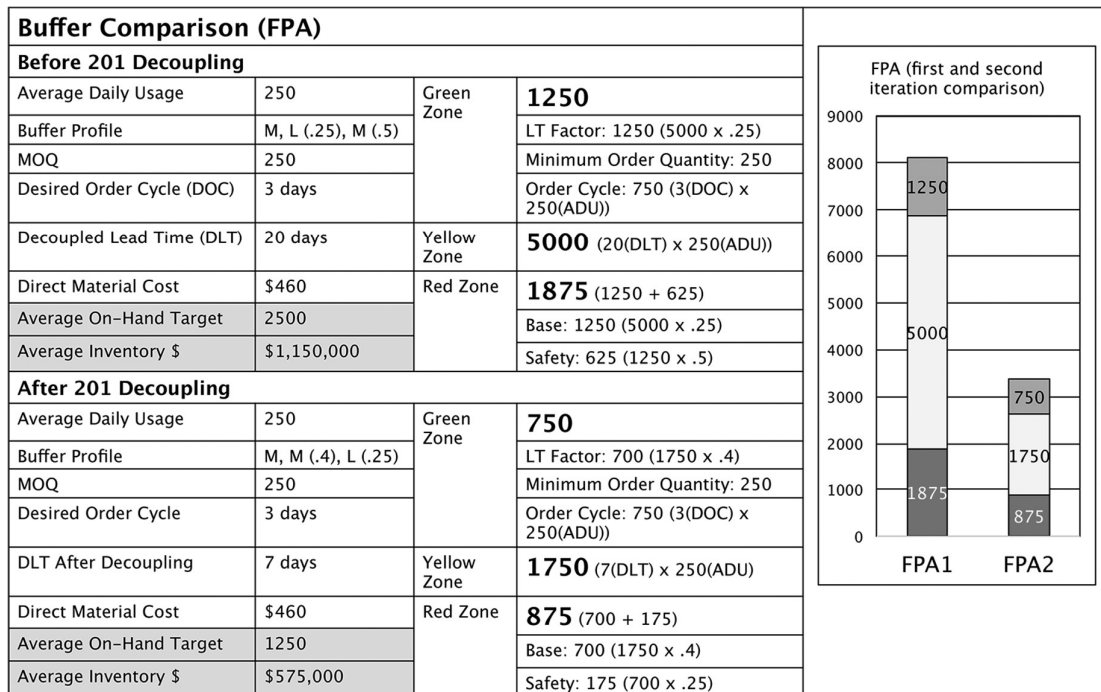

Figure II-XVIII: FPA Average on-hand target and inventory reduction (Ptak and Smith, 2016)

In order to be sure to validate this choice, the inventory impact on 201 must also be assessed with the same reasoning. Then the lead time compression must also be assessed for FPB and FPC. The results of this iteration (other buffers could be implemented in the BOM, such as with 203 and 401P) is summarised in Table II-III:

	FPA	FPB	FPC	201	Total Inventory
Start	1,150,000	\$575,250	\$1,535,473	\$0	\$3,260,723
Iteration 1	\$575,000	\$360,000	\$747,600	\$1,296,960	\$2,979,560
Reduction					\$281,163

Table II-III: Inventory impacts with 201 buffering (Ptak and Smith, 2016)

All this reasoning will be applied to a complete case study in Chapter III.

1.5. Dynamic Adjustment

The third DDMRP component deals with the dynamic buffer adjustment. As customer demands show more and more volatility, adjustment mechanisms must be implemented. The mechanisms can be the following:

- As demand changes, ADU can be recalculated with a rolling average (depending on the reference DLT) to cope with demand trend changes.
- In numerous sectors there are seasonality periods. DDMRP recommends the use of Planned Adjustment Factors (PAF) to manage this phenomena. A PAF is a percentage applied to the ADU in order to change the buffer zone dimensions. With this reasoning, a new ADU (ADU') is used to size buffers: $ADU' = ADU \times PAF$.
- PAF is projected for future supply order generation (because ADU will be changed).
- PAF can also be used for load balancing strategies in order to “artificially” change ADU for a period.
- ADU can also be adjusted for ramp-up, ramp-down or transition items. This reasoning can be equivalent to a PAF application to ADU.

These changes can contribute to lead time factor changes (with another buffer profile applied to the reference).

1.6. Demand Driven Planning

Up to now, the DDMRP environment has only been modelled. The system must now be monitored. The last two components concern the planning and then the execution steps.

Firstly, as regards Demand Driven Planning, its objective is to generate supply orders in appropriate quantity and with appropriate timing. DDMRP introduces the Net Flow Equation (NFE): NFE takes into account the on-hand inventory and the supply orders already generated. Then this current demand (of the day) must be removed from the equation in what is called

qualified spikes: these last two concepts are combined in a “qualified sales order demand”. This is the main difference with a “classical” stock position¹. To summarise, the equation is:

$$\text{NFE} = \text{On-hand} + \text{on order} - \text{qualified sales order demand}$$

In Demand Driven Planning, while the net flow position is in the green zone, no supply order is generated. However, as soon as the net flow position enters the yellow zone, a supply order can be released. This order quantity should be the difference between the net flow position and the TOG. This reasoning can be summarised as below:

While $\text{NFE} > \text{TOG}$

Do nothing

End While

If $\text{NFE} \leq \text{TOG}$ then

Supply order generated = $\text{TOG} - \text{NFE}$

End if

Compared to the TOG level, each reference has an applied percentage that fits to the net flow level compared to its TOG (Table II-IV). This planning form helps to visually manage its supply ordering flow as illustrated by this Table II-IV:

Today's Date: 15-July											
Part#	Planning Priority	On-Hand	On-Order	Qualified Demand	Net Flow Position	Order Recommendation	Request Date	Top RED	Top YELLOW	Top GREEN	Lead Time
406P	RED 19.8%	401	506	263	644	2606	4-Aug	750	2750	3250	20
403P	YELLOW 43.4%	1412	981	412	1981	2579	23-Jul	1200	3600	4560	8
402P	YELLOW 69.0%	601	753	112	1242	558	24-Jul	540	1440	1800	9
405P	YELLOW 74.0%	3400	4251	581	7070	2486	24-Jul	1756	7606	9556	9
401P	YELLOW 75.1%	2652	6233	712	8173	2715	25-Jul	2438	8938	10888	10
404P	GREEN 97.6%	1951	1560	291	3220	0		1050	2550	3300	6

Table II-IV: DDMRP Planning view example to manage priorities (Ptak and Smith, 2016)

As regards the qualified spikes, in DDMRP theory, they are taken into account in the NFE if they are superior to half of the red zone (this threshold can be adjusted by the company but also here without mathematical reasoning) and in a defined horizon. For example, it may not be interesting to qualify a spike for a demand known two months in advance, with a reference DLT of one week.

¹ Stock position: “Situation of a particular inventory item at a particular time, it is based on the relationship between its expected demand or requirement, quantity at hand, and outstanding orders issued for its procurement.” (Business Dictionary, 2016)

DDMRP Decoupled Explosion

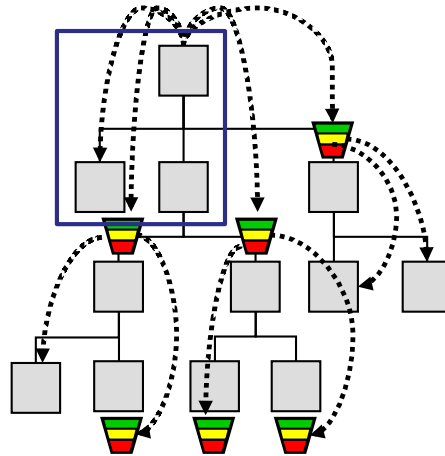

Figure II-XIX: DDMRP decoupled explosion (Ptak and Smith, 2016)

Finally, in DDMRP, demand is only exploded to the next buffer or a BOM ending, as illustrated in Figure II-XIX: this is called a “DDMRP Decoupled Explosion”. This reordering policy is dramatically different from the MRP explosion with independent demand which is directly transmitted to each part in the last BOM level. However, between the DDMRP decoupling points, a classical MRP calculation is performed to generate orders. An example is detailed with Figure II-XX below. It is notable that there are no safety stocks for the non-buffered parts (210 and 310), therefore the requirements are equal to the supply order. In addition, the decoupled explosion stops to next strategic DDMRP buffer.

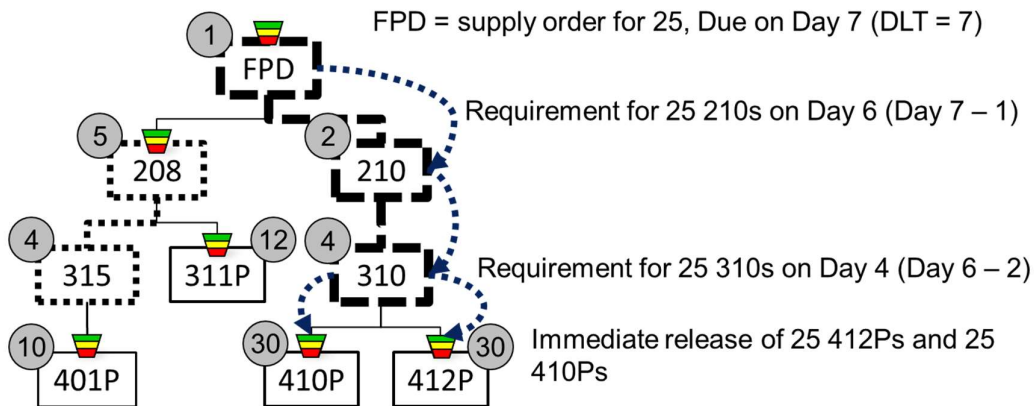

Figure II-XX: FPD decoupled explosion example (Ptak and Smith, 2016)

1.7. Visible and Collaborative Execution

From an execution point of view, DDMRP offers the use of different kinds of alerts, whether there are independent or dependent points in the BOM (Figure II-XXI). These alerts do not generate orders; their objectives are to prioritise orders already generated and highlight possible emergencies. As regards dependent point alerts, these alerts deal with synchronisation alerts (in terms of material or time alerts). These types of alerts are further detailed in the DDMRP book (Ptak and Smith, 2016). All alert types are illustrated in Figure II-XXI:

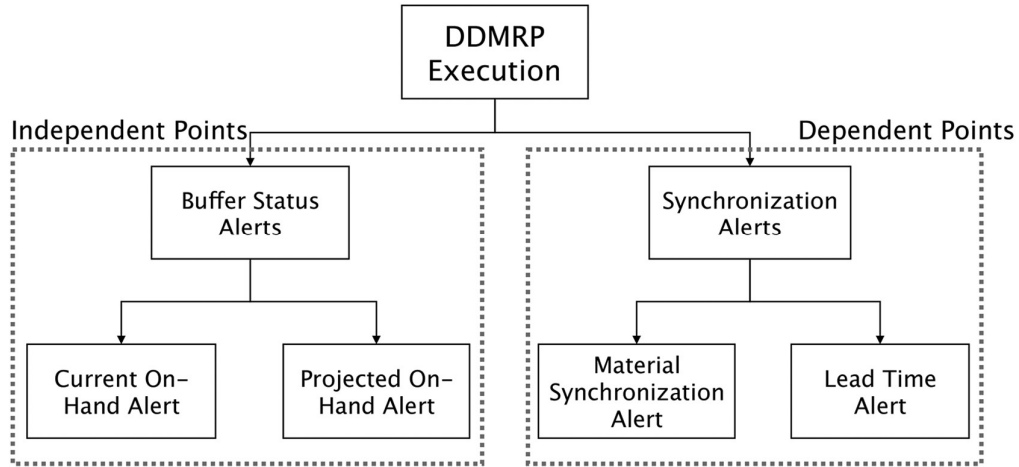

Figure II-XXI: DDMRP alert types (Ptak and Smith, 2016)

For independent points (DDMRP buffers), they emphasize buffer status alerts with current or projected alerts of physical inventory: on-hand inventory. Contrary to a classical dashboard prioritised by due date (Table II-V), execution order prioritisation is easier with DDMRP buffer status (Table II-V). Indeed, in this example the three purchase orders have the same due date, and it would be complicated to manage the execution priorities. Contrary to this due date view, the buffer status shows dramatic differences for these purchase orders, as with the execution priority is quite obvious that PO 831145 is the main priority.

Order #	Due date	Buffer Status	Supplier
PO 831145	05 / 12	RED - 12.3%	PNW Fabrication
PO 821158	05 / 12	YELLOW - 52.3%	PNW Fabrication
PO 831162	05 / 12	YELLOW - 56.1%	PNW Fabrication

Table II-V: Managing execution priorities by buffer status (Ptak and Smith, 2016)

From the execution point of view, the buffer zones are not equivalent to the buffer planning zones. As a reminder, NFE takes into account supply orders; however, for the execution component, priorities must be based on on-hand inventories. That is why the red planning zone is halved into red and yellow execution zones. Then the yellow planning zone becomes the green execution zone. The percentage buffer statuses for execution are based on execution TOY or planning TOR because the execution green zone can be too large and it only represents demand coverage for NFE. These changes are illustrated in Figure II-XXII.

These zones are different due to the main data for managing each view: the NFE for the planning side and the on-hand inventory for the execution side. The difference between these two sizes is the supply orders and the WIP in the system, corresponding to the yellow zone (and if there are spikes, other supply orders would be generated), which explains the zone size differences.

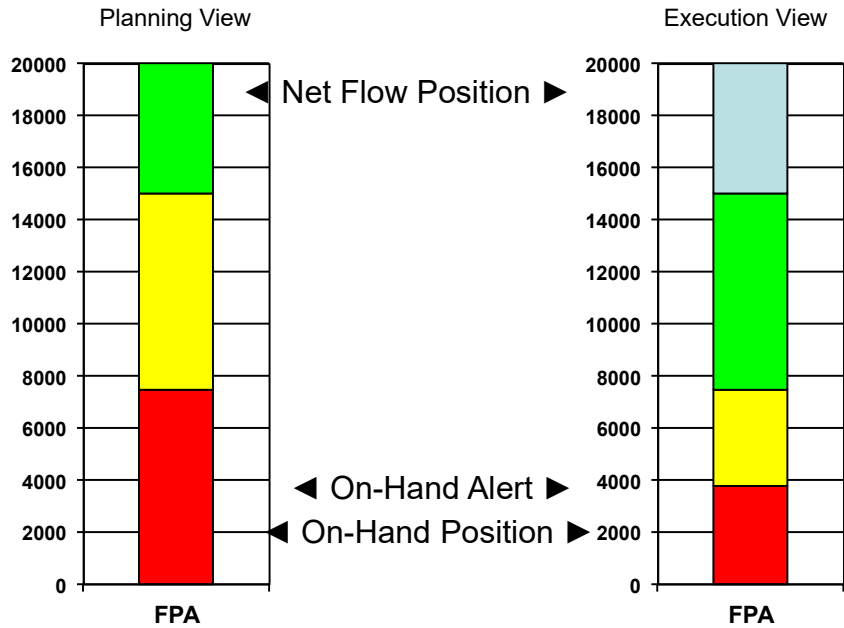

Figure II-XXII: DDMRP corresponding planning and execution views (Ptak and Smith, 2016)

In order to ensure system output, control points are used with DDMRP. These control points are located at a few critical points in the system in order to manage it. These critical points are called control points in driven demand. The control points are positioned to identify, schedule, protect, manage and measure flow. Otherwise, these critical points are called drums in the Theory of Constraints and pace setters in Lean terminology” (CDDL training).

The control points are defined as “Strategic locations in the logical product structure for a product or family that simplify the planning, scheduling, and control functions. Control points include gating operations, convergent points, divergent points, constraints, and shipping points. Detailed scheduling instructions are planned, implemented, and monitored at these locations.” (“APICS Dictionary 12th Edition,” 2008)

Control points are strategically positioned. The critical points in the process are the following:

- Pacing resources (the Drum in DBR, cf. Chapter II.2.4.2). These resources determine the process output throughput.
- Exit and Entry points in order to limit input and output variability.
- Common points where there are several references with convergent (assembling) or divergent activities.
- Points that have notorious process instability to limit internal variability spreading.

The five DDMRP components have been briefly detailed in this chapter. To summarise, “Demand-driven manufacturing is a manufacturing strategy of dramatic lead-time compression and the alignment of efforts to respond to market demands. This includes careful synchronization of planning, scheduling, and execution with consumption.” (Ptak and Smith, 2016)

In order to understand all these DDMRP mechanisms, we invite you, if you have not already done so, to read the main DDMRP books (Ptak and Smith, 2011, 2016; Smith and Smith, 2013) or to take the DDMRP trainings.

From a DDMRP perspective, the links between research and industrial worlds are likely to be improved in the future: “An improvement on both sides of this question can only come from better cooperation and dialogue between academia and industry. In the future, the inhabitants of the real world must take the initiative in articulating and communicating their problems to researchers and educators, and they should actively support valid research. Researchers, on the other hand, should make an attempt to validate their research targets before actually proceeding with projects” (Ptak and Smith, 2011). This is precisely what we intend to do: to find DDMRP points to challenge, to objectively compare DDMRP to other methods, to apply it to a real case study and to make a list of major future research work to plan.

2. DDMRP among the other material management methods

The main DDMRP components have just been explained in the previous part. In this part, DDMRP will be compared to the other types of flow management policies in Supply Chains. What are the main types of material management methods that already exist?

2.1. The different flow management types

Numerous material management methods have been developed and implemented during the last century. In order to understand them more easily, they can be grouped according to several features. The most well-known methods are classified in three categories: push, pull or hybrid push pull systems. Push systems are designed to release orders from forecasts and firm demand from a Material Production Schedule (MPS), contrary to pull systems that allow production from a WIP level directly linked to final demand (Hopp and Spearman, 1996).

These flow management types dramatically change system performance: pull systems want to increase the system's throughput with a minimum amount of WIP. Push systems follow a schedule in order to reach a targeted stock position. The push and pull systems can be illustrated as below with Figure II-XXIII:

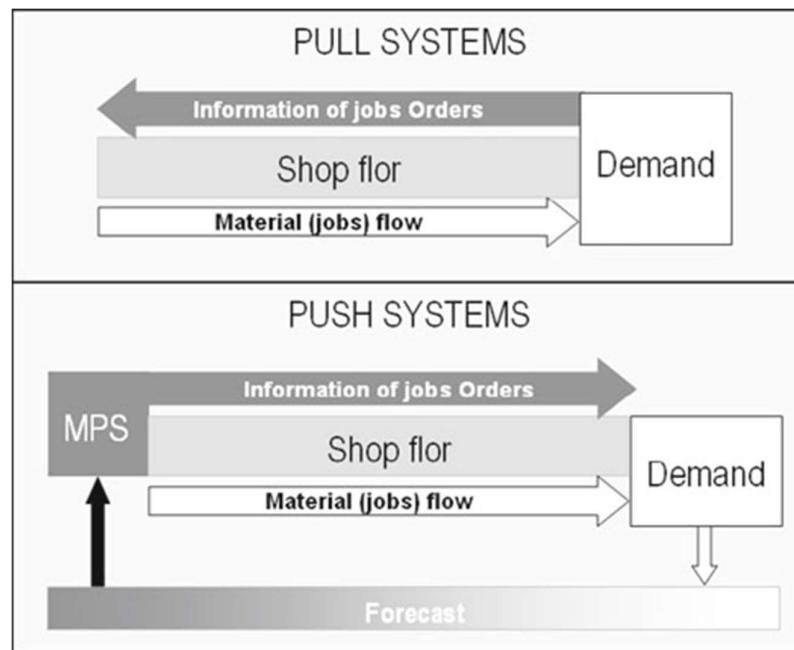

Figure II-XXIII: Pull and Push systems (González-R et al., 2011)

Furthermore, the methods can also be divided into three types according to (Gershwin, 2000) :

- Surplus-based systems: depending on the comparison between cumulative production and cumulative demand, a decision to stop or continue production is taken.

- Time-based systems: decisions are made from a time point of view; when operations must begin and must finish, and when the system must follow these events (such as in MRP II).
- Token-based systems: these systems use tokens or cards to decide whether to operate or not. When a demand arrives, a token (or card) moves from one location to another. An operation can be performed only if a token (or card) is available for the activity concerned and if there is enough space in the next activity.

In the next sections, the main methods will be described. Firstly, a push system vision, secondly a pull system vision and finally other types of material management methods. This decomposition is in part inspired by two previous works of research: (González-R et al., 2011; Olaitan, 2016).

2.2. Push system: Manufacturing Resources Planning (MRP II)

The most famous and most widespread material management method in the push system is the MRP method. The first Material Requirements Method was developed in 1975 by Joseph Orlicky (Orlicky, 1975). Then, what is often called the MRP method or MRP II (Manufacturing Resources Planning) was developed (Ptak and Smith, 2011; Wight, 1995).

MRP II is a forecasting management system for production that coordinates the entire production: from raw material or components purchasing, to material or human resources within the different plans. MRP II has three main objectives:

- Guaranteeing resource availability for production and for customer sales
- Minimising inventory
- Planning and scheduling production and purchasing activities

The following figure (Figure II-XXIV) illustrates the MRP II method from the Strategic Business Plan to the execution step and Production Activity Control. The planning steps are briefly described below:

2.2.1. Strategic Business Plan

The Strategic Business Plan (SBP) defines the main business objectives and orientations of a company. It is aimed at planning from the steering committee level to the commercial policy level for the company. This plan gives a long-term vision (in general, 5 to 10 years) for future sales and therefore production needs (Kotter, 2012; Slack and Lewis, 2015; Thompson et al., 2013).

2.2.2. Sales and Operations Planning and Resource Requirements Planning

Sales and Operations Planning (S&OP) expresses in operational terms the company's commercial policy. It is a medium-term vision (from 12 to 18 months in general). The workloads

are therefore planned on a monthly scale. The S&OP is created by a joint effort from the sales, production, procurement, and human resources departments and the CEO. The S&OP helps to check feasibility and match production needs, financial needs and sales objectives. This plan is realised with sales on a product family scale. This plan is built from forecasts that are uncertain by definition, which is why the plan must be periodically updated (in general each quarter) to remain consistent.

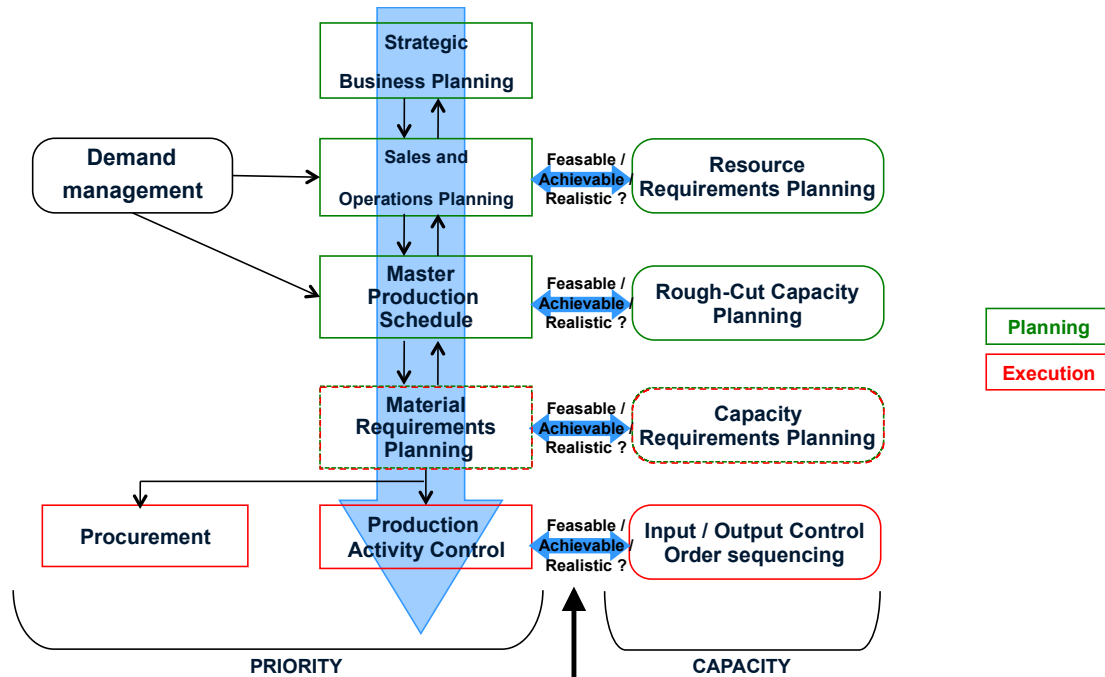

Figure II-XXIV: Manufacturing Resources Planning (MRP II)

2.2.3. Master Production Schedule and Rough-Cut Capacity Planning

The Master Production Schedule (MPS) is a more accurate expression than the S&OP's. Its role deals with transforming forecasts into a firm commitment for the production department. Contrary to the S&OP, MPS is generated for each end item (not a product families as for S&OP). The MPS is created each month and provides input to Material Requirements Planning (MRP). This plan enables companies to balance decisions according to workloads and available resources for the chosen horizon.

2.2.4. Material Requirements Planning

In a company, two types of item exist:

- Independent items: these are the end items which appear in the MPS. They represent customer demand and are therefore external company requirements.
- Dependant items: these are initial or intermediate items in the BOM, components or subassembly parts for which the demand depends on end items. These components are required to produce the final items. In this case they are considered internal company requirements.

In order to produce, MRP uses routings: these detail all the steps needed for a reference to be produced, with for each one its operating cycle time and the setting-up time.

Once the delivery or production lead time for each article is determined, it is then possible to schedule purchasing or production orders in order to have them in inventory. MRP is the heart of MRP II: it generates orders for each reference compared to the production plan realised with MPS (Chapter II.2.2.3).

2.2.5. Production Activity Control and Input / Output Control Order sequencing

Production Activity Control's (PAC) objective is to coordinate manufacturing resources, schedules and controls. The main goal is to follow the production program and track production orders. Another function is to report on the resources and the materials used all along the production process. In conclusion, PAC can be considered to be translations into actions of the different MRP II plans on the daily horizon.

2.3. Pull flow systems

Contrary to push flow systems, pull flow systems adapt to real customer demand with a minimum inventory amount. This philosophy was developed in the Toyota Production System (TPS) after the Second World War, as were Lean Manufacturing and Kanban (Ohno, 1988; Sugimori et al., 1977).

In this part, an overview of the main pull flow systems is given.

2.3.1. One piece flow

The one piece flow (or single piece flow) is the extreme pull flow system: between each activity a product is moved to the other activity one by one (Sekine, 2005). This method improves the flow throughput with a highly versatile operator. However, many constraints must be fixed, such as a setting-up time near zero, which is difficult to adapt in high diversity product environments (and which are more and more common).

2.3.2. Specific Kanban system

Kanban means "label" in Japanese: a Kanban system materializes the order taken from the customer post (the next activity in the process in general) to the supplier post in a production system. Kanban is a form of Just In Time (JIT) method based on the principle of real requirement. This is to say, the upstream activity production is limited to the requirements sent from the downstream activity and can be, in principle, generalized all along the supplier-customer chain.

The method is illustrated in Figure II-XXV below. Some figures in this section are taken from the same article (González-R et al., 2011) with the same terminology :

- “ IB_i , number of jobs in the input buffer of station i at time t .
- OB_i , number of jobs in the output buffer of station i at time t .
- M_i , number of jobs in station i .
- NC_i , number of cards in station i .
- NC , total number of cards in the process.”

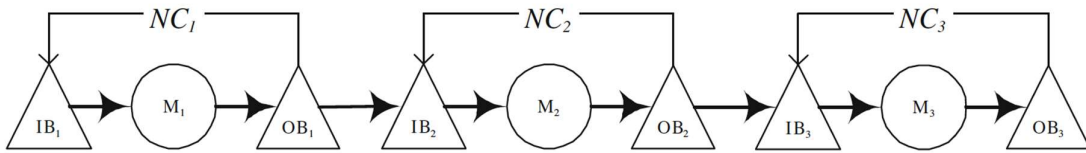

Figure II-XXV: Specific Kanban system (González-R et al., 2011)

The original Kanban characteristics in literature are the following (Lage Junior and Godinho Filho, 2010) :

- “use of two communication signals (dual card Kanban system): according to (Sipper and Bulfin, 1997), the dual card Kanban system uses production signals [...] and transportation signals.
- Pulled production: the production is pulled based on the inventory level or the scheduling of the last station.
- Decentralized control: the control of the production flow is performed through visual control by the employees of each step of the production process.
- Limited WIP: the inventory level is limited in each workstation, which means finite buffer capacity, depending on the number of signals.”

The main Kanban objective is to eliminate waste by maintaining the amount of intermediate inventory at a “reasonable” level: in other words, the final goal is not to target “zero inventory”.

With the initial Kanban development, OTD deliveries were satisfying several decades ago. However, with the changes in the market and the arrival of variability sources (or mostly, their increase) the card numbers must now be dynamically adjusted. Several works dealt with this issue (Gupta et al., 1999; Sivakumar and Shahabudeen, 2008; Tardif and Maaseidvaag, 2001).

2.3.3. Base-Stock system

The Base-Stock System is also a pull material management method because this system is directly linked to real customer consumption, or real customer demand. At the beginning, the method was used in inventory management (Kimball, 1988).

The principle is that a target inventory is expected at each activity: the base-stock level. Then when a customer demand occurs at the last activity, this demand is transmitted to all the upstream stations. What is more, when demand is spread to the upstream activities, inventories will be refilled to their base-stock objective.

However, this principle and this way of transmitting demand can lead to an increase in WIP level in the process (Buzacott, 1989). This is due to the lack of coordination between each station when demand is transmitted from the final activity. Moreover, when a station has demand (from the last station) but not the corresponding reference to work, this demand is recorded in a queue.

To deal with this issue, the Base-Stock System has evolved into a card system: demand is still directly transmitted but WIP is limited with a card number, as illustrated in Figure II-XXVI (Bonvik et al., 1997; Gaury, 2000).

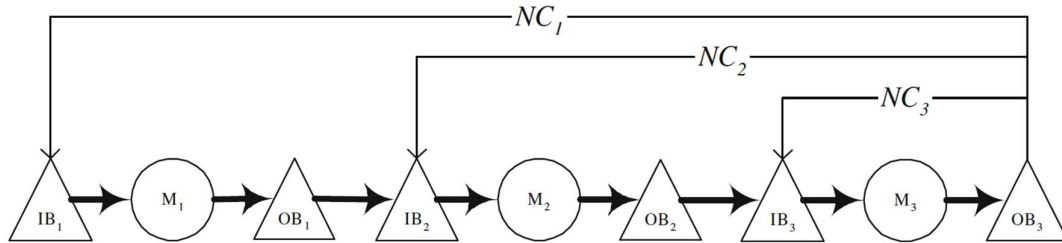

Figure II-XXVI: Base-Stock system (González-R et al., 2011)

2.3.4. Extended Kanban system

The extended Kanban system is a hybrid system between an inventory objective (nominal inventory such as Base-Stock) and Kanban policy (Dallery and Liberopoulos, 2000). The extended Kanban system uses two parameters: NC and “ S_i , target in terms of the number of products that must be produced to be stored in the output buffer” (González-R et al., 2011) where $NC_i \geq S_i$. When there is a demand at station i , it is automatically transmitted to all the upstream stations. In order to produce a part in station i , a demand from a downstream station is not sufficient: a Kanban card must also be available. Extended Kanban is illustrated in Figure II-XXVII below. This method stops supply generation if there is no longer any demand.

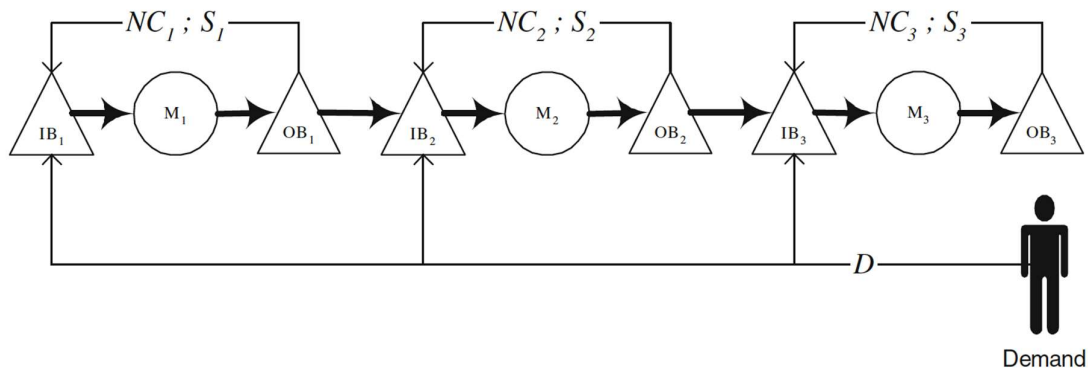

Figure II-XXVII: Extended Kanban system (González-R et al., 2011)

2.3.5. Generic Kanban system

The generic Kanban system looks like the specific Kanban (Figure II-XXV) but the main difference is that the different cards go from the output buffer of each station to the first process station (Figure II-XXVIII). In other words, when an activity finishes a job, the card is sent to the first station. The other rules are that the first station can only work when there is a Kanban card from each one of the downstream stations: this ensures that all released orders are complete and prevents waiting for missing parts.

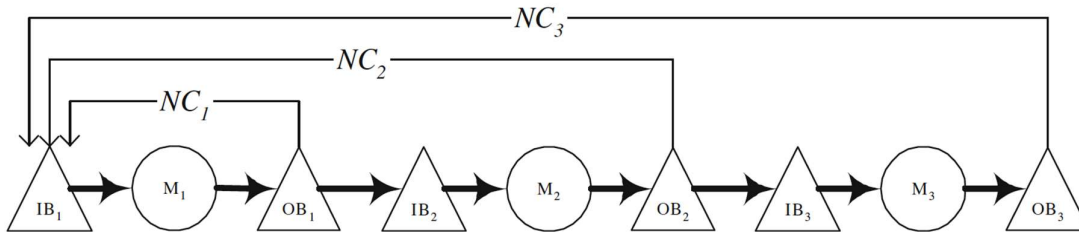

Figure II-XXVIII: Generic Kanban system (González-R et al., 2011)

2.3.6. Constant Work In Process

ConWIP (Constant Work In Process) keeps WIP constant and manages input processes according to output (Spearman et al., 1990). There is a fixed number of cards to produce and each production order can only begin if there is a card available. When all cards are in use, new production orders must wait (Figure II-XXIX).

With this functioning, the production line will not be overloaded with WIP: the card throughput is limited by demand throughput and bottleneck throughput. When a job is finished at the end of the process (at the last output buffer), the card becomes available at the beginning of the process: a new production order can begin. Furthermore, ConWIP manages flow between two BOM levels.

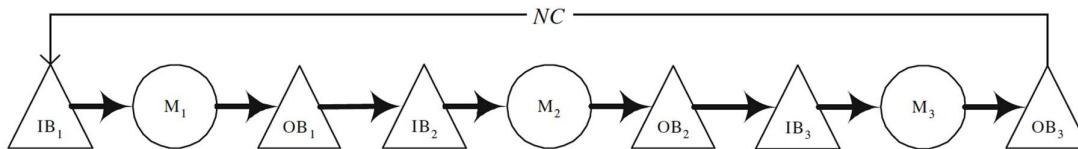

Figure II-XXIX: ConWIP system (González-R et al., 2011)

A study compared Kanban and ConWIP functioning (Takahashi and Nakamura, 2002) to demand variability. As a conclusion, the two methods are able to deal with the proposed demand variability (but with an increase in WIP). In this paper, the proposed Kanban has better results than the ConWIP. However, a limit is that the case study is realised for a single product and a linear process of 5 activities.

In the last decade, more and more research articles have dealt with ConWIP and different ConWIP versions (Jaegler et al., 2016): ConWIP is mainly applied to flowshop environments

and Make To Stock strategies. There are few applications in the Make To Order environment: is this a ConWIP limit? The authors also emphasise that there are few return of experiments but it is an interesting perspective.

2.3.7. Other methods

The main pull flow methods have been detailed but there are other specific methods, as for example:

- DFT for Demand Flow Technology¹ (Costanza, 1996) that is spread in companies with real applications with a philosophy close to Lean Manufacturing.
- CWIPL for Critical WIP Loops (Sepehri and Nahavandi, 2007)
- COBACABANA for Control Of BALance by CArd-BASed NAvigation (Land, 2009).

2.4. Other material management methods

As illustrated in the two previous parts, different “pure” push or pull systems were developed and implemented in companies. However, other methods were created in order to combine both push and pull strategies: hybrid push-pull systems.

2.4.1. Hybrid push-pull systems

The scientific community has been interested in hybrid push-pull systems for decades now (Hodgson and Wang, 1991a, 1991b; Karmarkar, 1986) and they were further developed later (Villa and Watanabe, 1993; Wang and Xu, 1997) .

These types of hybrid systems were often implemented in companies with good results (Bonney et al., 1999).

Hybrid push-pull systems can be classified into two categories with a vertical or horizontal push-pull integration (González-R et al., 2011; Olaitan, 2016).

2.4.1.1. Horizontal Hybrid systems

The horizontal hybrid push-pull system consists in having a succession of pull activities followed by push activities in the process. In this case, between pull and push activities, there are semi-

¹ Demand Flow Technology: “is a manufacturing process that incorporates many different methods of streamlining and efficiency to produce products in the least amount of time according to customer demands. This means that Demand Flow® Technology utilizes concepts such as just-in-time inventory, lean manufacturing, and six sigma efficiency standards to maximize production quality and speed. The process of demand flow manufacturing is unique, however, in that it changes the typical [assembly line](#) approach to labor that most manufacturers use. It does this by requiring employees to move from station to station as work flow needs require in order to keep the production process operating smoothly and at peak levels at all times. The other key aspect of lean concepts that this type of flexible work force supports more efficiently is that Demand Flow® Technology is geared towards product runs specifically designed to meet current customer orders, instead of generating traditional batches to be stored for later anticipated demand.” (definition from <http://www.wisegeek.com/what-is-demand-flow-technology.htm>)

finished items (Beamon and Bermudo, 2000; Cochran and Kaylani, 2008; Olhager and Östlund, 1990). These methods use decoupling points (as defined in Chapter II.1.1.3) by creating independent needs.

2.4.1.2. Vertical Hybrid systems

In general, a vertical hybrid system has the tactical phase combined with a push system and the execution phase dedicated to a pull strategy. For example, an MRP II system with the S&OP and MPS parts combined with a Kanban system at the execution level is a vertical hybrid push-pull system. Another example is a ConWIP-MRP system with MRP that generates orders and ConWIP that releases tokens at the last machine operation: “A second important difference between CONWIP and kanban systems [...] is that cards are typically part number-specific in a kanban system, but line-specific in a CONWIP system. In a CONWIP system, [...] cards do not identify any specific part number. Instead, they come to the front of the line and are matched against a backlog, which gives the sequence of parts to be introduced to the line. This backlog, or sequence, must be generated by a module outside the CONWIP loop, in a manner analogous to master production scheduling in an MRP system.” (Hopp, 2009)

Some works were also dedicated to the link between Just In Time (JIT) and MRP (Flapper et al., 1991; Huq and Huq, 1994): they proposed a method of embedding JIT into MRP and support MRP (a 3-step method) without changing too many MRP procedures or data in the database. The objective is to reap the benefits from JIT and its continuous improvement philosophy.

Paired-cell Overlapping Loops of Cards with Authorization, or POLCA, also enters into this category (Suri, 1998). With this method, instead of managing the system by reference, these references are grouped by product families. In this case, stations are grouped in pairs and the loops are overlapped to manage this system (Figure II-XXX). In this figure, this double loop provides a more accurate vision of the “M2” machine production with two card types.

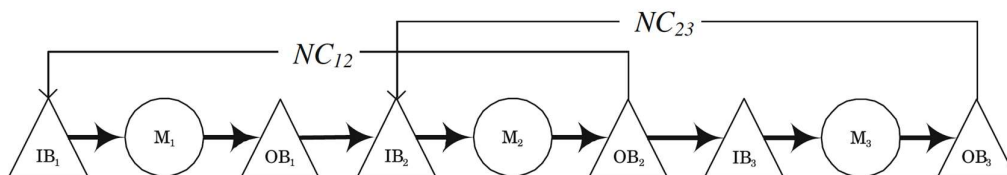

Figure II-XXX: POLCA System (González-R et al., 2011)

This loop system enables companies to manage the WIP level in the process with cards. What is more, this token system is coupled with an MRP system: production authorisations are delivered by a High Level MRP (HL/MRP) system (González-R et al., 2011). The POLCA method showed its advantages in an MTO environment with high diversity demand.

2.4.1.3. Other hybrid systems

For the moment, only hybrid push-pull has been dealt with. However, other hybrid systems have been developed. A flow management system is considered a hybrid when two systems are combined. An example of this is a mixed Kanban-ConWIP system (Bonvik and Gershwin, 1996) with Kanban loops inside the process, controlled with a ConWIP loop from the beginning to the end of the process (this also means two token types are needed).

2.4.2. Bottleneck management methods

The Drum-Buffer-Rope method, or DBR (Gilland, 2002; Stevenson et al., 2005), applies the principles of the Theory Of Constraints, or TOC (Goldratt, 1990; Goldratt and Cox, 1984) similar to the method and software of OPT for Optimized Production Technology (Spencer and Cox, 1995). That is to say, the output throughput level of a system is at best that of the bottleneck, which is the machine with the weakest throughput (machine “ M_{i+1} ” in Figure II-XXXI). This is the Drum in the DBR method illustrated below:

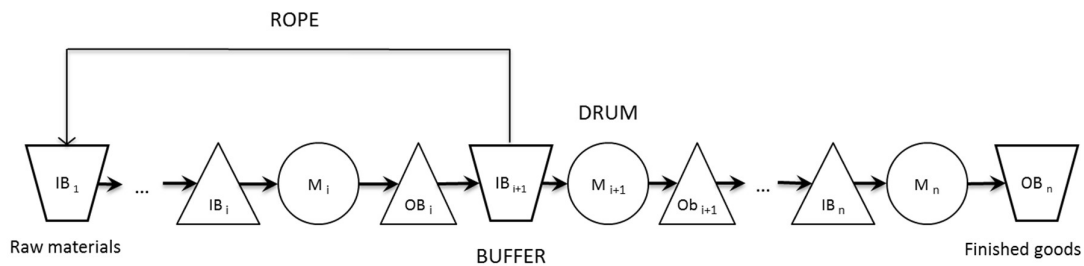

Figure II-XXXI: DBR system

As regards the Rope, it corresponds to the control loop in pull systems: the objective is to manage bottleneck utilisation. Finally, the Buffer's role is to manage potential shortages before the bottleneck. That would lead to a direct loss of productivity equivalent to the bottleneck's idleness and it is why orders are released in advance to always “feed the Drum”. The three main buffers (raw materials, buffer and finished goods in Figure II-XXXI) are strategically managed in DBR (this is why they are differently represented).

These types of methods are workload oriented. However, according to several authors, these types of system could be considered hybrid, with more of a pull system up until the Drum and afterwards a push system.

In this part, different types of methods have just been presented. The most well-known material management method is MRP II for push flow systems. The most well-known pull flow method is Kanban. The aim of this research work is to compare them objectively. That is why these main methods will be qualitatively compared in the next section.

2.5. And DDMRP?

In all this classification, the next question is: where to classify DDMRP?

DDMRP answers all the requirements from pull flow systems functioning according to real customer demand and consumption (“Demand Driven”). However, to nuance this statement, some authors would also classify DDMRP as a hybrid push-pull system like the DBR system for the pull flow comparison before the bottleneck and the push flow after. Furthermore, this would not be totally wrong because DDMRP is inspired from MRP (MRP calculations between operations that generate orders) and DBR to manage flow between the decoupling points (2.4.2).

As illustrated in this chapter, simplified DDMRP functioning could be described with Figure II-XXXII below:

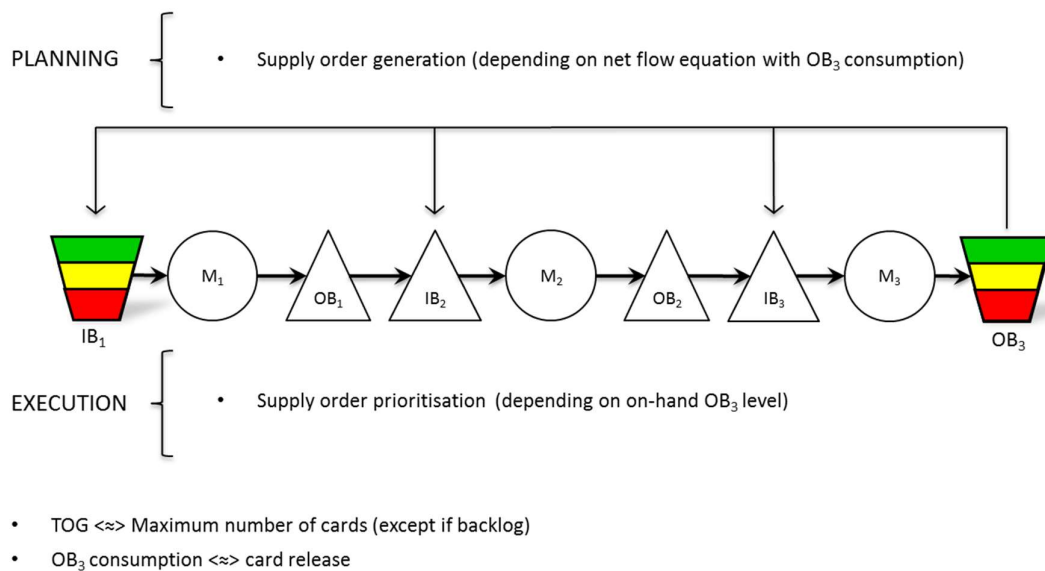

Figure II-XXXII: DDMRP System

To try to draw a parallel with other pull flow systems using cards, the TOG would be equivalent to a dynamic maximum number of cards (except if there is backlog that is integrated in the Net Flow Equation in DDMRP). In fact, buffer consumption could be compared to a card release because it is also integrated at this moment into the Net Flow Equation. Thus, it accentuates DDMRP’s affiliation to pull flow systems (without the tokens, however).

3. A qualitative comparison of material management methods

In this research work, DDMRP will be compared to other material management methods, which are MRP II and Kanban. Therefore, we will focus entirely on these three methods in the rest of this chapter.

3.1. Methods description according to the different horizons

SCM, as mentioned in chapter I, is a major topic for company competitiveness. In order to assess its performance, some frameworks were proposed (Gunasekaran et al., 2004), such as the Supply Chain Operations Reference model (SCOR®) by the Supply Chain Council. One important point is that each organisation, no matter which material management method is used, is decomposed into three different horizons: strategic, tactical and operational, in order to manage and control company policy (Ballou, 2003) and manage different levels of management (Rushton et al., 2010).

The strategic level consists in the steering committee choices for the company. These choices are long-term ones, such as for financial plans or company development strategies. As regards the strategic level, it is a mid-term horizon on resource management (human and material resources). In this step, the KPI levels help the company to stay in tune with its strategy. Finally, the operational level illustrates the day-to-day company life that is the result of all these decisions. It also helps ensure that the mid-term management strategy is well applied (or not) compared to the tactical objectives (Gunasekaran et al., 2004). This decomposition is illustrated by the Hoshin Kanri Lean method: “Align the goals of the company (Strategy), with the plans of middle management (Tactics) and the work performed on the plant floor (Action).”

In the previous part, material management methods were presented with a description of the functioning rules. However, as just explained, these methods should also be considered with the horizons illustrated in Table II-VI below:

Horizon	MRP II	DDMRP	Kanban
Strategic	Strategic Business Plan		
Tactical	S&OP MPS	DDS&OP PAF Demand Driven Planning	(1) Card dimensioning / Workload Levelling
Operational	MRP Scheduling	Demand Driven Operating Model	Loops and tokens / Visual Management

Table II-VI: MRP II, DDMRP and Kanban description depending on the horizon type

DDMRP and MRP II have previously been detailed. As regards Kanban, the tactical and strategic horizons are not often detailed. Most of the literature focuses on operational and bottom tactical levels. In the operational level of Kanban, loops and tokens are managed through implemented Visual Management. Then, on a tactical level, loops (and cards) are also sized with a step for the workload management. However, a more strategic layer is often missing (1 in Table II-VI). This lack can be solved with a vertical hybrid method such as the Heijunka plan (Jones, 2006). Otherwise, a study tried to deal with issue (Li, 2013) with different decision types taken on different horizons for a “robust Kanban” :

- Kanban card sizing (production and transport) at the operational level
- Capacity decisions (bottleneck) for the tactical level
- Sourcing decisions at the strategic level (urgent suppliers and numbers of servers for each station)

3.2. The main differentiation criteria

In this section the three methods will be compared according to several themes. As for Table II-VI, SCOR© model describes an organisation with the three horizons (strategic, tactical and operational). The table below deals with this comparison (Table II-VII) and the DDMRP promises in front of these different themes:

- Strategic : in order to improve the system flexibility by managing the Bullwhip effect.
- Tactical: in order to improve the system efficiency by managing WIP (so WC) and resources.
- Operational: in order to improve effectiveness by managing OTD.

Response to variabilities	Criteria	Kanban approach	MRP II approach	DDMRP approach	DDMRP Promises	Developed in this research work
STRATEGIC	Long term planning role	Capacity sizing and levelling strategy with overcapacity	Critical resources sizing and levelling strategy	Buffer positioning and sizing / PAF sizing	P1: DDMRP helps absorb variability spreading and amplification (the Bullwhip effect)	YES
	Flow Strategy	Pull flow	Push flow (forecasts)	Hybrid		
	Management strategy	Decentralised production generation and execution	Centralised production generation and execution	Hybrid: Centralised production generation Decentralised execution		
	Decoupling variability	All articles	All articles	Strategic articles buffered with the decoupled explosion application		

Response to variabilities	Criteria	Kanban approach	MRP II approach	DDMRP approach	DDMRP Promises	Developed in this research work
TACTICAL	Workload & Capacity analysis	Kanban card sizing & levelling strategy	All BOM levels	PAF / Control Points	P2: DDMRP improves WIP management	YES
	Human resources management	Real-time allocation	MPS	Real-time allocation	P3: DDMRP manages human resources well with flexibility	NO
	Supply grouping	Double Kanban system (eg. In a truck)	Post processing of MRP results	Priority management for dealing with available space for supplies (eg. A truck)	P4: DDMRP improves supply management with grouping mechanisms and priority management.	NO
	Demand transmission	Loops between 2 activities	MRP: On all references in BOM	Loops between 2 buffers and an MRP calculation between	P5: DDMRP improves demand transmission with buffer positioning choices and MRP integration.	NO

Response to variabilities	Criteria	Kanban approach	MRP II approach	DDMRP approach	DDMRP Promises	Developed in this research work
OPERATIONAL	Exceptional hazards: Spike management	∅	Only those known, forecasted in MRP Management of spikes with forecasts in the MPS process	In Net Flow Equation: spikes taken into account in a defined threshold	P6: DDMRP strives to adapt to extreme variability in spike demand.	YES
	"Normal" hazards absorption	Short term flexibility (quantity to produce and overcapacity) Alert levels	Safety stocks	Stock, time and capacity buffers Control points Red zone (base and safety)	P7: DDMRP helps guarantee OTD objectives with safety mechanisms and real-time adjustments	YES
	Priority management	Based on WIP urgencies (in real – time)	Based on scheduling (anticipation)	Based on buffer status (in real-time)		
	Visual Management	Decide what, when and how much to produce with a simple colour code	∅	Prioritise, speed up flow through a simple colour code. Visualise lateness	P8: DDMRP improves visual management by integrating it into the whole approach.	NO

Table II-VII: Response to variability for the three methods according to different horizons

In this table, MRP II, Kanban and DDMRP are compared through different criteria, classifying the promises of DDMRP according to height points. With Table II-VII, DDMRP seems to be complete and overcomes the main issues seen in companies with the other methods used.

However, DDMRP is recent and is evolving: are there, as for any material management method, potential issues and points to challenge?

3.3. DDMRP topics to challenge

As DDMRP has been described and positioned against other flow management systems, a list of DDMRP issues to challenge can now be detailed in order to scientifically validate them (or not).

DDMRP is based upon the assumption that MRP, Lean and other systems such as Kanban are currently inefficient in companies although they have each good practices. DDMRP is a complete tool that is said to manage all the current issues that other methods fail to cope with. DDMRP is thus described: “Planning systems since the 1920s evolved from the core perspective of inventory. This is no longer true. Now demand must be at the core. Thus DDMRP is not the next evolution in inventory management; it is a revolutionary shift in perspective and tactics. [...] Inherent in its rules and tools is a level of common sense and visibility that easily translates beyond the confines of a single entity” (Ptak and Smith, 2011).

So, in this section, the DDMRP promises are highlighted in order to be challenged in the next chapters or for future research work.

3.3.1. From a strategic point of view (P1)

DDMRP helps manage the environment by positioning, sizing and adjusting strategic buffers:

Buffer positioning: A research issue should deal with the positioning complexity step. Indeed, in a complex process with multiple references and with many BOM levels, it would be extremely complex (or impossible) to choose the best buffer positioning scenario: this may be a DDMRP limit for implementation in complex systems and worse, may lead to DDMRP project failures. An important decision-aiding tool could be developed in order to help users to position buffers (and periodically review them). This research has already begun with works on a scale of a unique BOM with or without multiple parents (Jiang and Rim, 2016; Rim et al., 2014). This issue is already complex for a unique BOM, so it will need further research before implementing it on a whole company scale. This work should also help to assess the DDMRP demand transmission improvement between buffers for the tactical horizon.

Buffer parameter choices: Each stock buffer is sized according to 4 factors: product type (Manufactured, Purchased or Distributed), variability, Lead Time and MOQ. Concerning variability and LT for buffer stock sizing, there are two factors (for green and red zones, Chapter II.1.2) which are Variability and LT factors. Two tables are given in DDMRP training (Figure II-VII) to help decide which factors to choose. However, it is an iterative step and a semi-automatic decision tool would help to better

choose these factors in a DDMRP implementation project. Indeed, for the moment, “[...] planning personnel will need to set the value based on their company’s environment and their comfort level” (Ptak and Smith, 2011) or “the simulation was based on some rules of thumb” (Ihme and Stratton, 2015).

DDMRP planning to execution buffer sizes: As detailed in Chapter II.1.7, the last two DDMRP steps deal with Demand-Driven Planning and Visible and Collaborative Execution. For these steps, buffer stock zones are translated and are not equivalent. The red planning zone becomes the red and yellow execution zones (50% each, which could be challenged) and the yellow planning zone becomes the green zone for execution: this choice could also be challenged because the on-hand position would oscillate between TOR planning and (TOR + Green Zone) planning position. Is the translation between planning and execution DDMRP buffers absolutely accurate?

DDMRP aims to manage demand that is transmitted with decoupled explosion:

LT challenge: DDMRP is based on the concept of DLT with decoupled explosion (Chapter II.1). As for other systems, this involves knowing precisely the different LTs in the BOM. This subject is already an issue for many companies (who enter incorrect LTs in their ERP, for example): when order generation is produced with this wrong LT (often overestimated with considerable waiting times), it congests the system. However, the main issue here is that when DDMRP is implemented, all this LT will be changed: when there is a change in the retained flow management strategy, LT will dramatically evolve. This could also lead to a non-fitted buffer positioning step. It would be interesting to be able to anticipate future LT with DDMRP implementation to be confident in the positioning step that could otherwise restrain improvement potential.

3.3.2. From a tactical point of view (P2 to P5)

WIP management: Another DDMRP promise is better WIP management for each reference. This concept is illustrated with the “bi-modal curve” (Figure II-II). Contrary to other flow management systems that have too little or too much WIP per reference, DDMRP seeks to centre the WIP at an appropriate level. Firstly, is this “bi-modal curve” really observed in such proportions compared to other material management methods? Secondly, is the WIP of each reference really centred after DDMRP implementation? How the supply grouping management and the resource management improvement impact the WIP management enhancement?

Financial assessment: The main DDMRP implementation step consists in positioning buffers with an ROI analysis. With stock buffers, if one stock buffer is able to manage variability and earn money, it must be positioned there (this point is also linked with DDMRP “LT Challenge” issue). For this reasoning, an average on-hand economic assessment is done in the process for each scenario. However, only the cost price is taken into account. The end item (Figure II-XVII) cost is only assessed with the raw materials cost. In reality, especially in some core businesses, a great deal of

added value is brought by the different activities along the process. Does this assumption lead to a non-fitted positioning step?

3.3.3. From an operational point of view (P6 to P8)

Spike management: DDMRP would help to manage demand spikes. In DDMRP theory, it is possible to integrate a spike in a Net Flow Equation as “a qualified spike” if it represents more than 50% of red zone planning (TOR execution zone). Is this a good allotment? In reality, in some companies and some demand profiles, would it lead to having only spikes in the Net Flow Equation? In this situation, qualified spikes would have less meaning and they might even be over-anticipated and lead to a Working Capital increase. It would be interesting for researchers to investigate what would be a “qualified spike” in different contexts. Furthermore, it would be interesting to analyse on what time horizon a spike must be integrated in the NFE.

Satisfactory OTD guarantee: DDMRP should be able to guarantee a satisfactory OTD level with safety mechanisms such as the red zone dimensioning and with a real-time adjustment and execution. Are these mechanisms reliable and do they enable the system to attempt near perfect OTD level?

Visual management: DDMRP has a full visual management strategy for all its steps (compared to MRP II). Is this visual management strategy efficient in reality? Is this visual management helpful for stakeholders when DDMRP is implemented?

In this chapter, DDMRP was described, as well as other flow management system types. Then DDMRP was compared to MRP II and Kanban from a qualitative point of view. In the next chapter, these three methods will be compared through a case study, and some DDMRP promises will be challenged. The main issue is variability management, which is why the three methods' behaviours will be assessed through different types and levels of variability. This comparison will give a quantitative point of view.

As regards the description of DDMRP, many orders of magnitude are given (buffer sizing, spike detection, execution buffer zone cutting out, alert management, etc.) and further research could help develop decision-aiding tools for these important issues. Therefore, Chapter IV will focus on DDMRP buffer sizing.

Chapter III.

MRP II, DDMRP AND KANBAN ASSESSMENT WITH A DESIGN OF EXPERIMENTS

“Experience is the name everyone gives to their mistakes.”

Oscar Wilde¹

In Chapter II, the three methods were qualitatively compared through several themes. In this chapter, they will be quantitatively assessed in a Design Of Experiments (DOE)² with several scenarios (Figure III-I).

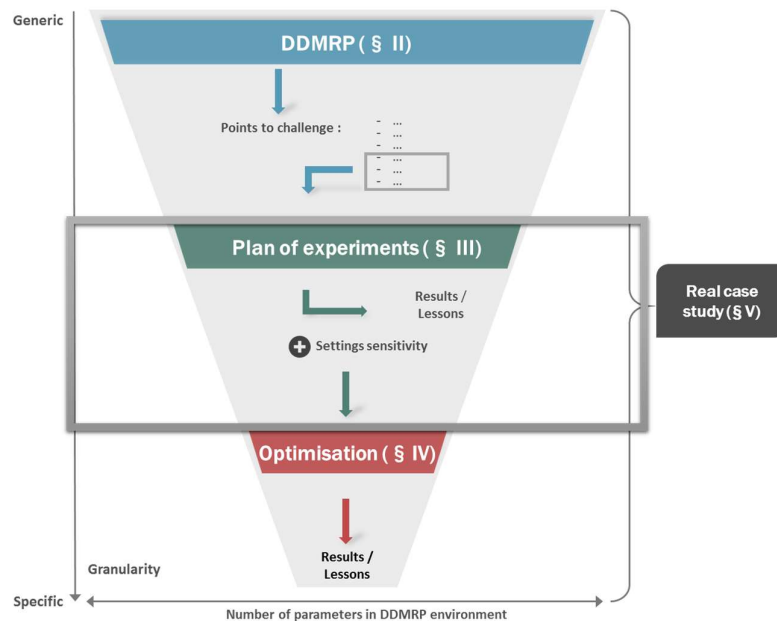

Figure III-I: Big Picture - DDMRP Plan of experiments

As regards the literature, there is already research work that has been produced to quantitatively assess material management method behaviours, such as:

- One of the first works on this subject was done in order to compare push flow systems to Kanban (Sarker and Fitzsimmons, 1989). The main conclusion is that pull systems

¹ : Irish playwright, novelist, essayist and poet (1854 – 1900)

² DOE: “An experiment is a series of tests conducted in a systematic manner to increase the understanding of an existing process or to explore a new product or process. Design of Experiments, or DOE, is a tool to develop an experimentation strategy that maximizes learning using a minimum of resources. Design of Experiments is widely used in many fields with broad application across all the natural and social sciences. It is extensively used by engineers and scientists involved in the improvement of manufacturing processes to maximize yield and decrease variability. Oftentimes, engineers also work on products or processes where no scientific theory or principles are directly applicable.” (Weibull website definition)

are more sensitive to high processing time variability than are push flow systems. However, it was assessed that pull systems always have better results in terms of WIP. The limit of this work is that it was carried out on a simple case: a linear process.

- Another work deals with a consequential MRP – Kanban – ConWIP comparison (Hochreiter, 1999). This research work also assessed impacts from several variability sources: lot size management, setting-up time and machine failures. One of the conclusions was the better resilience of pull material management methods. The limit of this work is again a study focused on a linear process of 10 machines.
- Important work has been done to assess different Kanban versions (Li, 2013). They were assessed compared to different sources of variability: demand, process and supply variabilities. The main results are that Kanban has very good behaviour and results with stable environments. However, when there is a high variability level, Kanban is not able to cope with risks or to “take” the appropriate actions. This evaluation was implemented on a simple case composed of 5 links that represent an entire linear supply chain and the perspectives were to implement Kanban in more realistic and complex systems.
- Another article deals with an assembling process in order to compare pull flow methods (Koulouriotis et al., 2010) such as Kanban, Base-Stock, ConWIP, ConWIP/Kanban hybrid, Generalised and Extended Kanban. The last two methods seem to have the best results (without major differences) in this case but with more parameters to deal with than for Kanban and Base Stock. The first limit is that it would be complicated to optimise Generalised and Extended Kanban on a real industrial scale. Secondly, the assembling process is also dramatically simplified compared with current industrial issues, with only 2 simple machines that feed the assembling operation.
- Other research work has been produced with more sophisticated processes in order to compare one Kanban and one ConWIP method (Khojasteh and Sato, 2015; Khojasteh-Ghamari, 2009, 2012). It was shown that a well-designed Kanban can outperform ConWIP in a linear case. Besides, Kanban is better than ConWIP or the others depending on the process structure. However, this case is only configured for a single end product and without lot-size issues.
- Finally, a review compared hybrid and pull production strategies: Hybrid push-pull, ConWIP, Kanban, Extended Kanban Control Strategy (EKCS) and Base Stock Control Strategy (BSCS) (Geraghty and Heavey, 2005). From this work, the conclusion was that Kanban is mostly behind the others in WIP terms: more WIP is required to reach the same OTD. EKCS has a WIP level equivalent compared to the other methods but this WIP is not located at the same point in the process. Indeed, WIP is more important in semi-finished products for EKCS compared to finished products for the others. This study was done on 5 machines (assembly and a linear process) but the limit is that it only deals with one finished product assembled from two components. Another limit is that the assessed scenario had a low variability level.

A considerable part of the literature focuses on comparing material management methods from a functioning point of view without comparing them and, most of all, without performance issues.

However, when there is a comparison, as just noticed, the works and the results from the literature that were compared to real industrial cases have at least two limits out of the three following features:

- Linear processes
- A single product
- No or almost no variability sources

This is why another case study, closer to reality, has been chosen for this assessment work. This case is detailed in the next section.

1. The case study

1.1. Overall presentation

The case study chosen for this work is based on the “Jeu du Kanban©” or Kanban game (Greif et al., 1984) that was developed by the Centre International de la Pédagogie d’Entreprise (CIPE). For the purpose of this research, some rules have been modified and some hypotheses have been made: these will be further detailed in Chapter III.1.4.

The Kanban game was originally a board game: its objective is to initiate learners to JIT philosophy and the differences between push and pull material management methods through the implementation of MRP II and Kanban.

The game focuses on a company, named “Redix”, that produces and assembles speed reducers. In this serious game, the company want to improve their performance in terms of OTD and inventories (cf. OTD is the percentage of orders delivered on time with the appropriate quantity compared to the total order amount).

The scale of the study is a single workshop: low power reducers. The workshop is composed of 5 workstations: 4 machining and 1 assembling stations. In order to assemble a reducer, one oil pan, one gear and one crown are required. In the process, there are two different crowns: an A crown or a B crown, with the A crown machined before the B crown (Figure III-II).

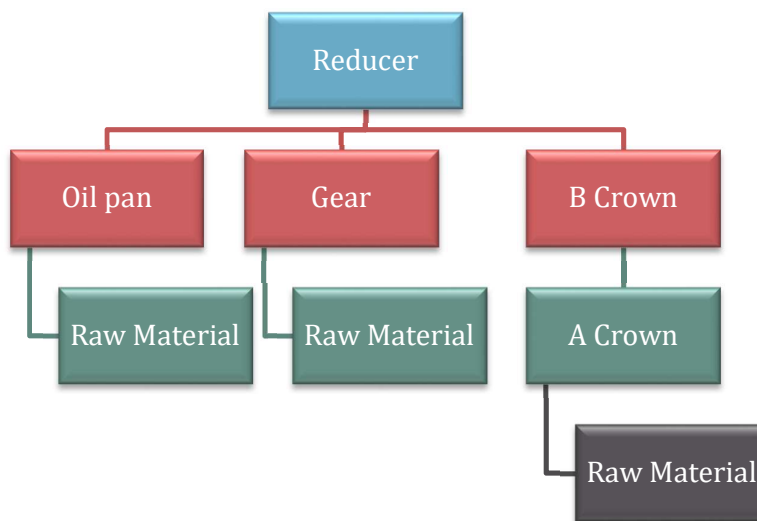

Figure III-II: Reducer Bill Of Material

As regards the stations to produce the reducers, there are 4 machining workstations (one for each type of reference to be assembled) with each time possible inventory after and before each station. The layout is arranged as illustrated by Figure III-III below:

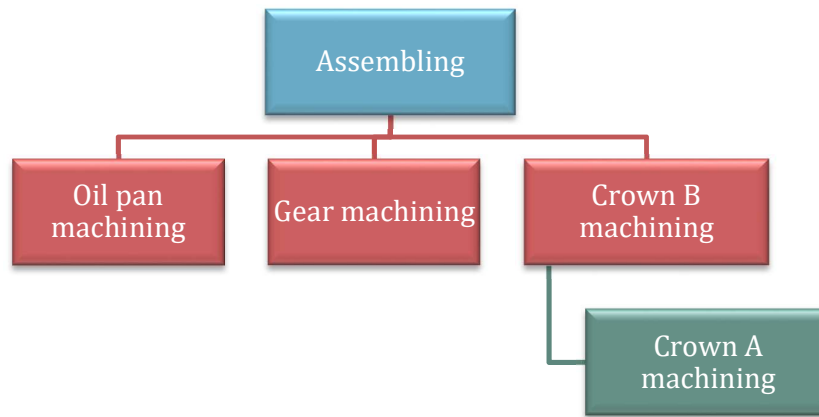

Figure III-III: Reducer machining and assembling process

1.2. Realistic representation of the case study

This case study was chosen for this research work because of its realistic representation of process manufacturing (such as the companies that AGILEA advises) for several reasons:

- It is complete with all types of data needed.
- There is a real mix of products (contrary to other studies with one reference for each activity)
- Several BOMs with more than one level
- Setting-up operations
- Different demand scenarios
- An assembling activity

This game has all the data needed (as detailed in Chapter III.1.4) to be simulated and to be able to change parameters. Indeed, this case study offers the possibility of implementing different variability sources that are further detailed (Chapter III.3). The case studies identified in other research work do not have this level of completeness. Besides, this case was experiment on multiple cases to illustrate and understand the MRP II and Kanban implementation steps. As in this research, one of the objectives is to identify and challenge material management methods. In consequence, this case is appropriate because it addresses all the limits detailed in Chapter III.1.1.

1.3. Discrete Event Simulation choice

In order to reach our research objectives and to test different scenarios, another tool was mandatory. Therefore, in the research, the system behaviour was computer simulated.

An appropriate tool for conducting this study is Discrete-Event Simulation (DES), one of the most widely used tools in operational research, with an increase in its use over the past sixty years (Hollocks, 2006). This tool presents major advantages (Fontanili et al., 2013; Law, 2014): DES provides a predictive point of view and assesses simulation model modifications. A main

DES advantage is also obtaining a dynamic view of system behaviour. Indeed, the WC assessment of inventory in the simulation will not only be a mean value but there will also be the minimum and especially the maximum values. DES gets the desired KPIs (WC and OTD in this case). Furthermore, DES is appropriate for modelling many types of systems, such as manufacturing, material handling, service, healthcare, communications or queuing systems in general (Schriber et al., 2012). This tool was used to study SC disruptions and propose strategies to counter these disruptions with a dynamic discrete event simulation approach (Melnik et al., 2009). DES is also appropriate for Business Process Reengineering (BPR) applications and most importantly, for modelling scheduling methods (such as MRP II) and optimisation works (Hollocks, 2006): two subjects that are dealt with in, respectively, Chapter III (this chapter) and Chapter IV. DES is also a communication and training tool because it is possible to see system behaviour dynamically. It is interesting for implementing methods and explaining them to stakeholders: this is the case for Chapter V.

However, some other tools or methods would be appropriate for modelling and simulating systems with a System Dynamics (SD) perspective (Forrester, 1961, 1995) or an Agent Based perspective (Bonabeau, 2002; Jennings, 2000).

In the end, DES was a good choice because the Mines Albi laboratory is an expert in DES (time savings) and mostly because this tool is compliant with all the parameters and variability sources we wanted to implement.

In this research work, the DES software used is Witness®, developed by Lanner. This software is one of the world leaders in DES.

1.4. Detailed data and hypotheses

After the overall presentation, each type of data used in the case study is detailed in this section. This data may be slightly modified and hypotheses may be made from the original game.

As regards items, there are 16:

- 6 types of reducers: R1 to R6
- 2 types of oil pans: one red and one blue
- 2 types of gears: one yellow and one white
- 3 B crowns, so 3 A crown types: one white, one green and one red

The final customer orders the six reducers and also a white A crown, sold as spare parts.

The 7 BOM references sold are given in Table III-I below (as a reminder, a B crown is machined from the same A crown type). Each BOM's coefficient is 1: one reducer, one oil pan, one gear and one B crown is required.

Sold part	Oil pan component	Gear component	Crown component
R1	Red oil pan	Yellow gear	White B crown
R2	Red oil pan	Yellow gear	Green B crown
R3	Red oil pan	Yellow gear	Red B crown
R4	Red oil pan	White gear	White B crown
R5	Blue oil pan	White gear	Green B crown
R6	Blue oil pan	White gear	Red B crown
Spare parts	/	/	White A crown

Table III-I: BOM matrix

The 5 workstations are initially configured using 5 parameters (Table III-II):

- Operation cycle time: for each station, a lot to produce or assemble takes 1 hour. In reality, the operation cycle time is not always fixed (it will vary in the DOE).
- Lot size: in one hour each station produces or assembles 100 references, except for both crown machining stations with 200 references per hour. These values simplify the modelling step but production lot sizes are common in industry.
- Each station has a setting-up time if it produces or assembles another reference (another colour for machining or another reducer configuration for the assembling activity).
- Mean Time Between Failure (MTBF): this time was assessed with Kanban game data and a negative exponential law¹ is used to model real system behaviour.
- Mean Time To Repair (MTTR): this time to repair a failure is also assessed with Kanban game data. This time a triangle distribution law² is used to model real system behaviour.

¹ Negative exponential: “a continuous single-parameter distribution used esp when making statements about the length of life of certain materials or waiting times between randomly occurring events. Its density function is $p(x) = \lambda e^{-\lambda x}$ for positive λ and nonnegative x , and it is a special case of the gamma distribution” (Collins English Dictionary)

² Triangle distribution: “A triangular distribution is a continuous probability distribution with a probability density function shaped like a triangle. It is defined by three values: the minimum value a , the maximum value b , and the peak value c . This is really handy as in a real-life situation we can often estimate the maximum and minimum values, and the most likely outcome, even if we don't know the mean and standard deviation.” (StatsLC.com)

Machines	Oil pan machining	Gear machining	Crown machining phase A	Crown machining phase B	Assembling
Cycle Time (hr)	1	1	1	1	1
Lot size	100	100	200	200	100
Setting-up time (hr)	3	3	2	4	1
MTBF (hr)	NegExp (17.80)	NegExp (11.6)	NegExp (9.70)	NegExp (15.19)	NegExp (21.25)
MTTR (hr)	Triangle (1.1, 2.2, 4.4)	Triangle(0.86, 1.73, 3.46)	Triangle (0.48, 0.96, 1.92)	Triangle (0.4, 0.8, 1.6)	Triangle (0.8, 1.6, 3.2)

Table III-II: Workstation parameters

For each of the 16 references, the following initial parameters are detailed in Table III-III below:

- Initial state: at the beginning of the simulation, each reference has an initial inventory as in reality.
- Forecasts: there is a weekly average forecast that is given in the serious game.
- Demand variations: there is a confidence interval compared to the weekly forecasts (e.g. R1 customer demand will be between 600 and 800 each week). In the Kanban game, the initial forecasts are accurate compared to what can be observed in some industrial sectors.
- Production costs: the production cost is given in euros
- Selling price: this is the price paid by the customers to get one of this reference.

References	R1	R2	R3	R4	R5	R6
Initial state	500	100	100	600	200	100
Forecasts (qty/week)	700	75	550	900	400	350
Demand Variations (+/- per week)	100	75	150	150	200	150
Production costs (€)	100	100	100	100	100	100
Selling price (€)	150	150	150	150	150	150

References	White A crown	Yellow gear	White gear	Red oil pan	Blue oil pan
Initial state	1000	700	700	1100	400
Forecasts (qty/week)	1100				
Demand Variations (+/- per week)	400				
Production costs (€)	9	25	25	55	55
Selling price (€)	30				

References	White B crown	Green B crown	Red B crown	Green A crown	Red A crown
Initial state	800	200	600	200	400
Forecasts (qty/week)					
Demand Variations (+/- per week)					
Production costs (€)	10	10	10	9	9
Selling price (€)					

Table III-III: Reference parameters

Then, as regards demand profile, each morning the customer orders a quantity unknown by the “Redix” company. That is to say the customer can order several references (the six reducers and the spare parts) at the same time in different quantities. The initial demand scenario (with quite a stable demand) is illustrated with Table III-IV below. Each line is a day of the week (with 5 working days in a week): the initial information is that this demand scenario respects, for each reference, forecasts with demand variations (Table III-III).

Period	R1	R2	R3	R4	R5	R6	White A crown
1	200		100	200			
2	100		200	300			500
3				100	200	100	500
4	200	100	100	200	100		
5	200		100	200	100	200	400
6	100		200	400			
7	200		200	400	100		
8				100	200	200	400
9	100		200		100	100	
10	200		100	200	100	200	400
11	100	100	200	300			600
12	200	100	100	400			
13				100	200	200	400
14	100		200		100		
15	200			200	100	100	400
16	200		100	200			
17	100		200	300			500
18				100	200	100	500
19	200	100	100	200	100		
20	200		100	200	100	200	400
21	100		200	400			
22	200		200	400	100		
23				100	200	200	400
24	100		200		100	100	
25	200		100	200	100	200	400
26	100	100	200	300			600
27	200	100	100	400			
28				100	200	200	400
29	100		200		100		
30	200			200	100	100	400

Table III-IV: Part of the demand scenario example

In the Kanban game, there are also breakdowns that are expected. These breakdowns (distributed with cards in the game) are listed and summarised in Table III-V below:

Machines	Average breakdowns time (hour) per week
Oil pan machining	4.4
Gear machining	5.2
A Crown machining	3.6
B Crown machining	2
Assembling	2.8

Table III-V: Breakdowns expected for each section

Furthermore, some hypotheses were made for the Kanban game and the simulation model:

- Each section is open 5 days a week and 9 hours per day.
- Human resources are not dealt with: at anytime, there are enough employees to have every machine available. This hypothesis depends on the company, and human resources can be the bottleneck.
- The different transfer operations are considered to be instantaneous: between inventories and machines, this will also be true for Kanban card transfers.
- Inventory capacities are considered infinite (no space constraints). In reality, this hypothesis is not true. However, one of the objectives is to compare WIP management, so infinite capacity will help analyse this promise (P2).
- No scraps are taken into account in the simulation model (scrap rate is not significant in the game and testing was not planned as a parameter in the DOE). This feature is sometimes one of the main issues for companies but it is not in our study scale.
- In this case study, there are 2 product types: produced or bought. We will not focus on products that are bought because the initial Kanban game hypothesis is that raw materials are considered infinite (and always available).
- All the final products have the same selling price: there is no strategy to implement in order to improve financial throughput (and turnover).

As previously explained, the main KPIs that will be assessed are OTD and WC. In order to evaluate WC and product cost evolution in a process, the Value Stream Accounting (VSA) method is applied (Gordon and Fischer, 2011). Indirect fixed costs are not considered. For entities that are circulating in the system, they consume direct costs. Thus, hourly activity costs (production and setup) and inventory costs are cumulated by each entity according to the time consumed. Consequently, at any moment of the simulation the sum of all the circulating entities value give the In Process Capital. Then, with the simulation tool, each entity will impact WC¹ from where it is in the process. An example of the VSA method's link to DES is provided in the research literature (Miclo et al., 2014), with VSA which "...appears to be the best alternative

¹ WC: Working Capital = Value of stock and In Process + customer receivable – supplier debt. In this work, only value of stock and in process are assessed (no delay for customer and supplier payments).

to provide a bridge between operational views and financial views of lean”(Li et al., 2012). Therefore, this tool is appropriate in such simulation projects.

In the case study, WC will only be assessed with production costs (Table III-III). The missing data (from the initial board game) will be created in order to implement VSA in this case. However, this case study focuses on a small scale with short lead times, so VSA would not be very interesting; VSA implementation is used in the real application (Chapter V) which is more representative of reality.

2. Material management methods applied to the case study

2.1. The issues

The main issue with this case study is the workload level management: how will the different material management methods manage the capacity? Indeed, the workstations are open 45 hours per week. As detailed in Table III-III, there is an average reducer demand of 2,975 up to 3,800 (with demand variation). A first workload/capacity analysis is realised in Table III-VI with only workload compared to demand and average breakdowns removed from capacity. Demand for Crown machining phase A is higher because they are spare parts (White A Crown).

This issue will help to challenge promises P4 and P5 with buffer positioning and sizing from this data and also to analyse WIP management with the workload / capacity analysis.

Machines	Demand (quantity)	Workload (hr)	Breakdowns (hr)	Capacity remaining (hr)
Oil pan machining	2975	29.75	4.4	10.9
Gear machining	2975	29.75	5.2	10.1
Crown machining phase A	4075	20.375	3.6	21
Crown machining phase B	2975	14.875	2	28.1
Assembling	2975	29.75	2.8	12.5

Table III-VI: Mean workload/capacity analysis, Part I

In this first part analysis, there is capacity remaining in order to produce sub-components and to assemble reducers. The last parameters deal with setting-up time: this duration depends on the strategy retained in the number of setups authorised for each machine. Table III-VII illustrates this strategy with 2 examples: each reference (for each activity) is produced (or assembled) once or twice a week. Without variability (average demand and breakdowns), all activities should have enough capacity to take each reference at least one time per week.

Then, if the strategy is to produce (or assemble) each reference twice a week, both crown machining stations have enough capacity. The second lesson is that 2 machines may be bottlenecks, even if they only have two types of references: oil pan machining and gear machining.

Machines	Capacity remaining (hr)	Capacity remaining for each reference if made once a week (hr)	Capacity remaining for each reference if made twice a week (hr)
Oil pan machining	10.9	4.85	-1.15
Gear machining	10.1	4.05	-1.95
Crown machining phase A	21	15.025	9.025
Crown machining phase B	28.1	16.125	4.125
Assembling	12.5	6.45	0.45

Table III-VII: Workload/capacity analysis, Part II

Depending on the number of setups required over time and thus on the product mix and the management strategy, the bottleneck can move from the gear machining to the oil pan machining (or the assembling activity).

Table III-VIII gives the mean lead time per 2 months for orders of each component reference in the case of one MRP II simulation (3.2.3). One can verify that the bottleneck is located in the gear machining step for months 7 to 8, in the oil pan machining for months 9 to 10 and again in the gear machining for months 11 to 12 (cf. months 1 to 6 are the transitional period).

	White A crown	Yellow gear	White gear	Red oil pan	Blue oil pan	White B crown	Green B crown	Red B crown	Green A crown	Red A crown
Average LT (7 to 8)	0.6	2.1	2.8	1	1	1.2	1.5	1.3	1.2	0.9
Average LT (9 to 10)	0.8	2	2.2	2.1	2.7	1.7	1.8	2.2	1.4	1.7
Average LT (11 to 12)	0.7	2.2	2.3	1.2	1.8	1.3	1.1	1.2	0.7	1
Average LT (7 to 12)	0.7	2.1	2.4	1.4	1.9	1.4	1.5	1.5	1.1	1.2

Table III-VIII: Lead Time sub-component comparison for different periods

These potentially high workload levels could lead to synchronisation issues for assembling, with here also an assembling activity which has a potentially high workload level. Therefore, the system must be flexible and agile enough to respond to variability and guarantee a high OTD level without having excessively high inventory costs. This will be assessed with the three material management methods implemented below.

2.2. MRP II

In the DES model, the MRP II method has been implemented from S&OP to the scheduling step (Figure III-IV). As regards S&OP, its objective is “only” to decide which quantity of all reducers can be produced in a month (from the reducer family point of view).

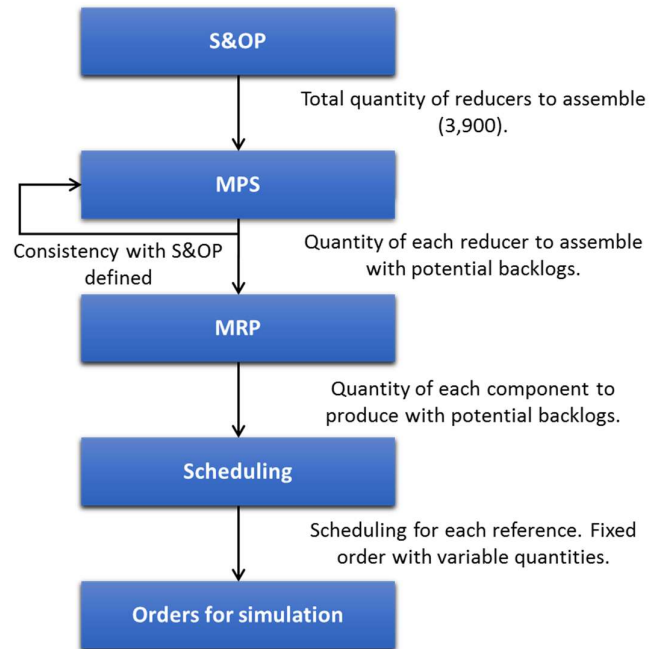

Figure III-IV: Chosen approach to implement MRP II

Then the MPS plans the assembling orders for each reducer (from R1 to R6) up to a maximum quantity of 3,900: this is equivalent to a week without breakdowns and one setup for each reference for assembling, oil pan machining and gear machining. The MPS is based on the average forecasted demand. Furthermore, it takes into account possible backlogs at the end of the month in order to plan for this backlog and future demand for the next month (with a 3,900 maximum). If the maximum threshold is reached, the orders are planned by reference priority (compared with the current on-hand level).

From this MPS, a weekly MRP is calculated with the BOM in order to satisfy assembly consumption. MRP is realised for oil pans, gears and both crowns. MRP also considers potential backlogs to plan for them in the future. Whether for MRP or MPS, a safety stock is initially calculated for each reference and will be adjusted for the different scenarios.

The final step deals with scheduling these production and assembly orders. An initial schedule was defined to meet customer demands from initial on-hand. This schedule was realised in order to use different components to assemble the reducers (e.g. assembly orders requiring red oil pans were not all planned in a row). A sequence was also defined for the components to limit the setup operations. This appropriate sequence will be repeated (for reducers and the other references) throughout the simulation. Therefore, the order is fixed (but according to where the scheduling stops, a different reference may be produced at the beginning of the week after

compared to the previous one). However, the quantity of each order will be modified each time MPS or MRP is calculated. An example of scheduling for the first week of the initial scenario is detailed below (Table III-IX):

Oil pan machining		Gear machining		A Crown machining		B Crown machining		Assembling	
Part	Qty	Part	Qty	Part	Qty	Part	Qty	Part	Qty
Blue oil pan	600	White gear	1100	Red A crown	600	Red B crown	600	R3	600
Red oil pan	2400	Yellow gear	1400	Green A crown	800	Green B crown	800	R2	100
Blue oil pan	300	White gear	800	Red A crown	400	White B crown	1800	R5	400
				White A crown	3000	Red B crown	400	R4	900
								R1	700
								R6	400

Table III-IX: MRP II scheduling example

What is more, in MRP II implementation, if an order is not completed when the MRP or MPS calculation is realised, the next period will continue with this order. However, the quantity of this order (or others that were already planned) can be adjusted.

For the DOE, safety stocks and MPS maximum quantity can be adjusted with MRP II.

2.3. DDMRP

2.3.1. Buffer positioning

Regarding DDMRP implementation, the first step deals with buffer positioning. As detailed in Chapter II.1.4, the buffer must be positioned where it will compress lead times and reduce variability. An ROI analysis must validate this first step. As far as the case study is concerned, the different questions are which type of products must be buffered. Firstly, due to the Make To Stock (MTS) environment (cf. the real customer demand is only known on the day of the order), the 6 reducers must be buffered. This assumption also concerns white A crowns (spare parts). Seven references out of 16 must already be buffered with stocks. The different scenarios for assessing the impacts of buffering references were realised: if all components are buffered, it dramatically decreases DLT for reducers; however, it may cost in terms of inventory.

In order to assess each DLT, a hypothesis is made with the setting-up number authorised for each reference in a week. If there are 2 setting-up operations each week, the reference lead time will be 2.5 days.

For each scenario, the stock buffers are also sized in order to assess average inventory from a financial point of view (as a reminder, the average inventory is the sum of the red zone and half of the green zone). Two scenarios are detailed: Table III-X is the first, with all references buffered except B crowns and green and red A crowns: this scenario leads to 834,915€ in average inventory. Indeed, the reducers' DLT is high because it takes into account the LT of non-buffered B and A crowns.

The second scenario also buffers B crowns (Table III-XI). The reducers' DLT is shortened to 5 days compared to the 9.5 days in the previous scenario. This scenario leads to 593,943€ in inventory (a 41% reduction). This scenario is the best theoretical buffer positioning scenario: 14 references out of 16 are buffered, which is all the references except for green and red A crowns. With all 16 references buffered, inventory costs would increase (Romain Miclo et al., 2015). This positioning step is challenged in the DOE by experts, in a scenario with high variability (Chapter III.3.2.5). Indeed, this positioning step dramatically depends on the hypothesis made (in this case the setup number). The implemented stock buffers could be changed with DLT variations.

In order to size buffers, each reference can have its own buffer profile because there is only a small number of references in this case. In reality, references are grouped with the same buffer profiles (in order to ease buffer management).

Table III-X: DDMRP
buffer positioning
example 1

	R1	R2	R3	R4	R5	R6	White A Crown	Yellow Gear	White Gear	Red Oil Pan	Blue Oil Pan	White B Crown	Green B Crown	Red B Crown	Green A Crown	Red A Crown
Forecasts	700	75	550	900	400	350	1100									
Average Daily Usage	140	15	110	180	80	70	220	265	330	445	150	320	95	180	95	180
Setups per week	1	1	1	1	1	1	2.7	0.8	0.8	1.0	1.0	1.9	1.9	1.9	2.7	2.7
DLT (days)	9.5	9.5	9.5	9.5	9.5	9.5	1.9	5.9	5.9	5.1	5.1	2.6	2.6	2.6	1.9	1.0
Lead Time factor Green	50%	50%	50%	50%	50%	50%	50%	50%	50%	50%	50%					
Variability factor	50%	50%	50%	50%	50%	50%	50%	50%	50%	50%	50%					
Lead Time factor Red	50%	50%	50%	50%	50%	50%	50%	50%	50%	50%	50%					
Yellow	1325	142	1041	1704	757	663	412	1574	1960	2282	769					
Green	663	100	521	852	379	331	206	787	980	1141	385					
Red Base	663	71	521	852	379	331	206	787	980	1141	385					
Red Safety	331	50	260	426	189	166	103	394	490	571	192					
Planning Top Of Red	1000	125	800	1300	575	500	325	1200	1475	1725	600					
Top Of Yellow	2350	275	1850	3025	1350	1175	750	2775	3450	4025	1375					
Top Of Green	3025	375	2375	3900	1750	1525	975	3575	4450	5175	1775					
834 915 € Average Inventory (€)	133133	17500	106033	172600	76433	66567	3852	39839	49127	126253	43577					

Table III-XI: Best
DDMRP buffer
positioning

	R1	R2	R3	R4	R5	R6	White A Crown	Yellow Gear	White Gear	Red Oil Pan	Blue Oil Pan	White B Crown	Green B Crown	Red B Crown	Green A Crown	Red A Crown
Forecasts	700	75	550	900	400	350	1100									
Average Daily Usage	140	15	110	180	80	70	540	265	330	445	150	320	95	180	95	180
Setups per week	1	1	1	1	1	1	2.7	0.8	0.8	1.0	1.0	1.9	1.9	1.9	2.7	2.7
DLT (days)	5	5	5	5	5	5	1.9	5.9	5.9	5.1	5.1	2.6	4.5	4.5	1.9	1.9
Lead Time factor Green	50%	50%	50%	50%	50%	50%	50%	50%	50%	50%	50%	50%	50%	50%		
Variability factor	50%	50%	50%	50%	50%	50%	50%	50%	50%	50%	50%	50%	50%	50%		
Lead Time factor Red	50%	50%	50%	50%	50%	50%	50%	50%	50%	50%	50%	50%	50%	50%		
Yellow	700	75	550	900	400	350	1011	1574	1960	2282	769	830	424	804		
Green	350	100	275	450	200	175	505	787	980	1141	385	415	212	402		
Red Base	350	37,5	275	450	200	175	505	787	980	1141	385	415	212	402		
Red Safety	175	26,25	137,5	225	100	87,5	253	394	490	571	192	208	106	201		
Planning Top Of Red	525	75	425	675	300	275	775	1200	1475	1725	600	625	325	625		
Top Of Yellow	1225	150	975	1575	700	625	1800	2775	3450	4025	1375	1475	750	1450		
Top Of Green	1575	250	1250	2025	900	800	2325	3575	4450	5175	1775	1900	975	1875		
593 943 € Average Inventory (€)	70000	12500	56250	90000	40000	36250	9250	39839	49127	126253	43577	8326	4311	8260		

2.3.2. Buffer positioning comparison with the experts

In order to challenge this theoretical DDMRP positioning, this step was presented to experts. The same data was given to them, apart from the high demand variability scenario. Indeed, the demand scenario given was the most complicated to reach satisfying results (that will be further detailed in 3.2.5).

Six AGILEA expert consultants who have already implemented DDMRP several times, separated into 3 groups, did the positioning step in order to compare it to the theoretical one. As noted earlier, in the DDMRP positioning step, 14 out of the 16 references are buffered with DDMRP stock buffers. Only red and green A crowns are not buffered.

Here are the 3 groups' results:

- The first one would also buffer 14 out of the 16 references (the same ones) but with a stock and time buffer coupling for the 6 reducers sold and the spare parts.
- The second one would buffer 10 out of the 16 references. The buffer strategy is the same for the components but only 2 out of the 6 reducers would be stock buffered: both of the most sold reducers would be buffered and the others would be planned because here, firm demand could be enough to have some references assembled with a Make To Order strategy and managed lead time alerts.
- The third group would buffer 14 out of the 16 references. The 14 references are the same and this group would only use stock buffers for this scenario. In other words, the DDMRP positioning step is exactly the same as the one we realised.

The main lesson is that these 3 strategies may be considered to be valid and possible to implement. As the strategies found by the experts are close to the one proposed (and one is totally equivalent) the 2.3.1 positioning results were retained and simulated for the DOE.

2.3.3. Buffer sizing

This step is not immediately detailed because the lead time and variability factors will depend on the scenario assessed in the DOE.

However, for the initial value, the DLT, LT factors and variability factors must be chosen:

- **DLT:** the initial DLT values are equivalent to those calculated from the buffer positioning step.
- **LT factors:** as we have seen, the assembling, oil pan machining and gear machining steps are potential bottlenecks. All these references have close DLTs. In addition, the DLT for the B crown (LT for A crown added to LT for B crown) is also close to other

references DLT . This is why the initial LT factor is the same for all references and is set at 50%. Green and red LT factors initially have equivalent percentages.

- The last parameter is the **variability factor**: all references must manage sources of variability (especially with this high demand level scenario). It is difficult to assess system behaviour and whether variability is lower or higher for final products or components. This is why variability factors are also initially set at 50% for the 14 references.

2.3.4. DDMRP management

Demand Driven Operating Planning is simulated, with the NFE updated each day. The theory will be followed: if the NFE for a buffer enters the yellow zone, a supply order with a quantity that reaches TOG must be generated. Spikes will not be qualified in the NFE because demand is unknown (no visibility).

Finally, the execution step will also follow DDMRP theory and a buffer status will be assessed:

Buffer status (reference)=on-hand level (reference) / TOY (buffer linked to this reference)

If there are several supply orders for an activity, the reference with the lowest buffer status is prioritised. In the simulation model, buffer status are always updated each time an order is ended.

As regards A crown planning: when a supply order is generated for a B crown, the same quantity is generated for a corresponding A crown supply order. Then, for execution, as soon as A crown machining is available, a hypothesis is made to assess buffer status, because only the white A crown is buffered (Figure III-V):

- Buffer status (A white) = On-hand (A white) / TOR (A white)
- Buffer status (A green) = [On-Hand (A green) + On-Hand (B green)] / TOR (B green)
- Buffer status (A red) = [On-Hand (A red) + On-Hand (B red)] / TOR (B red)

The lowest ratio is then prioritised.

Afterwards, a “classical” prioritisation is then realised for B crown machining, as well as for reducers, gears and oil pans (if there are supply orders).

The DDMRP parameters that will be changed in the DOE are the green, yellow and red buffer zones, with DLT, LT factors and variability factors.

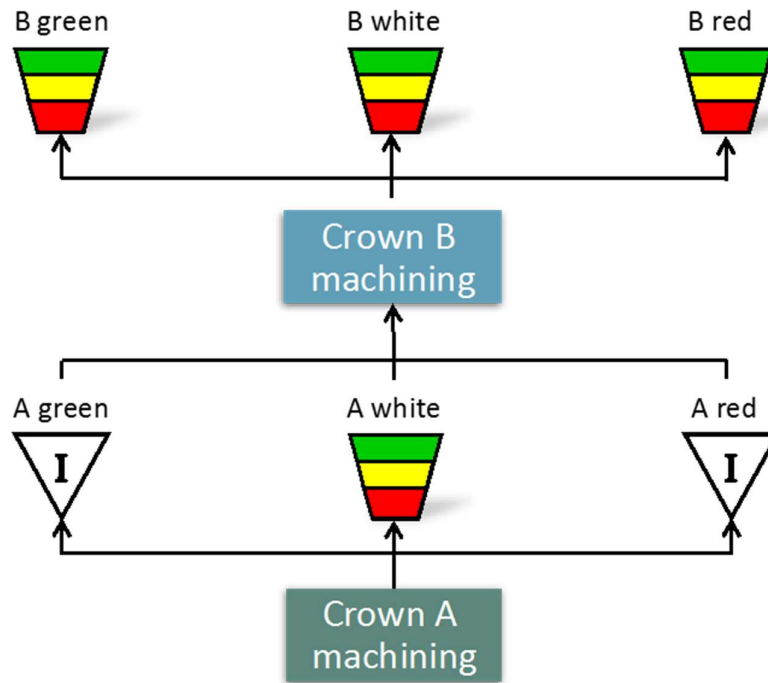

Figure III-V: DDMRP buffer positioning for A and B crowns

2.4. Kanban

The last method implemented in the Kanban game is – Kanban. With the load/capacity issues (Chapter III.2.1) previously detailed, a schedule is defined in order to assess the number of Kanban cards. The objective is to try to repeat this schedule and to have an adaptive system when there is variability (Figure III-VI). The grey time buckets are equivalent to setup operations. This schedule is realised with breakdown considerations (which is why it does not last 45 hours).



Figure III-VI: Gantt Diagram used to assess Kanban cards

From this schedule, the number of Kanban cards can be assessed. This number is calculated with the following formula (Sugimori et al., 1977):

$$N = \frac{D \times L + G}{C}$$

With:

- N = Number of Kanban cards
- D = Demand per unit time
- L = Maximum waiting time of Kanban and Processing Time
- G = Policy variable (equivalent to a safety zone)
- C = Container capacity
- N' = Number of Kanban cards without security (G=0)

The table below (Table III-XII) details the Kanban assessment. N' gives the Kanban number without security. In order to get the initial Kanban number (N), the following strategy has been applied: there is demand each day with several setup operations possible for assembling (with 6 reducers). The system must be able to be flexible but also to be able to produce several lots from the same reference if there is enough capacity (especially for assembling, gear and oil pan machining). The implemented L value depends on the number of times a reference is produced (once a week for some and twice a week for others). Furthermore, the schedule above (Figure III-VI) is a “perfect schedule” if demand is well distributed. This is why a safety factor (G) of 35% is initially defined (and rounded up) to have N for all the references.

As detailed, the Kanban implementation is an iterative method, so the cards would (and will) be changed after being compared to system behaviour.

		R1	R2	R3	R4	R5	R6	A White Crown	Yellow Gear	White Gear	Red Oil Pan	Blue Oil Pan	B White Crown	B Green Crown	B Red Crown	A Green Crown	A Red Crown
D	Weekly Demand	700	100	500	900	400	400	3200	1400	1800	2300	900	1600	600	1000	600	1000
C	Container size	100	100	100	100	100	100	200	100	100	100	100	200	200	200	200	200
L	Kanban transfer time (h)	0	0	0	0	0	0	0	0	0	0	0	0	0	0	0	0
	Setting-up time (h)	1	1	1	1	1	1	2	3	3	3	3	4	4	4	2	2
	Processing time (h)	1	1	1	1	1	1	1	1	1	1	1	1	1	1	1	1
	Waiting time (h)	16	37	22	25	34	34	7	21	17	12	26	13	27	15	31	19
N'	Kanban number	3,2	1,0	3,0	6,1	3,6	3,6	4,0	8,8	9,5	9,2	6,8	3,6	2,4	2,5	2,6	2,8
G	Security Factor (%)	35%	35%	35%	35%	35%	35%	35%	35%	35%	35%	35%	35%	35%	35%	35%	35%
N	Kanban number	5	2	5	9	5	5	6	12	13	13	10	5	4	4	4	4
	Red indicator	1	1	1	1	1	1	2	2	2	3	1	1	1	1	1	1
	Green indicator	2	0	1	3	2	2	2	4	5	5	3	2	1	1	1	1

Table III-XII: Kanban card sizing

The red indicator represents a reference production emergency and is calculated with a Kanban transfer time equivalent to zero. This assumption is representative of reality with more and more companies that use RFID technology or barcodes to reach this objective (electronic Kanban) and improve their processes with real-time location systems (R. Miclo et al., 2015).

This red value is in the “Red indicator” line: a reference becomes an emergency when there is only this amount of available space for this reference on the Kanban table. Furthermore, the “Green indicator” for each reference represents the amount of Kanban cards to produce in a row at a minimum. The objective is to limit the setup operation number, especially when there

are several emergencies (to avoid changing the reference each time one lot size has been produced). This parameter can be compared to the DDMRP green zone which is the minimum quantity for a supply order.

As regards Kanban execution, there are only 2 ways of changing the production reference (or assembly): when there is an emergency (a red indicator is reached, the current reference is not in an emergency zone and the green indicator has been reached) or when there is no Kanban card remaining for the current reference.

When the production of the reference changes, here also a prioritisation is made (as for DDMRP). The most highly prioritised reference (ref.) is the one with the highest ratio:

$$\text{Ratio (ref.)} = \text{Kanban cards available on the table (ref.)} / \text{total amount of Kanban cards (ref.)}$$

Furthermore, compared to DDMRP, Kanban implementation for the case study concerns the 16 references, thus 16 loops to assess and size cards.

With Kanban, the number of cards and red and green indicators will be changed in the DOE.

To conclude, the three methods' implementations are well coded and applied in order to follow the theory. This hypothesis already helps avoid numerous problems, identified daily by AGILEA consultants in reality, as well as the unacceptable results which companies have (especially for MRP II). The possible levers for reaching the OTD objective for each scenario and for each method are defined in Table III-XIII below:

	MRP II	DDMRP	Kanban
Possible levers	<p>Safety stocks</p> <p>Maximum MPS amount</p>	<p>Green, yellow and red zones, so:</p> <p>DLT</p> <p>LT factors (green and red)</p> <p>Variability factors</p>	<p>Kanban number</p> <p>Red indicator (alert threshold)</p> <p>Green indicator (minimum card to produce before changing)</p>

Table III-XIII: Possible levers for each method for the DOE

3. Design of experiments

3.1. DOE objectives and hypothesis

3.1.1. Objectives

The “single objective” is to challenge the theoretical pull flow promises and especially these DDMRP promises to:

- A) Improve variability source management in order to guarantee the best OTD possible: this concerns promises P6 and P7.
- B) Well design the system to improve inventory management in order to have the right references in the right quantities: promise P2.
- C) Be able to adapt to demand, even with high workload levels: that is to say having a flexible, agile system. Promise P1 is concerned here because lead time must be managed to be flexible (DLT for DDMRP).

From this statement, hypotheses are made in order to challenge these promises:

- Demand nervousness (1) represents external variability, and process variability (2) represents internal variability. These will be modified in order to challenge the different DDMRP management of variability sources (A).
- This same demand nervousness (1) and a global system workload change (3) will be implemented in order to challenge the DDMRP promises of inventory management improvement (B).
- Finally, demand nervousness (1) and most of all the global system workload change (3) will enable the DDMRP ability to adapt to demand to be confirmed (or not) (C).

Therefore, some types of parameters will be modified for each modification type. These parameters are the following:

- 1) Demand nervousness (external variability):
 - 0 – Initial scenario (stable demand)
 - 1 – Demand with spikes and troughs (more or less steep)
 - 2 – Demand seasonality
- 2) Process variability (internal variability):
 - 0 – Initial scenario (fixed value: determinist model)
 - 1 – High operating and setup time variability
- 3) System workload:
 - 0 – Initial scenario (production capable system)
 - 1 – Workload levels requiring load levelling and a flexible system

In order to confirm (or disconfirm) these hypotheses, a DOE will therefore be realised.

3.1.2. Scenario hypothesis

Before realising the DOE, the scenario hypotheses are detailed in this section:

All scenarios will be simulated for an entire year (48 weeks of 5 days) in order to have each variability repeated in the simulation enough times. As far as statistics are concerned, the year is halved: the first semester ensures that a stationary phase can be reached (even if there are initial on-hand inventories to begin simulation: the targeted level of these inventories will depend on the material management method and the scenario tested). The statistics are analysed only for the second semester. Therefore, the results analysis will be reliable for each stochastic model.

For each scenario, unless specified, the safety stocks, DDMRP buffers, and Kanban cards are not resized in this period because the demand is a repeated 6-week cycle. Indeed, in reality the sizing of the parameters for the three methods are rarely updated. The demand variability will be located in this 6-week cycle.

To have reliable scenario performances, the WC is recorded daily to get a representative average value at the end of the simulation. As far as OTD is concerned, the indicator is based on average OTD from the 7 references sold by the company (the 6 reducers and the white A crown).

As previously detailed, WC (1.4) and OTD (1.1) are the two main indicators followed. Additionally, the main flow management levers will be assessed: safety stock for MRPII, buffer size for DDMRP and the number of cards for Kanban. These indicators are described in 3.2.1.

3.2. The DOE

In this section each scenario is detailed according to the Witness® simulation model with the differences from the initial scenario (**Appendix A: Kanban Game® Witness® model**).

3.2.1. Initial scenario: the comparative basis scenario

3.2.1.1. Results

Firstly, before trying to challenge MRP II, Kanban and DDMRP with variability sources, the initial scenario objective is to assess the three system behaviours almost without variability.

Indeed, the demand scenario is here stable and can be considered “flat”. Table III-IV details this stable cycle demand: the weekly demand is split into small lots and the variability for this scenario can be considered to be nearly null. Furthermore, for each week in this scenario the real customer demand is included between forecasted values more or less “Demand variation” (Table III-III). Figure III-VII illustrates this stable demand with an example of the demand for the R1 reducer.

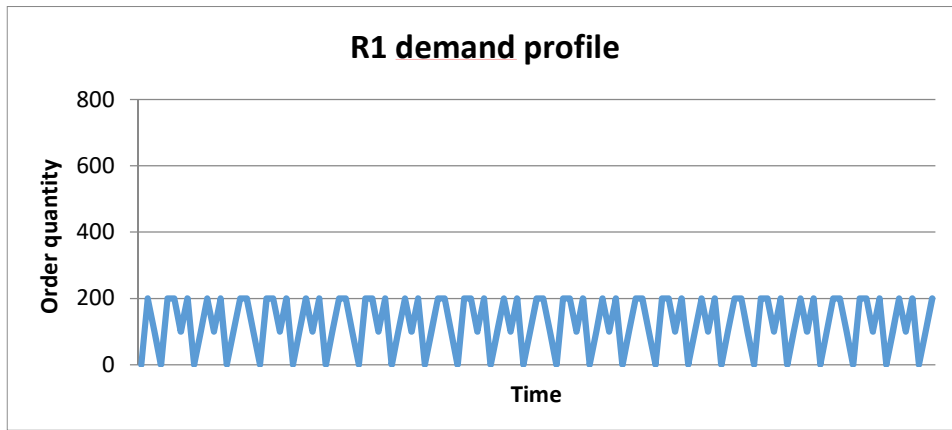

Figure III-VII: Stable demand example for reducer R1

As regards variability in this scenario, the only one to deal with is breakdowns (Table III-II) with MTBF and MTTR for each machine. Therefore, the systems should repeat their production cycles and get good results.

As detailed in the previous section, the simulation is conducted over an entire year (48 weeks of 5 days) and the statistics are taken into account for the second semester. The simulation results are detailed in Table III-XIV below:

	OTD (%)	WC (k€)
MRP II	99.3	424
DDMRP	100	429
Kanban	100	424

Table III-XIV: Initial scenario results

As expected, without variability sources the results are equivalent, whether in OTD or WC terms. What is more, these results reach the objective of 99.3% OTD.

3.2.1.2. The comparison basis for the other scenarios

In order to easily compare this scenario to the others, the evaluated KPIs must be normalised. Therefore, 424k€ (which is a meaningless value) is now equivalent to 100%.

In the previous section, other KPIs were assessed in order to analyse scenario impacts. The objective was to have an additional KPI for each method. To obtain representative KPIs, they are assessed for two types of references:

- End items: the 6 reducers
- Strategic sub-assembly items: 5 references with white A crown, blue and red oil pans, and white and yellow gears (the other crowns are not detailed because the activity has enough capacity and can manage WIP).

The results are detailed with Table III-XV below:

	End items	Components
MRP II safety stock total	2,000	4,400
DDMRP buffer zones total	3,900	10,700
Kanban cards total	38	57

Table III-XV: End item and component KPIs for each material management method

These KPIs are currently meaningful for quantifying the use of levers. But these KPIs are not comparable between methods (each method's KPI does not quantify the same parameter).

They will also be normalised (values above are equivalent to 100%) and the objective is to compare these KPIs with a future scenario. Table III-XVI below details the results of this first scenario. Visual indicators have been put into the table in order to more easily see the best scenario in terms of OTD and the best for WC. The rules followed for the visual indicators are detailed in Table III-XVII.

	MRP				DDMRP				Kanban			
	WC (%)	OTD (%)	Safety Stock		WC (%)	OTD (%)	Buffer Zone		WC (%)	OTD (%)	Kanban Number	
			Red	Comp			Red	Comp			Red	Comp
1 - Initial state (stable demand)	100%	99.3%	100%	100%	101%	100%	100%	100%	100%	100%	100%	100%

Table III-XVI: Initial state results

WC	>= 10%	>= 8%	>= 5%	>= 3%	0 to < 3%
OTD	>= 1%	>= 0.7%	>= 0.4%	>= 0.2%	0 to <0.2%

Table III-XVII: Visual indicators to quantify OTD and WC levels

3.2.2. Process variability

In Table III-II, operating cycle times and setup times are fixed values. Indeed, for each activity a lot is produced or assembled in exactly 1 hour. Furthermore, a setup operation is also done in exactly 1 to 4 hours (depending only on the machine type). An interesting scenario would consider a non-negligible variability with these parameters: in reality, the programmed 1-hour cycle time is never precisely respected. The value given is often a mean value (and companies do not have the corresponding distribution law nor the confidence interval).

In order to implement this variability source, the triangle distribution law is implemented: variability is included between the initial value and more or less 50%. The operating cycle times modelled follow the law below. This rule is also followed for setup operations.

iv = initial value

Operating cycle time = triangle (iv x 0.5, iv, iv x 1.5)

For this scenario, as the distribution laws have been implemented the simulation model is no longer deterministic. Therefore, with a stochastic model several simulations must be run in order to obtain representative results.

As regards results (Table III-XVIII), this first implemented variability source has insignificant impacts on the system. The different simulations realised for each method have the same OTD with some WC variations ($\pm 7\%$ WC between scenarios).

	MRP				DDMRP				Kanban			
	WC (%)	OTD (%)	Safety Stock		WC (%)	OTD (%)	Buffer Zone		WC (%)	OTD (%)	Kanban Number	
			Red	Comp			Red	Comp			Red	Comp
1 - Initial state (stable demand)	100% ↑	99.3% ↓	100%	100%	101% ↑	100% ↑	100%	100%	100% ↑	100% ↑	100%	100%
2 - Internal variability	101% ↓	99.6% ↓	105%	100%	98% ↑	100% ↑	105%	97%	99% ↑	99.9% ↑	100%	100%

Table III-XVIII: Process variability results

This internal variability therefore has no real impact on the results: the numerous lots produced and the setup numbers realised each week can explain these results. As these events often appear, on a weekly scale, the operating and setup times are close to the average or forecasted load.

It is notable that for DDMRP (one TOG changed for reducer R5 with 20% variability factor increase and one for an oil pan with a DLT reduction by 20%) and Kanban, WCs are even lower (slightly) than in the initial scenario. It can be surprising to have better results with variability. However, the reason is that with this scenario, the physical flow is sometimes slowed down but this does not lead to other (or higher) supply order generation or priority reference changes for Kanban.

3.2.3. Demand variability

The objective of the third scenario is to analyse an introduction of demand variability. At first, spikes and troughs are generated in the demand scenario: for each reference sold, from the initial demand scenario, spikes (3 to 4 times the daily order, at a maximum) are generated in the demand scenario. In other words, “Demand variations” from Table III-III are no longer respected.

In order to be able to representatively compare this scenario to the initial one, the demand amount for each reference is equal to the initial scenario: trough periods are also modelled. The R1 reducer demand profile with spikes and troughs (for the first semester) is illustrated below in Figure III-VIII. Compared to reality, this spike type is common and can be dramatically higher in some businesses.

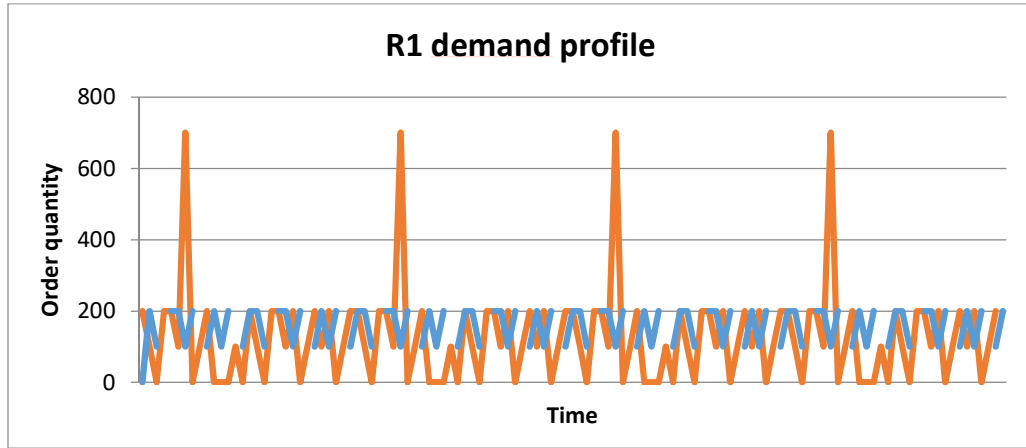

Figure III-VIII: R1 demand profile with spikes and troughs

As far as results are concerned, differences appear in this scenario. Indeed, in order to guarantee a good OTD, MRP II needs to dramatically increase its inventory (+25% WC) compared to the others with fewer WC impacts. The three methods require an increase in their reducer parameters: +5% DDMRP buffer zones (equivalent changes compared to “process variability”), +11% Kanban cards and most of all +45% safety stocks for MRP II. Therefore, for guaranteeing good OTD, the three methods need to concede in terms of WC (Table III-XIX).

There is a noticeable 6% WC gap to DDMRP’s advantage compared to Kanban. The reason lies in the component parameters: with demand variability here, DDMRP needs to have flexible component production, which is why the DDMRP component zones are reduced for this scenario.

	MRP				DDMRP				Kanban			
	WC (%)	OTD (%)	Safety Stock		WC (%)	OTD (%)	Buffer Zone		WC (%)	OTD (%)	Kanban Number	
			Red	Comp			Red	Comp			Red	Comp
1 - Initial state (stable demand)	100% ↑	99.3% 🟡	100%	100%	101% ↑	100% ↑	100%	100%	100% ↑	100% ↑	100%	100%
3 - External variability	125% ↓	99.5% 🟡	145%	107%	105% ↑	99.8% ↑	105%	87%	111% ➡	99.8% ↑	116%	102%

Table III-XIX: Demand variability results with spikes and troughs

The total of component buffer zones decreased from the initial scenario (to 87%): it can be quite surprising that reducing buffer zones improves OTD. Otherwise, if the component zones were higher (especially the green zones), the minimum supply orders would increase and there would not be enough flexibility in order to produce the right component at the right time (30% DLT reduction for an oil pan and 5% for a gear). Even for gear and oil pan machining, if there are bottlenecks, flexibility is needed with a possible setup operation. However, the total demand is equal, so buffers are replenished with trough periods. Besides, for these 2 bottlenecks, there are only two references to make. Therefore, even if more supply orders are generated, there is more chance of producing the same reference several times (due to the buffer status).

3.2.4. Foreseeable seasonality demand

Seasonality is common for many companies. Difficulties in managing this phenomenon are also common for these companies: the capacity required during a certain period is not enough to satisfy customers. Otherwise, numerous references are produced in advance, too much in advance, which leads to excessive levels of inventory and can lead to serious cash flow issues.

This scenario's objective is to analyse the behaviour of the three methods with seasonality. For each reference sold, forecasted seasonality has been manually implemented. Figure III-IX illustrates this with reducers R1 to R6 and a spare parts demand profile forecasted throughout the year. For each cycle (cf. 6 weeks), a seasonality demand coefficient has been implemented: the goal is to obtain on a monthly basis the same global demand for the 6 reducers as in the initial scenario. That is to say, each reference has different seasonality periods. With this hypothesis, the two scenarios can be compared and the workload capacity remains stable.

In order to cope with seasonality, DDMRP and Kanban are resized for each theoretical demand cycle. Kanban is sized each month with the equation in Chapter III.2.4 and the card number is updated. As regards DDMRP, PAFs (Chapter II.1.5) are used: this is a coefficient applied to the ADU that changes the three DDMRP zones in general (unless there is a high MOQ). Thus, DDMRP buffer zones are modified at each demand cycle.

As far as MRP II is concerned, in reality it is too time-consuming to resize safety stocks often (it is done once a year at best). As a consequence, safety stocks are not resized each month in this scenario.

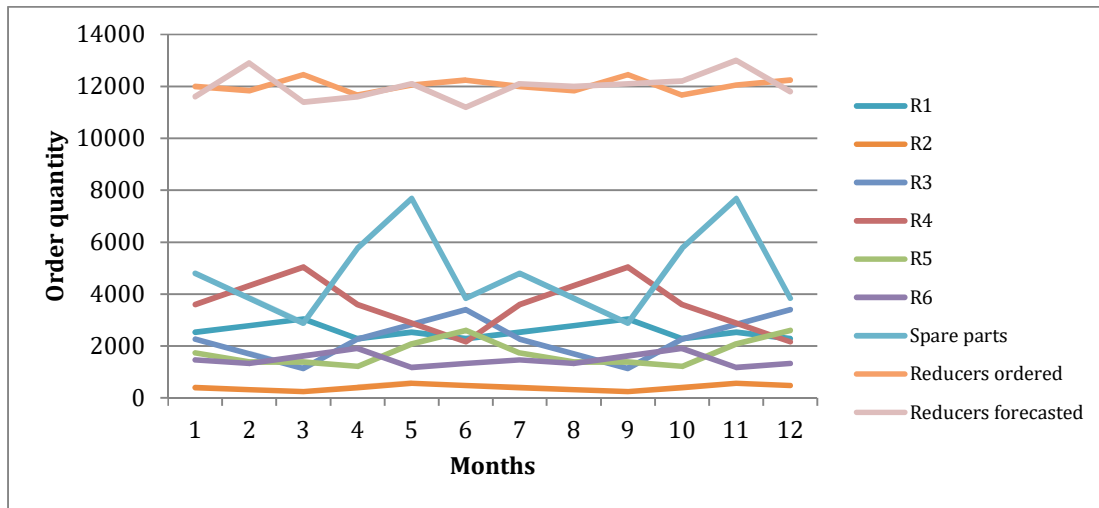

Figure III-IX: Theoretical demand profile with seasonality

To add variability, real demand will not follow theory: a random draw is made for each demand order with $\pm 40\%$ from the initial value. However, the scenario retained has a cumulative demand similar to the forecasted one on a monthly scale (Figure III-X). The differences are in the daily orders that can dramatically differ. The dotted lines represent real demand compared to the solid lines that represent forecasted demand.

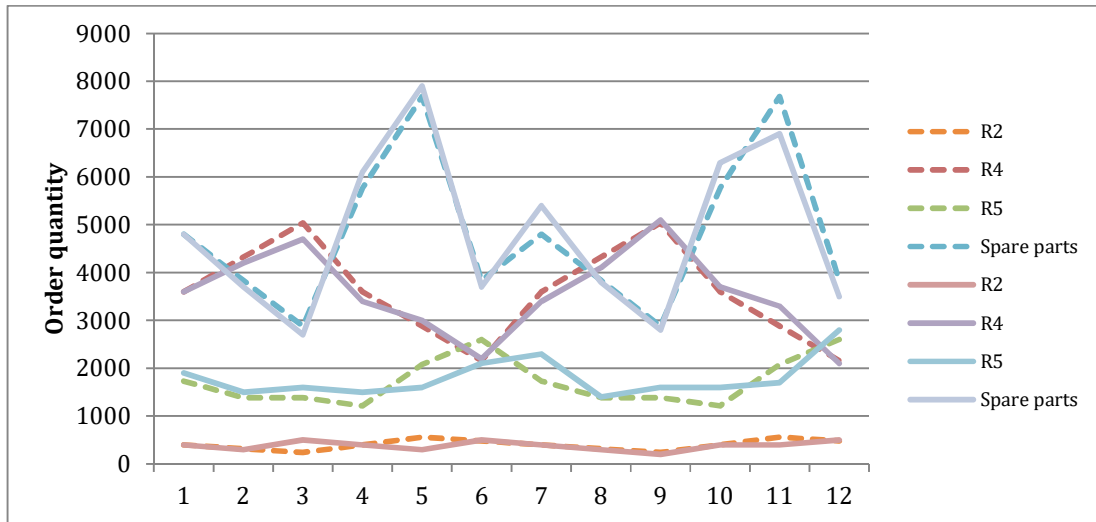

Figure III-X: Gaps between forecasted and real demand

Pull flow methods described in the literature are able to respond to real demand and are flexible: this should be an advantage compared to MPR II for this scenario.

As far as results are concerned, MRP II indeed has a high WC required (+38%) to reach the OTD objective compared to Kanban (+21%) and DDMRP (+16%). MRP II's lack of flexibility leads to a steep rise in the reducers' safety stock level: +75% and +16% for components (Table III-XX).

	MRP				DDMRP				Kanban									
	WC (%)		OTD (%)	Safety Stock		WC (%)		Buffer Zone		WC (%)		OTD (%)	Kanban Number					
				Red	Comp			Red	Comp				Red	Comp				
1 - Initial state (stable demand)	100%	↑	99.3%	↓	100%	100%	101%	↑	100%	↑	100%	100%	100%	100%				
4 - Seasonality	138%	↓	99.8%	↑	175%	116%	116%	↑	99.4%	→	111%	102%	121%	→	99.4%	→	98%	81%

Table III-XX: Demand variability results with seasonality

Contrary to MRP II, Kanban has on average the same number of cards for reducers and -19% of cards for components. With DDMRP, the buffer zones increase by 11% for reducers but are equivalent for components (+2%). For this scenario, Kanban needs fewer cards to be flexible, contrary to DDMRP. However, Kanban's WC is higher than DDMRP's (+21% compared to +16% respectively).

This is an interesting statement that we will focus on to explain the differences. The reason is located in the changing reference mechanisms and order quantities. On one hand, each time a DDMRP stock buffer enters the yellow zone, a supply order is generated (with TOG minus the NFE quantity). Each time the machine is available (after the end of an order), the buffer status is measured. There are several cases:

- There is no order for the same reference: another reference is produced

- There is an order for the same reference: if the buffer status is the lowest, the same reference is produced with a second order. Otherwise another reference is produced.

On the other hand, if a reference is produced with Kanban, a change is made only if there is an emergency for another reference (or if there are no more cards). Therefore, with Kanban the maximum amount may often be reached: this is why in this case, for a month the maximum amount is reached for several references. If the seasonality decreases the month after, there is too much inventory until a customer sends a demand. As regards DDMRP, the inventory levels are more regular (in terms of buffer status) so DDMRP adapts more easily to buffer sizing changes.

This difference in mechanisms is true from the DOE beginning, but it is highlighted more strongly with the seasonality that requires sizing changes. It is a DDMRP advantage to be more flexible: the risk of not being able to deliver an important order is lower. However, with this mechanism Kanban would be able to reach the maximum inventory amount more rapidly with fewer setup operations (if there is no demand, for example).

This scenario deals with a seasonality phenomenon sized to theoretically leave the system with enough capacity to manage the workload level. What would be the impacts for the different methods if this hypothesis were no longer true and levelling strategies had to be implemented?

3.2.5. High demand variability with demand visibility

Finally, this scenario is aimed at analysing the impacts on steep spikes (and troughs) on the system behaviours. To do this, for each reference sold, the spikes are implemented. The spikes in this case are up to three times higher than the spikes in Chapter III.3.2.3 with demand variability. Figure III-XI illustrates the demand profile for the R1 reducer (green dotted line) with steep spikes compared to initial scenario (blue line with squared markers) and with the first demand variability scenario (thick red line). For this scenario, the 6-week cycle is also repeated and the total demand is equivalent to the initial scenario and the demand variability scenarios.

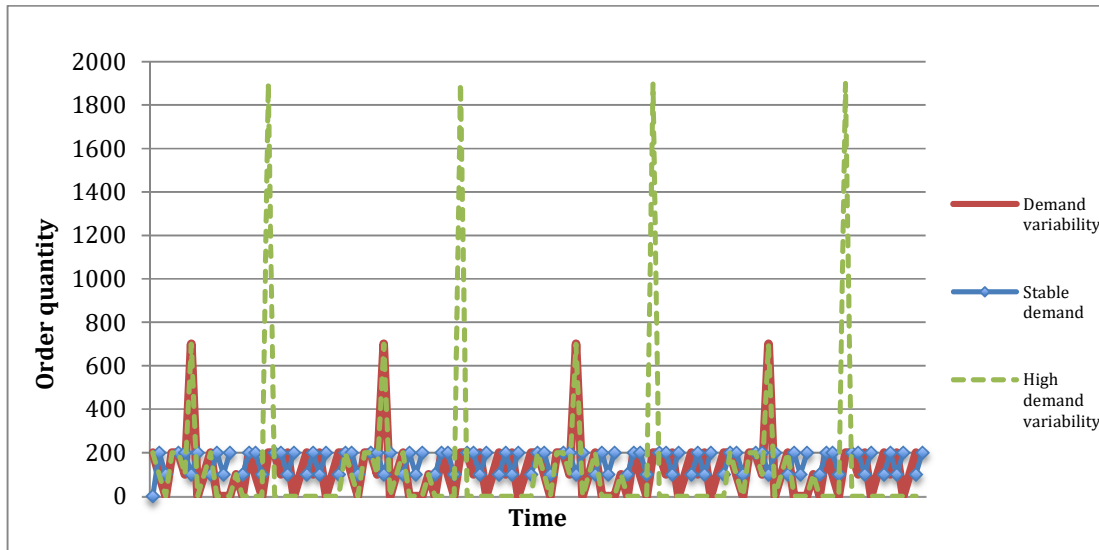

Figure III-XI: R1 demand profile for high demand variability and high spikes and troughs

As regards the spike profile, it would be complicated to satisfy customer demand if spikes were not anticipated. Thus, customer demand is frozen with 5 days of visibility. That is to say:

- MRP II: visible spikes are taken into account in the MPS process (MPS is realised monthly so the first week, spikes are visible).
- Kanban: the method suggests that card sizing is able to deal with these types of scenarios. In other words, spikes are not taken into account to manage reference production priority.
- DDMRP: as detailed in theory, spikes are integrated in the NFE. As each reference sold is buffered, all spikes will be integrated in NFE.

As far as this scenario's results are concerned, MRP II and Kanban are not able to satisfy customer demand (Table III-XXI). Indeed, even if inventory costs are doubled with MRP II, the OTD reached is only 94.5% with 80% more reducer safety stocks and 41% more components. With Kanban and no spike detection, OTD is not satisfactory, with only 93.5% OTD. Compared to these results and this high demand variability, DDMRP reaches 99.8% OTD. However, to be able to satisfy customer demand, 58% in additional inventory costs is required.

In DDMRP theory, spikes are normally taken into account with the NFE as soon as demand exceeds 50% of the red planning zone (or TOR). However, with this rule, in this scenario nearly 70% of demand would be considered spikes. This is due to the demand profile and the significant lot sizes compared to the red zone profiles. That is why (after several simulations), the spike detection threshold was set at 200% of the red zones. With this rule, nearly 20% of demand is considered spikes. For example, in the case of R1, the TOR level is at 525. So, this detection level means that only the highest spikes are detected (those higher than 1,100).

As regards parameters, it is the same approach as "demand variability" with a flexibility increase for components (90%) by reducing DLT for the 4 red oil pan and gear references. However,

the TOG zones increase for reducers (+ 26%) with LT factors for green zones that are raised by 50% on average (thus some LT green factor reach 140%).

	MRP				DDMRP				Kanban			
	WC (%)	OTD (%)	Safety Stock		WC (%)	OTD (%)	Buffer Zone		WC (%)	OTD (%)	Kanban Number	
			Red	Comp			Red	Comp			Red	Comp
1 - Initial state (stable demand)	100% ↑	99.3% 🟡	100%	100%	101% ↑	100% ↑	100%	100%	100% ↑	100% ↑	100%	100%
5 - External variability sharply increased with 5 days of frozen demand	197% ↓	94.5% ↓	180%	141%	158% ↓	99.8% ↑	126%	90%	106% ↑	93.5% ↓	116%	102%

Table III-XXI: High demand variability results

In order to detail Kanban’s difficulty in reaching OTD objectives, another result is detailed in Table III-XXII. The objective is once again not reached with Kanban, but here WC rises from 106 to 134% for “only” 2 OTD points (93.5 to 95.4%). This underscores the limits of Kanban for this scenario, even with a high Kanban number.

	MRP				DDMRP				Kanban			
	WC (%)	OTD (%)	Safety Stock		WC (%)	OTD (%)	Buffer Zone		WC (%)	OTD (%)	Kanban Number	
			Red	Comp			Red	Comp			Red	Comp
1 - Initial state (stable demand)	100% ↑	99.3% 🟡	100%	100%	101% ↑	100% ↑	100%	100%	100% ↑	100% ↑	100%	100%
5 - External variability sharply increased with 5 days of frozen demand	197% ↓	94.5% ↓	180%	141%	158% ↓	99.8% ↑	126%	90%	106% ↑	93.5% ↓	116%	102%
5' - External variability sharply increased with 5 days of frozen demand - V2 Kanban	197% ↓	94.5% ↓	180%	141%	158% ↓	99.8% ↑	126%	90%	134% ↑	95.4% ↓	139%	111%

Table III-XXII: High demand variability results – Version 2 for Kanban

This scenario illustrates the interest of DDMRP’s spike management compared to the other methods. Indeed, it shows clearly the difficulty, or rather the impossibility, for MRP II and Kanban to reach the OTD objective. This objective is reached with DDMRP: however, to be able to anticipate spikes, WC rose significantly. As noticed, however, the spike detection threshold is a real issue which depends on the demand profile context.

3.2.6. Scenario synthesis

In conclusion, the DOE helped to analyse the most widespread variability impacts for companies. The results are grouped in the table below (Table III-XXIII).

The main statements are the following:

- In a stable environment, MRP II, Kanban and DDMRP have the same results. This lesson can surely be generalised to all push or pull material management methods for this case.

- Kanban and DDMRP have comparable results when there is variability, but not an overly large variability such as for seasonality or, mostly, when demand variability is high. And this demand profile is more and more true in many core businesses.
- In order to reach a near-perfect OTD and be able to satisfy customer demand, DDMRP is able to anticipate production. However, this strategy has an impact from a financial point of view.

This last issue and the decision to take will depend on the strategy taken by the company. This choice (guaranteeing a near-perfect OTD with cost impacts or not) is often linked to the core business constraints (a near-perfect OTD is required in the aeronautical sector, for example).

	MRP				DDMRP				Kanban			
	WC (%)	OTD (%)	Safety Stock		WC (%)	OTD (%)	Buffer Zone		WC (%)	OTD (%)	Kanban Number	
			Red	Comp			Red	Comp			Red	Comp
1 - Initial state (stable demand)	100% ↑	99.3% ↓	100%	100%	101% ↑	100% ↑	100%	100%	100% ↑	100% ↑	100%	100%
2 - Internal variability	101% ↗	99.6% ↗	105%	100%	98% ↑	100% ↑	105%	97%	99% ↑	99.9% ↑	100%	100%
3 - External variability	125% ↓	99.5% ↗	145%	107%	105% ↑	99.8% ↑	105%	87%	111% ↗	99.8% ↑	116%	102%
4 - Seasonality	138% ↓	99.8% ↑	175%	116%	116% ↑	99.4% ↗	111%	102%	121% ↗	99.4% ↗	98%	81%
5' - External variability sharply increased with 5 days of frozen demand - V2 Kanban	197% ↓	94.5% ↓	180%	141%	158% ↓	99.8% ↑	126%	90%	134% ↑	95.4% ↓	139%	111%

Table III-XXIII: DOE scenario synthesis

3.3. Inventory management

One of the DDMRP promises deals with inventory management (P2). DDMRP is based on a statement that with the current market volatility, material management methods (especially MRP II), have reached their limits. Indeed, with systems such as MRP II, some references have too little inventory and the others have too much: this is known as the bi-modal curve in DDMRP training. Furthermore, an additional difficulty is that inventories oscillate between these two levels (Figure III-XII on the left): when there is an emergency, many references are produced and when there is too much inventory, the production only begins again when there is an emergency.

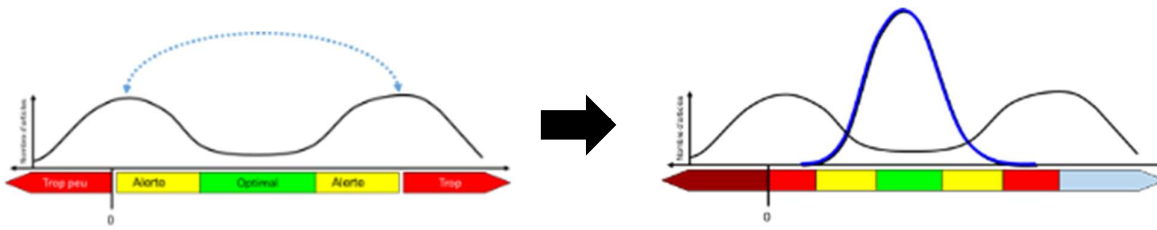

Figure III-XII: Inventory management difficulties (left) compared to a controlled inventory (right)

Inventory distribution is analysed here for 3 reference types: reducers, and then oil pans and gears. Crown analysis is not detailed here because there are no inventory issues (machines have high capacity and the crown costs are low, Table III-III). In the simulation model, each buffer level is recorded twice a day. These records help analyse the inventory level distribution for the second semester for each reference. To visually analyse these distributions, the abscissa axis is divided from TOG DDMRP buffer zone percentages split into parts of 5% TOG. All levels that are located above 105% of TOG are grouped into the “SUP” category. The ordinate axis is the number of records for the 5% TOG part. This analysis is made for DDMRP (blue or on the left of each part), MRP II (slashed grey or in the middle) and Kanban (green or on the right).

3.3.1. Inventory distribution with a demand variability scenario

The first scenario analysed is the demand variability scenario (Chapter III.3.2.3). As regards the inventory distribution of reducers (Figure III-XIII), MRP II distribution is widespread with many inventories in the “SUP” category. As far as Kanban is concerned, Kanban is more centred and nearly equivalent to DDMRP. The main difference is that the “SUP” category is also significant where DDMRP has no record in this category.

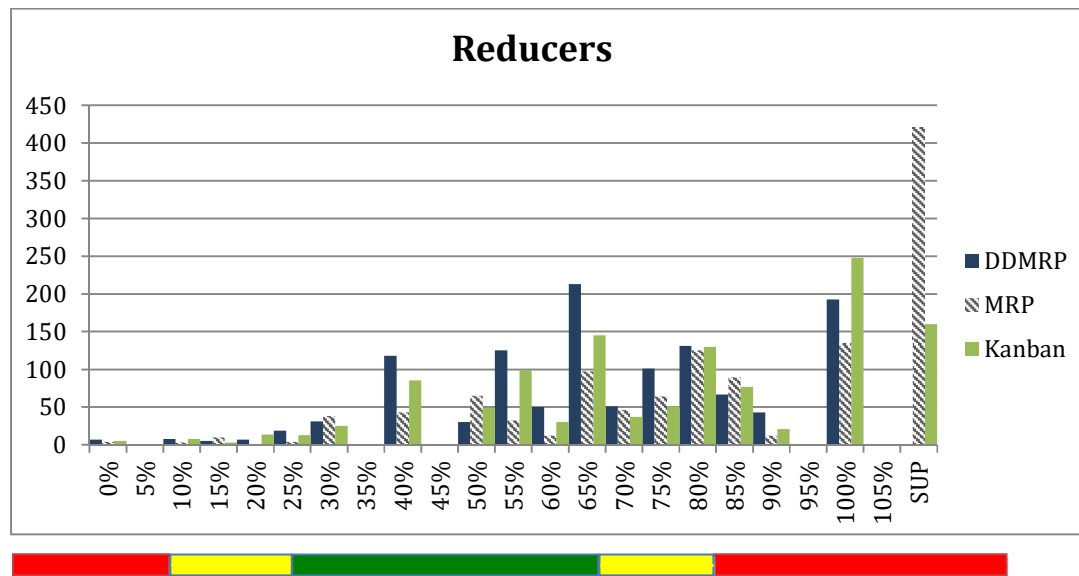

Figure III-XIII: Reducer inventory distribution for demand variability scenario

This low demand variability is absorbed after the reducers: for the three methods, inventory distribution is more centred (Figure III-XIII). It can however be noticed that MRP II has significant shortages and also quite substantial inventory levels. Furthermore, DDMRP and

Kanban have very similar distribution profiles. It can also be noticed that Kanban has more inventory in the “90% part” compared to DDMRP and the parts where inventory is low are more common for Kanban.

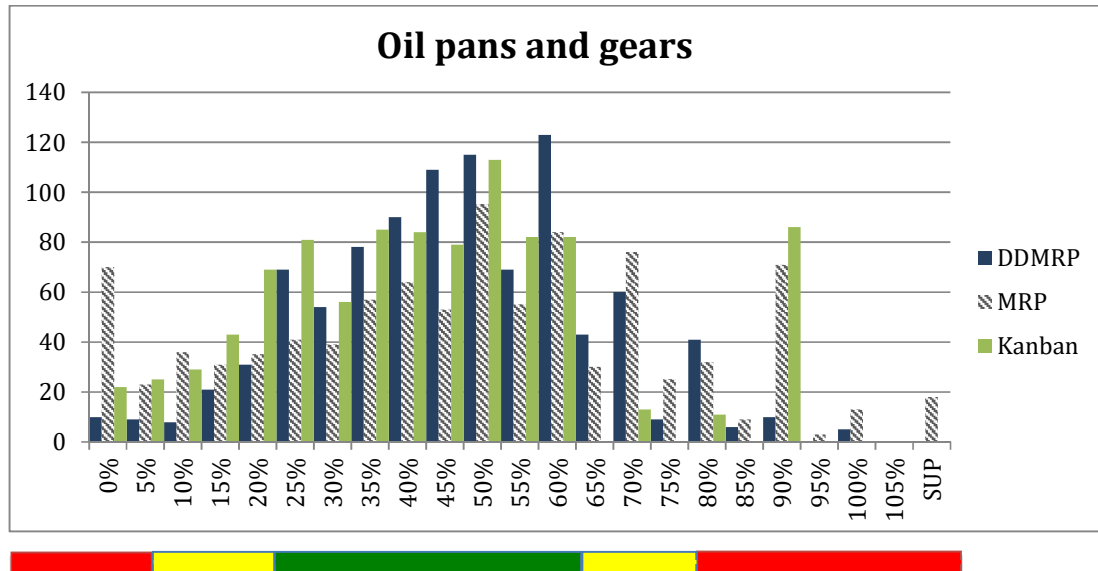

Figure III-XIV: Oil pan and gear inventory distribution for demand variability scenario

3.3.2. Inventory distribution with high demand variability and a demand visibility scenario

The inventory distribution analysis is then realised for the high demand variability scenario with 5-day visibility (Chapter III.3.2.5). As far as the reducers are concerned, the main differences are the rise in reducer inventories with DDMRP (the “SUP” category) and the rise of records in the lower parts (close to “0%”) for Kanban (Figure III-XV). This second point explains (with MRP II also in “0% part”) the shortages, with failure to reach the OTD objective. The DDMRP increases in inventories explains the WC increase in order to reach a near-perfect OTD (Table III-XXI).

As regards oil pans and reducers (Figure III-XVI), DDMRP absorbs demand variability with a well-centred distribution. Kanban has nearly the same distribution with nevertheless a “90% part” that is too high. Finally, variability is not absorbed at all with MRP II as shown by the huge “SUP” part and the significant “0% part”.

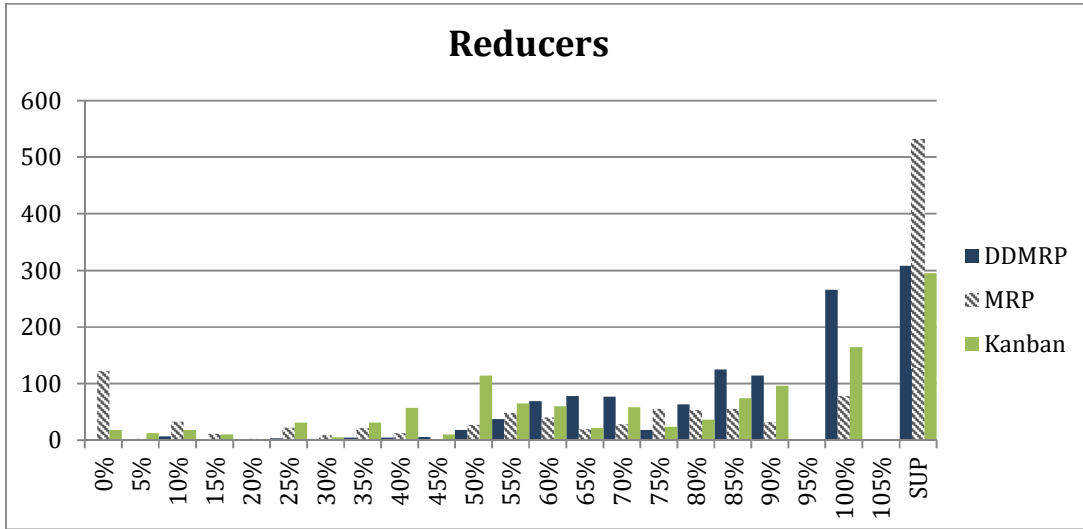

Figure III-XV: Reducer inventory distribution for high demand variability and visibility scenario

The inventory distribution analysis confirms the WC and OTD analysis realised in the previous section: DDMRP improves inventory management. It is dramatically true compared to MRP II and also true compared to Kanban: there are few differences in the first demand variability scenario but they are more significant for those with high demand variability.

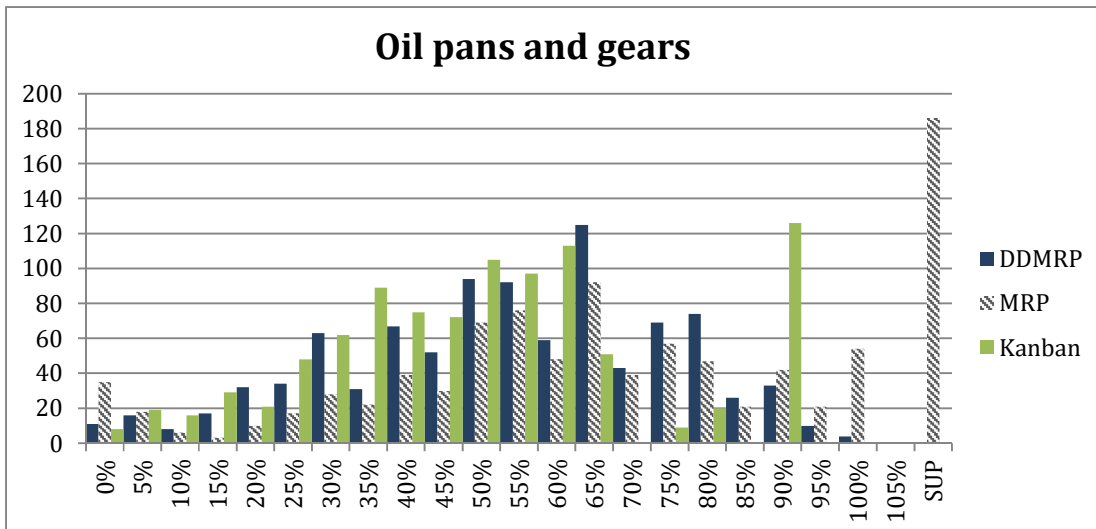

Figure III-XVI: Oil pan and gear inventory distribution for high demand variability and visibility scenario

Chapter III conclusion and future work

Conclusion

As detailed in the DOE, without variability sources, MRP, Kanban and DDMRP would have more or less the same results. However, this type of market is extremely rare. As soon as variability sources are implemented as noise around a stable forecast, DDMRP and Kanban have significantly better results, whether in OTD or WC values. And this lesson seems to be accentuated when there is more variability. Kanban and DDMRP have nearly similar results with some differences in execution mechanisms. However, when there is high seasonal demand variability or significant spikes, DDMRP can reach better OTD levels than Kanban.

Furthermore, a Kanban issue is the number of references used. The case study is quite simple in terms of reference amounts, however, it would be a problem in a real case with hundreds of references. Indeed, Kanban can be grouped in product families, for example, to maintain visual execution. However, the reference scale would be lost compared to DDMRP which is able to deal with hundreds of references at the reference scale. That is why DDMRP seems to be more adaptable to different environments and core businesses.

One of the DDMRP promises is to improve inventory management. It is (mostly) validated compared to Kanban and especially MRP II. What is more, DDMRP does not only focus on inventory reduction but also on anticipating production with spike detection: inventories can be higher (due to anticipated inventories) than the other methods to reach the OTD objective. However, the results are not as significant as with the bi-modal curve given in the DDMRP theory (but this curve also deals with management variability we were not able to model).

These results highlight differences between methods, but numerous differences could already be explained with mistakes, wrong decisions taken by companies with MRP II, Kanban or other implemented methods (it is management variability, Figure II-IX). The difficulty of the complete MRP II process can explain some difficulties compared to visual DDMRP or Kanban methods. However, MRP II involves stakeholders and teaches them that there are different planning views and strategies; features that the others material management methods must also manage. It can also be noticed that for Make To Order environments with well managed processes, MRP II would lead to satisfying results.

All initial hypotheses (3.1.1) and those made during the DOE are summarised in Table III-XXIV below. Some of these hypotheses are confirmed and some are not, and comments with future recommendations are also detailed.

Hypothesis	Confirmed?	Comments / Recommendations
Good behaviour for all material management methods in a stable environment	Confirmed	All results are nearly equivalent (§3.2.1.1).
DDMRP's adaptation is better compared to MRP's as soon as there is variability (P1 & 7)	Confirmed	Significant result gaps. It would often be more significant in reality because many MRPII good practices are not followed.
DDMRP is better than Kanban from an OTD point of view (P1 & 7)	<ul style="list-style-type: none"> • Not confirmed for several cases • Confirmed with high demand variability and/or significant spikes 	<p>The gap in favour of DDMRP results would increase with more references (with the Kanban management for hundreds of references).</p> <p>In a more complex case (more activities) DDMRP results may improve. With DDMRP implementation, fewer buffers would be implemented (not 88% of references buffered).</p>
DDMRP improves inventory management (P2)	Partially confirmed	<p>It is completely confirmed compared to MRP II.</p> <p>There is less difference compared to Kanban. However, DDMRP helps anticipate spikes: its WC increases in order to have the right references in the right quantities (one of the DDMRP promises)</p> <p>However, inventory distribution is not as "bi-modal or centred" as explained in theory.</p>
DDMRP manages demand spikes (P6)	Confirmed but *	<p>*: Special attention is needed for spike threshold detection: the notion of "spike" must remain a spike.</p> <p>It was not an issue here, but attention also must be paid to spike horizon (time point of view) detection.</p>

Table III-XXIV: DDMRP hypothesis confirmation (or not) and recommendations

Another contribution of this work is the case study method analysis, the DOE. Indeed, this case is complete in terms of data and variability sources would be implemented in other material management methods. Furthermore, different sources of variability could also be implemented to complete this study.

Future work

In the majority of scenarios, Kanban and DDMRP have similar results. There are 16 Kanban loops and 14 DDMRP stock buffers. Would the differences in results between DDMRP and Kanban be accentuated if DDMRP had more activities and more non-buffered references?

One of the main DDMRP issues deals with buffer positioning. This step does not have the same results and it depends on the person who conducts the study (even if in this case, for example, the results are very close). Future work can semi-automatically suggest buffer positioning, and a major issue is related to DDMRP stock, time and/or capacity buffer coupling.

Furthermore, for the high demand variability scenario with buffer positioning realised by experts: demand was known 5 days in advance. Therefore, it is a possible limit for choosing between a Make To Stock or a Make To Order Strategy. That is why a group chose one or the other strategy for some references. The other scenarios proposed by experts should also be modelled and simulated in order to analyse whether the results would be improved.

In this case study, a buffer status can be assessed for each reference to manage the execution step. In real case studies, some orders would follow the buffer status and others (such as for non-strategic references) would be prioritised from their due date or other criteria. It would be interesting to discuss and compare these different strategies.

A major DDMRP advantage deals with spike detection taken into account in qualified demand with a NFE. Spikes introduce the fact that some demands are Made or Assembled to order, while standard ones are Make To Stock. However, major issues deal with the horizon and the threshold detection of these spikes: in theory, spikes are considered to be 50% of the red zone but with this threshold level the majority of demand could be spikes (as for this case study). What is more, the demand spike horizon is the DLT in theory. However, when the workload is high, DLT may increase and lead to shortages: in some cases would it be more interesting to make horizon spike detection higher than the DLT reference?

As far as this case study is concerned, implemented internal variability has nearly no impact on results: it would be interesting to implement this variability in a more complex case (with more activities and more references).

Several variability sources are analysed in the DOE. However, the supply variability was not implemented here (a hypothesis of the Kanban game): what would be the impacts of implementation supply variability? And what would be the impacts with implemented supply and demand variability sources?

With seasonal demand, the method's parameters must be adapted. But what is the best frequency to update parameters in order to obtain a reactive system without bringing too much nervousness with these changes?

The DDMRP positioning step is a major issue. However, when buffers are positioned, the sizing step is also a major issue. What are the best DDMRP parameters, and how to precisely choose lead time factors and variability factors in order to reach targeted objectives? What is more, a lesson from this case study is the sensitivity of DDMRP to parameter changes. Indeed, the system workload is substantial, with 3 possible bottlenecks out of 5 activities, which is why the factor choices have significant impacts on simulation results.

Chapter IV.

ADJUSTING DDMRP PARAMETERS

“Ce n'est qu'en essayant continuellement que l'on finit par réussir....
En d'autres termes... Plus ça rate et plus on a de chances que ça marche”,

“It is only by continually trying that we finish by succeeding...
In other words... The more it fails, the more chances we have that it will work”,
Les shadoks, Jacques Rouxel

One of the major DDMRP issues after positioning buffers is to size them (as detailed in Chapter II). During the DOE (Chapter III) analysis, the sensitivity of DDMRP has been clearly identified, especially in a high workload level system. Until now, DDMRP parameters have been adjusted with our DDMRP experiment. However, this solution does not guarantee reaching the best solution and mostly it is a time-consuming approach. This challenge mostly focuses on parameter sizing for DDMRP buffers (P1).

With optimisation work, would the results be better? In this chapter, different optimisation strategies will be tried and analysed (Figure IV-I).

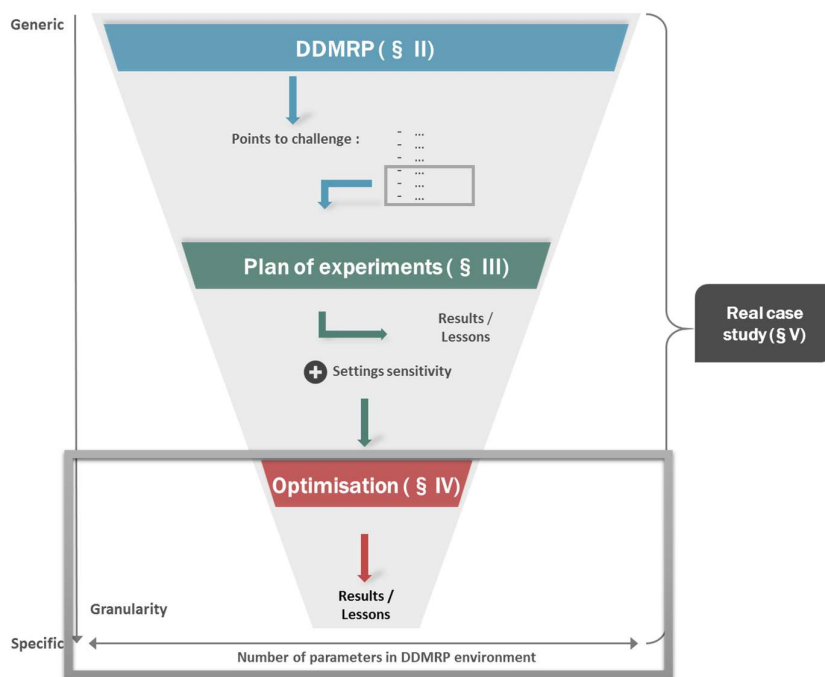

Figure IV-I: Big Picture – DDMRP parameter optimisation

1. DDMRP sizing improvement for the Kanban Game

1.1. Context

An assembling environment has been analysed with pull material management methods and card number optimisation. In (Gaury et al., 2001), the assembly process was split into several linear chain problems: the goal was to optimise the card numbers for each chain with a Kanban, ConWIP or hybrid system. This work was realised on a generic simulation model and the customisation method helped to improve WIP compared to a unique material management method implemented such as ConWIP. Research work also intended to optimise push or pull material management method implementation with Genetic Algorithms (Chiadamrong et al., 2007). The results are in favour of pull flow strategies (if the method is optimised) compared to push flow methods, from a profit point of view. This study was realised on a single case study, the objective being to propose a decision-aided tool.

In the DDMRP theory, buffers are sized (Chapter II.1.2) after the buffer positioning step (Chapter II.1.3). However, there is currently no tool to help make a decision as regards sizing DDMRP stock buffers. In theory, approximate sizes are given and then must be adapted (Ptak and Smith, 2016). What is more, current DDMRP research which aims to compare MRP and DDMRP results uses some “rules of thumb” for sizing buffers (Ihme and Stratton, 2015). This is why this chapter deals with a tool-aided method with a simulation in order to optimise the appropriate parameters for reaching the objectives.

In order to challenge the DDMRP buffer parameters, different optimisation methods are tried or combined. The method we propose for challenging these parameters is detailed in Figure IV-II below.

The first DDMRP implementation step is always to position the buffers (Chapter II.1.3). As soon as buffers are positioned, the initial parameters are chosen to size these buffers. However, in reality it is not sure that these parameters are the most appropriate (or among the most appropriate). In reality, it is a real challenge to find good parameters on the first try. Due to system inertia (from several weeks to several months), the results from the sizing chosen are not rapidly known. It takes time to change these parameters and most of all, to assess the impacts and know if there are improvements or not. It is one of the simulation’s interests to instantly try different scenarios and implement good parameters on the first try in a real system. This chapter will therefore challenge this initial parameter combination and try to propose better solutions with a simulation.

From this initial choice, two optimisation types can be followed. On one hand, what is called the “generic approach” (Figure IV-II on the left) can be followed: a metaheuristic application is realised with iterations in order to try to have a solution that reaches the objectives (“Good solution obtaining #1”). This work is detailed in Chapter IV.2.

On the other hand, a business algorithm adapted to the system can be defined and applied (Figure IV-II on the right). This represents this chapter’s main contribution. The goal is also to obtain a solution that reaches the initial objectives with iterations (Chapter IV.3). Therefore, it will be possible to compare both solutions obtained and analyse which optimisation method is the most appropriate (reasoning and analysis efforts).

Finally, in order to try to reach a better solution, the “generic” metaheuristic approach can be applied with best parameters obtained from the business algorithm (Chapter IV.4). The objective is to analyse if this combination brings advantages (see link “Benefits?” in Figure IV-II).

Normally, a metaheuristic approach finds a solution close to the global optimum. However, due to the long simulation runtimes (several days) it is possible that not all the optimisations will converge at the end of the optimisation.

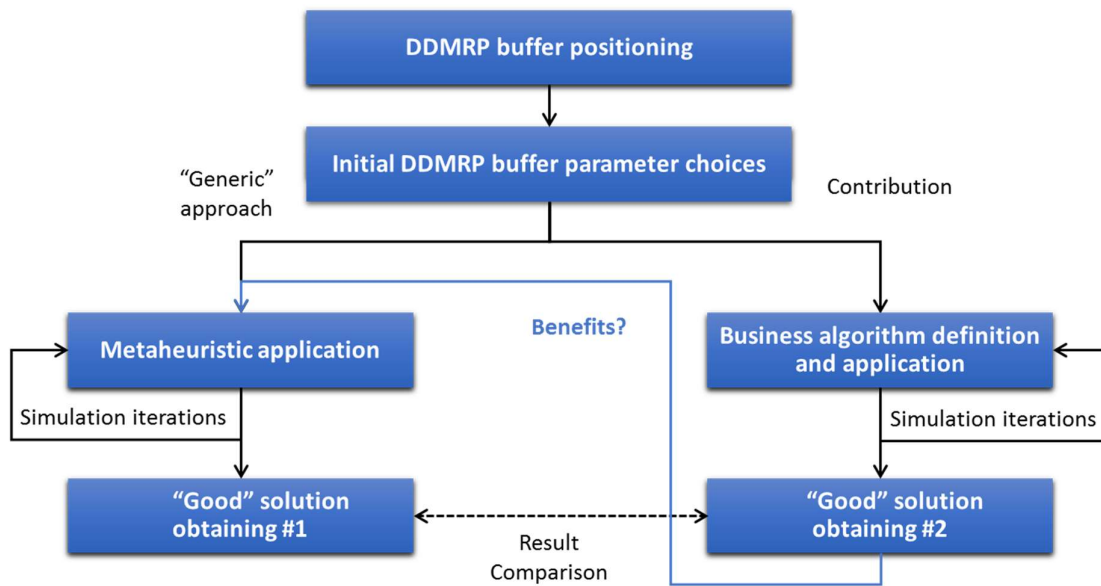

Figure IV-II: Parameter optimisation – proposed method

1.2. Scenario retained and initial sizing

The high demand variability scenario (Chapter III.3.2.5) clearly seems to be the most appropriate one for optimising DDMRP parameters. Indeed, it is the scenario where MRP and Kanban had the worst results (Table III-XXIII). Furthermore, it was the most complicated DDMRP scenario for reaching the OTD objective. Therefore, this optimisation work will focus on the high demand variability scenario with a 5-day firm demand.

The optimisation work’s objective here is not (only) to reach the best solution with a complex metaheuristic analysis: the purpose is to rapidly find an acceptable solution by fine-tuning DDMRP parameters. One of the main DES strengths is the simulation time: only 5 minutes are needed to simulate an entire year’s functioning. As noted earlier, Witness® software is used

(machine configuration: i7 processor of 3.4 GHz, 16 Go RAM). This is why DES is an appropriate tool here: in order to simulate an entire year's functioning, only 5 minutes are needed with DES. It is highly advantageous compared to the time needed in reality (without DES) to reach an acceptable simulation. In some businesses, several months may be required to find and adjust appropriate DDMRP parameters. Besides, this hypothesis is not only true if DDMRP parameters are too broad (with too much inventory). Indeed, the use of DES makes the identification of poorly chosen parameters possible and therefore avoids the possible consequences in cost. If so, it would not only be a time-saver but a key factor to DDMRP's implementation success.

For this scenario, buffer positioning has already been realised (Chapter III.2.3.1): 14 references have DDMRP stock buffers. The issue here is to know how to size them by choosing the proper buffer sizing parameters.

The parameters that can be optimised for DDMRP buffer sizing are the following: DLT, LT and variability factors. There are two possible LT factors: one for the green and one for the red zone (Chapter II.1.2). As a result, there are four input parameter types for the optimisation analysis: with the 16 references, there are therefore 58 input parameters that can be fine-tuned with optimisation (16 for DLT and 14 for each factor because the green and red A crowns are not buffered, cf. Chapter II.1.3).

As detailed in Figure IV-II, the initial parameter values must be implemented. DLT, LT factors (red and green) and variability factors are equivalent to the initial simulation in Chapter III.3.2.1: DLTs are those calculated with the buffer positioning; LT factors and variability factors are set at 50%.

From this initial buffer sizing, the optimisation work can begin with the different methods detailed in the next sections.

2. “Generic” metaheuristic approach

The first optimisation work deals with a metaheuristic approach (called the “Generic approach” in Figure IV-III). From the initial DDMRP buffer parameter choices, the optimisation is made through iterations with a simulation tool in order to get results that reach the initial objectives.

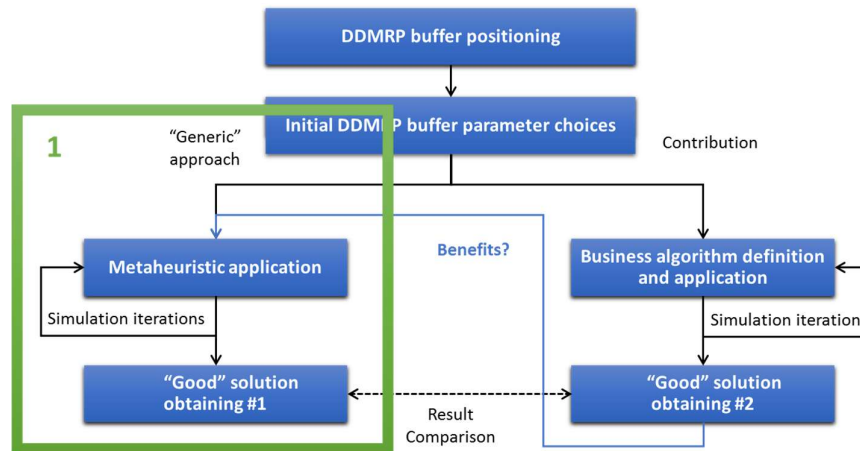

Figure IV-III: 1 – “Generic approach” – Parameter optimisation

Metaheuristics are generally iterative stochastic algorithms. The goal is to reach a global optimum, in other words the global extremum for a function from an objective function. The most “classical” metaheuristics are based on pathway concept. With this concept, for each iteration only one solution is changed by the algorithm. The neighbourhood concept is one of the most used. The most known methods are simulated annealing (Hwang, 1988), Tabu search (Glover and Laguna, 2013), variable neighbourhood search (Mladenović and Hansen, 1997) and GRASP method (Feo and Resende, 1989).

The other approach uses the concept of population. In other words, several solutions are manipulated in parallel for each iteration by the algorithm. Well-known algorithms are genetic algorithms (Holland, 1975), bee colony algorithms (Basturk and Karaboga, 2006) or ant colony algorithms (Dorigo et al., 1996).

This optimisation work is realised with the Witness® optimiser. This tool offers a choice among several algorithms. The one selected is Simulated Annealing for its good convergence properties (**Appendix B: Witness® Simulated Annealing explanations**). As a reminder, the goal is to rapidly obtain a good solution, so Simulated Annealing is appropriate with its low number of parameters to adjust. The parameters can easily be qualified with changes in a given step. The Simulated Annealing parameters retained for the optimisation are detailed in Table IV-I below:

Initial temperature	100
Cooling rate	0.91
Cooling step	25

Table IV-I: Simulated Annealing parameters

In the previous section, the initial parameters have been chosen. Other information required for each parameter are the minimum and maximum accepted values and their step. All this data is detailed in Table IV-II below for the 16 references. “Init” means initial value, “Min” means minimum and “Max” is for maximum. With these initial parameters, the simulation results are 82.5% for OTD and a corresponding 470k€ in WC (which is low because of the numerous shortages).

With these parameter numbers, ranges and steps, the combinatorial possibilities are 1.03×10^{82} and can be considered high. With this combinatorial possibilities, it is impossible to hope to find the best solution. That is why the optimisation may require several hundred simulations to reach a local optimum.

Reference	DLT				LT Factor Green	Variability Factor	LT Factor Red	LT and Variability Factors extremum			Buffer sizes		
	Init	Min	Max	Step	Init	Init	Init	Min	Max	Step	TOR	TOY	TOG
R1	2.50	0.5	7.5	0.25	0.5	0.5	0.5	0.1	1.5	0.05	200	500	700
R2	2.50	0.5	7.5	0.25	0.5	0.5	0.5	0.1	1.5	0.05	100	100	200
R3	2.50	0.5	7.5	0.25	0.5	0.5	0.5	0.1	1.5	0.05	200	500	600
R4	2.50	0.5	7.5	0.25	0.5	0.5	0.5	0.1	1.5	0.05	300	700	900
R5	2.50	0.5	7.5	0.25	0.5	0.5	0.5	0.1	1.5	0.05	100	300	400
R6	2.50	0.5	7.5	0.25	0.5	0.5	0.5	0.1	1.5	0.05	200	300	400
White A crown	1.50	0.5	5.0	0.25	0.5	0.5	0.5	0.1	1.5	0.05	600	1200	1800
Yellow gear	3.00	0.5	6.0	0.25	0.5	0.5	0.5	0.1	1.5	0.05	600	1300	1700
White gear	3.00	0.5	6.0	0.25	0.5	0.5	0.5	0.1	1.5	0.05	700	1500	2000
Red oil pan	2.75	0.5	6.0	0.25	0.5	0.5	0.5	0.1	1.5	0.05	800	1900	2500
Blue oil pan	2.75	0.5	6.0	0.25	0.5	0.5	0.5	0.1	1.5	0.05	300	700	900
White B crown	2.00	0.5	5.0	0.25	0.5	0.5	0.5	0.1	1.5	0.05	600	1200	1400
Green B crown	3.50	1.0	7.0	0.50	0.5	0.5	0.5	0.1	1.5	0.05	200	600	800
Red B crown	3.50	1.0	7.0	0.50	0.5	0.5	0.5	0.1	1.5	0.05	600	1200	1400

Table IV-II: Optimisation parameters

The essential objective is to reach the OTD objective used in the DOE (99.3%) and then minimise the corresponding WC. Therefore, the objective function here is a programming goal function (Hwang, 1988) which is appropriate for improving the two KPIs.

To deal with the imposed DOE criteria, the simulated annealing objective function implemented is the following:

$$\text{Objective function} = \text{Min} \{WC + \text{Max}(0 ; 100,000,000 \times [0.993 - \text{OTD}])\}$$

It is noticeable that the two summed types of data are not consistent with a financial term and a percentage. It must not be forgotten that it is mandatory to reach the OTD objective, and in order to reach it, the first step is to maximise OTD until it reaches the objective. This corresponds to the right term in the objective function. The purpose of the 100,000,000 value here is to penalise results of 100,000 for each OTD percentage tenth under 99.3%. The WCs obtained in the different simulations are between 500k€ and 1,000k€. In other words, it would be extremely difficult to minimise the objective function for each 100,000 “penalty” received. Therefore, only when the objective is reached is it possible to focus on WC (the left term in the equation) minimisation. As a result, the objective function rises rapidly if the targeted OTD is not reached. This responds to the objective with OTD that would normally be optimised in priority before WC.

The simulation results are detailed below. The objective function for each scenario is detailed in Figure IV-IV. The values are widespread because of the high impacts when the OTD objective is not reached. Better results are mainly achieved with the first hundred simulations: the initial situation is not satisfactory but the parameters begin to be well set. This is why after several hundred simulations, when some parameter values are totally different, the results are far from being satisfactory and it is difficult to find another local optimum.

The number of simulations here has been fixed at nearly 550, which represents roughly two days of simulation.

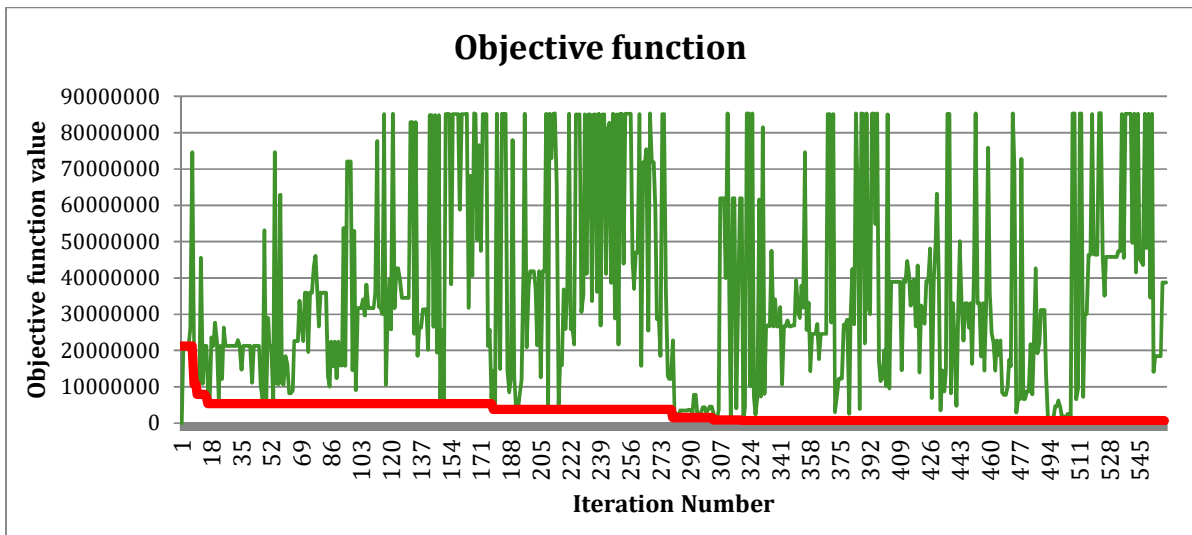

Figure IV-IV: “Generic” metaheuristic approach – objective function

A synthesis of results is detailed in Table IV-III for the 550 simulations realised. Most of these simulations have an OTD rate lower than 50% but none have a WC higher than 1m€.

Furthermore, only one result attains the initial OTD objective with a corresponding WC of 661,152€: this is a slight improvement compared to the 670k€ in WC from the DOE results (-1.3%). However, it is notable that 3 scenarios have an OTD rate higher than 99%.

Scenario number	559
Scenarios with OTD < 50%	421 (75.3%)
Scenarios with OTD > 99.3%	1 (0.2%)
Scenarios with WC > 1m€	0 (0.0%)
Scenarios with WC <1m€ and OTD > 99.3%	1 (0.2%)

Table IV-III: "Generic" metaheuristic approach results

Figure IV-V details the corresponding WC for the OTD level reached for each scenario. As already mentioned, many simulations have an unsatisfying OTD level (between 10 and 20%) and most of them attain around 70% OTD level on average, far from the initial objective of 99.3%.

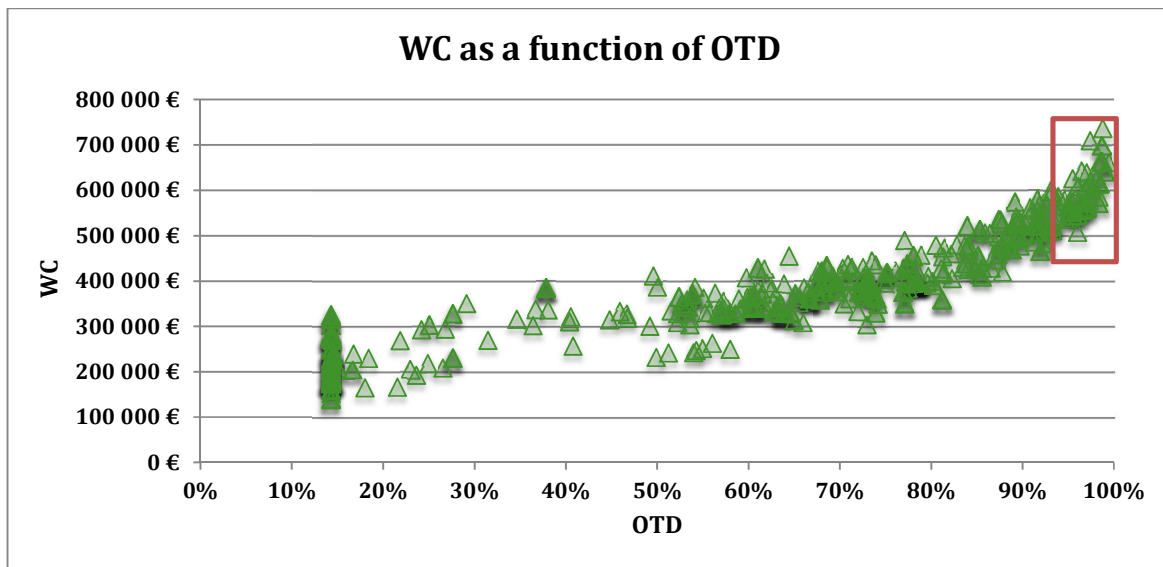

Figure IV-V: "Generic" metaheuristic approach - WC as a function of OTD

Figure IV-VI focuses on OTD results higher than 95%. The results are widespread from a WC point of view and also for OTD. Indeed, only 52 out of the many simulations have an OTD level higher than 95%: they represent 9.3% of the simulations. In conclusion, there are only a few acceptable solutions. The OTD objective here is 99.3%.

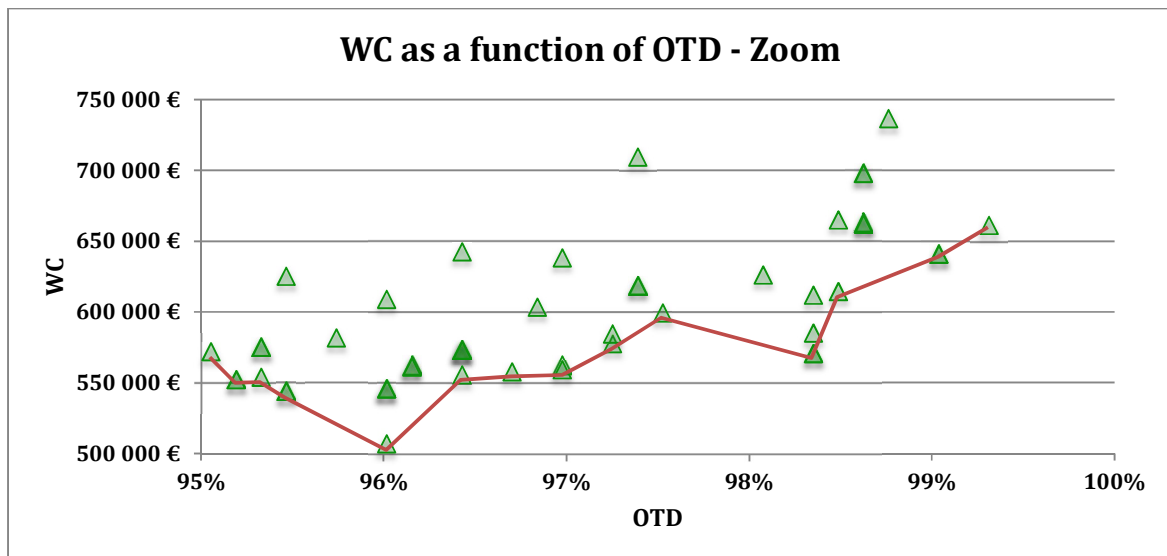

Figure IV-VI: “Generic” metaheuristic approach - WC as a function of OTD - Zoom

The Pareto frontier drawn (red line in Figure IV-VI) gives the best WC values corresponding to different OTD levels. As an example, some iterations attain 96% OTD with only 507k€. This decision-making tool gives all the possibilities to the stakeholders: in this case, the question would be to accept or not a decrease in OTD of nearly 3 points in order to save 23% WC.

3. Optimisation with business rules

With the previous metaheuristic approach, several hundreds of simulations are needed (several days of simulation) to find a solution that reaches the objectives. This is due to the lack of experience and information which leads the metaheuristic approach to test several solutions blindly. Would it be possible to implement another method to reach the objectives more rapidly?

For this second optimisation part, a business algorithm is defined and applied from the same initial buffer sizing in order to achieve OTD and WC objectives. This working goal is to analyse whether this method converges more rapidly than the “generic approach” and offers better results. As for the previous section, several iterations will be realised in order to obtain a “good” solution (Figure IV-VII). This solution will be then compared to the solution obtained with the generic approach to analyse the influence of the different parameters.

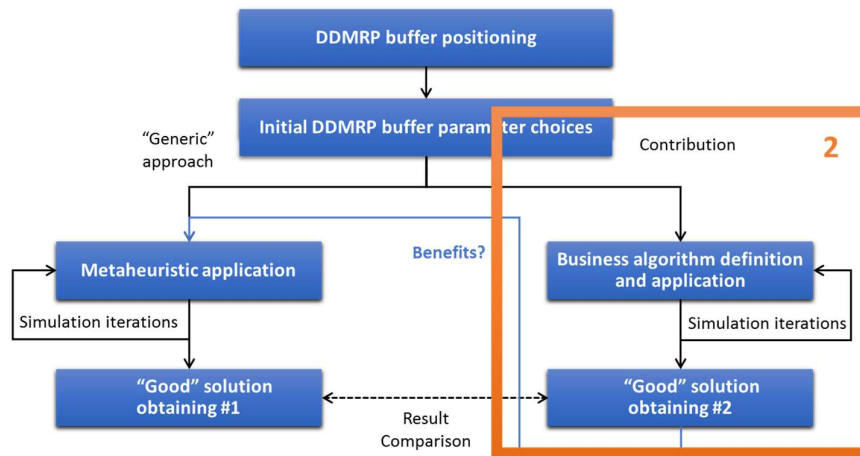

Figure IV-VII: 2 – Business algorithm definition and application – Parameter optimisation

3.1. Business algorithm definition

The business algorithm defined below is realised with a DDMRP sizing experiment and after DOE (Chapter III.3.2) work where DDMRP buffer sizing was changed with each scenario and variability source type.

3.1.1. Parameter and variable definitions

Let's consider:

nb_delay: number of shortages for all references sold (integer)

nb_delay (ref): number of shortages for this reference (integer)

Green_zone (ref): green zone amount for this reference (integer)

Initial_green_zone (ref): record of the green zone for this reference in case of a return with bad OTD results (integer)

DLT (ref): Decoupling Lead Time for this reference in days (decimal)

Min_WIP (ref): minimum Work-In-Process for this reference in the second semester of simulation (integer)

OTD (iteration): OTD for this iteration in % (decimal)

Reducer_delay (ref): for each reducer, if there are too many shortages, the variable is worth 1, otherwise 0 (integer)

counter: variable for counting (integer)

counter_2: another variable for counting (integer)

SIMULATE(): this is the action to run another iteration with the new sizing parameters in order to have the new OTD and WC values.

Counter and counter_2 are here to try a different approach with a defined number of times. It enables the other parameters to be checked and modified after a loop number is defined.

As regards the green zone, the LT factor is normally used to size the zones. However, in the DES model the software reads zone values directly. Therefore, green zone optimisation will directly focus on the zone level in the algorithm (3.1.2).

3.1.2. Algorithm definition

Variable initialisation:

```
counter = 0
```

```
counter_2 = 0
```

```
iteration = 1
```

For all reducers

```
    Reducer_delay(ref)=0
```

Next reducer

The algorithm is split into 4 blocks with comments (`// block_`). The following is the description of the different blocks: the 3 first objectives are to achieve the OTD objective (hence the use of “While OTD < 99.3%”) and the 4th is to reduce WC as long as the OTD objective is confirmed.

Furthermore, for the three first blocks, the number of shortages must not exceed 6 (“nb_delay > 6”). Otherwise, the 99.3% OTD objective cannot be reached.

3.1.2.1.1. Block 1

The main issue as learned from the DOE (Chapter III), is especially to size the yellow and green zones well (the appropriate DLT and LT green factors). And the first main issue was to find appropriate green zones with appropriate LT factors. Additionally, as also learnt from the DOE, the most important references to deal with are reducers. Indeed, it is these references that must cope with demand consumption and potential spikes. That is why this first block fine-tuned the reducer green zones.

The role of block 1 is as follows: if there are 2 shortages for a reducer (1 is accepted because the OTD objective could be attained with 6 shortages), it is recorded (“reducer_delay” worth 1) and its green zone raised by 100 (one lot-size), otherwise the green zone is not changed. Both counting variables and iteration are incremented with a simulation. Otherwise, the “reducer_delay” is worth 0.

Two “counting” variables are implemented in the algorithm: counter and counter_2.

- Counter is here for recording the number of times block 1 is realised. In this algorithm, block 1 is realised 3 times before trying the other parameters. This “3” value is here because it is enough to be nearly sure that only green zone sizing would not be enough to achieve the OTD objective. From this step, the yellow zone (with DLT) must be adjusted. That is why if the “counter” reaches “3”, another block (block 2) is realised.
- Counter_2 is also here for recording the number of times block 1 is realised. This variable is used in block 3 and to be fully understood it is explained at the end of block 3.

3.1.2.1.2. Block 2

If the green zone adjustment does not attain the OTD objective, the total buffer size is adjusted with block 2. From block 1, there are two possibilities: OTD has already been improved with the three iterations or it has not.

If OTD has been improved, the reducers that have shortages have their green zones that are reduced only to the previous iteration (because the yellow zones will increase in this iteration and it will surely lead to a green zone increase). Then, the DLT is increased by half a day (this value can be adjusted) which is representative but not overly so to be sure to go beyond a local optimum. This is “block 2.1”.

If the OTD is worse than at the beginning, the initial green zone values that have been recorded are again set up. Then the DLT is also increased by half a day. This is “block 2.2”

In both cases, the iteration is incremented and a simulation is carried out. When block 2 is finished, the “counter” is again worth “0”.

3.1.2.1.3. Block 3

If the green and yellow zone adjustments for reducers are not enough, the components buffers must be focused. For the next iteration (“counter_2”, which can also be adjusted), we will focus on components.

For each component that reaches “0” inventory in the simulation (“min_WIP”) one time, its buffer size enlarges with a DLT increase (here also 0.5 days).

In the business algorithm, the variability factor (and LT red factor) are not adjusted. The main issue was clearly focused on the workload issue with the supply order quantity being released to an appropriate yellow zone. This algorithm already leads to a good solution. However, it would surely be possible to improve results with variability factor focusing, but these improvements would not significantly improve the results.

3.1.2.1.4. Block 4

As soon as the OTD objective is reached, the next issue is to try to reduce WC. In this block, in comparison with the last iterations, all references that have never had zero inventory in the second semester (“min_WIP”) are changed. Indeed, this can be considered as extra inventory and can be reduced. In order to try to improve WC, the DLT is also reduced here by half a day in order to have new zone sizes. When the new sizes have been defined, another simulation is run for a new iteration.

Until now, this algorithm has been infinite: the only way to stop the algorithm is to perfectly reach 99.3% OTD (which is not possible). It is the user’s choice to decide how many times he wants to launch the algorithm. In the business algorithm application detailed in Table IV-IV, the loop is executed a single time. Indeed, as has been noted before, the objective is to rapidly reach a good solution and a single algorithm success must lead to a good solution.

The business algorithm is detailed here:

While OTD < 99.3% “This part of the goal is to achieve OTD objective”

If in the second semester nb_delay > 6 AND counter ≠ 3 AND counter_2 ≠ 4

// Block 1

For all reducers

Initial_green_zone (ref)=Green_zone (ref)

If nb_delay(ref) >=2

Reducer_delay (ref)=1

Green_zone (ref)=green_zone (ref)+100

Counter = counter +1

Counter_2 = counter_2 + 1

Else

Reducer_delay (ref)=0

End If

Next reducer

SIMULATE()

Iteration = iteration + 1

Else If counter=3 and nb_delay > 6

If OTD (iteration) > OTD (iteration-3)

// Block 2.1

```

    For all reducers
        If reducer_delay (ref)=1
            Green_zone (ref)=green_zone (ref)-100
            DLT (ref) = DLT (ref) + 0.5 day
        End If
    Next reducer
    SIMULATE()
    Iteration = iteration + 1
Else
    // Block 2.2
    For all reducers
        If reducer_delay (ref) = 1
            Green_zone (ref) = initial_green_zone (ref)
            DLT (ref) = DLT (ref) + 0.5 day
        End If
    Next reducer
    SIMULATE()
    Iteration = iteration + 1
    Counter = 0
End If

Else If counter_2 = 4 and nb_delay > 6
    //Block 3
    For all components
        If min_WIP(ref)=0
            DLT (ref) = DLT (ref) + 0.5 day
        End if
    Next component
    Counter_2=0
    SIMULATE()
    Iteration = iteration + 1
End If
End While

While OTD > 99.3% “This part of the goal is to reduce WC when the OTD objective is
reached”
    // Block 4
    For all references
        If min_WIP (ref) > 0
            DLT (ref) = DLT (ref) – 0.5 day
        End If
    Next reference
    SIMULATE()
    Iteration = iteration + 1
End While

```

3.2. Business algorithm application

This business algorithm is applied to the initial parameter buffering scenario. The results of each iteration are described in OTD and WC iteration results Table IV-IV and Table IV-V: “Generic” metaheuristic approach results. This second table also details each sizing parameter for the different iterations. Data in this table is the following:

- Iteration: the iteration number
- TOR / TOY / TOG: the level for each top of zone for the buffer
- Min WIP: the minimum WIP attained for this reference in the entire simulation. If at any time in the second semester the reference not does have inventory, the min WIP value would be “0”.
- Nb_Delays: the number of delays for each reference sold
- Coloured columns (one A and 3 B crowns): values for TOR/TOY/TOG are rounded to a multiple of 200 because it is the production lot size.

In this simulation, TOG, TOY and TOR are input data compared to Delays and min WIP that are output data, results from the simulation.

For each iteration, the colours are changed (for the font or the cell) for the modified parameters (in Table IV-V). With the initial values, at the beginning, the OTD level is slightly above 80% which is unsatisfying (cf. 99.3% OTD is targeted which means 6 delays at a maximum). As detailed in the algorithm, at first, several iterations change the TOG value in order to improve OTD (scenarios 1 to 4 with an OTD from 82.6% to 93.5%). Then, the DLT for reducers with delays is modified (scenario 5) which is not enough. Scenario 6 models changes for DLT for all components and the OTD objective is achieved in this case. The OTD objective is therefore achieved in only 6 iterations compared to the “generic” metaheuristic approach of the previous section.

However, the WC amount is higher and can be reduced. As the second algorithm part is defined, it focuses on WC diminution. All references with the minimum WIP which is higher than 0 have a DLT change (scenario 7). The OTD objective is still achieved but WC is dramatically reduced (-8%). This is the best scenario reached with the business algorithm defined in 3.1.2.

The business algorithm helps reach a satisfactory solution with 7 iterations and the algorithm stops (the following simulation would not satisfy OTD objectives). From these 7 iterations, in order to try to further improve results, manual reasoning is performed (iterations 8 to 10). The different steps followed are listed here:

- Iteration 8: to further decrease WC, the most sold reducers may be able to tolerate a TOG reduction. Therefore, a TOG reduction is applied for the two most sold reducers (reducers R1 and R4). With this iteration, OTD is no longer reached.
- Iteration 9: This is why only one TOG reduction is kept for scenario 9. However, here also the OTD objective is not reached.

- The minimum WIP of reducer R3 is not equal to zero, which is why its DLT is reduced for scenario 10. This scenario has better results from a WC point of view and the OTD objective is attained. These manual iterations reduce WC by 2.8%.

Iteration	OTD (%)	WC (€)	BLOCK #
1	82.6%	469,890	1
2	87.5%	408,871	1
3	94.1%	505,181	1
4	93.5%	517,464	2.1
5	96.2%	585,146	3
6	99.7%	756,113	4
7	99.5%	694,612	4
8	98.8%	679,189	N/A
9	99.0%	724,364	N/A
10	99.5%	675,184	N/A

Table IV-IV: OTD and WC iteration results

Iterations	Parameters	R1	R2	R3	R4	R5	R6	A white crown	Yellow gear	White gear	Red oil pan	Blue oil pan	B white crown	B green crown	B red crown	OTD (%)	WC (k€)
1	TOR	200	100	200	300	100	200	600	600	700	800	300	600	200	600	82.5%	470
	TOY	500	100	500	700	300	300	1200	1300	1500	1900	700	1200	600	1200		
	TOG	700	200	600	900	400	400	1800	1700	2000	2500	900	1400	800	1400		
	Nb delays	39	7	12	10	22	37	0									
	Min WIP	0	0	0	0	0	0	0	0	0	500	0	0	0	0		
2	TOR	200	100	200	300	100	200	600	600	700	800	300	600	200	600	87.5%	409
	TOY	500	100	500	700	300	300	1200	1300	1500	1900	700	1200	600	1200		
	TOG	800	300	700	1000	500	500	1800	1700	2000	2500	900	1400	800	1400		
	Nb delays	20	1	11	13	22	23	1									
	Min WIP	0	0	0	0	0	0	0	0	0	0	0	0	0	0		
3	TOR	200	100	200	300	100	200	600	600	700	800	300	600	200	600	94.1%	505
	TOY	500	100	500	700	300	300	1200	1300	1500	1900	700	1200	600	1200		
	TOG	900	300	800	1100	600	600	1800	1700	2000	2500	900	1400	800	1400		
	Nb delays	10	0	2	9	5	16	1									
	Min WIP	0	0	0	0	0	0	0	0	0	0	0	0	0	0		
4	TOR	200	100	200	300	100	200	600	600	700	800	300	600	200	600	93.5%	517
	TOY	500	100	500	700	300	300	1200	1300	1500	1900	700	1200	600	1200		
	TOG	1000	300	900	1200	700	700	1800	1700	2000	2500	900	1400	800	1400		
	Nb delays	10	0	3	12	6	16	0									
	Min WIP	0	0	0	0	0	0	0	0	0	0	0	0	0	0		
5	TOR	300	100	300	400	200	300	600	600	700	800	300	600	200	600	96.2%	585
	TOY	600	100	600	800	400	400	1200	1300	1500	1900	700	1200	600	1200		
	TOG	1000	300	900	1200	700	700	1800	1700	2000	2500	900	1400	800	1400		
	Nb delays	5	0	6	3	7	7	0									
	Min WIP	0	0	0	0	0	0	0	0	0	0	0	0	0	0		
6	TOR	300	100	300	400	200	300	800	700	800	900	400	800	400	800	99.7%	756
	TOY	600	100	600	800	400	400	1400	1400	1700	2100	800	1400	600	1400		
	TOG	1000	300	900	1200	700	700	2000	1800	2200	2700	1000	1600	1000	1600		
	Nb delays	0	0	0	2	0	0	0									
	Min WIP	0	200	0	0	0	0	0	0	100	100	0	0	0	0		
7	TOR	300	100	300	400	200	300	800	700	700	800	400	800	400	800	99.5%	695
	TOY	600	100	600	800	400	400	1400	1500	1600	2000	800	1400	600	1400		
	TOG	1000	200	900	1200	700	700	2000	1900	2100	2600	1000	1600	1000	1600		
	Nb delays	0	0	0	4	0	0	0									
	Min WIP	0	0	0	0	0	0	0	0	0	0	0	0	0	0		
8	TOR	300	100	300	400	200	300	800	700	700	800	400	800	400	800	98.8%	679
	TOY	600	100	600	800	400	400	1400	1500	1600	2000	800	1400	600	1400		
	TOG	900	200	900	1100	700	700	2000	1900	2100	2600	1000	1600	1000	1600		
	Nb delays	3	0	0	4	0	2	0									
	Min WIP	0	0	0	0	0	0	0	0	0	0	0	0	0	0		
9	TOR	300	100	300	400	200	300	800	700	700	800	400	800	400	800	99,0%	724
	TOY	600	100	600	800	400	400	1400	1500	1600	2000	800	1400	600	1400		
	TOG	900	200	900	1200	700	700	2000	1900	2100	2600	1000	1600	1000	1600		
	Nb delays	3	0	0	2	0	2	0									
	Min WIP	0	0	100	0	0	0	0	0	0	0	0	0	0	0		
10	TOR	300	100	200	400	200	300	800	700	700	800	400	800	400	800	99.5%	675
	TOY	600	100	500	800	400	400	1400	1500	1600	2000	800	1400	600	1400		
	TOG	900	200	800	1200	700	700	2000	1900	2100	2600	1000	1600	1000	1600		
	Nb delays	1	0	0	2	0	1	0									
	Min WIP	0	0	0	0	0	0	0	0	0	0	0	0	0	0		

Table IV-V: Business algorithm application

In conclusion, with this business algorithm application, a good solution is rapidly reached. In order to go further, some manual adjustments are also performed. The OTD objective is rapidly reached before focusing on WC reduction. Figure IV-VIII illustrates these indicator trends for the 10 iterations compared to the 319 iterations needed for the metaheuristic approach to achieve its best results. However, the main advantage of a “generic” approach is that the algorithm can be used without changes (or with only a few changes) if there are no project time constraints (or at least no serious constraints).

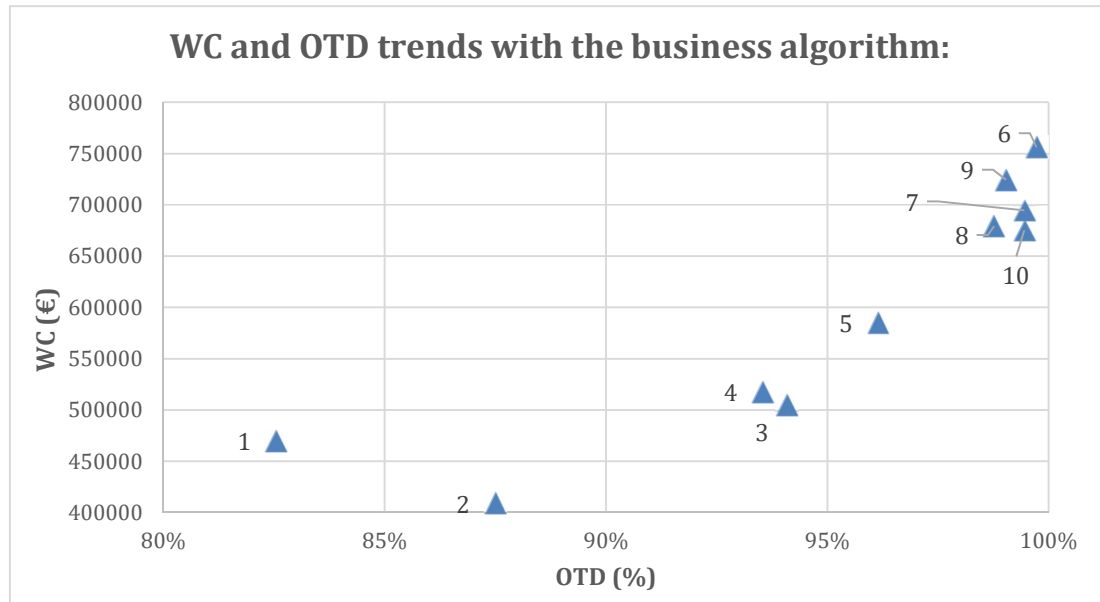

Figure IV-VIII: WC and OTD trends with the business algorithm

The difference in iterations needed is explained because the experiment is not coded with the simulated annealing algorithm. This is why this business algorithm is useful. The objective is to have reasoning focused on the references associated with bottlenecks. These references are then classified to work on their adjustments one after the other (cf. here, reducers first and gears and oil pans second). As regards the variability factor, it was used here to absorb “normal” noise but not to manage spikes. Hence its adjustments (for all references) was not a major issue. However, this business approach depends on the context because, for example, finished products may not be buffered with DDMRP stock buffers (as is the situation in the real case in Chapter V).

3.3. Better scenario results comparison for DDMRP parameters

The two best scenario results for the “generic” metaheuristic approach and for the business algorithm are quite close. What is the parameter sensitivity for each reference? It would help to decide which parameters to prioritise.

Table IV-VI details these parameters for both optimisation approaches: the business algorithm and the “generic” one. For each simulation 42 values can be modified: there are 14 buffered references and for each, one TOG, TOY and TOG value. These 42 values are sized with 58 parameters: 16 for DLT (all references) and 14 (all references except 2 B crowns) for green LT factors, red LT factors and variability factors.

	OTD (%)	WC (k€)		R1		R2		R3		R4		R5		R6		White A crown	
Initial scenario	82.5%	470	TOR	200		100		200		300		100		200		600	
			TOY	500		100		500		700		300		300		1200	
			TOG	700		200		600		900		400		400		1800	
Classical approach	99.3%	661	TOR	300	+ 50%	100	0%	300	+ 50%	200	-33%	200	+ 100%	200	0%	600	0%
			TOY	500	0%	100	0%	500	0%	600	-14%	300	0%	400	+ 33%	1400	+ 17%
			TOG	900	+ 29%	200	0%	900	+ 50%	1200	+ 33%	400	0%	700	+ 75%	1800	0%
Business algorithm	99.5%	675	TOR	300	+ 50%	100	0%	200	0%	400	+ 33%	200	+ 100%	300	+ 50%	800	+ 33%
			TOY	600	+ 20%	100	0%	500	0%	800	+ 14%	400	+ 33%	400	+ 33%	1400	+ 17%
			TOG	900	+ 29%	200	0%	800	+ 33%	1200	+ 33%	700	+ 75%	700	+ 75%	2000	+ 11%

		Yellow gear		White gear		Red oil pan		Blue oil pan		White B crown		Green B Crown		Red B Crown	
Initial scenario	TOR	600		700		800		300		600		200		600	
	TOY	1300		1500		1900		700		1200		600		1200	
	TOG	1700		2000		2500		900		1400		800		1400	
Classical approach	TOR	600	0%	600	-14%	1300	+ 63%	200	-33%	400	-33%	200	0%	600	0%
	TOY	1400	+ 8%	1400	-7%	2600	+ 37%	600	-14%	800	-33%	600	0%	1200	0%
	TOG	2000	+ 18%	1800	-10%	3200	+ 28%	1200	+ 33%	1200	-14%	800	0%	1600	+ 14%
Business algorithm	TOR	700	+ 17%	700	0%	800	0%	400	+ 33%	800	+ 33%	400	+ 100%	800	+ 33%
	TOY	1500	+ 15%	1600	+ 7%	2000	+ 5%	800	+ 14%	1400	+ 17%	600	0%	1400	+ 17%
	TOG	1900	+ 12%	2100	+ 5%	2600	+ 4%	1000	+ 11%	1600	+ 14%	1000	+ 25%	1600	+ 14%

Table IV-VI: DDMRP buffer comparison for the best solution with the business algorithm and the “generic” approach

The DDMRP values will be directly compared because two red LT factors and variability factors could be different yet create two equivalent red zones (Chapter II.1.2).

From the initial scenario, almost all zones for all references increased, whether for the generic approach or the business algorithm. This is the reason for the bad OTD results for the initial scenario. It can be noticed that the reducer R2 zones were initially well sized (with low volumetry).

The other lessons are that the main differences between the two approaches (generic and business algorithm) focus on reducers R4 and R5. The red and yellow zones for R4 are lower in the generic approach: with this difference, fewer supply orders (but with a higher quantity) are generated for R4 with the generic approach. The main issue is workload management: if there are more supply orders generated for R4 with business algorithms, fewer supply orders must be generated for another reducer; this is indeed the case for R5 with a higher green zone (700 compared to 400), which confirms our initial reasoning.

In Table IV-VI, compared to the classical approach, all the values that are different from the business algorithm are in red: 31 values out of the 42 are different. The main conclusions are:

- Even though many values are different, they are close (in general, one lot-size as a gap).
- In order to have good results, the priority is to well size reducer buffers. Indeed, the equivalent values are for these references (and for reducer R3, the values are different due to the last two manual iterations, cf. Table IV-V). This confirms that the parameter choices for components can lead to good solutions, contrary to those for reducers, where it is mandatory to find the right adjustment in order to reach the OTD objective: reducer parameter sensitivity is higher than for component parameters. The main reason for this lesson is that reducers are the first references to experience spikes. Hence, the variability made by spikes is already absorbed for the components that are easier to size (or at least have less sensitivity).
- Component buffer sizing is less important and has fewer impacts: only 2 values are equal (out of 24).
- It is confirmed that there are several local minima with different sets of parameters: there are several good solutions with different parameter choices (as shown in Table IV-VI).

4. Optimisation from a good solution obtained

A good solution was obtained rapidly with the business algorithm in the previous section 3.2. However, it is not sure that this solution could not be dramatically improved, especially from a WC point of view. What could be the possible improvements with a metaheuristic application to the best solution obtained rapidly with the business algorithm? This section deals with this issue and will try to improve results with several objective functions.

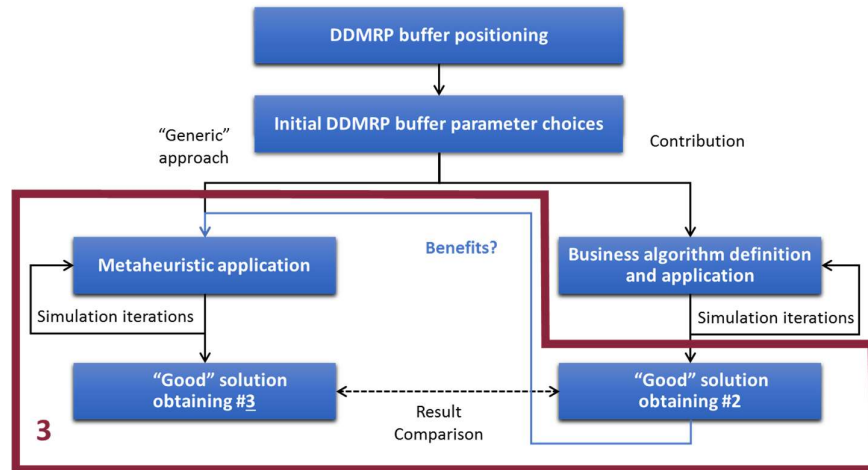

Figure IV-IX: 3 – “Generic approach” applied to a good solution obtained from business algorithm – Parameter optimisation

The initial parameters for the optimisation are the ones found for the best business algorithm scenario (Table IV-VI). For the other parameters which are minimum and maximum values and steps, they are equal to the first optimisation (Table IV-II).

The best groups of solutions are not necessarily paired with the most complicated objective functions. This is why several objective functions will be analysed in the next sections in order to analyse their impacts.

This chapter deals with 3 different objective functions:

- one focusing on OTD maximisation,
- one on a compromise between OTD maximisation and WC minimisation (OTD and WC weighting),
- the last one on a goal programming function (the goal is to reach the desired OTD and then minimise WC).

Firstly, the main objective is to maximise OTD (or at least reach 99.3%), which is why a single criteria is analysed with an OTD maximisation (4.1). This analysis helps to understand the possible WC gaps for several iterations (without trying to improve them). Secondly, the objective is also to minimise WC. Therefore, a first two-criteria approach is made: a weight is applied for OTD and WC in the objective function (4.2). Finally, as the main goal is to reach

OTD and only after that to minimise WC, a goal programming function is applied as a third objective function (4.3).

These analyses are detailed in the next three sections. Each optimisation scenario has been simulated nearly 750 times (to get representative comparisons). An iteration lasts between 4 and 5 minutes, so the criteria was to simulate a little more than 2 days in order to get results (cf. computer with an i7 processor of 3.4 GHz and 16 Go RAM).

For each analysis, the following points will be detailed (as in Chapter IV.2):

- The objective function description
- The objective function results diagram
- A WC – OTD diagram to show the distribution of results (with a global view and a detailed view for the best OTD and WC results).
- An analysis of the good results compared to the total simulation: a simulation is considered good if OTD > 99.3% and WC < 1m€.

4.1. OTD maximisation objective function

The first optimisation analysis targets “only” the best OTD possible. In other words, the WC is not challenged at all. With this scenario the objective is to try to see if it is possible to reach 100% OTD and furthermore to understand what the WC gap can be for scenarios that reach a near-perfect OTD.

The objective function is the following:

$$\text{Objective function} = \text{Max} \left(\frac{\exp^{(31 \times \text{OTD})} - 1}{\exp^{(31)} - 1} \right)$$

This objective function has been chosen in order to rapidly increase as soon as the 95% OTD stage is reached: the objective function increases from nearly 0.2 to 1 with 95% OTD to 100% OTD. It is the “31” factor in the exponential function that allows this fast rise.

The simulation results with this optimisation objective are illustrated in Figure IV-X. The sensitivity of the chosen parameters is highlighted: in a simulated annealing optimisation, the parameters are not changed much for each scenario (and in a great majority of cases only a single parameter is changed) but results (in OTD terms) have high variability.

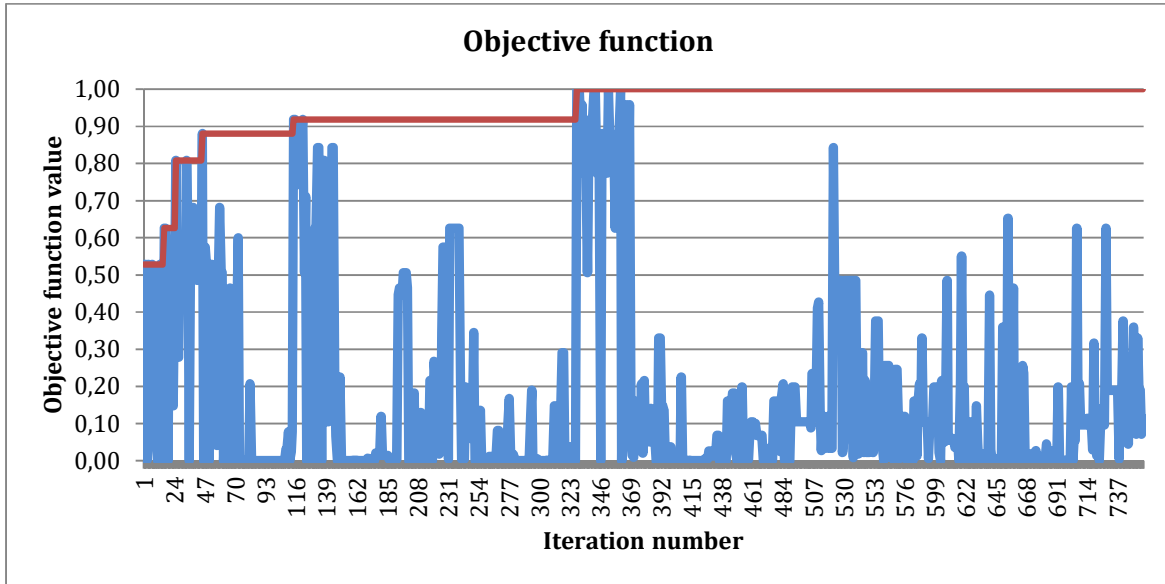

Figure IV-X: OTD objective function

Figure IV-XI shows the function's results: each result is positioned for its WC as a function of the OTD result. The main lessons are detailed here in Table IV-VII:

Scenario number	756
Scenarios with OTD < 50%	55 (7.3%)
Scenarios with OTD > 99.3%	41 (5.4%)
Scenarios with WC > 1m€	250 (33.1%)
Scenarios with WC <1m€ and OTD > 99.3%	13 (1.7%)

Table IV-VII: OTD objective function results

It is clear that the number of scenarios with a WC higher than 1m€ is considerable (33%), including some scenarios that exceed 1.6m€ (2.5 times the best DOE scenario). There are 13 scenarios considered good (with WC lower than 1m€ and OTD higher than 99.3%). The scenario distribution is detailed in Figure IV-XI. The best scenarios are in the bottom right-hand corner (as shown with the red circle).

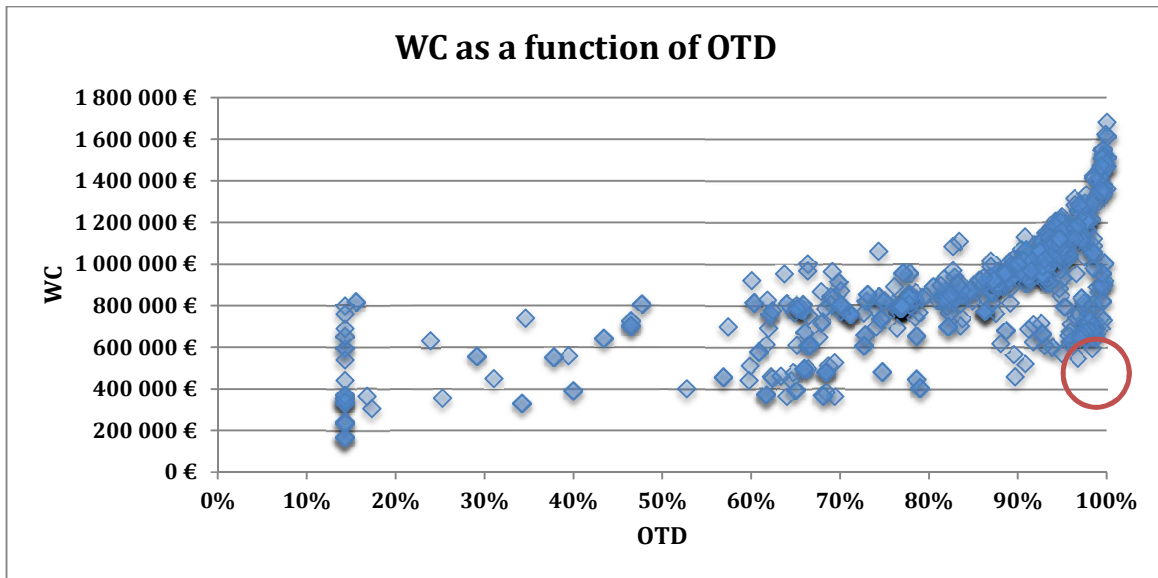

Figure IV-XI: OTD objective - WC as a function of OTD

These good results are represented in Figure IV-XII with OTD between 95% and 100%. With this figure, there are more scenarios with WC above 1m€ (15.2%) than below (10.6%).

Furthermore, the best results are in the red circle. They are widespread both in terms of OTD and WC with the OTD optimisation work. The best scenario obtained with this optimisation attains a 99.3% OTD and a 693k€ WC (+3.4% compared to the best DOE result). Therefore, the “manually” realised DOE had a better solution than the 756 simulations produced here.

The Pareto frontier (red line in Figure IV-XII) highlights some scenarios which do not satisfy OTD objective but have better WC. As an example, a scenario result reaches a 96.7% OTD with a 549k€. WC is reduced by 21% compared to the best solution. In other words, reaching the OTD objective is expensive.

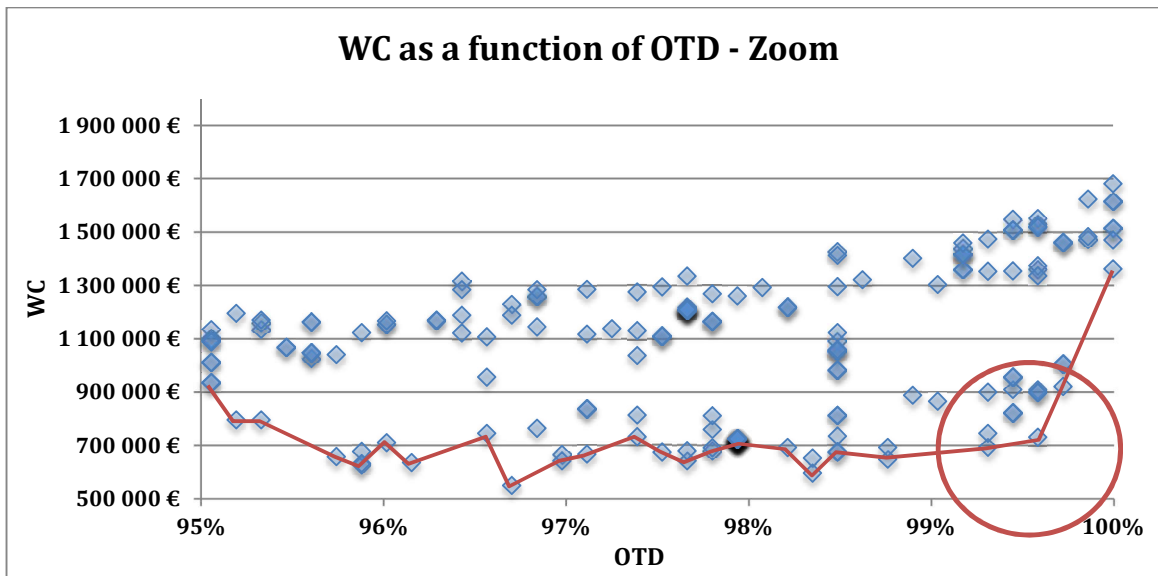

Figure IV-XII: OTD objective - WC as a function of OTD - Zoom

4.2. OTD and WC weighting objective function

The second optimisation work has OTD maximisation and WC minimisation objectives. In order to optimise these two criteria, a weighted approach (a weight applied for each criteria) is firstly realised. For this scenario, each criteria has an equivalent weight (50%).

The objective function is the following:

$$\text{Objective function} = \text{Min} \left(0.5 \times (1 - \text{OTD}) + 0.5 \times \frac{(\text{WC} - 200,000)}{1,000,000} \right)$$

On one hand, the left objective function part corresponds to the goal of maximising OTD. On the other hand, the right part is here to try to minimise the WC amount. The purpose of this function is to try to normalise this WC part, which is why the two values correspond to the potentially expected minimum and maximum WC (respectively the 200,000 and 1,000,000 values). However, with this approach some abnormal points will go beyond the [0; 0.5] expected range for the right term.

Figure IV-XIII details the results obtained with the weighted objective function. The resulting value represents the objective function results for each scenario. With this optimisation work, the best results trend is mainly reached at the beginning of the simulation before a rise and then a slight decrease at the end of the optimisation (the simulated annealing was about to converge).

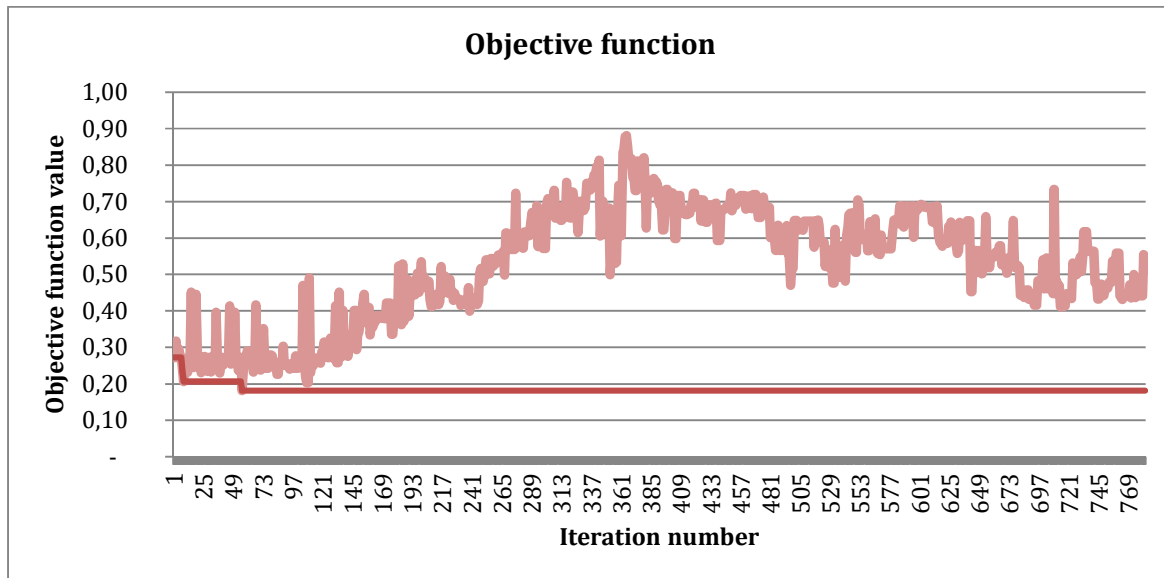

Figure IV-XIII: OTD and WC weighting objective function

OTD and WC results are detailed in Figure IV-XIV below. Many results are on the right (OTD more than 90%) but here also some scenarios with high WC (nearly 3 times the best DOE scenario).

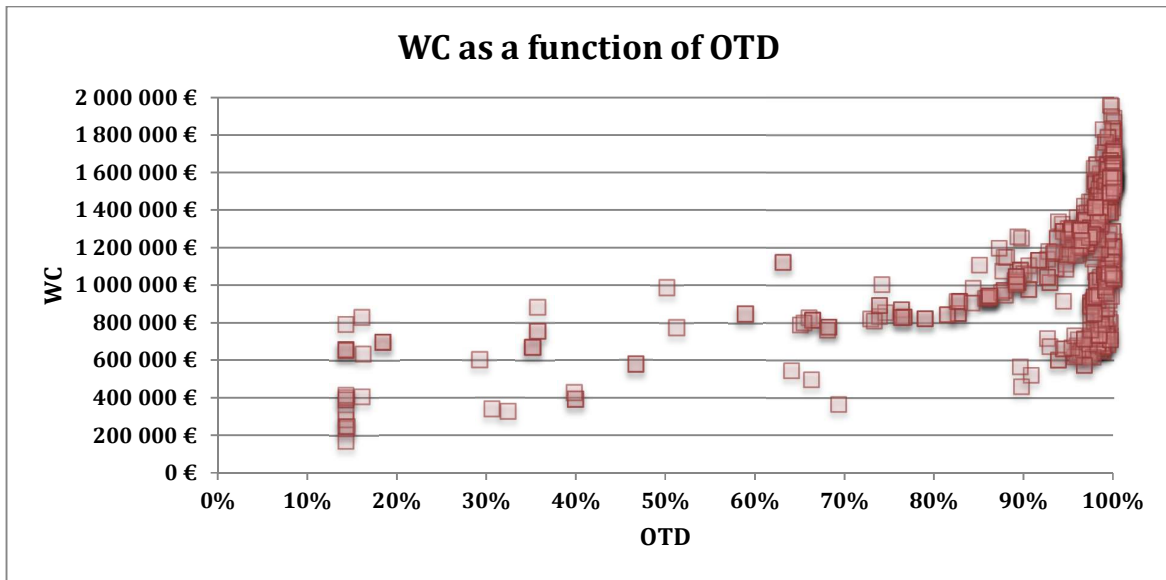

Figure IV-XIV: OTD and WC weighting objective - WC as a function of OTD

For this optimisation work, more than two-thirds of the results have a WC higher than 1m€ (Table IV-VIII). Furthermore, 29.2% of the scenarios have an OTD higher than 99.3%. The number of good results scenario is equivalent to the OTD optimisation (11 compared to 13).

Scenario number	782
Scenarios with OTD < 50%	35 (4.5%)
Scenarios with OTD > 99.3%	228 (29.2%)
Scenarios with WC > 1m€	520 (66.5%)
Scenarios with WC <1m€ and OTD > 99.3%	11 (1.4%)

Table IV-VIII: OTD and WC weighting objective function results

Compared to OTD optimisation, the density of results is dramatically higher for OTD superior to 95% (and especially for near-perfect OTD), as illustrated in Figure IV-XV.

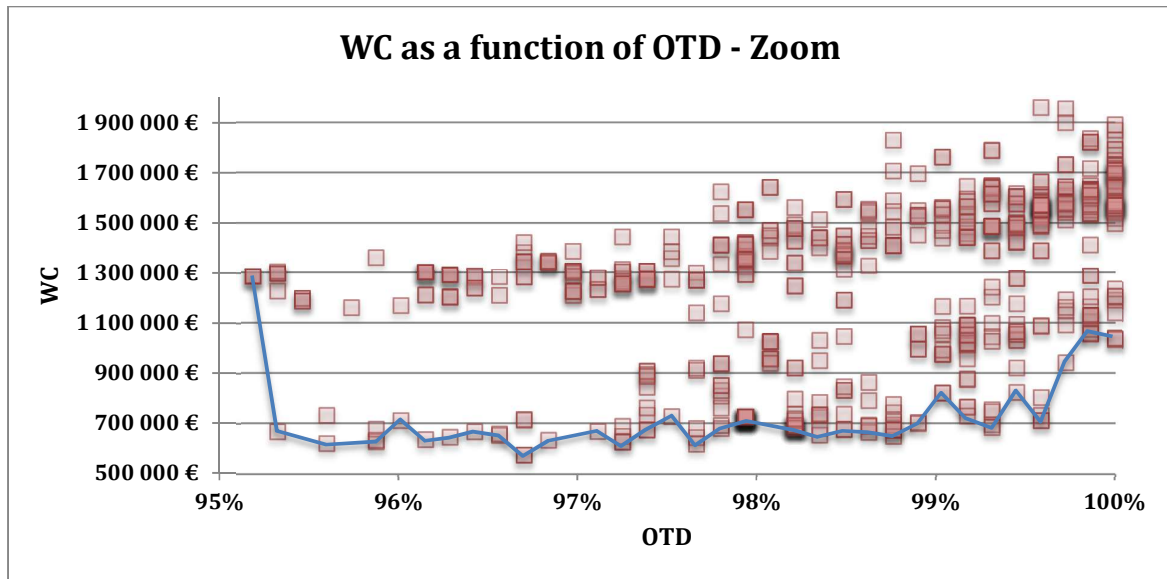

Figure IV-XV: OTD and WC weighting objective - WC as a function of OTD - Zoom

Finally, for this OTD and WC weighted optimisation, the best scenario has 99.3% OTD and 682k€ (+ 1.8%). These results are quite close to the best of the DOE's but are still inferior.

4.3. Goal programming objective function

The last objective function implemented is the same goal programming function as in Chapter IV.2. As a reminder, the goal is firstly to reach the OTD objective and then to minimise the corresponding WC.

Figure IV-XVI details the optimisation results for the objective function. The results are dramatically erratic from one simulation to the next. This is due to the OTD changes for each simulation (and the “penalty” applied, cf. Chapter IV.2).

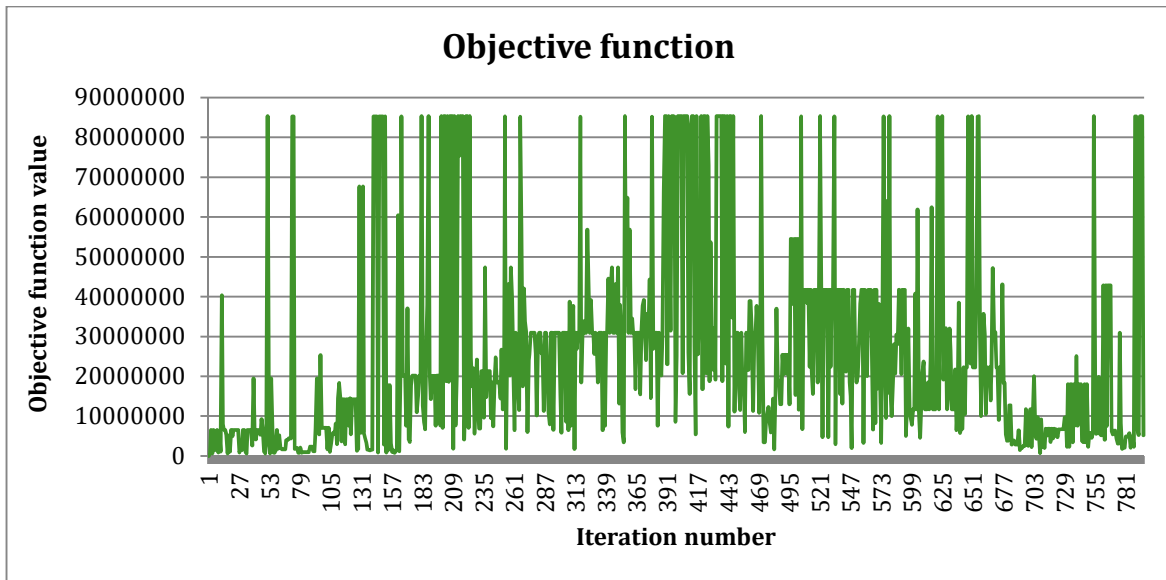

Figure IV-XVI: Goal programming objective function

For these 795 simulations analysed, there are 105 with an OTD lower than 50%: this is respectively nearly 2 and three times more than WC and OTD optimisations. Furthermore, only 8 simulations have an OTD higher than (or equal to) 99.3%. However, for these simulations, all scenarios tested have a WC lower than 1m€: this is a major difference compared to the two previous sections. Therefore, there are also 8 scenarios with at least 99.3 % OTD and less than 1m€ WC.

Scenario number	795
Scenarios with OTD < 50%	105 (13.2%)
Scenarios with OTD > 99.3%	8 (1.0%)
Scenarios with WC > 1m€	0 (0%)
Scenarios with WC <1m€ and OTD > 99.3%	8 (1.0%)

Table IV-IX: Goal programming objective function results

As regards the distribution of results, they are grouped much more densely compared to the other simulations (Figure IV-XVII): this is especially the case for high OTD results (Figure IV-XVIII) where the results are very dense compared to OTD and WC optimisations. In other words, the goal programming work is achieved with the OTD objective realised before trying to find the best WC amount.

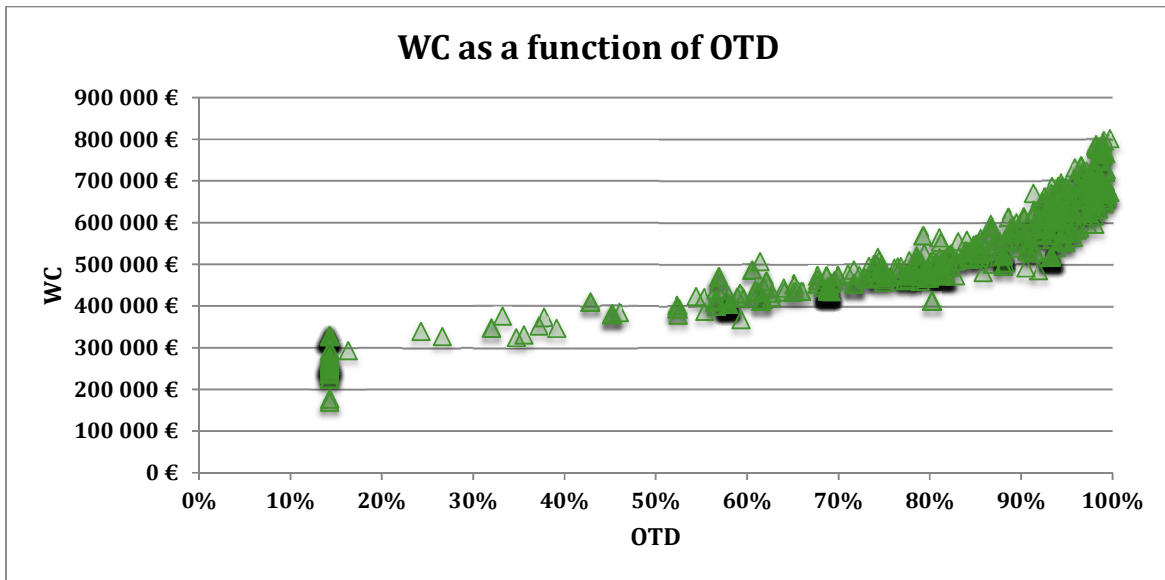

Figure IV-XVII: Goal programming objective - WC as a function of OTD

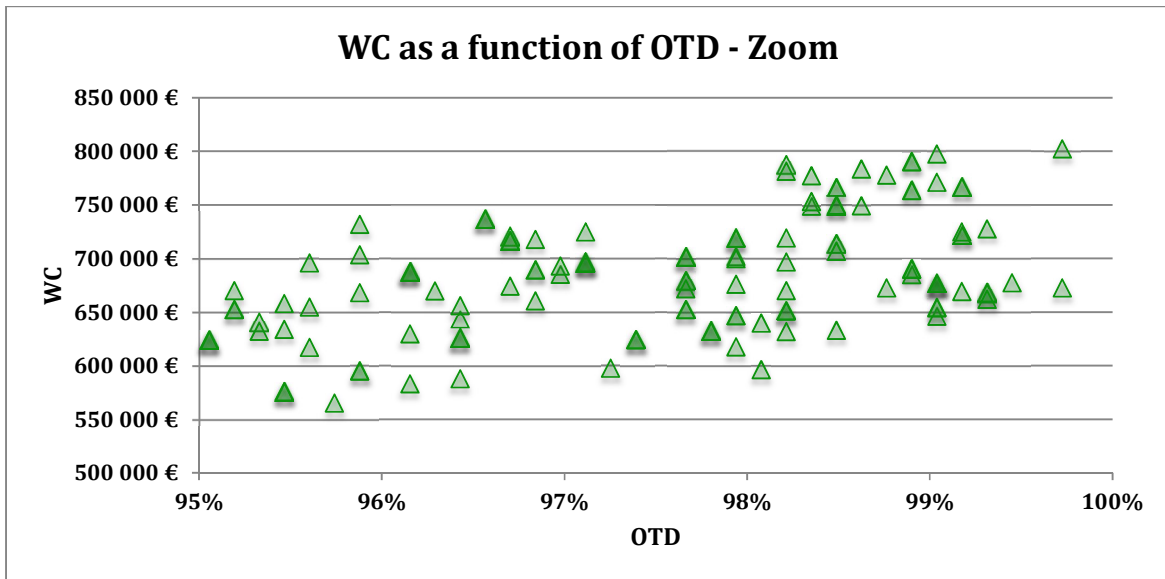

Figure IV-XVIII: Goal programming objective - WC as a function of OTD – Zoom

This approach has therefore obtained the highest number of good solutions. The ten best scenarios are detailed in Table IV-X below. Four scenarios have better results than the one which has been “manually” found for the DOE. However, the best scenario has only a 1.2% reduction in WC. With these 10 results, two have not reached the OTD objective, but due to their low WC their objective function is also lower (the “penalty” applied allows for limited exceptions from the OTD objective).

It can also be noticed that the simulation results were converging (or about to converge) because one of the ten best solutions is found with the 707th iteration.

Solution number	OTD (%)	WC (€)	Objective function
48	99.31	661,906	661,906
16	99.31	667,496	667,496
1	99.31	668,145	668,145
3	99.31	668,145	668,145
32	99.73	672,506	672,506
52	99.45	677,360	677,360
707	99.31	727,536	727,536
56	99.18	669,109	793,284
158	99.73	802,116	802,116
76	99.18	721,708	845,884

Table IV-X: Goal programming optimisation best results

4.4. WC and OTD global analysis

This section deals with the comparison between the three optimisation analyses. All the OTD results are at least 14% because for each scenario simulated, white A crowns have successfully been delivered (1 reference out of the 7). However, this means that an insignificant amount of simulations do not deliver reducers at all in the second semester.

As previously detailed, on one hand, the goal programming method has more scenarios with bad OTD levels (Figure IV-XIX), especially with OTD under 50%. On the other hand, WC results are considerably better with the goal programming objective function (Figure IV-XIX and Figure IV-XX).

As far as OTD and “OTD and WC weighting” optimisations are concerned, the results are nearly equivalent in terms of OTD and WC. The only difference is that the WC is, on average, slightly superior in the second optimisation rather than in the OTD optimisation.

With Figure IV-XIX, this diagram could be helpful for managers to manage which strategy to follow. Indeed, some companies might prefer to reduce their OTD objectives in order to reduce their WC: for example, it is possible to reach 90% of OTD with nearly 460,000€ in WC (-31% from the best DOE scenario). This is one of the main DES advantages coupled with optimisation: it enables the Pareto frontier to be identified so that the manager can quantify the impacts on concessions made for one or several parameters.

In conclusion, the goal programming objective function used for the first optimisation work (all parameters at 50% in Chapter IV.2) converges more rapidly, thus confirming that it was the appropriate objective function to use for this previous section.

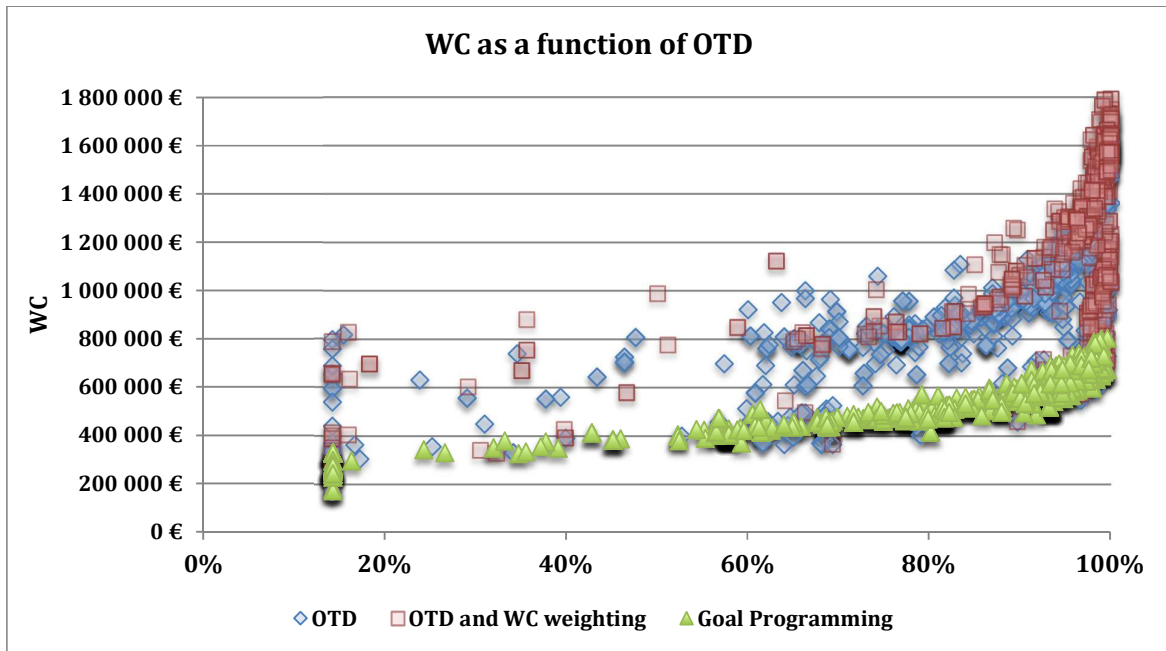

Figure IV-XIX: Objective function - comparison of results

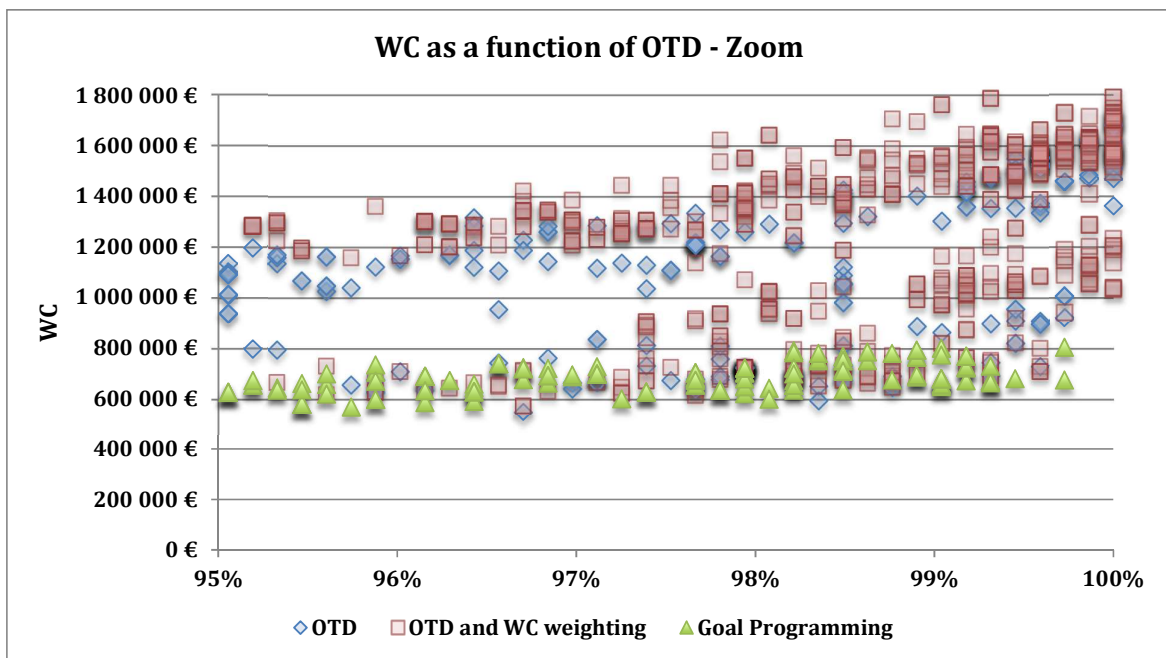

Figure IV-XX: Objective function - comparison of results - Zoom

Chapter IV conclusion and future work

Conclusion

In conclusion, it is confirmed that the DDMRP recommendations for buffer parameter choices must become finer according to the system studied. This is a major issue that can lead to extreme variations in results (from the same buffer positioning reasoning) as just assessed.

Parameter adjustment, as confirmed by this case study, can have high sensitivity. The main illustration is with Table IV-V: between iterations 2 and 3, the green LT factors rose from 15 to 30% only for the five reducers. These changes involve an OTD increase of nearly 7% (from 87.5% to 94.1%) with also a 23% increase in WC (from 409k€ to 505k€). These major gaps in results are attained whereas the settings were in the “short lead time” range of Figure II-VII.

The business algorithm that is defined and applied provides a scenario with good results more rapidly compared to a single “generic” metaheuristic approach. Indeed, with this second optimisation method, several hundred simulations are needed. However, contrary to the second approach, the business algorithm must be created (even though a part of the method can be generalised). Even with this algorithm definition, the time study was less important for the business algorithm study than it was for the metaheuristic approach. Furthermore, due to the simulation time, work has been carried out in order to reduce it.

As regards parameter sensitivity, it can be noticed that OTD is extremely variable with weak parameter changes. Furthermore, several satisfying scenarios are found with many different values: there are several local minima. In this context, the objective was to reach 99.3%: however, in some other contexts a compromise between a lower OTD for a lower WC could be retained. The simulation is a decision-making tool that helps giving all the information stakeholders need to make strategic decisions and choose the objectives to achieve. Indeed, Pareto frontiers help to decide which strategy to choose with the corresponding DDMRP parameters. These lessons help to deal with the buffer sizing issue in order to confirm the P1 promise and assist the system in managing variability sources, and in particular, the spikes in this scenario (P6).

The possibility of implementing a metaheuristic approach after the business algorithm application is not conclusive. Even after numerous iterations, improvement is extremely low. The business algorithm helps converge more rapidly with a local minimum that seems difficult to be greatly improved. The question is to know if it is also the global minimum, however this is impossible to answer here.

Another statement with the metaheuristics applied here is that the best or the very good results are identified mostly at the beginning of the optimisation application as detailed before: from the initial situation (all parameters at 50%) the results are not satisfactory but the parameters begin to be well chosen. Therefore, after hundreds of simulations when big changes are tried it

is extremely difficult to find another local optimum. This statement confirms the DDMRP sizing parameter sensitivity.

Better results are mainly achieved for the first hundred simulations: the initial situation is not satisfactory but the parameters begin to be well-set. This is why after several hundred simulations, when some parameter values are totally different, the results are far from being satisfactory and it is difficult to find another local optimum.

The goal programming objective function is appropriate here for the metaheuristic approach: the results are better with more “acceptable” ones than with the single objective methods.

Finally, implementing DDMRP with a previous DES study again helps save time and costs (for both OTD and WIP amounts). This decision-aiding tool is therefore relevant for confirming (or disconfirming) the initial parameter choice.

Future work

This first DDMRP optimisation work confirms that this is an important issue which the large majority of DDMRP implementation projects must cope with. In order to improve results, a business algorithm has been defined. However, interesting further research work could focus on this algorithm type generalisation for different types of systems. This future research work would be complicated, as illustrated with this case study which did not have numerous activities or references compared to real case studies. This is why this optimisation work must be implemented to other cases because current DDMRP literature on this work is limited due to its recentness.

One of the other issues highlighted here is to define what is a satisfying solution or not. Furthermore, it is complicated to identify whether or not the results found really are an interesting solution (if a local minimum is reached).

This optimisation analysis was performed with an equivalent DDMRP buffer positioning. However, with the scenario retained and the best parameter values, the buffer positioning step could be reconsidered.

The next chapter deals with all the previous chapters' contributions applied to a real case study.

Chapter V.

INDUSTRIAL APPLICATION: A REAL CASE STUDY

“It is always more easy to discover and proclaim general principles than to apply them.”

Winston S. Churchill ¹

Until now, DDMRP has been presented and challenged through a theoretical point of view. This chapter V offers a real case study: a DDMRP implementation (Figure V-I). This chapter aims to illustrate the previous three chapters with a real application in order to reinforce or challenge their conclusions.

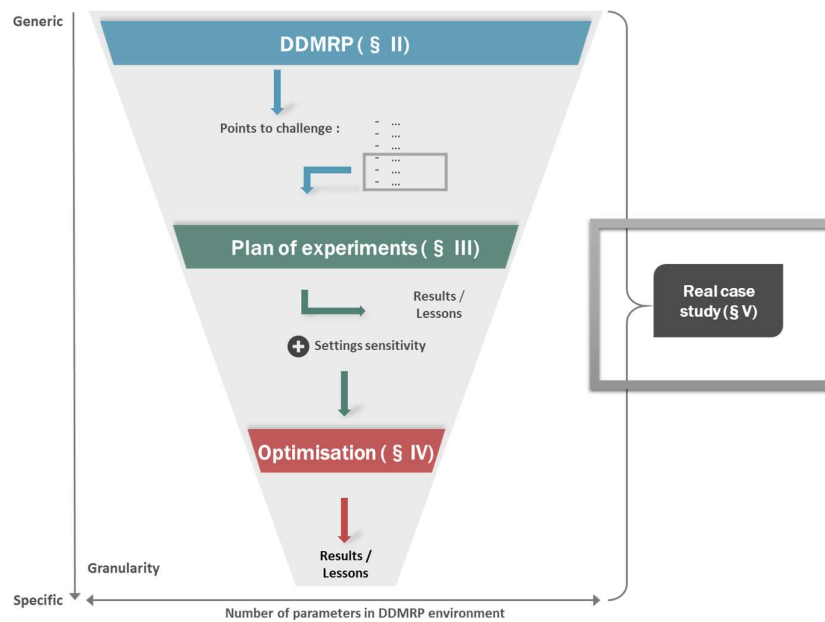

Figure V-I: Big picture – a real case study

¹ : British statesman and writer (1874 – 1965)

1. Context

This real DDMRP implementation is applied to a French company in Saintes which belongs to the JV Group¹. It is an SME created in 1973 specialised in aeronautical, railway, nuclear, and hobby products with machining and assembling operations.

JV Group wants to improve its OTD in order to meet the aeronautical market constraints that increasingly require near-perfect OTD. Most of the products are machined (the longest Lead Time LT ratio for a product) before assembling. However, assembling kits are too often not ready or complete. That is to say, the company begins the assembling operation before stopping the uncompleted assembling activity and then waits for the missing parts. Furthermore, they have already tried various things in order to achieve a near-perfect OTD level with MRP II but they seem to have reached the method's limits.

Therefore, DDMRP implementation could be appropriate to deal with these issues and JV Group's objectives. As far as this study is concerned, the scope is a new seat base production and assembly for first class airplane passengers. This product has a 14-month production lifecycle with 10 customers orders for the 10 planes to deliver. For each plane, 8 seat bases are required.

For confidentiality issues, the references, customers and machine names will remain anonymous.

¹ JV Group website:
http://www.jvgroup.fr/jvgroup_bienvenue.html

2. Case study modelling

2.1. Environment modelling

A seat base is composed of 67 references: 12 assembly and 55 component references. Figure V-II details the seat base BOM: the assembly parts are in reality composed of 5 BOM levels that use the 55 components. As regards lead times, the majority concerns production, with more than 10 weeks for several references. After production, the parts are assembled within a maximum of 5 weeks: this horizon is enough for an MTO strategy. This is why this chapter will focus especially on the P3 promise with the decoupled explosion application.

However, for the components, DDMRP is interesting for reducing lead times and ensuring availability for assembling operations (synchronisation). Out of the 55 references, 23 are buffered, because these references present the difficulties. Most of all, these references represent the majority of the product's added value. Thus, the other 32 references are buffered following the generic MRP functioning (they are not strategic parts). To conclude, compared to the theoretical case study (Chapter II and Chapter III), only the components are buffered here. Buffering a seat base would lead to an enormous Working Capital (WC) increase without ensuring better OTD.

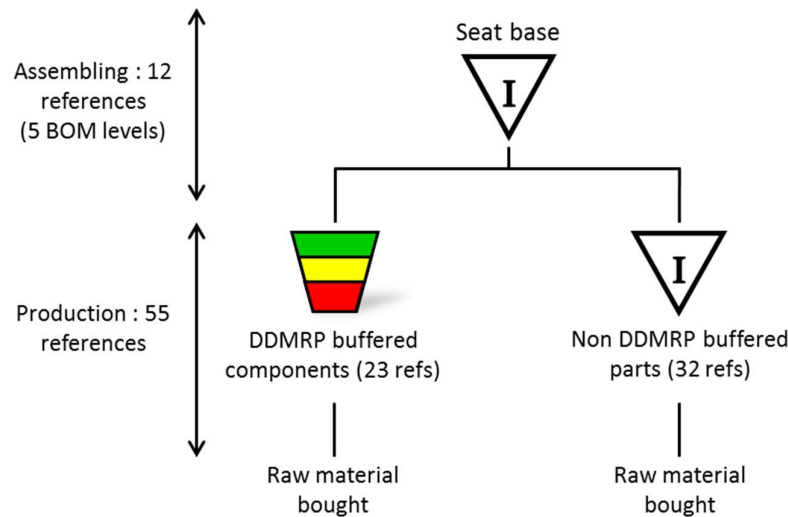

Figure V-II: Seat base BOM macro

To illustrate the difficulty of seat base management, the corresponding BOM matrix is detailed below (Table V-I). The 12 assembled references are at the top with the 87 different components. Nearly a third of the references are not modelled: these small parts are always available, with a non-significant value and without issues. That is why “only” 67 references are modelled and simulated.

PARENTS

	1001-05	3002	1110	1630-01	1631-01	1950-01	1200-01	1230-01	1231-01	1201-01	2322	1320-01
3002	1											
1110		1										
1630-01			1									
1602-31				1	1							
1320-31				1	1							
1651-01				1	1							
1329-01				2	2							
1327-20				1	1							
1325-20				2	2							
1328-31				1	1							
1820-06				2	2			4	4			
5319-07-25				2	4			1	1			
565A8H3				2	2							
1631-01			1									
1322-31					1							
1950-01			1									
1908-01						1						
1904-31						1						
1905-31						1						
1906-31						1						
1907-31						1						
1909-01						1						
679A08						2						
5319-05-18						1						
1801-04-5						2						
1149FN416P						2						
1601-31			1									
1350-20			1				1					
1101-01			1									
1200-01		1										
1230-01							1					
1235-31								1				
1235-32								1				
1237-31								2	2			
1253-31								1	1			
1251-31								1				
1257-31								1				
1801-08-9								4	4			
1149FN832P								4	4			
0043-280								1	1			
1231-01							1					
1235-31									1			
1235-32									1			
1252-31									1			
1258-31									1			
1201-01							1					
21075L08N										3		
21075L3N										2		
3685										10		
1220-01							1					
2322												
2314-31		1										
2310-01												1
2321-32												4
2315-31												1
2410-31												1
2411-31												1
2413-31												1
2412-31												1
0043-180												1
010-002-01												1
010-003-01												1
010-013-01												1
010-014-01												1
1149D0316J												2
23203AM0032T												2
514P632-6												4
1149D0363H												4
5527-03-04												1
5516-09ND												3
1149F0332P												3
5527-03-06												6
1801-3-8												1
1801-3-40												1
1801-3-11												1
1320-01		1										
1321-01												1
41713-31												1
1355-20												1
4-5A												1
1149G0432P												1
1314		1										
1410		1										
1421		1										
1425		1										
1426		1										
1427-01		1										
1427-02		1										
1510		1										
1432		1										
705		1										
1482		1										
2615		1										
2616		1										
1483		1										
1226		1										
0703-31		2										
KRV26X		2										
1431-01		1										
1270-31		1										

C
H
I
L
D
R
E
N

Table V-I: Seat base BOM Matrix

For the production phase, 29 activities are concerned. These activities group machines, control and subcontracting operations. For the assembly operations, only one activity type is required (workbenches) but with several workstations. The routings are therefore quite complex for a production step with an average of 9 operations for each component. In order to illustrate the complexity of the system, the corresponding Witness® model is given in “**Appendix C: JV Group Witness model**”.

In the DES model, 3 order types are modelled:

- Non-buffered component orders (MRP)
- Assembly orders (MRP in MTO)
- Buffered component supply orders (DDMRP in MTS)

This environment is an MTO environment for finished products and MTS for components: the DDMRP logic is applied to all the processes. As a consequence, from the DDMRP theory, the MRP calculation is kept for assembling references and non-buffered components.

Besides, demand is not considered a spike here; otherwise, there would only be spikes as demand. However, there is sporadic but regular demand in this context.

In conclusion, this environment is a large “A” type BOM, far from a linear process in favour of push material management methods. There are many assembling and machining steps that lead to implementing the decoupling explosion between the different buffers and MRP calculations for numerous references, except for strategic buffered components.

As for the previous chapters, DES is used to model this environment for its predictive and dynamic sizing to compare the DDMRP implementation to a classical MRP one.

2.2. Modelling hypothesis

The following hypotheses have been made, in agreement with JV Group, in order to model the system:

- Modelling only this seat base flow would not be realistic. Indeed, the new seat base represents only a small percentage of the workload for 2016. All the references (more than 1,600) produced in 2015 are simulated with the new product: there are more than 6,000 production orders. This hypothesis is justified because the global workload for 2016 is nearly equivalent to 2015's. The objective is to model real queues in the DES model. This production program corresponds to a 4th-order type for the DES model.
- The financial dimension is also taken into account: production and assembly costs are modelled with 10% in holding costs and hourly costs for each activity. Subcontracting costs and raw material costs are modelled (Chapter III.1.4).

- An assembly order can only begin if all the components required are available. Otherwise, another reference is prioritised.
- Company closures are modelled: two weeks in summer and one in winter.
- Raw materials are always available to begin component production. This hypothesis is made because supply issues are scarce.
- Subcontractor capacities are considered infinite: there is no impact from whether a few or a lot of products are sent to subcontractors.
- For each non-buffered component, only two orders are released for the 10 airplanes (the first one for the first 5 planes and the second one for the 5 others). This choice is made because these references are cheap.

2.3. Buffer sizing and dynamic adjustments

2.3.1. Buffer sizing

For the seat base, the ADU is already known and DLTs have been assessed for all references in the seat base BOM. In order to size DDMRP stock buffers, variability factors as well as LT factors must be chosen (Chapter II.1.2).

As far as LT factors are concerned, the higher the LT, the smaller the LT factor. In this industrial application, there are 10 planes ordered over 10 months, which is why LT factors are weak. They are implemented at 10% for each DDMRP reference buffered at the beginning.

Variability factors are also adjusted to 10%: the quantity ordered is precisely known and will not change in future. However, the delivery date may change (brought forward, in general).

As explained in Chapter II.1.2, the green zone represents the highest value between ADU times DLT, times LT factor and MOQ (Minimum Order Quantity):

$$\text{Green Zone} = \text{Max} (\text{ADU} \times \text{DLT} \times \text{Lead Time Factor}; \text{MOQ})$$

In this application, the industrial planner has fixed the MOQ for each reference to be at least equivalent to 2 planes (this hypothesis is challenged in 3.3). If the BOM coefficient is 1, the green zone is worth 16. Figure V-III illustrates a DDMRP buffer profile with these settings and with 2 parts needed for one seat base assembly. The other DDMRP buffers have similar profiles (zone distribution); the main difference involves the BOM coefficient for a seat base.

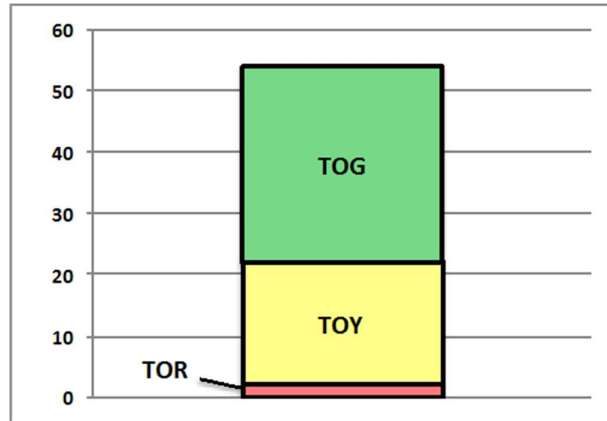

Figure V-III: Buffer profile for a buffered reference

These settings are sized from experience but could be adjusted with simulation and after real results.

2.3.2. Dynamic adjustments

The seat base reference is a new product with an end of life already known. As detailed in Chapter II.1.5, dynamic adjustments can be used: for seasonality, for example. In our case, this step helps manage ramp-up and ramp-down stages.

Ramp-up and ramp-down phases are not managed in the same way:

- Ramp-up: even if the ADU and DLT would not be changed afterwards, a ramp-up phase is implemented to prevent ordering too high a quantity (TOG if the buffer is empty, cf. Chapter II.1.6). If this is not the case, it could overload the shopfloor with numerous articles (the same reasoning for the 23 DDMRP buffered references) and a high WC gap. This is why TOG is firstly sized to the green zone (32 for the reference example in Figure V-IV below) which is equivalent to 2 planes.
- Ramp-down: the last order is forecasted for February 2017, so buffer profiles are sized to have enough inventory for 2 places. This is why the PAF is set at 0% starting from December 2016: if PAF is at 0%, the yellow zone is worth 0 and this is the same for the green (MOQ is also set at 0) and red zones (Chapter II.1.5).

The same reference buffer profile as for Figure V-III is detailed with ramp-up and ramp-down phases in Figure V-IV below:

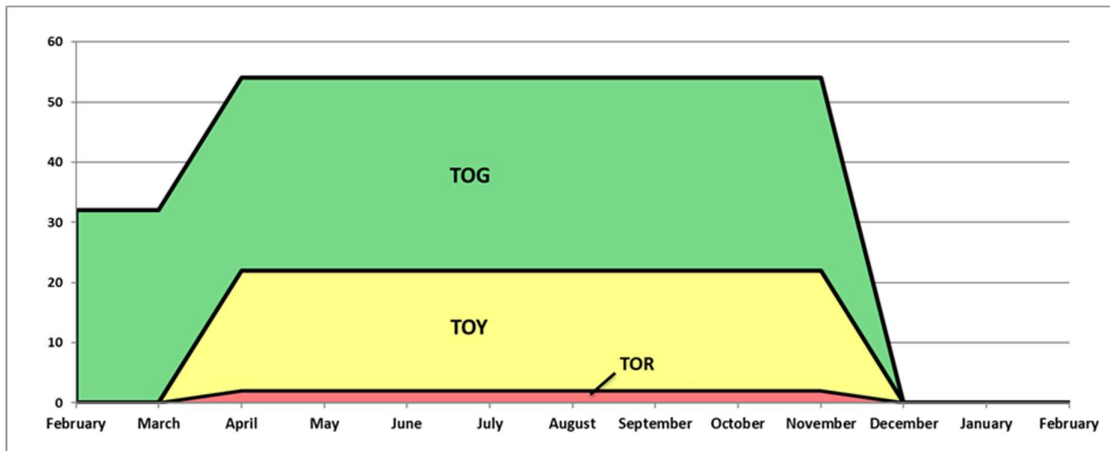

Figure V-IV: Buffer profile trend for a buffered reference

2.4. Planning modelling

As detailed in 2.1, there are several order types. MRP orders (for non-buffered components or for assembly references) are planned with a classical backward scheduling method with some delay security, if needed.

DDMRP planning theory is followed (cf. Chapter II.1.6): each time a buffer enters the yellow zone, a supply order is generated in order to achieve TOG with a NFE. For this simulation application, NFE is computed daily.

2.5. Execution modelling

As soon as the DES model is realised, the execution rule is implemented. Order generation will follow the DDMRP decoupled explosion rules with:

- MRP calculation for some components (non-buffered DDMRP parts in Figure V-II) and for assembly parts
- DDMRP visible and collaborative execution (Chapter II.1.7) for DDMRP buffered components

This is why this modelled system follows a complete DDMRP integration throughout the BOM.

As regards execution rules, the issue here is to manage MRP or DDMRP reference priorities. These orders are respectively prioritised with due dates or with TOR planning DDMRP zones. As detailed in Figure V-III above, the red zone is extremely small. Therefore, all DDMRP references would have the same priority each time references are consumed in buffers.

All references except seat bases have no delivery constraints (they are only modelled for queue issues). Therefore, there are no due dates and it is impossible to prioritise these references.

This is why a FIFO (First In First Out) execution rule for all references is realistic and can be implemented.

3. Simulation analysis

As for Chapter III, the experiments have been conducted in order to quantify DDMRP implementation interests for this new seat base production. Also, as in Chapter III, OTD and WC are the two main KPIs for assessing the performance of each scenario. The DDMRP implementation has been modelled in order to assess potential changes and its resilience to variability. Finally, with demand variability, MRP and DDMRP implementations are compared (3.4).

3.1. Initial situation

Firstly, the main DDMRP simulation issue is to ensure the deliveries of seat bases on time. Table V-II details the delivery dates provided by the customer for each plane. The delivery time slot accepted by the customer is $[0; -7]$, i.e. the delivery can be made one week in advance at a maximum up to the given date, otherwise penalties can be applied. In this simulation model, with the hypothesis that has been made, some possible problems have not been modelled and JV Group prefers to have a time buffer rather than to run the risk of having delays.

Due date	Earliest delivery date
05/27/2016	05/20/2016
06/29/2016	06/22/2016
07/22/2016	07/15/2016
09/07/2016	08/31/2016
10/05/2016	09/28/2016
10/26/2016	10/19/2016
11/16/2016	11/09/2016
01/04/2017	12/28/2016
02/01/2017	01/25/2017
03/01/2017	02/22/2017

Table V-II: Initial delivery dates provided by the customer

Table V-III details the delivery dates for each plane. They can be delivered nearly one week in advance (compared to the opening delivery schedule). The third plane is the only one to be precisely in the $[0; -7]$ range. This corresponds to the JV Group desire for 100% OTD. The corresponding WC amount (on average) for this product for the year is worth 95,000€. This amount will be compared to other scenarios. As, for example, in Table V-III, the first seat bases are ready to be delivered on 05/12/2016, that is to say 7.37 days before the earliest delivery date (which is acceptable compared to the nearly four months' of total lead time).

Delivery date	Compared to earliest delivery date (in days)
05/12/2016	7.37
06/18/2016	3.51
07/17/2016	-2.31
08/23/2016	7.55
09/15/2016	12.57
10/10/2016	8.58
11/03/2016	5.64
12/19/2016	8.60
01/16/2017	8.64
02/16/2017	6.64
OTD (%)	100
Average seat base WC (€)	95,000

Table V-III: Delivery and WC results – DDMRP Initial situation

The average WC amount given above (Table V-III) includes WC for:

- DDMRP buffered components: 60,000€ (63%)
- DDMRP non-buffered components: 18,000€ (19%)
- Assembled references: 17,000€ (18%)

As expected, the majority of WC is located in the DDMRP buffered components, compared to those that are managed with MRP. The WC is also higher than for the assembled references (on average) because their LT is short and the references are rapidly sold.

WC profiles during the year for each category are illustrated in Figure V-V below. WC profiles for components are clearly quite stable compared to assembled references: their WC rises rapidly when assembly orders for a plane begin (each delivery is represented by a vertical blue axis).

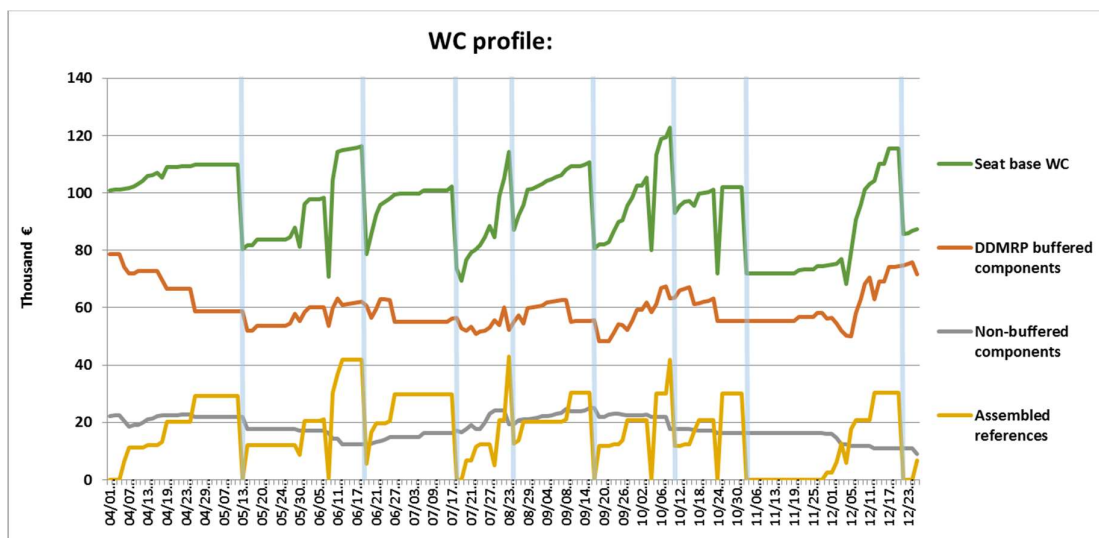

Figure V-V: WC profiles for seat base components and assembled parts

As regards DDMRP planning and buffer dimensions (2.3.1), 5 supply orders have been released to produce and assemble the 80 seat bases.

In the simulation model, the NFE calculation is realised each day in order to decide whether to release supply orders or not. What would be the impacts on the NFE if the calculation was done each week?

3.2. Daily to weekly NFE calculation

In the simulation, a supply order for a reference is released nearly every two months. The daily NFE calculation may be changed to assess impacts and analyse whether this could be a good practice for planners. Therefore, in the simulation, the parameter to calculate the NFE changes from one day to seven. The delivery dates are detailed in Table V-IV below:

Delivery date	Compared to earliest delivery date (in days)
05/12/2016	7.37
06/18/2016	3.57
07/17/2016	-2.31
08/23/2016	7.55
09/15/2016	12.50
10/10/2016	8.61
11/03/2016	5.63
12/19/2016	8.60
01/16/2017	8.64
02/16/2017	6.64
OTD (%)	100
Average seat base WC (€)	96,000

Table V-IV: Delivery and WC results – daily to weekly NFE calculation

The delivery dates are almost equivalent. This statement is true with a 1% difference from a WC point of view. Thus, it was decided to update the NFE once a week for this product.

3.3. Minimum lot-size challenge

Before DDMRP reconsideration, it was already forecasted with MRP to release orders (for DDMRP buffered components) for four planes. DDMRP offers the ability to challenge this lot-size with two planes at a minimum (equivalent to MOQ and green zone) and possibly even fewer, depending on where the NFE position is.

Without an imposed MOQ, the green zone would be worth:

$$\text{Green Zone} = \text{DLT} \times \text{ADU} \times \text{LT Factor}$$

The DDMRP buffered components have the longest lead time compared to the seat base total lead time. This is why initially, LT factors can be set at 30%. With this choice, all green zones

would have a size between 0.3 and 0.6 plane. From this assessment, it is interesting to challenge the 2-plane MOQ with a 1-plane MOQ in order to assess the impacts.

A simulation was realised to compare buffer sizing with 1 or 2 planes as the MOQ. The results are detailed in Table V-V below:

<u>1 plane as MOQ</u>		<u>2 planes as MOQ</u>	
Delivery date	Compared to earliest delivery date (in days)	Delivery date	Compared to earliest delivery date (in days)
05/12/2016	7.37	05/12/2016	7.37
06/18/2016	3.57	06/18/2016	3.57
07/17/2016	-2.32	07/17/2016	-2.31
08/23/2016	7.56	08/23/2016	7.55
09/15/2016	12.41	09/15/2016	12.56
10/06/2016	12.57	10/10/2016	8.61
11/05/2016	3.37	11/03/2016	5.63
12/15/2016	12.29	12/19/2016	8.60
01/12/2017	12.38	01/16/2017	8.64
02/10/2017	12.64	02/16/2017	6.64
OTD (%)	100	OTD (%)	100
Average seat base WC (€)	94,000	Average seat base WC (€)	95,000

Table V-V: Delivery and WC results – 1 or 2 plane(s) as MOQs

In conclusion, OTD is perfect for both, with deliveries quite close. It is interesting to note that some planes (especially the last three) can be delivered more in advance but there is no point here. Even if the MOQ (the supply order quantity here) is lower for each reference, the WC is equivalent: this could seem surprising.

In order to explain this, the production costs for the main assembled references are assessed to compare both strategies. Production costs include component costs, labour costs for each activity, subcontracting costs and holding costs for the time spent in inventory (Chapter III.1.4). Table V-VI below details the production cost assessment with “1001_05”, which corresponds to one seat base. The gap between both strategies is 6% in favour of the 2-plane MOQ. This gap is explained by three different factors:

- Many control operations must be performed for each order (this accounts for 43% of the gap).
- If there are more orders, more setup operations are done. Furthermore, these setup operations are time-consuming (31% of the gap).
- Finally, subcontractors change their prices with order quantities. If quantity is reduced, costs are higher (26% of the gap).

These gaps can be seen for each reference and are nearly equivalent. Furthermore, this cost analysis (and the gap found) is reliable because the final production cost found with DES is

equivalent to JV Group’s cost assessment with less than a 2% gap (explained by a more accurate holding cost considerations in the DES model).

Reference	Production cost (€): 2 planes as MOQ	Production cost (€): 1 plane as MOQ	Gap (€)	Gap (%)
1001_05	3,761	3,993	232	6%
3002_01	3,745	3,978	233	6%
1110_01	1,101	1,166	65	6%
1200_01	990	1063	73	7%
2322_01	376	384	8	2%
1631_01	356	374	17	5%
1231_01	301	324	23	8%
1630_01	306	323	16	5%
1230_01	295	318	23	8%
1950_01	170	180	10	6%
1320_01	46	50	4	10%

Table V-VI: Assembly reference production cost for both MOQ strategies

This is why here WC values are similar for both strategies: even if inventory is slightly lower, each component production cost is higher and this raises the WC amount. The 2-plane MOQ strategy is therefore validated for this seat base production.

3.4. Demand variability impacts for DDMRP and MRP implementations

As shown and validated in a first step in Chapter III.1.4, DDMRP must manage variability sources. The main variability source encountered by JV Group is demand variability. However, demand variability is not a quantity issue here but a time issue. Indeed, the quantity of planes ordered is and will remain fixed. What is more, this quantity may be known several years in advance. However, delivery dates will most probably be changed in the product lifecycle.

This is why demand variability is modelled in this section. When DDMRP project implementation began, MRP orders were already supposed to be released. The DES model will compare the DDMRP strategy to the MRP strategy and the orders that would be released in reality (with the ERP JV Group system).

Table V-VII below gives delivery date changes. A 3-week delivery change is simulated (3 weeks in advance) from the third plane. The objective is to analyse MRP and DDMRP reactions to this demand variability. The fourth plane faces a 40-day change due to the 2-week closure during summer.

Previous due date limit	New due date limit	Gap (in days)
05/27/2016	05/27/2016	0
06/29/2016	06/29/2016	0
07/22/2016	07/01/2016	21
09/07/2016	07/29/2016	40
10/05/2016	09/14/2016	21
10/26/2016	10/05/2016	21
11/16/2016	10/26/2016	21
01/04/2017	12/14/2016	21
02/01/2017	01/11/2017	21
03/01/2017	02/09/2017	20

Table V-VII: New delivery dates compared to those given at the beginning

For MRP, with orders that are released from forecasts, simulation results are detailed in Table V-VIII below. The first and the third planes are delayed (80% OTD). After the first six planes, demand date variability is absorbed with MRP.

Delivery date	Compared to earliest delivery date (in days)
05/29/2016	-9.63
06/18/2016	3.34
07/05/2016	-11.31
07/19/2016	2.67
08/25/2016	9.59
10/04/2016	-6.63
10/16/2016	2.63
12/19/2016	5.65
01/16/2017	1.64
02/16/2017	6.64

OTD (%)	80
Average seat base WC (€)	99,000

Table V-VIII: Delivery and WC results – MRP demand variability

Compared to MRP, DDMRP delivers all the seat bases on time (the sixth is also just-in-time) as detailed in Table V-IX. However, compared to MRP, the first is on time and so is, especially, the third one. Indeed, DDMRP mechanisms are able to manage this demand variability.

Delivery date	Compared to earliest delivery date (in days)
05/12/2016	7.37
06/19/2016	2.31
06/28/2016	-4.30
07/19/2016	2.66
08/31/2016	6.32
10/04/2016	-6.63
10/10/2016	8.61
12/19/2016	5.65
01/16/2017	1.64
02/16/2017	6.64
OTD (%)	100
Average seat base WC (€)	97,000

Table V-IX: Delivery and WC results – DDMRP demand variability

Besides, after the third delivery, DDMRP order ends are better managed with less variation compared to MRP (especially for planes three to five when demand variability occurs). DDMRP behaviour is better because strategic components are available sooner to begin the assembly process and to be delivered on time. Figure V-VI illustrates this statement:

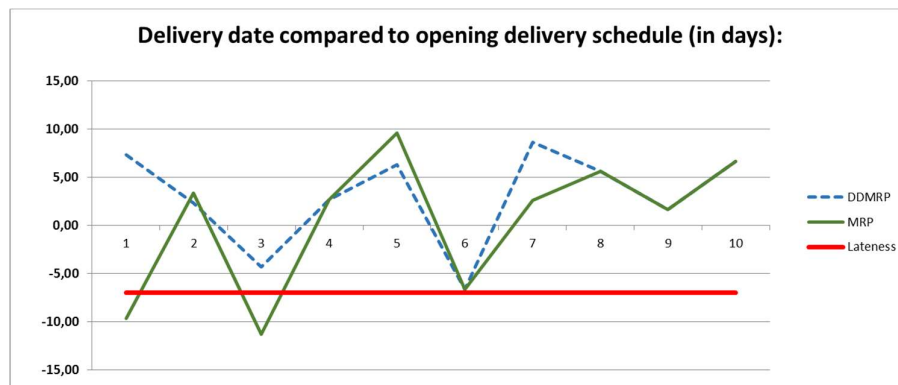

Figure V-VI: Delivery date compared to opening delivery schedule with MRP and DDMRP strategies

3.5. The limit of demand variability absorption with DDMRP

As detailed in the previous section, demand variability was implemented with due dates three weeks in advance up until the third plane. This is already a major change and JV Group would not have increased demand change for this reference. But what would the impacts be if customers actually did move forward their demands?

Two additional simulations have been realised: if the customer moves forward demand for 4 weeks, and for 5 weeks. For these two scenarios, additional demand change (compared to 3.4) has been implemented up until the fourth plane, otherwise the third plane would be delivered

before the second (without demand date change). All the results are detailed in Table V-X below:

Demand variability: 3 weeks		Demand variability: 4 weeks		Demand variability: 5 weeks	
Delivery date	Compared to earliest delivery date (in days)	Delivery date	Compared to earliest delivery date (in days)	Delivery date	Compared to earliest delivery date (in days)
05/12/2016	7.37	05/12/2016	7.37	05/12/2016	7.37
06/19/2016	2.31	06/18/2016	2.31	06/18/2016	2.31
06/28/2016	-4.30	06/26/2016	-2.34	06/26/2016	-2.63
07/19/2016	2.66	07/17/2016	-2.34	07/03/2016	4.65
08/31/2016	6.32	09/01/2016	-1.44	09/04/2016	-11.42
10/04/2016	-6.63	09/28/2016	-7.31	09/25/2016	-11.31
10/10/2016	8.61	10/04/2016	7.60	09/29/2016	5.37
12/01/2016	5.65	11/21/2016	8.64	11/14/2016	8.64
01/02/2017	1.64	12/19/2016	8.61	12/12/2016	8.62
01/26/2017	6.64	01/19/2017	6.64	01/12/2017	6.52

Table V-X: DDMRP results with 3, 4 and 5 week delivery changes

As far as these results are concerned, OTD begins to decrease with this demand variability increase each time another plane is late. The gap before has dramatically been reduced up to the fifth plane delivery for the 4 week and 5 week scenarios (which is already late now). The DDMRP variability limit has been assessed for this case with DES: however, the demand variability has in all the cases been absorbed up to the seventh plane (this is the same demand change and the system is again regulated).

Until now, all buffers have been sized from experience in order to assess the different scenarios. As for Chapter IV, is this sizing appropriate and are there significantly better results with a different buffer sizing?

4. DDMRP Optimisation

DDMRP implementation has better results compared to MRP. All the variability factors and LT factors have firstly been set at 10% in order to limit the WIP and therefore the WC amounts. As the lot-sizes are significant, are these parameters appropriate? And have these parameters had a major influence on the results?

In order to deal with these issues, an optimisation approach is realised. As for Chapter IV.2, a Simulated Annealing approach is used. The objective function is detailed below:

$$\text{Objective function} = \text{Min}((1 - \text{OTD}) \times 100,000 + \text{WC})$$

The objective function corresponds to bi-criteria objective function with a priority criteria which is OTD. This type of function is appropriate because JV Group's policy is to deliver to its customers absolutely on time (a perfect OTD) and then try to reduce their WC. The left term concerns the OTD objective with a 100,000-factor penalty for each OTD percentage. However, as "only" 10 orders are released, each time there is a shortage the OTD will decrease by 10%. This would lead to a 1,000,000 penalty in the objective function. The right term for the objective function deals with WC minimisation. The average WC is under 100,000€, in other words the OTD will be minimised before the WC (as in Chapter IV).

Two types of scenarios have been studied to analyse possible improvements in results: the first one with demand that remains stable (Chapter V.3.1) and the second one with demand variability (3 weeks in advance, Chapter V.3.4).

4.1. Objective function with stable demand

Both optimisation works have had nearly one thousand iterations (which corresponds to 3 days of simulation).

As far as the stable demand scenario is concerned, the results of the objective function are detailed in Figure V-VII below:

In the initial simulation, a 99k€ WC was found as a result of 100% OTD. With this optimisation work, the best simulation (iteration 1037) leads to 71k€, which is a strong improvement (nearly 30%). It can be observed that 6% of iterations (67) do not satisfy a 100% OTD even with a stable environment.

However, this strong improvement leads to very weak yellow and red sizing for all references: each time a possible variability occurs, it could lead in this case to a product shortage. The parameters retained from the manual simulation could be reduced but not as much as the best simulation proposed.

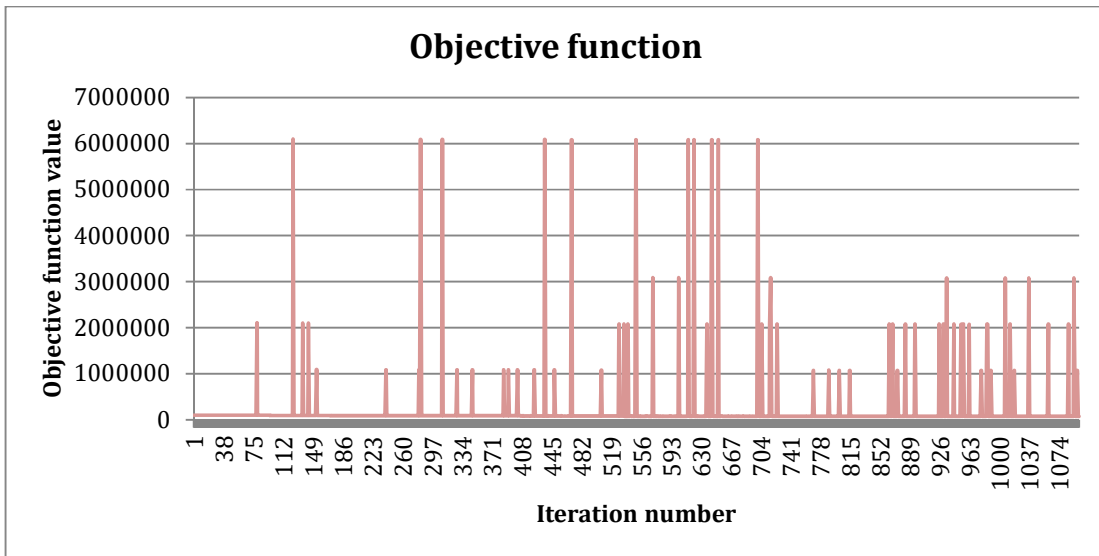

Figure V-VII: Bi-criteria objective function results with stable demand

4.2. Objective function with demand variability

With demand stability, WC would theoretically be improved by 30%. In this section, a 3-week delivery delay (3 weeks in advance) is optimised. The objective function results are detailed in Figure V-VIII below:

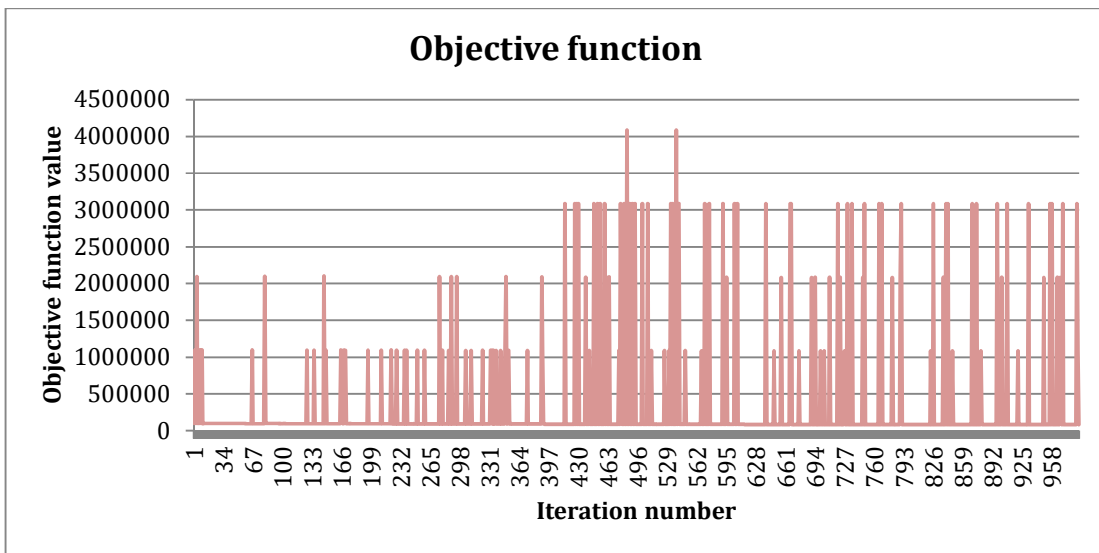

Figure V-VIII: Bi-criteria objective function with demand variability

For this optimisation, 12.7% of the iterations do not succeed in reaching the 100% objective. This confirms that it is more difficult to size buffers in a more variable environment.

The best solution (iteration 946) improves WC by 15.1% (from the 97k€ initially found) to reach 82.4k€ WC. This improvement is not insignificant, but it is lower compared to a stable environment.

In conclusion, the optimisation approach reduces WC but must be analysed with other variability scenarios that can occur to confirm the adaptation of buffer sizing to different variabilities. In addition, the optimisation work allows to find a compromise between a WC level and a hazard level accepted.

However, the parameter adjustment approach is limited because of the high green zone sizing with significant MOQ (cf. 2 planes for financial issues, Chapter V.3.3).

Chapter V Conclusion and future work

Conclusion

In reality, the first orders have been released with MRP mechanisms for all references. Changes have been implemented in JV Group's ERP to integrate the DDMRP NFE calculation. As far as these orders are concerned, the quantity ordered of DDMRP buffer components are equivalent to the ramp-up phase forecasted.

Also, in this on-going project the first two planes have been delivered on time, as well as the following two with the DDMRP strategy. Demand variability did occur but as a three-week delay (the customer was not ready to receive seat bases).

Furthermore, JV Group wants to implement DDMRP for other new products, which have a longer lifecycle with a higher demand volumetry.

This DDMRP implementation for JV Group highlights the method's interests, as listed below:

- MRP calculation integration with DDMRP: both methods are able to coexist by following decoupled explosion. A NFE is used for DDMRP buffered components and a "classical" MRP calculation can be performed for the other references (components and assembly references).
- At the beginning, the production environment was only an MTO environment. Due to some OTD issues, DDMRP was implemented with decoupling points located in strategic BOM points. These decoupling points helped manage variability and to have an MTO – MTS environment.
- This DDMRP implementation manages "original" demand variability: in the aeronautical core business, demand often changes only from a time point of view compared to the classical variability of both time and quantity. These statements reinforced DDMRP variability management capacity by improving the system flexibility (P1).
- DDMRP implementation (with pull material management method) leads to lot-size questioning. It was firstly forecasted to release three orders for the ten planes and DDMRP implementation leads to 5 orders with more flexibility.
- NFE calculation frequency can be adapted to production environments and especially with consideration of lead time. In this real case application, a weekly NFE calculation is enough.
- Dynamic adjustment buffers are implemented and prevent large orders from being released at the beginning of the product lifecycle. They limit shop floor overloading as

well as investing too much cash flow. It is also interesting for the end product lifecycle, but this step requires a decision for the last order quantity (with on-hand inventory, possible scraps and final on-hand inventory level that will be lost) with this short product lifecycle.

- As regards the buffer sizing sensitivity, optimisation allows to improve WC but it would run the risk to implement the best solution. Indeed, not all the constraints are modelled so a little safety (as currently implemented) must be kept.

Future work

This DDMRP implementation has been until now applied to one reference with a low volumetry which is often the case for the aeronautic market. Contrary to an entire DDMRP implementation, lead time will not be reduced with all the parallel flows managed only with MRP II. It would be interesting to apply DDMRP on a real total scale.

As regards this implementation, the FIFO modelling is appropriate. However, with more DDMRP flows, a policy to manage pull and push flow products (respectively, buffer status and due dates) must be created and applied. Control points would help to manage these strategic points. Furthermore, it would also be interesting to implement DDMRP with references that have higher volumetry. Indeed, the red planning zones here are extremely weak, which is why the buffer status is not that representative: it is also a specificity of the aeronautical market with low but reliable volumes. In this type of market, the prioritisation rules have more impact than the red zone sizing.

DDMRP is implemented “only” with stock buffers. It would be interesting to analyse the environment and also implement time buffers for appropriate references (or a couple of stock buffers with time buffers for the other). This would help to ensure the timeline without more WIP.

As far as optimisation is concerned, best solution found is set up for a specific scenario. It would be risky to implement the best parameters found if another variability occurs. In order to be sure and confirm the parameters found, they must be tested in other situations. Because, as we have seen in Table II-VII, DDMRP must bring and assure a high level of system flexibility.

Chapter VI.

CONCLUSION AND FUTURE WORK

1.1. General conclusion

As initially presented, DDMRP is thus described: “Planning systems since 1920s evolved from the core perspective of inventory. This is no longer true. Now demand must be at the core. Thus DDMRP is not the next evolution in inventory management; it is a revolutionary shift in perspective and tactics. [...] Inherent in its rules and tools is a level of common sense and visibility that easily translates beyond the confines of a single entity” (Ptak and Smith, 2011). The purpose of this research work was to challenge this definition and the different promises of DDMRP.

As a general conclusion, this method is clearly promising from scientific and industrial points of view. It resolves the main problems identified in the other methods that were implemented and developed several decades ago. DDMRP has good results indeed, (as demonstrated with this research work and the early implementations of DDMRP) and can be adapted to a wide variety of environments: the promises are therefore kept, but not always with high gaps with the other methods. Furthermore, it is possible to use several DDMRP steps (Figure I-II) or parameters, but not all. It depends on the system where DDMRP is implemented. As an example, the execution step is not used with JV Group, and some buffer types are not used in several production environments (such as time buffers also with JV Group).

The main difficulty that the main material flow methods like MRP II, Kanban or DDMRP must cope with is the management of variability sources. In this research work, this issue has been challenged with a discrete event simulation approach. As regards the main methods comparison, in a stable environment the results are equivalent as would be expected. However, as soon as there is noticeable variability, MRP II shows its limits. When variability becomes significant, the limits of Kanban are revealed. Kanban could be coupled with other methods in order to have a hybrid material management method (but this would be case specific). The main scientific contribution of this work focuses in particular on demand variability management. This variability was analysed separately from two types of variability: time (Chapter V) and quantity (Chapter III and IV).

This demand variability is closely linked with spike management. The scientific and industrial interests of dealing with spikes have been proven but there is an important issue with the definition of spikes as well as the definition of quantity and time to be taken into account in the Net Flow Equation. This is one of the major DDMRP promises that has been confirmed with this work.

Another major contribution deals with buffer sizing and simulation in order to have a decision-aiding method. This scientific contribution is significant because the sizing sensitivity of

DDMRP has been previously detailed. A business algorithm was developed from the experiments and enables scenarios with good results to be obtained more rapidly (compared to a metaheuristic approach) in order to manage this sizing variability issue.

Furthermore, DDMRP implementation, as promised, leads to better inventory management. If there are several BOM levels, variability is absorbed throughout the BOM (with DDMRP buffers for final products). However, the inventory distribution profile is not a bi-modal curve as it is for the other methods, as conceptually suggested.

From an industrial point of view, this research work proves that MRP and DDMRP mechanisms can live in parallel with strategic decoupling points and by following decoupled explosion. In addition, as noticed with JV Group, DDMRP implementation also helps to challenge the behaviour of the current system and the strategy retained.

Finally, the research work shows the interest of DDMRP for a company, JV Group, which are now convinced and want to implement the method on a larger scale. This field case study and the set of simulations made on the Kanban Game® have begun to augment the DDMRP case study base, which may be developed with future research work.

1.2. Future Work

The main manuscript contributions have just been highlighted. However, as it is one of the first works of research on this subject, several main issues need further developments.

1.2.1. Regarding variability management

The main research contributions are linked with variability management. However, there is further work that must be realised in a near future.

- As far as internal variability (such as processing and setup times) is concerned, this is a limitation in our work (Chapter III). Indeed, internal variability is not applied to enough references in order to be applied to a short process as well. It would be interesting from the scientific and industrial viewpoints to focus on a more complex case with more components. The JV Group case study would be appropriate but there are limits for a good internal variability assessment: the studied scale is limited and the production means have significant capacity remaining, so the internal variability effects are mostly insignificant.
- Demand variability has been thoroughly assessed but supply variability has not been implemented (demand variability had priority due to the challenge of spike management). Indeed, companies must often cope with supply variability source that prevents production orders from beginning. This is why supply variability impacts must be assessed in future work. Its combination with internal and demand variability would also be scientifically interesting.
- In this research work, management variability has not been implemented. From an industrial point of view, this variability may have significant impacts. DDMRP enables the workforce to be independent for the execution step, and the flow is the main point with DDMRP visual management. Change management must be managed for the stakeholders (with DDMRP training for example). Furthermore, the gaps between the As-Is situation (with MRP II for example) and the To-Be one with implemented DDMRP would not be as significant if the material management methods were well applied (a significant number of stakeholders are not accustomed to what is “behind” MRP II and what the different mechanisms are). This management variability is extremely difficult to model but would be interesting to assess.

1.2.2. Regarding decision support

The business algorithm that was developed had good results and converged rapidly. However, its limit would be its application to a complex case (large numbers of references and activities in the process). It would be interesting from an industrial point of view to create generalisable algorithm that would then be coupled to optimise DDMRP buffer sizing (and at least helping to provide a satisfactory solution).

The same reasoning could be adopted for a simulation project. Indeed, it can not take a month to create the DES model (with the appropriate material management method) and then to compare it to DDMRP. Generalisable simulation units to create the simulation model and the material management method would be required in future in order to save time for these types of simulation projects. This subject needs further development but it is a major point from an industrial perspective.

Another issue focuses on the execution step: more than one material management method will be applied in parallel in a system. DDMRP execution is based on the buffer status (a percentage) of the different buffers compared to MRP II and order due dates. How it is possible to manage these two different criteria? It is possible to define rules for several machines, but it is highly complex to apply to an entire company and it might lead to DDMRP project implementation failure. From an industrial point of view, it would be important to develop a decision-aiding tool to manage priority with these two types of data.

This previous development would then be applied to JV Group on the entire production scale.

1.2.3. Regarding positioning buffers

The first DDMRP step concerns positioning strategic buffers. The limit in this step is that “only” consultant experience is currently used to decide where to position strategic buffers. However, it would be exceedingly complex to adopt the DDMRP strategy for the entire BOMs and find the optimum buffer positioning configuration. Future work can suggest buffer positioning semi-automatically.

This tool would therefore enable buffers to be positioned. Compared to the Kanban game® where 14 references out of 16 have been buffered (16 Kanban loops), it would be interesting to analyse DDMRP and Kanban results for a complex process (or a different positioning configuration with fewer references buffered in proportion).

1.2.4. Regarding Lead Time considerations

DDMRP is based on the concept of DLT. As for other systems, it involves knowing precisely the different LTs in the BOMs. This subject is already an issue for numerous companies (which enter wrong LTs in their ERPs for example): order generation is produced with this wrong LT

(often overestimated with waiting time considerations) and it congests the system. However, the main issue here is that when DDMRP is implemented, all these LTs will be changed: when there is a change in the flow management strategy retained, LT will dramatically evolve.

Furthermore, DDMRP considers that the total LT for two references is the sum of the two corresponding LTs. With push material management methods, this is true (the orders are generated one after the other). But it can be an overestimation for pull flow methods because several activities can come rapidly one after another.

This could also lead to a non-fitted buffer positioning step. It would be interesting to be able to anticipate future LT with DDMRP implementation to be confident in the positioning step that could restrain the potential for improvement. This work is scientifically interesting and would lead to time savings for DDMRP implementation from an industrial point of view. The impact of LT savings would be assessed on a real case with a DES study.

1.2.5. Regarding the economic dimension

Finally, a main issue deals with the financial dimension. As we have seen, the DDMRP strategic buffer positioning is based on an ROI analysis. In order to assess financial impacts, an average on-hand economic assessment is done on the process for each positioning scenario. For this assessment, “only” cost prices are taken into account. In other words, end item costs are directly assessed with raw material costs. In reality, especially in some businesses, a great deal of added value is brought by the different activities throughout the process. As an example, this analysis could be important with JV Group where high value is added in the process (internal processes or with subcontractors). However, with JV Group, “only” components are strategically buffered. It would be interesting to study different positioning scenario with other references to analyse another economic assessment.

This work would be scientifically and industrially interesting and could be realised with DES on a real application.

RESUME DE THESE EN FRANÇAIS

1. Chapitre I. Contexte, problématiques scientifiques et industrielles

Le concept de Supply Chain Management (SCM) est perçu comme l'organisation de réseaux qui gèrent les flux physiques, d'informations et financiers. Ces réseaux impliquent des relations entre les différents maillons de la chaîne logistique qui fournissent un produit ou un service afin de satisfaire le client final (Christopher, 1992).

Alors que le marché a grandement évolué avec une augmentation de la variabilité, des systèmes et des chaînes logistiques plus complexes à gérer, les outils et les méthodes de pilotage n'ont qu'assez peu évolué et montrent leurs limites. Ce constat est vrai pour la méthode MRP II (Manufacturing Resources Planning) qui est la méthode la plus répandue dans le monde industriel. En effet, les hypothèses qui permettaient son bon fonctionnement sont maintenant inexactes dans la grande majorité des cas. Ce constat est le même pour la « boîte à outils Lean » qui a permis aux entreprises de s'améliorer, mais la démarche démontre également ses limites.

La méthode Demand Driven Material Requirements Planning (DDMRP) est une méthode prometteuse, créée pour faire face aux problématiques actuelles : DDMRP est une méthode complète de planification et d'exécution des flux qui promet de gérer la chaîne logistique à partir de la demande réelle du client final. DDMRP est une méthode qui a été créée et implémentée par des professionnels. L'implémentation de la méthode se répand de plus en plus, tant sur la mise en place de projets DDMRP dans les entreprises que dans la formation et la certification (Certified Demand Driven Planner ou Certified Demand Driven Leader).

DDMRP promet d'améliorer l'écoulement des flux en réduisant les différentes formes de variabilité et en détectant les variations de la demande. DDMRP souligne les limites des méthodes de pilotage des flux actuels, que ce soit en flux poussé ou tiré, et promet de les résoudre.

DDMRP a été le sujet de très peu de travaux scientifiques, même si des laboratoires commencent à s'intéresser à la méthode comme le « Laboratoire Poly-DDMRP ». AGILEA, entreprise de conseil et de formation en SCM créée en 2009 à Toulouse, est un acteur majeur pour la mise en place et pour la formation à la méthode DDMRP. Cette méthode intéresse donc particulièrement le monde industriel mais n'a que trop peu été scientifiquement traitée. C'est pourquoi ce travail de doctorat se concentre sur « Challenger les promesses du Demand Driven MRP ».

DDMRP a été créé par Carol Ptak et Chad Smith au début du 21^e siècle et a été présenté dans la 3^e version du livre d'Orlicky (Ptak and Smith, 2011) ou plus récemment dans le livre DDMRP (Ptak and Smith, 2016). La méthode regroupe des concepts connus qui ont fait leurs preuves : MRP, DRP, Lean, 6 Sigma, Théorie des Contraintes avec en plus de cela des innovations spécifiques (Figure I-I). L'implémentation de DDMRP se fait en 3 étapes (positionner, protéger et tirer) avec 5 composants (Figure I-II). Le positionnement permet de placer les points de découplage aux bons endroits (afin d'absorber la variabilité). Pour protéger le flux, les buffers stratégiques sont dimensionnés et dynamiquement ajustés dans le temps. Le flux est ensuite tiré à partir de d'un planning « Demand Driven » afin de générer des ordres de

réapprovisionnements. Ces ordres sont enfin priorisés et exécutés lors de la 5^{ème} phase de mise en place de DDMRP.

Vue d'ensemble du manuscrit

Les concepts de DDMRP ont été développés. Néanmoins, existe-t-il des points théoriques à challenger ? Avant de questionner la méthode, celle-ci doit être décrite. Les principaux mécanismes de DDMRP sont décrits dans le Chapitre II. Pour détailler DDMRP par rapport à la littérature, il est intéressant de la positionner et de la comparer par rapport aux autres méthodes de pilotage de flux qui sont utilisées en réalité. Ces méthodes sont dites en flux poussé (à partir de prévisions de la demande, des ordres de fabrication sont définis puis lancés dans le système), avec MRP II qui est la méthode la plus répandue, ou en flux tiré (gestion à partir de la consommation réel du client) avec Kanban, qui est la méthode en flux tiré la plus connue. Ce chapitre II va donc comparer qualitativement ces DDMRP à MRP II et Kanban selon différents critères afin d'avoir une liste de problématiques DDMRP à challenger.

A partir de cette liste, les plus importantes d'un point de vue scientifique et industriel seront retenues pour être cette fois quantitativement comparées dans le chapitre III. Ce chapitre va comparer le comportement de DDMRP, MRP II et Kanban sur un cas d'étude représentatif de la réalité à travers un plan d'expérience. Pour cela, la simulation de flux à événements discrets, qui est un outil parfaitement adapté à cette étude, va être utilisée. L'objectif de ce plan d'expérience est d'étudier le comportement des 3 méthodes avec différentes formes de variabilité implémentées. L'analyse se fera suivant 2 indicateurs essentiels et suivis dans les chaînes logistique : le taux de service et le Besoin en Fonds de Roulement (BFR). Le but sera d'atteindre à chaque scénario un taux de service presque parfait (comme le demande le marché dans la grande majorité des cas) tout en maîtrisant les coûts, et donc le BFR.

Avec les conclusions du plan d'expérience, une problématique principale identifiée concerne le dimensionnement des stocks stratégiques DDMRP. En effet, ce dimensionnement se révèle très sensible et engendre des résultats très différents avec parfois des modifications « légères ». Le chapitre IV traite donc de l'optimisation du dimensionnement des buffers stratégiques DDMRP. Ce travail d'optimisation sera réalisé avec une métaheuristique (et un algorithme de recuit simulé) et comparé à un algorithme métier, développé à partir de notre expérience.

Les 4 premiers chapitres se concentrent sur la littérature et/ou sur un cas d'étude théorique. Le chapitre V traite de l'implémentation de DDMRP sur un cas réel pour un sous-traitant aéronautique. Ce cas d'étude concerne un nouveau produit de JV Group qui est une embase de siège. Le but de ce chapitre est de comparer, avec un modèle de simulation de flux à événements discrets, le comportement du système avec DDMRP par rapport au fonctionnement actuel qu'ils auraient eu avec MRP II.

Les différents chapitres sont décrits à travers la Figure I-III. DDMRP est une méthode prometteuse mais récente. C'est pourquoi dans le chapitre VI un travail important de conclusion a été réalisé afin de définir également les nombreuses perspectives de recherche concernant ce sujet.

2. Chapitre II. Demand Driven Material Requirements Planning : présentation et analyse critique

Dans DDMRP, la dispersion des niveaux de stock est un point majeur : il a souvent été identifié qu'il y a des références en rupture et d'autres avec trop de stock, mais trop rarement au bon niveau (c'est ce qui est appelé la courbe « bi-modale », Figure II-II). Afin de maîtriser les stocks, DDMRP a pour but de positionner des buffers sur des références stratégiques, aux bons endroits de la nomenclature. Entre ces points de découplage, le flux est tiré. Entre les différents niveaux de nomenclature sans stock DDMRP, le Calcul des Besoins Nets (CBN) est conservé.

Les stocks stratégiques DDMRP sont découpés en 3 zones : verte, jaune et rouge (Figure II-V). Ces 3 zones sont dimensionnées par rapport :

- Au délai d'écoulement découplé (nouvelle notion de DDMRP qui, pour chaque référence stockée, est le délai le plus long dans une nomenclature avant un autre stock stratégique DDMRP).
- A la consommation moyenne journalière.
- A un facteur de temps d'écoulement (entre 0 et 1 avec un facteur plus important que le temps d'écoulement est faible), Figure II-VII.
- A un facteur de variabilité (plus la variabilité sur ce stock est importante, plus le facteur est important), Figure II-VII.

4 sources de variabilité doivent être absorbées par les stocks stratégiques DDMRP : la variabilité de la demande, la variabilité des fournisseurs, la variabilité opérationnelle et enfin la variabilité managériale qui est la plus importante.

Pour la planification, l'équation de flux disponible est une nouveauté apportée par DDMRP. C'est la définition d'une position de stock à l'exception que les pics de demande dans l'horizon du temps d'écoulement sont également pris en compte (Chapter II.1.6). Si l'équation de flux a une valeur dans la zone jaune ou rouge, un ordre de réapprovisionnement est déclenché avec une valeur permettant d'atteindre le top de la zone verte. Pour ensuite prioriser ces ordres, on utilise un statut de stock qui est la quantité réellement présente en stock par rapport au top de sa zone rouge. C'est le ratio le plus faible qui est prioritaire pour être exécuté.

DDMRP peut être comparé à d'autres méthodes en flux poussé comme MRP II ou d'autres en flux tiré tel que le Kanban spécifique, le Kanban étendu ou encore générique. Il existe également des méthodes hybrides qui comporte une partie de flux poussé et une partie de flux tiré, tels que les méthodes de gestion à partir du goulet d'étranglement (par exemple « Drum Buffer Rope »).

DDMRP a été qualitativement comparé à MRP II et à Kanban suivant 3 horizons (stratégique, tactique et opérationnel) et plusieurs critères pour chaque horizon (Table II-VII). Cette comparaison a permis d'identifier 8 principales promesses de DDMRP à challenger, dont 4 qui l'ont été dans ce travail de recherche (qui étaient les plus prioritaires à challenger d'un point de vue scientifique et industriel) :

- P1 : DDMRP aide à absorber la propagation et l'amplification de la variabilité dans la chaîne logistique, l'effet coup de fouet ou Bullwhip. *(développé dans ce travail de recherche)*
- P2 : DDMRP aide à mieux gérer les encours. *(développé dans ce travail de recherche)*
- P3 : DDMRP aide à la gestion de ressources humaines avec une augmentation de la flexibilité.
- P4 : DDMRP améliore la gestion des réapprovisionnements avec des mécanismes de regroupement et de gestion des priorités.
- P5 : DDMRP améliore la transmission de la demande tout au long de la chaîne avec le choix du positionnement de points de découplage et l'intégration du CBN.
- P6 : DDMRP réussit à s'adapter à une variabilité de la demande importante avec des pics de demande significatifs. *(développé dans ce travail de recherche)*
- P7 : DDMRP aide à garantir un objectif de taux de service avec des mécanismes de sécurité et un ajustement en temps réel. *(développé dans ce travail de recherche)*
- P8 : DDMRP améliore le management visuel en l'intégrant dans la globalité de son approche.

3. Chapitre III. Evaluation de MRP II, DDMRP et Kanban avec la réalisation d'un plan d'expériences

Pour challenger ces 4 promesses, un plan d'expérience a été défini sur un cas d'étude. Des travaux de comparaison de méthodes de pilotage de flux ont déjà été traités (Chapitre III), mais les cas étudiés n'étaient pas assez représentatifs de cas réels (processus linéaires, modélisation d'une seule référence ou pas de sources de variabilité).

C'est pourquoi le Jeu Kanban du CIPE a été retenu car représentatif de la réalité avec ses 16 références (dont 6 réducteurs, qui sont les produits finis vendus), 3 niveaux de nomenclature, une opération d'assemblage et 4 opérations d'usinage (Figure III-II and Figure III-III). MRP II, Kanban et DDMRP ont été modélisés en respectant la théorie de chaque méthode :

- MRP II : suivi de la méthode avec le Plan Industriel et Commercial (PIC) pour le nombre d'assemblage de réducteurs prévus. Le Programmeur Directeur de Production (PDP) pour la répartition du nombre de réducteurs à assembler pour chaque produit fini. Le CBN pour définir les besoins de chaque composant. En ce qui concerne l'ordonnancement, une bonne séquence a été définie pour chaque poste, « seule » la quantité change chaque semaine.
- Kanban : chaque boucle Kanban a été dimensionnée avec également un niveau pour les indicateurs rouge (niveau d'urgence) et vert (taille de lot minimale à produire).
- DDMRP : différents scénarios de positionnement des stocks stratégiques ont été définis. Le plus rentable et celui qui doit le plus compresser les temps d'écoulement a été retenu (14 références sur 16). Les stocks stratégiques ont ensuite été dimensionnés avant d'intégrer l'équation de flux disponible pour la phase de planification et le statut de stock pour la phase d'exécution.

La simulation de flux à événements discrets a été retenue car elle permet d'analyser dynamiquement un système, de modéliser toutes les contraintes, toutes les méthodes de pilotage souhaitées et d'implémenter toutes les sources de variabilité identifiées.

La simulation de chaque scénario dure 1 an avec le second semestre où les statistiques sont relevées afin d'être sûr d'avoir atteint le régime permanent. Les différents scénarios sont quantifiés suivant 2 principaux indicateurs : le taux de service et le BFR. L'objectif est d'atteindre un taux de service de 99,3% (ce qui correspond à un retard au maximum sur les 6 mois pour chaque référence vendue), tout en minimisant le BFR.

Résultats du plan d'expériences

Le scénario initial (scénario 1) ne comporte que très peu de variabilité, et dans ce cas les 3 méthodes ont un taux de service proche de 100% avec un BFR équivalent (Table III-XIV), ce qui était attendu. Les principaux enseignements des scénarios analysés sont les suivants (Table III-XXIII) :

- Scénario 2 - Implémentation de la variabilité interne : les résultats sont à nouveau comparables avec pourtant des temps opératoires et de réglage qui varient selon une loi triangulaire (plus ou moins 50% de la valeur modale).
- Scénario 3 - Implémentation de la variabilité de la demande : des pics de demande (3 à 4 fois supérieurs aux demandes du scénario initial) ont été modélisés. Le premier enseignement est qu'il faut ajouter 25% de BFR (respectivement +20% et +14% par rapport à Kanban) pour atteindre un taux de service satisfaisant.
- Scénario 4 - Implémentation d'un phénomène de saisonnalité : un lissage de charge est prévu par rapport à ce phénomène (changement du dimensionnement des stocks de sécurité pour MRP II, du nombre de cartes Kanban et des facteurs d'ajustement planifiés pour DDMRP). Il faut 38% de BFR en plus pour MRP II pour atteindre l'objectif d'OTD avec un écart constant par rapport à DDMRP et Kanban. DDMRP permet (comme pour le scénario précédent) de réduire le niveau de BFR de 5% par rapport à Kanban pour atteindre l'objectif d'OTD.
- Scénario 5 - Implémentation d'une variabilité de la demande plus importante : des pics de demande plus significatifs (encore 2 à 3 fois plus grands que pour le scénario 3) sont implémentés avec une vision de la demande ferme à 5 jours. Dans ce scénario, DDMRP est la seule méthode qui atteint l'objectif de taux de service : MRP II atteint seulement 94,5% et Kanban 95,4%. Cela confirme la difficulté de Kanban à absorber de grandes variations de la demande. En ce qui concerne le BFR, MRP II, sans réussir à atteindre l'objectif de taux de service a doublé le BFR par rapport au scénario initial (+97%). Afin de satisfaire l'objectif de taux de service (objectif prioritaire), DDMRP anticipe et augmente pour cela les encours (+58%, soit +24% par rapport à Kanban), ce qui était la seule manière de livrer le client final à temps avec un niveau de charge de travail moyen très élevé.

En conclusion, le plan d'expérience confirme la difficulté de MRP II à absorber la variabilité de la demande, sans trop augmenter les niveaux de stock. Kanban réussit à atteindre l'objectif de taux de service fixé, jusqu'à un certain niveau de variabilité. Au-delà de ce seuil, le taux de service ne peut plus être garanti (et c'est une tendance de plus en plus vraie dans les marchés actuels). Pour satisfaire le client, DDMRP utilise des mécanismes de détection de pics pour anticiper la production lorsque c'est nécessaire et permet de maîtriser les encours.

En ce qui concerne la répartition des encours, il est confirmé que DDMRP permet de mieux les maîtriser par rapport à MRP II et Kanban (Figure III-XIII and Figure III-XVI). C'est encore plus vrai lorsque la variabilité augmente. Cependant, la répartition des encours n'est pas aussi importante que celle définie dans la théorie avec la courbe bi-modale.

4. Chapitre IV. Ajuster les paramètres de DDMRP

Lors de la réalisation du plan d'expérience (Chapitre III), la sensibilité des résultats dans le paramétrage des buffers DDMRP s'est avérée très importante (eg. une perte de 10% d'OTD avec une modification légère du lead time factor d'une zone verte d'un buffer de réducteurs). C'est pourquoi il est intéressant de mener un travail d'optimisation afin d'analyser cette sensibilité et de s'assurer s'il est possible (ou non) de trouver une bonne solution avec un bon paramétrage des buffers stratégiques DDMRP, et ce le plus rapidement possible.

Le schéma ci-dessous présente notre proposition pour obtenir rapidement une « bonne » solution. Avant de réaliser les optimisations, il faut positionner et dimensionner initialement les buffers stratégiques DDMRP. Afin de tenter d'optimiser les résultats, le cas qui s'est révélé le plus contraignant pour obtenir manuellement de bon résultats a été retenu : c'est le scénario 5 avec les grands pics de demande, le positionnement des buffers stratégiques DDMRP a donc été conservé par rapport au plan d'expériences (14 des 16 pièces bufferisées stratégiquement). En ce qui concerne le choix des paramètres, l'optimisation va en optimiser 4 pour chaque buffer : les facteurs de Lead Time vert et rouge, le facteur de variabilité et le temps d'écoulement découplé avec les valeurs initiales, minimales, maximales et les pas d'itération décrits dans le Table IV-IV.

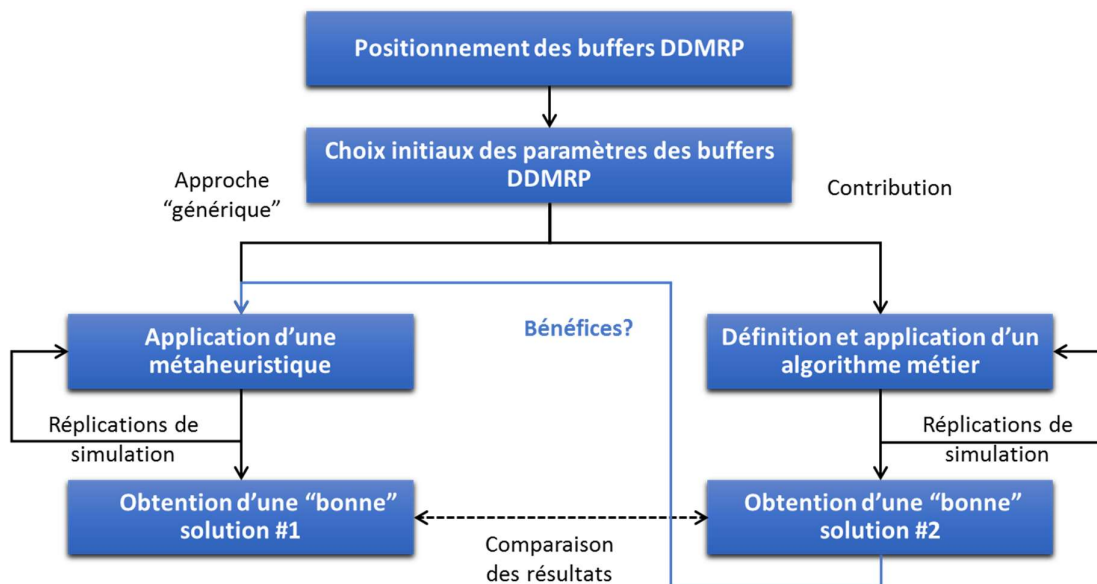

Proposition de méthode pour optimiser le paramétrage des buffers DDMRP

C'est à partir de là que nous proposons 2 approches. La première consiste à suivre une approche souvent utilisée qui est l'utilisation d'une métaheuristique. Dans ce cas d'étude, une optimisation avec un recuit simulé a été retenu. Le but est d'obtenir une bonne solution avec l'application de cet algorithme et avec des réplications de simulation. Une fonction objectif de type « goal programming » a été définie afin d'atteindre l'objectif de 99,3% d'OTD avant de tenter de minimiser le BFR. Avec cette méthode et 559 itérations ont été réalisées et une seule permet d'atteindre l'objectif (Table IV-III).

Afin de comparer cette approche et sa vitesse d'obtention d'une bonne solution, nous avons développé notre propre algorithme métier et appliqué celui-ci pour tenter d'obtenir plus rapidement une bonne solution. Cet algorithme a été défini avec l'expérience des consultants AGILEA qui implémentent DDMRP sur le terrain et avec l'expérience développée par la réalisation du plan d'expériences du chapitre précédent. L'algorithme métier est découpé en 4 parties principales, les 3 première tentant d'améliorer le dimensionnement des buffers de réducteurs puis des composants. La dernière partie a pour but de tenter de diminuer le BFR en diminuant certaines zones. Avec cette approche, il est nécessaire d'avoir 7 itérations pour obtenir une simulation qui satisfasse les objectifs. Une meilleure solution est obtenue à la 10ème itération, et celle-ci est très proche de celle obtenue avec la métaheuristique (Table IV-IV et Table IV-V).

Enfin, la meilleure solution de l'algorithme métier a été à nouveau optimisée avec l'algorithme de recuite simulé afin de voir s'il était possible de franchir un nouveau palier. Pour cela, les paramètres ont été dimensionnés initialement comme ceux de la meilleure solution de l'algorithme métier et les bornes minimales-maximales ont pu être resserrées. Pour valider le choix de la fonction objectif retenu, 3 ont été testées avec de meilleurs résultats pour le « goal programming » (Table IV-IX). Avec cette approche, le BFR est cependant légèrement amélioré.

En conclusion, la sensibilité du dimensionnement des buffers DDMRP a bien été confirmée et l'intérêt de l'utilisation d'un algorithme métier, qu'il serait intéressant de généraliser, a également montré ses avantages afin de trouver rapidement une bonne combinaison de paramètres.

5. Chapitre V. Application industrielle : un cas d'étude réel

Le dernier chapitre traite de l'application de DDMRP sur un cas réel pour une des entreprises de JV Group à Saintes en France. C'est une PME qui produit des ensembles et des sous-ensembles pour le marché aéronautique, ferroviaire, nucléaire et pour les produits de loisir.

Le but était d'implémenter DDMRP sur un cas pilote avec une nouvelle référence, des embases de siège, afin de garantir un bon OTD et de voir les effets de l'implémentation de DDMRP dans l'optique de le généraliser à d'autres références puis d'autres sites du groupe. Le cas d'étude traitait donc d'une référence d'embase de siège avec 8 sièges de ce type pour les 10 avions commandés sur la durée de vie du produit (1 an et demi environ). Cette embase résulte de l'assemblage de 67 références (55 composants et 12 sous-ensembles) avec 5 niveaux de nomenclature pour 29 opérations différentes dans les gammes.

Un modèle de simulation à événements discrets a été créé pour comparer et projeter le comportement du système pour cette référence avec un modèle type MPRII ou avec un fonctionnement DDMRP. Pour cela, les OFs générés par leur ERP étaient les données d'entrée du modèle en fonctionnement MRP II. En ce qui concerne DDMRP, 23 références de composants ont été bufferisés avec des stocks stratégiques DDMRP. Ce choix a été fait car sur un temps d'écoulement d'environ 15 semaines, la grande majorité de ce temps est passé avant les étapes d'assemblage. Il est donc possible de débiter ces opérations avec la commande client. 23 références ont été bufferisées car ce sont les plus stratégiques pour JV Group : soit les plus coûteuses, soit celles avec les temps d'écoulement les plus longs (Figure V-II et Table V-I). Afin d'avoir des files d'attente représentatives, la totalité des pièces a été modélisée dans l'atelier. DDMRP a également été créé pour gérer les phases de début et de fin de vie du produit (Figure V-IV).

Pour des raisons économiques (Chapter IV.3.3), les tailles de lot minimales (qui définissent la taille de la zone verte) étaient d'au moins 2 avions. Le but du modèle était de tester la variabilité de la demande : le système est-il capable de s'adapter si le client demande finalement ses pièces 3 semaines en avance ? Pour un BFR équivalent, MRP II rate 2 livraisons sur 10 (dont un OTD de 80%) et DDMRP arrive tout de même à livrer les embases à temps (OTD de 100%) (Table V-VIII et Table V-IX).

Ces 3 semaines d'écart de demande sont d'après la théorie la limite. En effet, pour DDMRP, l'OTD chute à 90% avec 4 semaines d'avance dans la demande et à 80% pour 5 semaines d'avance.

En conclusion, l'implémentation de DDMRP sur cette référence doit permettre de faire face aux variations de demande, auxquelles est régulièrement soumis le groupe, là où dans le marché aéronautique les exigences en terme d'OTD sont très élevées.

6. Conclusion générale et perspectives de recherche

Conclusion générale

Comme présenté initialement, DDMRP est décrit comme « une méthode qui se concentre sur la demande et non plus sur les niveaux de stocks comme d'autres méthodes. DDMRP possède les règles et les outils qui doivent permettre de gérer plus d'une entité.¹ » Le but de ce travail de recherche était de questionner cette définition et les principales promesses de cette méthode.

De manière générale, cette méthode est clairement prometteuse d'un point de vue scientifique et industriel. DDMRP permet de résoudre les principales limites identifiées dans les autres méthodes implémentées et développées il y a plusieurs décennies. DDMRP a des résultats satisfaisants (comme démontré sur les chapitres III, IV et V) et peut être adapté à une large variété d'environnements : les promesses sont par conséquent tenues, mais sans parfois de grands écarts avec les méthodes existantes. Un autre avantage concerne la possibilité de ne pas suivre toutes les étapes d'implémentation (Figure I-II), cela dépend du système où DDMRP est implémenté. Par exemple, la phase d'exécution sur le cas réel (Chapter V), n'est pas utilisée ou des buffers de certains types ne sont pas utilisés (comme des buffers de temps et de capacité chez JV Group).

La principale difficulté est que les méthodes de type MRP II, Kanban ou DDMRP doivent gérer les différentes sources de variabilité. Dans ce travail de recherche, cette problématique a été challengée avec une approche basée sur la simulation de flux. En ce qui concerne la comparaison des principales méthodes, dans un environnement stable les résultats sont équivalents, comme attendu. Cependant dès que la variabilité devient significative, les limites de MRP II et Kanban sont révélées. La méthode Kanban pourrait être couplée avec d'autres méthodes afin d'obtenir une méthode hybride de pilotage des flux (mais qui devrait être spécifique). La principale contribution scientifique de ce travail se concentre particulièrement sur la gestion de la variabilité issue de la demande. Cette forme de variabilité a été analysée suivant 2 formes qu'elle peut avoir : une variabilité de la demande dans le temps (Chapter V) ou de la quantité demandée (Chapter III et Chapter IV).

Cette variabilité de la demande est particulièrement liée à la gestion des pics de demande. Les intérêts scientifiques et industriels de la gestion de ces pics ont été démontrés mais il reste une problématique importante à traiter, qui est celle de la définition d'un « pic de demande », autant en terme de quantité que de délai pour être pris en compte dans l'équation de flux disponible. C'est l'une des principales promesses de DDMRP qui a été confirmée avec ce travail de recherche.

¹ : "Planning systems since 1920s evolved from the core perspective of inventory. This is no longer true. Now demand must be at the core. Thus DDMRP is not the next evolution in inventory management; it is a revolutionary shift in perspective and tactics. [...] Inherent in its rules and tools is a level of common sense and visibility that easily translates beyond the confines of a single entity" (Ptak and Smith, 2011).

Une autre contribution majeure concerne le dimensionnement des buffers et leur simulation pour disposer d'une méthode d'aide à la décision. La contribution scientifique est significative parce que la sensibilité dans le dimensionnement a bien été démontré. Un algorithme métier a été développé à partir de l'expérience engrangée et permet d'obtenir plus rapidement de bons résultats (par rapport à l'approche avec la métaheuristique) afin de gérer la problématique de la sensibilité du dimensionnement.

De plus, l'implémentation de DDMRP, comme promis, mène à une meilleure gestion des stocks. S'il y a plusieurs niveaux de nomenclatures, la variabilité est absorbée tout au long de la nomenclature (avec les buffers stratégiques sur les produits finis). Cependant, le profil de distribution des stocks n'est pas aussi marqué qu'une courbe bi-modale pour les autres méthodes comme conceptuellement suggéré.

D'un point de vue industriel, ce travail de recherche prouve que les mécanismes MRP et DDMRP peuvent exister en parallèle avec des points de découplage stratégiques en suivant la logique d'explosion découplée. Comme illustré par le cas JV Group, l'implémentation de DDMRP permet également de questionner le comportement actuel du système et la stratégie retenue.

Finalement, ce travail de recherche démontre les intérêts de DDMRP pour une entreprise de JV Group, qui est maintenant convaincue et souhaite implémenter la méthode sur un périmètre plus grand et sur d'autres sites.

Les cas d'études traités avec celui de JV Group et du Jeu Kanban® enrichissent également la base de cas d'étude DDMRP et pourront être modifiés, développés afin de traiter d'autres problématiques de recherche liées à ce sujet.

Perspectives de recherche

Les principales contributions de ce travail de recherche viennent d'être détaillées. Cependant, comme c'est l'un des premiers travail de recherche sur cette thématique, d'importantes problématiques nécessitent de futurs travaux.

Par rapport à la gestion de la variabilité

Les principales contributions de recherche sont liées à la gestion de la variabilité. Cependant, il y a des travaux supplémentaires qui doivent être réalisés dans un futur proche.

- En ce qui concerne la variabilité interne (tels que les temps de cycles unitaires et les temps de changement de série), ce travail de recherche présente des limites (Chapter III). En effet, la variabilité interne n'est appliquée qu'à un nombre limité de références et à un processus court. Il serait intéressant d'un point de vue scientifique et industriel de se concentrer sur un cas plus complexe avec un plus grand nombre de références. Le

cas d'étude JV Group serait approprié mais il y a des limites pour une quantification fiable de la variabilité interne : le périmètre étudié est limité et les moyens de production sont significativement sous-capacitaires. Par conséquent, l'implémentation de la variabilité interne n'a que peu d'effets.

- La variabilité de la demande a été quantifiée en détails mais la variabilité de l'approvisionnement n'a pas été testée (la variabilité de la demande était plus significative afin d'également challenger les pics de demande). En effet, les entreprises doivent souvent faire face à des aléas de la chaîne d'approvisionnement qui empêchent la production de débuter. Il serait également intéressant de combiner les variabilités internes, de l'approvisionnement et de la demande pour quantifier les impacts.
- Dans ce travail de recherche, la variabilité en lien avec le management n'a pas été implémenté. D'un point de vue industriel, cette variabilité peut avoir des impacts significatifs. DDMRP permet aux effectifs d'être indépendants pour l'étape d'exécution et le flux est le cœur de la méthode avec le management visuel DDMRP. La gestion du changement doit être gérée pour les parties prenantes (avec des formation DDMRP par exemple). De plus, les écarts entre la situation As-Is (avec un exemple MRP II) et celle To-Be avec une implémentation DDMRP ne serait pas aussi significative si les méthodes de pilotage des flux étaient bien appliquées (un nombre important de parties prenantes ne sont pas habituées à la logique qui est derrière MRP II et ses différents mécanismes). Cette gestion de la variabilité du management serait extrêmement difficile à modéliser mais serait intéressant à évaluer.

Par rapport à l'aide à la décision

L'algorithme métier développé a obtenu de bons résultats et a rapidement convergé. Cependant, sa limite serait son application à des cas complexes (un grand nombre de références et d'activités dans le processus). Il serait intéressant d'un point de vue industriel de rendre généralisable un tel algorithme qui pourrait ensuite être couplé à l'optimisation du dimensionnement des buffers DDMRP (ou au moins aider à fournir une solution satisfaisante).

Un raisonnement équivalent pourrait être adopté à un projet de simulation. En effet, il n'est pas envisageable de passer un mois à créer un modèle de simulation et ensuite comparer son fonctionnement avec une implémentation de DDMRP. Il serait intéressant de créer des modules de simulation généralisables afin de créer le modèle et appliquer une méthode de pilotage des flux. Cette étape est nécessaire afin de réaliser des gains significatifs en terme de délai de modélisation et est un sujet majeur d'un point de vue industriel.

Une autre problématique concerne la phase d'exécution : il y aura plus d'une méthode de pilotage qui vivront en parallèle dans un système étudié. L'exécution DDMRP est basée sur un indicateur de statut de stock (un pourcentage) par rapport à MRP II qui fonctionne sur des dates d'échéance. Comment est-il possible de gérer ces deux critères ? Il est possible de définir des règles pour plusieurs machines, mais c'est très compliqué de l'appliquer à une entreprise entière et cela pourrait mener à des échecs dans des projets d'implémentation de DDMRP. D'un point

de vue industriel, il serait nécessaire de développer un outil d'aide à la décision pour gérer les priorités avec ces deux types de données.

Par rapport au positionnement des buffers stratégiques

La première étape pour mettre en place DDMRP concerne le positionnement stratégique des buffers. La limite de cette étape est qu'actuellement « uniquement » l'expérience du consultant est utilisée afin de décider où positionner ces points stratégiques. Cependant, adopter une réflexion complète pour un nombre élevé de références et de nomenclatures afin de trouver une configuration optimale pourrait se révéler très complexe. De futurs travaux pourraient permettre de semi-automatiquement positionner ces buffers stratégiques.

Cet outil pourrait donc aider au positionnement et par rapport au jeu Kanban®, où 14 des 16 références avaient un buffer stratégique, il serait intéressant de comparer le fonctionnement DDMRP et Kanban sur un processus complexe.

Par rapport à la considération des temps d'écoulement

DDMRP se base sur le principe de délai d'écoulement découplé. Comme pour d'autres systèmes, cela implique de précisément connaître les différents temps d'écoulement dans une nomenclature. Ce sujet représente déjà une problématique importante pour de nombreuses entreprises (qui utilisent des temps d'écoulement erronés dans leur ERP par exemple). Les ordres de réapprovisionnement générés avec ces délais (souvent surestimés en prenant en compte les temps d'attente) engorgent le système. Cependant ici la problématique principale réside dans le fait que lorsque DDMRP est mis en place, le flux doit s'accélérer et les temps d'écoulement vont donc diminuer.

De plus, DDMRP considère que le délai d'écoulement total pour 2 références est la somme de ses 2 temps d'écoulement correspondant. Avec des méthodes en flux poussé, c'est réaliste (les ordres sont créés l'un après l'autre). Mais ça peut être une surestimation pour des méthodes en flux tirés parce que certaines activités peuvent être réalisées rapidement l'une après l'autre.

Une mauvaise estimation des temps d'écoulement peut également mener à un positionnement des buffers non adapté. Il serait intéressant de pouvoir anticiper ces futurs temps d'écoulement avec une mise en place de DDMRP pour être confiant dans l'étape du positionnement des buffers qui pourrait autrement « brider » les gains de la mise en place. Ce travail est scientifiquement intéressant et pourrait mener à des gains de temps dans l'implémentation de DDMRP et l'atteinte de son régime permanent de fonctionnement d'un point de vue industriel.

Par rapport à la dimension économique

Enfin, une problématique majeure traite de la dimension économique. Comme vu précédemment, la stratégie DDMRP de positionnement des buffers est basée sur une analyse de retour sur investissement. Afin d'estimer les impacts financiers, une évaluation du coût du stock moyen est réalisée pour chaque scénario de positionnement. Pour cette évaluation, « uniquement » les prix d'achats sont pris en compte. En d'autres termes, les coûts des produits

finis sont directement évalués par rapport aux coûts des matières premières et des composants. En réalité, et c'est encore plus vrai dans certains secteurs, une grande partie du coût du produit est apportée par les différentes activités au cours du processus. Par exemple, cette analyse pourrait être importante pour JV Group où la majeure partie du coût est apportée par le processus industriel en interne. Cependant, avec JV Group, « seulement » les composants sont bufferisés. Il serait donc intéressant d'étudier différentes stratégies de positionnement avec d'autres références pour analyser les impacts économiques.

Ce travail pourrait être intéressant autant d'un point vue scientifique qu'industriel et pourrait être réalisé avec un modèle de simulation à événements discrets sur un cas réel.

REFERENCES

- APICS Dictionary 12th Edition, 2008. <http://www.goodreads.com/book/show/5491300-apics-dictionary-12th-edition>.
- Ballou, R.H., 2003. Business Logistics: Supply Chain Management, 5 edition. ed. Prentice Hall, Upper Saddle River, N.J.
- Basturk, B., Karaboga, D., 2006. An artificial bee colony (ABC) algorithm for numeric function optimization, in: IEEE Swarm Intelligence Symposium. pp. 687–697.
- Beamon, B.M., Bermudo, J.M., 2000. A hybrid push/pull control algorithm for multi-stage, multi-line production systems. *Prod. Plan. Control* 11, 349–356. doi:10.1080/095372800232072
- Benyoucef, L., 2008. Mémoire HDR. Contrib. À Concept. Au Pilot. À L'Evaluation Chaîn. Logistiques Approch. Hybrides Anal. Univ. Paul Verlaine Metz.
- Bonabeau, E., 2002. Agent-based modeling: methods and techniques for simulating human systems. *Proc. Natl. Acad. Sci. U. S. A.* 99 Suppl 3, 7280–7287. doi:10.1073/pnas.082080899
- Bonney, M.C., Zhang, Z., Head, M.A., Tien, C.C., Barson, R.J., 1999. Are push and pull systems really so different? *Int. J. Prod. Econ.* 59, 53–64. doi:10.1016/S0925-5273(98)00094-2
- Bonvik, A.M., Couch, C.E., Gershwin, S.B., 1997. A comparison of production-line control mechanisms. *Int. J. Prod. Res.* 35, 789–804. doi:10.1080/002075497195713
- Bonvik, A.M., Gershwin, S.B., 1996. Beyond Kanban: Creating and analyzing lean shop floor control policies. In *Manufacturing and service operations management conference proceeding*, 46–51.
- Business Dictionary, 2016. What is stock position? definition and meaning [WWW Document]. BusinessDictionary.com. URL <http://www.businessdictionary.com/definition/stock-position.html> (accessed 9.8.16).
- Buzacott, J.A., 1989. Queueing models of Kanban and MRP controlled production systems. *Eng. Costs Prod. Econ.* 17, 3–20. doi:10.1016/0167-188X(89)90050-5
- Chiadamrong, N., Techalert, T., Pichalai, A., 2007. Decision Support Tool for Evaluating Push and Pull Strategies in the Flow Shop with a Bottleneck Resource. *Ind. Eng. Manag. Syst.* 6, 83–93.
- Christopher, M., 1992. *Logistics: The strategic issues*. Chapman & Hall.
- Cochran, J.K., Kaylani, H.A., 2008. Optimal design of a hybrid push/pull serial manufacturing system with multiple part types. *Int. J. Prod. Res.* 46, 949–965.
- Costanza, J.R., 1996. *The quantum leap in speed-to-market*. Irwin Professional Pub.
- Dallery, Y., Liberopoulos, G., 2000. Extended Kanban control system: combining Kanban and base stock. *IIE Trans.* 32, 369–386. doi:10.1023/A:1007651721842
- Dorigo, M., Maniezzo, V., Colorni, A., 1996. Ant system: optimization by a colony of cooperating agents. *IEEE Trans. Syst. Man Cybern. Part B Cybern.* 26, 29–41. doi:10.1109/3477.484436
- Feo, T.A., Resende, M.G.C., 1989. A probabilistic heuristic for a computationally difficult set covering problem. *Oper. Res. Lett.* 8, 67–71. doi:10.1016/0167-6377(89)90002-3
- Flapper, S.D.P., Miltenburg, G.J., Wijngaard, J., 1991. Embedding JIT into MRP. *Int. J. Prod. Res.* 29, 329–341. doi:10.1080/00207549108930074

- Fontanili, F., Lauras, M., Lamothe, J., 2013. Pour une ingénierie d'entreprise plus performante par couplage entre modélisation de processus et simulation. 10^e Congrès Int. Génie Ind. CIGI.
- Forrester, J.W., 1995. The Beginning of System Dynamics. McKinsey Q. 4.
- Forrester, J.W., 1961. Industrial Dynamics, MIT Press. ed. Cambridge.
- Gaury, E.G.A., 2000. Designing pull production control systems: Customization and robustness. Tilburg University, School of Economics and Management.
- Gaury, E.G.A., Kleijnen, J.P.C., Pierreval, H., 2001. A Methodology to Customize Pull Control Systems. J. Oper. Res. Soc. 52, 789–799.
- Geraghty, J., Heavey, C., 2005. A review and comparison of hybrid and pull-type production control strategies. Spectr. 27, 435–457. doi:10.1007/s00291-005-0204-z
- Gershwin, S.B., 2000. Design and operation of manufacturing systems: the control-point policy. IIE Trans. 32, 891–906. doi:10.1080/07408170008967448
- Gilland, W.G., 2002. A simulation study comparing performance of CONWIP and bottleneck-based release rules. Prod. Plan. Control 13, 211–219. doi:10.1080/09537280110069784
- Glover, F., Laguna, M., 2013. Tabu Search*, in: Pardalos, P.M., Du, D.-Z., Graham, R.L. (Eds.), Handbook of Combinatorial Optimization. Springer New York, pp. 3261–3362.
- Goldratt, E.M., 1990. Theory of constraints. North River.
- Goldratt, E.M., Cox, J., 1984. The goal: Excellence in manufacturing. North River Press.
- González-R, P.L., Framinan, J.M., Pierreval, H., 2011. Token-based pull production control systems: an introductory overview. J. Intell. Manuf. 23, 5–22. doi:10.1007/s10845-011-0534-4
- Gordon, G.A., Fischer, M., 2011. Accounting Strategy to Improve Public Higher Education Management. J. Account. Finance.
- Greif, M., Moisy, C., Pesnel, E., 1984. Guide du Kanban. CIPE.
- Gunasekaran, A., Patel, C., McGaughey, R.E., 2004. A framework for supply chain performance measurement. Int. J. Prod. Econ., Supply Chain Management for the 21st Century Organizational Competitiveness 87, 333–347. doi:10.1016/j.ijpe.2003.08.003
- Gupta, S.M., Al-Turki, Y. a. Y., Perry, R.F., 1999. Flexible kanban system. Int. J. Oper. Prod. Manag. 19, 1065–1093. doi:10.1108/01443579910271700
- Hochreiter, T.A., 1999. A Comparative Simulation Study of Kanban, CONWIP, and MRP Manufacturing Control Systems in a flow shop (M. Sc. Dissertation). University of Florida.
- Hodgson, T.J., Wang, D., 1991a. Optimal hybrid push/pull control strategies for a parallel multistage system: Part I. Int. J. Prod. Res. 29, 1279–1287. doi:10.1080/00207549108930133
- Hodgson, T.J., Wang, D., 1991b. Optimal hybrid push/pull control strategies for a parallel multistage system: Part II. Int. J. Prod. Res. 29, 1453–1460. doi:10.1080/00207549108948022
- Holland, J.H., 1975. Adaptation in natural and artificial systems: An introductory analysis with applications to biology, control, and artificial intelligence. U Michigan Press, Oxford, England.
- Hollocks, B.W., 2006. Forty Years of Discrete-Event Simulation: A Personal Reflection. J. Oper. Res. Soc. 57, 1383–1399.
- Hopp, M.S.E. (McGraw-H. (Paperback) by W., 2009. Factory Physics Second Edition, International Edition edition. ed. McGraw-Hill/Irwin, Boston, Mas.
- Hopp, W., Spearman, M., 1996. Factory Physics: Foundations of Factory. Chicago: Irwin.
- Huq, Z., Huq, F., 1994. Embedding JIT in MRP: The case of job shops. J. Manuf. Syst. 13, 153–164. doi:10.1016/0278-6125(94)90001-9
- Hwang, C.-R., 1988. Simulated annealing: Theory and applications. Acta Appl. Math. 12, 108–111. doi:10.1007/BF00047572

- Ihme, M., Stratton, R., 2015. Evaluating Demand Driven MRP: a case based simulated study.
- Jaegler, Y., Burlat, P., Lamouri, S., 2016. The ConWIP Production Control System: a Literature Review. 6th ILS Conf.
- Jennings, N.R., 2000. On agent-based software engineering. *Artif. Intell.* 117, 277–296. doi:10.1016/S0004-3702(99)00107-1
- Jiang, J., Rim, S.-C., 2016. Strategic Inventory Positioning in BOM with Multiple Parents Using ASR Lead Time. *Math. Probl. Eng.* 2016, 1–9. doi:10.1155/2016/9328371
- Johnson, L.A., Montgomery, D.C., 1974. *Operations Research in Production Planning, Scheduling and Inventory Control* / L.A. Johnson, D.C. Montgomery. ResearchGate.
- Jones, D., 2006. Heijunka: Leveling production. *Manuf. Eng.* 137, 29–+.
- Karmarkar, U., 1986. Push, Pull and Hybrid Control Schemes.
- Khojasteh, Y., Sato, R., 2015. Selection of a pull production control system in multi-stage production processes. *Int. J. Prod. Res.* 53, 4363–4379. doi:10.1080/00207543.2014.1001530
- Khojasteh-Ghamari, Y., 2012. Developing a framework for performance analysis of a production process controlled by Kanban and CONWIP. *J. Intell. Manuf.* 23, 61–71. doi:10.1007/s10845-009-0338-y
- Khojasteh-Ghamari, Y., 2009. A performance comparison between Kanban and CONWIP controlled assembly systems. *J. Intell. Manuf.* 20, 751–760. doi:10.1007/s10845-008-0174-5
- Kimball, G.E., 1988. General principles of inventory control. 119–130.
- Kotter, J.P., 2012. *Leading Change, With a New Preface by the Author*, 1 edition. ed. Harvard Business Review Press, Boston, Mass.
- Koulouriotis, D.E., Xanthopoulos, A.S., Tourassis, V.D., 2010. Simulation optimisation of pull control policies for serial manufacturing lines and assembly manufacturing systems using genetic algorithms. *Int. J. Prod. Res.* 48, 2887–2912. doi:10.1080/00207540802603759
- Lage Junior, M., Godinho Filho, M., 2010. Variations of the kanban system: Literature review and classification. *Int. J. Prod. Econ.* 125, 13–21. doi:10.1016/j.ijpe.2010.01.009
- Land, M.J., 2009. Cobacabana (control of balance by card-based navigation): A card-based system for job shop control. *Int. J. Prod. Econ.* 117, 97–103. doi:10.1016/j.ijpe.2008.08.057
- Law, A., 2014. *Simulation Modeling and Analysis*, 5 edition. ed. McGraw-Hill Education, Dubuque.
- Lee, H.L., Padmanabhan, V., Whang, S., 1997. Information Distortion in a Supply Chain: The Bullwhip Effect. *Manag. Sci.* 43, 546–558. doi:10.1287/mnsc.43.4.546
- Li, X., Sawhney, R., Arendt, E.J., Ramasamy, K., 2012. A comparative analysis of management accounting systems' impact on lean implementation. *Int. J. Technol. Manag.* 57, 33–48. doi:10.1504/IJTM.2012.043950
- Li, Z., 2013. *Design and Analysis of Robust Kanban System in an Uncertain Environment*. KIT Scientific Publishing.
- Melnyk, S.A., Piper, C.J., 1981. Implementation of material requirements planning: safety lead times. *Int. J. Oper. Prod. Manag.* 2, 52–61.
- Melnyk, S.A., Rodrigues, A., Ragatz, G.L., 2009. Using Simulation to Investigate Supply Chain Disruptions, in: Zsidisin, G.A., Ritchie, B. (Eds.), *Supply Chain Risk*, International Series in Operations Research & Management Science. Springer US, pp. 103–122.
- Miclo, R., Fontanili, F., Lauras, M., Lamothe, J., Milian, B., 2015. MRP vs. demand-driven MRP: Towards an objective comparison. *IEEE*, pp. 1072–1080. doi:10.1109/IESM.2015.7380288

- Miclo, R., Fontanili, F., Marquès, G., Bomert, P., Lauras, M., 2015. RTLS-based Process Mining: Towards an automatic process diagnosis in healthcare, in: 2015 IEEE International Conference on Automation Science and Engineering (CASE), pp. 1397–1402. doi:10.1109/CoASE.2015.7294294
- Miclo, R., Lauras, M., Fontanili, F., Lamothe, J., Bornert, P., Revenu, G., 2014. Working Capital Improvement through Value Stream Mapping Costing and Discrete-Event Simulation. Proc. 5th Int. Conf. Inf. Syst. Logist. Supply Chain Connect. WORLDS ILS 2014.
- Mladenović, N., Hansen, P., 1997. Variable neighborhood search. *Comput. Oper. Res.* 24, 1097–1100. doi:10.1016/S0305-0548(97)00031-2
- Ohno, T., 1988. *Toyota Production System: Beyond Large-Scale Production*
- Olaitan, O.A., 2016. A framework for creating production and inventory control strategies (doctoral). Dublin City University. Advanced Processing Technology Research Centre (APTREC).
- Olhager, J., Östlund, B., 1990. OR for Engineers Expert Systems and Decision-Aid An integrated push-pull manufacturing strategy. *Eur. J. Oper. Res.* 45, 135–142. doi:10.1016/0377-2217(90)90180-J
- Orlicky, J.A., 1975. *Material Requirements Planning: The New Way of Life in Production and Inventory Management, Underlining/Margin Notes/Highlighting.* ed. DA Information Services, New York.
- Ptak, C., Smith, C., 2016. *Demand Driven Material Requirements Planning (DDMRP)*, Industrial Press, Inc.
- Ptak, C., Smith, C., 2011. *Orlicky's Material Requirements Planning 3/E.* McGraw Hill Professional.
- Rim, S.-C., Jiang, J., Lee, C.J., 2014. Strategic Inventory Positioning for MTO Manufacturing Using ASR Lead Time, in: Golinska, P. (Ed.), *Logistics Operations, Supply Chain Management and Sustainability.* Springer International Publishing, Cham, pp. 441–456.
- Rushton, A., Croucher, P., Baker, D.P., Transport, C.I. of L. and, 2010. *The Handbook of Logistics and Distribution Management*, 4 edition. ed. Kogan Page, London ; Philadelphia.
- Sarker, B.R., Fitzsimmons, J.A., 1989. The performance of push and pull systems: a simulation and comparative study†. *Int. J. Prod. Res.* 27, 1715–1731. doi:10.1080/00207548908942650
- Schriber, T.J., Brunner, D.T., Smith, J.S., 2012. How discrete-event simulation software works and why it matters, in: *Simulation Conference (WSC), Proceedings of the 2012 Winter.* Presented at the Simulation Conference (WSC), Proceedings of the 2012 Winter, pp. 1–15. doi:10.1109/WSC.2012.6465274
- Sekine, K., 2005. *One-Piece Flow: Cell Design for Transforming the Production Process.* Productivity Press.
- Sepehri, M.M., Nahavandi, N., 2007. Critical WIP loops: a mechanism for material flow control in flow lines. *Int. J. Prod. Res.* 45, 2759–2773. doi:10.1080/00207540600787077
- Sipper, D., Bulfin, R.L.J., 1997. *Production: Planning, Control and Integration*, International Ed edition. ed. Primis Custom Publishing.
- Sivakumar, G.D., Shahabudeen, P., 2008. Design of multi-stage adaptive kanban system. *Int. J. Adv. Manuf. Technol.* 38, 321–336. doi:10.1007/s00170-007-1093-x
- Slack, N., Lewis, M., 2015. *Operations Strategy*, 4 edition. ed. Pearson, Harlow, England ; New York.

- Smith, D., Smith, C., 2013. Demand Driven Performance. McGraw-Hill Professional, New York.
- Spearman, M.L., Woodruff, D.L., Hopp, W.J., 1990. CONWIP: a pull alternative to kanban. *Int. J. Prod. Res.* 28, 879–894.
- Spencer, M.S., Cox, J.F., 1995. Optimum production technology (OPT) and the theory of constraints (TOC): analysis and genealogy. *Int. J. Prod. Res.* 33, 1495–1504. doi:10.1080/00207549508930224
- Stevenson, M., Hendry, L.C., Kingsman, B.G., 2005. A review of production planning and control: the applicability of key concepts to the make-to-order industry. *Int. J. Prod. Res.* 43, 869–898. doi:10.1080/0020754042000298520
- Sugimori, Y., Kusunoki, K., Cho, F., Uchikawa, S., 1977. Toyota production system and Kanban system Materialization of just-in-time and respect-for-human system. *Int. J. Prod. Res.* 15, 553–564. doi:10.1080/00207547708943149
- Suri, R., 1998. Quick response manufacturing: A company-wide approach to lead time reduction.
- Takahashi, K., Nakamura, N., 2002. Comparing reactive Kanban and reactive CONWIP. *Prod. Plan. Control* 13, 702–714. doi:10.1080/0953728031000057352
- Tardif, V., Maaseidvaag, L., 2001. An adaptive approach to controlling kanban systems. *Eur. J. Oper. Res.* 132, 411–424. doi:10.1016/S0377-2217(00)00119-3
- Thompson, A.A.J., Peteraf, M., Gamble, J.E., Iii, A.J.S., 2013. *Crafting & Executing Strategy: The Quest for Competitive Advantage: Concepts and Cases*, 19th ed. McGraw-Hill Higher Education, New York.
- Villa, A., Watanabe, T., 1993. Production management: Beyond the dichotomy between “push” and “pull.” *Comput. Integr. Manuf. Syst.* 6, 53–63. doi:10.1016/0951-5240(93)90028-O
- Wang, D., Xu, C.-G., 1997. Hybrid push pull production control strategy simulation and its applications. *Prod. Plan. Control* 8, 142–151. doi:10.1080/095372897235406
- Wight, O., 1995. *Manufacturing Resource Planning: MRP II: Unlocking America’s Productivity Potential*. John Wiley & Sons.

TABLE OF ILLUSTRATIONS

Figure I-I: The six DDMRP pillars.....	9
Figure I-II: the 3 steps and 5 components to implement DDMRP	10
Figure I-III: Manuscript Big Picture.....	13
Figure II-I: Big Picture – DDMRP presentation and critical analysis	14
Figure II-II: A bi-modal inventory distribution curve (Ptak and Smith, 2016).....	17
Figure II-III: Inventory distribution targeted with DDMRP (Ptak and Smith, 2016).....	17
Figure II-IV: Illustration of decoupling point impacts (Ptak and Smith, 2016).....	18
Figure II-V: Definition of DDMRP stock buffer zones (Ptak and Smith, 2016).....	18
Figure II-VI: Parameters required to size DDMRP stock buffers (Ptak and Smith, 2016)	20
Figure II-VII: DDMRP Lead-Time Factor and Variability Factor suggestions (Ptak and Smith, 2016).....	21
Figure II-VIII: DDMRP buffer zones and “top of” zones	21
Figure II-IX: 4 main variability sources (Ptak and Smith, 2011).....	22
Figure II-X: FPD BOM example.....	23
Figure II-XI: DDMRP buffer positioning example (Ptak and Smith, 2016).....	23
Figure II-XII: FPD DLT explanation (Ptak and Smith, 2016).....	24
Figure II-XIII: Another 208 DLT scenario (Ptak and Smith, 2016)	24
Figure II-XIV: DDMRP on-hand distribution target (Ptak and Smith, 2016)	25
Figure II-XV: FPA, FPB and FPC BOM examples (Ptak and Smith, 2016)	26
Figure II-XVI: Buffer comparison example with other DDMRP buffer positions(Ptak and Smith, 2016)	26
Figure II-XVII: Items purchase cost (Ptak and Smith, 2016)	27
Figure II-XVIII: FPA Average on-hand target and inventory reduction (Ptak and Smith, 2016)	27
Figure II-XIX: DDMRP decoupled explosion (Ptak and Smith, 2016).....	30
Figure II-XX: FPD decoupled explosion example (Ptak and Smith, 2016)	30
Figure II-XXI: DDMRP alert types (Ptak and Smith, 2016).....	31
Figure II-XXII: DDMRP corresponding planning and execution views (Ptak and Smith, 2016)	32
Figure II-XXIII: Pull and Push systems (González-R et al., 2011)	34
Figure II-XXIV: Manufacturing Resources Planning (MRP II).....	36
Figure II-XXV: Specific Kanban system (González-R et al., 2011)	38
Figure II-XXVI: Base-Stock system (González-R et al., 2011).....	39
Figure II-XXVII: Extended Kanban system (González-R et al., 2011).....	39
Figure II-XXVIII: Generic Kanban system (González-R et al., 2011)	40
Figure II-XXIX: ConWIP system (González-R et al., 2011).....	40
Figure II-XXX: POLCA System (González-R et al., 2011).....	42
Figure II-XXXI: DBR system	43
Figure II-XXXII: DDMRP System.....	44
Figure III-I: Big Picture - DDMRP Plan of experiments.....	53

Figure III-II: Reducer Bill Of Material	56
Figure III-III: Reducer machining and assembling process	57
Figure III-IV: Chosen approach to implement MRP II	67
Figure III-V: DDMRP buffer positioning for A and B crowns	73
Figure III-VI: Gantt Diagram used to assess Kanban cards	73
Figure III-VII: Stable demand example for reducer R1	78
Figure III-VIII: R1 demand profile with spikes and troughs.....	81
Figure III-IX: Theoretical demand profile with seasonality	82
Figure III-X: Gaps between forecasted and real demand.....	83
Figure III-XI: R1 demand profile for high demand variability and high spikes and troughs...	85
Figure III-XII: Inventory management difficulties (left) compared to a controlled inventory (right)	88
Figure III-XIII: Reducer inventory distribution for demand variability scenario	88
Figure III-XIV: Oil pan and gear inventory distribution for demand variability scenario.....	89
Figure III-XV: Reducer inventory distribution for high demand variability and visibility scenario	90
Figure III-XVI: Oil pan and gear inventory distribution for high demand variability and visibility scenario.....	90
Figure IV-I: Big Picture – DDMRP parameter optimisation.....	95
Figure IV-II: Parameter optimisation – proposed method	97
Figure IV-III: 1 – “Generic approach” – Parameter optimisation.....	99
Figure IV-IV: “Generic” metaheuristic approach – objective function	101
Figure IV-V: “Generic” metaheuristic approach - WC as a function of OTD	102
Figure IV-VI: “Generic” metaheuristic approach - WC as a function of OTD - Zoom.....	103
Figure IV-VII: 2 – Business algorithm definition and application – Parameter optimisation.	104
Figure IV-VIII: WC and OTD trends with the business algorithm.....	112
Figure IV-IX: 3 – “Generic approach” applied to a good solution obtained from business algorithm – Parameter optimisation.....	115
Figure IV-X: OTD objective function.....	117
Figure IV-XI: OTD objective - WC as a function of OTD.....	118
Figure IV-XII: OTD objective - WC as a function of OTD - Zoom	118
Figure IV-XIII: OTD and WC weighting objective function.....	119
Figure IV-XIV: OTD and WC weighting objective - WC as a function of OTD	120
Figure IV-XV: OTD and WC weighting objective - WC as a function of OTD - Zoom.....	121
Figure IV-XVI: Goal programming objective function.....	122
Figure IV-XVII: Goal programming objective - WC as a function of OTD	123
Figure IV-XVIII: Goal programming objective - WC as a function of OTD – Zoom.....	123
Figure IV-XIX: Objective function - comparison of results.....	125
Figure IV-XX: Objective function - comparison of results - Zoom.....	125
Figure V-I: Big picture – a real case study.....	128
Figure V-II: Seat base BOM macro	130
Figure V-III: Buffer profile for a buffered reference	134
Figure V-IV: Buffer profile trend for a buffered reference.....	135
Figure V-V: WC profiles for seat base components and assembled parts	137

Figure V-VI: Delivery date compared to opening delivery schedule with MRP and DDMRP strategies	142
Figure V-VII: Bi-criteria objective function results with stable demand	145
Figure V-VIII: Bi-criteria objective function with demand variability	145

Table II-I: Buffer profile classification example (Ptak and Smith, 2016).....	19
Table II-II: Two DDMRP stock buffer sizing examples (Ptak and Smith, 2016).....	25
Table II-III: Inventory impacts with 201 buffering (Ptak and Smith, 2016).....	28
Table II-IV: DDMRP Planning view example to manage priorities (Ptak and Smith, 2016)...	29
Table II-V: Managing execution priorities by buffer status (Ptak and Smith, 2016).....	31
Table II-VI: MRP II, DDMRP and Kanban description depending on the horizon type	46
Table II-VII: Response to variability for the three methods according to different horizons .	49
Table III-I: BOM matrix	59
Table III-II: Workstation parameters.....	60
Table III-III: Reference parameters	61
Table III-IV: Part of the demand scenario example	62
Table III-V: Breakdowns expected for each section.....	63
Table III-VI: Mean workload/capacity analysis, Part I.....	65
Table III-VII: Workload/capacity analysis, Part II.....	66
Table III-VIII: Lead Time sub-component comparison for different periods.....	66
Table III-IX: MRP II scheduling example	68
Table III-X: DDMRP buffer positioning example 1	70
Table III-XI: Best DDMRP buffer positioning.....	70
Table III-XII: Kanban card sizing.....	74
Table III-XIII: Possible levers for each method for the DOE.....	75
Table III-XIV: Initial scenario results	78
Table III-XV: End item and component KPIs for each material management method	79
Table III-XVI: Initial state results.....	79
Table III-XVII: Visual indicators to quantify OTD and WC levels.....	79
Table III-XVIII: Process variability results	80
Table III-XIX: Demand variability results with spikes and troughs.....	81
Table III-XX: Demand variability results with seasonality	83
Table III-XXI: High demand variability results.....	86
Table III-XXII: High demand variability results – Version 2 for Kanban.....	86
Table III-XXIII: DOE scenario synthesis.....	87
Table III-XXIV: DDMRP hypothesis confirmation (or not) and recommendations	92
Table IV-I: Simulated Annealing parameters.....	99
Table IV-II: Optimisation parameters	100
Table IV-III: “Generic” metaheuristic approach results	102
Table IV-IV: OTD and WC iteration results	110
Table IV-V: Business algorithm application.....	111
Table IV-VI: DDMRP buffer comparison for the best solution with the business algorithm and the “generic” approach.....	113
Table IV-VII: OTD objective function results.....	117

Table IV-VIII: OTD and WC weighting objective function results	120
Table IV-IX: Goal programming objective function results	122
Table IV-X: Goal programming optimisation best results	124
Table V-I: Seat base BOM Matrix	131
Table V-II: Initial delivery dates provided by the customer	136
Table V-III: Delivery and WC results – DDMRP Initial situation	137
Table V-IV: Delivery and WC results – daily to weekly NFE calculation	138
Table V-V: Delivery and WC results – 1 or 2 plane(s) as MOQs	139
Table V-VI: Assembly reference production cost for both MOQ strategies	140
Table V-VII: New delivery dates compared to those given at the beginning.....	141
Table V-VIII: Delivery and WC results – MRP demand variability.....	141
Table V-IX: Delivery and WC results – DDMRP demand variability.....	142
Table V-X: DDMRP results with 3, 4 and 5 week delivery changes.....	143

APPENDICES

Appendix A: Kanban Game® Witness® model

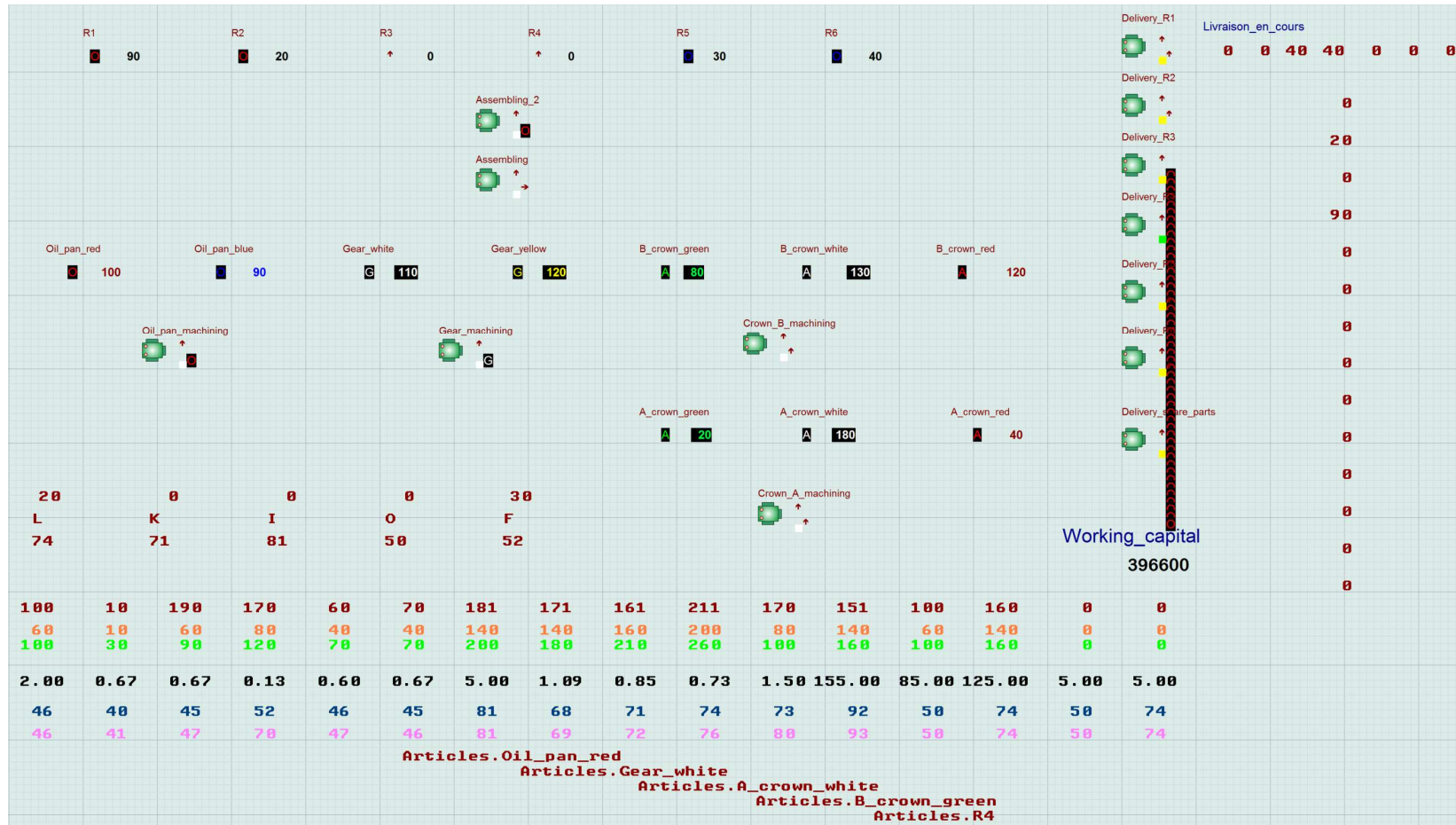

Appendix B: Witness® Simulated Annealing explanations

These explanations are taken from the Witness® optimiser user guide:

Simulated annealing is an optimization paradigm based on the structural properties of physical materials that are melted down and then cooled in a controlled manner. The technique is based on the concept of local search, and designed to reduce the risk of becoming trapped in local optima. At each stage of the search, a neighbour of the current solution is generated and either accepted as the new solution or rejected. This acceptance process is initially random, but becomes increasingly dependent on solution quality as time goes on. The temperature controls the degree of randomness present within the search and is modulated by a predetermined cooling schedule.

This is the Simulated Annealing algorithm:

```
generate an initial solution  $s_0$  ;
select an initial temperature  $t_0 > 0$ ;
set current temperature  $t = t_0$ ;
select a cooling schedule parameter  $\alpha < 1$ ;
select a number of iterations  $n$  to spend at each temperature;
repeat
  repeat
    generate a neighbor  $s$  of  $s_0$ ;
     $d = \text{quality}(s_0) - \text{quality}(s)$ ;
    if  $d < 0$  then  $s_0 = s$ 
    else
      begin
        generate random  $x$  uniformly in the range  $(0,1)$ ;
        if  $x < \exp(-d/t)$  then  $s_0 = s$ ;
      end
    until number of iterations performed at this temperature  $\text{step} = n$ ;
    update temperature by  $t = \alpha \times t$ ;
  until stopping condition is met
```

The initial temperature and cooling schedule used within Simulated Annealing is highly problem-dependent and can vary widely. The choice of cooling schedule has a considerable impact upon the quality of the resulting solution. Parameter optimization is therefore essential if high quality results are to be obtained.

The initial temperature determines the degree of randomness that is initially present in the search. Higher initial temperatures will introduce a greater degree of randomness within the search.

In the algorithm above, the cooling schedule parameter (α) controls the rate at which the

temperature is reduced; large values will produce slow cooling schedules. The parameter value must always be less than one, since it must reduce the temperature, and must be greater than zero, since the temperature must not become negative, nor reach zero in a single step. In practice, values of the parameter between 0.7 and 0.95 tend to be used.

The length of the temperature step also controls the cooling rate. Longer temperature steps will produce slower cooling rate if the parameter α remains fixed. The recommended number of temperature steps is approximately 25.

It is also good practice for the cooling schedule parameter and temperature step length to be set so that the final temperature is approximately 10% of the initial temperature.

Appendix C: JV Group Witness model

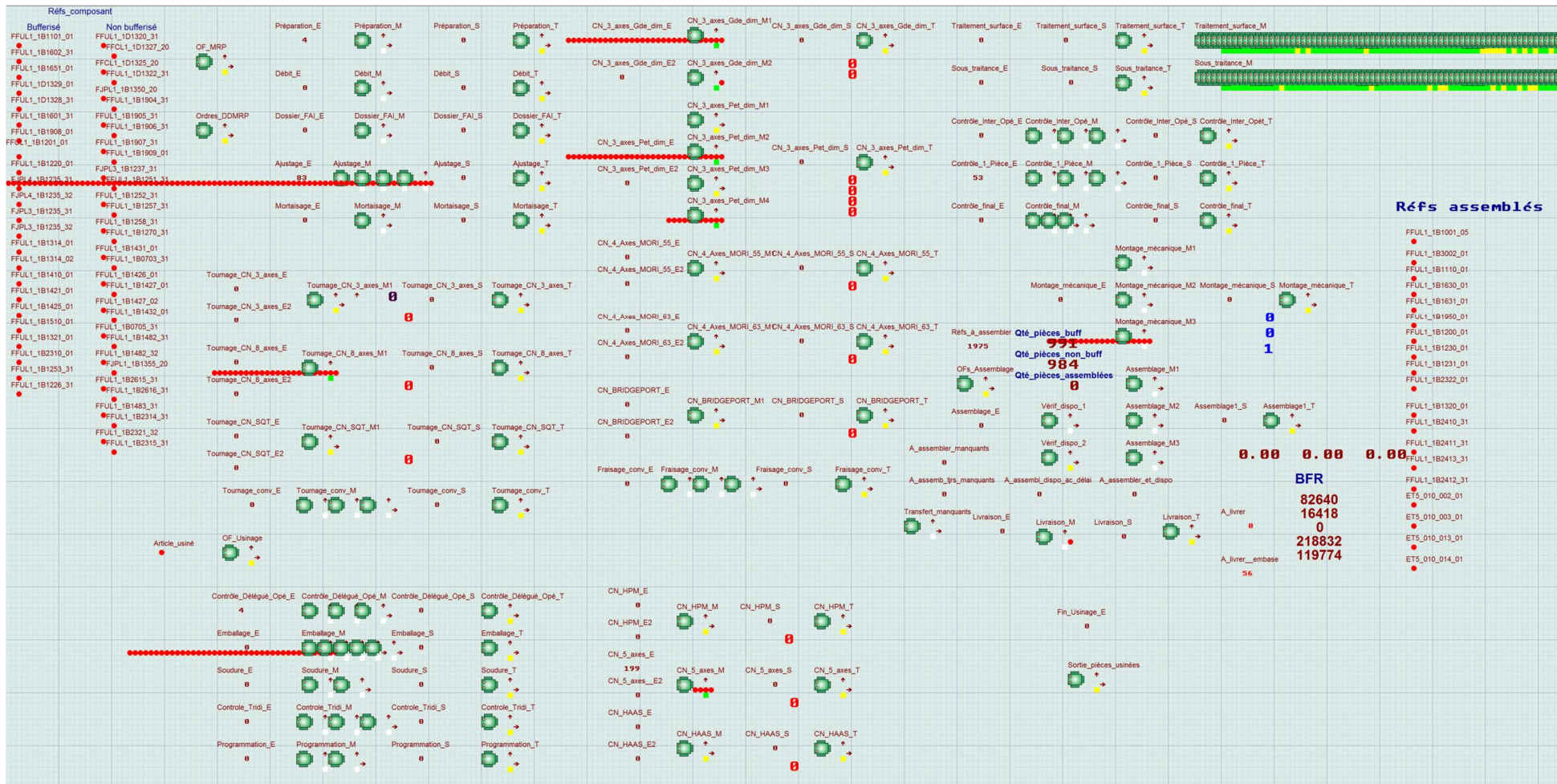

Challenger les promesses du « Demand Driven MRP » : une approche basée sur la simulation à événements discrets

Mots clés : Gestion chaîne logistique, DDMRP, Gestion de l'incertitude, Modélisation et simulation de flux, Aide à la décision.

Les principaux enjeux des supply chain d'aujourd'hui concernent l'adaptation à des environnements instables. Demand Driven Material Requirements Planning (DDMRP) est une méthode récente et prometteuse de gestion des flux qui a été conçue pour faire face aux problématiques actuelles.

Le travail de recherche réalisé détaille et positionne DDMRP par rapport aux autres méthodes connues de pilotage de flux. Le but de ce travail est de challenger les principales promesses de DDMRP. Pour cela, un plan d'expériences a été réalisé sur un cas d'étude pour évaluer le comportement de MRP II, Kanban et DDMRP face à différentes sources de variabilité. Le dimensionnement des buffers DDMRP est un sujet majeur pour la méthode. Il a été traité sur un cas d'étude avec un travail d'optimisation. Toutes les contributions ont été expérimentées avec l'implémentation de DDMRP sur un cas réel.

La thèse permet ainsi de valider certains atouts de DDMRP, tels que l'adaptation du système à différentes formes de variabilités, mais elle permet également de souligner des perspectives majeures de recherche sur ce sujet.

Challenging the “Demand Driven MRP” Promises: A Discrete Event Simulation Approach

Keywords : Supply Chain Management, DDMRP, Uncertainty Management, Flow modelling and simulation, Decision aid.

The main Supply Chain current issues concern the adaptation to unstable environments. Demand Driven Material Requirements Planning (DDMRP) is a recent and promising material management method that is designed to tackle these current issues.

The research work details and classifies DDMRP compared to the other material management methods known. The goal of this work is to challenge the main DDMRP promises. This is why a design of experiments was realised on a case study in order to assess MRP II, Kanban and DDMRP behaviours with different variability sources. The DDMRP buffer sizing is a major issue. It was dealt with an optimisation work on a case study. All the contributions were experimented with a DDMRP implementation on a real case.

The research work enables several DDMRP advantages to be validated, such as the system adjustment to different variability sources, however this work also allows research perspectives to be underlined.