



HAL
open science

Tropical geometry and polynomial systems

Boulos El Hilany

► **To cite this version:**

Boulos El Hilany. Tropical geometry and polynomial systems. General Mathematics [math.GM]. Université Grenoble Alpes, 2016. English. NNT : 2016GREAM037 . tel-01679316

HAL Id: tel-01679316

<https://theses.hal.science/tel-01679316>

Submitted on 9 Jan 2018

HAL is a multi-disciplinary open access archive for the deposit and dissemination of scientific research documents, whether they are published or not. The documents may come from teaching and research institutions in France or abroad, or from public or private research centers.

L'archive ouverte pluridisciplinaire **HAL**, est destinée au dépôt et à la diffusion de documents scientifiques de niveau recherche, publiés ou non, émanant des établissements d'enseignement et de recherche français ou étrangers, des laboratoires publics ou privés.

THÈSE

Pour obtenir le grade de

DOCTEUR DE L'UNIVERSITÉ DE GRENOBLE

Spécialité : **Mathématiques**

Arrêté ministériel : Arrêté du 7 août 2006 relatif à la formation doctorale

Présentée par

Boulos El Hilany

Thèse dirigée par **Frédéric Bihan**

préparée au sein **LAMA, Université Savoie Mont Blanc**
et de **Université Grenoble Alpes**

Géométrie Tropicale et Systèmes Polynomiaux

Thèse soutenue publiquement le **21 Septembre 2016**,
devant le jury composé de :

M. Erwan Brugallé

Maître de Conférences HDR, École polytechnique, Rapporteur

M. Joseph Maurice Rojas

Professeur, Texas A&M University, Rapporteur

M. Georges Comte

Professeur, Université Savoie Mont Blanc, Examineur

M. Ilia Itenberg

Professeur, Université Pierre et Marie Curie, Président

M. Krzysztof Kurdyka

Professeur, Université Savoie Mont Blanc, Examineur

M. Thorsten Theobald

Professeur, Goethe University Frankfurt, Examineur

M. Frédéric Bihan

Maître de Conférences HDR, Université Savoie Mont Blanc, Directeur de thèse



Acknowledgements

During this thesis, I have advanced a lot on both academic and personal levels. This three-year project came with the help of many people that participated directly or indirectly in my research.

Firstly, I would like to sincerely thank Frédéric Bihan for his huge help, and support in my PhD. Having immense patience to answer all my questions and to teach me different tools, he gave me a big push forward in my research. His guidance and our fruitful discussions gave me an important insight into my subject and in mathematics in general. I appreciate his massive efforts in correcting all my mistakes and helping me better write my papers and thesis. I feel very lucky having Frédéric as my advisor and mentor for his great personality inspired me even more to continue my journey in research.

I would like to thank Erwan Brugallé and J. Maurice Rojas for accepting to be examiners of my thesis, as well as Georges Comte, Ilia Itenberg, Krzysztof Kurdyka and Thorsten Theobald for accepting to be a part of my jury. I also appreciate the very helpful examples of particular polynomial systems which were provided by J. Maurice Rojas, and the much valuable computations made by Pierre-Jean Spaenlehauer both of which confirmed that my results are on the right track.

I owe my gratitude also to Michel Raibaut who always re-encouraged me during the common tough moments in research. The discussions we had answering my questions gave me a broader perspective in mathematics, and our hikes, dinners and all the activities we did have made my stay in France even much more enjoyable. I am very happy to have met such a great friend and colleague.

My old friends Emile, Hassan, Hisham, Ralph and the people that I became friends with during my stay in France made a firm positive impact on my thesis and my life. Each in their own way, I appreciate the great friendships of my colleagues Charlotte and Rodrigo which gave me a big support with all the fun and fascinating time spent together. Thanks to Pierre for interesting discussions and Rodolphe for helpful computations. The enjoyable companies of my peers Beni, Bilal, Clovis, Joseph, Lama, Marion and Rémy in the offices of PhD students made a friendly and satisfying ambience to work in.

I would like to thank all the members of our geometry group for the friendly ambience. I am grateful to Olivier Le Gale for interesting discussions and support. I would like to acknowledge the help of Christian Bourdarias, Philippe Briand, Georges Comte and Stéphane Simon for their various forms of help during my thesis. I appreciate also the beautiful environment of whole math department that is provided by all the nice people that are parts of it.

My biggest motivation and support comes from my parents and my little brother Albertik all of whom always encourage and are proud of me.

Last but not the least, a very special thanks to a very special person, Rona who made my life easier and my days brighter. . .

Résumé

Géométrie Tropicale et Systèmes Polynomiaux

Les systèmes polynomiaux réels sont omniprésents dans de nombreux domaines des mathématiques pures et appliquées. A. Khovanskii a fourni une borne *fewnomiale* supérieure sur le nombre de solutions positives non-dégénérées d'un système polynomial réel de n équations à n variables qui ne dépend que du nombre de monômes apparaissant dans les équations. Cette dernière borne a été récemment améliorée par F. Bihan et F. Sottile, mais la borne résultante peut être encore améliorée, même dans certains cas simples.

Le but de ce travail est d'aborder trois problèmes importants dans la théorie des Fewnomials. Considérons une famille de systèmes polynomiaux réels avec une structure donnée (par exemple, support ou le nombre de monômes). Un problème est de trouver de bonnes bornes supérieures pour leurs nombres de solutions réelles (ou positives). Un autre problème est de construire des systèmes dont le nombre de solutions réelles (ou positives) sont proches de la meilleure borne supérieure connue. Lorsqu'une borne supérieure optimale est bien connue, qu'est ce qu'on peut dire dans le cas où elle est atteinte?

Dans cette thèse, nous affinons un résultat de M. Avendaño en démontrant que le nombre de points d'intersection réels d'une droite réelle avec une courbe réelle plane définie par un polynôme avec au plus t monômes est soit infini ou ne dépasse pas $6t - 7$. En outre, on montre que notre borne est optimale pour $t = 3$ en utilisant les dessins d'enfant réels de Grothendieck. Cela montre que le nombre maximal de points d'intersection réels d'une droite réelle avec une courbe trinomiale réelle plane est onze.

Nous considérons ensuite le problème de l'estimation du nombre maximal de points d'intersection transverses positifs d'une courbe plane trinomiale et d'une courbe plane t -nomiale. T-Y Li, J.-M. Rojas et X. Wang ont montré que ce nombre est borné par $2^t - 2$, et récemment P. Koiran, N. Portier et S. Tavenas ont trouvé la borne supérieure $2t^3/3 + 5t$. Nous fournissons la borne supérieure $3 \cdot 2^{t-2} - 1$ qui est optimale pour $t = 3$ et est la plus petite pour $t = 4, \dots, 9$. Ceci est réalisé en utilisant la notion de dessins d'enfant réels. De plus, nous étudions en détail le cas $t = 3$ et nous donnons une restriction sur les supports des systèmes atteignant la borne optimale cinq.

Un circuit est un ensemble de $n+2$ points dans \mathbb{R}^n qui sont minimalement affinement dépendants. Il est connu qu'un système supporté sur un circuit a au plus $n+1$ solutions positives non dégénérées, et que cette borne est optimale. Nous utilisons les dessins d'enfant réels et le *patchwork combinatoire* de Viro pour donner une caractérisation complète des circuits supportant des systèmes polynomiaux avec le nombre maximal de solutions positives non dégénérées.

Nous considérons des systèmes polynomiaux de deux équations à deux variables avec cinq monômes distincts au total. Ceci est l'un des cas les plus simples où la borne supérieure optimale sur le nombre de solutions positives non dégénérées n'est pas connue. F. Bihan et F. Sottile ont prouvé que cette borne optimale est majorée par quinze. D'autre part, les meilleurs exemples avaient seulement cinq solutions positives non dégénérées.

Nous considérons des systèmes polynomiaux comme avant, mais défini sur le corps des *séries de Puiseux réelles généralisées et localement convergentes*. Les images par l'application de valuation des solutions d'un tel système sont des points d'intersection de deux courbes tropicales planes. En utilisant des intersections non transverses des courbes tropicales planes, on obtient une construction d'un système polynomial réel comme ci-dessus ayant sept solutions positives non dégénérées.

Mots clés— Géométrie Algébrique Réelle, Théorie des Fewnomials, Géométrie Tropicale, Systèmes Polynomiaux

Abstract

Tropical Geometry and Polynomial Systems

Real polynomial systems are ubiquitous in many areas of pure and applied mathematics. A. Khovanskii provided a *fewnomial* upper bound on the number of non-degenerate positive solutions of a real polynomial system of n equations in n variables that depends only on the number of monomials appearing in the equations. The latter bound was recently improved by F. Bihan and F. Sottile, but the resulting bound still has room for improvement, even in some simple cases.

The aim of this work is to tackle three main problems in Fewnomial theory. Consider a family of real polynomial systems with a given structure (for instance, supports or number of monomials). One problem is to find good upper bounds for their numbers of real (or positive) solutions. Another problem is to construct systems whose numbers of real (or positive) solutions are close to the best known upper bound. When a sharp upper bound is known, what can be said about reaching it?

In this thesis, we refine a result by M. Avendaño by proving that the number of real intersection points of a real line with a real plane curve defined by a polynomial with at most t monomials is either infinite or does not exceed $6t - 7$. Furthermore, we prove that our bound is sharp for $t = 3$ using Grothendieck's *real dessins d'enfant*. This shows that the maximal number of real intersection points of a real line with a real plane trinomial curve is eleven.

We then consider the problem of estimating the maximal number of transversal positive intersection points of a trinomial plane curve and a t -nomial plane curve. T-Y Li, J.-M. Rojas and X. Wang showed that this number is bounded by $2^t - 2$, and recently P. Koiran, N. Portier and S. Tavenas proved the upper bound $2t^3/3 + 5t$. We provide the upper bound $3 \cdot 2^{t-2} - 1$ that is sharp for $t = 3$ and is the tightest for $t = 4, \dots, 9$. This is achieved using the notion of real dessins d'enfant. Moreover, we study closely the case $t = 3$ and give a restriction on the supports of systems reaching the sharp bound five.

A *circuit* is a set of $n + 2$ points in \mathbb{R}^n that is minimally affinely dependent. It is known that a system supported on a circuit has at most $n + 1$ non-degenerate positive solutions, and that this bound is sharp. We use real dessins d'enfant and Viro's *combinatorial patchworking* to give a full characterization of circuits supporting polynomial systems with the maximal number of non-degenerate positive solutions.

We consider polynomial systems of two equations in two variables with a total of five distinct monomials. This is one of the simplest cases where the sharp upper bound on the number of non-degenerate positive solutions is not known. F. Bihan and F. Sottile proved that this sharp bound is not greater than fifteen. On the other hand, the best examples had only five non-degenerate positive solutions. We consider polynomial systems as before, but defined over the field of *real generalized locally convergent Puiseux series*. The images by the valuation map of the solutions of such a system are intersection points of two plane tropical curves. Using non-transversal intersections of plane tropical curves, we obtain a construction of a real polynomial system as above having seven non-degenerate positive solutions.

Keywords— Real Algebraic Geometry, Theory of Fewnomials, Tropical Geometry, Polynomial Systems

Contents

1	Introduction	9
1.1	Univariate polynomials	9
1.2	Sparse polynomial systems	10
1.2.1	Polyhedral bounds	10
1.2.2	Fewnomial bounds	11
1.3	Results prior to this thesis	12
1.3.1	Around Khovanskii’s bound	12
1.3.2	Using combinatorial patchworking	13
1.3.3	Systems supported on a circuit	13
1.3.4	Around Kuschnirenko’s conjecture	14
1.3.5	Around a polynomial-fewnomial conjecture	16
1.4	Results of the thesis	17
1.4.1	Chapter 3: Intersecting a sparse plane curve and a line	17
1.4.2	Chapter 4: Positive intersection points of a trinomial and a \mathbf{t} -nomial curves	18
1.4.3	Chapter 5: Characterization of circuits supporting polynomial systems with the maximal number of positive solutions	20
1.4.4	Chapter 6: Constructing polynomial systems with many positive solutions	21
2	Preliminaries	25
2.1	A brief introduction to real dessins d’enfant	25
2.2	A brief introduction to tropical geometry	26
2.2.1	Polytopes and subdivisions	27
2.2.2	Tropical polynomials and hypersurfaces	28
2.2.3	Tropical hypersurfaces and subdivisions	29
2.2.4	Intersection of tropical hypersurfaces	30
2.2.5	Generalized Viro theorem and tropical reformulation	31
2.2.6	Reduced systems and non-transversal intersections	33
3	Intersecting a sparse plane curve and a line	37
3.1	Preliminary results	37
3.2	Proof of Theorem 3.1	39
3.3	Optimality	41
4	Positive intersection points of a trinomial and a \mathbf{t}-nomial curves	45
4.1	Introduction and statement of the main results	45
4.2	Proof of Theorem 4.1	45

4.3	Proof of Theorem 4.2	47
4.3.1	Reduction to a simpler case	48
4.3.2	Analysis of dessins d'enfant	51
4.3.3	End of the proof of Theorem 4.2	60
4.4	The case of two trinomials: proof of Theorem 4.3	62
4.4.1	Proof of Proposition 4.33	69
4.4.2	End of proof of Theorem 4.3	70
5	Characterization of circuits	73
5.1	Technical preamble	75
5.2	Proof of the “only if” direction of Theorem 5.1	76
5.3	Proof of the “if” direction of Theorem 5.1	80
6	Constructing polynomial systems	83
6.1	Statement of the main results	83
6.1.1	For normalized systems	83
6.1.2	Transversal intersection points	84
6.2	Non-transversal intersection components of type (I)	85
6.3	Base fans and tropical intersections	93
6.4	Preliminary case-by-case analysis for $n = k = 2$	100
6.4.1	Approximation polynomials for type-(I) intersections	103
6.4.2	Reduced systems for type-(II) intersections	106
6.4.3	Reduced systems for type-(III) intersections at the origin	107
6.4.4	Type-(III) intersections outside the origin	108
6.5	Proof of Theorem 6.1	110
6.5.1	First part of Theorem 6.48	114
6.5.2	Construction: second part of Theorem 6.48	120
6.6	Proof of Theorem 6.3 (part 1).	124
6.6.1	First case: $0 < \alpha < \beta$	126
6.6.2	The case $\alpha = 0 < \beta$	137
6.6.3	The case $\alpha < 0 < \beta$	138
6.6.4	The case $\alpha < 0$ and $\beta = 0$	141
6.6.5	The case $\alpha < \beta < 0$	141
6.6.6	The case $\alpha = \beta < 0$	145
6.7	Proof of Theorem 6.3 (part 2).	145
6.7.1	The case $0 < \alpha \leq \beta$	146
6.7.2	The case $\alpha < 0 < \beta$	147
6.7.3	The case $\alpha \leq \beta < 0$	148
7	Introduction (en Français)	149
	Bibliography	166

Chapter 1

Introduction

One of the fundamental problems in mathematics is solving real polynomial equations since polynomial systems arise naturally and ubiquitously in mathematics and many of its applications. We see them appearing in such fields as control theory [Byr89], kinematics [BR90], chemistry [GH02, MFR⁺16] and many others where it is mainly the real solutions that matter. In this introduction we give a brief overview on solving polynomial equations and state the main results of this thesis. For a more detailed exposition on solving polynomial equations, see for example [Sot11] or [Stu02].

1.1 Univariate polynomials

Galois theory shows that for a univariate polynomial f with real coefficients and degree less or equal to four, there exists a general formula that explicitly determines the complex roots of f in terms of its coefficients. However this statement is false if f has degree larger than four. This means that computing the roots of high-degree polynomials is not an easy task. Nevertheless, there are many methods and results devoted especially to this problem (see for example [Stu02]). By the *Fundamental theorem of algebra*, any univariate polynomial f has at least one complex root. Moreover, the number of its complex roots (counted with multiplicities) is equal to its degree.

Unfortunately, in general the degree is a bad estimate for the number of real roots of f e.g. $1 - x^{100}$ has 98 non-real roots and only two real ones. Descartes' rule of sign [Des97], which dates back to 1637, is one of the earliest results that gives a more accurate estimation for the number of real roots of f . Suppose that we write the terms of f in increasing order of their exponents,

$$f(x) = b_0x^{k_0} + b_1x^{k_1} + \dots + b_mx^{k_m}, \quad (1.1.1)$$

where $b_i \neq 0$ and $k_0 < \dots < k_m$.

Theorem 1.1 (Descartes' rule of sign). *The number r of isolated positive roots of f , counted with multiplicity, is at most the number of sign changes of its coefficients,*

$$r \leq \{i \mid 1 \leq i \leq m \text{ and } b_{i-1}b_i < 0\}.$$

Theorem 1.1 also holds true for univariate polynomials with real exponents. The immediate consequence for this rule is that the number of positive solutions of f is bounded from above by

m . Moreover, replacing x by $-x$ and applying Theorem 1.1 to the resulting polynomial gives a similar estimation for the number of negative roots of f . Therefore, the number of non-zero real roots of f is less or equal to $2m$.

It is important to note that Descartes' rule of sign, and thus the resulting Descartes' bound, is independent of the degree. This naturally brings about the question of generalizing Theorem 1.1 to a polynomial system.

1.2 Sparse polynomial systems

Consider a real polynomial system

$$f_1(z_1, \dots, z_n) = \dots = f_n(z_1, \dots, z_n) = 0. \quad (1.2.1)$$

In general, we look for solutions of (1.2.1) in the complex torus $(\mathbb{C}^*)^n$ since solutions in coordinate hyperplanes are solutions in complex tori of smaller dimensions of truncated systems. A solution $\zeta \in \mathbb{C}^n$ of (1.2.1) is **non-degenerate** if the Jacobian of (1.2.1) evaluated at ζ has full rank. Non-degenerate solutions are easier to manipulate since their number will not decrease after any "slight" perturbation of the coefficients of the associated system.

1.2.1 Polyhedral bounds

Denote by d_i the total degree of f_i . Bézout's fundamental Theorem [Béz79] states that the number of non-degenerate complex solutions of (1.2.2) is less or equal to $d_1 \cdots d_n$. Moreover, this bound is sharp. Polynomial systems that arise naturally may have some special structure, for instance in terms of disposition of the exponent vectors or their number (cf. [Sot11]). However, a great part of this combinatorial data is disregarded when using the degree to bound the number of complex solutions, and thus the Bézout bound can be rough. In fact, there exist bounds that depend on the polyhedral structure associated to the polynomial system that we describe now.

To any $w = (w^1, \dots, w^n) \in \mathbb{Z}^n$ is associated a monomial $z^w \in \mathbb{R}[z_1^{\pm 1}, \dots, z_n^{\pm 1}]$. Consider a Laurent polynomial $f \in \mathbb{R}[z_1^{\pm 1}, \dots, z_n^{\pm 1}]$ written as

$$f(z) := \sum_{w \in \mathcal{W}} c_w z^w, \quad (1.2.2)$$

where $c_w \neq 0$ for all $w \in \mathcal{W}$. The set \mathcal{W} is called the **support** of f . The support of a system (1.2.1) is the union of the supports of f_1, \dots, f_n . The **Newton polytope** of f is the convex hull $\Delta_{\mathcal{W}}$ of \mathcal{W} . Write $\text{Vol}(\Delta)$ for the Euclidean volume of a polytope $\Delta \subset \mathbb{R}^n$. We have the following fundamental result due to A. Kushnirenko [Kus75].

Theorem 1.2 (Kushnirenko). *If (1.2.1) has support \mathcal{W} , then it has at most $n! \text{Vol}(\Delta_{\mathcal{W}})$ isolated solutions in $(\mathbb{C}^*)^n$, and exactly this number if the polynomials are generic among systems with support \mathcal{W} .*

D. N. Bernstein [Ber75] refined this result taking the individual supports into account. Let \mathcal{W}_i denotes the support of the polynomial f_i appearing in (1.2.1). The **Minkowski sum** of the convex hulls of \mathcal{W}_i for $i = 1, \dots, n$, is a pointwise sum

$$\Delta_{\mathcal{W}_1} + \dots + \Delta_{\mathcal{W}_n} = \{w_1 + \dots + w_n \mid w_1 \in \Delta_{\mathcal{W}_1}, \dots, w_n \in \Delta_{\mathcal{W}_n}\}.$$

Minkowski (see [Ewa12]) showed that given convex bodies K_1, \dots, K_n in \mathbb{R}^n and positive numbers $\lambda_1, \dots, \lambda_n$, the function $\text{Vol}(\lambda_1 K_1 + \dots + \lambda_n K_n)$ is a homogeneous polynomial in $\lambda_1, \dots, \lambda_n$ of degree n , so there exist coefficients $V(K_{i_1}, \dots, K_{i_n})$ for $i_1, \dots, i_n \in [n]$ such that

$$\text{Vol}(\lambda_1 K_1 + \dots + \lambda_n K_n) = \sum_{i_1, \dots, i_n \in [n]} V(K_{i_1}, \dots, K_{i_n}) \lambda_{i_1} \cdots \lambda_{i_n}. \quad (1.2.3)$$

The **mixed volume**, $MV(K_1, \dots, K_n)$ of K_1, \dots, K_n is $V(K_1, \dots, K_n)$. Now we state Bernstein's important generalization of Kushnirenko's Theorem.

Theorem 1.3 (Bernstein). *A system of n polynomials in n variables where the polynomials have support $\mathcal{W}_1, \dots, \mathcal{W}_n$ has at most $MV(\Delta_{\mathcal{W}_1}, \dots, \Delta_{\mathcal{W}_n})$ isolated solutions in $(\mathbb{C}^*)^n$, and exactly this number when the polynomials are generic for their given supports.*

It is worth noting that a non-degenerate solution of a system is an isolated one, thus both Kushnirenko and Bernstein Theorems give upper bounds for the number of non-degenerate solutions in $(\mathbb{C}^*)^n$ of a polynomial system. Although the degree and previous polyhedral bounds hold true for the number of non-degenerate solutions in $(\mathbb{R}^*)^n$ as well, the resulting bounds are not always sharp. This typically happens when the total support \mathcal{W} of (1.2.1) has few elements comparatively to $\Delta_{\mathcal{W}} \cap \mathbb{Z}^n$.

1.2.2 Fewnomial bounds

Denote by $\mathcal{W} \subset \mathbb{R}^n$ the support of (1.2.1). Multivariate generalizations of Descartes' bound (Theorem 1.1) for systems of multivariate polynomials are called **Fewnomial bounds**¹. A particular attention is paid to the positive solutions of (1.2.1), which are the solutions contained in the positive orthant of \mathbb{R}^n . Indeed, assume that there exists a sharp upper bound $N_{\mathcal{W}}$ on the number of non-degenerate positive solutions of (1.2.1) that depends only on \mathcal{W} . Then this $N_{\mathcal{W}}$ also bounds the number of solutions contained in any other orthant, and thus (1.2.1) will not have more than $2^n N_{\mathcal{W}}$ solutions in $(\mathbb{R}^*)^n$. Recall that Descartes showed that we have $N_{\mathcal{W}} = |\mathcal{W}| - 1$ for $n = 1$, but still, before Khovanskii's book [Kho91], it was not clear that such $N_{\mathcal{W}}$ even exists for any $n \geq 2$.

Theorem 1.4 (Khovanskii). *A system of n real polynomials in n variables involving $n + k + 1$ distinct monomials has fewer than*

$$2^{\binom{n+k}{2}} (n+1)^{n+k} \quad (1.2.4)$$

non-degenerate positive solutions.

The existence of a bound on the number of non-degenerate positive solutions that is independent of the degrees of the polynomials was revolutionary and is the main point of Khovanskii's result. It also confirms Kushnirenko's principle that the topological complexity of objects, defined by real-valued polynomials, can be controlled by the complexity of the definition of these polynomials rather than by degrees or by some characteristics of Newton polyhedra of equations.

Also, the bound in Theorem 1.4 is not sharp. In fact, Theorem 1.4 is a particular case of a Khovanskii's more general result involving solutions in \mathbb{R}^n of polynomial functions in logarithms of the coordinates and monomials (see [Kho91]). For example, when $k = 0$, the support \mathcal{W} of the system is a simplex, and there will be at most *one* real solution, which is smaller than $2^{\binom{n}{2}} (n+1)^n$.

¹The term "Fewnomial" was coined by A. Kushnirenko, where he replaced the term "poly" of the word "polynomial", by the term "Few" (c.f. [Kus08])

Although it was commonly believed that Khovanskii’s bound (1.2.4) was far from being sharp, improving it turns out to be not an easy task.

Fewnomial theory was mainly initiated by Kushnirenko’s famous conjecture which was formulated in the late 70’s as a tentative generalization of Descartes’ bound.

Conjecture 1.5 (Kushnirenko). *A system of n real polynomials in n variables, where the polynomials have supports $\mathcal{W}_1, \dots, \mathcal{W}_n$, has at most*

$$\prod_{i=1}^n (|\mathcal{W}_i| - 1)$$

non-degenerate positive solutions.

Constructing polynomial systems reaching Kushnirenko’s conjectured bound is not a difficult task. Namely, such a construction might be for instance a system

$$g_i(z_i) = 0, \quad \text{for } i = 1, \dots, n$$

consisting of univariate polynomials, where each g_i has m_i terms and $m_i - 1$ non-degenerate positive solutions (Descartes’ bound). In fact, the lack of efficient construction methods at the time instigated Kushnirenko to establish his conjecture.

1.3 Results prior to this thesis

After the famous Khovanskii’s Theorem, there were many recent contributions dedicated to the theory of Fewnomials, (c.f. [Sot11] for a survey). In this section, we give but a few of the many results developed in this millennia. Most of these results are further investigated and in some cases improved in this thesis.

1.3.1 Around Khovanskii’s bound

Consider a real polynomial system

$$f_1(z) = \dots = f_n(z) = 0 \tag{1.3.1}$$

in n variables supported on a set $\mathcal{W} \subset \mathbb{Z}^n$ such that $|\mathcal{W}| = n + k + 1$ for some $k \geq 1$. In [BS07], F. Bihan and F. Sottile significantly reduced Khovanskii’s fewnomial bound (1.2.4) by showing that there are fewer than

$$\frac{e^2 + 3}{4} 2^{\binom{k}{2}} n^k \tag{1.3.2}$$

non-degenerate positive solutions to (1.3.1). The method they used consists of reducing the original system to a system of k equations in k variables, called *Gale transform*. This Gale transform depends upon the vector configuration “Gale” dual to the exponents of the monomials in the original system (see [BS08]). This reduction gives that an upper bound on the Gale transform also holds true for the number of solutions of (1.3.1). The bound in (1.3.2) also holds true for polynomials with real exponents. Moreover, the significance of it is that (1.3.2) is asymptotically sharp in the sense that for fixed k , there are systems with $O(n^k)$ positive solutions [BRS08].

The constant $\frac{e^2+3}{4}$ appearing in (1.3.2) is artificial, its purpose is only to bound from above a more complicated expression. Moreover, the authors in [BS07] believe that the term $2^{\binom{k}{2}}$ in (1.3.2)

is considerably overstated. In fact, when $k = 2$, this smaller bound (1.3.2) is actually $2n^2 + \lfloor \frac{(n+3)(n+1)}{2} \rfloor$, and when $n = 2$ it is 15. Note that when plugging $n = k = 2$ in (1.2.4), we obtain $2^6 \cdot 3^4 = 5184$. Although the new bound 15 is a considerably smaller fewnomial bound for a system where $n = k = 2$, the authors of [BS07] maintain that the sharp bound is still smaller. The case $n = k = 2$ is the first case where we do not know much about. In fact, prior to this thesis, the first known construction, giving a lot of non-degenerate positive solutions of a system of two polynomials in two variables with five monomials was essentially that of B. Haas (1.3.5). Such a construction gives five non-degenerate positive solutions, and shows that the sharp upper bound on the number of non-degenerate positive solutions is greater or equal to 5. Later on, we will call a system of two equations in two variables with 5 distinct monomials a system of type $n = k = 2$.

1.3.2 Using combinatorial patchworking

Consider a system

$$f_{1,t}(z) = \cdots = f_{n,t}(z) = 0, \quad (1.3.3)$$

where each polynomial of (1.3.3) is obtained from a polynomial $\sum_w c_w z^w$ of (1.3.1) by multiplying each monomial $c_w z^w$ by some real power of t , where t is a positive parameter that will be taken close to zero. Let $V(f_{i,t})$ denote the zero set of $f_{i,t}$ in \mathbb{R}^n . For any $\epsilon \in \{\pm 1\}^n$, consider the orthant

$$(\mathbb{R}_{>0})^\epsilon := \{x \in \mathbb{R}^n \mid x_{i\epsilon_i} > 0 \quad i = 1, \dots, n\},$$

and let $V_\epsilon(f_{i,t})$ be the intersection of $V(f_{i,t})$ with $(\mathbb{R}_{>0})^\epsilon$.

O. Viro's Theorem states that one can construct combinatorially a space Q_ϵ together with a simplicial complex $\mathcal{Z}_\epsilon \subset Q_\epsilon$ such that the couple $(Q_\epsilon, \mathcal{Z}_\epsilon)$ is homeomorphic to $((\mathbb{R}_{>0})^\epsilon, V_\epsilon(f_{i,t}))$ for $t > 0$ small enough. From this, one can recover (up to homeomorphisms) the whole hypersurface $V(f_{i,t})$ (for $t > 0$ small enough) by gluing its different parts together with their ambient spaces.

This was generalized by B. Sturmfels [Stu94] for any complete intersection $V(f_{1,t}) \cap \cdots \cap V(f_{s,t})$, with $s \leq n$, given that the exponents of t are "sufficiently generic". When $s = n$, this method can be used to construct systems with many non-degenerate positive solutions and given supports. Recently, F. Bihan [Bih14] gave a bound on the number of non-degenerate real solutions that are constructed using Sturmfels' generalization of Viro's Theorem. This bound is given by the so-called *discrete mixed volume* of the supports of $f_{i,t}$. In fact, he proved that this bound is smaller than the one given in Kushnirenko's conjecture (see Subsection 1.3.4). When $n = 2$ and $k = 1$, the discrete mixed volume is not larger than 3 and the corresponding bound is sharp (see Subsection 1.3.3). When $n = k = 2$, it is easy to compute that the discrete mixed volume is not larger than 6 (see Lemma 6.4 in Chapter 6), and it is not known if the corresponding bound is sharp.

1.3.3 Systems supported on a circuit

One of the first non-trivial cases arises when $n \geq 2$ and $k = 1$, in which case the support \mathcal{W} of (1.3.1) is a set of $n + 2$ points in \mathbb{R}^n . F. Bihan [Bih07] proved that any polynomial system supported on such \mathcal{W} has at most $n + 1$ non-degenerate positive solutions and that this bound is sharp. Moreover, if this bound is reached, then \mathcal{W} is minimally affinely dependent, which means that it is a *circuit* in \mathbb{R}^n . Polynomial systems supported on a circuit in \mathbb{Z}^n whose all non-degenerate complex solutions are positive have been studied in [Bih15] (such systems are called *maximally positive*). As a main result, it is given for any positive integer n a finite list of circuits in \mathbb{Z}^n that

can support maximally positive systems up to the obvious action of the group of invertible integer affine transformations of \mathbb{Z}^n .

Also for the circuit case, F. Bihan and A. Dickenstein [BD16] presented the first multivariate version of Descartes' rule of signs to bound the number of positive real solutions of a system supported on a circuit, in terms of the sign variation of a sequence associated to both the exponent vectors and the given coefficients. In fact, it is also shown that the bound they gave is sharp and is related to the signature of the circuit.

The first time that Grothendieck's *real dessins d'enfant*, which are graphs embedded on the Riemann sphere, were used in the fewnomial context was due to F. Bihan [Bih07]. Namely, he uses dessins d'enfant to show the sharpness of the bound $n + 1$ for the number of positive solutions of a system supported on a circuit $\mathcal{W} \subset \mathbb{R}^n$. He also proves using the same technique the sharpness of bounds for the number of *real* solutions of such systems. As it turns out, if one can reduce a fewnomial system to a rational polynomial function $\mathbb{C}P^1 \rightarrow \mathbb{C}P^1$, then one can hope to use real dessins d'enfant in a fruitful way to closely study the original system. This technique gives an interesting point of view on constructing polynomial systems with a large number of real solutions (see Chapter 3), characterizing such systems (see Chapter 5) and even bounding the number of positive solutions of sparse polynomial systems (see Chapter 4).

Sturmfels' version of Viro's *combinatorial patchworking* is yet another effective technique from real algebraic geometry that can be used to construct polynomial systems with many real solutions. This generalisation [Stu94] is for complete intersections of real algebraic hypersurfaces. Among many other implementations in fewnomials, it was used by K. Phillipson and J.-M. Rojas [PR13, proof of Lemma 1.8] to construct a polynomial system over local fields supported on a circuit that has $n + 1$ positive solutions.

1.3.4 Around Kushnirenko's conjecture

Consider the system (1.3.1), and for $i = 1, \dots, n$, denote by m_i the number of points contained in the support of f_i . Recall that Kushnirenko' Conjecture 1.5 states that (1.3.1) cannot have more than

$$\prod_{i=1}^n (m_i - 1)$$

non-degenerate positive solutions.

1.3.4.1 First counterexamples

The conjectural bound is not a bound on the number of isolated positive solutions. W. Fulton gave a counterexample in [Ful13] that goes as follows (see also [Stu02]). Consider the system

$$\prod_{i=1}^m (z_1 - i)^2 + \prod_{i=1}^m (z_2 - i)^2 = 0, \quad z_1(z_3 - 1) = 0, \quad z_2(z_3 - 1) = 0, \quad (1.3.4)$$

where $m \geq 5$. Kushnirenko's Conjecture predicts that such a system has at most $(4m + 1 - 1)(2 - 1)(2 - 1) = 4m$ real positive solutions. However there are m^2 positive solutions of (1.3.4) of the form $(i, j, 1)$, for $i, j \in \mathbb{N}^*$ between 1 and m .

A particular case of A. Kushnirenko's conjecture states that when $n = 2$ and $m_1 = m_2 = 3$, the system (1.3.1) has at most four non-degenerate positive solutions. In an effort to disprove this conjecture, Haas had shown in [Haa02] that

$$10x^{106} + 11y^{53} - 11y = 10y^{106} + 11x^{53} - 11x = 0 \quad (1.3.5)$$

has five non-degenerate positive solutions. Konstantin A. Sevastyanov, a colleague of Kushnirenko, had found a similar counter-example much earlier. Unfortunately, this counterexample does not seem to have been recorded and, tragically, Sevastyanov died before publishing his counterexample.

It was later shown in [LRW03] using a case by case analysis that when $n = 2$ and $m_1 = m_2 = 3$, the sharp bound on the number of non-degenerate positive solutions is five. Moreover, it was proved in the same paper that if this bound is reached, then the Minkowski sum of the associated Newton polytopes Δ_1 and Δ_2 is an hexagon.

A simpler polynomial system

$$x^6 + (44/31)y^3 - y = y^6 + (44/31)x^3 - x = 0, \quad (1.3.6)$$

that also has five positive solutions was discovered by A. Dickenstein, J.-M. Rojas, K. Rusek and J. Shih [DRR07]. In addition, they showed that such systems are rare in the following sense. They study the discriminant variety of coefficients spaces of the polynomial system

$$x^{2d} + ay^d - y = y^{2d} + bx^d - x = 0, \quad (1.3.7)$$

with parameters (a, b, d) , and show that the chambers (connected components of the complement) containing systems with the maximal number of positive solutions are small.

1.3.4.2 A trinomial and a t -nomial

Real polynomial systems in two variables

$$f = g = 0, \quad (1.3.8)$$

where f has $t \geq 3$ non-zero terms and g has three non-zero terms have been studied by T.Y. Li, J.-M. Rojas and X. Wang [LRW03]. They showed that such a system, allowing real exponents, has at most $2^t - 2$ isolated positive solutions. The idea is to substitute one variable of the trinomial in terms of the other, and thus one can reduce the system to an analytic function in one variable

$$h(x) = \sum_{i=1}^t a_i x^{k_i} (1-x)^{l_i},$$

where all the coefficients and exponents are real. The number of positive solutions of (1.3.8) is equal to that of $h = 0$ contained in $]0, 1[$. The main techniques used in [LRW03] are an extension of Rolle's Theorem and a recursion involving derivatives of certain analytic functions. In fact, the results of Li, Rojas and Wang [LRW03] are more general. Consider a polynomial system

$$f_1 = \cdots = f_n = 0 \quad (1.3.9)$$

in n variables, where the functions f_1, \dots, f_{n-1} are trinomials and f_n has t distinct monomials. The authors in [LRW03] show that (1.3.9) has at most $n + n^2 + \cdots + n^{t-1}$ non-degenerate positive solutions.

The exponential upper bound $2^t - 2$ on the number of positive solutions of (1.3.8) has been recently refined by P. Koiran, N. Portier and S. Tavenas [KPT15b] into a polynomial one. They considered an analytic function in one variable

$$\sum_{i=1}^t \prod_{j=1}^m f_j^{\alpha_{i,j}}, \quad (1.3.10)$$

where all f_j are real polynomials of degree at most d and all the powers of f_j are real. Using the Wronskian of analytic functions, it was proved that the number of positive roots of (1.3.10) in an interval I (assuming that $f_j(I) \subset]0, +\infty[$) is equal to $\frac{t^3 md}{3} + 2tmd + t$. As a particular case (taking $m = 2$, $d = 1$ and $I =]0, 1[$), they obtain that $h(x) = \sum_{j=1}^t a_j x^{k_j} (1-x)^{l_j}$ has at most $2t^3/3 + 5t$ roots in I .

1.3.4.3 A plane curve and a line

Interestingly, when the trinomial g of (1.3.8) is a linear polynomial, then the sharp bound on the number of non-degenerate real solutions of (1.3.8) is a linear function in t .

Namely, M. Avendaño showed in [Ave09] that such a system has either an infinite number or at most $6t - 6$ solutions in $(\mathbb{R}^*)^2$, where the latter ones are counted with multiplicities. In particular, he proved that the number of non-degenerate *positive* solutions of the latter system is at most $2t - 2$. The method used in [Ave09] consists of substituting z_2 by $az_1 + b$ in (1.3.8) for some non-zero real numbers a and b . This way, with the help of Descartes' rule of sign applied to the resulting univariate polynomial, one eventually obtains the bound $2t - 2$.

1.3.5 Around a polynomial-fewnomial conjecture

A. Kushnirenko also formulated the following conjecture (see [Kus08] for more background). Consider a system

$$f(x, y) = g(x, y) = 0 \quad (1.3.11)$$

of two equations in two variables, where g is a polynomial with t distinct monomial terms, and f is a polynomial of degree d .

Conjecture 1.6. *The system (1.3.11) has at most $N(d, t)$ non-degenerate positive solutions, where $N(d, t)$ is a function depending only on the numbers d and t .*

Sevostyanov showed in 1978 that such $N(d, t)$ exists. However, his result (together with his counterexample to Kushnirenko's conjecture) was never published. According to [Sot11], this result was the inspiration for Khovanskii to develop his theory of fewnomials.

Clearly, by Khovanskii and Bihan-Sottile bounds, this $N(d, t)$ exists, however since (1.3.11) is a very particular case of the generic system (1.2.1), bounds (1.2.4) and (1.3.2) (which are exponential in d and t) might be too large. M. Avendaño's previously-discussed bound [Ave09] shows that $N(1, t) \leq 2t - 2$, which turns out to be a sharp bound for $t = 3$ (see [BEH15]).

The smallest bound so far for any values d and t was discovered by P. Koiran, N. Portier and S. Tavenas [KPT15a]. They showed that (1.3.11) has only $O(d^3t + d^2t^3)$ real solutions when it has a finite number of real solutions. Moreover, if the set of real solutions is infinite then it has at most $O(d^3t + d^2t^3)$ connected components.

1.4 Results of the thesis

We divide our main results into four chapters.

1.4.1 Chapter 3: Intersecting a sparse plane curve and a line

Chapter 3 is a joint work with F. Bihan [BEH15]. Consider a system

$$f(x, y) = ax + b - y = 0, \quad (1.4.1)$$

where $f \in \mathbb{R}[x, y]$, has t non-zero terms. In Chapter 3, all solutions in $(\mathbb{R}^*)^2$ are counted with multiplicities. This reduces to counting the number of real roots of a polynomial $f(x, ax + b)$, where $a, b \in \mathbb{R}$ and $f \in \mathbb{R}[x, y]$ has at most t non-zero terms. Substituting y by $ax + b$ in the polynomial f reduces the problem of computing real solutions of (1.4.1) to computing the real roots of $f(x, ax + b)$. M. Avendaño showed in [Ave09, Theorem 1.1] that (1.4.1) has at most $6t - 4$ real solutions counted with multiplicities except for the possible roots 0 and $-b/a$. The question of optimality was not addressed in [Ave09] and this was the motivation for the present work. We prove the following result.

Theorem 1.7. *Let $f \in \mathbb{R}[x, y]$ be a polynomial with at most t non-zero terms and let a, b be any real numbers. Assume that the polynomial $g(x) = f(x, ax + b)$ is not identically zero. Then g has at most $6t - 7$ real roots counted with multiplicities except for the possible roots 0 and $-b/a$ that are counted at most once.*

The methods used in proving the latter results are elementary, and constitute a refined version of those used in [Ave09]. This might look as a small improvement of the main result of [Ave09]. In fact, this refinement is a non-trivial one, and the bound in Theorem 1.7 is optimal at least for $t = 3$.

Theorem 1.8. *The maximal number of real intersection points of a real line with a real plane curve defined by a polynomial with three non-zero terms is eleven.*

Explicitly, the real curve with equation

$$-0.002404 xy^{18} + 29 x^6 y^3 + x^3 y = 0 \quad (1.4.2)$$

intersects the real line $y = x + 1$ in precisely eleven points in \mathbb{R}^2 .

The strategy to construct this example is first to deduce from the proof of Theorem 1.7 some necessary conditions on the monomials of the desired equation. Then, the use of real Grothendieck's dessins d'enfant in a novel way helps to test the feasibility of certain monomials, since manipulating this method gives a clear representation of the topology of the graph of $x \mapsto f(x, x + 1)$. Ultimately, computer experimentations lead to the precise equation (1.4.2).

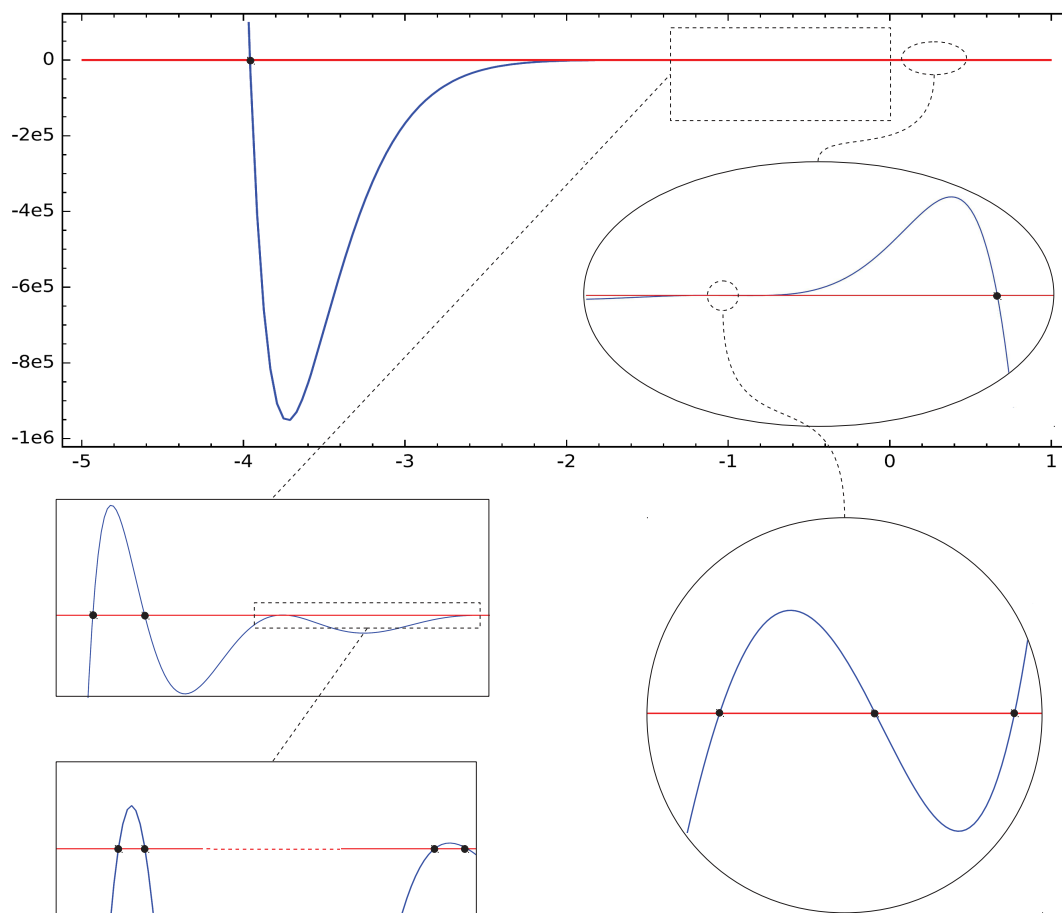

Figure 1.1: The blue curve represents the graph of $x \mapsto f(x, x + 1)$, and the red line represents the first-coordinate axis. (Some parts of the curve is stretched vertically on purpose for more clarity.)

1.4.2 Chapter 4: Positive intersection points of a trinomial and a trinomial curves

Consider a system (1.3.8) where f has $t \geq 3$ non-zero terms and g has three non-zero terms. Assume that the latter system has a finite number of solutions. Let $\mathcal{S}(3, t)$ denote the maximal number of non-degenerate positive solutions a system (1.3.8) can have. We prove the following result in Section 4.2.

Theorem 1.9. *We have $\mathcal{S}(3, t) \leq 3 \cdot 2^{t-2} - 1$.*

Note that since the number of positive solutions of two trinomials in two variables is bounded by five (see [LRW03]), the bound $\mathcal{S}(3, t)$ is sharp for $t = 3$. Moreover, for $t = 4, \dots, 9$, this new bound is smaller than the bounds $2^t - 2$ and $2t^3/3 + 5t$, obtained in [LRW03] and [KPT15b] respectively, and shows for example that $6 \leq \mathcal{S}(3, 4) \leq 11$.

Recall that substituting one variable of the trinomial g of (1.3.8) in terms of the other reduces the system to an analytic function in one variable

$$h(x) = \sum_{i=1}^t a_i x^{k_i} (1-x)^{l_i}.$$

The number of positive solutions of (1.3.8) is equal to that of $h = 0$ contained in $]0, 1[$. We prove Theorem 1.9 using the same approach that was considered in [LRW03] i.e. we consider a recursion involving derivatives of analytic functions in one variable associated to the system (1.3.8). Beginning with the function $f_1 = h$, at each step $1 < i < t$, we are left with a function f_i defined as a certain number of derivatives of f_{i-1} multiplied by powers of x and of $(1-x)$. Using Rolle's Theorem for each f_i , one can bound the number of its roots contained in $]0, 1[$ in terms of the roots of f_{i-1} in the same interval. It turns out that at the step $t-2$, we are reduced to bound the number of roots in $]0, 1[$ of the equation $\phi(x) = 1$, where

$$\phi(x) = \frac{x^\alpha (1-x)^\beta P(x)}{Q(x)},$$

$\alpha, \beta \in \mathbb{Q}$, and both P and Q are real polynomials of degree at most $2^{t-2} - 1$.

The larger part of Chapter 4 is devoted to the proof in Section 4.3 of the following result.

Theorem 1.10. *We have $\#\{x \in]0, 1[\mid \phi(x) = 1\} \leq \deg P + \deg Q + 2$.*

Choosing $m \in \mathbb{N}$ such that both $m\alpha$ and $m\beta$ are integers, we get a rational function $\varphi := \phi^m : \mathbb{C}P^1 \rightarrow \mathbb{C}P^1$. The inverse images of $0, 1, \infty$ are given by the roots of $P, Q, \varphi - 1$, together with 0 and 1 (if $\alpha\beta \neq 0$). These inverse images lie on the graph $\Gamma := \varphi^{-1}(\mathbb{R}P^1) \subset \mathbb{C}P^1$, which is an example of a Grothendieck's real dessin d'enfant. Although this latter object Γ appears in Chapter 4 as well, we use it this time in a yet another resourceful way. In fact, there are many restrictions on the topology of the graph of φ that appear explicitly as restrictions on $\Gamma = \varphi^{-1}(\mathbb{R}P^1)$. Namely, critical points of φ correspond to vertices of Γ . The number of roots of $\varphi - 1$ in $]0, 1[$ is controlled by the number of a certain type of critical points of φ called *useful positive* critical points. By doing a delicate analysis on Γ , we bound the number of vertices corresponding to these critical points in terms of $\deg P$ and $\deg Q$.

We consider in Section 4.4 the case $t = 3$ i.e. the case of two trinomials in two variables. Recall that when the maximal number of positive solutions is attained, the Minkowski sum $\Delta_1 + \Delta_2$ is a hexagon (see [LRW03]). In terms of normal fans, this means that the normal fan of the Minkowski sum $\Delta_1 + \Delta_2$, which is the common refinement of the normal fans of Δ_1 and Δ_2 , has six 2-dimensional cones (and six 1-dimensional cones). We give the following additional constraints on the Minkowski sum of Δ_1 and Δ_2 when (1.3.8) has five positive solutions. We say that Δ_1 and Δ_2 alternate if every 2-dimensional cone of the normal fan of Δ_1 contains a 1-dimensional cone of the normal fan of Δ_2 having only the origin as a common face. A further analysis of Γ in the case $t = 3$ allows us to obtain the following result.

Theorem 1.11. *If the system (1.3.8) has 5 positive solution, then Δ_1 and Δ_2 do not alternate.*

The Newton triangles Δ_1 and Δ_2 do not alternate means that there exist two consecutive edges of $\Delta_1 + \Delta_2$ which are translate of two consecutive edges of either Δ_1 or Δ_2 . Figure 7.2 illustrates this theorem for the system (7.3.6), and we provide another example in Section 4.4.

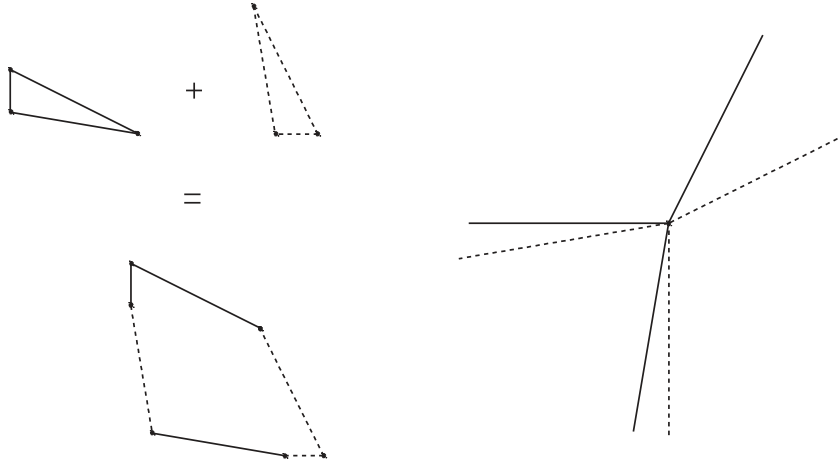

Figure 1.2: The Newton polytopes, their Minkowski sum and the associated normal fans of (7.3.6).

1.4.3 Chapter 5: Characterization of circuits supporting polynomial systems with the maximal number of positive solutions

Recall that a circuit $\mathcal{W} \subset \mathbb{R}^n$ is a set of $n+2$ distinct points that are minimally affinely dependent. A very recent generalization of Descartes' rule of sign was developed by F. Bihan and A. Dickenstein in [BD16]. This gave some conditions on both the circuit and the coefficient matrix that are necessary for the system to have $n+1$ non-degenerate positive solutions. More precisely, the authors in [BD16] show that if such a system has $n+1$ non-degenerate positive solutions, then all maximal minors of the coefficient matrix are nonzero and any affine relation $\sum_{i=1}^{n+2} \lambda_i w_i = 0$ on \mathcal{W} has the same number (up to 1 if n is odd) of positive coefficients as that of negative ones. In this chapter, we completely characterize the circuits which are supports of polynomial systems with $n+1$ non-degenerate positive solutions.

Theorem 1.12. *A circuit \mathcal{W} in \mathbb{R}^n supports a system with $n+1$ non-degenerate positive solutions if and only if there exists a bijection*

$$\begin{array}{ccc} \{1, \dots, n+2\} & \longrightarrow & \mathcal{W} \\ i & \longmapsto & w_i \end{array}$$

such that every affine relation on \mathcal{W} can be written as

$$\sum_{i=1}^s \alpha_i w_i = \sum_{i=s+1}^{n+2} \alpha_i w_i,$$

where $s = \lfloor (n+2)/2 \rfloor$ and all α_i are positive numbers which satisfy

$$\sum_{i=1}^r \alpha_i < \sum_{i=s+1}^{s+r} \alpha_i < \sum_{i=1}^{r+1} \alpha_i \quad \text{for } r = 1, \dots, s-1 \quad \text{if } n \text{ is even}$$

or

$$\sum_{i=1}^r \alpha_i < \sum_{i=s+2}^{s+r+1} \alpha_i < \sum_{i=1}^{r+1} \alpha_i \quad \text{for } r = 1, \dots, s-1 \quad \text{if } n \text{ is odd.}$$

F. Bihan proved in [Bih15] that if a circuit in \mathbb{Z}^n supports a maximally positive system with $n+1$ non-degenerate positive solutions, then it has a primitive affine relation (i.e. affine relation with coprime integer coefficients) as in Theorem 1.12 with $\alpha_1 = \alpha_{n+2} = 1$ and all other coefficients are equal to two. This can be seen as a consequence of Theorem 1.12 (see Example 5.13, Section 5.2). Indeed, if \mathcal{W} supports a maximally positive system with $n+1$ non-degenerate positive solutions, then the subgroup of \mathbb{Z}^n generated by \mathcal{W} is \mathbb{Z}^n . Moreover, if $\sum_{i=1}^s \alpha_i w_i = \sum_{s+1}^{n+2} \alpha_i w_i$ is a primitive affine relation, then $\sum_{i=1}^s \alpha_i = \sum_{s+1}^{n+2} \alpha_i = n+1$ (see [Bih15] for more details), which together with inequalities in Theorem 1.12 imply the desired equalities. In order to prove Theorem 1.12, one can reduce to the case where $\mathcal{W} \subset \mathbb{Z}^n$ (see the first part of Chapter 5). We prove the “only if” part of Theorem 1.12 in the following way. Consider a polynomial system supported on a circuit with n equations in n variables that has the maximal number of non-degenerate positive solutions. We associate to it using Gale duality (see Section 5.1), a univariate function

$$\varphi(y) = \prod_{i=1}^{n+1} P_i^{\lambda_i},$$

where P_i a polynomial of degree 1 that depends on the equations of the system, $\sum_{i=1}^{n+1} \lambda_i (w_i - w_0)$ is a linear relation on the vectors $w_i - w_0$ and the non-degenerate positive solutions of the initial system are in bijection with solutions of $\varphi(y) = 1$ contained in

$$\Delta_+ = \{y \in \mathbb{R}_{>0} \mid P_i(y) > 0, i = 1, \dots, n+1\}.$$

The homogenization of φ is a rational map $\mathbb{C}P^1 \rightarrow \mathbb{C}P^1$, so that the inverse image of $\mathbb{R}P^1$ by this homogenization is the real dessin d’enfant Γ (see Chapter 2). Since the valencies of the vertices of Γ are controlled by the integers λ_i and the roots of P_i for $i = 1, \dots, n+1$, by analysing Γ , we obtain the inequalities of Theorem 1.12.

The solutions of $\varphi(y) = 1$ in Δ_+ are roots of the *Gale polynomial*

$$G(y) = \prod_{\lambda_i > 0} P_i^{\lambda_i}(y) - \prod_{\lambda_i < 0} P_i^{-\lambda_i}(y) \tag{1.4.3}$$

in the same interval. In [PR13, proof of Lemma 1.8], K. Phillipson and J.-M. Rojas construct polynomial systems supported on a circuit in \mathbb{Z}^n with $n+1$ non-degenerate positive solutions using *Viro polynomials* $P_{i,t}(y) = a_i + t^{\alpha_i} b_i$, where $a_i, b_i, \alpha_i \in \mathbb{R}$, and $t > 0$ is a parameter that will be taken small enough. They apply the version of Viro’s combinatorial patchworking developed in [Stu94] which involves mixed subdivision of Newton polytopes. Here, we also use Viro polynomials $P_{i,t}$, and look directly at the roots of the corresponding Gale polynomial in Δ_+ . The inequalities in Theorem 1.12 appear explicitly as being necessary to construct polynomial systems supported on a circuit in \mathbb{Z}^n with $n+1$ non-degenerate positive solution using Viro polynomials $P_{i,t}$.

1.4.4 Chapter 6: Constructing polynomial systems with many positive solutions

Tropical geometry is a new domain in mathematics that is situated at the junction of fields such as toric geometry, complex or real geometry, and combinatorics [Mik06, MR05, MS15]. It turns out, that Sturmfels’ generalization of Viro’s Theorem can be reformulated in the context of tropical geometry (see [Mik04, Rul01]). This makes tropical geometry an effective tool to construct polynomial systems with prescribed support and many positive solutions.

Recall that the best known fewnomial bound on the number of non-degenerate positive solutions for a real polynomial system of n equations in n variables supported on a set of $n + k + 1$ points for $k, n \geq 1$ is equal to $\frac{\epsilon^2 + 3}{4} 2^{\binom{k}{2}} n^k$ [BS07]. In fact, the same paper contains the better upper bound 15 when $n = k = 2$. However, the best previously known constructions give 5 non-degenerate positive solutions (c.f. [Haa02]). The motivation behind this chapter is to implement Sturmfels' version of Viro's combinatorial patchworking and other tools and results (c.f. Chapter 2, Subsection 2.2.6) developed in tropical geometry for constructing a system of two equations in two variables and five monomials (a system of type $n = k = 2$ for short) having many positive solutions.

Let \mathbb{K} be the field of **generalized locally convergent Puiseux series**

$$a(t) = \sum_{r \in R} \alpha_r t^r,$$

where $R \subset \mathbb{R}$ is a well ordered set and $a(t)$ is a complex series convergent for $t > 0$ small enough. This is an algebraically closed field. Consider the subfield $\mathbb{R}\mathbb{K}$ of \mathbb{K} of *real* generalized Puiseux series, that is all α_r appearing in $a(t)$ are real numbers. We consider in this chapter a sparse (Laurent) polynomial system

$$f_1(z) = f_2(z) = 0, \tag{1.4.4}$$

with equations defined over $\mathbb{R}\mathbb{K}$. We assume that (1.4.4) has finitely many solutions, and all of them are non-degenerate. A **positive** element $a(t)$ of \mathbb{K} is an element of $\mathbb{R}\mathbb{K}^*$ whose first-order term has positive coefficient.

To a Laurent polynomial $f(z) = \sum_{w \in \mathcal{W}} c_w z^w \in \mathbb{R}\mathbb{K}[z]$, one associates a *tropical polynomial*

$$f_{\text{trop}}(x) = \sum_{w \in \mathcal{W}} \text{val}(c_w) x^w,$$

where $\text{val}(c_w)$ is minus the order (in the classical sense) of the Puiseux series c_w , and the operations are the tropical ones (the sum is the max, and the product is the classical sum). The associated *tropical hypersurface* T is the corner locus of the piecewise-linear convex function $\mathbb{R}^n \rightarrow \mathbb{R}^n$, $x \mapsto f_{\text{trop}}(x)$. By Kapranov's Theorem [Kap00] (see Subsection 2.2.2), the tropical hypersurface T coincides with the closure of

$$\text{Val}(\{z \in (\mathbb{K}^*)^n \mid f(z) = 0\}),$$

where Val is the extension of the function val coordinate-wise. The **positive part** of T is the closure of $\text{Val}(\{z \in (\mathbb{R}\mathbb{K}_{>0})^n \mid f(z) = 0\})$.

Consider now again polynomials $f_1, f_2 \in \mathbb{R}\mathbb{K}[z_1^{\pm 1}, z_2^{\pm 1}]$ defining two tropical curves $T_1, T_2 \subset \mathbb{R}^2$. Assume for the moment that T_1 and T_2 intersect transversally, which means that each intersection point is isolated and contained in the relative interiors of one 1-dimensional linear piece of T_1 and one 1-dimensional linear piece of T_2 . Then by Sturmfels' generalization of Viro's theorem, each intersection point of T_1 and T_2 contained in both positive parts (positive intersection point for short) lifts to a unique solution of (1.4.4) in $(\mathbb{R}\mathbb{K}_{>0})^2$, which gives a positive solution of a real system $g_1(z) = g_2(z) = 0$ by taking $t > 0$ small enough. Recall that in the case $n = k = 2$ (meaning that equations of T_1 and T_2 have a total of five monomials), the number of transversal intersection points of T_1 and T_2 is bounded from above by six (see Subsection 1.3.2). We prove that this bound is sharp and can be realized by positive intersection points.

Proposition 1.13. *There exist two plane tropical curves T_1 and T_2 defined by equations containing a total of five monomials and which have six positive transversal intersection points.*

Therefore, using Sturmfels' generalization of Viro's theorem (as explained above), this gives a real system of type $n = k = 2$ having six non-degenerate positive solutions. In order to get a real system of type $n = k = 2$ with more than six non-degenerate positive solutions, we thus consider tropical curves T_1 and T_2 which do not intersect transversally.

Note that $T_1 \cap T_2$ is piecewise-linear and its linear pieces are either isolated points or line segments. Luckily, if a linear piece $\xi \subset T_1 \cap T_2$ is an isolated point, then results in [Kat09, Rab12, OP13] and [BLdM12] show that ξ lifts to a solution of (1.4.4) in $(\mathbb{K}^*)^2$, and then non-degenerate positive solutions of (1.4.4) with valuation equal to ξ can be estimated by computing the real *reduced system* of (1.4.4) with respect to ξ (see Chapter 2, Subsection 2.2.6). However, if such a linear piece ξ has dimension 1, then ξ is an infinite set containing a finite (and possibly empty) set of points that are valuations of non-degenerate positive solutions of (1.4.4). Locating such valuations does not come easily. In fact, there is only one known method for achieving this, called *tropical modification* (see [Mik06, BLdM12]). This problem is addressed in Section 6.2 of Chapter 6 using another approach. Namely, for each linear piece ξ of dimension 1, we associate a univariate Viro polynomial $f_{t,\xi}$ so that all the first-order terms of non-degenerate positive solutions of (1.4.4) with valuations in the relative interior of ξ can be recovered from both the reduced system of (1.4.4) with respect to ξ , and the Viro polynomial $f_{t,\xi}$.

We now consider a system (1.4.4) of type $n = k = 2$. Assume that no three points of the support of the system belong to a line. We prove in Section 6.3 that one can associate to such a system a new system

$$\begin{aligned} a_0 + y_1^{m_1} + a_2 y_1^{m_2} y_2^{n_2} + a_3 t^\alpha y_1^{m_3} y_2^{n_3} &= 0, \\ b_0 + y_1^{m_1} + b_2 y_1^{m_2} y_2^{n_2} + b_4 t^\beta y_1^{m_4} y_2^{n_4} &= 0, \end{aligned} \tag{1.4.5}$$

with polynomials in $\mathbb{R}\mathbb{K}[y_1^{\pm 1}, y_2^{\pm 1}]$, that has the same number of positive non-degenerate solutions as (1.4.4), and satisfying that all a_i, b_j have zero order, all m_i, n_i belong to \mathbb{Z} with $m_1, n_2 > 0$, and both α, β are real numbers.

The two main results of Chapter 6 are the following.

Theorem 1.14. *If $(\alpha, \beta) \neq (0, 0)$, then (1.4.5) has at most nine non-degenerate positive solutions.*

We prove Theorem 1.14 in Section 6.5. Note that if $(\alpha, \beta) = (0, 0)$, then there is nothing that can be done using tropical geometry. Indeed, the task of bounding the number of non-degenerate positive solutions of (1.4.5) becomes equivalent to computing the number of positive solutions of a real polynomial system of type $n = k = 2$.

Theorem 1.15. *There exists a system (1.4.5) that has seven non-degenerate positive solutions.*

The construction of a system (1.4.5) that has seven non-degenerate positive solutions is made in Section 6.5. Namely, for any $0 < \alpha < \gamma_0$, the system

$$\begin{aligned} -1 + y_1^6 + y_1^3 y_2^6 - t^\alpha y_1^{-14} y_2^7 &= 0, \\ -1 + 0.36008 t^{\gamma_0} + y_1^6 + (1 - 0.36008 t^\alpha) y_1^3 y_2^6 - (44/31)^{\frac{5}{6}} t^\alpha y_1^{-12} y_2^9 &= 0, \end{aligned} \tag{1.4.6}$$

has seven non-degenerate positive solutions.

We made a tedious case-by-case analysis to get necessary conditions for (1.4.5) to have more than six non-degenerate positive solutions. As a by-product, we obtain in Sections 6.6 and 6.7 the following result.

Theorem 1.16. *If $(\alpha, \beta) \neq (0, 0)$, and one of the following is true*

1. *For $i = 0, 2$, the coefficient of the first order term of a_i is different from that of b_i ,*
2. *$\alpha \neq \beta$,*
3. *$\alpha = \beta < 0$,*

then (1.4.5) has at most six non-degenerate positive solutions.

Chapter 2

Preliminaries

2.1 A brief introduction to real dessins d'enfant

For more details, see [Ore03, Bru06, Bih07] for example. Consider a real rational map $\varphi = \frac{P}{Q} : \mathbb{C} \rightarrow \mathbb{C}$, where P and Q are two real polynomials. The degree of φ is the maximum of the degrees of P and Q . We extend φ to a rational homogeneous function $\mathbb{C}P^1 \rightarrow \mathbb{C}P^1$, $(x_0 : x_1) \mapsto (1 : P/Q)$, that we denote again by φ . Define

$$\Gamma := \varphi^{-1}(\mathbb{R}P^1).$$

This is a real graph on $\mathbb{C}P^1$ invariant with respect to the complex conjugation and which contains $\mathbb{R}P^1$. Any connected component of $\mathbb{C}P^1 \setminus \Gamma$ is homeomorphic to an open disk. Moreover, each vertex of Γ has even valency, and the multiplicity of a critical point with real critical value of φ is half its valency. The graph Γ contains the inverse images of $(1 : 0)$, $(0 : 1)$ and $(1 : 1)$, which are the sets of roots of P , Q and $P/Q - 1$ respectively. Denote by the same letter p (resp. q and r) the points of Γ which are mapped to $(1 : 0)$ (resp. $(0 : 1)$ and $(1 : 1)$). Orient the real axis on the target space via the arrows $0 \rightarrow \infty \rightarrow 1 \rightarrow 0$ (orientation given by the decreasing order in \mathbb{R}), which is equivalent to orienting $\mathbb{R}P^1$ via the arrows $(1 : 0) \rightarrow (0 : 1) \rightarrow (1 : 1)$. Pull back this orientation by φ , the graph Γ becomes an oriented graph, with the orientation given by arrows $p \rightarrow q \rightarrow r \rightarrow p$. A **cycle** of Γ is the boundary of a connected component of $\mathbb{C}P^1 \setminus \Gamma$. Any such cycle contains the same non-zero number of letters r, p, q (see Figure 2.1). We say that a cycle obeys the **cycle rule**. The graph Γ is called *real dessin d'enfant* associated to φ . Since Γ is invariant under complex conjugation, it is determined by its intersection with one connected component H (for half) of $\mathbb{C}P^1 \setminus \mathbb{R}P^1$. Since φ is real, its degree is the sum of the degrees of its restrictions to connected components of $\mathbb{C}P^1 \setminus \Gamma$. To represent the real dessin d'enfant, we draw a horizontal line corresponding to the real projective line and draw below one half $H\Gamma$ of Γ , see Figure 3.1 for instance.

Clearly, the arrangement of real roots of P , Q and $P/Q - 1$ together with their multiplicities can be extracted from the graph Γ . We encode this arrangement together with the multiplicities by what is called a root scheme.

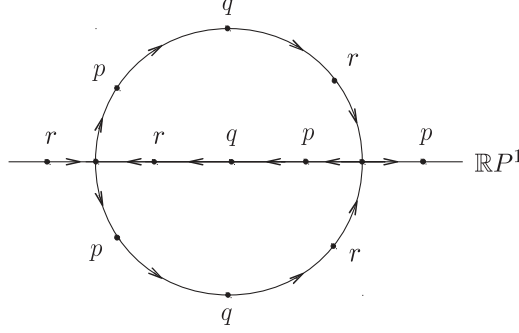
Figure 2.1: Cycles of Γ obeying the cycle rule.

Definition 2.1 ([Bru06, Ore03]). A **root scheme** is a k -tuple $(l_1, m_1), \dots, (l_k, m_k) \in (\{p, q, r\} \times \mathbb{N})^k$. A root scheme is realizable by polynomials of degree d if there exist real polynomials P and Q such that φ has degree d and if $x_1 < \dots < x_k$ are the real roots of P , Q and $P/Q - 1$, then $l_i = p$ (resp. q, r) if x_i is a root of P (resp. $Q, P/Q - 1$) and m_i is the multiplicity of x_i .

Conversely, suppose we are given a real graph $\Gamma \subset \mathbb{C}P^1$ that is invariant under complex conjugation, together with a real continuous map $\phi : \Gamma \rightarrow \mathbb{R}P^1$. Denote the inverse images of 0 , ∞ and 1 by letters p , q and r , respectively, and orient Γ with the pull back by ϕ of the above orientation of $\mathbb{R}P^1$. This graph is called a *real rational graph* [Bru06] if any vertex of Γ has even valency and any connected component of $\mathbb{C}P^1 \setminus \Gamma$ is homeomorphic to an open disk. Then, for any connected component D of $\mathbb{C}P^1 \setminus \Gamma$, the map $\phi|_{\partial D}$ is a covering of $\mathbb{R}P^1$ whose degree d_D is the number of letters p (resp. q, r) in ∂D . We define the degree of Γ to be half the sum of the degrees d_D over all connected components of $\mathbb{C}P^1 \setminus \Gamma$. Since ϕ is a real map, the degree of Γ is also the sum of the degrees d_D over all connected components D of $\mathbb{C}P^1 \setminus \Gamma$ contained in one connected component of $\mathbb{C}P^1 \setminus \mathbb{R}P^1$.

The following result [Ore03] explains the importance of real rational graphs in computing the roots of $P/Q - 1$.

Proposition 2.2 (Orevkov). A root scheme is realizable by polynomials of degree d if and only if it can be extracted from a real rational graph of degree d on $\mathbb{C}P^1$.

We show now how to prove the if part in Proposition 2.2 (see [Bih07, Bru06, Ore03]). For each connected component D of $\mathbb{C}P^1 \setminus \Gamma$, extend $\phi|_{\partial D}$ to a branched covering of degree d_D (use the map $z \mapsto z^{d_D}$) of one connected component of $\mathbb{C}P^1 \setminus \mathbb{R}P^1$, so that two adjacent connected components of $\mathbb{C}P^1 \setminus \Gamma$ project to different connected components of $\mathbb{C}P^1 \setminus \mathbb{R}P^1$. Then, it is possible to glue continuously these maps in order to obtain a real branched covering $\phi : \mathbb{C}P^1 \rightarrow \mathbb{C}P^1$ of degree d . The map ϕ becomes a real rational map of degree d for the standard complex structure on the target space and its pull-back by ϕ on the source space. There exist then real polynomials P and Q such that P/Q has degree d and $\phi = P/Q$, so that the points p (resp. q, r) correspond to the roots of P (resp. $Q, P/Q - 1$) and $\Gamma = \phi^{-1}(\mathbb{R}P^1)$.

2.2 A brief introduction to tropical geometry

The notations in this section are taken from [BLdM12, BB13, Ren15, GL15].

2.2.1 Polytopes and subdivisions

Let \mathbb{R}^n denote the n -dimensional Euclidean space, endowed with the standard inner product $\langle \cdot, \cdot \rangle: \mathbb{R}^n \times \mathbb{R}^n \rightarrow \mathbb{R}$.

Definition 2.3. A *rational polyhedron* in \mathbb{R}^n is a convex set of points x , defined by a finite number of inequalities of type

$$\langle x, w \rangle \leq c,$$

where $w \in \mathbb{Z}^n$ and $c \in \mathbb{R}$.

If a rational polyhedron is closed, then it is called an **integer convex polytope**. All polytopes considered in Chapter 6 are integer convex.

Definition 2.4. A *rational polyhedral complex* is a finite set of rational polyhedra $\mathcal{P} = \{\Delta_i\}_i$ such that

1. for every $\Delta \in \mathcal{P}$, if Δ' is a face of Δ , then $\Delta' \in \mathcal{P}$, and
2. if $\Delta, \Delta' \in \mathcal{P}$, then $\Delta \cap \Delta'$ is a face of both Δ and Δ' .

Let F be a field of characteristic zero. For $z = (z_1, \dots, z_n) \in F^n$ and $w = (w^1, \dots, w^n) \in \mathbb{R}^n$, set $z^w = z_1^{w^1} \cdots z_n^{w^n}$. Consider a polynomial $f = \sum_{w \in \mathcal{W}} c_w z^w \in F[z_1^{\pm 1}, \dots, z_n^{\pm 1}]$, with $\mathcal{W} \neq \emptyset$ a finite subset of \mathbb{Z}^n , and $c_w \in F^*$.

Definition 2.5. The *Newton polytope* $\Delta(f)$ of f is defined to be the convex hull $\text{Conv}(\mathcal{W})$ of \mathcal{W} .

Definition 2.6. A *polyhedral subdivision* of an integer convex polytope Δ is a set of integer convex polytopes $\{\Delta_i\}_{i \in I}$ such that

- $\cup_{i \in I} \Delta_i = \Delta$, and
- if $i, j \in I$, then if the intersection $\Delta_i \cap \Delta_j$ is non-empty, it is a common face of the polytope Δ_i and the polytope Δ_j .

Definition 2.7. Let Δ be an integer convex polytope in \mathbb{R}^n and let τ denote a polyhedral subdivision of Δ consisting of integer convex polytopes. We say that τ is **regular** if there exists a continuous, convex, piecewise-linear function $\varphi: \Delta \rightarrow \mathbb{R}$ which is affine linear on every simplex of τ .

Let Δ be an integer convex polytope in \mathbb{R}^n and let $\phi: \Delta \cap \mathbb{Z}^n \rightarrow \mathbb{R}$ be a function. We denote by $\hat{\Delta}(\phi)$ the convex hull of the graph of ϕ , i.e.,

$$\hat{\Delta}(\phi) := \text{Conv}(\{(i, \phi(i)) \in \mathbb{R}^{n+1} \mid i \in \Delta \cap \mathbb{Z}^n\}).$$

Then the polyhedral subdivision of Δ , induced by projecting the union of the lower faces of $\hat{\Delta}(\phi)$ onto the first n coordinates, is regular. In the following, we describe how we define ϕ using the polynomials that we will be working with.

2.2.2 Tropical polynomials and hypersurfaces

A **locally convergent generalized Puiseux series** is a formal series of the form

$$a(t) = \sum_{r \in R} \alpha_r t^r,$$

where $R \subset \mathbb{R}$ is a well-ordered set, all $\alpha_r \in \mathbb{C}$, and the series is convergent for $t > 0$ small enough. We denote by \mathbb{K} the set of all locally convergent generalized Puiseux series. It is naturally a field of characteristic 0, which turns out to be algebraically closed.

Notation 2.8. Let $\text{coef}(a(t))$ denote the coefficient of the first term of $a(t)$ following the increasing order of the exponents of t . We extend coef to a map $\text{Coef} : \mathbb{K}^n \rightarrow \mathbb{R}^n$ by taking coef coordinate-wise, i.e. $\text{Coef}(a_1(t), \dots, a_n(t)) = (\text{coef}(a_1(t)), \dots, \text{coef}(a_n(t)))$

An element $a(t) = \sum_{r \in R} \alpha_r t^r$ of \mathbb{K} is said to be **real** if $\alpha_r \in \mathbb{R}$ for all r , and **positive** if $a(t)$ is real and $\text{coef}(a(t)) > 0$.

Denote by $\mathbb{R}\mathbb{K}$ (resp. $\mathbb{R}\mathbb{K}_{>0}$) the subfield of \mathbb{K} composed of real (resp. positive) series. Since elements of \mathbb{K} are convergent for $t > 0$ small enough, an algebraic variety over \mathbb{K} (resp. $\mathbb{R}\mathbb{K}$) can be seen as a one parametric family of algebraic varieties over \mathbb{C} (resp. \mathbb{R}). The field \mathbb{K} has a natural non-archimedean valuation defined as follows:

$$\begin{aligned} \text{val} : \quad \mathbb{K} &\longrightarrow \mathbb{R} \cup \{-\infty\} \\ 0 &\longmapsto -\infty \\ \sum_{r \in R} \alpha_r t^r \neq 0 &\longmapsto -\min_R \{r \mid \alpha_r \neq 0\}. \end{aligned}$$

The valuation extends naturally to a map $\text{Val} : \mathbb{K}^n \rightarrow (\mathbb{R} \cup \{-\infty\})^n$ by evaluating val coordinate-wise, i.e. $\text{Val}(z_1, \dots, z_n) = (\text{val}(z_1), \dots, \text{val}(z_n))$. We shall often use the notation val and Val when the context is a *tropical polynomial* or a *tropical hypersurface*. On the other hand, define $\text{ord} := -\text{val}$, with $\text{ord}(0) = +\infty$, and use it as a notation when the context is an element in $\mathbb{R}\mathbb{K}^n$ or a polynomial in $\mathbb{R}\mathbb{K}[z_1^{\pm 1}, \dots, z_n^{\pm 1}]$.

Convention 2.9. For any $s \in \mathbb{K}$, we have $\text{coef}(s) = 0 \Leftrightarrow s = 0$ and $\text{ord}(s) = +\infty \Leftrightarrow s = 0$

Consider a polynomial

$$f(z) := \sum_{w \in \mathcal{W}} c_w z^w \in \mathbb{K}[z_1^{\pm 1}, \dots, z_n^{\pm 1}],$$

with \mathcal{W} a finite subset of \mathbb{Z}^n and all c_w are non-zero. Let $V_f = \{z \in (\mathbb{K}^*)^n \mid f(z) = 0\}$ be the zero set of f in $(\mathbb{K}^*)^n$

The **tropical hypersurface** V_f^{trop} associated to f is the closure (in the usual topology) of the image under Val of V_f :

$$V_f^{\text{trop}} = \overline{\text{Val}(V_f)} \subset \mathbb{R}^n,$$

endowed with a *weight function* which we will define later. There are other equivalent definitions of a tropical hypersurface. Namely, define

$$\begin{aligned} \nu : \quad \mathcal{W} &\longrightarrow \mathbb{R} \\ w &\longmapsto \text{ord}(c_w). \end{aligned}$$

Its **Legendre transform** is a piecewise-linear convex function

$$\begin{aligned} \mathcal{L}(\nu) : \mathbb{R}^n &\longrightarrow \mathbb{R} \\ x &\longmapsto \max_{w \in \mathcal{W}} \{ \langle x, w \rangle - \nu(w) \}. \end{aligned}$$

We have the fundamental Theorem of Kapranov [Kap00].

Theorem 2.10 (Kapranov). *A tropical hypersurface V_f^{trop} is the corner locus of $\mathcal{L}(\nu)$.*

The corner locus of $\mathcal{L}(\nu)$ is the set of points at which it is not differentiable. Tropical hypersurfaces can also be described as algebraic varieties over the *tropical semifield* $(\mathbb{R} \cup \{-\infty\}, "+", "\times")$, where for any two elements x and y in $\mathbb{R} \cup \{-\infty\}$, one has

$$"x + y" = \max(x, y) \quad \text{and} \quad "x \times y" = x + y.$$

A multivariate tropical polynomial is a polynomial in $\mathbb{R}[x_1, \dots, x_n]$, where the addition and multiplication are the tropical ones. Hence, a tropical polynomial is given by a maximum of finitely many affine functions whose linear parts have integer coefficients and constant parts are real numbers. The tropicalization of the polynomial f is a tropical polynomial

$$f_{\text{trop}}(x) = \max_{w \in \mathcal{W}} \{ \langle x, w \rangle + \text{val}(c_w) \}.$$

This tropical polynomial coincides with the piecewise-linear convex function $\mathcal{L}(\nu)$ defined above. Therefore, Theorem 2.10 asserts that V_f^{trop} is the corner locus of f_{trop} . Conversely, the corner locus of any tropical polynomial is a tropical hypersurface.

2.2.3 Tropical hypersurfaces and subdivisions

A tropical hypersurface induces a subdivision of the Newton polytope $\Delta(f)$ in the following way. The hypersurface V_f^{trop} is a $(n-1)$ -dimensional piecewise-linear complex which induces a polyhedral subdivision Ξ of \mathbb{R}^n . We will call **cells** the elements of Ξ . Note that these cells have rational slopes. The n -dimensional cells of Ξ are the closures of the connected components of the complement of V_f^{trop} in \mathbb{R}^n . The lower dimensional cells of Ξ are contained in V_f^{trop} and we will just say that they are cells of V_f^{trop} .

Consider a cell ξ of V_f^{trop} and pick a point x in the relative interior of ξ . Then the set

$$\mathcal{I}_x = \{ w \in \Delta(f) \cap \mathbb{Z}^n \mid \exists x \in \mathbb{R}^n, f_{\text{trop}}(x) = \langle x, w \rangle + \text{val}(c_w) \}$$

is independent of x , and denote by Δ_ξ the convex hull of this set. All together the polyhedra Δ_ξ form a subdivision τ of $\Delta(f)$ called the **dual subdivision**, and the cell Δ_ξ is called the **dual** of ξ . Both subdivisions τ and Ξ are dual in the following sense. There is a one-to-one correspondence between Ξ and τ , which reverses the inclusion relations, and such that if $\Delta_\xi \in \tau$ corresponds to $\xi \in \Xi$ then

1. $\dim \xi + \dim \Delta_\xi = n$,
2. the cell ξ and the polytope Δ_ξ span orthogonal real affine spaces,
3. the cell ξ is unbounded if and only if Δ_ξ lies on a proper face of $\Delta(f)$.

Note that τ coincides with the regular subdivision of Definition 2.7 described in Subsection 2.2.1. Indeed, let $\hat{\Delta}(f) \subset \mathbb{R}^n \times \mathbb{R}$ be the convex hull of the points $(w, \nu(w))$ with $w \in \mathcal{W}$ and $\nu(w) = \text{ord}(c_w)$. Define

$$\begin{aligned} \hat{\nu} : \Delta(f) &\longrightarrow \mathbb{R} \\ x &\longmapsto \min\{y \mid (x, y) \in \hat{\Delta}(f)\}. \end{aligned}$$

Then, the the domains of linearity of $\hat{\nu}$ form the dual subdivision τ .

Consider a facet (face of dimension $n-1$) ξ of V_f^{trop} , then $\dim \Delta_\xi = 1$ and we define the **weight** of ξ by $w(\xi) := \text{Card}(\Delta_\xi \cap \mathbb{Z}^n) - 1$. Tropical varieties satisfy the so-called balancing condition. Since in Chapter 6, we only work with tropical curves in \mathbb{R}^2 , we give here this property only for this case. We refer to [Mik06] for the general case. Let $T \subset \mathbb{R}^n$ be a tropical curve, and let v be a vertex of T . Let ξ_1, \dots, ξ_l be the edges of T adjacent to v . Since T is a rational graph, each edge ξ_i has a primitive integer direction. If in addition we ask that the orientation of ξ_i defined by this vector points away from v , then this primitive integer vector is unique. Let us denote by $u_{v,i}$ this vector.

Proposition 2.11 (Balancing condition). *For any vertex v , one has*

$$\sum_{i=1}^l w(\xi_i) u_{v,i} = 0.$$

2.2.4 Intersection of tropical hypersurfaces

Consider polynomials $f_1, \dots, f_k \in \mathbb{K}[z_1^{\pm 1}, \dots, z_n^{\pm 1}]$. For $i = 1, \dots, k$, let $\Delta_i \subset \mathbb{R}^n$ (resp. $T_i \subset \mathbb{R}^n$) denote the Newton polytope (resp. tropical curve) associated to f_i . Recall that each tropical curve T_i defines a piecewise linear polyhedral subdivision Ξ_i of \mathbb{R}^n which is dual to a convex polyhedral subdivision τ_i of Δ_i . The union of these tropical curves defines a piecewise-linear polyhedral subdivision Ξ of \mathbb{R}^n . Any non-empty cell of Ξ can be written as

$$\xi = \xi_1 \cap \dots \cap \xi_k$$

with $\xi_i \in \Xi_i$ for $i = 1, \dots, k$. We require that ξ does not lie in the boundary of any ξ_i , thus any cell $\xi \in \Xi$ can be uniquely written in this way. Denote by τ the mixed subdivision of the Minkowski sum $\Delta = \Delta_1 + \dots + \Delta_k$ induced by the tropical polynomials f_1, \dots, f_k . Recall that any polytope $\sigma \in \tau$ comes with a privileged representation $\sigma = \sigma_1 + \dots + \sigma_k$ with $\sigma_i \in \tau_i$ for $i = 1, \dots, k$. The above duality-correspondence applied to the (tropical) product of the tropical polynomials gives rise to the following well-known fact (see [BB13] for instance).

Proposition 2.12. *There is a one-to-one duality correspondence between Ξ and τ , which reverses the inclusion relations, and such that if $\sigma \in \tau$ corresponds to $\xi \in \Xi$, then*

1. if $\xi = \xi_1 \cap \dots \cap \xi_k$ with $\xi_i \in \Xi_i$ for $i = 1, \dots, k$, then σ has representation $\sigma = \sigma_1 + \dots + \sigma_k$ where each σ_i is the polytope dual to ξ_i .
2. $\dim \xi + \dim \sigma = n$,
3. the cell ξ and the polytope σ span orthonogonal real affine spaces,
4. the cell ξ is unbounded if and only if σ lies on a proper face of Δ .

Notation 2.13. In what follows, we denote such a σ by Δ_ξ and we say that each polytope Δ_ξ a *mixed polytope* of τ .

Definition 2.14. A cell ξ is *transversal* if it satisfies $\dim(\Delta_\xi) = \dim(\Delta_{\xi_1}) + \cdots + \dim(\Delta_{\xi_k})$, and it is *non transversal* if the previous equality does not hold.

2.2.5 Generalized Viro theorem and tropical reformulation

An important direction in real algebraic geometry is the construction of real algebraic hypersurfaces with prescribed topology (see [Ris92, Vir84] or [Vir89] for example). Central to these developments is a combinatorial construction due to O.Ya. Viro, which is based on regular triangulations of Newton polytopes. Using this technique, significant progress has been made in the study of low degree curves in the real projective plane (Hilbert's 16th problem). Since Chapter 6 of this thesis concerns algebraic sets of dimension zero contained in $(\mathbb{R}_{>0})^n$, we only describe in this section how to use *combinatorial patchworking* in that orthant of \mathbb{R}^n .

Following the description of B. Sturmfels [Stu94], we recall now Viro's Theorem for hypersurfaces. Let $\mathcal{W} \subset \mathbb{Z}^n$ be a finite set of lattice points, and denote by Δ the convex hull of \mathcal{W} . Assume that $\dim \Delta = n$ and let $\varphi : \mathcal{W} \rightarrow \mathbb{Z}$ be any function inducing a regular triangulation τ_φ of the integer convex polytope Δ (see Definition 2.7). Fix non-zero real numbers c_w , $w \in \mathcal{W}$. For each positive real number t , we consider a Laurent polynomial

$$f_t(z_1, \dots, z_n) = \sum_{w \in \mathcal{W}} c_w t^{\varphi(w)} z^w. \quad (2.2.1)$$

Let $\text{Bar}(\tau_\varphi)$ denote the first barycentric subdivision of the regular triangulation τ_φ . Each maximal cell μ of $\text{Bar}(\tau_\varphi)$ is incident to a unique point $w \in \mathcal{W}$. We define the sign of a maximal cell μ to be the sign of the associated real number c_w . The sign of any lower dimensional cell $\lambda \in \text{Bar}(\tau_\varphi)$ is defined as follows:

$$\text{sign}(\lambda) := \begin{cases} + & \text{if } \text{sign}(\mu) = + \text{ for all maximal cells } \mu \text{ containing } \lambda, \\ - & \text{if } \text{sign}(\mu) = - \text{ for all maximal cells } \mu \text{ containing } \lambda, \\ 0 & \text{otherwise.} \end{cases}$$

Let $\mathcal{Z}_+(\tau_\varphi, f)$ denote the subcomplex of $\text{Bar}(\tau_\varphi)$ consisting of all cells λ with $\text{sign}(\lambda) = 0$, and let $V_+(f_t)$ denote the zero set of f_t in the positive orthant of \mathbb{R}^n . Denote by $\text{Int}(\Delta)$ the relative interior of Δ .

Theorem 2.15 (Viro). *For sufficiently small $t > 0$, there exists a homeomorphism $(\mathbb{R}_{>0})^n \rightarrow \text{Int}(\Delta)$ sending the real algebraic set $V_+(f_t) \subset (\mathbb{R}_{>0})^n$ to the simplicial complex $\mathcal{Z}_+(\tau_\varphi, f) \subset \text{Int}(\Delta)$.*

Naturally, a signed version of Theorem 2.15 holds in each of the 2^n orthants

$$(\mathbb{R}_{>0})^\epsilon := \{(x_1, \dots, x_n) \in (\mathbb{R}^*)^n \mid \text{sign}(x_i) = \epsilon_i \text{ for } i = 1, \dots, n\},$$

where $\epsilon \in \{+, -\}^n$. In fact, O. Viro proves a more general Theorem for Theorem 2.15, in which he defines a set that is homeomorphic to the the zero set $V(f_t) \subset \mathbb{R}^n$ (not only the positive zero set $V_+(f_t)$) by means of gluing the zero sets of f_t contained in all other orthants of \mathbb{R}^n .

We now reformulate Theorem 2.15 using tropical geometry. We consider $g := f_t$ as a polynomial defined over the field of real generalized locally convergent Puiseux series, where each coefficient

$c_w t^{\varphi(w)} \in \mathbb{R}\mathbb{K}^*$ of g has only one term. Therefore $\text{coef}(c_w t^{\varphi(w)}) = c_w$, $\text{val}(c_w t^{\varphi(w)}) = -\varphi(w)$, and we associate to g a tropical hypersurface V_g^{trop} as defined in Subsection 2.2.2. Recall that V_g^{trop} induces a subdivision Ξ_g of \mathbb{R}^n that is dual to τ_φ . The tropical hypersurface V_g^{trop} is homeomorphic to the barycentric subdivision $\text{Bar}(\tau_\varphi)$. Indeed, τ_φ is a triangulation, and thus $\text{Bar}(\tau_\varphi)$ becomes dual to τ_φ in the sense of the duality described in Subsection 2.2.3.

We define for each n -cell $\xi \in \Xi_g$, dual to a 0-face (vertex) w of the triangulation τ_φ , a sign $\epsilon(w) \in \{+, -\}$, to be equal to the sign of c_w .

Definition 2.16. *The **positive part**, denoted by $V_{g,+}^{\text{trop}}$, is the subcomplex of V_g^{trop} consisting of all $(n-1)$ -cells of V_g^{trop} that are adjacent to two n -cells of V_g^{trop} having different signs. A **positive facet** ξ_+ is an $(n-1)$ -dimensional cell of $V_{g,+}^{\text{trop}}$.*

The following is a Corollary of Mikhalkin [Mik04] and Rullgard [Rul01] results, where they completely describe the topology of $V(f_t)$ using *amoebas*.

Theorem 2.17 (Mikhalkin, Rullgard). *For sufficiently small $t > 0$, there exists a homeomorphism $(\mathbb{R}_{>0})^n \rightarrow \mathbb{R}^n$ sending the zero set $V_+(f_t) \subset (\mathbb{R}_{>0})^n$ to $V_{g,+}^{\text{trop}} \subset \mathbb{R}^n$.*

B. Sturmfels generalized Viro's method for complete intersections in [Stu94]. We give now a tropical reformulation of one of the main Theorems of [Stu94].

Consider a system

$$f_{1,t}(z_1, \dots, z_n) = \dots = f_{k,t}(z_1, \dots, z_n) = 0, \quad (2.2.2)$$

of k equations, where all $f_{i,t}$ are polynomial (2.2.1). For $i = 1, \dots, k$, we define as before $g_i := f_{i,t}$ as a polynomial in $\mathbb{R}\mathbb{K}[z_1^{\pm 1}, \dots, z_n^{\pm 1}]$. Let $V_+(f_{1,t}, \dots, f_{k,t}) \subset (\mathbb{R}_{>0})^n$ denote the set of positive solutions of (2.2.2).

Theorem 2.18 (Sturmfels). *Assume that the tropical hypersurfaces $V_{g_1}^{\text{trop}}, \dots, V_{g_k}^{\text{trop}}$ intersect transversally. Then for sufficiently small $t > 0$, there exists a homeomorphism $(\mathbb{R}_{>0})^n \rightarrow \mathbb{R}^n$ sending the real algebraic set $\mathcal{Z}_+(f_{1,t}, \dots, f_{k,t}) \subset (\mathbb{R}_{>0})^n$ to the intersection $V_{g_1,+}^{\text{trop}} \cap \dots \cap V_{g_k,+}^{\text{trop}} \subset \mathbb{R}^n$.*

Similarly to O. Viro's work, B. Sturmfels generalizes Theorem 2.18 for the zero set $V(f_{1,t}, \dots, f_{k,t}) \subset \mathbb{R}^n$ (see [Stu94, Theorem 5]).

2.2.5.1 Transversal intersection points and discrete mixed volume

Assume now that the number of polynomials in (2.2.2) is equal to that of variables (i.e. $k = n$), and assume that the tropical hypersurfaces $V_{g_1}^{\text{trop}}, \dots, V_{g_n}^{\text{trop}}$ intersect transversally. Then the intersection set $V_+^{\text{trop}}(g_1, \dots, g_n) := V_{g_1,+}^{\text{trop}} \cap \dots \cap V_{g_n,+}^{\text{trop}}$ is a (possibly empty) set of points in \mathbb{R}^n . Each point p of $V_+^{\text{trop}}(g_1, \dots, g_n)$ is expressed in a unique way as a transversal intersection $\xi_{1,+} \cap \dots \cap \xi_{n,+}$, where for $i = 1, \dots, n$, the cell $\xi_{i,+} \subset V_{g_i,+}^{\text{trop}}$ is a positive cell. Theorem 2.18 is a powerful tool for constructing polynomial systems (2.2.2) with many non-degenerate positive solutions.

A consequence of F. Bihan's more general result [Bih14] is a bound on the number of positive mixed points for a system (2.2.2). For any number r of finite sets $\mathcal{W}_1, \dots, \mathcal{W}_r$ in \mathbb{R}^n , and for any non-empty $I \subset [r] = \{1, 2, \dots, r\}$, write \mathcal{W}_I for the set of points $\sum_{i \in I} w_i$ over all $w_i \in \mathcal{W}_i$ with $i \in I$. The associated *discrete mixed volume* of $\mathcal{W}_1, \dots, \mathcal{W}_r$ is defined as

$$D(\mathcal{W}_1, \dots, \mathcal{W}_r) = \sum_{I \subset [r]} (-1)^{r-|I|} |\mathcal{W}_I|, \quad (2.2.3)$$

where the sum is taken over all subsets I of $[r]$ including the empty set with the convention that $|\mathcal{W}_\emptyset| = 1$. Denote by \mathcal{W}_i the support of g_i for $i = 1, \dots, n$. Recall that the tropical hypersurfaces associated to g_1, \dots, g_n intersect transversally.

Theorem 2.19 (Bihan). *The number $\#\{V_{g_1}^{\text{trop}} \cap \dots \cap V_{g_n}^{\text{trop}}\}$ is less or equal to the discrete mixed volume $D(\mathcal{W}_1, \dots, \mathcal{W}_n)$.*

Obviously, we have

$$\#\{V_{g_1, +}^{\text{trop}} \cap \dots \cap V_{g_n, +}^{\text{trop}}\} \leq \#\{V_{g_1}^{\text{trop}} \cap \dots \cap V_{g_n}^{\text{trop}}\}$$

Moreover, Theorem 1.4 of [Bih14] states that for any finite sets $\mathcal{W}_1, \dots, \mathcal{W}_r \subset \mathbb{R}^n$, we have

$$D(\mathcal{W}_1, \dots, \mathcal{W}_r) \leq \prod_{i \in [r]} (|\mathcal{W}_i| - 1).$$

Combining the latter result with Theorem 2.19 shows that Kushnirenko's conjecture is true for polynomial systems constructed by the combinatorial patchworking method of Viro, or equivalently, for tropical polynomial systems given by transversal intersections of tropical hypersurfaces.

To our knowledge, we do not know if the discrete mixed volume bound is sharp for any polynomial system with n equations in n variables satisfying that the associated tropical hypersurfaces intersect transversally. An interesting direction to start, is to look at a system (2.2.2) such that all polynomials of (2.2.2) have the same support \mathcal{W} . For example, when $|\mathcal{W}| = 4$, then the bound of Theorem 2.19 is 3 and is sharp, see [Bih07].

When $|\mathcal{W}| = 5$ and $n = 2$, we have $D(\mathcal{W}, \mathcal{W}) = 6$. We construct using combinatorial patchworking (Theorem 2.18) a polynomial system of two equations in two variables having a total of five distinct monomials and six non-degenerate solutions in $(\mathbb{R}_{>0})^2$. Thus proving that the bound of Theorem 2.19 is sharp when $n = 2$ and $\mathcal{W}_1 = \mathcal{W}_2 = 5$.

2.2.6 Reduced systems and non-transversal intersections

Theorem 2.18 is only adapted for the case where the tropical intersections are transverse. Therefore, we need other machinery to locate the valuations of positive solutions.

2.2.6.1 Types of non-transversal cells

In Chapter 6 of this thesis, we only work with tropical hypersurfaces in dimension two. Therefore, we classify the types of mixed cells ξ in the case where two tropical plane curves intersect non-transversally at a cell ξ . Let $\overset{\circ}{\xi}$ denote the relative interior of ξ . Note that $\xi = \overset{\circ}{\xi}$ if ξ is a point. Assume that ξ is non-transversal, we distinguish three types for such ξ .

- A cell ξ is of **type (I)** if $\dim \xi = \dim \xi_1 = \dim \xi_2 = 1$.
- A cell ξ is of **type (II)** if one of the cells ξ_1 , or ξ_2 is a vertex, and the other cell is an edge.
- A cell ξ is of **type (III)** if ξ_1 and ξ_2 are vertices of the corresponding tropical curves.

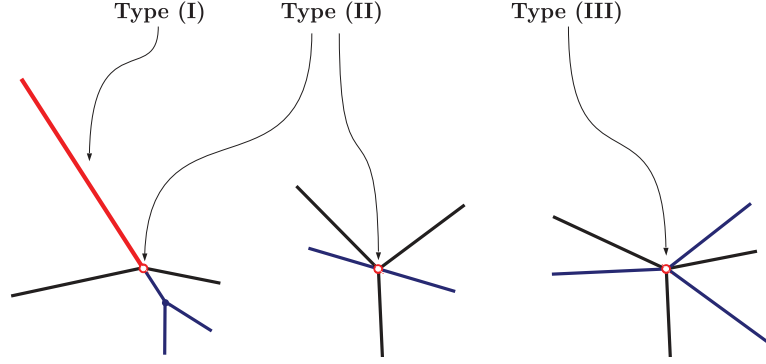

Figure 2.2: The three types of non-transversal intersection cells.

2.2.6.2 Reduced systems

Recall that for an element $a(t) \in \mathbb{K}^*$, we denote by $\text{coef}(a(t))$ the non-zero coefficient corresponding to the term of $a(t)$ with the smallest exponent of t .

Definition 2.20. Let $f = \sum_{w \in \Delta(f) \cap \mathbb{Z}^2} c_w z^w$ be a polynomial in $\mathbb{K}[z_1^{\pm 1}, z_2^{\pm 1}]$ with $c_w \in \mathbb{K}^*$, and let ξ denote a cell of V_f^{trop} . The **reduced polynomial** $f|_{\xi} \in \mathbb{C}[z_1^{\pm 1}, z_2^{\pm 1}]$ of f with respect to ξ is a polynomial defined as

$$f|_{\xi} = \sum_{w \in \Delta_{\xi} \cap \mathcal{W}} \text{coef}(c_w) z^w,$$

where \mathcal{W} is the support of f .

We extend this definition to the following. Consider a system

$$f_1(z) = f_2(z) = 0, \tag{2.2.4}$$

with f_1, f_2 in $\mathbb{K}[z_1^{\pm 1}, z_2^{\pm 1}]$ defined as above. Assume that the intersection set $T_1 \cap T_2$ of the tropical curves T_1 and T_2 is non-empty, and consider a mixed cell $\xi \in T_1 \cap T_2$. As explained in Subsection 2.2.4, the mixed cell ξ is written as $\xi_1 \cap \xi_2$ for some unique $\xi_1 \in T_1$ and $\xi_2 \in T_2$.

Definition 2.21. The **reduced system** of (2.2.4) with respect to ξ is the system

$$f_1|_{\xi_1} = f_2|_{\xi_2} = 0,$$

with $f_i|_{\xi_i}$ is the reduced polynomial of f_i with respect to ξ_i for $i = 1, 2$.

Let \mathcal{W}_1 and \mathcal{W}_2 denote the supports of f_1 and f_2 respectively, and write

$$f_1(z) = \sum_{v \in \mathcal{W}_1} a_v z^v \quad \text{and} \quad f_2(z) = \sum_{w \in \mathcal{W}_2} b_w z^w.$$

The following result also generalizes to a polynomial system defined on the same field with n equations in n variables.

Proposition 2.22. *If the system (2.2.4) has a solution $(\alpha, \beta) \in (\mathbb{K}^*)^2$ such that $\text{Val}(\alpha, \beta) \in \overset{\circ}{\xi}$, then $(\text{coef}(\alpha), \text{coef}(\beta))$ is a real solution of the reduced system*

$$f_1|_{\Delta_{\xi_1}} = f_2|_{\Delta_{\xi_2}} = 0. \quad (2.2.5)$$

Proof. Assume that (2.2.4) has a solution $(\alpha, \beta) \in (\mathbb{K}^*)^2$ such that $\text{Val}(\alpha, \beta) \in \overset{\circ}{\xi}$. Since $\text{Val}(\alpha, \beta)$ belongs to the relative interior of each of ξ_1 and ξ_2 , we have

$$\max\{\langle \text{Val}(\alpha, \beta), v \rangle + \text{val}(a_v), v \in \mathcal{W}_1 \setminus (\mathcal{W}_1 \cap \Delta_{\xi_1})\} < \langle \text{Val}(\alpha, \beta), v \rangle + \text{val}(a_v) \quad \text{for } v \in \mathcal{W}_1 \cap \Delta_{\xi_1}$$

and

$$\max\{\langle \text{Val}(\alpha, \beta), w \rangle + \text{val}(b_w), w \in \mathcal{W}_2 \setminus (\mathcal{W}_2 \cap \Delta_{\xi_2})\} < \langle \text{Val}(\alpha, \beta), w \rangle + \text{val}(b_w) \quad \text{for } w \in \mathcal{W}_2 \cap \Delta_{\xi_2}.$$

Consequently, since $\text{ord} = -\text{val}$, we have $M := -\langle \text{Val}(\alpha, \beta), v \rangle - \text{val}(a_v)$ and $N := -\langle \text{Val}(\alpha, \beta), w \rangle - \text{val}(b_w)$ are the orders of $f_1(\alpha, \beta)$ and $f_2(\alpha, \beta)$ respectively. Therefore, replacing (z_1, z_2) by $(t^{\text{ord}(\alpha)} z_1, t^{\text{ord}(\beta)} z_2)$ in (2.2.4), such a system becomes

$$\begin{aligned} f_1(t^{\text{ord}(\alpha)} z_1, t^{\text{ord}(\beta)} z_2) &= t^M \left(\sum_{v \in \mathcal{W}_1 \cap \Delta_{\xi_1}} \text{coef}(a_v) z^v + g_1(z) \right), \\ f_2(t^{\text{ord}(\alpha)} z_1, t^{\text{ord}(\beta)} z_2) &= t^N \left(\sum_{w \in \mathcal{W}_2 \cap \Delta_{\xi_2}} \text{coef}(b_w) z^w + g_2(z) \right), \end{aligned} \quad (2.2.6)$$

where all the coefficients of the polynomials g_1 and g_2 of $\mathbb{R}\mathbb{K}[z_1^{\pm 1}, z_2^{\pm 1}]$ have positive orders. Since (α, β) is a non-zero solution of (2.2.5), the system (2.2.6) has a non-zero solution (α_0, β_0) with $\text{ord}(\alpha_0) = \text{ord}(\beta_0) = 0$ and $\text{Coef}(\alpha, \beta) = \text{Coef}(\alpha_0, \beta_0)$. It follows that taking $t > 0$ small enough, we get that $\text{Coef}(\alpha_0, \beta_0)$ is a non-zero solution of

$$\sum_{v \in \mathcal{W}_1 \cap \Delta_{\xi_1}} \text{coef}(a_v) z^v = \sum_{w \in \mathcal{W}_2 \cap \Delta_{\xi_2}} \text{coef}(b_w) z^w = 0.$$

□

Note that Proposition 2.22 holds true for any type of tropical intersection cell ξ . However, the other direction does not always hold true when ξ is of type (I). Recall that a solution $(\alpha, \beta) \in (\mathbb{K}^*)^2$ is positive if $(\alpha, \beta) \in (\mathbb{R}\mathbb{K}_{>0}^*)^2$.

Proposition 2.23. *Assume that $\dim \xi = 0$ and that all solutions of (2.2.4) are non-degenerate. If the reduced system of (2.2.4) with respect to ξ has a non-degenerate solution $(\rho_1, \rho_2) \in (\mathbb{R}_{>0}^*)^2$, then (2.2.4) has a non-degenerate solution $(\alpha, \beta) \in (\mathbb{R}\mathbb{K}_{>0}^*)^2$ such that $\text{Val}(\alpha, \beta) = \xi$ and $\text{Coef}(\alpha, \beta) = (\rho_1, \rho_2)$.*

Proof. E. Brugallé and L. López De Medrano showed in [BLdM12, Proposition 3.11] (see also [Kat09, Rab12, OP13] for more details for higher dimension and more exposition relating toric varieties and tropical intersection theory) that the number of solutions of (2.2.4) with valuation ξ is equal to the mixed volume $\text{MV}(\Delta_{\xi_1}, \Delta_{\xi_2})$ of ξ_1 and ξ_2 (recall that $\Delta_{\xi} = \Delta_{\xi_1} + \Delta_{\xi_2}$). Since we assumed that (2.2.4) has only non-degenerate solutions in $(\mathbb{K}^*)^2$, we get $\text{MV}(\Delta_{\xi_1}, \Delta_{\xi_2})$ distinct solutions of the system (2.2.4) in $(\mathbb{K}^*)^2$ with given valuation ξ . By Proposition 2.22, if $f_1(z) = f_2(z) = 0$ and $\text{Val}(z) = \xi$, then $\text{Coef}(z)$ is a solution of the reduced system of (2.2.4) with respect to ξ . The number of solutions of the reduced system in $(\mathbb{C}^*)^2$ is $\text{MV}(\Delta_{\xi_1}, \Delta_{\xi_2})$. Assuming that this reduced

system has $MV(\Delta_{\xi_1}, \Delta_{\xi_2})$ distinct solutions in $(\mathbb{C}^*)^2$, we obtain that the map $z \mapsto \text{Coef}(z)$ induces a bijection from the set of solutions of (2.2.4) in $(\mathbb{K}^*)^2$ with valuation ξ onto the set of solutions in $(\mathbb{C}^*)^2$ of the reduced system of (2.2.4) with respect to ξ .

If z is a solution of (2.2.4) in $(\mathbb{K}^*)^2$ with $\text{Val}(z) = \xi$ and $\text{Coef}(z) \in (\mathbb{R}^*)^2$, then $z \in (\mathbb{R}\mathbb{K}^*)^2$ since otherwise, z, \bar{z} would be two distinct solutions of (2.2.4) in $(\mathbb{K}^* \setminus \mathbb{R}\mathbb{K}^*)^2$ such that $\text{Val}(z) = \text{Val}(\bar{z}) = \xi$ and $\text{Coef}(z) = \text{Coef}(\bar{z})$. \square

Chapter 3

Intersecting a sparse plane curve and a line

We prove in Section 3.2 the following result.

Theorem 3.1. *Let $f \in \mathbb{R}[x, y]$ be a polynomial with at most t non-zero terms and let a, b be any real numbers. Assume that the polynomial $g(x) = f(x, ax + b)$ is not identically zero. Then g has at most $6t - 7$ real roots counted with multiplicities except for the possible roots 0 and $-a/b$ that are counted at most once.*

In Section 3.3, we construct the equation (3.3.4) proving the following.

Theorem 3.2. *The maximal number of real intersection points of a real line with a real plane curve defined by a polynomial with three non-zero terms is eleven.*

3.1 Preliminary results

We present some results of M. Avendaño [Ave09] and add other ones. Consider a non-zero univariate polynomial $f(x) = \sum_{i=0}^d a_i x^i$ with real coefficients. Denote by $V(f)$ the number of change signs in the ordered sequence (a_0, \dots, a_d) disregarding the zero terms. Recall that the famous Descartes' rule of signs asserts that the number of (strictly) positive roots of f counted with multiplicities does not exceed $V(f)$.

Lemma 3.3. [Ave09] *We have $V((x + 1)f) \leq V(f)$.*

The following result is straightforward.

Lemma 3.4. [Ave09] *If $f, g \in \mathbb{R}[x]$ and g has t terms, then $V(f + g) \leq V(f) + 2t$.*

Denote by $\mathcal{N}(h)$ the Newton polytope of a polynomial h and by $\overset{\circ}{\mathcal{N}}(h)$ the interior of $\mathcal{N}(h)$.

Lemma 3.5. *If $f, g \in \mathbb{R}[X]$, g has t terms and $V(f + g) = V(f) + 2t$, then $\mathcal{N}(g)$ is contained in $\overset{\circ}{\mathcal{N}}(f)$.*

Proof. Assume that $\mathcal{N}(g)$ is not contained in $\overset{\circ}{\mathcal{N}}(f)$. Writing $f(x) = \sum_{i=1}^s a_i x^{\alpha_i}$ and $g(x) = \sum_{j=1}^t b_j x^{\beta_j}$ with $0 \leq \alpha_1 < \dots < \alpha_s$ and $0 \leq \beta_1 < \dots < \beta_t$, we get $\beta_1 \leq \alpha_1$ or $\alpha_s \leq \beta_t$. Assume that $\beta_1 \leq \alpha_1$ (the case $\alpha_s \leq \beta_t$ is symmetric). Then, obviously

$$V(f(x) + g(x)) \leq 1 + V(f(x) + g(x) - b_1 x^{\beta_1}).$$

By Lemma 3.4 we have

$$V(f(x) + g(x) - b_1 x^{\beta_1}) \leq V(f) + 2(t-1).$$

All together this gives $V(f+g) \leq 1 + V(f) + 2(t-1) = V(f) + 2t - 1$. \square

Proposition 3.6. [Ave09] *If $f \in \mathbb{R}[x, y]$ has t non-zero terms, then*

$$V(f(x, x+1)) \leq 2t - 2.$$

Proof. Write $f(x, y) = \sum_{k=1}^n a_k(x) y^{\alpha_k}$, with $0 \leq \alpha_1 < \dots < \alpha_n$ and $a_k(x) \in \mathbb{R}[x]$. Denote by t_k the number of non-zero terms of $a_k(x)$. Define

$$f_k(x, y) = \sum_{j=k}^n a_j(x) y^{\alpha_j - \alpha_k}, \quad k = 1, \dots, n,$$

and $f_{n+1} = 0$. Then $f_k(x, x+1) = (x+1)^{\alpha_{k+1} - \alpha_k} f_{k+1}(x, x+1) + a_k(x)$ for $k = 1, \dots, n-1$ and $f_n(x, x+1) = a_n(x)$. Therefore, $V(f_k(x, x+1)) \leq V(f_{k+1}(x, x+1)) + 2t_k$ by Lemma 3.3 and Lemma 3.4. Finally, $V(f(x, x+1)) \leq V(f_1(x, x+1))$ since $f(x, x+1) = (x+1)^{\alpha_1} f_1(x, x+1)$. We conclude that $V(f(x, x+1)) \leq -2 + 2(t_1 + \dots + t_n) = 2t - 2$. \square

Proposition 3.7. *Let $f \in \mathbb{R}[x, y]$ be a polynomial with t non-zero terms. Write it as $f(x, y) = \sum_{i=1}^t b_i x^{\beta_i} y^{\gamma_i}$ with $0 \leq \gamma_1 \leq \gamma_2 \leq \dots \leq \gamma_t$. If $V(f(x, x+1)) = 2t - 2$, then*

$$\mathcal{N}(b_i x^{\beta_i} (x+1)^{\gamma_i}) \subset \overset{\circ}{\mathcal{N}}(b_t x^{\beta_t} (x+1)^{\gamma_t})$$

(in other words, $\beta_t < \beta_i \leq \beta_i + \gamma_i < \beta_t + \gamma_t$) for $i = 1, \dots, t-1$.

Proof. We use the proof of Proposition 3.6 keeping its notations. Write $f(x, y) = \sum_{k=1}^n a_k(x) y^{\alpha_k}$ with $0 \leq \alpha_1 < \dots < \alpha_n$ and assume that $V(f(x, x+1)) = 2t - 2$. It follows from the proof of Proposition 3.6 that

$$V(f_k(x, x+1)) = V(f_{k+1}(x, x+1)) + 2t_k, \quad k = 1, \dots, n. \quad (3.1.1)$$

Recall that $f_k(x, x+1) = (x+1)^{\alpha_{k+1} - \alpha_k} f_{k+1}(x, x+1) + a_k(x)$ for $k \leq n-1$. By Lemma 3.5 and (3.1.1) we get $\mathcal{N}(a_k(x)) \subset \overset{\circ}{\mathcal{N}}((x+1)^{\alpha_{k+1} - \alpha_k} f_{k+1}(x, x+1))$ and thus

$$\mathcal{N}(a_k(x)(x+1)^{\alpha_k}) \subset \overset{\circ}{\mathcal{N}}((x+1)^{\alpha_{k+1}} f_{k+1}(x, x+1)) \quad (3.1.2)$$

for $k = 1, \dots, n-1$. We now show by induction on $n-k \geq 1$ that

$$\mathring{\mathcal{N}}((x+1)^{\alpha_{k+1}} f_{k+1}(x, x+1)) \subset \mathring{\mathcal{N}}(a_n(x)(x+1)^{\alpha_n}). \quad (3.1.3)$$

Together with (3.1.2) this will imply $\mathcal{N}(a_k(x)(x+1)^{\alpha_k}) \subset \mathring{\mathcal{N}}(a_n(x)(x+1)^{\alpha_n})$ for $k = 1, \dots, n-1$, and thus $\mathcal{N}(b_i x^{\beta_i}(x+1)^{\gamma_i}) \subset \mathring{\mathcal{N}}(b_i x^{\beta_i}(x+1)^{\gamma_i})$ for $i = 1, \dots, t-1$. For $n-k = 1$ the inclusion (3.1.3) is obvious. Since $f_k(x, x+1) = (x+1)^{\alpha_{k+1}-\alpha_k} f_{k+1}(x, x+1) + a_k(x)$ and $\mathcal{N}(a_k(x)) \subset \mathring{\mathcal{N}}((x+1)^{\alpha_{k+1}-\alpha_k} f_{k+1}(x, x+1))$, we get $\mathring{\mathcal{N}}(f_k(x, x+1)) = \mathring{\mathcal{N}}((x+1)^{\alpha_{k+1}-\alpha_k} f_{k+1}(x, x+1))$. Assuming (3.1.3) is true for k (hypothesis induction), this immediately gives $\mathring{\mathcal{N}}((x+1)^{\alpha_k} f_k(x, x+1)) \subseteq \mathring{\mathcal{N}}(a_n(x)(x+1)^{\alpha_n})$ and thus (3.1.3) is proved for $k-1$. \square

3.2 Proof of Theorem 3.1

We first recall the proof of the bound $6t-4$ in [Ave09]. Let $f(x, y) = \sum_{i=1}^t b_i x^{\beta_i} y^{\gamma_i} \in \mathbb{R}[x, y]$ be a polynomial with at most t non-zero terms, and let $a, b \in \mathbb{R}$. Set $g(x) = f(x, ax+b)$. If $a = 0$ or $b = 0$, then f has at most t non-zero terms and Descartes' rule of signs implies that either $g = 0$ or g has at most $2t-1 \leq 6t-4$ real roots (counted with multiplicities except for the possible root 0). If $ab \neq 0$, then the real roots of $f(x, ax+b)$ correspond bijectively to the real roots of $f(bx/a, b(x+1)) = \hat{f}(x, x+1)$, where $\hat{f}(x, y) = \sum_{i=1}^t b_i a^{-\beta_i} b^{\beta_i+\gamma_i} x^{\beta_i} y^{\gamma_i}$. Since this bijection preserves multiplicities and maps the possible roots 0 and $-b/a$ of g to the roots 0 and -1 of $\hat{f}(x, x+1)$, it suffices to consider the case $a = b = 1$, i.e. $g(x) = f(x, x+1)$. So we now consider $g(x) = f(x, x+1)$. Assume that $g \neq 0$ and denote by d the degree of g .

Descartes' rule of signs and Proposition 3.6 imply that the number of positive roots of g counted with multiplicities is at most $2t-2$. The roots of g in $] -\infty, -1[$ correspond bijectively to the positive roots of $g(-1-x) = f(-1-x, -x) = \sum_{i=1}^t b_i (-1)^{\beta_i+\gamma_i} x^{\beta_i} (x+1)^{\beta_i}$. Therefore, by Proposition 3.6 the number of roots (counted with multiplicities) of g in $] -\infty, -1[$ cannot exceed $2t-2$. Finally, the roots of g in $] -1, 0[$ correspond bijectively to the positive roots of $(x+1)^d g(\frac{-x}{x+1}) = (x+1)^d f(\frac{-x}{x+1}, \frac{1}{x+1}) = \sum_{i=1}^t b_i (-1)^{\beta_i} x^{\beta_i} (x+1)^{d-\beta_i-\gamma_i}$. Thus, by Proposition 3.6 there are at most $2t-2$ such roots.

All together, this leads to the conclusion that g has at most $3(2t-2) + 2 = 6t-4$ real roots counted with multiplicities except for the possible roots 0 and -1 that are counted at most once.

We now start the proof of Theorem 3.1.

Set $I_1 =]0, +\infty[$, $I_2 =]-\infty, -1[$ and $I_3 =]-1, 0[$. For $h \in \mathbb{R}[x]$ define

$$V_{I_1}(h) = V(h), \quad V_{I_2}(h) = V(h(-1-x)) \quad \text{and}$$

$$V_{I_3}(h) = V\left((x+1)^{\deg(h)} h\left(\frac{-x}{x+1}\right)\right).$$

By Descartes' rule of sign the number of roots of h in I_i does not exceed $V_{I_i}(h)$. To prove Theorem 3.1, it suffices to show that

$$V_{I_1}(g) + V_{I_2}(g) + V_{I_3}(g) \leq 3(2t-2) - 3 \quad (3.2.1)$$

Define polynomials

$$h_1(x) = x^d h\left(\frac{1}{x}\right), \quad h_2(x) = (x+1)^d h\left(\frac{-x}{x+1}\right) \quad \text{and} \quad h_3(x) = h(-1-x)$$

so that $V_{I_1}(h_1) = V_{I_1}(h)$, $V_{I_1}(h_2) = V_{I_3}(h)$ and $V_{I_1}(h_3) = V_{I_2}(h)$.

Lemma 3.8. *For any i, j, k such that $\{i, j, k\} = \{1, 2, 3\}$, we have*

$$V_{I_i}(h_i) = V_{I_i}(h) \quad \text{and} \quad V_{I_i}(h_j) = V_{I_k}(h)$$

Proof. We have $h_1(-x-1) = (-1)^d(x+1)^d h\left(-\frac{1}{x+1}\right)$. Therefore

$$V(h_1(-x-1)) = V\left((x^{-1}+1)^d h\left(-\frac{1}{x^{-1}+1}\right)\right), \text{ thus}$$

$$V(h_1(-x-1)) = V\left(\left(\frac{x+1}{x}\right)^d h\left(-\frac{x}{x+1}\right)\right) = V\left((x+1)^d h\left(-\frac{x}{x+1}\right)\right),$$

and we get $V_{I_2}(h_1) = V_{I_3}(h)$. We have $(x+1)^d h_1\left(-\frac{x}{x+1}\right) = (-x)^d h(-1-x^{-1})$ from which we obtain $V_{I_3}(h_1) = V_{I_2}(h)$.

Equalities $V_{I_2}(h_2) = V_{I_2}(h)$ and $V_{I_3}(h_2) = V_{I_1}(h)$ follow from $h_2(-1-x) = (-x)^d h(-1-x^{-1})$ and $(x+1)^d h_2\left(-\frac{x}{x+1}\right) = h(x)$.

Finally, $V_{I_2}(h_3) = V_{I_1}(h)$ comes from $h_3(-x-1) = h(x)$ and $V_{I_3}(h_3) = V_{I_3}(h)$ is a consequence of $(x+1)^d h_3\left(-\frac{x}{x+1}\right) = (x+1)^d h\left(-\frac{1}{x+1}\right)$ and the equality $V((x+1)^d h\left(-\frac{1}{x+1}\right)) = V_{I_3}(h)$ shown above. \square

We now proceed to the proof of (3.2.1). We already know that $V_{I_i}(g) \leq 2t-2$ for $i = 1, 2, 3$. If $V_{I_i}(g) \leq 2t-3$ for all i , then (3.2.1) is trivially true. With the help of Lemma 3.8, it suffices now to show that if $V_{I_1}(g) = 2t-2$ then $V_{I_2}(g) \leq 2t-3$, $V_{I_3}(g) \leq 2t-3$, and $V_{I_2}(g) + V_{I_3}(g) < 2(2t-3)$. So assume $V_{I_1}(g) = 2t-2$. Then by Proposition 3.7

$$\beta_t < \beta_i \leq \beta_i + \gamma_i < \beta_t + \gamma_t, \quad i = 1, \dots, t-1. \quad (3.2.2)$$

We have $g(-1-x) = \sum_{i=1}^t b_i (-1)^{\beta_i + \gamma_i} x^{\gamma_i} (x+1)^{\beta_i}$. Recall that $V_{I_2}(g) = V(g(-x-1)) \leq 2t-2$ by Proposition 3.6. From (3.2.2), we get $\gamma_t > \gamma_i$ for $i = 1, \dots, t-1$. It follows then from Proposition 3.7 that $V(g(-x-1)) \leq 2t-3$.

Write $g(-1-x) = \tilde{g}(-x-1) + b_t (-1)^{\beta_t + \gamma_t} x^{\gamma_t} (x+1)^{\beta_t}$, and then $g(-1-x)(x+1)^{-\beta_t} = \tilde{g}(-x-1)(x+1)^{-\beta_t} + b_t (-1)^{\beta_t + \gamma_t} x^{\gamma_t}$. We note that (3.2.2) implies $\beta_t < \beta_i$ for $i = 1, \dots, t-1$, so that both members of the previous equality are polynomials. Moreover, from (3.2.2) we also get $\beta_i - \beta_t + \gamma_i < \gamma_t$, and thus γ_t does not belong to the Newton polytope of the polynomial $\tilde{g}(-x-1)(x+1)^{-\beta_t}$. It follows that $V(g(-1-x)(x+1)^{-\beta_t}) \leq V(\tilde{g}(-x-1)(x+1)^{-\beta_t}) + 1$. By Lemma 3.3 we have $V(g(-1-x)) \leq V(g(-x-1)(x+1)^{-\beta_t})$. Therefore, $V(g(-1-x)) \leq V(\tilde{g}(-x-1)(x+1)^{-\beta_t}) + 1$. On the other hand Proposition 3.6 yields $V(\tilde{g}(-x-1)(x+1)^{-\beta_t}) \leq 2(t-1) - 2 = 2t-4$.

Therefore, if $V(g(-1-x)) = 2t-3$, then $V(\tilde{g}(-x-1)(x+1)^{-\beta_t}) = 2t-4$, and we may apply Proposition 3.7 to $\tilde{g}(-x-1)(x+1)^{-\beta_t}$ in order to get

$$\gamma_{i_0} < \gamma_i \leq \gamma_i + \beta_i < \gamma_{i_0} + \beta_{i_0} \text{ for all } i = 1, \dots, t-1 \text{ and } i \neq i_0, \quad (3.2.3)$$

where i_0 is determined by $\beta_{i_0} \geq \beta_i$ for $i = 1, \dots, t-1$.

Starting with $g_1(x) = x^d g(1/x) = \sum_{i=1}^t b_i x^{d-\beta_i-\gamma_i} (x+1)^{\gamma_i}$ instead of g in the previous computation, we obtain that if $V(g_1) = 2t-2$ then $V_{I_2}(g_1) \leq 2t-3$ and if $V_{I_2}(g_1) = 2t-3$, then the substitution of $d - \beta_i - \gamma_i$ for β_i in (3.2.3) holds true:

$$\gamma_{i_1} < \gamma_i \leq d - \beta_i < d - \beta_{i_1} \text{ for all } i = 1, \dots, t-1 \text{ and } i \neq i_1, \quad (3.2.4)$$

where i_1 is determined by $d - \beta_{i_1} - \gamma_{i_1} \geq d - \beta_i - \gamma_i$ for $i = 1, \dots, t - 1$.

On the other hand, $V(g) = V(g_1)$ and $V(g_1(-x - 1)) = V_{I_2}(g_1) = V_{I_3}(g)$ by Lemma 3.8. Thus if $V(g) = 2t - 2$ then $V_{I_3}(g) \leq 2t - 3$ and if $V_{I_3}(g) = 2t - 3$, then formula (3.2.4) holds true. It turns out that (3.2.3) and (3.2.4) are incompatible. Indeed, if (3.2.3) and (3.2.4) hold true simultaneously, then $i_0 = i_1$ but then (3.2.4) implies that $\gamma_{i_0} + \beta_{i_0} < \gamma_i + \beta_i$ for all $1, \dots, t - 1$ with $i \neq i_0$ which contradicts (3.2.3). Consequently, if $V(g) = V_{I_1}(g) = 2t - 2$, then $V_{I_2}(g) \leq 2t - 3$, $V_{I_3}(g) \leq 2t - 3$ and $V_{I_2}(g) + V_{I_3}(g) < 2(2t - 3)$.

3.3 Optimality

We prove that the bound in Theorem 3.1 is sharp for $t = 3$ (Theorem 3.2). We look for a polynomial $P \in \mathbb{R}[x, y]$ with three non-zero terms such that $P(x, x + 1)$ has nine real roots distinct from 0 and -1 . It follows from the previous section that if such P exists then, either $P(x, x + 1)$ has three roots in each interval I_1 , I_2 and I_3 , or $P(x, x + 1)$ has four roots in one interval, three roots in another interval, and two roots in the last one. We give necessary conditions for the second case, which thanks to Lemma 3.8 reduces to the case where $P(x, x + 1)$ has four roots in $I_1 =]0, +\infty[$, three roots in $I_3 =]-1, 0[$ and two roots in $I_2 =]-\infty, -1[$.

Multiplication of P by a monomial does not alter the roots of $P(x, x + 1)$ in $\mathbb{R} \setminus \{0, -1\}$, so dividing by the smallest power of x , we may assume that P has the following form

$$P(x, y) = ay^{l_1} + bx^{k_2}y^{l_2} + x^{k_3}y^{l_3},$$

where k_2, k_3, l_1, l_2, l_3 are nonnegative integer numbers and a, b are real numbers.

Lemma 3.9. *If $P(x, x + 1)$ has four real positive roots, then $k_2 > 0$, $k_3 > 0$, $l_1 > l_2 + k_2$ and $l_1 > l_3 + k_3$.*

Proof. If $P(x, x + 1)$ has four real positive roots, then $V(P(x, x + 1)) = 4$. Rewriting $P(x, x + 1) = \sum_{i=1}^3 b_i x^{\beta_i} (x + 1)^{\gamma_i}$ with $0 \leq \gamma_1 \leq \gamma_2 \leq \gamma_3$, Proposition 3.7 yields $\beta_3 < \beta_i \leq \beta_i + \gamma_i < \beta_3 + \gamma_3$ for $i = 1, 2$. Since k_2 and k_3 are nonnegative, we get $\beta_3 = 0$, $k_2, k_3 > 0$ and $\beta_3 + \gamma_3 = \gamma_3 = l_1$, so $l_1 > \max(l_2 + k_2, l_3 + k_3)$. \square

Since $l_1 > l_2$ and $l_1 > l_3$, we may divide $P(x, x + 1)$ by $(x + 1)^{l_2}$ or $(x + 1)^{l_3}$ to get a polynomial equation with the same solutions in $\mathbb{R} \setminus \{0, -1\}$. So without loss of generality we may assume that

$$P(x, x + 1) = a(x + 1)^{l_1} + bx^{k_2}(x + 1)^{l_2} + x^{k_3}, \quad (3.3.1)$$

where $k_2, k_3 > 0$, $l_2 \geq 0$, $l_1 > k_2 + l_2$ and $l_1 > k_3$.

Lemma 3.10. *Assume that the polynomial (3.3.1) has four roots in I_1 , and three roots in I_3 or I_2 . Then k_3 does not belong to the interval $[k_2, k_2 + l_2]$. Moreover, we have $a < 0$ and $b > 0$.*

Proof. We prove that if $k_2 \leq k_3 \leq k_2 + l_2$, then (3.3.1) has at most two roots in I_2 and in I_3 .

The roots in I_2 are in bijection with the positive roots of

$$P(-x - 1, -x) = (-1)^{l_1} ax^{l_1} + (-1)^{k_2 + l_2} bx^{l_2} (x + 1)^{k_2} + (-1)^{k_3} (1 + x)^{k_3}.$$

Recall that $l_2 \geq 0$. If $k_2 \leq k_3 \leq k_2 + l_2$ then Proposition 3.7 yields $V((-1)^{k_2 + l_2} bx^{l_2} (x + 1)^{k_2} + (-1)^{k_3} (1 + x)^{k_3}) \leq 1$. Now, since $l_1 > k_2 + l_2$ and $l_1 > k_3$, we get $V(P(-x - 1, -x)) \leq 2$, and thus (3.3.1) has at most two roots in I_2 .

The roots in I_3 are in bijection with the positive roots of

$$(1+x)^{l_1} P\left(\frac{-x}{x+1}, \frac{-x}{x+1} + 1\right) = a + b(-1)^{k_2} x^{k_2} (1+x)^{l_1-k_2-l_2} + (-1)^{k_3} x^{k_3} (1+x)^{l_1-k_3}$$

From $k_3 \leq k_2 + l_2$, we get $l_1 - k_2 - l_2 \leq l_1 - k_3$. Thus, Proposition 3.7 together with $k_2 \leq k_3$ yields $V(b(-1)^{k_2} x^{k_2} (1+x)^{l_1-k_2-l_2} + (-1)^{k_3} x^{k_3} (1+x)^{l_1-k_3}) \leq 1$. From $k_2, k_3 > 0$ we get $V((1+x)^{l_1} P(\frac{-x}{x+1}, \frac{-x}{x+1} + 1)) \leq 2$, and thus (3.3.1) has at most two roots in I_3 .

Finally, if (3.3.1) has four positive roots, then obviously $ab < 0$. If k_3 does not belong to $[k_2, k_2 + l_2]$ and $a > 0$, then $V((x+1)^{l_1} + bx^{k_2}(x+1)^{l_2} + x^{k_3}) = V((x+1)^{l_1} + bx^{k_2}(x+1)^{l_2})$ (recall that $k_2 \leq k_2 + l_2 < l_1$). But the second sign variation is at most two by Proposition 3.6. We conclude that $a < 0$ and $b > 0$. \square

Lemma 3.11. *Assume that the polynomial (3.3.1) has four roots in I_1 , two roots in I_2 and three roots in I_3 . Assume furthermore that $k_3 < k_2$. Then, l_1 is odd, k_2 is odd, k_3 is even and l_2 is even.*

Proof. Since (3.3.1) has exactly nine real roots counted with multiplicity, its degree l_1 is odd. We have already seen that if (3.3.1) has four roots in $I_1 =]0, +\infty[$, two roots in $I_2 =]-\infty, -1[$ and three roots in $I_3 =]-1, 0[$, then $a < 0$, $b > 0$, $l_1 > l_2$ and $k_3 \notin [k_2, k_2 + l_2]$. Assume from now on that $k_3 < k_2$.

Since (3.3.1) has two roots in $I_2 =]-\infty, -1[$, we have $V(P(-x-1, -x)) \geq 2$, where $P(-x-1, -x) = (-1)^{k_3} (1+x)^{k_3} + (-1)^{k_2+l_2} bx^{l_2} (x+1)^{k_2} + (-1)^{l_1} ax^{l_1}$. But since $k_3 < k_2 \leq k_2 + l_2 < l_1$, we get that $(-1)^{k_3} \cdot (-1)^{k_2+l_2} b < 0$ and $(-1)^{k_2+l_2} b \cdot (-1)^{l_1} a < 0$. Using $a < 0$ and $b > 0$, we obtain that $k_2 + l_2$ is odd and k_3 is even.

Since (3.3.1) has three roots in $I_3 =]-1, 0[$, we have $V((1+x)^{l_1} P(\frac{-x}{x+1}, \frac{-x}{x+1} + 1)) \geq 3$, where $(1+x)^{l_1} P(\frac{-x}{x+1}, \frac{-x}{x+1} + 1) = a + b(-1)^{k_2} x^{k_2} (1+x)^{l_1-k_2-l_2} + (-1)^{k_3} x^{k_3} (1+x)^{l_1-k_3-l_3}$. We know that k_3 is even and that $b > 0$. Thus in order to get coefficients with different signs in $b(-1)^{k_2} x^{k_2} (1+x)^{l_1-k_2-l_2} + (-1)^{k_3} x^{k_3} (1+x)^{l_1-k_3-l_3}$, the integer k_2 should be odd. Since we know that $k_2 + l_2$ is odd, this gives that l_2 is even. \square

Assume now that (3.3.1) has four roots in I_1 , two roots in I_2 and three roots in I_3 . Then $a < 0$, $b > 0$ and k_3 does not belong to $[k_2, k_2 + l_2]$ by Lemma 3.10. Assume that $k_3 < k_2$. Then l_1 is odd, k_2 is odd, k_3 is even and l_2 is even by Lemma 3.11. The roots of (3.3.1) are solutions to the equation $f(x) = -a$, where $f(x) = bx^{k_2}(1+x)^{l_2-l_1} + x^{k_3}(1+x)^{-l_1}$. Since the rational function f has no pole outside $\{-1, 0\}$, by Rolle's Theorem its derivative has at least three roots in I_1 , one root in I_2 and two roots in I_3 . We compute that $f'(x) = 0$ is equivalent to $\Phi(x) = 1$, where Φ is the rational map

$$\Phi(x) = \frac{-bx^{k_2-k_3}(1+x)^{l_2} A_1(x)}{A_2(x)}, \quad (3.3.2)$$

with $A_1(x) = (k_2 + l_2 - l_1)x + k_2$ and $A_2(x) = (k_3 - l_1)x + k_3$. From $0 < k_3 < k_2$, $l_2 \geq 0$ and $l_1 > 0$, we obtain that the roots of A_1 and A_2 satisfy $0 < \frac{k_3}{l_1 - k_3} < \frac{k_2}{l_1 - k_2 - l_2}$. Moreover, the roots of Φ are -1 with even multiplicity l_2 , 0 with odd multiplicity $k_2 - k_3$ and the positive root of A_1 (which is a simple root of Φ). The poles of Φ are the positive root of A_2 and the point at infinity which has multiplicity $\deg(\Phi) - 1$ if we homogenize Φ into a rational map from the Riemann sphere $\mathbb{C}P^1$ to itself.

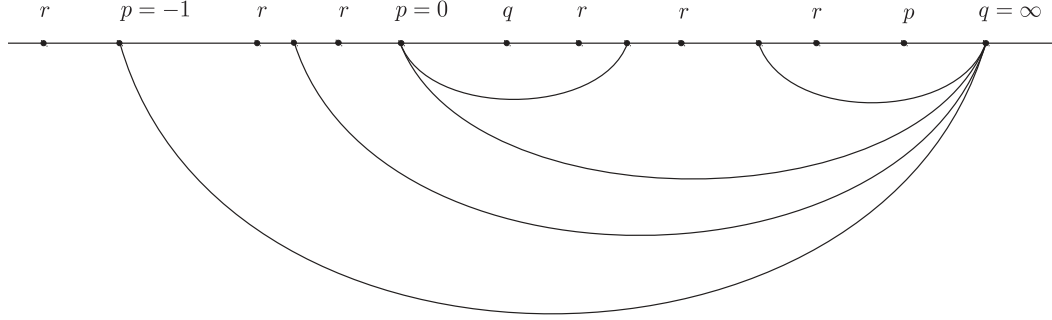
Figure 3.1: A real dessin d'enfant for φ .

We find exact values of coefficients and exponents of (3.3.2) in the following way. Note that the exponents of (3.3.2) are independent of l_1 . We first choose small values $k_2 = 5$, $k_3 = 2$, $l_2 = 2$ satisfying the above parity conditions. Then, we look for a function

$$\varphi(x) = \frac{cx^3(x+1)^2(x-\rho_1)}{x-\rho_2}, \quad (3.3.3)$$

such that c is some real constant, $0 < \rho_2 < \rho_1$ and $\varphi(x) = 1$ has three solutions in I_1 , one solution in I_2 and two solutions in I_3 .

The existence of such a function φ is certified by Figure 3.1 thanks to Proposition 2.2. Figure 3.1 shows $H\Gamma$ contained in one connected component of $\mathbb{C}P^1 \setminus \mathbb{R}P^1$. From Figure 3.1, we see that $0 < \rho_2 < \rho_1$ and that φ has the desired number of inverse images (letters r) of 1 in each interval I_i .

Now we want to identify (3.3.3) and (3.3.2). Recall that $k_2 = 5$, $k_3 = 2$, $l_2 = 2$ are fixed. We look at the function $\frac{x^3(x+1)^2(x-\rho_1)}{x-\rho_2}$, where $\rho_1 = \frac{k_2}{l_1-k_2-l_2}$ and $\rho_2 = \frac{k_3}{l_1-k_3}$, and increase l_1 so that some level set of this function has three solutions in I_1 , one solution in I_2 and two solutions in I_3 . It turns out that $l_1 = 17$ is large enough and the level set gives the value 29 for b . Finally, integrating Φ and choosing $a = -0,002404$, we get

$$-0.002404(x+1)^{17} + 29x^5(x+1)^2 + x^2 \quad (3.3.4)$$

for (3.3.1). This polynomial has four roots in I_1 , two roots in I_2 and three roots in I_3 . This has been computed using SAGE version 6.6 which gives the following approximated roots: 0.18859, 0.22206, 0.25196, 0.44416 in I_1 , -3.96032 , -1.15048 in I_2 , and -0.61459 , -0.58528 , -0.03594 in I_3 .

Multiplying this polynomial by $x(x+1)$ gives a polynomial of the form $P(x, x+1)$ (where $P \in \mathbb{R}[x, y]$ has three non-zero terms) having eleven real roots.

Chapter 4

Positive intersection points of a trinomial and a t-nomial curves

4.1 Introduction and statement of the main results

Consider a system

$$f = g = 0, \tag{4.1.1}$$

where f has $t \geq 3$ non-zero terms and g has three non-zero terms. We assume in this chapter that (4.1.1) has a finite number of solutions, and denote by $\mathcal{S}(3, t)$ the maximal number of non-degenerate positive solutions such a system can have. We prove the following result in Section 4.2.

Theorem 4.1. *We have $\mathcal{S}(3, t) \leq 3 \cdot 2^{t-2} - 1$.*

Consider now a function

$$\phi(x) = \frac{x^\alpha(1-x)^\beta P(x)}{Q(x)},$$

where $\alpha, \beta \in \mathbb{Q}$, and both P and Q are real polynomials. Using real dessins d'enfant, we prove in Section 4.3 the following result.

Theorem 4.2. *We have $\#\{x \in]0, 1[\mid \phi(x) = 1\} \leq \deg P + \deg Q + 2$.*

We say that two triangles Δ_1 and Δ_2 in \mathbb{R}^2 alternate when any two consecutive edges of their Minkowski sum $\Delta_1 + \Delta_2$ are not translate of two consecutive edges of Δ_1 or of Δ_2 (see Definition 4.30). We prove in Section 4.4 the following result.

Theorem 4.3. *If a system of two trinomials in two variables has 5 positive solutions, then the Newton triangles of the respective equations do not alternate.*

4.2 Proof of Theorem 4.1

Define the polynomials f and g of (4.1.1) as

$$f(u, v) = \sum_{i=1}^t a_i u^{\alpha_i} v^{\beta_i} \quad \text{and} \quad g(u, v) = \sum_{j=1}^3 b_j u^{\gamma_j} v^{\delta_j}, \quad (4.2.1)$$

where all a_i and b_i are real.

We suppose that the system (4.1.1) has positive solutions, thus the coefficients of g have different signs. Therefore without loss of generality, let $b_1 = -1$, $b_2 > 0$ and $b_3 > 0$. Since we are looking for positive solutions of (4.1.1) with non-zero coordinates, one can assume that $\gamma_1 = \delta_1 = 0$. Furthermore, the monomial change of coordinates $(u, v) \rightarrow (x, y)$ of $(\mathbb{C}^*)^2$ defined by $b_2 u^{\gamma_2} v^{\delta_2} = x$ and $b_3 u^{\gamma_3} v^{\delta_3} = y$ preserves the number of positive solutions. Therefore, we are reduced to a system

$$\sum_{i=1}^t c_i x^{k_i} y^{l_i} = -1 + x + y = 0, \quad (4.2.2)$$

where c_i is real for $i = 1, \dots, t$, and all k_i and l_i are rational numbers.

We now look for the positive solutions of (4.2.2). It is clear that since both x and y are positive, then $x \in]0, 1[$. Substituting $1 - x$ for y in (4.2.2), we get

$$F(x) := \sum_{i=1}^t c_i x^{k_i} (1-x)^{l_i}, \quad (4.2.3)$$

so that the number of positive solutions of (4.1.1) is equal to that of roots of F in $]0, 1[$. For any $d \in \mathbb{N}$, denote by $\mathbb{R}_d[x]$ the set of real polynomials of degree at most d .

Lemma 4.4. *Consider a function defined by $h(x) = \sum_{i=1}^s b_i x^{m_i} (1-x)^{n_i} h_{i,d}(x)$, where $h_{1,d}, \dots, h_{s,d} \in \mathbb{R}_d[x]$. Then for all $r \in \mathbb{N}$, there exist $h_{1,d+r}, \dots, h_{s,d+r} \in \mathbb{R}_{d+r}[x]$ such that the r -th derivative of h is defined by*

$$h^{(r)}(x) = \sum_{i=1}^s x^{m_i-r} (1-x)^{n_i-r} h_{i,d+r}(x).$$

Proof. One computes that

$$(x^m (1-x)^n h(x))' = x^{m-1} (1-x)^{n-1} \cdot [((n-m)x + m) h(x) + x(1-x) h'(x)].$$

□

Define f_1, \dots, f_t inductively by $f_1(x) = x^{-k_1} (1-x)^{-l_1} F(x)$ and

$$f_{j+1}(x) = x^{k_j - k_{j+1} + 2^{j-1}} \cdot (1-x)^{l_j - l_{j+1} + 2^{j-1}} \cdot f_j^{(2^{j-1})}(x), \quad j = 1, \dots, t-1.$$

Lemma 4.5. *For $j = 1, \dots, t$, there exist polynomials $h_{j,d_j}, \dots, h_{t,d_j} \in \mathbb{R}_{d_j}[x]$ such that $d_j = 2^{j-1} - 1$,*

$$f_j(x) = h_{j,d_j}(x) + \sum_{i=j+1}^t x^{k_i - k_j} (1-x)^{l_i - l_j} h_{i,d_j} \quad \text{for } j = 1, \dots, t-1 \quad (4.2.4)$$

and $f_t = h_{t,d_t}(x)$.

Proof. This follows easily from Lemma 4.4. \square

Let N_j denote the value $\#\{x \in]0, 1[\mid f_j(x) = 0\}$ for $j = 1, \dots, t$. Note that $N_1 = \#\{x \in]0, 1[\mid F(x) = 0\}$. Rolle's Theorem implies directly that

$$N_j \leq N_{j+1} + 2^{j-1} \quad \text{for } j = 1, \dots, t-1. \quad (4.2.5)$$

Moreover, $N_t \leq d_t = 2^{t-1} - 1$ by Lemma 4.5. Consequently, we get

$$\#\{x \in]0, 1[\mid F(x) = 0\} = N_1 \leq \sum_{j=1}^{t-2} 2^{j-1} + N_{t-1} = 2^{t-2} - 1 + N_{t-1}. \quad (4.2.6)$$

By (4.2.5), we have $N_{t-1} \leq N_t + 2^{t-2} \leq 2^{t-1} - 1 + 2^{t-2}$ (since $N_t \leq 2^{t-1} - 1$), which together with (4.2.6) gives

$$\#\{x \in]0, 1[\mid F(x) = 0\} \leq 2^t - 2.$$

This is the bound obtained in [LRW03]. The sharper bound that we give is obtained by improving the bound on N_{t-1} . This improvement uses the fact that f_{t-1}^m is a rational function for some $m \in \mathbb{N}$, thus one can use a different approach to get a sharp bound on N_{t-1} . We have already seen that

$$f_{t-1}(x) = -Q(x) + x^{k_t - k_{t-1}}(1-x)^{l_t - l_{t-1}}P(x),$$

where $P, Q \in \mathbb{R}_{d_{t-1}}[x]$ with $d_{t-1} = 2^{t-2} - 1$. We have

$$f_{t-1}(x) = 0 \iff \frac{x^{k_t - k_{t-1}}(1-x)^{l_t - l_{t-1}}P(x)}{Q(x)} = 1.$$

Therefore applying Theorem 4.2, we get $N_{t-1} \leq 2^{t-1} - 2 + 2 = 2^{t-1}$. Finally, by (4.2.5), we get

$$\#\{x \in]0, 1[\mid f(x) = 0\} \leq 2^{t-1} + 2^{t-2} - 1 = 3 \cdot 2^{t-2} - 1,$$

which finishes the proof of Theorem 4.1 assuming Theorem 4.2.

4.3 Proof of Theorem 4.2

Consider the function

$$\phi(x) = \frac{x^\alpha(1-x)^\beta P(x)}{Q(x)},$$

where $\alpha, \beta \in \mathbb{Q}$ and $P, Q \in \mathbb{R}[x]$. Let m be a positive integer such that $m\alpha$ and $m\beta$ are integers. Then $\varphi := \phi^m$ is a rational function. Here and in the rest of this chapter, we see the source and target spaces of φ as the affine charts of $\mathbb{C}P^1$ given by the non-vanishing of the first coordinate of homogeneous coordinates and denote with the same symbol φ the rational function from $\mathbb{C}P^1$ to $\mathbb{C}P^1$ obtained by homogenization with respect to these coordinates. In what follows, we apply the theory of Groethendieck's dessin d'enfant to the rational function φ .

Denote by $\Gamma := \varphi^{-1}(\mathbb{R}P^1)$. Since the graph is invariant under complex conjugation, it is determined by its intersection with one connected component H (for half) of $\mathbb{C}P^1 \setminus \mathbb{R}P^1$. In most figures we will only show one half part $H \cap \Gamma$ together with $\mathbb{R}P^1 = \partial H$ represented as a horizontal line. Moreover, for simplicity, we omit the arrows. The reader may refer to Chapter 2 for more details on real dessins d'enfant.

Definition 4.6. Any root or pole of φ is called a **special point** (of φ), and any other point of Γ is called **non-special**.

4.3.1 Reduction to a simpler case

We first need a definition.

Definition 4.7. Let a, b be two critical points of φ i.e. vertices of Γ . We say that a and b are **neighbours** if there is a branch of $\Gamma \setminus \mathbb{R}P^1$ joining them such that this branch does not contain any special or critical points of φ other than a or b .

In this section, we show how to reduce to the case where φ satisfies the following properties

- (i) All roots of P and Q are special points of φ with the same multiplicity m .
- (ii) Each non-special critical point of φ has multiplicity two and is not a solution of $\varphi = 1$. (4.3.1)
- (iii) All *real* non-special critical points of φ are neighbours to *real* critical points of φ .

We will introduce an algorithm that transforms any dessin d'enfant Γ of φ to a dessin d'enfant Γ' of a function satisfying the three properties mentioned above. Moreover, this transformation does not reduce the number of *real* letters r of φ . Therefore, to prove Theorem 4.2, it suffices to consider a function φ satisfying (4.3.1).

This algorithm is a series of transformations which are divided into two types. The first type, called type a), reduces the valencies of all critical points so they verify the conditions (i) and (ii). The second type, called type b), transforms a couple of conjugate points p (resp. q, r , non-special critical points) into a point p (resp. q, r , non-special critical point) which belongs to $\mathbb{R}P^1$.

4.3.1.1 Transformation of type a)

Consider a critical point α of φ , which does not belong to $\{0, 1, \infty\}$.

- Assume that $\alpha \in \mathbb{R}P^1$. Let \mathcal{U}_α be a small neighborhood of α in $\mathbb{C}P^1$ such that $\mathcal{U}_\alpha \setminus \{\alpha\}$ does not contain letters r , critical points or special points.

Assume that α is a special point (a root or a pole of φ). Then the valency of α is equal to $2km$ for some natural number k . We transform the graph Γ inside \mathcal{U}_α as in Figure 4.1. In the new graph Γ' , the neighborhood \mathcal{U}_α contains two real special points and a real non-special critical point of φ (and no other letters p, q, r and vertices). If α is a root (resp. pole) of φ then both special points are roots (resp. poles) of φ with multiplicities m and $(k-1)m$. Moreover, the new non-special critical point has multiplicity 2. It is obvious that the resulting graph Γ' is still a real dessin d'enfant.

Assume that α is a non-special critical point that is a letter r (a root of $\varphi-1$). Then the valency of α is equal to $2k$ for some natural number $k \geq 2$. We transform the graph Γ as in Figure 4.2. In the new graph Γ' , the neighborhood \mathcal{U}_α contains two letters r of multiplicity $2(k-1)$ and 1 respectively, and one non-special critical point of multiplicity 2, which is not a letter r (and no other letters p, q, r or vertices).

Assume that α is a non-special critical point that is *not* a letter r . Then the valency of α is equal to $2k$ for some natural number $k \geq 3$. We transform the graph Γ such that in the new graph Γ' , the neighborhood \mathcal{U}_α contains two non-special critical points, which are not letters r , with multiplicities 2 and $(k - 1)$ (and no other letters p, q, r or vertices).

- Assume now that $\alpha \notin \mathbb{R}P^1$. Consider a small neighborhood \mathcal{U}_α of α and the corresponding neighborhood of its conjugate $\bar{\alpha}$ (the image of \mathcal{U}_α by the complex conjugation). Assume that both neighborhoods are disjoint and both $\mathcal{U}_\alpha \setminus \{\alpha\}$ and $\mathcal{U}_{\bar{\alpha}} \setminus \{\bar{\alpha}\}$ do not contain letters r , critical points or special points. Recall that the valency of α is even. Choose two branches of $\Gamma \cap \mathcal{U}_\alpha$ starting from α such that the complement of these two branches in \mathcal{U}_α has two connected components containing the same number of branches of $\Gamma \cap \mathcal{U}_\alpha$. We transform $\Gamma \cap \mathcal{U}_\alpha$ similarly as in the case $\alpha \in \mathbb{R}P^1$ and do the corresponding transformation of the image of $\Gamma \cap \mathcal{U}_\alpha$ by the complex conjugation.

Assume that α is a special point (a root or a pole of φ). We transform the graph Γ inside \mathcal{U}_α as in Figure 4.3. In \mathcal{U}_α , the resulting graph Γ' contains two special points of φ with multiplicities m and $(k - 1)m$ respectively, and one non-special critical point with multiplicity 2 (and no other letters p, q, r or vertices), all of which belong to the previously chosen two branches.

Assume that α is a non-special critical point that is a letter r (a root of $\varphi - 1$). Then the valency of α is equal to $2k$ for some natural number $k \geq 2$. In the new graph Γ' , the neighborhood \mathcal{U}_α contains two letters r of multiplicity $2(k - 1)$ and 1 respectively, and one non-special critical point of multiplicity 2, which is not a letter r (and no other letters p, q, r or vertices), all of which belong to the previously chosen branches.

Assume that α is a non-special critical point that is *not* a letter r . Then the valency of α is equal to $2k$ for some natural number $k \geq 3$. We transform the graph Γ such that in the new graph Γ' , the neighborhood \mathcal{U}_α contains two non-special critical points, which are not letters r and which belong to the previously chosen two branches, with multiplicities 2 and $(k - 1)$ respectively (and no other letters p, q, r or vertices).

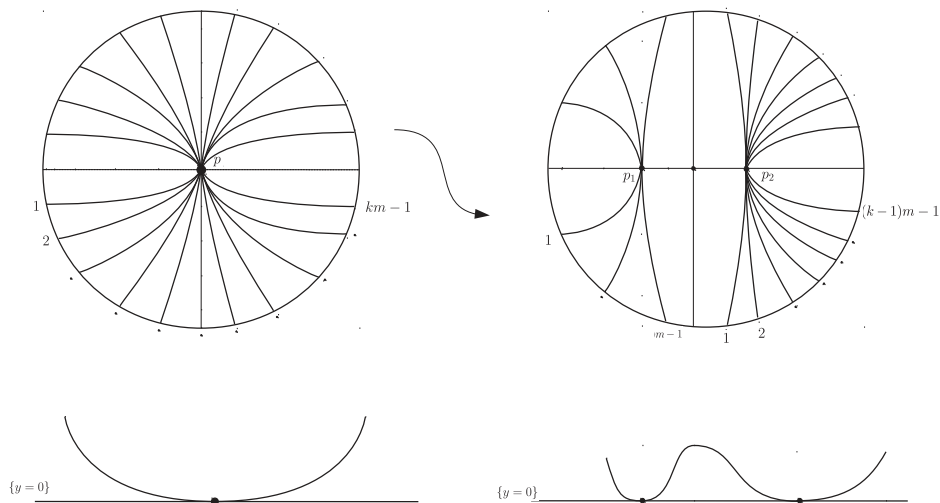

Figure 4.1: A transformation of type a) where α is a real root of P , $k = 3$ and $m = 4$.