



HAL
open science

Gestion énergétique sous incertitude: Application à la planification et à l'allocation de réserve dans un micro réseau électrique urbain comportant des générateurs photovoltaïques actifs et du stockage

Xingyu Yan

► To cite this version:

Xingyu Yan. Gestion énergétique sous incertitude: Application à la planification et à l'allocation de réserve dans un micro réseau électrique urbain comportant des générateurs photovoltaïques actifs et du stockage. Electric power. Ecole Centrale de Lille, 2017. English. NNT: 2017ECLI0005 . tel-01735289

HAL Id: tel-01735289

<https://theses.hal.science/tel-01735289v1>

Submitted on 15 Mar 2018

HAL is a multi-disciplinary open access archive for the deposit and dissemination of scientific research documents, whether they are published or not. The documents may come from teaching and research institutions in France or abroad, or from public or private research centers.

L'archive ouverte pluridisciplinaire **HAL**, est destinée au dépôt et à la diffusion de documents scientifiques de niveau recherche, publiés ou non, émanant des établissements d'enseignement et de recherche français ou étrangers, des laboratoires publics ou privés.

N° d'ordre : 320

CENTRALE LILLE

THESE

Présentée en vue d'obtenir le grade de

DOCTEUR

En

Spécialité : Génie Electrique

Par

Xingyu YAN

DOCTORAT DELIVRE PAR CENTRALE LILLE

Titre de la thèse:

**Energy management under uncertainty:
Application to the day-ahead planning and power reserve allocation of an urban
microgrid with active photovoltaic generators and storage systems**

**Gestion énergétique sous incertitude:
Application à la planification et à l'allocation de réserve dans un micro réseau électrique
urbain comportant des générateurs photovoltaïques actifs et du stockage**

Soutenance prévue le 18 Mai 2017 devant le jury d'examen :

Président	<i>Gérard CHAMPENOIS, Professeur, Université de Poitiers, LIAS</i>
Rapporteur	<i>Manuela SECHILARIU, Professeur, UTC Compiègne, AVENUE</i>
Rapporteur	<i>Quoc Tuan TRAN, Dr. HDR, Directeur Scientifique au CEA/INES</i>
Examineur	<i>George KARINIOTAKIS, Professeur, Ecole des Mines de Paris, PERSEE</i>
Examineur	<i>Didier DUMUR, Professeur, Centrale Supélec, LSS</i>
Examineur	<i>Gérard CHAMPENOIS, Professeur, Université de Poitiers, LIAS</i>
Membre invité	<i>François VALLEE, Professeur, Université de Mons, Belgique</i>
Directeur de thèse	<i>Bruno FRANCOIS, Professeur, Centrale Lille, L2EP</i>
Co-encadrant de thèse	<i>Dhaker ABBES, Enseignant Chercheur, Yncréa, L2EP</i>

Thèse préparée dans le Laboratoire L2EP
Ecole Doctorale SPI 072 (Lille I, Lille III, Artois, ULCO, UVHC, EC Lille)

Acknowledgements

The research work presented in this dissertation has been performed at Ecole Centrale de Lille (ECL), in the Laboratory of Electrical Engineering and Power Electronics (L2EP: Laboratoire d'Electrotechnique et d'Electronique de Puissance de Lille), from October 2013 to May 2017. I am extremely grateful to China Scholarship Council (CSC) who financed this work.

This dissertation is not only a result of my own dedication and perseverance, but is largely a credit to the patient and helpful people that I have worked with. During the study, I have been supported and accompanied by many understanding people. I would like to take this opportunity to express my gratitude to everyone who contributed to this work.

I would like to express my sincerest gratitude to Prof. Bruno François, my supervisor, and Dr. Dhaker Abbas, my co-supervisor, for accepting me to pursue my Ph.D. degree in their team, for the valuable guidance and continuous encouragement throughout my three years at Lille, for their kindness, for their advices, and for the valuable time that they have devoted.

For their participation in the scientific evaluation of this work, I would like to thank members of the jury, Prof. Manuela Sechilariu, Prof. Didier Dumur, Prof. George Kariniotakis, and Prof. Francois Vallée for their valuable discussions and insightful comments during the writing of the manuscript.

Many thanks go also to Hassan Bevrani, Xavier Cimetiere, Simon Thomy, Christophe Rymek, and Kongseng Bounvilay for their kindness during my study at ECL. I am very grateful to Florent Delhaye for his constructive suggestions and enormous help on the work of data collecting for the User-friendly Energy Management System in Chapter V.

I would like also to thank the professors in the Grid Network Team (Benoît ROBYNS, Frédéric COLAS, and Xavier GUILLAUD), and my colleagues in the L2EP (Silvio, Reda, Bili, Ghislain, Siyang, Haibo, Siyamak, and so many others that I cannot mention all of their names here) for their infinite friendship and encouraging supports.

My appreciation goes to my wife, Ran Chen, and my friends Qiang, Yan, Xiaokun, Zaidao, Tong, Yuchen and all the others for their friendship and supporting. So many unforgettable memories will with me forever.

Last but not least I would like to give my infinite gratefulness to my parents, who taught me the value of hard work by their own example. They rendered me enormous support during the whole tenure of my stay in Lille. Many thanks go also to my sister for the taking care of our parents in both spiritual and material.

Content

<i>Acknowledgements</i>	i
Content.....	ii
List of Figures	v
List of Tables.....	viii
List of Acronyms and Variables.....	ix
General Introduction	2
Chapter.I Integration of Renewable Energy Sources in Electrical System and Management Issues.....	8
I.1. General Introduction.....	8
I.2. Renewable Energy Sources (RES)	9
I.2.1. Introduction	9
I.2.2. The Issue of RES: Benefits	9
I.2.3. Constraints and limitations.....	10
I.3. Integration of the Decentralized Production into Electrical Grids	12
I.3.1. From a centralized network to a decentralized network	12
I.3.2. Perspectives for better integration of RES into electrical networks.....	13
I.3.3. RES Integration Impacts in Electricity Markets	14
I.4. Smart City, Smart Grid and Microgrid	15
I.4.1. Smart city	15
I.4.2. Smart grid.....	16
I.4.3. Microgrid.....	17
I.5. Electrical Energy Storage	19
I.5.1. Applications and Services	19
I.5.2. Energy Storage Forms	19
I.5.3. Long Term Energy Provision and Fast Dynamic Power Capability	20
I.6. Hybrid Active Generators.....	21
I.6.1. Interest	21
I.6.2. Configuration of an active PV generator.....	21
I.7. Micro Gas Turbine.....	22
I.8. Microgrid Management	23
I.8.1. General introduction.....	23
I.8.2. Control functions and management with a communication system.....	24
I.8.3. Energy management system of a residential microgrid	25
I.9. Research Tasks, Method, and Content	28
References	30
Chapter.II Uncertainty Analysis and Forecasting of PV Power and Load Demand	34
II.1. General Introduction.....	34
II.2. Mathematical Modeling of PV Generator	34
II.3. PV Power Uncertainty Analysis	37
II.3.1. Introduction	37
II.3.2. Variability and Uncertainty of PV Power Output	37
II.3.3. Variability Indices for Irradiance and PV Power Output Variability Quantification.....	40

II.4. Load Demand Uncertainty Analysis.....	43
II.5. PV power and load forecast.....	44
II.5.1. Interest of power forecasting for power systems	44
II.5.2. Solar PV Power Generation Forecast.....	45
II.5.3. Load Demand Forecast.....	46
II.6. Forecasting with Back-Propagation ANN.....	47
II.7. Day-ahead PV Power and Load Forecast by Using ANN.....	49
II.7.1. Data Description.....	49
II.7.2. Error Computing Method	51
II.7.3. PV Power Forecast Application	52
II.7.4. Load Demand Forecast Application with ANN.....	54
II.8. Conclusion	56
References	57
Chapter.III Operating Reserve Quantification in a Microgrid by Considering the PV Power and the Load Forecasting Uncertainties	60
III.1. Introduction	60
III.2. Power Generation Reliability	61
III.2.1. Reliability background	61
III.2.2. Reliability evaluation techniques	61
III.2.3. System reliability indices	62
III.2.4. Frequency control and energy balancing.....	63
III.2.5. Frequency control with MGT.....	66
III.2.6. Voltage control and reactive reserve	66
III.3. Operating Reserve (OR)	66
III.3.1. Reserve Types	66
III.3.2. European vs North American Reserve Definitions	67
III.3.3. Calculation of OR by Considering Uncertainties from RES.....	68
III.4. Net Demand (ND) Uncertainty Analysis.....	71
III.4.1. Net Demand Forecasting	71
III.4.2. ND Uncertainty	71
III.5. Forecasting uncertainty assessment.....	75
III.6. Probabilistic Reliability Assessment	78
III.7. Risk-constrained OR Quantification for Each Interval	79
III.8. Conclusion	82
References	83
Chapter.IV Day-ahead Optimal OR Dispatching and Energy Management of a Microgrid System with Active PV Generators.....	86
IV.1. Introduction	86
IV.2. State of the Art on Power Reserve Dispatching	87
IV.3. Day-ahead Optimal Dispatching of the Reserve Power	88
IV.3.1. Introduction	88
IV.3.2. Procedures and Problems under Certain Non-linear Constraints.....	90
IV.4. OR Dispatching Strategies Considering the Maximization of RES Usage.....	90
IV.4.1. Uncertainty Analysis According to PV Power Production	90
IV.4.2. Scenario H.....	91
IV.4.3. Scenario L	95
IV.5. UC Problem Optimization with Dynamic Programming (DP)	96
IV.5.1. Formulation of the UC	96
IV.5.2. Optimizing Objective Functions with Different Optimization Strategies.....	96

Content

IV.5.3. Dynamic Programming for the UC Problem.....	97
IV.6. A Case Study Application of the UCP with DP	101
IV.6.1. Presentation	101
IV.6.2. Different Scenarios of DP Application	101
IV.6.3. Comparison of the Power Reserve Dispatching.....	105
IV.6.4. Characteristics of PV based AG (with scenario H2).....	106
IV.6.5. Security Level Analysis	107
IV.6.6. Analysis of the Cost	108
IV.7. OR Dispatching with Different PV Power Penetration Rate.....	109
IV.8. Conclusion.....	111
References	112
Chapter.V Development of an Energy Management System for an Urban Microgrid and Practical Application	115
V.1. Introduction	115
V.2. Analysis of the Urban Microgrid System	115
V.2.1. Presentation of the Case Study.....	115
V.2.2. Sources of Data in Utilities	116
V.2.3. Data Management for Uncertainty Analysis and Predictive Procedures	117
V.2.4. Urban Microgrid Management Analysis.....	118
V.3. Urban Microgrid EMS Framework and Interface Design	118
V.3.1. GUI Description	118
V.3.2. Data Collection and System Uncertainty Analysis	120
V.3.3. System Uncertainties Assessment and OR Quantification	121
V.3.4. Operational and OR Dispatching	123
V.4. Results and Discussion	123
V.5. Conclusion.....	127
References	128
General Conclusion	131
Appendix I. Renewable Energy Sources	134
A.I.1. Renewable energy coming directly from sun: Solar power.....	134
A.I.2. Renewable energy coming indirectly from sun	134
A.I.3. Renewable energy from other natural movements and mechanisms	135
Appendix II. Photovoltaic Circuit-based Physical Model	137
A.II.1. Equivalent Circuit Model	137
A.II.2. PV characteristic curves	138
A.II.3. PV cells connection (parallel and/or series)	140
A.II.4. Maximum power point tracker (MPPT)	141
Appendix III. Characteristics of MGTs	143
A.III.1. Efficiency characteristic	143
A.III.2. Estimation of exhaust gas emissions	144
A.III.3. Estimation of fuel consumption	145
A.III.4. Estimation of carbon dioxide emission	146
Appendix IV. Artificial Neural Network	147
A.IV.1. General Introduction	147
A.IV.2. Model Representation	147
A.IV.3. Feed-forward Procedure and Cost Function.....	148
A.IV.4. Back-Propagation (BP) Algorithm.....	149
A.IV.5. Learning parameters using <i>fmincg</i>	151

List of Figures

Figure I-1 The NIST conceptual model for smart grid ([1]).	17
Figure I-2 The detailed classification of the smart grid infrastructure ([2]).	18
Figure I-3 Growth in world electricity demand and related CO ₂ emissions since 1990 (left) and related CO ₂ emissions by region (right) [13].	10
Figure I-4 Stability of RES and conventional power plant [28].	11
Figure I-5 PV based active power generator [14].	22
Figure I-6 Basic microgrid architecture with a MGCC [33].	23
Figure I-7 Framework of the central energy management system [33].	25
Figure I-8 Timing classification of control functions in the context of microgrid [33].	26
Figure I-9 Micro grid integration of a prosumer and micro gas turbines [14].	27
Figure II-1 PV power, solar radiation and temperature in three continuous days.	35
Figure II-2 Irradiance and Temperature vs. Power correlation (data: 2010).	36
Figure II-3 Irradiance and temperature vs. power correlation.	36
Figure II-4 Examples of variability and uncertainty.	37
Figure II-5. Time scales relevant to the operating of power systems [8].	39
Figure II-6 Classification of different conditions of irradiance caused by cloudy variations (data are in 5 minutes scale).	40
Figure II-7 Annual distribution of daily VI values (a) and daily RI values (b) in year 2010.	42
Figure II-8 Mean daily VI and RI by month: (a) Mean daily VI; (b) Mean daily RI.	42
Figure II-9. Scatter plot of daily radiation index and corresponding variability index in 2010.	43
Figure II-10 The structure of a three-layer BP network.	48
Figure II-11 Training procedure of a neural network.	49
Figure II-12 PV power output and solar irradiance of each month in 2010 at L2EP.	50
Figure II-13 Average temperature and precipitation in Lille.	50
Figure II-14 PV power forecasting database.	50
Figure II-15 Load forecasting database building.	51
Figure II-16 PV power forecasting with ANN.	52
Figure II-17 $nRMSE$ obtained on the validation set in function of the hidden layer units and input PV power measurement.	53
Figure II-18 PV power prediction results on 12/09/2013.	53
Figure II-19 PV power prediction errors for each hour from the validation test.	54
Figure II-20 Load forecasting with ANN.	54
Figure II-21 Load demand prediction results on 12/09/2013.	55
Figure II-22 Load demand prediction errors with data from the test set.	56
Figure III-1 Category of generation system reliability assessment indices [7].	62
Figure III-2 Deploying of the primary, secondary and tertiary regulation.	64
Figure III-3 Primary frequency regulation	65
Figure III-4 Example of operating reserve categories and how they are related [7].	67
Figure III-5. ENTSO-E/UCTE and NERC reserve terminology [3].	68
Figure III-6 Reserve management structure	71
Figure III-7. Net demand forecasting uncertainty calculation by directly ND errors forecast.	72
Figure III-8. Frequency distribution histogram and fitted Gaussian function of the forecasted net errors ($\varepsilon_{ND,F}^{t+12}$) at 12:00 am.	73
Figure III-9 PV power, load forecasting and errors prediction with ANN.	73

Figure III-10. Frequency distribution histogram and fitted Gaussian function of the PV power errors ($\varepsilon_{PV}, Ft + 12$) and Load errors ($\varepsilon_L, Ft + 12$) at 12:00 am.	75
Figure III-11 Net uncertainty calculation at time step t with a given probability.	76
Figure III-12 PV forecasting with uncertainty (a random day).....	77
Figure III-13 Load forecasting with uncertainty (a random day).....	77
Figure III-14 Next 24 hours ND forecasting with uncertainty (a random day).....	78
Figure III-15 Calculation of power reserve requirements based on the forecast ND uncertainty ($\varepsilon_{ND,F}^t$) with $x\%$ of LOLP, at time step t	79
Figure III-16 Created (PV power forecasting errors, load forecasting errors, and ND forecasting errors) cdf_s at each time step.	80
Figure III-17 Normal pdf and normal cdf of the forecasted ND, at 12:00.	80
Figure III-18 Risk/reserve curve for $LOLP^{t+12}$ and $EENS^{t+12}$, at 12:00.	81
Figure III-19. Required power reserve for each hour with $x\%$ LOLP.	81
Figure III-20. Hourly power reserve with the two different methods.	82
Figure IV-1 The flowchart of the energy management.	89
Figure IV-2 Day-ahead optimal operational planning scheme.	89
Figure IV-3 Probability distribution of ND uncertainty at 2 p.m.: (a) with only load uncertainty; (b) with both PV power uncertainty and load uncertainty.	91
Figure IV-4 Operating power reserve dispatching strategies with different scenarios.	93
Figure IV-5 Backward recursion DP algorithm.	99
Figure IV-6 Day-ahead PV power forecast, load forecast and reserve power with 1% of LOLP.	101
Figure IV-7 Load ratio of three MGTs and total fuel cost for scenario H1, with economic criteria.....	102
Figure IV-8 Load ratio of three MGTs and total fuel cost for scenario L1, with economic criteria.....	104
Figure IV-9 Load ratio of three MGTs and total fuel cost for scenario H2, with economic criteria.....	104
Figure IV-10 Load ratio of three MGTs and total fuel cost for scenario L2, with economic criteria.....	105
Figure IV-11 Power reserve dispatching with scenarios H1 and H2.	105
Figure IV-12 OR dispatching percentage in different generators with scenarios H1 and H2.	106
Figure IV-13 Load and OR power dispatching with scenarios H1 and H2.	106
Figure IV-14 Reference power of AG, battery power and energy, under H2.	107
Figure IV-15 Reference power of AG, battery power and energy, under L2.	107
Figure IV-16 Renewed LOLP in H1 and H2 scenarios (with the economic optimization strategy).....	108
Figure IV-17 Obtained cost with both OR dispatching strategies	108
Figure IV-18 Daily PV energy and reserve variation with the increasing of PV energy integration.....	110
Figure IV-19 Maximum battery power and maximum battery energy with the increase of PV energy integration rate.....	110
Figure V-1 Description of the studied microgrid [6].	116
Figure V-2 System block diagram of adopted methodologies for the MCEMS.....	119
Figure V-3 Graphical interface of the MCEMS.....	120
Figure V-4 Layout design of the “Uncertainty Analysis”.....	120
Figure V-5 Data collect for system uncertainty analysis interface.	121
Figure V-6 Layout design of the “OR Quantification”.....	122
Figure V-7 System uncertainties assessment and OR quantification interface.....	122

Figure V-8 Layout design of the “Optimal Operational and OR Dispatching”	123
Figure V-9 OR dispatching interface.	124
Figure V-10 PV panels installed at the roof of the student residence at Ecole Centrale de Lille.	124
Figure V-11 Three solar PV inverters with 0.6 kWh daily output for each.	125
Figure V-12 Individual interface window of MGT.	125
Figure V-13 Individual interface window of PV AG.	126
Figure AI-1 Installed geothermal capacity in 2015 worldwide [5].	136
Figure AII-1 Single-diode model of the theoretical photovoltaic cell and equivalent circuit of a practical photovoltaic device including the series and parallel resistances.	137
Figure AII-2 Characteristic I-V curve of a practical photovoltaic device and the three remarkable points: short circuit ($0, I_{sc}$), maximum power point (V_{mp}, I_{mp}) and open-circuit ($V_{oc}, 0$).	138
Figure AII-3 Location of the maximum power for regulating the voltage.	139
Figure AII-4 Change on the I-V curve and P-V curve.	140
Figure AII-5 Influence of the irradiance on the PV electrical qualities.	140
Figure AII-6 Types of connections among PV cells and their respective I-V curves: (a) series connection; (b) parallel connection.	141
Figure AII-7 MPP locating on the I-V characteristic considering solar radiation and temperature changes.	141
Figure AIII-1 Characteristic of efficiency according to utilization rate (p.u.) [1].	143
Figure AIII-2 Characteristic of NOx emissions factor based on generated power (p.u.) [17].	144
Figure AIII-3 Characteristic of CO emission factor depending on MGT utility (p.u.) [1].	145
Figure AIV-1 A three layer neural network model.	147
Figure AIV-2 Feed-forward algorithm.	149

List of Tables

Table II-1 Classification of days based on VI and RI	41
Table II-2 Clear sky, overcast, low variability, and high variability days at L2EP, LILLE. ...	43
Table II-3 Power system operation requirement with load variations according to various time scales.	44
Table II-4 Errors of the PV power forecasting with ANN.	54
Table II-5 Errors of the load demand forecast with ANN.....	55
Table III-1 Technical data for the frequency adjustment [2].	64
Table III-2 Errors of the estimation for the ND error.....	73
Table III-3 Errors of the error estimation for the PV power forecasting.	74
Table III-4 Errors of the error estimation for the load forecasting.....	74
Table IV-1 System states for three generators	99
Table IV-2 Day-ahead Operational Planning Results	103
Table IV-3 Power reserve, battery power and battery energy change with a rated PV power increase.....	109
Table V-1 Main and individual interfaces.....	119

List of Acronyms and Variables

Notations/Nomenclature

<i>Name</i>	<i>Abbreviations</i>
<i>AG</i>	Active Generators
<i>ANN</i>	Artificial Neural Networks
<i>AS</i>	Ancillary Services
<i>BP</i>	Back-Propagation
<i>cdf</i>	Cumulative Distribution Function
<i>CHP</i>	Combined Heat Production
<i>DC</i>	Direct Current
<i>DER</i>	Distributed Energy Resources
<i>DG</i>	Distributed Generators
<i>DMS</i>	Distribution Management System
<i>DP</i>	Dynamic Programming
<i>DSO</i>	Distribution System Operator
<i>E-box</i>	Energy Box
<i>EENS</i>	Expected Energy Not Served
<i>EMS</i>	Energy Management System
<i>ENTSO-E</i>	European Network of Transmission System Operators for Electricity
<i>EU</i>	European Union
<i>EV</i>	Electric Vehicles
<i>EWITS</i>	Eastern Wind Integration and Transmission Study
<i>ICT</i>	Information and Communication Technologies
<i>GUI</i>	Graphical User Interface
<i>L2EP</i>	Laboratory of Electrical Engineering and Power Electronics
<i>LC</i>	Local Controller
<i>LOLP</i>	Lose OF Load Probability
<i>LV</i>	Low Voltage
<i>MCEMS</i>	Microgrid Central Energy Management System
<i>MGCC</i>	Microgrid Central Controller
<i>MGT</i>	Micro Gas Turbines
<i>MPPT</i>	Maximum Power Point Tracking
<i>ND</i>	Net Demand
<i>NIST</i>	National Institute of Standards and Technology
<i>NERC</i>	North American Electric Reliability Corporation
<i>NOTC</i>	Normal Operating Cell Temperature
<i>nRMSE</i>	Normalized Root Mean Square Error
<i>nMAE</i>	Normalized Mean Absolute Error
<i>OR</i>	Operating Reserve

List of Acronyms and Variables

<i>pdf</i>	Probability Density Function
<i>p.u.</i>	Per Unit
<i>PV</i>	Photovoltaic
<i>RI</i>	Radiation Index
<i>RES</i>	Renewable Energy Sources
<i>SCADA</i>	Supervisory Control And Data Acquisition
<i>SOC</i>	State Of Charge
<i>UC</i>	Unit Commitment
<i>UCTE</i>	Union for Coordination of Transmission of Electricity
<i>UPS</i>	Uninterrupted Power Supply
<i>VI</i>	Variable Index
<i>WWSIS</i>	Western Wind and Solar Integration Study

NOTATIONS/ Parameters and Variables

<i>Name</i>	<i>Description (units)</i>
t	Index of the scheduling time step: from 1 to T .
x	Index of LOLP, from 1 to 100.
n	Index of active PV generator, from 1 to N .
m	Index of micro gas turbine, from 1 to M .
$z(t)$	MGT power reference vector.
$u(t)$	MGT state vector.
γ	Percentage index of best compromise optimization strategy.
J	Optimization objective function.
δ_i	State of each MGT
E_{bat}	State of charge for energy storage.
L_A^t	Actual load demand at time step t .
L_F^t	Forecasted load demand at time step t .
PV_A^t	Actual PV power at time step t .
PV_F^t	Forecasted PV power at time step t .
N_A^t	Actual net demand at time step t .
N_F^t	Forecasted net demand at time step t .
ε_l^t	Forecasted load error at time step t .
ε_{PV}^t	Forecasted PV error at time step t .
ε_N^t	Forecasted net demand error at time step t .
μ_N^t	Mean value of forecasted net demand error at time step t .
σ_N^t	Standard deviation of forecasted net demand error at time step t .
$P_{PV_n}^t$	Active PV power reference at time step t .

List of Acronyms and Variables

$P_{MGT_m}^t$	MGT power reference at time step t .
P_L^t	Load demand at time step t .
P_{OR}^t	Operating reserve reference at time step t .
$C_{M_i}^t$	MGT operational fuel cost at time step t .
$CO2_{M_i}^t$	MGT equivalent CO ₂ emission at time step t .
$C_{P_i}^t$	MGT start up and shunt down penalty fuel cost.
$CO2_{P_i}^t$	MGT start up and shunt down penalty equivalent CO ₂ emission.

General Introduction

General Introduction

During the last decade, to keep the temperature increase below two degree Celsius relative to pre-industrial levels, policies aimed to reduce fossil fuel consumption and greenhouse gas emissions by promoting the use of Renewable Energy Sources (RES) for electricity, such as the often cited 20-20-20 targets of the European Union and the contractual agreement of COP21 in Paris. Consequently, RES have been increased significantly around the world. According to the IEA Energy and Climate Change report in 2015, renewable energy based power generation capacity is estimated to have increased by 128 GW in 2014. 37% is coming from the wind power, almost one-third from the solar power and more than a quarter from hydropower [1-2].

Distributed generators (DG) integration in microgrids

There are various types of energy sources for electricity production:

- non-renewable generators that are based on fossil resources, such as combustion turbines or uranium for nuclear power plants;
- renewable generators, such as PV power, concentrated solar power, wind turbines; and others, such as fuel cell and hybrid systems, which are the combination of more than one kind of these technologies leading to an improvement of the generator performance and efficiency.

A significant part of electrical loads are in residential areas and cities. The individual consumption is enough low and leads to a light electrical sizing (low voltage, low power). Hence, a new market of small generators with a similar rating has appeared for residential or building use.

These types of generators are known as Distributed Generators (DG). Moreover, as they are connected closed to loads and so in areas with a large concentration of people, the restricted pollutant emission as well as the security requirement in these living places obliges the use of renewable energy to power these generators.

Benefits of DG are mainly the participation to the local electrical energy balancing and the reduction in power peaks. The increasing DG leads from today's unidirectional to a distributed and bi-directional power flow in current electrical networks. So, there are several challenges for large scale DG integration, such as:

- more complicated technologies and new electrical network infrastructures are required;
- new control and dispatch strategies are needed;
- grid safety needs to be ensured;
- the cost of DG integration that includes the cost of upgrading the connection and the electrical system management.

To solve local technical problems, microgrids and their electrical network management systems have been developed. Microgrids are small electrical distribution systems that use the small-scale power generation technologies and storages located close to the multiple customers being served. It permits to reduce costs and emissions, to improve reliability and to provide an efficient electrical generation to local loads without transmission losses.

From this context, it is clear that a sustainable electrical generation and energy conversion requires an efficient, reliable and secure electrical infrastructure and energy management.

Uncertainty challenges of RES integration into the microgrid

However, the integration of variable RES, especially solar and wind energy conversion systems, into electrical grids is limited because of their intermittences, fast power variations, highly dependence on meteorology and low inertia. The variability has to be characterized along a spatial and time dimension. For spatial dimension, PV generation covering a large spatial extent can have an hourly temporal resolution, while individual PV panel plants will have highly variable PV power outputs in a short time. When power systems are operating with variable RES, the operators have different major issues in different time scales. It concerns power quality of the electricity production for less than one second, regulation power reserves to balance variable generation with variable loads from one second to some hours and unit-commitment and scheduling to optimally operate the electrical network from some hours to days.

Since the variability and uncertainty in RES create new challenges in the planning and operation of electric power grids, they should be properly accounted to balance demand and supply. Generally, electrical system operators and planners use mechanisms including forecasting, scheduling, economic dispatch, and power reserves to ensure power grid performances that satisfy reliability standards within an acceptable cost. The forecasting of the power generation and load demand has been considered as a major solution to handle efficiently RES integration in electric power grids. However, the uncertainty associated with forecast errors cannot be eliminated even with the best models and methods. In addition, the combination of generation and consumption variability with forecast uncertainty makes the situation more difficult for power system operators to schedule and to set an appropriate power reserve level.

Therefore, uncertainties from both generation and consumption must be taken into account by accurate stochastic models to design energy management systems with a minimal cost.

Sizing of the operating power reserve

When an unexpected imbalance between supply and demand appears, system operators and automatic controllers use an available generating capacity that is called the Operating Reserve (OR). The OR should be carefully sized but also ideally minimized and dispatched to reduce operation costs while keeping a satisfying security level.

In traditional electrical systems, two main sources of uncertainty are considered:

- the large generator failing or network equipment failing has a low probability but a high impact if reserves are inadequate;
- the load forecast errors are common but usually are relatively small.

Hence utilities generally adopt deterministic criteria for the power reserve requirement: the required OR is set to be greater than the capacity of the largest online generator or a fraction of the load, or equal to some function of both of them. Those deterministic criteria are widely used because of their simplicity and understandable employing.

Due to the large scale development of renewable based DG, the increasing stochastic generation (PV and wind power) impacts strongly the uncertainty level of the electrical generation in electrical systems. The probability of missing of a high amount of electrical production must be now considered with new strategies for the OR setting. Hence, deterministic methods are gradually replaced by probabilistic methods that respond to stochastic factors corresponding to a system reliability level.

Due to the complexity and difficulty of managing probabilistic information, the decisions made under uncertainty must be informed by probabilistic information in order to correctly quantify the risks. Hence, new decision-making methods are required to estimate the OR amount.

Active distributed generators and day-ahead optimal OR dispatching

Nowadays, the OR is provided by conventional power plants as a constant reserve power in a fixed time horizon. However, power reserve are now required from DG in more and more grid codes in order to maintain the security and reliability of grids with a high share of renewable generators. If the output power of a renewable generator based DG is reduced (degradation from the maximum power point) to create a power reserve, a part of this primary renewable energy will be lost because it is not sure to recover it later (as the primary energy is intermittent). Hence, active renewable energy based DG with embedded storage systems have been proposed to be able to produce a prescribed output power while managing the inner energy with a dedicated local controller [3].

A lot of research works have been performed to develop storage applications for filtering or balancing power and electrical energy coming from intermittent renewable generators [4]. In the context of uncertainty, the power output from the renewable generator is assumed to be forecasted one day ahead. The distribution and transmission to the loads is also assumed to be planned through the electrical system by taking into account the filtering effect from uncorrelated other renewable generation and loads. In the context of uncertainty from bad forecasting, a new application of storage systems would be to manage the provision of a prescribed OR onto the active DG. Hence, a framework of an energy management system must be imagined to make useable this generator for the grid operator as a controllable generator like conventional ones.

In a traditional vertically integrated electricity market, the energy and the required OR are allocated separately and the OR is dispatched after completing firstly the energy dispatching. In a competitive market, these two products should be simultaneously dispatched in order to maximize the efficiency and reliability of the electrical system.

Different strategies for the OR dispatching onto conventional generators and DG can be considered regarding the responsibility of the various sources of uncertainty. These OR dispatching strategies will have different influences in the system security level and also in the sizing of active PV generators (required storage capacity as example).

In main applications, the goal is to find the best electricity production mix in order to decrease the economic costs of electricity production. So an optimal planning of the generator scheduling is implemented one day ahead to minimize operational costs. By taking into consideration start-up and shut down times and ensuring a minimum of start-ups, the Unit Commitment (UC) is a decision process that schedules the on states and off states of fuel based generating units in order to optimize criteria. Generally, the UC decisions are iteratively resolved and ensure an electrical system reliability level by using probabilistic measurements.

As the electrical power industry moves to new restructured forms, the UC must be adapted to distributed generators including DG (as Micro Gas Turbines and RES generators) and also to new environmental criteria. As example, the minimization of CO₂ emissions in future electrical systems must be considered in coherence with the goal to integrate more and more RES to reduce the planet footprint.

Data handling and practical application

In order to have a better understanding of uncertainties and to reduce their impact on electrical grid performance, a lot of monitoring technologies are required for electrical power system operators. Moreover, more and more sensors are installed in electrical power system and now large database are built. Collected data need to be analyzed and studied widely for forecast and decision-making purposes. Therefore, a huge amount of data and information are generated by those installed monitoring devices.

A well dynamic visualization of those collected data and the possible smart management decisions is a great help for understanding technical impacts and operational solutions of electrical power systems with a high penetration ratio of RES.

Layout of thesis

In the first chapter, a microgrid is introduced in details. It contains hybrid active generators composed of renewable energy sources and storage units, micro gas turbines and loads. This microgrid system provides not only a clean energy but also a high power quality. Moreover, the PV AGs can supply auxiliary services to the grid like conventional generators does right now. Then, the energy management of the microgrid with a communication system is presented to well understand its control architecture. Research background, objectives and research methods are presented.

In the second chapter, PV power and load uncertainty as well as variability are analyzed. Then, a simple metric to measure variability in irradiance at potential solar PV sites is introduced. The metric measures the amount of variability and uncertainty of solar irradiance relative to solar constant and classifies the daily solar irradiance variability into different types. Following uncertainty analysis, artificial neural network based prediction methods are applied to forecast PV power, load demand and errors.

In the third chapter, firstly, the power generation reliability and the OR concept are introduced. Then for each studied time step of the next day, the OR is calculated with the Net Demand (ND) forecasted uncertainty with a probabilistic method. The ND forecasted uncertainty is obtained as the difference between the PV power forecast uncertainty and the load forecast uncertainty. Two methods are proposed to calculate the ND forecast errors. Then, a method is explained to assess the accuracy of these predictions and to quantify the required OR power to compensate the system power unbalancing. The OR is obtained by choosing a risk level related to the reliability assessment indicators.

In the fourth chapter, techniques for dynamic joint dispatch of the power production and OR power dispatch are developed in a microgrid application. Firstly, two different OR power dispatching methods are proposed. Secondly, day-ahead optimal planning of operational and OR power with dynamic programming (DP) is proposed. Different constraints are considered. The proposed method uses DP to minimize economic and environmental objectives for various criteria.

In the fifth chapter, to facilitate the energy management and system optimization in an urban microgrid, a “User-friendly EMS and Operational Planning Supervisor” is developed. The designed energy management system is based on the Matlab GUI (Graphical User Interface). It provides a complete set of user-friendly graphical interfaces to properly model and study the details of PV AG, which includes PV panels and batteries, load demand, as well as MGTs. It shows the system uncertainties and the amount of dispatched OR in the different power generators. It allows the system operators to study their effects on system security with different dispatching scenarios and optimization criteria.

- [1] F. Birol, "World energy outlook," *Paris: International Energy Agency*, 2013.
- [2] I. E. Agency, "World Energy Outlook Special Report: Energy and Climate Change " 2015.
- [3] A. Ipakchi and F. Albuyeh, "Grid of the future," *Power and Energy Magazine*, IEEE, vol. 7, pp. 52-62, 2009.
- [4] H. Bevrani, B. François, T. Ise, "Microgrid Dynamics and Control," *Wiley, NY*, ISBN: 978-1-119-26367-8, 2017.

Chapter I

*Integration of Renewable Energy Sources in
Electrical System and Management Issues*

Chapter.I Integration of Renewable Energy Sources in Electrical System and Management Issues

I.1. General Introduction

Faced to energy challenges, primary energy demand in the world wide is growing. According to the IEA (International Energy Agency), the world's energy needs could be 50% higher in 2030 than those of 2011 [1]. However, the stock of oil and coal in our planet will be exhausted in next few decades with the same rate of current utilization.

Nowadays, global warming becomes more serious due to greenhouse effects. Some emissions of green-house gases, of course, come from human activities, for example the car emissions. Nevertheless, the production and processing of electrical energy is one of the main sources of greenhouse gases, especially for developing countries like China, India and Latin America [1]. To reduce greenhouse gas emissions and assure energy security, renewable energies are greatly required in the electrical power production.

Today different kinds of renewable energy technologies are established in world markets. Some renewable energy technologies, such as wind turbines, are becoming quickly competitive in growing markets, and some are widely recognized as the lowest cost option for stand-alone and off-grid applications, especially in islands where fuel and cost are expensive. The capital costs of certain renewable energy technologies have been obviously reduced over the last decade and may continually decreased over the next few decades. According to the "World Energy Outlook in 2013", there will be a massive growth of the renewable energy in the next 25 years because of fossil fuel crisis, energy production security, economic growth, and danger of environment deterioration [1].

However, an electrical generating system depending entirely on the fluctuating renewable energy sources (RES), such as wind and solar photovoltaic (PV) power, is not reliable because of their poor availability and intermittent nature. Compared to the conventional oil and coal based power plants, they cannot provide ancillary services (AS) to participate to the management of electrical power systems. Decentralized energy production is increasing on the basis of cogeneration units, RES or conventional generations, which have been installed by independent producers. In last two decades, research interests have been focused on the microgrids (smart grids) and the integration of distributed generations to increase the RES penetration level. Therefore, by considering the electrical system uncertainties (from both generation and consumption), this research work focuses on the integration of renewable energies in electrical systems.

In this chapter, some background knowledge and basic information about RES are previously presented. Then, problems, which result from the integration of this type of decentralized production in power systems, are explained and perspectives to solve them are listed. As the development of this considered "small size" of production is devoted to be consumed by local loads, concepts of smart cities, smart grids and microgrids are briefly introduced. As the power intermittency and the energy availability are weak points of conventional passive ES based generators, new hardware technologies are then considered to balance these drawbacks: storage systems, hybrid active generators and micro gas turbines (MGT). Thus, the energy management of future electrical systems must be adapted or changed in order to use these technologies. Hence, the energy management of a microgrid is presented to well understand the control architecture and functions. Finally, the research objectives and explored methods are summarized.

I.2. Renewable Energy Sources (RES)

I.2.1. Introduction

RES are defined as energy resources naturally regenerated over a short time scale. They are derived directly from the sun (such as solar thermal and photovoltaic), indirectly from the sun (such as wind, hydropower and photosynthetic energy stored in biomass), or from other natural movements and mechanisms of the environment (such as hydropower, geothermal and ocean energy). Conventional energy sources, which are based on oil, coal, and natural gas have proven to be highly effective, but at the same time are not environment-friendly and also are available in a limited quantity in one plant. While the potential of RES, such as wind, solar, biomass and geothermal, are enormous as they can meet many times the energy demand in the world [18].

RES development constitutes an energy political strategy to solve many problems like: climate change, global energy demand increase, limits of fossil fuel reserves, energy dependency, and low efficiency of the electric system. Moreover, the renewable technologies are becoming increasingly cost competitive in a number of countries and circumstances. RES power generation capacity is estimated to have increased by 128 GW in 2014, 37% is coming from the wind power, almost one-third solar power and more than a quarter from hydropower [19].

I.2.2. The Issue of RES: Benefits

As described in Appendix I, significant progresses in cost reduction have been made by wind and PV systems. While biomass, geothermal, and solar thermal technologies are also experiencing cost reductions and these are forecast to continue. These RES contribute to the energy supply portfolio diversity and provide alternative options to customers. In addition, RES are environmentally benign and contribute to a healthy economy by employment and investment opportunities. Although it is easy to recognize the advantages of utilizing alternative renewable energy forms, the different renewable sources are limited by different constraints depending on their intrinsic characteristics [19-23]. This part presents some benefits.

A. A vast and inexhaustible energy supplying

As the used energy is renewable, it is therefore sustainable and so will never run out. Strong winds, shining sun, and heat underneath earth surface can provide a constant energy supply.

B. Environmental benign with little to no global warming emissions

During the RES operating, they are clean and induce in little to no greenhouse and waste products such as carbon dioxide or other chemical pollutants, so have minimal impacts on the environment and human health.

According to [24], there are several mechanisms for potential reductions in electricity and CO₂ emissions: shifting load to get a more efficient electrical system, support from electric vehicles and plug-in hybrid electric vehicles, advanced voltage control, support penetration of renewable wind and solar generation, and etc. Among those mechanisms, the support penetration of renewable energies contributes to the most significant part: with a higher renewable portfolio standard, less CO₂ emission will be produced.

As it can be seen on the Figure I-1, since 1990, the CO₂ emission is highly related to the rising electricity demand. However, this link will be broken from now and the world CO₂ emissions from power generation will remain broadly flat through to 2030, even though the planet electricity demand is continually increasing. During this time, power generation related CO₂

emissions within developed countries like European Union and United State will decrease, while that in the developing countries will increase, especially in China and India [25]. The reason for this link broken is the massive development of the green energy sources.

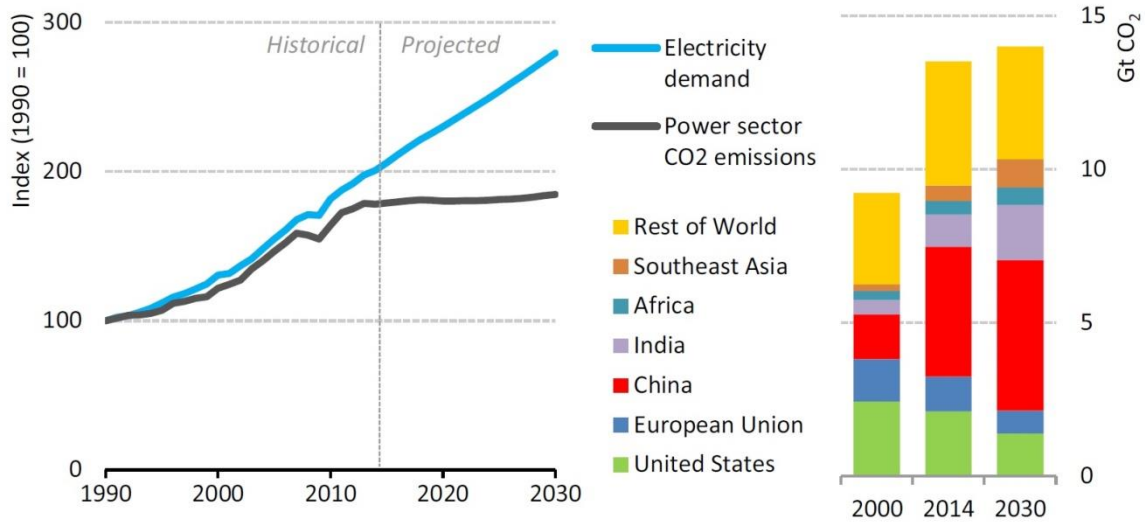

Figure I-1 Growth in world electricity demand and related CO₂ emissions since 1990 (left) and related CO₂ emissions by region (right) [13].

C. Economic benefits

First, increasing renewable energy has the potential to create new jobs. Then, it offers other trade of technologies and services development benefits. What’s more, RES require a less amount of maintenance, which reduces the costs. Finally, as most facilities are located away from urban centers of the capital cities, it will be profitable for regional areas, local services, and also tourism.

D. Energy security

The costs of renewable energy technologies have declined steadily and will be similar with those of fossil fuel generation in a near future [25]. Once built, the most of the RES operates at very low cost. What’s more, faced with challenges of energy crisis, RES can relieve some of the increasing of energy demand and reduce dependence on foreign sources. Moreover, distributed systems, as wind and solar, are less prone to large-scale failure because of their modular structure.

I.2.3. Constraints and limitations

Hydropower and geothermal power are naturally limited because of their geographic sites. Biomass requires large places for natural resources storage. For these resources, a large amount of units is needed to meet up with the large quantities of electricity produced by fossil fuels.

Another important limitation of RES is that they rely heavily upon the weather conditions: wind and sunshine. Unfortunately these RES are intermittent power sources (Figure I-2(a)). The electricity production from solar sources depends on the amount of solar irradiance. Solar output varies throughout the day and through the seasons because of the earth’s rotation plus its motion around the sun, and is affected by cloud cover. Wind power depends on wind speeds, air density and turbine characteristics (among other factors). These powers are not always available when necessary, such as solar in the night and wind power when the wind is not blowing.

The addition of intermittent resources causes large amounts of variable power. It decreases power system reliability. For example, when the PV power is injected into the electric system, the voltage at that location might increase beyond the acceptable range. Moreover, PV power inverters currently inject only real power into the electrical system. Therefore, advanced PV inverters are needed to absorb or inject reactive power to reduce the voltage impacts and may avoid the need for additional voltage-regulation equipment.

Moreover, the nature of the intermittency is, of course, different for the respective renewable energy technologies. Therefore, this difference could be a relevant factor to mitigating impacts. As the percentages of intermittent generation capacity become more and more significant, additional uncertainty is created in the management of the electrical system balance (between demand and generation) in real time. Increased amounts of conventional power reserve capacity are required and must be available immediately (spinning reserve) from plants capable of providing AS. These AS are required to manage the electrical power system securely.

Actual wind and PV generators must be considered as passive generators and they cannot participate to the grid management because of their variability and uncertainty [33]. As the percentage of intermittent RES generation capacity in a grid increases and becomes more significant, additional uncertainty is created in the management of real-time generation and consumption balance. This may require the increasing amount of conventional power reserve (spinning reserve) to manage the grid securely [26].

RES output power directly depends on the availability of their intermittent primary energy and so cannot be set to a prescribed value given by a grid operator. In most of the time, RES generators work far below their nominal capacity (Figure I-2(a)). Moreover, the reliability and efficiency of the electrical system cannot be ensured. So without energy storage systems, they are not dispatchable and by electrical system operators because their active and reactive power outputs are not controllable. Therefore, they cannot provide AS to the electrical grid.

On the contrary, the conventional power plants are controllable and can supply required powers to satisfy the grid requirements. They are considered as active generators and they can usually provide some AS: basically frequency regulation by active power control, voltage regulation by reactive power control, etc. They are mostly fossil and nuclear fueled and rely on the abundant fuel supply like coal, oil, natural gas or nuclear fuels. In fact, they can work at any power level below its nominal power by controlling the fuel supply (Figure I-2(b)). Therefore, passive RES cannot provide AS to the grid. A grid system operator cannot dispatch them because their outputs (active and reactive powers) are not controllable.

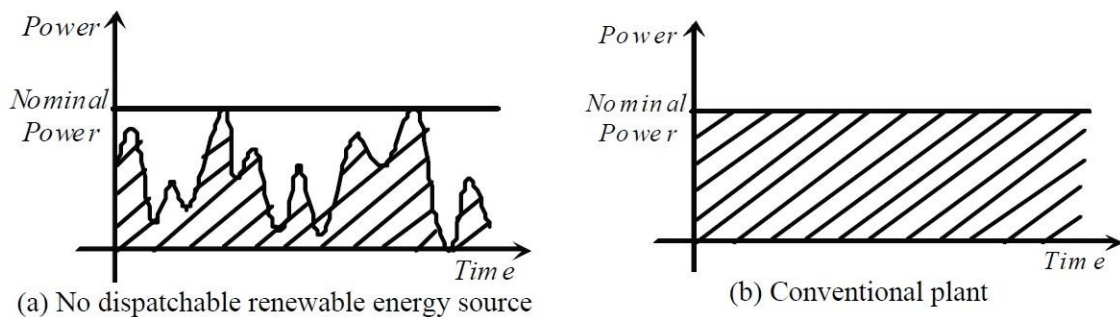

Figure I-2 Availability of the instantaneous power from RES and conventional power plant [33].

I.3. Integration of the Decentralized Production into Electrical Grids

I.3.1. From a centralized network to a decentralized network

The conventional electrical network organizations produce electrical power with centralized power units, such as nuclear, thermal or hydraulic power stations. In this centralized network structure, the distribution networks only host consumers and the power flows transit from high voltage levels towards the low voltage points. Thus, it only enables system operators to adjust the voltage level with a single power flow direction. The AS is provided on the transport network level by the production groups connected to it [2].

However, those centralized networks developed in the twentieth century have changed and generally evolved with decentralized power units, which are not dispatched in a centralized manner and generally connected to the distribution network (power does not exceed 50 to 100 MVA). In contrast to conventional production, the decentralized production is scattered over a territory and settled close to the power consumption facilities. They are especially favored by the development of RES. In many European countries, decentralized productions are based on cogeneration units, RES systems, and independent installed conventional producers. In this way, they can contribute to mitigate or solve technical, economic and environmental problems [3]. Here are some reasons of favoring the decentralized production systems [4]:

- the desire to reduce greenhouse gas emissions and thus encourages RES development;
- the use of cogeneration systems increases the energy efficiency;
- the opening up of the electricity market enables the independent producers emergence;
- the widen of the energy supply range decreases the fossil fuel energy dependence in the European Union;
- shorter construction periods and lower investments, compared to the conventional power units;
- a power production close to the consumption leads to a transportation costs reduction.

Moreover, the AS provided by the distribution generators enables the system operators to keep the electrical quantities (for example, frequency and voltage) in an appropriate range. However, the intermittent nature of the RES makes the management of the distributed electrical network more difficult [5]. There are two basic parameters, which must be considered: voltage control and frequency control.

The connection of a generation unit will change the voltage, especially around the connection point. For example, when a PV generator is placed at the end of a transmission line, the voltage along the line will be increased in comparison to the situation without PV generator. A similar result is obtained when the PV generator is replaced by a conventional diesel generator [6]. In order to be able to contribute to the voltage adjustment by supplying or absorbing reactive and real power, the decentralized production units must be controllable.

The sudden consumption variations can induce network frequency fluctuations. The fast variations of the RES have the same effect as load variations. However, as long as the penetration rate remains low, this influence can be considered negligible. Recently, wind turbines are participating in the primary frequency control to ensure the network stability. In fact, when the power generation is more than consumption and thus the frequency is higher than the reference value (e.g. 50 Hz in France), wind turbines might be requested to reduce their production [7].

I.3.2. Perspectives for better integration of RES into electrical networks

Limitations of the penetration level

The major problem of the decentralized RES integration into electrical networks is that they are not participating in AS, such as voltage and frequency control. As they are “passive” generators at the point view of system operators, voltage and frequency control is implemented by conventional generators that are equipped with alternators and turbines. Therefore, in order to guarantee the electrical network stability, the penetration level of such decentralized RES must be limited. For example, nowadays, the non-hydro RES penetration level is limited to 30 % of the power consumed in the French island electrical networks [4].

Decentralized power generation is sensitive to network disturbances, such as voltage drop or frequency deviation. It often leads to a disconnection of the power production from the network, or even aggravates the situation by a snowball effect. To avoid the worst situation, production facilities are requested to remain connected for limited periods of time in case of a voltage drop or frequency variation, according to the constraints that vary from an operator to another.

Production is another challenge that system operators need to deal with because of forecasting errors and uncertainties. For wind power production, 24-hour-ahead predictions are normally satisfying with 10 % of average uncertainty [4]. Even if the prediction accuracy is continually improving, controllable OR is required to compensate the forecasting uncertainties.

The capacity of electricity transport lines and power stations plays an important role. In the case of RES, such as wind power, PV power and hydraulic power, the production sites are sometimes far away from the consumption sites or the connection stations. Therefore, when the decentralized power production increases, new lines will be needed to prevent the transport lines congestion.

Perspectives for better integration into the networks

As presented in [4], three levels of evolution will be required for a significant increasing of distributed RES: the source level, the network level, and the consumer level.

At the source level, despite the intermittence nature and the forecasting uncertainties of the RES, it would be possible to increase the penetration level if the RES can operate in islanding mode, participate in the network management, and have an increased reliability. In order to fulfill these objectives, some advanced control technologies can be applied, such as

- developing new control strategies for power electronic power inverters,
- using energy storage systems for short and long term in order to be able to provide AS,
- developing multi-source systems with an integrated energy management system, and so on.

At the network level, the congestion management is essential to guarantee electrical system security. Corrective measures for preventing unexpected congestions are the modification of the network topology or the modification of the production plans of the generation units.

Moreover, new network architectures, such as smart grids and microgrids, are able to increase efficiency and security of electric networks. By adopting the new communication technologies associated with advanced energy management systems, the electrical network improves its intelligence level and, therefore, increases the potential ability of integrating more RES.

In order to ensure an available and stable power level from RES, different kinds of energy storage devices are widely used to compensate the random variations of the power output.

Normally, they are implemented either combined with large intermittent production units, or distributed in the distribution network. With the help of the storage devices and control strategies, a wide range of services can be provided, such as power quality improvement, peak load smoothing, reduction of transport losses, primary frequency control and frequency stability of the insular grids, and so forth [8].

At the consumer level, controlling the power consumption enables electric networks to use the power generation more efficiently. It helps to adjust some load to consume more energy when the RES power production is available. It can also manage the hourly power consumption to avoid the congestion of electric network lines. For example, recently, some researches and new technologies have been focused on the positive energy buildings, with a zero or negative energy consumption. Combined with the energy storage, it will be a great help for RES integration into the networks. Moreover, the massive development of the electric vehicles (EV) (plug-in hybrid and entirely electric) will have a significant impact on the electric network. For instance, EV can be used as loads to charge the batteries at the energy production peaks, or as generators by discharging the batteries (as energy storage devices) at load peaks, if necessary.

I.3.3. RES Integration Impacts in Electricity Markets

The Europe electricity markets have been fully liberalized since the 1st of July 2007. This electricity market liberalization aims to increase competition, thus decreasing electricity prices for the consumers. Moreover, the European Union has made the commitment to reduce their greenhouse gas emissions. Therefore, there is a need to promote electricity generation from RES and the penetration ratio will have to rise to 20% by 2020.

Theoretically, competitive markets should lead to efficiency gains in the economy, and consequently, reducing electricity prices. However, the real benefits from increasing the competition are object of debates because the market's opening-up does not necessary imply the market efficiency increase and competitive prices. For example, the analysis results of electricity power reforms on electricity prices in developing countries show that the introduction of a wholesale electricity price does not necessarily reduce the electricity prices. Some experiences of liberalized electricity markets in the South East Europe show that prices are increasing for household consumers [9].

The old integrated monopolies in the wholesale market reduce the effective competition. By controlling the electricity production, the monopolies averse the consumers to change from their traditional retail electricity company only if they pay a significant switching costs [10]. However, electricity markets are not solely wholesale markets but a number of different markets including regulating power markets, automatic reserve markets, etc. Regarding the participation of RES in the electricity market, a controversial debate has arisen about its effects on household electricity prices. A higher use of RES could reduce the wholesale electricity prices as they are characterized by lower variable costs than fossil conventional technologies. However, the RES development is mainly driven by public renewable support schemes, which are financed via the electricity market by increasing the final price paid by consumers. In addition, environmental costs related to CO₂ emissions in electricity generation usually have a significant negative effect on electricity prices. The substitution of conventional electricity generation by RES could reduce the electricity demand from fossil fuels and CO₂ emissions, and thus the wholesale electricity price is reduced [9].

Thus, the progress made towards the liberalization and also the increased RES participation in the electricity markets are important factors to explain the final electricity price paid by consumers. In recent years, several studies have been developed to explain the effect of

several variables on electricity prices by using cross-sectional, temporal or panel data. Some of them include separately explained variables related to energy use or liberalization market [9].

Regarding the RES generation companies, a large share of power generally gives lower electricity prices, reducing the profitability of investments in new electricity capacities. As the majority of RES technologies are not profitable at current energy prices, their development is mainly driven by different public renewable support schemes: feed in tariffs, quota obligations, green-certificate trading, fiscal measures as tax benefits, investment grants, etc. [11]. For example, in [12], the possible effects of the increased PV power capacity on the prices in electricity markets are investigated. The effects of these RES developments will be: (1) higher price volatility from hour-to-hour and day-to-day; (2) higher prices for fossil fuel electricity capacities and storage technologies for balancing the intermittent RES generation; and (3) growth of balancing markets and intensified competition at the level of decentralized balancing organizations. Much more details are given in [9, 12, 13].

Given the urgency of the challenge, the priority should be given to the researches that increase grid flexibility, such as smart city, smart/micro grid, and energy storage solutions. In addition, the future electricity system architecture can no longer be considered as a passive appendage to the transmission network. Continuously microgrid energy systems are under development to integrate massively RES, micro generators, energy storage devices, and controllable/non-controllable loads. The entire distributed system has to be designed and operated as an integrated unit. Moreover, a multilevel management electrical system is needed for the system operation. In the following parts of this chapter, the concepts of smart city, smart grid and microgrid are first presented. Then, different kinds of distributed energy sources (RES, energy storage, active PV generator, and micro gas turbine) are introduced. Finally, the fundamental principles of microgrid management system are recalled to highlight the constraints and required control functions for the grid control system.

I.4. Smart City, Smart Grid and Microgrid

A growing penetration of renewable generation leads to less pollution and energy diversity. This is a potential contribution to the reduction of CO₂ emissions and so of the carbon footprint of electrical grids. However, due to the variability and uncertainty nature of the RES, new needs are required for protection equipment and substations extending. Moreover, new ways for balancing load and generation with fast response times are necessary. With the assistance of advanced control systems, RES integration into power systems will be less influenced by the drawbacks of their intermittent nature. Therefore, in recent decades, the RES integration is more and more concerned with smart cities, smart grids, and micro grids. Nowadays, there is a clear movement toward driving more intelligence into substation equipments to increase the security level and to make them more ‘smart’.

I.4.1. Smart city

Nowadays, the concept of “Smart City” is frequently mentioned. It includes similar concepts such as ‘Cyber-Ville’, ‘Digital city’, ‘Electronic communities’, ‘Information city’, ‘Intelligent city’, ‘Knowledge-based city’, ‘Ubiquitous city’, ‘Energy hub’, and ‘Wired city’. However, there is still not a clear understanding and definition of the concept. Among the different nomenclatures and meanings all over the world, here we quote a definition from [14]:

“In a smart city, energy, water, transportation, public health and safety, and other key services are managed in concert to support smooth operation of critical infrastructure while providing for a clean, economic and safe environment in which to live, work and play. Timely

logistics information will be gathered and supplied to the public by all means available, but particularly through social media networks. Conservation, efficiency and safety will all be greatly enhanced.”

According to this description, a smart city is defined as the ability to integrate multiple technological solutions to manage the assets of a city, such as energy, water, transportation, public health and safety. The goal of building a smart city, which could be thought of as a large organic system connecting many subsystems and components, is to improve the service efficiency in all aspects with advanced technologies to improve the life quality and meets residents' needs.

The different factors used to characterize how to imagine a smart city include, but is not limited with, the followings: management and organization, technology, governance, policy, people and communities, the economy, infrastructure, and the natural environment [15]. Economic factor drives innovation and new technologies; then technology drives the way city officials interact with the city infrastructures.

Smart cities use information and communication technologies (ICT) to enhance quality, performance and interactivity of urban services and also to reduce resource consumption and system costs. For example a new generation of integrated hardware, software, and network technologies can provide real-time advanced analytics to make more intelligent decisions and actions that contribute to business processes optimization. Indeed, ICT infrastructure including wireless infrastructure, such as Wi-Fi networks and wireless hotspots, evoke crucial challenges related to its security and privacy. The European Union (EU) has devoted a range of programs and constant efforts in order to devise a strategy for its metropolitan city-regions to become 'smart'. In 2010, it highlighted its focus on strengthening innovation and investment in ICT services for the improvement of public services and life quality. Some of the smart city technologies and program examples have been implemented in Milton Keynes, Southampton, Amsterdam, Barcelona, Stockholm and so forth [15].

However, some major technological, economic and environmental changes of smart cities have generated important issues, such as: including ageing populations, moving to online retail and entertainment, pressures on public finances, economic restructuring, and especially climate change and electricity production transition from conventional fossil fuel to distributed RES.

I.4.2. Smart grid

Smart city depends on energy infrastructure to ensure resilient to supply the other functions (such as transportation, communication, and so forth). For this, the smart grid is capable of delivering power in more efficient ways by using modern information technologies. Smart grid works by combining advanced communication, sensing and metering infrastructures with the existing electricity network. It has enormous potential to improve the efficiency and reliability of electricity services and to transform the way consumers use energy in their homes and businesses. A smart grid can automatically identify and solve faults, better manage voltage and identify required infrastructure maintenance. By using the energy efficient '*smart appliances*' and pricing structures, it can also help consumers to better manage their individual electricity consumption to reduce costs. Therefore, a smart grid sits at the heart of the smart city, which cannot fully exist without it.

According to [14], although a precise and comprehensive definition of smart grid has not been proposed yet, its anticipated benefits and functions are the following:

- Modernization of power systems by self-healing designs, automation, remote monitoring and control, and establishment of microgrids.
- Informing and educating consumers about their energy usage, costs and alternative options, enabling them to make decisions autonomously about how and when to use electricity and fuels.
- Providing safe, secure and reliable integration of distributed RES.

The U.S. National Institute of Standards and Technology (NIST) provided a conceptual model to perform this new grid paradigm (as shown in Figure I-3) [16]. In this model, the smart grid is divided into seven domains. Each one encompassed with smart grid actors and applications. Actors include devices (such as smart meters, solar PV generators), system (control system, and so forth), or decision making and information exchanging programs. Applications are tasks performed by one or more actors within a domain. As shown in Figure I-3, in general actors interact with other actors in other domains to ensure the functionality of the smart grid.

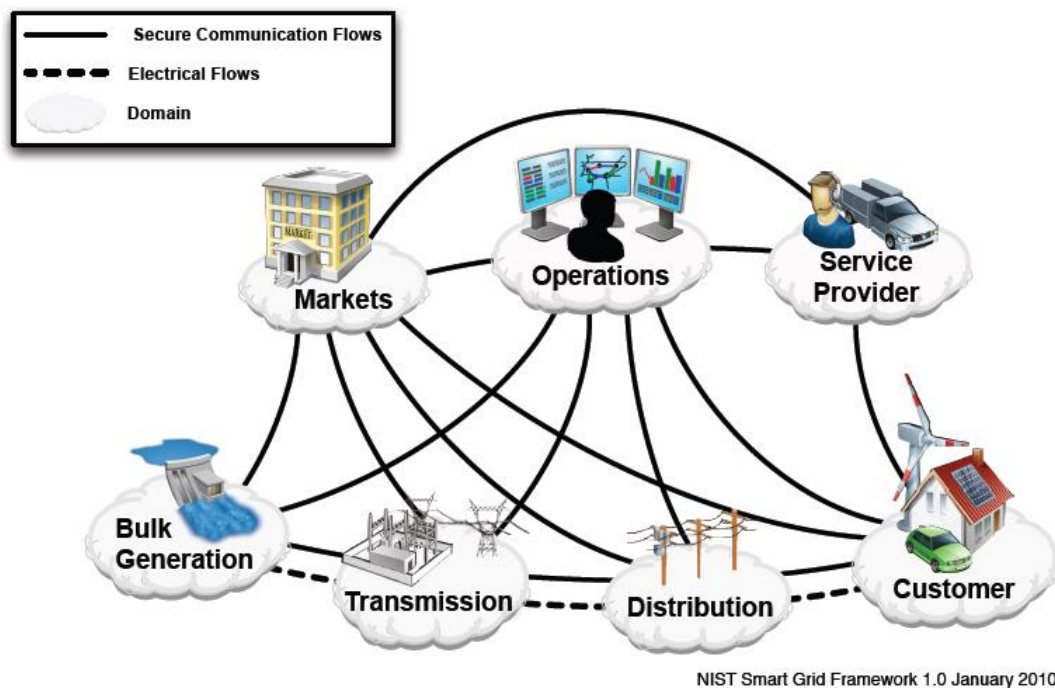

Figure I-3 The NIST conceptual model for smart grid ([16]).

In order to complement this energy infrastructure that is more reliable, more sustainable and more resilient, three major systems are illustrated from a technical perspective as follows:

- **Smart infrastructure system:** It handles: 1) advanced electricity generation, delivery, and consumption; 2) advanced information metering, monitoring, and management; and 3) advanced communication technologies.
- **Smart management system:** providing advanced management and control services.
- **Smart protection system:** providing advanced grid reliability analysis, failure protection, and security and privacy protection services.

The classifications of these three major systems are presented in Figure I-4 and much more details can be found in [17].

I.4.3. Microgrid

As described above, a smart grid is a modernized electrical grid that uses information and communication technologies to gather and act in an automated fashion to improve efficiency, reliability, economics, and sustainability of electricity production and distribution. This

broader concept involves the optimal operation of generation, transmission, distribution and operation in a local area.



Figure I-4 The detailed classification of the smart grid infrastructure ([2]).

A microgrid mainly focuses on the electrical distribution networks to deal with the integration of small-rated distributed energy resources and storage systems closer to consumptions. It includes multiple loads and distributed energy resources. It can increase the reliability with distributed generation and increase the system efficiency by reducing transmission length and combined heat with power (CHP). It also facilitates the integration of alternative RES to reduce pollution, be operated in parallel with the broader utility grid or as a small, independent islanded system. Applications are for communities, neighborhoods, corporate and academic campuses, buildings, military base camps, naval systems and so forth. More detailed information can be found later in part I.7.

I.5. Electrical Energy Storage

I.5.1. Applications and Services

Energy storage devices can serve as backup power plants. They can be used to store or to release electrical power like an energy buffer, supporting the operation of sources, transmission, distribution and loads. Therefore, they are useful to solve the problems of power intermittency and system low inertia in a RES-based power grid. The combination of energy storage devices and RES constitutes a hybrid power generator or a microgrid system which can provide power not only for the local loads but also can supply AS to the main grid like conventional generators.

Facing to the problem of RES intermittency, such as uncertainty and variability, system operating error, unplanned outage, and component failures, the use of electrical energy storage is considered as an effective solution. Even though they are not widely used today, the energy storage devices will be needed to provide additional flexibility by buffering the energy unbalancing between power generation and load demand. Also, they can provide ancillary services as frequency regulation and voltage regulations in an electrical network. According to [27], the benefits of using energy storage devices are as follows:

- Managing intermittent RES variability;
- Improving power quality;
- Supporting system regulation within the timescale from seconds to minutes;
- Supporting load following for timescales of minutes to hours;
- Unit commitment to meet forecasted load for timescales of hours to days;
- Seasonal storage applications for large energy capacity and low self-discharge usage.

A well-placed electrical energy storage system can help to manage the distributed nature of RES. However, the size of the storage system needs to be scalable and modular under consideration of economic justification. An energy storage system needs also to be rated both in terms of energy and power by considering provided services [28].

I.5.2. Energy Storage Forms

Electrical energy can be stored in forms of either potential energy (e.g. chemical, gravitational or electrical energy) or kinetic energy (e.g. thermal energy). There are various technologies in different states of development and used for various purposes, depending on their energy and power characteristics. Nowadays, these energy storage technologies continue to growth as the grid continues to welcome greener energy sources with more intermittent energy forms, like wind and solar power. Several different types of energy storage devices are recalled [29, 30].

A. Chemical and Electrochemical

Lead-acid batteries: are the oldest technologies of rechargeable batteries. They are made up of plates of lead and lead oxide sit in a bath of electrolyte solution. They are able to give quick short bursts of energy.

Deep-cycle battery: is a type of lead acid battery that uses a thicker lead plate and requires less maintenance. These are used in off-grid situations for charging (e.g. cell phone towers or for backup power) and also used for grid energy storage.

Flow batteries: typically made up of two tanks of liquids that are pumped previously, a membrane held between two electrodes. Electricity is produced when the chemicals combine with the electrodes. This energy storage is generally used in larger stationary applications, such as the grid for energy balancing or off-grid power supply.

Power-to-Gas: This technique uses hydrogen fuel cells to produce electricity. The hydrogen can be created from the excess of wind or solar power with electrolytes and stored in tanks to be used later.

Electrical:

Super-capacitor: The super-capacitor, also known as ultra-capacitor, has a very high capacitance which bridges the gap between electrolytic capacitors and rechargeable batteries. It has an unusually high dynamic characteristic. Thus, it is used in applications requiring many rapid charge/discharge cycles.

B. Mechanical

Pumped hydro: it works by pumping water from a lower elevation reservoir to a higher elevation reservoir and then takes advantage of gravity to pull the water through a turbine generating electricity. As the oldest, cheapest and most established storage technology, it represents 99 percent of the bulk energy storage capacity in the world today.

Compressed air energy storage: storage system compresses ambient air and pumps it into a tank to store energy. To deploy stored energy, air is heated and released to turn a turbine producing electricity.

Flywheels: A flywheel is used to store rotational energy by using a rotating mechanical device. The stored energy can be called up instantaneously. It contains a constantly spinning mass and releases energy by slowing down the spinning mass. The device uses a motor to increase its rotational speed to be recharged.

C. Thermal

Thermal: Using heat or cold to store energy such as in ice, water heater, or heated molten salt:

- Ice energy is used for air-conditioning in some pilot projects;
- By heating the water in the tank to store energy, water heater can be used to shift electricity consumption from higher-prices hours;
- Molten salt energy storage is sometimes a component of concentrating solar power plants.

I.5.3. Long Term Energy Provision and Fast Dynamic Power Capability

The energy storage technologies can be classified into two types based on the different energy and power densities: fast dynamic power storage and long term energy storage.

The fast dynamic power storage units have higher power density and they are suitable for the fast balancing of high variable power. Their response time for electrical power release and

restoration is significantly short: from several milliseconds to minutes. Thus they can provide a good dynamic characteristic for the applications. Especially in the domain of renewable energy based power production and electric vehicle, they can provide an improvement of the power quality by rapid voltage balancing for power exchanges and for the service provision.

On the contrary, the long term energy storage units have the higher energy density. They can continually release the electrical power during a relatively long time (from dozens of minutes to several hours), and thus usually be used as a long-term energy reserve. This kind of long term energy storage, such as batteries from various technologies, the hydrogen storage and the compressed air storage system, can be used in uninterrupted power supply (UPS) systems and for providing ancillary services. They have been also proposed for solving intermittency problem of RES: for example, by using batteries and/or pumped hydro system to store extra solar energy during the daytime and release the storage during the night when the solar power is not available.

Energy storage has applications along the entire electric value chain. It can be used to store energy from large scale, renewable generation for later use. It can be installed in power substations to provide power supply to substation equipment and computers. It can be deployed in a microgrid to supply power closer to the actual load or consumption. And it can also be installed at commercial, industrial, and residential customer premises to provide good, independent or emergency power [31].

I.6. Hybrid Active Generators

I.6.1. Interest

Since wind and solar energy generators depend on intermittent primary renewable sources, they cannot participate in the energy management of an electrical system and are defined as passive generators. On the contrary, conventional power generators, such as fossil fuel generators and nuclear power plants, are controllable, can provide necessary energy and can be dispatched. Compared to uncontrollable passive generators, these conventional controllable power plants can provide basic ancillary services: voltage regulation by reactive power control, and frequency regulation by active power control. However, conventional power plants must face to the environmental challenge and the danger of fossil fuel exhaustion.

Long term energy storage devices can serve as backup power plant and be used as an energy buffer to store or release electric power, while short term dynamic power storage device can be used to mitigate rapid variable power of intermittent sources. Therefore, they can help to solve the intermittent availabilities and fast transient problems of RES [32].

A hybrid power generator is the combination of energy storage devices and a renewable energy based generator. This hybrid power system is an active generator and provides clean energy with a high power quality. Moreover, it can be used to supply ancillary services like conventional generators. Previously, a PhD student Di LU at the L2EP laboratory has designed a PV power based active generator [33], and the following part is a retrospective general presentation.

I.6.2. Configuration of an active PV generator

Figure I-5 illustrates a PV power based active generator: photovoltaic panels, batteries and ultra-capacitors are coupled to a common DC voltage bus by three DC/DC power electronic converters. In this hybrid power system, PV panels work as the main power source. As long term energy storage device, a set of lead acid batteries aims to shave the PV power peak by storing energy surplus during daytime and discharge it during solar unavailability. In addition,

an ultra-capacitor bank is used for the fast dynamic power regulation to smooth transient PV power fluctuations. In the diagram, four different converters (PV chopper, battery chopper, ultra-capacitors chopper, and grid connection inverter) are used for power control to satisfy the power demand from the grid operator and provide ancillary grid services. They ensure:

- The control of the power generated by PV panels;
- The maintain of a constant DC bus voltage;
- The mastering of required power exchanges with the grid;
- Power buffering of each energy storage unit.

To satisfy the power demand (P_{ag_ref} , Q_{ag_ref}) from the grid operator, the control system sends control signals to each power electronic converter. The detailed control system of this active PV generator can be found in the previous work of Di LU [33].

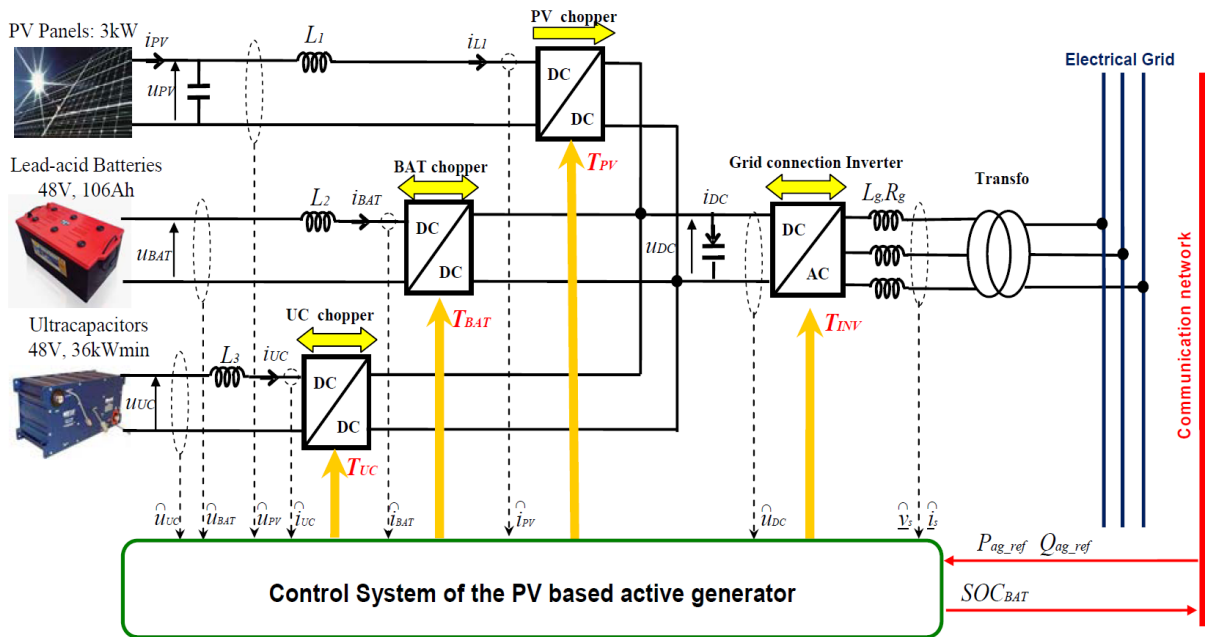

Figure I-5 PV based active power generator [14].

I.7. Micro Gas Turbine

A gas turbine, also called combustion turbine, is a type of internal combustion engine, which produces heat and electricity on relatively small scale (15-250 kW). It produces power by burning an air-fuel mixture to create hot gases that spin a turbine. Gas turbines use refined fuels, including natural gas, fuel oils, and synthetic biofuels. Today, the gas turbine is one of the most widely-used power generating technologies and the main applications are in gas-fired power plants and also aircraft, ships, and tanks. Normally, its efficiency is about 28 % to 33 %.

Gas turbines have three primary sections which are mounted on the same shaft: the compressor, the combustion chamber and the turbine. Fresh air flows through a compressor that brings it to a higher pressure. Then spraying fuel is added into the air. By igniting the mixture air-fuel the combustion generates a high-temperature and a high-pressure gas flow, which enters in the turbine, where it expands rapidly and imparts rotation to the shaft. This rotation drives the compressor to draw in and compress more air to sustain a continuous combustion. At the same time, the remaining shaft power is used to drive other devices such as an electric generator to produce electricity.

Micro turbines have many advantages, such as higher power-to-weight ratio, low emissions and few moving parts. They become widespread in distributed power systems and combined heat and power (CHP) applications. The characteristics of micro turbines are studied and presented in the previous work of Hristiyan KANCHEV ([34]). In this thesis, these micro gas turbines (Appendix III) are used as energy sources for day-ahead optimal power dispatching in chapter IV.

I.8. Microgrid Management

I.8.1. General introduction

In an active PV generator, PV power fluctuations can be compensated by storage units (batteries for long term storage and ultra-capacitor for fast dynamic power regulation). Hence, the active PV generator is able to generate a predetermined real and reactive power through an enhanced local controller. The availability of this type of generators must be checked before the design of the operational planning of generators.

Microgrids are developed to integrate massive RES, micro generators, energy storage systems, as well as controllable and non-controllable loads. Microgrids are small electrical distribution systems that connect multiple distributed generation sources and storages with multiple customers. Generally, a microgrid concept assumes a cluster of loads and distributed energy sources operating as a controllable system, which is supervised by a microgrid central controller (MGCC) to provide both power and heat to a local area. As shown in Figure I-6, the basic microgrid network is assumed to be radial with several feeders with a circuit breaker and a power flow controller.

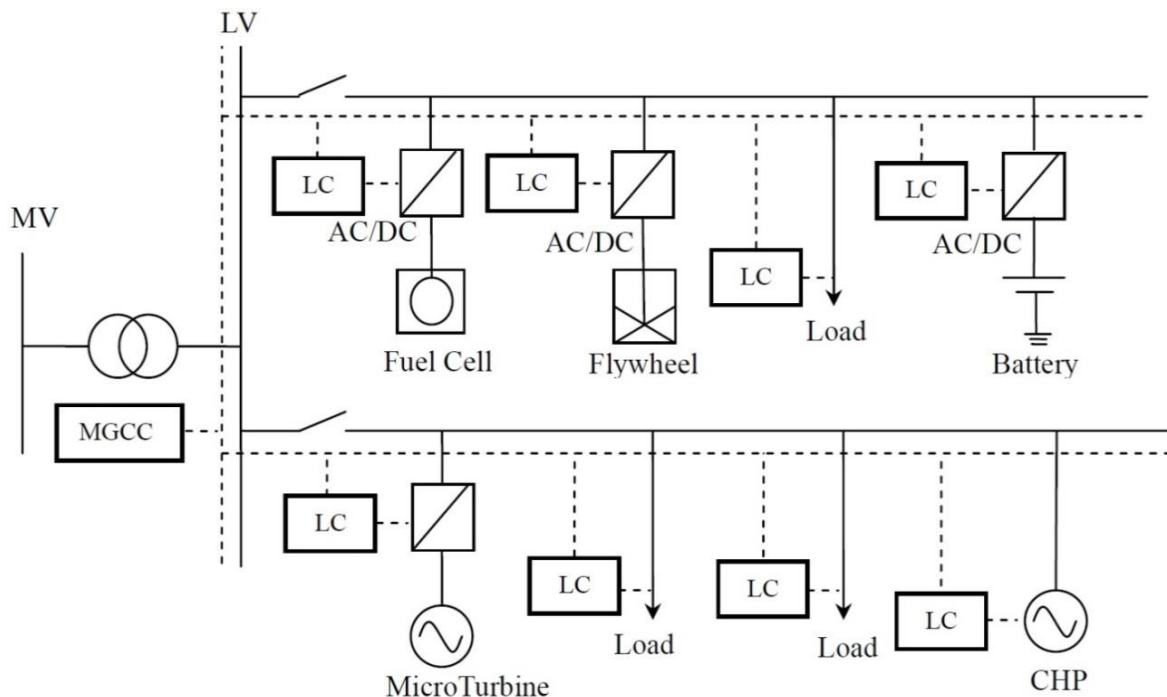

Figure I-6 Basic microgrid architecture with a MGCC [33].

It consists of a low voltage (LV) network, conventional and renewable energy generators, energy storage devices, loads (including interruptible load) and a hierarchical-type management. The MGCC uses a communication infrastructure to monitor and control power flows. Loads and generators exchange information with the MGCC through local controllers (LC) at the low hierarchical control level. The integration of the distributed energy production to an electrical network must satisfy a number of constraints related to its operation and

management. Indeed, the management of a network must respect the physical and technological constraints as well as ensure the energy supply security, the equipment security, the power quality and the system efficiency.

A technical-economic optimization of the electrical system operation must be carried out by taking into account: (1) the balancing constraints between the energy production and the energy consumption during the day; (2) the constraints related to voltage and frequency limits and their setting; (3) the price of the energy production; (4) the environmental impact.

The microgrid is intended to operate in the following conditions due to its flexibility:

- **Normal operation in a grid-connected mode:** In the normal operation the microgrid is connected to the main grid and can either inject some power into it. The energy balancing between consumption and productions is expected in this area.
- **Emergency operation in an islanded mode:** An islanded operating mode can be implemented in case of any event in the main grid: an intentional disconnection for maintenance needs or a forced disconnection (main grid fault).
- **Fault detection and safety analysis:** In islanded mode, any current fault must be covered by the generators within microgrid. Therefore, the fault detection techniques are essential and important.

Generally, the benefit of microgrids is to get an optimum solving of local problems with local solutions, such as:

- Enhancement of the local reliability;
- Reduction of feeder losses;
- Easier local voltage control;
- Efficiency increasing by using of CHP generators;
- Voltage sag correction;
- Provision of uninterruptible power supply functions.

In designing future electricity system, the specific problems to be solved include: information flows and communications in a microgrid, common resource sharing among microgrids, and trade and financial exchange between microgrids. Therefore, microgrid can work independently, in coordination with neighboring ones, and also with the grid.

I.8.2. Control functions and management with a communication system

Energy control system should respect criteria that govern the electric power system operation: safety, quality, reliability, and economy. According to proceeding criteria, the following tasks should be performed [35]:

- maintaining the balance between consumption and generation;
- maintaining the reactive power balance for voltage regulation;
- maintaining an optimal generation scheduling for cost and environment impact limitation;
- and ensuring the security against credible contingencies.

To implement the power system operation, electric utilities rely on a high sophisticated integrated system for monitoring and control [43]. The bottom tier is the automatic equipment, such as protective relays and automatic transformer tap-changers. Tier 1 consists of remote-control cabinets and provides facilities for actuator control, interlocking, and voltage and current measurement. Tier 2 is the data concentrators/master remote terminal unit, which typically includes a man/machine interface giving the operator access to data produced by the lower tier equipment. The top tier is the supervisory control and data acquisition (SCADA)

system (Figure I-7). It accepts remote-metered values and displays them in a meaningful way to operators [33].

Normally, there are two types of control system: energy management system (EMS) and distribution management system (DMS). The basic functions of EMS include:

- Real time data acquisition from monitoring equipment;
- Raw data processing and then power set points sending within the central control system.

So it consists of data acquisition, supervisory control, logical alarming, historical database, automatic data collection, load shedding function, and safety management. The functions related to generating subsystem operational scheduling involves the following: power generation and load forecasting, power reserve quantification, unit commitment, economic dispatch and interchange transaction scheduling.

I.8.3. Energy management system of a residential microgrid

As example, the microgrid shown in Figure I-7 is composed of active generators, loads and conventional power generator (gas turbine) and is controlled by a microgrid central energy management system (MCEMS).

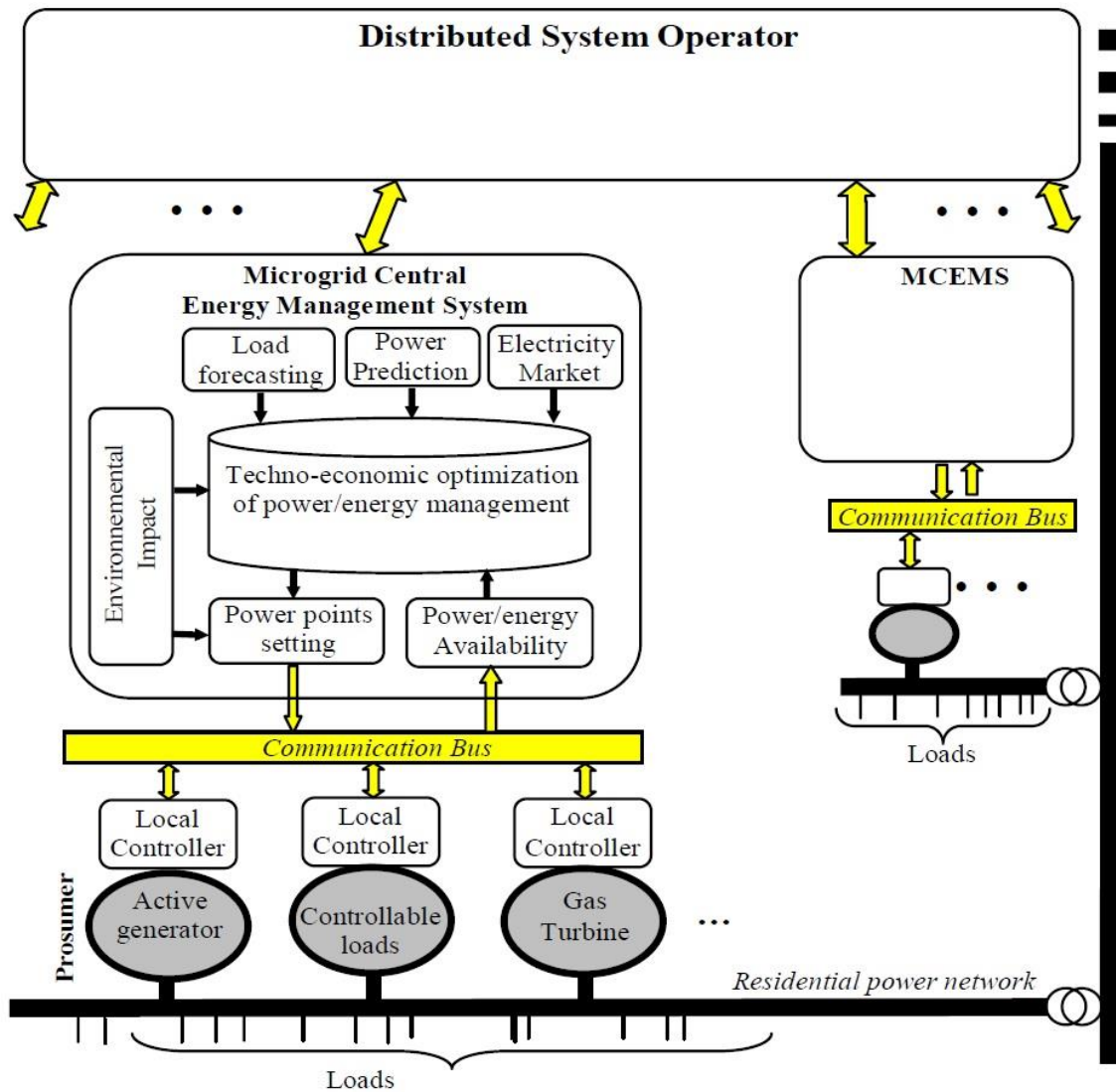

Figure I-7 Framework of the central energy management system [33].

The global objective consists in matching the total power production to demand with an optimal way through the combined use of an additional communication network within an intelligent EMS and LC. In this residential MG, there are two kinds of generators, which are grid connected with power electronic converters: PV based active generator and gas turbine. It can operate in either grid connected mode or islanded mode. In the former mode the energy flow is bidirectional between the residential network and the grid. While in the later mode all the power demand is provided by PV panels and the gas turbines. To maximize the renewable energy usage, PV power can be considered as a prior energy source and gas turbines are chosen as the master generator to compensate the remaining load demand. The MGCC measures the state variables and dispatches orders to different devices through the communication system. While LCs of active generators and gas turbines receive set points from the central controller and at the same time they send back the sensed power production at the coupling point.

The microgrid EMS can be analyzed and classified in different timing scales and various functions (Figure I-8).

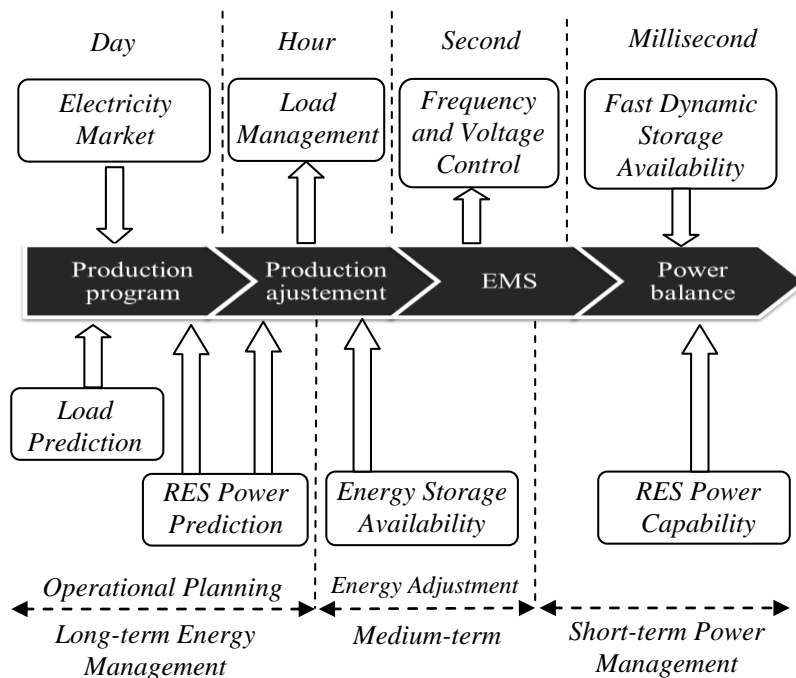

Figure I-8 Timing classification of control functions in the context of microgrid [33].

The management functions are conventionally organized in three main groups according to their dynamics: long-term, medium-term, and short-term supervision. The short-term management functions correspond to the primary control and are executed by the LC located within the generators. Long-term management corresponds to a secondary control and is carried out by a central controller located in a dispatch center for large networks. In a microgrid, this management must be able to be carried out independently to enable an islanding operating by MCEMS.

The long-term energy management includes:

- the hourly (or half-hourly) RES production forecast;
- the management of non-sensitive loads that can be disconnected/shed from electrical grid;
- the maintenance intervals;

- the provision of an appropriate level of OR power capacity by considering the energy production and the load demand forecast.

The medium-term energy management includes:

- the adjustment of RES production and load demand;
- the available storage energy estimation;
- the correction of power set-points of each source each half hour;
- the secondary regulation supply for the system AS.

The short-term power balancing includes:

- the instantaneous “Balancing and power dispatching” among DG units and storage devices based on the storage capacity and to the specific requirements/limitations of each DG unit;
- the voltage regulation and primary frequency control.

In order to implement these functions, DG must be coordinated either in a grid connected mode or in an islanded mode [36, 37]. The long-term and medium-term energy managements require a communication network to exchange information and control signals [38, 39], while the short-term power management is achieved by sensing electrical quantities of a droop control technique [40]. The power management by sensing electrical quantities is detailed in [33].

To facilitate the theoretical presentation of developments, a single prosumer, micro gas turbines and loads (controllable and critical) are considered (Figure I-9).

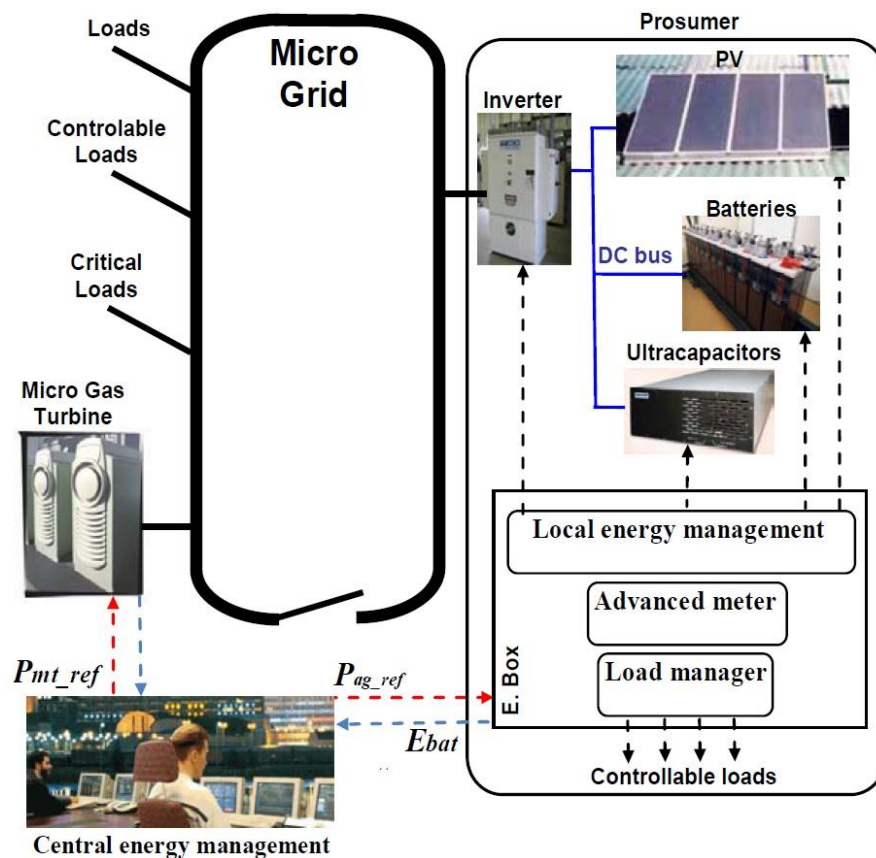

Figure I-9 Micro grid integration of a prosumer and micro gas turbines [14].

According to different management objectives, a MCEMS for the long term and medium term energy management and a local energy management in the E-box for real time balancing are

implemented. A communication network is used to implement interconnection between central energy management system and LC, such as data acquisition and information exchange. The adopted EMS is based on the PV power production, load prediction and optimized power planning for system operation in terms of technical, economical or ecological goals on the basis of available information (such as the network state, availability of micro gas turbines).

I.9. Research Tasks, Method, and Content

As energy prices get more and more high and CO₂ emissions should be limited, new electrical generators supply options based on distributed resources are required. RES energy productions are characterized by uncertainty and intermittence. Compared with conventional power plants, they are greatly influenced by meteorological conditions. Therefore, because of the uncertainties from both RES generation and load demand, the integration of renewable energies into electrical grids is considered to be a more and more important issue to maintain an efficient, reliable and secure electrical infrastructure.

Facing this problem, hybrid active generators with storage system and renewable generators have been yet proposed to provide a controllable power supply. In this PhD work, possibilities to use them are studied to cover unforeseen events caused by sudden decrease or increase of power from generators or/and in demand or/in addition to unexpected loss of generators/lines. Besides, some kinds of power reserves, such as batteries and ultra-capacitors, can also help to provide ancillary services in a local electrical network for frequency regulation and voltage regulation, etc. [41]. However, additional power reserve equipment will greatly increase the overall cost of the power generation system. Thus, the balance between required power reserve and system costs needs to be considered and power reserve needs to be minimized, while satisfying system security [42].

Targeted scientific problems and the followed methodology are now presented. The objective of this research work is firstly to study the uncertainty of PV power and load demand forecasting in a local microgrid system using adequate mathematical models. Uncertainties of an urban microgrid will be tackled through the study of the variability and uncertainty nature of the PV power generator. Based on this analysis, day-ahead operational OR will be calculated in order to satisfy a prescribed risk level of an energy unbalancing. Finally, the day-ahead optimal dispatching of this OR and the energy operational planning is studied by considering various possible participations of micro gas turbines and also PV based generators to decrease economical costs but also CO₂ emissions in a microgrid.

Original contributions have been organized in this report based on the following roadmap.

A great number of power forecasting methods for wind farms, solar PV power plants and the load demand have been proposed in recent years. The consideration of the uncertainty in the forecasting of the PV power and load variability may lead to a less expensive and a more secure network. So, an artificial neural network is designed to predict the forecasting error one day ahead in the next chapter.

Because of variability and/or uncertainty, an operating power reserve is required for the power balancing between the total energy supply and total load demand [44]. As small power distributed generators are new sources of uncertainty, a microgrid is considered to study the impact of local uncertainties. Local solutions to manage it are looked for in order to avoid the propagation in other parts of the grid. Then the microgrid will be considered as a control area where the balancing must be satisfied. So in chapter three, a method to analyze these uncertainties with a probabilistic method is proposed in order to correctly quantify the risks of unbalancing. Then, we present a decision making approach for a day ahead timing power

reserve quantification. It is computed by taking into account the probabilistic forecasting error and an associated reliability risk indices. The aim is to minimize the amount of reserves and so to decrease the balancing costs that result from the integration of RES based DGs.

The fourth chapter presents various strategies to dispatch this power reserve onto generators. The first one distributes it into MGTs only, while the other one considers MGTs and also PV AGs to provide the necessary reserve. The later implements a new application for distributed storage systems that are embedded in the PV AGs since they would provide the power reserve. The same security level must be achieved with the contribution of all distributed storage systems inside all PV AGs. Hence, distributed storage systems helps PV producers to produce the day ahead forecasted PV power within a power reserve. The second strategy also enables RES to provide all the load demand, including reserve power, in some periods of a day. To implement those methods, a day-ahead optimal planning with a dynamic programming method is applied to minimize the economic cost and the CO₂ emissions under several non-linear constrains.

An implementation into an Energy Management System (EMS) is proposed in the last chapter to conceptualize the overall system operation. It provides a complete set of user-friendly graphical interfaces to properly monitor the various origins of uncertainties and the distribution of the OR in the studied electrical system (PV panels, batteries, load demand, MGTs, ...) in addition to their effects on system security.

References

- [1] F. Birol, "World energy outlook," *Paris: International Energy Agency*, 2013.
- [2] N. Hadsaid and J.-C. Sabonnadière, *Power Systems and Restructuring*: John Wiley & Sons, 2013.
- [3] I. o. E. Engineers and N. Jenkins, *Embedded Generation (IEE power and energy series; 31)*: Institution of Engineering and Technology-IET, 2000.
- [4] B. Robyns, A. Davigny, B. Francois, A. Hennenon, and J. Sprooten, *Electricity Production from Renewables Energies*: John Wiley & Sons, 2012.
- [5] B. Robyns, A. Davigny, C. Saudemont, A. Ansel, V. Courtecuisse, B. Francois, *et al.*, "Impact de l'éolien sur le réseau de transport et la qualité de l'énergie," *J3eA*, vol. 5, 2006.
- [6] Y. Pankow, B. Francois, B. Robyns, and F. Minne, "Analysis of a photovoltaic generator integrated in a low voltage network," in *Proceedings of the 17th International Conference on Electricity Distribution, CIRED*, 2003.
- [7] T. Ackermann, *Wind power in power systems*, vol. 140, Wiley Online Library, 2005.
- [8] G. Delille, B. Francois, and G. Malarange, "Construction d'une offre de services de stockage pour les réseaux de distribution dans un contexte réglementaire dérégulé," *RIGE*, vol. 12, pp. 733-762, 2009.
- [9] B. Moreno, A. J. López, and M. T. García-Álvarez, "The electricity prices in the European Union. The role of renewable energies and regulatory electric market reforms," *Energy*, vol. 48, pp. 307-313, 2012.
- [10] K. Ek and P. Söderholm, "Households' switching behavior between electricity suppliers in Sweden," *Utilities Policy*, vol. 16, pp. 254-261, 2008.
- [11] R. Haas, C. Panzer, G. Resch, M. Ragwitz, G. Reece, and A. Held, "A historical review of promotion strategies for electricity from renewable energy sources in EU countries," *Renewable and sustainable energy reviews*, vol. 15, pp. 1003-1034, 2011.
- [12] R. Haas, G. Lettner, H. Auer, and N. Duic, "The looming revolution: How photovoltaics will change electricity markets in Europe fundamentally," *Energy*, vol. 57, pp. 38-43, 2013.
- [13] H. Auer and R. Haas, "On integrating large shares of variable renewables into the electricity system," *Energy*, 115, pp.1592-1601.
- [14] K. Geisler, "The relationship between smart grids and smart cities," *Newsletter*, 2013, url: <http://smartgrid.ieee.org/newsletters/may-2013/the-relationship-between-smart-grids-and-smart-cities>.
- [15] H. Chourabi, T. Nam, S. Walker, J. R. Gil-Garcia, S. Mellouli, K. Nahon, *et al.*, "Understanding smart cities: An integrative framework," in *System Science (HICSS), 2012 45th Hawaii International Conference on*, 2012, pp. 2289-2297.
- [16] G. Locke and P. D. Gallagher, "NIST framework and roadmap for smart grid interoperability standards, release 1.0," *National Institute of Standards and Technology*, vol. 33, 2010.
- [17] X. Fang, S. Misra, G. Xue, and D. Yang, "Smart grid—The new and improved power grid: A survey," *Communications Surveys & Tutorials, IEEE*, vol. 14, pp. 944-980, 2012.
- [18] A. V. Herzog, T. E. Lipman, and D. M. Kammen, "Renewable energy sources," *Encyclopedia of Life Support Systems (EOLSS). Forerunner Volume- 'Perspectives and Overview of Life Support Systems and Sustainable Development*, 2001.

- [19] I. E. Agency, "World Energy Outlook Special Report: Energy and Climate Change " 2015.
- [20] I. E. Agency, *Technology roadmap: solar photovoltaic energy-2014 edition*: OECD/IEA, 2014.
- [21] J. Movellan, "The 2016 Global PV Outlook: US, Asian Markets Strengthened by Policies to Reduce CO₂," January 25, 2016.
- [22] W. Steel, "Hydropower Outlook 2016: Exploring the Water-Energy Nexus and Energy Storage," 2016.
- [23] R. Bertani, "Geothermal power generation in the world 2010–2014 update report," *Geothermics*, vol. 60, pp. 31-43, 2016.
- [24] Pratt, Robert G., et al. "The smart grid: an estimation of the energy and CO₂ benefits." Pacific Northwest National Laboratory (2010), pp. 3-27.
- [25] IEA, "World Energy Outlook Special Briefing for COP21.pdf," 2015, url: https://www.iea.org/media/news/WEO_INDC_Paper_Final_WEB.PDF.
- [26] H. Bevrani, A. Ghosh, and G. Ledwich, "Renewable energy sources and frequency regulation: survey and new perspectives," *IET Renewable Power Generation*, vol. 4, pp. 438-457, 2010.
- [27] M. Beaudin, H. Zareipour, A. Schellenberglabe, and W. Rosehart, "Energy storage for mitigating the variability of renewable electricity sources: An updated review," *Energy for Sustainable Development*, vol. 14, pp. 302-314, 2010.
- [28] C. Abbey and G. Joós, "A stochastic optimization approach to rating of energy storage systems in wind-diesel isolated grids," *Power Systems, IEEE Transactions on*, vol. 24, pp. 418-426, 2009.
- [29] P. F. Ribeiro, B. K. Johnson, M. L. Crow, A. Arsoy, and Y. Liu, "Energy storage systems for advanced power applications," *Proceedings of the IEEE*, vol. 89, pp. 1744-1756, 2001.
- [30] J. P. Barton and D. G. Infield, "Energy storage and its use with intermittent renewable energy," *Energy Conversion, IEEE Transactions on*, vol. 19, pp. 441-448, 2004.
- [31] "Electrical energy storage", International Electrotechnical Commission, Dec. 2011, ISBN 978-2-88912-889-1."
- [32] H. Beltran, I. Etxeberria-Otadui, E. Belenguer, and P. Rodriguez, "Power management strategies and energy storage needs to increase the operability of photovoltaic plants," *Journal of Renewable and Sustainable Energy*, vol. 4, 2012.
- [33] D. Lu, "Conception et contrôle d'un générateur PV actif à stockage intégré: application à l'agrégation de producteurs-consommateurs dans le cadre d'un micro réseau intelligent urbain," PhD report, Ecole Centrale de Lille, 2010.
- [34] H. Kanchev, "Gestion des flux énergétiques dans un système hybride de sources d'énergie renouvelable: Optimisation de la planification opérationnelle et ajustement d'un micro réseau électrique urbain," Ecole Centrale de Lille, Ph.D report, 2014.
- [35] A. Ipakchi and F. Albuyeh, "Grid of the future," *Power and Energy Magazine, IEEE*, vol. 7, pp. 52-62, 2009.
- [36] F. Katiraei, R. Iravani, N. Hatziargyriou, and A. Dimeas, "Microgrids management," *IEEE Power and Energy Magazine*, vol. 6, pp. 54-65, 2008.
- [37] P. Li, "Formalisme pour la supervision des systèmes hybrides multi-sources de générateurs d'énergie répartie: application à la gestion d'un micro réseau," Ph.D report, Ecole Centrale de Lille, 2009.

- [38] A. L. Dimeas and N. D. Hatziargyriou, "Operation of a multiagent system for microgrid control," *IEEE Transactions on Power Systems*, vol. 20, pp. 1447-1455, 2005.
- [39] H. G. Arantzamendi, "Etude de structures d'intégration des systèmes de génération décentralisée: Application aux microréseaux," Thèse de doctorat, l'Institut National Polytechnique de Grenoble, le 15 décembre, 2006.
- [40] F. Katiraei and M. R. Iravani, "Power management strategies for a microgrid with multiple distributed generation units," *IEEE transactions on power systems*, vol. 21, pp. 1821-1831, 2006.
- [41] V. Fthenakis, J. E. Mason, and K. Zweibel, "The technical, geographical, and economic feasibility for solar energy to supply the energy needs of the US," *Energy Policy*, vol. 37, pp. 387-399, 2009.
- [42] G. Strbac, A. Shakoor, M. Black, D. Pudjianto, and T. Bopp, "Impact of wind generation on the operation and development of the UK electricity systems," *Electric Power Systems Research*, vol. 77, pp. 1214-1227, 2007.
- [43] Vandoorn, Tine L., Juan C. Vasquez, Jeroen De Kooning, Josep M. Guerrero, and Lieven Vandeveld, "Microgrids: Hierarchical control and an overview of the control and reserve management strategies". *IEEE industrial electronics magazine*, 7(4), pp.42-55, 2013.
- [44] H. Bevrani, "Robust power system frequency control," Springer, 2nd Ed, ISBN: 978-3-319-07277-7, 2014.

Chapter II

Uncertainty Analysis and Forecasting of PV Power and Load Demand

Chapter.II Uncertainty Analysis and Forecasting of PV Power and Load Demand

II.1. General Introduction

The constant increasing development of RES (especially PV power and wind power) is becoming a challenge for power system operators to maintain the energy balancing instantaneously. In recent decades, many research works have been dedicated to forecasting approaches and uncertainty analysis to calculate awaited power flows and to design a better energy management of electrical systems. The basic idea is to get a better forecast accuracy with existing database. Moreover, the forecasting accuracy is an important issue for an effective application. Calculation of PV variability and uncertainty can also increase the system distribution quality. This will allow system planners and operators to develop effective measurements to manage uncertainty at different levels of PV penetration into electrical systems.

The aim of this chapter is to investigate the uncertainty and variability of PV energy production through solar irradiance forecasting and daily irradiance variability classification. Firstly, solar PV generation model is recalled in details. Solar irradiance variability indices are used to better understand the variable characteristics of PV power generation. Following variability analysis, power generation and load demand forecasting methods are summarized and presented. Among the different possible forecasting methods, an artificial neural network (ANN) algorithm is developed and applied. The goal is not to improve a forecasting method but just to create forecasting errors. These errors are used for an uncertainty analysis in the next chapter. Subsequently, some application examples of PV power and load demand forecast with ANN are implemented.

II.2. Mathematical Modeling of PV Generator

For designers and installers, forecasting PV generator performances under natural sunlight is a key issue to deal with the variability and uncertainty of PV power generation. According to [1] and [2], the per unit area PV power output from a PV generator (PV_P) with a fixed orientation is represented by:

$$PV_P(t) = \eta_{pv}(t) \times A_{pv} \times I_r(t) \quad (\text{II-1})$$

where, η_{pv} is the power conversion efficiency of the module (power output from the system divided by power input from the sun); A_{pv} (m^2), is the surface area of PV panels; I_r (W/m^2), is the solar radiance. The PV generator efficiency is given by:

$$\eta_{pv}(t) = \eta_r \times \eta_{pc} \times [1 - \beta(T_c(t) - NOCT)] \quad (\text{II-2})$$

η_r is the reference module efficiency; it depends on the cell material. A polycrystalline silicon technology has been used with a 13% efficiency [3].

η_{pc} is the power conditioning efficiency and is equal to 0.9 with a perfect maximum point tracker.

β is the generator efficiency temperature coefficient, ranging from 0.004 to 0.006 /°C.

T_c is the cell temperature (°C). A PV module of polycrystalline silicon solar cells can be estimated from the ambient temperature T (°C) and the solar irradiation I_r as follows [4]:

$$T_c(t) = 30 + 0.0175 \times (I_r(t) - 300) + 1.14 \times (T(t) - 25) \quad (\text{II-3})$$

The normal operating cell temperature (*NOCT*) (°C) can be calculated when the cells operate under standard operating conditions: irradiance of 800 W/m², 20°C ambient temperature, average wind speed of 1 m/s, module in an electrically open-circuit state, wind oriented in parallel to the array's plane and all sides of the array fully exposed to wind. The effective area of PV generator (A_{pv}) is defined as the decision variable: if A_{pv} is measured in m², PV_P is numerically equal to the peak power rating of the array.

According to [1], this model can be simplified and the per unit area PV power output from PV generator with a fixed orientation is represented by:

$$PV_p(t) = \eta_{pv}(t) A_{pv} I_r(t) (1 - 0.0035(T(t) - 25)) \quad (II-4)$$

Among the factors which affect its power output, the intensity of solar radiation and the atmospheric temperature changes must be considered when the equation is applied for PV power forecasting. These variations of the solar radiation and temperature vary with seasons and different weather types. This will be further discussed in details in the later chapter.

The data (from 03/02/2010 to 30/11/2010) are collected from PV inverters, which are installed in the roof of the student residence at Ecole Centrale de Lille (GPS coordinates: 50°36'21.6"N 3°08'14.5"E). These sensed data are used as a database to evaluate the correlations. The PV power, solar irradiance and temperature of three continuous days (22/06/2010-24/06/2010) are presented respectively in Figure II-1.

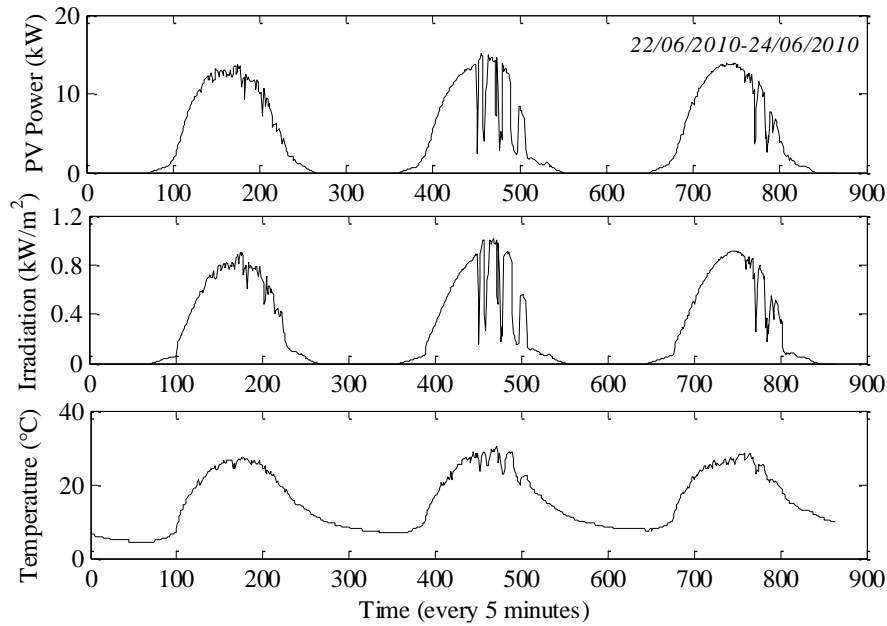

Figure II-1 PV power, solar radiation and air temperature in three continuous days.

Then, the sensed PV power data points can be drawn according to the sensed irradiation and temperature data points in order to highlight correlations (Figure II-2). The strength of association between PV power output and solar radiation is high, while the relationship with temperature is low. The correlation factor ($R^2=0.9774$)^① explains the intensity of

^① In statistics, “R squared (R^2)” is often used to determine how closely a certain function fits a particular set of experimental data. Here, the R^2 value is applied to determine how closely our data with a linear relationship. R^2 values range from 0 to 1, with 1 representing a perfect fit between the data and a linear relation through them, and 0 representing no statistical correlation between the data and a linear relation. This value (often referred to as the goodness of fit) is computed as follows:

$$R^2 = 1 - \frac{\sum(y_i - f_i)^2}{\sum(y_i - \bar{y})^2}$$

proportionality between PV power and irradiation. In this case, PV power will change instantaneously with an irradiance variation.

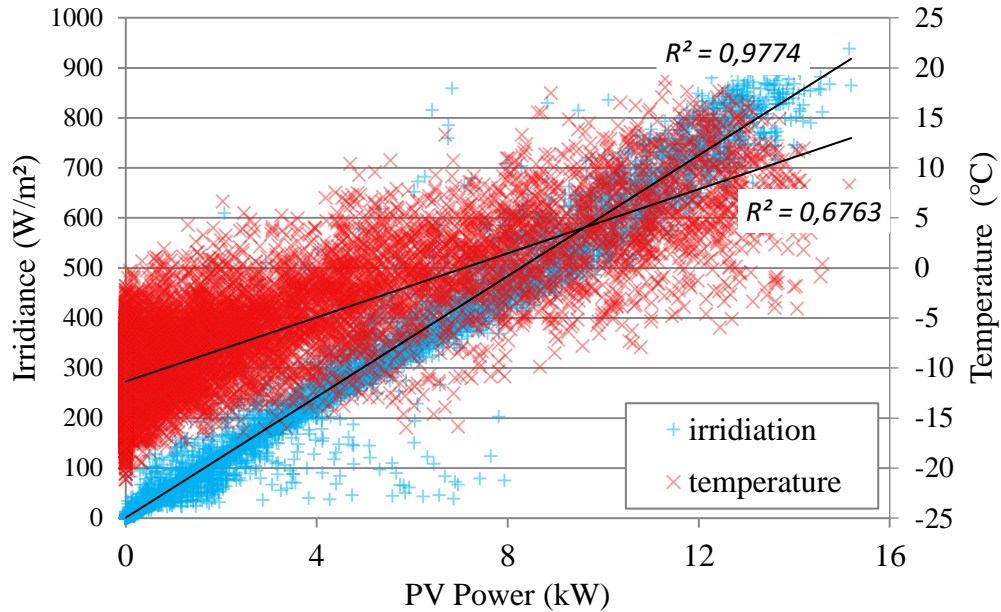

Figure II-2 Irradiance and Temperature vs. Power correlation (data: 2010).

Then a polynomial model has been fitted as shown in Figure II-3. X-coordinate is the solar irradiance, Y-coordinate is the temperature and Z-coordinate is the PV power output. Quantified correlations are:

$$PV_p(t) = 2.2 - 0.03T(t) + 3.5Ir(t) - 0.09 T(t)^2 + 0.02T(t) * Ir(t) - 0.04 Ir(t)^2 \quad (II-5)$$

Values of weights show a high influence of the solar radiation, while the influence of the temperature is lower. It explains fast changes of the PV power with irradiance variations.

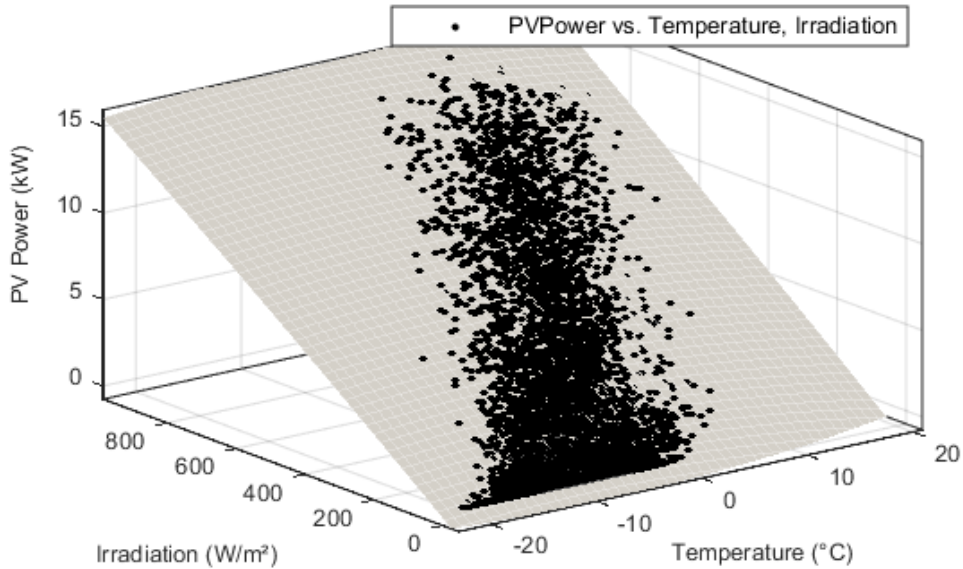

Figure II-3 Irradiance and temperature vs. power correlation.

where y_i represents an individual data point value, f_i represents the values of the data points projected onto the line (obtained with a linear relation). \bar{y} represents the average of the y_i values.

II.3. PV Power Uncertainty Analysis

II.3.1. Introduction

This part develops and evaluates a simple efficient approach for quantifying the PV power output variability over various cloud conditions. The approach involves two variable indexes, namely “Variability Index” and “Radiation Index”. Those indexes are calculated in order to classify the forecasting days into different kinds based on clouds. The obtained results are used in later chapters for the classification of different power dispatching scenarios.

II.3.2. Variability and Uncertainty of PV Power Output

II.3.2.1. Overview of solar generation characteristics

The amount of solar radiation reaching the top of earth’s atmosphere is considered as constant. Yet, atmospheric conditions such as cloudy, dust, and water vapor scatter the incident radiation. The power reaching the surface of the earth per unit area is defined as the solar irradiance (e.g. 1000 kW/m²). Variability is the expected change in generation while uncertainty is the unexpected change from what was anticipated, such as a suddenly cloudy cover or a load contingency or a forecast error. Figure II-4 shows an example of uncertainty and variability for an average global radiation.

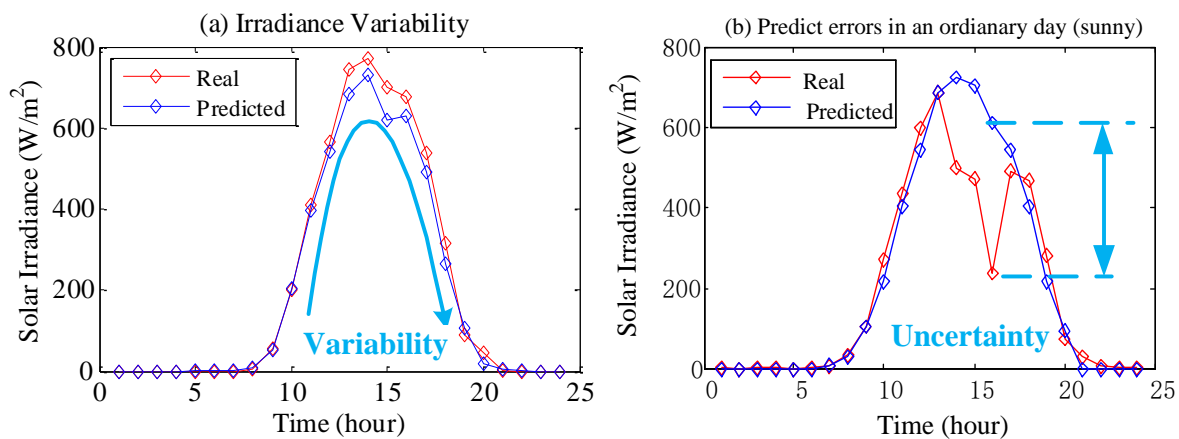

Figure II-4 Examples of variability and uncertainty.

The variability of solar energy depends on the latitude and rotation of Earth, which affects the output of all PV plants in a nearly uniform, highly correlated way, while the uncertain character is completely caused by uncertainty conditions in the sky, mostly the clouds. The presence and behavior of clouds introduce a significant uncertainty that can provoke severe and rapid fluctuations in solar irradiance and therefore solar PV output. Since the global climate cannot be controlled, this solar PV output uncertainty needs to be studied and can be considered as a function of cloud cover.

According to the previous studies of the PV power integration into the electric power system, the PV power penetration is limited into grid [5, 6]. This limitation, which is due to the fast variability and uncertainty of PV power, is a challenge. Moreover, grid operator, have to find additional energy balancing resources to stabilize the grid. However, increasing balancing reserves in one single PV point leads to a significant increase in cost and also could limit the amount of solar power that flows into the power system.

II.3.2.2. Managing variability and uncertainty in power system [7]

Variability and uncertainty are inherent characteristics of equipment in power systems, such as loads, power lines and generators. Moreover, small electrical systems and microgrids face

major challenges to integrate renewable energy sources due to their intermittent character, low inertia and limited availability. Data and its analysis are needed to understand the uncertainty of PV power generation. Understanding and characterizing PV uncertainty avoids unnecessary barriers to the rapid development and connection of PV to the electric power system. This will allow system planners and operators to develop effective actions to manage uncertainty for different levels of PV penetration.

There are many different ways to manage variability and uncertainty. Enforceable reliability standards, overseen by the North American Electric Reliability Corporation (NERC), generally focus on minimum performance standards for a reliable operation. These standards, however, do not dictate how to meet many of the performance requirements. In general, system operators use mechanisms including forecasting, scheduling, economic dispatch, and power reserves to ensure performances that satisfy reliability standards with a least cost.

Additional operating power reserves might be needed if an uncertainty is occurring or when the scheduling generation is mismatched the loads. Hence for electrical security reasons a power reserve must be scheduled one day ahead to deal with this type of uncertainty. So, the earlier that system operators and planners know what sort of variability and uncertainty that they will have to deal with, the more options they will have to accommodate it and the cheaper it will be. The key task of variability and uncertainty management is to maintain a reliable operation of power system (grid connected or isolated) while keeping costs down.

II.3.2.3. Uncertainty Classification into different time scales and spatial dimensions

A. Uncertainty based on Time Scales

To integrate PV power into grids, the studies have separated its variability into different time scales, and each one is associated with different impacts, management strategies, and costs. In the 10-min to hours' time scale system operators can change the output of committed units to follow the changes in load throughout the day. More capacity is committed to ensure that errors in forecasts or unexpected events can be accommodated without compromising the reliability. In the tens of minutes time scale, system operators have previously scheduled adequate regulation reserves to track minute-by-minute changes in the balance between generation and load. Managing variability and uncertainty is easier and less expensive when transmission lines are used to aggregate several sources of variability and uncertainty [8], as shown in Figure II-5.

The following list highlights general issues that are important when operating power systems for different time scales with variable generation:

- Power quality (e.g. voltage flicker): seconds (instantaneously).
- Regulation reserves: minutes (intraday).
- Load following: minutes to hours (intraday).
- Unit-commitment and scheduling: hours to days (one day ahead).

B. Variability based on Spatial Dimensions

It is also important to characterize the variability along a spatial dimension. A fundamental challenge in integration studies is to develop projections of variable power and loads across all of the temporal and spatial scales. Solar data covering a large spatial extent can have an hourly temporal resolution while individual points have high-time resolution PV data and solar irradiance measurements.

To develop projections of the PV variability for integration studies, analysis need to be able to model on the time scale of seconds to hours the output of:

- Large PV plants (about 1-10 km²).
- Dispersed PV plants on distributed transmission lines (about 10-100 km²).
- Aggregation of large PV plants that are managed by system operators (about 1,000-100,000 km²).

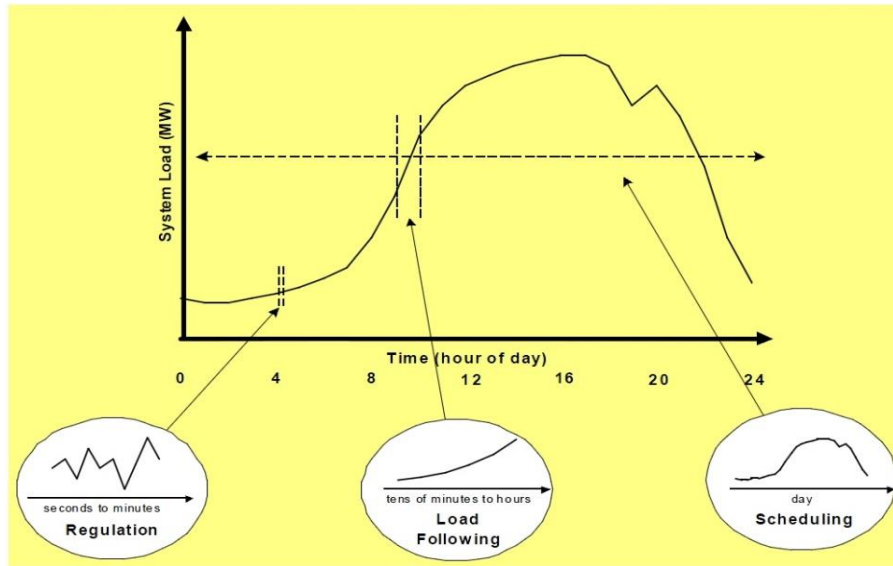

Source: Michael Milligan, NREL, presentation at PV Variability Workshop

Figure II-5. Operating time scales of power systems [8].

C. Smoothing by aggregation of dispersed production sites

According to the study of Mills and Wiser, the aggregated variability of multiple sites is significantly smoother than the variability of individual sites [5]. Based on their studies, the diversity could be reduced with a large spatial area for PV connections. For example, the solar irradiance output aggregation of several different power stations induces the reduction of the variability in comparison with a single site.

II.3.2.4. Impacts from Clouds

Clouds are largely responsible for rapid changes in the PV power output. The output power of PV plants is necessarily variable, simply because the sun position changes throughout the day and throughout the seasons. The rising and setting of the sun regularly leads to 10-13% changes in PV power over a period of 15 minutes for single-axis tracking PV plants. The time taken by a passing cloud to shade an entire PV system depends on the PV panel area, cloud speed, cloud height and other factors. Moreover, clouds are diverse and changes in PV output due to clouds are not driven by a similar uniform process. For a large scale PV system, clouds cause diverse changes in PV output between separate PV plants or even across a single plant. However, for locally PV system the situation could be different. Figure II-6 is an example of four different typical days solar irradiance at L2EP, LILLE in May 2010 (01/05, 12/05, 15/05 and 23/05). As it can be seen, they can be classified into four different types: clear sky, partly cloudy, highly variable, and overcast according to the received solar irradiation.

For a clear sky day, the curve can be divided into two intervals: in the first stage the radiation is gradually increasing and reaching the top at about 14:00 with 900 W/m²; the second stage is from 14:00 to sunset and the solar radiation is decreasing slowly until 0. For the overcasted

day, the variation is small but the total solar radiation is also very low. In this case, there is not much power output from PV panels. For low and high variable situations, unfortunately, the variation is so high that the solar radiation could arise from bottom to a very high value in just several minutes, also sometime from the top to a very low point. This kind of tremendous fluctuation in solar radiations is very difficult to predict and is the source of PV power generation uncertainties.

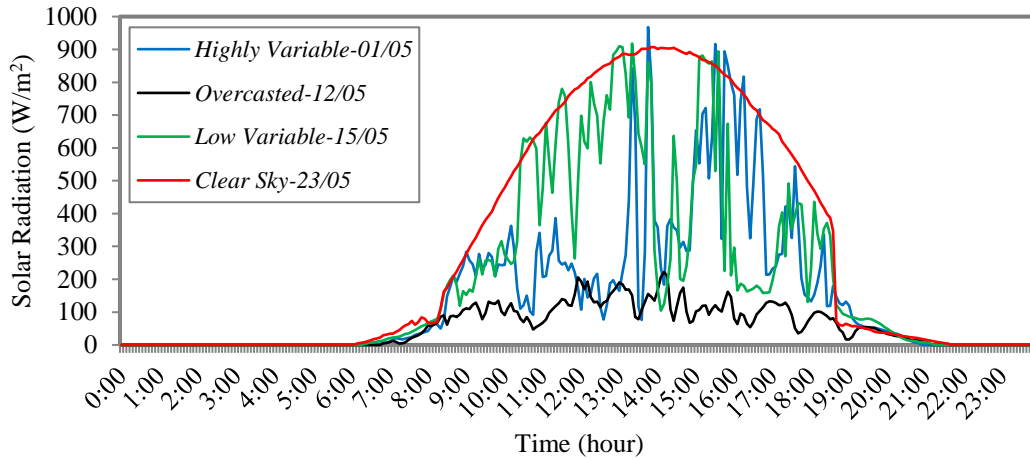

Figure II-6 Classification of different conditions of irradiance caused by cloudy variations (data in a 5 minutes scale).

II.3.3. Variability Indices for Irradiance and PV Power Output Variability Quantification

The PV variability and uncertainty may lead to an unstable network voltage and other impacts on the power quality in the distribution system. In this situation, additional equipment is needed to mitigate these bad effects. Therefore, those variability and uncertainty need to be studied for a better understanding of its characters. The variability index is a new and novel metric for quantifying the irradiance and PV output variability. In [9], an approach for quantifying the irradiance variability over various timescales is presented. The method used a variability index, which refers to the ratio of the length of the measured irradiance against time divided by the length of the reference clear sky irradiance signal. The method of this variability measurement consists in:

- Classifying days or other time periods in which variability and uncertainty effects can be compared;
- Classifying sites in terms of the timing, frequency and magnitude of variability and uncertainty;
- Providing a metric that can be forecasted in the future to enable utility planners to ensure generation resources availability to balance out variability and uncertainty on the grid.

However, with this method, a clear sky model is required and must correctly take into account for the diurnal shape of the irradiance, changings in the length of day light hours and the magnitude for each day of the year. This is the most complex part. In this part, a more simple method is proposed for quantifying solar irradiance uncertainty in 5 minutes time scales. The variable index is defined as the total radiance variation against the solar constant. Meanwhile, by calculating the daily radiation index, the day can be classified into different types in combining those two indices.

II.3.3.1. The Solar Constant

The radiation intensity on the surface of the sun is approximately 63.3 MW/m². Since the radiation spreads out as the distance squared, the radiant energy falling on 1 m² of surface area is reduced to 1367 W by the time it travels to the earth (1.496 × 10¹¹ m is the average earth-sun distance). The intensity of the radiation reaching the earth surface is relatively constant and this solar constant (I_{sc}) equals to 1367 W/m² [10].

II.3.3.2. Variable index and radiation index

Here two variability classification indices over a period of time are proposed: the daily Variable Index (VI) and the daily Radiation Index (RI).

$$VI = \frac{\sqrt{\frac{1}{N-2} \sum_{k=2}^N [2 \times SR_{k-1} - (SR_k + SR_{k-2})]^2}}{I_{sc}} \quad (II-6)$$

$$RI = \frac{1}{12} \frac{\sum_{k=2}^N SR_k}{I_{sc}} \quad (II-7)$$

where SR_k is the solar radiation during 5 minutes scale. Conceptually, VI can be thought as the variation of the measured irradiance divided by the solar constant. For a clear sky day, the curve of solar radiance is like a bell curve and the sum of the absolute values of the irradiance changes [$SR_{k-1} - (SR_k + SR_{k-2})$] is ideally small and so as VI . The fact that extreme overcast or rainy conditions will also have low VI values makes it hard to tell the difference from sunny day's situation. So we introduced RI index to well distinguish clear sky days and overcast days. The sum of solar radiance is high in sunny days while it is low in overcast days. Clear sky days and overcast days are characterized by a low variability. By considering both indices, we can classify a day as explained in Table II-1.

Table II-1 Classification of days based on VI and RI .

<i>Classification</i>	<i>Indices</i>	
	<i>VI</i>	<i>RI</i>
Clear sky	Low	High
Overcast	Low	Low
High variable	High	High
Low variable	High	Low

Figure II-7 illustrates the histogram of daily VI and RI indices. The Figure II-7(a) indicates that the VI is varying throughout the year, with 62 days extremely low (below 0.02) and 15 days very high (bigger than 0.15). The RI is also having a wide range of variation. The reason for this relative high VI and RI is that our studied PV system is located in a highly raining place. This can be proved by Figure II-12 where the solar radiation from November to February is relatively small, and the monthly average precipitation is around 50 millimeters (Figure II-13). The Figure II-8 (a) and (b) exhibits the mean daily VI and RI by month (data for January and December is vacant in lacking of detailed information for calculating the VI and RI). From the Figure II-8 (a), the most variable month is August. The variability during September, compared with July, is very serious as the daily radiation index is relatively small.

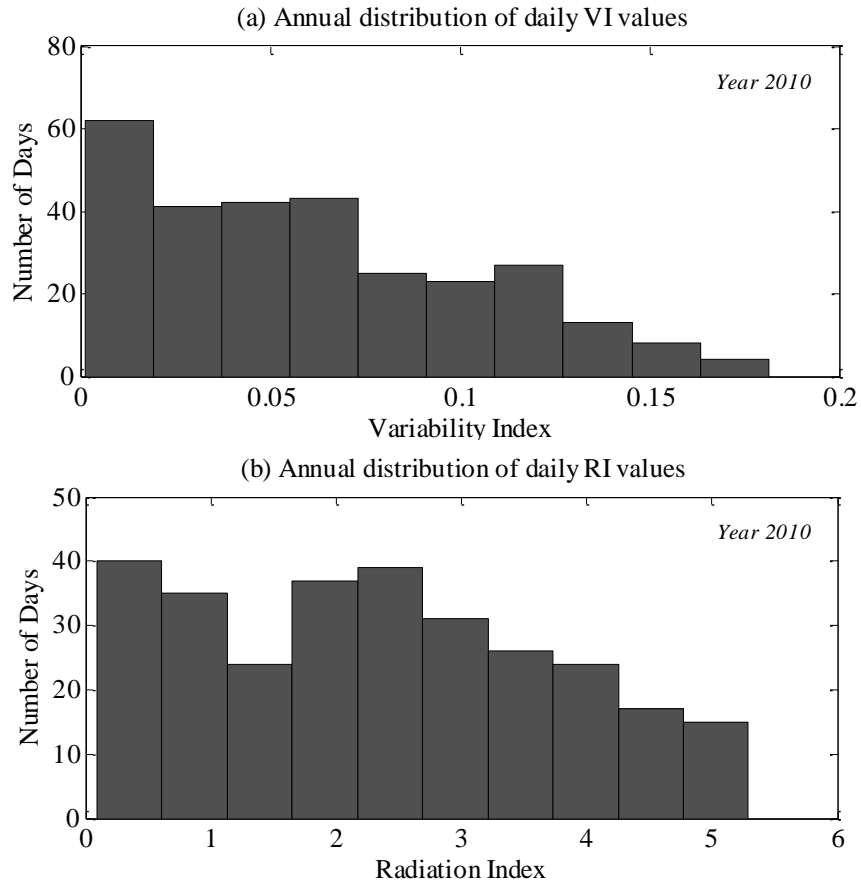

Figure II-7 Annual distribution of daily VI values (a) and daily RI values (b) in year 2010.

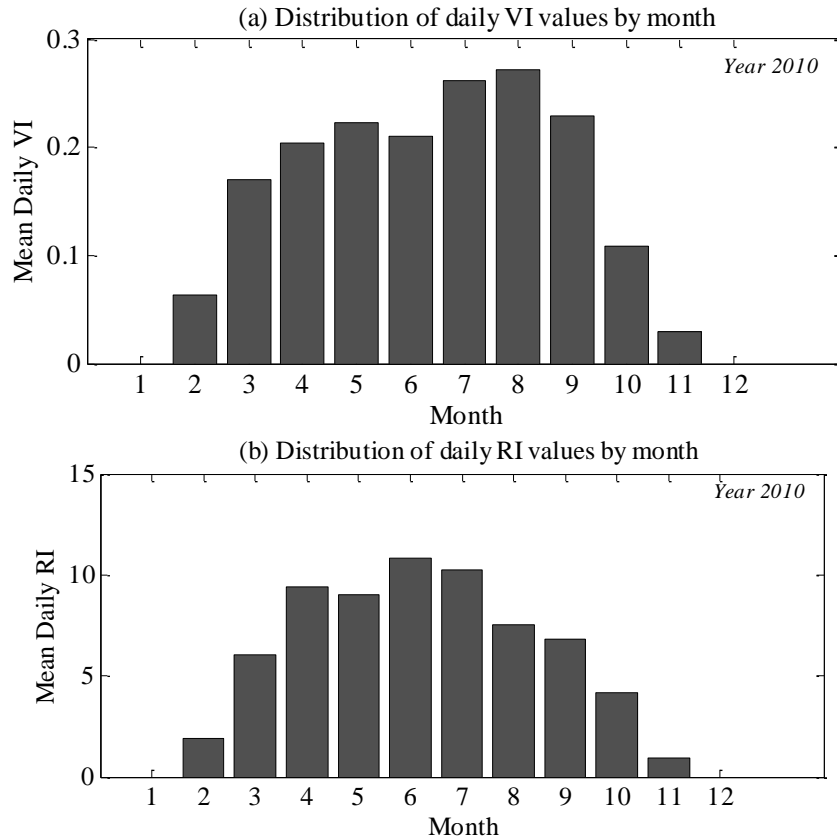

Figure II-8 Mean daily VI and RI by month: (a) Mean daily VI; (b) Mean daily RI.

II.3.3.3. Variability classification with VI and RI

Figure II-9 plots daily RI against VI . Again here four typical days are identified (01/05 (magenta point), 12/05 (red point), 15/05 (green point), 23/05 (blue point)). Different colors represent a conceptual interpretation of the position of the different days: clear sky days, overcast days, low variable days, and high variable days. Table II-2 shows the classification of clear sky, overcast, low variability, and high variability days.

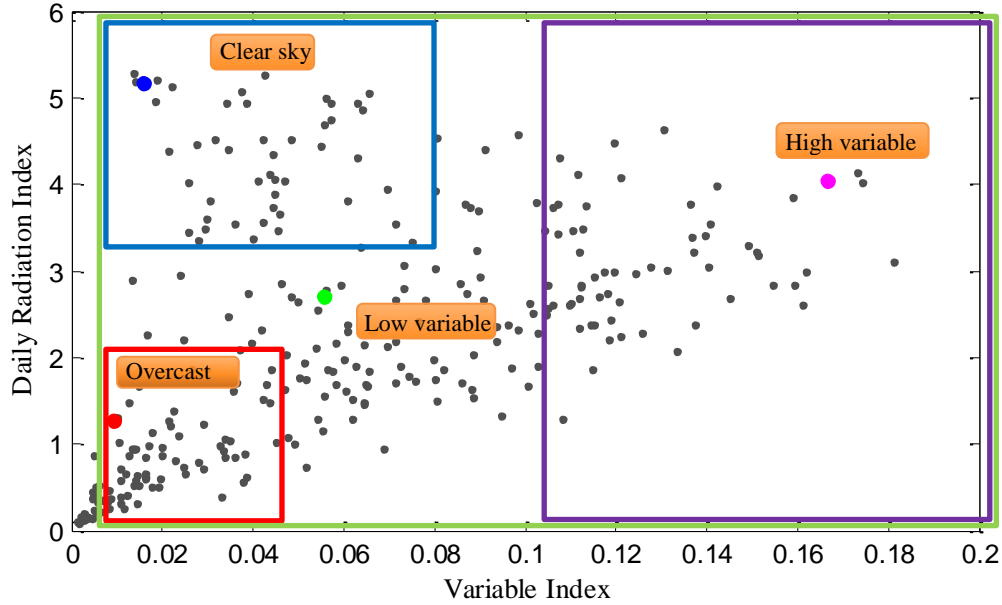

Figure II-9. Scatter plot of daily radiation index and corresponding variability index in 2010.

Table II-2 Clear sky, overcast, low variability, and high variability days at L2EP, LILLE.

Classification (Days)	Clear Sky	Overcast	Low Variability	High Variability
Parameters Limitation	$VI \leq 0.08$ & $RI \geq 3$	$VI \leq 0.04$ & $RI \leq 2$	<i>else</i>	$VI \geq 0.1$
Number of Days	49	82	89	68

In this part a simple metric to measure variability in irradiance at potential solar PV sites is detailed. The metric measures the amount of variability and uncertainty irradiation relative to the solar constant in each 5 minutes step. Combined with the daily radiation index, a classification scheme is using the variability index to distinguish four types of irradiance days that are caused by cloudy variations. This classification can be valuable for PV power forecasting and then grid integration studies.

II.4. Load Demand Uncertainty Analysis

The local load consumption demand is highly unpredictable and quite random. It depends on different factors [11], such as economy, time, weather, and other random effects.

However, for power system planning and operation, the load demand variation and uncertainty analysis are essential parts for control and scheduling. They are also crucial for power flow studies or contingency analysis. As shown in Table II-3, load demand variations exist in all time scales and system actions are needed for power control in order to maintain the balancing [32].

Table II-3 Power system operation requirement with load variations according to various time scales.

<i>Time Range</i>	<i>Variations</i>	<i>System operations</i>
Seconds	Small and random	Primary/Sectionary frequency control
Minutes	Large	Secondary control and economic dispatch function
Hours and Days	Wider	Start-up or shutdown of generation units
Weeks	Very wider	Energy and maintenance scheduling

Fortunately, the demand load in a system can be presented as an understandable pattern, which can be predicted. So that forecast results can contribute to a basic generation schedule, power system security and information dispatch. As explained in [11], the factors, which influence the system load behavior can be classified into four major categories:

Economic Factors: The economy significantly impacts the electric consumption growth/decline trend, such as the service area demographics, levels of industrial activity, economic trends, and so forth.

Time Factors: Principal time factors, which influence load patterns include: seasonal effects, weekly-daily cycle, and holidays. Certain changes in the load pattern occur gradually in response to seasonal variations in temperature. For example the summer and winter peak power. The weekly-daily periodicity of the load corresponds to the area with a work population, while a holiday has a different load demand compared with normal work days.

Weather Factors: As most utilities have temperature-sensitive load, such as air conditioning, and space heating, temperature plays an important role in shaping load patterns. Moreover, some other weather factors will also affect the system load, such as humidity, wind speed, precipitation, and cloud intensity.

Random Factors: All of the other random events are classified under this group, such as unpredictable disturbances and unforeseen shutdown of industrial facilities.

II.5. PV power and load forecast

II.5.1. Interest of power forecasting for power systems

As forecasting is the basic facet of decision making in power system planning, the purpose of forecasting is to minimize the risk in decision making and reduce unanticipated cost. One of the most important tasks of a grid operator is to correctly predict power generation and load requirements. Uncertainty concerns energy sources and load forecast. Conventional power sources are dispatchable and then power production can be exactly planned beforehand without uncertainty coming from the variability of their primary energy. While, during partly cloudy conditions PV power can easily fluctuate by three quarters of its rated power in ten seconds [8]. Fluctuations from PV power (on its size and time scale) and load demand may require additional equipment to provide primary and secondary power reserves. Additional power reserves to balance those fluctuations may not be required permanently. If periods of high fluctuations can be anticipated according to different time periods and situations, i.e. levels of cloud coverage (cloudy, sunny, or partly cloudy), additional power reserve can be allocated only when it is necessary and with an appropriate amount. Therefore, forecasts of RES production and load demand can be useful to estimate power reserves, to plan power plants, to manage congestion, to coordinate storage with renewable, or to trade in the electricity markets.

Consequently, forecasting the power output and the load for the next few hours or days is necessary for the optimal integration of RES into power systems. For power generators and

load demand forecasting, the priority is to minimize the deviation between forecasted and actual plant output. Different methods used for energy and load forecast have been developed and found in the bibliography. In this part, solar PV power and load demand forecast are discussed respectively.

II.5.2. Solar PV Power Generation Forecast

RES are continually increasing in the power grid worldwide due to technological advancements and governmental policies to solve global warming challenges. Unfortunately, RES are uncertain and are difficult to predict. This unpredicted impact of large volumes (quantities) of PV in an unprepared grid involves some issues as [12]:

- Maximum voltage violations;
- Flicker and other power quality issues;
- Reverse power flow and protection coordination issues;
- Increased wear on utility equipment;
- Real and reactive power imbalances.

Variability in solar irradiance makes the power reserve regulating and maintaining costly and challenging [16]. Thus the uncertainty from solar variability requires larger regulation and spinning reserve capacities to meet ancillary service requirements. Solar forecasting methods can help on mitigating the impact for relevant conditions including transient and dynamic voltage fluctuations. Efficient and dedicated forecast methods will help the grid operators to better manage the electric balance as well as adjust the power reserve during the day decreasing the system cost. However, PV power forecast is closely linked to the problem of weather forecasting. Moreover, it is highly specific to different regions. Therefore, the accuracy is affected by uncertainties related to the different modeling steps and forecast methods. It is determined mainly by the factors such as: local climate and weather conditions, single-site or regional forecast, forecast horizon, accuracy metric used and so forth. Different forecasting methods depend on the tools and information, which are available to forecasters, such as weather forecast data and PV system historical data.

In recent decades, several forecasting research works on solar PV energy production have been published [13-17]. One first method consists on forecasting solar radiation and then forecasting PV power with a mathematical model of the PV generator [18]. A second one proposes to directly predict the PV power output from environmental data (irradiation, temperature, etc.) [19, 20]. Obtained PV power predictions are very different because in a solar panel at a fixed temperature, the power production is strongly proportional with the global irradiance [21] (Figure II-2).

Statistical analysis tools are generally used, such as linear/multiple-linear/non-linear regression and autoregressive models based on time series regression analysis [22]. These forecasting models rely on modeling relationships between influent inputs and produced output power. Consequently, mathematical model calibration and parameter adjustment process take a long time. Meanwhile, some intelligent based electrical power generation forecast methods, as expert systems, fuzzy logic, artificial neural networks (ANN) are widely used to deal with uncertainties of RES power generation and load demand [13, 23]. Among these methods, ANN is the more universally applied technique. Compared with conventional statistical forecasting schemes, ANN has some additional advantages, such as ease in adaptability to online measurements, data error tolerance and lack of any excess information. In this work, a three-layer ANN is chosen to give a one day ahead PV power forecasting.

II.5.3. Load Demand Forecast

A. Importance of demand forecast

A power system supplies customers with electrical energy in order to minimize the cost with a maximum reliability. So, an accurate load demand forecast is essential to a utility company to schedule the operation and planning of generation with a minimal cost. It helps to make important decisions such as purchasing and generating electric power. Moreover, with the decentralization of energy industries, fluctuation and changes of weather conditions will have even more important influence in power supply and load demand. Thus, one of the fundamental challenges for electric utility companies is to avoid the decreasing of power system reliability regardless of energy resources limitations in addition to load demand variations.

According to different time horizons, load forecasts can be divided into three categories: Long term forecasts, which are more than a year, medium term forecasts, which are usually from a week to a year, and short term forecasts, which are from one hour to several days [24]. Long-term demand forecasts have an important role in planning, long-term maintenance, construction scheduling for developing new generation facilities [15]. While underestimation will result in customer dissatisfaction, an overestimation of load demand will also result in a substantial investment. Unfortunately, it is not easy to accurately estimate the load demand over a period of several years. Short-term load forecasting (few days ahead) is considered necessary in unit commitment analysis, maintenance schedule and diagnosis of economic dispatch. It can help to estimate load flows to prevent overloading. Load forecast is also concerned with the prediction of hourly, daily, weekly, monthly and yearly values of the system load, peak system load and system energy demand [22].

B. Important factors for forecast

The objective of load demand forecast is to improve the forecast accuracy in order to optimize the power system planning and to reduce costs. However, numerous variables affect directly or indirectly the accuracy. As different forecast models match different forecast time horizons, the factors corresponding to the different time horizons are various: short term load forecasting usually depends on time factors, weather data, and possible classes of customers; the medium term and long term forecasts take into account the historical load and weather data, the customer categories, the economic, the demographic data, and other factors.

The time factors represent different time periods in a year, the day and the hour. For example the load demand capacities can have important differences between weekdays and weekends. And energy consumption in the summer days will be different from it in the winter days. Weather conditions have a great influence on the load forecast for some important parameters: temperature and humidity are the most commonly used short term load forecast factors. Moreover, different types of consumptions, such as residential, commercial, and industrial, also have different influences on different electric usage patterns.

C. Forecast methods

Over the last few decades, many methods and models have already been developed. In [23], several long-term (month to year) load forecast methods are introduced and are very important for planning and developing future generation, transmission and distribution systems. Generally, those methods can be classified into two groups: parametric methods and artificial intelligence based methods.

Parametric Methods

- Trend analysis is focusing only on past changes in load demand to predict future demand. The advantage is that it is simple, quick and inexpensive to perform. The drawback is that it does not help explaining the details and so why load demand behaves the way it does.
- End-use models directly forecast load demand by using extensive information on end users. It has a high predict accuracy. The disadvantage is that it assumes a constant relationship between supply and end-use. However, in the long-term, it will change along with time.
- Econometric models estimate the relationship between demand and factors, which influence them by combining economic theory with statistical techniques. By calculating demand in different sectors, it then gathers those predicted demand with recent historical data. The advantage is that it offers detailed information on why and how the various factors affect demand. However, the assumption that electricity remains unchanged (to be accurate in forecast) may be hard to justify.

Artificial Intelligence Based Methods

Unfortunately, those traditional parametric methods cannot accurately present the complex nonlinear relationships between the load demand and the factors that influence it. Therefore, the artificial intelligence based methods have been developed for load demand forecasting, such as ANN, Wavelet networks, Genetic algorithms, Support vector machine, Fuzzy logic model, and Expert system. The detailed explanations, advantages and disadvantages of those methods can be found in [23]. While in [11] and [24, 25], the different methods for short term load forecast is summarized, such as the similar day approach, various regression models, time series, neural networks, expert systems, fuzzy logic, and statistical learning algorithms. Both long-term and short-term load forecast play important roles in the formulation of secure and reliable operating strategies for the electrical power system.

II.6. Forecasting with Back-Propagation (BP) ANN

Based on the idea of human neurons, ANN are aiming to imitate neural network capabilities. This multivariable, nonlinear, and nonparametric mathematical tool has been used wildly for modeling complex nonlinear systems. A neural network can learn, memorize and establish a system model through handling external information to get the capabilities of prediction and self-diagnosing. Nowadays, ANN have been succeeded in several power system problems, such as planning, control, analysis, protection, design, forecasting, security analysis, and fault diagnosis [26]. Compared with conventional statistical forecasting schemes, ANN have some additional advantages, such as simplicity in adaptability to online measurements, data error tolerance and lack of any excess information.

Fundamentals of ANN based predictors are now recalled. For the Feed-Forward propagation and prediction as well as for the Back-Propagation (BP), the method of the online Stanford Machine Learning course was used (Appendix IV) [27].

A basic structure of a three-layer ANN is composed of an input layer, one hidden layer, and one output layer (Figure II-10). Weights ($\Theta^{(1)}$, $\Theta^{(2)}$) and biases ($bais^{(1)}$, $bais^{(2)}$) are model parameters that will be adapted in order to get the best accuracy of the data forecast.

Before using an ANN prediction, weights and biases must be set previously. Initially, they are randomly settled and then are calculated by a training algorithm, which is divided into two parts: feed-forward stage and BP stage.

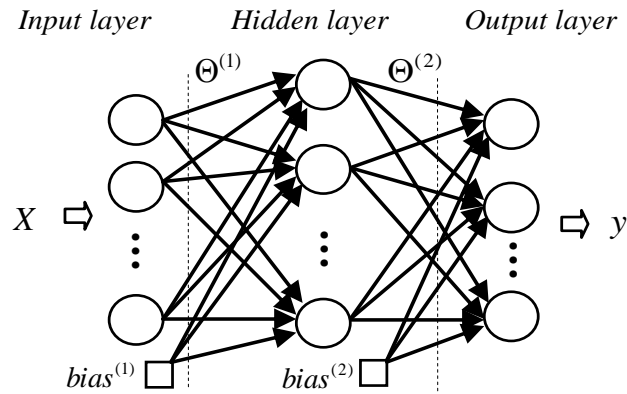

Figure II-10 The structure of a three-layer ANN.

In the feed-forward stage, predicted outputs are calculated for each training sample. The value of the cost function is calculated to measure the deviation between the forecast value (output of the ANN) and the real value.

Then the BP stage basically compares the output of the previous stage to the real value and calculates the errors. Errors (at the output layer) are then BP to calculation process. The error associated with each unit from the preceding layer. This goes on until you reach the input layer. These calculated errors for each unit are used to calculate the partial derivatives in order to update the weights to minimize the cost function. This is repeated until the gradient descent reports a convergence. The training procedure can be explained as follows:

- 1) Set up the architecture and equations of networks and randomly initialize weights and biases;
- 2) Set up the learning rate (α) of the algorithm and the training set of input and output data;
- 3) Consider a sample of inputs and outputs from the training set (X, y) and calculate the ANN output with a feed-forward algorithm. Also, a cost function depending on prediction errors is also calculated;
- 4) The error between target and output values is then back propagated through the hidden layer. A gradient descent algorithm is used to minimize the cost function by constantly changing the parameter weights;
- 5) Go back to the step 3 and repeat until the cost function converges to a minimum and reduced value.

This procedure is presented in the diagram of Figure II-11. The convergence of the gradient descent can be slow if α is too small. Whereas if α is too large, the gradient descent can overshoot the minimum and may fail to converge, or even diverge. As soon as the training process is finished, parameters are set and the ANN is ready to be used for predicting new outputs with proposed new inputs [28, 29].

A trained ANN will have good performances only for the system that has been previously considered through learned input/output data. If the system is variable (for example, electrical network with new consumers and producers), the ANN architecture may be remained the same, but a new training of the network will be required. To increase the potential for an accurate forecast in developing an ANN forecast model, some freedom degrees must be iterated, such as: fraction of the database used for different purpose (training, validation and testing); optimal stopping point during ANN training; and relative weights of input parameters.

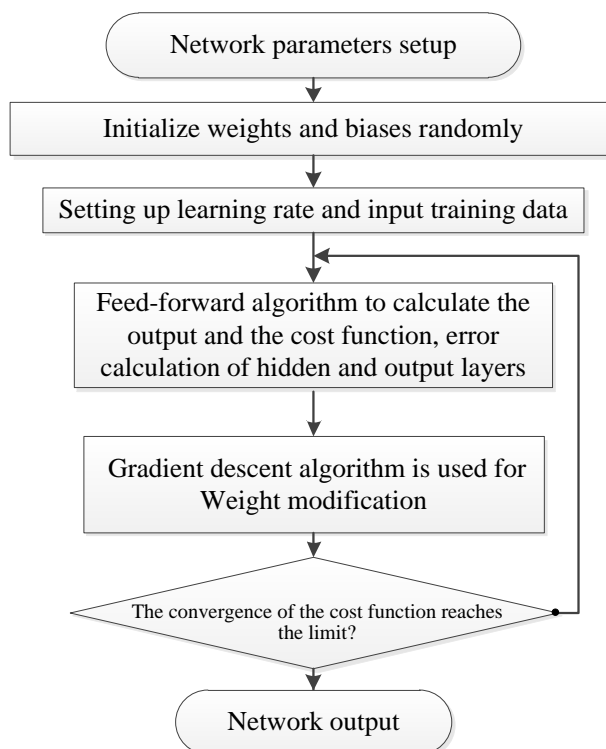

Figure II-11 Training procedure of a neural network.

Also, according to [30], due to the overtraining and excessive network complexity, an ANN may have a risk of over-fitting. The over-fitted ANN can replicate training data with low errors, but makes high errors with new data. This can be avoided by using cross-validation, which splits the training data into a training set and a validation set. The parameters of ANN are trained with the training set and tested every few iterations with the validation set. The training procedure is ended when errors, which are obtained with the validation set starts to decrease [31]. Also, according to [31], a simple ANN architecture usually has a better forecast than with a complex ANN architecture.

II.7. Day-ahead PV Power and Load Forecast by Using ANN

II.7.1. Data Description

A. PV forecasting database

The data needs to cover, at least, one year and should be synchronized with comparable load data in order to understand the net impact on the variability that must be managed by the electrical system operators. The PV power inverter data are coming from inverters at the student residence of Ecole Centrale de Lille, L2EP. These are PV power output (W), AC voltage (V), and DC voltage (V) for each inverter every five minutes time interval. For example, the Figure II-12 shows solar radiation distribution and PV power output in 2010[®]. Figure II-13 is the monthly average temperature and the average precipitation in Lille.

[®] Measured solar radiation data have been recorded at L2EP, from the software "[Sunways Photovoltaic Technology](#)", embedded in inverters; each 5 minutes from 01/01/2010 to 30/12/2010.

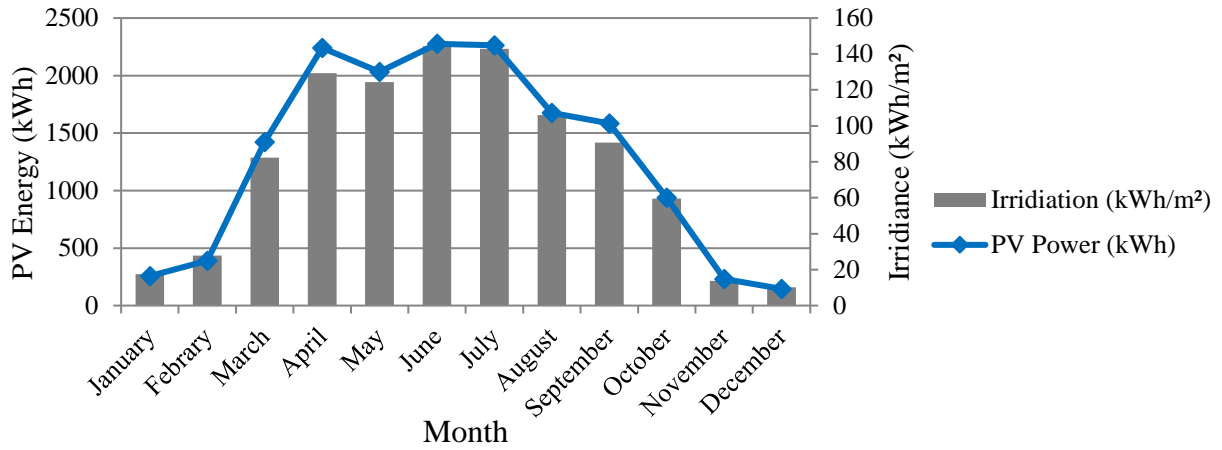

Figure II-12 PV energy output and solar irradiance of each month in 2010 at L2EP.

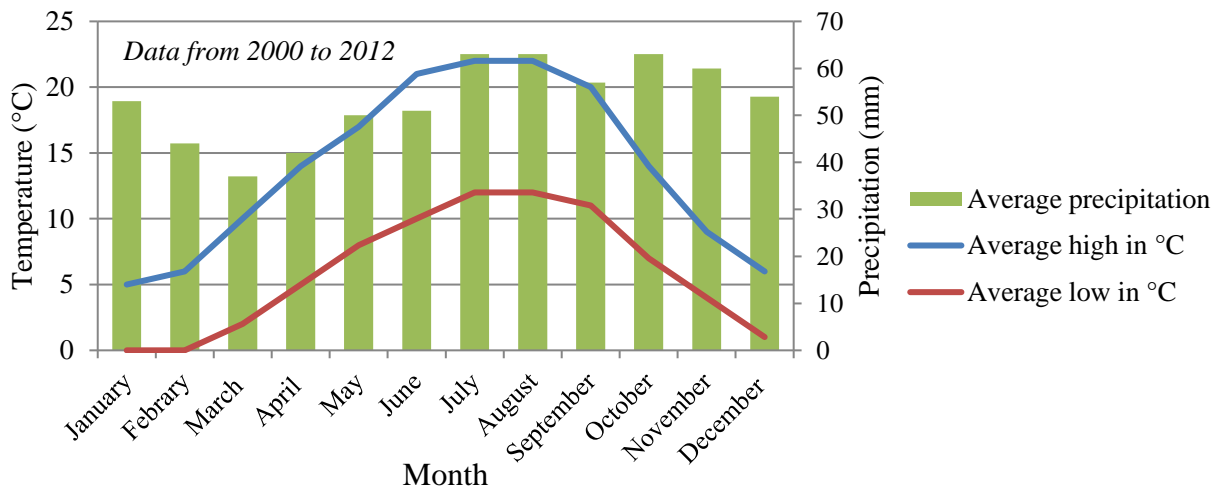

Figure II-13 Average temperature and precipitation in Lille.

PV power data and meteorological data are combined together to form the database. From the database, a part has been used to train the ANN based forecasting tool, a second part to assess the estimation quality and a third one to implement the application of the proposed method for tests in operation (Figure II-14).

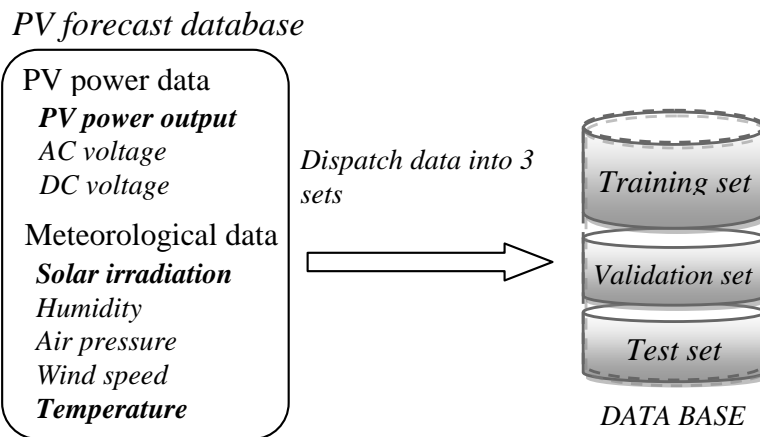

Figure II-14 PV power forecasting database.

B. Load forecasting database

For the load forecasting, per unit values of locally power consumption are assumed to have the same profile and dynamic characters of per unit values of the whole power consumption in France. Past half-hourly French power consumptions have been scaled to the size of the considered application. The meteorological database is the same as used for the PV power forecasting. A part of this database has been used also to design the ANN based forecasting tool, a part to assess the estimation quality and a third one to implement the application of the proposed method in a real situation (Figure II-15) [14].

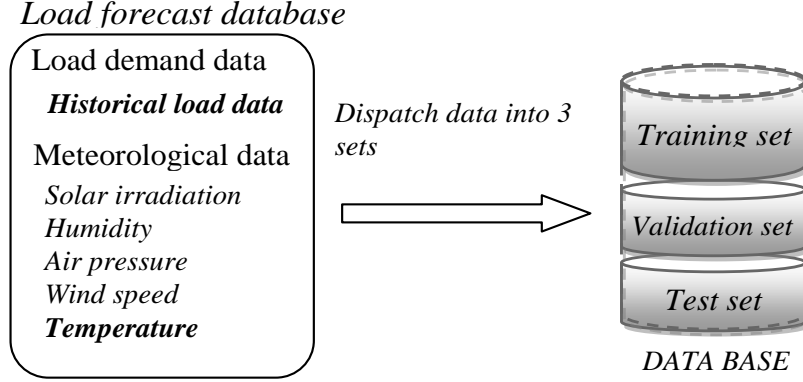

Figure II-15 Load forecasting database building.

C. Meteorological data

Since the PV power and load demand are highly meteorological sensitive, the different kinds of weather data are used. Firstly, the historical measured temperature (Fahrenheit (°F)) and solar irradiation (Wh/m²) data are recorded by the sensors installed at the student residence of the Ecole Centrale de Lille. The other one day-ahead forecasted meteorological data can be downloaded from the “Weather Underground” website. There are average specific humidity (g/Kg), average pressure (mBar), average wind speed (m/s) at ten meters above the ground and temperature.

D. Data normalization

The database should be previously normalized between 0 and 1 before application for model training:

$$f : \bar{x} \rightarrow x = \frac{x_i - x_{\min}}{x_{\max} - x_{\min}} \quad (\text{II-8})$$

where x_i is the i^{th} component in the original input data vector; x_{\max} and x_{\min} are respectively the maximum and the minimum values of each set.

II.7.2. Error Computing Method

In order to properly define prediction accuracy and relative errors, it is necessary to set different error definitions. The efficiency of the proposed method is validated by analyzing the normalized Root Mean Square Error ($nRMSE$) and the normalized Mean Absolute Error ($nMAE$) between predicted values \tilde{y}_k and measured values y_k with n forecasted samples.

$$nRMSE = \sqrt{\frac{1}{n} \sum_{i=1}^n (\tilde{y}_k - y_k)^2} \quad (\text{II-9})$$

$$nMAE = \frac{1}{n} \sum_{i=1}^n |\tilde{y}_k - y_k| \quad (\text{II-10})$$

II.7.3. PV Power Forecast Application

A. ANN forecast model designing

A three-layer BP-ANN model is developed for 24-hours-ahead PV power generation forecasting with:

- One input layer with the corresponding input parameters;
- One hidden layer with 180 neurons (which is determined by a trial-and-error method to minimize the forecast errors);
- One output layer with the 24-hours-ahead predicted PV power for the forecast day.

The input factors are selected according to the PV generator model. Since the two major factors that have great influences on PV power output are irradiance and temperature, the input layer includes measured PV power, solar irradiation and 24-hours-ahead of forecasted temperature (this temperature can be obtained from weather forecast) (Figure II-16).

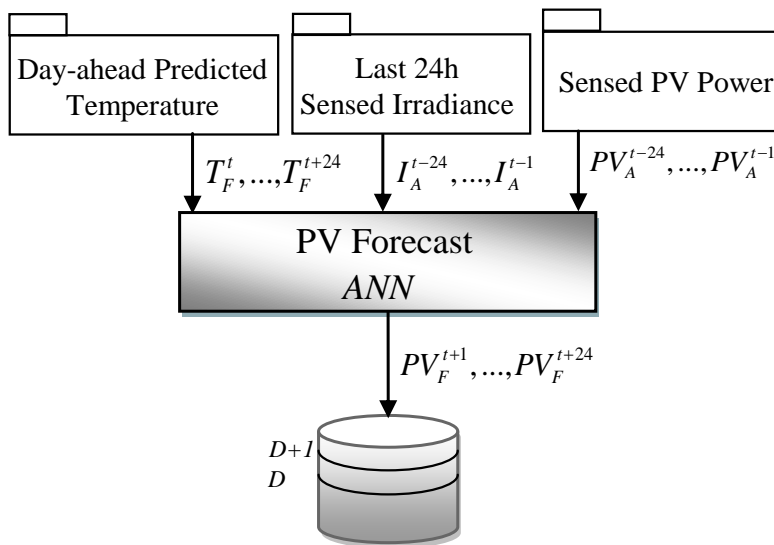

Figure II-16 PV power forecasting with ANN.

B. Training and evaluation of the ANN

Firstly, 50% of previously sensed data (among two years of data set from database) have been used for training the ANN. Then next 25% of sensed data are used to create a validation pattern set in order to assess the prediction quality and avoid over-fitting. To determine the input number of past historical PV power measurement and the number of hidden layer units, a trial-and-error method has been applied. As shown in Figure II-17, the past time horizon has a greater influence than the number of hidden layer units.

The optimal values are selected as the last 24 hours of measured PV power with 180 hidden layer units. Obtained $nRMSE$ and $nMAE$ for next 24 hours PV power forecasting are given in the Figure II-17. Obtained $nRMSE$ for the training set and validation set are 6.09 and 5.58 percent respectively, and the $nMAE$ are 3.69 and 3.13 percent respectively.

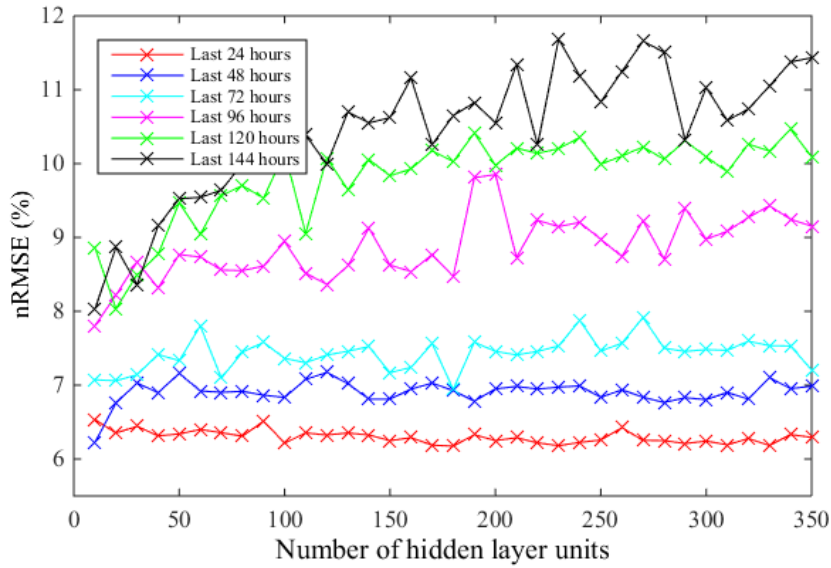

Figure II-17 $nRMSE$ obtained on the validation set in function of the hidden layer units and input PV power measurement.

C. Performance of the ANN in operation

The test set (the remaining 25% data) is used to test the accuracy of the trained ANN with non-learned data. The obtained $nRMSE$ and $nMAE$ for the test set are 5.98 and 3.12, respectively. Here, an example for predicted values and obtained sensed values for a clear sky autumn day (12/09/2013) is shown in the Figure II-18.

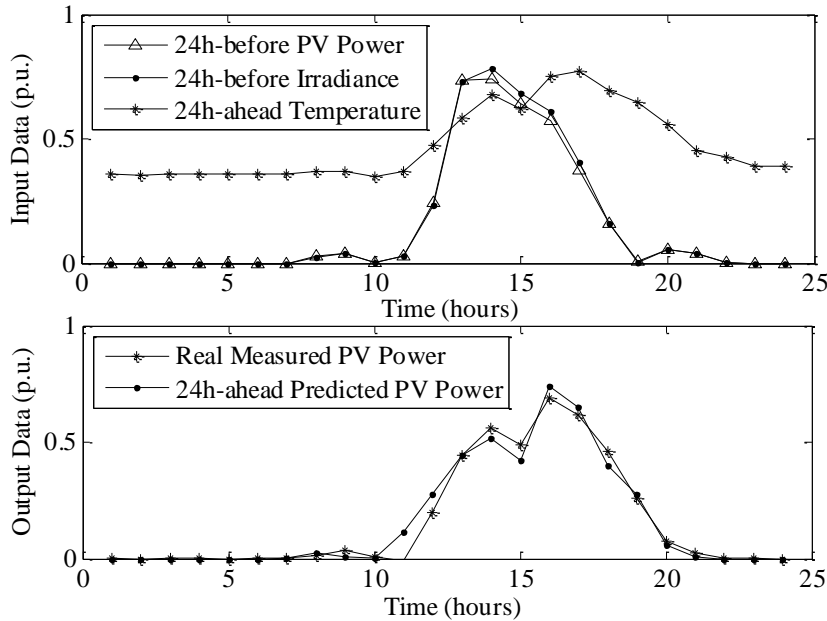

Figure II-18 PV power prediction results on 12/09/2013.

The recorded hourly PV power and solar irradiance in 11/09/2013, and predicted temperature for 12/09/2013 (one day ahead) are fed for the ANN. The predicted results have the same variations as recorded values in real time. As it can be seen, the power production rises at 10:00 and reaches a first peak at 14:00. At 15:00, there is a dip and then it rises again until a maximum power at 16:00. Then, it starts to decrease until to zero at about 21:00 (the time sun goes down).

Table II-4 Errors of the PV power forecasting with ANN.

	$nRMSE$ [%]	$nMAE$ [%]
Training Set	6.09	3.69
Validation Set	5.58	3.13
Test Set	5.95	3.12

The total forecast errors for each hour are shown in the Figure II-19 as a box-and-whisker plot. As it can be seen, the forecasting errors are increased and decreased, respectively, along with the PV power rise and down during the day. The median values are near to 0. For each hour, the blue box in the middle represents the up 25% and down 25% of forecasting errors. The red crosses represent the errors that are more than normal. However, the total absolute per unit (p.u.) errors are below 0.4.

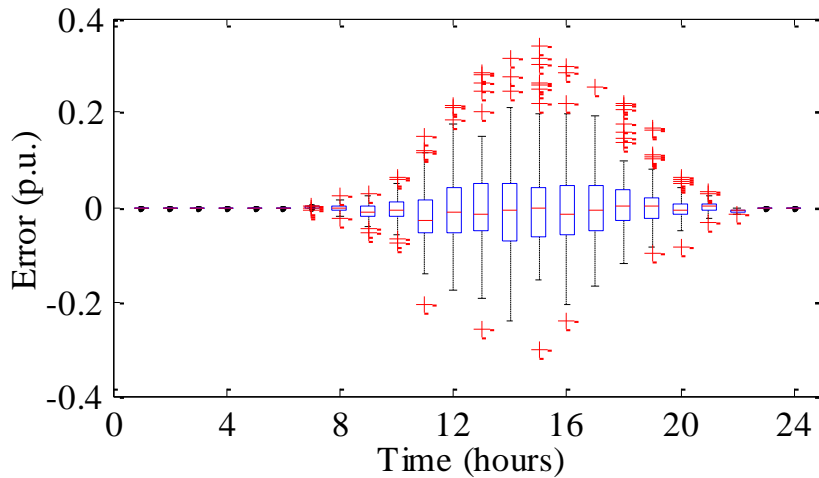

Figure II-19 PV power prediction errors for each hour from the validation test.

II.7.4. Load Demand Forecast Application with ANN

A. ANN forecasting model designing

Following the same procedures (as PV power forecasting), another three-layer BP-ANN model is applied for the load demand forecasting (Figure II-20):

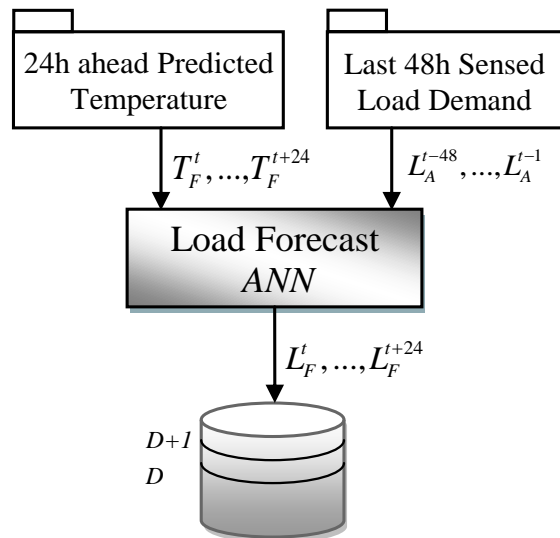

Figure II-20 Load forecasting with ANN.

- One input layer with last 48 hours load demand measurements and predicted temperatures for next 24 hours (obtained from weather forecast);
- One hidden layer (the number of neurons is determined by a trial-and-error method to minimize the forecast errors from the training set);
- One output layer that predicts next 24 hours load demand.

B. Training and validation of the ANN for load prediction

For the load forecasting, 60% of the available data set is used for the neural network training and 20% of the data for the validation set. *nRMSE* function has been used to optimize the number of past measured load inputs (last 48-hour sensed load demand), which are used for the network training. The number of hidden layer units is 30 neurons. Obtained results of *nRMSE* and *nMAE* are listed in the Table II-5.

Table II-5 Errors of the load demand forecast with ANN.

	<i>nRMSE</i> [%]	<i>nMAE</i> [%]
Training Set	3.18	2.45
Validation Set	3.57	2.76
Test Set	3.67	2.84

C. Performance of the ANN for load prediction

The obtained *nRMSE* and *nMAE* with data from the test set (the remaining 20% data) are 3.67 and 2.84 respectively. Here, an example of predicted values and obtained sensed values on 12/09/2013 are shown in the Figure II-21. The input data are recorded load demand on 10/09/2013 and 11/09/2013, and predicted temperature for 12/09/2013 (one day ahead). The predicted results have the same variation as recorded values in real time. As shown, the demand has two peaks at noon (13:00) and midnight (23:00).

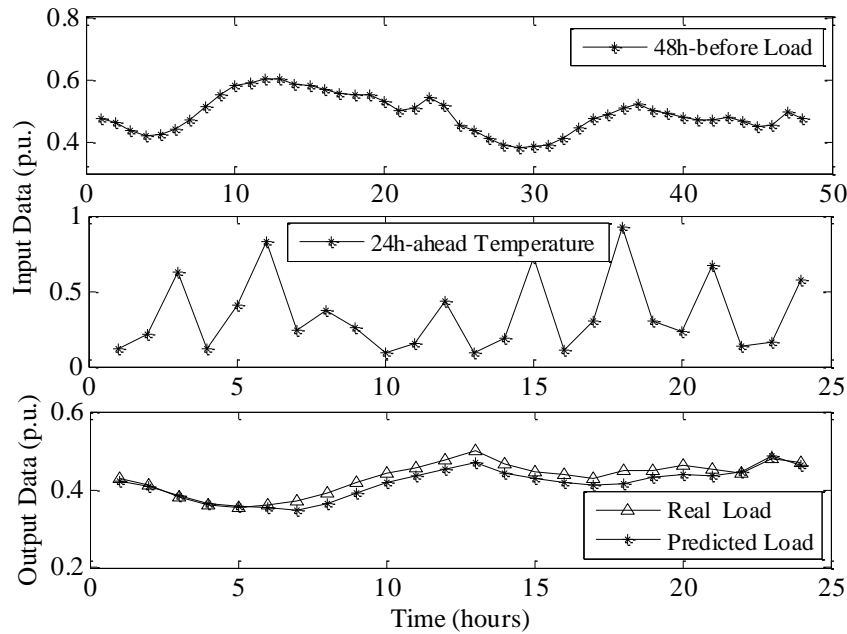

Figure II-21 Load demand prediction results on 12/09/2013.

The total forecasted errors with the test set are shown in Figure II-22. As it can be seen, the total absolute p.u. errors are below 0.2.

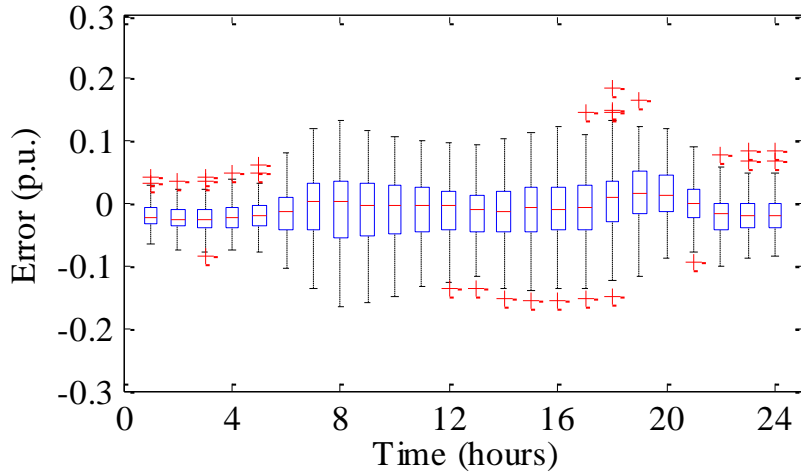

Figure II-22 Load demand prediction errors with data from the test set.

II.8. Conclusion

In this chapter, firstly the PV power generation model has been detailed. For the PV production prediction, influences of the solar radiation and temperature on PV output have been discussed. Following the proposed mathematical model, the PV power variability and demand variability have been studied. For a better understanding of the PV power output variability, two indexes have been introduced to measure the variable features.

An ANN based forecasting method has been presented and then applied to predict the load demand and the PV production. The priority for power generators and load demand forecasting is to minimize the deviation between forecasted and real plant output. In this part, 24-hour-ahead PV power and load demand have been predicted with ANNs.

These forecasting results will be used for the net uncertainty analysis and power reserve quantification in the chapter III. Compared to conventional power sources, PV power source will need much more additional power reserve to cover the PV power fluctuations for the same security level. Therefore, the application of the prediction methods for precisely PV power and load demand forecasting enables the system operators to size the additional power reserve with an appropriate amount.

References

- [1] M. Fuentes, G. Nofuentes, J. Aguilera, D. Talavera, and M. Castro, "Application and validation of algebraic methods to predict the behaviour of crystalline silicon PV modules in Mediterranean climates," *Solar Energy*, vol. 81, pp. 1396-1408, 2007.
- [2] J. Hofierka and J. Kaňuk, "Assessment of photovoltaic potential in urban areas using open-source solar radiation tools," *Renewable Energy*, vol. 34, pp. 2206-2214, 2009.
- [3] S. A. Kalogirou, *Solar energy engineering: processes and systems*, Ch.9, photovoltaic systems, pp. 480: Academic Press, 2013.
- [4] F. Lasnier, *Photovoltaic engineering handbook*, Ch. 11, p. 258, CRC Press, 1990.
- [5] A. Mills, "Implications of wide-area geographic diversity for short-term variability of solar power," *Lawrence Berkeley National Laboratory*, 2010.
- [6] F. Katiraei and J. R. Aguero, "Solar PV integration challenges," *Power and Energy Magazine, IEEE*, vol. 9, pp. 62-71, 2011.
- [7] A. Mills, "Understanding variability and uncertainty of photovoltaics for integration with the electric power system," *Lawrence Berkeley National Laboratory*, 2010.
- [8] C. Lenox, "Variability in a Large Scale PV Installation," in *Utility-scale PV Variability Workshop*, 2009.
- [9] J. S. Stein, C. W. Hansen, and M. J. Reno, "The variability index: A new and novel metric for quantifying irradiance and PV output variability," in *World Renewable Energy Forum, Denver, CO*, 2012.
- [10] "Green Rhino Energy, Solar Power," Accessed on 1 July 2016, (URL: <http://www.greenrhinoenergy.com/solar/>).
- [11] G. Gross and F. D. Galiana, "Short-term load forecasting," *Proceedings of the IEEE*, vol. 75, pp. 1558-1573, 1987.
- [12] B. Robyns, A. Davigny, B. Francois, A. Hennenon, and J. Sprooten, *Electricity Production from Renewables Energies*: John Wiley & Sons, 2012.
- [13] B. Espinar, J.-L. Aznarte, R. Girard, A. M. Moussa, and G. Kariniotakis, "Photovoltaic Forecasting: A state of the art," in *Proceedings 5th European PV-Hybrid and Mini-Grid Conference*, 2010.
- [14] X. Yan, B. Francois, and D. Abbes, "Solar radiation forecasting using artificial neural network for local power reserve," in *Electrical Sciences and Technologies in Maghreb (CISTEM), 2014 International Conference on*, 2014, pp. 1-6.
- [15] A. G. C. d. R. Vaz, "Photovoltaic forecasting with artificial neural networks," *University of Lisbon, 2014 (MSc thesis) Retrieved from, http://repositorio.ul.pt/bitstream/10451/11405/1/ulfc107351_tm_Andre_Vaz.pdf*.
- [16] R. Ulbricht, U. Fischer, W. Lehner, and H. Donker, "First Steps Towards a Systematical Optimized Strategy for Solar Energy Supply Forecasting," *Proc. of the Joint ECML/PKDD*, 2013.
- [17] S. Pelland, J. Remund, J. Kleissl, T. Oozeki, and K. De Brabandere, "Photovoltaic and Solar Forecasting: State of the Art," ed: Paris, France, International Energy Agency, 2013.
- [18] A. Yona, T. Senjyu, and T. Funabashi, "Application of recurrent neural network to short-term-ahead generating power forecasting for photovoltaic system," in *Power Engineering Society General Meeting, 2007, IEEE*, 2007, pp. 1-6.

- [19] J. Liu, W. Fang, X. Zhang, and C. Yang, "An Improved Photovoltaic Power Forecasting Model With the Assistance of Aerosol Index Data," *Sustainable Energy, IEEE Transactions on*, vol. 6, pp. 434-442, 2015.
- [20] H.-T. Yang, C.-M. Huang, Y.-C. Huang, and Y.-S. Huang, "A Weather-Based Hybrid Method for 1-Day Ahead Hourly Forecasting of PV Power Output," *IEEE Transactions on Sustainable Energy*, vol. 5, 2014.
- [21] D. Mayer, L. Wald, Y. Poissant, and S. Pelland, "Performance prediction of grid-connected photovoltaic systems using remote sensing", IEA International Energy Agency report, 2008, URL: <https://hal-mines-paristech.archives-ouvertes.fr/file/index/docid/466825/filename/7BAE9F5Bd01.pdf>.
- [22] M. G. De Giorgi, P. M. Congedo, and M. Malvoni, "Photovoltaic power forecasting using statistical methods: impact of weather data," *IET Science, Measurement & Technology*, vol. 8, pp. 90-97, 2014.
- [23] L. Ghods and M. Kalantar, "Different methods of long-term electric load demand forecasting; a comprehensive review," *Iranian Journal of Electrical & Electronic Engineering*, vol. 7, p. 249, 2011.
- [24] E. A. Feinberg and D. Genethliou, "Load forecasting," in *Applied mathematics for restructured electric power systems*, ed: Springer, 2005, pp. 269-285.
- [25] N. Huang, G. Lu, and D. Xu, "A Permutation Importance-Based Feature Selection Method for Short-Term Electricity Load Forecasting Using Random Forest," *Energies*, vol. 9, p. 767, 2016.
- [26] M. T. Haque and A. Kashtiban, "Application of neural networks in power systems; a review," *Trans. Eng. Comput. Technol*, vol. 6, 2000.
- [27] Coursera, (2014). Coursera. [online] Available at: <https://www.coursera.org/course/ML> [Accessed 07 Mar. 2014], Machine Learning Course, Instructor Andrew Ng, Stanford University, ed 2014.
- [28] R. Hecht-Nielsen, "Theory of the backpropagation neural network," in *Neural Networks, 1989. IJCNN., International Joint Conference on*, 1989, pp. 593-605.
- [29] B. Francois, "Orthogonal considerations in the design of neural networks for function approximation," *Mathematics and computers in simulation*, vol. 41, pp. 95-108, 1996.
- [30] E. L. Taylor, "Short-term electrical load forecasting for an institutional/industrial power system using an artificial neural network", Master Thesis, University of Tennessee, 2013.
- [31] H. S. Hippert, C. E. Pedreira, and R. C. Souza, "Neural networks for short-term load forecasting: A review and evaluation," *Power Systems, IEEE Transactions on*, vol. 16, pp. 44-55, 2001.
- [32] H. Bevrani, "Robust power system frequency control," Springer, 2nd revision, ISBN: 978-3-319-07277-7, 2014.

Chapter III

*Operating Reserve Quantification in a
Microgrid by Considering the PV Power and
Load Forecasting Uncertainties*

Chapter.III Operating Reserve Quantification in a Microgrid by Considering the PV Power and the Load Forecasting Uncertainties

III.1. Introduction

Generation system reliability is an important aspect in the investment planning of future electrical systems to make sure that the total installed electrical production capacity is sufficient to provide electricity. The investment planning process utilizes reliability indices as criteria to decide on new investments in new generation capacities in order to maintain a targeted security level.

As energy prices get increasingly higher and CO₂ emissions should be limited, new electrical generators supply options based on distributed resources are required. This development of RES contributes to the energy supply portfolio diversity and greatly reduces the expanded usage of fossil fuels. However, on one hand, compared with conventional fossil fuel power plants, they are greatly influenced by meteorological conditions and have a variable and uncertain nature. On the other hand, the load demand needs to be supplied instantaneously at any time. Therefore, system operators must take into account the uncertainty increasing coming from the loads as well as RES.

Another important effect on intermittency is the operational planning for the generation system adequacy. Most utilities give the intermittent RES energy credit but not the capacity credit. This is because system planners seem to disagree that these intermittent RES can be relied upon to contribute to the system reliability. Consequently, additional OR is reported on conventional generators and will increase the overall cost of power generation systems. In our research work, RES with embedded storage units as additional operation reserve are proposed to provide a controllable power supply for electrical system operators. Thus, the balance between OR and investment costs needs to be considered and OR needs to be minimized while satisfying the system security.

RES generation forecasting and load demand forecasting are required for system operation. However, forecasting errors can never be eliminated no matter the used model or tool. Therefore, the accurate calculation of the operating reserve by taking into account forecasting uncertainties from both power generation and consumption is essential.

Traditionally, OR is set by determinist methods as a percentage of the load demand or generation or as the capacity of the largest power generation unit. For the last method, in case of tripping of the largest generation unit, the OR is enough to restore the power. Nonetheless, when a large amount of RES with variable power production is integrated into the electrical grid, the problem becomes more complex. Required reserves are also impacted by energy scheduling practices, loads and RES forecasting accuracy, power system size, etc. Nowadays, determinist methods are gradually replaced by probabilistic methods for a much more accurate calculation and to set a desired security level. To manage high levels of renewable generation, a reserve setting mechanism should utilize the best understanding of meteorological uncertainties and combine it with traditional setting process. In this chapter a method is developed to calculate the OR by taking into account the uncertainties from RES.

The power generation reliability and the OR concept are introduced in the next part. Then in part three, for each studied time step of the next day, OR calculation is proposed with the Net Demand (ND) forecasted uncertainty by using a probabilistic method. The ND forecasted uncertainty is obtained as the difference between the forecasted production uncertainty and the forecasted load uncertainty. Two methods are proposed to predict the ND forecast errors

one day ahead: the first one is a direct forecast with historic ND errors; the second one is through a mathematical integration of both PV power and load forecasting errors. An hourly probability density function of all predicted ND forecasted errors has been used for the error analysis. In the fourth part, a method is explained to assess the accuracy of these predictions and to quantify the required operating power reserve to compensate the system power unbalancing due to these errors. Power reserve is obtained by choosing a risk level related to two reliability assessment indicators: loss of load probability (LOLP), and expected energy not served (EENS). Finally, this management tool is tested through an illustrative example.

III.2. Power Generation Reliability

III.2.1. Reliability background

Reliability, in terms of power system, is an inherent characteristic, which describes the system ability and credibility to perform its intended function of supplying electrical energy to its customers. Reliability levels are interdependent with the economy since a high reliability requires high investments [1]. Therefore, reliability and economy must be treated together to reach a cost-benefit situation with an acceptable risk level. Within reasonable economic constraints, it is mandatory that power system operators, designers, and planners ensure the electrical energy supply to consumers.

In a typical electrical power system, power generation units are not always available as unforeseen power unit failures may appear during operating or during planned maintenance and fuel loading periods. Therefore, the power reserve is required in case of emergency. The basic calculation method of the power reserve for a power system with several power generation units with a similar size and reliability is detailed in [2]. However, when RES, such as wind power and PV power are integrated into the power system, their inherent variability and uncertainty have impacts on the different time scales [3]. For example, the wind power will influence the local power quality and system stability in the minute (or less) time scale. In a one to 24 hours scale, it will impact local power distribution efficiency, regionally unit commitment, and transmission efficiency. Generally, RES power generators will affect system stability through decreasing the system inertia. Therefore, the commitment of quick-start generator unit should be increased to handle the power and load forecasting deviations to maintain the system reliability with a short response time.

III.2.2. Reliability evaluation techniques

Reliability evaluation is classified into two major areas: system adequacy and system security [4]. Adequacy is associated with static conditions. It is related to the existence of sufficient facilities within the system to satisfy the system operational constraints and the load demand. Security, however, is associated with the dynamic conditions. It is related to the system ability to respond to dynamic disturbances arising within the system that may cause transient or voltage instability.

According to [1, 5], two typical approaches exist for the generation reliability evaluation: analytic studies and simulation analysis. By using mathematical solutions, analytical techniques evaluate the reliability indices from a mathematical model. However, the disadvantage of this method is the frequent needs to make assumptions and approximations in order to give simplifications. Also it is often possible to evaluate expected values but not the underlying distributions. By simulating the actual process and random behaviors of the system, simulation techniques (usually known as Monte Carlo simulations) can estimate the reliability indices. It can be classified into two main categories: non-sequential and sequential approaches. The former considers each time interval independently and therefore cannot

model time correlations or sequential events. The later, however, takes each interval into a chronological order. Even though they are useful in modeling complex systems, one inherent problem in all simulation techniques is that results are depend on different factors, such as operation times, starting or initializing values used in the experiments, and the sequence of random numbers.

When RES generation is used to provide a significant proportion of the electrical system energy, additional operating costs will be needed [6]. The cost and impacts of RES fall into two broad categories: system balancing impacts and capacity to ensure system reliability. The unpredictable fluctuations will cause additional response and reserve provision. With a large part of RES generators production into the total power generation, the electric system margin needs to be enlarged to maintain the same security level as with thermal generations. The major factors are: (1) RES original nature sources, such as wind speed for wind power generation and solar irradiance for PV power generation; (2) installed capacity and the RES proportion in the electrical system; (3) distribution limits of transmission structure; (4) and the system flexibilities operating and controlling adjustment. Therefore, to satisfy an identical reliability level, irregular unforeseen fluctuations need extra reserve provision to continually accommodate the power unbalance over short term periods (from seconds to hours).

III.2.3. System reliability indices

Understanding the probabilistic criteria and indices is important for a reliability study. These reliability indices are used to assess the reliability performance of a generation system against some predetermined minimum requirements or reliability standards. Fundamentally, system reliability evaluations can be calculated by a deterministic approach and a probabilistic approach (Figure III-1).

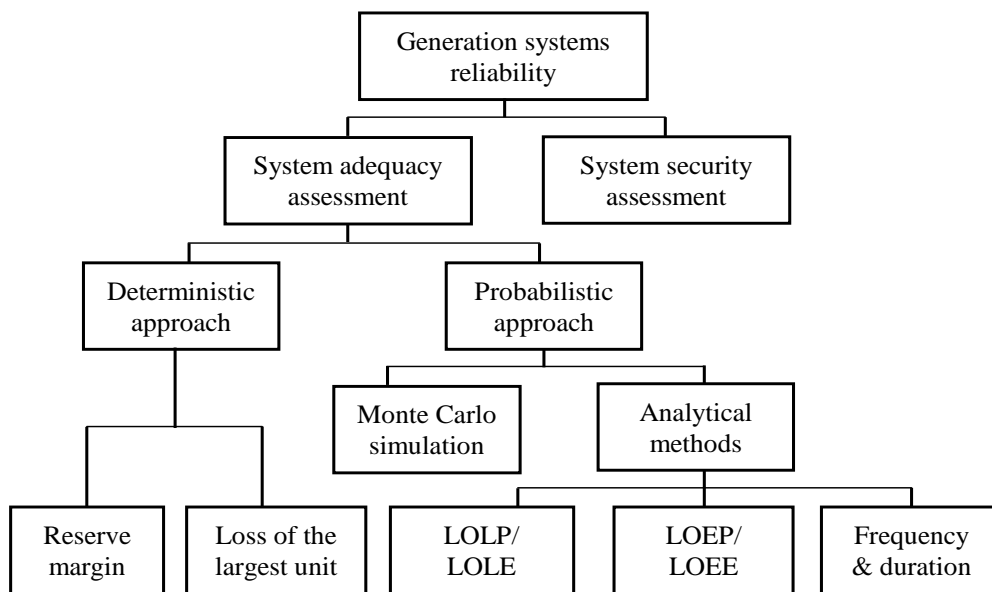

Figure III-1 Category of generation system reliability assessment indices [7].

For the deterministic approach, the most common indices are the Reserve Margin and the capacity of the largest power generation set in the system. Nonetheless, probabilistic methods can provide more meaningful information in resource for planning and allocation [5]. There are two kinds of probabilistic approach: the Monte Carlo simulation method and the analytical method. The former estimates reliability indices by simulating the actual random behaviour of the system; while the later uses direct analytical solutions to evaluate reliability indices from the mathematical models. Several most commonly used analytical method indices are listed as

followings and more information are detailed in [5, 7]: loss of load probability (LOLP), loss of load expectation (LOLE), loss of energy expectation (LOEE), and expected energy not supplied/severed (EENS).

LOLP: This basic probabilistic index is defined as the probability that the load will exceed the available power generation. This parameter represents the probability of generation to cover the load during a certain period.

LOLE: It is generally defined as the average number of days, on which the daily peak load is expected to exceed the available generating capacity. It indicates the expected number of days (or hours) for which a load deficiency may occur. The optimum LOLP value can be defined with it: $LOLP = LOLE / 8766h$.

LOEE: It is defined as the expected energy that will not be supplied when the load exceeds the generation. It indicates severity of the deficiencies and their likelihoods.

EENS: It defines the expected energy that the electrical system is not able to supply its customers.

III.2.4. Frequency control and energy balancing

The daily operation of a power system aims to match load variations with the power generation. It means that the operation planning department of a utility uses the forecasted load to match the real time load demand. However, the deviations, which should be minimized, will always exist. Additionally, power plants and transmission lines may have forced outages, which can cause disturbances. These unexpected deviations and disturbances should be managed by short term power reserves which are known as frequency control reserves and operating reserve [30].

The frequency stability corresponds to the balance between power production and consumption. It is set by the speed of synchronous generators, which are the main technology for the electricity production in traditional electrical system. Equation (III-1) gives the speed of an alternator (Ω_t) according to the variations in the produced torque (T_p) and the torque exercised by the consumption and losses (T_c):

$$J_s \frac{d\Omega_t}{dt} = T_p(t) - T_c(t) \quad (III-1)$$

J_s is the overall network inertia and is the sum of the inertia of all production groups. It constitutes the primary energy storage system of the electrical network in an inertial mechanical form. In the situation of a loss of production plants or an increase in consumption, the right side of the above equation decreases and so as Ω_t . This will result in a decrease in the frequency. Remember that the generation fleet consists mainly of synchronous generators, whose speed is proportional to the main frequency. The frequency drop will be either higher or lower according to the value of system inertia.

The above equation can be written by using the total power production (P_p) and the total power consumption (P_c), as equation (III-2). The difference between power production and consumption will be instantaneously added or subtracted from the total energy of the system rotating masses ($E_t = \frac{1}{2}J_s(\Omega_t)^2$).

$$J_s \frac{1}{2} \frac{d(\Omega_t)^2}{dt} = P_p(t) - P_c(t) = \frac{dE_t}{dt} \quad (III-2)$$

The equation shows that the energy stored in the rotating masses provides an instantaneous power reserve. This power reserve will determine the temporal evolution of the speed (or frequency). To stabilize the frequency, the balance between torques and between power

production and consumption must be maintained by modulating the power production, according to the variations found on the frequency [33]. Therefore, according to the activation time and duration, specific settings have been established (Figure III-2). In Table III-1, several technical data of frequency adjustment for different regulation power reserves are presented.

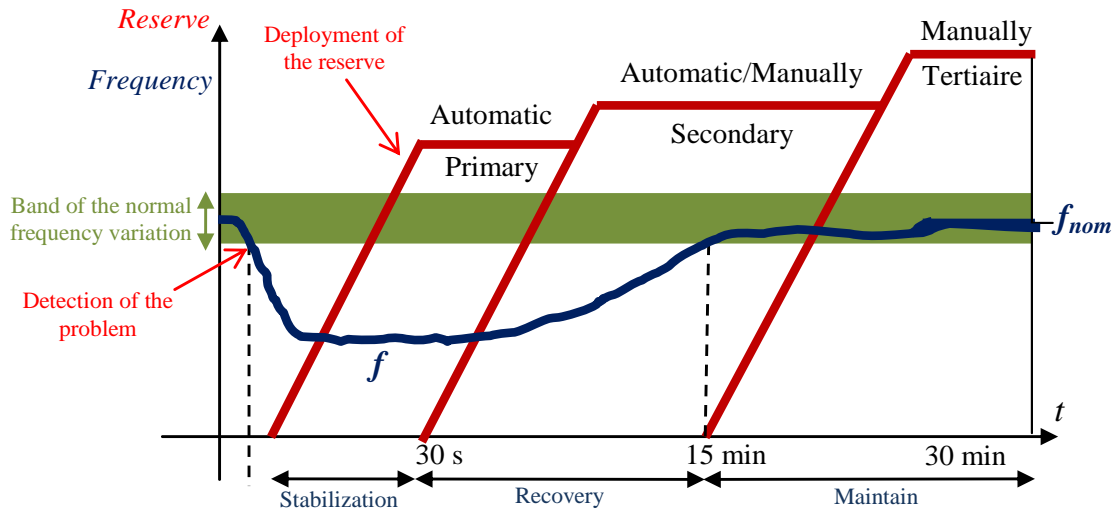

Figure III-2 Deploying of the primary, secondary and tertiary regulation.

Table III-1 Technical data for the frequency adjustment [2].

<i>Regulation</i>	<i>Active power variation</i>	<i>Response time</i>	<i>Duration</i>
<i>Inertial response</i>	according to the time derivative of f	200 ms	10 s
<i>Primary reserve</i>	in proportion to the error in f	Second	15 min
<i>Secondary reserve</i>	according to a remote control level	2 min	30 min
<i>Tertiary reserve</i>	according to a received program	-	-

The snapshot power reserve reacts immediately to cover the power generation absence. The primary reserve is activated several seconds later, after detecting the frequency variation for about fifteen minutes. The secondary control then takes over to cancel the residual static frequency error and try to automatically recover the frequency to a normal value. Finally, the tertiary control allocates this new level of power generation between power generators.

Primary frequency control

To avoid significant variations in the frequency, it is necessary to quickly restore the power balance between generation and consumption during a major incident. Primary adjustment is executed immediately because the first few seconds are critical (Figure III-2). This setting is a control loop at each alternator for regulating the electrical output based on frequency variations. The control is achieved through a proportional speed controller (the change in frequency outside a band of permitted variations), which acts on the intake of the fluid turbine motor organs. The adjustment feature is to detect any change in the frequency and then increase the power production in case of under frequency and vice versa (Figure III-3).

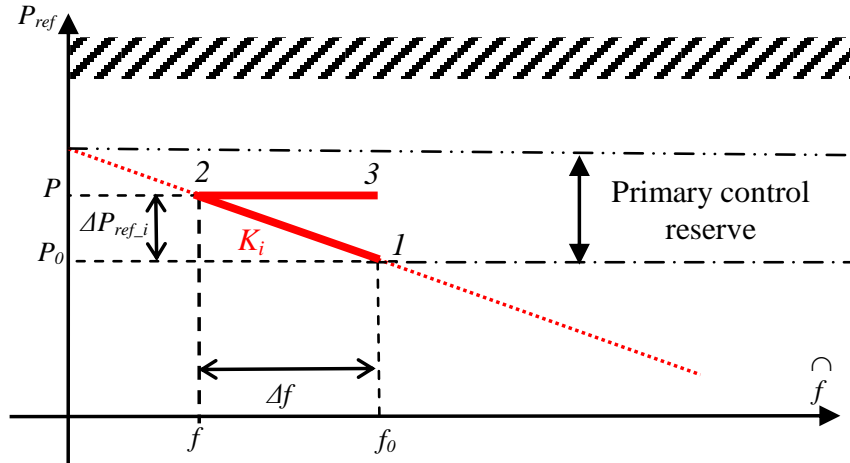

Figure III-3 Primary frequency regulation

The contribution of the generators for primary frequency control is based on a droop constant. It gives the additional power, which is supplied as a function of the frequency deviation:

$$P(t) - P_0 = K_i \cdot (f(t) - f_0) = K_i \cdot \Delta f(t) = \Delta P_{ref_i}(t) \quad (\text{III-3})$$

f_0 is the frequency in the normal operation (50 or 60 Hz), and f is the sensed frequency value. P_0 and P are respectively the reference power and the real time power, and K_i is the power frequency characteristic parameter. Hence the reference of the generated power will change from the value in normal conditions (P_0 in Figure III-3) to another value (P). After the instantaneous increasing of the power by the studied generator, the system is stable but at another frequency (f in Figure III-3). As all generators do not have the same response time, the frequency will finally be back to its normal value (f_0) and the power operating point of each generator is changed (point 3). The primary power reserve is the offered power capacity that may be used by the primary frequency control.

Secondary control

Secondary control operates slower than primary control, in a timeframe of minutes. It modifies the active power set points of generators that are located in an area in order to satisfy the programmed exchanged powers with other areas (generally planned one day ahead) while observing energy balance and frequency control with a minimal economical goal. Regarding Figure III-3, the output power should be set near P_0 . Therefore, it also ensures the fact that the full-activated power reserve of primary control will be available again. This can be performed by the microgrid central energy management with a power re-dispatching.

Tertiary control

In a major incident event, the primary and secondary reserves can be automatically initiated and exhausted. Then, they have to be reconstructed. Therefore tertiary reserve is established to renew the power reserves planning in order to get ready to react to a novel incident. The different reserves are decomposed according to their period of mobilization and duration of usage. The mobilizations of these actions are taken automatically and sometime manually. Automatic actions are normally initiated when the frequency drops below the given limits, while manual actions are initiated by starting the reserve power plants or by increasing the load of the operating plants. However, the latter is more commonly used [33].

III.2.5. Frequency control with MGT

A MGT can be used for primary and secondary frequency control [34]. Primary control is characterized by a static characteristic and does not maintain the required frequency. Within the first several minutes the power imbalance is covered by the first prior reserve started up by the turbine speed controller within several seconds (primary control). It is arranged by measuring the frequency and controlling the engine output in proportion to the frequency deviation. It is activated when the frequency variation is more than the dead band given to the MGT controller.

Secondary control can be implemented within five to ten minutes. The MGT can increase or decrease its output following on the requirements of the transmission system operator. This operation can be made either by receiving the automatic control signals from the dispatch center or manually. It should be noted that the efficiency is important when the MGT operates in the regulation mode. A drop in efficiency will increase the costs of the regulation power.

III.2.6. Voltage control and reactive reserve

The voltage is controlled by the reactive power balancing in the electric network. It is performed by the generator voltage controller and by transformers in the high voltage side.

Reactive power generation is obligatory required by the power system to compensate reactive losses in reactive loads and transmission power lines. Otherwise, it will cause instability of voltages and then trigger a blackout in large areas. However, in our case we only focus on the active power reserve. Reactive power reserve is out of our scope. So in our study, reserve power is defined as the real power capacity that can be called on any instance of imbalance between generation and load.

III.3. Operating Reserve (OR)

III.3.1. Reserve Types

The objective of electric power systems is to supply electrical energy to consumers at a low cost while simultaneously providing a service quality. The OR makes sure the electrical system has enough power to supply the load even if generation units are out of service, due to planned or unplanned outages. This power deficit could be caused by the primary energy sources inadequacy, the load fluctuations, and the integration of uncertain powers. Therefore, an additional OR is important and essential for the electrical power system stability.

Non-hydro RES, especially wind and PV power, have a feature of variability and uncertainty. Nowadays, as well as in the future, the fact that power generation from RES and load demand cannot be perfectly predicted gives new challenges for power system operators. Therefore, different amounts and types of OR are applied to compensate the fluctuations to keep the system frequency stable and serve the load reliability. In research works, the definitions of the OR are varying [8-11]. Here we quote the definition of [9] as following:

“The term operating reserves is defined as the real power capability that can be given or taken in the operating timeframe to assist in generation and load balance and frequency control.”

In [9], the OR is differentiated by different criteria: types of events (contingency events, non-contingency events or longer timescale events); response timescale (spinning reserve or non-spinning reserve); and service types (automatic generation control, upward regulation or down regulation). Then five different types of reserves are defined by using the following characteristics: frequency response reserve, regulating reserve, ramping reserve, load

following reserve, and supplemental reserve. While in [11] the OR is classified into four types that are based on respond speed as event or non-event: regulating reserve, following reserve, contingency reserve, and ramping reserve (Figure III-4).

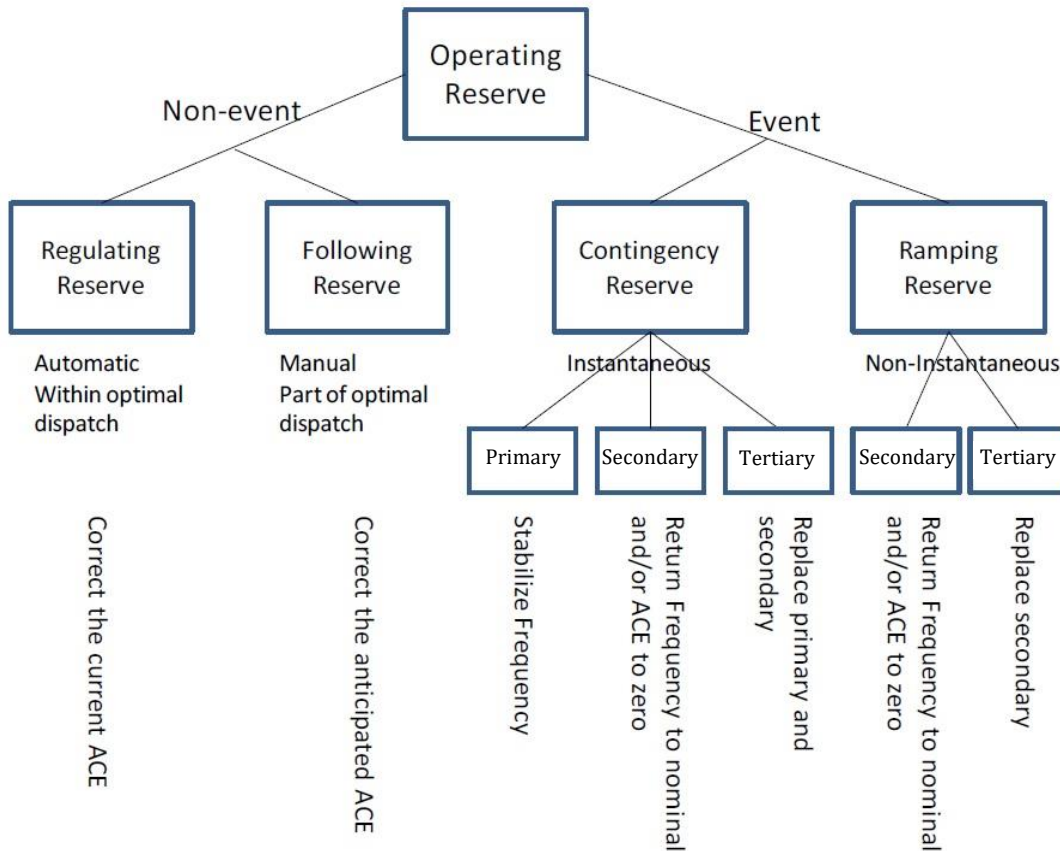

Figure III-4 Example of operating reserve categories and how they are related [7].

The non-event reserve purposes can be differentiated according to the correction of the current imbalance with a regulating reserve and the correction of the anticipated imbalance with a following reserve. The event reserve is then divided into contingency reserve (instantaneous) and ramping reserve (non-instantaneous). Specific reserve requirements are varying from region to region and they tend to be nonlinear with respect to the amount of power generation and load demand. In addition, the regulation and the following reserve requirements are also varying with different time scales [3].

III.3.2. European vs North American Reserve Definitions

The European Network of Transmission System Operators for Electricity (ENTSO-E) (Union for Coordination of Transmission of Electricity (UCTE) before 1 July 2009) and the North American Electric Reliability Corporation (NERC) specify power reserve requirements with different terminologies [3]. The relationship between the two reserve sets is shown in Figure III-5. Engineers in European use the technical terms of primary, secondary, and tertiary reserve, while the North American use some more specific definitions. The different reserve terminologies are now explained according to ENTSO-E/UCTE criterions.

Primary reserves

Within few seconds, the primary control reserve in ENTSO-E/UCTE is used to stabilize the system frequency. ENTSO-E/UCTE decides the primary control reserve by considering the maximum instantaneous power deviation. It does not specify the technologies used to provide the reserve, such as power generation, demand response, or storage.

In North America, specific response capability is not yet a regulatory requirement. It is the primary reserve response that will be provided, possibly with regional differences.

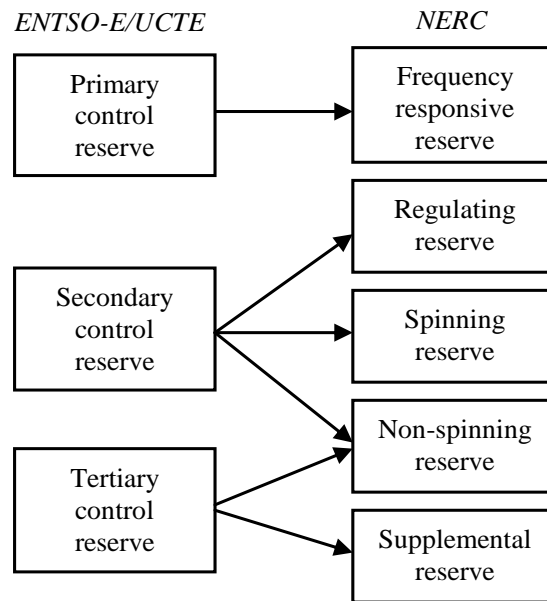

Figure III-5. ENTSO-E/UCTE and NERC reserve terminology [3].

Secondary reserves

In ENTSO-E/UCTE, there is no formal compliance measure set for secondary reserve requirements. Normally, it is based on empirical analysis or probabilistic methods. NERC distinguishes secondary reserve from normal conditions and contingency conditions. The former is responded by the regulation reserve, while the latter is covered by contingency reserve. For NERC, specific amounts of spinning and non-spinning reserve is needed for contingency response.

Tertiary reserves

Following a contingency, the tertiary reserve is used to replace the primary and the secondary reserve. Although the technologies are not restricted, the ENTSO-E/UCTE recommends that there should be enough tertiary reserve to cover the largest supply deficit in the individual control area. There are no specific clarifications about tertiary reserve based on reliability rules in North America. However, they may include a part or all of the non-spinning reserve, supplemental reserve or replacement reserve.

Among many different naming conventions, however, in this thesis the OR is defined as the real power that can be called on instantaneously for the imbalance between power generation and load demand (Primary and secondary reserve).

III.3.3. Calculation of OR by Considering Uncertainties from RES

The OR must be scheduled in order to maintain a specified level of system security. Enough reserve must be held to restore the balance of generation and consumption in the event of unplanned deviations from the forecast system operation state.

Historically, most conventional utilities have adopted deterministic criteria for the reserve requirement by considering only two sources of uncertainty: The possibility of multiple large generators failing has low probability but high impact if reserves are inadequate and load forecast errors are common but usually relatively small. Resulting operating rules require that

the OR must be greater than the capacity of the largest on-line generator or a fraction of the load, or equal to some function of both of them [12].

As the available primary renewable sources are intermittent and have a low energy production compared to conventional sources with the same peak power rating, RES are not often reaching their installed power during their operation. The output of variable generation is a new uncertainty. Therefore, the most common approach for adapting the grid codes is to accept also a certain risk level when connecting renewable sources in long-term planning.

Deterministic criteria are widely used because of their simplicity and understandable application. However, these deterministic calculation methods are gradually replaced by probabilistic methods that respond to the stochastic characteristics of RES based generators and loads and correspond to the system reliability. These probabilistic criterions, which are more complex, have been used for assessing available reserve capacity [13]. Moreover, those probability methods may be used for reserve dispatch in order to meet the required system security level with a certain risk and help for the reserve calculation [14].

Nevertheless, it is complicated to evaluate the impact of a high penetration of intermittent RES (generally wind and solar power) and so to quantify the power reserve. Such as in [31], the characteristics of the prediction uncertainty caused by intermittence of wind generation are discussed. The value of forecasting and the benefits from uncertainty estimation are presented. As mentioned above, the OR is not added linearly according to RES increase in the electrical grid. They are impacted by different factors, such as power system size, schedule strategies, accuracy of load and RES forecast, and so forth. Recently several research works on wind power integration have already advanced the art of analyzing RES integrating impact on power reserve calculation [15-17, 32]. As presented in [32], the ANEMOS.plus project aims at the optimal management of electricity grids with large-scale wind power generation. It focuses on two parts: (1) reliable provision of advanced wind power forecasts through alternative technologies; and (2) optimal integration of wind energy into power systems and electricity markets. Among those inspiring studies, two of them are particularly noteworthy: the Eastern Wind Integration and Transmission Study and the Western Wind and Solar Integration Study [18]. In addition, instead of deterministic methods, a significant work has been done to explore the benefits of probabilistic methods for the required OR calculation [16, 17, 19, 20].

Eastern Wind Integration and Transmission Study (EWITS)

The EWITS focused on the operational impacts of various wind penetrations for the U.S. Eastern Interconnection [3]. The analysis is applied with an average of a 100 MW wind plant system in short term (from minutes to one hour). Assuming that the wind plants are independent, the total standard deviation is calculated by geometrically adding the wind power forecasting standard deviation, which is determined as 1MW, for 100 MW wind power plant. While the reserve for load regulating only is assumed to be 1% of the total load. It is assumed to be equal to three times the load variability standard deviation. The variabilities of load and wind power are considered independent. Therefore, as shown in (III-4), the total standard deviation is calculated as the square root of their square addition. The increased standard deviation caused by wind power is then less than 1MW.

$$\begin{aligned}
 & \text{Regulation reserve} \\
 & = 3 * \sqrt{\left(\frac{1\% \text{ hourly load}}{3}\right)^2 + \sigma_{ST}(\text{hourly wind})^2} \quad \text{(III-4)}
 \end{aligned}$$

Here $\sigma_{ST}(\text{hourly wind})$ is the hourly wind power forecast errors standard deviation.

Western Wind and Solar Integration Study (WWSIS)

The WWSIS focused on the WestConnect region. It has analyzed the impacts of the OR with different penetration scenarios of wind power and solar power [3]. The study that discussed the OR requirement is dynamically relied on both the load and wind levels. The method also analyzed the reserve requirement for different situations: three-sigma rule for load only, three-sigma rule for load and wind, and 3% of total load demand. It also studied the total peak reserve according to 1% of peak load regulation rule and one sigma regulation rule. The team also developed a rule with a good compromise between accuracy and simplicity:

$$\text{Reserve} = X \times \text{Load} + Y \times \text{Wind}, \text{until Wind} > Z \quad (\text{III-5})$$

where the X and Y are coefficients applied respectively to the load capacity ($Load$) and the wind capacity ($Wind$). Z is the amount of the nameplate wind capacity for which further increases in wind power will not cause additional reserve.

Other probabilistic methods

Based on the available data for load demand and RES variability and their associated uncertainty, several research works have focused on calculating the total system uncertainty from all the variable sources. In [17, 21, 22], the net load demand forecast uncertainty has been taken into consideration. Since the load forecast errors and wind power forecast errors are considered as independent random variables, the net demand forecast uncertainty is computed as a combination of those two parts. However, the definition of standard deviation of load forecast errors and wind forecast errors are different in those works. In [21, 22], the forecast load and forecast wind are considered as the forecast value plus the distributed errors, which have a zero-mean Gaussian -distributed characteristic.

Based on dynamic simulations, the study in [23] focuses on the dynamic frequency control of an isolated power system and the reduction of the impact on system operation caused by large shares of wind and PV powers. However, this work did not consider other aspects, such as the variability and forecast accuracy. In [24], in order to help utility engineers to investigate the potential impact of PV integration into the grid, some tools and methodologies are introduced. The major obstacle is the lack of specific PV and load data for dynamic analysis. There are no detailed methods for operators to quantify the operating power reserve of such a high PV penetration system. Nevertheless, some research works on wind power uncertainty analysis and their highly penetration into electrical grid are available. As an example of a risk evaluation initiative, a reserve management tool is proposed in [19], via the setting of an acceptable risk level: a compromise between the economic issues and the risk of load loss is explored. The operating reserve is quantified by $\varepsilon \cdot \sqrt{\sigma_L^2 + \sigma_W^2 + \sigma_C^2}$, where σ is the Gaussian distributed standard deviation of loads, wind power, and conventional generation. ε is the parameter related to the desired confidence level (e.g. $\varepsilon=3$ means that 99.74% of variations are covered). A risk/reserve cost characteristic is used for this reserve quantification. However, authors have based their work on wind assessment with power forecast distributions, instead of using probabilistic forecasts from real data.

In [17], an approach to determine the spinning reserve requirements by considering errors in wind power generation and load forecasts has been presented. The standard deviation of load forecast error is equal to a percentage of the actual load. The standard deviation of the forecast wind error is approximated as one fifth of forecast wind plus one fiftieth of the total installed wind power capacity. Monte Carlo simulations have been used for spinning reserve assessment, which requires a significant calculation time. Most recently, authors in [20] use a non-parametric probability density approach (empirical cumulative distribution function) to model the uncertainty from variables. Authors considered the reserve allocation during its

sizing. While in this paper, the operating reserve calculation and allocation are separated from each other and the former is the only focus of the paper. In [25], the reserve requirements are calculated on not only the load forecast error and wind forecast error, but also the power plant outages. By using the LOLP to define the reliability level, a risk/reserve curve is used for the reserve quantification.

General Scheme for OR quantification

Among these studies, the reliability related indices such as LOLP and EENS are implemented for the reserve power quantification. Therefore, by knowing the risks caused by uncertainties based on above analysis, system operators have means to weigh the likelihood of occurrence and the magnitude of problems to mitigate adverse impacts caused by them. Succeeding the PV power and load demand forecasting in Chapter II, a probabilistic method considering the system uncertainty is developed for the OR quantification. An accurate uncertainty calculation will make power system much easier to control and also more economical. The uncertainties of the renewable energy system mainly come from two parts: energy sources forecasting errors and load forecasting errors. In our case, power generation uncertainty comes from PV power forecasting. Based on forecasting errors from both PV power and loads in the previous chapter, the OR can be quantified by taking into account a reliability risk index (such as LOLP). The overall scheme of this strategy is described in Figure III-6.

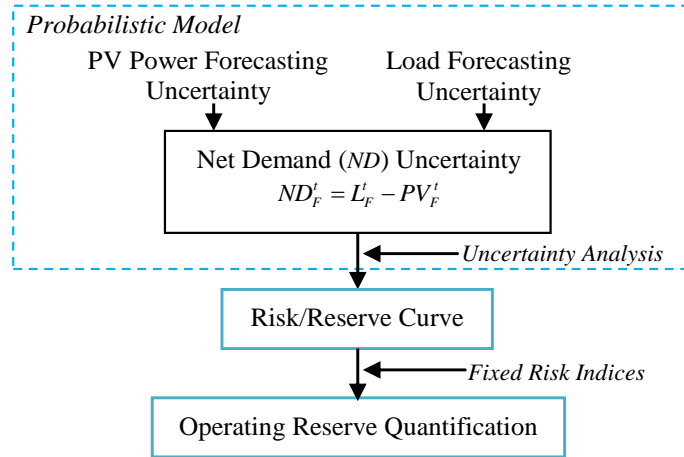

Figure III-6 Reserve management structure

III.4. Net Demand (ND) Uncertainty Analysis

III.4.1. Net Demand Forecasting

Knowing the PV power forecasting and the load demand forecasting for tomorrow, the ND forecasting (ND_F^t) for a given time step is expressed as the Load forecasting (L_F^t) minus PV power forecasting (PV_F^t):

$$ND_F^t = L_F^t - PV_F^t \quad (III-6)$$

The real net demand (ND_A^t) is composed of the forecasted day ahead ND and an error (ε_{ND}^t):

$$ND_A^t = ND_F^t + \varepsilon_{ND}^t \quad (III-7)$$

ε_{ND}^t represents of the ND forecasting error for the time step.

III.4.2. ND Uncertainty

To simplify the study, the uncertainties coming from conventional power generators and transmission line outages are ignored in the microgrid. Only the load uncertainty and the PV

power output uncertainty are considered in this study. Then the ND uncertainty can be represented as the ND forecasting errors. Two possible methods are proposed to calculate the forecasted ND errors.

A. First Method: OR Calculation from the Day-ahead Net Demand Error Forecast

The real ND is the difference of the sensed load and the sensed PV power. Based on the historical sensed and forecasted database of the load demand and PV production, the past forecasted ND is calculated as the difference between past forecasted load and past forecasted PV power at time step t . Then by using past real ND ($ND_A^{t-24}, \dots, ND_A^{t-1}$) and also past forecasted ND ($ND_F^{t-24}, \dots, ND_F^{t-1}$), the last 24h prediction ND errors are obtained ($\varepsilon_{ND}^{t-24}, \dots, \varepsilon_{ND}^{t-1}$). Hence these data are used to calculate the day-ahead forecast of ND errors $\varepsilon_{ND,F}^t$ for tomorrow. The obtained ND error forecast can be characterized by the mean and variance (respectively, μ_{ND}^t and σ_{ND}^t) (Figure III-7).

An ANN is applied for the ND errors forecast with:

- An input layer with last 24 hours predicted ND errors;
- One hidden layer with 10 neurons;
- An output layer that predicts next 24 hours forecasted net errors.

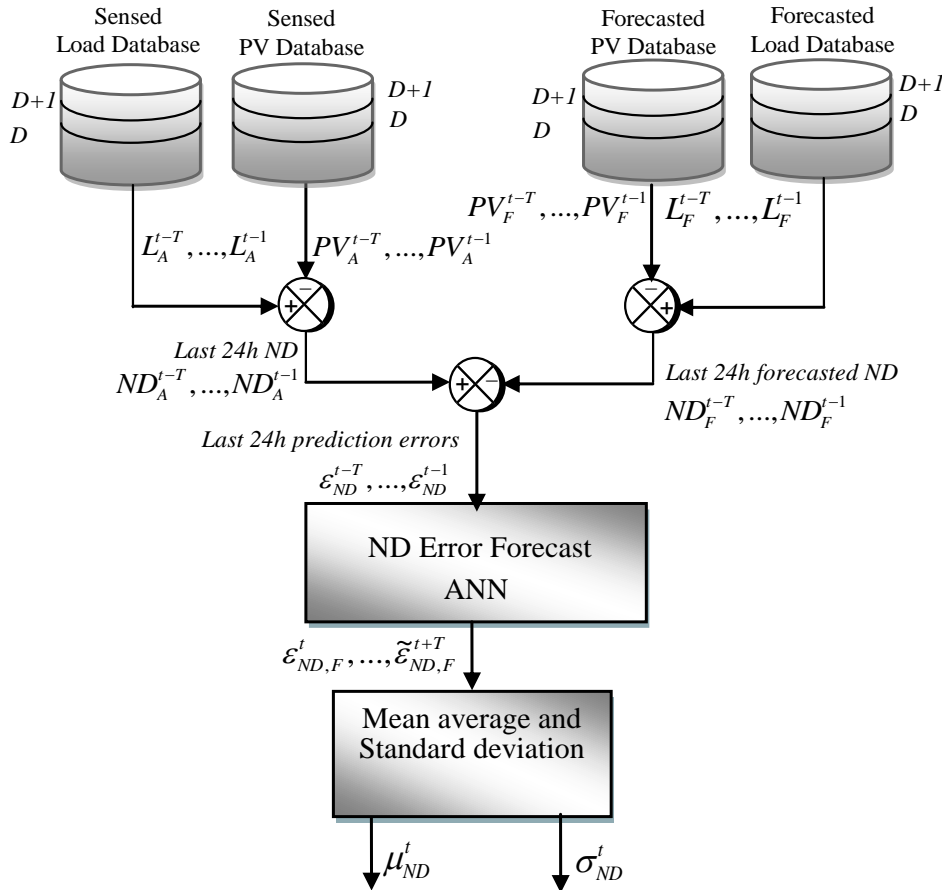
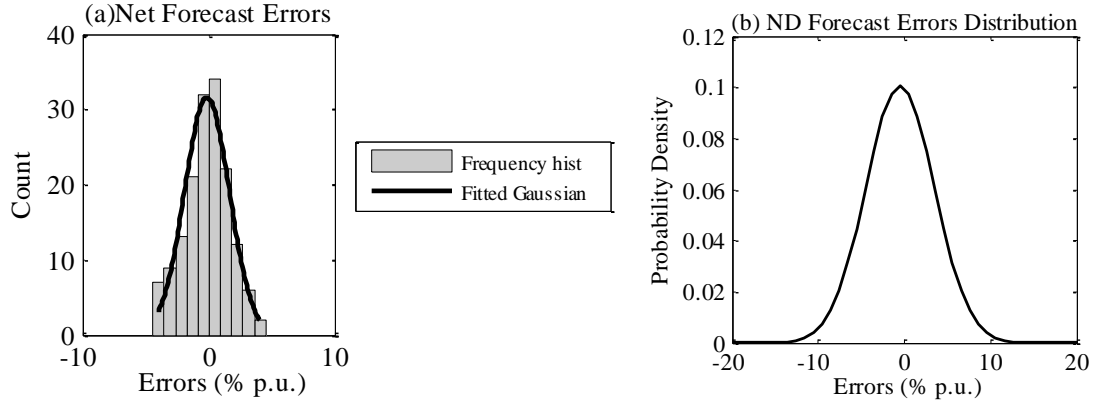

Figure III-7. Net demand forecasting uncertainty calculation by directly ND errors forecast.

The results in Table III-2 show the obtained $nRMSE$ and $nMAE$ with the training set, validation set and test set for the forecasting ANN (chapter II, part II.7). Figure III-8 (a) illustrates the frequency distribution of net error forecast at 12:00 am ($\mu_{12} = -0.1282$, $\sigma_{12} = 1.781$) as an example. The forecasting errors are below 5 percent per unit value. The distribution of the forecasting errors when uncertainties from generation and the load are not independent is shown on Figure III-8 (b).

Table III-2 Errors of the estimation for the ND error.

	$nRMSE$ [%]	$nMAE$ [%]
Training Set	13.00	8.64
Validation Set	12.80	8.58
Test Set	13.52	9.48

 Figure III-8. (a) Frequency distribution histogram and fitted Gaussian function of the forecasted net errors ($\varepsilon_{ND,F}^{t+12}$), and (b) ND errors distribution at 12:00 am.

B. Second Method: OR Calculation from Estimated PV Power and Load Forecast Errors

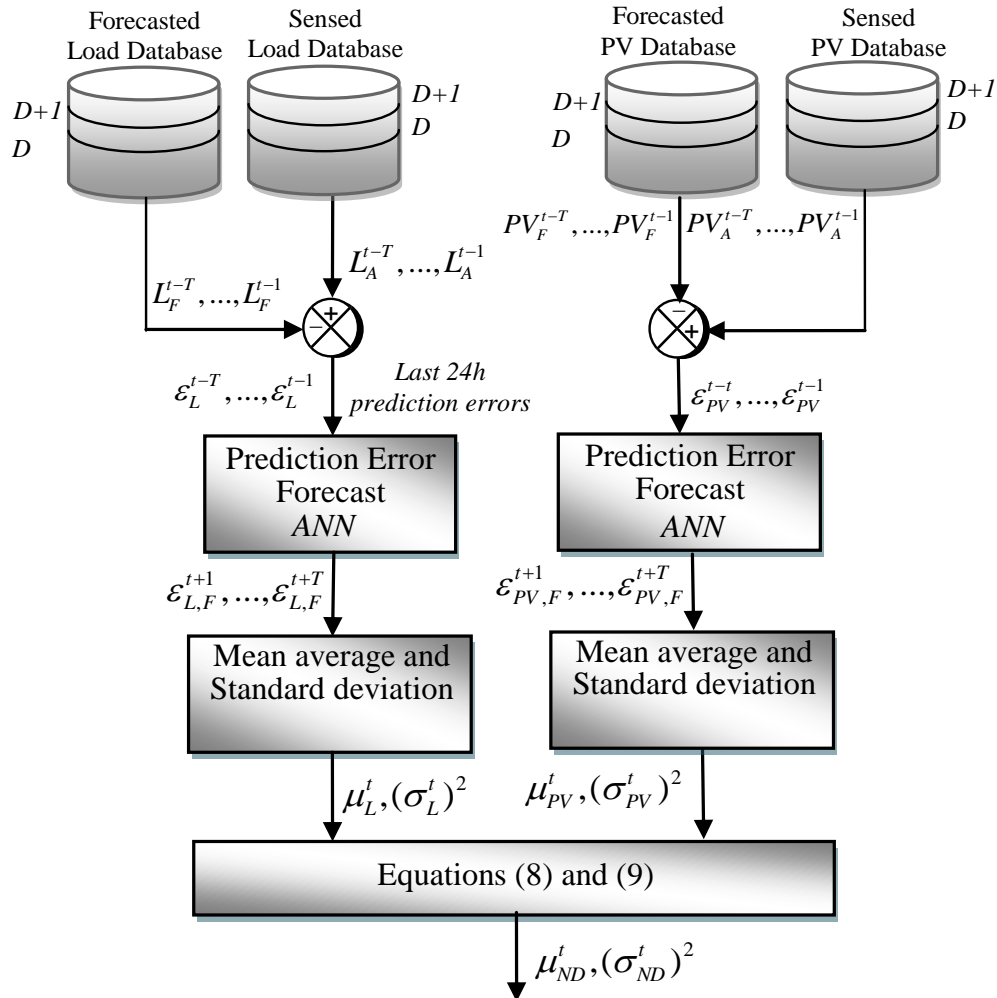

Figure III-9 PV power, load forecasting and errors prediction with ANN.

A second method is to define the ND uncertainty as the combination of PV power and load uncertainties. It is generally assumed that PV power and load forecast errors are unrelated random variables and then uncertainties in load and generation forecasts may be treated independently. So, firstly the day-ahead PV power and load forecasting errors ($\varepsilon_{PV,F}^t$ and $\varepsilon_{L,F}^t$) are independently estimated. Then, last 24-hour load forecast errors and PV power forecast errors are calculated as the difference of the sensed load and PV power, and forecasted load and PV power, respectively (Figure III-9).

The mean values and standard deviations of those forecasting errors can be obtained. Then the ND forecasting error can be attained as a new variable, which comes from those two independent variables. The new obtained *pdf* is also a normal distribution with the following mean and variance [22, 26]:

$$\mu_{ND}^t = \mu_L^t + \mu_{PV}^t \quad (III-8)$$

$$(\sigma_{ND}^t)^2 = (\sigma_L^t)^2 + (\sigma_{PV}^t)^2 \quad (III-9)$$

where, μ_L^t and μ_{PV}^t are respectively the mean values of load and PV power forecast errors prediction at time step t , $(\sigma_L^t)^2$ and $(\sigma_{PV}^t)^2$ are respectively the standard deviation square of load and PV power forecasted errors prediction.

As shown in Figure III-9, two additional three-layer ANN are used to forecast the errors of PV power and load forecasts ($\varepsilon_{PV,F}^t$ and $\varepsilon_{L,F}^t$).

The ANN for the load forecast error estimation has:

- An input layer with last 24 hours predicted load errors;
- One hidden layer with 10 neurons;
- An output layer that predicts next 24 hours forecasted load errors.

The ANN for the PV power forecast error estimation has:

- An input layer with last 24 hours predicted PV power errors;
- One hidden layer with 10 neurons;
- An output layer that predicts next 24 hours forecasted PV power errors.

The obtained *nRMSE* and *nMAE* of the training set, validation set and test set for the forecasting ANN of error prediction on PV power and load forecasting are listed in Table III-3 and Table III-4, respectively.

Table III-3 Errors of the error estimation for the PV power forecasting.

	<i>nRMSE</i> [%]	<i>nMAE</i> [%]
Training Set	4.37	2.14
Validation Set	5.28	2.93
Test Set	5.01	2.72

Table III-4 Errors of the error estimation for the load forecasting.

	<i>nRMSE</i> [%]	<i>nMAE</i> [%]
Training Set	4.00	3.05
Validation Set	4.04	3.27
Test Set	3.95	3.07

For each hour, the mean μ and standard deviation σ have been calculated and the corresponding normal *pdf* has been computed. As an example, the distributions (which define errors distribution probabilities) and normal *pdf* (which describes the relative likelihoods of

variables to a given error value) of predicted errors of load and PV power errors forecast at 12:00 am are shown, respectively, in Figure III-10.

Figure III-10(a) is obtained by calculating the PV power forecast error ($\mu_{12} = -0.0353$, $\sigma_{12} = 0.01571$), while Figure III-10(b) is obtained by calculating the load forecast error ($\mu_{12} = -0.0015$, $\sigma_{12} = 0.0113$). As it can be seen, forecasting errors for PV forecast uncertainties are below 30 percent per unit values, while load forecast uncertainties estimation errors are below 10 percent per unit values. Then, the ND forecasting uncertainty can be obtained by combining those two variables with (III-8) and (III-9). As an example, at 12:00, they are equal to $\mu_{12} = -0.0064$ and $\sigma_{12} = 0.1135$. The distribution of the ND errors when uncertainties in load and generation forecasts are treated independently is shown in Figure III-10(c) and is quite different from the first method.

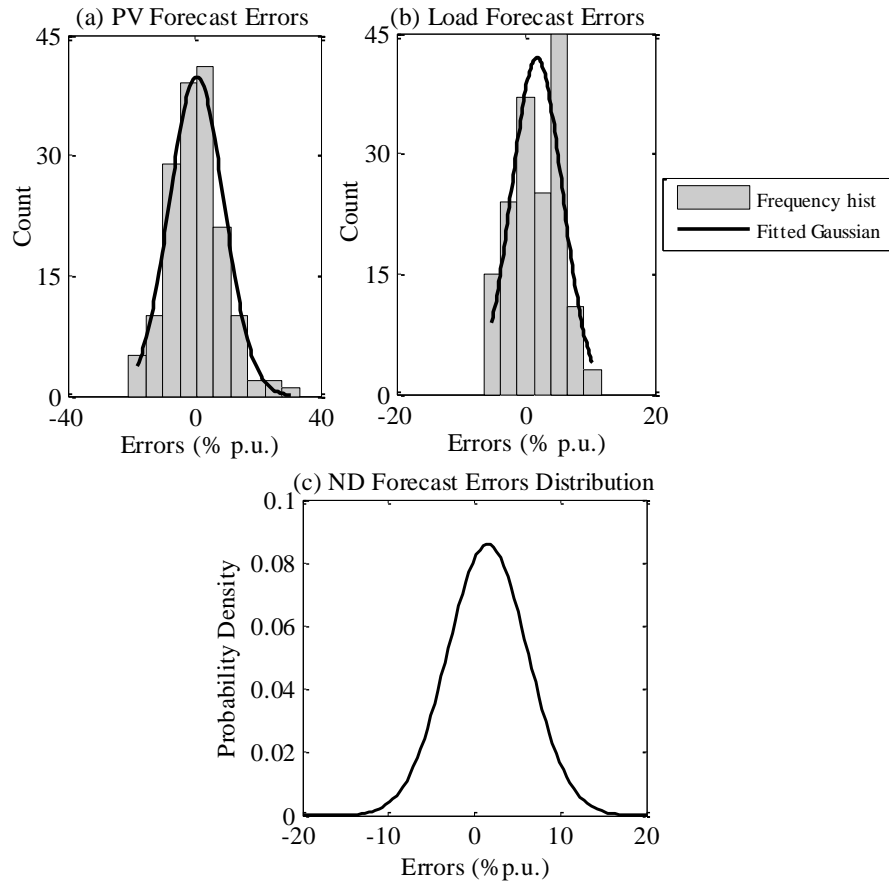

Figure III-10. Frequency distribution histogram and fitted Gaussian function of the PV power errors ($\epsilon_{PV,F}^{t+12}$) and Load errors ($\epsilon_{L,F}^{t+12}$), and ND errors distribution at 12:00 am.

III.5. Forecasting uncertainty assessment

The forecasting uncertainty can be represented as upper and lower bound margins around the forecast values. As for the ND forecast uncertainty, a predicted errors ($\epsilon_{ND,F}^t$) model of the ND forecast (ND_F^t) can be obtained by the normal probability density function with the mean and standard deviation (μ_{ND}^t and σ_{ND}^t , respectively). Bound margin (B) is extracted by a normal inverse cumulative distribution function with a desired probability index x (Figure III-11):

$$B = F^{-1}(x | \mu_{ND}^t, \sigma_{ND}^t) = \{B : F(B | \mu_{ND}^t, \sigma_{ND}^t) = x\} \quad (\text{III-10})$$

where x is the desired probability corresponding to the bound margin B :

$$x = F(B|\mu_{ND}^t, \sigma_{ND}^t) = \frac{1}{\sigma_{ND}^t \sqrt{2\pi}} \int_{-\infty}^B e^{-\frac{(\tau - \mu_{ND}^t)^2}{2(\sigma_{ND}^t)^2}} d\tau \quad (\text{III-11})$$

Then, the *cdf* represents the probability that the random variable (here the ND forecasting errors) is less or equal to x . This method can be used for PV power forecast and load forecast uncertainty assessment. The error estimation mean value and standard deviation of the PV power (μ_{PV}^t and σ_{PV}^t) and the load demand forecast (μ_L^t and σ_L^t) can be obtained with the normal probability density function of the predicted errors ($\varepsilon_{PV,F}^t$ and $\varepsilon_{L,F}^t$) for the PV power forecast (PV_F^t) and load forecast (L_F^t), as shown in Figure III-11. The upper bound (B_{up}) and the lower bound (B_{low}) are calculated with the desired probability x , which is explained in details in part III.6.

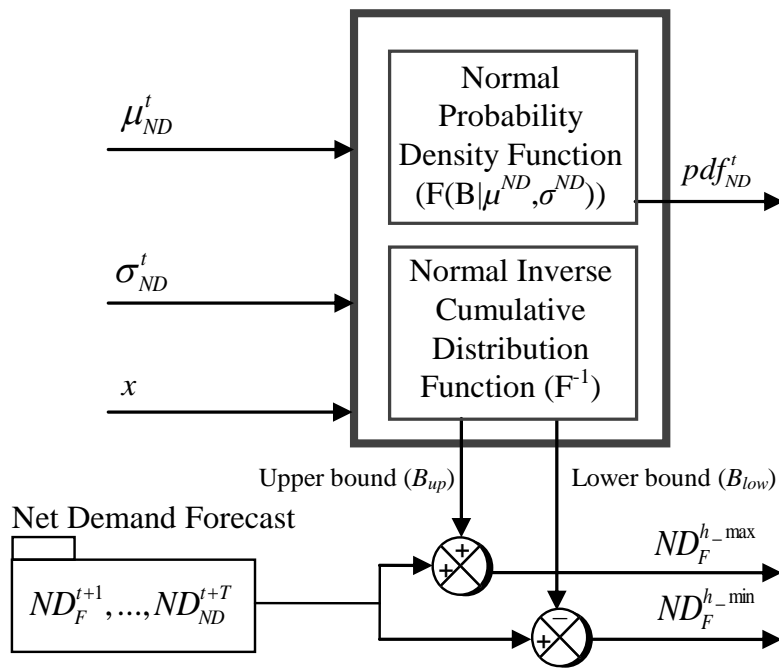

Figure III-11 Net uncertainty calculation at time step t with a given probability.

By applying this method, the uncertainties can be calculated according to different desired probabilities. As a result, PV power forecasting errors, load forecasting errors, and ND forecasting errors band can be obtained in per units by considering various probability indices (it means that x may vary from 90 % to 60%) for a random day. Results are scaled with the 20 kW PV rated power and the 110 kW rated load, as represented in Figure III-12, Figure III-13 and Figure III-14. The time step is set to one hour. (To simplify the methods explanation, only the Second Method results of III.4.2.B are given below).

As shown in Figure III-12, the PV power forecasting uncertainty is higher in the middle of the day when the PV power production is at the peak. While in the morning (from 6:00 to 10:00) and afternoon (from 17:00 to 21:00), the forecasting uncertainty is smaller. Obviously, the PV power forecasting uncertainty varies with the PV power production amount. The uncertainty is increased also when the time horizon is larger. For example, at 10:00 and 17:00 power outputs are almost at the same level (about 6.5 kW), however, uncertainty is larger at 17:00 than at 9:00.

The load forecasting uncertainty has the same variation trend (Figure III-13) as the PV power uncertainty. The uncertainties during the night are smaller than during the daytime. However, the total load forecasting uncertainty is much less than the PV power forecasting, because the load has a much smoother variation tendency than the PV power.

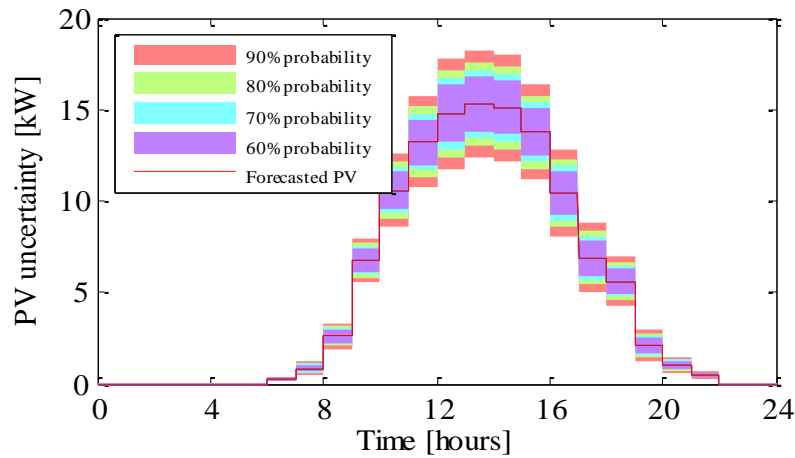

Figure III-12 PV forecasting with uncertainty (a random day).

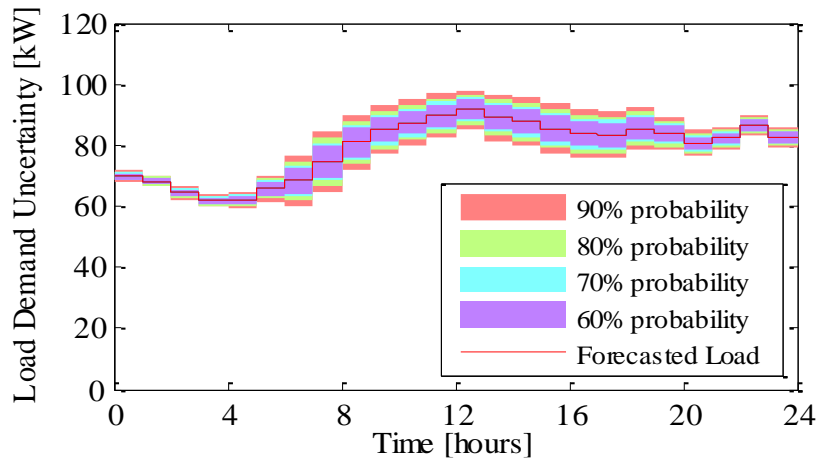

Figure III-13 Load forecasting with uncertainty (a random day).

Figure III-14 depicts the obtained ND forecasting uncertainty. During the daytime, the ND is smaller than the load demand on behalf of the PV power usage. If the forecasted ND is positive, then the additional power sources have to be programmed to cover this difference. Otherwise, if the forecasted ND is negative, it means that forecasted PV power is more than the predicted load demand. In this situation, the following three actions must be considered to deal with the low forecasted load demand:

- A part of the PV power generators must be switched off, or should be working at a sub-optimal level (without maximum power point tracking, MPPT).
- Controllable loads (as electrical vehicles, heating loads) must be switched on to absorb excess available PV power.
- Export the available excess energy to the main grid or to the storage devices.

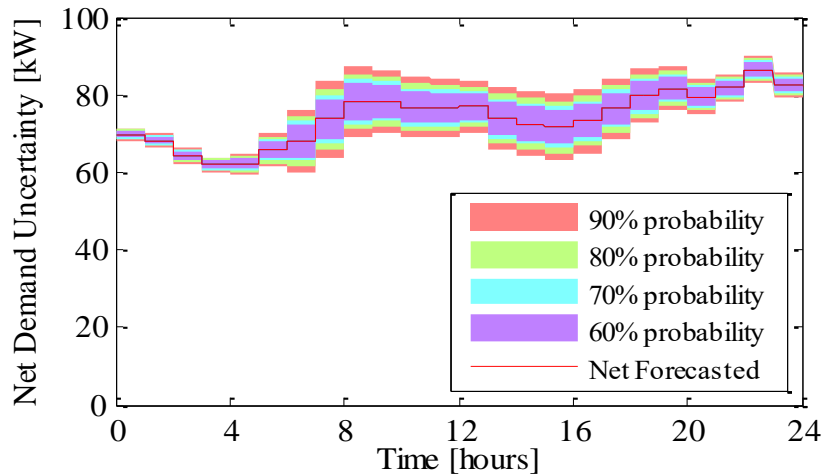

Figure III-14 Next 24 hours ND forecasting with uncertainty (a random day).

III.6. Probabilistic Reliability Assessment

In order to define an appropriate level of power reserve, it is necessary to identify risk indices that quantify the desired level of system security. Resulting from the uncertainty assessment, the *pdf* of the forecasted ND errors in a given time step is considered for the calculation of the OR [25]. To estimate the impact of the forecast ND uncertainty, two common reliability assessment parameters are used: the LOLP and the EENS [21, 27, 28].

LOLP

The electrical system unreliability is its inability to meet the peak load. A loss of load occurs whenever the system generating capacity is failed to satisfy the system load demand. The probability that a power shortage may occur is called LOLP. Note that the reserve power is usually established to avoid this risk. Therefore, the outage (load demand is greater than the operating power and the power reserve) contributes to the overall risk. According to [29], the year 1947 is considered as the starting point of probabilistic technique applications for the generating capacity reliability assessment in electrical power systems. Then probabilistic methods gradually play an important role in the reserve power capacity determination. The current acceptable service reliability standard in power system is 0.1 days during one year, or one day each 10 years [2].

In the studied microgrid, the uncertainties are supposed to come from the PV power forecasting errors and the load forecasting errors. Therefore, only these uncertainties are taken into consideration. Consequently, the LOLP is defined as the probability that the load demand exceeds the PV power at time step t :

$$LOLP^t = \text{prob}(L^t - PV^t > 0) = \int_R^{+\infty} pdf(\tau) d\tau \quad (\text{III-12})$$

PV^t and L^t are respectively the total available PV power and the load demand during the time step t , $\text{prob}(L^t - PV^t > 0)$ is the probability that the reserve power (R) is insufficient to satisfy the load demand during the time step t .

EENS

Meanwhile, the EENS measures the magnitude of the not served load demand:

$$EENS^t = \text{prob}(L^t - PV^t > 0) \times (L^t - PV^t) \quad (\text{III-13})$$

where $(L^t - PV^t)$ is the missed power during the time step t . In this situation, the grid operator can either disconnect a part of controllable loads or use the reserve power to increase the power production.

From the obtained pdf_s (probability distribution function) of the ND forecast errors, reliability index based reserve assessment for each time step and for the next day can be calculated. In addition, the electrical system operators can use this reliability index to assess the system security level.

III.7. Risk-constrained OR Quantification for Each Interval

According to the probability distribution of the difference between generation and load, the analysis can be done with a series of risk indices. For a certain amount of OR, ND forecasting uncertainty pdf can be used to calculate the probability that power generation cannot cover the load demand. As a result, the risk curves with different quantities of OR can be obtained.

By setting a risk/reserve characteristic curve, the operator can easily quantify the OR [19]. It is applied to compensate the remaining power unbalance. So, reliability assessment can be done with the cumulative distribution function (cdf) obtained from the normal difference distribution of the ND forecasting errors in each time step.

This assessment has been made under the assumption that the forecasted ND is positive in that time step. Otherwise, if the forecasted ND is negative (the power generation is more than the load demand), the power reserve for the same reliability level will be unnecessary. Therefore, the reliability has been assessed by considering only the positive forecasted ND errors $(L^t - P^t)$ for each time step. Then the LOLP is deduced with:

$$LOLP^t = 1 - prob(L^t - PV^t < 0) = 1 - \int_{-\infty}^R pdf(\tau) d\tau \quad (III-14)$$

where R is the required OR when the LOLP is equal to the wanted risk index ($x\%$). This reserve is used to cover the remaining probability that load exceeds PV power generation.

Figure III-15 illustrates the probability distribution of the ND forecasting errors. The left part (in grey) corresponds to the PV power generation excess. Without taking into account the reserve power, the right part (rather than grey) represents the power deficit corresponding to an over load demand. To increase the power system security, the reserve power (blue part) is planned according to the preset reliability index with $x\%$ of LOLP (red shaded area, which represents the accepted violation risk).

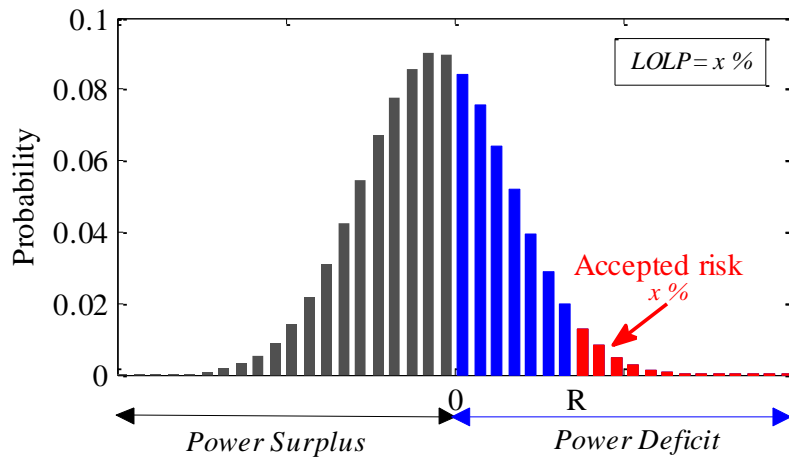

Figure III-15 Calculation of power reserve requirements based on the forecast ND uncertainty $(\varepsilon_{ND,F}^t)$ with $x\%$ of LOLP at time step t .

The cdf_s of PV power forecasting errors, load forecasting errors and ND forecasting errors have been considered for each time step with data from the test set (Figure III-16). Then, the risk/reserve criterion is applied to all ND uncertainty errors.

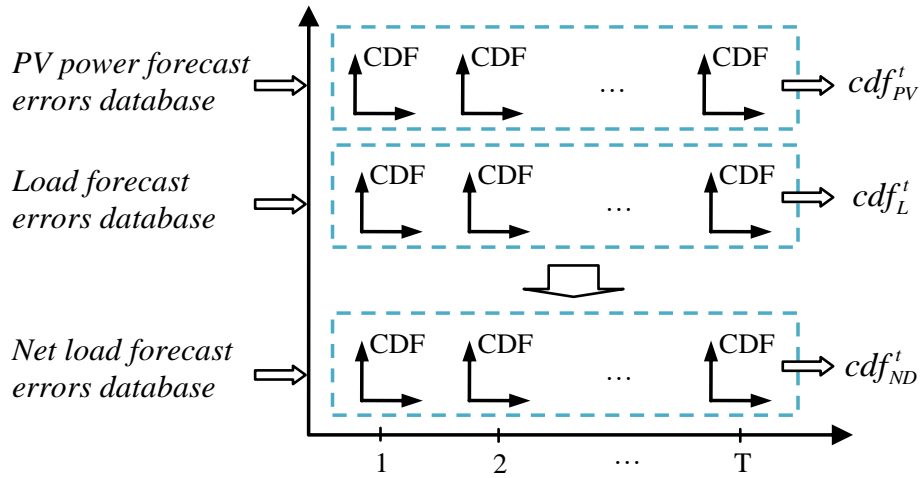

Figure III-16 Created (PV power, load, and ND forecasting errors) cdf_s at each time step.

Figure III-17 shows the normal pdf and normal cdf of the ND forecasting uncertainty at 12:00 (with the second method). The obtained cumulative probability with a null OR is $\int_{-\infty}^0 pdf(\tau)d\tau = 0.42$. As negative errors correspond to an excess produced power, the probability to have more load than produced power (LOLP) is $(1-42\%) = 58\%$ (Figure III-17).

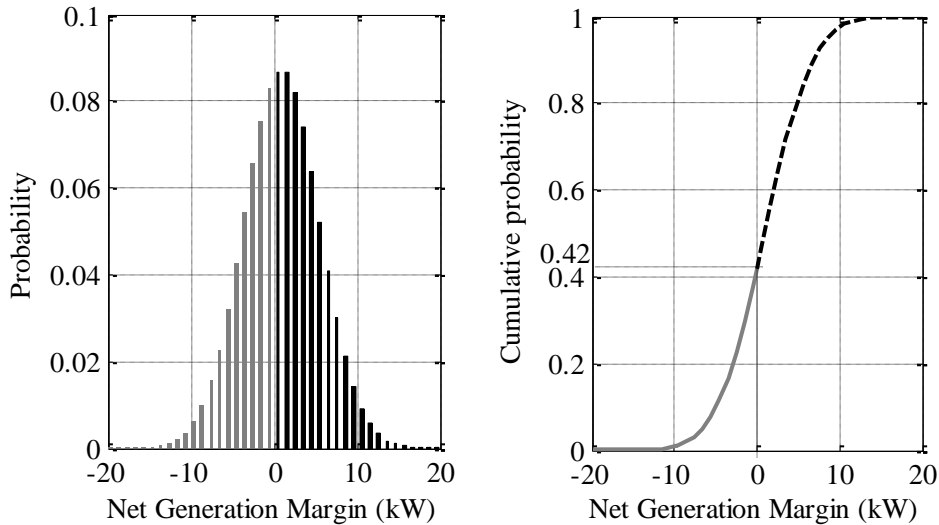

Figure III-17 Normal pdf and normal cdf of the forecasted ND at 12:00.

Since the ND forecasting errors can be expressed as an $x\%$ of the rated power, the OR can be calculated according to the LOLP. Then the EENS can be drawn with the LOLP and power deficit for different security level. Figure III-18 shows the variation relationship between LOLP and required OR and between EENS and required OR, which ranges from 0 to 15 kW. With a low LOLP, which means a high security level, the reserve power is much more than situations with a high LOLP, which represents a bigger risk. As it can be seen, 7 kW OR will be needed in order to get a security level with 10% of LOLP. In this circumstance, EENS will be 0.2 kW.

Therefore, an OR with $x\%$ of LOLP would be applied to cover the ND forecast uncertainty. In practice, this power reserve is limited not only by the risk indices but also by the availability of power reserve provided by other controllable generators, as MGTs. In Figure

III-19, an assessment of hourly OR required with the second method for different LOLP has been deduced. As it can be seen, much more power reserve will be needed when the LOLP rate is very low to get a high security level. For example with 1% of LOLP, the necessary power reserve will be 14 kW (EENS is almost zero) at 12:00, while the necessary power reserve will be 7 kW with a 10 % of LOLP and EENS increases to 0.25 kWh.

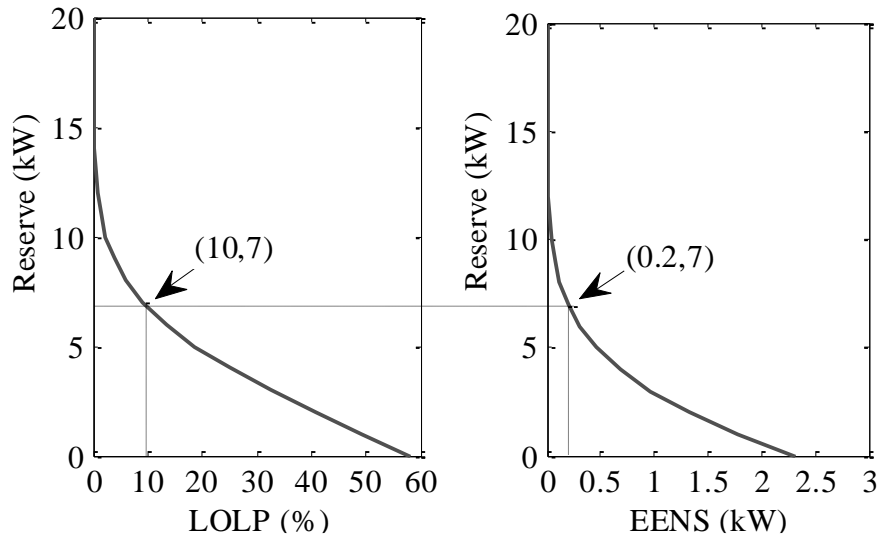

Figure III-18 Risk/reserve curve for $LOLP^{t+12}$ and $EENS^{t+12}$ at 12:00.

If a constant LOLP rate is set, the OR for each hour can be obtained. As shown in Figure III-20, at 1% of LOLP, more OR is needed in the middle of the day when larger PV power is generated. Moreover, the OR with the second method is higher than the method with a direct ND forecast. The most likely explanation of this result is because the second method has more forecasting procedure than the first method. In the first method, the ND forecast uncertainty is obtained from the ND error forecast, while in the second method it comes from the combination of the load forecast uncertainty and the PV forecast uncertainty. As it can be seen, integrated PV power and load uncertainties with the second method is greater than the direct ND forecasting uncertainty with the first method.

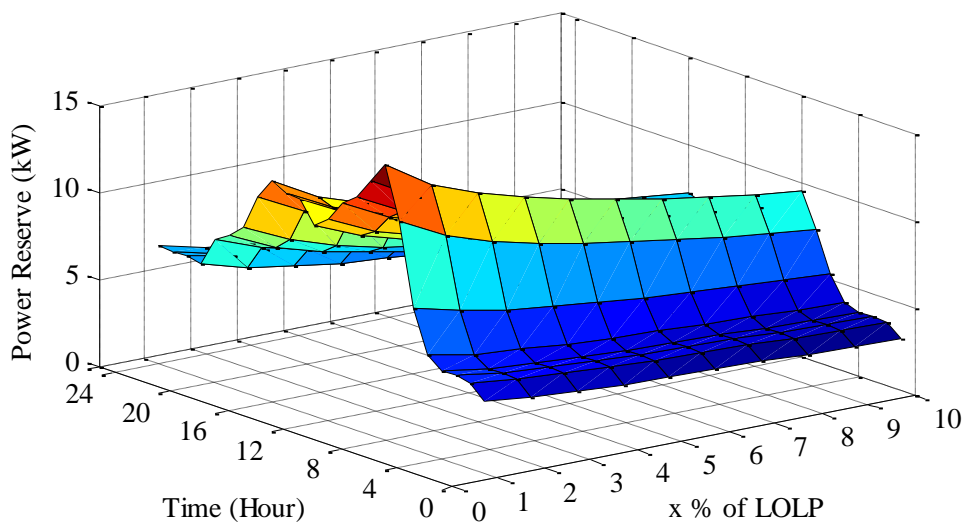

Figure III-19. Required power reserve for each hour with x% LOLP.

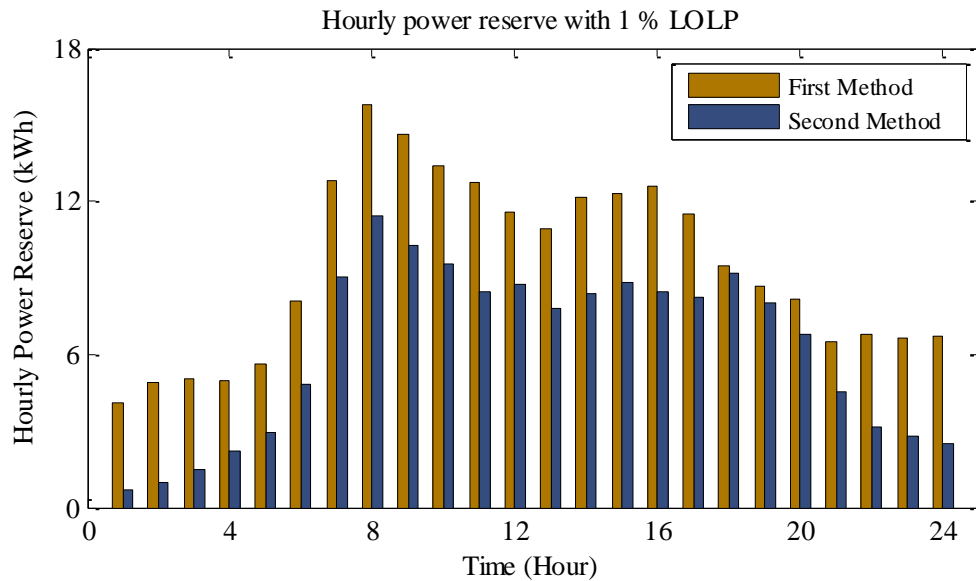

Figure III-20. Hourly power reserve with two different methods.

III.8. Conclusion

Current electrical systems cannot fully integrate the electricity produced by RES because of their non-dispatchable features (intermittent character, low inertia, and limited generation units availability). This limitation decreases their benefits for the society via energy diversity, fossil fuels reduction, and CO₂ emission elimination. Historical data and its analysis are needed to understand the uncertainty and to help operators and planners to avoid unnecessary reserve.

Historically, the reserve capacity has been set by using various deterministic criteria, such as a fraction of the expected load demand, the largest power generation unit or a line contingency during the dispatch period, or various combinations. Deterministic methods are easy to implement, however, it does not match the stochastic nature of the OR quantification problem. Decisions made under uncertainty must be informed by probabilistic information in order to correctly quantify the risk the decision maker is exposed. Therefore, probabilistic techniques have been proposed here to set the OR with a probabilistic risk index.

This work proposed a new technique to quantify the OR of a microgrid by taking into account the PV power forecasting uncertainty and the load forecasting uncertainty. Following the ANN based PV power and load forecasting, two methods are proposed to obtain the ND forecasting uncertainty. Uncertainties in load and generation forecasts are treated independently and then a probabilistic model is proposed to ND forecasting uncertainty distribution by integrating the uncertainties from both PV power and load. The other method consists on directly forecasting the ND errors and so may consider they are not independent as for example in countries where the weather is influent on both quantities. OR quantification results demonstrate that with a fixed risk index, the OR for next day or next few hours can be precisely evaluated.

The planning of the OR depends also on the start-up time and ramp rate of power plant. A detailed analysis of different typical power generators can be found in [2]. Such as for gas turbine, the general time to reach the full power output is about 7 minutes and the ramp is 32 MW/min (for a 160 MW gas engine). Obviously, a fast-starting or a flexible power plant can deliver more OR. OR planning strategies will be discussed in detail in Chapter IV.

References

- [1] R. Allan and R. Billinton, "Tutorial. Power system reliability and its assessment. Part 1: Background and generating capacity," *Power Engineering Journal*, vol. 6, pp. 191-196, 1992.
- [2] A. Vuorinen, *Planning of optimal power systems*: Ekoenergo Oy Espoo, Finland, 2009, ISBN: 9526705718.
- [3] L. E. Jones, *Renewable energy integration: practical management of variability, uncertainty, and flexibility in power grids*: Academic Press, 2014.
- [4] W. Li, *Probabilistic transmission system planning*, Book, John Wiley & Sons, 2011.
- [5] J. F. Prada, "The value of reliability in power systems-pricing operating reserves," Energy Laboratory Report, Massachusetts Institute of Technology, 1999, url: <http://web.mit.edu/energylab/www/pubs/el99-005wp.pdf>
- [6] J. Skea, D. Anderson, T. Green, R. Gross, P. Heptonstall, and M. Leach, "Intermittent renewable generation and maintaining power system reliability," *Generation, Transmission & Distribution, IET*, vol. 2, pp. 82-89, 2008.
- [7] P. H. Yau, "Generation System Reliability Evaluations with Intermittent Renewables," *Master thesis, University of Strathclyde*, 2006.
- [8] M. Dubitsky and A. Rykova, "*Classification of Power Reserves of Electric Power Systems.pdf*," 2015, URL: http://gnedenko-forum.org/Journal/2015/012015/RTA_1_2015-06.pdf.
- [9] M. Milligan, P. Donohoo, D. Lew, E. Ela, B. Kirby, H. Holttinen, *et al.*, "Operating reserves and wind power integration: an international comparison," in *proc. 9th International Workshop on large-scale integration of wind power into power systems*, 2010, pp. 18-29.
- [10] Y. Rebours and D. Kirschen, "What is spinning reserve," *The University of Manchester*, pp. 1-11, 2005.
- [11] E. Ela, M. Milligan, and B. Kirby, "Operating reserves and variable generation," *Contract*, vol. 303, pp. 275-3000, 2011.
- [12] A. J. Wood and B. F. Wollenberg, *Power generation, operation, and control*: John Wiley & Sons, 2012.
- [13] R. Allan, *Reliability evaluation of power systems*: Springer Science & Business Media, 2013.
- [14] D. Chattopadhyay and R. Baldick, "Unit commitment with probabilistic reserve," in *Power Engineering Society Winter Meeting, 2002. IEEE*, 2002, pp. 280-285.
- [15] J. C. Smith, M. R. Milligan, E. A. DeMeo, and B. Parsons, "Utility wind integration and operating impact state of the art," *Power Systems, IEEE Transactions on*, vol. 22, pp. 900-908, 2007.
- [16] E. Ela, B. Kirby, E. Lannoye, M. Milligan, D. Flynn, B. Zavadil, *et al.*, "Evolution of operating reserve determination in wind power integration studies," in *Power and Energy Society General Meeting, 2010 IEEE*, 2010, pp. 1-8.
- [17] M. A. Ortega-Vazquez and D. S. Kirschen, "Estimating the spinning reserve requirements in systems with significant wind power generation penetration," *Power Systems, IEEE Transactions on*, vol. 24, pp. 114-124, 2009.
- [18] B. Kirby, E. Ela, and M. Milligan, "Analyzing the Impact of Variable Energy Resources on Power System Reserves," No. NREL/CH-5D00-65372, National Renewable Energy Laboratory (NREL) 2014.

- [19] M. A. Matos and R. J. Bessa, "Setting the operating reserve using probabilistic wind power forecasts," *Power Systems, IEEE Transactions on*, vol. 26, pp. 594-603, 2011.
- [20] S. Khan, W. Gawlik, and P. Palensky, "Reserve Capability Assessment Considering Correlated Uncertainty in Microgrid," *IEEE Transactions on Sustainable Energy*, vol. 7, pp. 637 - 646, 2016.
- [21] G. Liu and K. Tomsovic, "Quantifying spinning reserve in systems with significant wind power penetration," *Power Systems, IEEE Transactions on*, vol. 27, pp. 2385-2393, 2012.
- [22] F. Bouffard and F. D. Galiana, "Stochastic security for operations planning with significant wind power generation," in *Power and Energy Society General Meeting- Conversion and Delivery of Electrical Energy in the 21st Century, 2008 IEEE*, 2008, pp. 1-11.
- [23] G. Delille, B. François, and G. Malarange, "Dynamic frequency control support by energy storage to reduce the impact of wind and solar generation on isolated power system's inertia," *IEEE Transactions on Sustainable Energy* vol. 3, pp. 931-939, 2012.
- [24] F. Katiraei and J. R. Aguero, "Solar PV integration challenges," *Power and Energy Magazine, IEEE*, vol. 9, pp. 62-71, 2011.
- [25] H. Holttinen, M. Milligan, E. Ela, N. Menemenlis, J. Dobschinski, B. Rawn, *et al.*, "Methodologies to determine operating reserves due to increased wind power," in *Power and Energy Society General Meeting (PES), IEEE*, 2013, pp. 1-10.
- [26] A. Arabali, M. Ghofrani, M. Etezadi-Amoli, and M. S. Fadali, "Stochastic performance assessment and sizing for a hybrid power system of solar/wind/energy storage," *IEEE Transactions on Sustainable Energy*, 5.2 (2014), pp. 363-371, 2014.
- [27] Y.-F. Li and E. Zio, "A multi-state model for the reliability assessment of a distributed generation system via universal generating function," *Reliability Engineering & System Safety*, vol. 106, pp. 28-36, 2012.
- [28] M. Wang and H. Gooi, "Spinning reserve estimation in microgrids," *Power Systems, IEEE Transactions on*, vol. 26, pp. 1164-1174, 2011.
- [29] R. Billinton and K. Chu, "Early Evolution of LOLP: Evaluating Generating Capacity Requirements [History]," *Power and Energy Magazine, IEEE*, vol. 13, pp. 88-98, 2015.
- [30] Vandoorn, Tine L., Juan C. Vasquez, Jeroen De Kooning, Josep M. Guerrero, and Lieven Vandevelde, "Microgrids: Hierarchical control and an overview of the control and reserve management strategies". *IEEE industrial electronics magazine*, 7(4), pp.42-55, 2013.
- [31] Pinson, Pierre. "*Estimation of the uncertainty in wind power forecasting*", Doctoral dissertation, École Nationale Supérieure des Mines de Paris, 2006.
- [32] ANEMOS.plus Project: "*Advanced Tools for the Management of Electricity Grids with Large-Scale Wind Generation*", Project period: 1.1.2008-30.6.2011, URL: http://www.anemos-plus.eu/index.php?option=com_content&view=frontpage&Itemid=1.
- [31] H. Bevrani, H. Takashi. "*Intelligent automatic generation control*," New York: CRC press, 2011.
- [34] H. Bevrani. "*Robust power system frequency control*," Springer, 2nd Ed, ISBN: 978-3-319-07277-7, 2014.

Chapter IV

*Day-ahead Optimal OR Dispatching and
Energy Management of a Microgrid System
with Active PV Generators*

Chapter.IV Day-ahead Optimal OR Dispatching and Energy Management of a Microgrid System with Active PV Generators

IV.1. Introduction

All electricity supply systems require mechanisms to ensure ancillary services (AS) provision with an adequate amount, in order to accomplish the desired security and reliability level. In electrical power systems, OR plays an important role to maintain acceptable security and reliability level because it enables the balancing of the power supply and load demand instantaneously in case of a missed power. Scheduling sufficient reserve capacity can help to overcome unscheduled power deficit in electrical power systems due to major forecasting errors and various outages (generators, lines, ...) [1]. OR power is needed to satisfy the reliability and security with a minimum cost and to fulfill security constraints.

With a great amount of variable RES integration into power systems, uncertainty from this forecasted production (chapter II) is growing. In the chapter III, based on the ND forecasting errors, the OR power has been quantified with a stochastic approach in different ways to meet an acceptable system security level.

In this chapter, different methods are proposed to optimal dispatch the required system OR into the different power generators without losing the electrical system security level.

Classically, today, OR are provided by fuel based generators. However, for a scenario with a penetration rate of 100 % renewable energy, it is not realist to consider only these types of generators for the OR provision. Hence new assets must be considered to provide the OR. In this chapter, distributed batteries, which are embedded into PV AG, are considered to also provide OR. New OR dispatching strategies over all local generators are then proposed in order to take into account the local uncertainty resulting of the local electricity production. A microgrid corresponding to a residential power network is considered to apply OR dispatching strategies, one day ahead, to capture load and generation forecast uncertainty.

Moreover, additional constraints from storage units and also new objectives as environmental criteria must be taken into account in future day-ahead operational planning strategies of all generators. As example, city authorities may aim to reduce local CO₂ emissions by reconsidering the use of fuel based DG for power balancing and regulation. So an optimal planning of both electrical production and OR is required to ensure that both electricity generation markets and AS market can be optimized at the same time. This new Unit Commitment is a way leading to a significant RES penetration percentage.

The problem here is to manage the uncertainties from RES without losing the system security level.

In the next part of this chapter, a state of the art on power reserve dispatching is first presented. Then in the third part, a scheme for the day ahead dispatching of the OR and the unit commitment of conventional generators is proposed to take into account the participation of PV based AG in a studied microgrid. Their OR power is provided by their batteries. In this proposed electrical system organization, the energy storage devices are used to help RES integration by providing the OR.

Since both PV AGs and MGTs are power generation sources, two different strategies are proposed in the fourth part and are based on different OR dispatching: the first one allocates the OR into MGTs only, while the other one simultaneously distributes the demand and the

OR into MGTs and PV AGs. The later strategy would use RES to provide the power reserve to get the same security level of the electrical system thanks to distributed batteries.

The remaining energy and OR are provided by a set of conventional generators that are then planned in order to decrease an objective function in the fifth part.

Application and results are presented in part sixth.

The sensibility of this method regarding the penetration ratio in PV and also the sizing of batteries is then analyzed in the last part of this chapter.

IV.2. State of the Art on Power Reserve Dispatching

In a traditional electricity market, the energy and the required power reserve are allocated separately. In [2], the design of an auction for AS (OR and automatic generation control) is discussed, as well as the real-time dispatching of those AS. In the paper, the reserve capacity is scheduled in advance. Then, the incremental energy is dispatched in response to a real-time imbalance. Different energy and AS dispatching methods (such as a merit order based dispatching, sequential dispatching, and joint dispatching) under deterministic criteria have been summarized and evaluated with details in [3].

In traditional vertically integrated electricity markets, the reserve power is dispatched after performing the energy dispatch. However, in competitive markets, operational and reserve capacity are dispatched simultaneously to maximize system efficiency and reliability [4]. In [5], a flexible joint reserve and energy dispatch approach is proposed. The contingency reserve capacity, which is considered as an important AS, is computed in advance. The method provides an effective reserve allocation and a pricing methodology taking in consideration many constraints, such as power balance, generation and reserve capacity limits, ramp-up/down limits, and reserve-energy coupling constraints. Paper [6] presents a cost-effective dispatching of emergency reserves (made up of a contracted additional reserve, which is provided by gas turbines, interruptible loads, and emergency generation) with a specific focus on supply and demand side options. Furthermore, paper [7] presents a spinning reserve allocation method by considering ramp-rate constraints. The impacts of these constraints on a strategy associated with clearing prices are investigated. The proposed dispatch method uses Memetic algorithm to determine the optimal reserve and energy allocation with a minimum cost. However, transmission constraints are not considered in the paper. In addition, a method for solving the problem of joint dispatch of energy and spinning reserve is introduced in [8]. The proposed method aims for the minimization of joint energy production and reserve procurement costs by considering transmission constraints as the most important constraint.

A recurrent differential evolution technique for dynamic joint operating and reserve power dispatch is developed in [9]. Different constraints have been considered: reserve requirements, ramp-rate limits and tie-line constraints. The proposed method uses both static and dynamic ways for instantaneous power dispatch in order to minimize the total cost with a given reserve capacity. Moreover, authors in [10] have developed a constrained particle swarm optimization method for generation and reserve joint dispatch in an electricity market. It provides an optimized solution for total cost reduction in multi-area electricity market. The accuracy and the effectiveness of the suggested method are verified in three different case study systems. In [11], the spinning reserve is allocated in a time step with sectional price offer curves while taking into consideration all constraints and security level in power system. To implement the optimization, a '*differential evolution algorithm*' is presented. This optimization method has several advantages, such as having a fast convergence rate, using less control parameters, and discovering the global minimum value without considering the initial factor values. The

suggested method was applied to integrate the electrical market with different block prices of energy and by considering reserve power. However, in [12], instead of considering AS as one of the system constraints, it is calculated according to system needs in order to minimize the operating cost and preserve transmission security limitations. The proposed dispatch method computes the reserve requirement according to system contingency analyses without any pre-specified reserve quantification. However, these promising works are focusing on the electrical grid, and not on microgrids.

In [13], a multi-agent simulator is developed for a competitive power market to simulate different models of AS. In the paper, models are divided into two categories: AS and energy allocation instantaneously or separately. Besides, optimization objective functions for dispatch models are classified as minimizing the payment and minimizing the total cost. Some optimization objective functions are applied in [14], which focus on the instantaneous energy and reserve power dispatch in an integrated electricity market. Considered physical and security constraints are transmission line limits, generator ramping rate of generator, and bus-line voltage limits. While in [15], the authors pay attention to distributed generation operation and planning. A Virtual Power Player is proposed for a jointed dispatch of distributed generation and load demand response to minimize operation costs. Interests of the proposed approach are: (1) taking into account the variability of distributed resources; (2) participating in reserve-oriented markets, for example, AS market. The proposed method provides both reserve power and energy to a distribution network while maintaining grid reliability and efficiency. The method has been tested in a 32 bus lines distribution network. Results conclude that variable parameters (required reserve power and supplier price) play important and direct roles in system operation cost.

To summarize these inspiring previous studies, research works have been done on operating and reserve power allocation (both simultaneously and separately) in electricity market. Nevertheless, the studies focus more on the electricity market connected to the main grid, rather than isolated distributed microgrid. Microgrids are small electrical distribution systems that use the small-scale power generation units and storages located close to the loads. Then, efficient and new technologies for power and reserve dispatching are needed to help system operators to lower system operation costs, improve reliability, reduce emissions, and expand energy options.

New flexibilities exist to provide operating reserve as controllable loads, storage systems, active distributed generators, ... In our presented work, we consider the distributed storage systems and we integrate them with PV generators to create a PV AG (chapter I, part I.6.2).

Then the reserve power has to be also dispatched into these new flexibilities, and research studies are even rarer. However, the largest challenge in power system planning is to combine AS and RES generation in an optimal manner to ensure system reliability. As mentioned in [16], at a local level, impacts of RES power generation on power system are power quality (less than minute) and distribution efficiency (1-24 hours). In the following part, we present various strategies to dispatch the OR while maximizing the use of renewable energy.

IV.3. Day-ahead Optimal Dispatching of the Reserve Power

IV.3.1. Introduction

As electricity industry moves to new restructured forms with renewable energy distributed generators in local electrical networks, the local energy management of these networks must be adapted or imagined. The objective is to satisfy the local load demand with local renewable resources local OR. The general problem of a local Energy Management System can be: how

to plan local controllable generators to achieve a local energy balancing and dispatch the total OR on them?

To solve this problem, a general case study is considered and consists in designing the one day-ahead energy management of a microgrid. It is powered by controllable generators: N active PV generators and M MGTs. This type of generators is very interesting as they can produce both electricity and heat that can be stored in a hot water tank. As explained in the previous chapter, load demand, PV production, and OR are forecasted one day ahead. As PV energy is considered as the prior energy source, MGTs are used to cover the power deficit. So power references of PV AG must be planned before MGT as shown in Figure IV-1.

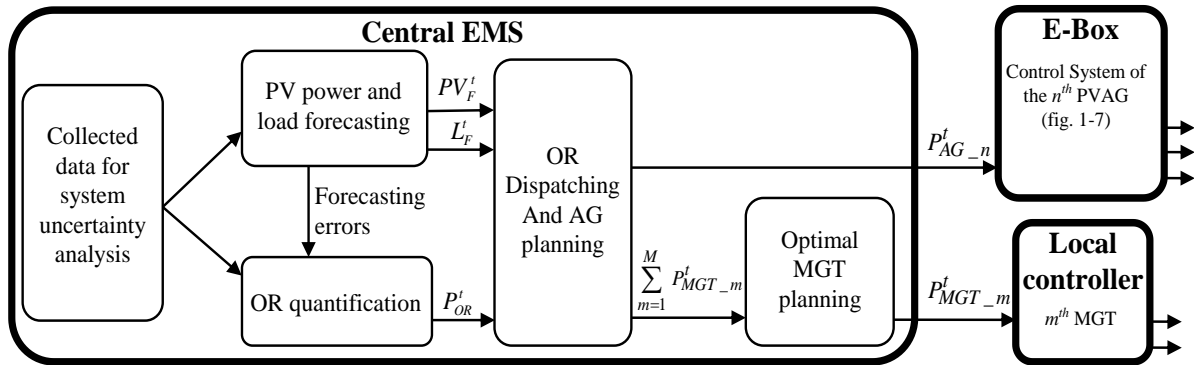

Figure IV-1 The flowchart of the energy management.

Remaining constraints about local energy balancing and OR must be provided by MGTs that have to be planned. As a park of MGTs is available, an optimal use must be adopted. This problem is known as a unit commitment (UC) problem. In our work, objective functions of the UC problem consist on minimizing equivalent CO₂ emissions and total fuel costs. Figure IV-2 shows the general scheme of day-ahead optimal operational planning.

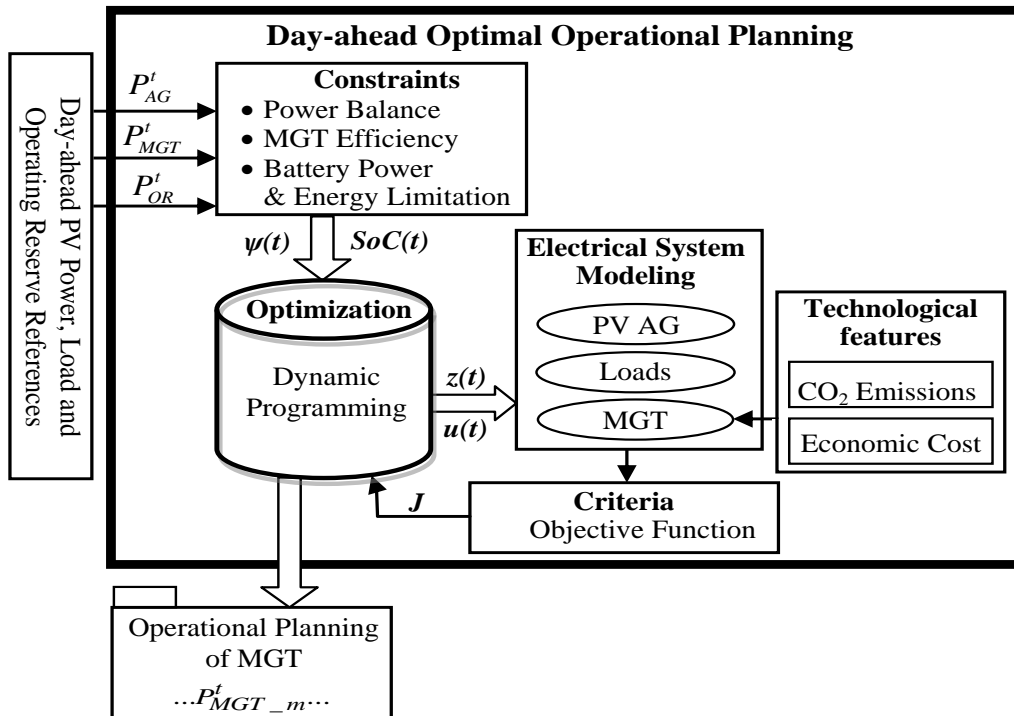

Figure IV-2 Day-ahead optimal operational planning scheme.

It aims to minimize objective functions with different optimization criteria, while satisfying all system constraints and providing the OR.

In the next part, the non-linear constraints are detailed. Then, UC problem with different objective functions for different optimization criteria (economic criteria, environmental criteria, and best compromise criteria) are presented in details. To minimize the objective functions, the dynamic programming (DP) technique is applied.

IV.3.2. Procedures and Problems under Certain Non-linear Constraints

In the presence of N active generators and M MGTs in a microgrid, an equality constraint for PV AG (P_{AG}), MGT generation (P_{MGT}), reserve power (P_{OR}), and load (L_F) represents the balancing between production and consumption. Restriction limits of the output related to each unit are as follows:

- 1) OR power (P_{OR}^t) is calculated with a certain security level ($x\%$ of LOLP) for each time step t ;
- 2) Power balancing among load demand, OR, and power generation. The total power generation must be equal to the total system demand plus the required reserve power:

$$\psi(t) = L_F^t + P_{OR}^t - \sum_{n=1}^N P_{AG_n}^t - \sum_{m=1}^M P_{MGT_m}^t = 0 \quad (IV-1)$$

- 3) MGT corresponding inequality constraint: By considering the efficient characteristics of MGT, each of them has to operate at a limited range to increase the efficiency (efficiency characteristics of different MGTs can be found in Appendix III).

$$50\% P_{MGT_m}^{\max} \leq P_{MGT_m}^t \leq 100\% P_{MGT_m}^{\max} \quad (IV-2)$$

- 4) Battery limitations
 - Batteries SoC have to be kept in a safety range: $SoC_i^{\min} \leq SoC_i \leq SoC_i^{\max}$.
 - During the operation period, batteries charge and discharge power cannot exceed the power limitations: $|P_{Bat_i}^t| \leq P_{Bat_i}^{\max}$.
 - If batteries reach their maximum capacity, PV power inverters must not work at their maximum power points (degradation mode).
- 5) Day-ahead power references of PV AG, MGT and OR for EMS. For each time step, the OR reference (P_{OR}^t) is calculated (see Chapter III), while the PV AG (P_{AG}^t) and MGT (P_{MGT}^t) reference calculation are detailed in the following parts.

IV.4. OR Dispatching Strategies Considering the Maximization of RES Usage

IV.4.1 Uncertainty Analysis According to PV Power Production

In the microgrid introduced in chapter I, PV AGs are managed as prior sources because of their low operating cost and absence of gas emissions. MGTs are set as backup sources for the missing energy. The batteries (included in the PV AG) must be managed to reduce PV AGs uncertainty:

- During time steps in the night, PV power production is surely unavailable, but the PV AG can produce if batteries are charged.
- During time steps in the day, if the PV forecasted power is superior to the load demand, hence, the exceeding power can be stored in batteries (until the batteries are fully charged). Otherwise, the deficit power will be provided by MGTs.

Thus, the OR dispatching procedure must be organized according to the battery energy sizing and calculated according to their SoC. If the daily forecasted PV energy is smaller than the battery sizing (scenario L), all PV power generation can be stored into the battery during the daytime. In this situation, there will be no uncertainty coming from the PV power forecasting during the day. So the required OR will be calculated only with the load uncertainty. While if the daily forecasted PV energy is larger than the battery energy sizing (scenario H), the OR must cover both PV power and load forecast uncertainties.

So two scenarios are considered:

- Scenario H:** daily forecasted PV energy is much more than the maximum battery capacity;
- Scenario L:** daily forecasted PV energy is less than the maximum battery capacity.

As it can be seen in Figure IV-3, the load uncertainty is smaller than the uncertainty coming from both load and PV production. Therefore, with the same committed security level, the calculated OR will be smaller in scenario L.

Regardless of those two situations, two different OR allocation strategies are proposed: into the MGTs or into MGTs and PV AGs. Traditionally, conventional power plants, such as MGTs, are used to provide the reserve power because they can produce a programmed power output, while PV power is considered as a non-dispatchable intermittent power. Since the integration percentage of PV power generation is increasing to a high level, it is necessary for PV generators to provide much more AS, such as OR provision. OR provision can be implemented by managing a distributed storage system within PV generators in order to create a PV AG (PV panels plus energy storage devices (Chapter I, part I.6)).

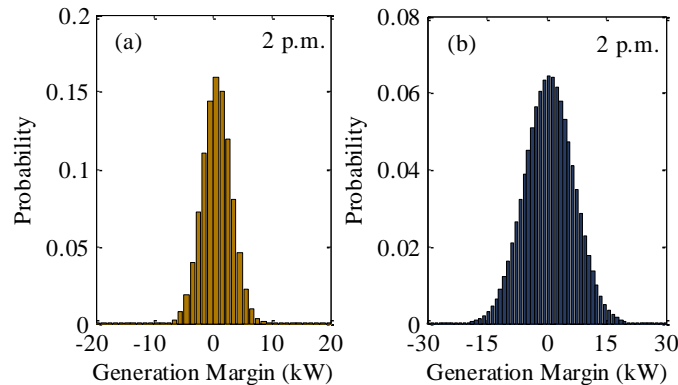

Figure IV-3 Probability distribution of ND uncertainty at 2 p.m.: (a) with only load uncertainty; (b) with both PV power uncertainty and load uncertainty.

As no power output is available from PV panels during the night, power references are calculated separately for the night and for the daytime. In certain time steps when the PV AG power (PV power during the day and battery power during the night) is more than the load demand added with OR power, only PV AG is used to provide the load demand and OR power, while all the MGTs will be shut down. During these time steps, there will be no fossil fuel cost and no air pollutant emissions. The detailed explanation is discussed below.

IV.4.2 Scenario H

IV.4.2.1. First strategy: OR provision by MGTs only

A. Operation during the day

In this strategy, the entire OR power for the electrical system is provided by MGTs, so at least one of them needs to work during all the time, while all the PV AGs power is only used to

supply the forecasted load demand. For the load supply, PV AG is considered as a prior source and must balance the load if it is possible. In each time step of the day, two cases may appear:

- a) If the predicted PV power is more than the predicted load demand at time step t ($PV_F^t \geq L_F^t$), then the PV AG power reference is set equal to the forecasted load demand. Since all PV panels are in the same location in the microgrid and they share the same environmental situation, this total power is dispatched to the N PV AGs according to their rated power ($P_{AG_rated_n}^t$):

$$P_{AG_n}^t = L_F^t \cdot \frac{P_{AG_rated_n}^t}{\sum_{n=1}^N P_{AG_rated_n}^t} \quad (IV-3)$$

While all the PV powers are used to feed the load demand, the extra remaining PV energy will be stored into the batteries for night use. The PV energy surplus is automatically stored into batteries, which are controlled by the local EMS of the PV AG [22]. So, the battery SoC must be checked to establish if they are available for loading the exceeding PV power (or to provide the missing PV power during the night). Batteries state of charge (SoC) is calculated by E-boxes (in PV AGs):

$$\sum_{n=1}^N E_{Bat}^{t+1} = \sum_{n=1}^N E_{Bat}^t + \tau \times (PV_F^t - L_F^t) \quad (IV-4)$$

The parameter τ is the duration of the available constant power (30 minutes for our study).

With the first strategy, the OR is only covered by MGTs ($P_{MGT}^t = P_{OR}^t$). For this operating mode, since the available PV power is higher than the load demand and the exceeding PV power is stored, the MGTs just provide the OR, which is coming only from the load uncertainty (case 1.1 in Figure IV-4). Consequently, at least one of them works all the time. In this scenario, if the power reference of MGT is less than the MGT minimum power output ($P_{MGT}^t < \min(P_{MGT_i}^t)$), the MGT must operate at the minimum point (with a low efficiency (Appendix III)). Hence, in fact, the power reserve will be more than needed and is scheduled to be: ($P_{MGT_rated_i} - \min(P_{MGT_i}^t) > P_{OR}^t$).

- b) If the predicted PV power is not enough for the predicted load at time step t ($PV_F^t < L_F^t$), during the day, the power references of PV AGs are set to the predicted values, which are obtained from a scaling of the full predicted PV power:

$$P_{AG_n}^t = PV_F^t \cdot \frac{P_{AG_rated_n}^t}{\sum_{n=1}^N P_{AG_rated_n}^t} \quad (IV-5)$$

Then, the uncertainty coming from the bad PV forecast is locally managed by batteries that produce or store the power in case of, respectively negative and positive forecast errors during this time step. Hence, the reference power of the PV AG will be equal to the day ahead forecasted PV power. The deficit power will be provided by MGTs. MGTs will provide deficit power in addition to OR, which is required by only the load demand uncertainty (case 2.1 in Figure IV-4):

$$\sum_{i=1}^M P_{MGT_m}^t = L_F^t - PV_F^t + P_{OR}^t \quad (IV-6)$$

B. Operation during the night

Since the extra PV energy is stored in the battery bank, stored energy will be used during the night and the decisions are made according to batteries SoC and energy demand.

- a) If batteries SoCs are enough to feed the predicted load demand, then MGTs are just working to provide the OR ($P_{MGT}^t = P_{OR}^t$), required by the load demand uncertainty (case 3.1 in Figure IV-4). At each time step, the SoC is updated with the equation IV-2 ($PV_F^t = 0$). The reference power of PV AGs equals the batteries SoC.
- b) Otherwise, MGTs must balance the remaining load demand and provide the OR, which is required by the load demand uncertainty (equation (IV-4) with $P_{PV}^t=0$) and we have a full MGTs mode (case 4 in Figure IV-4). In this situation, the reference power of PV AGs is 0.

IV.4.2.2. Second Strategy: OR provision by MGTs and PV AGs.

A. Operation during the day

With this strategy, the OR will be distributed into both MGTs and PV AGs. Then the test on PV AGs power capability must be revised by considering OR power.

- a) If the predicted PV power exceeds the predicted load demand and the necessary OR at time step t ($PV_F^t \geq L_F^t + P_{OR}^t$), then the power reference is set to the limited total demand (case 1.2 in Figure IV-4):

$$P_{AG_n}^t = (L_F^t + P_{OR}^t) \frac{P_{AG_rated_n}^t}{\sum_{n=1}^N P_{AG_rated_n}^t} \quad (IV-7)$$

All MGTs will be shut down and an autonomous PV supply is then implemented. In this situation, the load and the OR are seen as the total load (case 1.2 in Figure IV-4). The energy surplus is automatically stored in batteries by the local EMS controller for night use:

$$\sum_{n=1}^N E_{Bat}^{t+1} = \sum_{n=1}^N E_{Bat}^t + \tau \times (PV_F^t - (L_F^t + P_{OR}^t)) \quad (IV-8)$$

- b) If the predicted PV power is not enough for the predicted load demand and OR ($PV_F^t < L_F^t + P_{OR}^t$), then the MGTs will be used to cover the remaining load and OR. Then, the PV AGs are set to the forecasted values (case 2.2 in Figure IV-4). The uncertainties are arising from both load and PV power predictions. They are treated as a part of the system load. The OR (treated as a part of the system load) is dispatched proportionally to generator power ratings: in PV AGs and MGTs.

B. Operation during the night

Since the extra PV energy is stored in batteries, the stored energy will be used during the night and the decisions are made according to batteries SoC and energy demand.

- a) If the stored energy is enough to feed the predicted load and the OR, which is required by the load demand uncertainty, then MGTs are switched off and batteries power references are set to satisfy the total load demand (case 3.2 in Figure IV-4). The battery SoC calculation is refreshed and checked again at each time step:

$$\sum_{n=1}^N E_{Bat}^{t+1} = \sum_{n=1}^N E_{Bat}^t - \tau \times (L_F^t + P_{OR}^t) \quad (IV-9)$$

- b) Otherwise, MGTs must balance the remaining load demand and provide the OR, which is required by both PV power and load demand uncertainties, as explained by equation (IV-6)

with $PV_F^t = 0$ (case 4 in Figure IV-4). Therefore, the power references of PV AGs are equal to 0, and power references of MGTs are $(L_F^t + P_{OR}^t)$.

IV.4.3 Scenario L

IV.4.3.1. First Strategy: OR provision by MGTs only

A. Operation during the day

As explained in part IV.4.1, since the maximum battery energy size is more than the predicted daily PV energy, all the PV power is stored into the batteries during the daytime. Therefore, the system operators will calculate the OR only by taking into account the load demand forecasting uncertainty. This will lead to a smaller OR power, compared to the situation of scenario H. Then the PV AG power reference is set to 0 ($P_{AG_n}^t = 0$) during daytime. The battery SoC is renewed at each time step:

$$\sum_{n=1}^N E_{Bat}^{t+1} = \sum_{n=1}^N E_{Bat}^t + \tau \times PV_F^t \quad (IV-10)$$

The load demand and the OR (which is required by the load demand uncertainty) are provided by MGTs:

$$\sum_{m=1}^M P_{MGT_m}^t = L_F^t + P_{OR}^t \quad (IV-11)$$

In this situation, MGTs limitations are the same as in the scenario H.

B. Operation during the night

During the night, the extra PV energy stored in the battery is discharged during the night. To use the stored energy, the battery SoC is calculated first.

- a) If the energy stored in batteries is enough to feed the predicted load demand, then MGTs are just working to provide the OR power reference ($P_{MGT}^t = P_{OR}^t$). At each time step, the equation (IV-4) can be used to the battery discharge reference with $PV_F^t = 0$.
- b) Otherwise, MGTs must be active to balance the remaining load demand and reserve power as equation (IV-6) with $P_{PV}^t = 0$.

IV.4.3.2. Second Strategy: OR provision by MGTs and PV AGs.

A. Operation during the day

During the day, the PV power is stored into the batteries and the only power source is MGTs (as explained in part IV.4.1). Therefore, PV AG power references are set to 0 ($P_{AG_n}^t = 0$) during the daytime. Batteries SoC is renewed in each time step as equation (IV-10).

B. Operation during the night

During the night, the battery discharge strategy is the same as the second method in scenario H.

- a) If the battery energy is enough to feed the predicted load demand and OR, then MGTs are switched off and the power references of PV AG is set to supply load demand and OR. The battery SoC is renewed at each time step as expressed by equation (IV-9).
- b) Otherwise, MGTs must be switched on to balance the remaining load demand and OR as set by equation (IV-6) with $PV_F^t = 0$.

The flowchart of overall OR power dispatching strategies with committed scenarios is illustrated in the Figure IV-4.

IV.5. UC Problem Optimization with Dynamic Programming (DP)

IV.5.1. Formulation of the UC

Unit Commitment (UC) is an operation scheduling function and usually called predispatch [18]. The UC function fits between economic dispatch, maintenance, and production scheduling. Concerning time scales, the UC scheduling covers the scope of hourly power system operation decisions, with a time horizon ranging from one day to one week (in our case, UC is only for day-ahead market). By taking into consideration minimum start-up and shut down times, UC computes the minimum generation cost by scheduling the on-and-off states of generating units (here MGTs). UC decisions are iteratively solved. They ensure system reliability by using probabilistic measures. The use of UC has grown in recent years because it can promote the system economy and simulate the effect of unit selection methods on the choice of generation unit by an automated computing [18]. Thanks to its potential to greatly decrease the fuel and related cost in electrical power system, UC is widely used in power industry [19].

To meet a given target or a design goal, the optimal scheduling of units is usually referred to UC. The power system scheduling should take into consideration operation economy, system security, and generation unit start-up and downtime issues. Several optimization methods, such as lookup table approximation, evolutionary programming, genetic algorithms, and DP have been recommended in UC problem. DP is chosen in this study and is detailed in the later part (IV.5.3).

The 24-hour ahead operational planning is discretized with T periods whose durations are $\tau = 24/T$ hour. Power references are considered constant during each time step. In fact, they are not, and the short-term power balancing is handled by functions in the local EMS controller. The power references of the studied MGTs are represented as a vector $z(t)$:

$$z(t) = [P_{MGT_1}^t, P_{MGT_2}^t, \dots, P_{MGT_M}^t] \quad (IV-12)$$

And the states of each MGTs during time step t is set as a vector $u(t)$:

$$u(t) = [\delta_1^t, \delta_2^t, \dots, \delta_M^t] \quad (IV-13)$$

IV.5.2. Optimizing Objective Functions with Different Optimization Strategies

For the proposed microgrid energy management, the optimal process aims to find an output vector $z(t)$. It will provide the generation set points of MGTs to guarantee the minimum fuel cost or CO₂ equivalent emissions while satisfying the load balancing within the settled time interval (τ hour).

A. Economic criteria: minimizing the total fuel cost

The fuel cost of each MGT ($C_{M_i}^t$) is expressed as a non-linear function of its power output (Appendix III). The startup and shutdown penalties, which are considered to take into account the emissions and the lifetime reduction of the MGT units, can be expressed by a CO₂ cost function as: $C_{P_i}^{Cost}(\delta_i^{t+1}, \delta_i^t)$. Variables $(\delta_i^{t+1}, \delta_i^t)$ measures the over emissions in case of startup and more globally enables to take into account penalties during transient states of MGTs. It is used to decide the choice of the power plant (startup or shutdown). Here, consumed fuel cost during 5 minutes and 2.5 minutes at full load are declared, respectively, as

start-up and shutdown penalties. Therefore, the total fuel cost for each MGT at time step t can be expressed as:

$$J_{C_i}^t = \delta_i^t \times C_{M_i}^t + C_{P_i}^{Cost}(\delta_i^{t+1}, \delta_i^t) \quad (IV-14)$$

Then the objective function for the whole system is to minimize the total fuel cost after 24-hour operation. Therefore, the proposed microgrid energy management optimization objective function can be defined as:

$$J_{Cost} = \sum_{t=1}^T \sum_{i=1}^M J_{C_i}^t = \sum_{t=1}^T \sum_{i=1}^M (\delta_i^t \times C_{M_i}^t + C_{P_i}^{Cost}(\delta_i^{t+1}, \delta_i^t)) \quad (IV-15)$$

B. Environmental criteria: reducing equivalent CO₂ emissions

Like the economic criteria, equivalent CO₂ emissions for each MGT at time step t can be expressed as the combination of an operational part ($CO2_{M_i}^t$) and a penalty part ($C_{P_i}^{CO2}(\delta_i^{t+1}, \delta_i^t)$):

$$J_{CO2_i}^t = \delta_i^t \times CO2_{M_i}^t + C_{P_i}^{CO2}(\delta_i^{t+1}, \delta_i^t) \quad (IV-16)$$

Proposed microgrid energy management optimization objective function just concerns the equivalent CO₂ emissions minimization after a 24-hour operation:

$$J_{CO2} = \sum_{t=1}^T \sum_{i=1}^M J_{CO2_i}^t = \sum_{t=1}^T \sum_{i=1}^M (\delta_i^t \times CO2_{M_i}^t + C_{P_i}^{CO2}(\delta_i^{t+1}, \delta_i^t)) \quad (IV-17)$$

C. Best compromise criteria

A compromise can be considered between the reduction of total fuel cost and the reduction of CO₂ emissions. Like the economic strategy, the best compromise criteria for each MGT at time step t can be expressed as the combination of a part of total equivalent CO₂ emissions and a part of the total fuel cost. The parameter γ ($0 < \gamma < 1$) is the proportion rate, defining the compromise between each objective function.

$$J_{BC_i}^t = \gamma(\delta_i^t \times C_{M_i}^t + C_{P_i}^{Cost}(\delta_i^{t+1}, \delta_i^t)) + (1-\gamma)(\delta_i^t \times CO2_{M_i}^t + C_{P_i}^{CO2}(\delta_i^{t+1}, \delta_i^t)) \quad (IV-18)$$

The proposed microgrid energy management optimization objective function can be defined as a combination of those two parts after a 24-hour operation:

$$J_{BC} = \sum_{t=1}^T \sum_{i=1}^M J_{BC_i}^t \quad (IV-19)$$

IV.5.3. Dynamic Programming for the UC Problem

IV.5.3.1 Introduction

DP is applied to meet a given target or a design goal by optimizing the schedule of power reference and states of each MGT unit during certain operation periods. It was developed in the 1950s through the work of Richard Bellman [20]. DP technique decomposes a multi-stage decision problem as a sequence of simpler single-stage decision problems that are solved successively. It is widely used in dealing with not only both discrete and continuous problems, but also deterministic as well as stochastic models [18]. In recent decades, the DP principles have been used for UC problem solving both large power systems planning and distributed storage optimization [19]. DP is a methodical procedure, which systematically evaluates a large number of possible decisions in a multi-stage formulation of the problem. A subset of

possible decisions is associated with each sequential problem step and a single one must be selected, i.e., a single decision must be made in each problem step. There is a cost associated with each possible decision and this cost may be affected by the decision made in the preceding step. Additional costs, termed "transition costs", may be incurred in going from a decision in one problem step to a decision in the following problem step over what is termed a "transition path". The objective is to make a decision in each problem step, which minimizes the total cost for all the made decisions.

In the chapter 8 of [18], the characteristics of DP are listed as followings:

- Policy decision is needed in each sub-stage;
- Several associated states for each stage;
- Transformation information between conjoint stages is needed;
- A resolution procedure is ordered to get the overall optimum solution;
- Optimum strategy prescription for each possible state of remaining sub-stages;
- Optimum strategy is independent from the previous stage;
- Optimum procedure moves backward by using the recursive approach, finding the optimum policy stage by stage until the initial stage.

The multistage decision problem process is characterized by certain input parameters, certain decision variables, and certain output parameters. The serial multistage UC problem can be categorized into two classes:

- 1) Backward recursion: Then, during the recursion optimization procedure, the final state is regarded as the input and previous state is regarded as output for the stage. The recursive analysis proceeds from the first stage to the last stage T .
- 2) Forward recursion: If, conversely, the problem is to optimize the system with a given initial state value as input, it would be convenient to reverse the direction. The optimization procedure proceeds from the last stage T to the first stage.

It does not matter what recursion direction is used if the input of the first stage and the last stage are both known. In fact, there is not an essential difference between these two procedures for the most of multistage problems. In the following part, the backward recursion is chosen for our DP implementation.

IV.5.3.2 Multistage Decision Process Formulation with Backward Recursion

To have an independence of sub-stage, the objective function must be able to be represented as the composition of individual stage returns. For a system with T time steps, if at time step T , the minimum running cost of each possible decision for a different group of generating units is $F(T, z(T), u(T))$, then the total cost of remaining step ($T-1$) should be carried by the remaining time steps also at minimum cost [21]. In mathematical form $J(T)$ is explained as:

$$J(T) = F(T, z(T), u(T)) + \sum_{t=1}^{T-1} F(t, z(t), u(t)) \quad (\text{IV-20})$$

$F(T, x(T), u(T))$ is represented as an assumption of transition costs and fuel costs at that time step:

$$F(t, z(t), u(t)) = Tr(F(t), z(t), u(t)) + F(t+1, z(t+1), u(t+1)) \quad (\text{IV-21})$$

The objective is to find a vector of generator states ($u(t)$) and a vector of power references of MGTs ($z(t)$), in (IV-12, IV-13), which minimizes the total system cost. The optimal solution of the overall problem is obtained by selecting the optimal vector $u(t)$ for all time steps recursively from $t=T$ to $t=1$.

As illustrated in Figure IV-5, DP procedure consists of two typical parts:

- An evaluation of all possible configurations in each time step (Stages and States);
- A “back-track” operation from the end of the problem, back to the beginning, over the optimal path (Recursive Optimization).

Stages and States

The fundamental feature of DP approach is to structure the optimization problems into multiple stages. Then optimization problems are solved sequentially. In addition, the states associated with each step are calculated in each stage. In Figure IV-5, there are T total stages, each for one time step t ($F(T)$ to $F(1)$). In each stage, the states of a different group of generating units, committed to cover the demand, are calculated. For example, in time step T , the states are $F_1(T)$, $F_2(T)$, $F_3(T)$, ..., and so on. Each of them represents one of the possibilities, for instance, a different combination of MGTs. For each possible state, a total cost is computed. Each possible configuration in that step is associated with previous steps. For instance, $F_3(T)$ is then linked back to $F_1(T-1)$, $F_2(T-1)$, $F_3(T-1)$, ..., and so forth. This link back procedure determines the transition paths between the possible states in each stage. Finally, the transmission path becomes a network that traces any possible states back to the beginning: $F_1(1)$, to $F_3(2)$, to $F_2(T-1)$, ..., to $F_3(T)$.

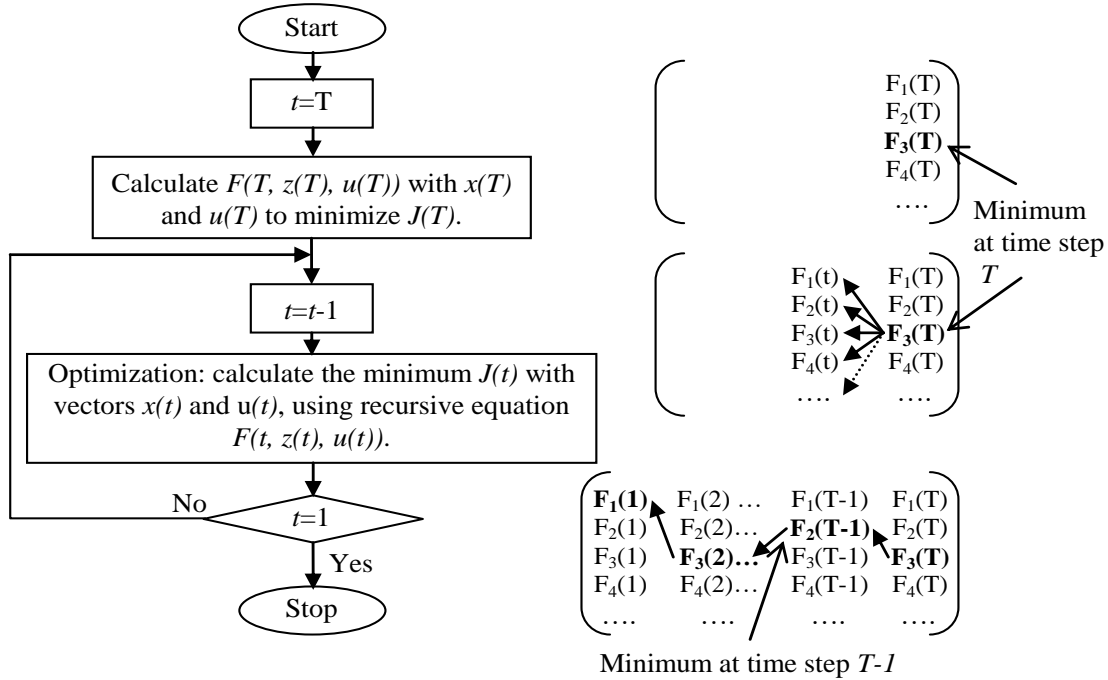

Figure IV-5 Backward recursion DP algorithm.

For each stage, there will be different states. For instance, system states for three generators are illustrated in Table IV-1.

Table IV-1 System states for three generators

Number of state	Generators states
1	$\delta_1=1; \delta_2=1; \delta_3=1$
2	$\delta_1=1; \delta_2=1; \delta_3=0$
3	$\delta_1=1; \delta_2=0; \delta_3=1$
4	$\delta_1=1; \delta_2=0; \delta_3=0$

5	$\delta_1=0; \delta_2=1; \delta_3=1$
6	$\delta_1=0; \delta_2=1; \delta_3=0$
7	$\delta_1=0; \delta_2=0; \delta_3=1$
8	$\delta_1=0; \delta_2=0; \delta_3=0$

Recursive Optimization

The recursive optimization procedure is used to find the transmission network. At each time step t , the procedure calculates the minimum $J(t)$ with vectors $z(t)$ and $u(t)$, by using the recursive equation $F(t, z(t), u(t))$. This procedure builds a solution of the overall T -stage problem by first solving a one-stage problem. Then, the remaining stages are solved, sequentially, one-by-one until the overall optimum is achieved. Here a “final value problem” method is applied for the problem solving.

IV.5.3.3 Criteria for DP Optimization

Three different optimization strategies are taken into consideration: economic, environmental, and an optimal compromization of these two.

A. Optimization under economic criteria

For any one of MGTs state $u(t)$, the operational cost is composed of two parts:

- Part one: total fuel cost during the time step t :

$$\sum_{i=1}^M \delta_i^t \times C_{M-i}^t \quad (\text{IV-22})$$

- Part two: by taking into account the transition cost due to generator startup or shutdown, the cost during the previous time step is explained as:

$$Tr(u(t-1), u(t)) = F(t-1, u(t-1)) + \sum_{i=1}^M C_{P-i}^{Cost}(\delta_i^{t+1}, \delta_i^t) \quad (\text{IV-23})$$

At step t , the UC problem formulation for the studied system is formulated by the following recursive dynamic programming equation:

$$F(t, z(t), u(t)) = \sum_{i=1}^M \delta_i^t \times C_{M-i}^t + Tr(u(t-1), u(t)) \quad (\text{IV-24})$$

B. Optimization under environmental criteria

A similar formulation can be found to evaluate CO₂ emissions. Like the economic strategy, equivalent CO₂ emissions optimization with DP at time step t can be expressed as:

$$Tr(u(t-1), u(t)) = F(t-1, u(t-1)) + \sum_{i=1}^M C_{P-i}^{CO_2}(\delta_i^{t+1}, \delta_i^t) \quad (\text{IV-25})$$

$$F(t, x(t), u(t)) = \sum_{i=1}^M \delta_i^t \times CO2'_{M-i} + Tr(u(t-1), u(t)) \quad (\text{IV-26})$$

C. Optimization under an optimal compromization criteria

Like the economic strategy, optimization with DP for the best compromise at time step t can be expressed as:

$$Tr(u(t-1), u(t)) = F(t-1, u(t-1)) + \sum_{i=1}^M (\gamma \times C_{P_i}^{CO_2}(\delta_i^{t+1}, \delta_i^t)) + (1-\gamma) \times C_{P_i}^{CO_2}(\delta_i^{t+1}, \delta_i^t)) \quad (IV-27)$$

$$F(t, x(t), u(t)) = Tr(u(t-1), u(t)) + \sum_{i=1}^M (\gamma \times \delta_i^t \times C_{M_i}^t + (1-\gamma) \times \delta_i^t \times CO_2_{M_i}^t) \quad (IV-28)$$

IV.6. A Case Study Application of the UC Problem with DP

IV.6.1. Presentation

In this case study, a system with 110 kW of rated load, 55 kW of rated PV power, three MGTs with rated power respectively 30 kW (MGT_1), 30 kW (MGT_2), 60 kW (MGT_3) and the OR for 1 % of LOLP coming from the uncertainty assessment of load and PV power forecasting are taken into consideration. Two different scenarios are shown in the Figure IV-6. Scenario H represents a sunny day with an estimated 269.5 kWh PV energy; while Scenario L represents a cloudy one with 128.4 kWh forecasted PV energy, and the forecasted PV energy is less than the total battery energy (150 kWh). The total corresponding daily load energy is 1082 kWh.

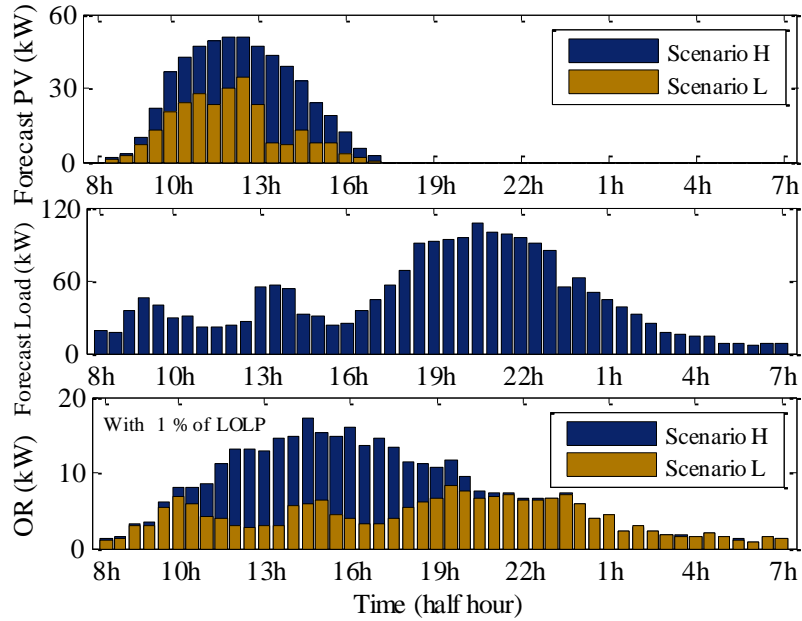

Figure IV-6 Day-ahead PV power forecast, load forecast and reserve power with 1% of LOLP.

ORs are also calculated differently: OR power in the scenario H must cover sometime both load and PV power forecasting uncertainty, because in this situation the PV power is used during the day. However, in scenario L, OR must cover only the load forecasting uncertainty because all the PV power is stored in the batteries and there is no PV power uncertainty during the day. The day-ahead optimal operational power planning algorithm presented in Section IV is applied and simulation results are displayed and discussed below.

IV.6.2. Different Scenarios of DP Application

DP procedure has been performed with two objective functions and for different strategies: without optimization criteria, economic criteria, environmental criteria, and best compromise criteria, under four different scenarios:

- Scenario H1: Under scenario H in Section IV (forecasted PV power is bigger than the maximum battery capacity), with strategy one (exclusive OR provision by MGTs).
- Scenario H2: Under scenario H, with strategy two (simultaneously dispatching of OR into MGTs and PV AGs).
- Scenario L1: Under scenario L in Section IV (forecasted PV power is less than the maximum battery capacity), with strategy one.
- Scenario L2: Under scenario L, with strategy two.

Table IV-2 illustrates the performance indices and corresponding used resources of those four scenarios on different aspects: total fuel cost, total equivalent CO₂ emission, percentage of OR provided by PV AG, and maximum energy storage in batteries. There are four different optimization strategies for each scenario: none (it means there is no optimization), environmental, economic, and best compromise with the γ equals to 0.5. E_{bat_Max} represents the maximum energy storage in the batteries. MGT power ratio is defined as the real power output of MGT divided by the rated power of MGT. It represents the power ratio of the MGT and is highly related to its efficiency (Figure AIII-1 in the Appendix III).

Generally, thanks to the larger PV energy (as shown in Figure IV-6), the total cost and pollution for scenarios H1 and H2 are less than in scenarios L1 and L2. Compared with scenario H1, scenario H2 has 38.9% of OR on PV AG (during a 24-hour of operation). Since there is no OR dispatched in PV AG with scenario H1, larger battery storage (78.6 kWh for scenario H1 vs. 52.7 kWh for scenario H2) is needed with the same fuel cost and pollution. While compared to scenario L1, scenario L2 has 11.8% of OR located on PV AG but with a similar PV stored energy (132.4 kWh), knowing that all the PV energies are stored into the batteries during the day. Among each scenario, system cost and pollution are lower with optimization then there is no optimization at all.

Figure IV-7, Figure IV-9, Figure IV-8, and Figure IV-10 show the time evolution of the power references of three MGTs and total fuel cost for the four different scenarios, respectively, with the economic optimization strategy.

A. Strategy 1

1) Economic criteria, Scenario H1

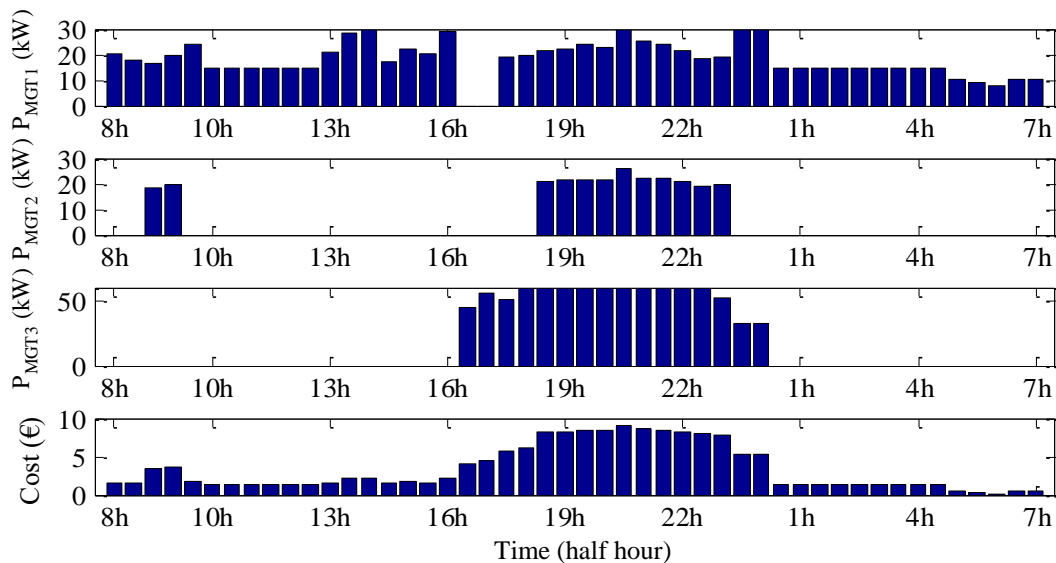

Figure IV-7 Load ratio of three MGTs and total fuel cost for scenario H1, with economic criteria.

Table IV-2 Day-ahead Operational Planning Results

Scenarios	Optimization strategies	Cost (€)	Pollution (kg)	OR on AG (%)	E _{bat_Max} (kWh)	MGT Power Ratio		
						MGT_1	MGT_2	MGT_3
H 1st strategy	None	173	1224	0	78.6	0.5166	0.7901	0.8032
	Environmental	169	1141	0	78.6	0.4871	0.8008	0.8480
	Economic	167	1167	0	78.6	0.5266	0.7342	0.9123
	Best compromise	171	1156	0	78.6	0.6684	0.8641	0.7843
H 2nd strategy	None	173	1027	35.4	52.7	0.7770	0.7901	0.8032
	Environmental	171	937	35.4	52.7	0.7851	0.8010	0.8390
	Economic	168	976	35.4	52.7	0.7511	0.7256	0.9054
	Best compromise	170	952	35.4	52.7	0.8243	0.8641	0.7855
L 1st strategy	None	185	1290	0	132.4	0.6679	0.7551	0.7702
	Environmental	182	1181	0	132.4	0.6619	0.7764	0.8068
	Economic	180	1245	0	132.4	0.6583	0.6881	0.8821
	Best compromise	183	1195	0	132.4	0.6941	0.8601	0.7664
L 2nd strategy	None	188	1119	11.8	132.4	0.7672	0.7464	0.7479
	Environmental	184	993	11.8	132.4	0.8178	0.7758	0.7930
	Economic	181	1063	11.8	132.4	0.7754	0.6826	0.8577
	Best compromise	185	1006	11.8	132.4	0.8739	0.8504	0.7543

2) Economic criteria, Scenario L1

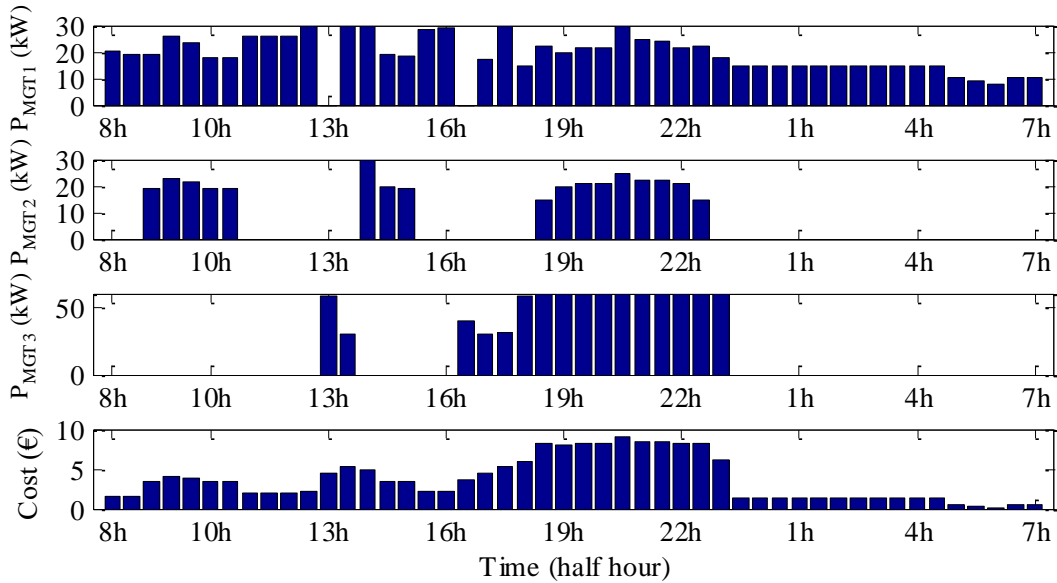

Figure IV-8 Load ratio of three MGTs and total fuel cost for scenario L1, with economic criteria.

In the scenarios H1 and L1, OR is only provided by MGT, so at least one of the MGTs is working at any time. The total fuel cost is 167 € in the scenario H1 and 180 € in the scenario L1, because the PV power output in the scenario H1 (269.5 kWh) is more than the PV power in the scenario L1 (128.4 kWh). During some time steps in the night, the MGT1 is working at the minimum power ratio (50%), which means a low electrical efficiency and a high equivalent CO_2 emissions (Appendix III).

B. Strategy 2

1) Economic criteria, Scenario H2

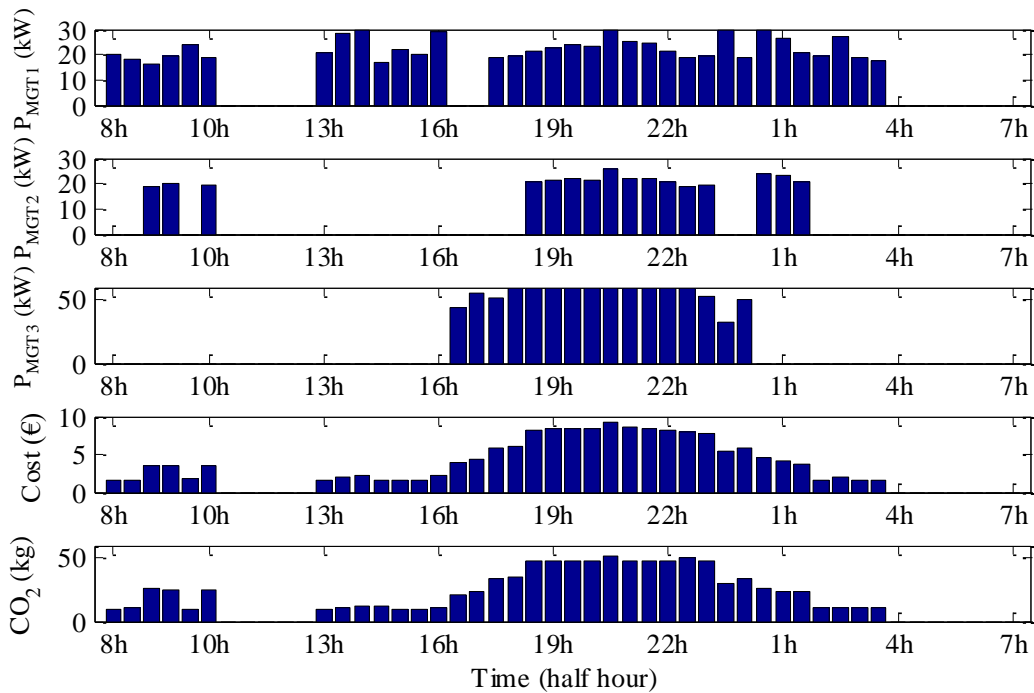

Figure IV-9 Load ratio of three MGTs and total fuel cost for scenario H2, with economic criteria.

2) Economic criteria, Scenario L2

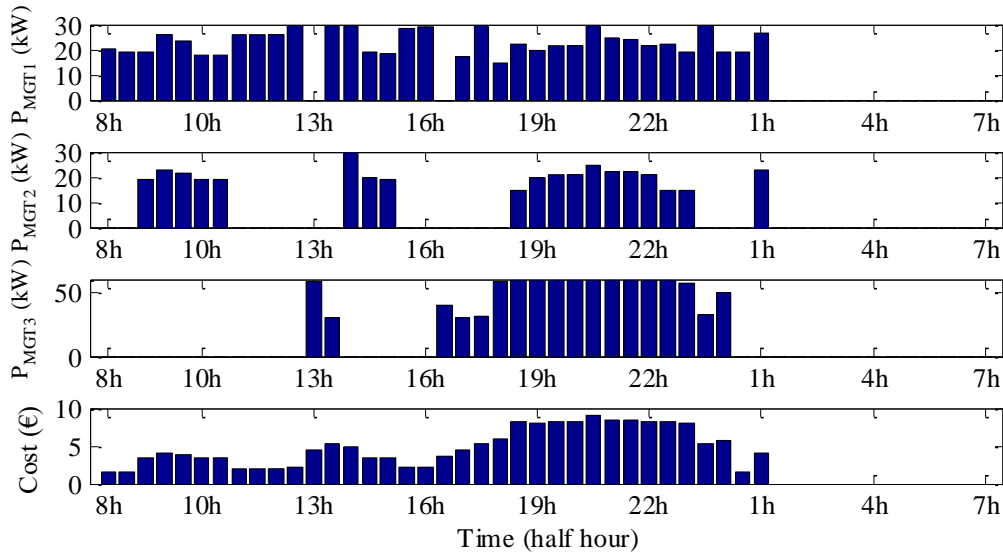

Figure IV-10 Load ratio of three MGTs and total fuel cost for scenario L2, (economic criteria).

However, for the scenarios H2 and L2, in some periods when the PV AGs energy (PV panels power production in the daytime and batteries energy storage in the night) is more than the load demand and OR, all the MGTs will be shutdown (from 4:00 to 7:00 in the scenario H2 and from 1:30 to 7:00 in the scenario L2). During these time steps, since only the PV AGs are working to provide the power for load and OR, the total fuel cost and the equivalent CO₂ emissions are both zero. Therefore, the power ratios of MGTs are improved. As it can be seen from the Table IV-2, the power ratio of MGT1 improved from 0.5266 in the scenario H1 and 0.6583 in the scenario L1 to 0.7511 in the scenario H2 and 0.7754 in the scenario L2. Compared to the scenarios H1 and L1, after 24 hours operation, the total equivalent CO₂ emissions are less in the scenarios H2 and L2 (976 kg in the scenario H2 versus 1167 kg in the scenario H1, and 1063 kg in the scenario L2 versus 1245 kg in the scenario L1).

IV.6.3. Comparison of the Power Reserve Dispatching

Figure IV-11 demonstrates the reserve power dispatching among different power generators with scenarios H1 and H2, respectively.

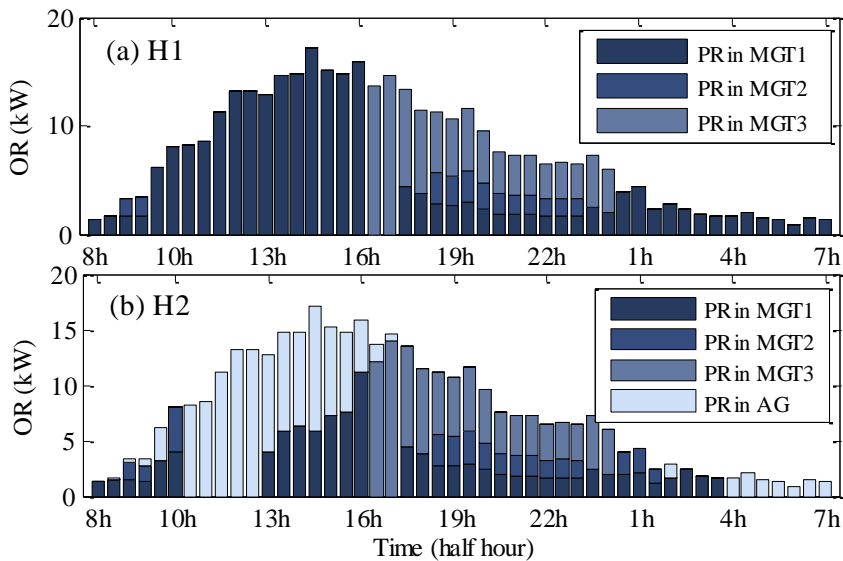

Figure IV-11 Power reserve dispatching with scenarios H1 and H2.

To simplify explanations, results are presented for the economic strategy and these results are similar with other strategies. As it can be seen in Figure IV-11 (b), from 11:00 to 13:00 and from 4:00 to 7:00 (next day) the power reserve is only provided by the AG, as well as in some other time steps it is covered by both MGTs and AGs. Instead in Figure IV-11 (a) it comes only from MGTs.

Figure IV-12 (a) and (b) illustrate the OR power dispatching percentage in different generators with scenarios H1 and H2. For the scenario H2, OR dispatching percentage on PV AGs is about 40%, while for scenario H1, it is zero.

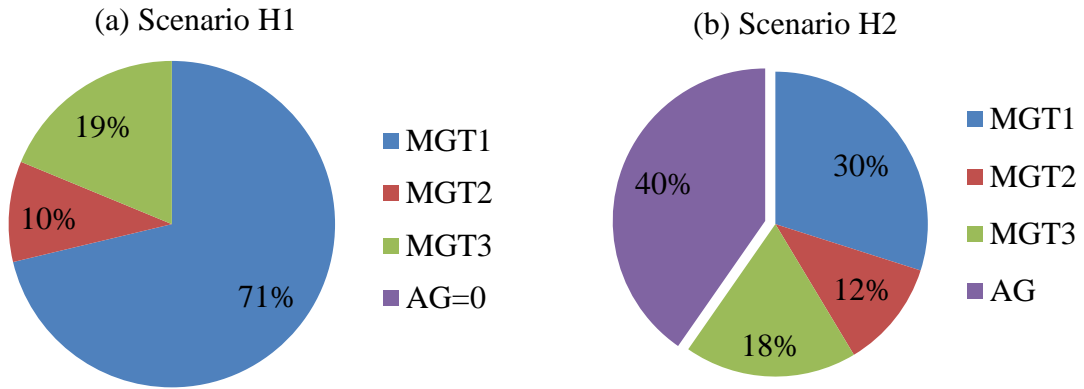

Figure IV-12 OR dispatching percentage in different generators with scenarios H1 and H2.

Overall load and reserve power dispatching among MGTs and AGs is illustrated in Figure IV-13. As it can be seen, PV based AGs provide the power both during the daytime and night. In the daytime the energy comes from PV panels while, during the night, it comes from the battery discharge. In fact, in this case study, the percentage of PV energy over load is 21.4%.

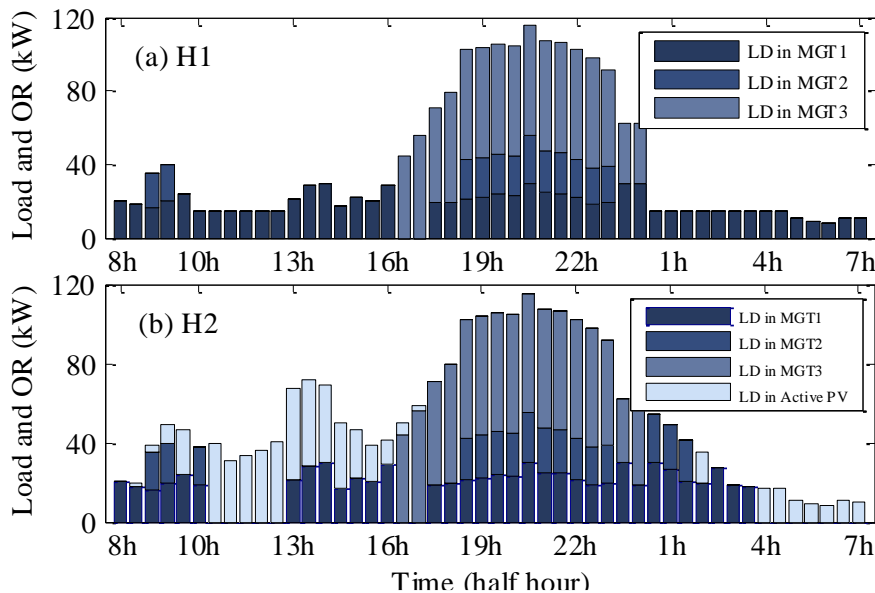

Figure IV-13 Load and OR power dispatching with scenarios H1 and H2.

IV.6.4. Characteristics of PV based AG (with scenario H2)

Figure IV-14 and Figure IV-15 show power references of PV AG, battery charge/ discharge power, and battery SoC in scenario H2 and L2, respectively. The percentage of the total PV energy in the energy mix is 21.3% in H2 and 10.9% in scenario L2.

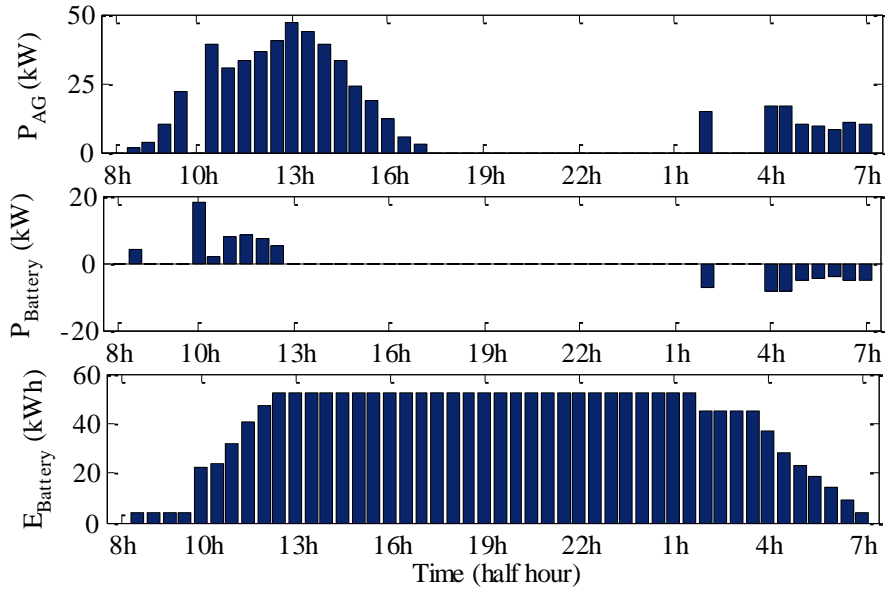

Figure IV-14 Reference power of AG, battery power and energy, under H2.

For scenario H2, maximum charge power is 18 kW and discharge power is about 15 kW. The maximum stored energy is 52.7 kWh, which is much smaller than 78.6 kWh in scenario L2 (Table IV-1). The reason is that much more PV power needs to be stored into the battery during the day in L2, while most of the PV power has been consumed during the day in scenario H2.

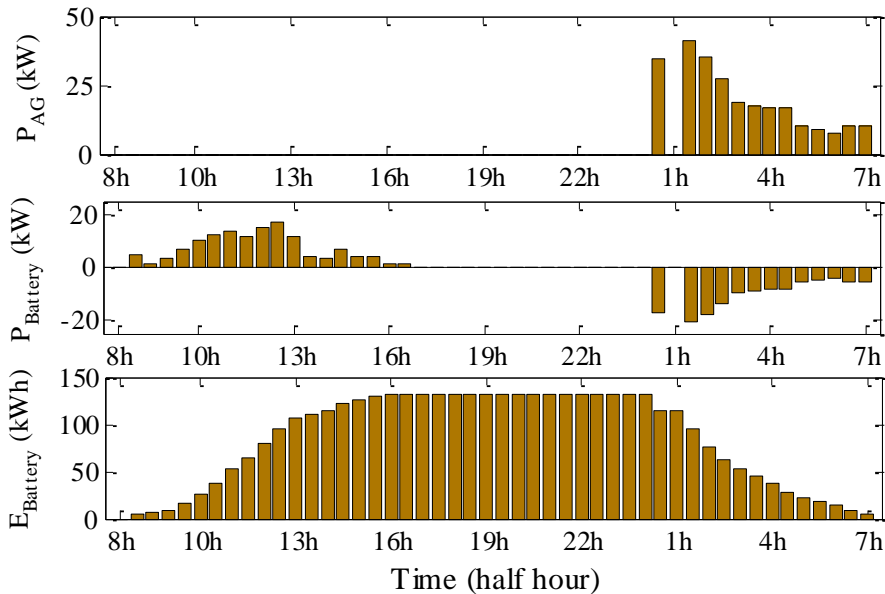

Figure IV-15 Reference power of AG, battery power and energy, under L2.

IV.6.5. Security Level Analysis

The daily average power ratio percentages of three MGTs with economic optimization strategy are respectively, 53%, 73%, and 91% in the H1 scenario, and 75%, 73%, and 91% in the H2 scenario (Table IV-2). As it can be seen, the MGT power ratio is higher with the second strategy than with the first strategy. Therefore for this studied day, by implementing the second method, the MGT power ratio could be improved, which means a higher efficiency and lower cost.

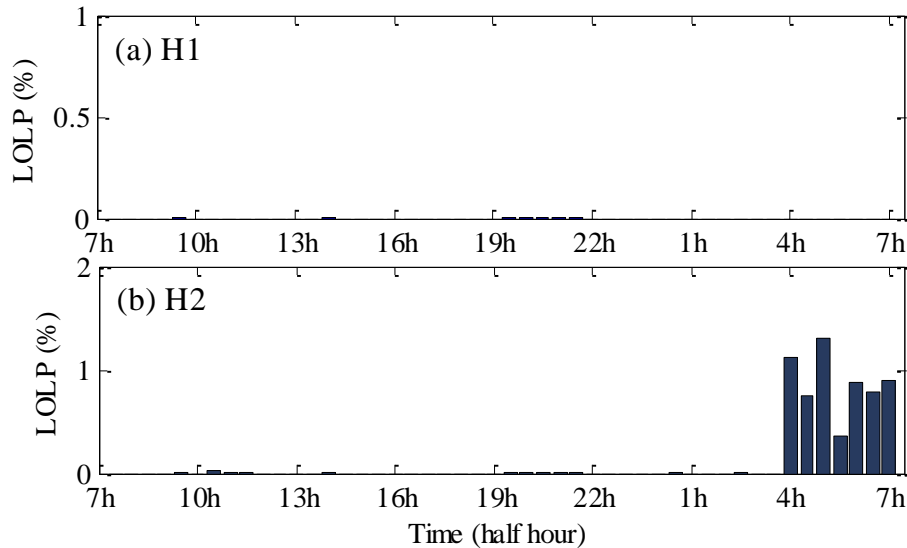

Figure IV-16 Renewed LOLP in H1 and H2 scenarios (with the economic optimization strategy).

After operational and reserve dispatching, MGTs usually do not work at their maximum power and so more OR are available when OR are distributed onto all generators. With this remaining power, a novel LOLP can be calculated. The H1 scenario has a great security level, the LOLP, at each time step, decreases from 1 % to almost below 0.1 % (Figure IV-16). The H2 scenario also has some improvement, excepted for the time steps when all power comes from PV AG (batteries) and MGTs are shut down. It corresponds to the risk that electricity power systems need to face in this situation.

IV.6.6. Analysis of the Cost

Figure IV-17 illustrates the relationship of load and the OR against the total fuel cost. The obtained fuel cost according to load and required OR decreases for low operating power points of the electrical system when the OR is dispatched also on PV AG. In addition, with the PV AG power, the total fuel cost from low level to medium level (10 to 75 kW) is smaller.

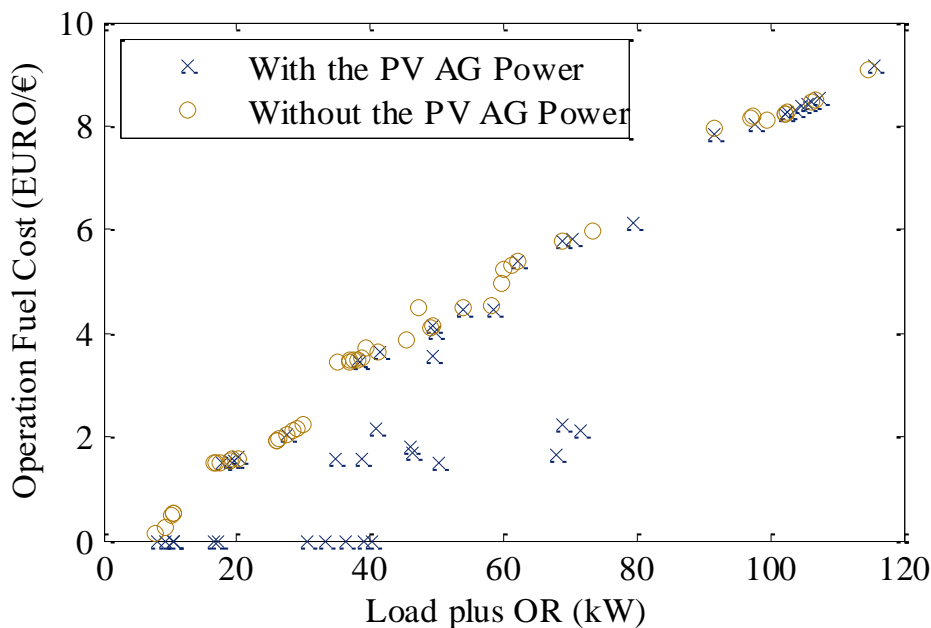

Figure IV-17 Obtained cost with both OR dispatching strategies

IV.7. OR Dispatching with Different PV Power Penetration Rate

The case study in the previous part assumed a fixed rated PV power at 55 kW. If the rated PV power is changed, OR power, battery power, and stored energy change too. Table IV-3 illustrates results with different PV power penetration rates (which represents the percentage of the PV energy over the load demand energy). The optimization strategy is with the economic criteria to simplify the explanation.

Table IV-3 Power reserve, battery power and battery energy change with a rated PV power increase.

Sunny Day, Optimization with Economic Criteria							
Load ^a (kW)	PV Energy Penetration Rate (%) ^d :	PV Energy (kWh)	Energy Reserve ^e (kWh)	Maximum Absolute Power of Battery (kW)		Maximum Battery Energy (kWh)	
				Scenario H1 ^a	Scenario H2 ^b	Scenario H1 ^a	Scenario H2 ^b
110	0	0	143.9	0	0	0	0
110	5	53.9	146.1	4	4	4	4
110	10	107.8	150.7	10.1	4	18.4	10
110	15	161.7	157.4	12.9	7.7	16.9	29.6
110	20	215.6	165.6	14.5	13.7	28.1	53.1
110	25	269.5	174.9	18.2	17.8	54.1	80.2
110	30	323.4	185.1	13.4	26.7	59.7	111.8
110	35	377.3	195.8	17.9	26.7	85.2	151.9
110	40	431.2	207	22.4	37.4	130.9	194.9
110	45	485.1	218.6	26.9	40.5	169.7	242.4
110	50	539	230.4	31.4	42.5	210.8	291.6
110	55	592.9	242.5	35.8	44.8	253.3	340.9
110	60	646.8	254.8	40.3	49.7	270.8	390.5
110	65	700.7	267.3	44.9	54.3	314.2	440.2
110	70	754.6	279.9	49.2	59.3	357.6	489.8
110	75	808.5	292.6	53.6	64.4	400.9	539.4

^aLoad demand is defined as a fixed curve, which is shown in Figure IV-6, with 110 kW rated power and 1080 kWh of total energy demand;

^bScenario H1 represents the strategy where the OR is provided only by MGT;

^cScenario H2 represents the strategy where the OR is provided by MGT and active PV generators;

^dIn this case study, it represents the percentage of the forecasted PV energy over load demand energy;

^eOR calculation strategy: calculation from the PV power and the estimated load forecast errors (Chapter III, part III.4.2(B)).

In this study, the rated load demand is 110 kW, while the rated PV power varies from 0 to 165 kW, which is 150 % of the rated load demand. As the rated PV power increases, the day-ahead total PV energy increases from 0 to 808.5 kWh. At the same time, the day-ahead total energy reserve is also increasing from 143.9 kWh to 292.6 kWh. Figure IV-18 illustrates the daily PV energy and the daily OR power accumulated when PV energy integration rate increases. So, we can observe that this energy is not increasing linearly, certainly because of the compensation of the uncertainty of the load forecasting.

The required maximum battery power and maximum battery energy increases too as they are embedded in PV based active generators. Figure IV-19 illustrates the maximum battery power and maximum battery energy changes with a PV energy integration rate increase (scenario H2). Compared with scenario H1, scenario H2 needs a larger battery size.

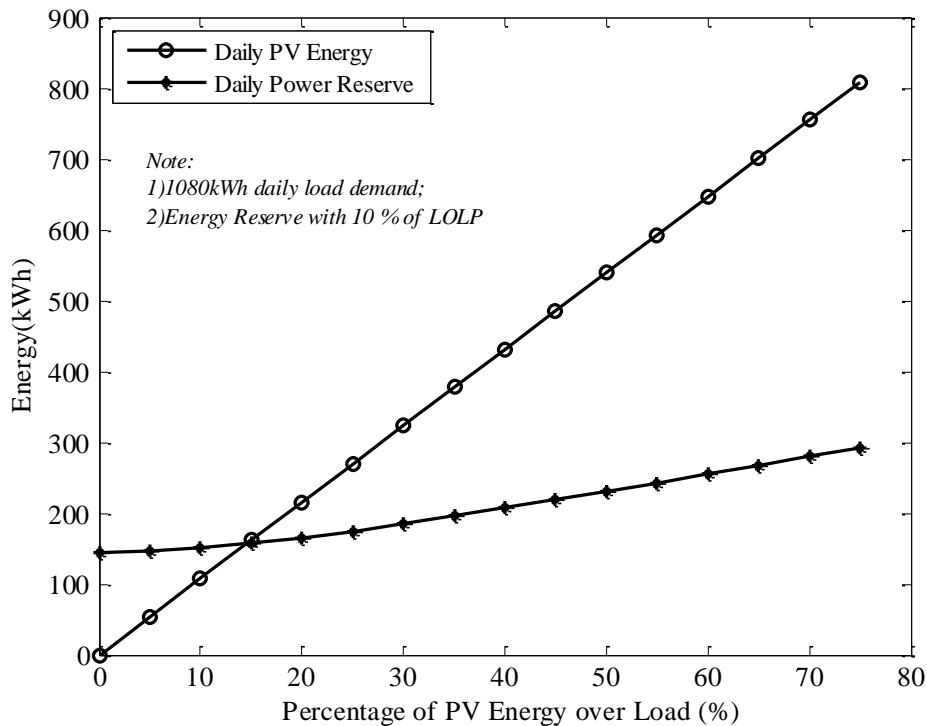

Figure IV-18 Daily PV energy and reserve variation with the increasing of PV energy integration.

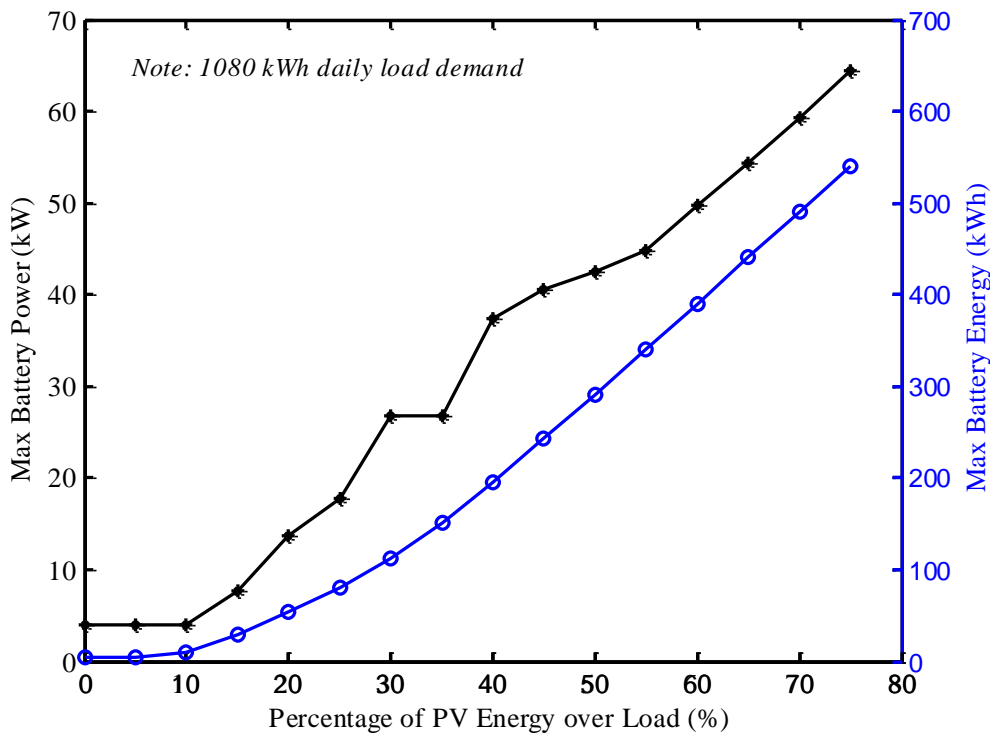

Figure IV-19 Maximum battery power and maximum battery energy with the increase of PV energy integration rate.

IV.8. Conclusion

In this chapter, two different day-ahead OR power dispatching strategies are proposed. In the first strategy, the OR power is only provided by MGT. The second strategy dispatches the OR capacity simultaneously to all generators in order to maximize the efficiency and reliability. The later implements a new application for distributed storage systems that are embedded in the PV AG generators since they are indirectly planned to provide a part of the power reserve for the electrical system with a settled security level. Hence distributed storage systems are a key hardware tool for PV producers since they enable the production of a prescribed day ahead forecasted PV power within a power reserve.

Then the optimal planning of conventional generators has been proposed. Different constraints are considered: OR power requirements with certain security level, MGTs efficiency constraints, battery charge/ discharge power, and maximum battery storage size. The proposed method uses the dynamic programming technique to minimize the objective for different goals: economic criteria, environmental criteria, and best compromise criteria. The accuracy and the effectiveness of the suggested method are verified for four different scenarios with a case study.

The effect of increasing PV power penetration rate from 0 to 150 % of the rated load demand is studied. This research work can be used to estimate the sizing of the distributed storage and also the battery cost. Furthermore, it can be used by system operators for business planning.

In the next chapter, presented algorithms and functions are integrated into an energy management system whose some implementation details are given. A user-friendly graphical interface optimization is also shown.

References

- [1] H. Gooi, D. Mendes, K. Bell, and D. Kirschen, "Optimal scheduling of spinning reserve," *Power Systems, IEEE Transactions on*, vol. 14, pp. 1485-1492, 1999.
- [2] H. Singh and A. Papalexopoulos, "Competitive procurement of ancillary services by an independent system operator," *Power Systems, IEEE Transactions on*, vol. 14, pp. 498-504, 1999.
- [3] X. Ma and D. Sun, "Energy and ancillary service dispatch in a competitive pool," *Power Engineering Review, IEEE*, vol. 18, pp. 54-56, 1998.
- [4] A. Shrivastava, A. Bhatt, M. Pandit, and H. M. Dubey, "Dynamic Energy and Reserve Dispatch Solutions for Electricity Market with Practical Constraints: Intelligent Computing Technique," in *Communication Systems and Network Technologies (CSNT), 2014 Fourth International Conference on*, 2014, pp. 990-994.
- [5] M. Rashidinejad, Y. Song, and M. J. Dasht-Bayaz, "Contingency reserve pricing via a joint energy and reserve dispatching approach," *Energy conversion and management*, vol. 43, pp. 537-548, 2002.
- [6] A. Van Deventer, S. Chowdhury, S. Chowdhury, and C. Gaunt, "Management of emergency reserves dispatching in electricity networks," in *Power System Technology (POWERCON), 2010 International Conference on*, 2010, pp. 1-5.
- [7] N. Hazrati, M. Rashidi-Nejad, and A.-A. Gharaveisi, "Pricing and allocation of spinning reserve and energy in restructured power systems via memetic algorithm," in *Power Engineering, 2007 Large Engineering Systems Conference on*, 2007, pp. 234-238.
- [8] M. Afkousi-Paqaleh and S. H. Hosseini, "Transmission constrained energy and reserve dispatch by harmony search algorithm," in *Power & Energy Society General Meeting, 2009. PES'09. IEEE*, 2009, pp. 1-8.
- [9] M. Pandit, L. Srivastava, and K. Pal, "Static/dynamic optimal dispatch of energy and reserve using recurrent differential evolution," *Generation, Transmission & Distribution, IET*, vol. 7, pp. 1401-1414, 2013.
- [10] E. N. Azadani, S. Hosseinian, and B. Moradzadeh, "Generation and reserve dispatch in a competitive market using constrained particle swarm optimization," *International journal of electrical power & energy systems*, vol. 32, pp. 79-86, 2010.
- [11] H. Hejazi, H. Mohabati, S. Hosseinian, and M. Abedi, "Differential evolution algorithm for security-constrained energy and reserve optimization considering credible contingencies," *Power Systems, IEEE Transactions on*, vol. 26, pp. 1145-1155, 2011.
- [12] J. Wang, M. Shahidehpour, and Z. Li, "Contingency-constrained reserve requirements in joint energy and ancillary services auction," *Power Systems, IEEE Transactions on*, vol. 24, pp. 1457-1468, 2009.
- [13] T. Soares, H. Morais, B. Canizes, and Z. Vale, "Energy and ancillary services joint market simulation," in *Energy Market (EEM), 2011 8th International Conference on the European*, 2011, pp. 262-267.
- [14] Y. Lin and J. Zhong, "Energy and reserve dispatch in the integrated electricity market with sectional price offers," in *Transmission and Distribution Conference and Exposition, 2008. D. IEEE/PES*, 2008, pp. 1-6.
- [15] P. Faria, Z. Vale, T. Soares, and H. Morais, "Energy and reserve provision dispatch considering distributed generation and demand response," in *Innovative Smart Grid*

- Technologies (ISGT Europe), 2012 3rd IEEE PES International Conference and Exhibition on*, 2012, pp. 1-7.
- [16] L. E. Jones, *Renewable energy integration: practical management of variability, uncertainty, and flexibility in power grids*: Academic Press, 2014.
- [17] X. Yan, B. Francois, and D. Abbes, "Operating power reserve quantification through PV generation uncertainty analysis of a microgrid," in *PowerTech, 2015 IEEE Eindhoven*, 2015, pp. 1-6.
- [18] J. A. Momoh, *Electric power system applications of optimization*: CRC Press, 2008.
- [19] W. L. Snyder, H. D. Powell, and J. C. Rayburn, "Dynamic programming approach to unit commitment," *Power Systems, IEEE Transactions on*, vol. 2, pp. 339-348, 1987.
- [20] R. E. Bellman and S. E. Dreyfus, *Applied dynamic programming*: Princeton university press, 2015.
- [21] N. P. Padhy, "Unit commitment-a bibliographical survey," *Power Systems, IEEE Transactions on*, vol. 19, pp. 1196-1205, 2004.
- [22] D. Lu, "Conception et contrôle d'un générateur PV actif à stockage intégré: application à l'agrégation de producteurs-consommateurs dans le cadre d'un micro réseau intelligent urbain," PhD report, Ecole Centrale de Lille, 2010.

Chapter V

*Development of an Energy Management
System for an Urban Microgrid and Practical
Application*

Chapter.V Development of an Energy Management System for an Urban Microgrid and Practical Application

V.1. Introduction

In recent decades, there are growing concerns on renewable portfolio standards and CO₂ emissions allowance. Also, the importance of developing tools to help electrical system planning under uncertainty has been recognized [1].

Several studies have been reported in the literature regarding the smart grid and microgrid simulation [2-8]. In [7], features and decision algorithms of a smart grid simulator are explained with detail in the paper and the test results are illustrated. In [3], an intelligent energy management system is proposed for grid power control in the case of a large amount of hybrid vehicles penetration in the market. As an integral part of the supervisory control and data acquisition (SCADA) system, a Graphical User Interface (GUI) was developed for the real time data monitoring and control. In addition, a Matlab GUI simulator for the generation of distribution grid models is proposed in [8]. It enables the power distribution in electrical grids by focusing on the particular features of distributed networks. In [4], a multi-agent system for real-time microgrid operation is presented. Considering constraints from the electrical system and distributed energy resources, the purposes of the proposed simulator are to maximize the power production of local generators, to minimize the operational cost, and to optimize the power exchange between the main power grid and the microgrid. A smart residential load simulator with several user-friendly graphical interfaces is developed in [6] to deal with residential power management. The proposed freeware is based on Matlab-Simulink-Guide toolboxes and aims to model residential energy consumption and local generation resources. Moreover, many research works on the microgrid energy management have been done [9-14]. However, none of the existing studies and simulation tools takes into accounts the uncertainties and power reserve distribution in an urban microgrid. Hence, there is a need for user-friendly simulator to understand how to manage the uncertainties in a microgrid, as well as to facilitate the study and visualization of power reserve dispatching.

To follow the work of last chapters, an Urban Microgrid Energy Management System (EMS) is developed in this chapter to conceptualize the overall system operation. The designed simulator is based on the Matlab GUI. It provides a complete set of user-friendly graphical interfaces to properly model and study the details of PV AGs, including PV panels and batteries, load demand, as well as MGTs. Also, the proposed simulator helps to model power flows from production to consumption. It enables a better understanding of uncertainties in terms of the dispatching of OR in the different power generators and in terms of their effects on the system security with different dispatching scenarios and optimization criteria.

Thus, this chapter is organized as follows: First, an urban microgrid is presented. In order to better understand the microgrid grid management system, different data sources and data managing methods are studied. Then, an urban microgrid energy management system with three main window interfaces and several individual modules are designed. Finally, results are presented and discussed.

V.2. Analysis of the Urban Microgrid System

V.2.1. Presentation of the Case Study

In the first chapter, a microgrid integration of PV AGs and MGTs is briefly presented. PV AGs, including PV panels combined with storage devices are considered as prior energy

production sources. Storage device, especially battery is the key point of PV AG. Therefore, the use of the PV AG can have an important impact on the energy management of the system.

Several previous research works on this topic have been published. They studied both the system structure and the energy managing framework [15-18]. In addition, MGTs are used as backup energy sources. Since gas turbines consume fossil fuel and emit pollutant gases, it is necessary to study its characters for the system operational optimization purpose to minimize gas emissions and the fuel cost. To design our EMS, an urban microgrid, which has been introduced previously in [19], is considered in Figure V-1. In this microgrid, a residential network with several prosumers and PV AGs, controllable loads, and MGTs is considered. Three MGTs (rated powers are 30 kW, 30 kW, and 60 kW) are connected to an AC bus and controlled by the local controller (LC), while the rated power of thirteen PV AGs, which are installed on the roofs of residential homes, is 3 kW each.

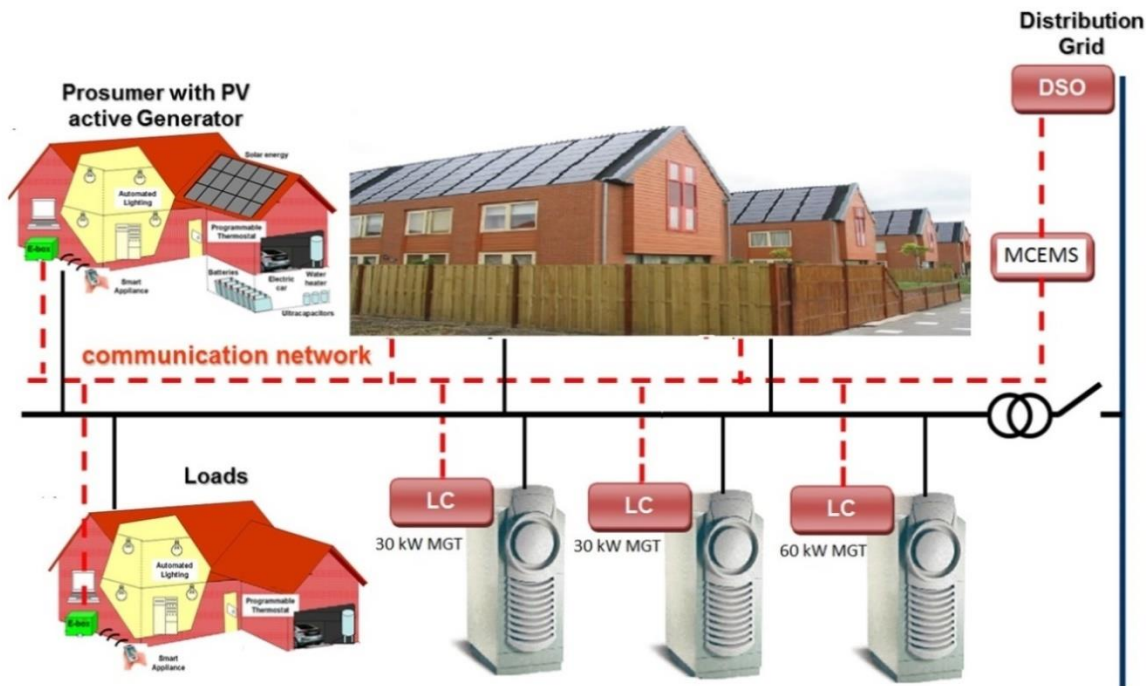

Figure V-1 Description of the studied microgrid [6].

V.2.2. Sources of Data in Utilities

Compared to traditional fossil fuel power generation, RES are smaller units, which are scattered throughout the electrical grids at distribution levels. Since the weather conditions have a major influence on them, their accessible power production is uncertain. Nowadays, uncertainties in both generation side (especially RES) and load demand side are increasing and becoming prevalent in electrical power systems. In order to have a better understanding of these uncertainties and to reduce their impact on electrical grid performance, a lot of monitoring technologies are invested in electrical power system operations. Therefore, a huge amount of data and information are generated by those installed monitoring devices. A well understand and smart management of those collected data will be a great help for RES integration into electrical power systems. Several major data sources are listed as the followings [20].

A. Grid operation data

A SCADA system is compulsory for electrical grid monitoring, operations and control. It collects numerous measurements, such as voltages, currents, power consumption, power

injection at each grid node, and so forth. Combined with various computer software applications, system operators can have a precise real-time view of the current grid state.

To overcome RES integrating challenges and to maintain the dynamic security of the power system, new monitoring systems (for instance, smart meters) have been installed. Consequently, a lot of data are flooded to the grid control center. These data need to be well studied and analyzed to be used wisely and efficiently for decision making.

B. Renewable production data

The major issue with RES, especially PV and wind power, is their strong dependency on local weather conditions. However, errors in weather forecasting are difficult to eliminate. In addition to the uncertainties from RES forecasting and other sources (such as unplanned power generator failure and power line breakdown) electrical system operators will have to learn to deal with more and more operational uncertainties. For these reasons, a lot of data and information are collected from wind farms and PV power plants. Generally, hundreds of data points are used to monitor electrical factors and mechanical components. With the fast development of present measurement technologies, more and more sophisticated sensors are offered on the market. Because the power generation from solar panels can change radically with clouds, airborne dust, or even snow, it is necessary to properly monitor the performance of solar panels. Also, with collected information from smart appliances in demand side, distribution system operator (DSO) can use solar panels and storage devices bundled with inverters to provide AS for voltage regulation and frequency control.

C. Load metering data

Advanced smart metering infrastructure allows bidirectional communication of electrical consumption in real time. Collected data can help electrical system operators to better understand the energy consumption patterns of the users. Further, the data processing enables energy suppliers and DSO to manage reserve power wisely and to regulate frequency.

D. Simulation data

In addition to real time collected data during operation, simulation tools can also generate many data to support the planning of system operation. For example, forecasting tools can be used to predict the day-ahead PV power production and load demand, which are useful to support day-ahead system operational and reserve power planning.

E. Market data

External factors, such as oil prices and electricity prices, can have a significant influence on supply-demand balance in a competitive electricity market. Moreover, a continuous information and data flow about market conditions is adding to the control center by intraday electricity market, AS, and capacity market to help controllers for decision making.

V.2.3. Data Management for Uncertainty Analysis and Predictive Procedures

A. Data Management

As more and more sensors are installed in electrical power system, large databases can be built. However, the value of collected data and information is limited if there is not enough valuable knowledge being extracted from huge volumes of datasets. To release the potential high value in the data and put them into decision making, collected data need to be analyzed and studied wisely. These increased data flows need to be clustered (chronologically and/or geographically) via statistical procedures, such as incremental and/or iterative approach, and

so forth. The purpose is thus to provide DSO a set of mathematical tools that help to reduce the data quantity and to improve their quality. To implement this, different data management tools and data mining techniques are necessary [21].

B. Predictive Analytics

In order to implement forecast procedures based on collected data, predictive analytics are applied to identify correlated patterns and parameters, which can be used for forecast models. For example, in chapter II, PV power and the load demand uncertainties have been analyzed from historical data. To implement the day-ahead ANN based PV power generation forecast and load demand forecast, different input parameters are chosen to improve the forecasting performance. For PV power forecasting, solar irradiance and temperature have been chosen as inputs, because these are most relevant parameters associated to the PV power production (Chapter II).

V.2.4. Urban Microgrid Management Analysis

Integration of RES is a world wide demand in recent years. However, increased uncertainties in electrical system complicate the traditional paradigm of dynamic security assessment. Currently, with the help of collected big data in all aspects and data mining, deterministic methods are gradually replaced by probabilistic methods. In offline applications, big data information helps to identify uncertainties probability distribution and their correlations (e.g. the probability density distributions of PV power forecasting uncertainty and load forecasting uncertainty, and their relations). Based on the forecasting methods (and Monte Carlo methods) for realistic simulations, the security level of a particular state of the grid can be calculated by a dynamic security assessment method [22]. For instance, in chapter III, PV power forecasting errors and load forecasting errors are used for ND forecasting uncertainty quantification. Then, LOLP for system security level and required OR are quantified from the knowledge of these uncertainties.

To implement power system operation, electric utilities rely on high-sophisticated integrated systems for monitoring and control. According to different management objectives, a microgrid central energy management system (MCEMS) for long term and medium term energy management and a local energy management in the E-box for real time balancing are implemented (Figure I-9). A communication network interconnects the central energy management system and LC for the data acquisition and information exchange.

As presented in chapter IV, different OR power dispatching methods are proposed with several optimization criteria. With those dispatching scenarios and optimization criteria, the microgrid will work at a minimum cost with an expected security level. All of this dispatching and optimization procedures are implemented through a MCEMS and within an intelligent EMS and LC (for PV AGs, MGTs, and load demands). The aggregators collect the requests and signals for prosumers from the DSO. They are the key mediators between prosumers and consumers to form grid services to the different power system participants via various markets [23]. The microgrid central controller measures the state variables and dispatches them to different sources via the communication bus. LC receives reference power points, in the same time, and sends real-time information back to the central controller.

V.3. Urban Microgrid EMS Framework and Interface Design

V.3.1. GUI Description

Instead of focusing on system controlling algorithms or real-time hardware-in-the-loop tests, an urban microgrid EMS is developed in this part so that its operation can be more convenient

and user-friendly. The proposed EMS includes three main interfaces and several individual modules, as summarized in Table V-1:

Table V-1 Main and individual interfaces

Main Interfaces	Individual Modules
Data Collection and System Uncertainty Analysis	<ul style="list-style-type: none"> Historical Data Collect for ANN Training Day-ahead Data Download: Weather Information, Load, and PV Power Data PV Power and Load Demand Forecast by Using a well-trained ANN
System Uncertainties Assessment and OR Power Quantification	<ul style="list-style-type: none"> PV Power Uncertainty Load Demand Uncertainty Net Demand Uncertainty OR Quantification
Operational and OR Dispatching	<ul style="list-style-type: none"> Dispatching Strategies PV AGs and MGTs Power References

For each different interface, numerous methods and strategies are applied. In addition, different criteria and scenarios are considered. For example, data collection, predictive data analysis, in addition to PV power and load forecasting with ANN are three key methodologies used for the first main interface “Data Collection and System Uncertainty Analysis”. Figure V-2 shows in details the system block diagram of adopted methodologies for the MCEMS.

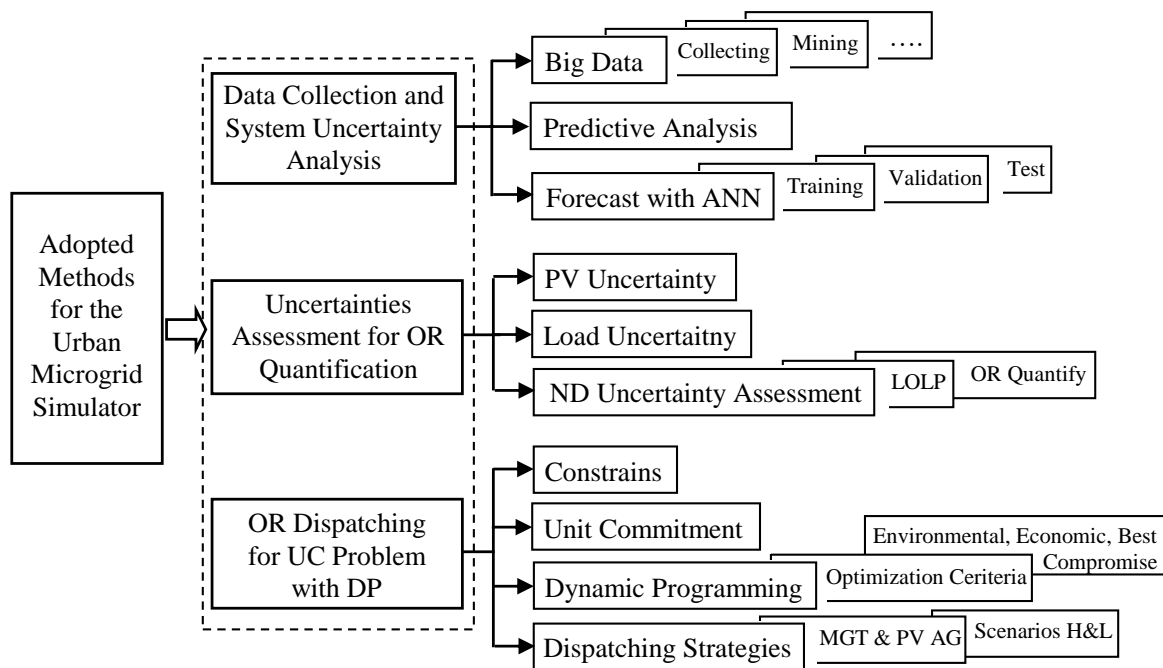

Figure V-2 System block diagram of adopted methodologies for the MCEMS.

The interface window is shown in Figure V-3. The interface provides a complete graphical interface window with three major interfaces: “Data collection, uncertainty analysis, PV power and load forecast”, “Uncertainty assessment for OR quantification”, and “Day-ahead optimization planning”. User can access to these three interfaces by clicking the blue buttons, as “Uncertainty Analysis”, “OR Quantification”, and “Dispatching”.

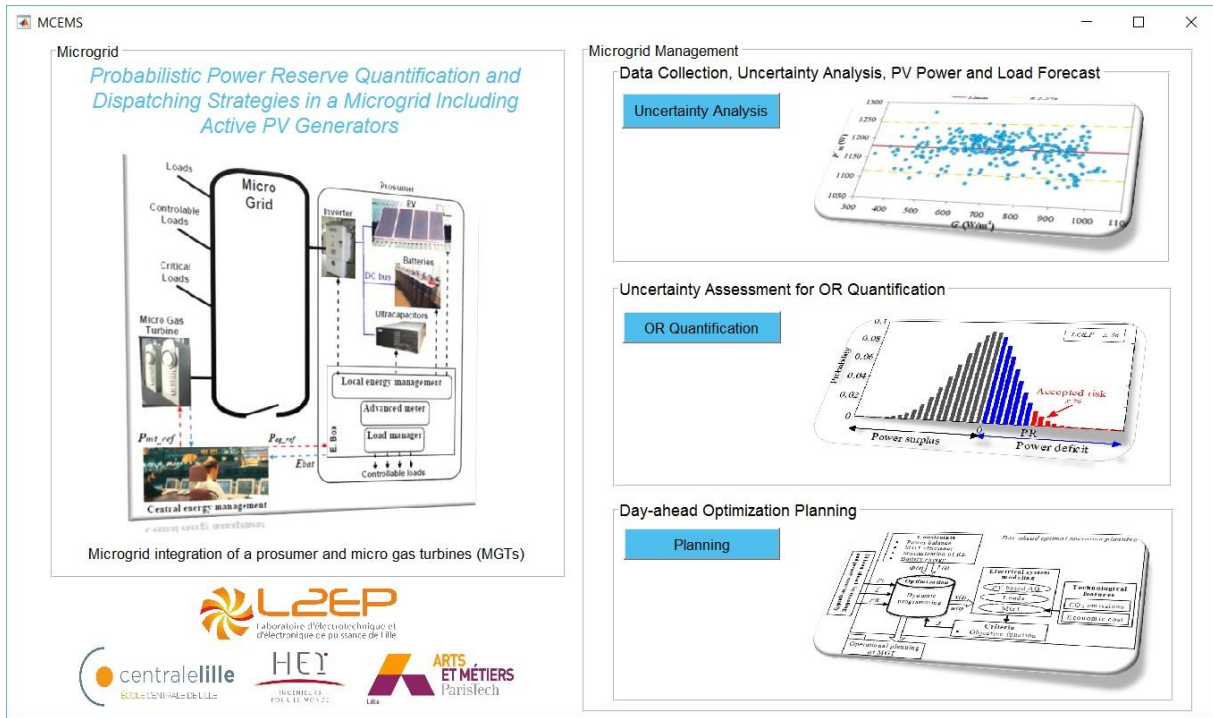

Figure V-3 Graphical interface of the MCEMS.

V.3.2. Data Collection and System Uncertainty Analysis

A. Layout design

As displayed in Figure V-2, three major modules are studied in this uncertainty analysis interface: data collection, predictive analysis, and forecasting. The designed layout is shown in Figure V-4.

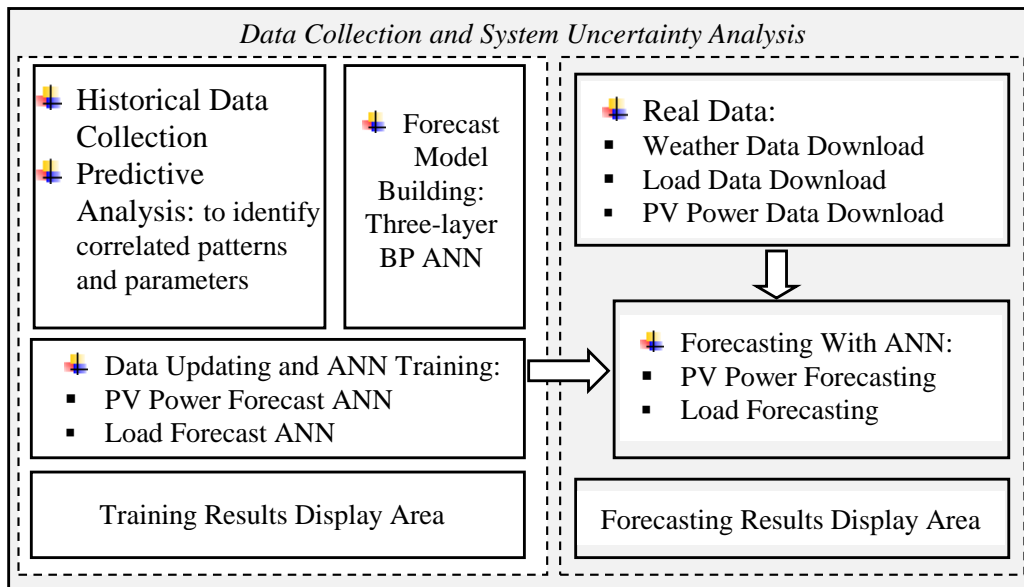

Figure V-4 Layout design of the “Uncertainty Analysis”.

a) Data collection for ANN training

Firstly, historical data are collected, for example past few months or years of weather data (temperature, solar irradiation, humidity, air pressure, wind speed, and so on), PV power data

(PV power output, AC voltage, AC voltage, and so on), and load demand data. The collected data are used for predictive analysis to identify correlated patterns and parameters, related to the PV power output and load demand. Then, forecasting models are built for PV power and load forecast. As presented in chapter II, a three-layer BP ANN is developed for both PV power and load forecast. Before implementing this tool for PV power and load demand prediction, ANNs need to be well trained with collected past data. The training, validation, and test procedures are explained in chapter II.

b) PV power and load demand forecasting with ANN

Once the ANN is well trained, it can be used for day-ahead forecast. The first step is to download the data one day-ahead to update the ANNs. Then, with the well trained ANN, PV power production and load demand for the forecast day (day D+1) can be obtained. ANN models and forecasting procedures are detailed in the chapter II.

B. Interface design

Figure V-5 shows the designed interface. The left part is the data collection and predictive analysis for PV power and load forecast ANN training. The right part is the downloaded data, the day-ahead PV power and load forecasting.

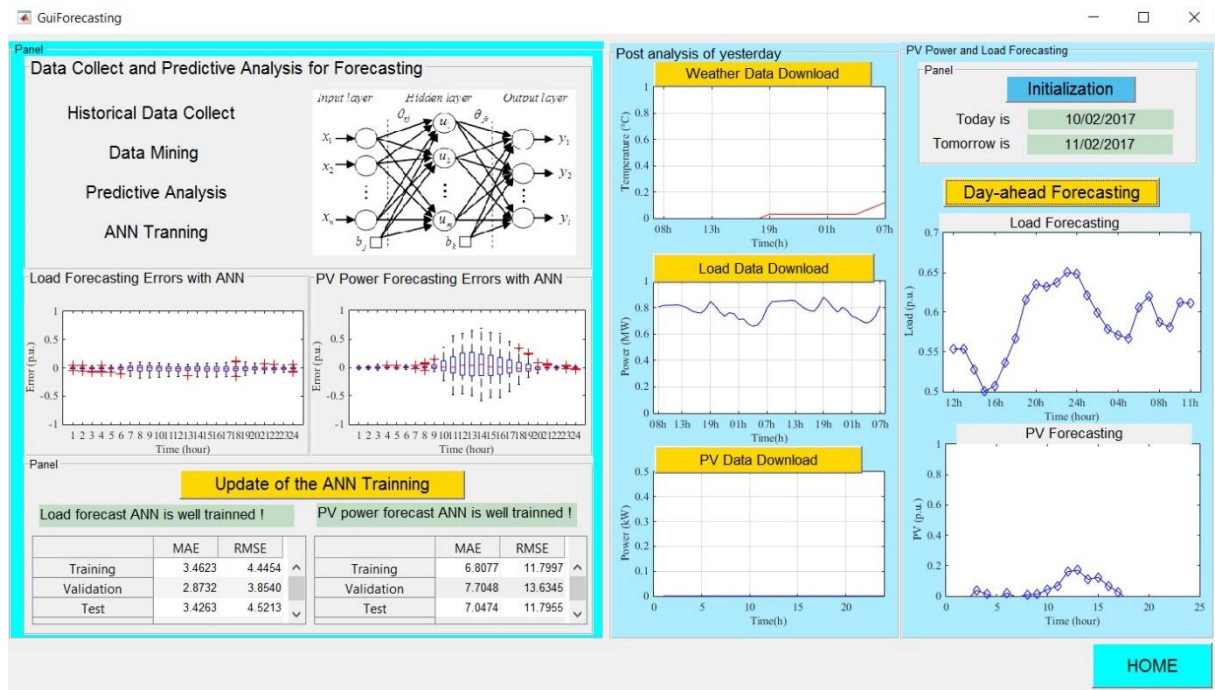

Figure V-5 Data collect for system uncertainty analysis interface.

V.3.3. System Uncertainties Assessment and OR Quantification

A. Layout design

Figure V-6 shows the designed layout of “System Uncertainties Assessment”.

a) Uncertainty assessment

First, PV power and load demand forecasting uncertainties are calculated, respectively. Then, ND uncertainty is computed according to those two independent variables. Two possible methods are proposed to calculate forecasted ND errors. As detailed in chapter IV, the first method is day-ahead net demand error forecast, and the second one is from PV power and load forecast errors estimation.

b) Risk-constrained OR Quantification

According to the probability distribution of ND uncertainty, a probabilistic risk-constrained method is proposed for OR quantification with the LOLP as a security factor. For a certain amount of OR, ND forecasting uncertainty *pdf* can be used to calculate the probability that power generation cannot cover the load demand. As a result, the risk/reserve characteristic curves with different quantity of OR can be obtained. If a constant LOLP is set, OR for each time interval can be obtained.

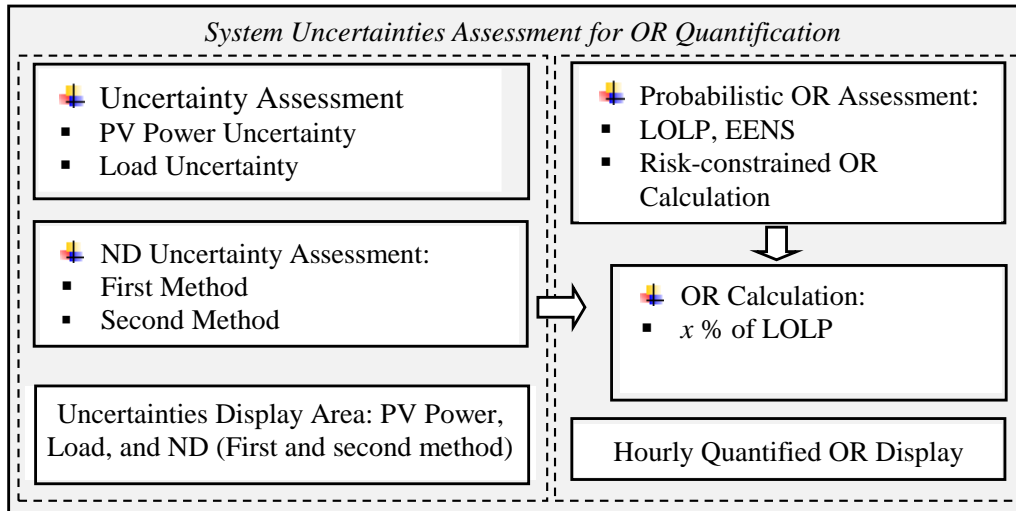

Figure V-6 Layout design of “OR Quantification”.

B. Interface design

Figure V-7 is the designed interface of OR quantification. The left part is the PV power, load, and ND uncertainty assessment, while in the right is the OR calculation.

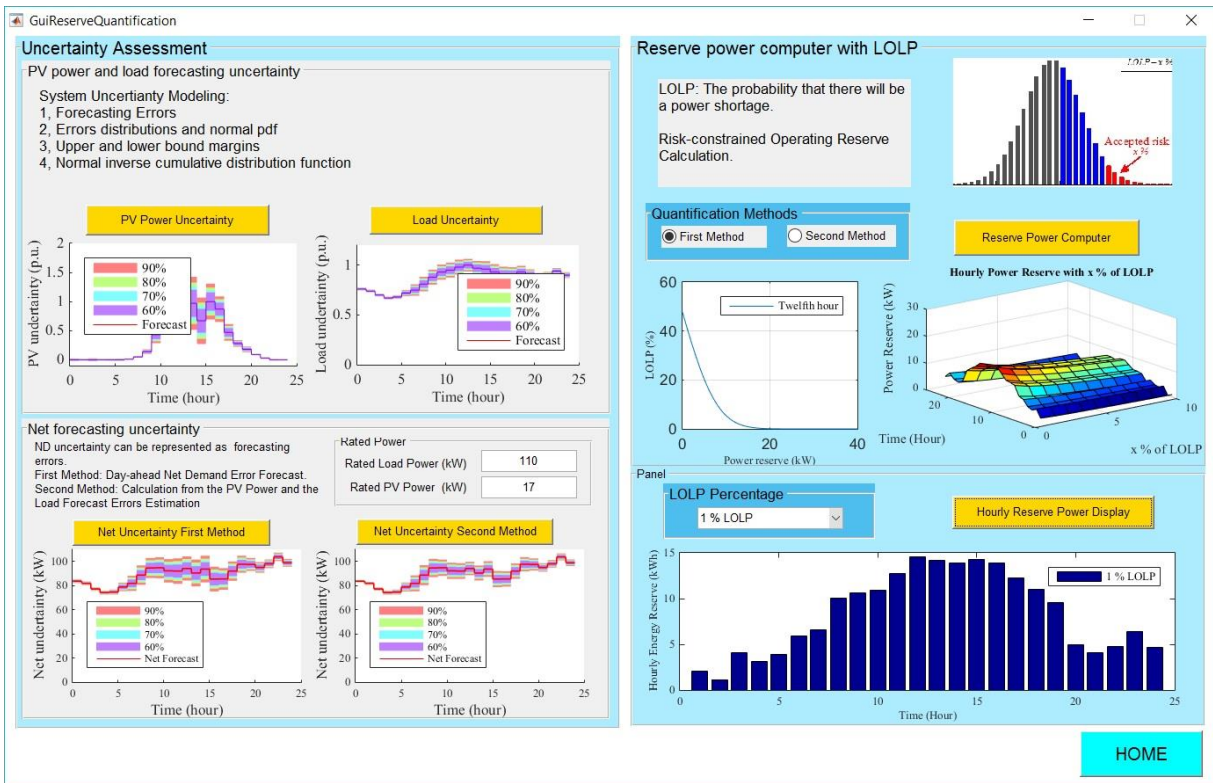

Figure V-7 System uncertainties assessment and OR quantification interface.

V.3.4. Operational and OR Dispatching

A. Layout design

Figure V-8 displays the layout design of OR dispatching interface window of OR dispatching for UC problem with DP.

a) Initialization

The system needs to be initialized (such as set the initial value of battery, set the rated power of MGTs, and so forth).

b) OR dispatching strategies

As presented in chapter IV, different strategies are considered, with high or low PV power scenarios, and OR dispatching into MGTs or into MGTs and PV AGs.

c) Dynamic programming for UC problem

The UC problem concerns the minimization of equivalent CO₂ emissions and total fuel cost by DP. To solve the objective function, different operational power and OR distribution strategies are proposed with several non-linear constraints. DP is applied for UC problem with different objective functions and different optimization criteria.

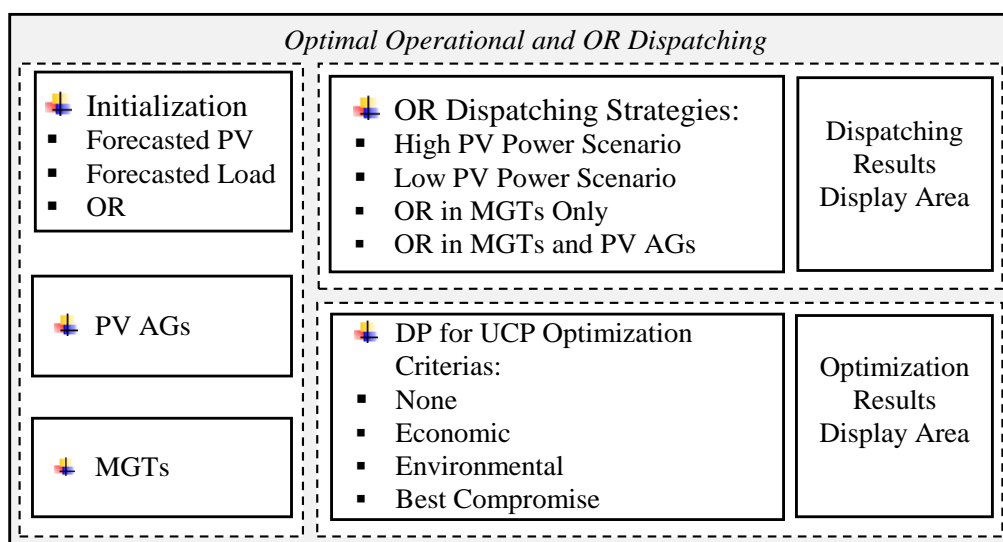

Figure V-8 Layout design of “Optimal Operational and OR Dispatching”.

B. Interface design

The designed interface window is illustrated in Figure V-9. In the right part, OR dispatching scenarios and DP for UC problem criteria are illustrated. In the left, there are two individual modules (PV AG and MGT), which will be demonstrated and discussed with details in the “Results and discussion” section.

V.4. Results and Discussion

ANNs are used here for both PV power and load forecasting. Before being applied for forecasting, they are trained with many data. To choose the inputs and outputs of each ANN, a predictive analysis is implemented. This part has been well explained in chapter II. The ANN training results are shown in the bottom-left tables of Figure V-5. Load demand data are downloaded from the RTE website (www.rte-france.com). For load forecast, the last 48 hours French power consumptions have been scaled as ANN input. With obtained inputs and well

trained ANNs, day-ahead PV power and load demand can be forecasted. Plots of downloaded PV data, load data, and predicted temperature at 9/29/2016 are shown in Figure V-5.



Figure V-9 OR dispatching interface.

For PV power forecast, day-ahead predicted temperatures can be obtained from the weather forecasting website (www.wunderground.com), and last 24 hours PV power output data are collected from three PV inverters (3 kW each), which are installed on the roof of the student residence of the Ecole Centrale de Lille (Figure V-10 and Figure V-11).



Figure V-10 PV panels installed on the roof of the student residence of Centrale de Lille.



Figure V-11 Three solar PV inverters with 0.6 kWh daily output for each.

Based on the forecasting database, uncertainties assessment results of PV power, load and ND can be found in Figure V-7. The results of OR calculation with a security factor LOLP are shown in the same interface window. Since the methods used in this part have been explained with details in chapter III, those results will not be explained again.



Figure V-12 Individual interface window of MGT.

In the top-right of Figure V-9, forecasted PV power, forecasted load demand, calculated OR with 1% of LOLP and power reference of all MGTs are presented. The OR is dispatched into both PV AGs and MGTs. The bottom-right of Figure V-9 illustrates the results of OR dispatching and OR plus load demand dispatching into the different power generators with the economic optimization criteria.

To have a much clear visual representation of MGTs and PV AGs working conditions, two individual interface windows have been developed, as shown in Figure V-12 and Figure V-13.

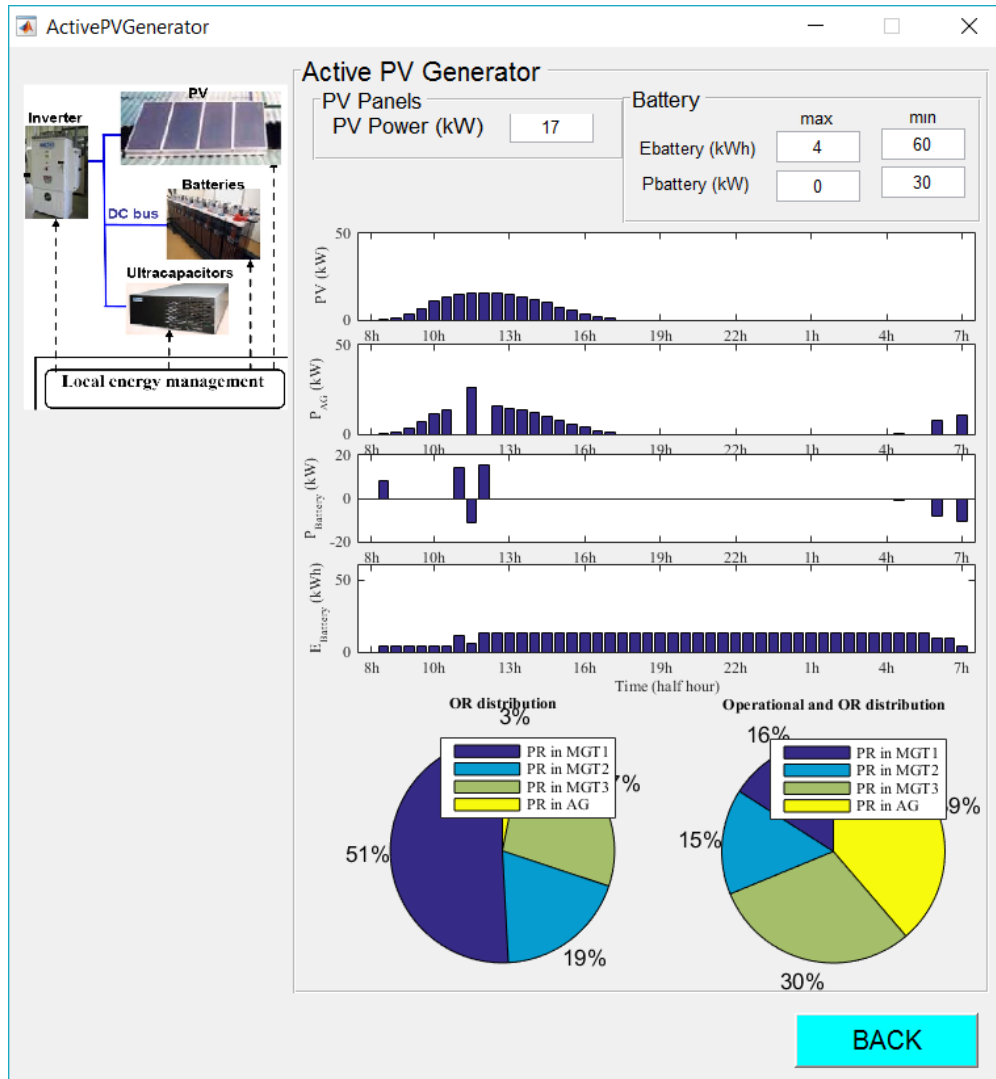

Figure V-13 Individual interface window of PV AG.

As shown in Figure V-12, all MGTs are shut down in some periods (from 10h to 13h, 14:30 to 15h, 15:30 to 16h, and 4h to 7h). The load demand and OR are covered by PV AGs during these operation steps. The energy is from the PV panels in the daytime and from batteries in the night. From the table in the top, the average power ratio of three MGTs is as high as 0.758 (0.7150, 0.6950, and 0.8639).

Figure V-13 shows the screen copy of the PV AG data. The PV power is used during the day time and the extra energy is stored into the battery. During the night, the battery is discharged. The two figures in the bottom presents the OR dispatching and the OR plus load demand dispatching into the different generators. The first OR dispatching pie chart shows that PV

AGs provide 20% of OR, while the second pie chart shows that 39% of the load plus the OR are provided by PV AG.

V.5. Conclusion

In this chapter, an EMS of an urban microgrid has been developed in Matlab environment. System uncertainties are analyzed with real data. Three main interfaces (Data collection for system uncertainty analysis, System uncertainty assessment, and OR dispatching) and several individual modules are designed to illustrate the details. This software platform can also be a useful tool to model and understand RES forecasting uncertainties and OR calculation in urban microgrids. This EMS and GUI could facilitate the day-ahead energy management in micro/smart grids as it proposes:

- An efficient information system: real time data collection (from smart meters, sensors, and meteorological observatory), predictive data analysis, and day-ahead PV power and load demand forecasting with artificial intelligence;
- An intelligent management.

References

- [1] C. Velásquez, D. Watts, H. Rudnick, and C. Bustos, "A Framework for Transmission Expansion Planning: A Complex Problem Clouded by Uncertainty," *IEEE Power and Energy Magazine*, vol. 14, pp. 20-29, 2016.
- [2] S. Karnouskos and T. N. De Holanda, "Simulation of a smart grid city with software agents," in *Computer Modeling and Simulation, EMS'09, Third UKSim European Symposium on*, 2009, pp. 424-429.
- [3] P. Kulshrestha, L. Wang, M.-Y. Chow, and S. Lukic, "Intelligent energy management system simulator for PHEVs at municipal parking deck in a smart grid environment," in *2009 IEEE Power & Energy Society General Meeting*, 2009, pp. 1-6.
- [4] T. Logenthiran, D. Srinivasan, A. M. Khambadkone, and H. N. Aung, "Multiagent system for real-time operation of a microgrid in real-time digital simulator," *IEEE Transactions on smart grid*, vol. 3, pp. 925-933, 2012.
- [5] J. Soares, B. Canizes, C. Lobo, Z. Vale, and H. Morais, "Electric vehicle scenario simulator tool for smart grid operators," *Energies*, vol. 5, pp. 1881-1899, 2012.
- [6] E. Poursmaeil, J. Gonzalez, K. Bhattacharya, and C. Canizares, "Development of a Smart Residential Load Simulator for Energy Management in Smart Grids," *IEEE Transactions on Power Systems*, submitted.
- [7] A. Ursachi and D. Bordeasu, "Smart grid simulator," *International Journal of Civil, Architectural, Structural and Construction Engineering*, vol. 8, pp. 519-522, 2014.
- [8] E. Schweitzer, K. Togawa, T. Schloesser, and A. Monti, "A Matlab GUI for the Generation of Distribution Grid Models," in *International ETG Congress 2015; Die Energiewende-Blueprints for the new energy age; Proceedings of*, 2015, pp. 1-6.
- [9] J. Oyarzabal, J. Jimeno, J. Ruela, A. Engler, and C. Hardt, "Agent based micro grid management system," in *2005 International Conference on Future Power Systems*, 2005, pp.1-6.
- [10] J.-H. Jeon, J.-Y. Kim, H.-M. Kim, S.-K. Kim, C. Cho, J.-M. Kim, *et al.*, "Development of hardware in-the-loop simulation system for testing operation and control functions of microgrid," *IEEE Transactions on Power Electronics*, vol. 25, pp. 2919-2929, 2010.
- [11] H. Kanchev, D. Lu, F. Colas, V. Lazarov, and B. Francois, "Energy management and operational planning of a microgrid with a PV-based active generator for smart grid applications," *Industrial Electronics, IEEE Transactions on*, vol. 58, pp. 4583-4592, 2011.
- [12] F. Katiraei and M. R. Iravani, "Power management strategies for a microgrid with multiple distributed generation units," *IEEE transactions on power systems*, vol. 21, pp. 1821-1831, 2006.
- [13] A. Hooshmand, M. H. Poursaeidi, J. Mohammadpour, H. A. Malki, and K. Grigoriadis, "Stochastic model predictive control method for microgrid management," in *2012 IEEE PES Innovative Smart Grid Technologies (ISGT)*, 2012, pp. 1-7.
- [14] A. Bagherian and S. M. Tafreshi, "A developed energy management system for a microgrid in the competitive electricity market," in *PowerTech, 2009 IEEE Bucharest*, 2009, pp. 1-6.
- [15] H. Fakhm, D. Lu, and B. Francois, "Power control design of a battery charger in a hybrid active PV generator for load-following applications," *Industrial Electronics, IEEE Transactions on*, vol. 58, pp. 85-94, 2011.

- [16] H. Kanchev, F. Colas, D. Lu, V. Lazarov, and B. Francois, "Energy management and power planning of a microgrid with a PV-based active generator for Smart Grid Applications," *IEEE Transactions on Industrial Electronics* 58.10 (2011), pp.4583-4592.
- [17] D. Lu, "Conception et contrôle d'un générateur PV actif à stockage intégré: application à l'agrégation de producteurs-consommateurs dans le cadre d'un micro réseau intelligent urbain," Ecole Centrale de Lille, 2010.
- [18] H. Kanchev, D. Lu, B. Francois, and V. Lazarov, "Smart monitoring of a microgrid including gas turbines and a dispatched PV-based active generator for energy management and emissions reduction," in *2010 IEEE PES Innovative Smart Grid Technologies Conference Europe (ISGT Europe)*, 2010, pp. 1-8.
- [19] H. Kanchev, "Gestion des flux énergétiques dans un système hybride de sources d'énergie renouvelable: Optimisation de la planification opérationnelle et ajustement d'un micro réseau électrique urbain," Ecole Centrale de Lille, Doctoral dissertation, 2014.
- [20] L. E. Jones, *Renewable energy integration: practical management of variability, uncertainty, and flexibility in power grids*: Academic Press, 2014.
- [21] P. D. Diamantoulakis, V. M. Kapinas, and G. K. Karagiannidis, "Big data analytics for dynamic energy management in smart grids," *Big Data Research*, vol. 2, pp. 94-101, 2015.
- [22] L. A. Wehenkel, *Automatic learning techniques in power systems*: Springer Science & Business Media, 2012.
- [23] E. Peeters, R. Belhomme, C. Batlle, F. Bouffard, S. Karkkainen, D. Six, *et al.*, "ADDRESS: scenarios and architecture for active demand development in the smart grids of the future," in *Electricity Distribution-Part 1, CIRED 2009, 20th International Conference and Exhibition on*, 2009, pp. 1-4.

General conclusion

General Conclusion

Aggregate generation and load must be balanced instantaneously to maintain security and reliability of electric power systems. The integration of variable RES has a negative impact on electric system security. Indeed, effective calculation and dispatching of operating reserve by considering inaccurate forecasting of both RES and load demand can provide substantial cost reductions.

By considering uncertainties from both RES and load demand, this Ph.D. thesis is focused on the probabilistic OR calculation and dispatching in a microgrid, which is powered by a significant amount of PV based active generators including storage.

In the first chapter, the general ideas of smart grids and microgrids are introduced. Faced with the problems of intermittent RES based electricity production, an active PV generator including storage devices has already been proposed and recalled. Thus main functions of a micro grid management system are presented. In this presented context, research objectives and methods to analyze and take into account the uncertainty from production/consumption are then explained.

In the second chapter, solar irradiance variability indices are proposed for a better understanding of the variable characteristics of PV power generation. ANN based forecasting methods are recalled and used to predict one day ahead the PV production and load demand.

Obtained forecasting errors are then used in the third chapter to analyze the PV power generation uncertainty and the load demand. Then for each studied time step of the next day, the OR is sized with the ND forecasted uncertainty by using a probabilistic method and a risk level related to reliability assessment indicator. Two methods have been proposed to calculate the ND forecast errors.

In the fourth chapter, a technique for a joint dispatch of the forecasted load demand and OR power in generators is proposed. Two different OR power dispatching strategies are compared:

- the OR power is only provided by MGT and the load demand is provided by all generators;
- the OR power is dispatched to all generators in order to maximize efficiency and reliability of the electrical supply.

For the second situation, OR can be covered by PV AGs and MGTs can be totally shutdown in certain time steps when PV power or battery energy is more than load and OR.

Then, a day-ahead optimal operational and OR power planning with dynamic programming has been proposed with different constraints. The proposed method uses DP to minimize the objective functions for different optimization strategies: economic criteria, environmental criteria, and best compromise criteria. The accuracy and the effectiveness of the suggested method are verified for four different scenarios.

In the last chapter, an urban micro-grid with MGTs and active PV generators is considered for applications of propositions. System uncertainties are analyzed with real data. Then, an implementation of the energy management system with three main graphical interfaces (Data collecting for system uncertainty analysis, system uncertainty assessment, and OR dispatching) and several individual modules are designed to illustrate the system operation results. The proposed EMS is opened and can be used by researchers to experiment other strategies and optimization algorithms, and to understand RES forecasting uncertainties and OR calculation in this urban microgrid.

The major contributions are as followings:

- PV power variability and load demand variability are analyzed.
- A probabilistic method for the OR calculation based on two different kinds of ND forecasted uncertainty assessment methods is proposed.
- Joint load demand and OR power dispatching strategies onto generators are developed.
- One-day-ahead optimal operational and OR planning with a dynamic programming technique are proposed by considering different constraints to minimize objective functions with different optimization strategies.
- A user friendly microgrid energy management, which is focusing on the uncertainty analysis and the management of generators, is developed for a systemic uncertainty analysis.

On the basis of these promising results, some points need to be studied much further, such as data flow analysis because of the increased installation of smart meters within the distributed power grid, and the stability analysis of microgrid because of using the battery energy storage system for increasing the intermittent RES penetration. Therefore, to lead to a further step of RES integration in the microgrid, the future work will involve several aspects:

- Firstly, extract and analyze useful information from “big data” (coming from smart meters in electrical networks, weather forecasting, and so on) for the decision making use and to increase the stability of distributed microgrid (voltage regulation, frequency regulation , ...);
- Secondly, apply other artificial intelligence methods to improve the energy from the RES and the load demand predict accuracy;
- Thirdly, analyze the impact of the uncertainty onto the operation of electrical networks, as the regulation of AC voltages, the local production of reactive power, the possible islanding of a part of an electrical network;
- Last but not least, optimize the battery management methodologies for a smart use of distributed storage systems to help to increase RES penetration levels and maximum fuel savings in a microgrid, and so forth.

Appendices

Appendix I. Renewable Energy Sources

A.I.1. Renewable energy coming directly from sun: Solar power

There are two categories of technologies that convert solar irradiation into useful energy forms. First, solar photovoltaic (PV) modules convert radiation directly into direct-current electricity through PV modules, which are solid-state semiconductor devices. Secondly, concentrating solar power (CSP) focuses the solar radiation to produce steam, which is then used to produce electricity with a turbine.

Enormous progresses have been made in PV performance and cost reduction since its first major application to power satellites in the late 1950s. The technical and economic driving forces the use of PV technologies in widely diverse applications. Consequently, the cost of PV system is declining; performance and efficiency have been steadily improved, and increased rapidly in solar power generation in recent years and also the years to come. According to IEA report in 2014 [1], solar PV and concentrated solar power would contribute about 16 and 11 percent respectively of the worldwide electricity consumptions by 2050.

Even in this year (2016), total global solar installations will reach 64.7 GW, according to a clean energy communication and research firm named Mercom Capital Grop [2]. The top three countries will be China, U.S., and Japan and they will account for about two thirds of the global market. For example, China, which is faced with serious pollution problems, considered to bring about 21 GW of annual installation between 2016 through 2020. It remains to be the largest market and is expected to install approximately 19.5 GW in 2016. Officials from China's National Energy Administration (NEA) are considering raising the 2020 target from 100 GW to 150 GW, which will bring about 21 GW of annual installations between 2016 through 2020. It also has pledged to reach an 'emissions peak' around 2030 with non-fossil fuels making up 20 percent of the nation's energy generation mix. And this will made renewable forms of energy a vital component of the Chinese economy for years to come. Even though the cost of electricity produced from PV systems is still higher than conventional power plant, these costs are expected to decline steadily [1].

A.I.2. Renewable energy coming indirectly from sun

A. Hydropower

Being the largest renewable resource used for electricity and providing over 80 percent of renewable energy capacity, hydropower plays an essential role in more than 150 countries all over the world [3]. In addition to the clean, low maintenance, flexibility, long operation lifetimes, it is a technologically mature industry with highly competitiveness. Well-established markets exist in Europe and North America. Large-scale plants (>100 MW) are expected to provide the vast majority of new capacity. While the growing pumped storage and small-scale hydropower will provide less than 10 percent of future capacity. Moreover, hydropower has the ability to function as a grid management asset: delivering base and peak load energy, frequency response and black-start capabilities. These solutions are recognized as critical to facilitate a successful transition to renewable energy. Moreover, ancillary hydropower functions can assist nations in adapting the climate change by providing freshwater for irrigation, drought management and flood protection solutions.

B. Wind power

Wind power is coming from the movement of a wind turbine, which converts kinetic energy from the wind into electrical power. Wind turbines can rotate about either a horizontal (more

common) or a vertical axis. With the development of modern engineering, wind turbines nowadays are manufactured in a wide range. Wind farms, formed by arrays of large turbines, are used by many countries as an important strategy to reduce their dependence on fossil fuels. Now, larger turbines, more efficient manufacturing, and careful siting of wind machines have brought down wind power costs: wind energy is currently considered as the most cost-competitive renewable energy technology [4].

C. Offshore Wind Power

The next major development in wind energy is offshore wind energy. Its advantages include:

- Reduction in visual impact;
- A higher mean wind speed;
- Reduced wind turbulence;
- Low wind shear leading to lower towers.

Its disadvantages include: higher capital cost, access restrictions due to weather conditions, and submarine cables requirement. Due to their size and remote location, a number of new challenges arise from the integration of offshore wind power with electrical networks. However, using HVDC transmission network, instead of AC high-voltage submarine cables, would be a solution to bring the power onto land.

D. Biomass Energy

Biomass energy, or bioenergy, is essentially the collection and storage of sun's energy through photosynthesis of plants, trees and crops. It is the conversion of biomass into useful forms of energy such as heat, electricity and liquid fuels. It can either be used directly via combustion to produce heat and release carbon dioxide, or indirectly after converting it to various forms of biofuel with different conversion technologies, such as gasification, anaerobic digestion, and liquid biofuels. The key issue for bioenergy is that its use must be modernized to fit into a sustainable development by decreasing its air pollution effect and improve its efficiency.

A.I.3. Renewable energy from other natural movements and mechanisms

A. Geothermal Energy

Geothermal energy is from the heat of the earth itself: either from the ancient heat remaining in the Earth's core, or from the decay of radioactive elements that occur naturally in small amounts in all rocks. Nowadays, technological advances and decreasing in cost have made it possible to locate and drill into hydrothermal reservoirs, pipe the steam or hot water to the surface, and use the heat directly (for space heating, aquaculture, and industrial processes) or to convert the heat into electricity.

The amount of geothermal energy is enormous and total installation capacity is increasingly growing. Figure AI-1 shows the global geothermal energy installed capacity in 2015 [5]. Following the indicator of the 21st Conference of Parties (COP21), geothermal will receive global support from the Global Geothermal Alliance to help the industry to realize a five-fold increase in global installed geothermal capacity by 2030 [6].

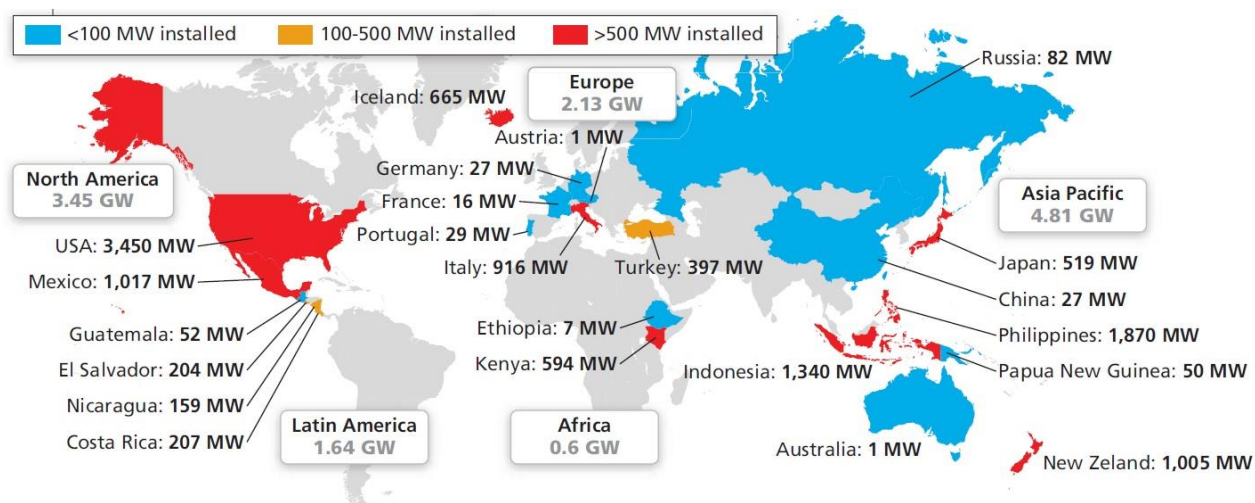

Figure AI-1 Installed geothermal capacity in 2015 worldwide [5].

B. Ocean energy

Marine energy (or marine power) refers to vast and largely untapped energy sources in the form of two kinds of energy: kinetic energies or energy in motion, which are surface waves and fluid flow; potential energies, which are salinity gradients, and thermal (ocean temperature differences). This energy can be harnessed by different devices, such as wave power converters, tidal turbines, ocean current turbines, and ocean thermal energy converters, to generate electricity to power homes, transport and industries.

References

- [1] I. E. Agency, "World Energy Outlook Special Report: Energy and Climate Change " 2015.
- [2] I. E. Agency, Technology roadmap: solar photovoltaic energy-2014 edition: OECD/IEA, 2014.
- [3] J. Movellan, "The 2016 Global PV Outlook: US, Asian Markets Strengthened by Policies to Reduce CO₂," January 25, 2016 2016.
- [4] W. Steel, "Hydropower Outlook 2016: Exploring the Water-Energy Nexus and Energy Storage," 2016.
- [5] R. Haas, C. Panzer, G. Resch, M. Ragwitz, G. Reece, and A. Held, "A historical review of promotion strategies for electricity from renewable energy sources in EU countries," Renewable and sustainable energy reviews, vol. 15, pp. 1003-1034, 2011.
- [6] R. Bertani, "Geothermal power generation in the world 2010–2014 update report," Geothermics, vol. 60, pp. 31-43, 2016.

Appendix II. Photovoltaic Circuit-based Physical Model

A.II.1. Equivalent Circuit Model

The basic device of a photovoltaic system is the PV cell, which converts sunlight into electricity. Panels can be grouped in series and/or parallel to form large PV arrays. Photovoltaic arrays present a nonlinear I - V characteristic. The mathematical model of the photovoltaic array may be useful in the study of the dynamic analysis of converters, in the study of maximum power point tracking (MPPT) algorithms and to simulate the photovoltaic system and its components [1, 2].

In the literature, a photovoltaic cell is often depicted as a current generator with a behavior equivalent to a current source shunted by a diode. As shown in Figure AIII-1, the model is completed by two resistors R_S and R_P to complete the model.

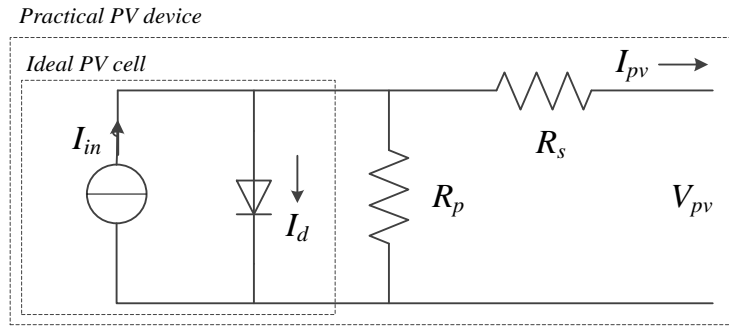

Figure AIII-1 Single-diode model of the theoretical photovoltaic cell and equivalent circuit of a practical photovoltaic device including the series and parallel resistances.

Based on the single-diode model in Figure AIII-1, current I_{pv} generated by the panel is expressed as a function of R_S and R_P resistors, voltage V_{pv} and currents I_{in} and I_0 , as follows:

$$I_{PV}(t) = I_{in} + I_0 \left[\exp\left(\frac{V_{PV}(t) + R_S I_{PV}(t)}{V_t a}\right) - 1 \right] - \frac{V(t) + R_S I_{PV}(t)}{R_P} \quad (\text{A.II-1})$$

which:

I_{in} is photovoltaic current due to irradiation. If the panel is composed of N cells connected in parallel, then $I_{in} = I_{in_cell} \times N$, where I_{in_cell} is the saturation current for a single cell;

I_0 is saturation current of the PV panel. $I_0 = I_{0_cell} \times N$, where I_{0_cell} is the current of a single cell and N is the number of cells in parallel;

V_t is thermal potential of the panel. $V_t = N_s \times K \times T / q$, N_s is the number of cells in series, K : Boltzmann constant [$1.3806503 \times 10^{-23}$ J/K], q is the charge of an electron [$1.60217646 \times 10^{-19}$ C] and T is the temperature of the p-n junction in Kelvin degree [°K]. Typically, T is assumed equal to the ambient temperature.

a is the ideal constant of the diode.

V_{PV} is the voltage across the panel.

The photovoltaic current I_{in} is linearly dependent on the irradiance (G) and is also influenced by the temperature T according to the following equation:

$$I_{in}(t) = (I_{in_n}(t) + K_I \Delta T(t)) \frac{G}{G_n} \quad (\text{A.II-2})$$

$I_{in,n}$ is the photovoltaic current generated at nominal conditions (usually 25 °C with 1000 W/m²), $\Delta T = T - T_n$ and K_I is coefficient of variation of current as a function of temperature.

$$I_{in,n} = \frac{R_p + R_s}{R_p} \times I_{sc,n} \quad (\text{A.II-3})$$

$I_{sc,n}$ is the rated short-circuit current under nominal conditions of temperature and irradiation (under T_n and G_n).

The saturation current I_0 also depends on the temperature according to the following expression:

$$I_0(t) = I_{0,n} \left(\frac{T_n}{T(t)} \right)^3 \exp \left[\frac{gE_g}{ak} \left(\frac{1}{T_n} - \frac{1}{T(t)} \right) \right] \quad (\text{A.II-4})$$

with: E_g is the energy band-gap of the semiconductor, $E_g \approx 1.12eV$ for polycrystalline silicon panels. k is the Boltzmann constant [$1.3806503 \cdot 10^{-23}$ J/K]. $I_{0,n}$ is the nominal saturation current given by:

$$I_{0,n} = \frac{I_{sc,n} + K_I \Delta T}{\exp \left(\frac{V_{oc,n} + K_V \Delta T}{aV_t} \right) - 1} \quad (\text{A.II-5})$$

where: $V_{oc,n}$ corresponds to nominal voltage vacuum and K_V is the variation coefficient of the voltage as a function of temperature.

A.II.2. PV characteristic curves

A. Theory of I-V Characterization

The I-V curve of an illuminated PV cell has the shape shown in Figure AIII-2.

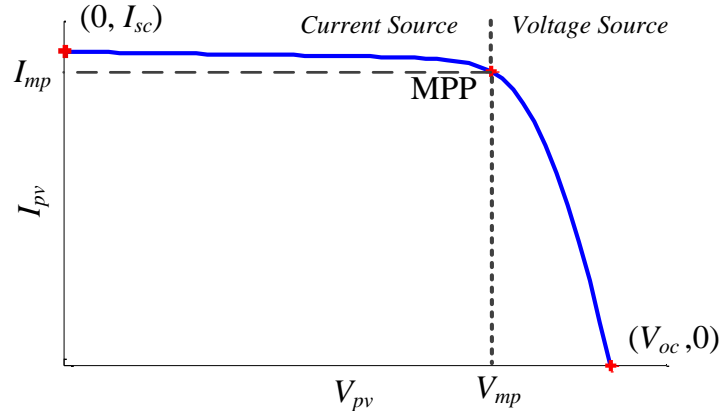

Figure AIII-2 Characteristic I-V curve of a practical photovoltaic device and the three remarkable points: short circuit ($0, I_{sc}$), maximum power point (V_{mp}, I_{mp}) and open-circuit ($V_{oc}, 0$).

The practical photovoltaic device presents a hybrid behavior, which may be of current or voltage source depending on the operating point. Here, three key points are highlighted: open-circuit voltage ($V_{oc}, 0$), short circuit current ($0, I_{sc}$) and maximum power point (MPP (V_{mp}, I_{mp})). The voltage across the measuring load is swept from zero to V_{oc} , and many performance parameters for the cell can be determined from this data, as described in the sections below.

- **Short Circuit Current (I_{sc})**

The short circuit current I_{SC} corresponds to the short circuit condition when the impedance is low and is calculated when the voltage equals 0 ($I_{SC} = I_{pv}$, at $V_{OC}=0$).

I_{SC} occurs at the beginning of the forward-bias sweep and is the maximum current value in the power quadrant. For an ideal cell, this maximum current value is the total current produced in the solar cell by photon excitation.

- **Open Circuit Voltage (VOC)**

The open circuit voltage (V_{OC}) occurs when there is no current passing through the cell. ($V_{OC} = V_{pv}$, at $I_{pv}=0$).

- **Maximum Power Point (MPP)**

The power produced by the cell in Watts can be easily calculated along the I-V sweep by the equation $P_{PV}=I_{pv}*V_{pv}$. At the I_{SC} and V_{OC} points, the power will be zero and the maximum value for power will occur between these two points. The voltage and current at this maximum power point are denoted as V_{MP} and I_{MP} respectively at point (V_{mp}, I_{mp}) . And before this point, this PV device can be regarded as a current source. The power is changing mainly with voltage variations, while after this point as a voltage source.

In Figure AIII-3, I-V and P-V curves are presented to illustrate the MPP.

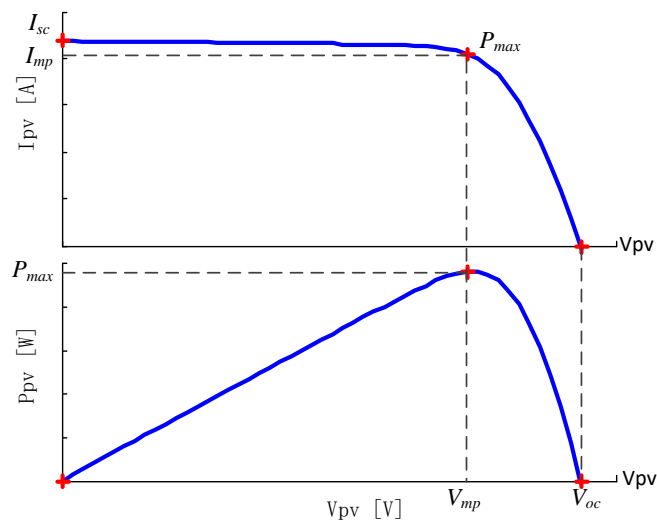

Figure AIII-3 Location of the maximum power for regulating the voltage.

The curve can be divided into 2 periods: the first from 0 to V_{mp} , the second from V_{mp} , to V_{OC} . During the first period, the P_{PV} curve is rising until it reaches the maximum point P_{max} (V_{mp} , I_{mp}). In this stage, the current is slightly dropped. After that peak, the P_{PV} falls dramatically. It reaches 0 at V_{OC} because of the current declines to 0.

B. Influence of the temperature on I-V and P-V curves

The output power of the photovoltaic cell is depending on the external ambient temperature and function of the illumination intensity. In a solar cell, the most affected parameter by an increase in temperature is the open-circuit voltage. The impact of increasing temperature is shown in the figure below. In Figure AIII-4, due to the external temperature variations, the photovoltaic cell exports the characteristic curves and changes too, thus the maximum power clicks and drifts. As temperature raises and PV module heats up, the open-circuit voltage (V_{OC}) decreases and its power production falls. At the same time, MPP decreases too.

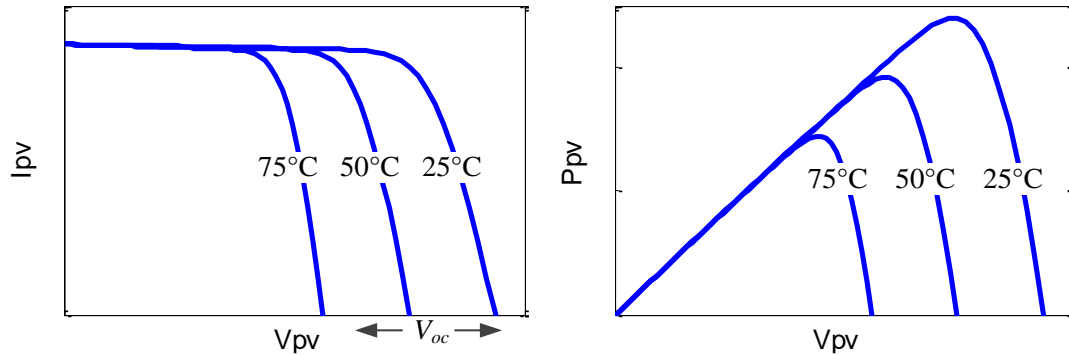

Figure AIII-4 Change on the I-V curve and P-V curve.

C. Influence of the irradiance on I-V and P-V curves

The amount of power delivered by the sun can be expressed in Watts per square meter. Ideally, the module should be oriented towards the equator because of the influence on inclination and orientation of the received irradiance. As irradiance varies, so does the photovoltaic current I_{in} following equation II.7. Figure AIII-5 provides the output characteristic curves for different irradiation intensities. Larger the irradiance intensity is, the larger is photovoltaic cell short circuit current I_{sc} and output power. The photovoltaic cell output power P_{pv} and output voltage V_{pv} are limited by $P_{pv} = I_{pv} \cdot V_{pv}$. Different irradiation intensity of Figure 8 makes the output characteristic of the photovoltaic cell. Lower I-V contours of different irradiation intensities make lower P-V contours of different irradiation intensities.

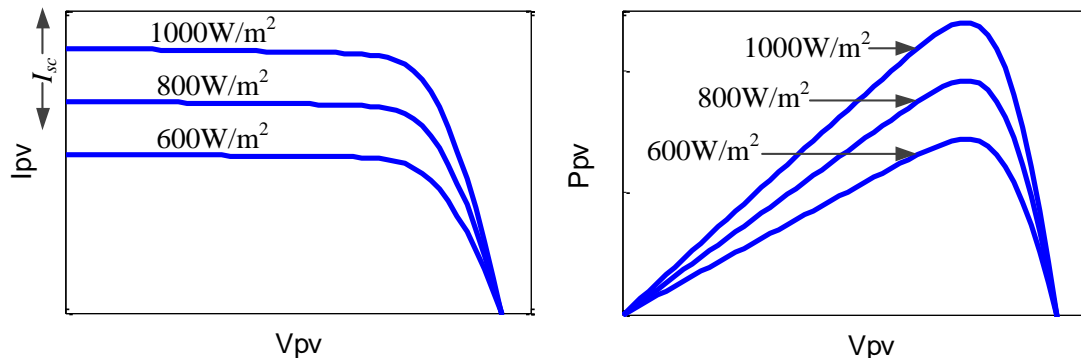

Figure AIII-5 Influence of the irradiance on the PV electrical qualities.

A.II.3. PV cells connection (parallel and/or series)

The characteristics of curves introduced above have shown that a PV cell is a light-dependent and voltage-controlled current source. The smallest part of the PV system is the cell and it can only generate a low voltage with certain surface. So, generally many PV cells need to be connected together in order to produce a certain power with certain voltage and current in parallel and/or series. The overall I-V curve properties change with several cells. Theoretically, connecting N cells in series raises the voltage V_{OC} to $N \times V_{OC}$, while connecting N cells in parallel raises the current I_{sc} to $N \times I_{sc}$. Figure AIII-6 (a) and (b) show the I-V curves for such connection schemes with only two identical PV cells under the same irradiance and temperature.

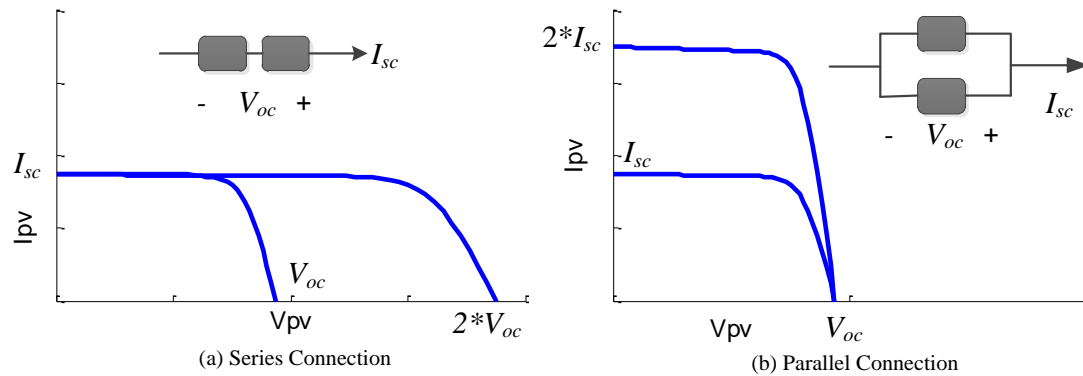

Figure AIII-6 Types of connections among PV cells and their respective I-V curves: (a) series connection; (b) parallel connection.

With a certain number of cells connecting in parallel and/or series, a PV module with a certain voltage is made. To build a PV plant, series connections will induce an increase of the voltage in a higher level (such as 12, 24, 48 and 60V). Then, those modules in strings are connected in parallels to reach a higher current. However, this power output is varying with solar irradiation and temperature changes, which depend on the weather conditions. So, the method used to track the maximum power output is applied to increase the efficiency as much as possible.

A.II.4. Maximum power point tracker (MPPT)

For maximizing the PV conversion efficiency, the incoming sun energy must be converted to electricity with the highest efficiency. This is accomplished when the photovoltaic module operates at the MPP. Nevertheless, since this operating point is strongly affected by the solar irradiation and temperature, it may dynamically vary along the I - V character graph, as shown in Figure AIII-7. MPP (red cross) decreases with the temperature while increases with solar irradiation growths.

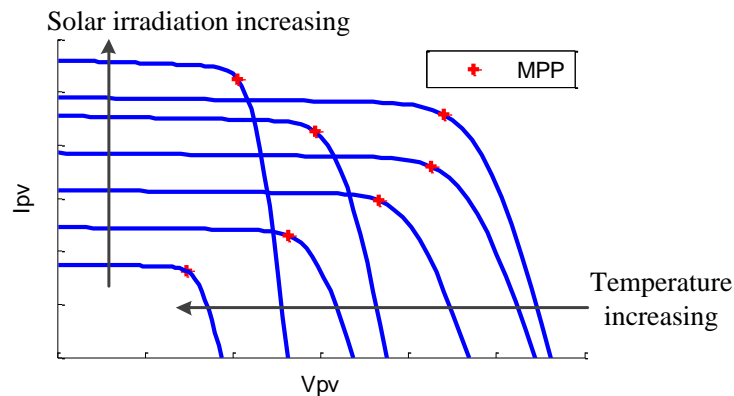

Figure AIII-7 MPP locating on the I - V characteristic considering solar radiation and temperature changes.

Thus, in order to dynamically set the MPP operation point for a wide range of solar radiation and temperature, a MPP tracking is required. The studies regarding the MPPT are grouped in two categories: the first is related to hardware, in which the influence of the dc-dc converter and load-type on the tracking quality is investigated, and the second refers to the software, where the tracking accuracy and speed are targeted. Also, in [3] the algorithms for seeking the MPP are grouped as either direct or indirect methods. Later ones have to measure the PV generator's voltage and current, the irradiance or use empirical data to estimate the MPP. In a same case, they can be inexpensive and simple. The direct methods enable to obtain the actual

maximum power from the measurement of the PV generator's voltage and current. The advantages of these methods are small database, less calculating, versatile with respect to the load, independently seeking of MPP. Finally, there are other methods existing, such as artificial methods and Fibonacci series based methods but two variables must be measured.

References

- [1] D. Abbes, G. Champenois, A. Martinez, and B. Robyns, "Modeling and simulation of a photovoltaic system: An advanced synthetic study," in *Systems and Control (ICSC), 2013 3rd International Conference on*, 2013, pp. 93-98.
- [2] M. G. Villalva and J. R. Gazoli, "Modeling and circuit-based simulation of photovoltaic arrays," in *Power Electronics Conference, 2009. COBEP'09. Brazilian*, 2009, pp. 1244-1254.
- [3] V. Salas, E. Olias, A. Barrado, and A. Lazaro, "Review of the maximum power point tracking algorithms for stand-alone photovoltaic systems," *Solar energy materials and solar cells*, vol. 90, pp. 1555-1578, 2006.

Appendix III. Characteristics of MGTs

A.III.1. Efficiency characteristic

To have a model that estimates the gas consumed by the micro turbine and also the exhaust gas, we assumed that the turbine works during a time interval (τ) with a constant power output [1]. In this case, the electrical efficiency is equal to:

$$\eta(t) = \frac{E_{MGT_i}(t)}{F_{MGT_i}(t)} \quad (\text{A.III-1})$$

E_{MGT_i} (kWh, electric) is the energy production and F_{MGT_i} (kWh, thermal) is the consumed fuel energy (calorific fuel energy).

In a microgrid with i micro turbines, the i^{th} micro gas turbine has a utilization rate (in %), which is equal to the instantaneous power of this micro turbine divided by the maximum power:

$$\alpha_i(t) = \frac{P_{MGT_i}(t)}{P_{MGT_max_i}} \quad (\text{A.III-2})$$

With the equations (A.III.1) and (A.III.2), the electrical efficiency is a function of the generated power:

$$\eta(t) = \frac{\tau \cdot P_{MGT_i}(t)}{F_{MGT_i}(t)} = \tau \cdot \frac{\alpha_i(t)}{F_{MGT_i}(t)} P_{MGT_max_i} \quad (\text{A.III-3})$$

Experimental results and researches show that micro turbine performances are not constant for all operating points. It depends on the utilization rate of micro turbine ($\alpha_i(t)$). Figure AIII-1 shows the micro turbines electrical efficiency with maximum capacities of 30 and 60 kW, in the range of 50-100% load with a pitch of 5% [1].

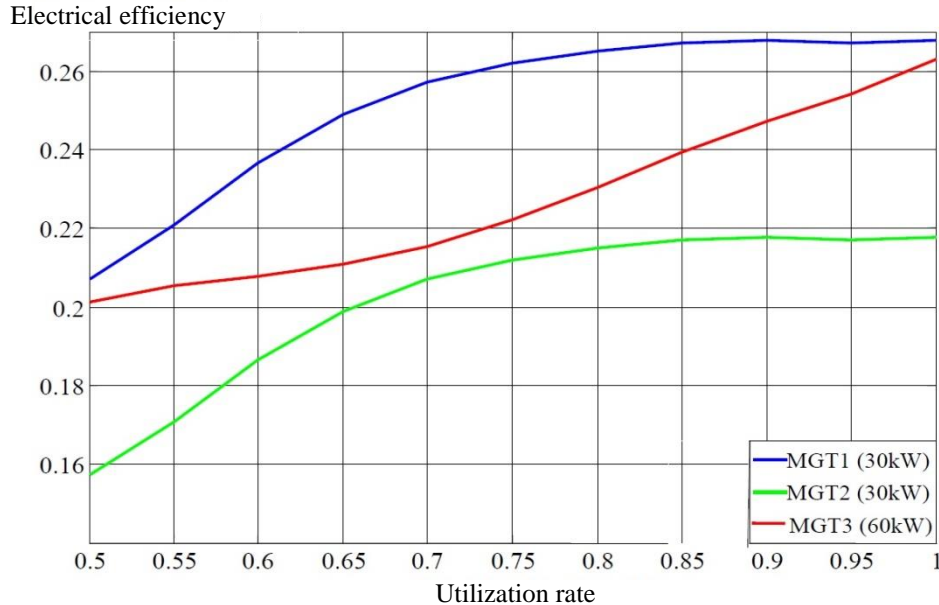

Figure AIII-1 Characteristic of efficiency according to utilization rate (p.u.) [1].

These experimental results are considered for a micro gas turbine with a 30 kW rated output and a characteristic slightly degraded compared to the others, which is due to aging. It is wise to avoid using a micro turbine below 50% of its rated power, because in that case the

efficiency is low and, in addition, emissions are high. These electrical performance characteristics have been approximated by a 6th order polynomial:

For the micro turbine 1, the maximum power is 30 kW:

$$\eta_1 = 10^2 \cdot (0.89 \cdot \alpha_1^6 - 4.13 \cdot \alpha_1^5 + 7.29 \cdot \alpha_1^4 - 8.00 \cdot \alpha_1^3 + 4.49 \cdot \alpha_1^2 - 1.32 \cdot \alpha_1^1 + 0.16) \quad (\text{A.III-4})$$

For the micro turbine 2, the maximum power is 30 kW:

$$\eta_2 = 10^2 \cdot (0.89 \cdot \alpha_2^6 - 4.13 \cdot \alpha_2^5 + 7.29 \cdot \alpha_2^4 - 8.00 \cdot \alpha_2^3 + 4.49 \cdot \alpha_2^2 - 1.32 \cdot \alpha_2^1 + 0.16) \quad (\text{A.III-5})$$

For the micro turbine 3, the maximum power is 60 kW:

$$\eta_3 = 10^2 \cdot (0.34 \cdot \alpha_3^6 - 1.43 \cdot \alpha_3^5 + 2.38 \cdot \alpha_3^4 - 2.04 \cdot \alpha_3^3 + 0.94 \cdot \alpha_3^2 - 0.22 \cdot \alpha_3^1 + 0.023) \quad (\text{A.III-6})$$

A.III.2. Estimation of exhaust gas emissions

To quantify the emissions of CO, CO₂ and NO_x, the "emission factors" model is used:

$$m_p = \mu_p \cdot X \quad (\text{A.III-7})$$

Where m_p (mg) is the mass of the emitted gas, μ_p (mg / kWh) is the emission factor of gas p to produce X (kWh) of electricity. Emission factors are not constant and depend on the operating point of the turbine.

Experimental characteristics of manufacturers give emission factors for each gas depending on turbine utilization (in percent).

From the NO_x emission characteristics (Figure AIII-2), interpolations of 6th order polynomial functions are deduced.

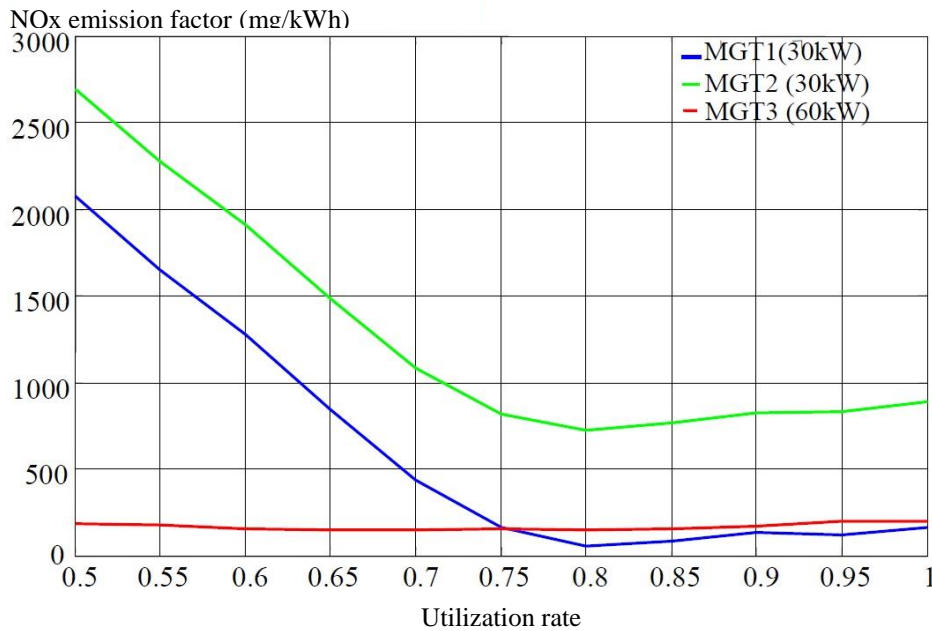

Figure AIII-2 Characteristic of NO_x emissions factor based on generated power (p.u.) [17].

For micro turbine 1:

$$\mu_{\text{NOx}_1} = 10^6 \cdot (5.70 \cdot \alpha_1^6 - 2.56 \cdot \alpha_1^5 + 4.73 \cdot \alpha_1^4 - 4.59 \cdot \alpha_1^3 + 2.74 \cdot \alpha_1^2 - 0.70 \cdot \alpha_1^1 + 0.81) \quad (\text{A.III-8})$$

For micro turbine 2:

$$\mu_{NOx_2} = 10^6 \cdot (5.69 \cdot \alpha_2^6 - 25.63 \cdot \alpha_2^5 + 47.53 \cdot \alpha_2^4 - 45.93 \cdot \alpha_2^3 + 24.68 \cdot \alpha_2^2 - 6.98 \cdot \alpha_2^1 + 0.81) \quad (\text{A.III-9})$$

For micro turbine 3:

$$\mu_{NOx_3} = 10^6 \cdot (-0.97 \cdot \alpha_3^6 + 4.33 \cdot \alpha_3^5 - 7.92 \cdot \alpha_3^4 + 7.64 \cdot \alpha_3^3 - 4.09 \cdot \alpha_3^2 + 1.15 \cdot \alpha_3^1 - 0.13) \quad (\text{A.III-10})$$

For each micro turbine, by using equations (A.III-8, A.III-9 and A.III-10) the masses of NOx (mg) for a constant utilization rate α_i during a time interval τ by an interpolation function may be inferred as:

$$m_{NOx_i}(t) = \mu_{NOx_i} \cdot \tau \cdot P_{MGT_max_i} \cdot \alpha_i(t) \quad (\text{A.III-11})$$

For CO emissions, there is also a relationship between the factor of CO emissions and the utilization rate. Experimental characteristics presented in Figure AIII-3 can also be expressed with a 6 order polynomial function:

For micro turbine 1:

$$\mu_{CO_1} = 10^6 \cdot (7.78 \cdot \alpha_1^6 - 34.68 \cdot \alpha_1^5 + 63.42 \cdot \alpha_1^4 - 60.83 \cdot \alpha_1^3 + 32.29 \cdot \alpha_1^2 - 9.01 \cdot \alpha_1^1 + 1.04) \quad (\text{A.III-12})$$

For micro turbine 2:

$$\mu_{CO_2} = 10^6 \cdot (7.78 \cdot \alpha_2^6 - 34.68 \cdot \alpha_2^5 + 63.42 \cdot \alpha_2^4 - 60.83 \cdot \alpha_2^3 + 32.29 \cdot \alpha_2^2 - 9.01 \cdot \alpha_2^1 + 1.04) \quad (\text{A.III-13})$$

For micro turbine 3:

$$\mu_{CO_3} = 10^6 \cdot (15.36 \cdot \alpha_3^6 - 68.56 \cdot \alpha_3^5 + 12.55 \cdot \alpha_3^4 - 12.07 \cdot \alpha_3^3 + 64.24 \cdot \alpha_3^2 - 17.9 \cdot \alpha_3^1 + 0.2) \quad (\text{A.III-14})$$

From the CO emission factor, the mass of CO of a micro turbine, which is operating at constant power during τ , can be calculated:

$$m_{CO_i}(t) = \mu_{CO_i} \cdot \tau \cdot P_{MGT_max_i} \cdot \alpha_i(t) \quad (\text{A.III-15})$$

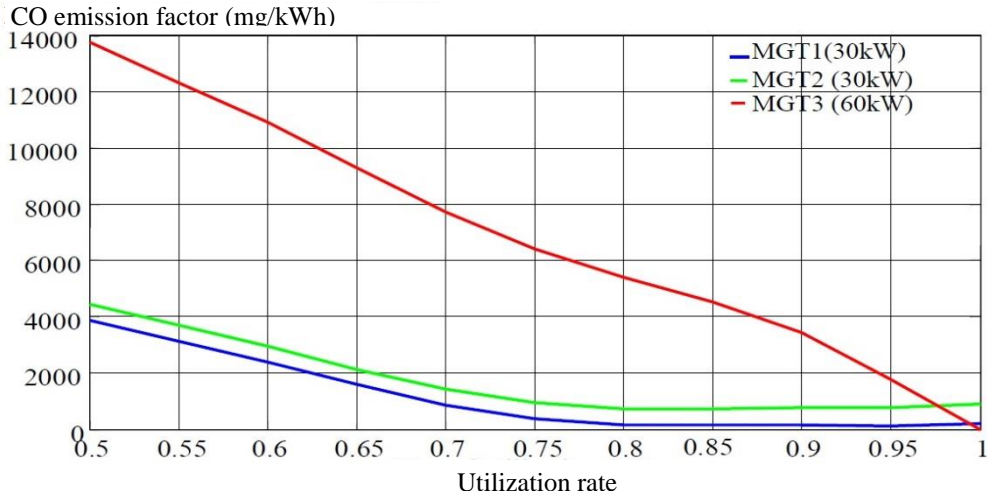

Figure AIII-3 Characteristic of CO emission factor depending on MGT utility (p.u.) [1].

A.III.3. Estimation of fuel consumption

In order to estimate gas consumption, equation (A.III-1) is reformulated as follows:

$$F_{MGT_i}(t) = \frac{E_{MGT_i}(t)}{\eta_i(t)} = \frac{\tau \cdot P_{MGT_i}(t)}{\eta_i(t)} = \frac{\tau \cdot \alpha_i(t) \cdot P_{MGT_max_i}}{\eta_i(t)} \quad (\text{A.III-16})$$

The amount of consumed fuel is proportional to its thermal energy. F_{MGT_i} is sufficient to estimate the gas consumption by a micro gas turbine that operates at a constant power P_{MGT_i}

during a time interval τ . The mass of the consumed gas can be calculated from the energy density of natural gas, which is 13.5 kWh/kg [2]:

$$m_{gas_i}(t) = \frac{F_{MGT_i}(t)}{13.5} \quad (\text{A.III-17})$$

A.III.4. Estimation of carbon dioxide emission

The CO₂ emissions are proportional to the amount of consumed gas. CO and NO_x depend on temperature in combustion chamber and air-fuel ration. They are more important in operating modes with low efficiency: their quantity is low in operating systems with nominal efficiency [3] and [1]. The CO₂ emission factor is constant for all operating regimes of a micro gas turbine:

$$m_{CO2_i}(t) = \mu_{CO2_i} \cdot F_{MGT_i} \quad (\text{A.III-18})$$

m_{CO2_i} (mg) is the CO₂ mass, $\mu_{CO2_i} = 202.10^3$ (mg/kWh_{thermal}) is the CO₂ emissions factor during the combustion of the gas thermal power product F_{MGT_i} (kWh_{thermal}). The amount of emitted CO₂ for an operation time interval $\tau = 30$ minutes at constant power is always a function of the power P_{MGT_i} because of electrical efficiency. And thus the gas consumed by the thermal energy to produce this electrical energy is different for different operating points of the micro turbine. From equations (A.III-19) and (A.III-18), we can deduce:

$$m_{CO2_i}(t) = \mu_{CO2_i} \cdot \frac{\tau \cdot \alpha_i(t) \cdot P_{MGT_max_i}}{\eta_i(t)} = 202.10^3 \cdot \frac{\tau \cdot \alpha_i(t) \cdot P_{MGT_max_i}}{\eta_i(t)} \quad (\text{A.III-19})$$

With estimated quantities of CO₂, CO and NO_x respectively before, it is easy to calculate the amount of equivalent CO₂ emissions. The CO and NO_x are toxic gases and have an influence on the greenhouse effect, because they are absorbed more slowly than CO₂. Global warming potential of 1 g NO_x is considered equal to 298 g of CO₂ equivalent and 1 g CO to 3 g CO₂ equivalent [2]. Therefore, the amount of CO₂ equivalent is calculated as follows:

$$m_{CO2_equivalent_i}(t) = m_{CO2_i}(t) + 3 \cdot m_{CO_i}(t) + 298 \cdot m_{NOx_i}(t) \quad (\text{A.III-20})$$

This calculation equation will be used in the chapter IV for system optimization usage.

References

- [1] A.-V. Boicea, G. Chicco, and P. Mancarella, "Optimal operation of a microturbine cluster with partial-load efficiency and emission characterization," in *PowerTech, 2009 IEEE Bucharest, 2009*, pp. 1-8.
- [2] H. Kanchev, "Gestion des flux énergétiques dans un système hybride de sources d'énergie renouvelable: Optimisation de la planification opérationnelle et ajustement d'un micro réseau électrique urbain," Ecole Centrale de Lille, Doctoral dissertation, 2014.
- [3] A. Canova, G. Chicco, G. Genon, and P. Mancarella, "Emission characterization and evaluation of natural gas-fueled cogeneration microturbines and internal combustion engines," *Energy Conversion and Management*, vol. 49, pp. 2900-2909, 2008.

Appendix IV. Artificial Neural Network

A.IV.1. General Introduction

Based on the idea of human neurons, an Artificial Neural Network (ANN) is an information processing paradigm aimed to imitate neural network capabilities. The key element of this paradigm is the novel structure of the information processing system. It is composed of a large number of highly interconnected processing elements, which are called neurons, working in unison to solve specific problems. In brief, ANNs, can learn, memorize and establish a system model through handling a large amount of external information (training data) to get the capabilities of prediction and self-diagnosing. Nowadays, ANNs have been succeeded in several power system problems, such as planning, control, analysis, protection, design, forecasting, security analysis, and fault diagnosis. Back-Propagation (BP) algorithm is one of the most widespread and representative learning rules in the ANN. Many ANN structures can be designed according to the application issues, which are generally mathematical approximations.

Neural networks are typically organized in layers. Normally there are one input layer, one output layer, and one or more hidden layers. In our work, several three-layer ANN models (only has one hidden layer) have been applied to energy, load, and errors forecasting. Therefore, the basic structure of a three-layer ANN and its learning procedures are elaborated below [1, 2].

A.IV.2. Model Representation

A basic structure of a three-layer ANN is composed of an input layer with h input variables: $X=[x_1, x_2, \dots, x_H]^T$, one hidden layer with l units, and one output layer with k units (Figure AIV-1). Weights $\Theta^{(1)} = [\theta_{11}, \dots, \theta_{1l}, \dots, \theta_{1L}; \dots; \theta_{h1}, \dots, \theta_{hl}, \dots, \theta_{hL}; \dots; \theta_{H1}, \dots, \theta_{HL}, \dots, \theta_{HL}]$, $\Theta^{(2)} = [\theta_{11}, \dots, \theta_{1k}, \dots, \theta_{1K}; \dots; \theta_{l1}, \dots, \theta_{lk}, \dots, \theta_{lK}; \dots; \theta_{L1}, \dots, \theta_{Lk}, \dots, \theta_{LK}]$ and biases b_l, b_k ($h=1, 2, \dots, H; l=1, 2, \dots, L; k=1, 2, \dots, K$) are model parameters that will be adapted in order to get the best accuracy of the data forecast. $a^{(1)}$ and $a^{(2)}$ are parameters vector of inputs and hidden layer units.

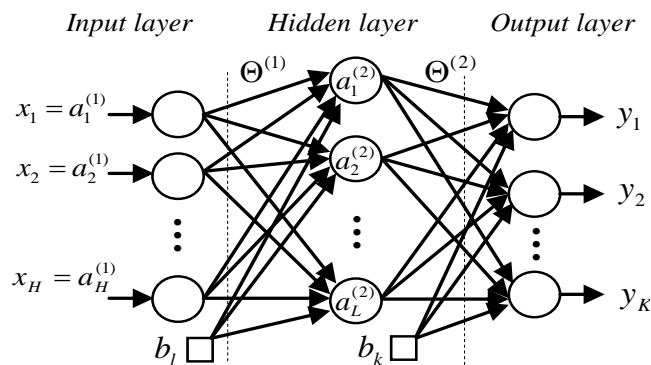

Figure AIV-2 A three layer neural network model.

Before starting the training procedures, weights and biases must be previously initialized with random values. Then, they are adjusted gradually by training procedures and learning algorithms. The algorithm is divided into two parts: feed-forward and BP stages. In the first stage, it starts out with randomly settled weights and biases. In the second back-propagation

stage, the weights are incrementally adjusted to minimize the error between the awaited output and the obtained ANN output. Then errors between target values and output values are propagated back to previous stages. At this stage, the back-propagation algorithm is based on the gradient descent method to modify the weights. Then, model parameters are gradually adjusted with a “supervised learning algorithm”.

A.IV.3. Feed-forward Procedure and Cost Function

Random initialization

Set up the architecture and equations of networks and randomly initialize weights and biases. When training neural networks, it is important to randomly initialize the parameters for symmetry breaking. Because instead of finding the global optimum, the training algorithm may get stuck in a “nearest” local solution. Therefore, starting from any fixed initialization biases leads your solution towards some one particular set of weights. If we do it randomly (and possibly many times), then there is much less probable that you will get stuck in some local optimum solutions.

One effective strategy for random initialization is to randomly select values for θ uniformly in the range $[-\epsilon_{inti}, \epsilon_{inti}]$. The ϵ_{inti} has been calculated based on the number of input and output units:

$$\epsilon_{inti} = \frac{\sqrt{6}}{\sqrt{L_{in} + L_{out}}} \quad (\text{A.IV-1})$$

where L_{in} and L_{out} are the number of units in the layers (see Figure AIV-2). This range of values ensures that the parameters are kept small and makes the learning more efficient.

Learning rate

Set up the learning rate (λ) of the algorithm and the training set of input and output data. If the learning rate is too small, the convergence will be too slow, while if it is too large, the cost function output may not decrease on every iteration and may not converge.

Sigmoid function

The hidden neurons transfer function is the sigmoid function:

$$g(z) = \frac{1}{1 + e^{-z}} \quad (\text{A.IV-2})$$

Feed-forward propagation

A basic structure of a feed-forward procedure is shown in the Figure AIV-2. For the first layer (input layer), $a^{(1)} = X$, where X represents a vector with all inputs. A bias unit $a_0^{(1)}$, with the value 1, has been added to X . Then a hidden layer implements intermediary calculations that compute the activations as:

$$z^{(2)} = \Theta^{(1)} a^{(1)} \quad (\text{A.IV-3})$$

$$a^{(2)} = g(z^{(2)}) \quad (\text{A.IV-4})$$

$\Theta^{(1)}$ is a matrix of weights (θ_{hl}), which is setting the function mapping from the input layer to the hidden layer. A bias unit $a_0^{(2)}$, with the value 1, is also added to $a^{(2)}$. Then output data are calculated by an output layer with the same transfer function:

$$z^{(3)} = \Theta^{(2)} a^{(2)} \quad (\text{A.IV-5})$$

$$a^{(3)} = g(z^{(3)}) = h_{\Theta}(x) \quad (\text{A.IV-6})$$

The weights $\Theta^{(2)}$ represent a matrix of weights (θ_{jk}), which is setting the function mapping from the hidden layer to the output layer. The output $h_{\Theta}(x)$ is a vector, which represents the prediction results.

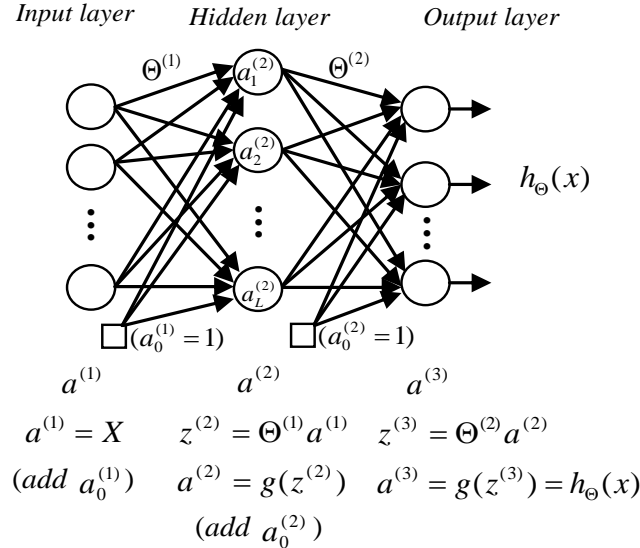

Figure AIV-3 Feed-forward algorithm.

Cost function

For every training set example $((X^{(i)}, y^{(i)}), i = 1, 2, \dots, m)$, the cost function for neural networks with regularization is calculated and depends on prediction errors:

$$J(\Theta) = \frac{1}{m} \sum_{i=1}^m \sum_{k=1}^K \left[-y_k^{(i)} \log((h_{\Theta}(x^{(i)}))_k) - (1 - y_k^{(i)}) \log(1 - (h_{\Theta}(x^{(i)}))_k) \right] + \frac{\lambda}{2m} \left[\sum_{k=1}^K \sum_{h=1}^H (\Theta_{j,k}^{(1)})^2 + \sum_{l=1}^L \sum_{k=1}^K (\Theta_{j,k}^{(2)})^2 \right] \quad (\text{A.IV-7})$$

This is the algorithm, which takes the initial inputs into the neural network and pushes them through the network. Then, the problem is how to minimize the cost function.

A.IV.4. Back-Propagation (BP) Algorithm

Back propagation basically takes the output ($h_{\Theta}(x)$) that you got from the feed-forward procedure, compares it to the real value (y) and calculates how wrong the network was (calculate the errors of prediction). Then, by using the calculated error, it back-calculates the error associated with each unit from the preceding layer (Figure AIV-3). This goes on back to the input layer. These computed "error" for each unit can be used to calculate the partial derivatives, which are used with gradient descent to minimize the cost function and update all the weight values. This procedure is repeated until the convergence of the gradient descent.

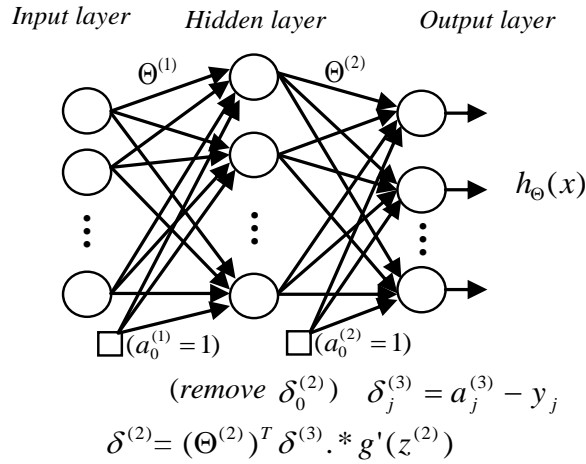

Figure AIV-3 Back-propagation algorithm.

Sigmoid gradient

The gradient for the sigmoid function can be computed as:

$$g'(z) = \frac{d}{dz} g(z) = g(z)(1 - g(z)) \quad (\text{A.IV-8})$$

Recall that the intuition behind the back-propagation algorithm is as follows. Given a training example $(X^{(i)}, y^{(i)})$, we will first run a “forward pass” to compute all the activations throughout the network, including the output value of the hypothesis $h_{\theta}(x)$. Then, for each node j in layer l , we would like to compute an “error term” $\delta_j^{(l)}$ that measures how much that node was “responsible” for any errors in our output. For an output node, we can directly measure the difference between the network’s activation and the true target value, and use that to define $\delta_j^{(3)}$ (since layer 3 is the output layer). For the hidden units, you will compute $\delta_j^{(l)}$ based on a weighted average of the error terms of the nodes in layer $(l + 1)$.

1) Set the input layer’s values $(a^{(1)})$ to the t -th training example $x(t)$. Perform a feed-forward pass, computing the activations $(z^{(2)}, a^{(2)}, z^{(3)}, a^{(3)})$ for hidden layer and output layer. Note that you need to add a bias term to ensure that the vectors of activations for layers $a^{(1)}$ and $a^{(2)}$ also include the bias unit.

2) for each output unit k in the output layer, set

$$\delta_k^{(3)} = (a_k^{(3)} - y_k) \quad (\text{A.IV-10})$$

3) For the hidden layer, set

$$\delta^{(2)} = (\Theta^{(2)})^T \delta^{(3)} .* g'(z^{(2)}) \quad (\text{A.IV-11})$$

4) Accumulate the gradient from this example using the following formula. Note that you should skip or remove $\delta_0^{(2)}$.

$$\Delta^l = \Delta^l + \delta^{(l+1)} (a^{(l)})^T \quad (\text{A.IV-12})$$

5) Obtain the gradient for the neural network cost function by dividing the accumulated gradients by $\frac{1}{m}$:

$$\frac{\partial}{\partial \Theta_{ij}^{(l)}} J(\Theta) = D_{ij}^{(l)} = \frac{1}{m} \Delta_{ij}^l \quad (\text{A.IV-13})$$

A.IV.5. Learning parameters using *fmincg*

After having successfully implemented the ANN cost function and gradient computation, the next step is to use *fmincg* to obtain good set parameters. After the training completes, it is possible to get higher accuracies by training the neural network for more iterations and also vary the regularization parameter λ . With the right learning settings, it is possible to get the neural network to perfectly fit the training set.

References

- [1] V. Kecman, *Learning and soft computing: support vector machines, neural networks, and fuzzy logic models*: MIT press, 2001.
- [2] "Andrew Ng, Stanford Machine Learning, [online] Available: <https://www.coursera.org/course/ml..>"

Résumé en français

Face aux défis énergétiques, la demande d'énergie primaire dans le monde entier augmente. Selon l'agence internationale de l'énergie, les besoins énergétiques mondiaux pourraient être 50 % plus élevés en 2030 que ceux de 2011. Cependant, le stock de pétrole et de charbon dans notre planète sera épuisé au cours des prochaines décennies avec le même taux d'utilisation courante. De nos jours, le réchauffement climatique devient plus grave en raison des effets de serre. Certaines émissions de gaz à effet de serre, bien sûr, proviennent d'activités humaines, par exemple les émissions de voitures. Au cours de la dernière décennie, pour maintenir l'augmentation de la température au-dessous de deux degrés Celsius par rapport aux niveaux préindustriels, les politiques envisagent de réduire la consommation de combustibles fossiles et les émissions de gaz à effet de serre en promouvant l'utilisation des énergies renouvelables (EnR), avec des cibles telles que 20-20-20 de l'Union européenne et l'accord contractuel de la COP21 à Paris. Par conséquent, l'exploitation des EnRs a considérablement progressé dans le monde. Selon le rapport de l'IEA en 2015 sur l'énergie et le changement climatique, on estime que la capacité de production d'EnR a augmenté de 128 GW en 2014, avec 37% de l'énergie éolienne, près d'un tiers de l'énergie solaire et plus d'un quart de l'hydroélectricité.

Néanmoins, la production et le traitement de l'énergie électrique sont l'une des principales sources de gaz à effet de serre, en particulier pour les pays en développement comme la Chine, l'Inde et l'Amérique latine. Pour réduire les émissions de gaz à effet de serre et assurer la sécurité énergétique, les EnRs sont fortement nécessaires dans la production d'énergie électrique.

Aujourd'hui, différents types de technologies d'énergie renouvelable sont exploités sur les marchés mondiaux. Certaines technologies, comme les éoliennes, sont de plus en plus compétitives et leur marché est en plein essor. D'autres sont largement reconnues comme l'option la moins chère pour les alimentations électriques autonomes et hors réseau, en particulier dans les îles où le carburant et les coûts d'installation et d'exploitation sont chers. En effet, les coûts d'investissement de certaines technologies d'énergie renouvelable ont été réduits au cours de la dernière décennie et peuvent continuer à diminuer au cours des prochaines décennies. Selon les « *World Energy Outlook in 2013* », il y aura une croissance massive des énergies renouvelables au cours des 25 prochaines années en raison de la crise des combustibles fossiles, de la sécurité d'approvisionnement des énergies primaires, de la croissance économique et du danger de la détérioration de l'environnement.

Cependant, un système de production d'électricité dépendant entièrement des sources d'EnR, telles que l'énergie solaire et photovoltaïque, n'est pas fiable en raison de leur faible disponibilité et de leur nature intermittente. Par rapport aux centrales électriques traditionnelles à base de pétrole et de charbon, elles ne peuvent fournir des services auxiliaires pour participer à la gestion du réseau électrique. Pour cette raison, au cours des deux dernières décennies, les intérêts de la recherche ont porté sur les micro-réseaux (ou réseaux intelligents) et l'intégration des générateurs distribués dans les réseaux énergétiques. Par conséquent, en considérant les incertitudes du système électrique (à la fois provenant de la génération et de la consommation), ce travail de recherche se concentre sur l'intégration des énergies renouvelables dans les systèmes électriques.

Intégration des générateurs distribués (GDs) dans le micro-réseau

Il existe différents types de sources d'énergie répartie :

- les générateurs distribués non renouvelables, tels que les micro-turbines à gaz et les turbines à combustion ;
- des générateurs distribués à EnR, tels que l'énergie photovoltaïque, l'énergie solaire à concentration et les éoliennes ;
- et d'autres, tels que les piles à combustible et les systèmes hybrides, qui sont la combinaison de plus d'un type de ces technologies conduisant à une amélioration de la performance du système et de l'efficacité.

Une partie importante des charges électriques se trouvent dans les zones résidentielles et les villes. La consommation individuelle est assez faible et conduit à un dimensionnement électrique (basse tension, faible puissance). Par conséquent, un nouveau marché de petits générateurs est apparu pour une utilisation résidentielle ou dans les bâtiments.

Ces types de générateurs sont connus sous le nom de GD (Générateur Distribué). En outre, étant donné qu'ils sont reliés à des charges et donc dans des zones à forte concentration de personnes, les émissions de polluants restreintes ainsi que les exigences de sécurité dans ces lieux de vie obligent l'utilisation d'énergie renouvelable pour alimenter ces générateurs.

Les avantages d'un GD sont principalement la participation à l'équilibrage local de l'énergie électrique et la réduction des pics de puissance. Un GD conduit à un changement du flux de puissance traditionnellement unidirectionnel en un flux bidirectionnel dans les réseaux électriques actuels. Ainsi, il existe plusieurs défis pour l'intégration à grande échelle des GDs, tels que :

- des technologies plus complexes de production d'énergie et de nouvelles infrastructures sont nécessaires ;
- de nouvelles stratégies de contrôle sont nécessaires pour une plus grande pénétration des GDs dans les réseaux électriques ;
- la sécurité du réseau doit être assurée ;
- le contrôle des coûts de l'intégration d'un GD. Le coût comprend le coût de l'interconnexion et les mises à niveau du système ; etc.

Un ensemble de DGs constitue un micro-réseau. Il s'agit d'un petit système de distribution électrique qui utilise les technologies de production d'énergie à petite échelle dans des zones situées à proximité des clients desservis. Il permet de réduire les coûts et les émissions, d'améliorer la fiabilité et de fournir une génération électrique efficace aux charges locales sans perte de transmission. Dans ce contexte, il est clair qu'une génération électrique et une conversion d'énergie durable nécessitent une infrastructure électrique efficace et fiable pour la gestion de l'énergie.

Les défis de l'incertitude des EnRs et l'intégration dans le micro-réseau

Les avantages du micro-réseau, comprenant une combinaison d'EnR et de stockage, sont la réduction des émissions, la production d'énergie propre, l'augmentation de la sécurité énergétique et de la résilience, ainsi que la transmission sans perte de l'énergie. Cependant, l'intégration de l'EnR, en particulier le PV et l'éolien, dans les réseaux électriques est limitée en raison de leurs intermittences, leur faible inertie et leur forte dépendance à la météorologie. Par conséquent, il est également important de caractériser la variabilité selon une dimension spatiale et/ou une dimension temporelle. Par exemple, lorsque les systèmes électriques fonctionnent avec l'EnR, les opérateurs ont des problèmes majeurs différents selon les échelles de temps. Le fonctionnement du système électrique implique la qualité de l'énergie pendant moins d'une seconde, les réserves de régulation pour moins d'une minute, la charge des batteries de quelques minutes à quelques heures, l'engagement de l'unité de production et

l'ordonnancement des différentes tranches de production vont de quelques heures et à quelques jours. En outre, l'énergie solaire photovoltaïque couvrant une grande étendue spatiale peut avoir une résolution temporelle horaire, tandis que les points individuels de puissance PV seront très variables dans un court laps de temps.

Étant donné que la variabilité et l'incertitude des sources d'énergie renouvelable créent de nouveaux défis dans la planification et l'exploitation du réseau électrique, elles devraient être correctement comptabilisées pour équilibrer la demande et l'offre. En général, les exploitants et les planificateurs d'installations électriques utilisent des mécanismes tels que la prévision, l'ordonnancement, et les réserves de puissance pour assurer la performance du réseau électrique qui satisfait sa fiabilité à un coût raisonnable. La prévision de la production d'électricité et de la demande de charge a été considérée comme une solution majeure pour gérer efficacement l'intégration d'EnR dans le réseau électrique. Cependant, l'incertitude prévue associée à la prévision ne peut être éliminée même avec les meilleurs modèles et outils. En plus de l'incertitude liée à la demande de la charge, la combinaison de la variabilité de la production et de la consommation avec l'incertitude des prévisions rend la situation plus difficile pour les exploitants de réseaux électriques pour planifier et fixer un niveau de réserve de puissance approprié. Par conséquent, les incertitudes de la génération et de la consommation doivent être prises en compte par des modèles stochastiques précis pour concevoir des systèmes de gestion de l'énergie avec un coût minimal.

Dimensionnement de la réserve de puissance

Lorsqu'un déséquilibre inattendu entre l'offre et la demande apparaît, les opérateurs du système électrique et les contrôleurs automatiques utilisent une capacité de génération disponible, appelée réserve de puissance (RO). La RO doit être dimensionnée mais idéalement réduite et répartie pour réduire les coûts d'exploitation tout en gardant un niveau de sécurité satisfaisant.

Dans les systèmes électriques traditionnels, deux principales sources d'incertitude sont considérées :

- la perte du plus grand générateur ou d'un matériel du réseau : elle a une faible probabilité, mais un impact élevé si les réserves sont insuffisantes ;
- les erreurs de prévision de charge qui sont courantes mais sont relativement faibles.

Par conséquent, les opérateurs adoptent généralement des critères déterministes pour l'exigence de réserve de puissance : la RO requise est supérieure à la capacité du plus grand générateur en fonctionnement ou une fraction de la charge ou, encore, égale à une fonction des deux. Ces critères déterministes sont largement utilisés en raison de leur simplicité et de leur compréhension.

En raison du développement à grande échelle de la génération distribuée à base de sources renouvelables, la production stochastique croît et influence fortement le niveau d'incertitude de la production d'électricité dans les systèmes électriques. La probabilité de manquer d'une grande quantité de production électrique doit maintenant être considérée avec de nouvelles stratégies pour calculer la RO. Par conséquent, les méthodes déterministes sont progressivement remplacées par des méthodes probabilistes avec des facteurs stochastiques correspondant aux niveaux de fiabilité du système.

En raison de la complexité et de la difficulté de la gestion de l'information probabiliste, les décisions prises sous incertitude doivent être éclairées par des informations probabilistes afin

de quantifier correctement les risques. Par conséquent, de nouvelles méthodes de décision sont nécessaires pour estimer le montant de la RO.

Générateurs distribués actifs et planification optimale un jour à l'avance (J-1)

De nos jours, la RO est fournie par des centrales électriques conventionnelles en tant que puissance de réserve constante dans un horizon de temps fixe. Cependant, les GDs sont désormais en mesure de stocker de la puissance afin de maintenir la sécurité et la fiabilité des réseaux avec une forte proportion de générateurs renouvelables. Si la puissance de sortie d'un GD à base de générateur renouvelable est réduite (dégradation du point de puissance maximum) pour créer une réserve, une partie de cette énergie renouvelable primaire sera perdue car il n'est pas sûr de la récupérer plus tard (puisque l'énergie primaire est intermittente). Par conséquent, un DG actif à base d'EnR avec des systèmes de stockage intégrés est proposé pour pouvoir produire la puissance de sortie prescrite avec une bonne gestion interne de l'énergie grâce à un contrôleur local. Beaucoup de travaux de recherche ont été réalisés pour développer des applications de stockage pour lisser ou équilibrer la puissance et l'énergie électrique provenant de générateurs renouvelables intermittents. En plus, pour remédier à l'incertitude, la puissance issue du générateur renouvelable est prévue un jour à l'avance. La distribution et la transmission aux charges sont également supposées planifiées par le système électrique en tenant compte de l'effet de foisonnement des autres générateurs renouvelables et des charges non corrélées. Ainsi, une nouvelle application des systèmes de stockage serait de gérer la fourniture de la RO prescrite au DG à J-1. Par conséquent, un système de gestion de l'énergie doit être imaginé pour rendre utilisable ce GD par un opérateur de réseau comme un générateur contrôlable conventionnel.

Dans un marché traditionnel de l'électricité, l'énergie et les ROs nécessaires sont attribuées séparément. Dans un marché concurrentiel, ces deux produits devraient être distribués simultanément afin de maximiser l'efficacité et la fiabilité du système électrique.

Différentes stratégies pour la répartition de la RO entre les générateurs conventionnels et GD actifs peuvent être considérées suivant l'origine de l'incertitude. Ces stratégies auront des influences différentes sur le niveau de sécurité du système et aussi sur le dimensionnement des générateurs PV actifs (GA PV : générateur photovoltaïque avec stockage). L'objectif est alors de trouver la meilleure répartition afin de réduire les coûts économiques et écologiques de la production d'électricité. Ainsi, une planification optimale à J-1 des générateurs est mise en place pour minimiser les coûts opérationnels. En prenant en compte les temps de démarrage et d'arrêt et en garantissant un minimum de démarrage, l'engagement de l'unité (UC) est un processus de décision qui planifie le démarrage des générateurs à carburant de manière à optimiser les différents critères économique, écologique et énergétique. Généralement, les décisions de UC sont résolues de façon itérative et assurent un niveau de fiabilité du système électrique en utilisant des mesures probabilistes.

À mesure que l'industrie de l'énergie électrique passe à de nouvelles formes de production non conventionnelles, l'UC doit être adapté aux générateurs distribués, y compris les DGs (comme les micro-turbines à gaz et générateurs d'EnR) ainsi que de nouveaux critères environnementaux. À titre d'exemple, la minimisation des émissions de CO₂ dans les futurs systèmes électriques doit être considérée en cohérence avec l'objectif d'intégrer de plus en plus d'EnR pour réduire l'empreinte humaine sur la planète.

Traitement des données et application pratique

Afin de mieux comprendre les incertitudes et réduire leur impact sur les performances du réseau électrique, de nombreuses technologies de surveillance sont nécessaires pour les opérateurs de systèmes d'alimentation électrique. En outre, de plus en plus de capteurs sont installés dans les réseaux électriques et maintenant de grandes bases de données sont construites. Les données collectées doivent être analysées et étudiées largement pour les prévisions et la prise de décision. Par conséquent, une quantité énorme de données et d'informations sont générées par ces dispositifs de surveillance installés.

Une visualisation dynamique des données recueillies et des décisions possibles grâce à une gestion intelligente sont une excellente aide pour comprendre les impacts techniques et les solutions opérationnelles des systèmes d'alimentation électrique comportant un taux de pénétration élevé d'EnR.

Plan de la thèse

À mesure que les prix de l'énergie deviennent de plus en plus élevés et que les émissions de CO₂ doivent être limitées, des nouvelles options d'approvisionnement électrique en fonction des ressources distribuées sont nécessaires. Les productions d'énergie à base d'EnR sont caractérisées par l'incertitude et l'intermittence. Par rapport aux centrales électriques traditionnelles, elles sont fortement influencées par les conditions météorologiques. Par conséquent, en raison des incertitudes liées à la production à base d'EnR et à la demande de charge, l'intégration des énergies renouvelables dans les réseaux électriques est considérée comme une question de plus en plus importante pour maintenir une infrastructure électrique efficace, fiable et sûre.

Face à ce problème, des générateurs actifs hybrides dotés d'un système de stockage et de générateurs renouvelables ont été proposés pour fournir une alimentation électrique contrôlable. Dans ce travail, les possibilités de les utiliser sont étudiées pour couvrir les événements imprévus causés par une diminution soudaine ou une augmentation de la puissance des générateurs et de la demande, ou de la perte inattendue d'autre générateurs ou des lignes. En outre, certains services de réserves de puissance, telles que les batteries et les super condensateurs, peuvent également aider à fournir des services auxiliaires dans un réseau électrique local pour la régulation de la fréquence et la régulation de la tension, etc. Cependant, un équipement supplémentaire de réserve d'énergie augmentera considérablement le coût global du système de génération d'énergie. Ainsi, il faut tenir compte de la quantité de la réserve de puissance requise et de ce coût afin de réduire la réserve de puissance tout en satisfaisant la sécurité du système.

Les problèmes scientifiques ciblés et la méthodologie suivie sont maintenant présentés. L'objectif de ce travail de recherche est d'abord d'étudier l'incertitude de la prévision de la puissance photovoltaïque et de la demande de charge dans un micro-réseau local en utilisant des modèles mathématiques adéquats. Les incertitudes d'un micro-réseau urbain seront abordées dans l'étude de la nature de la variabilité et de l'incertitude du générateur d'énergie photovoltaïque. Sur la base de cette analyse, la RO opérationnelle journalière sera calculée afin de satisfaire un niveau de risque prescrit. Enfin, la répartition optimale de cette RO et la planification opérationnelle de l'énergie sont étudiées. Diverses participations possibles de micro-turbines à gaz et de générateurs PV sont envisagées pour réduire les coûts économiques, mais également les émissions de CO₂.

Les contributions sont organisées dans le rapport de thèse en fonction du plan suivant.

Chapitre I Intégration des sources d'énergie renouvelable dans le système électrique

Dans le premier chapitre, un micro-réseau est présenté. Il contient des générateurs actifs hybrides composés de sources d'énergie renouvelables et d'unités de stockage, de micro-turbines à gaz et de charges. Ce système électrique fournit non seulement une énergie propre, mais aussi une qualité de puissance élevée. En outre, les GA PV peuvent fournir des services auxiliaires au réseau comme les générateurs classiques. Ensuite, les problèmes, résultant de l'intégration de ce type de production décentralisée dans les systèmes d'alimentation, sont expliqués et les perspectives pour les résoudre sont répertoriées. Comme la production est destinée à être consommée par des charges locales, les concepts de villes intelligentes, de réseaux intelligents et de micro-réseaux sont brièvement introduits. Étant donné que l'intermittence de puissance et la disponibilité énergétique sont des points faibles des générateurs passifs classiques, des nouvelles technologies matérielles sont alors considérées pour répondre à ces inconvénients : les systèmes de stockage, les générateurs actifs hybrides et les micro-turbines à gaz. Ainsi, la gestion de l'énergie des futurs systèmes électriques doit être adaptée ou modifiée afin d'utiliser ces technologies. La gestion de l'énergie d'un micro-réseau est présentée pour bien comprendre l'architecture et les fonctions de contrôle.

Chapitre II Analyse de l'incertitude et de la prévision de la puissance PV et de la charge

Le développement croissant constant d'EnR devient un défi pour les opérateurs de systèmes d'alimentation afin de maintenir l'équilibre énergétique instantanément. Au cours des dernières décennies, de nombreux travaux de recherche ont été consacrés aux approches de prévision et à l'analyse de l'incertitude pour calculer les flux de puissance attendus et pour concevoir une meilleure gestion de l'énergie des systèmes électriques. L'idée de base est d'obtenir une meilleure précision de la prévision avec la base de données existante. En outre, la précision de la prévision est un problème important pour une application efficace. Le calcul de la variabilité et de l'incertitude du PV peut également augmenter la qualité de la distribution électrique. Cela permettra aux planificateurs de système et aux opérateurs de développer des mesures efficaces pour gérer l'incertitude à différents niveaux de pénétration de PV dans les systèmes électriques.

L'objectif de ce chapitre est d'étudier l'incertitude et la variabilité de la production d'énergie photovoltaïque grâce à la prévision de l'irradiance solaire et à la classification quotidienne de la variabilité de l'irradiance. Tout d'abord, le modèle de génération à base de PV solaire est rappelé en détail. Les indices de variabilité de l'irradiance solaire sont utilisés pour mieux comprendre les caractéristiques variables de la production d'énergie photovoltaïque. La génération d'électricité et les méthodes de prévision de la demande de charge sont résumées et présentées. Parmi les différentes méthodes de prévision possibles, un algorithme de réseau neuronal artificiel (ANN) est développé et appliqué. L'objectif n'est pas d'améliorer une méthode de prévision, mais simplement de récolter des erreurs réalistes de prévision. Ces erreurs sont utilisées pour une analyse d'incertitude dans le chapitre suivant. Par la suite, certains exemples de prévision de la puissance photovoltaïque et de la demande de charge avec ANN sont mis en œuvre. Ces résultats de prévision seront utilisés pour l'analyse de l'incertitude nette et pour la quantification de la réserve de puissance dans le chapitre suivant. Par rapport aux sources d'alimentation classiques, la source d'alimentation photovoltaïque aura besoin de plus de réserve pour couvrir les fluctuations de puissance PV avec le même niveau de sécurité. Par conséquent, l'application de méthodes de prévision précises de la puissance photovoltaïque et de la demande de charge permet aux opérateurs du système électrique de dimensionner la réserve de puissance supplémentaire.

Chapitre III Quantification de réserve de puissance dans un micro-réseau

Le processus de planification des investissements utilise des indices de fiabilité pour décider de nouveaux investissements dans des capacités de nouvelle génération afin de maintenir un niveau de sécurité ciblé.

À mesure que les prix de l'énergie augmentent et que les émissions de CO₂ devraient être limitées, les nouvelles options d'approvisionnement des générateurs électriques en fonction des ressources distribuées sont nécessaires. Ce développement des RES contribue à la diversité du portefeuille d'approvisionnement en énergie et réduit considérablement l'utilisation accrue des combustibles fossiles. Cependant, d'une part, par rapport aux centrales électriques à combustibles fossiles classiques, elles sont fortement influencées par les conditions météorologiques et ont une nature variable et incertaine. D'autre part, la demande de charge doit être fournie instantanément à tout moment. Par conséquent, les opérateurs de réseaux doivent tenir compte de l'augmentation de l'incertitude provenant des charges ainsi que des EnRs.

Des RO supplémentaires sont assignées sur les générateurs conventionnels et augmenteront le coût global des systèmes de production d'électricité. Dans nos travaux de recherche, des générateurs basés sur l'EnR avec des unités de stockage intégrées comme réserve de fonctionnement supplémentaire sont proposés pour fournir une alimentation électrique contrôlable pour les opérateurs de systèmes électriques. Ainsi, les coûts d'investissement doivent être pris en considération et la RO doit être minimisée tout en satisfaisant la sécurité du système.

Les prévisions de génération d'EnR et la prévision de la demande de charge sont nécessaires pour le fonctionnement du système. Cependant, les erreurs de prévision ne peuvent jamais être éliminées, peu importe le modèle ou l'outil utilisé. Par conséquent, le calcul précis de la réserve d'exploitation en tenant compte des incertitudes de prévision à la fois de la production et de la consommation d'électricité est essentiel.

Traditionnellement, la RO est déterminée par des méthodes déterministes en pourcentage de la demande de charge ou de la génération ou comme la capacité de la plus grande unité de production d'énergie en fonctionnement. Pour la dernière méthode, en cas de déclenchement de la plus grande unité de génération, la RO est suffisante pour restaurer la puissance. Néanmoins, lorsqu'une grande quantité d'EnR avec production de puissance variable est intégrée au réseau électrique, le problème devient plus complexe. Les réserves requises sont également affectées par les pratiques d'ordonnancement de l'énergie, les charges et la précision des prévisions d'EnR, la taille du système d'alimentation, etc. De nos jours, les méthodes déterministes sont progressivement remplacées par des méthodes probabilistes pour un calcul beaucoup plus précis et pour définir un niveau de sécurité souhaité. Pour gérer des niveaux élevés de production renouvelable, un mécanisme de mise en réserve devrait utiliser une meilleure compréhension des incertitudes météorologiques et la combiner avec un processus de mise en place traditionnel. Dans ce chapitre, une méthode est développée pour calculer la RO en prenant en compte les incertitudes d'EnR.

La fiabilité de la génération d'énergie et le concept de RO sont introduits dans la partie suivante. Ensuite, dans la troisième partie, pour chaque pas temporel du lendemain, un calcul de la RO est proposé avec l'incertitude prévue de la demande nette (ND) en utilisant une méthode probabiliste. L'incertitude prononcée pour la ND est obtenue comme la différence entre l'incertitude de production prévue et l'incertitude de charge prévue. Deux méthodes sont proposées pour prédire les erreurs de prévision ND un jour plus tôt. La première est une prévision directe avec des erreurs historiques de ND. La seconde consiste à intégrer mathématiquement les erreurs de puissance PV et de prévision de demande. Une fonction de

densité de probabilité horaire de toutes les erreurs prédites prévues de ND a été utilisée pour l'analyse d'erreur. Dans la quatrième partie, une méthode est expliquée pour évaluer la précision de ces prédictions et pour quantifier la réserve de puissance de fonctionnement requise pour compenser le déséquilibre de puissance du système en raison de ces erreurs.

Chapitre IV Répartition de l'OR dispatching et gestion de l'énergie d'un système de micro-réseau

Dans ce chapitre, différentes méthodes sont proposées pour répartir la RO requise dans les différents groupes électrogènes sans perdre le niveau de sécurité du système électrique. Classiquement, les OR sont fournis par des générateurs à base de carburant. Cependant, pour un scénario avec un taux de pénétration d'énergie 100% renouvelable, il n'est pas réaliste de considérer uniquement ces types de générateurs pour la fourniture de la RO. Par conséquent, de nouveaux actifs doivent être considérés pour fournir les RO. Dans ce chapitre, les batteries distribuées, intégrées dans le GA PV, sont également considérées pour fournir la RO. De nouvelles stratégies de répartition de la RO sur tous les générateurs locaux sont ensuite proposées afin de tenir compte de l'incertitude locale résultant de la production locale d'électricité. Un micro-réseau correspondant à un réseau d'alimentation résidentiel est considéré avec une planification un jour avant, pour capturer l'incertitude des prévisions de charge et de génération.

En outre, les contraintes supplémentaires des unités de stockage et les nouveaux objectifs tels que les critères environnementaux doivent être pris en compte dans les futures stratégies de planification opérationnelle quotidiennes de tous les générateurs. Par exemple, les autorités de la ville peuvent viser à réduire les émissions locales de CO₂ en reconsidérant l'utilisation du GD en agissant sur le carburant pour l'équilibrage et la régulation de puissance. Ainsi, une planification optimale de la production électrique et de la RO sont nécessaires pour s'assurer que les marchés de production d'électricité et le marché des services auxiliaires peuvent être optimisés en même temps. Cette nouvelle planification opérationnelle est un moyen qui conduit à un pourcentage significatif de pénétration d'EnR.

Chapitre V Développement d'un système de gestion de l'énergie pour un micro-réseau

Dans le cinquième chapitre, pour faciliter la gestion de l'énergie et l'optimisation du système dans un micro-réseau urbain, un « Superviseur de planification opérationnelle et de gestion opérationnelle convivial » est développé. Le système de gestion de l'énergie conçu repose sur l'interface graphique Matlab. Il fournit un ensemble complet d'interfaces graphiques conviviales pour modéliser et étudier correctement les détails de la production venant des GAs PV, qui comprennent les panneaux photovoltaïques, les batteries, la demande de charge, ainsi que les micro-turbines à gaz. Il montre les incertitudes du système et la quantité de RO demandée aux différents groupes électrogènes. Il permet aux opérateurs du système d'étudier leurs effets sur la sécurité du système avec différents scénarios de répartition et critères d'optimisation.

Gestion énergétique sous incertitude: application à la planification et à l'allocation de réserve dans un micro réseau électrique urbain comportant des générateurs photovoltaïques actifs et du stockage

Résumé: Le développement massif des énergies renouvelables intermittentes dans les réseaux électriques affecte leur fonctionnement. En raison des limitations technologiques et des investissements nécessaires pour maintenir le niveau de sécurité électrique actuel, les questions liées à la stabilité statique et dynamique pourraient arrêter le développement de ces sources. Le sujet de la thèse est de développer un outil pour mesurer l'incertitude sur la disponibilité de la puissance produite par les générateurs photovoltaïques dans un microréseau urbain. L'incertitude est modélisée à partir de l'étude de la nature incertaine de la production PV et de la charge. Avec des méthodes stochastiques, la puissance de réserve (OR) est calculée un jour en avance en tenant compte d'un indice de risque associé. Ensuite, l'OR est répartie sur différents générateurs locaux (générateurs photovoltaïques actifs contenant du stockage distribué et micro-turbines à gaz). Afin de minimiser le coût opérationnel total et/ou les émissions équivalentes de CO₂, une planification optimale et une répartition quotidienne de l'OR dans les différents générateurs sont mises en œuvre. Enfin, un outil logiciel est développé pour conceptualiser cette planification opérationnelle du système électrique réalisée la veille pour le lendemain.

Mot-clefs: Analyse d'incertitude, fiabilité, énergie renouvelable, générateur distribué, gestion de l'énergie, micro réseau, répartition de réserve de puissance, problème d'engagement de l'unité.

Energy management under uncertainty: application to the day-ahead planning and power reserve allocation of an urban microgrid with active photovoltaic generators and storages

Abstract: The massive development of intermittent renewable energy technologies in power systems affects the operation of electrical systems. Due to technical limitations and investments needed to maintain the current electrical security level, issues related to dispatching, static and dynamic stability could stop the development of these distributed renewable energy sources (RES). The subject of the PhD is to develop a tool to study the uncertainties of PV power and load forecasting in an urban network. With stochastic methods, the day-ahead operating reserve (OR) is quantified by taking into account an associated reliability risk index. Then the OR is dispatched into different power generators (active PV generators and micro gas turbines). To minimize the microgrid total operational cost and/or equivalent CO₂ emissions, day-ahead optimal operational planning and dispatching of the OR into different power generators is implemented. Finally, a freeware "A User-friendly Energy Management System and Operational Planning Supervisor" is developed on the Matlab GUI to conceptualize the overall system operation.

Keywords: Uncertainty analysis, distributed generator, energy management, microgrid, power reserve dispatching, reliability, renewable energy, unit commitment problem.