



**HAL**  
open science

# Boundary control of a wave equation with in-domain damping

Christophe Roman

► **To cite this version:**

Christophe Roman. Boundary control of a wave equation with in-domain damping. Computer science. Université Grenoble Alpes, 2018. English. NNT : 2018GREAT053 . tel-01943937

**HAL Id: tel-01943937**

**<https://theses.hal.science/tel-01943937>**

Submitted on 4 Dec 2018

**HAL** is a multi-disciplinary open access archive for the deposit and dissemination of scientific research documents, whether they are published or not. The documents may come from teaching and research institutions in France or abroad, or from public or private research centers.

L'archive ouverte pluridisciplinaire **HAL**, est destinée au dépôt et à la diffusion de documents scientifiques de niveau recherche, publiés ou non, émanant des établissements d'enseignement et de recherche français ou étrangers, des laboratoires publics ou privés.

## THÈSE

pour obtenir le grade de

**DOCTEUR DE LA COMMUNAUTÉ UNIVERSITÉ DE  
GRENOBLE ALPES**

Spécialité : **AUTOMATIQUE-PRODUCTIQUE**

Arrêté ministériel : 25 mai 2016

Présentée par

**Christophe ROMAN**

Thèse codirigée par **Olivier SENAME**  
et par **Christophe PRIEUR**,  
co-encadrée par **Delphine BRESCH-PIETRI**

préparée au sein du **Laboratoire  
Grenoble Images Parole Signal Automatique (GIPSA-lab)**

dans l'École Doctorale **Electronique Electrotechnique Automatique  
et Traitement du Signal (EEATS)**

## **Contrôle frontière de l'équation d'onde avec amortissement distribué**

## **Boundary control of a wave equation with in-domain damping**

Thèse soutenue publiquement le **30 août 2018**,  
devant le jury composé de:

**Lucie BAUDOUIN**

CR, CNRS, LAAS, Toulouse, France, rapportrice

**Thomas MEURER**

PR, Christian-Albrechts-University Kiel, Faculty of Engineering,  
Kiel, Allemagne, rapporteur

**Federico BRIBIESCA ARGOMEDO**

MCF, INSA de Lyon, Ampère, Lyon, France, examinateur

**Yann LE GORREC**

PR, ENSMM, FEMTO-ST, Besançon, France, président du jury

**Eduardo CERPA**

Associate Professor, UTFSM, Dep. Mathematics, Santiago, Chili,  
invité

**Delphine BRESCH-PIETRI**

Associate Professor, MINES ParisTech, CAS, France, co-encadrante  
de thèse

**Christophe PRIEUR**

DR, CNRS, GIPSA-lab, France, co-directeur de thèse

**Olivier SENAME**

PR, Grenoble-INP, GIPSA-lab, University Grenoble Alpes, France,  
co-directeur de thèse





---

# Boundary control of the wave equation with in-domain damping

## Abstract

This thesis is concerned by the boundary control of the one dimensional wave equation, which can be used to model a string (like a guitar string). The objective is to act at one boundary to control and stabilize the other boundary which is considered to be an unstable dynamic boundary condition. This thesis suggests answers to both following questions:

Consider that the unstable dynamics boundary condition has some unknown parameters. Is a nonlinear adaptive control law still performing efficiently, if the viscous damping taken equal to zero for its design is no longer neglected?

How can we take into account the in-domain damping in order to stabilize the wave equation subject to dynamic boundary conditions?

This thesis suggests a method to derive a Lyapunov analysis in order to prove the robustness mismatch of particular nonlinear adaptive control law as the answer of the first question. Then using infinite dimensional backstepping technique we develop feedback control law that exponentially stabilize the considered wave equation.

## Résumé

Cette thèse se concentre sur le contrôle frontière de l'équation d'onde unidimensionnelle, qui peut être utilisée pour modéliser une corde (comme une corde de guitare). L'objectif est d'agir à une frontière pour contrôler et stabiliser l'autre frontière qui est considérée comme une condition aux frontières avec une dynamique instable. Cette thèse suggère des réponses aux deux questions suivantes:

Considérons que la condition à la frontière de dynamique instable a des paramètres inconnus. Une loi de contrôle adaptatif non linéaire est-elle toujours efficace, si l'amortissement visqueux pris égal à zéro pour sa conception n'est plus négligé?

Comment peut-on prendre en compte l'amortissement dans le domaine afin de stabiliser l'équation d'onde soumise à des conditions aux frontières dynamiques?

Cette thèse suggère une méthode pour effectuer une analyse de Lyapunov afin de prouver la robustesse, vis à vis d'une erreur de modèle, d'une loi de contrôle adaptatif non linéaire particulière comme réponse à la première question. Puis, en utilisant une technique de backstepping à dimension infinie, nous développons une loi de contrôle par rétroaction qui stabilise exponentiellement l'équation d'onde considérée.



# Contents

<b>Table des sigles et acronymes</b>	<b>xv</b>
<b>Introduction</b>	<b>1</b>
<b>1 Context and background</b>	<b>5</b>
1.1 Mathematical and control context . . . . .	6
1.2 The wave equation . . . . .	7
1.3 Notions of Mathematics . . . . .	16
1.4 Notions of Automatic control . . . . .	23
1.5 State of the art for the wave equation . . . . .	36
<b>I Robustness of prediction based adaptive control laws</b>	<b>41</b>
<b>Introduction</b>	<b>42</b>
<b>2 Model and control design under consideration</b>	<b>43</b>
2.1 Model under consideration . . . . .	43
2.2 Three different controls for three different measurements . . . . .	44
2.3 Riemann invariant and prediction based design . . . . .	44
2.4 The core of our method: the estimated and auxiliary systems . . . . .	47
2.5 Cartography of the different procedures for each control law . . . . .	49
Chapter conclusion . . . . .	51
<b>3 Boundary output feedback</b>	<b>53</b>
3.1 Boundary output adaptive control law . . . . .	53
3.2 Model mismatch of boundary output feedback . . . . .	54
3.3 Proof of robustness to internal damping . . . . .	55
Chapter conclusion . . . . .	66
<b>4 Delayed anti-collocated boundary output feedback</b>	<b>67</b>
4.1 Adaptive control law under consideration . . . . .	67
4.2 Model mismatch to in-domain viscous damping . . . . .	69

4.3	Proof of robustness . . . . .	69
	Chapter conclusion . . . . .	85
<b>5</b>	<b>Collocated boundary output feedback</b>	<b>87</b>
5.1	Control and adaptive law under consideration . . . . .	87
5.2	Mismatch collocated boundary output feedback . . . . .	89
5.3	Sketch of proof . . . . .	89
	Chapter conclusion . . . . .	92
<b>6</b>	<b>Numerical simulations</b>	<b>93</b>
6.1	Modeling of torsional vibrations during drilling . . . . .	93
6.2	Boundary output feedback velocity regulation of the nonlinear model . . . . .	96
6.3	Delayed anti-collocated output feedback velocity regulation of the nonlinear model . . . . .	101
6.4	Collocated output feedback velocity regulation of the nonlinear model . . . . .	105
6.5	A comparison of the three controls approaches . . . . .	109
	Chapter conclusion . . . . .	112
	<b>Part I conclusion</b>	<b>113</b>
<b>II</b>	<b>Backstepping control design</b>	<b>115</b>
	<b>Introduction</b>	<b>116</b>
<b>7</b>	<b>An explicit backstepping design</b>	<b>117</b>
7.1	An unstable wave equation with velocity distributed terms . . . . .	118
7.2	A exponential stable wave equation on a attractor . . . . .	119
7.3	Backstepping state feedback . . . . .	121
7.4	Proof of the closed-loop stability . . . . .	123
7.5	Observer design . . . . .	128
7.6	Comparison with prediction-based designs . . . . .	129
7.7	Comparison with the backstepping control law in [Sagert et al., 2013] . . . . .	130
7.8	Simulations . . . . .	134
	Chapter conclusion . . . . .	143

<b>8</b>	<b>An implicit backstepping design</b>	<b>145</b>
8.1	An unstable wave equation with velocity and position distributed terms . . . . .	145
8.2	An exponentially stable wave equation with velocity and position distributed terms . . . . .	147
8.3	Backstepping state feedback . . . . .	150
8.4	Proof of the closed-loop stability result . . . . .	152
8.5	Well-posedness of the closed-loop system and the target system . . . . .	158
	Chapter conclusion . . . . .	162
<b>9</b>	<b>Preliminary more advanced studies on backstepping and well-posedness</b>	<b>163</b>
9.1	Well-posedness of a unstable inhomogeneous wave PDE . . . . .	163
9.2	Exponentially stable space depending wave equation with distributed terms . . . . .	167
9.3	Backstepping transformation on a space depending wave equation . . . . .	170
	Chapter conclusion . . . . .	174
	<b>Part II conclusion</b>	<b>175</b>
	<b>Thesis conclusion and perspective</b>	<b>177</b>
<b>A</b>	<b>Intermediate results</b>	<b>179</b>
A.1	Relationship between transport and delay . . . . .	179
A.2	Intermediate result for Lyapunov stability . . . . .	179
A.3	Generalized Young inequality . . . . .	180
A.4	Complement on the uniform boundness of coupled hyperbolic PDE with uniform bounded input	180
A.5	Fubini's theorem computation details for relationship between functional $V$ and $\Gamma$ Section 3.3.3 and 4.3.3. . . . .	181
A.6	Minimal example for a set of conditions . . . . .	181
<b>B</b>	<b>Proof of the closed-loop wave equation without position distributed term well-posedness</b>	<b>183</b>
<b>C</b>	<b>Linear simulation of the wave equation</b>	<b>187</b>
C.1	Space semi-discretization . . . . .	187
C.2	Discretized feedback gain computation . . . . .	190
	<b>Bibliography</b>	<b>193</b>





# List of Figures

1.1	Illustration of a system. . . . .	6
1.2	Continuous, discrete and hybrid dynamics . . . . .	6
1.3	A pure wave illustration . . . . .	8
1.4	Schematic of a loudspeaker . . . . .	11
1.5	Elementary scheme of a rayon of the loudspeaker's diaphragm . . . . .	12
1.6	Illustration of the drillstring . . . . .	13
1.7	Elementary schematic of a transmission line . . . . .	14
1.8	Illustration of a semi-definite positive functional on a space $H$ , and on its associated quotient space.	25
1.9	Non coercive case of a semi-definite positive functional on a space $H$ , and on its associated quotient space. . . . .	26
2.1	Schematic of the Riemann invariant system. . . . .	45
2.2	Illustration of the <i>estimated system</i> and <i>auxiliary system</i> . . . . .	48
2.3	Cartography of the different procedures with respect to each control law. . . . .	50
2.4	Similarity between our method (left) and common finite method (right) for model mismatch robustness . . . . .	51
3.1	Illustration of the <i>extended system</i> for the <i>boundary output feedback</i> . . . . .	58
4.1	Illustration of the <i>delayed variable</i> together with the <i>estimated system</i> and <i>auxiliary system</i> for the <i>delayed anti-collocated output feedback</i> . . . . .	71
4.2	Illustration of the <i>target system</i> together with the <i>estimated system</i> and the <i>auxiliary system</i> for the <i>delay anti-collocated output feedback</i> . . . . .	73
4.3	Illustration of the <i>target system</i> when $\lambda = 0$ with the error terms for the <i>delayed anti-collocated output feedback</i> . . . . .	75
4.4	Illustration of the <i>target system</i> together with the <i>estimated system</i> , the <i>auxiliary system</i> and the error term $\tilde{d}(t)$ for the <i>delay anti-collocated output feedback</i> . . . . .	75
4.5	Schematic view of the successive transformations and extensions to obtain the <i>extended system</i> , the variables of which are encircled. . . . .	76
5.1	Illustration of the <i>delay system</i> together with the <i>estimated</i> and <i>auxiliary system</i> for the <i>collocated output feedback</i> . . . . .	90
5.2	Illustration of the <i>extended system</i> for the <i>collocated output feedback</i> . . . . .	91
5.3	Differences between Chapter 3 and Chapter 4 (left) and Chapter 5 (right) for model mismatch robustness . . . . .	92

6.1	Simulations of the top and bottom velocities for $\lambda = 0$ , for constant input, $\Omega(\tau) = cst.$ . . . . .	95
6.2	Simulations of the top and bottom velocities for $\lambda = 0.45$ , for constant input, $\Omega(\tau) = cst.$ . . . . .	95
6.3	Limit cycle $(\theta_\tau(L, \tau), \theta_\tau(0, \tau))$ for a range of $\lambda = 0 : 0.05 : 0.85.$ . . . . .	95
6.4	Simulation scheme for the <i>boundary output feedback</i> . . . . .	96
6.5	Simulation of the top and bottom velocities for $\lambda = 0$ , the <i>nominal case</i> for which the control has been developed (see [Bresch-Pietri and Krstic, 2014a]) for the <i>boundary output feedback</i> . . . . .	98
6.6	Simulation of the distributed position for $\lambda = 0$ , the <i>nominal case</i> for which the control has been developed (see [Bresch-Pietri and Krstic, 2014a]) for the <i>boundary output feedback</i> . . . . .	98
6.7	Simulation of the distributed velocity for $\lambda = 0$ , the <i>nominal case</i> for which the control has been developed (see [Bresch-Pietri and Krstic, 2014a]) for the <i>boundary output feedback</i> . . . . .	98
6.8	Simulation of the distributed shear stress for $\lambda = 0$ , the <i>nominal case</i> for which the control has been developed (see [Bresch-Pietri and Krstic, 2014a]) for the <i>boundary output feedback</i> . . . . .	98
6.9	Evolution of the parameter estimates $\hat{d}$ and $\hat{q}$ for $\lambda = 0$ for the <i>boundary output feedback</i> . (see [Bresch-Pietri and Krstic, 2014a]) . . . . .	98
6.10	Input time response $U(\tau)$ and $\Omega(\tau)$ for $\lambda = 0$ for the <i>boundary output feedback</i> . (see [Bresch-Pietri and Krstic, 2014a]) . . . . .	98
6.11	Simulation of the top and bottom velocities for $\lambda = 0.45$ , for the <i>boundary output feedback</i> . . . . .	99
6.12	Simulation of the distributed position for $\lambda = 0.45$ , for the <i>boundary output feedback</i> . . . . .	99
6.13	Simulation of the distributed velocity for $\lambda = 0.45$ , for the <i>boundary output feedback</i> . . . . .	99
6.14	Simulation of the distributed shear stress for $\lambda = 0.45$ , for the <i>boundary output feedback</i> . . . . .	99
6.15	Evolution of the parameter estimates $\hat{d}$ and $\hat{q}$ for $\lambda = 0.45$ the robust case for the <i>boundary output feedback</i> . . . . .	99
6.16	Input time response $U(\tau)$ and $\Omega(\tau)$ for $\lambda = 0.45$ for the <i>boundary output feedback</i> . . . . .	99
6.17	Simulation of the top and bottom velocities for $\lambda = 0.9$ , for the <i>boundary output feedback</i> . . . . .	100
6.18	Simulation of the distributed position for $\lambda = 0.9$ , for the <i>boundary output feedback</i> . . . . .	100
6.19	Simulation of the distributed velocity for $\lambda = 0.9$ , for the <i>boundary output feedback</i> . . . . .	100
6.20	Simulation of the shear stress for $\lambda = 0.9$ , for the <i>boundary output feedback</i> . . . . .	100
6.21	Evolution of the parameter estimates $\hat{d}$ and $\hat{q}$ for $\lambda = 0.9$ , for the <i>boundary output feedback</i> . . . . .	100
6.22	Input time response $U(\tau)$ and $\Omega(\tau)$ for $\lambda = 0.9$ for the <i>boundary output feedback</i> . . . . .	100
6.23	Simulation scheme for the <i>delay anti-collocated output feedback</i> . . . . .	101
6.24	Simulation of the top and bottom velocities for $\lambda = 0$ , the <i>nominal case</i> for which the control has been developed for the <i>delayed anti-collocated output feedback</i> . . . . .	102
6.25	Simulation of the distributed position for $\lambda = 0$ , for the <i>delayed anti-collocated output feedback</i> . . . . .	102
6.26	Simulation of the distributed velocity for $\lambda = 0$ , for the <i>delayed anti-collocated output feedback</i> . . . . .	102
6.27	Simulation of the shear stress for $\lambda = 0$ , for the <i>delayed anti-collocated output feedback</i> . . . . .	102

6.28	Evolution of the parameter estimates $\hat{d}$ and $\hat{q}$ for $\lambda = 0$ , for the <i>delayed anti-collocated output feedback</i> . . . . .	102
6.29	Input time response $U(\tau)$ and $\Omega(\tau)$ for $\lambda = 0$ for the <i>delayed anti-collocated output feedback</i> . . . . .	102
6.30	Simulation of the top and bottom velocities for $\lambda = 0.45$ , for the <i>delayed anti-collocated output feedback</i> . . . . .	103
6.31	Simulation of the distributed position for $\lambda = 0.45$ , for the <i>delayed anti-collocated output feedback</i> . . . . .	103
6.32	Simulation of the distributed velocity for $\lambda = 0.45$ , for the <i>delayed anti-collocated output feedback</i> . . . . .	103
6.33	Simulation of the shear stress for $\lambda = 0.45$ , for the <i>delayed anti-collocated output feedback</i> . . . . .	103
6.34	Evolution of the parameter estimates $\hat{d}$ and $\hat{q}$ for $\lambda = 0.45$ the robust case for the <i>delayed anti-collocated output feedback</i> . . . . .	103
6.35	Input time response $U(\tau)$ and $\Omega(\tau)$ for $\lambda = 0.45$ for the <i>delayed anti-collocated output feedback</i> . . . . .	103
6.36	Simulation of the top and bottom velocities for $\lambda = 0.9$ , for the <i>delayed anti-collocated output feedback</i> . . . . .	104
6.37	Simulation of the distributed position for $\lambda = 0.9$ , for the <i>delayed anti-collocated output feedback</i> . . . . .	104
6.38	Simulation of the distributed velocity for $\lambda = 0.9$ , for the <i>delayed anti-collocated output feedback</i> . . . . .	104
6.39	Simulation of the shear stress for $\lambda = 0.9$ , for the <i>delayed anti-collocated output feedback</i> . . . . .	104
6.40	Evolution of the parameter estimates $\hat{d}$ and $\hat{q}$ for $\lambda = 0.9$ the robust case for the <i>delayed anti-collocated output feedback</i> . . . . .	104
6.41	Input time response $U(\tau)$ and $\Omega(\tau)$ for $\lambda = 0.9$ for the <i>delayed anti-collocated output feedback</i> . . . . .	104
6.42	Simulation scheme for the <i>collocated output feedback</i> . . . . .	105
6.43	Simulation of the top, bottom and delayed bottom estimated velocities for $\lambda = 0$ , the <i>nominal case</i> for which the control has been developed (see [Bresch-Pietri and Krstic, 2014b]). . . . .	106
6.44	Simulation of the distributed position for $\lambda = 0$ , for the <i>collocated output feedback</i> . . . . .	106
6.45	Simulation of the distributed velocity for $\lambda = 0$ , for the <i>collocated output feedback</i> . . . . .	106
6.46	Simulation of the shear stress for $\lambda = 0$ , for the <i>collocated output feedback</i> . . . . .	106
6.47	Evolution of the parameter estimates $\hat{d}$ and $\hat{q}$ for $\lambda = 0$ , for the <i>collocated output feedback</i> . . . . .	106
6.48	Input time response $U(\tau)$ and $\Omega(\tau)$ for $\lambda = 0$ for the <i>collocated output feedback</i> . . . . .	106
6.49	Simulation of the top, and bottom and delayed bottom estimated velocities for $\lambda = 0.45$ , for the <i>collocated output feedback</i> . . . . .	107
6.50	Simulation of the distributed position for $\lambda = 0.45$ , for the <i>collocated output feedback</i> . . . . .	107
6.51	Simulation of the distributed velocity for $\lambda = 0.45$ , for the <i>collocated output feedback</i> . . . . .	107
6.52	Simulation of the shear stress for $\lambda = 0.45$ , for the <i>collocated output feedback</i> . . . . .	107
6.53	Evolution of the parameter estimates $\hat{d}$ and $\hat{q}$ for $\lambda = 0.45$ , for the <i>collocated output feedback</i> . . . . .	107

6.54	Input time response $U(\tau)$ and $\Omega(\tau)$ for $\lambda = 0.45$ for the <i>collocated output feedback</i> . . . . .	107
6.55	Simulation of the top, bottom and delayed bottom estimated velocities, for $\lambda = 0.9$ , for the <i>collocated output feedback</i> . . . . .	108
6.56	Simulation of the distributed position for $\lambda = 0.9$ , for the <i>collocated output feedback</i> . . . . .	108
6.57	Simulation of the distributed velocity for $\lambda = 0.9$ , for the <i>collocated output feedback</i> . . . . .	108
6.58	Simulation of the shear stress for $\lambda = 0.9$ , for the <i>collocated output feedback</i> . . . . .	108
6.59	Evolution of the parameter estimates $\hat{d}$ and $\hat{q}$ for $\lambda = 0.9$ , for the <i>collocated output feedback</i> . . . . .	108
6.60	Input time response $U(\tau)$ and $\Omega(\tau)$ for $\lambda = 0.9$ for the <i>collocated output feedback</i> . . . . .	108
6.61	Graph of $(\theta_\tau(0, \tau), \theta_\tau(L, \tau))$ for the three control laws with $\lambda = 0$ . . . . .	109
6.62	Graph of $(\theta_\tau(0, \tau), \theta_\tau(L, \tau))$ for the three control laws with $\lambda = 0.45$ . . . . .	110
6.63	Graph of $(\theta_\tau(0, \tau), \theta_\tau(L, \tau))$ for the three control laws with $\lambda = 0.9$ . . . . .	110
7.1	Eigenvalues of the target system (7.12), and the closed-loop system (7.1) with the control law (7.35), for $n = 35$ and $b_1 = 0.02$ , $b_2 = 0.6$ , $\lambda = 0.06$ , $c_1 = 1$ , $d_1 = b_1$ , and $b_2 = d_2$ . . . . .	135
7.2	Eigenvalues of the <i>original system</i> with zero input ( $U(t) = 0$ ), the target system (7.12), and the closed-loop system (7.1) with the control law (7.35), for the parameters set ① (see Table 7.1). . . . .	136
7.3	Eigenvalues of the <i>original system</i> with zero input ( $U(t) = 0$ ), the target system (7.12), and the closed-loop system (7.1) with the control law (7.35), for the parameters set ② (see Table 7.1). . . . .	136
7.4	Zero-input system boundary velocities time-domain response for non-zero initial conditions . . . . .	137
7.5	Closed-loop boundary velocities time-domain response for non-zero initial conditions. The full-state backstepping controller stabilizes the system . . . . .	138
7.6	Observer based-control: closed-loop boundary velocities time-domain response for non-zero initial conditions. . . . .	138
7.7	Control law time-domain response for non-zero initial conditions for the observer based backstepping controller. . . . .	138
7.8	Control scheme with the exogenous signals. . . . .	139
7.9	Observer based design bode diagram with parameter set ①. . . . .	140
7.10	Observer based design bode diagram with parameter set ②. . . . .	141
7.11	Observer based design bode diagram zoom with parameter set ①. . . . .	141
7.12	Observer based design bode diagram zoom with parameter set ②. . . . .	142
C.1	Eigenvalues of the closed-loop system ( $\Sigma_n(0, 0, 0.02, 0.6, 0, -0.06, 0)$ ), and of the <i>target system</i> ( $\Sigma_n(-1, 0, -0.02, -0.6, 0, -0.06, 0)$ ) for $N = 30$ and the derivative approximation in Section C.1.1. . . . .	188
C.2	Eigenvalues of the <i>original system</i> ( $\Sigma_n(0, 0, 2, 0.6, 0, -0.08, 0, U(t) = 0)$ ), the <i>closed-loop system</i> , and the <i>target system</i> ( $\Sigma_n(-1, 0, -2, 0.6, 0, -0.08, 0, 0)$ ) and for $N = 35$ and the derivative approximation in Section C.1.1. . . . .	190

---

C.3	Eigenvalues of the closed-loop system ( $\Sigma_n(0, 0, 2, 0.6, 0, -0.08, 0)$ ), the <i>closed-loop system</i> , and the <i>target system</i> ( $\Sigma_n(-1, 0, -2, 0.6, 0, -0.08, 0, 0)$ ) and for $N = 35$ for $N = 35$ and the derivative approximation in Section C.1.2. . . . .	190
-----	---	-----



# List of Tables

1.1	Elementary illustration of the wave propagation . . . . .	9
1.2	Several types of wave equation boundary conditions (inspired from [Graff, 1975] Page 30) . . . . .	10
6.1	Parameters values of the nonlinear model used in simulation . . . . .	94
6.2	Tuning parameters values . . . . .	96
6.3	Time laps in secondes between the actuation of the control law and the time to have all trajectory $(\theta_t(L, \tau), \theta_t(0, \tau))$ are contained in a ball of $\ell_1$ -norm, $\ell_2$ -norm, and $\ell_\infty$ -norm with different radius for the different control laws, with different $\lambda$ . . . . .	111
7.1	Parameter values for the simulation set ① and ② . . . . .	137





# Table des sigles et acronymes

**PDE** Partial differential equation

**ODE** Ordinary differential equation

**TAC** Transaction on Automatic Control

**ACC** American Control Conference

**CDC** Conference on Decision and Control

**LMI** Linear Matrix Inequalities

**LTI** Linear Time Invariant

**IEEE** Institute of Electrical and Electronics Engineers



---

# Introduction

In this thesis we focus on the boundary control of the wave equation.

The wave equation is a Partial Differential Equation (PDE) which implies a relation between second order time derivatives and second order space derivatives. It is classified as second order hyperbolic PDE. This type of equation is commonly used to model the propagation of a variable in an elastic media. This concerns the propagation of sound in air and water for example, in this case the variable which propagates is the pressure. The wave equation is also used to model the elongation in a nonrigid body. This is the case of a guitar string (or any string instrument). In practice linearity cannot be more than local, e.g. a simple resistor does not behave as a resistor outside its operative range. The same is true for the rigidity of body which is at best verified in a working window. For example earthquakes are due to the elasticity of the earth. In the recent decade with the increasing utilization and democratization of nonrigid body, e.g. robots arm, overhead crane in industrial facility, numberless studies propose answers to the vibration problem resulting from the use of nonrigid body. Many approaches with different points of view have been developed in order to respond to this general problem.

In this dissertation, we consider the subclass of problems which can be modeled by a one dimensional and scalar wave equation. This type of wave equation is commonly called string equation. As the considered wave PDE is one dimensional and limited in space, the wave equation is subject to two boundary conditions at the limits of its domain. The problem we consider is the stabilization/regulation of the wave equation subject to an unstable dynamic boundary condition with the actuation at the opposite boundary. The work presented on this dissertation is a suggested answer to two questions already exposed in the abstract:

Considering that the unstable dynamic boundary condition has some unknown parameters, adaptive control laws have been designed. Nevertheless, in the control design step the in-domain viscous damping is taken equal to zero, therefore the question is:

*Is a nonlinear adaptive control law still performing efficiently, if the viscous damping taken equal to zero for its design is no longer neglected?*

Considering this idea one can wonder why neglecting the in-domain damping? Can we generalize the previous work in order to consider the in-domain not as an unmodeled dynamics but as an inherent feature of the wave equation? To answer to this question the first step is:

*How can we take into account the in-domain damping in order to stabilize the wave equation subject to an unstable dynamic boundary condition with known parameters?*

Applying separation principle, if we are not able to answer to the last question, there is little chance to establish an adaptive control law which takes into account the in-domain damping.

In order to answer to these two questions, this thesis consists of nine chapters classified in two parts and a preliminary chapter. The content of each chapter is explained in the following.

**Chapter 1:** The preliminary chapter exposes the general context of this thesis. We deal with the control theory context and the associated mathematical definitions and notations. First, we present the wave equation in the physical context. This is followed by the mathematical definitions, and notions we used in this thesis. Finally, we develop some notions of automatic control. This chapter ends up with a state of the art for the wave equation.

For readers who are familiar with mathematical analysis and control theory notions, we suggest them to read only Section 1.2 which presents the model and Section 1.5 which consists in the state of the art.

**Part I:** This part consists of all chapters suggesting in order to answer the first question, and therefore concerns the model mismatch robustness of adaptive control laws. Note that the adaptive control laws considered are prediction based control laws and Lyapunov based estimation laws (indirect adaptive control).

**Chapter 2:** This chapter presents the design idea of the three predictive based adaptive control laws we consider in this part. These control laws have been designed assuming that there was no in-domain damping. In this chapter, the core of our method is presented. Our method proposes successive change of variables in order to perform a Lyapunov analysis. This Lyapunov analysis implies that the closed-loop system consisting of the considered adaptive control law and the wave equation with in-domain damping performs equivalently if the in-domain damping is small enough. What we mean by “perform equivalently” will be detailed in theorems associated with our robust results.

This chapter contains the principal idea of our method, and therefore is the key point of this part.

**Chapter 3:** The first adaptive control law considered used the measurement of both boundary velocities. It has been design in [Bresch-Pietri and Krstic, 2014a]. In this chapter, this control law is presented, associated with the robust result and its proof.

**Chapter 4:** The second adaptive control law, considered in this dissertation, used the measurement of both boundary velocities but the boundary velocity opposite to the actuation is delayed from one unit of time. It is inspired from the design in [Bresch-Pietri and Krstic, 2014b]. In this chapter, this control law is presented, associated with the robust result and its proof.

**Chapter 5:** The last adaptive control law considered used the measurement of the boundary velocity located at the actuation. It has been designed in [Bresch-Pietri and Krstic, 2014b]. In this chapter, this control law is presented, associated with the robust result with a sketch of proof. The complete proof is given in [Roman et al., 2017].

**Chapter 6:** The last chapter of this first part is devoted to simulation. The context of these simulations are the torsional vibration occurring in drilling facility. The simulations are performed on an associated nonlinear model for the three considered control laws.

As this chapter contains simulation it can be appreciated without the reading of the four chapter before.

A possible lecture of this part could be done starting with Chapter 6, which presents the application in mind of the adaptive control laws; and then Chapter 2 in order to get the idea behind the design of the adaptive control laws; and finally Chapter 3, Chapter 4 and Chapter 5 which contain the proof of the robustness result.

**Part II:** This part is a collection of suggested answers to the second question. In other words we suggest to use infinite dimensional backstepping in order to design boundary control exponentially stabilizing the wave equation subject to unstable dynamic boundary condition opposite to the actuation.

**Chapter 7:** This chapter presents the design of a backstepping control feedback in order to exponentially stabilize the same wave equation considered in Part I, but assuming that the unstable dynamic boundary condition parameters are known. As backstepping gives a full state feedback, an observer using both boundary velocities is also proposed. We compare the design control law with the control law in [Bresch-Pietri and Krstic, 2014a] the one study in Chapter 3, and with the control law developed in [Sagert et al., 2013]. At the end of this chapter some numerical simulations on the linear model are performed.

The backstepping method is done with relatively simple computations. Nevertheless, the interesting fact

about this chapter is the fact that the exponential stabilization is not done with respect to the origin but for an attractor for both the system and the observer.

**Chapter 8:** In this chapter a different wave equation is considered with in-domain velocity and position distributed terms. Here the propagation may also be unstable. A backstepping design is presented and the well-posedness of the closed-loop system is proven.

In this chapter, readers who are interested in backstepping, will find an innovative proof using the common method of successive approximations in order to prove the existence and uniqueness of the backstepping kernel.

**Chapter 9:** This chapter is the last of this thesis, and we choose to present some works in progress. We consider the problem of a space depending wave equation with in-domain velocity and position distributed terms subject to dynamic boundary conditions. By space dependent wave, we mean that the propagation velocity along the wave is space dependent. The preliminary computation of a backstepping design is presented. And the well-posedness of the inhomogeneous problem is established.

Some of the results presented in this thesis have been presented in a journal paper and in conferences, as given below

## Conference papers

- [Roman et al., 2016a] Roman, C., Bresch-Pietri, D., Cerpa, E., Prieur, C., and Sename, O. (2016a). Backstepping observer based-control for an anti-damped boundary wave PDE in presence of in-domain viscous damping. In *IEEE 55th Conference on Decision and Control*, pages 549–554, Las Vegas, NV.
- [Roman et al., 2016b] Roman, C., Bresch-Pietri, D., Prieur, C., and Sename, O. (2016b). Robustness of an adaptive output feedback for an anti-damped boundary wave PDE in presence of in-domain viscous damping. In *IEEE American Control Conference*, pages 3455–3460, Boston, MA.
- [Roman et al., 2017a] Roman, C., Bresch-Pietri, D., Prieur, C., and Sename, O. (2017a). Boundary Control of a Wave Equation With an Anti-Damped Boundary Dynamics in Presence of an In-Domain Velocity Source Term. In *20th IFAC World Congress*, Preprints of the 20th World Congress, pages 4870–4873, Toulouse, France.

## Journal paper

- [Roman et al., 2018] Roman, C., Bresch-Pietri, D., Cerpa, E., Prieur, C., and Sename, O. (2018). Backstepping control of a wave PDE with unstable source terms and dynamic boundary. *IEEE Control Systems Letters (L-CSS)*, 2:459–464.

## Conditionally accepted at a journal paper

- [Roman et al., 2017b] Roman, C., Bresch-Pietri, D., Prieur, C., and Sename, O. (2017b). Robustness to in-domain viscous damping of a collocated boundary adaptive feedback law for an anti-damped boundary wave PDE. Preprint. (submitted)



# Context and background

---

## Contents

<b>1.1</b>	<b>Mathematical and control context</b>	<b>6</b>
1.1.1	We need state and state space	6
1.1.2	The feedback	7
<b>1.2</b>	<b>The wave equation</b>	<b>7</b>
1.2.1	The wave propagation	8
1.2.2	The boundary conditions of the wave PDE	9
1.2.3	The wave in Physics	10
<b>1.3</b>	<b>Notions of Mathematics</b>	<b>16</b>
1.3.1	$L_p$ space	17
1.3.2	Sobolev space and associated notations	17
1.3.3	A class of equivalence: almost everywhere	17
1.3.4	Fixed point and method of successive approximation	18
1.3.5	Unbounded operator, maximal monotone operator and $C_0$ semigroup	19
1.3.6	Barbalat Lemma	22
<b>1.4</b>	<b>Notions of Automatic control</b>	<b>23</b>
1.4.1	Stability	24
1.4.2	Robustness	28
1.4.3	Backstepping approach	28
1.4.4	Adaptive control	31
<b>1.5</b>	<b>State of the art for the wave equation</b>	<b>36</b>
1.5.1	Stability, regularity, and well-posedness of the wave equation	37
1.5.2	Boundary control of the wave equation	38

---

It's the question we can't answer that teach us the most. They teach us to think. If you give a man an answer, all he gains is a little fact. But give him a question and he'll look for his own answers.

*The Wise Man's Fear, Patrick Rothfuss*

First, we propose a brief introduction of the mathematical and control theory ideas in Section 1.1. The wave equation is a partial differential equation which can be used to model various phenomena, from the sound propagation to electromagnetic field and so light propagation. In this thesis, the wave equation represents mostly mechanical systems, in particular vibrations in nonrigid body. Mechanical systems are mainly bounded, therefore in this thesis we are interested in the control of the scalar one-dimensional wave equation with respect to one boundary. After that, we present the wave propagation and its possible boundary conditions in Section 1.2, the mathematical notions needed to follow this dissertation are specified in Section 1.3. This allows us to present some control theory notions in Section 1.4. This first chapter is ended up by a brief state of the art concerning the well-posedness of the wave equation and some existing boundary control law designs.



## 1.1 Mathematical and control context

### 1.1.1 We need state and state space

Control theory aims at studying dynamical systems.

A system is a set of variables, these variables are referred to as, input, state or output variables. The inputs are the exogenous variables, they can influence the dynamics of the system. For a fix input the evolution of the system is only determined by the state variables. The output is the knowledge we have concerning the system input and state. This is illustrated in Figure 1.1, note that the fact that the system depends on the state variable is often omitted in this scheme.

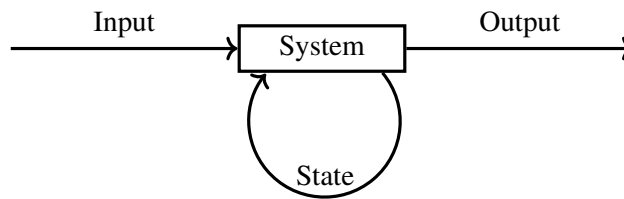

Figure 1.1: Illustration of a system.

All these variables are evolving within a space. In particular, the state variable space is referred to as the state space. The state represents all the variables that need to be known to predict the future evolution of the dynamic system. There are two types of input, control input which refers to input we can act on, and disturbance/noise input which corresponds to the input we cannot act on.

The dynamical behavior is usually classified in three types of systems: continuous time, discrete event, and the combination of both: hybrid. The three types of dynamics are illustrated in Figure 1.2. In this thesis we consider continuous dynamics only.

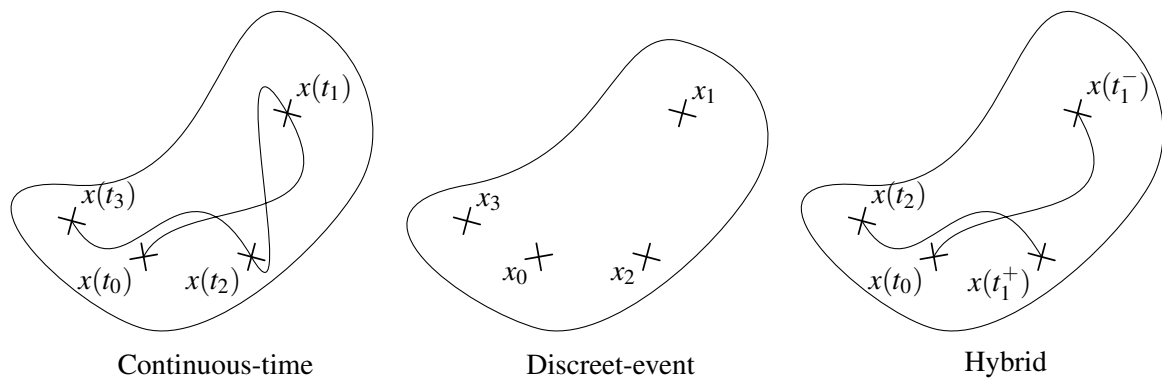

Figure 1.2: Continuous, discrete and hybrid dynamics

The definition of state space is actually intuitive for finite dimensional system, as the state space is the Cartesian space, the dimension of which is the number of variable state considered. For example, consider the state  $x(t)$  a real value vector of dimension  $n$ , the state space is  $\mathbb{R}^n$ . Assuming that we consider continuous-time dynamics, given as:

$$\frac{d}{dt}x(t) = f(x(t), u(t)), \quad (1.1)$$

in which

$$f: \quad \mathbb{R}^n \times \mathbb{R}^p \rightarrow \mathbb{R}^n \\ (x(t), u(t)) \mapsto f(x(t), u(t)), \quad (1.2)$$

where  $u(t) \in \mathbb{R}^p$  is the input space. Given some extra constraints on  $x(t)$  and  $u(t)$ , their associated space could be a subspace of respectively  $\mathbb{R}^n$  and  $\mathbb{R}^p$ . In the representation above we did not represent the output. And we have assumed that the system is time invariant, indeed  $f$  does not evolve with time, opposite to  $f(t, x(t), u(t))$ . In the dissertation, we consider time invariant systems only.

Now as we consider PDE, the state space is no longer a Cartesian space but it is an Hilbert space. The idea is no longer to describe the evolution of real values, but the evolution of functions. Indeed, for example consider the state variable to be  $\phi(t) \in L_2([0, 1]; \mathbb{R})$  (which will be denote abusively  $L_2(0, 1)$ ), which is the class of equivalence of square integrable functions. Consider the representation

$$\frac{d}{dt}\phi(t) + A\phi(t) = 0, \quad (1.3)$$

where  $A$  is an unbounded operator the domain of which is  $\text{Dom}(A) \subset L_2(0, 1)$ . The property unbounded means that the operator acts within the bound of its domain. We speak a little more about unbounded operator in Section 1.3.5. In PDE system, the state space associated with (1.3) can become quite complicated.

### 1.1.2 The feedback

In this thesis, we are interesting in feedback control, this means that we can act on the system dynamics by a control input. Nevertheless, let us speak a little about open-loop control

#### (i) Open-loop control

The idea is to act on the system control input in a blind way. For example, let us take the microwave oven system, the state considered is the water temperature for making tea. We are used to this system, as we drink tea all the time, we known that for our mug in 1:30min at 800W, the water will be hot enough, and we do not need more information. If we measure the temperature it is no longer a open-loop control it becomes a feedback control.

#### (ii) Feedback control

As previously said, the idea is to check the system state, or a image of it (output) in order to compute the control input. For the microwave system, we actually measure the temperature and if the temperature is the one we want we stop, if it is too cold we increase the time.

Open-loop control is a blind way to control system, if we have an absolute knowledge of the system or a large marge of tolerance it is working and it will always be less costly than feedback control. Indeed feedback control needs some knowledge about the system state, this is done using sensors. Moreover, feedback control can be more efficient and robust. It can also stabilize unstable systems. Nevertheless ill-designed feedback control may lead to instability. There is nothing more easy that to make a stable system unstable using feedback. We wish to certify that the latter will not happen.

The reason we choose feedback control, is first because the system we consider is unstable, then because in terms of performance. However we need to check that the control law we design/use is robust. This stability issue are explained in Section 1.4. Nevertheless we start by introducing the system, the class of system we consider, i.e., the wave equation.

## 1.2 The wave equation

In this section, we discus about the wave equation, and how it can be obtained for mechanical system. In the following, we proposed illustration/schema of the one-dimensional wave equation. First, several one dimensional wave propagation equations are presented in Section 1.2.1, then the main types of boundary conditions are shown in Section 1.2.2.

### 1.2.1 The wave propagation

We mean by wave propagation the equation of the wave within its domain. Indeed the wave can have in-domain source terms and depending on these source terms the behavior can vary.

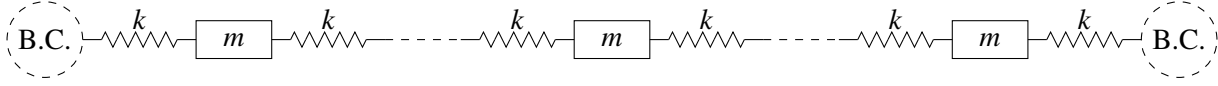

Figure 1.3: A pure wave illustration

In Figure 1.3 an illustration using mass and spring elements are presented. In this figure “B.C.” stand for boundary condition. The wave equation is the limit solution when the number of mass-spring elements goes towards infinity. Indeed denoting  $u_i$  the elongation (difference between the current position of the mass and its equilibrium position) of the  $i$ -th mass, using Newton’s Second Law of motion, it holds

$$m \frac{d^2}{dt^2} u_i(t) = k(u_{i-1}(t) - 2u_i(t) + u_{i+1}(t)). \quad (1.4)$$

We want to study this equation for an infinite number of elements. Therefore we need to consider elementary mass and spring stiffness of elementary length. In mathematical term one can replace ‘elementary’ by ‘non standard’. The non standard analysis is the rigorous justification of the infinitesimal small quantity, it is based on the work of Abraham Robinson in 1961. We consider a series where the distance between terms are non standard and infinity small. As the steps are infinity small  $u_{i-1}(t) \sim u(x - dx, t)$ . In order world we consider the following equation

$$dm \frac{\partial^2}{\partial t^2} u(x, t) = dk(u(x - dx, t) - 2u(x, t) + u(x + dx, t)), \quad (1.5)$$

where using linear mass and linear stiffness, it holds  $dk = \frac{k_l}{dx}$  and  $dm = m_l dx$  where  $dx$  in the length of the springs and the masses. It holds

$$\frac{\partial}{\partial t^2} u(x, t) = \frac{k_l}{m_l} \frac{\partial}{\partial x^2} u(x, t), \quad (1.6)$$

which is the wave equation. In order to shorten the writing of partial derivative the following notation is commonly used in PDE study,

$$\frac{\partial}{\partial t} u(x, t) = u_t(x, t), \quad \frac{\partial}{\partial x} u(x, t) = u_x(x, t). \quad (1.7)$$

Changing the time coordinate, one can normalize the velocity of the wave propagation, i.e.,  $\sqrt{\frac{k_l}{m_l}}$ , and the wave equation can be expressed as

$$u_{tt}(x, t) = u_{xx}(x, t). \quad (1.8)$$

Changing the space coordinate one can impose  $x \in [0, 1]$ . At  $x = 0$  and  $x = 1$  the wave is submitted to boundary conditions.

The different kinds of boundary conditions are presented in the next section. Note that what has been presented is the simplest wave propagation. In order to get a better approximation of the reality we can add elements. The main linear propagation and their associated elementary representations are displayed in Table 1.1.

Elementary scheme	Equation	Type
	$u_{tt}(x,t) = u_{xx}(x,t)$	Pure wave
	$u_{tt}(x,t) = u_{xx}(x,t) + \alpha u_{xxt}(x,t)$	Kelvin Voigt damping
	$u_{tt}(x,t) = u_{xx}(x,t) + \beta(x)u(x,t)$	Position distributed term
	$u_{tt}(x,t) = u_{xx}(x,t) + \lambda(x)u_t(x,t)$	Viscous distributed term
	$u_{tt}(x,t) = (a(x)u_x(x,t))_x$	Space dependent wave

Table 1.1: Elementary illustration of the wave propagation

In this thesis, we are mostly interested in the viscous distributed term, and Chapter 2, Chapter 3, Chapter 5, and Chapter 7 are considering only this type of distributed term. In Chapter 8 we consider in addition a position distributed term. At last, we present ongoing works for a space dependent wave with viscous and position distributed term in Chapter 9.

### 1.2.2 The boundary conditions of the wave PDE

As we have seen the wave equation can be seen as the infinite combination of infinity small mass spring elements. However, the domain is often limited. The number of elements is infinite but the domain remains bounded. There is the question of how the infinity small elements end up at the boundary. As the wave equation contains a second derivative in space we need two boundary conditions. Let us imagine the wave as a string, the behavior of the string changes if the string is fixed or free for example. Of course, the interaction at the boundary can be more complex than just free or fixed, as illustrated in Table 1.2

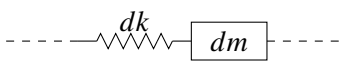
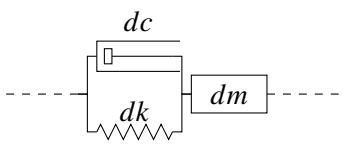
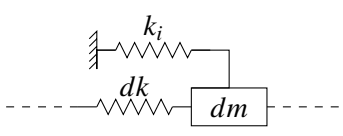
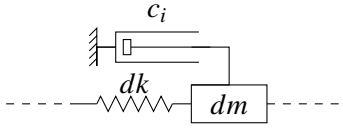
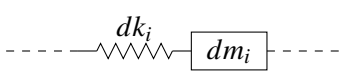
Scheme	Equation	Type
	$u(0, t) = 0$	Dirichlet
	$u_x(0, t) = 0$	Neumann
	$Tu_x(0, t) = ku(0, t)$	Robin
	$Tu_x(0, t) = cu_t(0, t)$	First order dynamic boundary
	$mu_{tt}(0, t) = Tu_x(0, t)$	Second order dynamic boundary

Table 1.2: Several types of wave equation boundary conditions (inspired from [Graff, 1975] Page 30)

The different boundary conditions in Table 1.2 can be coupled in order to get more precise models. In this thesis we consider that the control is acting on one boundary condition and that we are trying to stabilize the other boundary.

In the next section, we discuss about the wave equation with respect to some of its related physical problems.

### 1.2.3 The wave in Physics

The origin of the wave equation goes back to Pythagoras which studies the link between musical sound and vibrating string. In [Graff, 1975] on Page 8 a chronological list of the major development concerning the elastic body is presented, as briefly summarized below

6th B.C. Pythagoras

- 1638 Galileo Galilei, the factor influencing the vibrations of string.
- 1678 R. Hooke, Hooke's law, the proportionality between stress and strain in elastic bodies. (which we have used as the characteristic of the spring).
- 1686 I. Newton, speed of sound in air and speed of water wave.
- mid 18th J. D'Alembert, L. Euler and D. Bernoulli, controversy on the solution of the vibrating string (see [F. Wheeler and P. Crummett, 1987]).
- 1759 Lagrange, the string as a system of discrete mass particles (the same idea as we have presented to obtain the wave equation).

For more about non-rigid systems we refer the reader to [Lalanne et al., 1984] and [Graff, 1975]. One can classify the wave in two kinds, the mechanical wave, and the electromagnetic wave (including light propagation). The purpose of the next section is to present some physical systems which can be modeled by the wave equation.

### 1.2.3.1 String wave

The string wave is the one we are interested in this thesis. One interesting topic about one dimensional wave equation is presented in [F. Wheeler and P. Crummett, 1987], which presents the controversy about the solution of vibrating string between Jean d'Alembert, Leonhard Euler, and Daniel Bernoulli. J. d'Alembert exposed that the solution needs to be twice derivable for the wave equation to have sense (1.8), we can extrapolate this as the case of the strong solution. L. Euler wanted to consider non-differentiable function but integrable function, which corresponds to the weak solution. D. Bernoulli answers that he could build the solution with the same method for both cases, we can extrapolate this as the fact that the continuous function are dense in the set of integrable function. In order words that we can arbitrary approximate an integrable function by a sequence of continuous functions. This is detailed in [F. Wheeler and P. Crummett, 1987]. This can be considered as the starting point of problems solved by the development of the Lebesgue integral and the set of integrable function. These notions are detailed in Section 1.3.

The string wave can be used to model vibrations of three dimensional body with a high degree of symmetric, as illustrated below through a simple example

**Example 1.1** A string wave model of a loudspeaker.

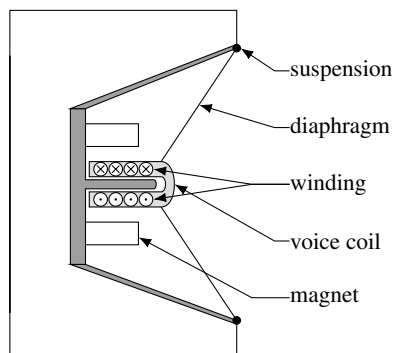

Figure 1.4: Schematic of a loudspeaker

We consider the circular symmetric of the loudspeaker, the elementary scheme of which is drawn in Figure 1.4.

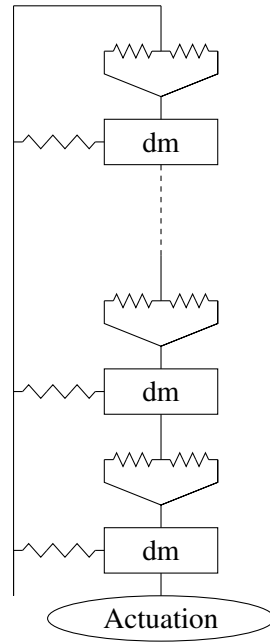

Figure 1.5: Elementary scheme of a rayon of the loudspeaker's diaphragm

The elementary scheme in Figure 1.5 can be associated with the following system equation

$$\begin{cases} u_{tt}(x,t) = u_{xx}(x,t) + \beta u(x,t) & (1.9a) \\ u_x(1,t) = au(1,t) & (1.9b) \\ u_{tt}(0,t) = b_1 u_t(0,t) + b_2 u_x(0,t) + b_3 u(0,t) + U(t). & (1.9c) \end{cases}$$

The  $\beta$  term represents the Hooke's law due to the air inside the enclosure of the loudspeaker. The  $a$  parameter is the stiffness of the suspension. The boundary condition at  $x = 0$  represents the dynamics of the voice coil. It has a mass different from the membrane. ★

### Example 1.2 Torsional vibrations in a cylinder.

For drilling facility, the torsional vibration can be modeled by the wave equation, which is the application in mind of this thesis at least for Chapter 3 at Chapter 7.

Note that, there exist plenty of works around this problem in control theory and modelization, let us introduce some of them. The thesis of Jansen [Jansen, 1993] and [Jansen and van der Steen, 1995] consider finite-dimensional approach, but they also present the control problem that needs to be solved. There is also the work of [Ritto et al., 2009] which proposes a stochastic computation model to represent model uncertainties in the bit-rock interaction. A comparative review of modeling and controlling torsional vibration with experimental point of view is done in [Patil and Teodoriu, 2013]. A overview on control theory in oilwell drilling vibration is presented in [Saldivar et al., 2016a]. A survey about the drilling structure modeling is given in [Ghasemloonia et al., 2015]. Let us come back to our example.

First consider the drilling system as illustrated in Figure 1.6.

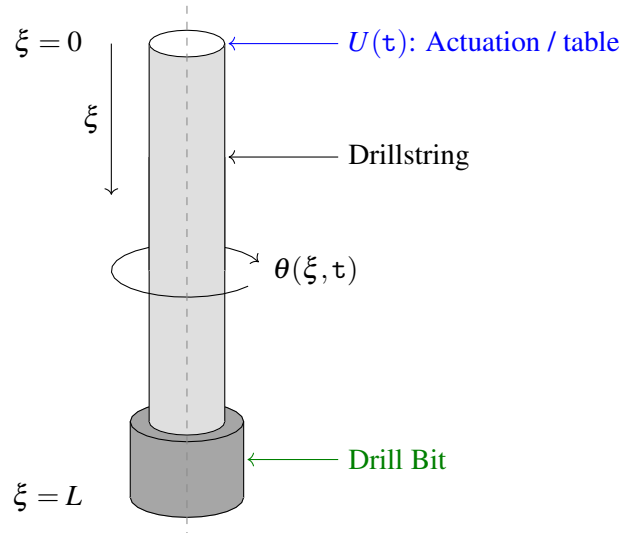

Figure 1.6: Illustration of the drillstring

From Newton's second law, one gets

$$dI\ddot{\theta}(\xi, \tau) = \sum_i dT_i(\xi, \tau), \quad (1.10)$$

where  $dI$  denotes the elementary inertia moment of the drillstring along the  $\xi$ -axis,  $\theta(\xi, \tau)$  is the angular position, and  $dT_i(x, \tau)$  denotes one elementary torque applied at coordinate  $\xi$ .  $\tau$  denotes the time, the time coordinate is going to change in the latter stage of this example. Under the condition that we have no warping, and that the drillstring stiffness satisfies Hooke law, it holds

$$dT_{\text{intern elasticity}}(\xi, \tau) = dk[\theta(\xi - \partial\xi, \tau) - 2\theta(\xi, \tau) + \theta(\xi + \partial\xi, \tau)], \quad (1.11)$$

where

$$dk = \frac{GJ}{\partial\xi}, \quad (1.12)$$

in which  $J$  is the second moment of inertia, and  $G$  is the shear modulus. Considering that the drillstring is subject to a viscous damping due to the presence of a viscous filed, it holds

$$dT_{\text{external viscous damping}} = \Lambda\dot{\theta}(\xi, \tau)\partial\xi, \quad (1.13)$$

in which  $\Lambda$  represents the linear damping coefficient due to the viscous field presence. Using,  $dI = I\partial\xi$ , with  $I$  the inertia moment of the drillstring, and gathering the three previous equations, one gets

$$I\ddot{\theta}(\xi, \tau) = GJ\frac{\partial^2}{\partial\xi^2}\theta(\xi, \tau) - \Lambda\dot{\theta}(\xi, \tau). \quad (1.14)$$

The boundary conditions are also obtained using Newton second law. For the boundary condition at  $\xi = L$  the drill bit has a inertia moment  $I_b$ , and is subject to a friction torque due to the contact, with the rock, therefore it holds

$$I_b\ddot{\theta}(L, \tau) = -GJ\frac{\partial}{\partial\xi}(\theta(\xi, \tau)) - T_{\text{friction}}(\dot{\theta}(\xi, \tau)). \quad (1.15)$$

The boundary condition at  $\xi = 0$  can be taken as a dynamic boundary condition if the inertia of the table is significant. If we neglect this inertia, the boundary condition can be taken as

$$GJ\frac{\partial}{\partial\xi}\theta(0, \tau) = c_\alpha\left(\dot{\theta}(0, \tau) - \Omega(\tau)\right). \quad (1.16)$$



in which  $c_\alpha$  denotes the viscous coupling between the input velocity  $\Omega$  and the boundary velocity. With a direct change of variables, using the measurement of the boundary velocity, the previous boundary condition is equivalent to

$$\frac{\partial}{\partial \xi} \theta(0, \tau) = U(\tau). \quad (1.17)$$

Using the following change of variables

$$u(x, t) = \theta(L(1-x), L\sqrt{\frac{I}{GJ}}t),$$

one gets that the drillstring angular position satisfies

$$\begin{cases} u_{tt}(x, t) = u_{xx}(x, t) - \lambda u_t(x, t) & (1.18a) \\ u_x(1, t) = U(t) & (1.18b) \\ u_{tt}(0, t) = aF(u_t(0, t)) + au_x(0, t), & (1.18c) \end{cases}$$

in which  $a$  is a parameters,  $\lambda$  is the in-domain damping normalized coefficient, and  $F$  is the normalized friction term. More information about the change of variable, the relation between parameters, and drilling torsional vibration are given in Chapter 6, as the Part I results are simulated for drilling inspired models. ★

### 1.2.3.2 Acoustic and water wave

The string wave corresponds to the one-dimensional mechanical wave equation. The two dimensional wave can be used to model membranes. For example the diaphragm of the loudspeaker Figure 1.4 can be modeled as a string if it is circularly symmetric, but, in case not, we could model it by a two-dimensional wave. We refer the reader to [Morse and Ingard, 1968] on Page 191, for an explanation this two-dimensional wave equation

$$u_{tt}(x, y, t) = u_{yy}(x, y, t) + u_{xx}(x, y, t). \quad (1.19)$$

The three-dimensional wave is mainly used to describe the propagation of the pressure in a medium (air or water in common cases), the establishment of it is detailed in [Morse and Ingard, 1968] on Page 243. Considering  $p(x, t)$  as the pressure at space  $x = (x_1, x_2, x_3) \in \mathbb{R}^3$ , it holds

$$p_{tt}(x, t) = \nabla^2 p(x, t) = \Delta p(x, t) = p_{xx}(x, t), \quad (1.20)$$

where  $\nabla$  and  $\Delta$  denote the operator nabla and the Laplace, i.e.,

$$\nabla = \left[ \frac{\partial}{\partial x_1} \quad \frac{\partial}{\partial x_2} \quad \frac{\partial}{\partial x_3} \right], \quad \Delta = \left[ \frac{\partial^2}{\partial x_1^2} \quad \frac{\partial^2}{\partial x_2^2} \quad \frac{\partial^2}{\partial x_3^2} \right]. \quad (1.21)$$

Note that for some case, the wave is not enough to model occurring vibrations, for example the dynamics of a bar study in [Morse and Ingard, 1968] on Page 178 is

$$u_{xxxx}(x, t) = -u_{tt}(x, t). \quad (1.22)$$

### 1.2.3.3 Electronic wave

The wave equation can also be used in Electronics.

Using the first and second law of Krichhoff, one can establish that the voltage and the intensity satisfy a wave equation for a transmission line. The scheme of the transmission line is presented in Figure 1.7.

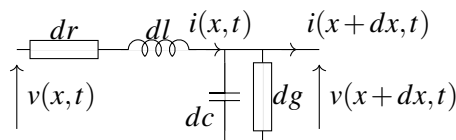

Figure 1.7: Elementary schematic of a transmission line

Consider the linear resistance  $dr = r_l dx$ , the linear inductance  $dl = l_l dx$ , the linear capacity of the dielectric  $dc = c_l dx$ , and the conductivity of the dielectric  $dg = g_l dx$ . Using Krichhoff laws, it holds the telegrapher equation, i.e.,

$$\begin{cases} c_l v_t(x+dx, t) + g_l v(x+dx, t) = i_x(x, t) & (1.23a) \\ l_l i_t(x, t) + r_l i(x, t) = v_x(x, t), & (1.23b) \end{cases}$$

in which  $v(x, t)$  represents the tension, and  $i(x, t)$  the intensity. For more information about this classical result we refer the reader to the text book [Stratton, 2007] on Page 550. Note that there exist more complete models relaxing the hypothesis of a “perfect” coaxial cable, [Imperiale and Joly, 2013] and [Beck et al., 2014]. What is interesting about these works is that the generalized telegrapher equation is derived from the Maxwell equation.

As it is explained in [Bastin and Coron, 2016] on Page 19, these equations can be studied as first order coupled hyperbolic PDEs. But they can also be studied as two uncoupled one-dimensional wave equations, since it holds

$$\begin{cases} v_{xx}(x, t) = l_l c_l v_{tt}(x, t) + (r_l c_l + g_l l_l) v_t(x, t) + r_l g_l v(x, t) & (1.24a) \\ i_{xx}(x, t) = l_l c_l i_{tt}(x, t) + (r_l c_l + g_l l_l) i_t(x, t) + r_l g_l i(x, t), & (1.24b) \end{cases}$$

which is also referred to as the telegraph equation in the literature, e.g. [Stratton, 2007] on Page 346, and [Fucik and Mawhin, 1978].

### 1.2.3.4 Electromagnetic wave

It is well known that the light can be considered as an electromagnetic wave. Indeed the Maxwell equation can be reformulated by two coupled wave equations. Let us first recall the Maxwell equation in matter,

(i) Gauss’ law

$$\nabla \cdot D(x, t) = \rho(x, t). \quad (1.25)$$

$D$  is called the displacement field. In the vacuum  $D = \epsilon_0 E$ , where  $\epsilon_0$  is the permittivity of the vacuum.

(ii) For the magnetism

$$\nabla \cdot B(x, t) = 0. \quad (1.26)$$

$B$  stands for the magnetic field, the previous equation means that experimentally there does not exist point-wise source of magnetic field. In the vacuum  $B = \mu_0 H$ , where  $\mu_0$  denotes the permeability of the vacuum.

(iii) Maxwell-Faraday

$$\nabla \times E(x, t) = -\frac{\partial}{\partial t} B(x, t). \quad (1.27)$$

$E$  represents the electric field.

(iv) Maxwell-Ampère

$$\nabla \times H(x, t) - \frac{\partial}{\partial t} D(x, t) = j(x, t), \quad (1.28)$$

in which  $H$  is called the magnetizing field.

These equations are commonly known, however they are details in [Stratton, 2007]. Considering a linear relation between  $D$  and  $E$ , and  $H$  and  $B$ , we can get that the field is modeled by a wave equation.

**Example 1.3** The electromagnetic wave in a linear homogeneous medium. Consider that  $D = \epsilon E$ , and  $B = \mu H$  with  $\epsilon, \mu \in \mathbb{R}$ . Using

$$\nabla \times (\nabla \times (\cdot)) = \nabla(\nabla \cdot (\cdot)) - \Delta(\cdot), \quad (1.29)$$

it follows

$$\mu\epsilon \frac{\partial^2}{\partial t^2} E(x,t) = \Delta E(x,t) - \nabla \left( \frac{\rho(x,t)}{\epsilon} \right) - \mu \frac{\partial j(x,t)}{\partial t}, \quad (1.30)$$

and for the magnetic field

$$\mu\epsilon \frac{\partial^2}{\partial t^2} B(x,t) = \Delta B(x,t) + \nabla \times (\mu j(x,t)). \quad (1.31)$$

The operator  $\nabla$  and  $\Delta$  have been defined in (1.21). ★

The following example is taken from [Stratton, 2007], and presents a one-dimensional wave equation.

**Example 1.4** Plane wave in unbounded, isotropic media

Consider that  $D = \epsilon E$ ,  $B = \mu H$ ,  $j = \sigma E$  and  $\rho = 0$ . One can get that the electric field satisfies

$$\mu\epsilon \frac{\partial^2 E(\xi, t)}{\partial t^2} = \frac{\partial^2}{\partial \xi^2} E(\xi, t) - \mu\sigma \frac{\partial E(\xi, t)}{\partial t}, \quad (1.32)$$

where  $\xi$  denotes the direction of the propagation. For the magnetizing field it holds

$$\mu\epsilon \frac{\partial^2 H(\xi, t)}{\partial t^2} = \frac{\partial^2}{\partial \xi^2} H(\xi, t) - \sigma\mu^2 \frac{\partial H(\xi, t)}{\partial t}, \quad (1.33)$$

we refer the reader to [Stratton, 2007] on Page 268 for details on how to obtain both previous equations. ★

We have succinctly presented the wave equation for two large fields of physics. Note that in the junction of quantum physic and relativist mechanic on can find the equation presented in the next section.

### 1.2.3.5 A third kind meeting

Reading through a world wide of article, one can found that the following equation

$$\phi_{tt}(x, t) - c^2 \phi_{xx}(x, t) + f(\phi(x, t)) = 0, \quad (1.34)$$

which is the Klein's Gordon equation. This equation describes relativistic particles with zero-spin, like the Higgs boson. A resolution of the Cauchy problem defined by this equation can be found in [Ginibre and Velo, 1985]. Note that there is recent work on this wave equation see for example [Jang, 2014].

In the next section, we focus on some mathematical notions used throughout this dissertation.

## 1.3 Notions of Mathematics

First as we are interesting on PDE, some notions of real analysis are presented: (i) the Sobolev spaces, (ii) the almost everywhere class of equivalence, (iii) the method of successive approximation and fixed point theorem, (iv) maximal monotone operator and  $C_0$ -semigroup and finally a note on Barbalat's lemma.

In the following, let us consider an open interval, possibly unbounded  $I = (a, b)$ . For our consideration it is enough to consider  $I \subset \mathbb{R}$ .

### 1.3.1 $L_p$ space

This section is largely inspired from the text book [Brezis, 2010].

**Definition 1.1** We consider the class of equivalence of integrable function which is denoted  $L_1(I)$ . Consider the following norm

$$\|u\|_{L_1} = \int_I |u| d\mu. \quad (1.35)$$

$u \in L_1(I)$  means that  $\|u\|_{L_1} < \infty$ .

**Definition 1.2** We consider the class of equivalence of power integrable function  $L_p(I)$  with  $p \in (0, \infty)$ .

$$L_p(I) = \left\{ u : I \mapsto \mathbb{R} : u^p \in L_1 \right\}. \quad (1.36)$$

### 1.3.2 Sobolev space and associated notations

Following the definition in [Brezis, 2010], note that the notation we use slightly differs from [Brezis, 2010].

**Definition 1.3** The Sobolev space  $W_{1,p}$ , where  $p \in [1, \infty]$ , is defined as

$$W_{1,p} = \left\{ u \in L_p(I) : \exists g \in L_p(I) : \int_I u\phi' = - \int_I g\phi, \forall \phi \in C_c^1(I) \right\}. \quad (1.37)$$

For  $u \in W_{1,p}(I)$  we denote

$$u' = g \quad (1.38)$$

It is clear that for  $u \in C^1(I) \cap L_p(I)$ ,  $u'$  denote the usual derivative of  $u$ .

**Definition 1.4** Consider  $m \geq 2$  and  $p \in [1, +\infty]$ , we define by induction the space

$$W_{m,p}(I) = \left\{ u \in W_{m-1,p} : u' \in W_{m-1,p}(I) \right\}. \quad (1.39)$$

The more considered Sobolev space is the one associated with  $L_2$  for PDE system. Thus we denote for  $d \in [1, \infty)$

$$H_d = W_{d,2}. \quad (1.40)$$

The following notation are massively used for PDE dynamics system. Consider  $z(t) \in H_1(I)$ ,  $z_x(x, \cdot) = z'(x)$ , and for  $z(t) \in H_2(I)$ ,  $z_{xx}(x, \cdot) = z''(x)$ .

### 1.3.3 A class of equivalence: almost everywhere

Consider a measure space  $(X, \Sigma, \mu)$ , in which  $X$  is the space,  $\Sigma$  is a  $\sigma$ -algebra on  $X$  and  $\mu$  a measure from  $\Sigma$  to  $[0, \infty]$ .

**Definition 1.5** A property  $P(x)$  is said to hold almost everywhere for  $x \in X$ , if there exist a set  $N$  of null measure ( $\mu(N) = 0$ ), such that for  $y \in X/N$ ,  $P(y)$  holds.

For example, consider  $g, f$  two functions defined on  $I$ , it holds

$$g \stackrel{a.e.}{=} f \Leftrightarrow \int_I (g - f) d\mu = 0. \quad (1.41)$$

Note that this is often omitted because for  $g \in L_1(I)$ , the expression  $g = 0$  is a abusive notation of  $g = 0_{L_1(I)}$ , which is the same as  $g \stackrel{a.e.}{=} 0_{\mathbb{R}}$

### 1.3.4 Fixed point and method of successive approximation

This section definitions and theorem are inspired from [Schwartz, 1970].

Consider  $E$  to be a complete metric space,  $f : E \rightarrow E$

**Definition 1.6**  $f$  is a contraction if there exists a constant  $k \in [0, 1)$  such that, for all  $x, y \in E$  it holds

$$d(f(x), f(y)) \leq kd(x, y). \quad (1.42)$$

where  $d$  is a distance on  $E$ .

**Definition 1.7**  $a \in E$  is a fixed point if it holds  $f(a) = a$ .

In the following, one of the fundamental theorem for the study of differential problem, which is at the same time intuitively easy to understand and still largely used.

**Theorem 1.1** [Banach and Picard fixed point theorem]  
All contractions on  $E$  have an unique fixed point.

The proof of this theorem can be done using the method of successive approximations.

*Proof:*

(i). Uniqueness: Consider  $a, b \in E$  to be two fixed point of  $f$ , if  $d(a, b) \neq 0$  then

$$d(a, b) \leq kd(a, b) < d(a, b), \quad (1.43)$$

therefore  $d(a, b) = 0$ .

(ii). Existence: the method of successive approximation.

Consider  $x_0 \in E$ , and  $x_{n+1} = f(x_n)$ , as  $f$  is a contraction on  $E$  it holds

$$d(x_{n+1}, x_n) \leq k^n d(x_1, x_0), \quad (1.44)$$

and it follows

$$d(x_{n+p}, x_n) \leq \frac{k^n}{1-k} d(x_1, x_0), \quad (1.45)$$

therefore  $(x)_n$  is a Cauchy sequence and its limit exists. This limit is the fixed point. ■

Let us use the method of successive approximations to solve a simple ODE. In the sequel, in particular in Part II, we use the method of successive approximation like in the following.

**Example 1.5** Consider

$$\frac{d}{dt}x(t) = Ax(t), \quad x(0) = x_0 \in \mathbb{R}^n, \quad A \in \mathbb{R}^{n \times n}. \quad (1.46)$$

Let us consider the associated integral equation

$$x(t) = \int_0^t Ax(s)ds + x_0. \quad (1.47)$$

Note that in order for (1.46) to have sense,  $x$  needs to be differentiable, whereas  $x$  just needs to be integrable for (1.47) to have sense. We speak of strong solution for (1.46), and of mild solution for (1.47).

Consider now the following sequence

$$\begin{cases} (\Delta x)^{n+1}(t) = \int_0^t A(\Delta x)^n(s)ds \\ (\Delta x)^0(t) = x_0. \end{cases} \quad (1.48a)$$

$$(1.48b)$$

(i). Existence: As  $x_0 \in \mathbb{R}^n$  there exist  $a \in \mathbb{R}^n$  such that it holds

$$(\Delta x)^0(t) \leq a, \quad (1.49)$$

the symbol  $\leq$  means here that each element of  $a$  is larger than the respective component of  $(\Delta x)^0(t)$ . For this simple example it is direct that

$$(\Delta x)^n(t) \leq a \frac{t^n}{n!} \quad (1.50)$$

holds. Therefore the sequence  $(\Delta x)^n$  converges exponentially towards zero. Consider the infinite sum of this sequence

$$x^*(t) = \sum_{i=0}^{\infty} (\Delta x)^i(t), \quad (1.51)$$

one gets

$$x^*(t) = \sum_{i=0}^{\infty} (\Delta x)^{n+1}(t) + (\Delta x)^0(t), \quad (1.52)$$

then using (1.48) and (1.51)

$$x^*(t) = \int_0^t Ax^*(s)ds + x_0, \quad (1.53)$$

therefore  $x^*$  is solution of (1.47).

(ii). Uniqueness: Consider  $x$  and  $x^*$  two solutions of (1.46),  $x - x^*$  is solution of

$$\frac{d}{dt}(x(t) - x^*(t)) = A(x(t) - x^*(t)), \quad x(0) - x^*(0) = 0, \quad (1.54)$$

therefore it holds  $x(t) - x^*(t) = 0$ .

Note that if we take  $a = x_0$ , all inequalities in the existence part are equalities and we find the definition of the matrix exponential. ★

For additional information of the method of successive approximations and the contraction principle see [Kantorovitch and Akilov, 1981] Page 210 and [Kolmogorov and Fomine, 1977] Page 68, some book about functional analysis. For a method of successive approximations applied on ODE see [Lindelöf, 1894] and [Cotton, 1928].

### 1.3.5 Unbounded operator, maximal monotone operator and $C_0$ semigroup

This section gives some definition taken from [Brezis, 2010] and from [Harauz, 1981] for the operator, and from [Curtain and Zwart, 2012], [Luo et al., 1999] and [Tucsnaak and Weiss, 2009] for  $C_0$ -semigroup.

#### Definition 1.8 Unbounded operator

Let  $E$  and  $F$  be two Banach spaces. An unbounded linear operator from  $E$  to  $F$  is a linear map  $A : \text{Dom}(A) \subset E \rightarrow F$ . The set  $\text{Dom}(A)$  is called the domain of  $A$ .

**Definition 1.9** Consider  $A$  an unbounded operator from  $E$  to  $F$ .

- The domain of  $A$  is

$$\text{Dom}(A) = \{u \in E : Au \text{ exists}\}. \quad (1.55)$$

- The graph of  $A$  is

$$\text{Graph}(A) = \{(u, Au) \in E \times F : u \in \text{Dom}(A)\}. \quad (1.56)$$

- The range of  $A$  is

$$\text{Range}(A) = \{Au : u \in \text{Dom}(A)\} \subset F. \quad (1.57)$$

- The kernel of  $A$  is

$$\ker(A) = \{u \in \text{Dom}(A) : Au = 0\}. \quad (1.58)$$

- $A$  is densely defined if  $\text{Dom}(A)$  is dense in  $E$

$$\overline{\text{Dom}(A)} = E. \quad (1.59)$$

- If  $A$  is densely defined, the adjoint of  $A$  is an unbounded operator denoted  $A^* : D(A^*) \subset E^* \rightarrow F^*$  such that

$$(i) \text{Dom}(A^*) = \{v \in F^* : \exists c \geq 0, |\langle v, Au \rangle| \leq c\|u\|, \forall u \in \text{Dom}(A)\}.$$

$$(ii) \forall u \in \text{Dom}(A) : v \in \text{Dom}(A^*), \quad \langle v, Au \rangle_{F^*, F} = \langle A^*v, u \rangle_{E^*, E}.$$

- $A$  is bounded (or continuous) if

$$(i) \text{Dom}(A) = E.$$

$$(ii) \exists c \geq 0 : \|Au\| \leq c\|u\|.$$

**Definition 1.10** Monotone and maximal monotone operator

Consider  $A$  an unbounded operator from  $H$  to  $H$ , where  $H$  is an Hilbert space associated with the scalar product  $\langle \cdot, \cdot \rangle$ .

- $A$  is monotone if it holds  $\forall u \in \text{Dom}(A)$

$$\langle Au, u \rangle \geq 0. \quad (1.60)$$

- $A$  is maximal monotone if in addition to be monotone, it holds

$$\text{Range}(I_d + A) = H, \quad (1.61)$$

where  $I_d$  denoted the identity of  $H$ .

The real objective, at checking that an unbounded operator is maximal monotone, is the use of the following theorem

**Theorem 1.2** Hille-Yosida [Brezis, 2010]

Let  $A$  be a maximal monotone operator. Then given for any  $u_0 \in \text{Dom}(A) \subset H$ , there exists a unique function

$$u \in C^1([0, \infty); H) \cap C([0, \infty); \text{Dom}(A)), \quad (1.62)$$

satisfying the following abstract problem

$$\begin{cases} \frac{d}{dt}u(t) + Au(t) = 0, & t \in [0, \infty) \\ u(0) = u_0 \end{cases} \quad (1.63a)$$

$$u(0) = u_0 \quad (1.63b)$$

Moreover  $\|u(t)\| \leq \|u_0\|, \quad \forall t \in [0, \infty)$ .

The following definitions are taken from the text book [Luo et al., 1999].

**Definition 1.11** Let  $X$  be a Banach space and let  $T(t) : X \rightarrow X$  be a family of bounded linear operator for  $t \in [0, \infty)$ .  $T(t)$  is called a semigroup of bounded linear operators, or simply a semigroup on  $X$ , if it holds

$$(i) \quad T(0) = I_d$$

$$(ii) \quad T(t+s) = T(t)T(s), \quad t, s \leq 0$$

Moreover the semigroup  $T(t)$  is called

- uniformly continuous if it holds

$$\lim_{t \downarrow 0} \|T(t) - I_d\| = 0 \quad (1.64)$$

- strongly continuous (or  $C_0$ -semigroup) if it holds

$$\lim_{t \downarrow 0} T(t)x = x, \quad \forall x \in X \quad (1.65)$$

**Definition 1.12** Let  $T(t)$  be a  $C_0$ -semigroup on  $X$ . The operator  $A$  defined by

$$Ax = \lim_{t \downarrow 0} \frac{T(t)x - x}{t}, \quad \forall x \in \text{Dom}(A) \quad (1.66)$$

is called the infinitesimal generators of  $C_0$ -semigroup  $T(t)$ .

In the following a classic example, on the wave equation subject to Dirichlet boundary conditions.

**Example 1.6** Consider the following wave equation

$$\begin{cases} u_{tt}(x, t) = u_{xx}(x, t) & (1.67a) \\ u(1, t) = 0 & (1.67b) \\ u(0, t) = 0 & (1.67c) \\ u(x, 0) = u_0, \quad u_t(x, 0) = v_0 & (1.67d) \end{cases}$$

and the associate operator  $A$  in the Hilbert space  $H = \{z \in H_1(0, 1) \times L_2(0, 1) : z_1(0) = 0, z_1(1) = 0\}$ , defined as

$$\forall z \in \text{Dom}(A) \subset H, \quad A = - \begin{bmatrix} 0 & 1 \\ \delta_{xx} & 0 \end{bmatrix} \quad (1.68)$$

in which  $\delta_{xx}z_1 = z_1''$ , and with

$$\text{Dom}(A) = \{z \in H_2(0, 1) \times H_1(0, 1) : z_1(0) = 0, z_1(1) = 0, z_2(0) = 0, z_2(1) = 0\} \quad (1.69)$$

First, using Poincaré inequality, one can get that for  $z = (z_1, z_2) \in H$

$$\|z\|_H = \|z_1'\|_{L_2} + \|z_2\|_{L_2} \quad (1.70)$$

is a norm of  $H$ , we denote  $\langle \cdot, \cdot \rangle_H$  its associated scalar product. It is easy to check that

$$\forall z \in H, \quad \langle z, Az \rangle_H \geq 0 \quad (1.71)$$

Therefore the operator  $A$  is monotone, if in addition it holds

$$\text{Range}(I_d + A) = H \quad (1.72)$$



then the operator  $A$  is maximal monotone. This is equivalent to

$$\forall y \in H, \exists z \in \text{Dom}(A) : z + Az = y \quad (1.73)$$

in other words

$$\begin{cases} z_1 - z_2 = y_1 \\ z_2 - z_1'' = y_2. \end{cases} \quad (1.74a)$$

$$(1.74b)$$

As  $z \in \text{Dom}(A)$  the previous system can be rewritten as

$$\begin{cases} z_1 - z_1'' = y_1 + y_2 \\ z_1(0) = 0 \\ z_1(1) = 0. \end{cases} \quad (1.75a)$$

$$(1.75b)$$

$$(1.75c)$$

This is a classical stationary problem with Dirichlet boundary conditions. Indeed as  $y_1 + y_2 \in L_2(0, 1)$ , this system is well-posed as shown in [Brezis, 2010] on Page 201. This means that for a given  $y \in H$  it holds a unique  $z_1 \in H_2(0, 1)$ . Now one checks that the element  $z = (z_1, z_2)$  with

$$\begin{cases} z_1 \text{ is solution of (1.75)} \\ z_2 = z_1 - y_1 \end{cases} \quad (1.76a)$$

$$(1.76b)$$

satisfies (1.74). Moreover one gets that  $z$  satisfying (1.76) is in  $\text{Dom}(A)$ . Therefore it holds (1.72).

Using Hille-Yosida theorem, the abstract problem

$$\begin{cases} \frac{d}{dt}X(t) + AX(t) = 0 \\ X(0) = X_0 \in \text{Dom}(A) \end{cases} \quad (1.77a)$$

$$(1.77b)$$

is well-posed, so is its associated PDE system (1.67). And  $A$  is the generator of a  $C_0$ -semigroup of contraction. The link between  $X(t)$ ,  $z$  and  $u$  is:

$$X(t) = z = \begin{bmatrix} z_1 \\ z_2 \end{bmatrix} = \begin{bmatrix} u(\cdot, t) \\ u_t(\cdot, t) \end{bmatrix}.$$

★

### 1.3.6 Barbalat Lemma

The following lemma is the original Barbalat lemma, it is taken from [Popov, 1973] and [Ioannou and Sun, 1996] (Lemma 3.2.6 Page 76).

#### Lemma 1.1 Barbalat's lemma

If  $\lim_{t \rightarrow \infty} f(t)$  exists and is finite, and  $f$  is uniformly continuous, then  $\lim_{t \rightarrow \infty} f(t) = 0$ .

Noting that if  $f$  and  $f'$  are uniformly bounded it holds that  $f$  is uniformly continuous, one gets the following lemma, which is referred also as Barbalat's Lemma in the sequel.

#### Lemma 1.2 (Lemma 3.2.5 Page 76 [Ioannou and Sun, 1996])

If  $f \in W_{1,\infty}$  (means  $f, f' \in L_\infty$ ) and  $f \in L_p$  for some  $p \in [1, \infty)$ , then  $f(t) \rightarrow 0$  as  $t \rightarrow \infty$ .

To study other variation of Barbalat's lemma we refer the reader to [Farkas and Wegner, 2014]. As it is explained in the aforementioned reference, it is usual to call "Barbalat's lemma" results on the convergence of a function given some assumption on the function and its derivatives.

The following example presents counter example of Barbalat lemma.

**Example 1.7** Barbalat lemma counter example

- $f'(t) \xrightarrow[t \rightarrow \infty]{} 0 \not\Rightarrow f(t) \xrightarrow[t \rightarrow \infty]{} c, c \in \mathbb{R}.$

Consider the following function

$$\begin{aligned} f: \mathbb{R} &\rightarrow \mathbb{R}, \\ t &\mapsto \sin(\log(t)). \end{aligned} \quad (1.78)$$

The function  $f$  has no finite limit, nevertheless it holds

$$f'(t) = \frac{\cos(\log(t))}{t} \xrightarrow[t \rightarrow \infty]{} 0. \quad (1.79)$$

- $f(t) \xrightarrow[t \rightarrow \infty]{} c, c \in \mathbb{R} \not\Rightarrow f'(t) \xrightarrow[t \rightarrow \infty]{} 0.$

Consider the following function

$$\begin{aligned} f: \mathbb{R} &\rightarrow \mathbb{R} \\ t &\mapsto \frac{\sin(t^2)}{t}. \end{aligned} \quad (1.80)$$

The function  $f$  has a finite limit equal to zero, nevertheless it holds

$$f'(t) = 2\cos(t^2) - \frac{\sin(t^2)}{t^2}, \quad (1.81)$$

which has no finite limit.

★

## 1.4 Notions of Automatic control

This section is devoted to some concepts used in the sequel.

**Principle:** Lyapunov stability

*The solutions of a dynamics system are said to be stable around an equilibrium if for any initial condition in a small enough neighborhood of this equilibrium, all state trajectories are contained in a neighborhood of the equilibrium, and the more the initial conditions are closed to the equilibrium the more the last neighborhood is small.* ◆

**Principle:** Attractivity

*The solutions of a dynamics system are said to be attractive toward an equilibrium if for any initial condition in a small enough neighborhood of this equilibrium, all state trajectories converge toward this equilibrium.* ◆

The term neighborhood has to be understood in a mathematical sense and in its classical sense. For measurable space it could be replaced by open set. Usually the equilibrium is a point of the state space, but for the topic of this thesis we need to consider the equilibrium as a subspace of the state space. Therefore the definition we use, derived from both previous principles and slightly differs in order to match with the ideas developed in this thesis. There is nothing new about the concept of Lyapunov stability and attractivity, except that we look at them with respect to a set opposite to an equilibrium (or the origin given a change of coordinate). If the property holds for all initial conditions in the state space, then they are said to be “global”.

Note that in the place of “the solutions of the system are stable around this equilibrium”, it is common use to say “the system is stable” if the equilibrium is the origin of the state space. Moreover “stable” in this thesis stand for “Lyapunov stable”. When one equilibrium is stable and attractive we call the “system is asymptotically stable”. If the system is asymptotically stable and the state trajectories can be bounded by a decreasing exponential, we say that the system is “exponentially stable”.

### 1.4.1 Stability

The following definitions are fairly common, they have been inspired from [Ioannou and Sun, 1996].

In the following  $x(t) \in H$  denote a solution of a dynamics system, and  $d$  is a distance.

**Definition 1.13** A system is said to be stable around  $I \subset H$  if for arbitrary  $\varepsilon > 0$ , there exists a  $\delta$  such that

$$d(x(0), I) < \delta \quad \Rightarrow \quad d(x(t), I) < \varepsilon \quad \forall t \geq 0. \quad (1.82)$$

This definition is consistent with the aforementioned Lyapunov stability, if  $x(t)$  lies in a measurable space.

**Definition 1.14** A system is said to converge (be attractive) towards  $I \subset H$  if there exists a  $\delta$  such that

$$d(x(0), I) < \delta \quad \Rightarrow \quad \lim_{t \rightarrow \infty} d(x(t), I) = 0. \quad (1.83)$$

If  $x(t)$  lies in a measurable space, the previous definition is consistent with the aforementioned attractivity principle.  $I$  is called an attractor.

**Definition 1.15** A system is said to be asymptotically stable with respect to an attractor  $I$ , if it is both stable around  $I$  and attractive towards  $I$ .

Note that for time-varying system,  $\delta$  may or may not depend on time. If  $\delta$  does not depend on time, we said uniformly stable, uniformly attractive and uniformly asymptotically stable.

**Definition 1.16** A system is said to be exponentially stable with respect to an attractor  $I$ , if there exist  $\alpha > 0$ , such that  $\forall \varepsilon > 0$  there exists a  $\delta(\varepsilon) > 0$  such that it holds

$$d(x(t), I) \leq \varepsilon e^{-\alpha t}, \quad (1.84)$$

whenever  $d(x(0), I) < \delta(\varepsilon)$ .

If  $\delta$  can go to infinity, in other words, if these definitions hold for all  $x(0)$  in the state space, then they are said to be global, e.g. globally asymptotically stable.

Classically when we consider a point-wise equilibrium, the stability properties can be studied using Lyapunov functional. In order world, we seek positive definite, decrescent and coercive functional which represents an evaluation of the distance between points in the state space and the equilibrium. Following the time-domain evaluation of this functional one can deduce the property of the system:

- If it is not increasing the system is stable.
- If it goes toward zero, the system is convergent (attractivity).
- If it strictly decreases, the system is asymptotically stable.
- If it decreases in an exponential manner, the system is exponentially stable.

In order to specify the terms decrescent and coercive, and for the sequel we defined functions of class  $\mathcal{K}$  and  $\mathcal{K}_\infty$ .

**Definition 1.17** A continuous function  $\phi : \mathbb{R}^+ \rightarrow \mathbb{R}^+$  is said to belong in class  $\mathcal{K}$  if

- (i)  $\phi(0) = 0$ .
- (ii)  $\phi$  is strictly increasing.

in addition if it holds that  $\lim_{r \rightarrow \infty} \phi(r) = \infty$ ,  $\phi$  belong to  $\mathcal{K}_\infty$ .

In order to consider a space equilibrium, let us consider a semi-definite positive functional  $\Gamma$  on a Hilbert space  $H$ . We denote  $ker(\Gamma(\cdot))$  (or abusively  $ker(\Gamma)$ ) the kernel of  $\Gamma$ .  $\Gamma$  is assumed to be coercive and decrescent in the quotient space  $H/ker(\Gamma(\cdot))$ . This means

(i) (functional) 
$$\Gamma : H \rightarrow \mathbb{R}. \tag{1.85}$$

(ii) (positive functional) 
$$\Gamma : H \rightarrow \mathbb{R}^+. \tag{1.86}$$

(iii) (definite) for  $z \in H$ , 
$$\Gamma(z) = 0 \iff z = 0. \tag{1.87}$$

(iv) (semi-definite) for  $z \in H$ , 
$$z = 0 \implies \Gamma(z) = 0. \tag{1.88}$$

(v) (coercive) it holds, 
$$\exists K \in \mathcal{K}_\infty, \quad \forall z \in H, \quad \Gamma(z) \geq K(\|z\|). \tag{1.89}$$

(vi) (coercive in  $H/ker(\Gamma(\cdot))$ ) it holds, 
$$\exists K \in \mathcal{K}_\infty, \quad \forall z \in H/ker(\Gamma(\cdot)), \quad \Gamma(z) \geq K(\|z\|). \tag{1.90}$$

(vii) (decrescent) there exist  $K \in \mathcal{K}$  such that, for all  $z \in H$ , it holds 
$$\Gamma(z) \leq K(\|z\|). \tag{1.91}$$

(viii) (decrescent in  $H/ker(\Gamma(\cdot))$ ), if there exist  $K \in \mathcal{K}$  such that, for all  $z \in H/ker(\Gamma(\cdot))$ , it holds 
$$\Gamma(z) \leq K(\|z\|). \tag{1.92}$$

Note that if  $ker(\Gamma(\cdot)) = \{0\}$  we come back to a point-wise equilibrium which is the origin. Note also that the decrescent and coercive properties are to avoid pathogen problems. The decrescent definition can be found in [Ioannou and Sun, 1996] on Page 111. Moreover in the manuscript as we are considering functionals which are semi-norm they satisfy the decrescent and coercive properties on their associated quotient space.

This is quite similar with the quotient space used in order to get that  $\|\cdot\|_{L_p}$  is a norm. Indeed this is a  $\|\cdot\|_{L_p}$  is a semi-norm on the set of  $p$ -th power integrable functions denoted  $\mathcal{L}_p(S, \mu)$  where  $(S, \Sigma, \mu)$  is a measure space. Taking the quotient space  $L_p(S, \mu) = \mathcal{L}_p(S, \mu)/ker(\|\cdot\|_{L_p})$ , then  $\|\cdot\|_{L_p}$  is a norm on  $L_p(S, \mu)$ .  $\Gamma$  has to be seen as a evaluation of the distance between  $\mathcal{X}(t) \in H$  and  $ker(\Gamma(\cdot))$ ; this is illustrated in Figure 1.8.

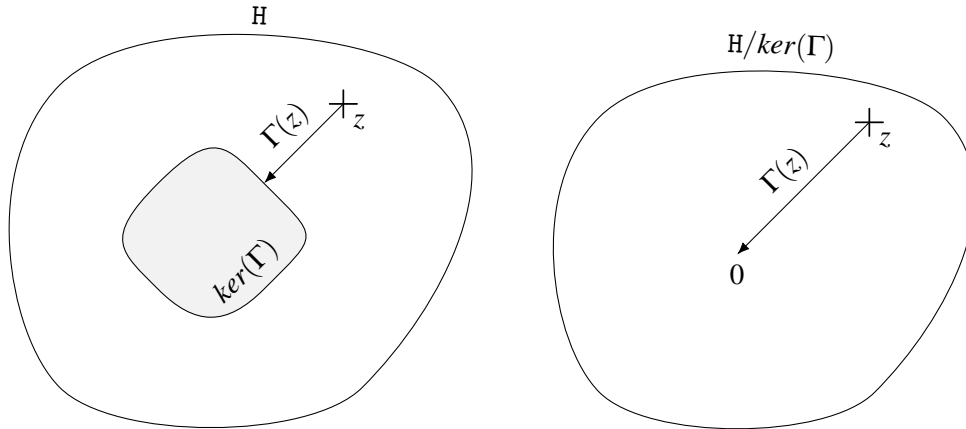

Figure 1.8: Illustration of a semi-definite positive functional on a space  $H$ , and on its associated quotient space.

In Figure 1.8 the fact that the quotient operation have put all the kernel of  $\Gamma$  elements equivalent to zero is illustrated.

Consider the following evolution problem

$$\begin{cases} \frac{d}{dt}X(t) + AX(t) = 0, & (1.93a) \\ X(0) \in H. & (1.93b) \end{cases}$$

The following theorem can be deduced from [Ioannou and Sun, 1996] Theorem 3.4.1 and Theorem 3.4.2.

**Theorem 1.3** Consider a functional  $\Gamma$  semi-definite positive in  $H$ , coercive and decrescent in  $H/\ker(\Gamma)$ , it holds

(i) If there exists  $K \in \mathcal{K}$  such that

$$\Gamma(X(t)) \leq K(\Gamma(X(0))), \quad (1.94)$$

then the state trajectories of the system are globally stable around  $\ker(\Gamma(\cdot))$ . From this characterization it is obvious that  $\ker(\Gamma(\cdot))$  is an invariant set (positive).

(ii) If

$$\dot{\Gamma}(X(t)) \leq 0, \quad (1.95)$$

then the system is also globally stable around  $\ker(\Gamma(\cdot))$ .

(iii) If

$$\Gamma(X(t)) \xrightarrow[t \rightarrow \infty]{} 0, \quad (1.96)$$

then the state trajectories of the system converge towards  $\ker(\Gamma(\cdot))$ . Note that in this case  $\ker(\Gamma(\cdot))$  is referred to as an attractor.

(iv) If

$$\dot{\Gamma}(X(t)) < 0, \quad (1.97)$$

then the system is globally asymptotically stable with respect to  $\ker(\Gamma(\cdot))$ .

(v) If there exist  $\alpha > 0$  such that it holds

$$\dot{\Gamma}(X(t)) \leq -\alpha\Gamma(X(t)), \quad (1.98)$$

then the system is globally exponentially stable with respect to  $\ker(\Gamma(\cdot))$ .

Note that for the Lyapunov derivative,  $\dot{\Gamma}(X(t))$  denote the left time Dini derivative, i.e.,

$$\dot{\Gamma}(X(t)) = \lim_{h \downarrow 0} \frac{\Gamma(X(t+h)) - \Gamma(X(t))}{h}. \quad (1.99)$$

If  $\Gamma \circ X(t)$  is differentiable,  $\dot{\Gamma}(X(t))$  denotes its time derivative. It is worth noticing that when we consider autonomous system, we can consider  $\Gamma(X)$ , here  $\dot{\Gamma}(X)$  denotes the derivative along the solution

$$\dot{\Gamma}(X) = \frac{\partial X^T}{\partial t} \frac{\partial \Gamma(X)}{\partial X}, \quad \frac{d}{dt} \Gamma \circ X(t) = \frac{\partial X(t)^T}{\partial t} \frac{\partial \Gamma(X(t))}{\partial X(t)}. \quad (1.100)$$

Note also that we will avoid to use  $\Gamma(t)$  to denote  $\Gamma \circ X(t)$  since it may lead to confusion.

The following example illustrates the importance of the coercive assumption.

**Example 1.8** In order to explain the coercive assumption, let us consider the case of a semi-definite positive functional  $\Gamma$  on  $H$ . Assume that is not coercive on  $H/\ker(\Gamma)$ , we denote  $\Gamma_{\max}(z) = \lim_{\|z\| \rightarrow \infty} \Gamma(z)$

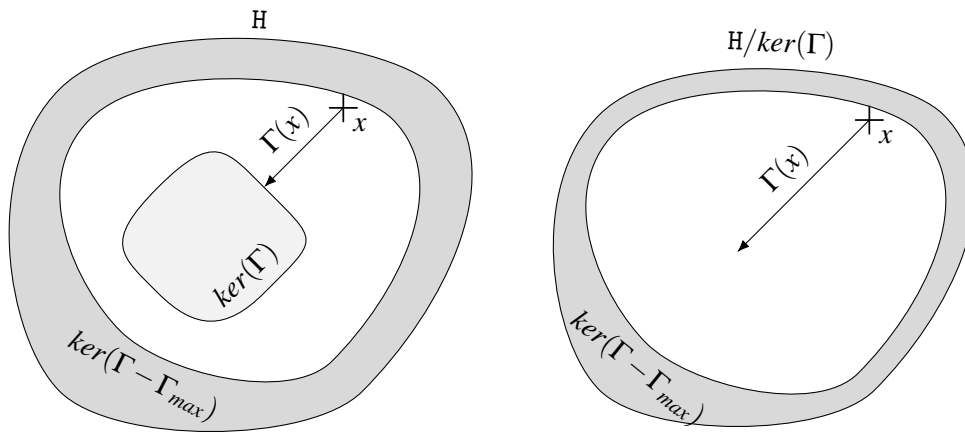

Figure 1.9: Non coercive case of a semi-definite positive functional on a space  $H$ , and on its associated quotient space.

The fact that the functional is not coercive in its associated quotient space means if the initial condition are within  $\ker(\Gamma - \Gamma_{max})$  then the condition (1.94) does not imply the stability as  $\|z\|$  can go to  $\infty$  with  $\Gamma(z)$  bounded. ★

Note that the decrescent property is to avoid decreasing functional with a lower positive bound. It is actually more important that the coercive property for asymptotic, exponential and attractive system. Indeed as  $\ker(\Gamma - \Gamma_{max}) \cap \ker \Gamma = \emptyset$  local property can be deduced from decrescent semi-definite positive functional.

Note also that, the stability property we used is quite similar with partial stability, where the stability of some parts of the system is established, as presented in the text book [Vorotnikov, 1997].

In the following, two simple finite dimensional examples illustrate the effect of damping for system. The first example presents the overdamping phenomenon: the more the system is damped the more it will approach the limit of stability. The second presents a system where too much damping can lead to instability.

These example can seem a little bit out of context, but it is just to show that even in finite cases adding damping is neither a sufficient nor necessary condition for system stability, furthermore it could go against stabilization and leads to instability.

### Example 1.9 Overdamping

The damping does not necessarily help the plant to be controllable, there is the case of overdamping: the more the system is damped the more it will be slow, to the limit case where it will not "move". Indeed consider the following second order damped ODE:

$$\theta'' = -\lambda \theta' - \beta \theta. \quad (1.101)$$

The state space representation is

$$\begin{bmatrix} \theta' \\ \theta'' \end{bmatrix} = \begin{bmatrix} 0 & 1 \\ -\beta & -\lambda \end{bmatrix} \begin{bmatrix} \theta \\ \theta' \end{bmatrix}. \quad (1.102)$$

This system is exponentially stable if  $\lambda, \beta > 0$  as its eigenvalues are (assuming that it holds  $\lambda^2 > 4\beta$  otherwise complex conjugate eigenvalues)

$$\kappa_1 = \frac{-\lambda - \sqrt{\lambda^2 - 4\beta}}{2}, \quad \kappa_2 = \frac{-\lambda + \sqrt{\lambda^2 - 4\beta}}{2}. \quad (1.103)$$

However in the limit case where  $\lambda$  goes to infinity

$$\kappa_2 = -\frac{2\beta}{\lambda} + o\left(\frac{1}{\lambda}\right) \rightarrow 0, \quad (1.104)$$

and thus the limit case is marginal stable.

Now consider that  $\beta < 0$  and  $\lambda > 0$ , it follows that  $\kappa_2 > 0$ , and thus for any viscous damping  $\lambda > 0$  the system is unstable. ★

### Example 1.10 Unstable damping

Consider the following system

$$\begin{cases} \theta_1'' = k(\theta_2 - \theta_1) - \lambda \theta_1', & (1.105a) \\ \theta_2'' = k(\theta_1 - \theta_2) + q\theta_2', & (1.105b) \end{cases}$$

in which  $k$  is a parameters,  $\lambda$  is the damping and  $q$  in an anti-damping. This example is inspired from drilling models, e.g. [Jansen and van der Steen, 1995]. The state representation is

$$\begin{bmatrix} \theta_1' \\ \theta_2' \\ \theta_1'' \\ \theta_2'' \end{bmatrix} = \begin{bmatrix} 0 & 0 & 1 & 0 \\ 0 & 0 & 0 & 1 \\ -k & k & -\lambda & 0 \\ k & -k & 0 & q \end{bmatrix} \begin{bmatrix} \theta_1 \\ \theta_2 \\ \theta_1' \\ \theta_2' \end{bmatrix}. \quad (1.106)$$

Note that there is a structural eigenvalue equal to zero, it is associated with the eigenvector  $\theta_1 + \theta_2$ . We consider the stability with respect to the velocities  $\theta'_1$  and  $\theta'_2$ . Intuitively one can say that if  $\lambda$  is large enough the system will be stable. Using Routh criterion we show that this is not true. First one computes the characteristic polynomial of the matrix written above

$$P(x) = (k\lambda - qk + 2kx - qx^2 + lx^2 + x^3 - q\lambda x)x. \quad (1.107)$$

Taking apart the zero eigenvalue, the Routh criterion gives

$x^3$	1	$2k - q\lambda$
$x^2$	$\lambda - q$	$k\lambda - qk$
$x^1$	$\frac{-q^2\lambda + q\lambda^2 + kq - k\lambda}{q - \lambda}$	0
$x^0$	$-k(q - \lambda)$	0

The polynomial  $P(x)/x$  is Hurwitz if and only if

$$\lambda > b, \quad -q^2\lambda + q\lambda^2 + kq - k\lambda < 0.$$

One gets that

$$-q^2\lambda + q\lambda^2 + kq - k\lambda = (q - \lambda)(k - q\lambda).$$

Therefore if and only if  $\lambda \in (q, \frac{k}{q})$  and  $k > q^2$  the polynomial is Hurwitz.

This result is interesting because the system will be asymptotically stable with respect to velocity if and only if  $\lambda \in (q, \frac{k}{q})$  and  $k > q^2$ . If  $k < q^2$  we cannot make the system asymptotically stable tuning  $\lambda$ . If  $k > q^2$  the system will be asymptotically stable only if  $\lambda \in (q, \frac{k}{q})$ , therefore if  $\lambda$  is too large the system will be unstable. ★

## 1.4.2 Robustness

I've seen men die because they were sure  
that what should not happen, would not.

*Robert Jordan, the eye of the world*

Models can at the best just be approximation of the reality. Indeed even for simple dynamics, parameters cannot be known perfectly. Moreover some system input can no be controlled, e.g. as noise. The robustness of a feedback control law is the ability to perform efficiently well with respect to

- (i) Input, output disturbance and noises.
- (ii) Model mismatch or unmodeled dynamics.

The design of control law staking explicitly into account the robust margin is a difficult problem, even if there exist many frequency criteria, from the premise of automatic control (see [Popov, 1973]). In this thesis we consider only the robustness to a parameters. In order words, we study the behavior of control law which were designed assuming certain parameters to be equal to zero when these parameters are no longer neglected.

In the following we present the backstepping approach.

## 1.4.3 Backstepping approach

The backstepping is an approach originally designed for nonlinear finite dimensional systems. This approach can be applied for a class of system which has a cascade feature. The following quote of the 1991 Bode prize lecture of Petar V. Kokotović describes so well the idea of backstepping.

“ The key idea of backstepping is to start with a system which is stabilizable with a known feedback law for a known Lyapunov function, and then to add to its input an integrator. For the augmented system a new stabilizing feedback law is explicitly designed and shown to be stabilizing for a new Lyapunov function, and so on...

This idea is so simple that most of you have probably used it without paying much attention to it. It is, therefore, surprising that the idea has become an explicit tool for systematic nonlinear design only very recently. At the risk of being unfair to many other author, let me mention the 1988-1991 works of Tsiniias, Sontag, Byrnes and Isidori, and my already quoted papers with Sussmann and Saberi which contains many other references”

P. V. Kokotović, 1991

We refer the reader for example of finite backstepping to the aforementioned lecture [Kokotovic, 1992], or to the chapter in book [Krener, 1999]. For more details we refer the reader to the text book [Sontag, 1998].

In this dissertation, we are interested in infinite dimensional backstepping for linear systems, therefore what is the link? First consider the paper [Krstic et al., 1994] where a adaptive control is designed using ideas closed to backstepping, the interesting fact is that the system control is linear but the proposed control is not. We use this as a starting point: backstepping can be used to control linear systems, which are actually a simple case of nonlinear systems. Then if one wants to give the starting point of infinite-dimensional backstepping, we should consider [Boskovic et al., 2001] and [Balogh and Krstic, 2002]. The former is the more close approach to what we are now referring as infinite-dimensional backstepping as we can see the typical Volterra transformation which maps two systems: the original one with a control input and a target one. The latter approach is closer to finite dimensional backstepping, where the cascade structure of the PDE is explicit.

The key idea of infinite-dimensional backstepping -abusively referred to as simply backstepping in the following- is to find a map between two systems. The first system -referred to as *original system*- may be potentially open-loop unstable, the second system -referred as *target system*- is chosen according to closed-loop system requirement. If such a mapping is found and proven to be invertible, we can deduce the associated control feedback.

The following example, is inspired by [Krstic and Smyshlyaev, 2008], and illustrates all steps of the backstepping design procedure. For more details the reader is referred to the latter book.

#### Example 1.11 A backstepping procedure

We consider the following heat PDE,

$$\begin{cases} v_t(x,t) = v_{xx}(x,t) + \lambda v_t(x,t), & (1.108a) \\ v(0,t) = 0, & (1.108b) \\ v(1,t) = U(t). & (1.108c) \end{cases}$$

The zero-input system ( $U(t) = 0$ ) is unstable.

- (i). Let us take an (exponentially) stable system of the same class of the one considered above.

This system is called the *target system*, it is often chosen by eliminating the unstable, undesired terms of the original system. The target system tends to be of the same PDE class, in order to ensure invertible mapping. Indeed, there is little chance to achieve a mapping between the wave equation and the heat equation. The stability of the target system is usually assured by finding a Lyapunov functional. We emphasize once again that the closed-loop system resulting from a backstepping control law design has the same behavior as the target system. Therefore the characteristics of the target system are of first importance given the considered control objective. For this example let us take the following *target system*

$$\begin{cases} w_t(x,t) = v_{xx}(x,t), & (1.109a) \\ w(0,t) = 0, & (1.109b) \\ w(1,t) = 0. & (1.109c) \end{cases}$$



## (ii). Volterra and Fredholm integral transformation.

It is common to look for Volterra and Fredholm type of transformation, more precisely, for backstepping we take usually second kind of Volterra linear integral, i.e.,

$$w(x,t) = u(x,t) - \int_0^x k(x,y)u(y,t)dy, \quad (1.110)$$

or Fredholm second type of linear integral

$$w(x,t) = u(x,t) - \int_0^1 k(x,y)u(y,t)dy, \quad (1.111)$$

these types of transformation work well for transport and heat equation, nevertheless for higher order time derivatives, we can consider more complex transformations. Indeed for the wave the basic transformation is

$$w(x,t) = u(x,t) - \int_0^x k(x,y)u(y,t)dy - \int_0^x s(x,y)u_t(y,t)dy. \quad (1.112)$$

Here, for the considered example, as previously said one kernel function  $k(x,y)$  is enough (of the Volterra kind). The Fredholm kind actually gives more degrees of freedom but it may be difficult to prove its uniqueness and existence. This step is equivalently complex than finding a Lyapunov functional.

## (iii). Establishment of the kernel PDE.

Computing the successive derivative of  $w$ , and using the fact that  $u$  is solution of the *original system* and  $w$  is solution of the *target system*. For the backstepping transformation to exist, the kernel needs to be solution of a PDE. What is to notice is the fact that the kernel satisfies a two-dimensional stationary PDE, the order of which is related to the order of the space derivative. Therefore even if the backstepping transformation of the heat equation is closer to the first-hyperbolic equation, the kernel of the heat equation transformation is similar to the one of the wave equation.

This is actually a procedural step, there is no real difficulty.

## (iv). Existence and uniqueness of the kernel

This is the key issue, either one establishes the well-posedness of the PDE the kernel is solution, or it could come back to the step (ii) or even (i). For simple PDE the kernel can actually be implicit or even constant. However the existence and uniqueness can be usually proven using the successive approximation method, but the kernel is to be computed as a solution of the PDE.

## (v). Compute the control input

Once the kernel existence and uniqueness is proven, the computation of  $U(t)$  can be done. Depending on the boundary conditions considered several steps are needed, for the considered example, it is straightforward that:

$$\underbrace{w(1,t)}_{=0} = \underbrace{v(1,t)}_{=U(t)} - \int_0^1 k(1,y)v(y,t)dy. \quad (1.113)$$

## (vi). Inverse transformation.

The last step is to find or prove the existence of the inverse transformation. Otherwise there is no guaranty that stability of the target system is equivalent to the stability of the closed-loop system.

It is worth noticing that for Volterra second kind of integral the inversibility is given. Note that the previous remark does not hold for (1.112). Therefore for the wave equation we will always prove the existence or compute the inverse transformation.

In both recent decades, the backstepping approach has become a very effective method in order to design control and observer for infinite dimensional systems. The reason is its relative simplicity with respect to, for example,  $C_0$ -semigroup control based design. Literature around infinite dimensional backstepping finds many different kinds of studies, e.g. higher-dimensional domains, observer design, bilateral backstepping, and some non-linear problems, let us mention the following few papers among others:

In [Jadachowski et al., 2014], a backstepping observer for periodic quasi-linear parabolic PDEs is established.

In [Jadachowski et al., 2015], backstepping observers for linear PDEs on higher-dimensional spatial domains are studied.

Even if backstepping has been originally developed and applied for boundary control problems, in [Wang and Woittennek, 2013], the authors extend its use to in-domain actuation.

In the three parts article, [Vazquez and Krstic, 2007a], [Vazquez and Krstic, 2007b], and [Vazquez and Krstic, 2007c] the boundary control for parabolic PDEs with Volterra nonlinearities is established.

Bilateral backstepping is investigated for hyperbolic and parabolic PDEs in [Vazquez and Krstic, 2016]

In [Cerpa and Coron, 2013], the rapid stabilization for a Korteweg-de Vries equation is established.

In [Marx and Cerpa, 2018] and in [Hasan, 2016] backstepping observers are proposed for the Korteweg-de Vries equations.

In [Koga and Krstic, 2017], an observer and a control law have been developed using backstepping method for the one-dimensional Stefan problem.

The minimum time control of heterodirectional linear coupled hyperbolic PDEs is established in [Auriol and Meglio, 2016].

The stabilization of coupled linear heterodirectional hyperbolic PDE-ODE systems is studied in [Meglio et al., 2018].

In [Bribiesca-Argomedo and Krstic, 2015], control and observation problems are studied for a class of hyperbolic PDEs with Fredholm integrals.

The adaptive stabilization of linear hyperbolic PDEs subject to unknown boundary parameters is presented in [Anfinson and Aamo, 2017].

For readers who are interested in the control of higher-dimensional systems, the book [Meurer, 2012] which focuses on flatness and backstepping is a good starting point.

#### 1.4.4 Adaptive control

We will start this section with another quote from the same lecture of P. V. Kokotović,

“ There are many systems with nonlinearities known from physical laws, such as kinematic nonlinearities, or energy, flow and mass balances nonlinearities. Some of these nonlinearities appear multiplied with unknown parameters and give rise to the problem of controlling nonlinear systems with parametric uncertainty. [...] ”

Adaptive state-feedback control of nonlinear plants has a short but eventful history which involves the names of Taylor, Marino, Kanellakopoulos, Sastry, Isidori, Arapostathis, Nam, Praly, Pomet, Campion, Bastin, Morse, and many others. ”

---

P. V. Kokotović, 1991

To mention a few references, more information can be found in [Martín-Sánchez et al., 2012] which is a survey

on optimal adaptive control with 172 references. There is also a survey on multivariable adaptive control in [Tao, 2014]. For adaptive control textbooks and monograph we refer the reader to the Section 3.1.1 of [Tao, 2014].

Nevertheless, we can argue that the starting point of the adaptive control is the integral action. Indeed the integral action allows to compute dynamically the feedforward term for a closed-loop system and to have the reference and the measured output equal in steady state. To be fair, the integral control is also the base of robust control, indeed, input constant disturbance can be canceled using integral control. The latter is linked with the intern model principle ([Francis and Wonham, 1976]). Adaptive control and robust control are indeed intrinsically linked, they respond to the same problem: input, output disturbance and model mismatch. Robustness can be seen as a static answer to these problems and adaptive control to a dynamic answer. But the robustness of adaptive control law must be studied to conclude. This thesis suggests a method of analysis to do so for infinite dimensional system and Lyapunov based adaptive control.

There are two major classes of adaptive design which are referred to as *indirect adaptive control* and *direct adaptive control*. As said in [Krstic, 2006], only indirect approach are considered as direct approach do not naturally extend from ODEs to PDEs.

- *Indirect adaptive control*

The control law is computed using a previously established estimation of the unknown parameters of the system. This estimation is based using the knowledge of inputs and outputs. This approach has been also referred to as explicit adaptive control, because the design is based on an explicit system model.

This class uses dynamics law to evaluate the unknown coefficient. These dynamic are referred to as update law, estimate law, adaptive law, and identifiers.

- *Direct adaptive control*

The control law coefficient are evaluated directly using input and output. This approach has been also referred to as implicit adaptive control because the design is based on the estimation of an implicit plant model.

More information about adaptive control and others categories can be found in [Ioannou and Sun, 1996], for PDE design we refer the reader to [Krstic, 2006] and references within.

*Indirect adaptive control* can also be split into categories. We follow the classification in [Krstic, 2006], which corresponds on how the closed-loop system stability is obtained.

- *Lyapunov approach*

The closed-loop system stability is directly established from a Lyapunov analysis which considers the extended state of the system, i.e., the state of the system with the estimation-error of the unknown parameters. The adaptive law and the control law are designed simultaneously. The latter imposes technical difficulties which are not present in *certainty equivalence approach*.

- *Certainty equivalence approach*

The control law is designed considering the unknown parameters to be known, then the parameter estimate laws are designed without considering the closed-loop system stability. Nevertheless they are designed such that the parameter estimation error is bounded, and the output estimation together with the estimate law are square integrable with respect to time. The adaptive control design is simpler than for *Lyapunov approach*, nevertheless the difficulty arise for the closed-loop stability analysis. The *certainty equivalence principle* has two categories, which are called *passivity-based identifiers* and *swapping identifiers*, we refer the reader to [Krstic, 2006] for details.

The following example, inspired from [Ioannou and Sun, 1996], illustrates the steps of a Lyapunov based adaptive control law design procedure with normalization. The adaptive control law we study the model mismatch robustness in the sequel are based on this design.

**Example 1.12** Consider the following first-order plant:

$$\dot{x} = ax + u, \quad x(0) = 0, \quad (1.114)$$

in which the parameter  $a$  is constant but unknown, the input  $u$  and state  $x$  are available from measurement. We assume that  $a > 0$ , and we make no assumptions about the boundness of  $x$  and  $u$ . The objective is to generate an adaptive law for a on-line parameters estimation by using the observed signals  $u(t)$  and  $x(t)$ . The adaptive law for generating the estimate  $\hat{a}$  is driven by the estimation error

$$\tilde{x} = x - \hat{x}, \quad (1.115)$$

in which  $\hat{x}$  is the estimated value of  $x$  formed by using the estimate  $\hat{a}$ . The estimated state  $\hat{x}$  is usually generated by an equation that has the same form as the plant but with  $a$  replaced by  $\hat{a}$ , e.g:

$$\dot{\hat{x}} = \hat{a}\hat{x} + u, \quad \hat{x}(0) = \hat{x}_0. \quad (1.116)$$

The equation (1.116) is known as the *parallel model* configuration [Landau, 1979] and the estimation method based on it as the *output error method* [Landau, 1979], [Narendra and Annaswamy, 1989]. The plant equation, however, may be rewritten in various different forms giving rise to different equations generating  $\hat{x}$ . For example, we can add and subtract the term  $a_mx$ , where  $a_m > 0$  is an arbitrary design constant, in (1.114) and rewrite the plant equation as

$$\dot{x} = -a_mx + (a_m + a)x + u, \quad (1.117)$$

in other words, with  $s$  the Laplace variable

$$x = \frac{s}{1 + a_m} [(a_m + a)x + u]. \quad (1.118)$$

Furthermore, we can proceed and rewrite the equation above as

$$x = \theta^{*\top} \phi, \quad (1.119)$$

in which  $\theta^* = [1, a_m + a]^\top$ ,  $\phi = \left[ \frac{u}{s+a_m}, \frac{x}{s+a_m} \right]^\top$ .

Consider now the first-order plant (1.114) with the following estimated state  $\hat{x}$

$$\dot{\hat{x}} = \hat{a}\hat{x} + u, \quad (1.120)$$

The derivative of the estimated error is

$$\dot{\tilde{x}} = \dot{x} - \dot{\hat{x}}. \quad (1.121)$$

With the use of equation (1.114) and (1.120), one can write:

$$\dot{\tilde{x}} = -\hat{a}\tilde{x} + ax, \quad (1.122)$$

$$= -\tilde{a}\tilde{x}, \quad (1.123)$$

where  $\tilde{a} := a - \hat{a}$ . Consider the following Lyapunov function:

$$V(x, \tilde{x}, \tilde{a}) = \frac{x^2}{2} + \frac{\tilde{x}^2}{2} + \frac{\tilde{a}^2}{2}. \quad (1.124)$$

The derivative of  $V$  along the state trajectory is

$$\dot{V}(x, \tilde{x}, \tilde{a}) = \dot{x}x + \dot{\tilde{x}}\tilde{x} + \dot{\tilde{a}}\tilde{a}, \quad (1.125)$$

$$= ax^2 + ux - \tilde{a}x\tilde{x} - \dot{\tilde{a}}\tilde{a}. \quad (1.126)$$

Now one can take as control law

$$u = -\hat{a}x - \alpha x, \quad (1.127)$$

and as adaptive law,

$$\hat{a} = -\tilde{x}x + \hat{a}x, \quad (1.128)$$

then the Lyapunov's functional derivative is

$$\dot{V}(x, \tilde{x}, \tilde{a}) = -\alpha x^2, \quad (1.129)$$

and therefore the system is stable. Moreover, from (1.129) time integration, one gets that  $V$  is bounded with respect  $V(x(0), \tilde{x}(0), \tilde{a}(0))$  and that  $x(t)$  is square integrable.  $V$  bounded implies that  $x$ ,  $\tilde{x}$ , and  $\tilde{a}$  are also bounded. The latter implies that  $\dot{x}$  is also bounded. In Brief  $x \in W_{1,\infty}(0, \infty) \cap L_2(0, \infty)$  using Barbalat lemma (Section 1.3.6) it holds that  $\lim_{t \rightarrow \infty} x(t) = 0$ .

This simple example cannot holds the complexity of the systems considered in the sequel. Indeed, here, the Lyapunov analysis allows to conclude on the boundeness of  $\tilde{a}$ , and therefore  $\dot{x}$ . It could be useful to constrain the boundeness of  $\tilde{a}$  and  $\hat{a}$  to the design. It can be done using respectively projection and normalization.

Let us explain the normalization on this simple example. In order to constrain the boundeness of the adaptive law, a solution is to choose:

$$\hat{a} = \frac{-\tilde{x}x + \hat{a}x}{1 + x^2 + \tilde{x}^2}, \quad (1.130)$$

Here  $\hat{a}$  is now bounded, we pose  $N = x^2 + \tilde{x}^2$ . We propose the associated Lyapunov function

$$V(x, \tilde{x}, \tilde{a}) = \log(1 + N) + \frac{\tilde{a}^2}{2}. \quad (1.131)$$

And with the use of (1.130) the derivative of  $V$  along the solution trajectory is

$$\dot{V}(x, \tilde{x}, \tilde{a}) = \frac{1}{2(1+N)} (ax^2 + ux - \tilde{a}x\tilde{x}) - \hat{a}\tilde{x} \quad (1.132)$$

$$= \frac{-\alpha x^2}{2(1+N)}. \quad (1.133)$$

Furthermore, in order to assure that  $\hat{a}$  stays in a interval,  $[\underline{a}, \bar{a}]$  we can use a projector:

**Definition 1.18** Consider  $\hat{a}(0) \in [\underline{a}, \bar{a}] \subset \mathbb{R}$ . We define the standard projector operator on the interval  $[\underline{a}, \bar{a}]$  as a function of two scalar arguments  $\hat{a}(t)$  (denoting the parameter estimate) and  $f$  which denotes the nominal update law (the nominal dynamics of  $\hat{a}(t)$ ) in the following manner:

$$\text{PROJ}_{[\underline{a}, \bar{a}]}(\hat{a}, f) = \begin{cases} 0 & \text{if } \hat{a} \leq \bar{a} \text{ and } f > 0, \\ 0 & \text{if } \hat{a} \geq \underline{a} \text{ and } f < 0, \\ f & \text{otherwise.} \end{cases} \quad (1.134)$$

Using  $\hat{a}(t) = \text{PROJ}_{[\underline{a}, \bar{a}]}(\hat{a}(t), f)$  we assure that  $\hat{a}(t) \in [\underline{a}, \bar{a}]$  if  $\hat{a}(0) \in [\underline{a}, \bar{a}]$ . The reader will find more details about projection algorithm associated with adaptive control in [Ioannou and Sun, 1996] on Page 791, Appendix B. Note that,  $\text{PROJ}_{[\underline{a}, \bar{a}]}(\hat{a}, \text{PROJ}_{[\underline{a}, \bar{a}]}(\hat{a}, f)) = \text{PROJ}_{[\underline{a}, \bar{a}]}(\hat{a}, f)$  is enough to prove that  $\text{PROJ}_{[\underline{a}, \bar{a}]}(\hat{a}, \cdot)$  is a projection.

For the present example, we take as new estimated update law

$$\hat{a} = \text{PROJ}_{[\underline{a}, \bar{a}]} \left( \hat{a}, \frac{-\tilde{x}x + \hat{a}x}{1 + N} \right). \quad (1.135)$$

Even if this example is interesting as an illustration of the different steps usually done in Lyapunov adaptive control law design. It is not the only way to proceed. In the following an example which matches with the several designs considered in this thesis.

**Example 1.13** Consider the following system

$$\dot{x} = ax + b + u, \quad (1.136)$$

in which  $a$  and  $b$  are unknown parameters and  $u$  is the control input. Assume that  $a \in [a, \bar{a}]$  and  $b \in [b, \bar{b}]$ . The control input is taken as

$$u = -\hat{a}x - cx - \hat{b}, \quad (1.137)$$

in which  $\hat{a}$  and  $\hat{b}$  are the estimate of the unknown parameters  $a$  and  $b$ .  $c$  is a tuning parameters. This gives as a closed-loop dynamics

$$\dot{x} = (\tilde{a} - c)x + \tilde{b}, \quad (1.138)$$

in which  $\tilde{a} = a - \hat{a}$  and  $\tilde{b} = b - \hat{b}$ . Now consider the following Lyapunov functional

$$V(x, \tilde{a}, \tilde{b}) = \log(1 + x^2) + \frac{\tilde{a}^2}{\gamma_a} + \frac{\tilde{b}^2}{\gamma_b}. \quad (1.139)$$

The derivative along the trajectory of  $V$  is

$$\dot{V}(x, \tilde{a}, \tilde{b}) = 2 \left( \frac{x\dot{x}}{1+x^2} - \frac{\dot{\tilde{a}}\tilde{a}}{\gamma_a} - \frac{\dot{\tilde{b}}\tilde{b}}{\gamma_b} \right). \quad (1.140)$$

Therefore by taking

$$\hat{a} = \text{PROJ}_{[a, \bar{a}]} \left( \hat{a}, \frac{\gamma_a x^2}{1+x^2} \right), \quad \hat{b} = \text{PROJ}_{[b, \bar{b}]} \left( \hat{b}, \frac{\gamma_b x}{1+x^2} \right), \quad (1.141)$$

it holds

$$\dot{V}(x, \tilde{a}, \tilde{b}) = -2cx^2. \quad (1.142)$$

From (1.142), one gets that  $V$  is bounded with respect to time and that  $x \in L_2([0, \infty) : \mathbb{R})$  (integrating directly (1.142)).  $V$  is bounded therefore  $x, \tilde{b}, \tilde{a} \in L_\infty([0, \infty) : \mathbb{R})$ , this implies that  $\dot{x} \in L_\infty([0, \infty) : \mathbb{R})$ , using Barbalat lemma (Section 1.3.6) it holds that  $\lim_{t \rightarrow \infty} x(t) = 0$ .

Notice that we can get that  $\lim_{t \rightarrow \infty} \tilde{b}(t) = 0$ , by contradiction using (1.138) or using the following Lyapunov functional

$$V(x, \tilde{a}, \tilde{b}) = \log(1 + x^2) + \frac{\tilde{a}^2}{\gamma_a} + \frac{\tilde{b}^2}{\gamma_b} + \alpha(\tilde{b} - cx)^2. \quad (1.143)$$

with  $\alpha$  a parameter to be found. Using an extra variable as in integral control in finite cases for state-space representation, e.g.

$$z = -cx + \tilde{b}. \quad (1.144)$$

$z$  is solution of

$$\dot{z} = -cz - \hat{b} - c\tilde{a}x. \quad (1.145)$$

The associated Lyapunov functional is

$$V(x, \tilde{a}, \tilde{b}, z) = \log(1 + x^2) + \frac{\tilde{a}^2}{\gamma_a} + \frac{\tilde{b}^2}{\gamma_b} + \alpha z^2. \quad (1.146)$$

Using the fact that there exist  $\sigma_1, \sigma_2 > 0$  such that  $\hat{b} \leq \sigma_1|x|$  and  $c\tilde{a}x \leq \sigma_2|x|$ , and applying Young and Cauchy-Schwarz inequalities one obtains that there exist  $\eta > 0$

$$\dot{V}(x, \tilde{a}, \tilde{b}, z) \leq -\eta(x^2 + z^2). \quad (1.147)$$

It follows that  $x, z \in W_{1, \infty}(0, \infty) \cap L_2(0, \infty)$  and therefore  $x(t), z(t)$  go to zero when  $t$  goes to infinity.

Notice that if  $\tilde{a} = 0$  (i.e.,  $a$  is known), from the previous inequalities one deduces the exponential stability of the system with respect to the origin. ★

In the following a short discussion about normalization and projection. Consider  $\hat{a}$  is estimation of an unknown parameters.

- Normalization
  - $\hat{a}(t)$  bounded for all  $t$  independently of the state.
  - Can allow the problem to be global.
  - Can improve transients and stability robustness.

As said in [Krstic, 2006], the logarithm (used in Lyapunov functional for the two previous examples) allows to tolerate the potentially destabilizing effect of the adaptive laws. This is linked with the work in [Praly, 1992].

- Projection
  - $\hat{a}$  bounded for all  $t$  independently of the state.
  - $\hat{a}$  lies in a subset of  $\mathbb{R}$  defined by a priori knowledge.
  - May speeds up convergence rate and reduces large transients.

We refer the reader to [Ioannou and Sun, 1996] on Page 530 and [Rohrs et al., 1985] for the importance of model mismatch robustness of adaptive control.

## 1.5 State of the art for the wave equation

In this work, when it shall be found that much is omitted, let it not be forgotten that much likewise is performed;

---

*Samuel Johnson 1755*

In this section we present several works which concern the wave equation, we have separated them in two subsections. On the one hand, a mathematical one, in sense that it concerns mainly the well-posedness of the wave equation and the stability and regularity of its solutions. And on the other hand, a automatic control one, which concerns the stabilization, regulation, control and control robustness of the wave equation. Both are linked and such distinction is somehow abusive. Indeed for example, we need that the well-posedness of the system we consider before applying a control. Indeed the system we consider models some deterministic behavior. Moreover, when we perform a feedback control, we impact the dynamics of the system which can lead to it ill-posedness problem. This is illustrated in Example 1.14. Therefore after the design of the feedback we need to study the well-posedness of the closed-loop system.

### Example 1.14 An ill-posed closed-loop system

Consider the following dynamic system of state  $x(t) \in \mathbb{R}^n$

$$\begin{cases} \dot{x} = u, \\ x(0) = 0. \end{cases} \quad \begin{array}{l} (1.148a) \\ (1.148b) \end{array}$$

We take  $u = \ddot{x}$ , the following system is ill-posed

$$\begin{cases} \dot{x} = \ddot{x}, \\ x(0) = 0. \end{cases} \quad \begin{array}{l} (1.149a) \\ (1.149b) \end{array}$$

however if we change a little bit the state and state space to  $(x(t), \dot{x}(t)) \in \mathbb{R}^{2n}$ , the system

$$\begin{cases} \dot{x} = \ddot{x}, \\ x(0) = 0, \\ \dot{x}(0) = 0. \end{cases} \quad \begin{array}{l} (1.150a) \\ (1.150b) \\ (1.150c) \end{array}$$

is well posed. When a feedback is performed it may change the system, e.g. with the use of delayed control, it can evolve from a finite dimensional system into an infinite dimensional one. A closed-loop system is a related yet different system from the original one. The fact that by changing the state space we can obtain a well-posed system is somehow linked to the Fredholm alternative [Brezis, 2010] on Page 160. ★

In the following, we present some related works, some of them are cited afterward along this thesis. The literature which can be qualified as mathematical are presented in Section 1.5.1. The control problem literatures on the wave equation are presented in Section 1.5.2.

### 1.5.1 Stability, regularity, and well-posedness of the wave equation

In this section, we present some work about the well-posedness of the wave equation, and therefore the regularity of its solutions. The purpose here is to give few interesting references about the wave equation well-posedness.

Note that there exists at least one more type of boundary to be added from the Table 1.2, it is called Wentzell boundary condition. This is a boundary condition which has a term in  $u_{xx}$  among other less order terms. Using the propagation phenomena one can observe that it is linked with what we called a second order dynamic boundary condition. It is worth noticing that the origin of Wentzell boundary condition was considering the heat equation ( $u_t = u_{xx}$ ).

In [Gal et al., 2004] an acoustic wave equation is considered. In more detail two wave equations without source terms are considered. One which is subject to a Wentzell boundary condition at the domain boundary and the other subject to what is called an acoustic boundary condition. This type of boundary is more physically correct than Robin's boundary which was used beforehand. It allows a better modeling of the boundary condition for acoustic system behavior. In [Gal et al., 2004] the link between both boundary conditions is established.

In [Favini et al., 2005] a one-dimensional non-autonomous space depending wave equation subject to general Wentzell boundary conditions is considered. The well-posedness of such a PDE is proven. One interesting fact about this paper is that they prove that the time-space depending unbounded operator  $A(t)u := (a(x,t)u_x)_x$ ,  $a(\cdot, \cdot) > 0$  is self-adjoint.

In [Nicaise and Pignotti, 2011] a multidimensional wave equation is considered, subject to Dirichlet and dynamic boundary conditions, and with general state depending coefficient. In addition the authors consider delay feedback (delay source term) at the dynamic boundary conditions, the well-posedness of this wave is established and its stability is studied. The interesting fact is that the study allows Kelvin-Voigt damping source term ( $u_{xxt}$ ).

In [Fourrier and Lasiecka, 2013] a viscous damped multidimensional wave equation subject to damped dynamical boundary in a measurable partition of the boundary where the remaining partition is subject to Dirichlet boundary condition is considered. The well-posedness, the regularity and the stability of this wave is proven.

In [Fiscella and Vitillaro, 2015] a semilinear multi-dimensional wave equation subject to semilinear first order dynamic boundary condition in a measurable partition of the boundary where the remaining partition is subject to Dirichlet boundary condition is considered. The purpose of [Fiscella and Vitillaro, 2015] is to improve blow-up criterion for this type of problem.

In [Vitillaro, 2017] the well-posedness of two and more dimensional wave equations subject to non-linear source term is presented. The boundary of the open bounded subset  $\Omega$  of  $\mathbb{R}^n$  with  $n \geq 2$  is split in two measurable partitions. One partition is subject to Dirichlet boundary condition, the other is subject to a second order dynamic boundary condition combined with a Laplace-Beltrami operator.



## 1.5.2 Boundary control of the wave equation

The following citations give a general background for the PDE in control theory, [Curtain and Zwart, 2012], [Tucsnak and Weiss, 2009], [Luo et al., 1999]. There is the survey in [Ervedoza and Zuazua, 2012], which presents in particular theories developed in order to study the wave controllability numerically. The idea is to analyze when discrete (in space) model of the wave equation shares the controllable property. In the same line of thought and by the same authors there is also the text book [Ervedoza and Zuazua, 2013].

Note that we are considering at this point -except said otherwise- that the wave is one-dimensional ( $u_{xx}(x, t) = u_{xx}(x, t)$ ,  $x \in I \subset \mathbb{R}$ ).

Below a short literature review is presented according to the type of method used to design control law. We are obviously not exhaustive.

### 1.5.2.1 Lyapunov/energy based method

In [d'Andréa-Novel et al., 1992] the feedback asymptotical stabilization of a overhead crane is established. The interesting point of this reference is the use of La Salle principle for infinite-dimensional systems. In [d'Andréa-Novel and Coron, 2000], the design of an exponential feedback law for the same system is obtained. The system under consideration is a boundary control on a second order dynamical boundary condition of a space depending wave, the opposite boundary is a Neumann type.

In [Conrad and Mifdal, 1998], with the same idea as [d'Andréa-Novel et al., 1992], an asymptotic feedback is proposed for an overhead crane which is modeled by a space depending wave with both second order dynamical boundary conditions.

In [Saldivar et al., 2016b] the wave equation is used to model both torsional and axis vibration occurring along a oilwell drillstring. The angular position boundary opposite to the actuation is depending on the elongation of the axial position. A systematic method to design feedback controllers establishing ultimate boundness is suggested in [Saldivar et al., 2016b].

### 1.5.2.2 Flatness based control

Flatness is a property of a system concerning its state and input. Flat systems are a generalization of linear systems. More information about flatness properties of (finite and infinite dimensional) dynamics systems can be found in [Martin et al., 2003].

In [Sagert et al., 2013] the wave equation subject to a nonlinear first order dynamics boundary condition opposite the Neumann actuation is presented. This system is proven flat, and using this property a proportional-integral control law exponentially stabilizing the system using only the collocated velocity is suggested. This wave equation can be used to model the torsional vibration of the drillstring which can appear in drilling system, if the inertia of the bit can be neglected.

Piezoelectric-stack actuator which can be modeled by a pure wave equation with second order dynamic boundary conditions see [Meurer and Kugi, 2011]. Both boundary dynamics have source term in position with respect to the other one, and the input considered acts on both boundary conditions (a scalar input which impacts both boundary dynamics). In [Meurer and Kugi, 2011] the flatness property of this system is established, then using this characteristic a control law performing asymptotical stability is obtained. In addition, it is worth noticing that the authors develop a Luenberger observer for the distributed parameters tracking error.

### 1.5.2.3 Root-locus design

There is an interesting approach using the root-locus to design boundary control of a pure wave equation with Neumann actuation opposite to a Neumann boundary condition in [Alli and Singh, 2000]. The stability of the closed-loop system with respect to the magnitude of the gains is studied using root-locus design technique. The wave considered in this reference models a flexible bar.

### 1.5.2.4 Smith predictor

In [Liang and Chen, 2004] the control of a pure wave equation subject to a Neumann actuation opposite to a Dirichlet boundary condition is proposed. A Smith predictor based control is considered in order to take into account the delay measurement. Note that the same authors have generalized their approach to wave equation with fractional time derivative subject to the same boundary in [Liang et al., 2007].

### 1.5.2.5 Control for flexible system

There are many works concerning flexible systems, and some are linked to the wave equation. We refer the reader to the two following surveys on the subject [Dwivedy and Eberhard, 2006] and [Benosman and Le Vey, 2004]. We present two methods which are related to the wave equation:

- (i). “Absolute vibration suppression” (AVS) is the use of Laplace transformation on the time variable in order to rewrite the one dimensional wave equation as an ODE in Laplace space. This is used in order to suppress vibrations in non-rigid bodies.
- (ii). The idea of “wave based control” (WBC) is that, for flexible systems, the actuation from one boundary condition travels toward the other boundary, then is reflected back to the controlled boundary. Therefore the control is designed in two parts, one for the real actuation desired, and the other for the cancellation of the reflected input. This was originally developed for lumped linear system. In [O’Connor, 2007] a lump modeled flexible robot is analyzed and controlled using wave based control. It is worth noticing that this method has been completed in order to consider the asymmetrical behavior (concerning the direction of propagation) in a more general framework the unilateral propagation in [Martinec et al., 2018].

In [Peled et al., 2013] the relationship between “wave based control” and “absolute vibration suppression” is studied.

### 1.5.2.6 Backstepping based control

In [Krstic et al., 2008] a backstepping based feedback law stabilizing the one-dimensional pure wave equation subject to a Dirichlet actuation and to a unstable Robin type boundary is developed. They proposed also two observers: the first on the anti-collocated output (the actuation and the measurement are at opposite boundaries), and a backstepping based observer for the collocated output (measurement and actuation are at the same boundary).

A backstepping based (observer-based) output feedback law for the one-dimensional pure wave equation subject to an unstable first order dynamical boundary condition opposite to a Neumann or Dirichlet actuation is established in [Smyshlyaev and Krstic, 2009].

Drilling torsional vibrations can be modeled by a wave equation with in-domain viscous damping subject to a non-linear dynamical boundary condition opposite to the actuation. In [Sagert et al., 2013] linearizing this

non-linearity at an unstable operating point, a backstepping control law is proposed. More information on this control is given in Section 7.7 where it is compared with a design suggested in Chapter 7.

In [Smyshlyaev et al., 2010] the following propagation

$$u_{tt}(x, t) = u_{xx}(x, t) + \alpha(x)u_x(x, t) + \lambda(x)u_t(x, t) + \beta(x)u(x, t) \quad (1.151)$$

with a Dirichlet actuation opposite to a Dirichlet boundary condition is considered. The authors suggest an exponentially stabilizing full-state feedback law using backstepping method. Comparing to the previous citations concerning backstepping based control, here the kernel of the backstepping transformation uniqueness and existence is obtained using the successive approximation method.

The wave equation can be used to model a hanging cable immersed in water, this is established in [Böhm et al., 2013]. A backstepping based feedback law is proposed to stabilize the considered wave subject to a dynamic boundary condition opposite to the actuation Dirichlet actuation. It is worth noticing that the in-domain damping is neglecting for the wave propagation and its dynamic boundary condition.

Note that when concerning the backstepping method, the wave equation and the heat equation leads to similar PDE the kernels need to be solution of. Concerning the heat equation control using backstepping method we refer the reader to [Liu, 2003], [Smyshlyaev and Krstic, 2004], and [Smyshlyaev and Krstic, 2005] as for the three the resolution of the kernel is interesting.

### 1.5.2.7 Adaptive and/or robust control

For a text book in finite dimensional system adaptive robust control, we refer the reader to [Ioannou and Sun, 1996].

In [Guo and Guo, 2016] a performance output reference tracking for a pure wave equation subject to general harmonic disturbance at the Neumann boundary opposite to the Neumann type actuation is solved. According to the introduction of [Guo and Guo, 2016], even in the finite-dimensional case the output tracking is still not sufficiently addressed: see for instance the text book [Lewis et al., 2012] on Page 315. Therefore, the infinite-dimensional case requires much more analysis. An interesting fact about [Guo and Guo, 2016] is the use of Galerkin method to establish the well-posed of the system under consideration, which is a non-autonomous nonlinear non-dissipative evolution system. The proof is not fully written but it is similar to the one of [Wei and Bao-Zhu, 2011].

In [Wei and Bao-Zhu, 2011] a backstepping based control associated with parameters estimation is considered to stabilize a pure wave equation with stable Robin boundary condition opposite to a Neumann actuation. An harmonic disturbance is considered in this system and it is collocated with the actuation.

Consider a pure wave equation subjects to an unstable boundary condition of unknown parameters opposite to the Neumann actuation. In [Bresch-Pietri and Krstic, 2014c] an adaptive control law is proposed which stabilizes this wave equation.

Anyone who claimed that old age had brought them patience was either lying or senile.

---

*Robert Jordan*

This ends the first chapter of this thesis. Let us now describe in details our contribution.

## **Part I**

# **Robustness of prediction based adaptive control laws**

# Introduction

---

In this part, we present the method we have developed to study the robustness of prediction based adaptive control laws. We study the robustness of these adaptive control laws with respect to model mismatch. This means that the model used for the control design differs from the actual one the control law is applied on. The method we present has given birth to two articles:

- [Roman et al., 2016b] conference paper, presented at the *American Control Conference*, Boston, MA.
- [Roman et al., 2017] journal paper under review, *Transactions on Automatic Control* 2017.

The considered adaptive control laws are taken from

- [Bresch-Pietri and Krstic, 2014a]
- [Bresch-Pietri and Krstic, 2014b]

The Part is organized as follows. First, in Chapter 2, the system under consideration is presented along with the prediction-based design methodology. This allows us to present the main differences between the three control laws we consider. Then, there is a chapter for each control law. Chapter 3 deals with the first control considered. This work has been presented at the ACC in 2016 [Roman et al., 2016b] but it is detailed here with more precision. The second adaptive control law and its robustness result are presented in Chapter 4. This corresponds to an unpublished result. Chapter 5 is dedicated to the last control. This corresponds to an article under review at TAC, [Roman et al., 2017]. The last chapter, before the conclusion, deals with simulations for the three control laws on a nonlinear drilling inspired model (Chapter 6).

---

**Disclaimer: Note that the notations between Chapter 3 for one part, Chapter 4 for an other part, and Chapter 5 are redundant. For example in each part the control  $U$  is redefined.**

---

# Model and control design under consideration

## Contents

2.1	Model under consideration . . . . .	43
2.2	Three different controls for three different measurements . . . . .	44
2.3	Riemann invariant and prediction based design . . . . .	44
2.4	The core of our method: the estimated and auxiliary systems . . . . .	47
2.5	Cartography of the different procedures for each control law . . . . .	49
	Chapter conclusion . . . . .	51

First the model under consideration is presented, this is a one-dimensional wave equation. Then the main differences between the adaptive control laws are explained in Section 2.2. The wave is then reformulated using the Riemann invariant into coupled transport phenomena. This allows us to present the prediction based design in Section 2.3. The following Section 2.4 is dedicated to the core of our method. The last Section 2.5 presented in schematic view the different steps we use to build the *extended system* (the system the stability of which is studied) for each adaptive control law.

## 2.1 Model under consideration

We consider the following one-dimensional wave equation with in-domain viscous damping, subject to an anti-damping boundary, with actuation on the opposite boundary

$$\begin{cases} u_{tt}(x,t) = u_{xx}(x,t) - 2\lambda u_t(x,t), & (2.1a) \\ u_x(1,t) = U(t), & (2.1b) \\ u_{tt}(0,t) = a q u_t(0,t) + a[u_x(0,t) - d], & (2.1c) \end{cases}$$

in which,  $\lambda$  is the in-domain damping coefficient,  $q > 0$  an unknown anti-damping boundary coefficient,  $d > 0$  is an unknown bias coefficient and  $a$  is a positive constant. The distributed variable of the system is  $u(x,t) \in \mathbb{R}$  with  $x$  the spatial variable, and  $t$  the time variable. The scalar  $U(t)$  is the control input. The in-domain damping in (2.1a) also makes the control design significantly harder by introducing an internal coupling, as appears in the following sections.

Note that the well-posedness of the zero-input system ( $U(t) = 0$  in (2.1)) is established in Appendix B.

Therefore, we make the following assumption on the system which consider to hold in the sequel of this part.

**Assumption 2.1** *There exist known constants  $\underline{q}$ ,  $\bar{q}$ ,  $\underline{d}$  and  $\bar{d}$  such that  $\underline{q} < \bar{q}$ ,  $\underline{d} < \bar{d}$  and  $q \in [\underline{q}, \bar{q}]$ ,  $d \in [\underline{d}, \bar{d}]$ .*

The adaptive control approach considered in this thesis uses estimation of the system parameters,  $q$  and  $d$ . As we are considering adaptive control, the state of the system is

$$\mathcal{X}(t) = [u(t), u_t(t), u(0,t), u_t(0,t), q - \hat{q}(t), d - \hat{d}(t)] \in H_1(0,1) \times L_2(0,1) \times \mathbb{R}^4, \quad (2.2)$$

in which  $\hat{q}(t)$  and  $\hat{d}(t)$  are the estimate of the unknown parameters  $q$  and  $d$ . The remaining state variables are the state of the wave PDE.

## 2.2 Three different controls for three different measurements

We suggest to study our robustness method for three different adaptive control laws. The first uses the measurement of both boundary velocities, i.e.,  $u_t(0,t)$  and  $u_t(1,t)$  and will be referred to as the *boundary output feedback*. The second uses also the collocated velocity but the delayed values of the anti-collocated velocity, i.e.,  $u_t(1,t)$  and  $u_t(0,t-1)$ . It will be referred to as the *delayed anti-collocated output feedback*. The last one uses only the collocated velocity, i.e.,  $u_t(1,t)$  and thus is called *collocated output control* or *surface based control*. All the previous talk is sum up in the following

1. *Boundaries output feedback*:  $u_t(1,t)$  and  $u_t(0,t)$  as measurement. Two sensors are therefore considered.

Chapter 3.

2. *Delay anti-collocated output feedback*:  $u_t(1,t)$  and  $u_t(0,t-1)$  as measurement. Here two sensors are also considered, but the information of the sensor which is not located with the actuation is considered delayed.

Chapter 4.

3. *Collocated output feedback*:  $u_t(1,t)$  as measurement. For this adaptive control law a only one sensor is needed and it is collocated with the actuation.

Chapter 5.

The complexities of the presented method increases for each adaptive control law. The *boundary output feedback* has been presented in [Roman et al., 2016b]. The presentation of it in this manuscript is self-content and it is used as a minimal example (i.e., a simple enough case) to present the idea of our method. The *delay anti-collocated* corresponds to an unpublished result, but it is a lessen problem with respect to the *collocated output feedback* which is under review at TAC, see [Roman et al., 2017]. Indeed the robust result in [Roman et al., 2017] contains the *delay anti-collocated output feedback* law model mismatch robustness for in-domain viscous damping. The *delay anti-collocated output feedback* mismatch robustness is allowing us to precisely present the growing of our method and is also self-content. The *collocated output feedback* mismatch robustness is presented but without complete development.

In the next section, in Section 2.3 we present the first step used for the control law design in [Bresch-Pietri and Krstic, 2014a] and [Bresch-Pietri and Krstic, 2014b]. This allows us to emphasize the differences between the three adaptive control laws other than measurement (which has just been explained above). Section 2.4 is dedicated to the core of the proposed method, indeed the development of this section is used for each robustness study.

## 2.3 Riemann invariant and prediction based design

First, using the following Riemann variables

$$\zeta(x,t) := u_t(x,t) + u_x(x,t) - \hat{d}(t), \quad (2.3)$$

$$\omega(x,t) := u_t(x,t) - u_x(x,t) + \hat{d}(t), \quad (2.4)$$

along with the notations

$$W(t) := U(t) + u_t(1,t) - \hat{d}(t), \quad (2.5)$$

$$v(t) := u_t(0,t), \quad (2.6)$$

one establishes into the following system

$$\begin{cases} \dot{v}(t) = a(q-1)v(t) + a[\zeta(0,t) - \hat{d}], & (2.7a) \\ \zeta_t(x,t) = \zeta_x(x,t) - \hat{d}(t) - \lambda(\zeta(x,t) + \omega(x,t)), & (2.7b) \\ \zeta(1,t) = W(t), & (2.7c) \\ \omega_t(x,t) = -\omega_x(x,t) + \hat{d}(t) - \lambda(\zeta(x,t) + \omega(x,t)), & (2.7d) \\ \omega(0,t) = 2v(t) - \zeta(0,t), & (2.7e) \end{cases}$$

in which  $W$  is the new control, and  $v$  is the  $x = 0$  boundary velocity.  $\hat{d}$  is the estimate of  $d$ . And  $\tilde{d}(t) = d - \hat{d}(t)$  is the error-estimate of  $d$ . This system (2.7) represents two coupled transport equations with source terms, coupled with the ODE (2.7a). We suggest to illustrate this structure with a schematic view of the interconnection as initially introduced in [Meglio et al., 2013]. This is done in Figure 2.1. The  $\rightarrow$  represents the transport phenomenon associated to  $\zeta$  or  $\omega$ . These two transport phenomena have opposite propagation direction, i.e.,  $\zeta$  goes from  $x = 1$  to  $x = 0$  referred to as the forward direction, and  $\omega$  goes from  $x = 0$  to  $x = 1$ , referred to as the backward direction. The  $|$  represents one boundary of the transport phenomenon. The purple circle, i.e.,  $\bigcirc$  represents an ODE, the state of which is written at the center. The pointwise dependence, i.e.,  $\dashrightarrow$  expresses the fact that the ODE is coupled with one transport phenomenon boundary, or the link between two transport boundaries. The in-domain viscous damping has induced coupling between the two transport phenomena, this coupling is illustrated in Figure 2.1 by  $\Rightarrow$ . The input  $W$  is pictured with  $\Rightarrow$ .

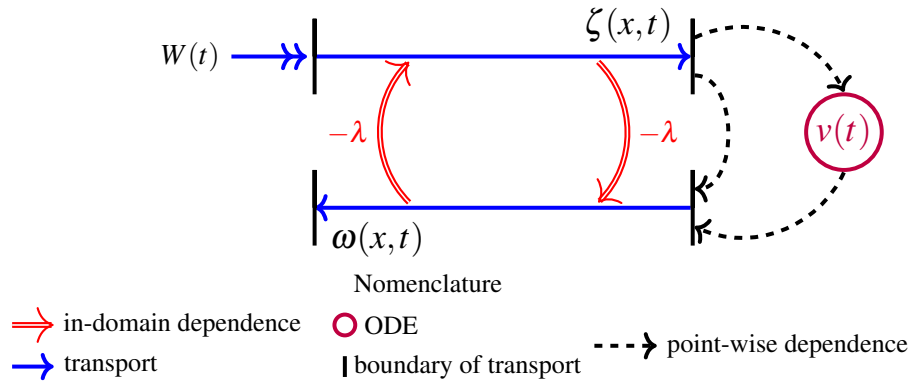

Figure 2.1: Schematic of the Riemann invariant system.

In the case where  $\lambda = 0$ , note that the two transport phenomena (2.7b) and (2.7d) are not coupled anymore. Then, for any  $x$ , the variable  $\zeta(x,t)$  can be expressed as a delayed value of the boundary (2.7c) (applying Lemma A.1 in Appendix A.1 to (2.7b)). This enables us to consider (2.7a) as an input-delay system, as studied in [Artstein, 1982], [Kwon and Pearson, 1980], and [Manitius and Olbrot, 1979] which are related with the early work of [Smith, 1957] and [Smith, 1959].

In order to explain the prediction-based designs proposed in the following chapters, consider that  $\lambda = 0$  and that we know the parameters  $q$  and  $d$ , e.i.,  $\hat{q}(t) = q$  and  $\hat{d}(t) = d$  in the system (2.7). Thus, from (2.7a) it holds

$$\dot{v}(t) = a(q-1)v(t) + aW(t-1). \quad (2.8)$$

Therefore if one assures that

$$W(t) = -(c_0 + q - 1)v(t+1), \quad (2.9)$$



then the closed-loop system state  $v$  satisfies

$$\dot{v}(t) = -ac_0v(t), \quad \text{for } t \geq 1. \quad (2.10)$$

From (2.8), applying the variations of constant formula, one gets

$$v(t+1) = e^{a(q-1)(t+1-\tau)}v(\tau) + a \int_{\tau}^{t+1} e^{a(q-1)(t+1-s)}W(s-1)ds, \quad \forall t, \tau \in \mathbb{R}. \quad (2.11)$$

This is a classic result for input-delay systems. It means that we can deduce  $v$  at time  $t+1$  from the knowledge of its previous values and the knowledge of the history of the input (inhomogeneous part). In Section 2.2, we have highlighted that the three control laws have three different measurements. The measurement fixes the value of  $\tau$  in (2.11), indeed one gets

1. For the *boundary output feedback* [Chapter 3], we take  $\tau = t$  in (2.11) and consequently choose

$$W(t) = -(c_0 + q - 1) \left( e^{a(q-1)}v(t) + a \int_t^{t+1} e^{a(q-1)(t+1-s)}W(s-1)ds \right). \quad (2.12)$$

This control law is related with the control law  $U$  presented in Chapter 3. It is taken from [Bresch-Pietri and Krstic, 2014a].

2. For the *delay anti-collocated output feedback* [Chapter 4], we take  $\tau = t-1$  in (2.11)

$$W(t) = -(c_0 + q - 1) \left( e^{2a(q-1)}v(t-1) + a \int_{t-1}^{t+1} e^{a(q-1)(t+1-s)}W(s-1)ds \right). \quad (2.13)$$

And again (2.9) holds therefore (2.10) follows. This is the idea of the control law design in [Bresch-Pietri and Krstic, 2014a]. This is analyzed in Chapter 4.

3. *Collocated output feedback* [Chapter 5]. In this case we propose to use the same control law as (2.13), but to reconstruct  $v(t-1)$  using both transport phenomena, indeed it holds

$$v(t-1) = \frac{1}{2}[u_t(1,t) - u_x(1,t) + u_t(1,t-2) + u_x(1,t-2)]. \quad (2.14)$$

And thus the control law can be computed using only the measurement of the collocated velocity (as  $u_x(1,t) = U(t)$  is known). For more details and comments about this design see Chapter 5. This is goal of the control design proposed in [Bresch-Pietri and Krstic, 2014b].

Note that, for the three cases, in the nominal case where  $\lambda = 0$ , with  $\hat{q} = q$  and  $\hat{d} = d$ , exponential stabilization is achieved. In the general case, applying the certainty equivalence principle, the different adaptive control laws follow: Chapter 3 for the *boundary output feedback*, Chapter 4 for the *delay anti-collocated output feedback*, and Chapter 5 for the *collocated boundary feedback*.

We want to study the robustness of these adaptive control laws designed for  $\lambda = 0$  when  $\lambda > 0$ . Note that the main difficulty of the *collocated output feedback* robust analysis is that when  $\lambda \neq 0$  (2.14) is no longer true, therefore there is a error which propagates in the system. More details are given in Chapter 5. The method we suggest consist of several successive change of variables in order to perform a Lyapunov analysis. The first step of this change of variable which is similar for the robust analysis of the three adaptive control laws is detailed in the next section.

## 2.4 The core of our method: the estimated and auxiliary systems

The core of our method is to extend the system in order to introduce a dynamics equivalent to the *nominal case* ( $\lambda = 0$ ). Consider the following set of variables

$$\widehat{\zeta}(x, t) := \zeta(x, t) + \lambda \int_x^1 (\zeta(\chi, t+x-\chi) + \omega(\chi, t+x-\chi)) d\chi, \quad (2.15)$$

$$\begin{aligned} \widehat{\omega}(x, t) := \omega(x, t) + \lambda \int_0^x (\zeta(\chi, t-x+\chi) + \omega(\chi, t-x+\chi)) d\chi \\ - \lambda \int_0^1 (\zeta(\chi, t-x-\chi) + \omega(\chi, t-x-\chi)) d\chi, \end{aligned} \quad (2.16)$$

$$\widetilde{\zeta}(x, t) := \zeta(x, t) - \widehat{\zeta}(x, t), \quad (2.17)$$

$$\widetilde{\omega}(x, t) := \omega(x, t) - \widehat{\omega}(x, t). \quad (2.18)$$

The hat variable dynamics are referred to as the *estimated system*. The tilde variable dynamics are referred to as the *auxiliary system*. The following proposition establishes both systems and expresses the dynamics of  $v$  with this set of variables.

**Proposition 2.1**  *$v$  defined in (2.6) satisfies*

$$\dot{v}(t) = a(q-1)v(t) + a[\widetilde{\zeta}(0, t) + \widehat{\zeta}(0, t) - \widehat{d}(t)]. \quad (2.19)$$

*The estimated system satisfies*

$$\begin{cases} \widehat{\zeta}_t(x, t) = \widehat{\zeta}_x(x, t) - \widehat{d}(t), & (2.20a) \\ \widehat{\zeta}(1, t) = W(t), & (2.20b) \\ \widehat{\omega}_t(x, t) = -\widehat{\omega}_x(x, t) + \widehat{d}(t), & (2.20c) \\ \widehat{\omega}(0, t) = 2v(t) - \widehat{\zeta}(0, t), & (2.20d) \end{cases}$$

*and the auxiliary system is*

$$\begin{cases} \widetilde{\zeta}_t(x, t) = \widetilde{\zeta}_x(x, t) - \lambda [\widetilde{\zeta}(x, t) + \widetilde{\omega}(x, t) + \widehat{\zeta}(x, t) + \widehat{\omega}(x, t)], & (2.21a) \\ \widetilde{\zeta}(1, t) = 0, & (2.21b) \\ \widetilde{\omega}_t(x, t) = -\widetilde{\omega}_x(x, t) - \lambda [\widetilde{\zeta}(x, t) + \widetilde{\omega}(x, t) + \widehat{\zeta}(x, t) + \widehat{\omega}(x, t)], & (2.21c) \\ \widetilde{\omega}(0, t) = -\widetilde{\zeta}(0, t). & (2.21d) \end{cases}$$

*Proof:* From (2.7a) and the definitions (2.15)-(2.18) one obtains (2.19).

From the definitions (2.15)-(2.16), considering the Riemann invariants (2.7b)-(2.7e) one gets (2.20a)-(2.20d). (2.21a)-(2.21d) are obtained in a similar manner. ■

The system (2.7b)-(2.7e) has been decomposed into two dynamics. The first part (2.20) is referred to as the *estimated system* and has the same decoupled dynamics as the *nominal system* (when  $\lambda = 0$  in (2.7b)-(2.7e)). It can be seen as the part the control acts on, while the second part (2.21) encapsulates all the remaining dynamics not taking in account in the feedback law. This second system is referred to as the *auxiliary system*. The idea is that, because the system (2.20), has the same dynamics as the nominal one (system (2.7) with  $\lambda = 0$ ) and that it had been build as the part the control acts on, the control law will stabilize (2.20). However, as the transformation (2.15)-(2.16) is not invertible, we need to add some ‘information’ to conclude on the original system behavior. The added ‘information’ is by considering the remaining dynamics, i.e., (2.21). Nevertheless, as far as we see, there is no particular constraint to chose others variables than the one we take in (2.17)-(2.18).

Figure 2.2 illustrates the system which consists of the *estimated system* and *auxiliary system* and the ODE. Note that a transport phenomenon without source and distributed terms, with zero input converges to zero in finite

time. The fact that the *estimated system* does not depend on the *auxiliary system* is shown in Figure 2.2. The dependence of the *auxiliary system* with respect to the *estimated system* is illustrated with  $\Rightarrow$ . This dependence is parametrized by the coefficient  $\lambda$  (see (2.21)). Intuitively, if the coefficient  $\lambda$  is small enough, the *estimated system* converges, therefore the *auxiliary system* also converges and thus the closed-loop system is stable.

As previously said the *estimated system* can be seen as the system's part the control acts on. This system behaves similarly as the *nominal system* for the control law, therefore the analysis perform for the nominal case can be applied similarly on the *estimated system*. This latter point is mandatory, due to the fact that we consider Lyapunov-based adaptive control design. Indeed, the adaptive laws are computed to cancel error estimate terms in the Lyapunov analysis (i.e., terms in  $\tilde{q}$  and  $\tilde{d}$ ). As the control act in a similar way on the *estimated system* (this is its purpose), the error estimate terms resulting from the *estimated system* are going to be canceled.

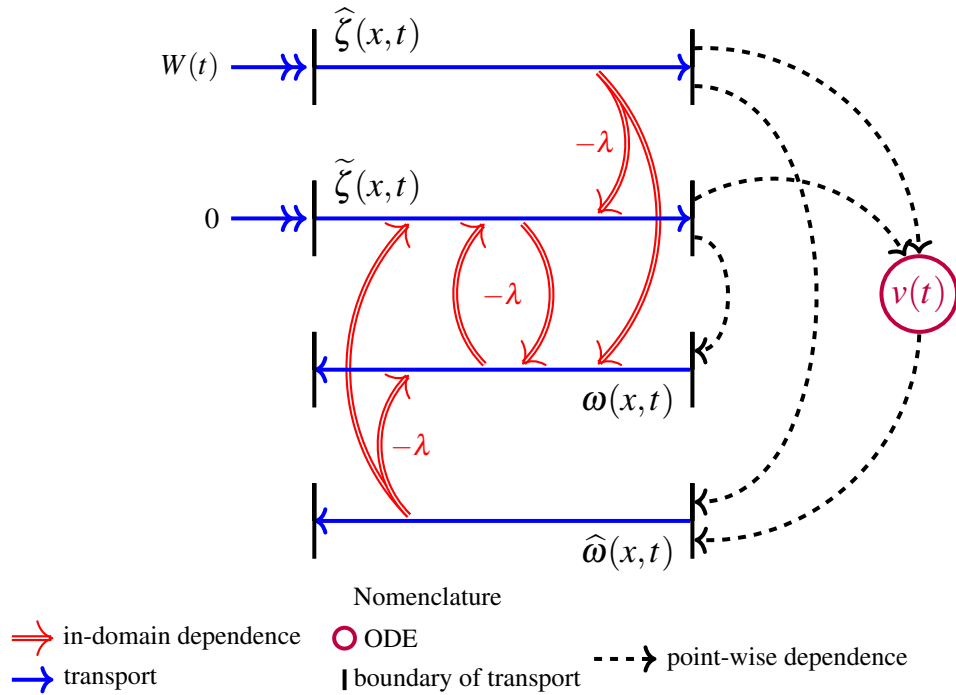

Figure 2.2: Illustration of the *estimated system* and *auxiliary system*

## 2.5 Cartography of the different procedures for each control law

As previously said, the idea of our method is to build a system the stability of which implies the stability of (2.1). In this section, we emphasize the different steps (presented in the sequel) for each procedure corresponding to a control law. In the previous section, the first step which is consistent for the three extended system constructions is presented. The schematic view of these different steps is presented in Figure 2.3.

For example, the *boundary output feedback* procedure's steps are shown with  $\rightarrow$ .

- (i). We start with the Riemann invariants.
- (ii). Then the *estimated* and *auxiliary system* are computed.
- (iii). Finally, we perform a backstepping transformation on the *estimated system* to get the *target system*.

The stability of the *target system* with the *auxiliary system* implies the stability of the closed-loop system (2.1) for the boundary output feedback. The details of which are presented in Chapter 3.

For the *delay anti-collocated output feedback* building of the extended system,

- (i). We start once again for the Riemann invariants, then the *estimated* and *auxiliary system*.
- (ii). Now, as the control law uses the delay of the uncontrolled velocity we enhance the system with the *delay system*,
- (iii). before performing backstepping transformation (as it is done in the nominal case. [Bresch-Pietri and Krstic, 2014b])
- (iv). Finally, it remains some adaptive error term which are not cancel by the adaptive law. Therefore we consider a additional state for the extended system to perform the Lyapunov analysis.

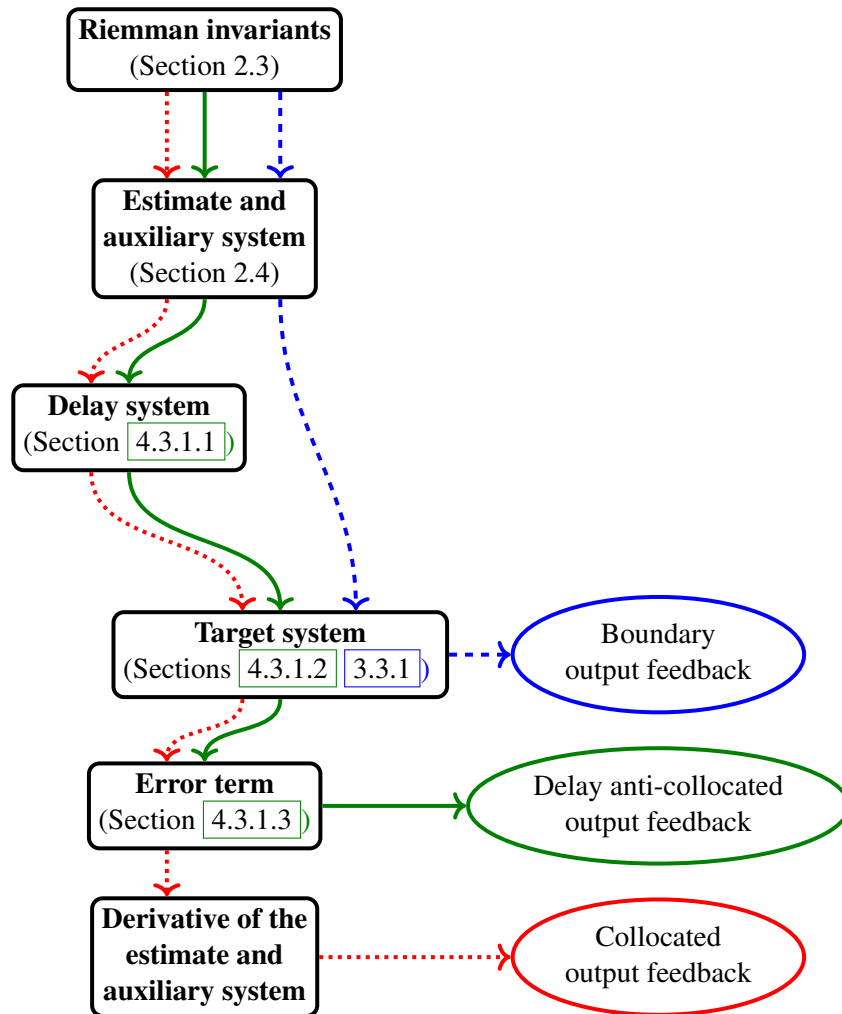

Figure 2.3: Cartography of the different procedures with respect to each control law.

We are now ready to start the analysis.

## Chapter closure and opening

In the sequel we study the model mismatch robustness of three adaptive control laws. The preliminary step is to split the Riemann invariant system into the -refereed as- *estimate system* and *auxiliary system*, this has been presented in Section 2.4. The next steps, which are listed in Figure 2.3, are detailed in the next chapters. Somehow the splitting can be related to the one often done in robust control design as for example  $H_\infty$ , where a model with uncertainty is split in both the nominal system and the normalize incertitude. This is illustrated in Figure 2.4

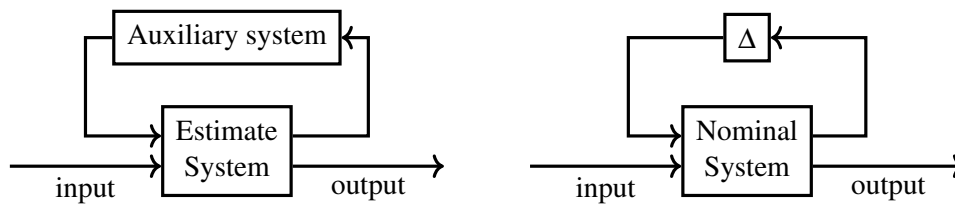

Figure 2.4: Similarity between our method (left) and common finite method (right) for model mismatch robustness

In robust control, like in  $H_\infty$  the model mismatch robustness is often deduced using small gain theorem. In our method the splitting is effectuated in order to perform Lyapunov stability analysis. An interesting article is [Zhang et al., 2001] which establishes the link between Lyapunov stability analysis and scaled small-gain conditions for time-delay system. It will be interesting to study if the suggested method here can be link to the same gain theorem. Nevertheless let us present the result we have for the adaptive control using both boundary velocities in the next chapter.

It is important to notice and understand that the successive change of variables we consider does not need to be invertible, indeed we just need that the stability of the transformed system implies the stability of the original system. This property is fundamental for our result and therefore is proven in each cases.





# Boundary output feedback

## Contents

<b>3.1 Boundary output adaptive control law</b> . . . . .	<b>53</b>
<b>3.2 Model mismatch of boundary output feedback</b> . . . . .	<b>54</b>
<b>3.3 Proof of robustness to internal damping</b> . . . . .	<b>55</b>
3.3.1 Extension of the system . . . . .	55
3.3.2 Stability analysis . . . . .	58
3.3.3 Relation between the functionals $\Gamma(\mathcal{X})$ and $V(\mathcal{X}_e)$ . . . . .	62
3.3.4 Convergence in terms of the functional $\Upsilon$ . . . . .	64
3.3.5 Conclusion on the proof of Theorem 3.2 . . . . .	64
<b>Chapter conclusion</b> . . . . .	<b>66</b>

This chapter is dedicated to a first adaptive control law, which makes use of both current boundary velocities. In Section 3.1, this adaptive control law is presented. Then, a robustness property to distributed damping ( $\lambda \neq 0$ ) is stated in Section 3.2. The proof of this result is established in Section 3.3.

As it has been said, the system under consideration is (2.1), recall

$$\begin{cases} u_{tt}(x, t) = u_{xx}(x, t) - 2\lambda u_t(x, t), & (3.1a) \\ u_x(1, t) = U(t), & (3.1b) \\ u_{tt}(0, t) = a q u_t(0, t) + a[u_x(0, t) - d]. & (3.1c) \end{cases}$$

The outputs considered in this chapter are  $u_t(1, t)$  and  $u_t(0, t)$ .

## 3.1 Boundary output adaptive control law

Consider the dynamics (2.1) with the following control law, designed in [Bresch-Pietri and Krstic, 2014a]

$$U(t) := -u_t(1, t) + \widehat{d}(t) - (c_0 + \widehat{q}(t) - 1) \left( e^{a(\widehat{q}(t)-1)} u_t(0, t) + a \int_{t-1}^t e^{a(\widehat{q}(t)-1)(t-\tau)} (\eta(\tau) - \widehat{d}(t)) d\tau \right), \quad (3.2)$$

in which  $c_0 > 0$  is a constant,  $\widehat{q}(t)$  is an estimate of the unknown parameter  $q$ ,  $\widehat{d}(t)$  is an estimate of  $d$ , and

$$\eta(t) := U(t) + u_t(1, t). \quad (3.3)$$

The parameter update laws are

$$\dot{\widehat{q}}(t) := \frac{a\gamma_q}{1+N(t)} \text{PROJ}_{[q, \bar{q}]} \left\{ \widehat{q}(t), u_t(0, t) \left( u_t(0, t) + b_1(c_0 + \widehat{q}(t) - 1) \int_{t-1}^t e^{(a(\widehat{q}(t)-1)-1)(\tau-t+1)} \sigma(\tau, t) d\tau \right) \right\}, \quad (3.4)$$

$$\dot{\widehat{d}}(t) := \frac{-a\gamma_d}{1+N(t)} \text{PROJ}_{[d, \bar{d}]} \left\{ \widehat{d}(t), u_t(0, t) + b_1(c_0 + \widehat{q}(t) - 1) \int_{t-1}^t e^{(a(\widehat{q}(t)-1)-1)(\tau-t+1)} \sigma(\tau, t) d\tau \right\}, \quad (3.5)$$

$$N(t) := u_t(0, t)^2 + b_1 \int_{t-1}^t e^{\tau-t+1} \sigma(\tau, t)^2 d\tau + b_2 \int_{t-1}^t e^{\tau-t+1} (2u_t(0, \tau) - \eta(\tau - 1) + \widehat{d}(t))^2 d\tau, \quad (3.6)$$



in which the bounds  $q, \bar{q}, \underline{d}, \bar{d}$  are defined in Assumption 2.1, PROJ is the standard projection operator over the interval  $[q, \bar{q}]$  (or  $[\underline{d}, \bar{d}]$ ) ( see its definition in Section 1.4.4, (1.134)),  $b_1, b_2 > 0$  are normalization constants, the update gains  $\gamma_d, \gamma_q > 0$  are tuning parameters and, for  $t \geq 0$  and  $t - 1 \leq \tau \leq t$ ,

$$\sigma(\tau, t) := \eta(\tau) - \hat{d}(t) + (c_0 + \hat{q}(t) - 1) \left( e^{a(\hat{q}(t)-1)(\tau-t+1)} u_t(0, t) + a \int_{t-1}^{\tau} e^{a(\hat{q}(t)-1)(\tau-\chi)} (\eta(\chi) - \hat{d}(t)) d\chi \right). \quad (3.7)$$

The adaptive laws (3.4)-(3.5) result from a Lyapunov-based design, i.e., from indirect adaptive control. Moreover  $\hat{d}$  and  $\hat{q}$  are bounded by definition, due to the normalization term  $N$  in (3.4)-(3.5). Besides, the projector operator allows to limit the estimated variables within their boundaries (for more details on adaptive control paradigm see [Ioannou and Sun, 1996]).

Finally, note that the control law is robust with respect to a constant input disturbance, due to the structure of (3.5), which can be seen as an integral term.

The following theorem states the stability result for the previously presented control law and adaptive laws for the nominal case ( $\lambda = 0$ ).

**Theorem 3.1** [Bresch-Pietri and Krstic, 2014a]

Consider the closed-loop system consisting of the plant (2.1) in which  $\lambda = 0$ , the control law  $U$  defined in (3.2) and the parameters update laws (3.4)-(3.4). Define the functionals

$$\Gamma_0(\mathcal{X}(t)) := u_t(0, t)^2 + \|u_x(t) - d\|_{L_2}^2 + \|u_t(t)\|_{L_2}^2 + (q - \hat{q}(t))^2 + (d - \hat{d}(t))^2 \quad (3.8)$$

$$\Upsilon_0(\mathcal{X}(t)) := u_t(0, t)^2 + \|u_t(t)\|_{L_2}^2 + \|u_x(t) - d\|_{L_2}^2 + (d - \hat{d}(t))^2 \quad (3.9)$$

in which  $\mathcal{X}(t)$  is defined in (2.2).

Then, for all  $c_0 > 0$ , there exist  $\bar{b}_2(c_0) > 0$ ,  $\underline{b}_1(c_0, \bar{b}_2) > 0$ ,  $\bar{\gamma}(c_0, \underline{b}_1, \bar{b}_2) > 0$ , such that, for

- $b_2 \in (0, \bar{b}_2)$ ,
- $b_1 \in (\underline{b}_1, \infty)$ ,
- $\gamma_d, \gamma_q \in (0, \bar{\gamma})$ ,

it holds, for suitable  $R > 0$  and  $\rho > 0$ ,

$$\Gamma_0(\mathcal{X}(t)) \leq R(e^{\rho \Gamma_0(\mathcal{X}(0))} - 1), \quad (3.10)$$

and

$$\lim_{t \rightarrow \infty} \Upsilon_0(\mathcal{X}(t)) = 0. \quad (3.11)$$

The parameters  $c_0, b_1, b_2, \gamma_q$  and  $\gamma_d$  are tuning parameters for the control law and adaptive laws. The scalar  $\bar{b}_2, \underline{b}_1$ , and  $\bar{\gamma}$  are the parameter bounds.

In indirect adaptive control there are usually two properties, stability, and attractivity (convergence). The stability property is expressed by the functional  $\Gamma_0$ . The expression (3.10) means that the system is stable around the subspace of the state space define by the kernel of  $\Gamma_0$ . The attractivity (convergence) is expressed by the functional  $\Upsilon_0$ . The expression (3.11) means that the system converges to the subspace of the state space defined by the kernel of  $\Upsilon_0$ .

The next section presents the robust result.

## 3.2 Model mismatch of boundary output feedback

Using the method we have developed, one can establish the following theorem. It states that the adaptive control law still stabilizes the system if the coefficient  $\lambda$  is small enough with respect to initial conditions and control law tuning parameters.

**Theorem 3.2** [Roman et al., 2016b]

Consider the closed-loop system consisting of the plant (2.1), the control law (3.2) and the parameter update laws (3.4)-(3.5). Under Assumption 2.1, define the functionals  $\Gamma$ ,  $\Xi$  and  $\Upsilon$  as

$$\Gamma(\mathcal{X}(t)) := u_t(0,t)^2 + \|u_t(t)\|_{L_2}^2 + \|u_x(t) - d\|_{L_2}^2 + (q - \widehat{q}(t))^2 + (d - \widehat{d}(t))^2, \quad (3.12)$$

$$\Xi(\mathcal{X}(t)) := \max_{s \in [0,2]} \Gamma(\mathcal{X}(t-s)), \quad (3.13)$$

$$\Upsilon(\mathcal{X}(t)) := u_t(0,t)^2 + \|u_t(t)\|_{L_2}^2 + \|u_x(t) - d\|_{L_2}^2 + (d - \widehat{d}(t))^2. \quad (3.14)$$

Then, for all  $c_0 > 0$ , there exist  $\bar{b}_2(c_0) > 0$ ,  $\underline{b}_1(c_0, \bar{b}_2) > 0$ ,  $\bar{\gamma}(c_0, \underline{b}_1, \bar{b}_2) > 0$ , such that, for

- $b_2 \in (0, \bar{b}_2)$ ,
- $b_1 \in (\underline{b}_1, \infty)$ ,
- $\gamma_d, \gamma_q \in (0, \bar{\gamma})$ ,

there exists  $\bar{\lambda}(c_0, b_1, b_2, \bar{\gamma}, \mathcal{X}(0)) > 0$  such that, when  $\lambda \in (0, \bar{\lambda})$ , it follows, for suitable  $R > 0$  and  $\rho > 0$

$$\Xi(\mathcal{X}(t)) \leq R(e^{\rho \Xi(\mathcal{X}(0))} - 1), \quad (3.15)$$

and

$$\lim_{t \rightarrow \infty} \Upsilon(\mathcal{X}(t)) = 0. \quad (3.16)$$

As in the former theorem (Theorem 3.1) the stability and the attractivity are stated. However, note that the stability (3.15) is expressed with the delayed functional  $\Xi$ . This means that the system is stable with the subspace defined by the kernel of  $\Xi$ . This is due to the PDE coupling introduced by the in-domain damping which generates distributed delays. To analyze these couplings, the suggested method uses the variables  $\widehat{w}$  and  $\widehat{\zeta}$  defined in (2.15)-(2.16) (in Section 2.4). These variables are constructed using space-time integrals. To bound these integrals we need to consider a delayed functional. Note that the maximal delay is two in (2.16), this is consistent with the delay of two in (3.13).

Besides, the stability and convergence are semi-global (i.e.,  $\bar{\lambda}$  depends on initial conditions) as a result of the normalization involved in (3.4) and (3.5).

### 3.3 Proof of robustness to internal damping

The proof of Theorem 3.2 consists of the following steps. In Section 3.3.1 we extend and transform the system (2.1). This enables us to perform a standard Lyapunov analysis on the previously extended system in Section 3.3.2. In Section 3.3.3 the stability result is expressed in terms of the variables of the *original system* (2.1). Finally the convergence is presented in Section 3.3.4. The last Section 3.3.5 is a brief conclusion on the proof of Theorem 3.2.

#### 3.3.1 Extension of the system

The different steps to build the *extended system* are the following

- The *original system* (2.1) is reformulated into (2.7) using the Riemann invariants presented in Section 2.3.
- The system (2.7) is decomposed into both the *estimated system* and the *auxiliary system*, as presented in Section 2.4.
- Then a backstepping transformation is applied on the *estimated system* (2.20).

All this procedure has been illustrated in Figure 2.3. The two first steps have been addressed in Chapter 2, we now detail the third one.

### Backstepping transformation

In order to perform the backstepping transformation, some preliminary computations are needed. Indeed, the previous form of the control and adaptive laws is useful for implementation, but another form is needed for the analysis.

**Claim 3.1** *Considering  $U$  taken as (3.2),  $W$  defined in (2.5) can be rewritten as*

$$W(t) = -(c_0 + \hat{q}(t) - 1) \left( e^{a(\hat{q}(t)-1)} v(t) + a \int_0^1 e^{a(\hat{q}(t)-1)(1-x)} \hat{\zeta}(x, t) dx \right). \quad (3.17)$$

*Proof:* From (3.2), using definition (2.5)-(2.6) and the change of variables  $\tau = t + x - 1$  in the integration, one obtains

$$W(t) = -(c_0 + \hat{q}(t) - 1) \left( e^{a(\hat{q}(t)-1)} v(t) + a \int_0^1 e^{a(\hat{q}(t)-1)(1-x)} [\eta(t+x-1) - \hat{d}(t)] dx \right). \quad (3.18)$$

Gathering (3.3) and (2.5), one gets

$$\eta(\tau) = W(\tau) + \hat{d}(\tau). \quad (3.19)$$

Now, we use the fact that the *estimated system* (2.20) presented in Section 2.4 consists in a pure transport PDE and thus satisfy, for  $(x, y) \in [0, 1]^2$ ,

$$\hat{\zeta}(x, t) = \hat{\zeta}(y, t+x-y) - \hat{d}(t) + \hat{d}(t+x-y), \quad (3.20)$$

$$\hat{\omega}(x, t) = \hat{\omega}(y, t-x+y) + \hat{d}(t) - \hat{d}(t-x+y). \quad (3.21)$$

The relationship between transport and delay is detailed in Appendix A.1. Taking  $y = 1$  in (3.20), with the boundary condition of the first transport phenomenon (2.20b), and matching (2.15), (3.18), and (3.19), one finally gets (3.17).  $\blacksquare$

Note that, in the non-adaptive case (that is  $\tilde{q} = 0$  and  $\tilde{d} = 0$ ), one finds that (3.18) is equivalent to (2.12).

Now consider the following backstepping transformation

$$\Pi : (\hat{\zeta}(t), v(t)) \mapsto \hat{z}(t) = \Pi[\hat{\zeta}(t), v(t)], \quad (3.22)$$

$$\Pi[\hat{\zeta}(x, t), v(t)] := \hat{\zeta}(x, t) + (c_0 + \hat{q}(t) - 1) \left( e^{a(\hat{q}(t)-1)x} v(t) + a \int_0^x e^{a(\hat{q}(t)-1)(x-\chi)} \hat{\zeta}(\chi, t) d\chi \right). \quad (3.23)$$

which enables to obtain

$$\hat{z}(1, t) = \hat{\zeta}(1, t) - W(t) = 0. \quad (3.24)$$

It is similar to the one considered in the nominal case for the establishment of Theorem 3.1 in [Bresch-Pietri and Krstic, 2014a]. However the  $\Pi$  map is now applied on the estimated variable,  $\hat{\zeta}$  instead of  $\zeta$  in the nominal case.

Note that we do not use the backstepping method to design the control law but only as a mean to study the stability of the system. Therefore, the control law is known, the backstepping transformation is deduced from it, and the following proposition establishes the corresponding target system.

**Proposition 3.1** *The estimated system and the ODE, i.e., respectively (2.20) and (2.19), can then be reformulated reversibly as the following target system,*

$$\begin{cases} \dot{v}(t) = -c_0av(t) + a[\widehat{z}(0,t) + \widehat{\zeta}(0,t) + v(t)\widehat{q}(t) - \widehat{d}(t)], & (3.25a) \\ \widehat{z}_t(x,t) = \widehat{z}_x(x,t) + \widehat{q}(t)g_q(x,t) + \widehat{d}(t)g_d(x,t) + [\widehat{q}(t)v(t) - \widehat{d}(t) + \widehat{\zeta}(0,t)]h(x,t), & (3.25b) \\ \widehat{z}(1,t) = 0, & (3.25c) \\ \widehat{\omega}_t(x,t) = -\widehat{\omega}(x,t) + \widehat{d}(t), & (3.25d) \\ \widehat{\omega}(0,t) = (c_0 + \widehat{q}(t) + 1)v(t) - \widehat{z}(0,t), & (3.25e) \end{cases}$$

where

$$g_q(x,t) := e^{a(\widehat{q}(t)-1)x}v(t) + a \int_0^x e^{a(\widehat{q}(t)-1)(x-y)}\Pi^{-1}[\widehat{z}(y,t),v(t)]dy + (c_0 + \widehat{q}(t) - 1) \left( axe^{a(\widehat{q}(t)-1)x}v(t) + a^2 \int_0^x (x-y)e^{a(\widehat{q}(t)-1)(x-y)}\Pi^{-1}[\widehat{z}(y,t),v(t)]dy \right), \quad (3.26)$$

$$g_d(x,t) := -1 - (c_0 + \widehat{q}(t) - 1)a \int_0^x e^{a(\widehat{q}(t)-1)(x-y)}dy, \quad (3.27)$$

$$h(x,t) := a(c_0 + \widehat{q}(t) - 1)e^{a(\widehat{q}(t)-1)x}, \quad (3.28)$$

in which  $\Pi^{-1}$  is the inverse backstepping transformation

$$\Pi^{-1} : (\widehat{z}(t), v(t)) \mapsto \widehat{\zeta}(t) = \Pi^{-1}[\widehat{z}(t), v(t)], \quad (3.29)$$

$$\Pi^{-1}[\widehat{z}(x,t), v(t)] := \widehat{z}(x,t) - (c_0 + \widehat{q}(t) - 1) \left( e^{-ac_0x}v(t) + a \int_0^x e^{-ac_0(x-\chi)}\widehat{z}(\chi,t)d\chi \right). \quad (3.30)$$

*Proof :* Computing (3.23) at  $x = 0$ , and expressing  $\widehat{\zeta}$  in terms of  $v$  and  $\widehat{z}$  in the dynamics of  $v$  (2.19), it follows (3.25a).

Then, from the time derivative of (3.23), using (2.20a), and an integration by parts, one gets

$$\begin{aligned} \widehat{z}_t(x,t) &= \widehat{\zeta}_x(x,t) - \widehat{d}(t) + \widehat{q}(t)(e^{a(\widehat{q}(t)-1)x}v(t) + a \int_0^x e^{a(\widehat{q}(t)-1)(x-s)}\widehat{\zeta}(s,t)ds) \\ &+ (c_0 + \widehat{q}(t) - 1) \left( (ax\widehat{q}(t)v(t) + a(q-1)v(t) + a[\widehat{\zeta}(0,t) + \widehat{\zeta}(0,t) - \widehat{d}(t)])e^{a(\widehat{q}(t)-1)x} \right. \\ &+ a^2\widehat{q}(t) \int_0^x (x-s)e^{a(\widehat{q}(t)-1)(x-s)}\widehat{\zeta}(s,t)ds - a\widehat{d}(t) \int_0^x e^{a(\widehat{q}(t)-1)(x-s)}ds + \left. [ae^{a(\widehat{q}(t)-1)(x-s)}\widehat{\zeta}(s,t)]_{s=0}^x \right. \\ &\left. + a^2(\widehat{q}(t) - 1) \int_0^x e^{a(\widehat{q}(t)-1)(x-s)}\widehat{\zeta}(s,t)ds \right). \end{aligned} \quad (3.31)$$

The space derivative of (3.23) is

$$\begin{aligned} \widehat{z}_x(x,t) &= \widehat{\zeta}_x(x,t) + (c_0 + \widehat{q}(t) - 1) \left( a(\widehat{q}(t) - 1)e^{a(\widehat{q}(t)-1)x}v(t) + a\widehat{\zeta}(x,t) \right. \\ &\left. + a \int_0^x a(\widehat{q}(t) - 1)e^{a(\widehat{q}(t)-1)(x-s)}\widehat{\zeta}(s,t)ds \right). \end{aligned} \quad (3.32)$$

Computing  $\widehat{z}_t - \widehat{z}_x$  and using  $\Pi^{-1}[\widehat{z}(x,t), v(t)] = \widehat{\zeta}(x,t)$  defined in (3.30), one gets (3.25b).

(3.24) is the same as (3.25c), (2.20c) is the same as (3.25d). Finally, computing (3.23) at  $x = 0$ , and expressing  $\widehat{\zeta}$  in term of  $v$  and  $\widehat{z}$  in the boundary condition of  $\widehat{\omega}$  (2.20d), it follows (3.25e).  $\blacksquare$

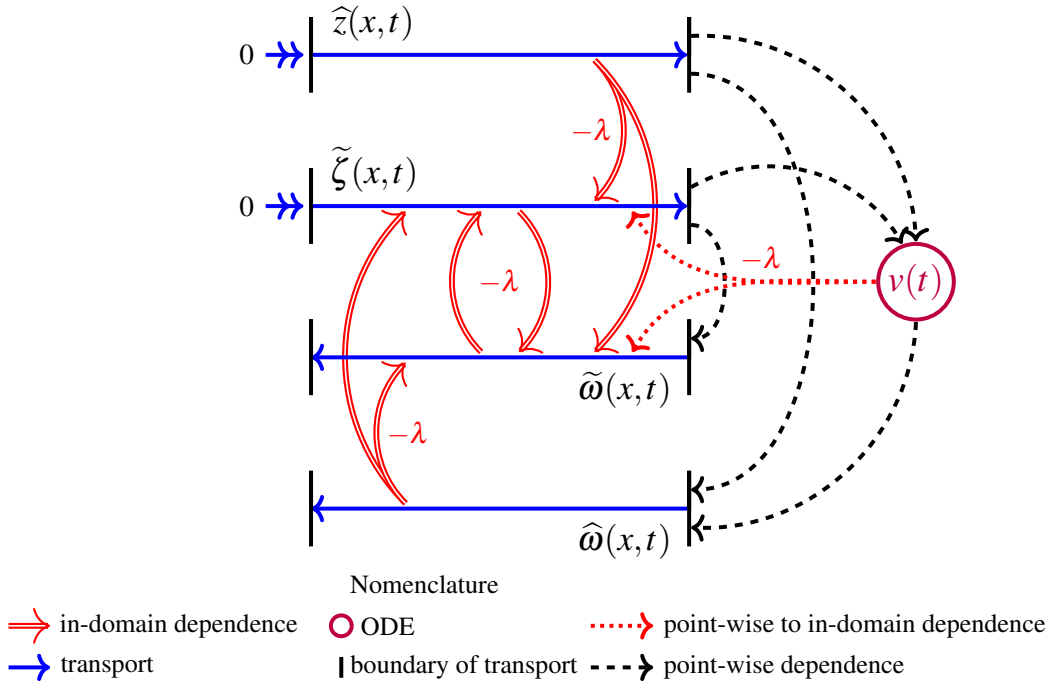

Figure 3.1: Illustration of the *extended system* for the *boundary output feedback*

The idea of the backstepping transformation is to transform the transport phenomenon  $\zeta$  with the feedback  $W$  to a zero input transport phenomenon. Now, as depicted in Figure 3.1, both transport  $\hat{z}$  and  $\tilde{\zeta}$  have a 0 input. Figure 3.1 is a schematic view of the *target system* (3.25) and *auxiliary system* (2.21) interconnection (where  $\tilde{\zeta}(x, t) = \Pi^{-1}[\hat{z}(x, t), v(t)]$  has been used to the *auxiliary system* in order to have consistent state variable). Without any input the dynamics of  $v$  (3.25a) is stable. Moreover, the remaining source terms of the dynamics of  $\tilde{\zeta}$  and  $\tilde{\omega}$  depend linearly on  $\lambda$  (this is illustrated by  $\Rightarrow$  and  $\cdots \Rightarrow$  in Figure 3.1). Therefore intuitively if  $\lambda$  is taken small enough, the *extended system* is stable.

### 3.3.2 Stability analysis

This section is dedicated to the stability analysis of the *extended system* of state

$$\mathcal{X}_e(t) = [v(t), \hat{z}(t), \hat{\omega}(t), \tilde{\zeta}(t), \tilde{\omega}(t), q - \hat{q}(t), d - \hat{q}(t)] \in \mathbb{R} \times L_2(0, 1)^4 \times \mathbb{R}^2. \quad (3.33)$$

Preliminary computations concern the adaptive laws. Similarly for the control law in Claim 3.1, the adaptive laws can be formulate as space integrals. This is the purpose of the following claim.

**Claim 3.2** *The adaptive laws (3.4)-(3.5) can be rewritten as*

$$\dot{\hat{q}}(t) = \frac{a\gamma q}{1+N(t)} \text{PROJ}_{[\underline{q}, \bar{q}]} \left\{ \hat{q}(t), v(t) \left( v(t) + b_1(c_0 + \hat{q}(t) - 1) \int_0^1 e^{(a(\hat{q}(t)-1)-1)x} \hat{z}(x, t) dx \right) \right\}, \quad (3.34)$$

$$\dot{\hat{d}}(t) = \frac{-a\gamma d}{1+N(t)} \text{PROJ}_{[\underline{d}, \bar{d}]} \left\{ \hat{d}(t), v(t) + b_1(c_0 + \hat{q}(t) - 1) \int_0^1 e^{(a(\hat{q}(t)-1)-1)x} \hat{z}(x, t) dx \right\}, \quad (3.35)$$

$$N(t) = v(t)^2 + b_1 \int_0^1 e^x \hat{z}(x, t)^2 dx + b_2 \int_0^1 e^{1-x} \hat{\omega}(x, t)^2 dx. \quad (3.36)$$

*Proof:* First, from (3.19) and (3.20), one obtains

$$\eta(x+t-1) - \hat{d}(t) = \tilde{\zeta}(x, t). \quad (3.37)$$

From the definition of  $\sigma$  (3.7), one gets

$$\begin{aligned}\sigma(x+t-1, t) &= \widehat{\zeta}(x, t) + (c_0 + \widehat{q}(t) - 1) \left( e^{a(\widehat{q}(t)-1)x} v(t) + a \int_0^x e^{a(\widehat{q}(t)-1)(x-s)} \widehat{\zeta}(s, t) ds \right) \\ &= \widehat{z}(x, t).\end{aligned}\quad (3.38)$$

From the definition of  $\zeta$  and  $\omega$  (2.3)-(2.4), the definition of  $\widetilde{\zeta}$  and  $\widetilde{\omega}$  (2.17)-(2.18), and the boundary condition (2.21d), one obtains

$$\widehat{\omega}(0, t-x) = 2u_t(0, t-x) - \widehat{\zeta}(0, t-x).\quad (3.39)$$

Using (3.20)-(3.21), and (3.37), it holds

$$\widehat{\omega}(x, t) = 2u_t(0, t-x) - \eta(t-x-1) + \widehat{d}(t).\quad (3.40)$$

Using change of variables on the integrals,  $\tau = x+t-1$  for the integral on  $\sigma$  and  $\tau = t-x$  for the integral in factor of  $b_2$ , one can conclude.  $\blacksquare$

Let us consider the following Lyapunov functional candidate

$$V(\mathcal{X}_e(t)) = \log(1+N(t)) + \frac{\widetilde{q}(t)^2}{\gamma_q} + \frac{\widetilde{d}(t)^2}{\gamma_d} + b_3 \int_0^1 e^x \widetilde{\zeta}(x, t)^2 dx + b_4 \int_0^1 e^{1-x} \widetilde{\omega}(x, t)^2 dx,\quad (3.41)$$

in which  $N$  is defined in (3.36).

Note that log form of  $V$  is related to the form of the adaptive law (3.34) (3.35) which is often used in adaptive control theory [Ioannou and Sun, 1996] and [Krstic, 2006].

**Lemma 3.1** *Let us consider the Lyapunov functional candidate  $V$  defined in (3.41) with  $b_1, b_2, b_3, b_4 > 0$ .*

*For all  $c_0 > 0$ , there exist  $\bar{b}_2(c_0) > 0$ ,  $\underline{b}_1(c_0, \bar{b}_2) > 0$ ,  $\bar{\gamma}(c_0, \underline{b}_1, \bar{b}_2) > 0$ , such that, for all*

- $b_2 \in (0, \bar{b}_2)$ ,
- $b_1 \in (\underline{b}_1, \infty)$ ,
- $\gamma_d, \gamma_q \in (0, \bar{\gamma})$ ,

*there exist  $b_i > 0, i \in \{3, 4\}$  and  $\bar{\lambda}(c_0, b_1, b_2, \bar{\gamma}, \mathcal{X}(0)) > 0$ , such that, for all  $\lambda \in (0, \bar{\lambda})$ , it follows, for a suitable  $\varsigma > 0$ ,*

$$\dot{V}(\mathcal{X}_e(t)) \leq -\frac{\varsigma}{1+N(t)} \left[ \widehat{z}(0, t)^2 + v(t)^2 + \widehat{\zeta}(0, t)^2 + \widetilde{\zeta}(0, t)^2 + \|\widehat{z}\|^2 + \|\widehat{\zeta}\|^2 + \|\widetilde{\zeta}\|^2 + \|\widehat{\omega}\|^2 + \|\widetilde{\omega}\|^2 \right],\quad (3.42)$$

and thus

$$V(\mathcal{X}_e(t)) \leq V(\mathcal{X}_e(0)), \quad t \geq 0.\quad (3.43)$$

Before stating the proof of the Lemma 3.1, consider the following proposition which concerns the computation of the Lyapunov functional derivative upper bound.

**Proposition 3.2** *There exist  $M_0, M_1, M_2, M_3, C_1$  and  $C_2$  positive, such that*

$$\begin{aligned}\dot{V}(\mathcal{X}_e(t)) &\leq \frac{1}{1+N(t)} \left( -ac_0 v(t)^2 + \frac{2a}{c_0} \widehat{z}(0, t)^2 + \frac{2a}{c_0} \widetilde{\zeta}(0, t)^2 \right. \\ &\quad \left. + b_1 \left[ -\widehat{z}(0, t)^2 - \frac{\|\widehat{z}\|^2}{2} + \gamma_q M_1(b_1) (v(t)^2 + \|\widehat{z}\|^2) + \gamma_d M_2(b_1) (v(t)^2 + \|\widehat{z}\|^2) + M_0 \widetilde{\zeta}(0, t)^2 \right] \right. \\ &\quad \left. + b_2 \left[ 2e(1+c_0+\widehat{q}(t))^2 v(t)^2 - \widehat{\omega}(1, t)^2 + 2e\widehat{z}(0, t)^2 - \|\widehat{\omega}\|^2 + \gamma_d M_3(b_1) (v(t)^2 + \|\widehat{z}\|^2 + \|\widehat{\omega}\|^2) \right] \right) \\ &\quad + b_3 \left[ -\widetilde{\zeta}(0, t)^2 - (1+2\lambda) \|\widetilde{\zeta}\|^2 + \lambda C_1 \left[ v(t)^2 + \|\widehat{z}\|^2 + \|\widetilde{\zeta}\|^2 + \|\widehat{\omega}\|^2 + \|\widetilde{\omega}\|^2 \right] \right] \\ &\quad + b_4 \left[ -\widetilde{\omega}(1, t)^2 + e\widetilde{\zeta}(0, t)^2 - (1+2\lambda) \|\widetilde{\omega}\|^2 + \lambda C_2 \left[ v(t)^2 + \|\widehat{z}\|^2 + \|\widetilde{\zeta}\|^2 + \|\widehat{\omega}\|^2 + \|\widetilde{\omega}\|^2 \right] \right].\end{aligned}\quad (3.44)$$

*Proof*: From the definition of  $V$  in (3.41), it yields

$$\dot{V}(\mathcal{X}_e(t)) = \frac{\dot{N}(t)}{1+N(t)} - \frac{\dot{\hat{q}}(t)\tilde{q}(t)}{\gamma_q} - \frac{\dot{\hat{d}}(t)\tilde{d}(t)}{\gamma_d} + 2b_3 \int_0^1 e^x \tilde{\zeta}_t(x,t) \tilde{\zeta}(x,t) dx + 2b_4 \int_0^1 e^{1-x} \tilde{\omega}_t(x,t) \tilde{\omega}(x,t) dx. \quad (3.45)$$

From the expression of  $N$  (3.36), it follows that

$$\dot{N}(t) = 2\dot{v}(t)v(t) + 2b_1 \int_0^1 e^x \hat{z}_t(x,t) \hat{z}(x,t) dx + 2b_2 \int_0^1 e^{1-x} \hat{\omega}_t(x,t) \hat{\omega}(x,t) dx. \quad (3.46)$$

Then, using (3.25a), and Young's inequality, one obtains

$$2\dot{v}(t)v(t) \leq -ac_0v(t)^2 + \frac{2a}{c_0} \hat{z}(0,t)^2 + \frac{2a}{c_0} \tilde{\zeta}(0,t)^2 + 2av(t)(v(t)\tilde{q}(t) - \tilde{d}(t)). \quad (3.47)$$

Finally using (3.25b)-(3.25e), Young's and Cauchy-Schwarz's inequalities, and one integration by parts, one obtains the existence of  $M_0$ ,  $M_1$  and  $M_2$  positive such that

$$\begin{aligned} 2 \int_0^1 e^x \hat{z} \hat{z}_t dx &\leq -\hat{z}(0,t)^2 - \frac{\|\hat{z}\|^2}{2} + \gamma_q M_1(b_1)(v(t)^2 + \|\hat{z}\|^2) + \gamma_d M_2(b_1)(v(t)^2 + \|\hat{z}\|^2) + M_0 \tilde{\zeta}(0,t)^2 \\ &+ a(c_0 + \hat{q}(t) - 1) \int_0^1 e^{a(\hat{q}(t)-1)+x} \hat{z}(x,t)[v(t)\tilde{q}(t) - \tilde{d}(t)] dx, \end{aligned} \quad (3.48)$$

and the existence of  $M_3$  positive such that

$$\begin{aligned} 2 \int_0^1 e^{1-x} \hat{\omega} \hat{\omega}_t dx &\leq -\hat{\omega}(1,t)^2 + 2e(1+c_0+\hat{q}(t))^2 v(t)^2 \\ &+ 2e\hat{z}(0,t)^2 - \|\hat{\omega}\|^2 + \gamma_d M_3(b_1)(v(t)^2 + \|\hat{z}\|^2 + \|\hat{\omega}\|^2). \end{aligned} \quad (3.49)$$

From (2.21a)-(2.21b), using the inverse backstepping transformation (3.30) on  $\hat{\zeta}$ , there exists  $C_1 > 0$

$$2 \int_0^1 e^x \tilde{\zeta}(x,t) \tilde{\zeta}_t(x,t) dx \leq -\tilde{\zeta}(0,t)^2 - (1+2\lambda)\|\hat{\zeta}\|^2 + \lambda C_1 [v(t)^2 + \|\hat{z}\|^2 + \|\tilde{\zeta}\|^2 + \|\hat{\omega}\|^2 + \|\tilde{\omega}\|^2]. \quad (3.50)$$

Then similarly from (2.21c)-(2.21d), using the inverse backstepping transformation (3.30) on  $\tilde{\zeta}$ , it holds the existence of  $C_2 > 0$

$$\begin{aligned} 2 \int_0^1 e^{1-x} \tilde{\omega}(x,t) \tilde{\omega}_t(x,t) dx &\leq -\tilde{\omega}(1,t)^2 + e\tilde{\zeta}(0,t)^2 - (1+2\lambda)\|\hat{\omega}\|^2 \\ &+ \lambda C_2 [v(t)^2 + \|\hat{z}\|^2 + \|\tilde{\zeta}\|^2 + \|\hat{\omega}\|^2 + \|\tilde{\omega}\|^2]. \end{aligned} \quad (3.51)$$

Gathering (3.45)-(3.51), and using Claim 3.2, one concludes the proof of (3.44).  $\blacksquare$

It is important to notice that the term  $N$  used in (3.4) and (3.5), constraints us to the consideration of the variable  $\hat{\zeta}$  and  $\hat{\omega}$  (Section 2.4, the dynamics of these variable satisfy (2.20)). Indeed, even if the system considered in linear (2.1), the dynamics enhanced by the adaptive error term  $\tilde{q}(t)$  and  $\tilde{d}(t)$  is nonlinear. These variables have been chosen in order to have the simplification described in the previous proof between error terms generated by the system and the adaptive control laws, i.e., the integral term in (3.48) and the last additive term in (3.47).

*Proof of Lemma 3.1*: From Proposition 3.2, we obtain

$$\dot{V}(\mathcal{X}_e(t)) \leq \sum_{\psi \in \mathcal{S}} \delta_\psi f_\psi(\cdot) \mathcal{V}^2, \quad (3.52)$$

in which

$$\mathcal{S} = \{v, \|\hat{z}\|, \|\hat{\omega}\|, \|\tilde{\zeta}\|, \|\tilde{\omega}\|, \hat{z}|0, \hat{\omega}|1, \tilde{\zeta}|0, \tilde{\omega}|1\}, \quad (3.53)$$

where  $\widehat{\omega}|1$  denotes the boundary of  $\widehat{\omega}$  for  $x = 1$ , i.e.,  $\widehat{\omega}(1, t)$ , and

$$\delta_{\mathcal{V}} = \begin{cases} \frac{1}{1+N(t)}, & \text{if } \mathcal{V} \in \{z|0, v, \|\tilde{z}\|, \|\widehat{\omega}\|, \widehat{\omega}|1\}, \\ 1, & \end{cases} \quad (3.54)$$

and with

$$f_{\tilde{z}|0} = -b_1 + \frac{2a}{c_0} + 2eb_2, \quad (3.55)$$

$$f_{\tilde{\xi}|0} = -b_3 + eb_4 + \frac{2a}{c_0} + b_1M_0, \quad (3.56)$$

$$f_v = -ac_0 + 2b_2(1 + c_0 + \bar{q})^2 + b_1\gamma_qM_1 + b_1\gamma_dM_2 + b_2\gamma_dM_3 + \lambda [b_3C_1 + b_4C_2]e^{V(t)}, \quad (3.57)$$

$$f_{\|\tilde{z}\|} = -\frac{b_1}{2} + b_1\gamma_qM_1 + b_1\gamma_dM_2 + b_2\gamma_dM_3 + \lambda [b_3C_1 + b_4C_2]e^{V(t)}, \quad (3.58)$$

$$f_{\|\widehat{\omega}\|} = -b_2 + b_2\gamma_dM_3 + \lambda [b_3C_1 + b_4C_2]e^{V(t)}, \quad (3.59)$$

$$f_{\|\tilde{\xi}\|} = -b_3(1 + 2\lambda) + \lambda (b_3C_1 + b_4C_2), \quad (3.60)$$

$$f_{\|\widehat{\omega}\|} = -b_4(1 + 2\lambda) + \lambda (b_3C_1 + b_4C_2), \quad (3.61)$$

$$f_{\widehat{\omega}|1} = -b_4, \quad (3.62)$$

$$f_{\widehat{\omega}|1} = -b_2. \quad (3.63)$$

Note that, we used that  $1 + N(t) \leq e^{V(t)}$  (from the definition of  $V$  (3.41)).

A sufficient condition for the stability of the extended target system of state  $\mathcal{X}_e$  (3.33) is therefore the existence of parameters  $b_i$ ,  $\gamma_q$ ,  $\gamma_d$ , and  $\lambda$  such that

$$f_{\mathcal{V}}(\cdot) < 0, \quad \forall \mathcal{V} \in \mathcal{S}. \quad (3.64)$$

This is the condition we investigate in the following. With this aim in view, the selection procedure is as follows:

$$b_2 \rightarrow b_1 \rightarrow (\gamma_q, \gamma_d) \rightarrow b_3 \rightarrow b_4 \rightarrow \lambda.$$

In Appendix A.6 we present a simple example on a simplified list of conditions to highlight the procedure we use to select the parameters. Nevertheless, the procedure for the case under consideration is detailed below.

For  $c_0 > 0$ , according to (3.57),  $b_2$  is chosen as

$$b_2 < \frac{ac_0}{2(1 + c_0 + \bar{q})^2}. \quad (3.65)$$

Next from (3.55),  $b_1$  is taken as

$$b_1 > \frac{2a}{c_0} + 2eb_2. \quad (3.66)$$

Then  $\gamma_q$  and  $\gamma_d$  are chosen according to (3.57), (3.58), and (3.59) such that

$$\gamma_d + \gamma_q < \min \left\{ \frac{ac_0 - 2b_2(1 + c_0 + \bar{q})^2}{b_1M_1 + b_1M_2 + b_2M_3}, \frac{b_1}{2(b_1M_1 + b_1M_2 + b_2M_3)}, \frac{1}{M_3} \right\}. \quad (3.67)$$

From (3.56),  $b_3$  is fixed as

$$b_3 > \frac{2a}{c_0} + b_1M_0. \quad (3.68)$$

Next according to (3.56),  $b_4$  is taken such that

$$b_4 < b_3 - \frac{2a}{c_0} + b_1M_0. \quad (3.69)$$



Finally the condition on  $\lambda$  according to (3.57), (3.58), (3.59), (3.60), and (3.61) is chosen as

$$\lambda < \min \left\{ \frac{ac_0 - 2b_2(1 + c_0 + \bar{q})^2 - b_1(\gamma_q M_1 + \gamma_q M_2) - b_2 \gamma_d M_3}{[b_3 C_1 + b_4 C_2] e^{V(0)}}, \right. \\ \left. \frac{\frac{b_1}{2} - b_1(\gamma_q M_1 + \gamma_q M_2) - b_2 \gamma_d M_3}{[b_3 C_1 + b_4 C_2] e^{V(0)}}, \frac{b_2 - b_2 \gamma_q M_3}{[b_3 C_1 + b_4 C_2] e^{V(0)}}, \right. \\ \left. \frac{b_3}{b_3 C_1 + b_4 C_2 - 2b_3}, \frac{b_4}{b_3 C_1 + b_4 C_2 - 2b_4} \right\}, \quad (3.70)$$

with  $C_1, C_2 > 2$  which can be taken as such (as  $C_1$  and  $C_2$  are upper bound constant, by assuming the latter we just have a more conservative result).

Using Proposition A.1 in Appendix A.2, with this choice of parameters, one obtains the existence of  $\vartheta > 0$  such that  $f_{\mathcal{V}}(\cdot) < -\vartheta$  for all  $\mathcal{V} \in \mathcal{S}$ . From (3.52), this implies that it holds (3.42). The former concludes the proof of Lemma 3.1.  $\blacksquare$

### 3.3.3 Relation between the functionals $\Gamma(\mathcal{X})$ and $V(\mathcal{X}_e)$

We need to establish the stability in terms of  $\Xi$  defined in (3.13). In previous section, the stability in terms of the *extended system variables*  $\hat{z}(t)$ ,  $\hat{\omega}(t)$ ,  $\tilde{\zeta}(t)$ ,  $\hat{\omega}(t)$ ,  $\tilde{q}(t)$ , and  $\tilde{d}(t)$  through a Lyapunov analysis has been established. The purpose of the current section is to study the relationship between the functional  $\Gamma$  defined in (3.12) and  $V$  defined in (3.41). Using this relationship (presented in the sequel) and the previous stability result we are able to prove that the stability result (3.15) holds for the system (2.1) extended by the dynamics of the unknown parameters, i.e.,  $\tilde{q}$  and  $\tilde{d}$ . The relationship is expressed in mathematical terms in the following lemma.

**Lemma 3.2** Consider the definition of  $\Gamma$  and  $V$  (3.12) and (3.41), it holds the existence of  $R > 0$  such that

$$\Gamma(\mathcal{X}(t)) \leq R \left( e^{V(\mathcal{X}_e(t))} - 1 \right), \quad (3.71)$$

and the existence of  $\rho > 0$  such that

$$V(\mathcal{X}_e(t)) \leq \rho \max_{s \in [0, 2]} \Gamma(\mathcal{X}(t-s)). \quad (3.72)$$

*Proof:*

First, from the definition of the Riemann variables (2.3) and (2.4), and the intermediate variables (2.15)-(2.18), one gets

$$u_t(x, t) = \frac{\hat{\zeta}(x, t) + \hat{\omega}(x, t) + \tilde{\zeta}(x, t) + \tilde{\omega}(x, t)}{2}. \quad (3.73)$$

It yields a similar form for  $u_x(x, t) - \hat{d}(t)$

$$u_x(x, t) - \hat{d}(t) = \frac{\hat{\zeta}(x, t) - \hat{\omega}(x, t) + \tilde{\zeta}(x, t) - \tilde{\omega}(x, t)}{2}. \quad (3.74)$$

Therefore, applying Young's and Cauchy-Schwarz's inequalities, one can get

$$\|u_t(t)\|^2 \leq \|\hat{\zeta}(t)\|^2 + \|\hat{\omega}(t)\|^2 + \|\tilde{\zeta}(t)\|^2 + \|\tilde{\omega}(t)\|^2, \quad (3.75)$$

$$\|u_x(t) - d\|^2 \leq \frac{5}{4} \left( \|\hat{\zeta}(t)\|^2 + \|\hat{\omega}(t)\|^2 + \|\tilde{\zeta}(t)\|^2 + \|\tilde{\omega}(t)\|^2 \right) + 5\tilde{d}(t)^2. \quad (3.76)$$

Second, from the backstepping transformation and its inverse, applying Young's and Cauchy-Schwarz's inequalities, one can show that there exist positive constants  $r_1, r_2$  such that

$$\|\widehat{\zeta}(t)\|^2 \leq r_1 [v(t)^2 + \|\widehat{z}(t)\|^2], \quad (3.77)$$

$$\|\widehat{z}(t)\|^2 \leq r_2 [v(t)^2 + \|\widehat{\zeta}(t)\|^2]. \quad (3.78)$$

Consequently, from the definition of  $V$  (3.41) and with the previous inequalities, it follows that

$$\|u_t\|^2 + \|u_x - d\|^2 \leq \left(\frac{9}{4}(1+r_1) + 5\gamma_d\right) (e^{V(t)} - 1), \quad (3.79)$$

and also that

$$v(t)^2 \leq e^{V(t)} - 1, \quad (3.80)$$

$$\widetilde{d}(t)^2 + \widetilde{q}(t)^2 \leq (\gamma_d + \gamma_q)V(t). \quad (3.81)$$

Therefore, we have that, for all  $t \geq 0$

$$\Gamma(t) \leq \left(1 + \frac{9}{4}(1+r_1) + \gamma_q + 6\gamma_d\right) (e^{V(t)} - 1). \quad (3.82)$$

Thus (3.71) holds.

From (3.41) using (3.78) one gets

$$V(t) \leq N(t) + \frac{\widetilde{d}(t)^2}{\gamma_d} + \frac{\widetilde{q}(t)^2}{\gamma_q} + eb_3 \|\widetilde{\zeta}(t)\|^2 + b_4 \|\widetilde{\omega}(t)\|^2, \quad (3.83)$$

in which  $N$  is defined in (3.36). Finally, by the definition of  $\widetilde{\zeta}$ ,  $\widetilde{\omega}$ ,  $\widehat{\zeta}$ , and  $\widehat{\omega}$ , (2.15)-(2.18) and using the expression (3.75), one gets

$$\widetilde{\zeta}(x, t) = -2\lambda \int_x^1 u_t(\chi, t+x-\chi) d\chi, \quad (3.84)$$

$$\widetilde{\omega}(x, t) = -2\lambda \int_0^x u_t(\chi, t-x+\chi) d\chi + 2\lambda \int_0^1 u_t(\chi, t-x-\chi) d\chi, \quad (3.85)$$

$$\widehat{\zeta}(x, t) = u_t(x, t) + u_x(x, t) - \widetilde{d}(t) - \widetilde{\zeta}(x, t), \quad (3.86)$$

$$\widehat{\omega}(x, t) = u_t(x, t) - u_x(x, t) + \widetilde{d}(t) - \widetilde{\omega}(x, t), \quad (3.87)$$

and concludes, applying Cauchy-Schwarz's inequality, that

$$\|\widetilde{\zeta}(t)\|^2 \leq 4\lambda^2 \max_{s \in [0,1]} \|u_t(t-s)\|^2, \quad (3.88)$$

$$\|\widetilde{\omega}(t)\|^2 \leq 8\lambda^2 \max_{s \in [0,2]} \|u_t(t-s)\|^2, \quad (3.89)$$

$$\|\widehat{\zeta}(t)\|^2 \leq 4(\|u_t(t)\|^2 + \|u_x(t) - d\|^2 + \widetilde{d}(t)^2 + 4\lambda^2 \max_{s \in [0,1]} \|u_t(t-s)\|^2), \quad (3.90)$$

$$\|\widehat{\omega}(t)\|^2 \leq 4(\|u_t(t)\|^2 + \|u_x(t) - d\|^2 + \widetilde{d}(t)^2 + 8\lambda^2 \max_{s \in [0,2]} \|u_t(t-s)\|^2). \quad (3.91)$$

Gathering (3.88)-(3.91), one gets (3.72). This concludes the proof of Lemma 3.2. ■

**Remark 1** One easily gets that  $e^{V(0)} \leq e^{\rho \max_{s \in [0,2]} \Gamma(-s)}$  and so the bound  $\bar{\lambda}$  defined in (3.70) can be expressed in terms of  $\max_{s \in [0,2]} \Gamma(-s)$  ○

### 3.3.4 Convergence in terms of the functional $\Upsilon$

Now we establish the convergence result (3.16).

**Lemma 3.3**  $v(t)$ ,  $\|\widehat{\omega}(t)\|$ ,  $\|\widehat{\zeta}(t)\|$ ,  $\|\widetilde{\zeta}(t)\|$ , and  $\|\widetilde{\omega}(t)\|$  tend to zero as  $t$  tends to infinity.

*Proof* : From (3.43), one can easily get that  $v(t)$ ,  $\|\widehat{z}(t)\|$ ,  $\|\widehat{\omega}(t)\|$ ,  $\widehat{q}(t)$ ,  $\widehat{d}(t)$ ,  $\|\widehat{\zeta}(t)\|$ , and  $\|\widetilde{\omega}(t)\|$  are uniformly bounded for  $t \geq 0$ . Consequently, from (3.77),  $\|\widehat{\zeta}(t)\|$  is also bounded for  $t \geq 0$ .

From there, first we establish that the state  $\mathcal{X}_e$  is uniformly bounded:

- Applying Young's inequality to (3.34) and (3.35), one can obtain that  $\widehat{q}(t)$  and  $\widehat{d}(t)$  are uniformly bounded for  $t \geq 0$ .
- Applying Cauchy-Schwarz's inequality to (3.17), one can obtain that  $\widehat{\zeta}(1, t)$  is uniformly bounded for  $t \geq 0$ . Moreover, as  $\widehat{\zeta}(x, t) = \widehat{\zeta}(1, t - 1 + x) - \widehat{d}(t) + \widehat{d}(t - 1 + x)$ ,  $\widehat{\zeta}(x, t)$  is also uniformly bounded for  $t \geq 1 - x$ .
- From the backstepping transformation, using Cauchy-Schwarz's inequality, one gets that  $\widehat{z}(x, t)$  is uniformly bounded for  $t \geq 0$ .
- Similarly, from (2.20d) one gets that  $\widehat{\omega}(x, t)$  is uniformly bounded for  $t \geq 1 + x$ .
- Getting  $\widetilde{\zeta}(x, t)$  and  $\widetilde{\omega}(x, t)$  uniform boundness requires more computation. The idea is to consider the *auxiliary system* (2.21) as two coupled hyperbolic PDE with uniformly bounded input. Using Proposition A.2 in Appendix A.1 one gets that  $\widetilde{\zeta}(x, t)$  and  $\widetilde{\omega}(x, t)$  are uniformly bounded for  $t \geq 4$ .

Second, we establish that the time derivative of the square of some state variable ( $\mathcal{X}_e(t)$ ) are uniformly bounded. From (3.25) and (2.20)-(2.21) one gets

$$\frac{d}{dt} v(t)^2 = 2av(t) \left( -c_0v(t) + \widehat{z}(0, t) + \widehat{\zeta}(0, t) + v(t)\widehat{q}(t) - \widehat{d}(t) \right), \quad (3.92)$$

$$\frac{d}{dt} \|\widehat{z}(t)\|^2 = -\widehat{z}(0, t)^2 + 2 \int_0^1 \widehat{z}(x, t) \left( g_q(x, t)\widehat{q}(t) + \widehat{d}g_d(x, t) + [\widehat{q}(t)v(t) + \widehat{\zeta}(0, t) - \widehat{d}(t)]h(x, t) \right) dx, \quad (3.93)$$

$$\frac{d}{dt} \|\widehat{\omega}(t)\|^2 = \widehat{\omega}(1, t)^2 - \widehat{\omega}(0, t)^2 + 2\widehat{d}(t) \int_0^1 \widehat{\omega}(x, t) dx, \quad (3.94)$$

$$\frac{d}{dt} \|\widetilde{\zeta}(t)\|^2 = -\widetilde{\zeta}(0, t)^2 - 2\lambda \int_0^1 \widetilde{\zeta}(x, t) [\widehat{\zeta}(x, t) + \widetilde{\zeta}(x, t) + \widehat{\omega}(x, t) + \widetilde{\omega}(x, t)] dx, \quad (3.95)$$

$$\frac{d}{dt} \|\widetilde{\omega}(t)\|^2 = \widetilde{\omega}(1, t)^2 - \widetilde{\omega}(0, t)^2 - 2\lambda \int_0^1 \widetilde{\omega}(x, t) [\widehat{\zeta}(x, t) + \widetilde{\zeta}(x, t) + \widehat{\omega}(x, t) + \widetilde{\omega}(x, t)] dx. \quad (3.96)$$

Using (3.26)-(3.28) and Cauchy-Schwarz's inequality and the previous considerations, it follows that the right-hand terms in the previous equations are all uniformly bounded for  $t \geq 4$ .

Finally, integrating (3.42) from 0 to  $\infty$ , it follows that  $v(t)$ ,  $\|\widehat{z}(t)\|$ ,  $\|\widehat{\omega}(t)\|$ ,  $\|\widehat{\zeta}(t)\|$ , and  $\|\widetilde{\omega}(t)\|$  are square integrable. The proof is concluded using Barbalat's Lemma (in Section 1.3.6 this common used lemma is presented). ■

### 3.3.5 Conclusion on the proof of Theorem 3.2

Gathering (3.71)-(3.72) from Lemma 3.2, one gets the existence of  $R > 0$  and  $\rho > 0$  such that

$$\Gamma(\mathcal{X}(t)) \leq R(e^{\rho \max_{s \in [0,3]} \Gamma(\mathcal{X}(-s))} - 1). \quad (3.97)$$

Then, (3.97) along with (3.43) from Lemma 3.1 give the stability result (3.15) in Theorem 3.2.

From Lemma 3.3 using (3.73) and (3.74), it follows that  $|u_t(0, t)|$ ,  $\|u_t(t)\|$  and  $\|u_x(t) - \widehat{d}(t)\|$  tend to zero as  $t$  tends to  $\infty$ .

## Chapter conclusion

This chapter focused on an adaptive control law using current boundary velocities. It has been established that there exist a limit value  $\bar{\lambda}$ , such that the closed-loop system is still stable and attractive similarly as the nominal case  $\lambda = 0$ . This limit value of in-domain damping coefficient is depending on the initial state and of the tuning parameters values.

The purpose of the presented adaptive control law is not to estimate the unknown parameters but to stabilize the system despite of them. Therefore there is no persistence of excitation condition, and as it is shown in numerical simulation, the input converge toward a constant value.

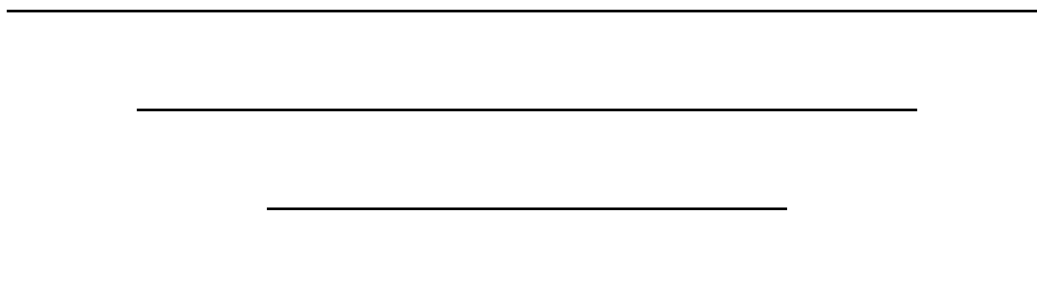

# Delayed anti-collocated boundary output feedback

## Contents

<b>4.1 Adaptive control law under consideration</b> . . . . .	<b>67</b>
<b>4.2 Model mismatch to in-domain viscous damping</b> . . . . .	<b>69</b>
<b>4.3 Proof of robustness</b> . . . . .	<b>69</b>
4.3.1 Extension of the system . . . . .	69
4.3.2 Stability analysis . . . . .	76
4.3.3 Relation between the functionals $\Gamma(\mathcal{X})$ and $V(\mathcal{X}_e)$ . . . . .	81
4.3.4 Convergence in terms of the functional $\Upsilon$ . . . . .	83
4.3.5 Conclusion on the proof of Theorem 4.2 . . . . .	84
<b>Chapter conclusion</b> . . . . .	<b>85</b>

This chapter focuses on the *delayed anti-collocated boundary output feedback*. The idea behind this set-up is to allow the anti-collocated measurement to have a delay. We assume that this delay is of one unit, but it is directly transportable for any delay. As previously the adaptive control law considered here is based on prediction method. Similarly to the previous chapter, delays will be represented using first-order hyperbolic PDEs. The adaptive control law under consideration is present in Section 4.1. Then the robust result of this control law is stated in Section 4.2. The last Section 4.3 contains the proof of it.

The system under consideration is still (2.1), recall

$$\begin{cases} u_{tt}(x,t) = u_{xx}(x,t) - 2\lambda u_t(x,t), & (4.1a) \\ u_x(1,t) = U(t), & (4.1b) \\ u_{tt}(0,t) = a q u_t(0,t) + a[u_x(0,t) - d]. & (4.1c) \end{cases}$$

The outputs considered are  $u_t(1,t)$  and  $u_t(0,t-1)$ .

## 4.1 Adaptive control law under consideration

In this chapter we consider that the controlled input  $U(t)$  is now defined as follows

$$U(t) := -u_t(1,t) + \hat{d}(t) - (c_0 + \hat{q}(t) - 1) \left( e^{2a(\hat{q}(t)-1)} X(t) + a \int_{t-2}^t e^{a(\hat{q}(t)-1)(t-\tau)} (\eta(\tau) - \hat{d}(t)) d\tau \right), \quad (4.2)$$

in which  $c_0 > 0$  is a tuning constant,  $\hat{q}$  and  $\hat{d}$  are estimates of the unknown parameters  $q$  and  $d$ , and

$$X(t) := u_t(0,t-1), \quad (4.3)$$

$$\eta(t) := U(t) + u_t(1,t). \quad (4.4)$$

The parameter update laws are now taken as

$$\hat{q}(t) := \frac{a\gamma_q}{1+N(t)} \text{PROJ}_{[\underline{q}, \bar{q}]} \left\{ \hat{q}(t), X(t) \left( X(t) + b_1(c_0 + \hat{q}(t) - 1) \int_{t-2}^t e^{(a(\hat{q}(t)-1)+\frac{1}{2})(\tau-t+2)} \sigma(\tau, t) d\tau \right) \right\}, \quad (4.5)$$

$$\hat{d}(t) := \frac{a\gamma_d}{1+N(t)} \text{PROJ}_{[\underline{d}, \bar{d}]} \left\{ \hat{d}(t), -X(t) - b_1(c_0 + \hat{q}(t) - 1) \int_{t-2}^t e^{(a(\hat{q}(t)-1)+\frac{1}{2})(\tau-t+2)} \sigma(\tau, t) d\tau \right\}, \quad (4.6)$$

$$N(t) := X(t)^2 + b_1 \int_{t-2}^t e^{\frac{\tau-t}{2}+1} \sigma(\tau, t)^2 d\tau + b_2 \int_{t-1}^t e^{\tau-t+1} (2X(\tau) - \eta(\tau-2) + \hat{d}(t))^2 d\tau, \quad (4.7)$$

$$\sigma(\tau, t) := \eta(\tau) - \hat{d}(t) + (c_0 + \hat{q}(t) - 1) \left( e^{a(\hat{q}(t)-1)(\tau-t+2)} X(t) + a \int_{t-2}^{\tau} e^{a(\hat{q}(t)-1)(\tau-\chi)} (\eta(\chi) - \hat{d}(t)) d\chi \right). \quad (4.8)$$

The tuning parameters of the control are  $c_0$ ,  $b_1$ ,  $b_2$ ,  $\gamma_q$  and  $\gamma_d$ .

Except from the adaptive part, the control law  $U$  is related to the one we have presented previously (2.13) (exactly modulo a change of variable). There is a factor two in the exponential factor of  $X$ , and the integral term is on a two-units of time window. This is consistent with the fact that the system can be considered as a delay input system with now a delay output.

The following theorem is adapted from [Bresch-Pietri and Krstic, 2014b].

**Theorem 4.1** [Bresch-Pietri and Krstic, 2014b]

Consider the closed-loop system consisting of the plant (2.1) in which  $\lambda = 0$ , the control law  $U$  defined in (4.2) and the parameters update laws (4.5)-(4.6). Define the functionals

$$\begin{aligned} \Gamma_0(\mathcal{X}(t)) &= \int_{t-1}^t u_t(0, s)^2 ds + \max_{s \in [t-1, t]} \int_0^1 [u_x(x, s) - d]^2 dx \\ &\quad + \max_{s \in [t-1, t]} \int_0^1 u_t(x, s)^2 dx + (q - \hat{q}(t))^2 + (d - \hat{d}(t))^2, \end{aligned} \quad (4.9)$$

$$\Upsilon_0(\mathcal{X}(t)) = u_t(0, t)^2 + \|u_t(t)\|^2 + \|u_x(t) - d\|^2 + (d - \hat{d}(t))^2. \quad (4.10)$$

Then, for all  $c_0 > 0$ , there exist  $\bar{b}_2(c_0) > 0$ ,  $\underline{b}_1(c_0, \bar{b}_2) > 0$ ,  $\bar{\gamma}(c_0, \underline{b}_1, \bar{b}_2) > 0$ , such that, for

- $b_2 \in (0, \bar{b}_2)$ ,
- $b_1 \in (\underline{b}_1, \infty)$ ,
- $\gamma_d, \gamma_q \in (0, \bar{\gamma})$ ,

it holds, for suitable  $R > 0$  and  $\rho > 0$ ,

$$\Gamma_0(\mathcal{X}(t)) \leq R(e^{\rho\Gamma_0(\mathcal{X}(0))} - 1), \quad (4.11)$$

and

$$\lim_{t \rightarrow \infty} \Upsilon_0(\mathcal{X}(t)) = 0. \quad (4.12)$$

It has been already said in Section 2.2 that in the nominal case ( $\lambda = 0$ ) the *delay anti-collocated output feedback* and the *collocated output feedback* are equivalent. However, when we are in presence of in-domain damping both of them do not lead to the same analysis nor the same stability result. This result is not formulated as such in [Bresch-Pietri and Krstic, 2014b]. Indeed the framework of this paper is the one of collocated output feedback, that is the focus of Chapter 5.

Once more we have both stability and convergence but in term of different functionals (at least for stability). Moreover, contrary to Theorem 3.1 the stability is expressed in terms of a delay functional. This is due to the fact that we now consider a output delay. However, we do not need these considerations in the definition of  $\Upsilon_0$ , because it concerns the convergence property (therefore invariant with respect to a constant change of time).

## 4.2 Model mismatch to in-domain viscous damping

In this section, we present the model mismatch robustness result

**Theorem 4.2** *Consider the closed-loop system consisting of the plant (2.1) satisfying Assumption 2.1, the control law (4.2) and the parameter estimation laws (4.5)-(4.6). Define the functionals  $\Gamma$ ,  $\Xi$  and  $\Upsilon$  as*

$$\Gamma(\mathcal{X}(t)) := u_t(0,t)^2 + \|u_t(t)\|^2 + \|u_x(t) - d\|^2 + (q - \hat{q}(t))^2 + (d - \hat{d}(t))^2, \quad (4.13)$$

$$\Xi(\mathcal{X}(t)) := \max_{s \in [0,3]} \Gamma(\mathcal{X}(t-s)), \quad (4.14)$$

$$\Upsilon(\mathcal{X}(t)) := u_t(0,t)^2 + \|u_t(t)\|^2 + \|u_x(t) - d\|^2 + (d - \hat{d}(t))^2. \quad (4.15)$$

Then, for all  $c_0 > 0$ , there exist  $\bar{b}_2(c_0) > 0$ ,  $\underline{b}_1(c_0, \bar{b}_2) > 0$ ,  $\bar{\gamma}(c_0, \underline{b}_1, \bar{b}_2) > 0$ , such that, for

- $b_2 \in (0, \bar{b}_2)$ ,
- $b_1 \in (\underline{b}_1, \infty)$ ,
- $\gamma_d, \gamma_q \in (0, \bar{\gamma})$ ,

there exists  $\bar{\lambda}(c_0, b_1, b_2, \bar{\gamma}, \mathcal{X}(0)) > 0$  such that, when  $\lambda \in (0, \bar{\lambda})$ , it follows, for suitable  $R > 0$  and  $\rho > 0$

$$\Xi(\mathcal{X}(t)) \leq R(e^{\rho \Xi(\mathcal{X}(0))} - 1), \quad (4.16)$$

and

$$\lim_{t \rightarrow \infty} \Upsilon(\mathcal{X}(t)) = 0. \quad (4.17)$$

Note that  $\Xi$  is expressed as a delay functional over a three units of time window. This is consistent with the fact that the variable  $\hat{\omega}$  used in the stability analysis (and defined in (2.16), in Section 2.4) involved an integral, the maximal window of which is two units of time. Considering in addition the output delay of one unit of time gives this three units of time window in  $\Xi$

## 4.3 Proof of robustness

The method proposed in this section to prove Theorem 4.2 is again to define an *extended system* (of state  $\mathcal{X}_e$ ), the stability of which implies the stability of the original system in the sense of (4.16) in Theorem 4.2.

The proof is organized as follows. First, in Section 4.3.1, an extension of the system referred to as the *extended system*, is presented. Second, we define a corresponding Lyapunov functional  $V(\mathcal{X}_e)$ , the stability of which is proved in Section 4.3.2. Then, in Section 4.3.3, two lemmas detail a equivalence properties between  $V(\mathcal{X}_e)$  and  $\Xi(\mathcal{X})$  introduced in (4.14). Finally, the convergence with respect to the functional  $\Upsilon$ , defined in (4.15), is established in Section 4.3.4, and the proof of Theorem 4.2 is concluded in Section 4.3.5.

### 4.3.1 Extension of the system

The different steps to build the *extended system* are listed below.

- Using Riemann invariants, the wave PDE (2.1) is expressed as two transport phenomena plus an ODE in Section 2.3.
- The two transport phenomena are divided into two dynamics: the *estimated system* and the *auxiliary system* in Section 2.4.



- Delayed state variables are introduced to handle the fact that the control design involves an output delay from (4.2) and (4.8) in Section 4.3.1.1.
- A backstepping transformation is performed on a sub-part of the *delayed system* and the corresponding target system is computed in Section 4.3.1.2.
- Finally a new state variable is added to handle an adaptive error term in the Lyapunov analysis in Section 4.3.1.3.

This procedure have been illustrated in Figure 2.3.

The last section, Section 4.3.1.4 is a summary of the *extended system*.

#### 4.3.1.1 Addition of the delayed variables

As the control law (4.2) uses delay measurements, a one unit part corresponding to the delay output, let us consider the following delayed variables

$$\widehat{\delta}(x, t) := \widehat{\zeta}(x, t - 1) + \widehat{d}(t - 1) - \widehat{d}(t), \quad (4.18)$$

$$\widehat{\beta}(x, t) := \widehat{\omega}(x, t - 1) - \widehat{d}(t - 1) + \widehat{d}(t), \quad (4.19)$$

$$\widetilde{\delta}(x, t) := \widetilde{\zeta}(0, t + x - 1), \quad (4.20)$$

$$\widehat{\alpha}(x, t) := \begin{cases} \widehat{\delta}(2x, t), & x \in [0, 1/2], \\ \widehat{\zeta}(2x - 1, t), & x \in [1/2, 1]. \end{cases} \quad (4.21)$$

**Proposition 4.1** *The variables  $X$  defined in (4.3),  $\widehat{\beta}$ ,  $\widehat{\alpha}$ , and  $\widetilde{\delta}$  satisfy*

$$\begin{cases} \dot{X}(t) = a(q-1)X(t) + a[\widehat{\alpha}(0, t) + \widetilde{\delta}(0, t) - \widehat{d}(t)], & (4.22a) \\ \widehat{\beta}_t(x, t) = -\widehat{\beta}_x(x, t) + \widehat{d}(t), & (4.22b) \\ \widehat{\beta}(0, t) = 2X(t) - \widehat{\alpha}(0, t), & (4.22c) \\ 2\widehat{\alpha}_t(x, t) = \widehat{\alpha}_x(x, t) - 2\widehat{d}(t), & (4.22d) \\ \widehat{\alpha}(1, t) = W(t), & (4.22e) \\ \widetilde{\delta}_t(x, t) = \widetilde{\delta}_x(x, t), & (4.22f) \\ \widetilde{\delta}(1, t) = \widetilde{\zeta}(0, t). & (4.22g) \end{cases}$$

*Proof:* From the definition of  $X$  (4.3), and according to the ODE satisfied by  $v$  (2.19) one gets (4.22a).

Now, from the definition of  $\widehat{\beta}$  (4.19), using the transport equation (2.20c) and the associated boundary condition (2.20d) along with the expression (4.3), one gets (4.22b) and (4.22c).

Using the definition (4.18), the transport equation (2.20a), and the associated boundary condition (2.20b), one gets (4.22d) and (4.22e).

Taking space and time derivatives of definition (4.20), one obtains the transport equation (4.22f) associated to the boundary condition (4.22g). ■

In the following, we give some comments on these additional states. First we consider the dynamics of  $u_t(0, \cdot)$  at  $t - 1$ , that is the one of  $X$  defined in (4.22a) as a result we introduce the variable  $\widetilde{\delta}$  to represent  $\widetilde{\zeta}(0, t - 1)$  in (4.22a). Similarly the variable  $\widehat{\beta}$  represents the delayed values of the variable  $\widehat{\omega}$ . Furthermore, the state variable  $\widehat{\alpha}$  represents the history of  $\widehat{\zeta}$  over a two units of time window. The idea behind gathering  $\widehat{\zeta}$  and

$\widehat{\delta}$  into (4.21) is to obtain a unique distributed variable to perform a backstepping transformation (see the next section). However, we still need the variable  $\widehat{\zeta}$ . Indeed the boundary condition (2.20d), recall

$$\widehat{\omega}(0,t) = 2v(t) - \widehat{\zeta}(0,t), \quad (4.23)$$

depends on  $\widehat{\zeta}(0,t)$ .  $v$  is defined in (2.6), recall  $v(t) = u_t(0,t)$ , it holds  $X(t) = v(t - 1)$ . Using variations of constant formulas one gets the existence of  $G_1$  such that

$$v(t) = G_1[X(t), \widehat{\alpha}(x,t), \widetilde{\delta}(x,t), \widetilde{d}(t), \widetilde{q}(t)]. \quad (4.24)$$

In order to illustrate the interaction of all previously cited variables, we suggest the schematic view in Figure 4.1. Let us compare this figure with Figure 2.2 which represents only the *estimated system* and *auxiliary system* plus the ODE in  $v$ . The fact that we now consider an output delay leads us to introduce the system with delay variables. Note that in the nominal case  $\lambda = 0$ , we do not need to consider  $\widehat{\zeta}$ ,  $\widetilde{\omega}$ ,  $\widetilde{\zeta}$ , and  $\widetilde{\delta}$  in Figure 4.1. However, when considering  $\lambda$  the number of considered variable has more than doubled. Furthermore, these variables are relatively more coupled than in the nominal case as it is shown in Figure 4.1. For example we have a loop traveling from  $X$  to  $\widehat{\omega}$ , to  $\widehat{\zeta}$ , to  $\widetilde{\delta}$ , to  $X$ .

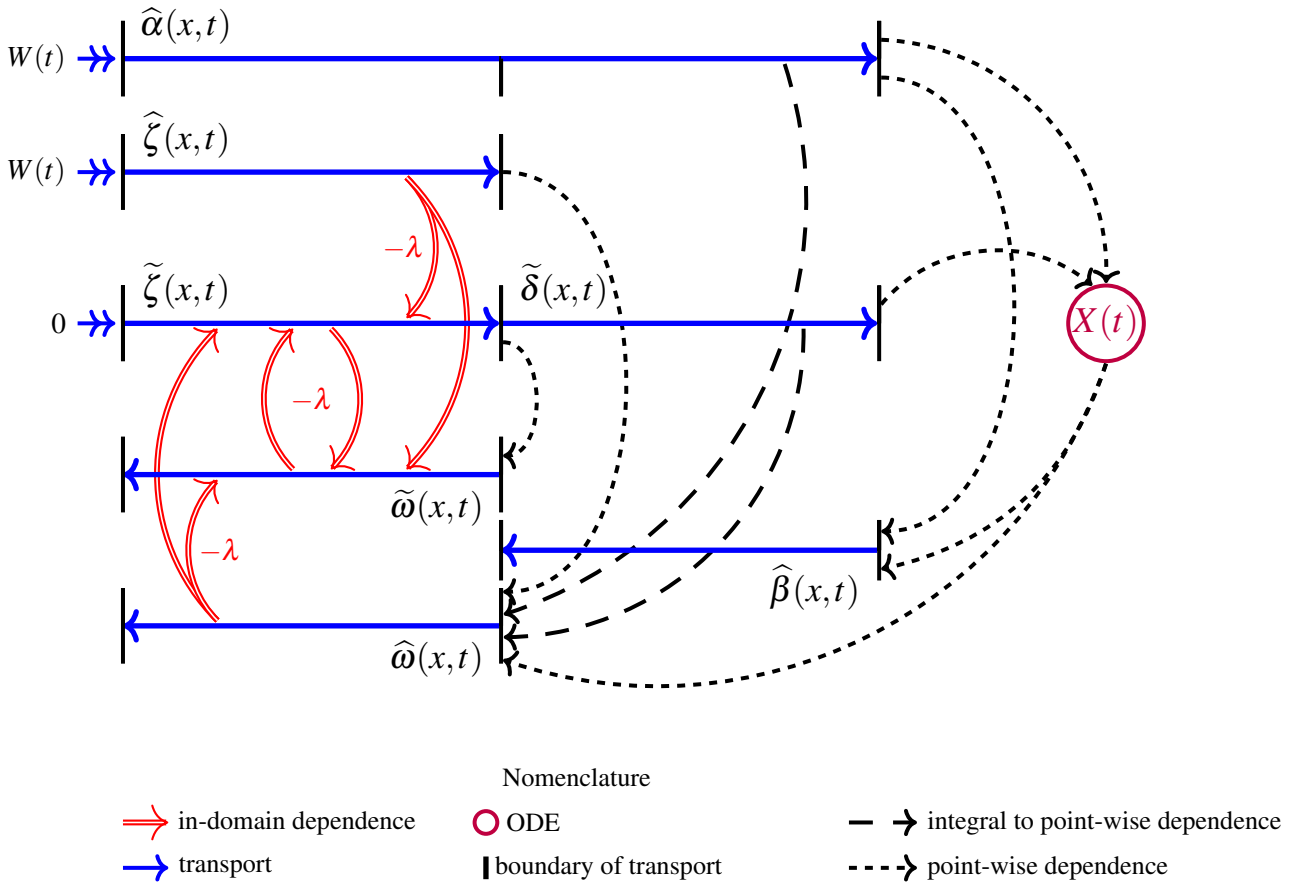

Figure 4.1: Illustration of the *delayed variable* together with the *estimated system* and *auxiliary system* for the *delayed anti-collocated output feedback*.

### 4.3.1.2 Backstepping transformation

Before presenting the Target system, the control law is reformulated as follows.

**Claim 4.1** Taking  $U$  as (4.2),  $W$  defined in (2.5) can be expressed as

$$W(t) = -(c_0 + \widehat{q}(t) - 1) \left( e^{2a(\widehat{q}(t)-1)} X(t) + 2a \int_0^1 e^{2a(\widehat{q}(t)-1)(1-\chi)} \widehat{\alpha}(\chi,t) d\chi \right). \quad (4.25)$$

*Proof*: From (4.2)-(4.4) and (2.5), with the change of variable  $\chi = t + 2x - 2$ , one gets

$$W(t) = -(c_0 + \hat{q}(t) - 1) \left( e^{2a(\hat{q}(t)-1)} X(t) + 2a \int_0^1 e^{2a(\hat{q}(t)-1)(1-x)} \right. \\ \left. \times (W(t+2x-2) + \hat{d}(t+2x-2) - \hat{d}(t)) dx \right). \quad (4.26)$$

Then, applying Lemma A.1 in Appendix A.1 with  $y = 1$  in (4.22d) and using (4.22e), one obtains (4.25). ■

Consider the following backstepping transformation

$$\Pi : [\hat{\alpha}(t), X(t)] \mapsto \hat{z}(t) = \Pi[\hat{\alpha}(t), X(t)], \quad (4.27)$$

$$\Pi[\hat{\alpha}(x, t), X(t)] := \hat{\alpha}(x, t) + (c_0 + \hat{q}(t) - 1) \left( e^{2a(\hat{q}(t)-1)x} X(t) + 2a \int_0^x e^{2a(\hat{q}(t)-1)(x-\chi)} \hat{\alpha}(\chi, t) d\chi \right), \quad (4.28)$$

one gets the inverse backstepping transformation

$$\Pi^{-1} : [\hat{z}(t), X(t)] \mapsto \hat{\alpha}(t) = \Pi^{-1}[\hat{z}(t), X(t)], \quad (4.29)$$

$$\hat{\alpha}(x, t) = \Pi^{-1}[\hat{z}(x, t), v(t)] := \hat{z}(x, t) - (c_0 + \hat{q}(t) - 1) \left( e^{-2ac_0x} X(t) + 2a \int_0^x e^{-2ac_0(x-\chi)} \hat{z}(\chi, t) d\chi \right). \quad (4.30)$$

Similarly as in the previous chapter, the backstepping transformation is introduced for the purpose of stability analysis. The *target system* associated with the backstepping transformation is given in the following proposition.

**Lemma 4.1** *The backstepping transformation (4.28) together with the control law (4.25) transforms the plant (4.22a)-(4.22e) into the following target system*

$$\begin{cases} \dot{X}(t) = -ac_0X(t) + a[\hat{z}(0, t) + \tilde{\delta}(0, t) + X(t)\tilde{q}(t) - \tilde{d}(t)], & (4.31a) \\ 2\hat{z}_t(x, t) = \hat{z}_x(x, t) + \hat{q}(t)g_q(x, t) + \hat{d}(t)g_d(x, t) + [\tilde{q}(t)X(t) - \tilde{d}(t) + \tilde{\delta}(0, t)]h(x, t), & (4.31b) \\ \hat{z}(1, t) = 0, & (4.31c) \\ \hat{\beta}_t(x, t) = -\hat{\beta}_x(x, t) + \hat{d}(t), & (4.31d) \\ \hat{\beta}(0, t) = (1 + c_0 + \hat{q}(t))X(t) - \hat{z}(0, t), & (4.31e) \end{cases}$$

in which

$$g_d(x, t) := -2 - 4a(c_0 + \hat{q}(t) - 1) \int_0^x e^{2a(\hat{q}(t)-1)(x-\chi)} d\chi, \quad (4.32)$$

$$h(x, t) := 2a(c_0 + \hat{q}(t) - 1)e^{2a(\hat{q}(t)-1)x}, \quad (4.33)$$

$$g_q(x, t) := 2e^{2a(\hat{q}(t)-1)x}X(t) + 4a \int_0^x e^{2a(\hat{q}(t)-1)(x-s)} \Pi^{-1}[\hat{z}(s, t)] ds \\ + (c_0 + \hat{q}(t) - 1) \left( 4axe^{2a(\hat{q}(t)-1)x}X(t) + 8a^2 \int_0^x (x-\chi)e^{2a(\hat{q}(t)-1)(x-\chi)} \Pi^{-1}[\hat{z}(\chi, t)] d\chi \right). \quad (4.34)$$

*Proof*: From the dynamics of  $X$  (4.22a) (respectively, the boundary condition (4.22c)), expressing the backstepping transformation (4.28) at  $x = 0$ , and expressing  $\hat{\alpha}$  in terms of  $X$  and  $\hat{z}$ , it follows (4.31a) (respectively (4.31e)).

The boundary condition (4.31c) follows from the backstepping transformation (4.28). It has been designed in particular with this property in view.

From the time derivative of (4.28), using the expressions (4.22d)-(4.22e) and (4.22a), and an integration by parts one obtains

$$\begin{aligned}
 2\widehat{z}_t(x,t) = & \widehat{\alpha}_x(x,t) - 2\widehat{d}'(t) + 2\widehat{q}(t) \left( e^{2a(\widehat{q}(t)-1)x} X(t) + 2a \int_0^x e^{2a(\widehat{q}(t)-1)(x-s)} \widehat{\alpha}(s,t) ds \right) \\
 & + 2(c_0 + \widehat{q}(t) - 1) \left[ ([2ax\widehat{q}(t) + a(q-1)]X(t) + a[\widehat{\alpha}(0,t) + \widetilde{\delta}(0,t) + X(t)\widetilde{q}(t) - \widetilde{d}(t)]) e^{2a(\widehat{q}(t)-1)x} \right. \\
 & + 4a^2\widehat{q}(t) \int_0^x (x-s) e^{2a(\widehat{q}(t)-1)(x-s)} \widehat{\alpha}(s,t) ds - 2a\widehat{d}'(t) \int_0^x e^{2a(\widehat{q}(t)-1)(x-s)} ds \\
 & \left. + [ae^{2a(\widehat{q}(t)-1)(x-s)} \widehat{\alpha}(s,t)]_{s=0}^x - 2a^2(\widehat{q}(t) - 1) \int_0^x e^{2a(\widehat{q}(t)-1)(x-s)} \widehat{\alpha}(s,t) ds \right] \quad (4.35)
 \end{aligned}$$

Computing the space derivative of  $\widehat{z}$ , it holds

$$\begin{aligned}
 \widehat{z}_x(x,t) = & \widehat{\alpha}_x(x,t) + (c_0 + \widehat{q}(t) - 1) \left( 2a(\widehat{q}(t) - 1) e^{2a(\widehat{q}(t)-1)x} X(t) + 2a\widehat{\alpha}(x,t) \right. \\
 & \left. + 4a^2(\widehat{q}(t) - 1) \int_0^x e^{2a(\widehat{q}(t)-1)(x-s)} \widehat{\alpha}(s,t) ds \right) \quad (4.36)
 \end{aligned}$$

Computing  $2\widehat{z}_t - \widehat{z}_x$  and expressing  $\widehat{\alpha}$  with the inverse backstepping transformation it follows (4.31b). To conclude, it remains to prove (4.31d), which is just the recall of (4.22b).  $\blacksquare$

The main purpose of the backstepping transformation used here is to map the transport phenomenon  $\widehat{\alpha}$  into a zero input transport phenomenon  $\widehat{z}$ . Note that the backstepping transformation is applied on a sub-part of the delayed system. The interactions of this transformation are illustrated in Figure 4.2. The main differences with the previous chapter (Chapter 3) are the fact that the backstepping transformation does not modify the variable interconnections (illustrated respectively in Figure 4.1 and in Figure 4.2). This is explained by the fact that we have kept the variable  $\zeta$  which, in some sense, is redundant with (a part of)  $\widehat{z}$ .

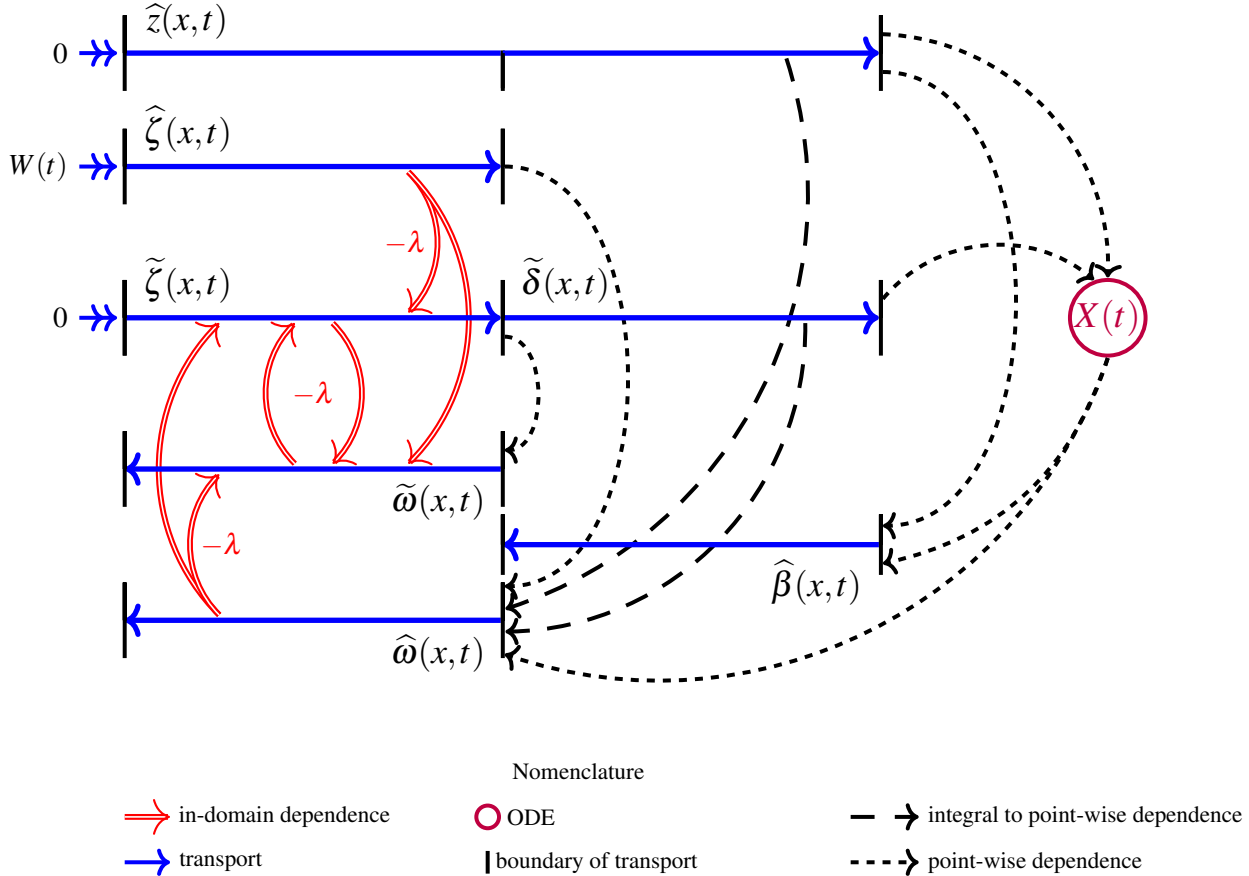

Figure 4.2: Illustration of the *target system* together with the *estimated system* and the *auxiliary system* for the *delay anti-collocated output feedback*.

Compare to Chapter 3, we introduce an additional state variable in order to perform the stability analysis. This is carried out in the following section.

### 4.3.1.3 Adaptive error term

Consider the following variable

$$\tilde{d}_X(t) := -ac_0X(t) - a\tilde{d}(t). \quad (4.37)$$

We first detail its dynamics, before commenting on its interest.

**Proposition 4.2** *The dynamics of  $\tilde{d}_X$  is*

$$\dot{\tilde{d}}_X(t) = -ac_0\tilde{d}_X(t) - a^2c_0 \left[ \tilde{z}(0,t) + \tilde{\delta}(0,t) + X(t)\tilde{q}(t) \right] + a\hat{d}(t), \quad (4.38)$$

and  $v$  in (2.20d) (recall  $v(t-1) = X(t) = u_t(0, t-1)$ ) can be expressed as

$$\begin{aligned} v(t) = G[X(t), \tilde{z}(x,t), \tilde{\delta}(x,t), \tilde{d}_X(t)] := & e^{a(q-1)}X(t) + a \int_0^1 e^{a(q-1)(1-\chi)} [\Pi^{-1}[\tilde{z}(\chi/2, t)] + \tilde{\delta}(\chi, t)] d\chi \\ & + \left[ c_0X(t) + \frac{\tilde{d}_X(t)}{a} \right] \left[ \frac{e^{a(q-1)} - 1}{q-1} \right], \end{aligned} \quad (4.39)$$

in which  $\Pi^{-1}$  is the inverse backstepping transformation (4.30).

Note that we denote abusively  $g(t)$  the evaluation of  $G[X(t), \tilde{z}(x,t), \tilde{\delta}(x,t), \tilde{d}_X(t)]$ .

*Proof:* Computing the time derivative of (4.37) and using (4.31a), one gets (4.38).

Using a prediction of the ODE (4.22a), Lemma A.1 in Appendix A.1 for the transport phenomena (4.22d) and (4.22f), and thanks to the definition (4.3), one obtains

$$v(t) = e^{a(q-1)}X(t) + a \int_0^1 e^{a(q-1)(1-\chi)} [\hat{\alpha}(\chi/2, t) + \tilde{\delta}(\chi, t)] d\chi - \tilde{d}(t) \left[ \frac{e^{a(q-1)} - 1}{q-1} \right]. \quad (4.40)$$

Finally, using (4.30) and (4.37), one gets (4.39). ■

A first objective of this proposition is to reformulate the variable  $v$  in terms of the variables of interest, that is  $X$ ,  $\tilde{z}$ ,  $\hat{\beta}$ ,  $\hat{\zeta}$ ,  $\hat{\omega}$ ,  $\tilde{\zeta}$ ,  $\tilde{\omega}$ ,  $\tilde{\delta}$ ,  $\tilde{q}$ , and  $\tilde{d}$ . A second objective is to handle the last term of (4.40) involving a  $\tilde{d}(t)$ . Usually, the update law  $\hat{d}$  could be designed to cope with this term. However, in the nominal case  $\lambda = 0$  in [Bresch-Pietri and Krstić, 2014b], the Lyapunov analysis was carried out in a cascaded manner. First, the stability of  $\tilde{z}$ ,  $X$ ,  $\hat{\beta}$ ,  $\tilde{q}$ , and  $\tilde{d}$  is established. Secondly using Grönwall's inequality the stability of  $\hat{\omega}$  is obtained (for more details see [Bresch-Pietri and Krstić, 2014b]). The cascade is illustrated in Figure 4.3 for the nominal case ( $\lambda = 0$ ). The dependencies of  $\tilde{z}$  and  $X$  on  $\tilde{d}$  and  $\tilde{q}$  are canceled in the Lyapunov analysis. These dependencies are illustrated by  $\cdots \rightarrow$  in Figure 4.3. The remaining dependencies which are not canceled are illustrated by  $= \Rightarrow$

Here, we cannot use the same developments, due to the interconnections between the variables generated by the in-domain damping. This compels us to perform a Lyapunov analysis of the entire system, and to deal with the  $\tilde{d}$  term appearing in (4.40), as illustrated in Figure 4.4. The additional variable  $\tilde{d}_X$  is thus introduced to overcome this difficulty.

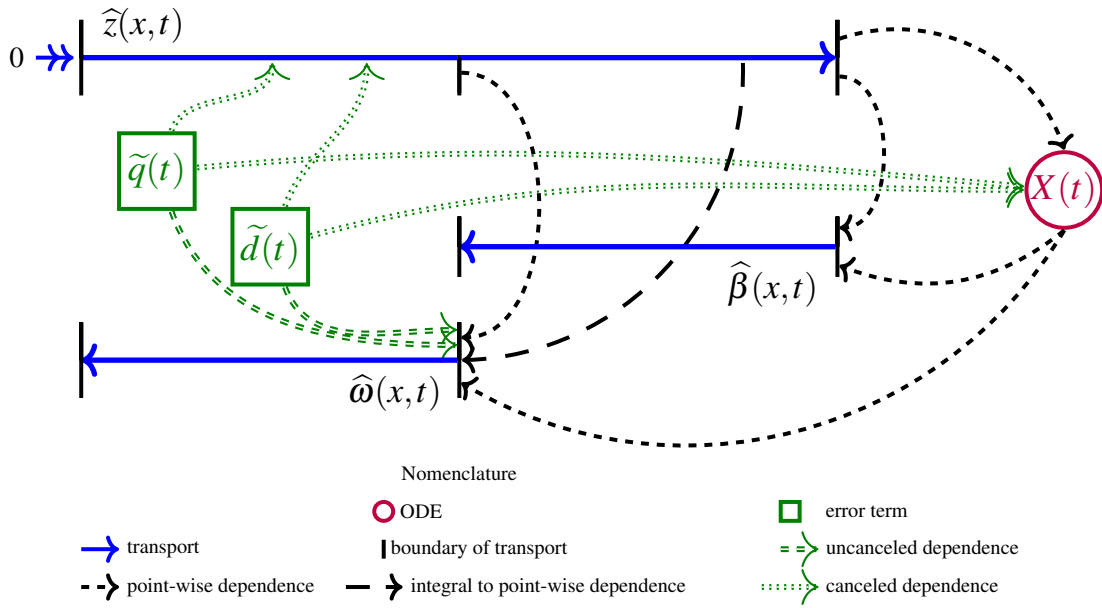

Figure 4.3: Illustration of the *target system* when  $\lambda = 0$  with the error terms for the *delayed anti-collocated output feedback*.

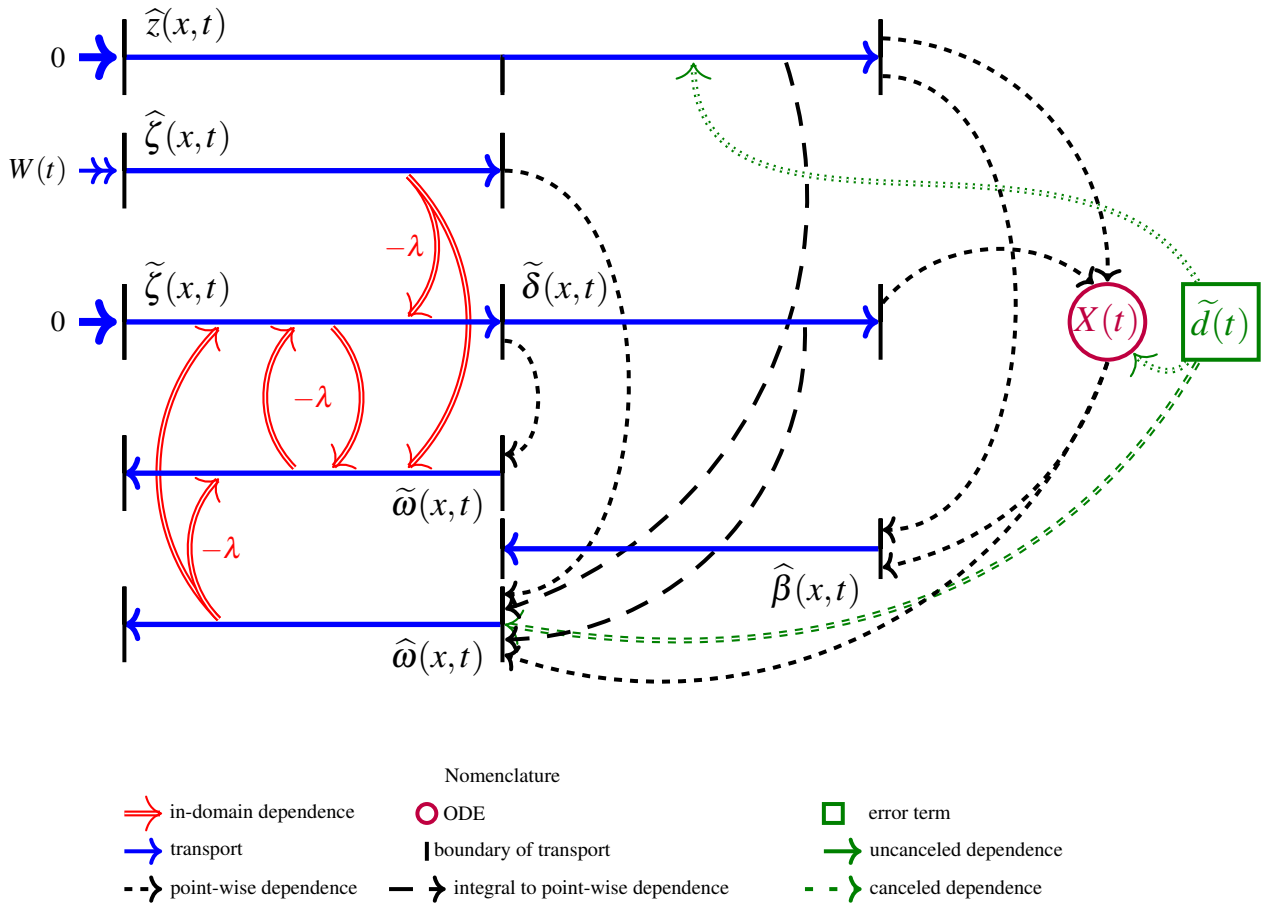

Figure 4.4: Illustration of the *target system* together with the *estimated system*, the *auxiliary system* and the error term  $\tilde{d}(t)$  for the *delay anti-collocated output feedback*.

In Figure 4.3, we see the cascade from  $X(t)$ ,  $\hat{z}(t)$ ,  $\hat{\beta}(t)$ ,  $\tilde{d}(t)$ , and  $\tilde{q}(t)$  to  $\hat{w}(t)$ . This is not the case in Figure 4.4. Figure 4.4 represents the same system as (4.2) but enhanced by estimate error term  $\tilde{d}$ . Note that we have not talked about the dependence of  $\hat{w}(0, t)$  with respect to  $\tilde{q}(t)$ . How can it be? It seems a more difficult

problem to handle than  $\tilde{d}(t)$  as it appear to be multiplied by  $X(t)$ . And thus we cannot perform the same idea used to take care of  $\tilde{d}(t)$ , i.e., adding the additional variable  $\tilde{d}_X$ . It is because  $\tilde{q}(t)$  is multiplied by a state variable that it is handled more easy but also more conservatively: we bound it by a constant.

#### 4.3.1.4 Summary of the extended system

To summarize, the *extended system* of state

$$\begin{aligned} \mathcal{X}_e(t) &= [X(t), \hat{z}(t), \hat{\beta}(t), \tilde{\delta}(t), \hat{\zeta}(t), \hat{\omega}(t), \tilde{\zeta}(t), \tilde{\omega}(t), \tilde{d}_X(t), \tilde{q}(t), \tilde{d}(t)]^T \\ &\in \{\mathbb{R}, L_2(0, 1)^7, \mathbb{R}^3\} \end{aligned} \quad (4.41)$$

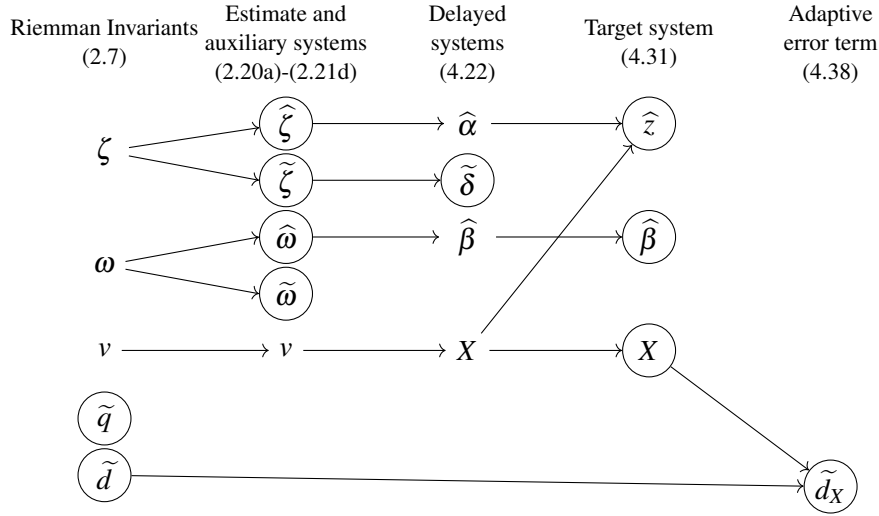

Figure 4.5: Schematic view of the successive transformations and extensions to obtain the *extended system*, the variables of which are encircled.

Figure 4.5 illustrates the different steps detailed previously to build the *extended system*.

#### 4.3.2 Stability analysis

This section focuses on the stability analysis of the *extended system*. First, we express the adaptive laws  $\hat{q}$  and  $\hat{d}$  from time integral to spatial integrals. As previously done for the control law in Claim 4.1.

**Claim 4.2** *The estimation laws (4.5)-(4.6) can be rewritten as*

$$\hat{q}(t) = \frac{a\gamma_q}{1+N(t)} \text{PROJ}_{[\underline{q}, \bar{q}]} \left\{ \hat{q}(t), X(t) \left( X(t) + 2b_1(c_0 + \hat{q}(t) - 1) \int_0^1 e^{2(a(\hat{q}(t)-1)+\frac{1}{2})x} \hat{z}(x,t) dx \right) \right\}, \quad (4.42)$$

$$\hat{d}(t) = - \frac{a\gamma_d}{1+N(t)} \text{PROJ}_{[\underline{d}, \bar{d}]} \left\{ \hat{d}(t), X(t) + 2b_1(c_0 + \hat{q}(t) - 1) \int_0^1 e^{2(a(\hat{q}(t)-1)+\frac{1}{2})x} \hat{z}(x,t) dx \right\}, \quad (4.43)$$

$$N(t) = X(t)^2 + 2b_1 \int_0^1 e^x \hat{z}(x,t)^2 dx + b_2 \int_0^1 e^{1-x} \hat{\beta}(x,t)^2 dx, \quad (4.44)$$

in which  $\hat{\beta}$  is defined in (4.19) and  $\hat{z}$  in (4.28).

*Proof:* From the definition of  $\eta$  in (4.4), and applying Lemma A.1 in Appendix A.1 to the dynamic of  $\hat{\alpha}$  (4.22d), it holds

$$\eta(2x+t-2) - \hat{d}(t) = \hat{\alpha}(x,t), \quad (4.45)$$

thus from the definition of  $\sigma$  (4.8), and the backstepping transformation (4.28), one gets

$$\begin{aligned}\sigma(2x+t-2,t) &= \widehat{\alpha}(x,t) + (c_0 + \widehat{q}(t) - 1) \left( e^{2a(\widehat{q}(t)-1)x} v(t) + 2a \int_0^x e^{2a(\widehat{q}(t)-1)(x-s)} \widehat{\alpha}(s,t) ds \right) \\ &= \widehat{z}(x,t).\end{aligned}\quad (4.46)$$

From the definition of  $\zeta$  and  $\omega$  (2.3)-(2.4), the definition of  $\widetilde{\zeta}$  and  $\widetilde{\omega}$  (2.17)-(2.18), and the boundary condition (2.21d), one obtains

$$\widehat{\omega}(x,t) = 2u_t(0,t-x) - \eta(t-x-1) + \widehat{d}(t), \quad (4.47)$$

and applying Lemma A.1 in Appendix A.1 to the dynamics of  $\widehat{\beta}$  (4.22b), it holds

$$\widehat{\beta}(x,t) = 2X(t-x) - \eta(t-x-2) + \widehat{d}(t), \quad (4.48)$$

Using some change of variables in the integral terms, one can conclude. ■

Using, the previous claim one is able to establish the following key lemma which state the stability of the extended system of state  $\mathcal{X}_e$  defined in (4.41).

**Lemma 4.2** *Let us consider the Lyapunov functional candidate*

$$V(\mathcal{X}_e(t)) = V_1(t) + V_2(t), \quad (4.49)$$

with

$$V_1(t) = \log(1+N(t)) + \frac{\widetilde{q}(t)^2}{\gamma_q} + \frac{\widetilde{d}(t)^2}{\gamma_d} + b_3 \int_0^1 e^x \widehat{\zeta}(x,t)^2 dx + b_4 \int_0^1 e^{1-x} \widehat{\omega}(x,t)^2 dx, \quad (4.50)$$

$$V_2(t) = b_5 \int_0^1 e^x \widetilde{\zeta}(x,t)^2 dx + b_6 \int_0^1 e^{1-x} \widetilde{\omega}(x,t)^2 dx + b_7 \int_0^1 e^x \widetilde{\delta}(x,t)^2 dx + b_8 \widetilde{d}_x(t)^2, \quad (4.51)$$

in which  $N$  is expressed as (4.44), and  $b_3, \dots, b_8 > 0$ .

For all  $c_0 > 0$ , there exist  $\bar{b}_2(c_0) > 0$ ,  $\underline{b}_1(c_0, \bar{b}_2) > 0$ ,  $\bar{\gamma}(c_0, \underline{b}_1, \bar{b}_2) > 0$ , such that, for all

- $b_2 \in (0, \bar{b}_2)$ ,
- $b_1 \in (\underline{b}_1, \infty)$ ,
- $\gamma_d, \gamma_q \in (0, \bar{\gamma})$ ,

there exist  $b_i > 0, i \in \{3, \dots, 12\}$  and  $\bar{\lambda}(c_0, b_1, b_2, \bar{\gamma}, \mathcal{X}(0)) > 0$ , such that, for all  $\lambda \in [0, \bar{\lambda})$ , it follows, for a suitable  $\varsigma > 0$ ,

$$\begin{aligned}\dot{V}(t) &\leq -\frac{\varsigma}{1+N(t)} \left[ \widehat{z}(0,t)^2 + \widetilde{\delta}(0,t)^2 + X(t)^2 + \widetilde{d}_\mu(t)^2 + \widehat{\zeta}(0,t)^2 + \widetilde{\zeta}(0,t)^2 + \|\widehat{z}\|^2 \right. \\ &\quad \left. + \|\widehat{\beta}\|^2 + \|\widehat{\zeta}\|^2 + \|\widetilde{\zeta}\|^2 + \|\widehat{\omega}\|^2 + \|\widetilde{\omega}\|^2 + \|\widetilde{\delta}\|^2 \right],\end{aligned}\quad (4.52)$$

and

$$V(\mathcal{X}_e(t)) \leq V(\mathcal{X}_e(0)), \quad t \geq 0. \quad (4.53)$$

Note that the Claim 4.2 is necessary because the Lyapunov functional uses the expression on  $N$  computed in the claim.

Before stating the proof of Lemma 4.2, one establishes the following proposition which computes the upper bound of the Lyapunov functional candidate derivative.



**Proposition 4.3** *There exist  $M_0, M_i(b_1), i \in \{1, 2, \dots, 6\}, C_i, i \in \{1, 2, \dots, 5\}$  positive, such that*

$$\begin{aligned} \dot{V}_1(t) \leq & \frac{1}{1+N(t)} \left[ -ac_0X(t)^2 + \frac{2a}{c_0}\widehat{z}(0,t)^2 + \frac{2a}{c_0}\widetilde{\delta}(0,t)^2 \right. \\ & + b_1 \left[ -\widehat{z}(0,t)^2 - \frac{\|\widehat{z}\|^2}{2} + \gamma_q M_1(b_1)(X(t)^2 + \|\widehat{z}\|^2) + \gamma_d M_2(b_1)(X(t)^2 + \|\widehat{z}\|^2) + M_0 \widetilde{\delta}(0,t)^2 \right] \\ & + b_2 \left[ -\widehat{\beta}(1,t)^2 + 2e(1+c_0+\widehat{q}(t))^2 X(t)^2 + 2e\widehat{z}(0,t)^2 - \|\widehat{\beta}\|^2 + \gamma_d M_3(b_1)(X(t)^2 + \|\widehat{z}\|^2 + \|\widehat{\beta}\|^2) \right] \\ & + b_3 \left[ -\widehat{\zeta}(0,t)^2 - \|\widehat{\zeta}\|^2 + C_1[X(t)^2 + \|\widehat{z}\|^2] + \gamma_d M_4(b_1)[X(t)^2 + \|\widehat{z}\|^2 + \|\widehat{\zeta}\|^2] \right] \\ & + b_4 \left[ -\widehat{\omega}(1,t)^2 - \|\widehat{\omega}\|^2 + 2e\widehat{\zeta}(0,t)^2 + C_2[X(t)^2 + \widetilde{d}_X(t)^2 + \|\widehat{z}\|^2 + \|\widetilde{\delta}\|^2] \right. \\ & \left. + \gamma_d M_5(b_1)[X(t)^2 + \|\widehat{z}\|^2 + \|\widehat{\omega}\|^2] \right], \end{aligned} \quad (4.54)$$

$$\begin{aligned} \dot{V}_2(t) \leq & b_5 \left[ -\widetilde{\zeta}(0,t)^2 - (1+2\lambda)\|\widetilde{\zeta}\|^2 + \lambda C_3(\|\widetilde{\zeta}\|^2 + \|\widehat{\zeta}\|^2 + \|\widehat{\omega}\|^2 + \|\widetilde{\omega}\|^2) \right] \\ & + b_6 \left[ -\widetilde{\omega}(1,t)^2 + e\widetilde{\zeta}(0,t)^2 - (1+2\lambda)\|\widetilde{\omega}\|^2 + \lambda C_4(\|\widetilde{\omega}\|^2 + \|\widehat{\zeta}\|^2 + \|\widehat{\omega}\|^2 + \|\widetilde{\zeta}\|^2) \right] \\ & + b_7 \left[ e\widetilde{\zeta}(0,t)^2 - \widetilde{\delta}(0,t)^2 - \|\widetilde{\delta}\|^2 \right] \\ & + b_8 \left[ -ac_0\widetilde{d}_X(t)^2 + \gamma_d M_6(b_1)[X(t)^2 + \|\widehat{z}\|^2] + C_5[X(t)^2 + \widehat{z}(0,t)^2 + \widetilde{\delta}(0,t)^2] \right]. \end{aligned} \quad (4.55)$$

*Proof:* For simplicity, we only detail the proof of (4.54), as the remaining inequality on  $\dot{V}_2$  can be obtained with similar arguments. From the definition of  $V_1$  one gets,

$$\dot{V}_1(t) = \frac{\dot{N}(t)}{1+N(t)} - 2\frac{\widehat{q}(t)\widehat{q}'(t)}{\gamma_q} - 2\frac{\widetilde{d}(t)\widetilde{d}'(t)}{\gamma_d} + 2b_3 \int_0^1 e^x \widehat{\zeta}(x,t) \widehat{\zeta}'_t(x,t) dx + 2b_4 \int_0^1 e^{1-x} \widehat{\omega}(x,t) \widehat{\omega}'_t(x,t) dx. \quad (4.56)$$

From the expression of  $N$  (4.44), it follows that

$$\dot{N}(t) = 2\dot{X}(t)X(t) + 4b_1 \int_0^1 e^x \widehat{z}(x,t) \widehat{z}'_t(x,t) dx + 2b_2 \int_0^1 e^{1-x} \widehat{\beta}(x,t) \widehat{\beta}'_t(x,t) dx. \quad (4.57)$$

Then, using (4.31a), and Young's inequality, one obtains

$$2\dot{X}(t)X(t) \leq -ac_0X(t)^2 + \frac{2a}{c_0}\widehat{z}(0,t)^2 + \frac{2a}{c_0}\widetilde{\delta}(0,t)^2 + 2aX(t)(X(t)\widehat{q}(t) - \widetilde{d}(t)). \quad (4.58)$$

Finally using (4.31b)-(4.31e), Young's and Cauchy-Schwarz's inequalities, and one integration by parts, one obtains the existence of  $M_0, M_1$  and  $M_2$  positive such that

$$\begin{aligned} 4 \int_0^1 e^x \widehat{z} \widehat{z}'_t dx \leq & -\widehat{z}(0,t)^2 - \frac{\|\widehat{z}\|^2}{2} + \gamma_q M_1(b_1)(X(t)^2 + \|\widehat{z}\|^2) + \gamma_d M_2(b_1)(X(t)^2 + \|\widehat{z}\|^2) + M_0 \widetilde{\delta}(0,t)^2 \\ & + 2a(c_0 + \widehat{q}(t) - 1) \int_0^1 e^{2(a(\widehat{q}(t)-1)+\frac{1}{2})x} \widehat{z}(x,t) [X(t)\widehat{q}(t) - \widetilde{d}(t)] dx, \end{aligned} \quad (4.59)$$

and the existence of  $M_3$  positive such that

$$\begin{aligned} 2 \int_0^1 e^{1-x} \widehat{\beta} \widehat{\beta}'_t dx \leq & -\widehat{\beta}(1,t)^2 + 2e(1+c_0+\widehat{q}(t))^2 X(t)^2 \\ & + 2e\widehat{z}(0,t)^2 - \|\widehat{\beta}\|^2 + \gamma_d M_3(b_1)(X(t)^2 + \|\widehat{z}\|^2 + \|\widehat{\beta}\|^2). \end{aligned} \quad (4.60)$$

From (2.20a) and (2.20b), it holds the existence of  $M_4 > 0$  such that

$$2 \int_0^1 e^x \widehat{\zeta}(x,t) \widehat{\zeta}'_t(x,t) dx \leq -\widehat{\zeta}(0,t)^2 + eW(t)^2 - \|\widehat{\zeta}\|^2 + \gamma_d M_4(b_1)[X(t)^2 + \|\widehat{z}\|^2 + \|\widehat{\zeta}\|^2]. \quad (4.61)$$

From (4.25) and (4.30), one gets the existence of  $C_1 > 0$  such that

$$eW(t)^2 \leq C_1 [X(t)^2 + \|\hat{z}\|^2]. \quad (4.62)$$

Then finally from (2.20c) and (2.20d) (recall that  $g(t) = v(t)$  (4.39)) it holds the existence of  $M_5(b_1) > 0$

$$2 \int_0^1 e^{1-x} \hat{\omega}(x,t) \hat{\omega}_t(x,t) \leq -\hat{\omega}(1,t)^2 + 8eg(t)^2 + 2e\hat{\zeta}(0,t)^2 - \|\hat{\omega}\|^2 + \gamma_d M_5(b_1) [X(t)^2 + \|\hat{z}\|^2 + \|\hat{\omega}\|^2], \quad (4.63)$$

using (4.39) there exists  $C_2 > 0$  such that

$$8eg(t)^2 \leq C_2 [X(t)^2 + \|\hat{z}\|^2 + \|\tilde{\delta}\|^2 + \tilde{d}_X(t)^2]. \quad (4.64)$$

Gathering (4.56)-(4.64), and using Claim 4.2 concludes the proof of (4.54).  $\blacksquare$

*Proof of Lemma 4.2:* Gathering both inequalities (4.54)-(4.55) of Proposition 4.3, we obtain

$$\dot{V}(\mathcal{X}_e(t)) \leq \sum_{\mathcal{V} \in \mathcal{S}} \delta_{\mathcal{V}} f_{\mathcal{V}}(\cdot) \mathcal{V}^2, \quad (4.65)$$

in which

$$\mathcal{S} = \{X, \|\hat{z}\|, \|\hat{\beta}\|, \|\tilde{\delta}\|, \|\hat{\zeta}\|, \|\hat{\omega}\|, \|\tilde{\zeta}\|, \|\tilde{\omega}\|, \tilde{d}_X, \hat{z}|0, \hat{\beta}|1, \tilde{\delta}|0, \hat{\zeta}|0, \hat{\omega}|1, \tilde{\zeta}|0, \tilde{\omega}|1\}, \quad (4.66)$$

where  $\hat{\omega}|1$  denotes the boundary of  $\hat{\omega}$  for  $x = 1$ , i.e.,  $\hat{\omega}(1,t)$

$$\delta_{\mathcal{V}} = \begin{cases} \frac{1}{1+N(t)}, & \text{if } \mathcal{V} \in \{X, \|\hat{z}\|, \hat{z}|0, \|\hat{\beta}\|, \hat{\beta}|1\}, \\ 1, & \text{otherwise} \end{cases} \quad (4.67)$$

and with

$$f_X(b_i, V(t)) = -ac_0 + b_1 \gamma_d M_1 + b_1 \gamma_d M_2 + 2eb_2(1 + c_0 + \bar{q})^2 + b_2 \gamma_d M_3 + e^{V(t)} [b_3 C_1 + b_3 \gamma_d M_4 + b_4 C_2 + b_4 \gamma_d M_5 + b_8 \gamma_d M_6 + b_8 C_5], \quad (4.68)$$

$$f_{\hat{z}|0}(b_i, V(t)) = \frac{2a}{c_0} - b_1 + 2eb_2 + b_8 C_5 e^{V(t)}, \quad (4.69)$$

$$f_{\tilde{\delta}|0}(b_i) = \frac{2a}{c_0} + b_1 M_0 - b_7 + b_8 C_5, \quad (4.70)$$

$$f_{\tilde{d}_X}(b_i) = b_4 C_2 - ac_0 b_8, \quad (4.71)$$

$$f_{\hat{\zeta}|0}(b_i) = -b_3 + 2eb_4, \quad (4.72)$$

$$f_{\tilde{\zeta}|0}(b_i) = -b_5 + eb_6 + eb_7, \quad (4.73)$$

$$f_{\hat{\omega}|1}(b_i) = -b_6, \quad (4.74)$$

$$f_{\hat{\beta}|1}(b_i) = -b_2, \quad (4.75)$$

$$f_{\tilde{\omega}|1}(b_i) = -b_4, \quad (4.76)$$

$$f_{\|\hat{z}\|}(b_i, V(t)) = -\frac{b_1}{2} + b_1 \gamma_d M_1 + b_1 \gamma_d M_2 + b_2 \gamma_d M_3 + e^{V(t)} [b_3 C_1 + b_3 \gamma_d M_4 + b_4 C_2 + b_4 \gamma_d M_5 + b_8 \gamma_d M_6], \quad (4.77)$$

$$f_{\|\hat{\beta}\|}(b_i) = -b_2 + b_2 \gamma_d M_3, \quad (4.78)$$

$$f_{\|\hat{\zeta}\|}(b_i, \lambda) = -b_3 + b_3 \gamma_d M_4 + b_5 \lambda C_3 + b_6 \lambda C_4, \quad (4.79)$$

$$f_{\|\tilde{\zeta}\|}(b_i, \lambda) = -b_5(1 + 2\lambda) + b_5 \lambda C_3 + b_6 \lambda C_4, \quad (4.80)$$

$$f_{\|\hat{\omega}\|}(b_i, \lambda) = -b_4 + b_4 \gamma_d M_5 + b_5 \lambda C_3 + b_6 \lambda C_4, \quad (4.81)$$

$$f_{\|\tilde{\omega}\|}(b_i, \lambda) = -b_6(1 + 2\lambda) + b_5 \lambda C_3 + b_6 \lambda C_4, \quad (4.82)$$

$$f_{\|\tilde{\delta}\|}(b_i) = b_4 C_2 - b_7. \quad (4.83)$$

Note that, we used that  $1 + N(t) \leq e^{V(t)}$  (from the definition of  $V$  (4.49)).

A sufficient condition for the stability of the *extended target system* of state  $\mathcal{X}_e$  (4.41) is therefore the existence of parameters  $b_i$ ,  $\gamma_q$ ,  $\gamma_d$ , and  $\lambda$  such that

$$f_{\mathcal{V}}(\cdot) < 0, \quad \forall \mathcal{V} \in \mathcal{S}. \quad (4.84)$$

This is the condition we investigate in the following. With this aim in view, the procedure we follow to select the different parameters is

$$b_2 \rightarrow b_1 \rightarrow b_7 \rightarrow b_5 \rightarrow b_6 \rightarrow (\gamma_q, \gamma_d) \rightarrow b_3 \rightarrow b_8 \rightarrow b_4$$

In Appendix A.6 we present the procedure we use to select the parameters on a simple example. In the following we details the procedure for the considered case.

First, from (4.69) and (4.68) we choose  $b_2$  and  $b_1$  such that

$$b_2 < \frac{ac_0}{2e(1+c_0+\bar{q})^2}, \quad (4.85)$$

$$b_1 > \frac{2a}{c_0} + 2eb_2. \quad (4.86)$$

Then from (4.70) we choose respectively  $b_7$  as

$$b_7 > \frac{2a}{c_0} + b_1 M_0. \quad (4.87)$$

$b_5$  is taken, according to (4.73), such that

$$b_5 > eb_7, \quad (4.88)$$

thus we choose  $b_6$  as

$$b_6 < \frac{b_5}{e} - b_7. \quad (4.89)$$

$\gamma_q$  and  $\gamma_d$  are chosen, according to (4.68), (4.77), (4.78), (4.79), and (4.81), as

$$\gamma_q + \gamma_d < \min \left\{ \frac{ac_0 - 2eb_2(1+c_0+\bar{q})^2}{b_1 M_1 + b_1 M_2 + b_2 M_3}, \frac{b_1}{2(b_1 M_1 + b_1 M_2 + b_2 M_3)}, \frac{1}{M_3}, \frac{1}{M_4}, \frac{1}{M_5} \right\}. \quad (4.90)$$

Note that, if  $b_i < 1, i \in \{3, 4, 8, 9, 10\}$ , this implies the existence of  $M(\mathcal{X}_e(0)) > 0$  independent of  $b_i, i \in \{3, 4, 8, 9, 10\}$ , such that  $V(\mathcal{X}_e(0)) \leq M(\mathcal{X}_e(0))$  which is simply denoted  $M$  in the following. Consequently, the parameter  $b_3$  is fixed, according to (4.68) and (4.77), as<sup>1</sup>

$$b_3 < \min \left\{ 1, \frac{-f_X(b_{3,4,8} = 0, M)}{e^M [C_1 + \gamma_d M_4]}, \frac{-f_{\|\tilde{z}\|}(b_{3,4,8} = 0, M)}{e^M [C_1 + \gamma_d M_4]} \right\}. \quad (4.91)$$

Then,  $b_8$  is taken according to (4.68)-(4.69), (4.74), and (4.77), as

$$b_8 < \min \left\{ 1, \frac{-f_{\tilde{z}|0}(b_{4,8} = 0, M)}{e^M C_5}, \frac{-f_{\tilde{\delta}|0}(b_{4,8} = 0)}{e^M C_5}, \frac{-f_X(b_{4,8} = 0, M)}{e^M [\gamma_d M_6 + C_5]}, \frac{-f_{\tilde{\omega}|1}(b_{4,8} = 0)}{C_5}, \frac{-f_{\|\tilde{z}\|}(b_{4,8} = 0, M)}{e^M \gamma_d M_6} \right\}. \quad (4.92)$$

From (4.68)-(4.71), (4.72), (4.74), (4.77), and (4.83),  $b_4$  is chosen with respect to

$$b_4 < \min \left\{ 1, \frac{-f_X(b_4 = 0, M)}{C_2 + \gamma_d M_5}, \frac{-f_{\tilde{d}_X}(b_4 = 0)}{C_2}, \frac{b_3}{2e}, \frac{-f_{\tilde{\omega}|1}(b_4 = 0)}{C_2}, \frac{b_7}{C_2}, \frac{-f_{\|\tilde{z}\|}(b_4 = 0, M)}{C_2 + \gamma_d M_5} \right\}. \quad (4.93)$$

<sup>1</sup>By  $f_{\mathcal{V}}(b_{3,4,8,9,10} = 0, M)$  we mean  $f_{\mathcal{V}}(b_1, b_2, b_3 = 0, b_4 = 0, b_5, b_6, b_7, b_8 = 0, b_9 = 0, b_{10} = 0, b_{11}, b_{12}, V = M)$ .

Finally, an upper bound for  $\lambda$  is found according to (4.79)-(4.82), as

$$\lambda < \min \left\{ \frac{b_3(1 - \gamma_q M_4)}{b_5 C_3 + b_6 C_4}, \frac{b_5}{b_5(C_3 - 2) + b_6 C_4}, \frac{b_4 - b_4 \gamma_q M_5}{b_5 C_3 + b_6 C_4}, \frac{b_6}{b_5 C_3 + b_6 C_4 - 2b_6} \right\}, \quad (4.94)$$

by assuming that  $C_3 > 2$ ,  $C_4 > 2$ ,  $C_8 > 2$  and  $C_9 > 2$ . They can be taken as expressed previously which can be taken as such.

Using Proposition A.1 in Appendix A.2, with this choice of parameters, one obtains the existence of  $\vartheta > 0$  such that  $f_{\mathcal{V}}(\cdot) < -\vartheta$  for all  $\mathcal{V} \in \mathcal{S}$ . From (4.84), this implies that it holds (4.52). The former concludes the proof of Lemma 4.2.  $\blacksquare$

### 4.3.3 Relation between the functionals $\Gamma(\mathcal{X})$ and $V(\mathcal{X}_e)$

In the previous section the stability of the *extended system* is established. Now, this section studies the link between the stability of the *extended system* and the *original system* (2.1). In other words, we want to establish the stability result (4.16), using Lemma 4.2. With this aim in view, first we formulate two lemmas, then the proof of them follows. The first lemma presents an upper bound of  $\Gamma$  in terms of  $V$

**Lemma 4.3** Consider  $\Gamma$  defined in (4.13) and  $V$  defined in (4.49). There exists  $R > 0$ , such that

$$\Gamma(\mathcal{X}(t)) \leq R(e^{V(\mathcal{X}_e(t))} - 1). \quad (4.95)$$

To establish the main result of this chapter (Theorem 4.2), we also need to upper bound  $V$  by a function of  $\Gamma$ . This is the purpose of this second lemma.

**Lemma 4.4** Consider  $\Gamma$  defined in (4.13) and  $V$  defined in (4.49). There exists  $\rho > 0$  such that

$$V(\mathcal{X}_e(t)) \leq \rho \max_{s \in [0,3]} \Gamma(\mathcal{X}(t-s)). \quad (4.96)$$

We start by the proof of Lemma 4.3, and right after, the one of Lemma 4.4

*Proof of Lemma 4.3:* From the definition of  $v$  and  $X$  respectively in (2.6) and (4.3), using the dynamics (4.31a), we start by observing that

$$u_t(0, \tau) = e^{a(q-1)(\tau-t-1)} X(t) + 2a \int_0^{\tau+1-t} e^{a(q-1)(\tau+1-t-\chi)} [\Pi^{-1}[\tilde{z}(\chi/2, t)] + \tilde{\delta}(\chi, t) - \tilde{d}(t)] d\chi, \quad (4.97)$$

which can be obtained by arguments similar to those used to establish (4.40). Therefore, from (4.97), using Young's inequality on (4.30), there exists  $C_1 > 0$  such that

$$u_t(0, t)^2 \leq C_1 \left[ X(t)^2 + \|\tilde{z}\|^2 + \|\tilde{\delta}\|^2 + \tilde{d}(t)^2 \right], \quad (4.98)$$

which gives, using (4.44) and (4.49), the existence of  $r_1 > 0$  satisfying

$$u_t(0, t)^2 \leq r_1 (e^{V(t)} - 1). \quad (4.99)$$

Furthermore, from the definition of the Riemann variables, (2.3)-(2.4) and (2.17)-(2.18), one gets

$$u_t(x, t) = \frac{\hat{\zeta}(x, t) + \hat{\omega}(x, t) + \tilde{\zeta}(x, t) + \tilde{\omega}(x, t)}{2}, \quad (4.100)$$

$$u_x(x, t) - \hat{d}(t) = \frac{\hat{\zeta}(x, t) - \hat{\omega}(x, t) + \tilde{\zeta}(x, t) - \tilde{\omega}(x, t)}{2}, \quad (4.101)$$

and, applying Young's and Cauchy-Schwarz's inequalities, one can get

$$\|u_t\|^2 \leq \|\widehat{\zeta}\|^2 + \|\widehat{\omega}\|^2 + \|\widetilde{\zeta}\|^2 + \|\widetilde{\omega}\|^2, \quad (4.102)$$

$$\|u_x - d\|^2 \leq \frac{5}{4} \left( \|\widehat{\zeta}\|^2 + \|\widehat{\omega}\|^2 + \|\widetilde{\zeta}\|^2 + \|\widetilde{\omega}\|^2 \right) + 5\widetilde{d}(t)^2. \quad (4.103)$$

Therefore, from (4.102)-(4.103), it holds

$$\|u_t\|^2 + \|u_x - d\|^2 \leq \left( r_2 + 5\gamma_d \right) (e^{V(t)} - 1). \quad (4.104)$$

for a given  $r_2 > 0$ . Finally, one obtains

$$\widetilde{d}(t)^2 + \widetilde{q}(t)^2 \leq (\gamma_d + \gamma_a)V(t). \quad (4.105)$$

Consequently, gathering (4.99), (4.104)-(4.105), we obtain (4.95). This concludes the proof of Lemma 4.3. ■

*Proof of Lemma 4.4:* From the definition of  $V$  (4.49), one obtains

$$\begin{aligned} V(t) \leq & X(t)^2 + 2eb_1 \|\widehat{z}\|^2 + eb_2 \|\widehat{\beta}\| + eb_3 \|\widehat{\zeta}\|^2 + eb_4 \|\widehat{\omega}\|^2 \\ & + eb_5 \|\widetilde{\zeta}\|^2 + eb_6 \|\widetilde{\omega}\|^2 + eb_7 \|\widetilde{\delta}\|^2 + b_8 \widetilde{d}_X(t)^2. \end{aligned} \quad (4.106)$$

Recall the definition of  $X$  in (4.3)

$$X(t) = u_t(0, t-1) \quad (4.107)$$

Then, from the backstepping transformation (4.28) and from the definition of  $\widehat{\alpha}$  (4.21), there exists  $C_2 > 0$  such that

$$\|\widehat{z}\| \leq C_2 \left[ X(t)^2 + \max_{s \in [0,1]} [\|\widehat{\zeta}(t-s)\|^2 + \widetilde{d}(t-s)^2] \right]. \quad (4.108)$$

Besides, according to the definition of  $\widehat{\beta}$  (4.19), one obtains the existence of  $C_3 > 0$

$$\|\widehat{\beta}\|^2 \leq C_3 \left[ \|\widehat{\omega}(t-1)\|^2 + \max_{s \in [0,1]} [\widetilde{d}(t-s)^2] \right]. \quad (4.109)$$

Furthermore, from the definition of  $\widetilde{d}_X$  (4.37) one writes

$$\exists C_4 > 0, \quad \widetilde{d}_X(t)^2 \leq C_4 [\mu(t)^2 + \widetilde{d}(t)^2]. \quad (4.110)$$

Finally, by the definition of  $\widetilde{\zeta}$ ,  $\widetilde{\omega}$ ,  $\widehat{\zeta}$ , and  $\widehat{\omega}$ , (2.15)-(2.18) and using the expression (4.100), one gets

$$\widetilde{\zeta}(x, t) = -2\lambda \int_x^1 u_t(\chi, t+x-\chi) d\chi, \quad (4.111)$$

$$\widetilde{\omega}(x, t) = -2\lambda \int_0^x u_t(\chi, t-x+\chi) d\chi + 2\lambda \int_0^1 u_t(\chi, t-x-\chi) d\chi, \quad (4.112)$$

$$\widehat{\zeta}(x, t) = u_t(x, t) + u_x(x, t) - \widehat{d}(t) - \widetilde{\zeta}(x, t), \quad (4.113)$$

$$\widehat{\omega}(x, t) = u_t(x, t) - u_x(x, t) + \widehat{d}(t) - \widetilde{\omega}(x, t), \quad (4.114)$$

and concludes, applying Young's and Cauchy-Schwarz's inequality, with Fubini's Theorem that (technical details are presented in Appendix A.5)

$$\|\widetilde{\zeta}(t)\|^2 \leq 4\lambda^2 \max_{s \in [0,1]} \|u_t(t-s)\|^2, \quad (4.115)$$

$$\|\widetilde{\omega}(t)\|^2 \leq 8\lambda^2 \max_{s \in [0,2]} \|u_t(t-s)\|^2, \quad (4.116)$$

$$\|\widehat{\zeta}(t)\|^2 \leq 4(\|u_t(t)\|^2 + \|u_x(t) - d\|^2 + \widetilde{d}(t)^2 + 4\lambda^2 \max_{s \in [0,1]} \|u_t(t-s)\|^2), \quad (4.117)$$

$$\|\widehat{\omega}(t)\|^2 \leq 4(\|u_t(t)\|^2 + \|u_x(t) - d\| + \widetilde{d}(t)^2 + 8\lambda^2 \max_{s \in [0,2]} \|u_t(t-s)\|^2). \quad (4.118)$$

Thus, gathering inequalities (4.106)-(4.110), and (4.115)-(4.118), it holds for a suitable  $\rho > 0$  (4.96). This concludes the proof of Lemma 4.4. ■

#### 4.3.4 Convergence in terms of the functional $\Upsilon$

We conclude on the convergence with respect to the functional  $\Upsilon$  defined in (4.15). The following lemma states that several variables converge toward zero.

**Lemma 4.5**  $v(t)$ ,  $\|\widehat{\omega}(t)\|$ ,  $\|\widehat{\zeta}(t)\|$ ,  $\|\widetilde{\zeta}(t)\|$ , and  $\|\widetilde{\omega}(t)\|$  tend to zero as  $t$  tends to infinity.

*Proof*: From (4.53), one can easily get that  $N(t)$ ,  $\widetilde{q}(t)$ ,  $\widetilde{d}(t)$ , and  $V_2(t)$  are uniformly bounded for  $t \geq 0$ . Therefore,  $X(t)$ ,  $\|\widehat{z}(t)\|$ ,  $\|\widehat{\beta}(t)\|$ ,  $\|\widehat{\omega}(t)\|$ ,  $\|\widehat{\zeta}(t)\|$ ,  $\|\widetilde{\zeta}(t)\|$ ,  $\|\widetilde{\omega}(t)\|$ ,  $\|\widetilde{\delta}(t)\|$ ,  $\widetilde{d}_X(t)$  are also uniformly bounded for  $t \geq 0$ .

From there, we establish that some of the state variables are uniformly bounded:

- (i). From the definition of (4.3),  $v(t)$  defined in (2.6) is uniformly bounded for  $t \geq 0$
- (ii). Applying Young's inequality to (4.42) and (4.43), one obtains that  $\widehat{q}(t)$  and  $\widehat{d}(t)$  are uniformly bounded for  $t \geq 0$ .
- (iii). Similarly, applying Cauchy-Schwarz's inequality to (4.25), one can obtain that  $\widehat{\zeta}(1, t)$  and thus  $\widehat{\alpha}(1, t)$  are uniformly bounded for  $t \geq 0$ .

Moreover, using Lemma A.1 in Appendix A.1,  $\widehat{\zeta}(x, t)$  is also uniformly bounded for  $t \geq (1-x)$  and, in particular,  $\widehat{\zeta}(0, t)$  is uniformly bounded for  $t \geq 1$ . Similarly, using Lemma A.1,  $\widehat{\alpha}(x, t)$  is also uniformly bounded for  $t \geq 2(1-x)$  and, in particular,  $\widehat{\alpha}(0, t)$  is uniformly bounded for  $t \geq 2$ .

- (iv). From (2.20d) one gets that  $\widehat{\omega}(0, t)$  is uniformly bounded for  $t \geq 1$  thus applying Lemma A.1 one gets that  $\widehat{\omega}(x, t)$  is uniformly bounded for  $t \geq 1+x$
- (v). Getting  $\widetilde{\zeta}(x, t)$  and  $\widetilde{\omega}(x, t)$  uniform boundness require more computation. The idea is to consider the *auxiliary system* (2.21a)-(2.21d) as two couple hyperbolic with uniformly bounded input. Using Proposition A.2 in Appendix A.1 one gets that  $\widetilde{\zeta}(x, t)$  and  $\widetilde{\omega}(x, t)$  are uniformly bounded for  $t \geq 4$ .

Further, from (2.20a)-(2.21d), and (2.19)

$$\frac{d}{dt}v(t)^2 = 2av(t) \left( (q-1)v(t) + \widehat{\zeta}(0, t) + \widetilde{\zeta}(0, t) + v(t)\widehat{q}(t) - \widetilde{d}(t) \right), \quad (4.119)$$

$$\frac{d}{dt}\|\widehat{\zeta}(t)\|^2 = \widehat{\zeta}(1, t)^2 - \widehat{\zeta}(0, t)^2 + 2 \int_0^1 \widehat{\zeta}(x, t)\widehat{d}(t)dx, \quad (4.120)$$

$$\frac{d}{dt}\|\widehat{\omega}(t)\|^2 = \widehat{\omega}(1, t)^2 - \widehat{\omega}(0, t)^2 + 2 \int_0^1 \widehat{\omega}(x, t)\widehat{d}(t)dx, \quad (4.121)$$

$$\frac{d}{dt}\|\widetilde{\zeta}(t)\|^2 = \widetilde{\zeta}(1, t)^2 - \widetilde{\zeta}(0, t)^2 + 2\lambda \int_0^1 \widetilde{\zeta}(x, t)[\widetilde{\zeta} + \widetilde{\omega} + \widehat{\zeta} + \widehat{\omega}](x, t)dx, \quad (4.122)$$

$$\frac{d}{dt}\|\widetilde{\omega}(t)\|^2 = \widetilde{\omega}(1, t)^2 - \widetilde{\omega}(0, t)^2 + 2\lambda \int_0^1 \widetilde{\omega}(x, t)[\widetilde{\zeta} + \widetilde{\omega} + \widehat{\zeta} + \widehat{\omega}](x, t)dx, \quad (4.123)$$

$$\frac{d}{dt}\widetilde{d}(t)^2 = -\widetilde{d}(t)\widehat{d}. \quad (4.124)$$

Using (4.42)-(4.42), Cauchy-Schwarz's inequality and the previous considerations, it is straightforward that the right-hand terms in the previous equations are all uniformly bounded for  $t \geq 2$ . Finally, integrating (4.52) from 0 to  $\infty$ , it follows that  $X(t)$ ,  $\widetilde{d}_\mu(t)$ ,  $\|\widehat{\omega}(t)\|$ ,  $\|\widehat{\zeta}(t)\|$ ,  $\|\widetilde{\zeta}(t)\|$ ,  $\|\widetilde{\omega}(t)\|$ , and  $v(t)$  are square integrable. Moreover, as  $\widetilde{d}_X(t)$  and  $X(t)$  are square integrable, so is  $\widehat{d}(t)$ .

We conclude this proof with Barbalat's lemma (the Section 1.3.6 presents this common used lemma). ■

### 4.3.5 Conclusion on the proof of Theorem 4.2

Gathering (4.95) from Lemma 4.3 and (4.96) from Lemma 4.4, one gets the existence of  $R > 0$  and  $\rho > 0$  such that

$$\Gamma(\mathcal{X}(t)) \leq R(e^{\rho \max_{s \in [0,3]} \Gamma(\mathcal{X}(-s))} - 1). \quad (4.125)$$

Then, (4.125) along with (4.53) from Lemma 4.2 give the stability result (4.16) in Theorem 4.2.

Finally, using Lemma 4.5, (2.3)-(2.4) and (2.17)-(2.18), it follows that  $u_t(0, t) = v(t)$ ,  $\|u_t(t)\|$  and  $\|u_x(t) - \widehat{d}(t)\|$  and also  $d - \widehat{d}(t)$  tend to zero as  $t$  tends to infinity. In other words, it holds (4.17). This concludes the proof of Theorem 4.2.

## Chapter conclusion

This chapter focuses on the delayed anti-collocated output feedback. In detail, the adaptive control law considered in this chapter needs the measurement of  $u_t(1, t)$  and  $u_t(0, t - 1)$ . The model mismatch robustness of the adaptive control law has been established. The general idea is to represent the delay as first-order hyperbolic PDE. The interesting addition is the consideration of  $\tilde{d}_X$  (see Section 4.3.1.3 and the explication within). This variable allows us to cancel the error term in the Lyapunov analysis.

Even if we consider that the delay for the anti-collocated measurement is of one unit, i.e.,  $u_t(0, t - 1)$ , the generalization to any known delay is direct, i.e.,  $u_t(0, t - d)$ ,  $\forall d \in \mathbb{R}^+$ . The velocity propagation of the transport phenomena added to represent the delay (in Section 4.3.1.1) need to be modified, but the rest is fairly similar. Following this idea: what is the delay is time variant, i.e.,  $u_t(0, t - d(t))$ ? One possible idea to tackle this problem could be to consider the transport phenomena associated to the maximum delay, and to consider that the input of the ODE are not at the  $x = 0$  boundary but at an in-domain point  $x = \frac{d(t)}{d_{max}}$ . With this we can represent the delay, but now we need to compute somehow a backstepping transformation with a time varying boundary. A related problem has been studied by Shumon Koga and his work on Stefan problem (he considers time dependent boundary of the integral of his backstepping transformation) PDEs in [Koga and Krstic, 2017].







# Collocated boundary output feedback

## Contents

<b>5.1 Control and adaptive law under consideration</b> . . . . .	<b>87</b>
<b>5.2 Mismatch collocated boundary output feedback</b> . . . . .	<b>89</b>
<b>5.3 Sketch of proof</b> . . . . .	<b>89</b>
<b>Chapter conclusion</b> . . . . .	<b>92</b>

We present the robustness analysis of the last adaptive control considered in this part, the *collocated boundary output feedback*. The main feature of this control law is that it only requires measurement at the actuator boundary. The control law is presented in Section 5.1. It is followed by its robustness result in Section 5.2. Section 5.3 is dedicated to the sketch of its proof. The complete proof is given in [Roman et al., 2017].

This chapter still focuses on the system (2.1), recall

$$\begin{cases} u_{tt}(x,t) = u_{xx}(x,t) - 2\lambda u_t(x,t), & (5.1a) \\ u_x(1,t) = U(t), & (5.1b) \\ u_{tt}(0,t) = a q u_t(0,t) + a[u_x(0,t) - d]. & (5.1c) \end{cases}$$

The output of this chapter is  $u_t(1,t)$ .

## 5.1 Control and adaptive law under consideration

The *collocated boundary output feedback*, which was developed in [Bresch-Pietri and Krstic, 2014b] for the system (2.1) assuming  $\lambda = 0$ , is

$$U(t) := -u_t(1,t) + \hat{d}(t) - (c_0 + \hat{q}(t) - 1) \left( e^{2a(\hat{q}(t)-1)} \mu(t) + a \int_{t-2}^t e^{a(\hat{q}(t)-1)(t-\tau)} (\eta(\tau) - \hat{d}(t)) d\tau \right), \quad (5.2)$$

in which  $c_0 > 0$  is a tuning constant,  $\hat{q}$  is an estimate of the unknown parameter  $q$ ,  $\hat{d}$  is an estimate of the unknown parameters  $d$ , and  $\mu$  and  $\eta$  are defined as

$$\mu(t) := \frac{1}{2} \left[ u_t(1,t) + u_t(1,t-2) - u_x(1,t) + u_x(1,t-2) \right], \quad (5.3)$$

$$\eta(t) := U(t) + u_t(1,t). \quad (5.4)$$

The parameter adaptation laws are

$$\hat{q}(t) := \frac{a\gamma_q}{1+N(t)} \text{PROJ}_{[\underline{q},\bar{q}]} \left\{ \hat{q}(t), \mu(t) \left( \mu(t) + b_1(c_0 + \hat{q}(t) - 1) \int_{t-2}^t e^{(a(\hat{q}(t)-1)+\frac{1}{2})(\tau-t+2)} \sigma(\tau,t) d\tau \right) \right\}, \quad (5.5)$$

$$\hat{d}(t) := \frac{-a\gamma_d}{1+N(t)} \text{PROJ}_{[\underline{d},\bar{d}]} \left\{ \hat{d}(t), \mu(t) + b_1(c_0 + \hat{q}(t) - 1) \int_{t-2}^t e^{(a(\hat{q}(t)-1)+\frac{1}{2})(\tau-t+2)} \sigma(\tau,t) d\tau \right\}, \quad (5.6)$$

in which

$$N(t) := \mu(t)^2 + b_1 \int_{t-2}^t e^{\frac{\tau-t}{2}+1} \sigma(\tau, t)^2 d\tau + b_2 \int_{t-1}^t e^{\tau-t+1} (2\mu(\tau) - \eta(\tau-2) + \widehat{d}(t))^2 d\tau, \quad (5.7)$$

$$\sigma(\tau, t) := \eta(\tau) - \widehat{d}(t) + (c_0 + \widehat{q}(t) - 1) \left( e^{a(\widehat{q}(t)-1)(\tau-t+2)} \mu(t) + a \int_{t-2}^{\tau} e^{a(\widehat{q}(t)-1)(\tau-\chi)} (\eta(\chi) - \widehat{d}(t)) d\chi \right). \quad (5.8)$$

The tuning parameters of the control law are  $c_0, b_1, b_2, \gamma_q$  and  $\gamma_d$ . In the case where the adaptive parameters are known (i.e.,  $\widehat{q} = q$  and  $\widehat{d} = d$ ) and without in-domain damping ( $\lambda = 0$ ),  $c_0$  represents the closed-loop decay rate of the velocity  $u_t(0, t)$ .

Note that, if we assume that  $\mu(t) = X(t) = u_t(0, t-1)$  the previous adaptive control law is the same as in Chapter 4. The idea is to reconstruct  $u_t(0, t-1)$  using only a sensor for  $u_t(0, t)$  ( $u_x(1, t) = U(t)$ ). In the following we prove that  $\mu(t)$  defined in (5.3) is equal to  $u_t(0, t-1)$  assuming that  $\lambda = 0$ ,  $\widehat{d}(t) = d$ ,  $\widehat{q}(t) = q$ . From the definition (2.3)-(2.4), one gets

$$\begin{aligned} u_t(1, t) - u_x(1, t) &= \omega(1, t), \\ u_t(1, t-2) + u_x(1, t-2) &= \zeta(1, t-2), \\ 2u_t(0, t-1) &= \zeta(0, t-1) + \omega(0, t-1). \end{aligned}$$

Moreover it holds

$$\zeta(1, t-2) = \zeta(0, t-1), \quad \omega(1, t) = \omega(0, t-1).$$

Gathering previous equation it follows that  $\mu(t) = u_t(0, t-1)$  when  $\lambda = 0$ ,  $\widehat{d}(t) = d$ ,  $\widehat{q}(t) = q$ . This is still the case when  $\lambda = 0$  and it is not the case when  $\lambda \neq 0$  as it is shown in Section 5.3.

The theorem stating the stability result is

**Theorem 5.1** [Bresch-Pietri and Krstic, 2014b]

Consider the closed-loop system consisting of the plant (2.1) in which  $\lambda = 0$ , the control law  $U$  defined in (5.2) and the parameters update laws (5.5)-(5.6). Define the functionals

$$\begin{aligned} \Gamma_0(\mathcal{X}(t)) &:= \int_{t-1}^t u_t(0, s)^2 ds + \max_{s \in [t-1, t]} \int_0^1 [u_x(x, s) - q]^2 dx \\ &\quad + \max_{s \in [t-1, t]} \int_0^1 u_t(x, s)^2 dx + (q - \widehat{q}(t))^2 + (d - \widehat{d}(t))^2, \end{aligned} \quad (5.9)$$

$$\Upsilon_0(\mathcal{X}(t)) := u_t(0, t)^2 + \|u_t(t)\|^2 + \|u_x(t) - d\|^2 + (d - \widehat{d}(t))^2. \quad (5.10)$$

Then, for all  $c_0 > 0$ , there exist  $\bar{b}_2(c_0) > 0$ ,  $\underline{b}_1(c_0, \bar{b}_2) > 0$ ,  $\bar{\gamma}(c_0, \underline{b}_1, \bar{b}_2) > 0$ , such that, for

- $b_2 \in (0, \bar{b}_2)$ ,
- $b_1 \in (\underline{b}_1, \infty)$ ,
- $\gamma_d, \gamma_q \in (0, \bar{\gamma})$ ,

it holds, for suitable  $R > 0$  and  $\rho > 0$ ,

$$\Gamma_0(\mathcal{X}(t)) \leq R(e^{\rho \Gamma_0(\mathcal{X}(0))} - 1), \quad (5.11)$$

and

$$\lim_{t \rightarrow \infty} \Upsilon_0(\mathcal{X}(t)) = 0. \quad (5.12)$$

For the nominal case ( $\lambda = 0$ ), the stability result associated to this adaptive control law is completely similar to the one for the *delay anti-collocated output feedback* (Chapter 4). This is due to the fact that when  $\lambda = 0$  it holds  $\mu(t) = u_t(0, t-1)$ .

## 5.2 Mismatch collocated boundary output feedback

The following theorem we are going to present can be proven using the method we have used so far. It concerns the model mismatch robustness of the previously presented adaptive control law.

**Theorem 5.2** [Roman et al., 2017]

Consider the closed-loop system consisting of the plant (2.1) satisfying Assumption 2.1, the control law (5.2) and the parameter estimation laws (5.6)-(5.5). Define the functionals  $\Gamma$ ,  $\Xi$  and  $\Upsilon$  as

$$\begin{aligned} \Gamma(\mathcal{X}(t)) := & u_t(0,t)^2 + \|u_t(t)\|_{L_2}^2 + \|u_x(t) - d\|_{L_2}^2 + \|u_{xt}(t)\|_{L_2}^2 \\ & + \|u_{xx}(t)\|_{L_2}^2 + (q - \hat{q}(t))^2 + (d - \hat{d}(t))^2, \end{aligned} \quad (5.13)$$

$$\Xi(\mathcal{X}(t)) := \max_{s \in [0,3]} \Gamma(\mathcal{X}(t-s)), \quad (5.14)$$

$$\Upsilon(\mathcal{X}(t)) := u_t(0,t)^2 + \|u_t(t)\|_{L_2}^2 + \|u_x(t) - d\|_{L_2}^2 + (d - \hat{d}(t))^2. \quad (5.15)$$

Then, for all  $c_0 > 0$ , there exist  $\bar{b}_2(c_0) > 0$ ,  $\underline{b}_1(c_0, \bar{b}_2) > 0$ ,  $\bar{\gamma}(c_0, \underline{b}_1, \bar{b}_2) > 0$ , such that, for

- $b_2 \in (0, \bar{b}_2)$ ,
- $b_1 \in (\underline{b}_1, \infty)$ ,
- $\gamma_d, \gamma_q \in (0, \bar{\gamma})$ ,

there exists  $\bar{\lambda}(c_0, b_1, b_2, \bar{\gamma}, \mathcal{X}(0)) > 0$  such that, when  $\lambda \in [0, \bar{\lambda})$ , it follows, for suitable  $R > 0$  and  $\rho > 0$

$$\Xi(\mathcal{X}(t)) \leq R(e^{\rho \Xi(\mathcal{X}(0))} - 1), \quad (5.16)$$

and

$$\lim_{t \rightarrow \infty} \Upsilon(\mathcal{X}(t)) = 0. \quad (5.17)$$

For reason which will be clarify in the sequel, we are constrained to assume more regular solution. Indeed, all previous theorem (i.e., Theorem 3.1, Theorem 3.2, Theorem 4.1, Theorem 4.2 and Theorem 5.1) are valid for the weak solution of their respective closed-loop system, i.e.,  $\mathcal{X}(t)$  defined in (2.2) is in  $H_1(0,1) \times L_2(0,1) \times \mathbb{R}^4$ . The following theorem has sense for the strong solution, i.e.,  $\mathcal{X}(t) \in H_2(0,1) \times H_1(0,1) \times \mathbb{R}^4$ , because the functional  $\Gamma$  and a fortiori  $\Xi$  have sense for solution in  $H_2(0,1) \times H_1(0,1) \times \mathbb{R}^4$ .

It is worth noticing that, if the adaptation parameter  $\hat{q}$  is perfectly known ( $\hat{q}(t) = q$ ), then the exponential stability of the closed-loop system (2.1) with respect to the subspace  $\ker(\Xi(\cdot))$  follows (by a Lyapunov argument see Lemma 2 in [Roman et al., 2017]).

## 5.3 Sketch of proof

A the proof of this result is technical and lengthy, in this section only the major step and idea are presented. The complete developments are in [Roman et al., 2017].

The first step is to get that  $\mu$  defined in (5.3) can be expressed as

$$\mu(t) = v(t-1) + \frac{\tilde{\omega}(1,t)}{2}, \quad (5.18)$$

in which  $v$  is defined in (2.6), and  $\tilde{\omega}$  in (2.18). From the definition (2.3)-(2.4), (2.17)-(2.18) one gets

$$u_t(1,t) - u_x(1,t) = \hat{\omega}(1,t) + \tilde{\omega}(1,t) - \hat{d}(t), \quad (5.19)$$

$$u_t(1,t-2) + u_x(1,t-2) = \hat{\zeta}(1,t-2) + \tilde{\zeta}(1,t-2) + \hat{d}(t-2), \quad (5.20)$$

$$2u_t(0,t-1) = \hat{\zeta}(0,t-1) + \tilde{\zeta}(0,t-1) + \hat{\omega}(0,t-1) + \tilde{\omega}(0,t-1). \quad (5.21)$$

From (2.20a) and (2.20c), one gets

$$\widehat{\zeta}(1, t-2) = \widehat{\zeta}(0, t-1) + \widehat{d}(t-1) - \widehat{d}(t-2), \quad (5.22)$$

$$\widehat{\omega}(1, t) = \widehat{\omega}(0, t-1) - \widehat{d}(t-1) + \widehat{d}(t). \quad (5.23)$$

And one obtains (5.18) (recall (2.21b)  $\widetilde{\zeta}(1, t) = 0$  and (2.21d)  $\widetilde{\omega}(0, t) = -\widetilde{\zeta}(0, t)$ ).

The control is acting on  $\mu$  thus the dynamics of  $\mu$  is consider as ODE. One gets that the dynamics of  $\mu$  is

$$\dot{\mu}(t) = \dot{v}(t-1) + \frac{1}{2}\widetilde{\omega}_t(1, t). \quad (5.24)$$

Using similar step as done in Section 4.3.1.1 (for the *anti-collocated output feedback*) the *delay system* together with the *auxiliary system* interconnection can be illustrated as Figure 5.1. The equivalent figure for the *delay anti-collocated output feedback* is Figure 4.1. The major difference with the *delay system* in the delay anti-collocated design illustrated Figure 4.1 is the loop from  $\widetilde{\omega}(1, t)$  and  $\mu$ . In particular, the boundary of  $\widetilde{\omega}$  depends on  $\mu$  and the dynamics of  $\mu$  has for input  $\widetilde{\omega}(1, t)$  and  $\widetilde{\omega}_t(1, t)$ .

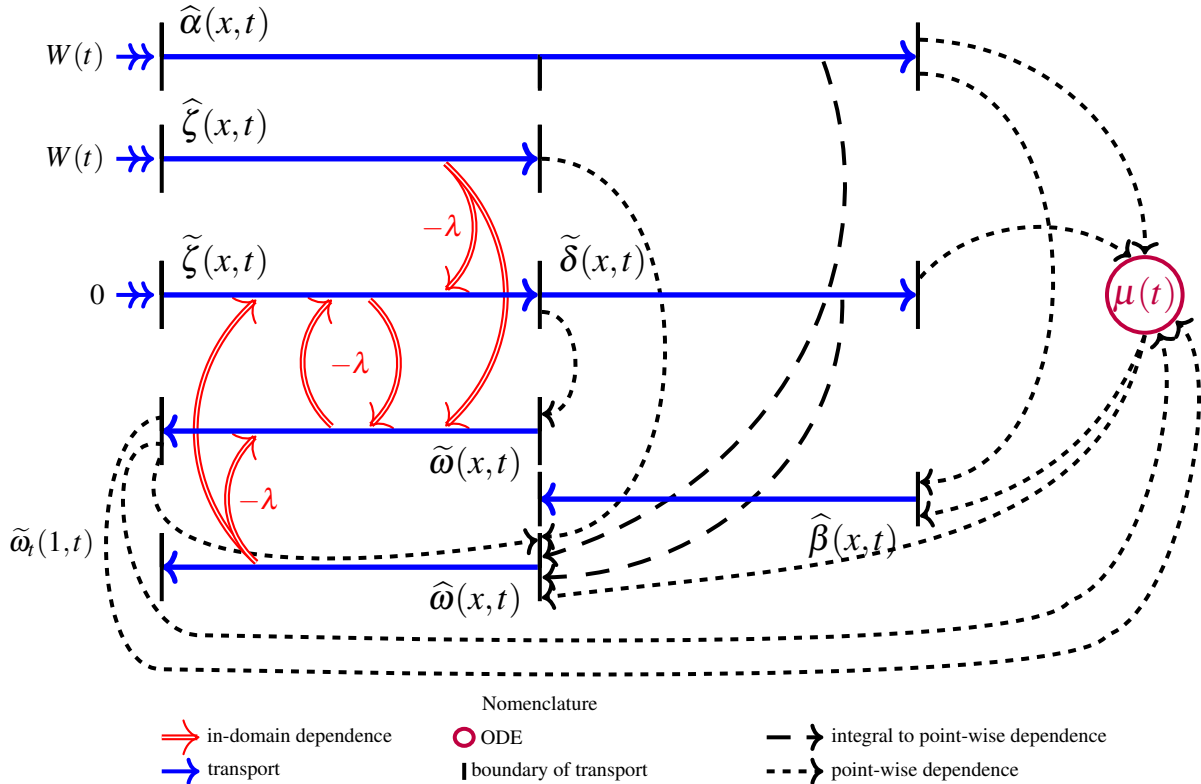

Figure 5.1: Illustration of the *delay system* together with the *estimated* and *auxiliary system* for the *collocated output feedback*.

Due to the appearance of  $\widetilde{\omega}_t(1, t)$  in (5.24), we propose to introduce a term in order to have negative terms of  $\widetilde{\omega}_t(1, t)$  in the Lyapunov analysis:

$$\int_0^1 e^{1-x} \widetilde{\omega}_t(x, t)^2 dx, \quad (5.25)$$

in the Lyapunov functional. Thus we consider in addition the dynamics of  $\widetilde{\omega}_t$ . However, this dynamics depends on  $\widetilde{\zeta}_t$ , so we also consider the dynamics of  $\widetilde{\zeta}_t(x, t)$ . Now observing that

$$\widehat{\omega}_t(x, t) + \widehat{\zeta}_t(x, t) = \widehat{\zeta}_x(x, t) - \widehat{\omega}_x(x, t), \quad (5.26)$$

it is easier to consider instead the dynamics of  $\widehat{\zeta}_x(x, t)$  and  $\widehat{\omega}_x(x, t)$  as it does not involve double derivative time derivative of the estimated parameters, e.g.  $\widehat{d}(t)$ . It remains to compute  $\dot{W}(t)$ , to perform the Lyapunov analysis

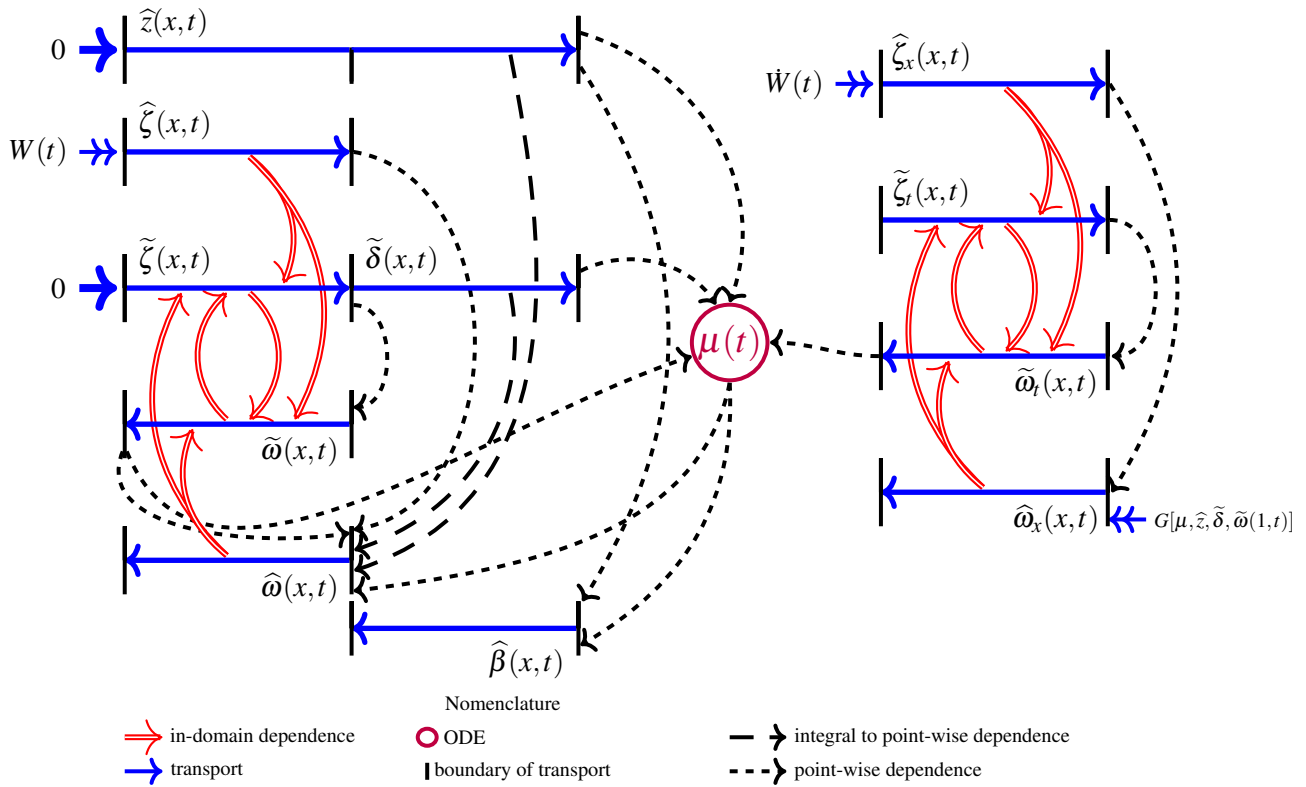

Figure 5.2: Illustration of the *extended system* for the *collocated output feedback*.

on this *extended system* (Figure 5.2 illustrated the interconnection of this system) and the convergence analysis. The complete proof is detailed in [Roman et al., 2017].

We can compare Figure 3.1, Figure 4.2 and Figure 5.2. They correspond respectively to the *extended system*, the system on which the analysis is performed, for the three considered adaptive control laws we have considered. The graphic complexities go in pair with the complexity of the associated *extended system* stability analysis.

Note that the additional constraint on the regularity of solution is due to the fact that the derivative of the *estimated* and *auxiliary system* are considered. This is the major difference between the *delay anti-collocated output feedback* and the *collocated output feedback*. One sees this directly looking at Figure 4.2 and Figure 5.2.

## Chapter conclusion

This chapter presents some elements concerning the collocated adaptive control law. The control law using only the measurement of  $u_t(1, t)$  (and the knowledge of its past value). The model mismatch robustness for it is stated. The proof of this result can be found in [Roman et al., 2017].

For the two previous design the presence of in-domain damping introduces a error, a mistake, but the impact of it is actually relatively simple. For an input to state stability point of view, the auxiliary system seems input to state stable for the previous system. In the adaptive control considered in this chapter, the derivative of the state also interact, this is illustrated in Figure 5.3.

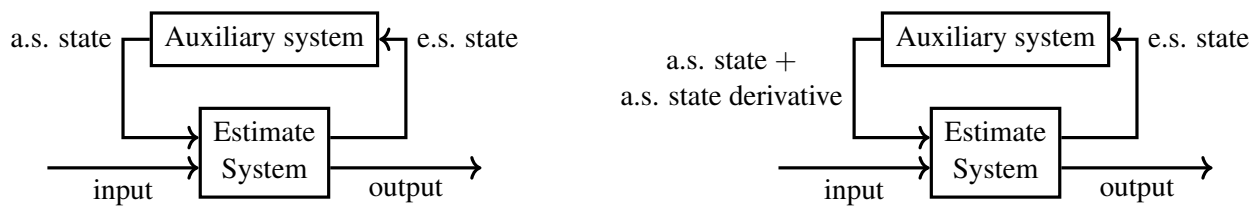

Figure 5.3: Differences between Chapter 3 and Chapter 4 (left) and Chapter 5 (right) for model mismatch robustness

Therefore, opposite to the robust result in Chapter 3 and in Chapter 4, the theorem stated in this chapter needs the assumption of more regular solution.

The following chapter illustrates the robust result we state so far with simulations on a nonlinear model.



# Numerical simulations

For illustration purposes, the adaptive control laws considered in Chapter 3, Chapter 4, and Chapter 5 are applied to a nonlinear drilling model in this chapter. The nonlinear model is presented in Section 6.1. The last Section 6.5 concerns a comparison of the three adaptive control laws.

## 6.1 Modeling of torsional vibrations during drilling

One of the possible applications of the control laws (3.2), (4.2), and (5.2) associated with the wave equation model (2.1) is to attenuate the torsional vibrations occurring in drilling facilities (e.g. [Bresch-Pietri and Krstic, 2014a], [Saldivar et al., 2011], and [Sagert et al., 2013]). Such vibrations can lead to the so called stick-slip phenomenon [Jansen and van der Steen, 1995]. Indeed, the friction at the bottom of the hole, between the rock and the drillbit, forces sometimes the bit to stop, while the surface is still rotating. After some time, the bit will start moving again at velocity higher than the top velocity. This is illustrated in Figure 6.1 which represents an open-loop simulation of the nonlinear model. This torsional dynamics can be modeled by a wave equation with a nonlinear boundary condition

$$u_{tt}(0, t) = aF(u_t(0, t)) + au_x(0, t), \quad (6.1)$$

accounting for the friction between the drillbit and the rock (see [Saldivar et al., 2016b], [Saldivar et al., 2011]). Even if there exist phenomenological expressions of this friction  $F$  (see [Zhang et al., 2010], [Saldivar et al., 2011] and [Ritto et al., 2009]), they depend on some parameters, such as the weight on the bit, drilling mud properties, and the nature of the rock. So they may change during operation. This is the reason why using an adaptive controller is of high interest for this application.

Following [Saldivar et al., 2011], we consider the drillstring rotatory angle denoted by  $\theta(\xi, \tau)$  at length  $\xi$  and time  $\tau$ . By convention, the top boundary is at  $\xi = 0$  and the bottom boundary at  $\xi = L$  (the link with the considered system (2.1) is detailed in the sequel), and the torsional dynamics can be modeled by

$$\begin{cases} GJ\theta_{\xi\xi}(\xi, \tau) - I\theta_{\tau\tau}(\xi, \tau) - \Lambda\theta_{\tau}(\xi, \tau) = 0, & (6.2a) \\ GJ\theta_{\xi}(0, \tau) = c_{\alpha}(\theta_{\tau}(0, \tau) - \Omega(\tau)), & (6.2b) \\ I_b\theta_{\tau\tau}(L, \tau) = -GJ\theta_{\xi}(L, \tau) - T_{BIT}(\theta_{\tau}(L, \tau)), & (6.2c) \end{cases}$$

in which  $\Omega(\tau)$  is the angular velocity of the rotatory table rotor which is the actual actuator at time  $\tau$ ,  $T_{BIT}$  is the nonlinear rock-on-the-bit friction term and other constants are listed in Table 6.1. Note that there exist alternative models of this phenomenon, such as [Saldivar et al., 2016b] which takes into account the axial vibrations.



Symbol	Description	Value
$L$	Length of the drillstring	2000 <i>m</i>
$J$	Drillstring second moment of area	1.19 e-5 <i>m</i> <sup>4</sup>
$G$	Shear modulus	79.3 e10 <i>N/m</i> <sup>2</sup>
$I$	Drillstring inertia's moment per length unit	9.5 e-2 <i>kg.m</i> <sup>2</sup>
$I_b$	BHA moment of inertia	311 <i>kg.m</i>
$D_{dp}$	Outer diameter of the drill pipe	1.27 e-1 <i>m</i>
$d_{dp}$	Inner diameter of the drill pipe	1.08 e-1 <i>m</i>
$\mu_m$	Field viscous coefficient	{0, 10, 20} <i>Pa.s</i>
$c_b$	Sliding torque coefficient	2 e3 <i>N.m.s/rad</i>
$T_{tob}$	Torque-on-the-bit parameter	7.5 e2 <i>N.m</i>
$\alpha_1, \alpha_2, \alpha_3$	Friction parameters	5.5; 2.2; 3500
$\gamma$	Damping parameter	0.03 <i>N.m.s/rad</i>

These values are taken from [Sagert et al., 2013] and [Jansen, 1993]. The friction phenomenon is described by the model in [Zhang et al., 2010].

Table 6.1: Parameters values of the nonlinear model used in simulation

Following [Sagert et al., 2013], we consider the change of variables

$$\xi = L(1 - x), \quad (6.3)$$

$$\tau = L\sqrt{\frac{I}{GJ}}t \triangleq c_t t, \quad (6.4)$$

$$u(x, t) = \theta(\xi, \tau), \quad (6.5)$$

$$U(t) = \frac{Lc\alpha}{GJ} \left( \Omega(c_t t) - \frac{1}{c_t} u_t(1, t) \right), \quad (6.6)$$

$$F(\cdot) = -\frac{L}{GJ} T_{BIT} \left( \frac{\cdot}{c_t} \right), \quad (6.7)$$

with the following constants

$$a = L\frac{I}{I_B}, \quad 2\lambda = \frac{\Lambda L}{\sqrt{GJI}}. \quad (6.8)$$

This allows to rewrite (6.2a)-(6.2c) as

$$u_{tt}(x, t) = u_{xx}(x, t) - 2\lambda u_t(x, t), \quad (6.9)$$

$$u_x(1, t) = U(t), \quad (6.10)$$

$$u_{tt}(0, t) = aF(u_t(0, t)) + au_x(0, t). \quad (6.11)$$

Now, we consider a first order Taylor approximation of  $F(\cdot)$  around an equilibrium  $u_t^{\text{ref}}$ , i.e.,

$$F(u_t(0, t)) = q(u_t(0, t) - u_t^{\text{ref}}) - d, \quad (6.12)$$

in which  $d = -F(u_t^{\text{ref}})$  and  $q = \dot{F}(u_t^{\text{ref}})$ . Then, assuming  $u_t^{\text{ref}} = 0$  for the sake of conciseness, the torsional dynamics model can be reformulated under the form (2.1).

For simulation, the friction term  $T_{BIT}(\cdot)$  is taken as (see [Zhang et al., 2010])

$$T_{BIT}(\chi) = \gamma\chi + \frac{2T_{tob}}{\pi} (\alpha_1\chi e^{-\alpha_2|\chi|} + \arctan(\alpha_3\chi)), \quad (6.13)$$

where the parameter values are gathered in Table 6.1.

The drill pipe is modeled as hollow cylinder of outer diameter  $D_{dp}$  and inner diameter  $d_{dp}$ . The drill is in contact with a viscous field, of viscous dynamical coefficient  $\mu_m$ . Direct computation gives the associated damping coefficient

$$\Lambda = \mu_m \frac{\pi}{2} (D_{dp}^2 + d_{dp}^2). \quad (6.14)$$

Open-loop simulations are performed on the non-linear model (6.2a)-(6.2c), with the input  $\Omega$  taken constant. The open-loop of the simulated model in the *nominal case* ( $\lambda = 0$ ) exhibits a limit cycle which corresponds with the stick-slip phenomenon. This is illustrated in Figure 6.1. In Figure 6.2, the same behavior is presented but with  $\lambda = 0.45$  which corresponds to a viscous field coefficient of  $10 \text{ Pa}\cdot\text{s}$ . For the sake of comparison the glycerin viscosity is  $1.4 \text{ Pa}\cdot\text{s}$  [Haynes, 2014]. Note that the period of the limit cycle is slightly reduced when  $\lambda = 0.45$  (Figure 6.1). The limit cycle  $(\theta_t(0, \tau), \theta_t(L, \tau))$  for a range of  $\lambda$  from 0 to 0.85 is presented in Figure 6.3. The magnitude of the oscillations is decreasing with respect to  $\lambda$ .

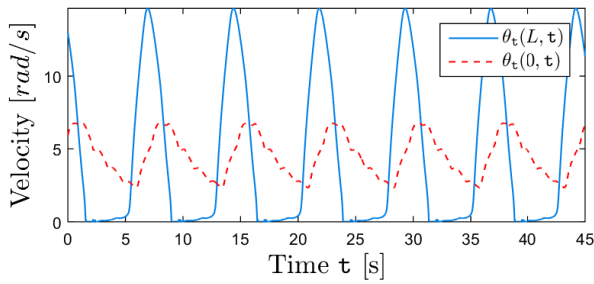

Figure 6.1: Simulations of the top and bottom velocities for  $\lambda = 0$ , for constant input,  $\Omega(\tau) = cst$ .

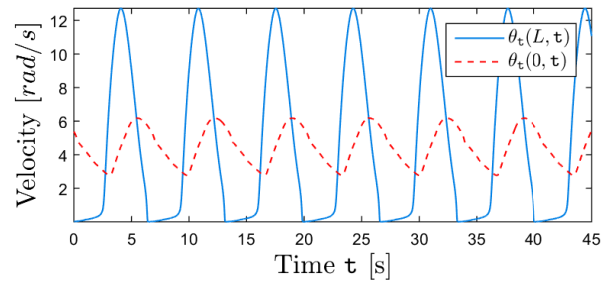

Figure 6.2: Simulations of the top and bottom velocities for  $\lambda = 0.45$ , for constant input,  $\Omega(\tau) = cst$ .

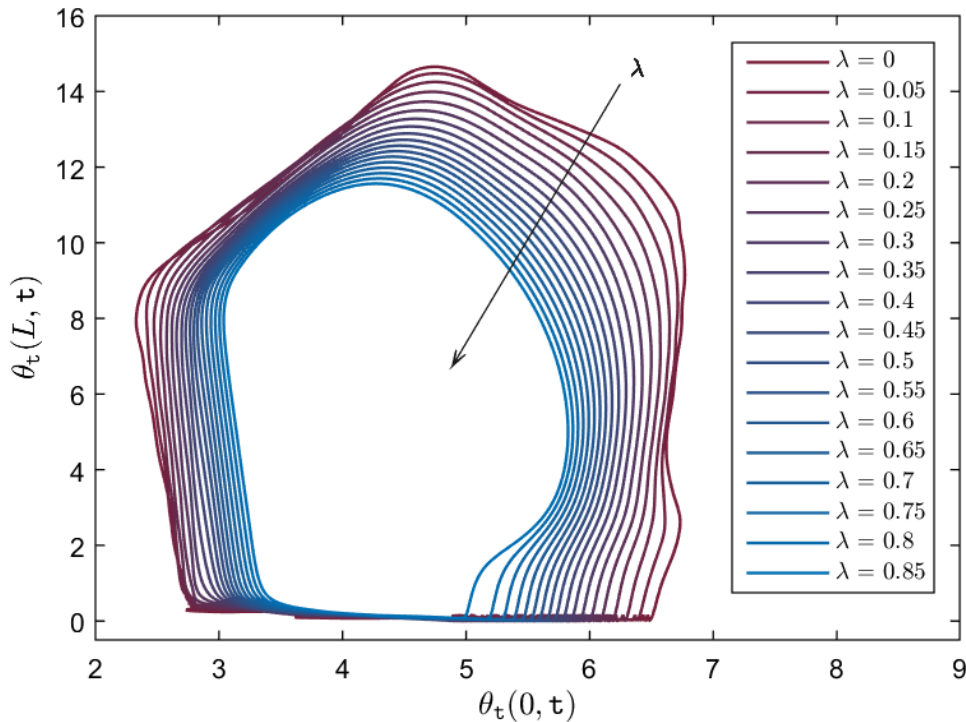

Figure 6.3: Limit cycle  $(\theta_t(L, \tau), \theta_t(0, \tau))$  for a range of  $\lambda = 0 : 0.05 : 0.85$ .

Simulations are performed in the sequel for  $\lambda = 0$  (*nominal case*),  $\lambda = 0.45$  and  $\lambda = 0.9$ . The tuning parameter values are taken as identical for the three control laws and are expressed in Table 6.2.

First Section 6.2 focuses on the simulation results for the *boundary output feedback*. Second, in Section 6.3, the simulation results for the *delayed anti-collocated output feedback* are shown. Third, Section 6.4 concerns the last control, the *collocated output feedback*, simulation. Finally, in Section 6.5, we draw a comparison between these results.

Symbol	Description	Value
$c_0$	Decay rate	1/a
$b_2$	Adaptive normalization parameter backward transport	10 e-4
$b_1$	Adaptive normalization parameter forward transport	1
$\gamma_d$	Update law $\hat{d}(t)$ coefficient	0.5
$\gamma_q$	Update law $\hat{q}(t)$ coefficient	0.01

Table 6.2: Tuning parameters values

## 6.2 Boundary output feedback velocity regulation of the nonlinear model

In this section the control law  $U$  (3.2), is considered along with the adaptation laws (3.4)-(3.5). We aim at stabilizing the velocity towards a reference velocity  $u_t^{\text{ref}}$ . As a result, we use these law in regulation rather than in stabilization as they were presented, that is, we replace  $u_t$  by  $u_t - u_t^{\text{ref}}$ . The tuning parameters values are given in Table 6.2 . It is worth noting that the simulations presented below have been performed using the nonlinear model (6.2) while the adaptive control laws were designed on a linearity version of it. An illustration of the simulation scheme is provided in Figure 6.4.

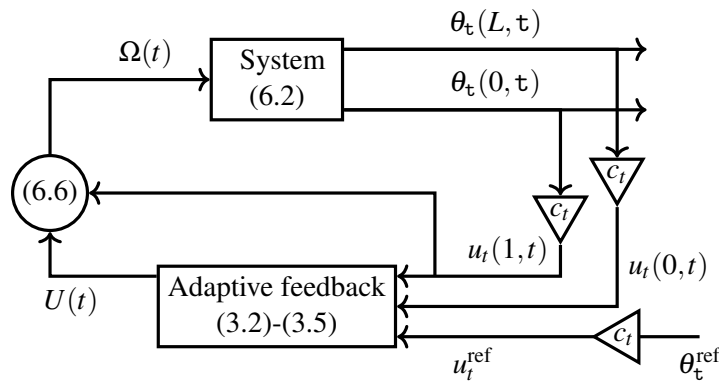

Figure 6.4: Simulation scheme for the *boundary output feedback*.

For all following simulations:

- The angular velocity reference is  $\theta_t^{\text{ref}} = 5 \text{ rad/s}$ , this gives  $u_t^{\text{ref}} = 5c_t$ .
- Before  $t = 15 \text{ s}$  the input  $\Omega$  is constant, then the actuation is turned on at  $t = 15 \text{ s}$ .
- The initial condition are taken indifferently, as we wait for the limit cycle to be established to start data storage. This allows to cancel numerical artefacts in the initialization: they appear but not in the time laps we show.

Note that, for the considered simulation,

$$u(x, t) \underset{t \rightarrow \infty}{\rightarrow} \lambda u_t^{\text{ref}} x^2 + t u_t^{\text{ref}} + dx + c, \quad c \in \mathbb{R}. \quad (6.15)$$

We do not regulate (stabilize) the system in position, which means that the subspace of convergence is invariant with respect to constant change of position. This is consistent with Theorem 3.1 and Theorem 3.2.

The evolution from a limit cycle behavior to the convergence toward the desired state of the boundary velocities in the *nominal case* ( $\lambda = 0$ ) is presented in Figure 6.5. Figure 6.9 shows the time response of the parameter estimations  $\hat{q}(t)$  and  $\hat{d}(t)$ . The distributed position  $\theta(\cdot, \tau)$ , velocity  $\theta_t(\cdot, \tau)$  and ‘torque’ or shear stress  $\theta_\xi(\cdot, \tau)$  time responses are presented in Figure 6.6, in Figure 6.7 and in Figure 6.8. The associated time responses of the input  $U(\tau)$  and  $\Omega(\tau)$  are given in Figure 6.10. These figures illustrate Theorem 3.1 from [Bresch-Pietri and Krstic, 2014a].

As the goal of the presented result is regulation, both control laws go to a constant, as shown in Figure 6.10 for  $\lambda = 0$ , in Figure 6.16 for  $\lambda = 0.45$ , and in Figure 6.22 for  $\lambda = 0.9$ . The goal is to regulate the velocity despite unknown parameters, it is not the estimation of them. Indeed a trade off between regulation and estimation has to be made. In general case when we desire the estimation of the parameters, we have a condition of permanent excitation which goes against regulation. Note that the estimation of  $d$  is needed to get the stability result as it represents a feedforward bias, the result gives the convergence of  $\hat{d}$  towards  $d$ , but not for  $\hat{q}$ .

Figure 6.11 and Figure 6.15 show the boundary velocities time response when  $\lambda$  is no longer equal to 0 but to 0.45 and 0.9 respectively. An open-loop limit cycle behavior is still present before  $\tau = 15$  s. The regulation is still achieved after the control is turned on. For the case  $\lambda = 0.9$ , presented in Figure 6.17 and Figure 6.21 the open-loop limit cycle vanishes under the effect of damping. However, a steady-state bias appears in open-loop due to parameters uncertainties and regulation to the desired reference is still achieved with the closed-loop control.

The distributed position  $\theta(\cdot, \tau)$ , velocity  $\theta_t(\cdot, \tau)$  and ‘torque’ or shear stress  $\theta_\xi(\cdot, \tau)$  time responses are presented in Figure 6.12, in Figure 6.13 and in Figure 6.14 for  $\lambda = 0.45$  and in Figure 6.18, in Figure 6.19 and in Figure 6.20 for  $\lambda = 0.9$ . The associated time responses of the input  $U(\tau)$  and  $\Omega(\tau)$  are given in Figure 6.16 and in Figure 6.22.

In the three cases, in Figure 6.9, in Figure 6.15 and in Figure 6.21, one gets that the parameter estimation  $\hat{d}$  converges towards  $d$ . This is consistent with Theorem 4.2. However, the parameter estimate  $\hat{q}$  does not converge toward  $q$  and got a steady state bias. This is also consistent with Theorem 4.2, as it already has been said, we did not established the convergence of  $\tilde{q}$  but only its stability (in terms of the functional  $\Xi$  (3.13)).

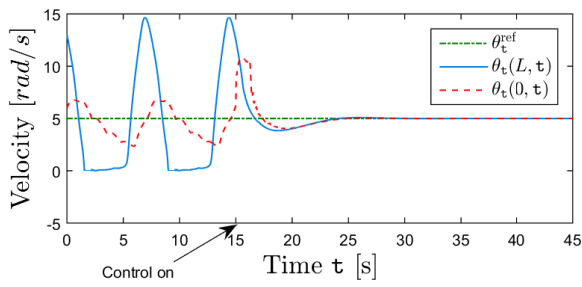

Figure 6.5: Simulation of the top and bottom velocities for  $\lambda = 0$ , the *nominal case* for which the control has been developed (see [Bresch-Pietri and Krstic, 2014a]) for the *boundary output feedback*.

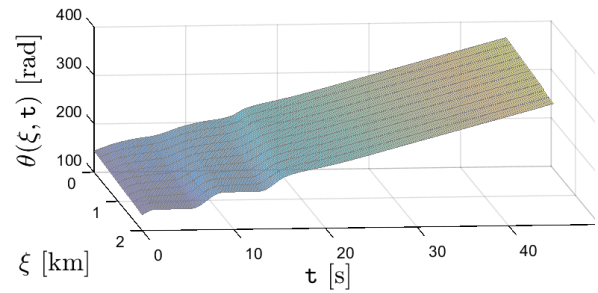

Figure 6.6: Simulation of the distributed position for  $\lambda = 0$ , the *nominal case* for which the control has been developed (see [Bresch-Pietri and Krstic, 2014a]) for the *boundary output feedback*.

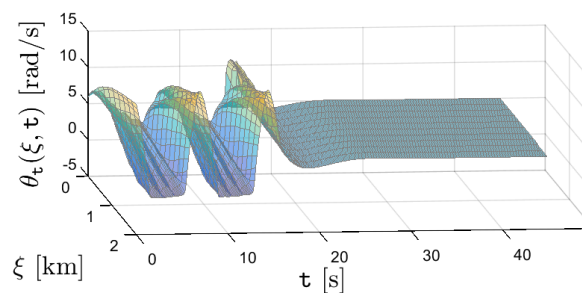

Figure 6.7: Simulation of the distributed velocity for  $\lambda = 0$ , the *nominal case* for which the control has been developed (see [Bresch-Pietri and Krstic, 2014a]) for the *boundary output feedback*.

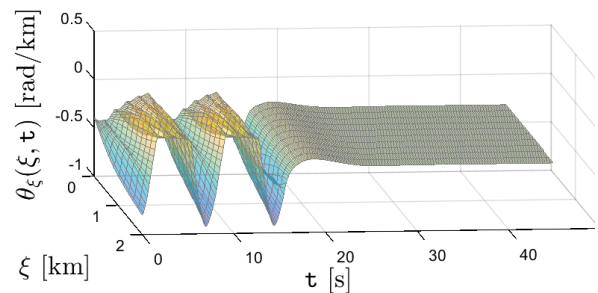

Figure 6.8: Simulation of the distributed shear stress for  $\lambda = 0$ , the *nominal case* for which the control has been developed (see [Bresch-Pietri and Krstic, 2014a]) for the *boundary output feedback*.

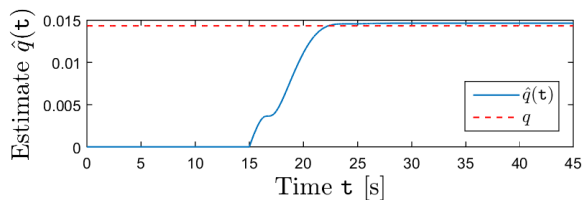
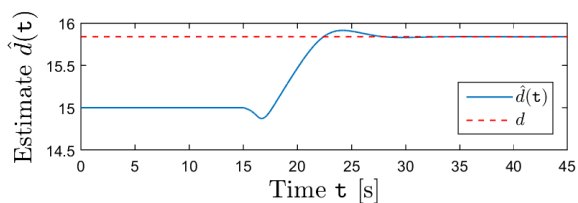

Figure 6.9: Evolution of the parameter estimates  $\hat{d}$  and  $\hat{q}$  for  $\lambda = 0$  for the *boundary output feedback*. (see [Bresch-Pietri and Krstic, 2014a])

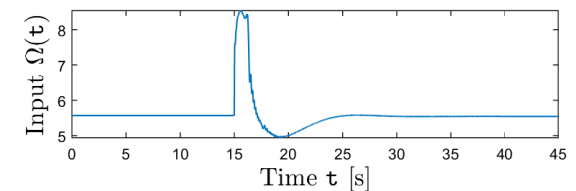
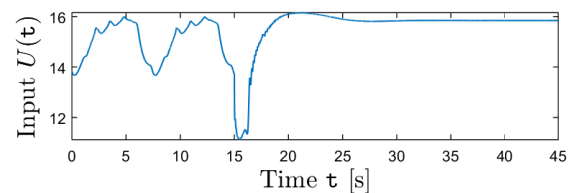

Figure 6.10: Input time response  $U(t)$  and  $\Omega(t)$  for  $\lambda = 0$  for the *boundary output feedback*. (see [Bresch-Pietri and Krstic, 2014a])

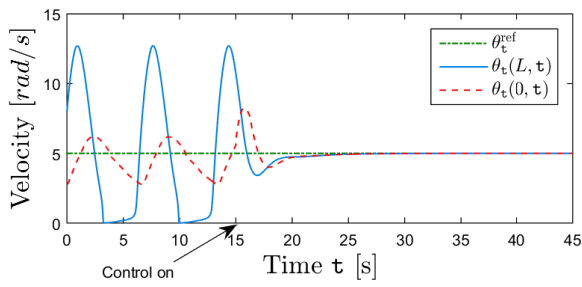

Figure 6.11: Simulation of the top and bottom velocities for  $\lambda = 0.45$ , for the *boundary output feedback*.

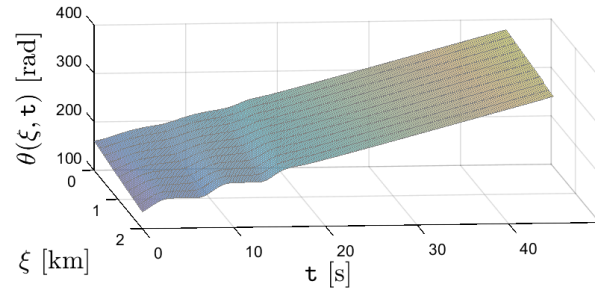

Figure 6.12: Simulation of the distributed position for  $\lambda = 0.45$ , for the *boundary output feedback*.

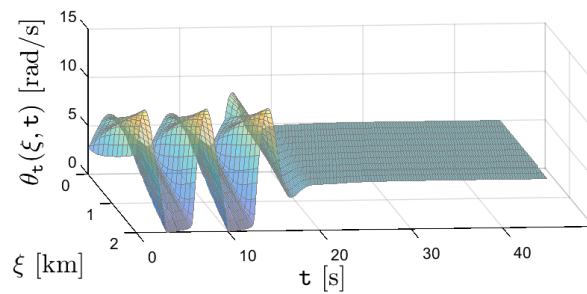

Figure 6.13: Simulation of the distributed velocity for  $\lambda = 0.45$ , for the *boundary output feedback*.

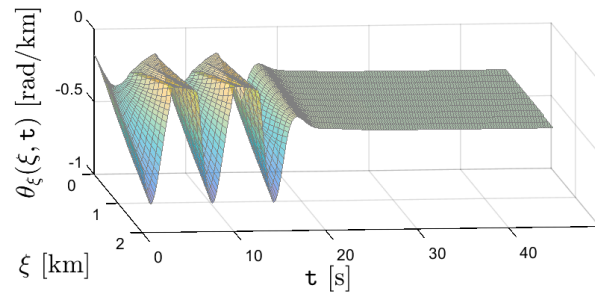

Figure 6.14: Simulation of the distributed shear stress for  $\lambda = 0.45$ , for the *boundary output feedback*.

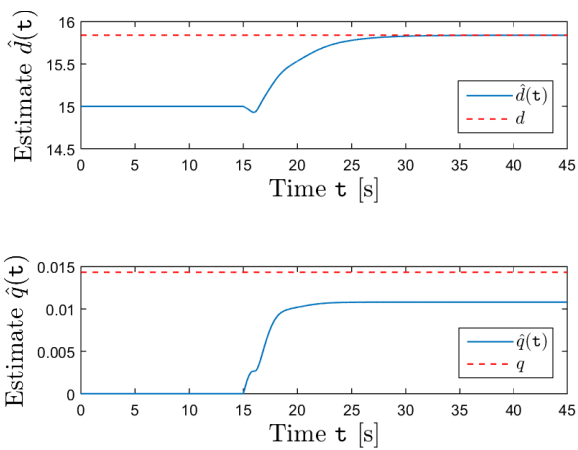

Figure 6.15: Evolution of the parameter estimates  $\hat{d}$  and  $\hat{q}$  for  $\lambda = 0.45$  the robust case for the *boundary output feedback*.

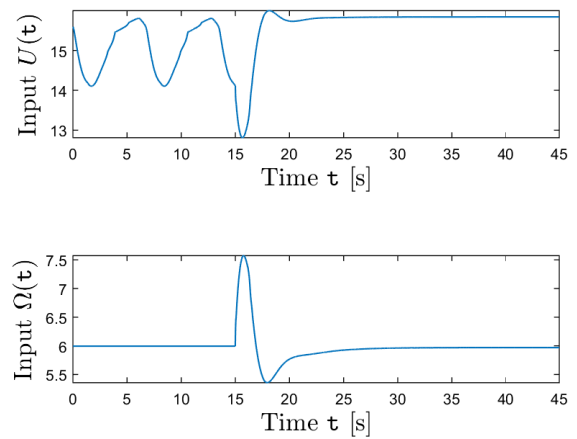

Figure 6.16: Input time response  $U(t)$  and  $\Omega(t)$  for  $\lambda = 0.45$  for the *boundary output feedback*.

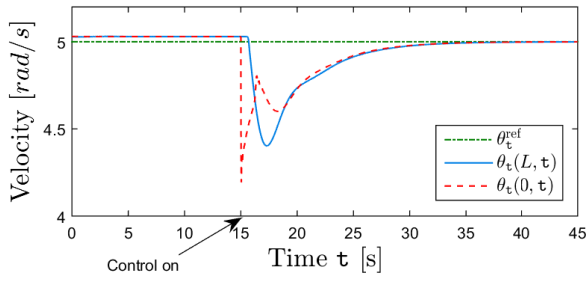

Figure 6.17: Simulation of the top and bottom velocities for  $\lambda = 0.9$ , for the *boundary output feedback*.

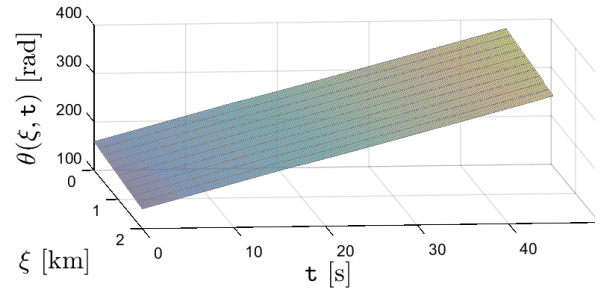

Figure 6.18: Simulation of the distributed position for  $\lambda = 0.9$ , for the *boundary output feedback*.

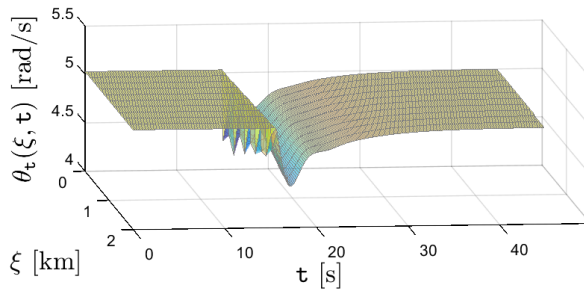

Figure 6.19: Simulation of the distributed velocity for  $\lambda = 0.9$ , for the *boundary output feedback*.

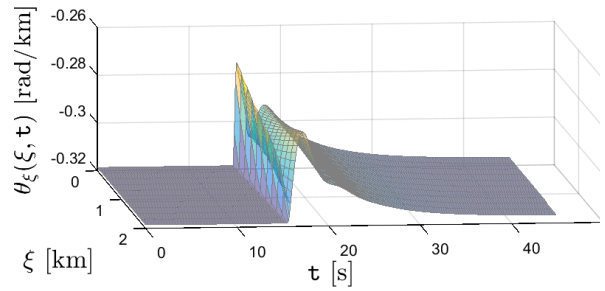

Figure 6.20: Simulation of the shear stress for  $\lambda = 0.9$ , for the *boundary output feedback*.

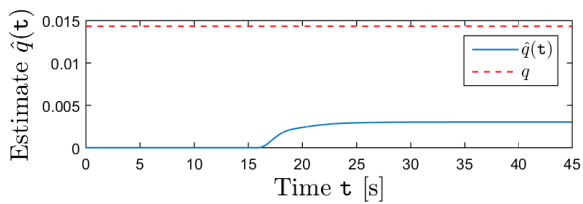
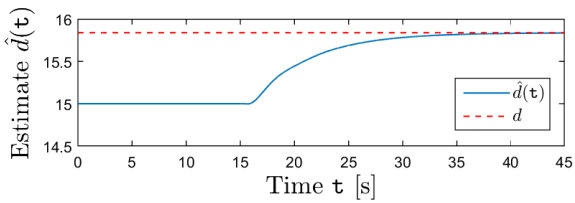

Figure 6.21: Evolution of the parameter estimates  $\hat{d}$  and  $\hat{q}$  for  $\lambda = 0.9$ , for the *boundary output feedback*.

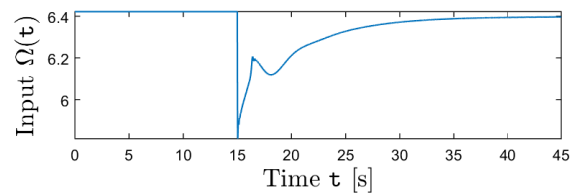
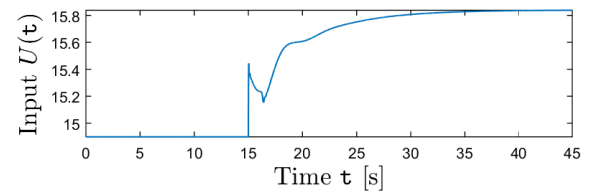

Figure 6.22: Input time response  $U(t)$  and  $\Omega(t)$  for  $\lambda = 0.9$  for the *boundary output feedback*.

### 6.3 Delayed anti-allocated output feedback velocity regulation of the nonlinear model

In this section, we consider the design of Chapter 4, that is, the control law  $U$  (4.2), the adaptation laws (4.5)-(4.6). The tuning parameters are taken as Table 6.2. Again, we aim at regulating the velocity to  $u_t^{\text{ref}}$  and thus replace  $u_t$  with  $u_t(x, t) - u_t^{\text{ref}}$  in (4.2)-(4.6). An illustration of the simulation scheme is provided in Figure 6.23.

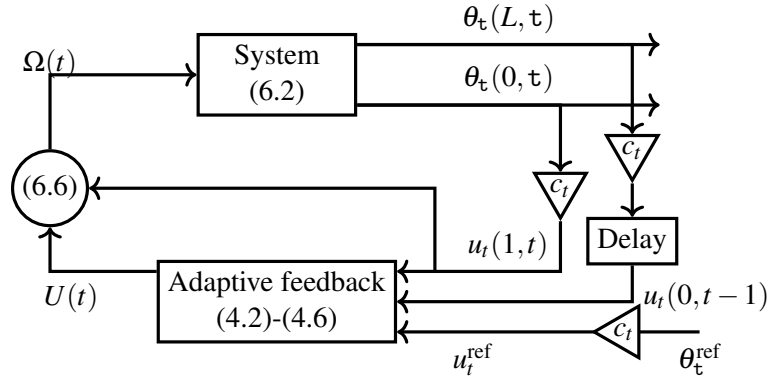

Figure 6.23: Simulation scheme for the *delay anti-allocated output feedback*.

Again for all following simulation:

- The angular velocity reference is  $\theta_t^{\text{ref}} = 5 \text{ rad/s}$ , this gives  $u_t^{\text{ref}} = 5c_t$ .
- Before  $t = 15 \text{ s}$  the input  $\Omega$  is constant, then the actuation is turned on at  $t = 15 \text{ s}$ .
- The initial condition are taken indifferently, as we wait for the limit cycle to be established to start data storage. This allows to cancel numerical artefacts in the initialization: they appear but not in the time laps we show.

The time responses from a limit cycle behavior of  $\theta_t(0, \tau)$  and  $\theta_t(L, \tau)$  to an equilibrium for  $\lambda = 0$  and  $\lambda = 0.45$  are depicted respectively in Figure 6.24 and in Figure 6.30. Regulation is achieved in both cases. The former is the illustration of Theorem 4.1, the latter illustrates Theorem 4.2. As previously, for  $\lambda = 0.9$  the in-domain damping is too large for an open-loop the limit cycle to appear. This is shown in Figure 6.36: both boundary velocities converge toward an equilibrium, but not the desired one. Indeed, the uncertainty leads to a feedforward bias. After  $\tau = 15 \text{ s}$ , yet, closed-loop regulation is still achieved.

The distributed position  $\theta(\cdot, \tau)$ , velocity  $\dot{\theta}_t(\cdot, \tau)$  and ‘torque’ or shear stress  $\theta_{\xi}(\cdot, \tau)$  time responses are presented

- for  $\lambda = 0$  in Figure 6.25, in Figure 6.26 and in Figure 6.27,
- for  $\lambda = 0.45$  in Figure 6.31, in Figure 6.32 and in Figure 6.33,
- for  $\lambda = 0.9$  in Figure 6.37, in Figure 6.38 and in Figure 6.39.

The associated time responses of the input  $U(\tau)$  and  $\Omega(\tau)$  are given in Figure 6.29, in Figure 6.35 and in Figure 6.41.

The time responses of the parameters estimates  $\hat{q}(\tau)$  and  $\hat{d}(\tau)$  for  $\lambda = 0$  and  $\lambda = 0.45$  are displayed respectively, in Figure 6.28 and Figure 6.34. They are associated respectively with the simulations in Figure 6.24 and Figure 6.30. It is worth noticing that in both figures,  $\hat{d}(\tau)$  correctly estimate  $d$ , whereas  $\hat{q}(\tau)$  converges but once above and once below  $q$ . The latter shows that the control does not need to overestimate  $q$  to converge. Both are consistent with the Theorem 4.2.



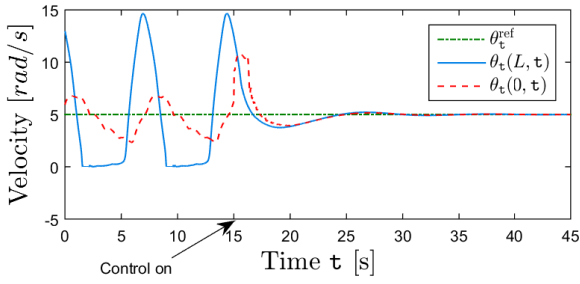

Figure 6.24: Simulation of the top and bottom velocities for  $\lambda = 0$ , the nominal case for which the control has been developed for the *delayed anti-collocated output feedback*.

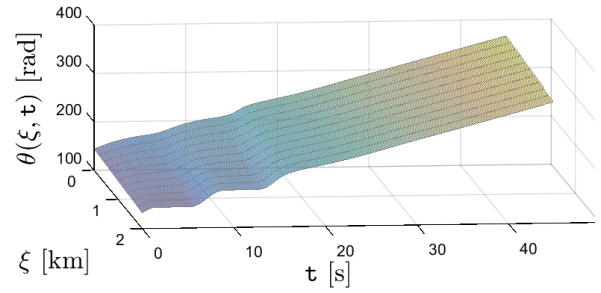

Figure 6.25: Simulation of the distributed position for  $\lambda = 0$ , for the *delayed anti-collocated output feedback*.

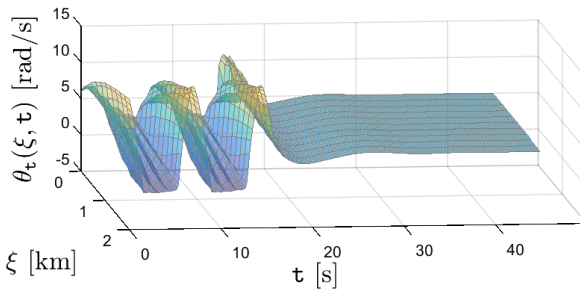

Figure 6.26: Simulation of the distributed velocity for  $\lambda = 0$ , for the *delayed anti-collocated output feedback*.

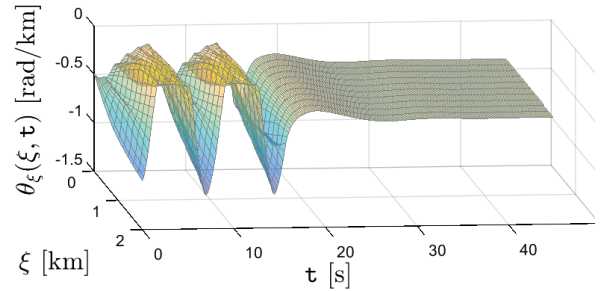

Figure 6.27: Simulation of the shear stress for  $\lambda = 0$ , for the *delayed anti-collocated output feedback*.

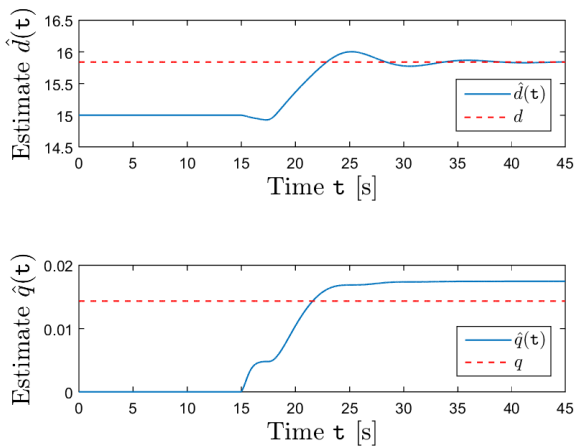

Figure 6.28: Evolution of the parameter estimates  $\hat{d}$  and  $\hat{q}$  for  $\lambda = 0$ , for the *delayed anti-collocated output feedback*.

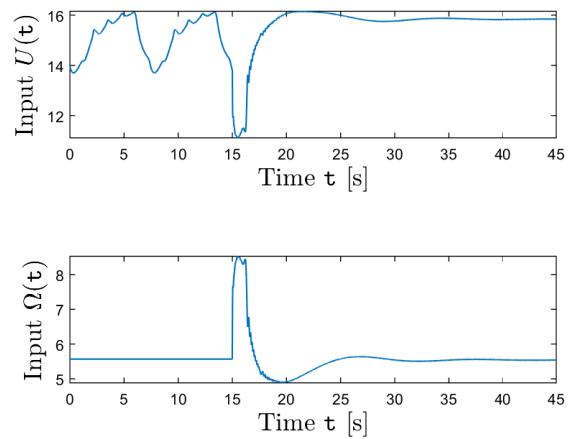

Figure 6.29: Input time response  $U(t)$  and  $\Omega(t)$  for  $\lambda = 0$  for the *delayed anti-collocated output feedback*.

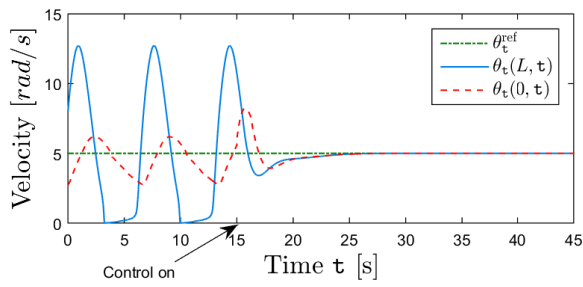

Figure 6.30: Simulation of the top and bottom velocities for  $\lambda = 0.45$ , for the *delayed anti-collocated output feedback*.

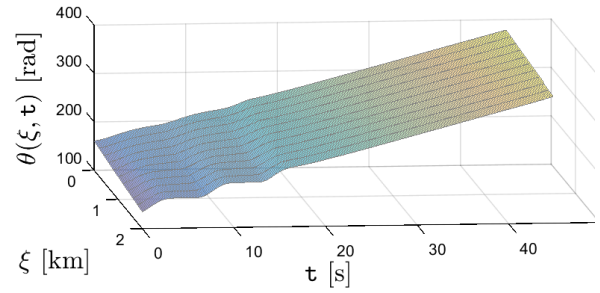

Figure 6.31: Simulation of the distributed position for  $\lambda = 0.45$ , for the *delayed anti-collocated output feedback*.

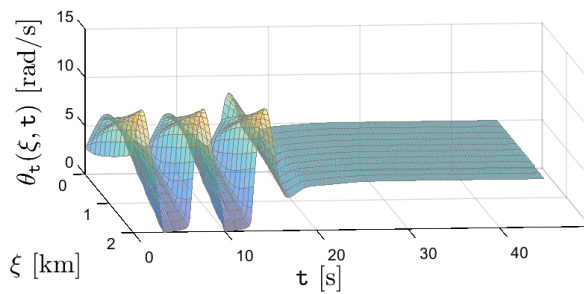

Figure 6.32: Simulation of the distributed velocity for  $\lambda = 0.45$ , for the *delayed anti-collocated output feedback*.

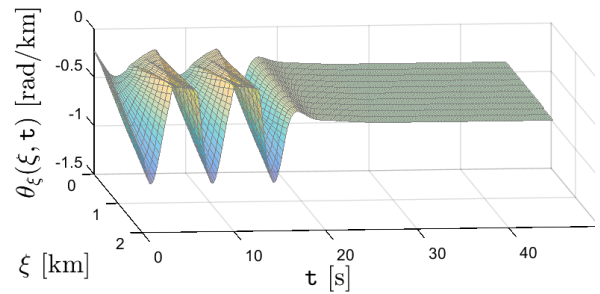

Figure 6.33: Simulation of the shear stress for  $\lambda = 0.45$ , for the *delayed anti-collocated output feedback*.

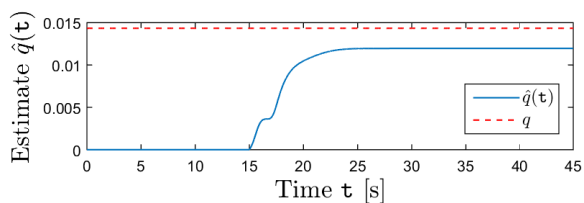
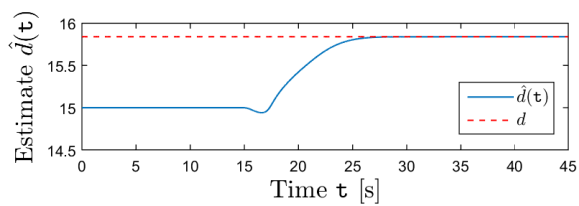

Figure 6.34: Evolution of the parameter estimates  $\hat{d}$  and  $\hat{q}$  for  $\lambda = 0.45$  the robust case for the *delayed anti-collocated output feedback*.

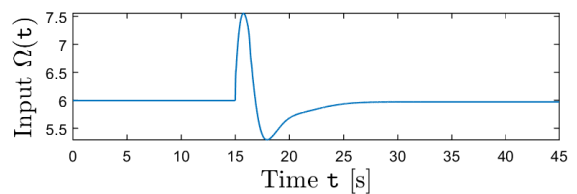
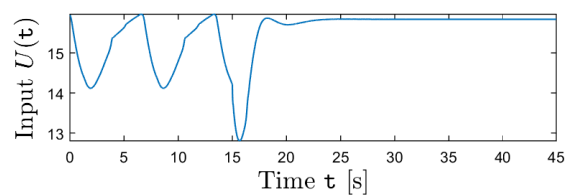

Figure 6.35: Input time response  $U(t)$  and  $\Omega(t)$  for  $\lambda = 0.45$  for the *delayed anti-collocated output feedback*.

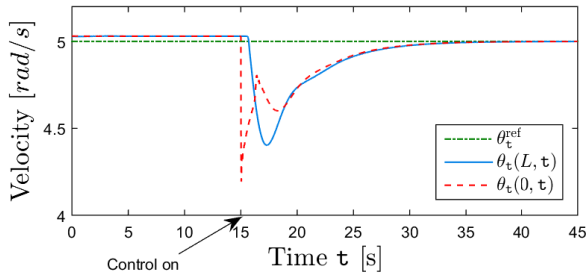

Figure 6.36: Simulation of the top and bottom velocities for  $\lambda = 0.9$ , for the *delayed anti-collocated output feedback*.

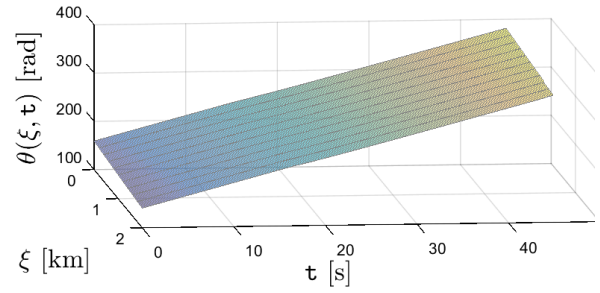

Figure 6.37: Simulation of the distributed position for  $\lambda = 0.9$ , for the *delayed anti-collocated output feedback*.

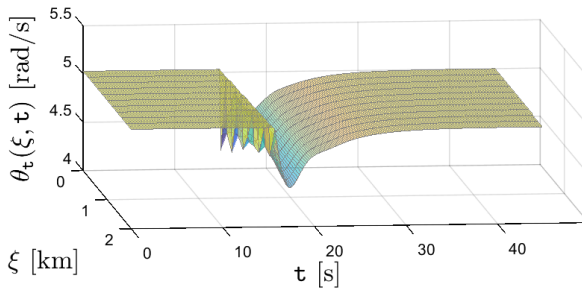

Figure 6.38: Simulation of the distributed velocity for  $\lambda = 0.9$ , for the *delayed anti-collocated output feedback*.

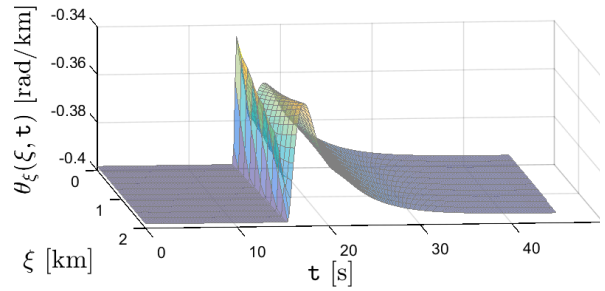

Figure 6.39: Simulation of the shear stress for  $\lambda = 0.9$ , for the *delayed anti-collocated output feedback*.

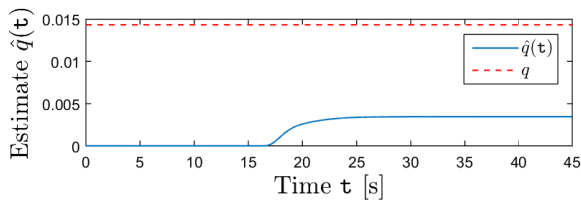
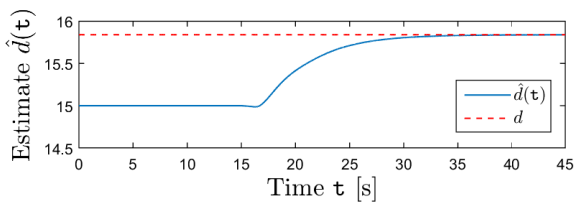

Figure 6.40: Evolution of the parameter estimates  $\hat{d}$  and  $\hat{q}$  for  $\lambda = 0.9$  the robust case for the *delayed anti-collocated output feedback*.

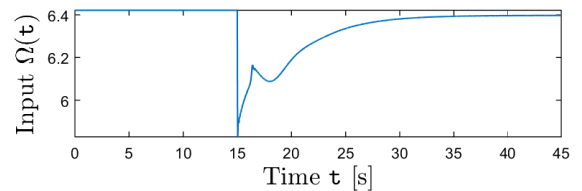
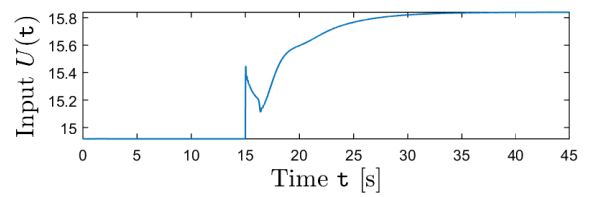

Figure 6.41: Input time response  $U(t)$  and  $\Omega(t)$  for  $\lambda = 0.9$  for the *delayed anti-collocated output feedback*.

## 6.4 Collocated output feedback velocity regulation of the nonlinear model

This section focuses on the *collocated output feedback*, in other words, the control law (5.2) and adaptation laws (5.5)-(5.5) are considered. Once more the objective is the regulation of the velocities towards  $u_t^{\text{ref}}$ , therefore, once again,  $u_t$  is replaced by  $u_t(x,t) - u_t^{\text{ref}}$  in (5.2)-(5.6). The tuning parameter values are given in Table 6.2. The simulations presented below have been performed using the nonlinear model (6.2), whose parameters are listed in Table 6.1. In Figure 6.42, we provide a brief illustration of the simulation scheme.

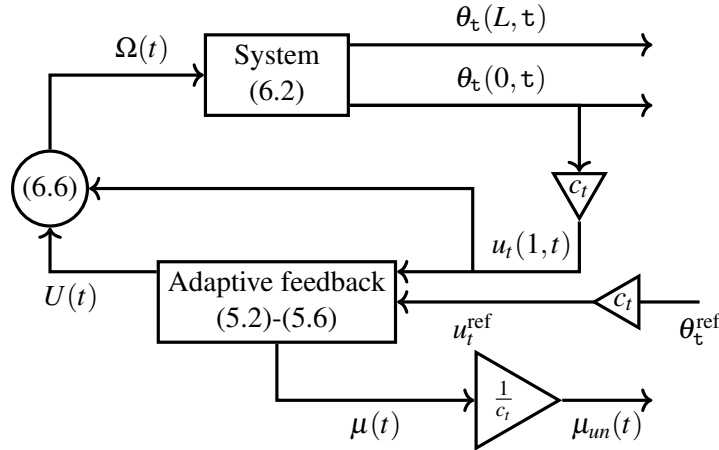

Figure 6.42: Simulation scheme for the *collocated output feedback*.

The reference  $u_t^{\text{ref}}$  is taken such that the unnormalized desired velocity is  $\theta_t^{\text{ref}} = 5 \text{ rad/s}$ . The top and bottom velocities  $\theta_t(0, \tau)$  and  $\theta_t(L, \tau)$  along with the unnormalized equivalent of  $\mu$  defined in (5.3) is

$$\mu_{\text{un}}(\tau) = \frac{\mu(t)}{c_t} \quad (6.16)$$

are all displayed in Figure 6.43, Figure 6.49, and Figure 6.55 for  $\lambda = 0, 0.45, 0.9$  respectively. The time response of the parameter estimates of  $d$  and  $q$  are displayed in Figure 6.47 for the case  $\lambda = 0$  and in Figure 6.53 for the case  $\lambda = 0.45$ .

One can notice that the oscillations existing in the open-loop phase, i.e., before 15 s in Figure 6.43 and Figure 6.49, are suppressed by the application of the closed-loop control law and regulation is obtained.

In Figure 6.49, as expected when  $\lambda = 0$  from (5.18), (6.5), and (6.16), one gets  $\mu_{\text{un}}(\tau) = \theta_t(L, \tau - c_t)$  (if  $\lambda = 0$  then  $\tilde{\omega}(1, t) = 0$ ). Moreover, the top and bottom velocities  $\theta_t(0, \tau)$  and  $\theta_t(L, \tau)$  reach 95% of the reference, at respectively 23.54 and 23.37 s, which are reasonable performances compared to the oscillation period. In Figure 6.49 ( $\lambda = 0.45$ ), the top and bottom velocities  $\theta_t(0, \tau)$  and  $\theta_t(L, \tau)$  reach 95% of the reference at respectively 22.00 and 21.74 s. One observes that these settling times are close to the nominal case. Here, as expected from (4.41), (6.5), and (6.16),  $\mu_{\text{un}}(t)$  is only an approximation of  $\theta_t(L, \tau - c_t)$ .

The fact that the system for  $\lambda = 0.45$  in Figure 6.49 has a settling time lower than in the nominal case ( $\lambda = 0$  in Figure 6.43) can probably be explained by the fact that the respective velocity values are not the same when the controller is turned on. Moreover, notice that the magnitude of the oscillations before  $\tau = 15 \text{ s}$  is lower in Figure 6.49 (case  $\lambda = 0.45$ ) than in Figure 6.43 (case  $\lambda = 0$ ), which is clearly explained by the fact that the in-domain damping adds dissipation. This has been already illustrated in Figure 6.3.

In Figure 6.53, as expected,  $\hat{d}(\tau)$  converges to  $d$ . Even if velocity regulation is obtained, one can observe that the estimation  $\hat{q}(\tau)$  does not converge to the value of  $q$ . Note that this latter observation does not contradict the conclusion of Theorem 5.2.

In Figure 6.55, a high damping value is considered ( $\lambda = 0.9$ ). Consequently, the open-loop system does not exhibit an oscillatory behavior. Therefore, the benefits of the feedback controller used after 15 s are quite

reduced. However, this simulation highlights the robustness capabilities of this adaptive control law as closed-loop convergence is again achieved.

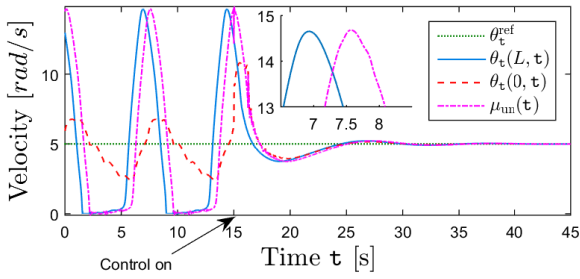

Figure 6.43: Simulation of the top, bottom and delayed bottom estimated velocities for  $\lambda = 0$ , the nominal case for which the control has been developed (see [Bresch-Pietri and Krstic, 2014b]).

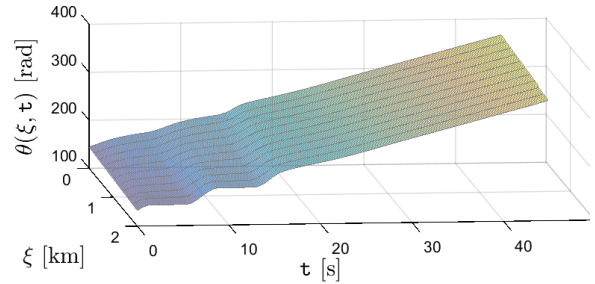

Figure 6.44: Simulation of the distributed position for  $\lambda = 0$ , for the *collocated output feedback*.

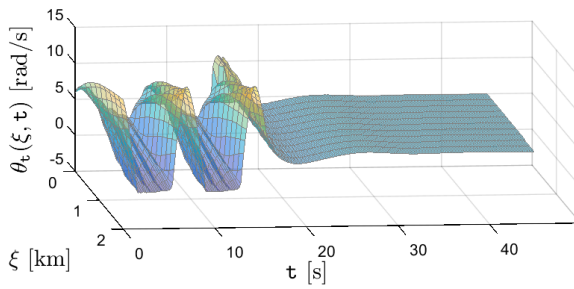

Figure 6.45: Simulation of the distributed velocity for  $\lambda = 0$ , for the *collocated output feedback*.

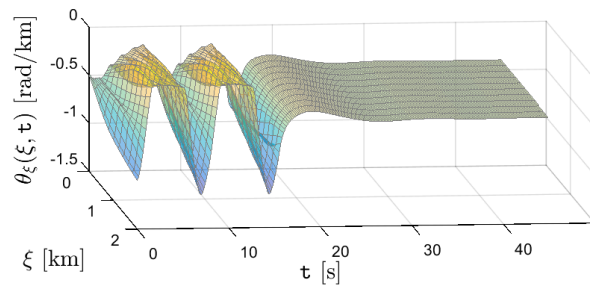

Figure 6.46: Simulation of the shear stress for  $\lambda = 0$ , for the *collocated output feedback*.

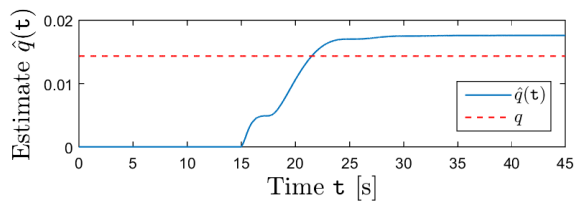
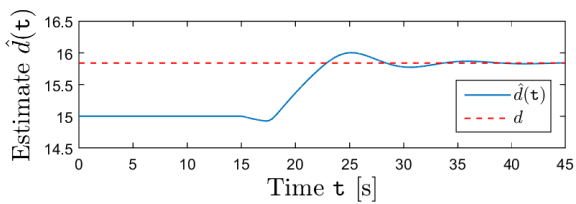

Figure 6.47: Evolution of the parameter estimates  $\hat{d}$  and  $\hat{q}$  for  $\lambda = 0$ , for the *collocated output feedback*.

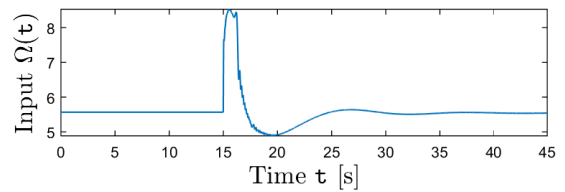
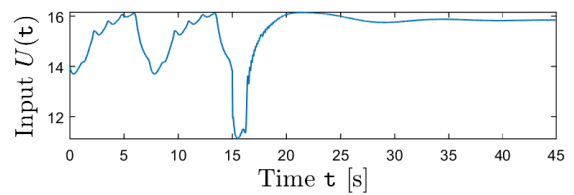

Figure 6.48: Input time response  $U(t)$  and  $\Omega(t)$  for  $\lambda = 0$  for the *collocated output feedback*.

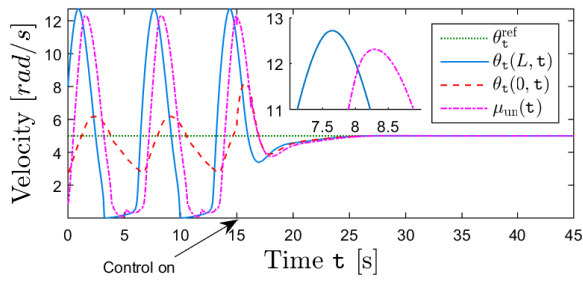

Figure 6.49: Simulation of the top, and bottom and delayed bottom estimated velocities for  $\lambda = 0.45$ , for the *collocated output feedback*.

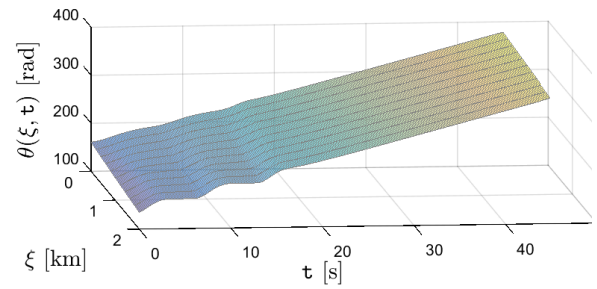

Figure 6.50: Simulation of the distributed position for  $\lambda = 0.45$ , for the *collocated output feedback*.

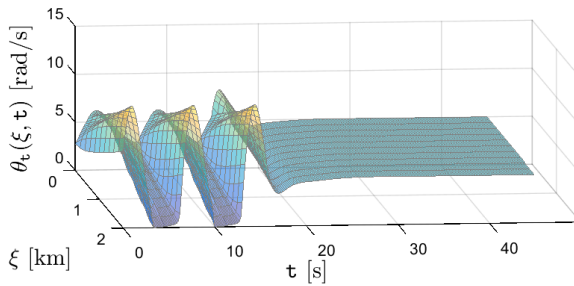

Figure 6.51: Simulation of the distributed velocity for  $\lambda = 0.45$ , for the *collocated output feedback*.

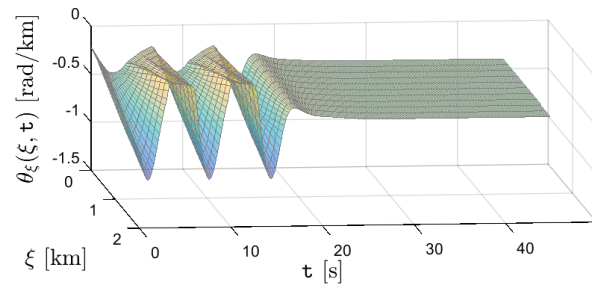

Figure 6.52: Simulation of the shear stress for  $\lambda = 0.45$ , for the *collocated output feedback*.

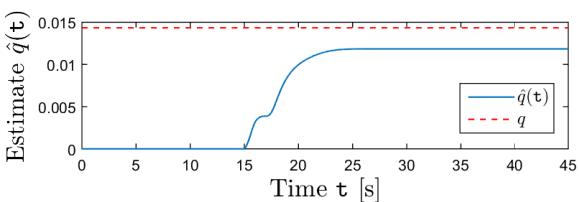
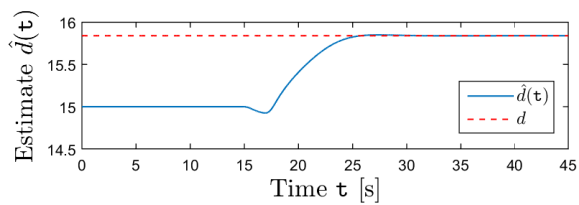

Figure 6.53: Evolution of the parameter estimates  $\hat{d}$  and  $\hat{q}$  for  $\lambda = 0.45$ , for the *collocated output feedback*.

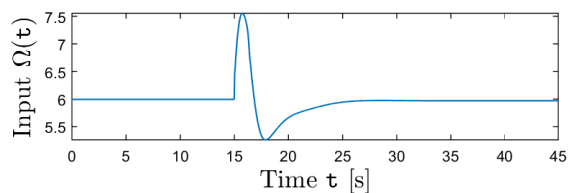
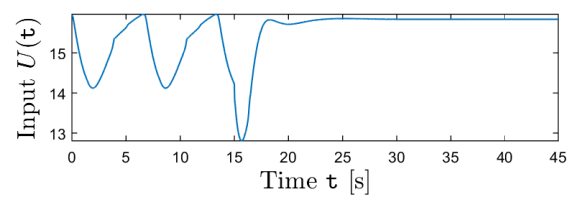

Figure 6.54: Input time response  $U(t)$  and  $\Omega(t)$  for  $\lambda = 0.45$  for the *collocated output feedback*.

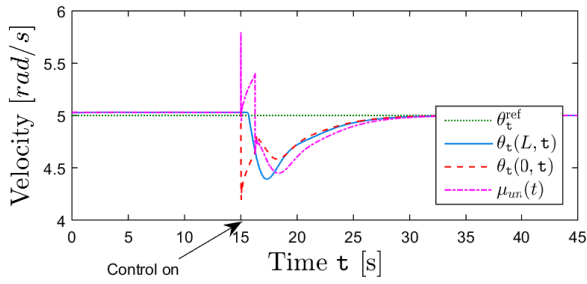

Figure 6.55: Simulation of the top, bottom and delayed bottom estimated velocities, for  $\lambda = 0.9$ , for the *collocated output feedback*.

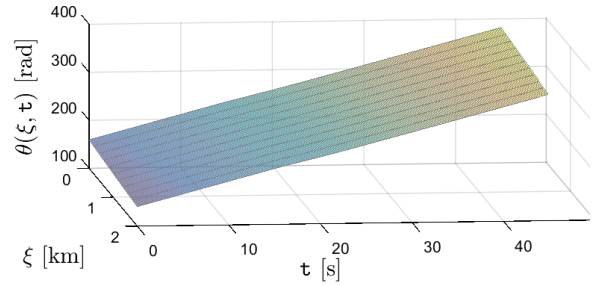

Figure 6.56: Simulation of the distributed position for  $\lambda = 0.9$ , for the *collocated output feedback*.

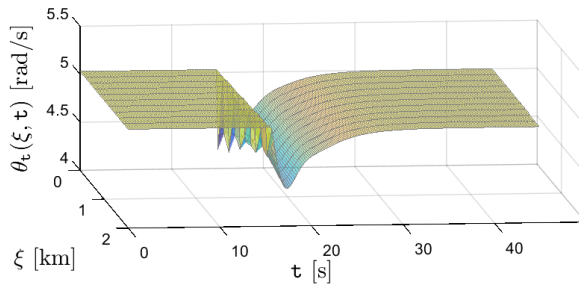

Figure 6.57: Simulation of the distributed velocity for  $\lambda = 0.9$ , for the *collocated output feedback*.

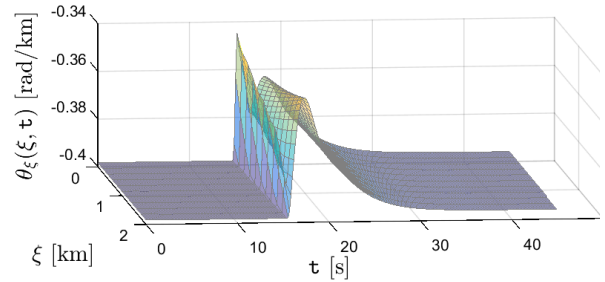

Figure 6.58: Simulation of the shear stress for  $\lambda = 0.9$ , for the *collocated output feedback*.

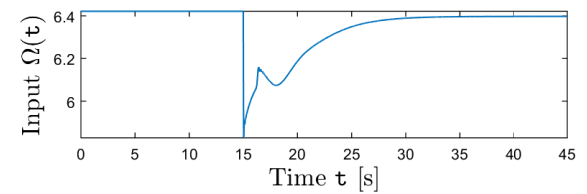
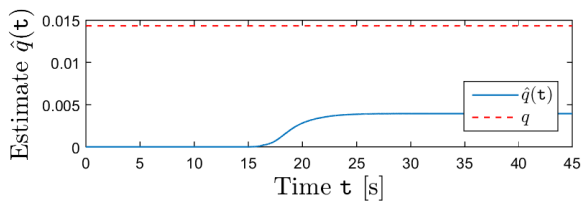
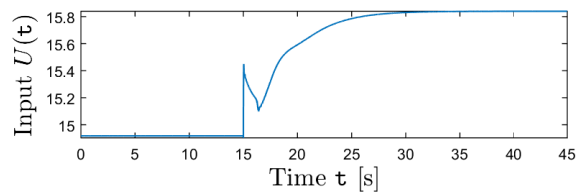
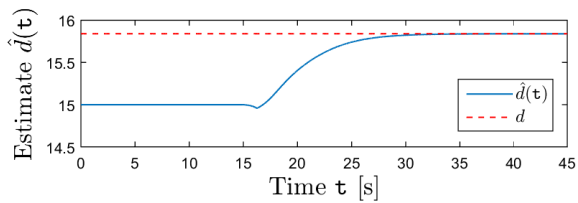

Figure 6.59: Evolution of the parameter estimates  $\hat{d}$  and  $\hat{q}$  for  $\lambda = 0.9$ , for the *collocated output feedback*.

Figure 6.60: Input time response  $U(t)$  and  $\Omega(t)$  for  $\lambda = 0.9$  for the *collocated output feedback*.

## 6.5 A comparison of the three controls approaches

In this section, we compare the responses of the closed-loop system for the three adaptive control laws defined in (3.2), (4.2) and (5.2), and for several different cases of  $\lambda$  ( $\lambda \in \{0, 0.45, 0.9\}$ ). To illustrate this comparison, we suggest to plot  $(\theta_t(0, \tau), \theta_t(L, \tau))$  for the three adaptive control laws for  $\lambda \in \{0, 0.45, 0.9\}$ . Note that the graph of  $(\theta_t(0, \tau), \theta_t(L, \tau))$  ( $\lambda = 0$ ) displayed in Figure 6.61 is less smooth than the one obtains in Figure 6.62 ( $\lambda = 0.45$ ).

In the previous section, we have presented settling time, but because we have not performed a reference step, this is not totally rigorous. The graph of  $(\theta_t(0, \tau), \theta_t(L, \tau))$  is more interesting than the time response of the boundary velocities in order to analyze the convergence of a limit cycle toward an equilibrium. Therefore, in order to characterize the performance of each control for each case, let our criterion be the time laps between the turned on of the actuation and the time the trajectory of  $(\theta_t(0, \tau), \theta_t(L, \tau))$  reaches a certain distance of the desired equilibrium. The time spent between the control actuation until the moment the trajectory reaches the ball of radius  $(0.01, 0.05, 0.10, 0.15)$  from the distance associated to the  $\ell_1$ -norm,  $\ell_2$ -norm, and  $\ell_\infty$ -norm is presented in Table 6.3. The reason we chose the radius to be  $(0.01, 0.05, 0.10, 0.15)$ , is that the two former represent somehow the precision rapidity of the control law, the two latter represent its rapidity of action.

It is worth noticing that in Figure 6.63, the system (in terms of  $\theta_t(0, \tau)$  and  $\theta_t(L, \tau)$ ) has already converged toward an equilibrium. This has been shown in Figure 6.55, Figure 6.36 and in Figure 6.17 before  $\tau = 15$  s. The application of the adaptive control law just changes this equilibrium to  $(\theta_t(0, \tau) = 5, \theta_t(L, \tau) = 5)$ . In Figure 6.63 the trajectories that link both equilibrium are not the most direct one. It can be a loss of performance with respect to other type of control.

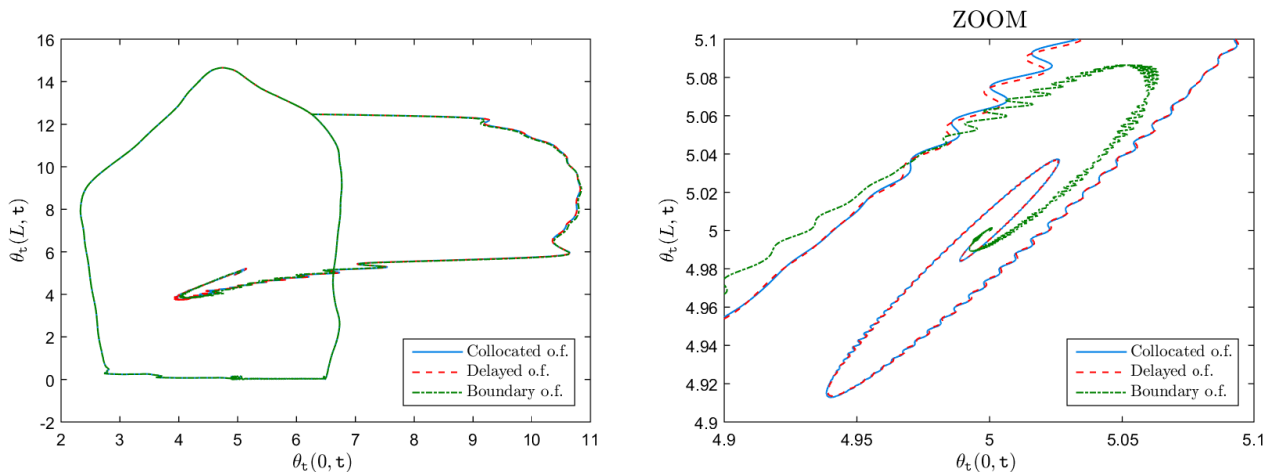

Figure 6.61: Graph of  $(\theta_t(0, \tau), \theta_t(L, \tau))$  for the three control laws with  $\lambda = 0$

To compare the three control laws with respect to  $\lambda$ , intuitively it would be better to perform a reference step. Nevertheless, the system state cannot be the same, cause the dynamics are different, at the exception of  $\theta_t(\cdot, \tau) = 0$ . When the regulation is performed, even if it is completely transparent (we do neither see it in the simulation scheme, nor for the model, nor the control, and nor adaptive control law),  $u_x(x, t)$  converges towards  $u_x^{\text{ref}}(x) = d + 2\lambda u_t^{\text{ref}} x$ . Thus even if a reference step is preformed, the comparison between different  $\lambda$  cannot be rigorous.

Note that if the control is turned on in the  $\theta_t(\cdot, \tau) = 0$  neighborhood it fails due to the fact that we are too far from the linearized point. Note that the state is not just the velocity at the boundaries.

In conclusion, these were the reasons, we suggest to compare the three adaptive control laws for each  $\lambda$  by their respective time laps between the limit cycle behavior to the reference (listed in Table 6.3).

- (i). First  $\lambda = 0$ , the *collocated output feedback* and the *delayed anti-collocated output feedback* are the same control law. They should have the same time laps. This is not the case. This can only be explained by



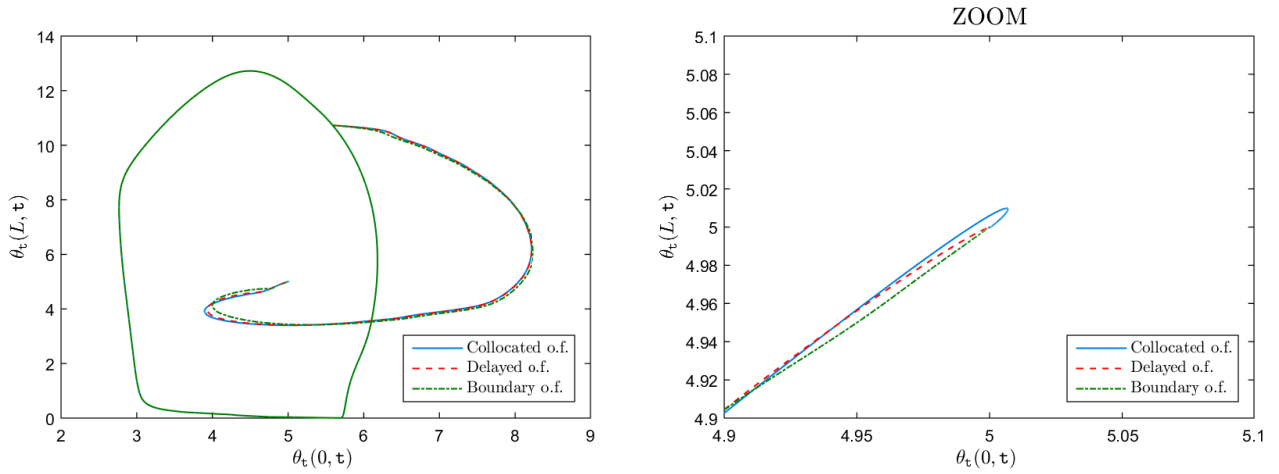

Figure 6.62: Graph of  $(\theta_t(0, \tau), \theta_t(L, \tau))$  for the three control laws with  $\lambda = 0.45$

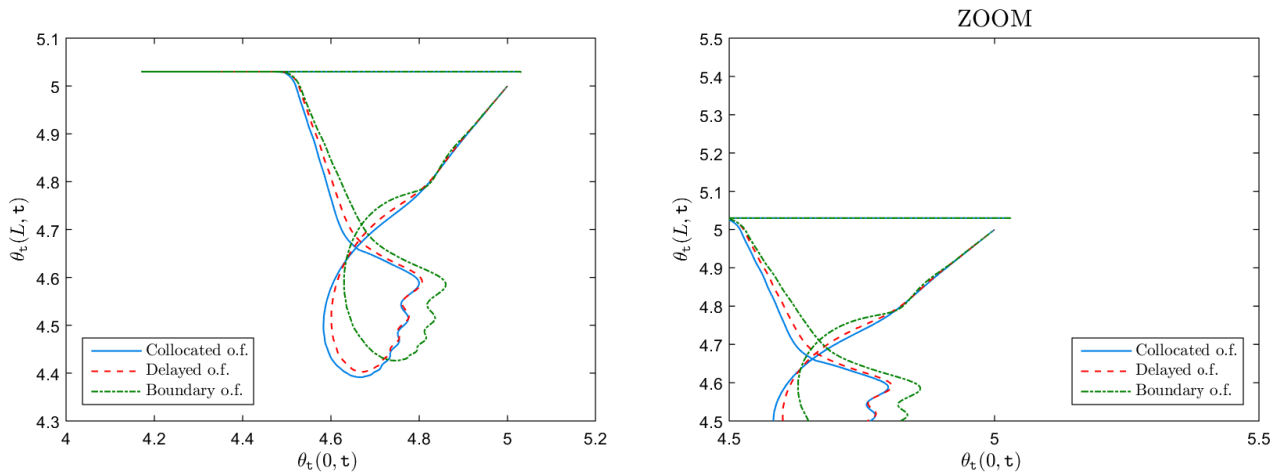

Figure 6.63: Graph of  $(\theta_t(0, \tau), \theta_t(L, \tau))$  for the three control laws with  $\lambda = 0.9$

the fact that we have numerical mistake when  $\mu$  is computed. Indeed, the remaining part of both adaptive control laws are identical. Therefore, the tolerance is a least of 0.05 s. Note that the *boundary output feedback* provides a faster time response which is consistent with the fact that it uses extra information.

- (ii). Second  $\lambda = 0.45$ , taking apart the time laps for the 0.01 radius the *delayed anti-collocated output feedback* is faster than the *collocated output feedback*, which is faster than the *boundary output feedback*.
- (iii). Third  $\lambda = 0.9$ , it is the *collocated output feedback* which is the faster. The *boundary output feedback* has a higher time laps than the *delayed anti-collocated output feedback*, neglecting the 0.15 radius for the  $\ell_\infty$ -norm.

According to these result, we can conclude that there is no particular inclination to deduce. There is no particular efficiency of a control law versus an others. Therefore, the measurement of  $u_t(0, t)$  (or even delay), does not seem to impact the efficiency of the adaptive control laws.

Even if it is not rigorous and with a few exception, all time laps are smaller when  $\lambda = 0.45$ . Note that for the *boundary output feedback* the case  $\lambda = 0.9$  has more higher time laps than when  $\lambda \in \{0, 0.9\}$ . We are possibly in presence of overdamping (see Section 1.9 for an explanation of it in a finite case), or we are probably at the limit of the adaptive control law robustness.

$\lambda$	radius	Boundary Chapter 3			Delayed Chapter 4			Collocated Chapter 5		
		0	0.45	0.9	0	0.45	0.9	0	0.45	0.9
$\ell_1$	0.01	18.76	17.79	24.87	29.12	13.04	20.73	29.14	15.22	17.40
	0.05	13.70	12.96	16.71	23.71	11.17	14.62	23.74	10.47	12.89
	0.10	12.96	10.84	13.20	18.76	10.19	11.97	18.76	9.70	10.89
	0.15	8.88	9.63	11.13	14.05	9.54	10.40	14.03	9.25	9.68
$\ell_2$	0.01	17.93	16.75	23.12	29.72	12.69	19.43	29.77	14.37	16.44
	0.05	13.26	11.90	14.95	19.22	10.70	13.30	19.24	10.16	11.90
	0.10	11.62	9.80	11.45	17.80	9.64	10.63	17.83	9.34	9.86
	0.15	8.75	8.66	9.35	13.62	8.93	9.08	13.62	8.72	8.60
$\ell_\infty$	0.01	17.08	15.71	21.54	29.31	12.46	18.26	29.36	11.28	15.58
	0.05	12.70	10.83	13.37	18.84	10.28	12.14	18.86	9.86	10.03
	0.10	8.97	8.89	9.81	13.75	9.08	9.45	13.74	8.84	8.94
	0.15	8.65	7.70	7.84	13.16	8.25	7.92	13.15	8.12	7.63

Table 6.3: Time laps in secondes between the actuation of the control law and the time to have all trajectory  $(\theta_t(L, \tau), \theta_t(0, \tau))$  are contained in a ball of  $\ell_1$ -norm,  $\ell_2$ -norm, and  $\ell_\infty$ -norm with different radius for the different control laws, with different  $\lambda$ .

## Chapter conclusion

In this chapter we have provided simulation on a drilling inspired model. The wave equation can be used to model the torsional vibrations occurring in drilling facility. The three adaptive feedback law can be used to regulate the angular velocity of the drillbit despite the fact bit-rock friction parameters are unknown. Note that when  $\lambda$ , the in-domain damping coefficient is too large the system does not exhibit an open-loop limit cycle. However even in this case the regulation is still achieved.

The first order Taylor approximation seems to be sufficient for the regulation of the considered nonlinear model. In this case, the unknown parameters of the dynamic boundary condition are the linearization of a nonlinear function. We can see this as an adaptive gain scheduling as the coefficient of the tangent of the nonlinearity are adapted. Note that the nonlinear closed-loop system is locally stable on an open set if the nonlinearity is Lipschitz and the intervals of the estimated parameters are large enough, i.e., encompass the range of the tangent approximation for this open set.



---

# Part I conclusion

---

We have proposed a method to study the mismatch robustness of prediction/backstepping and adaptive control law. One advantage of this method is that it allows to extend the used of promising control law. Indeed, the presented control laws are easy enough to implement in practice. Moreover, the needed knowledge is relatively easy to have in practice. For the drilling application for example, the unstable dynamics boundary condition parameters are complex to have in practice, as they depend on many physical properties: they are dealt with adaptive control. An other hard point to have in practice is the in-domain viscous damping coefficient, as the field consist of mud, water, rock, and gas: this coefficient is dealt through model mismatch robustness. Furthermore, the last studied adaptive control law, the *collocated output feedback* use only the collocated velocity and thus is of great interest, in particular for the drilling application. Indeed, so far as we known, an observer using only the collocated measurement for in-domain damped wave subject to dynamic boundary condition has still not be presented.

The proposed method seems flexible enough to establish the model mismatch robustness of other backstepping (in particular prediction) and adaptive control law. Moreover, we could use the same method to study different kind of mismatch robustness. For example it would be interesting to study the robustness with respect to Kelvin-Voigt damping, i.e., a term in  $u_{xx}$ . It represents the fact that the wave have a diffusion behavior. Note that in this case the *auxiliary system* behaves as couple diffusion-advection PDE.

Nevertheless, there are some points which can be improved. The Lyapunov analysis we propose may be ameliorated with cross term, to have a less conservative result. The simulation -as always- can be complemented for different tuning parameters, with other setups.

Furthermore, there is the question about the absolute knowledge of the delay, which in our case is transposed with the perfect knowing of  $c_t$  defined in (6.4). This latter case seems more problematic.

---

The following part suggests some developments on what can be achieved taking implicitly  $\lambda$  into account using backstepping control design.

---



## **Part II**

# **Backstepping control design**

# Introduction

---

In this part we present the work we have done concerning backstepping design. We present three different backstepping control designs for three different wave equations. Each chapter consider a more complete wave equation that the previous one.

In Chapter 7, we present a backstepping control for the same system to the one studied in Part I. The interesting fact is that the exponential stability of the closed-loop and the estimation-error system (an observer is also design) are towards an attractor.

In Chapter 8, a wave with position distributed term is considered. We extend the design established in Chapter 7. Indeed the backstepping control law allows to regulate the position if needed or to regulate only the velocity as before under minor change. This design requires full-state measurement.

In Chapter 9, we present on-going works. First around well-posedness of wave equation. Then, we consider a wave equation with space-dependent coefficient. The preliminary computation on a backstepping-based control law is presented.

---

# An explicit backstepping design

---

## Contents

<b>7.1</b>	<b>An unstable wave equation with velocity distributed terms</b>	<b>118</b>
<b>7.2</b>	<b>A exponential stable wave equation on a attractor</b>	<b>119</b>
<b>7.3</b>	<b>Backstepping state feedback</b>	<b>121</b>
7.3.1	Closed-loop stability result	122
7.3.2	Closed-loop system well-posedness	123
<b>7.4</b>	<b>Proof of the closed-loop stability</b>	<b>123</b>
7.4.1	Establishment of the kernel PDE	123
7.4.2	Vector reformulation and explicit solution of the kernel equation	126
7.4.3	Invertibility of the backstepping transformation	126
7.4.4	Relationship between $\Gamma_1(\mathcal{X}(t))$ and $V_1(\mathcal{X}_e(t))$	127
7.4.5	Conclusion of the closed-loop stability result proof	128
<b>7.5</b>	<b>Observer design</b>	<b>128</b>
<b>7.6</b>	<b>Comparison with prediction-based designs</b>	<b>129</b>
<b>7.7</b>	<b>Comparison with the backstepping control law in [Sagert et al., 2013]</b>	<b>130</b>
7.7.1	Presentation of both control laws	130
7.7.2	Exponential stability of the control in [Sagert et al., 2013]	133
7.7.3	Gain comparison of the two control laws	134
<b>7.8</b>	<b>Simulations</b>	<b>134</b>
7.8.1	Space semi-discretization and eigenvalues	135
7.8.2	Velocity time response simulations	135
7.8.3	Frequency response of the discretized system	139
	<b>Chapter conclusion</b>	<b>143</b>

---

This chapter focuses on an explicit backstepping control law design. This design is qualified as explicit because the backstepping transformation kernel, and therefore the gains of the control law are explicitly solved and thus formulated. The design gives rise to a full-state feedback. Therefore, an observer is proposed using both boundary velocities.

In Section 7.1, the *original system* is presented and an associated abstract representation is given. Then, in Section 7.2 the stability result of the *target system* is proved using a Lyapunov approach. In Section 7.3, we focus on the statement of the control law, the backstepping transformation, and *closed-loop system* stability result. The proof of the latter is established in Section 7.4. In Section 7.5, the observer is presented together with the observer-based design stability result. Then the equivalence of the developed control law and the prediction based design in the case without in-domain damping is presented in Section 7.6. We compare this design with the one proposed in [Sagert et al., 2013] in Section 7.7. This chapter ends up with some simulation results in Section 7.8.



## 7.1 An unstable wave equation with velocity distributed terms

Consider the following *original system*

$$(\Sigma_{O_1}) \quad \begin{cases} u_{tt}(x,t) = u_{xx}(x,t) - \lambda u_t(x,t), & (7.1a) \\ u_x(1,t) = U(t), & (7.1b) \\ u_{tt}(0,t) = b_1 u_t(0,t) + b_2 u_x(0,t), & (7.1c) \end{cases}$$

in which  $U(t)$  is the scalar control input,  $u(x,t) \in \mathbb{R}$  is the variable of the system. The in-domain viscous damping coefficient is  $\lambda \geq 0$ .  $b_1 > 0$  and  $b_2 > 0$  are boundary parameters.  $\lambda$ ,  $b_1$ , and  $b_2$  are supposed to be known constant parameters.

The control objective is to stabilize the system velocity (i.e.,  $\|u_t\|_{L_2}$ ) and torque (i.e.,  $\|u_x\|_{L_2}$ )<sup>1</sup>.

The purpose of the following is to express our control objective in term of an attractor.

The state of this system cannot be given rigorously without considering the abstract form of the system. Moreover as we consider feedback control, the interesting result is not the well-posedness of (7.1), but the well-posedness of the closed-loop system (which is stated in Section 7.3.2). Note that for reader interested in the well-posedness of the open-loop with  $U(t) \in W_{1,\infty}$  the framework of boundary output is introduced in [Curtain and Zwart, 2012].

Now in order to express the control objective rigorously we suggest to consider the zero input system (7.1). In other words, let us consider the abstract Cauchy problem resulting from the system  $(\Sigma_{O_1})$  defined in (7.1) with  $U(t) = 0$ . To this aim, let us define the Hilbert space  $H_1$

$$H_1 := \{(z_1, z_2, z_3, z_4) \in H_1(0,1) \times L_2(0,1) \times \mathbb{R}^2 : z_3 = z_1(0)\}. \quad (7.2)$$

$H_1$  is the state space of our system (the zero input system and the closed-loop system). Consider the following operator (the prime has been defined in (1.38))

$$\mathcal{A}_0 := - \begin{bmatrix} 0 & 1 & 0 & 0 \\ \delta_{xx} & -\lambda & 0 & 0 \\ 0 & 0 & 0 & 1 \\ b_2 \delta_{x|0} & 0 & 0 & b_1 \end{bmatrix}, \quad (7.3)$$

in which  $\delta_{xx} z_1 = z_1''$  and  $\delta_{x|0} z_1 = z_1'(0)$  and with  $\text{Dom}(\mathcal{A}_0)$  is defined as

$$\text{Dom}(\mathcal{A}_0) := \{(z_1, z_2, z_3, z_4) \in H_2(0,1) \times H_1(0,1) \times \mathbb{R}^2 : z_3 = z_1(0), z_4 = z_2(0), z_1'(1) = 0\}. \quad (7.4)$$

The strong solution of the system belongs to  $\text{Dom}(\mathcal{A}_0)$ , whereas the weak solution belongs to  $H_1$ . The abstract problem resulting from the system  $(\Sigma_{O_1})$  (with  $U(t)=0$ ) defined in (7.1) is

$$\begin{cases} \frac{d}{dt} X(t) + \mathcal{A}_0 X(t) = 0, & X(t) \in \text{Dom}(\mathcal{A}_0), & (7.5a) \\ X(0) = X_0. & & (7.5b) \end{cases}$$

We could prove that this abstract problem is well-posed (this is established Appendix B). But as it had been said this is not the purpose here. Finally, let us rigorously express the considered control objective by defining the desired attractor

$$\mathcal{S} := \left\{ z \in H_1 : z_1(\cdot) \stackrel{a.e.}{=} C, z_2(\cdot) \stackrel{a.e.}{=} 0, z_3 = C, C \in \mathbb{R}, z_4 = 0 \right\}. \quad (7.6)$$

The notation  $\stackrel{a.e.}{=}$  stands for equal almost everywhere and has been defined in (1.41). The control objective is to stabilize the system  $(\Sigma_{O_1})$  defined in (7.1) towards the attractor  $\mathcal{S}$ . Now we need to find a criterion which allows us to characterize the distance between the state and the attractor. This can be done using the following functional

$$\Gamma_1(z) := \int_0^1 z_1'(x)^2 dx + \int_0^1 z_2(x)^2 dx + z_4^2. \quad (7.7)$$

<sup>1</sup> Note that these denominations (velocity and torque) are abusive, as the system is normalized and so variables do not have units

Indeed  $\Gamma(\cdot)$  represents the distance between a point  $z \in \mathbb{H}_1$  and the attractor  $\mathcal{S}$ . Moreover, it holds

$$\Gamma_1(z) = 0 \Leftrightarrow z \in \mathcal{S}. \quad (7.8)$$

The link between  $X(t)$ ,  $z$  and  $u(\cdot, t)$  is

$$X(t) = z = \begin{bmatrix} z_1 \\ z_2 \\ z_3 \\ z_4 \end{bmatrix} = \begin{bmatrix} u(\cdot, t) \\ u_t(\cdot, t) \\ u(0, t) \\ u_t(0, t) \end{bmatrix},$$

one writes

$$\Gamma_1(\mathcal{X}(t)) = \int_0^1 u_x(x, t)^2 dx + \int_0^1 u_t(x, t)^2 dx + u_t(0, t)^2, \quad (7.9)$$

in which  $\mathcal{X}(t) \in \mathbb{H}_1$  is

$$\mathcal{X}(t) = [u(\cdot, t), u_t(\cdot, t), u(0, t), u_t(0, t)]. \quad (7.10)$$

It holds

$$\Gamma_1(\mathcal{X}(t)) = 0 \Leftrightarrow \|u_x\|_{L_2} = 0, \|u_t\|_{L_2} = 0, u_t(0, t) = 0 \quad (7.11)$$

It is worth noticing that the kernel of the functional  $\Gamma$  is the attractor  $\mathcal{S}$ .

Before presenting the considered control law, the backstepping transformation, and the stability result, and the well-posedness of the closed-loop system, the following section is dedicated to the *target system*. This is the chronological way to perform the backstepping approach. Note that usually the control, the backstepping transformation and the stability result are presented before the *target system*.

## 7.2 A exponential stable wave equation on a attractor

In this section, the chosen *target system* is presented. This choice of *target systems* is a crucial point for the backstepping control design. Indeed, assuming that we find a backstepping transformation, the closed-loop system will have the same dynamic as the *target system*. Consider the following *target system*

$$(\Sigma_{T_1}) \quad \begin{cases} w_{tt}(x, t) = w_{xx}(x, t) - \lambda w_t(x, t), & (7.12a) \\ w_x(1, t) = -c_1 w_t(1, t), & (7.12b) \\ w_{tt}(0, t) = -d_1 w_t(0, t) + d_2 w_x(0, t), & (7.12c) \end{cases}$$

in which  $\lambda$  is an in-domain viscous damping term.  $c_1$ ,  $d_1$ , and  $d_2$  are boundary parameters.

Consider the following Lyapunov functional candidate

$$V_1(\mathcal{X}_e(t)) = \int_0^1 (w_x^2 + w_t^2) dx + \frac{1}{b_2} w_t(0, t)^2 + \sigma \int_0^1 (1+x) w_x w_t dx, \quad (7.13)$$

in which

$$\sigma < \min \left\{ \sqrt{2}, \frac{8\lambda}{4\lambda^2 - 1} \text{ if } \lambda > \frac{1}{4}, \frac{2c_1}{1 + c_1^2} \right\}, \quad (7.14)$$

and  $\mathcal{X}_e(t) \in \mathbb{H}_1$  is

$$\mathcal{X}_e(t) = [w(\cdot, t), w_t(\cdot, t), w(0, t), w_t(0, t)]. \quad (7.15)$$

The functional  $V$  is thereby positive and definite on  $\mathcal{S}$  (7.6). This means

$$\forall z \in \mathbb{H}_1, \quad \begin{cases} V(z) \geq 0, \\ z \in \mathcal{S} \Leftrightarrow V(z) = 0. \end{cases} \quad (7.16)$$

The proof of the following lemma is not the same as the one exposed in [Roman et al., 2016a], and it result slightly differs from [Roman et al., 2016a]. Indeed, here we do not evaluate the decay rate.

**Lemma 7.1** *Adapted from [Roman et al., 2016a]*

Consider the target system  $(\Sigma_{T_1})$  defined in (7.12). If all parameters are positive, i.e.,  $\lambda > 0$ ,  $c_1 > 0$ ,  $d_1 > 0$ , and  $d_2 > 0$ , there exists  $\rho_1 > 0$ , such that

$$\dot{V}_1(\mathcal{X}_e(t)) \leq -\rho_1 V_1(\mathcal{X}_e(t)), \quad (7.17)$$

in which  $V_1$  is defined in (7.13).

Before entering into the details of the proof a proposition is stated. The idea is to use vector notation to get a more unified way to compute the Lyapunov function candidate derivative.

**Proposition 7.1** *Consider  $W(x, t) \in \mathbb{R}^n$  with  $n \in \mathbb{N}$ ,  $x \in [0, 1]$  and  $t \in [0, \infty)$ , whose dynamics is*

$$W_t(x, t) = A_1(x)W(x, t) + A_2 W_x(x, t), \quad (7.18)$$

in which  $A_1(x) \in \mathbb{R}^{n \times n}$  and  $A_2 \in \mathbb{R}^{n \times n}$ . Consider also  $W_1(t) \in \mathbb{R}^m$  with  $n \geq m \in \mathbb{N}$  and  $W_0(t) \in \mathbb{R}^p$  with  $n \geq p \in \mathbb{N}$ , whose dynamics satisfy

$$\frac{d}{dt} W_1(t) = A_3 W(1, t), \quad (7.19)$$

$$\frac{d}{dt} W_0(t) = A_4 W(0, t), \quad (7.20)$$

in which  $A_3 \in \mathbb{R}^{m \times n}$  and  $A_4 \in \mathbb{R}^{p \times n}$ . Furthermore, assume that there exist  $A_5 \in \mathbb{R}^{m \times n}$  and  $A_6 \in \mathbb{R}^{p \times n}$  such that it holds

$$W_1(t) = A_5 W(1, t), \quad (7.21)$$

$$W_0(t) = A_6 W(0, t). \quad (7.22)$$

Consider now the following functional

$$V_W(W) = \int_0^1 W^T(x, t) P_0(x) W(x, t) dx + W_1^T(t) P_1 W_1(t) + W_0^T(t) P_2 W_0(t), \quad (7.23)$$

in which  $P_0(x) \in \mathbb{R}^{n \times n}$ ,  $P_1 \in \mathbb{R}^{m \times m}$ , and  $P_2 \in \mathbb{R}^{p \times p}$ . If

$$A_2^T P_0(x) - P_0(x) A_2 = 0, \quad (7.24)$$

then it holds

$$\dot{V}_W(W) = - \int_0^1 W^T(x, t) Q_0(x) W(x, t) dx - W^T(1, t) Q_1 W(1, t) - W^T(0, t) Q_2 W(0, t), \quad (7.25)$$

with

$$Q_0(x) = -A_1^T(x) P_0(x) - P_0(x) A_1(x) + P_0'(x) A_2, \quad (7.26)$$

$$Q_1 = -A_3^T P_1 A_5 - A_5^T P_1 A_3 - P_0(1) A_2, \quad (7.27)$$

$$Q_2 = -A_4^T P_2 A_6 - A_6^T P_2 A_4 + P_0(0) A_2. \quad (7.28)$$

Equation (7.26)-(7.28) are similar to Lyapunov equation in finite dimensional case, therefore, we will also refer to as it. These equations can be used to evaluate the decay rate as it is done for hyperbolic PDEs in [Lamare et al., 2016] for example. Note that the dynamics under consideration is indeed somehow related to first-order hyperbolic PDEs.

*Proof of proposition 7.1:* From (7.23), the derivative along the state trajectory, using the dynamics of  $W$ ,  $W_1$ , and  $W_0$  in (7.18)-(7.20), is

$$\begin{aligned} \dot{V}_W(W) = & \int_0^1 (W^T [A_1(x)^T P_0(x) + P_0'(x) A_1(x)] W + W_x^T A_2^T P_0(x) W + W^T P_0(x) A_2 W_x) dx \\ & + W^T(1, t) A_3^T P_1 W_1(t) + W_1^T(t) P_1 A_3 W(1, t) + W^T(0, t) A_4^T P_2 W_0(t) + W_0^T(t) P_2 A_4 W(0, t). \end{aligned} \quad (7.29)$$

Using integration by parts, and (7.21)-(7.22), one concludes the proof. ■

Now using Proposition 7.1, the proof of Lemma 7.1 is straightforward.

*Proof of Lemma 7.1:* First, from (7.12) one observes that

$$\begin{bmatrix} w_{tt} \\ w_{tx} \end{bmatrix} (x, t) = \begin{bmatrix} 0 & -\lambda \\ 0 & 0 \end{bmatrix} \begin{bmatrix} w_t \\ w_x \end{bmatrix} (x, t) + \begin{bmatrix} 0 & 1 \\ 1 & 0 \end{bmatrix} \begin{bmatrix} w_{xt} \\ w_{xx} \end{bmatrix} (x, t), \quad (7.30)$$

and

$$w_{tt}(0, t) = [-d_1 \quad d_2] \begin{bmatrix} w_t(0, t) \\ w_x(0, t) \end{bmatrix} (x, t). \quad (7.31)$$

Consider  $P_1$  as

$$P_1 = \begin{bmatrix} p_1 & p_2 \\ * & p_3 \end{bmatrix}.$$

The condition (7.24) is equivalent to  $p_1 = p_3$ . This is the case of the considered Lyapunov functional. Indeed let us express  $V_1$  defined in (7.13) in vector form

$$V_1(\mathcal{X}_e(t)) = \int_0^1 \begin{bmatrix} w_t \\ w_x \end{bmatrix}^T \begin{bmatrix} 1 & \frac{\sigma(1+x)}{2} \\ * & 1 \end{bmatrix} \begin{bmatrix} w_t \\ w_x \end{bmatrix} dx + \frac{1}{d_2} w_t(0, t)^2.$$

Using Proposition 7.1, one computes the derivative of  $V_1$  (defined in (7.13)) along the trajectory of (7.30)-(7.31)

$$\begin{aligned} \dot{V}_1(\mathcal{X}_e(t)) = & - \int_0^1 \begin{bmatrix} w_t \\ w_x \end{bmatrix}^T \begin{bmatrix} 2\lambda + \frac{\sigma}{2} & \frac{\lambda\sigma(1+x)}{2} \\ * & \frac{\sigma}{2} \end{bmatrix} \begin{bmatrix} w_t \\ w_x \end{bmatrix} dx - \begin{bmatrix} w_t(0, t) \\ w_x(0, t) \end{bmatrix}^T \begin{bmatrix} \frac{\sigma}{2} + 2\frac{d_1}{d_2} & 0 \\ * & \frac{\sigma}{2} \end{bmatrix} \begin{bmatrix} w_t(0, t) \\ w_x(0, t) \end{bmatrix} \\ & - [2c_1 - \sigma - c_1^2\sigma] w_t(1, t)^2, \end{aligned} \quad (7.32)$$

according to the inequality on  $\sigma$  in (7.14), the matrices

$$\begin{bmatrix} 2\lambda + \frac{\sigma}{2} & \frac{\lambda\sigma(1+x)}{2} \\ * & \frac{\sigma}{2} \end{bmatrix}, \quad \begin{bmatrix} \frac{\sigma}{2} + 2\frac{d_1}{d_2} & 0 \\ * & \frac{\sigma}{2} \end{bmatrix}, \quad (7.33)$$

are symmetric positive definite and

$$2c_1 - \sigma - c_1^2\sigma > 0. \quad (7.34)$$

Thus (7.17) holds. This concludes the proof of Lemma 7.1.  $\blacksquare$

## 7.3 Backstepping state feedback

The backstepping approach is used to design a control law stabilizing system (7.1) towards  $\mathcal{S}$  defined in (7.6). The objective is to find a control law  $U(t)$  that matches the *original system* ( $\Sigma_{O_1}$ ) defined in (7.1) into the *target system* ( $\Sigma_{T_1}$ ) defined in (7.12).

The desired control law  $U$  is chosen as

$$\begin{aligned} U(u_t, u_x) := & -c_1 u_t(1, t) + \frac{1}{m(1, 1) - 1} \left[ \int_0^1 [g_{xy}(1, y) - s_x(1, y) + c_1(\lambda(s(1, y) - g_y(1, y)) + m_y(1, y))] u_t(y, t) dy \right. \\ & \left. + \int_0^1 [c_1(s_y(1, y) - g_{yy}(1, y)) - m_x(1, y)] u_x(y, t) dy + [g_x(1, 0) + c_1(m(1, 0) + b_1 g(1, 0))] u_t(0, t) \right], \end{aligned} \quad (7.35)$$

where  $b_1$   $c_1$  are the parameters of the wave equation (7.1a) and  $s$ ,  $m$ , and  $g$  are the kernels of the backstepping transformation which is defined as

$$w(x, t) = u(x, t) - \int_0^x s(x, y) u_t(y, t) dy - \int_0^x m(x, y) u_x(y, t) dy - \int_0^x g(x, y) u_{xt}(y, t) dy. \quad (7.36)$$

One may be surprised by the form of this transformation, as the last integral in (7.36) includes only boundary terms. Indeed, using an integration by parts, one can rewrite the last integral as an integral term of  $u_t(y, t)$  and

boundary terms,  $u_t(0,t)$  and  $u_t(x,t)$ . However, we will see that the existence and uniqueness of the kernel are more easily proven under this form. This idea of adding integrals term was used in [Smyshlyaev and Krstic, 2009] with a third-order kernel in  $u$ ,  $u_t$ , and  $u_x$ . Here, it is applied to a third-order kernel but in  $u_x$ ,  $u_t$ , and  $u_{xt}$ . It is worth noting that one may also choose to add an integral term in  $u$  in (7.36). However, due to the specific form of the considered *target system*, the corresponding kernel would be found equal to zero.

Note that  $u_x(y,t)$  means the derivative of  $u$  by its first variable applied at  $(y,t)$ .  $u_t$  denote the derivative of  $u$  with respect to its second variable. For the kernel  $k_x$  denotes the derivative of  $k$  by its first variable, and  $k_y$  by its second.

The kernels are defined as

$$\begin{bmatrix} s(x,y) \\ m(x,y) \\ g(x,y) \end{bmatrix} = e^{H(y-x)} F, \quad (7.37)$$

in which

$$F = \frac{1}{d_2} \begin{bmatrix} -(b_1 + d_1) \\ d_2 - b_2 \\ 0 \end{bmatrix}, \quad (7.38)$$

$$H = \begin{bmatrix} 0 & b_1 + \lambda & b_1(b_1 + \lambda) \\ 0 & b_2 & b_2(b_1 + \lambda) \\ 1 & 0 & b_2 \end{bmatrix}. \quad (7.39)$$

It is worth noticing that  $1 - m(1,1) = \frac{b_2}{d_2}$  and cannot be zero since  $b_2, d_2 > 0$  here. Thus, the control law is always well defined. Computation of the control law requires the knowledge of  $u_x(\cdot,t)$ ,  $u_t(\cdot,t)$  and the boundary velocities  $u_t(0,t)$  and  $u_t(1,t)$ . Moreover, using integration by parts one can express the control law in terms of  $u(\cdot,t)$  and  $u_t(\cdot,t)$  and their boundary values. Note that the derivatives of  $s(x,y)$ ,  $m(x,y)$ , and  $g(x,y)$  can be computed explicitly with (7.37).

### 7.3.1 Closed-loop stability result

**Theorem 7.1** [Roman et al., 2016a]

Consider the closed-loop system consisting of the original system ( $\Sigma_{O_1}$ ) defined in (7.1), together with the control law (7.35) in which the kernel are defined in (7.37)-(7.39) with  $c_1 > 0$ ,  $d_1 > 0$ , and  $d_2 > 0$ . Then there exist  $\rho > 0$  and  $R > 0$  such that, for all  $t \geq 0$

$$\Gamma_1(\mathcal{X}(t)) \leq R \Gamma_1(\mathcal{X}(0)) e^{-\rho t}, \quad (7.40)$$

in which  $\Gamma_1$  is defined in (7.7). Therefore the closed-loop system is exponentially stable with respect to the attractor  $\mathcal{S}$  defined in (7.6).

For the case  $\lambda = 0$ , using the fact that a pure wave equation (i.e., without distributed term) can be reformulated as two transport phenomena, one recovers the predictive control in [Bresch-Pietri and Krstic, 2014a] taking aside the adaptive part. This is detailed in Section 7.6.

The control law (7.35) has a structure similar to the one proposed in [Sagert et al., 2013] and thus requires knowledge of the same variables (namely  $u_t(\cdot,t)$ ,  $u_x(\cdot,t)$  modulo an intergration by part). Section 7.7 is dedicated to the comparison of both controllers. Nevertheless, note that the design approach we propose here is more straightforward -we are considering another target system which does not require a preliminary change of variables- and the stability result (Theorem 7.1) is obtained with a more usual norm. Indeed the result from [Sagert et al., 2013] is expressed in terms of  $u_x(\cdot,t)$ ,  $u_{xx}(\cdot,t)$ ,  $u_{tx}(\cdot,t)$  and  $u_t(0,t)$  and the evaluation of the norm requires more regular solution, namely, strong solution.

### 7.3.2 Closed-loop system well-posedness

Using the proof of Theorem 7.1, one can establish the closed-loop system well-posedness. This has to be seen as a complementary result of Theorem 7.1. Consider the following operator

$$\forall z \in \text{Dom}(\mathcal{A}_1) \subset \mathbb{H}_1, \quad \mathcal{A}_1 := - \begin{bmatrix} 0 & 1 & 0 & 0 \\ \delta_{xx} & -\lambda & 0 & 0 \\ 0 & 0 & 0 & 1 \\ b_2 \delta_{x|0} & 0 & 0 & b_1 \end{bmatrix}, \quad (7.41)$$

in which  $\delta_{xx} z_1 = z_1''$  and  $\delta_{x|0} z_1 = z_1'(0)$  and with  $\text{Dom}(\mathcal{A}_1)$  is defined as

$$\text{Dom}(\mathcal{A}_1) := \{(z_1, z_2, z_3, z_4) \in H_2(0,1) \times H_1(0,1) \times \mathbb{R}^2 : z_3 = z_1(0), z_4 = z_2(0), z_1'(1) = \mathcal{U}(z)\}. \quad (7.42)$$

The strong solution of the system belongs to  $\text{Dom}(\mathcal{A}_1)$ , whereas the weak solution belongs to  $\mathbb{H}_1$ . The abstract problem resulting from the system  $(\Sigma_{O_1})$  defined in (7.1) with  $\mathcal{U}$  (which is the functional associated with the control law  $U$  defined in (7.35)) is

$$\begin{cases} \frac{d}{dt} X(t) + \mathcal{A}_1 X(t) = 0, & X(t) \in \text{Dom}(\mathcal{A}_1), \\ X(0) = X_0. \end{cases} \quad (7.43a)$$

$$(7.43b)$$

The link between  $X(t)$ ,  $z$ , and  $u(\cdot, t)$  is

$$X(t) = \begin{bmatrix} X_1(t) \\ X_2(t) \\ X_3(t) \\ X_4(t) \end{bmatrix} = z = \begin{bmatrix} z_1 \\ z_2 \\ z_3 \\ z_4 \end{bmatrix} = \begin{bmatrix} u(\cdot, t) \\ u_t(\cdot, t) \\ u(0, t) \\ u_t(0, t) \end{bmatrix}.$$

Note that the only difference of  $\mathcal{A}_1$  with  $\mathcal{A}_0$  defined in (7.3) lies in the definition of their respective domains.

**Theorem 7.2** Consider  $\mathbb{H}_1$ ,  $\mathcal{A}_1$ , and  $\text{Dom}(\mathcal{A}_1)$  respectively defined in (7.2), (7.41), and (7.42).

(i). For all initial data  $X_0 \in \text{Dom}(\mathcal{A}_1)$ , the abstract problem (7.43) has a unique strong solution such that

$$\begin{cases} \forall t > 0, X(t) \in \text{Dom}(\mathcal{A}), \\ X_1 \in W_{1,\infty}(0, \infty; H_1(0,1)) \cap L_\infty(0, \infty; H_2(0,1)). \end{cases}$$

(ii). For all initial data  $X_0 \in \mathbb{H}_1$ , the abstract problem (7.43) has a unique weak solution

$$\begin{cases} \forall t > 0, X(t) \in \mathbb{H}, \\ X_1 \in W_{1,\infty}(0, \infty; L_2(0,1)) \cap L_\infty(0, \infty; H_1(0,1)). \end{cases}$$

given by  $X(t) = S(t)X_0$ , in which  $S$  is the  $C_0$ -semigroup of contraction generated by the unbounded operator  $\mathcal{A}_1$ .

*Proof* : The proof of well-posedness is detailed in Appendix B, as it uses ideas developed in Chapter 8 and Chapter 9. ■

## 7.4 Proof of the closed-loop stability

### 7.4.1 Establishment of the kernel PDE

**Lemma 7.2** Consider the backstepping transformation (7.36) which maps the closed-loop system  $(\Sigma_{O_1})$  defined in (7.1) with the control law (7.35) into the target system  $(\Sigma_{T_1})$  defined in (7.12). The kernel of this backstepping

transformation is solution of

$$(\Sigma_{K_1}) \quad \begin{cases} S_{xx}(x, y) = S_{yy}(x, y), & (7.46a) \\ S(x, x) = F, & (7.46b) \\ S_y(x, 0) = HS(x, 0), & (7.46c) \end{cases}$$

in which  $F$  and  $H$  have been introduced in (7.38) and (7.39). And with

$$S(x, y) = \begin{bmatrix} s(x, y) \\ m(x, y) \\ g(x, y) \end{bmatrix}. \quad (7.47)$$

*Proof*: From the time derivative of (7.36), using integrations by parts and (7.1a), it holds

$$\begin{aligned} w_t(x, t) = & u_t(x, t) + \lambda \int_0^x s(x, y) u_t(y, t) dy - [s(x, y) u_x(y, t)]_{y=0}^x + \int_0^x s_y(x, y) u_x(y, t) dy - \int_0^x m(x, y) u_{xt}(y, t) dy \\ & - [g(x, y) u_{xx}(y, t) - g_y(x, y) u_x(y, t)]_{y=0}^x - \int_0^x g_{yy}(x, y) u_x(y, t) dy + \lambda \int_0^x g(x, y) u_{xt}(y, t) dy. \end{aligned} \quad (7.48)$$

Similarly, one obtains the second order time derivative of  $w$

$$\begin{aligned} w_{tt}(x, t) = & u_{xx} - \lambda u_t(x, t) + \lambda [s(x, y) u_x(y, t)]_{y=0}^x - \lambda \int_0^x s_y(x, y) u_x(y, t) dy - \lambda^2 \int_0^x s(x, y) u_t(y, t) dy \\ & - [s(x, y) u_{xt}(y, t) - s_y(x, y) u_t(y, t)]_0^x - \int_0^x s_{yy}(x, y) u_t(y, t) dy - [m(x, y) u_{xx}(y, t) - m_y(x, y) u_x(y, t)]_{y=0}^x \\ & - \int_0^x m_{yy}(x, y) u_x(y, t) dy + \lambda \int_0^x m(x, y) u_{xt}(y, t) dy - [g(x, y) u_{xxt}(y, t) - g_y(x, y) u_{xt}(y, t)]_0^x \\ & - \int_0^x g_{yy}(x, y) u_{xt}(y, t) dy + \lambda [g(x, y) u_{xx}(y, t) - g_y(x, y) u_x(y, t)]_0^x + \lambda \int_0^x g_{yy}(x, y) u_x(y, t) dy \\ & - \lambda^2 \int_0^x g(x, y) u_{xt}(y, t) dy. \end{aligned} \quad (7.49)$$

Now, the first order space derivative of (7.36) can be computed as

$$\begin{aligned} w_x(x, t) = & u_x(x, t) - s(x, x) u_t(x, t) - \int_0^x s_x(x, y) u_t(y, t) dy - m(x, x) u_x(x, t) - \int_0^x m_x(x, y) u_x(y, t) dy \\ & - g(x, x) u_{xt}(x, t) - \int_0^x g_x(x, y) u_{xt}(y, t) dy, \end{aligned} \quad (7.50)$$

and finally the second order space derivative of (7.36) is

$$\begin{aligned} w_{xx}(x, t) = & u_{xx}(x, t) - s(x, x) u_{xt}(x, t) - (s'(x, x) + s_x(x, x)) u_t(x, t) - \int_0^x s_{xx}(x, y) u_t(y, t) dy \\ & - m(x, x) u_{xx}(x, t) - (m'(x, x) + m_x(x, x)) u_x(x, t) - \int_0^x m_{xx}(x, y) u_x(y, t) dy \\ & - g(x, x) u_{xxt}(x, t) - (g'(x, x) + g_x(x, x)) u_{xt}(x, t) - \int_0^x g_{xx}(x, y) u_{xt}(y, t) dy. \end{aligned} \quad (7.51)$$

As the considered backstepping transformation relies on Volterra integrals, we standardly solve the kernel equations on a triangle, i.e.,  $x \in [0, 1]$ ,  $y \in [0, x]$ . The propagation phenomenon (7.12a) imposes diagonal terms (e.g.  $s(x, x)$ ), horizontal terms (e.g.  $s(x, 0)$ ) and surface terms (e.g.  $s(x, y)$ ), using (7.1a) and (7.1c). Moreover, the (uncontrolled) boundary at  $x = 0$  of the *target system* (7.12c) imposes point-wise terms (e.g.  $s(0, 0)$ ), using (7.1c). The (controlled) boundaries at  $x = 1$  (7.1b) and (7.12b) impose the control law. From (7.48)-(7.51), the propagation phenomenon (7.12a) is equivalent to the following conditions<sup>2</sup>

<sup>2</sup>the nomenclature used here is "factory term" : "condition"

- Kernel surface terms  $(x, y)$

$$\int u_t(y, t) dy : s_{yy}(x, y) = s_{xx}(x, y), \quad (7.52)$$

$$\int u_x(y, t) dy : m_{yy}(x, y) = m_{xx}(x, y), \quad (7.53)$$

$$\int u_{xt}(y, t) dy : g_{yy}(x, y) = g_{xx}(x, y). \quad (7.54)$$

- Kernel diagonal terms  $(x, x)$

$$u_t(x, t) : s_y(x, x) = -s'(x, x) - s_x(x, x), \quad (7.55)$$

$$u_x(x, t) : m_y(x, x) = -m_x(x, x) - m'(x, x), \quad (7.56)$$

$$u_{xt}(x, t) : g_y(x, x) = -g_x(x, x) - g'(x, x). \quad (7.57)$$

- Kernel horizontal terms  $(x, 0)$

$$u_t(0, t) : s_y(x, 0) = (b_1 + \lambda)m(x, 0) + b_1(b_1 + \lambda)g(x, 0), \quad (7.58)$$

$$u_x(0, t) : m_y(x, 0) = am(x, 0) + b_2(b_1 + \lambda)g(x, 0), \quad (7.59)$$

$$u_{xt}(0, t) : s(x, 0) - g_y(x, 0) + b_2g(x, 0) = 0. \quad (7.60)$$

- Kernel point-wise terms  $(0, 0)$ : To inspect these terms, note that the boundary condition (7.12c) needs also to be verified. First one can get the following equation by expressing (7.36), (7.48), (7.49) and (7.50) for  $x = 0$ , and using the uncontrolled boundary condition of the initial system (7.1c)

$$w_{tt}(0, t) = aq u_t(0, t) + a u_x(0, t), \quad (7.61)$$

$$w_t(0, t) = u_t(0, t), \quad (7.62)$$

$$w_x(0, t) = u_x(0, t) - s(0, 0)u_t(0, t) - m(0, 0)u_x(0, t) - g(0, 0)u_{xt}(0, t). \quad (7.63)$$

Then for the boundary condition (7.12c) of the target system to be respected, one obtains the following conditions

$$u_t(0, t) : a_w s(0, 0) = -(aq + a_w q_w), \quad (7.64)$$

$$u_x(0, t) : a_w m(0, 0) = (a_w - a), \quad (7.65)$$

$$u_{tx}(0, t) : g(0, 0) = 0, \quad (7.66)$$

one can reformulate (7.55)-(7.60), and (7.64)-(7.66) as (7.46).

It remains to show that the control law fixed by the boundary condition (7.12b) and the backstepping transformation (7.36) can be expressed as (7.35). First, let us compute  $w_x(1, t)$  and  $w_t(1, t)$ . Using integrations by parts on (7.50), and also (7.46b), one obtains

$$\begin{aligned} w_x(1, t) = & (1 - m(1, 1))u_x(1, t) - (g_x(1, 1) + s(1, 1))u_t(1, t) + g_x(1, 0)u_t(0, t) \\ & + \int_0^1 (-s_x(1, y) + g_{xy}(1, y))u_t(y, t) dy - \int_0^1 m_x(1, y)u_x(y, t) dy, \end{aligned} \quad (7.67)$$

in which, using (7.37),  $g_x(1, 1) + s(1, 1) = 0$ . Then, from (7.48), using integrations by parts and (7.60), one can write

$$\begin{aligned} w_t(1, t) = & (1 - m(1, 1))u_t(1, t) + \int_0^1 (\lambda s(1, y) + m_y(1, y) - \lambda g_y(1, y))u_t(y, t) dy, \\ & + [g_y(1, 1) - s(1, 1)]u_x(1, t) + (m(1, 0) + b_1 g(1, 0))u_t(0, t) + \int_0^1 (s_y(1, y) - g_{yy}(1, y))u_x(y, t) dy. \end{aligned} \quad (7.68)$$

Now (7.37) allows to state that  $g_y(1, 1) - s(1, 1) = 0$ . Matching the expression (7.67) with (7.68), and using (7.1b), one establishes the control law (7.35). ■



### 7.4.2 Vector reformulation and explicit solution of the kernel equation

**Lemma 7.3** [Roman et al., 2016a]

The kernel PDE (7.46) has a unique solution which is (7.37).

*Proof:* As (7.46a) is a pure wave equation (i.e., without distributed term), there exist  $S^+$  and  $S^-$  such that

$$S(x, y) = S^+(x + y) + S^-(x - y), \quad (7.69)$$

by expressing it for  $y = x$  and using (7.46b), one gets

$$S(x, x) = S^+(2x) + S^-(0) = F, \quad (7.70)$$

and concludes that  $S^+(x)$  is constant, so there exists  $\tilde{S}(x - y)$  such that

$$S(x, y) = \tilde{S}(x - y), \quad (7.71)$$

and from (7.46b)-(7.46c), for all  $x \in [0, 1]$ ,

$$\tilde{S}'(x) = -H\tilde{S}(x), \quad (7.72)$$

$$\tilde{S}(0) = F, \quad (7.73)$$

which is a Cauchy problem. This proves the existence and uniqueness of the kernel. From (7.71)-(7.73) one can find (7.37). ■

The establishment of the kernel uniqueness and existence is not often as easily done, e.g. [Luo et al., 2012], [Smyshlyaev et al., 2010], [Di Meglio et al., 2018], [Meurer and Kugi, 2009]. In Chapter 8, we present a control design which results from an implicit kernel whose uniqueness and existence is proven through the method of successive approximations.

### 7.4.3 Invertibility of the backstepping transformation

This section completes the preliminary presentation in [Roman et al., 2016a], including the definition of the state space  $H_1$ . Let us consider the following map that transforms the original system (7.1) with  $U$  defined in (7.35) into the target system (7.12)

$$\begin{aligned} \Pi : \quad H_1 &\rightarrow H_1, \\ (q_1, q_2, q_3, q_4) &\mapsto (z_1, z_2, z_3, z_4), \end{aligned} \quad (7.74)$$

defined as

$$z_1(x) = q_1(x) + g(x, 0)q_4 - \int_0^x (s(x, y) - g_y(x, y))q_2(y)dy + \int_0^x m(x, y)q_1'(y)dy, \quad (7.75)$$

$$\begin{aligned} z_2(x) = &(1 - m(x, x))q_2(x) + (-s(x, x) + g_y(x, x))q_1'(x) + (g(x, 0)b_1 + m(x, 0))q_4 \\ &+ \int_0^x (\lambda s(x, y) + m_y(x, y) - \lambda g_y(x, y))q_2(y)dy + \int_0^x (s_y(x, y) - g_{yy}(x, y))q_1'(y)dy, \end{aligned} \quad (7.76)$$

$$z_3 = q_3, \quad (7.77)$$

$$z_4 = q_4, \quad (7.78)$$

where  $s$ ,  $m$ , and  $g$  are defined in (7.37).  $H_1$  is defined (7.2). We have used the fact that  $g(x, x) = 0$  and (7.60).

Let us check that  $z \in H_1$ . As  $q_1, q_2, q_1' \in L_2(0, 1)$  so is  $z_1$ , similarly  $z'(1), z_2 \in L_2(0, 1)$ . The following is obvious  $z_3, z_4 \in \mathbb{R}$ . As  $q_1(0) = q_3$  and  $g(0, 0) = 0$  then it holds  $z_3 = z_1(0)$ . Therefore  $z \in H_1$ .

The existence of the inverse map  $\Pi^{-1}$  can be obtained by simply replacing  $b_i$  with  $d_i$  and considering  $c_1 = 0$  in the previous analysis. One gets the invertibility of the backstepping transformation straightforwardly.

$$\begin{aligned} \Pi^{-1} : \quad H_1 &\rightarrow H_1, \\ (z_1, z_2, z_3, z_4) &\mapsto (q_1, q_2, q_3, q_4), \end{aligned} \quad (7.79)$$

defined as

$$q_1(x) = z_1(x) + \check{g}(x, 0)z_4 - \int_0^x (\check{s}(x, y) - \check{g}_y(x, y)z_2(y))dy + \int_0^x \check{m}(x, y)z_1'(y)dy, \quad (7.80)$$

$$q_2(x) = (1 - \check{m}(x, x))z_2(x) + (-\check{s}(x, x) + \check{g}_y(x, x))z_1'(x) + (\check{g}(x, 0)b_1 + \check{m}(x, 0))z_4 \\ + \int_0^x (\lambda\check{s}(x, y) + \check{m}_y(x, y) - \lambda\check{g}_y(x, y))z_2(y)dy + \int_0^x (\check{s}_y(x, y) - \check{g}_{yy}(x, y))z_1'(y)dy, \quad (7.81)$$

$$q_3 = z_3, \quad (7.82)$$

$$q_4 = z_4, \quad (7.83)$$

in which

$$\begin{bmatrix} \check{s}(x, y) \\ \check{m}(x, y) \\ \check{g}(x, y) \end{bmatrix} = e^{\check{H}(y-x)}\check{F}, \quad (7.84)$$

where  $\check{F}$  and  $\check{H}$  are as

$$\check{F} = \frac{1}{b_2} \begin{bmatrix} -(d_1 + b_1) \\ b_2 - d_2 \\ 0 \end{bmatrix}, \quad (7.85)$$

$$\check{H} = \begin{bmatrix} 0 & d_1 + \lambda & d_1(d_1 + \lambda) \\ 0 & d_2 & d_2(d_1 + \lambda) \\ 1 & 0 & d_2 \end{bmatrix}. \quad (7.86)$$

#### 7.4.4 Relationship between $\Gamma_1(\mathcal{X}(t))$ and $V_1(\mathcal{X}_e(t))$

To conclude on the exponential stability of the *original system* (7.1) along with the control law (7.35), the equivalence between  $V_1(\mathcal{X}_e(t))$  in (7.13) and  $\Gamma_1(\mathcal{X}(t))$  in (7.7) remains to be proved.

##### Lemma 7.4 [Roman et al., 2016a]

Considering  $V_1$  in (7.13) and  $\Gamma_1$  in (7.7), there exist  $\mu_1 > 0$  and  $\mu_2 > 0$  such that

$$\mu_1\Gamma_1(\mathcal{X}(t)) \leq V_1(\mathcal{X}_e(t)) \leq \mu_2\Gamma_1(\mathcal{X}(t)), \quad (7.87)$$

where  $\mathcal{X}(t)$  is the state of the original system ( $\Sigma_{O_1}$ ) respectively defined in (7.10) and (7.1).  $\mathcal{X}_e(t)$  is the state of the target system ( $\Sigma_{T_1}$ ) respectively defined in (7.15) and (7.12).

*Proof:* From the backstepping transformation (7.36), one can write

$$\|w_t\|^2 + \|w_x\|^2 \leq \alpha_1\|u_x\|^2 + \alpha_2\|u_t\|^2 + \alpha_3u_t(0, t)^2, \quad (7.88)$$

$$w_t(0, t)^2 = u_t(0, t)^2, \quad (7.89)$$

in which  $\alpha_1$ ,  $\alpha_3$ , and  $\alpha_3$  are positive constants. Thus, from the definition of  $V_1$  in (7.7), one obtains

$$V_1(\mathcal{X}_e(t)) \leq \alpha_1\|u_x\| + \alpha_2\|u_t\| + (\alpha_3 + 1)u_t(0, t)^2. \quad (7.90)$$

Similarly, from the inverse backstepping transformation investigated in Section 7.4.3, one can get

$$\|u_t\|^2 + \|u_x\|^2 \leq \alpha_4\|w_x\|^2 + \alpha_5\|w_t\|^2 + \alpha_6w_t(0, t)^2, \quad (7.91)$$

$$u_t(0, t)^2 = w_t(0, t)^2, \quad (7.92)$$

in which  $\alpha_4$ ,  $\alpha_5$ , and  $\alpha_6$  are positive constants. Thus, from the definition of  $\Gamma_1$  in (7.7), one obtains

$$\Gamma_1(\mathcal{X}(t)) \leq \alpha_4\|w_x\| + \alpha_5\|w_t\| + (\alpha_6 + 1)w_t(0, t)^2. \quad (7.93)$$

From both the definition of  $\Gamma_1$  in (7.7) and  $V_1$  in (7.13), using (7.90) and (7.93) one obtains (7.87). ■

**Remark 2** In mathematical words, (7.87) does not mean that the semi-norms,  $\sqrt{\Gamma_1(\cdot)}$  and  $\sqrt{V_1(\cdot)}$  are equivalent. Indeed this is not quite the same as

$$\forall z \in \mathbb{H}_1, \quad \exists \eta_1, \eta_2 > 0 : \eta_1 \Gamma_1(z) \leq V_1(z) \leq \eta_2 \Gamma_1(z). \quad (7.94)$$

Note that this holds. One question is: Given the fact that (7.94) holds, is Lemma 7.4 equivalent to the invertibility of the backstepping transformation ?  $\circ$

### 7.4.5 Conclusion of the closed-loop stability result proof

Using Lemma 7.3, there exists a unique solution to (7.46) which is (7.37). From Lemma 7.2, this solution defines a backstepping transformation which maps the system (7.1) into (7.12) with the control law  $U$  defined in (7.35). Moreover, from Lemma 7.1, one gets that (7.12) is exponentially stable if all its parameters are positive. Therefore, using Lemma 7.4, one establishes (7.40) and thus Theorem 7.1 holds.

## 7.5 Observer design

To provide a feedback law which can be implemented using only boundary measurements, we propose here to associate the full state feedback presented in the Section 7.3 with an observer. The following theorem is the extension of Theorem 7.1 in the case of observer-based control.

**Theorem 7.3** [Roman et al., 2016a]

Consider the closed-loop system consisting of the plant (7.1), the observer

$$(\Sigma_{Ob_1}) \quad \begin{cases} \hat{u}_{tt}(x,t) = \hat{u}_{xx}(x,t) - 2\lambda \hat{u}_t(x,t), & (7.95a) \\ \hat{u}_x(1,t) = U(\hat{u}_t, \hat{u}_x) + l_1(u_t(1,t) - \hat{u}_t(1,t)), & (7.95b) \\ \hat{u}_{tt}(0,t) = b_1 \hat{u}_t(0,t) + b_2 \hat{u}_x(0,t) + l_2(u_t(0,t) - \hat{u}_t(0,t)), & (7.95c) \end{cases}$$

in which  $l_1 > 0$  and  $l_2 > b_1$  and the control law  $U$  defined in (7.35) computed with the estimate value of  $u_t$  and  $u_x$ , i.e.,  $\hat{u}_t$  and  $\hat{u}_x$  and with (7.37)-(7.39) in which  $c_1 > 0$ ,  $d_1 > 0$  and  $d_2 > 0$ . Define the state

$$\hat{\mathcal{X}}(t) = [\hat{u}(\cdot, t), \hat{u}_t(\cdot, t), \hat{u}(0, t), \hat{u}_t(0, t)] \in \mathbb{H}_1, \quad (7.96)$$

and the functional  $\Gamma_e$

$$\Gamma_e : \quad \begin{aligned} \mathbb{H}_1 \times \mathbb{H}_1 &\rightarrow \mathbb{R}^+, \\ (\mathcal{X}(t), \hat{\mathcal{X}}(t)) &\mapsto \Gamma_1(\mathcal{X}(t)) + \Gamma_1(\hat{\mathcal{X}}(t) - \mathcal{X}(t)), \end{aligned} \quad (7.97)$$

then there exist  $\rho_e > 0$  and  $R_e > 0$  such that, for all  $t \geq 0$

$$\Gamma_e(\mathcal{X}(t), \hat{\mathcal{X}}(t)) \leq R_e \Gamma_e(\mathcal{X}(0), \hat{\mathcal{X}}(0)) e^{-\rho_e t}, \quad (7.98)$$

and therefore the extended closed-loop system, whose state is  $[\mathcal{X}(t), \hat{\mathcal{X}}(t) - \mathcal{X}(t)]$  is exponentially stable for the attractor  $\mathcal{S} \times \mathcal{S}$  defined in (7.6). Note that

$$\Gamma_e(\mathcal{X}(t), \hat{\mathcal{X}}(t)) = 0 \Leftrightarrow \mathcal{X}(t), \hat{\mathcal{X}}(t) - \mathcal{X}(t) \in \mathcal{S}. \quad (7.99)$$

Note that both the *original system* state and the *observer-error system* state are converging toward the same attractor and not the origin of the state space. Indeed the latter theorem does not imply that  $u(t) - \hat{u}(t) \xrightarrow{a.e.} 0$ , but  $u_t(t) - \hat{u}_t \xrightarrow{a.e.} 0$  and  $u_x(t) - \hat{u}_x \xrightarrow{a.e.} 0$ . We have in the current case no interest in the position. To illustrate this, one thinks about the torsional vibration occurring in drilling facility. The objective is the control of the angular velocity. The angle does not need to converge toward the origin, or toward some fixed value in case of regulation. We could design such a control law, using the design presented in the sequel, in Chapter 8. But if the control

objective is the velocity, adding the position would decrease the controller performances. The same idea occurs for the observer. Indeed, the observer (7.95) lacks the estimation of the position, which could be troublesome for certain applications.

*Proof:* Consider the observation-error  $\tilde{u} = u - \hat{u}$ , it can be shown that

$$\begin{cases} \tilde{u}_{tt}(x,t) = \tilde{u}_{xx}(x,t) - 2\lambda\tilde{u}_t(x,t), & (7.100a) \\ \tilde{u}_x(1,t) = -l_1\tilde{u}_t(1,t), & (7.100b) \\ \tilde{u}_{tt}(0,t) = -(l_2 - b_1)\tilde{u}_t(0,t) + b_2\tilde{u}_x(0,t). & (7.100c) \end{cases}$$

Following the same steps as in the proof of Lemma 7.1, the system (7.100) is exponentially stable with respect to the attractor  $\mathcal{S}$  defined in (7.6) if  $l_1 > 0$  and  $l_2 > b_1$ .

Using Lemma 7.2, the backstepping transformation map the system (7.1) with the control law  $U(\hat{u}_t, \hat{u}_x)$  (defined in (7.35) but applied on the estimated state  $\hat{u}$ ) into the following plant

$$\begin{cases} w_{tt}(x,t) = w_{xx}(x,t) - \lambda w_t(x,t), & (7.101a) \\ w_x(1,t) = -c_1 w_t(1,t) - U(\tilde{u}_t, \tilde{u}_x), & (7.101b) \\ w_{tt}(0,t) = -d_1 w_t(0,t) + d_2 w_x(0,t). & (7.101c) \end{cases}$$

Following the same computations as the ones given in the proof of Lemma 7.1, and using the Lyapunov function candidate  $V_1$  defined in (7.13) evaluated either for  $w$  or considering  $\tilde{u}$  instead of  $w$ , one can get the existence of  $\eta_w > 0$  and  $\eta_{\tilde{u}} > 0$  such that, for any  $\alpha > 0$

$$\dot{V}_1(\mathcal{X}_e(t)) + \alpha \dot{V}_1(\mathcal{X}(t) - \hat{\mathcal{X}}(t)) \leq -\eta_w V_1(\mathcal{X}_e(t)) + U(\tilde{u}_t, \tilde{u}_x)^2 - \alpha \eta_{\tilde{u}} V_1(\mathcal{X}(t) - \hat{\mathcal{X}}(t)), \quad (7.102)$$

in which  $V_1(\mathcal{X}_e(t))$  is the Lyapunov function defined in (7.13) computed for the system (7.101) instead of system (7.12).  $V_1(\mathcal{X}(t) - \hat{\mathcal{X}}(t))$  is the Lyapunov function defined in (7.13) computed for the system (7.100).

From the definition of  $U$  in (7.35), applying Young and Cauchy Schwartz inequalities, there exists  $\nu > 0$  such that

$$U(\tilde{u}_x, \tilde{u}_t)^2 \leq \nu V_1(\mathcal{X}(t) - \hat{\mathcal{X}}(t)), \quad (7.103)$$

thus by choosing  $\alpha < \frac{\nu}{\eta_{\tilde{u}}}$ , there exists  $\eta$  such that

$$\dot{V}_1(\mathcal{X}_e(t)) + \alpha \dot{V}_1(\mathcal{X}(t) - \hat{\mathcal{X}}(t)) \leq -\eta (V_1(\mathcal{X}_e(t)) + \alpha V_1(\mathcal{X}(t) - \hat{\mathcal{X}}(t))). \quad (7.104)$$

Finally, using Lemma 7.4, and the fact that the semi-norm  $\sqrt{\Gamma_1(\cdot)}$  and  $\sqrt{V_1(\cdot)}$  are equivalent (7.94), there exist  $\mu_3 > 0$  and  $\mu_4 > 0$  such that

$$\mu_3 \Gamma_e(\mathcal{X}(t), \hat{\mathcal{X}}(t)) \leq V_1(\mathcal{X}_e(t)) + \alpha V_1(\mathcal{X}(t) - \hat{\mathcal{X}}(t)) \leq \mu_4 \Gamma_e(\mathcal{X}(t), \hat{\mathcal{X}}(t)). \quad (7.105)$$

Gathering the last two equations one concludes the proof.  $\blacksquare$

Note that the proper estimation of  $\nu$  in (7.103) and thus  $\eta$  in (7.104) requires the computation of the backstepping kernel. According to the version of Lemma 7.1 in [Roman et al., 2016a], the decay rate is depending on  $\sigma$ , and thus cannot be freely imposed. It seems that we are in presence of the overdamping effect as  $\sigma < \frac{8\lambda}{4\lambda^2 - 1}$  if  $\lambda > \frac{1}{4}$ ; indeed the decay rate of the Lyapunov function  $V_1$  defined in (7.13) decreases as  $\lambda$  increases. Yet, one cannot conclude formally here as Lyapunov approach only gives sufficient conditions. However the consequence for the considered design is that the decay rate cannot be arbitrarily chosen a priori both for the target system (7.12) and our observer (7.95).

## 7.6 Comparison with prediction-based designs

In this section, we want to emphasize the relationship between the prediction based design we have studied in Part I, Chapter 3, and the current backstepping design. Let us consider the control law  $U$  defined in (7.35) with

$\lambda = 0$ ,  $c_1 = 1$ , and  $d_2 = b_2$ . In this case, we can compute the eigenvalues of the matrix  $H$  and its the exponential and thus the kernels  $s$ ,  $m$ , and  $g$  involved in the control law. Consider

$$P = \begin{bmatrix} -b_2 & b_1 & -b_1 \\ -b_1 & b_2 & -b_2 \\ 1 & 1 & 1 \end{bmatrix}, \quad P^{-1} = \begin{bmatrix} \frac{b_2}{b_1^2 - b_2^2} & \frac{-b_1}{b_1^2 - b_2^2} & 0 \\ \frac{1}{2(b_1 + b_2)} & \frac{1}{2(b_1 + b_2)} & \frac{1}{2} \\ \frac{-1}{2(b_1 - b_2)} & \frac{1}{2(b_1 - b_2)} & \frac{1}{2} \end{bmatrix}, \quad (7.106)$$

and

$$H_{\lambda=0} = \begin{bmatrix} 0 & b_1 & b_1^2 \\ 0 & b_2 & b_2 b_1 \\ 1 & 0 & b_2 \end{bmatrix}, \quad (7.107)$$

which is  $H$  defined in (7.39) but with  $\lambda = 0$ .  $P$  is the change of basis matrix, together with its inverse they allow to diagonalize  $H_{\lambda=0}$  as

$$P^{-1}H_{\lambda=0}P = \begin{bmatrix} 0 & 0 & 0 \\ 0 & b_1 + b_2 & 0 \\ 0 & 0 & b_2 - b_1 \end{bmatrix}, \quad (7.108)$$

which implies that the control law  $U$  defined in (7.35) with  $\lambda = 0$ ,  $c_1 = 1$ , and  $d_2 = b_2$ , can be expressed as

$$U(t) = -u_t(1,t) - \left[ \int_0^1 (b_1 + d_1)e^{(b_1 - b_2)(1-y)} u_t(y,t) dy + \int_0^1 (b_1 + d_1)e^{(b_1 - b_2)(1-y)} u_x(y,t) dy + (b_1 + d_1)e^{(b_1 - b_2)(1-y)} u_t(0,t) \right], \quad (7.109)$$

with  $d_1 = a(c_0 - 1)$ ,  $b_2 = a$ , and  $b_1 = aq$ , one recovers the prediction-based control law (3.2) studied in the previous Chapter (3). This is interesting because we can link together three approaches.

- The prediction based design, which finds his fondation at Smith predictor [Smith, 1959].
- The finite-dimensional backstepping, which use the cascade feature of system, to control its dynamic.
- The infinite-dimensional backstepping. One can see a PDE as a continuous cascade of subsystems. In some particular cases, a PDE can model a delay

Therefore, one can see this infinite dimensional backstepping control design as a generalization of the Smith predictor.

## 7.7 Comparaision with the backstepping control law in [Sagert et al., 2013]

This section discusses way to compare our control law design in [Roman et al., 2016a] and presented before (7.35) and the control law design in [Sagert et al., 2013]. We focus on the latter design because, up to our knowledge, it is the only one which consider the exactly the same dynamics.

### 7.7.1 Presentation of both control laws

Consider the *original system* defined in (7.1)

**The design in [Sagert et al., 2013]** First considering  $v(x,t) = u_x(x,t)$  and  $X(t) = u_t(0,t)$ , one gets

$$(\Sigma_{V_1}) \begin{cases} v_{tt}(x,t) = v_{xx}(x,t) - \lambda v_t(x,t), & (7.110a) \\ v(1,t) = U(t), & (7.110b) \\ v_x(0,t) = b_2 v(0,t) + (\lambda + aq)X(t), & (7.110c) \\ \dot{X}(t) = b_1 X(t) + b_2 v(0,t), & (7.110d) \end{cases}$$

then this last system is mapped to

$$(\Sigma_{W_1}) \begin{cases} w_{tt}(x,t) = w_{xx}(x,t) - \lambda w_t(x,t), & (7.111a) \\ w(1,t) = 0, & (7.111b) \\ w_x(0,t) = e_1 w_t(0,t), & (7.111c) \\ \dot{X}(t) = -e_2 X(t) + b_2 w(0,t), & (7.111d) \end{cases}$$

through a backstepping transformation. The control law is chosen as

$$U_W(t) = \int_0^1 \bar{k}(1,\chi) u_x(\chi,t) d\chi + \int_0^1 \bar{s}(1,\chi) u_{xt}(\chi,t) d\chi + \bar{\gamma}(1) u_t(0,t), \quad (7.112)$$

where the gains are computed using

$$\begin{bmatrix} \bar{k}(x,y) \\ \bar{s}(x,y) \\ \bar{\gamma}(x-y) \\ \bar{\gamma}'(x-y) \end{bmatrix} = e^{M(x-y)} E, \quad (7.113)$$

in which

$$E = \begin{bmatrix} b_2 - e_1(b_1 + e_2) \\ -e_1 \\ -\frac{b_1 + e_2}{b_2} \\ \lambda + b_1 - (b_1 + e_2)e_1 \frac{b_1}{b_2} \end{bmatrix}, \quad (7.114)$$

$$M = \begin{bmatrix} -b_2 & -b_2(\lambda + b_1) & b_2(\lambda + b_1) & 0 \\ 0 & -b_2 & b_2 & 0 \\ 0 & 0 & 0 & 1 \\ \lambda + b_1 & b_1(\lambda + b_1) & -b_1(\lambda + b_1) & 0 \end{bmatrix}. \quad (7.115)$$

**Our control design** Let us express the control law  $U$  (7.35) under the same form as (7.112), i.e., in term of  $u_t$ ,  $u_{xt}$ , and  $u_t(0,t)$ .

**Proposition 7.2** *The control  $U$  defined in (7.35) can be expressed as*

$$U(u_t, u_x) = \int_0^1 \underline{k}(1,\chi) u_x(\chi,t) d\chi + \int_0^1 \underline{s}(1,\chi) u_{xt}(\chi,t) d\chi + \underline{\gamma}(1) u_t(0,t), \quad (7.116)$$

where the gain are computed using

$$\underline{k}(1,y) = A_R S(1,y), \quad (7.117)$$

$$\underline{s}(1,y) = -B_R S(1,y) + B_R S(1,1) - c_1, \quad (7.118)$$

$$\underline{\gamma}(1) = (C_R - B_R) S(1,0) + B_R S(1,1) - c_1, \quad (7.119)$$

in which

$$A_R = \frac{1}{m(1,1) - 1} [-b_2 c_1 \quad b_2 \quad b_2(b_1 + \lambda - b_2 c_1)], \quad (7.120)$$

$$B_R = \frac{1}{m(1,1) - 1} \left[ c_1 \frac{b_2}{b_1 + \lambda} \quad 0 \quad -b_2 \right], \quad (7.121)$$

$$C_R = \frac{1}{m(1,1) - 1} [c_1 - 1 \quad 0 \quad b_1 c_1 - b_2], \quad (7.122)$$

where  $S$  is defined in (7.47), with  $s$ ,  $m$  and  $g$  taken as (7.37).

This proposition underlines that both control laws have indeed the same form.

*Proof:* First consider

$$\theta_1 = [1 \ 0 \ 0], \quad \theta_2 = [0 \ 1 \ 0], \quad \theta_3 = [0 \ 0 \ 1], \quad (7.123)$$

it holds

$$s(x, y) = \theta_1 S(x, y), \quad m(x, y) = \theta_2 S(x, y), \quad g(x, y) = \theta_3 S(x, y). \quad (7.124)$$

From the definition of  $S$  in (7.37), one gets

$$S_y(x, y) = HS(x, y), \quad S_x(x, y) = -HS(x, y). \quad (7.125)$$

Using these notations, one writes the control  $U$  defined in (7.35) as

$$\begin{aligned} U(u_t, u_x) = & -c_1 u_t(1, t) + \frac{1}{m(1, 1) - 1} \left[ \int_0^1 [\theta_1 H - \theta_3 H^2 + c_1(\lambda \theta_1 + \theta_2 H - \lambda \theta_3 H)] S(1, y) u_t(y, t) dy \right. \\ & \left. + \int_0^1 [c_1(\theta_1 - \theta_3 H) + \theta_2] HS(1, y) u_x(y, t) dy + (c_1(\theta_2 + b_1 \theta_3) - \theta_3 H) S(1, 0) u_t(0, t) \right]. \end{aligned} \quad (7.126)$$

Using integration by parts, it holds

$$\begin{aligned} U(u_t, u_x) = & -c_1 u_t(1, t) + \frac{1}{m(1, 1) - 1} \left[ \left[ [\theta_1 - \theta_3 H + c_1(\lambda \theta_1 H^{-1} + \theta_2 - \lambda \theta_3)] S(1, y) u_t(y, t) \right]_{y=0}^1 \right. \\ & - \int_0^1 [\theta_1 - \theta_3 H + c_1(\lambda \theta_1 H^{-1} + \theta_2 - \lambda \theta_3)] S(1, y) u_{xt}(y, t) dy \\ & \left. + \int_0^1 [c_1(\theta_1 - \theta_3 H) + \theta_2] HS(1, y) u_x(y, t) dy + (c_1(\theta_2 + b_1 \theta_3) - \theta_3 H) S(1, 0) u_t(0, t) \right]. \end{aligned} \quad (7.127)$$

Note that

$$A_R = \frac{1}{m(1, 1) - 1} [c_1(\theta_1 - \theta_3 H) + \theta_2], \quad (7.128)$$

$$B_R = \frac{1}{m(1, 1) - 1} [\theta_1 - \theta_3 H + c_1(\lambda \theta_1 H^{-1} + \theta_2 - \lambda \theta_3)], \quad (7.129)$$

$$C_R = \frac{1}{m(1, 1) - 1} c_1(\theta_2 + b_1 \theta_3) - \theta_3 H. \quad (7.130)$$

Using that

$$u_t(1, t) = \int_0^1 u_{xt}(y, t) dy + u_t(0, t), \quad (7.131)$$

one finally gets

$$\begin{aligned} U(u_t, u_x) = & \frac{1}{m(1, 1) - 1} \left[ \int_0^1 [B_R S(1, 1) - B_R S(1, y)] u_{xt}(y, t) dy + \int_0^1 A_R S(1, y) u_x(y, t) dy + C_R S(1, 0) u_t(0, t) \right. \\ & \left. + B_R (S(1, 1) - S(1, 0)) u_t(0, t) \right] - c_1 \int_0^1 u_{xt}(y, t) dy - c_1 u_t(0, t), \end{aligned} \quad (7.132)$$

therefore it follows (7.116). ■

In order to compare two control laws, they need to have the same goal, i.e., to ensure the convergence toward the same attractor. Nevertheless, even if their associated *closed-loop system* state variables converge towards the same attractor, the way they approach the attractor can differ. One idea is to compute and compare the eigenvalues of both target systems. Indeed, like in finite dimensional systems, the distribution of eigenvalues characterizes the behavior of these dynamical systems. But, on the one hand, there exists an infinite number of eigenvalues. On the other hand, as usual in backstepping method the target system has some tuning parameters, for one realization of tuning parameters one gets a set of eigenvalues, i.e., a set of infinite complex numbers. Therefore we need to compare an infinite family -one for each realization of tuning parameters- of infinite set of

eigenvalues. This cannot be done numerically, or somehow we need to fix the tuning parameters. For example, one may fix the tuning parameters by optimize some cost function. The problem is then to define this cost function because standardly -for example in LQ design for PDE- we need to compute the  $C_0$ -semigroup which are not trivial here (see [Curtain and Zwart, 2012] for a introduction on LQ for infinite dimensional system). Indeed, the computation of  $C_0$ -semigroup is the generalization of the exponential of finite linear ordinary differential equation. But, the issue is that we have nor the explicit eigenvalues of the operator  $\mathcal{A}_1$  (defined in (7.41)) which is associated to the original system (7.1), neither the ones of both target systems.

Let us review the latter paragraph. To compare two control laws we need to be sure that their associated *closed-loop system* state variables converge towards the same attractor. Because otherwise they do not just answer to the same problem. Then the questions are: are they different? If yes, can we quantify how they differ?

- Looking at *closed-loop system* eigenvalues.
  - The nice feature about eigenvalues is that they can illustrate how the control law differ. But in the case under consideration, we did not find a explicit computation of them. Moreover, the change of variables to get  $(\Sigma_{V_1})$  defined in (7.110), is not invertible. Thus even if one could compute the explicit set of eigenvalues, the comparison is not straightforward.
- Directly compare and compute the control laws.
  - The control laws are depending on tuning parameters. The exact computation is hard, even if both kernels have been given explicitly, because the computation of matrix exponential is required. To do it we need to compute the eigenvalues (coefficient of the diagonal matrices) and the computation of eigenvectors (which give us the change of basis matrix). If the matrix is not diagonalizable, we can transform the matrix onto one diagonal and one nilpotent. The issue is that the eigenvalues are not easy computed, i.e., symbolic root of polynomial of order 3 for our control and 4 for the control in [Sagert et al., 2013]. And this gives involved eigenvectors.
- The best and most standard way to quantify the differences between control laws is to select some criterion (settling time, robustness, control law magnitude, ...) and to illustrate how they differ with numerical simulations. It has not be done here. Because we need to fix somehow the tuning parameters (optimizing a cost function) and there is not straight way to do it, it requires more work to do it, and there is probably a lot of issues to be tackle down.

The method we suggest here is linked to the second item. The idea is to compare the differential equation of the control gains. Indeed if we prove that these differential equation are not the same (using the converse of the Cauchy problem), we can conclude that both control are different. First, in Section 7.7.2 we ensure that the control law objectives are the same. Then in Section 7.7.3, we compare the control laws, by comparing the differential equation the control gains are solution of.

### 7.7.2 Exponential stability of the control in [Sagert et al., 2013]

We need to define an other space, because the stability result of [Sagert et al., 2013] requires more regularity of the solution. Define  $H_W$  as

$$H_W := \{ (z_1, z_2, z_3, z_4) \in H_2(0, 1) \times H_1(0, 1) \times \mathbb{R}^2 \mid z_3 = z_1(0) \}, \quad (7.133)$$

which contains the strong solution state space adapted for the *original system* (7.1).

The following theorem is the rewriting of the stability result in [Sagert et al., 2013], we have adapted the notation in order to fit with the current presentation.

**Theorem 7.4** *Adapted from [Sagert et al., 2013]*

*Consider the closed-loop system consisting of the original system  $(\Sigma_{O_1})$  defined in (7.1), together with the*



control law (7.112)-(7.115) in which  $e_1 > 0$ , and  $e_2 > 0$ . Defining the following functional

$$\Gamma_W(\mathcal{X}(t)) = u_t(0,t)^2 + \int_0^1 u_x(x,t)^2 dx + \int_0^1 u_{xt}(x,t)^2 dx + \int_0^1 u_{xx}(x,t)^2 dx, \quad (7.134)$$

there exist  $\mu > 0$  and  $M$  such that, for all  $t \geq 0$

$$\Gamma_W(\mathcal{X}(t)) \leq M\Gamma_W(\mathcal{X}(0))e^{-\mu t}, \quad (7.135)$$

in which  $\mathcal{X}(t) \in \mathbb{H}_W$  is defined in (7.10).

The regulation leads to

$$\|u_x\| \rightarrow 0, \quad (7.136)$$

$$\|u_{xx}\| = \|u_{tt} + \lambda u_t\| \rightarrow 0, \quad (7.137)$$

and so the system is exponentially stable with respect to the attractor

$$\mathcal{S}_W := \left\{ z \in \mathbb{H}_W : z_2(\cdot) \stackrel{a.e.}{=} 0, z_1(\cdot) \stackrel{a.e.}{=} c, z_3 = c, c \in \mathbb{R}, z_4 = 0 \right\}. \quad (7.138)$$

The first mathematical analysis is the fact that the control law in [Sagert et al., 2013] has a stronger hypothesis on the state space regularity. It is due to the fact that they consider the space derivative of the state in (7.110). In order to compare them, let us consider the most restrictive state space, this is  $\mathbb{H}_W \subset \mathbb{H}_1$ , in which  $\mathbb{H}_1$  is defined in (7.39), this corresponds to the state space of the weak solution of (7.1).

### 7.7.3 Gain comparison of the two control laws

Now let us answer to the question: are the gains  $\bar{k}$ ,  $\bar{s}$ , and  $\bar{\gamma}$  defined in (7.113) different from  $\underline{k}$ ,  $\underline{s}$ , and  $\underline{\gamma}$  defined in (7.117)-(7.119)? The idea is not to compute the gains directly but to look at the differential equations they are solution of. One gets that  $\bar{k}$  satisfies

$$\bar{k}_y(1,y) = b_2\bar{k}(1,y) + b_2(\lambda + b_1)[\bar{s}(1,y) - \bar{\gamma}(1)], \quad (7.139)$$

and

$$\underline{k}_y(1,y) = A_R H S(1,y), \quad (7.140)$$

$$b_2\underline{k}(1,y) + b_2(\lambda + b_1)[\underline{s}(1,y) - \underline{\gamma}(1)] = [b_2A_R - b_2(\lambda + b_1)B_R]S(1,y) - b_2(\lambda + b_1)(C_R - B_R)S(1,0). \quad (7.141)$$

Thus, a necessary condition for the gains  $\bar{k}$  and  $\underline{k}$  to be equal is

$$(C_R - B_R)S(1,0) \stackrel{?}{=} 0, \quad (7.142)$$

which does never holds. Another necessary condition is

$$A_R H \stackrel{?}{=} b_2A_R - b_2(\lambda + b_1)B_R. \quad (7.143)$$

This also does not hold. Thus the gains  $\bar{k}$  and  $\underline{k}$  are not solutions of the same differential equation. Therefore using the contraposition of the Cauchy problem one gets that the gains are different. The control laws are different, but that does not mean they cannot provide the same equivalent performance for the *closed-loop system*. It is the only result we find so far concerning the comparison of both control laws.

## 7.8 Simulations

We consider here the simulation of the linear system (7.1) with the control law  $U$  defined in (7.35).

### 7.8.1 Space semi-discretization and eigenvalues

The following simulations are performed with the control design presented previously. The wave equation (7.1) is semi-discretized in space, i.e.,

$$\dot{X}(t) = AX(t) + BU(t), \quad (7.144)$$

in which  $X(t) = [u[1:n] \quad u_t[1:n]]^T$ , with  $A \in \mathbb{R}^{2n \times 2n}$  where  $n$  is the number of spatial points considered,  $B \in \mathbb{R}^{2n \times 1}$ . Under this form, the eigenvalues of the *target system* (7.12), and the *original (zero-input) system* (7.1) and the *closed-loop system* with the control law (7.35), have been computed for  $n = 30$  in Figure 7.1. The complete details of the semi-discretization are presented in Appendix C.

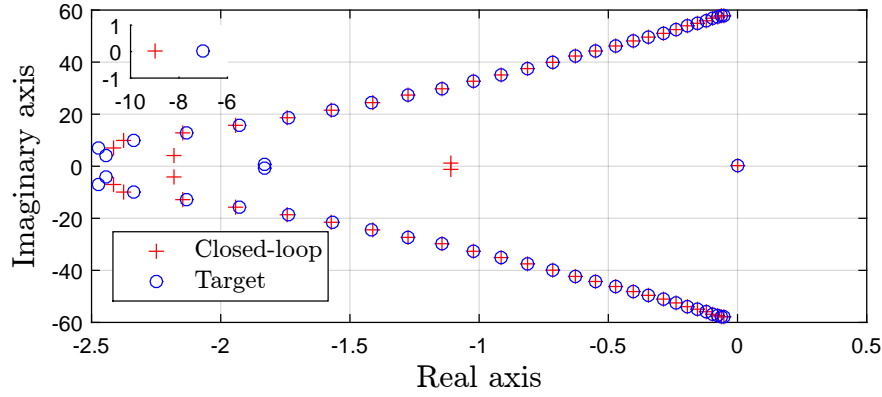

Figure 7.1: Eigenvalues of the target system (7.12), and the closed-loop system (7.1) with the control law (7.35), for  $n = 35$  and  $b_1 = 0.02$ ,  $b_2 = 0.6$ ,  $\lambda = 0.06$ ,  $c_1 = 1$ ,  $d_1 = b_1$ , and  $b_2 = d_2$ .

Figure 7.1 illustrates the fact that the *original system* (7.1) controlled by the control law (7.35) has the same behavior as the *target system* (7.12). Nevertheless, as we have approximated the space derivative, both set of eigenvalues are not perfectly equal. This means that the discretized systems has not exactly the same behavior. We suggest to illustrate the design for two sets of parameters, which are given Table 7.1. The eigenvalues of the *target system*, the *closed loop system* and the *open-loop system* are shown in Figure 7.2 for the first set and in Figure 7.3 for the second set.

Considering Figure 7.1, Figure 7.2 and Figure 7.3, one can get that the mistake we make at mapping the discretization of *closed-loop system* and of *the target system* are depending on the parameter values of both systems and on the space discretization  $n$ . Note also that both *original systems* with zero input ( $U(t) = 0$ ) are unstable for both sets of parameters. Indeed, they have positive real part eigenvalues in Figure 7.2 and in Figure 7.3. Moreover 0 is an eigenvalue of the three systems. Furthermore it is a structural eigenvalue, indeed

$$vec_0 = \begin{bmatrix} 1_{N,1} \\ 0_{N,1} \end{bmatrix}, \quad (7.145)$$

is an eigenvector of 0 for the three system. Each respective dynamics are invariant to a constant change of position. This invariant set is generated by  $vec_0$  and is related the the attractor  $\mathcal{S}$  defined in (7.6).

### 7.8.2 Velocity time response simulations

For the presented simulation we use two sets of parameters, the values of which are expressed in Table 7.1. Figure 7.4 depicts the evaluation of the boundary velocities (using  $X(0) = [u^0[1:n] \quad u_t^0[1:n]]^T$ ) of

- The *zero-input system*, i.e., (7.1) with  $U(t) = 0$  for parameter set ① (respectively Figure 7.4b for ②).

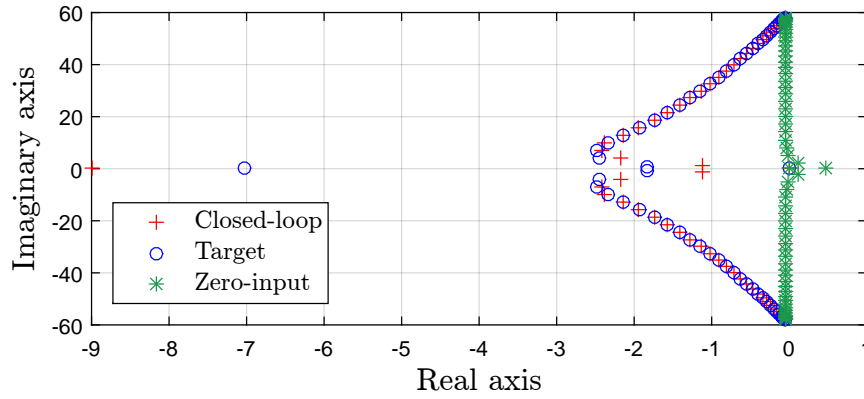

Figure 7.2: Eigenvalues of the *original system* with zero input ( $U(t) = 0$ ), the target system (7.12), and the closed-loop system (7.1) with the control law (7.35), for the parameters set ① (see Table 7.1).

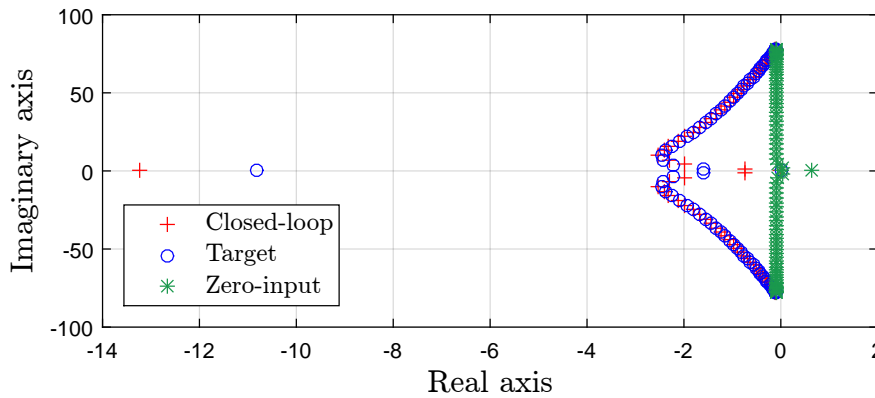

Figure 7.3: Eigenvalues of the *original system* with zero input ( $U(t) = 0$ ), the target system (7.12), and the closed-loop system (7.1) with the control law (7.35), for the parameters set ② (see Table 7.1).

- The *closed-loop system* evaluation of the boundary velocities in the case of the full state backstepping control law  $U$  defined in (7.35) for the parameter set ① is displayed in Figure 7.5 (respectively Figure 7.5b for ②)
- The evaluation of the boundary velocities in the case of the observer based control is shown in Figure 7.6 and the evaluation of the associated control law is pictured in Figure 7.7 (respectively Figure 7.6b and Figure 7.7b for ②).

One observe that set of parameters ① gives eigenvalues with real part lower *zero-input system* than the set of parameters ② as the boundary velocities reach a higher magnitude in Figure 7.4b than in Figure 7.4a. This observation can be explain by the fact that  $b_2$  is smaller for the set ②. Indeed, it represents the actuation of the wave propagation on the unstable boundary. The in-domain damping  $\lambda$  has been multiplied by 2, and  $b_2$  has been divided by 2, all other parameters being equal (for the *original system* with zero input), the open-loop system has higher real part of eigenvalues therefore  $b_2$  is more impactful than  $\lambda$  for stability.

In Figure 7.5, the full-state backstepping controller performs relatively well, as both boundary velocities are converging toward zero. Note that before  $t = 1$  the boundary velocity at  $x = 0$  increases due to the fact that the wave equation is not controlled for  $t \leq 1$ . Scrupulously  $(u(x, t), u_t(x, t))$  is not controllable for  $t \leq 1 - x$  from the boundary at  $x = 1$ . Indeed, the actuation needs to propagate thought the wave equation.

Symbol	Description	Value	set ①	set ②
$n$	Number of points of the space discretization		30	40
$\lambda$	In-domain damping coefficient		0.1	0.2
$b_2$	Uncontrolled boundary coefficient		1	0.5
$b_1$	Anti-damping boundary coefficient		1	1
$c_1$	Control boundary target coefficient		1	1
$d_2$	Anti-collocated boundary target coefficient		1	1
$d_1$	Anti-collocated Boundary damping target coefficient		1	1
$l_1$	Observer ‘controlled’ boundary coefficient		10	2
$l_2$	Observer ‘uncontrolled’ boundary coefficient		120% $b_1$	2 $b_1$
$u^0[1:n]$	Initial data for the state $u$		0	0
$u_t^0[1:n]$	Initial data for the state $u_t$		1	1
$\hat{u}^0[1:n]$	Initial data for the estimated state $u$		0	0
$\hat{u}_t^0[1:n]$	Initial data for the state estimated state $u_t$		0	0

Table 7.1: Parameter values for the simulation set ① and ②

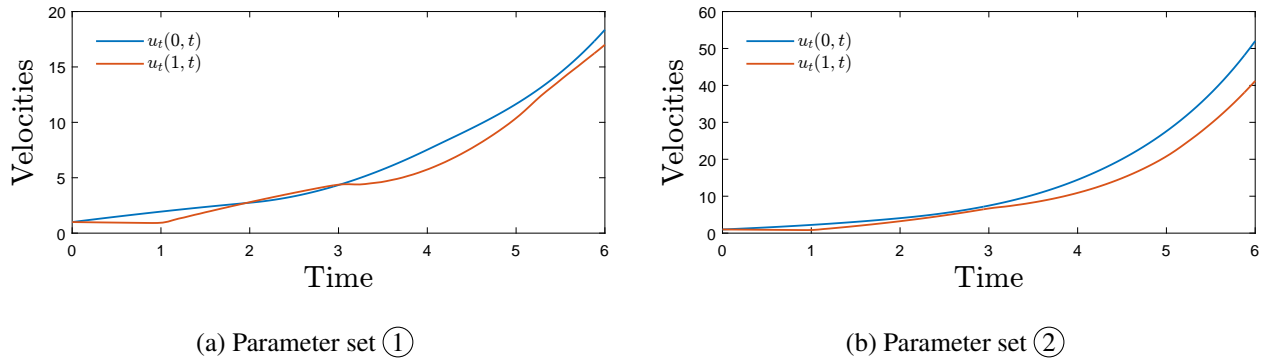
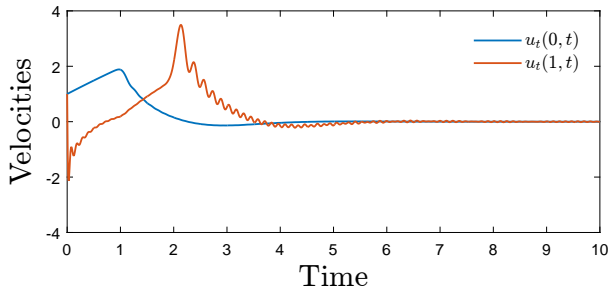

Figure 7.4: Zero-input system boundary velocities time-domain response for non-zero initial conditions

In Figure 7.5b (set ②), the full-state backstepping control law performs relatively well but less efficiently than in Figure 7.5a (set ①), as one observes damped oscillations of higher magnitude. It can be explained by the fact that the approximation error of our discretization is greater.

The time response of the observer-based control laws in Figure 7.6, are smoother than in the full-state feedback respectively in Figure 7.5. But they have also a higher settling time mostly due to the fact that the observer has not converged yet. The former explains also the fact that the amplitude of the boundary velocities at  $x = 0$  are more important for the observer-based design.

The differences of the two set of parameters apart from  $n$  and  $l_2$  are the fact that there is a 0.5 factor between the  $b_2$  (from set ① to ②), and a 0.5 factor between  $\lambda$  (from set ② to ①), and that in set ②  $d_2 \neq b_2$ . The latter seems to be the reason why the discretized approximation are performing less efficiently: there is slight oscillation in Figure 7.5b. Nevertheless, note that there is factor  $\approx 2$  between the magnitude of both control law time responses in Figure 7.7a and in Figure 7.7b. This is fitting with the factor between the  $b_2$ , as  $b_2$  is the actuation coefficient of the wave equation to its own boundary. Indeed, as the link is less decent, more energy is needed from the control law.



(a) Parameter set ①

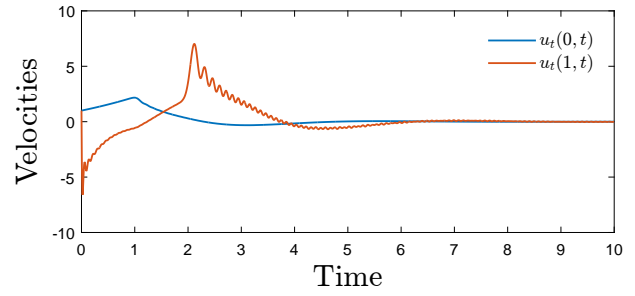

(b) Parameter set ②

Figure 7.5: Closed-loop boundary velocities time-domain response for non-zero initial conditions. The full-state backstepping controller stabilizes the system

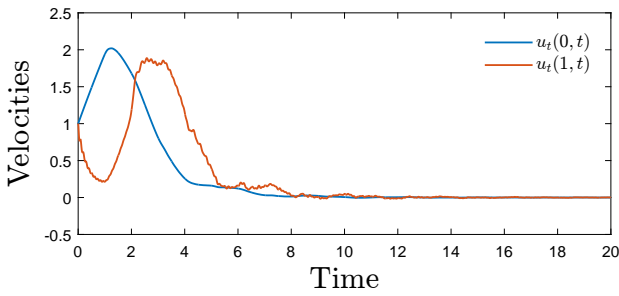

(a) Parameter set ①

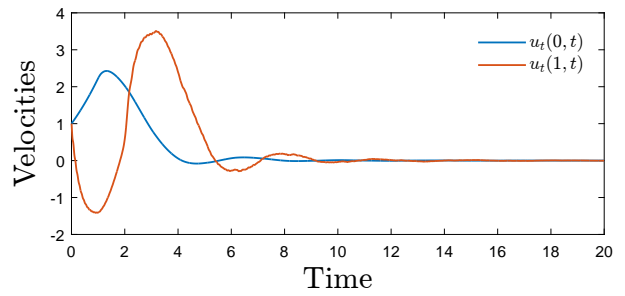

(b) Parameter set ②

Figure 7.6: Observer based-control: closed-loop boundary velocities time-domain response for non-zero initial conditions.

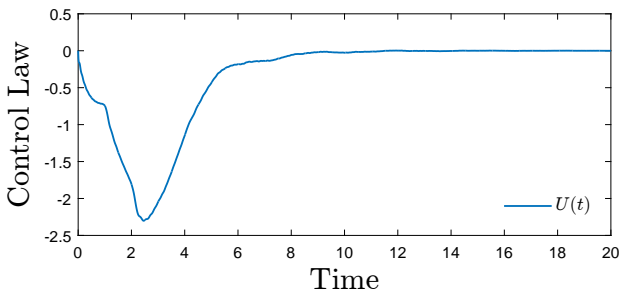

(a) Parameter set ①

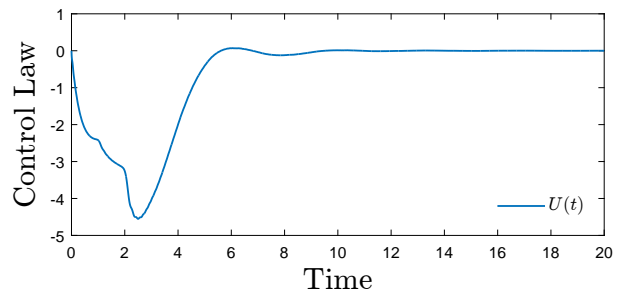

(b) Parameter set ②

Figure 7.7: Control law time-domain response for non-zero initial conditions for the observer based backstepping controller.

### 7.8.3 Frequency response of the discretized system

This section is actually an answer to a question arising at the presentation of this work at CDC 2016 in Las Vegas:

*Is the proposed observer-based control law is robust with respect to output noises?*

In order to answer to this question we suggest to draw the bode diagram associated with the numerical model. Indeed this seems the best way to illustrate the general behavior of the closed-loop system with respect to noises and disturbance.

It is always interesting (and mandatory) to study the control law robustness, as in practice, models are only an approximation of the reality. The previous part was focused on the model parameter mismatch. We want now to show the robustness with respect to signal noises. As we are considering a finite dimensional system, the bode diagram resulting from this study can be drawn easily. In the observer based design we consider three exogenous signals,  $d_U$ ,  $d_{y|1}$ , and  $d_{y|0}$  that symbolize respectively a actuation perturbation, and measurement perturbations at the boundary  $x = 1$  and  $x = 0$ . Figure 7.8 represents the control scheme.

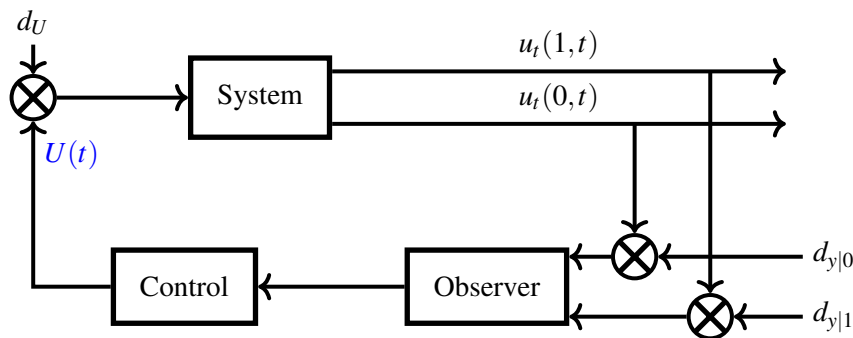

Figure 7.8: Control scheme with the exogenous signals.

The bode diagrams for the parameter set ① are presented in Figure 7.9, with a zoom-in view shown in Figure 7.11. In Figure 7.11, the frequency response is similar to the Padé approximation of a delay. This is consistent with

- The observation we have made about the uncontrollability of the wave for  $t \leq 1 - x$ .
- The Riemann invariant for the case without source term, where the wave equation can be reformulated as two transport.
- The remark we have made about the link between, prediction based control, infinite dimensional backstepping and backstepping in finite cases (in Section 7.6).

What we actually have is the Padé approximation of a wave equation as we have semi-discretized the system in space. The Padé approximation is the approximation of a function by a rational one. Here it is not strictly speaking a function but a operator.

Similarly the bode diagram for the set of parameters ② is shown in Figure 7.10, a zoom of which is depicted in Figure 7.12. All frequency responses are characterized by a low-pass filter feature. This means that high frequency noises are not disturbing the behavior of both systems.

The main specificity of the frequency responses is the more accentuated presence of a zero of transmission in the transfer from  $d_{y|1}$  to  $u_t(0,t)$ ,  $u_t(1,t)$  and a fortiori  $U(t)$  for the set ②. We can see it on Figure 7.10, and on Figure 7.12. The question is: where does this zero come from? Is it depending on tuning parameters? If it is the case, then we can design a control law robust to sinusoidal perturbation. There exists a lot of transmission

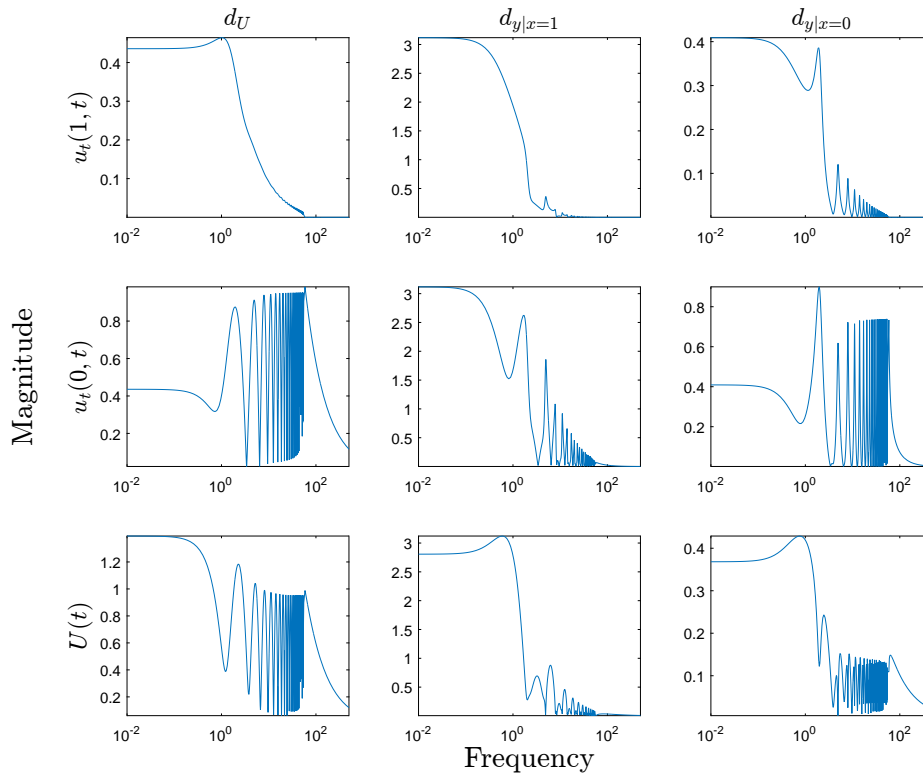

Figure 7.9: Observer based design bode diagram with parameter set ①.

zero on each transfer function. Our initial guess has been that they represent the Padé approximation of the delay contained in the wave equation. As the wave PDE is normalized, this delay is the unit. However it seems that changing the parameters modifies some of these zeros. We may be able to perform robust control directly from the backstepping controller. Nevertheless, a more promising design will be to adapt the result in [Guo and Guo, 2016] to our system (7.1).

With a quick lecture of the previous paragraph, one can say that it is obvious that the Padé change with  $\lambda$  as it is a parameter of the operator. But the localization of the zero and the interval of repetition are linked with the delay inside the wave, which according to Riemann invariants remains the same for any  $\lambda$ .

The bode diagram in Figure 7.9, Figure 7.10, Figure 7.11, and Figure 7.12 can be link together with the bode in the text book [Lalanne et al., 1984] which considers finite association of mass-spring elements.

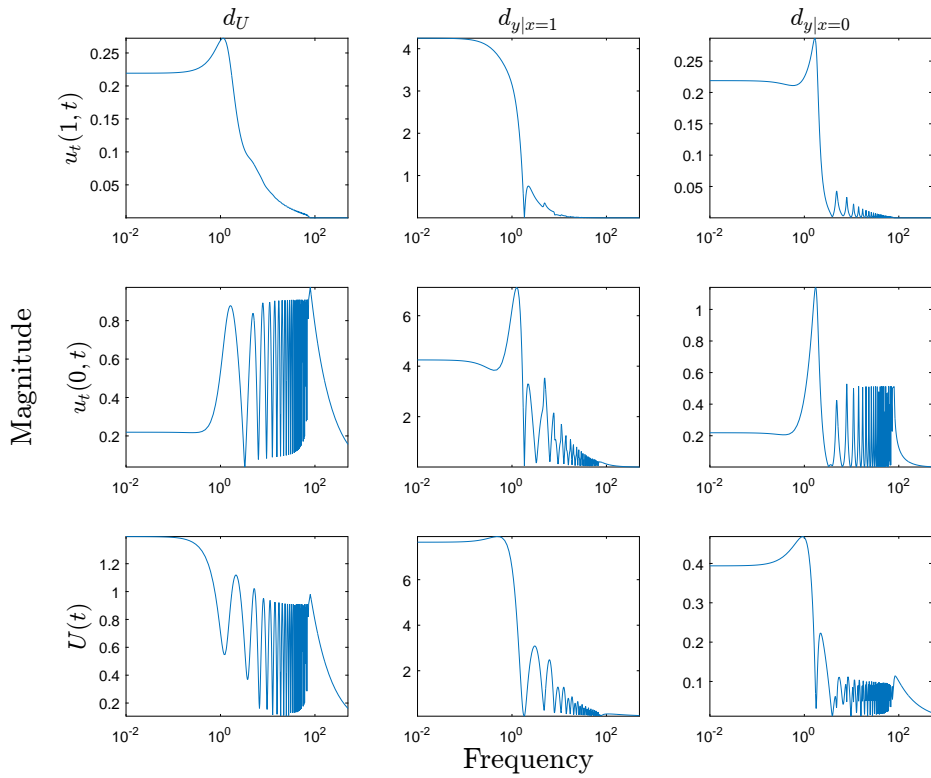

Figure 7.10: Observer based design bode diagram with parameter set ②.

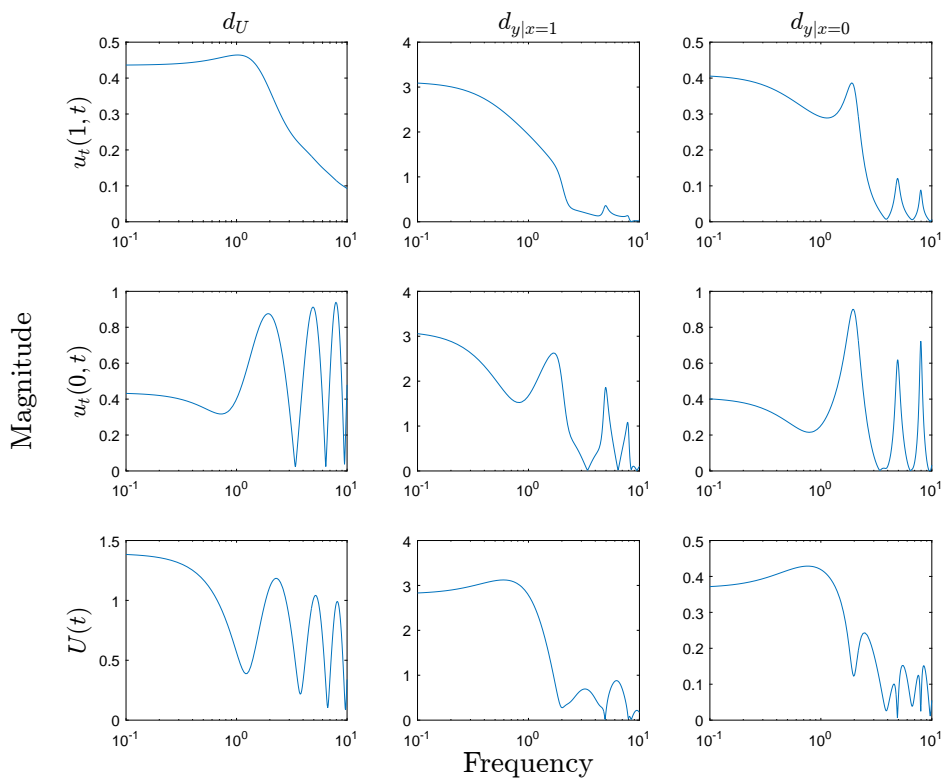

Figure 7.11: Observer based design bode diagram zoom with parameter set ①.



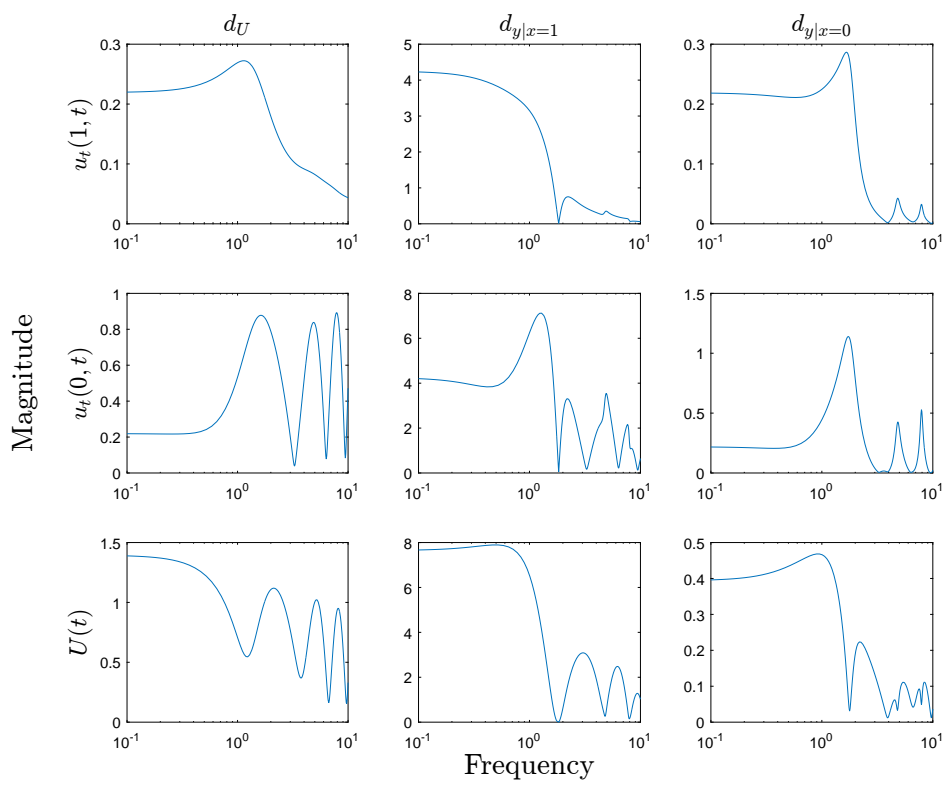

Figure 7.12: Observer based design bode diagram zoom with parameter set ②.

## Chapter conclusion

In this chapter, the establishment of a boundary output feedback has been presented. In details, (i) we have stated the exponential stability of a target system on a attractor, (ii) we have obtained the control law associated to a unique backstepping transformation which maps the *original system* into the *target system*, (iii) we suggest a boundary velocity observer on the same attractor, (iv) we prove that the full-state closed-loop system is well-posed. Then the considered control law is compared with two existent and related works. The chapter is closed with numerical simulation on a linear semi-discretized model.

In the continuity of this work, there are several possible track. We could enhance the design with adaptive control. We could design an observer using backstepping. But first, we suggest to improve the design, indeed the only parameter we can not fix is the in-domain damping in the *target system*, and as we have said the decay rate is depending on it. We propose a design which answer to this problem in Chapter 8.

Concerning the adaptive control associated to a backstepping design, the difficulty is that the equation of the kernels should be reevaluated online depending on the adaptive estimates. This can require a large constraint on computational capabilities. However, note that there has been works to improve the computation of the backstepping kernel resolution, e.g. [Ascencio et al., 2017].





# An implicit backstepping design

## Contents

<b>8.1</b>	<b>An unstable wave equation with velocity and position distributed terms</b>	<b>145</b>
<b>8.2</b>	<b>An exponentially stable wave equation with velocity and position distributed terms</b>	<b>147</b>
<b>8.3</b>	<b>Backstepping state feedback</b>	<b>150</b>
<b>8.4</b>	<b>Proof of the closed-loop stability result</b>	<b>152</b>
8.4.1	Backstepping transformation	152
8.4.2	Existence and uniqueness of the solution of (8.47a)-(8.47e)	154
8.4.3	Invertibility of the backstepping transformation	157
8.4.4	Relationship between functionals $\Gamma_2(\mathcal{X}_2(t))$ and $V_2(\mathcal{X}_{e_2}(t))$	158
8.4.5	Conclusion of the stability result	158
<b>8.5</b>	<b>Well-posedness of the closed-loop system and the target system</b>	<b>158</b>
	<b>Chapter conclusion</b>	<b>162</b>

This chapter presents the second proposed backstepping control law design. The first objective of this design, is to allow a change of in-domain viscous damping between the *original system* and the *target system*. However, the systems under consideration have also position distributed term. This allows to have an exponential stability (toward the origin) of the *target system*. The *original system* under consideration is exposed in Section 8.1. In the same section, we consider the associated homogeneous abstract problem (zero input) in order to specify the state space of the considered PDE. The *target system* and its exponential stability analysis are presented in Section 8.2. Then in Section 8.3, the control law, the backstepping transformation and the exponentially stability result are presented. The stability result proof is established in Section 8.4. Note that to prove the existence and uniqueness of the backstepping kernel we use the method of successive approximations, this is the reason why the current chapter is referred to "implicit". In Section 8.5, we prove the well-posedness of both the *closed-loop system* and *target system*.

This work extends the control design presented in Chapter 7, as it allows a change of velocity distributed term. However, the goal of the control design presented here is fundamentally different, as we no longer consider the stabilization towards an attractor but towards the origin of the state space. This could be of interest for system such as the one presented in [Meurer and Kugi, 2011], where the wave PDE models a piezoelectric stack actuator and the boundaries have position distributed terms. Nevertheless with a few change (assuming all position distributed terms to be zero), the present design could achieve the same goal as the previous one.

## 8.1 An unstable wave equation with velocity and position distributed terms

Consider the following *original system*

$$\begin{cases}
 u_{tt}(x,t) = u_{xx}(x,t) + \lambda u_t(x,t) + \beta u(x,t), & (8.1a) \\
 u_x(1,t) = a_1 u_t(1,t) + a_2 u(1,t) + U(t), & (8.1b) \\
 u_{tt}(0,t) = b_1 u_t(0,t) + b_2 u_x(0,t) + b_3 u(0,t), & (8.1c)
 \end{cases}
 (\Sigma O_2)$$

in which  $U(t) \in \mathbb{R}$  is the scalar control input,  $u(x,t) \in \mathbb{R}$  is the variable of the system. The in-domain viscous distributed term coefficient is  $\lambda \in \mathbb{R}$ .  $\beta \in \mathbb{R}$  is the in-domain position distributed term.  $a_1, a_2 \in \mathbb{R}$  are the controlled boundary coefficients.  $b_1, b_3 \in \mathbb{R}$  and  $b_2 \in \mathbb{R} - \{0\}$  are the uncontrolled boundary coefficients.

The control objective is to exponentially stabilize the system toward the origin.

Note that the condition  $b_2 \neq 0$  is mandatory. Indeed,  $u_x(0,t)$  can be considered as the input of the boundary: If  $b_2 = 0$ ,  $u(0,t)$  is no longer controllable because the dynamics of  $u(0,t)$  ((8.1c)) is in this case an ODE, therefore  $u(0,t)$  is only determined by the values of  $u(0,0)$  and  $u_t(0,0)$ .

Note also that this system (opposite to (7.1)) cannot be reformulated as coupled first-order hyperbolic PDE-ODE using only Riemann invariant. This is due to the presence position source term  $u(\cdot, t)$ .

In order to express the control objective and the state space, we consider the homogeneous abstract problem resulting from (8.1). Let us define the following space  $H_2$

$$H_2 := \{(z_1, z_2, z_3, z_4, z_5) \in H_1(0, 1) \times L_2(0, 1) \times \mathbb{R}^3 \mid z_3 = z_1(1), z_4 = z_1(0)\}. \quad (8.2)$$

The set  $H_2$  is a Hilbert space with the following scalar product,  $\forall z, y \in H_2$

$$\langle z, y \rangle_{H_2} := \int_0^1 (z_1 y_1 + z_1' y_1' + z_2 y_2) dx + z_3 y_3 + z_4 y_4 + z_5 y_5. \quad (8.3)$$

Let us consider the following operator

$$\forall z \in \text{Dom}(\mathcal{A}_2), \quad \mathcal{A}_2 z := - \begin{bmatrix} z_2 \\ z_1'' + \lambda z_2 + \beta z_1 \\ z_2(1) \\ z_5 \\ b_1 z_5 + b_2 z_1'(0) + b_3 z_4 \end{bmatrix}, \quad (8.4)$$

in which  $\text{Dom}(\mathcal{A}_2)$  is defined as

$$\text{Dom}(\mathcal{A}_2) := \{(z_1, z_2, z_3, z_4, z_5) \in H_2(0, 1) \times H_1(0, 1) \times \mathbb{R}^3 : z_3 = z_1(1), z_4 = z_1(0), \\ z_5 = z_2(0), z_1'(1) = a_1 z_2(1) + a_2 z_3\}. \quad (8.5)$$

The abstract problem resulting from the system  $(\Sigma_{O_2})$  with  $U(t) = 0$  defined in (8.1) is

$$\begin{cases} \frac{d}{dt} X(t) + \mathcal{A}_2 X(t) = 0, & X(t) \in \text{Dom}(\mathcal{A}_2), \\ X(0) = X_0. \end{cases} \quad (8.6a)$$

$$(8.6b)$$

The proof of the well-posedness of (8.6) can be found with similar argument as the one proposed in Section 9.1. We are not really interested by the well-posedness of the homogeneous problem. Indeed as we design an feedback control law we are more interested on the well-posedness of the *closed-loop system*, it is established in Section 8.5.

As previously said, the objective is to stabilize the system  $(\Sigma_{O_1})$  defined in (8.1) towards the origin. The considered distance between  $z \in H_2$  and the origin is

$$\Gamma_2(z) := \|z_1\|_{H_1}^2 + \|z_2\|_{L_2}^2 + z_3^2 + z_4^2 + z_5^2. \quad (8.7)$$

Considering  $z_1(x) = u(x,t)$ ,  $z_2(x) = u_t(x,t)$ ,  $z_3 = u(1,t)$ ,  $z_4 = u(0,t)$ , and  $z_5 = u_t(0,t)$ , one writes

$$\Gamma_2(\mathcal{X}_2(t)) = \int_0^1 u(x,t)^2 dx + \int_0^1 u_x(x,t)^2 dx + \int_0^1 u_t(x,t)^2 dx + u(1,t)^2 + u(0,t)^2 + u_t(0,t)^2, \quad (8.8)$$

in which  $\mathcal{X}_2(t) \in H_2$  is

$$\mathcal{X}_2(t) = [u(\cdot, t), u_t(\cdot, t), u(1, t), u(0, t), u_t(0, t)]. \quad (8.9)$$

**Remark 3** Note that the state space  $H_2$  (8.2) is different from the state space study in Chapter 7, i.e.,  $H_1$  defined in (7.2). It is due to the fact that we consider here a first order dynamic boundary condition at  $x = 1$ . The question is about if the following holds

$$\|z\|_{L_2} = \|z'\|_{L_2} = 0 \stackrel{?}{\Rightarrow} z(1) = 0. \quad (8.10)$$

If it is true we can drop the  $\mathbb{R}$  space of  $z_3$  in the state space, and gets the definition of the vector product by Poincarè inequality. Nevertheless, the presented idea work whatever (8.10) holds or does not.  $\circ$

## 8.2 An exponentially stable wave equation with velocity and position distributed terms

Consider the following target system

$$(\Sigma_{T_2}) \begin{cases} w_{tt}(x,t) = w_{xx}(x,t) - \lambda_w w_t(x,t) - \beta_w w(x,t), & (8.11a) \\ w_x(1,t) = -c_1 w_t(1,t) - c_2 w(1,t), & (8.11b) \\ w_{tt}(0,t) = -d_1 w_t(0,t) + d_2 w_x(0,t) - d_3 w(0,t), & (8.11c) \end{cases}$$

in which  $w(x,t) \in \mathbb{R}$  is the variable of the system.  $\lambda_w > 0$  is an in-domain viscous damping.  $\beta_w > 0$  is an in-domain static damping.  $c_1, c_2, d_1, d_2, d_3 > 0$  are boundary parameters.

Define the following Lyapunov functional candidate, for  $z \in H_2$

$$V_2(z) := \int_0^1 \begin{bmatrix} z_1(x) & z_2(x) & z'_1(x) \end{bmatrix} P_0 \begin{bmatrix} z_1(x) \\ z_2(x) \\ z'_1(x) \end{bmatrix} dx + z_3 P_1 z_3 + \begin{bmatrix} z_4 & z_5 \end{bmatrix}^T P_2 \begin{bmatrix} z_4 \\ z_5 \end{bmatrix}, \quad (8.12)$$

in which  $P_0 \in \mathbb{R}^{3 \times 3}$ ,  $P_1 \in \mathbb{R}$  and  $P_2 \in \mathbb{R}^{2 \times 2}$  are symmetric positive definite matrices.  $\sqrt{V_2}(\cdot)$  is a norm on  $H_2$  which is defined in (8.2). Consider

$$\mathcal{X}_{e_2}(t) := [w(\cdot, t), w_t(\cdot, t), w(1, t), w(0, t), w_t(0, t)]. \quad (8.13)$$

**Lemma 8.1** [Roman et al., 2018]

Consider the target system  $(\Sigma_{T_2})$  defined in (8.11). For all  $\lambda_w > 0$ ,  $\beta_w > 0$ ,  $c_i > 0$ , and  $d_i > 0$ , there exist  $P_0$ ,  $P_1$  and  $P_2$  symmetric positive definite matrices such that, it holds for a suitable  $\rho > 0$

$$\dot{V}_2(\mathcal{X}_{e_2}(t)) \leq -\rho V_2(\mathcal{X}_{e_2}(t)), \quad (8.14)$$

in which  $V$  is defined (8.12),  $H_2 \ni \mathcal{X}_{e_2}(t)$  is defined in (8.13).

We start by rewriting the target system (8.11) equations in a vector form, in order to give Lyapunov equations. Let us define

$$W(x,t) := \begin{bmatrix} w(x,t) \\ w_t(x,t) \\ w_x(x,t) \end{bmatrix}, \quad (8.15)$$

$$W_1(t) := w(1,t), \quad W_0(t) := \begin{bmatrix} w(0,t) \\ w_t(0,t) \end{bmatrix}. \quad (8.16)$$

It holds

$$W_t(x,t) = A_1 W(x,t) + A_2 W_x(x,t), \quad (8.17)$$

$$\frac{d}{dt} W_1(t) = A_3 W(1,t), \quad \frac{d}{dt} W_0(t) = A_4 W(0,t), \quad (8.18)$$

$$W_1(t) = A_5 W(1,t), \quad W_0(t) = A_6 W(0,t), \quad W(1,t) = A_7 \begin{bmatrix} w(1) \\ w_t(1) \end{bmatrix}, \quad (8.19)$$

in which

$$A_1 := \begin{bmatrix} 0 & 1 & 0 \\ -\beta_w & -\lambda_w & 0 \\ 0 & 0 & 0 \end{bmatrix}, \quad A_2 := \begin{bmatrix} 0 & 0 & 0 \\ 0 & 0 & 1 \\ 0 & 1 & 0 \end{bmatrix}, \quad (8.20)$$

$$A_3 := \begin{bmatrix} -\frac{c_2}{c_1} & 0 & -\frac{1}{c_1} \end{bmatrix}, \quad A_4 := \begin{bmatrix} 0 & 1 & 0 \\ -d_3 & -d_1 & d_2 \end{bmatrix}, \quad (8.21)$$

$$A_5 := \begin{bmatrix} 1 & 0 & 0 \end{bmatrix}, \quad A_6 := \begin{bmatrix} 1 & 0 & 0 \\ 0 & 1 & 0 \end{bmatrix}, \quad (8.22)$$

$$A_7 := \begin{bmatrix} 1 & 0 \\ 0 & 1 \\ -c_2 & -c_1 \end{bmatrix}. \quad (8.23)$$

Since  $w_x$  appears in  $W$  and  $W_x$ , the following proposition expresses this relation in a vector form.

**Proposition 8.1** *Define*

$$J_1 := \begin{bmatrix} 1 & 0 & 0 \\ 0 & 0 & 0 \\ 0 & 0 & 0 \end{bmatrix}, \quad J_2 := \begin{bmatrix} 0 & 0 & 0 \\ 0 & 0 & 0 \\ 1 & 0 & 0 \end{bmatrix}, \quad J_3 := \begin{bmatrix} 0 & 0 & 1 \\ 0 & 0 & 0 \\ 0 & 0 & 0 \end{bmatrix}. \quad (8.24)$$

It holds

$$W_x^T J_1 = W^T J_2, \quad (8.25)$$

$$J_1 W_x = J_3 W, \quad (8.26)$$

where  $W$  is defined in (8.15). Moreover it follows  $\forall \theta \in \mathbb{R}^{3 \times 3}$

$$\int_0^1 W^T(x) J_1 \theta W_x(x) dx = [W^T(x) J_1 \theta W(x)]_0^1 - \int_0^1 W^T(x) J_2 \theta W(x) dx, \quad (8.27)$$

$$\int_0^1 W_x^T(x) \theta J_1 W(x) dx = [W^T(x) \theta J_1 W(x)]_0^1 - \int_0^1 W^T(x) \theta J_3 W(x) dx. \quad (8.28)$$

*Proof:* One establishes the proof with algebraic manipulations. ■

**Remark 4** *We need some symmetry in the Lyapunov analysis for the wave equation to cancel product three order derivative, e.g.  $u_t u_{xx}$  or  $u_{tx} u_t$ . For example, for the wave without source terms ( $u_{tt} = u_{xx}$ )*

$$\frac{d}{dt} \left( \int_0^1 [u_x^2 + u_t^2] dx \right) = 2 \int_0^1 [u_t u_{xx} + u_x u_{xt}] dx = [2u_x u_t]_0^1, \quad (8.29)$$

*if the coefficients in factor of  $u_t^2$  and  $u_x^2$  are not equal, the product three order derivatives  $u_t u_{xx}$  and  $u_x u_{xt}$  are not canceled.* ○

Define the complementary of  $J_1$  to  $I_3$ , meaning it holds  $J_1 + J_4 = I_3$

$$J_4 = \begin{bmatrix} 0 & 0 & 0 \\ 0 & 1 & 0 \\ 0 & 0 & 1 \end{bmatrix}. \quad (8.30)$$

The idea is to decompose the computation of the Lyapunov functional candidate derivative in  $J_1$  and  $J_4$  parts. On the  $J_1$  part we can use Proposition 8.1, and the symmetry condition in Remark 4 is used to cancel the  $J_4$  part. This is expressed in the following proposition.

**Proposition 8.2** *If*

$$J_4(A_2P_0 - P_0A_2)J_4 = 0, \quad (8.31)$$

*then it holds*

$$\begin{aligned} \int_0^1 (W_x^T A_2 P_0 W + W^T P_0 A_2 W_x) dx = \int_0^1 W^T [J_2 A_2 P_0 - J_4 A_2 P_0 J_3 + P_0 A_2 J_3 - J_2 P_0 A_2 J_4] W dx \\ + \left[ W^T [J_4 A_2 P_0 J_1 + J_1 P_0 A_2 J_4 + J_4 P_0 A_2 J_4] W \right]_0^1, \end{aligned} \quad (8.32)$$

where  $J_1$ ,  $J_2$ , and  $J_3$  are defined in (8.24) and  $J_4$  is defined in (8.30).

The condition (8.31) is the symmetric condition we mentioned in Remark 4.

*Proof*: From the definition of  $J_1$ ,  $J_2$ , and  $J_3$  (8.24), for all  $\Theta \in \mathbb{R}^{3 \times 3}$  it holds

$$\Theta = J_1 \Theta + J_4 \Theta J_1 + J_4 \Theta J_4, \quad (8.33)$$

$$\Theta = \Theta J_1 + J_1 \Theta J_4 + J_4 \Theta J_4. \quad (8.34)$$

Applying this to  $A_2 P_0$  and  $P_0 A_2$ , using Proposition 8.1, and three integrations by parts and (8.31), one obtains (8.32). ■

**Proposition 8.3** *Consider  $V_2$  defined in (8.12) and  $P_0 \in \mathbb{R}^{3 \times 3}$ ,  $P_1 \in \mathbb{R}$ , and  $P_2 \in \mathbb{R}^{2 \times 2}$ , symmetric positive definite matrices, verifying (8.31), it holds*

$$\begin{aligned} \dot{V}_2(\mathcal{X}_w(t)) = - \int_0^1 [w(x,t) \quad w_t(x,t) \quad w_x(x,t)] Q_0 \begin{bmatrix} w(x,t) \\ w_t(x,t) \\ w_x(x,t) \end{bmatrix} dx - [w(1,t) \quad w_t(1,t)] Q_1 \begin{bmatrix} w(1,t) \\ w_t(1,t) \end{bmatrix} \\ - [w(0,t) \quad w_t(0,t) \quad w_x(0,t)] Q_2 \begin{bmatrix} w(0,t) \\ w_t(0,t) \\ w_x(0,t) \end{bmatrix}, \end{aligned} \quad (8.35)$$

in which  $Q_0$ ,  $Q_1$  and  $Q_2$  are defined as

$$Q_0 = -A_1^T P_0 - P_0 A_1 - J_2(A_2 P_0 - P_0 A_2 J_4) - (P_0 A_2 - J_4 A_2 P_0) J_3, \quad (8.36)$$

$$Q_1 = A_7^T (-A_3^T P_1 A_5 - A_5^T P_1 A_3 - (J_4 A_2 P_0 J_1 + J_1 P_0 A_2 J_4 + J_4 P_0 A_2 J_4) A_7), \quad (8.37)$$

$$Q_2 = -A_4^T P_2 A_6 - A_6^T P_2 A_4 + (J_4 A_2 P_0 J_1 + J_1 P_0 A_2 J_4 + J_4 P_0 A_2 J_4), \quad (8.38)$$

where  $J_i$  are defined in (8.24)-(8.30),  $A_i$  are defined in (8.20)-(8.23).

*Proof*: Compute the derivative of the Lyapunov functional candidate  $V_3$  (defined in (8.12)) along the state trajectory. Then applying (8.17)-(8.19), then using (8.31) and Proposition 8.3 one gets (8.35). ■

The so called Lyapunov equations are (8.36)-(8.38). As in the previous chapter, a future work could be to estimate the decay rate with more accurately, using these LMIs. Indeed to estimate the decay rate, one look for the greatest  $\rho$  such that  $Q_0 > \rho P_0$ ,  $Q_1 > \rho P_1$ ,  $Q_2 > \rho P_2$  (see [Boyd et al., 1994] for a textbook on LMI). Note that in the current case the matrices are constants, this is not the case in Section 7.2.

*Proof of Lemma 8.1*: Let us choose

$$P_0 = \begin{bmatrix} \beta_w & \sigma & 0 \\ * & 1 & 0 \\ * & * & 1 \end{bmatrix}, \quad P_2 = \begin{bmatrix} d_3 + \sigma d_1 & \sigma \\ d_2 & \frac{\sigma}{d_2} \\ * & \frac{1}{d_2} \end{bmatrix}, \quad (8.39)$$



$$P_1 = c_2, \quad (8.40)$$

in which

$$\sigma < \min\left\{\sqrt{\beta_w}, \frac{2d_1 + \sqrt{d_1^2 + 4d_3}}{2}\right\}, \quad (8.41)$$

such that  $P_0$  and  $P_2$  are symmetric positive definite matrices. Using Proposition 8.3, it holds

$$\begin{aligned} \dot{V}_2(\mathcal{X}_{e_2}) = & - \int_0^1 [w \quad w_t \quad w_x] Q_0 \begin{bmatrix} w \\ w_t \\ w_x \end{bmatrix} dx \\ & - [w(1) \quad w_t(1)] Q_1 \begin{bmatrix} w(1) \\ w_t(1) \end{bmatrix} - [w(0) \quad w_t(0)]^T Q_{2r} \begin{bmatrix} w(0) \\ w_t(0) \end{bmatrix}, \end{aligned} \quad (8.42)$$

in which, form (8.36)-(8.38),

$$Q_0 = \begin{bmatrix} 2\beta_w \sigma & \lambda_w \sigma & 0 \\ * & 2\lambda_w - 2\sigma & 0 \\ * & * & 2\sigma \end{bmatrix}, \quad Q_1 = \begin{bmatrix} 2c_2 \sigma & \sigma c_1 \\ * & 2c_1 \end{bmatrix}, \quad Q_{2r} = \begin{bmatrix} \frac{2\sigma d_3}{d_2} & 0 \\ * & \frac{2d_1}{d_2} - \frac{2\sigma}{d_2} \end{bmatrix}. \quad (8.43)$$

From (8.43) one obtains that if

$$0 < \sigma < \min\left\{\sqrt{\beta_w}, \lambda_w, \frac{4\beta_w \lambda_w}{\lambda_w^2 + 2\beta_w}, \frac{4c_2}{c_1}, d_1\right\}, \quad (8.44)$$

then  $Q_0$ ,  $Q_1$ , and  $Q_2$  are symmetric definite positive matrices, therefore, (8.14) holds.  $\blacksquare$

### 8.3 Backstepping state feedback

The backstepping transformation is chosen as

$$w(x, t) = u(x, t) - \int_0^x K^T(x, y) \chi(y, t) dy - \gamma(x) u_t(0, t), \quad (8.45)$$

in which  $K$  and  $\chi$  are defined as

$$K(x, y) := \begin{bmatrix} k(x, y) \\ s(x, y) \\ m(x, y) \end{bmatrix}, \quad \chi(x, t) := \begin{bmatrix} u(x, t) \\ u_t(x, t) \\ u_x(x, t) \end{bmatrix}. \quad (8.46)$$

The construction of (8.45) is inspired by [Sagert et al., 2013] and by [Smyshlyaev and Krstic, 2009] for the integral terms.

The kernel  $(K, \gamma)$  of the backstepping transformation (8.45) is chosen as the unique solution (see Lemma 8.3 of Section 8.4.2) of the following equations

$$\begin{cases} K_{xx}(x, y) - K_{yy}(x, y) = B_K K_y(x, y) + C_K K(x, y), & (8.47a) \\ K'(x, x) = D_K K(x, x) + E_K, & (8.47b) \\ \begin{bmatrix} k_y(x, 0) \\ m_y(x, 0) \end{bmatrix} = H_K K(x, 0), & (8.47c) \\ s_{xx}(x, 0) = b_2 s_y(x, 0) + H_S K(x, 0), & (8.47d) \\ \begin{bmatrix} K(0, 0) \\ s_x(0, 0) \end{bmatrix} = J_K, & (8.47e) \\ \gamma(x) = \frac{s(x, 0)}{b_2}, & (8.47f) \end{cases} \quad (\Sigma_{K_2})$$

in which

$$B_K^T := -(\Theta_2 \Theta_1 + \Theta_1 \Theta_2 + \lambda_w \Theta_2), \quad (8.48)$$

$$C_K^T := \Theta_1^2 + \lambda_w \Theta_1 + \beta_w I_3, \quad (8.49)$$

$$D_K^T := \frac{1}{2}(\Theta_2 \Theta_1 + \Theta_1 \Theta_2 + \lambda_w \Theta_2), \quad (8.50)$$

$$E_K^T := -\frac{1}{2} [(\beta + \beta_w) \quad (\lambda + \lambda_w) \quad 0], \quad (8.51)$$

$$H_K := \begin{bmatrix} \lambda_w & \beta - (\lambda_w + b_1) \frac{b_3}{b_2} & b_3 \\ 1 & \lambda - b_1 & b_2 \end{bmatrix}, \quad (8.52)$$

$$H_S := [0 \quad \beta_w + b_3 + \lambda_w b_1 + b_1^2 \quad -(b_2 \lambda_w + b_2 b_1)], \quad (8.53)$$

where  $I_n$  denotes the identity in  $\mathbb{R}^{n \times n}$ , and

$$\Theta_1 := \begin{bmatrix} 0 & 1 & -1 \\ \beta & \lambda & 0 \\ 0 & 0 & 0 \end{bmatrix}, \quad \Theta_2 := \begin{bmatrix} 1 & 0 & 0 \\ 0 & 0 & 1 \\ 0 & 1 & 0 \end{bmatrix}, \quad (8.54)$$

$$J_K := -\frac{1}{d_2} \begin{bmatrix} d_3 + b_3 \\ 0 \\ b_2 - d_2 \\ (b_1 + d_1) b_2 \end{bmatrix}. \quad (8.55)$$

The PDE (8.47) that the kernel needs to satisfy is different from both [Sagert et al., 2013] and [Smyshlyaev and Krstic, 2009]. Indeed, both have no distributed terms in (8.47a) as we have. Moreover, both have simpler boundary conditions. Note that the boundary condition (8.47c) is similar to the one of [Smyshlyaev and Krstic, 2004]. Nevertheless, the condition in [Smyshlyaev and Krstic, 2004] is scalar and has in addition an integral term. But the recursive assumption we use in the method of successive approximations (Section 8.4.2) needs to be different from [Smyshlyaev and Krstic, 2004] (otherwise we cannot conclude) and new, up to our knowledge.

Finally, the control law is defined as:

$$\begin{aligned} U(t) := & K^T(1,1)\chi(1,t) + \int_0^1 K_x^T(1,y)\chi(y,t)dy + \gamma'(1)u_t(0,t) - (a_1 + c_1)u_t(1,t) - (a_2 + c_2)u(1,t) \\ & + c_2[\gamma(1)u_t(0,t) + \int_0^1 K^T(1,y)\chi(y,t)dy] + c_1[[K^T(1,y)\Theta_2\chi(y,t)]_{y=0}^1] \\ & + \int_0^1 [K^T\Theta_1 - K_y^T\Theta_2](1,y)\chi(y,t)dy + \gamma(1)\Theta_3\chi(0,t), \end{aligned} \quad (8.56)$$

in which

$$\Theta_3 := [b_3 \quad b_1 \quad b_2]. \quad (8.57)$$

The control law  $U$  defined in (8.56) is expressed in terms of  $u$ ,  $u_t$  and  $u_x$ . Note that, using integrations by part, (8.11b) and (8.47f), one can express  $U$  in terms of  $u$  and  $u_t$ .

The stability result is stated in the following theorem

**Theorem 8.1** [Roman et al., 2018]

Consider the closed-loop system consisting of the plant (8.1) with  $b_2 \neq 0$ , together with the control law (8.56) in which the kernel  $(K, \gamma)$  is defined in (8.47) with  $\lambda_w > 0$ ,  $\beta_w > 0$ ,  $c_i > 0$ ,  $d_i > 0$ . Consider the functional  $\Gamma_2$  defines in (8.7). There exist  $\rho > 0$  and  $R > 0$  such that

$$\Gamma_2(\mathcal{X}_2(t)) \leq R\Gamma_2(\mathcal{X}_2(0))e^{-\rho t}, \quad t \geq 0, \quad (8.58)$$

i.e., the closed-loop system is exponentially stable towards the origin.  $\mathcal{H}_2 \ni \mathcal{X}_2(t)$  is defined in (8.9).

Note that  $\sqrt{\Gamma_2(\cdot)}$  defines a norm of the Hilbert space  $\mathcal{H}_2$  defined in (8.2). Opposite to the Chapter 7, here the exponential stabilization is obtained for the position also.

## 8.4 Proof of the closed-loop stability result

First, Section 8.4.1 presents the developments needed to get the backstepping kernel PDE (8.47). Second, the existence and uniqueness of a solution to these equations is proven in Section 8.4.2. In Section 8.4.3, we analyze the invertibility of the backstepping transformation. Then, in Section 8.4.4, the equivalence between the target system Lyapunov functional  $V_2$  defined in (8.12) and the functional  $\Gamma_2$  defined in (8.7) is established. Finally, using all previous developments, we conclude the proof of Theorem 8.1 in Section 8.4.5.

### 8.4.1 Backstepping transformation

This section is devoted to the establishment of (8.47). Before stating the corresponding result, consider the vector  $\chi(x, t)$  defined in (8.46). Using the system equation (8.1a) together with the boundary condition (8.1c), it is easy to show that

$$\chi_t(x, t) = \Theta_1 \chi(x, t) + \Theta_2 \chi_x(x, t), \quad (8.59)$$

$$u_{tt}(0, t) = \Theta_3 \chi(0, t), \quad (8.60)$$

$$\chi_t(0, t) = \Theta_4 \underline{\chi}(0, t), \quad (8.61)$$

$$\chi(0, t) = \Theta_5 \underline{\chi}(0, t), \quad (8.62)$$

where  $\Theta_1$ ,  $\Theta_2$ , and  $\Theta_3$  are defined in (8.54) and (8.57), and with

$$\underline{\chi}(0, t) := [u(0, t) \quad u_t(0, t) \quad u_x(0, t) \quad u_{xt}(0, t)]^T, \quad (8.63)$$

$$\Theta_4 := \begin{bmatrix} 0 & 1 & 0 & 0 \\ b_3 & b_1 & b_2 & 0 \\ 0 & 0 & 0 & 1 \end{bmatrix}, \quad \Theta_5 := \begin{bmatrix} 1 & 0 & 0 & 0 \\ 0 & 1 & 0 & 0 \\ 0 & 0 & 1 & 0 \end{bmatrix}. \quad (8.64)$$

Note that  $\Theta_1$  and  $\Theta_2$ , such that it holds (8.59), are not unique, however with this choice it holds  $\Theta_2^2 = I_3$ .

#### Lemma 8.2 [Roman et al., 2018]

If the kernel  $(K, \gamma)$  of the backstepping transformation (8.45) is solution of the PDE (8.47) then the backstepping transformation maps the original system (8.1) with the control law (8.56) into the target system (8.11).

*Proof of Lemma 8.2:* Consider the time derivative of (8.45)

$$w_t(x, t) = u_t(x, t) - \int_0^x K^T(x, y) \chi_t(y, t) dy - \gamma(x) u_{tt}(0, t). \quad (8.65)$$

Using (8.59), an integration by parts and (8.60), one can express (8.65) as

$$w_t(x, t) = u_t(x, t) - [K^T(x, y) \Theta_2 \chi(y, t)]_{y=0}^x - \int_0^x [K^T \Theta_1 - K_y^T \Theta_2](x, y) \chi(y, t) dy - \gamma(x) \Theta_3 \chi(0, t). \quad (8.66)$$

Consider the time derivative of (8.66). Using (8.1a), (8.59), knowing that  $\Theta_2^2 = I_3$ , plus an integration by parts, one obtains

$$\begin{aligned} w_{tt}(x, t) = & u_{xx}(x, t) + \lambda u_t(x, t) + \beta u(x, t) - \left[ K^T(x, y) \Theta_2 \chi_t(y, t) + (K^T(x, y) \Theta_1 \Theta_2 - K_y^T(x, y)) \chi(y, t) \right]_{y=0}^x \\ & - \int_0^x [(K^T \Theta_1 - K_y^T \Theta_2) \Theta_1 - (K_y^T \Theta_1 \Theta_2 - K_{yy}^T)](x, y) \chi(y, t) dy - \gamma(x) \Theta_3 \chi_t(0, t). \end{aligned} \quad (8.67)$$

Considering now the first and second space derivatives of (8.45), that can be written as

$$w_x(x,t) = u_x(x,t) - K^T(x,x)\chi(x,t) - \int_0^x K_x^T(x,y)\chi(y,t)dy - \gamma'(x)u_t(0,t), \quad (8.68)$$

$$\begin{aligned} w_{xx}(x,t) &= u_{xx}(x,t) - (K'^T(x,x) + K_x^T(x,x))\chi(x,t) \\ &\quad - K^T(x,x)\chi_x(x,t) - \int_0^x K_{xx}^T(x,y)\chi(y,t)dy - \gamma''(x)u_t(0,t). \end{aligned} \quad (8.69)$$

Gathering (8.45), (8.66), (8.67), and (8.69) the target system equation (8.11a) holds if the kernel  $(K, \gamma)$  satisfies the following conditions

$$\begin{aligned} K^T(x,y)\Theta_1^2 - K_y^T(x,y)\Theta_2\Theta_1 - K_y^T(x,y)\Theta_1\Theta_2 + K_{yy}^T(x,y) \\ - K_{xx}^T(x,y) + \lambda_w K^T(x,y)\Theta_1 - \lambda_w K_y^T(x,y)\Theta_2 + \beta_w K^T(x,y) = 0, \end{aligned} \quad (8.70)$$

$$\begin{aligned} K^T(x,x)\Theta_2\chi_t(x,t) - \lambda\Theta_6\chi(x,t) - \beta\Theta_8\chi(x,t) + [K^T(x,x)\Theta_1\Theta_2 - K_y^T(x,x)]\chi(x,t) - \lambda_w\Theta_6\chi(x,t) \\ + \lambda_w K^T(x,x)\Theta_2\chi(x,t) - \beta_w\Theta_8\chi(x,t) - (K'^T(x,x) + K_x^T(x,x))\chi(x,t) - K^T(x,x)\chi_x(x,t) = 0, \end{aligned} \quad (8.71)$$

$$\gamma(x)\Theta_3\chi_t(0,t) + (-K^T(x,0)\Theta_1\Theta_2 + K_y^T(x,0))\chi(0,t), \quad (8.72)$$

$$-K^T(x,0)\Theta_2\chi_t(0,t) - \gamma''(x)\Theta_6\chi(0,t) - \lambda_w K^T(x,0)\Theta_2\chi(0,t) + \lambda_w\gamma(x)\Theta_3\chi(0,t) + \beta_w\gamma(x)\Theta_6\chi(0,t) = 0$$

in which

$$\Theta_6 := [0 \ 1 \ 0], \quad \Theta_8 := [1 \ 0 \ 0]. \quad (8.73)$$

Considering  $B_K$  and  $C_K$  defined in (8.48)-(8.49), (8.70) can be rewritten as (8.47a). Moreover, using (8.59), (8.71) can be reformulated as (8.47b). Furthermore, using (8.61) and (8.62) one obtains that (8.72) is equivalent to the four following scalar conditions

$$\beta s(x,0) - k_y(x,0) + \lambda_w k(x,0) + b_3 m(x,0) - \lambda_w b_3 \gamma(x) - b_1 b_3 \gamma(x) = 0, \quad (8.74)$$

$$-\beta_w \gamma(x) - s_y(x,0) + \gamma''(x) + \lambda_w m(x,0) - b_3 \gamma(x) - \lambda_w b_1 \gamma(x) + b_1 m(x,0) - b_1^2 \gamma(x) = 0, \quad (8.75)$$

$$k(x,0) - m_y(x,0) + \lambda s(x,0) + b_2 m(x,0) - \lambda_w b_2 \gamma(x) - b_1 b_2 \gamma(x) + \lambda_w s(x,0) = 0, \quad (8.76)$$

$$s(x,0) - b_2 \gamma(x) = 0, \quad (8.77)$$

which can be reformulated as (8.47c), (8.47d), and (8.47f).

Now, the boundary condition (8.11c) gives one last condition on the kernel. As, from (8.45), (8.66), (8.67), and (8.68),

$$\begin{cases} w_{tt}(0,t) = \Theta_3\Theta_5\underline{\chi}(0,t) - \gamma(0)\Theta_3\Theta_4\underline{\chi}(0,t), & (8.78a) \\ w_t(0,t) = \Theta_6\Theta_5\underline{\chi}(0,t) - \gamma(0)\Theta_3\Theta_5\underline{\chi}(0,t), & (8.78b) \end{cases}$$

$$\begin{cases} w_x(0,t) = \Theta_7\Theta_5\underline{\chi}(0,t) - K^T(0,0)\Theta_5\underline{\chi}(0,t) - \gamma'(0)\Theta_6\Theta_5\underline{\chi}(0,t), & (8.78c) \\ w(0,t) = \Theta_8\Theta_5\underline{\chi}(0,t) - \gamma(0)\Theta_6\Theta_5\underline{\chi}(0,t), & (8.78d) \end{cases}$$

in which

$$\Theta_7 := [0 \ 0 \ 1], \quad (8.79)$$

thus a sufficient condition for (8.11c) to hold is

$$\begin{bmatrix} b_3 + d_3 \\ b_1 + d_1 \\ b_2 - d_2 \\ 0 \end{bmatrix} = -d_2 \begin{bmatrix} k(0,0) \\ s(0,0) \\ m(0,0) \\ 0 \end{bmatrix} + \gamma(0) \begin{bmatrix} * \\ * \\ * \\ b_2 \end{bmatrix} - \gamma'(0) \begin{bmatrix} 0 \\ d_2 \\ 0 \\ 0 \end{bmatrix}, \quad (8.80)$$

which, using (8.77), is (8.47e).

Finally the control law (8.56) can be obtained from (8.11b), with (8.45), (8.66), (8.68), and using (8.1b). ■

### 8.4.2 Existence and uniqueness of the solution of (8.47a)-(8.47e)

The PDE (8.47a)-(8.47e) presents two different types of boundary conditions at  $(x, 0)$ , namely (8.47c) and (8.47d). The key idea in the sequel is to address each condition separately. First, consider the following change of variable

$$G(\zeta, \eta) = e^{\frac{1}{2}B_K(\zeta-\eta)}K(\zeta + \eta, \zeta - \eta). \quad (8.81)$$

The idea behind (8.81) is, on the one hand to gather the high order derivative which appear in (8.47a) ( $K_{xx} - K_{yy}$ ) into one term ( $G_{\eta\zeta}$ ) with  $x = \zeta + \eta$  and  $y = \zeta - \eta$ , and on the other hand to canceled the term in  $K_y$  in (8.47a), this is done with  $G = e^{\frac{1}{2}B_K\gamma}K$ .

Consider the following definitions

$$\phi_{k,m} := \begin{bmatrix} 1 & 0 & 0 \\ 0 & 0 & 1 \end{bmatrix}, \quad \phi_s := [0 \quad 1 \quad 0], \quad (8.82)$$

$$K^{k,m} := \phi_{k,m}K, \quad G^{k,m} := \phi_{k,m}G, \quad K^s := \phi_s K, \quad G^s := \phi_s G. \quad (8.83)$$

One can notice that

$$G = \phi_{k,m}^T G^{k,m} + \phi_s^T G^s. \quad (8.84)$$

The previous notations allow to apply the method of successive approximations in a compact manner. Indeed, after addressing the boundary conditions separately we gather then in a vector (using (8.84)). Then the method of successive approximations is performed to a vector form PDE, opposite to three scalar coupled PDE.

Indeed it holds the following proposition

**Proposition 8.4** [Roman et al., 2018]

The two following statements are equivalent

(i).  $K$  is a solution of (8.47a)-(8.47e).

(ii).  $G$  is a solution of

$$\begin{cases} G_{\zeta\eta}(\zeta, \eta) = C_G(\zeta, \eta)G(\zeta, \eta), & (8.85a) \\ G(\zeta, 0) = F_G(\zeta), & (8.85b) \\ G_{\zeta}^{k,m}(\eta, \eta) = H_G G(\eta, \eta) + G_{\eta}^{k,m}(\eta, \eta), & (8.85c) \\ G^s(\eta, \eta) = 2 \int_0^{\eta} \int_0^z [b_2(G_{\zeta}^s(\mu, \mu) - G_{\eta}^s(\mu, \mu)) + H_{GS}G(\mu, \mu)] d\mu dz + J_{GS}(2\eta), & (8.85d) \end{cases}$$

in which

$$C_G(\zeta, \eta) := e^{\frac{1}{2}B_K(\zeta-\eta)}(C_K - \frac{1}{4}B_K^2)e^{-\frac{1}{2}B_K(\zeta-\eta)}, \quad (8.86)$$

$$F_G(\zeta) := e^{\frac{1}{2}B_K\zeta}F_K(\zeta), \quad (8.87)$$

$$F_K(\zeta) := K(x, x) = e^{D_K x}J_{GK} + \int_0^x e^{D_K(x-s)}E_K ds, \quad (8.88)$$

$$H_G := 2H_K + \phi_{k,m}B_K, \quad H_{GS} := 2H_S - b_2\phi_s B_K, \quad (8.89)$$

$$J_{GS}(x) := [0 \quad 1 \quad 0 \quad x]J_K, \quad (8.90)$$

$$J_{GK} := K(0, 0) = \Theta_5 J_K. \quad (8.91)$$

where  $B_K, C_K, D_K, E_K, H_K, J_K$  are defined in (8.48)-(8.55).

*Proof:* (i)  $\Rightarrow$  (ii). The way to get (8.85a) and (8.85b) is straightforward. Besides, from the fact that

$$s(x, 0) = \int_0^x \int_0^s s_{xx}(z, 0) dz ds + x s_x(0, 0) + s(0, 0), \quad (8.92)$$

using (8.47d), (8.47f), (8.90), and  $z = 2\mu$ , one gets

$$s(x, 0) = \int_0^x \int_0^{\frac{x}{2}} [2b_2 s_y(2\mu, 0) + 2H_S K(2\mu, 0)] d\mu ds + J_{GS}(x). \quad (8.93)$$

From (8.81), it holds

$$G_\zeta(\eta, \eta) - G_\eta(\eta, \eta) = 2K_y(2\eta, 0) + B_K K(2\eta, 0). \quad (8.94)$$

Thus multiplying (8.94) by  $\phi_s$  defined in (8.82), one writes

$$2s_y(2\eta, 0) = G_\zeta^s(\eta, \eta) - G_\eta^s(\eta, \eta) - \phi_s B_K G(\eta, \eta). \quad (8.95)$$

Replacing (8.95) into (8.93), for  $x = 2\eta$ , and  $2z = s$ , one obtains

$$G^s(\eta, \eta) = \int_0^\eta 2 \int_0^z [b_2(G_\zeta^s(\mu, \mu) - G_\eta^s(\mu, \mu) - \phi_s B_K G(\mu, \mu)) + 2H_S G(\mu, \mu)] d\mu dz + J_{GS}(2\eta), \quad (8.96)$$

and (8.85d) holds. Finally, multiplying (8.94) by  $\phi_{k,m}$ , one gets (8.85c).

(ii)  $\Rightarrow$  (i), the change of variable (8.81) is bijective, as it the composition of two bijective change of variables, a linear one and a exponential one. This concludes the proof.  $\blacksquare$

**Lemma 8.3** [Roman et al., 2018]

The system (8.85) has a unique solution  $G$ , given as the cumulative sum of the following sequence,

$$G(\zeta, \eta) = \sum_{n=0}^{\infty} (\Delta G)^n(\zeta, \eta), \quad (8.97)$$

which exponentially converges towards zero, where  $(\Delta G)^n$  is

$$(\Delta G)^{n+1}(\zeta, \eta) = \mathcal{F}((\Delta G)^n(\zeta, \eta)), \quad (8.98)$$

$$(\Delta G)^0(\zeta, \eta) = \phi_{k,m}^T \phi_{k,m} [2F_G(\eta) - F_G(0)] + \phi_s^T [J_{GS}(2\eta) - 2b_2 \eta \phi_s F_G(0)] + F_G(\zeta) - F_G(\eta), \quad (8.99)$$

in which  $\phi_{k,m}$ ,  $\phi_s$  are defined in (8.82), and

$$\begin{aligned} \mathcal{F}(G(\zeta, \eta)) := & \int_\eta^\zeta \int_0^\eta C_G(s, z) G(s, z) dz ds + \phi_{k,m}^T \left[ - \int_0^\eta H_G G(s, s) ds + 2\phi_{k,m} \int_0^\eta \int_0^s C_G(s, z) G(s, z) dz ds \right] \\ & + \phi_s^T \left[ \int_0^\eta \int_0^z 4b_2 \int_0^\mu \phi_s C_G(\mu, s) G(\mu, s) ds d\mu dz \right. \\ & \left. + \int_0^\eta 4b_2 \phi_s G(z, 0) dz - 2b_2 \int_0^\eta \phi_s G(z, z) dz + \int_0^\eta 2 \int_0^z H_{GS} G(\mu, \mu) d\mu dz \right]. \end{aligned} \quad (8.100)$$

*Proof*: Let us first notice that

$$G(\zeta, \eta) = \int_\eta^\zeta \int_0^\eta G_{\zeta\eta}(s, z) dz ds + G(\eta, \eta) + G(\zeta, 0) - G(\eta, 0). \quad (8.101)$$

On the one hand, the integration of  $G_{\zeta\eta}(\zeta, \eta)$  with respect to  $\eta$  from 0 to  $\zeta$  gives

$$\int_0^\zeta G_{\zeta\eta}(\zeta, s) ds = G_\zeta(\zeta, \zeta) - G_\zeta(\zeta, 0), \quad (8.102)$$

and, according to (8.85c), one can get

$$\frac{dG^{k,m}(\zeta, \zeta)}{d\zeta} = -H_G G(\zeta, \zeta) + 2G_\zeta^{k,m}(\zeta, \zeta). \quad (8.103)$$

Matching both previous equations along with (8.83) and (8.85a), it holds

$$\begin{aligned} G^{k,m}(\zeta, \zeta) &= - \int_0^\zeta H_G G(s, s) ds + 2G^{k,m}(\zeta, 0) \\ &\quad + 2\phi_{k,m} \int_0^\zeta \int_0^s C_G(s, z) G(s, z) dz ds - G^{k,m}(0, 0). \end{aligned} \quad (8.104)$$

On the other hand, using the fact that

$$G_\zeta(\eta, \eta) - G_\eta(\eta, \eta) = 2G_\zeta(\eta, \eta) - G'(\eta, \eta), \quad (8.105)$$

and (8.85d), (8.102), and (8.85a) one finally gets

$$\begin{aligned} G^s(\eta, \eta) &= 4b_2 \int_0^\eta \int_0^z \int_0^\mu \phi_s C_G(\mu, s) G(\mu, s) ds d\mu dz + \int_0^\eta 4b_2 G^s(z, 0) ds \\ &\quad - 4b_2 \eta G^s(0, 0) - 2b_2 \int_0^\eta G^s(z, z) dz + 2b_2 \eta G^s(0, 0) + 2 \int_0^\eta \int_0^z H_{GS} G(\mu, \mu) d\mu dz + J_{GS}(2\eta), \end{aligned} \quad (8.106)$$

Thus, gathering (8.101), (8.104), and (8.106), one finally gets

$$G(\zeta, \eta) = \mathcal{F}(G(\zeta, \eta)) + (\Delta G)^0(\zeta, \eta), \quad (8.107)$$

in which  $(\Delta G)^0(\zeta, \eta)$  and  $\mathcal{F}(\cdot)$  are defined in (8.99) and (8.100).

Now, we use a standard iterative method to prove that (8.107) has a unique solution. This is the method of the successive approximation, which has been detailed in Section 1.3.4. The initial guess is  $(\Delta G)^0$  defined in (8.99), and initiates the induction (8.98) for  $n \in \mathbb{N}$ . Define  $M$  as

$$|(\Delta G)^0(\zeta, \eta)|_\infty \leq \|J_{GS}\|_{L_\infty} + (5 + 2b_2)\|F\|_{L_\infty} =: M, \quad (8.108)$$

Assume that there exists  $\kappa$  such that the following inequality is true for a given rank  $n \in \mathbb{N}$

$$|(\Delta G)^n(\zeta, \eta)|_\infty \leq M \kappa^n \frac{\zeta^n + \eta^n}{n!}. \quad (8.109)$$

From (8.98), it follows

$$\begin{aligned} |(\Delta G)^{n+1}(\zeta, \eta)|_\infty &\leq \|C_G\|_{L_\infty} \int_\eta^\zeta \int_0^\eta |(\Delta G)^n(s, z)|_\infty dz ds + |H_G|_\infty \int_0^\eta |(\Delta G)^n(s, s)|_\infty ds \\ &\quad + 2\|C_G\|_{L_\infty} \int_0^\eta \int_0^s |(\Delta G)^n(s, z)|_\infty dz ds + 4|b_2| \|C_G\|_{L_\infty} \int_0^\eta \int_0^z \int_0^\mu |(\Delta G)^n(\mu, s)|_\infty ds d\mu dz \\ &\quad + 4b_2 \int_0^\eta |(\Delta G)^n(z, 0)|_\infty dz + 2|b_2| \int_0^\eta |(\Delta G)^n(z, z)|_\infty dz + 2|H_{GS}|_\infty \int_0^\eta \int_0^z |(\Delta G)^n(\mu, \mu)|_\infty d\mu dz. \end{aligned} \quad (8.110)$$

Consequently, using the recursive hypothesis (8.109), it holds

$$\begin{aligned} |(\Delta G)^{n+1}(\zeta, \eta)|_\infty &\leq \frac{M \kappa^n}{(n+1)!} \left( \|C_G\|_{L_\infty} (\eta \zeta^{n+1} + \zeta \eta^{n+1} + 4\eta^{n+2} + 8|b_2| \eta^{n+3}) \right. \\ &\quad \left. + 2|H_G|_\infty \eta^{n+1} + 8|b_2| \eta^{n+1} + 4|H_{GS}|_\infty \eta^{n+2} \right). \end{aligned} \quad (8.111)$$

From the fact that  $\zeta, \eta \leq 1$ , taking  $\kappa$  such that

$$\kappa \geq (5 + 8|b_2|) \|C_G\|_{L_\infty} + 2|H_G|_\infty + 8|b_2| + 4|H_{GS}|_\infty, \quad (8.112)$$

one concludes

$$|(\Delta G)^{n+1}(\zeta, \eta)|_\infty \leq \frac{M \kappa^{n+1}}{(n+1)!} (\zeta^{n+1} + \eta^{n+1}). \quad (8.113)$$

As the estimate (8.109) is proven for  $n = 0$  in (8.109), it follows by induction that the series  $(\Delta G)^n$  exponentially converges and that the solution of (8.85) is given by (8.97).  $\blacksquare$

**Remark 5** It is worth pointing out that the upper bound we consider in the induction assumption (8.109) is not standard. Indeed [Smyshlyaev et al., 2010], [Smyshlyaev and Krstic, 2004], among others, introduce the following bound

$$\frac{(\zeta + \eta)^n}{n!}, \quad (8.114)$$

which cannot be used here<sup>1</sup>. Indeed the integration of this bound for the specific boundaries (8.85c)-(8.85d) would cause the recursive method to fail. For example, in order to perform the iterative method, one needs to integrate

$$\int_0^\eta \int_0^s |(\Delta G)^n(z, s)|_\infty dz ds, \quad (8.115)$$

which appear in (8.100) and in (8.111). However, using the previous upper bound, one has

$$\int_0^\eta \int_0^s \frac{(z+s)^n}{n!} dz ds = (2^{n+1} - 1) \frac{\eta^{n+2}}{(n+2)!}. \quad (8.116)$$

The  $2^{n+1}$  term is too large to be compatible with the recessive hypothesis. This is why, instead, we suggest to consider (8.109), which is a smaller bound. However, note that the bound we use fail to establish the kernel existence and uniqueness of [Smyshlyaev et al., 2010].

**Disclaimer:** Actually the remark above is false, indeed using the fact that  $\eta \leq \zeta$ , one gets  $(2\eta)^{n+1} \leq (\zeta + \eta)^{n+1}$  (we saw this straightforward relation after the publication of the result, and after the thesis defense). Nevertheless we choose to keep it that way, because it could be useful for some design, with Freeholm integration for example where  $\eta \leq \zeta$  does not hold anymore. In the case we present we can use either  $\frac{(\zeta+\eta)^n}{n!}$  or  $\frac{\zeta^n + \eta^n}{n!}$ .  $\circ$

### 8.4.3 Invertibility of the backstepping transformation

Let us denote  $\Pi$  the map that transforms the system (8.1) with  $U(t)$  defined in (8.56) into the target system (8.11). It can be expressed as

$$\begin{aligned} \Pi : \quad \mathbb{H}_2 &\rightarrow \mathbb{H}_2, \\ (q_1, q_2, q_3, q_4, q_5) &\mapsto (z_1, z_2, z_3, z_4, z_5), \end{aligned} \quad (8.117)$$

defined as

$$z_1(x) = q_1(x) - \int_0^x K^T(x, y) \begin{bmatrix} q_1 \\ q_2 \\ q'_1 \end{bmatrix} (y) dy - \gamma(x) q_5, \quad (8.118)$$

$$\begin{aligned} z_2(x) = & q_2(x) - [q_1(x) \quad q_2(x) \quad q'_1(x)] \Theta_2 K(x, x) - \int_0^x [K^T(x, y) \Theta_1 - K_y^T(x, y) \Theta_2] \begin{bmatrix} q_1 \\ q_2 \\ q'_1 \end{bmatrix} (y) dy \\ & + (k(x, 0) - \gamma(x) b_3) q_4 + (m(x, 0) - \gamma(x) b_1) q_5, \end{aligned} \quad (8.119)$$

$$z_3 = q_3 - \int_0^1 [q_1 \quad q_2 \quad q'_1] (y) K(x, y) dy - \gamma(1) q_5, \quad (8.120)$$

$$z_4 = q_4, \quad (8.121)$$

$$z_5 = q_5, \quad (8.122)$$

where  $K$  is defined in (8.46) as the unique solution of (8.47a)-(8.47e) and  $\gamma$  in (8.47f), and with  $\Theta_1$  and  $\Theta_2$  defined in (8.54).  $\mathbb{H}_2$  is defined in (8.2)

Let us check that  $z \in \mathbb{H}_2$ . As  $q \in \mathbb{H}_2$ , using Cauchy-Schwarz's inequality, it holds  $z_1 \in L_2(0, 1)$ . Similarly, one gets that  $z'_1 \in L_2(0, 1)$ . Therefore  $z_1 \in H_1(0, 1)$ . Using Cauchy-Schwarz's inequality on (8.119), one gets that  $z_2 \in L_2(0, 1)$ . From (8.120), it holds that  $z_3 \in \mathbb{R}$ .  $z_4, z_5 \in \mathbb{R}$  is obvious. One obtains that  $z_1(1) = z_3$  as  $q_3 = q_1(1)$ . It holds that  $z_1(0) = z_4$ . Therefore  $z \in \mathbb{H}_2$ .

<sup>1</sup>we were not able to follow the arguments of [Smyshlyaev and Krstic, 2004] which has a boundary condition related to (8.85c)



Note that by construction  $\gamma(0) = 0$  and  $\gamma(x) = \frac{s(x,0)}{b_2}$ . They allow the backstepping transformation to map  $\mathbb{H}_2 \rightarrow \mathbb{H}_2$ . Indeed  $\gamma(x) = \frac{s(x,0)}{b_2}$  is a necessary condition for  $z_2$  to be in  $L_2(0,1)$ , otherwise a  $z_1'(0)$  term appears, which may be unbounded as  $z' \in L_2(0,1)$  does not implies that  $z'(0) < \infty$ . Similarly  $\gamma(0) = 0$  implies that  $z_5 \in \mathbb{R}$ .

The existence of the inverse map  $\Pi^{-1}$  can be obtained by simply replacing  $\lambda$ ,  $\beta$ ,  $a_i$  and  $b_i$  with respectively  $\lambda_w$ ,  $\beta_w$ ,  $c_i$  and  $d_i$  in the previous analysis. One gets the invertibility of the backstepping transformation straightforwardly.

#### 8.4.4 Relationship between functionals $\Gamma_2(\mathcal{X}_2(t))$ and $V_2(\mathcal{X}_{e_2}(t))$

To conclude on the exponential stability of (8.1) along with the control law (8.56), the equivalence between  $V_2(\mathcal{X}_{e_2})$  in (8.12) and  $\Gamma_2(\mathcal{X}_2)$  in (8.7) is proven in Lemma 8.4.

**Lemma 8.4** [Roman et al., 2018]

There exist  $\mu_1, \mu_2 > 0$  such that

$$\Gamma_2(\mathcal{X}_2(t)) \leq \mu_1 V_2(\mathcal{X}_{e_2}(t)), \quad (8.123)$$

$$V_2(\mathcal{X}_{e_2}(t)) \leq \mu_2 \Gamma_2(\mathcal{X}_2(t)). \quad (8.124)$$

*Proof :* Only (8.124) is detailed here, as similar argument holds for (8.123) using the inverse backstepping transformation (see Section 8.4.3). From (8.45), (8.66), and (8.68), there exist  $c_1, c_2, c_3, c_4 > 0$  such that

$$\|w\|_{L_2}^2 \leq c_1 [\|u\|_{H_1}^2 + \|u_t\|_{L_2}^2 + u_t(0,t)^2], \quad (8.125)$$

$$w(1,t)^2 \leq c_2 [\|u\|_{H_1}^2 + \|u_t\|_{L_2}^2 + u_t(0,t)^2 + u(1,t)^2], \quad (8.126)$$

$$\|w_t\|_{L_2}^2 \leq c_3 [\|u\|_{H_1}^2 + \|u_t\|_{L_2}^2 + u(0,t)^2 + u_t(0,t)^2], \quad (8.127)$$

$$\|w_x\|_{L_2}^2 \leq c_4 [\|u\|_{H_1}^2 + \|u_t\|_{L_2}^2 + u_t(0,t)^2]. \quad (8.128)$$

From (8.125)-(8.128) and the fact that  $w(0,t) = u(0,t)$  and  $w_t(0,t) = u_t(0,t)$  (as  $\gamma(0) = 0$  from (8.47e)-(8.47f)), one obtains (8.124). ■

#### 8.4.5 Conclusion of the stability result

Using Lemma 8.3, there exists a unique solution to (8.47). From Lemma 8.2, this solution defines a backstepping transformation which maps the *original system* (8.1) into the *target system* (8.11) with the control law  $U$  defined in (8.56). Moreover, from Lemma 8.1, one gets that (8.11) is exponentially stable if all its parameters are positive. Therefore, using Lemma 8.4, one establishes (8.58).

### 8.5 Well-posedness of the closed-loop system and the target system

This section is devoted to the well-posedness of the *closed-loop system* with the control law  $U$  defined in (8.56) and the *target system*. The idea is to prove that the abstract problem resulting from the *target system* defined in (8.11) is well-posed. It is relatively easy to get it because it is stable. Indeed it defines a maximal monotone operator, which is equivalent to a  $C_0$ -semigroup of contraction. Then using the inverse backstepping transformation Section 8.4.3 one concludes on the well-posedness of the *closed-loop system* with the control law  $U$  defined in (8.56).

Let us start by writing the abstract problem associated with the closed loop system with the control law  $U$  defined in (8.56).

Let us consider the following operator

$$\mathcal{A}_3 := - \begin{bmatrix} 0 & 1 & 0 & 0 & 0 \\ \delta_{xx} + \beta & \lambda & 0 & 0 & 0 \\ 0 & \delta_{|1} & 0 & 0 & 0 \\ 0 & 0 & 0 & 0 & 1 \\ b_2 \delta_{x|0} & 0 & 0 & b_3 & b_1 \end{bmatrix}, \quad (8.129)$$

in which  $\delta_{xx} z_1 = z_1''$ ,  $\delta_{|1} z_2 = z_2(1)$ , and  $\delta_{x|0} z_1 = z_1'(0)$  with  $\text{Dom}(\mathcal{A}_3)$  defines as

$$\text{Dom}(\mathcal{A}_3) := \{(z_1, z_2, z_3, z_4, z_5) \in H_2(0, 1) \times H_1(0, 1) \times \mathbb{R}^3 : z_3 = z_1(1), z_4 = z_1(0), z_5 = z_2(0), z_1'(1) = a_1 z_2(1) + a_2 z_3 + U(z)\}, \quad (8.130)$$

the abstract problem resulting from the system  $(\Sigma_{O_2})$  defined in (8.1) with  $U$  defined in (8.56) is

$$\begin{cases} \frac{d}{dt} X(t) + \mathcal{A}_3 X(t) = 0, & X(t) \in \text{Dom}(\mathcal{A}_3), \\ X(0) = X_0. \end{cases} \quad (8.131a)$$

$$(8.131b)$$

The link between  $X(t)$ ,  $z$  and  $u(\cdot, t)$  is

$$X(t) = \begin{bmatrix} X_1(t) \\ X_2(t) \\ X_3(t) \\ X_4(t) \\ X_5(t) \end{bmatrix} = z = \begin{bmatrix} z_1 \\ z_2 \\ z_3 \\ z_4 \\ z_5 \end{bmatrix} = \begin{bmatrix} u(\cdot, t) \\ u_t(\cdot, t) \\ u(1, t) \\ u(0, t) \\ u_t(1, t) \end{bmatrix}.$$

**Theorem 8.2** Consider  $H_2$ ,  $\mathcal{A}_3$ , and  $\text{Dom}(\mathcal{A}_3)$  respectively defined in (8.2), (8.129), and (8.130). The two statements below are true

(i). For all initial data  $X_0 \in \text{Dom}(\mathcal{A}_3)$ , the abstract problem (8.6) has a unique strong solution such that

$$\begin{cases} \forall t > 0, X(t) \in \text{Dom}(\mathcal{A}_3), \\ X_1 \in W_{1,\infty}(0, \infty; H_1(0, 1)) \cap L_\infty(0, \infty; H_2(0, 1)). \end{cases}$$

(ii). For all initial data  $X_0 \in H_2$ , the abstract problem (8.6) has a unique weak solution

$$\begin{cases} \forall t > 0, X(t) \in H_2, \\ X_1 \in W_{1,\infty}(0, \infty; L_2(0, 1)) \cap L_\infty(0, \infty; H_1(0, 1)). \end{cases}$$

given by  $X(t) = S(t)X_0$ , in which  $S$  is the  $C_0$ -semigroup of contraction generated by the unbounded operator  $\mathcal{A}_3$ .

In the light of the abstract formulation (8.131) one gets that, (8.58) can be expressed as

$$\|X(t)\|_{H_2}^2 \leq R \|X(0)\|_{H_2}^2 e^{-\rho t}, \quad (8.134)$$

in which  $\|\cdot\|_{H_2}$  is the associated norm of (8.3). We refer the reader to [Curtain and Zwart, 2012] for more information about  $C_0$ -semigroup.

We first prove that the target system is well-posed. To do so two lemmas are stated. This proof of well-posedness is adapted from [d'Andréa-Novel et al., 1992]. Consider  $\lambda_w, \beta_w, c_1, c_2, d_1, d_2, d_3$  positive real. It is easy to check that  $H_2$  defined in (8.2) is an Hilbert space for the following scalar product, adapted for the target system

$$\forall z, y \in H_2, \quad \langle z, y \rangle_T = \int_0^1 (\beta_w z_1 y_1 + z_1' y_1' + z_2 y_2) dx + c_2 z_3 y_3 + \frac{d_3}{d_2} z_4 y_4 + \frac{1}{d_2} z_5 y_5. \quad (8.135)$$

Let us define the following unbounded operator

$$\forall z \in \text{Dom}(\mathcal{A}_{e_2}) \subset \mathbb{H}, \quad \mathcal{A}_{e_2}z = - \begin{bmatrix} 0 & 1 & 0 & 0 & 0 \\ \delta_{xx} - \beta_w & -\lambda_w & 0 & 0 & 0 \\ 0 & \delta|_1 & 0 & 0 & 0 \\ 0 & 0 & 0 & 0 & 1 \\ d_2 \delta_x|_0 & 0 & 0 & -d_3 & -d_1 \end{bmatrix}, \quad (8.136)$$

in which  $\delta_{xx}z_1 = z_1''$ ,  $\delta|_1 z_2 = z_2(1)$ , and  $\delta_x|_0 z_1 = z_1'(0)$ , and where

$$\text{Dom}(\mathcal{A}_{e_2}) = \left\{ z = (z_1, z_2, z_3, z_4, z_5) \in H_2(0, 1) \times H_1(0, 1) \times \mathbb{R}^3 \mid \begin{aligned} z_3 &= z_1(1), \quad z_4 = z_1(0), \\ z_5 &= z_2(0), \quad z_1'(1) = -c_1 z_2(1) - c_2 z_3 \end{aligned} \right\}. \quad (8.137)$$

We are interested in the following abstract problem

$$\begin{cases} \frac{d}{dt}X(t) + \mathcal{A}_{e_2}X(t) = 0, & X(t) \in \text{Dom}(\mathcal{A}_{e_2}), \\ X(0) = X_0. \end{cases} \quad (8.138a)$$

$$(8.138b)$$

This is equivalent to (8.11).

**Lemma 8.5** Consider  $\mathbb{H}_2$ ,  $\mathcal{A}_{e_2}$ , and  $\text{Dom}(\mathcal{A}_{e_2})$  defined in (8.2), (8.136), and (8.137).

(i). For all initial data  $z_0 \in \text{Dom}(\mathcal{A}_{e_2})$ , the abstract problem (8.138) has a unique strong solution such that

$$\begin{cases} \forall t > 0, z(t) \in \text{Dom}(\mathcal{A}_{e_2}), \\ z_1 \in W_{1,\infty}(0, \infty; H_1(0, 1)) \cap L_\infty(0, \infty; H_2(0, 1)). \end{cases}$$

(ii). For all initial data  $z_0 \in \mathbb{H}_2$ , the abstract problem (8.138) has a unique weak solution

$$\begin{cases} \forall t > 0, z(t) \in \mathbb{H}_2, \\ z_1 \in W_{1,\infty}(0, \infty; L_2(0, 1)) \cap L_\infty(0, \infty; H_1(0, 1)). \end{cases}$$

given by  $z(t) = T_e(t)z_0$ , in which  $T_e$  is the  $C_0$ -semigroup of contraction generated by the unbounded operator  $\mathcal{A}_{e_2}$ .

**Lemma 8.6** The linear unbounded operator  $\mathcal{A}_{e_2}$  defined in (8.136) is maximal monotone on  $\mathbb{H}_2$  (8.2)

*Proof:* Computing  $\langle z, \mathcal{A}_{e_2}z \rangle_T$ , and using the fact that  $z \in \text{Dom}(\mathcal{A}_{e_2})$ , one obtains

$$\langle z, \mathcal{A}_{e_2}z \rangle_T = \int_0^1 \lambda_w z_2^2 dx + c_1^2 z_2(1) + \frac{d_1}{d_2} z_5^2 \geq 0. \quad (8.141)$$

Thus the operator  $\mathcal{A}_{e_2}$  is monotone (see [Brezis, 2010] Chapter 7). In addition if we establish that

$$R(\text{Id} + \mathcal{A}_{e_2}) = \mathbb{H}_2, \quad (8.142)$$

then the operator  $\mathcal{A}$  is maximal monotone (see [Brezis, 2010] Chapter 7,  $R$  stand for the range of the operator). Let  $y \in \mathbb{H}_2$ , we have to solve

$$z \in \text{Dom}(\mathcal{A}_{e_2}), \quad z + \mathcal{A}_{e_2}z = y, \quad (8.143)$$

in other words

$$z_1 - z_2 = y_1, \quad (8.144)$$

$$z_2 - z_1'' + \lambda_w z_2 + \beta_w z_1 = y_2, \quad (8.145)$$

$$z_3 - z_2(1) = y_3, \quad (8.146)$$

$$z_4 - z_5 = y_4, \quad (8.147)$$

$$z_5 + (d_3 z_4 - d_2 z_1'(0) + d_1 z_5) = y_5, \quad (8.148)$$

using the fact that  $z \in \text{Dom}(\mathcal{A}_{e_2})$  one gets

$$z_1(1 + \lambda_w) - z_1'' + \beta_w z_1 = y_1(1 + \lambda_w) + y_2, \quad (8.149)$$

$$z_1'(1) + (c_1 + c_2)z_1(1) = -c_1 y_3, \quad (8.150)$$

$$-d_2 z_1'(0) + z_1(0)(1 + d_3 + d_1) = y_4(1 + d_1) + y_5. \quad (8.151)$$

This is a classical stationary problem with Robin boundary conditions, using standard result (as done in [Brezis, 2010] p. 226 Example 6) one gets that as  $y_1(1 + \lambda_w) + y_2 \in L_2(0, 1)$ , (8.149)-(8.151) has a unique solution  $z_1 \in H_2(0, 1)$ . Now one can check that the element  $z = (z_1, z_2, z_3, z_4, z_5)$  with

$$\left\{ \begin{array}{l} z_1 \text{ is solution of (8.149)-(8.151)} \\ z_2 = z_1 - y_1, \\ z_3 = y_3 + z_2(1), \\ z_4 = \frac{y_4(1 + d_1) + d_2 z_1'(0)}{1 + d_3 + d_1}, \\ z_5 = \frac{-y_4 d_3 + d_2 z_1'(0)}{1 + d_3 + d_1}, \end{array} \right. \quad (8.152a)$$

$$(8.152b)$$

$$(8.152c)$$

$$(8.152d)$$

$$(8.152e)$$

satisfies (8.144)-(8.148). Moreover using (8.149)-(8.151) on (8.152) one gets that  $z$  satisfying (8.152) is in  $\text{Dom}(\mathcal{A}_{e_2})$ . ■

*Proof of Lemma 8.5:* Consider  $H_2$ ,  $\mathcal{A}_{e_2}$ , and  $\text{Dom}(\mathcal{A}_{e_2})$  defined in (8.2), (8.4) with  $U$  defined in (8.56), and (8.5). From Lemma 8.6, using Hille-Yosida Theorem (see [Brezis, 2010] Theorem 7.4), and argument of density of  $C^1$  into  $W^{1,\infty}$  (resp.  $C^0$  into  $L^\infty$ ) as standarly used one establishes Lemma 8.5. ■

*Proof of Theorem 8.2:* From Lemma 8.5, using the fact that the backstepping transformation is an invertible maps on  $H_2$  (see Section 8.4.3), one establishes Theorem 8.2. ■

## Chapter conclusion

In this chapter, we have considered a wave PDE which has velocity and position source terms. An exponentially stable target has been presented. Then, a backstepping transformation which maps the considered original system into the target one is obtained along with an associated control law. The well-posedness for the strong solution and weak solution has been established.

However, the designed control law is a full-state feedback. There are few possibilities that any application could provide full-state measurement. In order to relax this constraint, a future direction of work is the development of an observer for the considered wave equation. An observer considering both boundary measurements should be acceptable, but a collocated one would be more interesting.

---

---

---

---

# Preliminary more advanced studies on backstepping and well-posedness

## Contents

<b>9.1</b>	<b>Well-posedness of a unstable inhomogeneous wave PDE . . . . .</b>	<b>163</b>
<b>9.2</b>	<b>Exponentially stable space depending wave equation with distributed terms . . . . .</b>	<b>167</b>
<b>9.3</b>	<b>Backstepping transformation on a space depending wave equation . . . . .</b>	<b>170</b>
9.3.1	Problem statement . . . . .	170
9.3.2	Backstepping transformation . . . . .	171
<b>Chapter conclusion . . . . .</b>		<b>174</b>

This chapter presents some on-going work we have done so far around backstepping method and around well-posedness. First in Section 9.1, the well-posedness of an inhomogeneous wave equation with two dynamics boundary conditions with potential anti-damping source terms is presented. Then, we improve the wave model by considering that the propagation is space dependent. In Section 9.2 we establish the exponential stability of such a wave. Then in Section (9.3.2) we compute the PDE the kernel of the considered backstepping transformation is solution. However, the proof that there exists a unique solution to this PDE on a triangular domain is still under development.

In both Chapter 7 and Chapter 8, we have considered the homogeneous abstract problem in order to specify the control objective of the considered stabilization problem. The respective well-posedness can be deduced from the proof exposed in Section 9.1. The interesting fact of the considered system is that even if the input is at the boundary we do not need to consider the framework of boundary input system (which is introduced in [Curtain and Zwart, 2012]).

## 9.1 Well-posedness of a unstable inhomogeneous wave PDE

Consider the following system

$$\begin{cases}
 u_{tt}(x,t) = u_{xx}(x,t) + \lambda u_t(x,t) + \beta u(x,t), & (9.1a) \\
 u_{tt}(1,t) = a_1 u_t(1,t) - a_2 u_x(1,t) + a_3 u(1,t) + U(t), & (9.1b) \\
 u_{tt}(0,t) = b_1 u_t(0,t) + b_2 u_x(0,t) + b_3 u(0,t). & (9.1c)
 \end{cases}$$

The only assumption we make is  $a_2 > 0$  and  $b_2 > 0$ . Note that the fact that the coefficient of  $u_x(1,t)$  is  $-a_2$ , is mandatory for the establishment of the well-posedness result in the sequel. If all parameters are taken positive the wave is unstable. This have has been referred as inhomogeneous because the input is considered as a given function of  $W_{1,\infty}([1, \infty); \mathbb{R})$ .

Consider the following space

$$H_3 = \left\{ z = (z_1, z_2, z_3, z_4, z_5, z_6) \in H_1(0,1) \times L_2(0,1) \times \mathbb{R}^4; z_3 = z_1(1), z_5 = z_1(0) \right\}. \quad (9.2)$$

It is easy to check that  $H_3$  is an Hilbert space for the following scalar product (bilinear symmetric, positive, definite)

$$\forall z, y \in H_3, \quad \langle z, y \rangle_T = \int_0^1 (z_1 y_1 + z_1' y_1' + z_2 y_2) dx + z_3 y_3 + \frac{1}{a_2} z_4 y_4 + z_5 y_5 + \frac{1}{b_2} z_6 y_6. \quad (9.3)$$

Let us define the following unbounded operator

$$\mathcal{A}_4 = - \begin{bmatrix} 0 & 1 & 0 & 0 & 0 & 0 \\ \delta_{xx} + \beta & \lambda & 0 & 0 & 0 & 0 \\ 0 & 0 & 0 & 1 & 0 & 0 \\ -a_2 \delta_{x|1} & 0 & a_3 & a_1 & 0 & 0 \\ 0 & 0 & 0 & 0 & 0 & 1 \\ b_2 \delta_{x|0} & 0 & 0 & 0 & b_3 & b_1 \end{bmatrix}, \quad (9.4)$$

in which  $\delta_{xx} z_1 = z_1''$ ,  $\delta_{x|1} z_1 = z_1'(1)$ , and  $\delta_{x|0} z_1 = z_1'(0)$ . Moreover the domain of  $\mathcal{A}_4$  is

$$\text{Dom}(\mathcal{A}_4) = \left\{ z = (z_1, z_2, z_3, z_4, z_5, z_6) \in H_2(0, 1) \times H_1(0, 1) \times \mathbb{R}^4; \right. \\ \left. z_3 = z_1(1), z_5 = z_1(0), z_4 = z_2(1), z_6 = z_2(0) \right\}. \quad (9.5)$$

We are interested on the following abstract Cauchy problem, for  $X(t) \in \text{Dom}(\mathcal{A}_4)$

$$\begin{cases} \frac{d}{dt} X(t) + \mathcal{A}_4 X(t) = \mathcal{U}(t), & \text{on } [0, T], \\ X(0) = X_0, \end{cases} \quad (9.6a)$$

$$(9.6b)$$

in which

$$\mathcal{U}(t) = \begin{bmatrix} 0 \\ 0 \\ 0 \\ U(t) \\ 0 \\ 0 \end{bmatrix}. \quad (9.7)$$

The abstract Cauchy problem (9.6) is equivalent to the system (9.1). The link between  $X(t)$ ,  $z$ , and  $u(\cdot, t)$  is

$$X(t) = \begin{bmatrix} X_1(t) \\ X_2(t) \\ X_3(t) \\ X_4(t) \\ X_5(t) \\ X_6(t) \end{bmatrix} = z = \begin{bmatrix} z_1 \\ z_2 \\ z_3 \\ z_4 \\ z_5 \\ z_6 \end{bmatrix} = \begin{bmatrix} u(\cdot, t) \\ u_t(\cdot, t) \\ u(1, t) \\ u_t(1, t) \\ u(0, t) \\ u_t(0, t) \end{bmatrix}.$$

**Theorem 9.1** Consider  $H_3$ ,  $\mathcal{A}_4$ , and  $\text{Dom}(\mathcal{A}_4)$  defined respectively in (9.2), (9.4), and (9.5). The statement below are true

(i). For all initial data  $X_0 \in \text{Dom}(\mathcal{A}_4)$  and  $U \in C_1(0, \infty)$ , the abstract problem (9.6) has a unique strong solution such that

$$\begin{cases} \forall t > 0, X(t) \in \text{Dom}(\mathcal{A}_3), \\ X_1 \in C_1([0, \infty]; H_1(0, 1)) \cap C([0, \infty]; H_2(0, 1)). \end{cases} \quad (9.8a)$$

$$(9.8b)$$

(ii). For all initial data  $X_0 \in H_3$  and  $U \in W_{1,\infty}(0, \infty)$ , the abstract problem (9.6) has a unique weak solution

$$\begin{cases} \forall t > 0, X(t) \in H, & (9.9a) \\ X_1 \in W_{1,\infty}([0, \infty]; L_2(0, 1)) \cap L_\infty([0, \infty]; H_1(0, 1)). & (9.9b) \end{cases}$$

given by  $X(t) = T_3(t)X_0$ , in which  $T_3$  is the  $C_0$ -semigroup of contraction generated by the unbounded operator  $\mathcal{A}_4$ .

Note that this result is fundamentally different from that the one in Section 8.5, because there  $U$  is chosen as a specified state feedback. Here, we consider it as a general function in  $W_{1,\infty}(0, \infty)$ .

Even if the input act at the boundary of the PDE, it leads to a bounded input operator. Therefore the well-posedness analysis is much simpler, should we have considered an unbounded input operator.

The idea of the proof is to decompose the operator  $\mathcal{A}_4$  into one m-accretive part and a remaining part, then to perform a bijective change of variable which cancels the remaining part. Finally, we conclude using the following theorem

**Theorem 9.2** [Inhomogenous Abstract Problem, theorem 7.10 in [Brezis, 2010] ]

Consider, in a Banach space  $E$ , the problem

$$\begin{cases} \frac{dX}{dt}(t) + \mathcal{A}X(t) = f(t), & (9.10a) \\ X(0) = X_0. & (9.10b) \end{cases}$$

Assume that  $\mathcal{A}$  is m-accretive (equivalent to maximal monotone in a Hilbert space). Then for every  $X_0 \in \text{Dom}(\mathcal{A})$  and every  $f \in C_1([0, T]; E)$ , there exists a unique solution  $X$  of (9.10) with

$$f \in C_1([0, T]; E) \cap C([0, T]; \text{Dom}(\mathcal{A})) \quad (9.11)$$

Consider the following operator

$$\mathcal{G} = - \begin{bmatrix} 0 & 1 & 0 & 0 & 0 & 0 \\ \delta_{xx} - 1 & 1 & 0 & 0 & 0 & 0 \\ 0 & 0 & 0 & 1 & 0 & 0 \\ -a_2 \delta_{x|1} & 0 & -a_2 & 0 & 0 & 0 \\ 0 & 0 & 0 & 0 & 0 & 1 \\ b_2 \delta_{x|0} & 0 & 0 & 0 & -b_2 & 0 \end{bmatrix}, \quad (9.12)$$

and the following matrix

$$\mathcal{H} = \begin{bmatrix} 0 & 0 & 0 & 0 & 0 & 0 \\ -\beta - 1 & -\lambda - 1 & 0 & 0 & 0 & 0 \\ 0 & 0 & 0 & 0 & 0 & 0 \\ 0 & 0 & -a_3 - a_2 & -a_1 & 0 & 0 \\ 0 & 0 & 0 & 0 & 0 & 0 \\ 0 & 0 & 0 & 0 & -b_3 - b_2 & -b_1 \end{bmatrix}. \quad (9.13)$$

The domain of  $\mathcal{G}$  is equal to the domain of  $\mathcal{A}_4$ . One gets

$$\mathcal{A}_4 = \mathcal{G} + \mathcal{H}. \quad (9.14)$$

$\mathcal{G}$  is the m-accretive part, this is established in the following lemma

**Lemma 9.1** The linear unbounded operator  $\mathcal{G}$  defined in (9.12) is maximal monotone on  $H_3$  defined in (9.2).



*Proof*: Computing

$$\langle z, \mathcal{G}z \rangle_T = \int_0^1 [-z_1 z_2 - z_1' z_2' + z_2(-z_1'' + z_2 + z_1)] dx - z_3 z_4 + z_4 z_1'(1) + z_4 z_3 - z_5 z_6 - z_6 z_1'(0) + z_6 z_5 \quad (9.15)$$

$$= \int_0^1 z_2^2 dx - [z_2 z_1']_0^1 + z_2(1) z_1'(1) - z_2(0) z_1'(0), \quad (9.16)$$

using the fact that  $z \in \text{Dom}(\mathcal{A}_4)$ , one obtains

$$\langle z, \mathcal{G}z \rangle_T = \int_0^1 z_2^2 dx \geq 0 \quad (9.17)$$

Thus the operator  $\mathcal{G}$  is monotone (see [Brezis, 2010] Chapter 7). In addition if we establish that

$$R(I + \mathcal{G}) = H_3, \quad (9.18)$$

then the operator  $\mathcal{G}$  is maximal monotone (see [Brezis, 2010] Chapter 7,  $R$  stand for the range of the operator). Let  $y \in H_3$ , we have to solve

$$z \in \text{Dom}(\mathcal{A}_4), \quad z + \mathcal{G}z = y, \quad (9.19)$$

which means that

$$z_1 - z_2 = y_1, \quad (9.20)$$

$$z_2 - z_1'' + z_2 + z_1 = y_2, \quad (9.21)$$

$$z_3 - z_4 = y_3, \quad (9.22)$$

$$z_4 + a_2(z_1'(1) + z_3) = y_4, \quad (9.23)$$

$$z_5 - z_6 = y_5, \quad (9.24)$$

$$z_6 + (-b_2 z_1'(0) + b_2 z_5) = y_6, \quad (9.25)$$

using the fact that  $z \in \text{Dom}(\mathcal{A}_4)$  one gets

$$3z_1 - z_1'' = 2y_1 + y_2, \quad (9.26)$$

$$a_2 z_1'(1) + (1 + a_2) z_1(1) = y_3 + y_4, \quad (9.27)$$

$$-b_2 z_1'(0) + z_1(0)(1 + b_2) = y_5 + y_6. \quad (9.28)$$

This is a classical stationary problem (e.g. see [Brezis, 2010]) with Robin's boundaries conditions, using standard result (as done in [Brezis, 2010] p. 226 Example 6) one gets that as  $2y_1 + y_2 \in L_2(0, 1)$ , (9.26)-(9.28) has a unique solution  $z_1 \in H_2(0, 1)$ . Now one can check that the element  $z = (z_1, z_2, z_3, z_4, z_5, z_6)$  with

$$\left\{ \begin{array}{l} z_1 \text{ is solution of (9.26)-(9.28),} \\ z_2 = z_1 - y_1, \\ z_3 = y_3 + z_2(1), \\ z_4 = y_4 - a_2(z_1'(0) + z_3), \\ z_5 = y_5 - z_2(0), \\ z_6 = y_6 + b_2(z_1'(0) - z_5), \end{array} \right. \quad (9.29a)$$

$$\quad (9.29b)$$

$$\quad (9.29c)$$

$$\quad (9.29d)$$

$$\quad (9.29e)$$

$$\quad (9.29f)$$

satisfies (9.20)-(9.25). Moreover using (9.26)-(9.28) on (9.29) one gets that  $z$  satisfying (9.29) is in  $\text{Dom}(\mathcal{A}_4)$  ■

Now, we are ready to state the proof of the well-posedness of (9.6).

*Proof of Theorem 9.1*: Consider the bijective change of variable

$$X_e(t) = X(t)e^{\mathcal{H}t}. \quad (9.30)$$

$X$  is solution of (9.6) is equivalent to,  $X_e \in \text{Dom}(\mathcal{A}_4)$  is solution of

$$\left\{ \begin{array}{l} \frac{dX_e}{dt}(t) + \mathcal{G}X_e(t) = \mathcal{U}(t)e^{\mathcal{H}t}, \\ X_e(0) = X_0, \end{array} \right. \quad (9.31a)$$

$$\quad (9.31b)$$

where  $\mathcal{H}$  is defined in (9.13) and  $\mathcal{G}$  is defined in (9.12).

From Lemma 9.1, using Theorem 9.2 on (9.31), and the change of variable (9.30), one establishes (i). Using argument of density of  $C_1$  into  $W_{1,\infty}$  (resp.  $C$  into  $L_\infty$ ), one obtains (ii).  $\blacksquare$

## 9.2 Exponentially stable space depending wave equation with distributed terms

Consider the following system which is going to be used as *target system* in Section 9.3,

$$(\Sigma_{T_3}) \quad \begin{cases} w_{tt}(x,t) = (a(x)w_x(x,t))_x - \lambda_w(x)w_t(x,t) - \beta_w(x)w(x,t), & (9.32a) \\ w_{tt}(1,t) = -c_1w_t(1,t) - c_2w_x(1,t) - c_3w(0,t), & (9.32b) \\ w_{tt}(0,t) = -d_1w_t(0,t) + d_2w_x(0,t) - d_3w(0,t), & (9.32c) \end{cases}$$

in which the coefficients  $a(x)$ ,  $\lambda_w(x)$ ,  $\beta_w(x)$ ,  $\forall x \in [1,0]$ ,  $c_1$ ,  $c_2$ ,  $c_3$ ,  $d_1$ ,  $d_2$ , and  $d_3$  are positive.  $a(x)$  expresses the fact that the propagation velocity along the wave is not constant with respect to space, e.g. [d'Andréa-Novel et al., 1992] where the wave PDE models an overhead crane. To illustrate it, one can see the wave equation as an infinite combination of spring-mass elements,  $a(x)$  represents the fact that these elements are not constant with respect to space.

Consider the following Lyapunov functional candidate, for  $z \in \mathbb{H}_3$

$$V_3(z) = \int_0^1 \begin{bmatrix} z_1(x) \\ z_2(x) \\ a(x)z'_1(x) \end{bmatrix}^T P_0 \begin{bmatrix} z_1(x) \\ z_2(x) \\ a(x)z'_1(x) \end{bmatrix} dx + \begin{bmatrix} z_3 \\ z_4 \end{bmatrix}^T P_1 \begin{bmatrix} z_3 \\ z_4 \end{bmatrix} + \begin{bmatrix} z_5 \\ z_6 \end{bmatrix}^T P_2 \begin{bmatrix} z_5 \\ z_6 \end{bmatrix}, \quad (9.33)$$

in which  $P_0 \in \mathbb{R}^{3 \times 3}$ ,  $P_1 \in \mathbb{R}^{2 \times 2}$ , and  $P_2 \in \mathbb{R}^{2 \times 2}$  are symmetric positive definite matrices.  $\sqrt{V_3}(\cdot)$  is a norm on  $\mathbb{H}_3$ , the latter is defined in (9.2). Consider

$$\mathcal{X}_{e_3}(t) = [w(\cdot,t), w_t(\cdot,t), w(1,t), w_t(1,t), w(0,t), w_t(0,t)]. \quad (9.34)$$

**Lemma 9.2** Consider the system (9.32). For all  $x \in [0,1]$ ,  $a(x) > 0$ ,  $\lambda_w(x) > 0$ ,  $\beta_w(x) > 0$ ,  $c_i > 0$ , and  $d_i > 0$ , there exist  $P_0(x)$ ,  $P_1$  and  $P_2$  symmetric positive definite matrices such that, it holds for a suitable  $\rho > 0$

$$\dot{V}_3(\mathcal{X}_{e_3}(t)) \leq -\rho V_3(\mathcal{X}_{e_3}(t)), \quad (9.35)$$

in which  $V_3$  is defined (9.33),  $\mathbb{H}_3 \ni \mathcal{X}_e(t)$  is defined in (9.34).

Before establishing the proof of the above lemma, we start by rewriting the system (9.32) equations in vector form. In order to simplify the computation of the Lyapunov functional candidate derivative along the state trajectory. However, note that we do not consider  $w_x(x,t)$  as the third coordinate but  $a(x)w_x(x,t)$ . The reason is the simplicity it leads for the vector equation. As  $\forall x \in [0,1]$ ,  $a(x) > 0$  there is no problem with this change of variable. Let us consider

$$W(x,t) = \begin{bmatrix} w(x,t) \\ w_t(x,t) \\ a(x)w_x(x,t) \end{bmatrix}, \quad W_1(t) = \begin{bmatrix} w(1,t) \\ w_t(1,t) \end{bmatrix}, \quad W_0(t) = \begin{bmatrix} w(0,t) \\ w_t(0,t) \end{bmatrix}. \quad (9.36)$$

It holds

$$W_t(x,t) = A_1(x)W(x,t) + A_2(x)W_x(x,t), \quad (9.37)$$

$$\frac{d}{dt}W_1(t) = A_3W(1,t), \quad \frac{d}{dt}W_0(t) = A_4W(0,t), \quad (9.38)$$

$$W_1(t) = A_5W(1,t), \quad W_0(t) = A_5W(0,t), \quad (9.39)$$

in which

$$A_1(x) = \begin{bmatrix} 0 & 1 & 0 \\ -\beta_w(x) & -\lambda_w(x) & 0 \\ 0 & 0 & 0 \end{bmatrix}, \quad A_2(x) = \begin{bmatrix} 0 & 0 & 0 \\ 0 & 0 & 1 \\ 0 & a(x) & 0 \end{bmatrix}, \quad (9.40)$$

$$A_3 = \begin{bmatrix} 0 & 1 & 0 \\ -c_3 & -c_1 & -c_2 \end{bmatrix}, \quad A_4 = \begin{bmatrix} 0 & 1 & 0 \\ -d_3 & -d_1 & d_2 \end{bmatrix}, \quad A_5 = \begin{bmatrix} 1 & 0 & 0 \\ 0 & 1 & 0 \end{bmatrix}. \quad (9.41)$$

Similarly to Section 8.2, since  $w_x$  is in  $W$  and  $W_x$ . The following proposition expresses this in vector form. However, note that opposite to Section 8.2 there is a  $a(x)$  factor appearing in the relation.

**Proposition 9.1** *Consider*

$$J_1 = \begin{bmatrix} 1 & 0 & 0 \\ 0 & 0 & 0 \\ 0 & 0 & 0 \end{bmatrix}, \quad J_2 = \begin{bmatrix} 0 & 0 & 0 \\ 0 & 0 & 0 \\ 1 & 0 & 0 \end{bmatrix}, \quad J_3 = \begin{bmatrix} 0 & 0 & 1 \\ 0 & 0 & 0 \\ 0 & 0 & 0 \end{bmatrix}. \quad (9.42)$$

It holds

$$W_x^T J_1 = \frac{1}{a(x)} W^T J_2, \quad (9.43)$$

$$J_1 W_x = \frac{1}{a(x)} J_3 W, \quad (9.44)$$

in which  $W$  is defined (9.36).

Moreover it follows,  $\forall \theta(x) \in \mathbb{R}^{3 \times 3}$

$$\int_0^1 W^T J_1 \theta(x) W_x dx = [W^T J_1 \theta(x) W]_0^1 - \int_0^1 \frac{1}{a(x)} W^T J_2 \theta W + W^T J_1 \theta'(x) W dx, \quad (9.45)$$

$$\int_0^1 W_x^T \theta(x) J_1 W dx = [W^T \theta J_1 W]_0^1 - \int_0^1 \frac{1}{a(x)} W^T \theta(x) J_3 W + W^T \theta'(x) J_1 W dx. \quad (9.46)$$

*Proof*: The establishment of the proof is the rewriting of scalar. ■

Consider the complementary of  $J_1$  to  $I_3$ , meaning it holds  $J_1 + J_4 = I_3$

$$J_4 = \begin{bmatrix} 0 & 0 & 0 \\ 0 & 1 & 0 \\ 0 & 0 & 1 \end{bmatrix}. \quad (9.47)$$

The idea is to decompose the computation of the Lyapunov functional candidate derivative in  $J_1$  and  $J_4$  parts.

**Proposition 9.2** *If*

$$J_4(A_2^T P_0 - P_0 A_2)J_4 = 0, \quad (9.48)$$

then it holds

$$\begin{aligned} \int_0^1 (W_x^T A_2^T P_0 W + W^T P_0 A_2 W_x) dx &= \frac{1}{a(x)} \int_0^1 W^T [J_2 A_2^T P_0 - J_4 A_2^T P_0 J_3 + P_0 A_2 J_3 - J_2 P_0 A_2 J_4] W dx \\ &+ \int_0^1 W^T [-J_1 (A_2^T P_0)_x J_4 - J_4 (P_0 A_2)_x J_1 - J_4 (A_2^T P_0)_x J_4] W dx \\ &+ \left[ W^T [J_4 A_2 P_0 J_1 + J_1 P_0 A_2 J_4 + J_4 P_0 A_2 J_4] W \right]_0^1. \end{aligned} \quad (9.49)$$

*Proof*: From the definition of  $J_1$ ,  $J_2$ , and  $J_3$  in (9.42), and  $J_4$  in (8.30), for all  $\Theta \in \mathbb{R}^{3 \times 3}$  it holds

$$\Theta = J_1 \Theta + J_4 \Theta J_1 + J_4 \Theta J_4, \quad (9.50)$$

$$\Theta = \Theta J_1 + J_1 \Theta J_4 + J_4 \Theta J_4. \quad (9.51)$$

Applying this to  $A_2 P_0$  and  $P_0 A_2$ , one gets

$$\begin{aligned} \int_0^1 (W_x^T A_2^T P_0 W + W^T P_0 A_2 W_x) dx &= \int_0^1 W_x^T (J_1 A_2^T P_0 + J_4 A_2^T P_0 J_1 + J_4 A_2^T P_0 J_4) W dx \\ &+ \int_0^1 W^T (P_0 A_2 J_1 + J_1 P_0 A_2 J_4 + J_4 P_0 A_2 J_4) W_x dx. \end{aligned} \quad (9.52)$$

using Proposition 9.1, integration by parts and (9.48), one obtains (9.49).  $\blacksquare$

It is worth noticing that, considering  $P_0$  as

$$P_0 = \begin{bmatrix} p_1 & p_2 & p_3 \\ * & p_4 & p_5 \\ * & * & p_6 \end{bmatrix},$$

the condition (9.48) with  $A_2$  defined in (9.40) is equivalent to  $a(x)p_4 = p_6$ . Therefore the constraint of (9.48) is only on one parameter.

**Proposition 9.3** Consider  $V$  defined in (9.33). It can be rewritten as

$$V_3(\mathcal{X}_{e_3}(t)) = \int_0^1 W(x,t)^T P_0(x) W(x,t) dx + W_1(t)^T P_1 W_1(t) + W_0(t)^T P_2 W_0(t), \quad (9.53)$$

with  $P_0(x) \in \mathbb{R}^{3 \times 3}$ ,  $P_1 \in \mathbb{R}^{2 \times 2}$ , and  $P_2 \in \mathbb{R}^{2 \times 2}$ , symmetric positive definite, assuming that  $P_0$  verifies (9.48), it holds

$$\dot{V}_3(\mathcal{X}_{e_3}(t)) = - \int_0^1 W(x,t)^T Q_0(x) W(x,t) dx - W(1,t)^T Q_1 W(1,t) - W(0,t)^T Q_2 W(0,t), \quad (9.54)$$

in which  $Q_0$ ,  $Q_1$  and  $Q_2$  are defined as

$$\begin{aligned} Q_0(x) &= - \frac{1}{a(x)} [J_2(A_2(x)^T P_0(x) - P_0(x) A_2(x) J_4) + (-P_0(x) A_2(x) + J_4 A_2(x)^T P_0(x)) J_3] \\ &- A_1(x)^T P_0(x) - P_0(x) A_1(x) + J_1(A_2^T(x) P_0(x))_x J_4 + J_4(P_0(x) A_2(x))_x J_1 + J_4(A_2(x)^T P_0(x))_x J_4, \end{aligned} \quad (9.55)$$

$$Q_1 = -A_3^T P_1 A_5 - A_5^T P_1 A_3 - (J_4 A_2(1))^T P_0(1) J_1 + J_1 P_0(1) A_2(1) J_4 + J_4 A_2(1)^T P_0(1) J_4, \quad (9.56)$$

$$Q_2 = -A_4^T P_2 A_5 - A_5^T P_2 A_4 + J_4 A_2(0)^T P_0(0) J_1 + J_1 P_0(0) A_2(0) J_4 + J_4 A_2(0)^T P_0(0) J_4, \quad (9.57)$$

where  $J_1$ ,  $J_2$ ,  $J_3$  are given (9.42),  $J_4$  is given in (9.47),  $A_i$  are defined in (9.40)-(9.41).

*Proof*: Derivation (9.53) along the trajectory, then applying (9.37)-(9.39), then using (9.48) and Proposition 9.3 one gets (9.54).  $\blacksquare$

Here the Lyapunov equations (9.55)-(9.57) are more complex than in both previous cases (Section 7.2 and Section 8.2). Indeed, the derivative of  $A_2$  and  $P_0$  need to be considered in addition. An open question is: How can we optimize the evaluation of the decay rate for the *target system* (which is equivalent to the *closed-loop system*, changing both the *target system* parameters and the positive definite matrices  $P_0$ ,  $P_1$ , and  $P_2$ ?

Now we finally state the proof of the lemma, using all previous propositions

*Proof of Lemma 9.2:* Consider  $V_3$  defined in (9.33), with

$$P_0(x) = \begin{bmatrix} \beta_w(x) & \sigma & 0 \\ * & 1 & 0 \\ * & * & \frac{1}{a(x)} \end{bmatrix}, \quad P_1 = \begin{bmatrix} \frac{c_3 + \sigma c_1}{c_2} & \frac{\sigma}{c_2} \\ * & \frac{1}{c_2} \end{bmatrix}, \quad P_2 = \begin{bmatrix} \frac{d_3 + \sigma d_1}{d_2} & \frac{\sigma}{d_2} \\ * & \frac{1}{d_2} \end{bmatrix}, \quad (9.58)$$

in which

$$\sigma < \min_{x \in [0,1]} \left\{ \sqrt{\beta_w(x)}, \lambda_w(x), \frac{4\beta_w(x)\lambda_w(x)}{\lambda_w(x)^2 + 4\beta_w(x)}, c_1, d_1 \right\}. \quad (9.59)$$

One gets that  $P_0(x)$ ,  $P_1$ , and  $P_2$  are positive definite. Moreover the condition (9.48) is satisfied. Therefore using Proposition 9.3, it holds

$$\dot{V}_3(\mathcal{X}_{w_3}(t)) = - \int_0^1 W(x,t)^T Q_0(x) W(x,t) dx - W_1(t)^T Q_1 W_1(t) - W_0(t)^T Q_2 W_0(t), \quad (9.60)$$

where

$$Q_0(x) = \begin{bmatrix} 2\beta_w(x)\sigma & \lambda_w(x)\sigma & 0 \\ * & 2\lambda_w(x) - 2\sigma & 0 \\ * & * & \frac{2\sigma}{a(x)} \end{bmatrix}, \quad Q_1 = \begin{bmatrix} \frac{2\sigma c_3}{c_2} & 0 \\ * & \frac{2c_1}{c_2} - \frac{2\sigma}{c_2} \end{bmatrix}, \quad Q_2 = \begin{bmatrix} \frac{2\sigma d_3}{d_2} & 0 \\ * & \frac{2d_1}{d_2} - \frac{2\sigma}{d_2} \end{bmatrix}. \quad (9.61)$$

Note that  $(A_2^T(x)P_0(x))_x = 0$ . From (9.59), it holds that  $Q_0(x)$ ,  $Q_1$ , and  $Q_2$  are positive definite. It follows (9.35). ■

### 9.3 Backstepping transformation on a space depending wave equation

In this section, the on-going work on backstepping control design is presented. We are currently working on the well-posedness of the kernel PDE. Indeed all previous technique, change of variable used in order to perform the method of successive approximation fails. Therefore in the following is just presented the establishment of the kernel PDE.

#### 9.3.1 Problem statement

We want to design a backstepping transformation for a space depending wave PDE in order to control it. The reason are mainly that there exists a class of application which are space dependent.

We wish to find a backstepping transformation which maps into the *target system*  $(\Sigma_{T_3})$  defined in (9.32) the following *original system*

$$\begin{cases} u_{tt}(x,t) = (a(x)u_x(x,t))_x + \lambda(x)u_t(x,t) + \beta(x)u(x,t), & (9.62a) \\ u_{tt}(1,t) = a_1u_t(1,t) + a_2u_x(1,t) + a_3u(1,t) + U(t), & (9.62b) \\ u_{tt}(0,t) = b_1u_t(0,t) + b_2u_x(0,t) + b_3u(0,t), & (9.62c) \end{cases} \quad (\Sigma_{O_4})$$

in which,  $\forall x \in [0,1]$ ,  $a(x) > 0$  is an in-domain coefficient.  $\lambda(x)$  is an in-domain source dependent viscous source term coefficient.  $\beta(x)$  is an in-domain source dependent position source term coefficient.  $a_1, a_2 \neq 0, a_3, b_1, b_2 \neq 0$ , and  $b_3$  are boundary parameters.  $\lambda_w(x)$  is an space dependent viscous damping coefficient.  $\beta_w(x)$  is an in-domain space dependent static damping coefficient.  $c_1, c_2, c_3, d_1, d_2, d_3 > 0$  are boundary parameters.

The suggested backstepping transformation is

$$w(x,t) = u(x,t) - \int_0^1 K^T(x,y)\chi(y,t)dy - \gamma(x)u_t(0,t), \quad (9.63)$$

in which

$$K(x, y) = \begin{bmatrix} k(x, y) \\ s(x, y) \\ m(x, y) \end{bmatrix}, \quad \chi(x, t) = \begin{bmatrix} u(x, t) \\ u_t(x, t) \\ a(x)u_x(x, t) \end{bmatrix}. \quad (9.64)$$

Note that we use  $a(x)u_x(x, t)$  in place of  $u_x(x, t)$  due to the computation simplicity it leads.

### 9.3.2 Backstepping transformation

This section is devoted to the establishment of the kernel  $(K, \gamma)$  partial differential equation. Before stating the corresponding result, consider the vector  $\chi(x, t)$  defined in (9.64). Using the system equation (9.62a) together with the boundary condition (9.62c), it is easy to show that

$$\chi_t(x, t) = \Theta_1(x)\chi(x, t) + \Theta_2(x)\chi_x(x, t), \quad (9.65)$$

$$u_{tt}(0, t) = \Theta_3\chi(0, t), \quad (9.66)$$

$$\chi_t(0, t) = \Theta_4\underline{\chi}(0, t), \quad (9.67)$$

$$\chi(0, t) = \Theta_5\underline{\chi}(0, t), \quad (9.68)$$

with

$$\underline{\chi}(0, t) := [u(0, t) \quad u_t(0, t) \quad u_x(0, t) \quad u_{xt}(0, t)]^T, \quad (9.69)$$

and where

$$\Theta_1(x) = \begin{bmatrix} 0 & 1 & -\sqrt{a(x)} \\ \beta(x) & \lambda(x) & 0 \\ 0 & 0 & 0 \end{bmatrix}, \quad \Theta_2(x) = \begin{bmatrix} \sqrt{a(x)} & 0 & 0 \\ 0 & 0 & 1 \\ 0 & a(x) & 0 \end{bmatrix}, \quad (9.70)$$

$$\Theta_3 := \begin{bmatrix} b_3 & b_1 & \frac{b_2}{a(0)} \end{bmatrix}, \quad \Theta_4 := \begin{bmatrix} 0 & 1 & 0 & 0 \\ b_3 & b_1 & \frac{b_2}{a(0)} & 0 \\ 0 & 0 & 0 & a(0) \end{bmatrix}, \quad \Theta_5 := \begin{bmatrix} 1 & 0 & 0 & 0 \\ 0 & 1 & 0 & 0 \\ 0 & 0 & a(0) & 0 \end{bmatrix}. \quad (9.71)$$

Note that  $\Theta_1$  and  $\Theta_2$ , such that it holds (9.65), are not unique. The choice made in (9.70) however guarantees that  $\Theta_2^2 = a(x)I_3$ .

Consider

$$\begin{cases} a(x)K_{xx}(x, y) - a(y)K_{yy}(x, y) = B_K(x, y)K_y(x, y) + C_K K(x, y), & (9.72a) \\ K'(x, x) = D_K K(x, x) + E(x), & (9.72b) \\ \begin{bmatrix} k_y(x, 0) \\ m_y(x, 0) \end{bmatrix} = H_K K(x, 0), & (9.72c) \\ s_{xx}(x, 0) = b_2 s_y(x, 0) + H_S K(x, 0), & (9.72d) \\ \begin{bmatrix} K(0, 0) \\ s_x(0, 0) \end{bmatrix} = J_K, & (9.72e) \\ \gamma(x) = \frac{a(0)}{b_2} s(x, 0), & (9.72f) \end{cases} \quad (\Sigma_{K_3})$$

in which

$$B_K^T(x, y) = -\Theta_2(y)\Theta_1(y) - \Theta_1(y)\Theta_2(y) + 2\Theta_2'(y)\Theta_2(y) - \lambda_w(x)\Theta_2(y), \quad (9.73)$$

$$C_K^T(x, y) = \Theta_1(y)^2 - \Theta_2'(y)\Theta_1(y) + \Theta_1'(y)\Theta_2(y) + \Theta_2''(y)\Theta_2(y) + \lambda_w(x)[\Theta_1(y) - \Theta_2'(y)] + \beta_w(x)I_3, \quad (9.74)$$

$$D_K^T(x) = \frac{1}{2a(x)} [\Theta_2(x)\Theta_1(x) + \Theta_1(x)\Theta_2(x) - \Theta_2'(x)\Theta_2(x) + \lambda_w(x)\Theta_2(x)], \quad (9.75)$$

$$E_K^T(x) = -\frac{1}{2a(x)} [\beta(x) + \beta_w(x) \quad \lambda(x) + \lambda_w(x) \quad 0], \quad (9.76)$$

$$H_K(x) = \frac{1}{a(0)} \begin{bmatrix} \frac{a'(0)}{2} + \lambda_w(x)\sqrt{a(0)} & \beta(0)\sqrt{a(0)} - a(0)(\lambda_w(x)b_3 + b_1b_3)\frac{1}{b_2} & a(0)b_3 \\ 1 & \lambda(0) - b_1 & a'(0) + b_2 \end{bmatrix} \quad (9.77)$$

$$H_S(x) = \frac{1}{a(x)} \left[ (b_2(a(0) - 1))\frac{1}{\sqrt{a(0)}} \quad b_1^2 + \lambda_w(x) + \beta_w(x) - b_2 + b_3 \quad -b_2(\lambda_w(x) + b_1) \right], \quad (9.78)$$

$$J_K = -\frac{1}{d_2} \begin{bmatrix} b_3 + d_3 \\ 0 \\ \frac{b_2}{a(0)} - d_2 \\ \frac{b_2(b_1 + d_1)}{a(0)} \end{bmatrix}. \quad (9.79)$$

**Lemma 9.3** Consider the kernel of the backstepping transformation (9.63) to be solution of (9.72). Then the backstepping transformation maps the closed-loop system (9.62) (with the corresponding backstepping control law which remains to be computed) into the target system (9.32).

Note that if  $\beta(x) = \beta$ ,  $\lambda(x) = \lambda$ ,  $\lambda_w(x) = \lambda_w$ ,  $\beta_w = \beta_w$  and  $a(x) = 1$  it holds

- (9.32a) is the same as (8.11a).
- (9.32c) is the same as (8.11c).
- (9.62a) is the same as (8.1a).
- (9.62c) is the same as (8.1c).

The difficulty we have not solve so far in the current design is to prove that the system (9.72) is well-posed. Indeed we cannot use the same change of variable (8.81) as in Chapter 8. On the one hand  $B_K$  is depending on  $x$ , this cause the exponential part of (8.81) to not simplify the  $K_y$  term. And on the other hand the coefficient  $a$  before  $K_{xx}$  and  $K_{yy}$  cause that the standard change of variable  $x = \zeta + \eta$ ,  $y = \zeta - \eta$  fails to regroup the higher order derivative in one term  $G_{\zeta\eta} = K_{xx} - K_{yy}$ .

*Proof of Lemma 9.3:* Consider the time derivative of (9.63)

$$w_t(x,t) = u_t(x,t) - \int_0^x K^T(x,y)\chi_t(y,t)dy - \gamma(x)u_{tt}(0,t). \quad (9.80)$$

Using (9.65), an integration by parts and (9.66), one can express (9.80) as

$$w_t(x,t) = u_t(x,t) - [K^T(x,y)\Theta_2(y)\chi(y,t)]_{y=0}^x - \int_0^x [K^T\Theta_1(y) - K_y^T\Theta_2(y) - K^T\Theta_2'(y)]\chi(y,t)dy - \gamma(x)\Theta_3\chi(0,t). \quad (9.81)$$

Consider the time derivative of (9.81). Using (9.62a), (9.65), and an integration by parts, one obtains

$$\begin{aligned} w_{tt}(x,t) &= u_{xx}(x,t) + \lambda u_t(x,t) + \beta u(x,t) \\ &- \left[ K^T(x,y)\Theta_2(y)\chi_t(y,t) + [K^T(x,y)\Theta_1(y) - K_y^T(x,y)\Theta_2(y) - K^T(x,y)\Theta_2'(y)]\Theta_2(y)\chi(y,t) \right]_{y=0}^x \\ &- \int_0^x [(K^T\Theta_1(y) - K_y^T\Theta_2(y) - K\Theta_2'(y))\Theta_1(y) \\ &- [K_y^T\Theta_1(y) - K^T\Theta_1'(y) - K_{yy}^T\Theta_2(y) - 2K_y^T\Theta_2'(y) - K^T\Theta_2''(y)]\Theta_2(y)]\chi(y,t)dy - \gamma(x)\Theta_3\chi_t(0,t). \end{aligned} \quad (9.82)$$

Considering now the first and second space derivatives of (9.63), which can be written as

$$w_x(x,t) = u_x(x,t) - K^T(x,x)\chi(x,t) - \int_0^x K_x^T(x,y)\chi(y,t)dy - \gamma'(x)u_t(0,t), \quad (9.83)$$

$$\begin{aligned} w_{xx}(x,t) &= u_{xx}(x,t) - (K'^T(x,x) + K_x^T(x,x))\chi(x,t) \\ &- K^T(x,x)\chi_x(x,t) - \int_0^x K_{xx}^T(x,y)\chi(y,t)dy - \gamma''(x)u_t(0,t). \end{aligned} \quad (9.84)$$

Gathering (9.63), (9.81), (9.82), and (9.84) the target system equation (9.32a) holds if the kernel  $(K, \gamma)$  satisfies the following conditions

$$\begin{aligned} & (K^T(x, y)\Theta_1(y) - K_y^T(x, y)\Theta_2(y) - K(x, y)\Theta_2'(y))\Theta_1(y) \\ & - [K_y^T(x, y)\Theta_1(y) - K^T(x, y)\Theta_1'(y) - K_{yy}^T(x, y)\Theta_2(y) - 2K_y^T(x, y)\Theta_2'(y) - K^T(x, y)\Theta_2''(y)]\Theta_2(y) \\ & - a(x)K_{xx}^T(x, y) + \lambda_w(x)[K^T(x, y)\Theta_1(y) - K_y^T(x, y)\Theta_2(y) - K^T(x, y)\Theta_2'(y)] + \beta_w(x)K^T(x, y) = 0, \end{aligned} \quad (9.85)$$

$$\begin{aligned} & K^T(x, x)\Theta_2(x)\chi_t(x, t) - \lambda(x)\Theta_6\chi(x, t) - \beta(x)\Theta_8\chi(x, t) \\ & + [K^T(x, x)\Theta_1(x)\Theta_2(x) - K_y^T(x, x)\Theta_2(x)^2 - K^T(x, x)\Theta_2'(x)\Theta(y)]\chi(x, t) - \lambda_w(x)\Theta_6\chi(x, t) \\ & + \lambda_w(x)K^T(x, x)\Theta_2\chi(x, t) - \beta_w(x)\Theta_8\chi(x, t) - a(x)(K'^T(x, x) + K_x^T(x, x))\chi(x, t) - a(x)K^T(x, x)\chi_x(x, t) = 0, \end{aligned} \quad (9.86)$$

$$\begin{aligned} & \gamma(x)\Theta_3\chi_t(0, t) + (-K^T(x, 0)\Theta_1(0)\Theta_2(0) + K_y^T(x, 0)\Theta_2^2(0) - K^T(x, 0)\Theta_2'(0)\Theta_2(0))\chi(0, t) - K^T(x, 0)\Theta_2\chi_t(0, t) \\ & - a(x)\gamma''(x)\Theta_6\chi(0, t) - \lambda_w(x)K^T(x, 0)\Theta_2\chi(0, t) + \lambda_w(x)\gamma(x)\Theta_3\chi(0, t) + \beta_w(x)\gamma(x)\Theta_6\chi(0, t) = 0, \end{aligned} \quad (9.87)$$

in which

$$\Theta_6 := [0 \quad 1 \quad 0], \quad \Theta_8 := [1 \quad 0 \quad 0]. \quad (9.88)$$

Following the definitions in (9.73)-(9.74) of  $B_K$  and  $C_K$ , (9.85) can be rewritten as (9.72a). Moreover, using (9.65), (9.86) can be reformulated as (9.72b). Furthermore, using (9.67) and (9.68) one obtains that (9.87) is equivalent to the four following scalar conditions

$$\begin{aligned} & \beta(0)\sqrt{a(0)}s(x, 0) - a(0)k_y(x, 0) + \lambda_w(x)\sqrt{a(0)}k(x, 0) + a(0)b_3m(x, 0) - \lambda_w(x)b_3\gamma(x) \\ & - b_1b_3\gamma(x) - \frac{a'(0)}{2}k(x, 0) = 0, \end{aligned} \quad (9.89)$$

$$\begin{aligned} & a(x)\gamma''(x) - \beta_w(x)\gamma(x) - a(0)s_y(x, 0) + \lambda_w a(0)m(x, 0) - b_3\gamma(x) - \lambda_w b_1\gamma(x) + b_1 a(0)m(x, 0) - b_1^2\gamma(x) \\ & + \sqrt{a(0)}k(x, 0) + a(0)^{\frac{3}{2}}k(x, 0) = 0, \end{aligned} \quad (9.90)$$

$$\begin{aligned} & k(x, 0) - a(0)m_y(x, 0) + \lambda(0)s(x, 0) + b_2m(x, 0) - \lambda_w(x)b_2\gamma(x)\frac{1}{a(0)} - b_1b_2\gamma(x)\frac{1}{a(0)} + \lambda_w(x)s(x, 0) \\ & + a'(0)m(x, 0) = 0, \end{aligned} \quad (9.91)$$

$$a(0)s(x, 0) - b_2\gamma(x) = 0, \quad (9.92)$$

which can be reformulated as (9.72c), (9.72d), and (9.72f).

Now, the boundary condition (9.32c) gives one last condition on the kernel. As, from (9.63), (9.81), (9.82), and (9.83),

$$\begin{cases} w_{tt}(0, t) = (\Theta_3\Theta_5 - \gamma(0)\Theta_3\Theta_4)\underline{\chi}(0, t), & (9.93a) \\ w_t(0, t) = (\Theta_6 - \gamma(0)\Theta_3)\Theta_5\underline{\chi}(0, t), & (9.93b) \\ w_x(0, t) = (\Theta_7 - K^T(0, 0) - \gamma'(0)\Theta_6)\Theta_5\underline{\chi}(0, t), & (9.93c) \\ w(0, t) = (\Theta_8 - \gamma(0)\Theta_6)\Theta_5\underline{\chi}(0, t), & (9.93d) \end{cases}$$

in which  $\Theta_7 := [0 \quad 0 \quad 1]$  thus a sufficient condition for (9.32c) to hold is

$$\begin{bmatrix} b_3 + d_3 \\ b_1 + d_1 \\ \frac{b_2}{a(0)} - d_2 \\ 0 \end{bmatrix} = -d_2 \begin{bmatrix} k(0, 0) \\ s(0, 0) \\ m(0, 0) \\ 0 \end{bmatrix} + \gamma(0) \begin{bmatrix} * \\ * \\ * \\ b_2 \end{bmatrix} - \gamma'(0) \begin{bmatrix} 0 \\ d_2 \\ 0 \\ 0 \end{bmatrix}, \quad (9.94)$$

which, using (9.92), is (9.72e).

Finally the control law can be obtained from (9.32b), with (9.63), (9.81), (9.83), and using (9.62). ■



## Chapter conclusion

First, we have considered a particular boundary input PDE where the associated abstract problem could be deduced without using boundary input system theory. Therefore, the time derivative of the input does not need to be considered in the proof of system well-posedness. This allows us to present idea which can be used to study the well-posedness of the homogeneous abstract problem we consider in Chapter 7, Section 7.1 and in Chapter 8, Section 8.1.

Consider the backstepping on-going design. The final pieces of this design are to prove that the kernel is unique and exist, to compute the control law and to prove that the backstepping transformation is invertible. The key point is the well-posedness of the kernel PDE, we have several idea on this, (i) trying to find a change of variable which maps the kernel PDE towards a simpler PDE, (ii) there exist more developed method than the method of successive approximation to study PDE well-posedness, therefore the proof might be deduced using an other method.

---

---

---

---

# Part II conclusion

---

We have presented two backstepping designs, and the preliminary computations of a third one. The more finalized one is the first, because we proposed an additional observer for the *original system* (Chapter 7). In Chapter 8 we have presented a generalized design. Indeed, the design in Chapter 7 is a particular case of the design in Chapter 8. But there does not exist an observer for this case in general. There are several results which can be deduced directly using together Chapter 7 and Chapter 8 and ideas within. For example, considering in-domain damping, we could design observer using both boundary velocity and position. The idea is similarity between the target system and observer-error system, as we have done in Chapter 7. Note that, we can also mix control boundary between the first and second design.

As the stabilization and the observation problem are dual, intuitively these considered systems should be observable at the  $x = 1$  boundary. This is the case if the operator is auto-adjoint ([Curtain and Zwart, 2012] and controllability and observability gramian). This is often the case when the wave have no distributed terms. Therefore we need to check if it is the case for the considered wave equation. For obvious reason, we aim for a collocated observer but there is no reason that it is possible. As far as we know there is a the moment no collocated observer for the wave PDE (7.1), (8.1), and (9.62).

An interesting extension is to consider adaptive control on the system coefficient parameters. Indeed, the estimation of the wave parameters has to be done before applying these controllers. Using adaptive control we can relax this preliminary estimation. However the design of an observer seems more crucial. Nevertheless the design of both can be done separately, gathering them using the separation principle. Note that assuming an observer-based adaptive control law could be designed, we may study its robustness toward model mismatch as done in Part I.

An other but more direct extension of the Chapter 7 and Chapter 8, is the control of coupled one-dimension wave PDE. Indeed, the crucial part of backstepping control design method is the establishment of the kernel existence and uniqueness. Therefore, it seems to have no problem to design control of coupled one-dimensional wave equations, considering  $u(x, t) \in \mathbb{R}^n$  and matrix parameters. The practical interest of this could be the control of both torsional and axis vibrations occurring in drilling facility, as considered for example in [Germay et al., 2009], [Saldivar et al., 2016b].



# Thesis conclusion and perspective

---

We started this thesis with two questions, let us recall them

*Does a nonlinear adaptive control law still preform efficiently, if the viscous damping taken equal to zero for its design is no longer neglected?*

*How can we take into account the in-domain damping in order to stabilize the wave equation subject to a unstable dynamic boundary condition with known parameters?*

For the first question we have suggested a method, using successive change of variables in order to perform a Lyapunov analysis, where some features / characteristics of the Lyapunov function are kept. This is the case of the log form of the Lyapunov function. This point is really important and this is the notable feature of our method. Therefore, the answer to this question is: using our method the considered adaptive control laws are robust with respect to in-domain damping model mismatch, if the coefficient of the viscous damping is small enough. Nevertheless, as we are using Lyapunov functional the result is conservative. Note also that for one of the considered control law we have to assume more regular solutions.

For the second question we proposed two backstepping based control laws. Each one can be seen as a generalization of the adaptive control law using the measurement of both boundary velocities and taking apart the adaptive. Nevertheless, these approaches do not work for space depending viscous in-domain damping. Therefore the work in progress is mainly focused on the last presented idea of design. The missing part is the establishment of the kernel existence and uniqueness.

Several studies can be followed from the thesis result:

**Input-to-state stability:** In recent year an enormous effort has been done to adapt the input-to-state stability idea and result to infinite dimensional systems. We believe that it could be interesting to study the robustness of nonlinear adaptive control law with this point of view.

**Adaptive control on the nonlinear boundary condition:** The following comes from a remark of Giorgio Valmorbida in the early work of this thesis concerning the adaptive control law. If we known the equation of the nonlinear at the dynamics boundary, and that this nonlinearity depends on parameters, we could perform adaptive control on these parameters, and somehow respect the form of the nonlinearity.

**Comparison between second and first order hyperbolic:** For numerous authors some wave equations can be reformulated into two coupled hyperbolic PDEs. But, rigorously speaking, this is not a reformulation as the position is lost during the transformation. There is no problem according to this point in the thesis since all results are written in the point of view of the wave equation. But we believe that some clarification is needed: What wave equation can be property described by first order coupled hyperbolic?

**Robustness with respect to general unmodeled dynamics:** In our robust study, we have just looked at the robustness with respect to in-domain viscous damping. But using the same idea, i.e., splitting the dynamics in both, it will be interesting to study the robustness with general unmodeled dynamics, in other words, consider the same adaptive control laws but applied on the wave propagation

$$u_{tt}(x,t) = u_{xx}(x,t) + F(u(x,t)), \quad (9.95)$$

where  $F$  can be a differential operator.

**Backstepping design:** It seems that we can go further in the backstepping design, given that we establish the design, the idea of which is presented in Chapter 9. It could be really interesting to try to solve the stabilization of the nonlinear wave equation

$$u_{tt}(x,t) = [a(x,u(x,t))]_{xx}. \quad (9.96)$$

Indeed since the premise of infinite-dimensional backstepping the idea to use it to control nonlinear PDE is present in [Balogh and Krstic, 2002] sixteen year ago. So far as we known, at this day, there is no work concerning the control of this kind of nonlinear (at the propagation) PDE using infinite-dimensional backstepping. This is actually a really hard problem.

Still concerning backstepping transformation, it will be interesting to look at fractional derivative PDE, as it seems more simpler, as the system stays linear, the kernel will also stay linear. This gives birth to new questions:

*Can we approximate a nonlinear dynamics system by a linear fractional evolution system? If yes, can we choose arbitrary the approximation error? Is the converse true?*

A last point concerning backstepping, is that so far as we know that the only method used to prove the existence and uniqueness of the kernel solution is the successive approximation method. There exist a handful of method to study the well-posedness of stationary PDE. We believe this idea could lead to really successful results.

**Observer design:** As backstepping design gives full state feedback, an observer is needed and has to be developed. An interesting idea is to use the history of the measurement (delay) to enhance the performance of the observer. Note also that what seems to be the best idea is to design a control law on the adjoint problem.

**Backstepping adaptive control:** This is actually, one of the objective we wish to answer to. The idea is to use the backstepping control we have designed, assuming that the parameters of the wave PDE are unknown and compute adaptive law by Lyapunov design. Nevertheless, this should be done after the design of observer.

**Experimentation:** The final actual objective of all the work, is to experiment the different presented laws and many others on a real system. The manipulations we have in mind are listed in [Patil and Teodoriu, 2013], and concern torsional vibrations.

“ The key problem of all these interesting studies is the time, and the time, the key of these problems. ”

---

Christophe Roman, in his thesis, 2018

This end this dissertation, in the following you will find the appendices and the references.

# Intermediate results

## A.1 Relationship between transport and delay

**Lemma A.1** Consider

$$f_t(x,t) + cf_x(x,t) = \mathcal{F}(x,t), \quad (\text{A.1})$$

$$f(0,t) = \bar{f}(t) \text{ if } c > 0, \text{ and } f(1,t) = \bar{f}(t) \text{ if } c < 0, \quad (\text{A.2})$$

$$f(\cdot, 0) = f_0, \quad (\text{A.3})$$

in which  $\mathcal{F} \in L_2((0, \infty) \times (0, 1))$ ,  $\bar{f} \in L_2(0, \infty)$ ,  $f_0 \in L_2(0, 1)$ , and  $c \in \mathbb{R} \setminus \{0\}$ . There exists a unique weak solution  $f \in L_2((0, \infty) \times (0, 1))$  for the abstract Cauchy problem resulting from (A.1)-(A.3). This solution satisfies, for all  $x \in [0, 1]$ ,  $t \in [0, \infty)$ , and  $s$  such that  $0 \leq c(s-t) + x \leq 1$

$$f(c(s-t) + x, s) = f(x, t) + \int_t^s \mathcal{F}(c(\tau-t) + x, \tau) d\tau. \quad (\text{A.4})$$

Note that we can deduce for any  $x$  the value of the distributed state  $f(x, t)$  with the knowledge of its boundary and  $\mathcal{F}$ .

*Proof:* Without lack of generality, consider  $c < 0$  and the following variable

$$m(x, t) = f(x, t) - \int_0^x \frac{1}{c} \mathcal{F}(s, t + \frac{s-x}{c}) ds. \quad (\text{A.5})$$

One gets that, if  $\mathcal{F} \in L_2((0, \infty) \times (0, 1))$ ,

$$m \in L_2((0, \infty) \times (0, 1)) \Leftrightarrow f \in L_2((0, \infty) \times (0, 1)). \quad (\text{A.6})$$

Moreover,  $m$  satisfies

$$m_t(x, t) + cm_x(x, t) = 0, \quad (\text{A.7})$$

$$m(1, t) = \bar{f}(t) - \int_0^1 \frac{1}{c} \mathcal{F}(s, t + \frac{s-1}{c}) ds, \quad (\text{A.8})$$

$$m(x, 0) = f_0(x) - \int_0^x \frac{1}{c} \mathcal{F}(s, \frac{s-x}{c}) ds, \quad (\text{A.9})$$

which is a standard transport equation. Following [Curtain and Zwart, 2012] Example 2.2.4 or Exercise 3.14, this system is well-posed and its solution satisfies  $m(x, t) = m(1, t - \frac{x}{c})$  which, in turns, implies (A.4). ■

## A.2 Intermediate result for Lyapunov stability

**Proposition A.1** Consider  $x_i \in L_2(\mathbb{R})$ , ( $i \leq m$ ,  $i, m \in \mathbb{N}$ ), and  $V$  a positive definite functional of  $(x_i^2)_{i=1..m}$ . Assume there exists a increasing function  $K$  such that

$$\forall t \geq 0, \quad \dot{V}(t) \leq - \sum_{i=1}^m (a_i - K(V(t))) x_i(t)^2, \quad (\text{A.10})$$

in which  $\forall i \in \llbracket 0, m \rrbracket$ ,  $a_i > 0$ .

If  $\forall i$ ,  $a_i - K(V(0)) > 0$  then  $\forall i$ ,  $\forall t \geq 0$ ,  $a_i - K(V(t)) > 0$ .

*Proof:* For the sake of simplicity, take  $p = 1$  (similar arguments hold for the general case). By contradiction, assume the existence of  $t_0 > 0$  such that  $a_1 - K(V(t_0)) \leq 0$ . By continuity, there exists at least one  $t \in [0, t_0]$  such that  $a_1 - K(V(t)) = 0$ . We denote  $t_1 > 0$  the smallest. One has

$$\forall t \in [0, t_1[, \quad a_1 - K(V(t)) > 0, \quad (\text{A.11})$$

and thus  $V(t_1) < V(0)$  according to (A.10). Consequently,  $a_1 = K(V(t_1)) < K(V(0))$  as  $K$  is an increasing function, which is a contradiction. ■

### A.3 Generalized Young inequality

**Proposition A.2** one gets

$$\left( \sum_{i=1}^n a_i \right)^2 \leq n \sum_{i=1}^n a_i^2, \quad (\text{A.12})$$

and for all  $\varepsilon > 0$

$$\left( \sum_{i=1}^n a_i + b \right)^2 \leq n(1 + \varepsilon) \sum_{i=1}^n a_i^2 + \left(1 + \frac{1}{\varepsilon}\right) b^2. \quad (\text{A.13})$$

*Proof:*

$$\left( \sum_{i=1}^n a_i \right)^2 = \sum_{i=1}^n a_i \sum_{j=1}^n a_j, \quad (\text{A.14})$$

applying Young's inequality, one gets

$$\left( \sum_{i=1}^n a_i \right)^2 \leq \sum_{i=1}^n \sum_{j=1}^n \left( \frac{a_i^2 + a_j^2}{2} \right) = \frac{n}{2} \left( \sum_{i=1}^n a_i^2 + \sum_{i=1}^n a_j^2 \right) = n \sum_{i=1}^n a_i^2. \quad (\text{A.15})$$

■

### A.4 Complement on the uniform boundness of coupled hyperbolic PDE with uniform bounded input

**Lemma A.2** Consider

$$f_t(x, t) = \begin{bmatrix} 1 & 0 \\ 0 & -1 \end{bmatrix} f_x(x, t) + Bf(x, t) + F(x, t), \quad (\text{A.16})$$

$$[1 \quad 0] f(1, t) = F_1(t), \quad (\text{A.17})$$

$$[0 \quad 1] f(0, t) = F_0(t) + [1 \quad 0] f(0, t), \quad (\text{A.18})$$

$$f(\cdot, 0) = f_0, \quad (\text{A.19})$$

in which  $f \in L_2((0, 1) \times (0, \infty))^2$  is the vector state of the system.  $F \in L_\infty((0, 1) \times (0, \infty))^2$  is the vector in-domain input.  $F_1, F_0 \in L_\infty(0, \infty)$  are the boundary scalar inputs.  $B \in \mathbb{R}^{2 \times 2}$  is the matrix representing the coupling of source terms.  $f_0 \in L_2(0, 1)^2$  is the initial condition. The abstract Cauchy problem resulting from the previous system is well-posed, moreover  $f(x, t)$  is uniformly bounded for  $t \geq 2$ .

*Proof:* Considering  $g(x, t) = e^{Bx}f(x, t)$ , derivating  $g$  by space, using (A.16), then derivating  $g$  by time one gets

$$g_t(x, t) = \begin{bmatrix} 1 & 0 \\ 0 & -1 \end{bmatrix} g_x(x, t) + e^{Bx}F(x, t), \quad (\text{A.20})$$

$$\begin{bmatrix} 1 & 0 \end{bmatrix} g(1, t) = e^{-B}F_1(t), \quad (\text{A.21})$$

$$\begin{bmatrix} 0 & 1 \end{bmatrix} g(0, t) = F_0(t) + \begin{bmatrix} 1 & 0 \end{bmatrix} g(0, t), \quad (\text{A.22})$$

$$g(x, 0) = e^{Bx}f_0(x). \quad (\text{A.23})$$

From Lemma A.1 applying on the above form one gets the well-posedness. Using (A.4) one gets the uniform boundness of  $g(x, t)$  for  $t \geq 2$  and concludes on this proof. ■

## A.5 Fubini's theorem computation details for relationship between functional $V$ and $\Gamma$ Section 3.3.3 and 4.3.3.

**Proposition A.3** Consider

$$\tilde{\zeta}(x, t) = -2\lambda \int_x^1 u_t(\chi, t+x-\chi) d\chi, \quad (\text{A.24})$$

one gets

$$\|\tilde{\zeta}(t)\|^2 \leq 4\lambda^2 \max_{s \in [0,1]} \|u_t(t-s)\|^2. \quad (\text{A.25})$$

*Proof:* one gets

$$\|\tilde{\zeta}(t)\|^2 = \int_0^1 \tilde{\zeta}(x, t)^2 dx \leq 4\lambda^2 \int_0^1 \int_x^1 u_t(\chi, t+x-\chi)^2 d\chi dx. \quad (\text{A.26})$$

Using Fubini's theorem, it holds

$$\int_0^1 \int_x^1 u_t(\chi, t+x-\chi)^2 d\chi dx = \int_0^1 \int_0^\chi u_t(\chi, t+x-\chi)^2 dx d\chi, \quad (\text{A.27})$$

using  $s = x - \chi$ , we obtain

$$\int_0^1 \int_0^\chi u_t(\chi, t+x-\chi)^2 dx d\chi = \int_0^1 \int_{-\chi}^0 u_t(\chi, t+s)^2 ds d\chi. \quad (\text{A.28})$$

Then one can write

$$\int_0^1 \int_{-\chi}^0 u_t(\chi, t+s)^2 ds d\chi \leq \int_0^1 \int_{-1}^0 u_t(\chi, t+s)^2 ds d\chi, \quad (\text{A.29})$$

and thus conclude the proof. ■

## A.6 Minimal example for a set of conditions

Consider

$$V(x) = b_1x_1^2 + b_2x_2^2 + b_3x_3^2 + \frac{x_4}{\gamma}. \quad (\text{A.30})$$

Defining

$$f_1(b, \gamma) = -c + b_1\gamma + b_2\gamma + b_2c^2 + b_3e^{V(x)}, \quad (\text{A.31})$$

$$f_2(b, \gamma) = \frac{1}{c} - b_1 + b_2 + b_3e^{V(x)}, \quad (\text{A.32})$$

$$f_3(b, \gamma) = -b_1 + b_1\gamma + b_2\gamma + b_3e^{V(x)}, \quad (\text{A.33})$$

$$f_4(b, \gamma) = -b_2 + b_2\gamma, \quad (\text{A.34})$$

$$f_5(b, \gamma) = -b_3 + b_3\gamma, \quad (\text{A.35})$$



we want to find  $b_1, b_2, b_3$ , and  $\gamma > 0$  such that  $f_i < 0$

First let us take

$$b_2 < \frac{1}{c}, \quad (\text{A.36})$$

then

$$b_1 > \frac{1}{c_0} + b_2, \quad (\text{A.37})$$

now we choose

$$\gamma < \min \left\{ \frac{c - b_2 c^2}{b_1 + b_2}, \frac{b_1}{b_1 + b_2}, 1 \right\}. \quad (\text{A.38})$$

Finally taking  $M = e^V$  when  $b_3 = 1$ , one gets that if

$$b_3 < \min \left\{ 1, \frac{c_0 - b_1 \gamma - b_2 \gamma - b_2 c^2}{e^M}, \frac{b_1 - \frac{1}{c} + b_2}{e^M}, \frac{b_1 - b_1 \gamma - b_2 \gamma}{e^M} \right\}, \quad (\text{A.39})$$

with (A.36)-(A.38) then  $f_1, f_2, f_3, f_4$ , and  $f_5 < 0$ .

# Proof of the closed-loop wave equation without position distributed term well-posedness

This appendix deals with the well-posedness of the *closed-loop system* defined in Chapter 7, in details, here the proof of Theorem 7.2 is established. Note that this proof is valid with  $c_1 = 0$  and  $d_1 \in \mathbb{R}$  and therefore establishes also the well-posedness of the zero-input system (2.1).

The idea is to prove that the *target system* is well-posed and then using the fact that the backstepping transformation is an invertible maps. Similarly as it has been done in Chapter 8, in order to prove that the *target system* is well-posed, we suggest to use the same idea exposed in Chapter 9, to add positions terms. These position distributed terms will allows to prove that given a change of variable we have a monotone operator.

First let us consider the abstract problem associated with the *target system* defined in (7.12). Consider the following operator

$$\forall z \in \text{Dom}(\mathcal{A}_{e_1}), \quad \mathcal{A}_{e_1}z = - \begin{bmatrix} 0 & 1 & 0 & 0 \\ \partial_{xx} & -\lambda & 0 & 0 \\ 0 & 0 & 0 & 1 \\ d_2 \delta_x|_0 & 0 & 0 & -d_1 \end{bmatrix}, \quad (\text{B.1})$$

$$\text{Dom}(\mathcal{A}_{e_1}) := \{(z_1, z_2, z_3, z_4) \in H_2(0, 1) \times H_1(0, 1) \times \mathbb{R}^2 : z_3 = z_1(0), z_4 = z_2(0), z_1'(1) = -c_1 z_2(1)\}, \quad (\text{B.2})$$

in which  $\partial_{xx}z_1 = z_1''$ ,  $\delta_x|_0 z_1 = z_1'(0)$ . We are interested to the following abstract problem

$$\begin{cases} \frac{d}{dt}X(t) + \mathcal{A}_{e_1}X(t) = 0, & X(t) \in \text{Dom}(\mathcal{A}_{e_1}), \\ X(0) = X_0. \end{cases} \quad (\text{B.3a})$$

$$(\text{B.3b})$$

This is equivalent to the *target system* defined in (7.12).

The following lemma state the well-posedness of the previous abstract problem defined in (B.3)

**Lemma B.1** *Well-posedness of the target system*

Consider  $H_1$ ,  $\mathcal{A}_{e_1}$ , and  $\text{Dom}(\mathcal{A}_{e_1})$  defined in (7.2), (B.1), and (B.2).

(i). For all initial data  $z_0 \in \text{Dom}(\mathcal{A}_{e_1})$ , the abstract problem (B.3) has a unique strong solution such that

$$\begin{cases} \forall t > 0, z(t) \in \text{Dom}(\mathcal{A}_{e_1}), \\ z_1 \in W_{1,\infty}(0, \infty; H_1(0, 1)) \cap L_\infty(0, \infty; H_2(0, 1)). \end{cases}$$

(ii). For all initial data  $z_0 \in H_1$ , the abstract problem (B.3) has a unique weak solution

$$\begin{cases} \forall t > 0, z(t) \in H_1, \\ z_1 \in W_{1,\infty}(0, \infty; L_2(0, 1)) \cap L_\infty(0, \infty; H_1(0, 1)). \end{cases}$$

given by  $z(t) = T_e(t)z_0$ , in which  $T_e$  is the  $C_0$ -semigroup of contraction generated by the unbounded operator  $\mathcal{A}_{e_1}$ .

In order to prove the above Lemma B.1, as it has been said, we preform a change of variable to get a maximal monotone operator. Consider the following operator

$$\forall z \in \text{Dom}(\mathcal{A}_{e_1}), \quad \mathcal{G}_1 z = - \begin{bmatrix} 0 & 1 & 0 & 0 \\ \partial_{xx} - 1 & -1 & 0 & 0 \\ 0 & 0 & 0 & 1 \\ d_2 \partial_x|_0 & 0 & -1 & 0 \end{bmatrix}, \quad (\text{B.6})$$

and the following matrix

$$\mathcal{H}_1 = \begin{bmatrix} 0 & 0 & 0 & 0 \\ -1 & +\lambda - 1 & 0 & 0 \\ 0 & 0 & 0 & 0 \\ 0 & 0 & -1 & -b_1 \end{bmatrix}, \quad (\text{B.7})$$

one gets

$$\mathcal{A}_{e_1} = \mathcal{G}_1 + \mathcal{H}_1, \quad (\text{B.8})$$

$\mathcal{G}$  is a maximal monotone part of  $\mathcal{A}_{e_1}$ , this is established in the following lemma.

**Lemma B.2** *The linear unbounded operator  $\mathcal{G}_1$  defined in (B.6) is maximal monotone on the Hilbert space  $H_1$  defined in (7.2)*

*Proof :* Consider the following scalar product

$$\forall z, y \in H_1, \quad \langle z, y \rangle_{T_1} = \int_0^1 (z_1 y_1 + z_1' y_1' + z_2 y_2) dx + \frac{1}{d_2} z_3 y_3 + \frac{1}{d_2} z_4 y_4. \quad (\text{B.9})$$

Computing  $\langle z, \mathcal{G}_1 z \rangle_{T_1}$ , and using the fact that  $z \in \text{Dom}(\mathcal{G}_1)$ , one obtains

$$\langle z, \mathcal{G}_1 z \rangle_{T_1} = \int_0^1 z_2^2(x) dx - [z_2 z_1']_0^1 + z_1'(1) z_2(1) \quad (\text{B.10})$$

$$= \int_0^1 z_2^2(x) dx + c_1 z_2(1)^2 \quad (\text{B.11})$$

$$\geq 0. \quad (\text{B.12})$$

Thus the operator  $\mathcal{G}_1$  is monotone (see [Brezis, 2010] Chapter 7). In addition if we establish that

$$R(\text{Id} + \mathcal{G}_1) = H_1, \quad (\text{B.13})$$

then the operator  $\mathcal{G}_1$  is maximal monotone (see [Brezis, 2010] Chapter 7,  $R$  stand for the range of the operator). Let  $y \in H_1$ , we have to solve

$$z \in \text{Dom}(\mathcal{G}_1), \quad z + \mathcal{G}_1 z = y, \quad (\text{B.14})$$

in other words

$$z_1 - z_2 = y_1, \quad (\text{B.15})$$

$$z_2 - z_1'' + z_2 + z_1 = y_2, \quad (\text{B.16})$$

$$z_3 - z_4 = y_3, \quad (\text{B.17})$$

$$z_4 + z_3 - d_2 z_1'(0) = y_4, \quad (\text{B.18})$$

using the fact that  $z \in \text{Dom}(\mathcal{A}_{e_1})$  one gets

$$2z_1 - z_1'' + z_1 = 2y_1 + y_2, \quad (\text{B.19})$$

$$z_1'(1) = -c_1 z_2(1) = -c_1 (z_1(1) - y_1(1)), \quad (\text{B.20})$$

$$-d_2 z_1'(0) + 2z_1(0) = y_3 + y_4. \quad (\text{B.21})$$

This is a classical stationary problem with Robin's boundaries conditions, using standard result (as done in [Brezis, 2010] p. 226 Example 6) one gets that as  $2y_1 + y_2 \in L_2(0,1)$ , (B.19)-(B.21) has a unique solution  $z_1 \in H_2(0,1)$ . Now one can check that the element  $z = (z_1, z_2, z_3, z_4)$  with

$$\begin{cases} z_1 \text{ is solution of (B.19)-(B.21),} & \text{(B.22a)} \\ z_2 = z_1 - y_1, & \text{(B.22b)} \\ z_3 = \frac{y_4 + y_3 + d_2 z_1'(0)}{2}, & \text{(B.22c)} \\ z_4 = \frac{y_4 - y_3 + d_2 z_1'(0)}{2}, & \text{(B.22d)} \end{cases}$$

satisfies (B.15)-(B.18). Moreover using (B.19)-(B.21) on (B.22) one gets that  $z$  satisfying (B.22) is in  $\text{Dom}(\mathcal{A}_{e_1})$ . ■

*Proof of Lemma B.1:*

Consider the bijective change of variable

$$X_e(t) = X(t)e^{\mathcal{H}_1 t}, \quad \text{(B.23)}$$

in which  $X$  is solution of (B.3) is equivalent to,  $X_e \in \text{Dom}(\mathcal{A}_4)$  is solution of

$$\begin{cases} \frac{dX_e}{dt}(t) + \mathcal{G}_1 X_e(t) = 0, & \text{(B.24a)} \\ X_e(0) = X_0, & \text{(B.24b)} \end{cases}$$

where  $\mathcal{H}_1$  is defined in (B.7) and  $\mathcal{G}_1$  is defined in (B.6).

From Lemma B.2, using Hille-Yosida Theorem (see [Brezis, 2010] Theorem 7.4), on (B.24), and the change of variable (B.23), one establishes (i). Using argument of density of  $C_1$  into  $W_{1,\infty}$  (resp.  $C$  into  $L_\infty$ ) as standardly used, one obtains (ii). ■

*Proof of Theorem 7.2:* From Lemma B.1, using the fact that the backstepping transformation is an invertible maps on  $H_1$  (see Section 7.4.3), one establishes Theorem 7.2. ■



# Linear simulation of the wave equation

The purpose of this appendix, is to detail the simulation scheme. Because without it, it will be lucky to get the same simulation presented, especially the computation of the eigenvalues.

## C.1 Space semi-discretization

The idea of the space semi-discretization is to have an approximation of the operator associated to the PDE system. Let us denote

$$Par = [a_1 \ a_2 \ b_1 \ b_2 \ b_3 \ \lambda \ \beta], \quad (C.1)$$

and

$$\Sigma_n(Par) : \begin{cases} u_{tt}(x, t) = u_{xx}(x, t) + \lambda u_t(x, t) + \beta u(x, t), & (C.2a) \\ u_x(1, t) = a_1 u_t(1, t) + a_2 u(1, t) + U(t), & (C.2b) \\ u_{tt}(0, t) = b_1 u_t(0, t) + b_2 u_x(0, t) + b_3 u(0, t). & (C.2c) \end{cases}$$

And so  $\Sigma_n(a_1, a_2, b_1, b_2, b_3, \lambda, \beta)$  is the *original system* (8.1), and  $\Sigma_n(0, 0, b_1, b_2, 0, -\lambda, 0)$  is the *original system* (7.1). Moreover  $\Sigma_n(-c_1, 0, -d_1, d_2, 0, \lambda, 0)$  is the *target system* (7.12), and  $\Sigma_n(c_1, c_2, d_1, d_2, d_3, \lambda_w, \beta_w)$  is the *target system* (8.11)

### C.1.1 "Sound good, doesn't works"

Let us discretize this PDE, denoting  $u[i]$  the state at the  $i$ -th coordinate for  $i \in \mathbb{N}$ ,  $i \in \llbracket 1, N \rrbracket$ . The propagation phenomenon  $\forall i \in \llbracket 2, N-1 \rrbracket$

$$u_{tt}[i] = \frac{u[i-1] - 2u[i] + u[i+1]}{dx^2} + \lambda u_t[i] + \beta u[i] + O(dx^2), \quad (C.3)$$

the controlled boundary

$$u_{xx}[N] = \frac{u_x[N]}{dx} + \frac{u[N-2] - u[N]}{2dx^2} + O(dx), \quad (C.4)$$

therefore one gets

$$u_{tt}[N] = \frac{u[N-2] - u[N]}{2dx^2} + \left(\lambda + \frac{a_1}{dx}\right)u_t[N] + \left(\beta + \frac{a_2}{dx}\right)u[N] + \frac{U}{dx} + O(dx). \quad (C.5)$$

For the uncontrolled boundary

$$u_{tt}[1] = b_1 u_t[1] + \frac{b_2}{dx}(u[2] - u[1]) + b_3 u[1]. \quad (C.6)$$

Consider the finite dimensional approximation of the wave PDE for the current numerical scheme

$$\dot{X}_N(t) = A_{d_N} X_N(t) + B_{d_N} U_N X_N(t), \quad (C.7)$$

with

$$A_{dN} = \begin{bmatrix} 0_{N,N} & & I_N \\ & A_N[1] & \\ & \vdots & \\ & A_N[N] & \end{bmatrix}, \quad B_{dN} = \begin{bmatrix} 0 \\ \vdots \\ 0 \\ \frac{1}{dx} \end{bmatrix}, \quad (\text{C.8})$$

in which

$$A_d[i] = \begin{cases} i = 1, & [-\frac{b_2}{dx} + b_3 \quad \frac{b_2}{dx} \quad 0_{1,N-2} \quad b_1 \quad 0_{1,N-1}], \\ i \in \llbracket 2, N-1 \rrbracket, & [0_{1,i-2} \quad \frac{1}{dx^2} \quad -\frac{2}{dx^2} + \beta \quad \frac{1}{dx^2} \quad 0_{1,N-3} \quad \lambda \quad 0_{1,N+2-i}], \\ i = N, & [0_{1,N-3} \quad \frac{1}{2dx^2} \quad 0 \quad -\frac{1}{2dx^2} + \beta + \frac{a_2}{dx} \quad 0_{1,N-1} \quad \lambda + \frac{a_1}{dx}]. \end{cases} \quad (\text{C.9})$$

The control gain  $U_N$  computation is done in Section C.2.  $0_{p,m}$  is the origin of  $\mathbb{R}^{p \times m}$ .

Consider the *original system*  $\Sigma_n(0, 0, 0.02, 0.6, 0, -0.06, 0)$  with the feedback control law (7.35) with maps the *original system* to the *target system*  $\Sigma_n(-1, 0, -0.02, -0.6, 0, -0.06, 0)$ . In Figure C.1, the eigenvalues distribution for  $N = 30$  of both *closed-loop* and *target system* is presented for the current scheme.

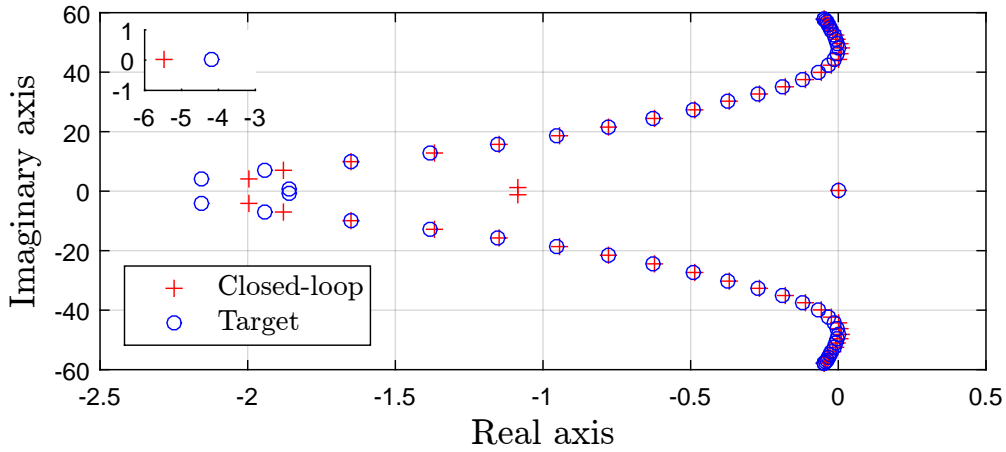

Figure C.1: Eigenvalues of the closed-loop system ( $\Sigma_n(0, 0, 0.02, 0.6, 0, -0.06, 0)$ ), and of the target system ( $\Sigma_n(-1, 0, -0.02, -0.6, 0, -0.06, 0)$ ) for  $N = 30$  and the derivative approximation in Section C.1.1.

In Figure C.1, both the *closed-loop system* and the *target system* discretization are unstable, as they both have positive real part eigenvalues. But by construction the target system should be stable. The current numerical scheme is not efficient at approximating the infinite behavior. Note that Figure C.1 is realized for the same parameter set as Figure 7.1.

### C.1.2 Ghost points

The idea is to apply the boundary condition outside the domain, i.e., our domain is  $i \in \llbracket 1, N \rrbracket$  the boundary conditions implies a condition on the position at 0 and  $N + 1$ .  $\forall i \in \llbracket 1, N \rrbracket$

$$u_{tt}[i] = \frac{u[i-1] - 2u[i](t) + u[i+1](t)}{dx^2} + \lambda u_t[i] + \beta u[i] + O(dx^2). \quad (\text{C.10})$$

For the controlled boundary

$$u_x[N] = U(t), \quad (\text{C.11})$$

From the center derivative approximation, it holds

$$u_x[N](t) = \frac{u[N+1] - u[N-1]}{2dx} + O(dx^2), \quad (\text{C.12})$$

therefore one gets

$$u_{tt}[N](t) = \frac{2u[N-1](t) - 2u[N](t)}{dx^2} + (\lambda + \frac{2a_1}{dx})u_t[N](t) + (\beta + \frac{2a_2}{dx})u[N] + \frac{2U(t)}{dx} + O(dx). \quad (C.13)$$

For the uncontrolled boundary

$$u_{tt}[1] = b_1u_t[1] + \frac{b_2}{2dx}(u[2] - u[0]) + b_3u[1] + O(dx^2), \quad (C.14)$$

one gets

$$\frac{b_2}{2dx}u[0] = b_1u_t[1] + \frac{b_2}{2dx}u[2] + b_3u[1] - u_{tt}[1] + O(dx^2), \quad (C.15)$$

in other words

$$\frac{u[0]}{dx^2} = \frac{2b_1}{b_2dx}u_t[1] + \frac{u[2]}{dx^2} + \frac{2}{b_2dx}b_3u[1] - \frac{2}{b_2dx}u_{tt}[1] + O(dx), \quad (C.16)$$

moreover from the propagation

$$u_{tt}[1](t) = \frac{u[0](t) - 2u[1](t) + u[2](t)}{dx^2} + \lambda u_t[1](t) + \beta u[1](t) + O(dx^2), \quad (C.17)$$

and so

$$u_{tt}[1](\frac{2}{b_2dx} + 1) = \frac{-2u[1](t) + 2u[2](t)}{dx^2} + (\frac{2b_1}{b_2dx} + \lambda)u_t[1](t) + (\frac{2b_3}{b_2dx} + \beta)u[1](t) + O(dx). \quad (C.18)$$

We can just postulate the reasons why this representation is better. On the one hand for the computation of  $i = 1$  and  $i = N$  we are using both the boundary conditions at  $x = 1$  and  $x = 0$  and the propagation phenomenon. On the other hand all of derivative approximation are centered. The fact that the current scheme is more efficient at approximating the wave PDE is shown in Section C.1.3.

Consider the finite dimensional approximation of the wave PDE for the current numerical scheme

$$\dot{X}_N(t) = A_N X_N(t) + B_N U_N X_N(t), \quad (C.19)$$

with

$$A_N = \begin{bmatrix} 0_{N,N} & & I_N \\ & A_g[1] & \\ & \vdots & \\ & & A_N[N] \end{bmatrix}, \quad B_N = \begin{bmatrix} 0 \\ \vdots \\ 0 \\ \frac{2}{dx} \end{bmatrix} \quad (C.20)$$

in which

$$A_g[i] = \begin{cases} i = 1, & \left[ -\frac{2b_2}{dx} + \frac{2b_3}{b_2dx} + \beta \quad \frac{2b_2}{dx} \quad 0_{1,N-2} \quad \frac{2b_1}{b_2dx} + \lambda \quad 0_{1,N-1} \right] \frac{b_2dx}{2+b_2dx}, \\ i \in \llbracket 2, N-1 \rrbracket, & \left[ 0_{1,i-2} \quad \frac{1}{dx^2} \quad -\frac{2}{dx^2} + \beta \quad \frac{1}{dx^2} \quad 0_{1,N-3} \quad \lambda \quad 0_{1,N+2-i} \right], \\ i = N, & \left[ 0_{1,N-3} \quad \frac{2}{dx^2} \quad 0 \quad -\frac{2}{dx^2} + \beta + \frac{2a_2}{dx} \quad 0_{1,N-1} \quad \lambda + \frac{2a_1}{dx} \right]. \end{cases} \quad (C.21)$$

The control gain  $U_N$  computation is done in Section C.2.

### C.1.3 Comparison of both derivative approximation scheme

The eigenvalues of the closed-loop, the target and the open-loop system for the finite approximation presented in Section C.1.1 are shown in Figure C.2. The same eigenvalues but for the finite approximation in Section C.1.2 are presented in Figure C.3. These two figures illustrate the fact that the scheme presented in Section C.1.2 is the best approximation of the wave PDE. Indeed, the backstepping maps the closed-loop system to the target system, therefore they have the same eigenvalues. The differences we observe in Figure C.2 and in Figure C.3 are only due to the space discretization. Note that in Figure C.2, there are several eigenvalues with positive real part, this cause the closed-loop simulation to be unstable. Where the same closed-loop system discretize with the other scheme have all its eigenvalue with positive real parts in Figure C.3. This is the reason, the simulations in Chapter 7 have been realized with the derivative approximation in Section C.1.2.



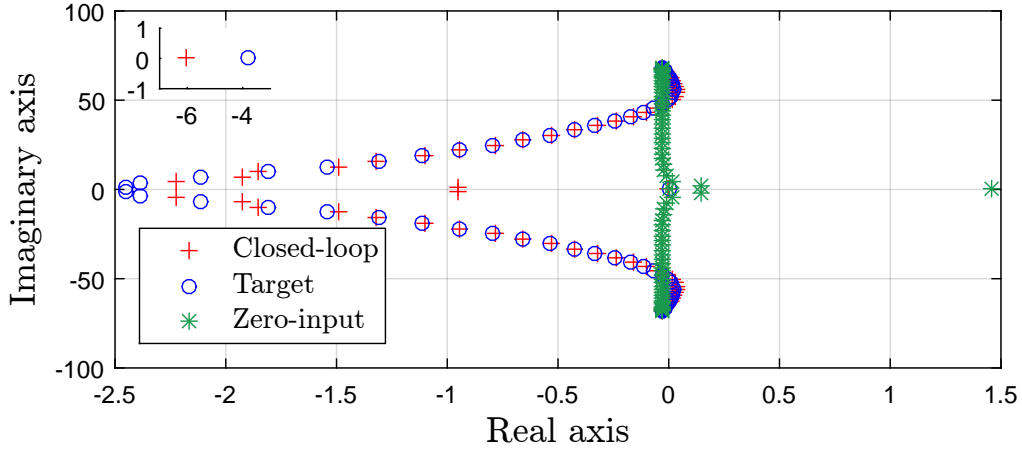

Figure C.2: Eigenvalues of the *original system* ( $\Sigma_n(0, 0, 2, 0.6, 0, -0.08, 0, U(t) = 0)$ ), the *closed-loop system*, and the *target system* ( $\Sigma_n(-1, 0, -2, 0.6, 0, -0.08, 0, 0)$ ) and for  $N = 35$  and the derivative approximation in Section C.1.1.

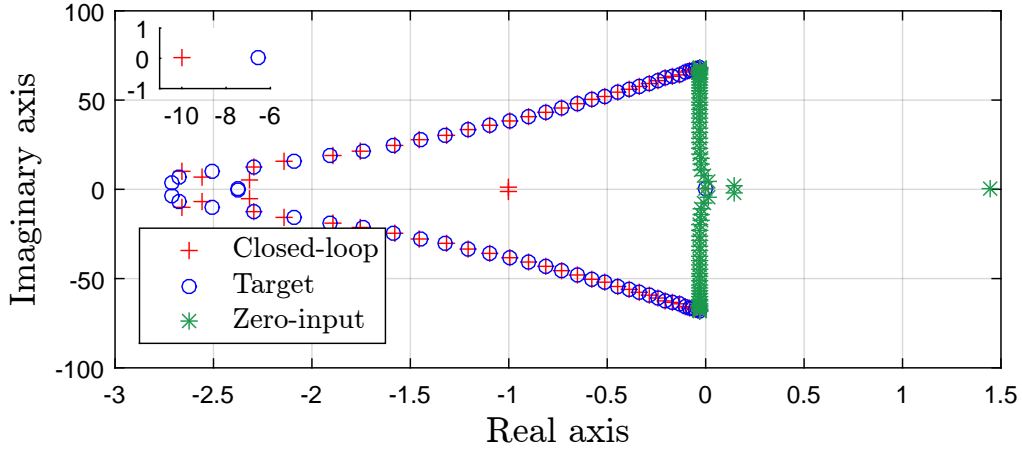

Figure C.3: Eigenvalues of the *closed-loop system* ( $\Sigma_n(0, 0, 2, 0.6, 0, -0.08, 0)$ ), the *closed-loop system*, and the *target system* ( $\Sigma_n(-1, 0, -2, 0.6, 0, -0.08, 0, 0)$ ) and for  $N = 35$  for  $N = 35$  and the derivative approximation in Section C.1.2.

## C.2 Discretized feedback gain computation

In this section, we just compute the control law with the same framework used in this appendix. Recall the control law (7.35)

$$U(u_t, u_x) := -c_1 u_t(1, t) + \frac{1}{m(1, 1) - 1} \left[ \int_0^1 [-s_x(1, y) + g_{xy}(1, y) + c_1(\lambda s(1, y) + m_y(1, y) - \lambda g_y(1, y))] u_t(y, t) dy + \int_0^1 [c_1(s_y(1, y) - g_{yy}(1, y)) - m_x(1, y)] u_x(y, t) dy + [g_x(1, 0) + c_1(m(1, 0) + b_1 g(1, 0))] u_t(0, t) \right]. \quad (\text{C.22})$$

It holds

$$s(x, y) = \theta_1 S(x, y), \quad m(x, y) = \theta_2 S(x, y), \quad g(x, y) = \theta_3 g(x, y), \quad (\text{C.23})$$

in which

$$\theta_1 = [1 \ 0 \ 0], \quad \theta_2 = [0 \ 1 \ 0], \quad \theta_3 = [0 \ 0 \ 1]. \quad (\text{C.24})$$

one gets

$$U(u_t, u_x) := -c_1 u_t(1, t) + \frac{1}{\theta_2 S(1, 1) - 1} \left[ \int_0^1 [\theta_1 H - \theta_3 H^2 + c_1(\lambda \theta_1 + \theta_2 H - \lambda \theta_3 H)] S(1, y) u_t(y, t) dy \right. \\ \left. + \int_0^1 [c_1(\theta_1 H - \theta_3 H^2) + \theta_2 H] S(1, y) u_x(y, t) dy + [-\theta_3 H + c_1(\theta_2 + b_1 \theta_3)] S(1, 0) u_t(0, t) \right], \quad (\text{C.25})$$

using integration by parts

$$U(u_t, u) := -c_1 u_t(1, t) + \frac{1}{\theta_2 S(1, 1) - 1} \left[ \int_0^1 [\theta_1 H - \theta_3 H^2 + c_1(\lambda \theta_1 + \theta_2 H - \lambda \theta_3 H)] S(1, y) u_t(y, t) dy \right. \\ \left. - \int_0^1 [c_1(\theta_1 H - \theta_3 H^2) + \theta_2 H] H S(1, y) u(y, t) dy + \left[ [c_1(\theta_1 H - \theta_3 H^2) + \theta_2 H] S(1, y) u(y, t) \right]_{y=0}^1 \right. \\ \left. + [-\theta_3 H + c_1(\theta_2 + b_1 \theta_3)] S(1, 0) u_t(0, t) \right]. \quad (\text{C.26})$$

Let us denote

$$U_{d_N}^T = \begin{bmatrix} -[c_1(\theta_1 H - \theta_3 H^2) + \theta_2 H] S(1, 0) \\ 0_{N-2, 1} \\ [c_1(\theta_1 H - \theta_3 H^2) + \theta_2 H] S(1, 1) \\ [-\theta_3 H + c_1(\theta_2 + b_1 \theta_3)] S(1, 0) \\ 0_{N-2, 1} \\ -c_1 \end{bmatrix} + \begin{bmatrix} U_{int_N}[1] \\ \vdots \\ U_{int_N}[2N] \end{bmatrix}, \quad (\text{C.27})$$

in which

$$U_{int_N}[i] = \begin{cases} i = 1, & [c_1(\theta_1 H - \theta_3 H^2) + \theta_2 H] H S(1, 0) \frac{dx}{2}, \\ i \in \llbracket 2, N-1 \rrbracket, & [c_1(\theta_1 H - \theta_3 H^2) + \theta_2 H] H S(1, \frac{i-1}{N-1}) dx, \\ i = N, & [c_1(\theta_1 H - \theta_3 H^2) + \theta_2 H] H S(1, 1) \frac{dx}{2}, \\ i = 1+N, & [\theta_1 H - \theta_3 H^2 + c_1(\lambda \theta_1 + \theta_2 H - \lambda \theta_3 H)] S(1, 0) \frac{dx}{2}, \\ i \in \llbracket N+2, 2N-1 \rrbracket, & [\theta_1 H - \theta_3 H^2 + c_1(\lambda \theta_1 + \theta_2 H - \lambda \theta_3 H)] S(1, \frac{i-1}{N-1}) dx, \\ i = 2N, & [\theta_1 H - \theta_3 H^2 + c_1(\lambda \theta_1 + \theta_2 H - \lambda \theta_3 H)] S(1, 1) \frac{dx}{2}. \end{cases} \quad (\text{C.28})$$



# Bibliography

- [Alli and Singh, 2000] Alli, H. and Singh, T. (2000). On the feedback control of the wave equation. *Journal of Sound and Vibration*, 234(4):625 – 640.
- [Anfinsen and Aamo, 2017] Anfinsen, H. and Aamo, O. M. (2017). Adaptive stabilization of  $2 \times 2$  linear hyperbolic systems with an unknown boundary parameter from collocated sensing and control. *IEEE Transactions on Automatic Control*, 62(12):6237–6249.
- [Artstein, 1982] Artstein, Z. (1982). Linear systems with delayed controls: a reduction. *IEEE Transactions on Automatic Control*, 27(4):869–879.
- [Ascencio et al., 2017] Ascencio, P., Astolfi, A., and Parisini, T. (2017). A convex optimization approach for backstepping pde design: Volterra and fredholm operators. *arXiv preprint arXiv:1710.03723*.
- [Auriol and Meglio, 2016] Auriol, J. and Meglio, F. D. (2016). Minimum time control of heterodirectional linear coupled hyperbolic pdes. *Automatica*, 71:300 – 307.
- [Balogh and Krstic, 2002] Balogh, A. and Krstic, M. (2002). Infinite dimensional backstepping-style feedback transformations for a heat equation with an arbitrary level of instability. *European Journal of Control*, 8(2):165 – 175.
- [Bastin and Coron, 2016] Bastin, G. and Coron, J.-M. (2016). *Stability and boundary stabilization of 1-d hyperbolic systems*, volume 88. Springer.
- [Beck et al., 2014] Beck, G., Imperiale, S., and Joly, P. (2014). Mathematical modelling of multi conductor cables. *Discrete and Continuous Dynamical Systems - Series S*, page 26.
- [Benosman and Le Vey, 2004] Benosman, M. and Le Vey, G. (2004). Control of flexible manipulators: A survey. *Robotica*, 22(5):533–545.
- [Böhm et al., 2013] Böhm, M., Krstic, M., Kuchler, S., and Sawodny, O. (2013). Modeling and boundary control of a hanging cable immersed in water. *Journal of Dynamic Systems, Measurement, and Control*, 136(1):011006.
- [Boskovic et al., 2001] Boskovic, D. M., Krstic, M., and Liu, W. (2001). Boundary control of an unstable heat equation via measurement of domain-averaged temperature. *IEEE Transactions on Automatic Control*, 46(12):2022–2028.
- [Boyd et al., 1994] Boyd, S., El Ghaoui, L., Feron, E., and Balakrishnan, V. (1994). *Linear matrix inequalities in system and control theory*, volume 15. Siam.
- [Bresch-Pietri and Krstic, 2014a] Bresch-Pietri, D. and Krstic, M. (2014a). Adaptive output feedback for oil drilling stick-slip instability modeled by wave PDE with anti-damped dynamic boundary. In *IEEE American Control Conference*, pages 386–391, Portland, OR.
- [Bresch-Pietri and Krstic, 2014b] Bresch-Pietri, D. and Krstic, M. (2014b). Adaptive output-feedback for wave PDE with anti-damping -Application to surface-based control of oil drilling stick-slip instability. In *IEEE Conference on Decision and Control*, pages 1295–1300, Los Angeles, CA.
- [Bresch-Pietri and Krstic, 2014c] Bresch-Pietri, D. and Krstic, M. (2014c). Output-feedback adaptive control of a wave PDE with boundary anti-damping. *Automatica*, 50(5):1407–1415.
- [Brezis, 2010] Brezis, H. (2010). *Functional analysis, Sobolev spaces and partial differential equations*. Springer Science & Business Media.

- [Bribiesca-Argomedo and Krstic, 2015] Bribiesca-Argomedo, F. and Krstic, M. (2015). Backstepping-forwarding control and observation for hyperbolic pdes with fredholm integrals. *IEEE Transactions on Automatic Control*, 60(8):2145–2160.
- [Cerpa and Coron, 2013] Cerpa, E. and Coron, J.-M. (2013). Rapid stabilization for a korteweg-de vries equation from the left dirichlet boundary condition. *IEEE Transactions on Automatic Control*, 58(7):1688–1695.
- [Conrad and Mifdal, 1998] Conrad, F. and Mifdal, A. (1998). Strong stability of a model of an overhead crane. *Control and Cybernetics*, 27(3):363–374.
- [Cotton, 1928] Cotton, E. (1928). Approximation successives et équations différentielles. *Mémorial des sciences mathématiques*, fascicule 28:56.
- [Curtain and Zwart, 2012] Curtain, R. F. and Zwart, H. (2012). *An introduction to infinite-dimensional linear systems theory*, volume 21. Springer Science & Business Media.
- [d’Andréa-Novel et al., 1992] d’Andréa-Novel, B., Boustany, F., and Conrad, F. (1992). Control of an overhead crane: Stabilization of flexibilities. *Boundary Control and Boundary Variation*, pages 1–26.
- [d’Andréa-Novel and Coron, 2000] d’Andréa-Novel, B. and Coron, J.-M. (2000). Exponential stabilization of an overhead crane with flexible cable via a backstepping approach. *Automatica*, 36(4):587–593.
- [Di Meglio et al., 2018] Di Meglio, F., Bribiesca Argomedo, F., Hu, L., and Krstic, M. (2018). Stabilization of coupled linear heterodirectional hyperbolic PDE–ODE systems. *Automatica*, 87:281–289.
- [Dwivedy and Eberhard, 2006] Dwivedy, S. K. and Eberhard, P. (2006). Dynamic analysis of flexible manipulators, a literature review. *Mechanism and Machine Theory*, 41(7):749 – 777.
- [Ervedoza and Zuazua, 2012] Ervedoza, S. and Zuazua, E. (2012). The wave equation: Control and numerics. In *Control of partial differential equations*, pages 245–339. Springer.
- [Ervedoza and Zuazua, 2013] Ervedoza, S. and Zuazua, E. (2013). *Numerical Approximation of Exact Controls for Waves*. Springer New York, New York, NY.
- [F. Wheeler and P. Crummett, 1987] F. Wheeler, G. and P. Crummett, W. (1987). The vibrating string controversy. 55:33–37.
- [Farkas and Wegner, 2014] Farkas, B. and Wegner, S.-A. (2014). Variations on Barbalat’s Lemma. *ArXiv e-prints*.
- [Favini et al., 2005] Favini, A., Gal, C. G., Goldstein, G., Goldstein, J., and Romanelli, S. (2005). The non-autonomous wave equation with general wentzell boundary conditions. 135:317 – 329.
- [Fiscella and Vitillaro, 2015] Fiscella, A. and Vitillaro, E. (2015). Blow-up for the wave equation with nonlinear source and boundary damping terms. *Proceedings of the Royal Society of Edinburgh: Section A Mathematics*, 145(4):759–778.
- [Fourrier and Lasiecka, 2013] Fourrier, N. and Lasiecka, I. (2013). Regularity and stability of a wave equation with a strong damping and dynamic boundary conditions. *Evolution Equations & Control Theory*, 2(4):631–667.
- [Francis and Wonham, 1976] Francis, B. A. and Wonham, W. M. (1976). The internal model principle of control theory. *Automatica*, 12(5):457–465.
- [Fucik and Mawhin, 1978] Fucik, S. and Mawhin, J. (1978). Generalized periodic solutions of nonlinear telegraph equations. *Nonlinear Analysis: Theory, Methods and Applications*, 2(5):609–617.
- [Gal et al., 2004] Gal, C. G., Goldstein, G. R., and Goldstein, J. A. (2004). *Oscillatory boundary conditions for acoustic wave equations*, pages 623–635. Birkhäuser Verlag, Basel.

- [Germa et al., 2009] Germa, C., Denoël, V., and Detournay, E. (2009). Multiple mode analysis of the self-excited vibrations of rotary drilling systems. *Journal of Sound and Vibration*, 325(1):362–381.
- [Ghasemloonia et al., 2015] Ghasemloonia, A., Rideout, G., and Butt, S. (2015). A review of drillstring vibration modeling and suppression methods. *Journal of Petroleum Science and Engineering*, 131.
- [Ginibre and Velo, 1985] Ginibre, J. and Velo, G. (1985). The global cauchy problem for the non linear klein-gordon equation. *Mathematische Zeitschrift*, 189(4):487–505.
- [Graff, 1975] Graff, K. F. (1975). *Wave motion in elastic solids*. Clarendon Press, Oxford.
- [Guo and Guo, 2016] Guo, W. and Guo, B.-Z. (2016). Performance output tracking for a wave equation subject to unmatched general boundary harmonic disturbance. *Automatica*, 68:194 – 202.
- [Haraux, 1981] Haraux, A. (1981). *Nonlinear evolution equations: global behavior of solutions*.
- [Hasan, 2016] Hasan, A. (2016). Output-feedback stabilization of the korteweg-de vries equation. *arXiv preprint arXiv:1603.08750*.
- [Haynes, 2014] Haynes, W. M. (2014). *CRC handbook of chemistry and physics*. CRC press.
- [Imperiale and Joly, 2013] Imperiale, S. and Joly, P. (2013). Mathematical modeling of electromagnetic wave propagation in heterogeneous lossy coaxial cables with variable cross section. *Applied Numerical Mathematics*.
- [Ioannou and Sun, 1996] Ioannou, P. A. and Sun, J. (1996). *Robust Adaptive Control*. Prentice Hall.
- [Jadachowski et al., 2014] Jadachowski, L., Meurer, T., and Kugi, A. (2014). Backstepping observers for periodic quasi-linear parabolic pdes. *IFAC Proceedings Volumes*, 47(3):7761 – 7766. 19th IFAC World Congress.
- [Jadachowski et al., 2015] Jadachowski, L., Meurer, T., and Kugi, A. (2015). Backstepping observers for linear pdes on higher-dimensional spatial domains. *Automatica*, 51:85 – 97.
- [Jang, 2014] Jang, T. (2014). An integral equation formalism for solving the nonlinear klein–gordon equation. *Applied Mathematics and Computation*, 243:322–338.
- [Jansen, 1993] Jansen, J. (1993). *Nonlinear dynamics of oilwell drillstrings*. PhD thesis, Delft University of Technology.
- [Jansen and van der Steen, 1995] Jansen, J. and van der Steen, L. (1995). Active damping of self-excited torsional vibrations in oil well drillstrings. *Journal of Sound and Vibration*, pages 179(4):647–688.
- [Kantorovitch and Akilov, 1981] Kantorovitch, L. V. and Akilov, G. P. (1981). *Analyse fonctionnelle. Tome 1, Opérateurs et fonctionnelles linéaires*, volume 1. 'Edition MIR . Moscou.
- [Koga and Krstic, 2017] Koga, S. and Krstic, M. (2017). Delay compensated control of the stefan problem. In *2017 IEEE 56th Annual Conference on Decision and Control (CDC)*, pages 1242–1247.
- [Kokotovic, 1992] Kokotovic, P. V. (1992). The joy of feedback: nonlinear and adaptive. *IEEE Control Systems*, 12(3):7–17.
- [Kolmogorov and Fomine, 1977] Kolmogorov, A. N. and Fomine, S. V. (1977). *Elément de la théorie des fonctions et de l'analyse fonctionnelle*. 'Edition MIR . Moscou.
- [Krener, 1999] Krener, A. (1999). Feedback linearization. In *Mathematical control theory*, pages 66–98. Springer.
- [Krstic, 2006] Krstic, M. (2006). Systematization of approaches to adaptive boundary stabilization of pdes. *International Journal of Robust and Nonlinear Control: IFAC-Affiliated Journal*, 16(16):801–818.
- [Krstic et al., 2008] Krstic, M., Guo, B.-Z., Balogh, A., and Smyshlyaev, A. (2008). Output-feedback stabilization of an unstable wave equation. *Automatica*, 44(1):63 – 74.

- [Krstic et al., 1994] Krstic, M., Kanellakopoulos, I., and Kokotovic, P. V. (1994). Nonlinear design of adaptive controllers for linear systems. *IEEE Transactions on Automatic Control*, 39(4):738–752.
- [Krstic and Smyshlyaev, 2008] Krstic, M. and Smyshlyaev, A. (2008). *Boundary Control of PDEs*. SIAM Advances in Design and Control.
- [Kwon and Pearson, 1980] Kwon, W. and Pearson, A. (1980). Feedback stabilization of linear systems with delayed control. *IEEE Transactions on Automatic Control*, 25(2):266–269.
- [Lalanne et al., 1984] Lalanne, M., Berthier, P., and Der Hagopian, J. (1984). Mechanical vibrations for engineers.
- [Lamare et al., 2016] Lamare, P.-O., Girard, A., and Prieur, C. (2016). An optimisation approach for stability analysis and controller synthesis of linear hyperbolic systems. *ESAIM: Control, Optimisation and Calculus of Variations*, 22(4):1236–1263.
- [Landau, 1979] Landau, I. (1979). Adaptive Control : The Model Reference Approach. *inc. New York*.
- [Lewis et al., 2012] Lewis, F. L., Vrabie, D., and Syrmos, V. L. (2012). *Optimal control*. John Wiley and Sons.
- [Liang and Chen, 2004] Liang, J. and Chen, Y. (2004). Boundary control of wave equations with delayed boundary measurement. In *Proceedings - 2004 IEEE International Conference on Robotics and Biomimetics, IEEE ROBIO 2004*, pages 849 – 854, Shenyang, China.
- [Liang et al., 2007] Liang, J., Zhang, W., Chen, Y., and Podlubny, I. (2007). *Robustness of Fractional-order Boundary Control of Time Fractional Wave Equations with Delayed Boundary Measurement Using the Simple Predictor*, pages 543–552. Springer Netherlands, Dordrecht.
- [Lindelöf, 1894] Lindelöf, E. (1894). Sur l’application des méthodes d’approximations successives à l’étude des intégrales réelles des équations différentielles ordinaires. *Journal de mathématiques pures et appliquées 4eme séries*, Tome 10:117–128.
- [Liu, 2003] Liu, W. (2003). Boundary feedback stabilization of an unstable heat equation. *SIAM Journal on Control and Optimization*, 42(3):1033–1043.
- [Luo et al., 1999] Luo, Z.-H., Guo, B.-Z., and , O. (1999). *Stability and Stabilization of Infinite Dimensional Systems with Applications*.
- [Luo et al., 2012] Luo, Z.-H., Guo, B.-Z., and Morgül, Ö. (2012). *Stability and stabilization of infinite dimensional systems with applications*. Springer Science & Business Media.
- [Manitius and Olbrot, 1979] Manitius, A. and Olbrot, A. W. (1979). Finite spectrum assignment problem for systems with delays. *IEEE Transactions on Automatic Control*, 24(4):541–552.
- [Martin et al., 2003] Martin, P., Murray, R., and Rouchon, P. (2003). Flat systems, equivalence and trajectory generation. Technical report, École des Mines de Paris.
- [Martín-Sánchez et al., 2012] Martín-Sánchez, J. M., Lemos, J. M., and Rodellar, J. (2012). Survey of industrial optimized adaptive control. *International Journal of Adaptive Control and Signal Processing*, 26(10):881–918.
- [Martinec et al., 2018] Martinec, D., Herman, I., and Šebek, M. (2018). On the necessity of symmetric positional coupling for string stability. *IEEE Transactions on Control of Network Systems*, 5(1):45–54.
- [Marx and Cerpa, 2018] Marx, S. and Cerpa, E. (2018). Output feedback stabilization of the korteweg–de vries equation. *Automatica*, 87:210–217.
- [Meglio et al., 2018] Meglio, F. D., Argomedo, F. B., Hu, L., and Krstic, M. (2018). Stabilization of coupled linear heterodirectional hyperbolic pde–ode systems. *Automatica*, 87:281 – 289.

- [Meglio et al., 2013] Meglio, F. D., Vazquez, R., and Krstic, M. (2013). Stabilization of a system of  $n + 1$  coupled first-order hyperbolic linear pdes with a single boundary input. *IEEE Transactions on Automatic Control*, 58(12):3097–3111.
- [Meurer, 2012] Meurer, T. (2012). *Control of Higher-Dimensional PDEs: Flatness and Backstepping Designs*. Springer Science & Business Media.
- [Meurer and Kugi, 2009] Meurer, T. and Kugi, A. (2009). Tracking control for boundary controlled parabolic pdes with varying parameters: Combining backstepping and differential flatness. *Automatica*, 45(5):1182 – 1194.
- [Meurer and Kugi, 2011] Meurer, T. and Kugi, A. (2011). Tracking control design for a wave equation with dynamic boundary conditions modeling a piezoelectric stack actuator. *International Journal of Robust and Nonlinear Control*, 21:542 – 562.
- [Morse and Ingard, 1968] Morse, P. M. and Ingard, K. U. (1968). *Theoretical Acoustics*. McGraw-Hill, Inc.
- [Narendra and Annaswamy, 1989] Narendra, K. and Annaswamy, A. (1989). *Stable Adaptive Systems*. Englewood Cliffs, New Jersey.
- [Nicaise and Pignotti, 2011] Nicaise, S. and Pignotti, C. (2011). Exponential stability of second-order evolution equations with structural damping and dynamic boundary delay feedback. *IMA Journal of Mathematical Control and Information*, 28(4):417–446.
- [O’Connor, 2007] O’Connor, W. J. (2007). Wave-based analysis and control of lump-modeled flexible robots. *IEEE Transactions on Robotics*, 23(2):342–352.
- [Patil and Teodoriu, 2013] Patil, P. A. and Teodoriu, C. (2013). A comparative review of modelling and controlling torsional vibrations and experimentation using laboratory setups. *Journal of Petroleum Science and Engineering*, 112:227 – 238.
- [Peled et al., 2013] Peled, I., O’Connor, W., and Halevi, Y. (2013). On the relationship between wave based control, absolute vibration suppression and input shaping. *Mechanical Systems and Signal Processing*, 39(1):80 – 90.
- [Popov, 1973] Popov, V. M. (1973). *Hyperstability of Control Systems*. Springer-Verlag, Berlin, Heidelberg.
- [Praly, 1992] Praly, L. (1992). Adaptive regulation: Lyapunov design with a growth condition. *International Journal of Adaptive Control and Signal Processing*, 6(4):329–351.
- [Ritto et al., 2009] Ritto, T., Soize, C., and Sampaio, R. (2009). Non-linear dynamics of a drill-string with uncertain model of the bit-rock interaction. *International Journal of Non-Linear Mechanics*, pages 44(8):865–876.
- [Rohrs et al., 1985] Rohrs, C., Valavani, L., Athans, M., and Stein, G. (1985). Robustness of continuous-time adaptive control algorithms in the presence of unmodeled dynamics. *IEEE Transactions on Automatic Control*, 30(9):881–889.
- [Roman et al., 2016a] Roman, C., Bresch-Pietri, D., Cerpa, E., Prieur, C., and Sename, O. (2016a). Backstepping observer based-control for an anti-damped boundary wave PDE in presence of in-domain viscous damping. In *IEEE 55th Conference on Decision and Control*, pages 549–554, Las Vegas, NV.
- [Roman et al., 2018] Roman, C., Bresch-Pietri, D., Cerpa, E., Prieur, C., and Sename, O. (2018). Backstepping control of a wave PDE with unstable source terms and dynamic boundary. *IEEE Control Systems Letters (L-CSS)*, 2:459–464.
- [Roman et al., 2016b] Roman, C., Bresch-Pietri, D., Prieur, C., and Sename, O. (2016b). Robustness of an adaptive output feedback for an anti-damped boundary wave PDE in presence of in-domain viscous damping. In *IEEE American Control Conference*, pages 3455–3460, Boston, MA.



- [Roman et al., 2017] Roman, C., Bresch-Pietri, D., Prieur, C., and Sename, O. (2017). Robustness to in-domain viscous damping of a collocated boundary adaptive feedback law for an anti-damped boundary wave PDE. Preprint (submitted).
- [Sagert et al., 2013] Sagert, C., Di Meglio, F., Krstic, M., and Rouchon, P. (2013). Backstepping and flatness approaches for stabilization of the stick-slip phenomenon for drilling. In *IFAC Systems Structure and Control*, pages 779–784, Grenoble, France.
- [Saldivar et al., 2016a] Saldivar, B., Mondié, S., Niculescu, S.-I., Mounier, H., and Boussaada, I. (2016a). A control oriented guided tour in oilwell drilling vibration modeling. *Annual Reviews in Control*, 42:100 – 113.
- [Saldivar et al., 2016b] Saldivar, B., Mondié, S., and Ávila Vilchis, J. C. (2016b). The control of drilling vibrations: A coupled PDE-ODE modeling approach. *International Journal of Applied Mathematics and Computer Science*, 26(2):335–349.
- [Saldivar et al., 2011] Saldivar, M. B., Mondie, S., Loiseau, J. J., and Rasvan, V. (2011). Stick-Slip Oscillations in Oilwell Drillstrings: Distributed Parameter and Neutral Type Retarded Model Approaches. In *IFAC World Congress*, pages 18:284–289, Milano, Italy.
- [Schwartz, 1970] Schwartz, L. (1970). *Analyse topologie générale et analyse fonctionnelle*, volume 1. Herman.
- [Smith, 1957] Smith, O. J. M. (1957). Closer control of loops with dead time. *Chemical Engineering Progress*, 53(5):217–219.
- [Smith, 1959] Smith, O. J. M. (1959). A controller to overcome dead time. *ISA Journal*, 6(2):28–33.
- [Smyshlyaev et al., 2010] Smyshlyaev, A., Cerpa, E., and Krstic, M. (2010). Boundary stabilization of a 1-D wave equation with in-domain antidamping. *SIAM Journal on Control and Optimization*, 48(6):4014–4031.
- [Smyshlyaev and Krstic, 2004] Smyshlyaev, A. and Krstic, M. (2004). Closed-form boundary state feedbacks for a class of 1-d partial integro-differential equations. *IEEE Transactions on Automatic Control*, 49(12):2185–2202.
- [Smyshlyaev and Krstic, 2005] Smyshlyaev, A. and Krstic, M. (2005). Backstepping observers for a class of parabolic PDEs. *Systems & Control Letters*, 54(7):613–625.
- [Smyshlyaev and Krstic, 2009] Smyshlyaev, A. and Krstic, M. (2009). Boundary control of an anti-stable wave equation with anti-damping on the uncontrolled boundary. *Systems & Control Letters*, 58(8):617–623.
- [Sontag, 1998] Sontag, E. D. (1998). *Mathematical Control Theory: Deterministic Finite Dimensional Systems (2Nd Ed.)*. Springer-Verlag, Berlin, Heidelberg.
- [Stratton, 2007] Stratton, J. A. (2007). *Electromagnetic theory*. John Wiley & Sons.
- [Tao, 2014] Tao, G. (2014). Multivariable adaptive control: A survey. *Automatica*, 50(11):2737 – 2764.
- [Tucsnak and Weiss, 2009] Tucsnak, M. and Weiss, G. (2009). *Observation and control for operator semi-groups*. Springer Science & Business Media.
- [Vazquez and Krstic, 2007a] Vazquez, R. and Krstic, M. (2007a). Boundary control laws for parabolic pdes with volterra nonlinearities—part i: Design. *IFAC Proceedings Volumes*, 40(12):146 – 151. 7th IFAC Symposium on Nonlinear Control Systems.
- [Vazquez and Krstic, 2007b] Vazquez, R. and Krstic, M. (2007b). Boundary control laws for parabolic pdes with volterra nonlinearities—part ii: Examples. *IFAC Proceedings Volumes*, 40(12):330–335.
- [Vazquez and Krstic, 2007c] Vazquez, R. and Krstic, M. (2007c). Boundary control laws for parabolic pdes with volterra nonlinearities—part iii: Analysis. *IFAC Proceedings Volumes*, 40(12):152 – 157. 7th IFAC Symposium on Nonlinear Control Systems.

- [Vazquez and Krstic, 2016] Vazquez, R. and Krstic, M. (2016). Bilateral boundary control of one-dimensional first-and second-order pdes using infinite-dimensional backstepping. In *Decision and Control (CDC), 2016 IEEE 55th Conference on*, pages 537–542. IEEE.
- [Vitillaro, 2017] Vitillaro, E. (2017). On the wave equation with hyperbolic dynamical boundary conditions, interior and boundary damping and source. *Archive for Rational Mechanics and Analysis*, 223(3):1183–1237.
- [Vorotnikov, 1997] Vorotnikov, V. I. (1997). *Partial Stability and Control*. Birkhauser Boston, Inc., Secaucus, NJ, USA, 1st edition.
- [Wang and Woittennek, 2013] Wang, S. and Woittennek, F. (2013). Backstepping-method for parabolic systems with in-domain actuation. volume 46, pages 43 – 48. 1st IFAC Workshop on Control of Systems Governed by Partial Differential Equations.
- [Wei and Bao-Zhu, 2011] Wei, G. and Bao-Zhu, G. (2011). Stabilization and regulator design for a one-dimensional unstable wave equation with input harmonic disturbance. *International Journal of Robust and Nonlinear Control*, 23(5):514–533.
- [Zhang et al., 2001] Zhang, J., Knopse, C. R., and Tsiotras, P. (2001). Stability of time-delay systems: equivalence between lyapunov and scaled small-gain conditions. *IEEE Transactions on Automatic Control*, 46(3):482–486.
- [Zhang et al., 2010] Zhang, Q.-Z., He, Y.-Y., Li, L., et al. (2010). Sliding mode control of rotatory drilling system with stick slip oscillations. In *Workshop on Intelligent Systems and Applications*, pages 1–4, Wuhan, China.

# Boundary control of the wave equation with in-domain damping

## Abstract

This thesis is concerned by the boundary control of the one dimensional wave equation, which can be used to model a string (like a guitar string). The objective is to act at one boundary to control and stabilize the other boundary which is considered to be an unstable dynamic boundary condition. This thesis suggests answers to both following questions:

Consider that the unstable dynamics boundary condition has some unknown parameters. Is a nonlinear adaptive control law still performing efficiently, if the viscous damping taken equal to zero for its design is no longer neglected?

How can we take into account the in-domain damping in order to stabilize the wave equation subject to dynamic boundary conditions?

This thesis suggests a method to derive a Lyapunov analysis in order to prove the robustness mismatch of particular nonlinear adaptive control law as the answer of the first question. Then using infinite dimensional backstepping technique we develop feedback control law that exponentially stabilize the considered wave equation.

## Résumé

Cette thèse se concentre sur le contrôle frontière de l'équation d'onde unidimensionnelle, qui peut être utilisée pour modéliser une corde (comme une corde de guitare). L'objectif est d'agir à une frontière pour contrôler et stabiliser l'autre frontière qui est considérée comme une condition aux frontières avec une dynamique instable. Cette thèse suggère des réponses aux deux questions suivantes:

Considérons que la condition à la frontière de dynamique instable a des paramètres inconnus. Une loi de contrôle adaptatif non linéaire est-elle toujours efficace, si l'amortissement visqueux pris égal à zéro pour sa conception n'est plus négligé?

Comment peut-on prendre en compte l'amortissement dans le domaine afin de stabiliser l'équation d'onde soumise à des conditions aux frontières dynamiques?

Cette thèse suggère une méthode pour effectuer une analyse de Lyapunov afin de prouver la robustesse, vis à vis d'une erreur de modèle, d'une loi de contrôle adaptatif non linéaire particulière comme réponse à la première question. Puis, en utilisant une technique de backstepping à dimension infinie, nous développons une loi de contrôle par rétroaction qui stabilise exponentiellement l'équation d'onde considérée.