



**HAL**  
open science

# Chaotic dynamics and partial hyperbolicity

Jinhua Zhang

► **To cite this version:**

Jinhua Zhang. Chaotic dynamics and partial hyperbolicity. General Mathematics [math.GM]. Université Bourgogne Franche-Comté; Université de Pékin, 2017. English. NNT: 2017UBFCK055. tel-01948392

**HAL Id: tel-01948392**

**<https://theses.hal.science/tel-01948392>**

Submitted on 7 Dec 2018

**HAL** is a multi-disciplinary open access archive for the deposit and dissemination of scientific research documents, whether they are published or not. The documents may come from teaching and research institutions in France or abroad, or from public or private research centers.

L'archive ouverte pluridisciplinaire **HAL**, est destinée au dépôt et à la diffusion de documents scientifiques de niveau recherche, publiés ou non, émanant des établissements d'enseignement et de recherche français ou étrangers, des laboratoires publics ou privés.



北京大學  
PEKING UNIVERSITY

UNIVERSITÉ DE BOURGOGNE & PEKING UNIVERSITY  
Institut de Mathématiques de Bourgogne & School of Mathematical sciences

*Établissement d'inscription:* Université de Bourgogne  
Institut de Mathématiques de Bourgogne

## THÈSE DE DOCTORAT EN MATHÉMATIQUES

*Spécialité :* Mathématiques fondamentales

**Jinhua ZHANG**

### DYNAMIQUES CHAOTIQUES ET HYPERBOLICITÉ PARTIELLE

*Date de soutenance :* le 3 mai 2017

SYLVAIN CROVISIER (Université Paris-Sud)

*Après avis des rapporteurs :* LORENZO DIAZ (Pontificia Universidade Católica  
do Rio de Janeiro)

*Jury de soutenance :*

|                   |  |
|-------------------|--|
| CHRISTIAN BONATTI | (Université de Bourgogne) Directeur de thèse |
| LAN WEN           | (Peking University) Directeur de thèse       |
| YUJUN ZHU         | (Hebei Normal University) Président          |
| JÉRÔME BUZZI      | (Université Paris-Sud) Examineur             |
| SYLVAIN CROVISIER | (Université Paris-Sud) Examineur             |
| GIOIA VAGO        | (Université de Bourgogne) Examineur          |
| SHAOBO GAN        | (Peking University) Examineur                |
| SHENGZHI ZHU      | (Beijing Jiaotong University) Examineur      |



Thesis

# Dynamiques chaotiques et Hyperbolicité partielle

By: Jinhua ZHANG

Supervisors: Christian Bonatti and Lan Wen

Doctor of Mathematics

Major in Differential dynamical systems

Peking University, China

Thèse

Pour obtenir le grade de

DOCTEUR DE L'UNIVERSITÉ DE BOURGOGNE

Discipline: Mathématiques

May, 2017

# Dynamiques chaotiques et hyperbolicité partielle

Jinhua Zhang (Mathématiques)

Directeurs de thèse: Professeur Christian Bonatti et Professeur Lan Wen

## RÉSUMÉ

La dynamique des systèmes hyperboliques est considérée bien comprise du point de vue topologique aussi bien que du point de vue stochastique. S. Smale et R. Abraham ont donné un exemple montrant que, en général, les systèmes hyperboliques ne sont pas denses parmi tous les systèmes différentiables.

Dans les années 1970, M. Brin et Y. Pesin ont proposé une nouvelle notion: *hyperbolicité partielle* pour affaiblir la notion d'hyperbolicité. Un but de cette thèse est de comprendre la dynamique de certains systèmes partiellement hyperboliques du point de vue stochastique aussi bien que du point de vue topologique.

Du point de vue stochastique, nous démontrons les résultats suivants:

- Il existe un sous-ensemble  $\mathcal{U}$  ouvert et dense de difféomorphismes non hyperboliques robustement transitifs loin de tangences homocliniques, tels que pour tout  $f \in \mathcal{U}$ , il existe des mesures ergodiques non hyperboliques qui sont limite faible des mesures périodiques, avec un seul exposant de Lyapunov nul, et dont les supports sont la variété entière;
- Il existe un sous-ensemble ouvert et dense de l'ensemble des difféomorphismes partiellement hyperboliques (mais non hyperboliques) de dimension centrale un dont les feuilletages forts sont robustement minimaux, de sorte que la fermeture de l'ensemble des mesures ergodiques est l'union de deux convexes qui sont la fermeture des ensembles de mesures ergodiques hyperboliques de deux  $s$ -indices différents respectivement; ces deux ensembles convexes se coupent le long de la fermeture de l'ensemble des mesures ergodiques non hyperboliques. Par conséquent, toute mesure ergodique non hyperbolique est approchée par des mesures périodiques. C'est le cas pour une perturbation robustement transitive du temps un d'un flot d'Anosov transitif, ou du produit fibré d'un difféomorphisme d'Anosov sur le tore par une rotation du cercle.

Ces résultats sont basés sur des résultats locaux dont les démonstrations impliquent beaucoup de définitions techniques.

Du point de vue topologique, pour tout flot d'Anosov non transitif sur des variétés de dimension 3 orientables, nous construisons de nouveaux difféomorphismes partiellement hyperboliques en composant le temps  $t$  des flots d'Anosov (pour  $t > 0$  large) avec des twists de Dehn le long des tores transver-

---

saux. Ces nouveaux difféomorphismes partiellement hyperboliques sont robustement dynamiquement cohérents. Cela généralise dans un cas général le processus spécial dans [BPP] pour construire de nouveaux difféomorphismes partiellement hyperboliques. De plus, nous démontrons que pour les nouveaux difféomorphismes partiellement hyperboliques que nous avons construits, leurs feuilletages centraux sont topologiquement équivalentes aux flots d'Anosov utilisés pour les construire. En conséquence, la structure des feuilles centrales des nouveaux difféomorphismes partiellement hyperboliques est la même que la structure des orbites d'un flot d'Anosov.

La présence de mesures ergodiques non hyperboliques montre la non hyperbolicité des systèmes. Dans cette thèse, nous cherchons également à comprendre: dans quelle mesure la présence de mesures ergodiques non hyperboliques peut-elle caractériser le degré de non-hyperbolicité des systèmes?

Nous démontrons que, pour les difféomorphismes génériques, si une classe homoclinique contient des orbites périodiques d'indices différents et sans certaines dominations, il existe une mesure ergodique non hyperbolique avec plus d'un exposant de Lyapunov qui s'annule et dont le support est la classe homoclinique entière. Le nombre d'exposants de Lyapunov nuls montre combien d'hyperbolicité a été perdue dans un tel type de systèmes.

**MOTS CLÉS :** mesure ergodique non hyperbolique, mesure périodique, exposant de Lyapunov, classe homoclinique, transitivité robuste, hyperbolicité partielle, flot d'Anosov, twist de Dehn, tores transversaux.

# Chaotic dynamics and partial hyperbolicity

Jinhua Zhang (Mathematical science)

Supervisors: Professor Christian Bonatti and Professor Lan Wen

## ABSTRACT

The dynamics of hyperbolic systems is considered well understood from topological point of view as well as from stochastic point of view. S. Smale and R. Abraham gave an example showing that, in general, the hyperbolic systems are not dense among all differentiable systems.

In 1970s, M. Brin and Y. Pesin proposed a new notion: *partial hyperbolicity* to release the notion of hyperbolicity. One aim of this thesis is to understand the dynamics of certain partially hyperbolic systems from stochastic point of view as well as from topological point of view.

From stochastic point of view, we prove the following results:

- There exists an open and dense subset  $\mathcal{U}$  of robustly transitive non-hyperbolic diffeomorphisms far from homoclinic tangency, such that for any  $f \in \mathcal{U}$ , there exist non-hyperbolic ergodic measures as the weak\*-limit of periodic measures, with only one vanishing Lyapunov exponent, and whose supports are the whole manifold;
- There exists an open and dense subset of partially hyperbolic (but non-hyperbolic) diffeomorphisms with center dimension one whose strong foliations are robustly minimal, such that the closure of the set of ergodic measures is the union of two convex sets which are the closure of the sets of hyperbolic ergodic measures of two different  $s$ -indices respectively; these two convex sets intersect along the closure of the set of non-hyperbolic ergodic measures. As a consequence, every non-hyperbolic ergodic measure is approximated by periodic measures. That is the case for robustly transitive perturbation of the time one map of a transitive Anosov flow, or of the skew product of an Anosov torus diffeomorphism by a rotation of the circle.

These results are based on some local results whose statements involve in lots of technical definitions.

From topological point of view, for any non-transitive Anosov flow on orientable 3-manifolds, we build new partially hyperbolic diffeomorphisms by composing the time  $t$ -map of the Anosov flow (for  $t > 0$  large) with Dehn twists along transverse tori. These new partially hyperbolic diffeomorphisms are robustly dynamically coherent. This generalizes the special process in [BPP] for constructing new partially hyperbolic diffeomorphisms to a general case. Furthermore, we prove that for the new partially hyperbolic diffeomorphisms

---

we built, their center foliations are topologically equivalent to the Anosov flows used for building them. As a consequence, one has that the structure of the center leaves of the new partially hyperbolic diffeomorphisms is the same as the structure of the orbits of an Anosov flow.

The presence of non-hyperbolic ergodic measures shows the non-hyperbolicity of the systems. In this thesis, we also attempt to understand: to what extent, can the presence of non-hyperbolic ergodic measures character how far from hyperbolicity the systems are?

We prove that, for generic diffeomorphisms, if a homoclinic class contains periodic orbits of different indices and without certain dominations, then there exists a non-hyperbolic ergodic measure with more than one vanishing Lyapunov exponents and whose support is the whole homoclinic class. The number of vanishing Lyapunov exponents shows how much hyperbolicity has been lost in such kind of systems.

**Keywords:** Non-hyperbolic ergodic measure, periodic measure, Lyapunov exponent, homoclinic class, robust transitivity, partial hyperbolicity, Anosov flow, Dehn twist, transverse torus.





# Contents

|          |   |           |
|----------|---|-----------|
| <b>1</b> | <b>Introduction and the statements of the results</b>   | <b>1</b>  |
| 1.1      | Introduction . . . . .  | 1         |
| 1.1.1    | Historical backgrounds . . . . .  | 1         |
| 1.1.2    | The robust existence of non-hyperbolic ergodic measures   | 2         |
| 1.1.3    | Existence of non-hyperbolic ergodic measures with more<br>than one vanishing Lyapunov exponents . . . . .   | 5         |
| 1.1.4    | Approximating non-hyperbolic ergodic measures by pe-<br>riodic measures and convexity of the closure of the set<br>of non-hyperbolic ergodic measures . . . . . | 8         |
|          | Results in the semi-local setting . . . . .   | 9         |
|          | Results in the global setting . . . . .   | 9         |
| 1.1.5    | Building new partially hyperbolic diffeomorphisms . . . .   | 12        |
| 1.1.6    | Completeness of invariant foliations . . . . .  | 16        |
| <b>2</b> | <b>Preliminaries</b>  | <b>19</b> |
| 2.1      | Dominated splitting, partial hyperbolicity and hyperbolicity . .  | 19        |
| 2.2      | Chain recurrence and homoclinic class . . . . .   | 20        |
| 2.3      | Lyapunov exponents, Oseledets splitting and hyperbolic ergodic<br>measure . . . . .   | 21        |
| 2.4      | Choquet and Poulsen Simplex . . . . .   | 22        |
| 2.5      | Good approximation and [GIKN] criterion . . . . .   | 22        |
| 2.6      | Shadowing lemma and approaching hyperbolic measures by pe-<br>riodic orbits . . . . .   | 23        |
| 2.7      | Plaque family and estimate on the size of invariant manifold . .  | 25        |
| 2.8      | Blender . . . . .   | 27        |
| 2.8.1    | Dynamically defined blender . . . . .   | 27        |
| 2.8.2    | Blender horseshoe . . . . .   | 28        |
| 2.9      | Flip-flop configuration . . . . .   | 33        |
| 2.10     | Flip flop family and the controlled at any scale . . . . .  | 34        |
| 2.11     | Flip flop configuration and flip flop family . . . . .  | 37        |
| 2.12     | Perturbation technics . . . . .   | 37        |
| 2.13     | Generic diffeomorphisms . . . . .   | 40        |
| 2.14     | Foliations on torus or on cylinder and its classification . . . . .   | 41        |

|          |  |           |
|----------|--|-----------|
| 2.14.1   | Pair of transverse foliations . . . . .  | 41        |
| 2.14.2   | Complete transversal . . . . .   | 42        |
| 2.14.3   | Reeb components and Compact leaves of foliations . . .   | 43        |
| 2.14.4   | Translation and rotation numbers . . . . .   | 44        |
| 2.14.5   | Foliations without compact leaves on the annulus . . . .   | 45        |
| 2.15     | Dehn twist along torus . . . . .   | 46        |
| 2.16     | Anosov flows and transverse tori . . . . .   | 47        |
| 2.17     | Dynamical coherence, Plaque expansiveness and completeness .   | 48        |
| 2.18     | Existence of compact leaf . . . . .  | 50        |
| <b>3</b> | <b>Existence of non-hyperbolic ergodic measures</b>  | <b>51</b> |
| 3.1      | Periodic orbits satisfying the [GIKN] criterion in a flip flop configuration: Proof of Theorem A . . . . .                                     | 52        |
| 3.2      | Existence of non-hyperbolic ergodic measures with full support for robustly transitive diffeomorphisms: Proof of Theorem B . .                 | 59        |
| 3.2.1    | Reduction of Theorem B . . . . .   | 59        |
| 3.2.2    | Existence of homoclinic classes robustly being the whole manifold . . . . .  | 60        |
| 3.2.3    | Periodic orbits satisfying [GIKN] criterion: Proof of Theorem 3.2.2 . . . . .  | 61        |
| 3.3      | Ergodic measure with multi-zero Lyapunov exponents for the case controlled by norm: Proof of Theorem C . . . . .                               | 65        |
| 3.3.1    | Proof of Theorem C . . . . .   | 65        |
| 3.3.2    | Good approximation with weaker center Lyapunov exponents: Proof of Proposition 3.3.1 . . . . .   | 68        |
| 3.4      | Ergodic measure with multi-zero Lyapunov exponents for the case controlled by Jacobian: Proof of Theorem 2 . . . . .                           | 76        |
| 3.4.1    | Proof of Theorem 2 . . . . .   | 76        |
| 3.4.2    | Good approximation with weaker center Jacobian: Proof of Proposition 3.4.1 . . . . .   | 78        |
| 3.5      | Partially hyperbolic homoclinic classes with volume expanding center bundle . . . . .  | 85        |
| 3.5.1    | Stability of normally hyperbolic compact manifolds . . .   | 86        |
| 3.5.2    | An example . . . . .   | 86        |
| <b>4</b> | <b>Non-hyperbolic ergodic measures approximated by periodic measures</b>   | <b>89</b> |
| 4.1      | Approximation of non hyperbolic ergodic measure by periodic orbits: Proof of Theorem E. . . . .  | 90        |
| 4.2      | The closure of periodic measures contains a segment joining $\delta_{\mathcal{O}_q}$ to a measure in the blender: Proof of Theorem D . . . . . | 100       |
| 4.3      | Non-hyperbolic ergodic measures approaching a non-ergodic measure with vanishing mean center Lyapunov exponent . . . . .                       | 108       |

|          |   |            |
|----------|---|------------|
| 4.4      | Approximating non-hyperbolic ergodic measures in global setting . . . . .   | 111        |
| 4.4.1    | Generation of blender horseshoes . . . . .  | 111        |
| 4.4.2    | Assuming minimality of both strong foliations: proof of Theorems F and G: . . . . .   | 112        |
| 4.5      | Invariant measures for Mañé's $DA$ example: Proof of Theorem 3 . . . . .  | 117        |
| 4.5.1    | Mañé's $DA$ -example . . . . .  | 117        |
| 4.5.2    | Proof of Theorem 3 . . . . .  | 118        |
| <b>5</b> | <b>Constructing new partially hyperbolic diffeomorphisms on 3-manifolds</b> . . . . .   | <b>123</b> |
| 5.1      | Reduction of Theorem 4 . . . . .  | 123        |
| 5.2      | Existence of a complete transversal for two transverse foliations without parallel compact leaves . . . . .                         | 125        |
| 5.3      | Deformation of a foliation along its transverse foliation . . . . .   | 127        |
| 5.4      | Deformation process for transverse foliations without parallel compact leaves: proof of Theorem 5.1.1 . . . . .                     | 129        |
| 5.4.1    | Separating transverse foliations by two linear ones and proof of Theorem 5.1.1 . . . . .  | 129        |
| 5.4.2    | Separating transverse foliations by a circle bundle . . . . .   | 130        |
| 5.4.3    | Building the second linear foliation: end of the proof of Theorem 5.4.1 . . . . .   | 135        |
| 5.5      | Deformation process of transverse foliations with parallel compact leaves and proof of Theorem 5.1.2 . . . . .                      | 136        |
| 5.5.1    | Normal form for two transverse foliations with parallel compact leaves and proof of Theorem 5.1.2 . . . . .                         | 137        |
| 5.5.2    | First decomposition in annuli . . . . .   | 138        |
| 5.5.3    | In the neighborhoods of the maximal $\mathcal{F}$ annuli . . . . .  | 140        |
| 5.5.4    | Between two maximal $\mathcal{F}$ and $\mathcal{G}$ -annuli . . . . .   | 143        |
| 5.6      | Dehn twists, transverse foliations and partially hyperbolic diffeomorphisms . . . . .   | 148        |
| 5.6.1    | Transverse foliations on 3-manifolds . . . . .  | 148        |
| 5.6.2    | Anosov flows, Dehn twists and partially hyperbolic diffeomorphisms . . . . .  | 149        |
| <b>6</b> | <b>Partially hyperbolic diffeomorphism with one-dimensional neutral center</b> . . . . .  | <b>153</b> |
| 6.1      | The topological structure of the center stable and center unstable foliations: Proof of Theorem 5 . . . . .                         | 154        |
| 6.2      | Center flow carried by the partially hyperbolic diffeomorphism of [BZ1] example: Proof of Theorem I and Proposition 1.1.2 . . . . . | 158        |
| 6.2.1    | Properties of the invariant foliations for $f_{bz}, f_B$ . . . . .  | 158        |
| 6.2.2    | Analyzing the center foliation of [BZ1] and [BPP] examples . . . . .  | 161        |



# Chapter 1

## Introduction and the statements of the results

### 1.1 Introduction

#### 1.1.1 Historical backgrounds

Let  $M$  be a compact smooth Riemannian manifold without boundary and  $\text{Diff}^r(M)$  be the set of  $C^r$  (for  $r \geq 1$ ) diffeomorphisms on  $M$ .

In the middle of last century, S. Smale presented the hyperbolic theory which highly promoted the development of dynamical systems. The hyperbolic systems are considered as well understood:

- From topological point of view, for instance, the dynamics of hyperbolic systems concentrates on finite many pieces called *hyperbolic basic sets* and each of them is structurally stable. Due to the results of S. Liao and R. Mañé [L2, M2], if the set where the dynamics of a system concentrates on is structurally stable, then this system is hyperbolic;
- From stochastic point of view, for instance, for each hyperbolic set, K. Sigmund [Sig1] proved that periodic measures are dense among all the invariant measures, and R. Bowen proved that for each Hölder continuous potential, there exists a unique *equilibrium state*.

However, on a 4-dimensional manifold, R. Abraham and S. Smale [AS] constructed an open set of diffeomorphisms each of which is not hyperbolic. The study of the systems beyond uniform hyperbolicity starts to be important, and people start to search for robustly non-hyperbolic phenomena. M. Shub [Sh] and R. Mañé [M1] construct the robustly transitive non-hyperbolic diffeomorphisms on  $\mathbb{T}^4$  and  $\mathbb{T}^3$  respectively. [BD1] gives more general examples on any manifold of dimension at least three. Nevertheless, the results in [BDP] imply that these examples always exhibit some weak form of hyperbolicity.

There are several notions which release the notion of hyperbolicity. On one hand, from stochastic point of view, inspired by the paper of V. Oseledec [O],

the notion of *non-uniform hyperbolicity*, which has asymptotic expanding and contracting behavior on the tangent bundle over a full measure set, was proposed. Pesin theory shows that many properties of hyperbolic systems survive in non-uniform hyperbolic systems, for instance the existence of stable and unstable manifolds and the existence of Markov partitions. The example in [CLR] shows that there exists a non-uniform hyperbolic system exhibiting a homoclinic tangency, hence non-uniform hyperbolic theory really generalizes the hyperbolic theory of Smale. Comparing with hyperbolic theory, it was natural to ask: are the non-uniform hyperbolic systems dense among all the differentiable systems? The first example is given by [KN], proving that there exists an open set of diffeomorphisms on the manifolds of the form  $M \times \mathbb{S}^1$  such that there exist non-hyperbolic ergodic measures. Recently, [BBD2] proves the existence of non-hyperbolic ergodic measures for an open and dense subset of the set of diffeomorphisms having robust cycles, which is a local setting.

On the other hand, M. Hirsch, C. Pugh and M. Shub [HPS] release the notion of hyperbolicity to partial hyperbolicity. The classification of partially hyperbolic systems has become a very active topic in recent years. The classification of partially hyperbolic systems has mainly followed two directions. One focuses on what kind of manifolds supporting partially hyperbolic systems. This thesis would not involve in this direction. We refer the readers to [BBI], [BI] and [GHO] for the progress on this subject. The second direction focuses on what kind of partially hyperbolic systems that a manifold could possess. Recently, [BPP] and [BGP] achieve remarkable results on dimension three. [BPP] built a non-transitive dynamically coherent partially hyperbolic diffeomorphism which is neither leaf conjugate to any of the known examples nor isotopic to identity. [BGP] constructed robustly transitive partially hyperbolic diffeomorphisms on 3-manifolds which are different from the known examples and are not homotopic to identity.

### 1.1.2 The robust existence of non-hyperbolic ergodic measures

Recall that the Lyapunov exponents of an ergodic measure are the asymptotic rates in different directions for a full measure set (see the precise definition in Section 2.3). An ergodic measure  $\mu$  is *non-hyperbolic* if  $\mu$  has vanishing Lyapunov exponents; otherwise, we say that  $\mu$  is *hyperbolic*.

In [GIKN], a criterion was presented for building non-hyperbolic ergodic measures as the limit of periodic measures. We call this criterion as *[GIKN] criterion*. This criterion can show us where the support of the ergodic measure is. Using this criterion, [KN] gives an example of robust existence of non-hyperbolic ergodic measures, and their result depends on the global structure of the system. Based on this criterion, [BBD1] constructs a  $C^2$  open set of IFS, each of which has a non-hyperbolic ergodic measure whose Lyapunov

exponents all vanish.

Recall that a  $Df$  invariant splitting  $T_\Lambda M = E \oplus F$  over a compact invariant set  $\Lambda$  is a *dominated splitting*, if the norm of  $Df$  along  $E$  is controlled by that along  $F$ ; and a compact invariant set  $\Lambda$  is *partially hyperbolic* if there exists a dominated splitting  $T_\Lambda M = E^s \oplus E^c \oplus E^u$  such that  $Df$  along  $E^s$  is uniform contracting,  $Df$  along  $E^u$  is uniform expanding, and the behavior along  $E^c$  is intermediate, see precise definitions in Section 2.1. If the center bundle  $E^c$  is one dimensional, then for any ergodic measure  $\mu$  supported on  $\Lambda$ , the center Lyapunov exponent of  $\mu$  is:

$$\lambda^c(\mu) = \int \log \|Df|_{E^c}\| d\mu.$$

In the recent work of [BBD2], a new criterion called *controlled at any scale* is introduced. The non-hyperbolic ergodic measure obtained by this criterion has positive metric entropy, but we lose the control on its support. [BBD2] works in the setting of *robust cycles*. Consider the open set  $\mathcal{RC}(M)$  of diffeomorphism  $f$  exhibiting a robust cycle between a transitive hyperbolic set  $\Lambda_f$  of  $s$ -index  $i$  and a hyperbolic periodic point  $q_f$  of  $s$ -index  $i+1$ . [BBD2] built an open and dense subset  $\widetilde{\mathcal{RC}}(M)$  in  $\mathcal{RC}(M)$  so that one can apply ‘controlled at any scale criterion’ to every  $f \in \widetilde{\mathcal{RC}}(M)$  and one gets that  $f$  admits a point  $x_f$  whose  $\omega$ -limit set  $\omega(x_f)$  has the following properties:

- the topological entropy of  $\omega(x_f)$  is positive;
- $\omega(x_f)$  is partially hyperbolic with 1-dimensional center bundle;
- every point  $y \in \omega(x_f)$  has a well defined and vanishing center Lyapunov exponent.

This result contrasts with the procedure in [KN] which builds non-hyperbolic measures as the limit of periodic orbits in a specific global setting. In particular, it is not clear a priori if the (non-hyperbolic) measures supported on the compact set  $\omega(x_f)$  built in [BBD2] are accumulated by periodic orbits.

**Question 1.** *In the same semi-local setting as [BBD2], could the existence of non-hyperbolic ergodic measures be obtained as the limit of periodic measures (ie. ergodic measures supported on a single periodic orbit)? Furthermore, could it have positive metric entropy?*

In the paper [BZ2], we partially answer this question. [BZ2] applies [GIKN] criterion together with a shadowing lemma in [G1] to every diffeomorphism in  $\widetilde{\mathcal{RC}}(M)$ , and one gets that:

**Theorem A.** *[BZ2] For any  $f \in \widetilde{\mathcal{RC}}(M)$ , there exist a partially hyperbolic set  $\tilde{\Lambda}_f$  (with 1-dimensional center bundle) and a sequence of periodic orbits  $\{\mathcal{O}_n\} \subset \tilde{\Lambda}_f$  such that:*

- *the center Lyapunov exponent of  $\mathcal{O}_n$  tends to zero;*



- the sequence of periodic orbits  $\{\mathcal{O}_n\}$  satisfies the [GIKN] criterion. As a consequence, one has that the Dirac measure  $\delta_{\mathcal{O}_n}$  converges to a non-hyperbolic ergodic measure.

As far as we know, it is still unknown if the ergodic measure obtained by [GIKN] criterion has positive metric entropy.

Besides, we can show that controlled at any scale criterion can be used with periodic orbits: the orbits follow this controlled at any scale criterion out of a very small orbit segment, whose weight in the corresponding periodic measure tends to 0; this small orbit segment is used for closing the orbit by using a shadowing lemma in [G1].

**Theorem 1.** [BZ2] *With the notations above, for any  $f \in \widetilde{\mathcal{RC}}(M)$ , there exists a sequence of hyperbolic periodic orbits  $\{\gamma_n\}$  homoclinically related to the orbit of  $q_f$ , whose center Lyapunov exponent tends to zero, and which converges for the Hausdorff distance to a compact invariant set  $K_f$  such that:*

- $q_f \in K_f$ ;
- the set  $K_f$  is partially hyperbolic with 1-dimensional center bundle;
- there exists a non-empty compact invariant set  $K'_f \subset K_f$  such that any point in  $K'_f$  has well defined and vanishing center Lyapunov exponent.
- the topological entropy of  $K'_f$  is positive:  $h_{\text{top}}f|_{K'_f} > 0$ ;
- For any  $x \in K_f \setminus (K'_f \cup \mathcal{O}_{q_f})$ , we have either  $\omega(x) \subset K'_f$  and  $x \in W^u(\mathcal{O}_{q_f})$  or  $\alpha(x) \subset K'_f$  and  $x \in W^s(\mathcal{O}_{q_f})$ .

In this thesis, we would not present the proof of Theorem 1.

One can apply the techniques in the semi-local setting to the global setting. Recall that a diffeomorphism  $f$  is *transitive*, if  $f$  has a dense orbit, furthermore, we say that  $f$  is *robustly transitive* if every small perturbation of  $f$  has a dense orbit. We denote by  $\mathcal{U}(M)$  the set of robustly transitive and robustly non-hyperbolic diffeomorphisms far from homoclinic tangencies. By definition,  $\mathcal{U}(M)$  is an open set. The result in [BDG] implies that for a residual subset of  $\mathcal{U}(M)$ , there exists a non-hyperbolic ergodic measure with full support. In this global setting, one can get the following:

**Theorem B.** [BZ2] *There exists an open and dense subset  $\mathcal{V}(M)$  of  $\mathcal{U}(M)$ , such that for any  $f \in \mathcal{V}(M)$ , there exists a non-hyperbolic ergodic measure as the weak\*-limit of a sequence of periodic measures and whose support is the whole manifold.*

Actually, for the open set  $\mathcal{U}(M)$ , one can apply the result from [BDPR] showing that for an open and dense subset of  $\mathcal{U}(M)$ , the diffeomorphism is partially hyperbolic whose center bundle splits into one dimensional dominated sub-bundles. We prove Theorem B by showing that for each one dimensional sub-bundle in the center bundle, there exists a non-hyperbolic ergodic measure

whose Lyapunov exponent vanishes along this one-dimensional bundle and whose support is the whole manifold.

We remark that a similar result to Theorem B is also obtained in [BBD3], using a very different method.

### 1.1.3 Existence of non-hyperbolic ergodic measures with more than one vanishing Lyapunov exponents

Recall that a property is called a  $C^1$ -generic property if it is satisfied for a dense  $G_\delta$  subset of  $\text{Diff}^1(M)$ . Recall that a compact invariant set  $\Lambda$  for a diffeomorphism  $f$  admits a dominated splitting of index  $i$ , if there exists a dominated splitting  $T_\Lambda M = E \oplus F$  over  $\Lambda$  such that  $\dim(E) = i$ .

The [GIKN] criterion combined with the perturbation techniques has been used for generic systems in [DG]: *for  $C^1$ -generic diffeomorphisms, if a homoclinic class contains periodic orbits with different indices, then the homoclinic class supports a non-hyperbolic ergodic measure with one vanishing Lyapunov exponent.* Recently, [CCGWY] proves that for a generic homoclinic class, either it is hyperbolic or it supports non-hyperbolic ergodic measures. It has been conjectured by Ch. Bonatti [B2] that beyond uniform hyperbolicity, the systems with robust cycles are dense. Exactly in the setting with robust cycles, [BBD3] shows that the existence of non-hyperbolic ergodic measures is robust for an open and dense subset. To some extent, one can think that one can characterize the non-hyperbolicity by showing the existence of non-hyperbolic ergodic measures.

It would be interesting to know to what extent the non-hyperbolicity of a system can be described by the existence of non-hyperbolic ergodic measures. Another weak form of hyperbolicity called *volume hyperbolic* describes the involution of the volume along two different directions in the way that one is uniformly contracting and the other is uniformly expanding for the volume. Volume hyperbolic systems can be non-hyperbolic, but along the volume contracting (or expanding) direction, at least one of the Lyapunov exponents is non-zero. To some extent, the number of vanishing Lyapunov exponents describes how far from the hyperbolicity the systems are. In the study of dynamics, one of the main aims is to describe ‘most’ of the systems: generic systems. One can ask the following question :

**Question 2.** *Under what kind of assumption, for generic systems, there exists a non-hyperbolic ergodic measure with more than one vanishing Lyapunov exponents?*

In [BBD1], the authors show that there exist iterated function systems (IFS) persistently exhibiting non-hyperbolic ergodic measures with all the Lyapunov exponents vanished. This can be used to step skew products showing

that there exist more than one vanishing Lyapunov exponents, but such examples are not generic.

In [WZ], we obtain the following result for generic systems:

**Theorem C.** [WZ] *For  $C^1$ -generic diffeomorphism  $f \in \text{Diff}^1(M)$ , consider a hyperbolic periodic point  $p$ . Assume the homoclinic class  $H(p, f)$  satisfies the following properties:*

- $H(p, f)$  contains hyperbolic periodic orbits of  $s$ -indices  $i$  and  $i + k$  respectively, where  $i, k > 0$ ;
- for any integer  $1 \leq j \leq k - 1$ , there is no dominated splitting of index  $i + j$  over  $H(p, f)$ .

*Then there exists an ergodic measure  $\nu$  whose support is  $H(p, f)$  such that the  $(i + j)^{\text{th}}$  Lyapunov exponent of  $\mu$  vanishes for any  $1 \leq j \leq k$ .*

The proof of Theorem C consists in applying the perturbation techniques in [BB] for the Lyapunov exponents of periodic orbits and the Franks-Gourmelon lemma in [Go2] which ensures that for certain perturbations, the heteroclinic intersections can be preserved. These two techniques allow us to change the Lyapunov exponents of a periodic orbit in a homoclinic class and keep the periodic orbit inside the homoclinic class after perturbations.

As a direct corollary of Theorem C, one has the following result which generalizes the result of [BDG] in the sense that one can obtain non-hyperbolic ergodic measures with more than one vanishing Lyapunov exponents.

**Corollary 1.** [WZ] *For a  $C^1$  generic diffeomorphism  $f \in \text{Diff}^1(M)$ , consider a hyperbolic periodic point  $p$ . Assume that the homoclinic class  $H(p, f)$  has a dominated splitting  $T_{H(p, f)}M = E \oplus F \oplus G$ . Assume, in addition, that the followings are satisfied:*

- $H(p, f)$  contains hyperbolic periodic orbits of  $s$ -indices  $\dim(E)$  and  $\dim(E \oplus F)$  respectively,
- the center bundle  $F$  has no finer dominated splitting.

*Then there exists an ergodic measure  $\nu$  whose Lyapunov exponents along the bundle  $F$  vanish, and whose support is  $H(p, f)$ .*

We point out that the assumption of the existence of both periodic orbits of  $s$ -indices  $\dim(E)$  and  $\dim(E \oplus F)$  is necessary. Actually, one can construct an example such that there is no periodic orbit of  $s$ -index  $\dim(E \oplus F)$  inside a generic homoclinic class, and the center bundle  $F$  has no finer domination but  $F$  is uniformly volume expanding, which implies that every ergodic measure has at least one positive Lyapunov exponent along  $F$ . Hence, one can also ask the following question, to consider the case when the center bundle  $F$  is not volume expanding.

**Question 3.** *In the assumption of Corollary 1, if we replace the existence of a hyperbolic periodic orbit of  $s$ -index  $\dim(E \oplus F)$  by the existence of a hyperbolic*

*periodic orbit whose absolute Jacobian along center bundle  $F$  is strictly less than 1, does there exist an ergodic measure  $\nu$  supported on  $H(p, f)$  such that all the Lyapunov exponents of  $\nu$  along  $F$  vanish ?*

The following theorem gives an affirmative answer to Question 3.

**Theorem 2.** [WZ] *For a  $C^1$ -generic diffeomorphism  $f \in \text{Diff}^1(M)$ , consider a hyperbolic periodic point  $p$ . Assume that the homoclinic class  $H(p, f)$  admits a dominated splitting  $T_{H(p,f)}M = E \oplus F \oplus G$ . Assume, in addition, that we have the following:*

- $H(p, f)$  contains a hyperbolic periodic orbit of  $s$ -index  $\dim(E)$  and a hyperbolic periodic point  $q \in H(p, f)$  such that

$$|\text{Jac}(\text{Df}^{\pi(q)}|_{F(q)})| < 1;$$

- the center bundle  $F$  has no finer dominated splitting.

*Then there exists an ergodic measure  $\nu$  whose support is  $H(p, f)$ , such that all the Lyapunov exponents of  $\nu$  along  $F$  vanish.*

Let's explain the relation between Theorem 2 and Corollary 1. If the  $s$ -index of  $q$  in Theorem 2 is no less than  $i + k$ , then we can conclude Theorem 2 directly from Corollary 1. If the  $s$ -index of  $q$  is smaller than  $i + k$ , indeed by the no-domination assumption along  $F$  and the technics of [BB], we can do an arbitrarily small perturbation to get a new hyperbolic periodic orbit of  $s$ -index  $i + k$ . However, we do not know if the new generated periodic orbits are still contained in the homoclinic class.

The proof of Theorem 2 is not by finding a hyperbolic periodic orbit of  $s$ -index  $i + k$  in the homoclinic class. We use a little different strategy to give the proof.

A more general statement than Theorem 2 can be expected to be true. We state it as the following question.

**Question 4.** *For a  $C^1$ -generic  $f \in \text{Diff}^1(M)$ , consider the finest dominated splitting  $E_1 \oplus \dots \oplus E_k$  over a homoclinic class  $H(p, f)$ . Assume that there exist two saddles  $q_1, q_2$  in the class such that*

$$|\text{Jac}(\text{Df}^{\pi(q_1)}|_{E_i(q_1)})| > 1 \text{ and } |\text{Jac}(\text{Df}^{\pi(q_2)}|_{E_j(q_2)})| < 1, \text{ where } i \leq j.$$

*Then for any  $i \leq l \leq j$ , does there exist an ergodic measure whose Lyapunov exponents along the bundle  $E_l$  all vanish?*

Comparing with Section 1.1.2, one can ask:

**Question 5.** *Does there exist an open set  $\mathcal{U}$  of diffeomorphisms such that for any  $f \in \mathcal{U}$ , there exists an ergodic measure with more than one vanishing Lyapunov exponents ?*

### 1.1.4 Approximating non-hyperbolic ergodic measures by periodic measures and convexity of the closure of the set of non-hyperbolic ergodic measures

K. Sigmund [Sig1] proved that periodic measures are dense in the set of invariant measures supported on a given hyperbolic basic set, which implies that the set of invariant measures on a hyperbolic basic set is a *Poulsen Simplex*.

One can ask to what extent we can extend Sigmund's result to the non-hyperbolic setting. Many results have been obtained:

- Under  $C^{1+\alpha}$  setting, using Pesin theory, A. Katok [Ka] proves that any hyperbolic ergodic measure is approximated by periodic measures. This result in the  $C^1$  setting is not always true, see for instance [BCS].
- Under  $C^{1+\alpha}$  setting, using slightly different Pesin blocks and lots of tools introduced by S. Liao, [LLS, SW] strengthen the result of A. Katok. [SW] shows that every hyperbolic ergodic measure is approximated by periodic measures in weak\*-topology and in spectrum. [LLS] shows that there exists a full measure invariant set, on which every invariant measure is approximated by periodic measures.
- Using the  $C^1$ -Pesin theory and shadowing lemma in [G1], and assuming the existence of some dominated splitting, S. Crovisier [C] proves that any hyperbolic ergodic measure is supported on a homoclinic class and is approximated by periodic orbits whose Hausdorff limit is the support of the hyperbolic ergodic measure.
- In the  $C^1$ -generic setting, [ABC] proves that the closure of the set of periodic measures supported on a single homoclinic class is a convex set.
- The ergodic closing lemma in [M2] implies that for  $C^1$ -generic diffeomorphisms, every ergodic measure is approached by periodic measures.
- In [SY], under  $C^1$ -setting, the authors prove that for each thin trapped chain hyperbolic homoclinic class, the periodic measures are dense among the invariant measures.
- In [STV], for  $C^1$  flows and for a hyperbolic ergodic measure supported away from singularities, if the hyperbolic splitting of the measure is limit-dominated, then this measure is approximated by periodic measures.
- For certain step skew-products with circle fiber over a horseshoe, [DGR] shows that every non-hyperbolic ergodic measure is approximated by hyperbolic sets in weak\*-topology and in entropy. The hyperbolic sets are provided by the multi-variable-time horseshoes.

In [BZ3], we recover some of the results above in the semi-local setting and in a global setting. To state our results, we need to define our setting carefully.

## Results in the semi-local setting

We start with our assumption in the semi-local setting without technical definitions and the precise definition of the terminology we use here would be given in the next chapter.

Consider  $f \in \text{Diff}^1(M)$ . Let  $(\Lambda, U, \mathcal{C}^{uu}, \mathfrak{D})$  be a *blender horseshoe* of u-index  $i + 1$  and  $\mathcal{O}_q$  be a hyperbolic periodic orbit of u-index  $i$ . We assume that  $\Lambda$  and  $\mathcal{O}_q$  form a special robust cycle called *split-flip-flop configuration*, for specific definition see Definitions 2.9.1 and 2.9.4.

We fix a small neighborhood  $V$  of the split flip-flop configuration so that the maximal invariant set  $\tilde{\Lambda}$  in the closure  $\bar{V}$  admits a partially hyperbolic splitting  $E^s \oplus E^c \oplus E^u$  with  $\dim(E^c) = 1$ . Assume, in addition, that there exists a  $Df$ -strictly invariant center unstable cone field  $\mathcal{C}_V^u$  which is a continuous extension of the center unstable cone field  $\mathcal{C}^u$  in  $U$ .

In [ABC], it has been shown that in the  $C^1$  generic setting, for each homoclinic class, the closure of the set of periodic measures is convex. Hence, for each partially hyperbolic homoclinic class with center dimension one, under  $C^1$ -generic setting, the closure of the set of hyperbolic ergodic measures is convex. Here, in the  $C^1$  open setting, we get some kind of ‘convexity’ and it would be used for the global setting.

**Theorem D.** *Under the assumption above, there exists an invariant measure  $\mu \in \mathcal{M}_{inv}(\Lambda, f)$  such that the segment  $\{\alpha\mu + (1 - \alpha)\delta_{\mathcal{O}_q}, \alpha \in [0, 1]\}$  is contained in the closure of the set of periodic measures whose supports are inside  $V$ .*

Actually, in the proof Theorem A, we show that in any small neighborhood of the split flip flop configuration, there exist non-hyperbolic ergodic measures approached by periodic measures. Conversely, we can prove that the non-hyperbolic ergodic measures supported on a small neighborhood of the robust cycle are approximated by hyperbolic periodic measures. To be precise:

**Theorem E.** *Under the assumption above, there exists a small neighborhood  $V_0 \subset V$  of the split flip flop configuration such that for any non-hyperbolic ergodic measure  $\nu$  supported on the maximal invariant set  $\tilde{\Lambda}_0$  in  $V_0$ , there exists a sequence of periodic orbits  $\{\mathcal{O}_{p_n}\}_{n \in \mathbb{N}}$  which are homoclinically related to  $\Lambda$  such that  $\delta_{\mathcal{O}_{p_n}}$  converges to  $\nu$ .*

**Remark 1.**

1. *If the support of  $\nu$  intersects the boundary of  $V_0$ , the sequence of periodic orbits we find might intersect the complement of  $\tilde{\Lambda}_0$ ;*
2. *The choice of  $V_0$  is uniform for the diffeomorphisms in a  $C^1$  small neighborhood of  $f$ .*

## Results in the global setting

We apply our techniques in the semi-local setting to the global setting.

We denote by  $\mathcal{PH}(M)$  the set of partially hyperbolic diffeomorphisms with center dimension one, ie. for any  $f \in \mathcal{PH}(M)$ , the manifold  $M$  is partially hyperbolic with splitting of the form

$$TM = E^s \oplus E^c \oplus E^u$$

where  $\dim(E^c) = 1$ .

For any  $f \in \mathcal{PH}(M)$ , we denote by  $\mathcal{M}_{inv}(f)$  and  $\mathcal{M}_{erg}(f)$  the sets of  $f$ -invariant measures and of  $f$ -ergodic measures respectively.

Let  $\mu \in \mathcal{M}_{erg}(f)$ , then the center Lyapunov exponent of  $\mu$  is

$$\lambda^c(\mu) = \int \log \|Df|_{E^c}\| d\mu.$$

We denote by  $\dim(E^s) = i$ . The  $s$ -index of a hyperbolic ergodic measure  $\mu$  is the number of negative Lyapunov exponents of  $\mu$ . In our setting, the  $s$ -index of a hyperbolic ergodic measure  $\mu$  is

$$ind(\mu) = \begin{cases} i & \text{if } \lambda^c(\mu) > 0 \\ i + 1 & \text{if } \lambda^c(\mu) < 0 \end{cases}.$$

We denote by  $\mathcal{M}^*(f)$ ,  $\mathcal{M}_i(f)$  and  $\mathcal{M}_{i+1}(f)$  the sets of ergodic measures with vanishing, positive and negative center Lyapunov exponents respectively, and we denote by  $\mathcal{M}_{Per,i}(f)$  and  $\mathcal{M}_{Per,i+1}(f)$  the set of periodic measures of  $s$ -indices  $i$  and  $i + 1$  respectively.

Similarly, for each  $\mu \in \mathcal{M}_{inv}(f)$ , one can define:

$$\lambda^c(\mu) = \int \log \|Df|_{E^c}\| d\mu,$$

and we call  $\lambda^c(\mu)$  as the *mean center Lyapunov exponent* of  $\mu$ .

Recall that a foliation  $\mathcal{F}$  on a manifold  $M$  is *minimal* if every leaf of  $\mathcal{F}$  is dense on the manifold  $M$ . Our result in the global setting depends strongly on the minimality of the strong stable and strong unstable foliations.

Let  $\mathcal{T}(M) \subset \mathcal{PH}(M)$  be the set of diffeomorphisms such that for any  $f \in \mathcal{T}(M)$ , one has that

- $f$  has both strong stable and strong unstable foliations which are robustly minimal;
- $f$  admits hyperbolic periodic points  $p_f$  of  $s$ -index  $i$  and  $q_f$  of  $s$ -index  $i + 1$ .

**Remark 2.**  $\mathcal{T}(M)$  is, by definition, an open subset of  $\text{Diff}^1(M)$ . [BDU] shows that there are compact 3-manifolds  $M$  for which  $\mathcal{T}(M)$  is not empty: the time one map of a transitive Anosov flow on a manifold  $M$  admits a smooth perturbation in  $\mathcal{T}(M)$ ; the same occurs in the skew product of linear Anosov automorphisms of the torus  $\mathbb{T}^2$  by rotations of the circle.

For any  $f \in \mathcal{T}(M)$  and any hyperbolic periodic point  $x$ , one has the following properties:

- the minimality of both foliations implies that the manifold  $M$  is the whole homoclinic class of  $x$ . Furthermore any two hyperbolic periodic points of same index are homoclinically related. This implies that the closure of the set of the hyperbolic periodic measures of a given index is convex. In other words  $\overline{\mathcal{M}_{Per,i}(f)}$  and  $\overline{\mathcal{M}_{Per,i+1}(f)}$  are convex.
- clearly  $\mathcal{M}_{Per,i}(f) \subset \mathcal{M}_i(f)$  and  $\mathcal{M}_{Per,i+1}(f) \subset \mathcal{M}_{i+1}(f)$ . According to [C], in this partially hyperbolic setting, every hyperbolic ergodic measure is weak\*-limit of periodic measures of same index. One gets therefore:

$$\overline{\mathcal{M}_{Per,i}(f)} = \overline{\mathcal{M}_i(f)} \text{ and } \overline{\mathcal{M}_{Per,i+1}(f)} = \overline{\mathcal{M}_{i+1}(f)}$$

Now, we are ready to present the results in the global setting.

**Theorem F.** [BZ3] *Let  $M$  be a closed manifold. There exists a  $C^1$  open and dense subset  $\tilde{\mathcal{T}}(M)$  of  $\mathcal{T}(M)$  such that for any  $f \in \tilde{\mathcal{T}}(M)$ , one has that*

$$\begin{aligned} \overline{\mathcal{M}^*(f)} &= \overline{\mathcal{M}_i(f) \cap \{\mu \in \mathcal{M}_{inv}(f), \lambda^c(\mu) = 0\}} \\ &= \overline{\mathcal{M}_{i+1}(f) \cap \{\mu \in \mathcal{M}_{inv}(f), \lambda^c(\mu) = 0\}} \\ &= \overline{\mathcal{M}_i(f) \cap \mathcal{M}_{i+1}(f)}. \end{aligned}$$

Theorem F shows that the closure of the set of ergodic measures for  $f \in \tilde{\mathcal{T}}(M)$  is the union of two convex sets  $\overline{\mathcal{M}_{Per,i}(f)}$  and  $\overline{\mathcal{M}_{Per,i+1}(f)}$ , which intersect along  $\overline{\mathcal{M}^*(f)}$ . As a consequence, the closure of the set of non-hyperbolic ergodic measures is a convex set and every non-hyperbolic ergodic measure is the weak\*-limit of hyperbolic periodic measures of different indices.

One can ask an ambitious question:

**Question 6.** *Does there exist an open and dense subset of  $\mathcal{T}(M)$  such that for each non-hyperbolic ergodic measure  $\mu$  with  $h_\mu(f) > 0$  and for any  $\epsilon > 0$ , there exists a transitive hyperbolic set  $\Lambda_\epsilon$  such that*

$$|h_\mu(f) - h_{top}(f|_{\Lambda_\epsilon})| < \epsilon \text{ and } d(\nu, \mu) < \epsilon \text{ for any } \nu \text{ supported on } \Lambda_\epsilon?$$

Roughly speaking, could we find an open and dense subset of  $\mathcal{T}(M)$  such that every non-hyperbolic ergodic measure with positive metric entropy can be approximated by transitive hyperbolic sets in the sense of measure and entropy? In [DGR], some results are obtained for some step skew-products.

[BZ3] did not get the convexity of the closure of the set of ergodic measures, but some sort of convexity is recovered:

**Theorem G.** [BZ3] *For any diffeomorphism  $f \in \tilde{\mathcal{T}}(M)$ , there exist two compact  $f$ -invariant (uniformly) hyperbolic sets  $K_i \subset M$  and  $K_{i+1} \subset M$  of  $s$ -indices  $i$  and  $i+1$  respectively, with the following property: for any  $\mu \in \overline{\mathcal{M}_i(f)}$*



(resp.  $\overline{\mathcal{M}_{i+1}(f)}$ ), there exists an invariant measure  $\nu$  supported on  $K_{i+1}$  (resp.  $K_i$ ) such that the segment  $\{\alpha\mu + (1-\alpha)\nu \mid \alpha \in [0, 1]\}$  is contained in the closure of the set of periodic measures.

Theorem G shows that the union of the convex sets  $\overline{\mathcal{M}_{Per,i}(f)}$  and  $\overline{\mathcal{M}_{Per,i+1}(f)}$  “is not far from being convex”, but the convexity is not obtained. In other words, we don’t know if any  $f$ -invariant measure is accumulated by ergodic measures.

**Question 7.** *Does there exist an open dense subset of  $\mathcal{T}(M)$  such that periodic measures are dense among invariant measures?*

In general, when only one of the strong foliations is minimal, we don’t know if the non-hyperbolic ergodic measures are accumulated by periodic orbits, and if the closure of the set of non-hyperbolic ergodic measures is convex. Nevertheless, there is an important example where we could recover these properties.

R. Mañé [M1] gave an example that for linear Anosov diffeomorphisms on  $\mathbb{T}^3$  of  $s$ -index 1 with three ways dominated splitting, one can do  $DA$  to get an open subset  $\mathcal{W}$  of  $\text{Diff}^1(\mathbb{T}^3)$  where all the diffeomorphisms are non-hyperbolic and transitive (see the precise definition of  $\mathcal{W}$  in Section 4.5). [BDU] proved that every robustly transitive diffeomorphism in  $\mathcal{W}$  has minimal strong stable foliation (see also [PS]).

**Theorem 3.** *There exists an open and dense subset  $\tilde{\mathcal{W}}$  of  $\mathcal{W}$  such that for any  $f \in \tilde{\mathcal{W}}$ , one has*

- *any non-hyperbolic ergodic measure is approximated by periodic measures of  $s$ -index 1;*
- *the closure of the set of non-hyperbolic ergodic measures is convex.*

For every  $f \in \mathcal{W}$ , the minimality of strong stable foliation implies that all hyperbolic periodic orbits of  $s$ -index 1 are homoclinically related; by transitivity, one can show that the unstable manifold of a hyperbolic periodic orbit of  $s$ -index 1 is dense on the manifold. Hence  $\mathbb{T}^3$  is the homoclinic class of every periodic orbit of  $s$ -index 1. By [BDPR, Theorem E], for an open and dense subset of  $\mathcal{W}$ , the manifold  $\mathbb{T}^3$  is also the homoclinic class of a periodic orbit of  $s$ -index 2.

**Question 8.** *For Mañé’s example, given two hyperbolic periodic orbits  $Q_1$  and  $Q_2$  of  $s$ -index 2, are  $Q_1$  and  $Q_2$  homoclinically related?*

**Remark 3.** *If the answer to Question 4 is yes, although we can not get the whole convexity of the closure of the set of periodic measures, one can show that for Mañé’s example, the set of ergodic measures is path connected (for the definition see [Sig3]).*

### 1.1.5 Building new partially hyperbolic diffeomorphisms

Recall that for a partially hyperbolic diffeomorphism  $f$  with the splitting  $TM = E^s \oplus E^c \oplus E^u$ , one says that  $f$  is *dynamically coherent* if there exist  $f$ -invariant foliations  $\mathcal{F}^{cs}$  and  $\mathcal{F}^{cu}$  tangent to  $E^s \oplus E^c$  and  $E^c \oplus E^u$  respectively. By taking intersection of these two foliations, one gets an invariant foliation  $\mathcal{F}^c$  tangent to  $E^c$ . Two dynamically coherent partially hyperbolic diffeomorphisms  $f, g \in \text{Diff}^1(M)$  are *leaf conjugate* if there exists a homeomorphism  $h : M \mapsto M$  such that for any  $x \in M$ , one has

$$h(\mathcal{F}_f^c(x)) = \mathcal{F}_g^c(h(x)) \text{ and } h(\mathcal{F}_f^c(f(x))) = \mathcal{F}_g^c(g(h(x))).$$

One of the main attempts in the study of partially hyperbolic systems is to classify the partially hyperbolic systems. The family of partially hyperbolic diffeomorphisms on 3-manifold was not big. Inspired by a conjecture of E. Pujals which was formulated in [BW], J. Rodriguez Hertz, F. Rodriguez Hertz and R. Ures [HHU3] conjectured that:

**Conjecture 1.** *Any dynamically coherent partially hyperbolic diffeomorphism on a 3-manifold is, up to finite iterations and finite lifts, leaf conjugate to one of the followings:*

- Anosov diffeomorphism on  $\mathbb{T}^3$ ;
- time one map of an Anosov flow;
- skew products over a linear Anosov automorphism of torus  $\mathbb{T}^2$ .

This conjecture has been proven to be true in some cases:

- In [BW], for transitive partially hyperbolic diffeomorphism, with extra assumption on the structure of the invariant manifold of a compact invariant center curve, the authors show that such kind of systems can only be leaf conjugate to one of the last two models;
- In [HaPo1], assuming that the fundamental group of the manifold is solvable, the conjecture is true.

Recently, [BPP] gives a counter example to this conjecture. Recall that a *Dehn twist*  $\Psi$  along an embedded torus  $T$  on a 3-manifold  $M$  is a diffeomorphism supported on a tubular neighborhood of  $T$  of the form

$$\Psi(t, x) = (t, \psi_t(x)), \text{ for any } (t, x) \in [0, 1] \times T,$$

where  $\{\psi_t\}$  is a family of diffeomorphisms on  $T$  such that for any point  $x \in \mathbb{T}$ , the closed loop  $\{\psi_t(x)\}$  is non-null homotopy and is independent of  $x$  (see details in Definition 2.15.2). [BPP] built a Franks-Williams type of non-transitive Anosov flow with two transverse tori and the construction of the flow gives very precise description about the transverse foliations on the transverse tori induced by the stable and unstable foliations, see Lemma 4.1 in [BPP]. The new partially hyperbolic diffeomorphism  $f_B$  by [BPP] is obtained by

composing time  $t$ -map (for  $t > 0$  large) of this special non-transitive Anosov flow  $\{\phi_s\}_{s \in \mathbb{R}}$  on a 3-manifold  $N$  with a Dehn twist along a *transverse torus*. Their construction strongly depends on the properties of the non-transitive Anosov flow. [BPP] asserts that  $f_B$  is *dynamically coherent* and is, up to finite iterations and finite lifts, neither isotopic to identity nor leaf conjugate to time one map of any Anosov flow. The dynamical coherence is guaranteed by the following property: there exists a constant  $C > 1$  such that

$$\frac{1}{C} \leq \|Df_B^n|_{E^c(x)}\| \leq C, \text{ for any } x \in N \text{ and any integer } n \in \mathbb{Z}.$$

The composed Dehn twist forbids  $f_B$  to be isotopic to identity and to be leaf conjugate to time one map of an Anosov flow. Since  $N$  supports an Anosov flow, by the result in [PT], the fundamental group of  $N$  has exponential growth, which cannot happen to  $\mathbb{T}^3$  or the lifts of  $\mathbb{T}^3$ . As a consequence, the diffeomorphism  $f_B$  is a counter example for Conjecture 1.

The main motivation of this section is to present a general construction of new examples of partially hyperbolic diffeomorphisms on closed 3-manifolds given in [BZ1]. We recall that each non-transitive Anosov flow on an oriented 3-manifold admits transverse tori in the wandering domain: *we first fix a smooth Lyapunov function for this Anosov flow, and we take a regular value in the range of the Lyapunov function out of the non-wandering part, then one can show that the pre-image of this regular value is the union of finite transverse tori and every orbit intersects at most one of the transverse tori in at most one point, see the precise explanation in Section 2.16*. Moreover, one can prove that such transverse tori are *incompressible*, that is, every non-null homotopic loop on the transverse torus is non-null homotopy on the manifold, see [Br].

For each transverse torus on this regular level, we would compose a Dehn twist along this transverse torus with time  $t$ -map of the Anosov flow (for  $t > 0$  large) and we keep the partial hyperbolicity of the diffeomorphism.

Now, we can state our main result on building new partially hyperbolic diffeomorphisms.

**Theorem H.** [BZ1] *Let  $X$  be a smooth (non-transitive) Anosov vector field on an oriented closed 3-manifold  $M$  and let  $T_1, \dots, T_k$  be the transverse tori on a regular level of a smooth Lyapunov function of  $X_t$ .*

*Then there exist  $t > 0$  large and a family  $\{\Psi_i\}_{i=1}^k$  of Dehn twists supported on  $\{X_s(T_i)\}_{s \in [0, t]}$  so that the composition*

$$f_{bz} = \Psi_1 \circ \Psi_2 \circ \dots \circ \Psi_k \circ X_t$$

*is an absolute partially hyperbolic diffeomorphism of  $M$ .*

*Furthermore,  $f_{bz}$  is robustly dynamically coherent; the center stable foliation  $\mathcal{F}^{cs}$  and center unstable foliation  $\mathcal{F}^{cu}$  are plaque expansive.*

**Remark 1.1.1.** *Using the argument in [BPP], one can show that*

- *if  $k \geq 2$ , any lift of the diffeomorphism  $f_{b_z}^n$  is not isotopic to identity;*
- *there exist center leaves which are not fixed by the iterations of  $f_{b_z}$ .*

To ensure that the time  $t$ -map of the non-transitive Anosov flow composed with a Dehn twist is partially hyperbolic, it's necessary to keep the transversality of some bundles, which requires us to choose an appropriate Dehn twist preserving some transversality. First, one requires the Dehn twists to keep the transversality of the two foliations on the transverse tori. The existence of such Dehn twists on transverse tori for the flow constructed in [BPP] is guaranteed by the construction, i.e. Lemma 4.1 in [BPP]. However, for general non-transitive of Anosov flows, the existence of such Dehn twists is not obvious. On each transverse torus, the existence of such kind of Dehn twist is guaranteed by a topological result on a pair of transverse  $C^1$  foliations on torus, which was missing for [BPP]. Nevertheless, this topological result deals with very elementary objects and is interesting by itself.

**Theorem 4.** [BZ1] *Let  $\mathcal{F}$  and  $\mathcal{G}$  be two  $C^1$  one-dimensional foliations on  $\mathbb{T}^2$  and they are transverse. Then there exists a continuous (for the  $C^1$ -topology) family  $\{\Phi_t\}_{t \in [0,1]}$  of  $C^1$  diffeomorphisms on  $\mathbb{T}^2$  such that*

- $\Phi_0 = \Phi_1 = Id$ ;
- *for every  $t \in [0, 1]$ , the  $C^1$  foliation  $\Phi_t(\mathcal{F})$  is transverse to  $\mathcal{G}$ ;*
- *for every point  $x \in \mathbb{T}^2$ , the closed curve  $\{\Phi_t(x)\}$  is non-null homotopic.*

Theorem 4 is proved separately in two cases, according to two cases for a pair of transverse foliations  $(\mathcal{F}, \mathcal{G})$  defined below:

- $\mathcal{F}$  and  $\mathcal{G}$  have *parallel compact leaves*, that is, there exist a compact leaf of  $\mathcal{F}$  and a compact leaf of  $\mathcal{G}$  which are in the same free homotopy class;
- $\mathcal{F}$  and  $\mathcal{G}$  have *no parallel compact leaves*. In this case either one of them has no compact leaves, or both of them have compact leaves which are in different free homotopy classes.

In the case with parallel compact leaves, we denote by  $\alpha$  the homotopy class of the compact leaves of  $\mathcal{F}$  and  $\mathcal{G}$ . The family of diffeomorphisms  $\{\Phi_t\}_{t \in [0,1]}$  in Theorem 4 can be chosen such that the homotopy class of non-null homotopic loop  $\Phi_t(x)$  is any given non-trivial element in the group  $\langle \alpha \rangle$ . The proof consists in endowing  $\mathbb{T}^2$  with coordinates in which  $\mathbb{T}^2$  is divided into vertical adjacent annuli in which the foliations are separated by affine foliations: now the vertical translations preserve the vertical annuli and map  $\mathcal{F}$  on foliations transverse to  $\mathcal{G}$ .

In the case without parallel compact leaves, for any  $0 \neq \beta \in \pi_1(\mathbb{T}^2)$ , one can show that there exists a family of diffeomorphisms  $\{\Phi_t\}_{t \in [0,1]}$  satisfying Theorem 4 such that the homotopy class of non-null homotopic loop  $\{\Phi_t(x)\}$  is  $\beta$ . The proof consists in endowing  $\mathbb{T}^2$  with coordinates in which the foliations

$\mathcal{F}$  and  $\mathcal{G}$  are separated by 2 affine foliations (i.e.  $\mathcal{F}$  and  $\mathcal{G}$  are tangent to two transverse constant cones). Thus in these coordinates every translation keeps  $\mathcal{F}$  transverse to  $\mathcal{G}$ , concluding.

### 1.1.6 Completeness of invariant foliations

The main motivation of the section is to study the invariant foliations of the new partially hyperbolic diffeomorphisms in [BZ1].

For the models in Conjecture 1, every leaf of the center stable (resp. center unstable) foliation is either a plane or a cylinder. Moreover, the center stable and center unstable foliations are complete. Recall that for a dynamically coherent partially hyperbolic diffeomorphism  $f$ , we say that the center stable foliation is *complete* if one has

$$\mathcal{F}^{ss}(\mathcal{F}^c(x)) = \mathcal{F}^{cs}(x), \text{ for any } x.$$

As we mentioned in the previous section, the diffeomorphism  $f_B$  in [BPP] is “highly different” from the Anosov flow for building it.

It is natural to ask to what extent, the properties of the three models are preserved by the new partially hyperbolic diffeomorphisms. To be precise:

**Question 9.** *Is every leaf of the center stable (resp. center unstable) foliation either a plane or a cylinder? Are the center stable and center unstable foliations complete? What is the relation between the new partially hyperbolic diffeomorphism and the Anosov flow for building it?*

In a more general context, we get the following result:

**Theorem 5.** [Z] *Let  $f$  be a partially hyperbolic diffeomorphism on a 3-manifold  $M$  with center dimension one such that there exists a constant  $c > 1$  satisfying that*

$$\frac{1}{c} \leq \|Df^n|_{E^c(x)}\| \leq c, \text{ for any } x \in M \text{ and any integer } n \in \mathbb{Z}.$$

*Then one has that*

- [HHU2] *the diffeomorphism  $f$  is dynamically coherent and is plaque expansive;*
- *the center stable foliation (resp. center unstable foliation) is complete;*
- *every leaf of the center stable foliation is a plane, a cylinder or a Möbius band. Moreover, the center stable leaf is a cylinder or a Möbius band if and only if the leaf contains a compact center leaf.*

Since the center stable and center unstable foliations are plaque expansive which is a robust property, the first and the third items are robust properties. One can ask the following:

**Question 10.** *For the partially hyperbolic diffeomorphism in Theorem 5, are the center stable and center unstable foliations robustly complete?*

By Theorem 5, for the new partially hyperbolic diffeomorphism  $f_{bz}$ , its center stable and center unstable foliations are ‘similar’ to those of the Anosov flows. Actually, we can prove that the center foliation  $\mathcal{F}^c$  of  $f_{bz}$  gives a continuous flow and this flow is topologically equivalent to the one for building it. To be precise:

**Theorem I.** *[Z] There exist a continuous flow  $\theta_t$  and a homeomorphism  $h : M \mapsto M$  such that*

- for any  $x \in M$ , one has  $\text{Orb}(x, \theta_t) = \mathcal{F}^c(x)$ ;
- for any point  $x \in M$ , one has that  $h(\text{Orb}(x, \theta_t)) = \text{Orb}(h(x), \phi_t)$ ;
- $h$  sends the positive orbits under the flow  $\theta_t$  to the positive orbits under flow  $\phi_t$ , that is,  $h(\text{Orb}^+(x, \theta_t)) = \text{Orb}^+(h(x), \phi_t)$ .

Hence, the diffeomorphism  $f_{bz}$  ‘exchanges’ the center leaves of the Anosov flow and preserves the original structure of the invariant foliations.

We don’t know if the center stable and center unstable foliations of the diffeomorphism  $f_{bz}$  are robustly complete, but with the help of the Theorem I, one can prove that

**Proposition 1.1.2.** *The center stable and center unstable foliations of  $f_B$  are robustly complete.*

**Further Questions** It is well known that the classical Lorenz attractor is *singular hyperbolic*. Its tangent bundle splits into a strong stable direction and a center direction which is volume expanding. The center direction is without dominated splitting. Lots of properties of time one map of Lorenz attractor is still unknown. One can ask the following question:

**Question.** *Let  $\Phi_1$  be the time one map of Lorenz attractor. Does there exist a neighborhood  $\mathcal{U}$  of  $\Phi_1$  such that there exists an open and dense subset  $\mathcal{V}$  of  $\mathcal{U}$  so that every  $g \in \mathcal{V}$  has a non-hyperbolic ergodic measure?*

For the flow, one can also ask:

**Question.** *Let  $X$  be a  $C^1$  vector field with a Lorenz attractor and  $\sigma_X$  be the singularity in this attractor. Does there exist an open neighborhood  $\mathcal{U}_X$  of  $X$  such that for an open and dense subset of  $\mathcal{U}_X$ , one has that the Dirac measure supported on  $\sigma_Y$  is approximated by periodic measures.*

**Organization of the thesis** In Chapter 2, we state the notations and known results that we need in this thesis. We contribute Chapter 3 to the existence of non-hyperbolic ergodic measures, we first give the proofs of Theorems A and B, then we give the proof of our result on the existence of non-hyperbolic ergodic measures with more than one vanishing Lyapunov exponents, that is, Theorem C. In Chapter 4, we first give the proofs of local results: Theorems

D and E, then we apply the local arguments to the global setting to give the proofs of Theorems F and G. We first give the proof of the topological result on  $\mathbb{T}^2$  for the existence of Dehn twists for keeping the transversality of transverse foliations, then we end Chapter 5 by giving the proof of Theorem H. In Chapter 6, we analyze the invariant manifolds of the new partially hyperbolic diffeomorphisms given in previous chapter, then we give the proof of Theorem I.

# Chapter 2

## Preliminaries

In this chapter, we will collect some notations and some results that we need. We start by recalling very classical notions, as hyperbolic basic set and dominated splitting. In this chapter, if it is not specifically mentioned, we would denote by  $f$  a diffeomorphism on a closed manifold  $M$ .

### 2.1 Dominated splitting, partial hyperbolicity and hyperbolicity

Given an integer  $T \in \mathbb{N}$ , we say that a compact  $f$ -invariant set  $K$  admits a *T-dominated splitting of index  $i$* , if there exists an invariant splitting  $T_K M = E \oplus F$  with  $\dim(E) = i$  such that

$$\frac{\|Df^T|_{E(x)}\|}{m(Df^T|_{F(x)})} < \frac{1}{2}, \text{ for any } x \in K.$$

One says that  $K$  admits a *dominated splitting*, if  $K$  admits a  $T$ -dominated splitting for some  $T \in \mathbb{N}$ .

Recall that a compact  $f$ -invariant set  $K$  is called a *hyperbolic set*, if there exists an invariant hyperbolic splitting  $T_K M = E^s \oplus E^u$ , that is,  $E^s$  is uniformly contracting and  $E^u$  is uniformly expanding under  $Df$ . A hyperbolic set  $K$  is called a *hyperbolic basic set of s-index  $i$*  if one has

- $K$  is transitive and  $\dim(E^s) = i$ ;
- there exists an open neighborhood  $U$  of  $K$  such that  $K$  is the *maximal invariant set in  $U$* , that is,

$$K = \bigcap_{i \in \mathbb{Z}} f^i(U).$$

We denote by  $ind(\Lambda)$  the s-index of  $\Lambda$ .

One important property of hyperbolic basic sets in the sense of measure is the following theorem:



**Theorem 2.1.1.** [Sig1, Theorem 1] *Let  $f \in \text{Diff}^1(M)$  and  $\Lambda$  be a hyperbolic basic set. Then any  $f$  invariant measure supported on  $\Lambda$  is approximated by periodic measures.*

Given a compact invariant set  $K$ . One says that  $K$  is *partially hyperbolic* if there is a  $Df$ -invariant splitting  $T_K M = E^s \oplus E^c \oplus E^u$  so that

**(P1):** there is an integer  $N > 0$  such that for any  $x \in K$  and any unit vectors  $u \in E^s(x)$ ,  $v \in E^c(x)$  and  $w \in E^u(x)$ , one has:

$$\|Df^N(u)\| < \inf\{1, \|Df^N(v)\|\} \leq \sup\{1, \|Df^N(v)\|\} < \|Df^N(w)\|.$$

One says that  $K$  is *absolute partially hyperbolic* if it is partially hyperbolic satisfying the stronger assumption

**(P2):** there are  $0 < \lambda < 1 < \sigma$  and an integer  $N > 0$  so that for any  $x, y, z \in K$  and any unit vectors  $u \in E^s(x)$ ,  $v \in E^c(y)$  and  $w \in E^u(z)$ , one has:

$$\|Df^N(u)\| < \lambda < \|Df^N(v)\| < \sigma < \|Df^N(w)\|.$$

Furthermore, a diffeomorphism  $f$  of a Riemannian closed manifold  $M$  is called *partially hyperbolic* if  $M$  is a partially hyperbolic set, and  $f$  is called *absolute partially hyperbolic* if  $M$  is a absolute partially hyperbolic set. We refer the readers to [BDV, Appendix B] for the first elementary properties and [HHU1] for a survey book of results and questions for partially hyperbolic diffeomorphisms.

## 2.2 Chain recurrence and homoclinic class

In the study of differential dynamics, there are two ways widely used to cut the dynamics into pieces: chain recurrence class and homoclinic class.

Let  $(X, d)$  be a compact metric space and  $h$  be a homeomorphism on  $X$ . Given two points  $x, y \in X$ , we define the relation  $x \dashv y$ , if and only if for any  $\epsilon > 0$ , there exist finite points  $x = z_0, z_1, \dots, z_k = y$ , where  $k \geq 1$ , such that

$$d(h(z_i), z_{i+1}) \leq \epsilon, \text{ for any } 0 \leq i \leq k - 1.$$

We define the relation  $x \dashv\vdash y$  if and only if  $x \dashv y$  and  $y \dashv x$ .

The *chain recurrent set* of  $f$  is defined as

$$\mathcal{R}(h) = \{x \in X : x \dashv\vdash x\}.$$

It's well known that  $\dashv\vdash$  is an equivalent relation on  $\mathcal{R}(h)$ . Hence,  $\mathcal{R}(h)$  can be decomposed into different equivalent classes, each of which is called a *chain recurrence class*.

Homoclinic classes can also be defined in the following way.

**Definition 2.2.1.** Let  $f \in \text{Diff}^1(M)$ . Given two hyperbolic periodic orbits  $\mathcal{O}_p$  and  $\mathcal{O}_q$  of  $f$ .  $\mathcal{O}_p$  and  $\mathcal{O}_q$  are said to be homoclinically related, if there exist a non-empty transverse intersection between  $W^s(\mathcal{O}_p)$  and  $W^u(\mathcal{O}_q)$ , and a non-empty transverse intersection between  $W^u(\mathcal{O}_p)$  and  $W^s(\mathcal{O}_q)$ .

Let  $\mathcal{O}_p$  be a hyperbolic periodic orbit, the *homoclinic class* of  $\mathcal{O}_p$  is defined as:

$$H(p, f) := \overline{\{\mathcal{O}_q \mid \mathcal{O}_q \text{ is homoclinically related to } \mathcal{O}_p\}}.$$

Let  $\mathcal{O}_p$  and  $\mathcal{O}_q$  be two hyperbolic periodic orbits and  $V$  be an open neighborhood of  $\mathcal{O}_p \cup \mathcal{O}_q$ . We say that  $\mathcal{O}_p$  and  $\mathcal{O}_q$  are *homoclinically related inside  $V$* , if there exist two transverse intersections  $x \in W^u(\mathcal{O}_p) \cap W^s(\mathcal{O}_q)$  and  $y \in W^s(\mathcal{O}_p) \cap W^u(\mathcal{O}_q)$  such that  $\overline{\text{Orb}(x)} \cup \overline{\text{Orb}(y)} \subset V$ .

One can check that a homoclinic class is a transitive set, hence it is contained in a chain recurrence class. In differential world, the following lemma from [BC] shows that for the ‘most’ dynamical systems, the homoclinic class is indeed a chain recurrence class.

**Lemma 2.2.2.** For  $C^1$ -generic diffeomorphisms, the chain recurrence class of a hyperbolic periodic orbit  $Q$  coincides with its homoclinic class  $H(Q)$ .

## 2.3 Lyapunov exponents, Oseledets splitting and hyperbolic ergodic measure

In the celebrated paper [O], V. Oseledets proves that for any ergodic measure  $\mu$  of a diffeomorphism  $f$ , we have the following:

1. there exists a  $\mu$ -full measure set  $K$  such that  $f(K) = K$ ;
2. there exist  $s \leq \dim(M)$  numbers  $\lambda_1 < \dots < \lambda_s$  and an invariant measurable splitting over  $K$  of the form  $T_K M = E_1 \oplus \dots \oplus E_s$  such that for any integer  $1 \leq t \leq s$ , any  $x \in K$  and any  $v \in \oplus_{i=1}^t E_i(x) \setminus \oplus_{i=1}^{t-1} E_i(x)$ , we have that

$$\lim_{n \rightarrow +\infty} \frac{1}{n} \log \| Df_x^n v \| = \lambda_t.$$

The numbers  $\lambda_1, \dots, \lambda_s$  are called the *Lyapunov exponents* of  $\mu$ , the full measure set  $K$  is called the *Oseledets basin* of  $\mu$  and the splitting  $T_K M = E_1 \oplus \dots \oplus E_s$  is called the *Oseledets splitting* of  $\mu$ .

An ergodic measure  $\mu$  is called a *hyperbolic ergodic measure*, if all the Lyapunov exponents of  $\mu$  are non-zero. Let  $K$  be the Oseledets basin of  $\mu$ , we denote by  $E^- \oplus E^+$  the invariant splitting over  $K$  such that all the Lyapunov exponents along  $E^-$  are negative and all the Lyapunov exponents along  $E^+$  are positive. Then the invariant splitting  $T_K M = E^- \oplus E^+$  is called the *non-uniform hyperbolic splitting*. We say that the *non-uniform hyperbolic splitting*

is *dominated* if there exists a dominated splitting over the closure of  $K$  of the form  $T_{\bar{K}}M = E \oplus F$  such that  $\dim(E) = \dim(E^-)$ .

There exists another expression for the Lyapunov exponents of an ergodic measure. Let  $f \in \text{Diff}^1(M)$  and  $\nu$  be an  $f$ -ergodic measure. We denote by

$$\chi_1(\nu, f) \leq \dots \leq \chi_d(\nu, f)$$

all the Lyapunov exponents of  $\nu$  counted by multiplicity. We define a continuous function on  $M$  as:

$$L_i^n(x, f) = \frac{1}{n} \log \| \wedge^i \text{Df}^n(x) \|.$$

Then, for  $\nu$ -a.e.  $x \in M$ , we have that

$$\chi_i(\nu, f) = \lim_{n \rightarrow \infty} (L_{d-i+1}^n(x, f) - L_{d-i}^n(x, f)).$$

## 2.4 Choquet and Poulsen Simplex

**Definition 2.4.1.** *Let  $K$  be a non-empty compact convex subset of a locally convex vector space. Then*

- $K$  is said to be a Choquet simplex, if every point of  $K$  is the barycenter of a unique probability measure supported on the set of extreme points of  $K$ .
- $K$  is said to be a Poulsen simplex if  $K$  is a Choquet Simplex so that the set of extreme points of  $K$  is strictly contained in  $K$  and is dense in  $K$ .

Recall that E. Poulsen [Poul] constructs the first Choquet simplex whose extreme points are dense. The result in [LOS] shows that any two metricable non-trivial simplices with dense extreme points are equivalent up to affine homeomorphisms, hence one can consider these spaces as Poulsen simplex<sup>1</sup>.

Let  $C$  be a compact  $f$ -invariant set. We denote by  $\mathcal{M}_{inv}(C, f)$  the set of invariant measures supported on  $C$ . A classical result is that  $\mathcal{M}_{inv}(C, f)$  is always a Choquet simplex, hence Sigmund's theorem (see [Sig1]) shows that if  $C$  is a hyperbolic basic set then  $\mathcal{M}_{inv}(C, f)$  is a Poulsen Simplex.

## 2.5 Good approximation and [GIKN] criterion

In this subsection, we state the [GIKN] criterion ensuring that a sequence of periodic measures converges to an ergodic measure. This criterion is firstly used in [GIKN, KN] and is developed in [BDG] for building non-hyperbolic ergodic measures as the limit of periodic measures.

---

1. I thank Lorenzo. Díaz for pointing out this fact.

**Definition 2.5.1.** *Given a compact metric space  $(X, d)$  and let  $f : X \mapsto X$  be a continuous map. Fix  $\epsilon > 0$  and  $\kappa \in (0, 1)$ . Let  $\gamma_1$  and  $\gamma_2$  be two periodic orbits of  $f$ , and we denote by  $\pi(\gamma_i)$  the period of the periodic orbit  $\gamma_i$  for  $i = 1, 2$ . Then, the periodic orbit  $\gamma_1$  is said to be a  $(\epsilon, \kappa)$  good approximation for  $\gamma_2$ , if there exist a subset  $\gamma_{1,\epsilon}$  of  $\gamma_1$  and a projection  $\mathcal{P} : \gamma_{1,\epsilon} \rightarrow \gamma_2$  such that:*

- for every  $y \in \gamma_{1,\epsilon}$  and every  $i = 0, \dots, \pi(\gamma_2) - 1$ , one has

$$d(f^i(y), f^i(\mathcal{P}(y))) < \epsilon;$$

- the proportion of  $\gamma_{1,\epsilon}$  in  $\gamma_1$  is larger than  $\kappa$ . In formula:

$$\frac{\#\gamma_{1,\epsilon}}{\pi(\gamma_1)} \geq \kappa.$$

- the cardinal of the pre-image  $\mathcal{P}^{-1}(x)$  is the same for all  $x \in \gamma_2$ .

We can now state the [GIKN] criterion refined in [BDG]:

**Lemma 2.5.2.** *[BDG, Lemma 2.5] Let  $(X, d)$  be a compact metric space and  $f : X \mapsto X$  be a homeomorphism. Let  $\{\gamma_n\}_{n \in \mathbb{N}}$  be a sequence of periodic orbits whose periods tend to infinity. We denote by  $\mu_n$  the Dirac measure of  $\gamma_n$ .*

*Assume that the orbit  $\gamma_{n+1}$  is a  $(\epsilon_n, \kappa_n)$  good approximation for  $\gamma_n$ , where  $\epsilon_n > 0$  and  $0 < \kappa_n < 1$  satisfy*

$$\sum_n \epsilon_n < \infty \text{ and } \prod_n \kappa_n > 0.$$

*Then the sequence  $\{\mu_n\}$  converges to an ergodic measure  $\nu$  whose support is given by*

$$\text{supp } \nu = \bigcap_{n=1}^{\infty} \overline{\bigcup_{k=n}^{\infty} \gamma_k}.$$

## 2.6 Shadowing lemma and approaching hyperbolic measures by periodic orbits

In this thesis, we use a shadowing lemma which is firstly given by S. Liao [L1] and is developed by S. Gan[G1]; this shadowing lemma allows us to find the periodic orbits without perturbing the dynamics.

Let  $\Lambda$  be an  $f$ -invariant compact set. Assume that there exists a  $Df$ -invariant continuous splitting  $T_\Lambda M = E \oplus F$ . For any  $\lambda < 0$ , an orbit segment  $\{x, n\} := \{x, \dots, f^n(x)\}$  contained in  $\Lambda$  is called a  $\lambda$ -quasi hyperbolic string, if the followings are satisfied:

- **Uniform contraction of  $E$  by  $Df$ , from  $x$  to  $f^n(x)$ :**

$$\frac{1}{k} \sum_{i=0}^{k-1} \log \|Df|_{E(f^i(x))}\| \leq \lambda,$$

for every  $k = 1, \dots, n$ ;

— **Uniform contraction of  $F$  by  $Df^{-1}$ , from  $f^n(x)$  to  $x$**

$$\frac{1}{n-k} \prod_{i=k}^{n-1} \log m(Df|_{F(f^i(x))}) \geq -\lambda,$$

for every  $k = 0, \dots, n-1$ ;

— **Domination of  $E$  by  $F$  from  $x$  to  $f^n(x)$**

$$\log \|Df|_{E(f^i(x))}\| - \log m(Df|_{F(f^i(x))}) \leq 2\lambda,$$

for every  $i = 0, \dots, n-1$ .

**Remark 2.6.1.** *From the definition, we can easily check that a  $\lambda$ -quasi hyperbolic string is also a  $\frac{\lambda}{2}$ -quasi hyperbolic string.*

**Definition 2.6.2.** *Consider  $d > 0$  and  $\lambda < 0$ . Let  $\{x_i\}_{i \in \mathbb{Z}}$  be a sequence of points in  $\Lambda$  and  $\{n_i\}_{i \in \mathbb{Z}}$  be a sequence of positive integers. We say that the sequence of orbit segments  $\{\{x_i, n_i\}\}_{i \in \mathbb{Z}}$  is a  $\lambda$ -quasi hyperbolic  $d$ -pseudo orbit if for any  $i$ , we have:*

- $d(f^{n_i}(x_i), x_{i+1}) \leq d$ ,
- the orbit segment  $\{x_i, n_i\}$  is a  $\lambda$ -quasi hyperbolic string.

We say that a  $\lambda$ -quasi hyperbolic  $d$ -pseudo orbit  $\{\{x_i, n_i\}\}_{i \in \mathbb{Z}}$  is *periodic*, if there exists a positive integer  $m$  such that  $n_{i+m} = n_i$  and  $x_{i+m} = x_i$  for all  $i$ . Then, assuming that  $m$  is the smallest such positive integer, the sum  $\sum_{i=0}^{m-1} n_i$  is the *period* of the pseudo orbit.

**Definition 2.6.3.** *Let  $\{x_i\}_{i \in \mathbb{Z}}$  be a sequence of points and  $\{n_i\}_{i \in \mathbb{Z}}$  be a sequence of strictly positive integers. We define*

$$T_i = \begin{cases} 0 & \text{if } i = 0 \\ n_0 + \dots + n_{i-1} & \text{if } i > 0 \\ -n_{-i} - \dots - n_{-1} & \text{if } i < 0 \end{cases}$$

*Let  $\epsilon > 0$ , we say that the orbit of a point  $x$   $\epsilon$ -shadows  $\{\{x_i, n_i\}\}_{i \in \mathbb{Z}}$  if for any  $i \in \mathbb{Z}$  and  $T_i \leq j \leq T_{i+1} - 1$ , we have that*

$$d(f^j(x), f^{j-T_i}(x_i)) < \epsilon.$$

Now, we are ready to state the shadowing lemma for quasi hyperbolic pseudo orbit.

**Lemma 2.6.4.** *[G1] Assume that  $\Lambda$  is an  $f$ -invariant compact set and there exists an  $f$ -invariant continuous splitting  $T_\Lambda M = E \oplus F$ .*

*Then, for any  $\lambda < 0$ , there exist  $L > 0$  and  $d_0 > 0$  such that for any  $d \in (0, d_0]$  and any  $\lambda$ -quasi hyperbolic  $d$ -pseudo orbit  $\{\{x_i, n_i\}\}_{i \in \mathbb{Z}}$ , there exists a point  $x$  whose orbit  $L \cdot d$  shadows  $\{\{x_i, n_i\}\}_{i \in \mathbb{Z}}$ .*

*If moreover the quasi hyperbolic pseudo-orbit  $\{\{x_i, n_i\}\}_{i \in \mathbb{Z}}$  is periodic, then the point  $x$  can be chosen to be periodic with the same period.*

**Remark 2.6.5.** *If the splitting  $T_\Lambda M = E \oplus F$  is a dominated splitting,*

Lemma 2.6.4 (together with the  $C^1$ -Pesin theory in [ABC]) has been used by S. Crovisier [C] for approaching hyperbolic ergodic measures with periodic orbits:

**Proposition 2.6.6.** *[C, Proposition 1.4] Let  $f \in \text{Diff}^1(M)$  and  $\mu$  be a hyperbolic ergodic measure whose non-uniform hyperbolic splitting  $E^- \oplus E^+$  is dominated. Then  $\mu$  is supported on a homoclinic class.*

*Moreover, there exists a sequence of periodic orbits  $\{\gamma_n\}_{n \in \mathbb{N}}$  of  $s$ -index  $\dim(E^-)$  which are pairwise homoclinically related, such that  $\gamma_n$  converges to the support of  $\mu$  for the Hausdorff topology and the Dirac measure supported on  $\gamma_n$  converges to  $\mu$  in the weak\*-topology.*

**Remark 2.6.7.** *This result is firstly obtained by [G2] on surfaces.*

## 2.7 Plaque family and estimate on the size of invariant manifold

In this section, let  $\Lambda$  be a compact  $f$ -invariant set with a dominated splitting  $T_\Lambda M = E \oplus F$ .

We recall the *Plaque family theorem* by [HPS] showing that there exist invariant plaque families for dominated splitting. Given a continuous bundle  $G$  over a set  $K$ , for any  $x \in K$  and  $r > 0$ , we denote by  $G_x(r) = \{v \in G_x \mid \|v\| \leq r\}$  and denote by  $G(r) = \cup_{x \in K} G_x(r)$ .

**Lemma 2.7.1.** *Let  $\Lambda$  be a compact  $f$ -invariant set admitting a dominated splitting  $T_\Lambda M = E \oplus F$ . Then there exist two continuous maps  $W^{cs} : E(1) \rightarrow M$  and  $W^{cu} : F(1) \rightarrow M$  satisfying the followings:*

- *for any  $x \in \Lambda$ , the induced map  $W_x^{cs} : E_x(1) \mapsto M$  (resp.  $W_x^{cu} : F_x(1) \mapsto M$ ) is a  $C^1$  embedding and is tangent to  $E_x$  (resp.  $F_x$ ) at the point  $x = W_x^{cs}(0)$  (reps.  $x = W_x^{cu}(0)$ ).*
- *the families  $\{W_x^{cs}\}_{x \in \Lambda}$  and  $\{W_x^{cu}\}_{x \in \Lambda}$  of  $C^1$  embedding maps are continuous;*
- *there exists a neighborhood  $U_E$  (resp.  $U_F$ ) of zero section in  $E$  (resp.  $F$ ) such that the image of  $W_x^{cs}(E_x \cap U_E)$  (resp.  $W_x^{cu}(F_x \cap U_F)$ ) by  $f$  (resp.  $f^{-1}$ ) is contained in  $W_x^{cs}(E_x)$  (reps.  $W_x^{cu}(F_x \cap U_F)$ ).*

We denote by  $W_\delta^{cu}(x) = W_x^{cu}(F_x(\delta))$  and  $W_\delta^{cs}(x) = W_x^{cs}(E_x(\delta))$ , for  $\delta \in (0, 1]$ .

**Definition 2.7.2.** *Let  $\Lambda$  be a compact invariant set admitting a dominated splitting  $T_\Lambda M = E \oplus F$ . Given  $\lambda < 0$ . A point  $x \in \Lambda$  is called a  $(\lambda, E)$*

hyperbolic time if we have the following:

$$\sum_{i=0}^{n-1} \log \|Df|_{E(f^i(x))}\| \leq n \cdot \lambda, \text{ for any integer } n \geq 1.$$

Similarly, we can define the  $(-\lambda, F)$ -hyperbolic time which is a  $(\lambda, F)$  hyperbolic time for  $f^{-1}$ .

By Lemma 2.7.1, we can fix a plaque family  $W^{cs}$  corresponding to the bundle  $E$ . The following lemma guarantees the existence of stable manifold at a  $(\lambda, E)$  hyperbolic time. The proof is classical (see for instance [ABC, Section8.2]).

**Lemma 2.7.3.** *For any  $\lambda < 0$ , there exists  $\eta > 0$  such that for any  $(\lambda, E)$  hyperbolic time  $x$ , we have that the disc  $W_\eta^{cs}(x)$  is contained in the stable manifold of  $x$ .*

**Remark 2.7.4.** *Similar result holds for  $(-\lambda, F)$  hyperbolic time.*

To find the  $(\lambda, E)$  hyperbolic time, we need the following well known result:

**Lemma 2.7.5.** *[Pl] Given a number  $b$ . Consider a sequence of numbers  $a_1, \dots, a_n$  bounded from above by  $b$ . Assume that there exists a number  $c < b$  such that  $\sum_{i=1}^n a_i \geq n \cdot c$ .*

*Then for any number  $c' < c$ , there exist  $l$  integers  $t_1, \dots, t_l \subset [1, n]$  satisfying that:*

$$\sum_{i=j}^{t_k} a_i \geq (t_k - j + 1)c', \text{ for any } k = 1, \dots, l \text{ and any } j = 1, \dots, t_k.$$

Moreover, we have  $\frac{l}{n} \geq \frac{c-c'}{b-c'}$ .

Let  $p$  be a periodic point and  $\lambda$  be a negative number. Assume that there exists a  $Df$  invariant splitting  $T_{\mathcal{O}_p}M = E \oplus F$  over the orbit  $\mathcal{O}_p$ . The point  $p$  is called a  $\lambda$  bi-hyperbolic time if for any  $k = 1, \dots, \pi(p)$ , we have that

$$\frac{1}{k} \sum_{i=0}^{k-1} \log \|Df|_{E(f^i(p))}\| \leq \lambda$$

and

$$\frac{1}{k} \sum_{i=0}^{k-1} \log \|Df^{-1}|_{F(f^{-i}(p))}\| \leq \lambda.$$

The following classical lemma gives the existence of bi-hyperbolic time (see for instance [Wa, Lemma 2.21]).

**Lemma 2.7.6.** *Let  $f \in \text{Diff}^1(M)$  and  $p$  be a periodic point. Assume that there exists a  $Df$  invariant splitting  $T_{\mathcal{O}_p}M = E \oplus F$  and a number  $\lambda < 0$  satisfying that*

$$\frac{1}{\pi(p)} \sum_{i=0}^{\pi(p)-1} \log \| Df|_{E(f^i(p))} \| \leq \lambda$$

$$\frac{1}{\pi(p)} \sum_{i=0}^{\pi(p)-1} \log \| Df^{-1}|_{F(f^{-i}(p))} \| \leq \lambda.$$

—  $\log \| Df|_{E(f^i(p))} \| + \log \| Df^{-1}|_{F(f^{i+1}(p))} \| \leq 2 \cdot \lambda$ , for any integer  $i$ .

Then for any  $\lambda' \in (\lambda, 0)$ , there exists a point  $q \in \mathcal{O}_p$  such that  $q$  is a  $\lambda'$  bi-hyperbolic time.

## 2.8 Blender

*Blender* is a powerful tool in the study of robustly non-hyperbolic phenomena. In this subsection, we will state a new definition of blender recently defined by [BBD3], and a special blender called *blender horseshoe* given in [BD2].

### 2.8.1 Dynamically defined blender

Let's first recall some notations in [BBD3]. Let  $D^i(M)$  be the set of  $C^1$  embedded  $i$ -dimensional compact discs on a compact Riemannian manifold  $M$ . We endow  $D^i(M)$  with  $C^1$ -topology in the following way: for any  $D \in D^i(M)$ , which is the image of the embedding  $\phi : \mathbb{D}^i \mapsto M$  where  $\mathbb{D}^i$  is the  $i$ -dimensional closed unit disc in  $\mathbb{R}^i$ , we define the  $C^1$  neighborhood of  $D$  as the set of the images of all the embedding maps contained in a  $C^1$  neighborhood of  $\phi$ .

For any  $D_1, D_2 \in D^i(M)$ , one can define their distance as

$$\rho(D_1, D_2) = d_{Haus}(TD_1, TD_2) + d_{Haus}(T\partial D_1, T\partial D_2),$$

where  $d_{Haus}(\cdot, \cdot)$  denotes the Hausdorff distance on the corresponding Grassmann manifold. It has been proven in [BBD3, Section 3.1] that the distance  $\rho(\cdot, \cdot)$  induces the  $C^1$ -topology in  $D^i(M)$ .

Let  $f \in \text{Diff}^1(M)$ , and  $\mathfrak{D}$  be a family of  $i$ -dimensional embedded discs. For any  $\epsilon > 0$ , we denote by  $\mathcal{V}_\epsilon(\mathfrak{D})$  the  $\epsilon$ -neighborhood of  $\mathfrak{D}$  for the distance  $\rho(\cdot, \cdot)$ .

The family  $\mathfrak{D}$  is called a *strictly invariant family*, if there exists  $\epsilon > 0$  such that for any  $D \in \mathcal{V}_\epsilon(\mathfrak{D})$ , its image  $f(D)$  contains an element of  $\mathfrak{D}$ . The number  $\epsilon$  is called the strength of the strictly invariant family  $\mathfrak{D}$ .



**Definition 2.8.1.** (*Dynamical Blender*) Let  $f \in \text{Diff}^1(M)$ . A hyperbolic basic set  $\Lambda$  of  $f$  is called a dynamically defined cu-blender of  $uu$ -index  $i$ , if the followings are satisfied:

- there exists a dominated splitting of the form  $T_\Lambda M = E^s \oplus E^c \oplus E^{uu}$  over  $\Lambda$ ; where  $\dim(E^s) = \text{ind}(\Lambda)$ ,  $\dim(E^c) > 0$  and  $\dim(E^{uu}) = i$ .
- there exists a neighborhood  $U$  of  $\Lambda$  such that  $\Lambda = \bigcap_{n \in \mathbb{Z}} f^n(U)$  and there exists a  $Df$ -strictly invariant continuous cone field  $\mathcal{C}^{uu}$  of index  $i$  defined on  $\bar{U}$ ;
- there is a strictly invariant family  $\mathfrak{D} \subset D^i(M)$  of discs with strength  $\epsilon > 0$  such that every disc  $D \in \mathcal{V}_\epsilon(\mathfrak{D})$  is tangent to  $\mathcal{C}^{uu}$  and is contained in  $U$ .

The set  $U$  is called the domain of  $\Lambda$ , the cone field  $\mathcal{C}^{uu}$  is called the strong unstable cone field of  $\Lambda$  and the family  $\mathfrak{D}$  is called strictly invariant family of discs. We denote the dynamically defined cu-blender as  $(\Lambda, U, \mathcal{C}^{uu}, \mathfrak{D})$

We can also define the *cs-blender* which is a *cu-blender* for the reversed dynamics.

**Remark 2.8.2.** [BBD3, Scholium 3.15] Let  $(\Lambda, U, \mathcal{C}^{uu}, \mathfrak{D})$  be a dynamically defined cu-blender, there exists a disc in the local strong unstable manifold of a point in  $\Lambda$  which is approximated by discs in  $\mathfrak{D}$ .

The main property of a dynamically defined blender is the following:

**Lemma 2.8.3.** [BBD3, Lemma 3.14] Let  $(\Lambda, U, \mathcal{C}^{uu}, \mathfrak{D})$  be a dynamically defined cu-blender and  $\epsilon$  be the strength of the strictly invariant family  $\mathfrak{D}$ .

Then there exists a  $C^1$  neighborhood  $\mathcal{U}$  of  $f$  such that for any  $g \in \mathcal{U}$ , one has

- Let  $\Lambda_g$  be the continuation of  $\Lambda$ . For any  $D \in \mathcal{V}_{\epsilon/2}(\mathfrak{D})$ , one has that  $W^s(\Lambda_g) \cap D \neq \emptyset$ ;
- the continuation  $(\Lambda_g, U, \mathcal{C}^{uu}, \mathcal{V}_{\epsilon/2}(\mathfrak{D}))$  is a dynamically defined blender for  $g$ .

We call the open family  $\mathcal{V}_{\epsilon/2}(\mathfrak{D})$  the superposition region of the blender  $(\Lambda, U, \mathcal{C}^{uu}, \mathfrak{D})$ .

## 2.8.2 Blender horseshoe

In this part, we recall the main feature of a special and simplest blender called *blender horseshoe* (for specific definition see [BD3]).

Consider  $\mathbb{R}^n = \mathbb{R}^s \oplus \mathbb{R} \oplus \mathbb{R}^u$ . For  $\alpha \in (0, 1)$ , we define the following cone fields:

$$\mathcal{C}_\alpha^s(x) = \{v = (v^s, v^c, v^u) \in \mathbb{R}^s \oplus \mathbb{R} \oplus \mathbb{R}^u = T_x M \mid \|v^c + v^u\| \leq \alpha \|v^s\|\}$$

$$\mathcal{C}_\alpha^u(x) = \{v = (v^s, v^c, v^u) \in \mathbb{R}^s \oplus \mathbb{R} \oplus \mathbb{R}^u = T_x M \mid \|v^s\| \leq \alpha \|v^c + v^u\|\}$$

$$\mathcal{C}_\alpha^{uu}(x) = \{v = (v^s, v^c, v^u) \in \mathbb{R}^s \oplus \mathbb{R} \oplus \mathbb{R}^u = T_x M \mid \|v^s + v^c\| \leq \alpha \|v^u\|\}.$$

For  $\alpha \in (0, 1)$ , one can check that  $\mathcal{C}_\alpha^s(x)$  is transverse to  $\mathcal{C}_\alpha^u(x)$  and  $\mathcal{C}_\alpha^{uu}(x)$  is contained in  $\mathcal{C}_\alpha^u(x)$  for any  $x \in \mathbb{R}^n$ .

Denote by  $C = [-1, 1]^s \times [-1, 1] \times [-1, 1]^u$ . A *blender horseshoe*  $\Lambda$  of  $u$ -index  $i + 1$  is a hyperbolic basic set of  $u$ -index  $i + 1$  for an embedding map  $f : C \mapsto \mathbb{R}^n$  such that:

- H1) the maximal invariant set in  $C$  is  $\Lambda$  and the dynamics restricted to  $C$  is a two-leg horseshoe ( hence it exhibits two fixed points  $P$  and  $Q$ ), that is, the intersection  $f^{-1}(C) \cap C$  consists of two horizontal disjoint sub-cubes  $A, B$  and the images  $f(A), f(B)$  are two vertical sub-cubes;
- H2) the set  $f(C) \cap [-1, 1]^s \times \mathbb{R} \times [-1, 1]^u$  consists of two connected components  $\mathcal{A}, \mathcal{B}$  such that  $P \in \mathcal{A}$  and  $Q \in \mathcal{B}$ . Furthermore, there exists  $\alpha \in (0, 1)$  such that the cone field  $\mathcal{C}_\alpha^s$  is strictly  $Df^{-1}$  invariant and the cone fields  $\mathcal{C}_\alpha^u, \mathcal{C}_\alpha^{uu}$  are strictly  $Df$  invariant. Moreover, for any  $x \in f^{-1}(\mathcal{A} \cup \mathcal{B})$  and any vector  $v \in \mathcal{C}_\alpha^u(x)$ ,  $v$  is uniformly expanded by  $Df$ . Similarly, the vector in  $\mathcal{C}_\alpha^s$  is uniformly contracted by  $Df$ .
- H3) A compact disc  $D^u$  of dimension  $i$  is called a *uu-disc*, if the relative interior of  $D^u$  is contained in the interior of  $C$ ,  $D^u$  is tangent to  $\mathcal{C}_\alpha^{uu}$  and the boundary of  $D^u$  is contained in  $[-1, 1]^s \times [-1, 1] \times \partial[-1, 1]^u$ . Then every uu-disc intersecting  $W_{loc}^s(P)$  (resp.  $W_{loc}^s(Q)$ ) is disjoint from  $W_{loc}^s(Q)$  (resp.  $W_{loc}^s(P)$ ).
- H4) A uu-disc  $D^u$  is *between*  $W_{loc}^s(P)$  and  $W_{loc}^s(Q)$ , if  $D^u$  is homotopic to  $W_{loc}^{uu}(P)$  in the set of uu-discs whose homotopy process is disjoint from  $W_{loc}^s(Q)$  and  $D^u$  is homotopic to  $W_{loc}^{uu}(Q)$  in the set of uu-discs whose homotopy process is disjoint from  $W_{loc}^s(P)$ . Then, for any uu-disc  $D^u$  *between*  $W_{loc}^s(P)$  and  $W_{loc}^s(Q)$ , at least one of the connected components of  $f(D^u) \cap C$  is a uu-disc between  $W_{loc}^s(P)$  and  $W_{loc}^s(Q)$ .

The existence of blender horseshoes is a robust property. The items H1) and H2) imply that there exists a dominated splitting  $T_\Lambda M = E^s \oplus E^{cu} \oplus E^{uu}$  such that  $\dim(E^{uu}) = i$  and  $\dim(E^{cu}) = 1$ .

A uu-disc  $D^u$  is said to be in the *characteristic region*, if  $D^u$  is between  $W_{loc}^s(P)$  and  $W_{loc}^s(Q)$ . According to item H4) above, for any uu-disc  $D^u$  in the characteristic region,  $f(D^u)$  contains a uu-disc in the characteristic region.

By items H1) and H2), there exists  $\epsilon_1 > 0$  such that

$$\mathcal{A} \cup \mathcal{B} \subset (-1 + \epsilon_1, 1 - \epsilon_1)^s \times [-1, 1] \times [-1, 1]^u$$

and

$$f^{-1}(\mathcal{A} \cup \mathcal{B}) \subset [-1, 1]^s \times [-1, 1] \times (-1 + \epsilon_1, 1 - \epsilon_1)^u.$$

A compact disc  $S$  of dimension  $i + 1$  is called a *cu-strip* if  $S$  is tangent to the cone field  $\mathcal{C}_\alpha^u$  and is the image of a  $C^1$ -embedding map

$$\Phi : [-1, 1] \times [-1, 1]^u \mapsto [-1 + \epsilon_1, 1 - \epsilon_1]^s \times [-1, 1] \times [-1, 1]^u$$

satisfying that  $\Phi(\{t\} \times [-1, 1]^u)$  is a uu-disc, for any  $t \in [-1, 1]$ . The *cu-strip*  $S$  is called in the characteristic region if for any  $t \in [-1, 1]$ ,  $\Phi(\{t\} \times [-1, 1]^u)$  is

between  $W_{loc}^s(P)$  and  $W_{loc}^s(Q)$ . The uu-discs  $\Phi(\{-1\} \times [-1, 1]^u)$  and  $\Phi(\{1\} \times [-1, 1]^u)$  are called *the vertical boundary components of  $S$* . For any  $cu$ -strip  $S$ , we define the *central length  $\ell^c(S)$  of  $S$*  as the minimum length of all  $C^1$  curves in  $S$  joining the two vertical boundary components of  $S$ .

In the rest of this subsection, we fix  $f \in \text{Diff}^1(M)$  exhibiting a blender horseshoe  $\Lambda$  corresponding to the cube  $C$ . We fix  $\tau > 1$  such that for any  $x \in C \cap f^{-1}(C)$  and  $v \in \mathcal{C}_\alpha^u(x)$ , one has  $\|Df(v)\| \geq \tau \cdot \|v\|$ .

**Lemma 2.8.4.** *The blender horseshoe  $\Lambda$  is a dynamically defined blender.*

*Proof.* Let  $\mathfrak{D}'$  be the set of uu-discs  $D$  satisfying that

- $D$  is in the characteristic region of the blender;
- $D$  is contained in  $[-1 + \epsilon_1, 1 - \epsilon_1]^s \times [-1, 1] \times [-1, 1]^u$ .

By item H3) above, there exists  $\epsilon_2 > 0$  such that for any  $cu$ -strip  $S_1$  of central length  $2\epsilon_2$  which intersects  $W_{loc}^s(P)$  and any  $cu$ -strip  $S_2$  of central length  $2\epsilon_2$  which intersects  $W_{loc}^s(Q)$ , we have that  $S_1$  and  $S_2$  are disjoint.

Since the existence of blender horseshoes is robust, there exists  $\epsilon_3 > 0$  such that for any diffeomorphism  $g$   $\epsilon_3$ -close to  $f$ , the continuation  $\Lambda_g$  is a blender horseshoe corresponding to the cube  $C$ . Let  $\epsilon = \min\{\epsilon_2, \epsilon_3\}$ .

For any  $\delta > 0$  small, we denote by  $\mathfrak{D}_\delta$  the set of uu-discs  $D^u \in \mathfrak{D}'$  such that there exists a  $cu$ -strip  $S$  which is disjoint from  $W_{loc}^s(P) \cup W_{loc}^s(Q)$  and is defined by

$$\phi : [-1, 1] \times [-1, 1]^u \mapsto [-1 + \epsilon_1, 1 - \epsilon_1]^s \times [-1, 1] \times [-1, 1]^u$$

satisfying that

- $\phi(\{0\} \times [-1, 1]^u) = D^u$ ,
- the central length of the  $cu$ -strips  $\phi([0, 1] \times [-1, 1]^u)$  and  $\phi([-1, 0] \times [-1, 1]^u)$  are  $\delta$ ;

One can check that

$$\emptyset \neq \mathfrak{D}_\delta \subsetneq \mathfrak{D}_{\delta'}, \text{ for any } \delta' < \delta \text{ small.}$$

**Claim 2.8.5.** *There exists  $\delta_0 > 0$  small such that  $\mathfrak{D}_{\delta_0}$  is a strictly invariant family.*

*Proof.* We denote by  $c = \sup_{x \in C} \|Df(x)\| > \tau$ . By the uniform expansion of  $Df$  along  $\mathcal{C}_\alpha^u$ , there exists  $\delta_1 < \frac{\epsilon}{2c}$  small enough such that for any  $\delta \leq \delta_1$  and any uu-disc  $D^u \in \mathfrak{D}_\delta \setminus \mathfrak{D}_{2\delta}$ , we have that  $f(D)$  contains a uu-disc in  $\mathfrak{D}_{\tau\delta}$ .

Let  $\delta_0 = \frac{1}{2}\delta_1$  and  $\delta' = \tau\delta_0 < \epsilon$ . We will prove that for any  $D \in \mathfrak{D}_{2\delta_0}$ ,  $f(D)$  contains a uu-disc in  $\mathfrak{D}_{\delta'}$ . Since the blender horseshoe is a horseshoe with two legs, for any  $D \in \mathfrak{D}_{\delta_0}$ , one has that  $f(D)$  contains two discs  $D_1, D_2$  such that

- $D_1 = f(D) \cap \mathcal{A}$  and  $D_2 = f(D) \cap \mathcal{B}$ ;
- $D_1, D_2$  are tangent to the cone field  $\mathcal{C}_\alpha^{uu}$ .

By item H4), either  $D_1$  or  $D_2$  is in the characteristic region of the blender. Without loss of generality, we assume that  $D_1$  is in the characteristic region. If  $D_1$  is contained in  $\mathfrak{D}_{\delta'}$ , we are done. Otherwise, one can do a  $\delta'$ -perturbation  $\tilde{f}$  of  $f$  in  $\mathcal{A}$  without changing  $W_{loc}^s(P)$  such that  $\tilde{f}(D) \cap \mathcal{A}$  is not in the characteristic region of  $\Lambda_{\tilde{f}}$ , then one has that  $D_2$  is in the characteristic region of  $\Lambda_{\tilde{f}}$  as well as of  $\Lambda$ . In this case, one has that  $D_2$  must be in  $\mathfrak{D}_{\delta'}$ , otherwise, one can do another  $\delta'$ -perturbation  $f'$  of  $\tilde{f}$ , supported in  $\mathcal{B}$  without changing  $W_{loc}^s(Q)$ , such that  $f'(D) \cap \mathcal{B}$  is not in the characteristic region of  $\Lambda_{f'}$  which contradicts to the item H4) for  $f'$ .

By the strictly invariant property of the strong unstable cone field, one has that  $\mathfrak{D}_{\delta_0}$  is a strictly invariant family.  $\square$

Let  $\mathfrak{D}$  be the restriction of the family  $\mathfrak{D}_{\delta_0}$  to the region  $[-1, 1]^s \times [-1, 1] \times [-1 + \epsilon_1, 1 - \epsilon_1]^u$ , then this gives a strictly invariant family  $\mathfrak{D}$  in the interior of  $C$ , ending the proof of Lemma 2.8.4.  $\square$

According to Lemma 2.8.4, we can also denote a cu-blender horseshoe as  $(\Lambda, C, \mathcal{C}_\alpha^u, \mathfrak{D})$ .  $C$  is also called the domain of  $\Lambda$ . Let  $\epsilon_0$  be the strength of  $\mathfrak{D}$ . In the whole thesis, for a blender horseshoe, we use the type of strictly invariant family given by Lemma 2.8.4.

Recall that  $\tau > 1$  is the number such that for any  $x \in C \cap f^{-1}(C)$ , we have that

$$\|Df(v)\| > \tau \cdot \|v\|, \text{ for any } 0 \neq v \in \mathcal{C}_\alpha^u(x).$$

We can prove that the central length of any cu-strip, "crossing" the characteristic region, is uniformly expanded by the dynamics. To be precise:

**Lemma 2.8.6.** *For any cu-strip  $S$  defined by  $\phi : [-1, 1] \times [-1, 1]^u \mapsto C$  satisfying that  $\phi(\{t_0\} \times [-1, 1]^u)$  contains an element of  $\mathfrak{D}$ , for some  $t_0 \in [-1, 1]$ , if the central length of  $S$  is less than  $\epsilon_0$ , one has that  $f(S)$  contains a cu-strip  $S_1$  in  $C$  such that*

- $\ell^c(S_1) > \tau \cdot \ell^c(S)$ ;
- $S_1$  is foliated by *wu*-discs, one of which contains an element of  $\mathfrak{D}$ .

*Proof.* By the strictly invariant property of  $\mathfrak{D}$ ,  $f(\phi(\{t_0\} \times [-1, 1]^u))$  contains a disc  $D_1^u$  in  $\mathfrak{D}$ . By item H2), the connected component of  $f(S) \cap C$  containing  $D_1^u$  is a cu-strip  $S_1$  in  $C$ . For any  $C^1$ -curve  $\gamma$  in  $S_1$  joining the two vertical boundary components of  $S_1$ , we have that  $f^{-1}(\gamma)$  is a  $C^1$  curve in  $S$  and joins the two vertical boundary components of  $S$ . Hence, we have that the length  $\ell(f^{-1}(\gamma))$  is no less than  $\ell^c(S)$ . Since  $S$  is tangent to  $\mathcal{C}_\alpha^u$ , by the uniform expansion of  $Df$  along the cone field  $\mathcal{C}_\alpha^u$ , we have that  $\ell(\gamma) > \tau \cdot \ell(f^{-1}(\gamma))$ , which implies that  $\ell^c(S_1) > \tau \cdot \ell^c(S)$ .  $\square$

**Remark 2.8.7.** *Lemma 2.8.6 allows us to iterate cu-strips crossing the superposition region and to gain some expansion in the center direction. This*

is also the reason why we use blender horseshoe instead of the more general dynamically defined blender.

By Lemma 2.8.3, we have that for any  $D^u \in \mathfrak{D}$ , there exists a non-empty intersection between  $D^u$  and  $W_{loc}^s(\Lambda)$ . Since  $\Lambda$  is a hyperbolic basic set, we have that there exists  $x \in \Lambda$  such that  $D^u$  intersects  $W_{loc}^s(x)$ . In general,  $x$  is not a periodic point. The following lemma shows that we can enlarge the disc  $D^u$  in the center direction, and after (uniformly) finite many iterations, the enlarged disc always intersects the local stable manifolds of periodic orbits in  $\Lambda$ .

**Lemma 2.8.8.** *Let  $(\Lambda, C, \mathcal{C}_\alpha^{uu}, \mathfrak{D})$  be a cu-blender horseshoe and  $\epsilon$  be the strength of  $\mathfrak{D}$ . Then there exists  $N \in \mathbb{N}$  such that for any cu-strip  $D^{cu}$  defined by  $\phi : [-1, 1] \times [-1, 1]^u \mapsto C$  satisfying that*

- the central length of  $D^{cu}$  is no less than  $\epsilon$ ;
- each uu-disc  $\phi(\{t\} \times [-1, 1]^u)$  contains an element of  $\mathcal{V}_{\epsilon/2}(\mathfrak{D})$ ;

and for any hyperbolic periodic orbit  $\mathcal{O}_p \subset \Lambda$ , one has that there exists a point  $x \in D^{cu}$  whose forward orbit is in  $C$ , such that  $f^N(x) \in W_{loc}^s(\mathcal{O}_p)$ .

*Proof.* By the hyperbolicity of  $\Lambda$ , there exist  $\eta > 0$  and  $\delta > 0$  small enough such that for any points  $x, y \in \Lambda$  with  $d(x, y) < \delta$ , one has that  $W_\eta^s(x)$  is contained in  $C$  and intersects  $W_\eta^u(y)$  transversely in a unique point.

Since for any  $D^u \in \mathcal{V}_{\epsilon/2}(\mathfrak{D})$ , the stable manifold  $W_{loc}^s(\Lambda)$  intersects  $D^u$  transversely, hence there exists  $\delta_0 > 0$  such that for any cu-strip  $D^{cu}$  satisfying the hypothesis of Lemma 2.8.8, there exists  $x \in \Lambda$  such that  $W_{loc}^s(x)$  intersects  $D^{cu}$  transversely in a point whose distance to the boundary of  $D^{cu}$  is no less than  $\delta_0$ .

By the uniform continuity of the local stable manifold, there exists  $\delta_1 < \delta$  such that for any points  $x, y \in \Lambda$  with  $d(x, y) < \delta_1$  and any disc  $D$  with inner radius no less than  $\delta_0/2$  and which is tangent to the center unstable cone field and is centered at a point in  $W_{loc}^s(x)$ , one has that  $W_{loc}^s(y)$  intersects  $D^{cu}$  transversely in the interior.

Since  $\Lambda$  is a hyperbolic basic set, there exists a periodic orbit  $\mathcal{O}_{p_0}$  and a positive integer  $N$  such that

- the orbit  $\mathcal{O}_{p_0}$  is  $\delta_1/2$  dense in  $\Lambda$ .
- for any two points  $p_1, p_2 \in \mathcal{O}_{p_0}$ , there exists an integer  $n \in [0, N]$  such that  $f^{-n}(W_\eta^u(p_1)) \subset W_{\delta_1/2}^u(p_2)$ .

By the choice of  $N$ , one has that  $N$  depends only on the number  $\delta_0$  and on the set  $\Lambda$  and one can check that  $N$  is the integer that we need, ending the proof of Lemma 2.8.8.  $\square$

## 2.9 Flip-flop configuration

In this section, we recall the definition and the properties of *flip-flop configuration*. Roughly speaking, a flip flop configuration is a robust cycle formed by a cu-blender and a hyperbolic periodic orbit of different indices in the way: the unstable manifold of the periodic orbit “crosses” the superposition region of the cu-blender, and every disc in the strictly invariant family intersects the stable manifold of the periodic orbit. To be specific:

**Definition 2.9.1.** *Consider a dynamically defined blender  $(\Lambda, U, \mathcal{C}^{uu}, \mathfrak{D})$  of  $uu$ -index  $i$  and a hyperbolic periodic point  $q$  of  $u$ -index  $i$ . We say that  $\Lambda$  and  $q$  form a flip-flop configuration, if there exist a disc  $\Delta^u \subset W^u(q)$  and a compact submanifold with boundary  $\Delta^s \subset W^s(q) \cap U$  such that:*

1.  $\Delta^u \in \mathfrak{D}$  and  $f^{-n}(\Delta^u) \cap \bar{U} = \emptyset$ , for any  $n \in \mathbb{N}^+$ ;
2. there exists  $N \in \mathbb{N}$  such that for any integer  $n > N$ ,  $f^n(\Delta^s) \cap \bar{U} = \emptyset$ ; Moreover, for any  $x \in \Delta^s$ , if  $f^j(x) \notin \bar{U}$  for some  $j > 0$ , the forward orbit of  $f^j(x)$  is in the complement of  $\bar{U}$ ;
3. for any  $y \in \Delta^s$ ,  $T_y W^s(q) \cap \mathcal{C}^{uu} = \{0\}$ ;
4. there exist a compact set  $K \subset \Delta^s$  and a number  $\eta > 0$  such that for any disc  $D \in \mathfrak{D}$ , the disc  $D$  intersects  $K$  in a point whose distance to  $\partial D$  is no less than  $\eta$ .

We denote the flip flop configuration as  $(\Lambda, U, \mathcal{C}^{uu}, \mathfrak{D}, \mathcal{O}_q, \Delta^s, \Delta^u)$ .

**Remark 2.9.2.**

1. By item (4) in Definition 2.9.1, for the discs in  $\mathfrak{D}$ , their diameters are uniformly bounded away from zero;
2. It's shown in [BBD3, Proposition 4.2] that the existence of flip-flop configurations is a robust property.

One says that a set  $V$  is a *neighborhood of the flip-flop configuration*  $(\Lambda, U, \mathcal{C}^{uu}, \mathfrak{D}, \mathcal{O}_q, \Delta^s, \Delta^u)$ , if its interior contains the set

$$\mathcal{O}_q \cup \bar{U} \cup \bigcup_{j \geq 0} f^j(\Delta^s) \cup \bigcup_{j \geq 0} f^{-j}(\Delta^u).$$

**Lemma 2.9.3.** [BBD3, Lemma 4.6] *Let  $f \in \text{Diff}^1(M)$ . Assume that there exists a flip-flop configuration  $(\Lambda, U, \mathcal{C}^{uu}, \mathfrak{D}, \mathcal{O}_q, \Delta^s, \Delta^u)$ . For any small enough compact neighborhood  $V$  of the flip-flop configuration, one has that the maximal invariant set in  $V$  has a partially hyperbolic splitting of the form  $E^{cs} \oplus E^{uu}$ , where  $\dim(E^{uu})$  equals the  $u$ -index of  $q$ . Moreover, there exists a strictly  $Df$ -invariant cone field  $\mathcal{C}_V^{uu}$  over  $V$  which continuously extends the cone field  $\mathcal{C}^{uu}$ , such that any vector in  $\mathcal{C}_V^{uu}$  is uniformly expanded by  $Df$ .*

**Definition 2.9.4.** *Given a flip-flop configuration  $(\Lambda, U, \mathcal{C}^{uu}, \mathfrak{D}, \mathcal{O}_q, \Delta^s, \Delta^u)$ . Let  $i$  be the  $u$ -index of the periodic point  $q$ . We say that this configuration is*

split if there exists a small compact neighborhood  $V$  of this configuration such that the maximal invariant set in  $V$  admits a partially hyperbolic splitting of the form  $E^{ss} \oplus E^c \oplus E^{uu}$ , where  $\dim(E^{ss}) = \text{ind}(\Lambda)$  and  $\dim(E^{uu}) = i$ .

The following proposition gives the existence of split flip-flop configurations, whose proof can be found in [BBD3, Section 5.2].

**Proposition 2.9.5.** [BBD3] *Let  $\mathcal{U}$  be an open set of diffeomorphisms such that for any  $f \in \mathcal{U}$ , there exist two hyperbolic periodic points  $p_f, q_f$  of  $u$ -indices  $i_p > i_q$  respectively which continuously depend on  $f$  and are in the same chain class  $C(p_f, f)$ .*

*Then there exists an open and dense subset  $\tilde{\mathcal{U}}$  of  $\mathcal{U}$  such that for any  $f \in \tilde{\mathcal{U}}$  and any  $i \in (i_q, i_p]$ , there exists a split flop-flop configuration formed by a dynamically defined cu-blender of  $uu$ -index  $i - 1$  and a hyperbolic periodic orbit of  $u$ -index  $i - 1$ .*

## 2.10 Flip flop family and the controlled at any scale

In this section, we restate a criterion given in [BBD2] for the existence of zero average for a continuous function along an orbit. We would also present an abstract mechanism called flip flop family where this criterion can be applied.

In this section, let  $(X, d)$  be a metric space,  $K \subset X$  be a compact subset,  $f : X \mapsto X$  be a homeomorphism and  $\varphi : K \rightarrow \mathbb{R}$  be a continuous function.

**Definition 2.10.1.** *Given  $\beta > 0$ ,  $t \in \mathbb{N}$  and  $T \in \mathbb{N}^+ \cup \{+\infty\}$ , we say that a point  $x \in K$  is  $(\beta, t, T)$ -controlled, if  $f^i(x) \in K$  for  $0 \leq i < T$  and there exists a subset  $\mathcal{P} \subset \mathbb{N}$  such that*

- $0 \in \mathcal{P}$  and  $T = \text{sup}(\mathcal{P})$ ;
- if  $k < l$  are two consecutive elements in  $\mathcal{P}$ , then we have

$$l - k \leq t \text{ and } \frac{1}{l - k} \left| \sum_{i=0}^{l-k-1} \varphi(f^{i+k}(x)) \right| \leq \beta.$$

A point  $x \in K$  is *controlled at any scale* if there exist monotone sequences  $(t_i)_i$  of natural numbers and  $(\beta_i)_i$  of positive numbers, with  $t_i \rightarrow +\infty$  and  $\beta_i \rightarrow 0$ , such that  $x$  is  $(\beta_i, t_i, +\infty)$ -controlled for every  $i$ . Note that this implies that the  $\omega$ -limit set  $\omega(x)$  is contained in  $K$ .

Denote by  $\varphi_n(x) := \sum_{i=0}^{n-1} \varphi(f^i(x))$ , for  $x \in \bigcap_{i=0}^{n-1} f^{-i}(K)$ . In particular, if  $x$  is controlled at any scale, its positive orbit remains in  $K$  so that  $\varphi_n$  is defined and continuous on the closure of this positive orbit. Now, for the points controlled at any scales, we have the following property:

**Lemma 2.10.2.** [BBD2, Lemma 2.2] *If  $x \in K$  is controlled at any scale, then every point  $y \in \omega(x)$  satisfies*

$$\lim_{n \rightarrow \infty} \frac{1}{n} \varphi_n(y) = 0.$$

Moreover, the limit is uniform over the  $\omega$ -limit set  $\omega(x)$ .

**Definition 2.10.3.** (*Flip – flop family*) *A flip-flop family, associated to the continuous function  $\varphi$ , is a family  $\mathfrak{F}$  of compact subsets of  $K$  with uniformly bounded diameters that splits as  $\mathfrak{F} = \mathfrak{F}^+ \cup \mathfrak{F}^-$  into two disjoint families satisfying:*

1. *There exists a constant  $\alpha$  such that for any  $D^+ \in \mathfrak{F}^+$ ,  $D^- \in \mathfrak{F}^-$  and any points  $x \in D^+$ ,  $y \in D^-$ , we have  $\varphi(x) > \alpha > 0 > -\alpha > \varphi(y)$ ;*
2. *For any  $D \in \mathfrak{F}$ , there exist two subsets  $D_+$ ,  $D_-$  of  $D$  such that  $f(D_+) \in \mathfrak{F}^+$  and  $f(D_-) \in \mathfrak{F}^-$ ;*
3. *There exists a constant  $\lambda > 1$  such that if  $x, y$  belong to the same element  $D_0$  of  $\mathfrak{F}$  and if  $f(x)$  and  $f(y)$  belong also to the same element  $D_1$  of  $\mathfrak{F}$  then*

$$d(f(x), f(y)) \geq \lambda d(x, y).$$

An important property of flip-flop family is the following:

**Lemma 2.10.4.** [BBD2, Theorem 2.1] *For any  $D \in \mathfrak{F}$ , there exists a point  $x \in D$  such that  $x$  is controlled at any scale with respect to  $\varphi$ .*

By Definition 2.10.3, we can iterate any element of  $\mathfrak{F}$  and its image contains an element of  $\mathfrak{F}$ . This leads to the notion  $\mathfrak{F}$ -segment below.

**Definition 2.10.5.** *Given  $T \in \mathbb{N}$ , a  $\mathfrak{F}$ -segment of length  $T$  is a sequence  $\mathcal{E} = \{E_i\}_{0 \leq i \leq T}$  of compact sets such that*

- $f(E_i) = E_{i+1}$ ,
- *there is a family  $\{D_i\}_{0 \leq i \leq T} \subset \mathfrak{F}$  so that the compact set  $E_i$  is contained  $D_i$  and  $D_T = E_T$*

We call  $E_0$  the entrance of  $\mathcal{E}$  and  $E_T$  the exit of  $\mathcal{E}$ .

**Definition 2.10.6.** *Given two  $\mathfrak{F}$ -segments  $\mathcal{E} = \{E_i\}_{0 \leq i \leq T}$  and  $\mathcal{F} = \{F_j\}_{0 \leq j \leq S}$ ; if the exit of  $\mathcal{E}$  contains the entrance of  $\mathcal{F}$ , the concatenation of  $\mathcal{E}$  and  $\mathcal{F}$  is a  $\mathfrak{F}$ -segment  $\mathcal{E} \star \mathcal{F} = \{G_i\}_{0 \leq i \leq T+S}$  defined as follows:*

$$G_i = \begin{cases} f^{i-T}(F_0) & \text{if } i \leq T \\ F_{i-T} & \text{if } i > T \end{cases}$$

Next straightforward lemma gives a precise meaning to the simple idea that, if one controls the averages of  $\varphi$  along  $\mathfrak{F}$  segments, one also controls the averages along the concatenation of these segments. This will allow us to build  $\mathfrak{F}$ -segment of arbitrarily long length on which we control the averages of  $\varphi$ .



**Lemma 2.10.7.** *Let  $\mathcal{E}_i = \{E_{i,j}\}_{j \in \{0, \dots, T_i\}}$ ,  $i \in \{0, \dots, n\}$ , be a family of  $\mathfrak{F}$ -segments of length  $T_i$  so that the exit of  $\mathcal{E}_i$  contains the entrance of  $\mathcal{E}_{i+1}$  for  $i \in \{0, \dots, n-1\}$ . Denote by  $T = \sum_{i=0}^n T_i$  and let  $\mathcal{F} = \{F_j\}_{j \in \{0, \dots, T\}}$  be the  $\mathfrak{F}$ -segment defined as the concatenation*

$$\mathcal{F} = \mathcal{E}_0 \star \mathcal{E}_1 \star \dots \star \mathcal{E}_n.$$

*Assume that there are  $\alpha < \beta$  so that for any  $i$  and any  $x \in E_{i,0}$ , one has*

$$\frac{1}{T_i} \varphi_{T_i} \in [\alpha, \beta].$$

*Then for every  $x \in F_0$  one has*

$$\frac{1}{T} \varphi_T \in [\alpha, \beta].$$

Given  $x \in D_0 \in \mathfrak{F}$ , a positive integer  $t$ , a point  $s = (s_0, s_1, \dots) \in \{+, -\}^{\mathbb{N}}$  and  $T \in \mathbb{N}^+ \cup \{+\infty\}$ , we say that  $x$  follows the  $t$ -pattern  $s$  up to time  $T$ , if for any  $n \in [0, T)$  which is a multiple of  $t$ , we have that  $f^{n+1}(x) \in \cup_{D \in \mathfrak{F}^{s_n}} D$ .

Given  $t \in \mathbb{N}^+$  and  $s \in \{+, -\}^{\mathbb{N}}$ , we say that a  $\mathfrak{F}$ -segment  $\mathcal{E} = \{E_i\}_{0 \leq i \leq T}$  follows  $t$ -pattern  $s$ , if for any  $x \in E_0$ , the point  $x$  follows  $t$ -pattern  $s$  up to time  $T$ .

The key lemma in [BBD2] to find zero center Lyapunov exponent set is the following:

**Lemma 2.10.8.** *[BBD2, Lemma 2.12] Given a flip-flop family  $(\mathfrak{F}, \varphi)$ , we fix two sequences of positive numbers  $\{a_k\}$  and  $\{b_k\}$  which will converge to zero and satisfy that  $b_k > a_k > b_{k+1}$  for any  $k \in \mathbb{N}$ .*

*Then there exists a sequence of integers  $1 = t_0 < t_1 < \dots$  satisfying that*

- *each  $t_{i+1}$  is a multiple of  $t_i$ , for any  $i \in \mathbb{N}$ ;*
- *for every integer  $k > 1$ , every member  $D \in \mathfrak{F}$  and every pattern  $s \in \{+, -\}^{\mathbb{N}}$ , there exist two integers  $T_+, T_- \in \mathbb{N}$  and two  $\mathfrak{F}$ -segments  $\mathcal{E}^+, \mathcal{E}^-$  of lengths  $T_+$  and  $T_-$  respectively such that:*
  - *the entrances of  $\mathcal{E}^+$  and  $\mathcal{E}^-$  are contained in  $D$ ;*
  - *$T_+$  and  $T_-$  are multiples of  $t_1$  and satisfy  $t_{k-1} < T_{\pm} \leq t_k$ ;*
  - *the segments  $\mathcal{E}^+$  and  $\mathcal{E}^-$  are  $(b_i, t_i)$ -controlled for  $i = 1, \dots, k-1$ ;*
  - *for all  $x$  in the entrance of  $\mathcal{E}^+$  and all  $y$  in the entrance of  $\mathcal{E}^-$ , we have*

$$a_k \leq \frac{1}{T_+} \varphi_{T_+}(x) \leq b_k \quad \text{and} \quad -b_k \leq \frac{1}{T_-} \varphi_{T_-}(y) \leq -a_k;$$

- *the segments  $\mathcal{E}^+$  and  $\mathcal{E}^-$  follow the  $t_1$ -pattern  $s$ .*

According to Lemma 2.10.8, we can find a sequence of orbit segments  $\{x_i, T_i\}$  whose lengths tend to infinity in the sense of time and those segments

are  $(b_j, t_j)$  controlled for any  $j < i$ . Then the accumulation  $x$  of  $x_i$  is controlled at any scale and finally any ergodic measure supported on the  $\omega$ -limit set of  $x$  is non-hyperbolic. The last item in the Lemma 2.10.8 guarantees that our system has positive topological entropy on  $\omega(x)$ .

## 2.11 Flip flop configuration and flip flop family

The following proposition shows that the dynamics on a flip-flop configuration induces a flip-flop family.

**Proposition 2.11.1.** *[BBD2, Proposition 4.9] Consider a diffeomorphism  $f$  exhibiting a flip-flop configuration formed by a dynamical blender  $\Lambda$  and a hyperbolic periodic orbit  $\mathcal{O}_q$ . Let  $V$  be a partially hyperbolic neighborhood of this flip-flop configuration,  $\mathcal{C}_V^{uu}$  be the associated strong unstable cone field in  $V$  and  $K$  be the maximal invariant set of  $f$  in  $V$ . Assume that  $\varphi : V \rightarrow \mathbb{R}$  is a continuous function that is positive on  $\Lambda$  and is negative on the periodic orbit  $\mathcal{O}_q$ .*

*Then there exist an integer  $N \geq 1$  and a flip-flop family  $\mathfrak{F}$  with respect to the dynamics  $f^N$  and the function*

$$\varphi_N := \sum_{j=0}^{N-1} \varphi \circ f^j \text{ defined on } \bigcap_{j=0}^{N-1} f^{-j}(V).$$

*Moreover, given any  $\epsilon > 0$ , one can choose the flip-flop family  $\mathfrak{F} = \mathfrak{F}^+ \cup \mathfrak{F}^-$  such that  $\cup \mathfrak{F}^+$  (resp.  $\cup \mathfrak{F}^-$ ) is contained in the  $\epsilon$ -neighborhood of  $\Lambda$  (resp.  $\mathcal{O}_q$ .)*

**Remark 2.11.2.** *If  $\varphi$  is obtained by extending  $\log \|Df|_{E^c}\|$  on  $K$  continuously to  $V$ , then the points in the  $\omega$ -limit set of an orbit which are controlled at any scale have a vanishing center Lyapunov exponent.*

**Remark 2.11.3.** *According to [BBD2, Section 4.4], one can choose the flip-flop family  $(\mathfrak{F}, \varphi_N)$  such that:*

- *the discs in  $\mathfrak{F}$  are tangent to the strong unstable cone field  $\mathcal{C}_V^{uu}$  and have uniform diameter;*
- *the disc  $\Delta^u \subset W^u(\mathcal{O}_q)$  in the definition of flip-flop configuration contains a disc which is an element of  $\mathfrak{F}$ .*
- *Denote by  $W_{loc}^s(\mathcal{O}_q)$  the connected component of  $W^s(\mathcal{O}_q) \cap V$ , which contains  $\mathcal{O}_q$ . For any  $D \in \mathfrak{F}$ , one of the followings is satisfied:*
  - *$f^{2N}(D) \in \mathfrak{D}$ ;*
  - *$f^{2N}(D)$  intersects  $W_{loc}^s(\mathcal{O}_q)$  transversely;*
  - *$D$  intersects  $W_{loc}^s(\mathcal{O}_q)$  transversely.*

## 2.12 Perturbation technics

Let  $A_1, \dots, A_l \in GL(d, \mathbb{R})$  and we denote by  $B = A_l \circ A_{l-1} \circ \dots \circ A_1$ . Let  $\lambda_1(B), \dots, \lambda_d(B)$  be the eigenvalues of  $B$ , counted by multiplicity and satisfying

$$|\lambda_1(B)| \leq \dots \leq |\lambda_d(B)|.$$

The  $i^{\text{th}}$  Lyapunov exponent of  $B$  is defined as

$$\chi_i(B) = \frac{1}{l} \log |\lambda_i(B)|.$$

We say that  $B$  has simple spectrum if all the Lyapunov exponents of  $B$  are mutually different.

We state a version of Theorem 4.11 in [BB] adapted to our situation. A similar result can be found in [G3].

**Lemma 2.12.1.** *For any  $d \geq 2$ ,  $\epsilon > 0$ , and  $R > 1$ , there exist two positive integers  $T, l_0$  such that:*

*Given  $l$  linear maps  $A_1, \dots, A_l \in GL(d, \mathbb{R})$  with  $l \geq l_0$  such that  $\|A_i\|, \|A_i^{-1}\| < R$ . Assume that  $B = A_l \circ A_{l-1} \circ \dots \circ A_1$  has no  $T$ -domination of index  $j$  for any  $j \in \{i_0 + 1, \dots, i_0 + k_0 - 1\}$*

*For any  $k_0$  numbers  $\xi_1, \dots, \xi_{k_0}$  satisfying:*

- $\xi_{k_0} \geq \dots \geq \xi_1$ ;
- $\sum_{i=1}^j \xi_i \geq \sum_{i=1}^j \chi_{i_0+i}(B)$ , for any  $j = 1, \dots, k_0$ ;
- $\sum_{i=1}^{k_0} \xi_i = \sum_{i=1}^{k_0} \chi_{i_0+i}(B)$ .

*Then there exist  $l$  one-parameter families of linear maps  $\{(A_{i,t})_{t \in [0,1]}\}_{i=1}^l$  such that:*

1.  $A_{i,0} = A_i$  for each  $i$ ;
2.  $\|A_{i,t} - A_i\| < \epsilon$  and  $\|A_{i,t}^{-1} - A_i^{-1}\| < \epsilon$ , for each  $i$  and any  $t \in [0, 1]$ ;
3. Consider the linear map  $B_t = A_{l,t} \circ A_{l-1,t} \circ \dots \circ A_{1,t}$ , then the Lyapunov exponents of  $B_t$  satisfy the following:
  - $\chi_j(B_t) = \chi_j(B)$ , for any integer  $j \in [1, i_0] \cup [i_0 + k_0 + 1, d]$ ;
  - $\sum_{j=1}^{k_0} \chi_{i_0+j}(B_t) = \sum_{j=1}^{k_0} \chi_{i_0+j}(B)$ , for any  $t \in [0, 1]$ ;
  - For any  $j \in [1, k_0]$ , the function  $\sum_{i=1}^j \chi_{i_0+i}(B_t)$  with respect to variable  $t$  is non-decreasing;
  - $\chi_{i_0+j}(B_1) = \xi_j$ , for any  $j = 1, \dots, k_0$ .

**Remark 2.12.2.** *In particular, we can take  $\xi_1 = \dots = \xi_{k_0} = \frac{1}{k_0} \sum_{i=1}^{k_0} \chi_{i_0+i}(B)$  in Lemma 2.12.1.*

The following lemma shows that for periodic orbit of large period, we can do certain small perturbation to make it have simple spectrum.

**Lemma 2.12.3.** [BC, Lemma 6.6] *Given a positive number  $K$ . For any  $\epsilon > 0$ , there exists an integer  $N$  such that for any  $n \geq N$  and any matrices  $A_1, \dots, A_n$  in  $GL(2, \mathbb{R})$  satisfying that  $\|A_i\| < K$  and  $\|A_i^{-1}\| < K$  for any  $i = 1, \dots, n$ .*

*Then there exist matrices  $B_1, \dots, B_n$  in  $GL(2, \mathbb{R})$  such that*

- $\|A_i - B_i\| < \epsilon$  and  $\|A_i^{-1} - B_i^{-1}\| < \epsilon$  for any  $i = 1, \dots, n$ ;
- the matrix  $B_n \circ \dots \circ B_1$  has simple spectrum.

**Remark 2.12.4.** *The original statement of Lemma 6.6 in [BC] is for the matrices in  $SL(2, \mathbb{R})$ , but with the assumption that the norm of the matrices and its inverse are uniformly bounded, the same conclusion is also true directly from [BC, Lemma 6.6].*

We state a generalized Franks lemma by N. Gourmelon [Go2], which allows us to do a Franks-type perturbation along a hyperbolic periodic orbit which keeps some homoclinic or heteroclinic intersections.

**Lemma 2.12.5** (Franks-Gourmelon Lemma). *Given  $\epsilon > 0$ , a diffeomorphism  $f \in \text{Diff}^1(M)$  and a hyperbolic periodic orbit  $Q = \text{Orb}(q)$  of period  $n$ . Consider  $n$  one-parameter families of linear maps  $\{(A_{i,t})_{t \in [0,1]}\}_{i=0}^{n-1}$  in  $GL(d, \mathbb{R})$  satisfying the following properties:*

- $A_{i,0} = \text{Df}(f^i(q))$  for any integer  $i \in [0, n-1]$ ;
- $\|A_{i,t} - \text{Df}(f^i(q))\| < \epsilon$  and  $\|A_{i,t}^{-1} - \text{Df}^{-1}(f^{i+1}(q))\| < \epsilon$ , for any  $t \in [0, 1]$ ;
- $A_{n-1,t} \circ \dots \circ A_{0,t}$  is hyperbolic for any  $t \in [0, 1]$ .

*Then for any neighborhood  $U$  of  $Q$ , any number  $\eta > 0$  and any pair of compact sets  $K^s \subset W_\eta^s(Q, f)$  and  $K^u \subset W_\eta^u(Q, f)$  which do not intersect  $U$ , there is a diffeomorphism  $g \in \text{Diff}^1(M)$  which is  $\epsilon$ - $C^1$ -close to  $f$ , such that*

- $g$  coincides with  $f$  on  $Q \cup M \setminus U$ ,
- $\text{Dg}(g^i(q)) = A_{i,1}$ , for any  $i \in \{0, 1, \dots, n-1\}$ ,
- $K^s \subset W^s(Q, g)$  and  $K^u \subset W^u(Q, g)$ .

**Definition 2.12.6.** *Consider a diffeomorphism  $f \in \text{Diff}^1(M)$ . An invariant compact set  $\Lambda$  is said to admit a partially hyperbolic splitting, if there is a splitting  $T_\Lambda M = E^s \oplus E^c \oplus E^u$  such that, the splittings  $(E^s \oplus E^c) \oplus E^u$  and  $E^s \oplus (E^c \oplus E^u)$  are dominated splittings, and the bundle  $E^s$  (resp.  $E^u$ ) is uniformly contracting (resp. expanding). Moreover, at least one of the two extreme bundles  $E^s$  and  $E^u$  is non-degenerate.*

Consider two hyperbolic periodic points  $p$  and  $q$  of indices  $i$  and  $i+k$  respectively. We say that  $p$  and  $q$  form a *heterodimensional cycle* if  $W^u(P)$  has transverse intersections with  $W^s(Q)$  along the orbit of some point  $y$ , and  $W^s(P)$  has quasi-transverse intersections with  $W^u(Q)$  along the orbit of some point  $x$ , i.e.  $T_x W^s(P) + T_x W^u(Q)$  is a direct sum. We say  $p$  and  $q$  form a *partially hyperbolic heterodimensional cycle*, if the  $f$ -invariant compact set  $\mathcal{C} = \overline{\text{Orb}(x)} \cup \overline{\text{Orb}(y)}$  admits a partially hyperbolic splitting of the form  $T_{\mathcal{C}} M = E^s \oplus E^c \oplus E^u$ , where  $\dim(E^s) = i$  and  $\dim(E^c) = k$ . Moreover, for any  $x \in \mathcal{C}$ ,

we denote by  $W^{ss}(x)$  (resp.  $W^{uu}(x)$ ) the *strong stable manifold* (resp. *strong unstable manifold*) of  $x$  which is tangent to the bundle  $E^s$  (resp.  $E^u$ ) at  $x$ .

We have the following theorem from [BDPR] to obtain *transition between two periodic orbits of different indices*.

**Theorem 2.12.7.** [BDPR, Theorem 3.1 and Lemma 3.5] *Consider a diffeomorphism  $f \in \text{Diff}^1(M)$ . Let  $p$  and  $q$  be two hyperbolic periodic points of indices  $i$  and  $i+k$  respectively and denote by  $P$  and  $Q$  their orbits respectively. Assume that there exist dominated splitting  $T_P M = E_1(P) \oplus E_2(P) \oplus E_3(P)$  and  $T_Q M = E_1(Q) \oplus E_2(Q) \oplus E_3(Q)$  satisfying that  $\dim(E_1(P)) = \dim(E_1(Q)) = i$  and  $\dim(E_2(P)) = \dim(E_2(Q)) = k$ . Assume, in addition, that  $P$  and  $Q$  form a heterodimensional cycle. Denote by  $M_P$  and  $M_Q$  the two linear maps:*

$$\text{Df}^{\pi(P)}(p) : T_p M \rightarrow T_p M \text{ and } \text{Df}^{\pi(Q)}(q) : T_q M \rightarrow T_q M.$$

*Then for any  $C^1$ -neighborhood  $\mathcal{U}$  of  $f$ , for any two neighborhoods  $U_P$  and  $U_Q$  of  $P$  and  $Q$  respectively, there are two matrices  $T_0$  and  $T_1$ , and two integers  $t_0$  and  $t_1$ , such that for any two positive integers  $m$  and  $n$ , there is a diffeomorphism  $g \in \mathcal{U}$  with a periodic point  $p_1$ , satisfying the following properties:*

- $g$  and  $\text{Dg}$  coincide with  $f$  and  $\text{Df}$  on  $P \cup Q$  respectively;
- For  $i = 1, 2, 3$ , we have that  $T_0(E_i(p)) = E_i(q)$  and  $T_1(E_i(q)) = E_i(p)$ ;
- The period of  $p_1$  equals  $t_0 + t_1 + n\pi(P) + m\pi(Q)$ ;
- the matrix  $\text{Dg}^{\pi(p_1)}(p_1) : T_{p_1} M \rightarrow T_{p_1} M$  is conjugate to

$$T_1 \circ M_Q^m \circ T_0 \circ M_P^n;$$

- we denote by  $P_1$  the orbit of  $p_1$  under  $g$ , then we have:

$$\#(P_1 \cap U_P) \geq n\pi(P) \text{ and } \#(P_1 \cap U_Q) \geq m\pi(Q).$$

**Remark 2.12.8.** *By Lemma 4.13 in [BDP], if the periodic orbits  $P$  and  $Q$  admit another dominated splitting of the same index, the two matrices  $T_0$  and  $T_1$  can be chosen to preserve the two dominated splitting at the same time.*

## 2.13 Generic diffeomorphisms

Let  $f \in \text{Diff}^1(M)$ ,  $P$  and  $Q$  be two hyperbolic periodic orbits of  $f$ . We say that  $P$  and  $Q$  are *robustly in the same chain recurrence class*, if there exists a  $C^1$  small neighborhood  $\mathcal{U}$  of  $f$  such that for any  $g \in \mathcal{U}$ , the continuation  $P_g$  of  $P$  and the continuation  $Q_g$  of  $Q$  are in the same chain recurrence class. A periodic orbit  $P$  is said to have *simple spectrum*, if the  $d$  Lyapunov exponents of  $P$  are mutually different. Denote by  $\text{Per}(f)$  the set of periodic points of  $f$ .

The following theorem summarizes some generic properties for  $\text{Diff}^1(M)$ , see for example [ABCDW, BC, BDPR, BDV, CCGWY, DG].

**Theorem 2.13.1.** *There exists a residual subset  $\mathcal{R}$  of  $\text{Diff}^1(M)$  such that for any  $f \in \mathcal{R}$ , we have the followings:*

1.  $f$  is Kupka-Smale.
2. Any chain recurrence class containing a hyperbolic periodic orbit  $P$  coincides with the homoclinic class  $H(P, f)$ . Hence two homoclinic classes either coincide or are disjoint.
3. Given a hyperbolic periodic orbit  $P$ , there exists a neighborhood  $\mathcal{U}$  of  $f$  such that the map  $g \mapsto H(P_g, g)$  is well defined and  $f$  is a continuous point of this map.
4. Given a homoclinic class  $H(P, f)$ , for any hyperbolic periodic orbit  $Q$  contained in  $H(P, f)$ , we have that  $P$  and  $Q$  are robustly in the same chain recurrence class.
5. Consider a non-trivial homoclinic class  $H(P, f)$ , the set

$\{q \in \text{Per}(f) : q \text{ has simple spectrum and is homoclinically related to } P\}$   
is dense in  $H(P, f)$ .

6. Consider a hyperbolic periodic orbit  $P$  of index  $i$ , whose homoclinic class contains a hyperbolic periodic orbit  $Q$  of index  $i + k$  for some integer  $k > 0$ . If there exist dominated splitting  $T_P M = E_1(P) \oplus E_2(P) \oplus E_3(P)$  and  $T_Q M = E_1(Q) \oplus E_2(Q) \oplus E_3(Q)$  satisfying that  $\dim(E_1(P)) = \dim(E_1(Q)) = i$  and  $\dim(E_2(P)) = \dim(E_2(Q)) = k$ . Then arbitrarily  $C^1$ -close to  $f$ , there is a diffeomorphism  $g$ , satisfying that:
  - $g$  and  $Dg$  coincide with  $f$  and  $Df$  on  $P \cup Q$  respectively,
  - under the diffeomorphism  $g$ , the periodic orbits  $P$  and  $Q$  form a partially hyperbolic heterodimensional cycle  $K$ , which is contained in an arbitrarily small neighborhood of  $H(P, f)$ .
7. Consider a hyperbolic periodic orbit  $P$  with simple spectrum whose homoclinic class  $H(P, f)$  is non-trivial. Then for any  $\epsilon > 0, \delta > 0$  and  $\kappa \in (0, 1)$ , there is a hyperbolic periodic orbit  $Q$  homoclinically related to  $P$ , such that the following properties are satisfied:
  - $Q$  has simple spectrum and is  $\epsilon$ -dense in  $H(P, f)$ ;
  - $Q$  is a  $(\delta, \kappa)$ -good approximation of  $P$ ;
  - $|\chi_i(Q, f) - \chi_i(P, f)| < \epsilon$ , for any  $i \in \{1, 2, \dots, d\}$ .

## 2.14 Foliations on torus or on cylinder and its classification

In this section, we give the definitions and the tools for dealing with foliations on torus or cylinder.

We denote by  $\mathbb{S}^1$  the circle  $\mathbb{S}^1 = \mathbb{R}/\mathbb{Z}$  and by  $\mathbb{T}^2$  the torus  $\mathbb{R}^2/\mathbb{Z}^2 = \mathbb{S}^1 \times \mathbb{S}^1$ .

### 2.14.1 Pair of transverse foliations

Given two  $C^1$  one-dimensional foliations  $\mathcal{F}$  and  $\mathcal{G}$  on the torus  $\mathbb{T}^2$ . We say that  $(\mathcal{F}, \mathcal{G})$  is a pair of transverse foliations if each leaf of  $\mathcal{F}$  is everywhere transverse to the leaves of  $\mathcal{G}$ , and vice versa.

For a pair of transverse foliations on torus, there are two cases for their relations defined by the following definition:

**Definition 2.14.1.** We say that two foliations  $\mathcal{F}$  and  $\mathcal{G}$  of the torus  $\mathbb{T}^2$  have parallel compact leaves if and only if there exist a compact leaf of  $\mathcal{F}$  and a compact leaf of  $\mathcal{G}$  which are in the same free homotopy class.

Otherwise, we say that  $\mathcal{F}$  and  $\mathcal{G}$  have no parallel compact leaves or that they are without parallel compact leaves.

According to the relations defined above, for pair of transverse foliations, we define a group associated to them in the following way:

**Definition 2.14.2.** Let  $(\mathcal{F}, \mathcal{G})$  be a pair of transverse foliations of  $\mathbb{T}^2$ . We denote by  $G_{\mathcal{F}, \mathcal{G}} \subset \pi_1(\mathbb{T}^2)$  the group defined as follows:

- if  $\mathcal{F}$  and  $\mathcal{G}$  have no parallel compact leaves, then  $G_{\mathcal{F}, \mathcal{G}} = \mathbb{Z}^2 = \pi_1(\mathbb{T}^2)$ ;
- if  $\mathcal{F}$  and  $\mathcal{G}$  have parallel compact leaves, let  $\alpha \in \pi_1(\mathbb{Z})$  be the homotopy class of these leaves. Then  $G_{\mathcal{F}, \mathcal{G}} = \langle \alpha \rangle = \mathbb{Z} \cdot \alpha \subset \pi_1(\mathbb{T}^2)$ .

### 2.14.2 Complete transversal

**Definition 2.14.3.** Given a  $C^r$  ( $r \geq 1$ ) foliation  $\mathcal{F}$  on  $\mathbb{T}^2$ . We say that a  $C^1$  simple closed curve  $\gamma$  is a complete transversal or a complete transverse cross section of the foliation  $\mathcal{F}$ , if  $\gamma$  is transverse to  $\mathcal{F}$  and every leaf of  $\mathcal{F}$  intersects  $\gamma$ .

**Lemma 2.14.4.** Consider a  $C^1$  foliation  $\mathcal{E}$  on  $\mathbb{T}^2$ . Assume that there is a simple smooth closed curve  $\gamma$  which is transverse to  $\mathcal{E}$  and is not a complete transversal of  $\mathcal{E}$ . Then there exists a compact leaf of  $\mathcal{E}$  which is in the homotopy class of  $\gamma$ .

This lemma is classical. As the proof is short, we include it for completeness.

*Proof.* Cut the torus along  $\gamma$ : we get a cylinder  $C$  endowed with a foliation transverse to its boundary. Furthermore, by assumption, this foliation admits a leaf which remains at a uniform distance away from the boundary of  $C$ .

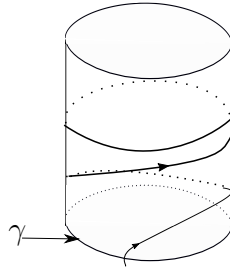

Figure 2.1 –

Hence, the closure of that leaf is also far from the boundary of  $C$ . By Poincaré-Bendixson theorem, the closure of this leaf contains a compact leaf, thus this



compact leaf is disjoint from the boundary  $C$ . Furthermore, as the foliation is not singular, this leaf cannot be homotopic to 0 in the annulus, hence it is homotopic to the boundary components.  $\square$

### 2.14.3 Reeb components and Compact leaves of foliations

**Definition 2.14.5** (Reeb component). *Given a foliation  $\mathcal{F}$  on  $\mathbb{T}^2$ , we say that  $\mathcal{F}$  has a Reeb component, if there exists a compact annulus  $A$  such that*

- *the boundary  $\partial A$  is the union of two compact leaves of  $\mathcal{F}$ ;*
- *there is no compact leaf in the interior of  $A$ ;*
- *first item above implies that  $\mathcal{F}$  is orientable restricted to  $A$ , so let us choose an orientation. We require that the two oriented compact leaves are in opposite homotopy classes.*

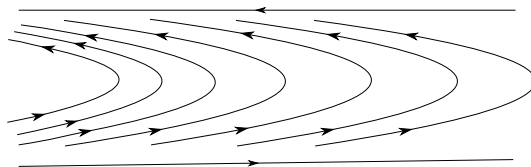

Figure 2.2 – Reeb component

By using the Poincaré-Bendixson theorem, one easily checks the following classical result:

**Proposition 2.14.6.** *Let  $\mathcal{F}$  and  $\mathcal{G}$  be two transverse foliations on  $\mathbb{T}^2$ . Assume that  $\mathcal{F}$  admits a Reeb component  $A$ . Then  $\mathcal{G}$  admits a compact leaf contained in the interior of  $A$ . Thus  $\mathcal{F}$  and  $\mathcal{G}$  have parallel compact leaves.*

**Definition 2.14.7.** *Given two  $C^r$  foliations  $\mathcal{F}$  and  $\mathcal{F}'$  on manifolds  $M$  and  $M'$ , respectively.  $\mathcal{F}$  and  $\mathcal{F}'$  are  $C^r$  conjugate if there exists a  $C^r$  diffeomorphism  $f: M \rightarrow M'$  such that  $f(\mathcal{F}) = \mathcal{F}'$ .*

We state now a classification theorem which can be found in [HH]:

**Theorem 2.14.8.** [HH, Proposition 4.3.2] *For any  $C^r$  foliation  $\mathcal{F}$  on  $\mathbb{T}^2$ , we have the following:*

- *Either  $\mathcal{F}$  has Reeb component;*
- *or  $\mathcal{F}$  is  $C^r$  conjugated to the suspension of a  $C^r$  diffeomorphism on  $S^1$ .*

In general the union of the compact leaves of a foliation may fail to be compact. But, for codimension 1 foliations we have the following theorem due to A. Haefliger.

**Theorem 2.14.9.** [H] For any  $C^r$  ( $r \geq 1$ ) codimension one foliation  $\mathcal{F}$  on a compact manifold  $M$ , the set

$$\{x \in M \mid \text{the } \mathcal{F}\text{-leaf through } x \text{ is compact}\}$$

is a compact subset of  $M$ .

### 2.14.4 Translation and rotation numbers

In this section we recall very classical Poincaré theory on the rotation number of a circle homeomorphism. We refer to [HK] for more details.

We denote by  $\widetilde{\text{homeo}}^+(\mathbb{R})$  the set of orientation preserving homeomorphisms on  $\mathbb{R}$  which commute with the translation  $t \mapsto t + 1$ . Recall that the elements of  $\widetilde{\text{homeo}}^+(\mathbb{R})$  are precisely the lifts on  $\mathbb{R}$  of the orientation preserving homeomorphisms of  $\mathbb{S}^1$ .

Let  $H \in \widetilde{\text{homeo}}^+(\mathbb{R})$  be the lift of  $h \in \text{Homeo}^+(\mathbb{S}^1)$ . Poincaré noticed that the ratio  $\frac{H^n(x) - x}{n}$  converges uniformly, as  $n \rightarrow \pm\infty$ , to some constant  $\tau(H)$  called the *translation number of  $H$* . The projection  $\rho(h)$  of  $\tau(H)$  on  $\mathbb{R}/\mathbb{Z}$  does not depend on the lift  $H$  and is called *the rotation number of  $h$* .

We can find the following observations in many books, in particular in [HK].

**Remark 2.14.10.** *The rotation number is rational if and only if  $h$  admits a periodic point.*

**Proposition 2.14.11.** [HK, Proposition 11.1.6]  $\tau(\cdot)$  varies continuous in  $C^0$ -topology.

**Proposition 2.14.12.** [HK, Proposition 11.1.9] Let  $H, F \in \widetilde{\text{homeo}}^+(\mathbb{R})$ . Assume that  $\tau(H)$  is irrational and  $H(x) < F(x)$ , for any  $x \in \mathbb{R}$ . Then we have that  $\tau(H) < \tau(F)$ .

Poincaré theory proves that a homeomorphism  $h$  of the circle with irrational rotation number is semi-conjugated to the rotation  $R_{\rho(h)}$ ; but  $h$  may fail to be conjugated to  $R_{\rho(h)}$  even if  $h$  is a  $C^1$ -diffeomorphism (Denjoy counter examples). However the semi-conjugacy is a  $C^0$ -conjugacy if  $h$  is a  $C^2$ -diffeomorphism (Denjoy theorem). In general, if  $h$  is a smooth circle diffeomorphism with irrational rotation number, the conjugacy to the corresponding rotation may fail to be a diffeomorphism. However M. Herman proved that there are generic conditions on  $\rho(h)$  ensuring the smoothness of the conjugacy:

**Theorem 2.14.13.** [He] Let  $f \in \text{Diff}^r(\mathbb{S}^1)$  ( $r \geq 3$ ) be a diffeomorphism of the circle. If the rotation number of  $f$  is diophantine, then  $f$  is  $C^{r-2}$  conjugated to an irrational rotation.

### 2.14.5 Foliations without compact leaves on the annulus

Let  $\mathcal{F}$  be a  $C^r$  foliation on the annulus  $\mathbb{S}^1 \times [0, 1]$  so that

- $\mathcal{F}$  is transverse to the boundary  $\mathbb{S}^1 \times \{0, 1\}$ ;
- $\mathcal{F}$  has no compact leaves in the annulus.

Thus Poincaré-Bendixson theorem implies that every leaf entering through  $\mathbb{S}^1 \times \{0\}$  goes out through a point of  $\mathbb{S}^1 \times \{1\}$ . The map  $\mathcal{P}_{\mathcal{F}}: \mathbb{S}^1 \times \{0\} \rightarrow \mathbb{S}^1 \times \{1\}$ , which associates an entrance point  $(x, 0)$  of a leaf in the annulus to its exit point at  $\mathbb{S}^1 \times \{1\}$ , is called the holonomy of  $\mathcal{F}$ .

Consider the universal cover  $\mathbb{R} \times [0, 1] \rightarrow \mathbb{S}^1 \times [0, 1]$ ; we denote by  $\tilde{\mathcal{F}}$  the lift of  $\mathcal{F}$  on  $\mathbb{R} \times [0, 1]$  and by  $\tilde{\mathcal{P}}_{\mathcal{F}}$  the holonomy of  $\tilde{\mathcal{F}}$ . Note that  $\tilde{\mathcal{P}}_{\mathcal{F}}$  is a lift of  $\mathcal{P}_{\mathcal{F}}$ .

We will use the following classical and elementary results:

**Proposition 2.14.14.** *Let  $\mathcal{F}, \mathcal{G}$  be  $C^r$ -foliations,  $r \geq 0$ , on the annulus  $\mathbb{S}^1 \times [0, 1]$  so that :*

- *The foliations  $\mathcal{F}$  and  $\mathcal{G}$  are transverse to the boundary  $\mathbb{S}^1 \times \{0, 1\}$  and have no compact leaves in the annulus;*
- *The foliations  $\mathcal{F}$  and  $\mathcal{G}$  coincide in a neighborhood of the boundary  $\mathbb{S}^1 \times \{0, 1\}$ ;*
- *The foliations  $\mathcal{F}$  and  $\mathcal{G}$  have same holonomy, that is  $\mathcal{P}_{\mathcal{F}} = \mathcal{P}_{\mathcal{G}}$ .*

*Then there is a  $C^r$  diffeomorphism  $\varphi: \mathbb{S}^1 \times [0, 1] \rightarrow \mathbb{S}^1 \times [0, 1]$  which coincides with the identity map in a neighborhood of the boundary  $\mathbb{S}^1 \times \{0, 1\}$  and so that*

$$\varphi(\mathcal{G}) = \mathcal{F}.$$

*If furthermore the lifted foliations  $\tilde{\mathcal{F}}$  and  $\tilde{\mathcal{G}}$  have same holonomies, that is  $\tilde{\mathcal{P}}_{\mathcal{F}} = \tilde{\mathcal{P}}_{\mathcal{G}}$ , then  $\varphi$  is isotopic (relative to a neighborhood of the boundary) to the identity map.*

An important step for proving Proposition 2.14.14 is the next classical result that we will also use several times:

**Proposition 2.14.15.** *[HH, Lemma 4.2.5] Let  $\mathcal{F}$  be a  $C^r$  ( $r \geq 1$ ) foliation on the annulus  $\mathbb{S}^1 \times [0, 1]$ , transverse to the boundary and without compact leaf. Then there is a smooth surjection  $\theta: \mathbb{S}^1 \times [0, 1] \rightarrow [0, 1]$  mapping  $\mathbb{S}^1 \times \{0\}$  on 0 and  $\mathbb{S}^1 \times \{1\}$  on 1 and so that  $\mathcal{F}$  is transverse to the fibers of  $\theta$ .*

As we did not find a reference for the precise statement of Proposition 2.14.14, we explain its proof below.

*Hint for the proof of Proposition 2.14.14.* One first notices that the surjection  $\theta$  given by Proposition 2.14.15 can be chosen so that  $\theta(x, t) = t$  for  $t$  close to 0 or to 1.

Let us fix such surjections  $\theta_{\mathcal{F}}$  and  $\theta_{\mathcal{G}}$  associated to  $\mathcal{F}$  and  $\mathcal{G}$  by Proposition 2.14.15.

We get a map  $\varphi_{\mathcal{F}}: \mathbb{S}^1 \times [0, 1] \rightarrow \mathbb{S}^1 \times [0, 1]$  defined as

$$\varphi_{\mathcal{F}}(x, t) = (y, \theta_{\mathcal{F}}(x, t)),$$

where  $(y, 0)$  is the intersection of the leaf of  $\mathcal{F}$  through  $(x, t)$  with  $\mathbb{S}^1 \times \{0\}$ . We define a map  $\varphi_{\mathcal{G}}$  in the same way.

As  $\mathcal{F}$  coincides with  $\mathcal{G}$  in a neighborhood of the boundary and  $\mathcal{F}, \mathcal{G}$  have the same holonomy map, and as  $\theta_{\mathcal{F}}$  coincides with  $\theta_{\mathcal{G}}$  close to the boundary, one easily checks that  $\varphi_{\mathcal{F}}$  coincides with  $\varphi_{\mathcal{G}}$  in a neighborhood of the boundary. Now the announced map  $\varphi$  is just

$$\varphi = \varphi_{\mathcal{G}}^{-1} \circ \varphi_{\mathcal{F}}.$$

One easily checks that  $\varphi$  satisfies all the announced properties. □

A classical consequence of Proposition 2.14.15 is that a foliation on  $\mathbb{T}^2$  admitting a complete transversal is conjugated to the suspension of the first return map on this transversal.

## 2.15 Dehn twist along torus

In the study of 3-dimensional topology, there is a classical surgery called *Dehn twist* aiming to create new diffeomorphism that is non-isotopy to identity.

**Definition 2.15.1.** *Let  $u = (n, m) \in \mathbb{Z}^2 = \pi_1(\mathbb{T}^2)$ . A diffeomorphism  $\psi: [0, 1] \times \mathbb{T}^2 \rightarrow [0, 1] \times \mathbb{T}^2$  is called a Dehn twist of  $[0, 1] \times \mathbb{T}^2$  directed by  $u$  if:*

- $\psi$  is of the form  $(t, x) \mapsto (t, \psi_t(x))$ , where  $\psi_t$  is a diffeomorphism of  $\mathbb{T}^2$  depending smoothly on  $t$ .
- $\psi_t$  is the identity map for  $t$  close to 0 or close to 1.
- the closed path  $t \mapsto \psi_t(O)$  on  $\mathbb{T}^2$  is freely homotopic to  $u$  (where  $O = (0, 0)$  in  $\mathbb{T}^2 = \mathbb{R}^2/\mathbb{Z}^2$ ).

Now, the Dehn twist along an embedded torus on a 3-manifold is defined as below:

**Definition 2.15.2.** *Let  $M$  be an oriented 3-manifold and let  $T: \mathbb{T}^2 \hookrightarrow M$  be an embedded torus. Fix  $u \in \pi_1(T)$ . We say that a diffeomorphism  $\psi: M \rightarrow M$  is a Dehn twist along  $T$  directed by  $u$  if there is an orientation preserving diffeomorphism  $\varphi: [0, 1] \times \mathbb{T}^2 \hookrightarrow M$  whose restriction to  $\{0\} \times \mathbb{T}^2$  induces  $T$ , and so that:*

- $\psi$  is the identity map out of  $\varphi([0, 1] \times \mathbb{T}^2)$ . In particular,  $\psi$  leaves invariant  $\varphi([0, 1] \times \mathbb{T}^2)$ ;
- The diffeomorphism  $\varphi^{-1} \circ \psi \circ \varphi: [0, 1] \times \mathbb{T}^2 \rightarrow [0, 1] \times \mathbb{T}^2$  is a Dehn twist directed by  $u$ .

## 2.16 Anosov flows and transverse tori

A vector field  $X$  on a 3-manifold  $M$  is called an *Anosov vector field* if there is a splitting  $TM = E^s \oplus \mathbb{R} \cdot X \oplus E^u$  as a direct sum of 1-dimensional bundles which are invariant by the flow  $\{X_t\}_{t \in \mathbb{R}}$  of  $X$ , and so that the vectors in  $E^s$  are uniformly contracted and the vectors in  $E^u$  are uniformly expanded by the flow of  $X$ .

Notice that  $X$  is Anosov if and only if  $X$  has no zeros and if there is  $t > 0$  so that  $X_t$  is partially hyperbolic.

The bundles  $E^{cs} = E^s \oplus \mathbb{R} \cdot X$  and  $E^{cu} = \mathbb{R} \cdot X \oplus E^u$  are called the weak stable and unstable bundles (respectively). They are tangent to transverse 2-dimensional foliations denoted by  $\mathcal{F}^{cs}$  and  $\mathcal{F}^{cu}$  respectively, which are of class  $C^1$  if  $X$  is of class at least  $C^2$ .

The bundles  $E^s$  and  $E^u$  are called the strong stable and strong unstable bundles, and are tangent to 1-dimensional foliations denoted by  $\mathcal{F}^{ss}$  and  $\mathcal{F}^{uu}$  which are called the strong stable and the strong unstable foliations, respectively.

Notice that being an Anosov vector field is an open condition in the set of  $C^1$ -vector fields and that the structural stability implies that all the flows  $C^1$ -close to an Anosov flow are Anosov flows topologically equivalent to it. The topological equivalence of two flows is defined as follow:

**Definition 2.16.1.** *Let  $\varphi_t : M \mapsto M$  and  $\theta_t : N \mapsto N$  be two continuous flows. We say that  $\varphi_t$  is topologically equivalent to  $\theta_t$ , if there exists a homeomorphism  $h : M \mapsto N$  preserving the orientation of the flows and sending the orbits of the flow  $\varphi_t$  to the orbits of the flow  $\theta_t$ , that is,*

$$h(\text{Orb}(x, \varphi_t)) = \text{Orb}(h(x), \theta_t), \text{ for any } x \in M.$$

Therefore, for our purpose here we may always assume, and we do it, that the Anosov flows we consider are smooth.

The most classical Anosov flows on 3-manifolds are the geodesic flows of hyperbolic closed surfaces and the suspension of hyperbolic linear automorphisms of  $\mathbb{T}^2$  (i.e. induced by an hyperbolic element of  $SL(2, \mathbb{Z})$ ). In 1979, [FW] built the first example of a non-transitive Anosov flow on a closed 3-manifold. Many other examples of transitive or non-transitive Anosov flows have been built in [BL, BBY].

If  $X$  is an Anosov vector field on an oriented closed 3-manifold  $M$  and if  $S \subset M$  is an immersed closed surface which is transverse to  $X$  then

- $S$  is oriented (as transversely oriented by  $X$ );
- $S$  is transverse to the weak foliations  $\mathcal{F}^{cs}$  and  $\mathcal{F}^{cu}$  of  $X$  and these foliations induce on  $S$  two 1-dimensional  $C^1$ -foliations  $\mathcal{F}_S^s$  and  $\mathcal{F}_S^u$ , respectively, which are transverse.
- as a consequence of the two previous items,  $S$  is a torus.

A *transverse torus* is an embedded torus  $T: \mathbb{T}^2 \hookrightarrow M$  transverse to  $X$  and we denote by  $\mathcal{F}_T^s$  and  $\mathcal{F}_T^u$  the 1-dimensional  $C^1$  foliations induced on  $T$  obtained by intersections of  $T$  with  $\mathcal{F}^{cs}$  and with  $\mathcal{F}^{cu}$ , respectively. These foliations are transverse. Therefore Theorem 4 associates to  $(\mathcal{F}_T^s, \mathcal{F}_T^u)$  and a subgroup  $G_{\mathcal{F}_T^s, \mathcal{F}_T^u}$  of  $\pi_1(T)$  which is either a cyclic group if  $\mathcal{F}_T^s$  and  $\mathcal{F}_T^u$  have parallel compact leaves or the whole  $\pi_1(T)$  otherwise.

Let  $T_1, \dots, T_k$  be a finite family of transverse tori. We say that  $X$  has no return on  $\bigcup_i T_i$  if each torus  $T_i$  is an embedded torus, the  $\{T_i\}$  are pairwise disjoint and each orbit of  $X$  intersects  $\bigcup_i T_i$  in at most 1 point.

A *Lyapunov function* for  $X$  is a function which is not increasing along every orbit, and which is strictly decreasing along every orbit which is not chain recurrent.

In [Br] Marco Brunella noticed that a non-transitive Anosov vector field  $X$  on an oriented closed 3-manifold  $M$  always admits a smooth Lyapunov function whose regular levels separate the *basic pieces* of the flow; such a regular level is a disjoint union of transverse tori  $T_1, \dots, T_k$ . One can check the following statement:

**Proposition 2.16.2.** *Let  $X$  be a (non-transitive) Anosov vector field on an oriented closed 3-manifold  $M$ . Then the two following assertions are equivalent:*

1.  $T_1, \dots, T_k$  are transverse tori so that  $X$  has no return on  $\bigcup_i T_i$ .
2. there is a smooth Lyapunov function  $\theta: M \rightarrow \mathbb{R}$  of  $X$  for which the  $T_i$ ,  $i \in \{1, \dots, k\}$  are (distinct) connected components of the same regular level  $\theta^{-1}(t)$  for some  $t \in \mathbb{R}$ .

## 2.17 Dynamical coherence, Plaque expansiveness and completeness

**Definition 2.17.1.** *Let  $f$  be a partially hyperbolic diffeomorphism. We say that  $f$  is cs (resp. cu)-dynamically coherent, if there exists an  $f$  invariant foliation  $\mathcal{F}^{cs}$  (resp.  $\mathcal{F}^{cu}$ ) everywhere tangent to  $E^s \oplus E^c$  (resp.  $E^c \oplus E^u$ ).  $f$  is dynamically coherent, if  $f$  is both cs-dynamically coherent and cu-dynamically coherent.*

A partially hyperbolic diffeomorphism might not be dynamical coherent even if the center dimension is one (see for instance [HHU5]).

Let  $\mathcal{F}$  be an  $f$ -invariant foliation. We denote by  $\mathcal{F}(x)$  the  $\mathcal{F}$ -leaf through the point  $x$ . A sequence of points  $\{x_n\}_{n \in \mathbb{Z}}$  is called an  $\epsilon$  pseudo orbit with respect to  $\mathcal{F}$ , if for any  $n \in \mathbb{Z}$ , one has that the points  $f(x_n)$  and  $x_{n+1}$  belong to the same  $\mathcal{F}$  leaf, and  $f(x_n)$  belongs to  $\mathcal{F}_\epsilon(x_{n+1})$ , where  $\mathcal{F}_\epsilon(x_{n+1})$  denotes the  $\epsilon$  ball in the leaf  $\mathcal{F}(x_{n+1})$  centered at  $x_{n+1}$ .

**Definition 2.17.2.** *Given an  $f$ -invariant foliation  $\mathcal{F}$ . We say that  $\mathcal{F}$  is plaque expansive, if there exists  $\epsilon > 0$  satisfying the following: if  $\{x_n\}_{n \in \mathbb{Z}}$  and  $\{y_n\}_{n \in \mathbb{Z}}$  are two  $\epsilon$ -pseudo orbits with respect to  $\mathcal{F}$  and if one has  $d(x_n, y_n) < \epsilon$  for any  $n \in \mathbb{Z}$ , then  $x_n$  and  $y_n$  belong to a common  $\mathcal{F}$ -leaf for any  $n \in \mathbb{Z}$ .*

By Theorem 7.5 and Corollary 7.6 in [HHU2], a partially hyperbolic diffeomorphism with neutral center is dynamically coherent; moreover, the center, center stable and center unstable foliations are plaque expansive. By Theorem 7.1 in [HPS] one has that the plaque expansiveness in this setting is a robust property and implies the structure stability of the invariant foliation (ie. leaf conjugacy). In [PSh], the authors prove that if the center foliation is plaque expansive, then the leaf conjugacy for the center foliation keeps the center stable and center unstable foliations invariant. To summarize, one has the following result:

**Theorem 2.17.3.** *Let  $f$  be a partially hyperbolic diffeomorphism. If  $f$  has one dimensional neutral center, there exists a  $C^1$  small neighborhood  $\mathcal{U}$  of  $f$  such that for any  $g \in \mathcal{U}$ , one has the following properties:*

- (dynamical coherence)  $g$  is dynamically coherent;
- (plaque expansive) the center, center stable and center unstable foliations  $g$  are plaque expansive;
- (leaf conjugacy) there exists a homeomorphism  $h_g : M \mapsto M$  such that for any point  $x \in M$  and  $i = c, cs, cu$ , one has that

$$h_g(\mathcal{F}_g^i(x)) = \mathcal{F}_f^i(h_g(x)) \text{ and } h_g(g(\mathcal{F}_g^i(x))) = f(h_g(\mathcal{F}_f^i(x))).$$

**Remark 2.17.4.** *For the homeomorphism  $h_g$ , one has that  $h_g$  tends to identity as  $g$  tends to  $f$ .*

Let  $f$  be a dynamically coherent partially hyperbolic diffeomorphism. A point  $y$  is called *an accessible boundary point* with respect to  $\mathcal{F}^{ss}(\mathcal{F}^c(x))$  for some  $x \in M$ , if there exists a  $C^1$  curve  $\sigma : [-1, 0] \mapsto M$  tangent to the center bundle such that

$$\sigma([-1, 0]) \subset \mathcal{F}^{ss}(\mathcal{F}^c(x)) \text{ and } \sigma(0) = y \notin \mathcal{F}^{ss}(\mathcal{F}^c(x)).$$

The set of accessible boundary points with respect to  $\mathcal{F}^{ss}(\mathcal{F}^c(x))$  is called *accessible boundary* with respect to  $\mathcal{F}^{ss}(\mathcal{F}^c(x))$ .

With the notations above, one has the following result due to [BW]:

**Proposition 2.17.5.** *The accessible boundary with respect to  $\mathcal{F}^{ss}(\mathcal{F}^c(x))$  is saturated by strong stable leaves.*

We will call each strong stable leaf in the accessible boundary with respect to  $\mathcal{F}^{ss}(\mathcal{F}^c(x))$  as a *boundary leaf with respect to  $\mathcal{F}^{ss}(\mathcal{F}^c(x))$*  or a *boundary leaf* for simplicity.

## 2.18 Existence of compact leaf

In 1965, S. Novikov gave a criterion for the existence of compact leaves of codimension one foliations on closed 3-manifolds.

**Theorem 2.18.1.** *[N] Let  $\mathcal{F}$  be a codimension one foliation on a 3-manifold  $M$ .  $\mathcal{F}$  has a compact leaf, if one of the followings is satisfied:*

- *there exists a null-homotopy closed transversal for  $\mathcal{F}$ ;*
- *there exists a non-null homotopic path in a  $\mathcal{F}$ -leaf which is null homotopy in  $M$ .*

We remark here that both conditions above would imply the existence of Reeb components, hence any one-dimensional foliation transverse to  $\mathcal{F}$  would admit a circle leaf.

With the help of Novikov's theorem, [HHU6] proves the non-existence of compact leaf for center stable (center unstable) foliation. More precisely,

**Theorem 2.18.2.** *[HHU6] Let  $f$  be a partially hyperbolic diffeomorphism on a 3-manifold  $M$  with the splitting  $TM = E^s \oplus E^c \oplus E^u$ . Assume that  $f$  is  $cs$ -dynamically coherent, then the center stable foliation  $\mathcal{F}^{cs}$  has no compact leaves.*





# Chapter 3

## Existence of non-hyperbolic ergodic measures

In this chapter, we deal with the existence of non-hyperbolic ergodic measures to characterize the non-hyperbolicity of certain systems.

We first prove the robust existence of non-hyperbolic ergodic measures for some robustly non-hyperbolic diffeomorphisms (up to removing a nowhere dense subset), using the [GIKN] criterion. Hence the non-hyperbolic ergodic measures are the limit of periodic measures. To prove this, we use the special partially hyperbolic robust cycle called flip-flop configuration (given by [BBD2]) and formed by a dynamically defined blender and a hyperbolic periodic point of different indices. In a small neighborhood of this robust cycle, for each hyperbolic periodic orbit, one can find some pieces of orbit segments which exhibit some hyperbolicity along the center and stay close to the fixed periodic orbit for a large proportion of time, then one can apply Liao-Gan's shadowing lemma to close the orbit. By choosing the pieces of orbit segments carefully, one can get that the new closed orbit obtained by the shadowing lemma is a good approximation of the fixed periodic orbit and the center Lyapunov exponent of the new periodic orbit gets closer to zero. Inductively, one can get a sequence of periodic orbits satisfying the [GIKN] criterion and whose center Lyapunov exponents tending to zero. The non-hyperbolic ergodic measures obtained in the way above have only one vanishing Lyapunov exponent. Using this technic, we also show that for an open dense subset of robustly transitive diffeomorphisms far from homoclinic tangencies, there exist non-hyperbolic ergodic measures whose supports are the whole manifold.

We also describe how far from hyperbolicity of the systems are by proving the existence of non-hyperbolic ergodic measures with more than one vanishing Lyapunov exponents. This involves in lots of perturbation technics by Bochi, Bonatti, Díaz, Crovisier, Gourmelon and many others. The non-hyperbolic ergodic measure is also obtained by [GIKN] criterion and the periodic orbits applied to this criterion are obtained by generic arguments. The proof

consists in perturbing the dynamics to get a ‘large’ partially hyperbolic heterodimensional cycle, then the no-domination assumption allows us to use Bochi-Bonatti’s result to equalize the center Lyapunov exponents of the two periodic orbits in the cycle. Then by mixing the center Lyapunov exponents of these two periodic orbits of different indices, one gets a new periodic orbit whose center Lyapunov exponents get closer to zero. Moreover, the new periodic orbit is still in the homoclinic class, which is guaranteed by Franks-Gourmelon lemma. By carefully choosing the sequence of periodic orbits, one can apply the argument in [CCGWY] showing that the ergodic measure has more than one vanishing Lyapunov exponents.

### 3.1 Periodic orbits satisfying the [GIKN] criterion in a flip flop configuration: Proof of Theorem A

Let  $(\Lambda, U, \mathcal{C}^{uu}, \mathfrak{D})$  be a dynamically defined blender and  $\mathcal{O}_q$  be a hyperbolic periodic orbit. Let  $\epsilon_0$  be the strength of the strictly invariant family. We assume that there are  $\Delta^s \subset W^s(\mathcal{O}_q)$  and  $\Delta^u \subset W^u(\mathcal{O}_q)$  so that  $(\Lambda, U, \mathcal{C}^{uu}, \mathfrak{D}, \mathcal{O}_q, \Delta^s, \Delta^u)$  is a split-flip-flop configuration.

We fix a partially hyperbolic neighborhood  $V$  of the split flip-flop configuration so that the maximal invariant set  $\tilde{\Lambda}$  of  $f$  in the closure  $\bar{V}$  admits a partially hyperbolic splitting  $E^s \oplus E^c \oplus E^u$  with  $\dim(E^c) = 1$ . Let  $\varphi: M \rightarrow \mathbb{R}$  be the continuous extension of the continuous function  $\log \|Df|_{E^c}\|: \tilde{\Lambda} \rightarrow \mathbb{R}$ .

Since  $\varphi|_{\Lambda} > 0$  and  $\Lambda$  is the maximal invariant set of  $U$ , hence there exist a number  $\tau > 0$  and an integer  $N$  such that for any  $x \in \cap_{i=-N}^N f^i(U)$ , we have that

$$\varphi(x) \geq 2\tau.$$

**Lemma 3.1.1.** *With the notation above. There exist two constants  $\rho \in (0, \frac{1}{\|\varphi\|_{C^0}})$  and  $\zeta \in (0, 1)$ , such that for any  $\epsilon > 0$  and any hyperbolic periodic orbit  $\gamma$  which is contained inside  $V$  and is homoclinically related to  $\mathcal{O}_q$  inside  $V$ , there exists a hyperbolic periodic orbit  $\gamma'$  which is homoclinically related to  $\gamma$  in  $V$  satisfying:*

- $\gamma'$  is  $(\epsilon, 1 - \rho \cdot |\lambda^c(\gamma)|)$  good for  $\gamma$ ;
- $\lambda^c(\gamma') > \zeta \lambda^c(\gamma)$ .

*Proof.* We denote by  $\lambda$  the center Lyapunov exponent of  $\gamma$ , then there exists a point  $y \in \gamma$  such that

$$\frac{1}{k} \sum_{i=0}^{k-1} \log \|Df|_{E^c(f^i(y))}\| \leq \lambda, \text{ for } k = 1, \dots, \pi(\gamma).$$

Consider the continuous function

$$h_1(t) = \frac{2\|\varphi\|_{C^0}}{2\|\varphi\|_{C^0} + |\lambda - t|} \cdot \frac{\lambda + t}{2} + t$$

and

$$h_2(t) = \frac{2\|\varphi\|_{C^0} - \tau}{2\|\varphi\|_{C^0} + |\lambda + t|} \lambda - \frac{3}{2}t,$$

for any  $t \geq 0$ .

Since  $h_1(0) < \frac{1}{4}\lambda$  and  $h_2(0) > \frac{2\|\varphi\|_{C^0} - \tau}{2\|\varphi\|_{C^0}}\lambda$ , there exists  $t_0$  such that for any  $t \in [0, t_0]$ , we have the following:

$$h_1(t) < \frac{\lambda}{4} \text{ and } h_2(t) > \frac{2\|\varphi\|_{C^0} - \tau}{2\|\varphi\|_{C^0}}\lambda.$$

We take a small positive number

$$\delta < \min\{t_0, \frac{1}{100}|\lambda|\}.$$

For the number  $\frac{1}{4}\lambda < 0$  and the splitting  $T_{\tilde{\Lambda}}M = (E^s \oplus E^c) \oplus E^u$ , by Lemma 2.6.4, there exist two numbers  $L > 1$  and  $d_0 > 0$  such that for any  $d \in (0, d_0]$ , any  $\frac{1}{4}\lambda$ -quasi hyperbolic  $d$ -pseudo orbit is  $L \cdot d$  shadowed by a real orbit. Now we choose a number  $d \in (0, d_0)$  small enough such that

- $(L + 1)d < \epsilon$ ;
- $|\varphi(z) - \varphi(w)| < \delta$  for any two points  $z, w$  satisfying  $z \in B_{L \cdot d}(w)$ .

The precise choice of  $d$  would be fixed at the end.

The proof of Lemma 3.1.1 consists in finding a quasi hyperbolic string which starts at a point on the unstable manifold of  $y$ , whose orbit is contained in  $\tilde{\Lambda}$ , such that it spends a very long time to follow the periodic orbit  $\gamma$ . Then it spends some proportion of time in the open set  $U$  to gain some expansion in the center direction and after that in a small proportion of time it goes into a small neighborhood of  $\mathcal{O}_q$ . Using the fact that  $\gamma$  and  $\mathcal{O}_q$  are homoclinically related in  $V$ , by the shadowing lemma for hyperbolic set, we can find a hyperbolic string starts from a small neighborhood of  $\mathcal{O}_q$  to  $y$ .

Since  $\gamma$  is homoclinically related to  $\mathcal{O}_q$  inside  $V$ , by Inclination Lemma, there exists an  $i$ -dimensional compact disc  $D^u \in W^u(y) \cap V$  and a positive integer  $n_1$  such that

- the backward orbit of  $f^{n_1}(D^u)$  is contained in  $V$ ;
- $f^{n_1}(D^u)$  is  $C^1$   $\epsilon_0/2$ -close to  $\Delta^u$ , which implies that  $f^{n_1}(D^u) \in \mathcal{V}_{\epsilon_0}(\mathfrak{D})$ .

We denote by  $D_0^u = f^{n_1}(D^u)$ . By the compactness of  $D^u$  and of  $\Delta^s$ , there exists an integer  $n_d$  such that  $f^{-n_d}(D_0^u) \subset W_{d/2}^u(y)$  and  $f^{n_d}(\Delta^s) \subset W_{d/2}^s(\mathcal{O}_q)$ .

By shadowing lemma for hyperbolic set, up to increase  $n_d$ , there exists an  $\lambda/2$ -quasi hyperbolic string  $\{w, n_d\}$  from  $d/2$ -neighborhood of  $q$  to  $d/2$ -neighborhood of  $y$ .

By the strictly invariant property of  $\mathfrak{D}$ , for any integer  $r$ , we have that

- $f^r(D_0^u)$  contains a uu-disc  $D_r^u \in \mathfrak{D}$ ;
- $f^{-i}(D_r^u)$  is contained in  $U$  for any  $i = 0, \dots, r$ .

By the definition of flip-flop configuration,  $D_r^u$  intersects  $\Delta^s$  in a point  $y_r$  transversely, for any positive integer  $r$ . We denote by  $x_r = f^{-r}(y_r)$ . By the choice of  $x_r$ , one gets that

- the orbit segment  $\{x_r, r\}$  is contained in  $U$  and  $x_r$  belongs to  $\tilde{\Lambda}$ ;
- for any  $n > n_d$  such that  $n - n_d$  is a multiple of  $\pi(\gamma)$ , we have that  $f^{-n}(x_r) \in W_{d/2}^u(y)$ .

For any  $r \geq 2N$ , where  $N$  is the integer fixed at the beginning of this section, one has that

$$\begin{aligned} \sum_{i=0}^{r-1} \varphi(f^i(x_r)) &= \sum_{i=0}^{N-1} \varphi(f^i(x_r)) + \sum_{i=N}^{r-N-1} \varphi(f^i(x_r)) + \sum_{i=r-N}^{r-1} \varphi(f^i(x_r)) \\ &> -N\|\varphi\|_{C^0} + (r-2N)\tau - N\|\varphi\|_{C^0} \\ &\geq r \cdot \tau - 4N\|\varphi\|_{C^0} \end{aligned}$$

Denote by  $x_{r,n} = f^{-n}(x_r)$  and  $\sigma_{n,r}$  the orbit segment

$$\sigma_{n,r} = \{x_{r,n}, \dots, x_r, \dots, y_r, \dots, f^{n_d}(y_r)\}$$

which is contained in  $\tilde{\Lambda}$ . We denote by  $\pi_{n,r} = n + r + n_d$ .

**Claim 3.1.2.** *There exist two integers  $n$  and  $r$  arbitrarily large such that*

$$\frac{n - n_d}{\pi_{n,r} + n_d} > 1 - \frac{2|\lambda|}{3\|\varphi\|_{C^0}};$$

$$\frac{2\|\varphi\|_{C^0} - \tau}{2\|\varphi\|_{C^0}} \lambda < \frac{1}{\pi_{n,r}} \sum_{i=0}^{\pi_{n,r}-1} \varphi(f^i(x_{r,n})) < \frac{1}{4}\lambda;$$

- $\sigma_{n,r}$  is a  $\frac{1}{4}\lambda$ -quasi hyperbolic string corresponding to the splitting  $(E^s \oplus E^c) \oplus E^u$ .

*Proof.* By the choice of  $\sigma_{n,r}$ , we have that

$$\begin{aligned} \sum_{i=0}^{\pi_{n,r}-1} \varphi(f^i(x_{r,n})) &= \sum_{i=0}^{n-n_d-1} \varphi(f^i(x_{r,n})) + \sum_{i=n-n_d}^{\pi_{n,r}-1} \varphi(f^i(x_{r,n})) \\ &< (n - n_d)(\lambda + \delta) + (r + 2n_d)\|\varphi\|_{C^0}. \end{aligned}$$

On the other hand, we have that

$$\begin{aligned}
 \sum_{i=0}^{\pi_{n,r}-1} \varphi(f^i(x_{r,n})) &= \sum_{i=0}^{n-n_d-1} \varphi(f^i(x_{r,n})) + \sum_{i=n-n_d}^{n-1} \varphi(f^i(x_{r,n})) \\
 &\quad + \sum_{i=n}^{n+r-1} \varphi(f^i(x_{r,n})) + \sum_{i=n+r}^{\pi_{n,r}-1} \varphi(f^i(x_{r,n})) \\
 &> (n-n_d)(\lambda-\delta) - n_d \|\varphi\|_{C^0} \\
 &\quad + r \cdot \tau - 4N \|\varphi\|_{C^0} - n_d \|\varphi\|_{C^0} \\
 &= (n-n_d)(\lambda-\delta) + r \cdot \tau - (2n_d + 4N) \|\varphi\|_{C^0}.
 \end{aligned}$$

Hence, there exists  $N_0$  such that for any integer  $n > N_0$  and any  $r \in \mathbb{N}$ , we have that

$$\frac{1}{\pi_{n,r}} \left( (n-n_d)(\lambda+\delta) + (r+2n_d) \|\varphi\|_{C^0} \right) < \frac{n}{n+r} \lambda + \frac{r}{n+r} \|\varphi\|_{C^0} + \delta$$

and

$$\frac{1}{\pi_{n,r}} \left( (n-n_d)(\lambda-\delta) + r \cdot \tau - (2n_d + 4N) \|\varphi\|_{C^0} \right) > \frac{n}{n+r} \lambda + \frac{r}{n+r} \tau - \delta.$$

There exist  $n$  and  $r$  arbitrarily large such that

$$\frac{r}{n} \in \left( \frac{|\lambda+\delta|}{2\|\varphi\|_{C^0}}, \frac{|\lambda-\delta|}{2\|\varphi\|_{C^0}} \right).$$

Hence, we have the following estimate:

$$\begin{aligned}
 \frac{n}{n+r} \lambda + \frac{r}{n+r} \|\varphi\|_{C^0} + \delta &= \frac{1}{1+\frac{r}{n}} \lambda + \frac{\frac{r}{n}}{1+\frac{r}{n}} \|\varphi\|_{C^0} + \delta \\
 &< \frac{1}{1+\frac{|\lambda-\delta|}{2\|\varphi\|_{C^0}}} \lambda + \frac{\frac{|\lambda-\delta|}{2\|\varphi\|_{C^0}}}{1+\frac{|\lambda-\delta|}{2\|\varphi\|_{C^0}}} \|\varphi\|_{C^0} + \delta \\
 &= \frac{1}{1+\frac{|\lambda-\delta|}{2\|\varphi\|_{C^0}}} \cdot \frac{\lambda+\delta}{2} + \delta \\
 &= \frac{2\|\varphi\|_{C^0}}{2\|\varphi\|_{C^0} + |\lambda-\delta|} \cdot \frac{\lambda+\delta}{2} + \delta \\
 &= h_1(\delta)
 \end{aligned}$$

and

$$\begin{aligned}
 \frac{n}{n+r}\lambda + \frac{r}{n+r}\tau - \delta &= \frac{1}{1+\frac{r}{n}}\lambda + \frac{\frac{r}{n}}{1+\frac{r}{n}}\tau - \delta \\
 &> \frac{1}{1+\frac{|\lambda+\delta|}{2\|\varphi\|_{C^0}}}\lambda + \frac{\frac{|\lambda+\delta|}{2\|\varphi\|_{C^0}}}{1+\frac{|\lambda+\delta|}{2\|\varphi\|_{C^0}}}\tau - \delta \\
 &= \frac{2\|\varphi\|_{C^0}}{2\|\varphi\|_{C^0} + |\lambda+\delta|}\lambda - \frac{\lambda+\delta}{2\|\varphi\|_{C^0} + |\lambda+\delta|}\tau - \delta \\
 &> \frac{2\|\varphi\|_{C^0} - \tau}{2\|\varphi\|_{C^0} + |\lambda+\delta|}\lambda - \frac{3}{2}\delta \\
 &= h_2(\delta)
 \end{aligned}$$

By the choice of  $\delta$ , we have that

$$\frac{2\|\varphi\|_{C^0} - \tau}{2\|\varphi\|_{C^0}}\lambda < \frac{1}{\pi_{n,r}} \sum_{i=0}^{\pi_{n,r}-1} \varphi(f^i(x_{r,n})) < \frac{1}{4}\lambda.$$

This proves the second item of Claim 3.1.2.

Since we have

$$\frac{r}{n} \in \left( \frac{|\lambda+\delta|}{2\|\varphi\|_{C^0}}, \frac{|\lambda-\delta|}{2\|\varphi\|_{C^0}} \right),$$

where  $n$  and  $r$  can be chosen arbitrarily large; when  $n$  and  $r$  are chosen large enough, we have the following

$$\frac{n - n_d}{\pi_{n,r} + n_d} = \frac{1 - \frac{n_d}{n}}{1 + \frac{r}{n} + \frac{2n_d}{n}} > \frac{1 - \frac{n_d}{n}}{1 + \frac{|\lambda-\delta|}{2\|\varphi\|_{C^0}} + \frac{2n_d}{n}} > \frac{1}{1 + \frac{2|\lambda|}{3\|\varphi\|_{C^0}}} > 1 - \frac{2|\lambda|}{3\|\varphi\|_{C^0}}.$$

Since  $\sigma_{n,r}$  is contained in  $\tilde{\Lambda}$  and  $\tilde{\Lambda}$  admits the partially hyperbolic splitting  $(E^s \oplus E^c) \oplus E^u$ , to prove that  $\sigma_{n,r}$  is a  $\frac{1}{4}\lambda$ -quasi hyperbolic string, we only need to show that for any integer  $j \in [1, \pi_{n,r}]$ , we have the following

$$\frac{1}{j} \sum_{k=0}^{j-1} \varphi(f^k(x_{r,n})) \leq \frac{1}{4}\lambda.$$

For any  $j \in [1, n+N]$ , when  $n$  is chosen large enough and  $d$  is small enough, we have the following:

$$\frac{1}{j} \sum_{k=0}^{j-1} \varphi(f^k(x_{r,n})) \leq \frac{1}{2}\lambda < \frac{1}{4}\lambda;$$

For any  $j \in [n + N, \pi_{n,r}]$ , we have that:

$$\begin{aligned} \frac{1}{j} \sum_{k=0}^{j-1} \varphi(f^k(x_{r,n})) &= \frac{1}{j} \sum_{k=0}^{n-n_d-1} \varphi(f^k(x_{r,n})) + \frac{1}{j} \sum_{k=n-n_d}^{j-1} \|\varphi\|_{C^0} \\ &< \frac{n-n_d}{j}(\lambda + \delta) + \frac{j-n+n_d}{j} \|\varphi\|_{C^0}. \end{aligned}$$

Since the last item of the inequality above is increasing when  $j$  increases in  $j \in [n + N, \pi_{n,r}]$ , one has that

$$\frac{1}{j} \sum_{k=0}^{j-1} \varphi(f^k(x_{r,n})) \leq \frac{1}{\pi_{n,r}} ((n-n_d)(\lambda + \delta) + (r+2n_d)\|\varphi\|_{C^0}).$$

By the proof of item two, one has that

$$\begin{aligned} &\frac{1}{\pi_{n,r}} ((n-n_d)(\lambda + \delta) + (r+2n_d)\|\varphi\|_{C^0}) \\ &< \frac{n}{n+r} \lambda + \frac{r}{n+r} \|\varphi\|_{C^0} + \delta \\ &< \frac{1}{4} \lambda. \end{aligned}$$

This ends the proof of Claim 3.1.2.  $\square$

By the choice of the  $\lambda/2$ -quasi hyperbolic string  $\{w, n_d\}$  and the Claim 3.1.2, we get a  $\frac{\lambda}{4}$ -quasi hyperbolic periodic  $d$ -pseudo orbit  $\{\sigma_{n,r}, \{w, n_d\}\}$  of period  $\pi_{n,r} + n_d$ . By Lemma 2.6.4, there exists a periodic orbit point  $p$  of period  $\pi_{n,r} + n_d$  such that

— For any  $j \in [0, \pi_{n,r}]$ , we have that

$$d(f^j(p), f^j(x_{r,n})) < L \cdot d;$$

— For any  $j \in [\pi_{n,r} + 1, \pi_{n,r} + n_d - 1]$ , we have that

$$d(f^j(p), f^{j-\pi_{n,r}}(w)) < L \cdot d.$$

Let  $\gamma'$  be the orbit of periodic point  $p$ . Since  $(L+1) \cdot d < \epsilon$ , we have that  $\gamma'$  is  $(\epsilon, \frac{n-n_d}{\pi_{n,r}+n_d})$  good for  $\gamma$ .

We take

$$\rho = \frac{2}{3\|\varphi\|_{C^0}} < \frac{1}{\|\varphi\|_{C^0}} \text{ and } \zeta = \frac{2\|\varphi\|_{C^0} - \tau}{2\|\varphi\|_{C^0}} < 1.$$

By the first item of Claim 3.1.2, we have that  $\gamma'$  is  $(\epsilon, 1 - \rho \cdot |\lambda|)$  good for  $\gamma$ .



When  $d$  is chosen small enough, by the uniform continuity of  $\varphi$  and the third item of Claim 3.1.2, one gets that

$$\frac{1}{j} \sum_{k=0}^{j-1} \varphi(f^k(p)) \leq \frac{1}{5}\lambda, \text{ for any integer } j \in [0, \pi_{n,r} + n_d - 1];$$

by the uniform continuity of  $\varphi$  and the second item of Claim 3.1.2, one gets that

$$\lambda^c(\gamma') = \frac{1}{\pi_{n,r} + n_d} \sum_{j=0}^{\pi_{n,r} + n_d - 1} \varphi(f^j(p)) > \zeta\lambda.$$

Hence,  $p$  is a  $(\frac{\lambda}{5}, E^s \oplus E^c)$  hyperbolic time whose distance to  $y$  is less than  $(L+1) \cdot d$ . By Lemma 2.7.3,  $p$  has uniform size of stable manifold of dimension  $\dim(E^s \oplus E^c)$ . When  $d$  is small enough, combining with the fact that  $E^u$  is uniformly expanding, we have that  $\gamma'$  is homoclinically related to  $\gamma$  in  $V$ .

This ends the proof of Lemma 3.1.1. □

**Remark 3.1.3.** *If  $f$  is globally partially hyperbolic with center dimension one, we can see from the proof of Lemma 3.1.1 that we can take  $V$  as the whole manifold  $M$ .*

Recall that  $\mathcal{RC}(M)$  is the set of diffeomorphisms with robust cycles formed by a hyperbolic set of s-index  $i$  and a hyperbolic periodic point of s-index  $i+1$ . We denote by  $d = \dim(M)$ . Now we can give the proof of Theorem A.

*Proof.* By Proposition 2.9.5, there exists an open and dense subset  $\widetilde{\mathcal{RC}}(M)$  of  $\mathcal{RC}(M)$  such that for every  $f \in \widetilde{\mathcal{RC}}(M)$ , there exists a split flip flop configuration formed by a dynamically defined cu-blender of uu-index  $d-i-1$  and a hyperbolic periodic point of u-index  $d-i-1$ .

We fix a sequence of positive numbers  $\{\epsilon_j\}$  such that

$$\lim_{n \rightarrow +\infty} \sum_{j=0}^n \epsilon_j < +\infty.$$

Using Lemma 3.1.1, for each  $f \in \widetilde{\mathcal{RC}}(M)$ , we will inductively find a sequence of hyperbolic periodic orbits satisfying the condition of Lemma 2.5.2.

Let  $\rho \in (0, \frac{1}{\|\varphi\|_{C^0}})$  and  $\zeta \in (0, 1)$  be the two numbers given by Lemma 3.1.1.

We denote by

$$\gamma_0 = \mathcal{O}_q \text{ and } \kappa_0 = 1 - \rho \cdot |\lambda^c(\gamma_0)|.$$

Assume that we already get  $\gamma_n$ . Then we denote by

$$\kappa_n = 1 - \rho \cdot |\lambda^c(\gamma_n)|.$$

By applying Lemma 3.1.1 to  $\gamma_n$  and  $\epsilon_n$ , we get a hyperbolic periodic orbit  $\gamma_{n+1}$  such that

- $\gamma_{n+1}$  is homoclinically related to  $\gamma_n$  in  $V$  ;
- $\gamma_{n+1}$  is  $(\epsilon_n, \kappa_n)$  good for  $\gamma_n$ ;
- $|\lambda^c(\gamma_{n+1})| < \zeta \cdot |\lambda^c(\gamma_n)|$ .

For any  $n$ , we have that

$$|\lambda^c(\gamma_n)| \leq \zeta^n \cdot |\lambda^c(\gamma_0)|.$$

Hence, the center Lyapunov exponent of  $\gamma_n$  exponentially tends to zero when  $n$  tends to infinity, which implies

$$\lim_{n \rightarrow +\infty} \prod_{i=0}^n \kappa_i \in (0, 1].$$

By Lemma 2.5.2, the sequence  $\{\delta_{\gamma_n}\}$  converges to a non-hyperbolic ergodic measure  $\mu$  whose support is

$$\bigcap_{n=1}^{\infty} \overline{\bigcup_{k=n}^{\infty} \gamma_k}.$$

□

## 3.2 Existence of non-hyperbolic ergodic measures with full support for robustly transitive diffeomorphisms: Proof of Theorem B

### 3.2.1 Reduction of Theorem B

Let  $\mathcal{RT}(M)$  be the subset of  $\text{Diff}^1(M)$  such that for any  $f \in \mathcal{RT}(M)$ , we have that

- $f$  is robustly transitive;
- $f$  admits a partially hyperbolic splitting of the form

$$TM = E^s \oplus E_1^c \oplus \cdots \oplus E_k^c \oplus E^u$$

satisfying that  $\dim(E_1^c) = \cdots = \dim(E_k^c) = 1$ .

- there exist two hyperbolic periodic orbits of indices  $\dim(E^s)$  and  $\dim(E^s) + k$  respectively.

We denote by  $\dim(E^s) = i_0$  and  $\dim(M) = d$ .

**Remark 3.2.1.** — *By definition,  $\mathcal{RT}(M)$  is an open subset of  $\text{Diff}^1(M)$ .*

- *By robust transitivity and [ABCDW, Theorem 1], there exists an open and dense subset  $\mathcal{RT}_p(M)$  of  $\mathcal{RT}(M)$  such that for any  $f \in \mathcal{RT}_p(M)$  and any  $j = 0, \dots, k$ , there exists a hyperbolic periodic orbit of index  $i_0 + j$ .*

For any  $f \in \mathcal{RT}(M)$  and any  $f$ -ergodic measure  $\mu$ , we denote by  $\lambda_i^c(\mu)$  the Lyapunov exponent of  $\mu$  along the bundle  $E_i^c$ , for any  $i = 1, \dots, k$ . As the bundle  $E_i^c$  is one dimensional, one has that

$$\lambda_i^c(\mu) = \int \log \|Df|_{E_i^c}\| d\mu.$$

Recall that  $\mathcal{U}(M)$  is the set of robustly transitive non-hyperbolic  $C^1$  diffeomorphisms far from homoclinic tangencies. Hence,  $\mathcal{U}(M)$  is an open set of  $\text{Diff}^1(M)$ . It is clear, by definition, that  $\mathcal{RT}(M)$  is a subset of  $\mathcal{U}(M)$ . In fact, by Theorem D in [BDPR], the set  $\mathcal{RT}(M)$  is an open and dense subset of  $\mathcal{U}(M)$ . Now, Theorem B is a straightforward result of the following theorem:

**Theorem 3.2.2.** *There exists an open and dense subset  $\widetilde{\mathcal{RT}}(M)$  of  $\mathcal{RT}(M)$ , such that for any  $f \in \widetilde{\mathcal{RT}}(M)$ , there exist  $k$  non-hyperbolic ergodic measures  $\mu_1, \dots, \mu_k$  such that for any  $i = 1, \dots, k$ , we have that*

- $\lambda_i^c(\mu_i) = 0$ ;
- The support of each  $\mu_i$  is the whole manifold  $M$ ;
- $\mu_i$  is the weak\*-limit of a sequence of hyperbolic periodic measures of index  $i_0 + i$ ;

Note that in the case  $k = 1$ , the existence of non-hyperbolic ergodic measure with full support is also announced in [BBD3], but the proof is quite different.

Let  $p_f$  be a  $f$ -hyperbolic periodic point. We say that the homoclinic class of  $p_f$  is *robustly being the whole manifold*, if there exists a  $C^1$  small neighborhood  $\mathcal{U}_f$  of  $f$  such that for any  $g \in \mathcal{U}_f$ , we have that

- the continuation  $p_g$  of  $p_f$  is well defined;
- the homoclinic class of  $p_g$  is the whole manifold.

### 3.2.2 Existence of homoclinic classes robustly being the whole manifold

By [BC], for  $C^1$  generic diffeomorphisms in  $\mathcal{RT}(M)$  and any  $j = 0, \dots, k$ , the set of periodic orbits of index  $i_0 + j$  is dense on  $M$  and periodic orbits of the same index are homoclinically related; As a consequence, we have that  $M$  is a homoclinic class. Recently, [ACS] proves that one can replace the generic assumption by open and dense assumption to show that  $M$  is a homoclinic class of periodic orbits of index  $i_0$  and  $i_0 + k$  in a robust way. Combining with [BDPR, Theorem E], we have the following:

**Proposition 3.2.3.** *There exists an open and dense subset  $\mathcal{RT}_h(M)$  of  $\mathcal{RT}(M)$  such that for any  $f \in \mathcal{RT}_h(M)$ , there exist  $k + 1$  hyperbolic periodic points  $p_1, \dots, p_{k+1}$  whose homoclinic classes are robustly being the whole manifold.*

### 3.2.3 Periodic orbits satisfying [GIKN] criterion: Proof of Theorem 3.2.2

For every  $f \in \mathcal{RT}(M)$ , up to changing a metric (due to [Go1]), we can assume that there exists  $\lambda_0 < 0$  such that

- $\log \|Df|_{E^s(x)}\| < \lambda_0$  and  $\log \|Df^{-1}|_{E^u(x)}\| < \lambda_0$ , for any  $x \in M$ ;
- For any  $x \in M$ , we have that

$$\log \|Df|_{E^s(x)}\| - \log \|Df|_{E_1^c(x)}\| < 2\lambda_0,$$

$$\log \|Df^{-1}|_{E^u(f(x))}\| + \log \|Df|_{E_k^c(x)}\| < 2\lambda_0,$$

and for any  $i = 1, \dots, k-1$ ,

$$\log \|Df|_{E_i^c(x)}\| - \log \|Df|_{E_{i+1}^c(x)}\| < 2\lambda_0.$$

To prove Theorem 3.2.2, we need the following proposition.

**Proposition 3.2.4.** *Let  $f \in \mathcal{RT}(M)$  and  $p$  be a hyperbolic periodic point of index  $i_0 + i$  for some integer  $i \in (0, k]$ . Assume that the homoclinic class of  $p$  is the whole manifold. Assume, in addition, that there exists a cu-blender  $(\Lambda^u, U, \mathcal{C}^{uu}, \mathfrak{D})$  of  $uu$ -index  $d - i_0 - i$  such that  $\mathcal{O}_p$  and  $\Lambda^u$  form a split flip-flop configuration.*

*Then there exist  $\rho > 0$  and  $\zeta \in (0, 1)$  such that for any  $\epsilon > 0$  and any hyperbolic periodic orbit  $p_0$  homoclinically related to  $p$  satisfying that  $\lambda_i^c(p_0) > \lambda_0$ , where  $\lambda_0$  is the number we fixed at the beginning of this section, there exists a hyperbolic periodic point  $\mathcal{O}_{p_1}$  such that*

- $\mathcal{O}_{p_1}$  is homoclinically related to  $\mathcal{O}_{p_0}$  and is  $\epsilon$  dense in  $M$ ;
- The orbit of  $p_1$  is  $(\epsilon, 1 - \rho \cdot |\lambda_i^c(p_0)|)$  good for  $p_0$ ;
- $\lambda_i^c(p_1) > \zeta \cdot \lambda_i^c(p_0)$ .

*Proof.* Since  $Df$  is uniformly expanding in the bundle  $E_i^c|_{\Lambda^u}$ , there exist  $\tau_1 > \tau_2 > 1$  and an integer  $N$  such that for any  $x \in \cap_{i=-N}^N f^i(U)$ , we have that

$$\tau_2 < \|Df|_{E_i^c(x)}\| < \tau_1.$$

For simplicity, we will take  $N = 1$ .

We denote by  $\lambda$  the Lyapunov exponent of  $p_0$  along  $E_i^c$ .

We take  $\delta \in (0, \frac{-\lambda}{4})$ , whose precise value would be fixed at the end. By the uniform continuity of the functions  $\log \|Df|_{E_i^c}\|$  and  $\log \|Df|_{E_{i+1}^c}\|$ , there exists  $\eta > 0$  such that for any two points  $y, w \in M$  satisfying that  $d(y, w) < \eta$ , we have that

$$|\log \|Df|_{E_i^c(y)}\| - \log \|Df|_{E_i^c(w)}\|| < \frac{\delta}{2}$$

and

$$|\log \|Df|_{E_{i+1}^c(y)}\| - \log \|Df|_{E_{i+1}^c(w)}\|| < \frac{\delta}{2}.$$

Since  $H(p_0, f) = M$ , for any  $\epsilon \in (0, \eta)$  and any  $\kappa \in (0, 1)$ , there exists a hyperbolic periodic point  $p'$  homoclinically related to  $p_0$  (therefore homoclinically related to  $p$ ) such that

- the orbit of  $p'$  is  $\frac{\epsilon}{2}$  dense in  $M$ ;
- the orbit of  $p'$  is  $(\frac{\epsilon}{2}, \kappa)$  good for the orbit of  $p_0$ .

Since  $E_i^c$  is one dimension, we have that

$$\frac{1}{\pi(p_0)} \sum_{j=0}^{\pi(p_0)-1} \log \| Df|_{E_i^c(f^j(p_0))} \| = \lambda.$$

By assumption that  $\lambda \in (\lambda_0, 0)$  and the domination

$$\frac{1}{\pi(p_0)} \cdot \sum_{j=0}^{\pi(p_0)-1} \log \| Df|_{E_i^c(f^j(p_0))} \| - \frac{1}{\pi(p_0)} \cdot \sum_{j=0}^{\pi(p_0)-1} \log \| Df|_{E_{i+1}^c(f^j(p_0))} \| \leq 2 \cdot \lambda_0,$$

we have that

$$\frac{1}{\pi(p_0)} \sum_{j=0}^{\pi(p_0)-1} \log \| Df|_{E_{i+1}^c(f^j(p_0))} \| > -\lambda_0.$$

Hence, by Lemma 2.7.6, there exists a  $\lambda + \delta/2$  bi-hyperbolic time on the orbit  $p_0$ . For notational convenience, we still denote the  $\lambda + \delta/2$  bi-hyperbolic time as  $p_0$ .

By the uniform continuity of  $\log \| Df|_{E_i^c} \|$  and of  $\log \| Df|_{E_{i+1}^c} \|$ , when  $\epsilon$  is taken small and  $\kappa$  is close to 1 enough, the orbit of  $p'$  has a  $\lambda + \delta$  bi-hyperbolic time in the  $\frac{\epsilon}{2}$  neighborhood of  $p_0$ . For simplicity, we denote the bi-hyperbolic time as  $p'$ .

By Lemma 2.6.4, there exist two numbers  $L$  and  $d_0$  corresponding to the number  $\frac{\lambda}{4}$  and to the splitting

$$TM = (E^s \oplus E_1^c \oplus \cdots \oplus E_i^c) \oplus (E_{i+1}^c \oplus \cdots \oplus E^u).$$

We take  $d < \epsilon/2$  small enough such that  $L \cdot d$  is much smaller than  $\epsilon/2$ . The precise value of  $d$  would be fixed at last. By the definition of flip-flop configuration and the homoclinic relation between  $\mathcal{O}_{p'}$  and  $\mathcal{O}_p$ , there exists an integer  $N_d$  such that

- $f^{N_d}(W_{d/2}^u(p'))$  contains a uu-disc  $D_0^u \in \mathfrak{D}$ ;
- For any disc  $D \in \mathfrak{D}$ , we have that  $f^{N_d}(D)$  intersects  $W_{d/2}^s(p')$  transversely.

For any positive integer  $m$ , we have that  $f^m(D_0^u)$  contains a uu-disc  $D_m^u \in \mathfrak{D}$ . By the choice of  $N_d$ , we have that  $f^{N_d}(D_m^u)$  intersects  $W_{d/2}^s(p')$  in a point  $x$ .

Then for any integers  $n, m$  and  $k$ , we consider the following orbit segment:

$$\sigma_{n,m,k} = \{f^{-n\pi(p')-m-2N_d}(x), \dots, x, \dots, f^{k\pi(p')}(x)\}.$$

We denote by

$$x_{n,m} = f^{-n\pi(p')-m-2N_d}(x) \in W_{d/2}^u(p') \text{ and } \pi_{n,m,k} = (n+k)\pi(p') + m + 2N_d.$$

Notice that  $d(x_{n,m}, f^{k\pi(p')}(x)) < d$ .

**Claim 3.2.5.** *There exist  $n, m, k$  which can be chosen arbitrarily large, such that when  $\delta$  is chosen small enough, we have*

$$\frac{n\pi(p')}{\pi_{n,m,k}} > 1 - \frac{2|\lambda|}{3 \log \tau_1}$$

$$\frac{1}{\pi_{n,m,k}} \sum_{j=0}^{\pi_{n,m,k}-1} \log \| Df|_{E_i^c(f^j(x_{n,m}))} \| \in \left( \frac{2 \log \tau_1 - \log \tau_2}{2 \log \tau_1} \cdot \lambda, \frac{\lambda}{4} \right).$$

—  $\sigma_{n,m,k}$  is a  $\frac{\lambda}{4}$  quasi hyperbolic string corresponding to the splitting

$$TM = (E^s \oplus E_1^c \oplus \cdots \oplus E_i^c) \oplus (E_{i+1}^c \oplus \cdots \oplus E^u).$$

The proof of the Claim 3.2.5 is similar to Claim 3.1.2 in the proof of Lemma 3.1.1. The difference is the last item, since the bundle  $E_{i+1}^c$  is not uniformly expanding. However,  $E_{i+1}^c$  is uniformly expanding when it is restricted to the neighborhood of the blender. Here, we explain a little bit about the uniform contraction of  $E_{i+1}^c$  by  $Df^{-1}$  from  $f^{k\pi(p')}(x)$  to  $x_{n,m,k}$ . From the proof of Claim 3.1.2, when we choose  $\delta$  small enough, for any integer  $k$ , we can choose  $n$  and  $m$  arbitrarily large such that  $\frac{k}{n}$  are small enough, the first item and the second item of the claim are satisfied, and  $x_{n,m,k}$  is  $(\frac{\lambda}{4}, E_i^c)$  hyperbolic time until the point  $f^{k\pi(p')}(x)$ . To make sure  $\sigma_{n,m,k}$  is a  $\frac{\lambda}{4}$  quasi hyperbolic string, we only need to show that  $f^{k\pi(p')}(x)$  is the  $(-\frac{\lambda}{4}, E_{i+1}^c)$  hyperbolic time until the point  $x_{n,m,k}$ . To guarantee this, we only need to ask that  $k$  is much larger than  $2N_d + \pi(p')$ , but still much smaller than  $n$ , and we can do that is because we have the following fact:

$$\lambda_0 < \lambda < 0$$

$$\tau_2 < \| Df|_{E_i^c(x)} \| < \tau_1, \text{ for any } x \in f(U) \cap U \cap f^{-1}(U).$$

$$\log \| Df|_{E_i^c(z)} \| - \log \| Df|_{E_{i+1}^c(z)} \| < 2\lambda_0, \text{ for any } z \in M.$$

We take  $\rho = \frac{2}{3 \log \tau_1}$  and  $\zeta = \frac{2\tau_1 - \log \tau_2}{2 \log \tau_1}$ .

By Lemma 2.6.4, there exists a periodic point  $p_1$  such that

$$d(f^j(x_{n,m,k}), f^j(p_1)) < L \cdot d < \epsilon/2, \text{ for any } j = 0, \dots, \pi_{n,m,k} - 1.$$

By the choice of  $\sigma_{n,m,k}$  and Claim 3.2.5, when  $d$  is chosen small, we have that

- $\lambda_i^c(p_1) \in (\zeta \cdot \lambda, \frac{\lambda}{4})$ ;
- the orbit of  $p_1$  is  $(\epsilon, 1 - \rho \cdot |\lambda|)$  good for  $p_0$ ;
- the orbit of  $p_1$  is  $\epsilon$  dense in  $M$ .

Once again when  $d$  is chosen small enough, by Lemma 2.7.3 and the uniform continuity of the functions  $\log \|Df|_{E_i^c}\|$  and  $\log \|Df|_{E_{i+1}^c}\|$ , we have that  $p_1$  has the uniform size of stable and unstable manifolds which implies that  $p_1$  is homoclinically related to  $p'$ .

This ends the proof Proposition 3.2.4.  $\square$

*Proof of Theorem 3.2.2.* For any  $j \in [1, k]$ , by Proposition 3.2.3 and Proposition 2.9.5, there exists an open and dense subset  $\widetilde{\mathcal{RT}}_j(M)$  of  $\mathcal{RT}(M)$ , such that for any  $f \in \widetilde{\mathcal{RT}}_j(M)$ ,

- there exists a split flip-flop configuration formed by a dynamically defined cu-blender  $\Lambda_j^u$  and a hyperbolic periodic orbit  $p_j$  of s-index  $i_0 + j$ ;
- there exists a hyperbolic periodic point  $q_j$  of s-index  $i_0 + j$  whose homoclinic class is robustly being the whole manifold.

By connecting lemma and robust transitivity, we can do arbitrarily  $C^1$  small perturbation to make  $q_j$  and  $p_j$  be homoclinically related. As a consequence, there exists an open and dense subset  $\mathcal{RT}_j(M)$  of  $\widetilde{\mathcal{RT}}_j(M)$ , such that for any  $f \in \mathcal{RT}_j(M)$ , there exists a split flip-flop configuration formed by a dynamically defined cu-blender  $\Lambda_j^u$  and a hyperbolic periodic orbit  $p_j$  of index  $i_0 + j$ ; moreover the homoclinic class of  $p_j$  is robustly being the whole manifold.

By Lemma 3.1.1, there always exists a hyperbolic periodic point  $q'_j$  homoclinically related to  $p_j$  whose Lyapunov exponent along the bundle  $E_j^c$  is much larger than  $\lambda_0$ .

Let  $\rho > 0$  and  $\zeta \in (0, 1)$  be the two constants given by Proposition 3.2.4. We fix a sequence of positive numbers  $\{\epsilon_n\}_{n \geq 1}$  such that  $\sum_n \epsilon_n$  converges.

We will inductively find a sequence of hyperbolic periodic orbits satisfying the condition in Lemma 2.5.2.

Denote by  $\gamma_0 = \mathcal{O}_{q'_j}$ . Assume that we already have a periodic orbit  $\gamma_n$  such that

- $\gamma_n$  is homoclinically related to  $\gamma_0$  and is  $\epsilon_n$  dense in  $M$ ;
- $\lambda_j^c(\gamma_n) > \zeta \cdot \lambda_j^c(\gamma_{n-1})$ ;
- $\gamma_n$  is  $(\epsilon_n, 1 - \rho|\lambda_j^c(\gamma_{n-1})|)$  good for  $\gamma_{n-1}$ .

By Proposition 3.2.4, there exists a hyperbolic periodic orbit  $\gamma_{n+1}$  such that

- $\gamma_{n+1}$  is homoclinically related to  $\gamma_0$  and  $\epsilon_{n+1}$  dense in  $M$ ;
- $\lambda_j^c(\gamma_{n+1}) > \zeta \cdot \lambda_j^c(\gamma_n)$ ;
- $\gamma_{n+1}$  is  $(\epsilon_n, 1 - \rho|\lambda_j^c(\gamma_n)|)$  good for  $\gamma_n$ .

One can see that  $\lambda_j^c(\gamma_n)$  converges to 0 exponentially which implies that the product  $\prod_n (1 - \rho|\lambda_j^c(\gamma_{n-1})|)$  converges to a positive number. By Lemma 2.5.2 and continuity of the function  $\log \|Df|_{E_j^c}\|$ , the Dirac measure  $\delta_{\gamma_n}$  converges to a non-hyperbolic ergodic measure  $\nu_j$  whose support is given by  $\bigcap_{n=1}^{\infty} \overline{\bigcup_{k=n}^{\infty} \gamma_k}$ . Since  $\epsilon_n$  tends to zero, we have that  $\text{supp } \nu_j = M$ .

We take the intersection  $\widetilde{\mathcal{RT}}(M) = \cap_{j=1}^k \mathcal{RT}_j(M)$ , which is an open and dense subset of  $\mathcal{RT}(M)$ . This ends the proof of Theorem 3.2.2.  $\square$

### 3.3 Ergodic measure with multi-zero Lyapunov exponents for the case controlled by norm: Proof of Theorem C

In this section, for a periodic point  $p$ , we denote  $P$  as its orbit and  $\pi(P)$  (or  $\pi(p)$ ) as its period.

#### 3.3.1 Proof of Theorem C

The following proposition is the main step for proving Theorem C.

**Proposition 3.3.1.** *For generic  $f \in \text{Diff}^1(M)$ . Consider a non-trivial homoclinic class  $H(P, f)$  of a hyperbolic periodic orbit  $P$  of index  $i$ . Assume that*

- *there is a hyperbolic periodic orbit  $Q$  of index  $i+k$  contained in  $H(P, f)$ , where  $k \geq 1$ ;*
- *there is no dominated splitting of index  $i+j$  over  $H(P, f)$ , for any  $j = 1, 2, \dots, k-1$ .*

*Then there is a constant  $\chi > 0$  such that for any  $\gamma > 0$  and any hyperbolic periodic orbit  $P_0$  with simple spectrum which is homoclinically related to  $P$ , there is a hyperbolic periodic orbit  $P_1$  homoclinically related to  $P$ , satisfying the following properties:*

1.  $P_1$  is  $\gamma$ -dense in  $H(P, f)$  and has simple spectrum;
2.  $\chi_{i+k}(P_1, f) < \frac{3}{4} \cdot \chi_{i+k}(P_0, f)$ ;
3.  $P_1$  is a  $(\gamma, 1 - \frac{\chi_{i+k}(P_0, f)}{\chi + \chi_{i+k}(P_0, f)})$ -good approximation of  $P_0$ .

Using Proposition 3.3.1, we give the proof of Theorem C.

*Proof of Theorem C.* By item 2 of Theorem 2.13.1, we can assume that  $P$  is of index  $i$ . We take the positive constant  $\chi$  from Proposition 3.3.1. We will inductively construct a sequence of periodic orbits  $\{P_n\}$  with simple spectrum, a sequence of positive numbers  $\{\gamma_n\}$  and a sequence of integers  $\{N_n\}$  satisfying the following properties:

1.  $\chi_{i+k}(P_{n+1}, f) < \frac{3}{4} \cdot \chi_{i+k}(P_n, f)$ ;
2.  $P_n$  is homoclinically related to  $P$  and is  $\frac{1}{2^n}$ -dense inside  $H(P, f)$ ;
3. the constants  $\gamma_n$  and  $N_n$  satisfy that:
  - $\gamma_n < \frac{1}{2} \gamma_{n-1}$  and  $N_n > N_{n-1}$ ;



– for any point  $x \in B_{2\gamma_n}(P_n) \cap H(P, f)$ , we have that

$$0 < L_{d-i}^{N_n}(x, f) - L_{d-i-1}^{N_n}(x, f),$$

$$0 < L_{d-i}^{N_n}(x, f) - L_{d-i-k}^{N_n}(x, f) < 2k \cdot \chi_{i+k}(P_n, f);$$

4.  $P_{n+1}$  is  $(\gamma_n, 1 - \frac{\chi_{i+k}(P_n, f)}{\chi + \chi_{i+k}(P_n, f)})$ -good approximation of  $P_n$ .

**Choice of  $P_0, N_0$  and  $\gamma_0$**  First we construct for  $n = 0$ . By the item 5 and item 7 of Theorem 2.13.1, we can choose a hyperbolic periodic orbit  $P_0$ , with simple spectrum, which is homoclinically related to  $P$  and is  $\frac{1}{2^0}$ -dense inside  $H(P, f)$ . Hence the item 2 is satisfied.

By the definition of the function  $L_j^n(x, f)$ , there exists an integer  $N_0$  such that for any  $y \in P_0$ , we have that

$$0 < L_{d-i}^{N_0}(y, f) - L_{d-i-1}^{N_0}(y, f),$$

$$0 < L_{d-i}^{N_0}(y, f) - L_{d-i-k}^{N_0}(y, f) < \frac{3k}{2} \cdot \chi_{i+k}(P_0, f).$$

By the uniform continuity of the functions  $L_{d-i}^{N_0}(x, f)$  and  $L_{d-i-k}^{N_0}(x, f)$ , there exists a number  $\gamma_0 > 0$  such that for any point  $x \in B_{2\gamma_0}(P_0) \cap H(P, f)$ , we have that

$$0 < L_{d-i}^{N_0}(x, f) - L_{d-i-1}^{N_0}(x, f),$$

$$0 < L_{d-i}^{N_0}(x, f) - L_{d-i-k}^{N_0}(x, f) < 2k \cdot \chi_{i+k}(P_0, f).$$

Hence the item 3 is satisfied. Notice that we do not have to check the items 1, 4 for  $n = 0$ .

**Construct  $P_n, N_n$  and  $\gamma_n$  inductively** Assume that  $P_j, N_j$  and  $\gamma_j$  are already defined for any  $j \leq n$ . We apply  $P_n, \gamma_n$ , and  $\frac{1}{2^{n+1}}$  to Proposition 3.3.1, then we get a periodic orbit  $P_{n+1}$  with simple spectrum, satisfying that:

- $\chi_{i+k}(P_{n+1}, f) < \frac{3}{4} \cdot \chi_{i+k}(P_n, f)$ ;
- $P_{n+1}$  is homoclinically related to  $P$  and is  $\frac{1}{2^{n+1}}$ -dense in  $H(P, f)$ ;
- $P_{n+1}$  is  $(\gamma_n, 1 - \frac{\chi_{i+k}(P_n, f)}{\chi + \chi_{i+k}(P_n, f)})$ -good approximation of  $P_n$ .

Then the items 1, 2, 4 are satisfied.

By the definition of the function  $L_j^n(x, f)$ , there is an integer  $N_{n+1} > N_n$  satisfying that: for any  $y \in P_{n+1}$ , we have that

$$0 < L_{d-i}^{N_{n+1}}(y, f) - L_{d-i-1}^{N_{n+1}}(y, f),$$

$$0 < L_{d-i}^{N_{n+1}}(y, f) - L_{d-i-k}^{N_{n+1}}(y, f) < \frac{3k}{2} \cdot \chi_{i+k}(P_{n+1}, f).$$

By the uniform continuity of the functions  $L_{d-i}^{N_{n+1}}(x, f)$  and  $L_{d-i-k}^{N_{n+1}}(x, f)$ , there exists a number  $\gamma_{n+1} \in (0, \frac{1}{2}\gamma_n)$  such that for any point  $x \in B_{2\gamma_{n+1}}(P_{n+1}) \cap H(P, f)$ , we have

$$\begin{aligned} 0 &< L_{d-i}^{N_{n+1}}(x, f) - L_{d-i-1}^{N_{n+1}}(x, f), \\ 0 &< L_{d-i}^{N_{n+1}}(x, f) - L_{d-i-k}^{N_{n+1}}(x, f) < 2k \cdot \chi_{i+k}(P_{n+1}, f). \end{aligned}$$

**End of proof of Theorem C** By Lemma 2.5.2, the sequence of ergodic measures  $\delta_{P_n}$  converges to an ergodic measure  $\nu$  whose support is  $H(P, f)$ . We will show that  $\nu$  has  $k$  vanishing Lyapunov exponents.

**Claim 3.3.2.** *The  $(i+j)^{\text{th}}$  Lyapunov exponent of  $\nu$  equals zero, for any  $j = 1, 2, \dots, k$ .*

*Proof.* By Definition 2.5.1, there exist a subset  $\tilde{P}_n$  of  $P_n$  and a map  $\Pi_n : \tilde{P}_n \mapsto P_{n-1}$  for each  $n \geq 2$ . Consider the set  $K_n = \Pi_n^{-1} \circ \Pi_{n-1}^{-1} \circ \dots \circ \Pi_1^{-1}(P_0)$ , then we have that

$$\delta_{P_n}(K_n) \geq \prod_{l=0}^{n-1} \left(1 - \frac{\chi_{i+k}(P_l, f)}{\chi + \chi_{i+k}(P_l, f)}\right).$$

We denote by

$$K = \bigcap_{n=1}^{\infty} \overline{\bigcup_{l=n}^{\infty} K_l},$$

then we have that  $\nu(K) \geq \lim_{n \rightarrow \infty} \delta_{P_n}(K_n) > 0$ .

On the other hand, for any point  $x \in B_{2\gamma_n}(P_n) \cap H(P, f)$ , we have that

$$\begin{aligned} 0 &< L_{d-i}^{N_n}(x, f) - L_{d-i-1}^{N_n}(x, f), \\ 0 &< L_{d-i}^{N_n}(x, f) - L_{d-i-k}^{N_n}(x, f) < 2k \cdot \chi_{i+k}(P_n, f). \end{aligned}$$

Since  $P_{n+1}$  is a  $(\gamma_n, 1 - \frac{\chi_{i+k}(P_n)}{\chi + \chi_{i+k}(P_n)})$ -good approximation of  $P_n$ , we have that  $K$  is contained in the  $\sum_{i=n}^{\infty} \gamma_i$  neighborhood of  $P_n$ , therefore is contained in  $2\gamma_n$  neighborhood of  $P_n$ . As a consequence, for any  $y \in K$ , we have the following

$$0 < L_{d-i}^{N_n}(y, f) - L_{d-i-1}^{N_n}(y, f), \quad (3.1)$$

$$0 < L_{d-i}^{N_n}(y, f) - L_{d-i-k}^{N_n}(y, f) < 2k \cdot \frac{3^n}{4^n} \cdot \chi_{i+k}(P, f). \quad (3.2)$$

Since  $\nu$  is ergodic, for  $\nu$ -a.e. point  $y$ , we have that

$$\sum_{j=1}^k \chi_{i+j}(\nu, f) = \lim_{n \rightarrow +\infty} (L_{d-i}^n(y, f) - L_{d-i-k}^n(y, f)), \quad (3.3)$$

$$\chi_{i+1}(\nu, f) = \lim_{n \rightarrow +\infty} (L_{d-i}^n(y, f) - L_{d-i-1}^n(y, f)). \quad (3.4)$$

By the fact that  $\nu(K) > 0$  and the formulas (3.2) and (3.3), we can see that

$$\sum_{j=1}^k \chi_{i+j}(\nu, f) = 0.$$

By the formulas (3.1) and (3.4), we get that  $\chi_{i+1}(\nu, f) \geq 0$ . Then by the fact that  $\chi_{i+1}(\nu, f) \leq \chi_{i+2}(\nu, f) \leq \cdots \leq \chi_{i+k}(\nu, f)$ , we have that

$$\chi_{i+j}(\nu, f) = 0, \text{ for any } j = 1, 2, \dots, k.$$

This ends the proof of Theorem C. □

Now it remains to prove Proposition 3.3.1.

### 3.3.2 Good approximation with weaker center Lyapunov exponents: Proof of Proposition 3.3.1

The proof of Proposition 3.3.1 is based on the following perturbation Lemma:

**Lemma 3.3.3.** *Consider a diffeomorphism  $f \in \text{Diff}^1(M)$ . Let  $P$  and  $Q$  be two hyperbolic periodic orbits of indices  $i$  and  $i+k$  respectively. Assume that  $Q$  and  $P$  form a partially hyperbolic heterodimensional cycle  $K$  with the splitting  $T_K M = E^s \oplus E^c \oplus E^u$ . Assume, in addition, that*

$$\chi_{i+j}(P, f) = \log \mu > 0 \text{ and } \chi_{i+j}(Q, f) = \log \lambda < 0, \text{ for any } j = 1, 2, \dots, k. (\star)$$

*Then for any  $\gamma > 0$  and any  $C^1$  neighborhood  $\mathcal{U}$  of  $f$ , there exist a diffeomorphism  $g \in \mathcal{U}$  and a hyperbolic periodic orbit  $P_1$  of  $g$  such that*

1.  $P_1$  has simple spectrum;
2.  $g$  and  $Dg$  coincide with  $f$  and  $Df$  on the set  $P \cup Q$  respectively ;
3.  $\frac{1}{4} \cdot \chi_{i+k}(P, g) < \chi_{i+1}(P_1, g) < \chi_{i+k}(P_1, g) < \frac{1}{2} \cdot \chi_{i+k}(P, g)$ ;
4.  $P_1$  is a  $(\gamma, 1 + \frac{\log \mu}{2 \log \lambda - \log \mu})$ -good approximation of  $P$ ;
5.  $W^{ss}(P_1)$  has transverse intersections with  $W^u(P)$  and  $W^{uu}(P_1)$  has transverse intersections with  $W^s(Q)$ .

**Remark 3.3.4.** *If  $P$  and  $Q$  are robustly in the same chain recurrence class, the last item of Lemma 3.3.3 implies that  $P_1$  is robustly in the same chain recurrence class with  $P$  and  $Q$ .*

The idea of the proof of Lemma 3.3.3 is that we mix two hyperbolic periodic orbits of different indices to get a new periodic orbit with weaker center Lyapunov exponents.

*Proof of Lemma 3.3.3.* We fix a small number  $\gamma > 0$  and a neighborhood  $\mathcal{U}$  of  $f$ . There exists  $\epsilon > 0$  such that the  $\epsilon$  neighborhood of  $f$  is contained in  $\mathcal{U}$ . There is a small number  $0 < \theta < 1$ , such that for any  $h \in \mathcal{U}$  and any two points  $z_1, z_2$  satisfying  $d(z_1, z_2) < \theta \cdot \gamma$ , we have that

$$d(h^i(z_1), h^i(z_2)) < \frac{\gamma}{2}, \text{ for any } i \in [-\pi(P), \pi(P)].$$

We take two neighborhoods  $U_P$  and  $U_Q$  of  $P$  and  $Q$  respectively, such that  $U_P$  is contained in the  $\theta \cdot \gamma$ -neighborhood of  $P$  and is disjoint from  $U_Q$ .

**Construction of the periodic orbit  $P_1$**  Let  $P = \text{Orb}(p)$  and  $Q = \text{Orb}(q)$ . We denote by  $M_P$  and  $M_Q$  the two linear maps:

$$\text{Df}^{\pi(P)}(p) : T_p M \rightarrow T_p M \text{ and } \text{Df}^{\pi(Q)}(q) : T_q M \rightarrow T_q M.$$

Since  $P$  and  $Q$  form a partially hyperbolic heterodimensional cycle  $K$ , by Theorem 2.12.7, there are two matrices  $T_0, T_1$  and two integers  $t_0, t_1$  such that for any two integers  $m$  and  $n$ , there is a diffeomorphism  $g$ , which is  $\frac{\epsilon}{4}$ - $C^1$ -close to  $f$  and has a periodic orbits  $P_1 = \text{Orb}(p_1, g)$ , satisfying the following properties:

- $g$  and  $\text{Dg}$  coincide with  $f$  and  $\text{Df}$  respectively on  $P \cup Q$ ,
- the matrix  $\text{Dg}^{\pi(p_1)}(p_1) : T_{p_1} M \rightarrow T_{p_1} M$  is conjugate to

$$T_1 \circ M_Q^m \circ T_0 \circ M_P^n.$$

- $\pi(p_1) = t_0 + t_1 + n\pi(P) + m\pi(Q)$ .
- $\#(P_1 \cap U_P) \geq n\pi(P)$ , and  $\#(P_1 \cap U_Q) \geq m\pi(Q)$ .

Moreover, by the continuity of partial hyperbolicity and the local stable and unstable manifolds of hyperbolic periodic orbit, by taking  $U_P$  and  $U_Q$  small enough at first, we have that  $W^{ss}(P_1, g)$  intersects  $W_{loc}^u(P, g)$  transversely and  $W^{uu}(P_1, g)$  intersects  $W_{loc}^s(Q, g)$  transversely.

By the second item of Theorem 2.12.7, we can take proper coordinates at  $T_P M$  and  $T_Q M$ , under which we have:

$$\mathbf{M}_P = \begin{pmatrix} A_s & 0 & 0 \\ 0 & A_c & 0 \\ 0 & 0 & A_u \end{pmatrix}, \quad \mathbf{M}_Q = \begin{pmatrix} B_s & 0 & 0 \\ 0 & B_c & 0 \\ 0 & 0 & B_u \end{pmatrix}$$

$$\mathbf{T}_1 = \begin{pmatrix} C_s & 0 & 0 \\ 0 & C_c & 0 \\ 0 & 0 & C_u \end{pmatrix}, \quad \mathbf{T}_0 = \begin{pmatrix} D_s & 0 & 0 \\ 0 & D_c & 0 \\ 0 & 0 & D_u \end{pmatrix}$$

**Choice of the integers  $m$  and  $n$**  We will adjust  $m, n$  to get the periodic orbit that satisfies the properties stated in Lemma 3.3.3. We take  $\eta > 0$  which will be decided later.

**Claim 3.3.5.** *There exists an integer  $N_\eta$  such that for any  $m \geq N_\eta$  and  $n \geq N_\eta$ , we have that all the center Lyapunov exponents of  $P_1$  belong to the interval:*

$$\left[ \frac{m \cdot \pi(P) \cdot \log \mu + n \cdot \pi(Q) \cdot \log \lambda}{m \cdot \pi(P) + n \cdot \pi(Q)} - 2\eta, \frac{m \cdot \pi(P) \cdot \log \mu + n \cdot \pi(Q) \cdot \log \lambda}{m \cdot \pi(P) + n \cdot \pi(Q)} + 2\eta \right].$$

*Proof.* By the Equation (★) in the assumption of Lemma 3.3.3, there exists an integer  $N_1(\eta)$  such that for any  $m, n \geq N_1(\eta)$ , we have that

$$\begin{aligned} \log \mu - \eta &< \frac{1}{m \cdot \pi(P)} \log m(A_c^m) \leq \frac{1}{m \cdot \pi(P)} \log \|A_c^m\| < \log \mu + \eta; \\ \log \lambda - \eta &< \frac{1}{n \cdot \pi(Q)} \log m(B_c^n) \leq \frac{1}{n \cdot \pi(Q)} \log \|B_c^n\| < \log \lambda + \eta. \end{aligned}$$

As a consequence, for any unit vector  $v \in E^c(P_1)$  and  $k \in \mathbb{N}$ , we have that

$$\begin{aligned} \log \| \text{Dg}^{k \cdot \pi(P_1)} v \| &\leq k \cdot (m \cdot \pi(P) \cdot (\log \mu + \eta) + n \cdot \pi(Q) \cdot (\log \lambda + \eta)) \\ &\quad + k \cdot \log (\|C_c\| \cdot \|D_c\|), \\ \log \| \text{Dg}^{k \cdot \pi(P_1)} v \| &\geq k \cdot (m \cdot \pi(P) \cdot (\log \mu - \eta) + n \cdot \pi(Q) \cdot (\log \lambda - \eta)) \\ &\quad + k \cdot \log (m(C_c) \cdot m(D_c)) \end{aligned}$$

Hence,

$$\begin{aligned} \frac{1}{k \cdot \pi(P_1)} \log \| \text{Dg}^{k \cdot \pi(P_1)} v \| &\leq \frac{m \cdot \pi(P) \cdot (\log \mu + \eta) + n \cdot \pi(Q) \cdot (\log \lambda + \eta)}{\pi(P_1)} \\ &\quad + \frac{\log (\|C_c\| \cdot \|D_c\|)}{\pi(P_1)} \\ \frac{1}{k \cdot \pi(P_1)} \log \| \text{Dg}^{k \cdot \pi(P_1)} v \| &\geq \frac{m \cdot \pi(P) \cdot (\log \mu - \eta) + n \cdot \pi(Q) \cdot (\log \lambda - \eta)}{\pi(P_1)} \\ &\quad + \frac{\log (m(C_c) \cdot m(D_c))}{\pi(P_1)} \end{aligned}$$

By the fact that  $\pi(P_1) = m\pi(P) + n\pi(Q) + t_0 + t_1$  and the matrices  $C_c, D_c$  are independent of  $m$  and  $n$ , there exists an integer  $N_2(\eta)$  such that for any  $m, n \geq N_2(\eta)$ , we have that

$$-\frac{\eta}{2} < \frac{\log (m(C_c) \cdot m(D_c))}{\pi(P_1)} \leq \frac{\log (\|C_c\| \cdot \|D_c\|)}{\pi(P_1)} < \frac{\eta}{2};$$

$$\left| \frac{m \cdot \pi(P) \cdot \log \mu + n \cdot \pi(Q) \cdot \log \lambda}{\pi(P_1)} - \frac{m \cdot \pi(P) \cdot \log \mu + n \cdot \pi(Q) \cdot \log \lambda}{m\pi(P) + n\pi(Q)} \right| < \frac{\eta}{2}.$$

We take  $N_\eta = \max\{N_1(\eta), N_2(\eta)\}$ . When  $m, n \geq N_\eta$ , we have that all the center Lyapunov exponents of  $P_1$  would belong to the interval:

$$\left[ \frac{m \cdot \pi(P) \cdot \log \mu + n \cdot \pi(Q) \cdot \log \lambda}{m \cdot \pi(P) + n \cdot \pi(Q)} - 2\eta, \frac{m \cdot \pi(P) \cdot \log \mu + n \cdot \pi(Q) \cdot \log \lambda}{m \cdot \pi(P) + n \cdot \pi(Q)} + 2\eta \right].$$

This ends the proof of Claim 3.3.5.  $\square$

To guarantee the item 3, we only need that

$$\frac{m\pi(P) \cdot \log \mu + n\pi(Q) \cdot \log \lambda}{m\pi(P) + n\pi(Q)} + 2\eta < \frac{1}{2} \log \mu \quad (3.5)$$

and

$$\frac{m\pi(P) \cdot \log \mu + n\pi(Q) \cdot \log \lambda}{m\pi(P) + n\pi(Q)} - 2\eta > \frac{1}{4} \log \mu. \quad (3.6)$$

By the choice of the numbers  $\theta$  and  $\gamma$ , to guarantee the item 4, we only need that

$$\frac{m\pi(P)}{m\pi(P) + n\pi(Q)} > 1 + \frac{\chi_{i+k}(P, g)}{2\chi_{i+k}(Q, g) - \chi_{i+k}(P, g)} = 1 + \frac{\log \mu}{2 \log \lambda - \log \mu}. \quad (3.7)$$

By calculation, to satisfy the inequalities (3.5), (3.6) and (3.7), we only have to show that there exist  $m, n$  large enough such that the following is satisfied:

$$\max \left\{ \frac{-2 \log \lambda}{\log \mu}, \frac{\log \mu - 4 \log \lambda + 8\eta}{3 \log \mu - 8\eta} \right\} < \frac{m\pi(P)}{n\pi(Q)} < \frac{\log \mu - 2 \log \lambda - 4\eta}{\log \mu + 4\eta}. \quad (3.8)$$

When  $\eta$  is chosen small, we have the following inequality

$$\max \left\{ \frac{-2 \log \lambda}{\log \mu}, \frac{\log \mu - 4 \log \lambda + 8\eta}{3 \log \mu - 8\eta} \right\} < \frac{\log \mu - 2 \log \lambda - 4\eta}{\log \mu + 4\eta}. \quad (3.9)$$

By Claim 3.3.5, the inequality (3.9) and the density of rational numbers on real line, there exist  $m, n$  arbitrarily large satisfying the inequality (3.8).

By an arbitrarily  $C^1$  small perturbation, the eigenvalues of the periodic orbit  $P_1$  are of multiplicity one (might have complex eigenvalue). Since the period of  $P_1$  can be chosen arbitrarily large, by Lemma 2.12.3, after another small Franks-type perturbation, we have that the periodic orbit  $P_1$  has simple spectrum.

This ends the proof of Lemma 3.3.3.  $\square$

**Remark 3.3.6.** *One can see from the proof of Lemma 3.3.3 that the perturbation is done in very small neighborhood of the heterodimensional cycle  $K$ .*

Now we are ready to give the proof of Proposition 3.3.1.

*Proof of Proposition 3.3.1.* We can see that the properties stated in Proposition 3.3.1 are persistent under  $C^1$  small perturbation. Let  $\mathcal{R}$  be the residual subset of  $\text{Diff}^1(M)$  from Theorem 2.13.1. Notice that for any  $f \in \mathcal{R}$ , by the item 5 of Theorem 2.13.1, there is a periodic orbit  $Q_0$  with simple spectrum which is homoclinically related to  $Q$ . We take  $\chi = -\chi_{i+k}(Q_0, f) > 0$ .

We only need to show that given  $f \in \mathcal{R}$ , for any  $\zeta > 0$  and  $\gamma > 0$ , there are a diffeomorphism  $g$  which is  $\zeta$ - $C^1$ -close to  $f$  and a hyperbolic periodic orbit  $P_1$  of  $g$ , such that the following properties are satisfied:

1.  $g$  coincides with  $f$  on  $P_0 \cup Q_0$ ;
2.  $P_1$  is robustly in the chain recurrence class of  $P_g$ ;
3.  $P_1$  has simple spectrum and the Hausdorff distance  $d_H(P_1, H(P_g, g)) < \gamma$ ;
4.  $\chi_{i+k}(P_1, g) < \frac{3}{4} \cdot \chi_{i+k}(P_0, g)$ ;
5.  $P_1$  is a  $(\gamma, 1 - \frac{\chi_{i+k}(P_0, f)}{\chi + \chi_{i+k}(P_0, f)})$ -good approximation of  $P_0$ .

Then Proposition 3.3.1 can be proved by a standard Baire argument.

By item 4 of Theorem 2.13.1, we can require that  $\zeta$  is chosen small enough such that after any  $\zeta$ -perturbation, the continuations of  $P$ ,  $Q$ ,  $P_0$ , and  $Q_0$  are still robustly in the same chain recurrence class. We take  $0 < \epsilon < \frac{\zeta}{4}$ , then there exist  $T > 0$  and  $l_0$  satisfying Lemma 2.12.1.

**Perturb to get a heterodimensional cycle** Since  $H(P, f)$  admits no dominated splitting of index  $j$  for any  $j \in \{i+1, \dots, i+k-1\}$ , there is a number  $\delta_0 \in (0, \frac{\gamma}{10})$  such that for any compact invariant subset  $\Lambda$  of  $H(P, f)$ , if  $d_H(\Lambda, H(P, f)) < \delta_0$ , then  $\Lambda$  admits no  $T$ -dominated splitting of index  $j$  for any  $j \in \{i+1, \dots, i+k-1\}$ .

We fix a positive number  $\delta < \min\{\delta_0, \frac{1}{4}\chi_{i+k}(P_0, f)\}$  small enough such that the following is satisfied:

$$\frac{\chi_{i+k}(P_0, f) + \delta}{-2\chi_{i+k}(Q_0, f) + \chi_{i+k}(P_0, f) - \delta} < \frac{\chi_{i+k}(P_0, f)}{-\frac{3}{2}\chi_{i+k}(Q_0, f) + \chi_{i+k}(P_0, f)}. \quad (3.10)$$

We take a number  $\kappa$  such that

$$\kappa \in \left( \frac{2\chi_{i+k}(P_0, f) - 3\chi_{i+k}(Q_0, f)}{3\chi_{i+k}(P_0, f) - 3\chi_{i+k}(Q_0, f)}, 1 \right).$$

We apply the item 7 of Theorem 2.13.1 to the constants  $\delta$  and  $\kappa$ , then there exist two hyperbolic periodic orbits  $P' = \text{Orb}(p')$  and  $Q' = \text{Orb}(q')$  such that:

- $P'$  and  $Q'$  are homoclinically related to  $P_0$  and  $Q_0$  respectively;
- Both  $P'$  and  $Q'$  are  $\delta/2$  dense in  $H(P, f)$  and have simple spectrum.
- $P'$  is a  $(\frac{\gamma}{10}, \kappa)$ -good approximation of  $P_0$  and  $Q'$  is  $(\frac{\gamma}{10}, \kappa)$ -good approximation of  $Q_0$ .
- For each  $j \in \{1, \dots, d\}$ , we have that

$$|\chi_j(P', f) - \chi_j(P_0, f)| < \delta \text{ and } |\chi_j(Q', f) - \chi_j(Q_0, f)| < \delta. \quad (3.11)$$

- Both of the periods of  $P'$  and  $Q'$  are larger than  $l_0$ .

By item 6 of Theorem 2.13.1, we can do an arbitrarily  $C^1$  small perturbation, keeping  $P'$  and  $Q'$  homoclinically related to  $P$  and  $Q$  respectively and without changing the Lyapunov exponents of  $P'$  and  $Q'$ , such that  $P'$  and  $Q'$  form a partially hyperbolic heterodimensional cycle. For simplicity, we still denote this diffeomorphism as  $f$ .

Notice that the periodic orbits  $P'$  and  $Q'$  have no  $T$ -domination of index  $j$  for any  $j \in \{i+1, \dots, i+k-1\}$ .

**Equalize the center Lyapunov exponents of both  $P'$  and  $Q'$**  By Lemma 2.12.1 and Remark 2.12.2, there exist  $\pi(P')$  one-parameter families

$\{(A_{l,t})_{t \in [0,1]}\}_{l=0}^{\pi(P')-1}$  and  $\pi(Q')$  one-parameter families  $\{(B_{m,t})_{t \in [0,1]}\}_{m=0}^{\pi(Q')-1}$  in  $GL(d, \mathbb{R})$  such that:

- $A_{l,0} = \text{Df}(f^l(p'))$  and  $B_{m,0} = \text{Df}(f^m(q'))$ , for any  $l, m$ ;
- $\|A_{l,t} - \text{Df}(f^l(p'))\| < \epsilon$  and  $\|A_{l,t}^{-1} - \text{Df}^{-1}(f^{l+1}(p'))\| < \epsilon$ , for any  $t \in [0, 1]$ ;
- $\|B_{m,t} - \text{Df}(f^m(q'))\| < \epsilon$  and  $\|B_{m,t}^{-1} - \text{Df}^{-1}(f^{m+1}(q'))\| < \epsilon$ , for any  $t \in [0, 1]$ ;
- $A_{\pi(P')-1,t} \circ \dots \circ A_{0,t}$  and  $B_{\pi(Q')-1,t} \circ \dots \circ B_{0,t}$  are hyperbolic, for any  $t \in [0, 1]$ ;
- For any integer  $s \in [1, i] \cup [i+k+1, d]$ , we have that

$$\chi_s(A_{\pi(P')-1,t} \circ \dots \circ A_{0,t}) = \chi_s(P', f) \text{ and } \chi_s(B_{\pi(Q')-1,t} \circ \dots \circ B_{0,t}) = \chi_s(Q', f);$$

- $\chi_{i+1}(A_{\pi(P')-1,1} \circ \dots \circ A_{0,1}) = \chi_{i+k}(A_{\pi(P')-1,1} \circ \dots \circ A_{0,1}) = \frac{1}{k} \sum_{j=i+1}^{i+k} \chi_j(P', f)$
- $\chi_{i+1}(B_{\pi(Q')-1,1} \circ \dots \circ B_{0,1}) = \chi_{i+k}(B_{\pi(Q')-1,1} \circ \dots \circ B_{0,1}) = \frac{1}{k} \sum_{j=i+1}^{i+k} \chi_j(Q', f)$ .

Fix a small number  $\eta > 0$ . Since  $P'$  and  $Q'$  form a heterodimensional cycle and  $P'$  is homoclinically related to  $P_0$ , there exist four points  $x, y, z, w \in M$  such that

$$x \in W_\eta^s(P') \cap W^u(Q') \text{ and } y \in W_\eta^u(P') \cap W^s(Q');$$

$$z \in W_\eta^s(P') \cap W^u(P_0) \text{ and } w \in W_\eta^u(P') \cap W^s(P_0).$$

We take  $K^s = \{x, z\}$  and  $K^u = \{y, w\}$ , and we choose a small neighborhood  $U$  of  $P'$  such that  $U$  is disjoint from  $\text{Orb}^-(x) \cup \text{Orb}^-(z), \text{Orb}^+(y) \cup \text{Orb}^+(w)$ ,



$Q'$ ,  $Q_0$  and two homoclinic orbits between  $Q'$  and  $Q_0$ , whose  $\omega$ -limit sets are  $Q'$  and  $Q_0$  respectively. By Lemma 2.12.5, there exists an  $\epsilon$  perturbation  $g_1$  whose support is contained in  $U$  such that

- $g_1$  keeps  $P'$ ;
- $\text{Dg}_1(f^l(p')) = A_{l,1}$ , for any  $l = 0, \dots, \pi(P') - 1$ ;
- $x \in W^s(P', g_1) \cap W^u(Q', g_1)$  and  $y \in W^u(P', g_1) \cap W^s(Q', g_1)$ .
- $W^s(P', g_1)$  intersects  $W^u(P_0, g_1)$  transversely at the point  $z$  and  $W^u(P', g_1)$  intersects  $W^s(P_0, g_1)$  transversely at the point  $w$ .

Following the same way above, we choose a small neighborhood  $V$  of  $Q'$  which is disjoint from certain homoclinic intersection and some orbit segments, and we apply Lemma 2.12.5. At the end, we get an  $\epsilon$  perturbation  $g_2$  of  $g_1$  such that

- For diffeomorphism  $g_2$ , the periodic orbits  $P'$ ,  $P$ ,  $Q$  and  $Q'$  are robustly in the same chain recurrence class;
- $P'$  and  $Q'$  form a partially hyperbolic heterodimensional cycle;
- $\text{Dg}_2(f^l(p')) = A_{l,1}$  and  $\text{Dg}_2(f^m(q')) = B_{m,1}$ , for any integer  $l \in [0, \pi(P') - 1]$  and  $m \in [0, \pi(Q') - 1]$ .

To sum up, the diffeomorphism  $g_2$  is  $2\epsilon$ - $C^1$ -close to  $f$  and satisfies that:

- S1.  $g_2$  coincides with  $f$  on  $P_0 \cup Q_0 \cup P' \cup Q'$ ;
- S2.  $\chi_j(P_0, g_2) = \chi_j(P_0, f)$  and  $\chi_j(Q_0, g_2) = \chi_j(Q_0, f)$ , for any  $j = 1, 2, \dots, d$ ;
- S3.  $\chi_j(P', g_2) = \chi_j(P', f)$  and  $\chi_j(Q', g_2) = \chi_j(Q', f)$ , for any  $j \in [1, i] \cup [i + k + 1, d]$ ;
- S4.  $\chi_{i+1}(P', g_2) = \chi_{i+k}(P', g_2)$  and  $\chi_{i+1}(Q', g_2) = \chi_{i+k}(Q', g_2)$ ;
- S5.

$$\sum_{j=i+1}^{i+k} \chi_j(P', g_2) = \sum_{j=i+1}^{i+k} \chi_j(P', f) \quad \text{and} \quad \sum_{j=i+1}^{i+k} \chi_j(Q', g_2) = \sum_{j=i+1}^{i+k} \chi_j(Q', f).$$

As a consequence, the diffeomorphism  $g_2$  satisfies the assumptions of Lemma 3.3.3.

**Construction of the periodic orbit  $P_1$**  By Lemma 3.3.3, there exist a diffeomorphism  $g$  which is  $\epsilon$ - $C^1$ -close to  $g_2$ , hence is  $\zeta$ - $C^1$ -close to  $f$ , and a hyperbolic periodic orbit  $P_1$  of index  $i$  for the diffeomorphism  $g$  such that

- $\chi_{i+k}(P_1, g) < \frac{1}{2} \cdot \chi_{i+k}(P', g)$ ;
- $P_1$  has simple spectrum;
- $g$  coincides with  $g_2$  in a small neighborhood of  $P_0 \cup Q_0$ ;
- $g$  and  $\text{Dg}$  coincide with  $g_2$  and  $\text{Dg}_2$  on  $P' \cup Q'$  respectively;
- $P_1$  is a  $(\frac{\gamma}{10}, 1 + \frac{\chi_{i+k}(P', g_2)}{2\chi_{i+k}(Q', g_2) - \chi_{i+k}(P', g_2)})$ -good approximation of  $P'$ .

Moreover, by Remark 3.3.4, we have that  $P_1$  is robustly in the same chain class with  $P_g$  and  $Q_g$ . By the choice of  $\delta$  and  $\gamma$ , we have that  $d_H(P_1, H(P, g)) < \gamma$ . Then the items 1, 2, 3 are satisfied.

By the properties S4 and S5, we have that

$$0 < \chi_{i+k}(P', g_2) < \chi_{i+k}(P', f) \quad \text{and} \quad \chi_{i+k}(Q', g_2) < \chi_{i+k}(Q', f) < 0,$$

which implies that

$$\frac{\chi_{i+k}(P', g_2)}{-2\chi_{i+k}(Q', g_2) + \chi_{i+k}(P', g_2)} < \frac{\chi_{i+k}(P', f)}{-2\chi_{i+k}(Q', f) + \chi_{i+k}(P', f)}. \quad (3.12)$$

By the inequalities (3.10), (3.11) and (3.12), we have that

$$\frac{\chi_{i+k}(P', g_2)}{-2\chi_{i+k}(Q', g_2) + \chi_{i+k}(P', g_2)} < \frac{\chi_{i+k}(P_0, f)}{-\frac{3}{2}\chi_{i+k}(Q_0, f) + \chi_{i+k}(P_0, f)}.$$

Recall that  $P'$  is a  $(\frac{\gamma}{10}, \kappa)$  good approximation of  $P_0$  (for the diffeomorphisms  $f$  and  $g$ ), hence we have that  $P_1$  is a  $(\gamma, \kappa \cdot (1 + \frac{\chi_{i+k}(P_0, f)}{\frac{3}{2}\chi_{i+k}(Q_0, f) - \chi_{i+k}(P_0, f)}))$ -good approximation of  $P_0$ .

By the choice of  $\kappa$ , we have that

$$\begin{aligned} & \kappa \cdot \left(1 + \frac{\chi_{i+k}(P_0, f)}{\frac{3}{2}\chi_{i+k}(Q_0, f) - \chi_{i+k}(P_0, f)}\right) \\ & > \left(\frac{\chi_{i+k}(P_0, f) - \frac{3}{2}\chi_{i+k}(Q_0, f)}{\frac{3}{2}\chi_{i+k}(P_0, f) - \frac{3}{2}\chi_{i+k}(Q_0, f)}\right) \cdot \left(1 + \frac{\chi_{i+k}(P_0, f)}{\frac{3}{2}\chi_{i+k}(Q_0, f) - \chi_{i+k}(P_0, f)}\right) \\ & = \frac{\chi_{i+k}(Q_0, f)}{\chi_{i+k}(Q_0, f) - \chi_{i+k}(P_0, f)} \\ & = 1 + \frac{\chi_{i+k}(P_0, f)}{\chi_{i+k}(Q_0, f) - \chi_{i+k}(P_0, f)} \\ & = 1 - \frac{\chi_{i+k}(P_0, f)}{\chi + \chi_{i+k}(P_0, f)} \end{aligned}$$

Hence,  $P_1$  is a  $(\gamma, 1 - \frac{\chi_{i+k}(P_0, f)}{\chi + \chi_{i+k}(P_0, f)})$ -good approximation of  $P_0$ . This implies that the item 5 is satisfied.

Besides, by the choice of  $\delta$ , we have the following estimation for the maximal center Lyapunov exponent of  $P_1$ :

$$\begin{aligned} \chi_{i+k}(P_1, g) & < \frac{1}{2} \cdot \chi_{i+k}(P', g) = \frac{1}{2} \cdot \frac{1}{k} \cdot \sum_{j=1}^k \chi_{i+j}(P', f) \\ & < \frac{1}{2} \cdot \frac{1}{k} \cdot \sum_{j=1}^k \chi_{i+j}(P_0, g) + \delta \\ & \leq \frac{3}{4} \cdot \chi_{i+k}(P_0, g). \end{aligned}$$

Hence the item 4 is satisfied. This ends the proof of Proposition 3.3.1.  $\square$

## 3.4 Ergodic measure with multi-zero Lyapunov exponents for the case controlled by Jacobian: Proof of Theorem 2

Consider a diffeomorphism  $f \in \text{Diff}^1(M)$  and a homoclinic class  $H(P, f)$  admitting a dominated splitting of the form  $T_{H(P, f)}M = E \oplus F \oplus G$ . We denote by  $k = \dim(F)$ . For any periodic orbit  $Q = \text{Orb}(q)$  contained in  $H(P, f)$ , the mean Lyapunov exponent along the bundle  $F$  of  $Q$  is defined as

$$L^F(Q, f) = \frac{1}{k \cdot \pi(Q)} \log |\text{Jac}(\text{Df}^{\pi(Q)}|_{F(q)})|.$$

Notice that  $L^F(Q, f)$  is the average of the Lyapunov exponents of  $Q$  along the bundle  $F$ .

### 3.4.1 Proof of Theorem 2

The main ingredient for the proof of Theorem 2 is the following proposition.

**Proposition 3.4.1.** *For generic diffeomorphism  $f \in \text{Diff}^1(M)$ , consider a hyperbolic periodic orbit  $P$  of index  $i$ . Assume the homoclinic class  $H(P, f)$  admits a dominated splitting  $T_{H(P, f)}M = E \oplus F \oplus G$ , such that  $\dim(E) = i$ . Assume, in addition, that we have the following:*

- $H(P, f)$  contains a hyperbolic periodic orbit  $Q = \text{Orb}(q)$ , whose index is no larger than  $\dim(E \oplus F)$ , such that

$$|\text{Jac}(\text{Df}^{\pi(Q)}|_{F(q)})| < 1;$$

- the center bundle  $F$  has no finer dominated splitting.

Then there exists a constant  $\rho \in (0, 1)$  which only depends on  $Q$ , such that for any hyperbolic periodic orbit  $P_0$  with simple spectrum, which is homoclinically related to  $P$ , and any  $\gamma > 0$ , there exists a hyperbolic periodic point  $P_1$  with simple spectrum such that:

1.  $L^F(P_1, f) < \rho \cdot L^F(P_0, f)$ ;
2.  $P_1$  is homoclinically related to  $P$  and is  $\gamma$  dense inside  $H(P, f)$ ;
3.  $P_1$  is  $(\gamma, 1 - \frac{L^F(P_0, f)}{L^F(P_0, f) - L^F(Q, f)})$  good approximation of  $P_0$ .

The proof of Proposition 3.4.1 is left to the next subsection. Now, we follow the strategy of the Proof of Theorem C to give the proof of Theorem 2.

*Proof of Theorem 2.* We denote by  $i = \dim(E)$ . By item 2, item 5 and item 7 of Theorem 2.13.1, we can assume that  $P$  is of index  $i$  and has simple spectrum. Let  $\rho \in (0, 1)$  be the number in Proposition 3.4.1, which only depends on  $Q$ .

We will inductively get a sequence of periodic orbits  $\{P_n\}$ , a sequence of positive numbers  $\{\epsilon_n\}$  and a sequence of integers  $\{N_n\}$  satisfying the following properties:

- $\epsilon_n < \frac{1}{2}\epsilon_{n-1}$ ;
- $L^F(P_{n+1}) < \rho \cdot L^F(P_n)$ ;
- $P_{n+1}$  is homoclinically related to  $P$  and is  $\epsilon_n$  dense inside  $H(p, f)$ ;
- $P_{n+1}$  is  $(\epsilon_n, 1 - \frac{2L^F(P_n, f)}{2L^F(P_n, f) - L^F(Q, f)})$  good approximation of  $P_n$ ;
- For any point  $x \in B_{2\epsilon_n}(P_n) \cap H(P, f)$ , we have that

$$0 < \frac{1}{N_n} \log m(\text{Df}^{N_n}|_{F(x)}) \leq \frac{1}{N_n} \log \|\text{Df}^{N_n}|_{F(x)}\| < 2\chi_{i+k}(P_n).$$

**Choice of  $P_0$ ,  $N_0$  and  $\epsilon_0$**  Let  $P_0 = P$ , then there exists an integer  $N_0$  large enough such that for any  $y \in P_0$ , we have that

$$0 < \frac{1}{N_0} \log m(\text{Df}^{N_0}|_{F(y)}) \leq \frac{1}{N_0} \log \|\text{Df}^{N_0}|_{F(y)}\| < \frac{3}{2}\chi_{i+k}(P_0).$$

By the uniform continuity of the function  $\log \|\text{Df}^{N_0}|_{F(x)}\|$  and the function  $\log m(\text{Df}^{N_0}|_{F(x)})$ , there exists a number  $\epsilon_0 > 0$  such that for any point  $x \in B_{2\epsilon_0}(P_0) \cap H(P, f)$ , we have that

$$0 < \frac{1}{N_0} \log m(\text{Df}^{N_0}|_{F(x)}) \leq \frac{1}{N_0} \log \|\text{Df}^{N_0}|_{F(x)}\| < 2\chi_{i+k}(P_0).$$

**Construct  $P_n$ ,  $N_n$  and  $\epsilon_n$  inductively** Assume that  $P_i$ ,  $N_i$  and  $\epsilon_i$  are already defined for any  $i \leq n$ . We apply  $P_n$  and  $\epsilon_n$  to the Proposition 3.4.1, then we get a periodic orbit  $P_{n+1}$  which is homoclinically related to  $P_n$  such that

- $L^F(P_{n+1}) < \rho \cdot L^F(P_n)$ ;
- $P_{n+1}$  is  $\epsilon_n$  dense in  $H(p, f)$ ;
- $P_n$  is  $(\epsilon_n, 1 - \frac{2L^F(P_n, f)}{2L^F(P_n, f) - L^F(Q, f)})$  good approximation of  $P_n$ .

Then there exists an integer  $N_{n+1}$  large enough such that for any  $y \in P_{n+1}$ , we have that

$$0 < \frac{1}{N_{n+1}} \log m(\text{Df}^{N_{n+1}}|_{F(y)}) \leq \frac{1}{N_{n+1}} \log \|\text{Df}^{N_{n+1}}|_{F(y)}\| < \frac{3}{2}\chi_{i+k}(P_{n+1}).$$

By the uniform continuity of the function  $\log \|\text{Df}^{N_{n+1}}|_{F(x)}\|$  and the function  $\log m(\text{Df}^{N_{n+1}}|_{F(x)})$ , there exists a number  $\epsilon_{n+1} \in (0, \frac{1}{2}\epsilon_n]$  such that for any point  $x \in B_{2\epsilon_{n+1}}(P_{n+1}) \cap H(P, f)$ , we have

$$0 < \frac{1}{N_{n+1}} \cdot \log m(\text{Df}^{N_{n+1}}|_{F(x)}) \leq \frac{1}{N_{n+1}} \log \|\text{Df}^{N_{n+1}}|_{F(x)}\| < 2\chi_{i+k}(P_{n+1}).$$

**End of proof of Theorem 2** Since  $1 - \frac{2L^F(P_n, f)}{2L^F(P_n, f) - L^F(Q, f)}$  exponentially tends to 1 and  $\sum_n \epsilon_n$  converges, by Lemma 2.5.2, the sequence of ergodic measures  $\delta_{P_n}$  converges to an ergodic measure  $\nu$  whose support is  $H(p, f)$ .

**Claim 3.4.2.** *The Lyapunov exponents of  $\nu$  along the center bundle  $F$  are all zero.*

Notice that  $\chi_{i+k}(P_n) \leq k \cdot L^F(P_n) \leq k \cdot \rho^n L^F(P_0)$ . The proof of Claim 3.4.2 follows the proof of the Claim 3.3.2. The only difference is that we control the sum of the center Lyapunov exponents by the function  $\frac{1}{N_n} \log \|\text{Df}^{N_n}|_F\|$  instead of the function  $L_{d-i}^{N_n} - L_{d-i-k}^{N_n}$ .

This ends the proof of Theorem 2. □

Now it remains to prove Proposition 3.4.1

### 3.4.2 Good approximation with weaker center Jacobian: Proof of Proposition 3.4.1

The proof of Proposition 3.4.1 is based on the following perturbation lemma:

**Lemma 3.4.3.** *Let  $P$  and  $Q$  be two hyperbolic periodic orbits of  $f \in \text{Diff}^1(M)$  with different indices. Assume that*

- $Q$  and  $P$  form a partially hyperbolic heterodimensional cycle  $K$ . In other words,  $K$  admits a partially hyperbolic splitting of the form

$$T_K M = E^s \oplus E^c \oplus E^u,$$

where  $\dim(E^s) = \text{ind}(P)$  and  $\dim(E^s \oplus E^c) = \text{ind}(Q)$ ;

- there exists another dominated splitting over  $K$  of the form

$$T_K M = E^s \oplus F \oplus G$$

such that  $\dim(F) \geq \dim(E^c)$ ;

- all the Lyapunov exponents of  $Q$  along  $E^c$  are equal.
- all the Lyapunov exponents of  $P$  along  $E^c$  are equal and are larger than  $L^F(P, f)/2$ ;
- $L^F(Q, f) < 0$ .

Then there exists a number  $\rho \in (0, 1)$  which only depends on  $Q$ , such that for any  $\gamma > 0$  and any  $C^1$  neighborhood  $\mathcal{U}$  of  $f$ , there exists  $g \in \mathcal{U}$  together with a hyperbolic periodic orbit  $P'$  of index  $\text{ind}(P)$ , with simple spectrum such that

1.  $g = f$  and  $\text{Dg} = \text{Df}$  on  $P \cup Q$  ;
2.  $L^F(P', g) < \rho \cdot L^F(P, g)$ ;
3.  $P'$  is  $(\gamma, 1 - \frac{L^F(P, g)}{L^F(P, g) - L^F(Q, g)})$  good approximation of  $P$ ;
4.  $W^{ss}(P', g)$  has transverse intersections with  $W^u(P, g)$  and  $W^{uu}(P', g)$  has transverse intersections with  $W^s(Q, g)$ , corresponding to the partially hyperbolic splitting  $T_{K_g} M = E^s \oplus E^c \oplus E^u$ .

- Remark 3.4.4.**
1. *Once again, if  $P$  and  $Q$  are robustly in the same chain recurrence class, the fourth item above implies that  $P'$ ,  $P$  and  $Q$  are robustly in the same chain recurrence class;*
  2. *Actually, the constant  $\rho$  is only and continuously depends on the mean Lyapunov exponent of  $Q$  along the bundle  $E^c$  and the mean Lyapunov exponent of  $Q$  along  $F$ .*

The idea of the proof of Lemma 3.4.3 is that we mix two hyperbolic periodic orbits with different sign of mean Lyapunov exponents to get a new hyperbolic periodic orbit with weaker mean Lyapunov exponent along the bundle  $F$ .

Similar to Section 3.3, we complete the proof of Proposition 3.4.1 by proving Lemma 3.4.3. To prove Lemma 3.4.3, we first follow the strategy of the proof of Lemma 3.3.3 to linearize the system in a small neighborhood of the cycle  $K$  by an arbitrarily small perturbation, then by another arbitrarily small perturbation, we get a periodic orbit. At the end, we will adjust the time of periodic orbit staying close to  $P$  and  $Q$  respectively.

*Proof of Lemma 3.4.3.* By the assumption, we can denote by  $\log \mu$  and  $\log \lambda$  the Lyapunov exponents of  $P$  and  $Q$  along  $E^c$  respectively. Then we have that

$$\frac{L^F(P, f)}{2} < \log \mu < \overline{L^F(P, f)} \text{ and } \log \lambda < L^F(Q, f).$$

Denote by  $P = \text{Orb}(p, f)$  and  $Q = \text{Orb}(q, f)$ .

We fix a small number  $\gamma > 0$  and a neighborhood  $\mathcal{U}$  of  $f$ . There exists  $\epsilon > 0$  such that the  $\epsilon$  neighborhood of  $f$  is contained in  $\mathcal{U}$ . There is a small number  $0 < \theta < 1$ , such that for any  $h \in \mathcal{U}$ , if  $d(z_1, z_2) < \theta \cdot \gamma$ , we have that

$$d(h^i(z_1), h^i(z_2)) < \frac{\gamma}{2}, \text{ for any } i \in [-\pi(P), \pi(P)].$$

We take two neighborhoods  $U_P$  and  $U_Q$  of  $P$  and  $Q$  respectively, such that  $U_P$  is contained in the  $\theta \cdot \gamma$ -neighborhood of  $P$  and is disjoint from  $U_Q$ .

**Construction of the periodic orbit  $P_1$**  Similar to the proof of Lemma 3.3.3, consider the splitting  $T_K M = E^s \oplus E^c \oplus E^u = E^s \oplus F \oplus G$  and the two neighborhoods  $U_P$  and  $U_Q$ , by Theorem 2.12.7 and Remark 2.12.8, there are two matrices  $T_0, T_1$  and two positive integers  $t_0, t_1$  such that for any two integers  $m$  and  $n$ , there exist  $g \in \mathcal{U}$  and a hyperbolic periodic orbit  $P_1 = \text{Orb}(p_1, g)$  satisfying s that:

- $g = f$  and  $\text{D}g = \text{D}f$  on  $P \cup Q$ ,
- The linear maps  $T_0 : T_p M \mapsto T_q M$  and  $T_1 : T_q M \mapsto T_p M$  preserve the two dominated splittings,
- $\pi(P_1) = m\pi(P) + n\pi(Q) + t_0 + t_1$ ,
- $\text{D}g^{\pi(P_1)}(p_1)$  is conjugate to  $T_1 \circ \text{D}f^{n\pi(Q)}(q) \circ T_0 \circ \text{D}f^{m\pi(P)}(p)$ ,

- $\#(P_1 \cap U_P) \geq m\pi(P)$  and  $\#(P_1 \cap U_Q) \geq n\pi(Q)$ ,
- $W^{ss}(P_1, g) \pitchfork W^u(P, g)$  and  $W^{uu}(P_1, g) \pitchfork W^s(Q, g)$  corresponding to the splitting  $T_{K_g}M = E^s \oplus E^c \oplus E^u$ .

As a consequence of the first item above, we have that

- $L^F(P, f) = L^F(P, g)$  and  $L^F(Q, f) = L^F(Q, g)$ ;
- $\chi_j(P, f) = \chi_j(P, g)$  and  $\chi_j(Q, f) = \chi_j(Q, g)$ , for any  $j = 1, \dots, d$ .

For simplicity, we denote them by  $L^F(P)$ ,  $L^F(Q)$ ,  $\chi_j(P)$  and  $\chi_j(Q)$ .

Since  $T_0$  and  $T_1$  preserve the dominated splittings, by choosing the proper coordinates, we assume that, corresponding to the two splittings, the two matrices  $T_1$  and  $T_0$  have the following forms respectively:

$$\mathbf{T}_0 = \begin{pmatrix} D_s & 0 & 0 \\ 0 & D_c & 0 \\ 0 & 0 & D_u \end{pmatrix} = \begin{pmatrix} D_s & 0 & 0 \\ 0 & D_F & 0 \\ 0 & 0 & D_G \end{pmatrix},$$

$$\mathbf{T}_1 = \begin{pmatrix} C_s & 0 & 0 \\ 0 & C_c & 0 \\ 0 & 0 & C_u \end{pmatrix} = \begin{pmatrix} C_s & 0 & 0 \\ 0 & C_F & 0 \\ 0 & 0 & C_G \end{pmatrix}.$$

Then we have that  $\text{Dg}^{\pi(P_1)}(p_1)|_{E^c}$  is conjugate to

$$C_c \circ \text{Df}^{n\pi(Q)}(q)|_{E^c} \circ D_c \circ \text{Df}^{m\pi(P)}(p)|_{E^c},$$

and  $\text{Dg}^{\pi(P_1)}(p_1)|_F$  is conjugate to

$$C_F \circ \text{Df}^{n\pi(Q)}(q)|_F \circ D_F \circ \text{Df}^{m\pi(P)}(p)|_F.$$

**Choice of  $m$ ,  $n$  and  $\rho$**  We will adjust  $m$  and  $n$  to get a periodic orbit satisfying the conclusion of Lemma 3.4.3. Let  $\eta > 0$  be a small number which will be decided later.

**Claim 3.4.5.** *There exists an integer  $N_\eta$  such that for any  $m, n \geq N_\eta$ , we have that*

- *all the Lyapunov exponents of  $P_1$  along the bundle  $E^c$  would belong to the interval*

$$\left[ \frac{m\pi(P) \cdot \log \mu + n\pi(Q) \cdot \log \lambda}{m\pi(P) + n\pi(Q)} - \eta, \frac{m\pi(P) \cdot \log \mu + n\pi(Q) \cdot \log \lambda}{m\pi(P) + n\pi(Q)} + \eta \right].$$

- *the mean Lyapunov exponent of  $P_1$  along the bundle  $F$  would belong to the interval*

$$\left[ \frac{m\pi(p) \cdot L^F(P) + n\pi(q) \cdot L^F(Q)}{m\pi(P) + n\pi(Q)} - \eta, \frac{m\pi(P) \cdot L^F(P) + n\pi(Q) \cdot L^F(Q)}{m\pi(P) + n\pi(Q)} + \eta \right].$$

The proof of Claim 3.4.5 is just like the proof of Claim 3.3.5 and we omit the proof here.

To guarantee the item 2 and that  $P_1$  has the same index as  $P$ , we only need to require that there exists a number  $\rho \in (0, 1)$  which will be decided later, such that:

$$\frac{m\pi(P) \cdot L^F(P) + n\pi(Q) \cdot L^F(Q)}{m\pi(P) + n\pi(Q)} + \eta < \rho \cdot L^F(P)$$

and

$$\frac{m\pi(P) \cdot \log \mu + n\pi(Q) \cdot \log \lambda}{m\pi(P) + n\pi(Q)} - \eta > 0,$$

which are equivalent to

$$\frac{\eta - \log \lambda}{\log \mu - \eta} < \frac{m\pi(P)}{n\pi(Q)} < \frac{\rho \cdot L^F(P) - L^F(Q) - \eta}{L^F(P) - \rho \cdot L^F(P) + \eta}.$$

**Claim 3.4.6.** *There exists  $\rho \in (0, 1)$  such that the following inequality is satisfied:*

$$\frac{-\log \lambda}{\log \mu} < \frac{\rho \cdot L^F(P) - L^F(Q)}{L^F(P) - \rho \cdot L^F(P)}.$$

*Proof.* The proof consists in solving the following inequality:

$$\frac{\rho \cdot L^F(P) - L^F(Q)}{L^F(P) - \rho \cdot L^F(P)} > \frac{-\log \lambda}{\log \mu},$$

which is equivalent to

$$\rho > \frac{L^F(Q) \cdot \log \mu - \log \lambda \cdot L^F(P)}{L^F(P) \cdot \log \mu - \log \lambda \cdot L^F(P)}.$$

By assumption that  $\log \mu \in (\frac{L^F(P)}{2}, L^F(P))$ , we have the estimation:

$$\begin{aligned} \frac{L^F(Q) \cdot \log \mu - \log \lambda \cdot L^F(P)}{L^F(P) \cdot \log \mu - \log \lambda \cdot L^F(P)} &= \frac{L^F(Q) \cdot \frac{\log \mu}{L^F(P)} - \log \lambda}{\log \mu - \log \lambda} \\ &< \frac{\frac{L^F(Q)}{2} - \log \lambda}{-\log \lambda} \\ &= 1 + \frac{L^F(Q)}{-2 \log \lambda}. \end{aligned}$$

We only need to take

$$\rho = 1 + \frac{L^F(Q)}{-2 \log \lambda} \in (0, 1).$$

Notice that  $\rho$  only depends on  $L^F(Q)$  and  $\log \lambda$ . □



We fix the value of  $\rho$  that we get from Claim 3.4.6, then when  $\eta$  is chosen small enough, we have that

$$\frac{\eta - \log \lambda}{\log \mu - \eta} < \frac{\rho \cdot L^F(P) - L^F(Q) - \eta}{L^F(P) - \rho \cdot L^F(P) + \eta}.$$

By the density of rational numbers among  $\mathbb{R}$  and Claim 3.4.5, there exist  $m$  and  $n$  arbitrarily large such that

$$\frac{m\pi(P)}{n\pi(Q)} \in \left( \frac{\eta - \log \lambda}{\log \mu - \eta}, \frac{\rho \cdot L^F(P) - L^F(Q) - \eta}{L^F(P) - \rho \cdot L^F(P) + \eta} \right),$$

which implies that  $P_1$  satisfies the properties of the conclusion of Lemma 3.4.3 except the item 3.

Now, we only need to check that the choice of  $m$  and  $n$  guarantees the item 3. By the fact that

$$\frac{m\pi(P)}{n\pi(Q)} > \frac{-\log \lambda}{\log \mu}, L^F(P) > \log \mu \text{ and } L^F(Q) > \log \lambda,$$

we have that

$$\begin{aligned} \frac{m\pi(P)}{m\pi(P) + n\pi(Q)} &> \frac{\frac{-\log \lambda}{\log \mu}}{\frac{-\log \lambda}{\log \mu} + 1} = \frac{-\log \lambda}{\log \mu - \log \lambda} \\ &> \frac{-L^F(Q)}{L^F(P) - L^F(Q)} \\ &= 1 - \frac{L^F(P)}{L^F(P) - L^F(Q)}. \end{aligned}$$

Hence by taking  $m$  and  $n$  much larger than  $t_0 + t_1$ , we have that  $P'$  is  $(\gamma, 1 - \frac{L^F(P)}{L^F(P) - L^F(Q)})$  good approximation of  $P$ . Just as the part of the proof of Lemma 3.3.3,  $P$  can be chosen with simple spectrum. This ends the proof of Lemma 3.4.3.  $\square$

**Remark 3.4.7.** *From the proof above, one can see that  $\rho$  only depends on  $L^F(Q)$  and the average of the Lyapunov exponents of  $Q$  along  $E^c$ .*

Now, we can give the proof of Proposition 3.4.1 whose proof is quite similar to that of Proposition 3.3.1.

*Proof of Proposition 3.4.1.* We denote by  $k = \dim(F)$  and assume that  $\text{ind}(Q) = i + k_0$ , then we have  $0 < k_0 \leq k$ .

We can see that the properties stated in Proposition 3.4.1 are persistent under  $C^1$  small perturbation. Let  $\mathcal{R}$  be the residual subset of  $\text{Diff}^1(M)$  from Theorem 2.13.1. We only need to show that given  $f \in \mathcal{R}$ , there is  $\rho \in (0, 1)$  such that for any  $\zeta > 0$  and  $\gamma > 0$ , there exist a diffeomorphism  $g$  which is  $\zeta$ - $C^1$ -close to  $f$ , and a  $g$  hyperbolic periodic orbit  $P_1$  of index  $i$  satisfying the followings:

- $H_1$ .  $g$  coincides with  $f$  on  $P_0 \cup Q$ ;  
 $H_2$ .  $P_1$  is robustly in the chain recurrence class of  $P_g$ ;  
 $H_3$ .  $P_1$  has simple spectrum and  $d_H(P_1, H(P_g, g)) < \gamma$ ;  
 $H_4$ .  $L^F(P_1, g) < \rho \cdot L^F(P_0, g)$ ;  
 $H_5$ .  $P_1$  is a  $(\gamma, 1 - \frac{L^F(P_0, g)}{L^F(P_0, g) - L^F(Q, g)})$ -good approximation of  $P_0$ .  
 Then Proposition 3.4.1 can be proved by a standard Baire argument.

**The previous settings** By item 4 of Theorem 2.13.1, we can require that  $\zeta$  is chosen small enough such that after any  $\zeta$ -perturbation, the continuations of  $P_0$ ,  $P$  and  $Q$  are still robustly in the same chain recurrence class.

We take  $0 < \epsilon < \frac{\zeta}{4}$ , then there exist  $T > 0$  and  $l_0$  satisfying Lemma 2.12.1. We denote by

$$\log \lambda = \frac{1}{k_0} \sum_{j=i+1}^{i+k_0} \chi_j(Q, f) \text{ and } \rho_0 = 1 + \frac{L^F(Q, f)}{-2 \log \lambda}.$$

Since  $H(P, f)$  admits no dominated splitting of index  $j$  for any  $j \in \{i+1, \dots, i+k-1\}$ , there is a number  $\delta_0 \in (0, \frac{\gamma}{10})$  such that for any compact invariant subset  $\Lambda \subset H(P, f)$ , if  $d_H(\Lambda, H(P, f)) < \delta_0$ , then  $\Lambda$  admits no  $T$ -dominated splitting of index  $j$  for any  $j \in \{i+1, \dots, i+k-1\}$ .

Notice that  $\log \lambda < 0$ ,  $L^F(Q, f) < 0$ ,  $0 < L^F(P_0, f)$  and  $\rho_0 \in (0, 1)$ , hence we have that

$$\rho_0 = 1 + \frac{L^F(Q, f)}{-2 \log \lambda} < \frac{1 + \rho_0}{2};$$

$$\frac{L^F(P_0, f)}{L^F(P_0, f) - L^F(Q, f)} \in \left(0, \frac{2L^F(P_0, f)}{2L^F(P_0, f) - L^F(Q, f)}\right).$$

As a consequence, we can take a number  $\delta \in (0, \frac{1-\rho_0}{2})$  small enough such that:

$$1 + \frac{L^F(Q, f) + \delta}{-2 \log \lambda + \delta} < \frac{1 + \rho_0}{2};$$

$$\frac{L^F(P_0, f) + \delta}{L^F(P_0, f) - L^F(Q, f) - 2\delta} \in \left(0, \frac{2L^F(P_0, f)}{2L^F(P_0, f) - L^F(Q, f)}\right)$$

We take a number  $\kappa$  such that

$$\kappa \in \left(\frac{2L^F(P_0, f) - L^F(Q, f)}{3L^F(P_0, f) - L^F(Q, f)}, 1\right).$$

We apply the item 7 of Theorem 2.13.1 to the constants  $\delta$  and  $\kappa$ , then there exist two hyperbolic periodic orbits  $P' = \text{Orb}(p')$  and  $Q' = \text{Orb}(q')$ , with simple spectrum such that:

- $P'$  and  $Q'$  are homoclinically related to  $P_0$  and  $Q$  respectively;
- Both  $P'$  and  $Q'$  are  $\delta/2$  dense in  $H(P, f)$ ;
- $P'$  is a  $(\frac{\gamma}{10}, \kappa)$ -good approximation of  $P_0$  and  $Q'$  is  $(\frac{\gamma}{10}, \kappa)$ -good approximation of  $Q$ ;
- $|L^F(P', f) - L^F(P_0, f)| < \delta$  and  $|L^F(Q', f) - L^F(Q, f)| < \delta$ ;

$$\left| \sum_{j=i+1}^{i+k_0} \chi_j(Q') - \sum_{j=i+1}^{i+k_0} \chi_j(Q) \right| < \delta;$$

- Both of the periods of  $P'$  and  $Q'$  are larger than  $l_0$ .

By item 6 of Theorem 2.13.1, we can do an arbitrarily  $C^1$  small perturbation, keeping  $P'$  and  $Q'$  homoclinically related to  $P$  and  $Q$  respectively and without changing the Lyapunov exponents of  $P'$  and  $Q'$ , such that  $P'$  and  $Q'$  form a partially hyperbolic heterodimensional cycle.

**Equalize the center Lyapunov exponents of both  $P'$  and  $Q'$**  By Lemma 2.12.1, there exist  $\pi(P')$  one-parameter families  $\{(A_{l,t})_{t \in [0,1]}\}_{l=0}^{\pi(P')-1}$  and  $\pi(Q')$  one-parameter families  $\{(B_{m,t})_{t \in [0,1]}\}_{m=0}^{\pi(Q')-1}$  in  $GL(d, \mathbb{R})$  such that:

- $A_{l,0} = \text{Df}(f^l(p'))$  and  $B_{m,0} = \text{Df}(f^m(q'))$ , for any  $l, m$ ;
- $\|A_{l,t} - \text{Df}(f^l(p'))\| < \epsilon$  and  $\|A_{l,t}^{-1} - \text{Df}^{-1}(f^{l+1}(p'))\| < \epsilon$ , for any  $t \in [0, 1]$ ;
- $\|B_{m,t} - \text{Df}(f^m(q'))\| < \epsilon$  and  $\|B_{m,t}^{-1} - \text{Df}^{-1}(f^{m+1}(q'))\| < \epsilon$ , for any  $t \in [0, 1]$ ;
- $A_{\pi(P')-1,t} \circ \cdots \circ A_{0,t}$  and  $B_{\pi(Q')-1,t} \circ \cdots \circ B_{0,t}$  are hyperbolic, for any  $t \in [0, 1]$ ;
- For any integer  $s \in [1, i] \cup [i+k+1, d]$ , we have that

$$\chi_s(A_{\pi(P')-1,t} \circ \cdots \circ A_{0,t}) = \chi_s(P', f).$$

- For any integer  $s \in [1, i] \cup [i+k_0+1, d]$ , we have that

$$\chi_s(B_{\pi(Q')-1,t} \circ \cdots \circ B_{0,t}) = \chi_s(Q', f);$$

- $\chi_{i+1}(A_{\pi(P')-1,1} \circ \cdots \circ A_{0,1}) = \chi_{i+k_0}(A_{\pi(P')-1,1} \circ \cdots \circ A_{0,1}) \in (\frac{1}{2}L^F(P'), L^F(P'))$ ;
- $\chi_{i+k_0+1}(A_{\pi(P')-1,1} \circ \cdots \circ A_{0,1}) = \chi_{i+k}(A_{\pi(P')-1,1} \circ \cdots \circ A_{0,1}) \geq L^F(P')$ ;
- $\chi_{i+1}(B_{\pi(Q')-1,1} \circ \cdots \circ B_{0,1}) = \chi_{i+k_0}(B_{\pi(Q')-1,1} \circ \cdots \circ B_{0,1}) = \frac{1}{k_0} \sum_{j=i+1}^{i+k_0} \chi_j(Q', f)$ .

Similar to the proof of Proposition 3.3.1, by Franks-Gourmelon Lemma, there exists an  $\epsilon$  perturbation  $g_1$  of  $f$ , which preserves the partially hyperbolic heterodimensional cycle formed by  $P'$  and  $Q'$ , such that

- S1.  $g_1$  coincides with  $f$  on  $P_0 \cup Q \cup P' \cup Q'$ ;
- S2.  $\chi_j(P_0, g_1) = \chi_j(P_0, f)$  and  $\chi_j(Q, g_1) = \chi_j(Q, f)$ , for any  $j = 1, 2, \dots, d$ ;
- S3.  $\text{ind}(P', g_1) = \text{ind}(P', f)$  and  $\text{ind}(Q', g_1) = \text{ind}(Q', f)$ ;
- S5.  $\chi_{i+1}(P', g_1) = \chi_{i+k_0}(P', g_1) \in (\frac{1}{2}L^F(P', f), L^F(P', f))$
- S6.  $\chi_{i+1}(Q', g_1) = \chi_{i+k_0}(Q', g_1)$ ;
- S7.  $L^F(P', g_1) = L^F(P', f)$  and  $L^F(Q', g_1) = L^F(Q', f)$ .

**Construction of the periodic orbit  $P_1$**  By Lemma 3.4.3 and Remark 3.4.4, we have that there exist  $g \in \text{Diff}^1(M)$ , which is  $\epsilon$ - $C^1$ -close to  $g_1$  and therefore is  $\zeta$ - $C^1$ -close to  $f$ , and a  $g$ -hyperbolic periodic orbit  $P_1$  of index  $i$  such that

- $L^F(P_1, g) < \rho_0 \cdot L^F(P', g_1)$ ;
- $P_1$  has simple spectrum;
- $g$  coincides with  $g_1$  on  $P_0 \cup Q \cup P' \cup Q'$ ;
- the Lyapunov exponents of  $P_0, Q, P'$  and  $Q'$  with respect to  $g_1$  are equal to those with respect to  $g$ , hence are equal to those with respect to  $f$ ;
- $P_1$  is a  $(\frac{\gamma}{10}, 1 - \frac{L^F(P', f)}{L^F(P', f) - L^F(Q', f)})$ -good approximation of  $P'$ ;
- $P_1$  is robustly in the same chain class with  $P_g$  and  $Q_g$ .

By the choice of  $\delta$  and  $\gamma$ , we have that  $d_H(P_1, H(P, g)) < \gamma$ . Then the items  $H_1, H_2, H_3$  are satisfied.

By the choice of  $\delta$ , we have the following estimation for the mean center Lyapunov exponent  $L^F(P_1)$  of  $P_1$ :

$$L^F(P_1, g) < \rho_0 \cdot L^F(P', g_1) = \rho_0 \cdot L^F(P', f) < \rho_0 \cdot L^F(P_0, f) + \delta < \frac{1 + \rho_0}{2} \cdot L^F(P_0, g).$$

We only need to take  $\rho = \frac{1 + \rho_0}{2}$ , hence item  $H_4$  is satisfied.

Besides, by the choice of  $\kappa$ , we have that

$$\begin{aligned} & \kappa \cdot \left( 1 - \frac{L^F(P', f)}{L^F(P', f) - L^F(Q', f)} \right) \\ & > \frac{2L^F(P_0, f) - L^F(Q, f)}{3L^F(P_0, f) - L^F(Q, f)} \cdot \frac{-L^F(Q, f)}{2L^F(P_0, f) - L^F(Q, f)} \\ & = 1 - \frac{3L^F(P_0, f)}{3L^F(P_0, f) - L^F(Q, f)}. \end{aligned}$$

Since  $P'$  is  $(\frac{\gamma}{10}, \kappa)$  good approximated of  $P_0$ , by the inequality above,  $P_1$  is a  $(\gamma, 1 - \frac{2L^F(P_0, f)}{2L^F(P_0, f) - L^F(Q, f)})$ -good approximation of  $P_0$ . Then item  $H_5$  is satisfied.

This ends the proof of Proposition 3.4.1.  $\square$

### 3.5 Partially hyperbolic homoclinic classes with volume expanding center bundle

In this section, we give an example showing that Corollary 1 may be not true if there is no periodic orbit of index  $\dim(E \oplus F)$ . We first give some known results about normally hyperbolic submanifolds in Section 3.5.1 and the example will be given in Section 3.5.2.

### 3.5.1 Stability of normally hyperbolic compact manifolds

Let  $f \in \text{Diff}^1(M)$ . A compact invariant submanifold without boundary  $N$  of  $M$  is called *normally hyperbolic*, if there exists a partially hyperbolic splitting of the form  $T_N M = E^s \oplus TN \oplus E^u$ .

We state a simple version of Theorem 4.1 in [HPS] which gives the stability theorem for normally hyperbolic compact submanifold.

**Theorem 3.5.1.** *Let  $f \in \text{Diff}^1(M)$  and  $N$  be a compact normally hyperbolic submanifold. We denote by  $i : N \hookrightarrow M$  the embedding map from  $N$  to  $M$ .*

*There exists a  $C^1$  small neighborhood  $\mathcal{U}$  of  $f$  such that for any  $g \in \mathcal{U}$ , there exists a  $C^1$  embedding map  $i_g : N \hookrightarrow M$ , such that  $N_g = i_g(N)$  is  $g$ -normally hyperbolic. Moreover,  $i_g$  would tend to  $i$  in the  $C^1$  topology, if  $g$  tends to  $f$ .*

**Remark 3.5.2.** *The map  $i_g^{-1}|_{N_g} \circ g \circ i_g$  is  $C^1$ -conjugate to the restriction of the map  $g$  to  $N_g$  and is  $C^1$  close to  $f$  if  $g$  is  $C^1$  close to  $f$ .*

### 3.5.2 An example

Ch. Bonatti [B1] (see also Section 6.2 in [BV]) constructs an open set  $\mathcal{U}$  of  $C^1$  diffeomorphism on  $\mathbb{T}^3$  such that for any  $f \in \mathcal{U}$ , we have the following:

- $f$  is robustly transitive;
- There exist a periodic orbit of index one having a complex eigenvalue and a periodic orbit of index two.

By Theorem 2 and Theorem 4 in [BDP], for the diffeomorphism  $f \in \mathcal{U}$ , there exists a partially hyperbolic splitting of the form  $T\mathbb{T}^3 = E^{ss} \oplus E^c$ , where  $\dim(E^{ss}) = 1$  and the center bundle  $E^c$  is volume expanding without any finer dominated splitting.

Now, we consider a north-south diffeomorphism  $h$  on  $\mathbb{S}^1$  such that the expanding rate of  $h$  at the source  $Q$  is strictly larger than the norm of  $f$ . We denote by

$$\tilde{f} = f \times h : \mathbb{T}^3 \times \mathbb{S}^1 \hookrightarrow \mathbb{T}^3 \times \mathbb{S}^1.$$

By Theorem 3.5.1 and continuity of partial hyperbolicity, there exists a  $C^1$  neighborhood  $\mathcal{V}$  of  $\tilde{f}$  such that any  $\tilde{g} \in \mathcal{V}$  has a partially hyperbolic repelling set  $\Lambda_{\tilde{g}}$  diffeomorphic to  $\mathbb{T}^3 \times \{Q\}$  admitting a splitting of the form  $T_{\Lambda_{\tilde{g}}}\mathbb{T}^4 = E^{ss} \oplus E^c \oplus E^{uu}$  where  $E^{ss} \oplus E^c = T\Lambda_{\tilde{g}}$ . Then by Remark 3.5.2, we have that  $\tilde{g}|_{\Lambda_{\tilde{g}}}$  is transitive and the dynamics  $\tilde{g} : \Lambda_{\tilde{g}} \hookrightarrow \Lambda_{\tilde{g}}$  is  $C^1$ -conjugated to a diffeomorphism  $C^1$  close to the dynamics  $f : \mathbb{T}^3 \hookrightarrow \mathbb{T}^3$ . Then the bundle  $E^c|_{\Lambda_{\tilde{g}}}$  is volume expanding and there is a periodic orbit of index one with complex eigenvalues along the bundle  $E^c$  contained in  $\Lambda_{\tilde{g}}$ . Hence the bundle  $E^c|_{\Lambda_{\tilde{g}}}$  also has no finer dominated splitting. As a consequence, we have the following conclusion.

**Lemma 3.5.3.** *For generic diffeomorphism in  $\mathcal{V}$ , there is a partially hyperbolic homoclinic class, such that any ergodic measure supported on it has at least one positive Lyapunov exponent along  $E^c$ .*



# Chapter 4

## Non-hyperbolic ergodic measures approximated by periodic measures

We recall that K. Sigmund proved that the periodic measures are dense among invariant measures supported on a hyperbolic basic set. In this chapter, we give the proofs of our results on extending Sigmund's result to the non-hyperbolic setting.

In the previous chapter, we prove the robust existence of non-hyperbolic ergodic measures for some robustly non-hyperbolic diffeomorphisms. To extend Sigmund's theorem to non-hyperbolic setting, one has to find a way to approximate non-hyperbolic ergodic measures by periodic measures. To do this, we 'add' some hyperbolicity to the non-hyperbolic ergodic measures by considering the convex combination of it with a hyperbolic ergodic measure. We first work in a semi-local setting where there exist partially hyperbolic robust cycles called flip-flop configuration and formed by blender horseshoes and periodic points of different indices. One can show that in a very small neighborhood of this robust cycle, the basin of a non-hyperbolic ergodic measure  $\mu$  intersects the unstable manifold of a periodic point  $p$  in the blender in a point  $x$ . The mechanism in this robust cycle allows us to find an arbitrarily large orbit segment following the positive orbit of  $x$  for a uniform proportion of time, then by an arbitrarily small proportion of time to get to the stable manifold  $p$ . Moreover, the orbit segment has some hyperbolicity along the center which allows us to apply Liao-Gan's shadowing lemma. Combining the [GIKN] criterion and Liao-Gan's shadowing lemma, one can show that the invariant measure approximated by hyperbolic measures and with vanishing center Lyapunov exponent is approached by non-hyperbolic ergodic measures. Using the arguments above, we also obtain some sort of convexity of the closure of the set of ergodic measures.

In the global setting, we consider the partially hyperbolic diffeomorphisms



with minimal strong foliations. We obtain the analogous results. To be precise, we show the convexity of the closure of the set of non-hyperbolic ergodic measures which is the intersection of the closures of the set of hyperbolic ergodic measures of two possible  $s$ -indices. Moreover, we show that in general, the closure of the set of hyperbolic ergodic measures of same index is no more a Choquet simplex. We also apply our arguments to the Mañé's example on  $\mathbb{T}^3$  and we get similar results. Here, we recall that for Mañé's example, only the minimality of strong stable foliation is known.

## 4.1 Approximation of non hyperbolic ergodic measure by periodic orbits: Proof of Theorem E.

In this section, we prove that all the non-hyperbolic ergodic measures supported in a small enough neighborhood of a split flip-flop configuration are approximated by hyperbolic periodic measures.

Consider  $f \in \text{Diff}^1(M)$ . Assume that there exists a split flip flop configuration formed by a cu-blender horseshoe  $(\Lambda, C, \mathcal{C}^{uu}, \mathfrak{D})$  of  $u$ -index  $i + 1$  and a hyperbolic periodic point  $q$  of  $u$ -index  $i$ . Let  $\epsilon_0$  be the strength of the strictly invariant family  $\mathfrak{D}$ . We denote by  $\mathcal{C}^u$  the center unstable invariant cone field defined in  $C$ . By the definition of a blender horseshoe, there exists  $\tau_1 > 1$  such that

$$\|Df(v)\| > \tau_1 \cdot \|v\|, \text{ for any } x \in C \cap f^{-1}(C) \text{ and } 0 \neq v \in \mathcal{C}^u(x).$$

By Lemma 2.9.3 and the definition of a split flip flop configuration, there exists a small neighborhood  $V$  of the configuration such that

- the maximal invariant  $\tilde{\Lambda}$  in  $\bar{V}$  admits a partially hyperbolic splitting  $T_{\tilde{\Lambda}}M = E^{ss} \oplus E^c \oplus E^{uu}$ , where  $\dim(E^c) = 1$  and  $\dim(E^{uu}) = i$ .
- there exist a continuous extension  $\mathcal{C}_V^{uu}$  of  $\mathcal{C}^{uu}$  in  $V$  and a number  $\tau_2 > 1$  such that

$$\|Df(v)\| \geq \tau_2 \cdot \|v\|, \text{ for any } x \in V \cap f^{-1}(V) \text{ and any } v \in \mathcal{C}^{uu}(x).$$

We assume, in addition, that there exists a  $Df$ -strictly invariant cone field  $\mathcal{C}_V^u$  in  $V$  which is a continuous extension of the center unstable cone field  $\mathcal{C}^u$  in  $C$ .

We denote by  $b = \max\{\sup_{x \in M} \|Df_x\|, \sup_{x \in M} \|Df_x^{-1}\|\}$ .

**Proposition 4.1.1.** *With the notation above. Let  $\nu$  be a non-hyperbolic ergodic measure supported on  $\tilde{\Lambda}$ . Assume that there exist a periodic orbit  $\mathcal{O}_p \subset \Lambda$  and a point  $y \in \tilde{\Lambda} \cap W_{loc}^u(\mathcal{O}_p)$  in the basin of  $\nu$  such that  $\overline{\text{Orb}(y, f)}$  is far away from the boundary of  $V$ .*

*Then  $\nu$  is approximated by hyperbolic periodic orbits which are homoclinically related to  $\Lambda$ .*

*Proof.* By plaque family theorem, we fix plaque families  $W^{cu}$  and  $W^{cs}$  for  $\tilde{\Lambda}$  such that  $W^{cu}(y)$  is foliated by discs tangent to cone field  $\mathcal{C}_V^{uu}$ . Since  $y \in W_{loc}^u(\mathcal{O}_p)$  and  $\Lambda$  is uniformly hyperbolic, there exists an integer  $N_0 \in \mathbb{N}$ , which only depends on the size of  $W_{loc}^u(\mathcal{O}_p)$  and  $\Lambda$ , such that  $f^{-N_0}(y)$  is a  $(\tau_1, E^c \oplus E^u)$  expanding point. By Lemma 2.7.3, there exists  $\delta_0$  independent of  $y$  such that  $W_{\delta_0}^{cu}(y)$  is contained in the unstable manifold of  $y$ , which implies that  $W_{\delta_0}^{cu}(y) \subset W_{loc}^u(\mathcal{O}_p)$ .

For any point  $z \in \tilde{\Lambda}$ , we denote by

$$W^c(z) = W^{cu}(z) \cap W^{cs}(z),$$

then this gives a plaque family for  $E^c$ . For any  $z \in \tilde{\Lambda}$  and any point  $w \in W^i(z)$ , we denote by  $\tilde{E}^i(w, z) = T_w W^i(z)$  for  $i = c, cu$ . When there is no ambiguity, for  $i = c, cu$ , we denote  $\tilde{E}^i(w, z)$  as  $\tilde{E}^i(w)$  for simplicity.

To fulfill the proof, we need the following lemma:

**Lemma 4.1.2.** *For any  $\varepsilon > 0$ , there exist an integer  $N > 0$  and a sequence of points  $\{z_k\}_{k \in \mathbb{N}} \subset W_{loc}^u(\mathcal{O}_p)$  together with a sequence of positive integers  $\{t_k\}_{k \in \mathbb{N}}$  such that*

$$f^{t_k}(z_k) \in W_{loc}^s(\mathcal{O}_p) \text{ and } d\left(\frac{1}{t_k} \sum_{j=0}^{t_k-1} \delta_{f^j(z_k)}, \nu\right) < \varepsilon;$$

— for any  $j \in [N, t_k]$ , we have that

$$-\varepsilon < \frac{1}{j} \sum_{i=0}^{j-1} \log \|Df|_{E^c(f^i(z_k))}\| < \varepsilon;$$

— the sequence  $\{t_k\}_{k \in \mathbb{N}}$  tends to infinity and the orbit segments  $\{\{z_k, t_k\}\}_{k \in \mathbb{N}}$  are contained in  $V$ .

*Proof.* For any  $\epsilon > 0$  small, by the uniform continuity of  $Df$  on the unit tangent bundle of  $TM$ , and compactness of  $M$  and  $\tilde{\Lambda}$ , there exists  $\delta \in (0, \delta_0)$  such that:

– Given  $x \in \tilde{\Lambda}$ . For any two points  $x_1, x_2 \in W_\delta^c(x)$ , one has that

$$-\epsilon \leq \log \|Df|_{\tilde{E}^c(x_1)}\| - \log \|Df|_{\tilde{E}^c(x_2)}\| \leq \epsilon;$$

– for any point  $z \in \tilde{\Lambda}$  and any point  $w \in W_\delta^{cu}(z)$ , one has that

$$-\epsilon \leq \log m(Df|_{\tilde{E}^{cu}(w)}) - \log \|Df|_{E^c(z)}\| \leq \epsilon;$$

– for any  $w_1, w_2 \in \tilde{\Lambda}$  satisfying that  $d(w_1, w_2) < \delta$ , we have that

$$|\log \|Df|_{E^c(w_1)}\| - \log \|Df|_{E^c(w_2)}\|| < \epsilon/2;$$

- for any two points  $z_1, z_2 \in M$  satisfying that  $d(z_1, z_2) < \delta$ , we have that  $d(\delta_{z_1}, \delta_{z_2}) < \epsilon/2$ , where  $\delta_{z_i}$  denotes the Dirac measure supported on the point  $z_i$ ;
- for any point  $x \in \tilde{\Lambda}$ , one has that  $f(W_\delta^{cu}(x)) \subset W^{cu}(f(x))$ .

By the choice of  $y$ , there exists an integer  $N$  such that for any  $n \geq N$ , we have that

$$-\epsilon < \frac{1}{n} \sum_{i=0}^{n-1} \log \|Df|_{E^c(f^i(y))}\| < \epsilon \text{ and } d\left(\frac{1}{n} \sum_{i=0}^{n-1} \delta_{f^i(y)}, \nu\right) < \epsilon/2. \quad (4.1)$$

For any  $C^1$  curve  $\gamma \subset M$ , we denote by  $\ell(\gamma)$  the length of  $\gamma$ . For any  $n \in \mathbb{N}$ , we take the  $C^1$  curve  $\gamma_n \subset W^c(y)$  such that

- $\ell(\gamma_n) = \delta \cdot e^{-4n\epsilon}$ ;
- the curve  $\gamma_n$  is centered at  $y$ .

**Claim 4.1.3.** *There exists an integer  $N_1$  such that for any  $n > N_1$ , we have that*

$$\ell(f^i(\gamma_n)) < \delta, \text{ for any integer } i \in [0, n].$$

*Proof.* Recall that  $b \geq \max_{x \in M} \|Df_x\|$ , then there exists an integer  $N_1$  satisfying that

$$e^{-n\epsilon} \cdot b^N < 1, \text{ for any } n > N_1,$$

Hence, for any  $n > N_1$  and any integer  $i \in [0, N]$ , we have the estimate:

$$\ell(f^i(\gamma_n)) = \int_0^1 \left\| \frac{d}{dt} f^i(\gamma_n(t)) \right\| dt \leq b^i \cdot \ell(\gamma_n) < \delta;$$

We will prove this claim for  $i \in (N, n]$  inductively. Assume that for any integer  $j \leq i \in (N, n)$ , we have that  $\ell(f^j(\gamma_n)) < \delta$ , then by the choices of  $\delta$  and  $N$ , we have that

$$\begin{aligned} \ell(f^{i+1}(\gamma_n)) &= \int_0^1 \left\| \frac{d}{dt} f^{i+1}(\gamma_n(t)) \right\| dt \leq \int_0^1 \prod_{j=0}^i \|Df|_{E^c(f^j(\gamma_n(t)))}\| \|\gamma'_n(t)\| dt \\ &\leq \int_0^1 e^{(i+1)\epsilon} \cdot \prod_{j=0}^i \|Df|_{E^c(f^j(y))}\| \|\gamma'_n(t)\| dt \\ &< \delta. \end{aligned}$$

□

By Claim 4.1.3 and the choice of  $\delta$ , for any  $n > N_1$ , we have the estimate:

$$\begin{aligned} \ell(f^n(\gamma_n)) &= \int_0^1 \left\| \frac{d}{dt} f^n(\gamma_n(t)) \right\| dt \\ &\geq \int_0^1 e^{-n\epsilon} \prod_{j=0}^{n-1} \|Df|_{E^c(f^j(y))}\| \|\gamma'_n(t)\| dt \\ &\geq \delta \cdot e^{-6n\epsilon}. \end{aligned}$$

A  $(i+1)$ -dimensional disc  $D^{cu} \subset V$  is called a *uu-foliated cu-disc*, if one has that

- the disc  $D^{cu}$  is tangent to the center unstable cone field  $\mathcal{C}_V^u$ ;
- there exists a  $C^1$  embedding  $\phi : [0, 1] \times [0, 1]^i \mapsto M$  such that  $\phi([0, 1] \times [0, 1]^i) = D^{cu}$  and for any  $t \in [0, 1]$ ,  $\phi(\{t\} \times [0, 1]^i)$  is a disc tangent to  $\mathcal{C}_V^{uu}$ .

The *central length*  $\ell^c(D^{cu})$  of  $D^{cu}$  is defined as the infimum of the length of the  $C^1$  curves contained in  $D^{cu}$  joining the discs  $\phi(\{0\} \times [0, 1]^i)$  and  $\phi(\{1\} \times [0, 1]^i)$ . The discs  $\phi(\{0\} \times [0, 1]^i)$  and  $\phi(\{1\} \times [0, 1]^i)$  are called *the vertical boundary components of  $D^{cu}$* .

Consider a submanifold  $S_n$  which is the  $\ell(\gamma_n)$  tubular neighborhood of  $W_\delta^{uu}(y)$  in  $W^{cu}(y)$ , then  $S_n$  is a uu-foliated cu-disc for  $n$  large and is contained in  $W_{loc}^u(\mathcal{O}_p)$ ; moreover, the central length of  $S_n$  is  $\delta \cdot e^{-4n\epsilon}$ . We denote by  $S_n(i)$  the connected component of  $f^i(S_n) \cap B_\delta(f^i(y))$  which contains  $f^i(y)$  (see Figure 4.1).

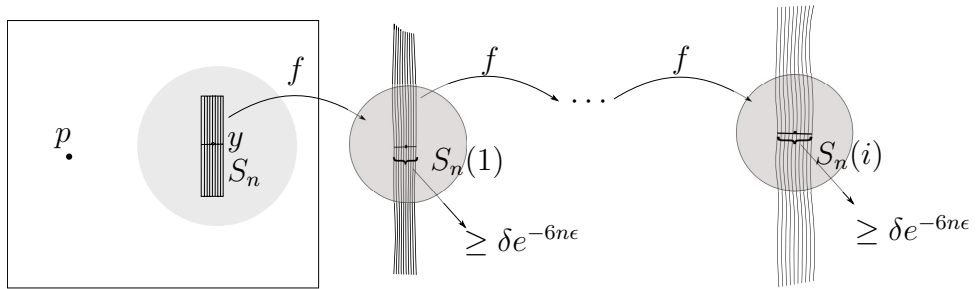

Figure 4.1 –

By Claim 4.1.3 and uniform expansion of  $Df$  along the cone field  $\mathcal{C}_V^{uu}$ , one has that

- $S_n(i)$  is a uu-foliated cu-disc whose vertical boundary components are contained in the  $f^i$ -image of the vertical boundary components of  $S_n$ ;
- $S_n(i)$  is saturated by the discs tangent to  $\mathcal{C}_V^{uu}$  with diameters of size  $\delta$ , for  $i = 1, \dots, n$ .

**Claim 4.1.4.** *The central length of  $S_n(i)$  is no less than  $\delta \cdot e^{-6n\epsilon}$ , for each  $i \in [1, n]$ .*

*Proof.* Given  $i \in [1, n]$ , for any  $C^1$  curve  $\{\xi(t)\}_{t \in [0,1]}$  contained in  $S_n(i)$  which joins the two vertical boundary components of  $S_n(i)$ , one has that  $f^{-i}(\xi(t))$  is a  $C^1$  curve joining the vertical boundary components of  $S_n$ . Moreover, by the definition of  $S_n(i)$ , one has that for any  $j \in [1, i]$ , one has that  $f^{-i+j}(\xi(t)) \subset W_\delta^{cu}(f^j(y))$ .

Since  $\ell(f^{-i}(\xi(t))) \geq \delta \cdot e^{-4n\epsilon}$ , by the choice of  $\delta$ , one has that

$$\begin{aligned} \ell(\xi(t)) &= \ell(f^i \circ f^{-i}(\xi(t))) \\ &= \int_0^1 \left\| Df^i \frac{d}{dt} f^{-i}(\xi(t)) \right\| dt \\ &\geq \int_0^1 e^{-n\epsilon} \cdot \prod_{j=0}^{i-1} \left\| Df|_{E^c(f^j(y))} \right\| \left\| \frac{d}{dt} f^{-i}(\xi(t)) \right\| dt \\ &\geq e^{-2n\epsilon} \cdot \ell(f^{-i}(\xi(t))) \\ &\geq \delta \cdot e^{-6n\epsilon} \end{aligned}$$

□

By the definition of a flip-flop configuration and the choice of  $y$ , there exists a sequence of positive integers  $\{n_k\}_{k \in \mathbb{N}}$  tending to infinity such that  $f^{n_k}(y)$  is in a small neighborhood of  $\Delta^u$ , hence  $f^{n_k}(y)$  is in  $C$ . Consider the  $cu$ -disc  $S_{n_k}$ , by Claim 4.1.4, we have that  $S_{n_k}(n_k)$  is a  $cu$ -disc of central length at least  $\delta \cdot e^{-6 \cdot n_k \cdot \epsilon}$ .

Recall that  $\tau_2 > 1$  is a number such that for any  $x \in V \cap f^{-1}(V)$  and  $v \in \mathcal{C}_V^{uu}(x)$ , one has that  $\|Df(v)\| \geq \tau_2 \|v\|$ . We denote by  $N(\delta)$  the smallest integer satisfying that  $\tau_2^{N(\delta)} \cdot \delta \geq b_0$ , where  $b_0$  is an upper bound for the diameters of the  $uu$ -discs in the family  $\mathfrak{D}$ , then  $N(\delta) \leq \frac{\log b_0 - \log \delta}{\log \tau_2} + 1$ . By the  $Df$ -strictly invariant property of the cone fields  $\mathcal{C}_V^u, \mathcal{C}_V^{uu}$  and the fact that  $\text{Orb}(y, f)$  is far away from the boundary of  $V$ , there exists an integer  $\tilde{n}_k$  such that

- $n_k - \tilde{n}_k \in (0, N(\delta)]$ ;
- Denote by  $\tilde{S}_{n_k}(n_k)$  the connected component of  $f^{n_k - \tilde{n}_k}(S_{n_k}(\tilde{n}_k)) \cap V$  containing  $f^{n_k}(y)$ . Then  $\tilde{S}_{n_k}(n_k)$  contains a  $cu$ -strip  $\tilde{S}_k$  in the characteristic region of blender horseshoe (see Figure 4.2) such that for the central length  $\ell^c(\tilde{S}_k)$  of  $\tilde{S}_k$ , one has

$$\ell^c(\tilde{S}_k) \geq b^{-N(\delta)} \cdot \delta \cdot e^{-6 \cdot n_k \cdot \epsilon}.$$

Due to the uniform expansion of  $Df$  along the cone field  $\mathcal{C}_V^{uu}$ , each point in  $f^{-n_k}(\tilde{S}_k)$  would stay close to the orbit segment  $\{y, \dots, f^{n_k}(y)\}$  for a large

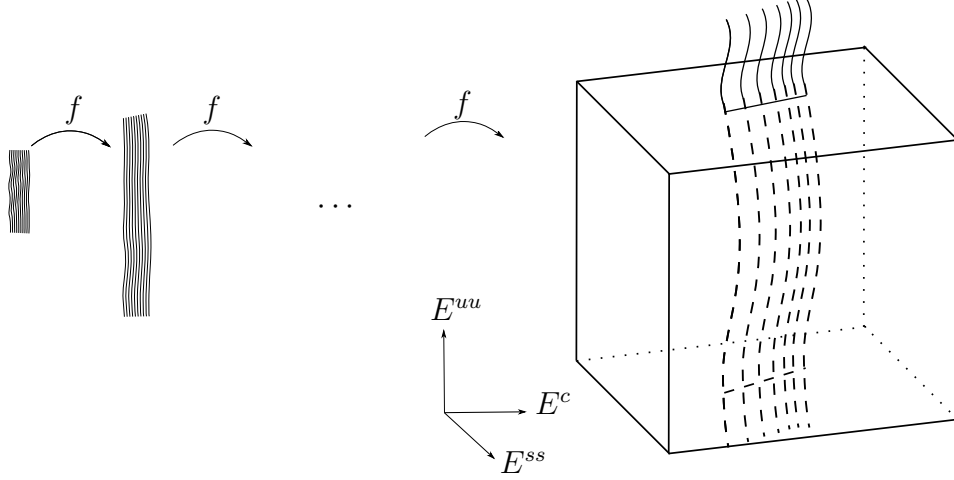

Figure 4.2 –

proportion of time in  $[0, n_k] \cap \mathbb{N}$ ; moreover, the proportion would tend to 1 when  $n_k$  tends to infinity.

We will iterate  $\tilde{S}_k$  to make it cut the local stable manifold of  $\mathcal{O}_p$  transversely. Let  $\epsilon_0$  be the strength of the strictly invariant family  $\mathfrak{D}$ , and we denote by

$$[r] = \sup\{n \in \mathbb{Z} : n \leq r\} \text{ and } N_k = \left\lceil \frac{6 \cdot n_k \cdot \epsilon}{\log \tau_1} + \frac{\log \epsilon_0 - \log \delta + \log b \cdot N(\delta)}{\log \tau_1} \right\rceil + 1.$$

Since the integer  $N$  in Lemma 2.8.8 is a constant, for simplicity, we take its value as 0. By Lemma 2.8.6, Lemma 2.8.8 and the choice of  $N_k$ , there exists an integer  $\tilde{N}_k \leq N_k$  such that  $f^{\tilde{N}_k}(\tilde{S}_k) \cap C$  contains a connected component which intersects the local stable manifold of  $\mathcal{O}_p$  in a point  $z$ . Denote by

$$t_k = \tilde{N}_k + n_k \text{ and } z_k = f^{-t_k}(z),$$

then one has that  $z_k \in \tilde{\Lambda}$  and satisfies the third item of Lemma 4.1.2.

Since the choice of  $\delta$  is independent of  $n_k$ , by the fact that  $|\tilde{n}_k - n_k| \leq N(\delta)$ , we can take  $n_k$  large enough such that

$$\frac{N(\delta) + N_k}{\tilde{n}_k} < \frac{7\epsilon}{\log \tau_1}.$$

By the choice of  $\delta$  and  $z_k$ , for any  $j \in [N, \tilde{n}_k]$ , we have that

$$d\left(\frac{1}{j} \sum_{i=0}^{j-1} \delta_{f^i(z_k)}, \frac{1}{j} \sum_{i=0}^{j-1} \delta_{f^i(y)}\right) < \frac{\epsilon}{2};$$

$$\left| \frac{1}{j} \sum_{i=0}^{j-1} \log \|Df|_{E^c(f^i(z_k))}\| - \frac{1}{j} \sum_{i=0}^{j-1} \log \|Df|_{E^c(f^i(y))}\| \right| < \frac{\epsilon}{2}.$$

On the other hand, when  $n_k$  is large enough, we have that

$$\begin{aligned}
 & d\left(\frac{1}{t_k} \sum_{i=0}^{t_k-1} \delta_{f^i(z_k)}, \frac{1}{\tilde{n}_k} \sum_{i=0}^{\tilde{n}_k-1} \delta_{f^i(y)}\right) \\
 & \leq d\left(\frac{1}{t_k} \sum_{i=0}^{t_k-1} \delta_{f^i(z_k)}, \frac{1}{\tilde{n}_k} \sum_{i=0}^{\tilde{n}_k-1} \delta_{f^i(z_k)}\right) + d\left(\frac{1}{\tilde{n}_k} \sum_{i=0}^{\tilde{n}_k-1} \delta_{f^i(z_k)}, \frac{1}{\tilde{n}_k} \sum_{i=0}^{\tilde{n}_k-1} \delta_{f^i(y)}\right) \\
 & \leq \frac{t_k - \tilde{n}_k}{t_k} \cdot \left(1 + \frac{1}{\tilde{n}_k}\right) + \frac{\epsilon}{2} \\
 & < \frac{7}{\log \tau_1} \epsilon + \frac{\epsilon}{2}
 \end{aligned}$$

and for any  $j \in (\tilde{n}_k, t_k]$

$$\begin{aligned}
 & \left| \frac{1}{j} \sum_{i=0}^{j-1} \log \|Df|_{E^c(f^i(z_k))}\| - \frac{1}{\tilde{n}_k} \sum_{i=0}^{\tilde{n}_k-1} \log \|Df|_{E^c(f^i(y))}\| \right| \\
 & \leq \left| \frac{1}{j} \sum_{i=0}^{\tilde{n}_k-1} \log \|Df|_{E^c(f^i(z_k))}\| - \frac{1}{\tilde{n}_k} \sum_{i=0}^{\tilde{n}_k-1} \log \|Df|_{E^c(f^i(y))}\| \right| \\
 & \quad + \left| \frac{1}{j} \sum_{i=\tilde{n}_k}^{j-1} \log \|Df|_{E^c(f^i(z_k))}\| \right| \\
 & < \frac{\epsilon}{2} + \frac{7}{\log \tau_1} \cdot \epsilon \cdot \log b.
 \end{aligned}$$

As a consequence, we have that

$$d\left(\frac{1}{t_k} \sum_{i=0}^{t_k-1} \delta_{f^i(z_k)}, \nu\right) < \epsilon + \frac{7}{\log \tau_1} \epsilon$$

and

$$\left| \frac{1}{j} \sum_{i=0}^{j-1} \log \|Df|_{E^c(f^i(z_k))}\| \right| < \epsilon + \frac{7 \log b}{\log \tau_1} \cdot \epsilon, \text{ for any } j = N, \dots, t_k.$$

Let  $c = \max\{1 + \frac{7 \log b}{\log \tau_1}, 1 + \frac{7}{\log \tau_1}\}$ , then we only need to take  $\epsilon$  small such that  $c \cdot \epsilon < \varepsilon$ , ending the proof of Lemma 4.1.2.  $\square$

Consider the convex sum  $\{\alpha \delta_{\mathcal{O}_p} + (1 - \alpha) \nu\}_{\alpha \in [0,1]}$ . We fix  $\alpha \in (0, 1]$ , then the mean center Lyapunov exponent of  $\alpha \delta_{\mathcal{O}_p} + (1 - \alpha) \nu$  is:

$$\lambda^c(\alpha \delta_{\mathcal{O}_p} + (1 - \alpha) \nu) = \alpha \lambda^c(\delta_{\mathcal{O}_p}) > 0.$$

Denote by

$$\lambda = \exp(-\lambda^c(\alpha \delta_{\mathcal{O}_p} + (1 - \alpha) \nu)) \in (0, 1).$$

We take  $\varepsilon < \frac{-\log \lambda}{16}$  small. By the uniform continuity of  $\log \|Df|_{E^c}\|$  over  $\tilde{\Lambda}$ , there exists  $\delta_1 > 0$  such that for any  $w_1, w_2 \in \tilde{\Lambda}$  satisfying that  $d(w_1, w_2) < \delta_1$ , we have that

$$\left| \log \|Df|_{E^c(w_1)}\| - \log \|Df|_{E^c(w_2)}\| \right| < \frac{-\log \lambda}{16}.$$

By Lemma 2.6.4, we get two numbers  $L > 0$  and  $d_0 > 0$  such that for any  $d \in (0, d_0)$ , one has that every  $\sqrt{\lambda}$ -quasi hyperbolic periodic  $d$ -pseudo orbit corresponding to the splitting  $T_{\tilde{\Lambda}}M = E^{ss} \oplus (E^c \oplus E^{uu})$  is  $L \cdot d$  shadowed by a periodic orbit.

For any  $d \in (0, \min\{d_0, \delta_1\})$  small enough whose precise value would be fixed later, there exists an integer  $N_d$  such that

$$f^{-N_d}(W_{loc}^u(\mathcal{O}_p)) \subset W_{d/2}^u(\mathcal{O}_p) \text{ and } f^{N_d}(W_{loc}^s(\mathcal{O}_p)) \subset W_{d/2}^s(\mathcal{O}_p).$$

By Lemma 4.1.2, there exist an integer  $N$ , a sequence of points  $\{z_k\}_{k \in \mathbb{N}}$  in  $\tilde{\Lambda}$  and a sequence of integers  $\{t_k\}_{k \in \mathbb{N}}$  tending to infinity such that

$$d\left(\frac{1}{t_k} \sum_{j=0}^{t_k-1} \delta_{f^j(z_k)}, \nu\right) < \varepsilon;$$

$$z_k \in W_{loc}^u(\mathcal{O}_p) \text{ and } f^{t_k}(z_k) \in W_{loc}^s(\mathcal{O}_p);$$

— for any  $j \in [N, t_k]$ , we have that

$$-\varepsilon < \frac{1}{j} \sum_{i=0}^{j-1} \log \|Df|_{E^c(f^i(z_k))}\| < \varepsilon. \quad (4.2)$$

**Claim 4.1.5.** *there exist integers  $m_k$  and  $t_k$  arbitrarily large such that*

$$\left| \frac{m_k}{t_k} - \frac{\alpha}{1-\alpha} \right| + \frac{2N_d}{t_k} < \varepsilon;$$

— *the orbit segment  $\{f^{-N_d}(z_k), \dots, f^{N_d+t_k+m_k}(z_k)\}$  is a  $\sqrt{\lambda}$ -quasi hyperbolic string corresponding to the splitting  $E^{ss} \oplus (E^c \oplus E^{uu})$ .*

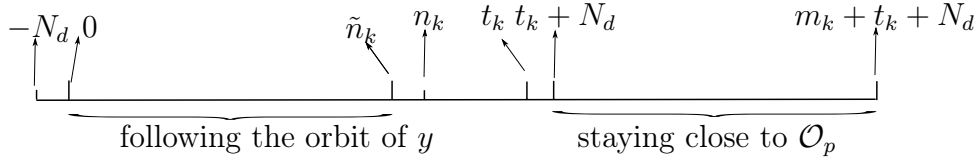

Figure 4.3 –



*Proof.* Since the sequence  $\{t_k\}$  tends to infinity, one can take a sequence of positive integers  $\{m_k\}_{k \in \mathbb{N}}$  tending to infinity such that

$$\lim_{k \rightarrow \infty} \left| \frac{m_k}{t_k} - \frac{\alpha}{1 - \alpha} \right| + \frac{2N_d}{t_k} = 0,$$

hence, for  $k$  large enough, the first item is satisfied.

We denote by  $\pi_{k,d} = 2N_d + t_k + m_k$ . By the choice of  $N_d$ , we have that

$$d(f^{-N_d}(z_k), f^{N_d+t_k+m_k}(z_k)) < d.$$

Since  $d$  is less than  $\delta_1$  and the integers  $t_k, m_k$  can be chosen arbitrarily large, by the choice of  $\varepsilon$  and Equation (4.2), one has the following estimate:

$$\begin{aligned} \frac{1}{\pi_{k,d}} \sum_{j=0}^{\pi_{k,d}-1} \log \|Df|_{E^c(f^{j-N_d}(z_k))}\| &= \frac{1}{\pi_{k,d}} \sum_{j=0}^{t_k+N_d-1} \log \|Df|_{E^c(f^{j-N_d}(z_k))}\| \\ &\quad + \frac{1}{\pi_{k,d}} \sum_{j=t_k+N_d}^{\pi_{k,d}-1} \log \|Df|_{E^c(f^{j-N_d}(z_k))}\| \\ &\geq \frac{t_k + N_d}{\pi_{k,d}} \frac{\log \lambda}{16} + \frac{m_k + N_d}{\pi_{k,d}} \left( -\frac{\log \lambda}{\alpha} + \frac{\log \lambda}{16} \right) \\ &> \frac{-3 \log \lambda}{4}. \end{aligned}$$

By Pliss lemma, there exist a number  $\rho \in (0, 1)$  only depending on  $\lambda$  and a sequence of points  $\{s_1, \dots, s_l\} \subset \{0, \dots, \pi_{k,d} - 1\}$  such that

$$\frac{l}{\pi_{k,d}} \geq \rho;$$

$$\prod_{l=j}^{s_i-1} \|Df|_{E^c(f^{l-N_d}(z_k))}\| \geq \left(\frac{1}{\sqrt{\lambda}}\right)^{s_i-j+1}, \text{ for any } j = 0, \dots, s_i - 1.$$

By Equation (4.2), we have that  $\{s_1, \dots, s_l\} \cap [N_d + N, N_d + t_k] = \emptyset$ . Since the center Lyapunov exponent of  $\mathcal{O}_p$  is  $\frac{-\log \lambda}{\alpha}$  and  $f^{t_k+N_d}(z_k) \in W_{d/2}^s(\mathcal{O}_p)$ , for  $k$  large, we have that

$$\frac{1}{\pi_{k,d} - i} \sum_{j=i}^{\pi_{k,d}-1} \log \|Df|_{E^c(f^{j-N_d}(z_k))}\| > \frac{-\log \lambda}{2}, \text{ for any } i = 0, \dots, \pi_{k,d} - 1.$$

Since  $E^{ss}$  is uniformly contracting and  $E^{ss} \oplus (E^c \oplus E^{uu})$  is a dominated splitting over  $\tilde{\Lambda}$ , the orbit segment  $\{f^{-N_d}(z_k), \dots, f^{N_d+t_k+m_k}(z_k)\}$  is a  $\sqrt{\lambda}$ -quasi hyperbolic string corresponding to the splitting  $E^{ss} \oplus (E^c \oplus E^{uu})$ .

This ends the proof of Claim 4.1.5.  $\square$

By Lemma 2.6.4, there exists a periodic orbit  $\mathcal{O}_{p_1}$  of period  $\pi_{k,d}$  such that

$$d(f^i(p_1), f^i(z_{k,d})) < L \cdot d, \text{ for any } i \in [0, \pi_{k,d} - 1].$$

When  $d$  is chosen small enough, by the second item of Claim 4.1.5 and uniform continuity of the function  $\log \|Df|_{E^c}\|$  defined on  $\tilde{\Lambda}$ , we have that  $p_1$  is a  $(\frac{1}{4\lambda}, E^c \oplus E^{uu})$  expanding point; by Lemma 2.7.3, the point  $p_1$  has uniform size of unstable manifold independent of  $d$ . Once again, when  $d$  is chosen small, by the fact that the strong stable manifolds of  $p_1$  and of  $\mathcal{O}_p$  are the stable manifolds of  $p_1$  and of  $\mathcal{O}_p$  respectively, we have that  $\mathcal{O}_{p_1}$  and  $\mathcal{O}_p$  are homoclinically related.

On the other hand, when  $d$  is chosen small, by the first item of Claim 4.1.5 and the first item of Lemma 4.1.2, one can check that

$$d(\delta_{\mathcal{O}_{p_1}}, \alpha\delta_{\mathcal{O}_p} + (1 - \alpha)\nu) < 4\varepsilon.$$

Hence,  $\alpha\delta_{\mathcal{O}_p} + (1 - \alpha)\nu$  is approximated by periodic measures whose supports are periodic orbits homoclinically related to  $\mathcal{O}_p$ .

By the arbitrary choice of  $\alpha$  and compactness of the set  $\{\alpha\delta_{\mathcal{O}_p} + (1 - \alpha)\nu \mid \alpha \in [0, 1]\}$ ,  $\nu$  is approximated by periodic measures, ending the proof of Proposition 4.1.1.  $\square$

Now we are ready to give the proof of Theorem E.

*Proof of Theorem E.* Recall that the open set  $V$  is a small neighborhood of the split flip flop configuration  $(\Lambda, C, \mathcal{C}^{uu}, \mathcal{D}, \mathcal{O}_q, \Delta^s, \Delta^u)$  such that the maximal invariant set  $\tilde{\Lambda}$  in  $\bar{V}$  is partially hyperbolic with center dimension one. Up to shrinking  $V$ , we can assume that  $V = U \cup V_1 \cup V_2 \cup W$  for which one has that

- $U$  is a small open neighborhood of  $C$  satisfying that the maximal invariant set in  $\bar{U}$  is  $\Lambda$ ;
- $V_1$  and  $V_2$  are small neighborhoods of  $\cup_{i \in \mathbb{N}} f^i(\Delta^s)$  and of  $\cup_{i \in \mathbb{N}} f^{-i}(\Delta^u)$  respectively;
- $W$  is a small neighborhood of  $\mathcal{O}_q$  such that the maximal invariant set in  $\bar{W}$  is  $\mathcal{O}_q$ .

Now, we will choose a small neighborhood  $V_0 \subset V$  of the flip flop configuration such that any non-hyperbolic ergodic measure supported on the maximal invariant set in  $\bar{V}_0$  satisfies the conditions in Proposition 4.1.1.

By assumption, there exists an integer  $N$  such that for any point  $x \in \cap_{i=-N}^N f^i(U) \cap \tilde{\Lambda}$ , there exists a periodic point  $p \in \Lambda$  such that  $W_{loc}^{ss}(x)$  intersects  $W_{loc}^u(p)$ . For simplicity, we assume that the periodic point  $q$  is a fixed point. We take a small neighborhood  $W' \subset W$  of  $\mathcal{O}_q$  such that

$$\log \|Df|_{E^c(x)}\| < \lambda < 0, \text{ for any point } x \in W' \cap \tilde{\Lambda}.$$

On the other hand, there exists an integer  $N_0$  such that  $f^{N_0}(\Delta^s) \cup f^{-N_0}(\Delta^u)$  is contained in  $W'$ . Let  $\tilde{N}$  be the smallest integer satisfying

$$\tilde{N} > (2N + 2N_0) \frac{b}{|\lambda|}, \text{ where } b = \max_{x \in M} \|Df(x)\|.$$

We take a small neighborhood  $W_0$  of  $\mathcal{O}_q$  such that

$$W_0 \cup \dots \cup f^{\tilde{N}}(W_0) \subset W'.$$

Let  $U_0 \subsetneq U$  be a neighborhood of  $C$ . By the first and the second items in the definition of a flip flop configuration, one can take small neighborhoods  $V'_1 \subset V_1$  and  $V'_2 \subset V_2$  of the sets  $Orb^+(\Delta^s, f)$  and  $Orb^-(\Delta^u, f)$  respectively such that for any point  $x \in \tilde{\Lambda}_0 \setminus \Lambda$ , where  $\tilde{\Lambda}_0$  is the maximal invariant set in  $U_0 \cup V'_1 \cup V'_2 \cup W_0$ , the positive orbit of  $x$  intersects  $W_0$ .

Let  $V_0 = U_0 \cup V'_1 \cup V'_2 \cup W_0 \subset V$ . By the choices of  $W'$  and  $W_0$ , for any non-hyperbolic ergodic measure  $\nu \in \mathcal{M}_{erg}(\tilde{\Lambda}_0, f)$  and any point  $x$  in the basin of  $\nu$ , the forward orbit of  $x$  contains an orbit segment of length  $2N + 1$  which is contained in  $U$ , hence there exists a point  $y$  in the basin of  $\nu$  such that  $W_{loc}^{ss}(y)$  intersects the local unstable manifold of a periodic point contained in  $\Lambda$  in a point  $z$ ; moreover, by the uniform contraction along the local strong stable manifold, the closure of the orbit of  $z$  is strictly contained in  $V$ . Now, by applying  $\nu$ ,  $\tilde{\Lambda}$  and  $V$  to Proposition 4.1.1, one has that  $\nu$  is accumulated by periodic measures, ending the proof of Theorem E.  $\square$

## 4.2 The closure of periodic measures contains a segment joining $\delta_{\mathcal{O}_q}$ to a measure in the blender: Proof of Theorem D

Given a split flip flop configuration  $(\Lambda, C, \mathcal{C}^{uu}, \mathcal{D}, \mathcal{O}_q, \Delta^s, \Delta^u)$  of  $f \in \text{Diff}^1(M)$  formed by a blender horseshoe  $(\Lambda, C, \mathcal{C}^{uu}, \mathcal{D})$  and a hyperbolic periodic point  $q$ . In this section, we prove that there exists an invariant measure  $\mu$  (maybe non-ergodic) supported on  $\Lambda$  such that the convex combination  $\{\alpha\mu + (1-\alpha)\delta_{\mathcal{O}_q}; \alpha \in [0, 1]\}$  is approximated by periodic measures.

We take a small neighborhood  $V$  of the split flip flop configuration such that the maximal invariant  $\tilde{\Lambda}$  in  $\bar{V}$  is partially hyperbolic with center dimension one. We assume, in addition, that there exist two  $Df$  strictly invariant cone fields  $\mathcal{C}_V^u$  and  $\mathcal{C}_V^{uu}$  in  $V$ , which are continuous extensions of the center unstable cone field  $\mathcal{C}^u$  and the strong unstable cone field  $\mathcal{C}^{uu}$  in  $C$  respectively.

Let's fix a sequence of functions  $\{g_i\}_{i=1}^{+\infty}$  which is a dense subset of  $C^0(M, \mathbb{R})$ . Then  $\{g_i\}_{i=1}^{+\infty}$  determines a metric on the probability measure space on  $M$  in

the following way: for any probability measures  $\nu_1, \nu_2$  on  $M$ , we have

$$d(\nu_1, \nu_2) = \sum_{i=1}^{\infty} \frac{|\int g_i d\nu_1 - \int g_i d\nu_2|}{2^i \|g_i\|_{C^0}}.$$

Since the disc  $\Delta^u \subset W^u(q)$  belongs to  $\mathfrak{D}$ , by the strictly invariant property of  $\mathfrak{D}$ , this segment would intersect the local stable manifold of  $\Lambda$  in a (Cantor) set which is denoted as  $\mathfrak{C}$ . For any point  $x \in \mathfrak{C}$ , there exists a sequence of discs  $\{D_i\}_{i \in \mathbb{N}} \subset \mathfrak{D}$  such that

- $f^i(x) \in D_i$  for any  $i \in \mathbb{N}$ ;
- $D_0 = \Delta^u$  and  $D_{i+1} \subset f(D_i)$ , for any  $i \in \mathbb{N}$ .

**Theorem 4.2.1.** *With the assumption above. Given  $x \in \mathfrak{C}$  and let  $\mu$  be an accumulation of  $\{\frac{1}{n} \sum_{i=0}^{n-1} \delta_{f^i(x)}\}_{n \in \mathbb{N}}$ . Then the convex combination  $\{\alpha\mu + (1-\alpha)\delta_{\mathcal{O}_q} \mid \alpha \in [0, 1]\}$  is contained in the closure of the set of periodic measures.*

Now Theorem D is directly from Theorem 4.2.1. Hence, we only need to prove Theorem 4.2.1.

Recall that the mean center Lyapunov exponent of the invariant measure  $\alpha\mu + (1-\alpha)\delta_{\mathcal{O}_q}$ , by definition, is

$$\lambda^c(\alpha\mu + (1-\alpha)\delta_{\mathcal{O}_q}) = \alpha\lambda^c(\mu) + (1-\alpha)\lambda^c(\delta_{\mathcal{O}_q}),$$

hence there exists  $\alpha_0 \in [0, 1]$  such that

$$\alpha_0\lambda^c(\mu) + (1-\alpha_0)\lambda^c(\delta_{\mathcal{O}_q}) = 0.$$

The proof of Theorem 4.2.1 consists of two parts. We first show that for any  $\alpha \in [0, \alpha_0]$ ,  $\alpha\mu + (1-\alpha)\delta_{\mathcal{O}_q}$  is accumulated by periodic measures. Then we show the other half convex combination is also approached by periodic measures. The proof of these two parts are quite different. But their proofs still consist in finding quasi hyperbolic periodic pseudo orbits and applying Lemma 2.6.4 to find the periodic orbits.

**Lemma 4.2.2.** *For any  $\alpha \in [0, \alpha_0]$ , the invariant measure  $\alpha\mu + (1-\alpha)\delta_{\mathcal{O}_q}$  is accumulated by a sequence of periodic orbits which are homoclinically related to  $\mathcal{O}_q$  in  $V$ .*

*Proof.* We fix  $\alpha \in (0, \alpha_0)$ , then  $\lambda^c(\alpha\mu + (1-\alpha)\delta_{\mathcal{O}_q})$  is negative.

Let  $\lambda = \exp(\lambda^c(\alpha\mu + (1-\alpha)\delta_{\mathcal{O}_q}))$ . By Lemma 2.6.4, there exist two positive numbers  $L$  and  $d_0$  such that for any  $d \in (0, d_0]$ , every  $(\lambda+1)/2$ -quasi hyperbolic periodic  $d$ -pseudo orbit corresponding to the splitting  $T_{\tilde{\Lambda}}M = (E^{ss} \oplus E^c) \oplus E^{uu}$  is  $L \cdot d$  shadowed by a periodic orbit.

By the continuity of center distribution, there exists  $\delta > 0$  such that for any  $z_1, z_2 \in \tilde{\Lambda}$  satisfying  $d(z_1, z_2) < \delta$ , we have that

$$\frac{4\lambda}{1+3\lambda} \leq \frac{\|Df|_{E^c(z_1)}\|}{\|Df|_{E^c(z_2)}\|} \leq \frac{1+3\lambda}{4\lambda}.$$

For any  $d \in (0, \min\{d_0, \frac{\delta}{L}\})$  whose precise value would be fixed at the end, there exists a positive integer  $N_d$  such that

$$f^{N_d}(\Delta^s) \subset W_{d/2}^s(q) \text{ and } f^{-N_d}(\Delta^u) \subset W_{d/2}^u(q).$$

Let  $\tau_0 > 1$  be a number such that for any point  $x \in V \cap f^{-1}(V)$  and  $v \in \mathcal{C}_V^{uu}(x)$ , one has  $\|Df(v)\| \geq \tau_0 \|v\|$ . We denote by  $N_\delta = \lceil \frac{\log b_0 - \log \delta}{\log \tau_0} \rceil + 1$ , where  $b_0$  is an upper bound for the diameters of the discs in  $\mathfrak{D}$ .

In the following, we will find a  $(\lambda + 1)/2$ -quasi hyperbolic periodic  $d$ -pseudo orbit which will spend almost  $\alpha$  proportion of time to follow an orbit segment of  $x$  and  $(1 - \alpha)$  proportion of time to follow the orbit of  $\mathcal{O}_q$ ; then we apply Lemma 2.6.4.

For any  $\epsilon > 0$ , there exists an integer  $n$  arbitrarily large such that

$$d\left(\frac{1}{n} \sum_{i=0}^{n-1} \delta_{f^i(x), \mu}\right) < \epsilon.$$

We choose the  $\delta$  neighborhood of  $x$  in  $W^u(\mathcal{O}_q)$  and denote it as  $D_x^u$ . Consider the connected component  $D_x^u(n)$  of  $f^n(D_x^u) \cap B_\delta(f^n(x))$  which contains  $f^n(x)$ . By the choice of  $N_\delta$ , one gets that  $f^{N_\delta}(D_x^u(n))$  contains a disc in  $\mathfrak{D}$ , hence  $f^{N_\delta}(D_x^u(n))$  has transverse intersection with  $\Delta^s$ . By the choice of  $N_d$ , there exists a transverse intersection  $y$  between  $f^{N_\delta + N_d}(D_x^u(n))$  and  $W_{d/2}^s(q)$ .

Consider the orbit segment  $\sigma_{m,n} = \{f^{-m\pi(q) - n - 2N_d - N_\delta}(y), \dots, y\}$ . We denote by

$$t_{m,n} = m\pi(q) + n + 2N_d + N_\delta \text{ and } t_n = n + 2N_d + N_\delta.$$

Notice that for any  $m \in \mathbb{N}$ , we have  $d(f^{t_{m,n}}(y), y) < d$ .

We denote by  $b = \max\{\sup_{x \in M} \|Df(x)\|, \sup_{x \in M} \|Df^{-1}(x)\|\}$ .

**Claim 4.2.3.** *There exist  $n$  and  $m$  arbitrarily large such that*

$$\left| \frac{n}{m\pi(q)} - \frac{\alpha}{1 - \alpha} \right| + \frac{2N_d + N_\delta}{n} \cdot b < \epsilon;$$

$$d\left(\frac{1}{t_n} \sum_{i=0}^{t_n-1} \delta_{f^{-i}(y), \mu}\right) < \epsilon;$$

—  $\sigma_{m,n}$  is a  $(1 + \lambda)/2$ -quasi hyperbolic string corresponding to the splitting  $(E^{ss} \oplus E^c) \oplus E^{uu}$ .

The proof of Claim 4.2.3 is just like the one of Claim 4.1.5.

Using Lemma 2.6.4, we can get a periodic orbit  $\mathcal{O}_{q_1}$  of period  $t_{m,n}$  such that

$$d(f^j(q_1), f^j(f^{-t_{m,n}}(y))) < L \cdot d, \text{ for any } j = 0, \dots, t_{m,n} - 1.$$

Arguing as before, when  $d$  is chosen small enough, one has that

- $d(\delta_{\mathcal{O}_{q_1}}, \alpha\mu + (1 - \alpha)\delta_{\mathcal{O}_q}) < 4 \cdot \epsilon$ ;
- $\mathcal{O}_{q_1}$  is homoclinically related to  $\mathcal{O}_q$ .

Hence,  $\alpha\mu + (1 - \alpha)\delta_{\mathcal{O}_q}$  is approximated by periodic orbits which are homoclinically related to  $\mathcal{O}_q$ .

This ends the proof of Lemma 4.2.2.  $\square$

For  $\alpha \in [0, \alpha_0)$ , the property of  $\Delta^u$  helps to find the type of quasi hyperbolic string that we need. For the case  $\alpha \in (\alpha_0, 1]$ , the quasi hyperbolic string that we need is another type, that is, we want  $Df$  along the center direction to have expanding behavior on the quasi hyperbolic string. Indeed, using the strategy above, we can start from a small neighborhood of  $\Lambda$  then go arbitrarily close to  $\mathcal{O}_q$  to stay for arbitrarily long time; however, after that, it is not clear if we can go arbitrarily close to  $x$  by an arbitrarily small proportion of time.

To deal with this situation, we change the strategy. The proof for the case  $\alpha \in (\alpha_0, 1]$  strongly depends on the fact that  $\alpha_0\mu + (1 - \alpha_0)\delta_{\mathcal{O}_q}$  is approximated by hyperbolic periodic orbits homoclinically related to  $\mathcal{O}_q$ .

**Proposition 4.2.4.** *With the assumption we posed at the beginning of this section. There exists a constant  $\rho > 0$ , such that for any hyperbolic periodic orbit  $\mathcal{O}_{q'}$  which is homoclinically related to  $\mathcal{O}_q$  in  $V$ , any  $\epsilon > 0$ , any hyperbolic periodic orbit  $\mathcal{O}_p \subset \Lambda$  and  $\alpha \in (0, 1)$  satisfying that*

$$\lambda^c(\alpha\delta_{\mathcal{O}_p} + (1 - \alpha)\delta_{\mathcal{O}_{q'}}) > 0,$$

*one has that there exists a hyperbolic periodic orbit  $\mathcal{O}_{p_0}$  homoclinically related to  $\mathcal{O}_p$  such that:*

$$d(\delta_{\mathcal{O}_{p_0}}, \alpha\delta_{\mathcal{O}_p} + (1 - \alpha)\delta_{\mathcal{O}_{q'}}) < \rho \cdot (1 - \alpha) \cdot |\lambda^c(\mathcal{O}_{q'})| + \epsilon.$$

*Proof.* For  $\epsilon > 0$ , there exists an integer  $N$  large enough such that

$$2 \sum_{i=N}^{\infty} \frac{1}{2^i} < \frac{\epsilon}{2}.$$

Then there exists  $\delta > 0$  such that for any  $x, y$  satisfying  $d(x, y) < \delta$ , we have that

$$|g_i(x) - g_i(y)| < \frac{\epsilon}{8} \|g_i\|_{C^0}, \text{ for any } i = 1, \dots, N.$$

Let  $\epsilon_0$  be the strength of  $\mathfrak{D}$ . Since  $\mathcal{O}_{q'}$  is homoclinically related to  $\mathcal{O}_q$  in  $V$ , by Inclination Lemma and the definition of a flip-flop configuration, there exist two compact submanifolds  $\Delta^s(q') \subset W^s(\mathcal{O}_{q'})$  and  $\Delta^u(q') \subset W^u(\mathcal{O}_{q'})$  such that

$$\Delta^u(q') \in \mathcal{V}_{\epsilon_0/4}(\mathfrak{D});$$

$$Orb^-(\Delta^u(q')) \cup Orb^+(\Delta^s(q')) \subset V;$$

— for any  $D^u \in \mathfrak{D}$ , the disc  $D^u$  intersects the interior of  $\Delta^s(q')$  transversely.

Let  $\lambda = \exp(-\lambda^c(\alpha\delta_{\mathcal{O}_p} + (1-\alpha)\delta_{\mathcal{O}_{q'}}))$ . By Lemma 2.6.4, there exist two positive numbers  $L$  and  $d_0$  such that for any  $d \in (0, d_0]$ , every  $(\lambda+1)/2$ -quasi hyperbolic periodic  $d$ -pseudo orbit corresponding to the splitting  $T_\Lambda^s M = E^{ss} \oplus (E^c \oplus E^{uu})$  is  $L \cdot d$  shadowed by periodic orbit.

We choose a number  $d \in (0, \min\{d_0, \delta\}]$  small enough such that  $L \cdot d$  is much less than  $\delta$ ; the precise value of  $d$  would be fixed at the end. By the choices of  $\Delta^s(q')$  and  $\Delta^u(q')$ , there exists an integer  $N_d^1$  satisfying that:

$$f^{N_d^1}(\Delta^s(q')) \cup f^{-N_d^1}(\Delta^u(q')) \subset B_{d/2}(\mathcal{O}_{q'}).$$

Up to increasing  $N_d^1$ , we can assume that  $f^{N_d^1}(W_{loc}^s(\Lambda)) \subset W_{d/2}^s(\Lambda)$ .

By the transitivity of  $\Lambda$ , Remark 2.8.2 and the strictly invariant property of  $\mathfrak{D}$ , there exist  $N_d^2 \in \mathbb{N}$  and a disc  $D_0 \subset W_{d/2}^u(\mathcal{O}_p)$  such that

$$f^{N_d^2}(D_0) \in \mathfrak{D} \text{ and } \cup_{i=0}^{N_d^2} f^i(D_0) \subset C.$$

Up to increasing  $N_d^1$  or  $N_d^2$ , we can assume that  $N_d^1 = N_d^2$  and we denote it by  $N_d$ .

We fix two plaque families  $W^{cs}$  and  $W^{cu}$  corresponding to the bundle  $E^{ss} \oplus E^c$  and to bundle  $E^c \oplus E^{uu}$  respectively.

By the choice of  $\Delta^s(q')$ , the disc  $f^{N_d}(D_0)$  intersects  $\Delta^s(q')$  transversely and we denote the intersection as  $y$ , then one has that

$$\overline{Orb(y, f)} \subset V;$$

$$Orb^-(f^{-N_d}(y)) \subset W_{d/2}^u(\mathcal{O}_p) \text{ and } Orb^+(f^{N_d}(y)) \subset W_{d/2}^s(\mathcal{O}_{q'}).$$

By Lemma 2.7.3, there exists a number  $\delta_d > 0$  such that

$$W_{2\delta_d}^{cs}(y) \subset f^{-N_d}(W_{d/2}^s(\mathcal{O}'_q)) \text{ and } W_{2\delta_d}^{cu}(y) \subset f^{N_d}(W_{d/2}^u(\mathcal{O}_p)).$$

Since  $\Delta^u(\mathcal{O}_{q'}) \subset W^u(\mathcal{O}_{q'})$ , by uniform expansion of  $Df$  along the strong unstable cone field  $\mathcal{C}_V^{uu}$ , there exists an integer  $N'_d$  large such that for any disc  $D$  tangent to the cone field  $\mathcal{C}_V^{uu}$ , if  $D$  intersects  $W_{d/2}^s(\mathcal{O}'_q)$  transversely in a point whose distance to the relative boundary of  $D$  is no less than  $\delta_d$ , we have that  $f^{N'_d}(D)$  contains a disc belong to  $\mathcal{V}_{\epsilon_0/2}(\mathfrak{D})$ . Up to increasing  $N_d$  or  $N'_d$ , we can assume that  $N_d = N'_d$ .

Let  $S(y)$  be the  $\delta_d$  tubular neighborhood of  $W_\delta^{uu}(y)$  in  $W^{cu}(y)$ , then one has  $S(y) \subset W_{2\delta_d}^{cu}(y)$ . We denote by  $S_n(y)$  the connected component of  $f^{n+N_d}(S(y)) \cap B_{d/2}(\mathcal{O}'_q)$  which contains  $f^{n+N_d}(y)$  for any  $n \in \mathbb{N}$ , and we denote by  $b = \max\{\sup_{x \in M} \|Df_x\|, \sup_{x \in M} \|Df_x^{-1}\|\}$ . Since the center Lyapunov exponent of the orbit of  $q'$  is negative, when  $n$  is chosen large enough, arguing as Claim 4.1.3 and Claim 4.1.4, one has that  $S_n(y)$  is a uu-foliated cu-disc satisfying that

- the central length of  $S_n(y)$  is at least  $\exp(n(\lambda^c(\mathcal{O}_{q'}) - \epsilon)) \cdot \delta_d \cdot b^{-N_d}$ ;
- $S_n(y)$  is foliated by discs of size  $\delta_d$  tangent to the cone field  $\mathcal{C}_V^{uu}$ .

Then  $f^{N_d}(S_n(y))$  contains a cu-strip  $D^{cu}$  in  $C$  foliated by uu-discs in  $\mathcal{V}_{c_0/2}(\mathfrak{D})$  such that for the central length  $\ell^c(D^{cu})$  of  $D^{cu}$ , one has

$$\ell^c(D^{cu}) \geq \exp(n\lambda^c(\mathcal{O}_{q'})) \cdot \delta_d \cdot b^{-N_d}.$$

Let  $\tau > 1$  be a number such that

$$\|Df(v)\| \geq \tau\|v\|, \text{ for any } x \in C \cap f^{-1}(C) \text{ and any } v \in \mathcal{C}^u(x).$$

Following the strategy in Lemma 4.1.2, there exist a constant  $c_d$  independent of  $n$  and an integer  $k$  such that

- $f^k(D^{cu})$  intersects the local stable manifold of  $\mathcal{O}_p$ ;
- $f^i(D^{cu})$  does not intersect the local stable manifold of  $\mathcal{O}_p$ , for  $i < k$ ;
- when  $n$  is chosen large enough, we have an upper bound for  $k$ :

$$k \leq \frac{2n \cdot \pi(q') \cdot |\lambda^c(\mathcal{O}_{q'})| + c_d}{\log \tau}. \quad (4.3)$$

Let  $x$  be the intersection of  $f^k(D^{cu})$  and  $W_{loc}^s(\mathcal{O}_p)$ .

We denote by  $x_{n,d} = f^{-2N_d - n\pi(q') - k}(x)$ . For any positive integer  $m$ , consider the orbit segment

$$\sigma_{m,n} = \{x_{n,d}, \dots, f^{m\pi(p) + N_d}(x)\},$$

Notice that  $d(x_{n,d}, f^{m\pi(p) + N_d}(x)) < d$ .

**Claim 4.2.5.** *There exist integers  $m$  and  $n$  arbitrarily large such that*

- $$\left| \frac{n\pi(q')}{m\pi(p)} - \frac{1 - \alpha}{\alpha} \right| + \left| \frac{m\pi(p)}{n\pi(q')} - \frac{\alpha}{1 - \alpha} \right| < \frac{\epsilon}{16};$$
- $$\frac{c_d + 3N_d}{n} \cdot \left(1 + \frac{1}{\log \tau}\right) < \frac{\epsilon}{16};$$
- $\{x_{n,d}, \dots, f^{m\pi(p) + N_d}(x)\}$  is a  $(1 + \lambda)/2$  quasi hyperbolic string corresponding to the splitting  $E^{ss} \oplus (E^c \oplus E^{uu})$ .

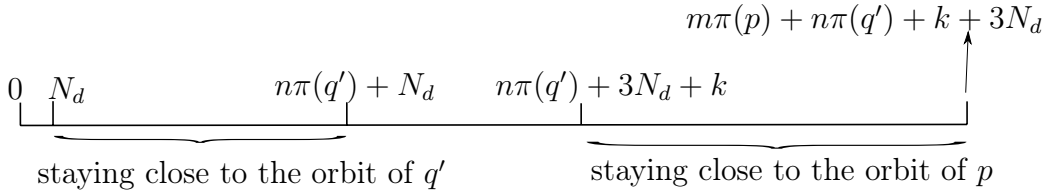

Figure 4.4 –

The proof of this claim is exactly as the proof of Claim 4.1.5.



By Lemma 2.6.4, there exists a periodic orbit  $\mathcal{O}_{p_0}$  of period  $n\pi(q') + m\pi(p) + 3N_d + k$  such that for any  $i = 0, \dots, \pi(p_0) - 1$ , we have

$$d(f^i(x_{n,d}), f^i(p_0)) < L \cdot d.$$

Arguing as before, when  $d$  is chosen small enough, we have that  $\mathcal{O}_{p_0}$  is homoclinically related to  $\mathcal{O}_p$  in  $V$ .

We denote by

- $I_1 = \{N_d, \dots, N_d + n\pi(q') - 1\}$ ;
- $I_2 = \{0, \dots, N_d - 1\} \cup \{N_d + n\pi(q'), \dots, 3N_d + k + n\pi(q') - 1\}$ ;
- $I_3 = \{3N_d + k + n\pi(q'), \dots, \pi(p_0) - 1\}$ .

By the choice of  $\sigma_{m,n}$  and the fact that the orbit of  $p_0$  shadows  $\sigma_{m,n}$  at a distance of  $L \cdot d$ , we have that

$$d(f^j(p_0), f^{j-N_d}(q')) < L \cdot d + d, \text{ for any } j \in I_1;$$

$$d(f^j(p_0), f^{j-3N_d-k-n\pi(q')}(p)) < L \cdot d + d, \text{ for any } j \in I_3.$$

**Claim 4.2.6.** *For each integer  $i \in [1, N]$ , we have that*

$$\left| \int g_i d\delta_{\mathcal{O}_{p_0}} - \alpha \int g_i d\delta_{\mathcal{O}_p} - (1-\alpha) \int g_i d\delta_{\mathcal{O}_{q'}} \right| < \left( \frac{\epsilon}{2} + \frac{2|\lambda^c(\mathcal{O}_{q'})|}{\log \tau} \cdot (1-\alpha) \right) \cdot \|g_i\|_{C^0}.$$

*Proof.* For each  $i \in [1, N]$ , we have that

$$\begin{aligned} & \left| \int g_i d\delta_{\mathcal{O}_{p_0}} - \alpha \int g_i d\delta_{\mathcal{O}_p} - (1-\alpha) \int g_i d\delta_{\mathcal{O}_{q'}} \right| \\ & \leq \left| \frac{1}{\pi(p_0)} \sum_{j \in I_1} g_i(f^j(p_0)) - (1-\alpha) \int g_i d\delta_{\mathcal{O}_{q'}} \right| + \left| \frac{1}{\pi(p_0)} \sum_{j \in I_2} g_i(f^j(p_0)) \right| \\ & \quad + \left| \frac{1}{\pi(p_0)} \sum_{j \in I_3} g_i(f^j(p_0)) - \alpha \int g_i d\delta_{\mathcal{O}_p} \right|. \end{aligned}$$

By the choice of  $I_1$ , we have the estimate:

$$\begin{aligned} & \left| \frac{1}{\pi(p_0)} \sum_{j \in I_1} g_i(f^j(p_0)) - (1-\alpha) \int g_i d\delta_{\mathcal{O}_{q'}} \right| \\ & < \left| \frac{1}{\pi(p_0)} \left( \sum_{j \in I_1} g_i(f^j(p_0)) - \sum_{j \in I_1} g_i(f^j(q')) \right) \right| + \left| \left( \frac{n\pi(q')}{\pi(p_0)} - 1 + \alpha \right) \int g_i d\delta_{\mathcal{O}_{q'}} \right| \\ & \leq \frac{\epsilon}{8} \|g_i\|_{C^0} + \left| \frac{n\pi(q')}{\pi(p_0)} - 1 + \alpha \right| \cdot \|g_i\|_{C^0}. \end{aligned}$$

By Equation (4.3) and Claim 4.2.5, when  $m, n$  are chosen large, we have that

$$\begin{aligned} \left| \frac{n\pi(q')}{\pi(p_0)} - 1 + \alpha \right| &\leq \left| \frac{n\pi(q')}{\pi(p_0)} - \frac{n\pi(q')}{n\pi(q') + m\pi(p)} \right| + \left| \frac{n\pi(q')}{n\pi(q') + m\pi(p)} - 1 + \alpha \right| \\ &\leq \frac{(k + 3N_d)}{n\pi(q') + m\pi(p)} \cdot \frac{n\pi(q')}{n\pi(q') + m\pi(p)} + \frac{\epsilon}{16} \\ &< \frac{3|\lambda^c(\mathcal{O}_{q'})|}{\log \tau} \cdot (1 - \alpha)^2 + \frac{\epsilon}{8}. \end{aligned}$$

Hence, we have that

$$\left| \frac{1}{\pi(p_0)} \sum_{j \in I_1} g_i(f^j(p_0)) - (1 - \alpha) \int g_i d\delta_{\mathcal{O}_{q'}} \right| < \frac{\epsilon}{4} \|g_i\|_{C^0} + \frac{3|\lambda^c(\mathcal{O}_{q'})|}{\log \tau} \cdot (1 - \alpha)^2 \cdot \|g_i\|_{C^0}.$$

Similarly, by choosing  $m, n$  large enough, we also have that

$$\begin{aligned} \left| \frac{1}{\pi(p_0)} \sum_{j \in I_2} g_i(f^j(p_0)) \right| &< \frac{3N_d + k}{\pi(p_0)} \|g_i\|_{C^0} < \frac{3|\lambda^c(\mathcal{O}_{q'})|}{\log \tau} \cdot (1 - \alpha) \|g_i\|_{C^0}, \\ \left| \frac{1}{\pi(p_0)} \sum_{j \in I_3} g_i(f^j(p_0)) - \alpha \int g_i d\delta_{\mathcal{O}_p} \right| &< \frac{\epsilon}{4} \|g_i\|_{C^0} + \frac{3|\lambda^c(\mathcal{O}_{q'})|}{\log \tau} \cdot \alpha \cdot (1 - \alpha) \cdot \|g_i\|_{C^0}. \end{aligned}$$

Hence, we have that for any  $i \in [1, N]$ ,

$$\left| \int g_i d\delta_{\mathcal{O}_{p_0}} - \alpha \int g_i d\delta_{\mathcal{O}_p} - (1 - \alpha) \int g_i d\delta_{\mathcal{O}_{q'}} \right| < \left( \frac{\epsilon}{2} + \frac{6|\lambda^c(\mathcal{O}_{q'})|}{\log \tau} \cdot (1 - \alpha) \right) \cdot \|g_i\|_{C^0}.$$

This ends the proof of Claim 4.2.6  $\square$

By the choice of  $N$  and Claim 4.2.6, we have

$$\begin{aligned} d(\delta_{\mathcal{O}_{p_0}}, \alpha\delta_{\mathcal{O}_p} + (1 - \alpha)\delta_{\mathcal{O}_{q'}}) &= \sum_{i=1}^{\infty} \frac{|\int g_i d\delta_{\mathcal{O}_{p_0}} - \alpha \int g_i d\delta_{\mathcal{O}_p} - (1 - \alpha) \int g_i d\delta_{\mathcal{O}_{q'}}|}{2^i \|g_i\|_{C^0}} \\ &< \frac{\epsilon}{2} + \frac{6|\lambda^c(\mathcal{O}_{q'})|}{\log \tau} \cdot (1 - \alpha) + \frac{\epsilon}{2} \\ &= \epsilon + \frac{6|\lambda^c(\mathcal{O}_{q'})|}{\log \tau} \cdot (1 - \alpha). \end{aligned}$$

We take  $\rho = \frac{\epsilon}{\log \tau}$ , ending the proof of Proposition 4.2.4.  $\square$

**Remark 4.2.7.** *The conclusion of Proposition 4.2.4 also explains the main obstruction to obtain the approximation of the convex combination between two hyperbolic ergodic measures of different indices by periodic measures.*

As an application of Proposition 4.2.4, we have the following corollary:

**Corollary 4.2.8.** *For any  $\alpha \in (\alpha_0, 1]$ , the measure  $\alpha\mu + (1 - \alpha)\delta_{\mathcal{O}_q}$  is accumulated by a sequence of periodic orbits which are homoclinically related to  $\Lambda$ .*

*Proof.* By Lemma 4.2.2, we have a sequence of hyperbolic periodic orbits  $\mathcal{O}_{q_n}$  which are related to  $\mathcal{O}_q$  such that  $\delta_{\mathcal{O}_{q_n}}$  converges to  $\alpha_0\mu + (1 - \alpha_0)\delta_{\mathcal{O}_q}$ .

By Theorem 2.1.1, there exists a sequence of periodic orbits  $\mathcal{O}_{p_n} \subset \Lambda$  such that  $\delta_{\mathcal{O}_{p_n}}$  converges to  $\mu$ .

We denote by

$$B_n = \overline{\{\beta \in [0, 1] : \lambda^c(\beta\delta_{\mathcal{O}_{q_n}} + (1 - \beta)\delta_{\mathcal{O}_{p_n}}) > 0\}}.$$

By Proposition 4.2.4, there exists a constant  $\rho > 0$  such that for any  $\beta \in B_n$ , we have that  $\beta\delta_{\mathcal{O}_{q_n}} + (1 - \beta)\delta_{\mathcal{O}_{p_n}}$  is approximated by periodic measures with an error bounded by  $\rho \cdot \lambda^c(\mathcal{O}_{q_n})$ .

Since the set  $\{\beta\delta_{\mathcal{O}_{q_n}} + (1 - \beta)\delta_{\mathcal{O}_{p_n}} : \beta \in B_n\}$  tends to the set  $\{\alpha\mu + (1 - \alpha)\delta_{\mathcal{O}_q} : \alpha \in [\alpha_0, 1]\}$  and  $\lambda^c(\mathcal{O}_{q_n})$  tends to zero, the invariant measure  $\alpha\mu + (1 - \alpha)\delta_{\mathcal{O}_q}$  is approximated by periodic measures, for any  $\alpha \in [\alpha_0, 1]$ .  $\square$

Now, Theorem 4.2.1 follows directly from Lemma 4.2.2 and Corollary 4.2.8.

### 4.3 Non-hyperbolic ergodic measures approaching a non-ergodic measure with vanishing mean center Lyapunov exponent

We fix a sequence of continuous functions  $\{g_i\}_{i \in \mathbb{N}} \subset C^0(M, \mathbb{R})$ , which determines a metric  $d(\cdot, \cdot)$  on the probability measure space on  $M$ : for any probability measure  $\mu$  and  $\nu$ , we have the distance:

$$d(\mu, \nu) = \sum_{i=1}^{\infty} \frac{|\int g_i d\mu - \int g_i d\nu|}{2^i \|g_i\|_{C^0}}.$$

Let  $f \in \text{Diff}^1(M)$ , consider a split flip flop configuration formed by a dynamically defined cu-blender  $(\Lambda, U, \mathcal{C}^{uu}, \mathcal{D})$  and a hyperbolic periodic orbit  $\mathcal{O}_q$ . We fix a small neighborhood  $V$  of the split flip flop configuration such that the maximal invariant set  $\tilde{\Lambda}$  in  $\bar{V}$  is partially hyperbolic with center dimension one.

In this section, we show that any invariant measure supported on  $\tilde{\Lambda}$ , which is approached by hyperbolic periodic measures of certain index and exhibits vanishing mean center Lyapunov exponent, is approached by non-hyperbolic ergodic measures. To be precise, we prove the following:

**Proposition 4.3.1.** *With the notation above. Given  $\mu \in \mathcal{M}_{inv}(\tilde{\Lambda}, f)$  such that*

$$\int \log \|Df|_{E^c}\| d\mu = 0.$$

*Assume that  $\mu$  is accumulated by periodic measures whose supports are periodic orbits homoclinically related to  $\mathcal{O}_q$  inside  $V$ .*

*Then  $\mu$  is approximated by non-hyperbolic ergodic measures.*

*Proof.* Let  $\{\mathcal{O}_{p_n}\}_{n \in \mathbb{N}}$  be a sequence of periodic orbits such that  $\delta_{\mathcal{O}_{p_n}}$  converges to  $\mu$  and  $\mathcal{O}_{p_n}$  is homoclinically related to  $\mathcal{O}_q$  inside  $V$ . We denote by  $\lambda_n$  the center Lyapunov exponent of  $\mathcal{O}_{p_n}$ , then  $\lambda_n$  tends to 0.

Using Lemma 3.1.1 and [GIKN] criterion, we will prove that there exists a constant  $c > 0$  such that for each periodic measure  $\delta_{\mathcal{O}_{p_n}}$ , there exists a non-hyperbolic ergodic measure  $\nu_n$  satisfying:

$$d(\nu_n, \delta_{\mathcal{O}_{p_n}}) < c \cdot |\lambda_n|.$$

We fix the periodic orbit  $\mathcal{O}_{p_n}$ , then there exists an integer  $N$  large such that

$$4 \sum_{i=N+1}^{\infty} \frac{1}{2^i} \leq |\lambda_n|.$$

By the uniform continuity of  $g_1, \dots, g_N$ , there exists  $\delta > 0$  such that for any two points  $x, y$  satisfying  $d(x, y) < \delta$ , we have

$$|g_i(x) - g_i(y)| < |\lambda_n| \cdot \|g_i\|_{C^0}, \text{ for any } i = 1, \dots, N.$$

We choose a sequence of decreasing positive numbers  $\{\epsilon_i\}_{i \in \mathbb{N}}$  such that  $\sum \epsilon_i < \delta$  and we denote  $\mathcal{O}_{p_n}$  as  $\gamma_n^0$ . Let  $\rho$  and  $\zeta \in (0, 1)$  be the two constants given by Lemma 3.1.1. Assume that we already have a periodic orbit  $\gamma_n^k$  which is homoclinically related to  $\mathcal{O}_q$  in  $V$ , then we apply  $\gamma_n^k$  to Lemma 3.1.1 and we get a periodic orbit  $\gamma_n^{k+1}$  such that:

- $\lambda^c(\gamma_n^{k+1}) > \zeta \lambda^c(\gamma_n^k)$
- $\gamma_n^{k+1}$  is a  $(\epsilon_{k+1}, 1 - \rho |\lambda^c(\gamma_n^k)|)$  good approximation for  $\gamma_n^k$ ;
- $\gamma_n^{k+1}$  is homoclinically related to  $\gamma_n^k$  inside  $V$ .

We denote by  $\kappa_i = 1 - \rho |\lambda^c(\gamma_n^i)|$ . By induction, we have that  $|\lambda^c(\gamma_n^i)| < \zeta^i |\lambda_n|$ , which implies that

$$\kappa_i \geq 1 - \rho \cdot \zeta^i \cdot |\lambda_n|, \text{ for each } i \in \mathbb{N}.$$

Therefore, for any integer  $k \in \mathbb{N}$ , we have the following estimate:

$$0 \geq \sum_{i=0}^k \log \kappa_i > \sum_{i=0}^k 2(\kappa_i - 1) \geq \sum_{i=0}^k -2\rho \cdot \zeta^i |\lambda_n| > \frac{2\rho}{1 - \zeta} \lambda_n.$$

Hence, we have that

$$\prod_{i=0}^k \kappa_i \in (1 + \frac{2\rho}{1-\zeta} \lambda_n, 1),$$

which implies  $\prod_{i=0}^{\infty} \kappa_i \in (0, 1]$ .

By Lemma 2.5.2,  $\delta_{\gamma_n^k}$  tends to an ergodic measure  $\nu_n$ . Since the center Lyapunov exponent of  $\gamma_n^k$  tends to zero when  $k$  tends to infinity, by the continuity of  $\log \|Df|_{E^c}\|$ ,  $\nu_n$  is a non-hyperbolic ergodic measure.

On the other hand, by construction of  $\gamma_n^k$ , we have that for any  $k \in \mathbb{N}$ , the periodic orbit  $\gamma_n^k$  is a  $(\sum_{i=1}^k \epsilon_i, \prod_{i=1}^k \kappa_i)$  good approximation for  $\mathcal{O}_{p_n}$ . We denote by  $\gamma(n, k)$  the subset of  $\gamma_n^k$  corresponding to the one in Definition 2.5.1.

For any integer  $i \in [1, N]$ , we have the following:

$$\int g_i d\delta_{\gamma_n^k} = \frac{1}{\pi(\gamma_n^k)} \sum_{x \in \gamma_n^k} g_i(x) = \frac{1}{\pi(\gamma_n^k) \cdot \pi(\gamma_n^0)} \sum_{x \in \gamma_n^k} \sum_{j=0}^{\pi(\gamma_n^0)-1} g_i(f^j(x)).$$

$$\begin{aligned} \left| \int g_i d\delta_{\gamma_n^0} - \int g_i d\delta_{\gamma_n^k} \right| &= \left| \frac{1}{\pi(\gamma_n^k) \pi(\gamma_n^0)} \sum_{x \in \gamma_n^k} \sum_{j=0}^{\pi(\gamma_n^0)-1} g_i(f^j(x)) - \frac{1}{\pi(\gamma_n^0)} \sum_{y \in \gamma_n^0} g_i(y) \right| \\ &= \frac{1}{\pi(\gamma_n^k) \pi(\gamma_n^0)} \left| \sum_{x \in \gamma(n, k)} \left( \sum_{j=0}^{\pi(\gamma_n^0)-1} g_i(f^j(x)) - \sum_{y \in \gamma_n^0} g_i(y) \right) \right. \\ &\quad \left. + \sum_{x \in \gamma_n^k \setminus \gamma(n, k)} \left( \sum_{j=0}^{\pi(\gamma_n^0)-1} g_i(f^j(x)) - \sum_{y \in \gamma_n^0} g_i(y) \right) \right| \\ &\leq \frac{1}{\pi(\gamma_n^k) \pi(\gamma_n^0)} \left( \pi(\gamma_n^k) \cdot \pi(\gamma_n^0) \cdot |\lambda_n| \cdot \|g_i\|_{C^0} \right. \\ &\quad \left. + 2 \left( 1 - \prod_{i=1}^k \kappa_i \right) \cdot \pi(\gamma_n^k) \cdot \pi(\gamma_n^0) \cdot \|g_i\|_{C^0} \right) \\ &\leq |\lambda_n| \|g_i\| + 2 \left( 1 - \prod_{i=1}^k \kappa_i \right) \|g_i\|_{C^0} \\ &\leq \left( 1 + \frac{4\rho}{1-\zeta} \right) |\lambda_n| \|g_i\|_{C^0}. \end{aligned}$$

Hence, for any  $k$ , we have that

$$\begin{aligned}
 d(\delta_{\mathcal{O}_{p_n}}, \delta_{\gamma_n^k}) &= \sum_{i=1}^{\infty} \frac{|\int g_i d\delta_{\mathcal{O}_{p_n}} - \int g_i d\delta_{\gamma_n}|}{2^i \|g_i\|_{C^0}} \\
 &= \sum_{i=1}^N \frac{|\int g_i d\delta_{\mathcal{O}_{p_n}} - \int g_i d\delta_{\gamma_n}|}{2^i \|g_i\|_{C^0}} + \sum_{i=N+1}^{\infty} \frac{|\int g_i d\delta_{\mathcal{O}_{p_n}} - \int g_i d\delta_{\gamma_n}|}{2^i \|g_i\|_{C^0}} \\
 &< \sum_{i=1}^N \frac{(1 + \frac{4\rho}{1-\zeta})|\lambda_n|}{2^i} + \sum_{i=N+1}^{\infty} \frac{2}{2^i} \\
 &\leq (1 + \frac{4\rho}{1-\zeta})|\lambda_n| + |\lambda_n|.
 \end{aligned}$$

Then, by taking the limit for  $k$  tending to infinity, we get that

$$d(\delta_{\mathcal{O}_{p_n}}, \nu_n) \leq (2 + \frac{4\rho}{1-\zeta}) \cdot |\lambda_n|.$$

Since  $\lambda_n$  tends to 0 and  $\delta_{\mathcal{O}_{p_n}}$  tends to  $\mu$ , the non-hyperbolic ergodic measure  $\nu_n$  tends to  $\mu$ .

This ends the proof of Proposition 4.3.1.  $\square$

**Remark 4.3.2.** *According to the proof of Proposition 4.3.1, one can check that when  $f$  is partially hyperbolic of center dimension one, one can take  $V$  to be  $M$  and the conclusion of Proposition 4.3.1 still holds.*

## 4.4 Approximating non-hyperbolic ergodic measures in global setting

In this section, we give the proof of Theorems F and G, then using the theorems we prove, we give some results in  $C^1$ -generic setting.

### 4.4.1 Generation of blender horseshoes

In this subsection, we state the results on the generation of blenders in [BD2], [BD3].

**Proposition 4.4.1.** *[BD3, Proposition 5.6] Let  $f$  be a diffeomorphism with a heterodimensional cycle associated to saddles  $P$  and  $Q$  with  $\text{ind}(P) = \text{ind}(Q) + 1$ . Then there is  $g$  arbitrarily  $C^1$  close to  $f$  exhibiting a cu-blender horseshoe  $\Lambda_g$ .*

From Proposition 4.4.1, we can build blender from co-index one heterodimensional cycle. To get heterodimensional cycle, we need the connecting lemma due to S. Hayashi:

**Theorem 4.4.2.** [H] *Let  $f \in \text{Diff}^1(M)$ . For any  $C^1$  neighborhood  $\mathcal{U}$  of  $f$ , there is an integer  $L = L(\mathcal{U}) > 0$  such that for any non-periodic point  $z$ , there exist two arbitrarily small neighborhoods  $B_z \subset \tilde{B}_z$  of  $z$  such that for any two points  $x, y \notin \cup_{i=0}^L f^i(\tilde{B}_z)$ , if both forward orbit of  $x$  and backward orbit of  $y$  intersect  $B_z$ , then there exists  $g \in \mathcal{U}$  such that  $y = g^n(x)$ , for some integer  $n > 0$ .*

#### 4.4.2 Assuming minimality of both strong foliations: proof of Theorems F and G:

Now, we can give the proof of theorem F.

*Proof of Theorem F.* By Hayashi's connecting lemma and the transitivity, there exists a dense subset of  $\mathcal{V}(M)$  such that every diffeomorphism inside this dense subset has a co-index one heterodimensional cycle. By Propositions 2.9.5 and 4.4.1, there exists an open dense subset  $\tilde{\mathcal{V}}(M)$  of  $\mathcal{V}(M)$  such that for any  $f \in \tilde{\mathcal{V}}(M)$ , one has that

- $f$  has a  $cu$ -blender horseshoe  $(\Lambda^u, V^u, \mathcal{C}^{uu}, \mathfrak{D}^u)$  and a  $cs$ -blender horseshoe  $(\Lambda^s, V^s, \mathcal{C}^{ss}, \mathfrak{D}^s)$ ;
- $f$  has a split flip flop configuration associated to a dynamically defined  $cu$ -blender;
- $f$  has a split flip flop configuration associated to a dynamically defined  $cs$ -blender.

Take any hyperbolic ergodic measure  $\mu$  and any non-hyperbolic ergodic measure  $\nu$ . We will prove that for any  $\alpha \in [0, 1]$ ,  $\alpha\mu + (1 - \alpha)\nu$  is approximated by periodic measures. By Proposition 2.6.6, the measure  $\mu$  is approximated by hyperbolic periodic measures. Hence, we only need to prove it when  $\mu$  is a hyperbolic periodic measure. Assume that  $\mu$  is a periodic measure with positive center Lyapunov exponent (for the negative case, we can argue for the system  $f^{-1}$ ). Let  $\mathcal{O}_p$  be the hyperbolic periodic orbit such that  $\mu = \delta_{\mathcal{O}_p}$ . By the minimality of the strong stable foliation,  $\mathcal{O}_p$  is homoclinically related to  $\Lambda^u$ .

Take a generic point  $x$  of measure  $\nu$ , by the minimality of strong stable foliation,  $\mathcal{F}^{ss}(x)$  intersects  $W^u(\mathcal{O}_p)$  in a point  $y$ . Then, we have that

$$\lim_{n \rightarrow +\infty} \frac{1}{n} \sum_{j=0}^{n-1} \delta_{f^j(y)} = \nu \text{ and } \lim_{n \rightarrow +\infty} \frac{1}{n} \sum_{j=0}^{n-1} \|Df|_{E^c(f^j(y))}\| = 0.$$

By the minimality of strong unstable foliation and the strictly invariant property of  $\mathfrak{D}$ , for any  $\delta > 0$ , there exists an integer  $N_\delta$  such that for any strong unstable disc  $D^{uu}$  of radius  $\delta$ , we have that  $f^{N_\delta}(D)$  contains an element of  $\mathfrak{D}^u$ . Hence, for any  $\delta > 0$  and any integer  $n \in \mathbb{N}$ , one has that  $f^{N_\delta}(W_\delta^{uu}(f^n(y)))$  contains a disc in  $\mathfrak{D}$ . Now we can apply the arguments for Proposition 4.1.1

to  $\mathcal{O}_p$  and the point  $y$ , proving that the invariant measure  $\alpha\mu + (1 - \alpha)\nu$  is approximated by periodic measures of s-index  $\text{ind}(p)$ .

As a consequence, one gets that every non-hyperbolic ergodic measure is approached by periodic measures of s-indices  $i$  and  $i + 1$  at the same time.

By the minimality of strong foliations, any two hyperbolic periodic orbits of same index are homoclinically related. As a consequence, for any two hyperbolic periodic orbits  $\gamma_1$  and  $\gamma_2$  of same index, one has that

$$\overline{\{(1 - \alpha)\delta_{\gamma_1} + \alpha\delta_{\gamma_2} : \alpha \in [0, 1]\}} \subset \overline{\mathcal{M}_{\text{per}}(f)}.$$

Hence for any two hyperbolic ergodic measures of same index, by Proposition 2.6.6, their convex combination can be approximated by periodic measures of same index, which implies that  $\overline{\mathcal{M}_i(f)}$  and  $\overline{\mathcal{M}_{i+1}(f)}$  are convex sets.

Given two invariant measures  $\mu, \nu \in \overline{\mathcal{M}^*(f)}$ , then  $\mu$  and  $\nu$  are approximated by a sequence of periodic measures  $\{\delta_{\mathcal{O}_{p_n}}\}$  and  $\{\delta_{\mathcal{O}_{q_n}}\}$  of same index respectively. Then the convex combination  $\overline{\{(1 - \alpha)\delta_{\mathcal{O}_{p_n}} + \alpha\delta_{\mathcal{O}_{q_n}} : \alpha \in [0, 1]\}}$  is contained in the closure of the set of hyperbolic periodic measures. Hence, the invariant measure  $(1 - \alpha)\mu + \alpha\nu$  is accumulated by hyperbolic periodic measures, for any  $\alpha \in [0, 1]$ . On the other hand, for any  $\alpha \in [0, 1]$ , we have

$$\int \log \|Df|_{E^c}\| d((1 - \alpha)\mu + \alpha\nu) = 0.$$

By Proposition 4.3.1 and Remark 4.3.2, we have that  $(1 - \alpha)\mu + \alpha\nu$  is accumulated by non-hyperbolic ergodic measures, that is,

$$\{(1 - \alpha)\mu + \alpha\nu; \alpha \in [0, 1]\} \subset \overline{\mathcal{M}^*(f)}.$$

This proves that  $\overline{\mathcal{M}^*(f)}$  is a convex set.

Since every non-hyperbolic ergodic measure is approximated by hyperbolic periodic measures of s-index  $i$  and s-index  $i + 1$  at the same time, we have that

$$\overline{\mathcal{M}^*(f)} \subset \overline{\mathcal{M}_i(f)} \cap \{\mu \in \mathcal{M}_{\text{inv}}(f), \lambda^c(\mu) = 0\};$$

$$\overline{\mathcal{M}^*(f)} \subset \overline{\mathcal{M}_{i+1}(f)} \cap \{\mu \in \mathcal{M}_{\text{inv}}(f), \lambda^c(\mu) = 0\};$$

$$\overline{\mathcal{M}^*(f)} \subset \overline{\mathcal{M}_i(f)} \cap \overline{\mathcal{M}_{i+1}(f)}.$$

On the other hand, for any  $\mu \in \overline{\mathcal{M}_i(f)} \cap \{\mu \in \mathcal{M}_{\text{inv}}(f), \lambda^c(\mu) = 0\}$ , we have that  $\mu$  is accumulated by hyperbolic ergodic measures of s-index  $i$ . By Proposition 2.6.6, we know that  $\mu$  is accumulated by hyperbolic periodic measures of s-index  $i$ . By Proposition 4.3.1, the measure  $\mu$  is accumulated by non-hyperbolic ergodic measures, ie.  $\mu \in \overline{\mathcal{M}^*(f)}$ . Hence, we have

$$\overline{\mathcal{M}_i(f)} \cap \{\mu \in \mathcal{M}_{\text{inv}}(f), \lambda^c(\mu) = 0\} \subset \overline{\mathcal{M}^*(f)}.$$



Similarly, we can prove that

$$\overline{\mathcal{M}_{i+1}(f)} \cap \{\mu \in \mathcal{M}_{inv}(f), \lambda^c(\mu) = 0\} \subset \overline{\mathcal{M}^*(f)}.$$

Besides, one can easily check that

$$\overline{\mathcal{M}_i(f)} \cap \overline{\mathcal{M}_{i+1}(f)} \subset \overline{\mathcal{M}_i(f)} \cap \{\mu \in \mathcal{M}_{inv}(f), \lambda^c(\mu) = 0\};$$

and

$$\overline{\mathcal{M}_i(f)} \cap \overline{\mathcal{M}_{i+1}(f)} \subset \overline{\mathcal{M}_{i+1}(f)} \cap \{\mu \in \mathcal{M}_{inv}(f), \lambda^c(\mu) = 0\}.$$

□

As mentioned before, combing the result in [ABC] and the ergodic closing lemma in [M2], one has that for  $C^1$ -generic  $f$  in the set  $\tilde{\mathcal{V}}(M)$ , the closure  $\overline{\mathcal{M}_{Per}(f)}$  of the set of hyperbolic periodic measures is convex, and coincides with the set  $\mathcal{M}_{inv}(f)$  of all invariant measures.

As a corollary of Theorem F, one has that:

**Corollary 4.4.3.** *For  $C^1$ -generic  $f \in \tilde{\mathcal{V}}(M)$ , every invariant (a priori non ergodic) measure whose mean center Lyapunov exponent vanishes is approached by non-hyperbolic ergodic measures. In formula:*

$$\{\mu \in \mathcal{M}_{inv}(f), \lambda^c(\mu) = 0\} = \overline{\mathcal{M}^*(f)}.$$

Now, we will use Theorem D to give the proof of Theorem G. The proof is quite straightforward:

*Proof of Theorem G.* Let  $\tilde{\mathcal{V}}(M)$  be the open and dense subset of  $\mathcal{V}(M)$  given in Theorem F. Given  $f \in \tilde{\mathcal{V}}(M)$  and a measure  $\nu \in \mathcal{M}_i(f)$ , then there exists a sequence of periodic orbits  $\{\mathcal{O}_{p_n}\}_{n \in \mathbb{N}}$  of s-index  $i$  such that  $\delta_{\mathcal{O}_{p_n}}$  converges to  $\nu$ . By the minimality of strong stable foliation and Inclination lemma, for each periodic orbit  $\mathcal{O}_{p_n}$ , one has that

- the stable manifold of  $\mathcal{O}_{p_n}$  contains a disc in  $\mathcal{V}_{\epsilon_0/2}(\mathfrak{D}^s)$ , where  $\epsilon_0$  is the strength of  $\mathfrak{D}^s$ ;
- there exists a compact submanifold  $\Delta_n$  of  $W^u(\mathcal{O}_{p_n})$  such that each disc in  $\mathfrak{D}^s$  intersects  $\Delta_n$ .

By Proposition 4.2.1, there exists an invariant measure  $\mu_n$  supported on  $\Lambda^s$  such that for any  $\alpha \in [0, 1]$ , we have that

$$\alpha \delta_{\mathcal{O}_{p_n}} + (1 - \alpha) \mu_n \in \overline{\mathcal{M}_{per}(f)}.$$

Let  $\xi$  be an accumulation of  $\mu_n$ , then for any  $\alpha \in [0, 1]$ , we have that

$$\alpha \nu + (1 - \alpha) \xi \in \overline{\mathcal{M}_{per}(f)}.$$

Similarly, we can prove that for any invariant measure belonging to  $\overline{\mathcal{M}_{i+1}(f)}$ , there exists an invariant measure supported on  $\Lambda^u$  such that their convex combination is approximated by periodic measures.

We only need to take  $K_i = \Lambda^u$  and  $K_{i+1} = \Lambda^s$ . Then the second item is satisfied.

This ends the proof of Theorem G.  $\square$

It is well known that the decomposition of an invariant measure in the convex sum of ergodic measures is unique and one calls  $\mathcal{M}_{inv}(f)$  a *Choquet simplex*. As we split  $\mathcal{M}_{inv}(f)$  into several convex sets (the ones with positive, vanishing and negative center Lyapunov exponents respectively) it is natural to ask if these sets are Choquet simplices too. We could not answer to this question in the whole general situation, but in the  $C^1$ -generic setting we can give a negative answer:

**Proposition 4.4.4.** *For  $C^1$ -generic  $f$  in  $\tilde{\mathcal{V}}(M)$ , none of the three compact convex sets  $\overline{\mathcal{M}_i(f)}$ ,  $\overline{\mathcal{M}_{i+1}(f)}$  and  $\overline{\mathcal{M}^*(f)}$  is a Choquet simplex.*

As we know that all the extreme points of  $\mathcal{M}_{inv}(f)$  are ergodic measures. In general, a convex subset of  $\mathcal{M}_{inv}(f)$  may have more extreme points. Under some assumption, we firstly show that there exist extreme points of  $\overline{\mathcal{M}^*(f)}$  which are not ergodic. Recall that  $\tilde{\mathcal{V}}(M)$  is an open and dense subset of  $\mathcal{V}(M)$  given by Theorem F.

**Lemma 4.4.5.** *Given  $f \in \tilde{\mathcal{V}}(M)$ . Let  $\mu$  and  $\nu$  be two hyperbolic ergodic measures of different indices. Assume that, for any  $\alpha \in [0, 1]$ , the measure  $\alpha\mu + (1 - \alpha)\nu$  is approached by hyperbolic periodic measures.*

*Then there exists  $\alpha_0 \in (0, 1)$  such that:*

$$\alpha_0\mu + (1 - \alpha_0)\nu \in \overline{\mathcal{M}^*(f)};$$

— *the invariant measure  $\alpha_0\mu + (1 - \alpha_0)\nu$  is an extreme point of the convex sets  $\overline{\mathcal{M}^*(f)}$ ,  $\overline{\mathcal{M}_i(f)}$  and  $\overline{\mathcal{M}_{i+1}(f)}$ .*

*Proof.* Since the indices of  $\mu$  and  $\nu$  are different, there exists a unique  $\alpha_0 \in (0, 1)$  such that

$$\int \log \|Df|_{E^c}\| d(\alpha_0\mu + (1 - \alpha_0)\nu) = 0.$$

Since  $\alpha_0\mu + (1 - \alpha_0)\nu$  is approximated by hyperbolic periodic measures, by the first item of Theorem F, we have that

$$\alpha_0\mu + (1 - \alpha_0)\nu \in \overline{\mathcal{M}^*(f)}.$$

Assume that there exist two measures  $\mu_1, \mu_2 \in \overline{\mathcal{M}^*(f)}$  and  $\beta_0 \in (0, 1)$  such that

$$\alpha_0\mu + (1 - \alpha_0)\nu = \beta_0\mu_1 + (1 - \beta_0)\mu_2. \quad (4.4)$$

Since  $\mathcal{M}_{inv}(f)$  is a Choquet simplex, by Equation (4.4) and the ergodicity of  $\mu$  and  $\nu$ , one has that  $\mu_1$  is a convex combination of  $\mu$  and  $\nu$ . By the

fact that  $\lambda^c(\mu_1) = 0$ , one has that  $\mu_1 = \alpha_0\mu + (1 - \alpha_0)\nu$ , which implies that  $\mu_1 = \mu_2 = \alpha_0\mu + (1 - \alpha_0)\nu$ . This proves that  $\alpha_0\mu + (1 - \alpha_0)\nu$  is an extreme point of the convex set  $\overline{\mathcal{M}^*(f)}$ .

Similarly, we can show that  $\alpha_0\mu + (1 - \alpha_0)\nu$  is an extreme point of the convex sets  $\overline{\mathcal{M}_i(f)}$  and  $\overline{\mathcal{M}_{i+1}(f)}$ .

This ends the proof of Lemma 4.4.5.  $\square$

Now, we are ready to give the proof of Proposition 4.4.4.

*Proof of Proposition 4.4.4.* By Theorem F, we know that  $\overline{\mathcal{M}^*(f)}$ ,  $\overline{\mathcal{M}_i(f)}$  and  $\overline{\mathcal{M}_{i+1}(f)}$  are convex sets. By Theorem 3.10 in [ABC], there exists a residual subset  $\mathcal{R}$  of  $\tilde{\mathcal{V}}(M)$  such that for any  $f \in \mathcal{R}$ , the closure of the set of periodic measures is convex, which implies that the convex combinations of hyperbolic ergodic measures of different indices are approached by hyperbolic periodic measures.

We will show that for any  $f \in \mathcal{R}$ , none of  $\overline{\mathcal{M}^*(f)}$ ,  $\overline{\mathcal{M}_i(f)}$  or  $\overline{\mathcal{M}_{i+1}(f)}$  is a Choquet simplex.

We take four hyperbolic ergodic measures  $\mu_1, \mu_2 \in \mathcal{M}_i(f)$  and  $\nu_1, \nu_2 \in \mathcal{M}_{i+1}(f)$ .

We denote by

$$\mathcal{H}_1 = \{(\alpha_1, \alpha_2, \alpha_3, \alpha_4) \in \mathbb{R}^4 \mid \alpha_i \text{ is non-negative and } \sum_{i=1}^4 \alpha_i = 1\}$$

and

$$\mathcal{H}_2 = \{(\beta_1, \beta_2, \beta_3, \beta_4) \in \mathbb{R}^4 \mid \beta_1\lambda^c(\mu_1) + \beta_2\lambda^c(\mu_2) + \beta_3\lambda^c(\nu_1) + \beta_4\lambda^c(\nu_2) = 0\}.$$

Since  $\lambda^c(\mu_i) > 0$  and  $\lambda^c(\nu_i) < 0$  for  $i = 1, 2$ , one gets that the hyperplane  $\mathcal{H}_2$  is transverse to  $\mathcal{H}_1$ . As a consequence, the intersection  $\mathcal{H}_1 \cap \mathcal{H}_2$  is a convex quadrilateral whose vertexes are corresponding to four different invariant measures; moreover, each of them is a convex sum of two hyperbolic ergodic measures of different indices among  $\{\mu_1, \mu_2, \nu_1, \nu_2\}$ . By the generic assumption, these four invariant measures are approximated by hyperbolic periodic measures; hence by Theorem F, they belong to the set  $\overline{\mathcal{M}^*(f)}$ .

By the convexity of the set  $\overline{\mathcal{M}^*(f)}$ , the diagonals of  $\mathcal{H}_1 \cap \mathcal{H}_2$  intersect in a point which corresponds to an invariant measure  $\mu \in \overline{\mathcal{M}^*(f)}$ . By Lemma 4.4.5, the vertexes of  $\mathcal{H}_1 \cap \mathcal{H}_2$  are extreme points of  $\overline{\mathcal{M}^*(f)}$ . Hence,  $\mu$  is the convex combination of two different pairs of extreme points of  $\overline{\mathcal{M}^*(f)}$ , which implies that  $\overline{\mathcal{M}^*(f)}$  is not a Choquet simplex.

Similarly, one can show that neither  $\overline{\mathcal{M}_i(f)}$  nor  $\overline{\mathcal{M}_{i+1}(f)}$  is a Choquet simplex.  $\square$

## 4.5 Invariant measures for Mañé's $DA$ example: Proof of Theorem 3

In this section, we first recall Mañé's  $DA$ -example, that is, what exactly the open set  $\mathcal{W}$  in the statement of Theorem 3 is. Then we give the proof the Theorem 3.

### 4.5.1 Mañé's $DA$ -example

In [M1], by doing  $DA$  from a linear Anosov diffeomorphism on  $\mathbb{T}^3$  whose center is uniformly expanding, R. Mañé constructs an open subset  $\mathcal{W}$  of  $\text{Diff}^1(\mathbb{T}^3)$  such that for any  $f \in \mathcal{W}$ , the following properties are satisfied:

- there exists a  $Df$ -invariant partially hyperbolic splitting

$$T\mathbb{T}^3 = E^{ss} \oplus E^c \oplus E^{uu}$$

with  $\dim(E^{ss}) = \dim(E^c) = 1$ ,

- there exists a constant  $\lambda \in (0, 1)$  such that  $\|Df^{-1}|_{E^{uu}}\| < \lambda$ ;
- there exist two hyperbolic periodic orbits of different indices;
- the center bundle  $E^c$  is integrable and the center foliation is minimal.
- there exist two open sets  $U$  and  $V$ , a constant  $\tau > 1$  and five positive numbers  $\epsilon_1, \dots, \epsilon_5$  such that

1.  $\bar{V}$  is a proper subset of  $U$
2. for any point  $x \in \mathbb{T}^3 \setminus V$ , we have that

$$\|Df|_{E^c(x)}\| > \tau;$$

3. every strong unstable curve of length at least  $\epsilon_1$  contains a strong unstable curve of length at least  $\epsilon_2$  which is disjoint from  $U$ ; moreover, we have that  $\lambda\epsilon_1 < \epsilon_2$ ;
4. every center plaque of length at least  $\epsilon_3$  contains a center plaque of length at least  $\epsilon_4$  which is disjoint from  $\bar{V}$ ; moreover, we have that  $\tau\epsilon_4 > 2\epsilon_3$ ;
5. for every center leaf  $\mathcal{F}^c(x)$ , every connected component of  $\mathcal{F}^c(x) \cap (U \setminus \bar{V})$  has length larger than  $\epsilon_5$ ; moreover, we have that  $\tau\epsilon_5 > \epsilon_3$ .

By construction, the diffeomorphism  $f$  is isotopic to a linear Anosov.

R. Mañé proved the followings:

**Theorem 4.5.1.** [M1, Theorem B] *For every  $f \in \mathcal{W}$ , the diffeomorphism  $f$  is robustly transitive and non-hyperbolic.*

**Lemma 4.5.2.** [M1, Lemma 5.2] *Let  $f \in \mathcal{W}$ . For any  $x \in \mathbb{T}^3$ , there exists  $y \in W_{\epsilon_1}^{uu}(x)$  such that the forward orbit of  $y$  is contained in  $\mathbb{T}^3 \setminus U$ .*

A recent result by R. Potrie [Po] implies that  $f \in \mathcal{W}$  is dynamically coherent, that is, there exist invariant foliations  $\mathcal{F}^{cs}$  and  $\mathcal{F}^{cu}$  tangent to  $E^{ss} \oplus E^c$  and  $E^c \oplus E^{uu}$  respectively.

### 4.5.2 Proof of Theorem 3

We deal with Mañé's example separately because we only know that strong stable foliation and center foliation are minimal. The minimality of strong unstable foliation is still unknown.

The minimality of strong stable foliation is due to [BDU, PS]:

**Lemma 4.5.3.** [BDU, PS] *There exists an open dense subset  $\mathcal{W}^s$  of  $\mathcal{W}$  such that for any  $f \in \mathcal{W}^s$ , the strong stable foliation is minimal.*

The proof of Theorem 3 strongly depends on the properties of  $\mathcal{W}$ , ie. the DA construction of Mañé's example.

*Proof of Theorem 3.* By Hayashi's connecting lemma and transitivity, there exists a dense subset of  $\mathcal{W}$  such that every diffeomorphism in this dense subset has a co-index one heterodimensional cycle. By Propositions 2.9.5 and 4.4.1, there exists an open dense subset of  $\mathcal{W}$  such that every diffeomorphism in this set has a split flip flop configuration associated to a dynamically defined  $cs$ -blender. On the other hand, by Lemma 4.5.3, there exists an open dense subset  $\mathcal{W}^s$  of  $\mathcal{W}$  such that the strong stable foliation is minimal for any  $f \in \mathcal{W}^s$ .

To sum up, there exists an open and dense subset  $\tilde{\mathcal{W}}$  of  $\mathcal{W}$  such that for any  $f \in \tilde{\mathcal{W}}$ , we have that:

- $f$  has minimal strong stable foliation;
- $f$  has a split flip flop configuration associated to a dynamically defined  $cs$ -blender.

Now, we fix a  $Df$  strictly invariant strong unstable cone field  $\mathcal{C}^{uu}$  around  $E^{uu}$  on  $\mathbb{T}^3$  such that  $Df$  is uniformly expanding along  $\mathcal{C}^{uu}$ .

#### **Non-hyperbolic ergodic measures approached by hyperbolic periodic measures of s-index one.**

We will prove that for any hyperbolic periodic measure of s-index 1 and any non-hyperbolic ergodic measure, their convex combination is approximated by periodic measures.

By construction, there exists  $\delta_0 > 0$  such that  $B_{\delta_0}(V) \subset U$ . We fix a hyperbolic periodic point  $p$  of s-index 1, the size of local unstable manifold  $W_{loc}^u(\mathcal{O}_p)$  and the size of local strong stable manifold  $W_{loc}^s(\mathcal{O}_p)$ . By the minimality of the foliation  $\mathcal{F}^{ss}$  and the fact that  $W^s(\mathcal{O}_p) = W^{ss}(\mathcal{O}_p)$ , there exists a positive integer  $k$  such that

- the integer  $k$  only depends on the size of  $W_{loc}^s(p)$  and on  $\delta_0$ ;
- for any  $x \in \mathbb{T}^3$ ,  $f^{-k}(W_{loc}^s(p))$  intersects  $\mathcal{F}_{\delta_0}^{cu}(x)$  transversely, where  $\mathcal{F}_{\delta_0}^{cu}(x)$  denotes the  $\delta_0$  neighborhood of  $x$  in the leaf  $\mathcal{F}^{cu}(x)$ .

Given a non-hyperbolic ergodic measure  $\nu \in \mathcal{M}_{erg}(\mathbb{T}^3, f)$ , and consider the convex sum  $\alpha\delta_{\mathcal{O}_p} + (1 - \alpha)\nu$ , for  $\alpha \in [0, 1]$ . Then for any  $\alpha \in (0, 1]$ , we have that

$$\lambda^c(\alpha\delta_{\mathcal{O}_p} + (1 - \alpha)\nu) > 0.$$

We fix  $\alpha \in (0, 1]$  and we denote by

$$\lambda' = \exp(-\lambda^c(\alpha\delta_{\mathcal{O}_p} + (1 - \alpha)\nu)).$$

Lemma 2.6.4 provides two positive numbers  $L$  and  $d_0$ , corresponding to the number  $\sqrt{\lambda'}$  and to the splitting  $E^{ss} \oplus (E^c \oplus E^{uu})$ , such that for any  $d \in (0, d_0)$ , we have that any  $\sqrt{\lambda'}$ -quasi hyperbolic periodic  $d$ -pseudo orbit is  $L \cdot d$  shadowed by a periodic orbit.

We choose a number  $d \in (0, d_0)$  such that  $L \cdot d$  is small enough, whose precise value would be fixed at the end. Then there exists an integer  $N_d$  such that

$$f^{-N_d}(W_{loc}^u(\mathcal{O}_p)) \subset W_{d/2}^u(\mathcal{O}_p) \text{ and } f^{N_d}(W_{loc}^s(\mathcal{O}_p)) \subset W_{d/2}^s(\mathcal{O}_p).$$

Now, we fix a point  $x$  in the basin of  $\nu$ . Since strong stable foliation is minimal and  $W_{loc}^u(p)$  is everywhere tangent to  $E^c \oplus E^{uu}$ , there exists a transversely intersection  $y$  between the strong stable manifold of  $x$  and  $W_{loc}^u(\mathcal{O}_p)$ . By the choice of  $y$ , we have that

$$\lim_{n \rightarrow +\infty} \frac{1}{n} \sum_{i=0}^{n-1} \delta_{f^i(y)} = \nu \text{ and } \lim_{n \rightarrow +\infty} \frac{1}{n} \sum_{i=0}^{n-1} \log \|Df|_{E^c(f^i(y))}\| = 0.$$

In the following, we will find a  $\sqrt{\lambda'}$ -quasi hyperbolic periodic  $d$ -pseudo orbit, with large period, such that it spends almost  $1 - \alpha$  proportion of its period to follow the forward orbit of  $y$  and also spends almost  $\alpha$  proportion of its period to follow the periodic orbit  $\mathcal{O}_p$ .

Take  $\epsilon < \frac{-\log \lambda'}{16}$  small, then we have the following:

- there exists  $\delta > 0$  such that for any two points  $z, w \in \mathbb{T}^3$  satisfying  $d(z, w) < \delta$ , we have that

$$-\epsilon \leq \log \|Df|_{E^c(w)}\| - \log \|Df|_{E^c(z)}\| \leq \epsilon;$$

- there exists an integer  $N$  such that for any  $n \geq N$ , we have the following:

$$-\epsilon < \frac{1}{n} \sum_{i=0}^{n-1} \log \|Df|_{E_{f^i(y)}^c}\| < \epsilon \text{ and } d\left(\frac{1}{n} \sum_{i=0}^{n-1} \delta_{f^i(y)}, \nu\right) < \epsilon/2.$$

For any  $C^1$  curve  $\gamma$  in  $\mathbb{T}^3$ , we denote by  $\ell(\gamma)$  the length of  $\gamma$ .

We choose a  $C^1$  curve  $\gamma_n \subset W^c(y)$ , centered at  $y$ , such that  $\ell(\gamma_n) = \delta e^{-2n\epsilon}$ . Now, consider the set  $S_n$  which is the  $\ell(\gamma_n)$  tubular neighborhood of  $W_\delta^{uu}(x)$  in the leaf  $\mathcal{F}^{cu}(x)$ .

Similar to Claim 4.1.3, for  $n$  large enough, one has that

$$\ell(f^i(\gamma_n)) \leq \|Df\|^i \ell(\gamma_n) < \delta, \text{ for any } i = 0, \dots, n.$$

According to this estimate and the choice of  $\delta$ , we have that

$$\ell(f^n(\gamma_n)) = \int_0^1 \left\| \frac{d}{dt} f^n(\gamma_n(t)) \right\| dt \geq \int_0^1 e^{-n\epsilon} \prod_{j=0}^{n-1} \|Df|_{E^c(f^j(y))}\| \|\gamma'_n(t)\| dt \geq \delta e^{-4n\epsilon}.$$

Consider the connected component of  $f^n(S_n) \cap B_\delta(f^n(y))$  which contains  $f^n(y)$ , and we denote it as  $\tilde{S}_n$ ; then  $\tilde{S}_n$  is a  $C^1$  surface tangent to  $E^c \oplus E^u$  satisfying that

- $f^n(\gamma_n) \subset \tilde{S}_n$ ;
- $\tilde{S}_n$  is foliated by curves tangent to  $\mathcal{C}^{uu}$ , whose lengths are  $2\delta$ ;
- For any center plaque  $\gamma \subset \tilde{S}_n$  joining the two boundary components of  $\tilde{S}_n$  which are tangent to  $\mathcal{C}^{uu}$ , one has that  $\ell(\gamma) \geq \delta e^{-5n\epsilon}$ .

Now, we will iterate  $\tilde{S}_n$  to make it cut the local stable manifold of  $\mathcal{O}_p$ . By the uniform expansion in the strong unstable direction, there exists an integer  $N_\delta$  such that for any curve  $D^{uu}$  tangent to  $\mathcal{C}^{uu}$  of length at least  $\delta/2$ , we have that

$$\ell(f^{N_\delta}(D^{uu})) \geq \epsilon_1.$$

Hence,  $f^{N_\delta}(\tilde{S}_n)$  is foliated by curves tangent to  $\mathcal{C}^{uu}$ , whose lengths are no less than  $4\epsilon_1$ . By Lemma 4.5.2, there exists  $z \in W_{\delta/2}^{uu}(f^n(y))$  such that  $Orb^+(f^{N_\delta}(z))$  is contained in  $\mathbb{T}^3 \setminus B_{\delta_0}(V)$ .

We denote by  $W_n$  the connected component of  $f^{N_\delta}(\tilde{S}_n) \cap B_{\delta/2}(f^{N_\delta}(z))$  containing  $f^{N_\delta}(z)$ . Let  $[\cdot]$  denote the integer part of a number, and we denote by

$$T_n = \left\lceil \frac{5\epsilon n + \log \delta_0 - \log \delta + N_\delta \cdot \log b}{\log \tau} \right\rceil + 1, \text{ where } b > \sup_{x \in \mathbb{T}^3} \|Df^{-1}(x)\|.$$

Since for any point  $x \in \mathbb{T}^3 \setminus V$ , we have

$$\|Df|_{E^c(x)}\| \geq \tau,$$

hence  $f^{T_n}(W_n)$  contains a disc tangent  $E^c \oplus E^u$  whose diameter is no less than  $\delta_0$ . By the choice of  $k$ ,  $f^{T_n}(W_n)$  intersects  $f^{-k}(W_{loc}^s(p))$  transversely. We denote by

$$t_n = 2N_d + k + N_\delta + T_n.$$

To sum up, there exists a point  $w \in W_{d/2}^u(p)$  such that

$$f^{n+t_n}(w) \in W_{d/2}^s(p);$$

- the orbit segment  $\{f^{N_d}(w), \dots, f^{n+N_d}(w)\}$  follows the orbit segment  $\{y, \dots, f^n(y)\}$  at a distance less than  $\delta$ .

When we choose  $n$  large, we have that

$$\frac{t_n}{n} \leq \frac{6\epsilon}{\log \tau}.$$

Moreover, we have the following:

$$\left| \frac{1}{n+t_n} \sum_{i=0}^{n+t_n-1} \log \|Df|_{E_{f^i(w)}^c}\| \right| < \epsilon,$$

$$d\left(\frac{1}{n+t_n} \sum_{i=0}^{n+t_n-1} \delta_{f^i(w)}, \nu\right) < \frac{6}{\log \tau} \epsilon + \epsilon.$$

**Claim 4.5.4.** *There exist integers  $n$  and  $m$  arbitrarily large such that*

$$\left| \frac{m\pi(p)}{n} - \frac{\alpha}{1-\alpha} \right| + \frac{2N_d}{n} < \epsilon;$$

— *the orbit segment  $\{w, t_n + n + m\pi(p)\}$  is a  $\sqrt{\lambda'}$ -quasi hyperbolic string corresponding to the splitting  $E^{ss} \oplus (E^c \oplus E^{uu})$ .*

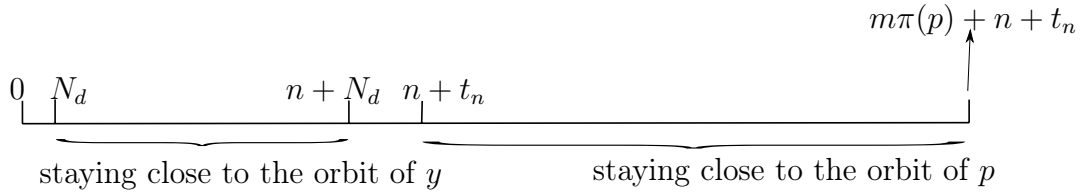

Figure 4.5 –

The proof of the claim above is similar to the one of Claim 4.1.5. Once again, by Lemma 2.6.4, we have a periodic orbit  $\mathcal{O}_{p'}$  of s-index one which shadows the orbit segment  $\{w, t_n + n + m\pi(p)\}$  at a distance less than  $L \cdot d$ . Moreover, when  $d$  is chosen small, one has that

$$d(\delta_{\mathcal{O}_{p'}}, \alpha\delta_{\mathcal{O}_p} + (1-\alpha)\nu) < c \cdot \epsilon, \text{ where } c \text{ is a constant independent of } \epsilon.$$

By the arbitrary choice of  $\alpha$  and compactness of the set  $\{\alpha\delta_{\mathcal{O}_p} + (1-\alpha)\nu | \alpha \in [0, 1]\}$ , the ergodic measure  $\nu$  is approximated by hyperbolic ergodic measures of index 1.

**Convexity of the set  $\overline{\mathcal{M}^*(f)}$ .** Since any non-hyperbolic ergodic measure is approximated by hyperbolic periodic measures of s-index 1, we have that for any  $\mu, \nu \in \overline{\mathcal{M}^*(f)}$ , both  $\mu$  and  $\nu$  are approximated by hyperbolic periodic measures of s-index 1. Since the hyperbolic periodic orbits of s-index 1 are homoclinically related to each other, one has that

$$\{\alpha\mu + (1-\alpha)\nu; \alpha \in [0, 1]\}$$



is contained in the closure of the set of hyperbolic periodic measures of s-index 1. Notice that  $\alpha\mu + (1 - \alpha)\nu$  has zero mean center Lyapunov exponent, for any  $\alpha \in [0, 1]$ . By Proposition 4.3.1 and Remark 4.3.2, we have that  $\alpha\mu + (1 - \alpha)\nu$  is approximated by non-hyperbolic ergodic measures. Hence, we have that

$$\{\alpha\mu + (1 - \alpha)\nu; \alpha \in [0, 1]\} \subset \overline{\mathcal{M}^*(f)}.$$

This ends the proof of Theorem 3. □

# Chapter 5

## Constructing new partially hyperbolic diffeomorphisms on 3-manifolds

We contribute this chapter to building new partially hyperbolic diffeomorphisms on  $M^3$ .

We first show the existence of Dehn twists which keep the transversality of certain bundles. We first reduce the proof of Theorem 4 to two theorems according to the two cases for a pair of transverse foliations  $(\mathcal{F}, \mathcal{G})$ :

- $\mathcal{F}$  and  $\mathcal{G}$  do not have compact leaves that are homotopic. In this case, one can find a closed curve which is a complete transversal for both  $\mathcal{F}$  and  $\mathcal{G}$ . Then by putting  $\mathcal{F}$  and  $\mathcal{G}$  in a good position, one can construct two linear foliations which separate  $\mathcal{F}$  and  $\mathcal{G}$ . One of the linear foliation is a circle foliation, and the other one has irrational holonomy.
- $\mathcal{F}$  and  $\mathcal{G}$  have compact leaves that are homotopic. In this case, one decomposes the torus into several cylinders. In each cylinders, one can modify the foliations to make them in a good position such that the linear translation directed by the homotopy class of the compact leaves of  $\mathcal{F}$  keeps the transversality of two foliations.

Then, we compose the Dehn twists along the transverse tori with time  $t$ -map of the flow; by applying the argument in [BPP], one can show that for  $t$  large enough the diffeomorphism is partially hyperbolic whose center is neutral.

### 5.1 Reduction of Theorem 4

Recall that for a pair of transverse foliations  $(\mathcal{F}, \mathcal{G})$  on  $\mathbb{T}^2$ , either  $\mathcal{F}$  and  $\mathcal{G}$  have parallel compact leaves or they have no compact leaves. According to this fact,

**Theorem 5.1.1.** *Let  $\mathcal{F}$  and  $\mathcal{G}$  be two  $C^1$  one-dimensional transverse foliations on  $\mathbb{T}^2$ , without parallel compact leaves. Then for any  $\alpha \in \pi_1(\mathbb{T}^2)$ , there exists a  $C^1$ -continuous family  $\{\Phi_t\}_{t \in [0,1]}$  of  $C^1$  diffeomorphisms on  $\mathbb{T}^2$  such that*

- $\Phi_0 = \Phi_1 = Id$ ;
- For every  $t \in [0, 1]$ , the  $C^1$  foliation  $\Phi_t(\mathcal{F})$  is transverse to  $\mathcal{G}$ ;
- For every point  $x \in \mathbb{T}^2$ , the closed curve  $\Phi_t(x)$  is in the homotopy class of  $\alpha$ .

The proof of Theorem 5.1.1 consists in endowing  $\mathbb{T}^2$  with coordinates in which the foliations  $\mathcal{F}$  and  $\mathcal{G}$  are separated by 2 affine foliations (i.e.  $\mathcal{F}$  and  $\mathcal{G}$  are tangent to two transverse constant cones). Thus in these coordinates every translation leaves  $\mathcal{F}$  transverse to  $\mathcal{G}$ , concluding.

**Theorem 5.1.2.** *Let  $\mathcal{F}$  and  $\mathcal{G}$  be two  $C^1$  one-dimensional foliations on  $\mathbb{T}^2$  and they are transverse. Assume that  $\mathcal{F}$  and  $\mathcal{G}$  have parallel compact leaves which are in the homotopy class  $\alpha \in \pi_1(\mathbb{T}^2)$ . Then, for each  $\beta \in \pi_1(\mathbb{T}^2)$ , one has that  $\beta \in \langle \alpha \rangle$  if and only if there exists a  $C^1$ -continuous family  $\{\Phi_t\}_{t \in [0,1]}$  of  $C^1$  diffeomorphisms on  $\mathbb{T}^2$  such that*

- $\Phi_0 = \Phi_1 = Id$ ;
- For every  $t \in [0, 1]$ , the  $C^1$  foliation  $\Phi_t(\mathcal{F})$  is transverse to  $\mathcal{G}$ ;
- For every point  $x \in \mathbb{T}^2$ , the closed curve  $\Phi_t(x)$  is in the homotopy class of  $\beta$ .

One easily checks that, if  $\mathcal{F}$  and  $\mathcal{G}$  are transverse  $C^1$  foliations having compact leaves in the same homotopy class, then every compact leaf  $L_{\mathcal{F}}$  of  $\mathcal{F}$  is disjoint from every compact leaf  $L_{\mathcal{G}}$  of  $\mathcal{G}$ . If  $\{\Phi_t\}_{t \in [0,1]}$  is an isotopy so that  $\Phi_0$  is the identity map and  $\Phi_t(\mathcal{F})$  is transverse to  $\mathcal{G}$ , then  $\Phi_t(L_{\mathcal{F}})$  remains disjoint from  $L_{\mathcal{G}}$ : this implies the *if* part of Theorem 5.1.2. The *only if* part will be the aim of Section 5.5.

**Remark 5.1.3.** *First notice that every continuous path (for the  $C^1$ -topology) of  $C^1$  diffeomorphisms can be approached, in the  $C^1$ -topology, by a smooth path of smooth diffeomorphisms.*

*Now, as the transversality of foliations is an open condition, any loop  $\{\Psi_t\}_{t \in [0,1]}$  of diffeomorphisms  $C^1$ -close to the loop  $\{\Phi_t\}_{t \in [0,1]}$  (announced in Theorems 4, 5.1.1, and 5.1.2) satisfies that  $\Psi_t(\mathcal{F})$  is transverse to  $\mathcal{G}$  for every  $t$ .*

*Therefore, in Theorems 4, 5.1.1, and 5.1.2, one can choose the loop  $t \mapsto \Phi_t$  so that the map  $(t, x) \mapsto \Phi_t(x)$ , for  $(t, x) \in \mathbb{S}^1 \times \mathbb{T}^2$ , is smooth.*

## 5.2 Existence of a complete transversal for two transverse foliations without parallel compact leaves

In this section, we consider two foliations  $\mathcal{F}, \mathcal{G}$  on the torus  $\mathbb{T}^2$  which do not have parallel compact leaves (see Definition 2.14.1). According to Proposition 2.14.6, the foliations  $\mathcal{F}$  and  $\mathcal{G}$  have no Reeb component. In particular,  $\mathcal{F}$  and  $\mathcal{G}$  are orientable. By Theorem 2.14.8, for each of them, there exist complete transverse cross sections. In this section, we prove that any two transverse foliations without parallel compact leaves share a complete transverse cross section.

**Proposition 5.2.1.** *If two  $C^1$  foliations  $\mathcal{F}$  and  $\mathcal{G}$  are transverse on  $\mathbb{T}^2$  and have no parallel compact leaves, then there exists a smooth simple closed curve  $\gamma$  which is a complete transversal to both  $\mathcal{F}$  and  $\mathcal{G}$ .*

*Proof.* As noticed before the statement of Proposition 5.2.1, the foliations  $\mathcal{F}$  and  $\mathcal{G}$  have no Reeb component and therefore  $\mathcal{F}$  and  $\mathcal{G}$  are orientable. Thus there exist two unit vector fields  $X, Y$  such that  $X$  and  $Y$  are tangent to the foliations  $\mathcal{F}$  and  $\mathcal{G}$  respectively.

Since  $X$  and  $Y$  are transverse, the vector field  $\frac{1}{2}X + \frac{1}{2}Y$  is transverse to both  $\mathcal{F}$  and  $\mathcal{G}$ . Let  $Z$  be a smooth vector field  $C^0$  close enough to  $\frac{1}{2}X + \frac{1}{2}Y$  so that  $Z$  is non-singular and transverse to both foliations  $\mathcal{F}$  and  $\mathcal{G}$ . Furthermore, up to perform a small perturbation, we can assume that  $Z$  admits a periodic orbit  $\tilde{\gamma}$  which is a simple closed curve transverse to both  $\mathcal{F}$  and  $\mathcal{G}$ .

According to Lemma 2.14.4, if  $\tilde{\gamma}$  is not a complete transversal of one of the foliations  $\mathcal{F}$  or  $\mathcal{G}$ , this foliation admits a compact leaf homotopic to  $\tilde{\gamma}$ . As  $\mathcal{F}$  and  $\mathcal{G}$  have no parallel compact leaves, this may happen to at most one of  $\mathcal{F}$  and  $\mathcal{G}$ . In other words,  $\tilde{\gamma}$  is a complete transversal for at least one of the foliations, thus we assume that  $\tilde{\gamma}$  is a complete transversal for  $\mathcal{F}$ . If  $\tilde{\gamma}$  is a complete transversal for  $\mathcal{G}$ , we are done.

Thus we assume that it is not the case. Therefore Lemma 2.14.4 implies that  $\mathcal{G}$  has compact leaves which are in the homotopy class of  $\tilde{\gamma}$ . We denote by  $C_{\mathcal{G}}$  a compact leaf of  $\mathcal{G}$ , and we denote by  $L$  a segment of a leaf of  $\mathcal{F}$  with endpoints  $p, q$  on  $\tilde{\gamma}$  and whose interior is disjoint from  $\tilde{\gamma}$ ; furthermore, if  $\mathcal{F}$  has a compact leaf, we choose  $L$  contained in a compact leaf of  $\mathcal{F}$ . We denote by  $\sigma \subset \tilde{\gamma}$  the (unique) non trivial oriented segment so that

- $\sigma$  joins the final point  $q$  of  $L$  to its initial point  $p$ ;
- the interior of  $\sigma$  is disjoint from  $\{p, q\}$ ;
- the orientation of  $\sigma$  coincides with the transverse orientation of the foliation  $\mathcal{G}$ , given by the vector field  $X$  directing  $\mathcal{F}$ .

Thus the concatenation  $\gamma_0 = L \cdot \sigma$  is a closed curve (which is simple unless  $p = q$  in that case  $p = q$  is the unique and non topologically transverse intersection

point) consisting of one leaf segment and one transverse segment to  $\mathcal{F}$ . A classical process allows us to smooth  $\gamma_0$  into a smooth curve  $\gamma$  transverse to  $\mathcal{F}$  (see Figure 5.1 for the case  $p \neq q$  and Figure 5.2 for the case  $p = q$ ), and the choice of the oriented segment  $\sigma$  allows us to choose  $\gamma$  transverse to  $\mathcal{G}$ . Furthermore, we have that

- $\gamma$  cuts the compact leaf  $C_g$  of  $\mathcal{G}$  transversely and in exactly one point;
- if  $\mathcal{F}$  has compact leaves, then  $\gamma$  cuts the compact leaf containing  $L$  transversely and in exactly 1 point;
- $\gamma$  is a closed simple curve (even in the case  $p = q$ ).

Now  $\gamma$  is a simple closed curve transverse to  $\mathcal{G}$  and has non-vanishing intersection number with a compact leaf of  $\mathcal{G}$ , and therefore  $\gamma$  is not homotopic to the compact leaves of  $\mathcal{G}$ . Lemma 2.14.4 implies therefore that  $\gamma$  is a complete transversal of  $\mathcal{G}$ . The same argument show that, if  $\mathcal{F}$  has a compact leaf, then  $\gamma$  is a complete transversal of  $\mathcal{F}$ . Finally, if  $\mathcal{F}$  has no compact leaves, any closed transversal is a complete transversal, ending the proof.  $\square$

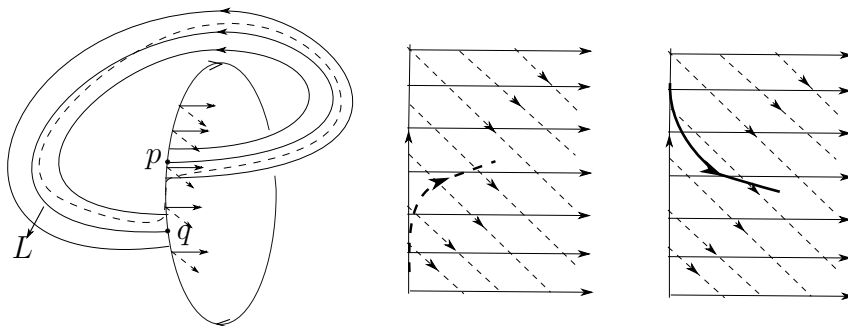

Figure 5.1 – In the first figure: the dash line is the transversal  $\gamma$ ; the dash and real arrows on the circle pointing outside give the orientations of  $\mathcal{G}$  and  $\mathcal{F}$  respectively. The second and the third figure show the good choice of curve and bad choice of curve respectively.

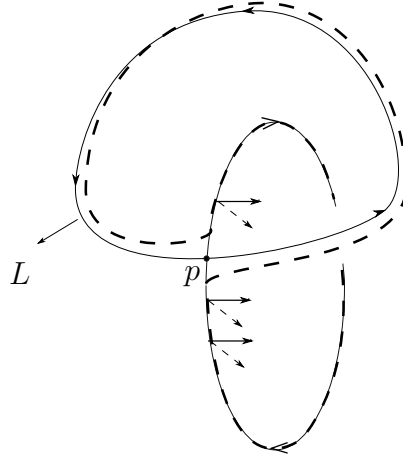

Figure 5.2 – The dash line is the transversal  $\gamma$ . The dash and real arrows on the circle pointing outside give the orientations of  $\mathcal{G}$  and  $\mathcal{F}$  respectively.

### 5.3 Deformation of a foliation along its transverse foliation

For any  $C^1$  foliation  $\mathcal{E}$ , we will denote by  $\mathcal{E}_x$  the leaf of  $\mathcal{E}$  through  $x$ . For any two points  $x, y$  on a common leaf of  $\mathcal{E}$ , we denote  $d_{\mathcal{E}}(x, y)$  as the distance between  $x, y$  on the  $\mathcal{E}$ -leaf.

**Proposition 5.3.1.** *Let  $S = \mathbb{R} \times [0, 1]$  be a horizontal strip on  $\mathbb{R}^2$ . Assume that  $\tilde{\mathcal{E}}, \tilde{\mathcal{F}}$  and  $\tilde{\mathcal{G}}$  are  $C^1$  foliations on  $S$  satisfying that*

- *the foliation  $\tilde{\mathcal{G}}$  is transverse to  $\tilde{\mathcal{F}}$  and  $\tilde{\mathcal{E}}$ , that is,  $\tilde{\mathcal{E}} \pitchfork \tilde{\mathcal{G}}$  and  $\tilde{\mathcal{F}} \pitchfork \tilde{\mathcal{G}}$ ;*
- *the foliations  $\tilde{\mathcal{E}}, \tilde{\mathcal{F}}$  and  $\tilde{\mathcal{G}}$  are invariant under the map  $(r, s) \mapsto (r+1, s)$ ;*
- *the foliations  $\tilde{\mathcal{E}}$  and  $\tilde{\mathcal{F}}$  have the same holonomy map from  $\mathbb{R} \times \{0\}$  to  $\mathbb{R} \times \{1\}$ ;*
- *Each leaf of each foliation intersects the two boundary components of  $S$  transversely.*

*Then there exists a continuous family  $\{\Phi_t\}_{t \in [0, 1]}$  of  $C^1$  diffeomorphisms on  $\mathbb{R} \times [0, 1]$  such that*

- $\Phi_0 = Id$ ;
- $\Phi_1(\tilde{\mathcal{E}}) = \tilde{\mathcal{F}}$ ;
- $\Phi_t(\tilde{\mathcal{E}}) \pitchfork \tilde{\mathcal{G}}$ , for every  $t \in [0, 1]$ ;
- $\Phi_t$  commutes with the map  $(r, s) \mapsto (r+1, s)$ , for any  $t \in [0, 1]$ ;
- $\Phi_t$  coincides with the identity map on  $\mathbb{R} \times \{0, 1\}$ , for any  $t \in [0, 1]$ .

*If furthermore  $\tilde{\mathcal{E}}$  and  $\tilde{\mathcal{F}}$  coincide in a neighborhood of the boundary  $\mathbb{R} \times \{0, 1\}$  of  $S$  then we can choose the family  $\{\Phi_t\}_{t \in [0, 1]}$  of diffeomorphisms so that there is a neighborhood of  $\mathbb{R} \times \{0, 1\}$  on which the  $\Phi_t$  coincides with the identity map, for any  $t \in [0, 1]$ .*

*Proof.* By assumption, for each  $x \in \mathbb{R} \times \{0\}$ , the leaf  $\tilde{\mathcal{E}}_x$  and the leaf  $\tilde{\mathcal{F}}_x$  have

the same boundary.

**Claim 5.3.2.** *For each  $y \in \tilde{\mathcal{E}}_x$ , the leaf  $\tilde{\mathcal{G}}_y$  intersects  $\tilde{\mathcal{F}}_x$  in a unique point.*

*Proof.* Since  $\tilde{\mathcal{E}}$  and  $\tilde{\mathcal{F}}$  are transverse to  $\tilde{\mathcal{G}}$ , one can prove that every leaf of  $\tilde{\mathcal{G}}$  intersects every leaf of  $\tilde{\mathcal{E}}$  and  $\tilde{\mathcal{F}}$  in at most one point. If  $y$  is an end point of  $\tilde{\mathcal{E}}_x$ , it is also an end point of  $\tilde{\mathcal{F}}_x$ , concluding. Consider now  $y$  in the interior of  $\tilde{\mathcal{E}}_x$ .

Recall that  $\tilde{\mathcal{G}}_y$  is a segment joining the two boundary components of  $S$ . Thus  $S \setminus \tilde{\mathcal{G}}_y$  has two connected components. Moreover each connected component of  $S \setminus \tilde{\mathcal{G}}_y$  contains exactly one end point of  $\tilde{\mathcal{E}}_x$ . As  $\tilde{\mathcal{F}}_x$  has the same end points as  $\tilde{\mathcal{E}}_x$ , it intersects  $\tilde{\mathcal{G}}_y$ .  $\square$

Now, we can define a map  $h_{\tilde{\mathcal{E}}}$  from  $S$  to itself. For each  $x \in S$ , there exists a unique leaf of  $\tilde{\mathcal{F}}$  which has the same boundary as  $\tilde{\mathcal{E}}_x$ , by the claim above,  $\tilde{\mathcal{G}}_x$  intersects that unique leaf of  $\tilde{\mathcal{F}}$  in only one point and we denote it as  $h_{\tilde{\mathcal{E}}}(x)$  (see Figure 5.3 below).

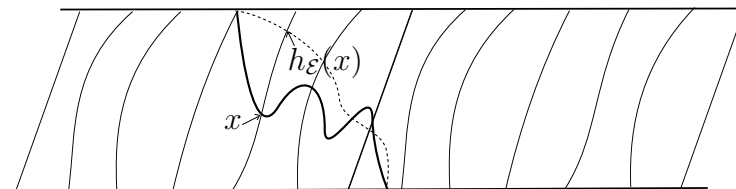

Figure 5.3 – The light line, the dark line and dash line denote the leaves of  $\tilde{\mathcal{G}}$ ,  $\tilde{\mathcal{E}}$  and  $\tilde{\mathcal{F}}$  respectively.

Since  $\tilde{\mathcal{E}}$ ,  $\tilde{\mathcal{F}}$  and  $\tilde{\mathcal{G}}$  are  $C^1$ -foliations,  $h_{\tilde{\mathcal{E}}}$  is a  $C^1$  map, and its inverse  $h_{\tilde{\mathcal{F}}}$  is obtained by reversing the roles of  $\tilde{\mathcal{E}}$  and  $\tilde{\mathcal{F}}$ , proving that  $h_{\tilde{\mathcal{E}}}$  is a diffeomorphism. Since each foliation is invariant under horizontal translation  $(r, s) \mapsto (r + 1, s)$ , the diffeomorphisms  $h_{\tilde{\mathcal{E}}}$  and  $h_{\tilde{\mathcal{F}}}$  commute with the map  $(r, s) \mapsto (r + 1, s)$ .

Since  $x$  and  $h_{\tilde{\mathcal{E}}}(x)$  are on the same  $\tilde{\mathcal{G}}$  leaf, the map  $d_{\tilde{\mathcal{G}}}(x, h_{\tilde{\mathcal{E}}}(x))$  is well defined from  $S$  to  $\mathbb{R}$  and one can check that it is a  $C^1$  map which is invariant under the translation  $(r, s) \mapsto (r + 1, s)$ .

Now, for each  $t \in [0, 1]$ , we define  $\Phi_t(x)$  as the point, in the segment joining  $x$  to  $h_{\tilde{\mathcal{E}}}(x)$  in the leaf  $\tilde{\mathcal{G}}_x$ , so that

$$d_{\tilde{\mathcal{G}}}(x, \Phi_t(x)) = t \cdot d_{\tilde{\mathcal{G}}}(x, h_{\tilde{\mathcal{E}}}(x)) \text{ and } d_{\tilde{\mathcal{G}}}(\Phi_t(x), h_{\tilde{\mathcal{E}}}(x)) = (1 - t) \cdot d_{\tilde{\mathcal{G}}}(x, h_{\tilde{\mathcal{E}}}(x)).$$

Then, we have that  $\Phi_0 = Id$ ,  $\Phi_1 = h_{\tilde{\mathcal{E}}}$  and  $\Phi_t$  commutes with the horizontal translation  $(r, s) \mapsto (r + 1, s)$  and preserves each leaf of the foliation  $\tilde{\mathcal{G}}$ . One easily checks that  $\Phi_t$  is of class  $C^1$  and depends continuously on  $t$ . Furthermore, its derivative along the leaves of  $\tilde{\mathcal{G}}$  does not vanish, so that  $\Phi_t$  is a diffeomorphism restricted to every leaf of  $\tilde{\mathcal{G}}$ . As  $\Phi_t$  preserves every leaf of  $\tilde{\mathcal{G}}$ , one deduces that  $\Phi_t(\tilde{\mathcal{E}})$  is transverse to  $\tilde{\mathcal{G}}$  and  $\Phi_t$  is a diffeomorphism of  $S$ .

Thus,  $\{\Phi_t\}_{t \in [0,1]}$  is the announced continuous path of  $C^1$  diffeomorphisms of  $S$ . □

For any  $C^1$  simple closed curve  $\gamma$  on  $\mathbb{T}^2$  whose homotopy class is non-trivial, we can cut the torus along  $\gamma$  to get a cylinder. The universal cover of the cylinder is a strip denoted by  $S_\gamma$  and diffeomorphic to  $\mathbb{R} \times [0, 1]$ . For any  $C^1$  foliation  $\mathcal{E}$  on  $\mathbb{T}^2$  transverse to  $\gamma$ , one denotes by  $\tilde{\mathcal{E}}$  the lift of  $\mathcal{E}$  on  $S_\gamma$ .

**Corollary 5.3.3.** *Let  $\mathcal{E}$ ,  $\mathcal{F}$  and  $\mathcal{G}$  be three  $C^1$  foliations on  $\mathbb{T}^2$ . Assume that:*

- $\mathcal{E} \pitchfork \mathcal{G}$  and  $\mathcal{F} \pitchfork \mathcal{G}$ ;
- there exists a  $C^1$  simple closed curve  $\gamma$  such that
  1. the curve  $\gamma$  is a complete transversal of the foliations  $\mathcal{E}$ ,  $\mathcal{F}$  and  $\mathcal{G}$ ;
  2. the lifted foliations  $\tilde{\mathcal{E}}$  and  $\tilde{\mathcal{F}}$  have the same holonomy map defined from one boundary component of  $S_\gamma$  to the other;

Then there exists a continuous family of  $C^1$  diffeomorphisms  $\{\Phi_t\}_{t \in [0,1]} \subset \text{Diff}^1(\mathbb{T}^2)$  such that

- $\Phi_0 = Id$ ;
- $\Phi_t(\mathcal{E}) \pitchfork \mathcal{G}$ , for every  $t \in [0, 1]$ ;
- $\Phi_1(\mathcal{E}) = \mathcal{F}$ .

*Sketch of proof.* If we just apply Proposition 5.3.1, one obtains a family of homeomorphisms of  $\mathbb{T}^2$  which are  $C^1$  diffeomorphisms on the complement of  $\gamma$  and which coincide with the identity map on  $\gamma$  and satisfy all the announced properties. Thus the unique difficulty is the regularity along  $\gamma$ . For that we check that the construction in the proof of Proposition 5.3.1 can be done on the whole universal cover of  $\mathbb{T}^2$  commuting with all the deck transformations, leading to diffeomorphisms on  $\mathbb{T}^2$ . □

## 5.4 Deformation process for transverse foliations without parallel compact leaves: proof of Theorem 5.1.1

### 5.4.1 Separating transverse foliations by two linear ones and proof of Theorem 5.1.1

**Theorem 5.4.1.** *Let  $\mathcal{F}$  and  $\mathcal{G}$  be two transverse  $C^1$  foliations on  $\mathbb{T}^2$  without parallel compact leaves. Then there are two affine foliations  $\mathcal{H}$  and  $\mathcal{I}$  on  $\mathbb{T}^2$  and a diffeomorphism  $\theta: \mathbb{T}^2 \rightarrow \mathbb{T}^2$  so that*

- the foliations  $\theta(\mathcal{F})$ ,  $\theta(\mathcal{G})$ ,  $\mathcal{H}$  and  $\mathcal{I}$  are pairwise transverse;
- there are local orientations of the foliations at any point  $p \in \mathbb{T}^2$  so that
  - $\theta(\mathcal{F})$  and  $\theta(\mathcal{G})$  cut  $\mathcal{H}$  with the same orientation;



—  $\theta(\mathcal{F})$  and  $\theta(\mathcal{G})$  cut  $\mathcal{I}$  with opposite orientations.

The two affine foliations  $\mathcal{H}$  and  $\mathcal{I}$  divide the tangent space  $T_pM$  at each point  $p \in \mathbb{T}^2$  into four quadrants, and Theorem 5.4.1 asserts that the tangent lines at  $p$  of  $\theta(\mathcal{F})$  and  $\theta(\mathcal{G})$  are contained in different quadrants.

The proof of Theorem 5.4.1 is the aim of the whole section. Let us first deduce the proof of Theorem 5.1.1

*Proof of Theorem 5.1.1.* We consider two transverse  $C^1$  foliations  $\mathcal{F}$  and  $\mathcal{G}$  on  $\mathbb{T}^2$  without parallel compact leaves, the diffeomorphism  $\theta$  and the affine foliations  $\mathcal{H}$  and  $\mathcal{I}$  given by Theorem 5.4.1. Consider any vector  $u \in \mathbb{R}^2$  and let  $T_u$  be the affine translation of  $\mathbb{T}^2$  directed by  $u$ , that is  $T_u(p) = p + u$ .

**Claim 5.4.2.** *For any  $u \in \mathbb{R}^2$ , the foliation  $T_u(\theta(\mathcal{F}))$  is transverse to  $\theta(\mathcal{G})$*

*Proof.* The foliations  $\mathcal{H}$  and  $\mathcal{I}$  are invariant by  $T_u$ , and the quadrants defined by  $\mathcal{H}$  and  $\mathcal{I}$  are preserved by  $T_u$  so that  $T_u(\theta(\mathcal{F}))$  is still transverse to both  $\mathcal{H}$  and  $\mathcal{I}$  and its tangent bundle is contained in the same quadrants as  $\theta(\mathcal{F})$ , and therefore  $T_u(\theta(\mathcal{F}))$  is not contained in the same quadrants as the tangent bundle of  $\theta(\mathcal{G})$ .

Thus  $T_u(\theta(\mathcal{F}))$  is transverse to  $\theta(\mathcal{G})$ , concluding. □

Consider  $(m, n) \in \mathbb{Z}^2 = H_1(\mathbb{T}^2, \mathbb{Z})$  and let  $u = (r, s)$  be the image of  $(m, n)$  by the natural action of  $\theta$  on  $H_1(\mathbb{T}^2, \mathbb{Z})$ . Then the announced loop of diffeomorphisms is  $\{\varphi_t = \theta^{-1}T_{tu}\theta\}_{t \in [0,1]}$ . Then  $\varphi_t(\mathcal{F})$  is transverse to  $\mathcal{G}$  for every  $t \in [0, 1]$ ,  $\varphi_0 = \varphi_1 = id_{\mathbb{T}^2}$ , and the loop  $t \mapsto \varphi_t(p)$  is in the homology class of  $(m, n)$  for every  $p \in \mathbb{T}^2$ . □

Therefore, it remains to prove Theorem 5.4.1. The proof is divided into two main steps corresponding to the next subsections.

## 5.4.2 Separating transverse foliations by a circle bundle

In this section, consider two transverse foliations  $\mathcal{F}$  and  $\mathcal{G}$  without parallel compact leaves. We first choose a coordinate to make  $\mathcal{G}$  in a “good position”, then we apply Proposition 5.3.1 to deform  $\mathcal{F}$  in “good position”, keeping  $\mathcal{G}$  invariant.

By Lemma 5.2.1, there exists a smooth simple closed curve  $\gamma$  which is a complete transversal of  $\mathcal{F}$  and  $\mathcal{G}$ . The aim of this section is to prove next result which can be seen as the first step for proving Theorem 5.4.1.

**Theorem 5.4.3.** *Let  $\mathcal{F}$  and  $\mathcal{G}$  be two transverse  $C^1$  foliations on  $\mathbb{T}^2$  and assume that they share the same complete transversal  $\gamma$ . Then there exists  $\theta \in \text{Diff}^1(\mathbb{T}^2)$  such that*

—  $\theta(\gamma) = \mathbb{S}^1 \times \{0\}$ ;

- Both  $\theta(\mathcal{F})$  and  $\theta(\mathcal{G})$  are transverse to the horizontal circle  $\mathbb{S}^1 \times \{t\}$ , for any  $t \in \mathbb{S}^1$ .

Up to now,  $\mathcal{F}$  and  $\mathcal{G}$  are two transverse foliations on  $\mathbb{T}^2$  which share the same complete transversal  $\gamma$ . In particular,  $\mathcal{G}$  is conjugated to the suspension of its holonomy (first return map) on  $\gamma$ . In other words, we can choose an appropriate coordinate on  $\mathbb{T}^2 = \mathbb{S}^1 \times \mathbb{S}^1$  such that:

- the circle  $\gamma = \mathbb{S}^1 \times \{0\}$  is a complete transversal for  $\mathcal{F}$  and  $\mathcal{G}$ ;
- the foliation  $\mathcal{G}$  is everywhere transverse to the horizontal circles;
- the foliation  $\mathcal{G}$  is vertical in a small neighborhood of  $\mathbb{S}^1 \times \{0\}$ .

Under this coordinate, we cut the torus along  $\gamma$  and we get a cylinder  $\mathbb{S}^1 \times [0, 1]$ . Thus  $\mathbb{T}^2$  is obtained from  $\mathbb{S}^1 \times [0, 1]$  by identifying  $(x, 0)$  with  $(x, 1)$ , for  $x \in \mathbb{S}^1$ .

Now, we take a universal cover of that cylinder, we get a strip  $S = \mathbb{R} \times [0, 1]$ . The foliations  $\mathcal{F}$  and  $\mathcal{G}$  can be lifted as two foliations  $\tilde{\mathcal{F}}$  and  $\tilde{\mathcal{G}}$  on  $S$ , respectively. Moreover,  $\tilde{\mathcal{G}}$  is everywhere transverse to the horizontal direction.

The proof of Theorem 5.4.3 has two steps: first we build a foliation  $\mathcal{E}$  on  $\mathbb{T}^2$  transverse to  $\mathcal{G}$  and to the horizontal foliation, so that  $\mathcal{E}$  has the same holonomy as  $\mathcal{F}$ . Then we push  $\mathcal{F}$  on  $\mathcal{E}$  by a diffeomorphism preserving  $\mathcal{G}$ , by using Proposition 5.3.1. Thus the main step of the proof is:

**Proposition 5.4.4.** *With the notations above, there exist  $\epsilon > 0$  and a  $C^1$  foliation  $\mathcal{E}$  transverse to  $\mathcal{G}$  on  $\mathbb{T}^2$  such that the foliation  $\tilde{\mathcal{E}}$  induced by  $\mathcal{E}$  on the strip  $S = \mathbb{R} \times [0, 1]$  satisfies:*

- the foliation  $\tilde{\mathcal{E}}$  is transverse to the horizontal direction;
- For any  $x \in \mathbb{R} \times \{0\}$ , we have that

$$\tilde{\mathcal{E}}_x \cap (\mathbb{R} \times ([0, \epsilon] \cup [1 - \epsilon, 1])) = \tilde{\mathcal{F}}_x \cap (\mathbb{R} \times ([0, \epsilon] \cup [1 - \epsilon, 1])).$$

**Remark 5.4.5.** *The last item of Proposition 5.4.4 means that*

- the foliations  $\mathcal{E}$  and  $\mathcal{F}$  coincide in a neighborhood of  $\gamma$
- the holonomy maps from  $\mathbb{R} \times \{0\}$  to  $\mathbb{R} \times \{1\}$  associated to  $\tilde{\mathcal{E}}$  and  $\tilde{\mathcal{F}}$  are the same.

*Proof.* We denote by

$$f, g : \mathbb{R} \times \{0\} \mapsto \mathbb{R} \times \{1\}$$

the  $C^1$  holonomy maps of  $\tilde{\mathcal{F}}$  and  $\tilde{\mathcal{G}}$  respectively.

As  $\tilde{\mathcal{F}}$  is transverse to  $\tilde{\mathcal{G}}$ , we have that  $f(x) \neq g(x)$ , for any  $x \in \mathbb{R} \times \{0\}$ . Hence, we can assume that  $f(x) > g(x)$  for any  $x \in \mathbb{R} \times \{0\}$  (the other case is similar).

We denote by  $g_t : \mathbb{R} \rightarrow \mathbb{R}$  the holonomy of  $\tilde{\mathcal{G}}$  from  $\mathbb{R} \times \{0\}$  to  $\mathbb{R} \times \{t\}$ . In particular,  $g_0$  is the identity map and  $g_1 = g$ . Our assumption that  $\mathcal{G}$  is vertical close to the boundary, implies that  $g_t$  is the identity map for  $t$  small enough and  $g_t = g$  for  $t$  close to 1.

Let  $\psi_0: S \rightarrow S$  be defined by  $(x, t) \mapsto (g_t(x), t)$ . Then  $\psi_0$  is a diffeomorphism which commutes with the translation  $T_1: (x, t) \mapsto (x + 1, t)$ .

Consider the foliations  $\tilde{\mathcal{G}}_0 = \psi_0^{-1}(\tilde{\mathcal{G}})$  and  $\tilde{\mathcal{F}}_0 = \psi_0^{-1}(\tilde{\mathcal{F}})$ . Now we have

- $\tilde{\mathcal{G}}_0$  is the vertical foliation;
- $\tilde{\mathcal{F}}_0$  is a  $C^1$  foliation transverse to the vertical foliation and transverse to the boundary of  $S$ , and invariant by the translation  $T_1$ . We denote by  $\mathcal{F}_0$  its quotient on the annulus  $\mathbb{S}^1 \times [0, 1]$ .
- every leaf of  $\tilde{\mathcal{F}}_0$  goes from  $\mathbb{R} \times \{0\}$  to  $\mathbb{R} \times \{1\}$  so that the holonomy map  $f^0$  is well defined and  $f^0 = g^{-1} \circ f$ . Our assumption  $f(x) > g(x)$  means that  $f^0(x) > x$  for every  $x$ .

As  $\mathcal{F}_0$  is transverse to the boundary of  $\mathbb{S}^1 \times [0, 1]$ , there is  $\delta > 0$  so that  $\tilde{\mathcal{F}}_0$  is transverse to the horizontal foliation on  $\mathbb{R} \times [0, \delta]$  and on  $\mathbb{R} \times [1 - \delta, 1]$ . Thus the holonomy  $f_t^0: \mathbb{R} \times \{0\} \rightarrow \mathbb{R} \times \{t\}$  of the foliation  $\tilde{\mathcal{F}}_0$  is well defined for  $t \in [0, \delta] \cup [1 - \delta, 1]$  and satisfies:

- $f_t^0(x) > x$  for  $t > 0$ , and moreover  $f_{t_1}^0(x) < f_{t_2}^0(x)$  for  $t_1, t_2 \in [0, \delta] \cup [1 - \delta, 1]$  and  $t_1 < t_2$ .
- The map  $(x, t) \mapsto f_t^0(x)$  is  $C^1$  and  $\frac{\partial f_t^0(x)}{\partial t} > 0$  (because  $\tilde{\mathcal{F}}_0$  is transverse to the vertical foliation).

Consider  $\varepsilon > 0$  so that

$$\varepsilon < \inf_{x \in \mathbb{R}} \{f_{1-\delta}^0(x) - f_\delta^0(x), \text{ for } x \in \mathbb{R}\}$$

$$\varepsilon < \inf \left\{ \frac{\partial f_t^0(x)}{\partial t}, \text{ for } x \in \mathbb{R} \text{ and } t \in [0, \delta] \cup [1 - \delta, 1] \right\}$$

With this choice of  $\varepsilon$ , one can easily check the following inequalities

**Claim 5.4.6.** — for any  $t \in [0, \delta]$  and  $x \in \mathbb{R}$ , one has

$$f_t^0(x) < \frac{f_{1-\delta}^0(x) + f_\delta^0(x)}{2} + (t - \frac{1}{2})\varepsilon; \quad (5.1)$$

— for any  $t \in [1 - \delta, 1]$  and  $x \in \mathbb{R}$ , one has

$$\frac{f_{1-\delta}^0(x) + f_\delta^0(x)}{2} + (t - \frac{1}{2})\varepsilon < f_t^0(x). \quad (5.2)$$

Let  $\alpha: [0, 1] \rightarrow [0, 1]$  be a smooth function so that:

- $\alpha(t) \equiv 1$ , for  $t$  close to 0 and close to 1;
- $\alpha(t) \equiv 0$ , for  $t \in [\frac{\delta}{2}, 1 - \frac{\delta}{2}]$ ;
- $\frac{d\alpha}{dt} \leq 0$  on  $[0, \delta]$  and  $\frac{d\alpha}{dt} \geq 0$  on  $[1 - \delta, 1]$ .

For  $x \in \mathbb{R}$  and  $t \in [0, 1]$ , we define  $h_t(x)$  as follows

— If  $t \in [0, \delta] \cup [1 - \delta, 1]$ , then

$$h_t(x) = \alpha(t)f_t^0(x) + (1 - \alpha(t)) \left( \frac{f_\delta^0(x) + f_{1-\delta}^0(x)}{2} + \varepsilon(t - \frac{1}{2}) \right);$$

— if  $t \in [\delta, 1 - \delta]$ , then

$$h_t(x) = \frac{f_\delta^0(x) + f_{1-\delta}^0(x)}{2} + \varepsilon\left(t - \frac{1}{2}\right).$$

**Claim 5.4.7.** *The map  $\psi_1: (x, t) \mapsto (h_t(x), t)$  is well defined and is a  $C^1$  diffeomorphism of  $S$  such that*

—  $\psi_1$  preserves the horizontal foliation and commutes with the translation  $T_1$ ;

—

$$\frac{\partial h_t(x)}{\partial t} > 0, \text{ for every } (x, t) \in S.$$

*Proof.* One easily checks that  $\psi_1$  is continuous and of class  $C^1$ . The formula gives also that  $\psi_1$  commutes with  $T_1$ . Now

$$\frac{\partial h_t(x)}{\partial x} = \frac{1}{2} \left( \frac{\partial f_\delta^0(x)}{\partial x} + \frac{\partial f_{1-\delta}^0(x)}{\partial x} \right) > 0 \text{ if } t \in [\delta, 1 - \delta]$$

and

$$\frac{\partial h_t(x)}{\partial x} = \alpha(t) \frac{\partial f_t^0(x)}{\partial x} + (1 - \alpha(t)) \cdot \frac{1}{2} \left( \frac{\partial f_\delta^0(x)}{\partial x} + \frac{\partial f_{1-\delta}^0(x)}{\partial x} \right) > 0 \text{ if } t \notin [\delta, 1 - \delta].$$

This shows that  $h_t$  is a diffeomorphism of  $\mathbb{R}$  for every  $t \in [0, 1]$ .

It remains to prove the last item of the claim.

One can observe that

$$\frac{\partial h_t(x)}{\partial t} = \varepsilon > 0, \text{ if } t \in [\delta, 1 - \delta]$$

and if  $t \notin [\delta, 1 - \delta]$  the derivative  $\frac{\partial h_t(x)}{\partial t}$  is equal to :

$$\frac{d\alpha(t)}{dt} \left( f_t^0(x) - \left( \frac{1}{2}(f_\delta^0(x) + f_{1-\delta}^0(x) + \varepsilon\left(t - \frac{1}{2}\right)) \right) \right) + \alpha(t) \frac{\partial f_t^0}{\partial t} + (1 - \alpha(t))\varepsilon.$$

The last two terms of this sum are positive, as product of positive numbers.

For  $t \in [0, \delta]$ , the first term is product of two negative numbers, as the derivative of  $\alpha$  is negative and (5.1) implies:

$$f_t^0(x) - \left( \frac{1}{2}(f_\delta^0(x) + f_{1-\delta}^0(x) + \varepsilon\left(t - \frac{1}{2}\right)) \right) < 0.$$

For  $t \in [1 - \delta, 1]$ , the first term is product of two positive numbers, as the derivative of  $\alpha$  is positive and (5.2) implies:

$$f_t^0(x) - \left( \frac{1}{2}(f_\delta^0(x) + f_{1-\delta}^0(x) + \varepsilon\left(t - \frac{1}{2}\right)) \right) > 0.$$

Thus  $\frac{\partial h_t(x)}{\partial t} > 0$  for every  $(x, t)$ . □

Now the foliation  $\tilde{\mathcal{H}}$  defined as the image of the vertical foliation by  $\psi_1$  satisfies:

- $\tilde{\mathcal{H}}$  is transverse to the horizontal foliation.
- $\tilde{\mathcal{H}}$  is transverse to the vertical foliation (that is, to  $\tilde{\mathcal{G}}_0$ ).
- its holonomy from  $\mathbb{R} \times \{0\}$  to  $\mathbb{R} \times \{t\}$  is  $h_t$ . In particular, it coincides with  $f_t$  for  $t$  so that  $\alpha(t) = 1$ , that is, in the neighborhood of  $\mathbb{R} \times \{0\}$  and  $\mathbb{R} \times \{1\}$ .
- as a consequence of the previous item, the foliation  $\tilde{\mathcal{H}}$  coincides with  $\tilde{\mathcal{F}}_0$  in the neighborhood of  $\mathbb{R} \times \{0\}$  and  $\mathbb{R} \times \{1\}$ .

We can now finish the proof of Proposition 5.4.4: the announced foliation on the strip  $S$  is  $\tilde{\mathcal{E}} = \psi_0(\tilde{\mathcal{H}})$ . This foliation is invariant under the translation  $T_1$ , so it passes to the quotient in a foliation  $\mathcal{E}$  on the annulus  $\mathbb{S}^1 \times [0, 1]$ . As  $\tilde{\mathcal{E}}$  coincides with  $\tilde{\mathcal{F}}$  in a neighborhood of the boundary of  $S$ , one gets that  $\mathcal{E}$  coincides with  $\mathcal{F}$  on the boundary of the annulus, and therefore this foliation induces a  $C^1$  foliation, still denoted by  $\mathcal{E}$  on the torus  $\mathbb{T}^2$ .  $\square$

Next remark ends the proof of Theorem 5.4.3:

**Remark 5.4.8.** *According to Proposition 5.3.1, there is a continuous path of diffeomorphisms  $\{\varphi_s\}_{s \in [0,1]}$  of  $S$  so that:*

- $\varphi_s$  commutes with the translation  $T_1: (x, t) \mapsto (x + 1, t)$ ;
- $\varphi_0$  is the identity map;
- for every  $s \in [0, 1]$ , the diffeomorphism  $\varphi_s$  coincides with the identity map in a neighborhood of the boundary of  $S$ ;
- $\varphi_s(\tilde{\mathcal{G}}) = \tilde{\mathcal{G}}$  for every  $s$ ; in particular  $\varphi_s(\tilde{\mathcal{F}})$  is transverse to  $\tilde{\mathcal{G}}$  for every  $s$ ;
- $\varphi_1(\tilde{\mathcal{F}}) = \tilde{\mathcal{E}}$ .

We now state a small variation of the statement of Theorem 5.4.3 which follows (exactly as Theorem 5.4.3) from of Propositions 5.4.4 and 5.3.1, and that we will use in a next section.

**Lemma 5.4.9.** *Let  $\mathcal{F}$  and  $\mathcal{G}$  be two transverse  $C^1$ -foliations on the annulus  $\mathbb{S}^1 \times [0, 1]$ . Assume that*

- $\mathcal{G}$  is transverse to every circle  $\mathbb{S}^1 \times \{t\}$ ;
- $\mathcal{F}$  is transverse to the boundary  $\mathbb{S}^1 \times \{0, 1\}$  and has no compact leaf in  $\mathbb{S}^1 \times (0, 1)$ .

*Then there is a  $C^1$  diffeomorphism  $\theta$  of  $\mathbb{S}^1 \times [0, 1]$  which coincides with the identity map in a neighborhood of the boundary and which preserves every leaf of  $\mathcal{G}$ , so that  $\theta(\mathcal{F})$  is transverse to every circle  $\mathbb{S}^1 \times \{t\}$ .*

### 5.4.3 Building the second linear foliation: end of the proof of Theorem 5.4.1

**Proposition 5.4.10.** *Let  $\mathcal{F}$  and  $\mathcal{G}$  be two transverse  $C^1$  foliations on  $\mathbb{T}^2$  without parallel compact leaves. Assume that both  $\mathcal{F}$  and  $\mathcal{G}$  are transverse to the horizontal foliation. We endow  $\mathcal{F}$  and  $\mathcal{G}$  with orientations so that they cut the horizontal foliation with the same orientation.*

*Then there exists a smooth ( $C^\infty$ ) foliation  $\mathcal{E}$  on  $\mathbb{T}^2$  such that*

- *the circle  $\mathbb{S}^1 \times \{0\}$  is a complete transversal to  $\mathcal{E}$ ;*
- *the holonomy map induced by  $\mathcal{E}$  on  $\gamma$  has a diophantine rotation number;*
- *the foliation  $\mathcal{E}$  is transverse to the foliations  $\mathcal{F}$ ,  $\mathcal{G}$  and to the horizontal direction. We endow it with an orientation so that it cuts the horizontal foliation with the same orientation as  $\mathcal{F}$  and  $\mathcal{G}$ .*
- *the foliation  $\mathcal{E}$  cuts  $\mathcal{F}$  and  $\mathcal{G}$  with opposite orientations.*

*Proof.* As already done before, we cut the torus along  $\mathbb{S}^1 \times \{0\}$ , getting an annulus, and we denote by  $\tilde{\mathcal{F}}$  and  $\tilde{\mathcal{G}}$  the lift of  $\mathcal{F}$  and  $\mathcal{G}$  on the strip  $\mathbb{R} \times [0, 1]$  which is the universal cover of the annulus. We denote by  $f$  and  $g$  the holonomy maps from  $\mathbb{R} \times \{0\}$  to  $\mathbb{R} \times \{1\}$  associated to the lifted foliations  $\tilde{\mathcal{F}}$  and  $\tilde{\mathcal{G}}$ , respectively. By transversality of  $\mathcal{F}$  with  $\mathcal{G}$ , we have that either  $f(x) < g(x)$  for any  $x$ , or  $f(x) > g(x)$  for any  $x$ . Without loss of generality, we assume that  $f(x) < g(x)$ . Let  $\tau(f)$  and  $\tau(g)$  be the translation numbers of  $f$  and  $g$ .

**Claim 5.4.11.**  $\tau(f) \neq \tau(g)$ .

*Proof.* We prove it by contradiction. Assume that  $\tau(f) = \tau(g)$ , then  $\tau(f) = \tau(g)$  is either rational or irrational. When they are irrational, since  $f(x) < g(x)$ , by Proposition 2.14.12, we have that  $\tau(f) < \tau(g)$ , a contradiction. When they are both rational, then there exist  $m, n \in \mathbb{N}$  such that  $\tau(f) = \tau(g) = \frac{n}{m}$ . Hence, there exist two points  $x_0, y_0 \in \mathbb{R}$ , such that

$$f^m(x_0) = x_0 + n \text{ and } g^m(y_0) = y_0 + n,$$

which implies that there exist compact leaves of  $\mathcal{F}$  and  $\mathcal{G}$  that are in the homotopy class of  $(m, n)$ , contradicting the non-parallel assumption.  $\square$

We endow  $\tilde{\mathcal{F}}$  and  $\tilde{\mathcal{G}}$  with orientations such that they point inward the strip  $S$  at  $\mathbb{R} \times \{0\}$  and point outward at  $\mathbb{R} \times \{1\}$ , and  $\mathcal{F}$  and  $\mathcal{G}$  are endowed with the corresponding orientations. Let  $X$  and  $Y$  be the unit vector fields tangent to  $\mathcal{F}$  and  $\mathcal{G}$  respectively, pointing to the orientation of the corresponding foliation, and  $\tilde{X}$  and  $\tilde{Y}$  be their lifts on  $S$ .

**Claim 5.4.12.** *There are smooth vector fields  $U$  and  $V$  on  $\mathbb{T}^2$  so that*

- *at each point  $x \in \mathbb{T}^2$ , the vertical coordinates of  $U(x)$  and  $V(x)$  are strictly positive. In particular,  $U$  and  $V$  are transverse to the horizontal foliation. We denote by  $\tilde{U}$  and  $\tilde{V}$  the lifts of  $U$  and  $V$  on the strip  $S$ .*

— let  $h$  and  $k$  be the holonomies of  $\tilde{U}$  and  $\tilde{V}$ , respectively, from  $\mathbb{R} \times \{0\}$  to  $\mathbb{R} \times \{1\}$ . These holonomies commute with the translation  $T_1$ , and let  $\tau(h)$  and  $\tau(k)$  denote their translation numbers. Then

$$\tau(f) \leq \tau(h) < \tau(k) \leq \tau(g).$$

*Proof.* Just consider a small enough  $\varepsilon > 0$  and consider smooth vector fields  $U$  and  $V$  arbitrarily  $C^0$  close to  $X + \varepsilon Y$  and  $\varepsilon X + Y$ , respectively.  $\square$

Now the vector fields  $U_t = (1 - t)U + tV$ ,  $t \in [0, 1]$ , are all transverse to both foliations  $\mathcal{F}$ ,  $\mathcal{G}$  and to the horizontal foliation, and they cut  $\mathcal{F}$  and  $\mathcal{G}$  with opposite orientations. We denote by  $\tilde{U}_t$  the lift of  $U_t$  on the strip  $S$ . Let  $\tau_t$  denote the translation number of the holonomy of  $\tilde{U}_t$  from  $\mathbb{R} \times \{0\}$  to  $\mathbb{R} \times \{1\}$ . According to Proposition 2.14.11, the map  $t \mapsto \tau_t$  is a continuous monotonous function joining  $\tau(h)$  to  $\tau(k)$ . As  $\tau(h) < \tau(k)$ , there is  $t \in (0, 1)$  for which  $\tau_t$  is an irrational diophantine number, ending the proof.  $\square$

We end the proof of Theorem 5.4.1 by noticing that Theorem 2.14.13 implies

**Lemma 5.4.13.** *Let  $\mathcal{E}$  be a smooth foliation on  $\mathbb{T}^2$  transverse to the horizontal foliation and so that its holonomy on  $\mathbb{S}^1 \times \{0\}$  is a diffeomorphism with an irrational diophantine rotation number. Then there is a diffeomorphism  $\theta$  of  $\mathbb{T}^2$  which preserves each horizontal circle  $\mathbb{S}^1 \times \{t\}$ , for any  $t \in \mathbb{S}^1$ , and satisfies that  $\theta(\mathcal{E})$  is an affine foliation.*

## 5.5 Deformation process of transverse foliations with parallel compact leaves and proof of Theorem 5.1.2

We dedicate this whole section to give the proof of Theorem 5.1.2. We state a definition which is only used in this section.

**Definition 5.5.1.** *Given a  $C^1$  foliation  $\mathcal{E}$  on the annulus  $[0, 1] \times \mathbb{S}^1 = [0, 1] \times \mathbb{R}/\mathbb{Z}$  without compact leaves such that  $\mathcal{E}$  is transverse to the vertical circle  $\{t\} \times \mathbb{S}^1$ , for any  $t \in [0, 1]$ . The leaves of such a foliation  $\mathcal{E}$  are called*

- not increasing (resp. not decreasing), if the lifted foliation  $\tilde{\mathcal{E}}$  on  $[0, 1] \times \mathbb{R}$  satisfies that every leaf of  $\tilde{\mathcal{E}}$  is not increasing (resp. not decreasing);
- non-degenerate increasing (resp. non-degenerate decreasing), if the lifted foliation  $\tilde{\mathcal{E}}$  on  $[0, 1] \times \mathbb{R}$  satisfies that every leaf of  $\tilde{\mathcal{E}}$  is strictly increasing (resp. strictly decreasing) and transverse to the horizontal foliation  $\{[0, 1] \times \{t\}\}_{t \in \mathbb{R}}$ .

### 5.5.1 Normal form for two transverse foliations with parallel compact leaves and proof of Theorem 5.1.2

The aim of this section is the proof of Theorem 5.1.2. The main step for this proof is the following result which puts any pair of transverse  $C^1$  foliations in a canonical position.

**Theorem 5.5.2.** *Let  $\mathcal{F}$  and  $\mathcal{G}$  be two transverse  $C^1$  foliations on  $\mathbb{T}^2$  admitting parallel compact leaves. Then there are an integer  $k$ , a set of points  $\{t_i\}_{i \in \mathbb{Z}/k\mathbb{Z}}$  in  $\mathbb{S}^1$  which are cyclically ordered on  $\mathbb{S}^1$ , and a diffeomorphism  $\theta: \mathbb{T}^2 \rightarrow \mathbb{T}^2$  so that*

- *the foliations  $\theta(\mathcal{F})$  and  $\theta(\mathcal{G})$  are transverse to  $\{t_i\} \times \mathbb{S}^1$ , for any  $i \in \mathbb{Z}/k\mathbb{Z}$ ;*
- *for each  $i \in \mathbb{Z}/k\mathbb{Z}$ , the restrictions of the foliations  $\theta(\mathcal{F})$  and  $\theta(\mathcal{G})$  to the annulus  $C_i = [t_i, t_{i+1}] \times \mathbb{S}^1$  satisfy one of the six possibilities below*
  1.  *$\theta(\mathcal{F})$  coincides with the horizontal foliation on  $C_i$  and  $\theta(\mathcal{G})$  admits compact leaves in  $C_i$ ;*
  2.  *$\theta(\mathcal{G})$  coincides with the horizontal foliation on  $C_i$  and  $\theta(\mathcal{F})$  admits compact leaves in  $C_i$ ;*
  3. *the foliations  $\theta(\mathcal{F})$  and  $\theta(\mathcal{G})$  are transverse to the vertical foliation on  $C_i$ . Furthermore, every leaf of  $\theta(\mathcal{F})$  (resp. of  $\theta(\mathcal{G})$ ) on  $C_i$  is non-degenerate increasing (resp. not increasing);*
  4. *the foliations  $\theta(\mathcal{F})$  and  $\theta(\mathcal{G})$  are transverse to the vertical foliation on  $C_i$ . Furthermore, every leaf of  $\theta(\mathcal{F})$  (resp. of  $\theta(\mathcal{G})$ ) on  $C_i$  is not increasing (resp. non-degenerate increasing);*
  5. *the foliations  $\theta(\mathcal{F})$  and  $\theta(\mathcal{G})$  are transverse to the vertical foliation on  $C_i$ . Furthermore, every leaf of  $\theta(\mathcal{F})$  (resp. of  $\theta(\mathcal{G})$ ) on  $C_i$  is non-degenerate decreasing (resp. not decreasing);*
  6. *the foliations  $\theta(\mathcal{F})$  and  $\theta(\mathcal{G})$  are transverse to the vertical foliation on  $C_i$ . Furthermore, every leaf of  $\theta(\mathcal{F})$  (resp. of  $\theta(\mathcal{G})$ ) on  $C_i$  is not decreasing (resp. non-degenerate decreasing).*

The proof of Theorem 5.5.2 will be done in the next subsections. We start below by ending the proof of Theorem 5.1.2.

*Proof of Theorem 5.1.2.* Let  $\mathcal{F}$  and  $\mathcal{G}$  be two  $C^1$  foliations of  $\mathbb{T}^2$  admitting parallel compact leaves, and let  $\alpha \in \pi_1(\mathbb{T}^2)$  be the homotopy class of the compact leaves of  $\mathcal{F}$  and  $\mathcal{G}$ . Let  $k > 0$ ,  $\{t_i\}_{i \in \mathbb{Z}/k\mathbb{Z}}$  and  $\theta$  be the integer, the elements of  $\mathbb{S}^1$  and the diffeomorphism given by Theorem 5.5.2, respectively.

One easily checks that there is at least one annulus of the type (1) or (2). As a consequence, the compact leaves of  $\theta(\mathcal{F})$  are isotopic to the vertical circle  $\{0\} \times \mathbb{S}^1$ .



Consider any vertical vector  $(0, t)$ , for  $t \in \mathbb{R}$ , and let  $V_t$  be the vertical translation defined by  $(r, s) \mapsto (r, t + s)$ . Then  $V_t$  preserves each annulus  $C_i$ . Now one can check, on each annulus  $C_i$ , that  $V_t(\theta(\mathcal{F}))$  is transverse to  $\theta(\mathcal{G})$ .

Consider now  $\beta \in \langle \alpha \rangle$ , so that  $\beta = n\alpha$  for some  $n \in \mathbb{Z}$ . Then the announced loop of diffeomorphisms is  $\{\theta^{-1} \circ V_{nt} \circ \theta\}_{t \in [0,1]}$ .  $\square$

## 5.5.2 First decomposition in annuli

By Theorem 2.14.9, the sets of compact leaves of  $\mathcal{F}$  and  $\mathcal{G}$  are all compact sets. We denote the unions of compact leaves of  $\mathcal{F}$  and  $\mathcal{G}$  as  $K_F$  and  $K_G$  respectively. Note that every compact leaf of  $\mathcal{F}$  is disjoint from any compact leaf of  $\mathcal{G}$ , because they are in the same homotopy class, and by assumption,  $\mathcal{F}$  and  $\mathcal{G}$  are transverse. Thus  $K_G$  and  $K_F$  are disjoint compact sets.

The aim of this section is to prove Proposition 5.5.3 below which is an important step for proving Theorem 5.5.2.

**Proposition 5.5.3.** *Let  $\mathcal{F}$  and  $\mathcal{G}$  be two transverse  $C^1$ -foliations on  $\mathbb{T}^2$  having parallel compact leaves. Then there are  $k_0$  and a family  $\{B_i\}_{i \in \mathbb{Z}/4k_0\mathbb{Z}}$  of annuli so that*

- each  $B_i$  is an annulus diffeomorphic to  $[0, 1] \times \mathbb{S}^1$  and embedded in  $\mathbb{T}^2$  whose boundary is transverse to both foliations  $\mathcal{F}$  and  $\mathcal{G}$ .
- $B_i$  is disjoint from  $B_j$  if  $j \notin \{i - 1, i, i + 1\}$ , and  $B_i \cap B_{i+1}$  consists of a common connected component of the boundaries  $\partial B_i$  and  $\partial B_{i+1}$ . In particular, the interiors of these  $B_i$  are pairwise disjoint;
- each annulus  $B_{2j+1}$  is disjoint from the compact leaves of  $\mathcal{F}$  and of  $\mathcal{G}$ , that is

$$B_{2j+1} \cap (K_F \cup K_G) = \emptyset;$$

- each annulus  $B_{4i}$  contains compact leaves of  $\mathcal{F}$  and is disjoint from the compact leaves of  $\mathcal{G}$ ;
- each annulus  $B_{4i+2}$  contains compact leaves of  $\mathcal{G}$  and is disjoint from the compact leaves of  $\mathcal{F}$ .

We say that a compact set  $C$  is a  $\mathcal{F}$ -annulus (resp. a  $\mathcal{G}$ -annulus) if we have the following:

- the compact set  $C$  is diffeomorphic to either  $\mathbb{S}^1$  or  $\mathbb{S}^1 \times [0, 1]$ ;
- the compact set  $C$  is disjoint from  $K_G$  (resp. of  $K_F$ );
- the boundary of  $C$  consists in compact leaves of  $\mathcal{F}$  (resp. of  $\mathcal{G}$ ).

We say that two compact leaves  $L_1, L_2$  of  $\mathcal{F}$  (resp. of  $\mathcal{G}$ ) are  $K_G$ -homotopic (resp.  $K_F$ -homotopic) if  $L_1 \cup L_2$  bounds a  $\mathcal{F}$ -annulus (resp. a  $\mathcal{G}$ -annulus).

**Remark 5.5.4.** — *The union of two non-disjoint  $\mathcal{F}$ -annuli is a  $\mathcal{F}$ -annulus.*  
 — *two compact leaves of  $\mathcal{F}$  are  $K_G$ -homotopic if and only if they are contained in the same  $\mathcal{F}$ -annulus.*

- there is  $\delta > 0$  so that any two compact leaves of  $\mathcal{F}$  passing through points  $x, y$  with  $d(x, y) \leq \delta$  are  $K_G$ -homotopic.

As a direct consequence of Remark 5.5.4, one gets

- Lemma 5.5.5.**
1. The relation of  $K_G$ -homotopy (resp. of  $K_F$ -homotopy) is an equivalence relation on  $K_F$  (resp. of  $K_G$ ).
  2. there are finitely many  $K_G$ -homotopy classes (resp.  $K_F$ -homotopy classes).
  3. There are  $k \in \mathbb{N} \setminus \{0\}$  and pairwise disjoint compact sets  $\{A_i\}_{i \in \mathbb{Z}/2k\mathbb{Z}}$ , so that
    - $A_{2i}$  is a  $\mathcal{F}$ -annulus and  $A_{2i+1}$  is a  $\mathcal{G}$ -annulus.
    - For each  $K_G$ -homotopy class (resp.  $K_F$ -homotopy class) of compact leaves of  $\mathcal{F}$  (resp. of  $\mathcal{G}$ ), there is a (unique)  $i$  so that the class is precisely the set of compact leaves of  $\mathcal{F}$  (resp. of  $\mathcal{G}$ ) contained in  $A_{2i}$  (resp. in  $A_{2i+1}$ ).
    - these  $\{A_i\}$  are cyclically ordered in the following meaning: for any  $i \in \mathbb{Z}/2k\mathbb{Z}$ , the set  $\mathbb{T}^2 \setminus (A_{i-1} \cup A_{i+1})$  consists precisely in two disjoint open annuli such that one of them contains  $A_i$  and is disjoint from  $A_j$  for  $j \neq i$ .

*Proof.* The set  $\{A_i\}$  is defined as the set of the unions of all the  $\mathcal{F}$ -annuli containing compact leaves of  $\mathcal{F}$  in a given  $K_G$  homotopy class and the unions of all the  $\mathcal{G}$ -annuli containing compact leaves of  $\mathcal{G}$  in a given  $K_F$  homotopy class. Then  $\{A_i\}$  bound a family of disjoint compact annuli (or circles) whose boundary are non-null homotopic simple curves on  $\mathbb{T}^2$ . Thus these curves are in the same homotopy class and the annuli are cyclically ordered on  $\mathbb{T}^2$ . Thus, up to reorder the annuli, we assume that the order is compatible with the cyclic order. Finally if  $A_i$  is a  $\mathcal{F}$  annulus then  $A_{i+1}$  cannot be a  $\mathcal{F}$ -annulus, otherwise there would exist a  $\mathcal{F}$ -annulus containing both  $A_i$  and  $A_{i+1}$ , contradicting to the maximality of  $A_i$ .  $\square$

The annuli  $A_{2i}$  and  $A_{2i+1}$  will be called the *maximal  $\mathcal{F}$ -annuli* and *maximal  $\mathcal{G}$ -annuli*, respectively.

**Lemma 5.5.6.** *With the hypotheses and terminology above, each maximal  $\mathcal{F}$ -annulus (resp. maximal  $\mathcal{G}$ -annulus)  $A$  admits a base of neighborhoods  $\{B_n\}_{n \in \mathbb{N}}$  which are diffeomorphic to  $[0, 1] \times \mathbb{S}^1$  and whose boundaries are transverse to both  $\mathcal{F}$  and  $\mathcal{G}$ .*

*Proof.* Assume for instance that  $A$  is a maximal  $\mathcal{F}$ -annulus. Its boundary consists in compact leaves of  $\mathcal{F}$ , and in particular is transverse to  $\mathcal{G}$ . Furthermore any neighborhood  $V$  of  $A$  contains an annulus  $U$  which is a neighborhood of  $A$  and satisfies that  $U \setminus A$  is disjoint from  $K_F$  and  $K_G$ . Now each connected component of  $U \setminus A$  contains an embedded circle which consists in exactly one segment of leaf of  $\mathcal{F}$  and one segment of leaf of  $\mathcal{G}$ . Exactly as in Section 5.2,

we get a simple closed curve transverse to both  $\mathcal{F}$  and  $\mathcal{G}$  by smoothing such a curve.

One gets the announced annulus by considering such a transverse curve to both  $\mathcal{F}$  and  $\mathcal{G}$  in each connected component of  $U \setminus A$ .  $\square$

*Proof of Proposition 5.5.3.* The announced annuli  $B_{4i}$  and  $B_{4i+2}$  are pairwise disjoint neighborhoods of the maximal  $\mathcal{F}$ -annuli and maximal  $\mathcal{G}$ -annuli, respectively, given by Lemma 5.5.6. Each annulus  $B_{2j+1}$  is given by the closure of a connected component of  $\mathbb{T}^2 \setminus \bigcup_i (B_{4i} \cup B_{4i+2})$ .  $\square$

### 5.5.3 In the neighborhoods of the maximal $\mathcal{F}$ annuli

The aim of this section is to prove the following Proposition which implies that, in the neighborhoods of the maximal  $\mathcal{F}$  and  $\mathcal{G}$ -annuli, one can put  $\mathcal{F}$  and  $\mathcal{G}$  in the position announced by Theorem 5.5.2.

**Proposition 5.5.7.** *Let  $\mathcal{F}$  and  $\mathcal{G}$  be two transverse foliations on  $\mathbb{T}^2$  having parallel compact leaves. Let  $\{B_j\}_{j \in \mathbb{Z}/4k\mathbb{Z}}$  be the annuli, which are built in Proposition 5.5.3 and whose boundaries are transverse to both  $\mathcal{F}$  and  $\mathcal{G}$ , and  $A_{4i}$  (resp.  $A_{4i+2}$ ) be the maximal  $\mathcal{F}$ -annuli (resp.  $\mathcal{G}$ -annuli) contained in  $B_{4i}$  (resp. in  $B_{4i+2}$ ), for  $i \in \mathbb{Z}/k\mathbb{Z}$ .*

*Then there exists  $\theta \in \text{Diff}^1(\mathbb{T}^2)$  such that for every  $j \in \mathbb{Z}/4k\mathbb{Z}$ , one has*

$$\theta(B_j) = \left[ \frac{j}{4k}, \frac{j+1}{4k} \right] \times \mathbb{S}^1;$$

and for every  $i \in \mathbb{Z}/k\mathbb{Z}$ , one has:

- the foliation  $\theta(\mathcal{G})$  coincides with the horizontal foliation  $\left\{ \left[ \frac{4i}{4k}, \frac{4i+1}{4k} \right] \times \{t\} \right\}_{t \in \mathbb{S}^1}$  on  $\theta(B_{4i}) = \left[ \frac{4i}{4k}, \frac{4i+1}{4k} \right] \times \mathbb{S}^1$ ;
- there are  $\frac{4i}{4k} < a_{4i} \leq b_{4i} < \frac{4i+1}{4k}$  such that  $\theta(A_{4i}) = [a_{4i}, b_{4i}] \times \mathbb{S}^1$ . In particular,  $\{a_{4i}\} \times \mathbb{S}^1$  and  $\{b_{4i}\} \times \mathbb{S}^1$  are compact leaves of  $\theta(\mathcal{F})$ ;
- the foliation  $\theta(\mathcal{F})$  is transverse to the vertical circle  $\{r\} \times \mathbb{S}^1$ , for any  $r \in \left[ \frac{4i}{4k}, a_{4i} \right) \cup (b_{4i}, \frac{4i+1}{4k}]$ .

and similarly:

- the foliation  $\theta(\mathcal{F})$  coincides with the horizontal foliation  $\left\{ \left[ \frac{4i+2}{4k}, \frac{4i+3}{4k} \right] \times \{t\} \right\}_{t \in \mathbb{S}^1}$  on  $\theta(B_{4i+2}) = \left[ \frac{4i+2}{4k}, \frac{4i+3}{4k} \right] \times \mathbb{S}^1$
- there are  $\frac{4i+2}{4k} < a_{4i+2} \leq b_{4i+2} < \frac{4i+3}{4k}$  so that  $\theta(A_{4i+2}) = [a_{4i+2}, b_{4i+2}] \times \mathbb{S}^1$ . In particular,  $\{a_{4i+2}\} \times \mathbb{S}^1$  and  $\{b_{4i+2}\} \times \mathbb{S}^1$  are compact leaves of  $\theta(\mathcal{G})$ ;
- the foliation  $\theta(\mathcal{G})$  is transverse to the vertical circle  $\{r\} \times \mathbb{S}^1$ , for any  $r \in \left[ \frac{4i+2}{4k}, a_{4i+2} \right) \cup (b_{4i+2}, \frac{4i+3}{4k}]$ .

Proposition 5.5.7 is a straightforward consequence of Lemma 5.5.8 below:

**Lemma 5.5.8.** *Let  $\mathcal{F}$  and  $\mathcal{G}$  be two transverse  $C^1$ -foliations of the annulus  $[0, 1] \times \mathbb{S}^1$  so that the boundary  $\{0, 1\} \times \mathbb{S}^1$  is transverse to both  $\mathcal{F}$  and  $\mathcal{G}$ . Assume that  $\mathcal{G}$  has no compact leaves (in  $(0, 1) \times \mathbb{S}^1$ ) and  $\mathcal{F}$  admits compact leaves in  $(0, 1) \times \mathbb{S}^1$ .*

*Then there exists  $\theta \in \text{Diff}^1([0, 1] \times \mathbb{S}^1)$  so that*

1. *the foliation  $\theta(\mathcal{G})$  is the horizontal foliation  $\{[0, 1] \times \{t\}\}_{t \in \mathbb{S}^1}$ .*
2. *there are  $0 < a \leq b < 1$  so that  $\{a\} \times \mathbb{S}^1$  and  $\{b\} \times \mathbb{S}^1$  are compact leaves of  $\theta(\mathcal{F})$  and every compact leaf of  $\theta(\mathcal{F})$  is contained in  $[a, b] \times \mathbb{S}^1$ ;*
3. *the foliation  $\theta(\mathcal{F})$  is transverse to the vertical circle  $\{r\} \times \mathbb{S}^1$  for  $r \notin [a, b]$ .*

The proof of Lemma 5.5.8 uses the Lemma 5.5.9 below

**Lemma 5.5.9.** *For any continuous function  $\varphi : [0, 1] \mapsto [0, +\infty)$  such that  $\varphi > 0$  on  $(0, 1)$ , and any interval  $(c, d) \subset (0, 1) \subset \mathbb{S}^1$ , there exists  $\theta \in \text{Diff}^\infty(\mathbb{R} \times \mathbb{S}^1)$  such that*

- *the diffeomorphism  $\theta$  coincides with the identity map out of  $[0, 1] \times \mathbb{S}^1$ ;*
- *$\theta([0, 1] \times \{y\}) = [0, 1] \times \{y\}$ ;*
- *$D\theta(\frac{\partial}{\partial y}) = \frac{\partial}{\partial y} + a(x, y)\frac{\partial}{\partial x}$ ;*
- *$a(x, y) > 0$ , for any  $(x, y) \in (0, 1) \times (c, d)$ ;*
- *$a(x, y) > -\varphi(x)$ , for any  $(x, y) \in (0, 1) \times \mathbb{S}^1$ .*

*Proof.* We fix  $c < d$  and take a point  $e \in (d, 1)$ . We take  $\theta(x, y) = (x + \alpha(x)\beta(y), y)$  where  $\alpha : \mathbb{R} \rightarrow [0, +\infty)$  and  $\beta : \mathbb{S}^1 \rightarrow [0, 1]$  are smooth functions so that

- $\alpha(x)$  is defined on  $\mathbb{R}$  and equals to zero in  $(-\infty, 0] \cup [1, +\infty)$ ;
- $0 < \alpha(x) < \varphi(x)$  in the set  $(0, 1)$  and  $\alpha \equiv 0$  out of  $[0, 1]$  (the existence of such a function is not hard to check);
- the derivative  $\alpha'(x)$  is everywhere strictly larger than  $-1$ ;
- $\beta(y)$  is equal to zero in the set  $[0, c] \cup [e, 1]$ ;
- the derivative  $\beta'(y)$  is strictly positive for  $y \in (c, d)$ ;
- the derivative  $\beta'(y)$  is larger than  $-1$  everywhere.

With this choice, one gets that the restriction of  $\theta$  to any horizontal line has a non-vanishing derivative, hence is a diffeomorphism. One deduces that  $\theta$  is a diffeomorphism of  $[0, 1] \times \mathbb{S}^1$ . Furthermore, the function  $a(x, y)$  in the statement is  $\alpha(x) \cdot \beta'(y)$  which is strictly positive on  $(0, 1) \times (c, d)$  and larger than  $-\alpha(x) > -\varphi(x)$  for  $x \in (0, 1)$ , concluding the proof.  $\square$

**Remark 5.5.10.** *In the proof of Lemma 5.5.9, if we define  $\theta_t$  by*

$$\theta_t(x, y) = (x + t\alpha(x)\beta(y), y), \text{ for any } t \in [0, 1],$$

*one gets a continuous family of diffeomorphisms for the  $C^\infty$  topology so that  $\theta_0$  is the identity map and every  $\theta_t$ ,  $t \neq 0$ , satisfies the conclusion of Lemma 5.5.9. In particular, in Lemma 5.5.9 one may choose  $\theta$  arbitrarily  $C^\infty$  close to identity.*

*Proof of Lemma 5.5.8.* As  $\mathcal{G}$  is transverse to the boundary and has no compact leaves in  $[0, 1] \times \mathbb{S}^1$ , then as a simple corollary of Proposition 2.14.14 one gets that, up to consider the images of  $\mathcal{F}$  and  $\mathcal{G}$  by a diffeomorphism of the annulus, we may assume that  $\mathcal{G}$  is the horizontal foliation and that there are compact leaves  $\{a\} \times \mathbb{S}^1$  and  $\{b\} \times \mathbb{S}^1$ ,  $0 < a \leq b < 1$ , so that the compact leaves of  $\mathcal{F}$  are contained in  $[a, b] \times \mathbb{S}^1$ . In other words, we may assume that items (1) and (2) are already satisfied. It remains to get item (3), that is, to get the transversality of  $\mathcal{F}$  with the vertical fibers out of  $[a, b] \times \mathbb{S}^1$ .

We first show

**Claim 5.5.11.** *There is a  $C^1$  foliation  $\mathcal{H}$  defined in a neighborhood of the compact leaf  $\{a\} \times \mathbb{S}^1$  so that*

- *the leaves of  $\mathcal{H}$  are transverse to the horizontal foliation  $\mathcal{G}$ ;*
- *$\{a\} \times \mathbb{S}^1$  is a compact leaf of  $\mathcal{H}$ ;*
- *the holonomies  $h$  and  $f$  on the transversal  $[0, 1] \times \{0\}$  for the foliations  $\mathcal{H}$  and  $\mathcal{F}$  are equal;*
- *the foliation  $\mathcal{H}$  is transverse to the vertical circle  $\{r\} \times \mathbb{S}^1$ , for  $r < a$ .*

*Proof.* We fix  $0 < \varepsilon < 1/2$  and a function  $\alpha: [0, 1] \rightarrow [0, 1]$  so that  $\alpha \equiv 0$  in  $[0, \varepsilon]$ ,  $\alpha \equiv 1$  in  $[1 - \varepsilon, 1]$  and  $\alpha'(s) > 0$  for  $s \in (\varepsilon, 1 - \varepsilon)$ .

Consider the foliation  $\mathcal{H}_0$ , defined in a neighborhood of the compact leaf  $\{a\} \times \mathbb{S}^1$ , whose holonomy map  $h_s: [0, 1] \times \{0\} \rightarrow [0, 1] \times \{s\}$ , for any  $s \in \mathbb{S}^1$ , is defined by  $r \mapsto \alpha(s)f(r) + (1 - \alpha(s))r$ , where  $f: [0, 1] \times \{0\} \rightarrow [0, 1] \times \{0\}$  is the holonomy map of  $\mathcal{F}$ .

As  $\mathcal{F}$  has no compact leaves on  $[0, a) \times \mathbb{S}^1$ , one gets that  $f(r) \neq r$  for every  $r < a$ . Thus, by the choice of  $\mathcal{H}_0$ , we have that

- $\mathcal{H}_0$  is transverse to the horizontal foliation everywhere;
- $\mathcal{H}_0$  is transverse to the vertical foliation at each point  $(r, s)$  with  $r < a$  and  $s \in (\varepsilon, 1 - \varepsilon)$ ;
- $\mathcal{H}_0$  is vertical for  $s$  in the interval  $[0, \varepsilon] \cup [1 - \varepsilon, 1] = [-\varepsilon, \varepsilon] \subset \mathbb{R}/\mathbb{Z} = \mathbb{S}^1$ .

We fix an interval  $[e, f] \subset \mathbb{S}^1$  disjoint from  $[-\varepsilon, \varepsilon]$ . The foliation  $\mathcal{H}_0$  is directed by vectors of the form  $\frac{\partial}{\partial s} + \delta(r, s) \frac{\partial}{\partial r}$ , where the function  $\delta$  is continuous and non-vanishing on  $[0, a) \times [e, f]$ . We define  $\varphi(r) = \inf_{s \in [e, f]} |\delta(r, s)|$ . By the absolute continuity of  $\delta$ , the map  $\varphi$  is continuous and positive for  $r < a$ . The map  $\varphi$  is only defined on a small neighborhood of  $a$ , and we extend it to  $[0, a]$  as a continuous function which is positive on  $(0, a)$ .

Applying Lemma 5.5.9 to  $\varphi$  and to an interval  $(c, d)$  containing  $[-\varepsilon, \varepsilon]$  and disjoint from  $[e, f]$ , one gets a smooth diffeomorphism  $\theta_0$  of  $[0, a] \times \mathbb{S}^1$ , preserving each horizontal leaf, such that  $\theta_0(\mathcal{H}_0)$  is transverse to the vertical foliation on  $[0, a) \times \mathbb{S}^1$ , concluding the proof of the claim. □

The foliation  $\mathcal{H}$  defined by the claim in a neighborhood of  $\{a\} \times \mathbb{S}^1$ , is conjugated to  $\mathcal{F}$  by a diffeomorphism preserving the compact leaf  $\{a\} \times \mathbb{S}^1$  and

every horizontal segment  $[0, 1] \times \{s\}$ . We can do the same in a neighborhood of the compact leaf  $\{b\} \times \mathbb{S}^1$ .

Thus there is a diffeomorphism  $\theta_1$  of  $[0, 1] \times \mathbb{S}^1$  preserving the leaves  $\{a\} \times \mathbb{S}^1$  and  $\{b\} \times \mathbb{S}^1$  and preserving every horizontal segment  $[0, 1] \times \{s\}$ , and there is  $\varepsilon > 0$  so that  $\theta_1(\mathcal{F})$  is transverse to the vertical circles on  $[a - \varepsilon, a) \times \mathbb{S}^1$  and on  $(b, b + \varepsilon] \times \mathbb{S}^1$ .

For concluding the proof, it remains to put the foliation  $\mathcal{F}$  transverse to the vertical circles on the annuli  $[0, a - \varepsilon] \times \mathbb{S}^1$  and  $[b + \varepsilon, 1] \times \mathbb{S}^1$ . On each of these annuli, we have that

- $\mathcal{G}$  is a foliation transverse to the circle bundle;
- $\mathcal{F}$  is transverse everywhere to  $\mathcal{G}$ ;
- Both  $\mathcal{F}$  and  $\mathcal{G}$  are transverse to the boundary and have no compact leaf.

Thus applying Lemma 5.4.9 to these annuli, one gets diffeomorphisms which preserve each leaf of  $\mathcal{G}$  and equal to the identity map on the boundary, such that these diffeomorphisms send  $\mathcal{F}$  on a foliation transverse to the circle bundle, concluding the proof.  $\square$

Let us add a statement that we will not use, but it is obtained by a slight modification of the proof of Lemma 5.5.8:

**Corollary 5.5.12.** *Let  $\mathcal{F}$  and  $\mathcal{G}$  be two transverse  $C^1$ -foliations of the annulus  $[0, 1] \times \mathbb{S}^1$  which are both transverse to the boundary. We assume that  $\mathcal{G}$  has no compact leaves in the interior of the annulus. Then there is a diffeomorphism  $\theta$  of the annulus so that  $\theta(\mathcal{G})$  is the horizontal foliation  $\{[0, 1] \times \{s\}\}_{s \in \mathbb{S}^1}$  and  $\theta(\mathcal{F})$  satisfies the following properties:*

- every compact leaf of  $\theta(\mathcal{F})$  is a vertical circle;
- every non compact leaf of  $\theta(\mathcal{F})$  is transverse to the vertical circles.

*Furthermore,  $\theta$  has the same regularity as  $\mathcal{F}$  and  $\mathcal{G}$ . Finally, if  $\mathcal{G}$  is already the horizontal foliation, then  $\theta$  can be chosen preserving every leaf of  $\mathcal{G}$  and equal to the identity map in a neighborhood of the boundary of the annulus.*

*Proof.* The unique change is that, in the last part of the proof, we will need to use Lemma 5.5.9 in any connected component of the complement of the compact leaves of  $\mathcal{F}$ , that is, countably many times. For that we uses Remark 5.5.10 for choosing these diffeomorphisms arbitrarily  $C^\infty$ -close to identity.  $\square$

#### 5.5.4 Between two maximal $\mathcal{F}$ and $\mathcal{G}$ -annuli

The aim of this section is to end the proof of Theorem 5.5.2 and therefore to end the proof of Theorem 5.1.2. We consider two transverse  $C^1$  foliations  $\mathcal{F}, \mathcal{G}$  on  $\mathbb{T}^2$  with parallel compact leaves.

According to Propositions 5.5.3 and 5.5.7, there is a diffeomorphism  $\theta_0$  of the torus  $\mathbb{T}^2$  so that, up to replace  $\mathcal{F}$  and  $\mathcal{G}$  by  $\theta_0(\mathcal{F})$  and  $\theta_0(\mathcal{G})$ , there is an integer  $k > 0$  for which  $\mathcal{F}$  and  $\mathcal{G}$  satisfy the following properties

- both foliations  $\mathcal{F}$  and  $\mathcal{G}$  are transverse to every vertical circle  $\{\frac{j}{4k}\} \times \mathbb{S}^1$ , for any  $j \in \mathbb{Z}/4k\mathbb{Z}$ ;
- both foliations  $\mathcal{F}$  and  $\mathcal{G}$  have no compact leaves on the vertical annuli  $[\frac{2i+1}{4k}, \frac{2i+2}{4k}] \times \mathbb{S}^1$ , for any  $i \in \mathbb{Z}/2k\mathbb{Z}$ ;
- the foliation  $\mathcal{G}$  coincides with the horizontal foliation on each vertical annulus  $[\frac{4i}{4k}, \frac{4i+1}{4k}] \times \mathbb{S}^1$ , for any  $i \in \mathbb{Z}/k\mathbb{Z}$ ;
- there are  $\frac{4i}{4k} < a_{4i} \leq b_{4i} < \frac{4i+1}{4k}$  such that
  - $\{a_{4i}\} \times \mathbb{S}^1$  and  $\{b_{4i}\} \times \mathbb{S}^1$  are compact leaves of  $\mathcal{F}$ ;
  - every compact leaf of  $\mathcal{F}$  in  $[\frac{4i}{4k}, \frac{4i+1}{4k}] \times \mathbb{S}^1$  is contained in  $[a_{4i}, b_{4i}] \times \mathbb{S}^1$ ;
  - $\mathcal{F}$  is transverse to the vertical circles on  $([\frac{4i}{4k}, a_{4i}] \cup (b_{4i}, \frac{4i+1}{4k}]) \times \mathbb{S}^1$ ;
- the foliation  $\mathcal{F}$  coincides with the horizontal foliation on each vertical annulus  $[\frac{4i+2}{4k}, \frac{4i+3}{4k}] \times \mathbb{S}^1$ , for any  $i \in \mathbb{Z}/k\mathbb{Z}$ ;
- there are  $\frac{4i+2}{4k} < a_{4i+2} \leq b_{4i+2} < \frac{4i+3}{4k}$  such that
  - $\{a_{4i+2}\} \times \mathbb{S}^1$  and  $\{b_{4i+2}\} \times \mathbb{S}^1$  are compact leaves of  $\mathcal{G}$ ;
  - every compact leaf of  $\mathcal{G}$  in  $[\frac{4i+2}{4k}, \frac{4i+3}{4k}] \times \mathbb{S}^1$  is contained in  $[a_{4i+2}, b_{4i+2}] \times \mathbb{S}^1$ ;
  - $\mathcal{G}$  is transverse to the vertical circles on  $([\frac{4i+2}{4k}, a_{4i+2}] \cup (b_{4i+2}, \frac{4i+3}{4k}]) \times \mathbb{S}^1$ .

The following Proposition ends the proof of Theorem 5.5.2:

**Proposition 5.5.13.** *With the hypotheses and notations above, for any  $i \in \mathbb{Z}/2k\mathbb{Z}$ , there is a diffeomorphism  $\theta_i$  of  $\mathbb{T}^2$  supported on  $(b_{2i}, a_{2i+2}) \times \mathbb{S}^1$  such that for the restrictions  $\mathcal{F}_i$  of  $\theta_i(\mathcal{F})$  and  $\mathcal{G}_i$  of  $\theta_i(\mathcal{G})$  to  $[b_{2i}, a_{2i+2}] \times \mathbb{S}^1$ , we have the followings:*

- the leaves of both  $\mathcal{F}_i$  and  $\mathcal{G}_i$  are transverse to every vertical circle  $\{r\} \times \mathbb{S}^1$ , for any  $r \in [b_{2i}, a_{2i+2}]$ ;
- the leaves of  $\mathcal{F}_i$  and  $\mathcal{G}_i$  satisfy one of the four possibilities below:
  1. the leaves of  $\mathcal{F}_i$  (resp. of  $\mathcal{G}_i$ ) are not decreasing (resp. non-degenerate decreasing) on  $[b_{2i}, \frac{b_{2i}+a_{2i+2}}{2}] \times \mathbb{S}^1$  and are non-degenerate increasing (resp not increasing) on  $[\frac{b_{2i}+a_{2i+2}}{2}, a_{2i+2}] \times \mathbb{S}^1$ ;
  2. the leaves of  $\mathcal{F}_i$  (resp. of  $\mathcal{G}_i$ ) are not increasing (resp. non-degenerate increasing) on  $[b_{2i}, \frac{b_{2i}+a_{2i+2}}{2}] \times \mathbb{S}^1$  and are non-degenerate decreasing (resp. not decreasing) on  $[\frac{b_{2i}+a_{2i+2}}{2}, a_{2i+2}] \times \mathbb{S}^1$ ;
  3. the leaves of  $\mathcal{G}_i$  (resp. of  $\mathcal{F}_i$ ) are not decreasing (resp. non-degenerate decreasing) on  $[b_{2i}, \frac{b_{2i}+a_{2i+2}}{2}] \times \mathbb{S}^1$  and are non-degenerate increasing (resp. not increasing) on  $[\frac{b_{2i}+a_{2i+2}}{2}, a_{2i+2}] \times \mathbb{S}^1$ ;
  4. the leaves of  $\mathcal{G}_i$  (resp. of  $\mathcal{F}_i$ ) are not increasing (resp. non-degenerate increasing) on  $[b_{2i}, \frac{b_{2i}+a_{2i+2}}{2}] \times \mathbb{S}^1$  and are non-degenerate decreasing (resp. not decreasing) on  $[\frac{b_{2i}+a_{2i+2}}{2}, a_{2i+2}] \times \mathbb{S}^1$ .

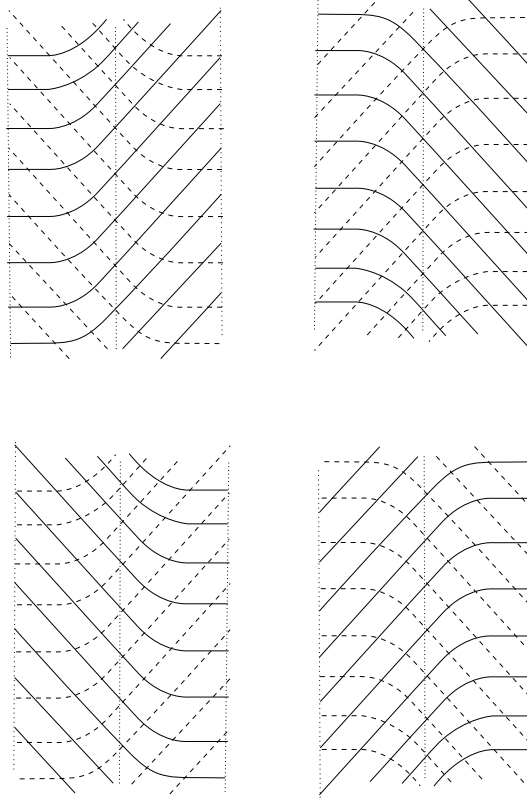

Figure 5.4 – In each figure, the real lines denote the leaves of  $\mathcal{F}_i$  and the dash lines denote the leaves of  $\mathcal{G}_i$ .

We start by using Proposition 5.5.13 to end the proof of Theorem 5.5.2

*Proof of Theorem 5.5.2.* Let  $\{\theta_\ell\}_{\ell \in \mathbb{Z}/2k\mathbb{Z}}$  be the sequence of diffeomorphisms on annuli, which are given by Proposition 5.5.13. We take four sets of points  $\{d_{4i}\}_{i \in \mathbb{Z}/k\mathbb{Z}}$ ,  $\{c_{4i+2}\}_{i \in \mathbb{Z}/k\mathbb{Z}}$ ,  $\{d_{4i+2}\}_{i \in \mathbb{Z}/k\mathbb{Z}}$  and  $\{c_{4i+4}\}_{i \in \mathbb{Z}/k\mathbb{Z}}$  on  $\mathbb{S}^1$  such that

$$b_{4i} < d_{4i} < \frac{b_{4i} + a_{4i+2}}{2} < c_{4i+2} < a_{4i+2};$$

$$b_{4i+2} < d_{4i+2} < \frac{b_{4i+2} + a_{4(i+1)}}{2} < c_{4(i+1)} < a_{4(i+1)};$$

— The set  $\{c_{4i+2}, c_{4i+4}, d_{4i+2}, d_{4i+2}\}_{i \in \mathbb{Z}/k\mathbb{Z}}$  is disjoint from the union of the supports of all  $\{\theta_\ell\}_{\ell \in \mathbb{Z}/2k\mathbb{Z}}$ .

We choose the annuli  $\{C_j\}_{j \in \mathbb{Z}/6k\mathbb{Z}}$  as follows

- each annulus  $C_{6i}$  is the vertical annulus  $[c_{4i}, d_{4i}] \times \mathbb{S}^1$ ; notice that it contains  $[a_{4i}, b_{4i}] \times \mathbb{S}^1$  in its interior;
- each annulus  $C_{6i+1}$  is the vertical annulus  $[d_{4i}, \frac{1}{2}(b_{4i} + a_{4i+2})] \times \mathbb{S}^1$ ;
- each annulus  $C_{6i+2}$  is the vertical annulus  $[\frac{1}{2}(b_{4i} + a_{4i+2}), c_{4i+2}] \times \mathbb{S}^1$ ;



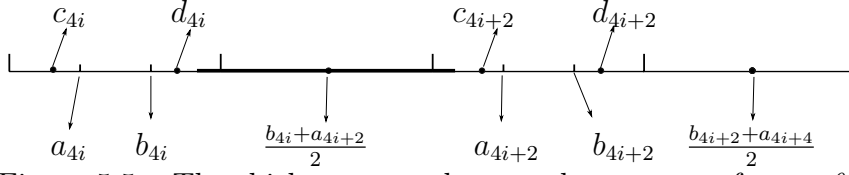

Figure 5.5 – The thick segment denotes the support of some  $\theta_\ell$ .

- each annulus  $C_{6i+3}$  is the vertical annulus  $[c_{4i+2}, d_{4i+2}] \times \mathbb{S}^1$  containing  $[a_{4i+2}, b_{4i+2}] \times \mathbb{S}^1$  in its interior;
- each annulus  $C_{6i+4}$  is the vertical annulus  $[d_{4i+2}, \frac{1}{2}(b_{4i+2} + a_{4(i+1)})] \times \mathbb{S}^1$ ;
- each annulus  $C_{6i+5}$  is the vertical annulus  $[\frac{1}{2}(b_{4i+2} + a_{4(i+1)}), c_{4(i+1)}] \times \mathbb{S}^1$ . □

It remains to prove Proposition 5.5.13.

**Lemma 5.5.14.** *Let  $\mathcal{F}$  and  $\mathcal{G}$  be two transverse foliations on  $[0, 1] \times \mathbb{S}^1$  so that:*

- $\{0\} \times \mathbb{S}^1$  is a compact leaf of  $\mathcal{F}$ ;
- $\{1\} \times \mathbb{S}^1$  is a compact leaf of  $\mathcal{G}$ ;
- $\mathcal{F}$  and  $\mathcal{G}$  have no compact leaves in  $(0, 1) \times \mathbb{S}^1$ ;
- there is a neighborhood  $U_0 = [0, \varepsilon_0] \times \mathbb{S}^1$  of  $\{0\} \times \mathbb{S}^1$  on which  $\mathcal{G}$  coincides with the horizontal foliation and  $\mathcal{F}$  is transverse to the vertical circles;
- there is a neighborhood  $U_1 = [1 - \varepsilon_0, 1] \times \mathbb{S}^1$  of  $\{1\} \times \mathbb{S}^1$  on which  $\mathcal{F}$  coincides with the horizontal foliation and  $\mathcal{G}$  is transverse to the vertical circles.

Then for any  $0 < \varepsilon < \varepsilon_0$  the holonomies of  $\mathcal{F}$  and  $\mathcal{G}$  from  $\Sigma_{0,\varepsilon} = \{\varepsilon\} \times \mathbb{S}^1$  to  $\Sigma_{1,\varepsilon} = \{1 - \varepsilon\} \times \mathbb{S}^1$  are well defined. Consider the lifts  $\tilde{\mathcal{F}}$  and  $\tilde{\mathcal{G}}$  of  $\mathcal{F}$  and  $\mathcal{G}$  on the universal cover  $[0, 1] \times \mathbb{R}$ . The holonomies  $f_\varepsilon$  and  $g_\varepsilon$  of  $\tilde{\mathcal{F}}$  and  $\tilde{\mathcal{G}}$  from  $\{\varepsilon\} \times \mathbb{R}$  to  $\{1 - \varepsilon\} \times \mathbb{R}$  are well defined. Then for any  $\varepsilon > 0$  small enough one has:

$$(f_\varepsilon(x) - x) \cdot (g_\varepsilon(x) - x) < 0, \text{ for every } x \in \mathbb{R}.$$

*Proof.* On  $U_0 \setminus \{0\} \times \mathbb{S}^1$ , the foliation  $\mathcal{F}$  is transverse to the horizontal segments and to the vertical circles. Therefore its leaves are either non-degenerate increasing or non-degenerate decreasing curves. Let us assume that they are non-degenerate increasing (the other case is similar).

Notice that, on  $[\varepsilon_0, 1 - \varepsilon_0] \times \mathbb{S}^1$ , the foliations  $\mathcal{F}$  and  $\mathcal{G}$  are transverse to the boundary and are transverse to each other. We orient  $\mathcal{F}$  and  $\mathcal{G}$  from  $\{\varepsilon_0\} \times \mathbb{S}^1$  to  $\{1 - \varepsilon_0\} \times \mathbb{S}^1$ . As  $\mathcal{F}$  is increasing along  $\{\varepsilon_0\} \times \mathbb{S}^1$  and horizontal along  $\{1 - \varepsilon_0\} \times \mathbb{S}^1$ , and as  $\mathcal{G}$  is horizontal along  $\{\varepsilon_0\} \times \mathbb{S}^1$ , one gets that  $\mathcal{G}$  is decreasing along  $\{1 - \varepsilon_0\} \times \mathbb{S}^1$ . Thus the leaves of  $\mathcal{G}$  are decreasing curves on  $U_1 \setminus \{1\} \times \mathbb{S}^1$ .

Let us denote by

$$f_{\varepsilon,0}: \{\varepsilon\} \times \mathbb{R} \rightarrow \{\varepsilon_0\} \times \mathbb{R}$$

$$f_{1,\varepsilon}: \{1 - \varepsilon_0\} \times \mathbb{R} \rightarrow \{1 - \varepsilon\} \times \mathbb{R}$$

and

$$g_{\varepsilon,0}: \{\varepsilon\} \times \mathbb{R} \rightarrow \{\varepsilon_0\} \times \mathbb{R}$$

$$g_{1,\varepsilon}: \{1 - \varepsilon_0\} \times \mathbb{R} \rightarrow \{1 - \varepsilon\} \times \mathbb{R}$$

the holonomies of  $\tilde{\mathcal{F}}$  and  $\tilde{\mathcal{G}}$  on the corresponding transversals. We consider them as diffeomorphisms of  $\mathbb{R}$  (that is we forget the horizontal coordinate).

Then  $g_{\varepsilon,0} = f_{1,\varepsilon}$  are equal to the identity map as they are horizontal foliations in the corresponding regions.

Thus one gets that

$$f_\varepsilon = f_{\varepsilon_0} \circ f_{\varepsilon,0} \text{ and } g_\varepsilon = g_{1,\varepsilon} \circ g_{\varepsilon_0}.$$

Now Lemma 5.5.14 follows directly from the following claim:

**Claim 5.5.15.**  $f_{\varepsilon,0}(x) - x$  and  $g_{1,\varepsilon}(x) - x$  converge uniformly to  $+\infty$  and  $-\infty$ , respectively, as  $\varepsilon$  tends to 0.

The claim follows directly from the fact that the leaves of  $\tilde{\mathcal{F}}$  (resp.  $\tilde{\mathcal{G}}$ ) are non-degenerate increasing (resp. non-degenerate decreasing) curves asymptotic to the vertical line  $\{0\} \times \mathbb{R}$  (resp.  $\{1\} \times \mathbb{R}$ ) according to the negative orientation (resp. positive orientation).  $\square$

One ends the proof of Proposition 5.5.13 by proving:

**Lemma 5.5.16.** *Let  $\mathcal{F}$  and  $\mathcal{G}$  be two transverse  $C^1$  foliations on the annulus  $[0, 1] \times \mathbb{S}^1$  which are transverse to the boundary and do not have any compact leaf in the interior. We denote by  $\tilde{\mathcal{F}}$  and  $\tilde{\mathcal{G}}$  the lifts of  $\mathcal{F}$  and  $\mathcal{G}$  to  $[0, 1] \times \mathbb{R}$ . Under that hypotheses, the holonomies of  $\tilde{\mathcal{F}}$  and  $\tilde{\mathcal{G}}$  from  $\{0\} \times \mathbb{R}$  to  $\{1\} \times \mathbb{R}$  are well defined and we denote them as  $f$  and  $g$ , respectively (and we consider them as diffeomorphisms of  $\mathbb{R}$ ). Assume that:*

- the foliation  $\mathcal{G}$  (resp.  $\mathcal{F}$ ) coincides with the horizontal foliation on a neighborhood of  $\{0\} \times \mathbb{S}^1$  (resp.  $\{1\} \times \mathbb{S}^1$ );
- for every  $x \in \mathbb{R}$ , one has  $f(x) > x$  and  $g(x) < x$ .

*Then there is a diffeomorphism  $\theta$  of  $[0, 1] \times \mathbb{S}^1$ , equal to the identity map on a neighborhood of the boundary, and isotopic to the identity relative to the boundary, and so that (denoting by  $\tilde{\mathcal{F}}_\theta$  and  $\tilde{\mathcal{G}}_\theta$  the lifts of  $\theta(\mathcal{F})$  and  $\theta(\mathcal{G})$  to  $[0, 1] \times \mathbb{R}$ ):*

- the leaves of  $\theta(\mathcal{F})$  and of  $\theta(\mathcal{G})$  are transverse to the vertical circles;
- the leaves  $\tilde{\mathcal{F}}_\theta$  are non-degenerate increasing on  $[0, \frac{1}{2}] \times \mathbb{R}$  and are not decreasing on  $[\frac{1}{2}, 1] \times \mathbb{R}$ ;
- the leaves of  $\tilde{\mathcal{G}}_\theta$  are not increasing on  $[0, \frac{1}{2}] \times \mathbb{R}$  and are non-degenerate decreasing on  $[\frac{1}{2}, 1] \times \mathbb{R}$ ;

*Sketch of proof.* We just need to choose a pair of transverse  $C^1$  foliations  $\mathcal{F}_0$  and  $\mathcal{G}_0$  so that, denoting by  $\tilde{\mathcal{F}}_0$  and  $\tilde{\mathcal{G}}_0$  their lifts on  $[0, 1] \times \mathbb{R}$ , one has:

- $\mathcal{F}_0$  and  $\mathcal{G}_0$  are transverse to the vertical foliation,
- $\mathcal{F}_0$  and  $\mathcal{G}_0$  coincide with  $\mathcal{F}$  and  $\mathcal{G}$  in a neighborhood of the boundary,
- the holonomies of  $\tilde{\mathcal{F}}_0$  and  $\tilde{\mathcal{G}}_0$  from  $\{0\} \times \mathbb{R}$  to  $\{1\} \times \mathbb{R}$  are  $f$  and  $g$ , respectively,
- the leaves  $\tilde{\mathcal{F}}_0$  are non-degenerate increasing on  $[0, \frac{1}{2}] \times \mathbb{R}$  and are not decreasing on  $[\frac{1}{2}, 1] \times \mathbb{R}$ ;
- the leaves of  $\tilde{\mathcal{G}}_0$  are not increasing on  $[0, \frac{1}{2}] \times \mathbb{R}$  and are non-degenerate decreasing on  $[\frac{1}{2}, 1] \times \mathbb{R}$ ;

The fact that we can choose such a pair of foliations is similar to the proof of Proposition 5.4.4.

Then the pair  $(\mathcal{F}, \mathcal{G})$  is conjugated to  $(\mathcal{F}_0, \mathcal{G}_0)$  by a unique diffeomorphism equal to the identity map in a neighborhood of the boundary. The lift  $\tilde{\theta}$  on  $[0, 1] \times \mathbb{R}$  of the announced diffeomorphism  $\theta$  is build as follows: consider a point  $p \in [0, 1] \times \mathbb{R}$  and let  $q_F(p)$  and  $q_G(p)$  be the intersections with  $\{0\} \times \mathbb{R}$  of the leaves  $\tilde{\mathcal{F}}_p$  and  $\tilde{\mathcal{G}}_p$  through  $p$ . The transversality of  $\tilde{\mathcal{F}}$  and  $\tilde{\mathcal{G}}$  implies that  $q_F(p)$  is below  $q_G(p)$  and  $f(q_F(p))$  is over  $g(q_G(p))$ . As  $\tilde{\mathcal{F}}_0$  and  $\tilde{\mathcal{G}}_0$  have the same holonomies as  $\tilde{\mathcal{F}}$  and  $\tilde{\mathcal{G}}$ , one gets that the leaves of  $\tilde{\mathcal{F}}_0$  and of  $\tilde{\mathcal{G}}_0$  through  $q_F(p)$  and  $q_G(p)$  have a unique intersection point that we denote by  $\tilde{\theta}(p)$ .  $\square$

## 5.6 Dehn twists, transverse foliations and partially hyperbolic diffeomorphisms

The aim of this section is to give the proof of Theorem H.

### 5.6.1 Transverse foliations on 3-manifolds

We first state a result which is a simple application of Theorem 4 to the pair of transverse co-dimension one  $C^1$ -foliations on 3-manifolds.

**Proposition 5.6.1.** *Let  $\mathcal{F}, \mathcal{G}$  be a pair of 2-dimensional foliations on a 3-manifold  $M$ , and let  $\mathcal{E}$  be the 1-dimensional foliation obtained as  $\mathcal{E} = \mathcal{F} \cap \mathcal{G}$ . Assume that there is an embedded torus  $T \subset M$  which is transverse to  $\mathcal{E}$  (hence  $T$  is transverse to  $\mathcal{F}$  and  $\mathcal{G}$ ). We denote by  $\mathcal{F}_T, \mathcal{G}_T$  the 1-dimensional foliations on  $T$  obtained as intersection of  $\mathcal{F}$  and  $\mathcal{G}$  with  $T$ , respectively.*

*Then for every  $u \in G_{\mathcal{F}_T, \mathcal{G}_T} \subset \pi_1(T)$ , there is a Dehn twist  $\psi$  along  $T$  directed by  $u$  so that  $\psi(\mathcal{F})$  is transverse to  $\mathcal{G}$ .*

**Idea of the proof** There is a collar neighborhood  $U$  of  $T$  and an orientation preserving diffeomorphism  $\theta: U \rightarrow T \times [0, 1]$  inducing the identity map from  $T$  to  $T \times \{0\}$ , so that  $\theta(\mathcal{E})$  is the trivial foliation  $\{\{p\} \times [0, 1]\}_{p \in T}$ . Then  $\theta(\mathcal{F})$  and  $\theta(\mathcal{G})$  are the product foliations of  $\mathcal{F}_T \times [0, 1]$  and  $\mathcal{G}_T \times [0, 1]$ , respectively

(meaning that their leaves are the product by  $[0, 1]$  of the leaves of  $\mathcal{F}_T$  and  $\mathcal{G}_T$ , respectively).

Let  $u$  be an element of  $G_{\mathcal{F}_T, \mathcal{G}_T} \subset \pi_1(T)$ . By definition of  $G_{\mathcal{F}_T, \mathcal{G}_T}$ , there is a loop  $\{\varphi_t\}_{t \in [0, 1]}$  of  $C^1$  diffeomorphisms of  $T$  so that  $\varphi_0 = \varphi_1$  is the identity map,  $\varphi_t(\mathcal{F}_T)$  is transverse to  $\mathcal{G}_T$  and for any  $p \in T$ , the loop  $\{\varphi_t(p)\}_{t \in [0, 1]}$  belongs to the homotopy class of  $u$ .

We consider the diffeomorphism  $\Phi$  on  $T \times [0, 1]$  defined by  $(p, t) \mapsto (\varphi_{\alpha(t)}(p), t)$ , where  $\alpha: [0, 1] \rightarrow [0, 1]$  is a smooth function equal to 0 in a neighborhood of 0 and to 1 in a neighborhood of 1. Then  $\Phi$  is a Dehn twist directed by  $u$  and  $\Phi$  is the identity map in a neighborhood of the boundary of  $T \times [0, 1]$ .

Consider  $\Phi(\mathcal{F}_T \times [0, 1])$ . It is a foliation transverse to any torus  $T \times \{t\}$  and it induces  $\varphi_{\alpha(t)}(\mathcal{F}_T)$  on  $T \times \{t\}$ . Therefore it is transverse to  $\mathcal{G}_T$ .

This proves that  $\Phi(\mathcal{F}_T \times [0, 1])$  is transverse to the foliation  $\mathcal{G}_T \times [0, 1]$ .

Now the announced Dehn twist on  $M$  directed by  $u$  is the diffeomorphism  $\psi$  with support in  $U$  and whose restriction to  $U$  is  $\theta^{-1} \circ \Phi \circ \theta$ . By construction,  $\psi(\mathcal{F})$  is transverse to  $\mathcal{G}$ , ending the proof.

## 5.6.2 Anosov flows, Dehn twists and partially hyperbolic diffeomorphisms

Let  $X$  be a non-transitive Anosov vector field of class at least  $C^2$  on a closed 3-manifold  $M$  and we denote by  $X_t$  the flow generated by  $X$ . According to Proposition 2.16.2, any family of transverse tori on which  $X$  has no return, are contained in a regular level of a smooth Lyapunov function.

Let  $L(x) : M \mapsto \mathbb{R}$  be a smooth Lyapunov function of the flow  $X_t$ , and let  $c$  be a regular value of  $L$ . Thus each connected component of  $L^{-1}(c)$  is a torus transverse to  $X$ .

Let  $T_1, \dots, T_k$  be the disjoint transverse tori such that

$$\cup_{i=1}^k T_i = L^{-1}(c).$$

Consider the set  $M^r = L^{-1}(c, +\infty)$  and  $M^a = L^{-1}(-\infty, c)$ . Then  $M^r$  and  $M^a$  are two disjoint open subsets of  $M$  and share the same boundary  $\cup_{i=1}^k T_i$ . Since  $L(x)$  is strictly decreasing along the positive orbits of the points in the wandering domain, one gets that  $M^a$  and  $M^r$  are attracting and repelling regions of the vector field  $X$ . We denote by  $\mathcal{A}$  and  $\mathcal{R}$ , respectively, the maximal invariant sets of  $X$  in  $M^a$  and  $M^r$ . Thus  $\mathcal{A}$  is a hyperbolic (not necessarily transitive) attractor and  $\mathcal{R}$  is a hyperbolic (not necessarily transitive) repeller for  $X$ .

By [HP, Corollary 4], the center stable foliation  $\mathcal{F}_X^{cs}$  and center unstable foliation  $\mathcal{F}_X^{cu}$  of the Anosov flow  $X_t$  are  $C^1$  foliations. For each  $i = 1, \dots, k$ , we denote by  $\mathcal{F}_i^s$  and  $\mathcal{F}_i^u$  the  $C^1$  foliation induced by  $\mathcal{F}_X^{cs}$  and  $\mathcal{F}_X^{cu}$  on  $T_i$  respectively.

As  $X$  has no return on  $\bigcup_i T_i$ , the sets  $\{X_t(T_1)\}_{t \in \mathbb{R}}, \dots, \{X_t(T_k)\}_{t \in \mathbb{R}}$  are pairwise disjoint embeddings of  $T_i \times \mathbb{R}$  into  $M$ . As a consequence, for any integer  $N$ , the sets  $\{X_t(T_1)\}_{t \in [0, N]}, \dots, \{X_t(T_k)\}_{t \in [0, N]}$  are pairwise disjoint and diffeomorphic to  $\mathbb{T}^2 \times [0, N]$ .

For each  $i$ , we define the diffeomorphism

$$\psi_{i,N} : \{X_t(T_i)\}_{t \in [0, N]} \mapsto T_i \times [0, 1]$$

by  $(X_t(p)) \mapsto (p, t/N)$ , for any  $p \in T_i$  and  $t \in [0, N]$ . Thus  $D\psi_{i,N}(X) = \frac{1}{N} \frac{\partial}{\partial s}$  is tangent to the vertical segment  $\{p\} \times [0, 1]$ , for any  $p \in T_i$ .

We fix a smooth function  $\alpha(s) : [0, 1] \mapsto [0, 1]$  such that  $\alpha(s)$  is a non-decreasing function on  $[0, 1]$ , equals to 0 in a small neighborhood of 0 and equals to 1 in a small neighborhood of 1. For each  $i$ , the group  $G_i = G_{\mathcal{F}_i^s, \mathcal{F}_i^u}$  is the subgroup of  $\pi_1(\mathbb{T}^2)$  associated to the pair of transverse foliations  $(\mathcal{F}_i^s, \mathcal{F}_i^u)$  by Definition 2.14.2. Given an element  $u_i \in G_i$ , let  $\{\varphi_t\}_{t \in [0, 1]}$  be the loop in  $\text{Diff}^1(T_i)$  associated to  $u_i$  by Theorem 4.

Consider the map  $\Phi_i : T_i \times [0, 1] \mapsto T_i \times [0, 1]$  defined as

$$(x, s) \mapsto (\varphi_{\alpha(s)}(x), s).$$

Hence, the map  $\Psi_{i,N} = \psi_{i,N}^{-1} \circ \Phi_i \circ \psi_{i,N}$  is a Dehn twist directed by  $u_i$ . Notice that  $\Psi_{i,N}$  can be  $C^1$ -smoothly extended on the whole manifold  $M$  to be the identity map outside  $X_t(T_i)$ .

The main part of Theorem H is directly implied by the following theorem:

**Theorem 5.6.2.** *With the notations above, when  $N$  is chosen large enough, the diffeomorphism  $\Psi_{k,N} \circ \dots \circ \Psi_{1,N} \circ X_N$  is absolute partially hyperbolic.*

*Proof.* We denote

$$\Psi_N = \Psi_{k,N} \circ \dots \circ \Psi_{1,N}.$$

Then  $\Psi_N \circ X_N$  coincides with  $X_N$  on the attracting region  $M^a$ . Thus  $\mathcal{A}$  is the maximal invariant set of  $\Psi_N \circ X_N$  in  $M^a$  and is an absolute partially hyperbolic attractor. Furthermore the center stable bundle and the strong stable bundle on  $\mathcal{A}$  admit unique continuous and  $(\Psi_N \circ X_N)$ -invariant extensions  $E_{\mathcal{A}}^{cs}$  and  $E_{\mathcal{A}}^s$ , respectively, on  $M^a$  which coincide with the tangent bundles of the center stable and strong stable foliations  $\mathcal{F}_X^{cs}$  and  $\mathcal{F}_X^s$  of the vector field  $X$ .

In the same way,  $(\Psi_N \circ X_N)^{-1}$  coincides with  $X_{-N}$  on the repelling region  $M^r$ . Thus  $\mathcal{R}$  is still an absolute partially hyperbolic repeller of  $\Psi_N \circ X_N$  and its center unstable and strong unstable bundles admit unique continuous and  $(\Psi_N \circ X_N)$ -invariant extensions  $E_{\mathcal{R}}^{cu}$  and  $E_{\mathcal{R}}^u$  on  $M^r$  which coincide with, respectively, the tangent bundles of  $\mathcal{F}_X^{cu}$  and  $\mathcal{F}_X^u$ .

Notice that the center unstable and strong unstable bundles  $E_{\mathcal{R}}^{cu}$  and  $E_{\mathcal{R}}^u$ , of the repeller  $\mathcal{R}$  for  $\Psi_N \circ X_N$  extend in a unique way on  $M \setminus \mathcal{A}$ , just by pushing by the dynamics of  $\Psi_N \circ X_N$ .

Thus the bundles  $E_{\mathcal{R}}^{cu}$ ,  $E_{\mathcal{R}}^u$ ,  $E_{\mathcal{A}}^{cs}$  and  $E_{\mathcal{A}}^s$  coincide with the tangent bundles of the foliations  $\Psi_N(\mathcal{F}_X^{cu})$ ,  $\Psi_N(\mathcal{F}_X^u)$ ,  $\mathcal{F}_X^{cs}$ , and  $\mathcal{F}_X^s$  respectively, on the fundamental domain  $\bigcup_i X_{[0,N]}(T_i)$ .

One can easily check the following classical result:

**Lemma 5.6.3.**  $\Psi_N \circ X_N$  is absolute partially hyperbolic if and only if

$$\Psi_N(\mathcal{F}_X^u) \pitchfork \mathcal{F}_X^{cs} \text{ and } \Psi_N(\mathcal{F}_X^{cu}) \pitchfork \mathcal{F}_X^s.$$

Notice that  $\{X_t(T_1)\}_{t \in \mathbb{R}}, \dots, \{X_t(T_k)\}_{t \in \mathbb{R}}$  are pairwise disjoint, the same argument of Lemma 6.2 in [BPP] gives the following:

**Lemma 5.6.4.** With the notation above, we have that for each  $i = 1, \dots, k$ ,

$$\lim_{N \rightarrow +\infty} \psi_{i,N}(\mathcal{F}_X^{uu}) = \{\mathcal{F}_i^u\} \times \{s\} \text{ and } \lim_{N \rightarrow +\infty} \psi_{i,N}(\mathcal{F}_X^{ss}) = \{\mathcal{F}_i^s\} \times \{s\}$$

uniformly in the  $C^1$ -topology.

As a consequence of Lemma 5.6.4, when  $N$  is chosen large, for each  $i = 1, \dots, k$ , we have that

$$\Phi_i(\psi_{i,N}(\mathcal{F}_X^{uu})) \pitchfork \mathcal{F}_i^s \times [0, 1] \text{ and } \Phi_i(\psi_{i,N}(\mathcal{F}_X^{ss})) \pitchfork \mathcal{F}_i^u \times [0, 1].$$

Now Theorem 5.6.2 follows directly from Lemma 5.6.3.  $\square$

Now, we end the proof of Theorem H by proving that the (absolute) partially hyperbolic diffeomorphism  $f = \Psi_N \circ X_N$  is robustly dynamically coherent and plaque expansive. We denote by  $E_f^c$  the center bundle of  $f$ .

Recall that  $f$  coincides with  $X_N$  on the repelling region  $X_{-N}(M^r)$  and on the attracting region  $M^a$ . Just as Lemma 9.1 in [BPP], we have that:

**Lemma 5.6.5.** There exists a constant  $C > 1$  such that for any unit vector  $v \in E_f^c$ , we have the following:

$$\frac{1}{C} \leq \|Df^n(v)\| \leq C, \text{ for any integer } n \in \mathbb{Z}.$$

As a consequence of Lemma 5.6.5, we have that  $f$  is *Lyapunov stable* and *Lyapunov unstable* in the directions  $E_f^{cs}$  and  $E_f^{cu}$  respectively.

To show the dynamically coherent and plaque expansive properties, we follow the same argument in [BPP, Theorem 9.4]:

- According to [HHU1, Theorem 7.5],  $f$  is *dynamically coherent*, and center stable foliation  $\mathcal{W}_f^{cs}$  and center unstable foliation  $\mathcal{W}_f^{cu}$  are *plaque expansive*;
- By [HPS], the center stable foliation  $\mathcal{W}_f^{cs}$  and center unstable foliation  $\mathcal{W}_f^{cu}$  are *structurally stable*, proving that  $f$  is robustly dynamically coherent.



## Chapter 6

# Partially hyperbolic diffeomorphism with one-dimensional neutral center

In this chapter, we study the properties of the partially hyperbolic diffeomorphisms that we build in the previous chapter. Although the diffeomorphism constructed in previous chapter is no more leaf conjugate to the time one map of any Anosov flow, many properties of the flow are preserved by the diffeomorphisms. To be specific, we show that each leaf of the center stable (center unstable) foliation is a plane, a cylinder or a Möbius band, and the center foliation defines a flow which is topologically equivalent to the Anosov flow for the construction. One of main ingredients for the proof is the completeness of the center stable and center unstable foliations.

We recall that a partially hyperbolic diffeomorphism has neutral center, if there exists a constant  $c > 1$  such that

$$\frac{1}{c} < \|Df^n|_{E^c(x)}\| < c, \text{ for any } n \in \mathbb{Z} \text{ and any } x \in M.$$

Such diffeomorphisms are always dynamically coherent, see for instance [HHU2]. We recall that the center stable foliation is complete, if one has

$$\cup_{y \in \mathcal{F}^c(x)} \mathcal{F}^{ss}(y) = \mathcal{F}^{cs}(x), \text{ for any } x \in M.$$

The completeness of center unstable foliation can be defined analogously.

We denote by  $f_{bz}$  the partially hyperbolic diffeomorphism built in [BZ1], and  $f_B$  the partially hyperbolic diffeomorphism built in [BPP].



## 6.1 The topological structure of the center stable and center unstable foliations: Proof of Theorem 5

Let  $f$  be a partially hyperbolic diffeomorphism on a 3-manifold  $M$ , exhibiting neutral behavior along one dimensional center. Since it has already been proven that  $f$  is dynamically coherent, we denote the center stable and center unstable foliations as  $\mathcal{F}^{cs}$  and  $\mathcal{F}^{cu}$  respectively. We will first show that  $\mathcal{F}^{cs}$  and  $\mathcal{F}^{cu}$  are complete, then we give the description of their leaves.

*Proof of Theorem 5.* By the uniform transversality of strong stable direction and center direction restricted to every center stable leaf, there exists  $\delta > 0$  such that for any point  $x \in M$ , the  $\delta$  neighborhood of the leaf  $\mathcal{F}^c(x)$  in the center stable leaf  $\mathcal{F}^{cs}(x)$  is contained in  $\mathcal{F}^{ss}(\mathcal{F}^c(x))$ .

We will prove the completeness of  $\mathcal{F}^{cs}$  by contradiction. Assume that  $\mathcal{F}^{cs}$  is not complete, by Proposition 2.17.5, there exists a point  $x \in M$  such that  $\mathcal{F}^{ss}(\mathcal{F}^c(x))$  has a boundary leaf  $\mathcal{F}^{ss}(y)$  for some  $y \in M$ . By the invariant property of the center and strong stable foliations, we have that  $\mathcal{F}^{ss}(f^n(y))$  is a boundary leaf with respect to  $\mathcal{F}^{ss}(\mathcal{F}^c(f^n(x)))$ , for any integer  $n \in \mathbb{Z}$ . By the choice of  $\delta$ , one has that when it is restricted to the center stable leaf  $\mathcal{F}^{cs}(f^n(x))$ , the strong stable leaf  $\mathcal{F}^{ss}(f^n(y))$  is  $\delta$  away from the center leaf  $\mathcal{F}^c(f^n(x))$ .

By the definition of boundary leaves, there exists a  $C^1$ -curve  $\sigma : [0, 1] \mapsto M$  such that

$$\sigma(t) \subset \mathcal{F}^c(y), \sigma(0) = y \text{ and } \sigma((0, 1]) \subset \mathcal{F}^{ss}(\mathcal{F}^c(x)).$$

Up to shrinking  $\sigma$ , we can assume that the length  $\ell(\sigma)$  of  $\sigma$  is strictly less than  $\frac{\delta}{4K^2}$ , where  $K > 1$  is the number satisfying

$$\frac{1}{K} \leq \|Df^n|_{E^c(p)}\| \leq K, \text{ for any } n \in \mathbb{Z} \text{ and any point } p \in M.$$

Since  $\sigma(1)$  is on the strong stable manifold of a point  $z \in \mathcal{F}^c(x)$ , there exists an integer  $N$  large enough such that  $f^N(\sigma(1))$  is in the  $\frac{\delta}{2}$  neighborhood of  $f^N(z)$  with respect to the distance on the center stable leaf  $\mathcal{F}^{cs}(f^N(x))$ . Since  $f^N(y)$  is still on the boundary leaf  $\mathcal{F}^{ss}(f^N(y))$ , we have that the length

$$\ell(f^N(\sigma)) > \frac{\delta}{2}.$$

On the other hand, we have the estimate

$$\ell(f^N(\sigma)) \leq \max_{w \in M} \|Df^N|_{E^c(w)}\| \cdot \ell(\sigma) < \frac{\delta}{4K} < \frac{\delta}{2},$$

a contradiction. This proves the first item of Theorem 5.

Let  $\tilde{M}$  be the universal cover of  $M$ . The metric on  $\tilde{M}$  is the pull back of the metric on  $M$  by the covering map. We denote by  $\tilde{\mathcal{F}}^i$  the lift of  $\mathcal{F}^i$  on the universal cover  $\tilde{M}$ , for  $i = ss, cs, c, cu, uu$ .

To prove the second item, we need the following lemma:

**Lemma 6.1.1.** *For any  $x \in \tilde{M}$ , the lifted leaves  $\tilde{\mathcal{F}}^{cs}(x)$  and  $\tilde{\mathcal{F}}^{cu}(x)$  are planes.*

*Proof.* For any  $x \in \tilde{M}$ , the lifted leaf  $\tilde{\mathcal{F}}^{cs}(x)$  is a two dimensional manifold without boundary; to prove that it is a plane, we only need to show that its fundamental group is trivial. Assume that there exists a closed curve  $\gamma$  in  $\tilde{\mathcal{F}}^{cs}(x)$  which is non-null homotopy in the leaf. Since  $\gamma$  is null homotopy in  $\tilde{M}$ , then the projection of  $\gamma$  on  $M$  is null homotopy in  $M$  and is non-null homotopy in a  $\mathcal{F}^{cs}$  leaf. By Theorem 2.18.1, the foliation  $\mathcal{F}^{cs}$  has a compact leaf which contradicts to Theorem 2.18.2.

Similarly, we can show that  $\tilde{\mathcal{F}}^{cu}(x)$  is also a plane.  $\square$

**Claim 6.1.2.** *The lifted foliations  $\tilde{\mathcal{F}}^{cs}$  and  $\tilde{\mathcal{F}}^{cu}$  are complete, that is, they are trivially bi-foliated by  $\tilde{\mathcal{F}}^{ss}$  and  $\tilde{\mathcal{F}}^c$ .*

*Proof.* Let  $\tilde{f}$  be a lift of  $f$ , then  $\tilde{f}$  is a partially hyperbolic diffeomorphism with one dimensional neutral center and whose invariant manifolds are the lifts of the invariant manifolds of  $f$ . Hence, the argument for  $f$  applies for  $\tilde{f}$ .  $\square$

For any compact center leaf  $\gamma$  of  $f$ , we prove the following:

**Lemma 6.1.3.** *The center stable leaf contains  $\gamma$  is either a cylinder or a Möbius band.*

*Proof.* Up to taking a double cover of the manifold, we can assume that the strong stable bundle is orientable and we give it an orientation. If every strong stable leaf through a point on  $\gamma$  intersects  $\gamma$  only once, then by completeness, the center stable leaf is a cylinder. If not, there exists a strong stable leaf intersects  $\gamma$  at least twice. Consider the universal cover  $\tilde{M}$  and the lift  $\mathcal{P}$  of the leaf  $\mathcal{F}^{cs}(\gamma)$  which is a plane, one has that there exist two center curves which are the lifts of  $\gamma$  on  $\mathcal{P}$ , by the completeness of the center stable foliation on the universal cover, one has that for every point on  $\gamma$ , the strong stable curve through this point positively goes back to  $\gamma$  after finite length, which implies that the center stable leaf  $\mathcal{F}^{cs}(\gamma)$  is a closed surface, a contradiction.  $\square$

The following lemma ends the proof of Theorem 5:

**Lemma 6.1.4.** *Any center stable leaf which contains no compact center leaves is a plane.*

*Proof.* Let  $\mathcal{F}^{cs}(x)$  be a center stable leaf which contains no compact center leaves. We will first use the argument from [BW] to prove that  $\mathcal{F}^{cs}(x)$  is either a plane or cylinder, then we show that  $\mathcal{F}^{cs}(x)$  can only be a plane.

Consider a lift  $\tilde{\mathcal{F}}^{cs}(y)$  of  $\mathcal{F}^{cs}(x)$  and let  $\Gamma$  be the subgroup of  $\pi_1(M)$  which leaves the leaf  $\tilde{\mathcal{F}}^{cs}(y)$  invariant, then  $\mathcal{F}^{cs}(x)$  is the quotient of  $\tilde{\mathcal{F}}^{cs}(y)$  by the action  $\Gamma$ . By Claim 6.1.2, we have that the space of center leaves in  $\tilde{\mathcal{F}}^{cs}(y)$  is a real line, as well as the space of strong stable leaves in  $\tilde{\mathcal{F}}^{cs}(y)$ . Hence,  $\Gamma$  induces two actions on these two spaces and the action  $\Gamma$  is a sub-action of Cartesian product of these two actions.

The action of  $\Gamma$  on the space of center leaves corresponds to a subgroup of  $\text{Homeo}(\mathbb{R})$ . Moreover every non-trivial element of  $\Gamma$  acts on the space of center leaves without fixed point and preserving the orientation, otherwise there exists a non-trivial element of  $\Gamma$  leaving a center leaf invariant which implies that  $\mathcal{F}^{cs}(x)$  has a compact center leaf. Similar argument applies to the action of  $\Gamma$  on the space of the strong stable leaves, proving that this action is orientation preserving and has no fixed points. Hölder theorem [Ho] asserts that any group acting freely on  $\mathbb{R}$  is Abelian, hence these two actions are Abelian actions. As a consequence, the action  $\Gamma$  is Abelian and is orientation preserving, which implies that  $\mathcal{F}^{cs}(x)$  is an orientable two dimensional manifold whose fundamental group is Abelian. Once again, by Theorem 2.18.2, we have that  $\mathcal{F}^{cs}(x)$  is either a cylinder or a plane.

By assumption, one has that  $\mathcal{F}^{cs}(f^n(x))$  contains no compact leaves for any integer  $n \in \mathbb{Z}$ . We will prove that  $\mathcal{F}^{cs}(x)$  is a plane, by contradiction. Assume that  $\mathcal{F}^{cs}(x)$  is a cylinder, then one has the following result:

**Claim 6.1.5.** *The center leaf  $\mathcal{F}^c(x)$  intersects  $\mathcal{F}^{ss}(x)$  at least twice.*

*Proof.* Let  $y$  be a lift of  $x$ . Since leaf  $\tilde{\mathcal{F}}^{cs}(y)$  is complete and the group  $\Gamma$  is non-trivial, given a non-trivial element  $\varphi \in \Gamma$ , then  $\varphi(\tilde{\mathcal{F}}^c(y))$  is a leaf different from  $\tilde{\mathcal{F}}^c(y)$  (otherwise  $\mathcal{F}^c(x)$  is compact), as a consequence  $\varphi(\tilde{\mathcal{F}}^c(y))$  intersects  $\tilde{\mathcal{F}}^{ss}(y)$  in a point different from  $y$  and  $\varphi(y)$ , hence  $\mathcal{F}^c(x)$  intersects  $\mathcal{F}^{ss}(x)$  at least twice.  $\square$

One can take a point  $z \in \mathcal{F}^c(x) \cap \mathcal{F}^{ss}(x) \setminus \{x\}$  such that the interior of the center curve  $L$  with endpoints  $\{x, z\}$  does not intersect  $\mathcal{F}^{ss}(x)$ . By the transversality and completeness of the foliation  $\tilde{\mathcal{F}}^{cs}$ , one has that for any point  $w \in \mathcal{F}^{cs}(x) \setminus \mathcal{F}^{ss}(x)$ , the strong stable leaf  $\mathcal{F}^{ss}(w)$  intersects  $L$  in a unique point. Since  $z \in \mathcal{F}^{ss}(x)$  and  $f$  has neutral behavior along  $E^c$ , we have that a subsequence of  $f^n(L)$  tends to a closed center leaf  $C$  in the  $C^1$ -topology. By the uniform transversality between  $E^s$  and  $E^c \oplus E^u$ , and the compactness of  $M$ , there exist two small positive numbers  $\epsilon$  and  $\delta$  such that for any two points  $x_1, x_2$  satisfying  $d(x_1, x_2) < \delta$ , the  $\epsilon$  neighborhood  $\mathcal{F}_\epsilon^{ss}(x_1)$  of  $x_1$  in its strong stable leaf intersects the  $\epsilon$  neighborhood  $\mathcal{F}_\epsilon^{cu}(x_2)$  of  $x_2$  in its center unstable leaf in a unique point which is strictly contained in  $\mathcal{F}_{\epsilon/2}^{ss}(x_1) \cap \mathcal{F}_{\epsilon/2}^{cu}(x_2)$ .

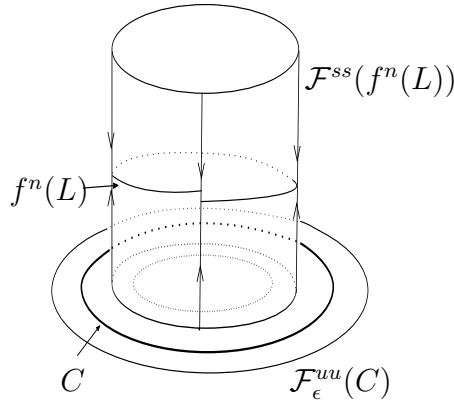

Figure 6.1 –

We take  $n$  large enough such that  $f^n(L)$  is  $\delta$  close to  $C$ , then  $\mathcal{F}_\epsilon^{ss}(f^n(L))$  intersects the annulus or Möbius band  $\mathcal{F}_\epsilon^{cu}(C)$  in a compact center curve without boundary in the interior of  $\mathcal{F}_\epsilon^{cu}(C)$  (see Figure 6.1), which, therefore, is a compact center leaf in  $f^n(\mathcal{F}^{cs}(x))$ , a contradiction. This ends the proof of Lemma 6.1.4. □

Now, the proof of Theorem 5 is completed. □

At the end, we prove a property for the lifted foliations of the partially hyperbolic diffeomorphism, which will be used in the next section.

**Lemma 6.1.6.** *Let  $f$  be a partially hyperbolic diffeomorphism on a 3-manifold  $M$  such that  $f$  has neutral behavior along the center. We denote by  $\tilde{M}$  the universal cover of  $M$  and by  $\tilde{\mathcal{F}}^i$  the lift of  $\mathcal{F}^i$  for  $i = ss, cs, c, cu, uu$ .*

*Then for any  $x, y \in \tilde{M}$ , the leaf  $\tilde{\mathcal{F}}^{cs}(x)$  intersects  $\tilde{\mathcal{F}}^{cu}(y)$  in at most one center leaf.*

*Proof.* Assume that there exist two points  $x, y \in \tilde{M}$  such that the intersection of  $\tilde{\mathcal{F}}^{cs}(x)$  and  $\tilde{\mathcal{F}}^{cu}(y)$  contains two different center leaves  $L_1, L_2$ .

By the completeness, there exists a strong stable segment  $\sigma$  whose end-points are contained in  $L_1, L_2$  respectively. Since  $L_1, L_2$  are contained in the same center unstable leaf, using a classical argument, one has that  $\tilde{\mathcal{F}}^{cu}$  admits a closed transversal which implies that  $\mathcal{F}^{cu}$  admits a null-homotopy closed transversal. By Theorem 2.18.1, one gets that center unstable foliation  $\mathcal{F}^{cu}$  has compact leaves, contradicting to Theorem 2.18.2. □

## 6.2 Center flow carried by the partially hyperbolic diffeomorphism of [BZ1] example: Proof of Theorem I and Proposition 1.1.2

In this section, we first recall the properties of the invariant foliations of [BPP] and [BZ1] example, then we analyze the center behavior of the partially hyperbolic diffeomorphism.

### 6.2.1 Properties of the invariant foliations for $f_{bz}, f_B$

We denote by  $\mathcal{F}^l$  the  $f_{bz}$ -invariant foliation tangent to  $E^l$ , for  $l = ss, cs, c, cu, uu$ . For each transverse torus  $T_i$ , we lift the foliations  $\mathcal{F}_i^s, \mathcal{F}_i^u$  to the universal cover  $\mathbb{R}^2$ , and we denote them as  $\tilde{\mathcal{F}}_i^s$  and  $\tilde{\mathcal{F}}_i^u$  respectively. By transversality, a  $\tilde{\mathcal{F}}_i^s$ -leaf intersects a  $\tilde{\mathcal{F}}_i^u$ -leaf in at most one point.

**Lemma 6.2.1.** *Let  $\alpha_i$  be automorphism on  $\mathbb{R}^2$  decided by  $v_i \in G_{\mathcal{F}_i^s, \mathcal{F}_i^u}$ . For any  $x \in \mathbb{R}^2$ , one has that the leaf  $\alpha_i(\tilde{\mathcal{F}}_i^s(x))$  intersects  $\tilde{\mathcal{F}}_i^u(x)$  in a unique point.*

*Proof.* For notational convenience, we denote by

$$L_i^s = \tilde{\mathcal{F}}_i^s(x) \text{ and } L_i^u = \tilde{\mathcal{F}}_i^u(x).$$

Now, we only need to check that  $\alpha_i(L_i^s)$  intersects  $L_i^u$ .

If  $G_{\mathcal{F}_i^s, \mathcal{F}_i^u}$  is  $\pi_1(\mathbb{T}^2)$ , then  $\mathcal{F}_i^s$  and  $\mathcal{F}_i^u$  are orientable and we fix an orientation to each of them. By Theorem 5.4.1, one can find a  $C^1$  coordinate on  $\mathbb{T}^2$  and two transverse linear foliations on  $\mathbb{T}^2$  such that  $\mathcal{F}_i^s$  and  $\mathcal{F}_i^u$  cut one of linear foliations in same orientation and cut the other in different orientation. In this case, for any automorphism  $\beta$  on  $\mathbb{T}^2$ , one has that  $\beta(L_i^s)$  intersects  $L_i^s$ .

If  $G_{\mathcal{F}_i^s, \mathcal{F}_i^u}$  is  $\mathbb{Z}$ , then  $\mathcal{F}_i^s$  and  $\mathcal{F}_i^u$  have compact leaves which are in the same homotopy class. If  $\pi(L_i^s)$  or  $\pi(L_i^u)$  is a compact leaf, let say  $L_i^s$ , then  $L_i^s$  is invariant under  $\alpha_i$  which implies that  $\alpha_i(L_i^u)$  intersects  $L_i^s$ , the other case follows analogously. Now, one can assume that neither  $L_i^s$  nor  $L_i^u$  is a compact leaf. By Poincaré Bendixson theorem, there exist two cylinders  $C_{u,i}$  and  $C_{s,i}$  such that

- $C_{u,i}$  and  $C_{s,i}$  are bounded by two compact leaves of  $\mathcal{F}_i^u$  and two compact leaves of  $\mathcal{F}_i^s$  respectively;
- $\pi(L_i^s)$  accumulates to the boundary of  $C_{s,i}$  and  $\pi(L_i^u)$  accumulates to the boundary of  $C_{u,i}$ .

Since  $L_i^s$  intersects  $L_i^u$ , one has that either  $C_{s,i}$  contains a boundary component of  $C_{u,i}$  or  $C_{u,i}$  contains a boundary component of  $C_{s,i}$ . One can assume that  $C_{s,i}$  contains a boundary component of  $C_{u,i}$  (the other case is similar). Then on the universal cover, the leaf  $L_i^u$  accumulates on a  $\tilde{\mathcal{F}}_i^u$ -leaf which is invariant under  $\alpha_i$  and  $L_i^s$  intersects that  $\alpha_i$ -invariant  $\tilde{\mathcal{F}}_i^u$ -leaf. Notice that the foliation

$\mathcal{F}^u$  restricted in the cylinder  $C_{u,i}$  is either a Reeb component or an orientable foliation. As a consequence, one has that  $\alpha_i(L_i^u)$  intersects  $L_i^s$ .  $\square$

Now, one can define a homeomorphism  $\eta_i \in \text{Homeo}(\mathbb{R}^2)$  which maps the point  $x$  to the point  $\alpha_i(\tilde{\mathcal{F}}_i^u(x)) \cap \tilde{\mathcal{F}}_i^s(x)$ . One can check that  $\eta_i$  induces a homeomorphism on  $T_i$  and for notational convenience, we still denote it as  $\eta_i$ . By definition, one has that  $\eta_i$  keeps every leaf of  $\mathcal{F}_i^s$  and every leaf of  $\mathcal{F}_i^u$  invariant. Moreover, if  $G_{\mathcal{F}_i^s, \mathcal{F}_i^u}$  is isomorphic to  $\mathbb{Z}$ , the homeomorphism  $\eta_i$  coincides with identity on union of the compact leaves of  $\mathcal{F}_i^s$  and the union of the compact leaves of  $\mathcal{F}_i^u$ .

Consider the  $C^1$  coordinate  $\vartheta_{\tau,i}$  for  $W_i = \{\phi_t(T_i)\}_{t \in [0, \tau]}$ , which we chose before. Under this coordinate, we lift  $W_i$  to the universal cover  $\tilde{W}_i$ . The lifts of the non-compact leaves of  $\mathcal{F}^{cu}|_{W_i}$  intersect the lifts of the non-compact leaves of  $\mathcal{F}^{cs}|_{W_i}$  in the way shown in Figure 6.2. Since each  $\varphi_i$  coincides with identity in a neighborhood of the boundary of  $\{\phi_t(T_i)\}_{t \in [0, \tau]}$ , the diffeomorphism  $f_{bz}$  sends the center leaf through  $x \in T_i$  to the center leaf through  $\phi_\tau(x)$ . By Lemma 6.2.1, the center leaf through the point  $\phi_\tau(x)$  is the one through the point  $\eta_i^{-1}(x)$ .

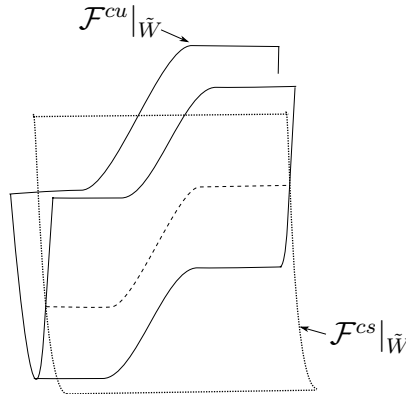

Figure 6.2 – The dash line denotes the center leaf obtained by the intersection of center stable and center unstable leaves.

Directly, one has the following result:

**Lemma 6.2.2.** *For each  $i \in \{1, \dots, k\}$ , the action of the diffeomorphism  $f_{bz}$  on the space of center leaves intersecting  $T_i$  is equivalent to the homeomorphism  $\eta_i^{-1}$ .*

Consider  $M^+ = L^{-1}([c, +\infty))$  and  $M^- = L^{-1}((-\infty, c])$ . Then  $M^+$  and  $M^-$  are the repelling and attracting regions of the flow  $\phi_t$ . We denote by  $\mathcal{R}$  and  $\mathcal{A}$  the maximal invariant sets in  $M^+$  and  $M^-$  respectively. Hence,  $\mathcal{R}$  (resp.  $\mathcal{A}$ ) is a repelling (resp. attracting) set and is foliated by the weak stable (resp.

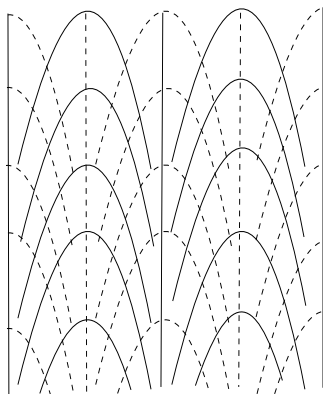

Figure 6.3 – The real lines and the dash lines denote the leaves of the lifts of foliations  $\mathcal{F}_i^s$  and  $\mathcal{F}_i^u$  on the universal cover respectively.

weak unstable) leaves. By construction of  $f_{bz}$ , one has that  $f_{bz}|_{M^-} = \phi_\tau|_{M^-}$  and  $f_{bz}^{-1}|_{M^+} = \phi_{-\tau}|_{M^+}$ , which implies that

$$W^l|_{M^- \cup \mathcal{R}} = \mathcal{F}^l|_{M^- \cup \mathcal{R}}, \text{ for } l = ss, cs$$

and

$$W^l|_{M^+ \cup \mathcal{A}} = \mathcal{F}^l|_{M^+ \cup \mathcal{A}}, \text{ for } l = uu, cu.$$

By construction, the chain recurrent set of  $f_{bz}$  is contained in the union of the attracting set  $\mathcal{A}$  and the repelling set  $\mathcal{R}$ . Moreover, the diffeomorphism  $f_{bz}$  has neutral behavior along center bundle, hence it is dynamically coherent. Since the Dehn twists are supported in a fundamental domain of  $\phi_\tau$  and keeps every center stable (resp. center unstable) leaf invariant.

In [BPP], the authors built a non-transitive Anosov flow  $\psi_t$  on a manifold  $N$  with only two transverse tori separating the hyperbolic basic sets of the Anosov flow. Moreover, the Anosov flow  $\psi_t$  has only one (transitive) attractor and one (transitive) repeller. One can check that there exists a smooth Lyapunov function such that these two transverse tori are in a regular level of this function. One can take a  $C^1$  coordinate for each transverse torus so that under such coordinates, the induced foliations  $\mathcal{F}_i^s$  and  $\mathcal{F}_i^u$  on transverse torus  $T_i$  are exactly as shown in Figure 6.3 (for details see Lemma 4.1 in [BPP]).

In this case, the existence of Dehn twist is trivial, and one only needs to take the translation along the vertical direction. The partially hyperbolic diffeomorphism  $f_B$  in [BPP] is obtained by composing a Dehn twist along one of the transverse torus with the time with the time  $\psi_\tau$  (for  $\tau > 0$ ) large. Hence, as a Corollary of Lemma 6.2.2, one has the following:

**Corollary 6.2.3.** *For the partially hyperbolic diffeomorphism  $f_B$ , for any  $j = 1, 2$  and any leaf  $\mathcal{F}_j^s(y)$  (resp.  $\mathcal{F}_j^u(y)$ ) of the foliation  $\mathcal{F}_j^s$  (resp.  $\mathcal{F}_j^u$ ), there*

exists a point  $x \in \mathcal{F}_j^s(y)$  (resp.  $\mathcal{F}_j^u(y)$ ) such that  $f_B$  preserves the center leaf through  $x$ , that is,  $f_B(\mathcal{F}^c(x)) = \mathcal{F}^c(x)$ .

## 6.2.2 Analyzing the center foliation of [BZ1] and [BPP] examples

In this section, we first prove that the center foliation  $\mathcal{F}^c$  of  $f_{bz}$  gives a continuous flow, then we build a homeomorphism sending the center flow of the diffeomorphism to the Anosov flow.

For the diffeomorphism  $f_{bz}$ , since the Dehn twist  $\varphi_i$  equals to identity in a neighborhood of  $T_i$ , one has that in a small neighborhood  $V_i$  of  $T_i$ , the center foliation  $\mathcal{F}^c$  coincides with  $W^c$ . For each leaf passing through  $V_i$ , we give it the same orientation as the one of  $W^c$  given by the flow direction. Since in the region  $M^-$ , the center stable and strong stable foliations of  $f_{bz}$  coincide with the ones of the Anosov flow, by the fact that  $\mathcal{F}^c$  is everywhere transverse to the strong stable direction in each center stable leaf, one has that in the region  $M^- \setminus \mathcal{A}$ , restricted to each center stable leaf, each leaf of  $\mathcal{F}^c$  cuts the strong stable leaf with the same (locally) orientation as  $W^c$  does. As a consequence, one has that the orientation of the leaves of  $\mathcal{F}^c$  passing through  $T_i$  induces the same orientation of the center leaves in  $\mathcal{A}$  as the one given by the flow. One can apply the same argument to the region  $M^+$ . As a consequence, one gets that the center foliation  $\mathcal{F}^c$  is orientable, and one can give it an orientation such that

- it gives the same orientation on the set  $\mathcal{A} \cup \mathcal{R}$  as the one given by the flow  $\phi_t$ ;
- it gives the same normal orientation to the transverse tori as the one given by the flow  $\phi_t$ .

Hence, the center foliation  $\mathcal{F}^c$  can give a continuous flow, denoted as  $\theta_t$ , whose orbits are the leaves of  $\mathcal{F}^c$ . This proves the first item of Theorem I.

Let  $\theta_t$  be the flow generated by the center direction such that its direction coincides with  $\phi_t$  on the set  $\mathcal{A} \cup \mathcal{R}$  and gives the same normal orientation for the two transverse tori as the one given by  $\phi_t$ .

We shall build the conjugation between the center flow  $\theta_t$  and the original Anosov flow  $\phi_t$ . We shall first define the conjugation on the set  $M^- \setminus \mathcal{A}$  which is Id restricted to the boundary of  $M^-$ , then we extend the homeomorphism to  $\mathcal{A}$  as Id. Similarly, we define the conjugation on the set  $M^+$ . In the end, we get the conjugation between two flows.

Let  $\pi : \tilde{M} \mapsto M$  be the universal cover of  $M$ . We denote by  $\tilde{\mathcal{F}}^l$  and  $\tilde{W}^l$  the lifts of the foliations  $\mathcal{F}^l$  and  $W^l$  respectively, for any  $l = ss, cs, c, cu, uu$ . Given a foliation  $\mathcal{F}$  on  $M$  and a submanifold  $M' \subset M$ , the leaf of  $\mathcal{F}|_{M'}$  through a point  $x \in M'$  means the connected component of  $\mathcal{F}(x) \cap M'$  containing  $x$ . We denote by  $\partial M^-$  the boundary of  $M^-$ , then  $\partial M^- = T_1 \cup \dots \cup T_k$ .



**Proposition 6.2.4.** *There exists a homeomorphism  $h^s : M^- \mapsto M^-$  such that*

- *the map  $h^s$  preserves every leaf of the foliation  $W^{cs}|_{M^-} = \mathcal{F}^{cs}|_{M^-}$ ;*
- *the map  $h^s$  takes the orbits of the flow  $\phi_t|_{M^-}$  to the ones of  $\psi_t|_{M^-}$ ;*
- *the map  $h^s$  coincides with  $Id$  on the set  $\mathcal{A} \cup \partial M^-$ .*

We denote  $\tilde{M}^j = \pi^{-1}(M^j)$ , for  $j = +, -$ . To prove Proposition 6.2.4, we need the following lemma:

**Lemma 6.2.5.** *For any points  $x \in \tilde{M}^+$  and  $y \in \tilde{M}^-$ , the center unstable leaf  $\tilde{W}^{cu}(x)$  intersects the center stable  $\tilde{W}^{cs}(y)$  non-empty if and only if the center unstable leaf  $\tilde{\mathcal{F}}^{cu}(x)$  intersects the center stable  $\tilde{\mathcal{F}}^{cs}(y)$  non-empty. More precisely, we have the following:*

$$z \in \tilde{W}^{cu}(x) \cap \tilde{W}^{cs}(y) \cap \pi^{-1}(T_1 \cup \dots \cup T_k) \Leftrightarrow z \in \tilde{\mathcal{F}}^{cu}(x) \cap \tilde{\mathcal{F}}^{cs}(y) \cap \pi^{-1}(T_1 \cup \dots \cup T_k).$$

*Proof of Lemma 6.2.5.* Given  $x \in \tilde{M}^-$  and  $y \in \tilde{M}^+$ , by Lemma 6.1.6, the intersection of  $\tilde{W}^{cs}(x)$  and  $\tilde{W}^{cu}(y)$  consists in at most one leaf of  $W^c$ , as well as for the foliations corresponding to  $f_{bz}$ . If the intersection of  $\tilde{W}^{cs}(x)$  and  $\tilde{W}^{cu}(y)$  is not empty, by the choice of  $x, y$ , there exists a unique point  $z \in \pi^{-1}(\partial M^-)$  contained in  $\tilde{W}^{cu}(x)$  and  $\tilde{W}^{cs}(y)$ , which is equivalent to that  $z \in \pi^{-1}(\partial M^-)$  is contained in  $\tilde{\mathcal{F}}^{cu}(x)$  and  $\tilde{\mathcal{F}}^{cs}(y)$ , since these foliations coincide on the corresponding region.  $\square$

Now, we are ready to give the proof of Proposition 6.2.4.

*Proof of Proposition 6.2.4.* For any  $x \in \tilde{M}^- \setminus \tilde{\mathcal{A}}$ , there exists a point  $y \in \tilde{M}^+ \setminus \tilde{\mathcal{R}}$  such that  $x$  is on the positive orbit of  $y$  for the lifted flow  $\tilde{\phi}_t$ . Let  $z$  be the unique intersection between  $\text{Orb}(x, \tilde{\phi}_t) = \tilde{W}^c(x)$  and the transverse section  $\pi^{-1}(\partial M^-)$ , then one has that

$$z \in \tilde{W}^{cu}(y) \cap \tilde{W}^{cs}(x) \cap \pi^{-1}(\partial M^-).$$

By Lemma 6.2.5, one has that

$$z \in \tilde{\mathcal{F}}^{cu}(y) \cap \tilde{\mathcal{F}}^{cs}(x) \cap \pi^{-1}(\partial M^-).$$

Since each leaf of the foliation  $\tilde{\mathcal{F}}^{cs}$  is a plane, by completeness and transversality, the center leaf  $\tilde{\mathcal{F}}^c(z)$  intersects the strong stable leaf  $\tilde{\mathcal{F}}^{ss}(x)$  in a unique point and we denote it as  $h^s(x)$  (as it is shown in Figure 6.4). Similarly, we can define a map  $\tau^s$  by exchanging the roles of  $(\tilde{\phi}_t, \tilde{W}^{ss})$  and  $(\tilde{\theta}_t, \tilde{\mathcal{F}}^{ss})$  in the definition  $h^s(x)$ .

By definition, one can check that the maps  $h^s, \tau^s : \tilde{M}^- \setminus \tilde{\mathcal{A}} \mapsto \tilde{M}^- \setminus (\tilde{\mathcal{A}} \cup \tilde{\mathcal{R}})$  are continuous and commutative with the automorphisms of  $\tilde{M}$  induced by  $\pi_1(M)$ . Moreover, one has that

- the maps  $h^s, \tau^s$  coincide with  $Id$  in a neighborhood of  $\widetilde{\partial M^-}$  restricted in  $\tilde{M}^-$ , where  $\widetilde{\partial M^-}$  is the lift of  $\partial M^-$ ;

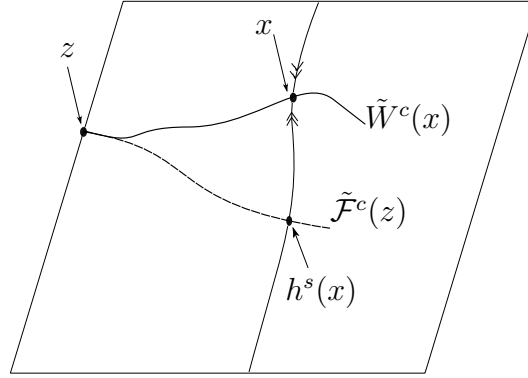

Figure 6.4 –

- the maps  $h^s, \tau^s$  preserve the orientation of the foliations  $\tilde{\mathcal{F}}^{cs}|_{\tilde{M}^-}, \tilde{\mathcal{F}}^{ss}|_{\tilde{M}^-}$  and send the positive orbits of one center flow to the positive orbits of the other.

The maps  $h^s$  and  $\tau^s$  are injective.

*Proof.* Assume that  $h^s$  is not injective, then there exist two different points  $x, y \in \tilde{M}^- \setminus \tilde{\mathcal{A}}$  such that  $h^s(x) = h^s(y)$ . By definition, one has that  $x \in \tilde{\mathcal{F}}^{ss}(y)$ . Moreover,  $x$  and  $y$  are on the same orbit of the Anosov flow  $\tilde{\phi}_t$ . Hence,  $x$  and  $y$  are joint by a segment  $L(x, y)$  which is contained in the leaf  $\tilde{\mathcal{F}}^{cs}(x)$  and transverse to  $\tilde{\mathcal{F}}^{ss}$ . Since the leaf  $\tilde{\mathcal{F}}^{cs}(x)$  is a plane and the leaf  $\tilde{\mathcal{F}}^{ss}(x)$  intersects  $L(x, y)$  twice, we get the contradiction.

The same argument applies for  $\tau^s$ . □

**Claim 6.2.7.** *The images of  $h^s$  and  $\tau^s$  are contained in  $\tilde{M}^- \setminus \tilde{\mathcal{A}}$ .*

*Proof.* Let us first recall that

$$\tilde{\mathcal{F}}^{cs}|_{\tilde{M}^-} = \tilde{W}^{cs}|_{\tilde{M}^-} \text{ and } \tilde{\mathcal{F}}^{cu}|_{\tilde{M}^+} = \tilde{W}^{cu}|_{\tilde{M}^+}.$$

By definition, for any point  $x \in \tilde{M}^- \setminus \tilde{\mathcal{A}}$ ,  $h^s$  maps the connected component of  $\tilde{\mathcal{F}}^{cs}(x) \cap (\tilde{M}^- \setminus \tilde{\mathcal{A}})$  containing  $x$  to a connected component of  $\tilde{\mathcal{F}}^{cs}(x) \cap (\tilde{M} \setminus \mathcal{A})$ . Notice that each connected component of  $\tilde{\mathcal{F}}^{cs}(x) \cap (\tilde{M} \setminus \mathcal{A})$  has non-empty interior in  $\tilde{\mathcal{F}}^{cs}(x)$  and its boundary consists in lines in  $\tilde{\mathcal{A}}$  and  $\widetilde{\partial M^-}$ . Since  $h^s$  coincides with identity in a neighborhood of  $\widetilde{\partial M^-}$  restricted in  $\tilde{M}^-$ , by the continuous and injective property of  $h^s$ , one has that  $h^s$  maps the connected component of  $\tilde{\mathcal{F}}^{cs}(x) \cap (\tilde{M}^- \setminus \tilde{\mathcal{A}})$  containing  $x$  into itself, for any  $x \in \tilde{M}^- \setminus \tilde{\mathcal{A}}$ .

The same arguments can be applied to  $\tau^s$ , ending the proof of Claim 6.2.7.  $\square$

**Claim 6.2.8.** *For any points  $x, y \in \tilde{M}^-$ , one has that*

$$y \in \tilde{\mathcal{F}}^{ss}(x) \iff y \in \tilde{W}^{ss}(x).$$

*Proof.* Since  $f_{bz}|_{M^-} = \phi_\tau|_{M^-}$ , one can take a lift  $\tilde{f}_{bz}$  of  $f_{bz}$  such that the forward orbit of  $x$  under  $\tilde{f}_{bz}$  coincides with the one under  $\tilde{\phi}_\tau$ . If  $y \in \tilde{\mathcal{F}}^{ss}(x) \cap \tilde{M}^-$ , then the forward orbit of  $y$  under  $\tilde{f}_{bz}$  coincides with the one under  $\tilde{\phi}_\tau$  since  $f_{bz}|_{M^-} = \phi_\tau|_{M^-}$ . Hence, the distance  $d(\tilde{f}_{bz}^n(x), \tilde{f}_{bz}^n(y)) = d(\tilde{\phi}_{n\tau}(x), \tilde{\phi}_{n\tau}(y))$  tends to zero exponentially. Since  $\tilde{\phi}_\tau$  has neutral behavior along the center, one has that  $y \in \tilde{W}^{ss}(x)$ . One can argue for the other side analogously, concluding.  $\square$

By definition of  $h^s$  and  $\tau^s$ , one has that  $h^s(x) \in \tilde{W}^{ss}(x)$  and  $\tau^s(x) \in \tilde{\mathcal{F}}^{ss}(x)$ . By Claims 6.2.7, 6.2.8 and the definitions of  $h^s, \tau^s$ , one has that  $\tau^s \circ h^s = h^s \circ \tau^s = Id$ . Hence,  $h^s$  is an orientation preserving homeomorphism on the set  $\tilde{M}^- \setminus \tilde{\mathcal{A}}$ . Moreover,  $h^s$  maps each leaf of  $\tilde{\mathcal{F}}^{ss}|_{\tilde{M}^- \setminus \tilde{\mathcal{A}}}$  into itself surjectively as a homeomorphism, hence one can extend  $h^s$  to  $\tilde{\mathcal{A}}$  as  $Id$ . Now  $h^s$  is continuous along each leaf of  $\tilde{\mathcal{F}}^{ss}|_{\tilde{M}^-}$ .

**Lemma 6.2.9.** *The map  $h^s, \tau^s : \tilde{M}^- \mapsto \tilde{M}^-$  are continuous.*

*Proof.* One only needs to prove that the map  $h^s$  is continuous at  $\tilde{\mathcal{A}}$ . The case for  $\tau^s$  follows analogously.

Assume, on the contrary, there exists a point  $x_0 \in \tilde{\mathcal{A}}$  where  $h^s$  is not continuous. Then there exist  $\epsilon_0 > 0$  and a sequence of points  $\{x_n\}_{n>0} \subset \tilde{M}^- \setminus \tilde{\mathcal{A}}$  such that

$$\lim x_n = x_0 \text{ and } d(h^s(x_n), h^s(x_0)) > \epsilon_0.$$

To continue the proof, we need the following result:

**Claim 6.2.10.** *On the universal cover  $\tilde{M}$ , for the lifts of  $f_{bz}$  and  $\phi_\tau$ , each center unstable leaf intersects a strong stable leaf in at most one point.*

*Proof.* If there exists a strong stable leaf intersects a center unstable leaf in two points, since the center unstable foliation is transverse orientable and the strong stable foliation is orientable, by a classical argument, one gets a closed transversal for the center unstable foliation, which implies that the center unstable foliation for the diffeomorphism on  $M$  admits a null-homotopy closed transversal. By Novikov's theorem, the center unstable foliation for the diffeomorphism on  $M$  has compact leaves, contradicting to Theorem 2.18.2.  $\square$

Since  $x_n$  tends to  $x_0$ , by Claim 6.2.10, the center unstable leaf  $\tilde{W}^{cu}(x_n)$  intersects the strong stable leaf  $\tilde{W}_{\epsilon_0}^{ss}(x_0) = \tilde{\mathcal{F}}_{\epsilon_0}^{ss}(x_0)$  in a unique point  $y_n$ , for  $n$  large. Then  $y_n$  tends to  $x_0$ . Moreover, since each connected component of  $\tilde{W}^{cu}(x_n) \cap \tilde{M}^-$  is the forward  $\tilde{\phi}_t$ -orbit of a connected component of  $\tilde{W}^{cu}(x_n) \cap \widetilde{\partial M}^-$ , the backward orbits of  $x_n$  and  $y_n$  under the flow  $\tilde{\phi}_t$  intersect the same connected component  $P_n$  of  $\widetilde{\partial M}^- \cap \tilde{W}^{cu}(x_n)$  into  $p_n$  and  $q_n$  respectively, where  $P_n$  is a line, and the distance  $d|_{P_n}(p_n, q_n)$  restricted to the line  $P_n$  tends to zero. Since  $\tilde{W}^{cu}$  coincides with  $\tilde{\mathcal{F}}^{cu}$  in a neighborhood of  $\widetilde{\partial M}^-$ , one has that the forward orbits of  $p_n$  and  $q_n$  under the flow  $\tilde{\theta}_t$  are on the same center unstable leaf  $\tilde{\mathcal{F}}^{cu}(q_n)$ . By the choices of  $p_n, q_n$  and Claim 6.2.10, one has that the center unstable leaf  $\tilde{\mathcal{F}}^{cu}(q_n)$  intersects  $\tilde{\mathcal{F}}^{ss}(x_0)$  and  $\tilde{\mathcal{F}}^{ss}(x_n)$  into a unique point  $h^s(y_n)$  and  $h^s(x_n)$  respectively. By definition,  $h^s$  is continuous restricted to the strong stable leaf  $\tilde{\mathcal{F}}^{ss}(x_0)$ , hence  $d(h^s(y_n), x_0)$  tends to zero. By the continuity of center unstable foliation, the center unstable leaf  $\tilde{\mathcal{F}}_{\epsilon_0/3}^{cu}(h^s(y_n)) \subset \tilde{\mathcal{F}}^{cu}(q_n)$  intersects the strong stable leaf  $\tilde{\mathcal{F}}^{ss}(x_n)$  into a point  $z_n$  for  $n$  large, hence

$$d(z_n, x_0) < d(z_n, h^s(y_n)) + d(h^s(y_n), x_0) < \epsilon_0, \text{ for } n \text{ large.}$$

Once again, by Claim 6.2.10, one has that  $z_n = h^s(x_n)$ , contradicting to  $d(h^s(x_n), x_0) < \epsilon_0$ .  $\square$

Now, the map  $h^s : \tilde{M}^- \mapsto \tilde{M}^-$  is a homeomorphism. By definition of  $h^s$ , one

has that  $h^s$  maps the orbit segment of  $\tilde{\phi}_t|_{\tilde{M}^-}$  to  $\tilde{\theta}_t|_{\tilde{M}^-}$ , and preserves the orientation of the orbits. Since  $h^s$  commutes with the automorphism on  $\tilde{M}$  induced by  $\pi_1(M)$ , the projection of  $h^s$  on the base manifold defines a homeomorphism of  $M^-$  satisfying the announced properties, ending the proof Proposition 6.2.4.  $\square$

*Ending the proof of Theorem I.* By applying Proposition 6.2.4 to the reversed dynamics on the set  $M^+$ , one gets a homeomorphism  $h^u : M^+ \mapsto M^+$  satisfying the analogous properties. We define a homeomorphism  $h : M \mapsto M$  in the following way:

$$h(x) = \begin{cases} h^s(x) & \text{if } x \in M^- \\ h^u(x) & \text{if } x \in M^+ \end{cases}$$

The homeomorphism  $h$  coincides with  $Id$  on the set  $\mathcal{A} \cup \mathcal{R} \cup T_1 \cup \dots \cup T_k$ . One can check that  $h$  sends the orbits of  $\phi_t$  to the orbits of  $\theta_t$  and preserves the orientation of the flows. This also proves that  $\theta_t$  is topologically equivalent to Anosov flow  $\phi_t$ .  $\square$

For the general example in [BZ1], we don't know if the center stable and center unstable foliations are robustly complete or not, but for the special example in [BPP], we get the robust completeness. We denote by  $\psi_t$  the

Anosov flow for building  $f_B$ . Now, we will use Theorem I to give the proof of Proposition 1.1.2.

*Proof of Proposition 1.1.2.* Since  $f_B$  has neutral behavior along the center, by Theorem 2.17.3, there exists a small neighborhood  $\mathcal{V}$  of  $f_B$  such that for any  $g \in \mathcal{V}$ , one has that

- $g$  is dynamically coherent;
- there exists a homeomorphism  $h_g : N \mapsto N$  such that for any  $x \in N$  and  $i = c, cs, cu$ , one has

$$h_g(\mathcal{F}^i(x)) = \mathcal{F}_g^i(h_g(x)) \text{ and } h_g(f(\mathcal{F}^i(x))) = g(\mathcal{F}_g^i(h_g(x)));$$

- the homeomorphism  $h_g$  tends to identity in the  $C^0$ -topology when  $g$  tends to  $f$ .

We denote by  $\mathcal{A}$  and  $\mathcal{R}$  the attractor and repeller of  $\psi_t$  respectively. Then the maximal invariant set of  $f_B$  in  $N^+$  and  $N^-$  are  $\mathcal{R}$  and  $\mathcal{A}$  respectively. By Theorem 7A.1 in [HPS], one can choose a small enough neighborhood  $\mathcal{U} \subset \mathcal{V}$  of  $f_B$  such that for any  $g \in \mathcal{U}$ , one has that the maximal invariant set of  $g$  in the region  $N^-$  (resp.  $N^+$ ) is  $h_g(\mathcal{A})$  (resp.  $h_g(\mathcal{R})$ ). Hence, the chain recurrent set of  $g$  is contained in  $h_g(\mathcal{A} \cup \mathcal{R})$ .

We will first show the following:

**Lemma 6.2.11.** *For any point  $x \in h_g(\mathcal{R})$ , one has that*

$$\mathcal{F}_g^{ss}(\mathcal{F}_g^c(x)) = \mathcal{F}_g^{cs}(x).$$

*Proof.* Notice that  $\mathcal{F}_g^{cs}(x) = h_g(\mathcal{F}^{cs}(h_g^{-1}(x)))$ . We lift the foliations to the universal cover  $\tilde{N}$ . Let  $\tilde{\mathcal{F}}_g^c(y)$  be a lift of  $\mathcal{F}_g^c(x)$ . Notice that  $g$  fixes every center leaf in  $h_g(\mathcal{R})$ .

**Claim 6.2.12.** *There exists a lift  $\tilde{g}$  of  $g$  such that  $\tilde{g}$  keeps every center leaf in  $\tilde{\mathcal{F}}_g^{cs}(y)$  invariant.*

*Proof.* By leaf conjugacy, there is at most one compact center leaf contained in  $\mathcal{F}_g^{cs}(x)$ . We take a non-compact center leaf  $L \subset \mathcal{F}_g^{cs}(x)$ , and we denote by  $\tilde{L} \subset \tilde{\mathcal{F}}_g^{cs}(y)$  a lift of  $L$ . Then there exists a unique lift  $\tilde{g}$  of  $g$  such that  $\tilde{L}$  is  $\tilde{g}$ -invariant.

For any center leaf  $\tilde{\mathcal{F}}_g^c(z) \subset \tilde{\mathcal{F}}_g^{cs}(y)$ , by the fact that  $\mathcal{F}^c$  is topologically Anosov, there exists a strong stable curve  $\tilde{\sigma}(t)_{t \in [0,1]} \subset \tilde{\mathcal{F}}_g^{cs}(y)$  such that  $\tilde{\sigma}(0) \in \tilde{L}$  and  $\tilde{\sigma}(1) \in \tilde{\mathcal{F}}_g^c(z)$ . Let  $\sigma(t)$  be the projection of  $\tilde{\sigma}(t)$  on  $\mathcal{F}_g^{cs}(x)$ , by the invariance of the center leaves, one has that there exists a continuous family of center curves  $\gamma_t(s)$  joining the curve  $\sigma(t)$  with  $g(\sigma(t))$ . Now, we lift the family of center curves to the leaf  $\tilde{\mathcal{F}}_g^{cs}(y)$ , then one gets a continuous family of center curves  $\tilde{\gamma}_t(s)$  joining  $\tilde{\sigma}(t)$  to a lift  $\alpha(t)$  of  $g(\sigma(t))$ . By the uniqueness of  $\tilde{g}$  and the non-compactness of  $L$ , the lift of  $g(\sigma(0))$  can only be  $\tilde{g}(\tilde{\sigma}(0))$  which implies that the  $\alpha(t)$  can only be  $\tilde{g}(\tilde{\sigma}(t))$ . Hence, one has that  $\tilde{\mathcal{F}}_g^c(z)$  is invariant under  $\tilde{g}$ .  $\square$

We only need to prove that, restricted to the leaf  $\tilde{\mathcal{F}}^{cs}(y)$ , every strong stable leaf intersects every center leaf. Assume, on the contrary, that there exists a strong stable leaf  $\tilde{\mathcal{F}}_g^{ss}(p)$  which is a boundary leaf of  $\tilde{\mathcal{F}}_g^{ss}(\tilde{\mathcal{F}}_g^c(q))$ . Since  $\mathcal{F}^c$  is topologically Anosov,  $\tilde{\mathcal{F}}_g^c$  has the same feature. The strong stable leaf  $\tilde{\mathcal{F}}_g^{ss}(p)$  separates the leaf  $\tilde{\mathcal{F}}^{cs}(y)$ , which is a plane, into two connected components. The center leaves converge in one connected component and separate in the other connected component. Notice that  $\tilde{\mathcal{F}}_g^{ss}(\tilde{\mathcal{F}}_g^c(q))$  is a  $\tilde{g}$ -invariant set, and the map  $\tilde{g}$  fixes every center leaf in  $\tilde{\mathcal{F}}^{cs}(y)$ . Since  $\tilde{g}$  sends a boundary leaf to a boundary leaf,  $\tilde{\mathcal{F}}_g^{ss}(\tilde{\mathcal{F}}_g^c(q))$  is a path connected set, and  $\tilde{g}$  preserves the orientation of each invariant bundle, hence the strong stable leaf  $\tilde{\mathcal{F}}^{ss}(p)$  is  $\tilde{g}$ -invariant. Since every center leaf in  $\tilde{\mathcal{F}}_g^{ss}(\tilde{\mathcal{F}}_g^c(q))$  is fixed by  $\tilde{g}$  and intersects  $\tilde{\mathcal{F}}^{ss}(p)$  in at most one point, one has that every point in  $\tilde{\mathcal{F}}^{ss}(p)$  is fixed by  $\tilde{g}$ , contradicting to the fact that  $\tilde{\mathcal{F}}^{ss}(p)$  is a strong stable leaf, ending the proof of Lemma 6.2.11.  $\square$

Now, we consider the center stable leaves in the region  $N \setminus h_g(\mathcal{R})$ . Assume, on the contrary, that there exists a point  $x$  such that  $\mathcal{F}_g^{ss}(\mathcal{F}_g^c(x)) \subsetneq \mathcal{F}_g^{cs}(x)$ , then let  $p$  be a point such that  $\mathcal{F}_g^{ss}(p)$  is a boundary leaf of  $\mathcal{F}_g^{ss}(\mathcal{F}_g^c(x))$ . Since  $h_g(\mathcal{A})$  is the maximal invariant set in  $N^-$  and is saturated by center unstable leaves, there exists an integer  $n$  large enough such that  $\mathcal{F}_g^{ss}(g^n(p))$  intersects  $h_g(\mathcal{A})$  in a point  $q'$ . Since  $g$  keeps every center leaf in  $h_g(\mathcal{A})$  invariant, the center leaf through  $q'$  is contained in  $\mathcal{F}_g^{cs}(x)$  and intersects  $\mathcal{F}_g^{ss}(p)$ . We denote by  $q = g^{-n}(q')$ , then  $q \in \mathcal{F}_g^{ss}(p) \cap \mathcal{F}_g^c(q')$ .

Now, we lift those leaves to the universal cover. Let  $\tilde{x}$ ,  $\tilde{p}$  and  $\tilde{q}$  be the lifts of  $x$ ,  $p$  and  $q$  respectively such that they are on the same center stable leaf  $\tilde{\mathcal{F}}_g^{cs}(\tilde{x})$  and  $\tilde{\mathcal{F}}_g^c(\tilde{q})$  intersects  $\tilde{\mathcal{F}}_g^{ss}(\tilde{p})$ .

**Lemma 6.2.13.** *There exist a lift  $\tilde{g}$  of  $g$  and a center leaf  $L \subset \tilde{\mathcal{F}}_g^{cs}(\tilde{x})$  such that*

- the leaf  $L$  is disjoint from  $\tilde{\mathcal{F}}_g^{ss}(\tilde{p})$ ;
- the center leaf  $\tilde{\mathcal{F}}_g^c(\tilde{q})$  and  $L$  are  $\tilde{g}$ -invariant.

*Proof.* If  $\mathcal{F}_g^c(x)$  is fixed by  $g$ , then at most one of invariant center leaves  $\mathcal{F}_g^c(x)$  and  $\mathcal{F}_g^c(q)$  is a compact leaf. Assume that  $\mathcal{F}_g^c(q)$  is not compact (the other case follows analogously). Then there exists a unique lift  $\tilde{g}$  of  $g$  such that the center leaf  $\tilde{\mathcal{F}}_g^c(\tilde{q})$  is  $\tilde{g}$ -invariant. By Theorem I and leaf conjugacy, one has the following:

- the strip bounded by  $\tilde{\mathcal{F}}_g^c(\tilde{q})$  and  $\tilde{\mathcal{F}}_g^c(\tilde{x})$  is trivially foliated by center leaves;
- there exists a segment with infinity length  $\ell \subset \tilde{\mathcal{F}}_g^c(\tilde{q})$  such that for any point  $z \in \ell$ , the strong stable leaf  $\tilde{\mathcal{F}}_g^{ss}(z)$  through  $z$  intersects the center leaf  $\tilde{\mathcal{F}}_g^c(\tilde{x})$ .

Since  $f_B$  preserves the orientation of the center foliation, by leaf conjugacy, there exists a point  $w \in \ell$  such that  $\tilde{g}(w) \in \ell$ . We take the strong stable segment  $\tilde{\sigma}(t)$  through  $w$  whose endpoints are contained in  $\tilde{\mathcal{F}}_g^c(\tilde{q}) \cup \tilde{\mathcal{F}}_g^c(\tilde{x})$ . Now, one can check that the arguments in Claim 6.2.12 apply here and one gets that  $\tilde{\mathcal{F}}_g^c(\tilde{x})$  is  $\tilde{g}$ -invariant. We only need to take  $L = \tilde{\mathcal{F}}_g^c(\tilde{x})$ .

If center leaf  $\mathcal{F}_g^c(x)$  is not fixed by  $g$ , then the center leaf  $h_g^{-1}(\mathcal{F}_g^c(x))$  for  $f$  intersects the transverse torus  $T_1$  and it is not fixed by  $f$ . Consider the connected component  $\mathcal{P}$  of  $\mathcal{F}^{cs}(h_g^{-1}(x)) \setminus \mathcal{A}$  which contains the center leaf  $\mathcal{F}^c(h_g^{-1}(x))$ , then  $\mathcal{P}$  is a topological plane. Recall that on each transverse torus, the foliation  $\mathcal{F}^{cs}$  induces a foliation consisting in exactly two Reeb components. Since  $\mathcal{P}$  intersects  $T_1$  into a line which accumulates to two circles contained in the stable manifolds of two different periodic orbits of the Anosov flow  $\psi_t$ , one has that the boundary of  $\mathcal{P}$  restricted to  $\mathcal{F}^{cs}(h_g^{-1}(x))$  consists in two center leaves belonging to the unstable manifolds of two different periodic orbits of  $\psi_t$  in  $\mathcal{A}$ .

Hence, by leaf conjugacy, there exist two leaves  $L_1, L_2$  of the foliation  $\tilde{\mathcal{F}}_g^c$  such that

- $L_1 \cup L_2 \subset \tilde{\mathcal{F}}_g^{cs}(\tilde{x})$ ;
- the leaves  $L_1$  and  $L_2$  bound a strip containing  $\tilde{\mathcal{F}}^c(\tilde{x})$ ;
- the projections of the two center leaves  $L_1, L_2$  on the base manifold is invariant under  $g$ .

By the choice of  $L_1, L_2$ , neither  $\pi(L_1)$  nor  $\pi(L_2)$  is a compact leaf, hence one can apply the argument in the first case and one gets a lift  $\tilde{g}$  of  $g$  such that the center leaves  $L_1, L_2, \tilde{\mathcal{F}}_g^c(\tilde{q})$  are  $\tilde{g}$ -invariant. Then there exists  $i \in \{1, 2\}$  such that  $\tilde{\mathcal{F}}_g^c(\tilde{x})$  is contained in the strip  $S$  bounded by  $L_i$  and  $\tilde{\mathcal{F}}_g^c(\tilde{q})$ . Since  $\tilde{\mathcal{F}}^{ss}(\tilde{p})$  does not intersect  $\tilde{\mathcal{F}}^c(\tilde{x})$ , the strong stable leaf  $\tilde{\mathcal{F}}^{ss}(\tilde{p})$  does not intersect  $L_i$ . We take  $L = L_i$ , ending the proof of Lemma 6.2.13.  $\square$

**Claim 6.2.14.** *There exists a  $\tilde{g}$ -fixed point on  $\tilde{\mathcal{F}}_g^c(\tilde{q})$  whose strong stable leaf does not intersect  $L$ .*

*Proof.* If  $\tilde{q}$  is a  $\tilde{g}$ -fixed point, we are done. Now, we assume that  $\tilde{q}$  is not a fixed point. Denote by  $I_q$  the connected component of  $\tilde{\mathcal{F}}_g^c(\tilde{q}) \setminus \{\tilde{q}\}$  such that under leaf conjugacy, it corresponds to the forward orbit of  $\tilde{h}_g^{-1}(q)$  under the Anosov flow  $\psi_t$ . Up to replacing  $\tilde{g}$  by  $\tilde{g}^{-1}$ , we can assume that  $\tilde{g}(\tilde{q})$  is contained in the interior of  $I_q$ . Since the leaf  $L$  is fixed by  $\tilde{g}$ , the strong stable leaf through the orbit of  $\tilde{q}$  is disjoint from  $L$ . We identify  $I_q$  with  $(0, +\infty)$ , where  $q$  corresponds to 0. For the points on  $I_q$  tending to infinity, their strong stable leaves would intersect  $L$ . Hence, one has that the forward orbit of  $\tilde{q}$  tends to a fixed point whose strong stable leaf is disjoint from  $L$ .  $\square$

By Claim 6.2.14, for notational convenience, we assume that  $\tilde{q}$  is the fixed point of  $\tilde{g}$ . Since the projection of  $\tilde{\mathcal{F}}_g^c(\tilde{q})$  on the base manifold is contained in

$h_g(\mathcal{A})$  and  $\mathcal{A}$  is an attractor of the Anosov flow  $\phi_t$ , hence  $\mathcal{F}_g^c(q)$  is accumulated by invariant center leaves on the center stable leaf  $\mathcal{F}_g^{cs}(q)$ . Hence, there exist center leaves on  $\tilde{\mathcal{F}}_g^{cs}(\tilde{q})$  contained in  $\widetilde{h_g(\mathcal{A})}$  which intersect the strong stable leaf  $\tilde{\mathcal{F}}_g^{ss}(\tilde{q})$ . One can check that those center leaves are invariant under  $\tilde{g}$ . Since those center leaves and the strong stable leaf  $\tilde{\mathcal{F}}_g^{ss}(\tilde{q})$  are invariant under  $\tilde{g}$ , one has that those center leaves intersect  $\tilde{\mathcal{F}}_g^{ss}(\tilde{q})$  into fixed points which contradicts to the uniform contraction of  $\tilde{g}$  along  $\tilde{\mathcal{F}}_g^{ss}(\tilde{q})$ . Hence, the center stable foliation of  $g$  is complete.

Similar argument applies for the center unstable foliation of  $g$ . □





# Bibliography

- [ABC] F. Abdenur, Ch. Bonatti and S. Crovisier, *Nonuniform hyperbolicity for  $C^1$  generic diffeomorphisms*. Israel J. Math.183(2011), 1–60.
- [ABCDW] F. Abdenur, Ch. Bonatti, S. Crovisier, L. J. Díaz and L. Wen, *Periodic points and homoclinic class*. Ergodic Theory Dynamic System 27 (2007), no.1, 1–22.
- [AS] R. Abraham and S. Smale, *Nongenericity of  $\Omega$ -stability*. Global Analysis I, Proc. Symp. Pure Math, 1968, AMS 14(1970), 5–8.
- [ACS] A. Arbieto, T. Catalan and B. Santiago, *Mixing-like properties for some generic and robust dynamics*. Nonlinearity 28 (2015), no. 11, 4103–4115.
- [BaBS] V. Baladi, Ch. Bonatti and B. Schmitt, *Abnormal escape rates from nonuniformly hyperbolic sets*. Ergodic Theory Dynam. Systems 19 (1999), no. 5, 1111–1125.
- [BBY] F. Béguin, Ch. Bonatti, and B. Yu, *Building Anosov flows on 3-manifolds*. To appear at Geometry & Topology. Preprint arXiv:1408.3951
- [BB] J. Bochi and Ch. Bonatti, *Perturbation of the Lyapunov spectra of periodic orbits*. Proc. Lond. Math. Soc. 105 (2012), 1–48.
- [BBD1] J. Bochi, Ch. Bonatti and L. J. Díaz, *Robust vanishing of all Lyapunov exponents for iterated function systems*. Math. Z. 276 (2014), 469–503.
- [BBD2] J. Bochi, Ch. Bonatti and L. J. Díaz, *Robust criterion for the existence of nonhyperbolic ergodic measures*. Comm. Math. Phys. 344(2016), no.3, 751–795.
- [BBD3] J. Bochi, Ch. Bonatti and L. J. Díaz, *A criterion for zero averages and full support of ergodic measures*. arXiv:1609.07764.
- [B1] Ch. Bonatti, *A semi-local argument for robust transitivity*. Lecture at IMPA’s Dynamical Systems Seminar, August, 1996.
- [B2] Ch. Bonatti, *Survey: Towards a global view of dynamical systems, for the  $C^1$ -topology*. Ergodic Theory Dynam. Systems 31 (2011), no. 4, 959–993.
- [BC] Ch. Bonatti and S. Crovisier, *Récurrence et genericité*. Invent. Math. 158 (2004), 33–104.
- [BCDG] Ch. Bonatti, S. Crovisier, L. J. Díaz and N. Gourmelon, *Internal perturbations of homoclinic classes: non-dominance, cycles, and self-replication*. Ergodic Theory & Dynamical Systems 33 (2013), 739–776.

- [BCS] Ch. Bonatti, S. Crovisier and K. Shinohara, *The  $C^{1+\alpha}$  hypothesis in Pesin theory revisited*. J. Mod. Dyn 7(2013), no.4, 605–618.
- [BD1] Ch. Bonatti and L. J. Díaz. *Persistent nonhyperbolic transitive diffeomorphism*. Annals of Mathematics 143, no.2(1996), 357–396.
- [BD2] Ch. Bonatti and L. J. Díaz. *Robust heterodimensional cycles and  $C^1$  generic dynamics*. J. Inst. Math. Jussieu 7(2008), no.3, 469–525.
- [BD3] Ch. Bonatti and L. J. Díaz. *Abundance of  $C^1$ -robust homoclinic tangencies*. Trans. Amer. Math. Soc. 364(2012), no.10, 5111–5148.
- [BDPR] Ch. Bonatti, L. J. Díaz, E. Pujals and J. Rocha. *Robustly transitive sets and heterodimensional cycles*. Geometric methods in dynamics. I. Astérisque No. 286 (2003), xix, 187–222.
- [BDG] Ch. Bonatti, L. J. Díaz and A. Gorodetski. *Non-hyperbolic ergodic measures with large support*. Nonlinearity 23 (2010), no.3, 687–705.
- [BDP] Ch. Bonatti, L. J. Díaz and E. R. Pujals, *A  $C^1$  generic dichotomy for diffeomorphisms: Weak forms of hyperbolicity or infinitely many sinks or sources*. Ann. of Math. 158 (2003), 355–418.
- [BDU] Ch. Bonatti, L. J. Díaz and R. Ures, *Minimality of strong stable and unstable foliations for partially hyperbolic diffeomorphisms*. J. Inst. Math. Jussieu 1(2002), no.4, 513–541.
- [BDV] Ch. Bonatti, L. Díaz, and M. Viana, *Dynamic beyond uniform hyperbolicity; A global geometric and probabilistic perspective*. Encyclopaedia of Mathematical Sciences, 102. Mathematical Physics, III. Springer-Verlag, Berlin, 2005. xviii+384 pp.
- [BG] Ch. Bonatti and K. Gelfert, *Dominated Pesin theory: convex sum of hyperbolic measures*. arXiv:1503.05901.
- [BGP] Ch. Bonatti, A. Gogolev and R. Potrie, *Anomalous partially hyperbolic diffeomorphisms II: stably ergodic examples*. Invent. Math. 206 (2016), no. 3, 801–836.
- [BL] Ch. Bonatti and R. Langevin, *Un exemple de flot d’Anosov transitif transverse à un tore et non conjugué à une suspension*. Ergodic Theory Dynam. Systems 14 (1994), no. 4, 633–643.
- [BPP] Ch. Bonatti, K. Parwani, and R. Potrie, *Anomalous partially hyperbolic diffeomorphisms I: dynamically coherent examples*. Annales scientifiques de l’ENS 49, fascicule 6 (2016), 1387–1402.
- [BV] Ch. Bonatti and M. Viana, *SRB measures for partially hyperbolic systems whose central direction is mostly contracting*. Israel J. Math. 115 (2000), 157–193.
- [BW] Ch. Bonatti and A. Wilkinson, *Transitive partially hyperbolic diffeomorphisms on 3-manifolds*. Topology 44 (2005), no. 3, 475–508.

- [BZ1] Ch. Bonatti and J. Zhang, *Transverse foliations on the torus  $\mathbb{T}^2$  and partially hyperbolic diffeomorphisms on 3-manifolds*, To appear at Comment. Math. Helv. arXiv:1602.04355
- [BZ2] Ch. Bonatti and J. Zhang, *On the existence of non-hyperbolic ergodic measure as the limit of periodic measures*. arXiv:1606.06119.
- [BZ3] Ch. Bonatti and J. Zhang, *Periodic measures and partially hyperbolic homoclinic classes*. arXiv:1609.08489.
- [Bo1] R. Bowen, *Some systems with unique equilibrium states*. Math. Systems Theory 8 (1974/75), no. 3, 193–202.
- [Bo2] R. Bowen, *Equilibrium states and the ergodic theory of Anosov diffeomorphisms*. Second revised edition. With a preface by David Ruelle. Edited by Jean-René Chazottes. Lecture Notes in Mathematics, 470. Springer-Verlag, Berlin, 2008. viii+75 pp.
- [BBI] M. Brin, D. Burago and S. Ivanov, *On partially hyperbolic diffeomorphisms of 3-manifolds with commutative fundamental group*. Modern dynamical systems and applications, 307-312, Cambridge Univ. Press, Cambridge, 2004.
- [Br] M. Brunella, *Separating the basic sets of a nontransitive Anosov flow*. Bull. London Math. Soc. 25 (1993), no. 5, 487–490.
- [BI] D. Burago and S. Ivanov, *Partially hyperbolic diffeomorphisms of 3-manifolds with abelian fundamental groups*. J. Mod. Dyn. 2 (2008), no. 4, 541–580.
- [CN] C. Camacho and A. Lins Neto, *Geometric Theory of Foliations*, Birkhäuser Boston, Inc., Boston, MA, 1985.
- [CC1] A. Candel and L. Conlon, *Foliations. I*. Graduate Studies in Mathematics, 23. American Mathematical Society, Providence, RI, 2000.
- [CC2] A. Candel and L. Conlon, *Foliations. II*. Graduate Studies in Mathematics, 60. American Mathematical Society, Providence, RI, 2003. xiv+545 pp. ISBN: 0-8218-0881-8.
- [CLR] Y. Cao, S. Luzatto and I. Rios, *Some non-hyperbolic systems with strictly non-zero Lyapunov exponents for all invariant measures: horseshoes with internal tangencies*. Disc. Cont. Dyn. Syst. 15(2006), no.1, 61–71.
- [CCGWY] C. Cheng, S. Crovisier, S. Gan, X. Wang and D. Yang, *Hyperbolicity versus non-hyperbolic ergodic measures inside homoclinic classes*. arXiv:1507.08253
- [C] S. Crovisier, *Partial hyperbolicity far from homoclinic bifurcations*. Advance in Math. 226(2011), 673–726.
- [DG] L.J. Díaz and A. Gorodetski, *Non-hyperbolic ergodic measures for non-hyperbolic homoclinic classes*. Ergodic Theory Dynam. Systems 29 (2009), no. 5, 1479–1513.

- [DGR] L.J. Díaz, K. Gelfert and M. Rams, *Nonhyperbolic step skew-products: Ergodic approximation*. To appear in Annales de l'Institut Henri Poincaré Analyse non linéaire.
- [DHRS] L.J. Díaz, V. Horita, I. Rios, M. Sambarino, *Destroying horseshoes via heterodimensional cycles: generating bifurcations inside homoclinic classes*. Ergodic Theory Dynam. Systems 29 (2009), no. 2, 433–474.
- [FF] B. Farb and J. Franks, *Groups of homeomorphisms of one-manifolds, I: Nonlinear group actions*, June 2001 preprint.
- [FW] J. Franks, and B. Williams, *Anomalous Anosov flows*. Global theory of dynamical systems (Proc. Internat. Conf., Northwestern Univ., Evanston, Ill., 1979), pp. 158–174, Lecture Notes in Math., 819, Springer, Berlin, 1980.
- [G1] S. Gan, *A generalized shadowing lemma*. Disc. Cont. Dyn. Syst. 8(2002), no.3, 527–632.
- [G2] S. Gan, *Horseshoe and entropy for  $C^1$  surface diffeomorphisms*. Nonlinearity 15(2002), 1–8.
- [G3] S. Gan, *A necessary and sufficient condition for the existence of dominated splitting with a given index*. Trends in Mathematics 7 (2004), 143–168.
- [GK] K. Gelfert and D. Kwietniak, *The (Poulsen) simplex of invariant measures*. arXiv:1404.0456.
- [Gh] E. Ghys, *Codimension one Anosov flows and suspensions*. Dynamical systems, Valparaiso 1986, 59–72, Lecture Notes in Math., 1331, Springer, Berlin, 1988.
- [GH] A. Gogolev and F. Rodriguez Hertz, *Manifolds with higher homotopy which do not support Anosov diffeomorphisms*. Bull. Lond. Math. Soc. 46 (2014), no. 2, 349–366.
- [GHO] A. Gogolev, P. Ontaneda and F. Rodriguez Hertz, *New partially hyperbolic dynamical systems I*. Acta Math. 215 (2015), no. 2, 363–393.
- [GIKN] A. Gorodetski, Yu. Ilyashenko, V. Kleptsyn and M. Nalsky. *Nonremovability of zero Lyapunov exponents*. (Russian) Funktsional. Anal.i Prilozhen. 39 (2005), no.1, 27–38; translation in Funct. Anal. Appl.39(2005), no.1, 21–30.
- [GP] . Gorodetski and Y. Pesin, *Path connectedness and entropy density of the space of hyperbolic ergodic measures*. To appear in Contemporary Mathematics.
- [Go1] N. Gourmelon, *Adapted metrics for dominated splittings*. Ergodic Theory Dynamic Systems 27 (2007), no.6, 1839–1849.
- [Go2] N. Gourmelon, *A Frank's lemma that preserves invariant manifolds*. Ergodic Theory Dynam. Systems 36 (2016), no. 4, 1167–1203

## BIBLIOGRAPHY

---

- [HaPo1] A. Hammerlindl and R. Potrie, *Classification of partially hyperbolic diffeomorphisms in 3-manifolds with solvable fundamental group*. J. Topol. 8 (2015), no. 3, 842–870.
- [HaPo2] A. Hammerlindl and R. Potrie, *Partial hyperbolicity and classification: a survey*. to appear in Ergodic Theory and Dynamical Systems.
- [Ha] A. Hatcher, *Algebraic topology*. Cambridge University Press, 2002.
- [H] S. Hayashi, *Connecting invariant manifolds and the solution of  $C^1$ -stability and  $\Omega$ -stability conjectures for flows*. Annals of Mathematics, 145(1997), 81-137.
- [HK] B. Hasselblatt and A. Katok, *Introduction to the modern theory of dynamical systems*. Encyclopedia of Mathematics and its Applications, 54. Cambridge University Press, Cambridge, 1995. ISBN: 0-521-34187-6.
- [Ha] A. Hatcher, *Algebraic topology*. Cambridge University Press, 2002.
- [HH] G. Hector and U. Hirsch, *Introduction to the geometry of foliations. Part A. Foliations on compact surfaces, fundamentals for arbitrary codimension, and holonomy*. Second edition. Aspects of Mathematics, 1. Friedr. Vieweg&Sohn, Braunschweig, 1986. ISBN: 3-528-18501-5.
- [He] M. Herman, *Sur la conjugaison différentiable des difféomorphismes du cercle à des rotations*. Publ. Math. de I.H.E.S (1979), 5–233.
- [HHU1] F. Rodriguez Hertz, J. Rodriguez Hertz, and R. Ures, *Partially hyperbolic dynamics*. Publicações Matemáticas do IMPA. 28º Colóquio Brasileiro de Matemática. (IMPA), Rio de Janeiro, 2011. vi+132 pp.
- [HHU2] F. Rodriguez Hertz, J. Rodriguez Hertz, and R. Ures, *A survey of partially hyperbolic dynamics. Partially hyperbolic dynamics, laminations, and Teichmüller flow*. 35–87, Fields Inst. Commun., 51, Amer. Math. Soc., Providence, RI, 2007.
- [HHU3] F. Rodriguez Hertz, J. Rodriguez Hertz, and R. Ures, *Partial hyperbolicity in 3-manifolds*, [http://www.impa.br/opencms/pt/eventos/extra/2013\\_balzan/attach/apresentacao\\_maria\\_alejandra\\_hertz.pdf](http://www.impa.br/opencms/pt/eventos/extra/2013_balzan/attach/apresentacao_maria_alejandra_hertz.pdf).
- [HHU4] F. Rodriguez Hertz, J. Rodriguez Hertz and R. Ures, *Some results on the integrability of the center bundle for partially hyperbolic diffeomorphisms*. Partially hyperbolic dynamics, laminations, and Teichmüller flow, 103–109, Fields Inst. Commun., 51, Amer. Math. Soc., Providence, RI, 2007.
- [HHU5] F. Rodriguez Hertz, J. Rodriguez Hertz and R. Ures, *A non-dynamically coherent example on  $\mathbb{T}^3$* . arXiv:1409.0738.
- [HHU6] F. Rodriguez Hertz, J. Rodriguez Hertz and R. Ures, *Center-unstable foliations do not have compact leaves*. arXiv:1502.00125.

- [HP] M. Hirsch and C. Pugh, *Stable manifolds for hyperbolic sets*. Bull. Amer. Math. Soc. 75. 1969. 149–152.
- [HPS] M. Hirsch, C. Pugh and M. Shub, *Invariant manifold*. Lecture Notes in Mathematics, Vol. 583. Springer-Verlag, Berlin-New York, 1977. ii+149 pp.
- [Ho] O. Hölder, *Die Axiome der Quantität und die Lehre vom Mass*. Ber. Verh. Sachs. Ges. Wiss. Leipzig, Math. Phys. C1. 53, 1-64 (1901).
- [Ka] A. Katok, *Lyapunov exponents, entropy and periodic orbits for diffeomorphisms*. Publ. Math. I.H.E.S, 51 (1980), 137–173.
- [KN] V. Kleptsyn and M. Nalsky, *Stability of the existence of non-hyperbolic measures for  $C^1$  diffeomorphisms*. (Russian) Funktsional. Anal.i Prilozhen. 41 (2007), no.4, 30–45; translation in Funct. Anal. Appl.41(2007), no.4, 271–283.
- [LLS] C. Liang, G. Liu and W. Sun, *Approximation properties on invariant measure and Oseledec splitting in non-uniformly hyperbolic systems*. Trans. Amer. Math. Soc. 361 (2009), no. 3, 1543–1579.
- [L1] S. Liao, *An existence theorem for periodic orbits*. Acta Sci. Natur. Univ. Pekinensis, 1(1979), 1–20.
- [L2] S. Liao, *Obstruction sets. II*. Beijing Daxue Xuebao 1981, no. 2, 1–36. (in Chinese).
- [L3] S. Liao, *Certain uniformity properties of differential systems and a generalization of an existence theorem for periodic orbits*. Acta Sci. Natur. Univ. Pekinensis, 2(1985), 1–19.
- [LOS] J. Lindenstrauss, G. Olsen and Y. Sternfeld, *The Poulsen simplex*. Ann. Inst. Fourier (Grenoble) 28 (1978), no. 1, 91–114.
- [M1] R. Mañé, *Contributions to the stability conjecture*. Topology 17 (1978), 383–396.
- [M2] R. Mañé, *An ergodic closing lemma*. Annals of Mathematics, 116(1982), 503–540.
- [N] S. Novikov, *The topology of foliations*. (Russian) Trudy Moskov. Mat. Obšv. 14 1965 248-278.
- [O] V. Oseledets, *A multiplicative ergodic theorem: Lyapunov characteristic numbers for dynamical systems*. Trans. Moscow. Math. Soc. 19 (1968), 197–231.
- [Pei] M. Peixoto, *Structural stability on two-dimensional manifolds*. Topology 1 (1962) 101–120.
- [Pe] Y. Pesin, *Characteristic Lyapunov exponents and smooth ergodic theory*. Usp. Mat. Nauk. 32 (1977), 55–112.

## BIBLIOGRAPHY

---

- [PT] J. Plante and W. Thurston, *Anosov flows and the fundamental group*. Topology 11 (1972), 147–150.
- [Pl] V. Pliss, *On a conjecture due to Smale*. Differ. Uravn. 8 (1972), 262–268.
- [Po] R. Potrie, *Partial hyperbolicity and foliations in  $\mathbb{T}^3$* . J. Mod. Dyn. 9 (2015), 81–121.
- [Poul] E. Poulsen, *A simplex with dense extreme points*. Ann. Inst. Fourier. Grenoble 11 1961 83–87, XIV.
- [PSh] C. Pugh and M. Shub, *Stably ergodic dynamical systems and partial hyperbolicity*, Journal of Complexity 13 (1997), no. 1, 125–179.
- [PS] E. Pujals and M. Sambarino, *A sufficient condition for robustly minimal foliations*. Ergodic Theory Dynamic System.26 (2006), 281–289.
- [R] Ph. Robert, *Lectures on Choquet’s theorem. Second edition*. Lecture Notes in Mathematics, 1757. Springer-Verlag, Berlin, 2001.
- [Sh] M. Shub, *Topological transitive diffeomorphisms on  $\mathbb{T}^4$* . Lecture Notes in Math. vol.206, 39, Springer-Verlag, 1971.
- [Sig1] K. Sigmund, *Generic properties of invariant measures for Axiom A diffeomorphisms*. Invent. Math. 11, (1970), no.2, 99–109.
- [Sig2] K. Sigmund, *On dynamical systems with the specification property*. Trans. Amer. Math. Soc. 190 (1974), 285–299.
- [Sig3] K. Sigmund, *On the connectedness of ergodic systems*. Manuscripta Math. 22 (1977), no.1, 27–32.
- [Si] C. Simon, *A 3-dimensional Abraham-Smale example*. Proc. Amer. Math. Soc. 34 (1972), 629–630.
- [S] S. Smale, *Global stability questions in dynamical systems*. 1969 Lectures in Modern Analysis and Applications. I pp. 150–158 Springer, Berlin.
- [STV] W. Sun, X. Tian and E. Vargas, *Non-uniformly hyperbolic flows and shadowing*. J. Differential Equations 261 (2016), no. 1, 218–235.
- [SW] Z. Wang and W. Sun, *Lyapunov exponents of hyperbolic measures and hyperbolic periodic orbits*. Trans. Amer. Math. Soc. 362 (2010), no. 8, 4267–4282.
- [SY] W. Sun and Y. Yang, *Hyperbolic periodic points for chain hyperbolic homoclinic classes*. Discrete Contin. Dyn. Syst. 36 (2016), no. 7, 3911–3925.
- [W] P. Walter, *An introduction to ergodic theory*. Graduate Texts in Mathematics 79, Springer, New York-Berlin, 1982.
- [Wa] X. Wang, *Hyperbolicity versus weak periodic orbits inside homoclinic classes*. to appear in Ergodic theory and dynamical systems. arXiv:1504.03153.



- [We] L. Wen, *Homoclinic tangencies and dominated splittings*. Nonlinearity 15 (2002), no. 5, 1445–1469.
- [WZ] X. Wang and J. Zhang, *Ergodic measures with multi-zero Lyapunov exponents inside homoclinic classes*. arXiv:1604.03342.
- [WX] L. Wen and Z. Xia,  *$C^1$  connecting lemmas*. Trans. Amer. Math. Soc. 352, 11(2000), 5213–5230.
- [Z] J. Zhang, *Paritally hyperbolic diffeomorphism with one dimensional neutral center on 3-manifolds*. arXiv:1701.06176.

# Acknowledgements

First, I want to thank my parents who teach me to be positive in life and never to give up in the study. I also thank my brother Jintao Zhang and my sister Xiaojuan Zhang for support.

I'm grateful to my supervisors Prof. Lan Wen at Peking University and Prof. Christian Bonatti at Université de Bourgogne. Both of them are very patient with me during my doctoral study. Lan led me into the field of dynamical systems. At his class, Lan taught me from very basic theory to the splendid hyperbolic theory. To us students in the dynamical group, Lan helped us a lot, and we are impressed with his knowledge and his rigorous attitude on math. As his student, I met him at least once a week in his office to talk about math and he generously shared his idea with me. For Christian, definitely, I cannot finish this thesis without him. I first met him when he visited Peking University three years ago, and I was impressed with his intuition on math. For me, he is my mentor on research and a good friend in life. Many conversations about math were taken during our hiking in forests, drinking in a bar or the break of our biking between mountains. He also taught me lots of knowledge of foliation theory and patiently corrected me when I made mistakes. He generously shared his new ideas and new results on dynamics with us at our 'weekly reunion'. His kindness to me did not influence being restrictive on me. I still remember that he told me I should be responsible for what I have written down in a paper. I also owe him a lot for helping me with the administration of the University.

I would like to thank Prof. Shaobo Gan and Prof. Wenxiang Sun. They help me a lot not only on math but also on my daily life. I have learnt a lot from them in our seminars. They are good examples for me. I'm impressed with their enthusiasm and knowledge on math. Their rigorous style on math is admired by us. I specially thank Prof. Dawei Yang at Soochow University for his encouragement. I firstly met him when I was at Jilin University and he introduced me to Lan for studying dynamical systems, and this step has profound influence on my life.

I also want to express my gratitude to Jérôme Buzzi, Sylvain Crovisier and Lorenzo Díaz for their help. Jérôme and Sylvain offered me a chance to give a talk in their seminar, which is a good opportunity for me to let people know my work. Especially Sylvain, he is so kind, and every time I visited Université Paris-Sud 11, he always snatched up some time for me to ask questions. The comments made by Lorenzo on one of my papers helped me to strengthen my results. Also, it's a great honor for me that Sylvain and Lorenzo are the referees of this long thesis for Université de Bourgogne. When I wrote a paper, Rafael Potrie gave lots of useful comments and many suggestions on improving the presence of that paper, and I'm very appreciated for that. I would like to thank Adriana da Luz, Bruno Santiago, Sébastien Alvarez and Katsutoshi Shinohara, as I benefited a lot from the discussions with them. Especially Adriana, as my sister in math, she always encourages me when I encounter with critical difficulties in study. I also thank Ben-Michael Kohli and Martin Vogel for their help on the French administration, and their presence made the life in office much more relaxed than I thought.

I would like to thank Xiao Wen, Shengzhi Zhu, Chao Liang, Peng Sun, Fang Wang, Gang Liao, Pengfei Zhang, Baolin He, Yi Shi, Weisheng Wu, Xiaodong Wang, Yan Ren, Rusong Zheng, Yun Yang, Shirou Wang, Xiankun Ren, Cheng Cheng, Zhaonan Liu, Qianying Xiao, Xufeng Guo, Sixu Liu for their help and their accompany in our dynamical group. I have learnt a lot from them not only on math but also on life.

I want to express my gratitude to my Chinese friends in Dijon: Weiwei Pan, Yebai Hu, Xinyi Cheng, Yige Luo, Jin Huang, Yuhua Chen, Qianwen Zhang, Siqi Huang, Meiyun Xu, Shu Yan. So many times we cooked, hiked, traveled even got drunk together; with their accompany, I did not have to suffer from being alone in the daily life. I also want to express my gratitude to my friends at Peking University: Zhenxiao Xie, Yuancheng Xie, Liangze Li, Yi Gu, Lifan Guan, Xiaomeng Xu, Wenlong Wang, Weiming Shen, Xiaochun Shi, Guangjian Zhang, Longting Wu, Guohuan Zhao, Zhenhua Zhao, Xiangyun Meng, Liwei Zeng, Yue Wang, Honglei Lang. Thanks to them, I experienced wonderful life at Peking University!

At last, I want to thank China Scholarship Council for financial support during my stay in France.

# Publications

Ch. Bonatti and J. Zhang, *Transverse foliations on the torus  $\mathbb{T}^2$  and partially hyperbolic diffeomorphisms on 3-manifolds*. arXiv:1602.04355, to appear at Comm. Math. Helv.

Ch. Bonatti and J. Zhang, *On the existence of non-hyperbolic ergodic measure as the limit of periodic measures*. arXiv:1606.06119.

Ch. Bonatti and J. Zhang, *Periodic measures and partially hyperbolic homoclinic classes*. arXiv:1609.08489, to appear at Transaction of AMS.

X. Wang and J. Zhang, *Ergodic measures with multi-zero Lyapunov exponents inside homoclinic classes*. arXiv:1604.03342.

J. Zhang, *Partially hyperbolic diffeomorphism with one dimensional neutral center on 3-manifolds*. arXiv:1701.06176.